

C&G No. 3-A  
Deluxe Model  
Saw Trimmer

PRICE LIST OF



Saw Trimmers

And Other Products

NOVEMBER, 1938

Milwaukee Saw Trimmer Corporation

610-612 East Clybourn Street

Milwaukee, Wisconsin

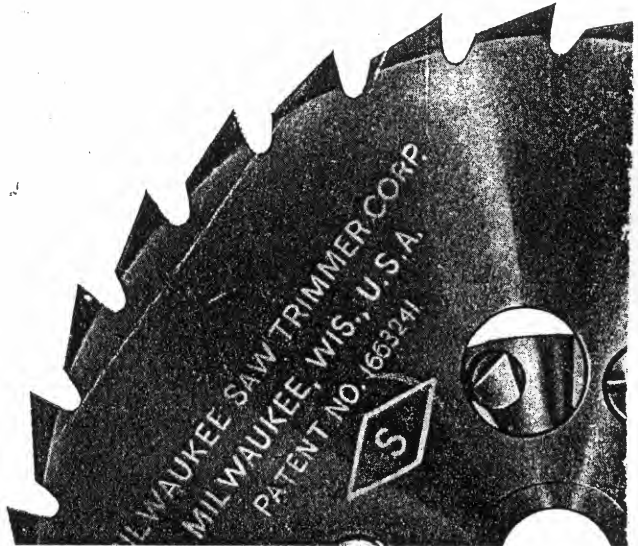

# C&G No. 3-A DELUXE MODEL SAW TRIMMER

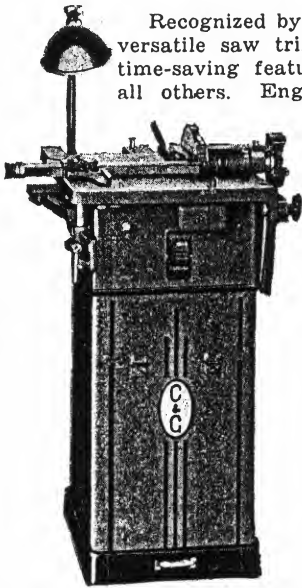

Recognized by printers everywhere as the most versatile saw trimmer ever designed. Its many time-saving features place it far in advance of all others. Engineered to eliminate waste motion, and constructed of the finest materials. You will find the conveniences you have always wanted in this machine.

Any compromise with accuracy and safety in selecting a saw trimmer can result only in ultimate dissatisfaction.

If your present equipment is old and obsolete, you are paying for one of these new models with lost time. Send for literature.

## SPECIFICATIONS:

Size of table.....	30"x18"
Height from floor.....	37½"
Net weight, complete equipment .....	387 lbs.
Shipping weight, domestic .....	525 lbs.

**Standard Equipment:** 73 Pica Gauge and Work Holder, Miter Gauge (standard), Miter Vise right and left hand, 6" Saw Blade Assembly (64 swaged teeth) with head and trimmer knives, 6" Saw Blade (64 swaged teeth), 4" Emery Wheel and Guard, Adjustable Lighting Fixture, Screw Driver, Open End Wrench and Spanner Wrench, No. 20 Waste Receptacle, iron wheels, V Belt, ¼ HP, 110 or 220 AC or DC Motor, with cord and plug. Price \$398.00.

**Deluxe Equipment:** 73 Pica Gauge and Work Holder, Miter and Lineup Gauge, Miter Vise right and left hand, 5½" Universal Saw Blade Assembly, with head and trimmer knives (30 formed teeth), 5½" Universal Saw Blade (only), 4" Emery Wheel and Guard, Saw Grinder for Universal Blades with Emery Wheel, Cutter Grinder, 135 Pica Extension Gauge, Extension Vise Jaw Bar, No. 20 Waste Receptacle, iron wheels, Screw Driver, Open End Wrench and Spanner Wrench, V Belt, ¼ HP, 110 or 220 volt, AC or DC motor, with cord and plug. Price \$475.00.

## MODEL NO. 3-A PARTS

E-1-1 Stop Pin (gauge frame and saw arm).....	\$ .30
E-88 Table Slot Bar (for shell plate work).....	5.50
E-89 Table Plug (use in place of PE-16).....	.30
E-31 Sub-Table, with oiler.....	6.60
E-32 Sub-Table Shaft, with screw.....	1.55
E-33 Washer.....	.05
E-34 Collar, with screw.....	.60
E-35 Saw Guard.....	7.80
E-70-1 Friction Collar Assembly.....	1.90
E-70 Friction Collar with screw and nut.....	1.60
E-71 Friction Collar Spring and Screw.....	.30
<b>E-4 SAW BRACKET ASSEMBLY (complete).....</b>	<b>54.00</b>
E-5 Saw Bracket, arm only.....	24.00
E-5-1-1 Lock Bushing Assembly.....	.95
E-5-3 Felt Wicking, for saw oiler.....	.50
C-112 Oiler Cover for saw.....	.35
C-170 Lock Pin for Mandrel.....	.45
C-171 Mandrel Pulley.....	3.50
C-172 Rear Retainer for Mandrel.....	.95
C-173 Front Retainer for Mandrel.....	.95
C-174 Spacer for Front Retainer.....	.50
C-175 Ball Bearing.....	2.10
C-161 Felt Washer.....	.10
C-25 Cover Plate.....	.25
C-26 Mandrel.....	7.50
C-29-1 Mandrel Nut and Washer.....	1.55
C-31 Emery Wheel Washer.....	.45
C-33 Emery Wheel Guard.....	1.85
C-34 Emery Wheel (½"x½"x4" plain).....	1.25
E-20 Index Pin.....	.65
E-21 Index Spring.....	.10
E-22 Index Pin Head (knurled).....	.35
E-23 Lock Screw.....	1.10
E-24 Lock Screw Washer.....	.05
E-25 Hand Nut.....	.50
<b>E-58 GAUGE AND WORKHOLDER ASSEMBLY.....</b>	<b>\$57.00</b>
E-58-1 Gauge Frame Assembly.....	34.50
E-59 Gauge Frame.....	22.00
E-59-1 Friction Plug.....	.20
E-59-2 Friction Screw.....	.20
E-59-3 Friction Spring.....	.20
E-60 Strip, with screws.....	1.05
E-61 Scale.....	1.40
E-62 Bearing.....	.30
E-63 Bearing Clamp with screw.....	.18
E-64 Pica Screw.....	4.90
E-65 Keeper with screws.....	.95

C-16 Index Dial with screws.....	1.55
C-14-1 Pica Screw Knob with screws.....	1.00
C-17 Index Dial Spring and Ball.....	.10
<b>E-38 PICA GAUGE ASSEMBLY.....</b>	<b>8.00</b>
E-39 Pica Gauge.....	4.65
E-39-1 Pica Gauge Pin.....	.05
E-40 Latch Nut.....	1.75
E-41 Latch Nut Screw.....	.55
E-42 Latch Nut Screw Spring.....	.25
E-43 Latch Lever.....	.70
E-44 Latch Lever Pin.....	.05
<b>E-45 VISE ASSEMBLY.....</b>	<b>11.00</b>
E-46 Vise Body, with screws and pin.....	3.55
E-48 Vise Cover Plate with screws.....	.80
E-49 Vise Clamp Bar.....	2.75
E-50 Vise Spring.....	.30
C-3 Vise Lever with oiler and wick.....	1.75
C-5 Eccentric Slide.....	.60
C-6 Eccentric Bearing.....	1.25
<b>E-54 VISE JAW BAR ASSEMBLY.....</b>	<b>3.50</b>
E-56 Vise Jaw Bar Dog (insert).....	.35
<b>E-54-1 EXTENSION VISE JAW BAR ASSEMBLY (special).....</b>	<b>4.50</b>
E-56 Vise Jaw Bar Dog (insert).....	.35
<b>E-72 MITER GAUGE ASSEMBLY.....</b>	<b>8.75</b>
E-73 Miter Gauge Base.....	2.75
E-74 Miter Gauge Screw.....	.95
E-75 Miter Gauge Nut.....	1.90
C-14-1 Miter Gauge Knob, with screw.....	1.00
C-16 Miter Gauge Index Dial, with screw.....	1.55
C-17 Index Dial Spring and Ball.....	.10
E-80 Miter Gauge Lock Screw.....	.35
E-81 Miter Gauge Lock Screw Knob, with screw.....	.25
<b>RL-1 RIGHT AND LEFT HAND MITER VISE ASSEMBLY.....</b>	<b>\$13.50</b>
RL-6 Slide Bearing, with screws.....	1.35
RL-7 Adjusting Screw.....	1.00
RL-8 Adjusting Screw Knob, with screw.....	.90
RL-10 Miter Slide Assembly, with screws, etc.....	5.70
RL-11 Miter Jaw Bar Assembly, with screws, etc. (Can be applied to Model No. 2).....	4.55
<b>ML-1 MITER AND LINEUP GAUGE ASSEMBLY.....</b>	<b>22.50</b>
ML-2 Gauge Arm.....	3.75
ML-3 Gauge Strip, with screws.....	.90
ML-4 Gauge Adjuster, with screws and nut.....	1.60
ML-5 Gauge Adjuster Knob with screws.....	.55
ML-6 Slide, with screws.....	5.45
ML-7 Gb.....	.25
ML-8 Slide Bar, with screw.....	.55
ML-9 Shaft.....	.30
ML-10 Base.....	4.80
ML-11 Keeper, with screw.....	.95
ML-12 Miter Gauge Screw.....	.85
C-17 Index Dial Spring and Ball.....	.10
C-16 Index Dial with screw.....	1.55
C-14-1 Knob, with screw.....	1.00
ML-19 Miter and Lineup Clamp Assembly (new style).....	1.45
ML-20 Clamp Sleeve, with screw.....	.55
ML-21 Clamp.....	.65
ML-22 Handle.....	.15
<b>PE-1-1 PICA EXTENSION GAUGE ASSEMBLY (complete).....</b>	<b>31.50</b>
PE-1 Pica Extension Arm Assembly.....	24.25
PE-2 Arm.....	9.65
PE-3 Pica Screw.....	4.90
E-65 Keeper, with screw.....	.95
C-16 Index Dial with screws.....	1.55
C-17 Spring and Ball.....	.10
C-14-1 Knob, with screw.....	.95
PE-10 Bearing.....	.30
E-63 Bearing Clamp, with screw.....	.18
PE-12 Scale, 73 to 135 picas.....	1.40
PE-13 Clamp Screw and Washer.....	1.30
PE-15 Handle.....	.40
PE-16 Shaft and Screw.....	1.95
PE-17 Washer.....	.95
PE-17-1 Leather Washer.....	.65
<b>PE-18 PICA GAUGE SLIDE ASSEMBLY.....</b>	<b>7.25</b>
PE-19 Pica Gauge Slide.....	3.90
E-39-1 Pica Gauge Pin.....	.05
E-40 Latch Nut.....	1.75
E-41 Latch Nut Screw, with screw.....	.25
E-42 Latch Nut Screw Spring.....	.25
E-43 Latch Lever.....	.70
E-44 Latch Lever Pin.....	.05
Open End Wrench.....	.60
Screw Driver.....	.50
C-176 Spanner Wrench.....	.75
C-129 Toggle Switch.....	1.30
C-132 No. 20A Plain Outlet Box Cover, punched.....	.25
E-113 Adjustable Lighting Fixture.....	5.40
C-134 Cord 10 ft. long.....	.85
E-36 Drive Sheave for motor.....	1.75
E-37 V-belt.....	1.90

# DIAGRAM OF PARTS FOR C&G No. 3-A SAW TRIMMER

All Nos. 3 and 3-A Parts Are Interchangeable

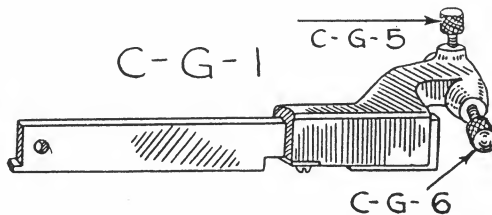
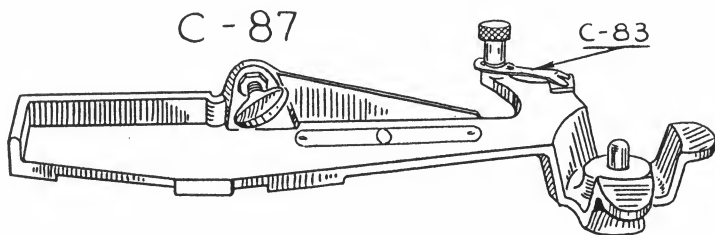
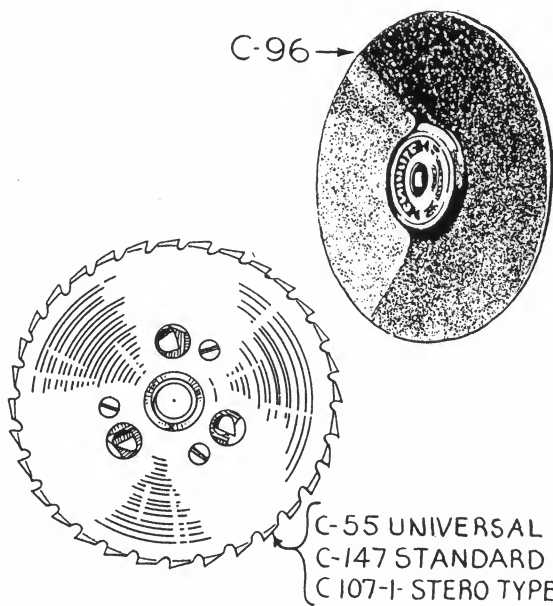
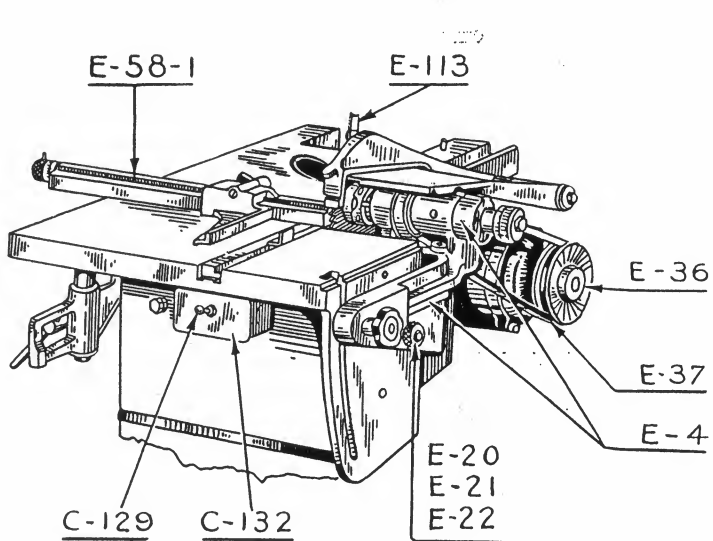
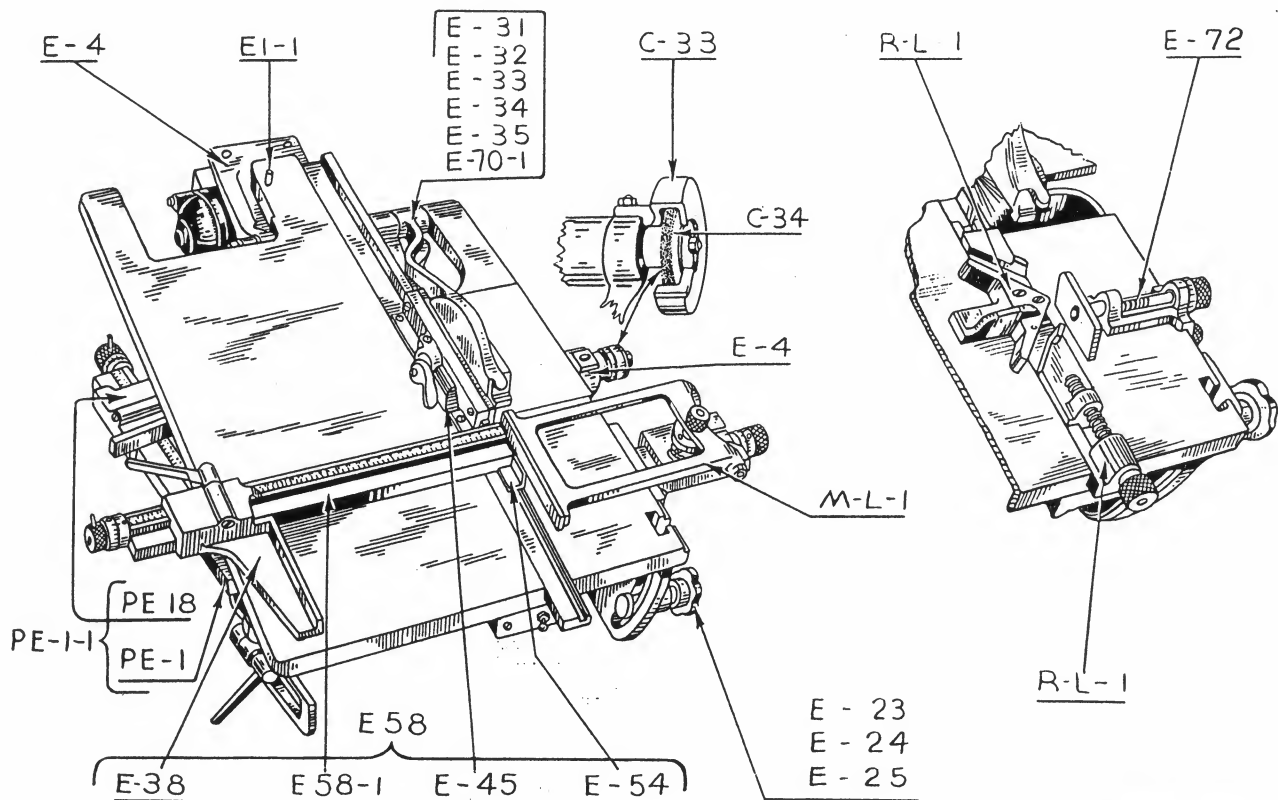

# C&G No. 2 PEDESTAL

# MODEL SAW TRIMMER

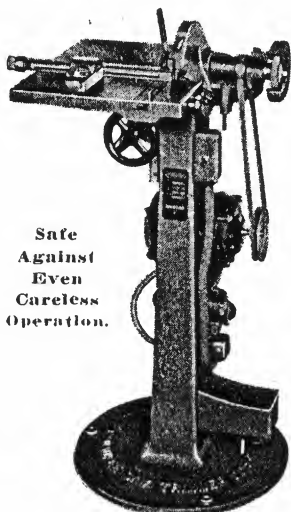

Sturdiness of construction and low cost of operation is evidenced by reports from thousands of No. 2 C&G saw trimmer users throughout the United States and foreign countries.

It is fast in action, positive in accuracy, constructed of the finest materials, and its safety features reduce the possibility of injury to the operator to a minimum.

Send for literature.

### SPECIFICATIONS:

Size of table.....14½"x18"  
 Height from floor.....36"  
 Net weight .....220 lbs.  
 Shipping weight, domestic .....290 lbs.

**Standard Equipment:** 60 Pica Gauge and Work Holder, Miter Vise, Miter Gauge, Side Table Extension, Sub-Table, Dust Basin, 4" Emery Wheel and Guard, 6" Saw Blade Assembly (64 swaged teeth with head and trimmer knives), 6" Saw Blade (64 swaged teeth), Spanner Wrench, Open End Wrench, Screw Driver, V-Belt, Motor ¼ HP, 110 or 220 volt, AC or DC, with cord and plug. Price \$250.00.

**Universal Equipment:** 60 Pica Gauge and Work Holder, Miter Vise, Miter Gauge, Side Table Extension, Sub-Table, Dust Basin, 4" Emery Wheel and Guard, 5½" Universal Saw Blade (30 formed teeth) with head and trimmer knives, Saw Grinder for Universal Blades with Emery Wheel, Trimmer Grinder, Saw Blade Oiler, Spanner Wrench, Open End Wrench, Screw Driver, V-Belt, Motor ¼ HP, 110 or 220 volt, AC or DC, with cord and plug. Price \$273.00.

### MODEL NO. 2 PARTS

C-43 Rear Table Extension, installed at factory.....	\$21.55
C-61 Sub-Table .....	4.50
C-62 Side Table Extension .....	2.75
C-80 Chip Basin .....	3.50
<b>C-79 TABLE CLAMP ASSEMBLY (complete).....</b>	
C-68 Stud, with washer .....	2.35
C-66 Lock Nut .....	.25
C-67 Lock Lever .....	.90
C-67 Lock Lever .....	1.20
<b>C-78 ELEVATING BRACKET ASSEMBLY (complete).....</b>	
C-74 Elevating Bracket, with screws.....	8.40
C-70 Hand Wheel .....	3.25
C-71 Elevating Pinion and Shaft, with taper pin.....	1.75
C-75 Friction Cone .....	2.55
C-76 Friction Cone .....	.50
C-76 Friction Cone Spring.....	.30
C-77 Friction Cone Pin.....	.05
<b>C-89 MOTOR BRACKET ASSEMBLY (complete).....</b>	
C-167 Motor Bracket (for Century Motor), screws.....	8.35
C-54 Motor Bracket Pin, with cotter pins.....	6.85
C-65 Take-up Stud, with nut and washer.....	.40
C-64 Take-up Hand Nut .....	.60
C-64 Take-up Hand Nut .....	.50
<b>C-186 UNIVERSAL MOTOR BRACKET ASSEMBLY (complete).....</b>	
C-118 Motor Bracket, with bolts and washers.....	9.20
C-119 Motor Bracket Bar, with bolts and washers.....	6.15
C-54 Bracket Pin, with cotter pins.....	2.65
C-54 Bracket Pin, with cotter pins.....	.40
<b>C-69 TABLE, WITH SCREWS.....</b>	
C-63 Table Elevating Rack, with screws.....	36.38
C-49 Shoulder Thumb Screw, for miter gauge.....	.87
C-184 Table Slot Bar, for shell plate work.....	.35
C-184 Table Slot Bar, for shell plate work.....	4.25
<b>C-106 SAW GUARD AND STUD ASSEMBLY (complete).....</b>	
C-38 Saw Guard .....	5.50
C-102 Stud for Saw Guard, pin and nut.....	4.50
C-103 Spring for Saw Guard, with washers.....	.70
C-103 Spring for Saw Guard, with washers.....	.30
<b>C-94 GAUGE AND WORKHOLDER ASSEMBLY (complete).....</b>	
C-23 Gauge Frame Assembly .....	47.50
C-12 Gauge Frame, with screws .....	29.20
C-143 Plug .....	20.05
C-13 Pica Scale, with screws .....	.40
C-14 Pica Screw .....	.40
C-14-1 Knurled Knob, with screw .....	4.90
C-15 Keeper, with screws .....	1.00
C-16 Point Index, with screw .....	.80
C-17 Spring and Ball .....	1.55
C-17 Spring and Ball .....	.10
<b>C-22 VISE ASSEMBLY.....</b>	
C-1 Vise Body, C-8 Pin .....	8.55
C-2 Cover Plate, with screws .....	2.75
C-3 Vise Handle, with Gits Oiler No. 501.....	.35
C-3 Vise Handle, with Gits Oiler No. 501.....	1.70

C-4 Vise Clamp Bar.....	1.65
C-5 Eccentric Slide .....	.60
C-6 Eccentric Bearing .....	1.25
C-7 Vise Spring .....	.25
<b>C-39 PICA GAUGE ASSEMBLY.....</b>	
C-18 Pica Gauge .....	6.00
C-19 Latch Nut Lever.....	4.00
C-20 Latch Nut .....	.35
C-21 Latch Nut Spring.....	1.50
C-21 Latch Nut Spring.....	.15
<b>C-97 VISE JAW BAR ASSEMBLY.....</b>	
C-97 VISE JAW BAR ASSEMBLY.....	3.75
<b>C-97-1 EXTENSION VISE JAW BAR ASSEMBLY (clamps 8-in.)</b>	
C-97-1 EXTENSION VISE JAW BAR ASSEMBLY (clamps 8-in.)	6.00
<b>C-168 MANDREL BEARING ASSEMBLY (complete).....</b>	
C-169 Mandrel Bracket (screws and Gits No. 501 Oilers).....	33.85
C-25 Cover Plate .....	9.40
C-170 Lock Pin for Mandrel .....	.23
C-171 Mandrel Pulley .....	.45
C-172 Rear Retainer for Mandrel .....	3.50
C-173 Front Retainer for Mandrel .....	.95
C-174 Spacer for Front Retainer .....	.95
C-175 Ball Bearing .....	.50
C-161 Felt Washer .....	2.10
C-26 Mandrel, with key and nut .....	.10
C-29-1 Mandrel Nut (C-29 and C-122 combined) .....	7.50
C-31 Emery Wheel Washer .....	1.55
C-33 Emery Wheel Guard .....	.45
C-34 Emery Wheel .....	1.85
C-34 Emery Wheel .....	1.25

<b>C-50 MITER GAUGE ASSEMBLY (complete).....</b>	
C-46 Miter Gauge Base .....	8.75
C-47 Miter Gauge Nut .....	2.45
C-48 Miter Gauge Pica Screw .....	1.90
C-16 Point Index .....	1.75
C-17 Spring and Ball .....	1.55
C-14-1 Knurled Knob with screw .....	.10
C-14-1 Knurled Knob with screw .....	1.00
<b>C-45 MITER VISE ASSEMBLY.....</b>	
C-41 Miter Vise Jaw .....	4.00
C-42 Miter Vise Base, with screw and pin.....	1.40
C-44 Miter Vise Hinge Pin.....	2.35
C-44 Miter Vise Hinge Pin.....	.25

C-129 Toggle Switch .....	1.25
C-132 Outlet Box Cover, punched for switch.....	.25
C-134 Type "S" Cord, 10 ft. long with plug.....	.85
C-178 Drive Sheave for motor .....	1.75
C-177 V-Belt .....	1.80
C-60 Flat Leather Belt, 48 in. ....	2.25
C-108 Open End Wrench.....	.60
C-109 Screw Driver .....	.50
C-176 Spanner Wrench .....	.75

<b>C-181 SAW OILER ASSEMBLY.....</b>	
C-111 Saw Oiler Bracket, with screws and washer.....	3.75
C-112 Saw Oiler Cover.....	3.05
C-113 Saw Oiler Wick.....	.35
C-113 Saw Oiler Wick.....	.35

<b>F-25 150 PICA GAUGE ASSEMBLY (complete).....</b>	
P-1-1 Gauge Body, Spacing Rod and Guide .....	21.00
P-3 Indicator Plate with screws .....	6.50
P-5-1 Clamp Bracket Assembly .....	.85
P-9 Pica Nut .....	3.25
P-12-1 End Gauge Assembly .....	.60
P-19 Filler Block with pin .....	5.10
P-19 Filler Block with pin .....	1.10

### SUPPLIES---MODELS 1, 2, 3 AND 3-A

(Always give serial number of machine)

<b>C-107-1 STEREOTYPE SAW BLADE ASSEMBLY (complete).....</b>		
C-107 Stereotype Saw Blade (32 swedged teeth) 6-in. diam.....	<del>4.50</del>	10.00
C-80 Saw Head with screws.....	<del>3.00</del>	4.50
C-35 Trimmers @ 40c (set of 3).....	1.20	
C-36 Trimmer Clamps (set of 3).....	.40	
<b>C-117 STANDARD SAW BLADE ASSEMBLY (complete).....</b>		
C-52 Saw Blade (64 swedged teeth) 6" diam.....	<del>9.00</del>	9.50
C-80 Saw Head with screws.....	<del>3.00</del>	4.00
C-35 Trimmers @ 40c (set of 3).....	1.20	
C-36 Trimmer Clamps (set of 3).....	.40	
<b>C-55 UNIVERSAL SAW ASSEMBLY (complete).....</b>		
C-53 Universal Saw Blade (30 formed teeth) 5½" diam.....	<del>12.50</del>	14.50
C-57 Universal Saw Head with screws.....	<del>8.00</del>	9.00
C-35 Trimmers @ 40c (set of 3).....	3.90	
C-36 Trimmer Clamps (set of 3).....	1.20	
C-36 Trimmer Clamps (set of 3).....	.40	
<b>C-87 UNIVERSAL SAW BLADE GRINDER (complete).....</b>		
C-82 Shoulder Screw and washer.....	12.50	
C-83 Flat Spring .....	.45	
Thumb Screw and Lock Nut.....	.45	
C-96 Dished Emery Wheel.....	.20	
C-96 Dished Emery Wheel.....	2.25	
<b>CG-1 TRIMMER GRINDER ASSEMBLY (complete).....</b>		
CG-5 Trimmer Clamp Screw.....	5.75	
CG-6 Trimmer Adjusting Screw.....	.25	
CG-6 Trimmer Adjusting Screw.....	.25	
<b>LS-10 LOW SLUG ASSEMBLY (complete).....</b>		
LS-4 Register Plate .....	15.00	
LS-4 Register Plate .....	1.15	
C-34 Standard Emery Wheel ½"x½"x4".....	1.25	
C-153 Saw Swage .....	1.50	

# DIAGRAM OF PARTS FOR C&G No. 2 SAW TRIMMER

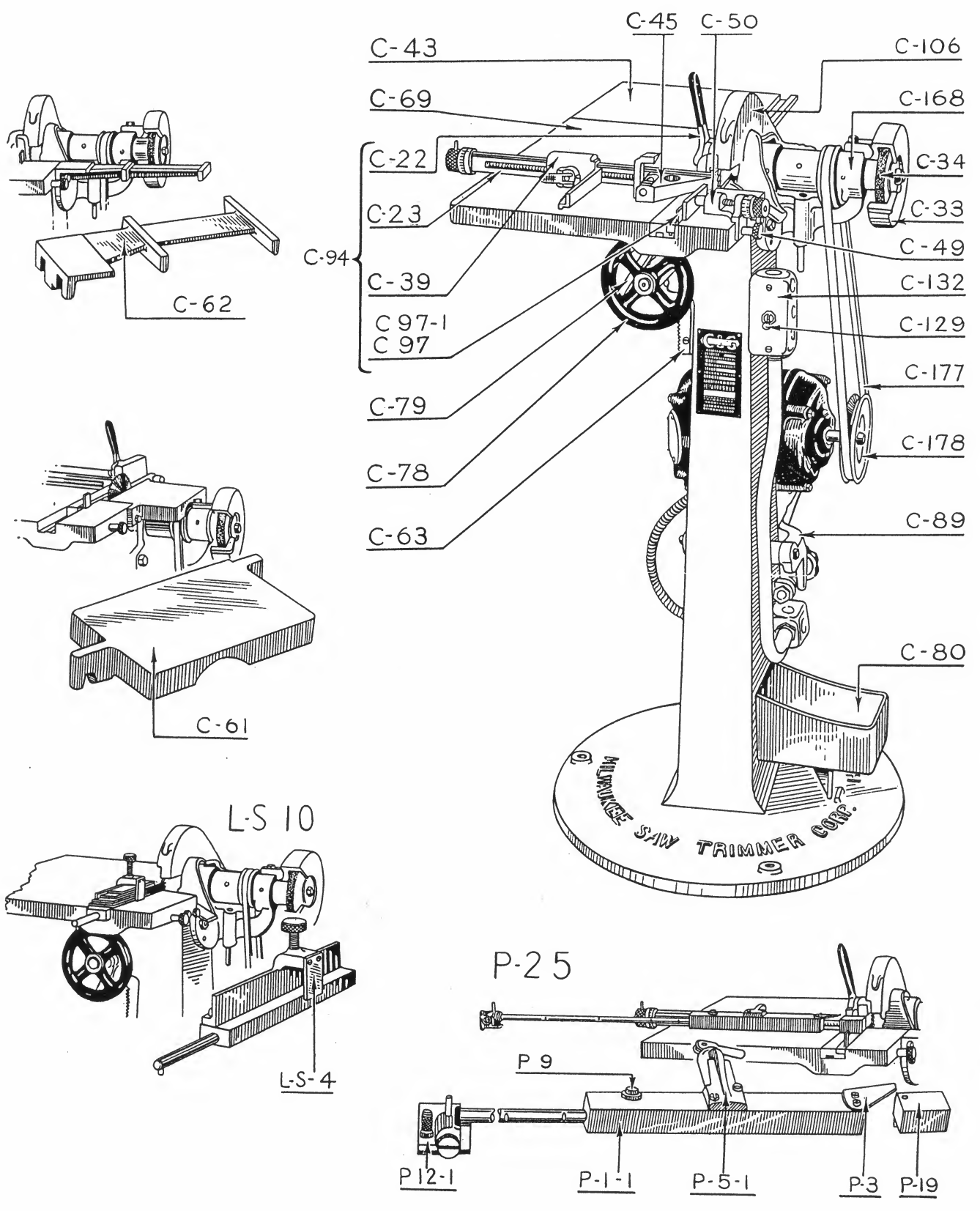

## IMPROVED C&G ANGLE GAUGE

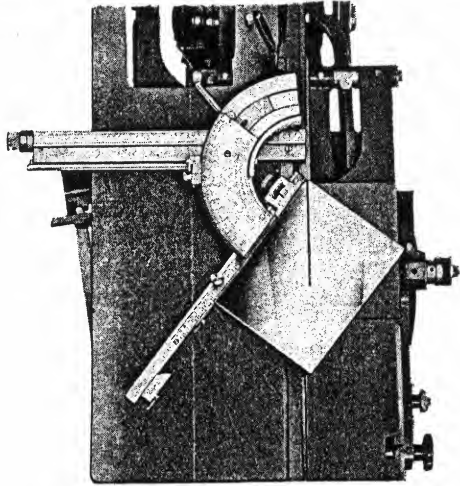

Angle Gauge in position for cutting. Clamping provided for strip materials to lengths as short as one pica, and of all widths to 72 points. Handles angles from 2 to 88 degrees. Applied only on Nos. 3 and 3-A. Price \$75.00.

Protractor, for use with Angle Gauge, 30c.

### IMPORTANT INFORMATION

Where possible wear might effect cut, trim and miter on C&G saw trimmers, adequate provision has been made to take care of these adjustments.

Loaner service for Gauge Frame Assembly repairs on all C&G saw trimmers, and for Mandrel Assemblies on Models 1 and 2. You pay only the express charges on loaners. This enables you to have use of your machine while work is being done at our factory, and assures a first-class job.

Always include serial number of your machine when ordering C&G parts and supplies.

When either Nos. 2, 3 or 3-A models are ordered equipped with Universal saw blades, credit will be allowed for Standard blades.

When ordering new C&G saw trimmers be sure to furnish complete motor information; otherwise it might delay shipment.

All prices quoted in this folder are subject to change without notice.

Motors are long hour duty, and if machines are equipped with 110 AC or DC current, standard lights can be used in lighting fixture.

Oiling Device should always be used with Universal saw blades. It spreads a thin film of oil on the blade, preventing metal from adhering to teeth, and also helps the cutting action. It is included in the deluxe and universal equipments.

When Miter and Linup Gauge is purchased with No. 3-A machine, credit will be allowed on Standard miter gauge.

If Right and Left Hand Miter Vise is purchased with No. 2 machine, credit will be allowed on Standard miter vise.

Shell plates require a smooth table top. A slot bar can be furnished for Nos. 3 and 3-A at \$5.50, and for No. 2 at \$4.50.

The Saw Grinder, for sharpening Universal blades on the machine, should always be purchased with these blades.

All materials used in C&G equipment are of the highest grade, and castings are heat treated to prevent distortion.

## C&G ROUTER, JIGSAW AND TYPE-HIGH

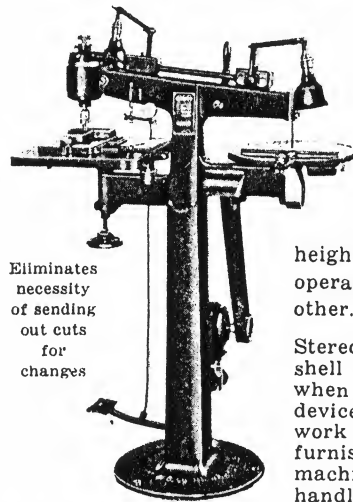

Eliminates necessity of sending out cuts for changes

Designed to enable printers to handle plate changes and corrections. You can drill, rout high spots, change key numbers, notch, mortise either outside or inside, and finish cuts to exact type height. Each end of machine operates independent of the other. Operate from light socket.

Stereotype casts — typehigh or shell plate — jigsawed readily when blade is lubricated. Oiling device furnished where this work is to be done. Subtable furnished on router end of either machine where shell plates are handled. Send for literature.

Specifications: Height overall 50", length 39", width 23", size of tables, jigsaw 17" x 15", router 18" x 18", height of table from floor 39", distance from column to center of router or jigsaw table 11". Net weight 290 lbs., domestic shipping weight 385 lbs.

Standard equipment: 2 each Nos. 1, 2 and 3 jigsaw blades, and 1 each 1/16, 1/8, 3/16, 1/4, 1/2, and 3/4 inch router bits, 5 drills, 1 No. 2 broach, also dial indicator, typehigh gauge, work vice, lighting fixtures, switches, belt and 10 feet cord and plug. Price \$420.00, 39¢

Attachments: Circle Cutting attachment, Ellipse Cutting attachment.

Shipped complete, ready to run with 1/4 H.P. Universal motor for router, and 1/4 H.P. repulsion motor for jigsaw.

## C&G ROUTER AND TYPE-HIGH

Built for those who have but infrequent use for a jigsaw. If an office has even a moderate amount of mortising and irregular cutting, they should choose the complete Router and Jigsaw. Drilling, routing, and typehigh planing operations are the same for either machine. Send for literature.

Specifications: Height overall 50", length 25", width 18", size of table 18" x 16", height of table from floor 39", distance from column to center of table 11". Net weight 240 lbs., domestic shipping weight, 300 lbs.

Standard equipment: 1 each 1/16, 1/8, 3/16, 1/4, 1/2, and 3/4 inch router bits, 5 drills, also dial indicator, typehigh gauge, work vise, lighting fixture, switch, belt, and 10 feet cord and plug. Price \$290.00, 26¢

Attachments: Circle Cutting attachment, Ellipse Cutting attachment.

Shipped complete, ready to run with 1/4 H.P. Universal motor.

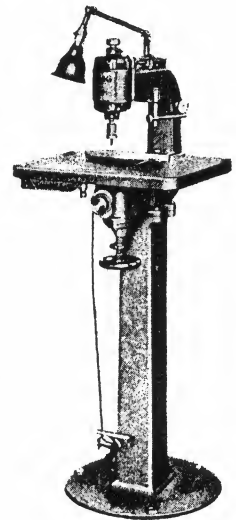

New style improvements that can be applied to all outstanding C&G Router, Jigsaw and Typehigh machines:

R 14-1 Jig Connecting Rod (ball bearings).....	\$ 8.00
R 48-1 Lower Slide Assembly .....	6.65
R 51-2 Crank Shaft Assembly, one piece steel construction .....	8.50

R 94 Dial Indicator .....	10.00
R 106 Motor Clamp Bracket .....	8.00
R 108-1 1/4 H.P. Universal Router Motor Assembly....	55.00

Intense competition in advertising creates a wide demand for the unusual. You can make your own tint blocks with the ellipse and circle attachments. Striking designs can be achieved, and cutting circular, and especially oval tint blocks, each geometrically exact, is the most unusual thing ever achieved on a router.

**SAVE** by buying Jigsaw Blades, Router Bits or Broaches in dozen lots. A selection of the different size Router Bits to make up a dozen lot is permissible. This applies also to Jigsaw Blades or Broaches.

**Jig-saw Blades**  
Full Size

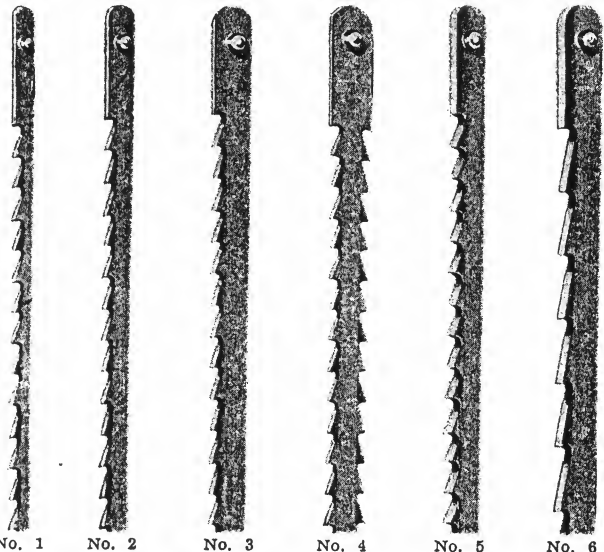

Jig-saw Blade	Width, Points	Thick., Pts.	Price, Each	Per Dozen
No. 1	8	2	25c	\$2.50
No. 2	12	3	25c	2.50
No. 3	16	3	25c	2.50
No. 4	17	3	35c	3.50
No. 5	17	5	45c	4.50
No. 6	20	6	50c	5.00

No. 5 Jigsaw Blade is extra heavy and specially designed for notching and sawing to gauge. Lighter ones may swerve in sawing a straight line.

No. 6 is for type-high stereo plates. Work should be fed slowly and blade oiled frequently. Extra heavy and strong.

With the proper blades you will never have any difficulty with the most exacting work. Be sure they are C&G—you will get more use and satisfaction.

**Router Bits**  
Full Size

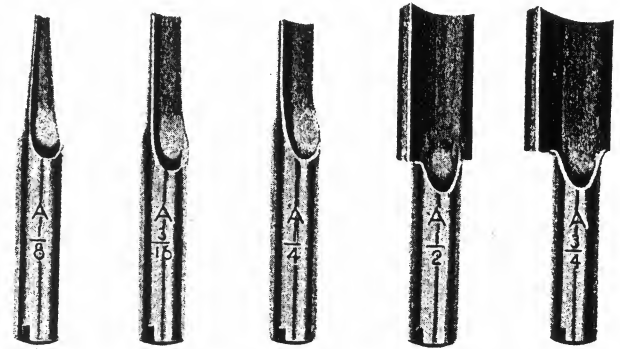

Router Bits shown are for a wide range of work. Made to the highest limit of toughness and endurance. Those marked by letters "A" and "D" are for cutting wood, electros, stereos and soft zinc. For cutting hard zinc or copper order those marked "B." Sharpen Router Bits by grinding end of bit, preserving original angle. All Drills and Router Bits have 1/4" shank.

**PRICES**

Style	Doz.	Each
Style "A"—1/16, 1/8, 3/16, 1/4.....	\$4.00	\$.45
Style "A"—1/2 .....	8.40	.90
Style "D"—3/4, 2 lip.....	16.20	1.60
Style "B"—1/16, 1/8, 3/16, 1/4.....	4.00	.45

**Broaches**  
Full Size

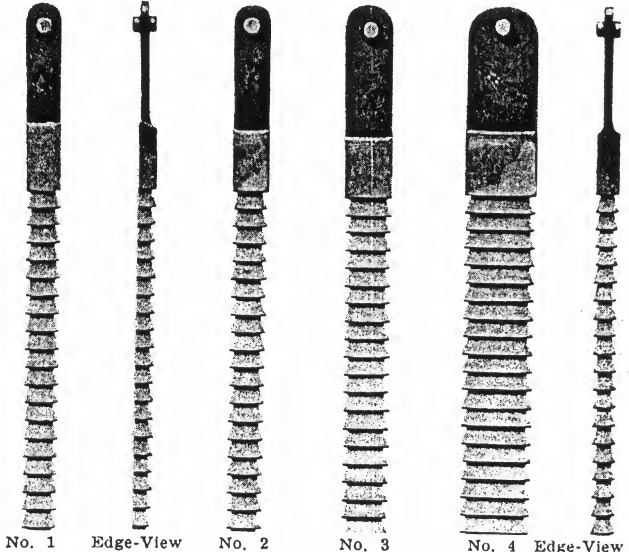

Broach	Width, Points	Thick., Pts.	Price, Each	Per Dozen (Assorted)
No. 1	14	7	\$2.75	\$30.00
No. 2	14	9	2.75	30.00
No. 3	18	9	2.75	30.00
No. 4	24	9	2.75	30.00

Note: Dimensions of all C&G Cutting Tools given in points are approximate.

These finishing tools are used to square the walls of inside mortises. In finishing wood, wood-mounted electros and stereos, the maximum cut should not exceed one point; for wood-mounted halftones, zincs and solid metal bases, it should not exceed one-half point. No time is saved by taking off too much at one time. Following these suggestions will make the work better and the tools last longer. Have a complete assortment on hand and be sure they are C&G.

**Drills**  
Full Size

Price each, 75c; \$8.00 per dozen.

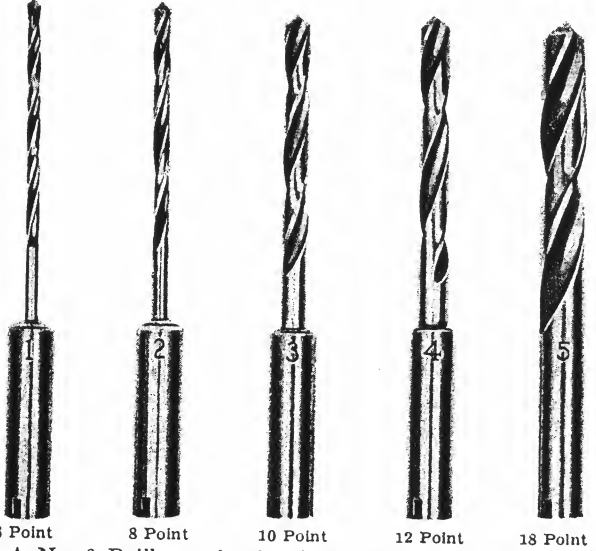

A No. 6 Drill can be furnished. The hole drilled with it is large enough to accommodate the Nos. 3, 4, 5 and 6 Jigsaw Blades. Price same as above.

All equipment, accessories and supplies sold f. o. b. Milwaukee, Wisconsin. Prices subject to change without notice.

## SAW GRINDING UNIT

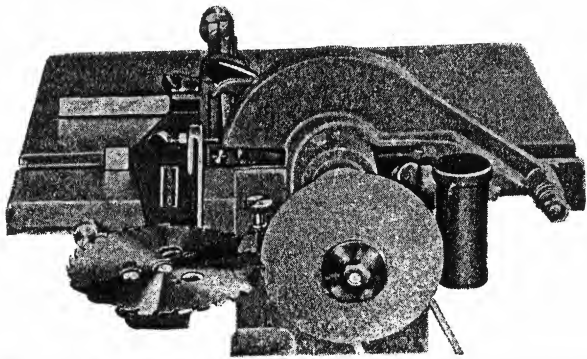
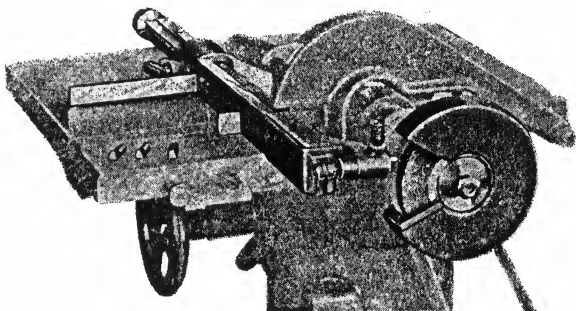

Illustration shows Universal saw blade in position for sharpening. This unit can be applied on all C&G Saw Trimmers for sharpening Universal saw blades. The Oiling Device is also shown in position for the No. 2 machine. This feature is built into the Nos. 3 and 3-A models. Universal saw blades, grinding unit and oiling device pay for themselves many times in direct savings over the Standard blades which must be swaged and filed. Price \$12.50.

## TRIMMER GRINDER



Positive accuracy on the saw trimmer can be obtained only when the trimmers are kept sharpened and in good condition. The Trimmer Grinder makes it easy to keep trimmers sharp. The attachment definitely positions trimmers for the grinding operation and insures proper cutting angles while sharpening. Several sets of trimmers may be sharpened in a few minutes. The Trimmer Grinder is easy to operate and requires no special experience. It is extra equipment that will save its small investment. It may be placed on outstanding machines. Price \$5.75.

## UNIVERSAL SAW BLADE

(Illustration on front page)

Exclusive for C&G saw trimmers. Developed and patented to eliminate the need of changing saw blades when cutting hard materials. It has 30 formed teeth and is made of finest high speed tool steel. Due to the shape of the teeth the side clearance is maintained during its life. Cuts all materials commonly used in composing rooms, and stays sharp many times longer than ordinary saw blades when cutting softer materials. Price \$8.00.

## C&G STRIP MATERIAL CABINET

Every saw trimmer owner can use this cabinet to advantage. Speeds production, places strip material where it belongs. Built of heavy sheet steel, height 34", length 24½", width 13", net weight 215 lbs., shipping weight 293 lbs. Holds over 1200 lbs of metal, and can be used with any saw trimmer. Top makes convenient work bench. Opening at top for tools and accessories or additional strip and basing material. Price \$35.00.

### OUR GUARANTEE

Every C&G product is performance-guaranteed, and you can place your order with an understanding that you have the privilege to return equipment within ten days should you find it in any way misrepresented by us, and any money paid on same will be refunded.



## C&G WASTE RECEPTICLES

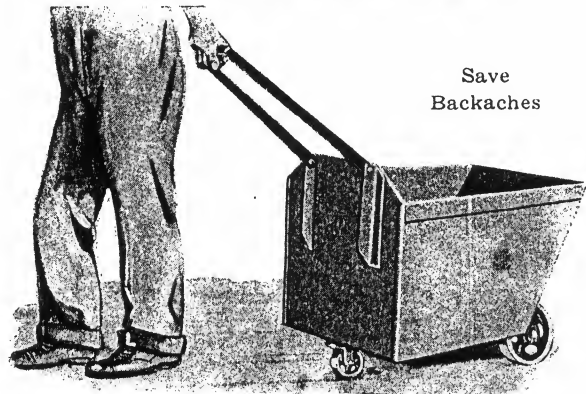

Keep your floors clean with waste receptacles — and save metal by keeping it clean. Handy for dump, makeup and ad room.



No. 20

No. 20—16" high, 16" long, 11" wide; handle swivels to height of 26". Made of heavy sheet steel; has capacity of 1567 cu. in. Shipping weight 41 lbs. Price, with iron wheels \$14.50; with rubber tired wheels \$17.50.

No. 20 regular equipment with No. 3-A.

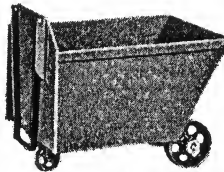

No. 21

No. 21—14" high, 19" long, 13½" wide; back wall from which handle projects is 16" high; handle swivels to 26". Made of same material, capacity 2000 cu. in. Shipping weight 52 lbs. Price, with iron wheels \$16.50; with rubber tired wheels \$19.50.

No. 21 is an accessory for No. 3

## MITER AND LINEUP GAUGE

The Miter and Line-up Gauge on No. 3 and 3-A has a number of uses. It is to basically set all the gauges accurately, and definitely registers all rule sizes up to 72 points wide for mitering. Lines up odd indentions so that five inches of slugs can be sawed at one time. Display slugs regardless of size, such as cast on Ludlow, All-Purpose Linotype, and Intertype can be registered for separating words or characters. It also affords a definite straight edge for lining up plate matter. Gauge may be adjusted to three positions up and down—first, for mitering; second, for lining up plate matter; third, for registering display slugs or aligning odd indentions. The sawed part of slug remains on sub-table. Micrometer adjustment permits definite movement from right to left. Price \$22.50.

## C&G SEE-THROUGH SAW GUARD

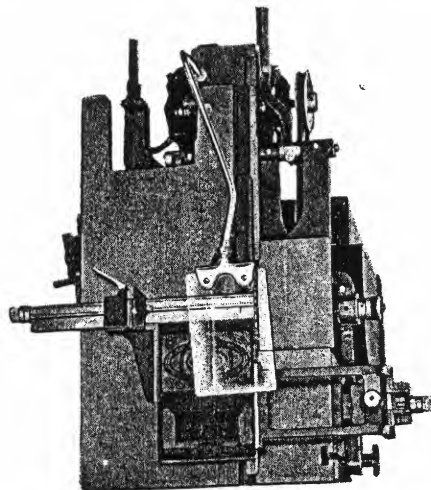

Easy to attach, swivels to side so regular guard can be used. Applies to Nos. 2, 3 and 3-A C&G Saw Trimmers. Price \$7.50.

**MILWAUKEE SAW TRIMMER CORPORATION**

610-612 E. Clybourn St.  
Milwaukee, Wis.