

NACOMATIC

Effective: 08-April-2010

Expires: 06-May-2010

Your Ad Here

~ 100,000 Page views/month

Contact:

Doug Ranz

248-318-0011

NACOMATIC@hotmail.com

Warranty

I make absolutely no warranty nor guarantee whatsoever about the accuracy, availability, applicability and/or correctness of any of the information in this document.

The official, original NACO documents are available for your downloading pleasure from: <http://naco.faa.gov/index.asp?xml=naco/onlineproducts>

Copyright

This compilation is protected by US copyright laws and international copyright treaties.

Limitations

The sale, hosting and/or distribution of this document in any and all forms, is prohibited.

Release from Liability

All users of this compilation must agree to be legally bound hereby, that Douglas R. Ranz ("Released Party") SHALL NOT BE LIABLE FOR MY DEATH OR INJURY TO MY PERSON, OR FOR ANY LOSS FOR DAMAGE TO MY PROPERTY OR REPUTATION caused in any manner whatsoever, whether attributable to the negligence of the Released Party, or for any other reason, occurring during the time that I am operating an aircraft.

I do hereby waive any right of action against the Released Party from any and all causes or claims that I may have against them from the beginning of time. I further agree not to sue on any such cause or claim. This agreement shall not release liability for gross negligence or willful misconduct of the Released Party. I agree to indemnify and hold the Released Party harmless for any losses, judgments, damages or fees he may incur, including but not limited to attorneys fees, arising out any lawsuit related to the planning, flight and/or enforcement of or legal challenge to this agreement. It is my intention that this agreement be interpreted and enforced to the maximum extent allowed by Michigan law.

SD Min Alt#1	-	5
SD Min Rdr#1	-	10
SD Min TO#1	-	13
OD8	-	45
1D1	-	58
49B	-	110
84D	-	44
9D1	-	47
9V6	-	57
9V9	-	42
ABR	-	26
ATY	-	112
BKX	-	37
BTN	-	35
EFC	-	34
FSD	-	94
HON	-	49
HSR	-	48
ICR	-	121
IEN	-	77
LEM	-	54
MBG	-	66
MDS	-	55
MHE	-	61
MKA	-	59
PHP	-	69
PIR	-	70
RAP	-	78
RCA	-	84
SPF	-	108
VMR	-	111
YKN	-	124

SD Mins - Alternates #1	-	5
SD Mins - Radar #1	-	10
SD Mins - Take-Off #1	-	13
ABERDEEN	ABR	- 26
BELLE FOURCHE	EFC	- 34
BRITTON	BTN	- 35
BROOKINGS	BKX	- 37
CHAMBERLAIN	9V9	- 42
EAGLE BUTTE	84D	- 44
GETTYSBURG	0D8	- 45
GREGORY	9D1	- 47
HOT SPRINGS	HSR	- 48
HURON	HON	- 49
LEMMON	LEM	- 54
MADISON	MDS	- 55
MARTIN	9V6	- 57
MILBANK	1D1	- 58
MILLER	MKA	- 59
MITCHELL	MHE	- 61
MOBRIDGE	MBG	- 66
PHILIP	PHP	- 69
PIERRE	PIR	- 70
PINE RIDGE	IEN	- 77
RAPID CITY	RAP	- 78
RAPID CITY	RCA	- 84
SIOUX FALLS	FSD	- 94
SPEARFISH	SPF	- 108
STURGIS	49B	- 110
VERMILLION	VMR	- 111
WATERTOWN	ATY	- 112
WINNER	ICR	- 121
YANKTON	YKN	- 124

INSTRUMENT APPROACH PROCEDURE CHARTS



IFR ALTERNATE AIRPORT MINIMUMS

Standard alternate minimums for non precision approaches are 800-2 (NDB, VOR, LOC, TACAN, LDA, VORTAC, VOR/DME, ASR or WAAS LNAV); for precision approaches 600-2 (ILS or PAR). Airports within this geographical area that require alternate minimums other than standard or alternate minimums with restrictions are listed below. NA - means alternate minimums are not authorized due to unmonitored facility or absence of weather reporting service. Civil pilots see FAR 91. IFR Alternate Airport Minimums: Ceiling and Visibility Minimums not applicable to USA/USN/USAF. Pilots must review the IFR Alternate Airport Minimums Notes for alternate airfield suitability.

NAME	ALTERNATE MINIMUMS	NAME	ALTERNATE MINIMUMS
------	--------------------	------	--------------------

ABERDEEN, SD
 ABERDEEN RGNL **RNAV (GPS) Rwy 13**
 RNAV (GPS) Rwy 31
 RNAV (GPS) Rwy 35
 VOR Rwy 31
 VOR/DME Rwy 13
 NA when local weather not available.

ALBERT LEA, MN
 ALBERT LEA MUNI **RNAV (GPS) Rwy 16**
 NA when local weather not available.

ALEXANDRIA, MN
 CHANDLER FIELD **RNAV (GPS) Rwy 31**
 NA when local weather not available.

AUSTIN, MN
 AUSTIN MUNI **RNAV (GPS) Rwy 17**
 RNAV (GPS) Rwy 35
 VOR/DME-A
 NA when local weather not available.

BAUDETTE, MN
 BAUDETTE INTL **RNAV (GPS) Rwy 30¹**
 VOR/DME Rwy 12²
 VOR Rwy 30²
¹NA when local weather not available.
²Category C, 800-2¼; Category D, 800-2½.

BEMIDJI, MN
 BEMIDJI RGNL **RNAV (GPS) Rwy 13**
 RNAV (GPS) Rwy 31
 NA when local weather not available.

BENSON, MN
 BENSON MUNI **RNAV (GPS) Rwy 14**
 RNAV (GPS) Rwy 32
 NA when local weather not available.

BISMARCK, ND
 BISMARCK MUNI **ILS Rwy 13¹²**
 ILS Rwy 31¹²
 RADAR-1³
¹ILS, Category D, 800-2½; Category E, 900-3.
 LOC, NA.
²NA when control tower not in operation.
³NA when control tower closed.

BRAINERD, MN
 BRAINERD LAKES RGNL ... **ILS or LOC Rwy 23**
 RNAV (GPS) Rwy 12
 RNAV (GPS) Rwy 23
 RNAV (GPS) Rwy 30
 RNAV (GPS) Rwy 34
 NA when local weather not available.

BROOKINGS, SD
 BROOKINGS RGNL **RNAV (GPS) Rwy 12**
 RNAV (GPS) Rwy 30
 NA when local weather not available.

CANBY, MN
 MYERS FIELD **RNAV (GPS) Rwy 12**
 RNAV (GPS) Rwy 30
 NA when local weather not available.

CLOQUET, MN
 CLOQUET CARLTON
 COUNTY **RNAV (GPS) Rwy 35**
 NA when local weather not available.

COOK, MN
 COOK MUNI **RNAV (GPS) Rwy 31**
 NA when local weather not available.

CROOKSTON, MN
 CROOKSTON MUNI-
 KIRKWOOD FIELD **RNAV (GPS) Rwy 13¹**
 RNAV (GPS) Rwy 31¹
 VOR Rwy 31²
¹NA when local weather not available.
²Category A,B, 900-2; Category C, 900-2¼.

08 APR 2010 to 06 MAY 2010



NAME ALTERNATE MINIMUMS

DETROIT LAKES, MN

DETROIT LAKES-

WETHING FIELD RNAV (GPS) Rwy 13
RNAV (GPS) Rwy 31

NA when local weather not available.

Category D, 800-2¼.

DEVILS LAKE, NDDEVILS LAKE RGNL RNAV (GPS) Rwy 3
RNAV (GPS) Rwy 13
RNAV (GPS) Rwy 31
VOR Rwy 3¹
VOR Rwy 21²

NA when local weather not available.

¹Categories A,B, 900-2; Category C, 900-2½;

Category D, 900-2¼.

²Category C, 800-2¼, Category D, 800-2½.**DICKINSON, ND**

DICKINSON-THEODORE

ROOSEVELT TRGNL RNAV (GPS) Rwy 14
RNAV (GPS) Rwy 32
VOR-A

NA when local weather not available.

DODGE CENTER, MNDODGE CENTER RNAV (GPS) Rwy 16
RNAV (GPS) Rwy 34
VOR-A

NA when local weather not available.

DULUTH, MNDULUTH INTL COPTER ILS Rwy 9
COPTER ILS Rwy 27
ILS Rwy 9

LOC, NA.

EVELETH, MN

EVELETH-VIRGINIA

MUNI VOR/DME or GPS-A
Category C, 800-2¼; Category D, 800-2½.**FAIRMONT, MN**FAIRMONT MUNI RNAV (GPS) Rwy 13
RNAV (GPS) Rwy 31
VOR Rwy 13
VOR Rwy 31

NA when local weather not available.

NAME ALTERNATE MINIMUMS

FARGO, NDHECTOR INTL ILS or LOC Rwy 18¹
ILS or LOC Rwy 36¹
RNAV (GPS) Rwy 18²
RNAV (GPS) Rwy 36²
VOR/DME or TACAN Rwy 18²
VOR or TACAN Rwy 36³¹ILS, Category E, 700-2¼. LOC, Category E, 800-2¼.²Category E, 800-2¼.³Category D, 800-2¼, Category E, 800-2¼.**FERGUS FALLS, MN**

FERGUS FALLS MUNI-EINAR

MICKELSON FIELD ILS or LOC Rwy 31¹
NDB Rwy 31²
RNAV (GPS) Rwy 31²
RNAV (GPS) Rwy 35

NA when local weather not available.

¹ILS, Category D, 700-2¼. LOC, Category D, 800-2¼.²Category D, 800-2¼.**GLENCOE, MN**GLENCOE MUNI RNAV (GPS) Rwy 31
NA when local weather not available.**GRAND FORKS, ND**GRAND FORKS INTL ... ILS or LOC Rwy 35L¹²
LOC BC Rwy 17R¹
RNAV (GPS) Rwy 9L³
RNAV (GPS) Rwy 17R³
RNAV (GPS) Rwy 27R³
RNAV (GPS) Rwy 35L³
VOR Rwy 17R³
VOR Rwy 35L³¹NA when control tower closed.²ILS, Category E, 700-2½. LOC, Category E, 800-2¼.³NA when local weather not available.**GRAND MARAIS, MN**

GRAND MARAIS/

COOK COUNTY RNAV (GPS) Rwy 27
NA when local weather not available.**GRAND RAPIDS, MN**

GRAND RAPIDS/ITASCA CO-

GORDON NEWSTROM RNAV (GPS) Rwy 16
RNAV (GPS) Rwy 34
VOR Rwy 34

NA when local weather not available.

GRANITE FALLS, MN

GRANITE FALLS MUNI/LENZEN-ROE

MEMORIAL FIELD RNAV (GPS) Rwy 33
NA when local weather not available.



ALTERNATE MINS

E3



NAME ALTERNATE MINIMUMS

HIBBING, MN

RANGE RGNL ILS OR LOC/DME Rwy 13¹
VOR Rwy 13²

¹ILS, Categories A, B, C, D, 800-2.

²Categories A, B, 900-2; Category C, 900-2½; Category D, 900-2¾; ILS, 700-2.

HURON, SD

HURON RGNL ILS or LOC Rwy 12¹²
LOC/DME BC Rwy 30²³
RNAV (GPS) Rwy 12²³
RNAV (GPS) Rwy 30²³
VOR Rwy 12²³

¹ILS, Category D, 700-2¼. LOC, Category D, 800-2¼.

²NA when local weather not available.

³Category D, 800-2¼.

INTERNATIONAL FALLS, MN

FALLS INTL COPTER ILS or LOC Rwy 31¹
ILS or LOC/DME Rwy 13, 700-2²
ILS or LOC Rwy 31²
RNAV (GPS) Rwy 13²
RNAV (GPS) Rwy 31²
VOR Rwy 13²³
VOR/DME Rwy 31²

¹LOC, NA; ILS, NA when local weather not available.

²NA when local weather not available.

³Category D, 800-2¼.

JACKSON, MN

JACKSON MUNI RNAV (GPS) Rwy 13
RNAV (GPS) Rwy 31
NDB Rwy 13

NA when local weather not available.

JAMESTOWN, ND

JAMESTOWN RGNL RNAV (GPS) Rwy 4
RNAV (GPS) Rwy 13
RNAV (GPS) Rwy 22
RNAV (GPS) Rwy 31
VOR Rwy 31

NA when local weather not available.

MANKATO, MN

MANKATO RGNL RNAV (GPS) Rwy 4
RNAV (GPS) Rwy 15
RNAV (GPS) Rwy 22
RNAV (GPS) Rwy 33
VOR Rwy 15
VOR Rwy 33

NA when local weather not available.

MAPLE LAKE, MN

MAPLE LAKE MUNI VOR-A
NA when local weather not available.

NAME ALTERNATE MINIMUMS

MARSHALL, MN

SOUTHWEST MINNESOTA RGNL MARSHALL/
RYAN FLD RNAV (GPS) Rwy 12
VOR Rwy 12

NA when local weather not available.

MINNEAPOLIS, MN

ANOKA COUNTY-BLAINE ARPT
(JANES FIELD) ILS or LOC/DME Rwy 27
RNAV (GPS) Rwy 9
RNAV (GPS) Rwy 18
RNAV (GPS) Rwy 27
VOR Rwy 9
VOR/DME Rwy 27

NA when local weather not available.

CRYSTAL RNAV (GPS) Rwy 14L
NA when local weather not available.

FLYING

CLOUD COPTER ILS or LOC Rwy 10R¹
ILS or LOC Rwy 10R¹
RNAV (GPS) Rwy 10L
RNAV (GPS) Rwy 28R
VOR Rwy 10R
VOR/DME Rwy 36

NA when local weather not available.

¹NA when control tower closed.

MINNEAPOLIS-ST. PAUL INTL/
WOLD CHAMBERLAIN ILS Rwy 4¹

ILS or LOC Rwy 12L²
ILS or LOC Rwy 12R¹
ILS or LOC Rwy 30L¹
ILS or LOC Rwy 30R²
ILS or LOC Rwy 35³
LOC Rwy 4⁴
LOC Rwy 22⁴
RNAV (GPS) Rwy 4⁴
RNAV (GPS) Rwy 12L⁵
RNAV (GPS) Rwy 12R⁴
RNAV (GPS) Rwy 22⁴
RNAV (GPS) Rwy 30L⁴
RNAV (GPS) Rwy 30R⁴
RNAV (GPS) Z Rwy 35⁶

¹ILS, Category D, 700-2; Category E, 900-3. LOC, Category E, 900-3.

²ILS, Categories A, B, C, 700-2; Category D, 700-2¼; Category E, 900-3. LOC, Category D, 800-2¼; Category E, 900-3.

³ILS, Categories A, B, 800-2; Category C, 800-2¼; Category D, 800-2½; Category E, 900-3. LOC, Category C, 800-2¼; Category D, 800-2½; Category E, 900-3.

⁴Category E, 900-3.

⁵Category D, 800-2¼; Category E, 900-3.

⁶Category D, 800-2¼.

08 APR 2010 to 06 MAY 2010

RADAR INSTRUMENT APPROACH MINIMUMS

BISMARCK, ND

Amdt. 3A, DEC 13, 2002 (FAA)

ELEV 1661

BISMARCK MUNI

RADAR - 126.3 298.9 ▽ ▲

	RWY	GS/TCH/RPI	CAT	HAT/ HATH/			CAT	HAT/ HATH/		
				DA/ MDA-VIS	HAA	CEIL-VIS		DA/ MDA-VIS	HAA	CEIL-VIS
ASR	13		AB	2100-1	445	(500-1)	C	2100-1¼	445	(500-1¼)
			D	2100-1½	445	(500-1½)				
	31		AB	2100/24	455	(500-½)	C	2100/40	455	(500-¾)
			D	2100/50	455	(500-1)				
	21		AB	2120-1	459	(500-1)	C	2120-1¼	459	(500-1¼)
			D	2120-1½	459	(500-1½)				
3		AB	2120-1	459	(500-1)	C	2120-1¼	459	(500-1¼)	
		D	2120-1½	459	(500-1½)					
CIRCLING		A	2180-1	519	(600-1)	B	2220-1	539	(600-1)	
		C	2220-1½	559	(600-1½)					D

Inoperative table does not apply to MALS Rwy 13.

DULUTH, MN

Amdt. 20, OCT 7, 1999 (FAA)

ELEV 1428

DULUTH INTL

RADAR - 125.45 255.9

	RWY	GS/TCH/RPI	CAT	HAT/ HATH/			CAT	HAT/ HATH/		
				DA/ MDA-VIS	HAA	CEIL-VIS		DA/ MDA-VIS	HAA	CEIL-VIS
ASR	3		ABC	1820-1	400	(400-1)	D	1820-1¼	400	(400-1¼)
			E	1820-1½	400	(400-1½)				
			AB	1860/24	439	(500-½)				
DE	1860/50	439	(500-1)							
27		AB	1860-1	440	(500-1)	C	1860-1¼	440	(500-1¼)	
		DE	1860-1½	440	(500-1½)					
21		AB	1860-1	440	(500-1)	C	1860-1¼	440	(500-1¼)	
		DE	1860-1½	440	(500-1½)					
9		AB	1880/24	452	(500-½)	C	1880/40	452	(500-¾)	
		DE	1880/50	452	(500-1)					
CIRCLING		AB	1920-1	492	(500-1)	C	1920-1½	492	(500-1½)	
		DE	1980-2	552	(600-2)					

Category E circling NA southeast of Rws 3 and 27.

RADAR INSTRUMENT APPROACH MINIMUMS

ELLSWORTH AFB (KRCA) (Rapid City), SD (Amdt 1, 08045 USAF)

ELEV 3276

RADAR - (E) 119.5 259.1¹

	<u>RWY</u>	<u>GS/TCH/RPI</u>	<u>CAT</u>	<u>DH/</u> <u>MDA-VIS</u>	<u>HAT/</u> <u>HATH/</u> <u>HAA</u>	<u>CEIL-VIS</u>
ASR	13 ²		AB	3820/40	544	(600-¾)
			C	3820/50	544	(600-1)
			D	3820/60	544	(600-1¼)
	31 ²		E	3820-1½	544	(600-1½)
			AB	3820/40	628	(600-¾)
			C	3820/60	628	(600-1¼)
CIR	All Rwy ³	D	3820-1½	628	(600-1½)	
		E	3820-1¾	628	(600-1¾)	
		A	3860-1¼	584	(600-1¼)	
		B	3880-1¼	604	(700-1¼)	
		C	3880-1¾	604	(700-1¾)	
		D	3880-2	604	(700-2)	
		E	4040-2¾	764	(800-2¾)	

¹Opr 1300-0730Z++ Mon-Thu, 1300-0500Z++ Fri. 1400-0500Z++ Sat, Sun and hol. ²When ALS inop, increase CAT AB RVR to 60 and vis to 1¼, increase CAT CDE vis ½ mile. ³CAT E circling restricted to 28th BW aircraft only; 28th BW aircraft will remain within class D airspace.

MANDAN, ND

Amdt. 4, NOV 09, 1995 (FAA)

ELEV 1942

MANDAN MUNI

RADAR - 126.3 298.9 NA

	<u>RWY</u>	<u>GS/TCH/RPI</u>	<u>CAT</u>	<u>DA/</u> <u>MDA-VIS</u>	<u>HAT/</u> <u>HATH/</u> <u>HAA</u>	<u>CEIL-VIS</u>		<u>DA/</u> <u>MDA-VIS</u>	<u>HAT/</u> <u>HATH/</u> <u>HAA</u>	<u>CEIL-VIS</u>		
ASR	31		AB	2360-1	418	(500-1)		CD	2360-1¼	418	(500-1¼)	
			13	AB	2460-1	520	(600-1)		C	2460-1½	520	(600-1½)
				D	2460-1¾	520	(600-1¾)					
CIRCLING			A	2460-1	518	(600-1)		B	2500-1	558	(600-1)	
				C	2500-1½	558	(600-1½)		D	2500-2	558	(600-2)

Use Bismarck altimeter setting.
When Bismarck control tower closed, ASR NA.

RADAR INSTRUMENT APPROACH MINIMUMS

ROCHESTER, MN

Amdt. 8, JAN 15, 2009 (FAA)

ELEV 1317

ROCHESTER INTL

RADAR - 119.8 251.125

		HAT/ HATH/			HAT/ HATH/					
	RWY	GS/TCH/RPI	CAT	DA/ MDA-VIS	HAA	CEIL-VIS	CAT	DA/ MDA-VIS	HAA	CEIL-VIS
ASR	2	ABC		1680-1	363	(400-1)	D	1680-1¼	363	(400-1¼)
	13	ABC		1640/24	360	(400-½)	D	1640/50	360	(400-1)
	20	ABC		1660-1	356	(400-1)	D	1660-1¼	356	(400-1¼)
	31	ABC		1660/24	356	(400-½)	D	1660/50	356	(400-1)
CIRCLING		A		1720-1	403	(500-1)	B	1780-1	463	(500-1)
		C		1780-1½	463	(500-1½)	D	1880-2	563	(600-2)

When control tower closed, procedure NA. For inoperative MALSR, increase S-13 and S-31 Cat D visibility to RVR 6000. Visibility reduction by helicopters NA Rwy 2-20.

SIoux FALLS, SD

Amdt. 10A, OCT 3,2003 (FAA)

ELEV 1429

JOE FOSS FIELD

RADAR - 125.8 353.6

		HAT/ HATH/			HAT/ HATH/					
	RWY	GS/TCH/RPI	CAT	DA/ MDA-VIS	HAA	CEIL-VIS	CAT	DA/ MDA-VIS	HAA	CEIL-VIS
ASR	3	AB		1940/24	517	(600-½)	C	1940/50	517	(600-1)
		DE		1940/60	517	(600-1¼)				
	33	AB		1920-1	497	(500-1)	C	1920-1¼	497	(500-1¼)
		D		1920-1½	497	(500-1½)	E	1920-1¼	497	(500-1¼)
	21	AB		1960/24	531	(600-½)	C	1960/50	531	(600-1)
		D		1960/60	531	(600-1¼)	E	1960-1½	531	(600-1½)
	15	AB		1960-1	534	(600-1)	C	1960-1½	534	(600-1½)
		D		1960-1¾	534	(600-1¾)	E	1960-2	534	(600-2)
CIRCLING		AB		1960-1	531	(600-1)	C	1960-1½	531	(600-1½)
		D		2040-2	611	(700-2)	E	2300-3	871	(900-3)

When control tower closed, procedure not authorized.

Category E S-3 visibility increased 1¼ mile for inoperative MALSR.

Category E S-21 visibility increased to 2 miles for inoperative MALSR.

INSTRUMENT APPROACH PROCEDURE CHARTS

IFR TAKE-OFF MINIMUMS AND (OBSTACLE) DEPARTURE PROCEDURES

Civil Airports and Selected Military Airports

ALL USERS: Airports that have Departure Procedures (DPs) designed specifically to assist pilots in avoiding obstacles during the climb to the minimum enroute altitude, and/or airports that have civil IFR take-off minimums other than standard, are listed below. Take-off Minimums and Departure Procedures apply to all runways unless otherwise specified. Altitudes, unless otherwise indicated, are minimum altitudes in MSL.

DPs specifically designed for obstacle avoidance are referred to as Obstacle Departure Procedures (ODPs) and are described below in text, or published separately as a graphic procedure. If the (Obstacle) DP is published as a graphic procedure, its name will be listed below, and it can be found in either this volume (civil), or a separate Departure Procedure volume (military), as appropriate. Users will recognize graphic obstacle DPs by the term "(OBSTACLE)" included in the procedure title; e.g., TETON TWO (OBSTACLE). If not assigned a SID or radar vector by ATC, an ODP may be flown without ATC clearance to ensure obstacle clearance.

Graphic DPs designed by ATC to standardize traffic flows, ensure aircraft separation and enhance capacity are referred to as "Standard Instrument Departures (SIDs)". SIDs also provide obstacle clearance and are published under the appropriate airport section. ATC clearance must be received prior to flying a SID.

CIVIL USERS NOTE: Title 14 Code of Federal Regulations Part 91 prescribes standard take-off rules and establishes take-off minimums for certain operators as follows: (1) Aircraft having two engines or less - one statute mile. (2) Aircraft having more than two engines - one-half statute mile. These standard minima apply in the absence of any different minima listed below.

MILITARY USERS NOTE: Civil (nonstandard) take-off minima are published below. For military take-off minima, refer to appropriate service directives.

NAME TAKE-OFF MINIMUMS

ABERDEEN, SD

ABERDEEN RGNL (ABR)

ORIG 09239 (FAA)

NOTE: **Rwy 17**, trees 1138' from DER, 432' right of centerline, 41' AGL/1336' MSL. **Rwy 31**, multiple trees beginning 1391' from DER, 326' left of centerline, up to 65' AGL/1360' MSL.

AITKIN, MN

AITKIN MUNI-STEVE KURTZ FIELD (AIT)

AMDT 2 96172 (FAA)

TAKE-OFF MINIMUMS: **Rwys 8, 26**, 300-1. **Rwy 16**, 300-1 or std. with a min climb of 400' per NM to 1500.
DEPARTURE PROCEDURE: **Rwys 16, 26**, climb runway heading to 1700 before turning.

ALBERT LEA, MN

ALBERT LEA MUNI (AEL)

ORIG 85241 (FAA)

DEPARTURE PROCEDURE: **Rwys 16, 22**, climb runway heading to 1800 before turning on course.

ALEXANDRIA, MN

CHANDLER FIELD (AXN)

DEPARTURE PROCEDURE: **Rwys 4, 13, 22**, when weather is below 200-1, climb runway heading to 1800 before turning.

NAME TAKE-OFF MINIMUMS

APPLETON, MN

APPLETON MUNI (AQP)

ORIG 94146 (FAA)

DEPARTURE PROCEDURE: **Rwy 4**, climb to 2000 before turning right. **Rwy 31**, climb to 2000 before turning left. **Rwy 13**, climb to 2400 before turning right. **Rwy 22**, climb to 2400 before turning left.

AUSTIN, MN

AUSTIN MUNI (AUM)

ORIG 08045 (FAA)

NOTE: **Rwy 17**, Multiple trees beginning 809' from departure end of runway, 663' right of centerline, up to 61' AGL/1285' MSL. **Rwy 35**, Tree 1380' from departure end of runway, 484' right of centerline, 100' AGL/1314' MSL.

BAUDETTE, MN

BAUDETTE INTL (BDE)

ORIG 01193 (FAA)

DEPARTURE PROCEDURE: **Rwy 12**, climb runway heading to 1700 before turning northbound.

TAKE-OFF MINIMUMS AND (OBSTACLE) DEPARTURE PROCEDURES

BELLE FOURCHE, SD

BELLE FOURCHE MUNI (EFC)
AMDT 2 09015 (FAA)

TAKE-OFF MINIMUMS: **Rwys 18,36**, NA. **Rwy 14**, std. w/min. climb of 240' per NM to 9000 or 1400-3 for climb in visual conditions. **Rwy 32**, std. w/min. climb of 413' per NM to 3900.

DEPARTURE PROCEDURE: **Rwy 14**, for climb in visual conditions: cross Belle Fourche Muni airport at or above 4400 MSL before proceeding on course. **Rwy 32**, climb heading 321° to 3900 before proceeding southbound.

NOTE: **Rwy 14**, trees 651' from departure end of runway, 547' left of centerline, up to 20' AGL/3299' MSL. **Rwy 32**, trees 857' from departure end of runway, 150' left of centerline, up to 20' AGL/3199' MSL. Trees 3880' from departure end of runway, 966' right of centerline, up to 20' AGL/3289' MSL.

BEMIDJI, MN

BEMIDJI RGNL (BJI)
AMDT 3 08213 (FAA)

NOTE: **Rwy 7**, vegetation beginning 859' from departure end of runway, 544' right of centerline, up to 62' AGL/1442' MSL. Vegetation beginning 1404' from departure end of runway, 683' left of centerline, up to 44' AGL/1424' MSL. **Rwy 13**, vehicle on road, 541' from departure end of runway, 525' right of centerline, 15' AGL/1398' MSL. **Rwy 25**, poles beginning 1337' from departure end of runway, 205' right of centerline up to 61' AGL/1445' MSL. Trees beginning 1414' from departure end of runway, 254' left of centerline, up to 57' AGL/1441' MSL. Tree 1406' from departure end of runway, 233' right of centerline, 53' AGL/1437' MSL.

BENSON, MN

BENSON MUNI (BBB)
AMDT 1 09127 (FAA)

NOTE: **Rwy 14**, numerous trees beginning 838' from DER, 246' right of centerline, up to 33' AGL/1087' MSL. Numerous trees beginning 1232' from DER, 64' left of centerline, up to 69' AGL/1108' MSL. Sign 206' from DER, 198' left of centerline, 19' AGL/1044' MSL. Tower 4884' from DER, 274' right of centerline, 126' AGL/1161' MSL. **Rwy 32**, Tree 2380' from DER, 646' left of centerline, 68' AGL/1107' MSL. Multiple fences beginning 13' from DER, 361' left of centerline, up to 8' AGL/1043' MSL.

BIGFORK, MN

BIGFORK MUNI (FOZ)
ORIG 97198 (FAA)

TAKE-OFF MINIMUMS: **Rwy 15**, 400-1 or std. with a min. climb of 250' per NM to 1800.

BISMARCK, ND

BISMARCK MUNI (BIS)
AMDT 7 01137 (FAA)

DEPARTURE PROCEDURE: **Rwys 3, 31**, climb runway heading to 2500 before proceeding on course. **Rwys 13, 21**, climb runway heading to 3800 before proceeding south.

BOTTINEAU, ND

BOTTINEAU MUNI (D09)
ORIG 98113 (FAA)

TAKE-OFF MINIMUMS: **Rwy 13**, 800-1 or std. with a min. climb of 280' per NM to 2500. **Rwy 31**, 900-2 or std. with a min. climb of 360' per NM to 2900. **Rwys 3, 21**, NA.

BRAINERD, MN

BRAINERD LAKES RGNL (BRD)
AMDT 5 07074 (FAA)

NOTE: **Rwy 12**, multiple trees beginning 165' from departure end of runway, 417' left of centerline, up to 78' AGL/1279' MSL. Multiple trees and vehicle on road beginning 304' from departure end of runway, 206' right of centerline, up to 66' AGL/1277' MSL. **Rwy 16**, multiple trees beginning 1830' from departure end of runway, 749' left of centerline, up to 74' AGL/1314' MSL. **Rwy 23**, multiple trees beginning 1495' from departure end of runway, 179' left of centerline, up to 48' AGL/1285' MSL. Tree 2437' from departure end of runway, 716' right of centerline, 50' AGL/1279' MSL. **Rwy 30**, multiple trees beginning 243' from departure end of runway, 131' left of centerline, up to 61' AGL/1287' MSL. Multiple trees 48' from departure end of runway, 328' right of centerline, up to 59' AGL/1329' MSL.

BRITTON, SD

BRITTON MUNI (BTN)
AMDT 2 96060 (FAA)

TAKE-OFF MINIMUMS: **Rwy 13**, 300-1 or std. with a min. climb of 450' per NM to 1600. **Rwy 19**, 300-1. DEPARTURE PROCEDURE: **Rwy 19**, climb runway heading to 2000 before turning.

BROOKINGS, SD

BROOKINGS RGNL (BKX)
ORIG 09015 (FAA)

NOTE: **Rwy 12**, pole and trees beginning 1041' from departure end of runway, 207' left of centerline, up to 65' AGL/1705' MSL. Building 1277' from departure end of runway, 825' right of centerline, 38' AGL/1618' MSL. **Rwy 17**, vehicle on road 799' from departure end of runway, on centerline, up to 15' AGL/1687' MSL. Trees beginning 906' from departure end of runway, 464' left of centerline, up to 100' AGL/1749' MSL. **Rwy 30**, railroad beginning 547' from departure end of runway, 502' right of centerline, 23' AGL/1626' MSL. Tree 132' from departure end of runway, 433' left of centerline, 20' AGL/1615' MSL. **Rwy 35**, trees 2892' from departure end of runway, 944' right of centerline, up to 100' AGL/1709' MSL.

CANBY, MN

MYERS FIELD (CNB)
ORIG 07186 (FAA)

NOTE: **Rwy 12**, truck on road 183' from departure end of runway, 220' right of centerline, 15' AGL/1204' MSL.

CASSELTON, ND

CASSELTON ROBERT MILLER RGNL (5N8)
ORIG 07354 (FAA)

TAKE-OFF MINIMUMS: **Rwy 31**, 400-2½ or std. w/a min. climb of 212' per NM to 1400 or alternatively, with standard takeoff minimums and a normal 200'/NM climb gradient, takeoff must occur no later than 1700' prior to departure end of runway.

NOTE: **Rwy 13**, railroad 30' from departure end of runway, 505' right of centerline, 23' AGL/945' MSL. Vehicle on road 449' from departure end of runway, 300' left of centerline, 15' AGL/949' MSL. **Rwy 31**, trees 2251' from departure end of runway, 456' left of centerline, up to 100' AGL/1052' MSL.

CAVALIER, ND

CAVALIER MUNI (2C8)
ORIG 03191 (FAA)

TAKE-OFF MINIMUMS: **Rwy 16**, 300-1 or std. with a min. climb of 430' per NM to 1200.

NOTE: **Rwy 16**, grain elevator 3731' from departure end of runway, 284' left of centerline, 168' AGL/1060' MSL.

CLOQUET, MN

CLOQUET CARLTON COUNTY (COQ)
AMDT 1 80248 (FAA)

TAKE-OFF MINIMUMS: **Rwy 7**, 300-1 or std. with a min. climb of 400' per NM to 1400.

CROOKSTON, MN

CROOKSTON MUNI-KIRKWOOD FIELD (CKN)
AMDT 2 07298 (FAA)

TAKE-OFF MINIMUMS: **Rwys 6, 17, 24, 35**, NA-turf runways.

NOTE: **Rwy 13**, tree 1998' from departure end of runway, 587' left of centerline, 94' AGL/970' MSL. Pole 1127' from departure end of runway, 662' left of centerline, 46' AGL/926' MSL.

DETROIT LAKES, MN

DETROIT LAKES-WETHING FIELD (DTL)
ORIG 05132 (FAA)

TAKE-OFF MINIMUMS: **Rwys 17, 35**, NA.

NOTE: **Rwy 31**, highway 243' from departure end of runway, 267' right of centerline, 15' AGL/1404' MSL. Railroad 534' from departure end of runway, 298' right of centerline, 23' AGL/1411' MSL.

DEVILS LAKE, ND

DEVILS LAKE RGNL (DVL)
AMDT 1A 09351 (FAA)

TAKE-OFF MINIMUMS: **Rwy 31**, 300-1 or std. with a min. climb of 350' per NM to 1600.

NOTE: **Rwy 3**, tree 1528' from DER, 319' left of centerline, 100' AGL/1490' MSL. Tree 1520' from DER, 136' right of centerline, 100' AGL/1489' MSL. **Rwy 13**, bush 266' from DER, 523' left of centerline, 17' AGL/1451' MSL. Road, light pole and antenna on building beginning 95' from DER, 414' right of centerline, up to 17' AGL/1484' MSL. **Rwy 21**, roads beginning 335' from DER, 2' right of centerline, 15' AGL/1447' MSL, multiple poles, trees and towers beginning 552' from DER 355' left of centerline, up to 123' AGL/1548' MSL. **Rwy 31**, road 470' from DER, 424' right of centerline, 15' AGL/1472' MSL. Multiple poles and trees beginning 1180' from DER, 354' left of centerline, up to 49' AGL/1545' MSL.

DICKINSON, ND

DICKINSON-THEODORE ROOSEVELT RGNL (DIK)

AMDT 1 05244 (FAA)

DEPARTURE PROCEDURE: **Rwy 25**, climb via heading 250° to 3100 before turning left.

NOTE: **Rwy 7**, road 887' from departure end of runway, on rwy centerline, 15' AGL/2631' MSL.

DODGE CENTER, MN

DODGE CENTER (TOB)
ORIG 09015 (FAA)

TAKE-OFF MINIMUMS: **Rwy 22**, NA-Environmental.

NOTE: **Rwy 16**, trees 3945' from departure end of runway, 1542' left of centerline, 100' AGL/1409' MSL.

DULUTH, MN

DULUTH INTL (DLH)
ORIG 06327 (FAA)

NOTE: **Rwy 3**, multiple trees beginning 21' from departure end of runway, 226' right of centerline, up to 68' AGL/1477' MSL. Multiple trees beginning 246' from departure end of runway, 26' left of centerline, up to 64' AGL/1473' MSL. **Rwy 9**, electrical equipment 207' from departure end of runway, 408' left of centerline, 6' AGL/1425' MSL. **Rwy 21**, tower 3762' from departure end of runway, 410' left of centerline, 92' AGL/1522' MSL. **Rwy 27**, tree 2426' from departure end of runway, 1127' right of centerline, 53' AGL/1522' MSL. Bush and multiple trees beginning 347' from departure end of runway, 484' left of centerline, up to 44' AGL/1533' MSL.

SKY HARBOR (DYT)

ORIG 83174 (FAA)

TAKE-OFF MINIMUMS: **Rwy 14**, 300-1. **Rwy 32**, 1500-2 or std. with a min. climb of 360' per NM to 2300.

DEPARTURE PROCEDURE: **Rwy 14**, northwest departures (260° CW 030°) climb to 2300 via heading 260° or 030° before proceeding on course.

EAGLE BUTTE, SD

CHEYENNE EAGLE BUTTE (84D)
ORIG 96228 (FAA)

TAKE-OFF MINIMUMS: **Rwys 13, 31**, 300-1.

TAKE-OFF MINIMUMS AND (OBSTACLE) DEPARTURE PROCEDURES

ELY, MN

ELY MUNI (ELO)
AMDT 2 97086 (FAA)

TAKE-OFF MINIMUMS: **Rwy 12**, 300-1 or std. with a min. climb of 200' per NM to 1600.
DEPARTURE PROCEDURE: **Rwy 30**, northbound departures climb runway heading to 2000 before turning.

EVELETH, MN

EVELETH-VIRGINIA MUNI (EVM)
AMDT 2 94118 (FAA)

TAKE-OFF MINIMUMS: **Rwy 32**, 800-2 or std. with a min. climb to 330' per NM to 2300.
DEPARTURE PROCEDURE: **Rwy 27**, northwest departures (270°-050°) climb runway heading to 2200 before turning.

FAIRMONT, MN

FAIRMONT MUNI (FRM)
AMDT 3 09127 (FAA)

NOTE: **Rwy 2**, trees beginning 2466' from DER, 1105' right of centerline, up to 100' AGL/1269' MSL. **Rwy 13**, tree 2340' from DER, 1039' left of centerline, 100' AGL/1269' MSL. **Rwy 20**, trees beginning 1640' from DER, 914' right of centerline, up to 100' AGL/1289' MSL. Trees beginning 913' from DER, 449' left of centerline, up to 100' AGL/1299' MSL. **Rwy 31**, trees beginning 954' from DER, 161' left of centerline, up to 100' AGL/1299' MSL. Trees and road beginning 791' from DER, 339' right of centerline, up to 57' AGL/1226' MSL.

FARGO, ND

HECTOR INTL (FAR)
AMDT 4 04330 (FAA)

TAKE-OFF MINIMUMS: **Rwys 13, 31**, NA.
NOTE: **Rwy 9**, multiple light poles 1124' from departure end of runway, 305' left of centerline, 20' AGL/927' MSL.

FERGUS FALLS, MN

FERGUS FALLS MUNI-EINAR MICKELSON FIELD (FFM)
ORIG 09239 (FAA)

NOTE: **Rwy 13**, trees beginning 2612' from DER, 128' right of centerline, up to 100' AGL/1269' MSL. Trees beginning 2514' from DER, 42' left of centerline, up to 100' AGL/1259' MSL. **Rwy 17**, trees beginning 1100' from DER 663' right of centerline, up to 100' AGL/1269' MSL. Road 222' from DER, 469' right of centerline, 15' AGL/1173' MSL. **Rwy 35**, trees beginning 2156' from DER, 176' right of centerline, up to 100' AGL/1289' MSL.

FOSSTON, MN

FOSSTON MUNI (FSE)
AMDT 1 87351 (FAA)

TAKE-OFF MINIMUMS: **Rwys 14, 32**, IFR takeoff not authorized.
DEPARTURE PROCEDURE: **Rwy 16**, climb runway heading to 2000 before turning.

GETTYSBURG, SD

GETTYSBURG MUNI (0D8)
AMDT 1 07018 (FAA)

NOTE: **Rwy 4**, multiple trees beginning 1011' from departure end of runway, 420' left of centerline, up to 60' AGL/2119' MSL. **Rwy 13**, multiple trees beginning 1897' from departure end of runway, 975' left of centerline, 60' AGL/2119' MSL. **Rwy 22**, multiple trees beginning 679' from departure end of runway, 117' left of centerline, up to 60' AGL/2109' MSL.

GLENCOE, MN

GLENCOE MUNI (GYL)
ORIG 09071 (FAA)

NOTE: **Rwy 13**, trees beginning 349' from DER, 257' right of centerline, up to 100' AGL/1099' MSL. Trees beginning 1211' from DER, 314' left of centerline, up to 100' AGL/1109' MSL. Terrain beginning 53' from DER, 166' left of centerline, up to 998' MSL. Terrain beginning 286' from DER, 435' right of centerline, up to 1001' MSL. **Rwy 31**, trees beginning 501' from DER, 530' right of centerline, up to 100' AGL/1099' MSL. Tree 2577' from DER, 129' left of centerline, 100' AGL/1109' MSL.

GLENWOOD, MN

GLENWOOD MUNI (GHW)
AMDT 2 98337 (FAA)

TAKE-OFF MINIMUMS: **Rwy 5**, 1200-2 or std. with a min. climb of 220' per NM to 2900.

GRAFTON, ND

HUTSON FIELD (GAF)
ORIG 97086 (FAA)

TAKE-OFF MINIMUMS: **Rwy 35**, 400-2 or std. with a min. climb of 420' per NM to 1300.

GRANDFORKS, ND

GRAND FORKS INTL (GFK)
AMDT 2 09071 (FAA)

NOTE: **Rwy 9L**, tree 127' from DER, 451' left of centerline, 12' AGL/853' MSL. **Rwy 27R**, bush 38' from DER, 474' right of centerline, 5' AGL/844' MSL. **Rwy 35L**, obstruction light on DME 645' from DER, 198' left of centerline, 21' AGL/860' MSL. **Rwy 35R**, tree 1259' from DER, 521' right of centerline, 41' AGL/880' MSL. Tree 1655' from DER, 271' left of centerline, 45' AGL/884' MSL.

GRANT MARAIS, MN

GRANT MARAIS/COOK COUNTY (CKC)
ORIG 09015 (FAA)

NOTE: **Rwy 9**, trees beginning 58' from departure end of runway, 168' right of centerline up to 54' AGL/1833' MSL. Bushes 112' from departure end of runway, 142' left of centerline, 11' AGL/1805' MSL. Tree 464' from departure end of runway, 75' left of centerline, 14' AGL/1813' MSL. **Rwy 27**, trees beginning 85' from departure end of runway, 187' left of centerline, up to 59' AGL/1858' MSL. Trees beginning 282' from departure end of runway, 115' right of centerline, up to 42' AGL/1861' MSL.

GRAND RAPIDS, MN

GRAND RAPIDS/ITASCA COUNTY-GORDON
NEWSTROM FIELD (GPZ)

AMDT 4 09127 (FAA)

TAKE-OFF MINIMUMS: **Rwys 5, 10, 23, 28**, NA-
Environmental.

NOTE: **Rwy 16**, tree 1655' from DER, 899' left of
centerline, 51' AGL/1410' MSL. Tree 3236' from DER,
1130' right of centerline, 82' AGL/1441' MSL. **Rwy 34**,
tree 3416' from DER, 1253' right of centerline, 100'
AGL/1399' MSL.

GREGORY, SD

GREGORY MUNI, FLYNN FIELD (9D1)

ORIG 97142 (FAA)

TAKE-OFF MINIMUMS: **Rwy 31**, 400-2 or std. with a
min. climb of 210' per NM to 2600.

GWINNER, ND

GWINNER-ROGER MELROE FIELD (GWR)

ORIG 09183 (FAA)

TAKE-OFF MINIMUMS: **Rwys 6, 24**, NA-Environment.
Rwy 34, Std. w/ min. climb of 216' per NM to 2000, or
900-2½ for climb in visual conditions.

DEPARTURE PROCEDURE: **Rwy 34**, for climb in
visual conditions, cross Gwinner-Roger Melroe Field at
or above 2000, before proceeding on course.

NOTE: **Rwy 16**, terrain beginning 15' from DER, 73'
right of centerline, 1257' MSL. **Rwy 34**, road and vehicle
436' from DER, on centerline, 15' AGL/1286' MSL.

HAWLEY, MN

HAWLEY MUNI (04Y)

ORIG 07074 (FAA)

NOTE: **Rwy 34**, road 15' from departure end of runway,
421' left of centerline, 15' AGL/1224' MSL.

HETTINGER, ND

HETTINGER MUNI (HEI)

AMDT 1 98225 (FAA)

TAKE-OFF MINIMUMS: **Rwy 12**, 300-1 or std. with a
min. climb rate of 220' per NM to 3000. **Rwys 17, 35** NA.

HIBBING, MN

RANGE RGNL (HIB)

AMDT 6 04218 (FAA)

DEPARTURE PROCEDURE: **Rwy 22**, climb via heading
227° to 2200 before turning right. **Rwy 31**, climb via
heading 310° to 2200 before turning left.

NOTE: **Rwy 4**, antenna on pole, 361' from departure end
of runway, 409' right of centerline, 1377' MSL. **Rwy 13**,
obstacle light on pole, 1184' from departure end of
runway, 636' left of centerline. Numerous trees
beginning 1291' from departure end of runway, 745' left
of centerline up to 1419' MSL. Trees 1497' from
departure end of runway, 563' right of centerline, 1388'
MSL. **Rwy 22**, multiple trees beginning 368' from
departure end of runway, 170' right of centerline, up to
1416' MSL. Multiple trees beginning 413' from
departure end of runway, 117' left of centerline, up to
1400' MSL. **Rwy 31**, light standard, 865' from departure
end of runway, 595' right of centerline, 1381' MSL.

HILLSBORO, ND

HILLSBORO MUNI (3H4)

ORIG 97198 (FAA)

DEPARTURE PROCEDURE: **Rwys 16, 34**, climb runway
heading to 2000 prior to turning westbound.

HINCKLEY, MN

FIELD OF DREAMS (04W)

ORIG 08045 (FAA)

NOTE: **Rwy 6**, Tree 82' from departure end of runway,
480' right of centerline, 100' AGL/1114' MSL. Tree 143'
from departure end of runway, 161' left of centerline, 100'
AGL/1114' MSL. **Rwy 24**, Tree 48' from departure end of
runway, 165' left of centerline, 100' AGL/1124' MSL.

HOT SPRINGS, SD

HOT SPRINGS MUNI (HSR)

ORIG 97142 (FAA)

TAKE-OFF MINIMUMS: **Rwy 1**, 300-1 or std. with a min.
climb of 360' per NM to 5000. **Rwy 19**, 300-2 or std. with
a min. climb of 250' per NM to 5000.

DEPARTURE PROCEDURE: **Rwys 1, 19**, climb runway
heading to 5000 before proceeding westbound.

HURON, SD

HURON RGNL (HON)

AMDT 5 09239 (FAA)

NOTE: **Rwy 12**, trees and pole beginning 918' from DER,
525' left of centerline, up to 62' AGL/1341' MSL. Trees
beginning 291' from DER, 234' right of centerline, up to
100' AGL/1389' MSL. **Rwy 17**, trees beginning 236'
from DER, 307' left of centerline, up to 67' AGL/1346'
MSL. Trees beginning 264' from DER, 262' right of
centerline, 73' AGL/1352' MSL. **Rwy 30**, trees
beginning 3428' from DER, 1378' left of centerline, up to
100' AGL/1394' MSL. **Rwy 35**, trees beginning 60' from
DER, 104' left of centerline, up to 49' AGL/1328' MSL.
Trees beginning 251' from DER, 97' right of centerline,
52' AGL/1331' MSL.

INTERNATIONAL FALLS, MN

FALLS INTL (INL)

AMDT 3 08101 (FAA)

NOTE: **Rwy 4**, Tree 392' from departure end of runway
311' left of centerline, 51' AGL/1231' MSL. **Rwy 13**,
multiple trees beginning 1999' from departure end of
runway, 773' left of centerline, up to 63' AGL/1233' MSL.
Pole 1091', from departure end of runway, 703' right of
centerline, 37' AGL/1207' MSL. Road 1005' from
departure end of runway, 766' left of centerline, 15' AGL/
1195' MSL. **Rwy 22**, Multiple trees beginning 433' from
departure end of runway 273' left of centerline, up to 33'
AGL/1213' MSL. Trees 1144' from departure end of
runway 136' right of centerline, 28' AGL/1208' MSL.
Rwy 31, Trees 968' from departure end of runway, 752'
left of centerline, 56' AGL/1236' MSL.

JACKSON, MN

JACKSON MUNI (MJQ)

ORIG 08045 (FAA)

TAKE-OFF MINIMUMS: **Rwys 4,22**, NA-TURF.
DEPARTURE PROCEDURE: **Rwy 13**, Climb heading 134° to 1900 before turning right.

NOTES: **Rwy 13**, Trees beginning 1474' from departure end of runway, 556' left of centerline, up to 80' AGL/1539' MSL. Vehicle on road 258' from departure end of runway, 559' from centerline, 15' AGL/1459' MSL. **Rwy 31**, Vehicle on road 465' from departure end of runway, 618' left of centerline, 15' AGL/1446' MSL. Trees beginning 1616' from departure end of runway, 580' right of centerline, up to 80' AGL/1519' MSL. Trees beginning 1110' from departure end of runway, 429' left of centerline, up to 80' AGL/1509' MSL.

JAMESTOWN, ND

JAMESTOWN RGNL (JMS)

AMDT 1 07242 (FAA)

NOTE: **Rwy 22**, antenna and tank beginning 2960' from departure end of runway, 1007' left of centerline, up to 150' AGL/1631' MSL. **Rwy 31**, multiple trees beginning 2129' from departure end of runway 47' right of centerline, up to 60' AGL/1560' MSL.

KINDRED, ND

HAMRY FIELD (K74)

ORIG 10042 (FAA)

NOTE: **Rwy 29**, tree 991' from DER, 367' left of centerline, 38' AGL/982' MSL. Tree 1073' from DER, 221' left of centerline, 38' AGL/982' MSL.

LITCHFIELD, MN

LITCHFIELD MUNI (LJF)

DEPARTURE PROCEDURE: **Rwys 13, 31**, climb to 1800 on runway heading before proceeding on course.

LITTLE FALLS, MN

LITTLE FALLS/MORRISON COUNTY

CHARLES A. LINDBERGH FIELD (LXL)

AMDT 3 96172 (FAA)

TAKE-OFF MINIMUMS: **Rwy 13**, 300-1 or std. with a min. climb of 250' per NM to 1500. **Rwy 36**, 600-1½ or std. with a min. climb of 345' per NM to 1700.

DEPARTURE PROCEDURE: **Rwy 31**, climb to 1700 before turning.

LONG PRAIRIE, MN

TODD FIELD (14Y)

ORIG 08157 (FAA)

NOTE: **Rwy 16**, tree 273' from departure end of runway, 310' right of centerline, 100' AGL/1436' MSL. **Rwy 34**, tree 70' from departure end of runway, 100' right of centerline, 100' AGL/1439' MSL. Tree 122' from departure end of runway, 105' left of centerline, 100' AGL/1436' MSL. Tree 18' from departure end of runway, 106' right of centerline, 100' AGL/1433' MSL.

MANKATO, MN

MANKATORGNL (MKT)

ORIG 09267 (FAA)

NOTE: **Rwy 4**, trees beginning 447' from DER, 408' right of centerline, up to 100' AGL/1078' MSL. Trees beginning 1996' from DER, 17' left of centerline, up to 100' AGL/1084' MSL. **Rwy 15**, trees beginning 1552' from DER, 719' left of centerline, up to 100' AGL/1088' MSL. **Rwy 22**, trees beginning 2370' from DER, 989' right of centerline, up to 100' AGL/1069' MSL. **Rwy 33**, trees beginning 2085' from DER, 780' right of centerline, up to 100' AGL/1077' MSL. Rising terrain 9' from DER, 65' right of centerline, up to 1029' MSL. Terrain beginning 82' from DER, 60' left of centerline, up to 1029' MSL.

MARSHALL, MN

SOUTHWEST MINNESOTA RGNL MARSHALL/

RYAN FIELD (MML)

AMDT 2 08101 (FAA)

TAKE-OFF MINIMUMS: **Rwy 20**, Std. w/ min. climb of 270' per NM to 2000, or 1000-3 for climb in visual conditions.

DEPARTURE PROCEDURE: **Rwy 20**, for climb in visual conditions, cross Marshall Airport at or above 2000 MSL before proceeding on course.

NOTE: **Rwy 12**, Pole 706' from departure end of runway, 671' right of centerline, 60' AGL/1212' MSL, pole 1580' from departure end of runway, 732' left of centerline, 70' AGL/1225' MSL, antenna 1496' from departure end of runway, 620' right of centerline, 64' AGL/1219' MSL, pole 1185' from departure end of runway, 540' right of centerline, 55' AGL/1210' MSL, tree 3564' from departure end of runway, 400' right of centerline, 110' AGL/1269' MSL, tree 2135' from departure end of runway, 113' left of centerline, 77' AGL/1232' MSL. **Rwy 30**, Vehicle on road 1' from departure end of runway, 435' left of centerline, 24' AGL/1200' MSL.

MILBANK, SD

MILBANK MUNI (1D1)

ORIG 08101 (FAA)

TAKE-OFF MINIMUMS: **Rwy 25**, Std. w/a min. climb of 207' per NM to 1900, or 900-2½ for climb in visual conditions.

DEPARTURE PROCEDURE: **Rwy 25**, For climb in visual conditions cross Milbank Muni airport at or above 1900 before proceeding on course.

NOTE: **Rwy 7**, trees beginning 1207' from departure end of runway, 387' left of centerline, up to 100' AGL/ 1219' MSL. Vehicle on road 829' from departure end of runway, 373' right of centerline, 15' AGL/ 1134' MSL. Building 322' from departure end of runway, 582' right of centerline, 25' AGL/ 1134' MSL. **Rwy 13**, trees beginning 1448' from departure end of runway, 394' right of centerline, up to 100' AGL/ 1219' MSL. Vehicle on road 218' from departure end of runway, 490' left of centerline, 15' AGL/ 1134' MSL. Building 78' from departure end of runway, 397' left of centerline, 25' AGL/ 1134' MSL. **Rwy 25**, tree 3584' from departure end of runway, 477' left of centerline, 100' AGL/ 1249' MSL. **Rwy 31**, tree 2992' from departure end of runway, 715' left of centerline, 100' AGL/ 1239' MSL.

MILLER, SD

MILLER MUNI (MKA)
ORIG 08269 (FAA)

NOTE: **Rwy 15**, vehicle on road 769' from departure end of runway, 642' right of centerline, 15' AGL/1599' MSL. Snow removal equipment 206' from departure end of runway, 475' right of centerline, 21' AGL/1594' MSL. Tree 3903' from departure end of runway, 998' left of centerline, 100' AGL/1684' MSL. **Rwy 33**, vehicle on road 450' from departure end of runway, 560' left of centerline, 15' AGL/1584' MSL. Tree 762' from departure end of runway, 628' left of centerline, 100' AGL/1669' MSL.

MINNEAPOLIS, MN

ANOKA COUNTY-BLAINE AIRPORT
(JANES FIELD) (ANE)
AMDT 5 10042 (FAA)

TAKE-OFF MINIMUMS: **Rwy 9**, 300-1½ or std. w/min. climb of 204' per NM to 1200, or alternatively, with standard takeoff minimums and a normal 200'/NM climb gradient, takeoff must occur no later than 1200' prior to DER.

DEPARTURE PROCEDURE: **Rwy 9**, climb heading 089° to 2200 before turning right. **Rwy 18**, climb heading 179° to 2600 before turning left. **Rwy 27**, climb heading 269° to 1700 before proceeding southeast bound. **Rwy 36**, climb heading 359° to 1700 before proceeding southeast bound.

NOTE: **Rwy 9**, tank and multiple trees beginning 822' from DER, 619' right of centerline, up to 170' AGL/1082' MSL. Trees 2248' from DER, 966' left of centerline, 100' AGL/1009' MSL. **Rwy 18**, aircraft on taxiway 36' from DER, 481' right of centerline, up to 21' AGL/928' MSL. Multiple trees beginning 406' from DER, 287' left of centerline, up to 49' AGL/959' MSL. **Rwy 27**, multiple trees beginning 7' from DER, 235' right of centerline, up to 83' AGL/983' MSL. Multiple trees beginning 558' from DER, 406' left of centerline, up to 57' AGL/957' MSL. **Rwy 36**, multiple trees beginning 86' from DER, 10' right of centerline, up to 87' AGL/987' MSL. Multiple trees beginning 1282' from DER, 53' left of centerline, up to 70' AGL/970' MSL.

CRYSTAL (MIC)
AMDT 2 81050 (FAA)

TAKE-OFF MINIMUMS: **Rwys 14L, 14R, 32L, 32R**, 300-1. **Rwys 24L, 24R**, 300-1 or std. with a min. climb of 215' per NM to 1000. **Rwys 6L, 6R**, 300-1 or std. with a min. climb of 285' per NM to 1000.

DEPARTURE PROCEDURE: **Rwys 6L, 6R, 14L, 14R**, eastbound departures (050°-130°) climb runway heading to 2800 before turning.

MINNEAPOLIS, MN (CON'T)

FLYING CLOUD (FCM)
AMDT 4 08157 (FAA)

NOTE: **Rwy 10L**, multiple antenna's on hangar's beginning 270' from departure end of runway, 330' left of centerline, up to 26' AGL/932' MSL. Tree 682' from departure end of runway, 668' right of centerline, 26' AGL/932' MSL. **Rwy 10R**, multiple obstruction light on poles beginning 287' from departure end of runway, 345' right of centerline, up to 36' AGL/939' MSL. Hangar 150' from departure end of runway, 422' right of centerline, 21' AGL/920' MSL. Antenna on building, 536' from departure end of runway, 263' right of centerline, 14' AGL/913' MSL. **Rwy 18**, multiple trees beginning 338' from departure end of runway, 166' left of centerline, up to 62' AGL/961' MSL. Obstruction light on fence 176' from departure end of runway, 127' left of centerline, 10' AGL/910' MSL. Vehicle and road 198' from departure end of runway, 196' left of centerline, 15' AGL/918' MSL. Floodlight 148' from departure end of runway, 374' right of centerline, 38' AGL/938' MSL. Obstruction light on hangar 282' from departure end of runway, 317' right of centerline, 37' AGL/937' MSL. **Rwy 28R**, Hangar 259' from departure end of runway, 355' right of centerline, 18' AGL/931' MSL. **Rwy 36**, wind vane 923' from departure end of runway, 404' left of centerline, 61' AGL/960' MSL. Vent on building 943' from departure end of runway, 295' left of centerline, 44' AGL/943' MSL. Pole 714' from departure end of runway, 351' left of centerline, 33' AGL/932' MSL. Multiple trees beginning 504' from departure end of runway, 324' right of centerline, up to 67' AGL/966' MSL.

MINNEAPOLIS, MN (CON'T)

MINNEAPOLIS-ST. PAUL INTL
(WOLD CHAMBERLAIN) (MSP)
AMDT 11 07130 (FAA)

TAKEOFF MINIMUMS: **Rwy 35**, std. with a min. climb of 219' per NM to 2100.

DEPARTURE PROCEDURE: **Rwy 4**, climb heading 043° to 2100 before turning left. **Rwy 30L**, climb heading 299° to 2100 before turning right. **Rwy 30R**, climb heading 299° to 2100 before turning right.

Rwy 35, climb via heading 348° to 2100 before turning left.
NOTE: **Rwy 4**, multiple trees beginning 800' from departure end of runway, 264' left of centerline, up to 75' AGL/921' MSL. Rod on building 2528' from departure end of runway, 1175' left of centerline, 78' AGL/922' MSL. Fence 803' from departure end of runway, 585' left of centerline, 15' AGL/860' MSL. Antenna on OL building 456' from departure end of runway, 319' left of centerline, 13' AGL/850' MSL. Light poles 1932' from departure end of runway, 718' left of centerline, 45' AGL/885' MSL. Stack 4535' from departure end of runway, 481' left of centerline, 139' AGL/949' MSL. **Rwy 12R**, multiple trees beginning 1477' from departure end of runway, 407' left of centerline, up to 86' AGL/851' MSL. Multiple trees beginning 1426' from departure end of runway, 124' right of centerline, up to 111' AGL/847' MSL. Light pole 1408' from departure end of runway, 746' right of centerline, 85' AGL/843' MSL. Radar RFLTR 983' from departure end of runway, 32' left of centerline, 15' AGL/829' MSL. Pipe on building, 826' from departure end of runway, 576' left of centerline, 10' AGL/825' MSL. Obstruction light on localizer 766' from departure end of runway, on centerline, 7' AGL/821' MSL. **Rwy 17**, antenna 1272' from departure end of runway, 562' right of centerline, 57' AGL/891' MSL. Pole 409' from departure end of runway, 530' right of centerline, 29' AGL/866' MSL. WDI on building 2619' from departure end of runway, 881' left of centerline, 97' AGL/918' MSL. Building 2619' from departure end of runway, 859' left of centerline, 84' AGL/905' MSL. Light 1176' from departure end of runway, 291' right of centerline, 11' AGL/875' MSL. Tree 2619' from departure end of runway, on centerline, 79' AGL/900' MSL. **Rwy 22**, tree 2906' from departure end of runway, 833' right of centerline, 94' AGL/934' MSL.

Hopper 1717' from departure end of runway, 456' left of centerline, 48' AGL/888' MSL. **Rwy 30L**, multiple trees beginning 1113' from departure end of runway, 701' left of centerline, up to 80' AGL/919' MSL. Tree 1230' from departure end of runway, 633' right of centerline, 30' AGL/877' MSL. Ground 28' from departure end of runway, 490' right of centerline, 0' AGL/844' MSL.

Rwy 30R, building 1056' from departure end of runway, 198' left of centerline, 13' AGL/853' MSL. Multiple trees beginning 3010' from departure end of runway, 334' left of centerline, up to 94' AGL/940' MSL. Light pole 1849' from departure end of runway, 698' right of centerline, 17' AGL/871' MSL. Fence 1327' from departure end of runway, 667' right of centerline, 8' AGL/857' MSL. Tree 3703' from departure end of runway, 350' right of centerline, 67' AGL/914' MSL. Rod on pole 3143' from departure end of runway, 47' right of centerline, 38' AGL/898' MSL. **Rwy 35**, tree 175' from departure end of runway, 398' right of centerline, 73' AGL/883' MSL. Multiple trees beginning 1989' from departure end of runway, 351' left of centerline, up to 65' AGL/902' MSL. Multiple buildings beginning 5.45 NM from departure end of runway, 1787' left of centerline, up to 811' AGL/1743' MSL.

MINOT, ND

MINOT INTL (MOT)
AMDT 3 06103 (FAA)

TAKE-OFF MINIMUMS: **Rwy 26**, 300-1½ or std. with a min. climb of 219' per NM to 2000.

DEPARTURE PROCEDURE: **Rwy 13**, climb via heading 128° to 2200 before turning right. **Rwy 26**, climb via heading 260° to 2300 before turning left.

NOTE: **Rwy 8**, tree 1801' from departure end of runway, 292' left of centerline, 56' AGL/1714' MSL. Tree 1459' from departure end of runway, 528' left of centerline, 47' AGL/1705' MSL. **Rwy 26**, tree 1750' from departure end of runway, 618' right of centerline, 71' AGL/1786' MSL. Tree 1829' from departure end of runway, 376' left of centerline, 65' AGL/1780' MSL. Light pole 1110' from departure end of runway, 610' left of centerline, 44' AGL/1759' MSL. Tank 1.1 NM from departure end of runway, 1810' right of centerline, 184' AGL/1899' MSL. Tree 1782' from departure end of runway, 273' right of centerline, 49' AGL/1764' MSL. Light pole 1294' from departure end of runway, 452' right of centerline, 29' AGL/1751' MSL. Tree 2019' from departure end of runway, 393' right of centerline, 54' AGL/1769' MSL. Building 1431' from departure end of runway, 301' right of centerline, 38' AGL/1753' MSL. Light pole 1418' from departure end of runway, 23' right of centerline, 36' AGL/1751' MSL.

MITCHELL, SD

MITCHELL MUNI (MHE)
AMDT 1 86240 (FAA)

DEPARTURE PROCEDURE: **Rwys 12, 17**, climb to 1800 before turning.

MOBRIDGE, SD

MOBRIDGE MUNI(MBG)
ORIG 88154 (FAA)

TAKE-OFF MINIMUMS: **Rwy 35**, 300-1.
DEPARTURE PROCEDURE: **Rwys 12, 17, 30, 35**, climb runway heading to 2500 before turning on course.

MONTEVIDEO, MN

MONTEVIDEO-CHIPPEWA COUNTY (MVE)
TAKE-OFF MINIMUMS: **Rwy 21**, 400-1½.

DEPARTURE PROCEDURE: **Rwy 14**, climb runway heading to 1500 before turning.

MOOSE LAKE, MN

MOOSE LAKE CARLTON COUNTY (MZH)
ORIG 94006 (FAA)

TAKE-OFF MINIMUMS: **Rwys 4, 22**, 300-1.

MORRIS, MN

MORRIS MUNI-CHARLIE SCHMIDT FLD
(MOX)

ORIG 08045 (FAA)

TAKE-OFF MINIMUMS: **Rwys 4, 22**, NA-
Environmental.

NOTE: **Rwy 32**, Trees 2888' from departure end of runway, 1125' left of centerline, 100' AGL/1209' MSL.

OAKES, ND

OAKES MUNI (2D5)
ORIG 97142 (FAA)

TAKE-OFF MINIMUMS: **Rwy 30**, 300-1 or std. with a min. climb of 260' per NM to 1700.

OLIVIA, MN

OLIVIA RGNL (OVL)
AMDT 1 86044 (FAA)
TAKE-OFF MINIMUMS: **Rwy 11**, 300-1.

ORR, MN

ORR RGNL (ORB)
AMDT 1 80136 (FAA)
TAKE-OFF MINIMUMS: **Rwy 13**, 500-2 or std. with a min. climb of 260' per NM to 1900.

ORTONVILLE, MN

ORTONVILLE MUNI-MARTINSON FIELD (VVV)
ORIG 81274 (FAA)
TAKE-OFF MINIMUMS: **Rwy 16**, 300-1 or std. with a min. climb of 210' per NM to 1300.

OWATONNA, MN

OWATONNA DEGNER RGNL (OWA)
AMDT 2 97030 (FAA)
DEPARTURE PROCEDURE: **Rwy 12**, climb runway heading to 1500 before turning on course.

PEMBINA, ND

PEMBINA MUNI (PMB)
ORIG 85325 (FAA)
DEPARTURE PROCEDURE: **Rwy 33**, climb runway heading 3200 before turning left.

PERHAM, MN

PERHAM MUNI (16D)
ORIG 98113 (FAA)
TAKE-OFF MINIMUMS: **Rwy 12**, 500-2 or std. with a min. climb of 210' per NM to 2000. **Rwy 30**, 400-1 or std. with a min. climb of 270' per NM to 1800.
DEPARTURE PROCEDURE: **Rwy 12**, climb runway heading to 2000 before proceeding on course. **Rwy 30**, climb runway heading to 1800 before proceeding on course.

PIERRE, SD

PIERRE RGNL (PIR)
AMDT 2 85115 (FAA)
TAKE-OFF MINIMUMS: **Rwy 25**, 300-1.

PINERIDGE, SD

PINE RIDGE (IEN)
ORIG 97226 (FAA)
TAKE-OFF MINIMUMS: **Rwy 12**, 300-1 or std. with a min. climb of 350' per NM to 3600. **Rwy 24**, 300-1 or std. with a min. climb of 220' per NM to 3500. **Rwy 30**, 300-1 or std. with a min. climb of 300' per NM to 3600.

PIPESTONE, MN

PIPESTONE MUNI (PQN)
ORIG 08045 (FAA)
TAKE-OFF MINIMUMS: **Rwys 9,27**, NA-Environmental.
NOTE: **Rwy 18**, Trees beginning 3811' from departure end of runway, 854' right of centerline, up to 100' AGL/1859' MSL.

PRESTON, MN

FILLMORE COUNTY (FKA)
ORIG 98113 (FAA)
TAKE-OFF MINIMUMS: **Rwys 11,29**, 300-1.

PRINCETON, MN

PRINCETON MUNI (PNM)
AMDT 1 05132 (FAA)
NOTE: **Rwy 15**, trees 982' from departure end of runway, 335' right of centerline, 50' AGL/1029' MSL. Trees 1449' from departure end of runway, 387' left of centerline, 50' AGL/1029' MSL. **Rwy 33**, barn 1159' from departure end of runway, 780' right of centerline, 50' AGL/1139' MSL, multiple trees, terrain, and road beginning 36' from departure end of runway, 84' right of centerline, up to 50' AGL/1045' MSL.

RAPID CITY, SD

RAPID CITY RGNL (RAP)
AMDT 6 07130 (FAA)
DEPARTURE PROCEDURE: **Rwy 5**, climb on heading between 255° clockwise to 210° from departure end of runway, or min. climb of 240' per NM to 8800 for all other courses. **Rwy 14**, climb on heading between 325° clockwise to 210° from departure end of runway, or min. climb of 245' per NM to 8900 for all other courses. **Rwy 23**, climb on heading between 210° counter clockwise to 055° from departure end of runway, or min. climb of 268' per NM to 8900 for all other courses. **Rwy 32**, climb on heading between 255° clockwise to 140° from departure end of runway, or min. climb of 242' per NM to 8800 for all other courses.
NOTE: **Rwy 5**, fence 133' from departure end of runway, 249' left of centerline, 10' AGL/3215' MSL. **Rwy 23**, hangar 201' from departure end of runway, 299' left of centerline, 24' AGL/3193' MSL. Fence 334' from departure end of runway, 256' right of centerline, 10' AGL/3184' MSL. **Rwy 32**, obstruction light 662' from departure end of runway, 243' left of centerline, 54' AGL/3213' MSL. Fence 1002' from departure end of runway, 751' right of centerline, 10' AGL/3233' MSL. Tower 1.9 NM from departure end of runway, 3503' right of centerline, 152' AGL/3520' MSL.

RAY S. MILLER AAF (KRYM)

CAMP RIPLEY, MN AMDT 2, 09155
TAKE-OFF OBSTACLES: **Rwy 13**, Terrain 1270' MSL, 73' from DER, 8' left and right of centerline. Vehicle 15' AGL/1180' MSL, 765' from DER, 638' left of centerline. **Rwy 31**, Terrain 1273' MSL, 54' from DER, 9' left and right of centerline. Trees 64' AGL/1282' MSL, 798' from DER, 325' left and right of centerline.

RED WING, MN

RED WING RGNL (RGK)
AMDT 1 01137 (FAA)
DEPARTURE PROCEDURE: **Rwy 9**, 700-4 or std. with a min. climb of 270' per NM to 1700.

REDWOOD FALLS, MN

REDWOOD FALLS MUNI (RWF)

ORIG 09071 (FAA)

TAKE-OFF MINIMUMS: **Rwy 5, 23**, NA-Environmental.
 NOTE: **Rwy 12**, numerous buildings beginning 388' from DER, 376' right of centerline, up to 13' AGL/1052' MSL. Numerous fences beginning 6' from DER, 329' right of centerline, up to 13' AGL/1052' MSL. Tree 62' from DER, 444' left of centerline, 11' AGL/1040' MSL. **Rwy 30**, multiple trees beginning 865' from DER, 401' right of centerline, up to 100' AGL/1119' MSL. Vehicle on road 128' from DER, 306' right of centerline, 15' AGL/1027' MSL.

ROCHESTER, MN

ROCHESTER INTL (RST)

ORIG 09015 (FAA)

NOTE: **Rwy 2**, road 73' from departure end of runway, 385' right of centerline, 10' AGL/1292' MSL. Tree 4377' from departure end of runway, 1132' right of centerline, 100' AGL/1399' MSL. Road 268' from departure end of runway, 366' right of centerline, 10' AGL/1290' MSL. **Rwy 13**, tree 1498' from departure end of runway, 840' right of centerline, 44' AGL/1348' MSL. **Rwy 20**, pole 259' from departure end of runway, 407' right of centerline, 23' AGL/1338' MSL. Roads beginning 1' from departure end of runway, 231' right of centerline, up to 10' AGL/1327' MSL. **Rwy 31**, tree 4760' from departure end of runway, 1103' left of centerline, 100' AGL/1389' MSL.

ROSEAU, MN

ROSEAU MUNI-RUDY BILLBERG FIELD (ROX)

ORIG 07242 (FAA)

NOTE: **Rwy 16**, building 258' from departure end of runway, 505' right of centerline, 24' AGL/1078' MSL. Tree 1582' from departure end of runway, 337' left of centerline, 47' AGL/1101' MSL. **Rwy 34**, truck on road 41' from departure end of runway, 511' left of centerline, 15' AGL/1069' MSL.

RUSHFORD, MN

RUSHFORD MUNI (55Y)

AMDT 1 96228 (FAA)

TAKE-OFF MINIMUMS: **Rwy 34**, 300-1 or std. with a min. climb of 300' per NM to 1500.

DEPARTURE PROCEDURE: **Rwy 16**, climb runway heading to 1700 before turning eastbound.

ST. CLOUD, MN

ST. CLOUD RGNL (STC)

ORIG 09239 (FAA)

TAKE-OFF MINIMUMS: **Rwy 5**, 300-1 ¼ or std. w/min. climb of 201' per NM to 1300 or alternatively, with standard take-off minimums and a normal 200'/NM climb gradient, take-off must occur no later than 1100' prior to DER.

NOTE: **Rwy 5**, tower 6201' from DER, 1416' left of centerline, 149' AGL/1179' MSL. Multiple trees beginning 17' from DER, 373' right of centerline, up to 59' AGL/1081' MSL. Multiple trees beginning 1752' from DER, 56' left of centerline, up to 80' AGL/1102' MSL. **Rwy 13**, tree 1654' from DER, 884' right of centerline, 61' AGL/1078' MSL. Tree 1265' from DER, 794' left of centerline, 42' AGL/1059' MSL. **Rwy 23**, trees 2109' from DER, 29' right of centerline, up to 61' AGL/1082' MSL. Trees 1725' from DER, 93' left of centerline, up to 55' AGL/1076' MSL. Fence 74' from DER, 216' left of centerline, 2' AGL, 1023' MSL. **Rwy 31**, terrain beginning 29' from DER, 50' right of centerline, up to 1083' MSL. Terrain beginning 107' from DER, 7' left of centerline, up to 1060' MSL.

ST. JAMES, MN

ST. JAMES MUNI (JYG)

ORIG 94342 (FAA)

DEPARTURE PROCEDURE: **Rwy 15**, climb to 1900 before turning eastbound.

ST. PAUL MN

LAKE ELMO (21D)

ORIG 80318 (FAA)

TAKE-OFF MINIMUMS: **Rwy 22**, 300-1 or std. with a min. climb of 225' per NM to 1100.

ST. PAUL DOWNTOWN HOLMAN FIELD

(STP)

AMDT 7 08157 (FAA)

TAKE-OFF MINIMUMS: **Rwy 9**, std. w/min. climb of 346' per NM to 1500. **Rwy 13**, std. w/min. climb of 266' per NM to 1500. **Rwy 14**, std. w/min. climb of 216' per NM to 1500. **Rwy 27**, std. w/min. climb of 436' per NM to 1500. **Rwy 31**, NA-obstacles. **Rwy 32**, std. w/min. climb of 340' per NM to 3000.

DEPARTURE PROCEDURE: **Rwy 9**, climb heading 088° to 1500 before proceeding on course. **Rwy 13**, climb heading 125° to 1500 before proceeding on course.

Rwy 14, climb heading 143° to 1500 before proceeding on course. **Rwy 27**, climb heading 268° to 1700 before proceeding on course. **Rwy 32**, climb heading 323° to 1300 before proceeding on course.

NOTE: **Rwy 9**, multiple trees beginning 1265' from departure end of runway, 167' right of centerline, up to 75' AGL/1055' MSL. Multiple trees beginning 1.1 NM from departure end of runway, 124' left of centerline, up to 100' AGL/1099' MSL. Obstruction light tank 1571' from departure end of runway, 771' right of centerline, 50' AGL/811' MSL. Mobile crane 1163' from departure end of runway, 123' left of centerline, 50' AGL/758' MSL.



ST. PAUL DOWNTOWN HOLMAN FIELD (STP) (CONT)

Rwy 13, Obstruction light stack 2695' from departure end of runway, 842' right of centerline, 50' AGL/820' MSL. Tree 1563' from departure end of runway, 25' right of centerline, 61' AGL/748' MSL. Multiple trees beginning 1004' from departure end of runway, 607' left of centerline, 50' AGL/767' MSL. Tower 1,725' from departure end of runway, 930' left of centerline, 47' AGL/753' MSL. Vent on building 3029' from departure end of runway, 629' right of centerline, 10' AGL/783' MSL. Multiple bushes beginning 194' from departure end of runway 88' left of centerline, 7' AGL/712' MSL. Stack 1,879' from departure end of runway, 25' left of centerline, 51' AGL/751' MSL. **Rwy 14**, multiple trees beginning 805' from departure end of runway, 2' right of centerline, up to 112' AGL/811' MSL. Multiple trees beginning 1205' from departure end of runway, 64' left of centerline, up to 80' AGL/770' MSL. Poles 2810' from departure end of runway 715' right of centerline, 91' AGL/778' MSL. **Rwy 27**, multiple trees beginning 803' from departure end of runway, 122' left of centerline, up to 100' AGL/994' MSL. Tree 783' from departure end of runway, 105' right of centerline, 25' AGL/725' MSL. Obstruction light antenna 996' from departure end of runway, 304' right of centerline, 67' AGL/767' MSL. Light pole 1328' from departure end of runway, 222' left of centerline, 50' AGL/747' MSL. Building 2049' from departure end of runway, 837' right of centerline, 57' AGL/761' MSL. Flagpole 2333' from departure end of runway, 199' left of centerline, 78' AGL/778' MSL. Stack 1.8 NM from departure end of runway, 635' left of centerline, 569' AGL/1279' MSL. **Rwy 32**, road and vehicle 211' from departure end of runway, 482' left of centerline, 17' AGL/717' MSL. Railroad beginning 369' from departure end of runway, 329' left of centerline, up to 23' AGL/727' MSL. Pipe on DME 383' from departure end of runway, 269' right of centerline, 17' AGL/722' MSL. Tree 1152' from departure end of runway, 209' left of centerline, 44' AGL/744' MSL. Tree 1685' from departure end of runway, 277' right of centerline, 75' AGL/770' MSL. Sign 5668' from departure end of runway, 1924' left of centerline, 86' AGL/874' MSL. Trees 5614' from departure end of runway, 1796' right of centerline, 100' AGL/939' MSL. Building 5779' from departure end of runway, 1733' right of centerline, 72' AGL/910' MSL. Pole 1.0 NM from departure end of runway, 1835' right of centerline, 157' AGL/973' MSL. Building 1.1 NM from departure end of runway, 2170' left of centerline, 122' AGL/886' MSL. Multiple buildings beginning 1.1 NM from departure end of runway, 378' left of centerline, up to 142' AGL/918' MSL.

SILVER BAY, MN

SILVER BAY MUNI (BFW)

ORIG 93035 (FAA)

TAKE-OFF MINIMUMS: **Rwys 7, 25**, 300-1.

SIoux FALLS, SD

JOE FOSS FIELD (FSD)

AMDT 7 07242 (FAA)

TAKE-OFF MINIMUMS: **Rwy 15**, 200-1 or std. w/min. climb of 404' per NM to 1700. **Rwy 33**, 200-1¼ or std. w/min. climb of 343' per NM to 1700.

DEPARTURE PROCEDURE: **Rwy 33**, climb heading 030° to 2300 before turning eastbound. **Rwy 9**, climb heading 098° to 2000, then left turn direct FSD VORTAC. **Rwy 15**, climb heading 150° to 2000, then right turn direct FSD VORTAC. **Rwy 21**, climb heading 210° to 2200 before turning eastbound. **Rwy 27**, climb heading 278° to 2100 before turning eastbound. **Rwy 33**, climb heading 330° to 2200 before turning eastbound.

NOTE: **Rwy 9**, antenna 2238' from departure end of runway, 919' right of centerline, 87' AGL/1506' MSL. Pole 1256' from departure end of runway, 23' left of centerline, 43' AGL/1464' MSL. Windssock 331' from departure end of runway, 582' right of centerline, 14' AGL/1433' MSL. **Rwy 15**, antenna 3056' from departure end of runway, 983' left of centerline 117' AGL/1576' MSL. Multiple trees beginning 1211' from departure end of runway, 471' left of centerline, up to 38' AGL/1477' MSL. Tower 3102' from departure end of runway, 972' left of centerline, 61' AGL/1520' MSL. Trees and pole beginning 1746' from departure end of runway, 316' right of centerline, up to 87' AGL/1516' MSL. **Rwy 21**, multiple trees beginning 428' from departure end of runway, 522' right of centerline, up to 75' AGL/1497' MSL. **Rwy 27**, multiple trees beginning 2528' from departure end of runway, 1027' left of centerline, up to 100' AGL/1509' MSL. **Rwy 33**, 2 lighted radio towers 3639' from departure end of runway, 894' left of centerline, 88' AGL/1585' MSL, multiple trees beginning 5370' from departure end of runway, 891' left of centerline, up to 175' AGL/1603' MSL, pole 5724' from departure end of runway, 1701' left of centerline, 45' AGL/1594' MSL.

SPEARFISH, SD

BLACK HILLS-CLYDE ICE FIELD (SPF)

TAKE-OFF MINIMUMS: **Rwys 3, 8, 21, 35**, 700-2 (NA at night). **Rwy 13**, 900-2 or std. with a min. climb of 300' per NM to 5400. **Rwy 17**, NA. **Rwys 26, 31**, 700-2 or std. with a min. climb of 370' per NM to 4700.

DEPARTURE PROCEDURE: **Rwys 3, 8**, turn left. Climb to 6500, intercept the 046° bearing outbound from SPF NDB. Thence... **Rwy 13**, climb runway heading to 4300, then climbing left turn to 6500 via heading 360° to intercept the 046° bearing outbound from SPF NDB. Thence... **Rwys 21, 35**, turn right. Climb to 6500 intercept the 046° bearing outbound from SPF NDB. Thence... **Rwy 26**, climbing right turn to 6500 via heading 330°, intercept the 297° bearing outbound from SPF NDB. Thence... **Rwy 31**, after take-off, intercept 297° bearing outbound from SPF NDB. Climb to 6500. Thence... THENCE... Continue climb to enroute MEAs before proceeding on course.

STAPLES, MN

STAPLES MUNI (SAZ)

AMDT 2 87211 (FAA)

TAKE-OFF MINIMUMS: **Rwy 14**, 400-2.

STURGIS, SD

STURGIS MUNI (49B)

ORIG 96284 (FAA)

DEPARTURE PROCEDURE: **Rwy 11**, climb runway heading to 6000, then direct RAP VORTAC.**Rwy 29**, climb runway heading to 5000, then climbing right turn to 6000 direct RAP VORTAC.**THIEF RIVER FALLS, MN**

THIEF RIVER FALLS RGNL (TVF)

ORIG 09071 (FAA)

NOTE: **Rwy 3**, trees beginning 3058' from DER, 678' right of centerline, up to 100' AGL/1229' MSL.**Rwy 13**, trees beginning 565' from DER, 372' left of centerline, up to 100' AGL/1214' MSL. Trees beginning 1337' from DER, 531' right of centerline, up to 100' AGL/1209' MSL. **Rwy 21**, trees beginning 214' from DER, 544' right of centerline, up to 100' AGL/1204' MSL. Trees beginning 2185' from DER, 33' left of centerline, up to 100' AGL/1209' MSL. **Rwy 31**, trees beginning 126' from DER, 410' right of centerline, up to 100' AGL/1214' MSL. Trees beginning 199' from DER, 413' left of centerline, up to 100' AGL/1209' MSL. Trees beginning 1204' from DER, 449' right of centerline, up to 100' AGL/1199' MSL. Trees beginning 1579' from DER, 495' left of centerline, up to 100' AGL/1214' MSL.**TIOGA, ND**

TIOGA MUNI (D60)

ORIG 09239 (FAA)

TAKE-OFF MINIMUMS: **Rwys 3, 21**, NA - Environmental.NOTE: **Rwy 12**, vehicle on road 1243' from DER, 78' left of centerline, 15' AGL/2304' MSL. Vehicle on road, tree and pole beginning 618' from DER, 50' right of centerline, up to 100' AGL/2419' MSL. Ground 21' from DER, 481' right of centerline, 2272' MSL. **Rwy 30**, vehicle on road 1' from DER, 144' left of centerline, 15' AGL/2256' MSL.**TOWER, MN**

TOWER MUNI (12D)

ORIG 09127 (FAA)

TAKE-OFF MINIMUMS: **Rwy 8**, NA - Obstacles.NOTE: **Rwy 26**, tree 2315' from DER, 700' right of centerline, 100' AGL/1479' MSL.**VALLEY CITY, ND**

BARNES COUNTY MUNI (6D8)

ORIG 10098 (FAA)

NOTE: **Rwy 13**, vehicle on road, 111' from DER, 356' right of centerline, 15' AGL/1396' MSL. Trees beginning 644' from DER, 242' right of centerline, up to 40' AGL/1421' MSL. **Rwy 31**, terrain beginning 32' from DER, 20' right of centerline, up to 1424' MSL. Vehicle on road 38' from DER, 285' right of centerline, 15' AGL/1418' MSL. Fence 71' from DER, 292' left of centerline, 4' AGL/1407' MSL. Terrain beginning 120' from DER, 125' left of centerline, up to 1447' MSL. Fence 198' from DER, 299' right of centerline, 4' AGL/1408' MSL. Trees beginning 365' from DER, 10' left of centerline, up to 40' AGL/1457' MSL. Tree 545' from DER, 607' right of centerline, 16' AGL/1436' MSL.**VERMILLION, SD**

HAROLD DAVIDSON FIELD (VMR)

AMDT 1 09239 (FAA)

NOTE: **Rwy 12**, road 1' from DER, 200' right of centerline, up to 15' AGL/1156' MSL. Multiple trees beginning 541' from DER, 366' right of centerline, up to 62' AGL/1202' MSL. **Rwy 30**, road 79' from DER 342' left of centerline 15' AGL/1155' MSL. Road 200' from DER, 450' right of centerline, 15' AGL/1160' MSL. Fence 199' from DER, 347' left of centerline, 6' AGL/1150' MSL.**WAHPETON, ND**

HARRY STERN (BWP)

ORIG 93259 (FAA)

TAKE-OFF MINIMUMS: **Rwy 3**, 300-1.**WARREN, MN**

WARREN MUNI (D37)

ORIG 02108 (FAA)

DEPARTURE PROCEDURE: **Rwy 30**, climb runway heading to 1400 before turning on course.**WARROAD, MN**

WARROAD INTL MEMORIAL (RRT)

ORIG 08101 (FAA)

TAKE-OFF MINIMUMS: **Rwys 4, 22**, NA - Environmental.**WASECA, MN**

WASECA MUNI (ACQ)

ORIG 09015 (FAA)

NOTE: **Rwy 15**, tree 560' from departure end of runway, 560' right of centerline, 100' AGL/1239' MSL. Terrain beginning 172' from departure end of runway, on centerline, up to 1149' MSL. **Rwy 33**, tree 5042' from departure end of runway, 1533' right of centerline, 100' AGL/1259' MSL.**WATERTOWN, SD**

WATERTOWN RGNL (ATY)

ORIG 07242 (FAA)

NOTE: **Rwy 12**, tree 2015' from departure end of runway, 328' right of centerline, 100' AGL/1783' MSL. **Rwy 30**, trees 2149' from departure end of runway, 10' right of centerline, 51' AGL/1810' MSL. Tree 2200' from departure end of runway, 441' left of centerline, 70' AGL/1810' MSL. Tree 2082' from departure end of runway, 121' right of centerline, 55' AGL/1806' MSL.**WATFORD CITY, ND**

WATFORD CITY MUNI (S25)

ORIG 98225 (FAA)

TAKE-OFF MINIMUMS: **Rwy 30**, 400-1 or std. with a min. climb of 340' per NM to 2600. **Rwy 12**, 300-1 or std. with a min climb of 300' per NM to 2600.

WHEATON, MN

WHEATON MUNI (ETH)

AMDT 1 92177 (FAA)

TAKE-OFF MINIMUMS: **Rwy 16**, 300-1. **Rwys 4, 22**, NA.

WILLISTON, ND

SLOULIN FIELD INTL (ISN)

AMDT 3 00251 (FAA)

TAKE-OFF MINIMUMS: **Rwy 29**, 300-1 or std. with a min. climb of 270' per NM to 2300.

DEPARTURE PROCEDURE: **Rwy 20**, climb runway heading to 2300 before turning westbound.

WILLMAR, MN

WILLMAR MUNI-JOHN L. RICE FIELD

(BDH)

ORIG 06327 (FAA)

NOTE: **Rwy 31**, tree 1338' from departure end of runway, 740' left of centerline, 67' AGL/1193' MSL.

WINNER, SD

WINNER RGNL (ICR)

AMDT 3 09127 (FAA)

TAKE-OFF MINIMUMS: **Rwys 3, 21**, NA-Environmental.

WINONA, MN

WINONA MUNI-MAX CONRAD FIELD

(ONA)

AMDT 3 96228 (FAA)

TAKE-OFF MINIMUMS: **Rwy 12**, 300-1 or std. with a min. climb of 320' per NM to 800. **Rwy 17**, 600-1 or std. with a min. climb of 500' per NM to 1300.

Rwy 30, 500-1 or std. with a min. climb of 500' per NM to 1200. **Rwy 35**, 700-1 or std. with a min. climb of 390' per NM to 1500.

DEPARTURE PROCEDURE: **Rwy 12**, climb to 1900 via ONAR-110 before turning. **Rwys 17, 30, 35**, climb runway heading to 1900 before turning.

WORTHINGTON, MN

WORTHINGTON MUNI (OTG)

AMDT 2 88154 (FAA)

TAKE-OFF MINIMUMS: **Rwy 17**, 300-1.

DEPARTURE PROCEDURE: **Rwys 11, 17, 29, 35**, when weather is below 800-1 climb runway heading to 2400 before turning.

YANKTON, SD

CHAN GURNEY MUNI (YKN)

AMDT 2 85003 (FAA)

TAKE-OFF MINIMUMS: **Rwy 31**, 300-1.

DEPARTURE PROCEDURE: **Rwys 1, 13, 19, 31**, climb runway heading to 2400 before turning.

LOC/DME I-ABR 109.9 Chan 36	APP CRS 308°	Rwy Idg TDZE Apt Elev 6901 1300 1301
---	------------------------	--



MISSED APPROACH: Climb to 3000 then right turn direct RENEY LOM and hold.

ASOS 125.875	MINNEAPOLIS CENTER 120.6 371.9	CTAF 122.7	UNICOM 122.95
------------------------	--	----------------------	-------------------------

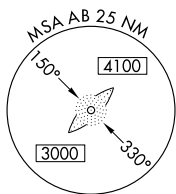
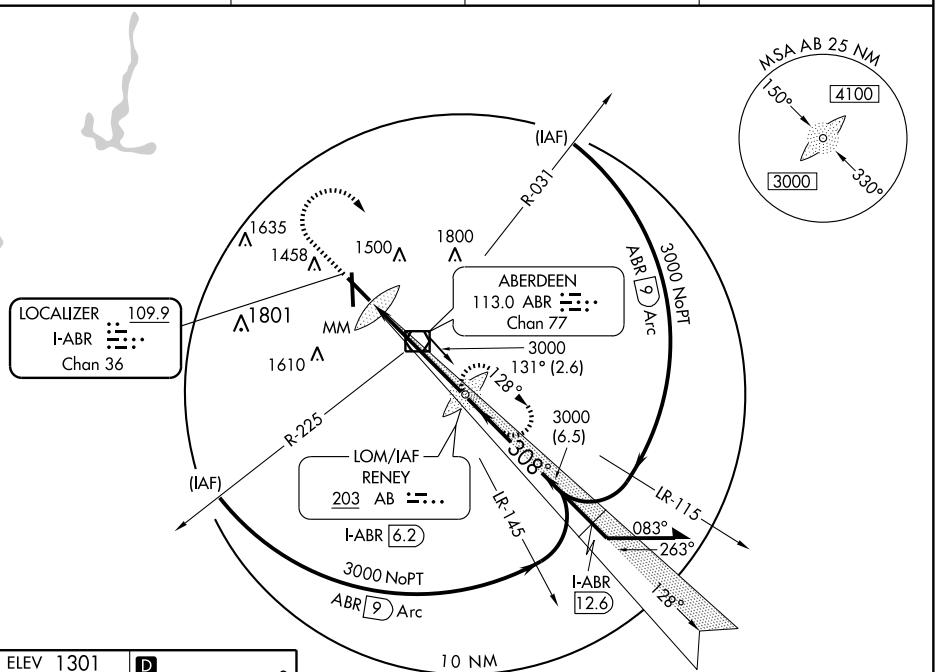

LOCALIZER 109.9
I-ABR
Chan 36

ABERDEEN
113.0 ABR
Chan 77

LOM/IAF
RENEY
203 AB

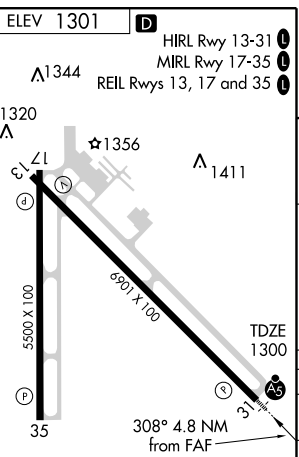

ADF or DME REQUIRED

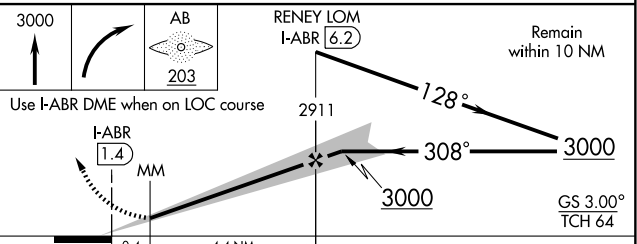

CATEGORY	A	B	C	D
S-ILS 31	1500-½ 200 (200-½)			
S-LOC 31	1660-½ 360 (400-½)		1660-¾ 360 (400-¾)	
CIRCLING	1760-1 459 (500-1)		1760-1½ 459 (500-1½) 1860-2 559 (600-2)	

FAF to MAP 4.8 NM					
Knots	60	90	120	150	180
Min:Sec	4:48	3:12	2:24	1:55	1:36

NC-1, 08 APR 2010 to 06 MAY 2010

LOC/DME BC RWY 13

ABERDEEN RGNL (ABR)

LOC/DME I-ABR	APP CRS	Rwy Idg	6901
109.9	128°	TDZE	1301
Chan 36		Apt Elev	1301

MISSED APPROACH: Climb to 3500 direct ABR VOR/DME and hold.

ASOS 125.875	MINNEAPOLIS CENTER 120.6 371.9	CTAF 122.7	UNICOM 122.95
-----------------	-----------------------------------	---------------	------------------

BACK COURSE

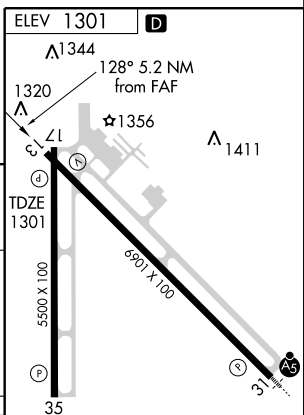
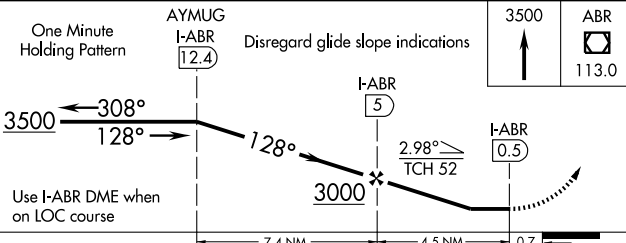
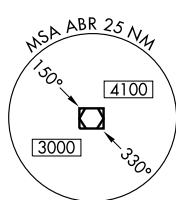
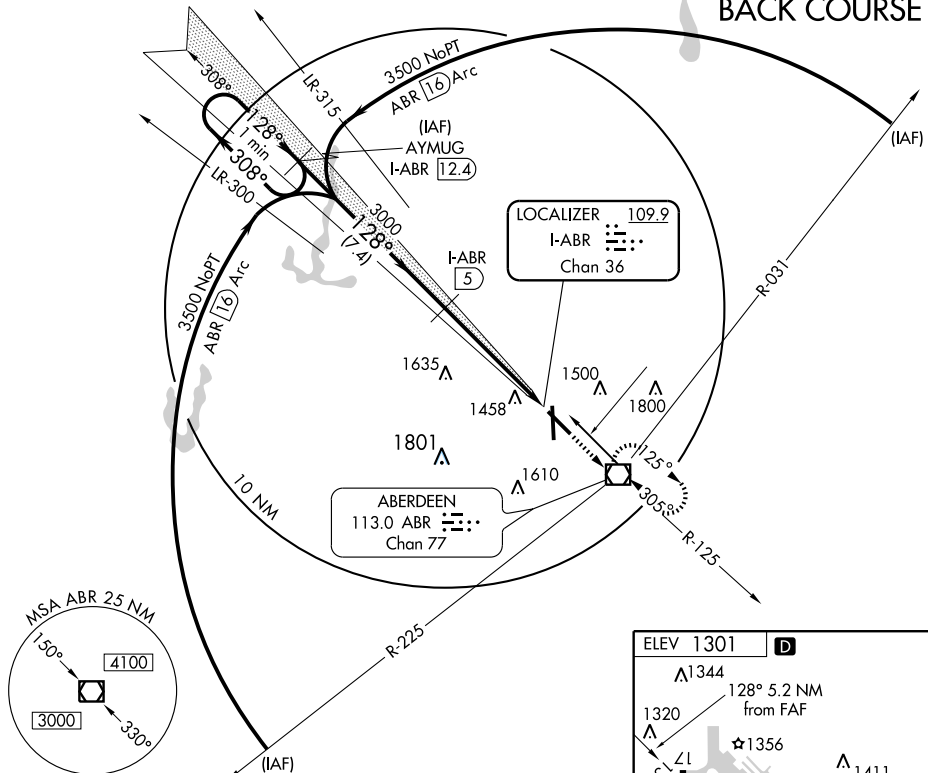

CATEGORY	A	B	C	D
S-13	1760-1	459 (500-1)	1760-1½ 459 (500-1½)	1760-1½ 459 (500-1½)
CIRCLING	1760-1	459 (500-1)	1760-1½ 459 (500-1½)	1860-2 559 (600-2)

HIRL Rwy 13-31
MIRL Rwy 17-35
REIL Rws 13, 17 and 35

NDB RWY 31

ABERDEEN RGNL (ABR)

LOM AB 203	APP CRS 308°	Rwy Idg TDZE Apt Elev	6901 1300 1301
----------------------	------------------------	-----------------------------	---



MISSED APPROACH: Climb to 2000 then climbing right turn to 3000 direct AB LOM and hold.

ASOS 125.875	MINNEAPOLIS CENTER 120.6 371.9	CTAF 122.7	UNICOM 122.95
------------------------	--	----------------------	-------------------------

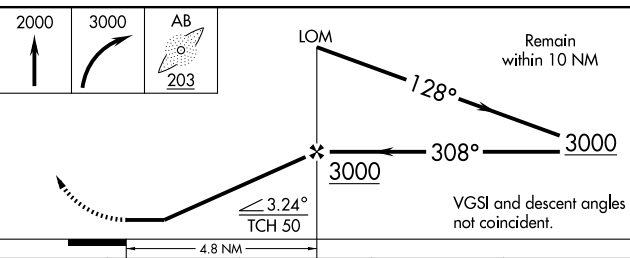
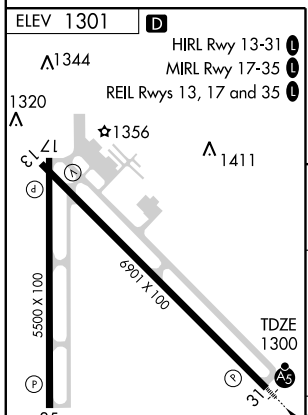
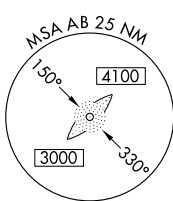
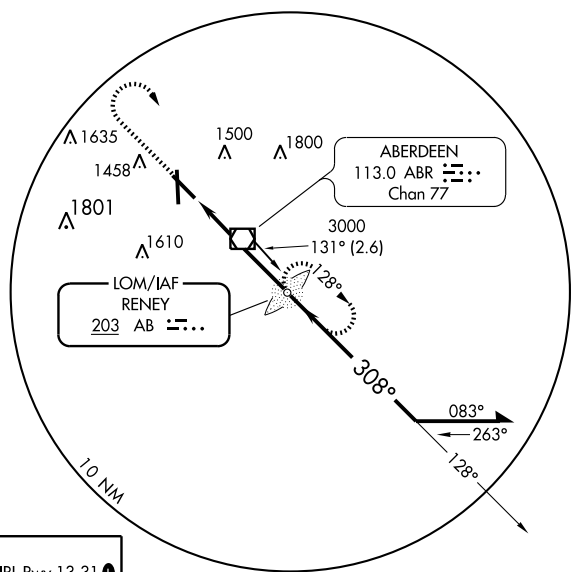

		A	B	C	D
CATEGORY		A	B	C	D
S-31		1820-¾	520 (600-¾)	1820-1 520 (600-1)	1820-1½ 520 (600-1½)
CIRCLING		1820-1	519 (600-1)	1820-1½ 519 (600-1½)	1860-2 559 (600-2)

FAF to MAP 4.8 NM					
Knots	60	90	120	150	180
Min:Sec	4:48	3:12	2:24	1:55	1:36

NC-1. 08 APR 2010 to 06 MAY 2010

RNAV (GPS) RWY 13

ABERDEEN RGNL (ABR)

APP CRS	Rwy Idg	6901
128°	TDZE	1302
	Apt Elev	1302

DME/DME RNP-0.3 NA. Visibility reduction by helicopters NA. VDP NA when using Watertown altimeter setting. When local altimeter setting not received use Watertown altimeter setting and increase all MDA 220 feet, increase LNAV Cat C visibility ½ mile, Cat D visibility ¾ mile and Circling Cats C and D visibility ½ mile.

MISSED APPROACH: Climb to 3000 direct DOXCU and hold.

ASOS 125.875	MINNEAPOLIS CENTER 120.6 371.9	CTAF 122.7	UNICOM 122.95
------------------------	--	----------------------	-------------------------

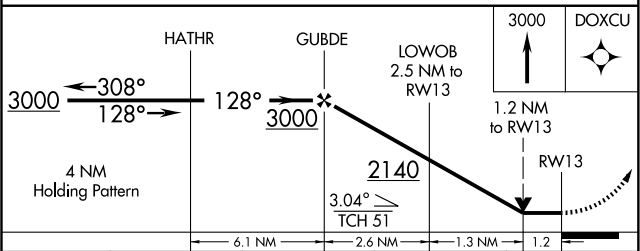
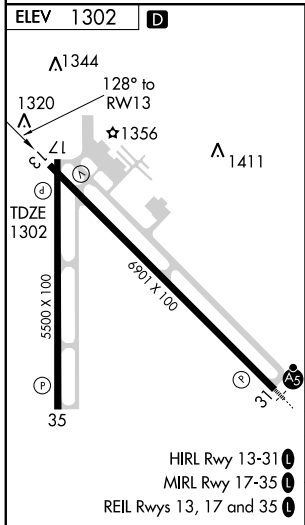
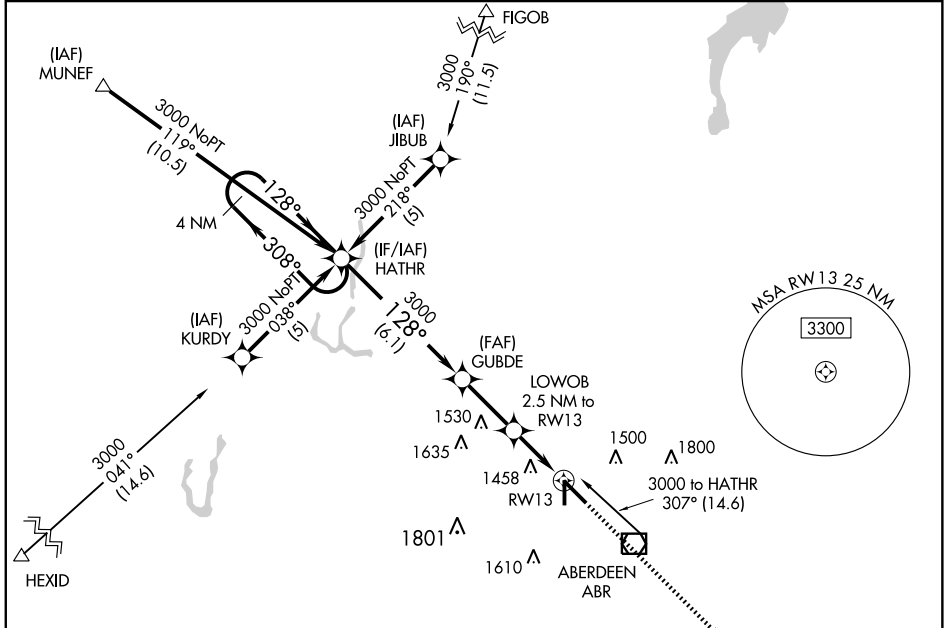

CATEGORY	A	B	C	D
LNAV MDA	1720-1	418 (500-1)	1720-1¼	418 (500-1¼)
CIRCLING	1760-1	458 (500-1)	1760-1½	1860-2 458 (500-1½) 558 (600-2)

RNAV (GPS) RWY 31

ABERDEEN RGNL (ABR)

WAAS CH 42914 W31A	APP CRS 308°	Rwy ldg 6901 TDZE 1301 Apt Elev 1302
--	------------------------	---

Inoperative table does not apply to LNAV Cat D visibility. For inoperative MALSR, increase LNAV/VNAV Cat D visibility to 1. Baro-VNAV NA when using Watertown altimeter setting. For uncompensated Baro-VNAV systems, LNAV/VNAV NA below -17°C (2°F) or above 46°C (114°F). DME/DME RNP-0.3 NA. VDP NA when using Watertown altimeter setting. For inoperative MALSR when using Watertown altimeter setting increase LPV all Cats visibility to 1½. When local altimeter setting not received, use Watertown altimeter setting and increase all DA 207 feet, all MDA 220 feet, LPV all Cats visibility ¼ mile, LNAV/VNAV Cats A, B and C visibility ¾ mile, Cat D visibility ½ mile, LNAV Cat C visibility ½ mile, Cat D visibility ¼ mile and Circling Cats C and D visibility ½ mile.

MALSR

MISSED APPROACH: Climb to 3000 direct HATHR and hold.

ASOS 125.875	MINNEAPOLIS CENTER 120.6 371.9	CTAF 122.7	UNICOM 122.95
------------------------	--	----------------------	-------------------------

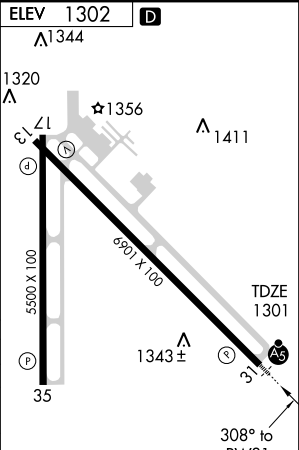
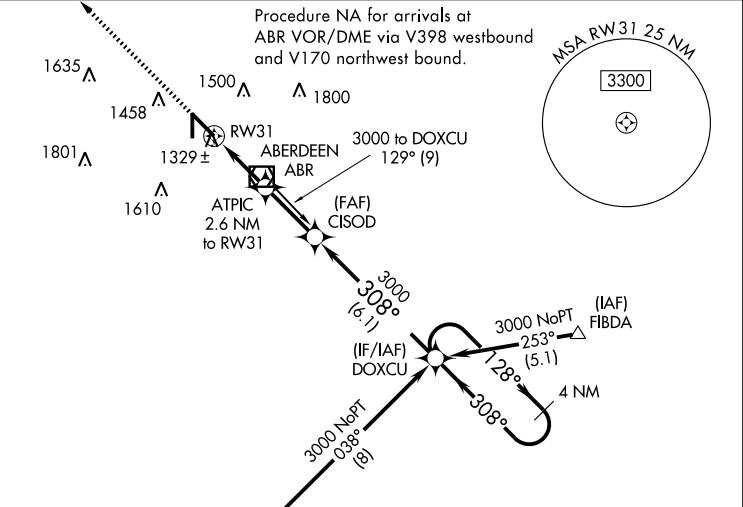
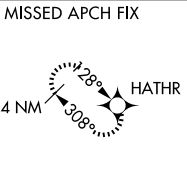

CATEGORY	A	B	C	D
LPV DA	1501-½ 200 (200-½)			
LNAV/VNAV DA	1599-½ 298 (300-½)		1599-¾ 298 (300-¾)	
LNAV MDA	1620-½ 319 (400-½)		1620-1 319 (400-1)	
CIRCLING	1760-1 458 (500-1)		1760-1½ 458 (500-1½)	

HIRL Rwy 13-31 Δ

MIRL Rwy 17-35 Δ

REIL Rws 13, 17 and 35 Δ

RNAV (GPS) RWY 35

ABERDEEN RGNL (ABR)

WAAS CH 65800 W35A	APP CRS 353°	Rwy Idg TDZE Apt Elev	5500 1301 1302
--	------------------------	-----------------------------	---

▼ If local altimeter setting not received, use Watertown Rgnl altimeter setting and increase all DAs/MDAs 220 feet.
▲ Baro-VNAV and VDP NA when using Watertown Rgnl altimeter setting. DME/DME RNP -0.3 NA.
 For uncompensated Baro-VNAV systems, LNAV/VNAV NA below -17°C (2°F) or above 46°C (115°F).

MISSED APPROACH: Climb to 5000 direct HODLU and via 083° track to COYAY and right turn via 173° track to AZZOZ and hold.

ASOS 125.875	MINNEAPOLIS CENTER 120.6 371.9	CTAF 122.7	UNICOM 122.95
------------------------	--	----------------------	-------------------------

Procedure NA for arrival at ABR VOR/DME via V15 northbound.

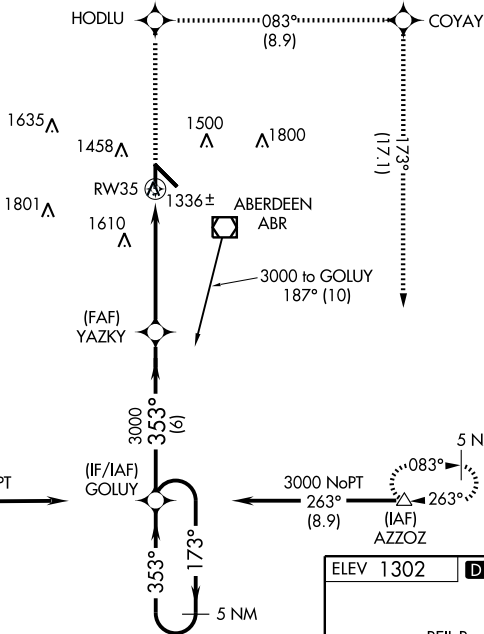
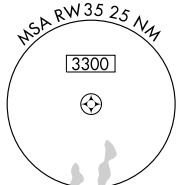

VGSI and RNAV glidepath not coincident

5 NM Holding Pattern

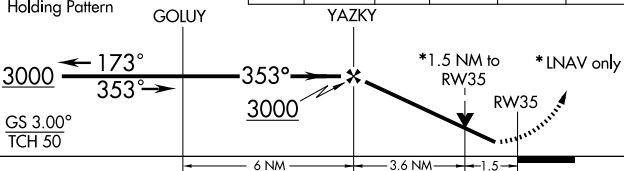

CATEGORY	A	B	C	D
LPV DA		1551-3/4	250 (300-3/4)	
LNAV/VNAV DA		1586-1	285 (300-1)	
LNAV MDA	1820-1	519 (600-1)	1820-1 1/2 519 (600-1 1/2)	1820-1 3/4 519 (600-1 3/4)
CIRCLING	1820-1	518 (600-1)	1820-1 1/2 518 (600-1 1/2)	1860-2 558 (600-2)

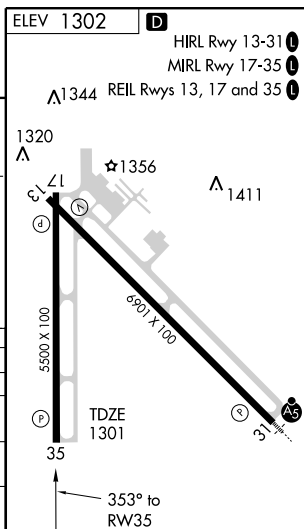

VOR/DME ABR 113.0 Chan 77	APP CRS 125°	Rwy Idg TDZE Apt Elev	6901 1302 1302
--	------------------------	-----------------------------	---

VOR/DME RWY 13

ABERDEEN RGNL (ABR)

Visibility reduction by helicopters NA. When local altimeter setting not received, use Watertown altimeter setting and increase all MDA 220 feet, increase S-13 Cats C and D visibility 3/4 mile and Circling Cats C and D visibility 1/2 mile. VDP NA when using Watertown altimeter setting.

MISSED APPROACH: Climb to 3000 direct ABR VOR/DME and hold.

ASOS 125.875	MINNEAPOLIS CENTER 120.6 371.9	CTAF 122.7	UNICOM 122.95
------------------------	--	----------------------	-------------------------

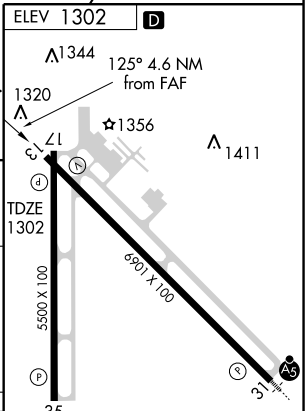
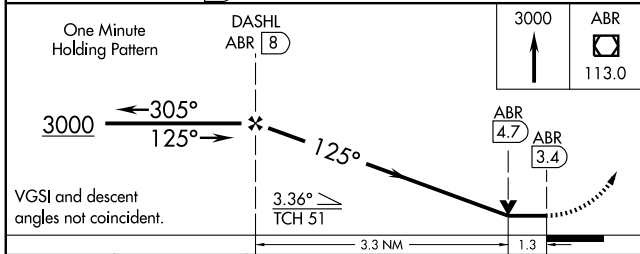
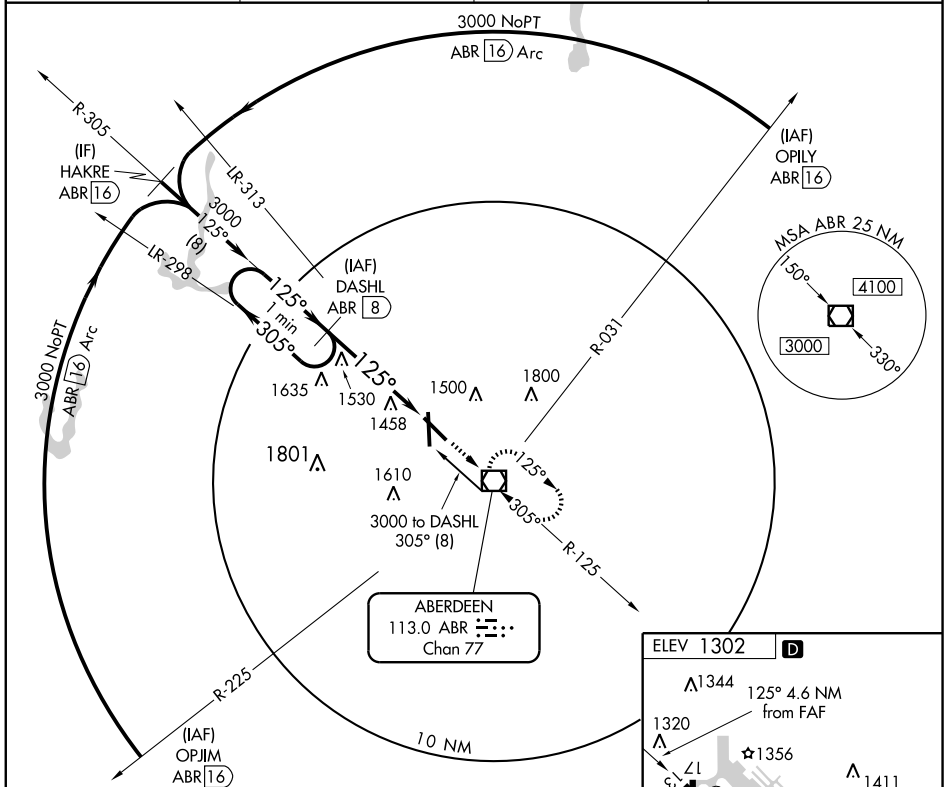

CATEGORY	A	B	C	D
S-13	1780-1	478 (500-1)	1780-1 1/4 478 (500-1 1/4)	1780-1 1/2 478 (500-1 1/2)
CIRCLING	1780-1	478 (500-1)	1780-1 1/2 478 (500-1 1/2)	1860-2 558 (600-2)

HIRL Rwy 13-31

MIRL Rwy 17-35

REIL Rwys 13, 17 and 35

VOR/DME ABR 113.0 Chan 77	APP CRS 304°	Rwy Idg TDZE Apt Elev	6901 1301 1302
---	------------------------	-----------------------------	---

VOR RWY 31

ABERDEEN RGNL (ABR)

For inoperative MALS, increase S-31 Cat D visibility to 1 1/4 .
 When local altimeter setting not received, use Watertown altimeter setting and increase all MDA 220 feet, increase S-31 Cat C visibility 1/2 mile, Cat D visibility 1/4 mile, and Circling Cats C and D 1/2 mile.
 VDP NA when using Watertown altimeter setting.

MALS



MISSED APPROACH: Climb to 3000 then right turn direct ABR VOR/DME and hold.

ASOS 125.875	MINNEAPOLIS CENTER 120.6 371.9	CTAF 122.7	UNICOM 122.95
------------------------	--	----------------------	-------------------------

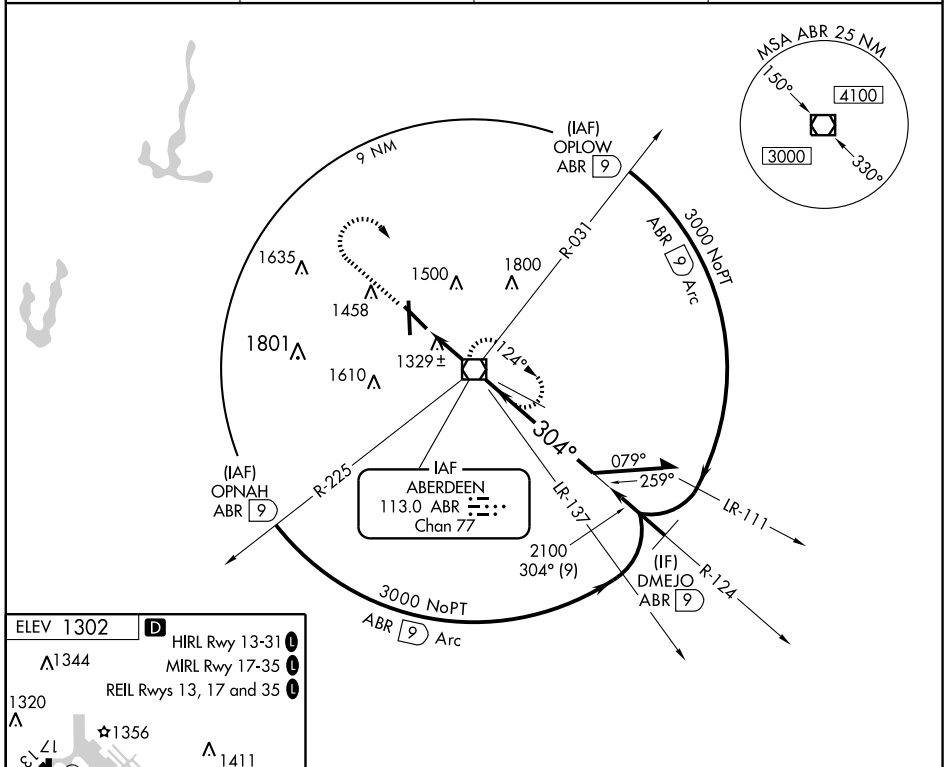

ELEV 1302 **D** HIRL Rwy 13-31 **L**
 MIRL Rwy 17-35 **L**
 REIL Rwys 13, 17 and 35 **L**

1320 **A** 1344 **A** 1356 **☆** 1411 **A**

5500 X 100 **P** 5901 X 100 **P**

35 **P** TDZE 1301 **AS**

304° 2.3 NM from FAF

FAF to MAP 2.3 NM

Knots	60	90	120	150	180
Min:Sec	2:18	1:32	1:09	0:55	0:46

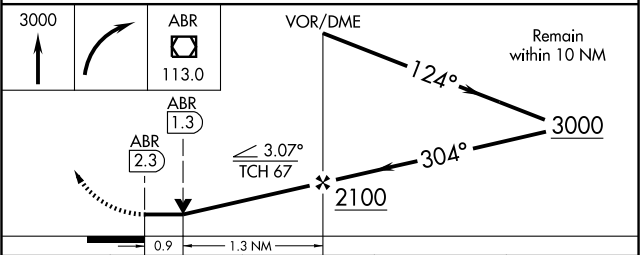

CATEGORY	A	B	C	D
S-31	1660-1/2	359 (400-1/2)		1660-1 359 (400-1)
CIRCLING	1760-1	458 (500-1)	1760-1/2 458 (500-1/2)	1860-2 558 (600-2)

RNAV (GPS) RWY 32

BELLE FOURCHE MUNI (EFC)

APP CRS	Rwy Idg	4501
321°	TDZE	3179
	Apt Elev	3190

NA DME/DME RNP -0.3 NA.
 Visibility reduction by helicopters NA.
 Use Ellsworth AFB altimeter setting, when not received, use Rapid City Rgnl altimeter setting.

MISSED APPROACH: Climbing right turn to 7300 direct SOMLE and hold.

DENVER CENTER
127.95 338.2

UNICOM
122.8 (CTAF) 0

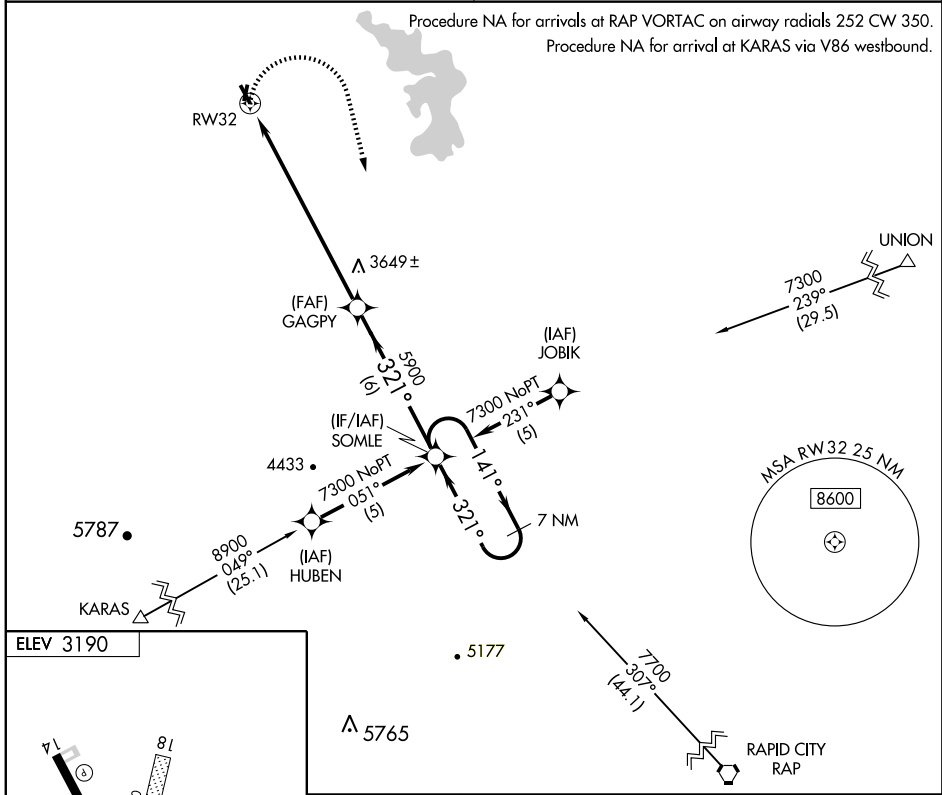

ELEV 3190

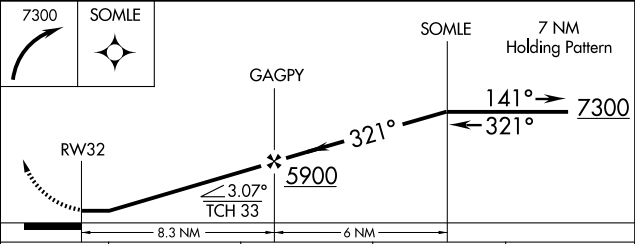
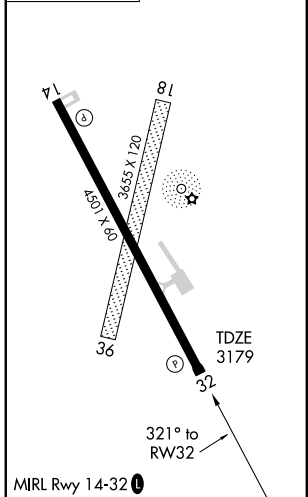

CATEGORY	A	B	C	D
RNAV MDA	4140-1½ 961 (1000-1¼)	4140-1½ 961 (1000-1½)	4140-3 961 (1000-3)	NA
CIRCLING	4140-1½ 950 (1000-1¼)	4140-1½ 950 (1000-1½)	4140-3 950 (1000-3)	NA

NC-1. 08 APR 2010 to 06 MAY 2010

APP CRS 129°	Rwy Idg 4210
	TDZE 1318
	Apt Elev 1318

RNAV (GPS) RWY 13

BRITTON MUNI (BTN)

▽ DME/DME RNP-0.3 NA.
△ NA If local altimeter setting not received, use Aberdeen altimeter setting and increase all MDAs 100 feet.
 Visibility reduction by helicopters NA.

MISSED APPROACH: Climb to 3500 direct RNORD and hold.

AWOS-3
122.8

MINNEAPOLIS CENTER
120.6 371.9

UNICOM
122.8 (CTAF)

Procedure NA for arrivals at ABR VOR/DME via V170 southbound.

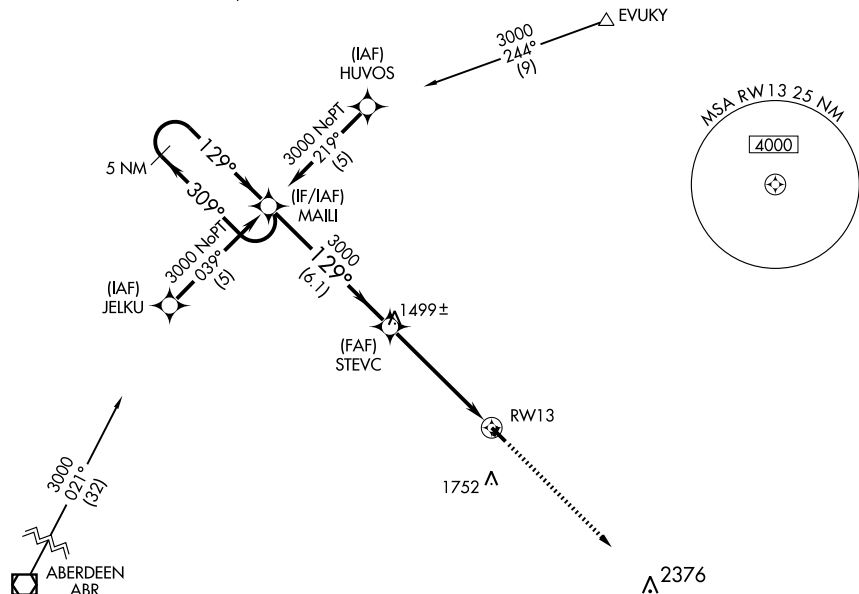

ELEV 1318

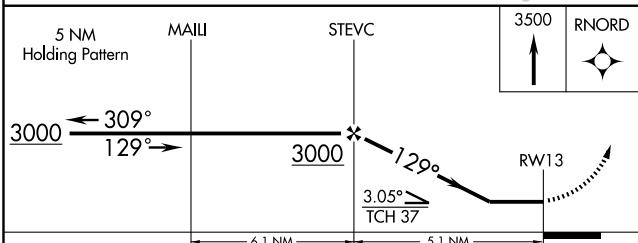
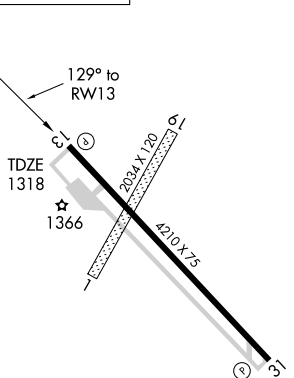

CATEGORY	A	B	C	D
LNAV MDA	1840-1	522 (600-1)	1840-1½ 522 (600-1½)	NA
CIRCLING	1900-1	582 (600-1)	2060-2¼ 742 (800-2¼)	NA

APP CRS 309°	Rwy Idg 4210
	TDZE 1318
	Apt Elev 1318

RNAV (GPS) RWY 31

BRITTON MUNI (BTN)

▽ DME/DME RNP-0.3 NA.
△NA If local altimeter setting not received, use Aberdeen altimeter setting and increase all MDAs 100 feet.
 Visibility reduction by helicopters NA.

MISSED APPROACH: Climb to 3000 direct MAILL and hold.

AWOS-3 122.8	MINNEAPOLIS CENTER 120.6 371.9	UNICOM 122.8 (CTAF)
------------------------	--	-------------------------------

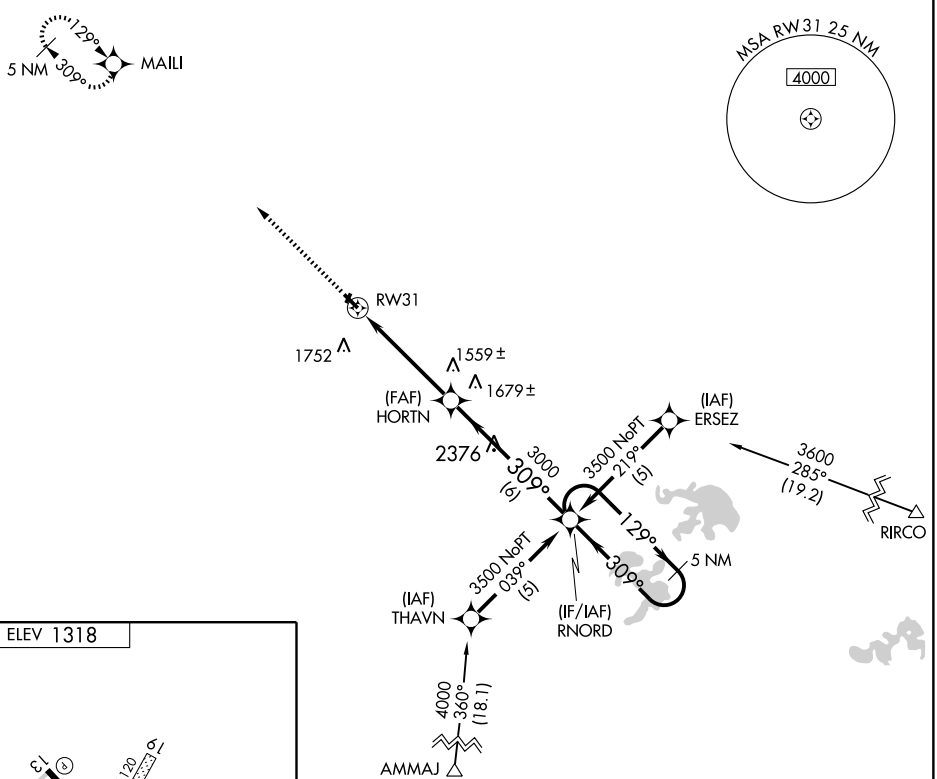

ELEV 1318

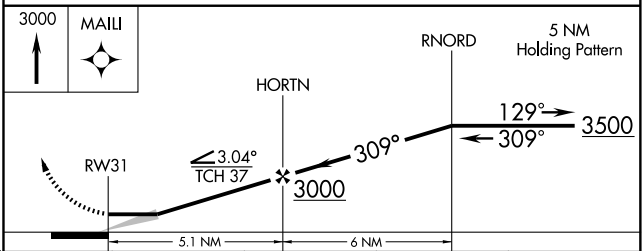
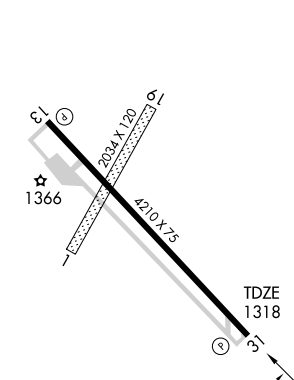

CATEGORY	A	B	C	D
LNAV MDA	1820-1	502 (600-1)	1820-1½ 502 (600-1½)	NA
CIRCLING	1900-1	582 (600-1)	2060-2¼ 742 (800-2¼)	NA

MIRL Rwy 13-31

NC-1, 08 APR 2010 to 06 MAY 2010

ILS or LOC RWY 30

BROOKINGS RGNL (BKX)

LOC I-BKX 110.9	APP CRS 303°	Rwy Idg TDZE Apt Elev	5231 1629 1648
---------------------------	------------------------	-----------------------------	---

NA

MALS R

MISSED APPROACH: Climb to 3600 then left turn direct BKX VOR/DME and hold.

AWOS-3 108.8	HURON RADIO 122.65	UNICOM 123.0 (CTAF)
------------------------	------------------------------	-------------------------------

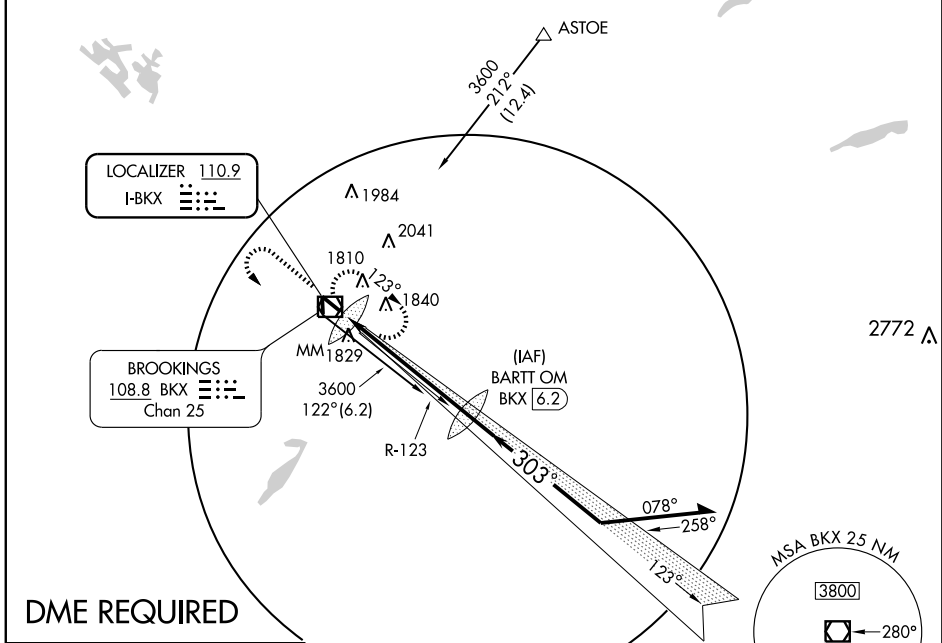

ELEV 1648	D
-----------	----------

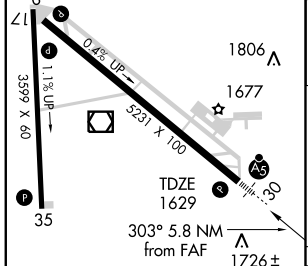

HIRL Rwy 12-30
MIRL Rwy 17-35
REIL Rwy 30
REIL Rwys 12, 17 and 35

FAF to MAP 5.8 NM

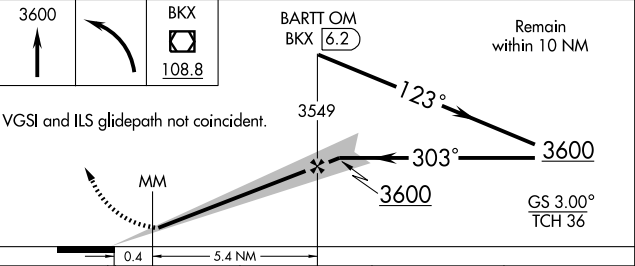

CATEGORY	A	B	C	D
S-ILS 30	1829-½ 200 (200-½)			
S-LOC 30	2040-½	411 (400-½)	2040-¾	411 (400-¾)
CIRCLING	2140-1	492 (500-1)	2140-1½ 492 (500-1½)	2200-2 552 (600-2)

NC-1, 08 APR 2010 to 06 MAY 2010

RNAV (GPS) RWY 12

BROOKINGS RGNL (BKX)

WAAS Chan 72799	APP CRS 123°	Rwy Idg TDZE 5231 1620
W12A		Apt Elev 1648

▼ If local altimeter setting not received, use Pipestone Muni altimeter setting and increase all DAs/MDAs 100 feet.
▲ VDP and Baro-VNAV NA when using Pipestone Muni altimeter setting. Baro-VNAV NA below -18°C (0°F). DME/DME RNP-0.3 NA.

MISSED APPROACH: Climb to 3400 direct KAPOA and hold.

AWOS-3 108.8	HURON RADIO 122.65	UNICOM 123.0 (CTAF) ①
---------------------	---------------------------	------------------------------

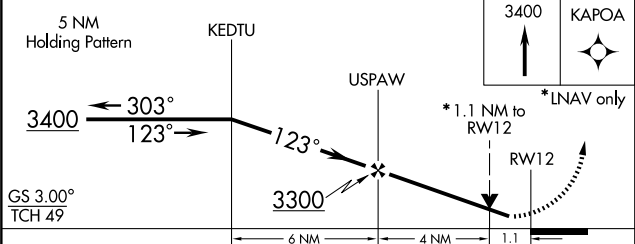
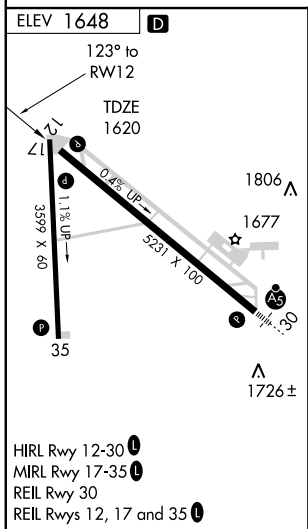
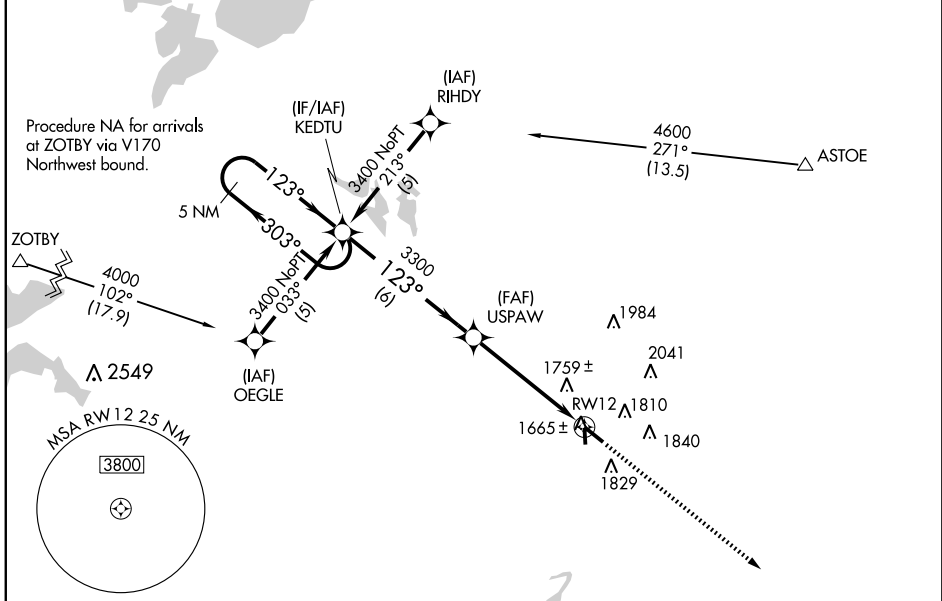

GS 3.00° TCH 49	6 NM			4 NM	1.1
CATEGORY	A	B	C	D	
LPV DA	1870-1		250 (300-1)		
LNAV/VNAV DA	1956-1¼		336 (400-1¼)		
LNAV MDA	2020-1		400 (400-1)		2020-1¼ 400 (400-1¼)
CIRCLING	2140-1¼		492 (500-1¼)		2140-1½ 492 (500-1½)
					2200-2 552 (600-2)

HIRL Rwy 12-30 ①
 MIRL Rwy 17-35 ①
 REIL Rwy 30
 REIL Rws 12, 17 and 35 ①

NC-1, 08 APR 2010 to 06 MAY 2010

RNAV (GPS) RWY 30

BROOKINGS RGNL (BKX)

WAAS Chan 69399 W30A	APP CRS 303°	Rwy Idg TDZE Apt Elev 5231 1629 1648
-----------------------------------	------------------------	--

▲ If local altimeter setting not received, use Pipestone Muni altimeter setting and increase all DAs/MDAs 100 feet.
▲ Baro-VNAV NA below -18°C (0°F). DME/DME RNP-0.3 NA. VDP and Baro-VNAV NA when using Pipestone Muni altimeter setting. For inoperative MALSRL increase LPV alt to Cats visibility to 1.

MALSRL 

MISSED APPROACH: Climb to 3400 direct KEDTU and hold.

AWOS-3 108.8	HURON RADIO 122.65	UNICOM 123.0 (CTAF) 0
------------------------	------------------------------	--

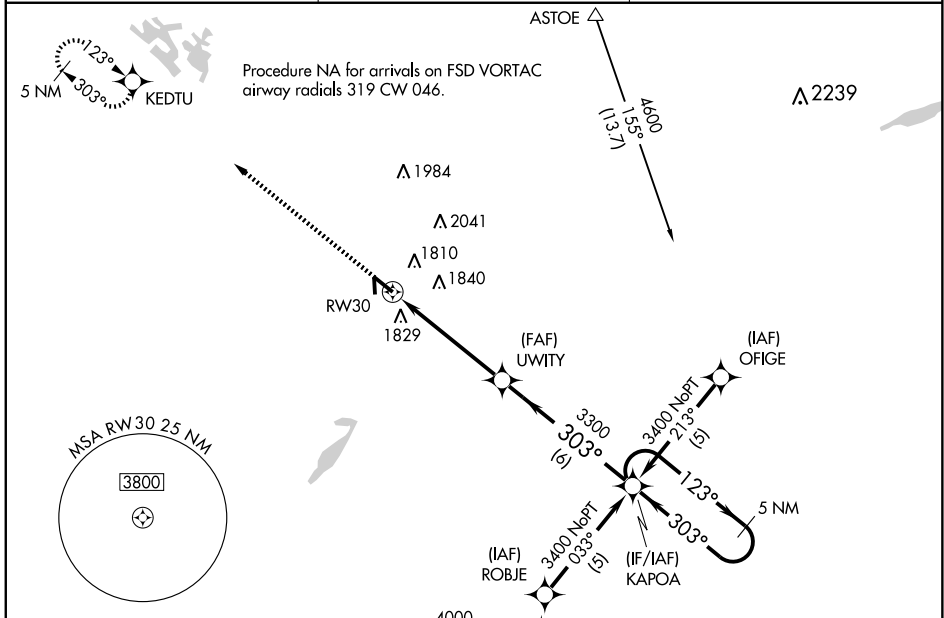

ELEV 1648 **D**

35, 1806, 1677, 5231, TDZE 1629, 303° to RW30, 1726±.

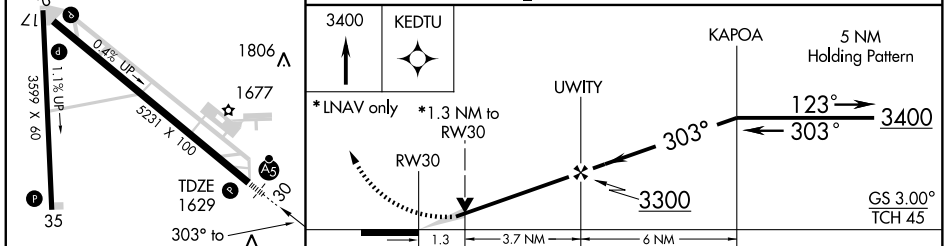

CATEGORY	A	B	C	D
LPV DA	1934-1/2 305 (300-1/2)			
LNAV/VNAV DA	2138-1/4 509 (500-1/4)			
LNAV MDA	2080-1/2 451 (500-1/2)	2080-3/4 451 (500-3/4)	2080-1 451 (500-1)	2080-1 451 (500-1)
CIRCLING	2140-1-3/4 492 (500-1-3/4)			2200-2 552 (600-2)

- HIRL Rwy 12-30 **0**
- MIRL Rwy 17-35 **0**
- REIL Rwy 30
- REIL Rws 12, 17 and 35 **0**

VOR RWY 12

BROOKINGS RGNL (BKX)

VOR/DME BKX 108.8 Chan 25	APP CRS 138°	Rwy Idg TDZE Apt Elev 5231 1620 1648
---	------------------------	--

MISSED APPROACH: Climb to 3300 then right turn direct BKX VOR/DME and hold.

AWOS-3
108.8

HURON RADIO
122.65

UNICOM
123.0 (CTAF) 0

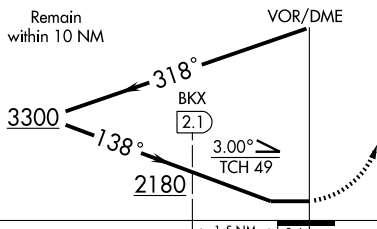
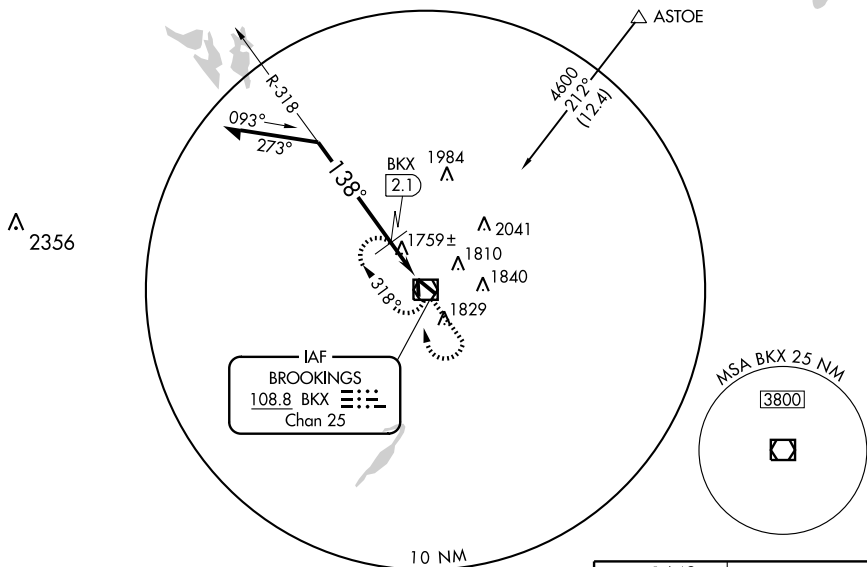

3300 ↑

138° ↘

BKX 108.8

ELEV 1648 **D**

138° to VOR/DME

TDZE 1620

0.8% UP

1.1% UP

3599 X 60

5231 X 100

1806 A

1677

35

1726± A

HIRL Rwy 12-30 **L**

MIRL Rwy 17-35 **L**

REIL Rwy 30

REIL Rws 12, 17 and 35 **L**

CATEGORY	A	B	C	D
S-12	2180-1	560 (600-1)	2180-1½ 560 (600-1½)	2180-1¾ 560 (600-1¾)
CIRCLING	2180-1	532 (600-1)	2180-1½ 532 (600-1½)	2200-2 552 (600-2)
DME MINIMUMS				
S-12	2040-1	420 (400-1)	2040-1¼	420 (400-1¼)
CIRCLING	2140-1	492 (500-1)	2140-1½ 492 (500-1½)	2200-2 552 (600-2)

VOR RWY 30

BROOKINGS RGNL (BXX)

VOR/DME BXX	APP CRS	Rwy Idg	5231
108.8	295°	TDZE	1629
Chan 25		Apt Elev	1648

MALS



MISSED APPROACH: Climb to 3300 then left turn direct BXX VOR/DME and hold.

AWOS-3
108.8

HURON RADIO
122.65

UNICOM
123.0 (CTAF) **0**

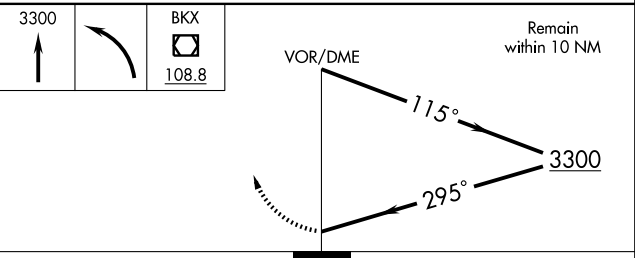
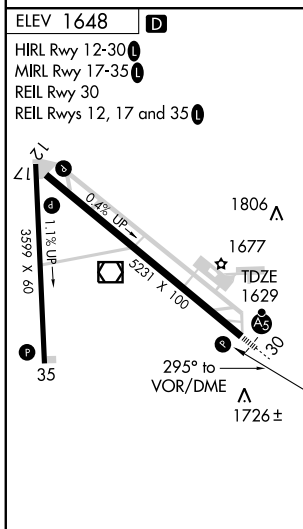
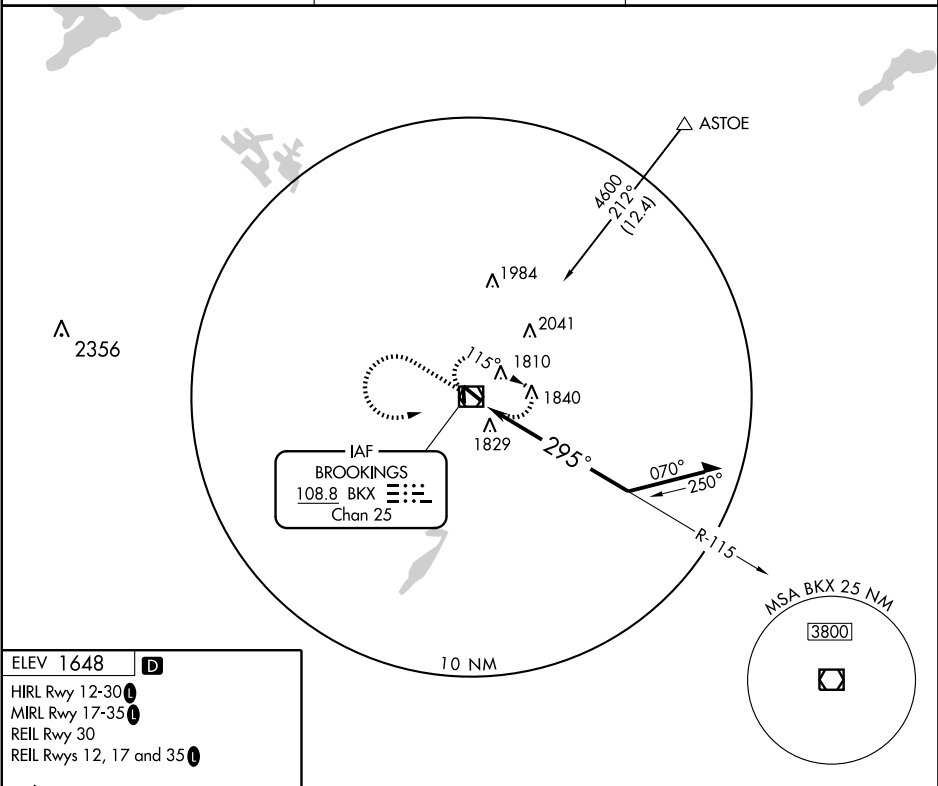

CATEGORY	A	B	C	D
S-30	2660-3/4 1031 (1100-3/4)	2660-1 1031 (1100-1)	2660-2 1/2	1031 (1100-2 1/2)
CIRCLING	2660-1 1/4 1012 (1100-1 1/4)	2660-1 1/2 1012 (1100-1 1/2)	2660-3	1012 (1100-3)

NC-1, 08 APR 2010 to 06 MAY 2010

RNAV (GPS) RWY 13

CHAMBERLAIN MUNI (9V9)

APP CRS	Rwy Idg	4300
133°	TDZE	1688
	Apt Elev	1695

▲ NA DME/DME RNP-0.3 NA.
 Use Winner altimeter setting; if not received, use Pierre Rgnl altimeter setting and increase all MDAs 20 feet.
 When VGSI inoperative, Straight-in/Circling Rwy 13 NA at night.

MISSED APPROACH: Climb to 3600 direct COCOA and hold.

WINNER ASOS 126.775	MINNEAPOLIS CENTER 125.1 269.1	UNICOM 122.8 (CTAF) 0
--------------------------------------	---	--

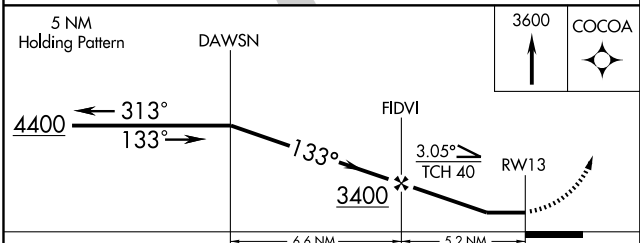
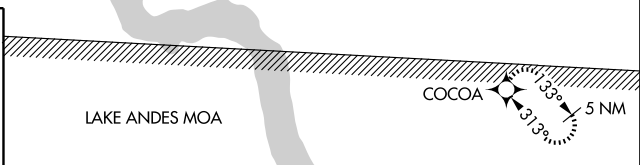
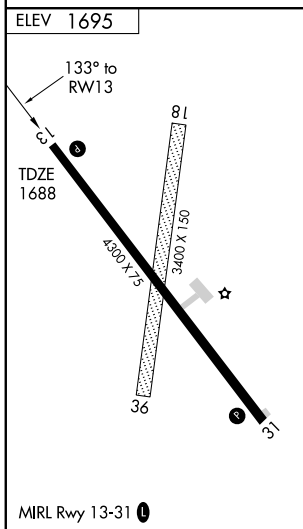
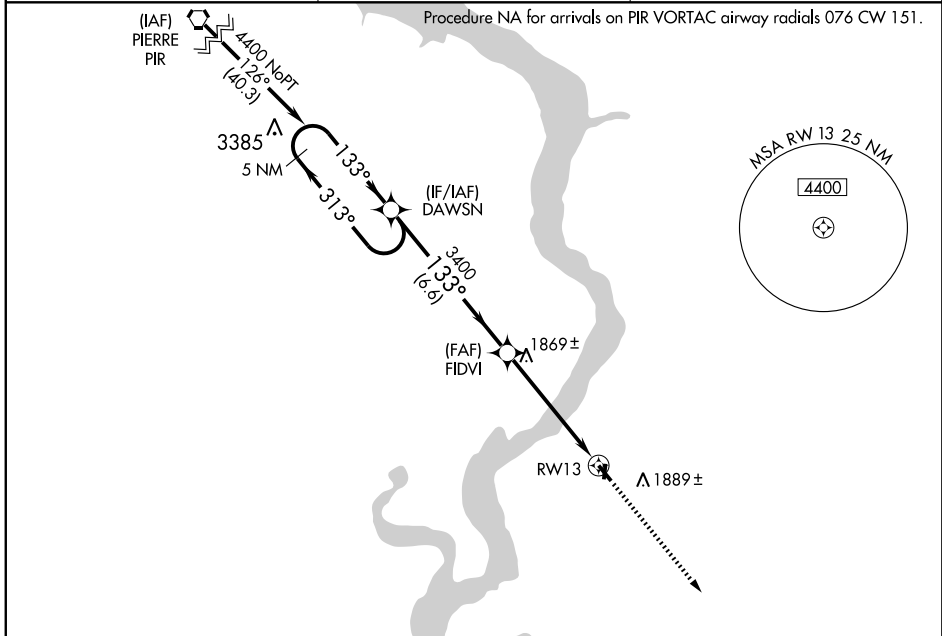

CATEGORY	A	B	C	D
RNAV MDA	2240-1	552 (600-1)	NA	
CIRCLING	2360-1	665 (700-1)	NA	

RNAV (GPS) RWY 31

CHAMBERLAIN MUNI (9V9)

APP CRS	Rwy Idg	4300
313°	TDZE	1684
	Apt Elev	1695

NA DME/DME RNP-0.3 NA.
Use Winner altimeter setting; if not received, use Pierre Rgnl altimeter setting and increase all MDAs 20 feet.

MISSED APPROACH: Climb to 4400 direct DAWSN and hold.

WINNER ASOS 126.775	MINNEAPOLIS CENTER 125.1 269.1	UNICOM 122.8 (CTAF) 0
-------------------------------	--	---------------------------------

Procedure NA for arrivals at MHE VOR/DME via V120 eastbound.

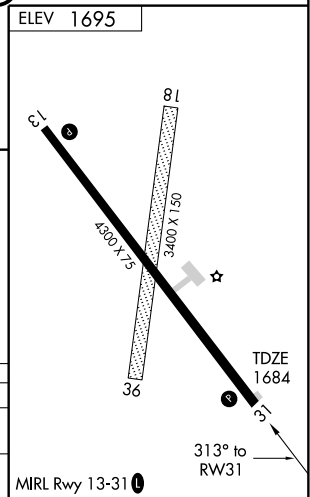
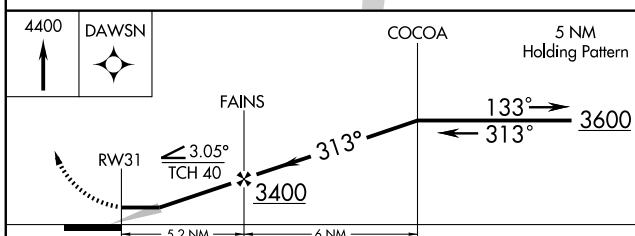
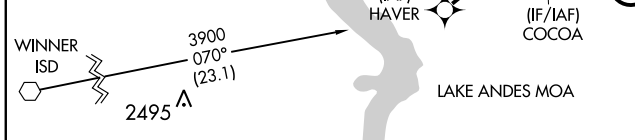
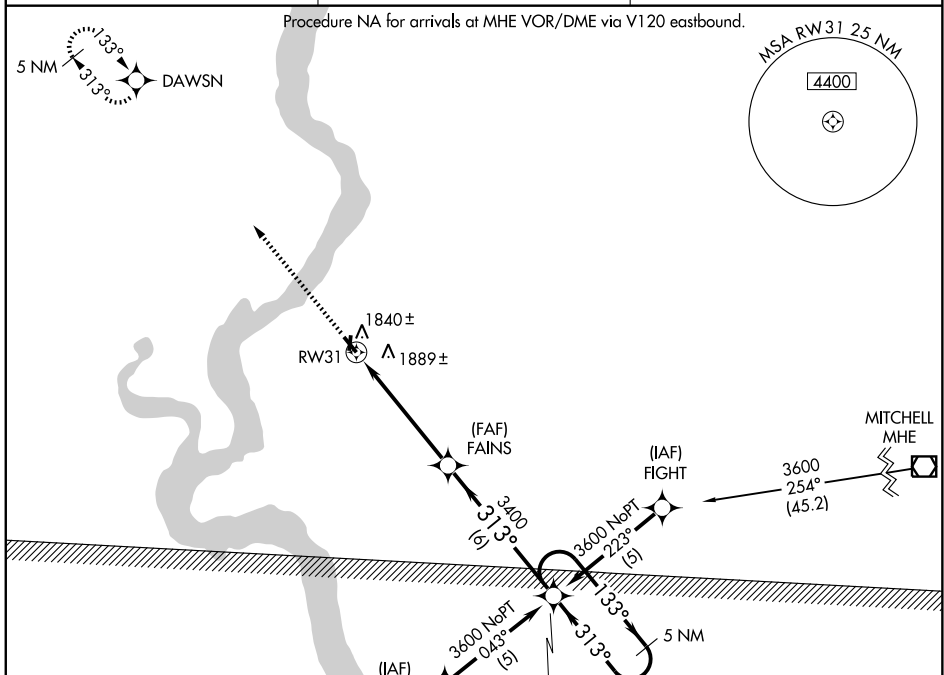

CATEGORY	A	B	C	D
RNAV MDA	2220-1	536 (600-1)	NA	
CIRCLING	2360-1	665 (700-1)	NA	

RNAV (GPS) RWY 31

EAGLE BUTTE/CHEYENNE EAGLE BUTTE (84D)

APP CRS
306°

Rwy Idg **4200**
TDZE **2447**
Apt Elev **2447**

GPS or RNP-0.3 required. DME/DME RNP- 0.3 NA.

NA Use Pierre altimeter setting.

MISSED APPROACH: Climb to 4100 then turn left direct OJPOT WP and hold.

MINNEAPOLIS CENTER
126.8 256.7

CTAF
122.9

122.8

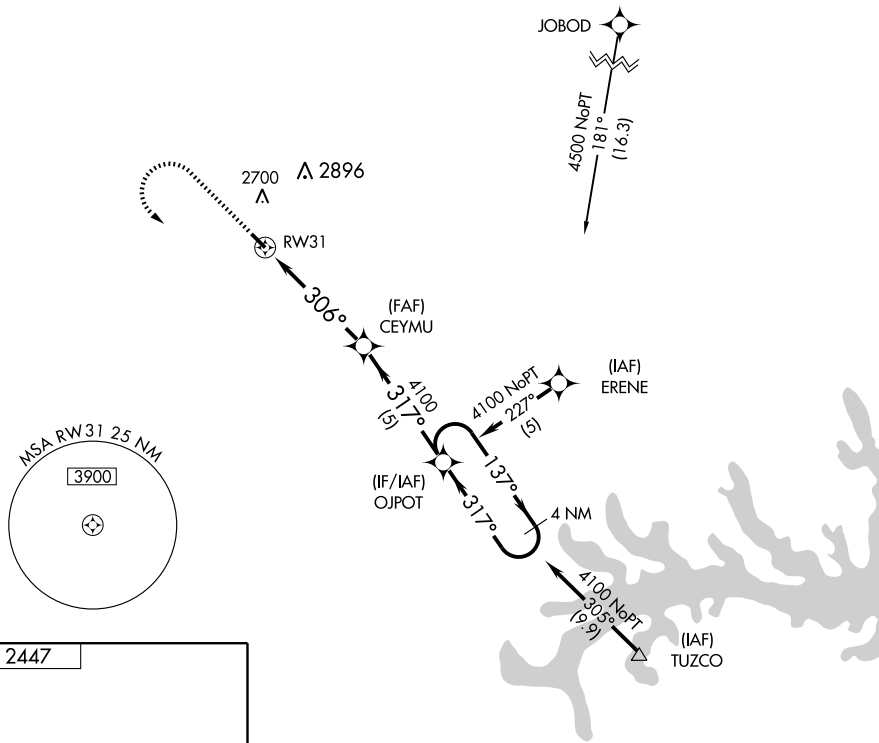

ELEV **2447**

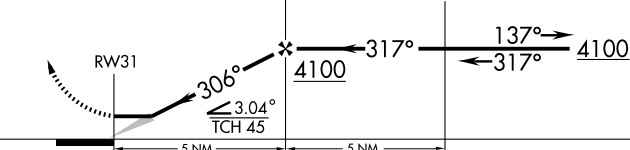
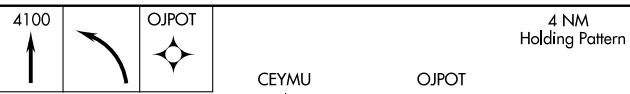
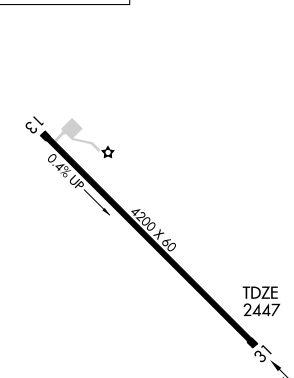

CATEGORY	A	B	C	D
RNAV MDA	3020-1	573 (600-1)		NA
CIRCLING	3240-1 793 (800-1)	3240-1¼ 793 (800-1¼)		NA

MRL Rwy 13-31

RNAV (GPS) RWY 13

GETTYSBURG MUNI (ØD8)

APP CRS **135°**
 Rwy Idg **4400**
 TDZE **2061**
 Apt Elev **2061**

▼ Use Pierre Rgnl altimeter setting; if not received, use
 ▲ NA Moberge Muni altimeter setting.
 DME/DME RNP-0.3 NA.

MISSED APPROACH: Climb to 3500 direct ZEWOX and hold.

PIERRE RGNL ASOS
119.025

MINNEAPOLIS CENTER
125.1 269.1

UNICOM
122.8 (CTAF) Ø

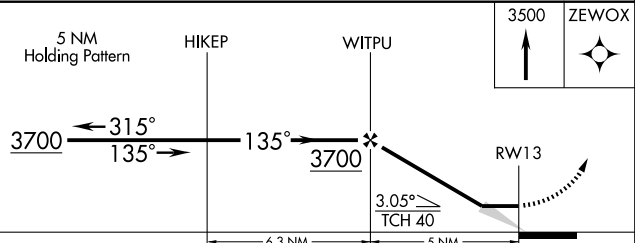
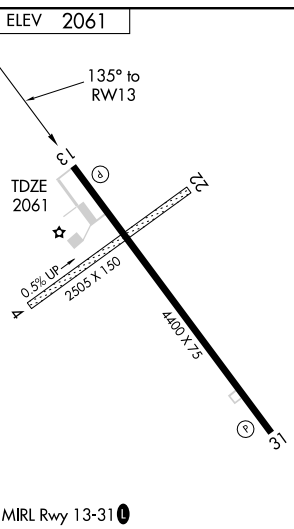
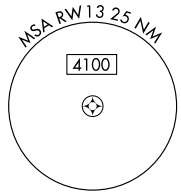
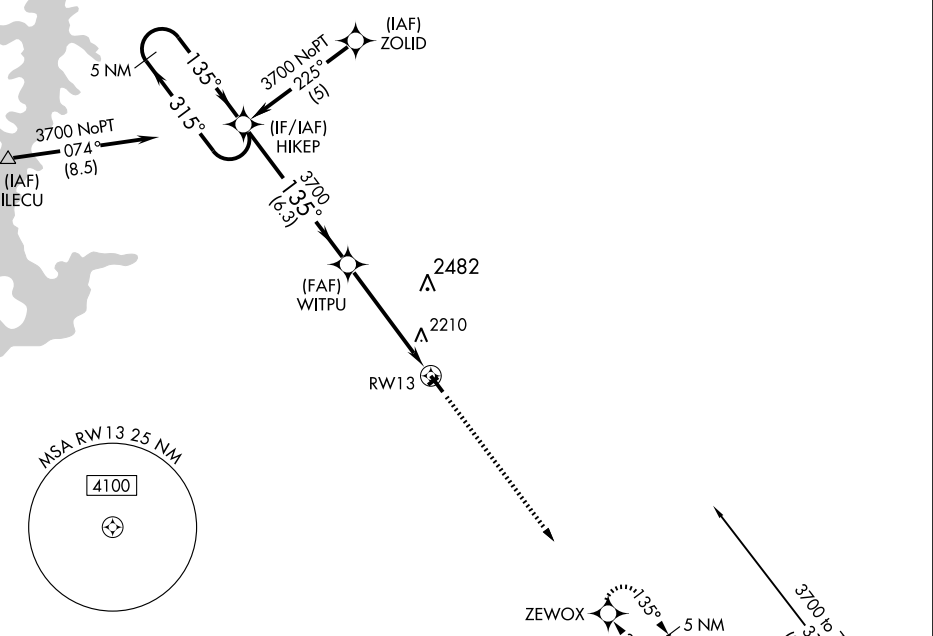

CATEGORY	A	B	C	D
LNAV MDA	2600-1	539 (600-1)	2600-1½ 539 (600-1½)	NA
CIRCLING	2660-1	599 (600-1)	2660-1½ 599 (600-1½)	NA

NC-1, 08 APR 2010 to 06 MAY 2010

RNAV (GPS) RWY 31

GETTYSBURG MUNI (ØD8)

APP CRS **315°**
 Rwy Idg **4400**
 TDZE **2061**
 Apt Elev **2061**

Use Pierre Rgnl altimeter setting; if not received, use Mobridge Muni altimeter setting.
 DME/DME RNP-0.3 NA.

MISSED APPROACH: Climb to 3700 direct HIKEP and hold.

PIERRE RGNL ASOS
119.025

MINNEAPOLIS CENTER
125.1 269.1

UNICOM
122.8 (CTAF) Ø

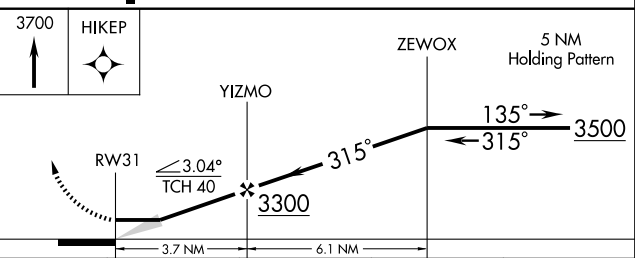
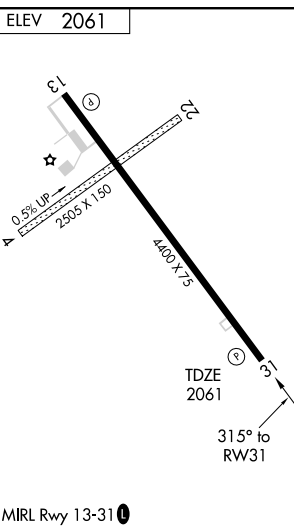
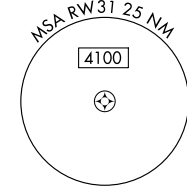
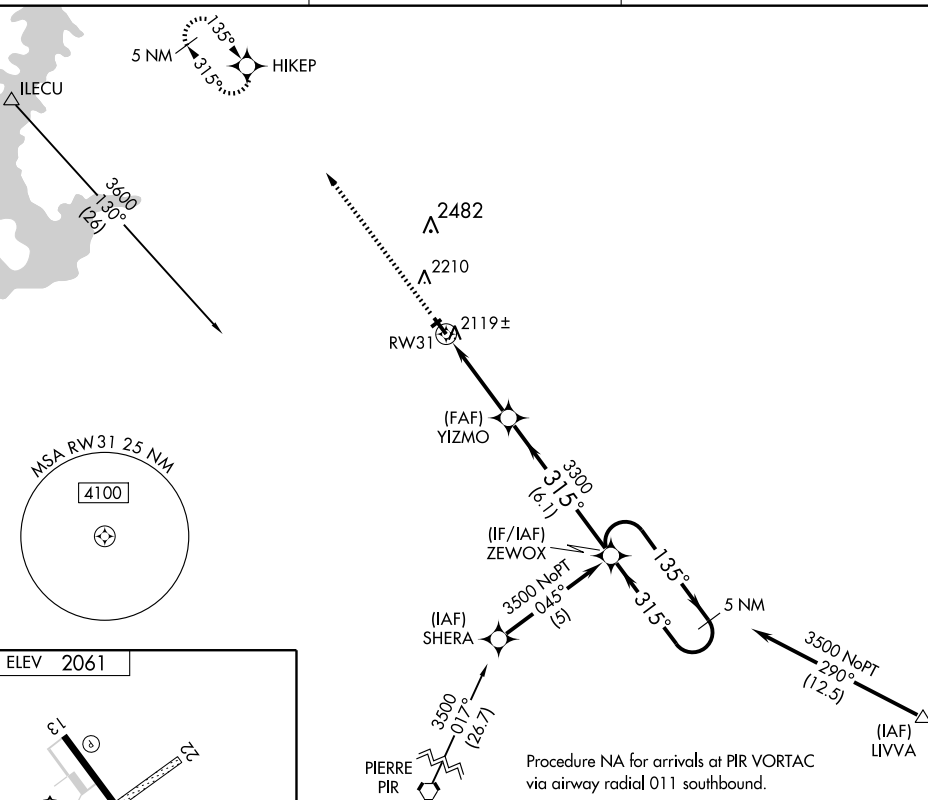

CATEGORY	A	B	C	D
LNAV MDA	2540-1	479 (500-1)	2540-1¼ 479 (500-1¼)	NA
CIRCLING	2660-1	599 (600-1)	2660-1½ 599 (600-1½)	NA

NC-1, 08 APR 2010 to 06 MAY 2010

GPS RWY 31

GREGORY MUNI, FLYNN FIELD (9D1)

APP CRS 308°	Rwy Idg TDZE Apt Elev	3800 2168 2168
------------------------	-----------------------------	---

▼ Use O'Neill altimeter setting.
 ▲ NA

MISSED APPROACH: Climb to 3200 then climbing left turn to 4000 direct ADEDY WP and hold.

HURON RADIO
122.1R

UNICOM
122.8 (CTAF)

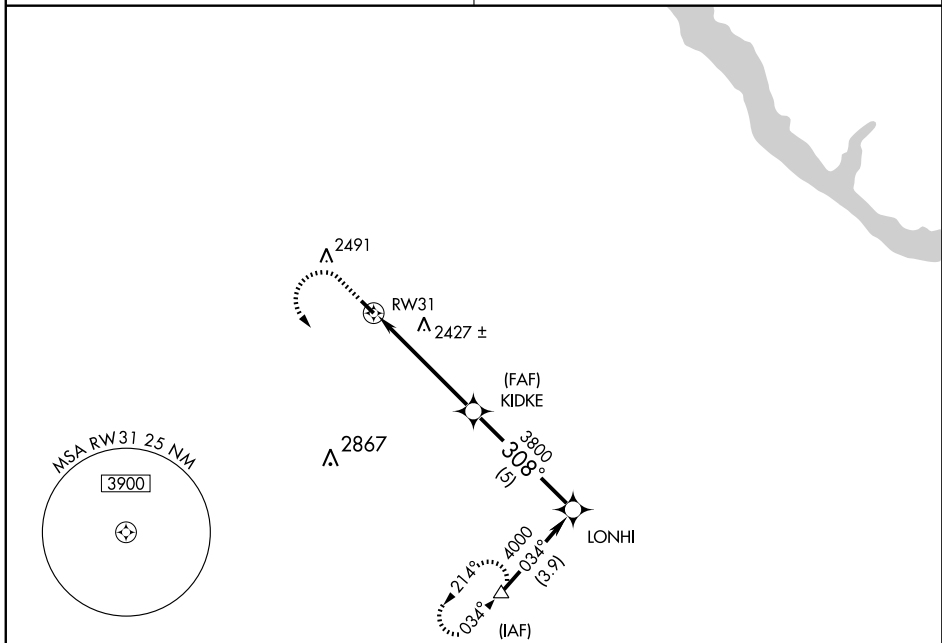

ELEV 2168

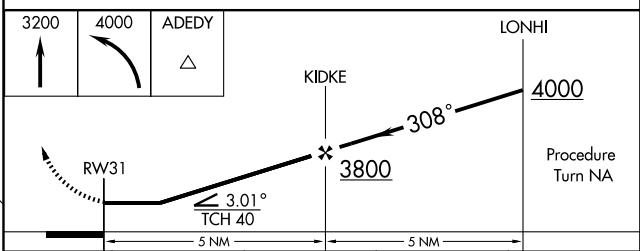
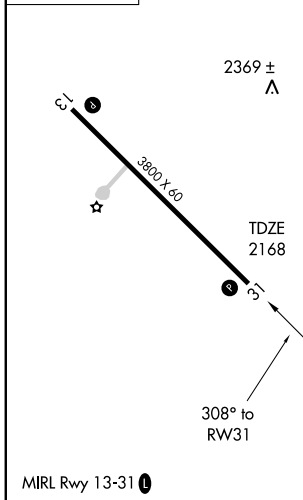

CATEGORY	A	B	C	D
S-31	2780-1	612 (700-1)	2780-1¾ 612 (700-1¾)	NA
CIRCLING	2820-1	652 (700-1)	2840-2 672 (700-2)	NA

NC-1, 08 APR 2010 to 06 MAY 2010

GPS RWY 19

HOT SPRINGS MUNI (HSR)

APP CRS	Rwy Idg	4506
192°	TDZE	3144
	Apt Elev	3148

▼ Use Rapid City Rgnl altimeter setting.
 ▲ NA

MISSED APPROACH: Climb to 4200 then climbing left turn to 6500 direct PAZNU WPT and hold.

DENVER CENTER
127.95 338.2

UNICOM
122.8 (CTAF) 0

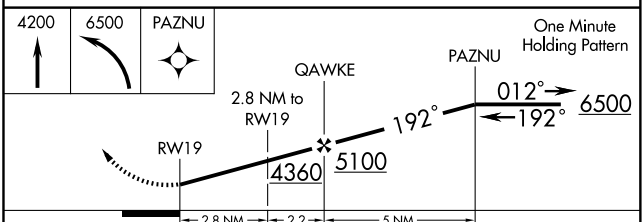
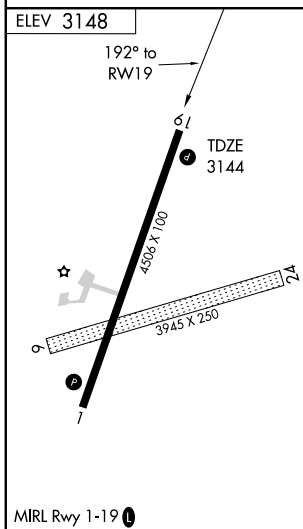
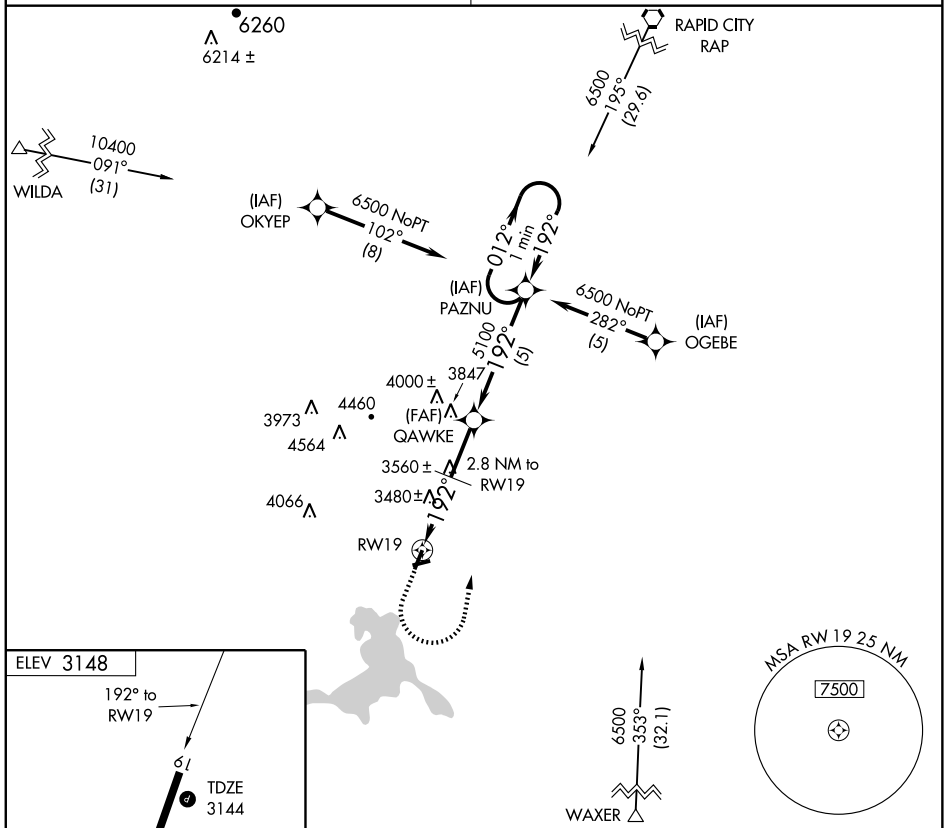

CATEGORY	A	B	C	D
S-19	3840-1 696 (700-1)		3840-2 696 (700-2)	3840-2 696 (700-2 1/4)
CIRCLING	3840-1 692 (700-1)		3840-2 692 (700-2)	3900-2 1/2 752 (800-2 1/2)

NC-1, 08 APR 2010 to 06 MAY 2010

ILS or LOC RWY 12

HURON RGNL (HON)

LOC/DME I-HON 110.3 Chan 40	APP CRS 121°	Rwy Idg 7201 TDZE 1289 Apt Elev 1289
---	------------------------	---

▼ For inoperative MALSRS when using Mitchell altimeter setting increase S-ILS 12 all cats visibility to 1 mile. When local altimeter setting not received, use Mitchell Muni altimeter setting and increase all DA 89 feet and all MDA 100 feet, increase S-LOC 12 Cats C and D visibility ¼ mile and Circling Cats C and D ¼ mile. VDP NA when using Mitchell altimeter setting.

MALSRS
MISSED APPROACH:
Climb to 3000 then left turn direct HON VORTAC and hold.

ASOS 118.125	MINNEAPOLIS CENTER 126.25 339.8	HURON RADIO 123.6 (CTAF)	UNICOM 123.0
------------------------	---	------------------------------------	------------------------

ADF or DME REQUIRED

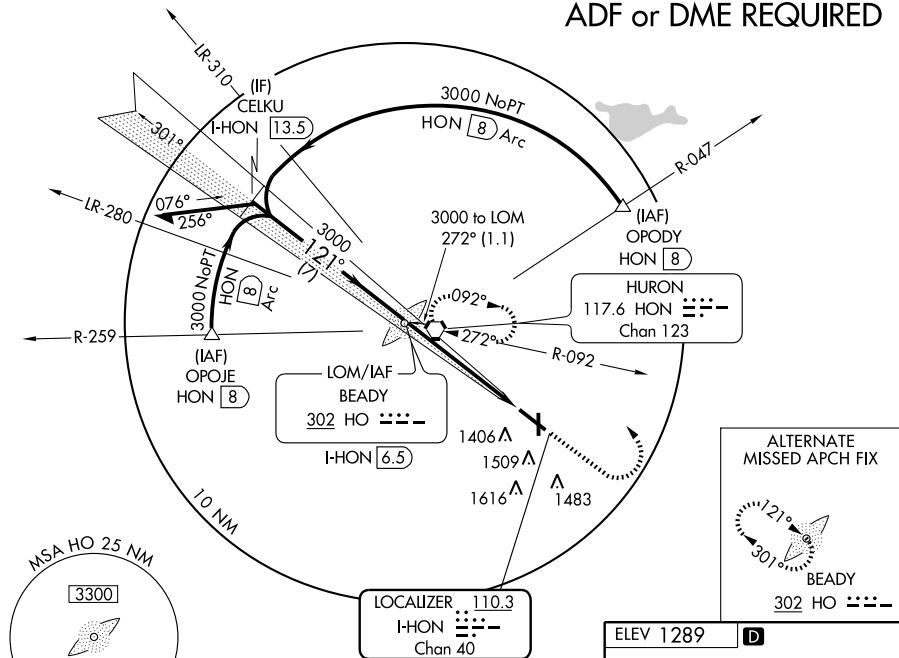

NC-1, 08 APR 2010 to 06 MAY 2010

LOC/DME BC RWY 30

HURON RGNL (HON)

LOC/DME I-HON 110.3 Chan 40	APP CRS 301°	Rwy Idg 7201
		TDZE 1286
		Apt Elev 1289

▼ If local altimeter setting not received, use Mitchell Muni altimeter setting and increase all MDAs 100 feet.

MISSED APPROACH: Climb to 3000 direct HON VORTAC and hold.

ASOS 118.125	MINNEAPOLIS CENTER 126.25 339.8	HURON RADIO 123.6 (CTAF)	UNICOM 123.0
------------------------	---	------------------------------------	------------------------

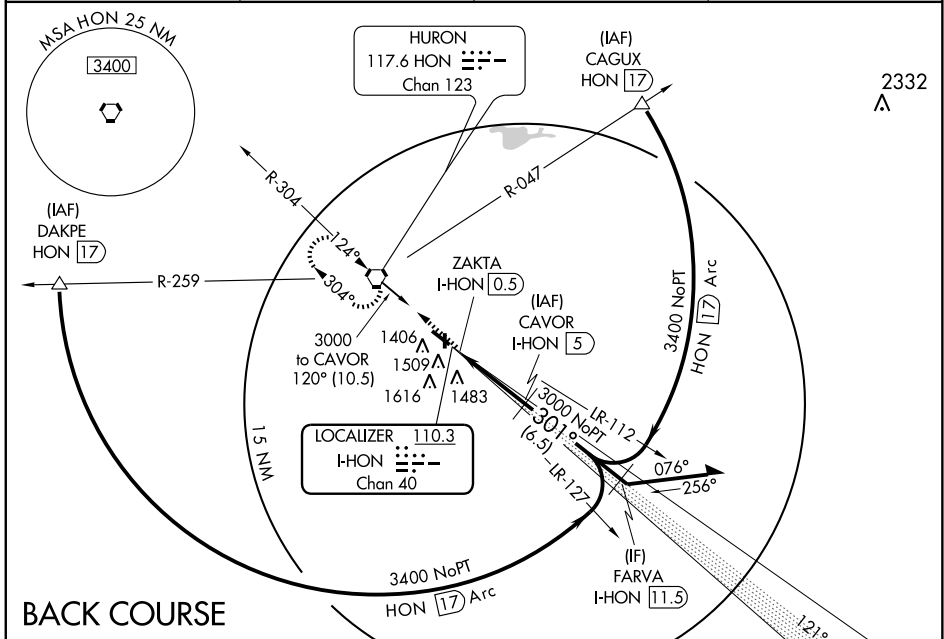

BACK COURSE

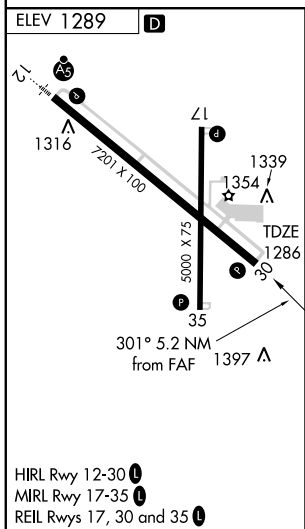

DME REQUIRED

3000	HON 117.6	CAVOR I-HON 5	Remain within 10 NM	
	ZAKTA I-HON 0.5	3000	121°	
		3000	301°	
			3000	
			Disregard glide slope indications Use I-HON DME when on LOC course	
	0.7	4.5 NM		
CATEGORY	A	B	C	D
S-30	1700-1 414 (500-1)		1700-1½ 414 (500-1½)	
CIRCLING	1820-1 531 (600-1)		1820-1½ 531 (600-1½)	1980-2¼ 691 (700-2¼)

HIRL Rwy 12-30
MIRL Rwy 17-35
REIL Rwy 17, 30 and 35

RNAV (GPS) RWY 12

HURON RGNL (HON)

WAAS CH 70314 W12A	APP CRS 121°	Rwy Idg 7201 TDZE 1289 Apt Elev 1289
---------------------------------	------------------------	--

▼ For uncompensated Baro-VNAV systems, LNAV/VNAV NA below -17°C (2°F) or above 46°C (114°F). DME/DME RNP-0.3 NA. Baro-VNAV and VDP NA when using Mitchell

▲ Muni altimeter setting. When local altimeter setting not received, use Mitchell Muni altimeter setting and increase all DA 89 feet and all MDA 100 feet. Increase LNAV/VNAV all Cats, LNAV and Circling Cat C/D visibility ½ mile. For inoperative MALSRS when using Mitchell Muni altimeter setting increase LPV all Cats visibility to 1 mile.

MALSRS

MISSED APPROACH:
Climb to 3000 direct CAVOR and via 121° track to FARVA and hold.

ASOS 118.125	MINNEAPOLIS CENTER 126.25 339.8	HURON RADIO 123.6 (CTAF)	UNICOM 123.0
------------------------	---	------------------------------------	------------------------

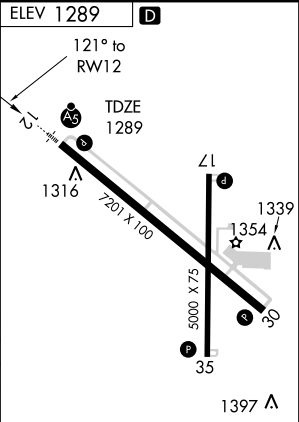
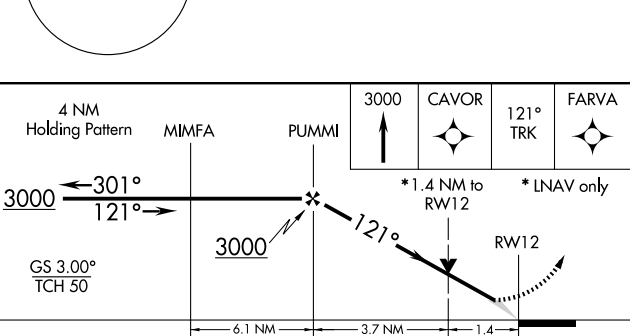
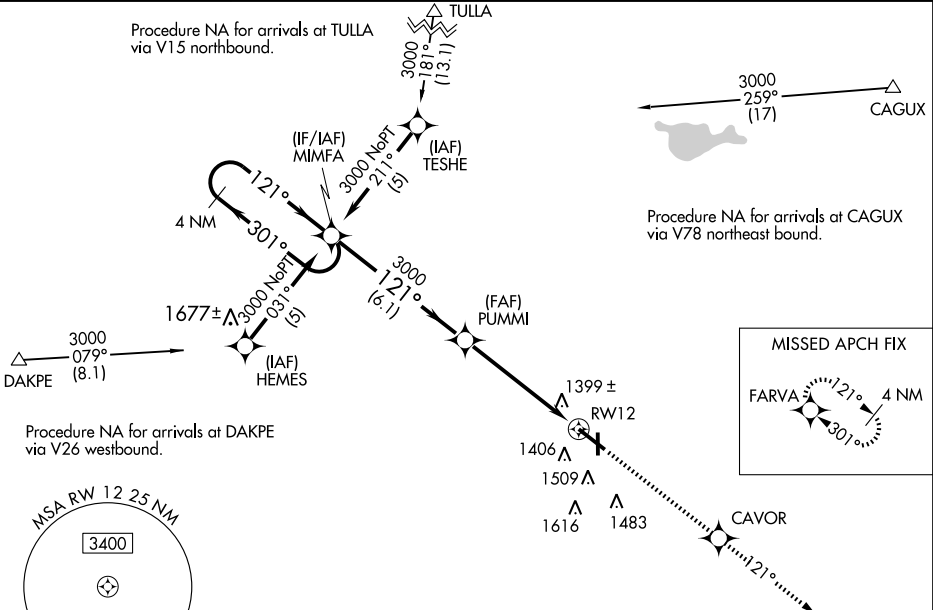

CATEGORY	A	B	C	D
LPV DA	1489-½ 200 (200-½)			
LNAV/VNAV DA	1699-1	410 (500-1)	1699-1½ 410 (500-1½)	
LNAV MDA	1780-½ 491 (500-½)	1780-¾ 491 (500-¾)	1780-1 491 (500-1)	
CIRCLING	1820-1 531 (600-1)	1820-1½ 531 (600-1½)	1980-2¼ 691 (700-2¼)	

HIRL Rwy 12-30

MIRL Rwy 17-35

REIL Rws 17, 30 and 35

NC-1. 08 APR 2010 to 06 MAY 2010

WAAS CH 77514 W30A	APP CRS 301°	Rwy Idg TDZE Apt Elev	7201 1286 1289
--	------------------------	-----------------------------	---

RNAV (GPS) RWY 30

HURON RGNL (HON)

▼ DME/DME RNP - 0.3 NA. When local altimeter setting not received, use Mitchell Muni altimeter setting and increase all DA 89 feet and all MDA 100 feet, increase LPV and LNAV/VNAV all Cats C/D, and Circling Cats C/D visibility ¼ mile. For uncompensated Baro-VNAV systems, LNAV/VNAV NA below -17°C (2°F) or above 46°C (114°F). Baro-VNAV NA when using Mitchell Muni altimeter setting.

MISSED APPROACH:
Climb to 3000 direct COGAC and via 309° track to HON VORTAC and hold.

ASOS
118.125

MINNEAPOLIS CENTER
126.25 339.8

HURON RADIO
123.6 (CTAF)

UNICOM
123.0

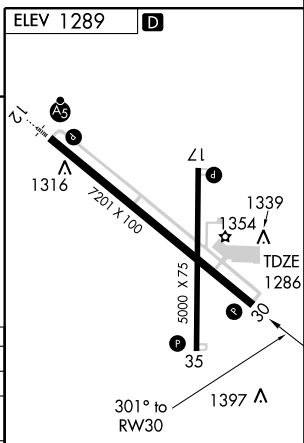
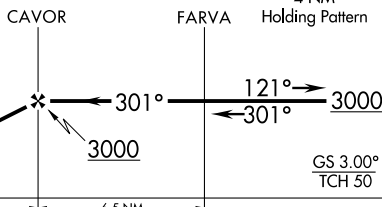
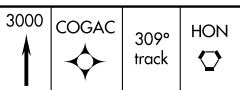
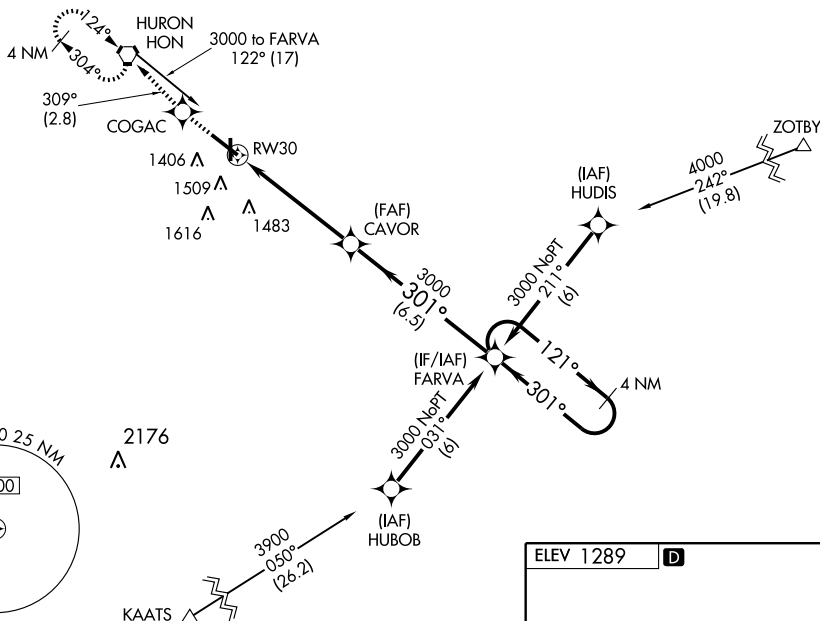

CATEGORY	A	B	C	D
LPV DA	1559-1		273 (300-1)	
LNAV/VNAV DA	1721-1½		435 (500-1½)	
LNAV MDA	1760-1	474 (500-1)	1760-1½ 474 (500-1½)	1760-1½ 474 (500-1½)
CIRCLING	1820-1	531 (600-1)	1820-1½ 531 (600-1½)	1980-2¼ 691 (700-2¼)

HIRL Rwy 12-30
MIRL Rwy 17-35
REL Rws 17, 30 and 35

VOR RWY 12

HURON RGNL (HON)

VORTAC HON 117.6 Chan 123	APP CRS 124°	Rwy Idg 7201 TDZE 1289 Apt Elev 1289
---	------------------------	---

MALSRL
 MISSED APPROACH: Climb to 3000 via HON VORTAC R-124 then left turn direct HON VORTAC and hold.

▽ When local altimeter setting not received, use Mitchell Muni altimeter setting and increase all MDA 100 feet, increase S-12 Cat C visibility ¼ mile and circling Cats C and D ¼ mile. For inoperative MALSRL increase S-12 Cat D visibility 1¼ mile. VDP NA when using Mitchell Muni altimeter setting.

ASOS 118.125	MINNEAPOLIS CENTER 126.25 339.8	HURON RADIO 123.6 (CTAF)	UNICOM 123.0
------------------------	---	------------------------------------	------------------------

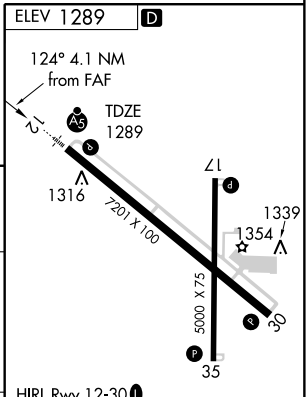
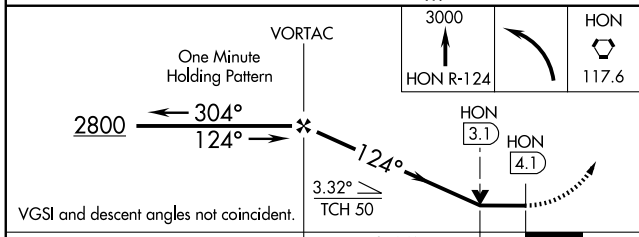
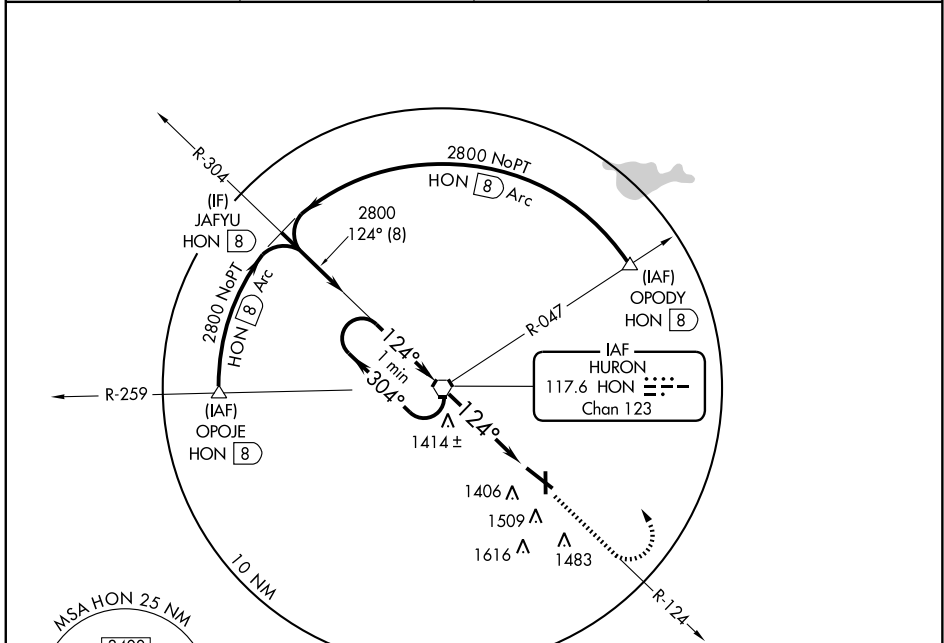

CATEGORY	A	B	C	D
S-12	1680-½ 391 (400-½)			1680-1 391 (400-1)
CIRCLING	1820-1 531 (600-1)	1820-1½ 531 (600-1½)	1980-2¼ 691 (700-2¼)	

FAF to MAP 4.1 NM					
Knots	60	90	120	150	180
Min:Sec	4:06	2:44	2:03	1:38	1:22

APP CRS	Rwy Idg	4501
296°	TDZE	2571
	Apt Elev	2571

NA
Use Hettinger altimeter setting.

MISSED APPROACH: Climbing right turn to 4100 direct
CODTO WP and hold.

MINNEAPOLIS CENTER
124.25 380.3

UNICOM
122.8 (CTAF)

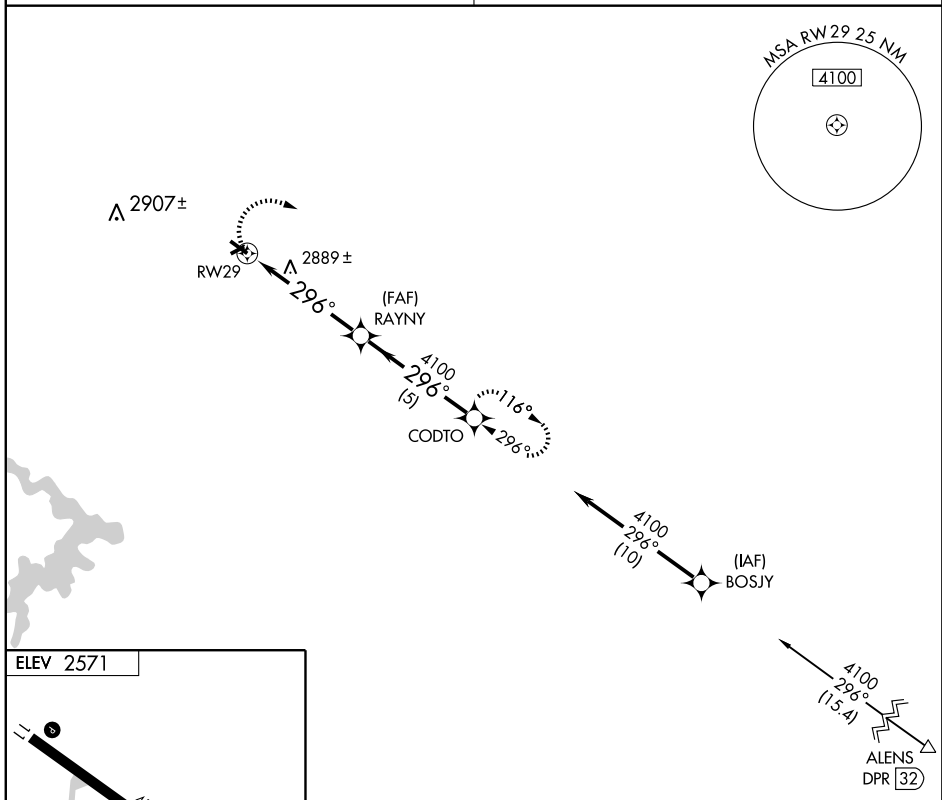

ELEV 2571

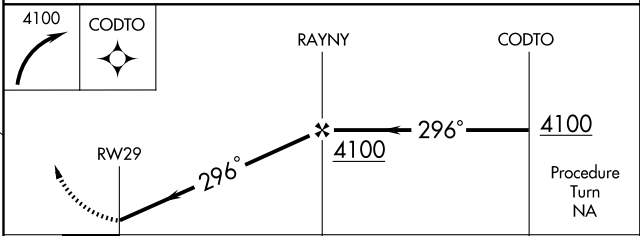
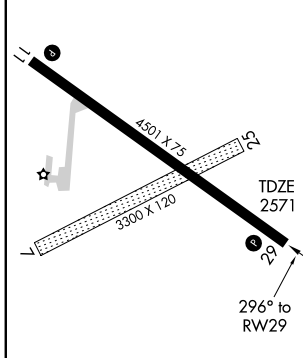

CATEGORY	A	B	C	D
S-29	3220-1 649 (700-1)		3220-1 3/4 649 (700-1 3/4)	3220-2 649 (700-2)
CIRCLING	3220-1 649 (700-1)		3280-2 709 (800-2)	3280-2 1/4 709 (800-2 1/4)

MIRL Rwy 11-29

NC-1, 08 APR 2010 to 06 MAY 2010

GPS RWY 33

MADISON MUNI (MDS)

APP CRS 329°	Rwy Idg 5000
	TDZE 1714
	Apt Elev 1717

NA Category D Circling not authorized west of Rwy 15-33. Obtain local altimeter setting on CTAF; when not received, use Brookings altimeter setting.

MISSED APPROACH: Climb to 3400 then right turn direct YUVED WP and hold.

AWOS-3
118.35

MINNEAPOLIS CENTER
132.05 317.4

UNICOM
122.8 (CTAF) 0

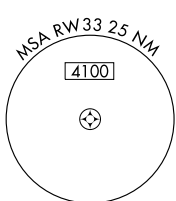
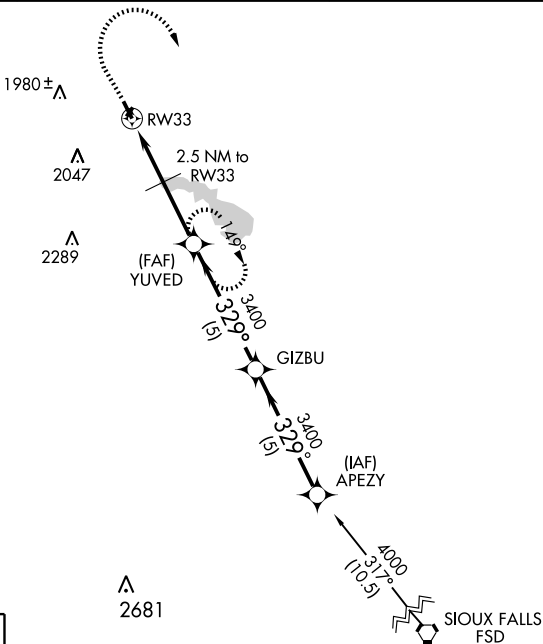

ELEV 1717

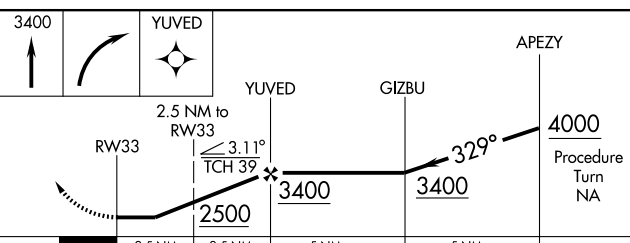
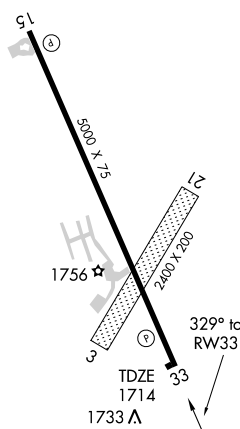

CATEGORY	A		B		C		D	
	S-33	2140-1	426 (500-1)			2140-1¼	426 (500-1¼)	
CIRCLING	2220-1	503 (600-1)			2220-1½	503 (600-1½)	2280-2	563 (600-2)
BROOKINGS ALTIMETER SETTING MINIMUMS								
S-33	2200-1	486 (500-1)			2200-1¼	486 (500-1¼)	2200-1½	486 (500-1½)
CIRCLING	2280-1	563 (600-1)			2280-1½	563 (600-1½)	2280-2	563 (600-2)

REIL Rwy 15 and 33 0
MRL Rwy 15-33 0

NDB MDS
400

APP CRS
157°

Rwy Idg
TDZE
Apt Elev

5000
1717
1717

NDB or GPS RWY 15

MADISON MUNI (MDS)

NA Category D Circling not authorized west of Rwy 15-33. Obtain local altimeter setting on CTAF; when not received, use Brookings altimeter setting.

MISSED APPROACH: Climb to 3300 then left turn direct MDS NDB and hold.

AWOS-3
118.35

MINNEAPOLIS CENTER
132.05 317.4

UNICOM
122.8 (CTAF)

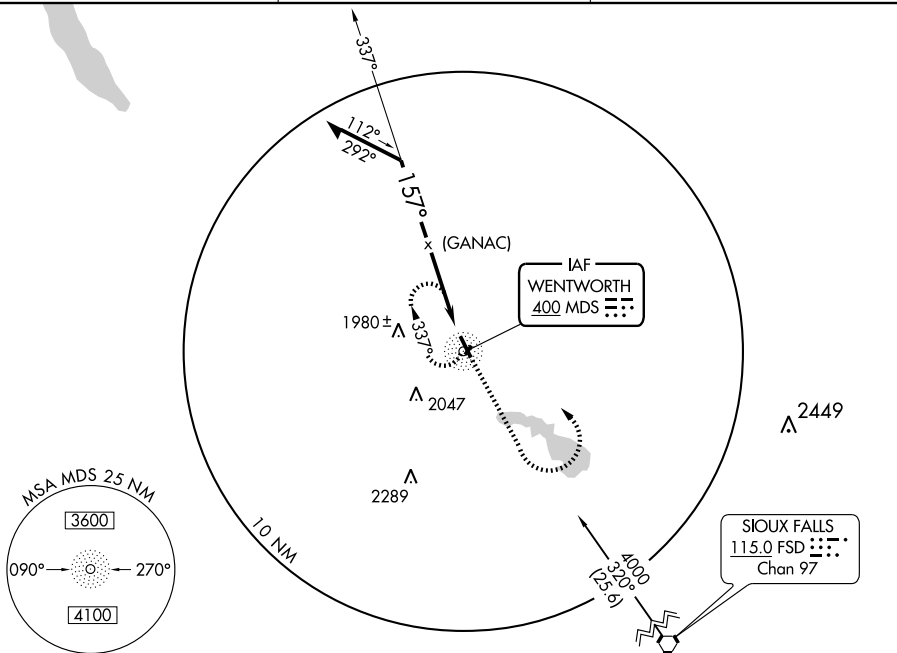

Remain within 10 NM

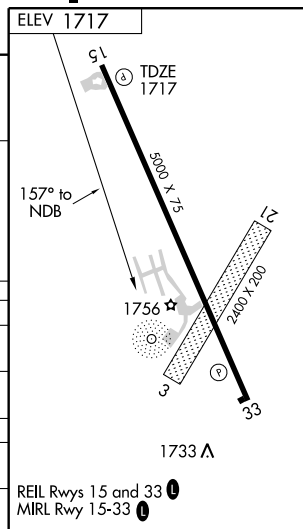
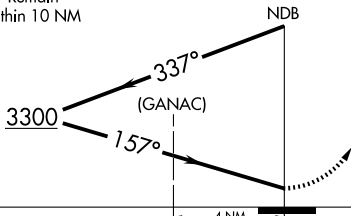

CATEGORY	A		B	C	D
S-15	2280-1	563 (600-1)	2280-1½ 563 (600-1½)	2280-1¾ 563 (600-1¾)	2280-2 563 (600-2)
CIRCLING	2280-1	563 (600-1)	2280-1½ 563 (600-1½)	2280-2 563 (600-2)	2280-2 563 (600-2)
BROOKINGS ALTIMETER SETTING MINIMUMS					
S-15	2340-1	623 (700-1)	2340-1¾ 623 (700-1¾)	2340-2 623 (700-2)	2340-2 623 (700-2)
CIRCLING	2340-1	623 (700-1)	2340-1¾ 623 (700-1¾)	2340-2 623 (700-2)	2340-2 623 (700-2)

REIL Rwy 15 and 33
MIRL Rwy 15-33

APP CRS **317°**
 Rwy Idg **3709**
 TDZE **3293**
 Apt Elev **3293**

GPS RWY 32

MARTIN MUNI (9V6)

▲ NA Use Pine Ridge, SD altimeter setting.
IAF ARM APPROACH MODE PRIOR TO IAF.

MISSED APPROACH: Climbing right turn to 4900 direct VUGGI WP and hold.

DENVER CENTER
127.95 338.2

UNICOM
123.0 (CTAF)

122.9 0

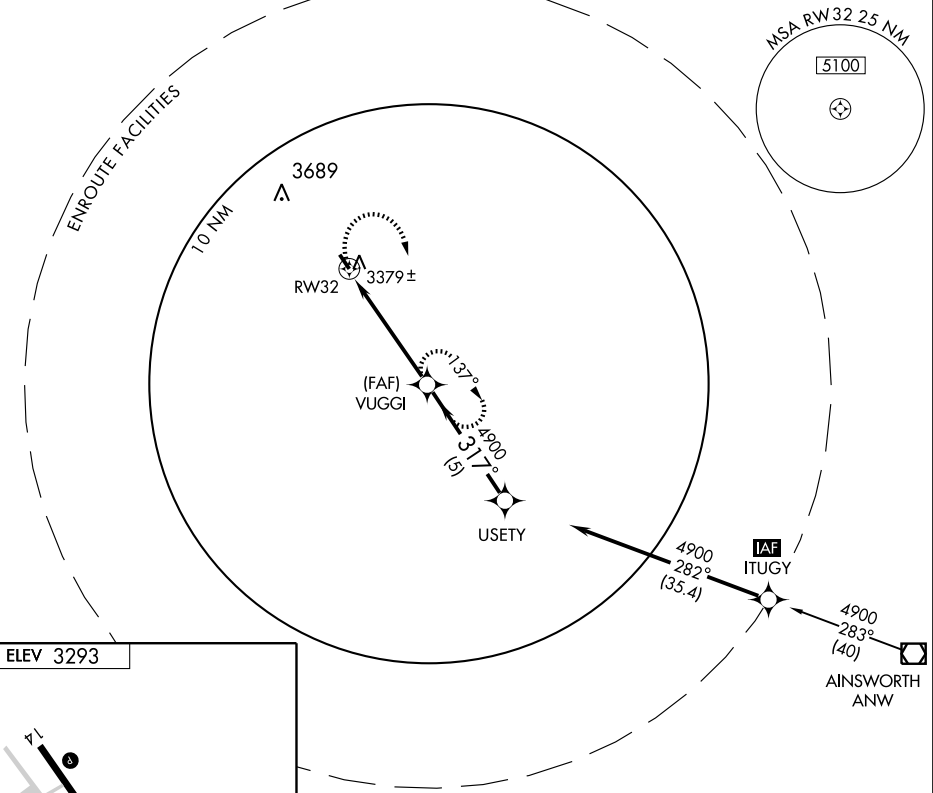

ELEV 3293

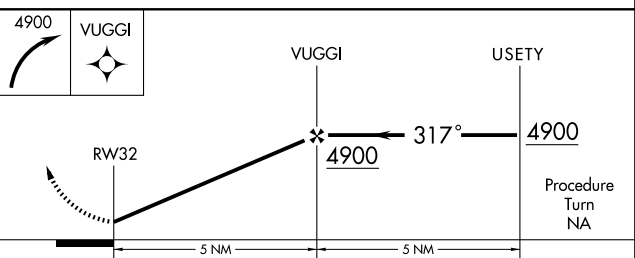
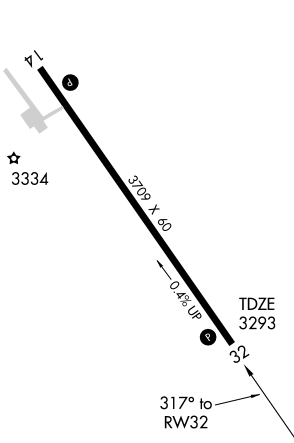

CATEGORY	A	B	C	D
S-32	3780-1	487 (500-1)	3780-1¼ 487 (500-1¼)	NA
CIRCLING	3940-1	647 (700-1)	3940-1¾ 647 (700-1¾)	NA

NC-1, 08 APR 2010 to 08 MAY 2010

RNAV (GPS) RWY 31

MILBANK MUNI (1D1)

APP CRS	Rwy Idg	4000
312°	TDZE	1114
	Apt Elev	1116

NA Use Watertown Muni, SD altimeter setting.
GPS or RNP-0.3 required. DME/DME RNP-0.3 NA.

MISSED APPROACH: Climb to 3400 direct MORRE WP and hold.

AWOS-3 122.8	MINNEAPOLIS CENTER 128.5 306.2	UNICOM 122.8 (CTAF) 0
------------------------	--	---------------------------------

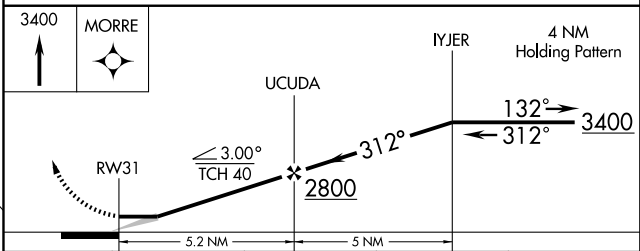
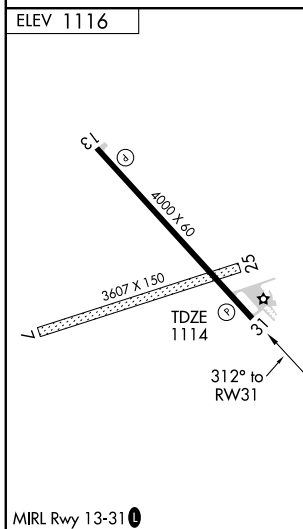
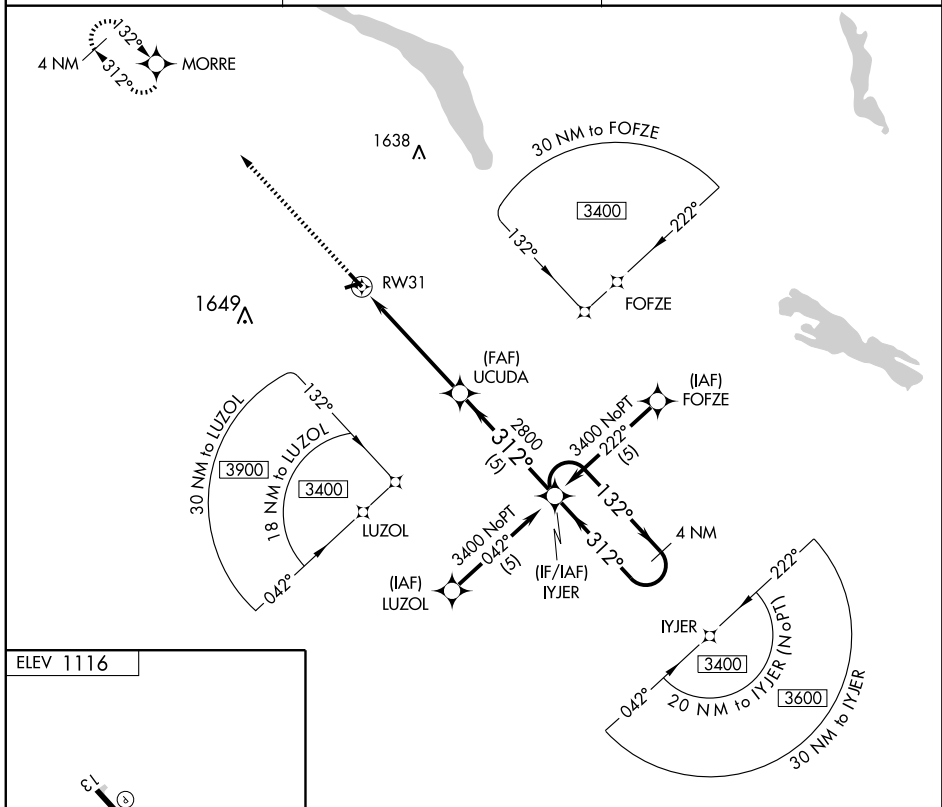

CATEGORY	A	B	C	D
RNAV MDA	1720-1	606 (700-1)		NA
CIRCLING	1720-1	604 (700-1)		NA

NC-1, 08 APR 2010 to 08 MAY 2010

APP CRS 151°	Rwy Idg TDZE Apt Elev	3600 1567 1569
------------------------	-----------------------------	---

GPS RWY 15

MILLER MUNI (MKA)

NA Use Huron altimeter setting. MISSED APPROACH: Climb to 2500 then climbing left turn to 3200 direct OCADE WP and hold.

MINNEAPOLIS CENTER 125.1 269.1	CTAF 122.9	122.8
--	----------------------	--------------

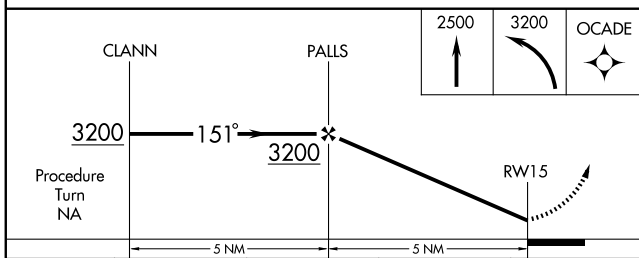
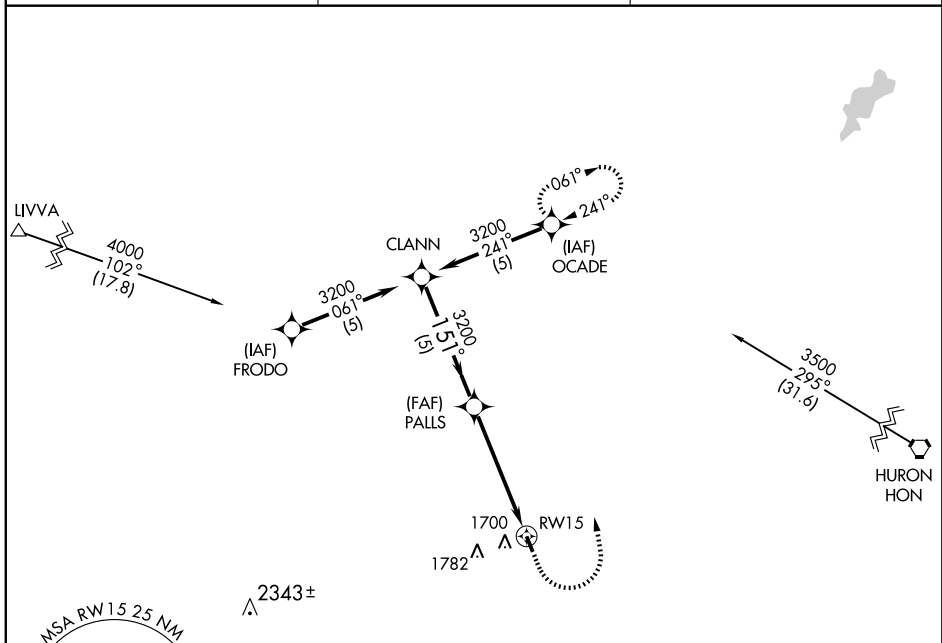

CATEGORY	A	B	C	D
S-15	2040-1	473 (500-1)	NA	
CIRCLING	2180-1 611 (700-1)	2220-1 651 (700-1)	NA	

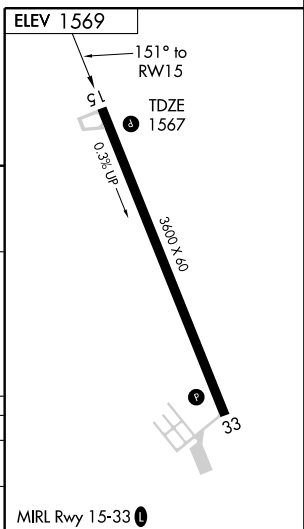

NC-1, 08 APR 2010 to 06 MAY 2010

APP CRS 331°	Rwy Idg TDZE Apt Elev	3600 1569 1569
------------------------	-----------------------------	---

GPS RWY 33

MILLER MUNI (MKA)

NA Use Huron altimeter setting.

MISSED APPROACH: Climb to 2500 then climbing right turn to 3400 direct ONDUC WP and hold.

MINNEAPOLIS CENTER 125.1 269.1	CTAF 122.9	122.8
--	----------------------	--------------

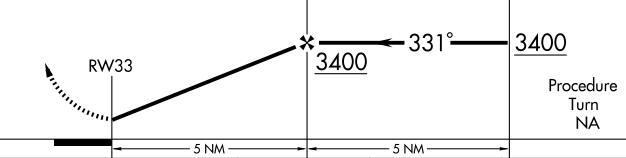
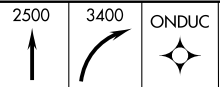
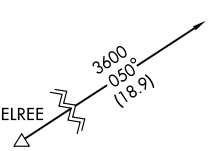
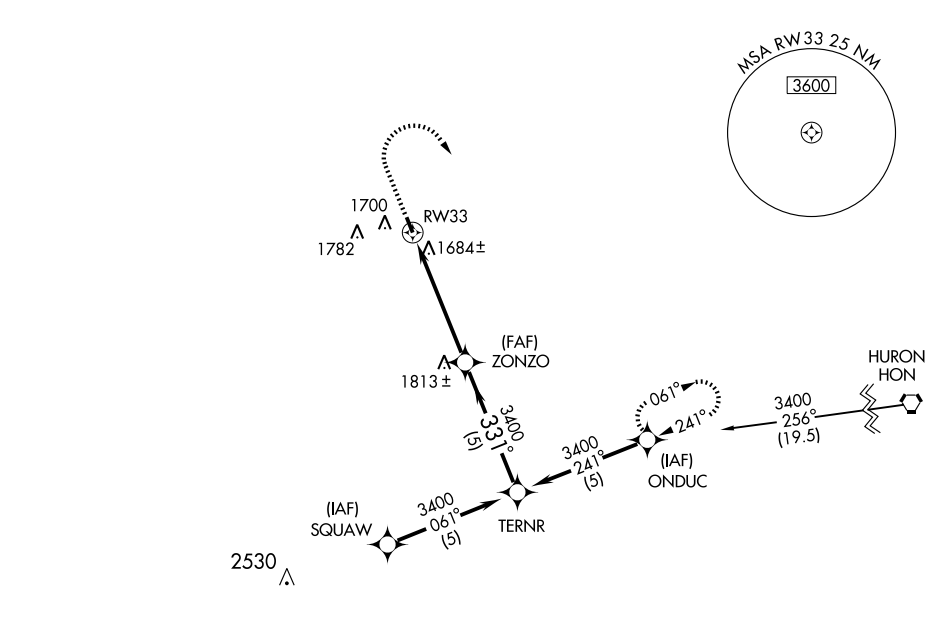

CATEGORY	A	B	C	D
S-33	2060-1	491 (500-1)		NA
CIRCLING	2180-1 611 (700-1)	2220-1 651 (700-1)		NA

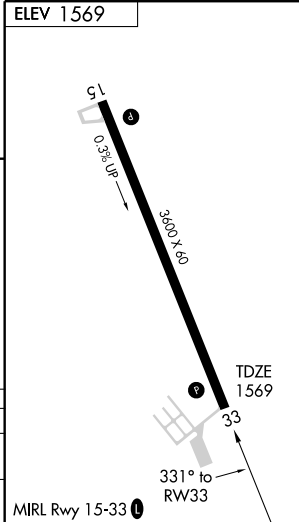

NC-1, 08 APR 2010 to 06 MAY 2010

ILS or LOC RWY 30

MITCHELL MUNI (MHE)

LOC I-LPA 109.7	APP CRS 307°	Rwy Idg TDZE Apt Elev	6700 1304 1304
---------------------------	------------------------	-----------------------------	---

NA Autopilot coupled approach NA below 2174 MSL. **MALS R** MISSED APPROACH: Climb to 3200 then right turn direct MHE VOR/DME and hold.

ASOS 124.175	HURON RADIO 122.3	UNICOM 122.8 (CTAF) 0
------------------------	-----------------------------	--

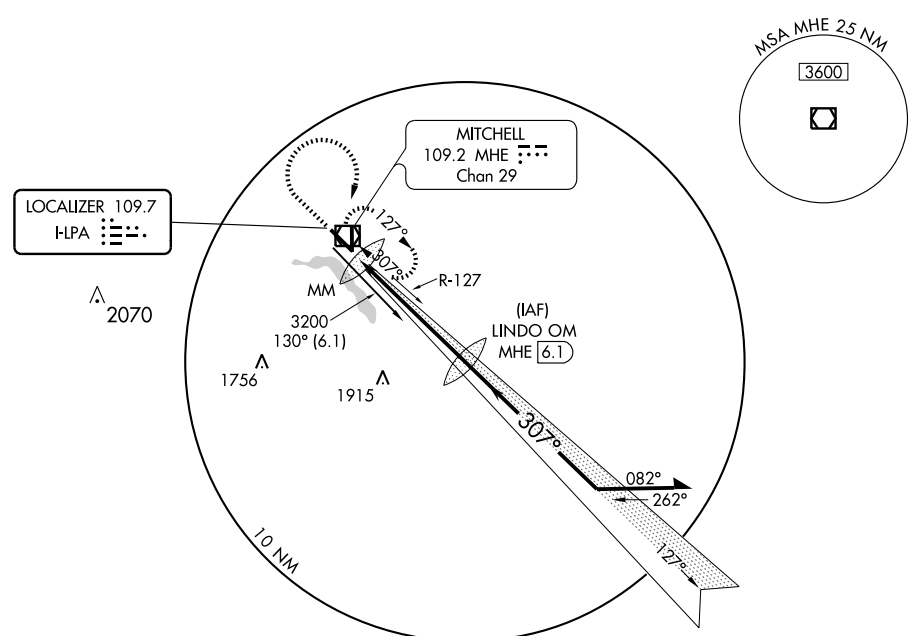

ELEV 1304

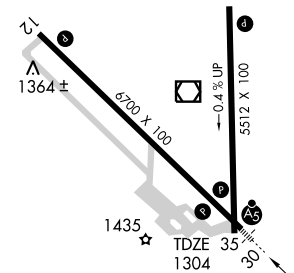

HIRL Rwy 12-30	MIRL Rwy 17-35	REIL Rwys 12 and 17			
307° 5.6 NM from FAF	307° 5.6 NM from FAF				
FAF to MAP 5.6 NM					
Knots	60	90	120	150	180
Min:Sec	5:36	3:44	2:48	2:14	1:52

DME REQUIRED

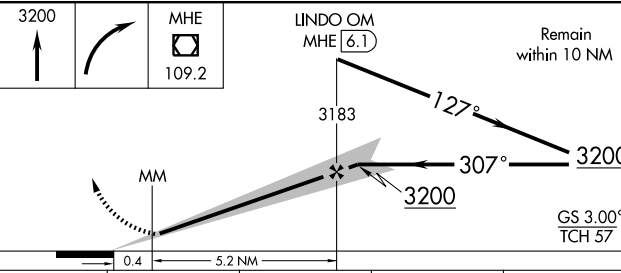

CATEGORY	A	B	C	D
S-ILS 30	1504-½ 200 (200-½)			
S-LOC 30	1700-½ 396 (400-½)			1700-¾ 396 (400-¾)
CIRCLING	1740-1 436 (500-1)	1760-1 456 (500-1)	1760-1½ 456 (500-1½)	1860-2 556 (600-2)

RNAV (GPS) RWY 12

MITCHELL MUNI (MHE)

WAAS CH 77900 W12A	APP CRS 127°	Rwy Idg TDZE Apt Elev	6700 1301 1304
--	------------------------	-----------------------------	---

▼ DME/DME RNP-0.3 NA.
▲ For uncompensated Baro-VNAV systems, LNAV/VNAV NA below -17°C (2°F) or above 46°C (115°F).
 VDP and Baro VNAV NA with Huron Rgnl altimeter setting.
 If local altimeter setting not received, use Huron Rgnl altimeter setting and increase all DAs/MDAs 100 feet.

MISSED APPROACH: Climb to 3200 direct JUTUB and hold.

ASOS 124.175	HURON RADIO 122.3	UNICOM 122.8 (CTAF) 0
------------------------	-----------------------------	---------------------------------

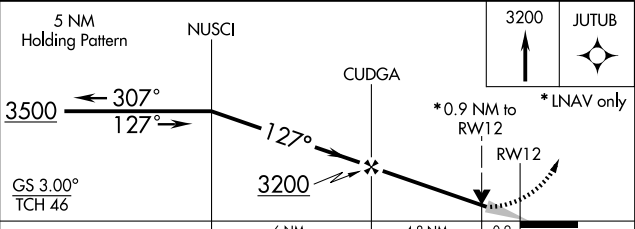
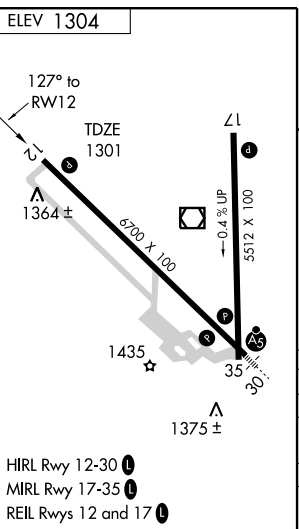
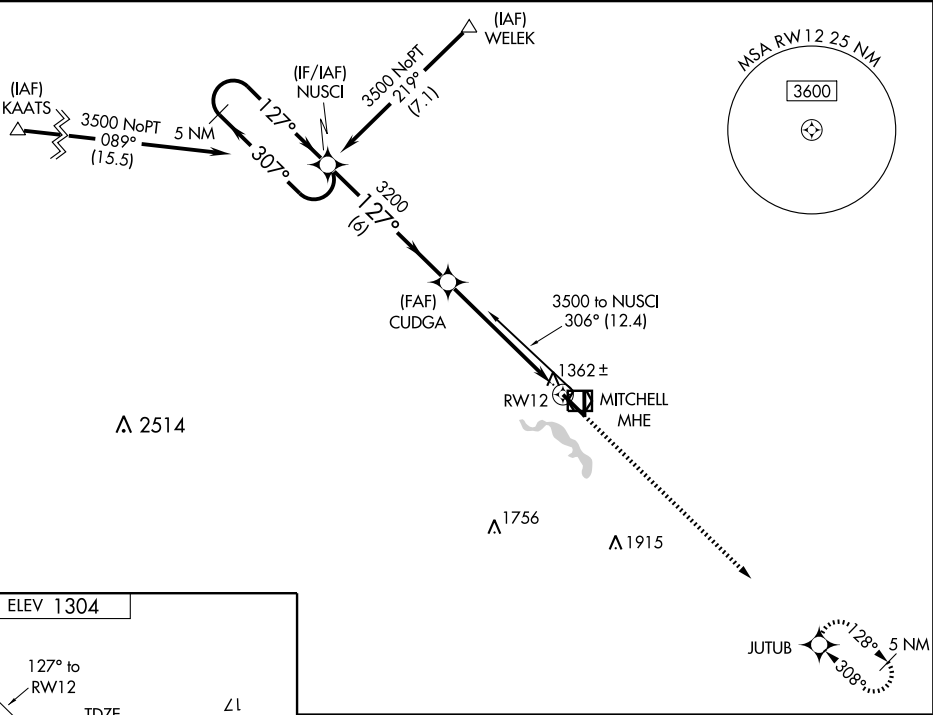

CATEGORY	A	B	C	D
LPV DA	1575-1 274 (300-1)			
LNAV/VNAV DA	1627-1¼ 326 (400-1¼)			
LNAV MDA	1620-1 319 (400-1)			
CIRCLING	1740-1¼ 436 (500-1¼)	1760-1¼ 456 (500-1¼)	1760-1½ 456 (500-1½)	1860-2 556 (600-2)

NC-1, 08 APR 2010 to 06 MAY 2010

RNAV (GPS) RWY 30

MITCHELL MUNI (MHE)

WAAS CH 70700 W30A	APP CRS 307°	Rwy Idg TDZE Apt Elev	6700 1304 1304
--	------------------------	-----------------------------	---

▲ If local altimeter setting not received, use Huron Rgnl altimeter setting and increase all DAs/MDAs 100 feet.
▲ For uncompensated Baro-VNAV systems, LNAV/VNAV NA below -17°C (2°F) or above 46°C (115°F).
 For inoperative MALSR, increase LPV all Cats. visibility to ¾, and LNAV/VNAV Cat. D to 1. DME/DME RNP-0.3 NA.
 VDP and Baro-VNAV NA with Huron Rgnl altimeter setting.

MALSR

 MISSED APPROACH: Climb to 3500 direct NUSCI and hold.

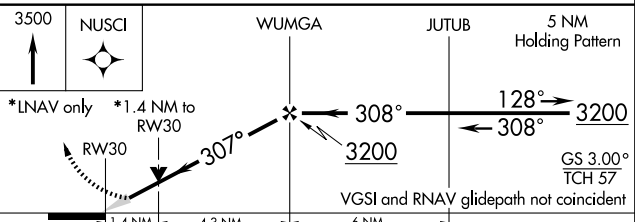
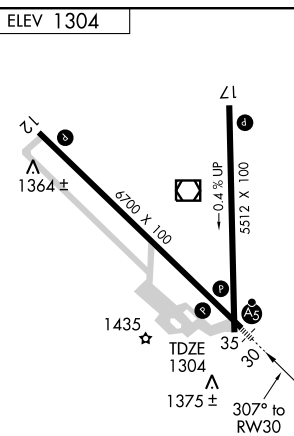
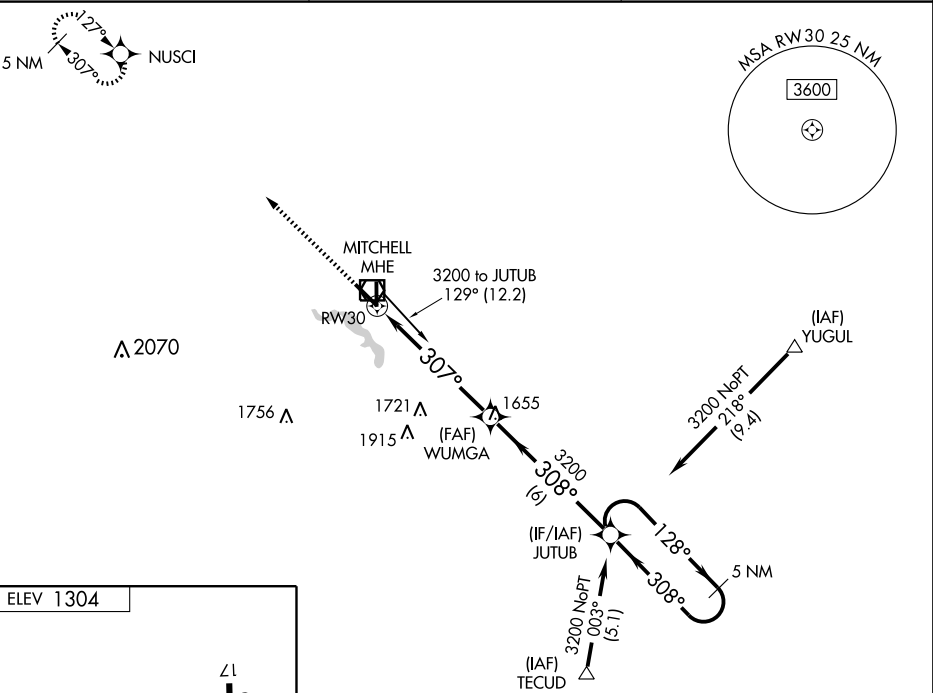
ASOS 124.175	HURON RADIO 122.3	UNICOM 122.8 (CTAF) 0
------------------------	-----------------------------	---------------------------------



CATEGORY	A	B	C	D
LPV DA	1554-1/2 250 (300-1/2)			
LNAV/VNAV DA	1625-1/2 321 (400-1/2)			1625-3/4 321 (400-3/4)
LNAV MDA	1800-1/2 496 (500-1/2)	1800-3/4 496 (500-3/4)	1800-1 496 (500-1)	1800-1 496 (500-1)
CIRCLING	1800-1 496 (500-1)	1800-1/2 496 (500-1/2)	1860-2 556 (600-2)	1860-2 556 (600-2)

HIRL Rwy 12-30
 MRL Rwy 17-35
 REIL Rwy 12 and 17

VOR RWY 12

MITCHELL MUNI (MHE)

VOR/DME MHE 109.2 Chan 29	APP CRS 114°	Rwy Idg TDZE Apt Elev 6700 1301 1304
---	------------------------	--

⚠ If local altimeter setting not received, use Huron Rgnl altimeter setting and increase all MDAs 100 feet.
⚠ VDP NA when using Huron Rgnl altimeter setting.

MISSED APPROACH: Climb to 2900 then climbing left turn to 3000 direct MHE VOR/DME and hold.

ASOS 124.175	HURON RADIO 122.3	UNICOM 122.8 (CTAF) 0
------------------------	-----------------------------	--

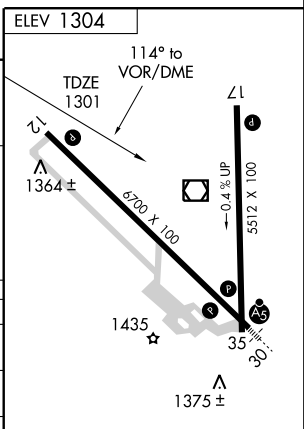
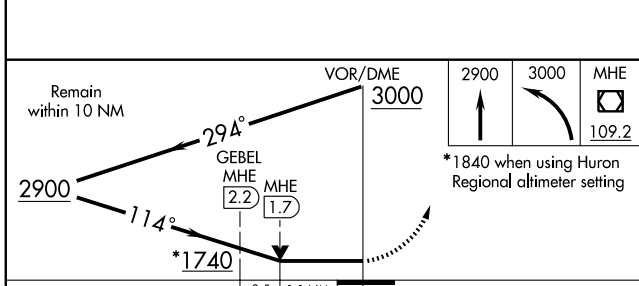
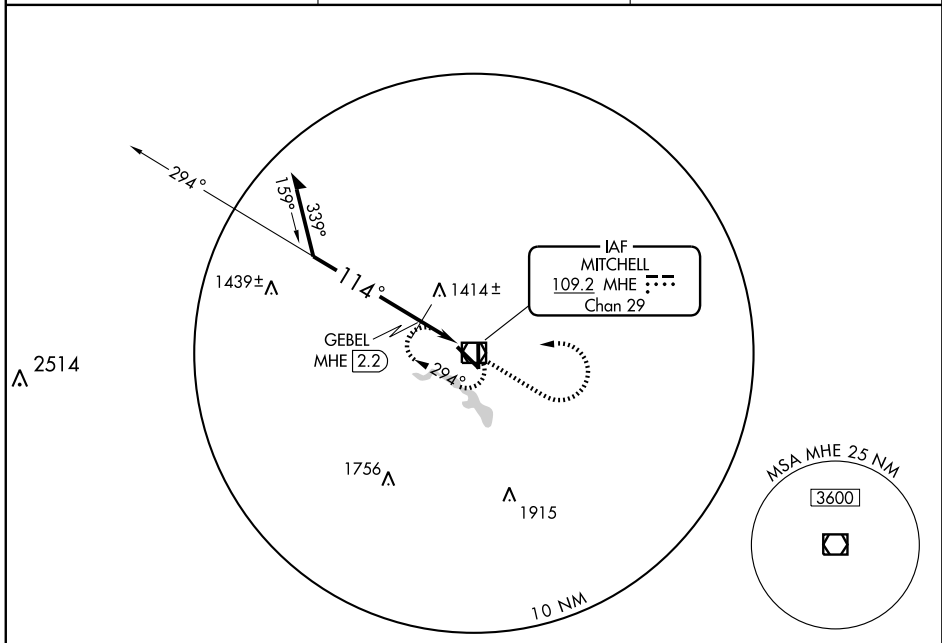

CATEGORY	A	B	C	D
S-12	1740-1	439 (500-1)	1740-1¼ 439 (500-1¼)	1740-1½ 439 (500-1½)
CIRCLING	1740-1 436 (500-1)	1760-1 456 (500-1)	1760-1½ 456 (500-1½)	1860-2 556 (600-2)

GEBEL FIX MINIMUMS

S-12	1680-1	379 (400-1)	1680-1¼ 379 (400-1¼)
CIRCLING	1740-1 436 (500-1)	1760-1 456 (500-1)	1760-1½ 456 (500-1½)

HIRL Rwy 12-30 **Ⓛ**
 MIRL Rwy 17-35 **Ⓛ**
 REIL Rws 12 and 17 **Ⓛ**

VOR RWY 30

MITCHELL MUNI (MHE)

VOR/DME MHE 109.2 Chan 29	APP CRS 322°	Rwy Idg TDZE Apt Elev	6700 1304 1304
---	------------------------	-----------------------------	---

⚠ If local altimeter setting not received, use Huron Rgnl altimeter setting and increase all MDAs 100 feet.
⚠ VOR MINIMUMS: Inoperative table does not apply to S-30 Cats. C and D. RORFE FIX MINIMUMS: For inoperative MALSR, increase S-30 Cat. D visibility to 1¼ mile. VDP NA when using Huron Rgnl altimeter setting.



MISSED APPROACH: Climb to 2900 then climbing right turn to 3000 direct MHE VOR/DME and hold.

ASOS 124.175	HURON RADIO 122.3	UNICOM 122.8 (CTAF)
------------------------	-----------------------------	-------------------------------

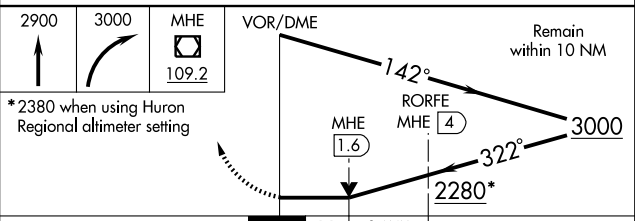
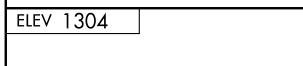
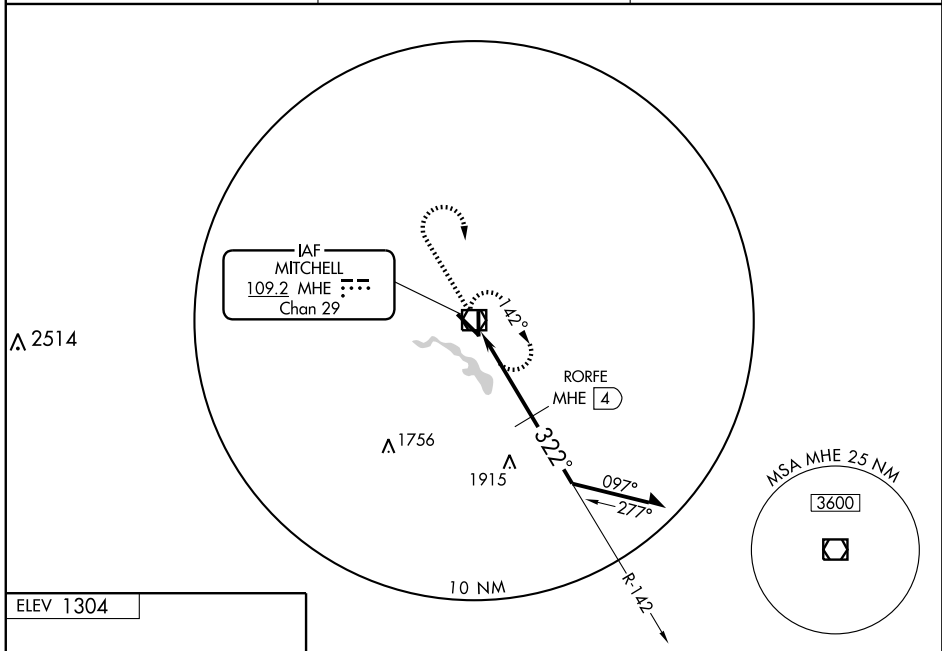

CATEGORY	A	B	C	D
S-30	2280-¾ 976 (1000-¾)	2280-1 976 (1000-1)	2280-3	976 (1000-3)
CIRCLING	2280-1¼ 976 (1000-1¼)	2280-1½ 976 (1000-1½)	2280-3	976 (1000-3)
RORFE FIX MINIMUMS				
S-30	1700-½ 396 (400-½)		1700-1 396 (400-1)	
CIRCLING	1740-1 436 (500-1)	1760-1 456 (500-1)	1760-1½ 456 (500-1½)	1860-2 556 (600-2)

HIRL Rwy 12-30
 MIRL Rwy 17-35
 REIL Rws 12 and 17

NDB RVB 407	APP CRS 108°	Rwy Idg TDZE Apt Elev 4411 1703 1715
-----------------------	------------------------	--

NDB RWY 12

MOBRIDGE MUNI (MBG)

NA If local altimeter setting not received, use Pierre Rgnl altimeter setting and increase all MDAs 180 feet.

MISSED APPROACH: Climb to 3600 then right turn direct RVB NDB and hold.

ASOS
121.425

HURON RADIO
122.35

UNICOM
122.8 (CTAF) 0

△ 2671

YAITS
BIS (40)

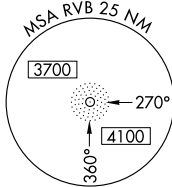
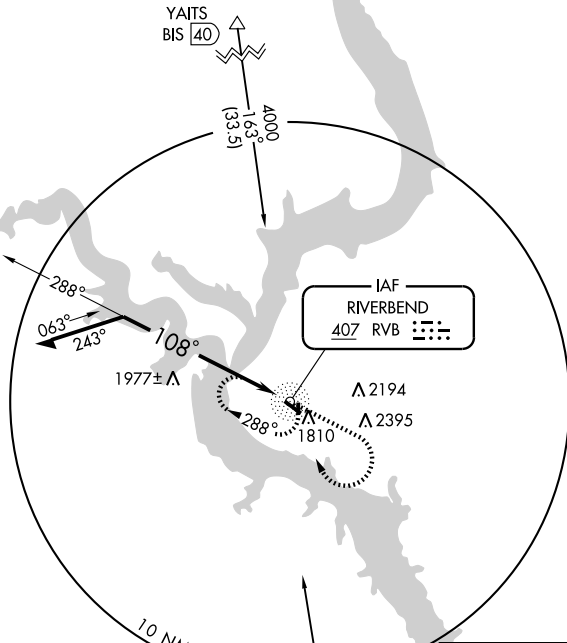

ELEV 1715

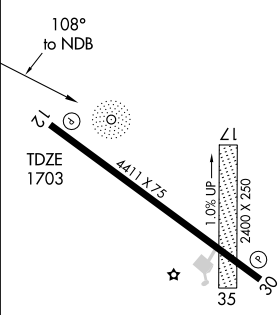

Remain within 10 NM

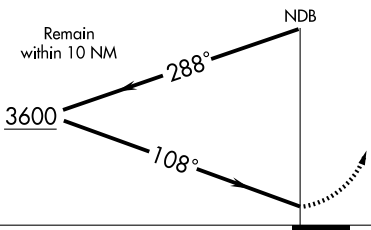

CATEGORY	A	B	C	D
S-12	2340-1	637 (700-1)	2340-1¾ 637 (700-1¾)	2340-2 637 (700-2)
CIRCLING	2360-1	645 (700-1)	2360-1¾ 645 (700-1¾)	2560-2¾ 845 (900-2¾)

MIRL Rwy 12-30 0

RNAV (GPS) RWY 12

MOBRIDGE MUNI (MBG)

APP CRS **118°**
 Rwy Idg **4411**
 TDZE **1703**
 Apt Elev **1715**

MISSED APPROACH: Climbing right turn to 4000 direct JIGVO and hold.

▼ DME/DME RNP-0.3 NA.
▲ Visibility reduction by helicopters NA.
 If local altimeter setting not received, use Pierre Rgnl altimeter setting and increase all MDAs 180 feet.

ASOS
121.425

HURON RADIO
122.35

UNICOM
122.8 (CTAF) ①

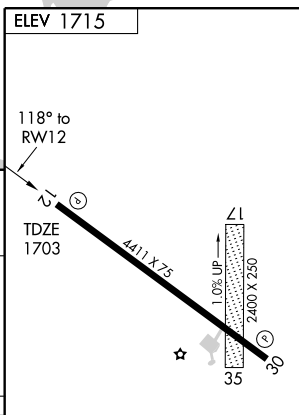
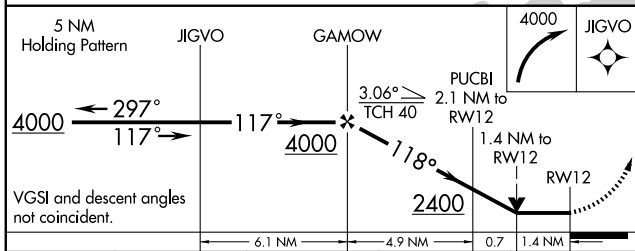
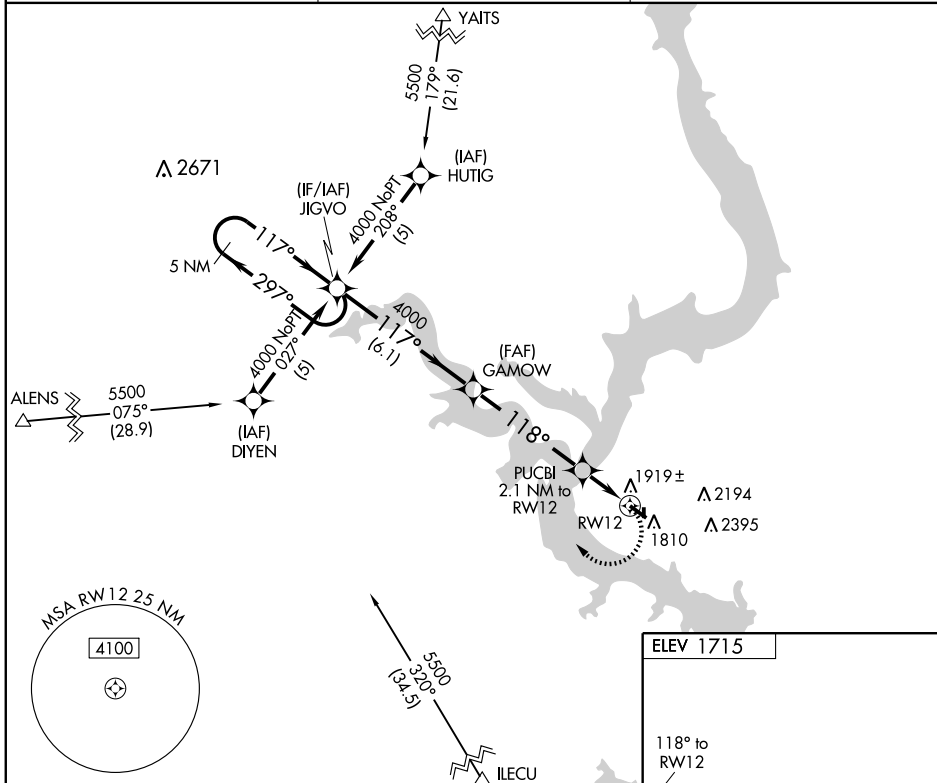

CATEGORY	A	B	C	D
RNAV MDA	2180-1	477 (500-1)	2180-1¼ 477 (500-1¼)	2180-1½ 477 (500-1½)
CIRCLING	2360-1	645 (700-1)	2360-1¾ 645 (700-1¾)	2560-2¾ 845 (900-2¾)

MIRL Rwy 12-30 ①

RNAV (GPS) RWY 30

MOBRIDGE MUNI (MBG)

APP CRS	Rwy Idg	4411
308°	TDZE	1703
	Apt Elev	1715

▼ DME/DME RNP-0.3 NA.
▲ Visibility reduction by helicopters NA.
 If local altimeter setting not received, use Pierre Rgnl altimeter setting and increase all MDAs 180 feet.

MISSED APPROACH: Climbing left turn to 4000 direct OVD0E and hold.

ASOS
121.425

HURON RADIO
122.35

UNICOM
122.8 (CTAF) 0

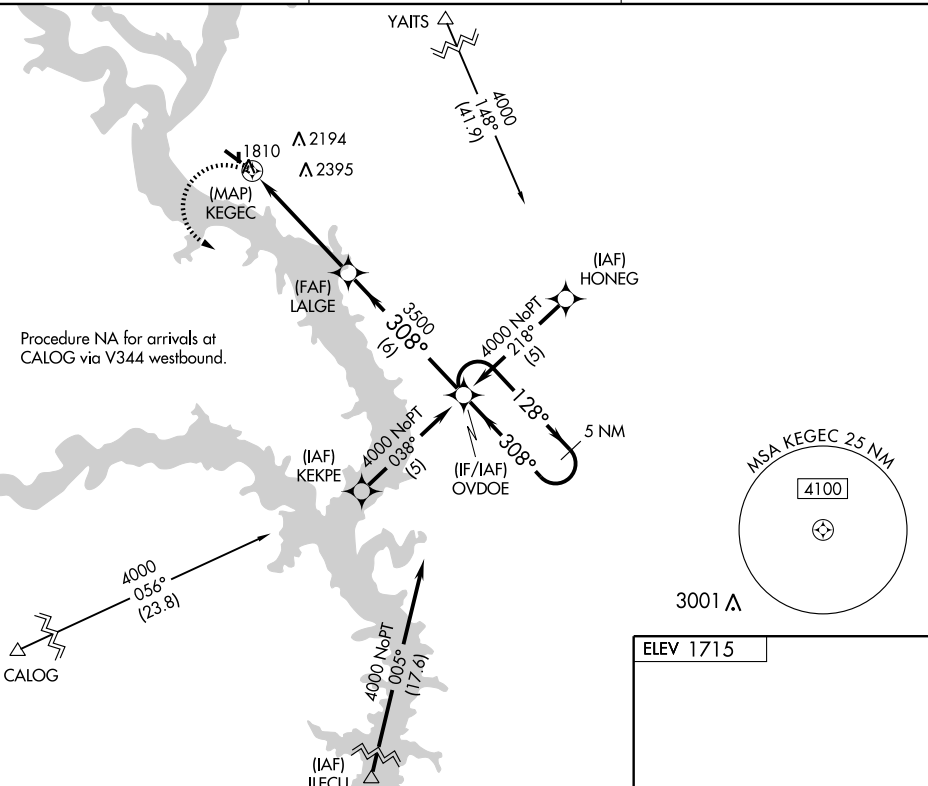

NC-1, 08 APR 2010 to 06 MAY 2010

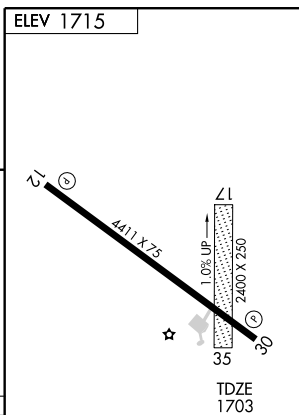
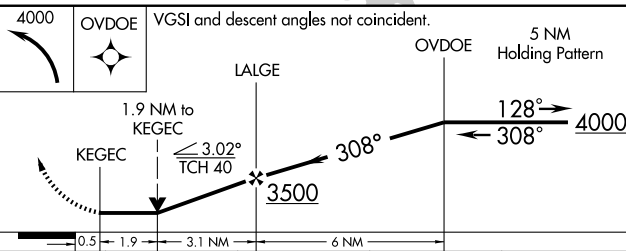

CATEGORY	A	B	C	D
RNAV MDA	2500-1 797 (800-1)	2500-1¼ 797 (800-1¼)	2500-2¼ 797 (800-2¼)	2500-2½ 797 (800-2½)
CIRCLING	2500-1 785 (800-1)	2500-1¼ 785 (800-1¼)	2500-2¼ 785 (800-2¼)	2560-2¾ 845 (900-2¾)

MIRL Rwy 12-30 0

VOR/DME PHP 108.4 Chan 21	APP CRS 090°	Rwy Idg TDZE Apt Elev	N/A N/A 2207
---	------------------------	-----------------------------	---

<p>▲ NA</p>		<p>MISSED APPROACH: Climb to 4500 via PHP R-090, then left turn direct PHP VOR/DME and hold.</p>	
ASOS 118.375	DENVER CENTER 127.95 338.2	HURON RADIO 122.4	UNICOM 122.8 (CTAF) 0

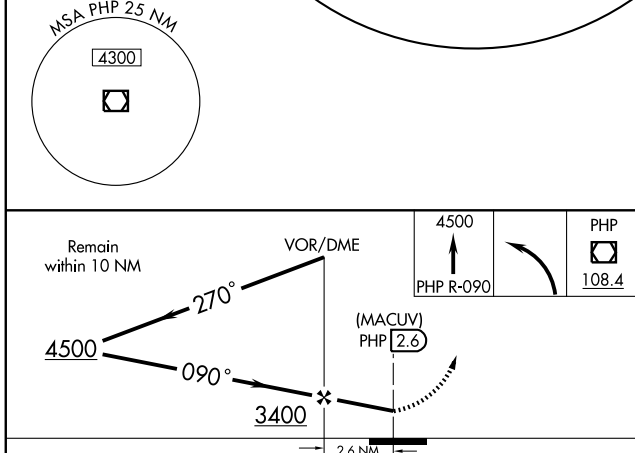
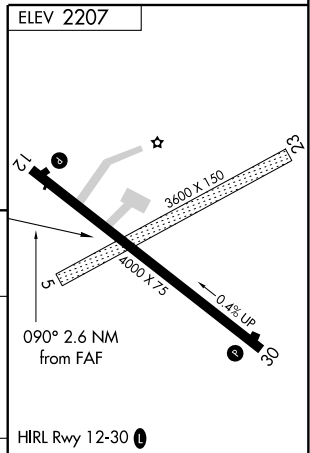
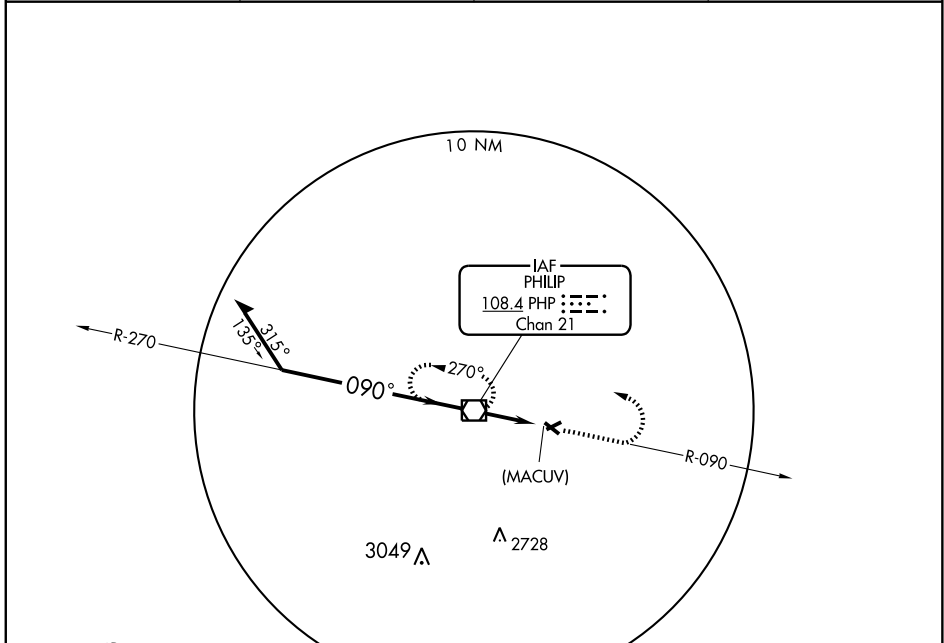

	FAF to MAP 2.6 NM					
CATEGORY	A	B	C	D		
CIRCLING	2720-1 513 (600-1)	2740-1 533 (600-1)	2780-1½ 573 (600-1½)	2820-2 613 (700-2)		
	Knots	60	90	120	150	180
	Min:Sec	2:36	1:44	1:18	1:02	0:52

ILS or LOC RWY 31

PIERRE RGNL (PIR)

LOC/DME I-PIR 111.9 Chan 56	APP CRS 313°	Rwy Idg TDZE Apt Elev	6900 1720 1744
---	------------------------	-----------------------------	---

Autopilot coupled approach NA below 2255. MALS MISSED APPROACH: Climb to 2400 then climbing right turn to 4000 direct PIR VORTAC and hold, continue climb-in-hold to 4000.

ASOS 119.025	MINNEAPOLIS CENTER 125.1 269.1	CTAF 122.7
------------------------	--	----------------------

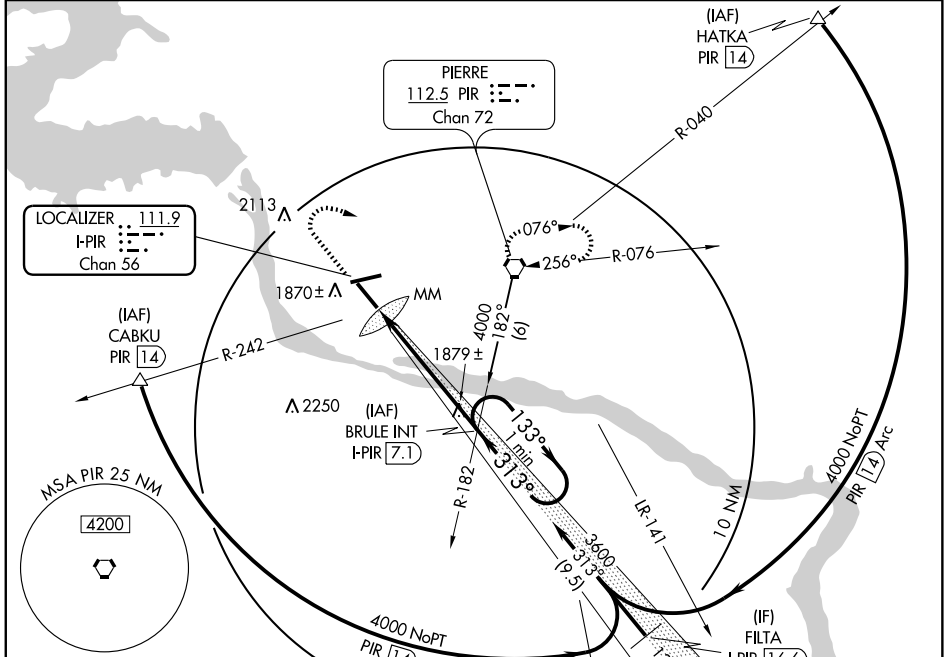

ELEV 1744 D

REIL Rwy 7, 13 and 25 L
HIRL Rwy 7-25 and 13-31 L

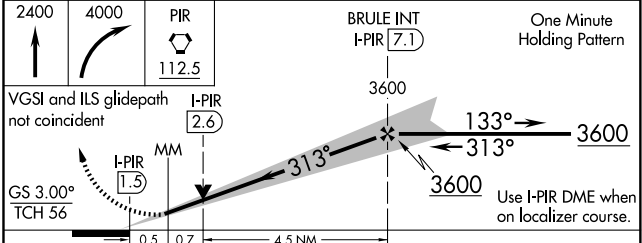
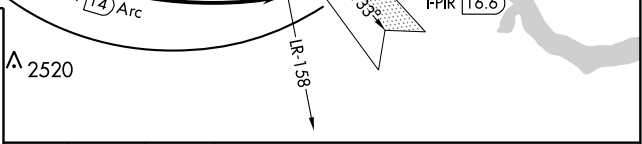
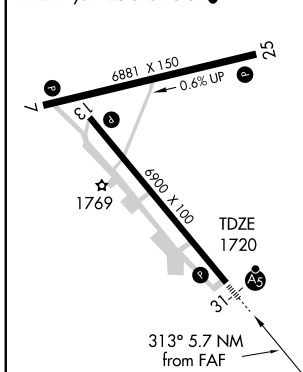

CATEGORY	A	B	C	D
S-ILS 31	1920-1/2		200 (200-1/2)	
S-LOC 31	2140-1/2 420 (400-1/2)		2140-3/4 420 (400-3/4)	
CIRCLING	2240-1 496 (500-1)		2260-1 1/2 2300-2 516 (600-1 1/2) 556 (600-2)	

FAF to MAP 5.7 NM					
Knots	60	90	120	150	180
Min:Sec	5:42	3:48	2:51	2:17	1:54

NC-1, 08 APR 2010 to 06 MAY 2010

RNAV (GPS) RWY 7

PIERRE RGNL (PIR)

WAAS CH 45804 W07A	APP CRS 069°	Rwy Idg TDZE Apt Elev	6881 1744 1744
--	------------------------	-----------------------------	---

▼ For uncompensated Baro-VNAV systems, LNAV/VNAV NA below -18°C (0°F) or above 45°C (113°F).
DME/DME RNP-0.3 NA. Visibility reduction by helicopters NA.

MISSED APPROACH: Climb to 4000 direct HIWRE and hold.

ASOS
119.025

MINNEAPOLIS CENTER
125.1 269.1

CTAF
122.7 0

Procedure NA for arrivals at PIR VORTAC via V26 northeast bound.

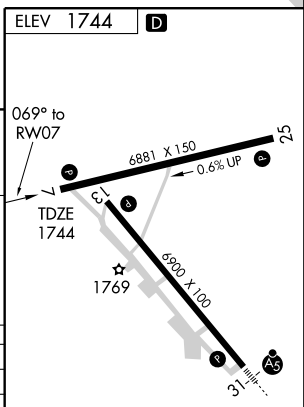
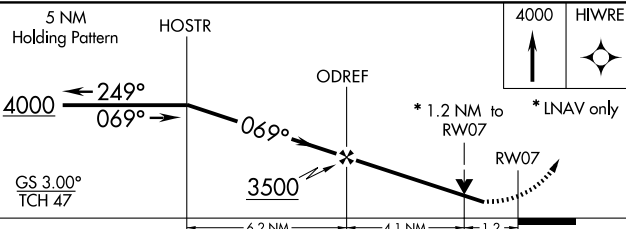
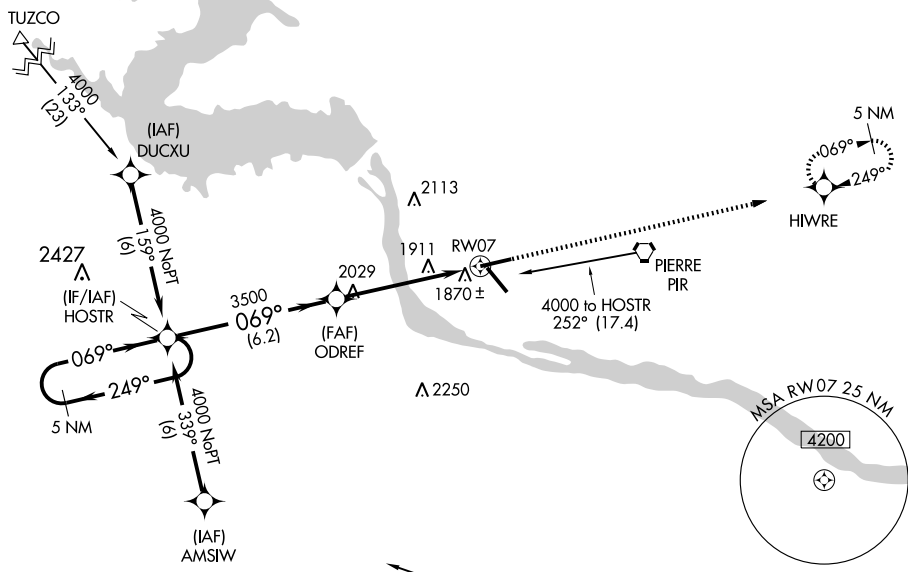

CATEGORY	A	B	C	D
LPV DA		2057-1	313 (400-1)	
LNAV/VNAV DA		2170-1½	426 (500-1½)	
LNAV MDA	2180-1	436 (500-1)	2180-1¼ 436 (500-1¼)	2180-1½ 436 (500-1½)
CIRCLING	2240-1	496 (500-1)	2260-1½ 516 (600-1½)	2300-2 556 (600-2)

REIL Rwy 7, 13, and 25
HIRL Rwy 7-25 and 13-31

RNAV (GPS) RWY 13

PIERRE RGNL (PIR)

WAAS CH 53404 W13A	APP CRS 133°	Rwy Idg TDZE Apt Elev	6900 1731 1744
--	------------------------	-----------------------------	---

▼ For uncompensated Baro-VNAV systems, LNAV/VNAV NA below -18°C (0°F) or above 45°C (113°F).
DME/DME RNP-0.3 NA.

MISSED APPROACH: Climb to 4000 direct HOGEX and hold.

ASOS 119.025	MINNEAPOLIS CENTER 125.1 269.1	CTAF 122.7
------------------------	--	----------------------

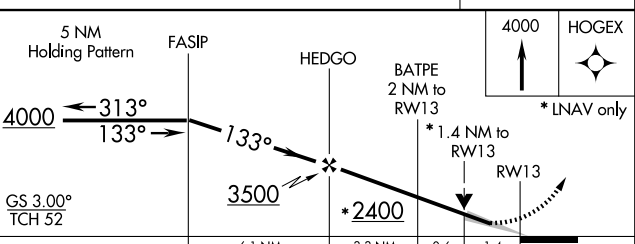
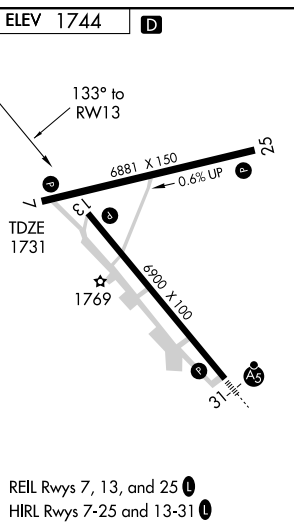
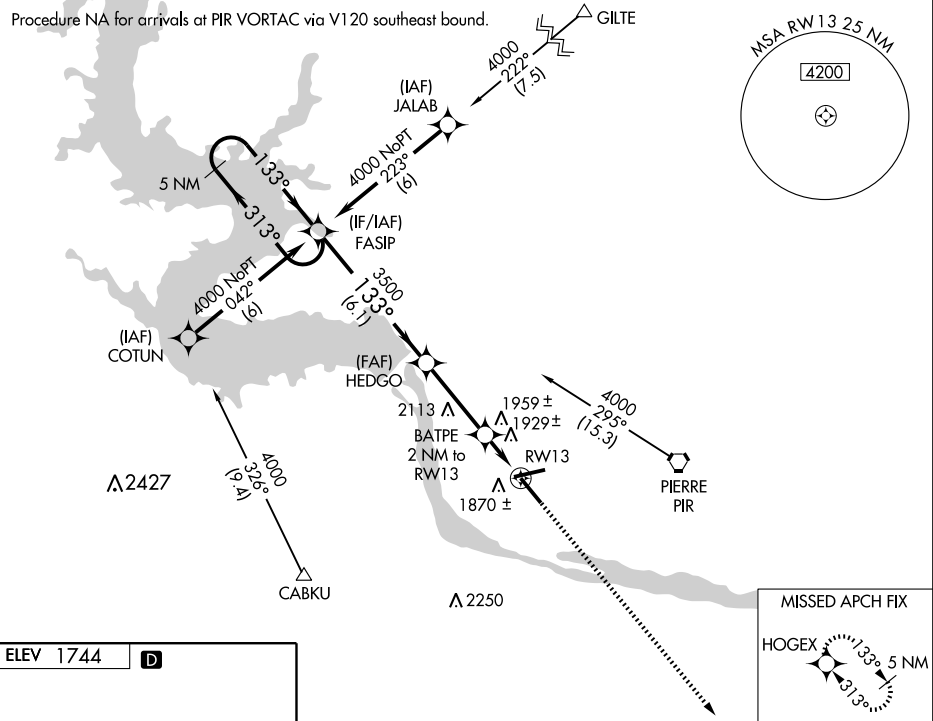

CATEGORY	A	B	C	D
LPV DA		1981-3/4	250 (300-3/4)	
LNAV/VNAV DA		2285-2	554 (600-2)	
LNAV MDA	2220-1	489 (500-1)	2220-1 1/4 489 (500-1 1/4)	2220-1 1/2 489 (500-1 1/2)
CIRCLING	2240-1	496 (500-1)	2260-1 1/2 516 (600-1 1/2)	2300-2 556 (600-2)

NC-1, 08 APR 2010 to 06 MAY 2010

RNAV (GPS) RWY 25

PIERRE RGNL (PIR)

WAAS CH 63104 W25A	APP CRS 249°	Rwy ldg TDZE Apt Elev	6881 1725 1744
--	------------------------	-----------------------------	---

For uncompensated Baro-VNAV systems, LNAV/VNAV NA below -18°C (0°F) or above 45°C (113°F).
DME/DME RNP-0.3 NA.

MISSED APPROACH: Climb to 4000 direct HOSTR and hold.

ASOS
119.025

MINNEAPOLIS CENTER
125.1 269.1

CTAF
122.70

Procedure NA for arrivals at PIR VORTAC via V26 westbound and via V561 southbound.

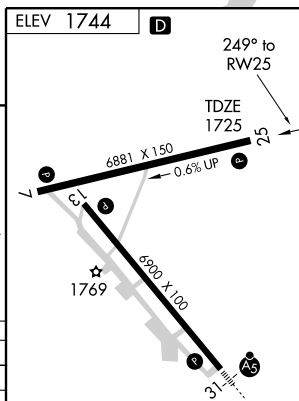
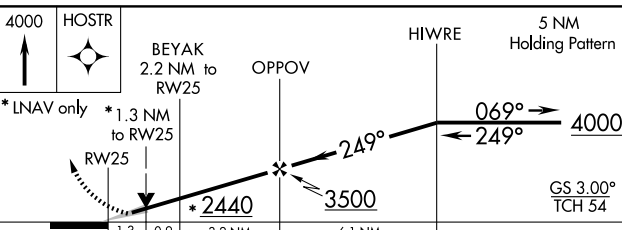
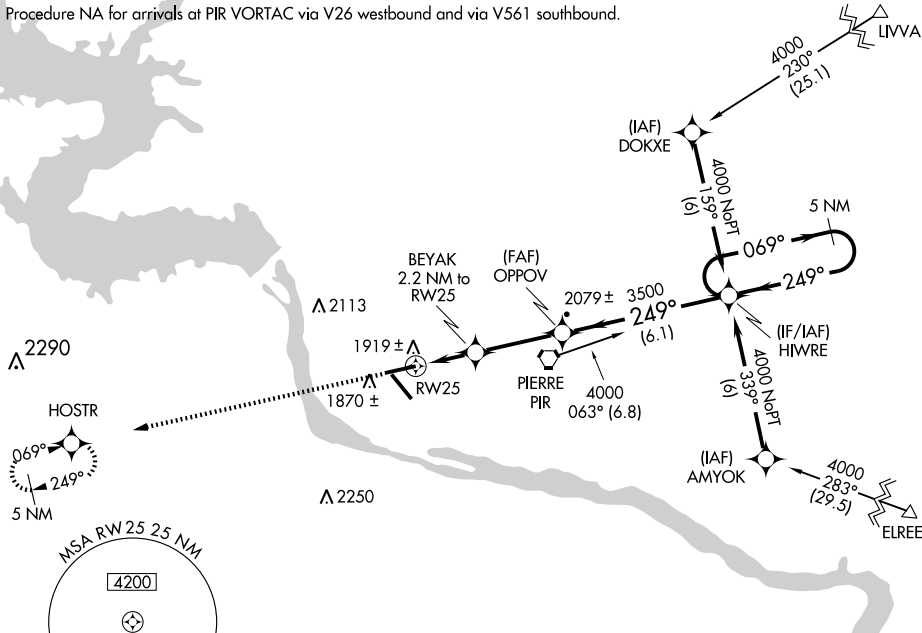

CATEGORY	A	B	C	D
LPV DA		1975-1	250 (300-1)	
LNAV/VNAV DA		2179-1¾	454 (500-1¾)	
LNAV MDA	2180-1	455 (500-1)	2180-1¼ 455 (500-1¼)	2180-1½ 455 (500-1½)
CIRCLING	2240-1	496 (500-1)	2260-1½ 516 (600-1½)	2300-2 556 (600-2)

REIL Rwy 7, 13, and 25
HIRL Rwy 7-25 and 13-31

RNAV (GPS) RWY 31

PIERRE RGNL (PIR)

WAAS Chan 65623 W31A	APP CRS 313°	Rwy Idg TDZE Apt Elev	6900 1720 1744
-----------------------------------	------------------------	-----------------------------	---

▼ DME/DME RNP-0.3 NA.
Baro-VNAV NA below -18°C (0°F).
For inoperative MALSR increase LPV visibility to ¾ all Cats,
and LNAV Cat D visibility to 1¼.

MALSR

MISSED APPROACH: Climb to 4000 direct
FASIP and hold.

ASOS 119.025	MINNEAPOLIS CENTER 125.1 269.1	CTAF 122.7
------------------------	--	----------------------

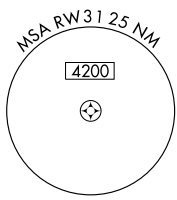
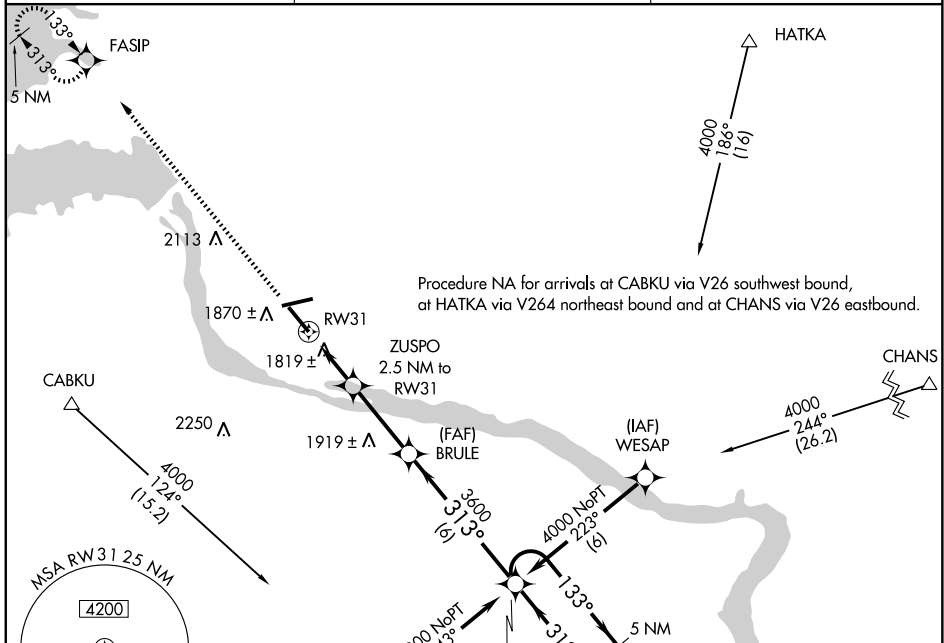

ELEV 1744	D
-----------	----------

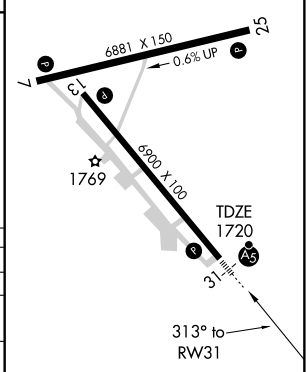
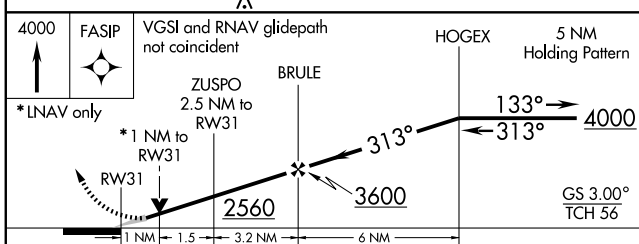

CATEGORY	A	B	C	D
LPV DA	1970-½ 250 (300-½)			
LNAV/VNAV DA	2115-¾ 395 (400-¾)			
LNAV MDA	2080-½ 360 (400-½)		2080-1 360 (400-1)	
CIRCLING	2240-1¼ 496 (500-1¼)		2260-1½ 516 (600-1½)	
			2300-2 556 (600-2)	

REIL Rwy 7, 13, and 25 **L**
HIRL Rwy 7-25 and 13-31 **L**

VOR/DME or TACAN RWY 7

PIERRE RGNL (PIR)

VORTAC PIR 112.5 Chan 72	APP CRS 074°	Rwy Idg TDZE Apt Elev	6881 1744 1744
--	------------------------	-----------------------------	---

MISSED APPROACH: Climb to 4000 then right turn direct PIR VORTAC and hold. (TACAN aircraft continue via PIR R-076 to HARZO 10 DME and hold East, right turns, 256° inbound).

ASOS
119.025

MINNEAPOLIS CENTER
125.1 269.1

CTAF
122.7

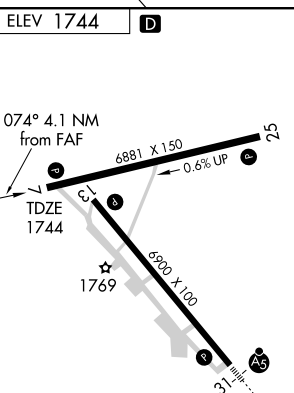
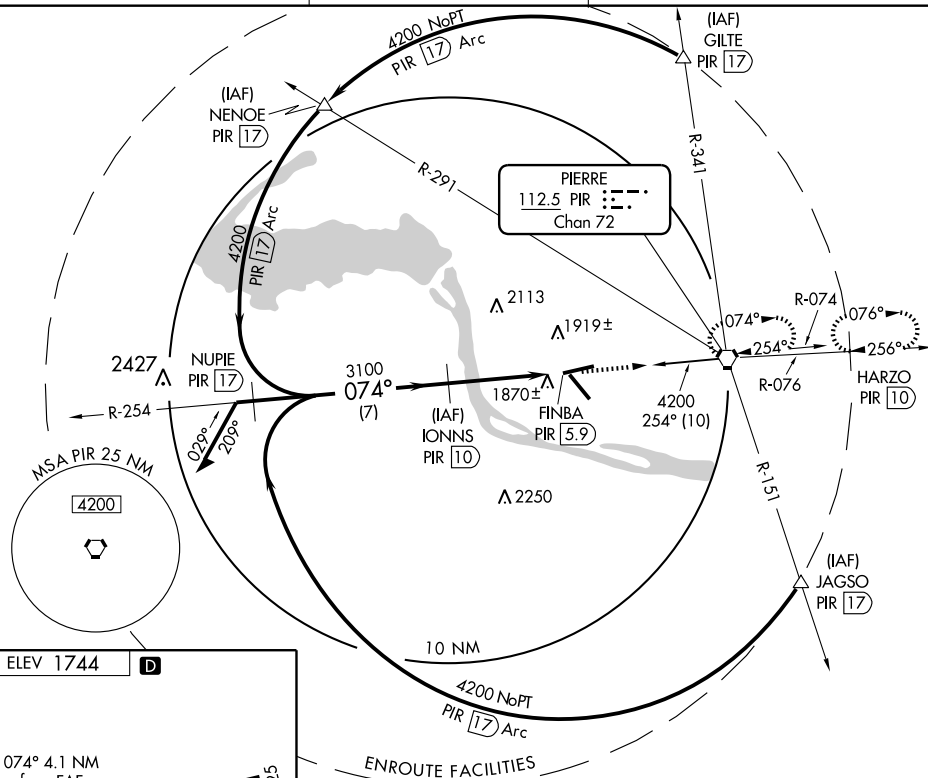

REIL Rwy 7, 13 and 25
HIRL Rwy 7-25 and 13-31

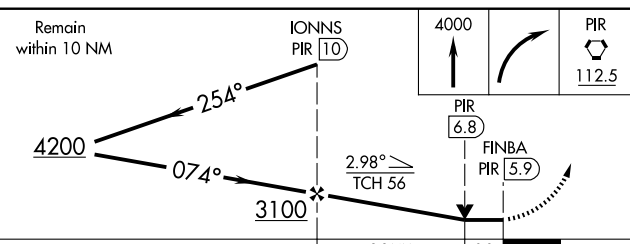

CATEGORY	A	B	C	D
S-7	2180-1	436 (500-1)	2180-1¼ 436 (500-1¼)	2180-1½ 436 (500-1½)
CIRCLING	2240-1	496 (500-1)	2260-1½ 516 (600-1½)	2300-2 556 (600-2)

NC-1. 08 APR 2010 to 06 MAY 2010

VOR or TACAN RWY 25

PIERRE RGNL (PIR)

VORTAC PIR	APP CRS	Rwy Idg	6881
112.5	256°	TDZE	1725
Chan 72		Apt Elev	1744

MISSED APPROACH: Climb to 3700 then right turn direct PIR VORTAC and hold. (TACAN aircraft continue via PIR R-076 to HARZO 10 DME and hold east, right turns, 256° inbound)

ASOS
119.025

MINNEAPOLIS CENTER
125.1 269.1

CTAF
122.7

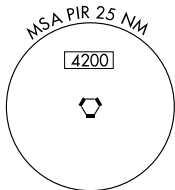
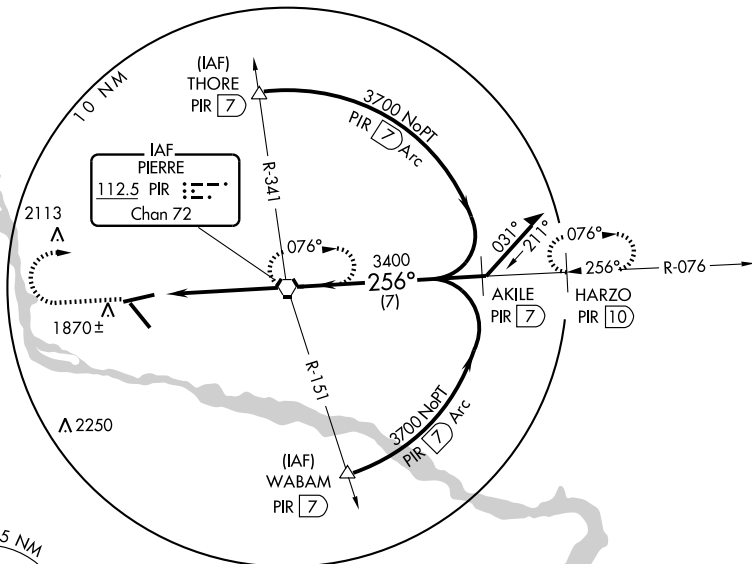

2520

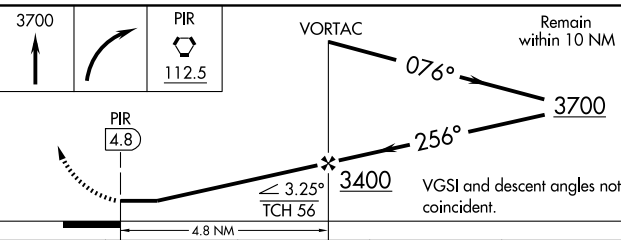
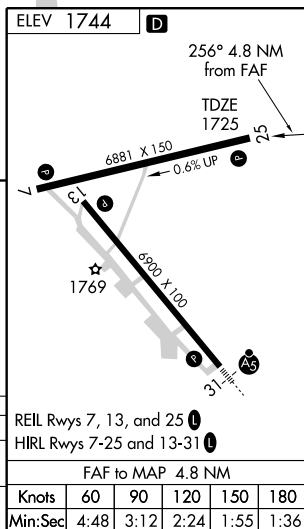

CATEGORY	A	B	C	D
S-25	2120-1 395 (400-1)			2120-1¼ 395 (400-1¼)
CIRCLING	2240-1 496 (500-1)		2260-1½ 516 (600-1½)	2300-2 556 (600-2)

REIL Rwy 7, 13, and 25 (L)
HIRL Rwy 7-25 and 13-31 (L)

FAF to MAP 4.8 NM

Knots	60	90	120	150	180
Min:Sec	4:48	3:12	2:24	1:55	1:36

RNAV (GPS) RWY 30

PINE RIDGE (IEN)

APP CRS	Rwy Idg	5000
299°	TDZE	3333
	Apt Elev	3333

▼ DME/DME RNP-0.3 NA. Visibility reduction by helicopters NA.
▲ VDP NA when using Chadron altimeter setting.
 When local altimeter setting not received, use Chadron altimeter setting and increase all MDA 80 feet, and Cat A visibility 1/4 mile.

MISSED APPROACH: Climbing left turn to 5700 direct IROVE and hold.

ASOS 126.775	DENVER CENTER 127.95 338.2	CTAF 122.9 ①
------------------------	--------------------------------------	-------------------------------

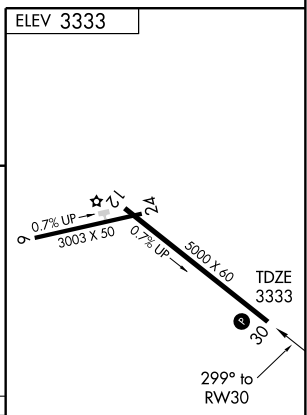
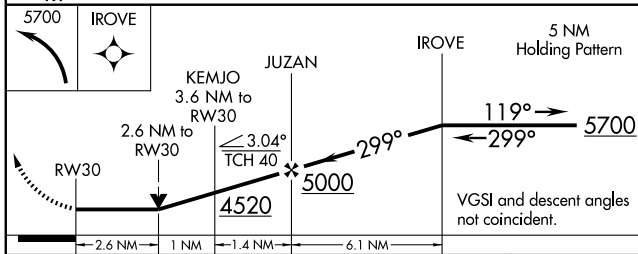
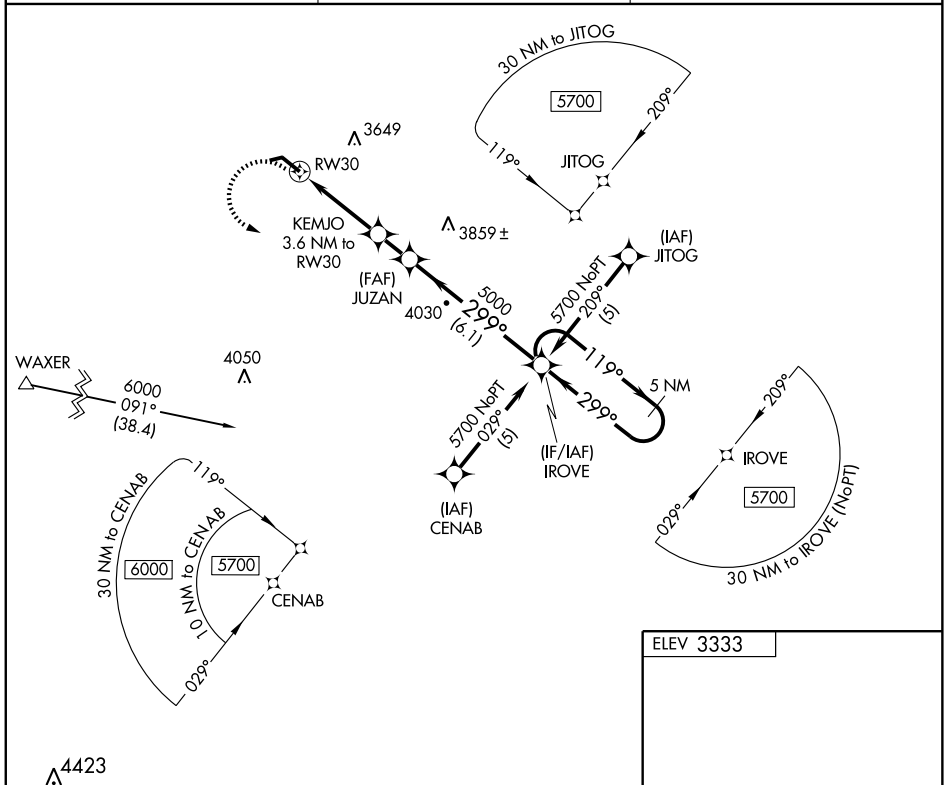

CATEGORY	A	B	C	D
LNAV MDA	4180-1 847 (900-1)	4180-1¼ 847 (900-1¼)		NA
CIRCLING	4180-1 847 (900-1)	4180-1¼ 847 (900-1¼)		NA

MIRL Rwy 12-30 **①**

AIRPORT DIAGRAM

AL-877 (FAA)

RAPID CITY RGNL (RAP)
RAPID CITY, SOUTH DAKOTA

ASOS
118.525
RAPID CITY TOWER ★
125.85 257.8
GND CON
121.9



△ 3233 ±



JANUARY 2005
ANNUAL RATE OF CHANGE
0.2° W

FIELD
ELEV
3204

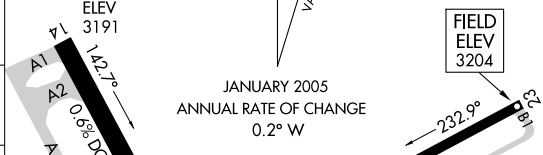

44° 03'N

GENERAL AVIATION RAMP

ELEV 3173
5
B2 0.9% UP

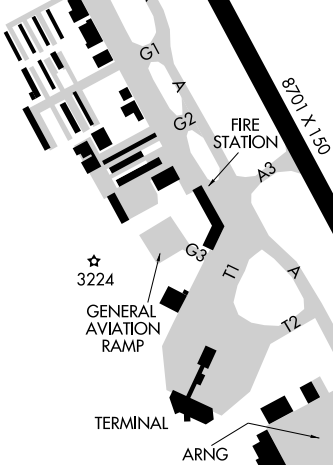

★ 3224

TERMINAL

ARNG

CONTROL
TOWER
3233

RWY 5-23
S12.5
RWY 14-32
S140, D190, ST175, DT300

8701 X 150
A

3227.7
A5
0.5% UP

44° 02'N

CAUTION: BE ALERT TO RUNWAY CROSSING CLEARANCES.
READBACK OF ALL RUNWAY HOLDING INSTRUCTIONS IS REQUIRED.

103° 04'W

103° 03'W

ELEV
3143

NC-1 - 08 APR 2010 to 06 MAY 2010

LOC/DME I-RAP 109.3 Chan 30	APP CRS 324°	Rwy Idg TDZE 8701 3160 Apt Elev 3204
--	------------------------	---

ILS or LOC RWY 32

RAPID CITY RGNL (RAP)

⚠ Circling to Rwy 5-23 NA at night. When local altimeter setting not received, use Ellsworth AFB altimeter setting and increase all DA 26 feet and all MDA 40 feet, increase S-LOC 32 Cat E visibility 1/2 mile. For inoperative MALSR, increase S-LOC 32 Cat E visibility to 1 1/2 and S-ILS 32 Cat E visibility to RVR 4000. VDP NA with Ellsworth AFB altimeter setting. *RVR 1800 authorized with the use of FD or AP or HUD to DA. For inoperative MALSR, when using Ellsworth AFB altimeter setting, increase S-ILS 32 Cat E visibility to RVR 4000 and S-LOC 32 Cat E visibility to 1 3/4.

MALSR
MISSED APPROACH: Climb to 5500 then left turn direct RAP VORTAC and hold. (TACAN aircraft continue via RAP VORTAC R-142 to MUDDY 5 DME and hold SE, RT, 322° inbound.)

ASOS 118.525	ELLSWORTH APP CON * 119.5 259.1	RAPID CITY TOWER * 125.85 (CTAF) 0 257.8	GND CON 121.9	UNICOM 122.95
------------------------	---	--	-------------------------	-------------------------

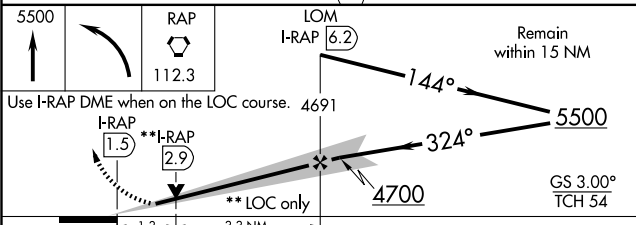
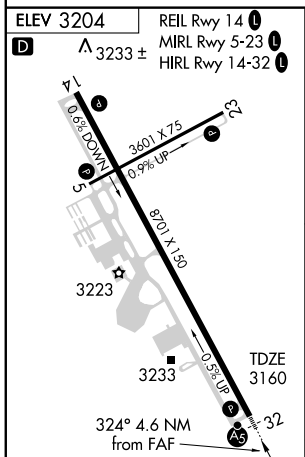
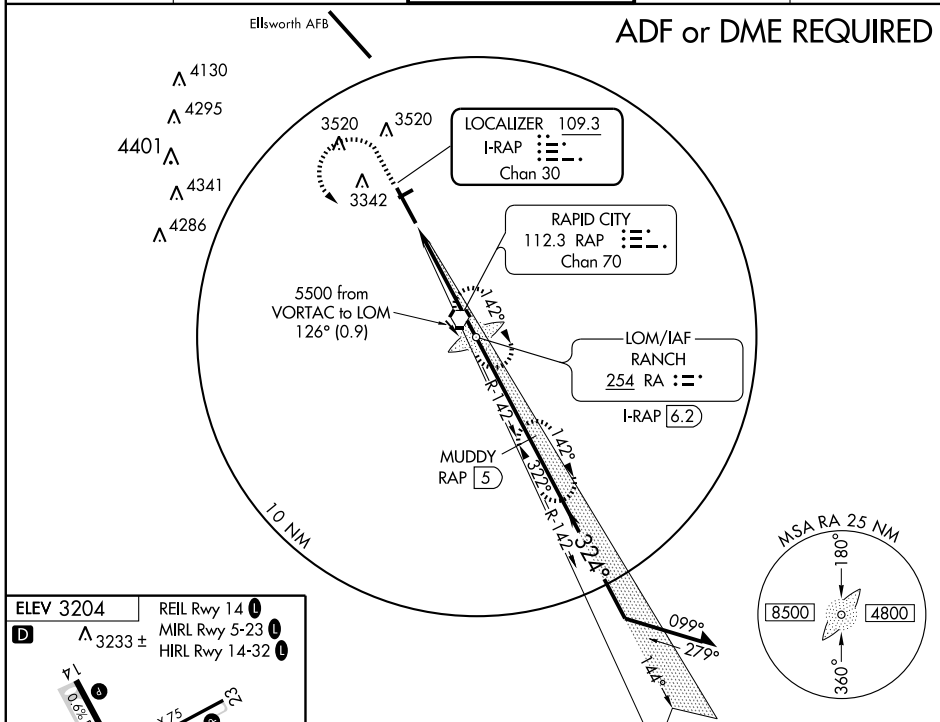

CATEGORY	A	B	C	D	E
S-ILS 32	* 3360/24			200 (200-1/2)	3360/24 200 (200-1/2)
S-LOC 32	3620/24	460 (500-1/2)	3620/40 460 (500-3/4)	3620/50	460 (500-1)
CIRCLING	3660-1 456 (500-1)	3680-1 476 (500-1)	3680-1 1/2 476 (500-1 1/2)	3820-2 616 (700-2)	3960-2 3/4 756 (800-2 3/4)

NC-1. 08 APR 2010 to 06 MAY 2010

WAAS CH 60919 W14A	APP CRS 144°	Rwy Idg TDZE Apt Elev	8701 3191 3204
--	------------------------	-----------------------------	---

RNAV (GPS) RWY 14

RAPID CITY RGNL (R.A.P)

⚠ Circling to Rwy 5-23 NA at night. For uncompensated Baro-VNAV systems, LNAV/VNAV NA below -21°C (-5°F) or above 42°C (107°F). DME/DME RNP-0.3 NA. Visibility reduction by helicopters NA.
⚠ When local altimeter setting not received, use Ellsworth AFB altimeter setting and increase all DA 26 feet and all MDA 40 feet and increase LNAV Cats C/D/E and Circling Cat C visibility ¼ mile.
 VDP NA with Ellsworth AFB altimeter setting.
 Baro-VNAV NA when using Ellsworth AFB altimeter setting.

MISSED APPROACH:
Climb to 5500 direct COTYU and hold.

ASOS 118.525	ELLSWORTH APP CON * 119.5 259.1	RAPID CITY TOWER * 125.85 (CTAF) 0 257.8	GND CON 121.9	UNICOM 122.95
------------------------	---	--	-------------------------	-------------------------

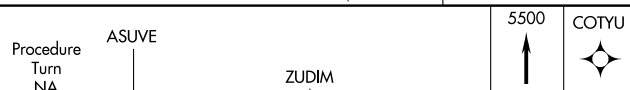
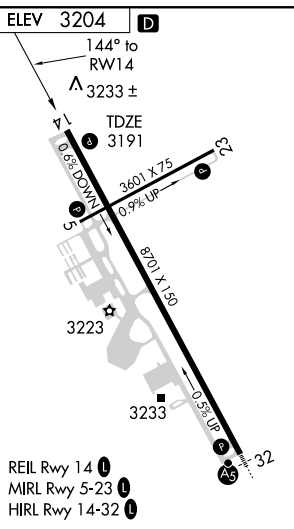
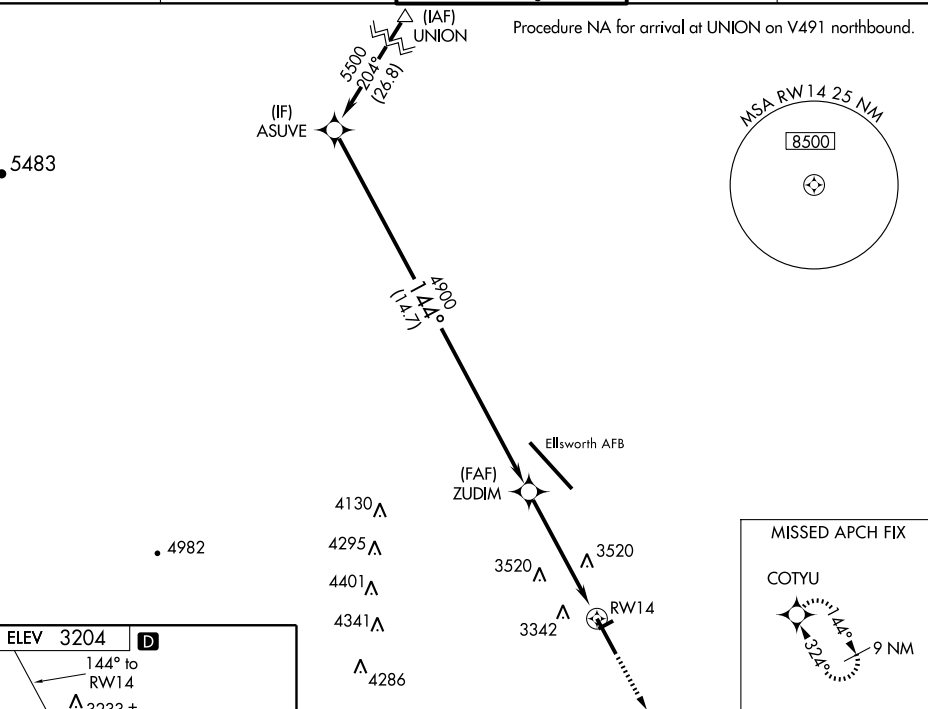

GS 3.00°	14.7 NM	3.5 NM	1.7 NM	
TCH 47				

CATEGORY	A	B	C	D	E
LPV DA	3450-1 259 (300-1)				
LNAV/VNAV DA	3871-2½ 680 (700-2½)				
LNAV MDA	3780-1 589 (600-1)	3780-1½ 589 (600-1½)	3780-1¾ 589 (600-1¾)	3780-2 589 (600-2)	3780-2 589 (600-2)
CIRCLING	3780-1 576 (600-1)	3780-1½ 576 (600-1½)	3820-2 616 (700-2)	3960-2¾ 756 (800-2¾)	

WAAS CH 93717 W32A	APP CRS 324°	Rwy Idg TDZE Apt Elev	8701 3160 3204
--	------------------------	-----------------------------	---

RNAV (GPS) RWY 32

RAPID CITY RGNL (RAP)

MALSRL



MISSED APPROACH:
Climb to 6500 direct KAKGU and left turn on track 234° to HOZWU and left turn on track 131° to NIRYO and hold.

⚠ Circling to Rwy 5-23 NA at night. For uncompensated Baro-VNAV systems, LNAV/VNAV NA below -21°C (-5°F) or above 42°C (107°F). DME/DME RNP-0.3 NA. When local altimeter setting not received, use Ellsworth AFB altimeter setting and increase all DA 26 feet and all MDA 40 feet and increase LNAV Cat E visibility ¼ mile. VDP NA with Ellsworth AFB altimeter setting.

⚠ Baro-VNAV NA when using Ellsworth AFB altimeter setting. For inoperative MALSRL, increase LPV Cat E visibility to RVR 4000, LNAV/VNAV Cat D and E visibility to RVR 5000 and LNAV Cat E visibility to 1½. For inoperative MALSRL, when using Ellsworth AFB altimeter setting, increase LPV Cat E visibility to RVR 4000, LNAV/VNAV Cat D and E visibility to RVR 5000 and LNAV Cat E visibility to 1¾.

ASOS 118.525	ELLSWORTH APP CON * 119.5 259.1	RAPID CITY TOWER * 125.85 (CTAF) 0 257.8	GND CON 121.9	UNICOM 122.95
------------------------	---	---	-------------------------	-------------------------

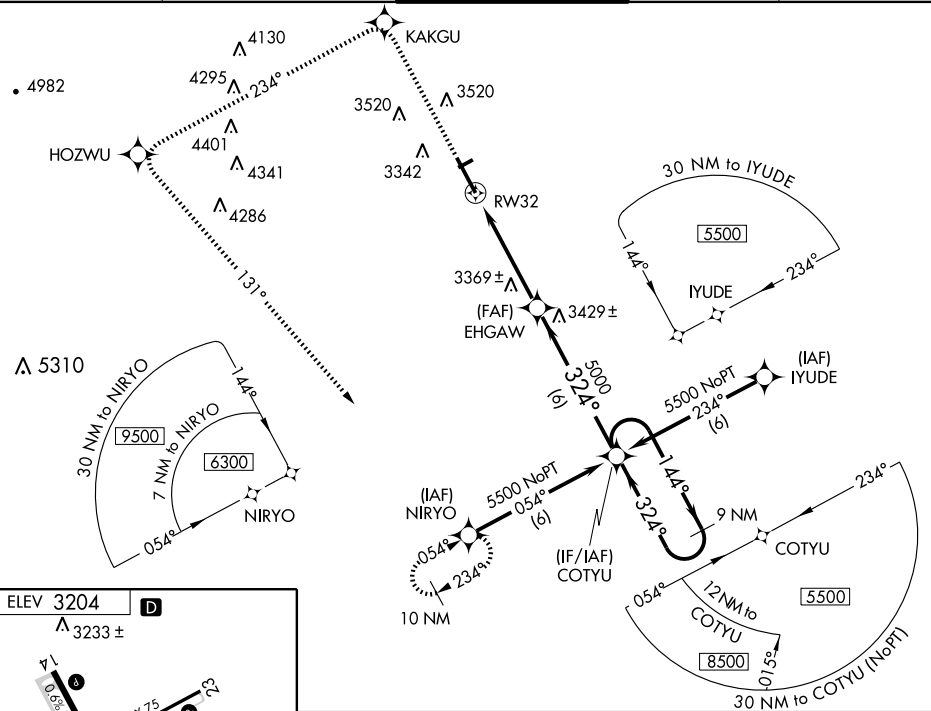

ELEV 3204	D
------------------	----------

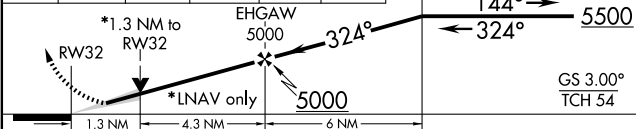
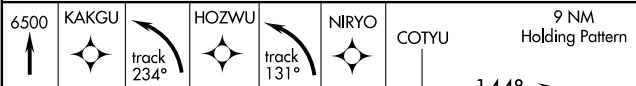
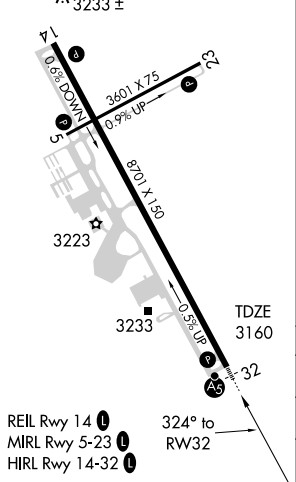

CATEGORY	A	B	C	D	E
LPV DA	3360/24 200 (200-½)				
LNAV/VNAV DA	3410/24 250 (300-½)		3410/40 250 (300-¾)		
LNAV MDA	3620/24 460 (500-½)	3620/40 460 (500-¾)		3620/50 460 (500-1)	
CIRCLING	3660-1 456 (500-1)	3680-1 476 (500-1)	3680-1½ 476 (500-1½)	3820-2 616 (700-2)	3960-2¾ 756 (800-2¾)

VOR or TACAN RWY 14

RAPID CITY RGNL (RAP)

VORTAC RAP 112.3 Chan 70	APP CRS 141°	Rwy Idg 8701 TDZE 3191 Apt Elev 3204
--	------------------------	--

▲ If local altimeter setting not received, use Ellsworth AFB altimeter setting and increase all MDAs 40 feet.
▲ MISSED APPROACH: Climb to 5600 direct RAP VORTAC and hold, continue climb-in-hold to 5600. (TACAN aircraft continue via RAP R-142 to MUDDY 5 DME and hold SE, RT, 322° inbound.)

ASOS 118.525	ELLSWORTH APP CON ★ 119.5 259.1	RAPID CITY TOWER ★ 125.85 (CTAF) 257.8	GND CON 121.9	UNICOM 122.95
------------------------	---	--	-------------------------	-------------------------

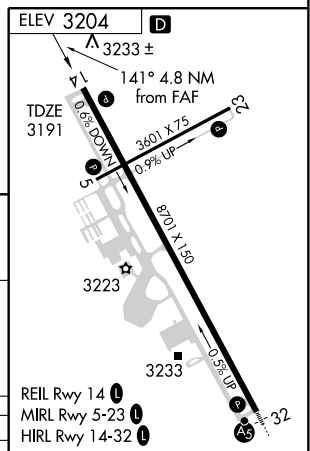
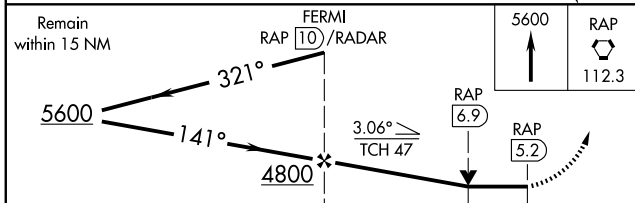
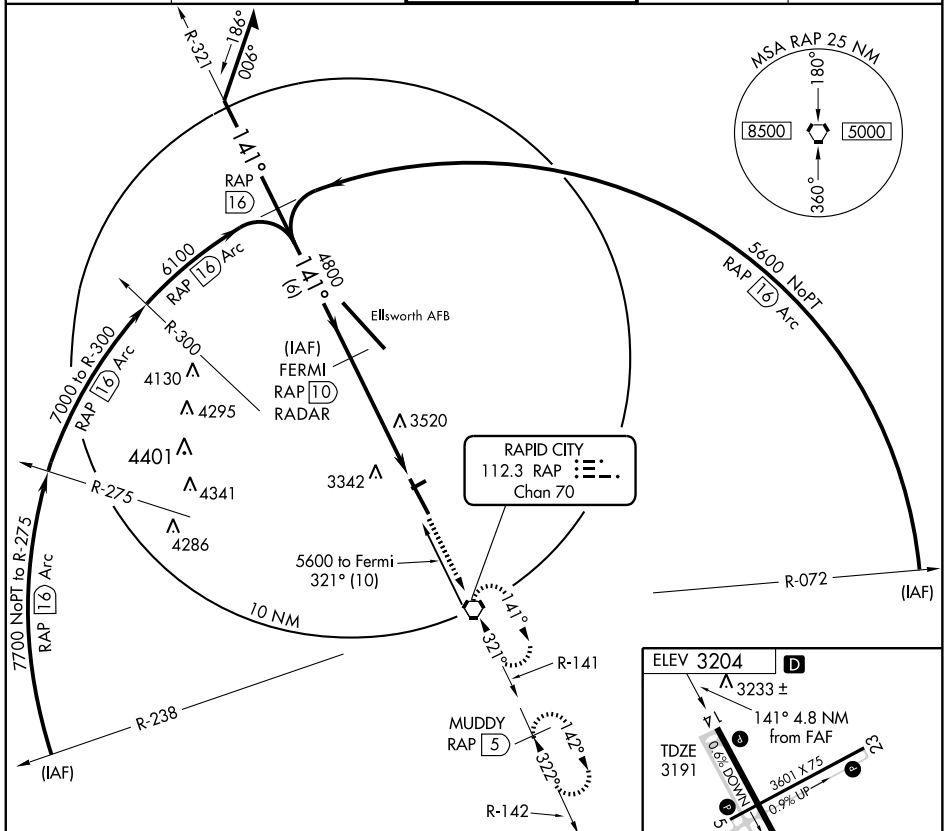

CATEGORY	FAF to MAP 4.8 NM				
	A	B	C	D	E
S-14	3780-1 589 (600-1)	3780-1½ 589 (600-1½)	3780-1¾ 589 (600-1¾)	3780-2 589 (600-2)	3780-2 589 (600-2)
CIRCLING	3780-1 576 (600-1)	3780-1½ 576 (600-1½)	3820-2 616 (700-2)	3820-2 616 (700-2)	3820-2 616 (700-2)

Knots	60	90	120	150	180
Min:Sec	4:48	3:12	2:24	1:55	1:36

VOR or TACAN RWY 32

RAPID CITY RGNL (RAP)

VORTAC RAP 112.3 Chan 70	APP CRS 322°	Rwy Idg TDZE Apt Elev 8701 3160 3204
--	------------------------	--

▼ Inoperative table does not apply to Cats D and E.
▲ If local altimeter setting not received, use Ellsworth AFB altimeter setting and increase all MDAs 40 feet.

MALSR MISSED APPROACH: Climb to 5500 via RAP R-322 then left turn direct RAP VORTAC and hold. (TACAN aircraft continue via RAP R-142 to MUDDY 5 DME and hold SE, RT, 322° inbound.)

ASOS 118.525	ELLSWORTH APP CON * 119.5 259.1	RAPID CITY TOWER * 125.85 (CTAF) 257.8	GND CON 121.9	UNICOM 122.95
------------------------	---	--	-------------------------	-------------------------

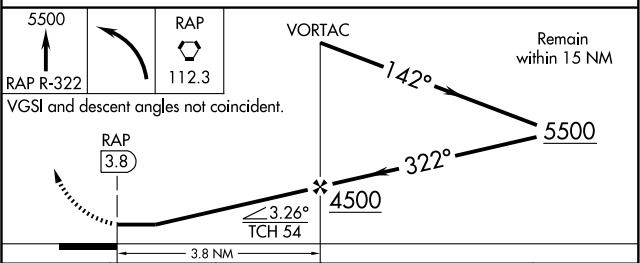
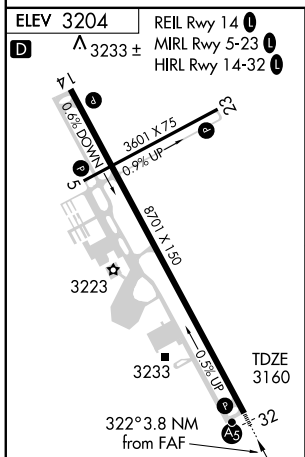
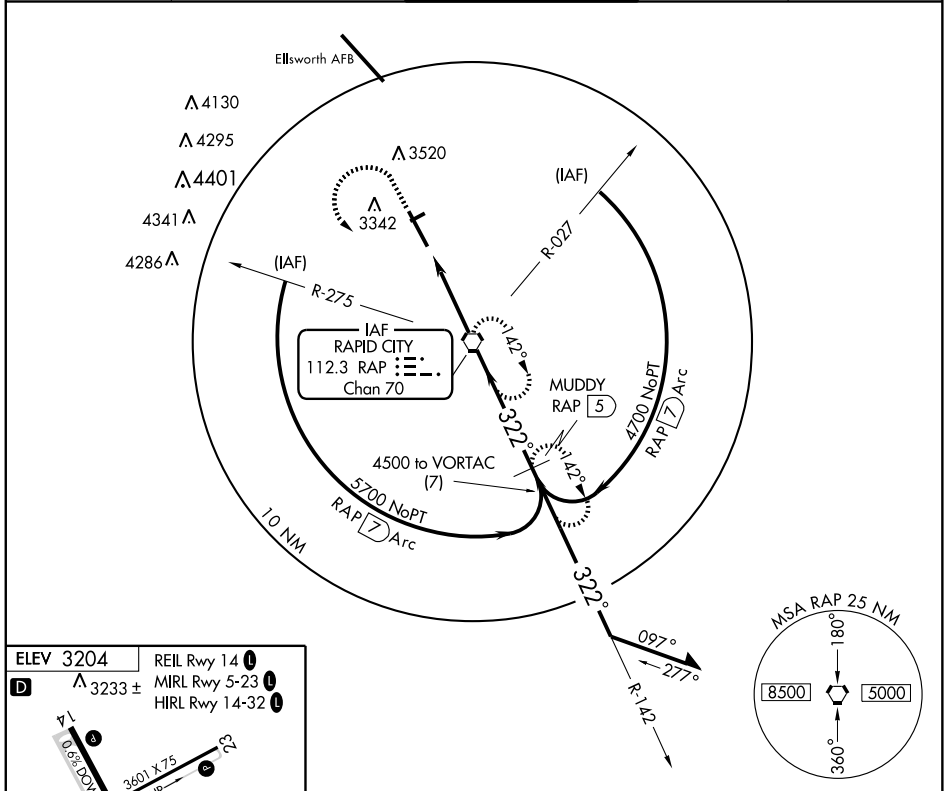

		CATEGORY	A	B	C	D	E
FAF to MAP 3.8 NM		S-32	3440/24 280 (300-1/2)			3440/50 280 (300-1)	
Knots	60 90 120 150 180	CIRCLING	3660-1	456 (500-1)	3660-1 1/2 456 (500-1 1/2)	3820-2 616 (700-2)	3820-2 1/4 616 (700-2 1/4)
Min:Sec	3:48 2:32 1:54 1:31 1:16						

ATIS ★ 120.625 269.9
 ELLSWORTH TOWER ★
 126.05 253.5
 GND CON
 121.8 275.8

FIELD
 ELEV
 3276



AUGUST 2009
 ANNUAL RATE OF CHANGE
 0.2°W

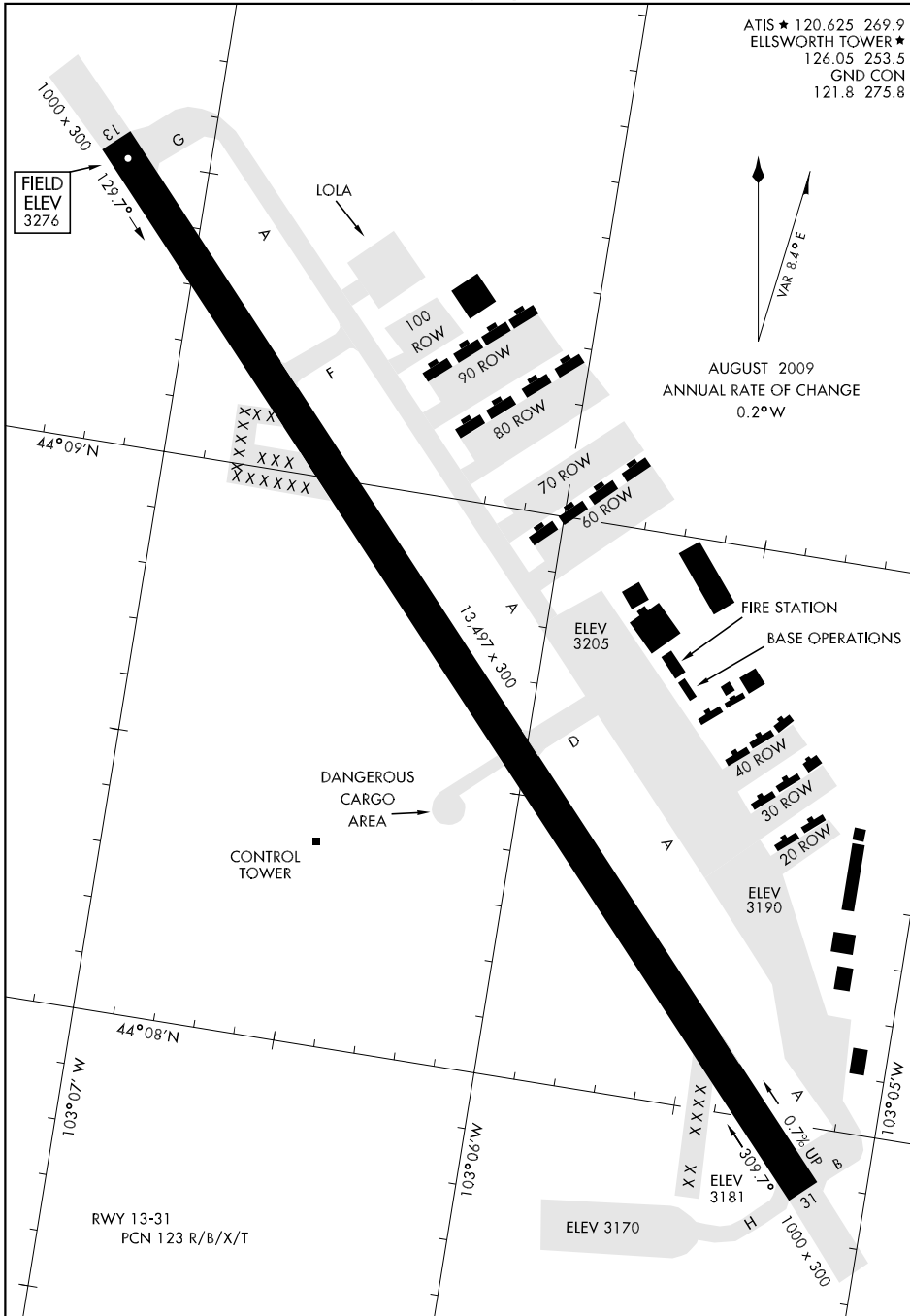

NC-1, 08 APR 2010 to 06 MAY 2010

RWY 13-31
 PCN 123 R/B/X/T

ELLSWORTH-ONE DEPARTURE (RCA1 • RCA)

SHL-343 [USAF] RAPID CITY, SOUTH DAKOTA

ATIS ★ 120.625 269.9
 GND CON
 121.8 275.8
 ELLSWORTH TOWER ★
 126.05 253.5
 ELLSWORTH DEP CON
 119.5 289.4
 DENVER CENTER
 127.95 338.2
 ELLSWORTH APP CON
 119.5 259.1

Rwy	Knots	60	120	180	240	300	360
31	V/V(fpm)	240	480	720	960	1200	1440

ATC Climb Rate to 10,000

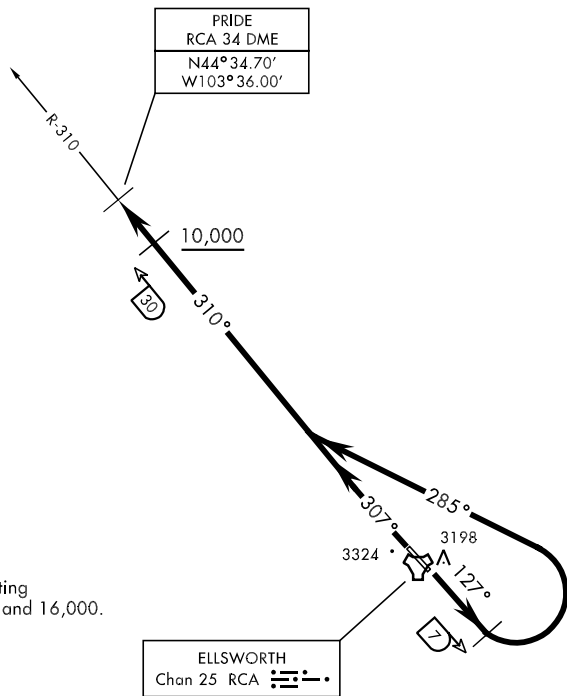

CAUTION: Traffic transiting
 IR-492 between 10,000 and 16,000.

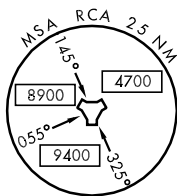

Radar required for
 Rwy 13 departure.

DEPARTURE ROUTE DESCRIPTION

TAKE-OFF RWY 13: Track 127° to RCA 7 DME. Turn left track 285° to intercept RCA R-310, outbound to PRIDE. Cross RCA 30 DME at or above 10,000.

TAKE-OFF RWY 31: Track 307° to intercept RCA R-310, outbound to PRIDE. Cross RCA 30 DME at or above 10,000.

LOC I-ELR 111.5	APCH CRS 127°	Rwy Idg 13,497 TDZE 3276 Arprt Elev 3276
---------------------------	-------------------------	--

JAL-343 [USAF]

ELLSWORTH AFB (KRCA)

* When ALS inop, increase RVR to 40 and vis to 3/4 mile.
 ** When ALS inop, increase CAT CD vis to 1 1/2 miles, CAT E vis to 1 3/4 miles.
 *** CAT E circling restricted to 28th BW aircraft only; 28th BW aircraft will remain within Class D airspace.
 † When ALS inop, increase CAT C vis to 1 1/2 miles, CAT D vis to 1 3/4 miles, CAT E vis to 2 miles.



MISSED APPROACH: Track outbound RCA R-127 to 3 DME (CAVET), then turn left to join RCA R-040 outbound to (RUUSH) RCA 15 DME and hold. Maintain 6000.

ATIS * 120.625 269.9	ELLSWORTH APP CON 119.5 259.1	ELLSWORTH TOWER * 126.05 253.5	GND CON 121.8 275.8	ASR
--------------------------------	---	--	-------------------------------	-----

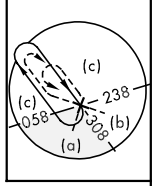
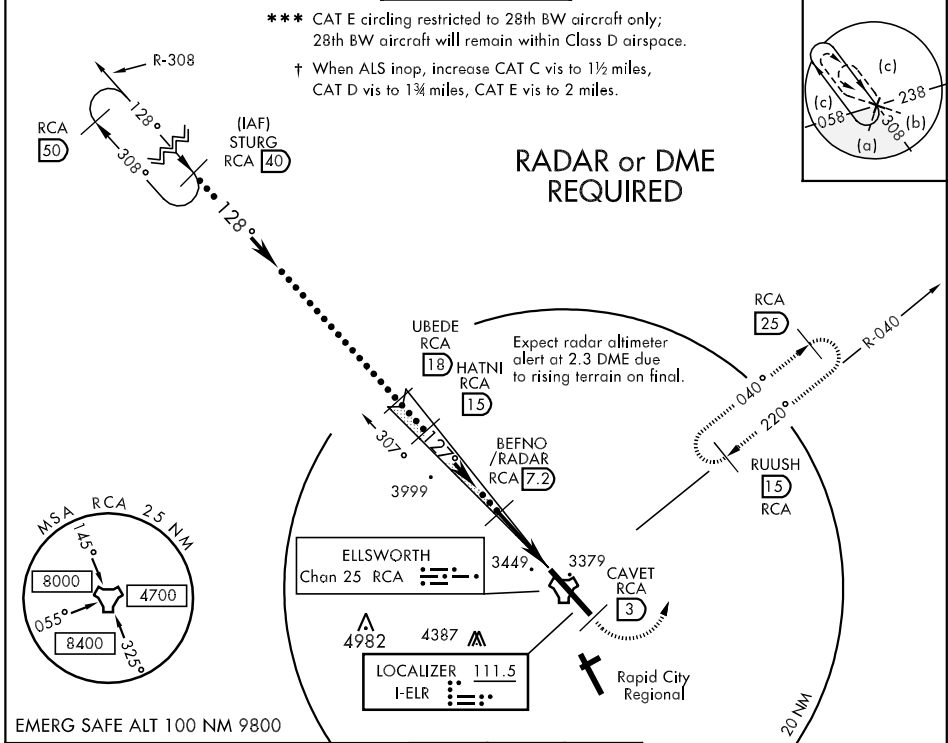

RADAR or DME REQUIRED

NC-1, 08 APR 2010 to 06 MAY 2010

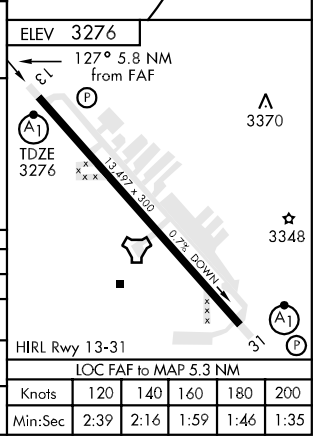
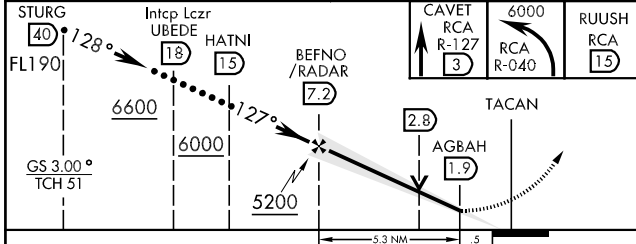

CATEGORY	C	D	E
S-ILS 13 *	3476/24		200 (200-1/2)
S-LOC 13 **	3780/50	504 (600-1)	3780/60 504 (600-1 1/4)
CIRCLING ***	3880-1 3/4 604 (700-1 3/4)	3880-2 604 (700-2)	4040-2 3/4 764 (800-2 3/4)
S-ASR 13 †	3820/50 544 (600-1)	3820/60 544 (600-1 1/4)	3820-1 1/2 544 (600-1 1/2)

LOC I-RCA **110.3** APCH CRS **307°** Rwy ldg **13,497**
 TDZE **3192**
 Arprt Elev **3276**

JAL-343 [USAF]

ELLSWORTH AFB (KRCA)

* When ALS inop, increase RVR to 40 and vis to 3/4 mile.
 ** When ALS inop, increase CAT C vis to 1 3/4 miles, CAT D vis to 2 miles, CAT E vis to 2 1/4 miles.



MISSED APPROACH: Track outbound RCA R-307 to 3 DME (APOGE), then turn right to join RCA R-040 outbound to (RUUSH) RCA 15 DME and hold. Maintain 6000.

ATIS ★ 120.625 269.9	ELLSWORTH APP CON 119.5 259.1	ELLSWORTH TOWER ★ 126.05 253.5	GND CON 121.8 275.8	ASR
--------------------------------	---	--	-------------------------------	-----

*** CAT E circling restricted to 28th BW aircraft only; 28th BW aircraft will remain within Class D airspace.

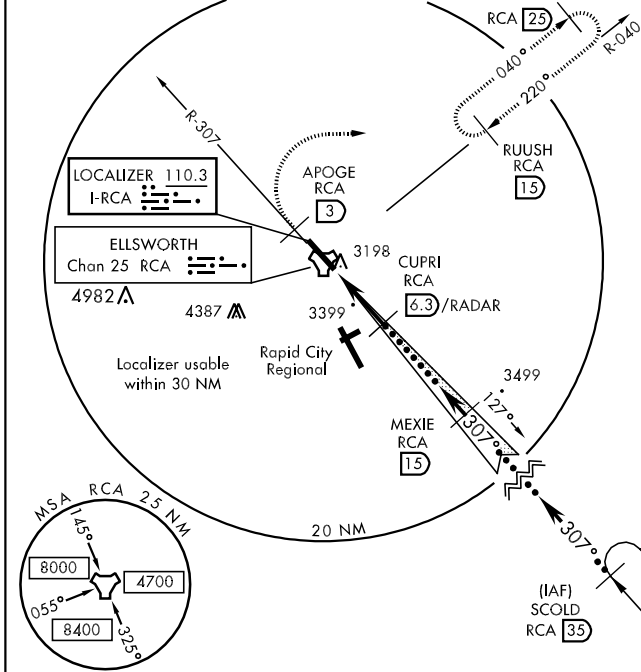
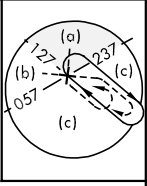

RADAR or DME REQUIRED

EMERG SAFE ALT 100 NM 9800

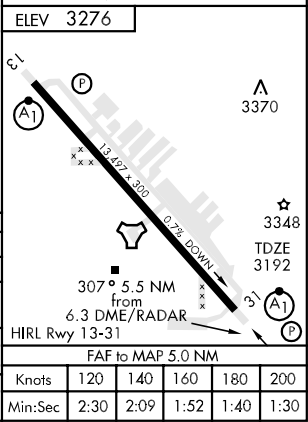
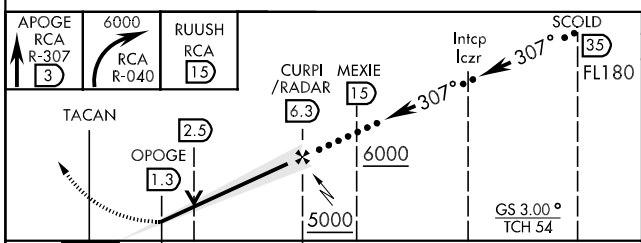

APAGE RCA R-307 (3)	6000	RUUSH RCA R-040 (15)	
TACAN	OPOGE (1.3)	CURPI/RADAR (6.3)	MEXIE (15)
FL 180	5000	6000	Intcp lczr
GS 3.00°	TCH 54		SCOLD (35)
CATEGORY	C	D	E
S-ILS 31 *	3392/24 200 (200-1/2)		
S-LOC 31 **	3800/60 608 (600-1 1/4)	3800-1 1/2 608 (600-1 1/2)	3800-1 3/4 608 (600-1 3/4)
CIRCLING ***	3880-1 3/4 604 (700-1 3/4)	3880-2 604 (700-2)	4040-2 3/4 764 (800-2 3/4)
S-ASR 31 **	3820/60 628 (600-1 1/4)	3820-1 1/2 628 (600-1 1/2)	3820-1 3/4 628 (600-1 3/4)

NC-1, 08 APR 2010 to 06 MAY 2010

TACAN RCA Chan 25	APCH CRS 133°	Rwy Idg 13,497 TDZE 3276 Arprt Elev 3276
----------------------	------------------	---

JAL-343 [USAF]

ELLSWORTH AFB (KRCA)

* When ALS inop, increase CAT CDE vis ½ mile.
 ** CAT E circling restricted to 28th BW aircraft only; 28th BW aircraft will remain within Class D airspace.



MISSED APPROACH: Track outbound RCA R-127 to 3 DME (CAVET), then turn left to join RCA R-040 outbound to (RUUSH) RCA 15 DME and hold. Maintain 6000.

ATIS ★ 120.625 269.9	ELLSWORTH APP CON 119.5 259.1	ELLSWORTH TOWER ★ 126.05 253.5	GND CON 121.8 275.8	ASR
-------------------------	----------------------------------	-----------------------------------	------------------------	-----

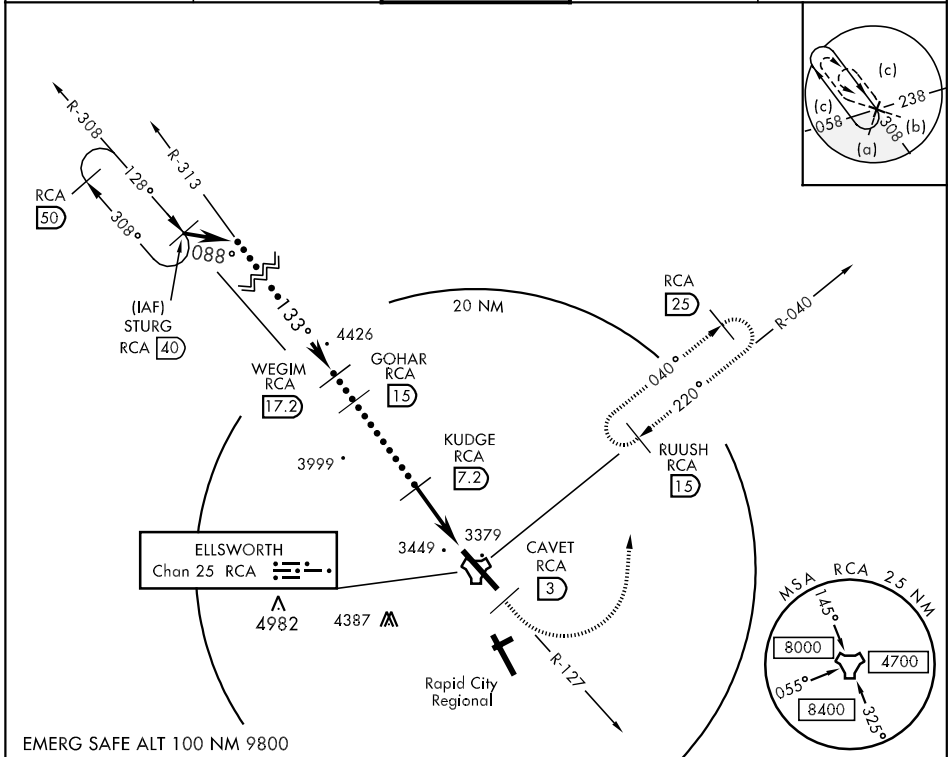

EMERG SAFE ALT 100 NM 9800

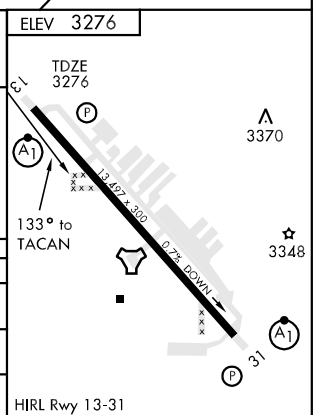
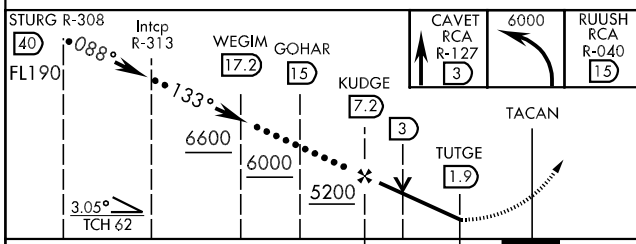

CATEGORY	C		D		E	
	3820/50 544 (600-1)	3880-1¾ 604 (700-1¾)	3820/60 544 (600-1½)	3880-2 604 (700-2)	3820-1½ 544 (600-1½)	4040-2¾ 764 (800-2¾)
S-13 *	3820/50 544 (600-1)	3880-1¾ 604 (700-1¾)	3820/60 544 (600-1½)	3880-2 604 (700-2)	3820-1½ 544 (600-1½)	4040-2¾ 764 (800-2¾)
CIRCLING **	3820/50 544 (600-1)	3880-1¾ 604 (700-1¾)	3820/60 544 (600-1½)	3880-2 604 (700-2)	3820-1½ 544 (600-1½)	4040-2¾ 764 (800-2¾)
S-ASR 13 *	3820/50 544 (600-1)	3880-1¾ 604 (700-1¾)	3820/60 544 (600-1½)	3880-2 604 (700-2)	3820-1½ 544 (600-1½)	4040-2¾ 764 (800-2¾)

NC-1, 08 APR 2010 to 06 MAY 2010

TACAN RCA Chan 25
 APCH CRS 299°
 Rwy Idg 13,497
 TDZE 3192
 Arpt Elev 3276

JAL-343 [USAF]

ELLSWORTH AFB (KRCA)

* When ALS inop, increase CAT CDE vis 1/2 mile.
 ** CAT E circling restricted to 28th BW aircraft only; 28th BW aircraft will remain within Class D airspace.



MISSED APPROACH: Track outbound RCA R-307 to 3 DME (APOGE), then turn right to join RCA R-040 outbound to (RUUSH) RCA 15 DME and hold. Maintain 6000.

ATIS ★ 120.625 269.9
 ELLSWORTH APP CON 119.5 259.1
 ELLSWORTH TOWER ★ 126.05 253.5
 GND CON 121.8 275.8
 ASR

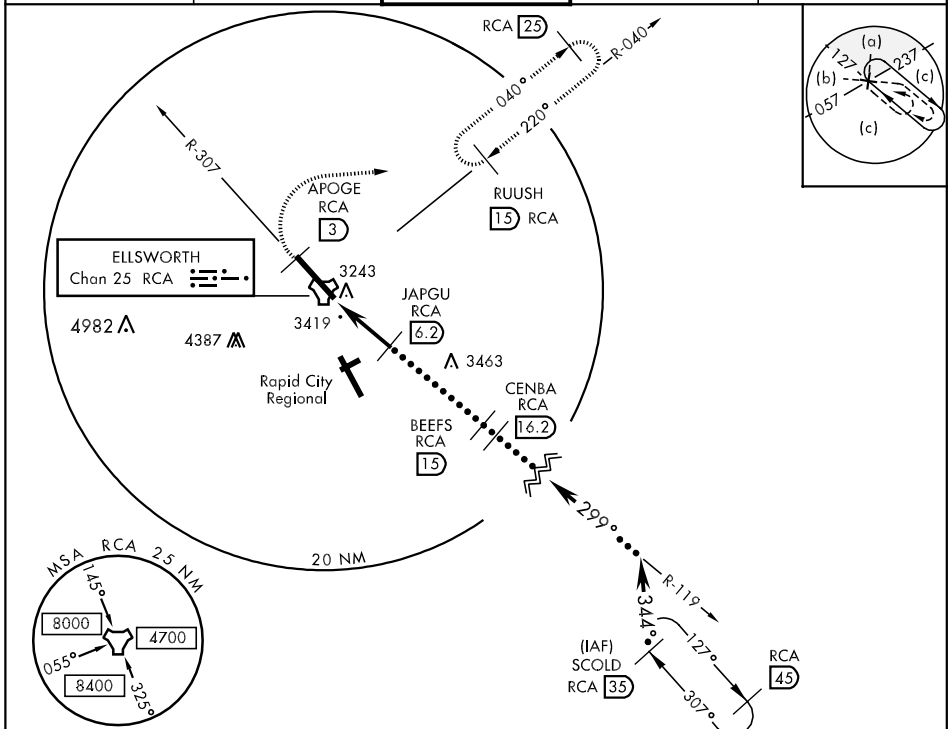

EMERG SAFE ALT 100 NM 9800

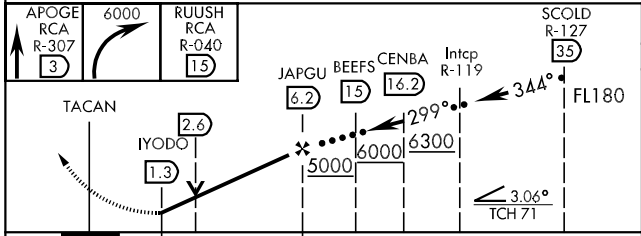

CATEGORY	C	D	E
S-31 *	3820/60 628 (600-1¼)	3820-1½ 628 (600-1½)	3820-1¾ 628 (600-1¾)
CIRCLING **	3880-1¾ 604 (700-1¾)	3880-2 604 (700-2)	4040-2¾ 764 (800-2¾)
S-ASR 31 *	3820/60 628 (600-1¼)	3820-1½ 628 (600-1½)	3820-1¾ 628 (600-1¾)

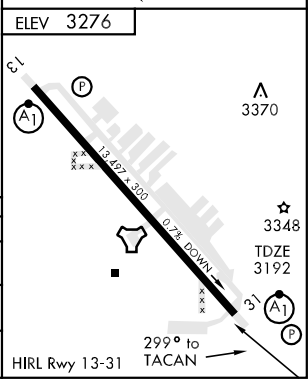

NC-1, 08 APR 2010 to 06 MAY 2010

LOC I-ELR 111.5	APCH CRS 127°	Rwy Idg 13,497 TDZE 3276 Arp't Elev 3276
---------------------------	-------------------------	---

AL-343 [USAF]

ELLSWORTH AFB (KRCA)

* When ALS inop, increase RVR to 40 and vis to 3/4 mile.
 ** When ALS inop, increase CAT AB RVR to 50 and vis to 1 mile, CAT CD vis to 1 1/2 miles, CAT E vis to 1 3/4 miles.

ALS-1
 MISSED APPROACH: Track outbound RCA R-127 to RCA 3 DME (CAVET), then turn left to join RCA R-040 outbound to (RUUSH) RCA 15 DME and hold. Maintain 6000.

ATIS ★ 120.625 269.9	ELLSWORTH APP CON 119.5 259.1	ELLSWORTH TOWER ★ 126.05 253.5	GND CON 121.8 275.8	ASR
--------------------------------	---	--	-------------------------------	-----

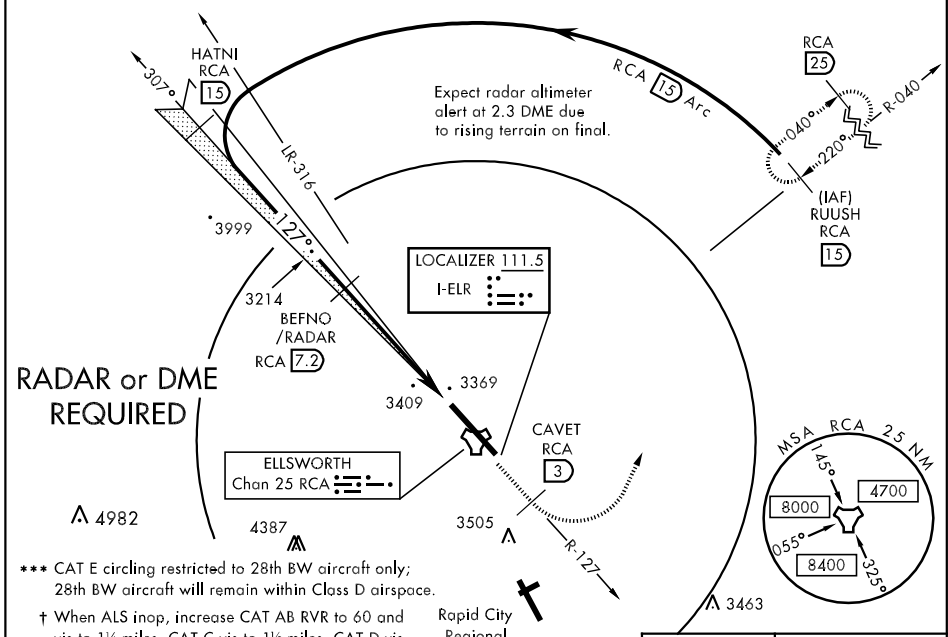

RADAR or DME REQUIRED

*** CAT E circling restricted to 28th BW aircraft only; 28th BW aircraft will remain within Class D airspace.
 † When ALS inop, increase CAT AB RVR to 60 and vis to 1 1/4 miles, CAT C vis to 1 1/2 miles, CAT D vis to 1 3/4 miles, CAT E vis to 2 miles.

EMERG SAFE ALT 100 NM 9800

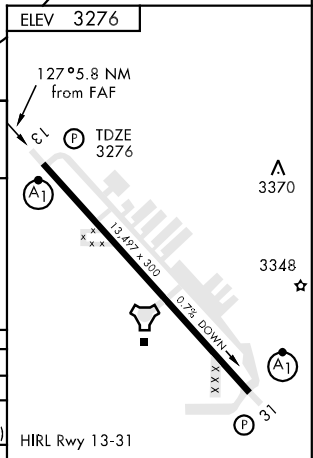
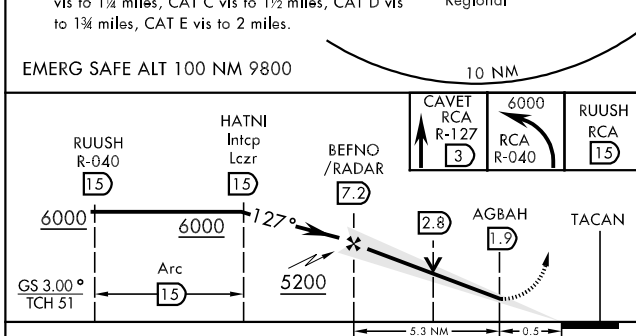

CATEGORY	A	B	C	D	E
S-ILS 13 *	3476/24		200	(200-1/2)	
S-LOC/DME 13 **	3780/24	504 (600-1/2)	3780/50	504 (600-1)	3780/60 504 (600-1 1/4)
CIRCLING ***	3860-1 584 (600-1)	3880-1 604 (700-1)	3880-1 1/4 604 (700-1 1/4)	3880-2 604 (700-2)	4040-2 1/4 764 (800-2 1/4)
S-ASR 13 †	3820/40	544 (600-3/4)	3820/50 544 (600-1)	3820/60 544 (600-1 1/4)	3820-1 1/2 544 (600-1 1/2)

LOC FAF to MAP 5.3 NM					
Knots	60	90	120	150	180
Min:Sec	5:18	3:32	2:39	2:07	1:46

NC-1, 08 APR 2010 to 06 MAY 2010

LOC I-RCA **110.3** APCH CRS **307°** Rwy ldg **13,497** TDZE **3192** Arprt Elev **3276**

AL-343 [USAF]

ELLSWORTH AFB (KRCA)

* When ALS inop, increase RVR to 40 and vis to ¾ mile.
 ** When ALS inop, increase CAT AB RVR to 50 and vis to 1 mile, CAT C vis to 1¼ miles, CAT D vis to 2 miles, CAT E vis to 2¼ miles.



MISSED APPROACH: Track outbound RCA R-307 to 3 DME (APOGE), then turn right to join RCA R-040 outbound to (RUUSH) RCA 15 DME and hold. Maintain 6000.

ATIS ★ 120.625 269.9	ELLSWORTH APP CON 119.5 259.1	ELLSWORTH TOWER ★ 126.05 253.5	GND CON 121.8 275.8	ASR
--------------------------------	---	--	-------------------------------	-----

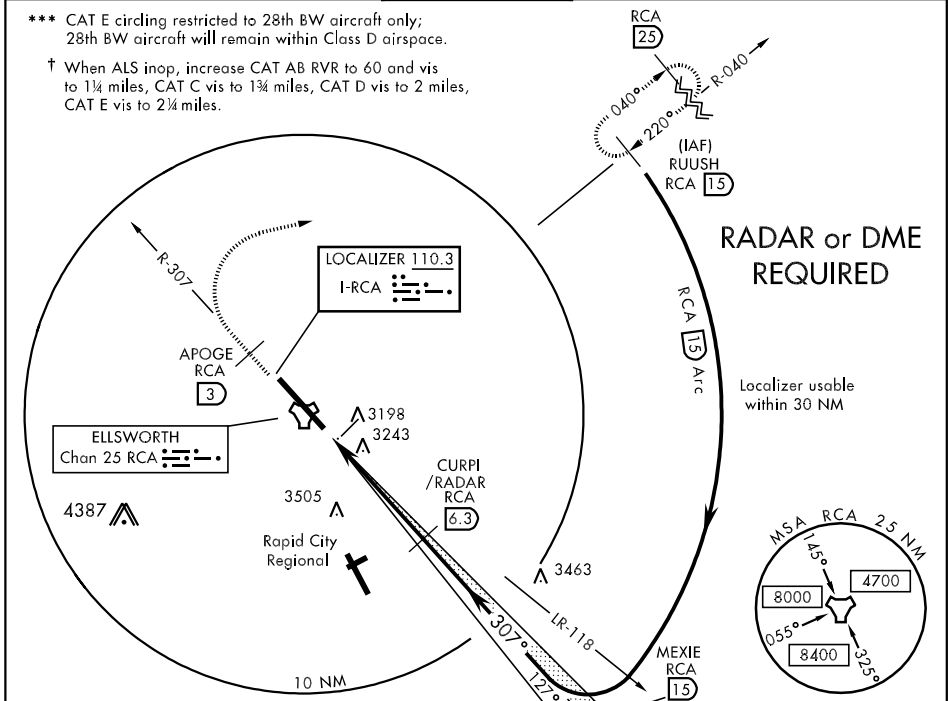

NC-1, 08 APR 2010 to 06 MAY 2010

EMERG SAFE ALT 100 NM 9800

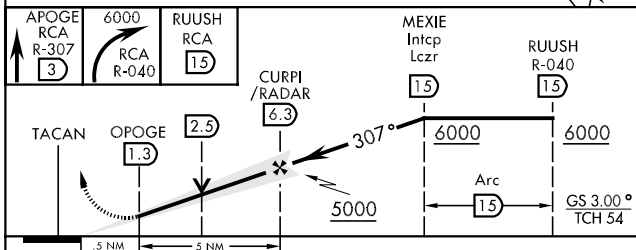

ELEV 3276 HIRL Rwy 13-31

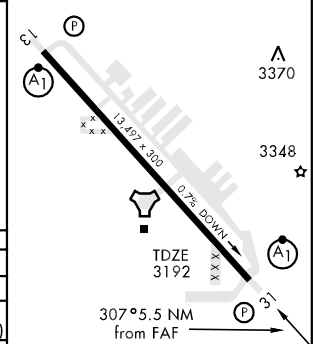

CATEGORY	A	B	C	D	E
S-ILS 31 *	3392/24		200	(200-1/2)	
S-LOC/DME 31 **	3800/24	608 (600-1/2)	3800/60 608 (600-1¼)	3800-1½ 608 (600-1½)	3800-1¾ 608 (600-1¾)
CIRCLING ***	3860-1 584 (600-1)	3880-1 604 (700-1)	3880-1¾ 604 (700-1¾)	3880-2 604 (700-2)	4040-2¾ 764 (800-2¾)
S-ASR 31 †	3820/40	628 (600-¾)	3820/60 628 (600-1¼)	3820-1½ 628 (600-1½)	3820-1¾ 628 (600-1¾)

LOC FAF to MAP 5 NM					
Knots	60	90	120	150	180
Min:Sec	5:00	3:20	2:30	2:00	1:40

TACAN RCA Chan **25** APCH CRS **133°** Rwy Idg **13,497**
 TDZE **3276**
 Arprt Elev **3276**

AL-343 [USAF]

ELLSWORTH AFB (KRCA)

* When ALS inop, increase CAT AB RVR to 50 and vis to 1 mile, increase CAT CDE vis ½ mile.
 ** CAT E circling restricted to 28th BW aircraft only; 28th BW aircraft will remain within Class D airspace.

ALSF-1
 MISSED APPROACH: Track outbound RCA R-127 to 3 DME (CAVET), then turn left to join RCA R-040 outbound to (RUUSH) RCA 15 DME and hold. Maintain 6000.

ATIS ★ 120.625 269.9	ELLSWORTH APP CON 119.5 259.1	ELLSWORTH TOWER ★ 126.05 253.5	GND CON 121.8 275.8	ASR
--------------------------------	---	--	-------------------------------	-----

† When ALS inop, increase CAT AB RVR to 60 and vis to 1¼ miles, increase CAT CDE vis ½ mile.

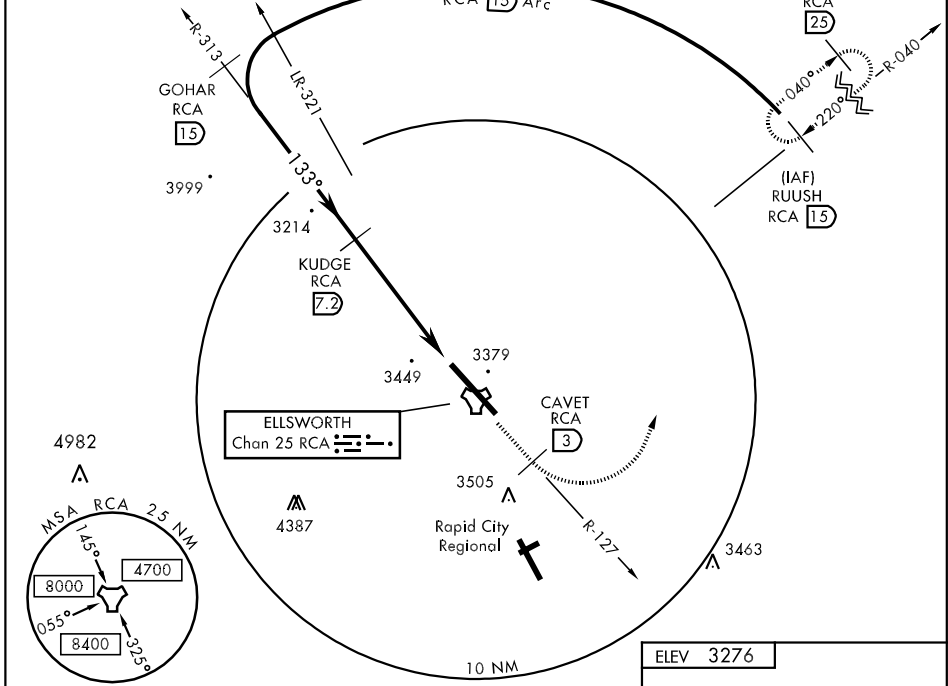

EMERG SAFE ALT 100 NM 9800

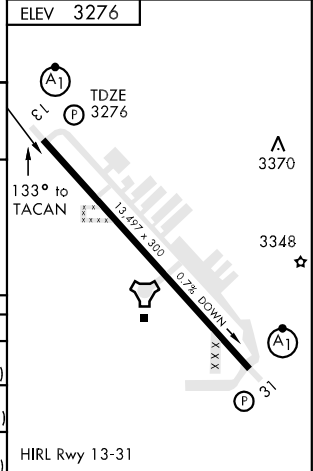
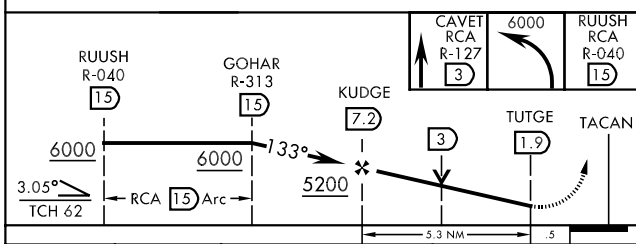

CATEGORY	A	B	C	D	E
S-13 *	3820/24 544 (600-½)		3820/50 544 (600-1)	3820/60 544 (600-1¼)	3820-1½ 544 (600-1½)
CIRCLING **	3860-1 584 (600-1)	3880-1 604 (700-1)	3880-1¼ 604 (700-1¾)	3880-2 604 (700-2)	4040-2¾ 764 (800-2¾)
S-ASR 13 †	3820/40 544 (600-¾)		3820/50 544 (600-1)	3820/60 544 (600-1¼)	3820-1½ 544 (600-1½)

NC-1, 08 APR 2010 to 06 MAY 2010

TACAN RCA Chan 25	APCH CRS 299°	Rwy Idg 13,497 TDZE 3192 Arprt Elev 3276
----------------------	------------------	--

AL-343 [USAF]

ELLSWORTH AFB (KRCA)

* When ALS inop, increase CAT AB RVR to 50 and vis to 1 mile, increase CAT CDE vis ½ mile.
 ** CAT E circling restricted to 28th BW aircraft only; 28th BW aircraft will remain within Class D airspace.



MISSED APPROACH: Track outbound RCA R-307 to 3 DME (APOGE), then turn right to join RCA R-040 outbound to (RUUSH) RCA 1.5 DME and hold. Maintain 6000.

ATIS ★ 120.625 269.9	ELLSWORTH APP CON 119.5 259.1	ELLSWORTH TOWER ★ 126.05 253.5	GND CON 121.8 275.8	ASR
-------------------------	----------------------------------	-----------------------------------	------------------------	-----

† When ALS inop, increase CAT AB RVR to 60 and vis to 1¼ miles, increase CAT CDE vis ½ mile.

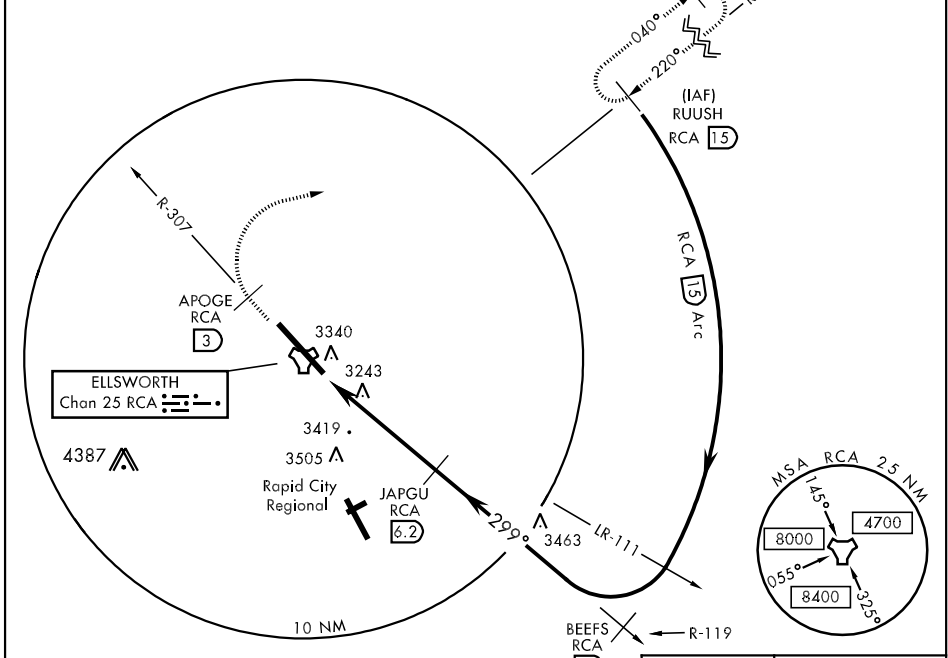

NC-1, 08 APR 2010 to 06 MAY 2010

EMERG SAFE ALT 100 NM 9800

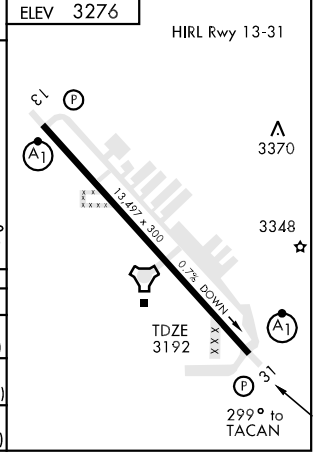
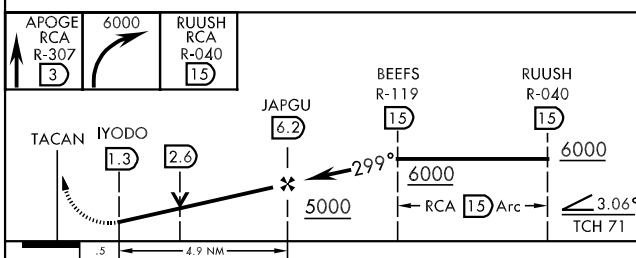

CATEGORY	A	B	C	D	E
S-31 *	3820/24 628 (600-½)		3820/60 628 (600-1¼)	3820-1½ 628 (600-1½)	3820-1¾ 628 (600-1¾)
CIRCLING **	3860-1 584 (600-1)	3880-1 604 (700-1)	3880-1¾ 604 (700-1¾)	3880-2 604 (700-2)	4040-2¾ 764 (800-2¾)
S-ASR 31 †	3820/40 628 (600-¾)		3820/60 628 (600-1¼)	3820-1½ 628 (600-1½)	3820-1¾ 628 (600-1¾)

AIRPORT DIAGRAM

AL-396 (FAA)

SIoux FALLS/JOE FOSS FIELD (FSD)
SIoux FALLS, SOUTH DAKOTA

ATIS
126.6
SIoux FALLS TOWER*
118.3 257.8
GND CON
121.9 348.6

D

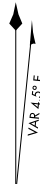

VAR 4.5° E

JANUARY 2005
ANNUAL RATE OF CHANGE
0.1° W

BOMB THREAT/
HAZARDOUS EXPLOSIVE
AREA

WEST
CARGO
RAMP

FIELD
ELEV
1429

FUEL
TANKS
EAST
CARGO
RAMP
1523
NEXRAD
1501 ±
NWS
FBO

CONTROL
TOWER
1519

TERMINAL

BAK
12/14

8999 X 150

3152 X 75

BAK
12/14

8000 X 150

ELEV
1423

FIRE
STATION

HANGAR

ANG
OPERATIONS

BAK
12/14

278.7°
ELEV
1421

RWY 3-21
S200, D200, ST175, DT444
RWY 9-27
S30
RWY 15-33
S150, D175, ST175, DT260

CAUTION: BE ALERT TO RUNWAY CROSSING CLEARANCES.
READBACK OF ALL RUNWAY HOLDING INSTRUCTIONS IS REQUIRED.

96°45'W

96°44'W

43°34'N

NC-1, 08 APR 2010 to 06 MAY 2010

LOC I-FSD 109.9	APCH CRS 030°	Rwy Idg TDZE Arprt Elev 8999 1423 1429	JAL-396 [USAF]	SIoux FALLS/JOE FOSS Rwy (KFSD)
---------------------------	-------------------------	--	----------------	---------------------------------

▼ * RVR 1800 authorized with the use of Flight Director or Auto Pilot or Heads Up Display to DA. When ALS inop, increase CAT E vis to ¾ mile.

MALS R

MISSED APPROACH: Climb to 3400, then climbing left turn to 5000 via heading 240° and via FSD VORTAC R-269 to FRYRE (FSD 1.5 DME) and hold.

ATIS 126.6	SIoux FALLS APP CON 125.8 126.9 353.6	SIoux FALLS TOWER ★ 118.3 257.8	GND CON 121.9 348.6	ASR
----------------------	---	---	-------------------------------	-----

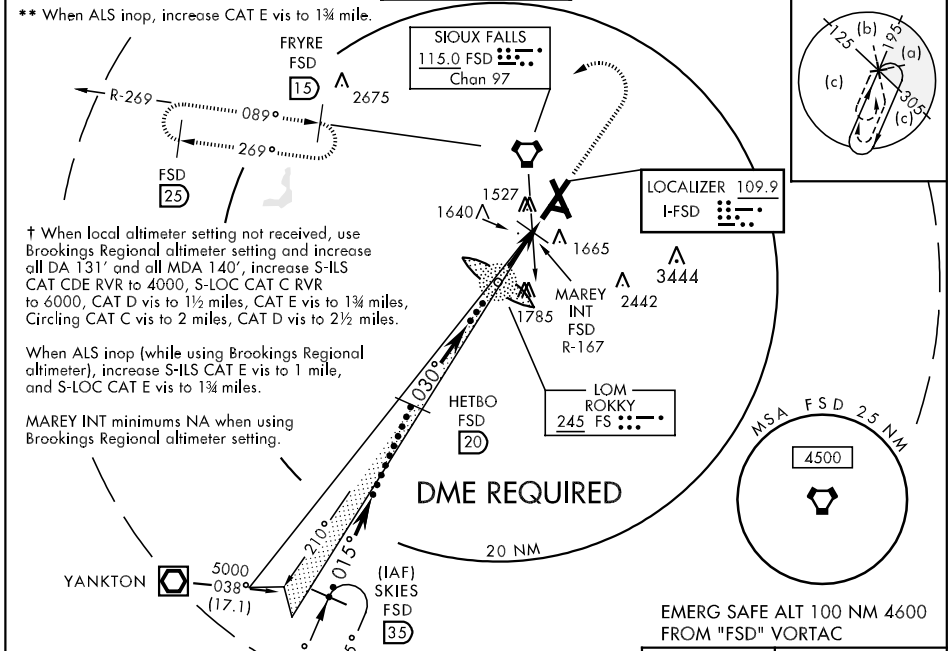

† When local altimeter setting not received, use Brookings Regional altimeter setting and increase all DA 131' and all MDA 140', increase S-ILS CAT CDE RVR to 4000, S-LOC CAT C RVR to 6000, CAT D vis to 1½ miles, CAT E vis to 1¾ miles, Circling CAT C vis to 2 miles, CAT D vis to 2½ miles.

When ALS inop (while using Brookings Regional altimeter), increase S-ILS CAT E vis to 1 mile, and S-LOC CAT E vis to 1¾ miles.

MAREY INT minimums NA when using Brookings Regional altimeter setting.

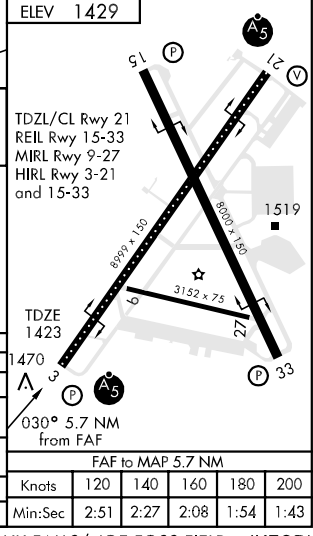
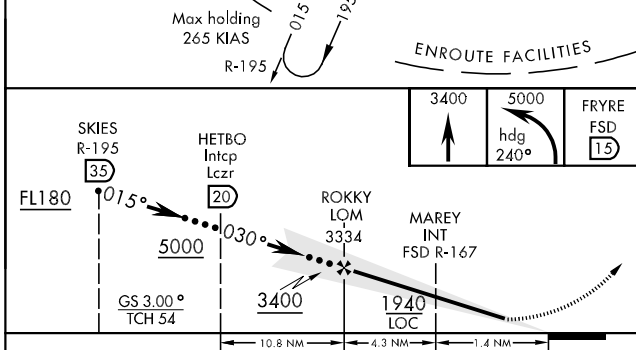

CATEGORY	C	D	E
S-ILS 3*†	1623/24	200	(200-½)
S-LOC 3**†	1940/50 517 (600-1)	1940/60	517 (600-1¼)
CIRCLING †	1960-1½ 531 (600-1½)	2040-2 611 (700-2)	2300-3 871 (900-3)
MAREY FIX MINIMA			
S-LOC 3 †	1780/24 357 (400-½)	1780/40	357 (400-¾)

NC-1, 08 APR 2010 to 06 MAY 2010

LOC I-JOU **111.1**
 APCH CRS **210°**
 Rwy Idg **8999**
 TDZE **1429**
 Arpt Elev **1429**

JAL-396 [USAF] **SIoux FALLS/JOE FOSS FIELD (KFSD)**

▼

MALSR **A5**
 MISSED APPROACH: Climb to 3400 then climbing right turn to 5000 via heading 300° and FSD R-269 to FRYRE 15 DME and hold.

ATIS **126.6**

SIoux FALLS APP CON **125.8 126.9 353.6**

SIoux FALLS TOWER ★ **118.30 257.8**

GND CON **121.9 348.6**

ASR

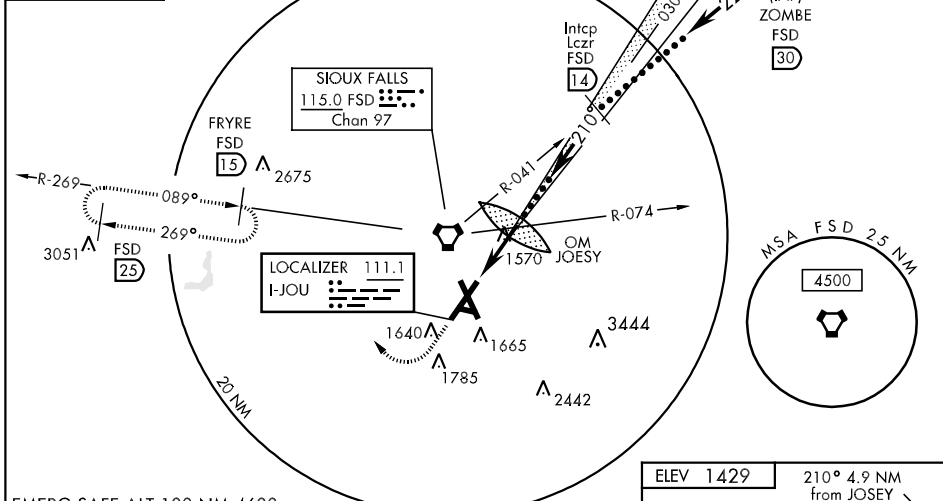
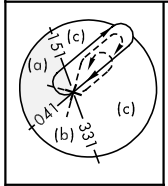

EMERG SAFE ALT 100 NM 4600

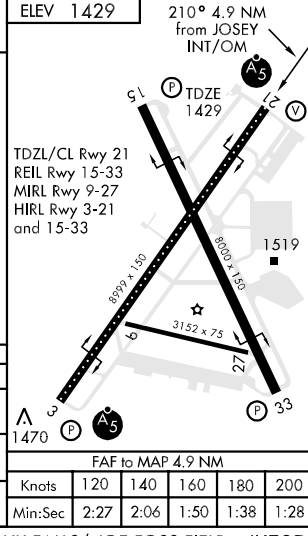
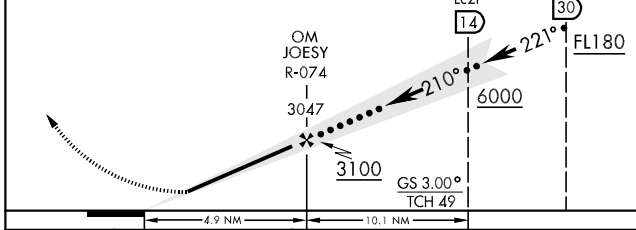
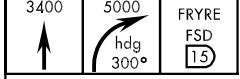

CATEGORY	C		D		E	
S-ILS 21	1629/18	200 (200-3/8)	1629/24	200 (200-1/2)	1629/24	200 (200-1/2)
S-LOC 21	1920/40	491 (500-3/4)	1920/50	491 (500-1)	1920/60	491 (500-1 1/4)
CIRCLING	1960-1 1/2	531 (600-1 1/2)	2040-2	611 (700-2)	2300-3	871 (900-3)

NC-1, 08 APR 2010 to 06 MAY 2010

VORTAC FSD
115.0
 Chan 97

APCH CRS
147°

Rwy Idg **8000**
 TDZE **1428**
 Arprt Elev **1429**

JAL-396 [USAF]

SIoux FALLS/JOE FOSS FIELD (KFSD)

MISSED APPROACH: Climb to 5000 then right turn via heading 320° and FSD R-269 to FRYRE 15 DME and hold.

ATIS
126.6

SIoux FALLS APP CON
125.8 126.9 353.6

SIoux FALLS TOWER ★
118.3 257.8

GND CON
121.9 348.6

ASR

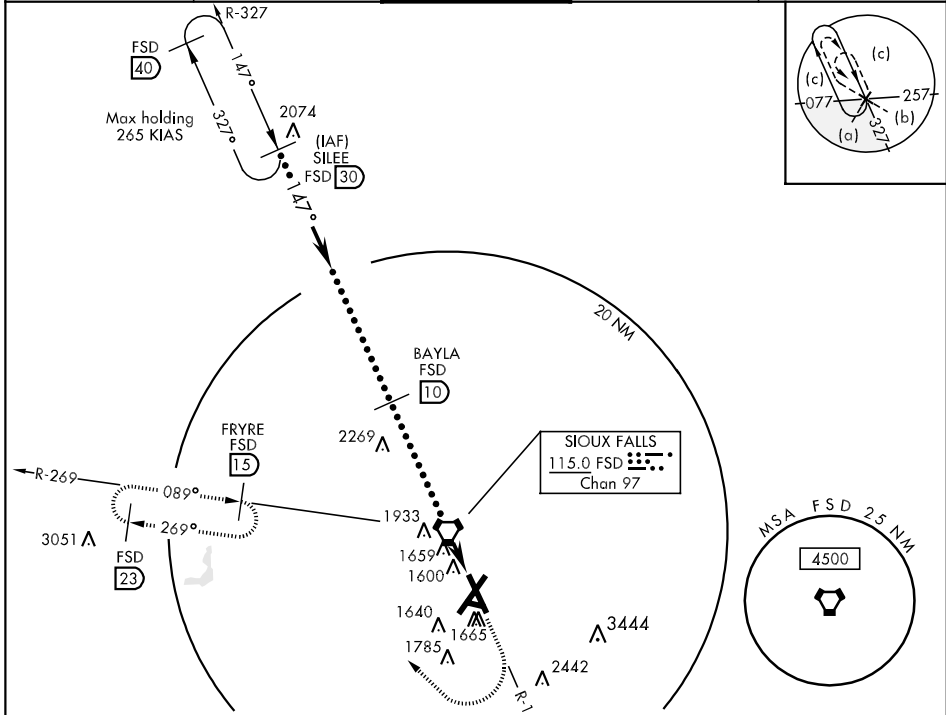

EMERG SAFE ALT 100 NM 4600

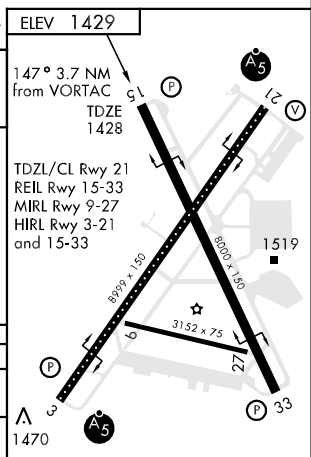
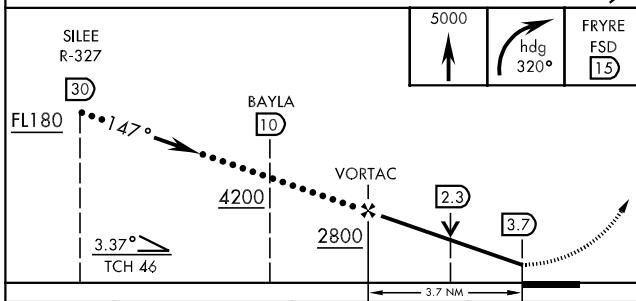

CATEGORY	C	D	E
S-15	1920-1¼ 492 (500-1¼)	1920-1½ 492 (500-1½)	1920-1¾ 492 (500-1¾)
CIRCLING	1960-1½ 531 (600-1½)	2040-2 611 (700-2)	2300-3 871 (900-3)

NC-1, 08 APR 2010 to 06 MAY 2010

ILS or LOC RWY 3

SIoux FALLS/JOE FOSS FIELD (FSD)

LOC I-FSD 109.9	APP CRS 030°	Rwy Idg TDZE Apt Elev	8999 1423 1429
---------------------------	------------------------	-----------------------------	---

ASR # RVR 1800 authorized with use of FD or AP or HUD to DA.



MISSED APPROACH: Climb to 3400 then left turn direct FSD VORTAC and hold.

ATIS 126.6	SIoux FALLS APP CON * 125.8 353.6	SIoux FALLS TOWER * 118.3 (CTAF) 0 257.8	GND CON 121.9 348.6	UNICOM 122.95
----------------------	---	--	-------------------------------	-------------------------

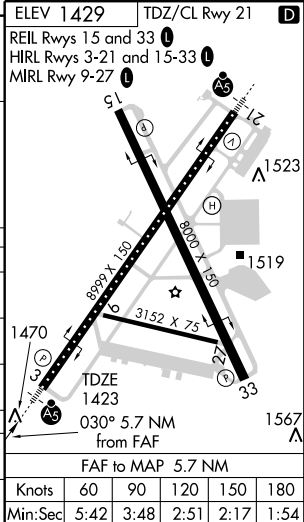
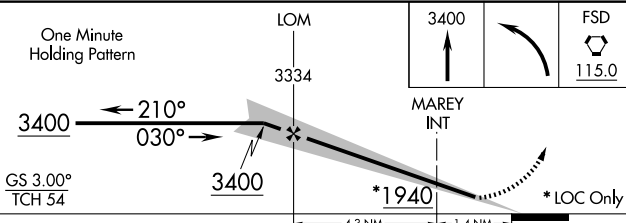
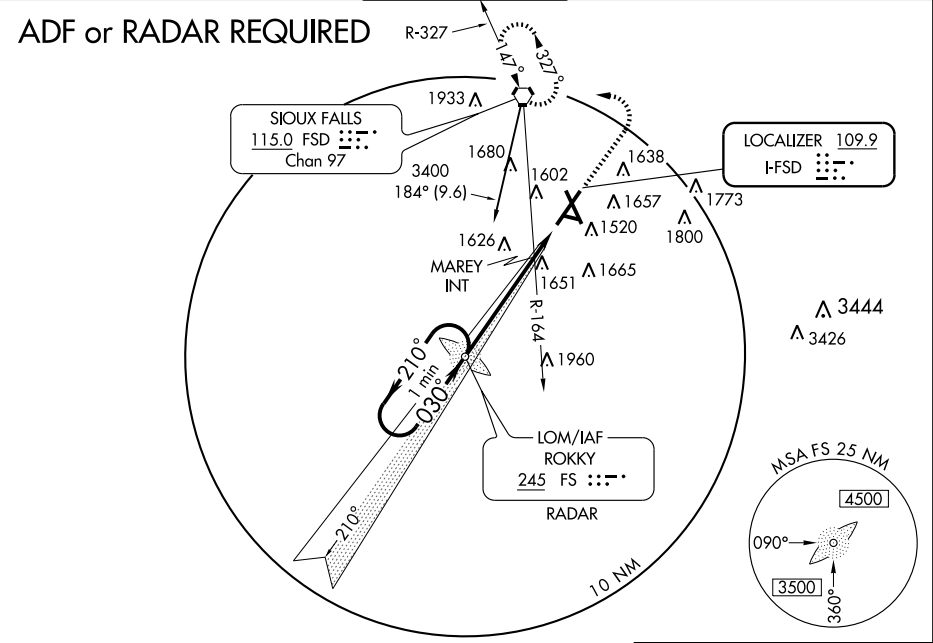

CATEGORY	A	B	C	D
S-ILS 3	# 1623/24 200 (200-½)			
S-LOC 3	1940/24	517 (600-½)	1940/50 517 (600-1)	1940/60 517 (600-1½)
CIRCLING	1960-1	531 (600-1)	1960-1½ 531 (600-½)	2040-2 611 (700-2)
MAREY FIX MINIMUMS				
S-LOC 3	1780/24 357 (400-½)		1780/40 357 (400-¾)	
CIRCLING	1960-1	531 (600-1)	1960-1½ 531 (600-½)	2040-2 611 (700-2)

NC-1. 08 APR 2010 to 06 MAY 2010

ILS or LOC RWY 21

SIoux FALLS/JOE FOSS FIELD (FSD)

LOC I-JOU 111.1	APP CRS 210°	Rwy Idg 8999
		TDZE 1429
		Apt Elev 1429



MISSED APPROACH: Climb to 3400 then right turn direct FSD VORTAC and hold.

ATIS 126.6	SIoux FALLS APP CON* 125.8 353.6	SIoux FALLS TOWER* 118.3 (CTAF) 257.8	GND CON 121.9 348.6	UNICOM 122.95
----------------------	--	---	-------------------------------	-------------------------

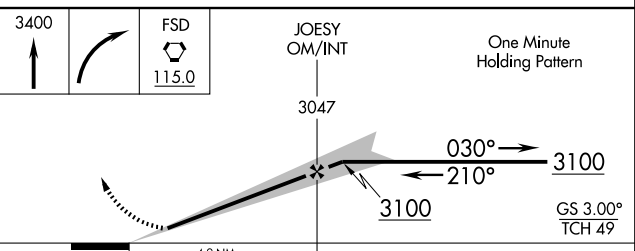
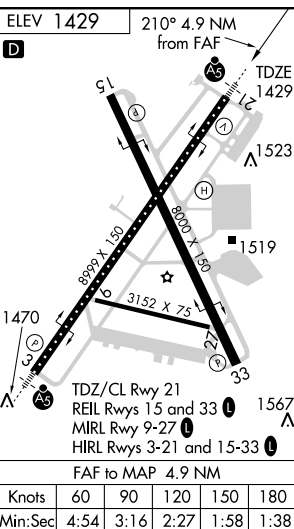
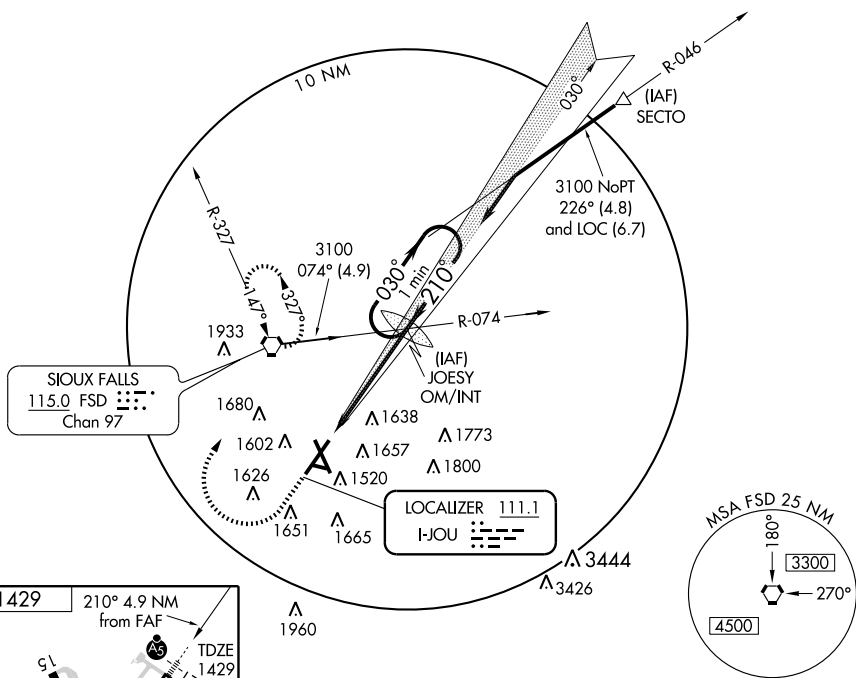

CATEGORY	A	B	C	D
S-ILS 21	1629/18		200 (200-½)	
S-LOC 21	1920/24 491 (500-½)		1920/40 491 (500-¾)	1920/50 491 (500-1)
CIRCLING	1960-1 531 (600-1)		1960-1½ 531 (600-1½)	2040-2 611 (700-2)

APP CRS 030°	Rwy Idg TDZE Apt Elev	8999 1423 1429
------------------------	-----------------------------	---

RNAV (GPS) RWY 3

SIoux FALLS/JOE FOSS FIELD (FSD)

<p>NA ASR</p> <p>Baro-VNAV NA below -17°C (2°F). DME/DME RNP-0.3 NA.</p>	<p>MALSR</p>	<p>MISSED APPROACH: Climb to 4000 direct MOPUE WP and hold.</p>
---	--------------	---

<p>ATIS 126.6</p>	<p>SIoux FALLS APP CON* 125.8 353.6</p>	<p>SIoux FALLS TOWER* 118.3 (CTAF) 257.8</p>	<p>GND CON 121.9 348.6</p>	<p>UNICOM 122.95</p>
------------------------------	--	---	---------------------------------------	---------------------------------

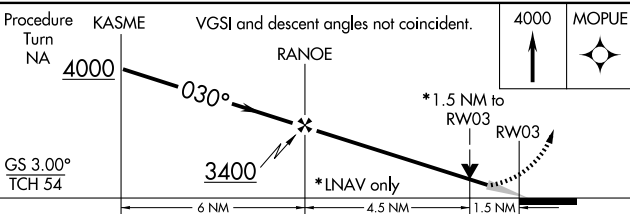
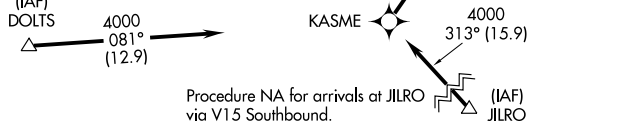
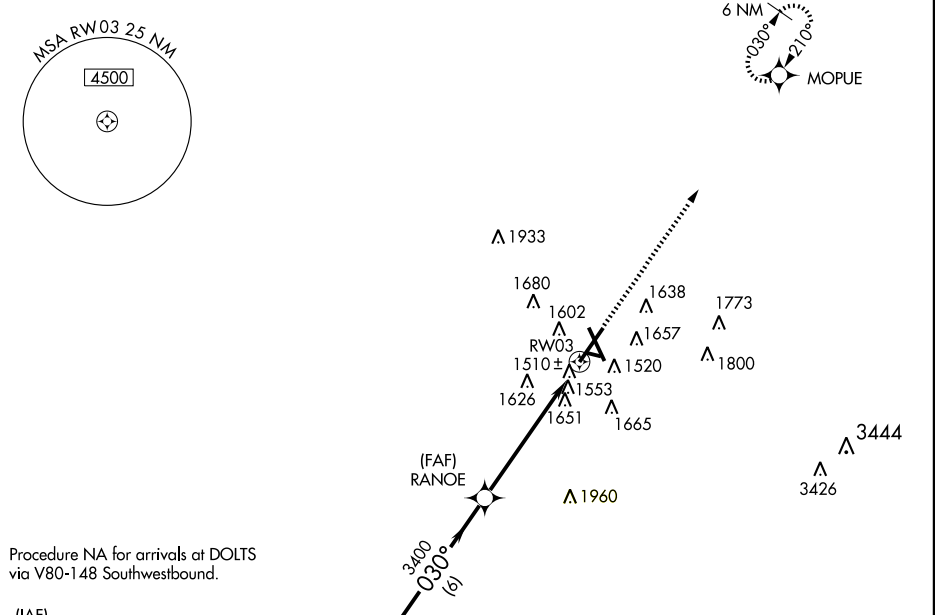

CATEGORY	A			B		C		D
GLS PA DA	NA							
LNAV/VNAV DA	1893/60 470 (500-1¼)							
LNAV MDA	1940/24	517 (600-½)	1940/50	517 (600-1)	1940/60	517 (600-1¼)		
CIRCLING	1960-1	531 (600-1)	1960-1½	531 (600-1½)	2040-2	611 (700-2)		

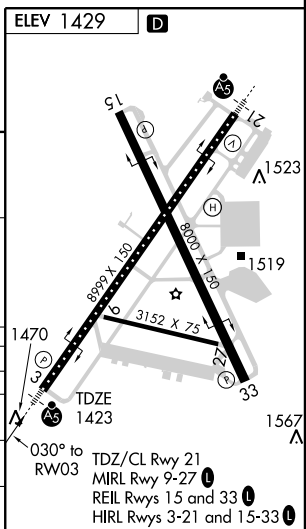

NC-1. 08 APR 2010 to 06 MAY 2010

RNAV (GPS) RWY 9

SIoux FALLS/JOE FOSS FIELD (FSD)

APP CRS	Rwy Idg	3152
098°	TDZE	1423
	Apt Elev	1429

NA
DME/DME RNP-0.3 NA.
ASR

MISSED APPROACH: Climb to 2500 then climbing left turn to 4000 direct MOPUE WP and hold.

ATIS 126.6	SIoux FALLS APP CON* 125.8 353.6	SIoux FALLS TOWER* 118.3 (CTAF) 257.8	GND CON 121.9 348.6	UNICOM 122.95
----------------------	--	---	-------------------------------	-------------------------

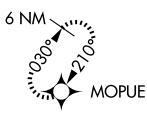

Procedure NA for arrivals on FSD VORTAC
airway radials 202 CW 297.

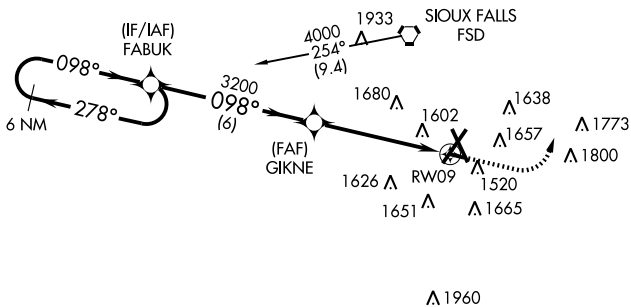

△ 3444
△ 3426

△ 1960

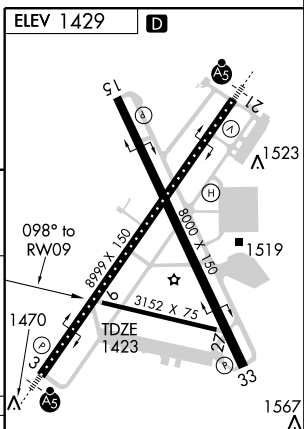
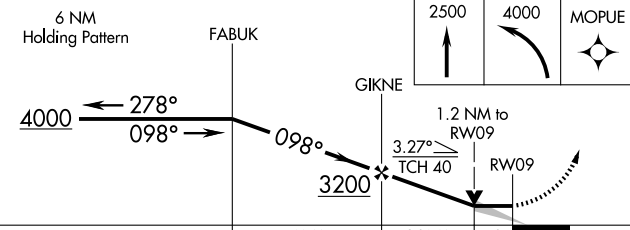
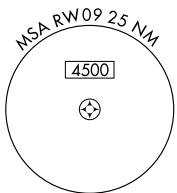

CATEGORY	A	B	C	D
LNNAV MDA	1880-1	457 (500-1)		NA
CIRCLING	1960-1	531 (600-1)		NA

TDZ/CL Rwy 21
MIRL Rwy 9-27
REIL Rwys 15 and 33
HIRL Rwys 3-21 and 15-33

APP CRS 150°	Rwy Idg TDZE Apt Elev	8000 1428 1429
------------------------	-----------------------------	---

RNAV (GPS) RWY 15

SIoux FALLS/JOE FOSS FIELD (FSD)

NA
ASR

DME/DME RNP-0.3 NA.
Baro-VNAV NA below -17°C (2°F).

MISSED APPROACH: Climb to 3800 direct GIWFI WP and hold.

ATIS 126.6	SIoux FALLS APP CON * 125.8 353.6	SIoux FALLS TOWER * 118.3 (CTAF) 0 257.8	GND CON 121.9 348.6	UNICOM 122.95
----------------------	---	--	-------------------------------	-------------------------

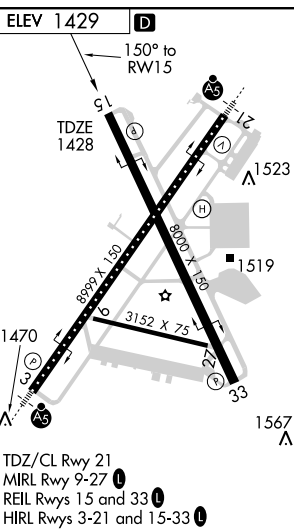
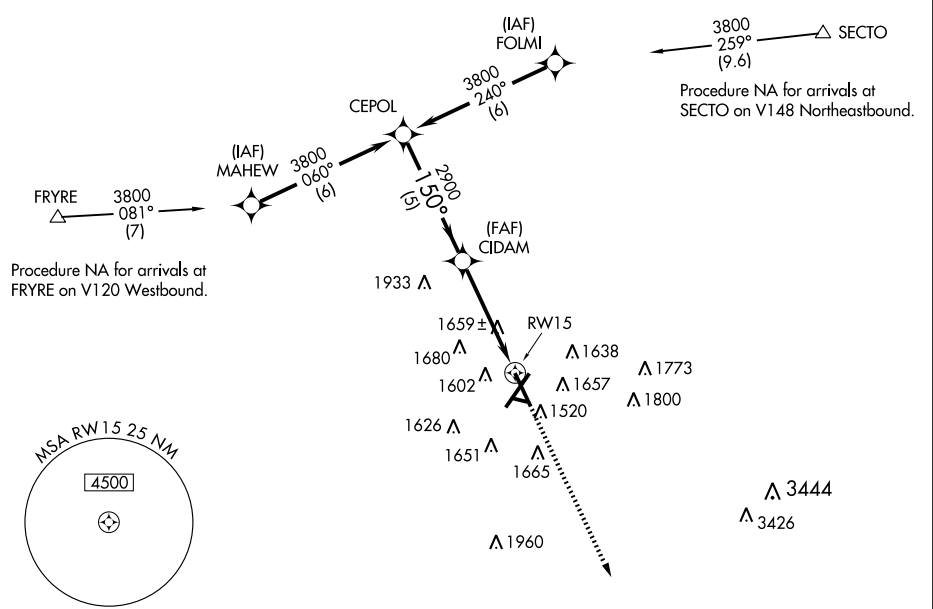

	CEPOL	Procedure Turn NA	CIDAM	3800	GIWFI Δ
	3800	150°	2900	5 NM	4.4 NM
GS 3.00° TCH 46					
CATEGORY	A	B	C	D	E
GLS PA DA	NA				
LNAV/VNAV DA	1893-1¼ 465 (500-1¼)				
LNAV MDA	1920-1	492 (500-1)	1920-1¼ 492 (500-1¼)	1920-1½ 492 (500-1½)	1920-1¾ 492 (500-1¾)
CIRCLING	1960-1	531 (600-1)	1960-1½ 531 (600-1½)	2040-2 611 (700-2)	2300-3 871 (900-3)

NC-1, 08 APR 2010 to 06 MAY 2010

RNAV (GPS) RWY 21

SIoux FALLS/JOE FOSS FIELD (FSD)

APP CRS 210°	Rwy Idg 8999
	TDZE 1429
	Apt Elev 1429

NA DME/DME RNP-0.3 NA.
Baro-VNAV NA below -17°C (2°F).



MISSED APPROACH: Climb to 4000 direct KASME WP and hold.

ATIS 126.6	SIoux FALLS APP CON 125.8 353.6	SIoux FALLS TOWER* 118.3 (CTAF) 0 257.8	GND CON 121.9 348.6	UNICOM 122.95
----------------------	---	---	-------------------------------	-------------------------

Procedure NA for arrivals at FSD VORTAC via V170 Westbound, V148 Southwestbound, V120 Westbound, V462 Westbound.

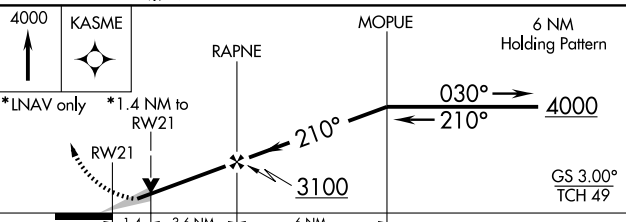
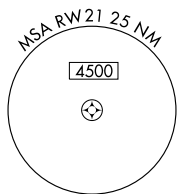
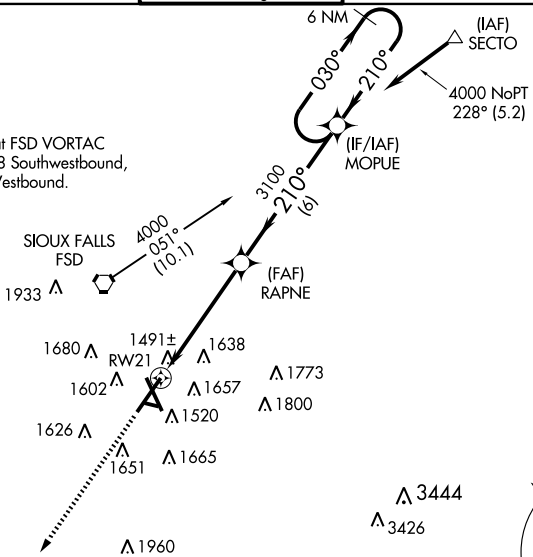

CATEGORY	NA			
GLS PA DA				
LNAV/VNAV DA	1760/40 331 (400-3/4)			
LNAV MDA	1940/24 511 (600-1/2)	1940/50 511 (600-1)		
CIRCLING	1960-1 1/4 531 (600-1 1/4)	1960-1 1/2 531 (600-1 1/2)	2040-2 611 (700-2)	

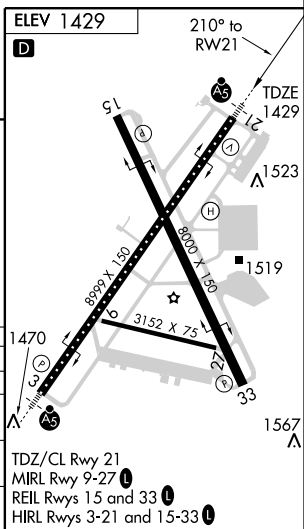

NC-1, 08 APR 2010 to 06 MAY 2010

APP CRS 272°	Rwy Idg 3152
	TDZE 1423
	Apt Elev 1429

RNAV (GPS) RWY 27

SIoux FALLS/JOE FOSS FIELD (FSD)

NA DME/DME RNP-0.3 NA.
ASR

MISSED APPROACH: Climb to 2500, then climbing right turn to 4000 direct MOPUE WP and hold.

ATIS 126.6	SIoux FALLS APP CON* 125.8 353.6	SIoux FALLS TOWER* 118.3 (CTAF) 0 257.8	GND CON 121.9 348.6	UNICOM 122.95
----------------------	--	---	-------------------------------	-------------------------

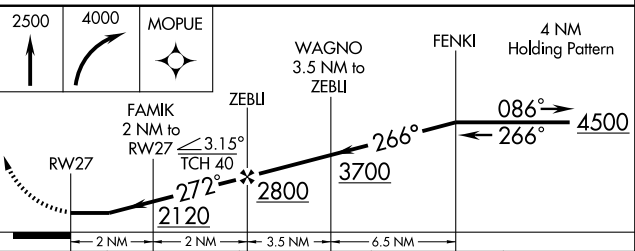
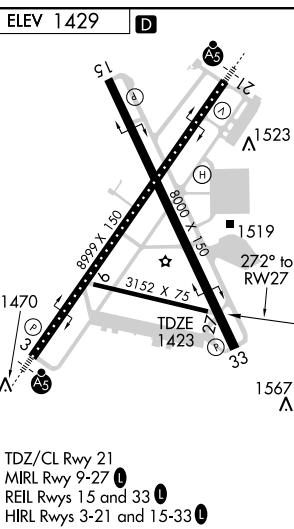
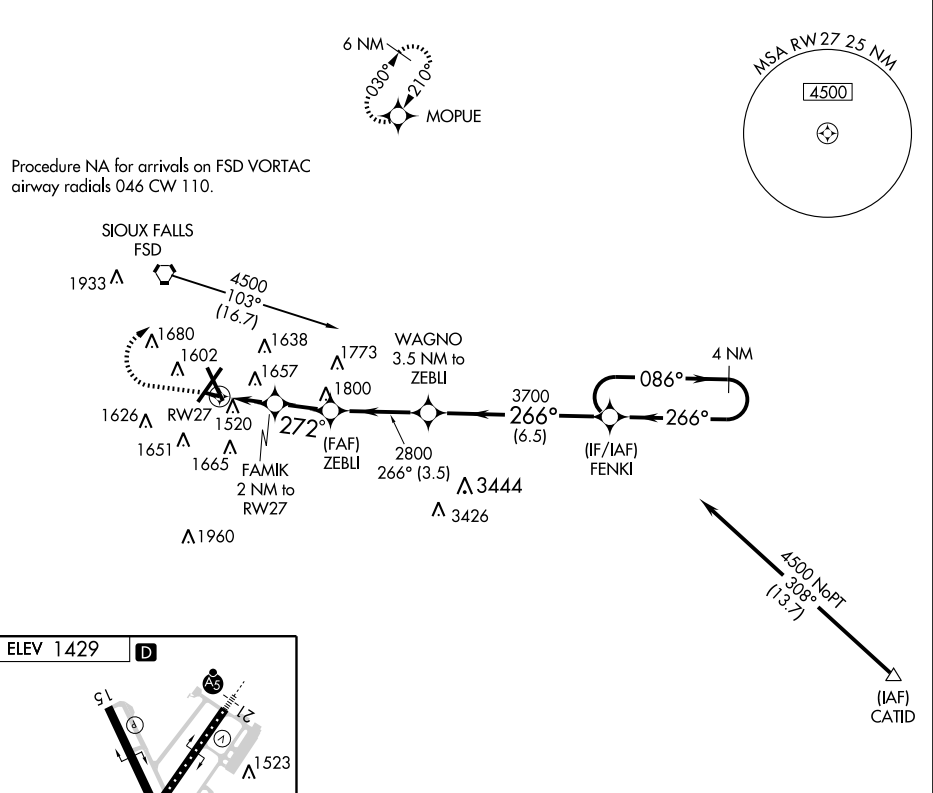

CATEGORY	A	B	C	D
RNAV MDA	1960-1	537 (600-1)		NA
CIRCLING	1960-1	531 (600-1)		NA

NC-1, 08 APR 2010 to 08 MAY 2010

APP CRS 330°	Rwy Idg 8000
	TDZE 1423
	Apt Elev 1429

RNAV (GPS) RWY 33

SIoux FALLS/JOE FOSS FIELD (FSD)

NA DME/DME RNP-0.3 NA.
Baro-VNAV NA below -17°C (2°F).
ASR

MISSED APPROACH: Climb to 3800 direct CEPOL WP and hold.

ATIS 126.6	SIoux FALLS APP CON * 125.8 353.6	SIoux FALLS TOWER * 118.3 (CTAF) 0 257.8	GND CON 121.9 348.6	UNICOM 122.95
----------------------	---	--	-------------------------------	-------------------------

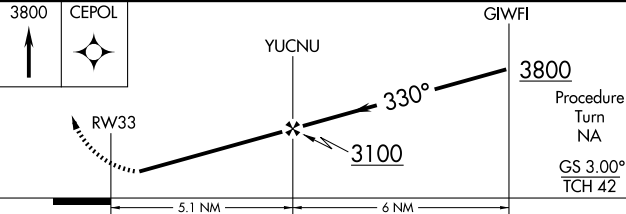
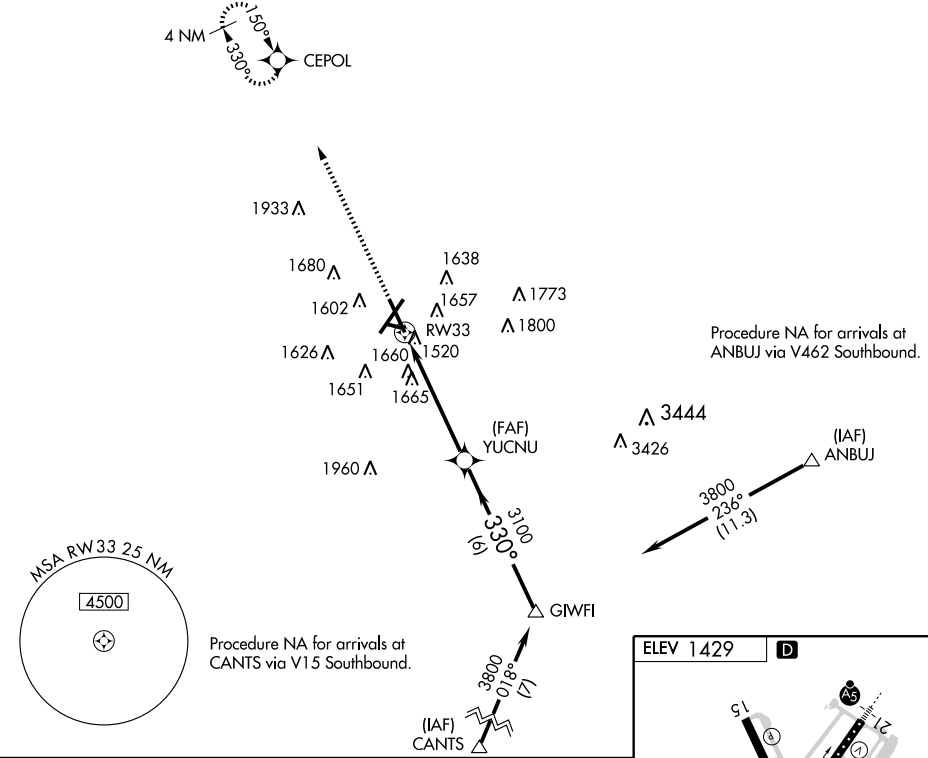

CATEGORY	A	B	C	D
GLS PA DA	NA			
LNAV/VNAV DA	1964-2 541 (600-2)			
LNAV MDA	1920-1 497 (500-1)	1920-1¼ 497 (500-1¼)	1920-1½ 497 (500-1½)	
CIRCLING	1960-1 531 (600-1)	1960-1½ 531 (600-1½)	2040-2 611 (700-2)	

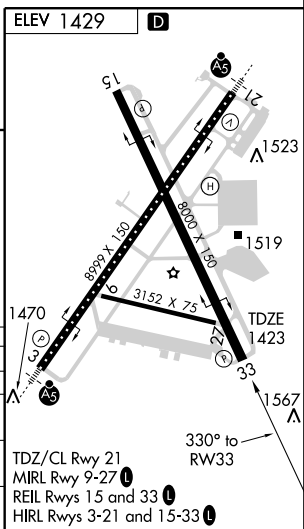

NC-1, 08 APR 2010 to 06 MAY 2010

VOR/DME or TACAN RWY 33

SIoux FALLS/JOE FOSS FIELD (FSD)

VORTAC FSD 115.0 Chan 97	APP CRS 326°	Rwy Idg TDZE Apt Elev 8000 1423 1429
---------------------------------------	------------------------	--

MISSED APPROACH: Climb to 3400 direct FSD VORTAC and hold. (TACAN aircraft continue climb to 5000 via FSD R-269 to FRYRE 1.5 DME and hold west, right turns, 089° inbound.)

ASR

ATIS 126.6	SIoux FALLS APP CON* 125.8 353.6	SIoux FALLS TOWER* 118.3 (CTAF) 257.8	GND CON 121.9 348.6	UNICOM 122.95
----------------------	--	---	-------------------------------	-------------------------

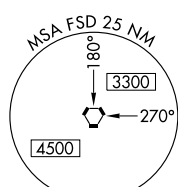
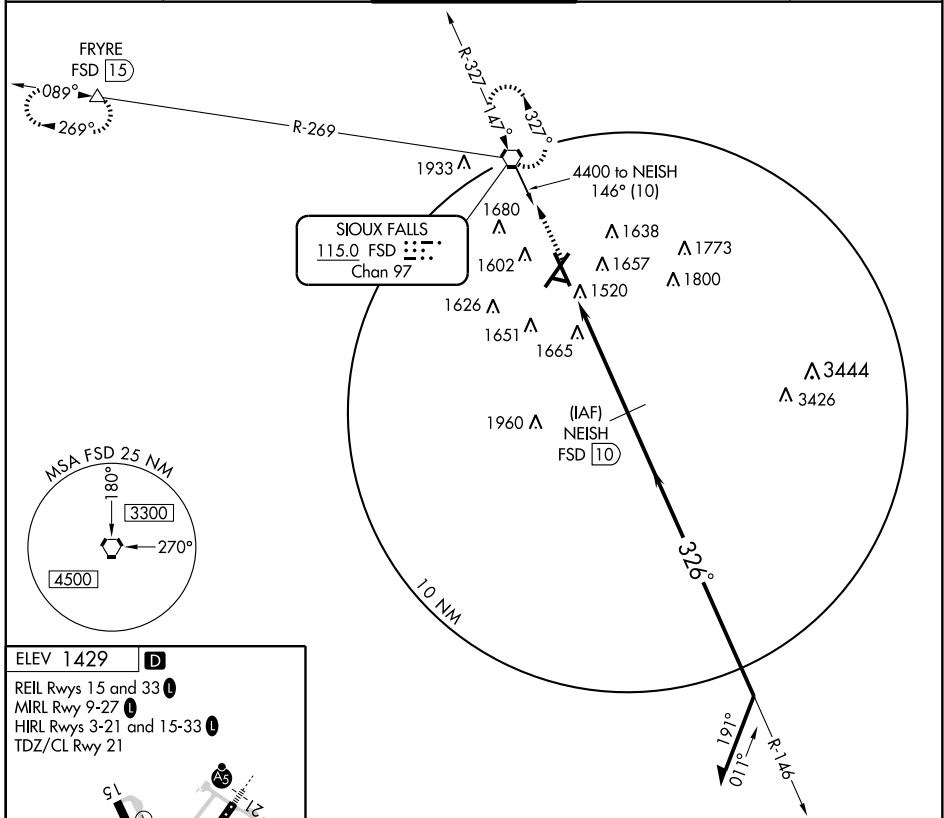

ELEV 1429 **D**

REIL Rwy 15 and 33 **I**
MIRL Rwy 9-27 **I**
HIRL Rwy 3-21 and 15-33 **I**
TDZ/CL Rwy 21

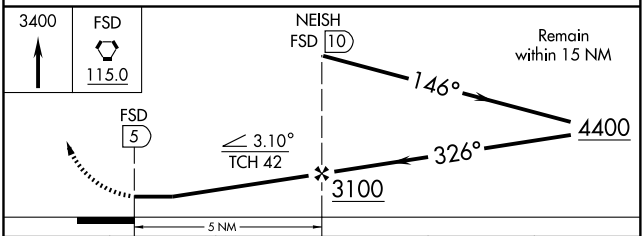
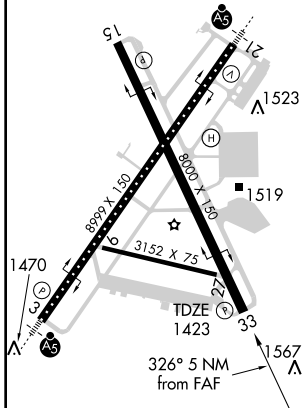

CATEGORY	A	B	C	D	E
S-33	1940-1	517 (600-1)	1940-1½ 517 (600-1½)	1940-1¾ 517 (600-1¾)	517 (600-1¾)
CIRCLING	1960-1	531 (600-1)	1960-1½ 531 (600-1½)	2040-2 611 (700-2)	2300-3 871 (900-3)

VOR or TACAN RWY 15

SIoux FALLS/JOE FOSS FIELD (FSD)

VORTAC FSD 115.0 Chan 97	APP CRS 147°	Rwy Idg TDZE Apt Elev 8000 1428 1429
---------------------------------------	------------------------	--

MISSED APPROACH: Climb to 3500 then right turn direct FSD VORTAC and hold. (TACAN aircraft continue climb to 5000 via FSD R-269 to FRYRE 15 DME and hold west, right turns, 089° inbound)

V A ASR	ATIS 126.6	SIOUX FALLS APP CON* 125.8 353.6	SIOUX FALLS TOWER* 118.3(CTAF) 257.8	GND CON 121.9 348.6	UNICOM 122.95
---------------	----------------------	--	--	-------------------------------	-------------------------

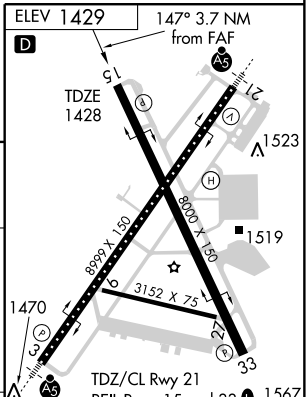
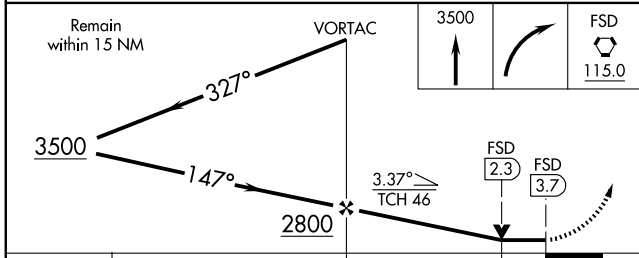
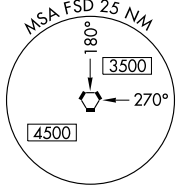
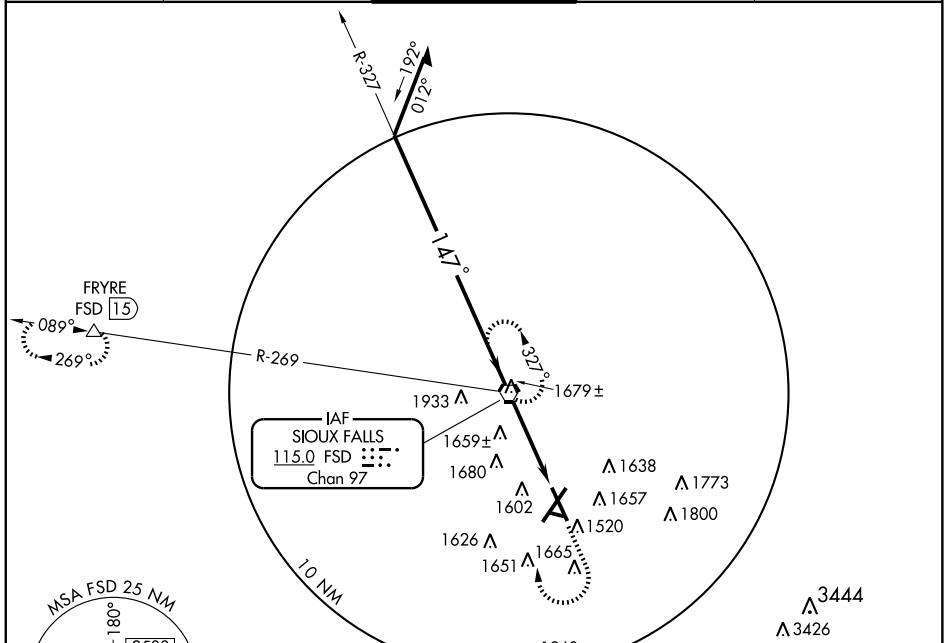

CATEGORY	A	B	C	D	E	Knots	60	90	120	150	180
S-15	1920-1	492 (500-1)	1920-1¼ 492 (500-1¼)	1920-1½ 492 (500-1½)	1920-1¾ 492 (500-1¾)	Min:Sec	3:42	2:28	1:51	1:29	1:14
CIRCLING	1960-1	531 (600-1)	1960-1½ 531 (600-1½)	2040-2 611 (700-2)	2300-3 871 (900-3)	FAF to MAP 3.7 NM					

GPS RWY 13

SPEARFISH/BLACK HILLS-CLYDE ICE FIELD (SPF⁺)

APP CRS 114°	Rwy Idg 6400
	TDZE 3888
	Apt Elev 3931

NA

MISSED APPROACH: Climbing left turn to 7000 direct ELRAP WP and hold.

AWOS-3
118.325

ELLSWORTH APP CON*
119.5 259.1

UNICOM
122.7 (CTAF)

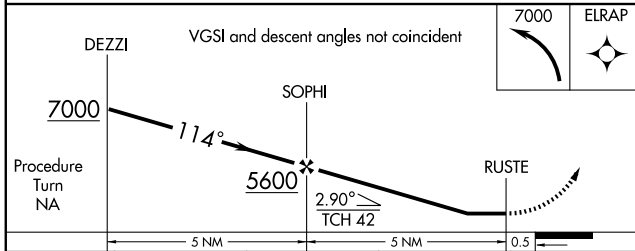
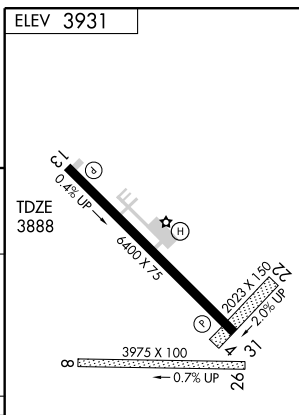
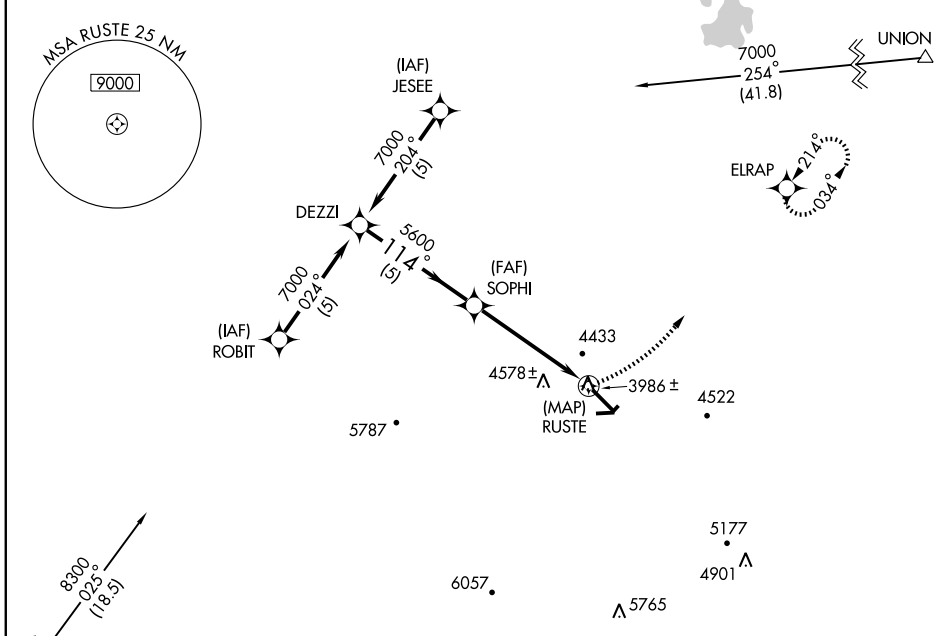

CATEGORY	A	B	C	D
S-13	4740-1 852 (900-1)	4740-1¼ 852 (900-1¼)		NA
CIRCLING	4800-1 869 (900-1)	4800-1¼ 869 (900-1¼)		NA

MIRL Rwy 13-31

NDB or GPS-A

SPEARFISH/ BLACK HILLS-CLYDE ICE FIELD (SPF)

NDB SPF 300	APP CRS 226°	Rwy Idg TDZE Apt Elev	N/A N/A 3931
-----------------------	------------------------	-----------------------------	---------------------------

NA

MISSED APPROACH: Climbing right turn to 7900 via heading 046° then right turn direct SPF NDB and hold.

AWOS-3
118.325

ELLSWORTH APP CON*
119.5 259.1

UNICOM
122.7 (CTAF)

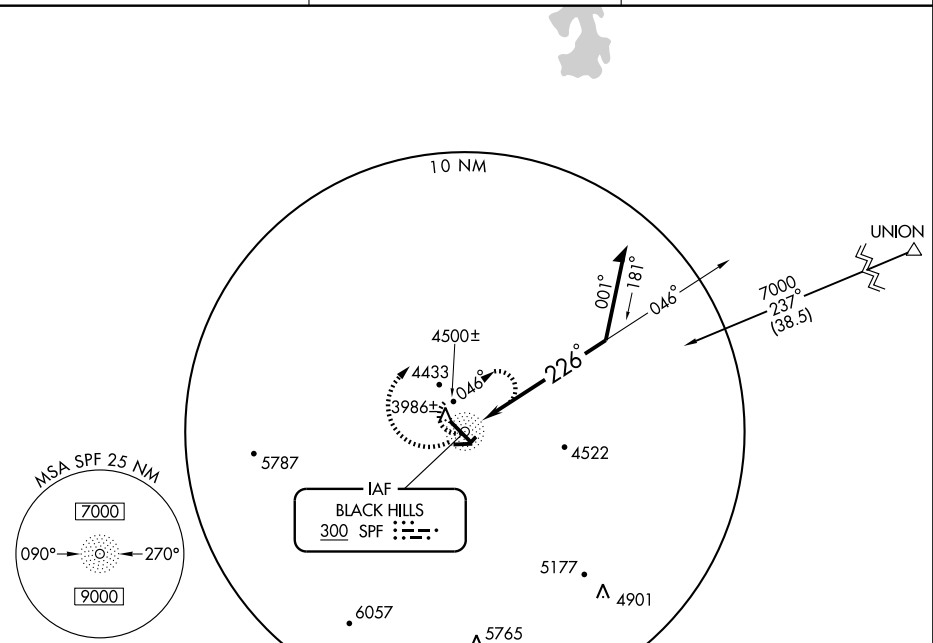

ELEV 3931

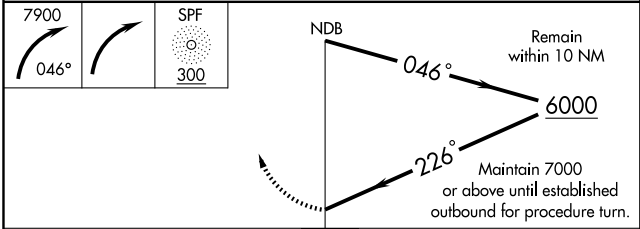
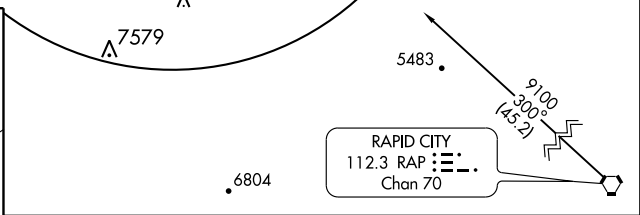
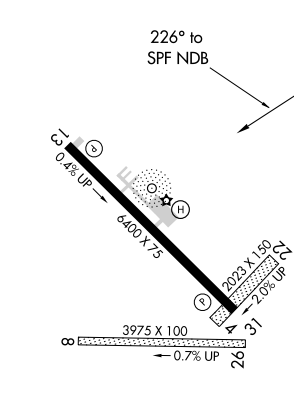

MIRL Rwy 13-31	CATEGORY	A	B	C	D
	CIRCLING	4860-1¼ 929 (1000-1¼)	4860-1½ 929 (1000-1½)	NA	

NC-1, 08 APR 2010 to 06 MAY 2010

GPS RWY 29

STURGIS MUNI (49B)

APP CRS	Rwy Idg	5100
292°	TDZE	3228
	Apt Elev	3239

▼ Use Ellsworth AFB altimeter setting.
 ▲ NA

MISSED APPROACH: Climb to 3900 then climbing left turn to 6000 direct LEMDY WP and hold.

ELLSWORTH APP CON ★
119.5 259.1

UNICOM
122.8 (CTAF) 0

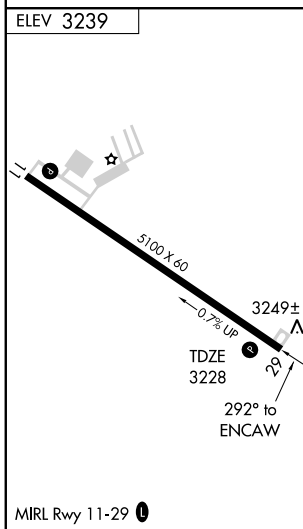
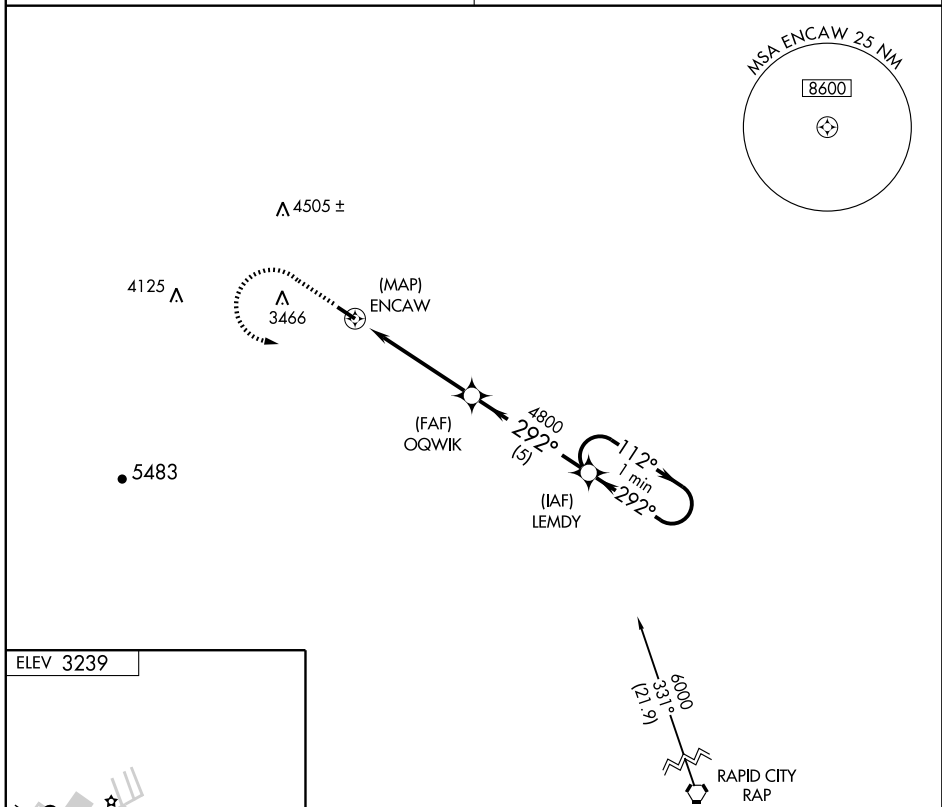

	3900	6000	LEM DY	
	↑	↶	✧	
	OGWIK		LEM DY	One Minute Holding Pattern
	ENCAW		LEM DY	6000
	4800		112°	← 292°
	5 NM		5 NM	
CATEGORY	A	B	C	D
S-29	3560-1	332 (400-1)	NA	
CIRCLING	3700-1	461 (500-1)	NA	

NC-1, 08 APR 2010 to 06 MAY 2010

WAAS CH 53614 W30A	APP CRS 300°	Rwy Idg TDZE Apt Elev	4105 1146 1146
--	------------------------	-----------------------------	---

RNAV (GPS) RWY 30

VERMILLION/HAROLD DAVIDSON FIELD (VMR)

Baro-VNAV NA when using Yankton altimeter setting. For uncompensated Baro-VNAV systems, LNAV/VNAV NA below -17°C (2°F) or above 54°C (130°F). DME/DME RNP -0.3 NA.
 Visibility reduction by helicopters NA. When local altimeter setting not received, use Yankton altimeter setting and increase all DA 73 feet and LPV and LNAV/VNAV visibility ¼ mile all Cats, increase all MDA 80 feet and LNAV Cat C visibility ¼ mile and Circling Cat C visibility ½ mile.

MISSED APPROACH: Climb to 3500 direct MOKTE and via track 210° to CIERA and direct IKUBE and hold.

AWOS-3 122.8	SIOUX CITY APP CON * 124.6 307.0	UNICOM 122.8 (CTAF) 0
------------------------	--	---------------------------------

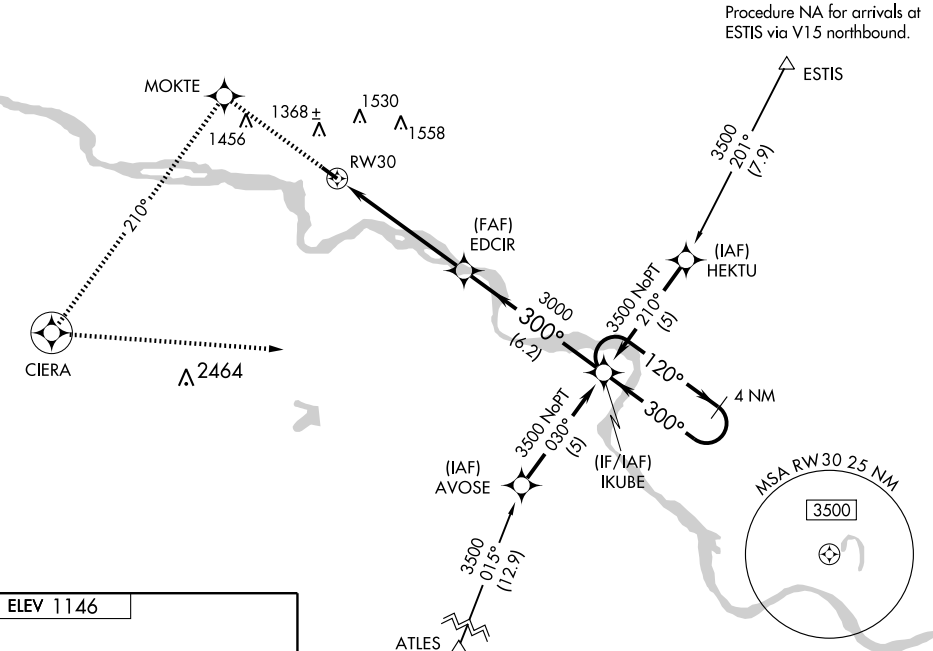

ELEV 1146

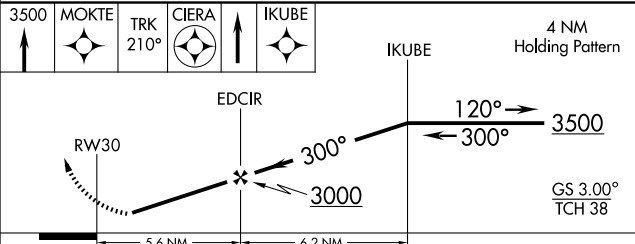
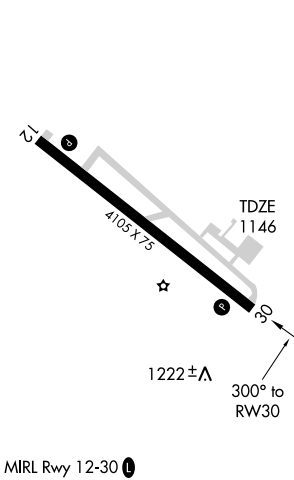

CATEGORY		A	B	C	D
LPV	DA	1434-1 288 (300-1)			NA
LNAV/VNAV	DA	1559-1½ 413 (500-1½)			NA
LNAV	MDA	1680-1	534 (600-1)	1680-1½ 534 (600-1½)	NA
CIRCLING		1740-1	594 (600-1)	1740-1½ 594 (600-1½)	NA

ILS or LOC RWY 35

WATERTOWN RGNL (ATY)

LOC/DME I-ATY	APP CRS	Rwy Idg	6894
111.9	354°	TDZE	1745
Chan 56		Apt Elev	1749

MALSRL



MISSED APPROACH: Climb to 4000 then left turn direct ILCAN LOM/I-ATY 7.3 DME and hold.

ASOS 126.625	MINNEAPOLIS CENTER 128.5 306.2	UNICOM 123.05 (CTAF) 0
------------------------	--	----------------------------------

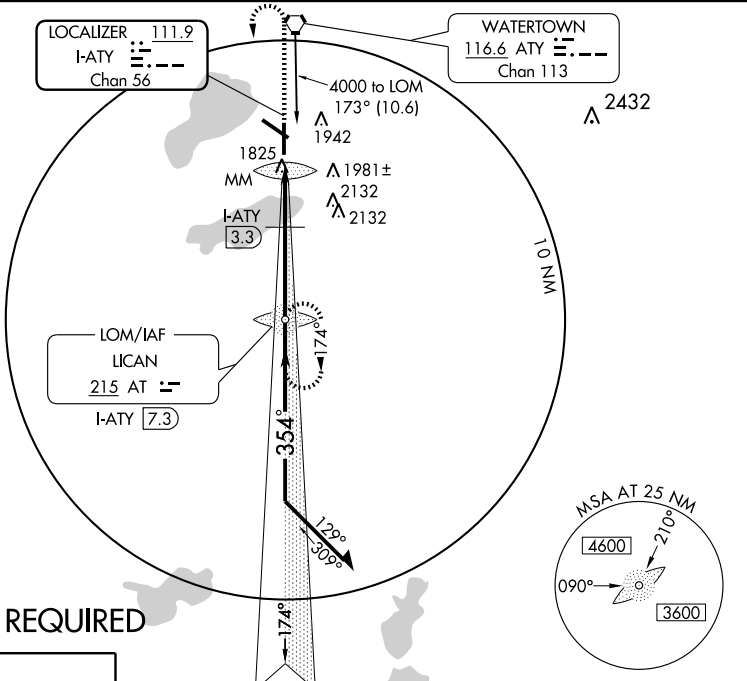

ADF or DME REQUIRED

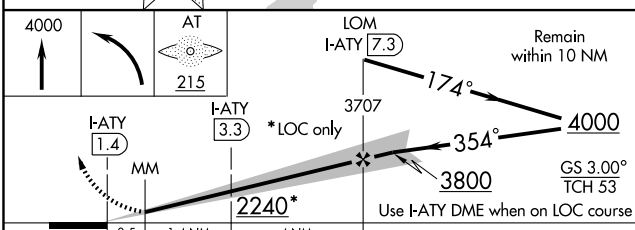
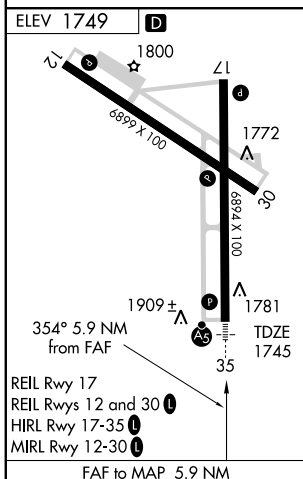

CATEGORY	A	B	C	D
S-ILS 35	1945-1/2		200 (200-1/2)	
S-LOC 35	2240-1/2	495 (500-1/2)	2240-3/4 495 (500-3/4)	2240-1 495 (500-1)
CIRCLING	2260-1	511 (600-1)	2260-1 1/2 511 (600-1 1/2)	2340-2 591 (600-2)
DME MINIMUMS				
S-LOC 35	2080-1/2	335 (400-1/2)		2080-3/4 335 (400-3/4)
CIRCLING	2260-1	511 (600-1)	2260-1 1/2 511 (600-1 1/2)	2340-2 591 (600-2)

NC-1. 08 APR 2010 to 06 MAY 2010

LOC/DME BC RWY 17

WATERTOWN RGNL (ATY)

LOC/DME I-ATY 111.9 Chan 56	APP CRS 174°	Rwy Idg TDZE Apt Elev	6894 1740 1749
---	------------------------	-----------------------------	---

▼ When local altimeter setting not received, use Brookings altimeter setting and increase all MDA 120 feet and increase all Cat C and D visibilities ¼ mile.

MISSED APPROACH: Climb to 4000 via I-ATY south course to ILCAN LOM/I-ATY 7.3 DME and hold.

ASOS
126.625

MINNEAPOLIS CENTER
128.5 306.2

UNICOM
123.05 (CTAF) 0

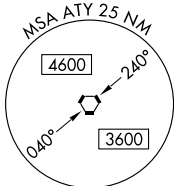
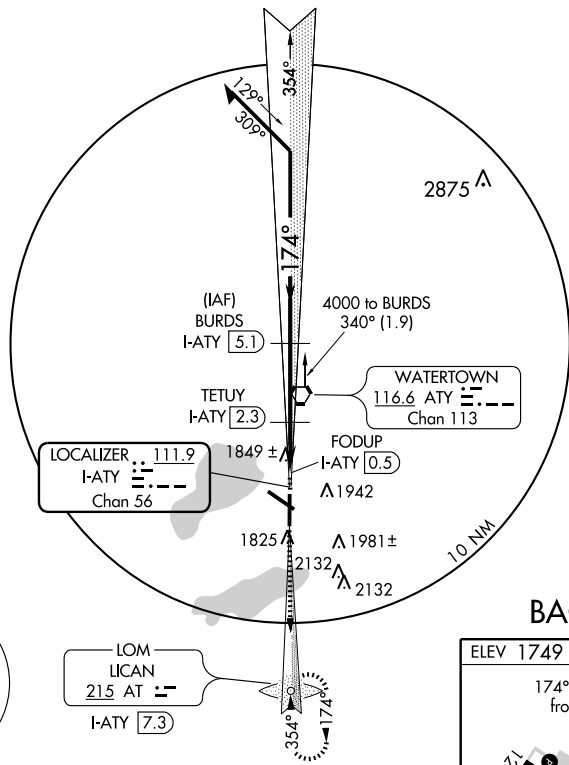

BACK COURSE

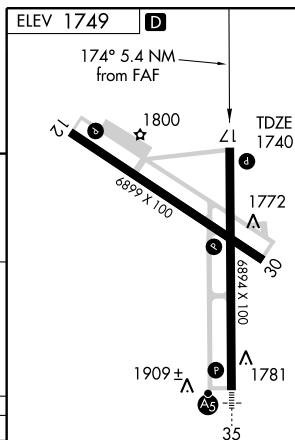

Use I-ATY DME when on the LOC course.

Remain within 10 NM

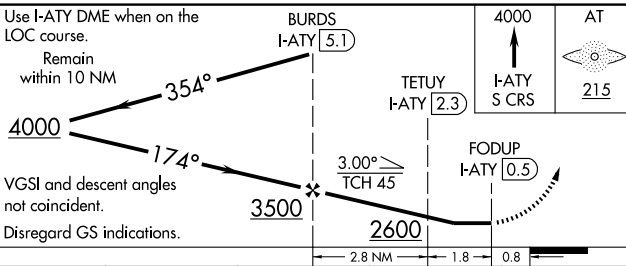

VGSI and descent angles not coincident.

Disregard GS indications.

CATEGORY	A	B	C	D
S-17	2120-1	380 (400-1)		2120-1½ 380 (400-1½)
CIRCLING	2260-1	511 (600-1)	2260-1½ 511 (600-1½)	2340-2 591 (600-2)

REIL Rwy 17
REIL Rwys 12 and 30
HIRL Rwy 17-35
MIRL Rwy 12-30

NDB RWY 35

WATERTOWN RGNL (ATY)

LOM AT 215	APP CRS 354°	Rwy Idg TDZE Apt Elev	6894 1745 1749
----------------------	------------------------	-----------------------------	---

▼ When local altimeter setting not received, use Brookings altimeter setting and increase all MDA 120 feet, increase S-35 Cat C/D visibility ½ mile, increase Circling Cat C visibility ½ mile and Cat D visibility ¼ mile. Inoperative table does not apply to S-35 Cat A and B.

MALSR



MISSED APPROACH:
Climb to 4000 then left turn direct LICAN LOM and hold.

ASOS
126.625

MINNEAPOLIS CENTER
128.5 306.2

UNICOM
123.05 (CTAF)

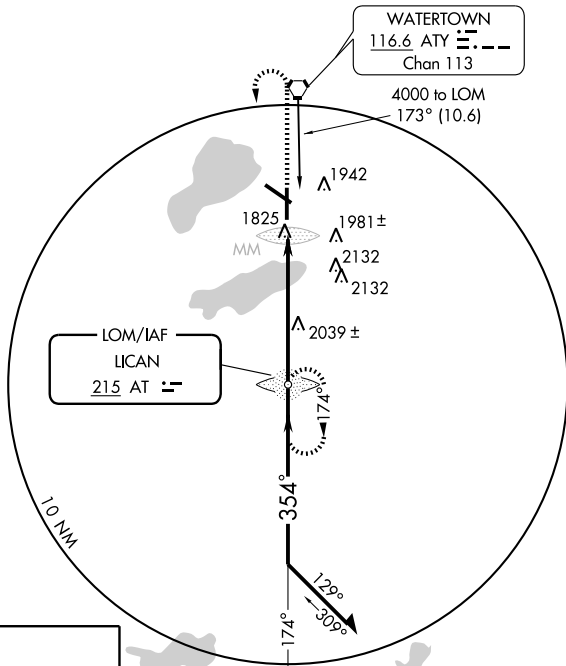

△ 2446

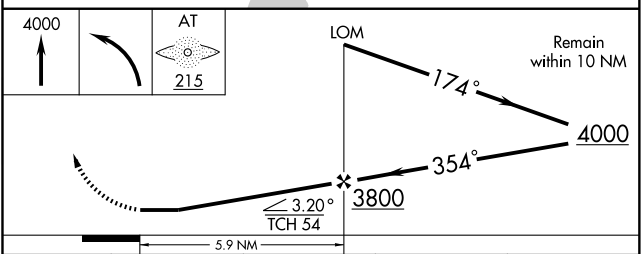
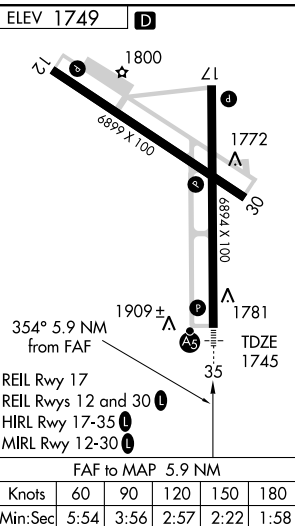
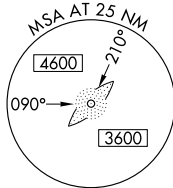

CATEGORY	A	B	C	D
S-35	2340-1 595 (600-1)			2340-1½ 595 (600-1½)
CIRCLING	2340-1 591 (600-1)		2340-1½ 591 (600-1½)	2340-2 591 (600-2)

RNAV (GPS) RWY 12

WATERTOWN RGNL (ATY)

WAAS CH 53405 W12A	APP CRS 118°	Rwy Idg TDZE Apt Elev	6899 1749 1749
--	------------------------	-----------------------------	---

⚠ For uncompensated Baro-VNAV systems, LNAV/VNAV NA below -18°C (0°F) or above 45°C (113°F). DME/DME RNP -0.3 NA. Visibility reduction by helicopters NA. If local altimeter setting not received, use Brookings altimeter setting and increase all DAs 105 feet and all MDAs 120 feet. VDP NA when using Brookings altimeter setting. Baro-VNAV NA when using Brookings altimeter setting.

MISSED APPROACH:
Climb to 3600 direct DELDE and hold.

ASOS 126.625	MINNEAPOLIS CENTER 128.5 306.2	UNICOM 123.05 (CTAF) 0
------------------------	--	----------------------------------

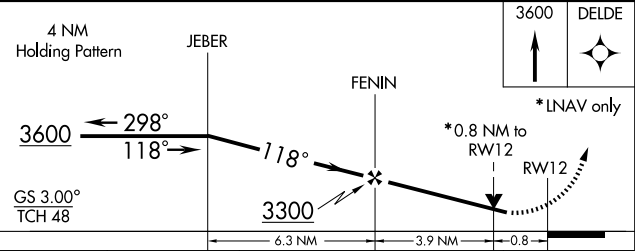
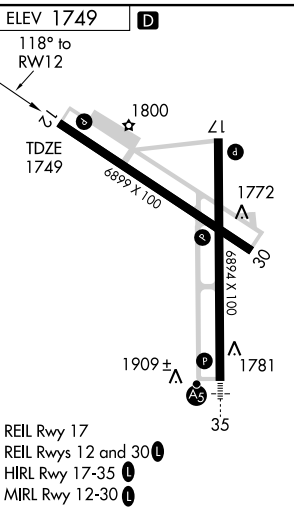
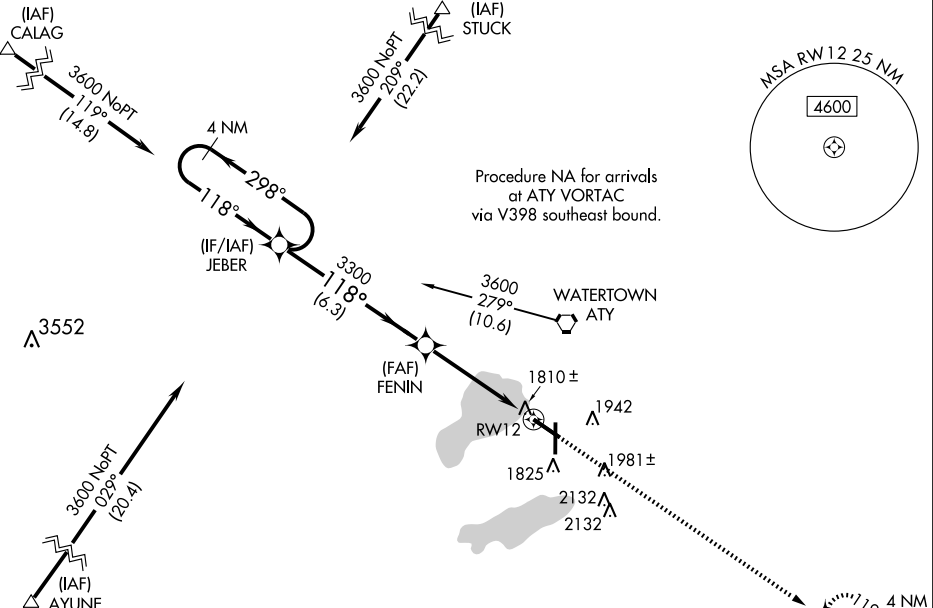

CATEGORY	A	B	C	D
LPV DA	2021-1 272 (300-1)			
LNAV/VNAV DA	2076-1¼ 327 (400-1¼)			
LNAV MDA	2060-1 311 (400-1)			
CIRCLING	2260-1 511 (600-1)	2260-1½ 511 (600-1½)		2340-2 591 (600-2)

RNAV (GPS) RWY 17

WATERTOWN RGNL (ATY)

WAAS CH 82305 W17A	APP CRS 174°	Rwy Idg TDZE Apt Elev	6894 1740 1749
--	------------------------	-----------------------------	---

⚠ Baro-VNAV NA when using Brookings altimeter setting. DME/DME RNP-0.3 NA.
⚠ For uncompensated Baro-VNAV systems, LNAV/VNAV NA below -18°C (0°F) or above 45°C (113°F). VDP NA when using Brookings altimeter setting.
 If local altimeter setting not received, use Brookings altimeter setting and increase all DAs 105 feet and all MDAs 120 feet.

MISSED APPROACH: Climb to 4000 direct APEDE and via 154° track to VESTY and hold.

ASOS 126.625	MINNEAPOLIS CENTER 128.5 306.2	UNICOM 123.05 (CTAF) 0
------------------------	--	----------------------------------

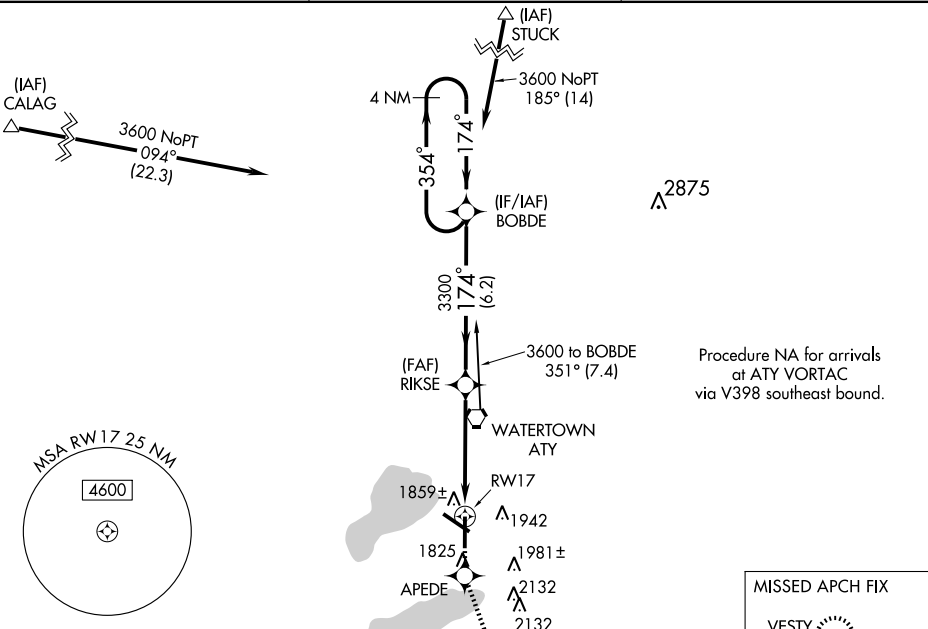

△ 2875

Procedure NA for arrivals at ATY VORTAC via V398 southeast bound.

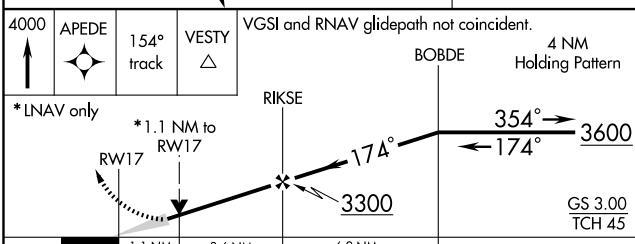
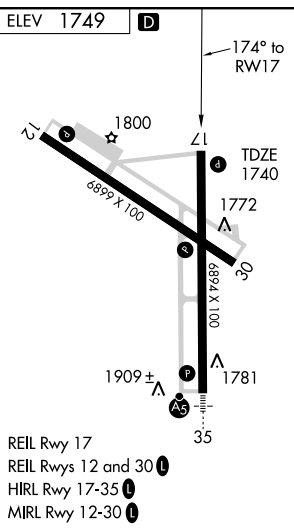
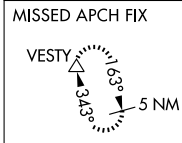
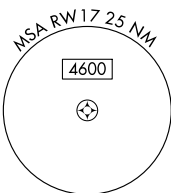

CATEGORY	A	B	C	D
LPV DA	2054-1 314 (400-1)			
LNAV/VNAV DA	2129-1¼ 389 (400-1¼)			
LNAV MDA	2120-1 380 (400-1)		2120-1¼ 380 (400-1¼)	
CIRCLING	2260-1 511 (600-1)		2260-1½ 2340-2 511 (600-1½) 591 (600-2)	

RNAV (GPS) RWY 30

WATERTOWN RGNL (ATY)

WAAS CH 50305 W30A	APP CRS 299°	Rwy Idg TDZE Apt Elev	6899 1736 1749
---------------------------------	------------------------	-----------------------------	---

▼ For uncompensated Baro-VNAV systems, LNAV/VNAV NA below -18°C (0°F) or above 45°C (113°F). DME/DME RNP-0.3 NA. When local altimeter setting not received, use Brookings altimeter setting and increase all DA 105 feet and all MDA 120 feet, increase LPV and LNAV/VNAV all Cats. visibility ¼ mile, LNAV and Circling Cat. B visibility ¼ mile, Cat. C/D visibility ½ mile. VDP NA when using Brookings altimeter setting. Baro-VNAV NA when using Brookings altimeter setting.

MISSED APPROACH:
Climb to 3600 direct JEBER and hold.

ASOS
126.625

MINNEAPOLIS CENTER
128.5 306.2

UNICOM
123.05 (CTAF) 0

Procedure NA for arrivals at ATY VORTAC via V78 westbound.

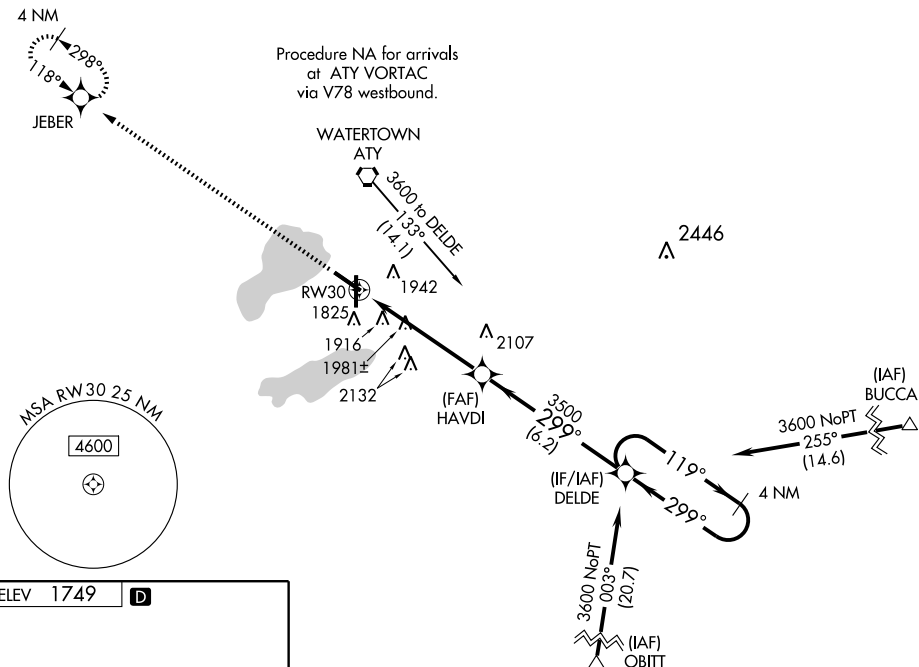

ELEV 1749 **D**

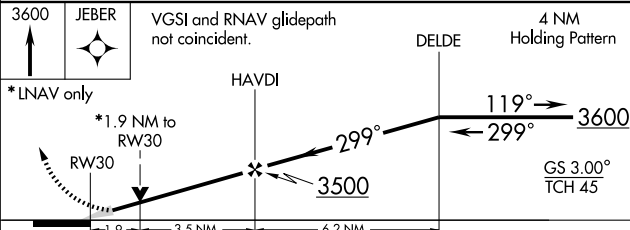
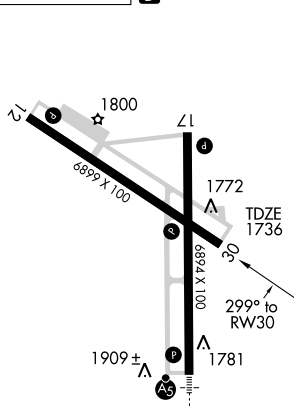

CATEGORY	A	B	C	D
LPV DA	1990-1 254 (300-1)			
LNAV/VNAV DA	2208-1¾ 472 (500-1¾)			
LNAV MDA	2360-1 624 (700-1)	2360-1¾ 624 (700-1¾)	2360-2 624 (700-2)	2360-2 624 (700-2)
CIRCLING	2360-1 611 (700-1)	2360-1¾ 611 (700-1¾)	2360-2 611 (700-2)	2360-2 611 (700-2)

REIL Rwy 17
REIL Rwys 12 and 30
HIRL Rwy 17-35
MIRL Rwy 12-30

RNAV (GPS) RWY 35

WATERTOWN RGNL (ATY)

WAAS CH 82614 W35A	APP CRS 354°	Rwy Idg TDZE Apt Elev	6894 1745 1749
--	------------------------	-----------------------------	---

⚠ For uncompensated Baro-VNAV systems, LNAV/VNAV NA below -18°C (0°F) or above 45°C (113°F). DME/DME RNP -0.3 NA. VDP and Baro-VNAV NA when using Brookings altimeter setting. When local altimeter setting not received, use Brookings altimeter setting and increase all DA 105 feet and all MDA 120 feet, increase LNAV/VNAV all Cats visibility ½ mile, increase LNAV Cat C/D visibility ¼ mile. For inoperative MALS increase LNAV Cat C/D visibility ¼ mile. Inoperative table does not apply to LPV all Cats, LNAV Cats A/B. When using Brookings altimeter setting, inoperative table does not apply to LPV all Cats, LNAV Cats A/B.



MISSED APPROACH:
Climb to 3600 direct BOBDE and hold.

ASOS 126.625	MINNEAPOLIS CENTER 128.5 306.2	UNICOM 123.05 (CTAF) 0
------------------------	--	----------------------------------

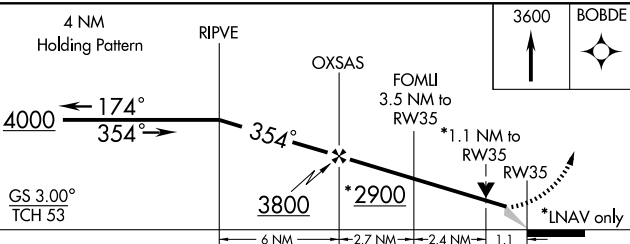
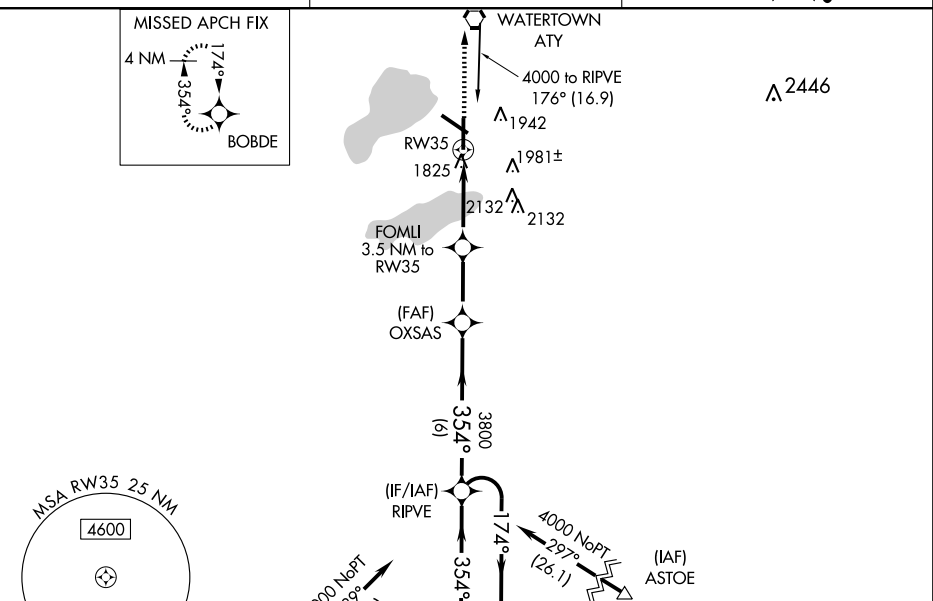

ELEV 1749	D
-----------	----------

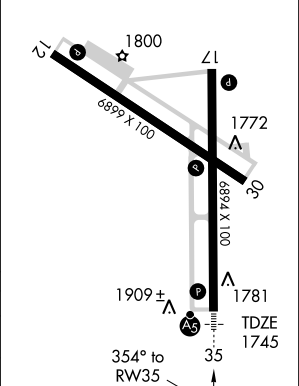

CATEGORY	A	B	C	D
LPV DA		1945-1	200 (200-1)	
LNAV/VNAV DA		2180-1	435 (500-1)	
LNAV MDA		2160-1	415 (500-1)	
CIRCLING	2260-1	511 (600-1)	2260-1½ 511 (600-1½)	2340-2 591 (600-2)

REIL Rwy 17
REIL Rwy 12 and 30
HIRL Rwy 17-35
MIRL Rwy 12-30

NC-1, 08 APR 2010 to 06 MAY 2010

VOR/DME or TACAN RWY 35

WATERTOWN RGNL (ATY)

VORTAC ATY 116.6 Chan 113	APP CRS 356°	Rwy Idg TDZE Apt Elev	6894 1745 1749
---	------------------------	-----------------------------	---



MISSED APPROACH: Climb to 4000 then left turn direct ASTLE and hold.

ASOS
126.625

MINNEAPOLIS CENTER
128.5 306.2

UNICOM
123.05 (CTAF) **I**

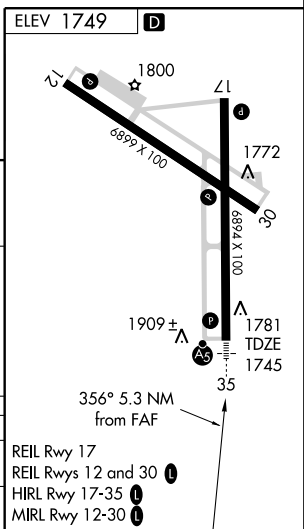
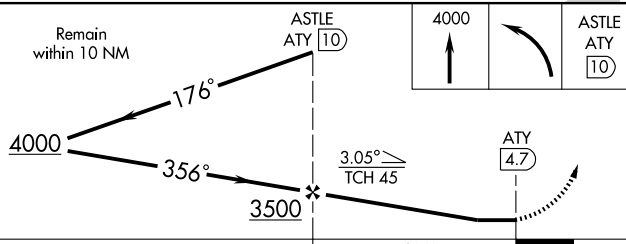
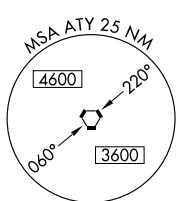
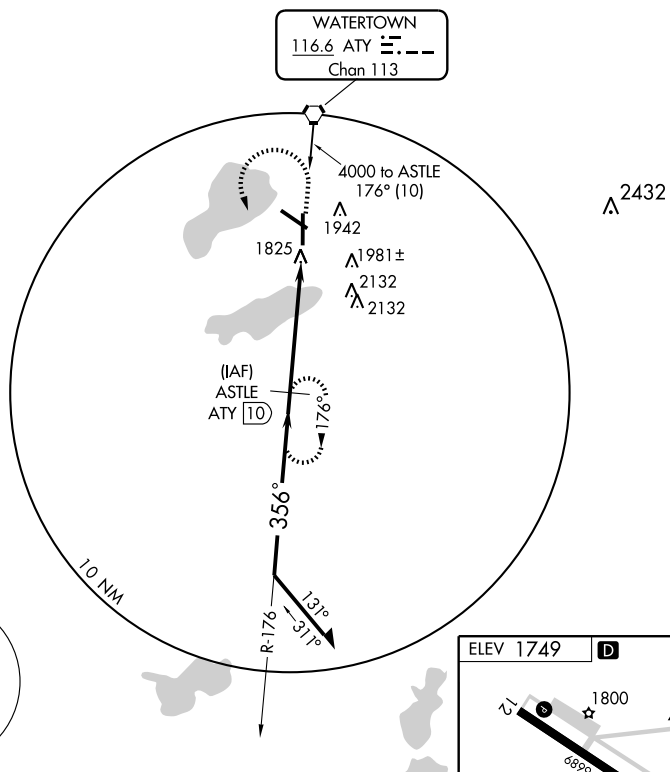

CATEGORY	A	B	C	D
S-35	2240-½ 495 (500-½)		2240-¾ 495 (500-¾)	2240-1 495 (500-1)
CIRCLING	2260-1 511 (600-1)		2260-1½ 511 (600-1½)	2340-2 591 (600-2)

REIL Rwy 17
REIL Rwys 12 and 30 **I**
HIRL Rwy 17-35 **I**
MIRL Rwy 12-30 **I**

VOR or TACAN RWY 17

WATERTOWN RGNL (ATY)

VORTAC ATY 116.6 Chan 113	APP CRS 177°	Rwy Idg TDZE Apt Elev	6894 1740 1749
---	------------------------	-----------------------------	---

Visibility reduction by helicopters NA.
 If local altimeter not received, use Brookings altimeter setting and increase all MDAs 120 feet.
 VDP NA when using Brookings altimeter setting.

MISSED APPROACH: Climb to 2400 then climbing right turn to 4000 direct ATY VORTAC and hold. (TACAN aircraft climb to 5000 via ATY VORTAC R-160 to VESTY/15 DME and hold south, right turns, 340° inbound.)

ASOS 126.625	MINNEAPOLIS CENTER 128.5 306.2	UNICOM 123.05 (CTAF)
------------------------	--	--------------------------------

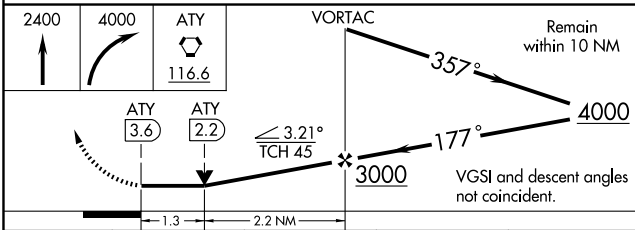
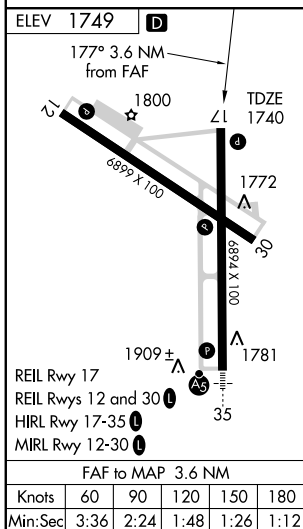
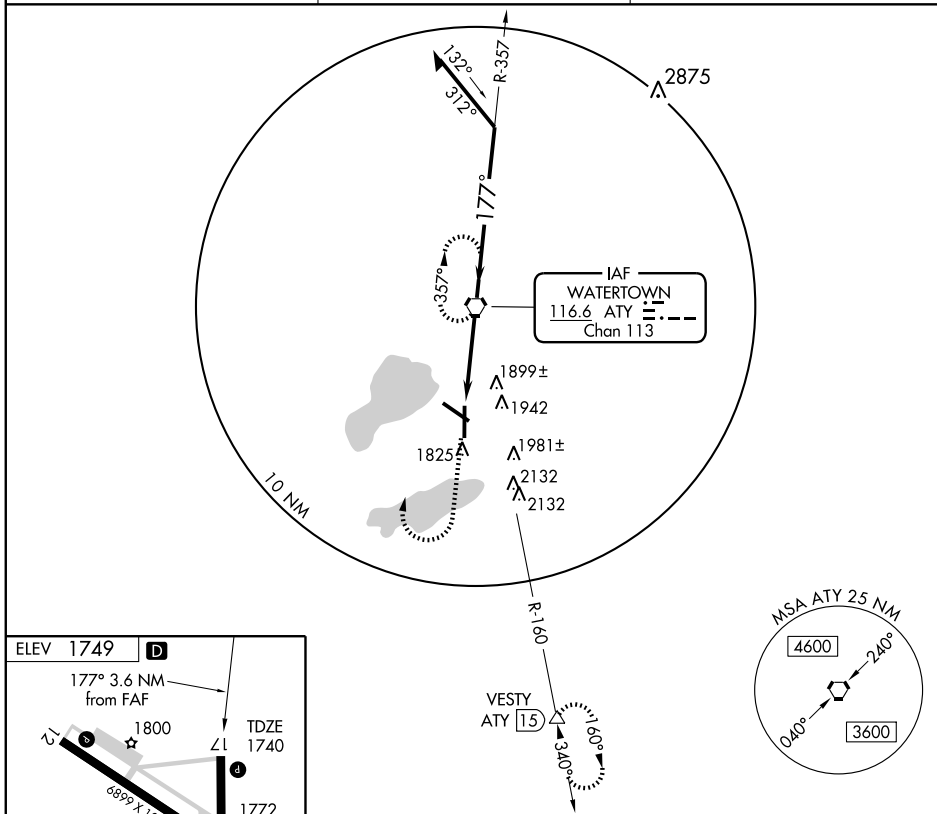

CATEGORY	A	B	C	D
S-17	2200-1	460 (500-1)	2200-1¼ 460 (500-1¼)	2200-1½ 460 (500-1½)
CIRCLING	2260-1	511 (600-1)	2260-1½ 511 (600-1½)	2340-2 591 (600-2)

RNAV (GPS) RWY 13

WINNER RGNL (ICR)

WAAS CH 61212 W13A	APP CRS 129°	Rwy Idg TDZE Apt Elev	4500 2020 2033
--	------------------------	-----------------------------	---

▼ DME/DME RNP-0.3 NA. For uncompensated Baro-VNAV systems, LNAV/VNAV NA below -19°C (-2°F) or above 54°C (130°F).
▲ Baro-VNAV and VDP NA when using Valentine altimeter setting. When local altimeter setting not received, use Valentine, NE altimeter setting and increase all DA/MDA 240 feet; increase LPV all Cats visibility ¾ mile, LNAV/VNAV all Cats visibility 1 mile, LNAV Cat C visibility ¾ mile, circling Cat B visibility ¼ mile and Cat C visibility 1 mile.

MISSED APPROACH: Climb to 4100 direct AGUFY and hold.

ASOS
126.775

HURON RADIO
122.1R

UNICOM
122.8 (CTAF) ①

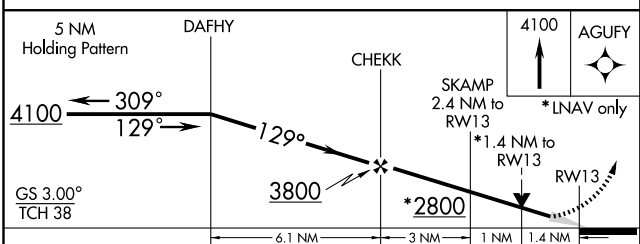
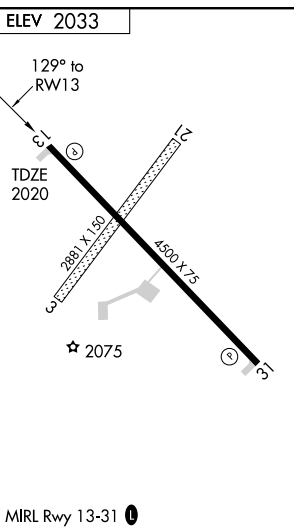
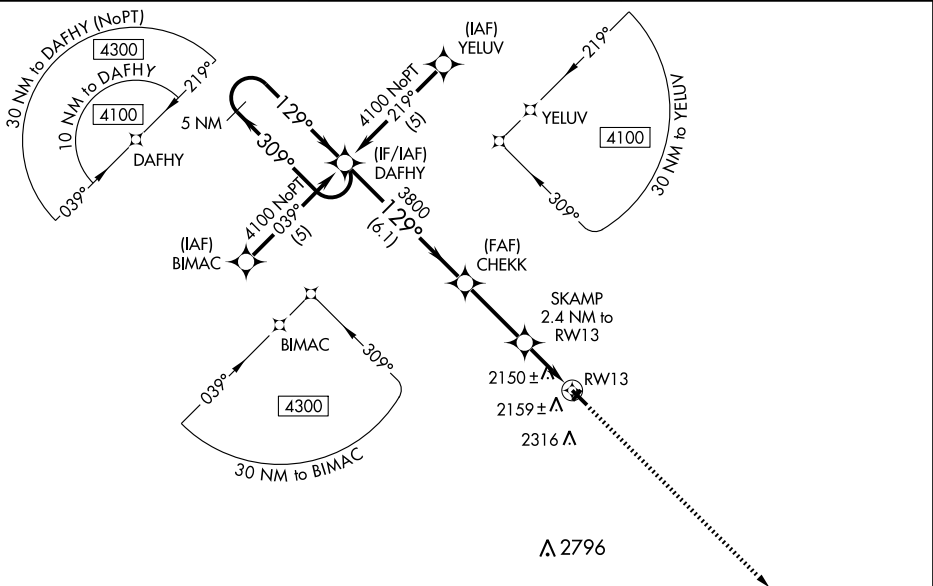

CATEGORY	A	B	C	D
LPV DA	2270-1 250 (300-1)			NA
LNAV/VNAV DA	2456-1½ 436 (500-1½)			NA
LNAV MDA	2480-1	460 (500-1)	2480-1¼ 460 (500-1¼)	NA
CIRCLING	2580-1	547 (600-1)	2680-1¾ 647 (700-1¾)	NA

NC-1, 08 APR 2010 to 06 MAY 2010

RNAV (GPS) RWY 31

WINNER RGNL (ICR)

WAAS CH 97612 W31A	APP CRS 309°	Rwy Idg TDZE Apt Elev	4500 2021 2033
--	------------------------	-----------------------------	---

▼ DME/DME RNP-0.3 NA.
▲ When local altimeter setting not received, use Valentine, NE altimeter setting and increase all DA/MDA 240 feet; increase LPV all Cats visibility 3/4 mile, LNAV/VNAV all Cats visibility 1 mile, LNAV Cat C visibility 1/2 mile, circling Cat B visibility 1/4 mile and Cat C visibility 1 mile.
 For uncompensated Baro-VNAV systems, LNAV/VNAV NA below -19°C (-2°F) or above 54°C (130°F). Baro-VNAV and VDP NA when using Valentine altimeter setting.

MISSED APPROACH: Climb to 4100 direct DAFHY and hold.

ASOS 126.775	HURON RADIO 122.1R	UNICOM 122.8 (CTAF) 0
------------------------	------------------------------	---------------------------------

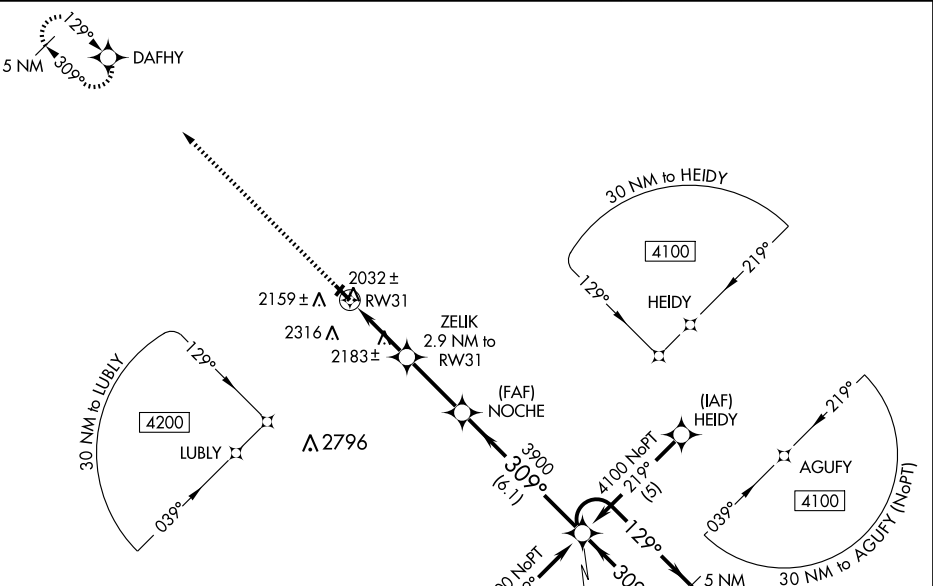

ELEV 2033

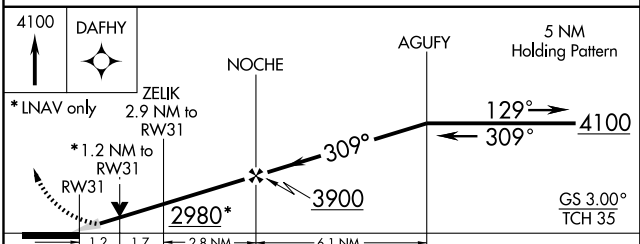
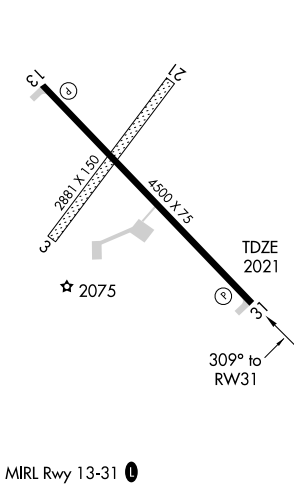

CATEGORY	A	B	C	D
LPV DA	2271-1 250 (300-1)			NA
LNAV/VNAV DA	2581-2 560 (600-2)			NA
LNAV MDA	2440-1	419 (500-1)	2440-1 1/4 419 (500-1 1/4)	NA
CIRCLING	2580-1	547 (600-1)	2680-1 3/4 647 (700-1 3/4)	NA

MIRL Rwy 13-31 0

NC-1, 08 APR 2010 to 06 MAY 2010

VOR ISD 112.8	APP CRS 203°	Rwy Idg TDZE Apt Elev	N/A N/A 2033
-------------------------	------------------------	-----------------------------	---

⚠ When local altimeter setting not received, use Valentine, NE altimeter setting and increase all MDA 240 feet and visibility Cat B ¼ mile, Cats C and D 1 mile.

MISSED APPROACH: Climbing right turn to 4100 direct ISD VOR and hold.

ASOS 126.775	HURON RADIO 122.1R	UNICOM 122.8 (CTAF) 0
------------------------	------------------------------	---------------------------------

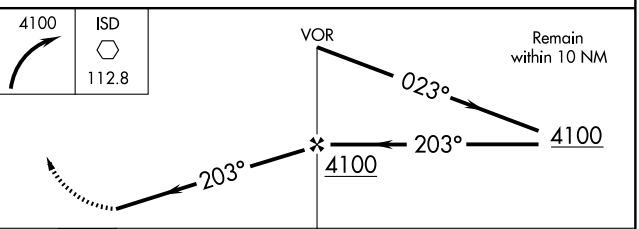
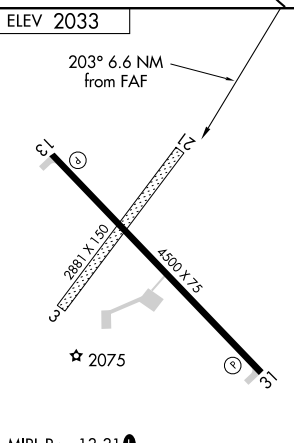
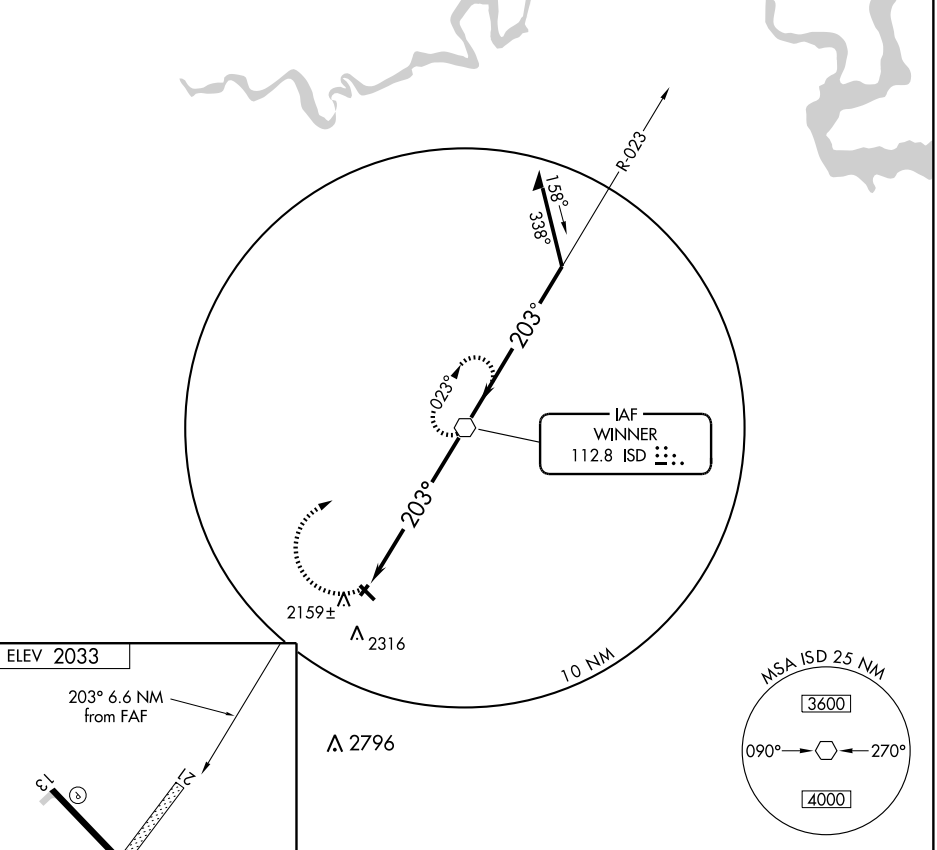

FAF to MAP 6.6 NM						CATEGORY	A	B	C	D
Knots	60	90	120	150	180	CIRCLING	2580-1	547 (600-1)	2680-1¾ 647 (700-1¾)	2680-2 647 (700-2)
Min:Sec	6:36	4:24	3:18	2:38	2:12					

LOC I-YKN 109.5	APP CRS 313°	Rwy Idg TDZE Apt Elev	6095 1284 1305
---------------------------	------------------------	-----------------------------	---

▼ DME minimums: for inoperative MALS, increase
▲ NA S-LOC-31 Cat D visibility to 1 mile.



MISSED APPROACH: Climb to 3100 then direct YKN VOR/DME and hold.

AWOS-3 111.4	MINNEAPOLIS CENTER 124.1 269.0	HURON RADIO 122.55	UNICOM 122.8 (CTAF) 0
------------------------	--	------------------------------	---------------------------------

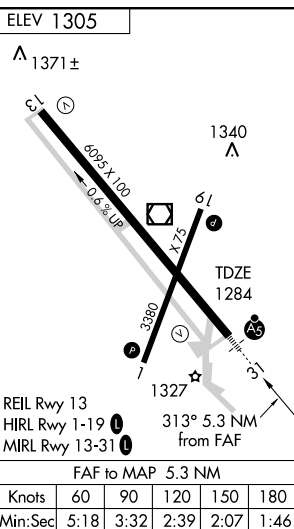
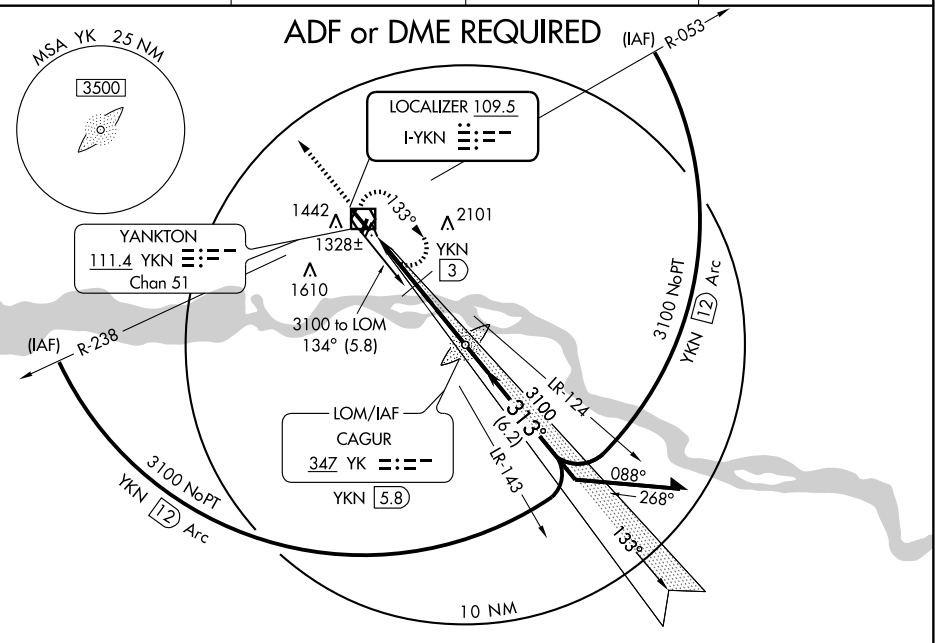

ELEV 1305		▲ 2464	
3100	YKN 111.4	LOM YKN 5.8	Remain within 10 NM
YKN 0.5	YKN 3	3042	133°
		3100	313°
		1680	3100
		2.5 NM	2.8 NM
CATEGORY	A	B	C
S-ILS 31	1484-½ 200 (200-½)		
S-LOC 31	1680-½	396 (400-½)	1680-¾ 396 (400-¾)
CIRCLING	1780-1	475 (500-1)	1780-1½ 475 (500-1½)
DME MINIMUMS			
S-LOC 31	1580-½	296 (300-½)	1580-¾ 296 (300-¾)
CIRCLING	1780-1	475 (500-1)	1780-1½ 475 (500-1½)

NDB or GPS RWY 31

YANKTON/CHAN GURNEY MUNI (YKN)

LOM YK 347	APP CRS 313°	Rwy Idg TDZE Apt Elev	6095 1284 1305
----------------------	------------------------	-----------------------------	---

▲ If local altimeter setting not received, use Sioux Falls altimeter setting and increase all MDAs 220 feet.



MISSED APPROACH: Climb to 3100 via YK LOM bearing 313° then left turn direct YK LOM and hold.

AWOS-3 111.4	MINNEAPOLIS CENTER 124.1 269.0	HURON RADIO 122.55	UNICOM 122.8 (CTAF) 0
------------------------	--	------------------------------	---------------------------------

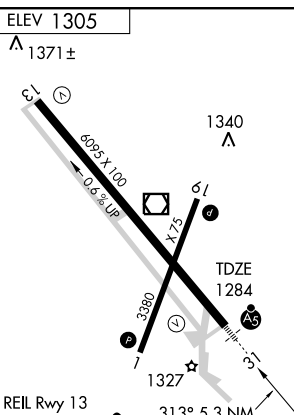
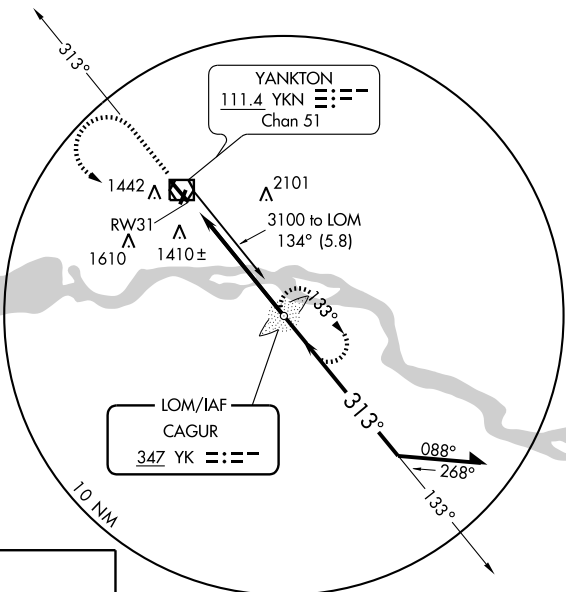
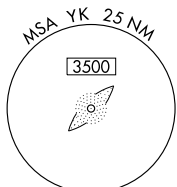

FAF to MAP 5.3 NM

Knots	60	90	120	150	180
Min:Sec	5:18	3:32	2:39	2:07	1:46

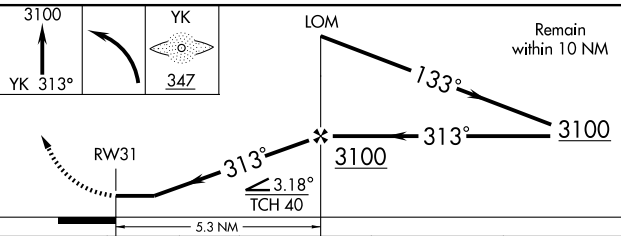

CATEGORY	A	B	C	D
S-31	1720- ³ / ₄ 436 (500- ³ / ₄)		1720-1 ¹ / ₄ 436 (500-1 ¹ / ₄)	
CIRCLING	1780-1 475 (500-1)		1780-1 ¹ / ₂ 475 (500-1 ¹ / ₂)	1860-2 555 (600-2)

WAAS CH 50400 W13A	APP CRS 133°	Rwy Idg TDZE Apt Elev	6095 1306 1306
--	------------------------	-----------------------------	---

RNAV (GPS) RWY 13

YANKTON/ CHAN GURNEY MUNI (YKN)

▼ If local altimeter setting not received, use Sioux Falls altimeter setting and increase all DAs/MDAs 140 feet.
▲ DME/DME RNP -0.3 NA.
 Visibility reduction by helicopters NA.

MISSED APPROACH: Climb to 4000 direct KUYEP and via 111° track to ZUSBU and hold, continue climb-in-hold to 4000.

AWOS-3 111.4	MINNEAPOLIS CENTER 124.1 269.0	HURON RADIO 122.55	UNICOM 122.8 (CTAF) ☉
------------------------	--	------------------------------	--

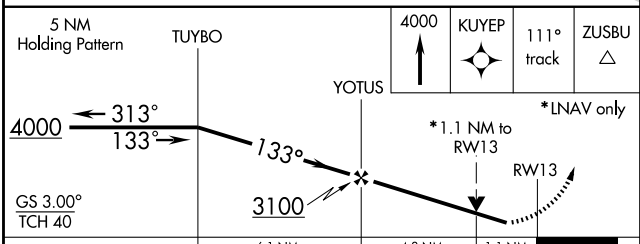
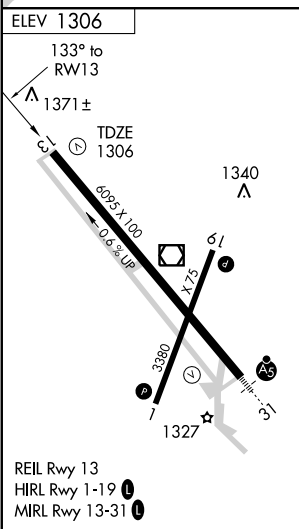
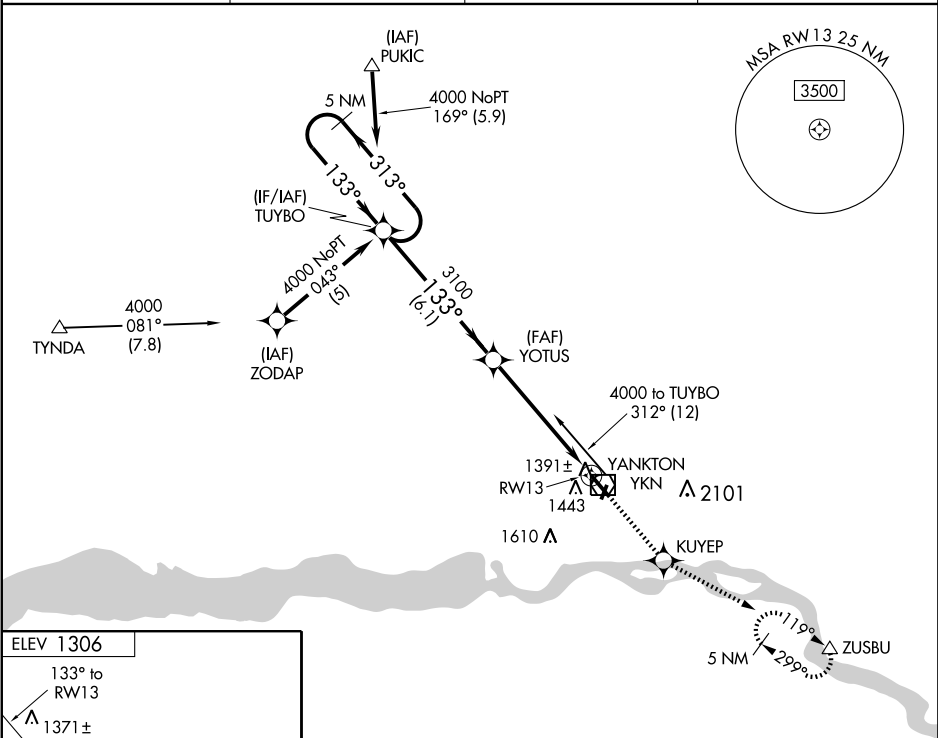

CATEGORY	A	B	C	D
LPV DA	1556-1 250 (300-1)			
RNAV MDA	1700-1 394 (400-1)			1700-1¼ 394 (400-1¼)
CIRCLING	1780-1 474 (500-1)		1780-1½ 474 (500-1½)	1860-2 554 (600-2)

NC-1, 08 APR 2010 to 06 MAY 2010

VOR RWY 13

YANKTON/CHAN GURNEY MUNI (YKN)

VOR/DME YKN 111.4 Chan 51	APP CRS 132°	Rwy Idg TDZE Apt Elev	6095 1306 1306
---	------------------------	-----------------------------	---

⚠ If local altimeter setting not received, use Sioux Falls altimeter setting and increase all MDAs 140 feet. VDP NA when using Sioux Falls altimeter setting. Visibility reduction by helicopters NA.

MISSED APPROACH: Climb to 3200 via YKN VOR/DME R-132 then right turn direct YKN VOR/DME and hold.

AWOS-3 111.4	MINNEAPOLIS CENTER 124.1 269.0	HURON RADIO 122.55	UNICOM 122.8 (CTAF) ①
------------------------	--	------------------------------	--

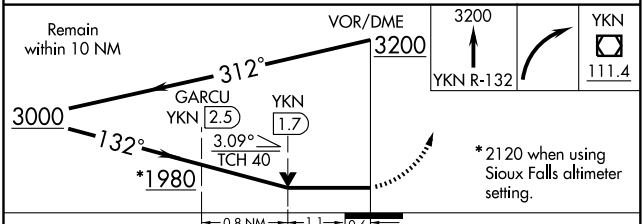
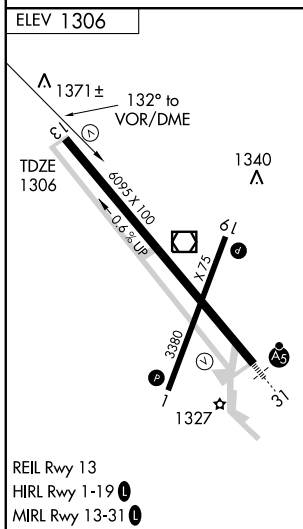
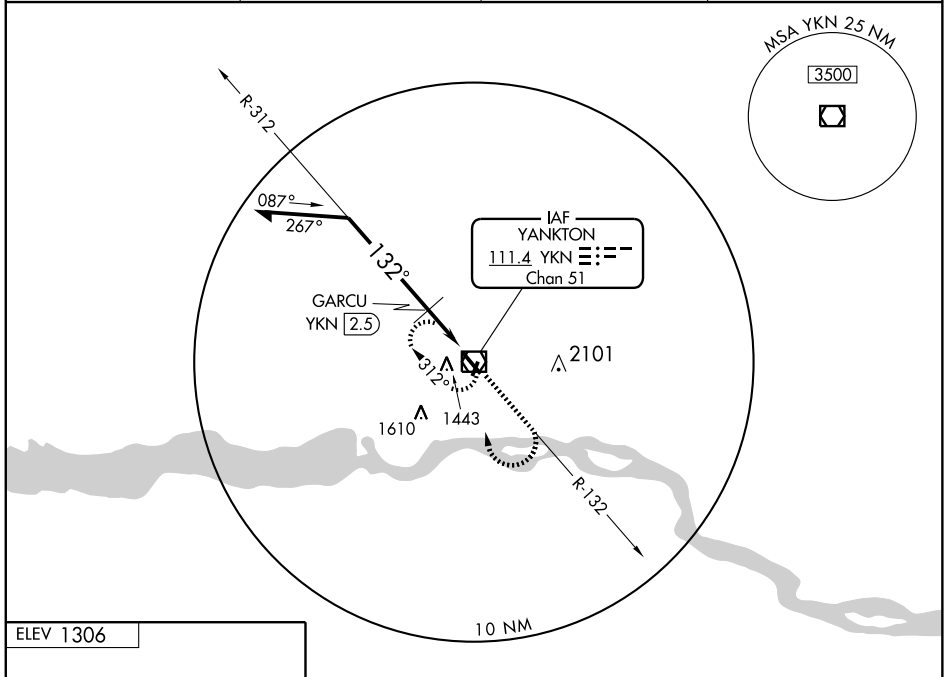

CATEGORY	A	B	C	D
S-13	1980-1 674 (700-1)		1980-2 674 (700-2)	1980-2 1/4 674 (700-2 1/4)
CIRCLING	1980-1 674 (700-1)		1980-2 674 (700-2)	1980-2 1/4 674 (700-2 1/4)
GARCUN FIX MINIMUMS				
S-13	1700-1 394 (400-1)		1700-1 1/4 394 (400-1 1/4)	
CIRCLING	1780-1 474 (500-1)		1780-1 1/2 474 (500-1 1/2)	1860-2 554 (600-2)

NC-1, 08 APR 2010 to 06 MAY 2010

VOR RWY 31

YANKTON/CHAN GURNEY MUNI (YKN)

VOR/DME YKN 111.4 Chan 51	APP CRS 318°	Rwy Idg TDZE Apt Elev 6095 1284 1305
--	------------------------	--

	MALSRL	MISSED APPROACH: Climb to 3100, then left turn direct YKN VOR/DME and hold.

AWOS-3 111.4	MINNEAPOLIS CENTER 124.1 269.0	HURON RADIO 122.55	UNICOM 122.8 (CTAF)
------------------------	--	------------------------------	-------------------------------

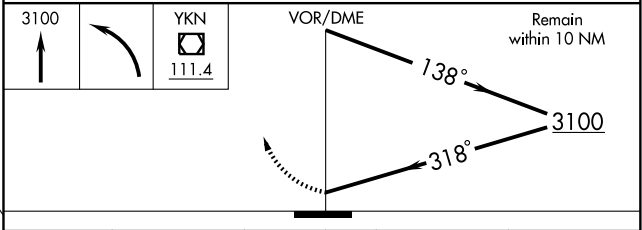
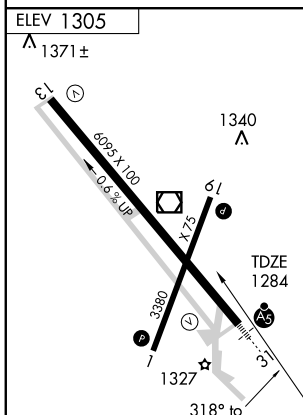
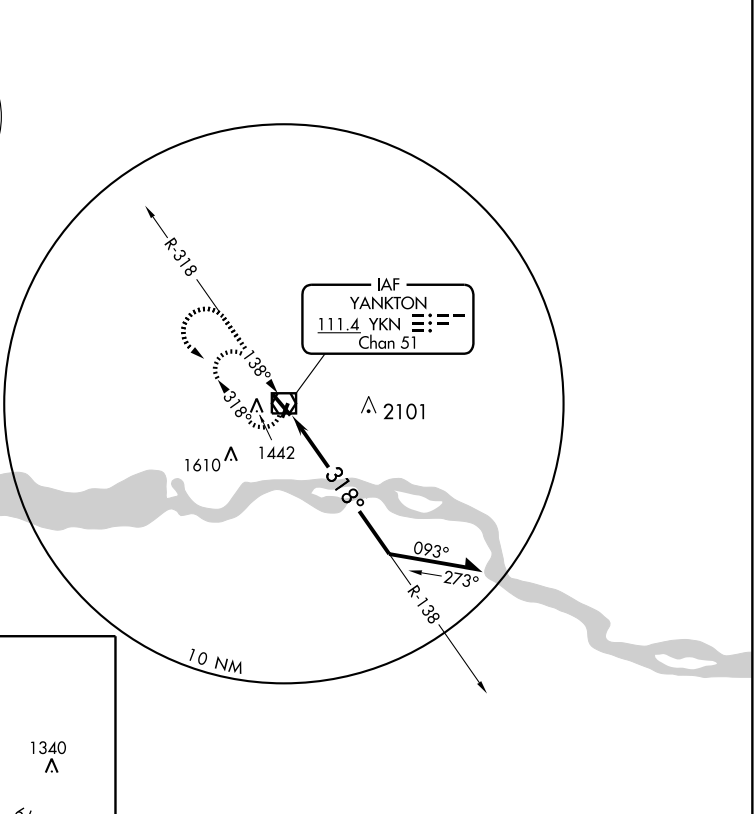
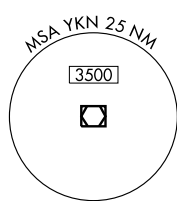

CATEGORY	A	B	C	D
S-31	1980-½ 696 (700-½)		1980-1½ 696 (700-1½)	1980-1¾ 696 (700-1¾)
CIRCLING	1980-1 675 (700-1)		1980-2 675 (700-2)	1980-2¼ 675 (700-2¼)

REIL Rwy 13
HIRL Rwy 1-19
MIRL Rwy 13-31