

8316-4 — DE 1005
8316-3 — DOP 17

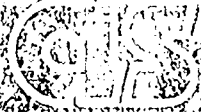
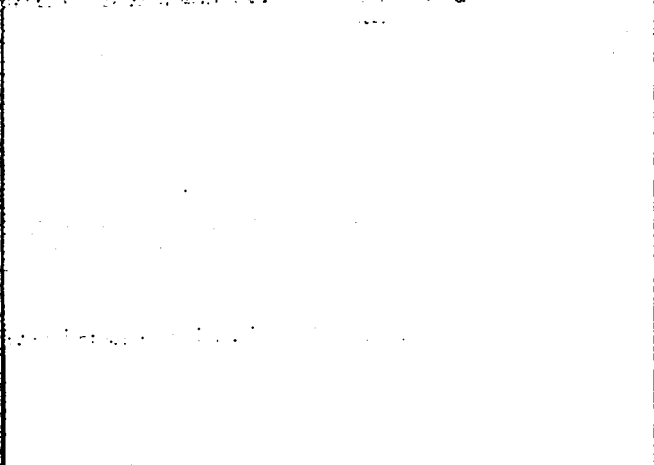

Dynamic Science Inc

A SUBSIDIARY OF TALLEY INDUSTRIES

Report No. (To be assigned by NHTSA)

DEVELOPMENT OF A TEST METHODOLOGY
FOR EVALUATING CRASH
COMPATIBILITY AND AGGRESSIVENESS

TEST REPORT 2
1975 FORD TORINO-TO-NHTSA
TEST DEVICE

Contract DOT-HS-7-01758



March 1979

FINAL REPORT

Document is available to the public through the
National Technical Information Service,
Springfield, Virginia 22161

Prepared for:

U.S. DEPARTMENT OF TRANSPORTATION
NATIONAL HIGHWAY TRAFFIC SAFETY ADMINISTRATION
WASHINGTON, D.C. 20590

Prepared for the Department of Transportation, National Highway
Traffic Safety Administration, under Contract No. DOT-HS-7-01758.
This document is disseminated under the sponsorship of the Depart-
ment of Transportation in the interest of information exchange.
The United States Government assumes no liability for the contents
or use thereof.

TECHNICAL REPORT STANDARD TITLE PAGE

1. Report No.	2. Government Accession No.	3. Recipient's Catalog No.	
4. Title and Subtitle TEST REPORT #2, 1975 FORD TORINO-TO-NHTSA TEST DEVICE		5. Report Date March 1979	
		6. Performing Orgn Code	
7. Author(s) R. Yee, R. Cropper, S. Davis		8. Performing Orgn Rpt No. 8316-78-106A	
9. Performing Organization Name and Address Dynamic Science, Inc. A Talley Industries Company 1850 West Pinnacle Peak Road Phoenix, Arizona 85027		10. Work Unit No.	
		11. Contract or Grant No. DOT-HS-7-01758	
12. Sponsoring Agency Name and Address U.S. Department of Transportation National Highway Traffic Safety Administration Washington, D.C. 20590		13. Type of Report and Period Covered TEST REPORT May - Sept 1978	
		14. Sponsoring Agency Code	
15. Supplementary Notes Test No. 3 and 4 of a Series of 8 Tests			
16. Abstract This report presents the results of two full-scale, head-on collisions between the NHTSA Test Device and 1975 Ford Torino four-door sedans. The objective of these tests was to help establish a test methodology for evaluating crash compatibility and aggressiveness. The Test Device is a unique honeycomb faced, load-measuring tool which is adaptable to both moving barrier and fixed barrier collisions. Data contained in this report include graphical and tabular presentations of vehicle deformation, Test Device load cell data, vehicle and simulated occupant acceleration, velocity and displacement values, dynamic displacement of string potentiometers, and restraint survival distances. Also included are tabular summaries of occupant injury criteria, exterior and interior static vehicle deformation, and restraint system loads and vehicle descriptions. Data for a 40-mph fixed Test Device collision is compared to that for an "equivalent" moving Test Device collision.			
17. Key Words Fixed Test Device, Moving Test Device, Compatibility, Aggressiveness, Ford Torino		18. Distribution Statement Document is available to the public through the National Technical Information Service, Springfield, Virginia 22161	
19. Security Classif. (of this report) Unclassified	20. Security Classif. (of this page) Unclassified	21. No. Pages 226	22. Price

METRIC CONVERSION FACTORS

Approximate Conversions From Metric Measures

Symbol	When You Know	Multiply by	To Find	Symbol
--------	---------------	-------------	---------	--------

LENGTH

mm	millimeters	0.04	inches	in
cm	centimeters	0.4	inches	in
m	meters	3.3	feet	ft
m	meters	1.1	yards	yd
km	kilometers	0.6	miles	mi

AREA

cm ²	square centimeters	0.16	square inches	in ²
m ²	square meters	1.2	square yards	yd ²
km ²	square kilometers	0.4	square miles	mi ²
ha	hectares (10 000 m ²)	2.5	acres	

MASS (weight)

g	grams	0.035	ounces	oz
kg	kilograms	2.2	pounds	lb
t	metric ton (1000 kg)	1.1	short tons	

VOLUME

mL	milliliters	0.03	fluid ounces	fl oz
mL	milliliters	0.06	cubic inches	in ³
L	liters	2.1	pints	pt
L	liters	1.06	quarts	qt
L	liters	0.26	gallons	gal
m ³	cubic meters	35	cubic feet	ft ³
m ³	cubic meters	1.3	cubic yards	yd ³

TEMPERATURE (exact)

°C	degrees Celsius	9/5 (then add 32)	degrees Fahrenheit	°F
----	-----------------	-------------------	--------------------	----

Approximate Conversions to Metric Measures

Symbol	When You Know	Multiply by	To Find	Symbol
--------	---------------	-------------	---------	--------

LENGTH

in	inches	2.5	centimeters	cm
ft	feet	30	centimeters	cm
yd	yards	0.9	meters	m
mi	miles	1.6	kilometers	km

AREA

in ²	square inches	6.5	square centimeters	cm ²
ft ²	square feet	0.09	square meters	m ²
yd ²	square yards	0.8	square meters	m ²
mi ²	square miles	2.6	square kilometers	km ²
acres	acres	0.4	hectares	ha

MASS (weight)

oz	ounces	28	grams	g
lb	pounds (2000 lb)	0.45	kilograms	kg
	short tons	0.9	metric ton	t

VOLUME

tsp	teaspoons	5	milliliters	mL
Tbsp	tablespoons	15	milliliters	mL
in ³	cubic inches	16	milliliters	mL
fl oz	fluid ounces	30	milliliters	mL
c	cups	0.24	liters	L
pt	pints	0.47	liters	L
qt	quarts	0.95	liters	L
gal	gallons	3.8	liters	L
ft ³	cubic feet	0.03	cubic meters	m ³
yd ³	cubic yards	0.76	cubic meters	m ³

TEMPERATURE (exact)

°F	degrees Fahrenheit	5/9 (after subtracting 32)	degrees Celsius	°C
----	--------------------	----------------------------	-----------------	----

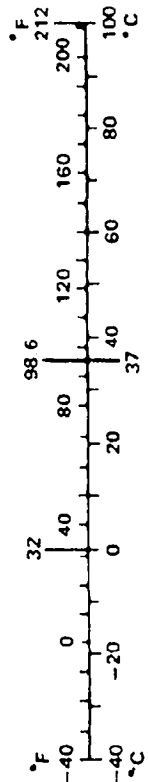
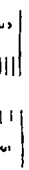
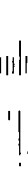
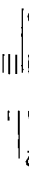
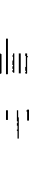
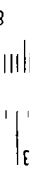
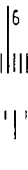
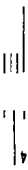
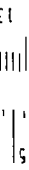

TABLE OF CONTENTS

	<u>Page</u>
1.0 INTRODUCTION.	1
2.0 TEST METHODOLOGY AND PROCEDURE.	5
2.1 VEHICLE DESCRIPTION.	5
2.2 FIXED TEST DEVICE TESTS.	5
2.3 MOVING TEST DEVICE TESTS	9
3.0 DATA ACQUISITION.	15
3.1 DATA ACQUISITION METHODS	15
3.2 INSTRUMENTATION.	17
3.2.1 Test Vehicle Instrumentation.	17
3.2.2 Test Vehicle Occupant Instrumentation . .	19
3.2.3 Moving Test Device Instrumentation. . . .	19
3.2.4 Fixed Test Device Instrumentation	20
3.3 PHOTO-INSTRUMENTATION REQUIREMENTS	25
3.3.1 Fixed Test Device Photography	25
3.3.2 Moving Test Device Photography.	25
4.0 SUMMARY OF TEST RESULTS	28
4.1 TEST SUMMARY: FORD-TO-TEST DEVICE TESTS	28
4.1.1 Fixed Test Device Test.	28
4.1.2 Moving Test Device Test	39
4.2 VEHICLE STRUCTURAL RESPONSE.	40
4.3 TEST DEVICE SUMMARY.	54
4.4 OCCUPANT KINEMATICS.	86

TABLE OF CONTENTS (CONTD)

	<u>Page</u>
5.0 TEST FACILITIES AND EQUIPMENT	104
5.1 GENERAL.	104
5.2 FACILITY AND EQUIPMENT DESCRIPTION	106
5.2.1 Test Track and Guidance System.	106
5.2.2 Tow System and Velocity Control	106
5.2.3 Abort System.	106
5.2.4 Master Control System	107
5.2.5 Fixed Impact Barrier.	108
5.2.6 Midrange Impact Site.	108
5.2.7 High-speed Photography.	108
APPENDIX A - CAR-TO-TEST DEVICE CRASH ANALYSIS	A-1
APPENDIX B - CALCOMP PLOTS, TEST 3, 1975 FORD TORINO-TO-FIXED TEST DEVICE	B-1
APPENDIX C - CALCOMP PLOTS, TEST 4, 1975 FORD TORINO-TO-MOVING TEST DEVICE.	C-1
APPENDIX D - CALCULATION OF RESTRAINT SURVIVAL DISTANCE (RSD).	D-1

LIST OF ILLUSTRATIONS

<u>Figure</u>		<u>Page</u>
1-1	Moving Test Device Configuration	3
1-2	Fixed Test Device Configuration.	4
2-1	Monorail Impact Facility	8
2-2	Data Acquisition - Vehicle-to-Fixed Barrier Tests.	10
2-3	Data Acquisition - Vehicle-to-Moving Test Device Tests	14
3-1	Vehicle Accelerometer Instrumentation.	18
3-2	Typical Instrumentation Model (B5)	21

LIST OF ILLUSTRATIONS (CONTD)

<u>Figure</u>		<u>Page</u>
3-3	1975 Ford Torino/Test Device Honeycomb Interface and String Potentiometer Locations.	22
3-4	Moving Test Device Instrumentation	23
3-5	Fixed Test Device Installation and Strain Gauge Location	24
4-1	Pre-test Vehicle Configuration - Test 3.	37
4-2	Post-test Vehicle Configuration - Test 3	37
4-3	Pre-test Vehicle Configuration - Test 4.	38
4-4	Post-test Vehicle Configuration - Test 4	38
4-5	Pre-test Bumper Match - Test 3	42
4-6	Post-test Bumper Match - Test 3.	42
4-7	Pre-test Bumper Match - Test 4	43
4-8	Post-test Bumper Match - Test 4.	43
4-9	Post-test Driver Compartment - Test 3.	49
4-10	Post-test Driver Compartment - Test 4.	49
4-11	Post-test Passenger Compartment - Test 3	50
4-12	Post-test Passenger Compartment - Test 4	50
4-13	Post-test Fixed Test Device Configuration - Test 3	55
4-14	Post-test Moving Test Device Configuration - Test 4	55
4-15	Test Device Load Cell Forces on Row A for Test 8316-3.	58
4-16	Test Device Load Cell Forces on Row B for Test 8316-3.	59
4-17	Test Device Load Cell Forces on Row C for Test 8316-3.	60
4-18	Test Device Load Cell Forces on Row D for Test 8316-3.	61

LIST OF ILLUSTRATIONS (CONTD)

<u>Figure</u>		<u>Page</u>
4-19	Test Device Load Cell Forces on Row A for Test 8316-4.	62
4-20	Test Device Load Cell Forces on Row B for Test 8316-4.	63
4-21	Test Device Load Cell Forces on Row C for Test 8316-4.	64
4-22	Test Device Load Cell Forces on Row D for Test 8316-4.	65
4-23	1975 Ford Torino/Fixed Test Device Load Distribution at 25 msec.	66
4-24	1975 Ford Torino/Fixed Test Device Load Distribution at 56 msec.	67
4-25	1975 Ford Torino/Fixed Test Device Load Distribution at 90 msec.	68
4-26	1975 Ford Torino/Moving Test Device Load Distribution at 23 msec.	69
4-27	1975 Ford Torino/Moving Test Device Load Distribution at 32 msec.	70
4-28	1975 Ford Torino/Moving Test Device Load Distribution at 43 msec.	71
4-29	Strain Gauge Data - Row B Horizontal Beam. . . .	76
4-30	Dynamic Crush During Collision for Fixed Test Device - Test 3	80
4-31	Dynamic Crush During Collision for Moving Test Device - Test 4	81
4-32	Comparison of Total Load Cell Force From Fixed Test Device Load Cell and Vehicle Accelerometer Data for Test 3.	82
4-33	Comparison of Total Load Cell Force From Moving Test Device Load Cell and Vehicle Accelerometer Data for Test 4.	83
4-34	Comparison of Load Cell Force-Deflection Characteristics for 1975 Ford Torino	84

LIST OF ILLUSTRATIONS (CONTD)

<u>Figure</u>		<u>Page</u>
4-35	Car Interior Intrusion Versus Exterior Car Crush.	87
4-36	Car Exterior Crush and Interior Intrusion Versus Time for Fixed Test Device - Test 3 . . .	88
4-37	Car Exterior Crush and Interior Intrusion Versus Time for Moving Test Device - Test 4. . .	89
4-38	Centroid of Load Cell Force for Fixed Test Device Test.	90
4-39	Centroid of Load Cell Force for Moving Test Device Test.	91
4-40	Pre-test Driver Position - Test 3.	92
4-41	Post-test Driver Position - Test 3	92
4-42	Pre-test Passenger Position - Test 3	93
4-43	Post-test Passenger Position - Test 3.	93
4-44	Pre-test Driver Position - Test 4.	94
4-45	Post-test Driver Position - Test 4	94
4-46	Pre-test Passenger Position - Test 4	95
4-47	Post-test Passenger Position - Test 4.	95
4-48	1975 Ford Torino - Driver Profile - Test 3 . . .	100
4-49	1975 Ford Torino - Passenger Profile - Test 3	101
4-50	1975 Ford Torino - Driver Profile - Test 4	102
4-51	1975 Ford Torino - Passenger Profile - Test 4	103

LIST OF TABLES

<u>Table</u>		<u>Page</u>
1-1	Summary of Car-to-Test Device Test Conditions	2
2-1	Vehicle Description - Fixed Test Device Test	6
2-2	Vehicle Description - Moving Test Device Test	7
2-3	Crash Test Summary 8316-3.	11
2-4	Crash Test Summary 8316-4.	13
3-1	Data Requirements.	15
3-2	Occupant Instrumentation	20
3-3	Camera Locations - Fixed Test Device	26
3-4	Camera Locations - Moving Test Device.	27
4-1	Crash Test Summary	29
4-2	Summary of Car Test Data	30
4-3	Summary of Pre-test Engine/Bumper/Firewall Characteristics.	31
4-4	Summary of Pre-test Dummy Position Data Characteristics.	31
4-5	Summary of Post-test Observations.	32
4-6	Injury Criteria Summary.	34
4-7	Chronology of Crash Events	35
4-8	Pre- and Post-test Dimension Measurements.	41
4-9	Car Exterior Profiles and Static Crush for Test 3	44
4-10	Car Exterior Profiles and Static Crush for Test 4	45
4-11	Car Interior Profiles and Static Intrusion for Fixed Test Device Test 3	46

LIST OF TABLES (CONTD)

<u>Table</u>		<u>Page</u>
4-12	Car Interior Profiles and Static Intrusion for Moving Test Device Test 4	47
4-13	Steering Wheel Displacement Values	48
4-14	Summary of Car Accelerometer Data for Fixed Test Device Test 3	51
4-15	Summary of Averaged Car Accelerometer Data for Fixed Test Device Test 3	51
4-16	Summary of Car Accelerometer Data for Moving Test Device Test 4	52
4-17	Summary of Averaged Car Accelerometer Data for Moving Test Device Test 4	52
4-18	Summary of Car String Potentiometer Data for Fixed Test Device Test 3	53
4-19	Summary of Car String Potentiometer Data for Moving Test Device Test 4	53
4-20	Summary of Maximum Load Cell Data for Fixed Test Device Test 3	56
4-21	Summary of Maximum Load Cell Data for Moving Test Device Test 4	56
4-22	Summary of Grouped Load Cell Data - Test 3	57
4-23	Summary of Grouped Load Cell Data - Test 4	57
4-24	Summary of Moving Test Device Accelerometer Data	73
4-25	Comparison of Total Force From Load Cell and Accelerometer Data - Fixed Test Device	73
4-26	Comparison of Total Force From Load Cell and Accelerometer Data - Moving Test Device.	73
4-27	Summary of Fixed Test Device String Potentiometer Data	74
4-28	Summary of Fixed Test Device Strain Gauge Data	74

LIST OF TABLES (CONTD)

<u>Table</u>		<u>Page</u>
4-29	Summary of Moving Test Device String Potentiometer Data	75
4-30	Summary of Moving Test Device Strain Gauge Data	75
4-31	Fixed Test Device Honeycomb Crush Profile.	78
4-32	Moving Test Device Honeycomb Crush Profile	79
4-33	Frontal Stiffness of Cars as a Function of Crush Distance	85
4-34	Occupant Response Data Summary	96
4-35	Summary of Restraint System Data	97
4-36	Summary of Occupant Restraint Survival Distance (RSD)	99
5-1	Test Equipment List and Function	104

1.0 INTRODUCTION

A series of eight full-scale crash tests was conducted to establish a test methodology for evaluating vehicle crash compatibilities and aggressiveness. The objectives of these tests were:

- To obtain the necessary data for establishing appropriate criteria for evaluating vehicle aggressiveness of intermediate, subcompact, and lightweight subcompact-size cars. The vehicles tested were all 1975 model cars which included Honda Civic CVCC, Volvo 244DL, Ford Torino, and Plymouth Fury.
- To investigate the Dynamic Science segmented load cell Test Device concept for sensitivity to measure the basic types of aggressiveness, namely, architectural, mass, and structural aggressiveness.

A summary of the car-to-Test Device test conditions is shown in Table 1-1. This test report presents the results of Tests Numbers 3 and 4, head-on collisions between the NHTSA Test Device and the 1975 Ford Torino four-door sedans.

The Test Device is a unique honeycomb-faced load-measuring tool which is adaptable to both moving barrier collisions (see Figure 1-1) and fixed-barrier collisions (see Figure 1-2). The barrier face of the Test Device is made up of 40 six-inch-thick energy-absorbing aluminum honeycomb modules, each individually connected to load cells. At selected locations, 6 string potentiometers were added to record honeycomb dynamic displacement. The Ford car was first crashed into the fixed Test Device (Test 3), and then a similar model was tested into the moving Test Device (Test 4). The closing speed for the moving Test Device tests was selected to give the same energy change (ΔE)* as in the corresponding fixed Test Device test. (See Appendix A for determination of equivalent closing speed for moving Test Device collisions.)

*Note: This and subsequent moving Test Device tests used equal energy absorption ΔE instead of equal velocity change (ΔV) as the equivalent speed criteria.

TABLE 1-1. SUMMARY OF CAR-TO-TEST DEVICE TEST CONDITIONS

Test Number	Test Date	Test Configuration	Car Model	Car Weight (lb)	Barrier Weight (lb)	Closing Velocity (mph)
1	April 17, 1978	Honda Front-to-Fixed Test Device (Head-On)	1975 Honda CVCC 2-door sedan	2205	Fixed**	40.83
2	April 20, 1978	Honda Front-to-Moving Test Device (Head-On)	1975 Honda CVCC 2-door sedan	2205	3994	62.24***
3	May 9, 1978	Ford Front-to-Fixed Test Device (Head-On)	1975 Ford Torino 4-door sedan	4550	Fixed**	40.52
4	May 16, 1978	Ford Front-to-Moving Test Device (Head-On)	1975 Ford Torino 4-door sedan	4550	4002	59.10*
5	June 6, 1978	Volvo Front-to-Fixed Test Device (Head-On)	1975 Volvo 244DL 4-door sedan	3351	Fixed**	45.11
6	June 8, 1978	Volvo Front-to-Moving Test Device (Head-On)	1975 Volvo 244DL 4-door sedan	3353	4007	61.38*
7	June 13, 1978	Plymouth Front-to-Fixed Test Device (Head-On)	1975 Plymouth Fury 4-door sedan	4439	Fixed**	40.73
8	June 16, 1978	Plymouth Front-to-Moving Test Device (Head-On)	1975 Plymouth Fury 4-door sedan	4444	4012	58.02*

*Based on equal energy absorption (ΔE).

**Fixed barrier test device weight > 100,000 pounds.

***Based on equal velocity change (ΔV).

6/20/78

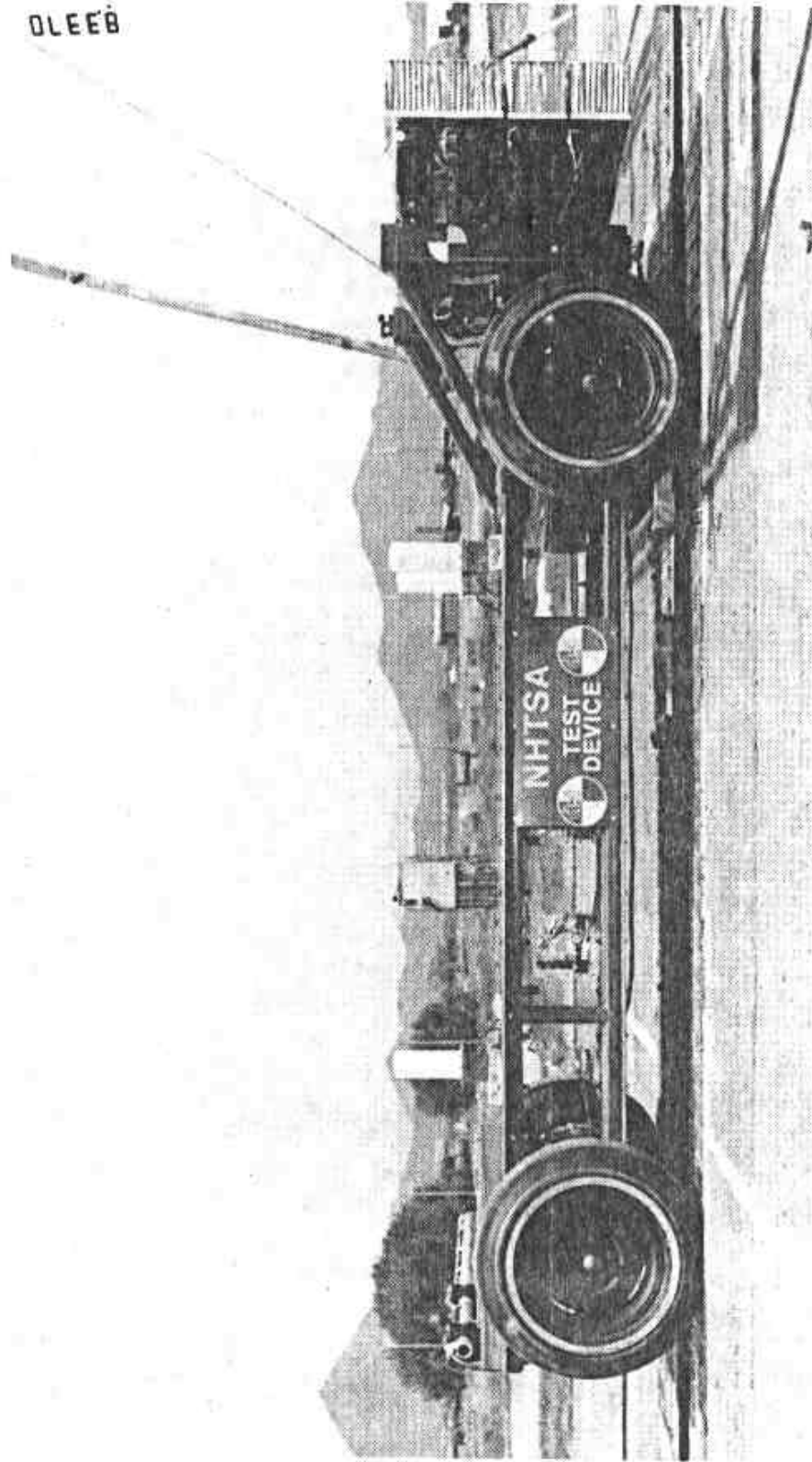

Figure 1-1. Moving Test Device Configuration.

83292

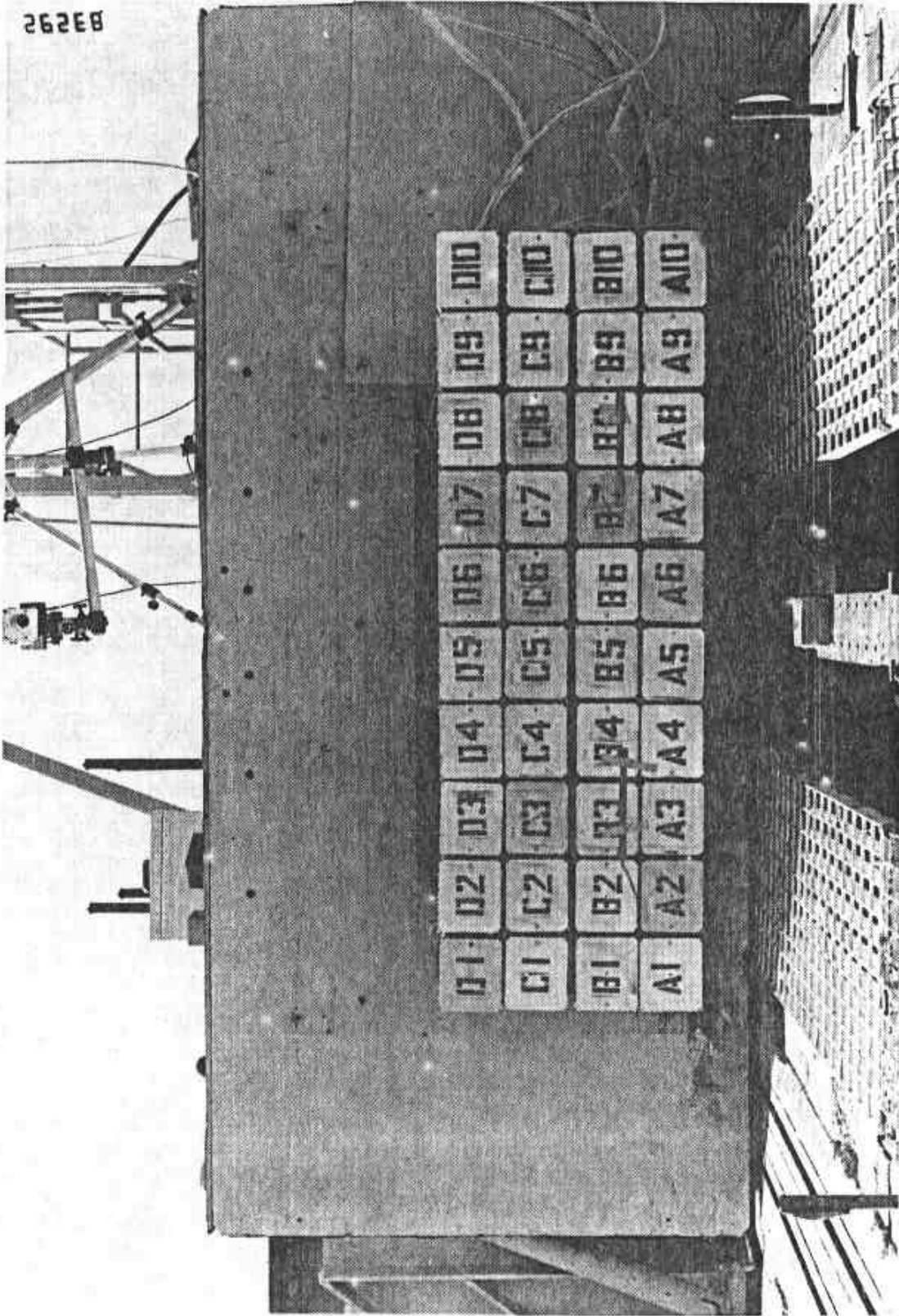

Figure 1-2. Fixed Test Device Configuration.

2.0 TEST METHODOLOGY AND PROCEDURE

This section presents a brief description of the test methodology and procedures used for conducting the car-to-Test Device head-on collisions.

2.1 VEHICLE DESCRIPTION

The vehicles used in these tests were both 1975 Ford Torino four-door sedans. Tables 2-1 and 2-2 present the incoming vehicle inspection performed on each car used for the fixed and moving Test Device tests, respectively.

For the tests to be conducted, two Part 572, male 50th percentile Alderson anthropomorphic dummies (GFE) were in the two front seating positions of the car. Each occupant was properly restrained with the vehicle's lap and shoulder belt restraint system. The seat tracks were welded in their midposition with the seat back latches secured to prevent breakaway and rotation. Test weights for the Fords were determined by averaging test weights of cars used in other crashes. All collisions were head-on with no lateral offset distance between car and Test Device face.

2.2 FIXED TEST DEVICE TESTS

The Ford-to-fixed Test Device test was conducted at the barrier impact facility (see Figure 2-1) with the centerline of the test car in line with the centerline of the fixed Test Device face. The vehicle impact velocity (see Table 1-1) was controlled to within ± 1 mph.

TABLE 2-1. VEHICLE DESCRIPTION - FIXED TEST DEVICE TEST

Contractor: Dynamic Science, Inc. Contract No.: DOT-HS-7-01758

VIN NO.: 5H27H182053 Make: Ford

NHTSA No.: --

Year: 1975 Color: White/Blue Vinyl Top Model: Torino 4-Door

Auto Trans:	<input checked="" type="radio"/> yes	<input type="radio"/> no	Pwr Steering:	<input checked="" type="radio"/> yes	<input type="radio"/> no	Seats:	Bench: <u>X</u>
						(front)	
Pwr Brakes:	<input checked="" type="radio"/> yes	<input type="radio"/> no	Auto Speed Cont:	yes	<input type="radio"/> no	Bucket:	<u> </u>
Pwr Seats:	yes	<input type="radio"/> no	Anti Skid Brake:	yes	<input type="radio"/> no	Split	<u> </u>
Pwr Windows:	yes	<input type="radio"/> no	Air Conditioning:	<input checked="" type="radio"/> yes	<input type="radio"/> no	Bench:	<u> </u>
Tinted Glass:	<input checked="" type="radio"/> yes	<input type="radio"/> no	Rear Window Def.:	yes	<input type="radio"/> no	Split	<u> </u>
Radio:	<input checked="" type="radio"/> yes	<input type="radio"/> no	Brakes: drum:	<u>R</u>	disc:	Back	<u> </u>
					<u>F</u>	Bench:	<u> </u>
Clock:	yes	<input type="radio"/> no					

Tire Size: HR78-14 Ply Rating: 4 Mfg. & Line: Wards Radial

Bias Ply: Steel Eng. Total 351
 Belted: X Radial X / Type: V-8 Cylinders: 8 Displ: CID

Trans, # Fwd. Speeds: 3 Shipping Weight: 4188 lb Odometer: 62,048 miles

Dealer (name, address, and phone number)
Canyon Ford
2600 Grand Avenue
Phoenix, Arizona

Remarks (list additional accessories not listed above)

Date of Manufacture: 2/75 Dynamic Science No.: 640 Date Received: 2/78

Tilting Steering Wheel: yes no Telescoping Steering Wheel: yes no

Fuel Capacity: "Space Saver" Spare Tire yes no
 (from owner's manual)

Restraint System: Std. 3-point Production Belts

- Is the vehicle stock throughout? Describe: No, removed rear window prior to testing to meet weight goal.
- Does vehicle show evidence of prior accident history? Describe: Yes, replaced front right fender and front windshield due to previous damage.
- Does vehicle show any significant corrosion? Describe: No
- Check condition of the front bumper and frame: Okay

TABLE 2-2. VEHICLE DESCRIPTION - MOVING TEST DEVICE TEST

Contractor: Dynamic Science, Inc. Contract No.: DOT-HS-7-01758

VIN NO.: 5A27H125599 Make: Ford

NHTSA No.: --

Year: 1975 Color: Dark Blue Model: Torino 4-Door

Auto Trans: yes no Pwr Steering: yes no Seats: Bench: X
(front)

Pwr Brakes: yes no Auto Speed Cont: yes no Bucket: _____

Pwr Seats: yes no Anti Skid Brake: yes no Split Bench: _____

Pwr Windows: yes no Air Conditioning: yes no Split Back Bench: _____

Tinted Glass: yes no Rear Window Def.: yes no

Radio: yes no Brakes: drum: R disc: F

Clock: yes no

Tire Size: * Ply Rating: 4 Mfg. & Line: Front: Dayton Steel Radial
Rear: Uniroyal Steel Belted Radial

Bias Ply: Steel Eng. Total 351
Belting: X Radial X / Type: V-8 Cylinders: 8 Displ: CID

Trans, # Fwd. Speeds: 3 Shipping Weight: 4180 lb Odometer: 31995 miles

Dealer (name, address, and phone number)
Olsen Chevrolet
Williams, Arizona

Remarks (list additional accessories not listed above)

*FR-GR78-14 and RR-HR78-14.

Date of Manufacture: 11/74 Dynamic Science No.: 604 Date Received: 1/78

Tilting Steering Wheel: yes no Telescoping Steering Wheel: yes no

Fuel Capacity: _____ "Space Saver" Spare Tire yes no
(from owner's manual)

Restraint System Std. 3-point Production Belts

1. Is the vehicle stock throughout? Describe: Yes
2. Does vehicle show evidence of prior accident history? Describe: No
3. Does vehicle show any significant corrosion? Describe: No
4. Check condition of the front bumper and frame: D Added front bumper guards.

51850108

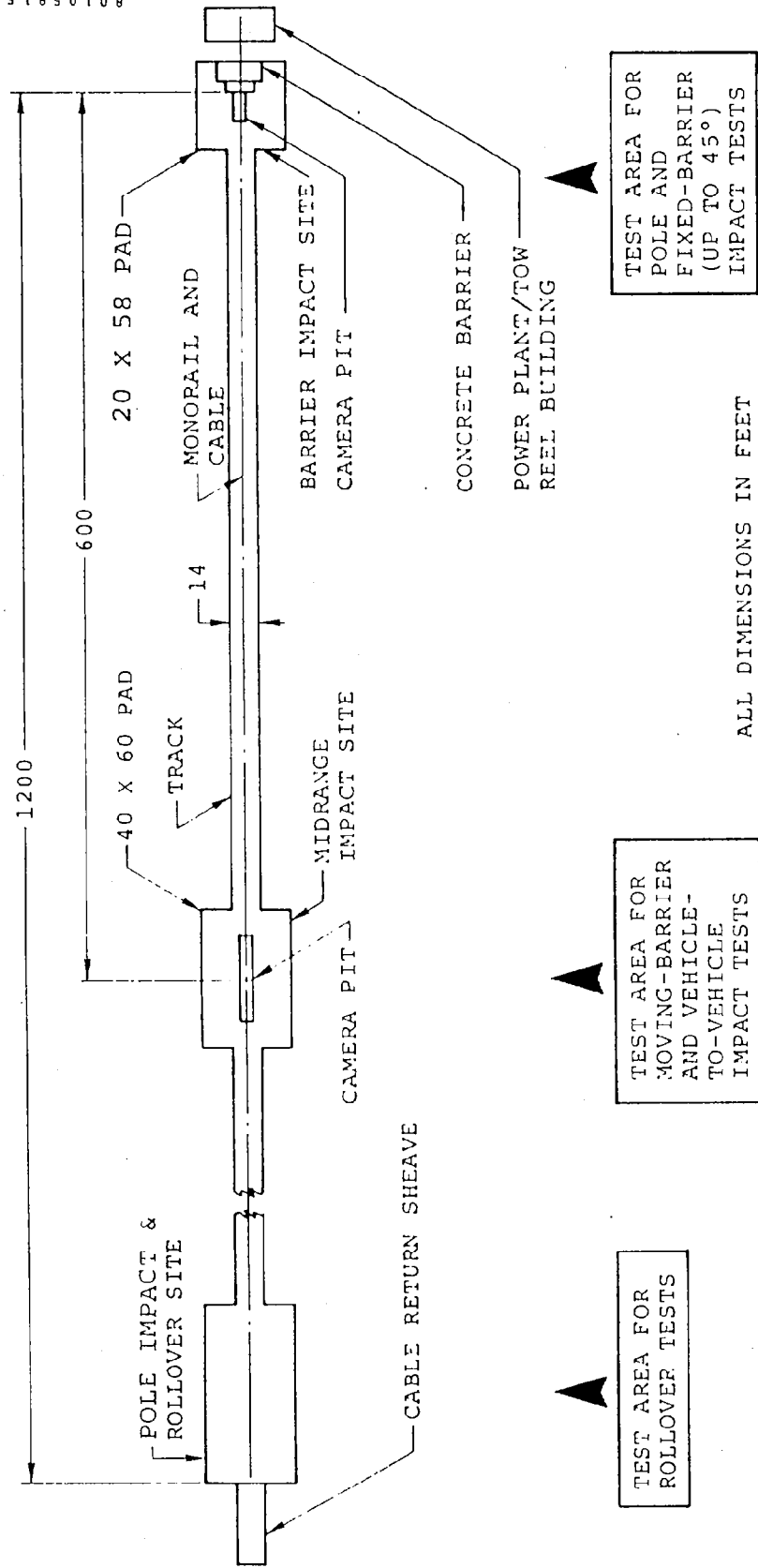

Figure 2-1. Monorail Impact Facility.

The test vehicle was instrumented with 16 accelerometers, 1 string potentiometer, 6 seat belt loads, and an impact sensor. The test vehicle was placed at the head of the test track facing the barrier where it was attached to the tow and guidance system. The fixed Test Device was instrumented with 40 load cells, 6 string potentiometers, 2 strain gauges, and an impact sensor.

Upon completion of the pre-crash checkout of the instrumentation, the vehicle was towed to the specified test speed and released from the tow system just prior to impact. The data from the test vehicle was transmitted to the data acquisition center via umbilical cable with telemetry as a backup. The data from the fixed Test Device was transmitted by umbilical cable only (see Figure 2-2). In order to achieve the weight goal outlined in the test plan, the rear windows of the test vehicle were removed prior to testing. See Table 2-3 for a crash test summary of the fixed Test Device configuration.

2.3 MOVING TEST DEVICE TESTS

The Ford-to-moving Test Device test was conducted at the mid-range station of the crash track facility (see Figure 2-1) with the centerline of the test car in line with the center of the moving Test Device face. The vehicle impact velocity of each test vehicle (see Table 1-1) was controlled to within ± 1 mph.

The test vehicle was instrumented exactly the same as the vehicle used in the fixed Test Device test with the abort bottle placed inside the trunk of the vehicle. This was done for safety reasons. The test vehicle was placed at the head of the test track, facing the barrier. The moving Test Device was instrumented the same as the fixed Test Device with the addition of 2 longitudinal accelerometers and an additional strain gauge attached to the frame rails of the moving Test Device. The moving Test Device was placed

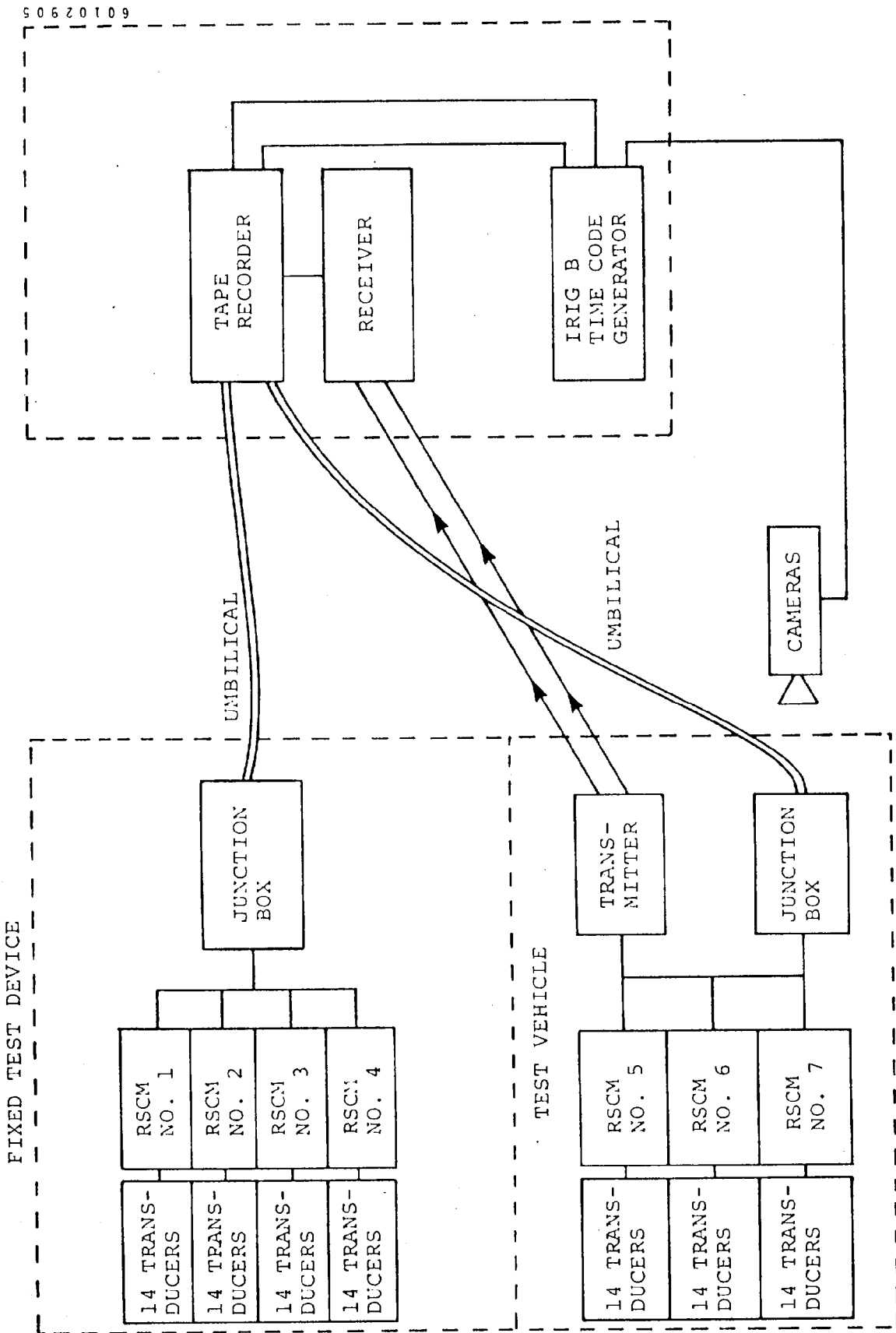

Figure 2-2. Data Acquisition - Vehicle-to-Fixed Barrier Tests.

TABLE 2-3. CRASH TEST SUMMARY 8316-3

Test No. 8316-3 Contract DOT-HS-7-01758
 Test Date May 9, 1978 Time 1000 Temperature 83 °F
 Test Configuration Front-to-Front, Head-on
 Vehicle No. 1 (A) 1975 Ford Torino 4-door Sedan
 Vehicle No. 2 (B) Fixed Test Device

VEHICLE DATA

	Vehicle A	Vehicle B
Test Weight (lb)	4550	>100,000
Impact Angle (deg)*	0°	180°
Offset Distance (in.)	0	0
Impact Velocity (mph)**	40.52	0

DUMMY DATA

Type	Part 572 Alderson	None
Locations	LF (Driver) - # 759***	-
	RF (Passenger) - # 760***	-
Restraints	Lap/Shoulder Belt	None
	Lap/Shoulder Belt	

INSTRUMENTATION

Number of Data Channels	41	48
Number of Cameras	7	

*With respect to tow track centerline facing fixed barrier.
 **Speed trap measurement.
 ***Alderson Dummy Serial No.

at the barrier end of the track. See Table 2-4 for a crash test summary of the moving Test Device configuration. The rear window of the Ford was not removed for this test.

Both vehicles were attached to the tow and guidance system. After the pre-crash checkout of the instrumentation, the vehicles were towed to the specified test speed and released from the tow system just prior to impact. The data from the test vehicle and moving Test Device were transmitted to the data acquisition center via umbilical cable with telemetry as a backup (Figure 2-3).

TABLE 2-4. CRASH TEST SUMMARY 8316-4

Test No. 8316-4 Contract DOT-HS-7-01758
 Test Date May 16, 1978 Time 1422 Temperature 88 °F
 Test Configuration Front-to-Front, Head-on
 Vehicle No. 1 (A) 1975 Ford Torino 4-door sedan
 Vehicle No. 2 (B) Moving Test Device

VEHICLE DATA

	VEHICLE A	VEHICLE B
Test Weight (lb)	4550	4002
Impact Angle (deg)*	0°	180°
Offset Distance (in.)	0	0
Impact Velocity (mph)**	29.55	29.55

DUMMY DATA

Type	Part 572 Alderson	None
Locations	LF (Driver) - # 759***	-
	RF (Passenger) - # 760***	-
Restraints	Lap/Shoulder Belt	None
	Lap/Shoulder Belt	

INSTRUMENTATION

Number of Data Channels	41	53
Number of Cameras	7	

*With respect to tow track centerline facing fixed barrier.
 **Speed trap measurement.
 ***Alderson Dummy Serial No.

MOVING TEST DEVICE

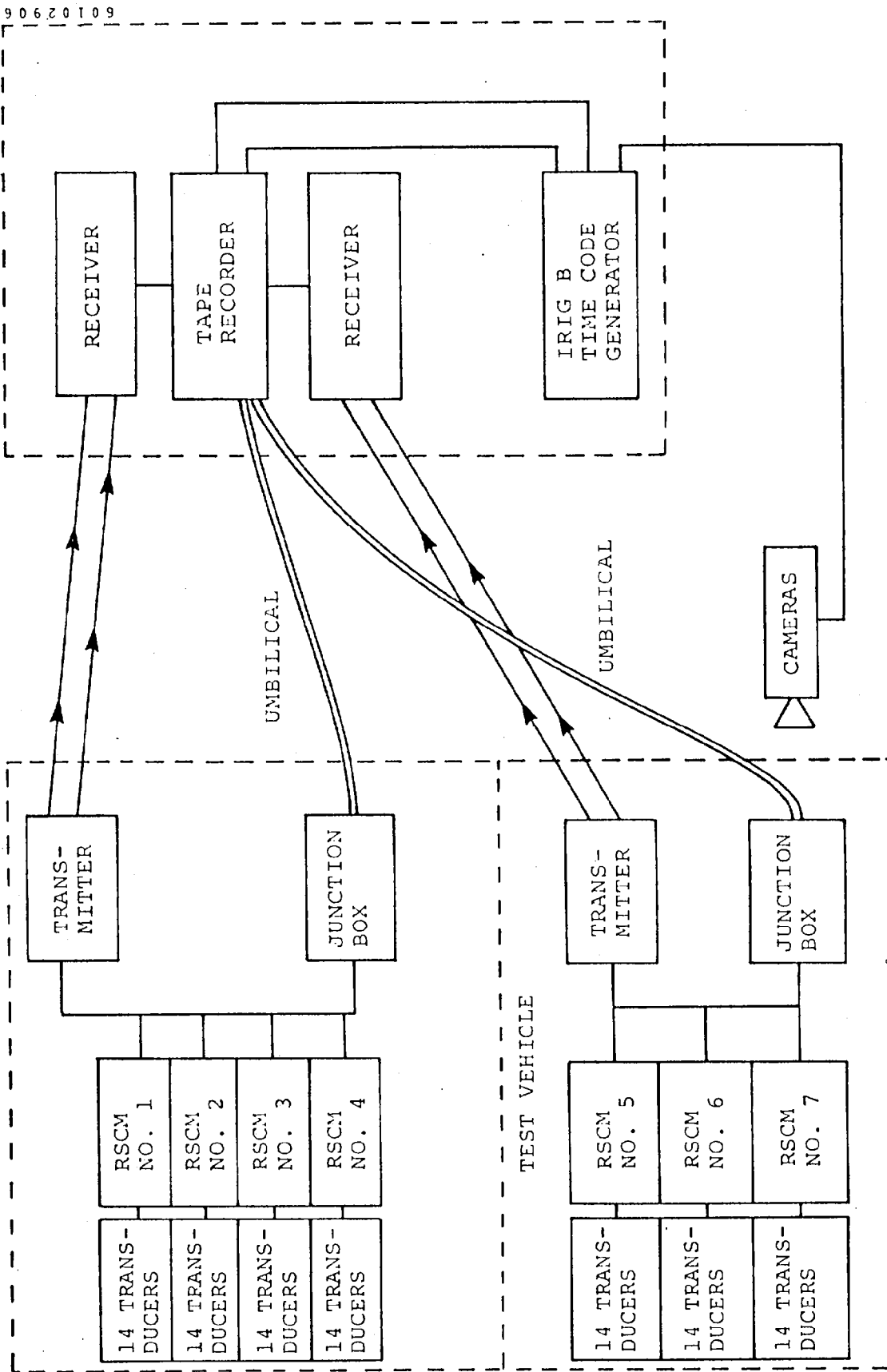

Figure 2-3. Data Acquisition - Vehicle-to-Moving Test Device Tests.

3.0 DATA ACQUISITION

3.1 DATA ACQUISITION METHODS

The overall plan for obtaining the necessary data is outlined in Table 3-1. The table defines the test parameter, measurement method, and recording method used during the conduct of this program.

TABLE 3-1. DATA REQUIREMENTS

Test Parameter	Measurement Method	Magnetic Tape	Written Log	Photo-graphic Analysis
Impact Time	Contact switch signal impressed on millisecond time base	X		
Approach Velocity	Tow cable velocity sensor	X		
Impact Velocity	Speed trap entrance and exit signals from speed trap	X*		
Rebound Velocity	Calculated from high-speed film analysis and compartment accelerometer data	X		X
Test Device and Vehicle Acceleration Measurements	Accelerometers, unbound strain gauge type	X		
Test Device Honeycomb Crush	String potentiometer and direct linear measurement	X	X	
Stress in Test Device frame and Horizontal Beams	Strain gauges	X		
Forces on Test Device Honeycomb	Load cells	X		

*Velocity is also measured by electronic counter.

TABLE 3-1. DATA REQUIREMENTS (CONTD)

Test Parameter	Measurement Method	Magnetic Tape	Written Log	Photo-graphic Analysis
Vehicle Structural Deformation	Direct linear measurement		X	
Vehicle Static Crush	Direct linear measurement		X	
Vehicle Static Crush	Film analysis			X
Restraint Survival Distance	Direct linear measurement		X	
Steering Column Intrusion	Direct linear measurement		X	
Firewall Intrusion	String potentiometer and static measurements	X	X	
Fuel Leakage	Observation and timed measurement		X	
Windshield Retention	Direct measurement and observation		X	
Occupant Head and Chest Acceleration	Triaxial accelerometers	X		
Occupant Femur Loads	Load cells	X		
Seat Belt Loads	Load cells	X		
Vehicle Weight by Wheel	Direct pre-test measurement using balance scales		X	
Ballast Weight	Balance scale		X	

3.2 INSTRUMENTATION

3.2.1 Test Vehicle Instrumentation

The test vehicle contained two Part 572 anthropomorphic dummies positioned in the left and right front seating locations. Prior to each test use, the dummies were inspected and adjusted to meet the torque and characteristic requirements for these devices. Sixteen structural accelerometers and one string potentiometer were installed on the vehicle and consisted of the following (see Figure 3-1):

1. A biaxial (X, Z) mount located on the left rocker panel near the B-pillar to measure accelerations of the occupant compartment.
2. A biaxial (X, Z) mount similar to No. 1, but on the right side of the vehicle.
3. A biaxial mount (X, Z) located on the rear floor structure over the rear axle.
4. A biaxial mount (X, Z) located on the upper centerline of the firewall in the engine compartment to measure acceleration of the forward section of the passenger compartment.
5. A biaxial mount (X, Z) located on the centerline of the rear axle to measure acceleration of the rear drive train and rear suspension assembly.
6. A single mount (X) located on the top of the engine block in a protective case to measure acceleration of the engine.
7. A single mount (X) located on the front frame cross-member in a protective case to measure axial acceleration of the front frame.
8. A triaxial mount (X, Y, Z) located near the vehicle center of gravity on the drive tunnel at the longitudinal C.G. to measure acceleration of the compartment.
9. A single mount (X) located in a position similar to that in No. 6, but on the bottom of the engine.

30105813

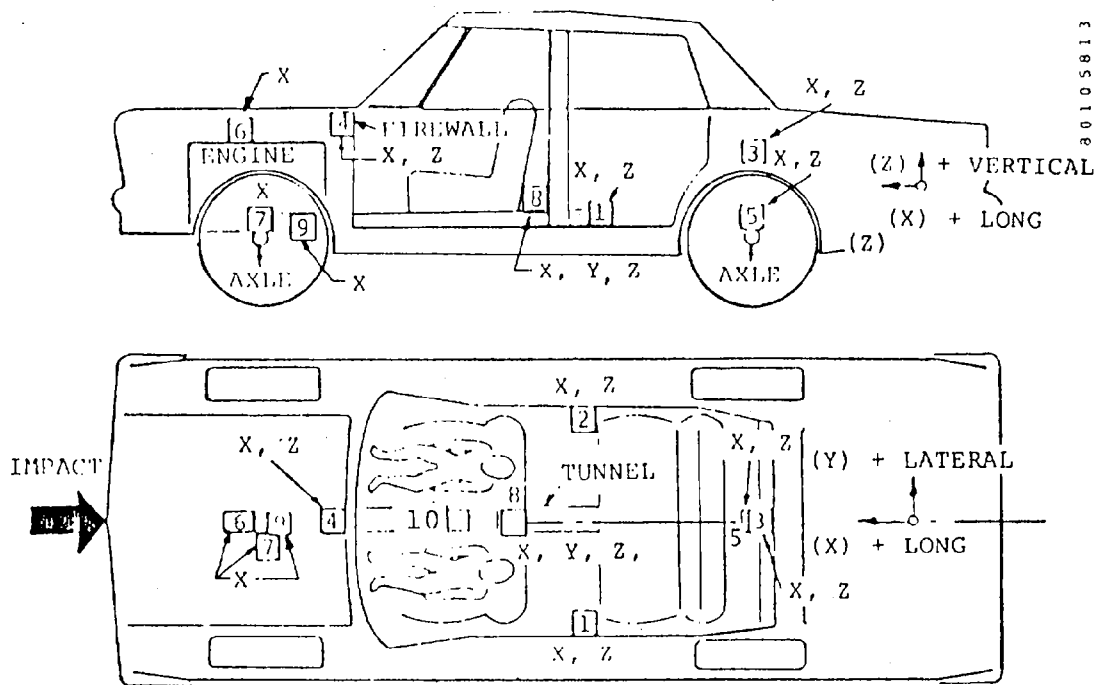

VEHICLE ACCELEROMETER LOCATIONS AND PHYSICAL COORDINATES				MAXIMUM EXPECTED READINGS			
NO.	DESCRIPTION OF LOCATION	X**	Y**	Z**	LONG*	LAT*	VERT*
1	Rocker panel near B-pillar behind driver's seat	98	-27	15	50		50
2	Rocker panel near B-pillar behind passenger's seat	98	+27	15	50		50
3	Centerline of rear deck above rear axle	58	0	27	50		50
4	Centerline of firewall at A-pillar inside engine compartment	155	-3	+33	100		100
5	Centerline of rear axle	55	0	6	100		100
6	Engine block (Top centerline)	120	0	+29	200		
7	Front crossmember	171	0	6	200		
8	Longitudinal center of gravity of car	117	0	16	50	50	50
9	Engine block (Bottom centerline)	129	0	6	200		
10	String Potentiometer	132	0	24	15 in.		

*In G.

**Reference points:

X - Direction - Centerline of rear bumper

Y - Direction - Centerline of vehicle - left centerline (-), right centerline (+)

Z - Direction - Ground level

Figure 3-1. Vehicle Accelerometer Instrumentation.

10. A string potentiometer installed on the interior firewall to measure the intrusion of the firewall into the occupant compartment.
11. A tape switch mounted onto the forwardmost portions of the car to record impact.

3.2.2 Test Vehicle Occupant Instrumentation

The following test dummy instrumentation was installed for the driver and right front passenger positions:

1. A triaxial accelerometer mount located in the head to measure its acceleration.
2. A triaxial accelerometer mount located in the chest cavity to measure chest acceleration.
3. A femur load cell mounted in the femur of each leg to measure femur loads.
4. Two seat belt load cells were mounted onto the lap belt with an additional seat belt load cell mounted onto the shoulder belt for each of the two front occupant restraint systems. The lap belt load cells were mounted on each side of the occupant.

The instrumentation requirements for the dummy occupants are given in Table 3-2.

3.2.3 Moving Test Device Instrumentation

The moving Test Device was instrumented with 40 load cells, 6 displacement string potentiometers, 3 strain gauges, 2 accelerometers, and 1 tape switch. Their purposes and locations were as follows:

1. A load cell mounted between each honeycomb module and Test Device rigid face to measure impact forces.
2. A string potentiometer displacement transducer mounted at selected honeycomb locations to measure dynamic honeycomb displacement.

TABLE 3-2. OCCUPANT INSTRUMENTATION

Occupant Accelerometer and Load Cell Locations	Maximum Expected Readings					
	Description of Locations	Long	Lat	Vert	Long*	Lat*
Driver head accelerometer	X	X	X	200	100	200
Passenger head accelerometer	X	X	X	200	100	200
Driver chest accelerometer	X	X	X	100	50	100
Passenger chest accelerometer	X	X	X	100	50	100
Driver left and right femur load cell				3000		1b
Passenger left and right femur load cell				3000		1b

*In G.

3. A single (X) accelerometer mounted on the longitudinal frame rails (mounted on each side) to measure acceleration of the Test Device.
4. Two strain gauges mounted on selected horizontal impact face beams to measure strains developed in the front structure due to the impact force.
5. One strain gauge mounted on the right side of the Test Device longitudinal frame rail to measure strain in the vehicle frame structure.
6. One tape switch mounted onto a selected honeycomb module to record the time of impact.

Figure 3-2 defines the typical instrumentation honeycomb module; Figure 3-3 describes the location of instrumentation on the Test Device impact face; and Figure 3-4 shows the location of the instrumentation on the Test Device vehicle structure.

3.2.4 Fixed Test Device Instrumentation

The instrumentation on the fixed Test Device was the same as on the moving Test Device except that the strain gauges and accelerometers on the Test Device frame were deleted (Figure 3-5).

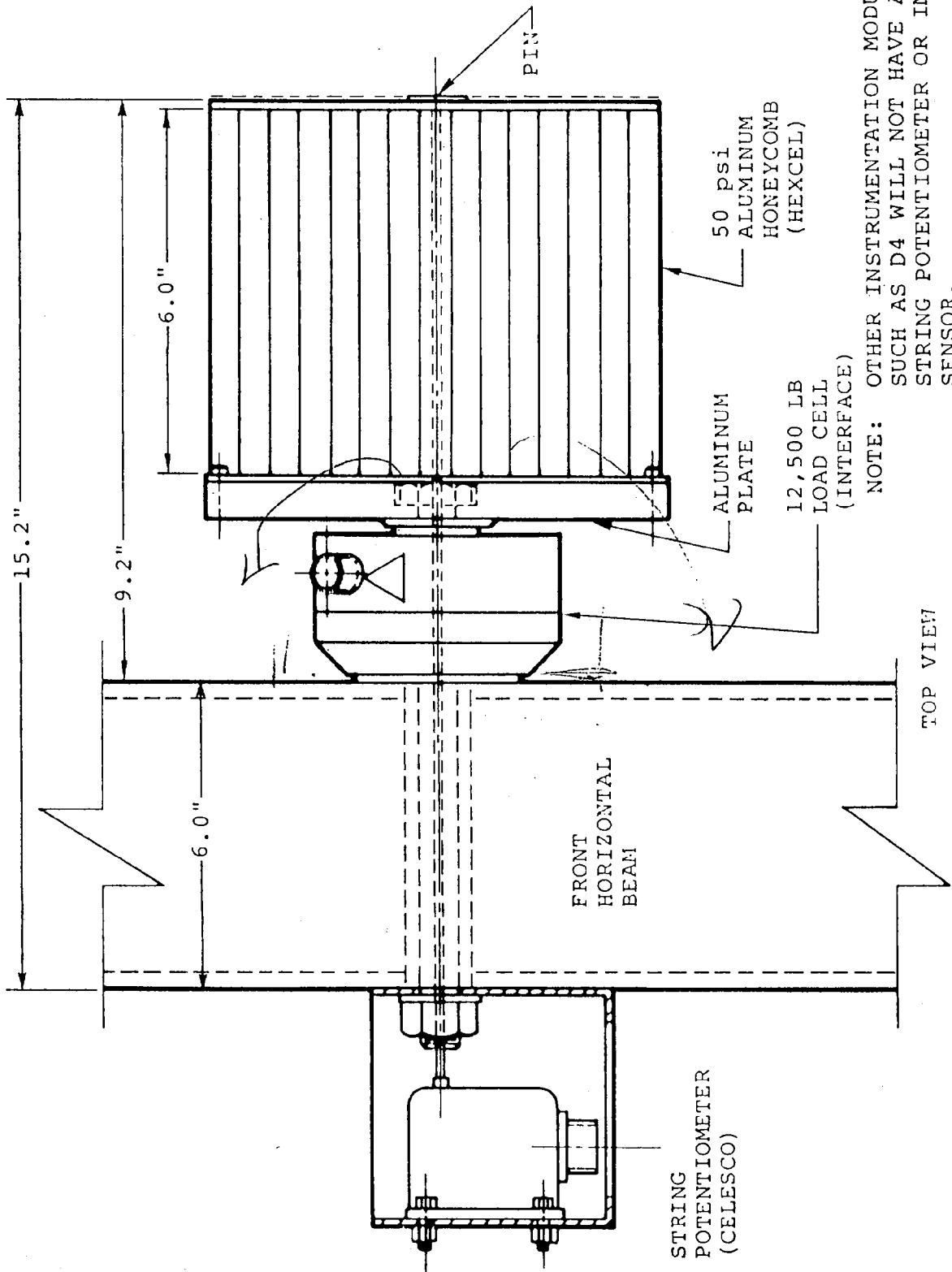

Figure 3-2. Typical Instrumentation Model (B5).

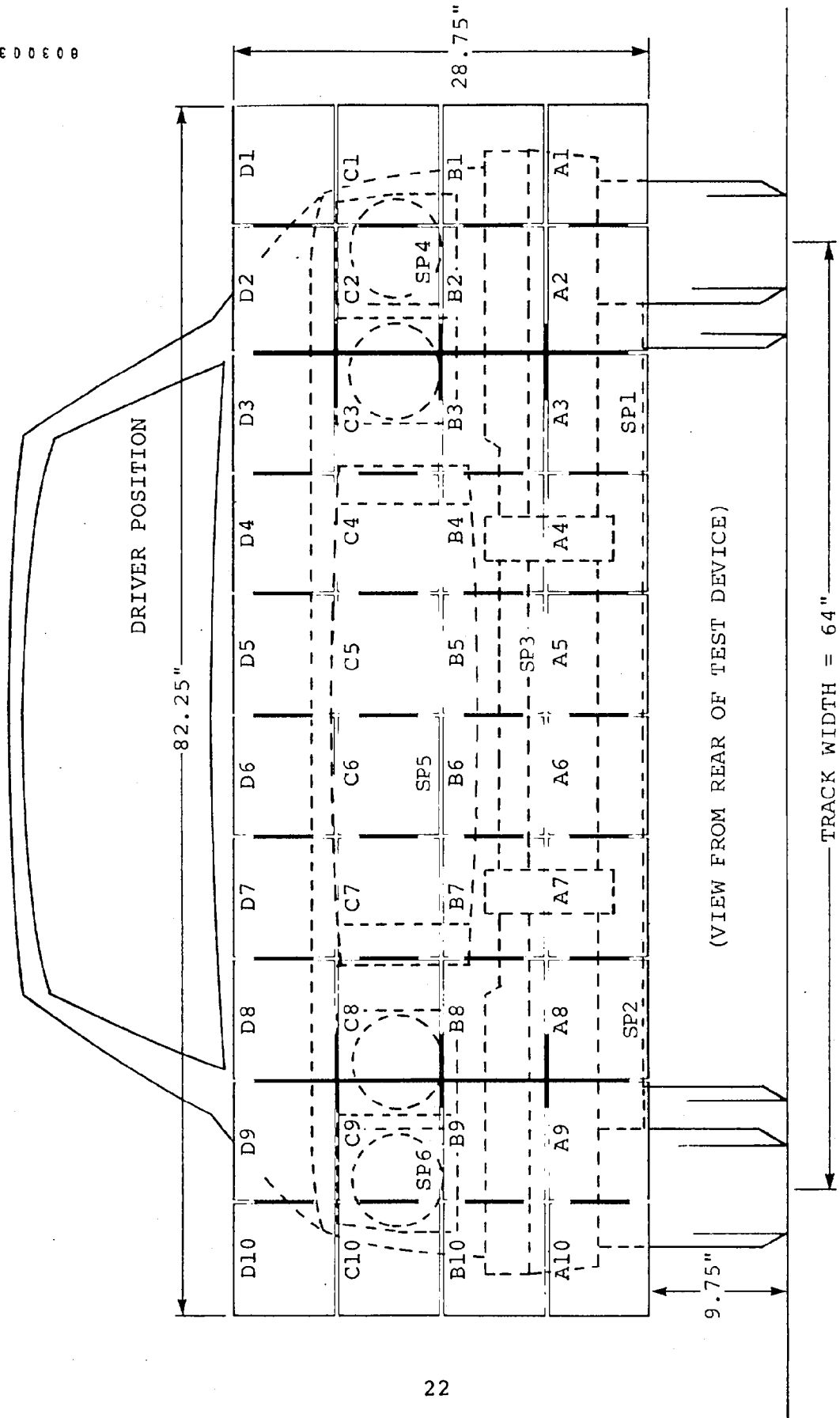
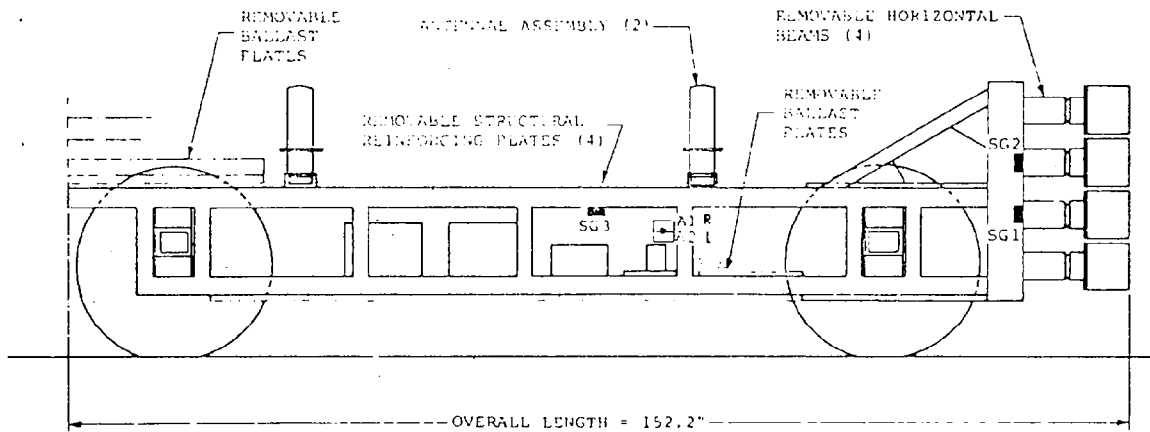
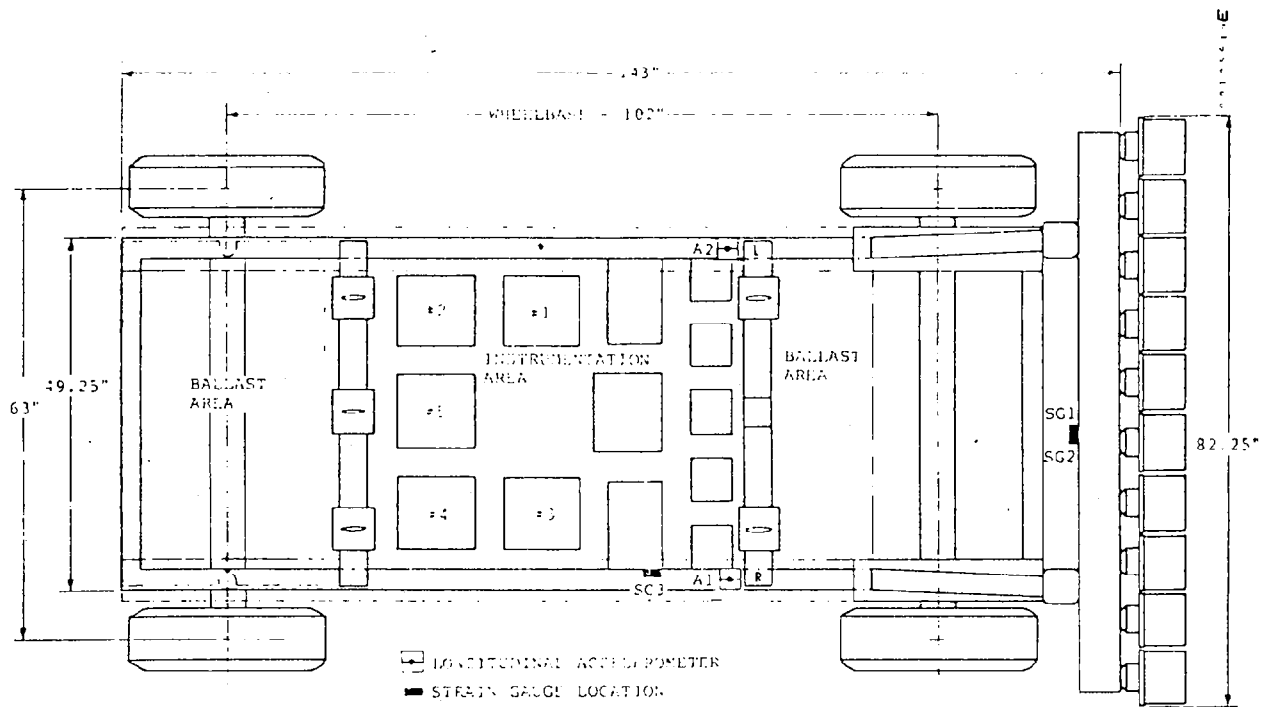

Figure 3-3. 1975 Ford Torino/Test Device Honeycomb Interface and String Potentiometer Locations.



VEHICLE INSTRUMENTATION LOCATIONS AND PHYSICAL COORDINATES				MAXIMUM EXPECTED READINGS			
NO.	DESCRIPTION OF LOCATION	X*	Y*	Z*	LONG	LAT	VERT
A1R	Test Device Accelerometer frame rail right side	84	46	20	100 G		
A2L	Test Device Accelerometer frame rail left side	84	-46	20	100 G		
SG1	Row B horizontal beam	140	0	20	7500 μ in./in.		
SG2	Row C horizontal beam	140	0	28	7500 μ in./in.		
SG3	Test device frame rail right side	78	46	21	7500 μ in./in.		
40	Load cells				15.0 Flb		

*Reference Points:

X Direction - Rear End of Test Device

Y Direction - Centerline of Test Device - Left Q (-), Right Q (+)

Z direction - Ground Level.

Figure 3-4. Moving Test Device Instrumentation.

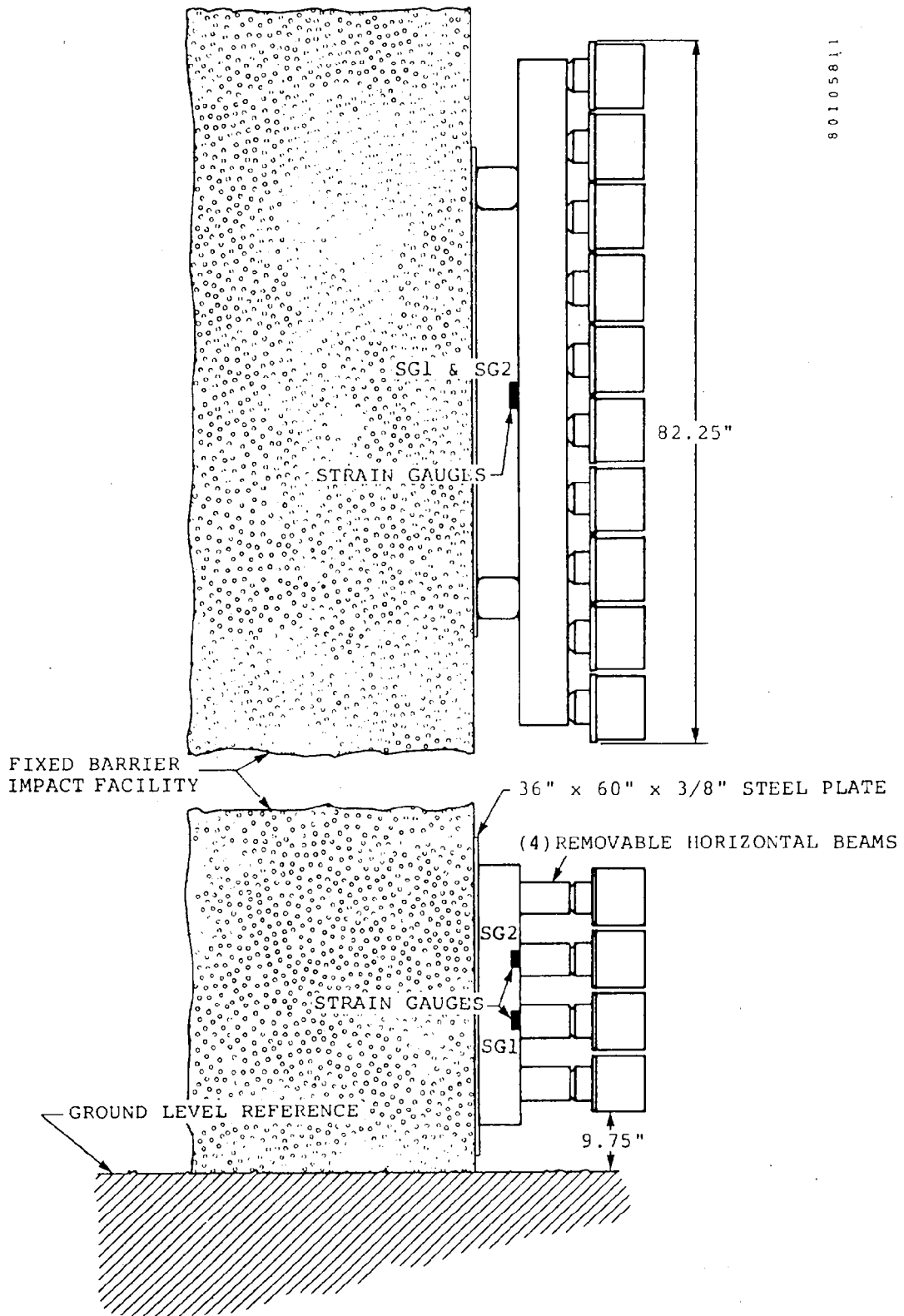

Figure 3-5. Fixed Test Device Installation and Strain Gauge Location.

3.3 PHOTO-INSTRUMENTATION REQUIREMENTS

3.3.1 Fixed Test Device Photography

Six high-speed (four 1000 fps and two 500 fps) cameras and one panning (24 fps) camera were used as shown in Table 3-3 for the fixed Test Device/moving vehicle tests.

The panning camera documented the instrumentation, pre-test and post-test configurations, pre-test and post-test dummy positions, and the Test Device and vehicle crush profiles.

3.3.2 Moving Test Device Photography

Six high-speed (four 1000 fps and two 500 fps) cameras and one panning (24 fps) camera were used as shown in Table 3-4 for the moving Test Device/moving vehicle tests.

TABLE 3-3. CAMERA LOCATIONS - FIXED TEST DEVICE

80105812A

Test No: 8316-3 Test Date: 5/9/78

Test Type: Car-to-Fixed Test Device Head-on

Vehicle A (Away): 1975 Ford Torino

Vehicle B (Barrier): Fixed Test Device

Comments: Camera locations are approximate and may be moved at the discretion of the Test Engineer.

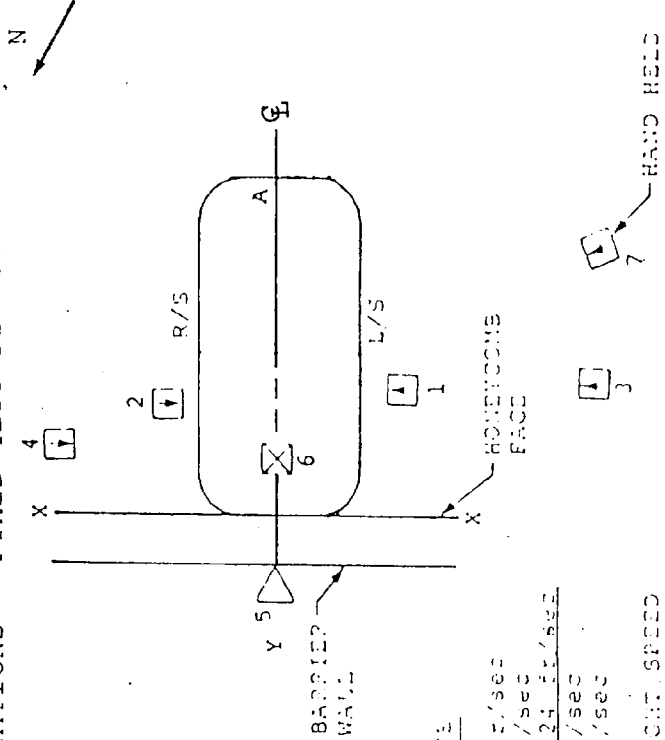

- CAMERA SYMBOLS
- PIT
 - GROUND
 - BARRIER
 - OVERHEAD
 - ON-BOARD
- FRAME RATE
- ①. 1000 ft./sec
 - ②. 200 ft./sec
 - ③. Other 24 ft./sec
 - ④. 400 ft./sec
 - ⑤. 500 ft./sec
- TIMING LIGHT SPEED
- ①. 100 Hz (10 msec/light)
 - ②. 200 Hz (5 msec/light)
 - ③. Other

CAMERA	YES
STILLS	V
SLIDES	V
MOVIE	V
POLAROID	
	↓

Loc. No.	Location	Field of View	Lens Size	Frm. Rate	Trans. Spd.
1	Left Side**	Left Front Occupant Compartment	25mm	1	1
2	Right Side**	Right Front Occupant Compartment	25mm	1	1
3	Left Side**	Overall of Car and Barrier Wall	13mm	1	1
4	Right Side**	B-Pillar of Car and Honeycomb Crush	25mm	1	1
5	Barrier	Occupants Through Front Windshield	13mm	5	1
6	Overhead	B-Pillar of Car and Honeycomb Crush	13mm	5	1
7	Left Side	Panning Test and Overall Results		3	

**Camera perpendicular to line of vehicle travel.

TABLE 3-4. CAMERA LOCATIONS - MOVING TEST DEVICE

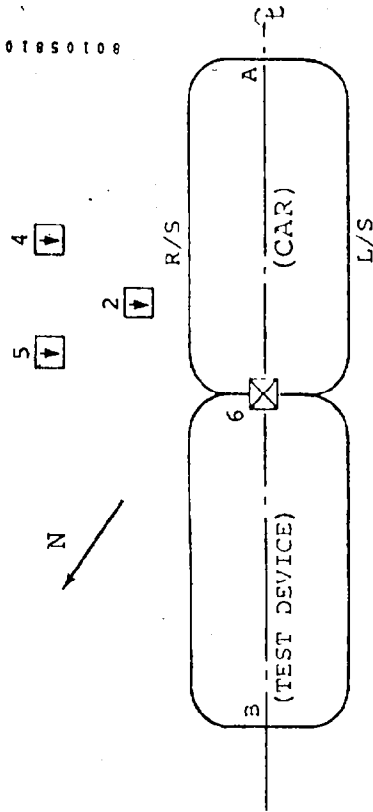

01650108

Test No: 8316-4 Test Date: 5/16/78

Test Type: Car-to-Moving Test Device Head-on

Vehicle A (Away): 1975 Ford Torino

Vehicle B (Barrier): Moving Test Device

Comments: Camera locations are approximate and may be moved at the discretion of the Test Engineer

CAMERA	YES	CAMERA SYMBOLS	FRAME RATE
STILLS	V	<input type="checkbox"/> PIT	①. 1000 fr./sec
SLIDES	V	<input checked="" type="checkbox"/> GROUND	2. 200 fr./sec
MOVIE	V	<input type="checkbox"/> BARRIER	3. Other 24 fr./sec
POLAROID		<input checked="" type="checkbox"/> OVERHEAD	4. 400 fr./sec
		<input type="checkbox"/> ON-BOARD	⑤. 500 fr./sec
			TIMING LIGHT SPEED
			①. 100 Hz (10 msec/light)
			2. 200 Hz (5 msec/light)
			3. Other _____

Loc. No.	Location	Field of View	Lens Size	Film Rate	Trans Spd
1	Left Side **	Right Front Occupant Compartment	25mm	1	1
2	Right Side**	Left Front Occupant Compartment	25mm	1	1
3	Left Side**	Overall of Moving Barrier and Car A	13mm	1	1
4	Right Side**	B-Pillar to B-pillar of Both Vehicles	13mm	1	1
5	Right Side **	Overall of Car A	25mm	5	1
6	Overhead at Centerline**	Front Half of Both Vehicles at Impact	13mm	5	
7	Left Side	Panning Test and Overall Results		3	

**Cameras perpendicular to line of vehicle travel.

4.0 SUMMARY OF TEST RESULTS

This section of the report presents the results of the Ford-to-Test Device crash tests performed under Task 4. Copies of instrumentation data traces (Calcomp plots) are included in Appendix B for Test No. 3 and in Appendix C for Test No. 4.

4.1 TEST SUMMARY: FORD-TO-TEST DEVICE TESTS

A summary of pertinent pre-test and post-test Test Device conditions are given in Tables 4-1 through 4-7. Pre-test and post-test views of crash configurations are shown in Figures 4-1 and 4-2 for fixed Test Device tests and in Figures 4-3 and 4-4 for moving Test Device tests.

Test weights for each vehicle were determined by weighing each wheel of the car to obtain a total weight. The vehicle was then rotated 180 degrees and the weighing procedure repeated to obtain an average weight for the vehicle.

Compartment and engine acceleration was determined by an averaging of accelerometers located near the B-pillar of the vehicle and the top and bottom of the engine block (see Figure 3-1).

Maximum mutual dynamic crush data, as well as the chronology of events for each vehicle, were determined by high-speed film analysis. Maximum dynamic crush on the car was determined by subtracting 6 inches of honeycomb crush from the maximum mutual dynamic crush for each test.

4.1.1 Fixed Test Device Test

In the fixed Test Device test, the Ford impacted the aluminum honeycomb modules at a speed of 40.5 mph, causing approximately 31 inches of static crush to the vehicle. The final speed

TABLE 4-1. CRASH TEST SUMMARY

Test No.	7	8		
Test Date	June 13, 1978	June 16, 1978		
Time	1242	1119		
Temperature	101° F	95° F		
Test Configuration	Front-to-Front Head-on	Front-to-Front Head-on		
Vehicle A	1975 Plymouth Fury	1975 Plymouth Fury		
Vehicle B	Fixed Test Device	Moving Test Device		
VEHICLE A DATA				
Test Weight by Wheel (lb)	LF-1224 LR- 984	RF-1236 RR- 995	LF-1221 LR-1021	RF-1235 RR- 967
Total Weight (lb)	4439		4444	
Longitudinal C.G. (from center of front axle) (in.)	52.5		52.5	
Impact Angle (deg)*	0		0	
Offset Distance (in.)	0		0	
Impact Velocity (mph)**	40.73		58.02	
OCCUPANTS				
Type	Part 572 Alderson		Part 572 Alderson	
Locations	LF (Driver) - #759 RF (Passenger) - #760		LF (Driver) - #759 RF (Passenger) - #760	
Restraints	Standard Production Lap/Shoulder Belt		Standard Production Lap/Shoulder Belt	
INSTRUMENTATION				
Number of Data Channels	Vehicle A - 41 Vehicle B - 48		Vehicle A - 41 Vehicle B - 53	
Number of Cameras	7		7	
*With respect to tow track centerline facing fixed barrier.				
**Closing speed from speed trap measurement.				

TABLE 4-2. SUMMARY OF CAR TEST DATA

VEHICLE: 1975 Ford Torino 4-door Sedan

Vehicle Parameter	Test 3 (Fixed Test Device)	Test 4 (Moving Test Device)
Car Test Weight (lb)	4550	4550
Overall Vehicle Length/Width (in.)	218.1/79.3	217.8/79.3
Car Speed (mph)	40.5	29.6
Final Speed (mph @ msec)	-6.6 @ 152	-1.9 @ 115
Coefficient of Restitution	0.16	0.12
Velocity Change (mph @ msec)	47.1 @ 152	31.5 @ 115
Maximum Compartment Acceleration (G @ msec)	-48.2 @ 66	-44.6 @ 61
Maximum Engine Acceleration (G @ msec)	-79.9 @ 52	-116.6 @ 40
Maximum Dynamic Crush (in.)	37.8 (F)	36.5 (F)
Maximum Static Crush		
• Hood Level (in.)	30.4	30.3
• Between Bumper/Hood (in.)	30.6	29.3
• Bumper Level (in.)	31.8	31.0
Maximum Post-test Intrusion (in.)	8.1	4.3
Maximum Mutual Dynamic Crush (in.)	43.8 (F)	42.5 (F)
Maximum Individual Load Cell Force (klb @ msec)***	12.36 @ 58 (B7)	9.79 @ 44 (C5)
Maximum Total Load Cell Force (klb @ msec)***	108.5 @ 56	99.9 @ 43
Normalized Maximum Force* (lb/lb)	23.8	22.0
Vehicle Damage Index**	12FCAW9	12FCAW9

(F) = Film Data

*Maximum total load cell force/car test weight.

**Refer to SAE J224A

***Some load may have been lost due to load cell contact with backing plate (see Figures 4-32 and 4-33).

TABLE 4-3. SUMMARY OF PRE-TEST ENGINE/BUMPER/FIREWALL CHARACTERISTICS

Test No.	3	4
Type of Test	Fixed Test Device	Moving Test Device
Impact Velocity (Closing, mph)	40.5	59.1
Engine Size (CID)	351	351
Engine Weight* (lb)	891	891
Engine Height/Width (in.)	23/24	23/24
Bumper to Engine (in.)	30.8	30.6
Engine Length (in.)	28.0	28.0
Engine to Firewall (in.)	33.0	33.0
Bumper to Firewall (in.)	63.8	63.6

*Includes engine and rigid attachments such as transmission and drive train.

TABLE 4-4. SUMMARY OF PRE-TEST DUMMY POSITION DATA CHARACTERISTICS

	Test 3		Test 4	
	Fixed Test Device		Moving Test Device	
	Left Front Occupant	Right Front Occupant	Left Front Occupant	Right Front Occupant
Seat Range (in.)	5.3	5.3	5.3	5.3
Seat Position* (in.)	2.6	2.6	2.6	2.6
Front Seat to Firewall (in.)	26.8	26.8	27.0	26.8
Forehead to Windshield (in.)	20.4	20.3	21.4	21.1
Torso to Steering Wheel** (in.)	13.8	18.8	13.5	18.4
Left/Right Knee to Dash Panel (in.)	5.5/5.1	8.5/8.3	5.8/5.1	7.8/7.8

*From rearmost position to midpoint.

**To dash panel for RF passenger.

TABLE 4-5. SUMMARY OF POST-TEST OBSERVATIONS

VEHICLE: 1975 Ford Torino 4-door Sedan

Test No. 3 (Fixed Test Device)

Dummy Contact Points:	Left Front	Right Front
Head-----	Dash Panel and Top of Steering Wheel	Dash Panel
Chest-----	Steering Wheel Hub	None
Knees-----	Knee Bolsters.	Glove Compartment

Glazing: Windshield cracked and 50 percent retained.

Doors: Required tools to open all doors.

Seat Belt Anchorages: Okay

Restraints: Okay

Fuel Leakage: None

General Observations: Radiator leakage. Oil from differential leaked out when drive line broke. Exhaust pipe was bent. Honeycomb modules B5 and C5 were pulled off when hood latch on vehicle pinched aluminum and tearing off module from Test Device face.

Dash panel on passenger side separated from firewall. Rear of vehicle rotated counterclockwise 3-3/4 inches. Vehicle rebounded 3 inches from impact location. Front bumper rotated upward.

TABLE 4-5. SUMMARY OF POST-TEST OBSERVATIONS (CONTD)

VEHICLE: 1975 Ford Torino 4-door Sedan

Test No. 4 (Moving Test Device)

Dummy Contact Points:	Left Front	Right Front
Head-----	Dash Panel	Dash Panel
Chest-----	Steering Wheel	None
Knees-----	Knee Bolsters,	Glove Compartment

Glazing: Windshield was cracked and was 80 percent retained.

Doors: Required tools to open all doors.

Seat Belt Anchorages: Okay

Restraints: Okay

Fuel Leakage: None

General Observations: Radiator leakage. Exhaust pipe was bent. Honeycomb module D1 was pulled off by car. Modules C1, D2, and A10 were sheared off by car at impact. Passenger dash panel was destroyed by striking of occupant's head on dash. Centerline of vehicle was on centerline of monorail after test. Front bumper rotated upward. Vehicle pushed Test Device 21 feet past impact location before stopped by technicians.

TABLE 4-6. INJURY CRITERIA SUMMARY

<u>Occupant Position</u>	<u>Left Front</u>		<u>Right Front</u>	
TEST 3 (FIXED TEST DEVICE)				
HIC	1824 @ 94-116		1691 @ 88-122	
Head G* @ msec	112.2 @ 106		113.0 @ 109	
CSI	942 @ 200		668 @ 200	
Chest G* @ msec	84.5 @ 90		58.8 @ 98	
Femur Load (lb)	<u>Left</u>	<u>Right</u>	<u>Left</u>	<u>Right</u>
	-1407	-1635	-807	-1173
RSD (in.)**	<u>Pre</u>	<u>Post</u>	<u>Pre</u>	<u>Post</u>
	13.5	13.3	13.7	13.2
TEST 4 (MOVING TEST DEVICE)				
HIC	765 @ 80-127		1211 @ 89-118	
Head G* @ msec	75.4 @ 102		1060 @ 109	
CSI	518 @ 200		326 @ 200	
Chest G* @ msec	58.8 @ 89		40.5 @ 90	
Femur Load (lb)	<u>Left</u>	<u>Right</u>	<u>Left</u>	<u>Right</u>
	-2169	-1588	-692	-609
RSD (in.)**	<u>Pre</u>	<u>Post</u>	<u>Pre</u>	<u>Post</u>
	10.7	9.8	9.5	8.4

*3-msec clip.

**RSD computed with 7-msec time shift to correct for honey-comb crush of Test Device.

TABLE 4-7. CHRONOLOGY OF CRASH EVENTS

VEHICLE: 1975 Ford Torino 4-door Sedan

Time (msec)	Test 3 - Fixed Test Device Event
0	Impact (visual)
18	Right front fender starts to deform
20	Left front fender starts to deform
31	Driver starts forward motion
32	Hood starts failure
62	Passenger starts forward motion
82	Driver hits steering wheel with chin
96	Driver hits dash with head
101	Passenger hits dash with head, driver starts rebound
104	Maximum mutual dynamic crush (43.8 in.), passenger hits dash
105	Vehicle rebound begins
114	Rear wheels leave ground
120	Passenger starts rebound
175	Maximum pitch angle 4.6°
183	Driver recontacts seat
206	Passenger recontacts seat
297	Rear wheels touch ground

TABLE 4-7. CHRONOLOGY OF CRASH EVENTS (CONTD)

VEHICLE: 1975 Ford Torino 4-door Sedan

Time (msec)	Test 4 - Moving Test Device Event
0	Impact (visual)
12	Hood buckles
14	Left front fender starts to deform
24	Honeycomb module A10 sheared off
29	Honeycomb module D2 sheared off
35	Honeycomb module D1 sheared off
55	Driver begins forward motion
56	Passenger begins forward motion
65	Windshield cracks
78	Maximum mutual dynamic crush (42.5 in.) with pitch angle 1°
88	Driver hits dash panel
91	Passenger hits dash panel
115	Vehicles separate, Test Device begins rebound
131	Passenger begins rebound
140	Driver begins rebound
238	Passenger recontacts seat
240	Driver recontacts seat



Figure 4-1. Pre-test Vehicle Configuration - Test 3.



Figure 4-2. Post-test Vehicle Configuration - Test 3.

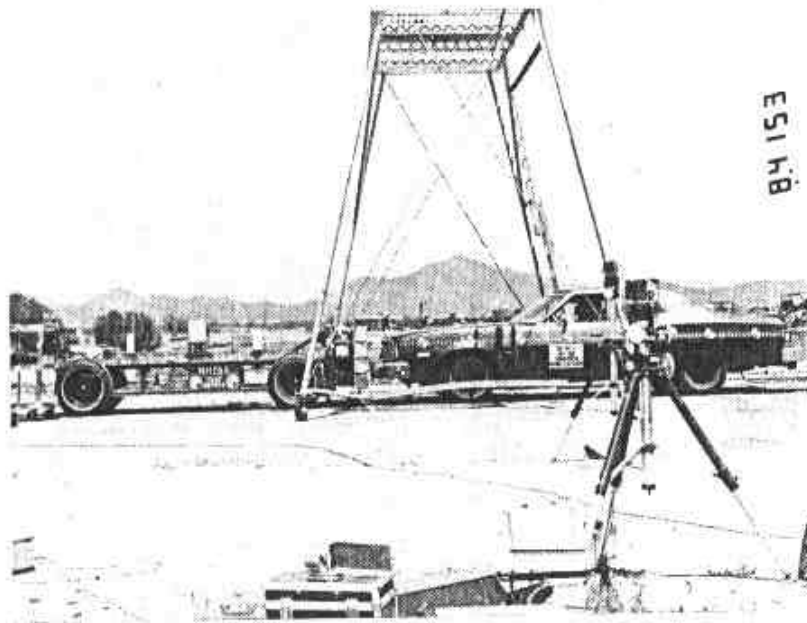

Figure 4-3. Pre-test Vehicle Configuration - Test 4.

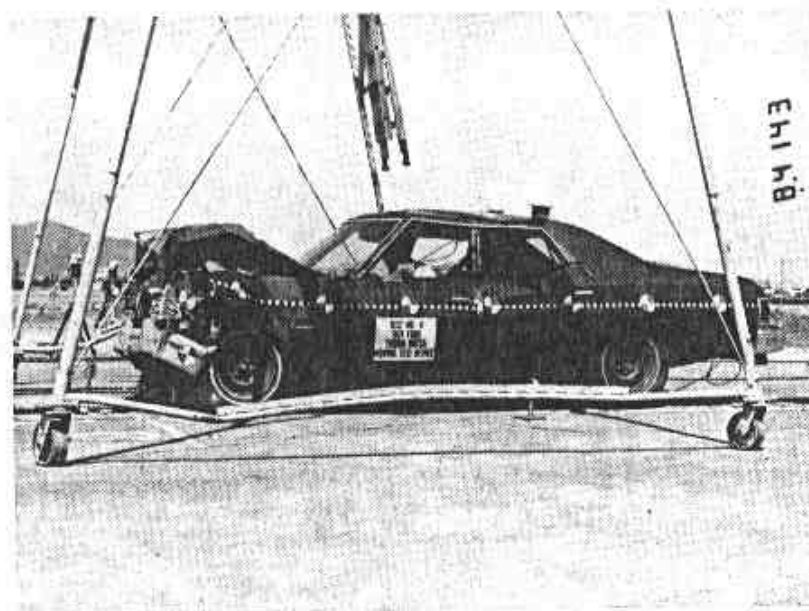

Figure 4-4. Post-test Vehicle Configuration - Test 4.

NOTE: TEST DEVICE PUSHED BACK BY CAR APPROXIMATELY 21 FEET.

of the Ford was -6.6 mph, giving a total velocity change of 47.1 mph.

The maximum dynamic crush on the car was 37.8 inches at 104 milliseconds, with a pitch angle of 4.6 degrees. Rebound of the Ford off of the face of the fixed Test Device caused the rear of the car to rotate 3.8 inches counterclockwise from the barrier centerline. The Ford rebounded approximately 3 inches from the initial impact point, pulling off honeycomb modules B5 and C5 with the structure of the car.

4.1.2 Moving Test Device Test

In the moving Test Device test, the Ford impacted the aluminum honeycomb module at a closing speed of 59.1 mph, causing approximately 30.5 inches of static crush to the vehicle. The final speed of the Ford was -1.9 mph. The final speed of the Test Device was -5.3 mph. The total velocity change to the car was 43.7 mph.

The maximum dynamic crush on the car was 36.5 inches at 78 milliseconds and a pitch angle of 1.0 degree. Moving Test Device tests conducted under this program have been adjusted to give the same ΔE for moving barrier collisions for a similar fixed barrier collision (see Appendix A). Upon impact of the moving Test Device with the Ford, the moving Test Device was pushed back by the car approximately 21 feet before being manually stopped by test personnel. After impact, the Ford appeared to remain stationary near the impact location, putting the remaining energy from the collision into pushing the Test Device backwards. Since the Test Device has no sheet metal deforming around the tires and the Ford was 550 pounds heavier, the energy transmitted by the Ford caused the Test Device to be put in a free wheeling state in the reverse direction of travel. The centerline of the Ford remained in line with the centerline of the track after impact.

Vehicle data, including all pre-test and post-test measurements and summaries of vehicle accelerometer and string potentiometer data, are discussed in Section 4.2. Test Device data, including summaries of load cell, string potentiometer, accelerometer, strain gauge data, and honeycomb crush profiles, are discussed in Section 4.3. Occupant response data is discussed in Section 4.4.

4.2 VEHICLE STRUCTURAL RESPONSE

This section of the report presents data on the Ford's structural response to the collision with the fixed and moving Test Devices. This includes pre-test and post-test measurements made at selected locations on the vehicle, steering wheel displacements, vehicle exterior and interior profiles, and accelerometer data.

Static crush measurements of the Ford for both fixed and moving Test Device tests are shown in Table 4-8. Pre-test and post-test bumper match-ups are shown in Figures 4-5 through 4-8. In both tests, the car deformed uniformly with the flat surface of the Test Device. Since the closing speed for the moving Test Device test was selected to give the same change in energy (ΔE), the crush measurements were very similar for both tests.

Exterior profiles are given in Tables 4-9 and 4-10. Measurements for the frontal exterior profile of the Ford were made at three levels: the hood level, the bumper level, and a level between the hood and bumper level. In both tests, the bumper of the Ford rotated upward due to the force of impact. The rotation of the front bumper guards caused concentrated loads to be recorded by the Test Device's load cells.

Vehicle interior intrusion profiles and steering wheel displacement values are given in Tables 4-11 through 4-13. Compartment intrusion is shown in Figures 4-9 through 4-12. In both tests the dash panel became detached from the frame of the car and the

TABLE 4-8. PRE- AND POST-TEST DIMENSION MEASUREMENTS

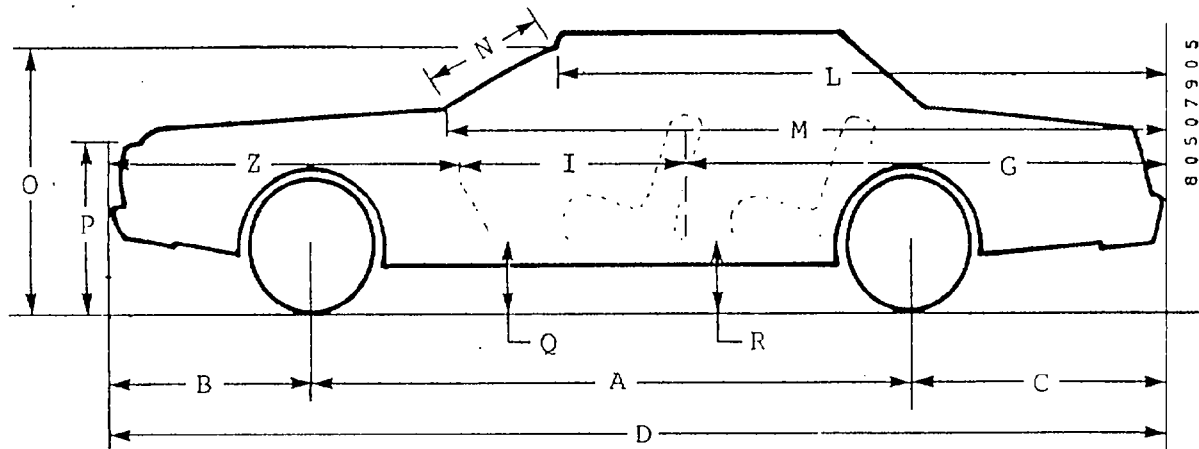

VEHICLE: 1975 Ford Torino 4-door Sedan

	(Fixed Test Device Test)						(Moving Test Device Test)					
	Test 3						Test 4					
	Pre-test		Post-test		Difference		Pre-test		Post-test		Difference	
	LS	RS	LS	RS	LS	RS	LS	RS	LS	RS	LS	RS
A	118.1	117.8	108.9	109.1	9.2	8.7	118.1	117.8	110.3	112.2	7.8	5.6
B	46.5	46.4	25.0	22.5	21.5	23.9	46.0	46.6	22.3	22.0	23.7	24.6
C	53.6	53.8	53.6	53.9	0.0	-0.1	53.4	53.6	53.8	53.8	-0.4	-0.2
D	218.2	218.0	187.5	185.5	30.7	32.5	217.5	218.0	186.4	188.0	31.1	30.0
I	36.6	36.6	36.5	35.6	0.1	1.0	36.6	36.6	36.0	36.1	0.6	0.5
G	102.4	102.3	101.5	101.5	0.9	0.8	102.1	102.1	102.0	102.8	0.1	-0.7
L	116.6	116.6	116.0	115.8	0.6	0.8	116.5	116.8	115.8	115.4	0.7	1.4
M	135.5	135.5	133.5	132.8	2.0	2.7	135.4	135.5	134.1	134.0	1.3	1.5
N	24.4	24.4	24.4	24.4	0.0	0.0	24.4	24.4	24.4	24.4	0.0	0.0
O	51.8	51.8	54.0	53.4	-2.2	-1.6	51.8	52.0	53.0	52.9	-1.2	-0.9
P	31.5	31.4	32.5	33.4	1.0	1.0	30.5	31.4	31.1	31.8	-0.6	-0.4
Q	12.9	12.9	13.1	12.4	-0.2	0.5	13.1	13.4	12.8	12.3	0.3	1.1
R	13.3	13.5	13.9	13.3	-0.6	0.2	13.5	13.8	13.3	12.9	0.2	0.9
Z	79.2	79.1	51.5	47.4	27.7	31.7	78.8	79.3	48.4	49.1	30.4	30.2

Note: All measurements in inches.

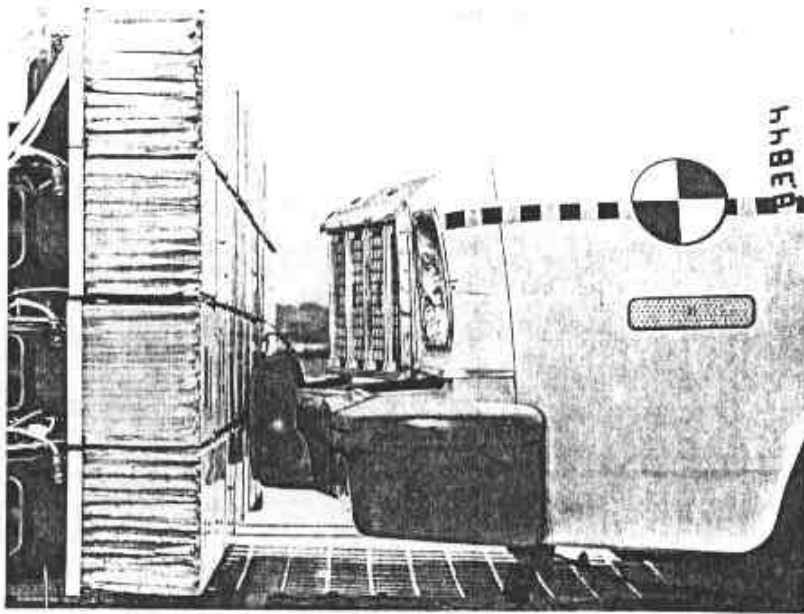

Figure 4-5. Pre-test Bumper Match - Test 3.

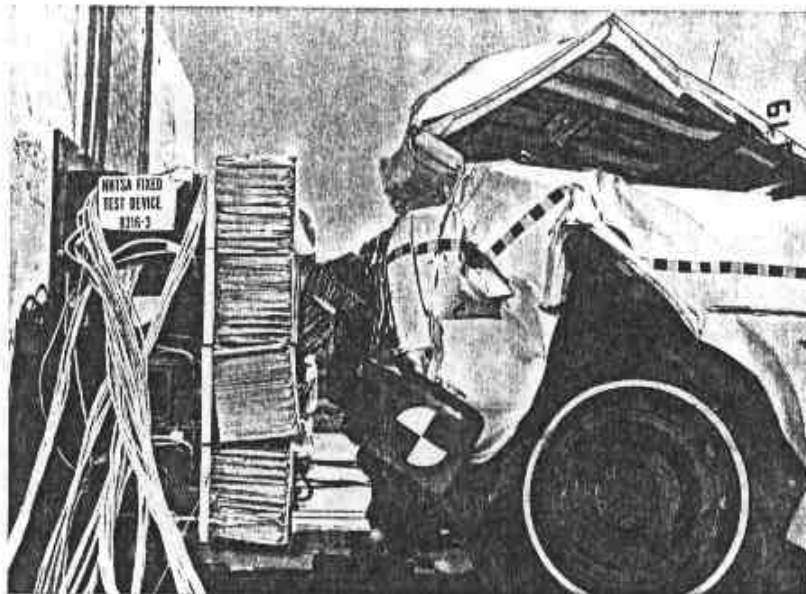

Figure 4-6. Post-test Bumper Match - Test 3. → DOT 0017

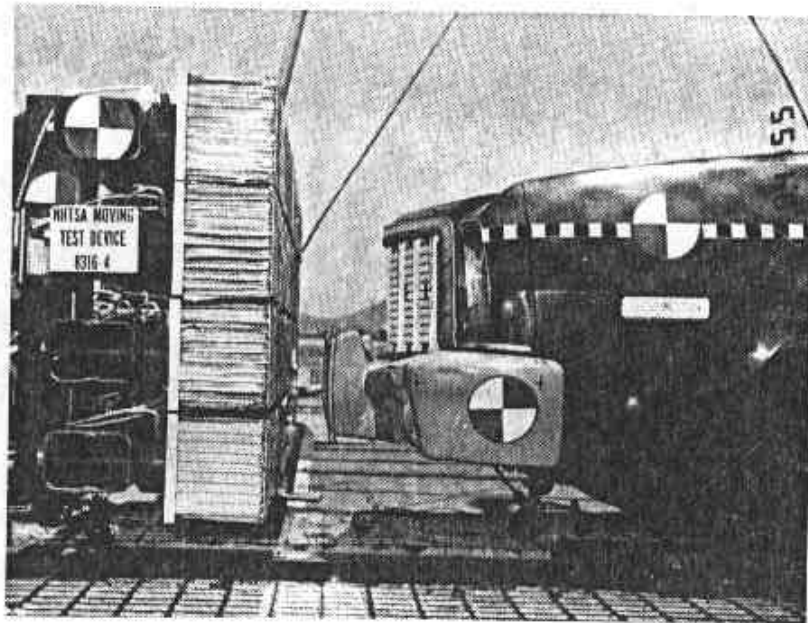

Figure 4-7. Pre-test Bumper Match - Test 4.

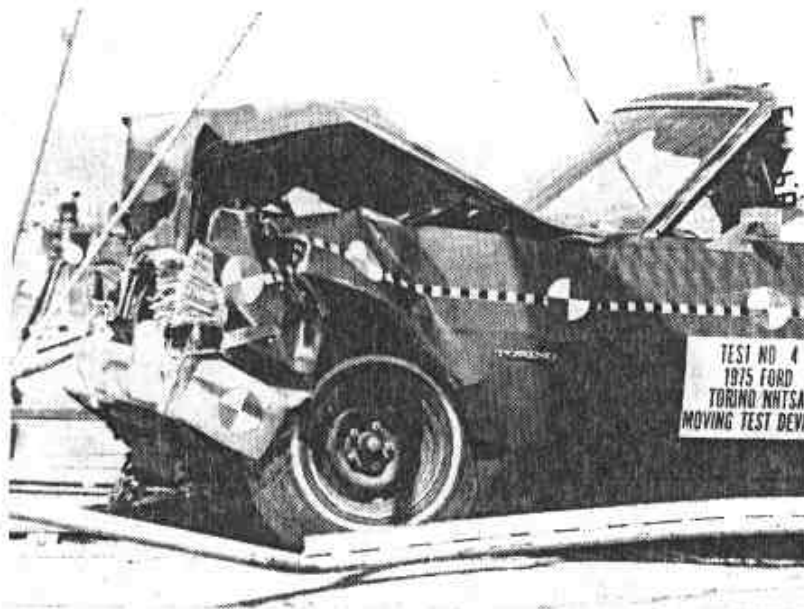

Figure 4-8. Post-test Bumper - Test 4.

DOT 0008

TABLE 4-9. CAR EXTERIOR PROFILES AND STATIC CRUSH FOR TEST 3

Location	R.P.* Height (in.)	Distance Left of Center (in.)**						Distance Right of Center (in.)**							
		36	30	24	18	12	6	6	12	18	24	30	36		
Pre-test Profile (Distance from R.P. - in.)															
Hood Level	220	30.9	-	11.6	11.4	11.6	10.0	8.4	7.1	8.4	10.0	11.6	11.5	11.6	-
Between Bumper/Hood	220	26.1	-	13.8	13.6	11.8	11.0	9.4	7.5	9.3	10.9	11.6	13.5	13.6	-
Bumper Level	220	17.8	8.3	7.3	7.1	7.0	2.0	3.6	2.1	3.6	2.1	6.9	7.3	7.5	8.6
Post-test Profile (Distance from R.P. - in.)															
Hood Level	220	34.0	-	37.9	39.6	39.8	38.8	37.6	34.8	38.3	40.4	39.0	38.8	38.0	-
Between Bumper/Hood	220	31.1	-	40.1	40.0	39.1	41.0	39.4	35.5	39.0	41.5	38.9	40.3	41.1	-
Bumper Level	220	25.0	40.0	39.3	39.1	39.0	34.6	35.4	33.5	34.8	33.3	36.3	35.8	35.1	35.0
Post-test Static Crush (in.)															
Hood Level	3.1	-	26.3	28.2	28.2	28.8	29.2	27.7	29.9	30.4	27.4	27.3	26.4	-	-
Between Bumper/Hood	5.0	-	26.3	26.4	27.3	30.0	30.0	28.0	29.7	30.6	27.3	26.8	27.5	-	-
Bumper Level	7.2	31.7	32.0	32.0	32.0	32.6	31.8	31.4	31.2	31.2	29.4	28.5	27.6	26.4	-

*Reference plane from rear bumper of car.

**As viewed from driver position in car.

TABLE 4-10. CAR EXTERIOR PROFILES AND STATIC CRUSH FOR TEST 4

Location	R.P.* Height (in.)	Distance Left of Center (in.)**						Distance Right of Center (in.)**							
		36	30	24	18	12	6	6	12	18	24	30	36		
Pre-test Profile (Distance from R.P. - in.)															
Hood Level	220	31.0	-	12.8	12.5	11.8	10.0	8.5	7.4	8.6	10.1	11.6	12.5	12.6	-
Between Bumper/Hood	220	26.3	-	13.8	13.5	11.9	11.0	9.5	8.0	10.0	11.6	11.8	13.5	13.6	-
Bumper Level	220	18.3	9.0	7.9	7.6	7.1	2.4	4.0	2.4	3.9	2.3	6.9	7.4	7.6	8.6
Post-test Profile (Distance from R.P. - in.)															
Hood Level	220	32.0	-	37.1	38.8	39.6	39.1	38.8	35.3	38.0	39.9	38.4	37.4	36.1	-
Between Bumper/Hood	220	29.0	-	38.4	40.3	39.6	40.5	37.3	36.3	39.3	40.8	37.4	39.0	37.5	-
Bumper Level	220	22.0	35.9	35.8	36.4	34.4	33.4	34.4	32.7	33.8	32.8	35.8	35.6	35.0	35.2
Post-test Static Crush (in.)															
Hood Level	1.0	-	24.3	26.3	27.8	29.1	30.3	27.9	29.4	29.8	26.8	24.9	23.5	-	-
Between Bumper/Hood	2.7	-	24.6	26.8	27.7	28.5	27.8	28.3	29.3	29.2	26.8	25.5	23.9	-	-
Bumper Level	3.7	26.9	27.9	28.8	27.3	31.0	30.4	30.3	29.9	30.5	28.9	28.2	27.4	26.6	-

*Reference plane from rear bumper of car.
 **As viewed from driver position in car.

TABLE 4-11. CAR INTERIOR PROFILES AND STATIC INTRUSION FOR FIXED TEST DEVICE TEST 3

VEHICLE: 1975 Ford Torino 4-door Sedan

Location	R.P.* (in.)	Height (in.)	Left Front Occupant		At String Potentiometer Centerline	Right Front Occupant			
			L**	C**		R**	L**	C**	R**
Pre-test Profile (Distance from R.P. - in.)									
Dash Level	115	39.5	14.5	15.0	14.8	14.3	14.6	14.4	14.0
Knee Level	115	26.5	19.0	19.4	19.4	18.9	21.8	22.5	22.8
Floor Level	128	17.0	25.3	25.6	25.3	19.9	25.1	25.9	25.5
Post-test Profile (Distance from R.P. - in.)									
Dash Level	115	39.3	11.6	11.1	10.8	10.7	11.3	10.3	10.0
Knee Level	115	24.3	22.5	18.4	21.5	17.1	22.9	23.4	23.9
Floor Level	128	20.6	21.0	18.5	17.4	11.8	17.3	19.1	20.8
Post-test Static Intrusion (in.)									
Dash Level		-0.2	2.9	3.9	4.0	3.6	3.3	4.1	4.0
Knee Level		-2.0	-3.5	1.0	-2.1	1.8	-1.1	-0.9	-1.1
Floor Level		3.6	4.3	7.1	7.8	8.1	7.8	6.8	4.7

*Reference plane from rear bumper of car.

**L = Left, C = Center, R = Right side of occupant seating positions.

TABLE 4-12. CAR INTERIOR PROFILES AND STATIC INTRUSION FOR MOVING TEST DEVICE TEST 4

VEHICLE: 1975 Ford Torino 4-door Sedan

Location	R.P.* (in.)	Height (in.)	Left Front Occupant		At String Potentiometer Centerline	Right Front Occupant			
			L**	C**		R**	L**	C**	R**
Pre-test Profile (Distance from R.P. - in.)									
Dash Level	115	39.4	14.0	14.6	14.5	14.6	14.5	14.4	14.0
Knee Level	115	24.5	19.6	19.4	19.4	18.9	22.3	22.1	21.8
Floor Level	128	19.1	25.3	25.0	24.6	20.1	24.0	24.6	24.1
Post-test Profile (Distance from R.P. - in.)									
Dash Level	115	38.4	11.8	12.3	12.7	13.3	13.4	13.4	13.4
Knee Level	115	26.3	19.5	19.0	19.3	18.6	22.1	22.2	21.3
Floor Level	128	19.1	22.8	21.8	20.3	15.8	20.9	21.1	21.7
Post-test Static Intrusion (in.)									
Dash Level		-1.0	2.2	2.3	1.8	1.3	1.1	1.0	0.6
Knee Level		1.8	0.1	0.4	0.1	0.3	0.1	-0.1	0.5
Floor Level		0	2.5	3.2	4.3	4.3	3.1	3.5	2.4

*Reference plane from rear bumper of car.

**L = Left, C = Center, R = Right side of occupant seating positions.

TABLE 4-13. STEERING WHEEL DISPLACEMENT VALUES

VEHICLE: 1975 Ford Torino 4-door sedan

Wheel Location	Displacement (in.)					
	Test 3 (Fixed Test Device)			Test 4 (Moving Test Device)		
	X*	Y*	Z*	X*	Y*	Z*
Top	+1.8	-2.5	-3.6	-2.8	+2.3	-3.4
Hub	-2.3	+0.1	-1.3	-2.1	-1.9	-2.4
Bottom	+2.3	+1.0	-1.3	0.0	-0.1	-2.7

*Reference for X, Y, Z measurements are the rear bumper (+ forward), vehicle centerline (+ right), and ground level (+ up), respectively.

areas that were struck by the occupants' heads were severely damaged. In the moving Test Device test the occupant compartment intrusion was less severe than in the fixed Test Device test due to the fact that some of the energy was used in pushing back the moving Test Device after impact. In the fixed Test Device test, the steering wheel rim was bent forward and downward by the left front occupant, which exposed the steering wheel hub. This was the cause of large pulses seen on data from the driver's chest. The left front occupant of Test 4 caused less damage to the occupant compartment compared to Test 3, again due to the energy transfer.

A summary of Ford accelerometer and string potentiometer data for both tests is given in Tables 4-14 through 4-19. Refer to Figure 3-1 for their locations in the vehicle. Compartment accelerometers and engine accelerometers were averaged to obtain a more representative picture of what was occurring at those locations. String potentiometer data was used to measure firewall intrusion in the occupant compartment. However, if the peak intrusion does not occur at the location where the measurement was taken, the readings will be low compared to the post-test static measurements.



Figure 4-9. Post-test Driver Compartment - Test 3.



Figure 4-10. Post-test Driver Compartment - Test 4.



Figure 4-11. Post-test Passenger Compartment - Test 3.

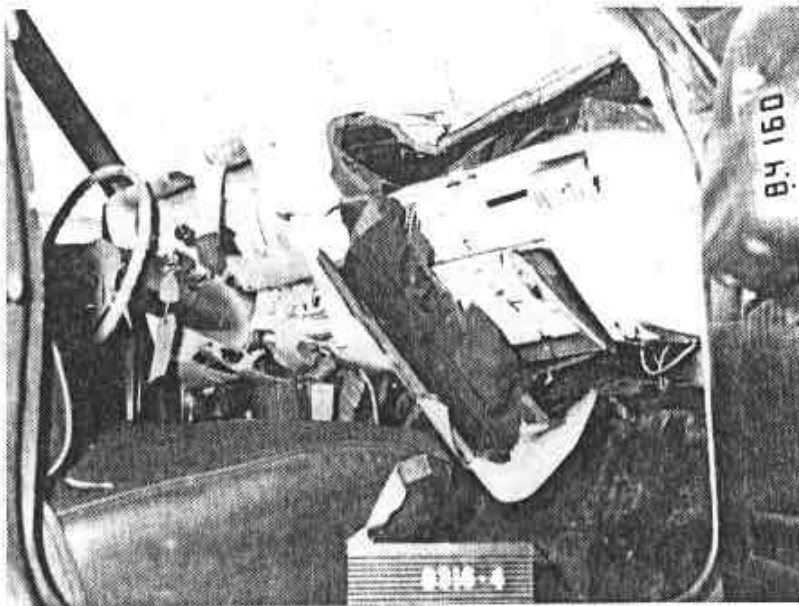

Figure 4-12. Post-test Passenger Compartment - Test 4.

TABLE 4-14. SUMMARY OF CAR ACCELEROMETER DATA FOR
FIXED TEST DEVICE TEST 3

VEHICLE: 1975 Ford Torino 4-door Sedan

Accelerometer Number	Maximum Acceleration		Minimum Velocity		Maximum Displacement	
	A (G)	Time (msec)	V (mph)	Time (msec)	S (in.)	Time (msec)
1X	-45.0	65	-6.5	153	+46.2	105
1Z	+16.3	71	-3.1	141	-2.6	200
2X	-51.9	66	-6.6	151	+46.5	105
2Z	-19.0	88	-2.4	141	+1.6	88
3X	-48.8	66	-6.2	142	+49.0	108
3Z	-50.0	70	-4.8	90	-5.5	200
4X	-93.3	67	-8.6	173	+43.0	90
4Z	+53.8	63	-1.2	40	+0.03	47
5X	-72.7	84	-7.8	147	+50.7	101
5Z	-27.5	82	-3.7	97	-1.7	127
6X	-83.8	57	-3.1*	69	+33.7*	62
7X	-95.4	56	-3.4	161	+37.0*	110
8X	-48.7	81	-6.8	153	+47.0	106
8Y	-21.3	82	-2.2	87	-1.8	200
8Z	-47.1	83	-1.5	162	+3.3	152
9X	-87.4	52	-2.8*	171	34.0*	99

See Figure 3-1 for definition of accelerometer numbers.
*Data invalid because of rotation of accelerometer.

TABLE 4-15. SUMMARY OF AVERAGED CAR ACCELEROMETER
DATA FOR FIXED TEST DEVICE TEST 3

Accelerometer Number	Maximum Acceleration		Minimum Velocity		Maximum Displacement	
	A (G)	Time (msec)	V (mph)	Time (msec)	S (in.)	Time (msec)
Average of 1X and 2X (Compartment)	-48.2	66	-6.6	152	46.3	105
Average of 6X and 9X (Engine)	-79.9	52	-2.6*	169	33.8*	67

*Data invalid because of rotation of accelerometer.

TABLE 4-16. SUMMARY OF CAR ACCELEROMETER DATA FOR MOVING TEST DEVICE TEST 4

VEHICLE: 1975 Ford Torino 4-door Sedan

Accelerometer Number	Maximum Acceleration		Minimum Velocity		Maximum Displacement	
	A (G)	Time (msec)	V (mph)	Time (msec)	S (in.)	Time (msec)
1X	-44.6	61	-2.1	116	+25.6	89
1Z	-21.6	78	-2.1	90	+1.5	78
2X	-44.7	60	-1.7	114	+25.8	88
2Z	+26.1	61	-2.7	106	+1.9	83
2X	-49.4	57	-1.8	104	+27.2	80
3Z	-28.1	81	-2.2	119	+0.9	200
4X	-101.8	56	-4.4*	134	+24.4	63
4Z	+87.5	52	-1.7	48	+8.5	200
5X	+88.3	54	+0.7*	89	+3.4*	200
5Z	-30.8	57	-2.9	59	+0.4	165
6X	-96.3	42	-12.2*	54	+18.3*	44
7X	-129.1	46	+3.7*	55	+43.8*	200
8X	-42.0	64	+0.5*	114	+37.4*	200
8Y	-18.6	56	-0.9	76	-0.8	172
8Z	-34.0	67	-3.1	114	-2.8	200
9X	-141.4	40	-6.2*	53	+17.5	43

See Figure 3-1 for definition of accelerometer numbers.
*Data questionable due to rotation of accelerometer.

TABLE 4-17. SUMMARY OF AVERAGED CAR ACCELEROMETER DATA FOR MOVING TEST DEVICE TEST 4

Accelerometer Number	Maximum Acceleration		Minimum Velocity		Maximum Displacement	
	A (G)	Time (msec)	V (mph)	Time (msec)	S (in.)	Time (msec)
Average of 1X and 2X (Compartment)	-44.6	61	-1.9	115	25.7	89
Average of 6X and 9X (Engine)	-116.6	40	-9.1*	54	17.9*	44

*Data questionable due to rotation of accelerometer.

TABLE 4-18. SUMMARY OF CAR STRING
POTENTIOMETER DATA FOR
FIXED TEST DEVICE TEST 3

<u>Displacement Potentiometer</u>		<u>Maximum Dynamic Displacement</u>	
<u>(Number)</u>	<u>(Location)</u>	<u>D (in.)</u>	<u>Time (msec)</u>
SP7	Firewall	8.5	199

TABLE 4-19. SUMMARY OF CAR STRING
POTENTIOMETER DATA FOR
MOVING TEST DEVICE TEST 4

<u>Displacement Potentiometer</u>		<u>Maximum Dynamic Displacement</u>	
<u>(Number)</u>	<u>(Location)</u>	<u>D (in.)</u>	<u>Time (msec)</u>
SP7	Firewall	Data System Failure	

In Test 4, the string potentiometer data for the vehicle was lost because of the difficulty in placing the string potentiometer in an area that would not be disturbed during the crash impact.

In both tests, since the amount of crush was high, rotation of engine accelerometers (Nos. 6 and 9) occurred giving erroneous velocity and displacement peaks. In addition, displacement data from the accelerometer located at the front crossmember of the car (Location 7) was suspect, also due to the rotation of the accelerometer during impact.

4.3 TEST DEVICE SUMMARY

This section of the report presents a summary of data gathered from the fixed and moving Test Devices. This includes summaries of load cell, string potentiometer, strain gauge, and accelerometer data, and post-test honeycomb profiles for both fixed and moving Test Device tests.

Post-test Test Device configurations for fixed and moving Test Device tests are shown in Figures 4-13 and 4-14.

A summary of peak values of load cell data is shown in Table 4-20 for Test 3 and Table 4-21 for Test 4. These were the maximum measured forces for each load cell along with its corresponding time recorded during the event. Tables 4-22 and 4-23 present a summary of grouped load cell data for each test. The front face of the Test Device was divided into six areas of loading. These data show which areas of the car tended to be more aggressive. Load cell forces for individual load cells are shown in Figures 4-15 through 4-22. These plots also show the relative lateral symmetry of car data recorded with the Test Device face. Some load may have been lost during the period 50-63 msec in Test 3 and 28-53 msec in Test 4, due to load cell contact with the backing plate (A4, A5, A7, B4, B5, B7).

A load cell distribution at selected time intervals for the car/Test Device interface for each test is shown in Figures 4-23 through 4-28. These values are shown for forces over 1,000 pounds at a particular time segment. Any location with a value below 1,000 pounds was not considered an aggressive part of the car at that particular time frame. Calcomp plots of all load cell data by columns and grouped load cell summations are shown in Appendix B for Test 3 and Appendix C for Test 4.

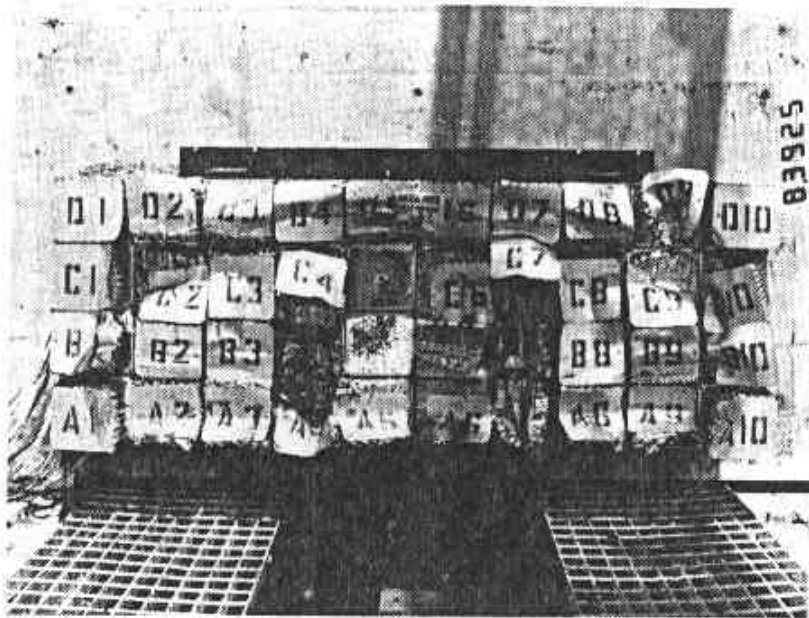

Figure 4-13. Post-test Fixed Test Device Configuration - Test 3.

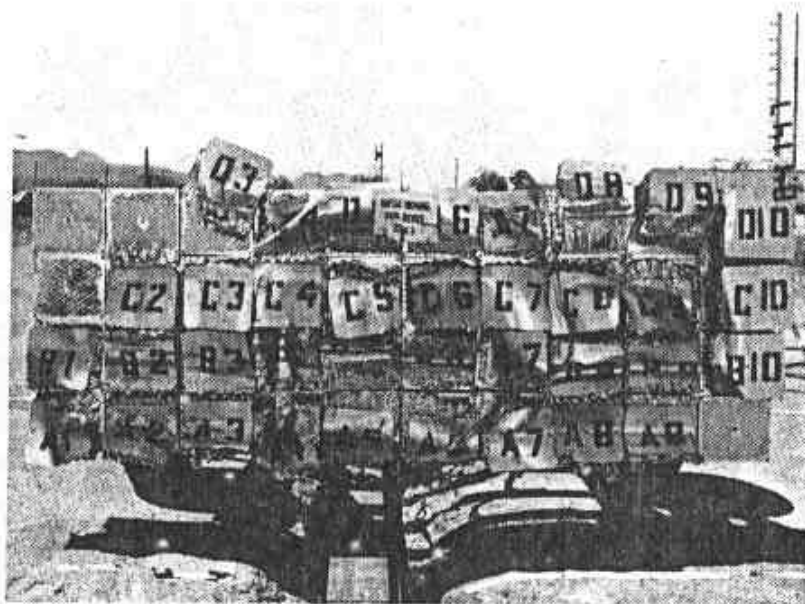

Figure 4-14. Post-test Moving Test Device Configuration - Test 4.

TABLE 4-20. SUMMARY OF MAXIMUM LOAD CELL DATA FOR FIXED TEST DEVICE TEST 3

Parameter	Right Half of Car					Left Half of Car				
Load Cell (No.)	D10	D9	D8	D7	D6	D5	D4	D3	D2	D1
Force (klb)	0.35	4.57	2.23	1.79	2.11	1.92	2.16	2.25	4.37	0.56
Time (msec)	75	65	49	56	26	60	61	59	59	69
Load Cell (No.)	C10	C9	C8	C7	C6	C5*	C4	C3	C2	C1
Force (klb)	1.15	5.90	2.97	3.20	3.11	5.38	2.63	2.60	4.27	0.60
Time (msec)	28	63	61	61	55	61	56	21	67	50
Load Cell (No.)	B10	B9	B8	B7	B6	B5*	B4	B3	B2	B1
Force (klb)	1.84	2.94	2.93	**	5.13	5.25	9.54	2.64	2.78	1.32
Time (msec)	30	27	55	58	48	52	58	26	27	56
Load Cell (No.)	A10	A9	A8	A7	A6	A5	A4	A3	A2	A1
Force (klb)	1.05	2.39	2.70	8.50	5.43	3.09	8.56	2.58	2.89	1.07
Time (msec)	28	24	58	44	55	60	44	63	29	22

*Honeycomb module pulled off from impact with car.

**12.36 (maximum measured force).

TABLE 4-21. SUMMARY OF MAXIMUM LOAD CELL DATA FOR MOVING TEST DEVICE TEST 4

Parameter	Right Half of Car					Left Half of Car				
Load Cell (No.)	D10	D9	D8	D7	D6	D5	D4	D3	D2	D1
Force (klb)	0.24	1.37	2.78	2.12	1.95	2.32	2.41	2.30	2.60	2.58*
Time (msec)	56	57	40	28	42	43	42	45	38	52
Load Cell (No.)	C10	C9	C8	C7	C6	C5	C4	C3	C2	C1
Force (klb)	0.51	6.48	2.58	1.48	3.45	**	3.41	2.77	3.42	4.96
Time (msec)	37	25	17	50	44	44	44	22	23	24
Load Cell (No.)	B10	B9	B8	B7	B6	B5	B4	B3	B2	B1
Force (klb)	0.89	3.28	3.29	5.76	5.10	8.18	9.47	2.69	2.89	2.26
Time (msec)	24	22	22	22	43	45	45	21	18	18
Load Cell (No.)	A10	A9	A8	A7	A6	A5	A4	A3	A2	A1
Force (klb)	0.41	6.40	2.82	6.31	3.75	7.23	8.28	2.13	5.81	1.89
Time (msec)	17	50	50	20	43	35	50	26	47	80

*Honeycomb module pulled off from impact with car.

**9.79 (maximum measured force).

TABLE 4-22. SUMMARY OF GROUPED LOAD CELL DATA - TEST 3

<u>Parameter</u>	<u>Right Side of Car</u>	<u>Center of Car</u>	<u>Left Side of Car</u>
Load Cells (No.)	D8 - D10 & C8 - C10	D4 - D7 & C4 - C7	D1 - D3 & C1 - C3
Force (klb)	15.30	21.58	10.21
Time	64	61	59
Load Cells (No.)	B8 - B10 & A8 - A10	B4 - B7 & A4 - A7	B1 - B3 & A1 - A3
Force (klb)	12.25	49.93	12.40
Time (msec)	26	52	28

TABLE 4-23. SUMMARY OF GROUPED LOAD CELL DATA - TEST 4

<u>Parameter</u>	<u>Right Side of Car</u>	<u>Center of Car</u>	<u>Left Side of Car</u>
Load Cells (No.)	D8 - D10 & C8 - C10	D4 - D7 & C4 - C7	D1 - D3 & C1 - C3
Force (klb)	8.66	26.07	12.05
Time	25	44	23
Load Cells (No.)	B8 - B10 & A8 - A10	B4 - B7 & A4 - A7	B1 - B3 & A1 - A3
Force (klb)	12.85	49.92	13.74
Time (msec)	22	43	23

In the fixed Test Device test, the maximum total load cell force recorded was 108,490 pounds at 56 milliseconds after impact and the maximum individual load cell force recorded was 12,360 pounds on module B7 at 58 milliseconds. This was caused mostly from the bumper guard on the passenger side of the vehicle rotating upwards. Most of the loads were caused by the bumper and the bumper guards hitting rows A and B simultaneously, with row D seeing small loads from the hood, and columns 1 and 10 seeing very small forces. Loads recorded on row C were caused by engine/radiator area of the car. Modules B5 and C5 were pulled off the

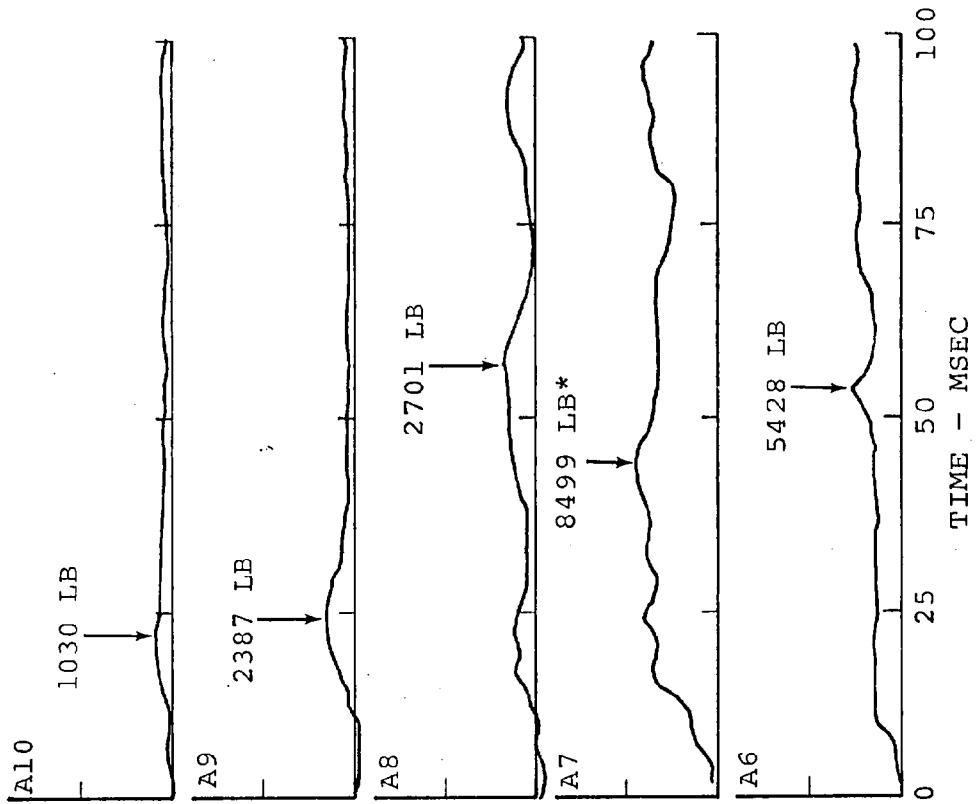
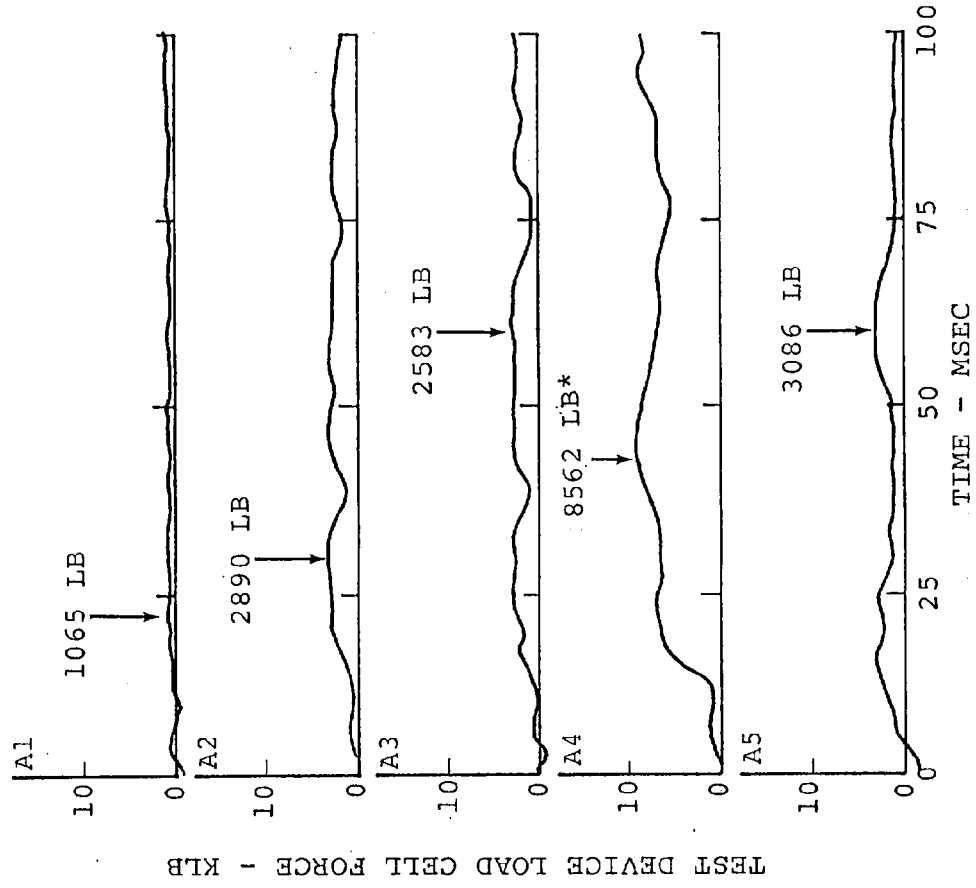

*Some load may have been lost between 50 and 63 msec (see Figure 4-32).

Figure 4-15. Test Device Load Cell Forces on Row A for Test 8316-3.

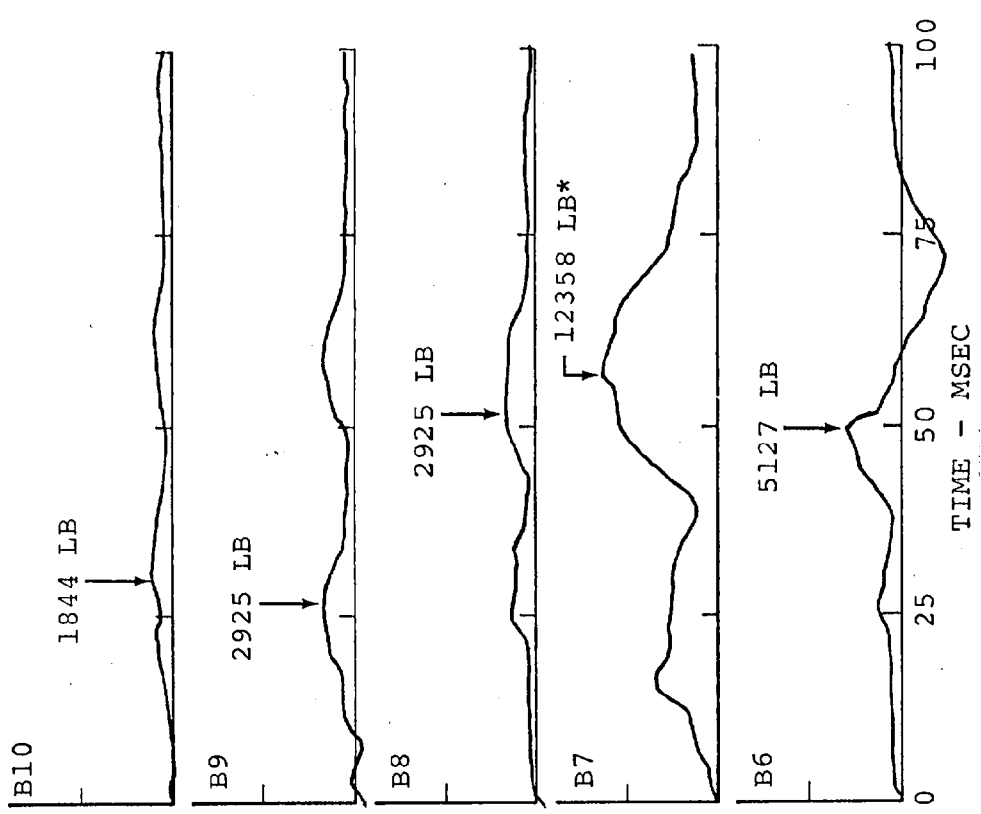
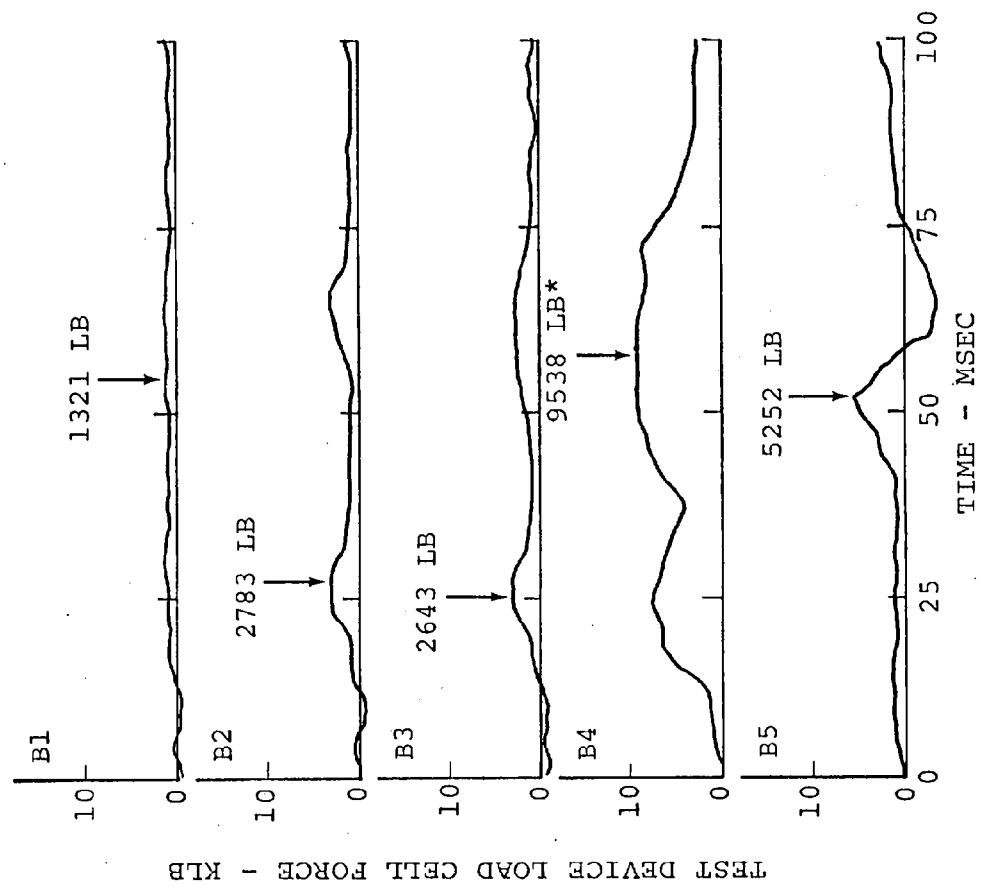

*Some load may have been lost between 50 and 63 msec (see Figure 4-32).

Figure 4-16. Test Device Load Cell Forces on Row B for Test 8316-3.

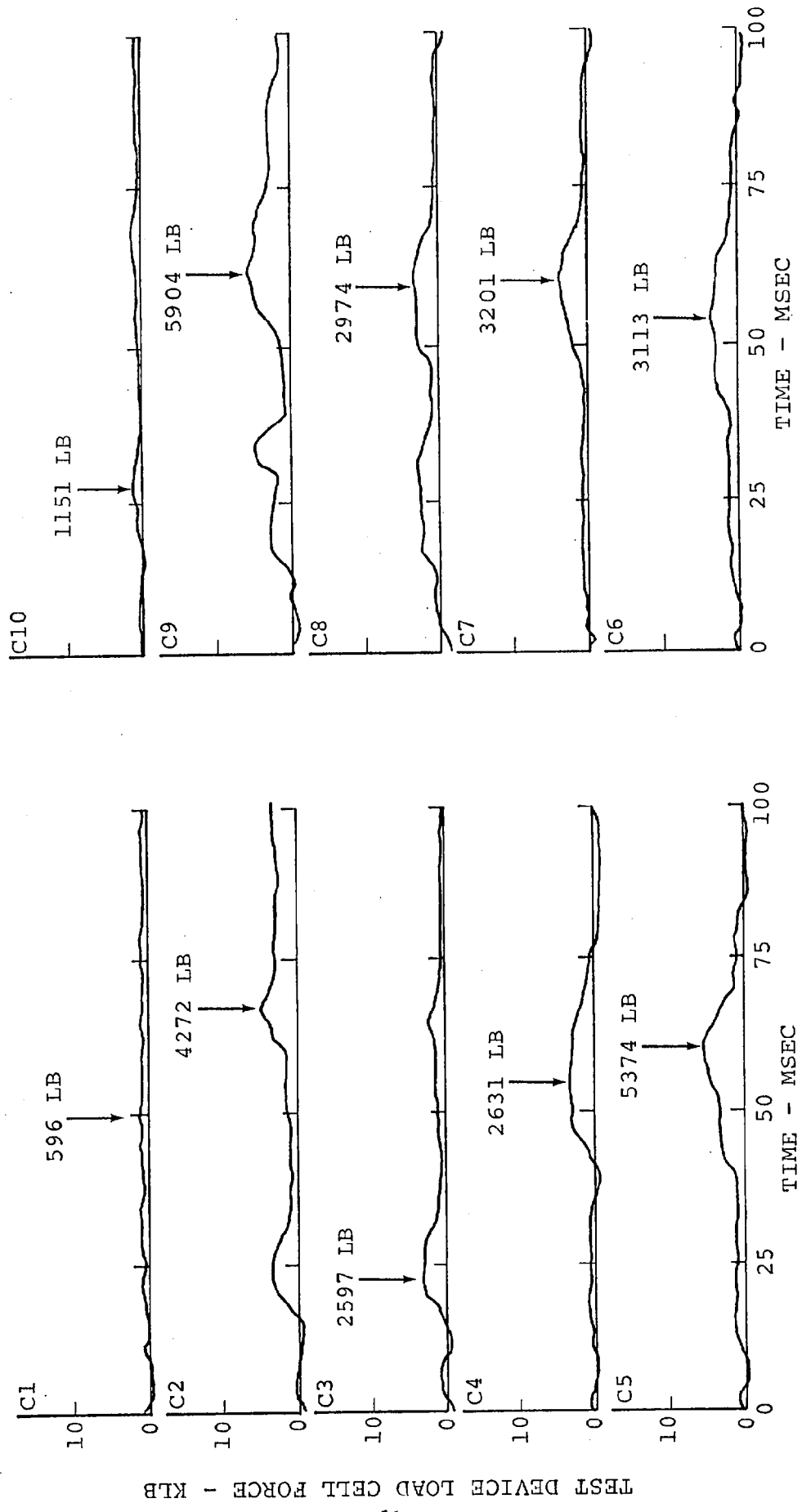

Figure 4-17. Test Device Load Cell Forces on Row C for Test 8316-3.

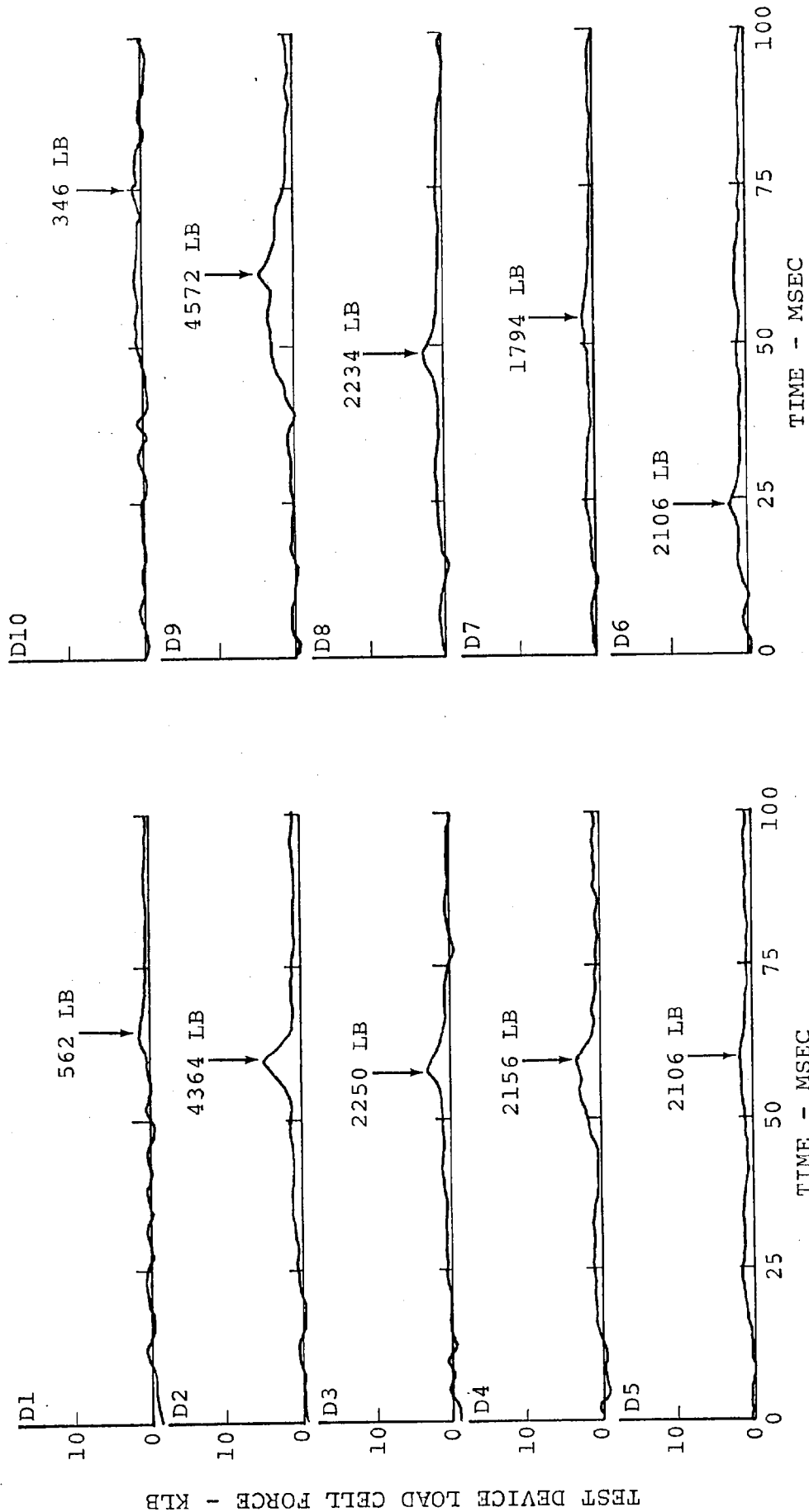
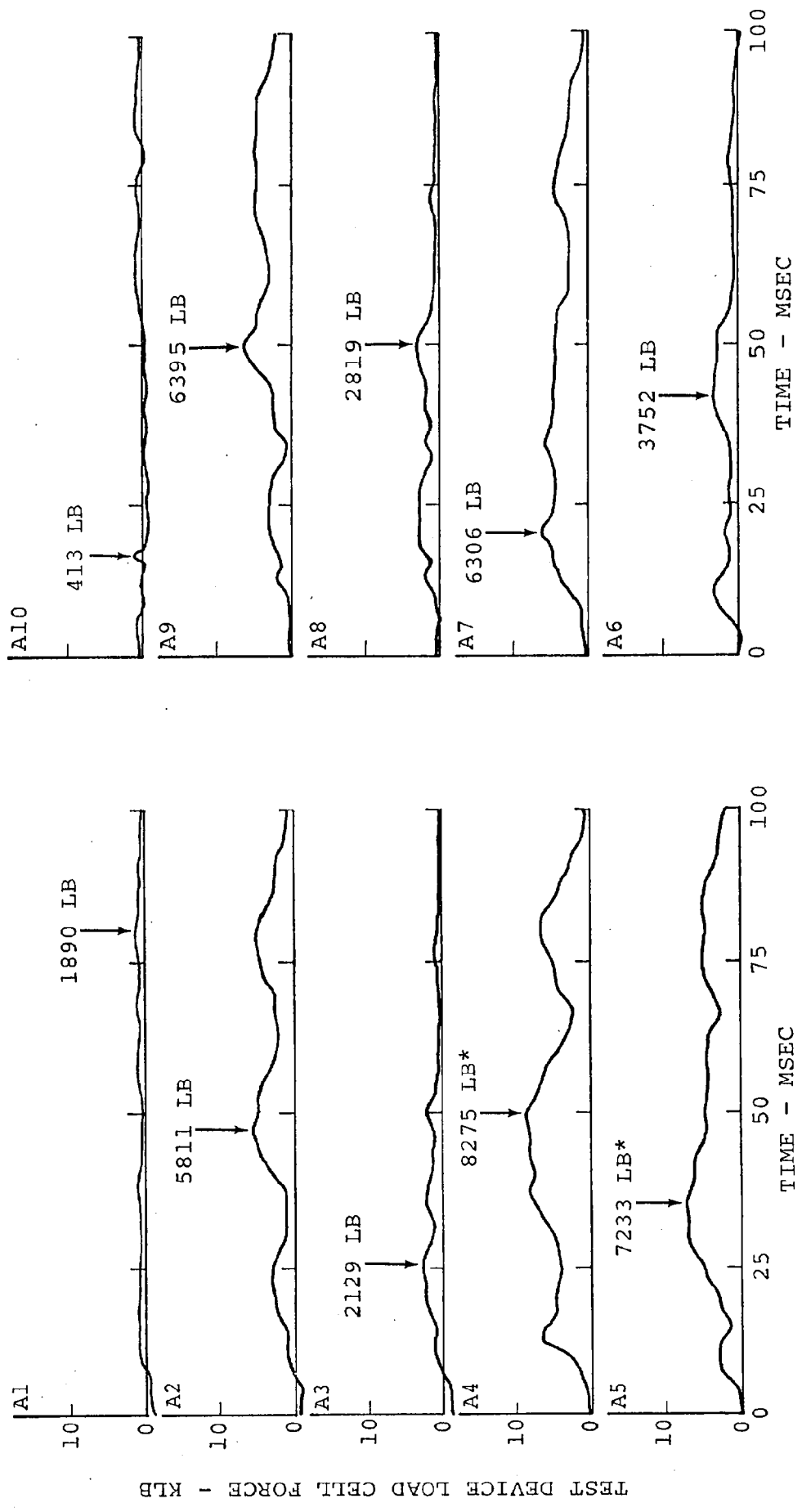
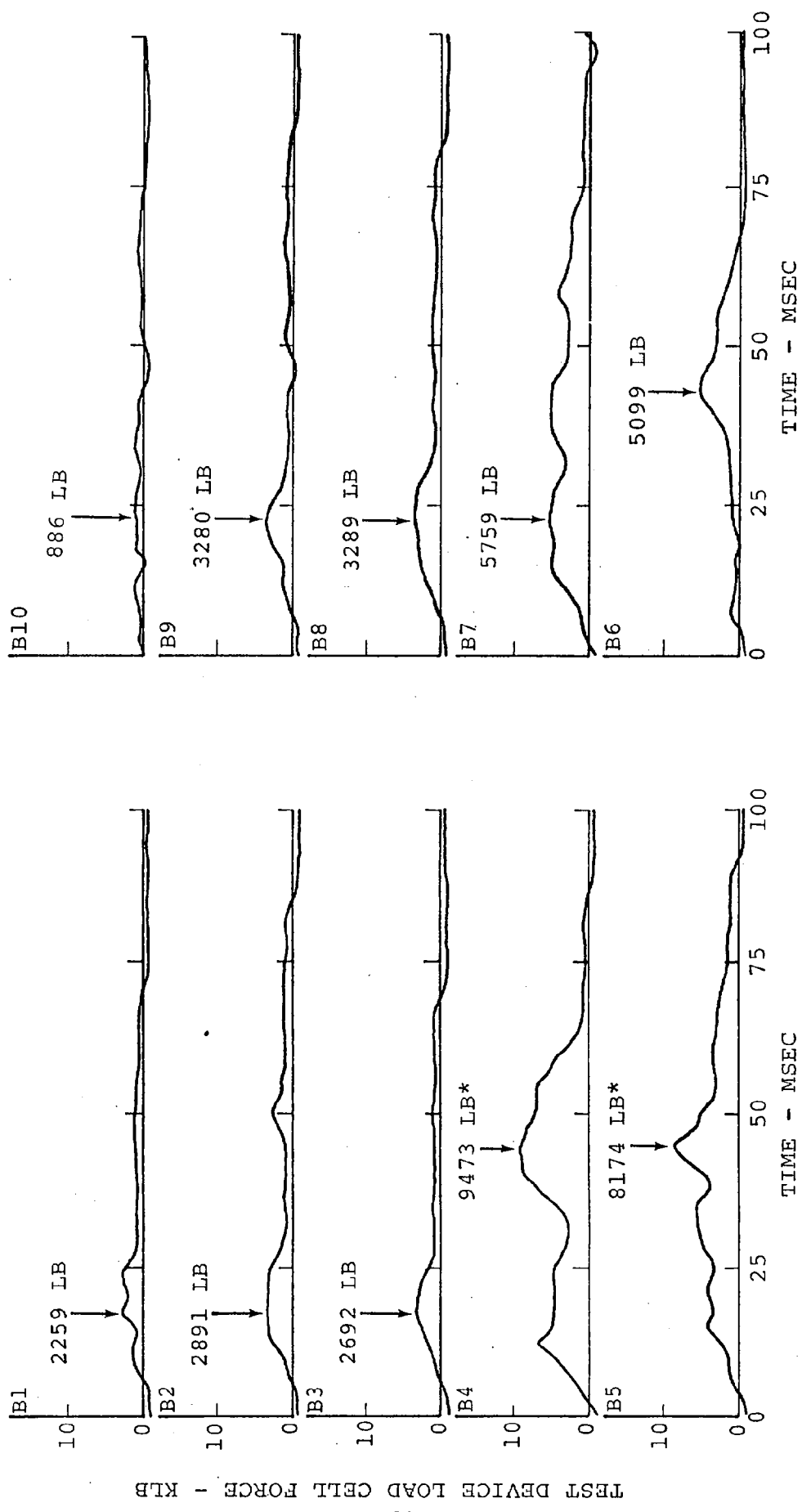

Figure 4-18. Test Device Load Cell Forces on Row D for Test 8316-3.



*Some load may have been lost between 28 and 53 msec (see Figure 4-33).

Figure 4-19. Test Device Load Cell Forces on Row A for Test 8316-4.



*Some load may have been lost between 28 and 53 msec (see Figure 4-33).

Figure 4-20. Test Device Load Cell Forces on Row B for Test 8316-4.

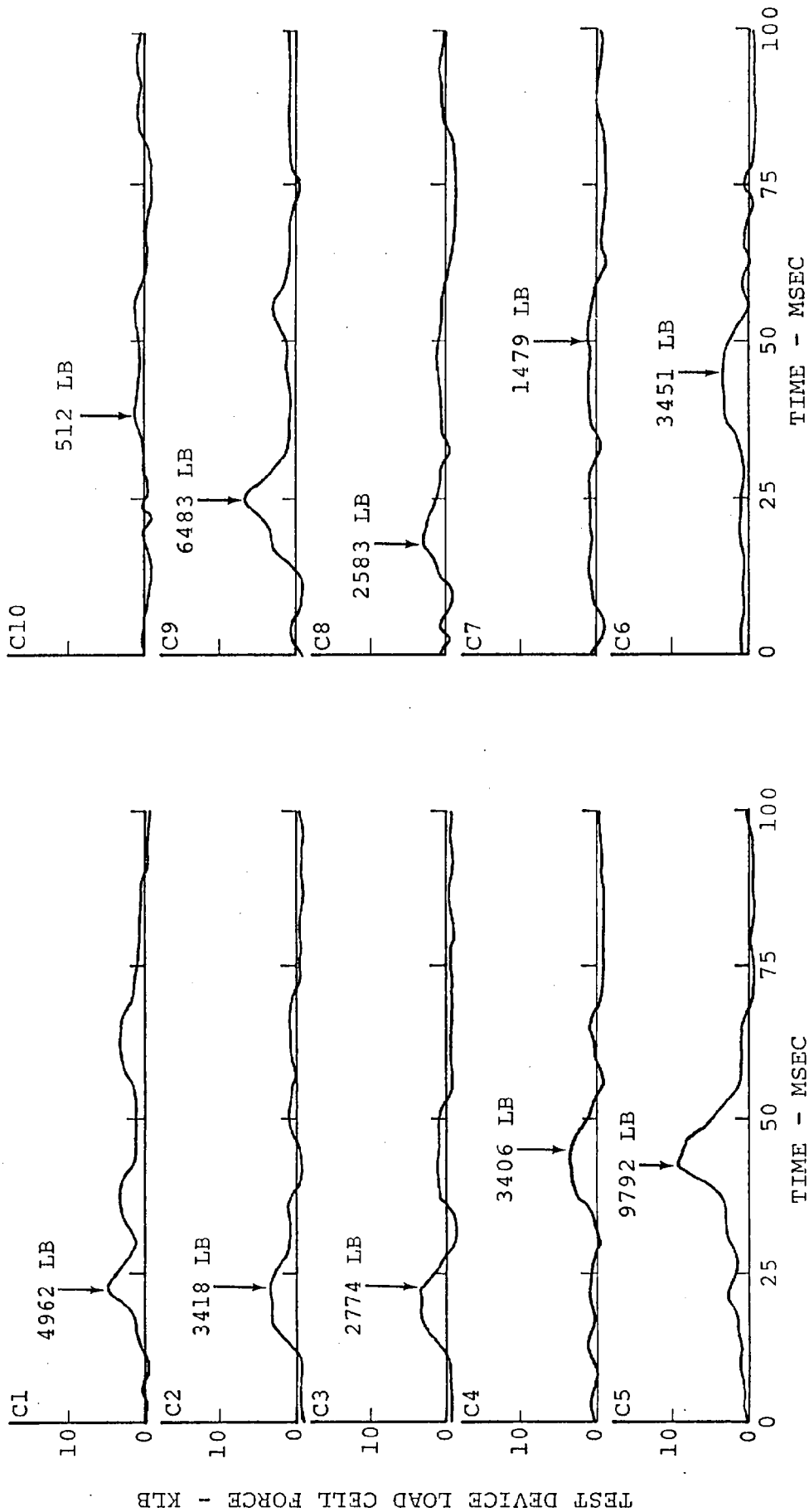

Figure 4-21. Test Device Load Cell Forces on Row C for Test 8316-4.

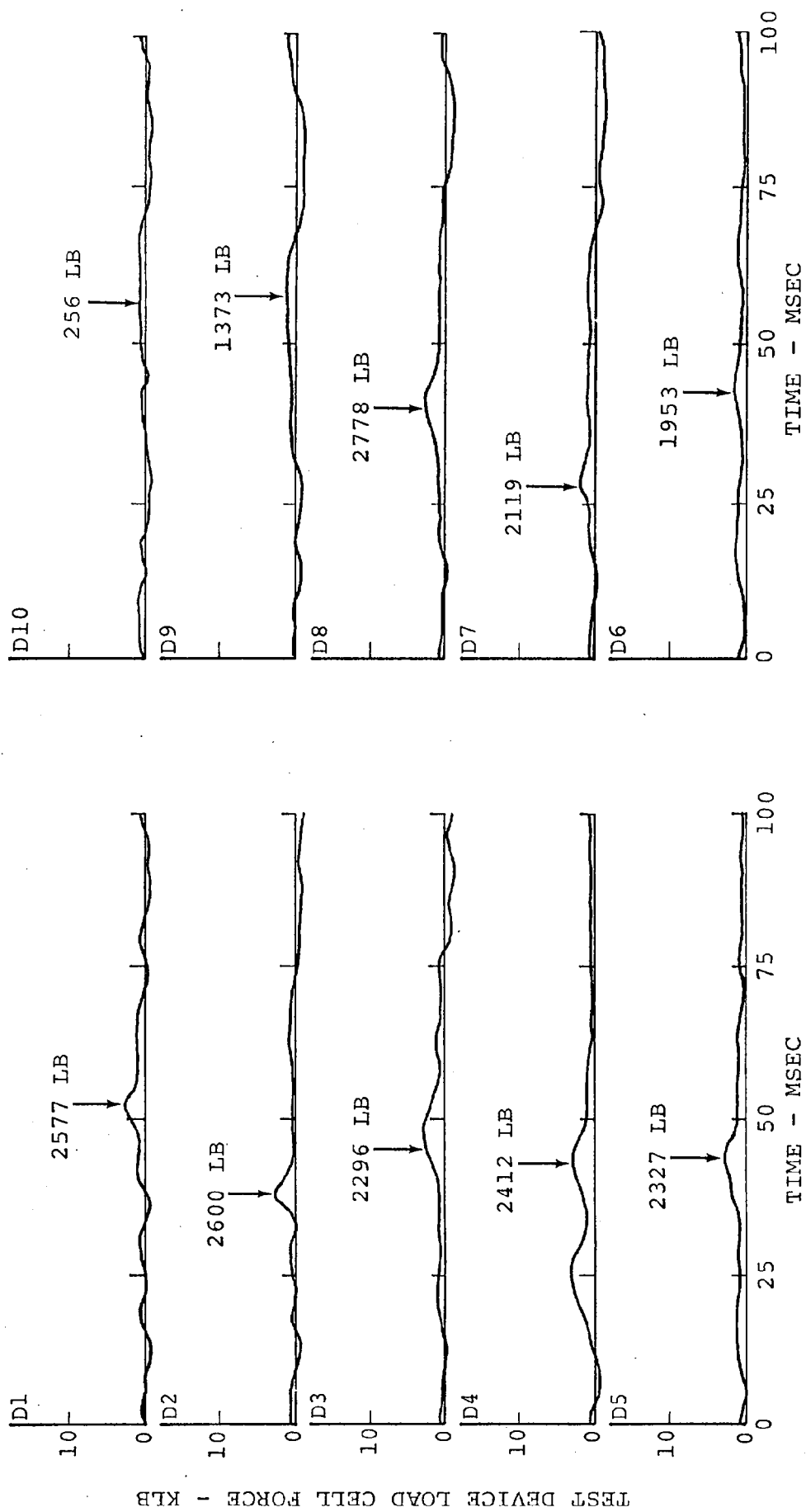

Figure 4-22. Test Device Load Cell Forces on Row D for Test 8316-4.

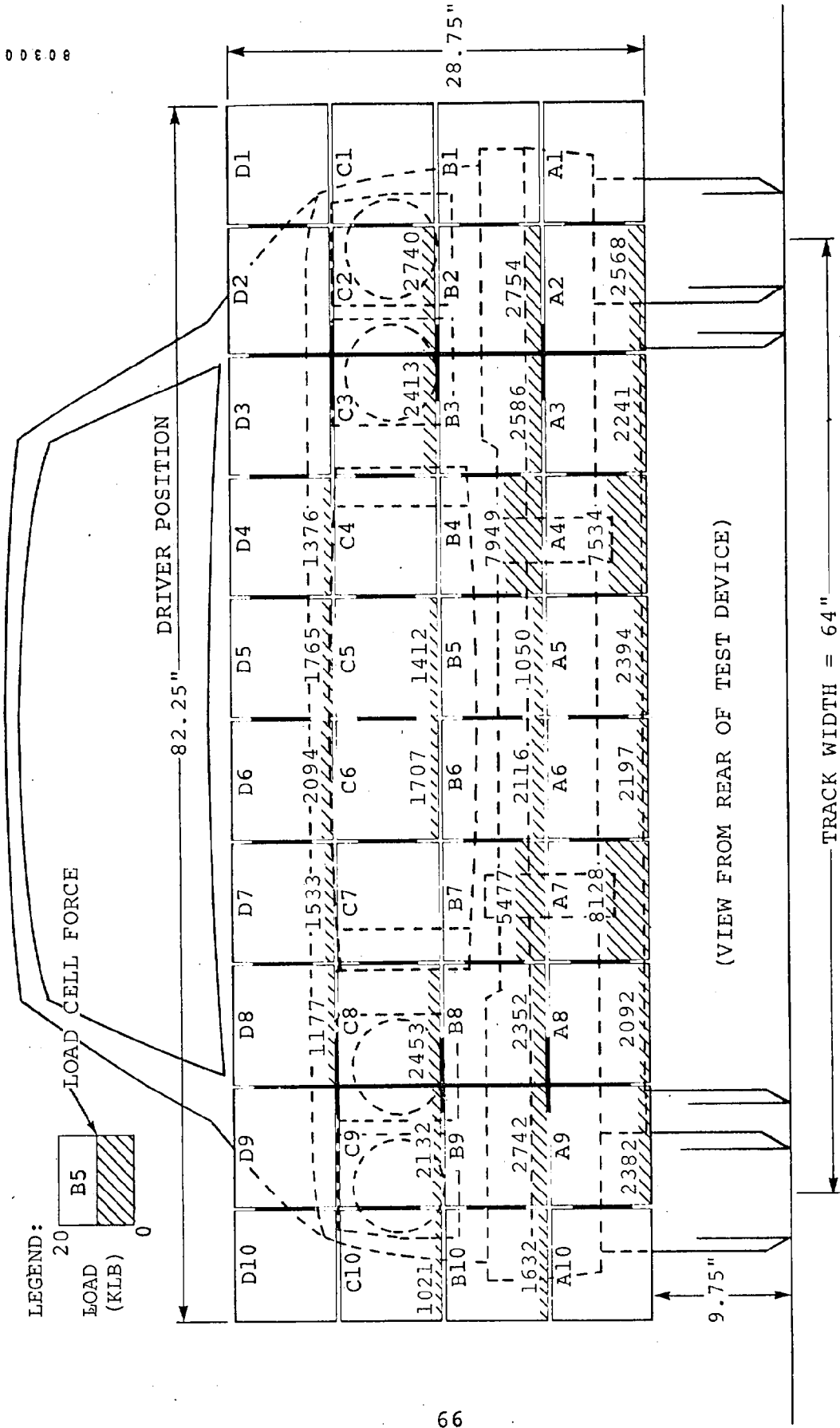

Figure 4-23. 1975 Ford Torino/Fixed Test Device Load Distribution at 25 msec.

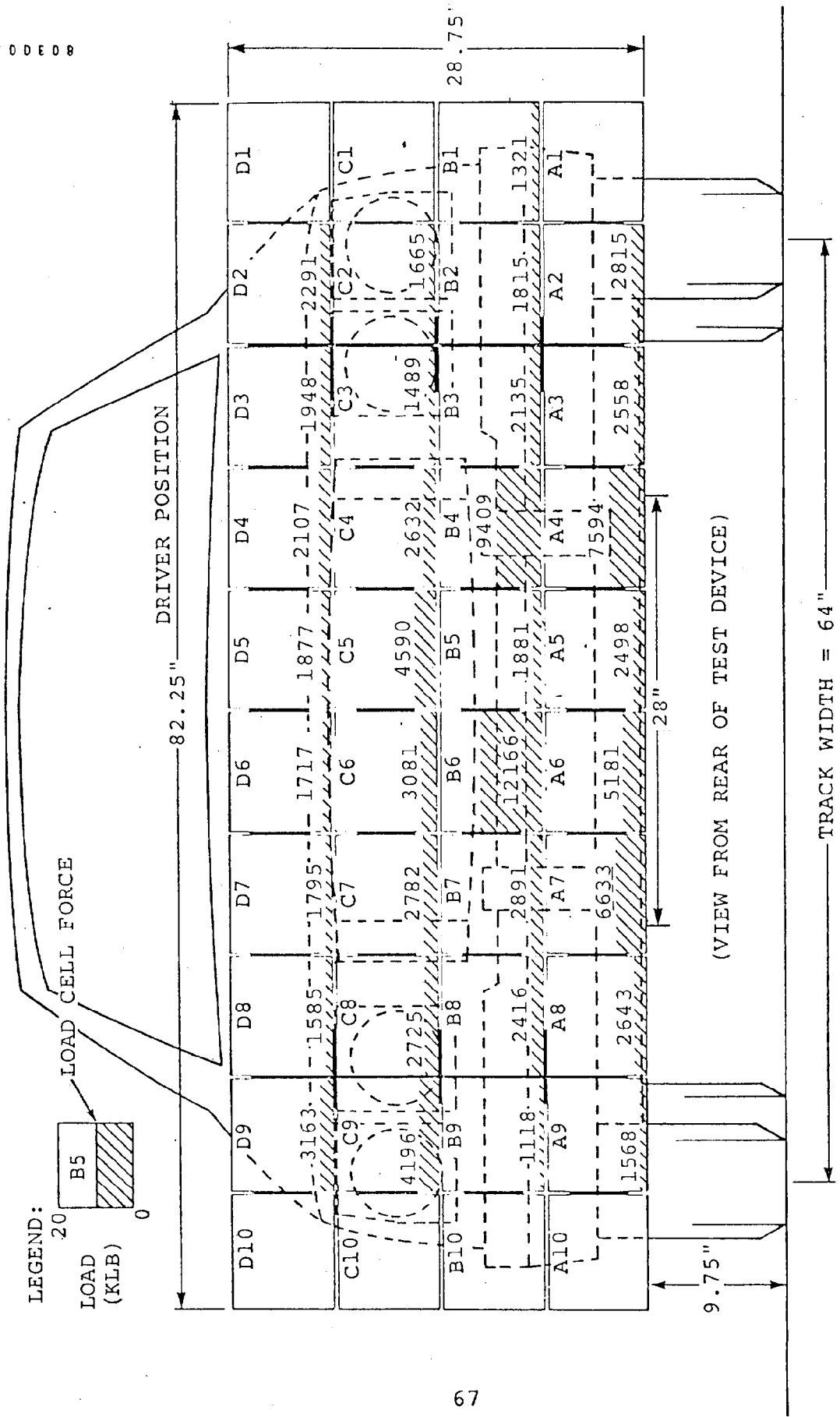

Figure 4-24. 1975 Ford Torino/Fixed Test Device Load Distribution at 56 msec.

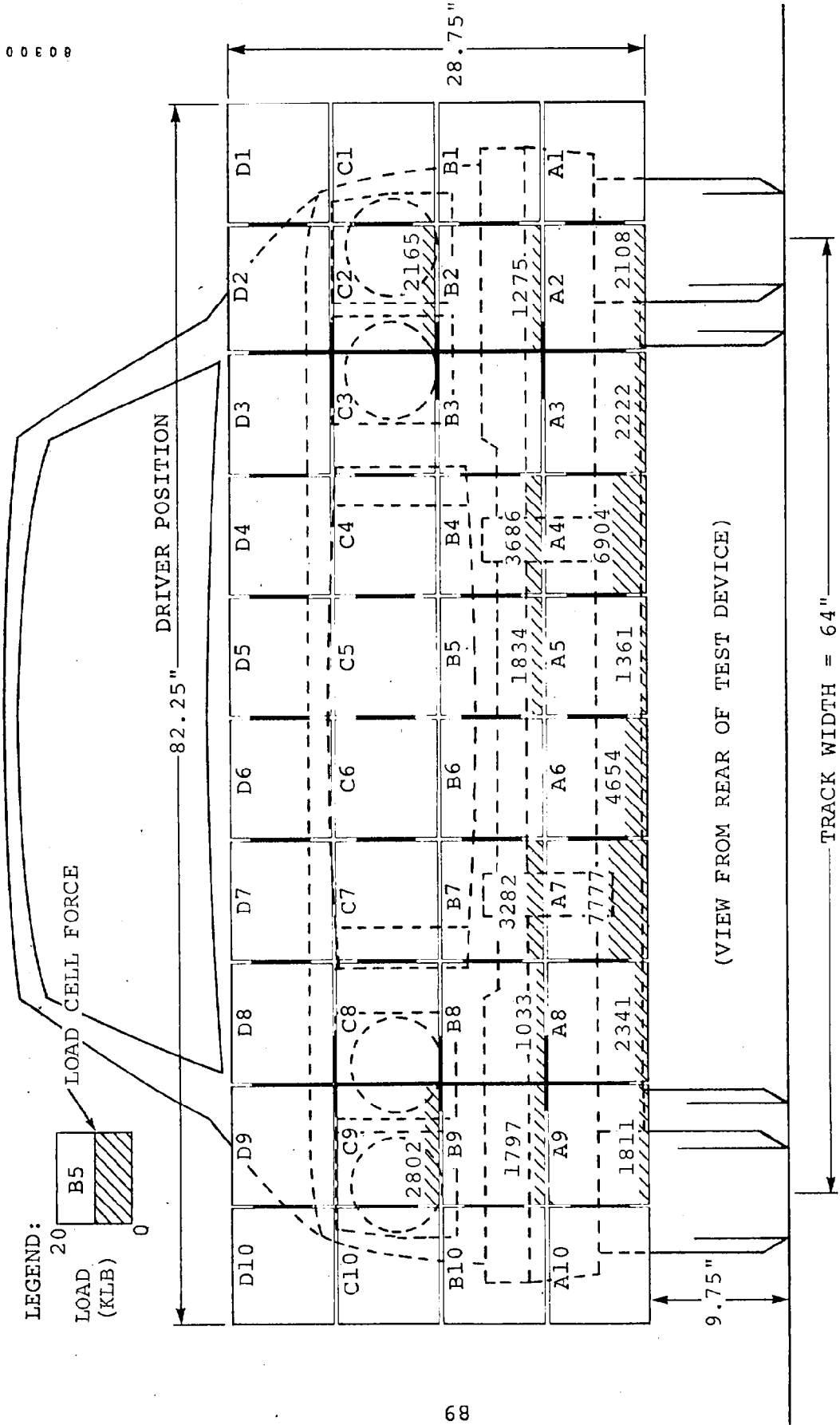

Figure 4-25. 1975 Ford Torino/Fixed Test Device Load Distribution at 90 msec.

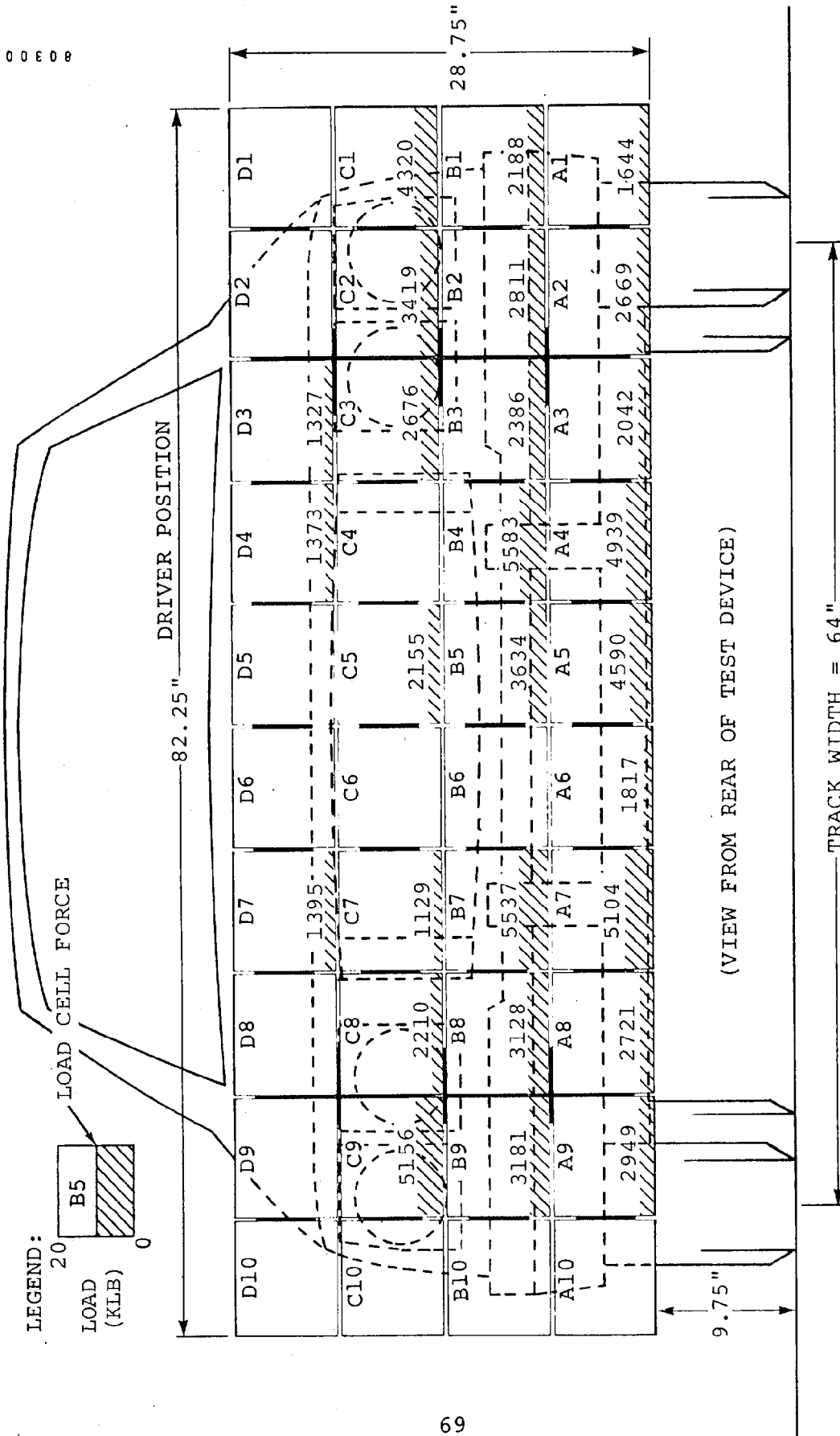

Figure 4-26. 1975 Ford Torino/Moving Test Device Load Distribution at 23 msec.

00000000

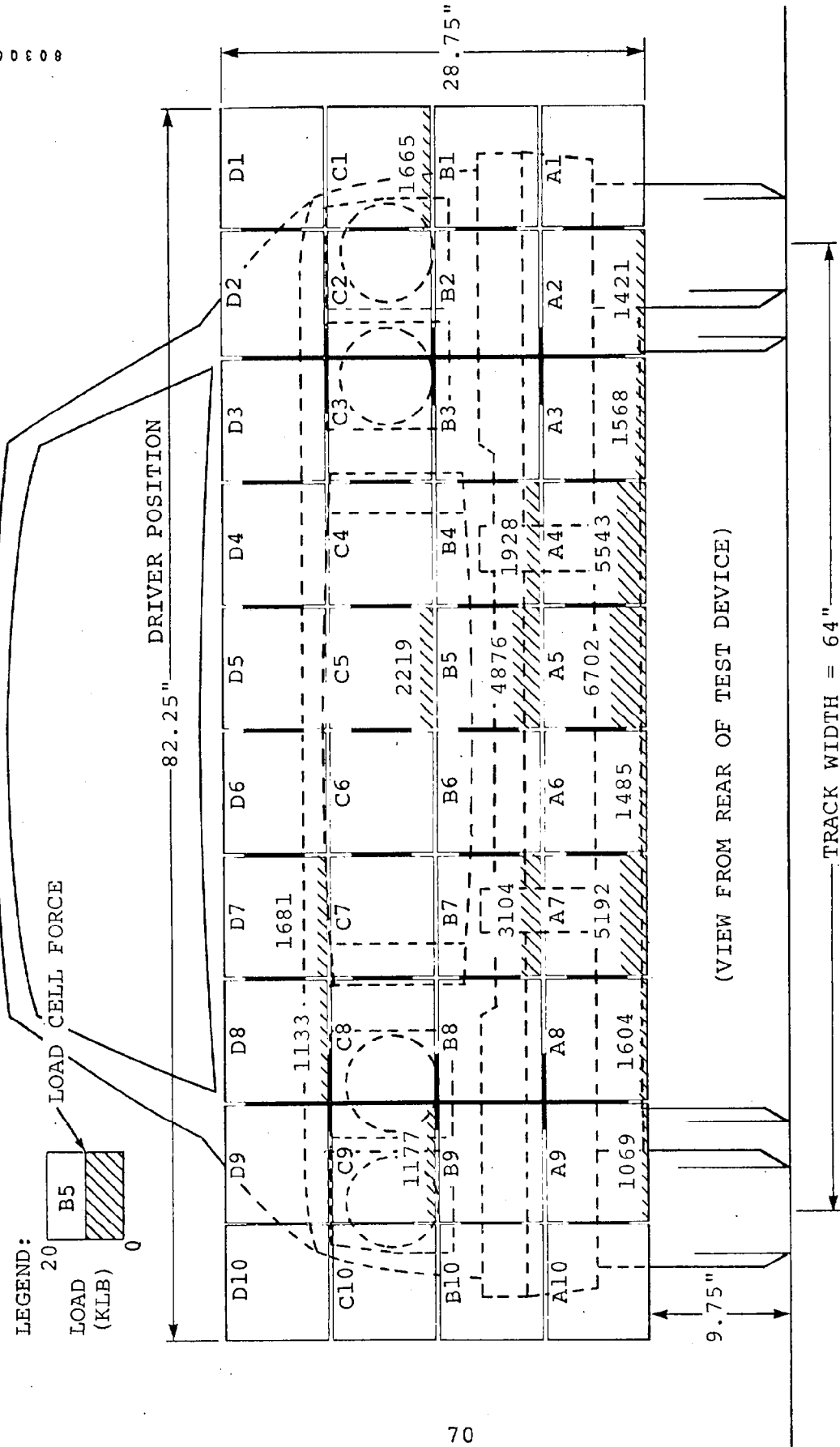

Figure 4-27. 1975 Ford Torino/Moving Test Device Load Distribution at 32 msec.

80300303

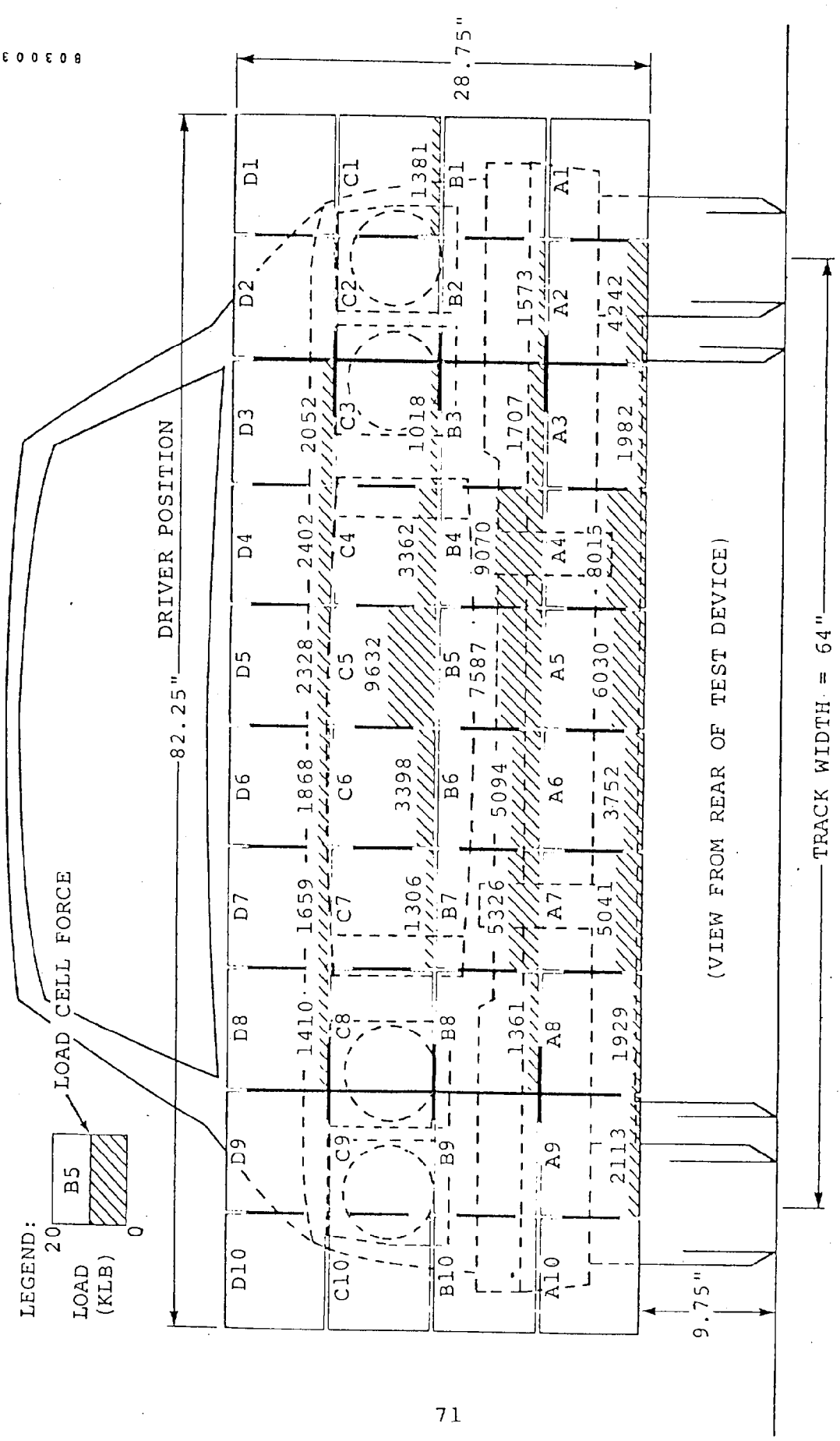

Figure 4-28. 1975 Ford Torino/Moving Test Device Load Distribution at 43 msec.

face of the Test Device when the hood latch grabbed the honeycomb material.

For the moving Test Device test, the total load cell force recorded was 99,940 pounds* at 43 milliseconds after impact and the maximum individual load cell force recorded was 9,790 pounds on module C5 at 44 milliseconds. Loads recorded during this test were smaller than those in Test 3, mainly because of the energy loss in causing the moving Test Device to rebound. As in Test 3, most of the loads were caused by the bumper and bumper guards on rows A and B, with row D seeing small loads from deformation of the hood. Honeycomb modules C1, D2, and A10 were sheared off of the Test Device face from impact. Module D1 was pulled off by deforming sheet metal of the car.

Accelerometer data recorded from the moving Test Device are given in Table 4-24. Accelerometers were located on the right and left frame members of the Test Device and were averaged to give acceleration, velocity, and displacement curves for the Test Device. This data was used in comparing the total force from both load cell and accelerometer data for both tests, which is presented in Tables 4-25 and 4-26.

String potentiometer and strain gauge data for each test are presented in Tables 4-27 through 4-30. String potentiometers were placed at selected locations on the Test Device to measure dynamic crush of the honeycomb. The displacement measured on the honeycomb is an indication of the dynamic crush at one particular point on the honeycomb modules, in all cases, the center of the module. Since the vehicle striking the honeycomb is not a uniformly flat surface, the crush measurement at the center of the module is not necessarily an indication of crush to the remainder of the aluminum honeycomb. Strain gauge data was used to see how typical loads would affect key structural members in bending on the Test Device. Figure 4-29 shows typical strain gauge curves for the

*The actual force may have reached 169,000 pounds (see Figure 4-33).

TABLE 4-24. SUMMARY OF MOVING TEST DEVICE
ACCELEROMETER DATA

Accelerometer Number	Maximum Acceleration		Minimum Velocity		Maximum Displacement	
	A (G)	Time (msec)	V (mph)	Time (msec)	S (in.)	Time (msec)
A1R	-41.5	41	-5.2	154	20.9	79
A2L	-44.7	45	-5.4	200	21.2	77
Average of A1R and A2L	-42.2	45	-5.3	156	21.1	78

TABLE 4-25. COMPARISON OF TOTAL FORCE FROM LOAD CELL AND
ACCELEROMETER DATA - FIXED TEST DEVICE

Parameter	Test Device Force Data*	Test Device Acceleration Data**	Engine/Car Acceleration Data***
Force (lb)	108,490	NA	194,900
Time (msec)	56		66

*Sum of 40 load cells.

**Average of test device accelerometers 1 and 2 times test device weight.

***Average of car accelerometers 1 and 2 times car weight plus average of engine accelerometers 6 and 9 times engine weight.

TABLE 4-26. COMPARISON OF TOTAL FORCE FROM LOAD CELL AND
ACCELEROMETER DATA - MOVING TEST DEVICE.

Parameter	Test Device Force Data*	Test Device Acceleration Data**	Engine/Car Acceleration Data***
Force (lb)	99,940	168,900	169,700
Time (msec)	43	45	49

*Sum of 40 load cells.

**Average of test device accelerometers 1 and 2 times test device weight.

***Average of car accelerometers 1 and 2 times car weight plus average of engine accelerometers 6 and 9 times engine weight.

TABLE 4-27. SUMMARY OF FIXED TEST DEVICE STRING POTENTIOMETER DATA

Displacement Potentiometer (Number)	Maximum Dynamic Displacement	
	D (in.)	Time (msec)
Individual Units		
● SP1 @ A3	3.7	89
● SP2 @ A8	3.6	81
● SP3 @ B5	1.9	108
● SP4 @ C2	2.4	107
● SP5 @ C6	3.4	80
● SP6 @ C9	2.4	182

TABLE 4-28. SUMMARY OF FIXED TEST DEVICE STRAIN GAUGE DATA

Strain Gauge (Number)	Strain Gauge (Location)	Maximum Strain (μ in./in.)	Maximum Stress (psi)*	Maximum Time (msec)
SG1	Row B Front Beam	2343	70,290	61
SG2	Row C Front Beam	568	17,040	57

*Stress = Strain x E (E = 30×10^6 for steel).

most highly stressed member. The maximum allowable (yield) strain was 3350 μ in./in., which is quite adequate for the strain data recorded for this test. At the end of the test series involving the Ford vehicle, it was noted that small localized bending of the high strength horizontal beams of row B occurred where the load cells attach to the Test Device. The bending of the material was due to the fact that the aluminum impact plates were subjected to high torque loads when struck on the outer edges of the plate. For the next series of tests, the front face of row B beam will be rotated 180° in order to maintain a flat surface for the load cells.

TABLE 4-29. SUMMARY OF MOVING TEST DEVICE
STRING POTENTIOMETER DATA

Displacement Potentiometer (Number)	Maximum Dynamic Displacement	
	D (in.)	Time (msec)
Individual Units		
• SP1 @ A3	3.9	141*
• SP2 @ A8	4.7	141
• SP3 @ B5	-3.6	162**
• SP4 @ C2	4.2	50
• SP5 @ C6	2.9	60
• SP6 @ C9	3.5	69

*Questionable data.
**Data system failure.

TABLE 4-30. SUMMARY OF MOVING TEST DEVICE STRAIN GAUGE DATA

Strain Gauge (Number)	(Location)	Maximum Strain (μ in./in.)	Maximum Stress (psi)*	Maximum Time (msec)
SG1	Row B Front Beam	2425	72,750	49
SG2	Row C Front Beam	848	25,440	46
SG3	Right Frame Rail	-554**	16,620	38

*Stress = Strain x E (E = 30×10^6 for steel).
**Questionable data.

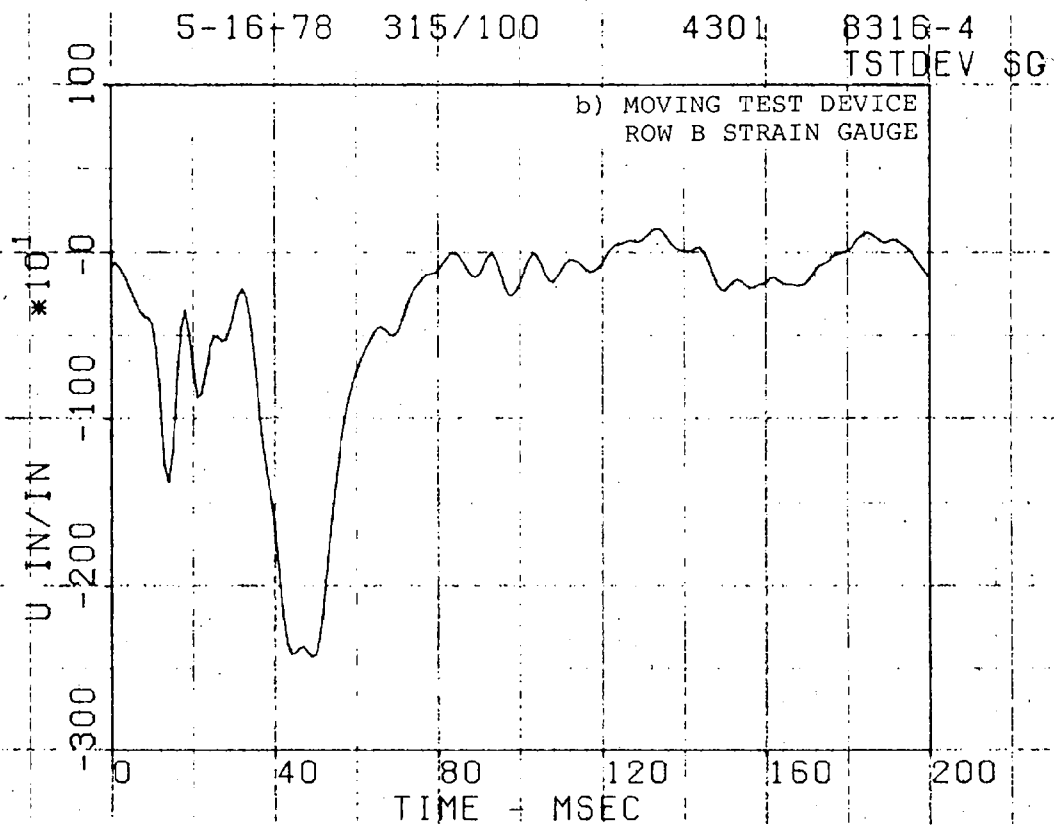
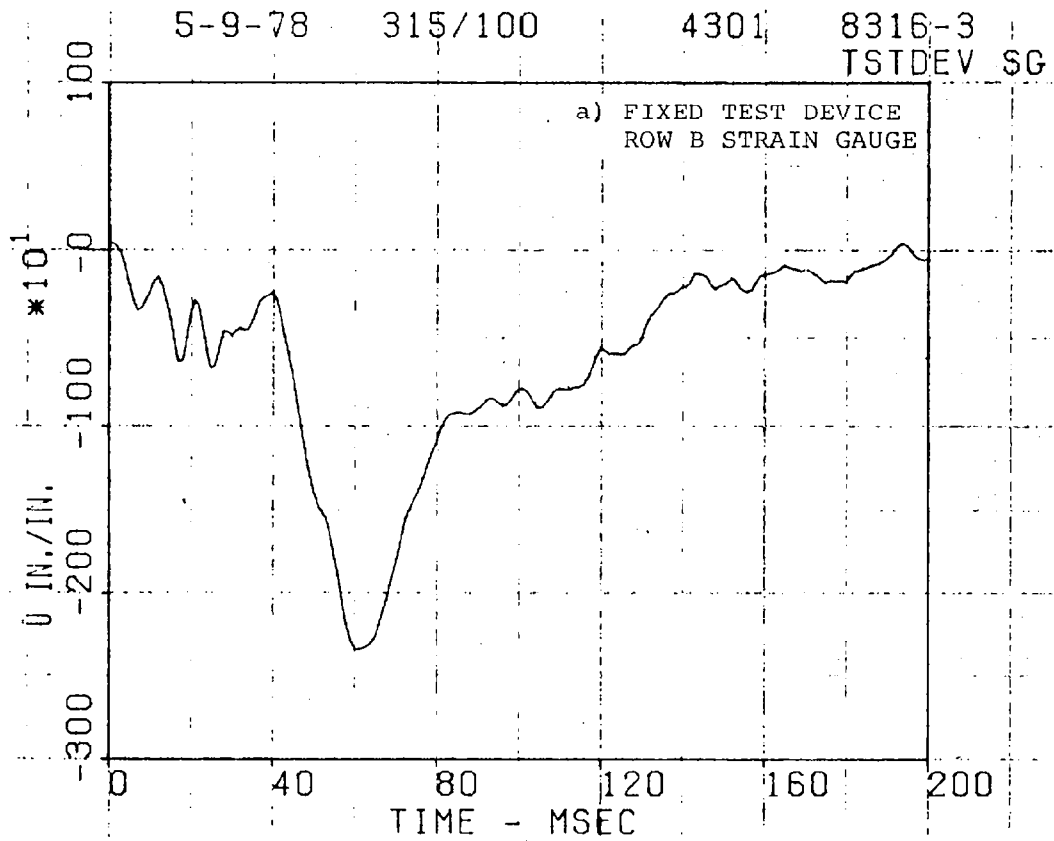

Figure 4-29. Strain Gauge Data - Row B Horizontal Beam.

The aluminum honeycomb crush profiles for fixed and moving Test Device tests are presented in Tables 4-31 and 4-32. Refer to Figures 4-13 and 4-14 for a view of the post-test configuration of the honeycomb. Most of the bottoming out of the honeycomb occurred at rows A and B, where it was struck by the bumper and bumper guards. In Test 3, honeycomb modules B5 and C5 were pulled off of the vehicle at rebound while modules C4 and C7 were pulled out by rotation of the bumper. In Test 4, modules C1, D2, and A10 sheared off the Test Device face at impact and module D1 was pulled off the Test Device face at rebound.

A comparison of dynamic crush from accelerometer data and film analysis for each test is shown in Figures 4-30 and 4-31. Since the vehicle does not act as a rigid body during the test, and vehicle accelerometer data is only representative of one location in an elastic body (at the B-pillar of the car), this data tends to be consistently higher than the data from film analysis. The data from film analysis is considered more accurate since a visual measurement of crush versus time is taken.

Total load cell force data and calculated inertia force from accelerometer data is shown in Figure 4-32 for Test 3 and Figure 4-33 for Test 4. Since the fixed Test Device is not instrumented with accelerometers, the inertia force was calculated using the car data, namely the vehicle's averaged accelerometer data along with its test weight. In this case, the engine and car mass were considered as separate masses, since their dynamics during the event are different. The total inertia force was calculated by using $F = ma$ for the engine and car mass separately, and adding the two together. In the moving Test Device test, the inertia force can also be calculated using accelerometer data from the Test Device. In this case, the Test Device is considered a rigid body. Figure 4-34 shows the load cell force-deflection characteristics for both tests. The vehicle rate of stiffness as load is applied is given in Table 4-33.

TABLE 4-31. FIXED TEST DEVICE HONEYCOMB CRUSH PROFILE

VEHICLE: 1975 Ford Torino 4-door Sedan

Crush Location	Height Above Ground (in.)	Distance Right of Center (in.)						Distance Left* of Center (in.)				Average	
		37.1	28.9	20.6	12.4	4.1	£	4.1	12.4	20.6	28.9		37.1
Row D	34.3	-0.2	4.2	0.7	0.5	1.5	2.0	0.8	0.6	0.8	0.8	-0.2	1.1
Row C	27.0	1.8	3.0	4.3	0.7	4.0	5.7	**	0.5	2.6	3.1	-0.3	2.5
Row B	19.8	0.6	2.6	3.9	5.5	1.0	3.7	**	5.7	3.1	5.6	-0.3	3.1
Row A	12.5	-0.3	4.6	3.6	5.7	4.1	6.1	4.0	3.2	3.7	4.7	0.0	3.6
Column		10	9	8	7	6	5	4	3	2	1		

*The left side of the test device is as viewed from the car driver's position.

**Honeycomb modules pulled or sheared off of Test Device from impact of car.

TABLE 4-32. MOVING TEST DEVICE HONEYCOMB CRUSH PROFILE

VEHICLE: 1975 Ford Torino 4-door Sedan

Crush Location	Height Above Ground (in.)	Distance Right of Center (in.)			G	Distance Left* of Center (in.)			Average					
		37.1	28.9	20.6		12.4	4.1	4.1		12.4	20.6	28.9	37.1	
Row D	34.3	-1.8	-0.3	3.4	2.3	0	1.3	0.7	4.1	1.0	4.4	**	**	1.2
Row C	27.0	-1.5	3.5	2.2	-0.4	2.3	3.3	4.2	2.8	2.0	3.4	**	**	2.2
Row B	19.8	1.3	0.3	1.3	1.0	0.5	2.7	0.4	5.2	2.5	3.3	3.3	3.3	2.0
Row A	12.5	**	4.4	4.3	3.2	3.8	5.5	4.1	4.3	4.0	4.6	2.6	2.6	4.1
Column		10	9	8	7	6	5	4	3	2	1			

*The left side of the test device is as viewed from the car driver's position.
 **Honeycomb modules pulled or sheared off of Test Device from impact of car.

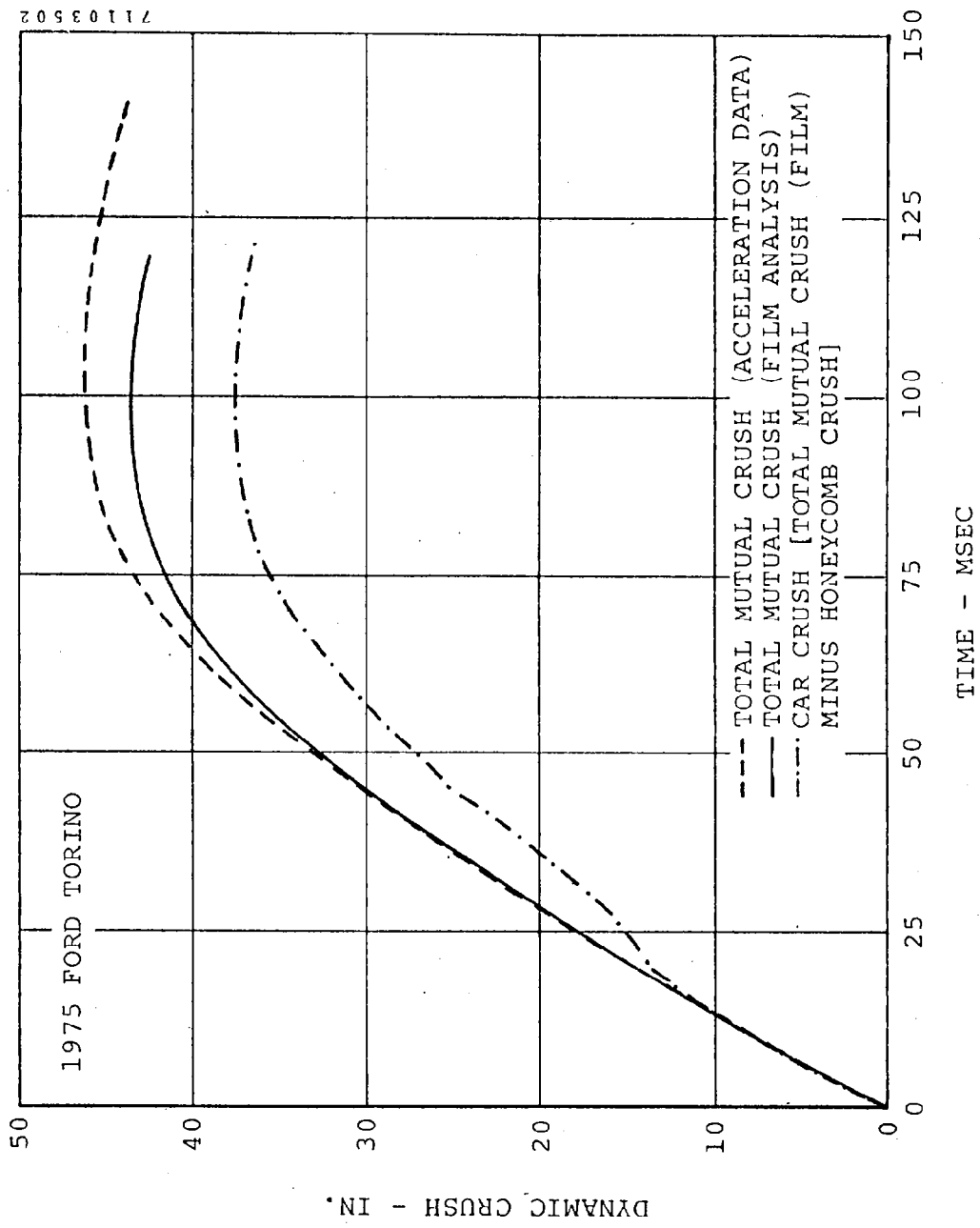

Figure 4-30. Dynamic Crush During Collision for Fixed Test Device - Test 3.

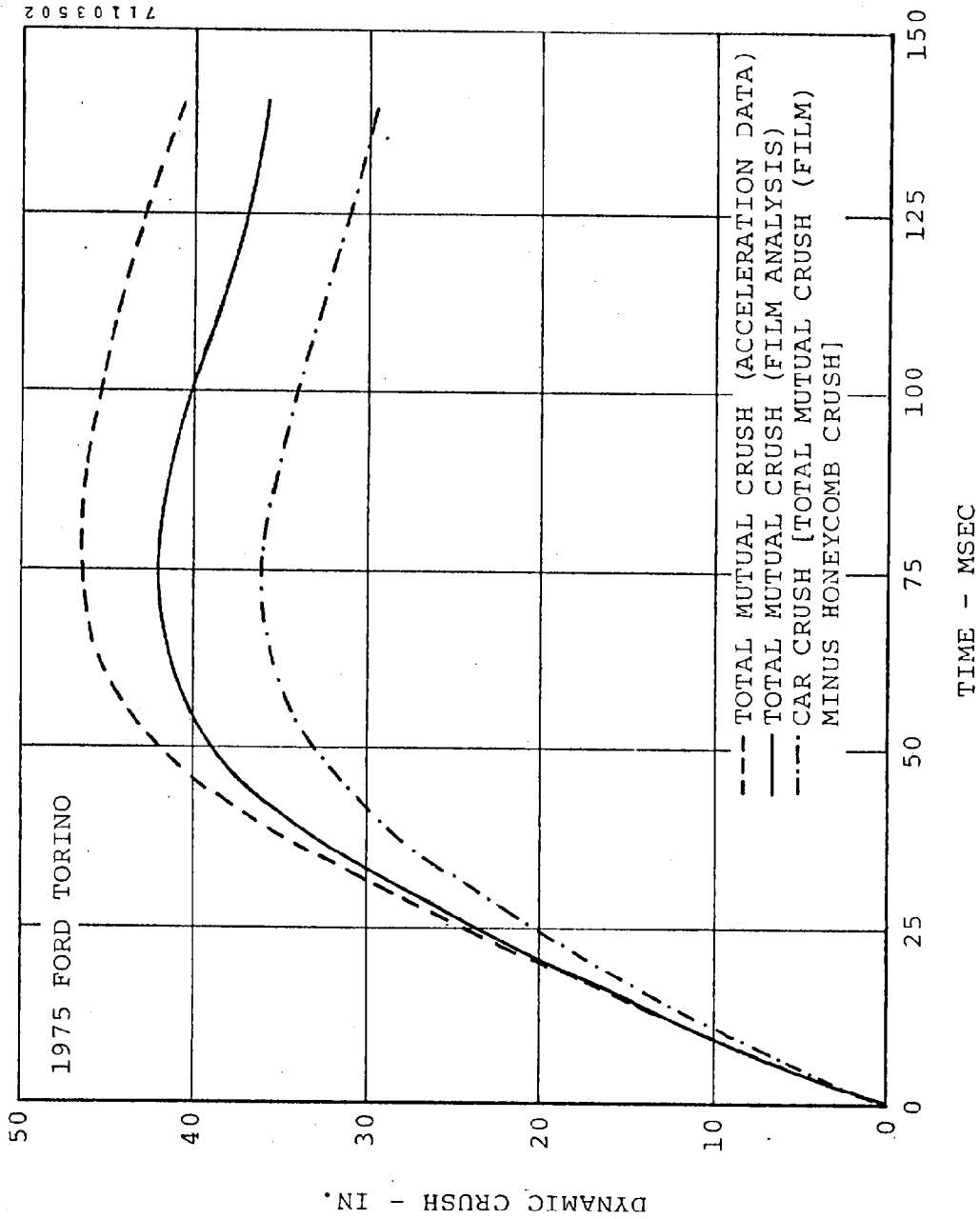

Figure 4-31. Dynamic Crush During Collision for Moving Test Device - Test 4.

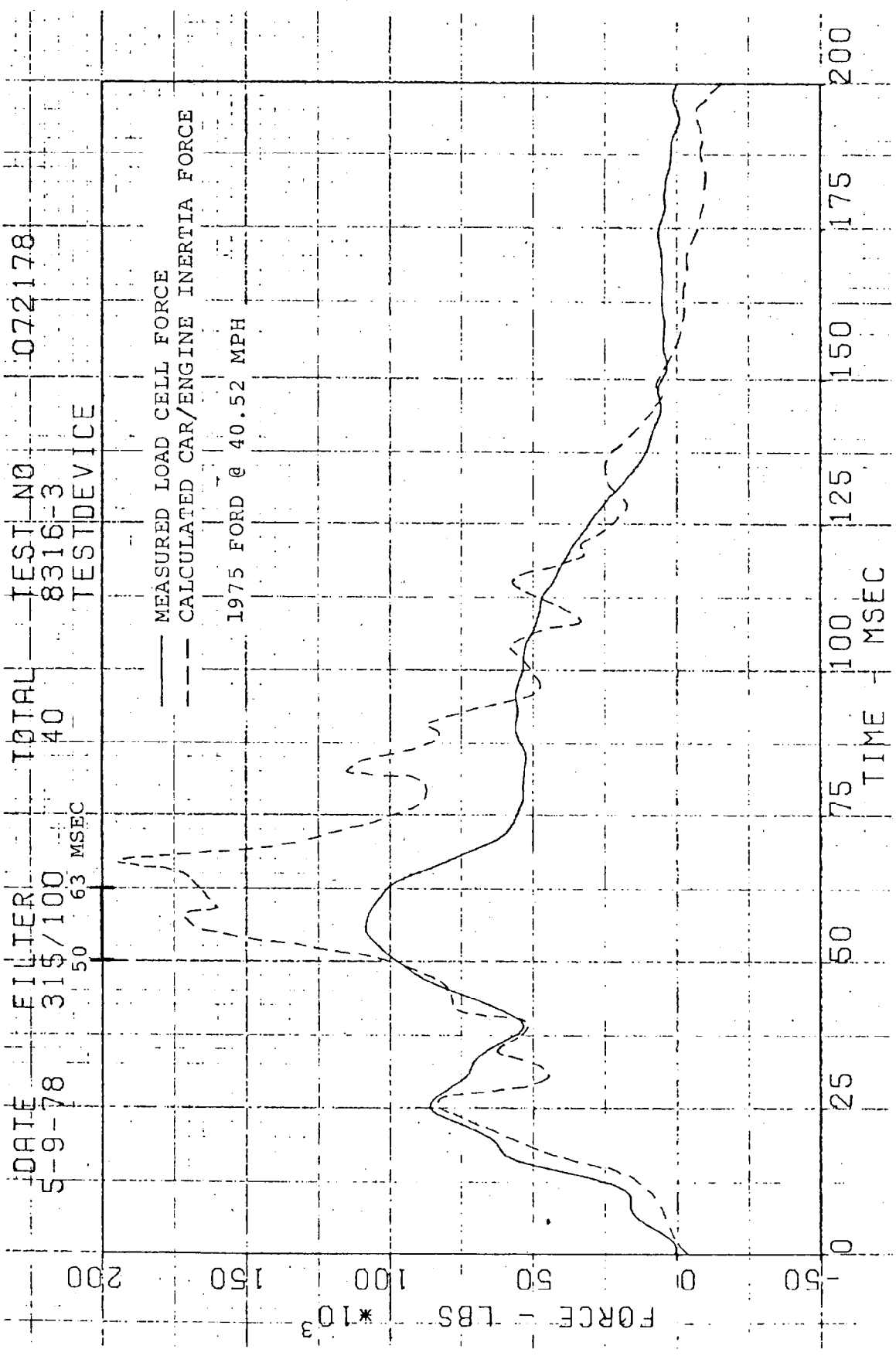

Figure 4-32. Comparison of Total Load Cell Force From Fixed Test Device Load Cell and Vehicle Accelerometer Data for Test 3.

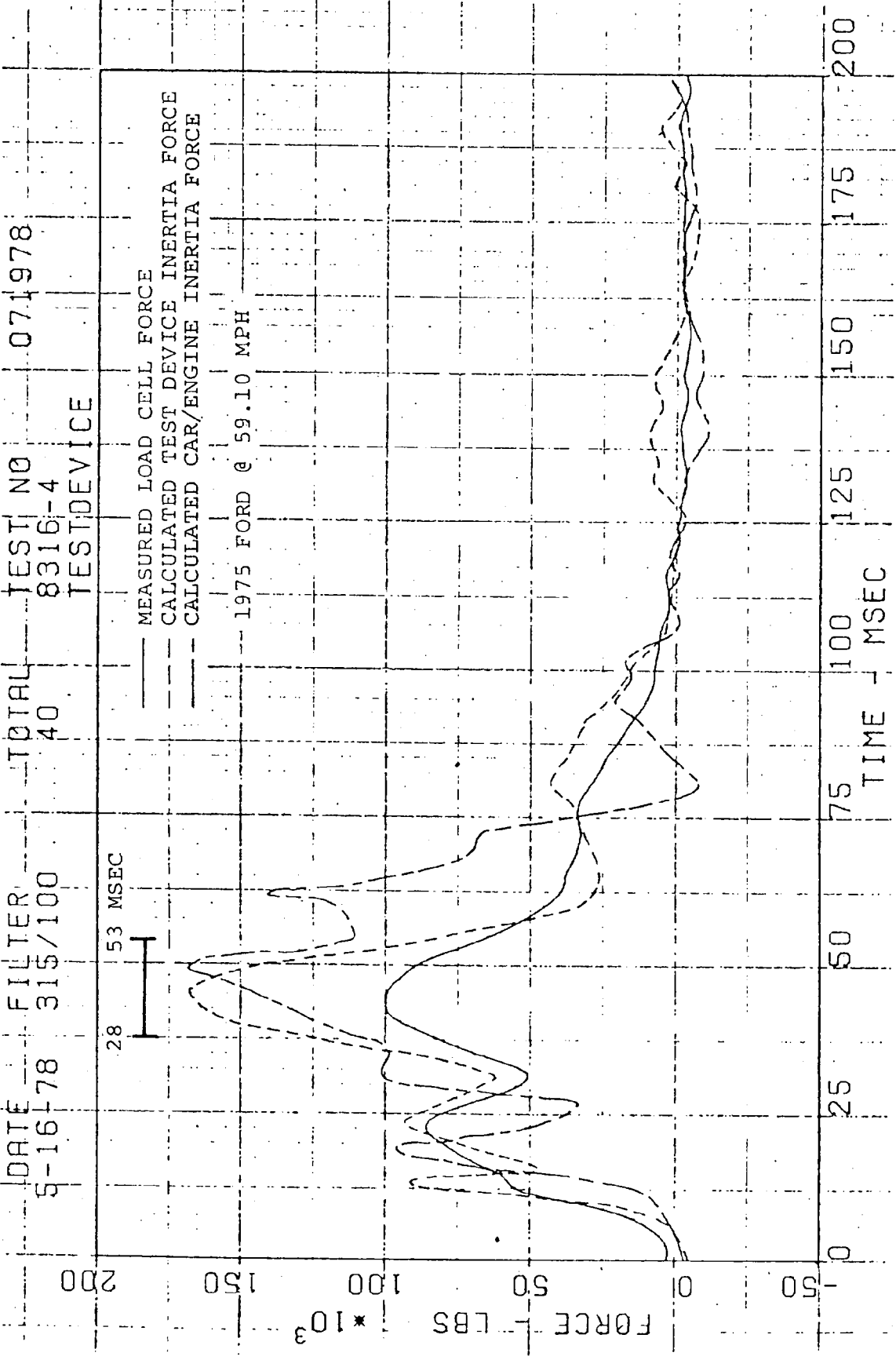

Figure 4-33. Comparison of Total Load Cell Force From Moving Test Device Load Cell and Vehicle Accelerometer Data for Test 4.

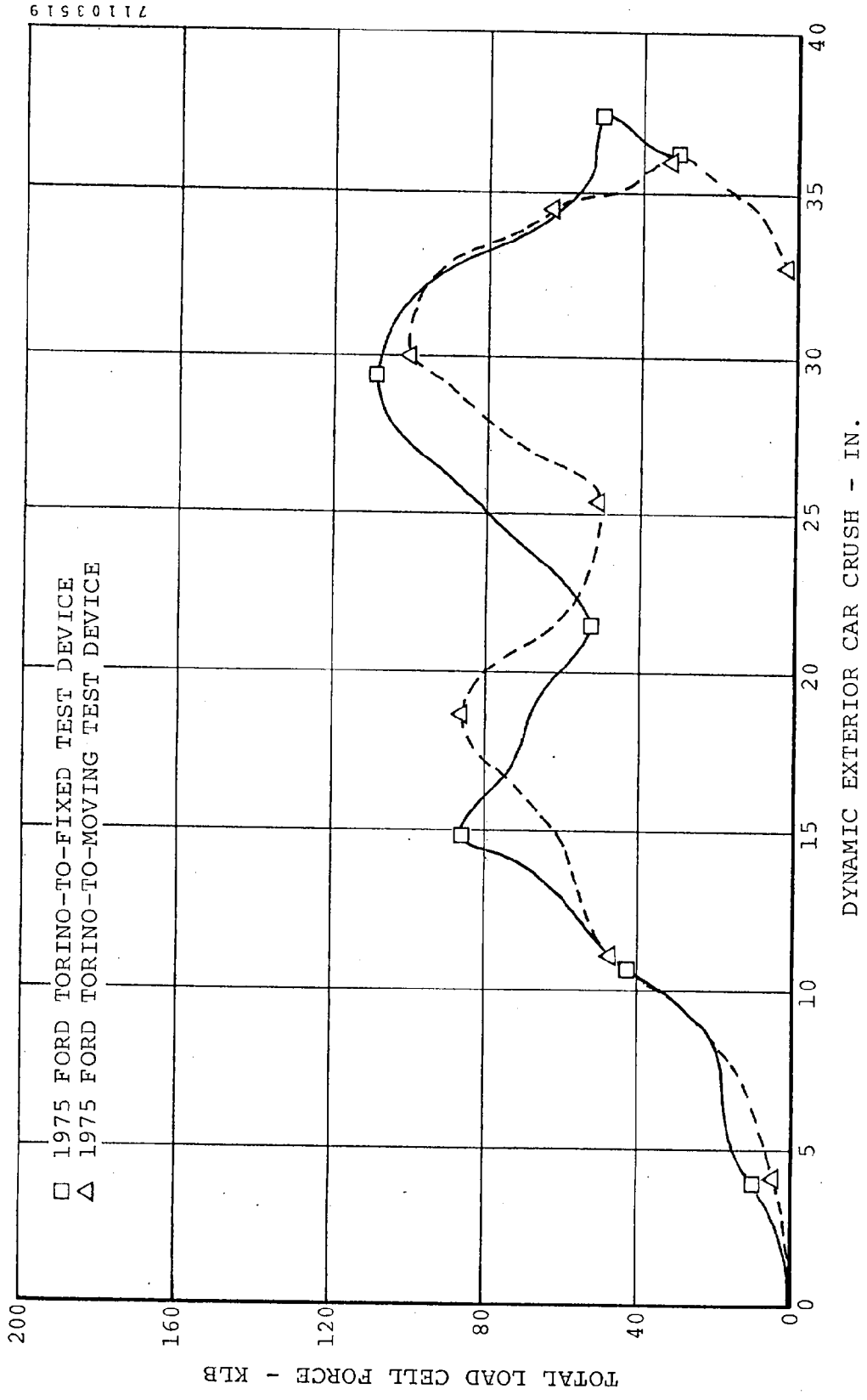

Figure 4-34. Comparison of Load Cell Force-Deflection Characteristics for 1975 Ford Torino.

TABLE 4-33. FRONTAL STIFFNESS OF CARS AS A FUNCTION OF CRUSH DISTANCE

Test Car No.	For 6" Crush		For 12" Crush		For 18" Crush		For 24" Crush		For 30" Crush						
	Peak (klb)	Avg. Rate (*) (klb)	Peak (klb)	Avg. Rate (*) (klb)	Peak (klb)	Avg. Rate (*) (klb)	Peak (klb)	Avg. Rate (*) (klb)	Peak (klb)	Avg. Rate (*) (klb)					
3 Ford	16.0	6.9	2.30	59.6	17.7	2.95	86.1	35.9	3.99	86.1	42.1	3.51	108.5	52.4	3.49
4 Ford	9.9	3.5	1.18	56.4	15.6	2.59	85.5	32.1	3.57	86.1	41.5	3.46	99.3	46.9	3.12

*Rate in klb/in.

Car interior intrusion is plotted against exterior dynamic crush of the vehicle in Figures 4-35 through 4-37. Dynamic interior crush was measured by means of a string potentiometer located along the centerline of the vehicle. A difficulty sometimes occurs during impact when outside influences interfere with the displacement of the string potentiometer, causing misleading data.

A crash pulse may be monitored on the Test Device face to determine the "hard" points on the vehicle. Figures 4-38 and 4-39 show where on the Test Device face the centroid of the total load cell force was acting, as a function of time.

4.4 OCCUPANT KINEMATICS

This section of the report presents the results of dummy response during the fixed and moving Test Device collisions. This includes peak values for each occupant's head, chest, and femur, restraint survival distance, and restraint system summaries.

In evaluating occupant response data, it must be remembered that, because of the high crash speeds, pulses measured by each occupant are very high and may exceed FMVSS 208 Standards. Figures 4-40 through 4-47 show pre-test and post-test configurations of the occupant for each test. A summary of occupant response data is presented in Table 4-34 with restraint system data presented in Table 4-35.

In both tests, the left front occupant's head and chest made contact with the steering wheel and dash panel. In Test 4, the damage to the steering wheel and dash panel was less severe than in Test 3. The driver's head in Test 3 had a maximum longitudinal displacement of 76.6 inches at $t = 130$ milliseconds, while in Test 4, the maximum longitudinal displacement was 47.3 inches at $t = 111$ milliseconds. Post-test observations showed that both driver femurs made contact with the knee bolsters, causing severe damage to the area. In both tests, the driver's chest struck the steering wheel

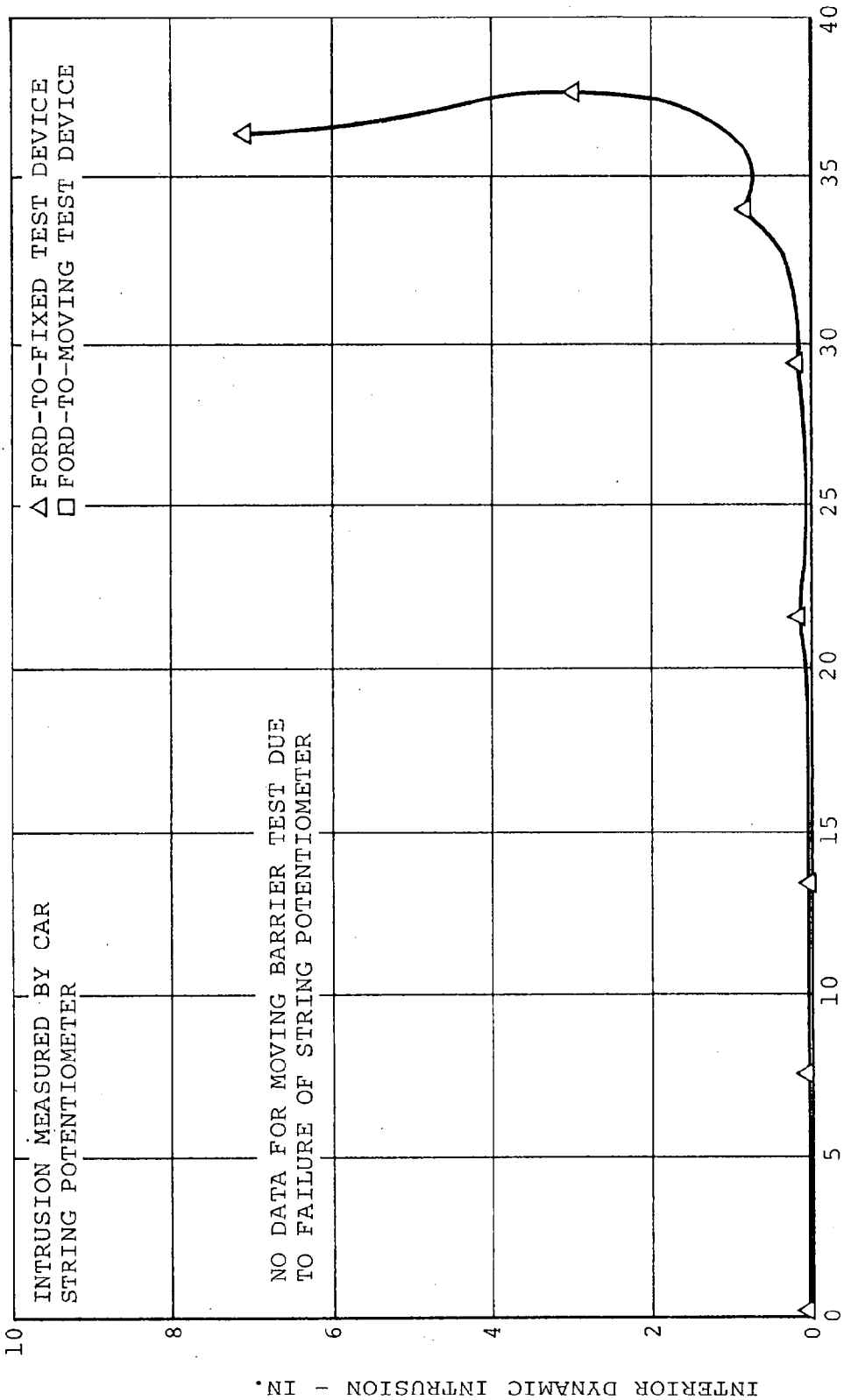

EXTERIOR DYNAMIC CAR CRUSH - IN.

Figure 4-35. Car Interior Intrusion Versus Exterior Car Crush.

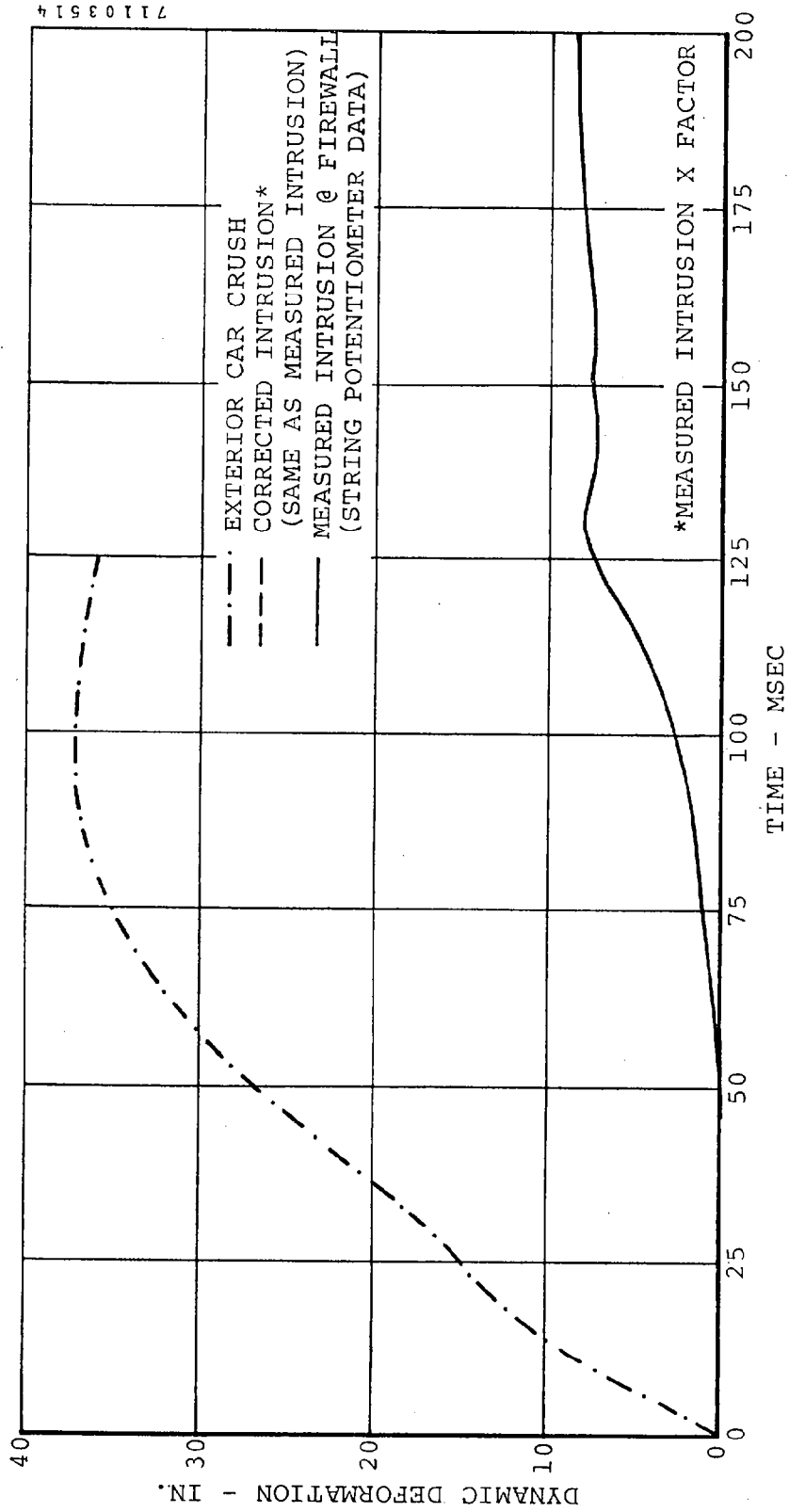

Figure 4-36. Car Exterior Crush and Interior Intrusion Versus Time for Fixed Test Device - Test 3.

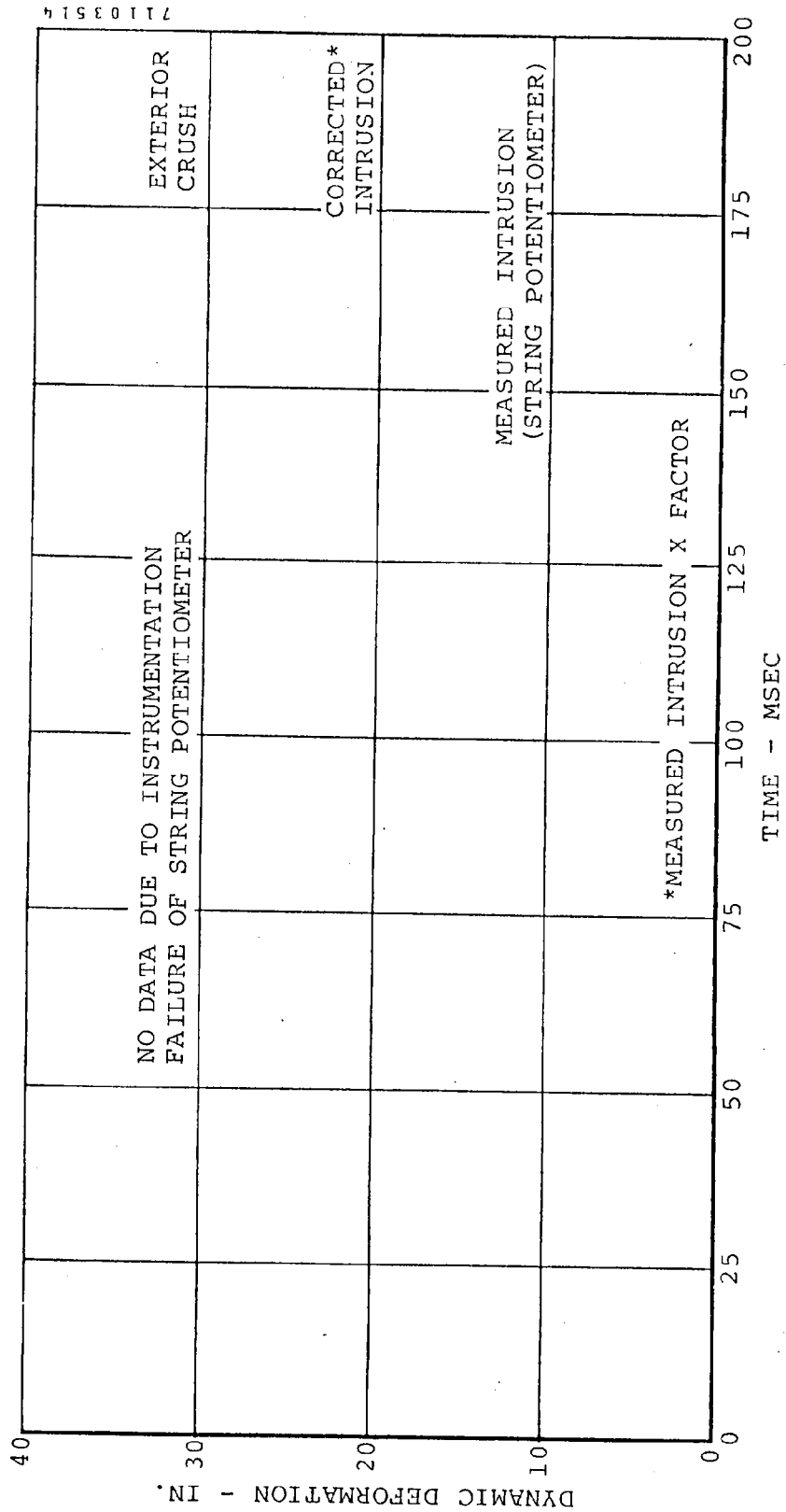

Figure 4-37. Car Exterior Crush and Interior Intrusion Versus Time for Moving Test Device - Test 4.

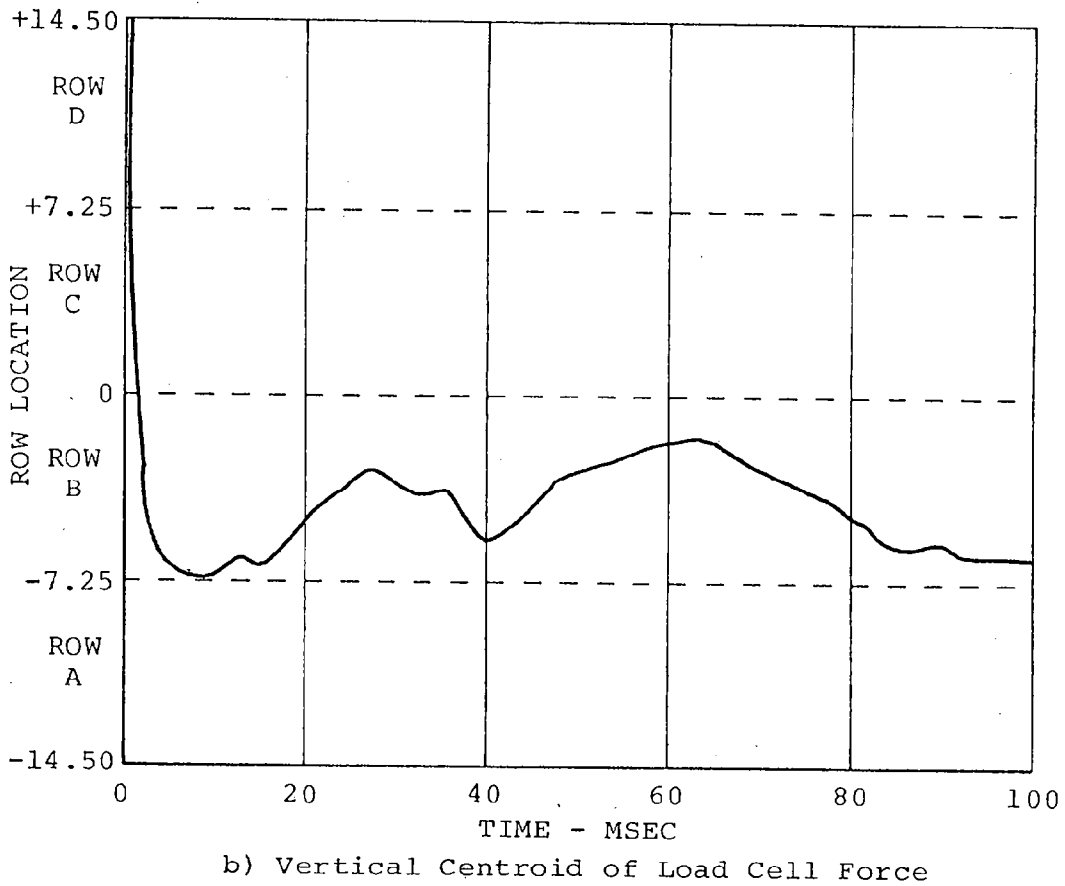
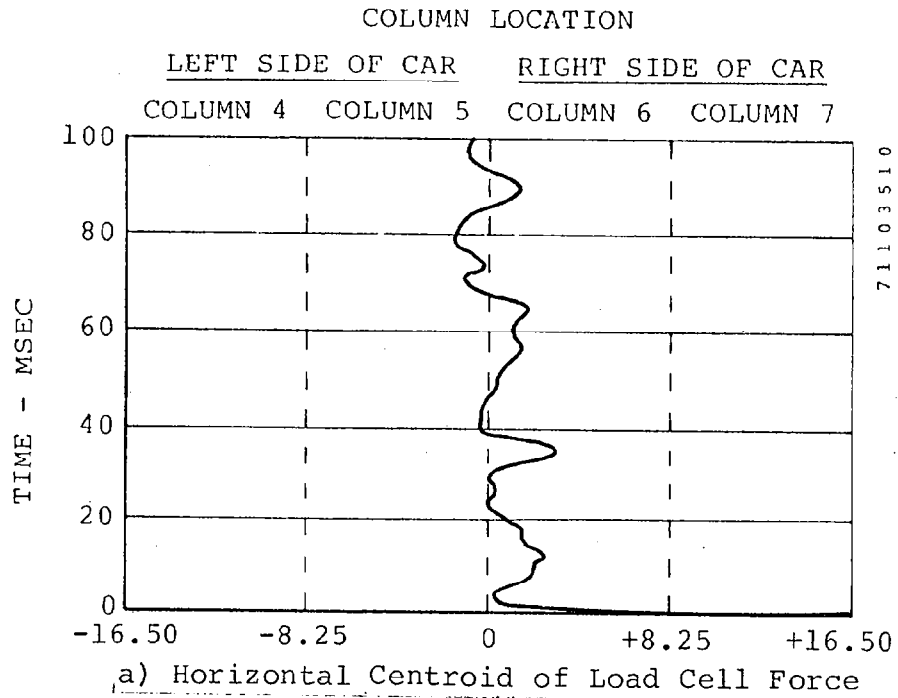

Figure 4-38. Centroid of Load Cell Force for Fixed Test Device Test.

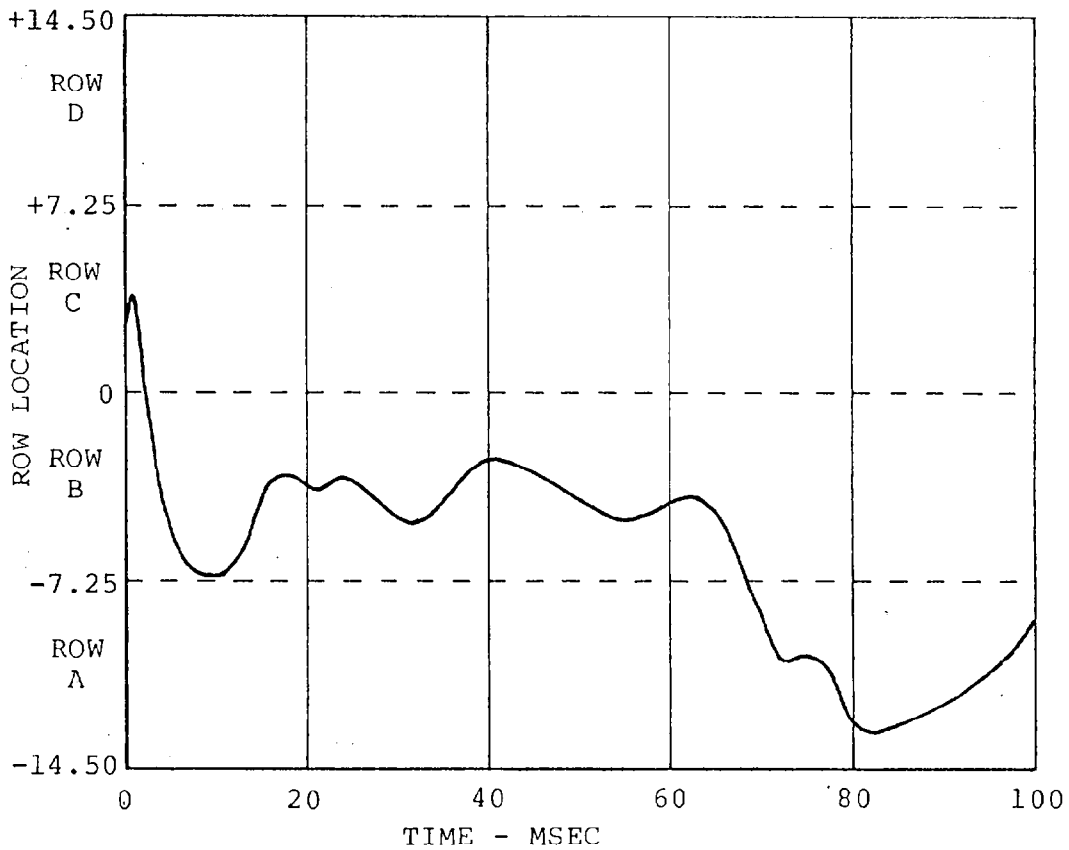
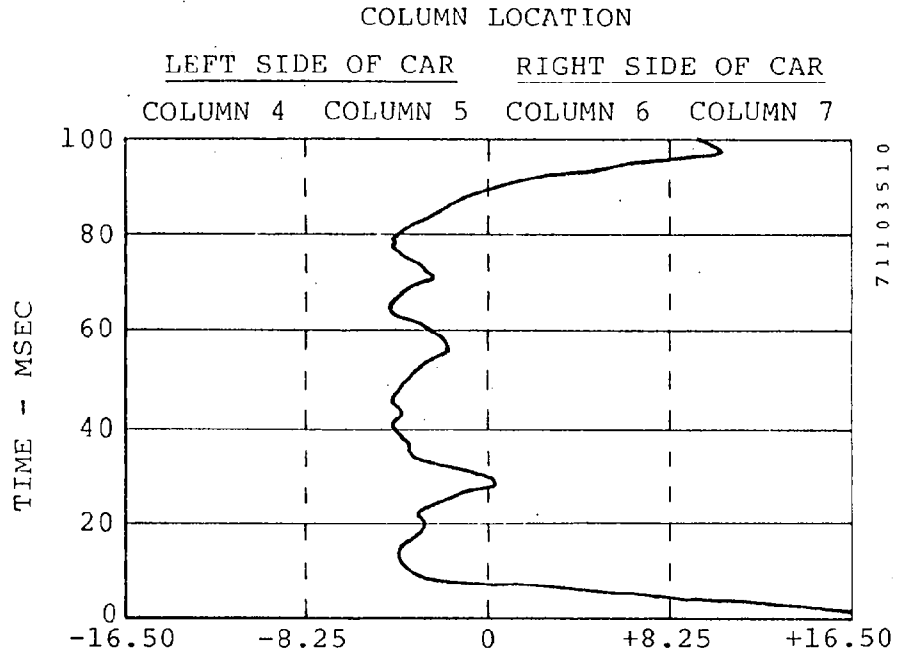

Figure 4-39. Centroid of Load Cell Force for Moving Test Device Test.

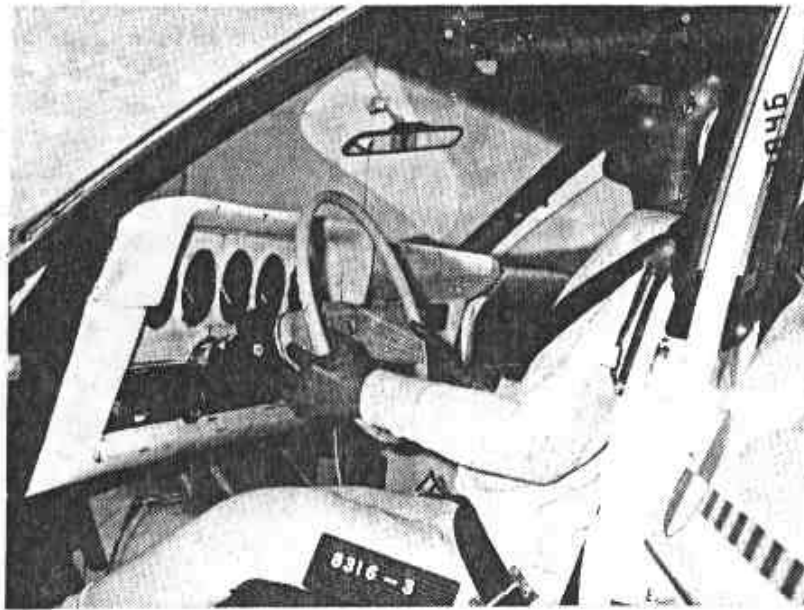

Figure 4-40. Pre-test Driver Position - Test 3.



Figure 4-41. Post-test Driver Position - Test 3.



Figure 4-42. Pre-test Passenger Position - Test 3.



Figure 4-43. Post-test Passenger Position - Test 3.



Figure 4-44. Pre-test Driver Position - Test 4.



Figure 4-45. Post-test Driver Position - Test 4.



Figure 4-46. Pre-test Passenger Position - Test 4.



Figure 4-47. Post-test Passenger Position - Test 4.

TABLE 4-34. OCCUPANT RESPONSE DATA SUMMARY

VEHICLE: 1975 Ford Torino

	Fixed Test Device (No. 3)				Moving Test Device (No. 4)			
	Left Front Occupant		Right Front Occupant		Left Front Occupant		Right Front Occupant	
	Maximum Value (G)	T (msec)	Maximum Value (G)	T (msec)	Maximum Value (G)	T (msec)	Maximum Value (G)	T (msec)
<u>Head</u>								
X	-160.3	89	-102.7	107	-55.0	92	-126.5	91
Y	-30.4	114	+42.6	108	-22.6	104	+54.7	91
Z	+98.2	100	+62.2	111	+64.6	101	+58.0	98
R*	112.2	106	113.0	109	75.4	102	106.0	109
HIC	1824 @ 94-116		1691 @ 88-122		765 @ 80-127		1211 @ 89-118	
<u>Chest</u>								
X	-85.8	88	-49.5	100	-58.7	88	-36.4	87
Y	-42.1	93	+38.5	100	-26.9	86	+28.9	88
Z	-10.7	125	+25.3	91	-16.6	99	+12.8	75
R*	84.5	90	58.8	98	58.8	89	40.5	90
SI	924 @ 200		668 @ 200		518 @ 200		326 @ 200	
	Maximum Value (lb)	T (msec)	Maximum Value (lb)	T (msec)	Maximum Value (lb)	T (msec)	Maximum Value (lb)	T (msec)
<u>Femurs</u>								
LF	-1407	66	-807	101	-2169	74	-692	77
RT	-1635	78	-1173	87	-1588	89	-609	45

*3-msec clip.

TABLE 4-35. SUMMARY OF RESTRAINT SYSTEM DATA

VEHICLE: 1975 Ford Torino 4-door sedan

<u>Fixed Test Device (No. 3)</u>	<u>Load @</u>	<u>Time</u>
	<u>(lb)</u>	<u>(msec)</u>
Left Front Occupant		
Peak Shoulder Belt Load	1411 @	86
Peak Left Lap Belt Load	1297 @	86
Peak Right Lap Belt Load	1868 @	81
Right Front Occupant		
Peak Shoulder Belt Load	1761 @	110
Peak Left Lap Belt Load	2149 @	101*
Peak Right Lap Belt Load	1852 @	91
<u>Moving Test Device (No. 4)</u>		
Left Front Occupant		
Peak Shoulder Belt Load	1323 @	86
Peak Left Lap Belt Load	966 @	70
Peak Right Lap Belt Load	1753 @	73
Right Front Occupant		
Peak Shoulder Belt Load	1429 @	103
Peak Left Lap Belt Load	1678 @	80
Peak Right Lap Belt Load	1533 @	80

*Instrumentation failure >100 msec

hub, which showed little sign of yielding and caused high acceleration values to appear. Since the energy transfer in Test 4 was different, the damage to the driver compartment was less severe and the occupant responses were less severe.

In each test, the right front passenger's head made contact with the dash panel. Post-test observations showed that the knees struck and completely destroyed the glove compartment area. In both tests, the dash panel became separated from the frame of the car from the impact. The passenger's chest loads were caused mainly by the shoulder belt restraint system. No visible contact was made with the passenger's chest in the occupant compartment.

Restraint Survival Distance (RSD) criteria is presented in Table 4-36. This value was used in efforts to determine relative vehicle crashworthiness. Values in this table reflect RSD values with and without a 7-millisecond shift. This shift is to account for crush of the honeycomb on the Test Device. The vehicle compartment deceleration pulse and restraint system pulse were used to compare available compartment space with the space necessary to decelerate the occupant. A critical element in calculating this value is the relative positioning of the dummy in the occupant compartment. Figures 4-48 through 4-51 show the pre-test and post-test occupant compartments for each test. Refer to Appendix D for an explanation of the methodology used to determine RSD values.

TABLE 4-36. SUMMARY OF OCCUPANT RESTRAINT SURVIVAL DISTANCE (RSD)

Test No.	Vehicle	Occupant	t' (msec)	D _C (in.)	D _P (in.)	AID (in.)		RSD (in.)		RSD* (in.)	
						Pre	Post	Pre	Post	Pre	Post
3	1975 Ford Torino 4-door sedan	Driver	46.0	30.3	32.0	13.7	13.6	12.0	11.9	13.5	13.3
		Passenger	46.0	30.4	32.0	13.9	13.4	12.3	11.8	13.7	13.2
4	1975 Ford Torino 4-door sedan	Driver	50.1	22.5	25.0	14.7	14.8	12.3	12.4	10.7	9.8
		Passenger	50.1	22.3	20.5	14.3	14.1	11.7	11.5	9.5	8.4

t' = time when occupant velocity = compartment velocity
 D_C = displacement of compartment from initial impact to t = t'
 D_P = displacement of occupant from initial impact to t = t'
 AID = Available Interior Distance
 RSD = Restraint Survival Distance = AID - (D_P - D_C) t = t'

NOTE: AID and RDS are shown for pre- and post-crash vehicle geometry, respectively.
 *Seven-msec shift in time made to RSD value to correct for crush of honeycomb of Test De-vice.

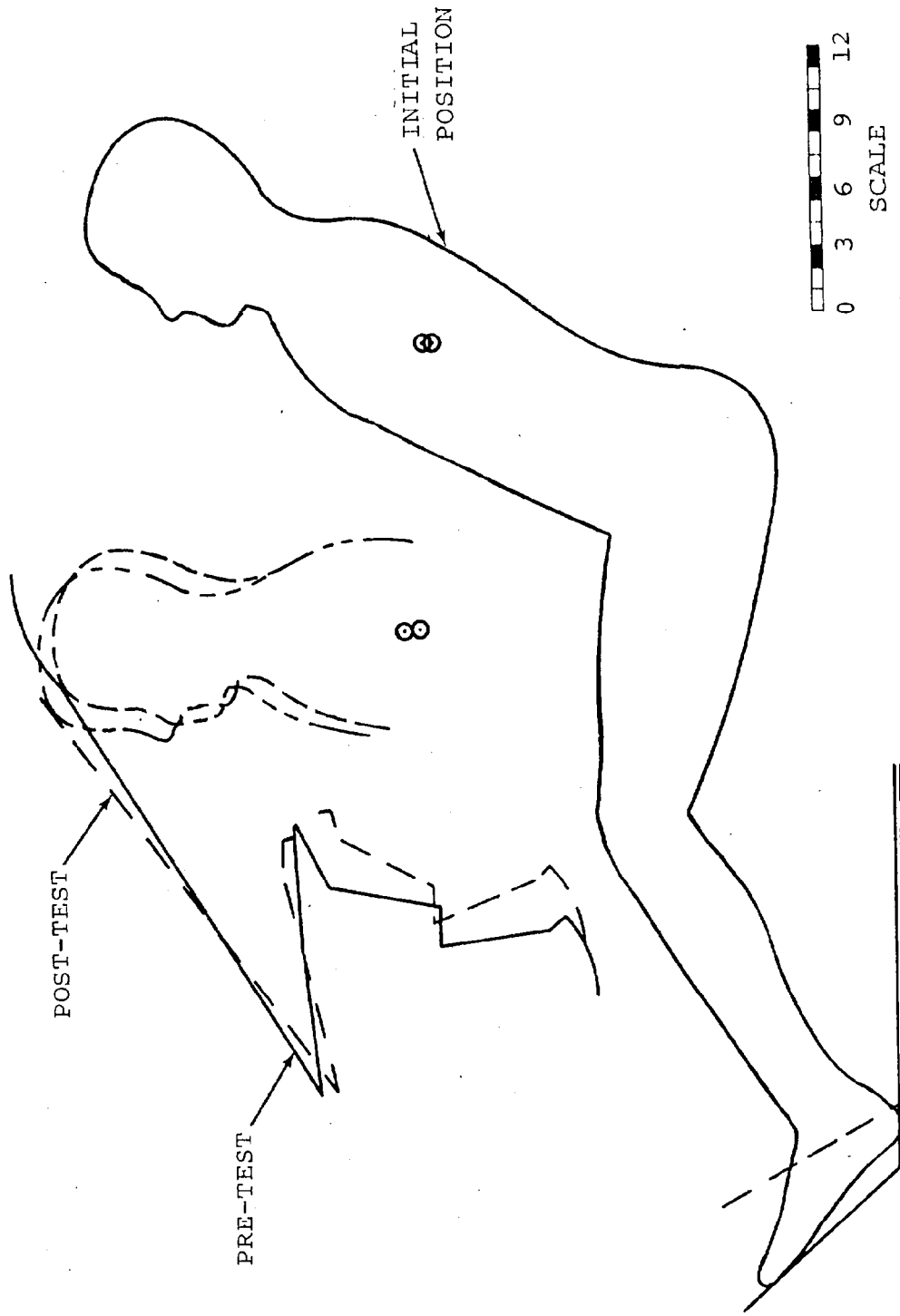

Figure 4-48. 1975 Ford Torino - Driver Profile - Test 3.

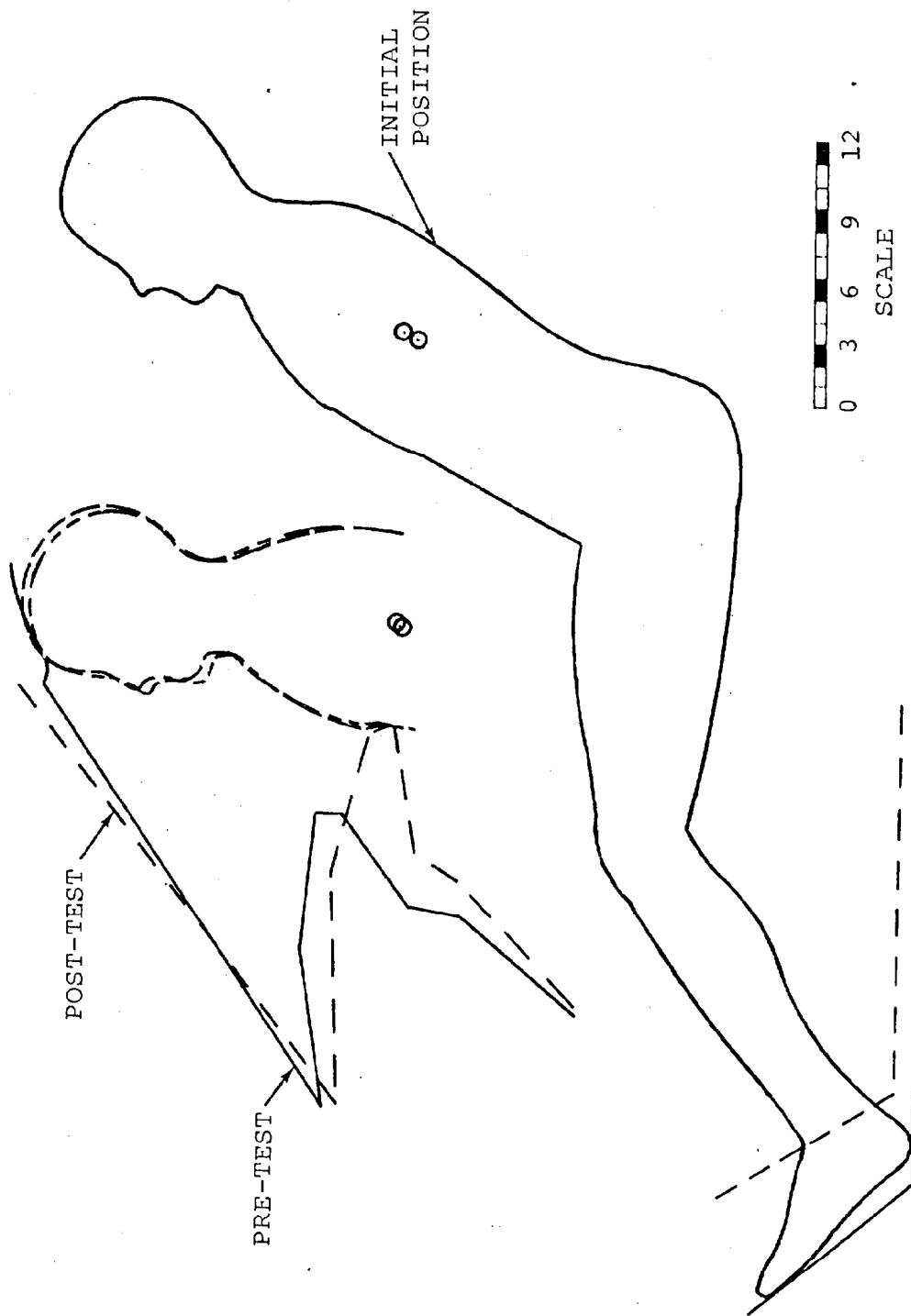

Figure 4-49. 1975 Ford Torino - Passenger Profile - Test 3.

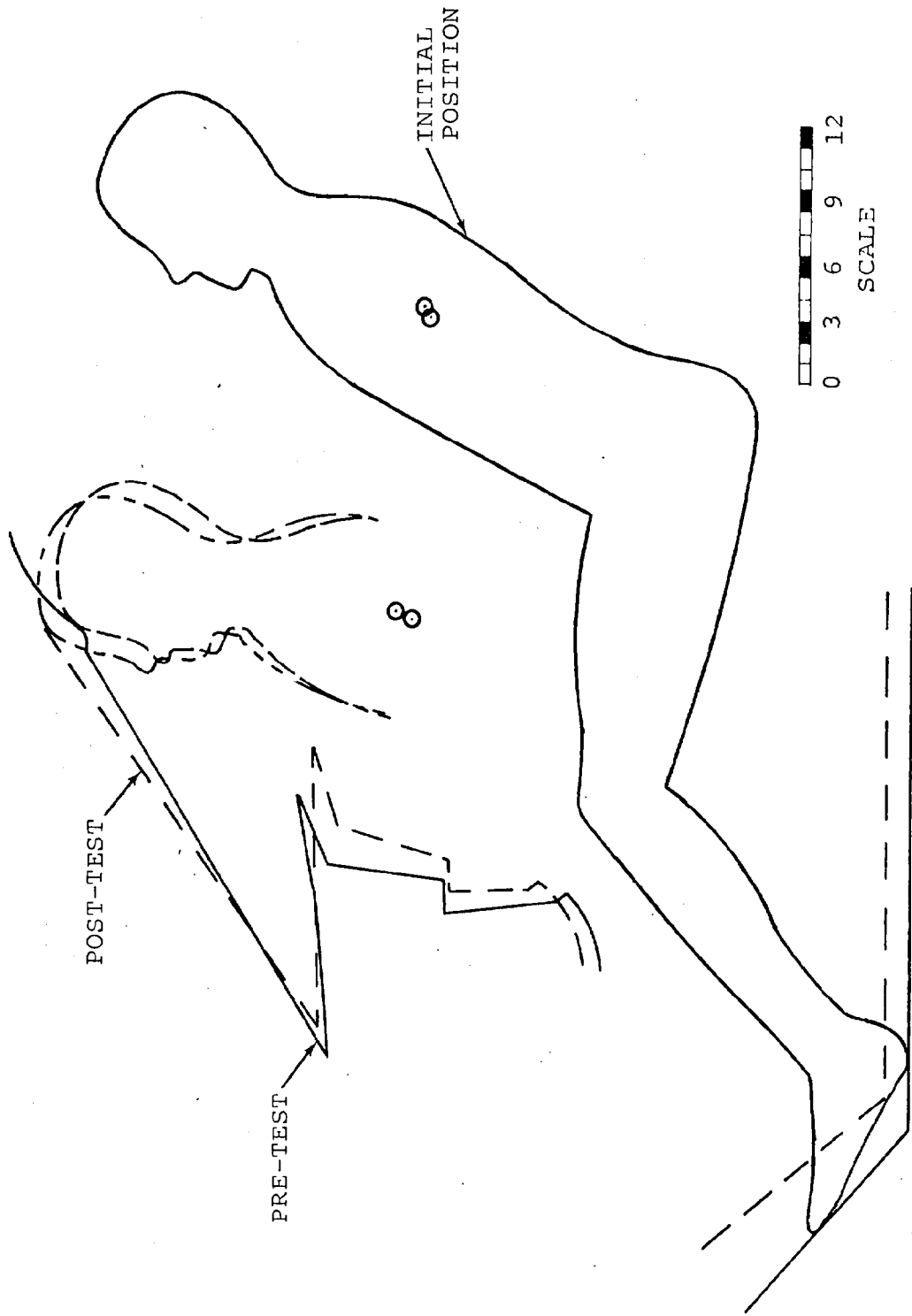

Figure 4-50. 1975 Ford Torino - Driver Profile - Test 4.

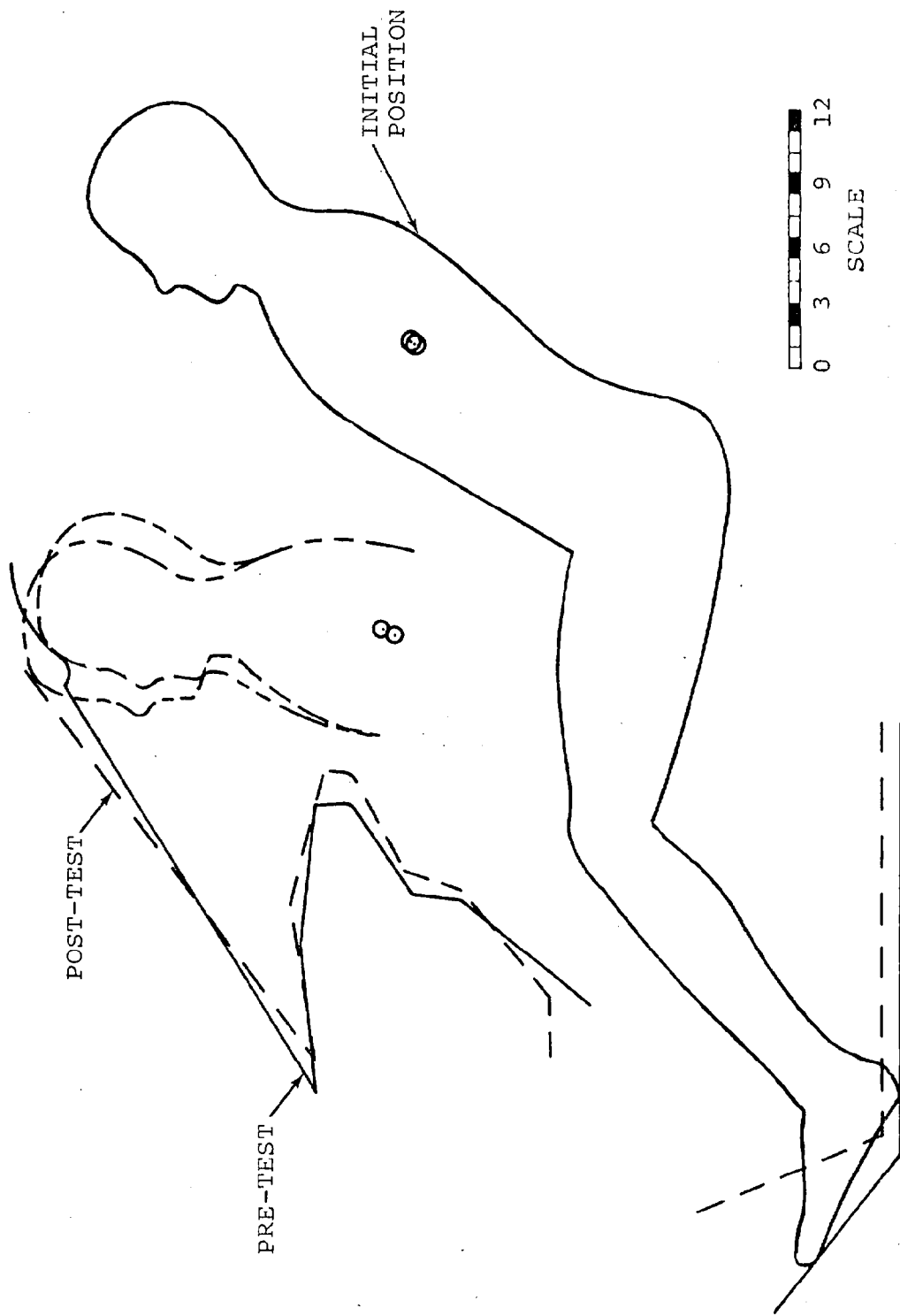

Figure 4-51. 1975 Ford Torino - Passenger Profile - Test 4.

5.0 TEST FACILITIES AND EQUIPMENT

5.1 GENERAL

The impact tests in this program were conducted at the Monorail Impact Facility, shown in Figure 2-1. The barrier impact and midrange impact sites were used for the fixed Test Device/vehicle and moving Test Device/vehicle tests, respectively.

Table 5-1 describes the test equipment and its function as it applies to the test parameters.

TABLE 5-1. TEST EQUIPMENT LIST AND FUNCTION

Item	Manufacturer	Model	Purpose
Timing Trap	Dynamic Science	None	Determine impact speed by furnishing a start and stop signal to recording oscillograph.
Oscillograph	Bell and Howell	5-134	Records timing start and stop signals from timing traps, cable drum drive rpm, and impact switch.
Speed Control	Dynamic Science	None	Precision control of cable drive drum rpm.
Beam Scales	Western	WP2000	Used to determine vehicle test weights.
High-speed Motion Picture Cameras	Photosonics	16-1B	Used for side, overhead, barrier, pit, and on-board film coverage as required.
Motion Picture Camera	Bolex	H-16	Panning and documentation.
Still Camera	Kowa	6	Documentary photo coverage.

TABLE 5-1. TEST EQUIPMENT LIST AND FUNCTION (CONTD)

Item	Manufacturer	Model	Purpose
100 and 1000 Hz Time Code Generators	Dynamic Science	None	Furnish timing signal for high-speed cameras and a 1 milli-second timing for velocity determination.
Stop Watch	Brietling	None	Time for collection of fuel leak samples.
Containers	-	-	Collection for fuel leak samples.
Graduated Cylinder	Kimes	-	Fuel volume measurement.
Calibrated Steel Rule	Starret	48 in.	Precision measurement of velocity trap spacing.
Anthropomorphic Dummies	Alderson	(GFE)	To ballast the vehicle and to gather occupant response data.
Dummy and Vehicle Accelerometers	Endevco	7233C	Measures acceleration.
String Pots	Celesco	PT-101-15	Measures displacement
12.5K Load Cells	Interface	1210 FS 1210 LT	Force on honeycomb modules.
3K Load Cell (Femur)	GSE	2435	Determines femur load forces.
3500-pound Load Cell (Belt)	LeBow	3419	Measures belt loads.
F.M. Multiplexor Tape Recorder	Sangamo	Sabre III	Records instrumentation signals.
Oscillograph	Bell and Howell	5-134	Records real-time quick-look data.
Signal Conditioner	Ectron	M140	Conditions instrument output signal for recording.

5.2 FACILITY AND EQUIPMENT DESCRIPTION

The following paragraphs briefly describe the track facility and equipment, their function, and mode of operation.

5.2.1 Test Track and Guidance System

The test track consists of 1,200 feet of asphalt pavement (SN = 75 ±5), 14 feet in width. The length allows sufficient acceleration distance to accommodate impact speeds in excess of 60 mph with sufficient distance remaining to abort the test if necessary. Guidance for the test vehicle is provided by a sliding shoe attached to the vehicle. The sliding shoe rides on the mono-rail embedded in the test track. Prior to impact, the shoe is mechanically released from the test vehicle.

5.2.2 Tow System and Velocity Control

The tow system consists of a drum-driven endless cable powered by a pair of 390-cubic-inch engines driven in tandem driving a modified three-speed C-6 automatic truck transmission. The tow system can propel a 6,000-pound vehicle into the fixed barrier at 75 mph or two 4,000-pound vehicles into each other at a closing speed of 90 mph. Velocity control is achieved through a manually controlled throttle system. A visual readout of speed versus distance is provided and compared with the "ideal curve." Velocity control under ±0.5 mph is realizable down to 20 mph and ±2.0 percent down to zero mph.

5.2.3 Abort System

Automatic abort capability is provided through the vehicle service brakes which are actuated by releasing high-pressure air into the hydraulic system. Abort criteria consists of vehicle speed, data acquisition and instrumentation system readiness, and

stability of the vehicle on the test track. The first two criteria are automatically monitored by the test control system while the third criterion is visually monitored by the test conductor. Manual abort provisions are available to the test conductor. Upon verifying vehicle speed, the test control system automatically deactivates the abort system to preclude an inadvertent test abort immediately prior to impact.

5.2.4 Master Control System

The master control system used for impact tests controls and monitors all primary system functions that must operate throughout a predetermined interval during a test. This includes the starting and stopping of the FM multiplexer tape recorder, high-speed cameras, and oscillograph, and the control of the power winch which propels the test vehicle. The operations of the various devices is confirmed, including vehicle velocity and tape recorder speed synchronization, before it passes through a "commit" window. When the vehicle is committed, the abort system is disarmed, preventing an accidental abort after the point of no return is reached.

Any system malfunction, including improper vehicle velocity up to the commit window, generates an abort. The control system uses the pulse output from the IRIG time base generator as a clock with a manual push button defining time zero. The logic circuits compare pulse counts from time zero to preset values dialed in at the control panel. As each control circuit gets an equal comparison, that circuit is turned on. If the self-test circuit does not verify, the abort system is automatically activated. After a successful vehicle test, the last control circuit shuts the entire system down. The manual backup control system provides the test conductor with the option of manually aborting the test if the need arises.

5.2.5 Fixed Impact Barrier

The basic fixed impact barrier consists of a reinforced concrete structure, 6 feet high, 6 feet thick, and 12 feet wide, weighing approximately 100,000 pounds and complying with SAE J850. This barrier can be fitted with various modules including a flat-faced barrier adjustable to angles up to 45 degrees, as well as a pole barrier. This barrier system conforms to the definition of a "fixed collision barrier" as defined in Federal Register, Vol. 35, No. 135, page 11242 (July 14, 1970).

A camera pit is located immediately in front of the impact barrier and is 6 feet wide, 8 feet deep, and 20 feet long. The pit is covered with a metal grid which supports the vehicle as it passes over, yet allows photographing of the vehicle underside when required. Electrical outlets are provided for powering floodlights and high-speed cameras. A fixed overhead camera tower cantilevered over the barrier test site provides over-site photography.

5.2.6 Midrange Impact Site

The midrange test site consists of a 40-foot by 60-foot asphalt pad. Centrally located within this area is a camera pit constructed of reinforced concrete which is 6 feet wide, 8 feet deep, and 24 feet long. A metal grid covers the camera pit, allowing photographs to be taken of the vehicle underside. A movable overhead camera tower is provided for over-site photography.

5.2.7 High-speed Photography

Six high-speed 16mm cameras with 100 Hz timing marks and one panning camera are used for photographic test documentation. Precise field of view monitoring is accomplished by bore sighting with the vehicle at the impact site prior to the test.

APPENDIX A

CAR-TO-TEST DEVICE CRASH ANALYSIS

Prepared by:

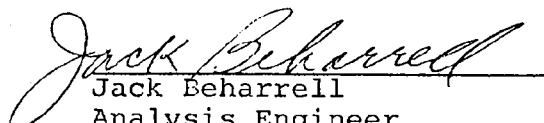
Jack Beharrell
Analysis Engineer
Special Projects
Department
5/8/78

1.0 DETERMINATION OF EQUIVALENT CLOSING SPEED FOR MOVING BARRIER COLLISION

- Moving Barrier Collision:

$$\Delta V_{\Lambda} = \frac{W_B}{(W_{\Lambda} + W_B)} [V_{\Lambda}(0) - V_B(0)] = \frac{W_B}{(W_{\Lambda} + W_B)} [\Delta V(0)] \quad (1)$$

where ΔV_{Λ} = velocity change of Vehicle A in moving barrier impact (mph)

W_{Λ}, W_B = weight of Vehicles A and B, respectively (lb)

$V_{\Lambda}(0), V_B(0)$ = initial velocities of Vehicles A and B, respectfully (mph)

$\Delta V(0)$ = initial closing velocity (mph)

- Fixed Barrier Collision:

$$\Delta V'_{\Lambda} = V'_{\Lambda}(0) \quad (2)$$

where $\Delta V'_{\Lambda}$ = velocity change in fixed barrier impact (mph)

$V'_{\Lambda}(0)$ = initial velocity of Vehicle A (mph)

- Equality Conditions

The desired equality condition (the same vehicle velocity change in the moving barrier and fixed barrier impacts) implies:

$$\Delta V_{\Lambda} = \Delta V'_{\Lambda} \quad (3)$$

Therefore Equations (1) and (2) result in the following condition for the "equivalent" closing speed, $\Delta V(0)$, for the moving barrier test:

$$\Delta V(0) = V'_{\Lambda}(0) \left[\frac{W_B}{(W_{\Lambda} + W_B)} \right]^{-1} \quad (4)$$

For $W_B = 4000$ lb, and $V'_{\Lambda}(0) = 40$ mph, Equation (4) becomes:

$$\Delta V(0) = 40 \left[\frac{4000}{(W_{\Lambda} + 4000)} \right]^{-1} \quad (5)$$

2.0 DERIVATION OF EQUATIONS OF MOTION

The vehicle-barrier impact was modeled as a system of two masses connected by a linear spring. m_2 represents the mass of the barrier test device; m_1 that of the car.

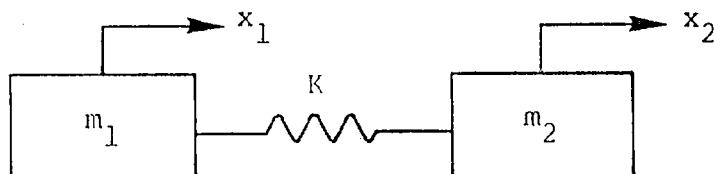

The displacements x_1 and x_2 are measured from the positions of static equilibrium. The equations of motion are:

$$m_1 \ddot{x}_1 + K (x_1 - x_2) = 0 \quad (1)$$

$$m_2 \ddot{x}_2 + K (x_2 - x_1) = 0 \quad (2)$$

Substitution of the solutions

$$x_1 = X_1 \cos \omega_n t, \quad x_2 = X_2 \cos \omega_n t$$

leads to the normal mode shape

$$\rho = \frac{X_2}{X_1} = \frac{K}{K - m_2 \omega_n^2} = \frac{-m_1 \omega_n^2 + K}{K} \quad (3)$$

The characteristic equation for the system has the solutions

$$\omega_{n1}^2 = 0, \quad \omega_{n2}^2 = K \left(\frac{m_1 + m_2}{m_1 m_2} \right) \quad (4)$$

The solution $\omega_n = 0$ represents a lateral displacement of the system with no spring compression or extension.

The general solution of the equations (1) and (2) is of the form

$$\begin{aligned}x_1 &= B_1 + B_2 t + B_3 \cos \omega_{n_2} t + B_4 \sin \omega_{n_2} t \\x_2 &= B_1 + B_2 t + B_3 \rho \cos \omega_{n_2} t + B_4 \rho \sin \omega_{n_2} t\end{aligned}\quad (5)$$

where

$$\begin{aligned}B_1 &= \frac{x_{20} - \rho x_{10}}{1 - \rho}, & B_3 &= \frac{x_{10} - x_{20}}{1 - \rho} \\B_2 &= \frac{V_{20} - \rho V_{10}}{1 - \rho}, & B_4 &= \frac{V_{10} - V_{20}}{(1 - \rho) \omega_{n_2}}\end{aligned}\quad (6)$$

x_{10} , V_{10} , x_{20} , V_{20} are the initial displacements and velocities of the vehicle and barrier, respectively. We may set $x_{10} = x_{20} = 0$; then $B_1 = B_3 = 0$. Differentiation of (5) with respect to time and substitution of (6) leads to the following relations for the displacements, velocities, and accelerations of the car and barrier:

$$\begin{aligned}x_1 &= \left(\frac{V_{20} - \rho V_{10}}{1 - \rho} \right) t + \left(\frac{V_{10} - V_{20}}{(1 - \rho) \omega_{n_2}} \right) \sin \omega_{n_2} t \\x_2 &= \left(\frac{V_{20} - \rho V_{10}}{1 - \rho} \right) t + \left(\frac{V_{10} - V_{20}}{(1 - \rho) \omega_{n_2}} \right) \rho \sin \omega_{n_2} t\end{aligned}\quad (7)$$

$$\begin{aligned}\dot{x}_1 &= \frac{V_{20} - \rho V_{10}}{1 - \rho} + \left(\frac{V_{10} - V_{20}}{1 - \rho} \right) \cos \omega_{n_2} t \\ \dot{x}_2 &= \frac{V_{20} - \rho V_{10}}{1 - \rho} + \left(\frac{V_{10} - V_{20}}{1 - \rho} \right) \rho \cos \omega_{n_2} t\end{aligned}\quad (8)$$

$$\begin{aligned}\ddot{x}_1 &= - \left(\frac{V_{10} - V_{20}}{1 - \rho} \right) \omega_{n_2} \sin \omega_{n_2} t \\ \ddot{x}_2 &= - \left(\frac{V_{10} - V_{20}}{1 - \rho} \right) \rho \omega_{n_2} \sin \omega_{n_2} t\end{aligned}\quad (9)$$

Using equations (3) and (4), the quantities ρ and $1-\rho$ become:

$$\begin{aligned}\rho &= \frac{-m_1}{m_2} \\ 1-\rho &= \frac{m_1 + m_2}{m_2}\end{aligned}\quad (10)$$

For the fixed barrier case, the above equations for ρ and $1-\rho$ reduce to $\rho=0$, $1-\rho = 1$, $\omega_n = \left(\frac{K}{m_1}\right)^{1/2}$; then x , \dot{x} , \ddot{x} become: ($m_2 = \infty$, $V_{20} = 0$)

$$\begin{aligned}x_1 &= V_{10} \left(\frac{m_1}{K}\right)^{1/2} \sin \left(\frac{K}{m_1}\right)^{1/2} t \\ x_2 &= 0\end{aligned}\quad (11)$$

$$\begin{aligned}\dot{x}_1 &= V_{10} \cos \left(\frac{K}{m_1}\right)^{1/2} t \\ \dot{x}_2 &= 0\end{aligned}\quad (12)$$

$$\ddot{x}_1 = -v_{10} \left(\frac{K}{m_1}\right)^{1/2} \sin \left(\frac{K}{m_1}\right)^{1/2} t$$

$$\ddot{x}_2 = 0 \tag{13}$$

3.0 CALCULATION OF EQUIVALENT CLOSING VELOCITIES FOR SELECTED CRASH PARAMETERS

Maintaining selected crash parameters constant for both the fixed barrier and the moving barrier conditions, equivalent vehicle-barrier closing velocities were calculated. The applicable equations and some equivalent closing speeds are summarized in Table 1. Table 2 presents a summary of the times of occurrence for selected vehicle parameters. It should be noted that the closing speeds may be obtained by adjusting either the vehicle speed, the barrier speed, or both.

P is the parameter to be maintained constant.

Barred quantities refer to moving barrier case.

(1) P: Initial relative velocity of vehicle and barrier.

Fixed barrier case:

$$\text{Initial relative velocity} = v_{10} - v_{20} = v_{10}$$

Moving barrier case:

$$\text{Initial relative velocity} = \bar{v}_{10} - \bar{v}_{20}$$

The equivalent closing speed is then given by the equality:

$$\bar{v}_{10} - \bar{v}_{20} = v_{10}$$

- (2) P: Maximum velocity change of vehicle.
Velocity change = $\Delta V = V_{10} - x_1 \text{ final}$.

$$\begin{aligned} \therefore \Delta V &= V_{10} - \left(\frac{V_{20} - \rho V_{10}}{1 - \rho} \right) \\ &= \frac{V_{10} - V_{20}}{1 - \rho} \end{aligned}$$

Fixed barrier case:

$$\Delta V = V_{10}$$

Moving barrier case:

$$\bar{\Delta V} = \frac{(\bar{V}_{10} - \bar{V}_{20})}{(m_1 + m_2)} m_2$$

For $\Delta V = \bar{\Delta V}$

$$\bar{V}_{10} - \bar{V}_{20} = \left(\frac{m_1 + m_2}{m_2} \right) V_{10}$$

- (3) P: Maximum momentum change of vehicle.

The condition here is

$$m_1 \Delta V = m_1 \bar{\Delta V}$$

Therefore the result is the same as in (2):

$$\bar{V}_{10} - \bar{V}_{20} = \left(\frac{m_1 + m_2}{m_2} \right) V_{10}$$

- (4) P: Maximum passenger compartment acceleration (deceleration)

Fixed barrier case:

From equation (13)

$$|\ddot{x}_1|_{\max} = V_{10} \left(\frac{K}{m_1}\right)^{1/2}$$

Moving barrier case:

From equation (9)

$$|\ddot{x}_1|_{\max} = (\bar{V}_{10} - \bar{V}_{20}) \left[K \frac{(m_1 + m_2)}{m_1 m_2} \right]^{1/2} \left(\frac{m_2}{m_1 + m_2} \right)$$

Equating $|\ddot{x}_1|_{\max}$ and $|\ddot{x}_1|_{\max}$ gives

$$\bar{V}_{10} - \bar{V}_{20} = \left(\frac{m_1 + m_2}{m_2} \right)^{1/2} V_{10}$$

- (5) P: Maximum spring crush

Maximum spring crush = $|x_1 - x_2|_{\max}$

$$= \frac{V_{10} - V_{20}}{\omega_n}$$

Fixed barrier case:

$$\text{Maximum crush} = V_{10} \left(\frac{m_1}{K}\right)^{1/2}$$

Moving barrier case:

$$\text{Maximum crush} = (\bar{V}_{10} - \bar{V}_{20}) \left(\frac{m_1 m_2}{K(m_1 + m_2)} \right)^{1/2}$$

The equivalent closing speed for equality of maximum spring crush is then

$$\bar{V}_{10} - \bar{V}_{20} = \left(\frac{m_1 + m_2}{m_2} \right)^{1/2} V_{10}$$

(6) P: Maximum energy absorbed by vehicle.

This calculation is based upon the assumption that all the energy of spring compression represents energy absorbed by the vehicle.

$$\text{Energy absorbed} = \frac{1}{2} K (x_1 - x_2)^2$$

Maximum energy absorbed is then given by the quantity

$$\frac{1}{2} K \left[\frac{(V_{10} - V_{20})}{\omega_n} \right]^2$$

Fixed barrier case:

$$\text{Maximum energy absorbed} = \frac{1}{2} K \left[V_{10} \sqrt{\frac{m_1}{K}} \right]^2$$

Moving barrier case:

$$\text{Maximum energy absorbed} = \frac{1}{2} K \left[\frac{(\bar{V}_{10} - \bar{V}_{20}) (m_1 m_2)^{1/2}}{[K(m_1 + m_2)]^{1/2}} \right]^2$$

Equivalent closing speed for equal maximum energy absorption is then:

$$\bar{V}_{10} - \bar{V}_{20} = \left(\frac{m_1 + m_2}{m_2} \right)^{1/2} V_{10}$$

3.1. TIME OF OCCURRENCE OF MAXIMUM VELOCITY AND MOMENTUM CHANGE, MAXIMUM ACCELERATION, MAXIMUM SPRING CRUSH, AND MAXIMUM ENERGY ABSORPTION

From equations (7), (8), and (9), it is apparent that this time of occurrence is given by

$$\omega_n t = \frac{\pi}{2}$$

$$\text{or } t = \frac{\pi}{2\omega_n}$$

Fixed barrier case ($t \equiv T$)

$$T = \frac{\pi}{2} \left(\frac{m_1}{K} \right)^{1/2}$$

Moving barrier case ($t \equiv \tau$)

$$\tau = \frac{\pi}{2} \left[\frac{m_1 m_2}{K(m_1 + m_2)} \right]^{1/2}$$

$$\text{The ratio } \frac{\tau}{T} = \left(\frac{m_2}{m_1 + m_2} \right)^{1/2}$$

Values for this ratio for several cars are given in Table 2.

4.0 DYNAMIC TEST CONDITIONS AND VEHICLE DATA

4.1 DEFINITIONS OF SYMBOLS

W_2 (m_2) = weight (mass) of barrier test device.

W_1 (m_1) = weight (mass) of vehicle.

V_{10} = initial velocity of vehicle for fixed barrier case.

\bar{V}_{10} = initial velocity of vehicle for moving barrier case

\bar{V}_{20} = initial velocity of moving barrier.

- K = spring constant of vehicle crush structure.
- T = time of occurrence of vehicle parameter maximum (fixed barrier case).
- τ = time of occurrence of vehicle parameter (moving barrier case).
- ρ = mode shape.
- ω_n = natural frequency of system.

4.2 TEST CONDITIONS

$W_2 = 4000$ pounds (moving barrier)

$V_{20} = 0$

$W_2 = \infty$ (fixed barrier)

4.3 VEHICLE DATA

<u>Vehicle</u>	<u>Weight (lb)</u>	<u>Velocity V_{10} Fixed Barrier Condition (mph)</u>
Honda	2200	40
Ford	4550	40
Plymouth	4440	40
Volvo	3220	45

TABLE 1. EQUIVALENT CAR-TO-MOVING TEST DEVICE CLOSING SPEEDS FOR SELECTED CRASH PARAMETERS

Crash Parameter Held Constant	Applicable Equations		Equivalent Closing Speeds ($\bar{V}_{10} - \bar{V}_{20}$) (mph)			
	Moving Device = Fixed Device Parameter	Parameter	Honda	Ford	Plymouth	Volvo
(1) Initial velocity of vehicle relative to initial velocity of barrier	$\bar{V}_{10} - \bar{V}_{20} = V_{10}$		40.00	40.00	40.00	45.00
(2) Maximum vehicle velocity change	$\bar{V}_{10} - \bar{V}_{20} = \left(\frac{m_1 + m_2}{m_2} \right) V_{10}$		62.00	85.50	84.40	81.22
(3) Maximum vehicle momentum change	$\bar{V}_{10} - \bar{V}_{20} = \left(\frac{m_1 + m_2}{m_2} \right) V_{10}$					
(4) Maximum compartment acceleration (deceleration)	$\bar{V}_{10} - \bar{V}_{20} = \left(\frac{m_1 + m_2}{m_2} \right)^{1/2} V_{10}$					
(5) Maximum spring crush	$\bar{V}_{10} - \bar{V}_{20} = \left(\frac{m_1 + m_2}{m_2} \right)^{1/2} V_{10}$		49.80	58.48	58.10	60.46
(6) Maximum energy absorbed by vehicle	$\bar{V}_{10} - \bar{V}_{20} = \left(\frac{m_1 + m_2}{m_2} \right)^{1/2} V_{10}$					

Note: m_1 = mass of car; m_2 = mass of test device.

TABLE 2. TIME OF OCCURRENCE RATIO FOR SELECTED CRASH PARAMETERS

Crash Parameter	Time of Occurrence Equations		Ratio for Vehicle Model*		
	Moving Device	Fixed Device	Honda	Ford	Plymouth Volvo
Maximum velocity change			.803	.684	.688
Maximum momentum change					.744
Maximum spring crush					
Maximum energy absorption					

$$\tau = \frac{\pi}{2} \frac{1/2}{K} \left(\frac{m_1 m_2}{n_1 + m_2} \right) \quad \tau = \frac{\pi}{2} \left(\frac{m_1}{K} \right)^{1/2}$$

Ratio:

$$\tau/T = \left(\frac{m_2}{m_1 + m_2} \right)^{1/2}$$

*Ratio = $\frac{\text{Time for Moving Device Crash } (\tau)}{\text{Time for Fixed Device Crash } (T)}$

APPENDIX B

CALCOMP PLOTS

TEST 3

1975 FORD TORINO-TO-FIXED TEST DEVICE

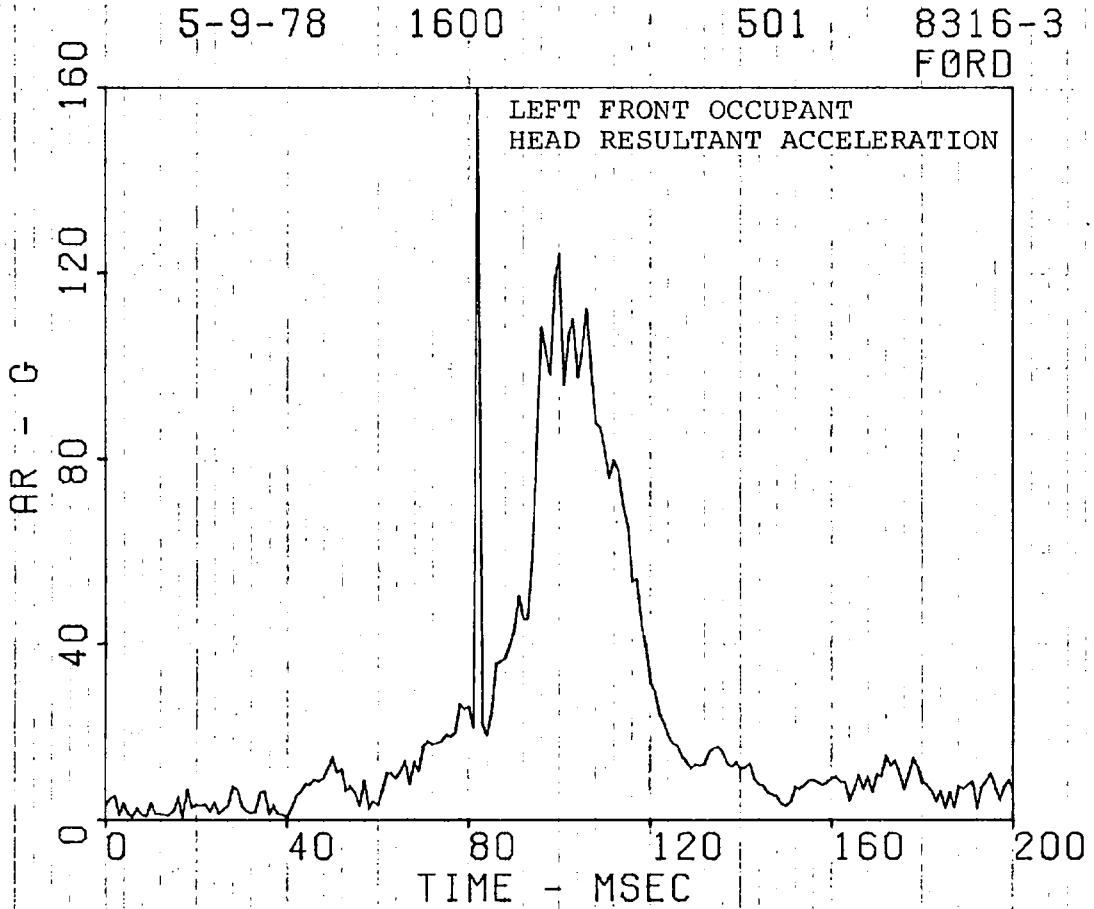
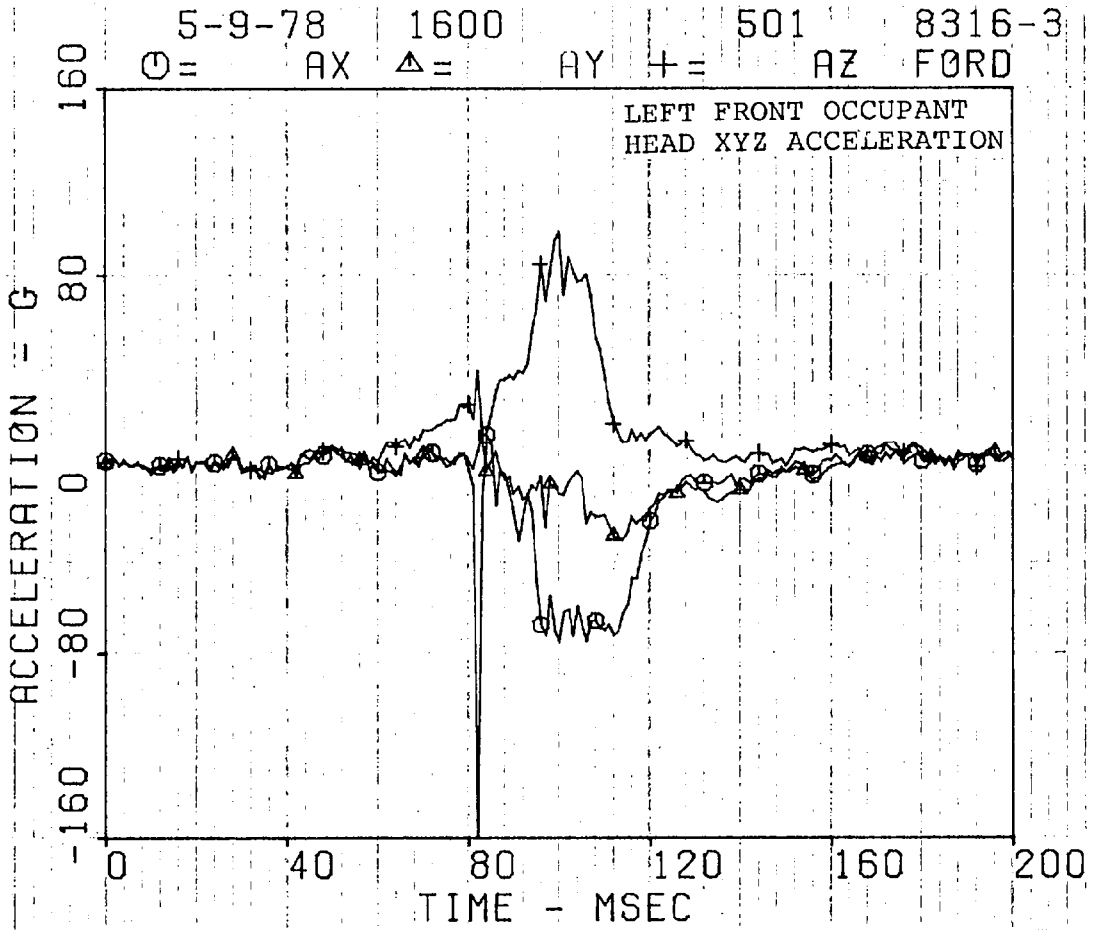

5-9-78 315/100 1101 8316-3
⊖ = AX Δ = AY += AZ FORD

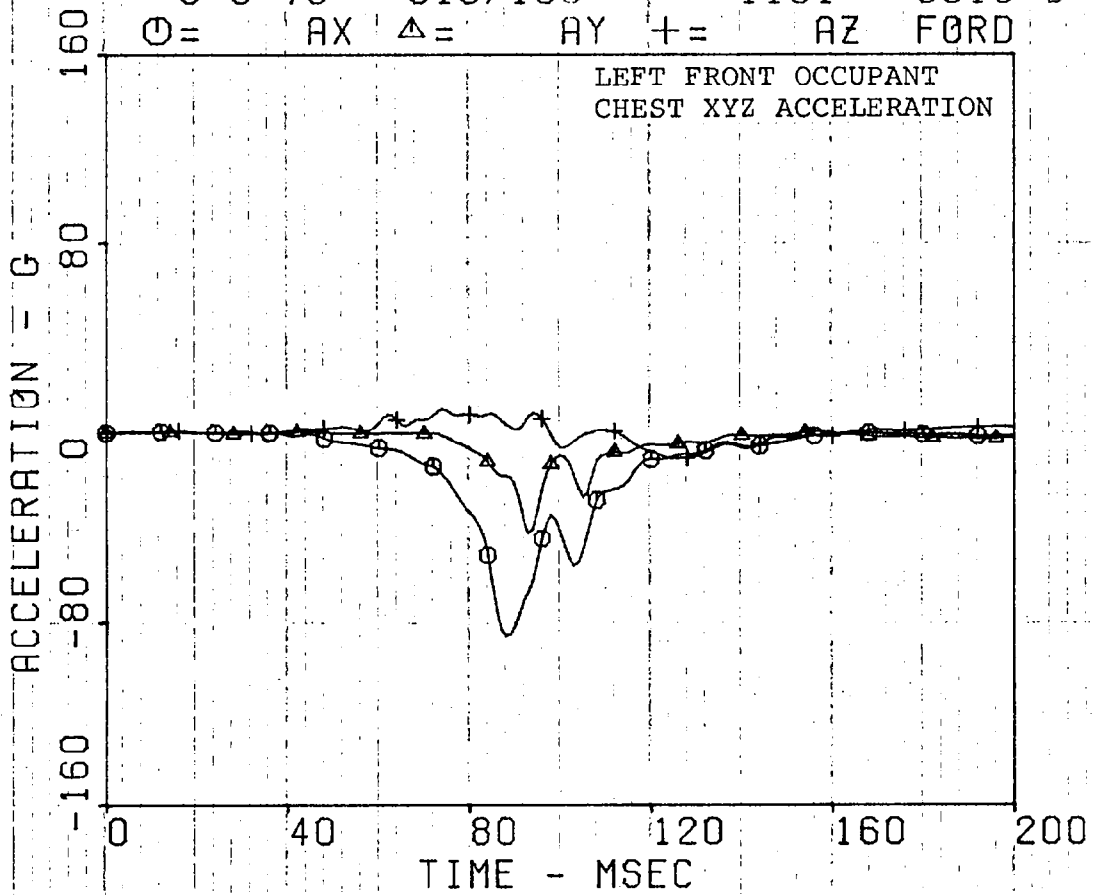

5-9-78 315/100 1101 8316-3
FORD

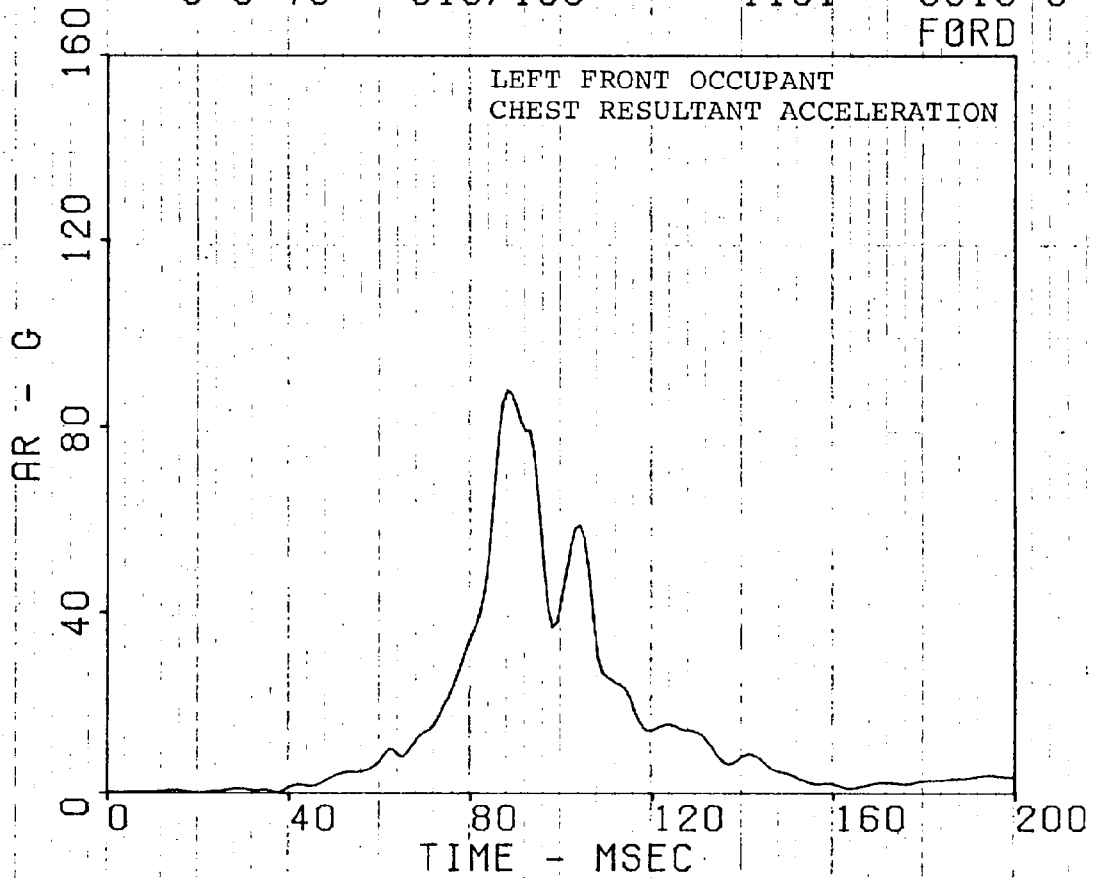

5-9-78

315/100

1101

8316-3

FORD

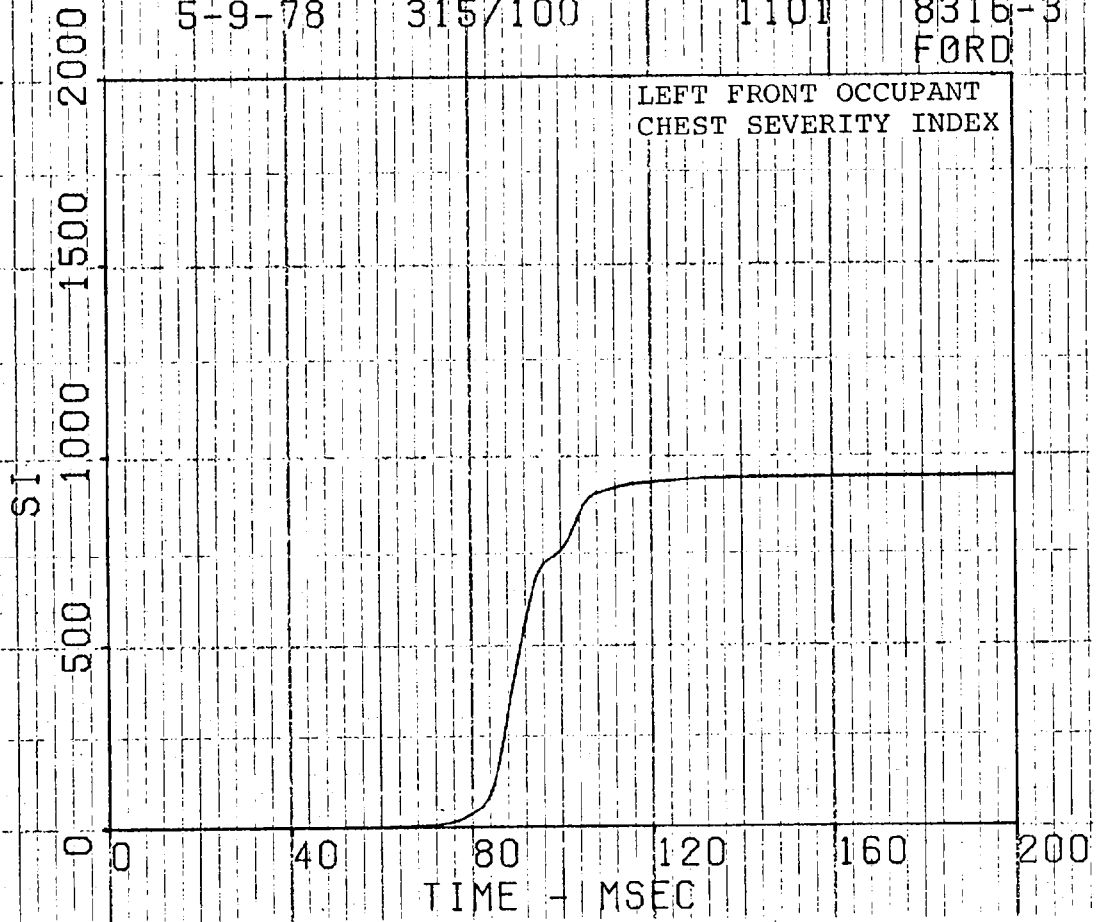

5-9-78

1000

2001

8316-3
FORD

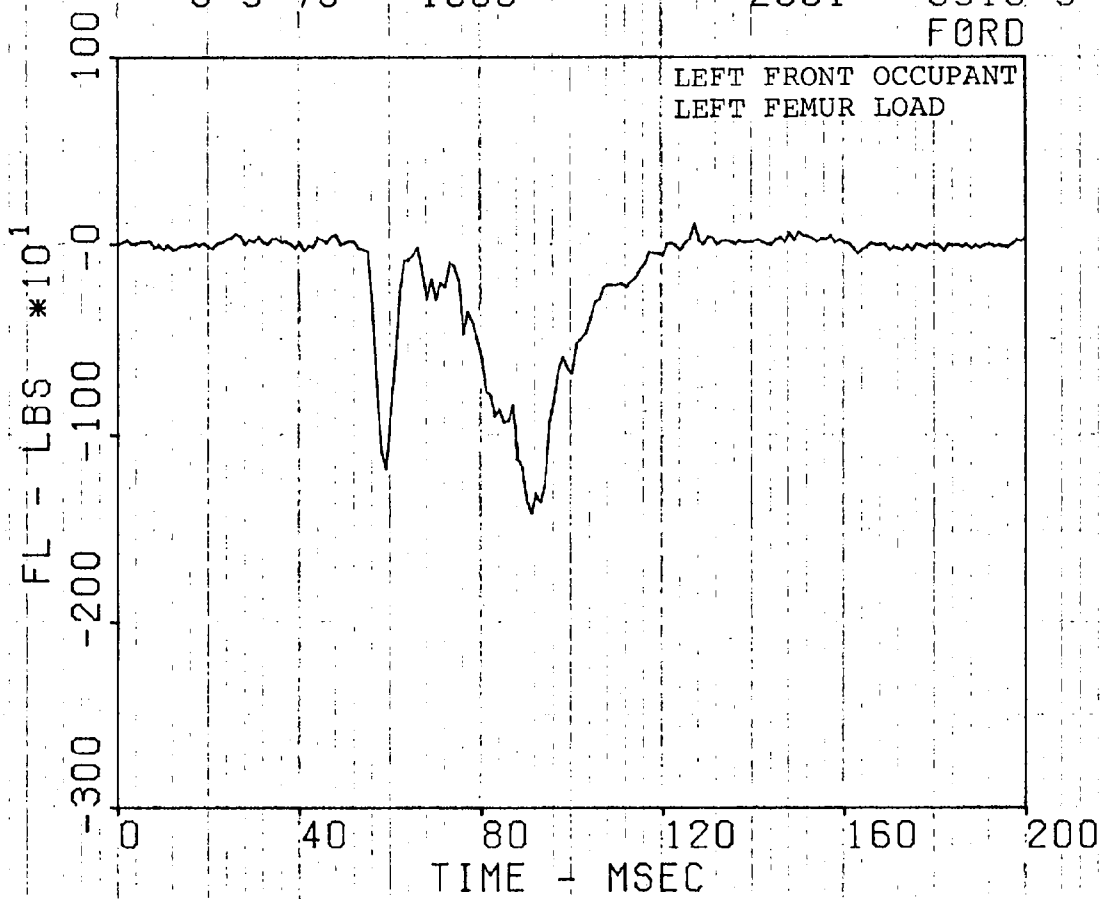

5-9-78

1000

2001

8316-3
FORD

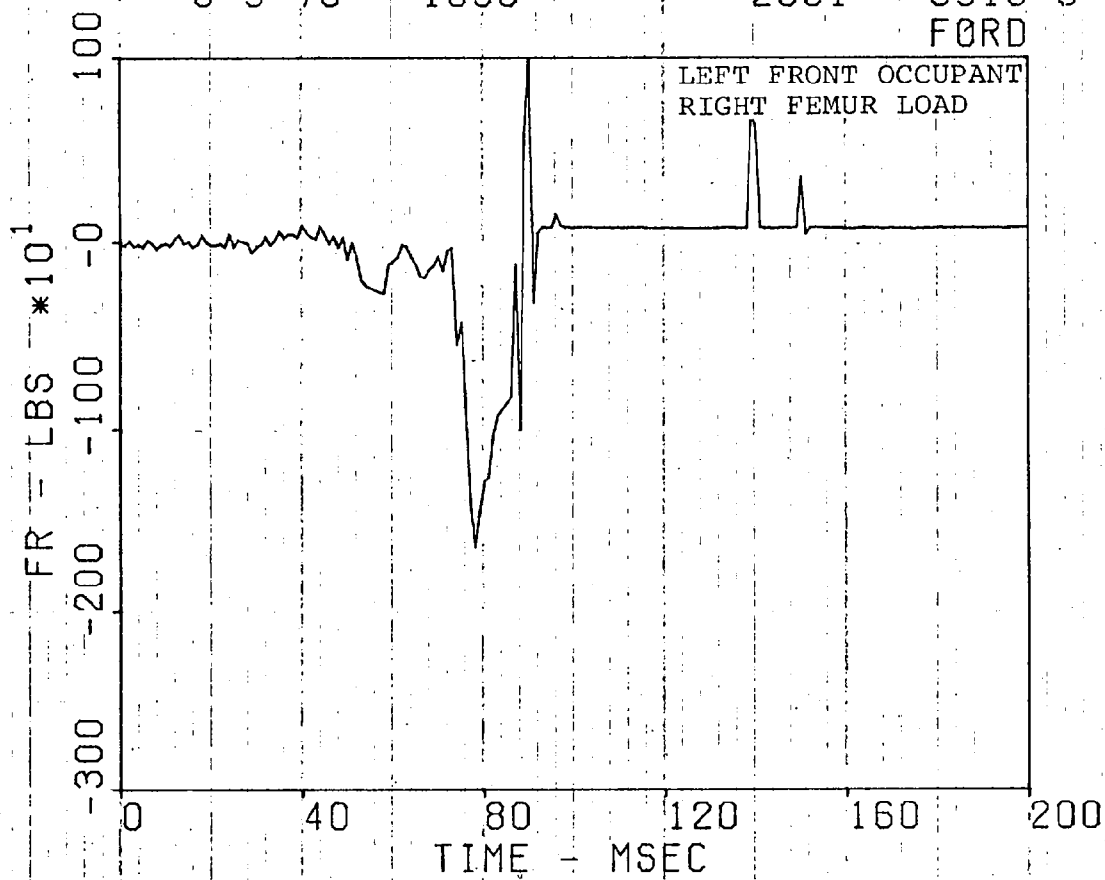

5-9-78

315/100

4201

8316-3

FRD LFLB-L

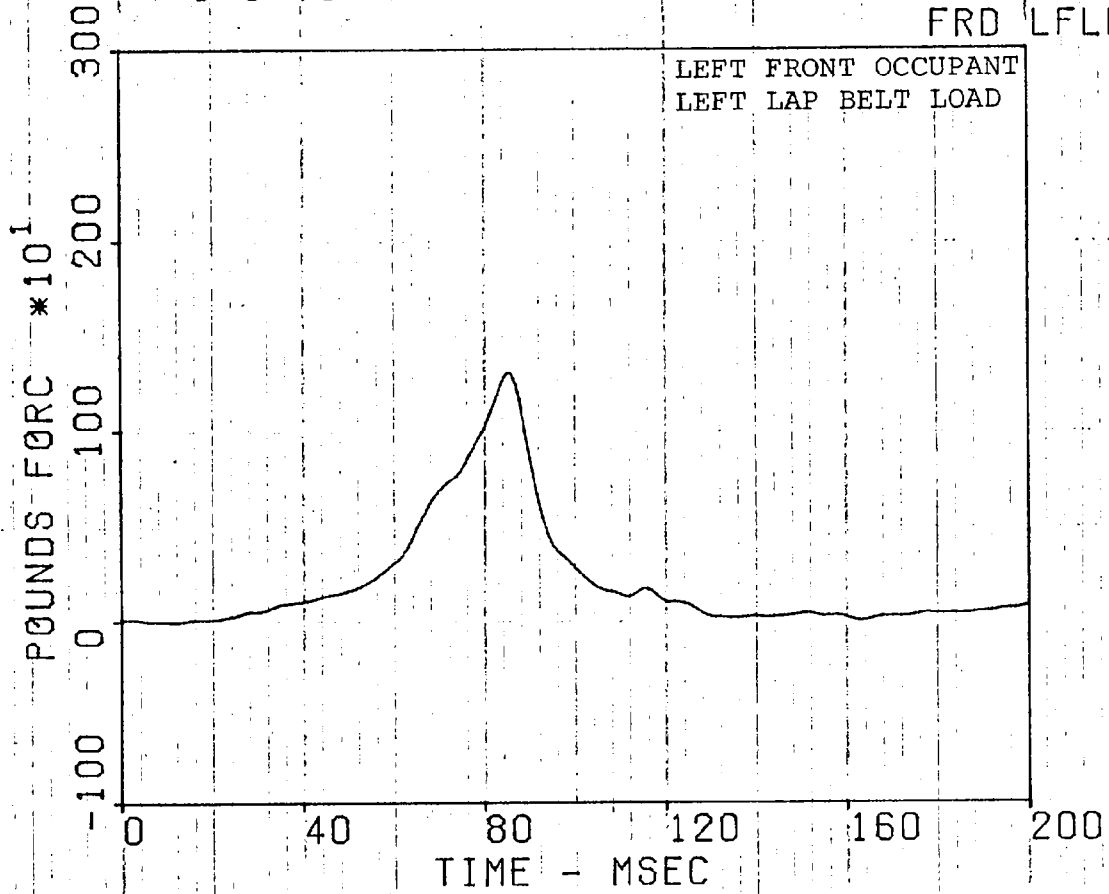

5-9-78

315/100

4201

8316-3

FRD LFLB R

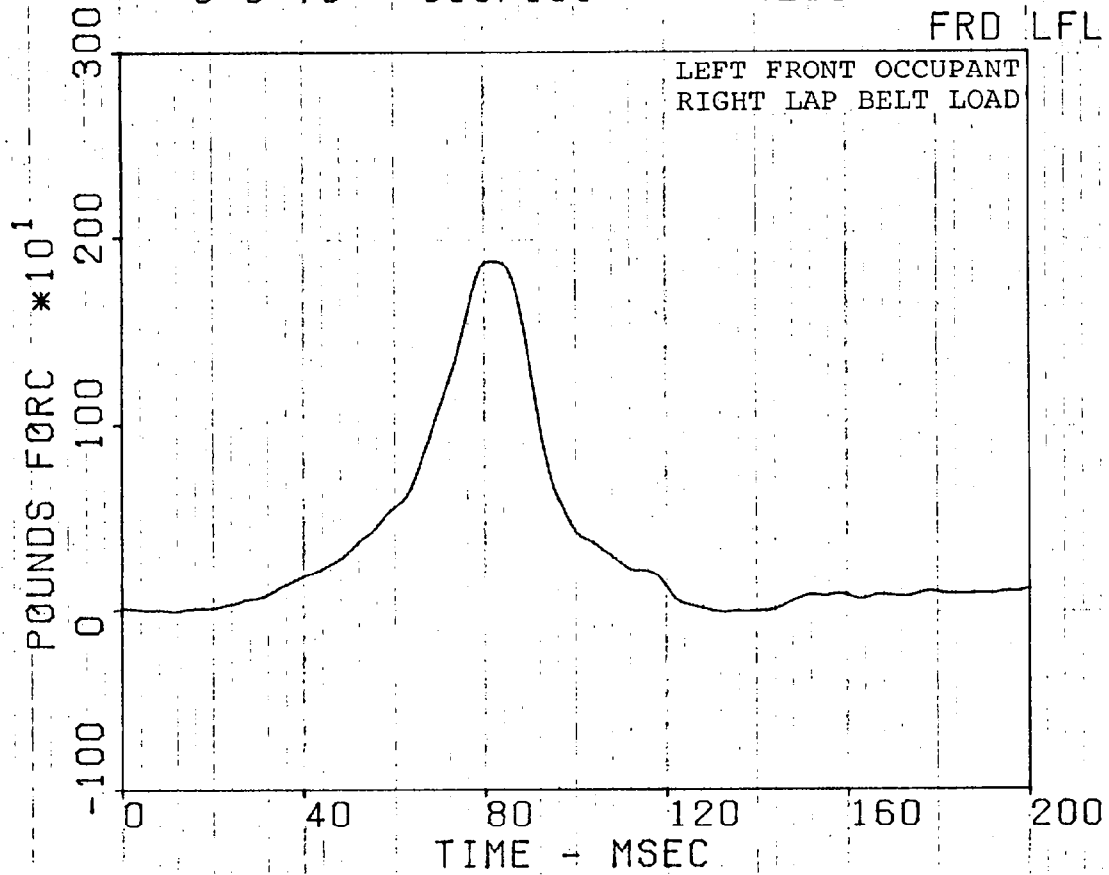

5-9-78

315/100

4201

8316-3

FRD LFTORB

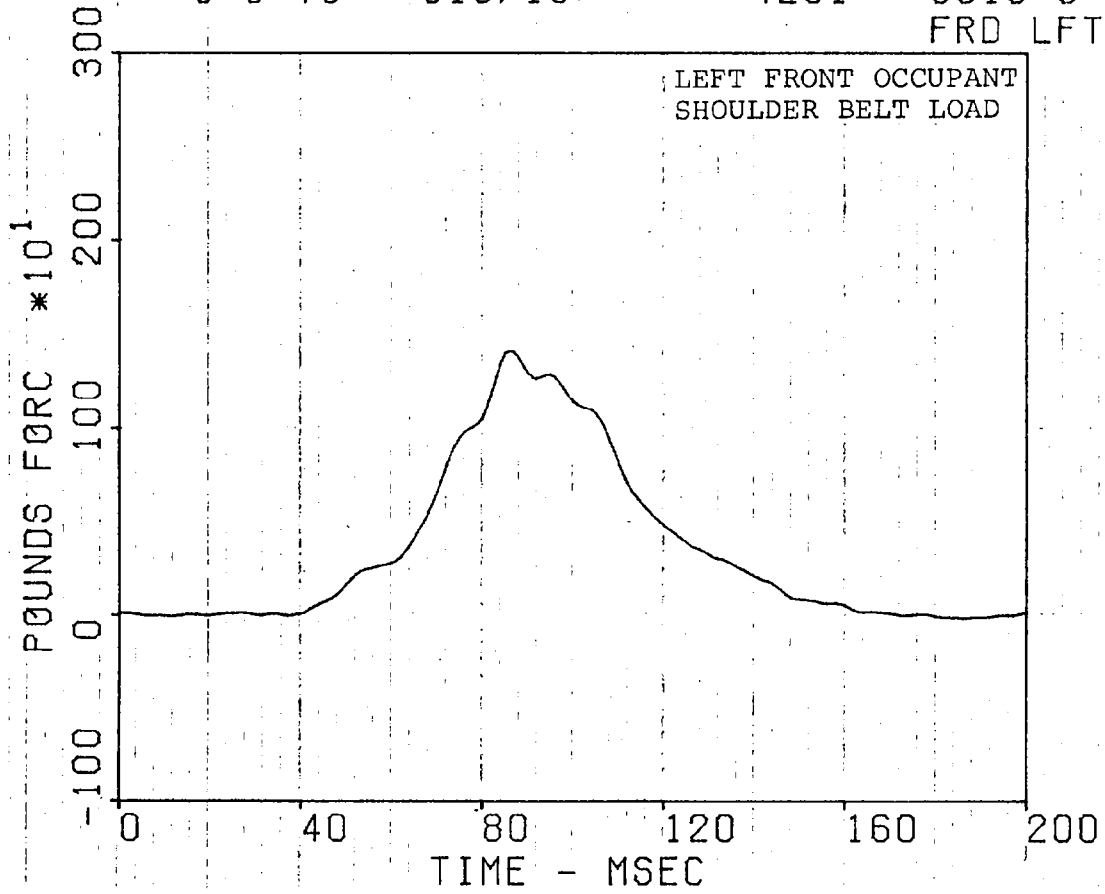

5-9-78 1600 503 8316-3
⊖ = AX Δ = AY + = AZ FORD

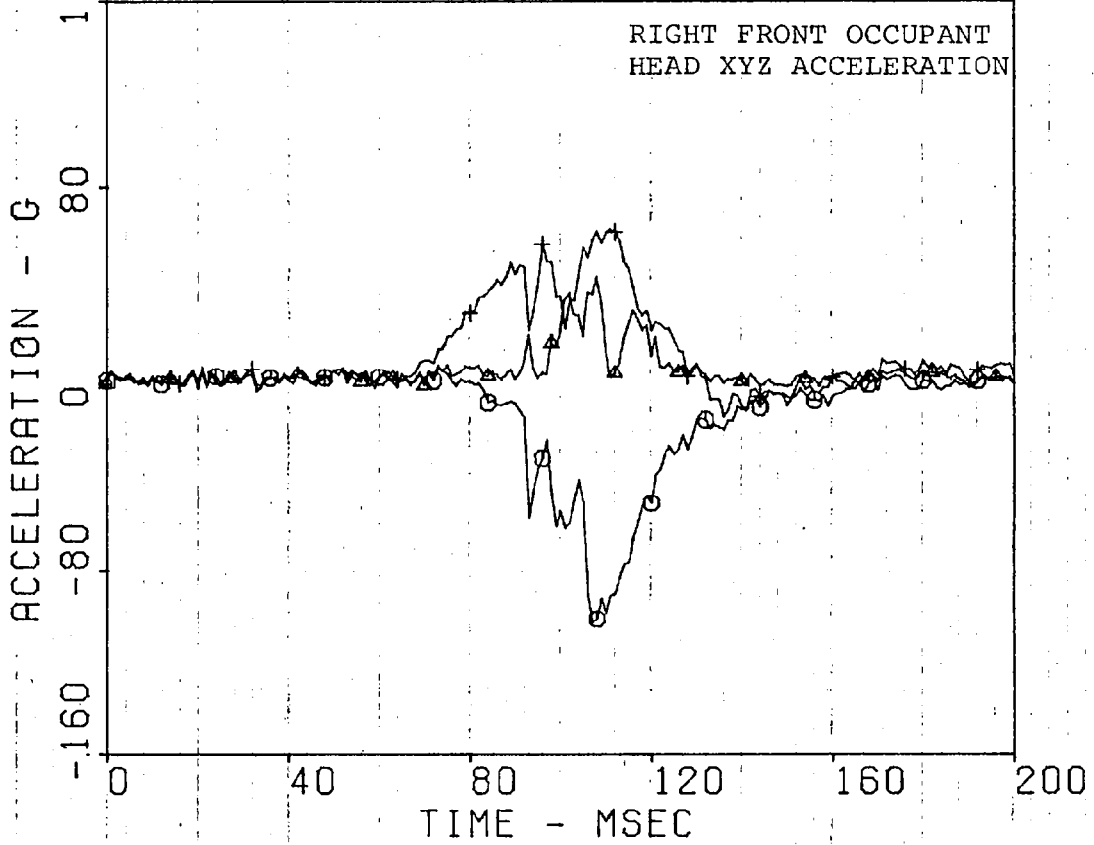

5-9-78 1600 503 8316-3
FORD

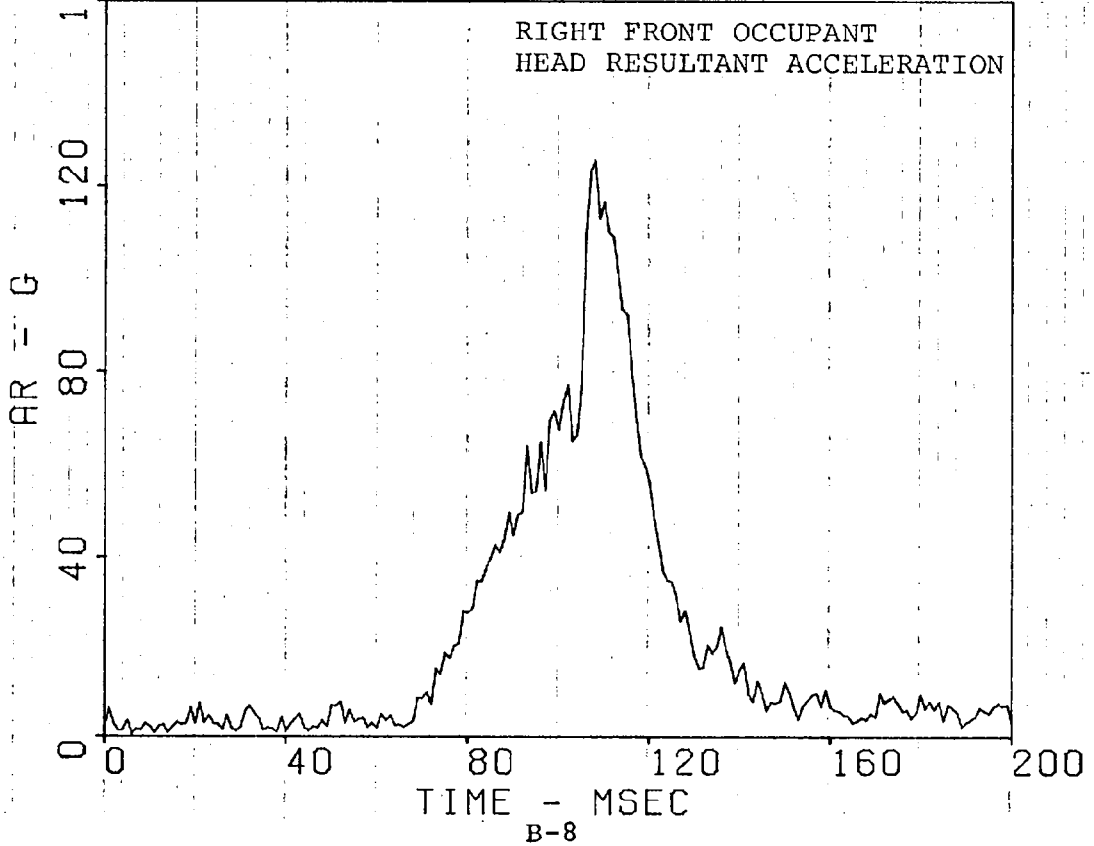

5-9-78 315/100 1103 8316-3
O = AX Δ = AY + = AZ FORD

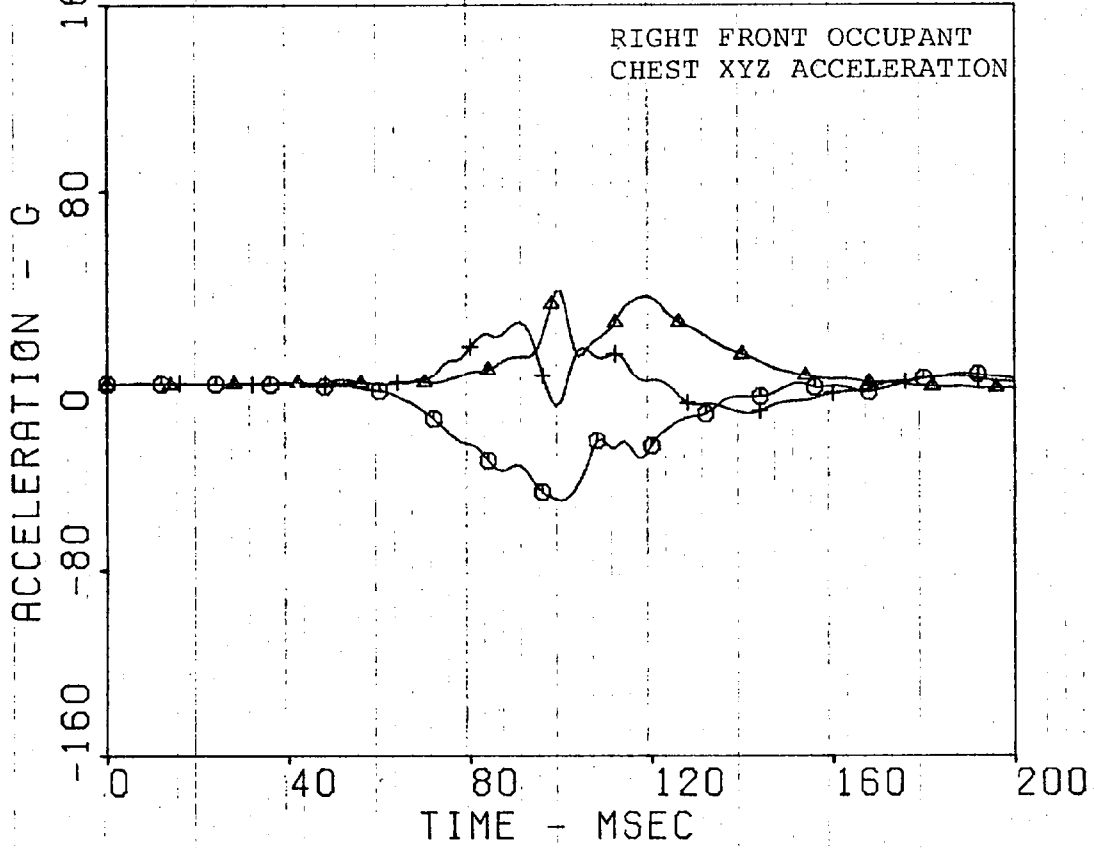

5-9-78 315/100 1103 8316-3
FORD

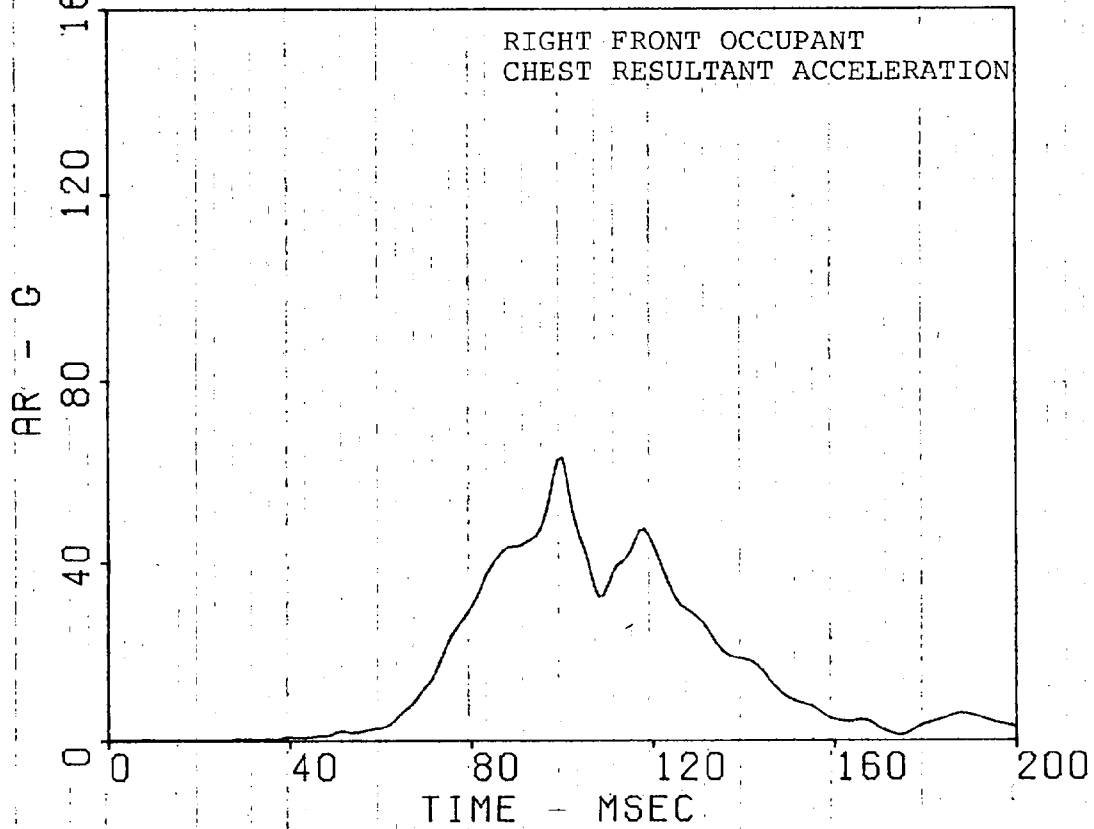

5-9-78

315/100

1103

8316-3

FORD

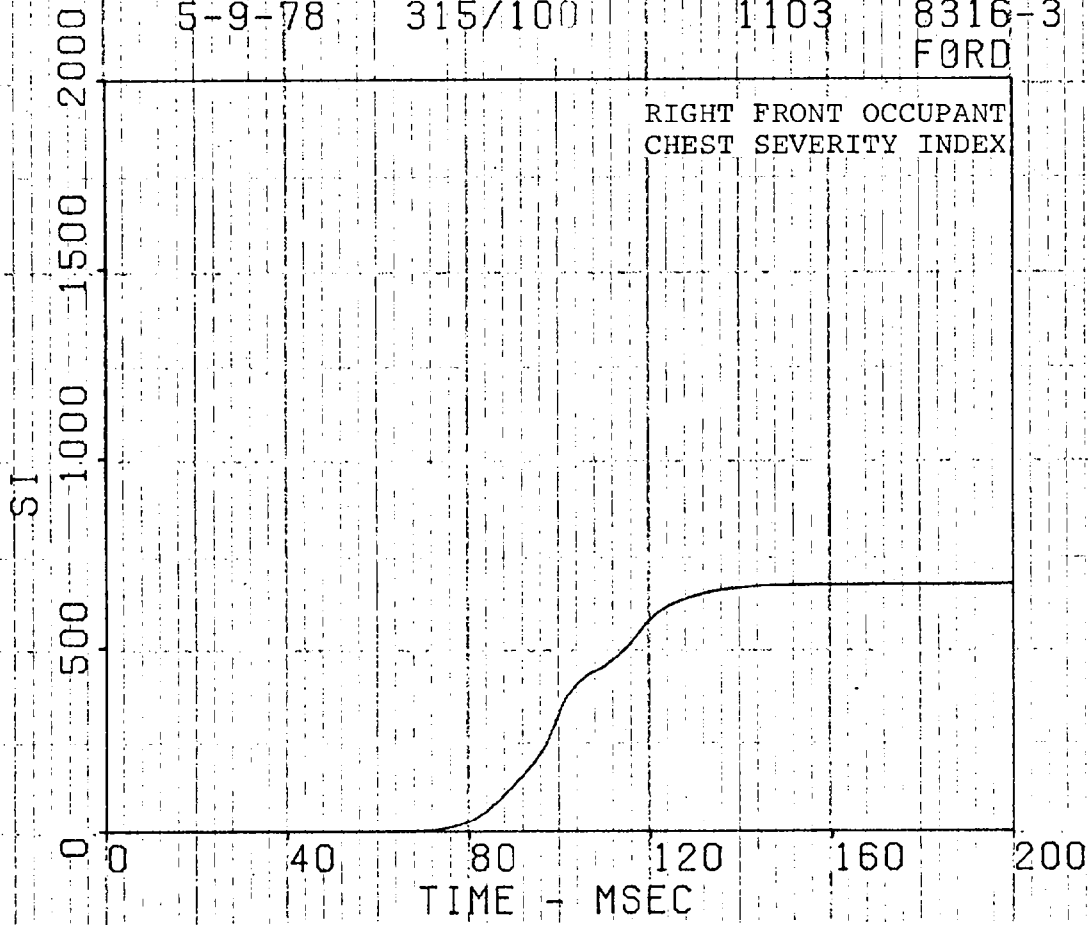

5-9-78

1000

2003

8316-3

FORD

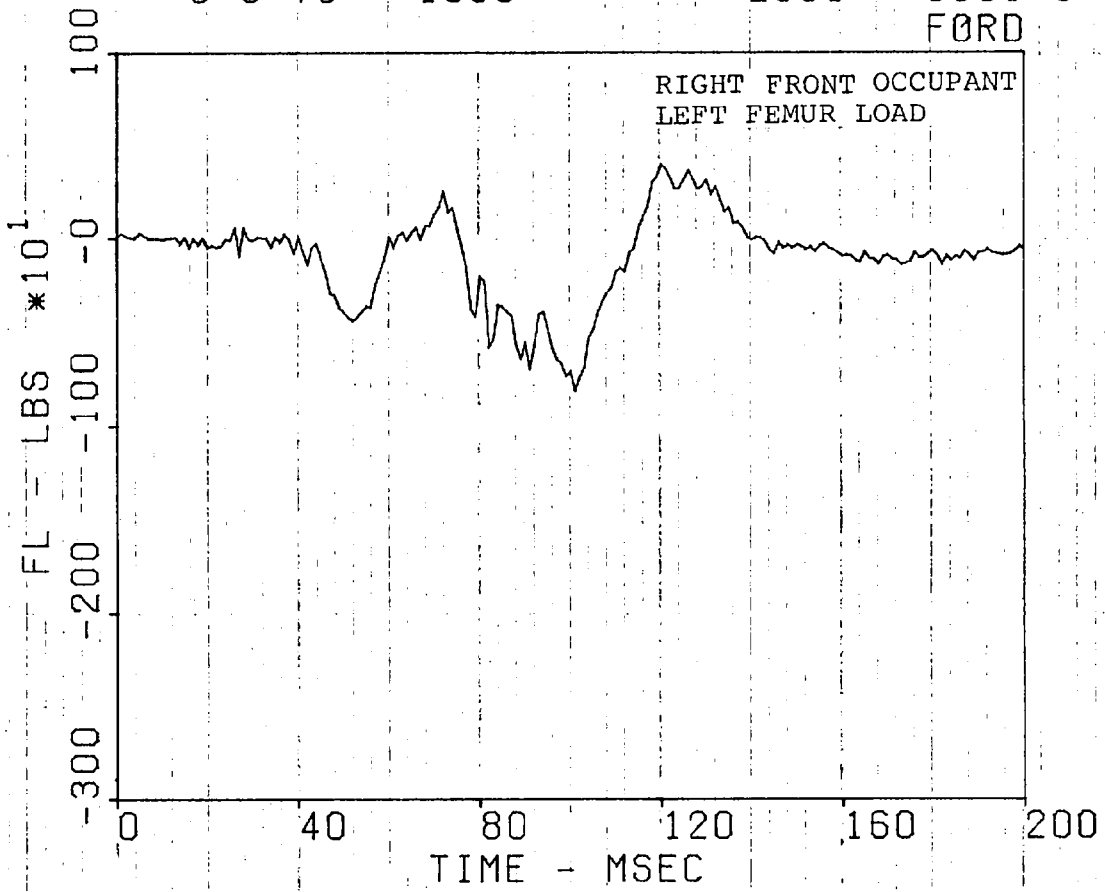

5-9-78

1000

2003

8316-3

FORD

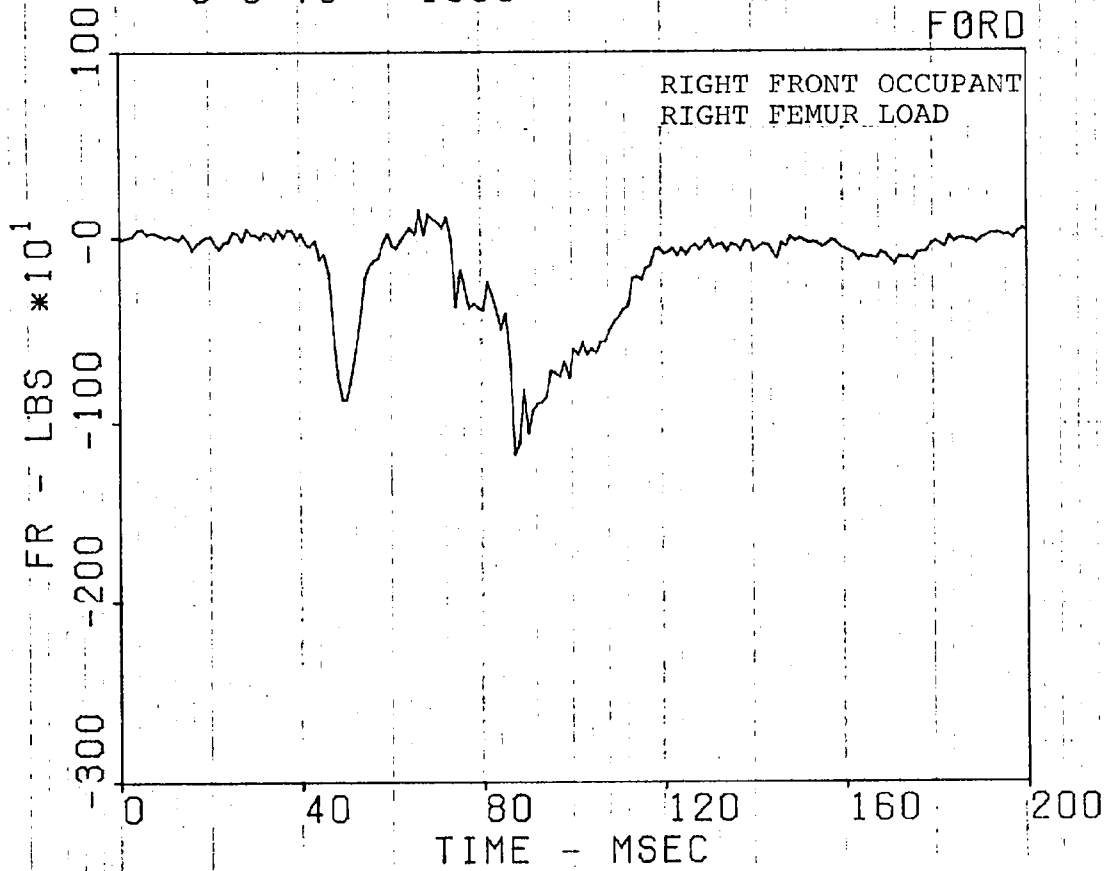

5-9-78

315/100

4203

8316-3

FRD RFLB-L

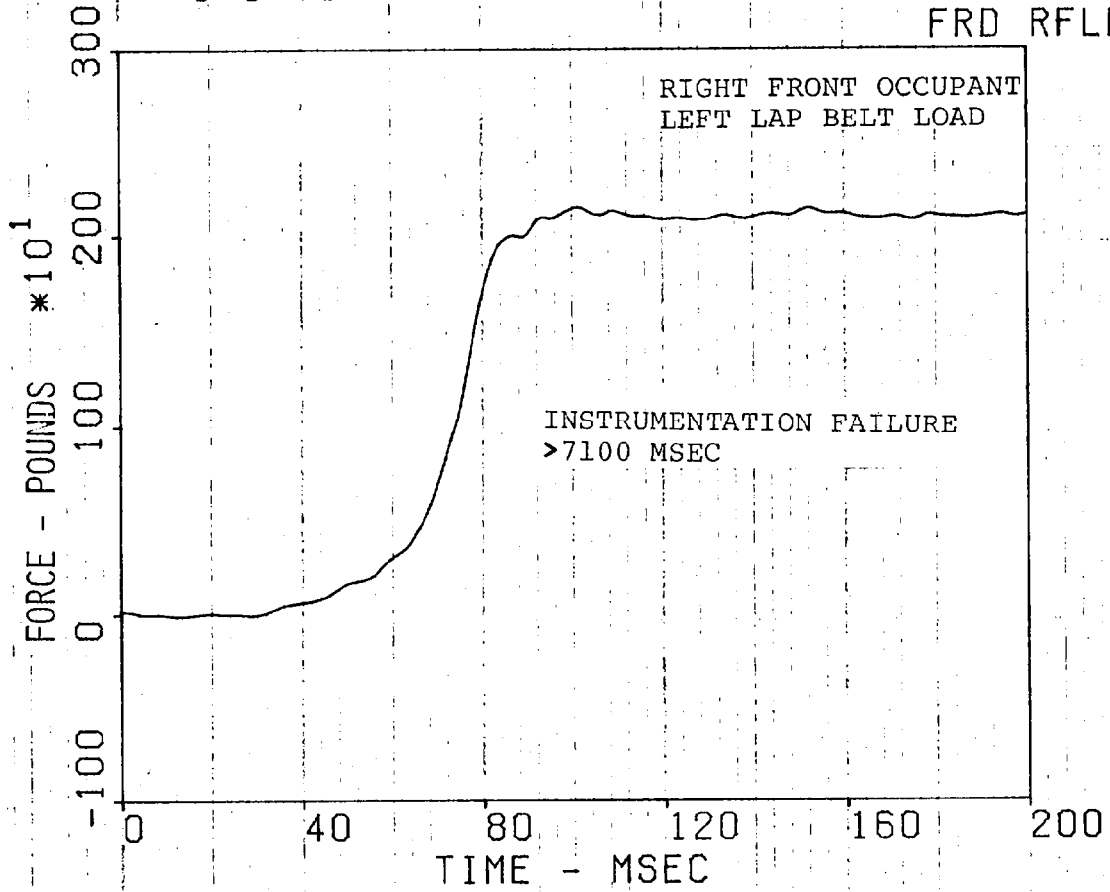

5-9-78

315/100

4203

8316-3

FRD RFLB-R

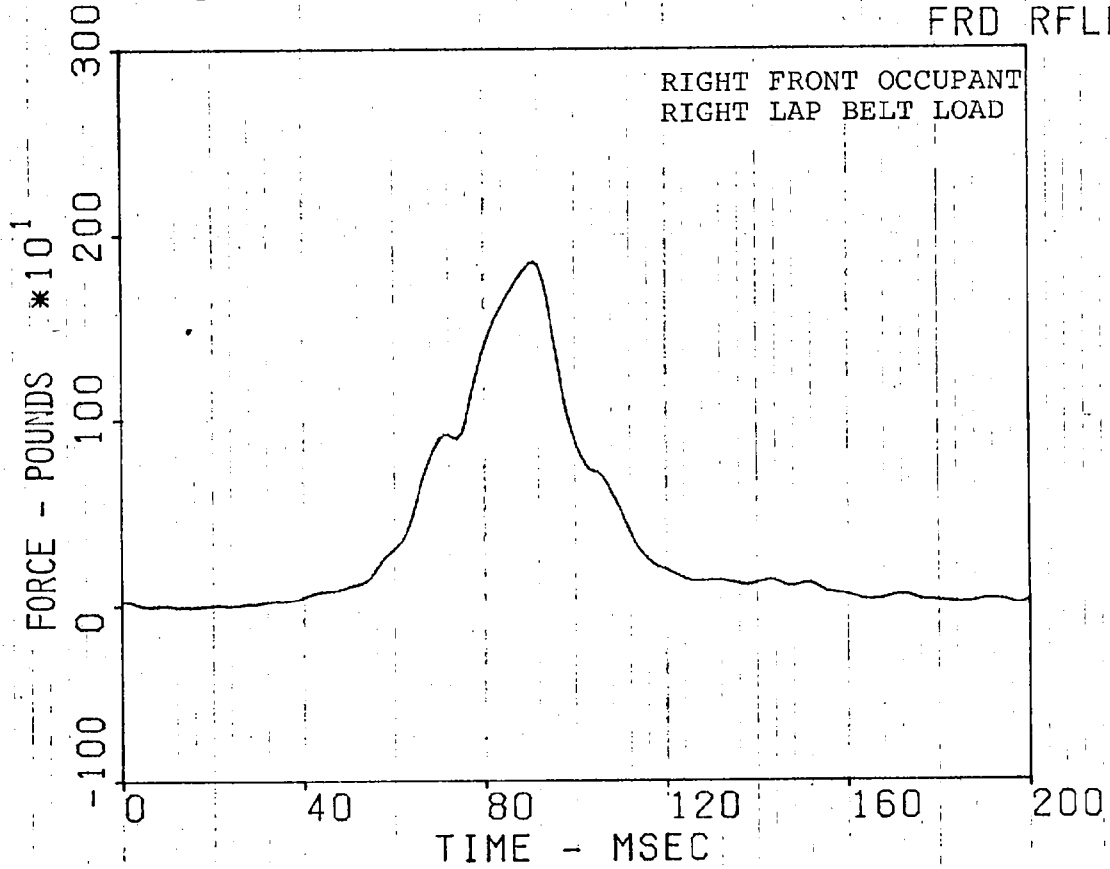

5-9-78

315/100

4203

8316-3

FRD RFT0RB

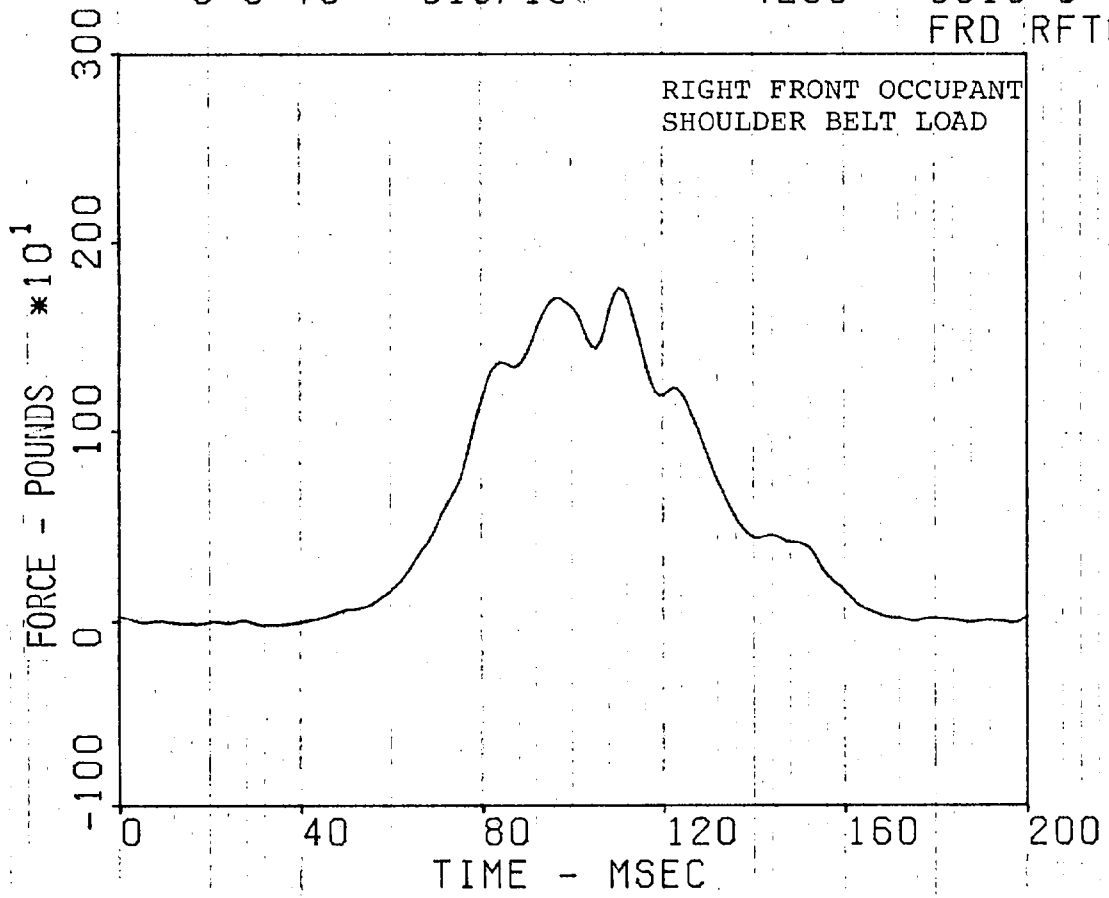

5-9-78

315/100

101

8316-3

○ = AX

△ = AZ

FORD

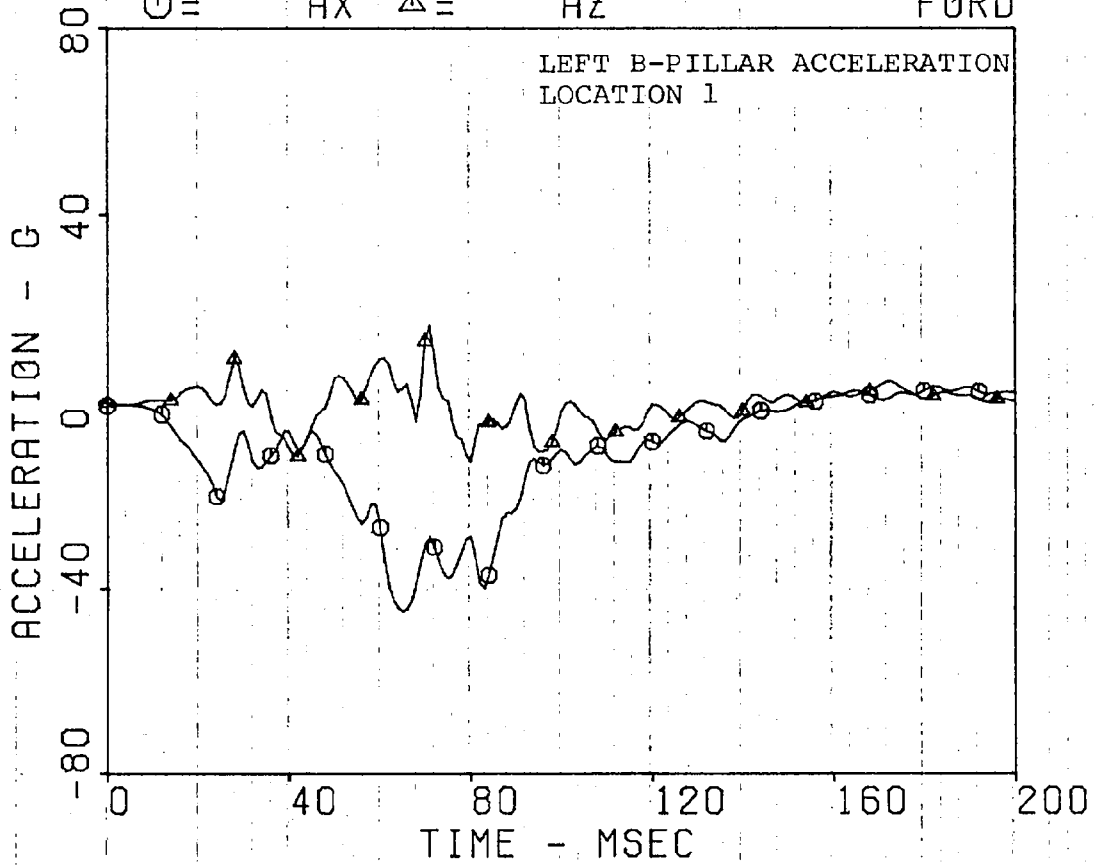

5-9-78

315/100

102

8316-3

○ = AX

△ = AZ

FORD

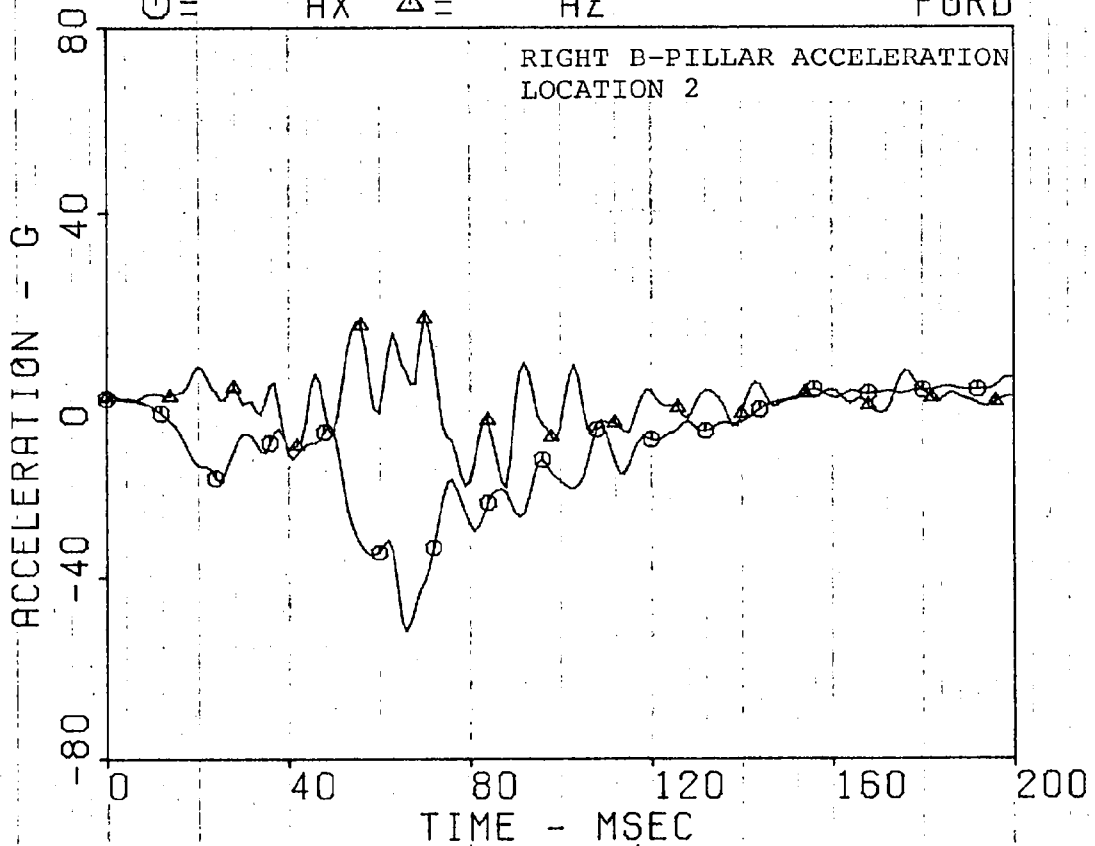

5-9-78 315/100 401 8316-3
⊖ = AX Δ = VX += SX FORD AV1.2

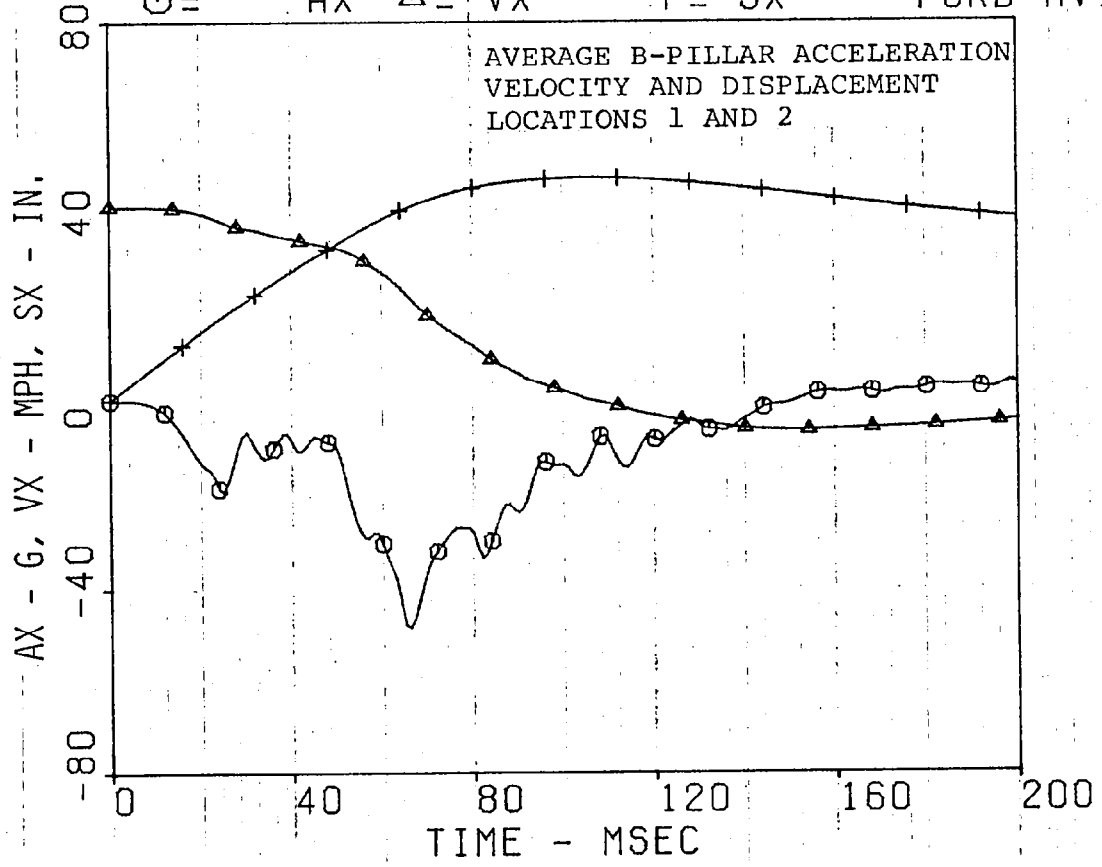

5-9-78

315/100

103

8316-3

○ =

AX

△ =

AZ

FORD

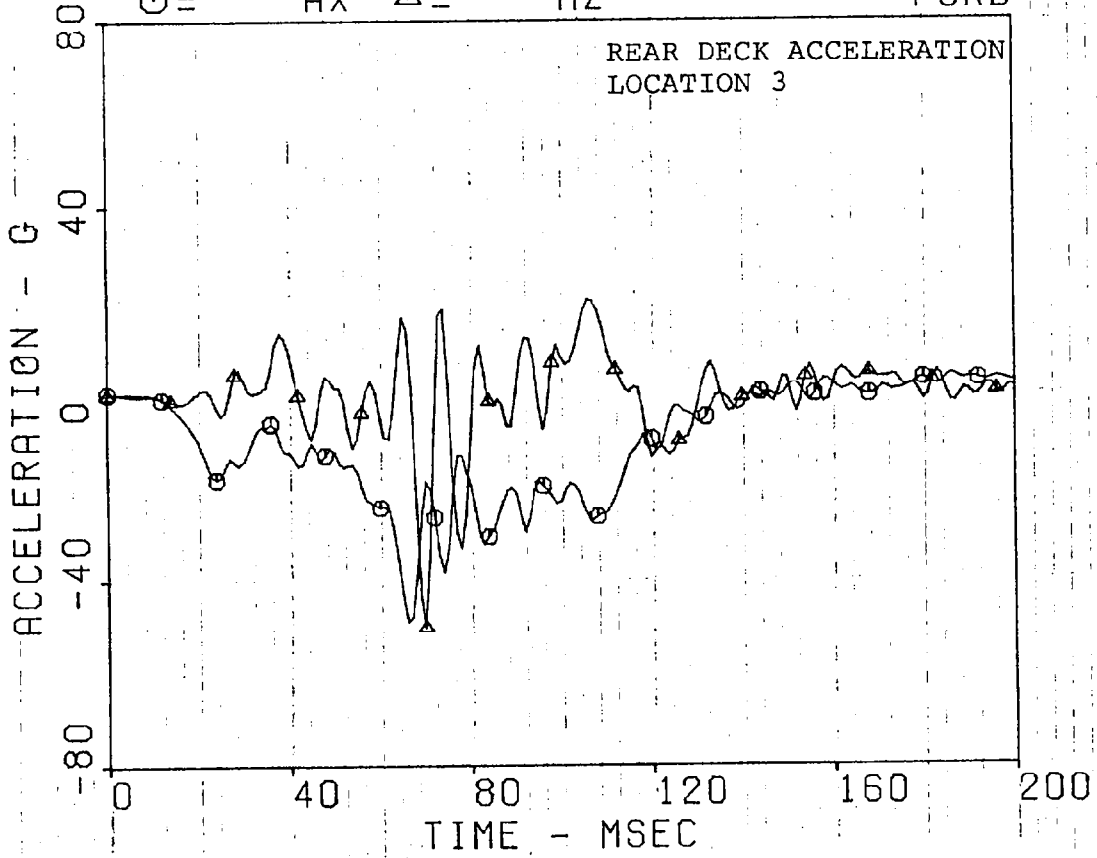

5-9-78

315/100

105

8316-3

○ =

AX

△ =

AZ

FORD

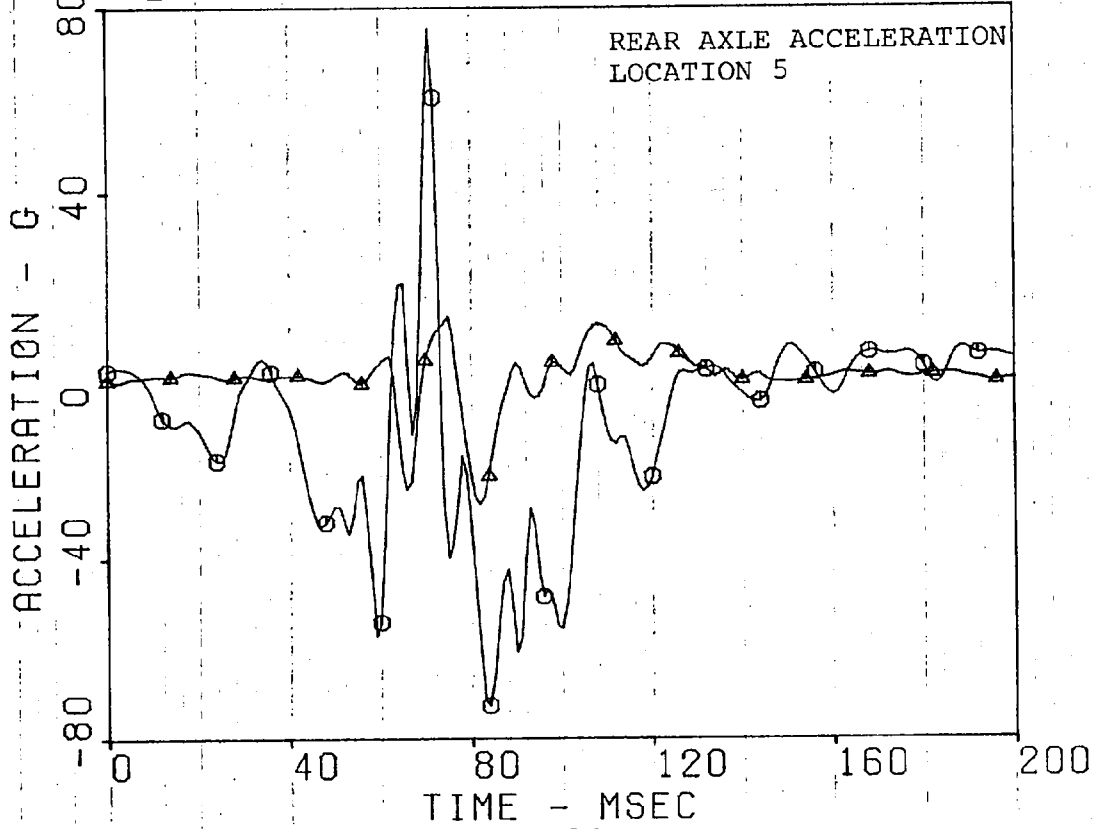

5-9-78 315/100 104 8316-3
⊖ = AX Δ = AZ FORD

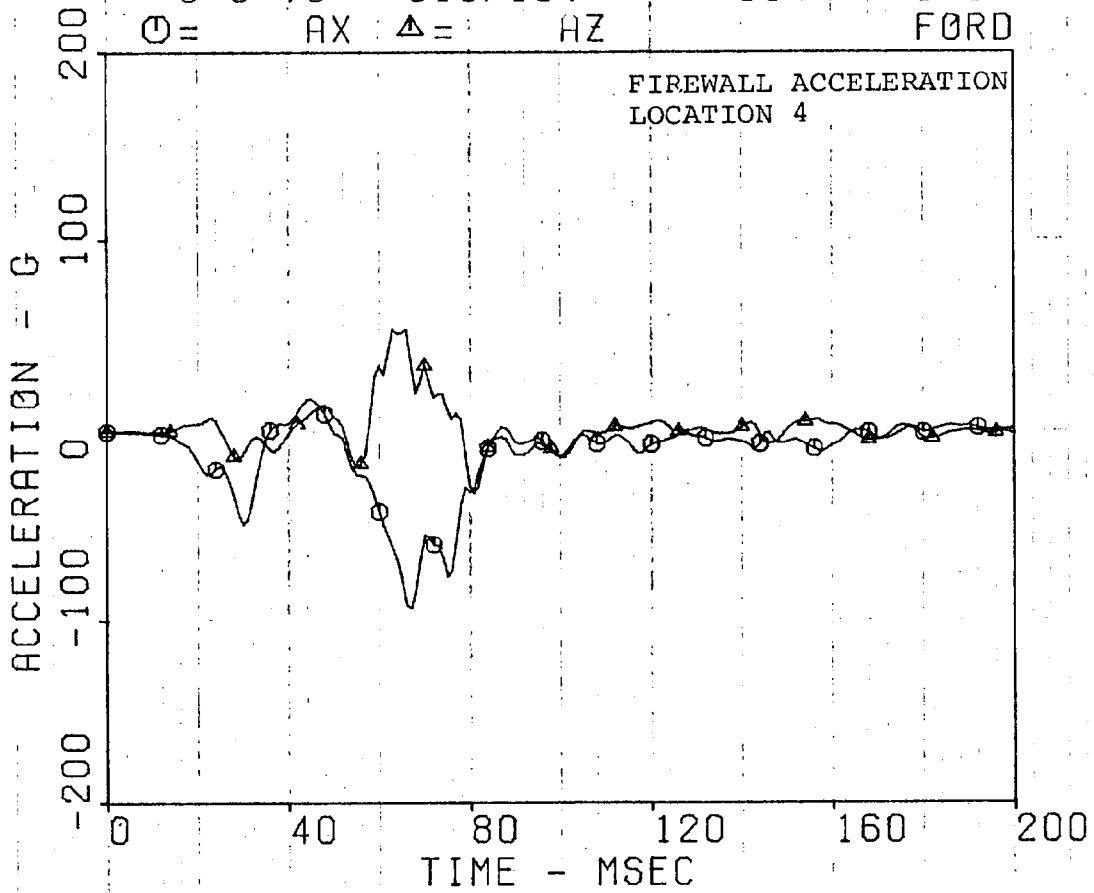

5-9-78 315/100 107 8316-3
FORD

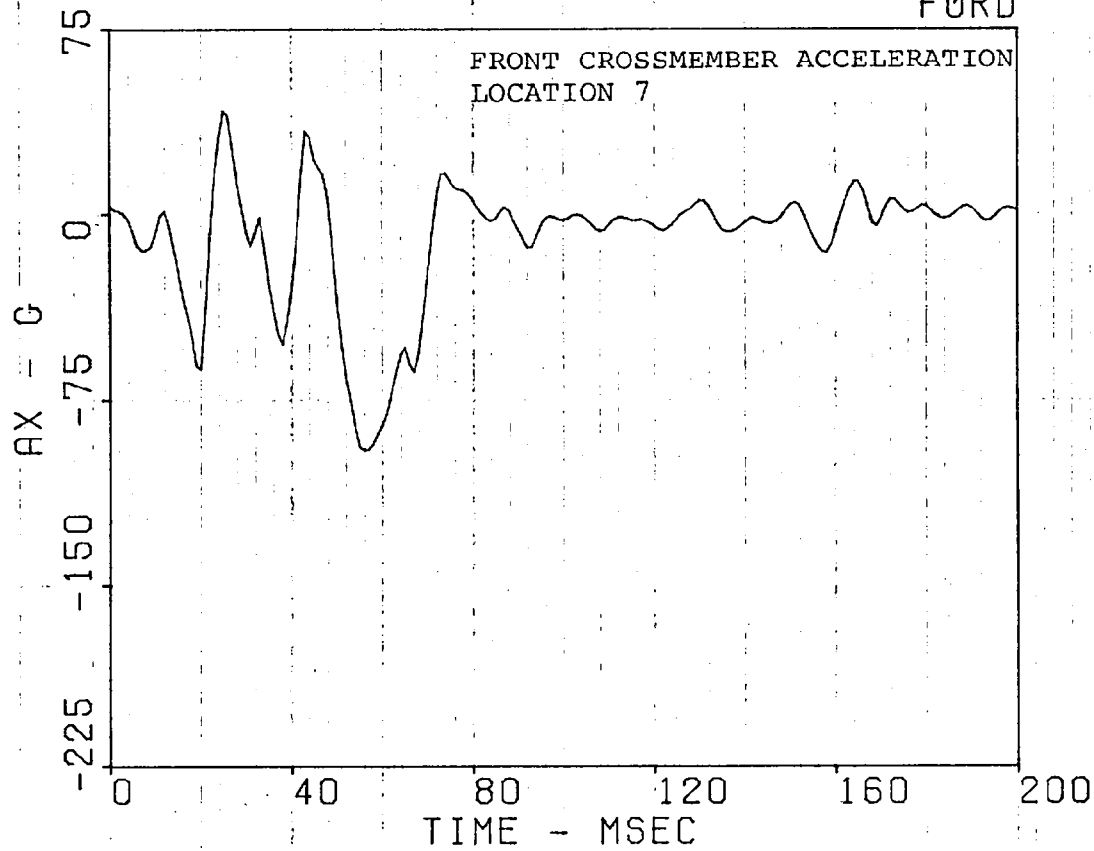

5-9-78

315/100

106

8316-3
FORD

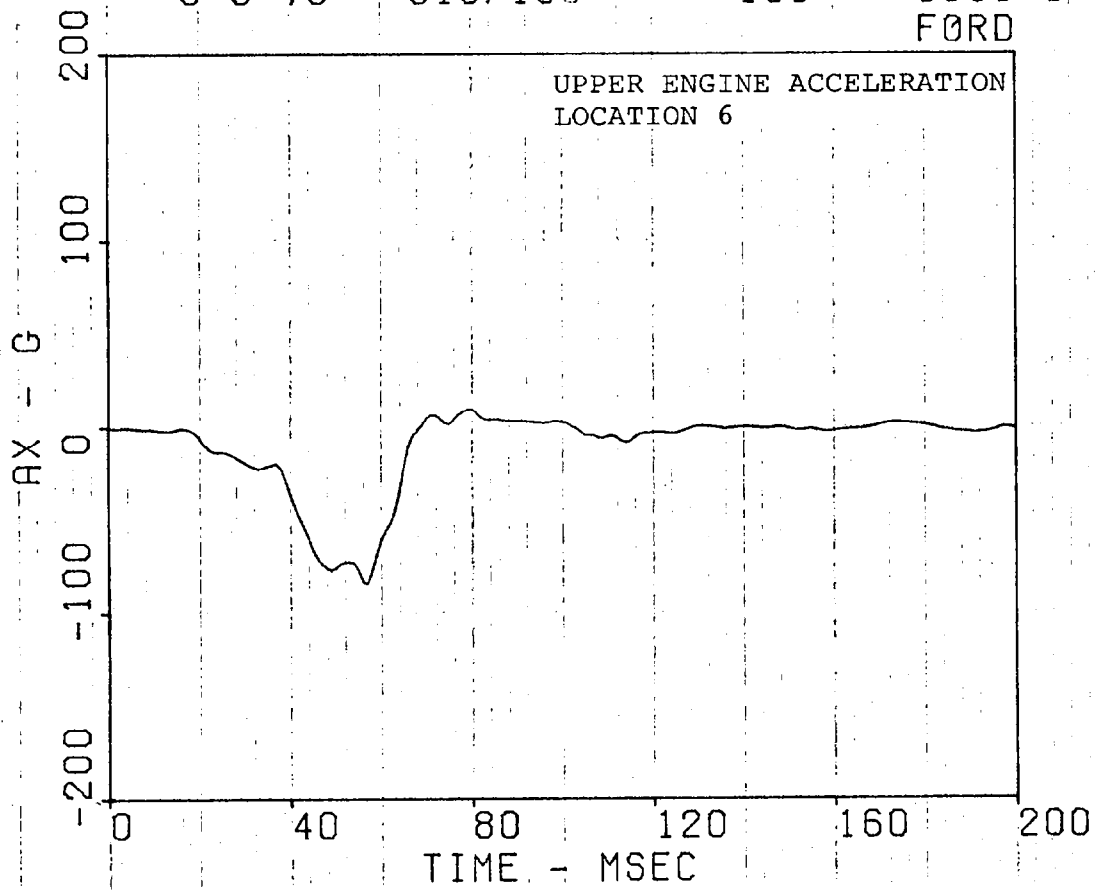

5-9-78

315/100

109

8316-3
FORD

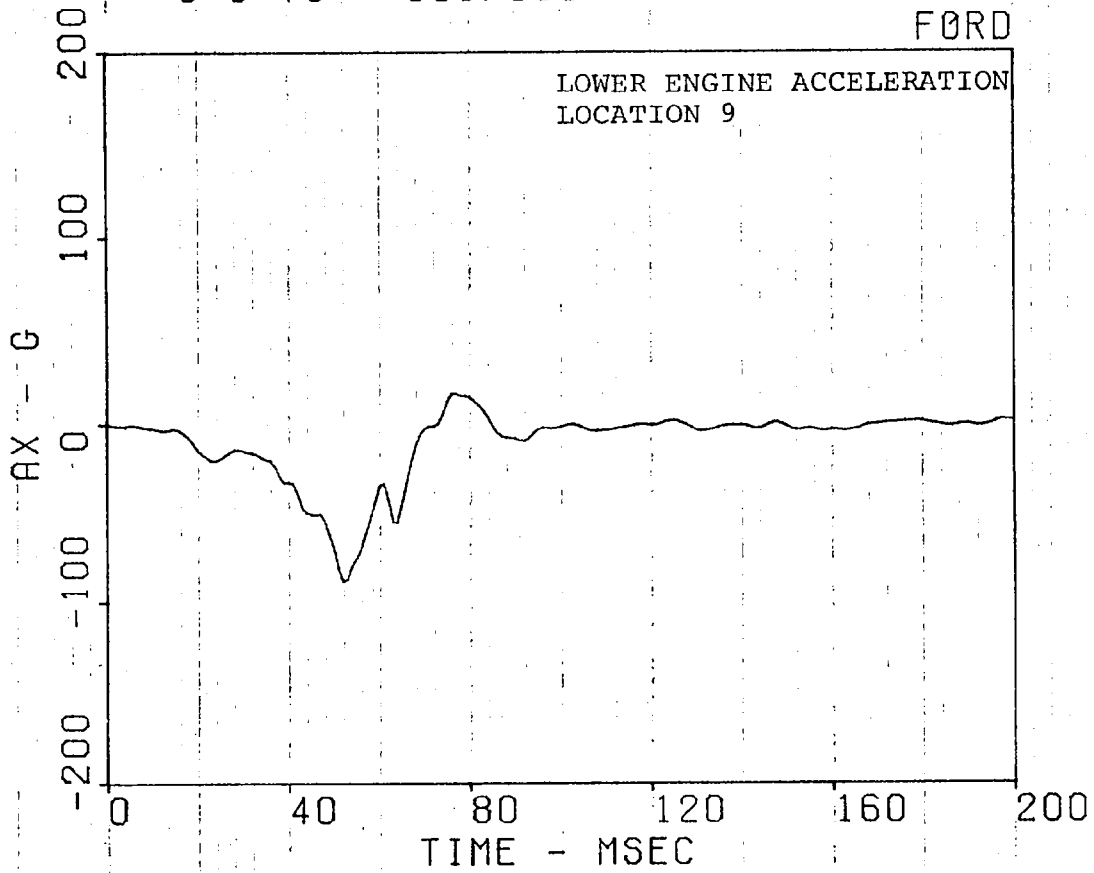

5-9-78

315/100

402

8316-3

⊖ =

AX

△ =

VX

+ =

SX

FORD AV6.9

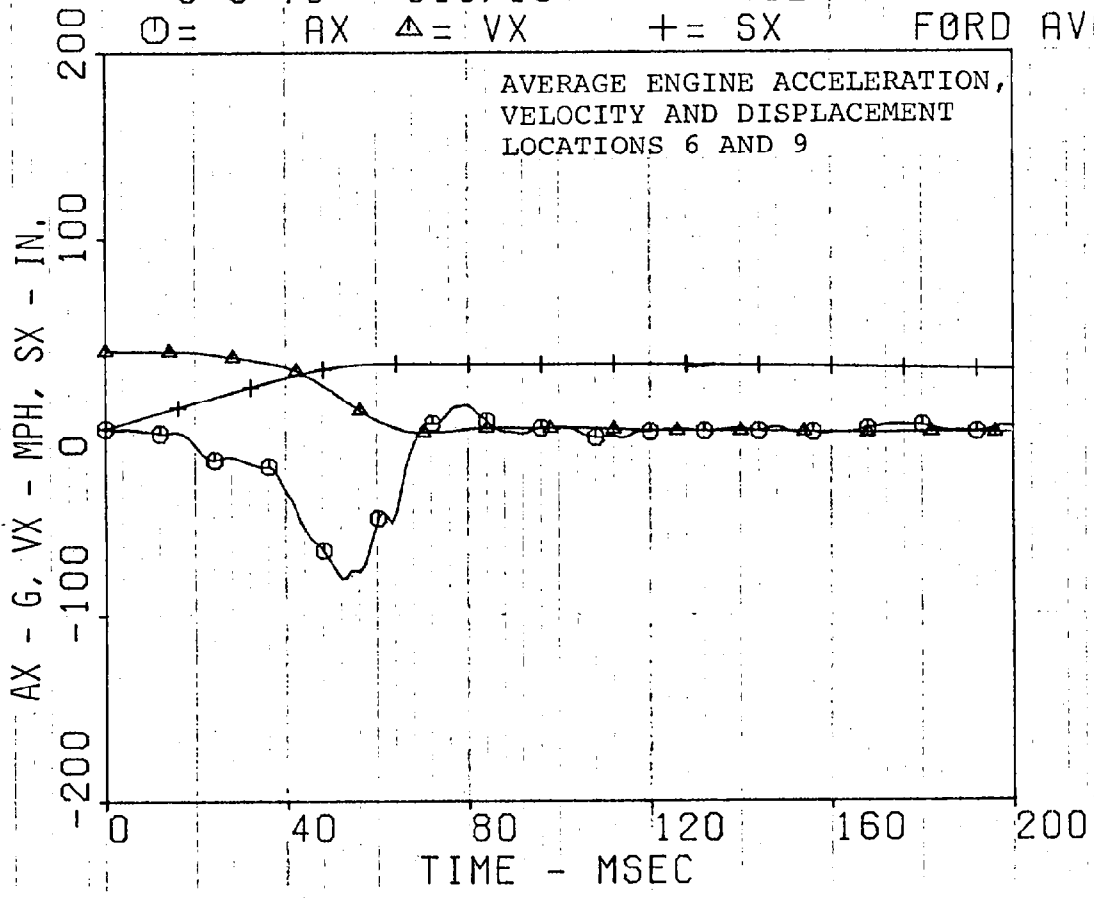

5-9-78 315/100 108 8316-3
⊙ = AX Δ = AY + = AZ FORD

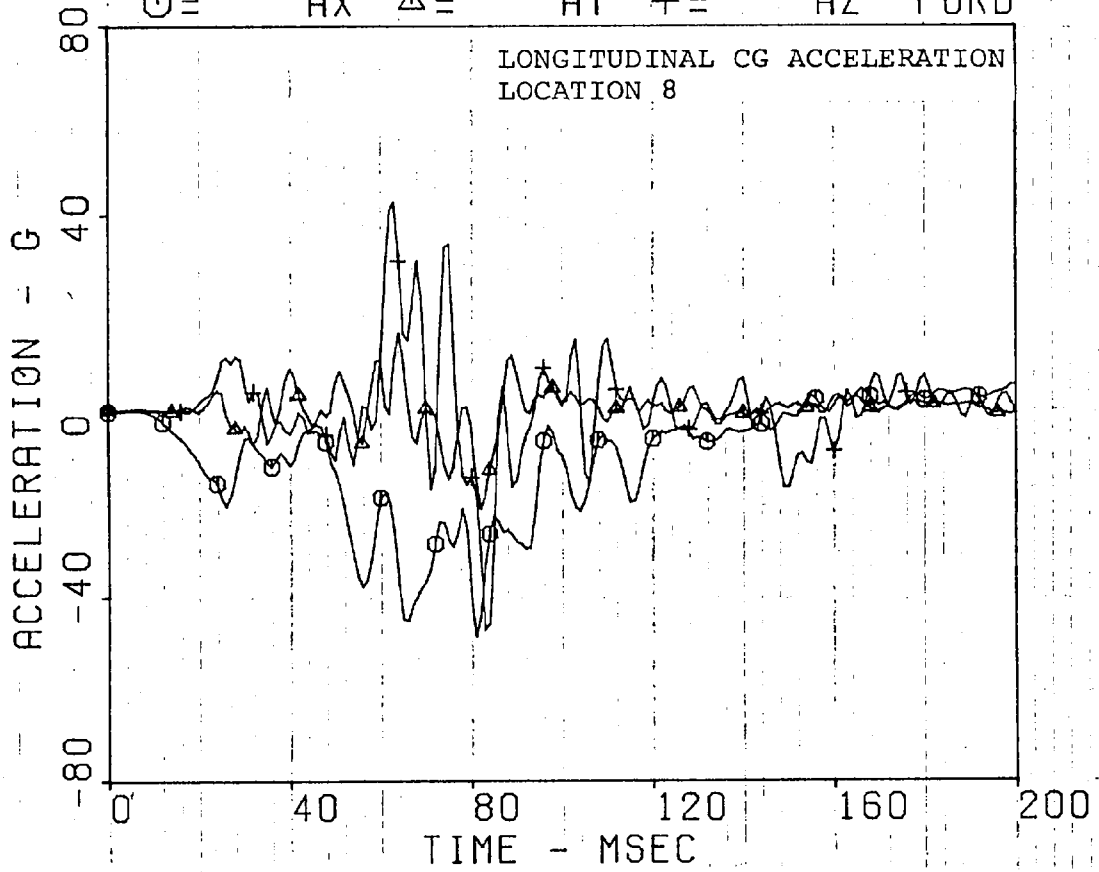

DATE
5-9-78

FILTER
315/100

LOCATION
4101

TEST NO
8316-3
FORD SP-1

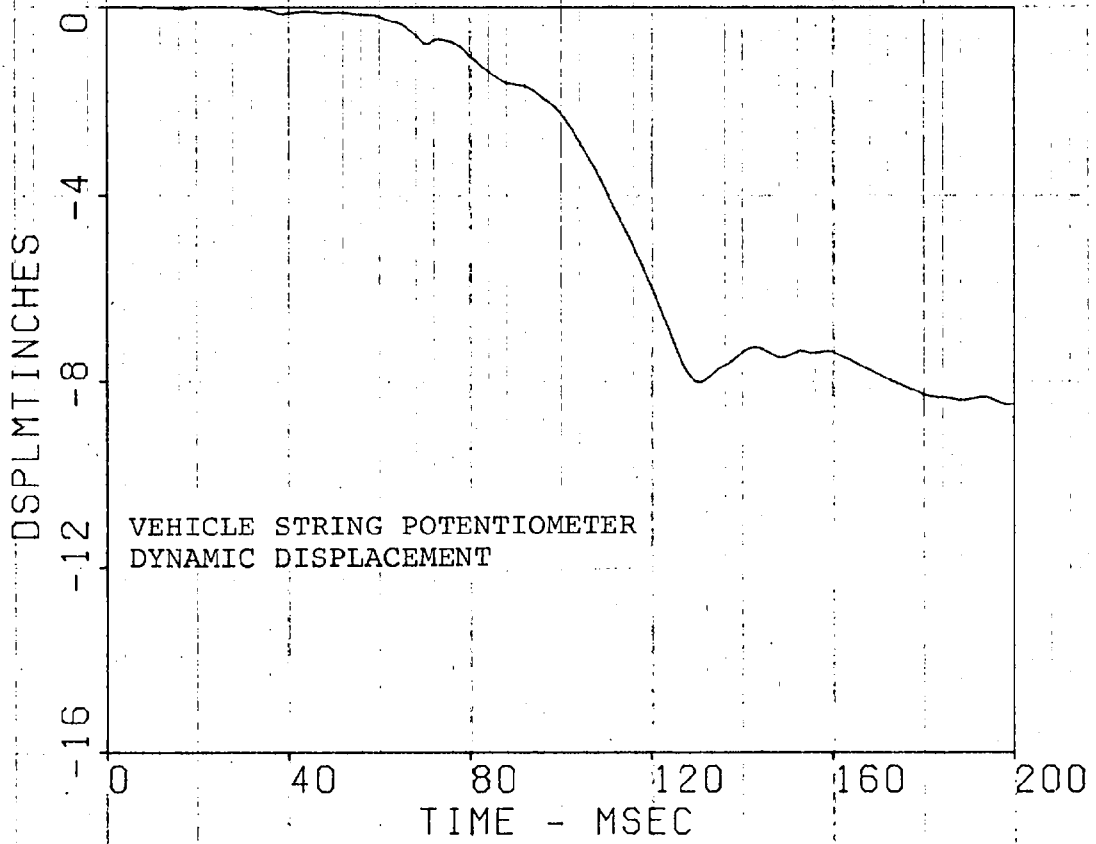

5-9-78

315/100

4001

8316-3

TSTDEV SP1

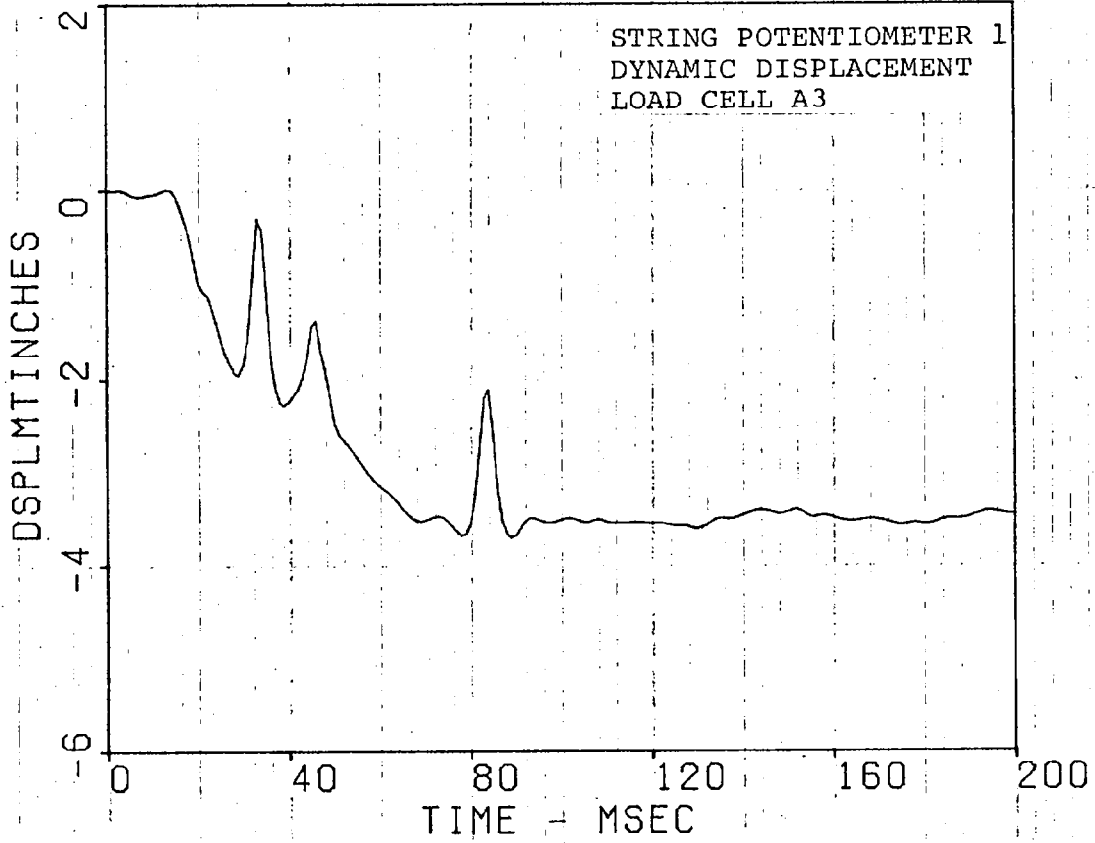

5-9-78

315/100

4002

8316-3

TSTDEV SP2

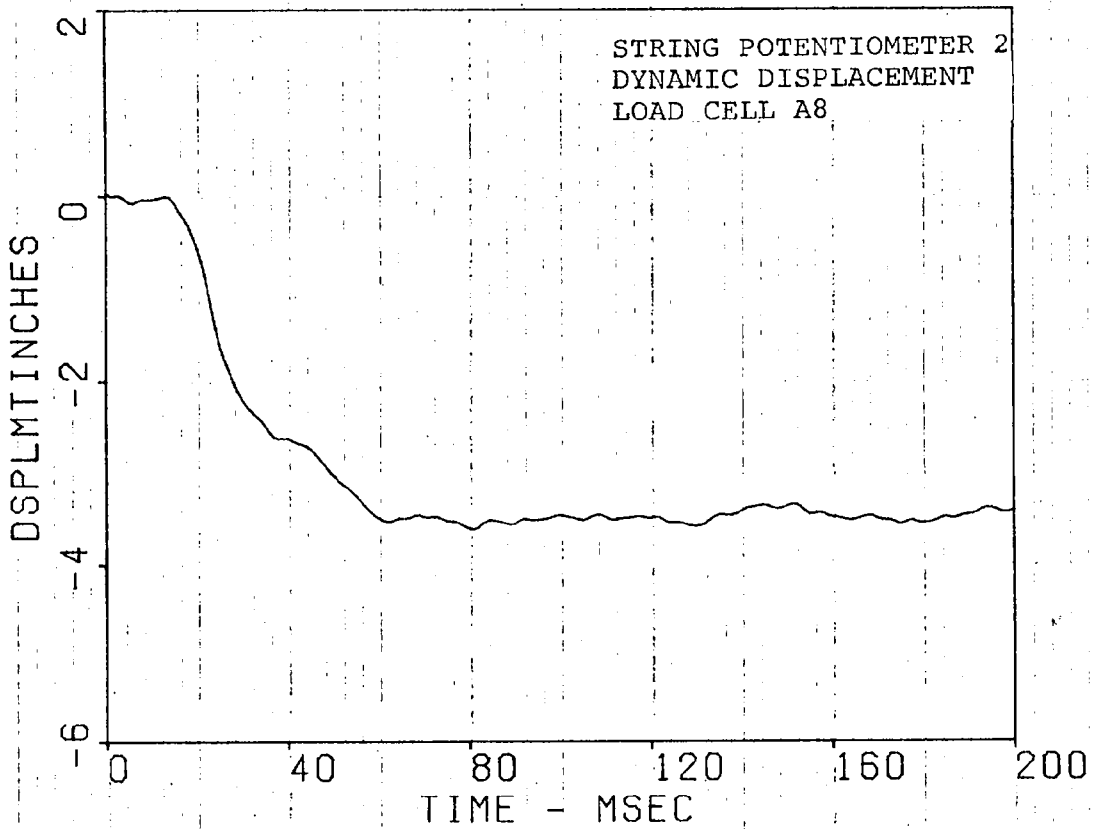

5-9-78

315/100

4003

8316-3

TSTDEV SP3

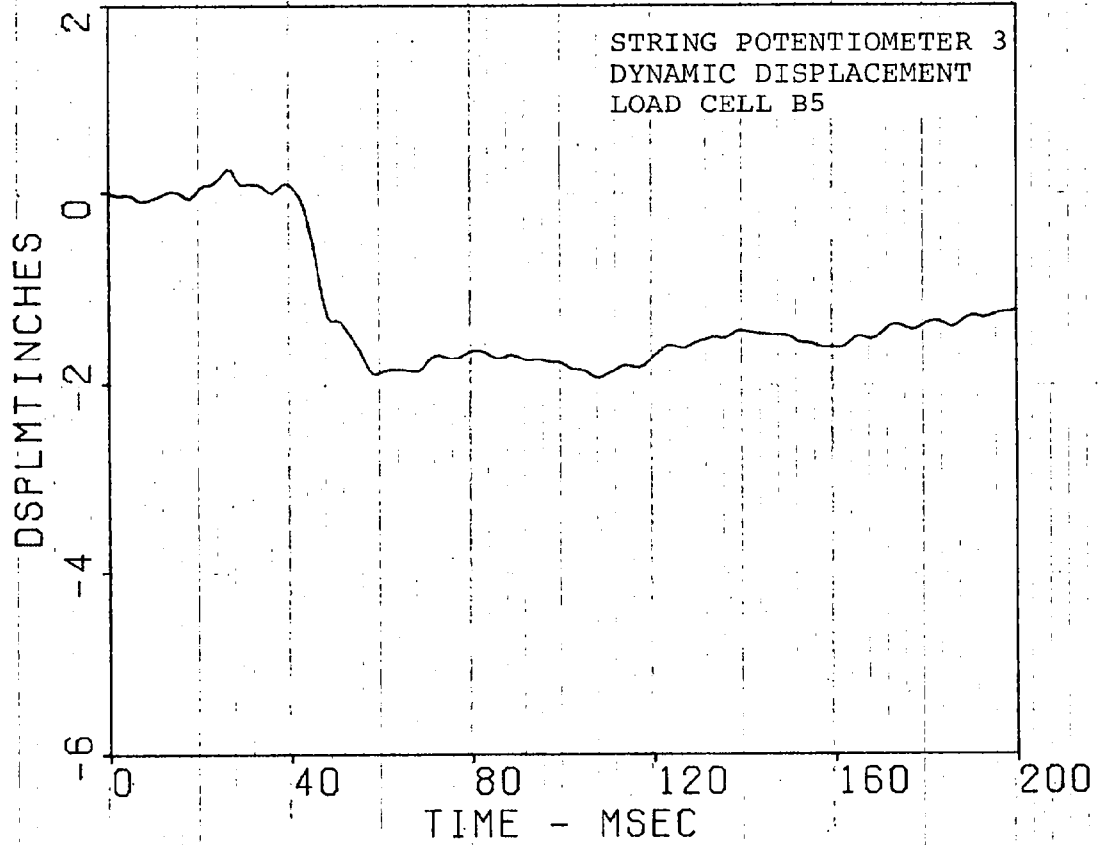

5-9-78

315/100

4004

8316-3

TSTDEV SP4

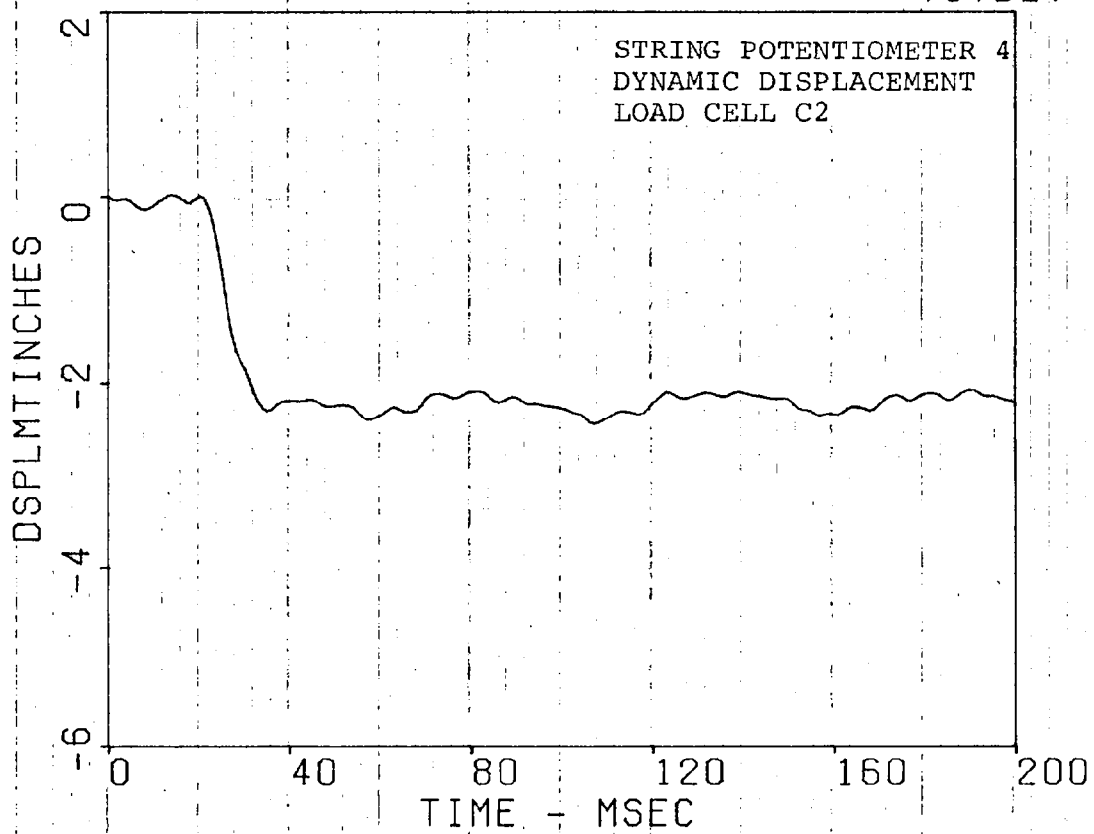

5-9-78

315/100

4005

8316-3

TSTDEV SP5

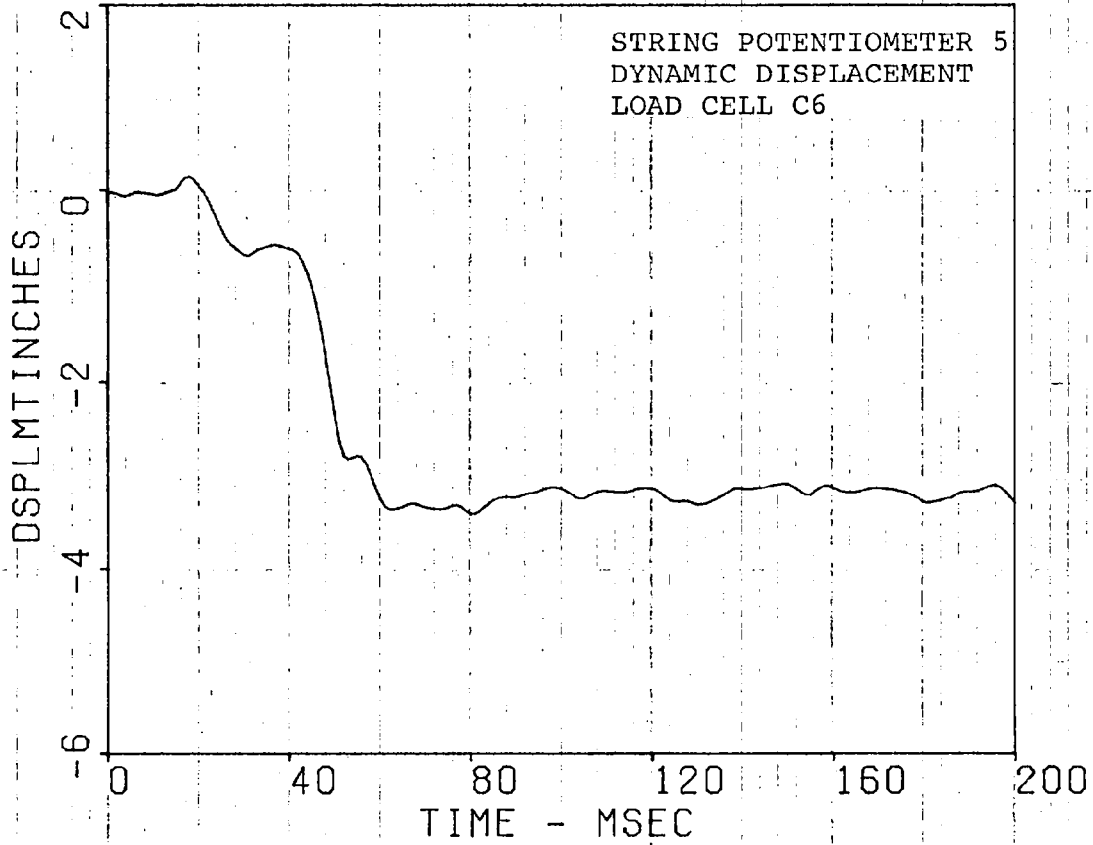

5-9-78

315/100

4006

8316-3

TSTDEV SP6

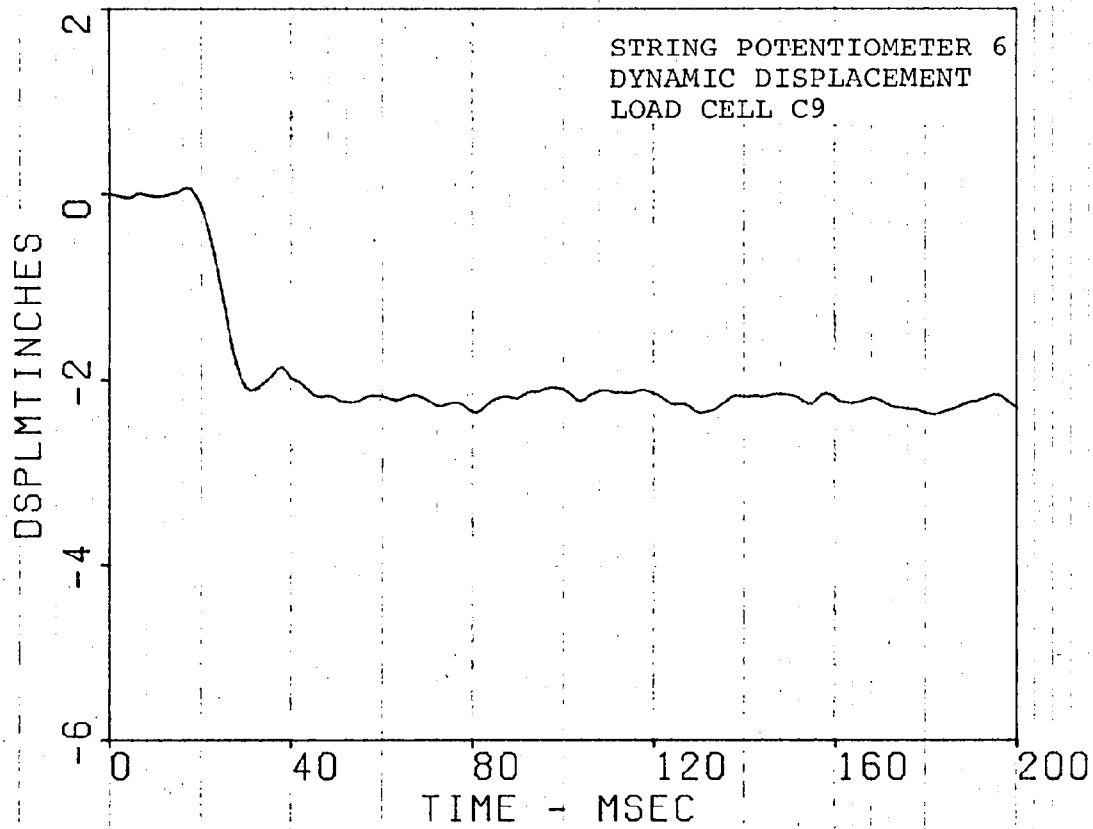

5-9-78

315/100

4301

8316-5

TSTDEV SG1

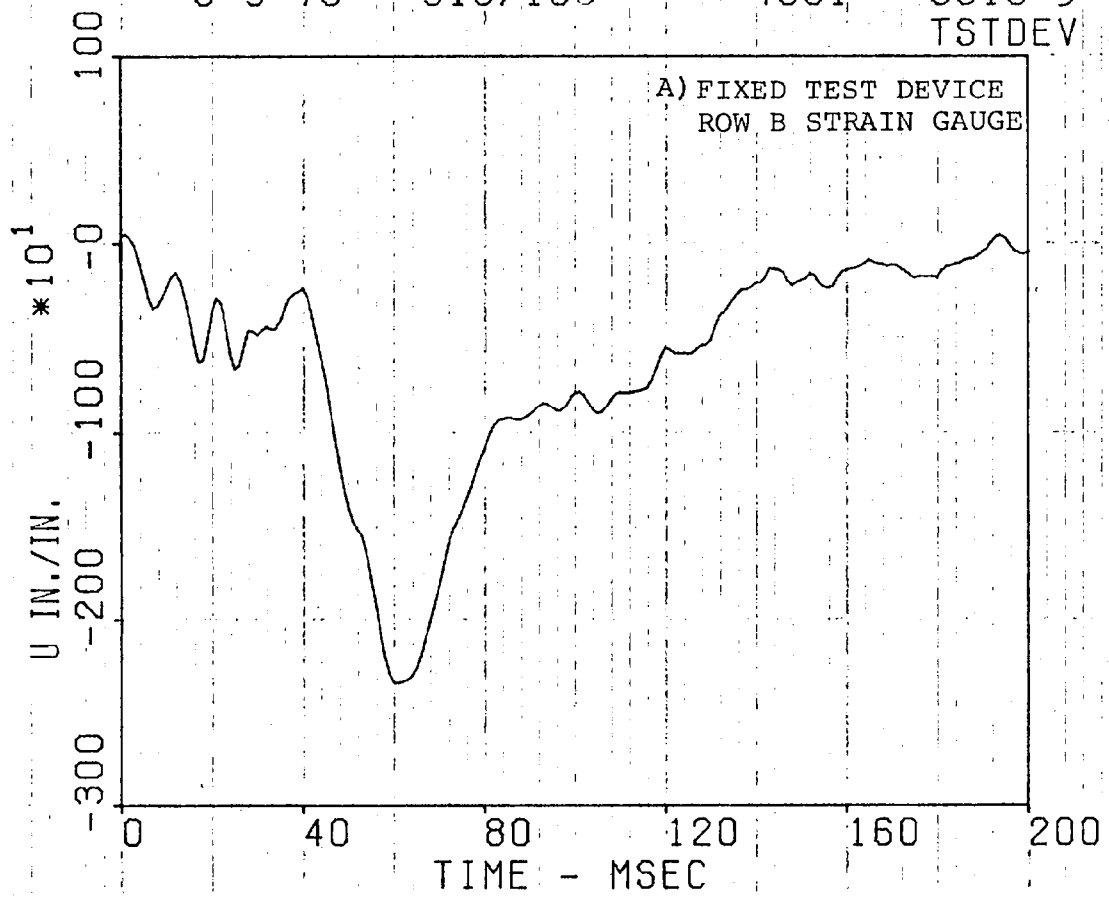

DATE 5-9-78 FILTER 315/100 TEST NO 8316-3 TEST DEVICE 072178
 O=A Δ=B H=C X=D COLUMN 1

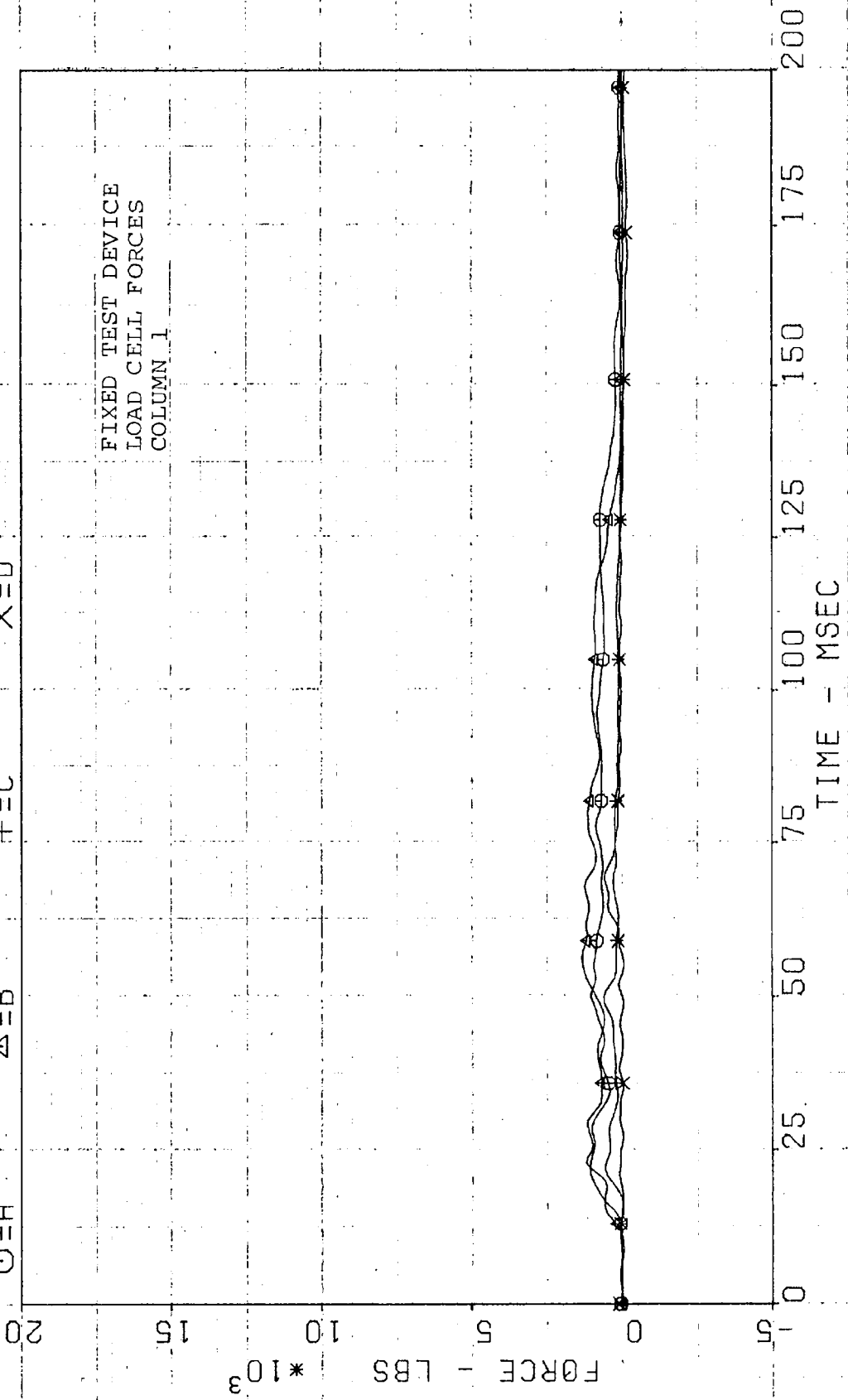

FIXED TEST DEVICE
 LOAD CELL FORCES
 COLUMN 1

DATE 5-9-78
 FILTER 315/100
 COLUMN 2
 TEST NO 8316-3
 TESTDEVICE
 0=A
 Δ=B
 †=C
 X=D
 072178
 TESTDEVICE

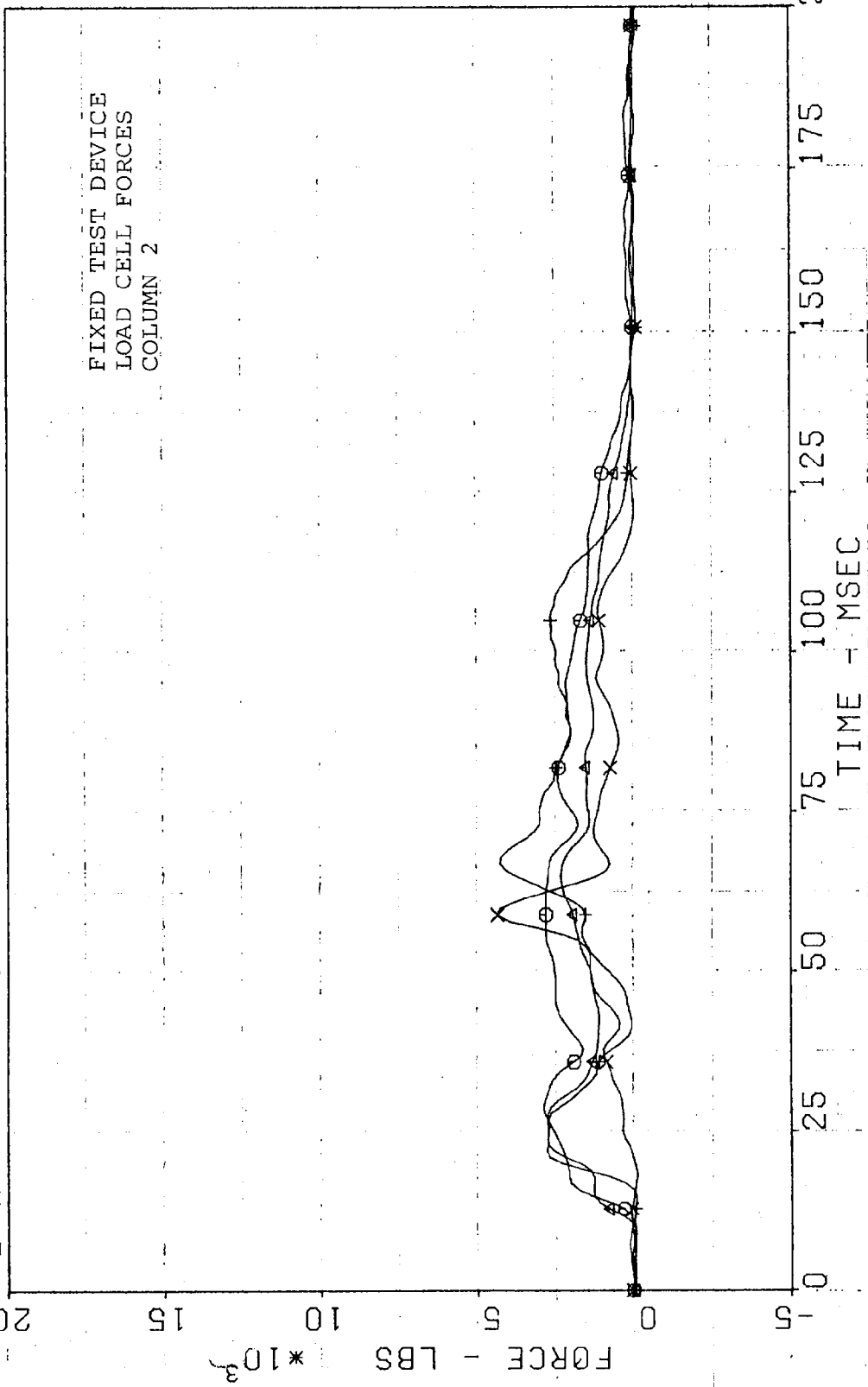

DATE 5-9-78
 FILTER 315/100
 COLUMN 3
 TEST NO 8316-3
 TEST DEVICE
 O=A
 A=B
 T=C
 X=D

072178
 TEST DEVICE

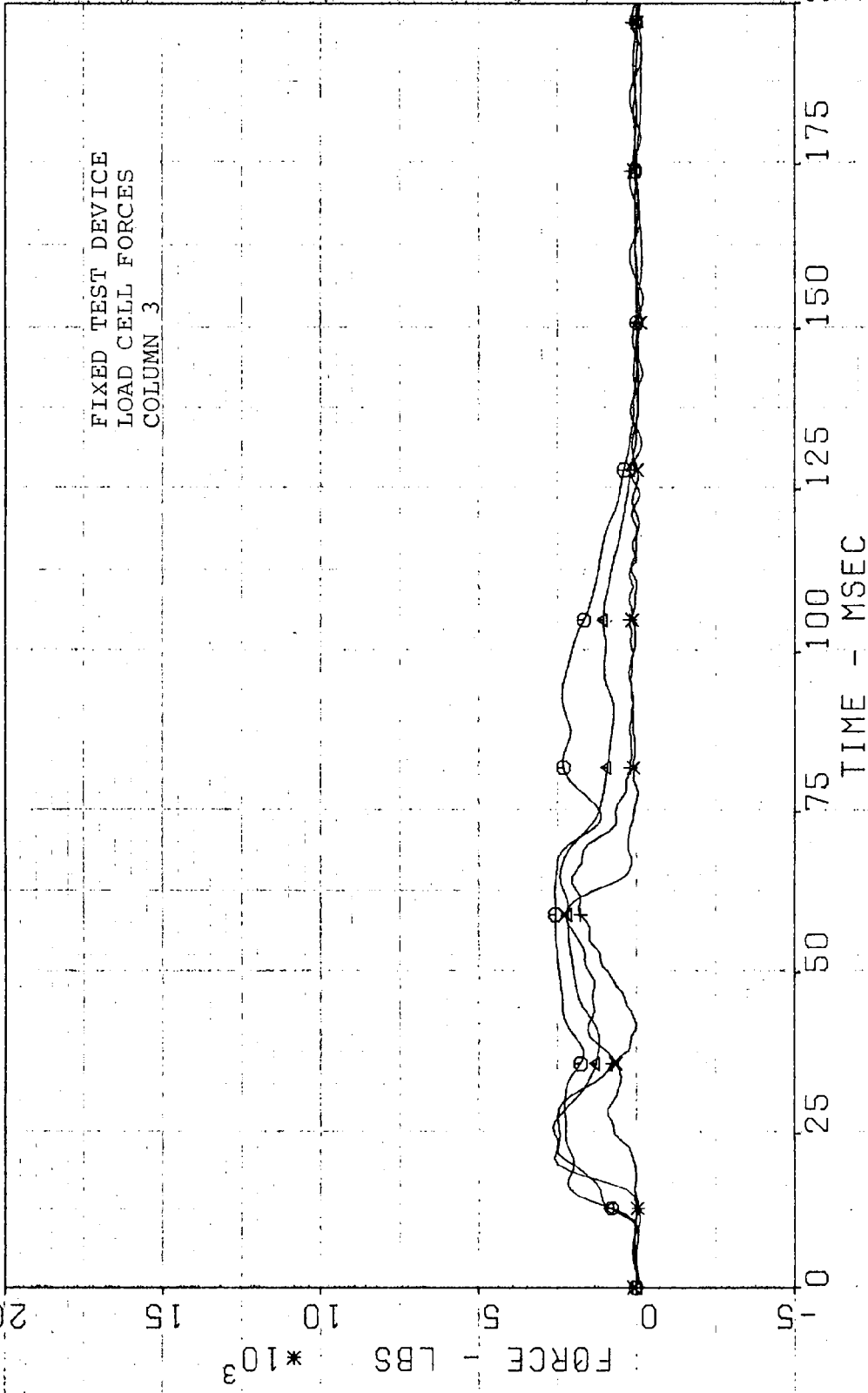

DATE 5-9-78 FILTER 315/100 COLUMN 4 TEST NO 8316-3 TEST DEVICE 072178
 O=A Δ=B +=C X=D

FIXED TEST DEVICE
 LOAD CELL FORCES
 COLUMN 4

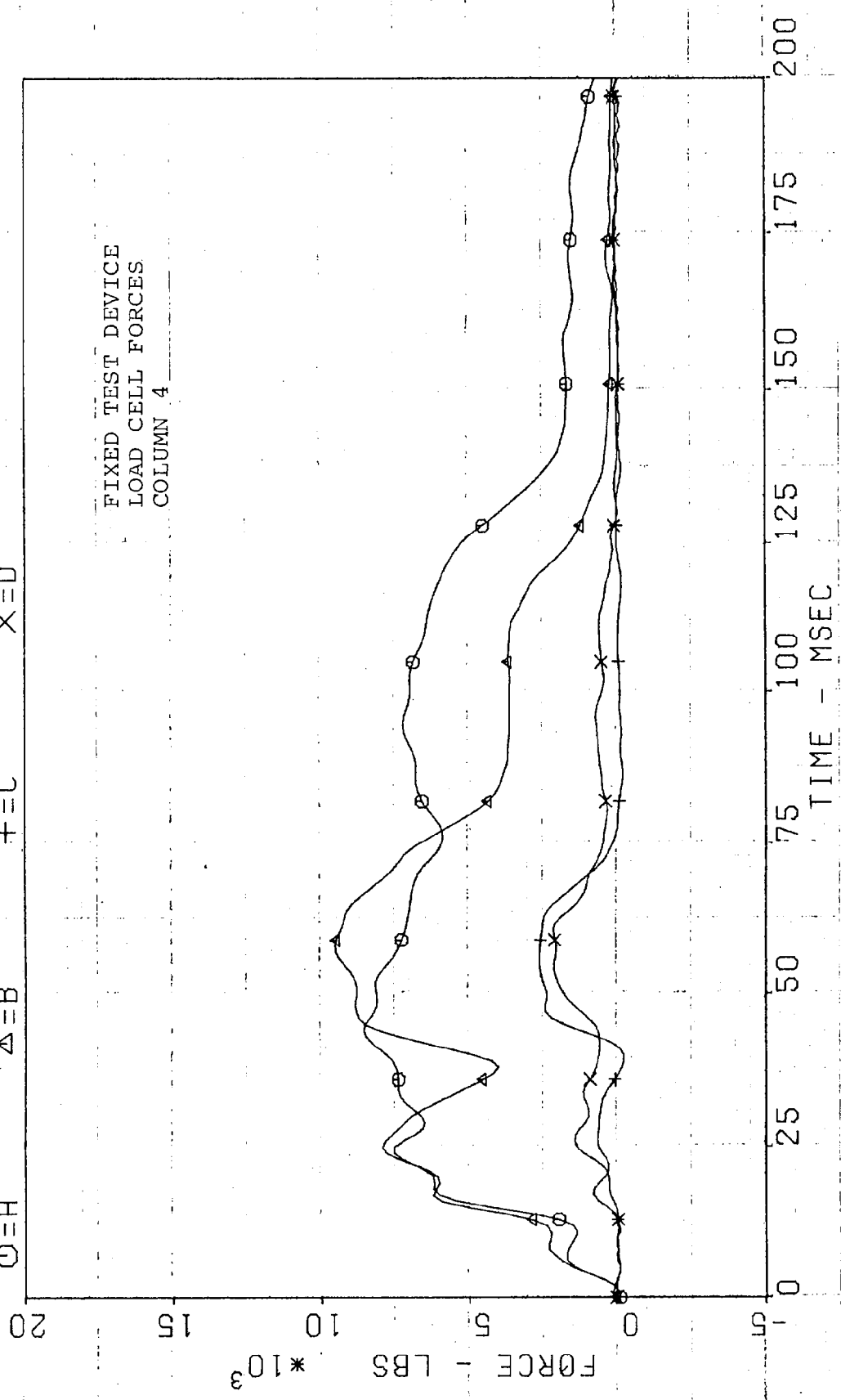

DATE 5-9-78
 FILTER 315/100
 COLUMN 5
 TEST NO 8316-3
 TEST DEVICE
 O=A
 A=B
 +=C
 X=D

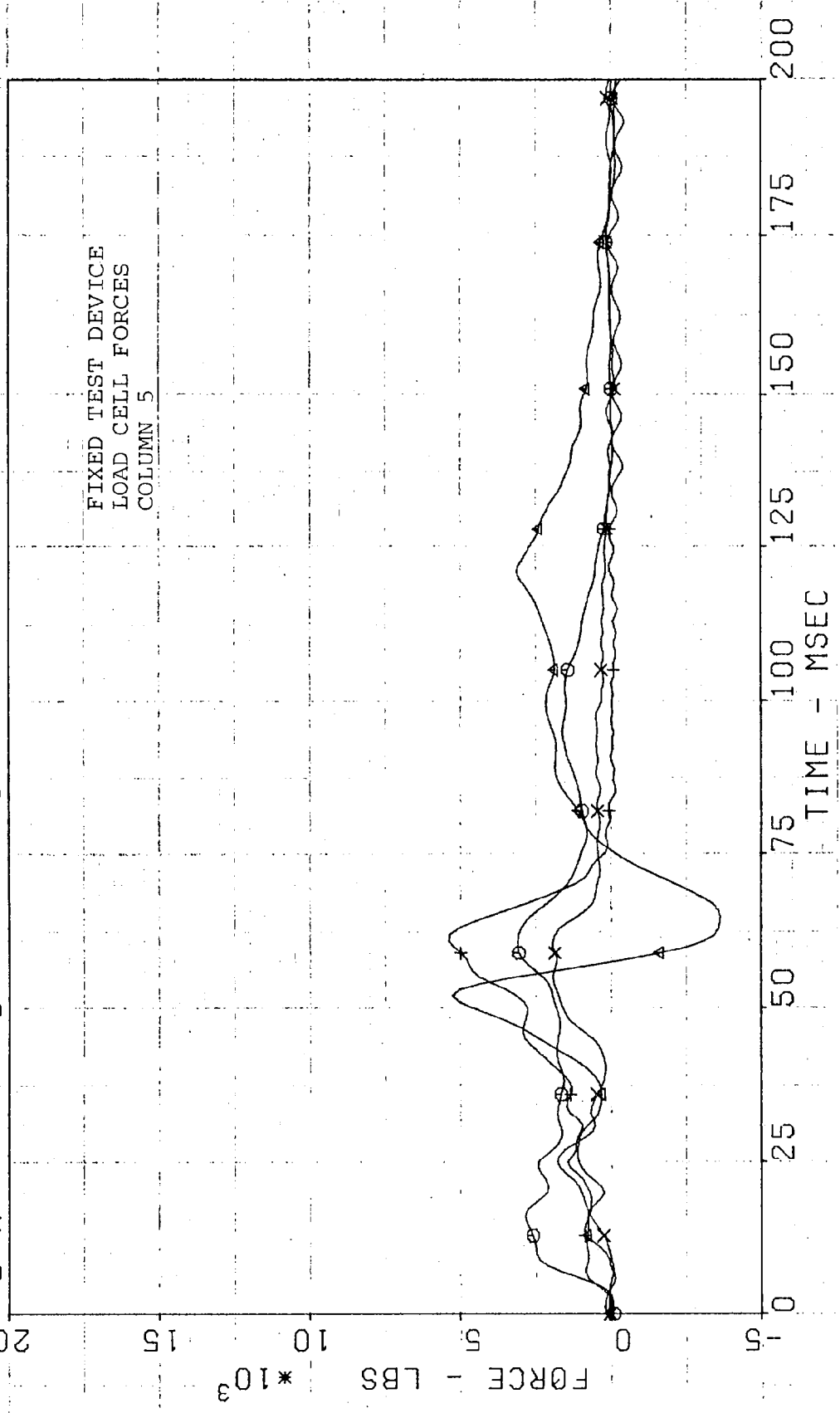

DATE 5-9-78 FILTER 315/100 COLUMN 6 TEST NO 072178
 O=A Δ=B +=C X=D 8316-3 TESTDEVICE

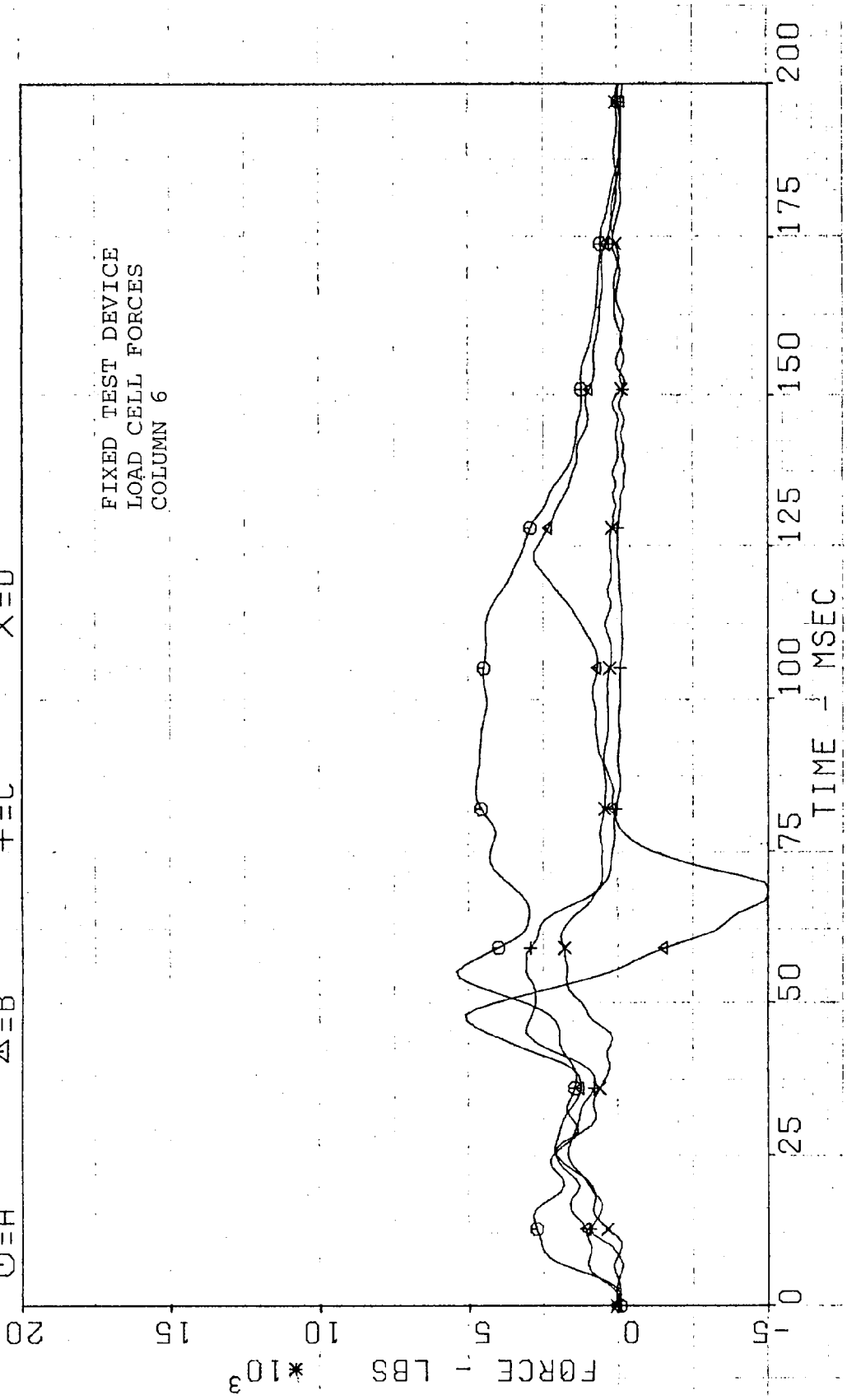

DATE 5-9-78 FILTER 315/100 TEST NO 072178
 O=A Δ=B +=C X=D 8316-3 TEST DEVICE
 COLUMN 7

FIXED TEST DEVICE
 LOAD CELL FORCES
 COLUMN 7

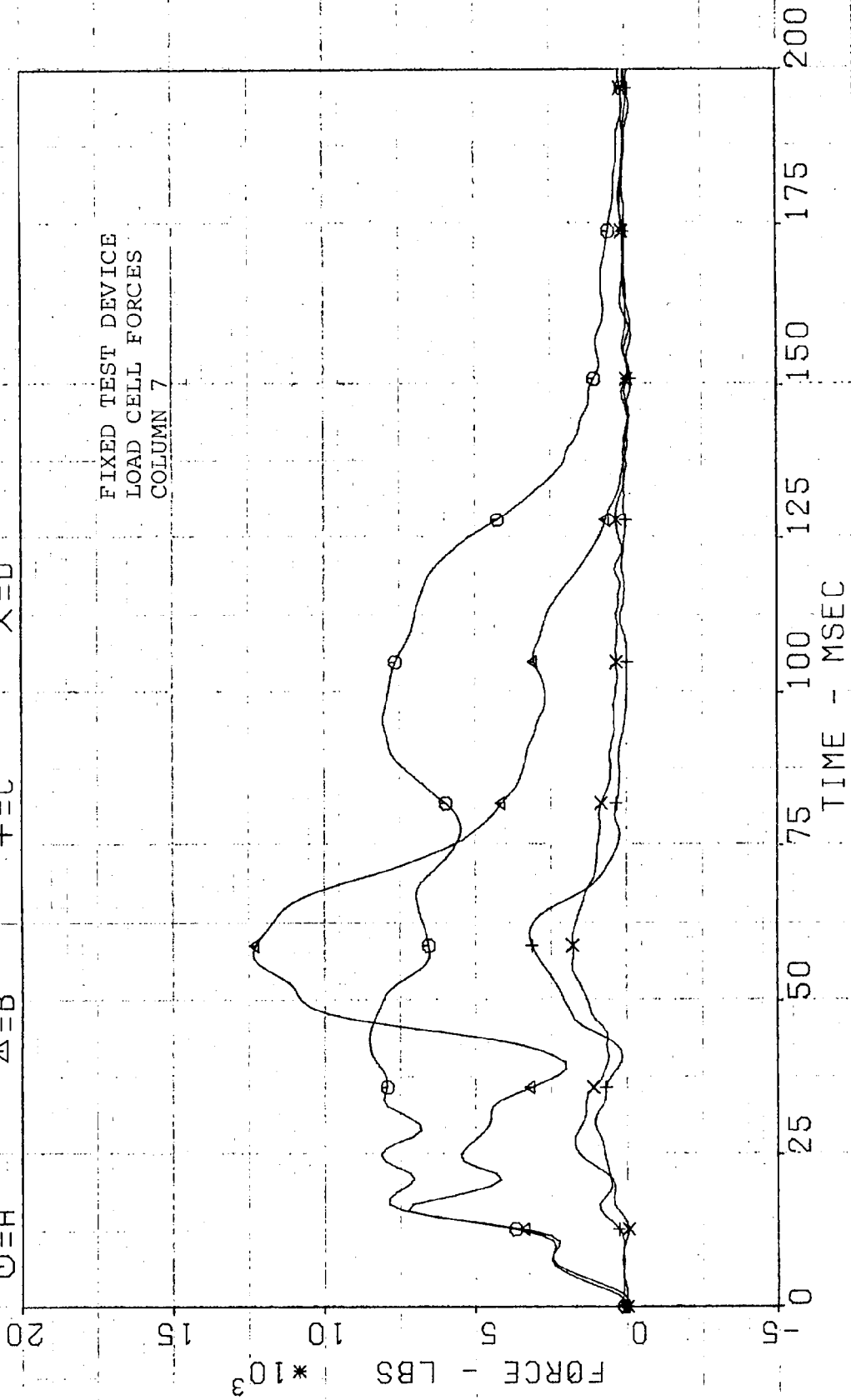

DATE 5-9-78 FILTER 315/100 TEST NO 072178
 O=A Δ=B +=C X=D 8316-3 TESTDEVICE

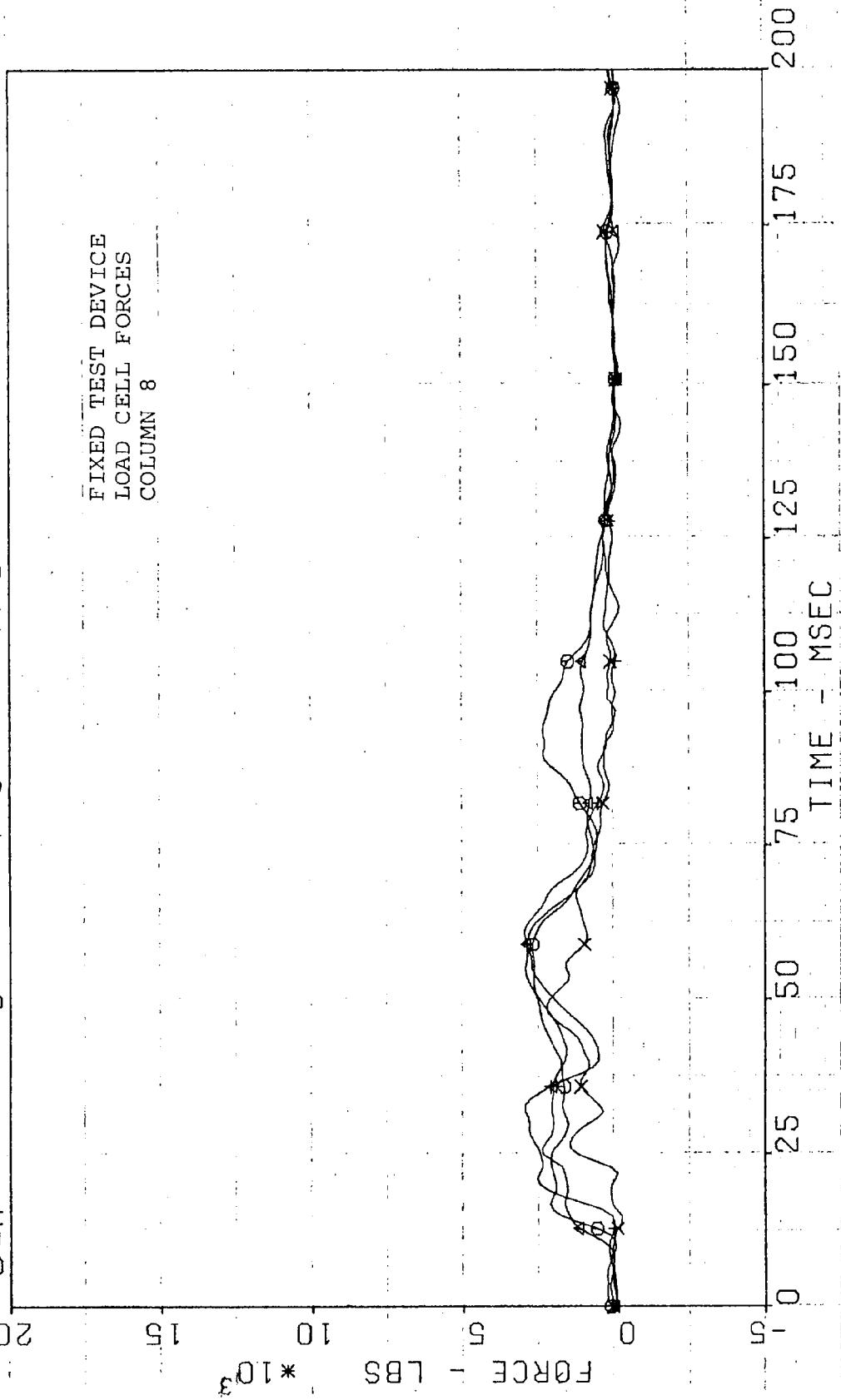

DATE 5-9-78
 FILTER 315/100
 COLUMN 9
 TEST NO 8316-3
 TEST DEVICE
 O=A
 Δ=B
 +=C
 X=D

072178
 TEST DEVICE

FIXED TEST DEVICE
 LOAD CELL FORCES
 COLUMN 9

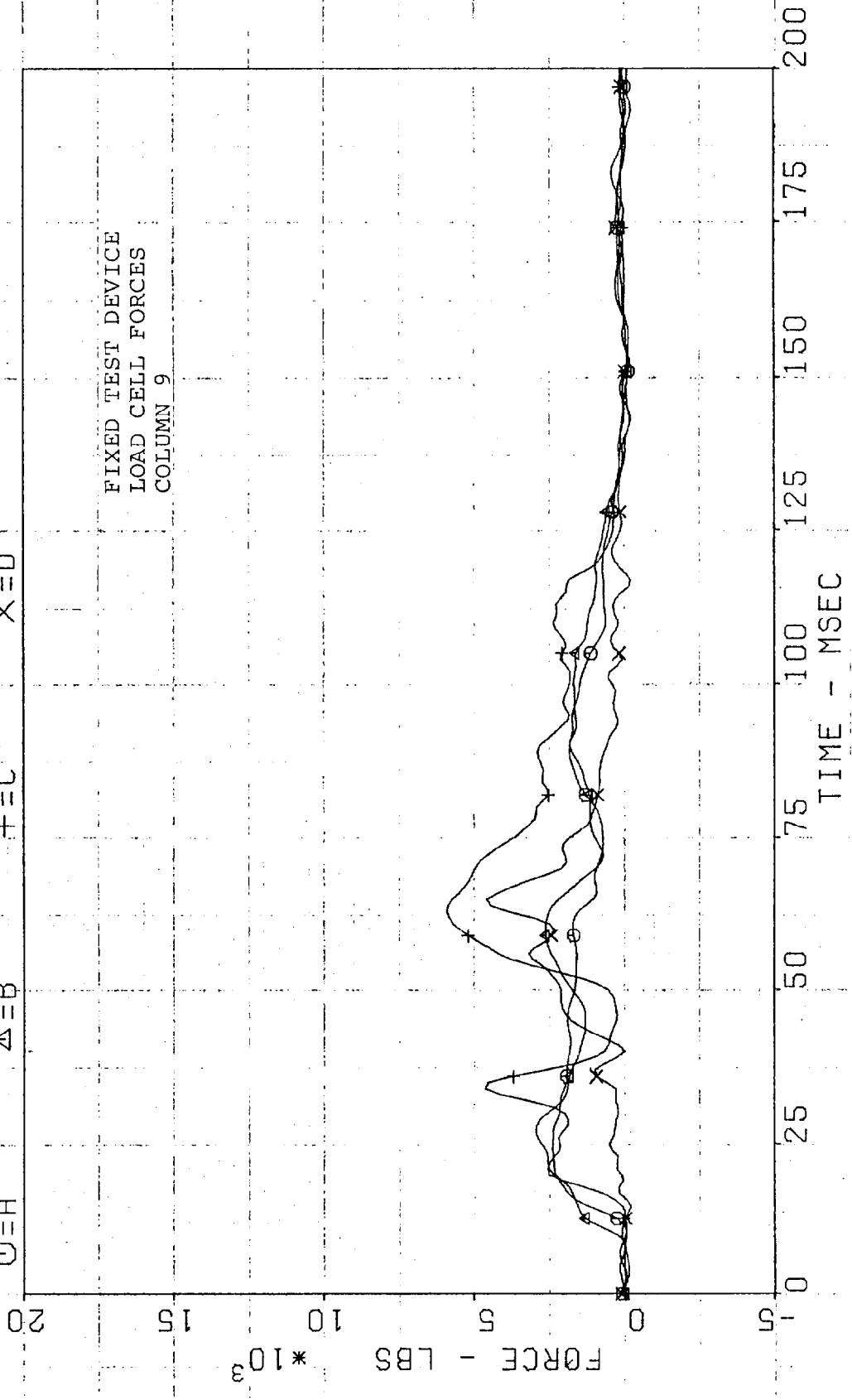

DATE 5-9-78 FILTER 315/100 COLUMN 10 TEST NO 8316-3 072178
 $\Phi=A$ $\Delta=B$ $\dagger=C$ $X=D$ TESTDEVICE

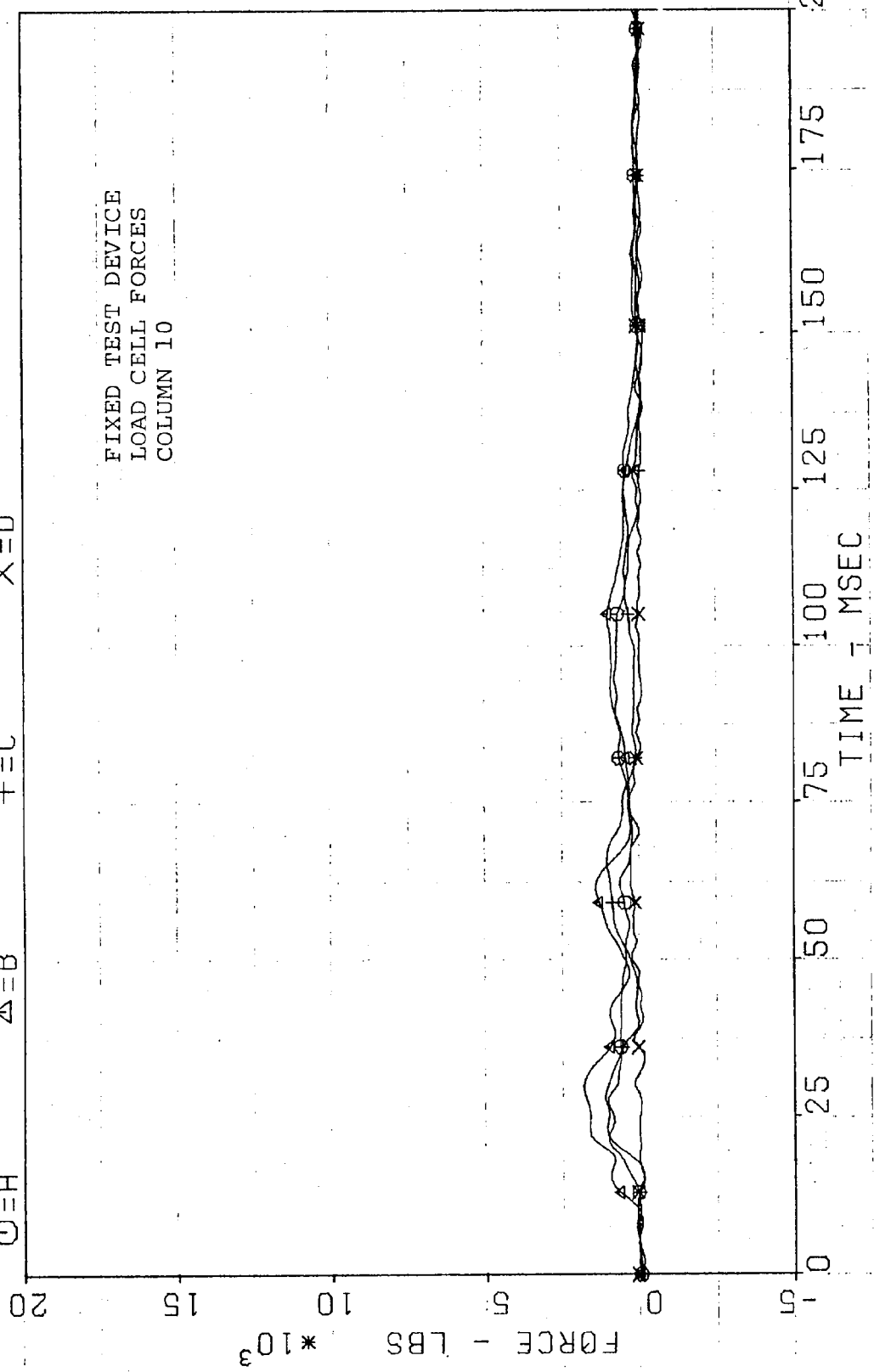

DATE 5-9-78 PARTIAL TEST NO 072178
 FILTER 315/100 TESTDEVICE
 Δ=1 Δ=2

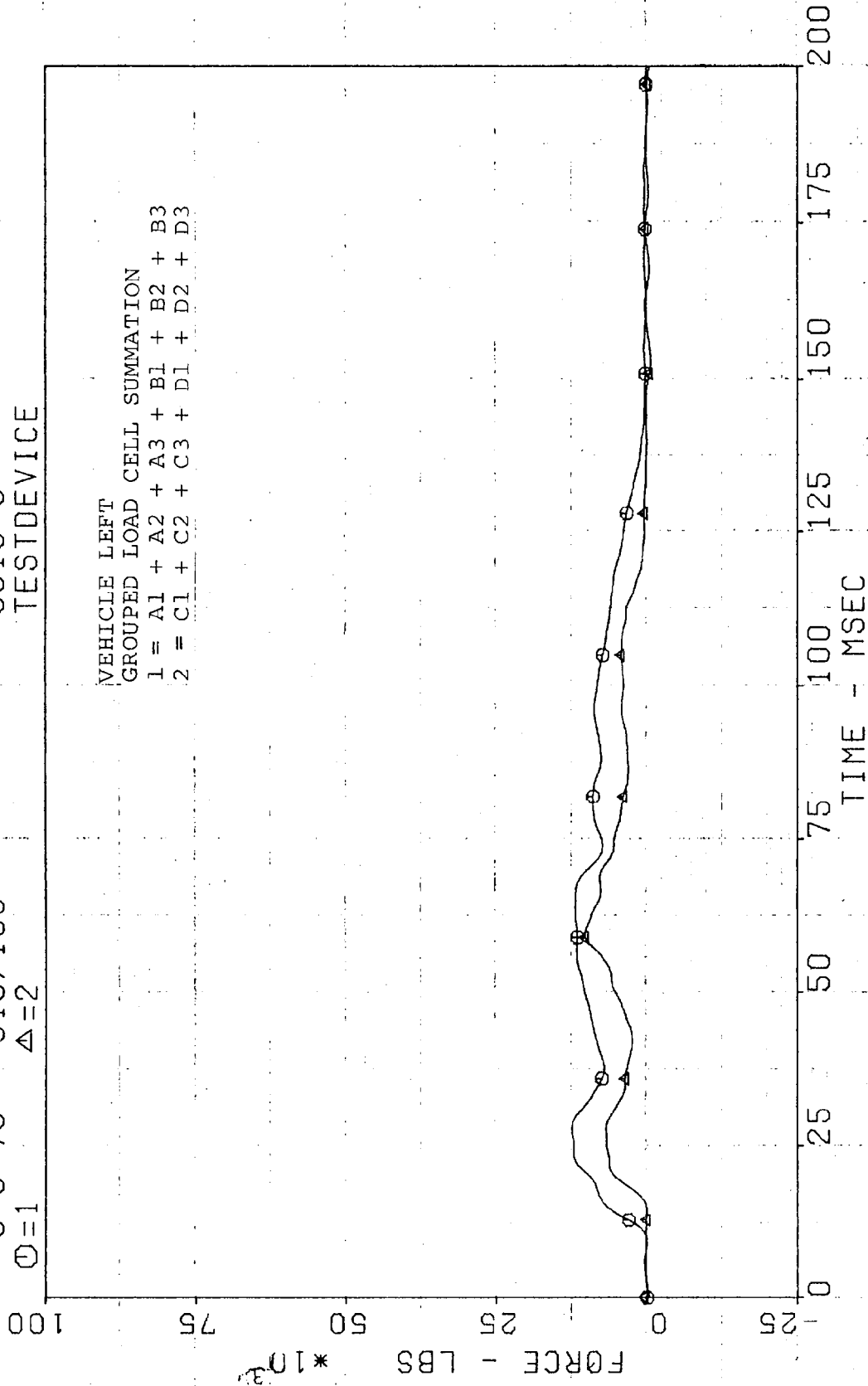

DATE 5-9-78
O=3
FILTER 315/100
Δ=4
PARTIAL TEST NO 072178
8316-3
TESTDEVICE

VEHICLE CENTER
GROUPED LOAD CELL SUMMATION
3 = A4 + A5 + A6 + A7 + B4 + B5 + B6 + B7
4 = C4 + C5 + C6 + C7 + D4 + D5 + D6 + D7

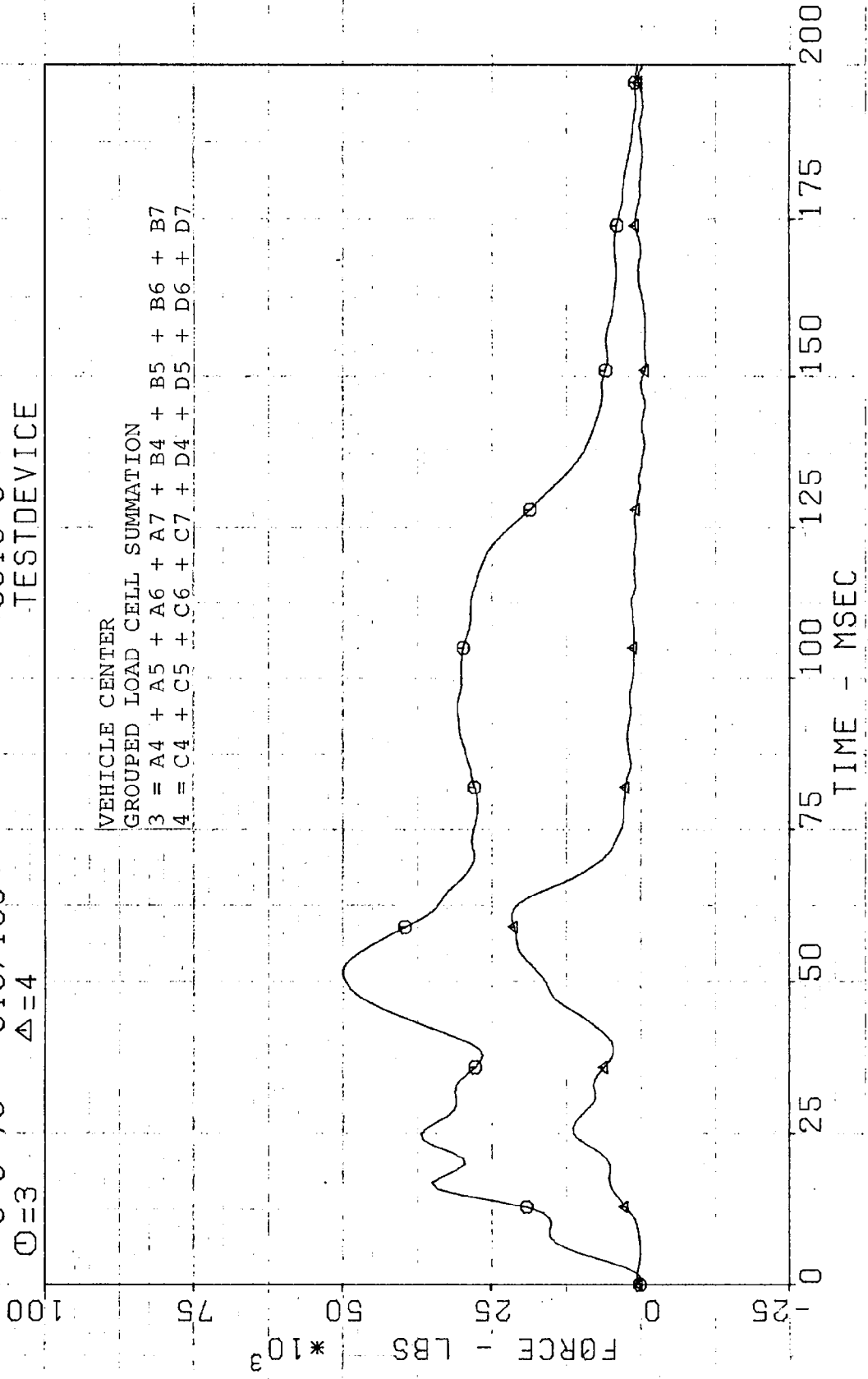

DATE 5-9-78
 FILTER 315/100
 $\Delta=5$
 PARTIAL TEST NO 072178
 8316-3
 TESTDEVICE

VEHICLE RIGHT SIDE
 GROUPED LOAD CELL SUMMATION
 5 = A8 + A9 + A10 + B8 + B9 + B10
 6 = C8 + C9 + C10 + D8 + D9 + D10

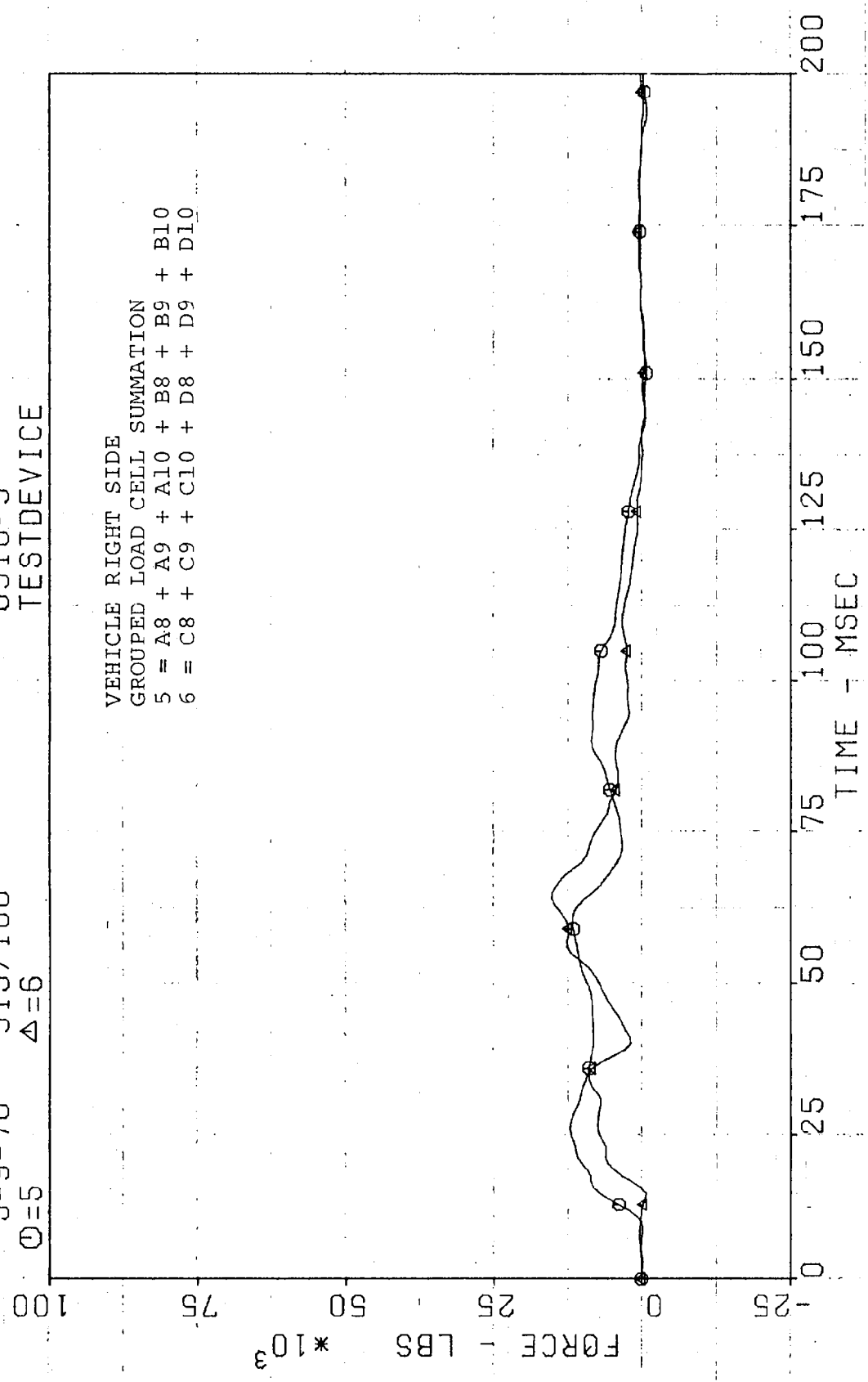

DATE 5-9-78 FILTER 315/100 PARTIAL TEST-NO 071978
 0=1 5-9-78 315/100 8316-3 TESTDEVICE
 Δ=2 Δ=2 X=4
 +=3

FIXED TEST DEVICE
 GROUPED LOAD CELL SUMMATION
 1 = ROW D
 2 = ROW D AND ROW C
 3 = ROW D, ROW C, AND ROW B
 4 = ROW D, ROW C, ROW B, AND ROW A

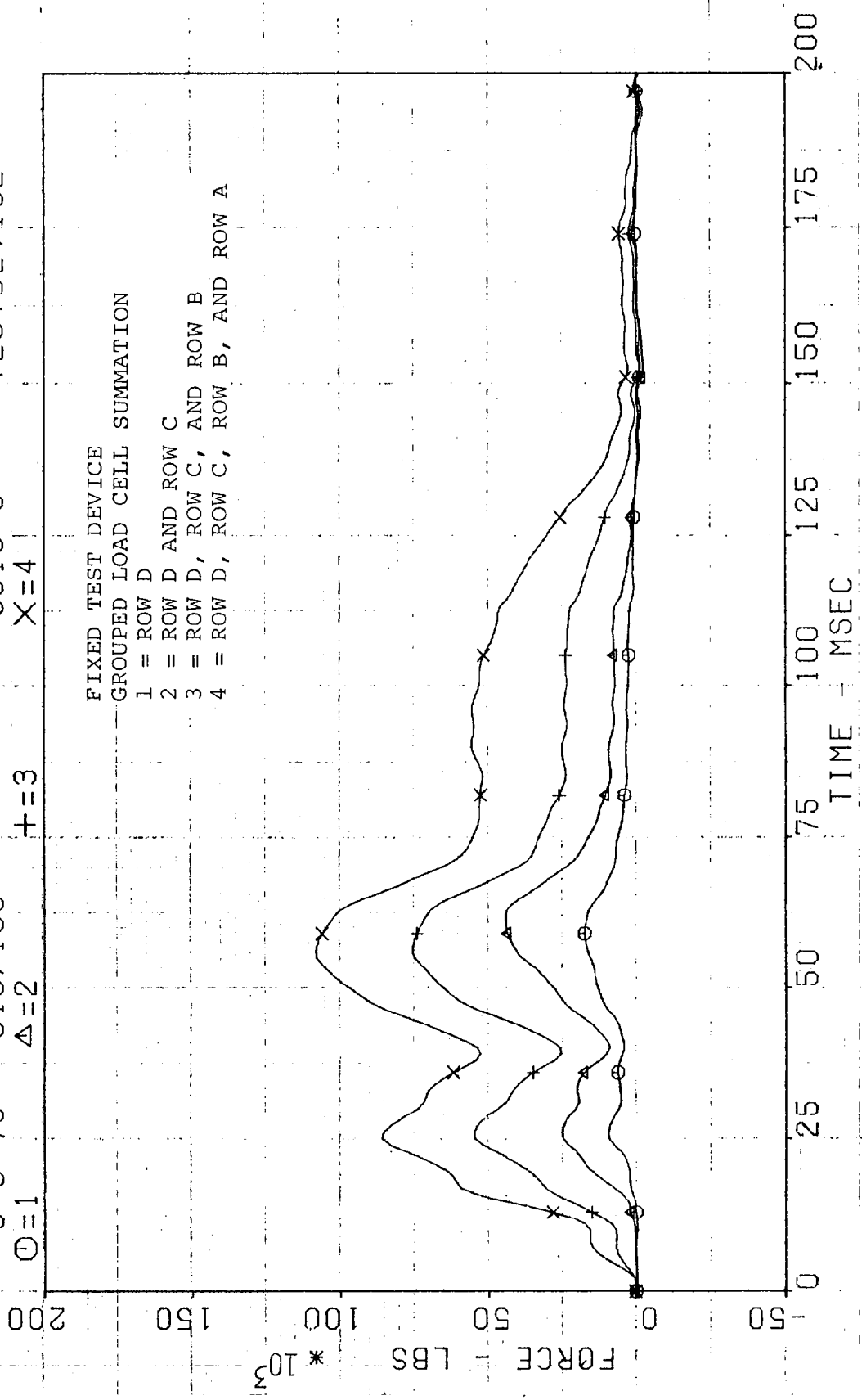

APPENDIX C

CALCOMP PLOTS

TEST 4

1975 FORD TORINO-TO-MOVING TEST DEVICE

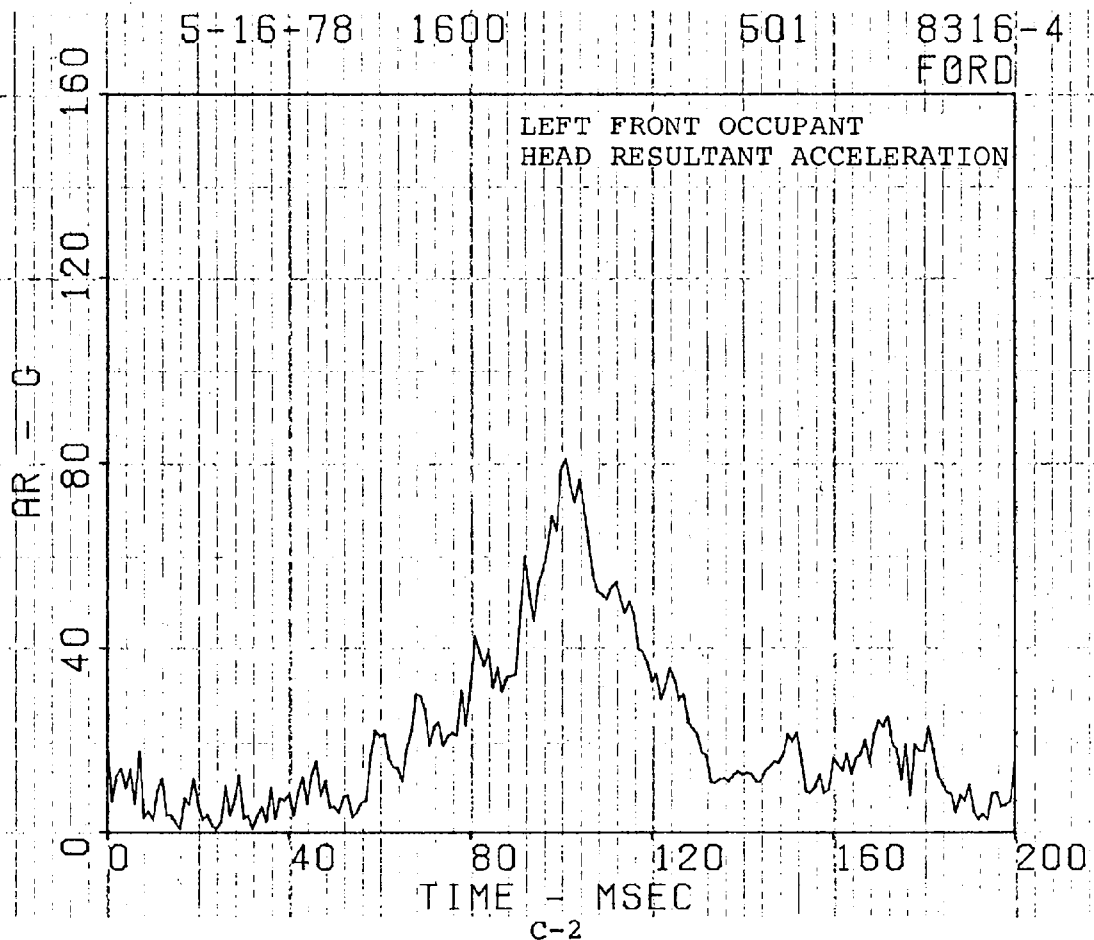
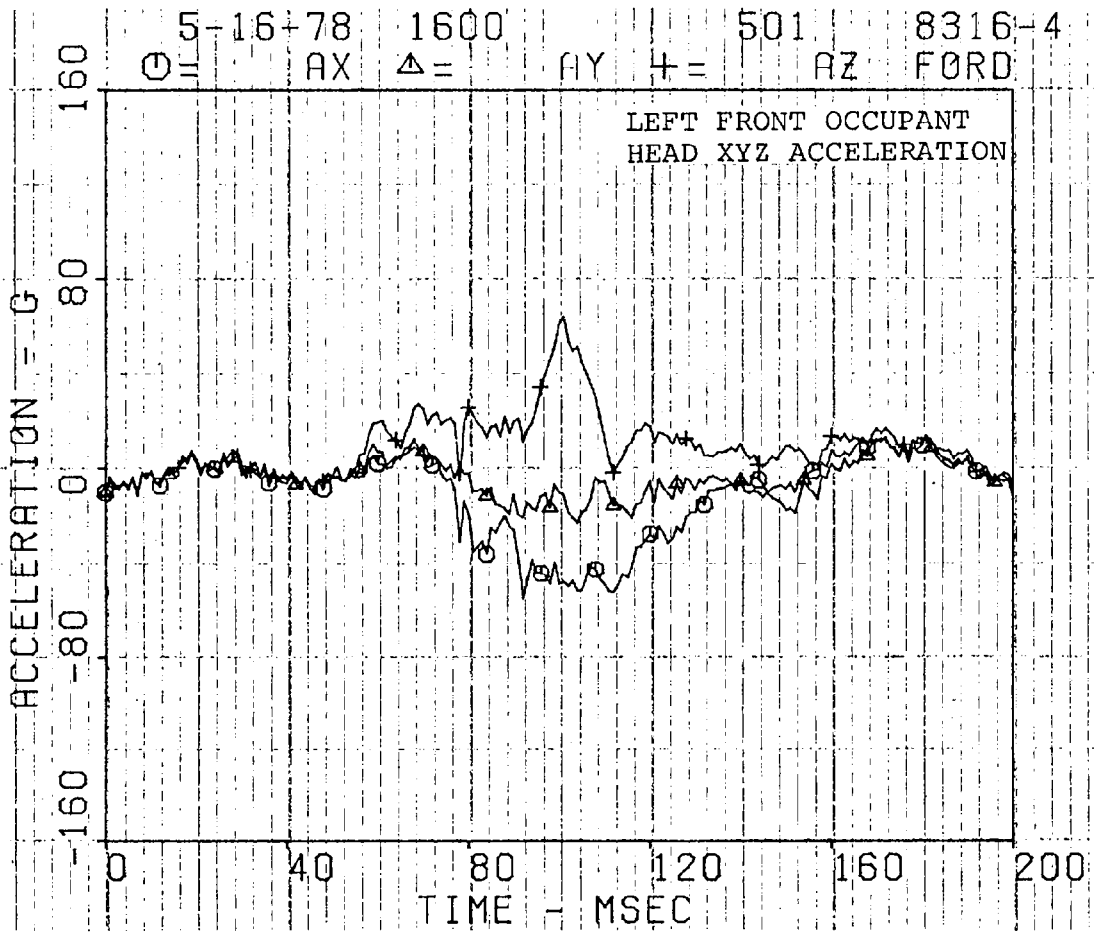

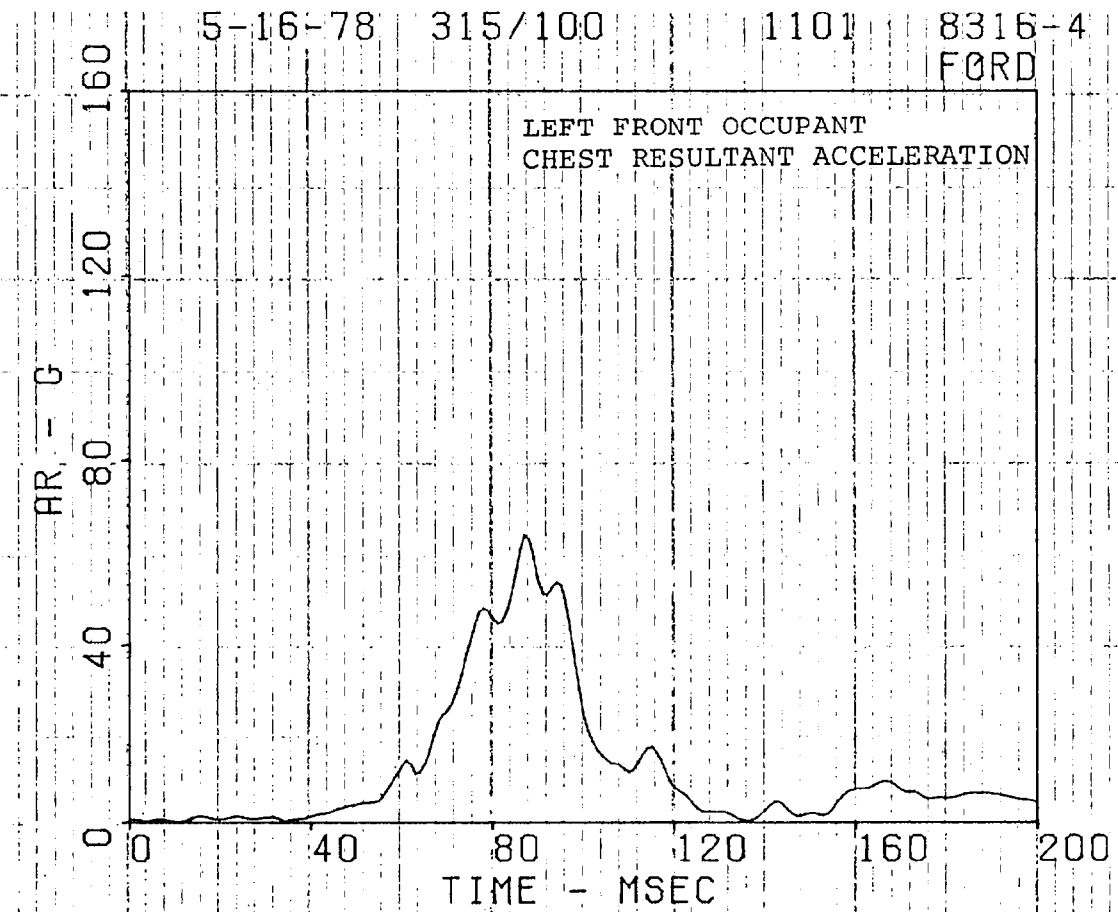
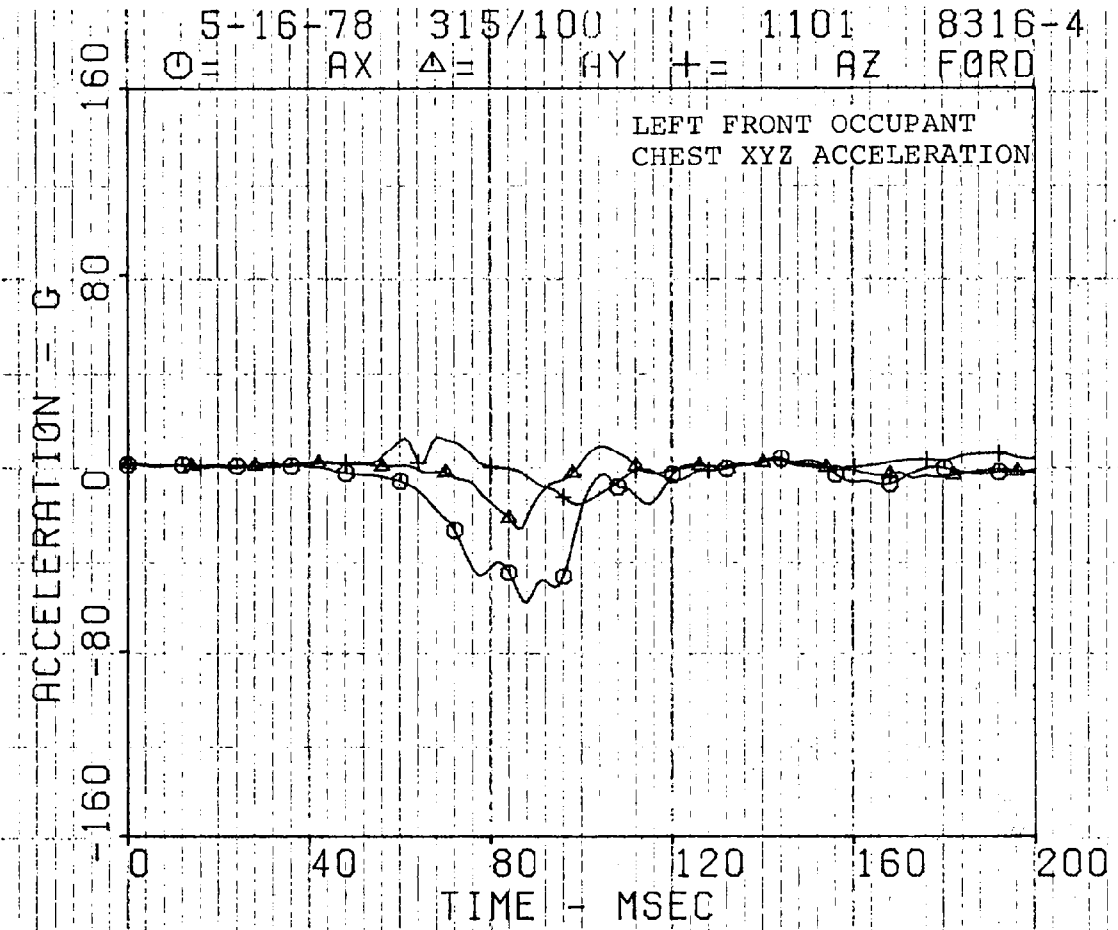

5-16-78

3.15/100

1101

8316-4

FORD

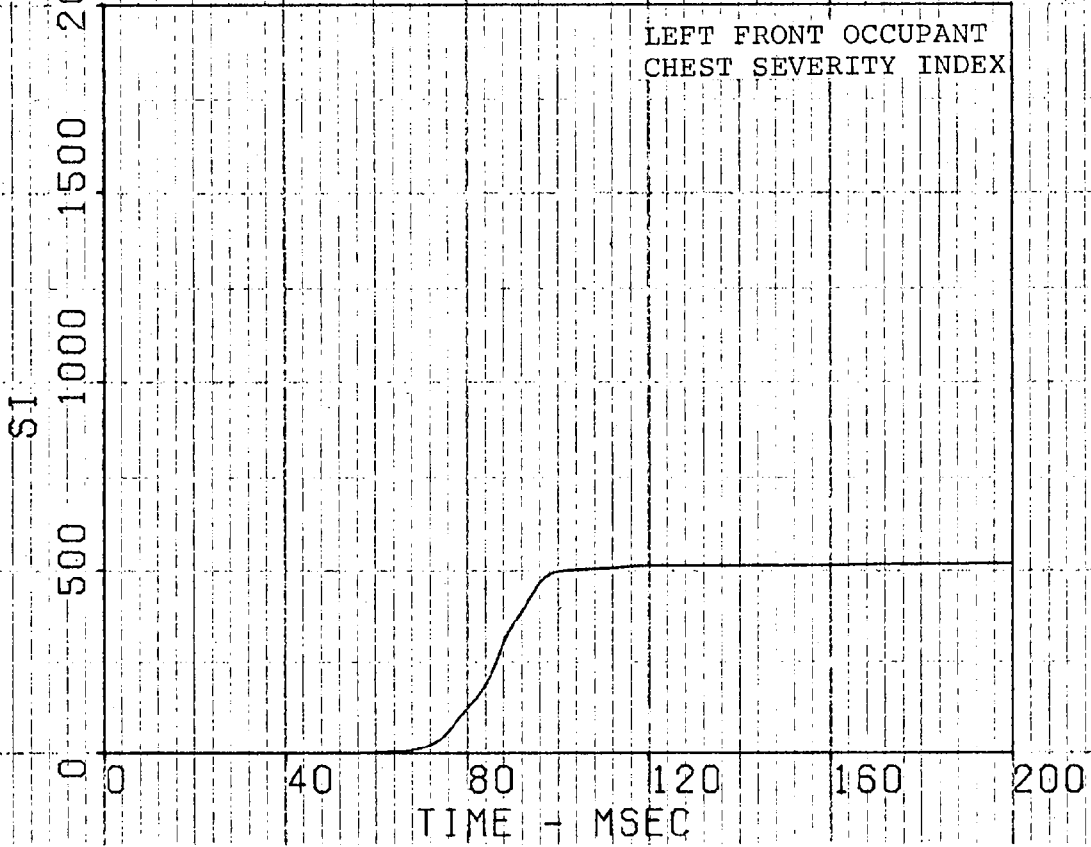

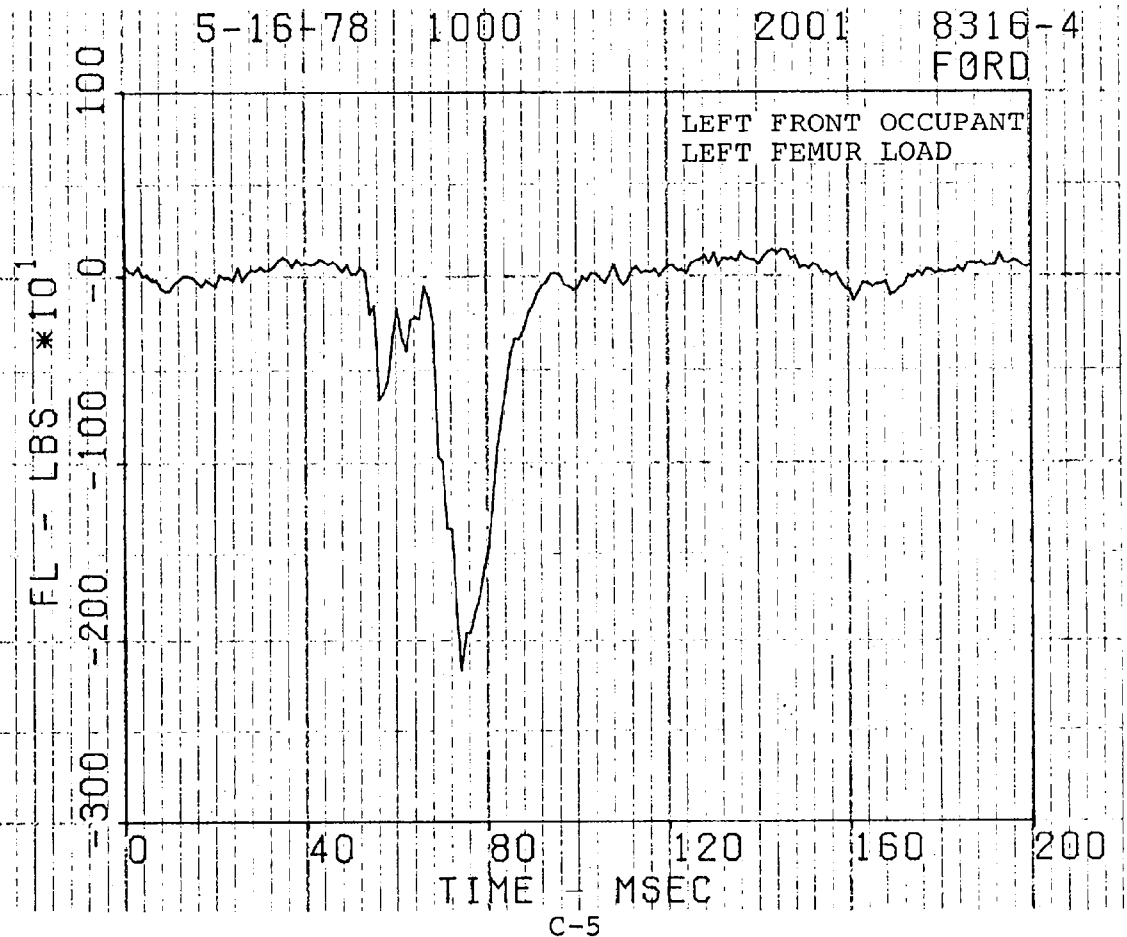
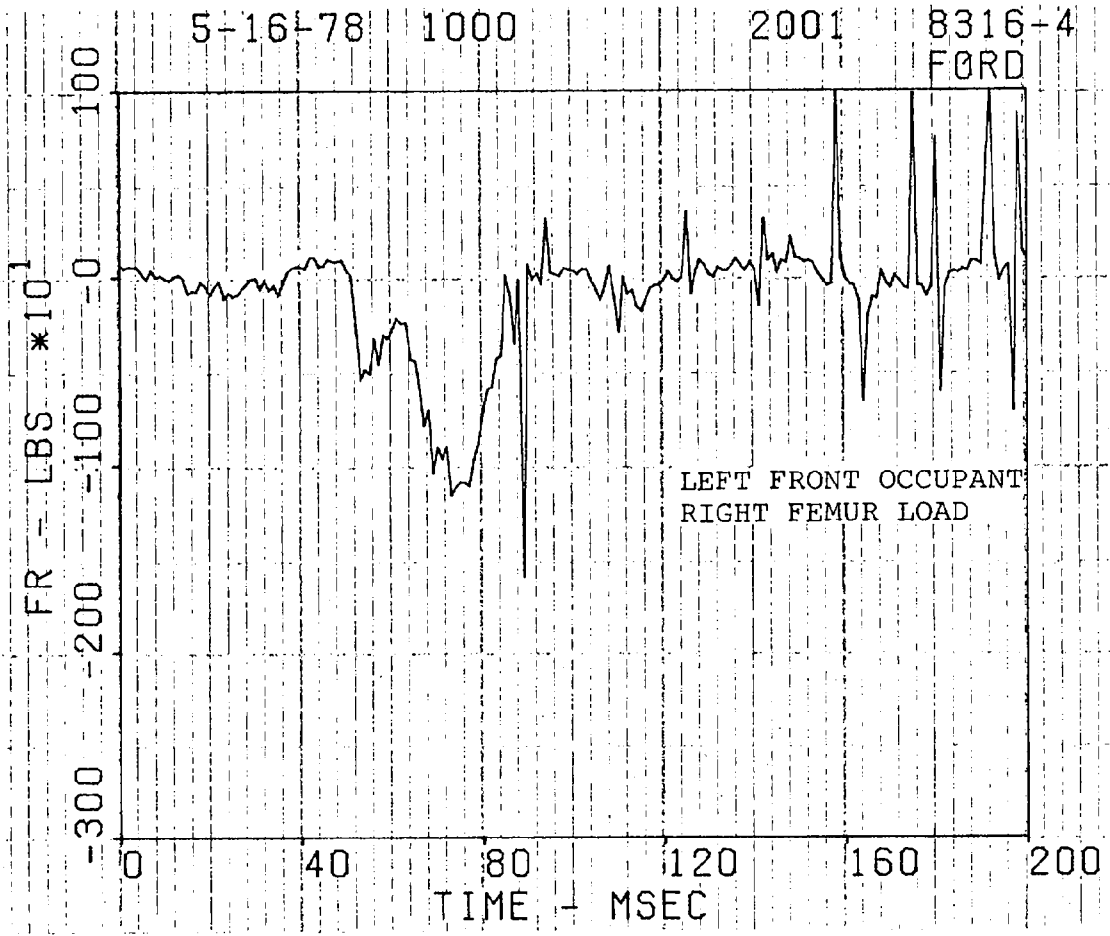

5-16-78

315/100

4201

8316-4

FRD LFLB-L

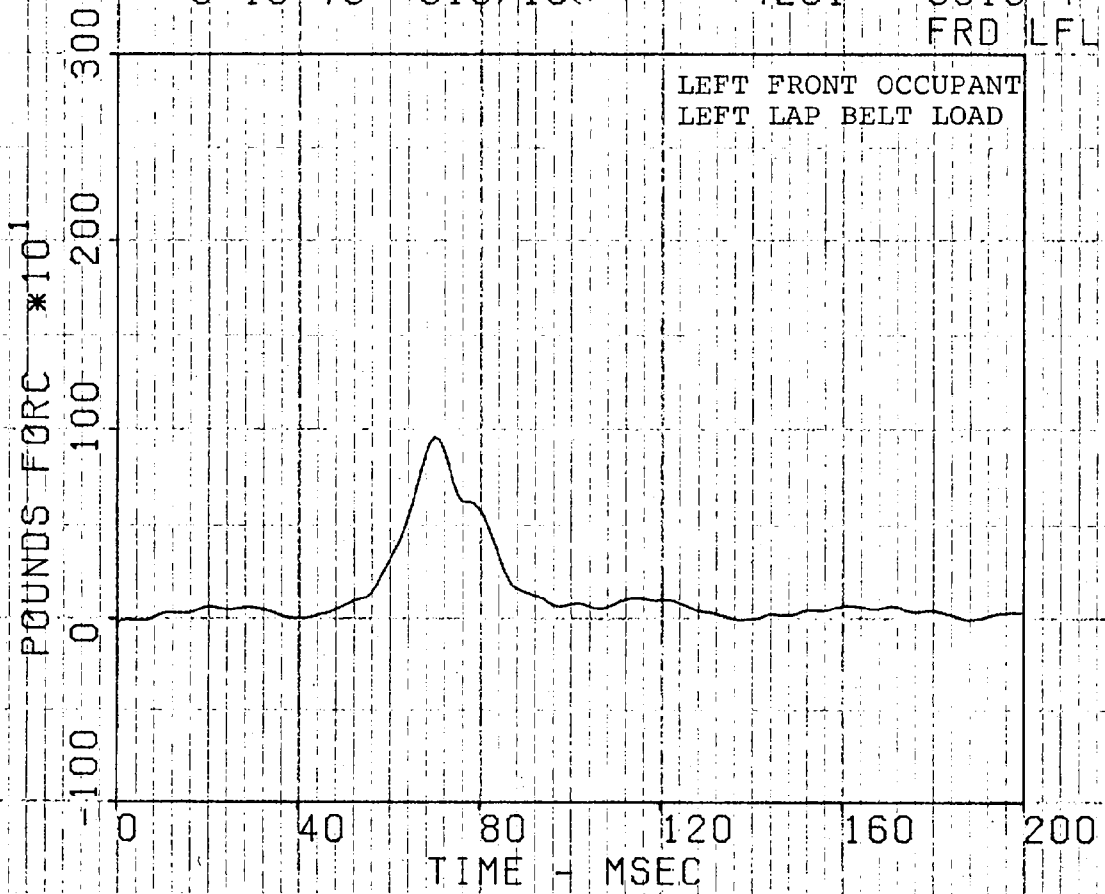

5-16-78

315/100

4201

8316-4

FRD LFLB R

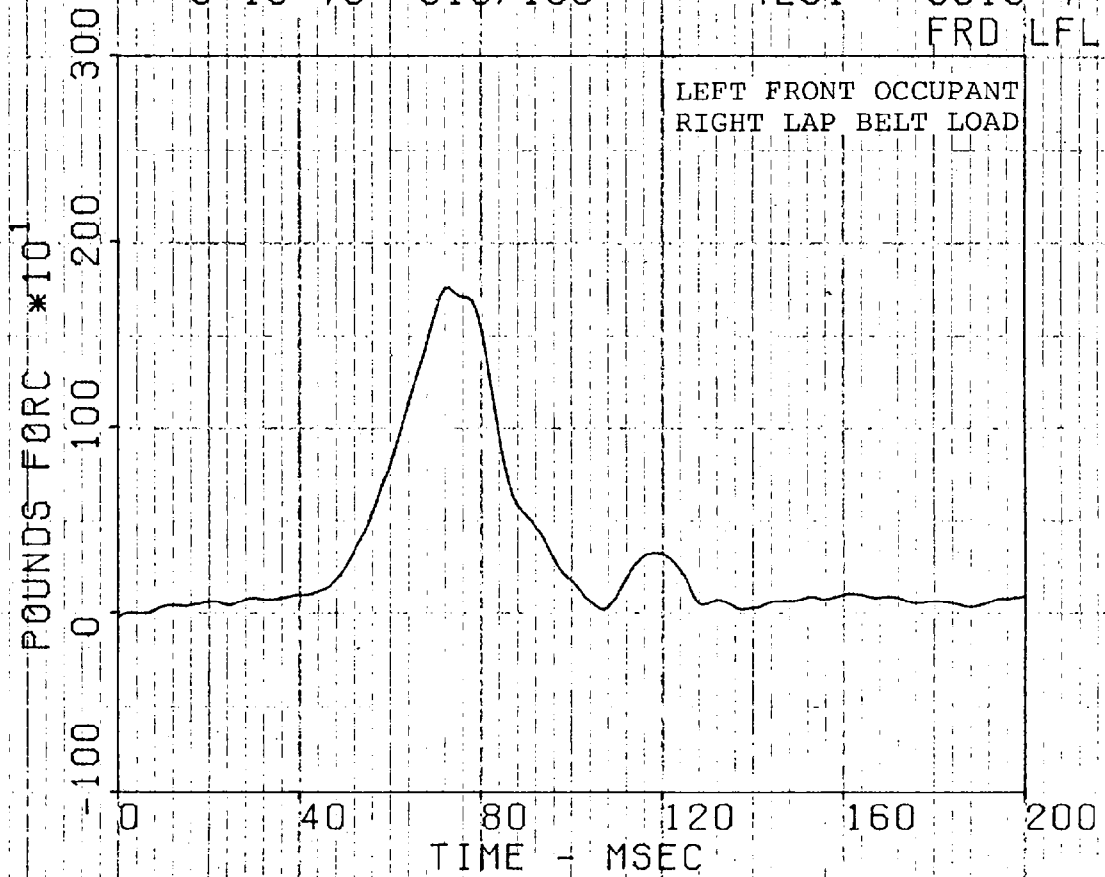

5-16-78 315/100 4201 8316+4
FRD LFTORB

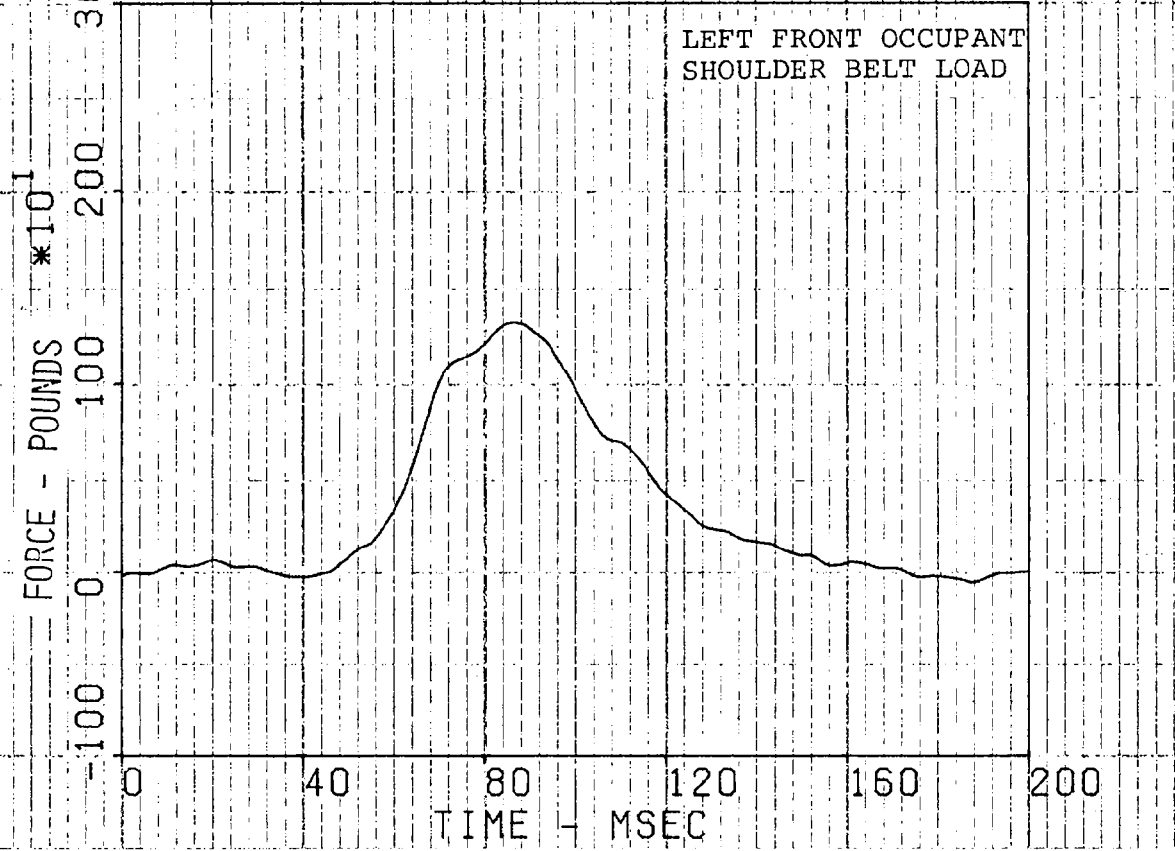

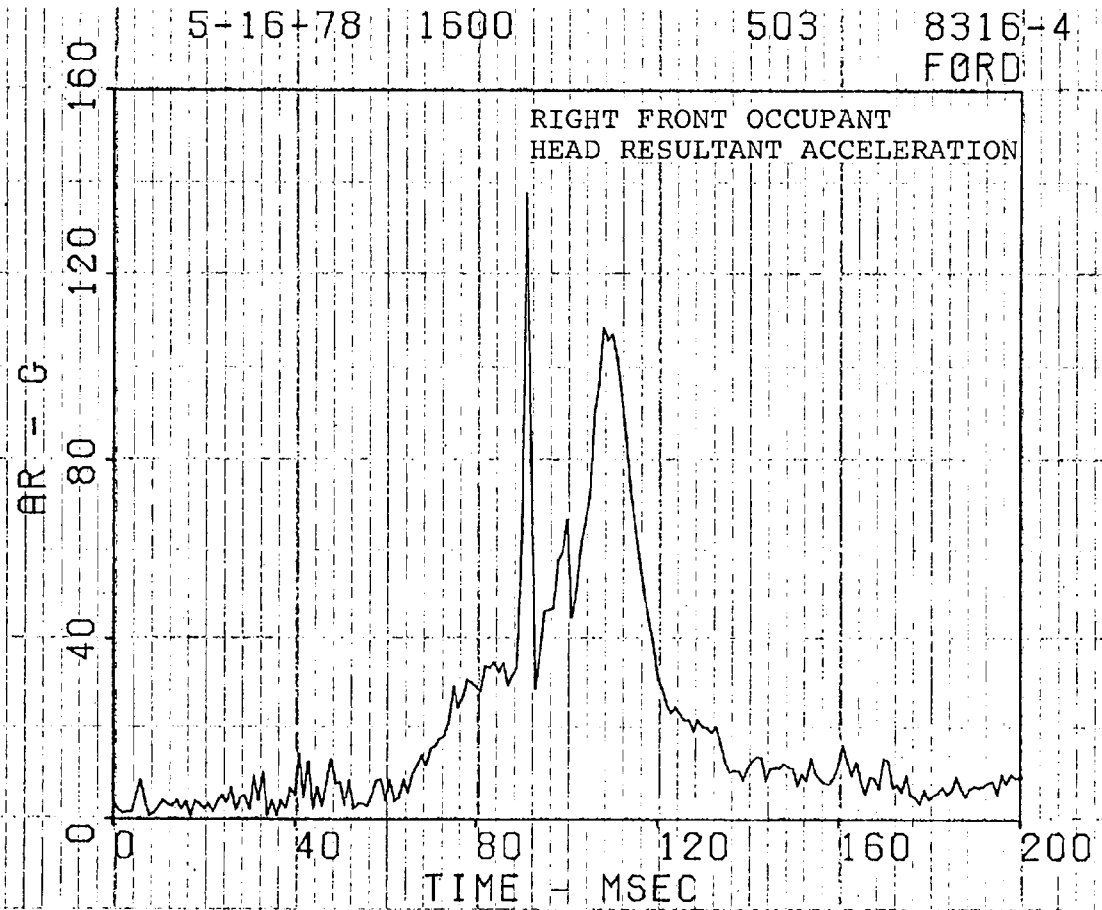
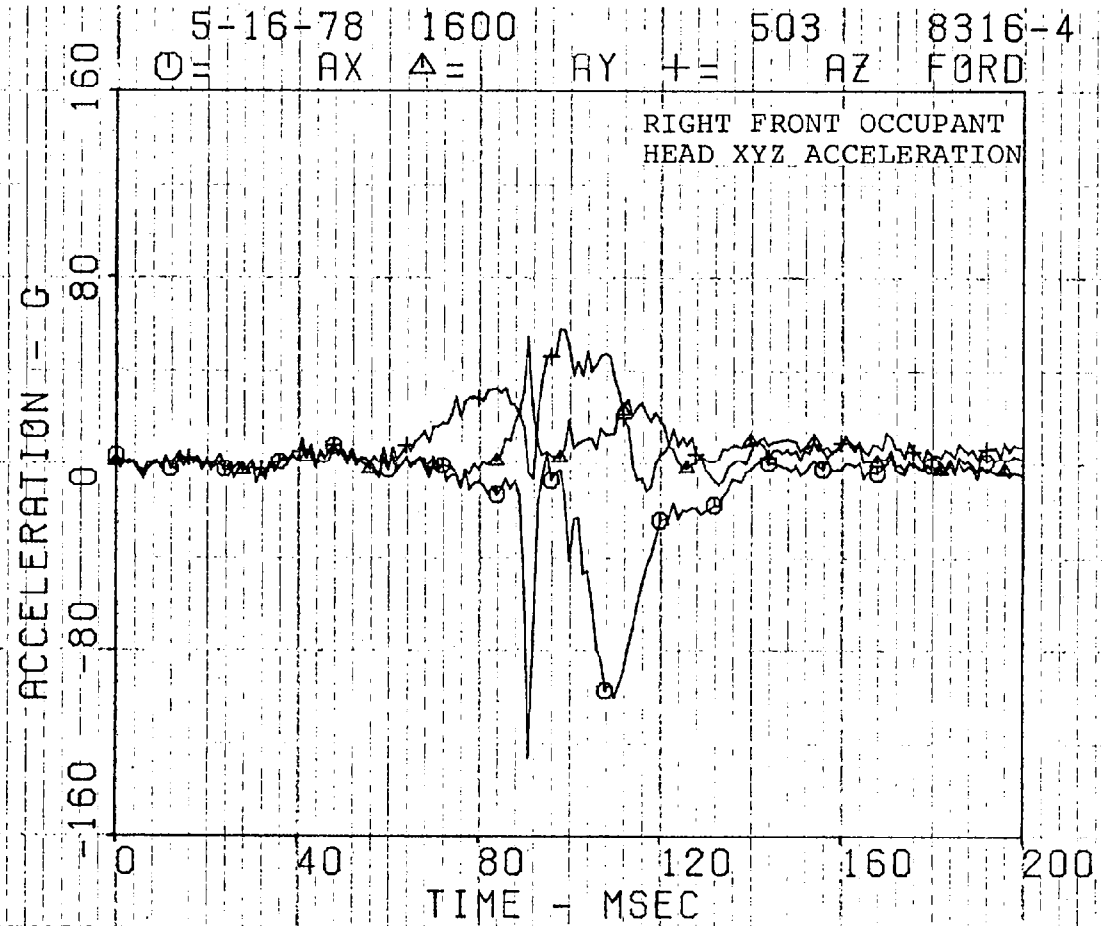

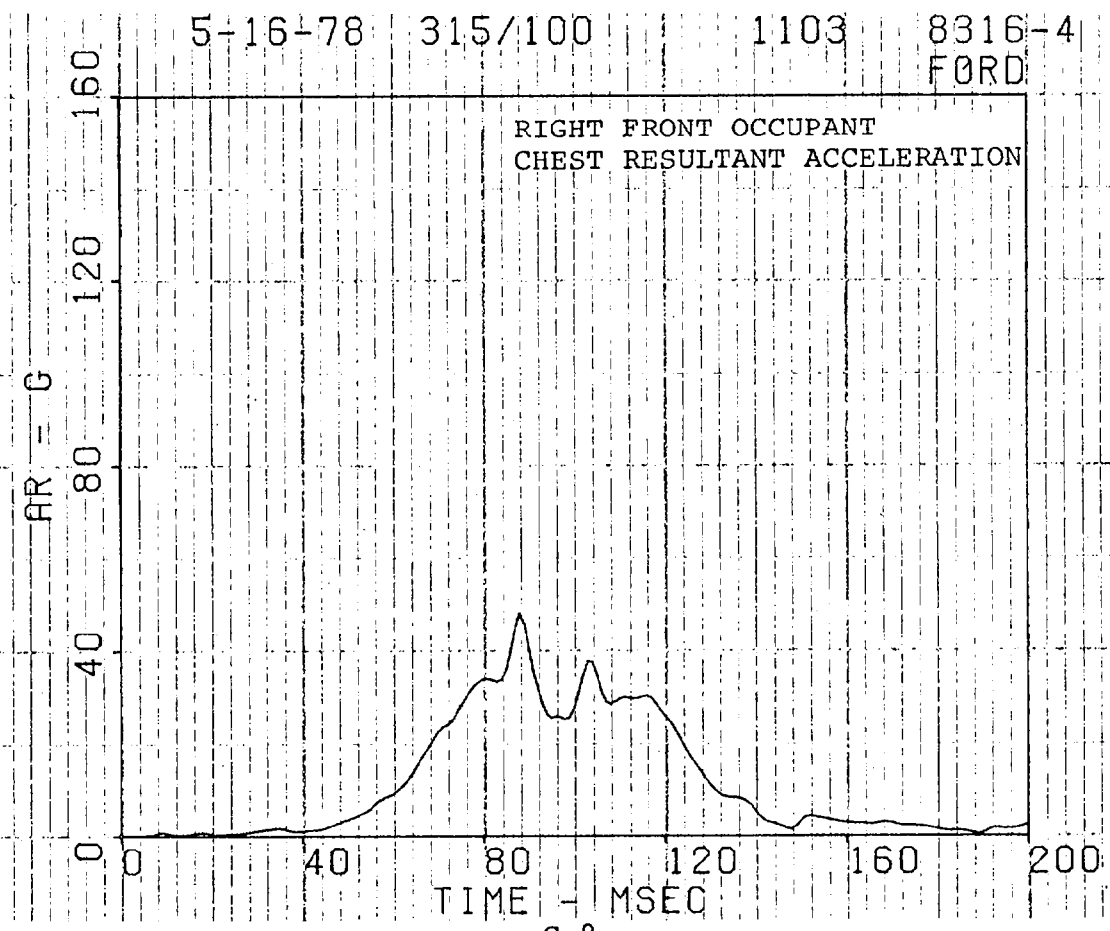
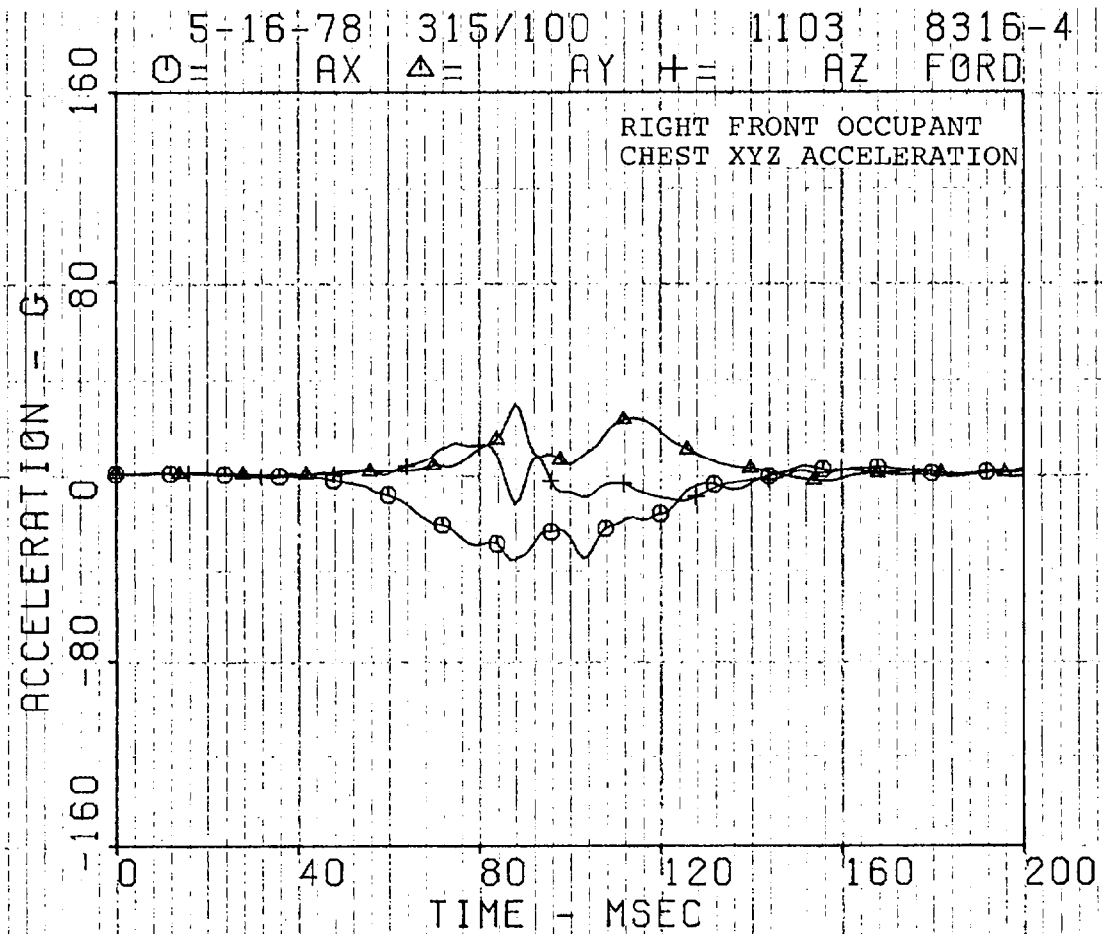

5-16-78

315/100

1103

8316-4

FORD

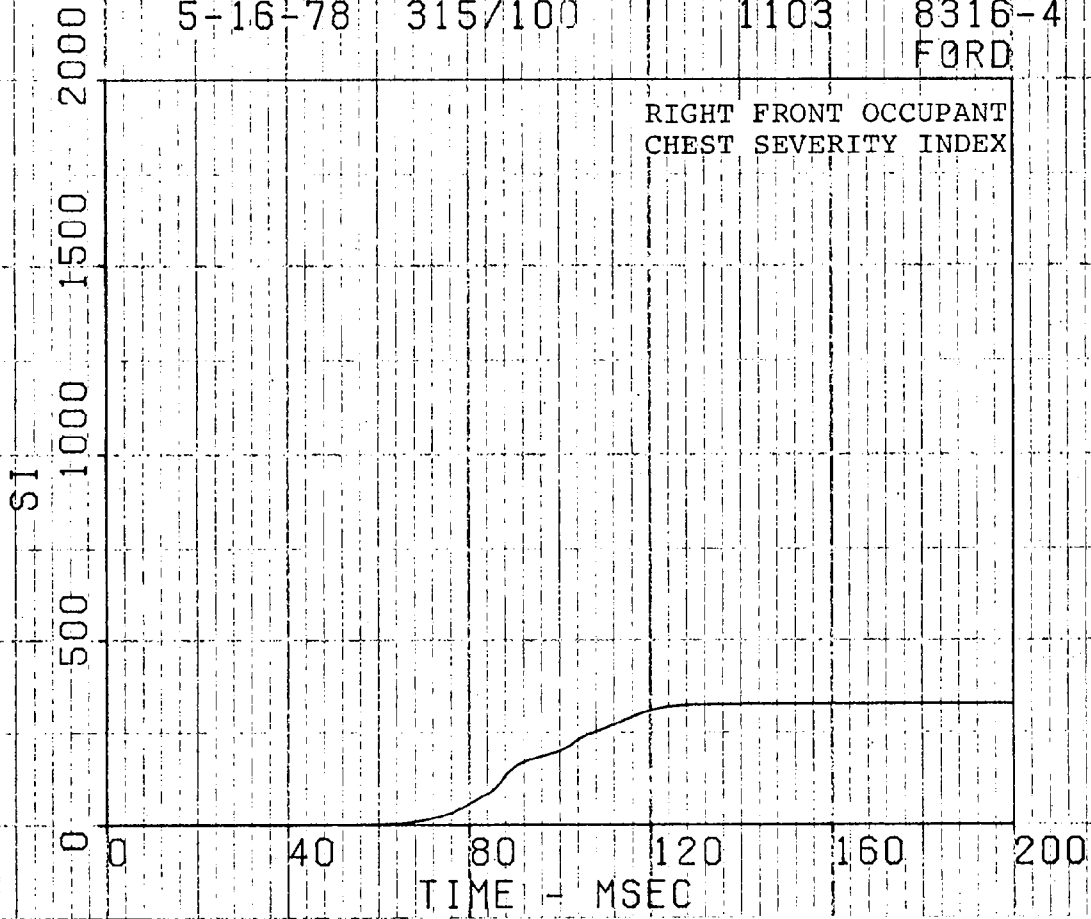

5-16-78 1000

2003

8316-4
FORD

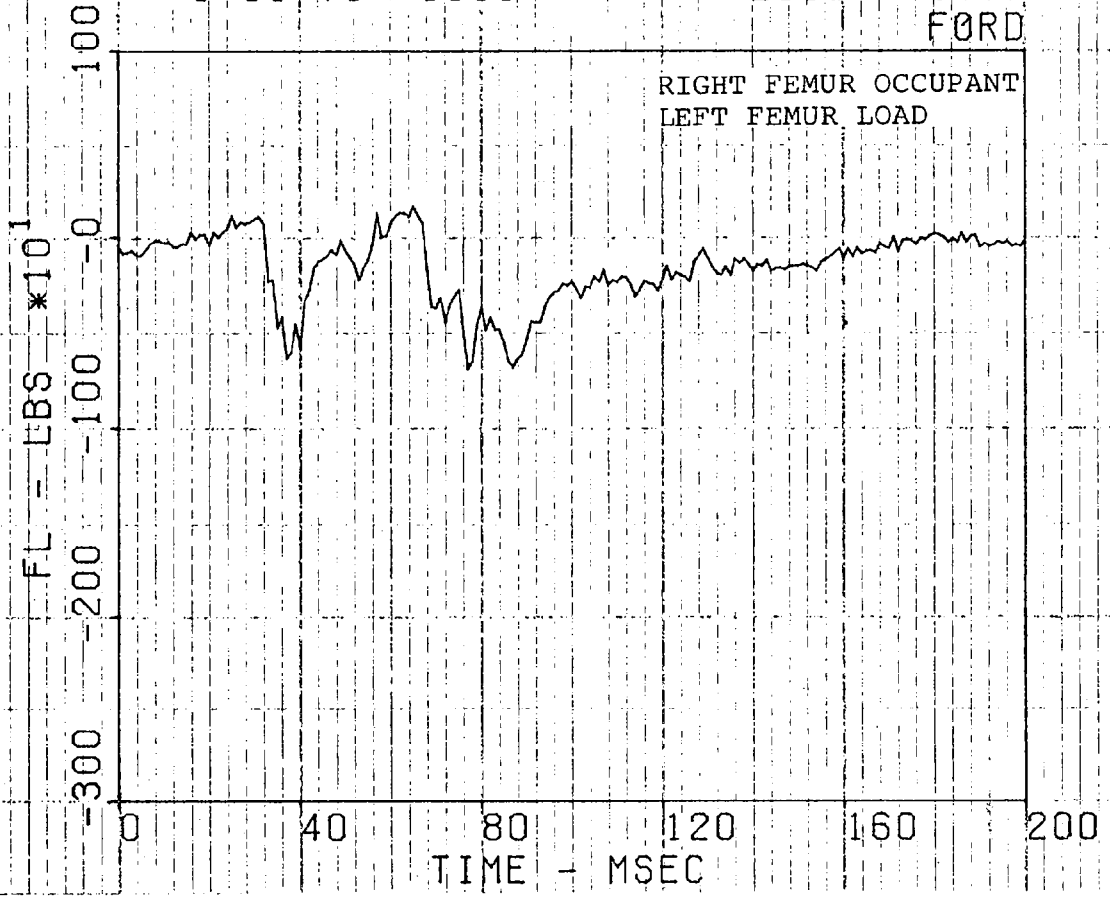

5-16-78 1000

2003

8316-4
FORD

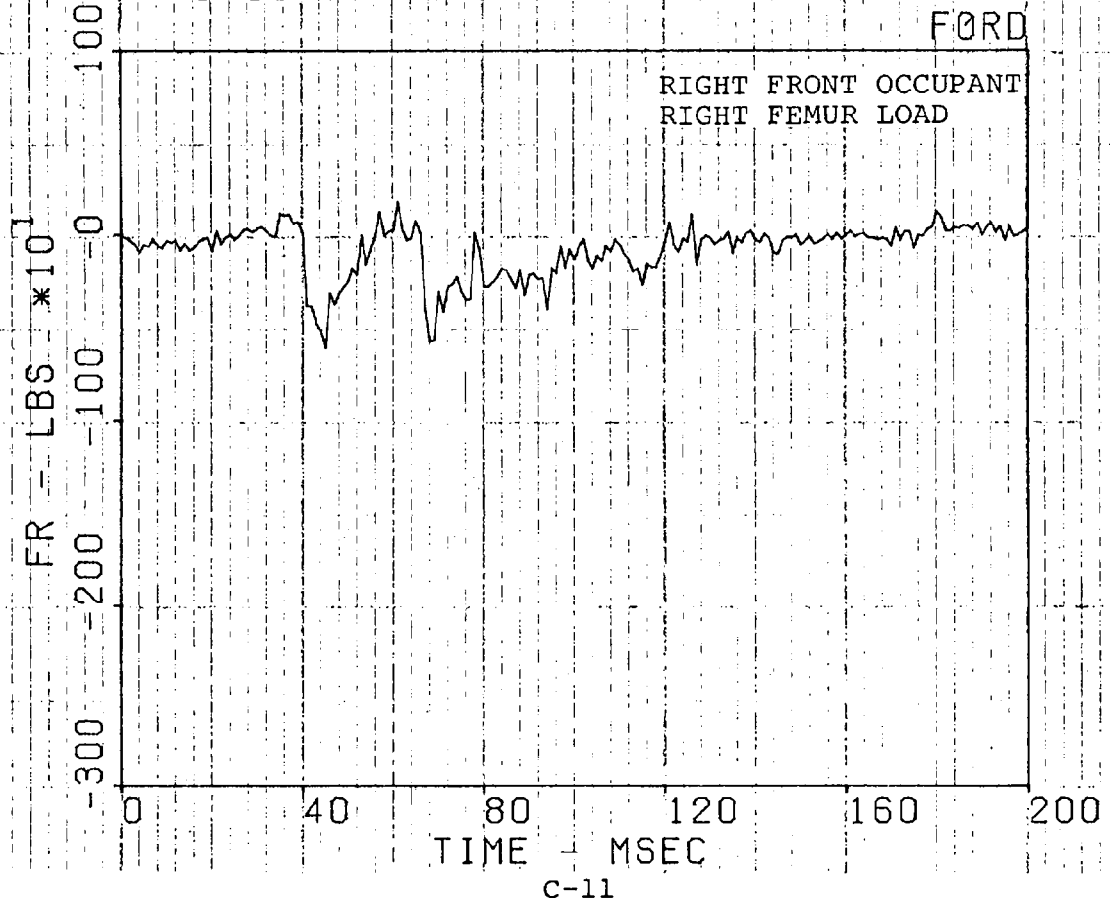

5-16-78 315/100 4203 8316-4
FRD RFLB-L

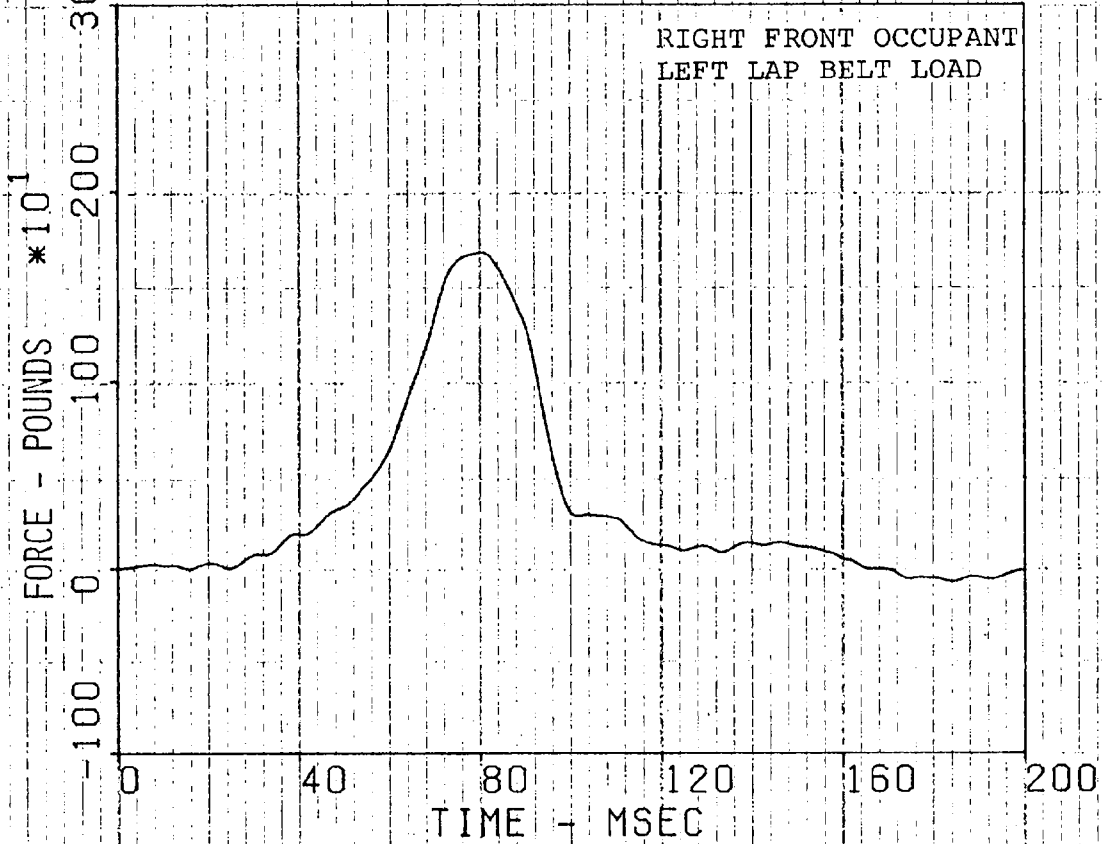

5-16-78 315/100 4203 8316-4
FRD RFLB-R

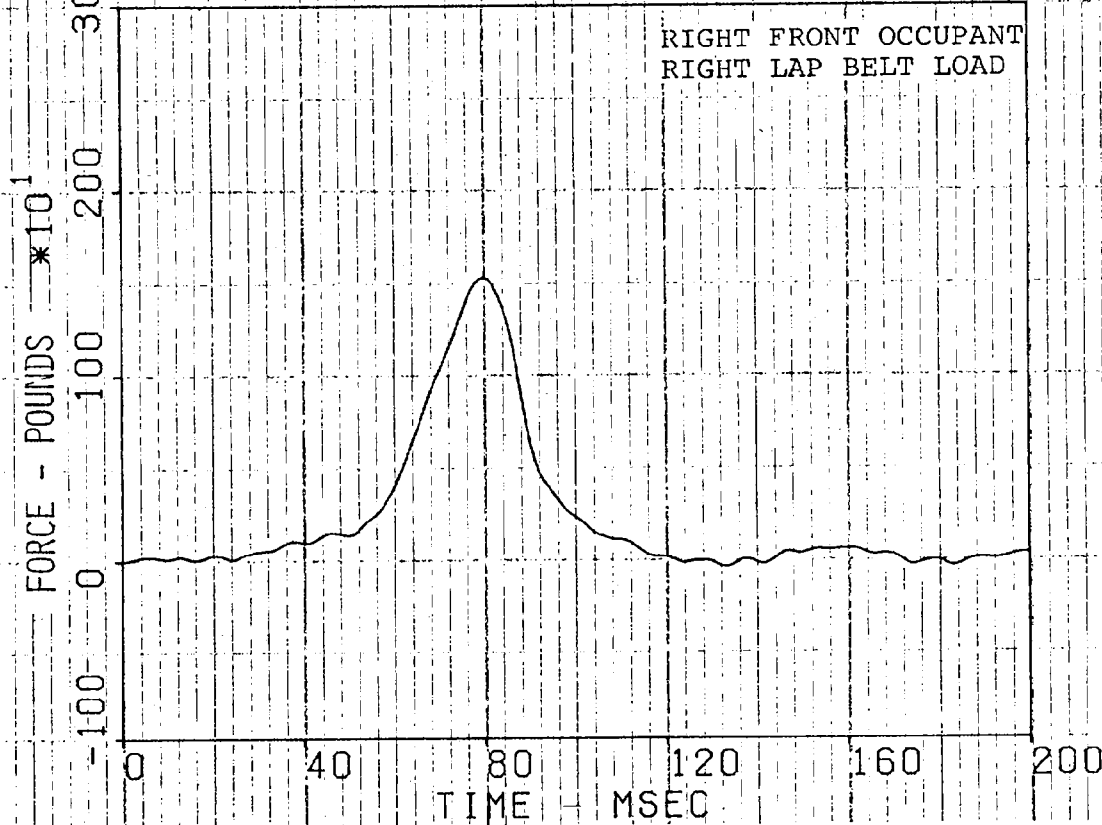

5-16-78 315/100

4203

8316-4

FRD RFTORB

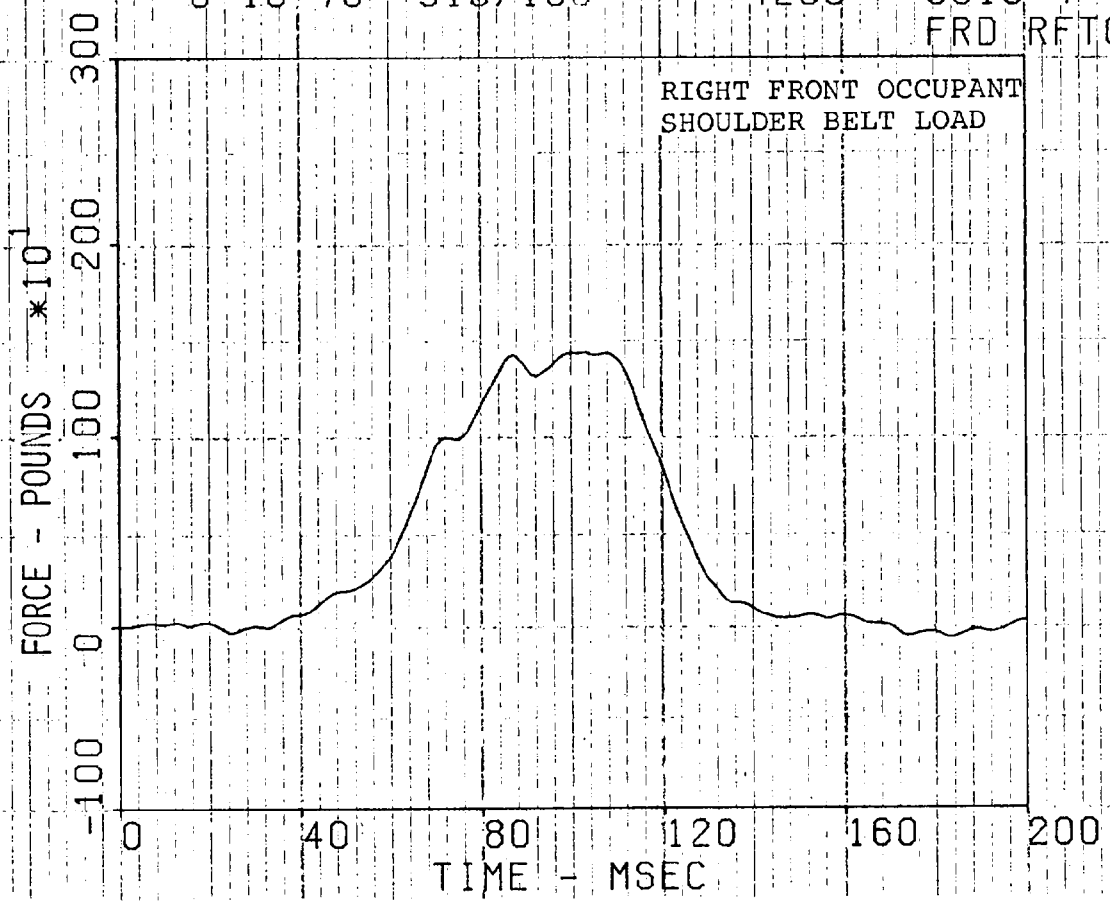

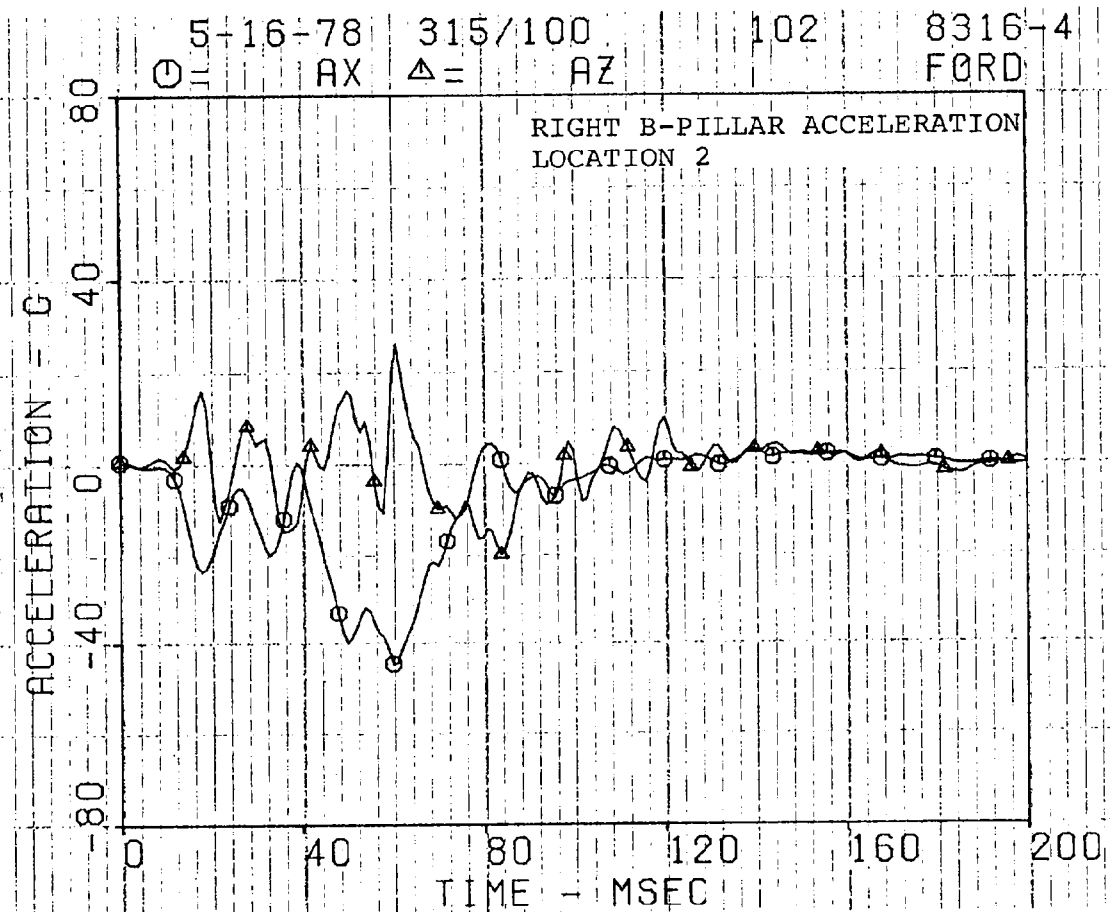
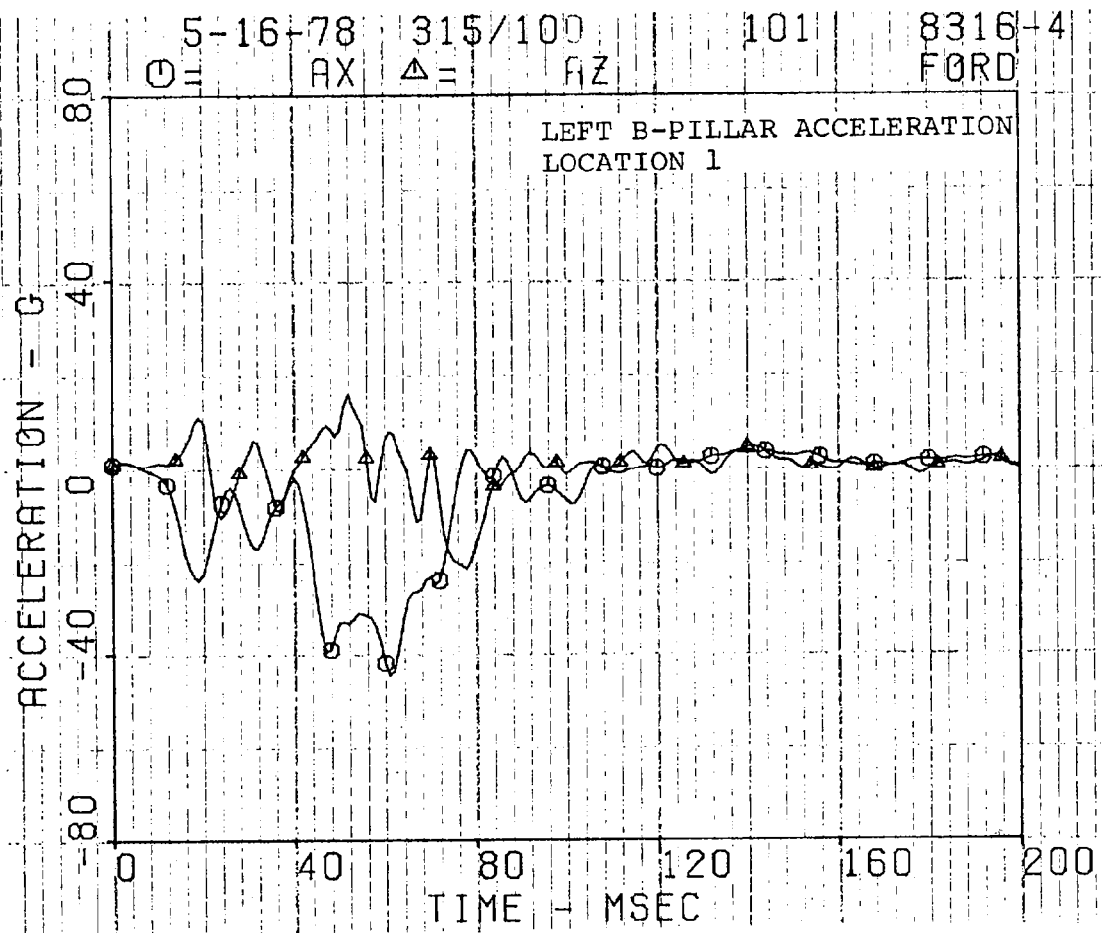

5-16-78 315/100 401 8316-4
O = AX Δ = VX + = SX FORD AV1.2

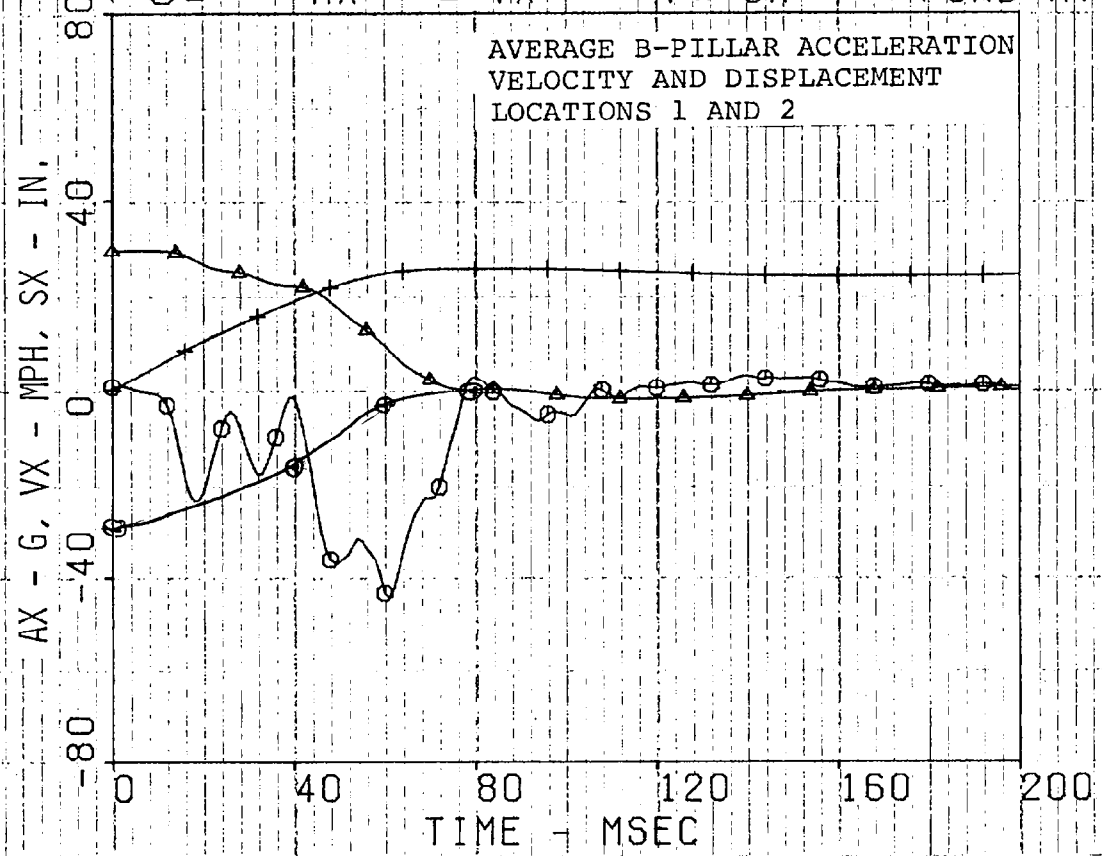

5-16-78 315/100 103 8316-4
O = AX Δ = AZ FORD

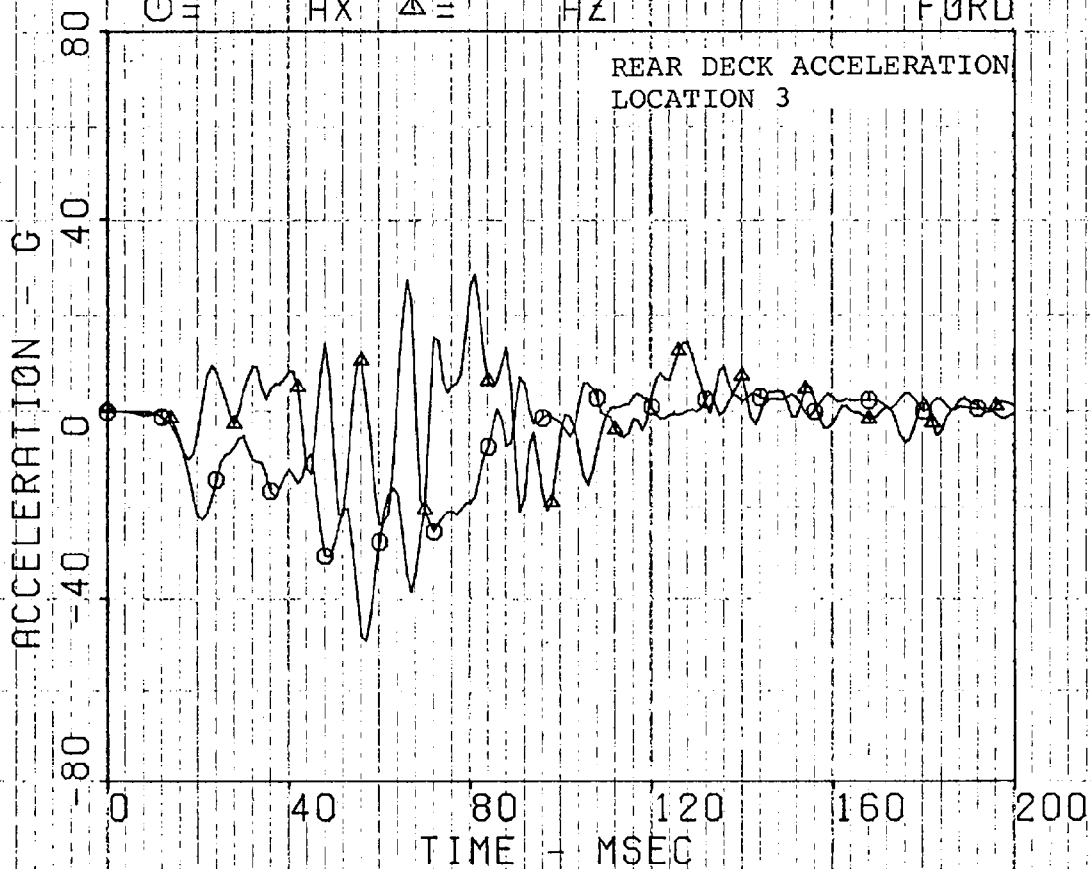

5-16-78 315/100 105 8316-4
O = AX Δ = AZ FORD

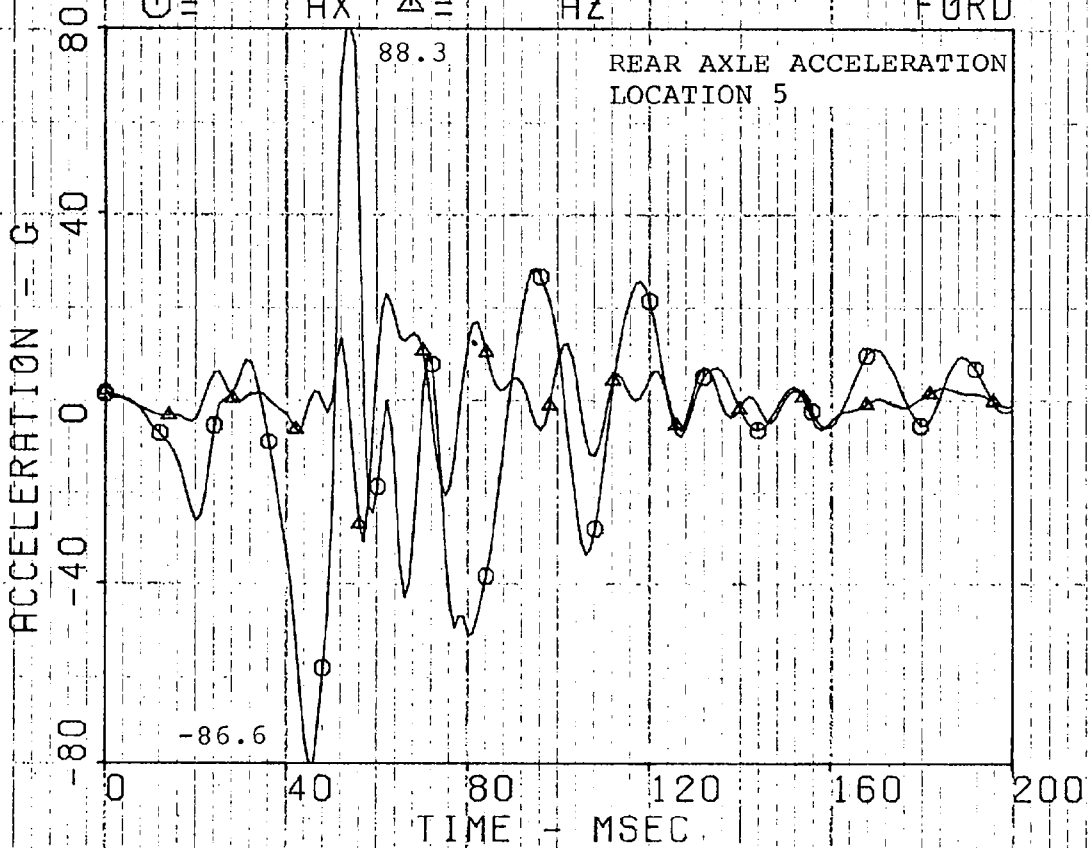

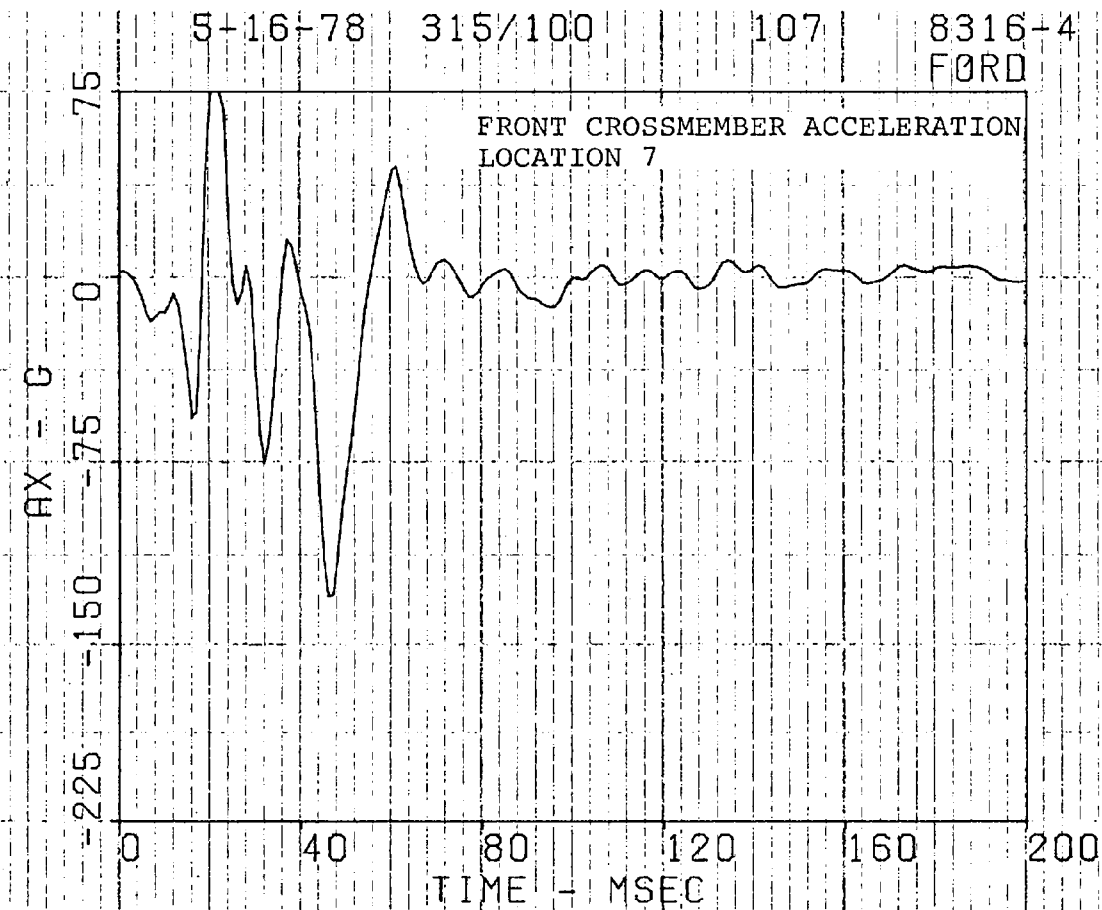
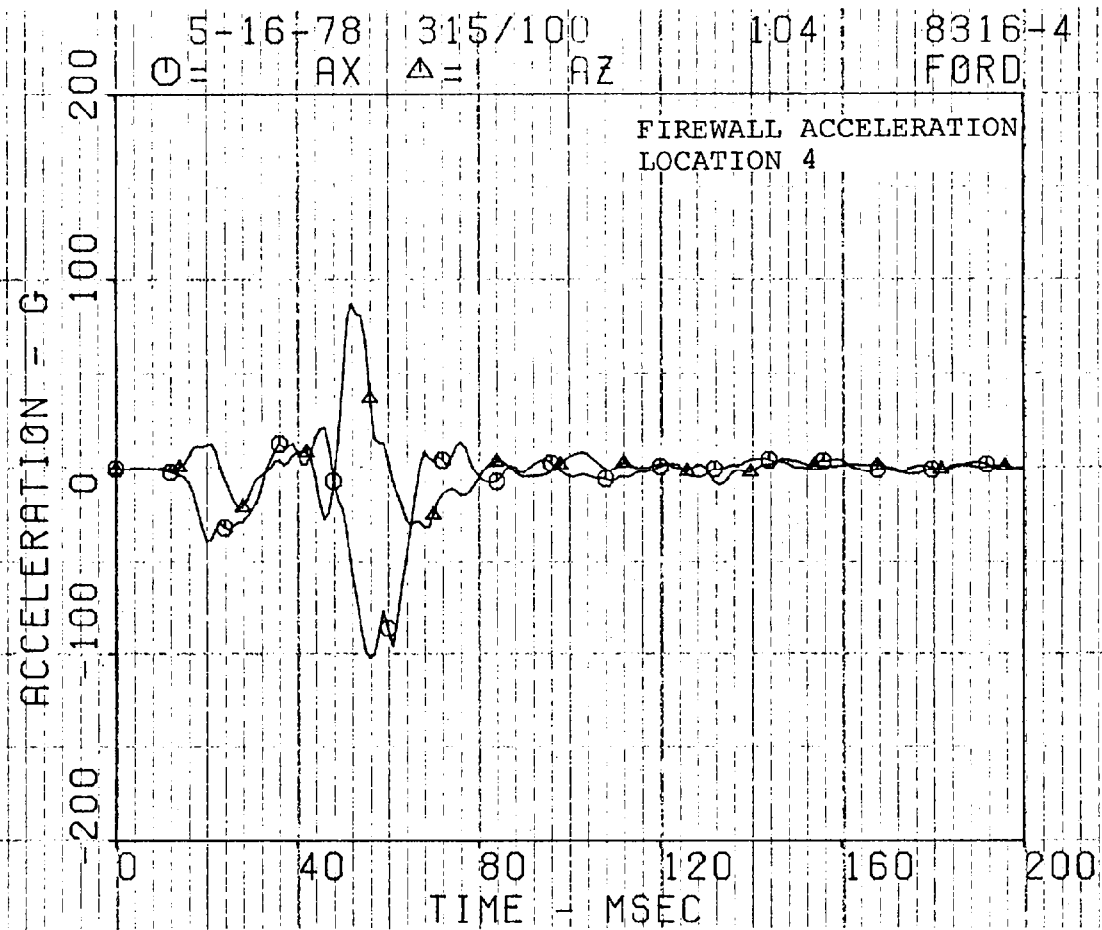

5-16-78 315/100 106 8316-4
FORD

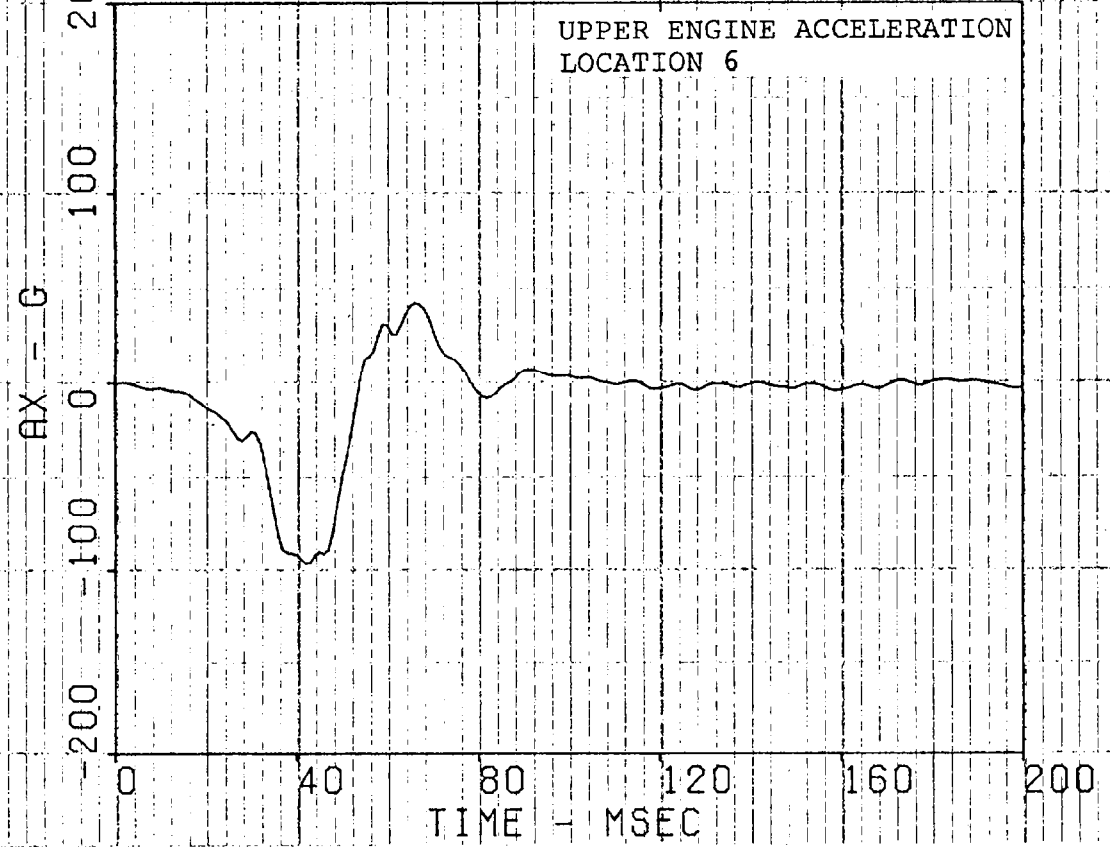

5-16-78 315/100 109 8316-4
FORD

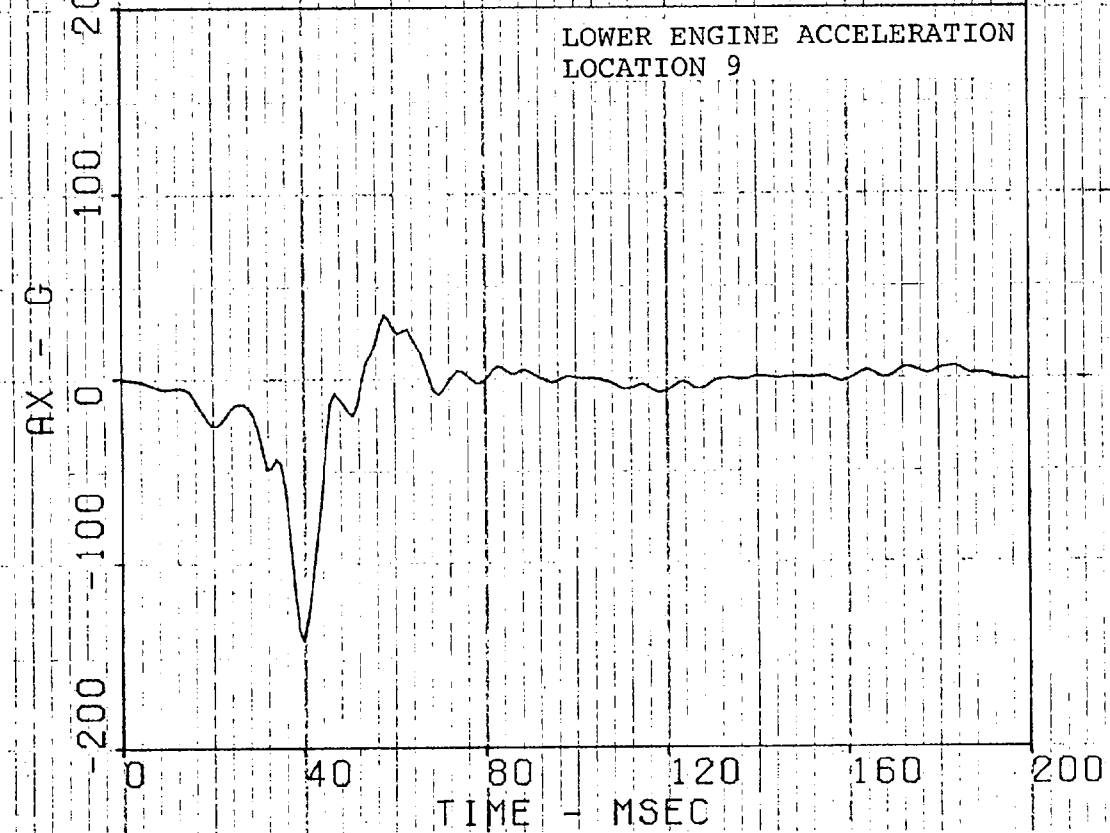

5-16-78 315/100 402 8316-4
AX $\Delta = VX$ $+ = SX$ FORD AV6.9

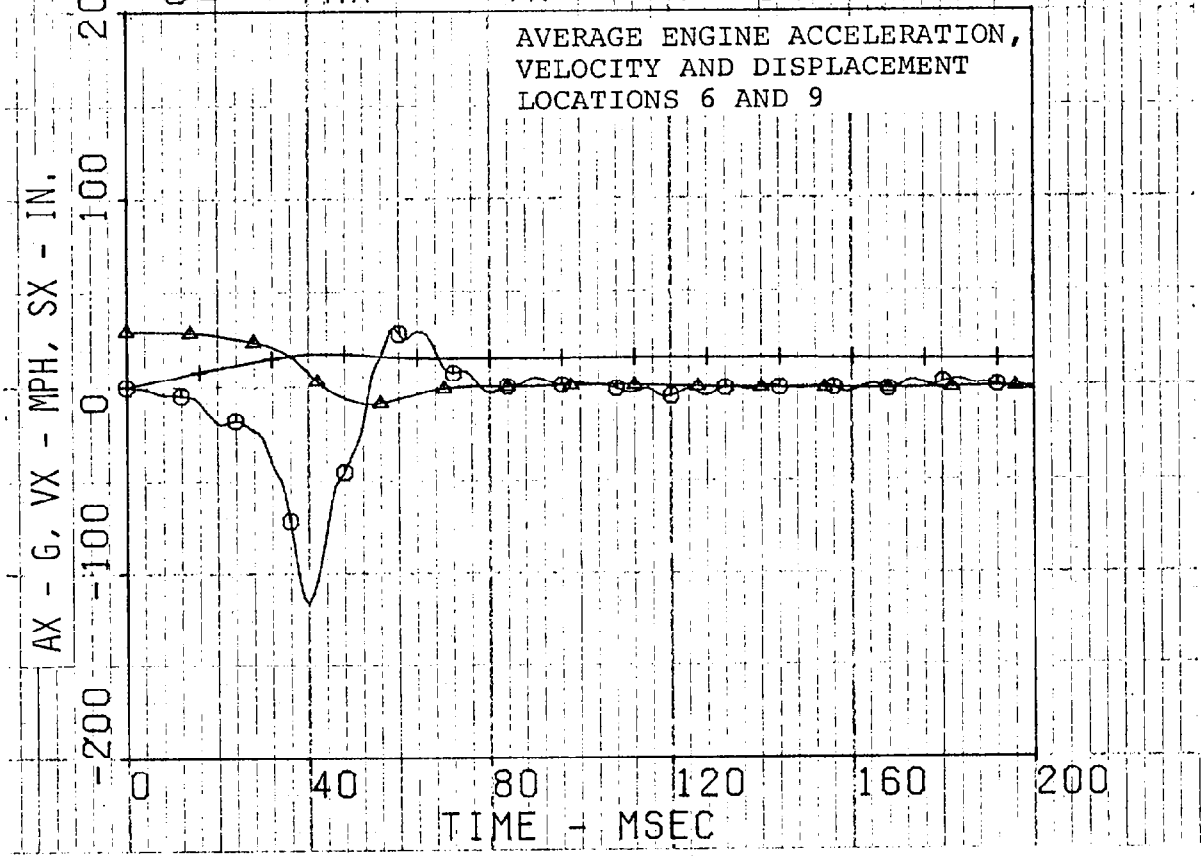

5-16-78 315/100 108 8316-4
O = AX Δ = HY + = AZ FORD

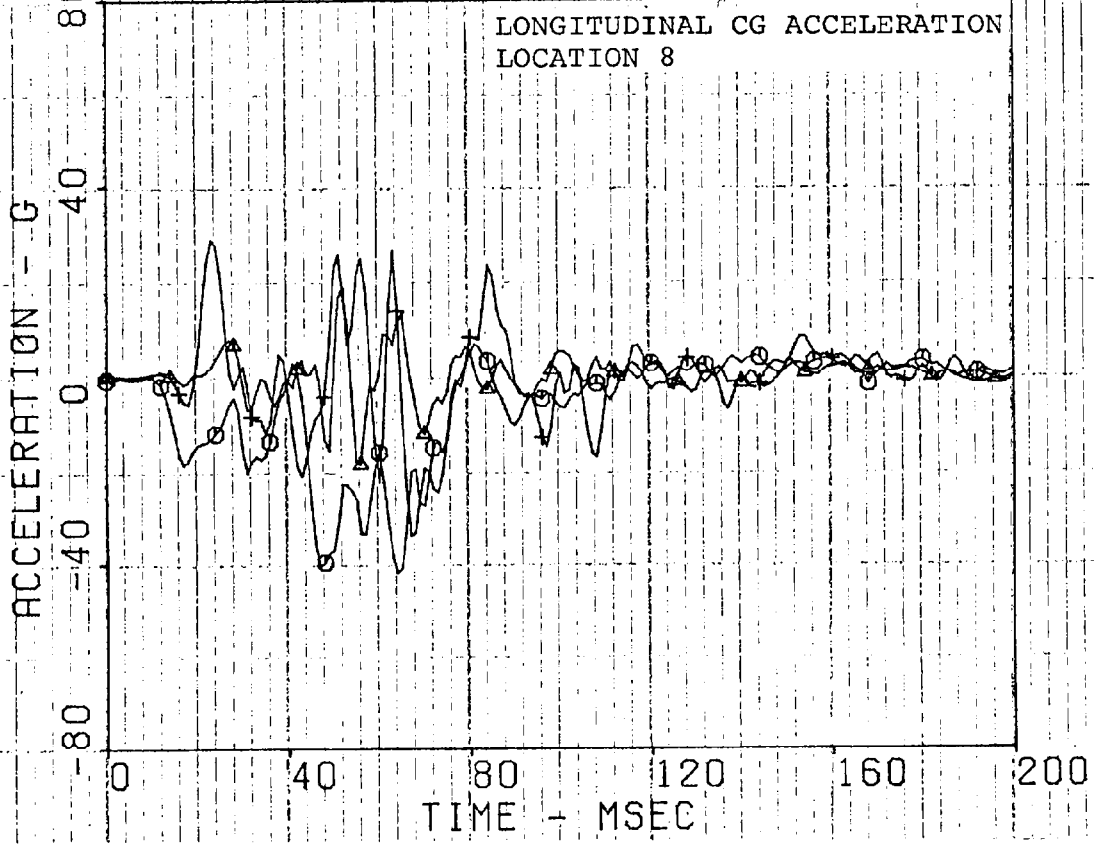

5-16-78

315/100

4101

8316-4

FORD SP-1

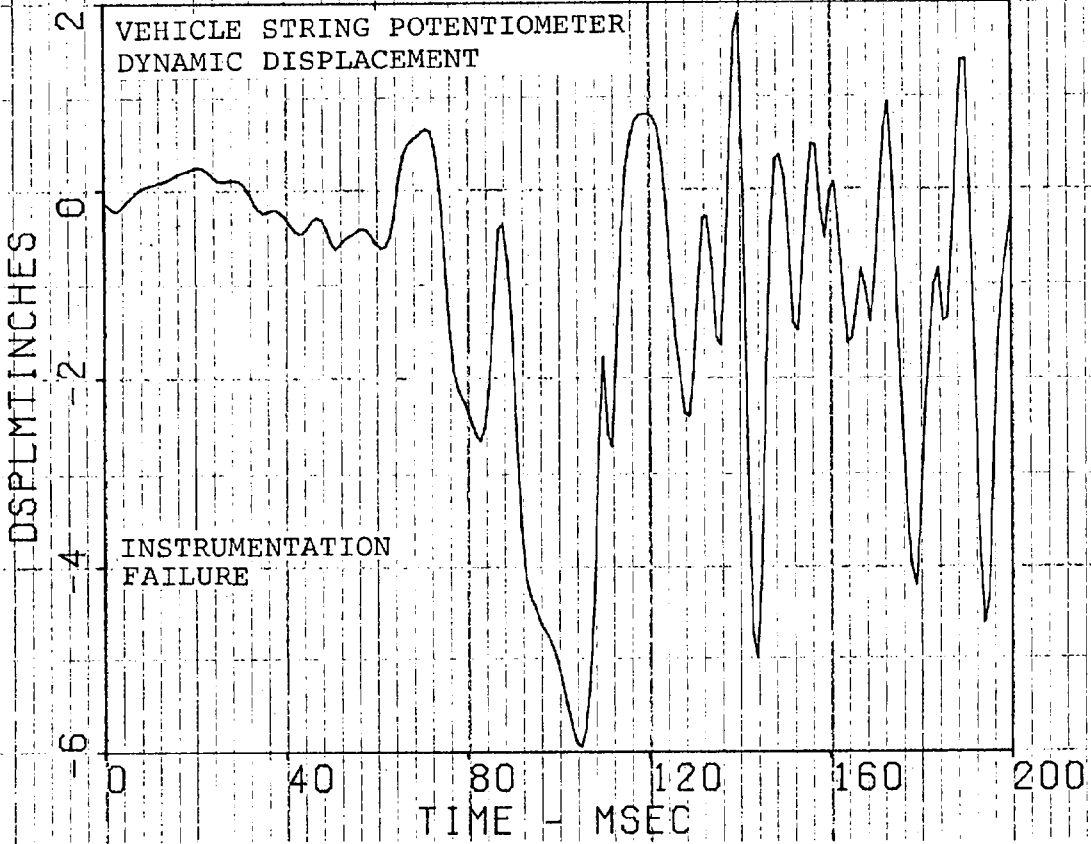

5-16-78 315/100 4001 8316-4
TSTDEV SP1

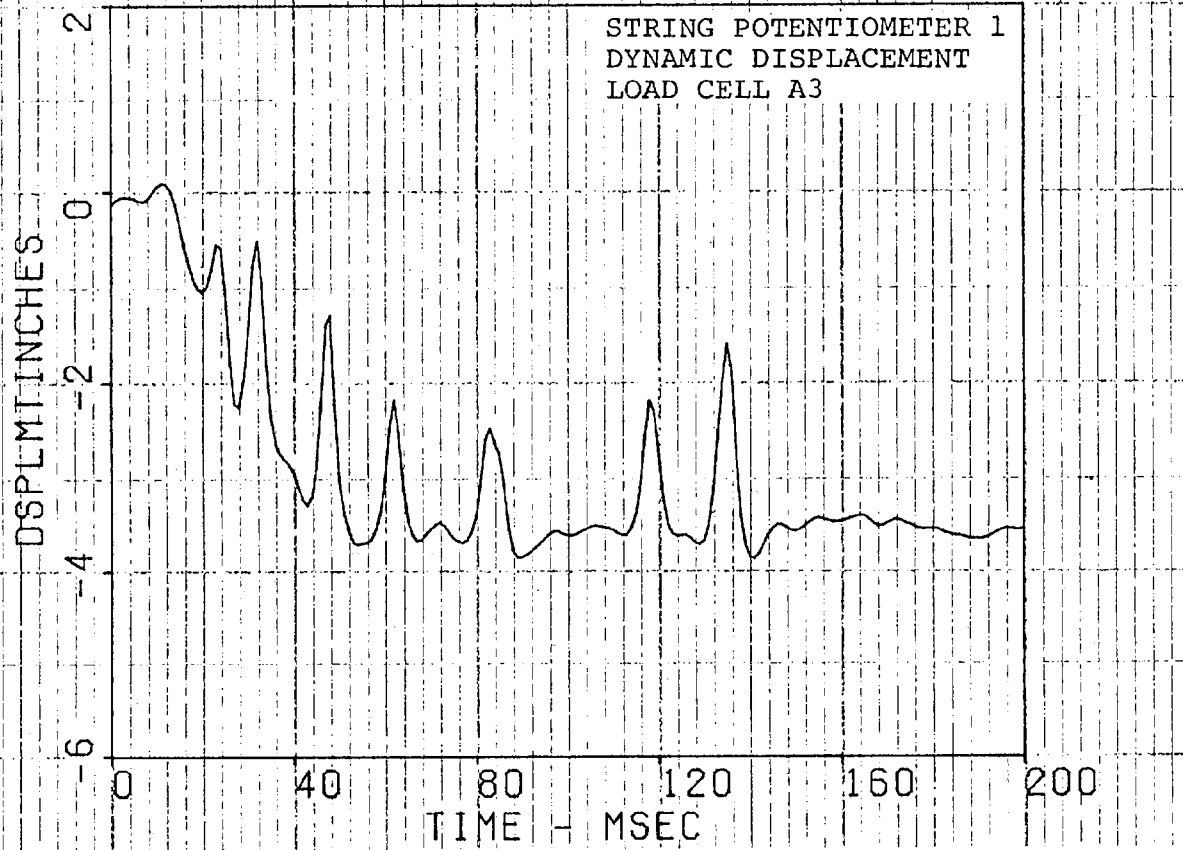

5-16-78 315/100 4002 8316-4
TSTDEV SP2

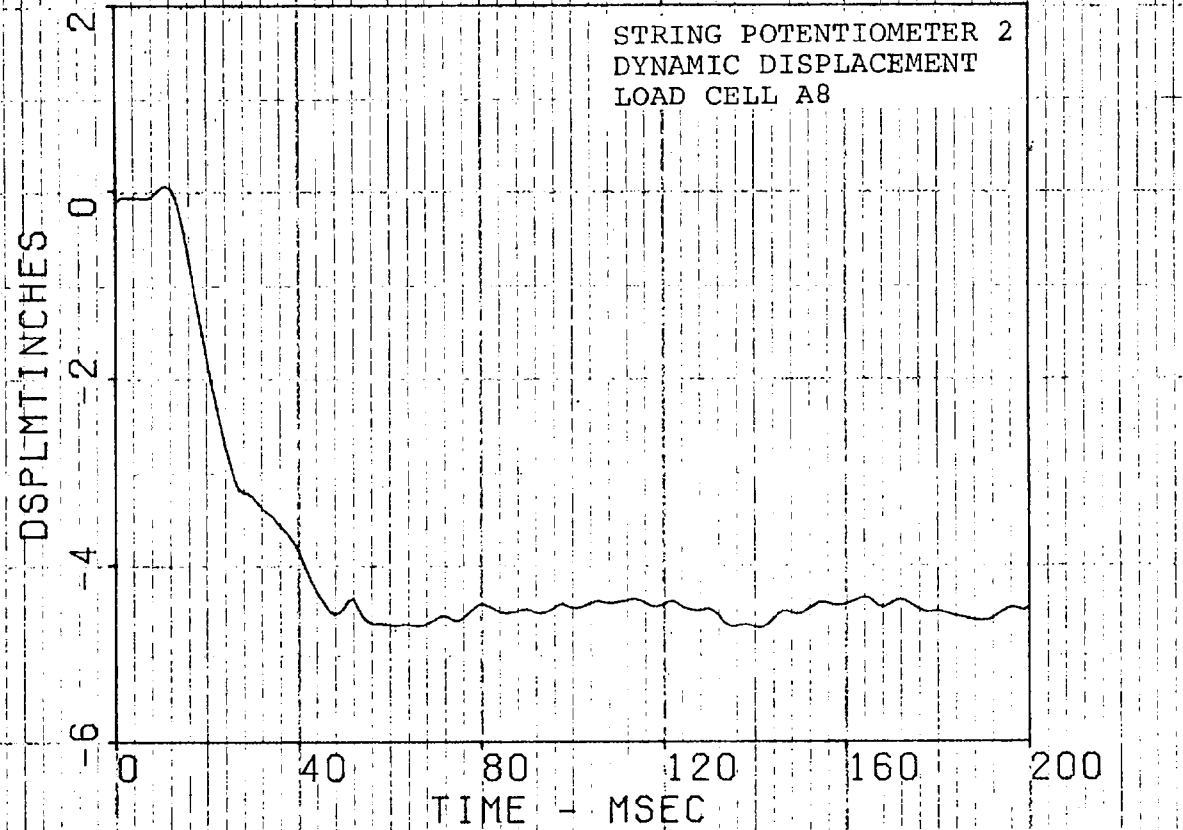

5-16-78

315/100

4003

8316-4

TSTDEV SP3

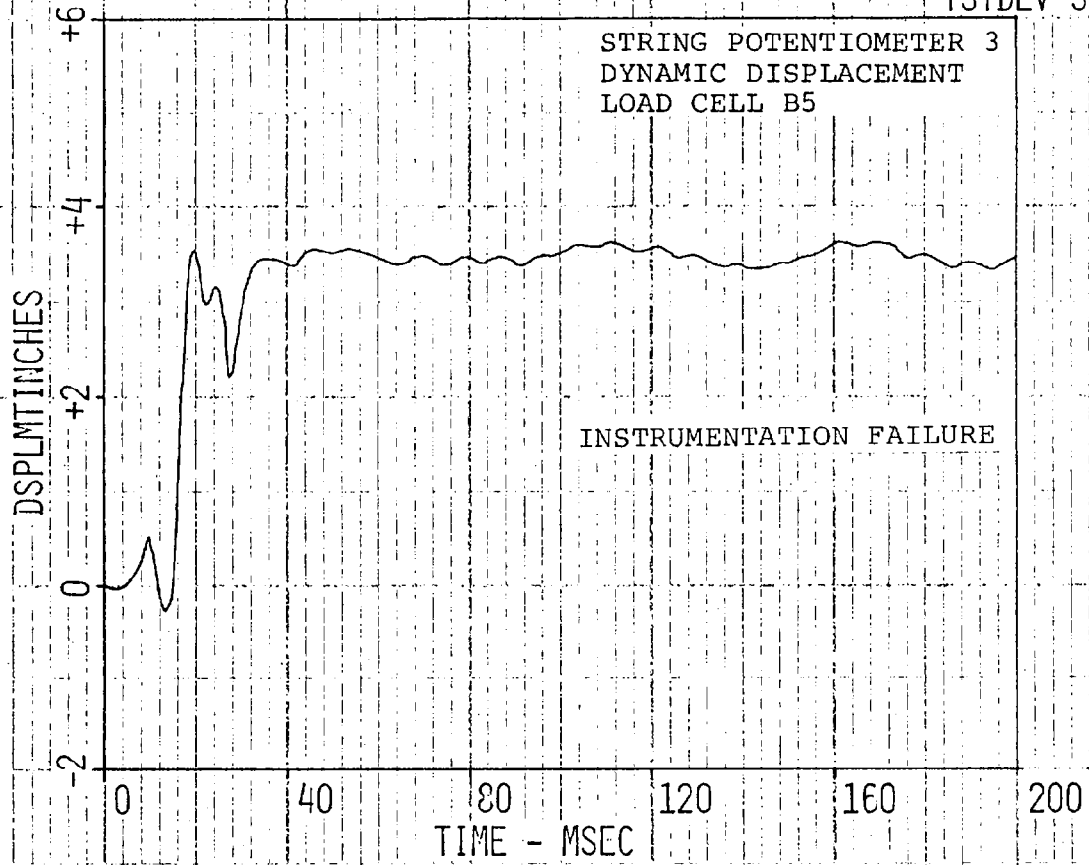

5-16-78

315/100

4004

8316-4

TSTDEV SP4

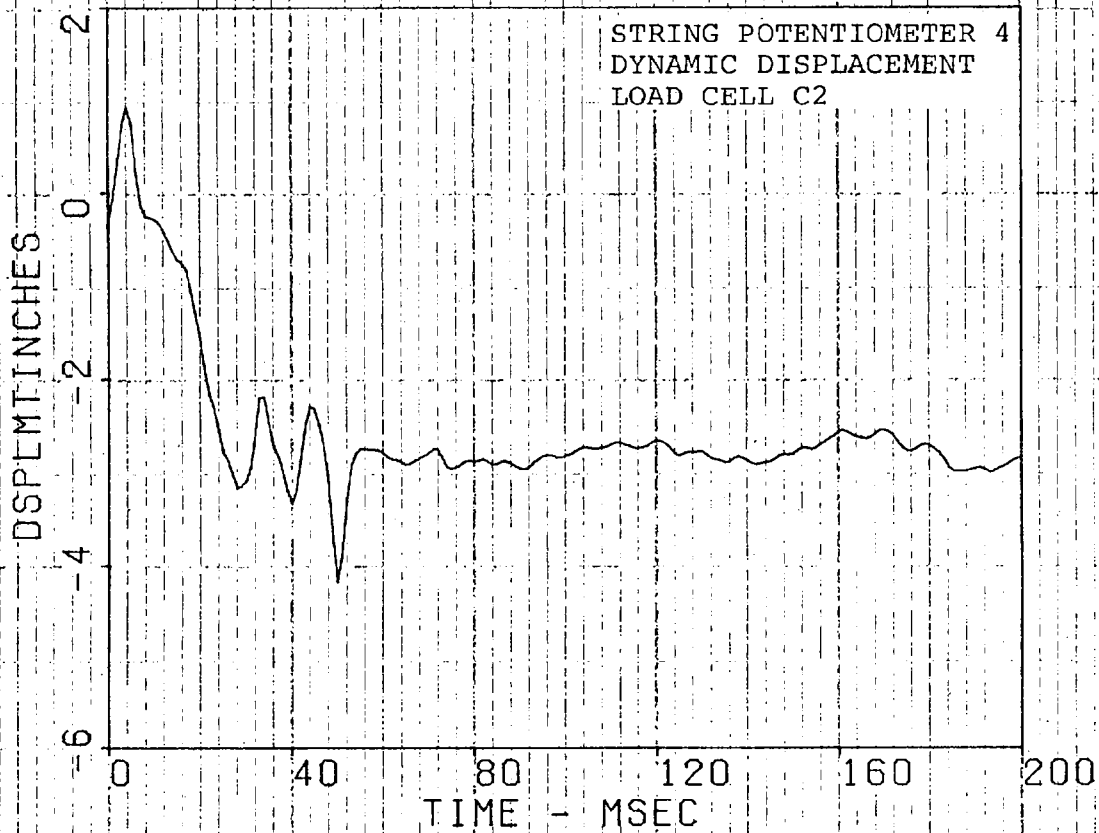

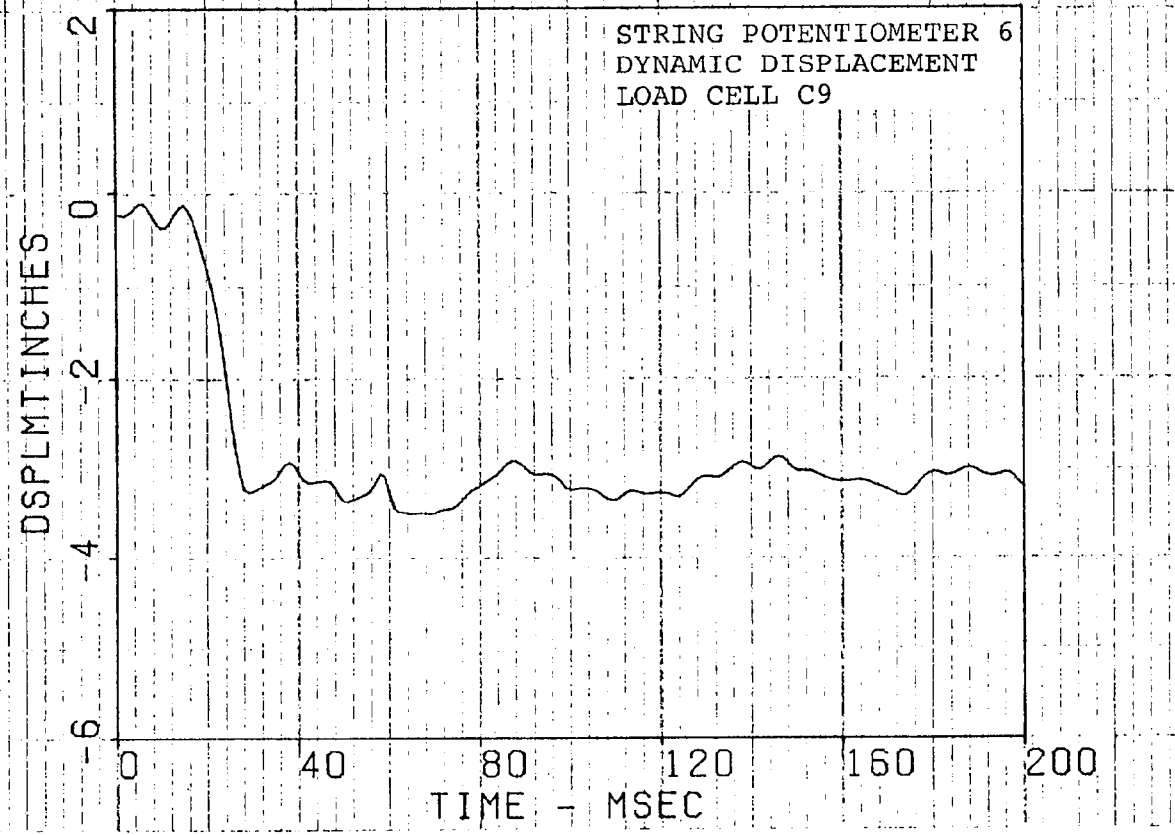
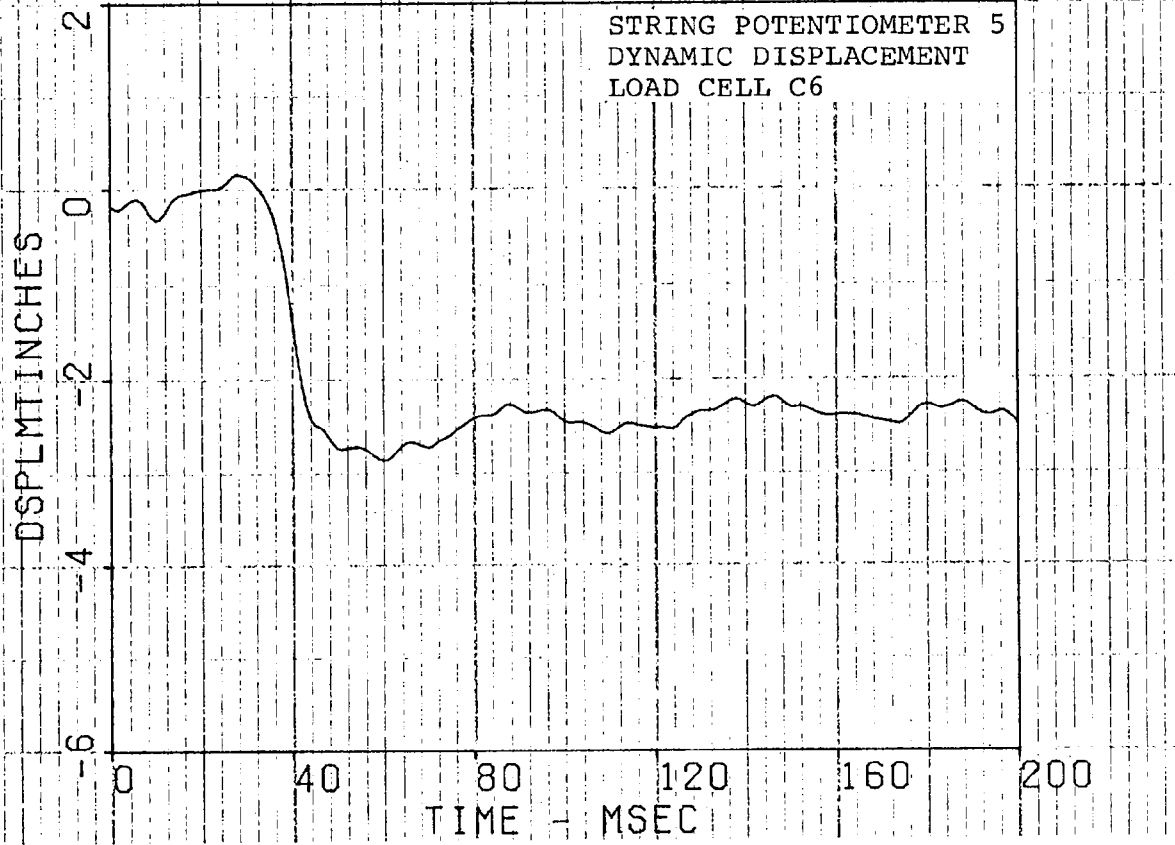

5-16-78

315/100

4301

8316-6

TSTDEV SG1

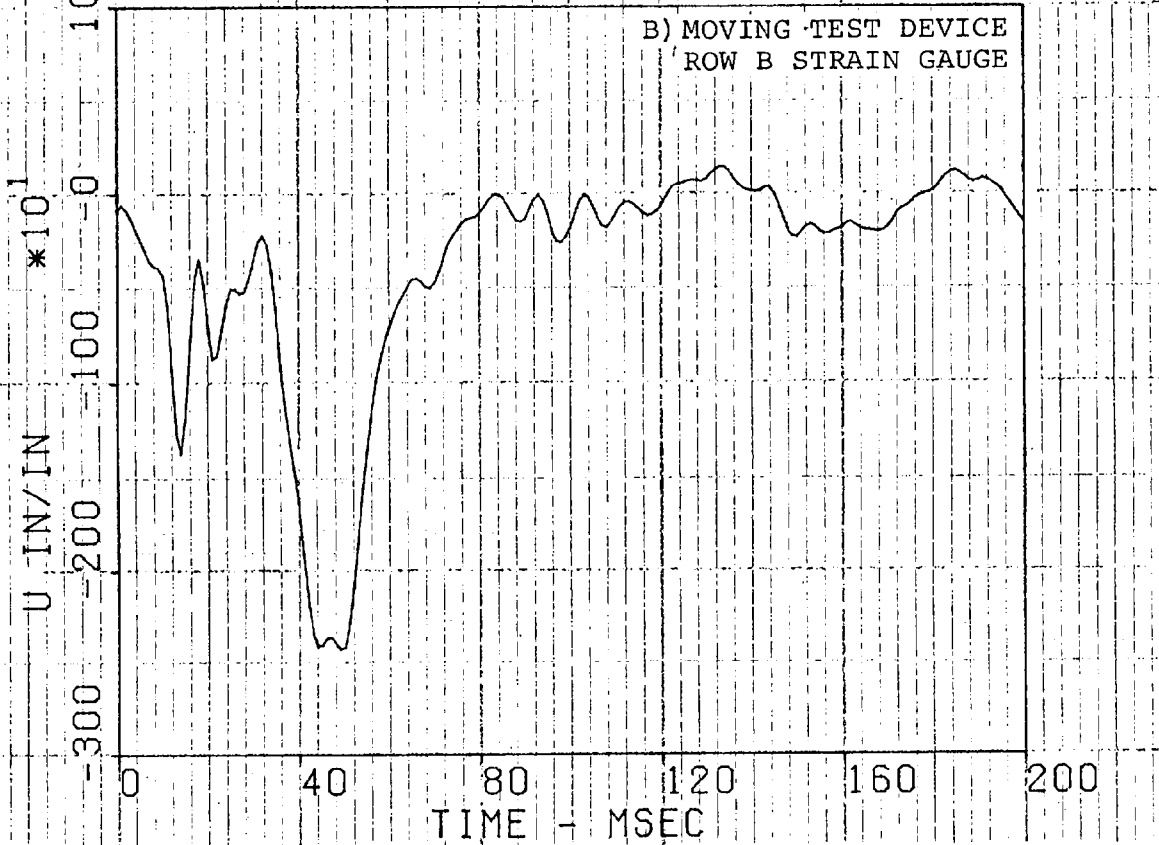

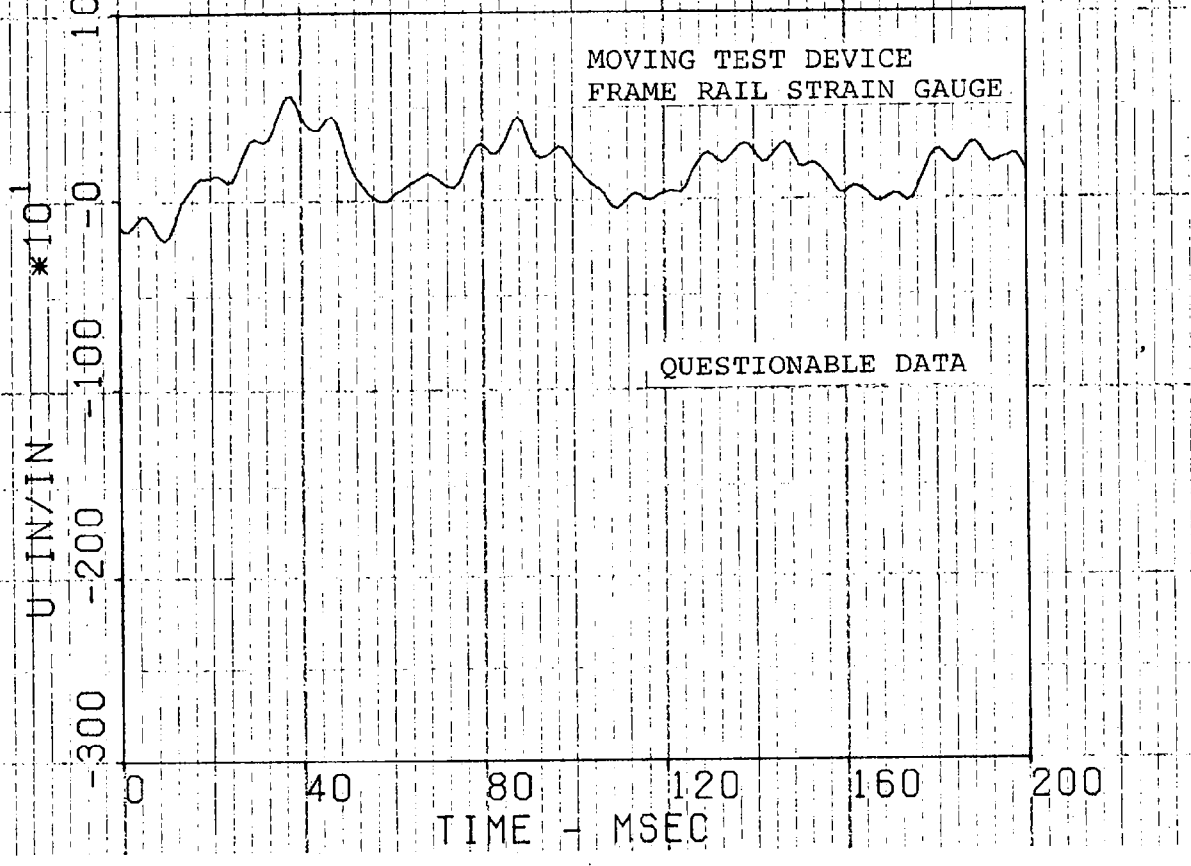

5-16-78 315/100 201 8316-4
TSTDEV A1R

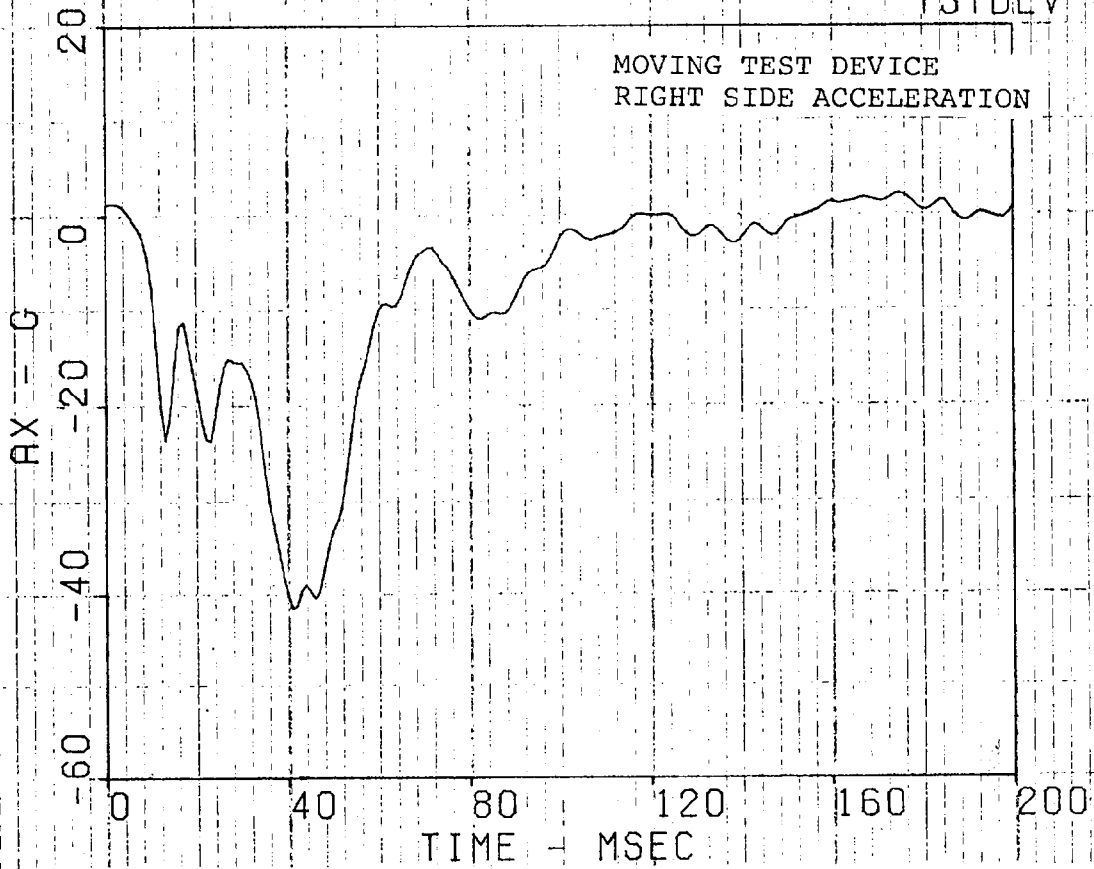

5-16-78 315/100 202 8316-4
TSTDEV A2L

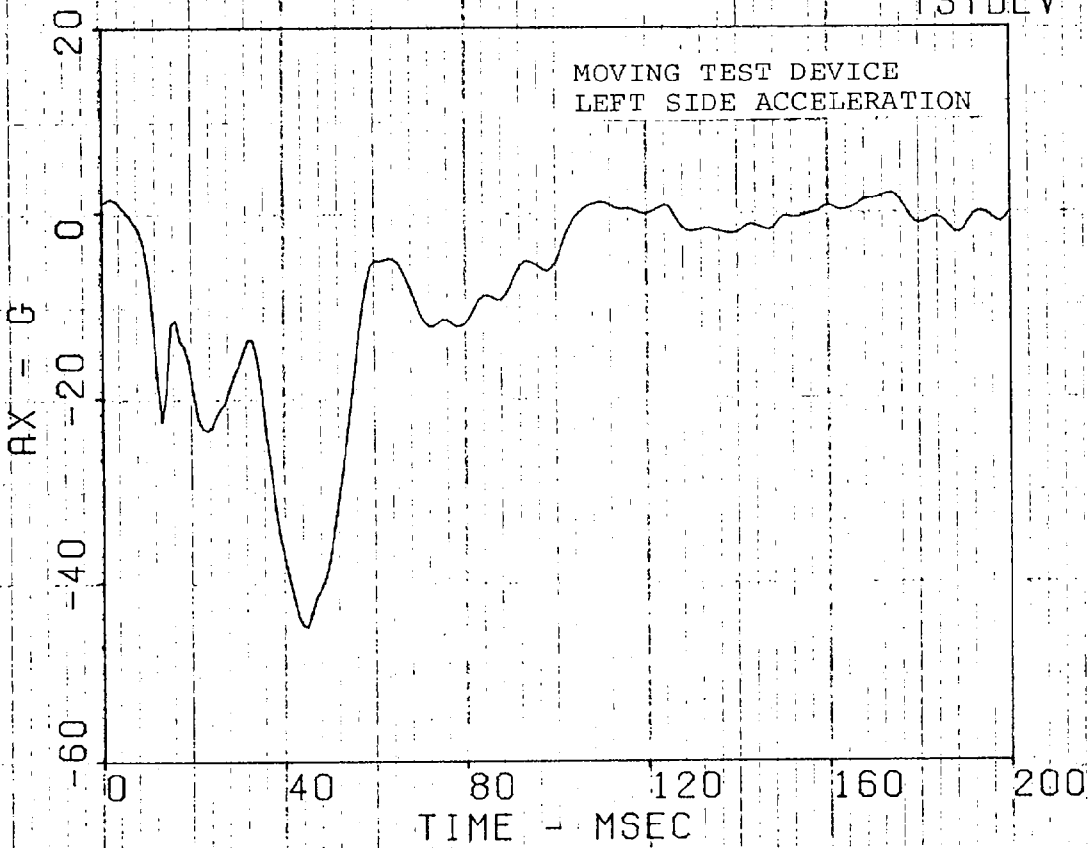

5-16-78 315/100 400 8316-4
 O = AX Δ = VX + = SX T/D AV 1.2

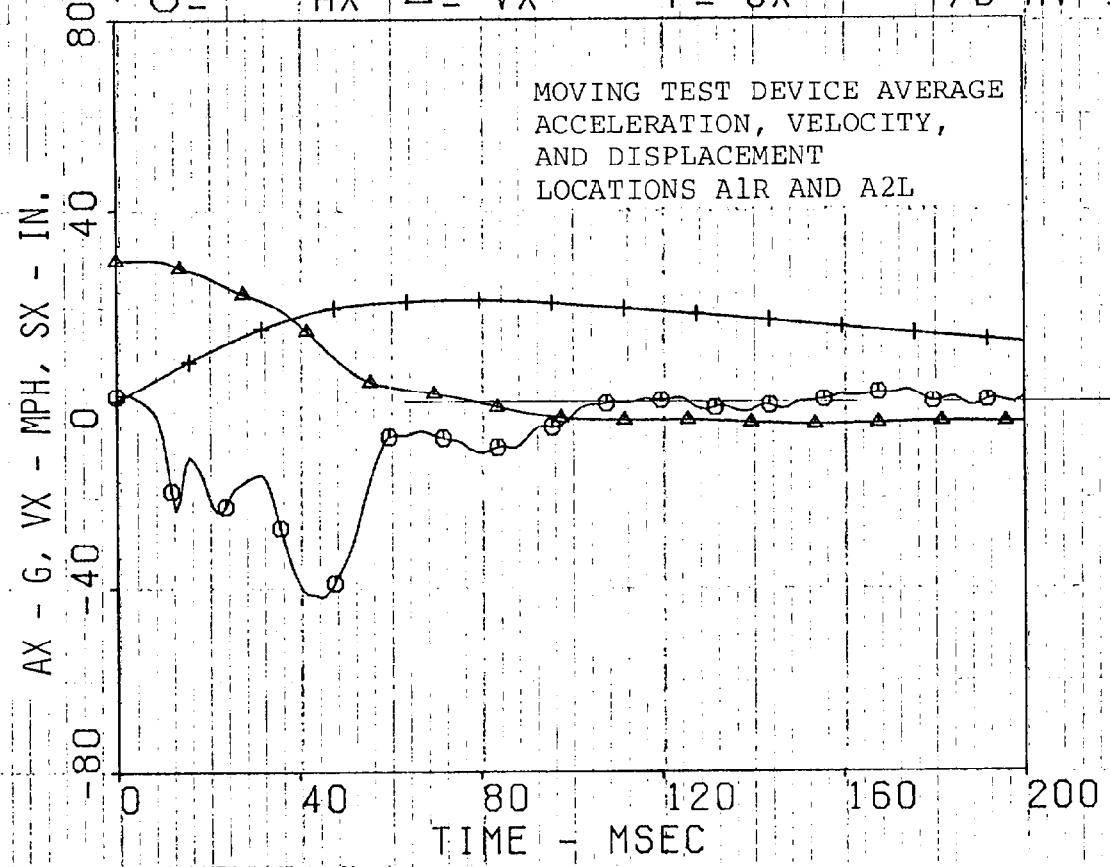

DATE 5-16-78 FILTER 315/100 COLUMN 1 TEST NO 8316-4 TEST DEVI 071978
 O=A A=B +=C X=D

MOVING TEST DEVICE
 LOAD CELL FORCES
 COLUMN 1

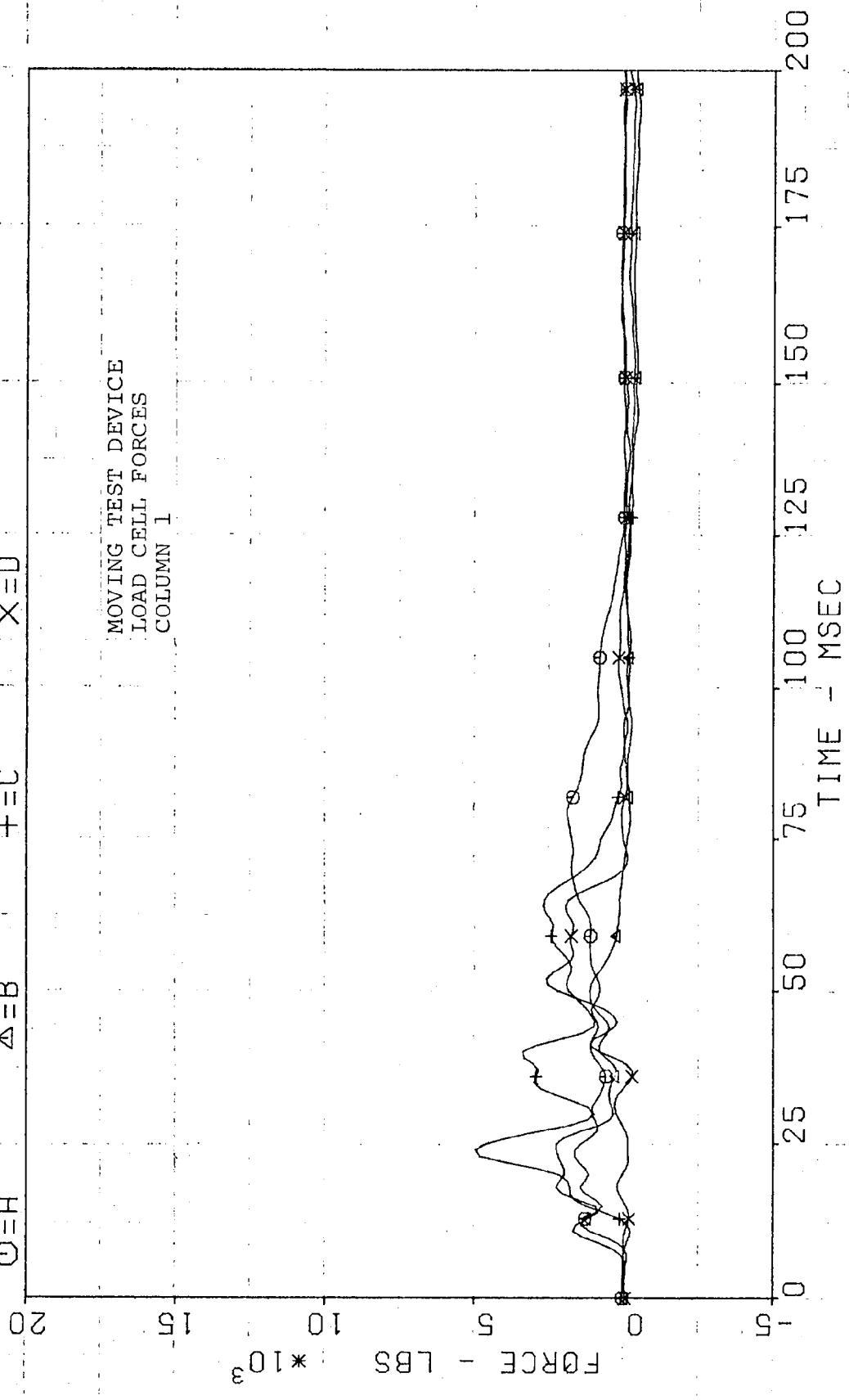

DATE 5-16-78 FILTER 315/100 COLUMN 2
 TEST NO 8316-4 TESTDEVICE
 ①=A Δ=B +=C X=D

MOVING TEST DEVICE
 LOAD CELL FORCES
 COLUMN 2

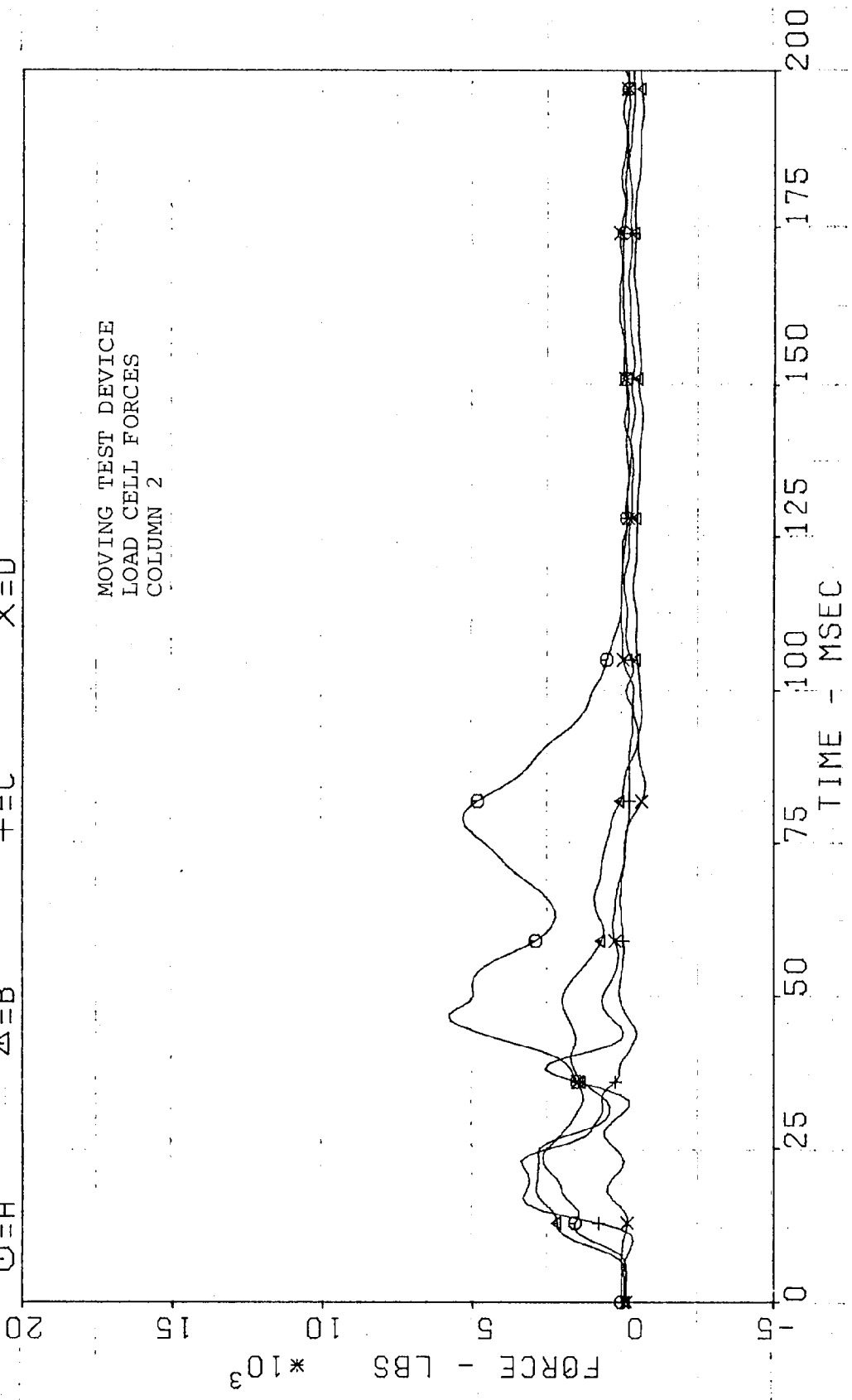

DATE 5-16-78 FILTER 315/100 COLUMN 3 TEST NO 8316-4 TEST DEVICE 071978
O=A Δ=B ±=C X=D

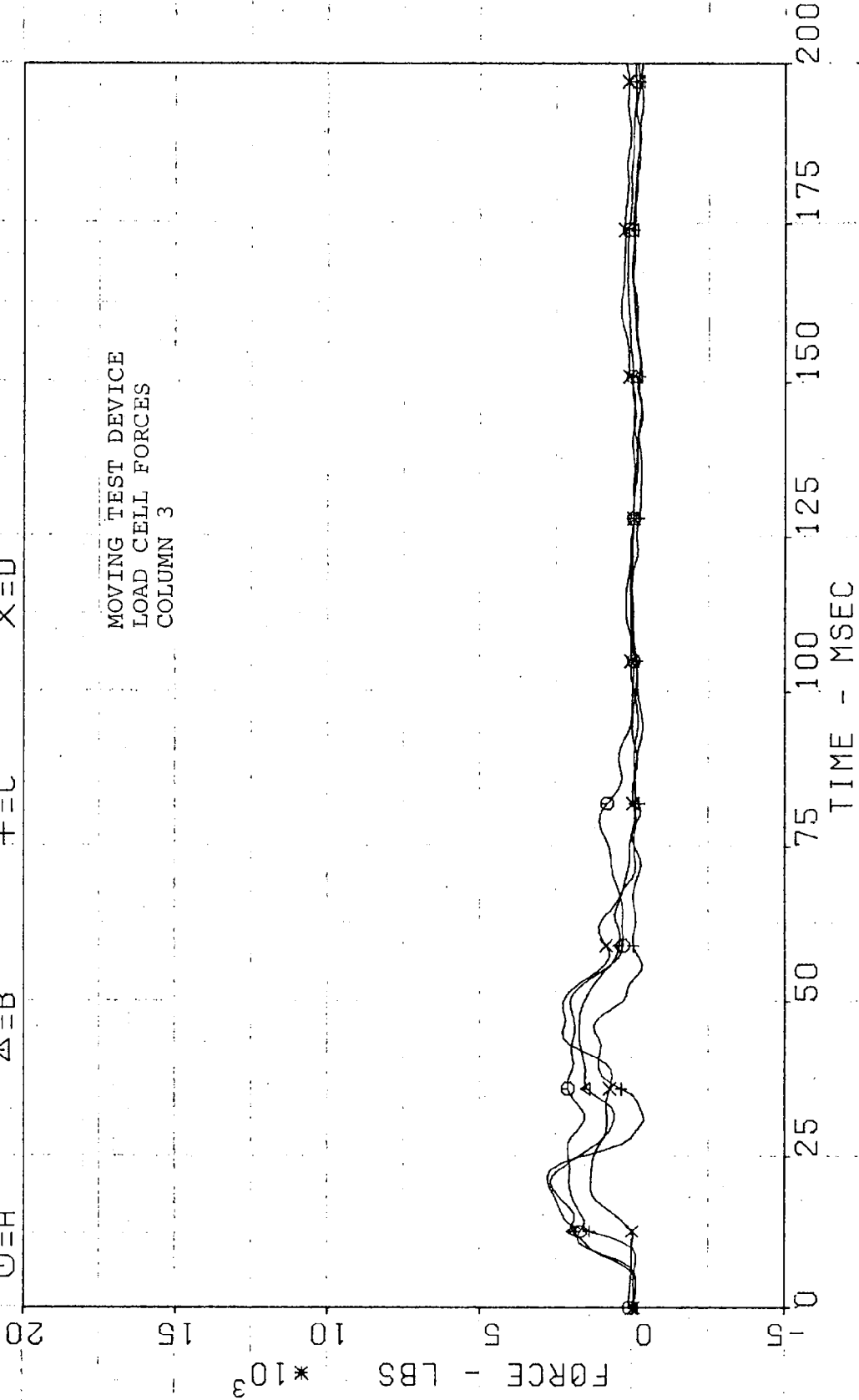

DATE 5-16-78 FILTER 315/100 COLUMN 4 TEST NO 8316-4 TEST DEVICE 071978
O=A Δ=B +=C X=D

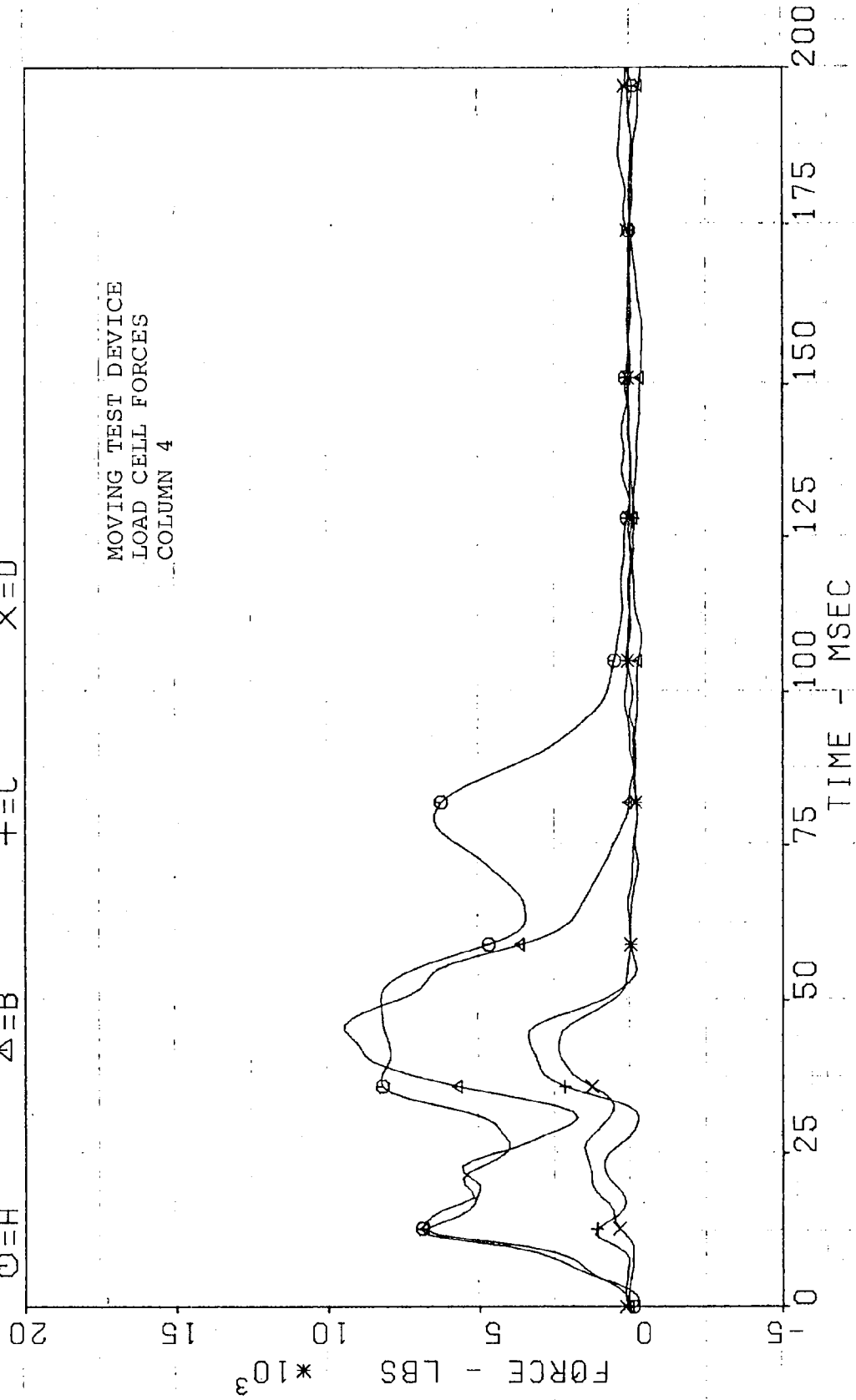

DATE 5-16-78
 FILTER 315/100
 COLUMN 5
 TEST NO 8316-4
 TEST DEVICE 071978
 X=D
 +=C
 Δ=B
 ○=A

MOVING TEST DEVICE
 LOAD CELL FORCES
 COLUMN 5

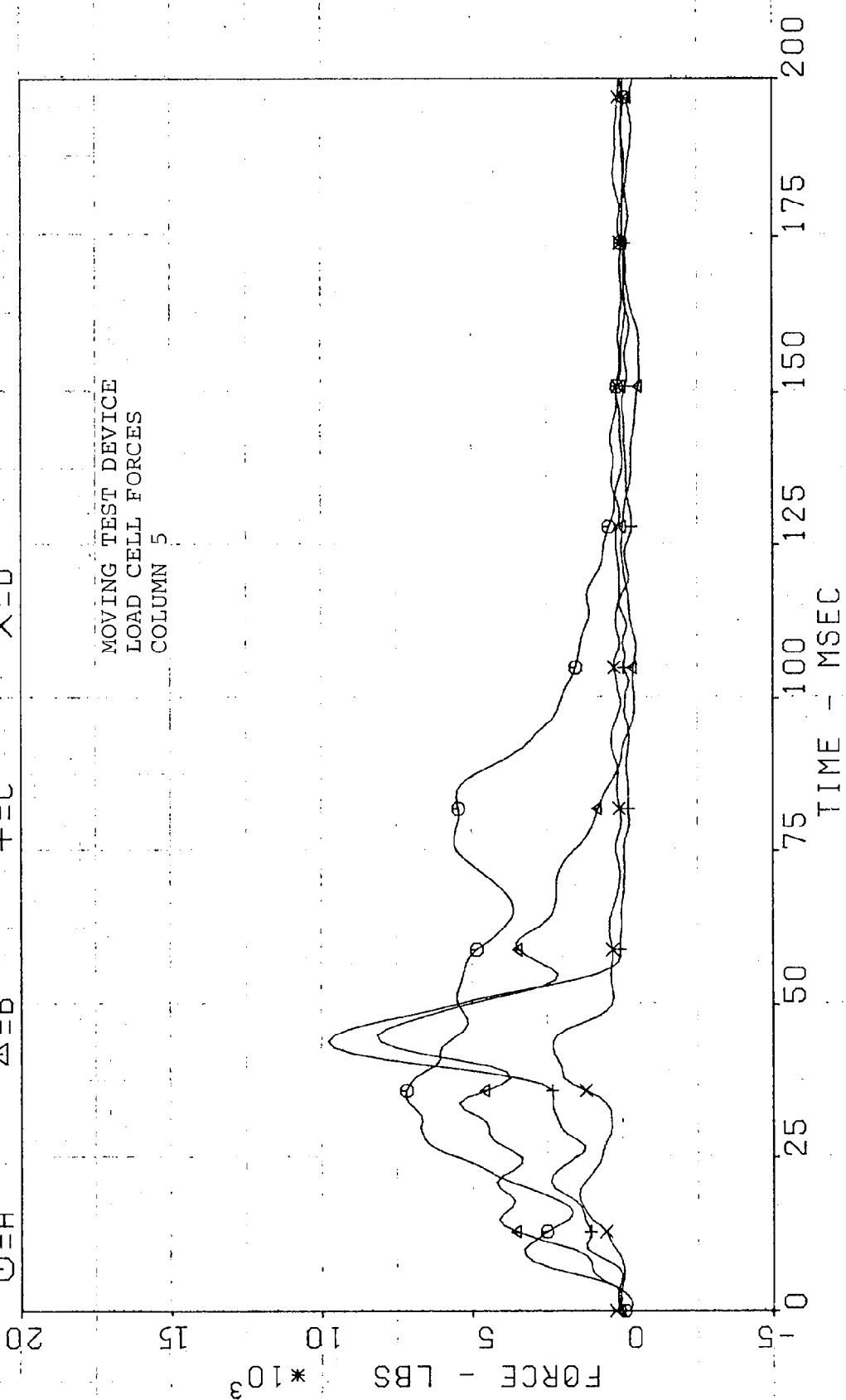

DATE 5-16-78 FILTER 315/100 COLUMN 6 TEST NO 8316-4 071978
 ○=A Δ=B +=C X=D TESTDEVICE

MOVING TEST DEVICE
 LOAD CELL FORCES
 COLUMN 6

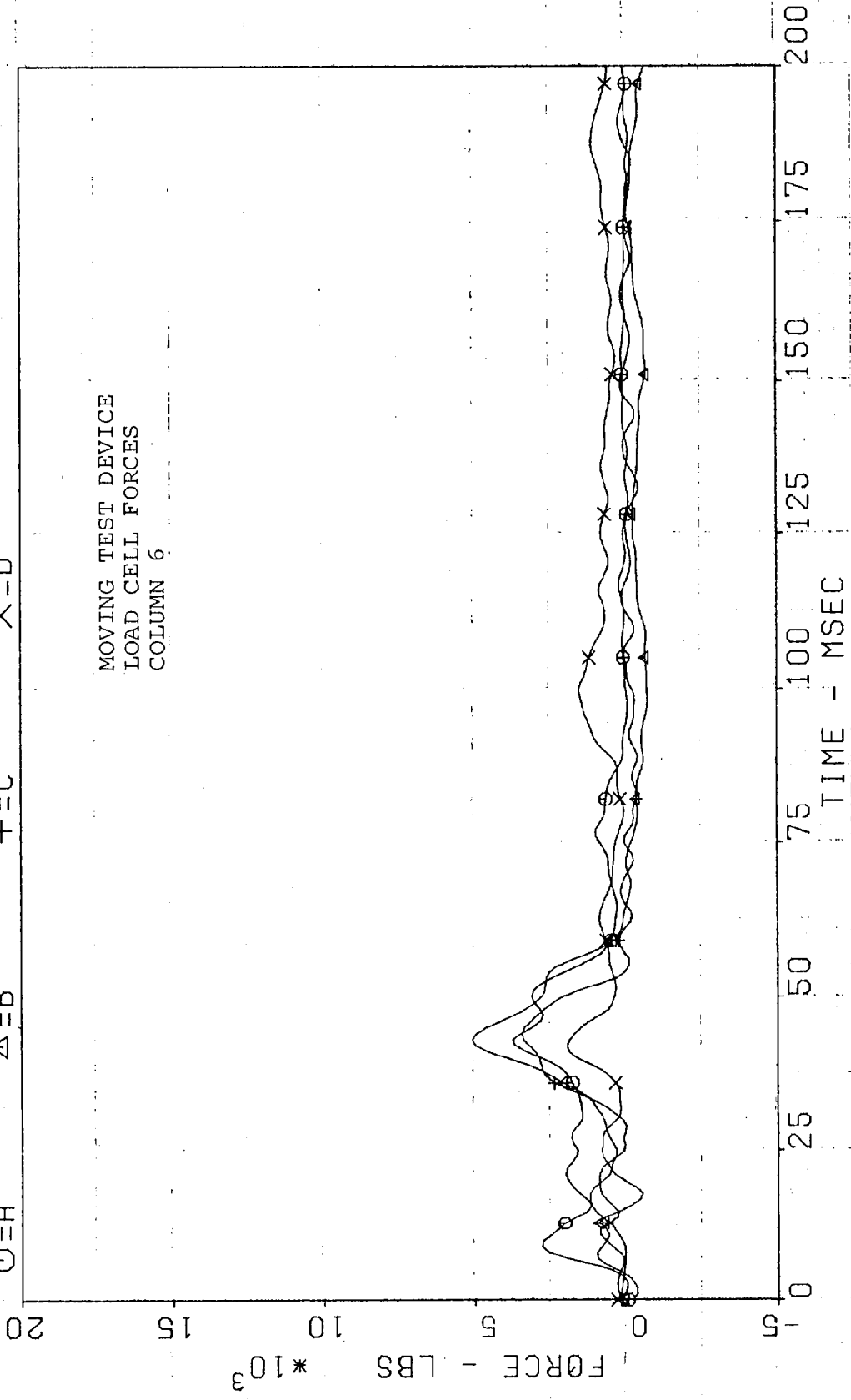

DATE 5-16-78 FILTER 315/100 TEST NO 8316-4 TEST DEVICE 071978
 O=A Δ=B +=C X=D

MOVING TEST DEVICE
 LOAD CELL FORCES
 COLUMN 7

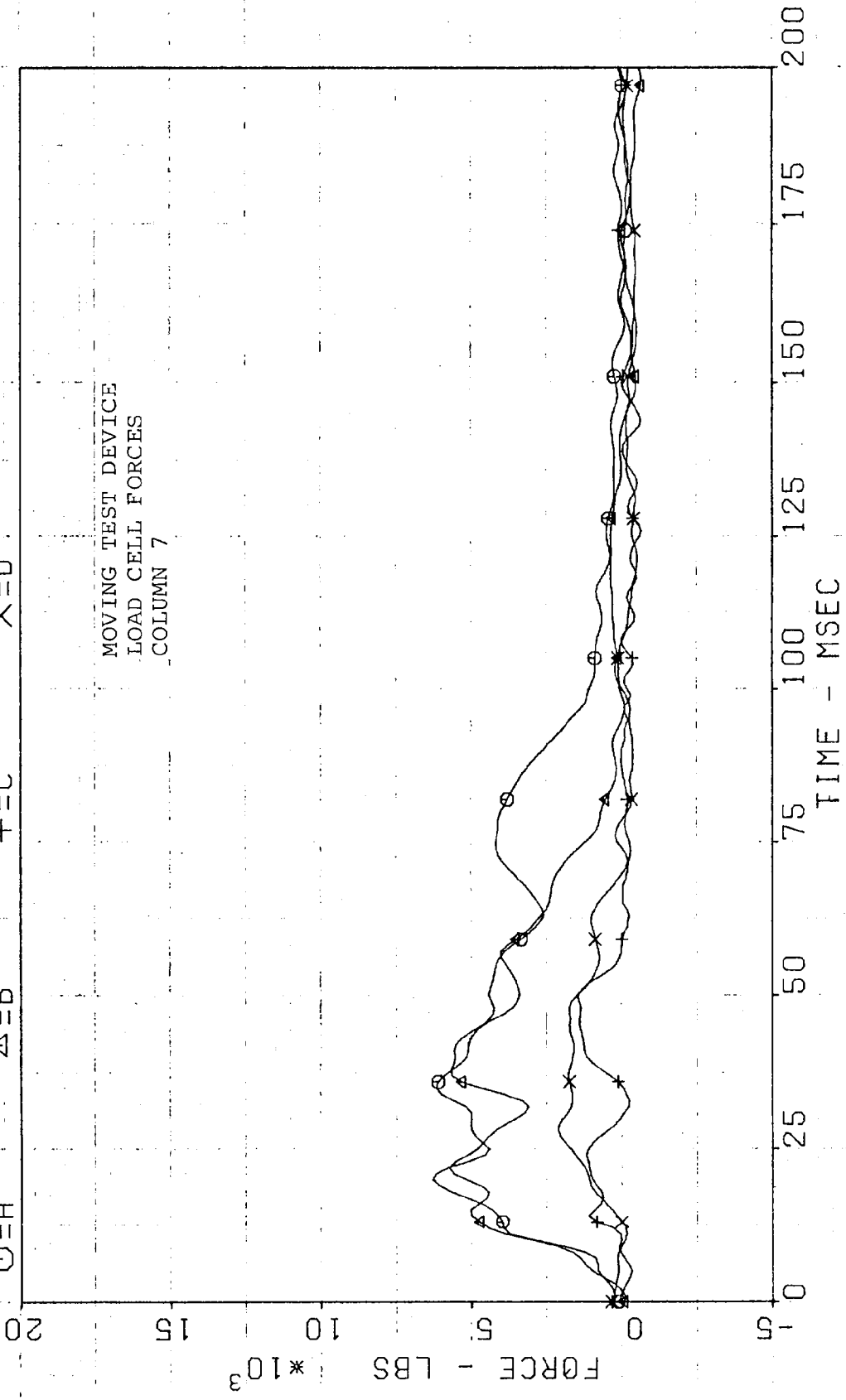

DATE 5-16-78 FILTER 315/100 COLUMN 8 TEST NO 8316-4 TEST DEVICE 071978
 O=A A=B +C X=D

MOVING TEST DEVICE
 LOAD CELL FORCES
 COLUMN 8

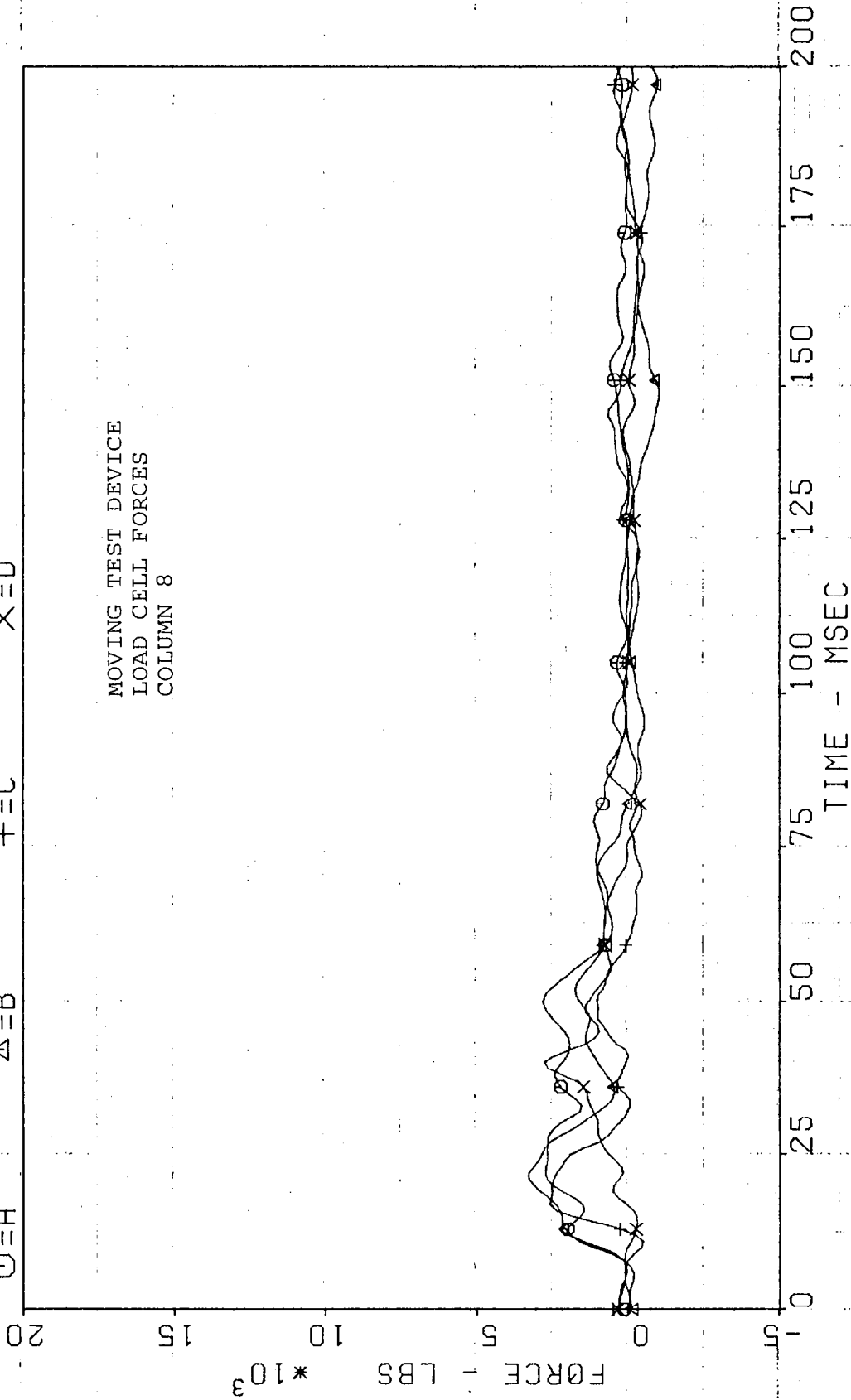

DATE 5-16-78 FILTER 315/100 COLUMN 9 TEST NO 8316-4 TEST DEVICE 071978
 O=A Δ=B +=C X=D

MOVING TEST DEVICE
 LOAD CELL FORCES
 COLUMN 9

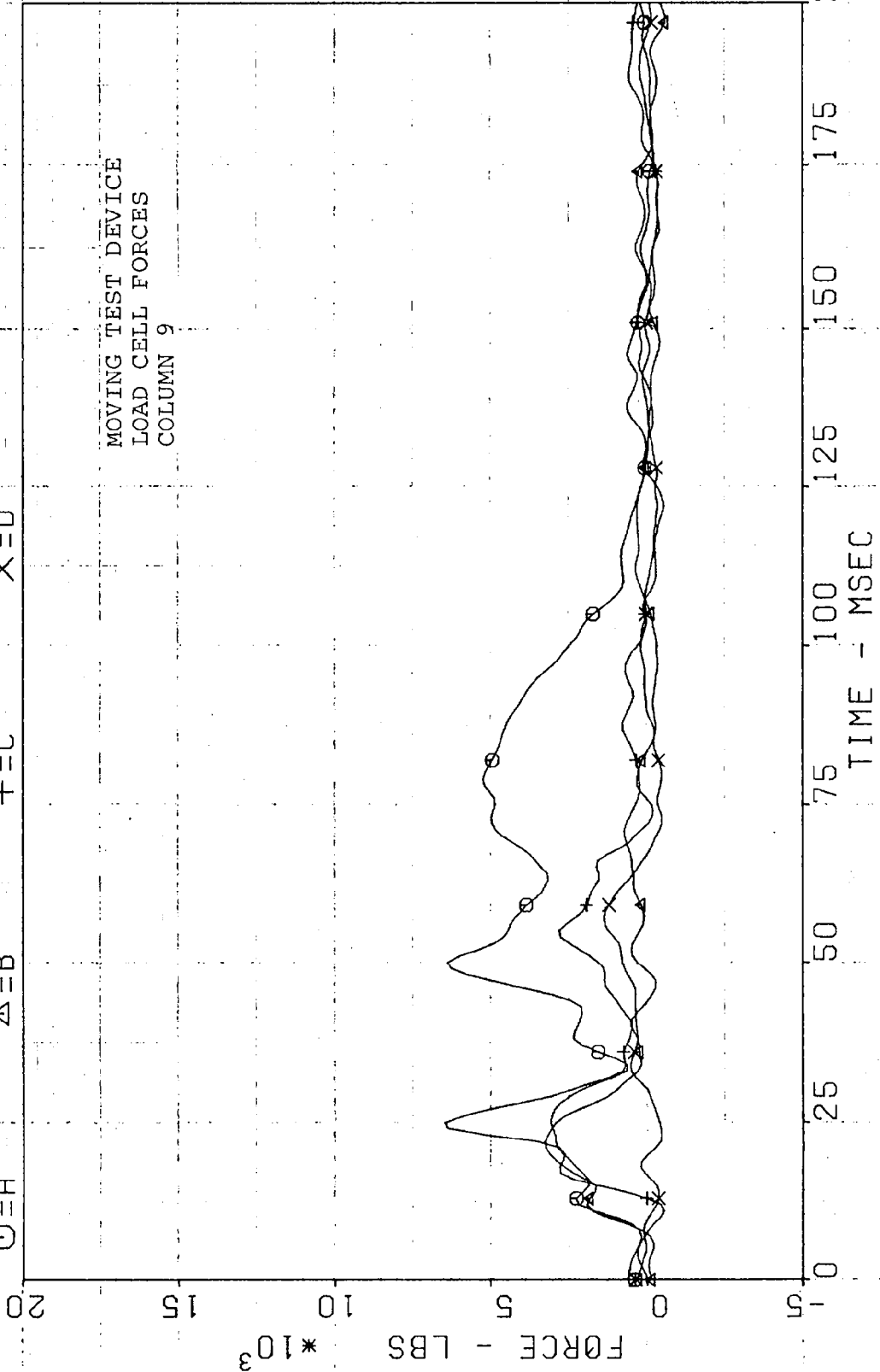

DATE 5-16-78 FILTER 315/100 COLUMN 10 TEST NO 8316-4 TEST DEVICE 071978
O=A Δ=B +=C X=D

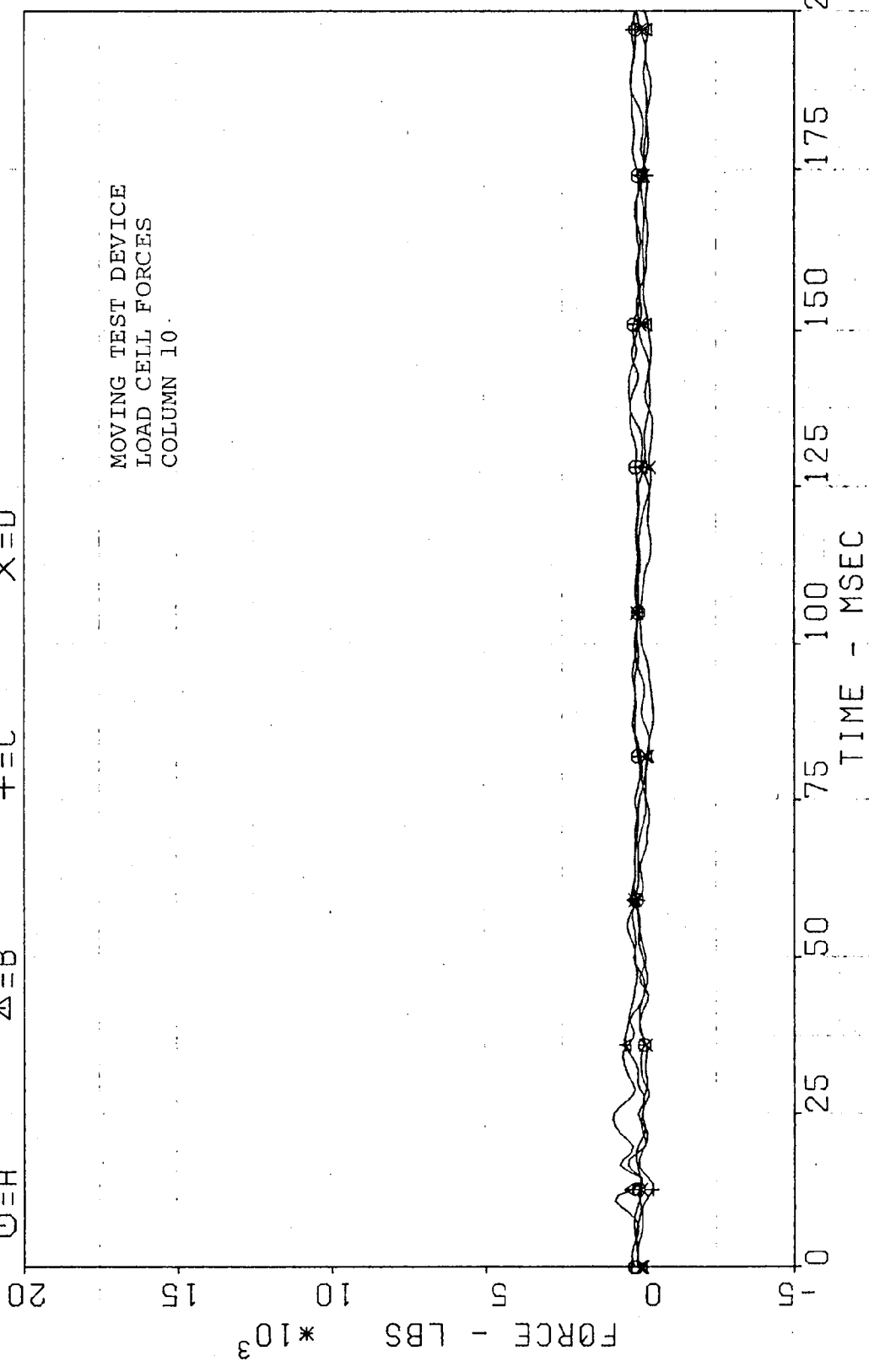

DATE: 5-16-78
 FILTER: 315/100
 TOTAL: 40
 TEST NO: 8316-4
 TEST DEVICE: TEST DEVICE
 071978

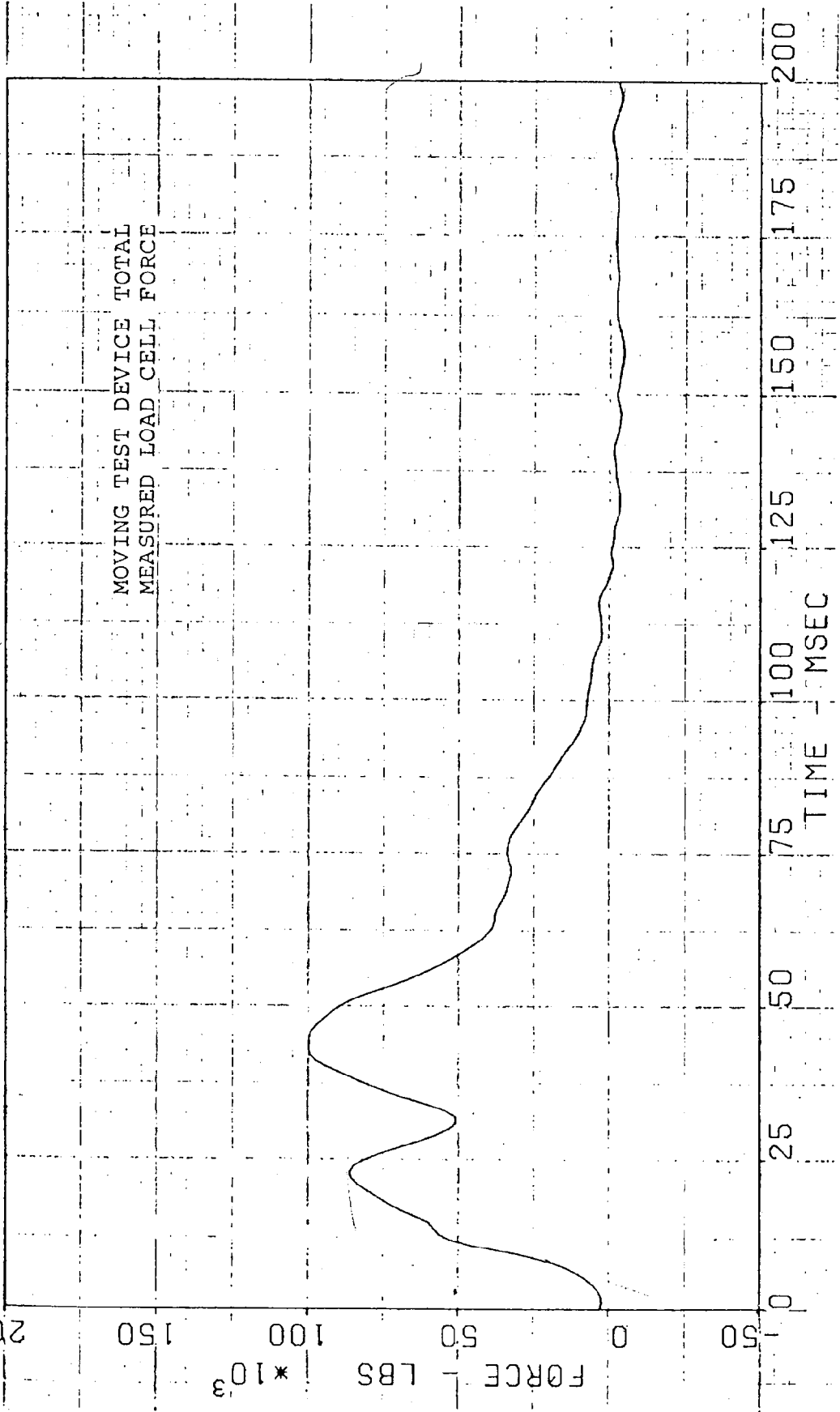

Note: Some load may have been lost between 28 and 53 msec.

DATE 5-16-78 FILTER 315/100 PARTIAL TEST NO 8316-4 TEST DEVICE
 $\Delta=1$ $\Delta=2$ 071978

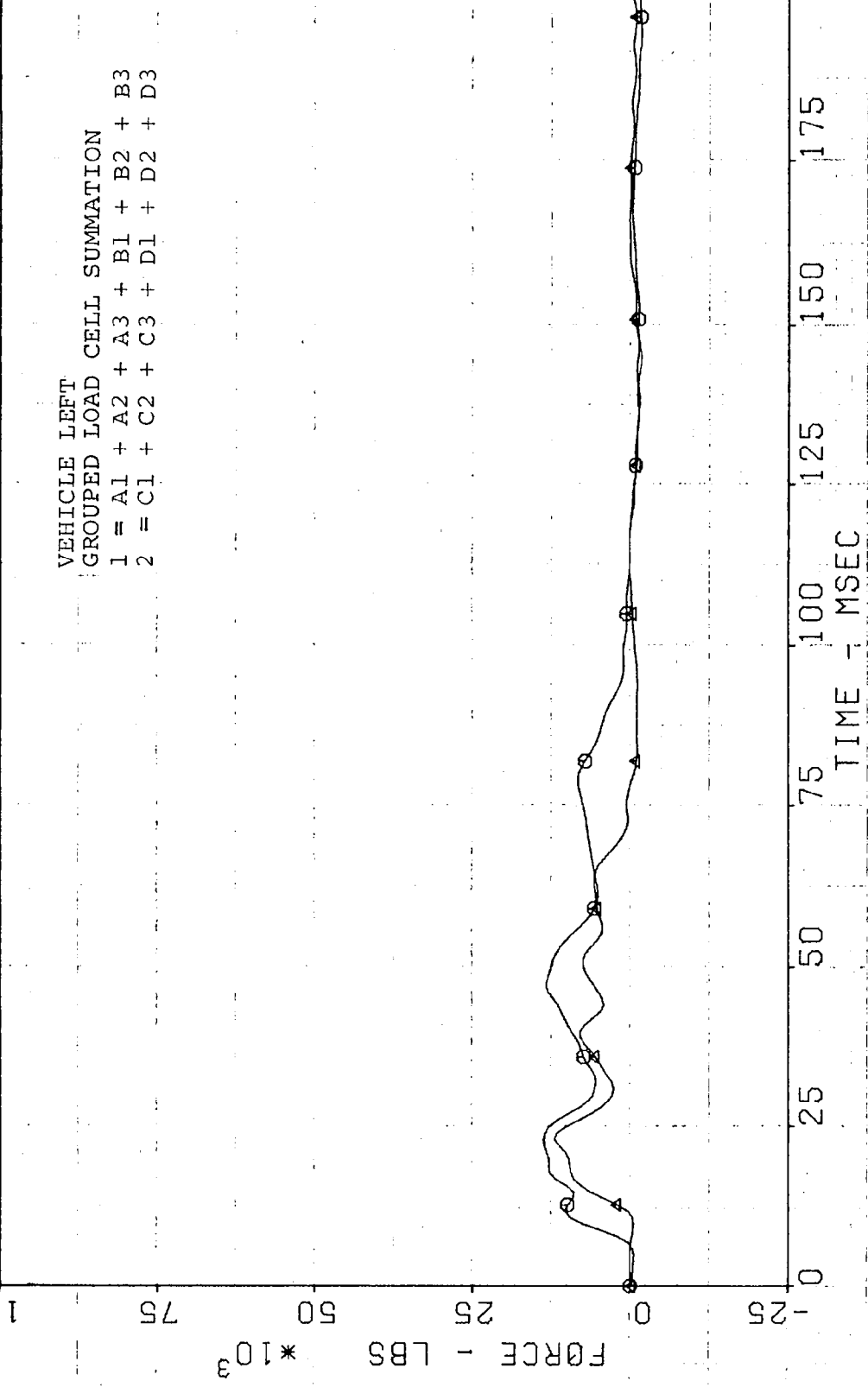

DATE 5-16-78
 FILTER 315/100
 PARTIAL TEST NO 071978
 8316-4
 TESTDEVICE
 $\phi=3$
 $\Delta=4$

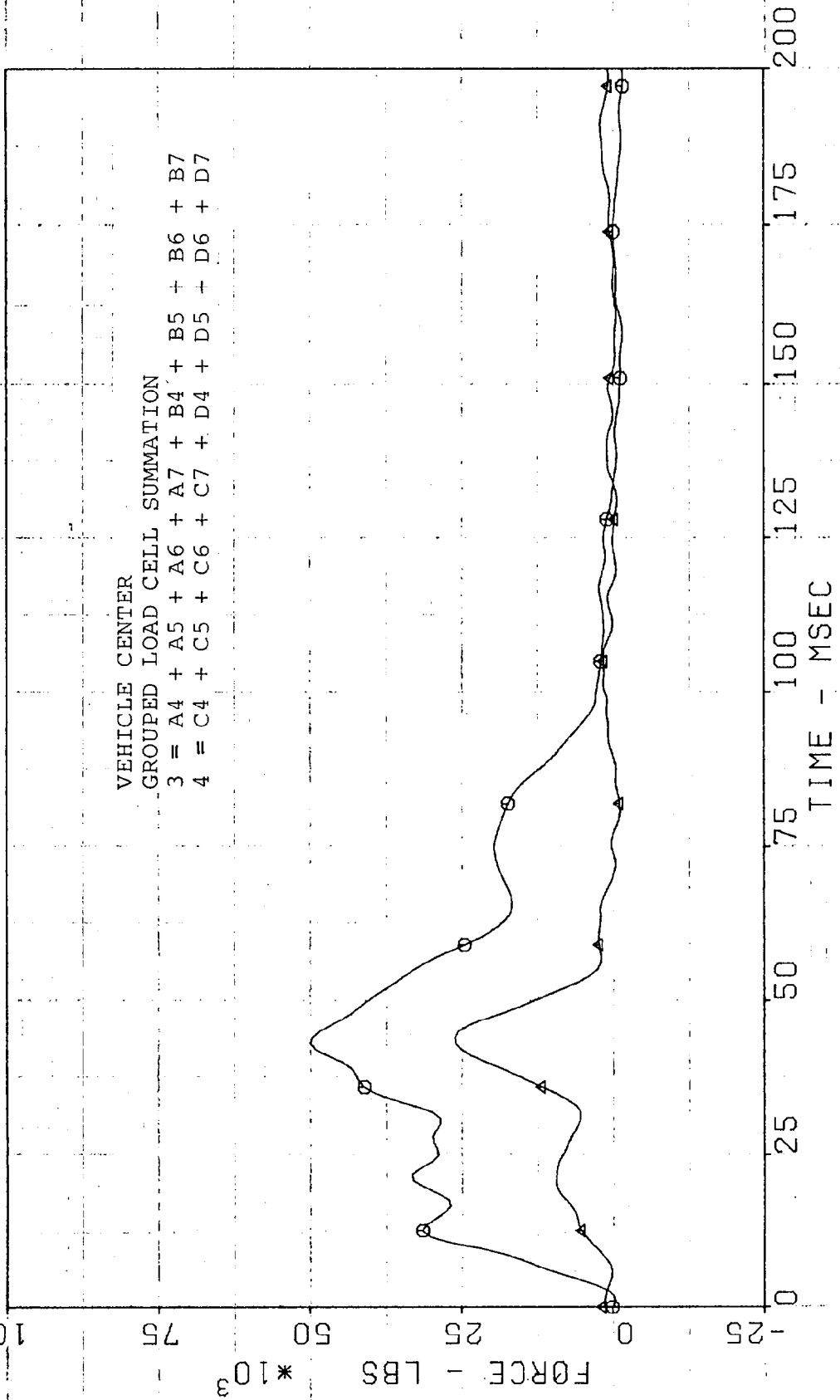

DATE 5-16-78
 FILTER 315/100
 PARTIAL TEST NO 071978
 TEST DEVICE 8316-4
 $\Delta=6$

100

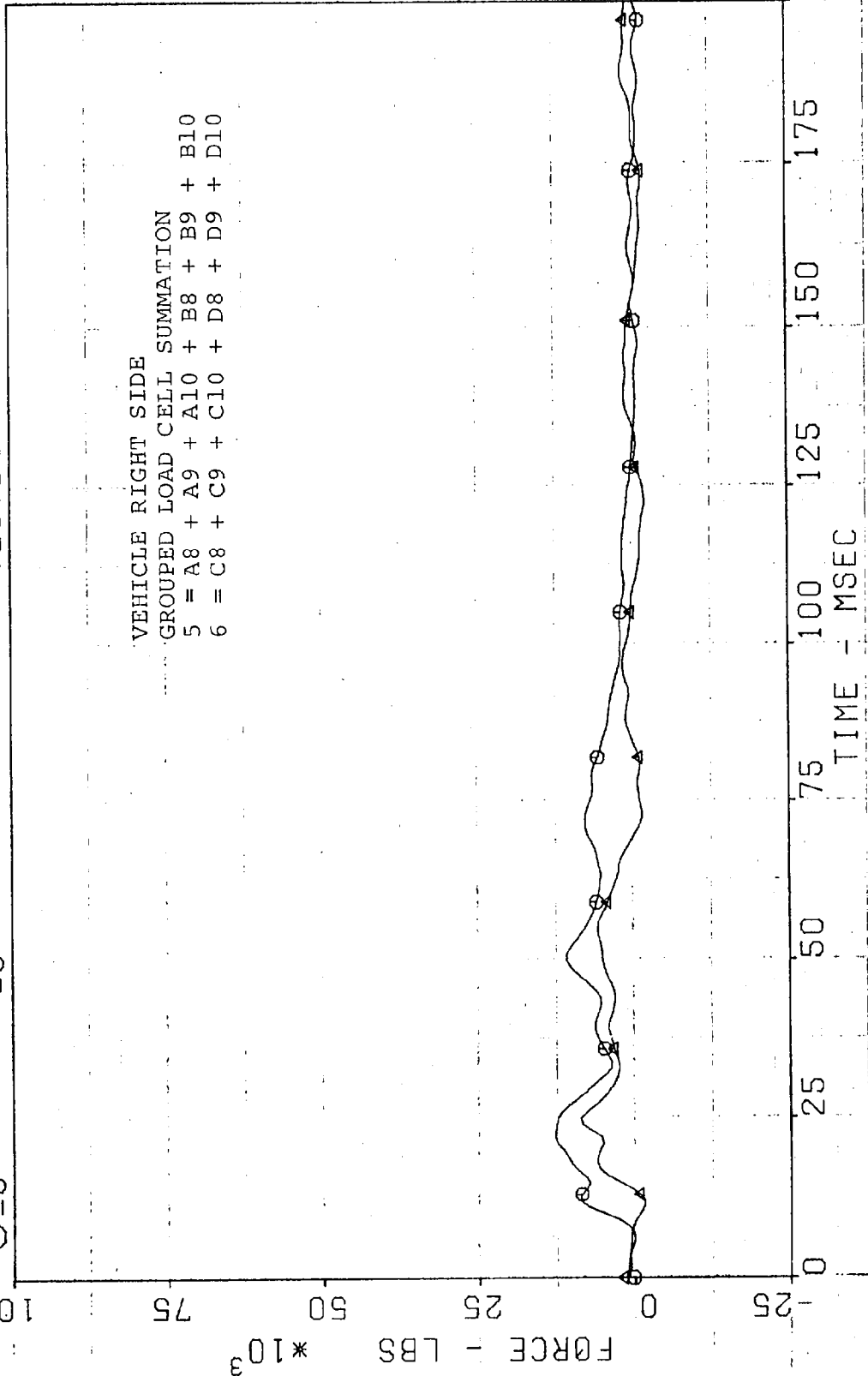

FORCE - LBS * 10³

TIME - MSEC

DATE 5-16-78 FILTER 315/100 PARTIAL TEST NO 071878
 0=1 Δ=2 Δ=3 X=4 TESTDEVICE

MOVING TEST DEVICE
 GROUPED LOAD CELL SUMMATION
 1 = ROW D
 2 = ROW D AND ROW C
 3 = ROW D, ROW C, AND ROW B
 4 = ROW D, ROW C, ROW B, AND ROW A

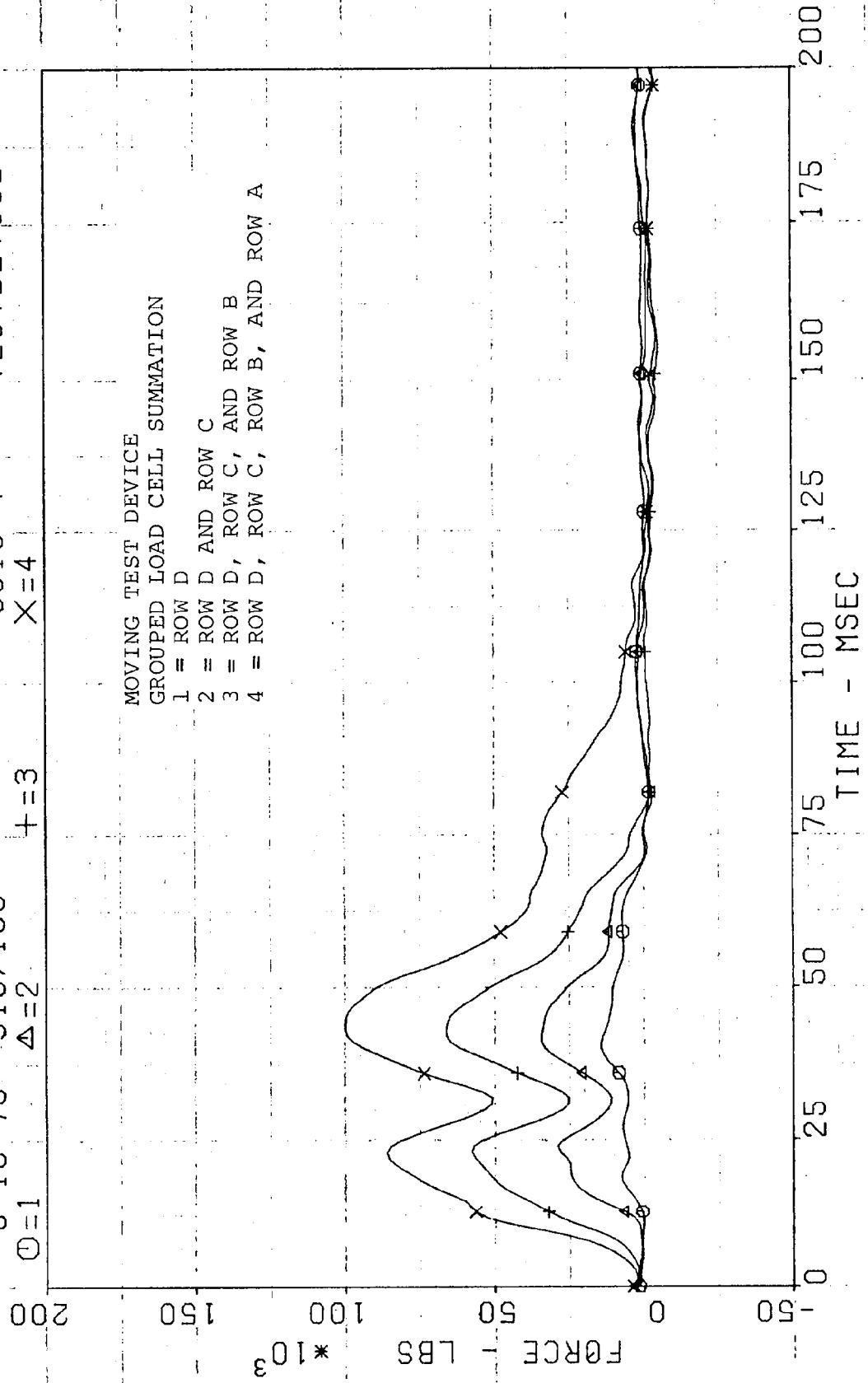

APPENDIX D

CALCULATION OF RESTRAINT SURVIVAL DISTANCE (RSD)

Prepared by:

Jack Beharrell
Analysis Engineer
Special Projects Department
May 8, 1978

APPENDIX D

CALCULATION OF RESTRAINT SURVIVAL DISTANCE (RSD)

1.0 METHODOLOGY FOR CALCULATION OF RSD

1.1 INTRODUCTION

A hypothetical air bag restraint system force-deflection characteristic is used in conjunction with barrier crash test results to calculate a relative crashworthiness parameter, the Restraint Survival Distance (RSD).

The RSD involves the occupant stroking distance (which includes the available vehicle interior space plus some portion of the vehicle front structure crush which provides occupant ride-down). The degree of vehicle structural ridedown is determined by the combination of the vehicle crash pulse characteristic and the restraint system force-deflection properties.

1.2 DETERMINATION OF RSD

The Restraint Survival Distance (RSD) is determined from the following relation:

$$RSD = AID - (D_p - D_c) (t = t^*)$$

where: AID is the available interior occupant stroking distance based on vehicle interior dimensions

t^* is the time at which the occupant velocity equals compartment velocity

D_p is the absolute displacement of the occupant from initial crash impact until t^*

D_c is the absolute displacement of the vehicle compartment from initial impact to t^* . This displacement is determined from longitudinal vehicle accelerometer data at positions (1) and (2) for the driver and passenger, respectively (Figure D-1).

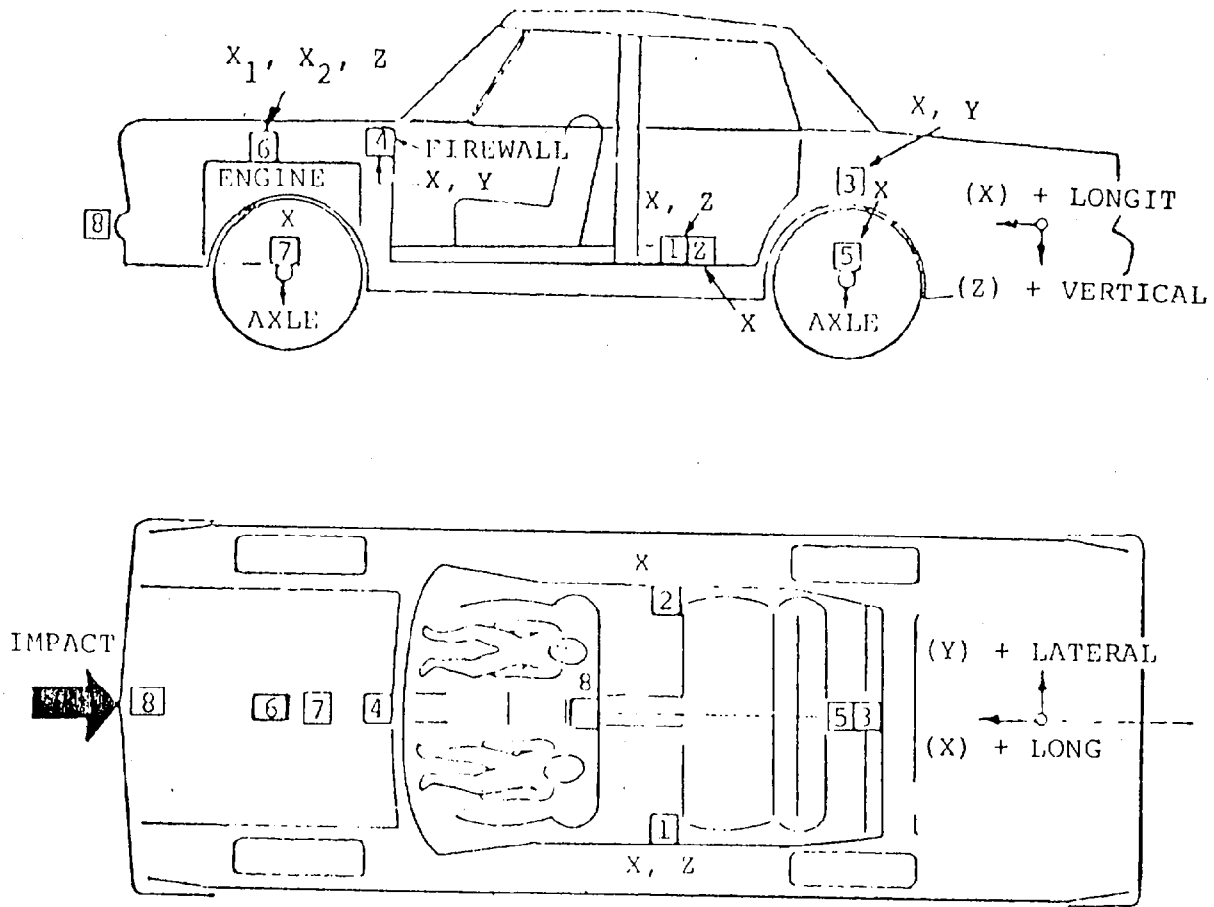

80105813

Figure D-1.

The absolute displacement of the occupant (D_p) is determined assuming the following restraint system deceleration pulse (hypothetical air bag system)

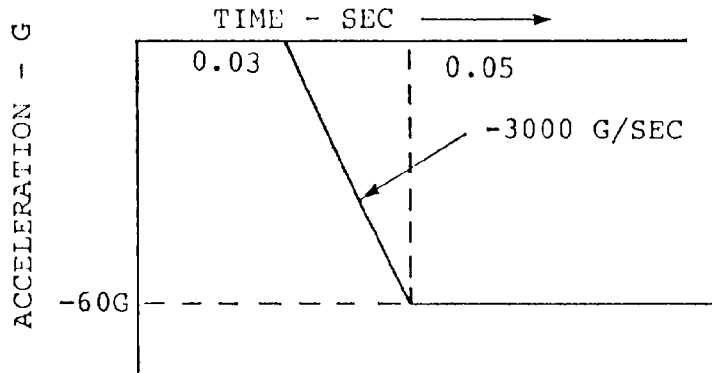

Integrating this pulse from 0 to t^* gives the occupant velocity history

$$\dot{D}_p = V_i - 43.47 + 2898t^* - 48300t^{*2} \quad (.03 \leq t^* \leq .05) \quad (\text{ft/sec})$$

$$\dot{D}_p = V_i + 77.28 - 1932t^* \quad (t \geq .05) \quad (\text{ft/sec})$$

Integrating once more gives the occupant displacement history.

$$D_p = .4347 + (V_i - 43.47)t^* + 1449t^{*2} - 16100t^{*3} \quad (.03 \leq t^* \leq .05) \quad (\text{ft})$$

$$D_p = -1.5778 + (V_i + 77.78)t^* - 966t^{*2} \quad (t \geq 0.05 \text{ sec}) \quad (\text{ft})$$

V_i is the velocity at impact.

The time t^* is most easily obtained by plotting the compartment velocity (obtained from test accelerometer data) and superimposing this curve on that obtained from \dot{D}_p above. The time at which the curves cross gives t^* . The corresponding compartment displacement is determined from the test accelerometer data. The occupant displacement at time t^* is determined from the D_p relation above.

The Available Interior Distance (AID) is determined for both pre-test and post-test compartment geometries under the following assumptions:

1. Knee restraint is located 6 inches forward of occupant's knee (horizontal measurement) if there is sufficient room in the car. The occupant's knee point is located by drawing a line tangent to the knee surface and parallel to the knee-joint to ankle-joint line. (The Cal-span knee bar was a crushable honeycomb knee padding. It is part of the assumed passive air bag restraint system.) For the purposes of the AID calculation, the knee restraint is assumed to be 10 inches thick and capable of crushing 8 inches (both measurements are taken horizontally). The knee restraint remains stationary during the collision.
2. The knee will penetrate 8 inches into the restraint, or will translate to a point located 2 inches from the deformed firewall, whichever point is reached by the knee first. This translation is performed under the restriction that the bottom of the foot remains in contact with the sloping part of the firewall (or as close to this as possible). Pivoting therefore takes place about the occupant's ankle bone pivot point.
3. Having located the occupant's knees by the preceding sequence of steps, the occupant is rotated about the hip pivot point until either:
 - a. The head hits the header or windshield.
 - b. The chest hits the dash (steering column is ignored).
4. The AID is then the horizontal displacement of the chest C.G. from the initial seated position to the position when either 3a or 3b above occurs. The chest C.G. is located 14 inches above the hip pivot point and 4 inches forward of the back of the torso.

2.0 DSI-CALSPAN RSD COMPARISON

An evaluation was made of the similarities and differences between the Dynamic Science and Calspan (Reference 1) results of fixed-barrier frontal crash tests on presumably identical 1975 Honda CVCC's.

Basic to the calculation of the RSD are the occupant and passenger compartment velocity and displacement time histories. These are derived from the respective acceleration profiles.

Figures D-2 and D-3 show the left and right compartment acceleration, velocity, and displacement histories for the DSI and for the Calspan tests. Superimposed on the velocity and displacement curves are the occupant velocity and displacement curves for the DSI test conditions (initial velocity 40.83 mph). [The Calspan occupant response curves would differ very little from these, since both are calculated on the basis of the standardized passive restraint deceleration pulse. The Calspan initial velocity was 40.25 mph.]

It is apparent from the acceleration curves (Figures D-2 and D-3) that there is a lag in the DSI acceleration-time history. This is largely due to the difference in test configuration. The DSI fixed barrier includes a 6-inch-thick layer of aluminum honeycomb on the front face. In the DSI tests, initial impact is defined as the instant of vehicle-honeycomb contact, since the test instrumentation detects this contact.

The occupant velocity and displacement curves shown in Figures D-2 and D-3 were calculated on the basis of this initial time instant. However, the occupant velocity and displacement equations are obtained by integrating the restraint deceleration pulse, assuming the initial restraint deployment-triggering signal and bag deployment requires 30 milliseconds. This signal would occur

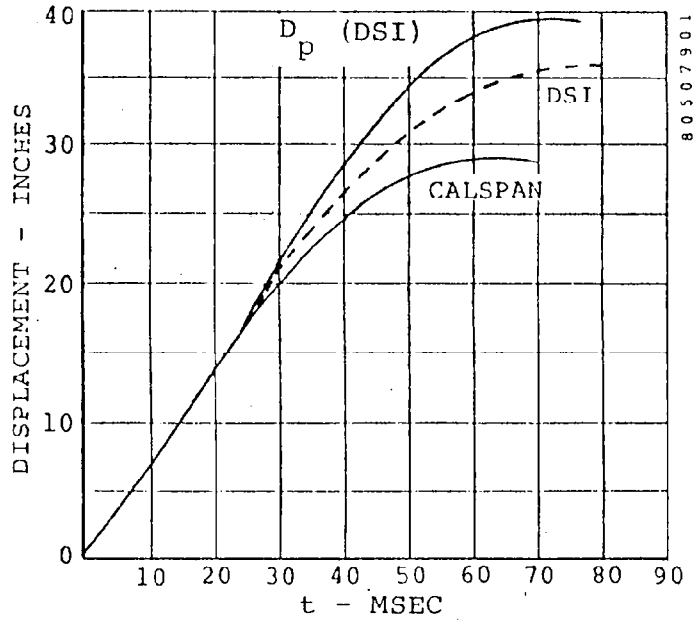

(A) DISPLACEMENT

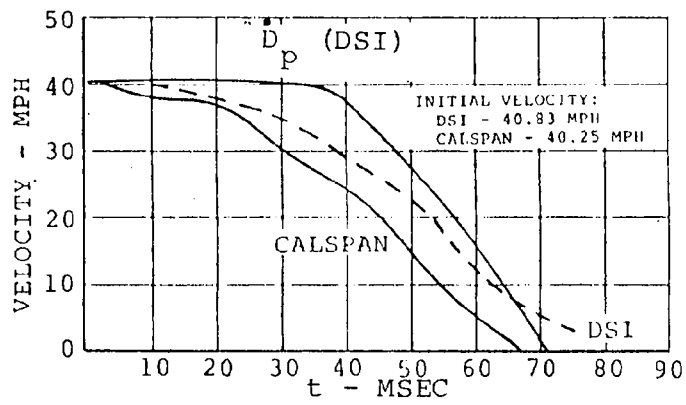

(B) VELOCITY

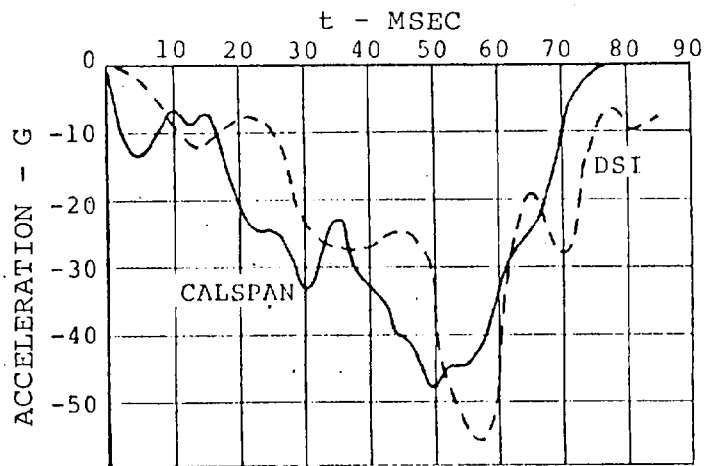

(C) ACCELERATION

Figure D-2. 1975 Honda CVCC - Fixed Barrier Test
Left Compartment.

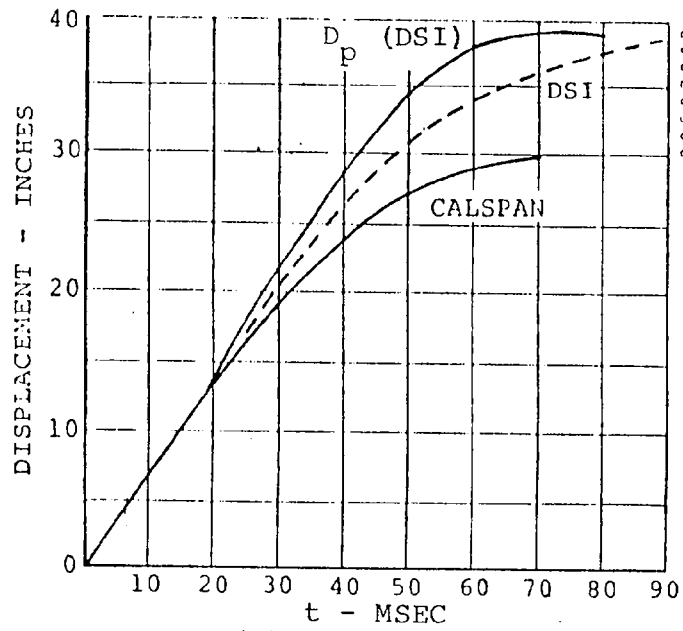

(A) DISPLACEMENT

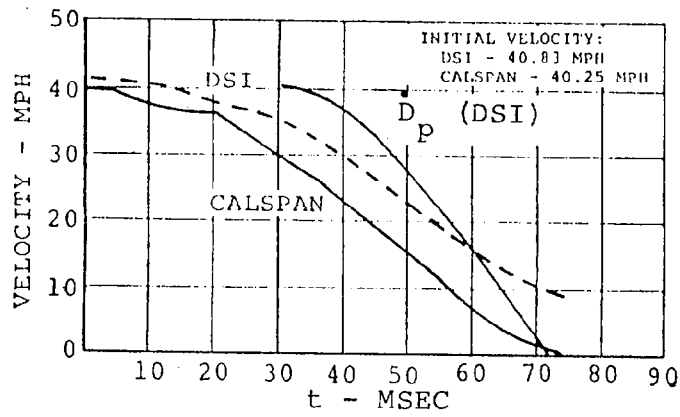

(B) VELOCITY

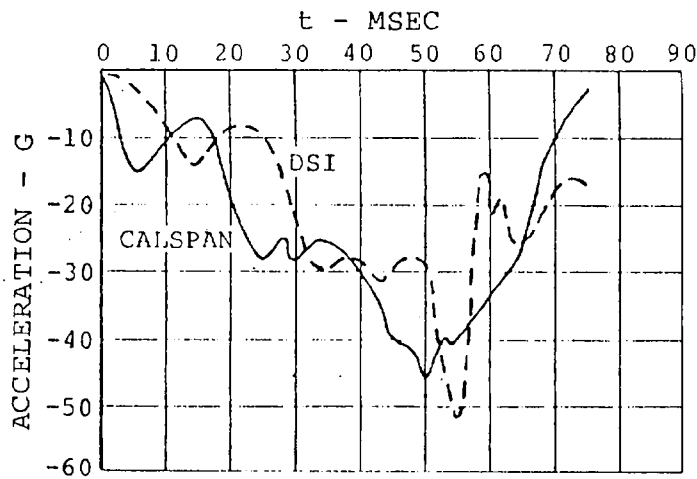

(C) ACCELERATION

Figure D-3. 1975 Honda CVCC - Fixed Barrier Test. Right Compartment.

in the DSI test some time later and thus air bag deployment would be correspondingly delayed.

For purposes of comparison, the RSD's were recalculated assuming a 7-millisecond delay in the DSI restraint deployment signal. This corresponds to a constant velocity traversal of about 5 inches of honeycomb, at 40 mph. This delay produced changes in t^* , the time at which occupant velocity equals compartment velocity, and a corresponding change in the quantity $(D_p - D_c)$ which appears in the RSD equation. The AID's are not affected, being dependent only upon compartment geometry. Table D-1 summarizes these results, along with the corresponding Calspan values.

TABLE D-1. COMPARISON OF RSD'S DSI VERSUS CALSPAN -
1975 HONDA CVCC-TO-FIXED BARRIER

	Driver		Passenger	
	Pre	Post	Pre	Post
DSI (D_p curves not shifted)	6.2	15.5	6.2	9.6
DSI (D_p curves shifted 7 msec)	1.5	10.8	3.0	6.4
Calspan	1.0	3.9	1.8	4.5

All values are in inches.

It is apparent that taking the triggering signal delay into account produces better correlation between the Calspan and DSI tests. It should be pointed out that the use of a 7-millisecond delay is somewhat arbitrary since the actual restraint deployment signal is generated on the basis of compartment deceleration. Comparison of the acceleration curves of Figures D-2 and D-3 suggests that a 7-millisecond delay is reasonable. However, the comparative results are a good indication of the care that must be taken to ensure equivalent test evaluation procedures.

REFERENCES

1. CLASSIFICATION OF AUTOMOBILE FRONTAL STIFFNESS/CRASHWORTHINESS BY IMPACT TESTING, DOT-HS-801-966, Calspan Corporation, August 1976.

dsi Dynamic Science Inc.

a **TALLEY INDUSTRIES** Company

8316

March 20, 1979

Mr. Carl Ragland (NRD-12)
Contract Technical Manager
National Highway Traffic
Safety Administration
Transpoint Building
2100 Second Street, S.W.
Washington, D.C. 20590

Subject: Transmittal of Reproducible Test Report No. 2

Reference: Contract DOT-HS-7-01758, "Develop Test Methodology for
Evaluating Crash Compatibilities and Aggressiveness"

Dear Carl:

As required by the referenced contract, we are enclosing the
reproducible and eight copies of Test Report No. 2, covering the
two Ford Torino tests:

Test 8316-3 Ford into Fixed Test Device @ 40.5 mph

Test 8316-4 Ford into Moving Test Device @ 59.1 mph

If you have any questions, please do not hesitate to contact me.

Sincerely,



Sol Davis
Manager
Special Projects Department

SD:bmv

Enclosures