





4216

Science Museum
of V



PRACTICAL TREATISE
ON
THE LEATHER INDUSTRY

SR x 575

THE ABERDEEN UNIVERSITY PRESS LIMITED

675.2
VIL

Practical Treatise

ON

The Leather Industry

BY
A. M. VILLON

A TRANSLATION OF VILLON'S "TRAITÉ PRATIQUE DE LA FABRICATION DES
CUIRS ET DU TRAVAIL DES PEAUX"

BY
FRANK T. ADDYMAN, B.Sc. (LOND.), F.I.C., F.C.S.

Science Museum
of Victoria

ONE HUNDRED AND TWENTY-THREE ILLUSTRATIONS



LONDON

SCOTT, GREENWOOD AND CO.

Publishers of Technical Works

19 LUDGATE HILL, E.C.

1901

[The Sole Right of Publishing this Work in English rests with the above Firm]

0122

18926

P R E F A C E.

AMONGST the innumerable results for which we are indebted to the steady progress of science we cannot afford to neglect those which, during the last half century, have revolutionised the leather industry.

In these days of keen competition, the *quality* of leather is of the utmost importance. Old-fashioned methods, even when backed up by cheap labour, economical motive power, and large capital, are thus unable to compete with the methods introduced by modern science.

But when anything happens to upset the established order, and to abolish or threaten old-fashioned errors, no matter whether it be in the professional, industrial, or commercial world, protestations are immediately heard on all sides.

Tant le monde se plait au joug de la routine
Tant dans son vieux sillon l'habitude s'obstine
Tant une vérité, pour beau que soit son prix
Subjuge lentement les rebelles esprits.

After a little while the new ideas begin to gain ground, and the new methods slowly become established.

This is exactly what has happened in the leather industry. Every improvement has been fought against

with violence, but always in vain, for the law of all manufactures is that improvements and changes are inevitable.

The object of this book is to set forth the best processes which are actually in use in the leather industry, selecting only those which give high-class products, and to do this without fear or favour.

The leather industry is one which requires the performance of many and varied operations. For instance, the skin of a calf, before it is made up into a part of a boot, must go through the hands of 150 workmen, whilst that of a kid passes through 156 operations before a glove is finished.

To describe clearly the work of tanning and currying, we have divided the book into seven parts.

The first contains general information with regard to the materials used for tanning. 1. Skin and its varieties. 2. Tannin and its properties. 3. Tans and methods of analysis.

The second part deals with all the operations of tanning.

The third is set apart for the description of currying in all its branches.

The fourth describes special methods of preparing skins, such as Hungarying, chamoying, tawing, morocco, parchment, fur and artificial leather manufacture, and the enamelling and gilding of leather.

The fifth is taken up with the testing of leather and the important question of the theory of tanning. For the purposes of this section, we have made over 800 analyses, a work which has required five years' constant industry.

In the sixth, we have described the chief industrial uses of leather, and given a glance at the methods of manufacturing important leather articles.

Lastly, in the seventh part, we have given a set of statistics with regard to the world's commerce in leather.

A. M. VILLON,

Chemical Engineer.

GRANDE RUE,

LYONS.

TRANSLATOR'S PREFACE.

THIS English edition of Villon's work on leather manufacture has been prepared in the hope that the French methods which it describes may be of interest and profit to English tanners. The methods used in France differ so widely from those which are used here that it has been very difficult, in many cases, to find English equivalents for the French technical terms.

It has been my good fortune to receive the help of Mr. J. T. Wood in reading and revising the proofs. Without his knowledge and experience, it would have been impossible for me to have overcome these difficulties. To him, therefore, my hearty thanks are due.

Very few changes have been made from the original book, and the arrangement of the subject-matter is entirely unaltered. An index has been added, which will, it is hoped, increase the value of the work.

F. T. A.

CHEMICAL LABORATORY,
ST. GEORGE'S HOSPITAL,
2nd November, 1900.

LIST OF ILLUSTRATIONS.

FIG.	PAGE
1. Section of skin	2
2. Nervous papillæ	4
3. Diagram showing formation of hair	5
4. Bacteria from decomposing skin	8
5. Skinning knife, designed by Brion	12
6. <i>Aspergillus Niger</i>	40
7. <i>Pencillum Glaucum</i>	41
8. Peeling iron (lozenge-shaped blade)	50
9. The <i>Extromètre</i>	85
10. Plan of a model tannery	89
11. The Bréval Press	91
12. Bark cutter	105
13. Nut mill	107
14. Grinding machine	109
15-21. Knives used in tanning	122
22. Tanner's beam	122
23. Leachers on spender pits	128
24. Pump	140
25. Tan basket	140
26. Tan spade	140
27. Tan scoop	140
28. Mechanical fan	147
29. Arrangement of drying loft	148
30. Bérendorf Press	151
31. Liming tongs	156
32. "Tumbler"	158
33. Paddles or graining wheels	169
34. Absorption estimating apparatus	199
35. Shaving knife	213
36. Moon knife	213
37. Currier's steel	213
38. Turning steel	213
39. Vice for extracting knife	213
40-42. Stones for sharpening knives	213
43. Shaving beam	213
44-49. Tools used for slicking	215
50. Diagram showing direction of stroke in slicking	216

FIG.	PAGE
51-59. Curryng tools	230
60. Tallow grinding mill	239
61. The Fleury Graining Machine	252
62. Poisson Horizontal Fulling Mill	257
63-67. Curryng tools	258
68. Swedish still	271
69. Diagram showing Payen's Spherical Receiver	273
70-71. Varnishing tools	288
72. Villon's Machine for Dressing (roller system)	299
73. Iwaskiewiez's square "Tumbler"	307
74. Fleshing knife for glove leather	313
75. Fleshing knife for sheep and goat leather	313
76. Wool shears	313
77. Unhairing knife	313
78. Scudding knife	313
79. Tongs	313
80. Knee stake	313
81. French frizing knife	313
82. "Fluffing" Machine	314
83. Fulling machine	318
84. Glazing machine	349
85. Fleshing knife (parchment maker's)	357
86. Paring knife for skins slack in the frame	357
87. Paring knife for skins stretched in the frame	357
88. Polishing tool for vellum	357
89. Steel	357
90. Furrier's stocking machine	379
91. Machine for denoting "breaking strain"	398
92. Diagram showing curves of good and bad leather	399
93. The Thomasset Testing Machine	400
94. Apparatus for measuring degree of brittleness	401
95. Micro-organisms	408
96-99. Various methods of belt stitching	435-437
100-104. Patterns of rivets and screws	438
105-112. Showing how chain belts are pieced together	440-443
113-118. Showing arrangement of belts on pulleys	445
119. Bending machine	448
120. Tools used in shoemaking	450
121. Lace-making punch	452
122. Perforated plate for rounding and polishing laces	452
123. Various tools for working leather	456

CONTENTS.

	PAGE
PREFACE	v
TRANSLATOR'S PREFACE	viii
LIST OF ILLUSTRATIONS	ix, x

PART I.—MATERIALS USED IN TANNING.

CHAPTER I.—SKINS—

I. Skin and its Structure	1
II. Skins used in Tanning	9
III. Various Skins and their Uses	23

CHAPTER II.—TANNIN AND TANNING SUBSTANCES—

I. Tannin	30
II. Barks (Oak)	45
III. Barks other than Oak	59
IV. Tanning Woods	61
V. Tannin-bearing Leaves	65
VI. Excrescences	67
VII. Tan-bearing Fruits	70
VIII. Tan-bearing Roots and Bulbs	72
IX. Tanning Juices	72
X. Tanning Substances used in Various Countries	75
XI. Tannin Extracts	76
XII. Estimation of Tannin and Tannin Principles	79

PART II.—TANNING.

CHAPTER I.—THE INSTALLATION OF A TANNERY—

I. Tan Furnaces	90
II. Chimneys, Boilers, etc.	100
III. Steam Engines	101

CHAPTER II.—GRINDING AND TRITURATION OF TANNING SUBSTANCES—

I. Cutting up Bark	103
II. Grinding Bark	105
III. The Grinding of Tan Woods	108
IV. Powdering Fruit, Galls and Grains	110
V. Notes on the Grinding of Bark	111

	PAGE
CHAPTER III.—MANUFACTURE OF SOLE LEATHER—	
I. Preparation for Tanning	113
II. Sweating and Unhairing	117
III. Plumping and Colouring	126
IV. Handling	136
V. Tanning	137
VI. Tanning Elephants' Hides.	142
VII. Drying	143
VIII. Striking or Pinning	150
CHAPTER IV.—MANUFACTURE OF DRESSING LEATHER—	
I. Soaking	153
II. Depilation	154
III. New processes for the Depilation of Skins	163
IV. Tanning	168
V. Cow Hides	172
VI. Horse Hides.	173
VII. Goat Skins	174
Manufacture of Split Hides	174
CHAPTER V.—ON VARIOUS METHODS OF TANNING—	
I. Mechanical Methods	177
II. Physical Methods	183
III. Chemical Methods	185
IV. Tanning with Extracts	190
CHAPTER VI.—QUANTITY AND QUALITY—	
I. Quantity	195
II. Net Cost	196
III. Quality of Leather	197
CHAPTER VII.—VARIOUS MANIPULATIONS OF TANNED LEATHER—	
I. Second Tanning :	201
II. Grease Stains	202
III. Bleaching Leather	203
IV. Waterproofing Leather	204
V. Weighting Tanned Leather	205
VI. Preservation of Leather	206
CHAPTER VIII.—TANNING VARIOUS SKINS	208

PART III.—CURRYING.

	PAGE
CHAPTER I.—WAXED CALF—	
I. Preparation	211
II. Shaving	212
III. Slicking or Striking Out	214
IV. Oiling the Grain	217
V. Oiling the Flesh Side	217
VI. Whitening and Graining	229
VII. Waxing	231
VIII. Finishing	234
IX. Dry Finishing	242
X. Finishing in Colour	242
XI. Cost	244
CHAPTER II.—WHITE CALF—	
Finishing in White	245
CHAPTER III.—COW HIDE FOR UPPER LEATHERS—	
I. Black Cow Hide	248
II. White Cow Hide	248
III. Black Cow Hide	249
IV. Coloured Cow Hide	249
CHAPTER IV.—SMOOTH COW HIDE	251
CHAPTER V.—BLACK LEATHER	256
CHAPTER VI.—MISCELLANEOUS HIDES—	
I. Horse	265
II. Goat	266
III. Waxed Goat Skin	267
IV. Matt Goat Skin	267
CHAPTER VII.—RUSSIA LEATHER—	
I. Russia Leather	269
II. Artificial Russia Leather	272
PART IV.—ENAMELLED, HUNGARY AND CHAMOY LEATHER, MOROCCO, PARCHMENT, FURS AND ARTIFICIAL LEATHER.	
CHAPTER I.—ENAMELLED LEATHER—	
I. Varnish Manufacture	275
II. Application of the Enamel	288
III. Enamelling in Colour	290

	PAGE
CHAPTER II.—HUNGARY LEATHER—	
I. Preliminary	293
II. Wet Work or Preparation	295
III. Aluming	295
IV. Dressing or Loft Work	298
V. Tallowing	299
VI. Hungary Leather from Various Hides	303
CHAPTER III.—TAWING—	
I. Preparatory Operations	305
II. Dressing	309
III. Dyeing Tawed Skins	313
IV. Rugs	314
CHAPTER IV.—CHAMOY LEATHER	315
CHAPTER V.—MOROCCO—	
I. Preliminary Operations	320
II. Morocco Tanning	321
III. Mordants used in Morocco Manufacture	322
IV. Natural Colours used in Morocco Dyeing	325
V. Artificial Colours	332
VI. Different Methods of Dyeing	332
VII. Dyeing with Natural Colours	338
VIII. Dyeing with Aniline Colours	343
IX. Dyeing with Metallic Salts	344
X. Leather Printing	345
XI. Finishing Morocco	347
XII. Shagreen	350
XIII. Bronzed Leather	351
CHAPTER VI.—GILDING AND SILVERING—	
I. Gilding	352
II. Silvering	354
III. Nickel and Cobalt	354
CHAPTER VII.—PARCHMENT	355
CHAPTER VIII.—FURS AND FURRIERY—	
I. Preliminary Remarks	359
II. Indigenous Furs	360
III. Foreign Furs from Hot Countries	370
IV. Foreign Furs from Cold Countries	374

CONTENTS.

XV

	PAGE
V. Furs from Birds' Skins	376
VI. Preparation of Furs	377
VII. Dressing	378
VIII. Colouring	380
IX. Preparation of Birds' Skins	387
X. Preservation of Furs	388

CHAPTER IX.—ARTIFICIAL LEATHER—

I. Leather made from Scraps.	391
II. Compressed Leather	391
III. American Cloth	392
IV. Papier Mâché	393
V. Linoleum	393
VI. Artificial Leather	394

PART V.—LEATHER TESTING AND THE THEORY OF TANNING.

CHAPTER I.—TESTING AND ANALYSIS OF LEATHER 396

I. Physical Testing of Tanned Leather	397
II. Chemical Analysis	402

CHAPTER II.—THE THEORY OF TANNING AND OTHER OPERATIONS

IN THE LEATHER AND SKIN INDUSTRY—

I. Theory of Soaking	406
II. Theory of Unhairing	407
III. Theory of Swelling	413
IV. Theory of Handling	415
V. Theory of Tanning	417
VI. Theory of the Action of Tannin on the Skin	418
VII. Theory of Hungary Leather Making	425
VIII. Theory of Tawing	428
IX. Theory of Chamoy Leather Making	430
X. Theory of Mineral Tanning	432

PART VI.—USES OF LEATHER.

CHAPTER I.—MACHINE BELTS—

I. Manufacture of Belting	433
II. Leather Chain Belts	438
III. Various Belts	441
IV. Use of Belts	441

	PAGE
CHAPTER II.—BOOT AND SHOEMAKING—	
I. Boots and Shoes	447
II. Laces	451
CHAPTER III.—SADDLERY—	
I. Composition of a Saddle	453
II. Construction of a Saddle	455
CHAPTER IV.—HARNESS—	
I. The Pack Saddle.	458
II. Harness	459
CHAPTER V.—MILITARY EQUIPMENT	463
CHAPTER VI.—GLOVE MAKING	467
CHAPTER VII.—CARRIAGE BUILDING	469
CHAPTER VIII.—MECHANICAL USES	471
APPENDIX.—THE WORLD'S COMMERCE IN LEATHER.	
I. Europe	473
II. America	483
III. Asia	485
IV. Africa	486
V. Australasia	487
INDEX	489

THE LEATHER INDUSTRY.

PART I.

MATERIALS USED IN TANNING.

CHAPTER I.

SKINS.

I.—SKIN AND ITS STRUCTURE.

THE skin is a membranous tissue which covers the bodies of men and most other animals. When grasped, it is found to be both tough and elastic.

This toughness has been made use of, in the art of tanning, for the manufacture of leather.

As to the elasticity of the skin, which can attain incredible proportions, the example may be mentioned of a glutton who lived at the end of the last century named Tarare, who could hide away in his cheeks twelve eggs and twelve apples; and who, before he had partaken of his breakfast, could draw away the skin from his belly and stretch it completely round his body.

1. Physiology of the Skin.—The skin is the seat of those nervous elements, the corpuscles of touch, which are spread over the surface to protect us from outside dangers, and also of a series of exceedingly elastic blood-vessels which have the power of swelling or contracting. The influx of blood into these vessels produces an increase of temperature in the body, and they are in consequence the principal heating agents. To compensate for this warmth, the surface of the skin secretes, by means of the perspiratory glands, a special liquid, "the sweat," whose evaporation moderates this heating effect. The sweat has another duty; it carries away from

the body various poisonous substances nearly identical with those occurring in urine.

Under ordinary conditions, even in the cold, considerable evaporation of water takes place from the surface of the skin, which is known as transpiration. It is usually invisible, because the water disappears in the air as vapour even through clothing. Further, this evaporation of water is accompanied by considerable quantities of carbonic acid. Since these two substances are also given off

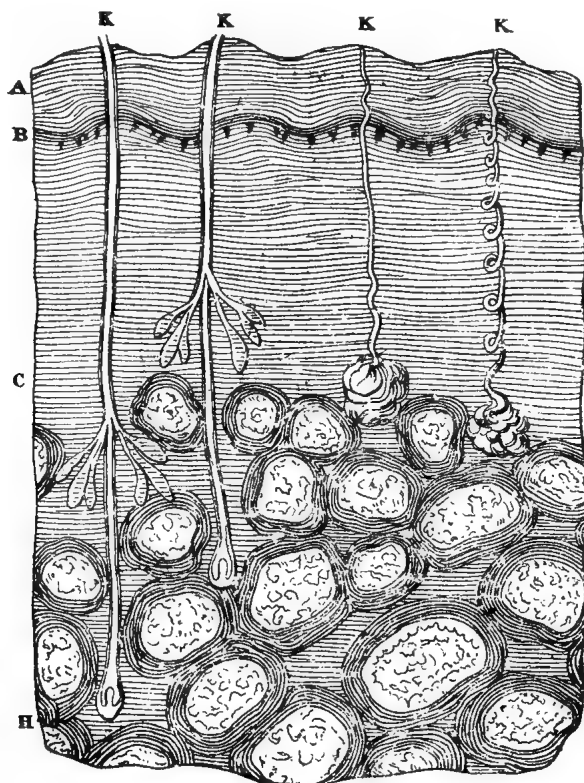

FIG. 1.—Section of skin: A, epidermis; B, malpighian layer; C, dermis; H, hypodermis.

from the lungs, it must be admitted that the skin is a kind of external lung, and that it is the seat of true respiration.

The sebaceous glands attached to all hairs secrete another substance, a fatty matter which helps to maintain the suppleness and brilliancy of the hair. The openings of the skin, whether they give out sweat or sebaceous matter, are known as the pores.¹

¹ Conference at the Conservatoire des Arts et Metiers, 22nd January, 1888, Dr. Hector George's *Hygiene of the Skin*.

2. Anatomy of the Skin.—The skin, which appears to be a simple membrane, is in reality composed of two layers—the one deep and thick, the *dermis*: the other superficial and much thinner, the *epidermis* (Fig. 1).

The *epidermis* contains neither blood nor nerves; pricking it causes neither bleeding nor pain. It is produced by secretion from the dermis. It is always being renewed from below, and destroyed at its surface, where it is rubbed off in scales which get mixed up with the other substances secreted from the skin.

The epidermis consists of two layers. The first, superficial (A), known as the cuticle or lamellar layer, consists of dry transparent tissue which is very thin and elastic, and covered either with hair, or, in certain parts, with nails.

The other, deeper layer (B), named the mucous or malpighian layer, consists of tissue made up like the superficial layer of nucleated cells, which may be considered as the seat of the nervous papillæ and of the colouring matter which gives to the skin its peculiar tint.

The *dermis*, or *chorion*, is a thick membrane composed of matted fibres forming a close and elastic pelt. The dermis, again, consists of two layers. The first or deeper one, which is the dermis, properly so called, encloses the papillæ, the perspiratory glands, the sebaceous glands, the hair follicles, the arteries, the veins, the nerves, the muscles, and the lymphatics. The second superficial and pigmented layer is directly in contact with the malpighian layer, and is named the papillary or pigmented layer.

Strictly speaking, the papillæ make up the papillary layer of the dermis; they are divided into two classes, (*a*) vascular papillæ, enclosing vascular systems, each made up of an artery and a vein; and, (*b*) the nervous papillæ which contain no blood-vessels. The blood-vessels (arteries and veins) occupy two regions, one in the dermis and the other in the papillary layer, whence they give rise to the capillary systems which penetrate the papillæ.

The *nerves* of the skin ramify in the superficial portion of the dermis and in the papillæ, and they come to an end in the nervous papillæ (Fig. 2).

The *hypodermis*, or subcutaneous connective tissue, consists of fibres extending from the deeper face of the skin to the flesh. It contains the fat cells and the sweat glands whose channels cross the thickness of the other layers.

The hairs are simple epidermic productions. They come from pits in the epidermis which sink deeply into the dermis. They start thus from the dermis, and extend to the outside. All hairs are terminated by a bulb in the dermis, which contains albuminous matter. They spring from a follicle fixed in the thickness of the skin, and are produced by a papilla. At the neck of this follicle is a little gland which secretes a peculiar fatty substance (Fig. 3).



FIG. 2.—Nervous papillæ.

The space between the wall of the follicle and the hair is filled with cells which are continuous with the epidermis of the skin on the one hand and the hair itself on the other. These cells are filled with a special albuminous substance to which the name of *pilline* has been given.

Each hair is made up of three parts. Firstly, a fundamental substance or corticle, hard, elastic, hygrometric, and showing longitudinal striæ, broken here and there; secondly, a central, spongy portion consisting of little granular cells of various shapes; and thirdly, of an epidermal scaly layer formed of little polygonal scales, which overlap like the scales of a fish.

Hairs are usually round, like those of a man or an ape; but occasionally they are oval, as in the beaver, or else flattened or channeled, like those of the sloth.

3. Physical Constitution of Skin.—Skin which is ready for tanning is not in the same condition as when it was first removed from the animal, but has already been prepared by the preliminary operations of the tanner. It is in reality a corium or dermis from which has been removed, either by mechanical or chemical means, all foreign or superfluous substances. The physical properties of skin mentioned in this section apply to this dermis, which constitutes the principal portion of the skin.

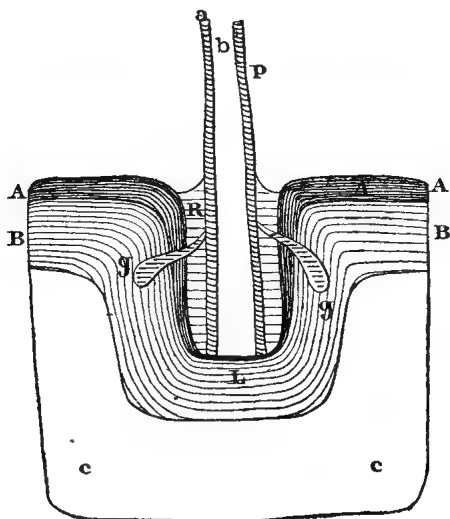

FIG. 3.—Diagram showing formation of a hair. A, epidermis; B, dermis dipping to form the bulb; c, subcutaneous tissue; p, hair; R, albuminous cells; L, portion of dermis from which the hair develops; gg, sebaceous glands; a, cortical substance; b, medullary substance.

In the damp state, skin preserves all the properties which it possessed whilst on the body of the animal. It is a very soft, flexible, milk-white tissue, formed of bundles of fibres very loosely entangled with one another, and running parallel with the surface of the skin.

The fibres are colourless, translucent, and have numerous branches. The milk-white colour and opacity are only caused by an optical phenomenon—the dispersion of light.

When this tissue is dried it contracts into a homogeneous, horny mass, translucent and without apparent structure. This

phenomenon—that skin loses its milk-white appearance in drying—shows that the fibres of the fibrous and elastic tissue cake or stick together so closely that the spaces between them disappear, and there is no longer any dispersion of the light.

The tenacity with which the fibres adhere to each other is so great that it is impossible to separate them by purely mechanical means, or to give back its suppleness to the skin by any dry method. It remains hard, rigid and parchment-like. When it is soaked in water it recovers its softness.

4. Chemical Composition of the Skin.—At ordinary temperatures skin is insoluble in water, but when it is boiled for some time it softens, becomes mucous and translucent, and finally dissolves. On cooling, the solution sets to a jelly and forms what is known as gelatine. The skin is thus converted into glue.

Skin consists principally of an animal substance, which is converted by boiling with water into gelatine, and is therefore closely allied to this body.

Reimer considers that skin consists of a gelatinous substance having the formula $C_{15}H_{23}N_5O_6$ (containing 18·9 per cent. of nitrogen), together with about 5 per cent. of a special substance *coriine* having the formula $C_{30}H_{50}N_{10}O_{15}$, which would contain 17·7 per cent. of nitrogen.

Müntz, on the other hand, has found for the percentage composition of skin :—

Carbon	51·43
Hydrogen	6·64
Nitrogen	18·16
Oxygen	23·06
Mineral ash	0·17
	99·46

The mineral ash consists of :—

Silica soluble in hydrochloric acid	·066
Sulphate of lime	·624
Equal to lime	·2568
Pyrophosphate of magnesia	·228
Equal to phosphoric acid	·144
Oxide of iron and alumina	·158
Oxide of manganese	not estimated
Alkaline chlorides	·204

Skin is insoluble in alcohol, ether, fatty, or mineral oils. Dilute acids or alkalies very slowly convert it to glue, even at the ordinary temperature.

Proximate analysis gives the following results (Müntz):—

Cellular tissue not attacked by boiling water	3.080
Fat	1.058
Mineral ash467
Substances convertible to gelatine	95.395
	<hr/>
	100.000

The cellular tissue is soluble in Schweitzer's reagent (oxide of copper dissolved in ammonia); and is precipitated from this solution by acetic acid in which it resembles the substance which forms the framework of plants.

When a skin is left to soak in water for some time it begins to smell putrid, showing that some kind of decomposition has taken place. It loses its thickness, and later on becomes filled with holes which grow larger and larger, until, in the end, the skin is entirely destroyed.

This entire change of the dermal tissue is due to certain septic micro-organisms which swarm in the air and on the surface of animal bodies, particularly where any dead matter exists. Amongst the many micro-organisms which help in the putrefaction of skin, the principal is one named *bacterium termo*. It is a short cylindrical rod from 1 to $1\frac{1}{2}$ μ ¹ in diameter by 5 to 7 μ in length. It is flagellated, and has a contraction around its middle. These rods unite to form either irregular colonies, round zoogloæ or chains. *Bacillus subtilis* also takes a leading part in the work of putrefaction; it is a little rod 2 to 5 μ in length and about half that in thickness. *Bacillus ulna*, longer and thicker than the preceding ones, and sometimes even *bacillus septicus*, help the others in their work. Under their influence the skin is transformed firstly into gelatine, then into peptones, leucine, tyrosine, butyric, margaric and palmitic acids. It gives off nauseous volatile matters—ammonia, scatol, indol, etc., and finally it forms putrid poisons which have been studied under the name of *coriidines*.

¹ μ is the unit generally used in measuring these minute organisms; it is $\frac{1}{1000}$ millimetre or about $\frac{1}{254000}$ inch.—Trans.

This alteration of the skin may be prevented by the use of antiseptics such as alum, corrosive sublimate, mercuric iodide, etc.

In practice, tanners usually leave the skins in clear lime-water, but under these conditions the surface deteriorates slowly under the influence of a special micro-organism which will be described in detail when we are treating of depilation.

5. The Object of Tanning.—The tanner's art consists of giving to the skin the property of remaining supple, tough and unalterable ; in fact, of transforming it into leather.

This result is achieved :—

1. By the action of *tannin*, a substance occurring in many vegetables, or *tanning* properly so called.
2. By the action of alum or common salt, as in the manufacture

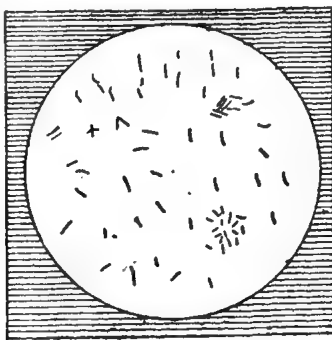

FIG. 4.—Bacteria from decomposing skin.

of Hungarian leather and in tawing ; or of salts of iron, chromium, copper, etc., in mineral tanning.

3. By the action of either animal, vegetable, or mineral fats, as in the making of chamois leather.

The different operations of tanning, considered generally, have a double object : (1) to take away any tendency to putrefaction from the skin ; and (2) to prevent its becoming hard and horny on drying, and to form a fibrous opaque tissue, more or less supple and flexible, which will not easily wear away by rubbing.

A skin which has been submitted to these operations is said to be tanned. To attain these two objects, the skin must undergo three principal operations : (1) preparation for tanning or the "wet work" ; (2) tanning, which changes it into leather ; and (3)

currying, which makes it supple and prepares it for the various uses for which it is intended.

II.—SKINS USED FOR TANNING.

Skins used for tanning are obtained from the following sources :—

1. Beasts slaughtered for butcher meat.
2. Horses which have died naturally.
3. Horses which have died accidentally or which have been slaughtered because they have become unfit for service, through illness or contact with contagious disease.
4. Imported skins, salted, dried, with or without hair.
5. Various animals peculiar to certain districts.

1. **Butchered Beasts.**—The skins of the ox, the cow, the calf, the mule, the ass, and the horse are those most commonly used by the tanner.

The Ox.—The ox is the most useful animal of which we have any knowledge. Whilst alive, it is used in many countries as the principal agricultural beast of burden, whilst its produce (milk and manure) is very valuable ; when dead, its meat serves for our food and its skin is one of those most commonly used by the tanner. Old or young it renders us service.

The common ox (*bos taurus*) has a great number of breeds, which by crossing give varieties more or less adapted for work, for fattening, or for milk. On page 10 we have drawn up in tabular form a list of the best known breeds and their yield of leather, fat and beef. From these figures it will be seen that, on an average, a beast weighing 1,000 lb. will give :—

Meat	680 lb.
Fat	89 „
Leather	54 „
Blood, etc.	74 „
Intestines, fæces and loss	103 „
	<hr style="width: 10%; margin: 0 auto;"/> 1,000 lb.

The skinning of the animal, which is known as trussing, is accomplished in the following manner : After killing and bleeding, the animal is placed on its back, the head bent over on its right shoulder to serve as a handle. A wooden peg is fixed on the

other side to do a like duty; the four legs are lifted up, and two circular holes $\frac{1}{2}$ in. to $\frac{3}{4}$ in. in diameter are made in the thickness

Breed.	Locality.	Colour.	Live Weight.	Weight of Meat.	Weight of Skin.	Weight of Tallow.
			lb.	lb.	lb.	lb.
Agen	Garonne between Agen and Marmande	Yellowish grey.	1483	933	117	121
Durham	Yorkshire and Durham	White and red.	1958	1298	114	213
Charolles	Department of Seine and Loire	White or yellowish.	2037	1342	121	183
Vendée	Vendée	Yellow, deep buff.	1870	1144	112	260
Auvergne	Auvergne	Bright red.	2046	1364	136	198
Garonne	From Agen to Bordeaux	Straw coloured.	1483	935	117	121
Gascon	Ariège	Dun.	1958	1316	123	203
Norman	Normandy	Mottled.	2167	1386	114	227
Angus	North of Scotland	Black.	1474	904	117	121
Breton	Brittany	Black and white.	1386	935	86	172
Ayrshire	South-west of Scotland	Pale red and white.	1982	1309	114	218
Bazas	Gironde (Bazas)	Grey, brown and black.	1791	1122	117	203
Bearnaise	Valley of Ossan (Pyrenees)	Yellow, pale red.	1738	1137	121	189
Boulogne	Coast of Pas-de-Calais	Red.	1870	1144	112	260
Algerian	Algeria and the Mediterranean coast	Dark brown.	1995	1322	130	216
Morvan	Nievre and Yonne	Yellow, flesh tint.	1362	891	110	203
Aubrac	North-west of Aveyron and south of Cantal	Russet, chestnut.	1716	1144	121	150
Hereford	Herefordshire. Furnishes London with meat	Red.	2011	1316	117	165
Devon	Devon, Barnstaple to Tiverton	Light red.	1566	946	110	178
Steppes	Central Russia and Hungary	Dull white.
Camargues	Central France and Bouches-du-Rhone	Black.	1784	1192	120	187
Shorthorn	Northern England	Red.

of the skin, one in the rump, close to the anus, the other in the neck. Iron rods are thrust in through these holes, between the

skin and the flesh, and moved about in all directions so as to form many channels. The rods are then drawn out and the nozzles of two powerful pairs of bellows are introduced into the holes, and air is forced in. During the introduction of the air, assistants strike the body all over with sticks to help in tearing the subcutaneous tissues. Afterwards a cut is made in the skin running from one hole to the other along the abdomen and chest. The animal is then hung up by its hind legs on the gambrel tied to the cord of a windlass. Beginning with the cut in the belly, the skin is taken from the back and carefully folded.

Calves.—The skins of calves are very fine, the best being furnished by animals five or six months old. Calves are slaughtered by making a wide gash in the neck and skinned much in the same manner as oxen, though more care has to be exercised in the process.

Cows.—Cows give two different qualities of skin according to whether they have calved or not. Milch-cows only furnish skin for dressing leather, because the distention which they have undergone during the period of gestation has weakened it too much for the manufacture of sole leather.

An average cow gives :—

Meat (dry)	70 lb.
Leather	70 "
Bone	110 "
Fat	70 "

These numbers are given as they have been collected from different skimmers.

Horses.—The horse is killed much in the same way as the ox. A horse which is slightly above the average size gives :—

Meat (dried)	80 lb.
Bone	136 "
Leather	80 "
Hair, mane, tail, etc.	11 "

Preference should be given to nervous animals, which are thin but healthy.

Horses accustomed to long and rapid journeys and those which

have been allowed considerable freedom give excellent leather with a compact and strong texture.

Sheep and Goats.—There is nothing especially worth mentioning with regard to these skins, excepting that their yield is about 6 or 8 per cent. of their live weight.

2. Dead Animals.—Animals which have died naturally or accidentally are either cut up on the farm or removed to the knacker's yard. The separation of meat, blood, fat, bone, tendons, etc., is carried out much in the same way as in the slaughter-houses, excepting that the meat is used for the manufacture of manure, which contains from 8 to 9 per cent. of nitrogen after being boiled and dried.

3. Defects in Butcher's Hides.—Skins which come from slaughter-houses or knacker's yards are delivered to the tanner in the raw

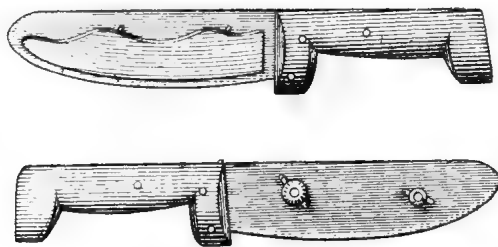

FIG. 5. —Skinning Knife (designed by Brion).

state. They are usually known as *green hides*. They have four chief defects, cuts, dung, holes and brands.

Cuts.—These are incisions which find their way into the skin and leave scars which lessen the value of the leather. The flayers ought to be very careful—especially when they are not experienced, or when the animal is thin—to guide the sharp edge of the blade towards the muscles, of which they must always cut off some portions, thus avoiding any damage to the skin.

Brion has designed a knife for skinning without making holes or scars. It is an ordinary knife carrying a guard a little below the blade. It is usually fixed about $\frac{1}{24}$ inch. below the sharp edge (see Fig. 5). It will at once be seen that the guard coming in contact with the skin keeps the cutting edge at a regular and

invariable distance, so that a cut never takes place. The "Darso" knife is based on the same principle.

Another knife, in which electricity is brought to bear, has been invented in America by Newgass, the manager of the enormous slaughter-houses of the Fairbank Canning Company. This electric skinning knife consists of a curved platinum blade protected on each side by some insulating material. By means of two copper wires an electric current is passed through it either from a battery or some other generator. Under the influence of the current the platinum becomes red hot, like the filaments in the Edison-Swan lamp. This compound blade is thrust between the skin and the flesh in all directions, just like an ordinary knife. The hot blade easily separates the skin from the flesh; it is only necessary to move the knife, which cannot make any scars. The inner surface of the leather is very clean, almost polished, and without a trace of meat.

The loss in value of cut skins is a matter which must be arranged between the butcher and the tanner or his agent. A skin loses in value according as the cuts are deeper, more frequent, or whether they are situated in the flanks or towards the centre.

The punctures made by the bot-fly should be noticed, as they are often very abundant. These diptera, so fatal and so annoying to horses and cattle, drill through the tissue of the skin to find a home for their larvæ.

Other insects act in the same way as the bot-fly by continually torturing the animals and damaging their skins. Unfortunately, there is a superstition fixed firmly in the minds of some farmers that these insects are beneficial to the health of the animals, just as in certain towns there are good people who hold fast to the belief that lice are necessary for the healthy existence of children. The tanner ought to pay great attention to these punctures, and demand a rebate from butchers proportional to the amount of damage caused by their occurrence. When they find their profits less, they will take care to guard against the ravages of these noxious insects.

Animals which have suffered from diseases of the skin, but which are not cut, give more or less defective leathers, according

to the extent of the disease ; their depreciation should be valued as in the former cases.

It is only during the last few years that any notice has been taken of the losses occasioned by the branding of cattle, but to-day this barbarous method is scarcely employed in Europe. It is different, however, with beasts from America and India. This subject will be returned to later.

To fight against these troubles, societies have been formed in England for the inspection of slaughter-houses, both in the great centres of population and in the country. So far as cutting is concerned, the best results have been obtained where a small premium has been offered for each faultless skin. The finest practical results have been shown in the cities of Manchester, Glasgow, Birmingham, Nottingham and Sheffield. We are aware also of a number of French tanners, notably in Lyons, who give a premium to the butchers' boys (fifty centimes a calf) for each skin delivered faultless.

The organisation of these societies is very simple. They elect a committee containing an equal number of butchers and tanners ; this committee, some ten or so, appoints an inspector who tests and arranges the skins in three classes according to the style of flaying and the general conditions laid down by the association. The inspection is made in neutral store-houses, so that the inspector cannot tell to whom the skins belong, nor can he tell who is the butcher or who will be the buyer.

The committee is responsible both to buyers and sellers for the correct classification of the skins ; any dispute is submitted to their arbitration, without appeal. When a claim is established the committee indemnifies the injured party. Complaints are very rare, the average being only two or three during the year.

Hides classed in the first set give the butcher boys a claim to a premium of twopence a hide. They are at once given a mean increase in value of two or three shillings, by the mere fact of their having been inspected and passed ; that is, in the case of hides weighing 80 to 90 lb. This causes a cheapening of the second class, which is made in the hope that they may receive the increase in value by being placed in the first class.

The expenses of the association are covered by a charge for inspection of 1d. per skin.

Here is a list of the usual results of the classification of a hundred hides :—

First class	32-37
Second class	60-54
Third class	8-9

With these fine results before us, it becomes very desirable that such societies should be established in France.

4. Weight of Fresh Skins.—Hides are weighed in the fresh state. A skin just as it is taken from the animal, still warm, weighs 3 per cent. more than it does a few hours afterwards.

The weight is marked on the neck with a knife, by means of a set of conventional marks. The pound is generally taken as the unit.

One vertical cut represents 20 lb. thus :—

I

Two vertical incisions side by side represent 40 lb., and each further cut represents an addition of 20 lb., thus we have :—

II	III	IIII
40 lb.	60 lb.	80 lb.

A horizontal cut placed above the preceding marks denotes an addition of 10 lb. Thus 30 lb. would be represented by one vertical and one horizontal cut.

— I

We have also

— II	— III	— IIII
50 lb.	70 lb.	90 lb.

If the horizontal line be placed below, it represents a value of 5 lb., giving us :—

— I	— II
25 lb.	55 lb.

Single pounds are marked underneath the lower horizontal line by vertical bars, for instance 57 lb. would be :—

— II
II

With this conventional alphabet all numbers from 1 to 99 may

be denoted; 100 is marked as a cross (+), and all above the hundred just as before. To mark 99 lb., a fairly common weight, the following cuts are made.

$$\frac{\text{III}}{\text{III}}$$

Skins weighing 60 lb. and downwards are classed as small; above that they are paid for as large skins.

Abuses exist in the selling of skins which it has been quite impossible to suppress, and for which the tanner should always be on the look out. Frauds occurring in the sale of fresh skins may be arranged in three sets: (1) false weight; (2) skins overweighted with débris,; and (3) dirty skins.

1. By the method just explained of marking the weight of skins, it is made very easy for unscrupulous people to add one or two cuts and thus to increase the nominal weight of the skin by one or two pounds. This fraud may readily be recognised when the skins are received.

2. Butchers do not often separate the horns, sinews, flanks, bones of the head, lips, ears, etc., from the skin to any greater extent than is absolutely necessary.

A fresh skin weighing 100 lb. contains on an average:—

Horns and skull	6½ lb.
Hair	6½ „
Water and blood in the hair	4¼ „
Flesh	6½ „
Ears, muzzle, sinews, etc	6½ „
	30¼ „

There is thus a forced loss of 30 per cent., which is very great. In Lyons, hides are delivered without horns or skull, also at Glasgow, in which case there is 6 to 7 per cent. less loss. (Horns and skull in a bullock weigh 7 to 8 lb.; in a cow 3 lb.) We suggest as a fair loss 22 per cent. On the other hand, it is easy for the tanner to note the excess weight, to subtract it from the total, and only pay for the true weight of skin delivered.

A fresh hide is often adulterated with excessive moisture, but a practical man can easily recognise this by the feel of the skin, or more surely of the hair.

3. The question of dirt (principally dung) is of great importance. In order to make the skins heavier, butchers make the beasts lie down in the mud before killing them, or else they drag the skins through it after flaying. An increase in weight may thus be accumulated to the extent of 15 lb. per hide, and it must be remembered that dirt often helps the skin to retain excess of moisture. From the tanner's point of view dirt presents the following disadvantages: (1) a necessary overcharge on skins, which are several pounds heavier than they should be; (2) dirt, for which the price of skin is paid, costs a considerable amount for carriage before it is delivered; (3) those who buy in the yards, often purchase as heavy skins those which when cleaned are medium or light; (4) an additional cost is incurred in cleaning; (5) a dirty skin is less easily stripped than a clean one, and is more liable to damage in the process.

A good skin contains only about 2 lb. of dirt. Ordinary ones contain 4 lb. At certain times of the year, especially in the winter, skins are very dirty. These times are called dirty months, and at such times hides are sensibly cheaper, three or four shillings per 100 lb. The weight of the dirt is then 12 to 14 lb. Tanners ought to insist on having skins delivered clean. In Lyons, Glasgow, Rome, Lisbon, Toulouse and Bordeaux they are delivered free from dirt, and there is thus no need for the cleaning of hides on the beam.

When skins are received either defective or weighted—if for instance 100 lb. of goods be received and the loss is 4 lb.—then the money loss is not, as one might at first sight imagine, 4 per cent. of the first cost, but double that. For a raw hide is worth only about 50 per cent., or half as much as the finished leather, so that in the end the dirty skin fetches 4 per cent. *of the final price, or 8 per cent. of the first cost* less than the perfectly clean one, whilst the tanning of the cleaner skin will not cost more than that of the dirty one.

5. **Salting Skins.**—Fresh skins which have to be carried some distance, and those which the tanner does not wish to use at once, are preserved by means of antiseptics, which prevent their decomposition. The usual treatment is *salting*. The skin is stretched on the ground with the hair below and the flesh above and covered

with crushed salt, care being taken to place an extra quantity on the strong parts, especially on the back and the edges. It is left in this state for a day or two. Next it is folded lengthways foot to foot, then the legs are folded over. A second longitudinal fold is made so as to bring the covering of the belly over the back. A cross fold brings the head to the tail, and finally the whole is doubled up. The skin then forms a square of twelve or fourteen inches arrayed in eight thicknesses. It is said to be folded "en toison". Calf skins are folded first longitudinally, then twice transversely. The skins are tied up and piled one on top of the other with a layer of salt between each. In summer 11 lb. of salt is needed for an average ox hide of 112 lb., and in winter a little less, generally 9 lb. To keep a skin for a week about $2\frac{1}{2}$ lb. is required, whilst for those which have to be kept for a month 9 lb. should be used. Fifteen to 18 lb. must be used when the hides are to be transported from such places as Montevideo or Buenos Ayres, which requires several months.

Speaking generally, very little salt should be used for skins which are intended for the manufacture of soft leather or for oiling, because salting takes away a considerable amount of the suppleness which they should retain. On the other hand, for skins which are to be tanned into sole leather, a strong salting is beneficial. For these last, a large dose of salt should be given to the loins, close up to the tail, on the throat and on the head. The salt which is added to skins with the idea of preserving them, at first increases their weight, but after a time salted skins lose their size and thickness and become set, the salt absorbing a certain amount of the moisture which runs away as brine. Salt has the property of absorbing moisture from animal tissues, until they no longer agglutinate. Thus the skins become lighter without actually drying up, and at the same time acquire the necessary keeping qualities.

Salting should be done very evenly, otherwise it is apt to form hard places which after tanning show dark stains. In currying, when the finished leather shows a marbled appearance, it is usual to put down any faults to salt—when it is really the uneven salting of which we have just spoken. When the salting is

not uniform, some portions of the skins do not receive sufficient salt for their preservation. Fermentation and putrefaction are set up in these parts by micro-organisms which are not affected by small quantities of salt. They destroy the grain and penetrate to a considerable depth in the tissue of the dermis. When once this destructive action has started it is impossible to repair it either by chemical or mechanical means, and these places produce those stained areas which are so much dreaded by the currier.

The salt used is ordinary sea salt, and should be as pure as possible. Salt containing such impurities as the oxides of iron or manganese should never be used, as it is most deleterious to the skins. Seeing that salt is subject, in France, to a tax, when it is used as food, it is customary to render it unfit for eating purposes by the addition of foreign matter. In tanning, the most common adulterants are tar and soap powder.¹

These substances have been very badly chosen by the "Comité consultatif des Arts et Manufactures". Tar has the objectionable qualities of staining the skin and giving it a peculiar smell. Soap powder is less objectionable, but it is apt to form a lime soap on the surface of the skin which produces stains in the tanning process.

Salt which has been adulterated with alum renders the later tanning operations very laborious. Leather on which this salt has been used has already begun to tan and the hair is only removed with difficulty or else comes off in patches. Moreover, the leather will not swell under the action of acid liquors. Again, a double decomposition is apt to take place between the alum and the lime contained in the skin, forming sulphate of lime (plaster of Paris) which gives a marbled appearance after tanning.

Alum, which should never be used for adulterating the salt used for skins, is nevertheless desirable in the salt used for tawing.

Naphthalin, which has been proposed by the "Comité consultatif," has the great disadvantage that it hardens the skin, and

¹Of course, the recommendations in the following paragraphs with regard to the adulteration of salt do not hold good in England, where there is no salt tax to be evaded.

this hardness is increased by all the subsequent operations of tanning. The same may be said of creosote, pyroligneous acid, fish oil, petroleum, pine oil, slate and lignite.

Carbolic acid, as recommended by M. Müntz, in the proportion of .4 per cent., is very useful. It does not hurt the skin, and being in such small quantity it leaves no recognisable smell. Still, this method of adulteration will never be accepted by the government, because of the exceedingly small quantity of carbolic acid that is added. In fact, it is easy to remove it by washing with water containing a small quantity of caustic soda.

We recommend sulphate of soda, which has no action on skin, and is at the same time very cheap. If the dry salt be used, about 5 per cent. will be sufficient, or 10 per cent. of the hydrated sulphate.

Whilst on this subject, it should be mentioned that the Bohemian Society of Tanners, adopted in 1880, a method of salting skins with dried, crushed sulphate of soda. This substance acts exactly like common salt; the water is withdrawn from the skin, but it remains combined with the sulphate of soda, which becomes crystalline and does not form brine. The whole remains dry, the water merely changing its place, consequently the package of skin does not vary in weight.

Finally, all the following substances, which we have successfully tried many times, may be used to the extent of about 10 per cent. of the weight of salt. Barium chloride, borax, magnesium sulphate (Epsom salts), nitrate of soda, zinc sulphate and sulphate of ammonia.

Salted skins stiffen and lose weight more or less according to the time during which they remain in the salt. The flesh and hair glue themselves to the skin, and make the detection of cuts, punctures, etc., very difficult. This is especially the case when the hair is long, though a practical tanner can easily recognise them when the hair is short.

Salting in pits is carried out as follows: The skins are washed and cleaned, and then hung for four days in a saturated solution of salt, with certain other heavy, soluble mineral matters known as weightings; they are next sprinkled with coarse salt,

folded, tied up and sent away. This is a fraudulent method, because the skins have the same appearance as after ordinary salting, and are bought according to the butchers' weights. In the later processes the weighting flows away, and the loss instead of being 10 to 12 per cent., becomes 15, 18, or even 20 per cent. Tanners ought always to make certain that skins are delivered to them by the weight which they possessed before placing them in brine.

The weighting substances most commonly used are sulphate of zinc, chloride of calcium or barium, glucose or potassium silicate. Sometimes skins are *double salted*, that is salted twice.

When salted skins have to be carried long distances, they are sometimes dried by stretching them in the shade, flesh side out. Well salted skins cleanse readily, tan easily and give a good yield, and therefore, for equal weights are worth more than dry skins.

6. Foreign Skins.—Skins of a foreign origin come mostly from South America and India. They include wild cattle, buffaloes, bisons and horses killed in hunting. These skins have been very badly treated and are full of defects.

1. It is customary in these countries to mark huge flocks by branding either on the thighs or worse still on their backs, so that they may be easily recognisable. That part of the skin which has been burned is inactive, will not tan, and greatly lowers the value of the hide, especially when the mark has been made on the best part of the skin. The losses caused by the use of the red hot iron have been estimated at \$12,000,000 (£2,400,000 sterling). Other methods of marking, such as branding the horns, the head or the legs have been suggested, but have not been acted on.

In North America a method has been used which ought to be followed everywhere. The ear is pierced, and a plated iron ring inserted which on one side bears the name of the owner, and on the other the number by which the animal is known.

2. Animals are often killed and flayed by unskilled workmen, and the skins are covered with cuts and holes. This trouble, however, has been decreasing for some years.

3. Skins are merely submitted to a primitive and careless drying. On the immense plains of the Rio de la Plata, skins are stretched in the sun, flesh above, at a height of ten inches or so from the ground, by means of wooden pegs. The sun quickly dries the skin on the flesh side, whilst the hair, turned towards the earth, remains moist by condensation of the moisture rising from the soil. Under the influence of this moist heat, skins ferment and lose their texture. In summer the putrefaction reaches half way through their thickness. Since these skins are dry it is very difficult to recognise any decomposition, even by the most practised eye. No external sign exists which can put the buyer on his guard, but the operations of soaking and tanning cause them to tear and partly dissolve. In certain cases the total yield of leather falls to 15 or 20 per cent.

South American skins are the most valued in England and France, which are their principal markets. The best come from Buenos Ayres and Montevideo, and bear the name of the port from which they come. These are the thickest and heaviest, and after tanning give excellent sole leather.

The wild cattle still existing in South America are of two species, *Bos Americanus* and *Bos Moschatus*, which live in the wild state in the pampas and the llanos. They are hunted by the gauchos by means of the *lasso*. This lasso is a leather thong, twisted whilst fresh, an inch and a half or less in circumference and twenty or thirty feet long, with a running noose at one end. The lasso is greased during its manufacture, is very supple, lasts a long time, and is as strong as an ordinary cord of three times its thickness. To use this instrument, the hunter widens the opening of the noose and swings it round and round above his head, taking care that it cannot shut. When he has gauged his distance he throws it with such accuracy that he seldom misses his aim. The ox is caught by its horns, or, if it be a sheep or other animal, by the neck, and as it gallops away the horseman binds the end which he still holds around his body, and suddenly stops his horse, which receives the full weight of the shock, and is sometimes thrown down.

Animals caught in this fashion are led to huge pastures, where

they live and multiply in herds, forming the wealth of the *hatos* brought up in the *manos*.

They are slaughtered in the *saladeros* of Montevideo.

After these come the thinner skins of Rio Grande.

The East and West Indies and Cape Colony export dry and salted skins to the European markets. The skins from the Cape are thick, and rival those of Buenos Ayres; next in value come those from Madras, Calcutta, Manilla and Borneo.

Chilian skins come through Valparaiso. In Peru they come from Lima. Finally Brazil sends her skins through Rio Janeiro, Pernambuco and Para.

III.—VARIOUS SKINS AND THEIR USES.

1. **Skins of Mammals.**—Skins used for tanning are generally taken from the mammalia. Skins of the ox and the buffalo are manufactured into the heavy leather used in the soles of boots and shoes. For this purpose, buffalo hide is inferior to ox leather. Buffalo skins prepared with oil are more used for military equipment and razor strops.

The skins of cows and calves give soft leather known in commerce as dressing leather. They are made up into boots or "uppers". The skins of young calves are used for women's shoes.

The little Indian cows give us sword belts and shoulder straps.

Skins of bulls, which are very thick and fibrous, are generally cut into two sheets with a splitting machine. The grain side is used for carriage work and the flesh layer for sole lifts.

Horse skin is used for harness, aprons, covers, etc. Leather made from horse or mule skin does not make good soles; it is scarcely used except for uppers.

Leather from the bison and Illinois ox is used in the making up of foot rugs and hot-water bottles for carriages.

The skin of elephants, rhinoceri and hippopotami gives a rigid and tough leather, which is employed principally in machinery, engine covers, washers, buffing wheels, shuttle blocks, machines for washing linen, etc.

Sheep skins have numerous uses, especially where suppleness

is required, as in shoes and boots for ladies, bellows, bookbinding, cushions, linings, whips, gaiters, etc. They come to us principally from Southern France, Spain and Italy. The skins of lambs, used for making light shoes, and also those of kids, come from the Crimea, Persia and Ukraina.

Goat skins are used for the manufacture of morocco leather, light shoemaking, and, in the South, for bottles to carry wine and oil. The countries which produce them in the largest quantities are North Africa, Morocco, Algeria, Turkey, the Cape, Mexico, China and the East Indies. In Spain and Africa buck skins are used for making bottles.

Kid, sheep and ram skins are used for higher qualities of boot-making, and morocco.

The skin of asses goes to make saddlery and shagreen; that of the pig for saddlery, trunks, bags and shoes. The wild boar gives a skin much like that of the deer, and is used in much the same way as ordinary pig skin. Walrus skin is used in England for making machine belts.

Dog skin is used in the manufacture of "scotch leather" and in shoemaking. When well curried it is used in making up dress shoes.

Skins of the wild boar, wolf, sow, hare, rabbit, cat, rat and deer, have various uses, mostly ornamental.

Skins of the chamois, roebuck, quagga, llama, etc., are prepared by the chamois leather maker for the manufacture of breeches, gloves, piano keys, and leathers for cleaning silver, etc.

The elk, which becomes rarer every year, gives a very strong thick leather. It is still met with in Siberia, Norway, Sweden, Livonia and North America, where the Indians use it as money for buying implements, etc.

Kangaroo skins are much prized in Australia. They were introduced into America in 1870, and into France in 1875. They give a leather of great density, very tenacious and very supple. The principal places of export are Melbourne, Newcastle and Sydney in Australia, and Masterton in New Zealand. The heavier skins are used mostly for men's boots, and the lighter make a good substitute for kid.

The wallaby and other like marsupials give good leathers, which are put to the same uses as those of the kangaroo.

2. Bird Skins.—Birds are of very little use to the tanner. Swan skins are used by fan makers. A few years ago the skin of the agami (gold-breasted trumpeter) was tried for tanning. This bird was originally a native of Central America, and belongs to the tribe of cranes. Several species are known. The trumpeter, which is 60-70 cm. (24-28 in.) high, and the white-winged agami are the chief. It lives in the wild state in Brazil and Paraguay, but has been domesticated, and is treasured by the inhabitants of these countries on account of its peculiar habits, which make it as good as a watch-dog. The leather which it gives is very soft and flexible, and is used for ornamental purposes.

Ostrich skins are used for fan-making and fancy goods.

3. Snake Skins, especially that of the boa constrictor, which is found in the depths of Asiatic and African forests, are treated in such a manner that they become perfectly supple and yet retain their natural appearance and colour. In New York snake skin is shown in the windows of the more fashionable shops, in the shape of belts, card boxes, cigarette cases, purses and bags.

Skins of the cobra de capello, living chiefly in North Africa and India, have the same uses. In the same way the tanner makes use of vipers and adders.

4. Fish Skins.—Skins of amphibians, reptiles and fishes have numerous uses.

First and foremost comes the skin of the alligator, a kind of cayman, which abounds in Central America and the Southern States. The great reptile which furnishes skins to the trade in the United States and Europe (principally England, where several thousands are imported yearly, salted or tanned) is the *Alligator Mississippiensis* which, as its name indicates, inhabits the Mississippi. The first attempts at tanning the skin of this animal were made at New Orleans in the year 1855. It is said that an old Canadian revealed to the chief of a large shoemaking establishment in Boston the secret of a special process for tanning these skins. The first experiments did not succeed, but were started again in Massachusetts

in 1870, when it was seen that the new product might give rise to a flourishing industry.

At first Louisiana provided the greater part of the alligators, and New Orleans became the centre of the trade in their skins. But the great slaughter of these unhappy reptiles caused them to disappear entirely from the country, where they have now become very rare. Nowadays they are hunted in the great marshes of Florida; and Jacksonville and Brooklyn have become the great emporia.

Alligators are killed in large numbers by the crews of steam-boats which serve on the rivers of the State, and by hunters specially engaged in this pursuit. As soon as they are caught and killed, their skins are stripped off, but only those parts are kept which can be utilised, namely, the flanks and the belly, which are put into a cask of strong brine to keep them until they can be sent to the tanners in the North.

Alligator skins may attain a length of seventeen or twenty feet, but the skins of younger animals are preferred, because they are much more supple and easier to tan. Experts say that the supply of these skins is inexhaustible, so great is the fecundity of the animal.

The alligator gives a leather at the same time firm and flexible. It is used for the manufacture of ladies' slippers, for which it is specially adapted, for shoes and boots, satchels, portfolios, purses, cigar cases, and all kinds of fancy articles and toys.

Seals and sea calves, walruses or sea cows, which come from the Arctic regions, Newfoundland and Alaska, are used in bootmaking and for travelling trunks. The skin of the shark and the porpoise is used by wood-turners to smooth and polish wood; it is also used for covering boxes and fancy goods.

Skins of the ray and the dog-fish are employed chiefly in fancy goods and for shagreen in Turkey, Syria, Tunis and Tripoli. When this skin is raw, it may be used for belting, for washers, for the pistons of air pumps, for steel polishers, etc.

The manatee or sea elephant gives belting leather.

In the English Fisheries Exhibition of 1877 a series of skins,

both of fishes and cetaceans, was shown, which had been prepared in different ways according to the uses for which each was intended. A Norwegian tanner from Christiania exhibited bands of whale skin sixty feet long intended for machine belting, eel skins prepared for the manufacture of bridles and harness, shark skins ten feet long by more than three feet wide, giving excellent leather for shoe-making and saddlery, and leather from flat fish for gloves and purses.

There were also exhibited the rough skin of a ray, to be used in place of emery paper for polishing ebony, etc. The skins of rays most frequently used for this purpose, and for clarifying the wort in brewing are those of a species (*Hypolophus Sephen*) which is caught off the coast of Malabar. A Parisian house (Giraudon) has made a specialty of applying ray leather to fancy turnery and toy-work.

The skin of the lote (*Lota Maculata*) is used in Siberia for ornamenting coats; a species of cod is used in the same way. In Egypt, saddles are made from the skin of a fish caught in the Red Sea. In Canada gloves are made from the skins of silurus.

Lastly, it should be mentioned that in various localities the skins of the following fish are made use of in various ways: The wolf fish, conger, haddock, ling, etc.

5. Human Skin.—We cannot finish this chapter without speaking of human skin, which is susceptible of being tanned as well as that of any other animal. Human skin is sometimes harsh and dry, sometimes soft and glossy; its colour varies from the palest pink to the deepest brown. Its thickness varies from a seventieth of an inch to a sixth of an inch, its greatest thickness being found over the belly. When tanned, it increases in thickness and gives a very tough leather, fine-grained and very soft.

Although the tanning of human skin has never been tolerated in a civilised country, there nevertheless exist a certain number of historical facts which prove that human skin has been thus used; for instance, there are certain book bindings existing to-day which are recent examples. There is the instance of the great Bohemian general, John Ziska, who, when dying, ordered his soldiers to make

his skin into a drum, so that he might still march at their head, and lead them on to victory.

In the library of Marlborough House, near Methley in Yorkshire, there were formerly two books bound in the skin of the Yorkshire witch Mary Bateman, executed for murder at the beginning of the present century. These books disappeared when the Duke of Marlborough sold the library. The alchemists were very fond of tanning small pieces of human skin, wherewith to bind their books of secrets, or prayer books. In Paris there was a Bible bound in a woman's skin.

A London binder, Zaehnsdorf, has bound two Elzevirs in human leather, and another in the same place has bound the *Danse macabre* of Hans Holbein to order in the same material.

At the end of last century the tannery of Meudon had a bad reputation; every one knows the story of the slippers of human leather offered to Louis XIV. from this tannery. We read even in the *Souvenirs de la Marquise Créqui* that pecuniary encouragement was given to Citizen Palaprat, who tanned human skins. Valmont de Bomare, in his *Dictionary of Natural History*, in 1775, describes experiments carried out at Meudon and gives a recipe for the tanning of this class of skin. "Allow it to macerate for several days in a wash charged with alum, Roman vitriol and common salt; take it out, dry it in the shade, then taw it."

The Marquise de Créqui gives us the following description:—

"At Meudon they tan human skins, and when it comes from this factory it leaves nothing to be desired in either quality or condition. It is well known that many people wear breeches of the same kind and of the same material; this material having been furnished by the bodies of those executed in the revolution of 1789." And she adds to complete the information: "The skin which is provided by men is of a consistency and excellence superior to that of the chamois; but it has less solidity because of the softness of its tissue".

Georges Duval, in his *Souvenirs de la Terreur*, completes the description of the Marquise by the following note: ". . . it took place principally at Meudon. No one had any doubt about it.

The inhabitants of the village showed a mysterious terror of the windows of the lower room of the old chateau where, according to them, this horrible work was carried on. They told how each night they heard the dismal roll of covered carts which carried the human bodies sent by the scaffold in the Place de la Revolution to feed the tannery."

At Tewkesbury (United States), only a few years back, the skins of pauper orphans were tanned and used for shoes. This led Mr. Mellen to present a bill to the legislative assembly of Massachusetts, which made the sale or use of human skins punishable by five years' imprisonment. In the same State it is said that the skin from the bodies provided by a hospital was used in boot-making.

Lastly, so recently as 1887, the skin of the celebrated criminal Pranzini was made up into two card cases and presented by Inspector Rossignol to Messrs. Taylor and Goron, chief and vice-chief of the police. The piece of skin was about 16 inches square, and was tanned by Destresse of Paris.

CHAPTER II.

TANNIN AND TANNING SUBSTANCES.

I.—TANNIN.

1. **Definition.**—The name *tannin* or *tannic acid* has been given to a certain number of substances having the following properties: A slightly acid reaction, solubility in water, an astringent taste, the power of precipitating albumen, gelatine, alkaloids and metallic salts. The most characteristic reaction is given with the salts of iron, which give a precipitate which is sometimes black, sometimes green, and sometimes olive green. The property of tannins with which we are chiefly concerned in this volume is that they are able to combine with skin, forming a stable substance known as leather.

Astringency, that is, the property of shrivelling the tissues, or shutting up the openings of certain organs, as, for instance, the papillæ of the tongue, is not peculiar to tannin, which is, however, the astringent *par excellence*; it is possessed by a large number of styptic salts, such as alum, sulphate of iron, sulphate of zinc, acetate of lead, and certain acids, as dilute sulphuric, dilute acetic, and gallic acid.

2. **Natural Condition.**—These substances are widely distributed in nature. Formerly it was supposed that tannin was produced solely by the vegetable kingdom, but, in 1887, the author discovered its presence in the animal kingdom.

In plants it is found nearly everywhere, in bark, roots, leaves, flowers, fruit, excrescences, juice, sap and seeds. The names given to the different tannins are usually indicative of their source.

At present animal tannin has only been detected in two insects: (1) the corn weevil (*Calandra Granaria*), a coleopterous insect of the genus *Curculionius*, family *Fracticornes*; (2) the flour-moth (*Ephestia*

Kuchniella), an insect which has only been known since 1880, and to which the author has devoted much study.

3. Varieties of Tannin.—Proust has remarked that we know a great number of different tannins. Names have been given to them according to the botanical genus from which they are derived, thus indicating their origin. The following is a list:—

Gallotannic acid	from gall nuts.
Quercitannic acid	oak.
Rhusitannic acid	sumach.
Mimotannic acid	mimosa.
Catechutannic acid	catechu.
Morintannic acid	yellow wood.
Coccotannic acid	kino.
Pinitannic acid	pine.
Cafetannic acid	coffee or tea.
Cinchotannic acid	cinchona.
Ziziphotannic acid	jujube tree.
Quinovatannic acid	<i>Portlandia Grandiflora</i> .
Aspertannic acid	lily of the valley.
Rubitannic acid	madder.
Gallitannic acid	<i>Galium Verum</i> .
Ratanhiatannic acid	ratanhia.
Filixitannic acid	fern.
Tannocortepinic acid	fir.
Salicytannic acid	poplar.
Tormentillotannic acid	tormentillo.
Bistortannic acid	snake weed.
Nuphartannic acid	water lily.
Ellagotannic acid	pomegranate bark.
Ipecacuanhatannic acid	ipecacuanha.
Aspidospertannic acid	<i>Quebracho</i> (Villon).
Castaneatannic acid	chestnut (Villon).
Curnusitannic acid	dog berry (Villon).
Dyospirosptannic acid	khaki (Villon).
Andromedatannic acid	andromeda (Villon).
Trichomanotannic acid	tenaki.
Curupatannic acid	curupai.
Cascalotannic acid	cascalote.
Yervamatetannic acid	Paraguay tea (Villon).
Osiristannic acid	<i>Osiris Compressa</i> (Villon). *
Leucosptannic acid	<i>Leucospermum Conocarpum</i> (Villon).
Mangostanatannic acid	<i>Garcina Mangootana</i> (Villon).
Cayotitannic acid	cayota.
Fracticornitannic acid	animal (Villon).

All these tannic acids have been obtained in the pure state, and studied separately. It is easily seen that they are different from one another, that each possesses particular properties, which in

some cases give special value to certain tannins, but that they all have the same fundamental properties. In tanning, then, all these different varieties of tannic acid, from whatsoever plant or part of a plant they may come, go by the one name of *tannin*.

4. Classification of Tannins.—The tannins have been classed according to their action on salts of iron, and in this way have been divided into three groups :—

(a) Those which give a blue-black colour with ferric salts, *e.g.*, gall nuts, oak, sumach.

(b) Those which give a green colour with ferric salts, as catechu, gambier, kino, coffee, tea, cinchona, willow and yellow wood.

(c) Those to which ferric salts impart a greenish-grey colour, as rathany, wormwood, arnica, etc.

This classification is quite arbitrary, as the blue colour may be obtained from the gallic acid in the tannin.

Wagner arranges the tannins in two classes, *pathological* and *physiological*. This method has received little attention from chemists, and is only mentioned here because it has a certain interest as applying to the origin of tannins.

Pathological tannic acid ought merely to be considered as a pathological product which develops on the genera *Quercus* and *Rhus*, and is furnished principally by the puncture of an insect *cynips*. This puncture leads to the formation of the gall nuts and peduncles which form on *Quercus Infectoria*, *Quercus Cervis*, *Quercus Oustrica* and *Quercus Ilex*. The little excrescences known as galls formed by the expansion of the sap in the young acorns are also due to a *cynips*. The Chinese galls, which are produced by an aphid which lives on two varieties of sumach, *Rhus Javanica* and *Rhus Smialata*, are also pathological. It does not exist in oak bark.

This acid (pathological), according to Wagner, is distinguished by the following characteristics :—

(a) It is split up, by the action of dilute acids or by fermentation, giving gallic acid, together with some substance analogous to sugar, probably glucose, which always ferments further, forming alcohol and carbonic acid and later, lactic, propionic and butyric acid and humus.

(b) It alone amongst the tannins, can furnish pyrogallic acid.

(c) It completely precipitates gelatin from its solutions in water, but will not transform dermis into true leather.¹

Physiological tannic acid is found in the bark of oaks, pines, willows, bablah, acorn cups, dividivi and sumach. It is distinguished from the pathological acid in that it is not split up into gallic acid, either by dilute acids or fermentation, and on distillation it does not form pyrogallic but oxyphenic acid.

It is the physiological acid that is the true tanning agent. The pathological never takes the leading part, but merely helps in the work.

Nevertheless, these two tannins have many identical properties. They act in the same way on the papillæ in the mucous membrane of the tongue, producing an astringent taste. Both precipitate gelatin, though the precipitates have different properties—the one given by the pathological acid decomposing easily in water, and the one given by the physiological remaining unaltered even when kept in water for a month.

This classification is not a very good one, or at least it does not divide the acids very sharply. Thus gallotannic acid and rhusitannic acid come under different headings, whereas they have very similar properties.

5. Constitution of Tannins.—The chemical constitution of tannins leads to their division into three groups:—

(a) In the first group come all those tannins which are not glucosides; that is to say, those which are not split up into glucose and gallic acid by boiling with dilute acids, such as catechutannic, ratanhiatannic, bistortannic, callutannic.

(b) In the second group are found the glucoside tannic acids which give, with dilute acids, glucose and *crystalline* compounds, such as gallotannic, ellagotannic, nymphetannic and nuphartannic.

(c) Lastly, the third group contains those glucoside tannins which give *amorphous* products of decomposition analogous to the phtobaphènes, such as quercitannic, filixitannic, malitannic, etc.

¹ Prof. Procter has since shown that gallotannic acid will produce true leather.

Wurtz considers the glucoside tannins to be compounds of dextrine or gum with tannin ; glucose being formed by a secondary reaction of the weak acid on the dextrine.

The author has shown that the glucoside tannins are only different ethers of gallic acid and sugar, of very high molecular weight.

The tannins of the first and second of these classes are digallic acids. Schiff has proved that tannin is a gallic anhydride formed by the union of two molecules of gallic acid with the loss of one molecule of water. This reaction may be represented in the following manner :—

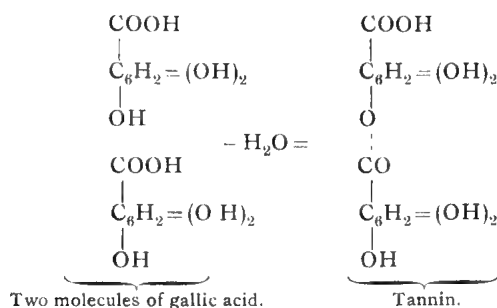

This pure tannin is always intimately mixed with other substances, which are either decomposition products from the tannin under atmospheric influences, or vegetable products of a similar nature.

This constitution is the one universally accepted at the present day.

The foreign matters mixed or combined with the tannins, which cannot be separated physically or chemically, give to each its distinctive properties.

6. Synthesis of Tannin.—This synthesis was worked out by Lowe and Schiff, who obtained tannin from gallic acid which they had prepared synthetically.

Starting from phenol, which is found in coal tar, the phenol was first combined with caustic soda to form phenate of soda ; this substance was heated to redness in a current of carbonic acid, which gave salicylic acid. By the action of iodine on this acid di-iodosalicylic was formed, which when fused with potash gave gallic acid—

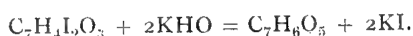

Gallic acid was transformed into tannin by dehydration, according

to the equation given in paragraph 5. To effect this change Lowe used silver nitrate, whilst Schiff employed phosphorus oxychloride at a temperature of 100° to 120° C.

Link obtained it directly from phloroglucine, which he had obtained by fusing resorcin with caustic soda. By treating with strong sulphuric acid, sulphophloroglucic acid was formed, and this substance, under the influence of phosphorus oxychloride, gave a kind of tannin.

7. Preparation of Pure Tannin.—For this preparation either gall nuts or some other vegetable substance, rich in tannin and fairly free from colouring matter, is used. These substances are extracted with various neutral solvents—ether containing 10 per cent. of water (Lambert and Dizé's process improved by Pelouza), or a mixture of two volumes of ether with one volume of alcohol at 69° C. (Guibourt)—or acetone or commercial methyl alcohol, which contains 20 per cent. of acetone. This may be done in any of the various forms of extraction apparatus invented by Robiquet, Guibourt, Payen, Gerhard, Liebig, etc. These processes are described in elementary treatises on chemistry. The resulting substance is the pure tannin of commerce.

This, however, is not perfectly pure. The following is an analysis made by the author :—

Tannin	Per Cent.
Water	93.69
Gallic acid	5.11
Fatty matter	1.09
Chlorophyll	0.11
	traces
	<hr/>
	100.00

To purify this product, it must be dissolved in water, filtered, and the solution shaken up with ether to remove the gallic acid and fat. The ether is removed by a separator, and the process repeated several times. The solution is next saturated with pure crushed salt (NaCl), and acetic ether is added. It is shaken up and allowed to separate. The acetic ether will then contain pure tannin which may be obtained by careful evaporation.

To isolate and purify the tannin from some new vegetable source, so that it may be studied, the acetate of lead process, which

is very long and tedious, has generally been used. The author described a general process in a note to the Academie des Sciences in April, 1886.

In this process, the tannin-containing substance is bruised or crushed and allowed to soak in 90° alcohol, and then boiled under a reflux condenser for an hour. The alcoholic liquor is decanted and evaporated on the water bath, first in a retort, to recover the alcohol, and then, when it has reached a syrupy consistency, in a basin. The dry residue is taken up by acetic ether at 50° C., the solution is filtered, diluted with half its volume of water, and precipitated with ammoniacal acetate of zinc, prepared by dissolving acetate of zinc in commercial ammonia which has been diluted with half its volume of water. The first formed precipitate is rejected, as also is the last. The intermediate portion (about one-third of the whole) is used as described below.

Under these conditions acetate of zinc precipitates nothing but tannin, in the form of tannate of zinc. All other substances, such as gallic and ellagic acids, phtobaphènes, albuminous matter, pectins, etc., remain dissolved.

The precipitate of tannate of zinc is well washed with ammoniacal water, and finally with a little pure water. It is then suspended in water, and sufficient oxalic acid added to precipitate all the zinc; it is heated nearly to boiling and well shaken. The zinc is precipitated as an insoluble oxalate, and tannin remains dissolved in the liquid.

After filtration the liquor is evaporated *in vacuo* at 50° or 60° C. until it becomes syrupy, and then it is allowed to continue evaporation in the cold, but still *in vacuo*, over sulphuric acid. To completely purify it, the residue is re-dissolved in acetic ether, filtered and evaporated gently.

8. Properties of Tannin.—Pure tannin is a colourless, uncrystallisable substance. In commerce it exists as fine needles which have the appearance of being crystalline, but these needles are obtained mechanically, as we shall explain when we treat of crystallised extracts.

It is soluble in water, alcohol, glycerin (10 per cent.), chloro-

form, acetic ether, acetone and methyl alcohol, slightly soluble in ether, and insoluble in petroleum ether, benzene, hydrocarbons carbon disulphide, etc.

THE SPECIFIC GRAVITY OF AQUEOUS TANNIN SOLUTIONS OF VARIOUS STRENGTHS
AT 17.5° C.

Tannin per 100.	Specific gravity.	Degrees Baumé.	Tannin per 100.	Specific gravity.	Degrees Baumé.	Tannin per 100.	Specific gravity.	Degrees Baumé.
0.25	1.0010	...	5.25	1.0212	...	10.25	1.0416	...
0.50	1.0020	...	5.50	1.0222	...	10.50	1.0427	...
0.75	1.0030	0.5	5.75	1.0232	3.5	10.75	1.0437	...
1.00	1.0040	...	6.00	1.0242	...	11.00	1.0447	6.5
1.25	1.0050	...	6.25	1.0252	...	11.25	1.0458	...
1.50	1.0060	1.0	6.50	1.0263	...	11.50	1.0468	...
1.75	1.0070	...	6.75	1.0273	4.0	11.75	1.0479	...
2.00	1.0080	...	7.00	1.0283	...	12.00	1.0489	7
2.25	1.0090	1.5	7.25	1.0293	...	12.25	1.0499	...
2.50	1.0100	...	7.50	1.0304	4.5	12.50	1.0510	...
2.75	1.0110	...	7.75	1.0314	...	12.75	1.0520	...
3.00	1.0120	2	8.00	1.0324	...	13.00	1.0530	7.5
3.25	1.0130	...	8.25	1.0334	...	13.25	1.0541	...
3.50	1.0140	...	8.50	1.0345	5.0	13.50	1.0551	...
3.75	1.0150	...	8.75	1.0355	...	13.75	1.0562	8
4.00	1.0160	2.5	9.00	1.0365	...	14.00	1.0572	...
4.25	1.0171	...	9.25	1.0375	5.5	14.25	1.0583	...
4.50	1.0181	...	9.50	1.0385	...	14.50	1.0593	8.5
4.75	1.0191	...	9.75	1.0396	...	14.75	1.0604	...
5.00	1.0201	3	10.00	1.0406	5	15.00	1.0614	9

Tannin is precipitated from its aqueous solutions by many mineral acids: sulphuric, hydrochloric, boracic, phosphoric, arsenic, etc. Many salts remove tannin from solution, as alum, common salt, sulphate of soda, sulphate of magnesia, chloride of barium, etc.

The precipitates so obtained are not combinations of tannin with the acids or salts, but precipitates of tannin itself which is less soluble in water containing either acids or salts.

The percentage composition of digallic acid is:—

Carbon	52.42
Hydrogen	3.56
Oxygen	44.02
	100.00

which corresponds to the formula $C_{14}H_{10}O_9$.

The different tannic acids have slightly different compositions and formulæ. In the following table we give the percentage composition, etc., of the principal tannins which have been analysed.

ELEMENTARY COMPOSITION OF THE TANNINS.

Name of Tannin.	Composition.			Formulae.	Authority.
	Carbon.	Hydrogen.	Oxygen.		
Caffetannic acid . . .	56.75	5.41	37.84	$C_{14}H_{18}O_7$	Rochelder.
Callutannic acid . . .	51.53	4.30	44.17	$C_{14}H_{14}O_9$	
Quercitannic acid . . .	53.85	5.13	41.02	$C_{28}H_{16}O_{16}$	
Ellagotannic acid . . .	49.69	3.16	47.25	$C_{14}H_{10}O_{10}$	
Gallitannic acid . . .	48.34	4.65	46.51	$C_7H_8O_5$	
Ipecacuanhatannic acid	56.37	6.04	37.59	$C_{14}H_8O_7$	
Kinotannic acid . . .	60.60	5.09	34.31	...	
Quinotannic acid . . .	44.84	5.33	49.83	$C_{42}H_{20}O_{35}$	
Ratanhiatannic acid . . .	59.40	4.95	35.65	$C_{20}H_{20}O_9$	
Quinovatannic acid . . .	52.01	5.88	42.11	$C_{29}H_{34}O_{17}$	
Aspidospermannic acid . . .	54.18	4.85	40.97	$C_{14}H_8O_8$	Villon.
Castaneotannic acid . . .	59.23	5.64	41.13	$C_{27}H_{18}O_{15}$	"
Diospyrostanic acid . . .	59.11	6.07	34.82	$C_{20}H_{20}O_9$	"
Carnusitanic acid . . .	49.03	4.32	56.65	$C_{14}H_{10}O_{10}$	"
Animal tannin . . .	53.15	5.68	41.17	$C_{28}H_{16}O_{16}$	"

It precipitates gelatin, albumen, fibrin, starch, vegetable and artificial alkaloids.

It precipitates most metallic salts, giving variously coloured substances: white with calcium, barium, magnesium, zinc, antimony and tin; yellow with lead, mercury, cobalt and bismuth; red with uranium, titanium, tantalum and osmium; green with platinum; brown with copper, gold and silver, and black with iron.

Nitrate of iron gives a fine blue.

Tannin is coloured violet-red by aniline, and violet by Schulze's reagent (25 grammes of zinc chloride and 8 grammes of potassium iodide dissolved in 10 cc. water, and iodine added until the solution is saturated).

Potassium cyanide gives a pale red colour with tannin; if it be shaken up with one-third its volume of ether and allowed to stand, it will separate into three layers. The lower layer, which is an aqueous solution of tannin, only shows the colour feebly. Ammonia gives a rose colour, nitric acid an insoluble purple, and strong hydrochloric acid a rose-coloured precipitate.

It does not alter when exposed to the air in the dry state, but when moist or in solution it slowly absorbs oxygen and is transformed into gallic acid and other oxidation products, which are more or less brown. Ozonised air browns tannin, causes it to

liquefy, and eventually oxidises it to water and carbonic acid. Ozone burns it and gives a substance which reduces Fehling's solution (copper hydrate dissolved in excess of caustic potash) and oxalic acid. It is because of this objectionable reaction that the application of electricity to tanning has never succeeded; the tannin is always burned up.

When tannin is dissolved in water and then evaporated to dryness several times, in contact with the air, it changes little by little to a brown insoluble substance (oxidised tannin), which the author has studied under the name of gallate of tannin.

When treated with alkalis in a current of nitrogen or hydrogen, it changes into gallic acid and gummy substances. In contact with the air, alkalis turn it brown. It absorbs oxygen and turns to humus.

Chlorine attacks tannin and destroys it, giving brown bodies. Bromine and iodine act in the same way but less energetically. Chromic acid decomposes it on warming, giving carbonic acid and brown matter. Nitric acid gives a yellow mass which contains picric acid.

It is an energetic reducing agent, reducing permanganate of potash, ferric, cupric, mercuric and argentic salts.

When heated it gives gallic acid at 150° C., pyrogallic at 200° C. and metagallic at 250° - 280° C. When fused with potash, it gives pyrocatechuic acid and phloroglucine.

Tannin acts as a feeble acid, reddening litmus and decomposing carbonates.

9. Fermentation of Tannin.—When an aqueous solution of tannin is left in contact with the air it becomes covered with green and white mould, and the tannin disappears. Van Tieghem, after having made numerous experiments on gallic fermentation, read a paper before the Academie des Sciences in which he came to the following conclusions:—

- (a) Tannin does not change into gallic acid in the absence of air.
- (b) Tannin cannot change merely by the action of the air.
- (c) In order to alter tannin a mycelium of some mucedine must develop in the solution.

(d) Under the influence of life, and the development of this mycelium, tannin splits up into gallic acid and glucose.

(e) For this change to take place, it is necessary that the living plant shall develop in the *interior* of the solution. The weight of the mycelium is about $\frac{1}{500}$ of that of the tannin transformed. If it be at the surface it acts differently, burning up the tannin and giving off carbonic acid. It only splits up the tannin by the action of those parts which are below the surface. The glucose is also burned up by a superficial mycelium.

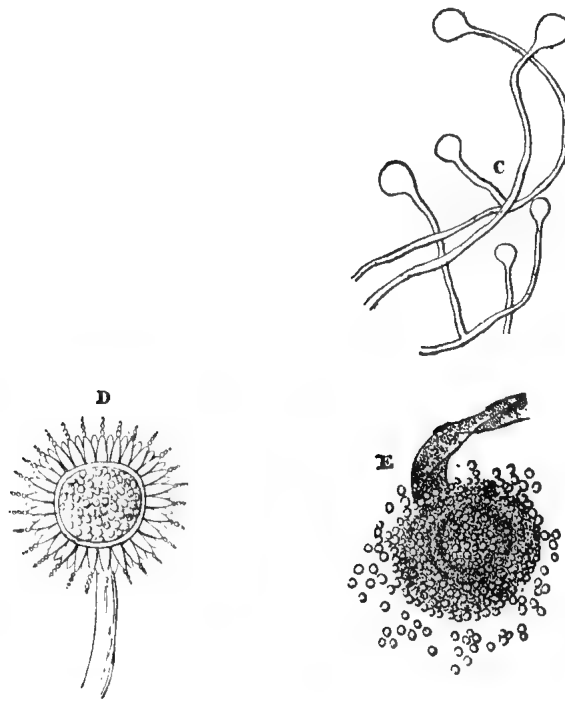

FIG. 6.—*Aspergillus Niger*.

(f) The reaction is brought about by the life and development of the plant, and not by its secretion of any soluble principle which could act if the plant were removed.

Aspergillus Niger is the mucedine which plays the principal part in changing tannic to gallic acid. The mycelium of this plant consists of fine tubular fibres matted together on the surface of the liquid. This may be considered as the root or food absorber of the microscopic plant. From this mat fertile filaments shoot upwards into the air, ending with a club-shaped swelling. In this swelling

are formed radiating cells which eventually become spores. They are globular, sometimes smooth, sometimes rough, and either grey or bluish-green. They often adhere to one another in strings. In Figs. 6, 7 the detailed structure of this plant is shown. Its total height does not exceed $\frac{1}{2}$ in.

The spores of this vegetable develop enormously. In twenty-

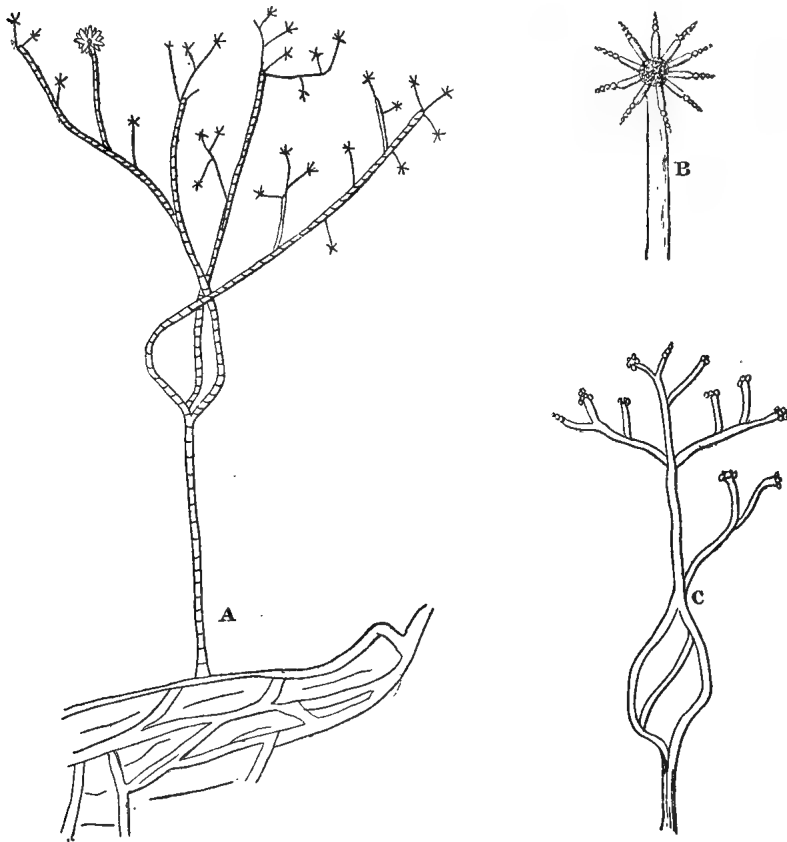

FIG. 7.—*Penicillium Glaucum*.

four hours a membrane covers the liquid, and at the end of three days the development becomes complete.

The conditions which favour its growth are, moist air, a temperature above 10° C. (50° F.), and a nutrient liquid (tannin, potash, phosphoric acid and nitrogen). When the vegetable finds itself in a suitable medium it grows in great quantities; thus, 25 grammes of aspergillus have been taken from a solution containing 80 grammes of nutrient matter, more than a third of it thus having become

organised. If one considers the surface, it is found that it gives a crop of 10,000 kilos. per hectare.¹

The fermenting power of the mycelium is thus considerable. When once the tannin is split up, the mould continues to develop to the bottom of the vessel. It lives at the expense of glucose, which steadily diminishes. When it has disappeared, the gallic acid, which has not been attacked before, vanishes in its turn.

Other microscopic plants, such as *Aspergillus Glaucus*, *Penicillium Glaucum* and various other members of the aspergilli as *Alternaria*, *Cladrotichum*, *Septomena* and *Trimmatostroma* split up tannin by fermentation.

Müntz has pointed out that when the mycelium of *Penicillium Glaucum* ceases to develop, it absorbs the tannin and becomes tanned. It can take up as much as 66 per cent. of its weight of tannin.

This fermentation of tannin causes great losses in tanneries by changing part of this tanning agent into acids which have no tanning power, and give no weight of leather.

We have tried various antiseptics with the view of stopping this fermentation. Here is a list of the substances used with the smallest quantities which will preserve tan liquor, in parts per million:—

Mercuric iodide	35
Mercuric chloride	80
Osmic acid	150
Cupric chloride	700
Cupric sulphate	900
Salicylic acid	900
Zinc sulphate	1,000

10. Tannates.—Tannin being a feeble acid, combines with bases and oxides to form salts known as tannates, which are insoluble in water, with the exception of the tannates of potassium, sodium and ammonium. They dissolve in water containing carbonic acid, or mineral or organic acids, with decomposition, the tannin being set free. These tannates have no definite composition, the percentage of tannin or oxide varying according to whether the

¹ Three tons 12 cwt. per acre.

tannate has been made in the hot or cold solution, in dilute or strong solutions, and on which of the substances has been in excess, etc.

11. Gallic Acid.—We proceed to give some properties of those substances which are formed by the decomposition of tannin, or are found intimately mixed with it in commerce. The presence of these substances often has considerable effect, either good or bad, on the value of the main substance.

Gallic acid was discovered by Scheele in 1786. It occurs naturally in gall nuts, sumach, the capsules of *Quercus Ægilops*, the fruit of *Cesalpinia Cariara*, the grains of the mango, etc. It is produced from tannin by fermentation, under the influence of *Aspergillus Niger*; by the action of dilute acids, especially sulphuric; by slow oxidation in moist air; by rapid oxidation in the presence of caustic alkalies; by the action of heat, and, generally, whenever it is subjected to the action of oxidising agents.

Its formula is $C_7H_6O_5$, or rationalised $C_6H_2(OH)_3COOH$. It is a triphenolic acid.

This acid is a solid, crystallising in soft, prismatic, inodorous, colourless needles, with an astringent taste and feebly acid. The crystals contain a molecule of water, which is lost at $100^\circ C$. A hundred parts of water dissolve 1 part of the acid at the ordinary temperature and 3.3 parts at boiling point. A hundred parts of alcohol dissolve 40 parts of gallic acid at $15^\circ C$. and 100 parts of ether dissolve $2\frac{1}{2}$ parts at the same temperature.

It does not precipitate gelatin, albumen, fibrin or starch, but it precipitates metallic salts, giving reactions similar to those of tannin.

Bicarbonate of lime, in contact with the air and gallic acid, gradually becomes deep blue; the addition of an acid at first changes it to red, but it gradually changes back again to blue. Under these conditions an oxidation product is formed known as *gallerythronic acid*.

Uranium acetate gives a deep red colouration. Potassium plumbite boiled with gallic acid gives a rose-violet colour, by which means one part of the acid may be detected in 2,500 parts of water.

The cold aqueous solution alters on standing in contact with the

air or oxygen ; it gives off carbonic acid, acquires a deep red colour, and forms an oxidation product known as *tannoxylic* or *tannomellanic acid*.

Potash or soda rapidly oxidise gallic acid. At the boiling point, the liquid becomes quite black from the formation of ulmic acid.

Chlorine, bromine, iodine and chromic acid destroy it completely.

Sulphuric acid produces a reddish-brown substance, *rufigallic acid*.

Heat gives the same products as have been described under tannic acid.

The percentage composition is :—

Carbon	Per Cent.
Oxygen	49'41
Hydrogen	3'53
	47'06
	<hr/>
	100'00

Gallic acid combines with bases to form insoluble salts, which are stable when dry, but which readily absorb oxygen and become brown when damp.

12. Rufigallic Acid.—Discovered in 1836 by Robiquet. It is formed by the action of strong sulphuric acid on gallic acid at 140° C. Its formula is $C_{28}H_6O_{16}$. It is brownish-red, insoluble in water, which only takes up 1 part in 3,400, but soluble in alkalis. Iron salts colour it madder-red, alkalis blue, and sulphuric acid red.

13. Ellagic Acid.—This acid is formed in the decomposition of ellagitannic acid, 5 to 6 per cent. of which is found in the pods of dividivi. Tannin fermentation is always complicated by the formation of ellagic acid at the expense either of the tannin or the gallic acid. Its formula is $C_{28}H_8O_{18} + H_2O$. It is a tetraphenolic dibasic acid, colourless, tasteless, scarcely soluble in water or alcohol, and insoluble in ether. Alkalis turn it black, forming *glaucomelanic* acid and other products.

14. Gallate of Tannin.—This body is produced by the combination of tannin with gallic acid under the influence of heat, by the oxidising action of air, light, alkalis, dilute acids, etc. It is met with in vegetable tans which have been long exposed to

the air. The author discovered it in 1886 whilst studying extracts which had been made under pressure at a high temperature. Under these conditions it is formed in large quantities; its composition is:—

	Per Cent.
Carbon	52'55
Hydrogen	3'60
Oxygen	43'84
	99'99

It is soluble in water and it is not absorbed by skin or gelatin. In fact it is in every way a substance whose production should be avoided.

II.—TANNING SUBSTANCES—(BARKS).

As we have already said, no principle is more widely distributed in the vegetable kingdom than tannin. Tan-bearing plants specially adapted for leather-making are found in all parts of the world.

The tanning substance *par excellence* is oak bark, with which we commence our study.

1. Oak (*Quercus*).— Trees of the acorn-bearing family. There are more than 280 varieties of oak. The eleven varieties which grow in France and Algeria belong to two groups, those with deciduous leaves and those with alternate leaves.

The common oak is the best known and the most important. It has two varieties (*a*) the oak with sessile flowers (*Q. Sessiflora*), commonly called the red or male oak, and (*b*) the pedunculate oak (*Q. Pedunculata*), called the white or female oak. There are considerable differences between these two forms. The sessile one gives 2'52 parts of bark to 100 of wood, whilst the pedunculate variety only gives 1'9. The first, again, is much richer in tannin.

The evergreen oak (*Q. Ilex*), *Quercus Tauzza*, *Quercus Cerris*, *Quercus Fontanesii*, *Quercus Castanæfolia*, *Quercus Ballota*, *Quercus Suber*, *Quercus Coccifera*, *Quercus Ægilops* and *Quercus Tinctoria* are the chief varieties used in France.

The cut underwood gives more valuable bark than full grown or massive trees. The quantity of tannin varies according to whether

the tree has grown in a thick wood or in the open. Whilst in forest bark about 14·5 of tannin is found, trees grown in the open give bark containing 15·8 and more of tannin. In the market three boxes of bark from full-grown forest trees are only worth about as much as two boxes of fine bark or underwood. If 100 cases of fine bark weigh 1,700 kilos. ($33\frac{1}{2}$ cwt.), 100 cases of coarse or forest bark will weigh nearly 3,000 kilos. (59 cwt.). Supposing then that the same price is given for three cases of coarse as two cases of fine, it will be seen that it requires 4,500 kilos. of coarse bark to fetch the same amount of money as 1,700 kilos. of the finer material. Moreover, the carriage will cost twice as much.

In all countries, the best bark is that which is taken from an undergrowth twenty or thirty years of age.

It should be noted here that the cutting takes place on the average once in twenty years, and the produce is divided into five classes. Soiled, underwood, staddle, new and old. The soiled has no particular age, and is cut from dead wood. The underwood is cut at about twenty years—if younger it has less volume, weight and quality; if older it gives a very rough bark, especially at the base, covered with a useless layer, objectionable because it absorbs the tannin contained in the lower layer. In spite of all its advantages, this young bark is only used to half the extent of the new and old.

A damp soil gives a fine light bark containing very little tannin. Sandy soils are more favourable to the bark than calcareous or clay soils.

Dry earth sloping to the south gives a thick heavy bark of a silvery tint having a high percentage of tannin and fetching a high price on the market.

Taken from the straight, smooth, slender shoots it is worth more than from crooked or thick shoots. It is better on the trunk than on the branches. Its value varies from twig to twig and along each twig according to its height. The quantity of tannin increases from the outside towards the centre, the heart of the wood containing more tannin than the outside. It is the same with the bark. Wolff has found:—

	Per cent. of Tannin.	Age in Years.
Wrinkled coarse bark with the internal cortical layer	10·86	41-53
Liber layer of old bark	14·43	41-53
Internal layer	13·23	14-53
Internal and external layers	11·69	41-53
Liber layer and external layer	13·92	41-53
Internal layer	13·95	14-15
" " 	15·83	2-7

The development of the bark follows a regular course, growing steadily, until it reaches the age of twenty-five years, after which it becomes quite irregular.

The increase is more rapid on the southern than on the northern side of the tree, where it increases in thickness annually by about one-tenth.

The varieties of a single species of oak give bark having sensibly different percentages of tannin.

Bark is richer in spring than in winter, thus two branches of the same stem were stripped in winter and two others in the following spring. The winter bark, on analysis, showed 8·575 of tannin and 1·425 of gallic acid; the spring bark gave 8·690 tannin and 1·89 gallic acid.

2. Stripping.—Natural stripping takes place in the spring between the 15th of April and the 15th of June, that is, at the time when the sap begins to circulate and finds its way between the wood and the bark. It dissolves or softens the connecting tissue as it forces its passage and separates the two parts, forming new layers of wood and bark which, when the winter returns, will become perfectly adherent the one with the other.

The time chosen is when this adhesion ceases to exist, when the *cambium* (the tissue separating the bark from the wood) has very little strength, and when the newly-formed cells may easily be broken.

This method of stripping depends entirely on the movement of the sap, which various circumstances may delay or accelerate. Thus it is impossible to strip in a fog, after frost, or after a sudden change of temperature. Hail, caterpillars, cockchafers, and anything that destroys the leaves or suppresses their functions will render the detachment of the bark more difficult.

The time for stripping is shown by the buds beginning to swell and open, and the appearance of the first leaves. One might, if necessary, wait until the tree is in full leaf, but the bark is then more difficult to remove, and the quantity of tannin which it contains is smaller, and hence it is of less value.

Such trees as cannot be stripped at once should be kept until the second flow of sap which takes place in August, at the time when the wood is cut for charcoal burning. But, in spite of the excellence of the bark thus obtained, it is very little practised, because the shoots have not time to ripen their wood before winter, and the result is loss later on.

Stripping is carried on in mild damp weather, and in the absence of north or east winds. The bark comes off better in the morning than in the evening.

The barking is effected either as the tree stands or after cutting it down.

3. Stripping the Standing Tree.—Two circular cuts are made, one at the foot of the tree and the other five or six feet above. Then by means of a kind of spatula made of wood, iron or bone, and known as the "peeling-iron," the bark is cloven vertically from one cut to the other so as to form a series of strips. The peeling-iron is slid in between the wood and the bark to detach the end, and then by pulling this end outwards, the strip comes readily from the tree.

The tree is then cut down and the upper part is stripped as described in the next paragraph. Great care should be taken that the trunks do not become splintered or cracked. Usually the splitting occurs when the tree is allowed to fall before sufficient work has been done in the actual cutting.

This method of stripping allows the workman to choose a day and hour favourable to the movement of the sap, but it ruins the trunk of the tree, and renders impossible any fresh growths from the stumps. Further the French Forest Department has forbidden this class of work. In Articles 36 and 40 of the Forest Code fines are imposed for removing the bark in this fashion.

4. Stripping after Felling.—In this system the felling of the tree is the first operation, and in order that the work may be

carried out systematically, the portion of forest to be cut is divided into sections. Each section is worked by four wood-cutters, who never cut down more trees than can be stripped during the day.

The cutters cut down the young trees of the underwood, level with the ground one after the other. Those which are more than 4 inches in diameter are cut with a hatchet. The smaller branches are cut with a reaping hook. They are cut off as close as possible to the ground in such a manner that rain water cannot find any cracks wherein to lodge. An oblique cut is always the best. If the undergrowth contains trunks which are already of considerable age, or if the species do not bud easily, the cut is made above the first front bud; otherwise it is customary to cut close to ground. An improvement was introduced into this system in 1883 by Arbey; we refer to the steam saw which bears his name.

It consists of a steam cylinder of small diameter and long stroke fixed to a light stand of wrought iron on which it is pivoted so as to move about its middle point. The rotation on this pivot is governed by a hand-wheel which, by a screw adjustment, is able to alter the direction of the cylinder's axes through an angle of 90°.

The blade is fixed directly on the piston rod and is kept straight by means of guides, the teeth of the blade being cut in such a way that they only come into action on the return stroke. The saw thus works by traction. By means of this extremely simple arrangement, saws can be used up to 10 ft. in length without any precautions being taken to prevent twisting, as the actual stroke of the saw is sufficient to keep it straight. The steam is supplied from a portable boiler, through a flexible tube. With this apparatus forty trees having stems over a yard in diameter can be cut down during a ten hours' working day.

The wood so cut down is delivered in pieces 4 to 6 ft. in length.

Each of these logs is placed on a rack formed by two parallel bars, which carry notches above to hold the wood steady whilst it is being stripped.

The bark is cut transversely into 4 ft. lengths, then split longitudinally into strips a foot broad by means of the peeling-iron.

This instrument varies in form in different places. Some wood-

cutters use the tibia of a horse, sharpened at one end and having at the other end a blade with which to make incisions.

Others employ a lozenge-shaped iron blade fixed into a handle. This blade, shown in Fig. 8, is about 15 in. long by 2 in. wide.

After making the incisions, the end of the instrument is thrust underneath the bark to detach a portion, this is then gripped and the strip of bark is torn away from the wood. As soon as it is removed the elasticity of the bark asserts itself and the strips roll themselves up into cylinders.

Knotty wood of irregular shape or very fine shoots are stripped by hammering with a mallet which loosens the bark. When obtained thus, the bark is of a lower quality and is named cleats.

5. Drying the Bark.—The bark is spread on the ground, which



FIG. 8.—Peeling-iron.

has been first covered with twigs and brushwood to preserve it from damp, the bark being laid across the brushwood with its inner side downwards.

The bark taken from the branches and the waste or broken pieces should be placed inside the long strips taken from the trunks, and these should be placed on top of the pieces of stripped wood so that the air may have access to the heap. The whole should be covered by two or three layers of bark turned with the concave side upwards which, forming a series of gutters, will protect the heart of the pile.

For some years now the system of drying on racks has been resorted to; that is, the bark has been piled on two poles supported by pegs fixed in the ground. These poles form an inclined plane on which the bark is placed by hand, the convex portion turned

up so that if there be any rain it will merely glide off the upper surface and not do any damage. A space is left between the different layers of bark so that the air may circulate in the interior and dry all the layers. Whenever the sun shines strongly the two poles which form a rack are removed to some convenient place, generally leaned up against an oak tree, and the bark is turned with the concave side above. In this position the sap sets in a few hours and shuts up the tannin in the interior of the bark. If bad weather should come on before the bark is quite dry, it is returned to its first position and the racks are replaced in a heap.

Drying is complete in two or three days; when the weather is favourable, twenty-four hours is sufficient. It ought never to be left, as unfortunately is often the case, for eight or ten days, because it blackens and stains and loses its best qualities.

6. Stacking Bark.—Stacking is practised in Spain, Africa and the Pyrenees. When the bark is thoroughly dry, a place is chosen, well out of the way of violent winds or water courses, and the earth is covered with branches of trees to a depth of ten or fifteen inches. On this the bark is carefully placed so as to form a stack in much the same manner as if the stack were to consist of straw. The strips of bark are piled one on the other, pressing them down with the feet, as the stack gains in height. The strongest are kept flat by being weighted as soon as they are removed from the tree, so that they may be used as a sort of roof for the stack after it is finished. The roofing is brought up to a point, and cords are passed over it with heavy stones tied to their ends so as to keep the whole edifice in position; lastly, the roofing is covered with brushwood.

When the bark is to be sold, a dry day is chosen, and the bark is broken up with sticks or mallets. It is then placed in bags for shipping.

This method of working bark has the following advantages: rapid drying, an easy removal of the bark at exactly the right time, and good preservation.

7. Packing the Bark.—When the bark is dry—that is, when it breaks up readily—it is riddled to remove foreign matter, lichens,

moulds, etc., then placed in cases about 4 ft. in circumference by 4 ft. high and weighing 35 to 40 lb. The boxes are piled in the woods under branching trees, and covered with large sheets to protect them from changes of weather.

Bark is sold, according to the custom of the country, in 100 or 1,000 kilo. lots or 104 cases to the hundred. The average price is 105 to 110 francs per 1,000 kilos. or 150 to 160 francs per 104 cases.¹

8. Yield of Bark.—An acre of oak underwood twenty years old will yield:—

In bad soil	3·2 cubic yards of wood.
„ medium soil	5·8 „ „ „
„ good soil	8·0 „ „ „

Whilst a cubic yard of wood will give according to the diameter of the pieces, from 75 to 117 lb. of bark.

This applies chiefly to the rouvre and pedunculate oak, which supply four-fifths of the bark used in France. A cubic yard of cuttings from twenty to twenty-five years old weighs in the green state 590 lb. and yields 117 lb. of green bark.

In drying, bark loses half its weight. The tauzin oak yields only 550 lb. per ton. The removal of the bark diminishes the volume of the wood, according to its thickness; on an average this diminution is between one-fifth and one-seventh. In the tauzin oak it rises to a quarter. The diminution of weight caused by stripping wood of its bark varies from a twentieth to a twenty-fifth.

The cost in France of stripping 1,000 kilos. (nearly a ton) of bark is about 30 francs (£1 4s.).

9. Quality of Bark.—Bark of good quality is white, smooth and shining on the outside surface; reddish and wrinkled on its inner surface. The fracture is whitish, the liber and the epidermis ought to be as fine as possible.

Bark is classed in four varieties: yellow, red, white and black, according to the colour of the fracture.

Yellow is the best in every way; next comes the red; then the white. Black bark comes from the collar and the base of the trunk.

¹ 105 to 110 francs = £4 4s. to £4 8s.; 1,000 kilos. = 2,200 lb.

It is always better than that of the trunk, properly so called, and the branches, and it is often mixed with white bark to improve its quality. These qualities are generally produced by the evergreen oak.

Bark which has grown exposed to the south has always the greatest density.

	Density.
White bark has a density of	0.970
Red „ „ „	0.978
Yellow „ „ „	0.982
Black „ „ „	0.985

As to percentage of tannin, they give :—

	Per Cent.
White	5.50
Red	6.75
Yellow	7.50
Black	8.20

10. Steam Stripping.—Natural stripping is dependent on all sorts of untoward circumstances. The time during which it can be carried out is relatively short. Knotty wood and small shoots are difficult to decorticate. In face of these and many other difficulties, means have been sought for stripping which may be used all the year round, and on all parts of the tree.

The first attempt was made by Maître at Chatillon-sur-Seine (Côte d'Or) in 1864. His idea was to separate the bark from the wood by saturating it with steam in closed vessels. At the 1867 Exhibition Maître gave a public demonstration showing that artificial decortication was possible.

In 1876 a commission for experimenting on steam stripping under the presidency of M. Meynier, Administrateur des forêts de l'Etat, undertook a series of experiments and arrived at the following conclusions :—

- (a) That an oak could be stripped at any time, even when the cutting up occupied several months.
- (b) Steam stripping costs more than the ordinary methods.
- (c) Steam-stripped bark is not so rich in tannin as naturally-stripped bark.

De Nomaison improved Maître's apparatus, making it both practical and portable.

His idea was to let the steam merely swell the bark, which expands more rapidly than the wood; whereas Maitre's idea was to make the steam dissolve certain soluble principles, to effect which he had always used saturated steam.

The first improvement of Nomaison was to let dry steam act on the wood. He used steam at 170° C. (338° F.), as being the hottest he could use without hurting the tan.

The apparatus consists of a steam generator and a reservoir in which the wood may be placed.

The generator is a vertical tubular boiler about 4 ft. 6 in. high and 2 ft. 6 in. diameter. It is furnished with a smoke box and a chimney a little over a yard long. A water jacket surrounds the smoke box which allows the boiler to be fed with warm water. The furnace is inside. Water descends to the bottom and completely surrounds it. The sixty water tubes expose a total surface of about 80 sq. ft to the direct action of the fire, thus producing within a small volume a large quantity of steam. This boiler vapourises about 120 gals. of water per day using $1\frac{1}{3}$ cubic yards of wood as fuel. It is very light, weighing less than 5 cwt., and can easily be taken about by two men. When it has to be transported any distance it is mounted on wheels.

The steam produced passes into the superheater, a kind of copper vessel above the tubes, where it is superheated and whence it passes on to the reservoirs.

The reservoirs are the vats in which the wood is placed—they are cylindrical, and made either of wood or of sheet iron. Their size, of course, varies with the length of the logs which have to be steamed, but with an increase of length, the diameter is diminished, so as to keep a constant cubical capacity (about 1 cub. metre).¹

The vats, three or four in number, are arranged symmetrically around the boiler on logs. Each is slightly inclined, so that liquids formed by the action of the steam on the wood may be run off. The steam enters the vat at its lower end, at a pressure of 4 or 5 atmospheres.

Seven hundred décistères (rather over $\frac{9}{10}$ cubic yard) of wood

¹ 1.31 cubic yards.

are introduced into each vat, having first been prepared by making a series of longitudinal slits through the bark. The first operation of each day lasts about two hours, but afterwards, when the vats are thoroughly heated, an hour and a half is sufficient. When the work has once commenced it goes on continuously. As soon as a vat is empty it is refilled with fresh wood and allowed to steam, whilst the others, each in its turn, are being emptied and refilled.

The workman can tell when the wood is ready by the fact that a juice begins to come away, and steam comes off from the joints. The wood is then taken out of the vats, and stripped in the ordinary way. Three men, with a woman or a boy, are sufficient to manage the apparatus. One man does the emptying and refilling, whilst the others strip off the bark.

A vat of wood takes about a quarter of an hour to strip, and in a day this number of men can remove the bark from 10 to 12 stères (13 to 16 cubic yards) of wood and produce 12 or 15 cwt. of bark.

Bark thus obtained is white and very clean. The wood is of a dull appearance, without stringiness or cracks. The products are less damp and therefore more easy to dry than when full of sap.

It is dried either in the open air, under sheds, on hurdles, or by hot air, from a stove or steam pipes, or, lastly, by allowing a current of air to pass through it as it is spread on a rack made of poles. It should not be dried in December or January.

The cost of this operation is about £1 per ton.

The yield is four cases per stère (1½ cubic yards).

Here is the detailed cost of preparing 100 cases of bark, valuing the wood at 14 francs per stère (8s. 4d. per cubic yard).

Bringing wood to the apparatus :—

Twenty-five stères (32½ cubic yards) at 3d.	£0	6	3
Fuel (wood or coal)	0	8	0
Water, including carriage	0	3	9
Labour	0	15	0
Drying	0	1	0
Loss in weight of wood	1	13	6
Depreciation in value of wood	0	9	6
Total cost	£3	17	0
One hundred cases of bark are worth	8	0	0
Profit	£4	3	0
Or rather more than 2s. 6d. per cubic yard.			

Comparative experiments on tanning with steamed bark leave no doubt as to its value, though the quantity of tannin which it contains is slightly lower.

Müntz gives the following analysis:—

	Natural.	Steamed.
Tannin	8.55	7.53
Saccharine matter	1.27	1.49
Pectin, extractives, etc.	3.54	6.96
Fibre, etc.	86.64	84.22
	<hr/> 100.00	<hr/> 100.20

11. Storage of Bark.—The bark ought to be stored in well-closed rooms on a ground floor, care being taken to prevent the damp from getting on to the racks; or else on a first floor, when the arrangement of the establishment allows of having such storehouses. The principal precaution is to avoid damp which, as has been shown in the previous chapter, causes considerable decomposition and loss.

Here are the results of several experiments showing the necessity of careful storage:—

(a) The bark of a Sologne oak contained:—

	February, 1879.	June, 1880.
Tannin	12.	6.9
Extractives	5.2	5.8

In sixteen months it had lost 5.1 per cent. of tannin.

(b) The bark of a green African oak gave the following percentages of tannin:—

November, 1878	14.8
April, 1879	10.6
January, 1880	8.75

showing a loss of 6.05 or 40 per cent. of the total tannin in fourteen months.

(c) A sample of bark containing 8.44 per cent. tannin was submitted to the action of the rain, but stored dry. At the end of two months it only contained 5.3 per cent. Another portion of the same sample stored whilst still moist only gave 3.5 per cent.; whilst another portion, stored in a damp ill-ventilated place, contained, at the end of three months, only 2.6 per cent. of tannin.

Ventilation is most important, as is shown by an experiment on the same sample of bark, which was stored in a perfectly dry but

ill-ventilated place for three months, at the end of which time it only contained 5.5 per cent. tannin.

The following table contains a *resumé* of a series of experiments by the author:—

LOSSES SUSTAINED BY BARK WHEN KEPT UNDER VARYING CONDITIONS.
(Bark originally contained 12 per cent. tannin.)

Conditions of Storage.	Tannin per cent. after				
	1 month.	3 months.	6 months.	1 year.	2 years.
Gathered in rainy season	11.12	8.40	6.15	5.00	2.16
„ after frost	10.23	8.10	5.80	4.12	2.16
„ in a dry season	11.60	10.60	9.50	8.08	6.50
Stored damp	10.00	7.13	5.28	2.15	1.19
Stored dry, in a damp place	10.90	8.37	6.71	4.19	2.07
Stored in a dry place	11.60	10.44	9.23	6.81	4.33
Stored in a dry, well-ventilated place	11.88	11.00	10.53	10.00	8.88
Gathered at a dry time, stored dry and in a dry, well-ventilated place	11.90	11.50	10.90	10.50	9.75

12. Composition of Oak Bark.—The composition of good oak bark is:—

	Per Cent.
Moisture	9.5 to 10.5
Extractive matter	20.5 „ 21.5
Tannin	9 „ 12
Gallic acid	1
Fibre	51 „ 47
Ash	5 „ 7

The ash contains:—

	Per Cent.
Silica	0.52
Lime	3.01
Phosphoric acid	0.90
Magnesia	0.55
Oxides of iron and alumina	0.50
Alkaline chloride	0.05
	<hr/> 5.53

The mean percentages of tannin in bark coming from various parts of France are:—

Normandy	10 per cent.	Berry	8.5 per cent.
Burgundy	9 „	Perigord	8 „

13. Varieties of Oak used in Different Countries.—The principal portion of the tan bark supplied by French forests is produced by the two species known as *Quercus Sessiflora* and *Quercus Pedun-*

culata. The annual yield, according to government returns, is 43,000,000 kilos. of dry bark.¹ The species *Q. Ilex* and *Q. Touzza* from the Basses-Pyrenees, Provence and Landes, produce 5,000,000 kilos. of bark.

Here is the percentage of tannin which is found in the different classes of oak used in France :—

Quercus	Sessiliflora	12
„	Pedunculata	12
„	Ilex	10
„	Touzza	8
„	Mirbeki	13
„	Cerris	10
„	Fontanesii	11
„	Ballota	10
„	Suber	11
„	Rubra	5
„	Alba	8
„	Ægilops.	8
„	Tinctoria	7
„	Coccinea	7
„	Macrocapa	8

Garouille is the root bark of the dwarf or kermes oak (*Q. Cocci-fera*) which is very plentiful in the Midi, Aude, Herault, Tarn, Gard, and the Pyrenees-Orientales, and in Africa at Oran and Mostaganem in Algeria. It is a shrub whose height rarely exceeds 3 ft. 6 in.

African garouille contains 14 to 17 per cent. of tannin. When dried at 100° C. it loses 12 per cent. of its weight and gives, on analysis, 9.76 per cent. of soluble and about 1 per cent. of slightly soluble tannin. It gives a disagreeable red tint and a peculiar smell to leather. The best class of this material is yellow, and free from dust and black particles, which increase the colouring power and lower the percentage of tannin.

Most European countries use the barks enumerated above, together with those from *Q. Banisteri* and *Q. Phellos*.

In the United States red oak (*Q. Rubra*), black oak (*Q. Tinctoria*), white oak (*Q. Alba*) and rock chestnut oak (*Q. Castanea*) are used. The chestnut oak is the most abundant; its bark contains 12 per cent. of tannin.

¹ One thousand kilos. is slightly less than a ton; thus 43,000,000 kilos. is about 42,340 tons.

In China, the northern provinces contain little or no wood, with the exception of Shen-King, which still possesses oak forests. There are at least three varieties, *Q. Obovata*, *Q. Mongolica* and *Q. Catana folia*. The Japanese oak (*Q. Dentata*) contains 7 per cent. of tannin.

The French colonies of Martinique, Guadeloupi and Guiana export the bark of the Antilles oak (*Catalapa Longissima*).

III.—BARKS OTHER THAN OAK.

1. **Hemlock** (*Abies Canadensis*).—A tree of the coniferous family. It grows in Pennsylvania, Michigan, Canada and New York. Common or white hemlock bark contains 8 per cent. of tannin. White spruce (*Picea Alba*) contains 10 per cent. This bark is mostly used in America, but a certain quantity is exported to Europe, principally in the form of extract. It produces a thick, spongy, coloured leather.

2. **Fir**.—The bark of the false fir (*Abies Excelsa*) contains 8 per cent. of tannin, and is largely used in Austria, Bohemia, Switzerland and various parts of Germany. It has a less pronounced colour than that of the hemlock. The bark of the true fir (*Abies Pectina*) contains 7 per cent. of tannin. The only way to distinguish between these two barks is to test their extracts with ferric chloride when the false fir will give a blue-black precipitate and the true fir a deep green one.

3. **Pine**.—The bark of the Aleppo or Jerusalem pine (*Pinus Halepensis*) is one which deserves the notice of tanners. It consists of two distinct parts—one, interior, fleshy, brick-red, containing 25 per cent. of tannin, is known as the red bark (*scorza-rossa*), and another, the outer one, which only contains some 3 or 4 per cent.

Pinus Cembra gives a bark containing 8 per cent. of tannin. The well-known Syrian leathers are tanned with pine bark, as also are those known as Algerian.

4. **Larch** (*Larix Europa*).—A coniferous plant, very common in Scotland, Belgium, Italy and North America. The bark contains 9 per cent. of tannin.

The percentage of tannin is greatly influenced by the height to which the tree is stripped. At the foot of the tree, it contains

6.25 per cent., whereas at a height of twenty-seven feet it contains 12 per cent. This tannin is always mixed with 10 per cent. insoluble tannin. It gives a good colour to leather.

5. **Alder** (*Alnus Glutinosa* Order *Betulinae*).—It contains as much tannin as oak bark, and is used in Japan, Russia and Sclavonia. It gives a deep colour to leather and ferments quickly. The bark of a nineteen-year old alder contains 14 per cent. of tannin, whilst at forty years it contains 14.25 per cent. Besides this soluble tannin it contains 3 or 4 per cent. of gallic acid and 2 per cent. of insoluble tannin. The white alder (*Alnus Incana*) contains 15 per cent. of tannin in its bark, together with 1 per cent. of insoluble tannin and 2 per cent. of gallic acid.

The Japanese alder (*Alnus Firma*) growing in Totomi, Idzu, Kai and Iwaki, gives a bark containing 25 per cent. of tannin which makes an almost colourless decoction.

6. **Willow** (*Salix*).—The bark from several kinds of willow is used for tanning, especially in Russia; 7,000,000, kilos. is used annually in the preparation of youfte. In Germany, Austria, Sweden and Denmark, willow tanning is practised more and more. Certain classes of leather cannot be produced without this bark. Appended is a table showing the percentage of tannin in different varieties:—

	Per Cent.
Salix Acutipolia	14
„ Amygdala	3.42
„ Purpurea (red willow)	4.86
„ Capisca	3.12
„ Caprea (water willow)	4.21
„ Cinerea	3.92
„ Alba (white willow)	3.21
„ Russeliana	12
„ Viminalis (white osier)	11.8
„ Fragilis	9.4
„ Capraen	12
„ Arenaria	11
„ Pentandra	12

7. **Mimosa**.—Bark is provided by different kinds of acacia, of which the most important, both as to yield and richness in tannin, are, *Acacia Mollissima*, *Acacia Dealbata*, *Acacia Penninervis*, which are all varieties of a plant *Acacia Decurrens*, known in Australia as black wattle, *Acacia Cyanantha* (broad leaf) and *Acacia Pycnophylla*.

The bark is ripe for stripping between the fifth and the eighth years of its growth. At six years, a tree gives about 40 lb. of bark and at twelve years about 120 lb. In Australia, the fresh bark fetches 16s. per ton. The crop comes to 5,600 kilos. per hectare (5,000 lb. per acre).

These barks are rich in tannin and give good-coloured leather. Appended is a list of the different known acacias, with their percentages of tannin:—

	Per Cent.
Acacia <i>Horrida</i> (Cape of Good Hope)	12
„ <i>Arabica</i> (India)	20-25
„ <i>Penninewis</i> (New South Wales)	18
„ <i>Cyanophylla</i> (Australia, Algeria)	25
„ <i>Sisirs</i> a (India)	15
„ <i>Subporosa</i> , hickory acacia (New South Wales)	7
„ <i>Cavenia</i> (Argentine Republic)	6
„ <i>Cebil</i> (Argentine Republic)	12
„ <i>Decurrens</i> (Victoria)	29-40
„ <i>Leiophylla</i> (Algeria)	28
„ <i>Pyenantha</i> (Australia, Algeria)	30-45
„ <i>Sentis</i> (New South Wales)	6-32
„ <i>Aneura</i> „	8.62
„ <i>Pendula</i> „	8.15
„ <i>Glaucescens</i> „	8.10
„ <i>Mellanoxylo</i> n „	11.12
„ <i>Longifolia</i> „	18.93
„ <i>Dealbata</i> „	21.22
„ <i>Vestita</i> „	27.96
„ <i>Binerwata</i> „	30.40
„ <i>Curupay</i> (Paraguay)	18-19
„ <i>Angico</i>	15

8. Various.—The bark of the following plants contain tannin:—

	Per Cent.
Pomegranate	18-20
Mountain ash (<i>Sorbis Aucuparia</i>)	6-7
Elm (<i>Almus Campestris</i>)	7-8
Pistachio (<i>Pistacia Lentiscus</i>)	12
Wild cherry (<i>Prunus Avium</i>)	10
Silver birch (<i>Betula Alba</i>)	3
Poplar (<i>Populus Fastigiata</i>)	3
Dog berry (<i>Cornus Masculata</i>)	8-9

IV.—TANNING WOODS.

1. **Chestnut** (*Castanea Vesca*: Order *Cupuliferæ*).—A native of Central Europe. It is cultivated in Savoy, Auvergne, Dauphiné, Perigord, Provence, Brittany, etc. Tannin was first discovered in

Green wood, from the trunk, containing 75 per cent. water, will yield 4 per cent. tannin. Ordinary wood with 40 per cent. water will give 6 per cent. of tannin, whilst perfectly dry wood will contain from 8 to 9 per cent. During the drying of this wood, a curious phenomenon may be noticed. A portion of the tannin resinifies, especially during the first loss of water.

The author has made the following series of experiments. The wood of a chestnut tree, still standing, gave on analysis 4·128 per cent. tannin and 69 per cent. water. This was cut down, and the percentages of tannin and water estimated from time to time with the following results :—

Age of the wood.	Tannin determined.	Percentage of Moisture.	Tannin calculated from loss of water.
Tree standing	4·128	69	4·128
Twelve hours after cutting	4·118	68	4·392
Four days	4·187	65	4·660
Eight days	4·220	65	4·660
One month	4·337	63	4·926
Three months	4·447	61	5·182
One year	4·829	48	6·921
Wood completely dried at 100° C.	9·638	0	13·316
Wood dried in absence of air	11·812	0	13·316

The percentage of tannin in samples from different provinces shows little variation, not more than 1 to 1·5 per cent. Those from the North are less rich than those from the South, and those from the West less than those from the East. The roots contain 7 per cent. of tannin and the bark 4 per cent.

Chestnut wood gives 4·74 to 5·71 per cent. of ash which contains 75 to 80 per cent. of lime, 5 per cent. of potash, and 4 per cent. of phosphoric acid.

In addition to the ordinary chestnut, there is a species indigenous to North America, *Castanea Pumila*, which contains 8 or 9 per cent. of tannin.

2. Quebracho (*Aspidospermum Quebracho*: Order *Aponicæ*) is an exotic wood which comes from the Argentine Republic, Uruguay, Brazil and Guiana. The firm of Duboscq was the first to import quebracho into France for the manufacture of extracts.

the wood of the chestnut tree in 1818 by Michel, a Lyons dyer. About 1860 new processes of silk dying caused the extract to fall into disuse. Michel set to work to find some other use for this valuable tan bearer. He made experiments for four years, and discovered how to use it for sole leather. At the same time Allégatière of Lyons made the first chestnut leathers. Chestnut tan at once entered into commerce, chiefly in the form of extracts.

The wood of old trees is used. It is split up into blocks weighing about 60 lb., so that it may be easily carried about. The blocks should contain no rotten or dead wood, nor should there be any portions of branches of less than 4 in. diameter at their smaller end, nor any little roots. The blocks should be about from 18 in. to 4 ft. 6 in. long. All refuse wood ought to be thrown on one side and treated separately.

A stère of chestnut wood weighs from 340 to 385 kilos. (743 to 842 lb. per cubic yard). The wood contains a large amount of water, which varies considerably, according to the position of the tree, the date of cutting down, splitting, etc. A large number of experiments made by the author have given the following mean results:—

	Per cent. water.
Freshly cut wood	68
Green wood cut three months	55
" " cut three months and split up at the time	49·2
" " with bark	45·2
Wood with bark	43
Green wood without bark	40·5
Wood without bark	39·3
Wood without bark split five months	35
Old roots	29

This water has naturally a considerable influence on the total weight of the wood, as it evaporates more or less quickly according to the hygrometric state of the air. Thus the loss of weight in transit often amounts to 15 per cent. For instance, the loss in going from Montluçon to Lyons is about 10 per cent. on wood containing 45 per cent. of water. Further, it affects the yield. The wood is ordinarily stacked in heaps weighing 200 to 300 tons, and allowed to dry for one or two years before it is sold. It loses on an average 20 per cent. of water, and still contains 33 to 35 per cent.

It is an excessively hard, red wood, very strong, but of small elasticity, in fact, rather brittle. Its density is 1·250.

Quebracho Colorado contains 16 to 19 per cent. of tannin, and *Quebracho Blanco* 12 to 13 per cent.

An analysis gives :—

	Per Cent.
Moisture	15
Tannin (in dry matter)	20
Extractives	10
Wood	55

Amongst the extractives there are certain colouring matters very difficult to separate, which cause much annoyance in practice as they impart a disagreeable red colour to the leather.

When quebracho wood is ground it rapidly loses its tannin on exposure to the air, whereas blocks of the wood keep almost indefinitely. The author has made experiments on a lot of this wood, consisting of about 300 tons of logs, exposed to the variations of the weather, and on another lot of ten tons of ground wood exposed to the air under a covered shed. The following table shows the results arrived at :—

Age of the wood.	Wood in logs.		Wood ground up.	
	Tannin.	Water.	Tannin.	Water.
Original wood	18·23	15·15	18·23	15·15
After three months	18·20	15·15	18·10	15·15
„ six months	18·16	15·30	17·11	15·15
„ one year	18·16	15·10	14·23	14·20
„ two years	18·15	15	10·65	12·10
„ three years	18·12	15	8·20	12·10

The bark of this wood does not tan ; contrary to the statement of certain authors. Analysis always gives from 1·55 to 2·27 per cent. of tannin. It has evidently been confused with the bark of the *Acacia Curupy*.

Other woods resemble quebracho in hardness and appearance, but no others contain so much tannin. *Aspidospermum Churneau* contains 7 per cent. ; *A. Peroba* 5 per cent., and *A. Sessiflora* 10 per cent. Fever bark contains 4 per cent.

3. **Oak Wood.**—The wood of the oak contains about 5 per cent.

of tannin in addition to that in the bark. Hartig found that the small wood, cut at the commencement of May, contained from 4 to 7 per cent., whilst in winter it rises as high as from 11 to 18.5 per cent. of the dry matter. The same author found between 12 and 14 per cent. of tannin in the heart of an oak aged 160 years. This quantity remains unchanged if the felled trees are at once cut up into planks or beams; but if they be left in the bark for a few months the tannin quickly diminishes. The quantity diminishes from the centre to the circumference. The sap wood, which forms 35 per cent. of the wood, contains very little tannin, so that it is useless for tanning, besides which it contains large quantities of extractive matters, which form dirty deposits. The lowest parts of the trees give the highest percentage. Oak wood is much more readily fermented than chestnut or quebracho.

4. Wattle Tree : (Order *Celtidæ*).—This tree is met with in Provence (*Celtis Australis*), where it is called *bois de Perpignan*, in Languedoc and in Central Europe. The wood is blackish, hard, compact, of high density, and almost without sapwood. It contains 6 per cent. of tannin.

Andromeda, box-wood, angelina and carapa wood contain from 4 to 8 per cent. of tannin, but are scarcely ever employed in tanning.

V.—TANNIN-BEARING LEAVES.

1. Sumach (*Rhus*).—The different sumachs (Order *Terebenthacea*) are shrubs whose leaves and smaller branches contain a large quantity of tannin. The two kinds which are most used and which are of the greatest value are curriers' sumach (*Rhus Coriaria*) and dyers' sumach (*Rhus Myrtifolia*). The following are the known varieties:—

(a) *Sicilian Sumach*.—A more or less fine powder, well sifted, of a delicate velvety green colour, slightly inclined to yellow, and with a peculiar penetrating odour suggestive of violets. The most valuable samples come from Alcano (24 per cent. of tannin), Carieri (22 per cent.) and Val de Mazzana, about seven leagues from Palermo, (20 per cent.).

(b) *Malaga Sumach*.—A fine powder, full of little lumps, fairly

well crushed, but often containing the seeds of the plant. Its colour is yellowish green, not quite so light as Sicilian sumach, and having a strong tea-like smell. It is called *Priego*, and contains 16 per cent. tannin.

(c) The so-called *Spanish Sumach*, which comes from Molina and Valladolid, is a light-coloured powder containing many badly ground portions. It is inferior to those mentioned above (12 to 14 per cent. of tannin).

(d) *Portuguese Sumach*.—A coarse powder, badly crushed, sometimes containing sand. Very much like Malaga sumach (14 per cent. of tannin).

(e) *Italian Sumach*.—Dark green powder, rough to the touch, free from lumps, and smelling like tanned leather. It comes from Venice (13 per cent.), and is often made from false sumach (13 per cent.) or from fustic (8 per cent.).

(f) *French Sumach* is of several kinds : (1) the “Fauvis” sumach (11 per cent.) which, when of good quality, is very like Sicilian, but its colour is usually duller ; (2) “Donzère” sumach (13 to 14 per cent.), which is prepared in the neighbourhood of the Rhone department at Donzère and Montélimar ; a coarse gritty powder of a uniform dull green colour, having a strong smell of leather and a harsh astringent taste ; (3) “Redon” or “Redoul” sumach (13 to 14 per cent.), produced by a plant known as the dyer’s plant, or the black plant, which grows wild throughout Central France, on the banks of the Lot, the Tarn and the Garonne. It is a fine powder, soft to the touch, greenish grey in colour, and possessing a herbaceous smell ; (4) “Pudis” sumach (10 per cent.), a fine powder, yellowish green in colour, with a very strong smell. The last two are of much less value than any of the others. Germany produces *Rhus Pentaphylla*.

(g) *American Sumach* is obtained from various kinds of rather large sumachs : *Rhus Glabra*, *R. Copallina*, *R. Cotinoïdes*, *R. Pumila*, *R. Aromatica*, *R. Metopium*. They grow in the States of Alabama, Tennessee, Kentucky, Carolina, Georgia and Maryland.

All qualities are mixed, Staghorn sumach containing from 15 to 20 per cent. of tannin.

In Virginia, sumach is prepared from *Rhus Typhina*, which the Indians call Killikinick.

At the Cape two varieties of sumach are cultivated: *Rhus Lucida* and *R. Tomentosa*.

In North Africa *Rhus Oxyacantoïde* is used for tanning.

(h) *Australian Sumach* is derived from *Rhus Glabrum*, whose leaves contain from 16 to 20 per cent. of tannin.

2. Mangrove Leaves.—The mangrove (*Rhizophora Mangle*) grows on the sea-shore in most tropical countries. The leaves contain 20 per cent. of tannin.

The mango (*Mangifera Indica*) gives leaves containing 22 per cent.

3. Various.—The following list gives the names and percentages of tannin in the leaves of various trees which have been used by the tanner:—

	Per cent.
Andromeda (<i>Andromeda Arborea</i>)	10
Whortleberry (<i>Arctotaphyllos</i>)	14
Pistachio (<i>Pistacia Lentiscus</i>)	12
<i>Osyris Compressa</i>	17
<i>Prunus Spharocarpa</i>	15
Paraguay tea (<i>Yerva Mathé</i>)	7
Mastic	12
Eucalyptus	10-15
<i>Acacia Vestita</i>	15

VI.—EXCRESCENCES.

1. Gall Nuts.—Gall nuts are excrescences which develop on the petioles and young branches of foreign oaks in places where they have been punctured by an insect, either a cynips (*Hymenopterae*) or an aphid (*Hemipterae*). The female insect pierces the bud and deposits an egg in each hole which she makes. As the bud develops, the sap of the plant runs to the wound, and forms a sort of bulb in which the young insect is hatched and developed.

The best galls are those which have been gathered before the insect has escaped, that is, those which have no hole in their surface.

The varieties of gall nuts are:—

(a) *Aleppo Galls*, which are gathered from the gall oak (*Quercus Infectoria*) growing in the Levant and on the shores of the Mediter-

ranean. They are from $\frac{1}{2}$ in. to $1\frac{1}{2}$ in. in diameter and are rough. The black kind contains 37 to 41 per cent., the green 48 to 53 per cent., and the white 50 to 65 per cent. of tannin.

(b) *Smyrna Galls*, from the same tree and of the same three kinds as the Aleppo galls: black 33 to 37 per cent., green 53 to 60 per cent., and white 60 to 63 per cent. They are exported in horse-hair bags weighing about 300 lb. each.

(c) *Moreau Galls* are imported in cloth bags containing about 160 lb. They yield about 40 per cent.

(d) *Marmora Galls*.—Small, round, slightly elongated where they have been attached to the plant, and iron-grey in colour; they are either united together in bunches or armed with sharp points. The inside is yellow; tannin 40 per cent. They are imported in hair sacks containing 218 to 328 lb.

(e) *Istrian Galls* (41 per cent.), in light cloth sacks of about 160 lb.

(f) *Royal Galls*, 31.9 per cent.

(g) *Pouille Galls*, 40 per cent.

(h) *French Galls* are gathered from *Quercus Ilex*, *Q. Robur* and *Q. Tauzin*. They contain 8 per cent. of tannin. German galls contain 18.16 per cent. of soluble and 13.96 of insoluble tannin.

2. Chinese Galls.—Are produced by the puncture of *Aphis Chinensis* on *Rhus Javanica*, *Rhus Osbecky*, *Rhus Semialata* and *Dys-tilium Racemosum*. Commercially they are divided into two kinds: (1) those from Tse-Chuen, which are the best and have a rose-coloured fracture; (2) those from the province of Ito-nan, much larger and darker. The shell is much thicker than that of Tse-Chuen. In China, galls bear the name of Wuh-pei-tse; they are elongated, pear-shaped or globular, about 2 in. long by $\frac{3}{4}$ of an in. thick. Chinese galls contain 76 per cent. (Buechner), 69 per cent. (Stein), 69 per cent. (Bley), 72 per cent. (Villon). Galls from *Rhus Semialata* contain 77 per cent. of tannin (Johikawa).

Another kind of gall comes from the oak (*Q. Obovata*); they are called Mu-shi-tse, are oval, without points, brown, 78 per cent.

3. Tamarisk Galls.—Caused by the puncture of various tamarisks. The Indian tamarisk (*Tamarix Indica*), called Mahee in

British India, gives galls known as Sakum or Sakoon, or sometimes as Bokhara nuts, which contain, according to Walz, 35 per cent. of tannin.

The galls of an African tamarisk (*Tamarix Africana*) come from Egypt, where they are called Tarfeh, Algerian or Takkaout galls (30 per cent.).

4. Pistachio Galls.—*Aphis Pistaciæ* forms growths on pistachio trees known in commerce as carobs or *baisonges* (25 per cent.). They are also known as terebinthine, Bojekind, etc., galls.

5. Rore Galls is a gall nut produced by cynips in the little oak of Asia Minor. It was introduced into Europe by Messrs. Charles and Elie Guiffroy of Smyrna. The diameter of these galls often reaches $1\frac{1}{2}$ in. They contain 27 per cent. of soluble and only 3 per cent. of insoluble tannin.

Their outside colour is reddish-brown when they are fresh, but it deepens with keeping. When exposed to the air, or left on the tree for a year, they become greyish-black. A dozen spines grow in a perpendicular circle around the outside of the nut. They have a very fine epidermis, which prevents loss of tannin so long as its colour remains reddish. The appearance of a blackish colour indicates the decaying of the epidermis. The interior of the galls is very porous, which allows the tannin to dissolve out rapidly when they are placed in water.

Lastly, Rore tannin is mild, very similar to that of oak bark, and contains scarcely any colour.

6. Gallons are growths caused by the punctures of *Cynips Calicis* on *Quercus Stagnosa*, *Q. Pedunculata*, *Q. Sessiflora* and *Q. Pubescens*. The wasp alights on the acorn, and deposits an egg between the cup and the shell. The fruit appears, but it is more or less deformed, the cup and the acorn being indistinguishable. They are known by the German name of knopporns (Hungarische or Serbische knopporn). They come from Hungary, Styria, Croatia, Sclavonia and Piedmont in cloth bags containing about 200 lb. They contain from 25 to 31 per cent. of tannin.

VII.—TAN-BEARING FRUITS.

1. **Valonia** is the acorn-cup of the valonia oak (*Quercus Aegilops*) which grows in the East, in Asia Minor and in the south-east of Europe. It has received various names: acorn-cups (avelanèdes), Levant galls, Eastern knopporns, akerdoppen, Orientalische knopporn, Levantische knopporn, palamou klouks.

Valonia is obtained from all pachyleptic oaks, *i.e.*, oaks which have very thick and fleshy acorn-cups, such as *Quercus Oophora*, *Q. Græca*, *Q. Valonea*, *Q. Ungerii*.

Albanian valonia or *camatina* consists of the capsules of *Quercus Coccifera*.

It is composed of hemispherical cups about $\frac{1}{2}$ to $\frac{1}{6}$ in. in thickness, rather light, and very difficult to break, especially when dry. Inside they are reddish-grey, whilst outside they are covered with dull grey scales, with sometimes an acorn fitting into the cup. This is reddish, excepting for the part shut up in the cup, which is white. The acorn is very light and hollow. It contains a black powder. Only the cup itself is useful.

It is classed in three qualities according to the time of gathering: (1) *Chamada* consists of cups gathered in April before ripening—these are the richest; (2) the *Rhabdista* are those collected in September or October—they are knocked down with poles; (3) the *Charcala* or third quality fall of their own accord after the first autumnal rains—they are the least valuable.

The principal places of export are Smyrna, Trieste and Liverpool.

Their average percentage of tannin is 27 to 34. Those from Smyrna, which are the best, give from 30 to 38 per cent.; those from Croatia 25 to 30; those from Styria 20 to 25; those from Roumania 21, and those from Epirus about 14.

2. **Dividivi**.—Also called Libi-dibi, nacasol and Wouta-pana, is the pod of *Cæsalpina Coriara*, a tree growing in Columbia, Mexico, the Antilles and Venezuela. This fruit is about 3 in. long and $\frac{1}{3}$ to $\frac{2}{3}$ in. broad. Those obtained from the wild tree weigh 60 grains, and those from the cultivated tree about 120 grains. They are bent

into the form either of an S or a C, looking very much like snake-weed root. Their outer surface is brown-red. Beneath this is dry yellow pulp, and in the centre a ligneous endocarp divides one seed from another by transverse fibres. Each pod contains seven or eight seeds fixed in little cavities.

The best dividivi comes from Maracaibou and Caracas. The department of Rulia (Venezuela) produces the finest pods.

Dividivi contains 30 to 35 per cent. tannin.

3. Bablah, also called Babool, is the fruit of *Acacia Arabica* and *Acacia Nicolata*. These are pods 4 to 8 in. long by $\frac{1}{2}$ in. across, divided by a constriction into two rounded lobes. Each lobe contains a seed surrounded by dry pulp. Those from Egypt (*Santh* or *Karath*) and those from Nubia (*Nebnsnebs*) contain 30 per cent. of tannin. They are blackish and covered with a light dust.

Acacia adansonii gives pods 6 to 8 in. long by $\frac{3}{4}$ in. broad, containing 32 per cent. of tannin.

The fruit of *Acacia Seyal* is nearly 3 in. long by $\frac{1}{2}$ in. broad, and contains 25 per cent. of tannin. That of *Acacia Indica* is 2 to $2\frac{1}{2}$ in. long, and contains 28 per cent. These pods are known as Balibabalahs.

4. Algarobillas (*Algarobas*).—Fruit or pods rather long, straight or curved, cylindrical or compressed; the monocarp is fleshy and pulpy, the endocarp hard and in separate compartments. The fruits give the following percentage of tannin:—

	Per Cent.
<i>Balsamocarpum Brevifolium</i> (Chili)	65
<i>Prosopis Pallida</i> (Valparaiso)	60
„ <i>Dulcis</i> (Cardola)	62
Spanish carob (<i>Caratonia Siliqua</i>)	55

5. Various.—A large number of fruits may be used. This table gives the chief ones with their percentage of tannin:—

	Per Cent.
Areca nut (<i>Acacia Catechu</i>)	44
Myrobolans (<i>Terminalia</i>)	17
(Peru)	20
Alder (<i>Alnus Glutinosa</i>)	15
Pomegranate skins	24
Kaki (<i>Dyospiras Ebenum</i>)	18
Oak apples	15
Pine cones	7

VIII.—TAN-BEARING ROOTS AND BULBS.

1. **Scilla Maritima.**—The sea-onion or squill grows abundantly on the sea-shore in Spain, Italy, Aude and Herault. The bulb is large, fleshy and pear-shaped. On the outside it has several reddish skins, thin and inactive, whilst inside are pale pink fleshy skins.

Two varieties are known, one the female or Spanish, and the other the male or Italian. The Spanish, which has a red coat, contains 22 per cent. of tannin, whilst the Italian contains 24 per cent.

2. **Rumex Hymenoseplum.**¹—A plant growing abundantly in Texas. The bulbs of the plant weigh from half a pound to two pounds. They contain 21 to 25 per cent. of tannin.

3. **Palmetto Root.**—The stems and twigs of the Florida palm *Sabal Serrulata*. The stems of this wood wander about in the soil, interlacing with one another and covering considerable surfaces. Tannin 15 per cent.

IX.—TANNING JUICES.

1. **Catechu.**—Catechu is the extract from various acacias and cabbage palms. In India, acacia catechu is used under the name of *Kheir*. The inner part of the wood is cut up into shavings and an earthenware vessel with a narrow opening is filled with them. The lower half is filled with water and boiled until it has lost half its bulk. It is then turned out into a shallow bowl and allowed to evaporate in the sun until it is reduced to one-third. This liquor is kept in a cold place for a day and then exposed to the sun again, stirring every now and then as it thickens. The mass is finally spread out on matting to dry, and cut up into square cakes. It is known as Cate or Kaath.

Another kind of catechu is extracted from a conifer known as *Driemmi* or *Siami* and also from the *Acacia Farnesiana*.

Areca nuts (fruit of the *Areca Catechu* called Penang), are used in the preparation of two kinds of catechu.

They are boiled in water containing a little lime for six hours, at the end of which time the liquid is allowed to settle and Tjaarna

¹ *Rumex Hymenoseplum* is "Canaigre," now a well-known American tanning agent.

bark and the bark of the black Egyptian pine (*Acacia Arabica*), which has been soaked in water, is added. It is boiled again for two hours and exposed to the sun until dry. The product is kassu catechu.

True kassu is prepared by boiling the nuts with water in an iron vessel for four hours, taking out the nuts and continuing the evaporation until the liquor is quite thick. It is then allowed to dry on mats of rice straw. The nuts after drying are boiled a second time, and a second crop of liquid is thus obtained which on thickening and drying gives a dirty catechu known as *Coury*.

Many different kinds of catechu are known to commerce, of which the following are the chief:—

(a) *Pegu Catechu*.—Extracted from leaves, in cakes of from 80 to 90 lb. The cakes are in the form of a parallelopiped $6\frac{1}{2} \times 9 \times 2\frac{1}{2}$ in. It is reddish-brown, with a lustrous fracture. It is called Bengal. It comes from Bombay.

Eighty-four per cent. of this catechu is soluble in water, with about 2 per cent. of ash, and 14 per cent. insoluble organic matter. Density 1.39. Tannin 55 per cent.

(b) *Brown Catechu*.—In cubical cakes of 80 to 90 lb. weight in bags; it yields 50 per cent. of tannin, and is exported from Singapore by way of Calcutta.

(c) *Dull Brown Catechu*.—In cakes $21\frac{1}{2}$ in. square by 1 in. thick. It is dried on the bare earth or sand, so that no rice glumes are seen on its surface. It is compact, with a dull, irregular fracture displaying laminæ which are easily separated.

(d) *Bengal Catechu*.—In 14 in. cakes, very friable and of a chocolate brown colour. Density 1.3. It contains 55 per cent. of soluble matter, 48 per cent. being tannin.

2. Gambier.—Gambier is the extract from the leaves of *Uncaria Gambir*, a shrub of the order *Rubiaceæ*, very widely distributed in India and Malasia.

It is prepared by boiling the leaves with water, evaporating the liquor to the consistency of treacle, allowing the mass to solidify, and cutting into little cakes, which are allowed to dry in the sun. In this preparation, the leaves are carefully separated from the stems.

In Sumatra, an infusion is made of both the leaves and the young branches.

At Singapore, the leaves are boiled with water in a cauldron called a *qualie*, made of pressed bark with an iron bottom.

The following varieties are used :—

(a) *Singapore Gambier*.— $1\frac{1}{4}$ in. cakes weighing about $\frac{2}{3}$ oz. Outside they are dark brown, and inside reddish-white. They are very porous.

An analysis gave the following percentage composition :—

	Per Cent
Tannin	65.79
Extractive substances	18.50
Ash	3.21
Water	12.50
	100.00

(b) *Brown Gambier*.—Hemispherical cones about 5 in. high, and weighing from 2 to $3\frac{1}{2}$ oz.; it is blackish-brown, with a black glistening fracture. Pieces of palm leaf are found inside the cakes but not on the surface.

(c) *Yellow Gambier*.—In square cakes $1\frac{1}{2}$ in. long by $\frac{1}{3}$ in. thick. It is pale yellow, and the microscope shows needles of catechu-tannic acid.

3. Kino.—This is the extract from a large number of different plants, amongst which are *Pterocarpus Erinocceus*, *P. Marsupium*, *Eucalyptus*, *Butea Frondosa*, and *Rhizophora Mangle*. Kino runs from these trees either through natural fissures or by wounds made in the bark, or by the long incisions made during the budding. A eucalyptus tree gives 45 gallons of this juice, which is dried by the air and sun. Kino contains 50 per cent. of tannin and 20 per cent. of soluble gum. The principal varieties are :—

(a) *African Kino*.—Black, opaque, dark red in the interior, very friable, soluble in water.

(b) *Bengal Kino*.—Red-brown, friable, not softened by heat, soluble in water and alcohol.

(c) *Indian Kino*.—Small pieces, black, glistening, very friable.

(d) *Botany Bay Kino*.—Pieces weighing about a pound, $1\frac{1}{2}$ in. thick, opaque, rough and friable.

(e) *American Kino*.—Pieces from $\frac{1}{10}$ to $\frac{1}{2}$ oz. about an inch thick. Black, glistening, uneven fracture, opaque, entirely soluble in water, and 75 per cent. soluble in alcohol.

(f) *Columbian Kino*.—Flat cakes weighing a little over 1 lb., glistening brown uneven fracture.

(g) *Brazil Kino*.—Uneven angular lumps with a glistening black fracture.

X.—TANNING SUBSTANCES USED IN VARIOUS COUNTRIES.

The tans which we have just described are those used in the different parts of Europe.

Our (French) colonies produce their own tanning materials. Guadeloupe uses the bark of the mangrove; Guiana, the bark of the yayamados and the mangrove; Martinique, the bark of the West Indian Oak and the red mangrove; New Caledonia, the bark of *Baloghia Pancheri* and the mangrove; Madagascar and Tahiti use the mangrove and the conocarpes. Bucida and the sweet pea are also used as supplementary tans.

Réunion gives the barks of ebony, filao, benjoin, jamrosa.

Senegal supplies khaya bark, the glumes and stems of black sorghum, the skins of gonakia, bablah and dividivi; Tonquin produces kounao or false gambier.

In India, the chief tans used are bablah, myrobolans known as *Har*, bark of bahira and mimosa, known as *Sal*, and various acacias,

In Chili sole leather is tanned with *Persea Lingua*.

Brazil bark from guabari, genubata, byrsonima spicata, areca, pimento, mimusops, trumpet wood, vaingra, schinus mollis, garabi, santarita, canella, monesia, grannaniumba, etc.

Paraguay furnishes algarobilla, curupai, quebracho, nandipa, mangrove and yerva tea.

In China, besides the three varieties of oak already mentioned, the pine, the banana tree, the pandanus and the bamboo are used.

In Japan, leather is tanned with khaki, alder catkins, betel nut, pomegranate skins, oak bark, sumach and galls. Shibuki is also used.

In Persia, tanning is performed with oak, beech, jujube, citron, orange, mulberry and vine woods.

In Tunis, tanners use oak bark, soubar, pine bark, arna and tabarca tan.

In the United States, the chief tans are chestnut oak, red oak, white oak, hemlock, larch and sumach.

The Argentine Republic uses quebracho, cebil, and goyacan fruit.

The Transvaal uses silverboom, doornboom, outeniqua geelhout, asagai hout, hœnderspoor, doornspoor, etc.

Guatemala has curupy, timbo, laurel oak and dividivi.

Peru has ebony bark, lignum vitæ, acacia, jacaranda.

Australia uses the bark and leaves of various acacias, mimosas and eucalyptus.

In Venezuela, the chief tans are mango bark and dividivi; besides these are cocoa palm, yagrumo, aguacate, simaruba, gateodo, botoncillo, tamarindo, urape, etc.

XI.—TANNIN EXTRACTS.

1. Manufacture.—The object of making these extracts is to separate the tannin and soluble matter of the wood from fibres and other insoluble substances, and thus to obtain a product which is richer in tannin and more readily soluble in water.

The manufacture is very simple in theory. Tannic acid and the substances useful for tanning are soluble in water. The bark or wood, having been first broken up (see page 103) is submitted, either by maceration, decoction, or filtration, to the action of hot or cold water, in large vats which hold as much as three tons of the substance.

They are generally arranged in batteries, so that the tannin may be extracted methodically or completely. The extraction may be made (1) with water heated under pressure in autoclaves, or without pressure in rotating casks or open vats, in which the liquor is kept circulating by pumps; (2) by cold water in vats arranged in steps, in rotating casks, in vats with stirrers, or in closed vessels under pressure of carbonic acid; (3) in water kept warm by waste steam.

The solvent power of the water is greatly increased by the addition of 1 per cent. of borax.

The colouring matter and insoluble substances which get into the liquor either by too high a temperature or too long heating, are removed as far as possible by clarification. This may be done mechanically, physically or chemically, though all methods unfortunately lead to more or less loss of tannin.

A centrifugal method was proposed by the *Société Civile des Études* in 1884. Extreme cold seems to give good results, but the loss of tannin is still considerable. Animal charcoal (Vourloud) is useless.

Chemical methods are not lacking. Many have been called but few chosen. The chief ones are : Blood albumen (Gondolo); casein (Morand); dialysed alumina (Coez); sulphites (Gondolo); hyposulphites (Schutzenberg and Lalande); hyposulphite of alumina (Doutreleau); chlorine (David); chloride of tin (Sérrière); acetate of lead (Levinstein); oxygenated water (Villon).

The liquor obtained by any of these methods has a gravity of 4° or 5° Baume. It is concentrated in copper vacuum pans until it acquires a density of 20°, 25°, 30°, or 35° Baumé, or, if required dry, is taken on to 50° or 55°.

The powdered extract is made by grinding the dry substance between vertical mill-stones, the object being to render it more readily soluble.

Fibrous extracts are made by causing the extract at 30° Baumé to run through a series of fine metallic sieves, arranged one under the other about six inches apart; eight or ten sieves are sufficient. A current of hot air is forced up gently from below, and when the tan gets to the last sieve it is in solid threads which may be cut across. Sometimes the extract is concentrated to 45° Baumé before being passed through the wire gauze.

The chief extracts met with in commerce are prepared from chestnut, quebracho, oak, hemlock and oak bark. These are the most important. The more uncommon ones are made from sumach, fir bark, Aleppo pine, mimosa, dividivi, valonia, gall nuts and myrobolans.

2. **Analysis.**—Commercial extracts contain the following quantities of tanning and non-tanning principles :—

Nature of Extract.	Tanning Substances.	Non-tanning Substances.
Chestnut extract 20° Baumé . . .	18 per cent.	14 per cent.
" " 25° " " "	21 " "	17 " "
" " 30° " " "	25 " "	21 " "
" " 35° " " "	29 " "	25 " "
" " dry " " "	48 " "	35 " "
Quebracho " 20° " " "	29 " "	10 " "
" " 25° " " "	36 " "	12 " "
" " 30° " " "	45 " "	15 " "
" " dry " " "	57 " "	20 " "
Oak " 20° " " "	20 " "	16 " "
" " 25° " " "	24 " "	20 " "
" " 30° " " "	27 " "	25 " "
" " dry " " "	38 " "	47 " "
Oak bark " 20° " " "	21 " "	12 " "
" " 30° " " "	32 " "	18 " "
" " dry " " "	55 " "	30 " "
False fir " 25° " " "	24 " "	22 " "
" " dry " " "	33 " "	52 " "
Hemlock " 30° " " "	25 " "	25 " "
Pine " 30° " " "	21 " "	22 " "
Valonia " 25° " " "	24 " "	20 " "
" " dry " " "	60 " "	30 " "
Knoppers " 30° " " "	34 " "	15 " "
Sumach " 30° " " "	25 " "	25 " "
Gall nuts " 30° " " "	32 " "	12 " "
Alder bark " 30° " " "	18 " "	24 " "
Mimosa " 30° " " "	30 " "	20 " "

3. **Mixed Extracts.**—As tannin is not the only substance that tans; and as there are certain analogous substances contained in greater or smaller quantities, in plants which give colour or quality to leather, it has been found convenient to mix those which are too poor with others which can supply the tannin which the former lack.

These mixtures are extremely easy to extract. Appended is a list of those most commonly used. It is also a simple matter to vary these mixtures according to the price or the class of leather desired :—

- Oak and chestnut.
- Oak, chestnut and quebracho.
- Oak bark and mimosa bark.
- Oak bark, fir bark and mimosa bark.
- The same with dividivi.
- Oak bark, fir bark and myrobolans.
- Valonia, quebracho and oak bark.

XII.—ESTIMATION OF TANNIN AND TANNING PRINCIPLES.

Tanning materials should always be bought with a guarantee of their contents of "tannin available in the cold," that is, tannin soluble in cold water and readily absorbed by skin under the same conditions. In order to control such quantities accurate methods of estimating tannin are very necessary. We therefore give in this section a *résumé* of the best known methods of effecting this determination with rapidity and precision.

The different methods may be classified as follows :—

1. By means of gelatin.
2. By density.
3. By precipitation with metallic solutions.
4. By absorption of oxygen.
5. By precipitation with organic alkaloids.

1. Preliminary Sampling.—The taking of a sample for analysis is always a crucial matter. To sample bark, pieces should be taken both from the centre and the outer portions of the case, and different cases should be selected from various parts of the consignment. Five or six samples are thus collected of about 1 lb. each which must be mixed or ground up in a coffee mill or pestle and mortar. The whole is then well mixed. From this mixed sample 50 grammes are taken. This final sample is exhausted with 200 cc. of water (either cold or hot according to whether the soluble matter is to be estimated in one or the other). After decantation, another 200 cc. is added until eventually a litre of liquid is obtained which contains all the soluble matter of the 50 grammes.

Other vegetable substances are treated in the same way.

In extracts, the whole mass is well shaken and a sample drawn off from the middle.

2. Estimation with Gelatin.—This process is due to Davy, who added a solution of gelatin (4 grammes per litre) to the tannin solution until the precipitate ceased forming. It has been improved by Fehling (1854); Müller (1859), who added alum to the solution so that the precipitate might settle more readily; Hallwachs; Schulze (1866), who formed the gelatin-tannate precipitate in a saturated solution of sal-ammoniac; Lehmann (1881) and de Rouquès.

The following is the most accurate way of carrying out the process. The solutions required are:—

Standard Gelatin.—Prepared by dissolving 5 grammes of white gelatin in a litre of distilled water. To preserve this 10 cc. of the following solution is added:—

Water	100 cc.
Mercuric chloride	5 gram.
Potassium iodide	20 gram.

The whole solution is then made up to 1½ litre.

A Standard Solution of Pure Tannin.—Ten gram. of tannin and 10 cc. of the preservative solution in 1 litre of water.

The apparatus necessary is:—

A 250 cc. flask, a 50 cc. tap burette, and a supply of sulphate of barium or sulphate of lead.

The first operation is to standardise the gelatin.

Two hundred and fifty cc. of the standard tannin is measured out into a beaker, and about 50 gram. of barium sulphate added. The liquid is stirred vigorously, and the gelatin solution run in from the burette. At first the precipitate subsides very slowly, but quite suddenly, when saturation is complete, the liquid becomes clear. By adding another drop of gelatin it is easy to see whether any more precipitate is formed.

Supposing that 100 cc. of gelatin is required to precipitate the tannin contained in the 250 cc., then 1 gram. of tannin requires $\frac{100}{2.5} = 40$ cc. of the gelatin solution for its complete precipitation, *i.e.*, 1 cc. of gelatin corresponds to .025 gram. tannin, after the gelatin solution has been accurately standardised. The same operation is repeated with the solution which is to be assayed. The calculation of the quantity of tannin is then easily made.

Suppose that the gelatin solution has given the results shown above, *i.e.*, 1 cc. = .025 tannin. Further, suppose that 250 cc. of the the sample extract require 30 cc. of gelatin. Then in 250 cc., the 1½ litres which has been made up, there is $30 \times .025 = .75$ gram. of tannin, and seeing that 50 gram. were dissolved in the 1½ litres, of which 250 cc. or $\frac{1}{6}$ was taken for titration, the total amount of tannin contained in that 50 gram. was $.75 \times 6 = 4.50$ or 9.0 per cent.

Instead of using barium sulphate the operation may be carried out by dipping into the solution, from time to time, a tube over the lower end of which is stretched a piece of linen. A small quantity of the liquid will filter up into the tube, and may be tested with a drop of gelatin. If it form a precipitate it is poured back into the beaker and the operation continued.

3. Estimation with Hide Powder.—A solution is made having a strength of about 2° Baumé, the substance used being, of course, carefully weighed. The density of the liquid is then taken with a hydrometer. Next the hide powder is added in the proportion of about 4 grammes for every gramme of tannin likely to be present. It is allowed to stand for two hours, stirring from time to time. It is then filtered through linen, made up to its former volume, if necessary, and the density again taken. The second density is subtracted from the first. One is added for the density of water, and the tannin contents is read off from the table given on page 37. As an example: Suppose that the first reading of the hydrometer was 1·0058, and the second 1·0022, the difference will be 0·0036. Adding 1 we get 1·0036, which on reference to the table gives 9 per cent. of tannin, which will be the strength of our extract.

A special form of hydrometer is made (the barkometer) which has graduations on the stem corresponding to the percentage of tannin. This renders the operation very easy. We have only to subtract the number given after soaking with powdered hide from the original density number, and we get the actual percentage of the extract.

Messrs. Müntz and Ramspacher have constructed an apparatus in which fresh skins may be used, but the method is exactly the same as the one here described.

4. Estimation by Ossein.—There are undoubtedly many objections to powdered hide. A far better substance, which may easily be prepared in a state of purity, is ossein, which gives both rapid and accurate results.

The chemicals and apparatus necessary for this operation are:—

(a) *A Supply of Ossein.*—Small bones are exhausted in the cold with hydrochloric acid diluted with nine times its volume of water.

After some time the liquid is decanted off and more acid added. This operation is repeated several times, each time using weaker acid. After several days' immersion in the acid liquid, the bones become transparent and elastic. They are washed with a large quantity of water, dried and powdered.

(b) A hydrometer and a thermometer.

(c) A tall cylinder to the top of which an indiarubber stopper may be fixed.

For the estimation, 100 grammes of tanning matter are weighed out and extracted so as to make 1 litre of liquid. This liquid is poured into the cylinder, and its temperature and density taken. The ossein is then placed in the cylinder, which is corked up and well shaken, then the vessel is laid down on the table so as to present as large a surface of ossein as possible to the liquid. After an hour the cylinder is uncorked, the temperature taken (which ought to be the same as at starting), the fresh density is read off from the hydrometer and the quantity of tannin is calculated from the formula:—

$$\frac{D - d}{0.00405} \times 10,$$

where D = the first density and d = the second density. When a barkometer is used, the quantity of tannin is found directly.

Horn is sometimes used instead of ossein.

3. Exact Estimation of Pure Tannin.—If tannin has to be estimated, apart from other tanning substances, the following method, which gives excellent results, may be used.

The following solutions must be prepared:—

(a) *A solution of permanganate of potash* containing 1.5 gram. per litre.

(b) *A solution of pure tannin* containing 10 gram. per litre.

(c) *A decinormal solution of oxalic acid.*—This may be made up by dissolving either 6.3 gram. of crystallised acid or 4.5 gram. of the anhydrous acid (dried at 110° C.) in a litre of water. Better still is a solution of 14.2 gram. of pure crystallised ammonium oxalate in a litre of water, which keeps indefinitely; 1 cc. of either of these solutions contains .0063 gram of oxalic acid.

(d) A solution of 10 gram. of pure *indigo carmine* per litre.

(e) A *sulphuric acid solution* containing 200 gram. of the 66° Baumé acid per litre.

(f) A *gelatin solution* prepared by dissolving 25 gram. of gelatin and 150 gram. of salt in a litre of water.

(g) A *saturated solution of salt* containing either 50 cc. of sulphuric, or 25 cc. of hydrochloric acid per litre.

The apparatus required consists of a porcelain basin, capable of holding a litre of liquid, a burette, several pipettes and a filter.

The permanganate is standardised either by means of the oxalic acid or the tannin solution.

1. *By Oxalic Acid*.—Ten cc. of oxalic acid solution are placed in a flask of about 200 cc. capacity; 18 cc. of sulphuric acid and 40 cc. of distilled water are added. The temperature is raised to between 60° and 80° C., and the permanganate is added drop by drop until the solution remains slightly coloured. The number of cc. used should be about 30. Let us call it N.

One cc. oxalic acid (.0063 acid) corresponds to .0008 of oxygen.

One cc. of permanganate will correspond to $\frac{.008}{N}$ of oxygen.

It has been experimentally shown that 16 parts of oxygen from permanganate will oxidise:—

32	parts of	gall nut	tannin.
33	„	sumach	„
32	„	oak	„
31.4	„	quebracho	„
30.9	„	chestnut	„

Thus $\frac{.008}{N} \times \frac{16}{32}$ gives the average weight of tannin which is oxidised by 1 cc. of potassium permanganate.

2. *By Tannin*.—If it be wished to avoid all calculations, the standard tannin solution is directly titrated with the permanganate, as will be described later.

Let T be the weight of tannin corresponding to 1 cc. of permanganate.

The next operation is to titrate the indigo with the perman-

ganate. Twenty cc. of the indigo carmine solution are placed in the porcelain basin with 10 cc. of sulphuric acid and a litre of water. The permanganate is run in from the burette, until the indigo is bleached, stirring the while with a glass rod. The liquor ought to take a yellow colour, with a slight green shade and a faint pink tint at the edges. Let V be the number of cc. of permanganate used in the titration of 20 cc. of indigo.

We now come to the actual estimation. The extract is made so as to contain 5 to 10 gram. per litre.

A litre of water is poured into the porcelain basin, together with 10 cc. of the extract, 10 cc. of sulphuric acid, and 20 cc. of indigo. This is well stirred with a glass rod, and the permanganate added until it is just bleached. This should take three or four minutes. Let R be the number of cc. of permanganate required.

Whilst this is going on, another portion of the extract (100 cc.) is mixed with a 100 cc. gelatin solution, 10 cc. of sulphuric acid, and 40 cc. salt solution. A precipitate of tannate of gelatin is formed, which settles quickly.¹ It is filtered at the end of half an hour.

To 25 cc. of the filtered liquid (= 10 cc. of the original extract) are added 10 cc. of sulphuric acid, and 20 cc. of indigo and a litre of water. This is again titrated in the permanganate. Let the number of cc. required to bleach it be r .

The calculations are as follows:—

r is subtracted from R , which gives the number of cc. of permanganate required to oxidise the pure tannin. The difference is multiplied by T (the weight of tannin oxidised by 1 cc. permanganate);

$\therefore (R - r) \times T =$ the quantity of tannin contained in 10 cc. of the extract; in a litre then there is $(R - r) \times T \times 100$.

If a litre contains the extract from 5 grammes of bark, or other material, then 100 grammes will contain $(R - r) \times T \times 100 \times 20$, which will be the percentage of pure tannin.

¹ A clear filtrate is not easily obtained unless the liquid is shaken up with a little kaoline before filtering.

In this estimation, the tannin may be removed by dried ossein instead of by gelatin.

6. Analysis of Extracts.—The estimation of tannin and of tanning substances is made by the methods already described. The soluble matter contained in the extracts is estimated by means of the instrument shown in Fig. 9., which the author has named the *extromètre*. It consists of two tubes joined together, holding altogether 110 cc. of liquid. The capacity of the smaller tube is 3.5 cc., and its length is 7.5 centimetres. It is divided by a scale into fifteen equal parts, the graduation starting from the lower closed end. The larger tube has a mark at 20 cc. and another at 100 cc.

To make an estimation, the extract is run in until it rises to the



FIG. 9.—The *Extromètre*.

20 cc. mark, then water is added up to the 100 cc. line. It is shaken well and allowed to stand vertically. The insoluble particles fall to the bottom and rise to a certain point in the smaller tube, where their volume may be read off, the number so found being their percentage.

A good extract ought not to deposit more than 2 per cent., with the exception of quebracho, which may rise to 3 or 4 per cent.

Lead may be detected after burning the residue. A good extract should not leave more than 3.5 per cent. of ash.

The acidity of the extract is measured by dissolving 10 cc. in 100 cc. of water, adding 10 gram. of dissolved albumen, boiling, filtering through animal charcoal, and titrating with standard caustic soda.

7. Testing the Colouring Power of Tans.—Either the tan or its extract is made up with water to $\frac{1}{2}^{\circ}$ Baumé, and a piece of skin 35 mm. square is allowed to soak in it for twelve hours. Then the liquor is poured off and a fresh lot poured in, and allowed to act on the skin for a further twelve hours. At the end of this time the skin is taken out, placed on a piece of clean linen, and exposed to the air for twenty-four hours, by which time the colour will be fully developed, and may be compared with that given by a standard extract.

The author has invented a method on the principle used in the Mulhouse strips. The strips for tan judging, which are called "Bandes de Villon," consist of eleven strips of paper impregnated with different mordants showing proportional intensity of colour in different tans in the following manner:—

The first mordant is very dilute ferric chloride to judge whether the tannin gives a black, blue-black, green, or greenish-black colour.

The second is still weaker ferric chloride to judge of the intensity of the colour.

The third is bichromate of potash, which shows the extent to which the tannin will oxidise. This is seen by the colour of the strip: yellow, or brown, or intermediate colours.

The fourth is iodochloride of zinc, which will take up a violet tint, proportional in intensity to the molecular weight of the tannin.

The fifth is uranium acetate, which will acquire a red tint varying in depth with the amount of gallic acid present.

The sixth is plumbite of potassium. This varies from rose to violet according to the quantity of gallic acid.

The seventh is vanadate of ammonia, which will blacken more and more with the increased concentration of the tannin.

The eighth is nitrate of iron, which will be more or less blue according as the percentage of resinous material is low or high.

The ninth is basic acetate of copper, which will give a reddish-brown.

The tenth is chloride of tin, which will indicate by its depth in colour the colouring power of the tannin.

A decoction containing 2 gram. of tannin per litre is prepared either by weighing out 10 to 15 gram. of vegetable matter or 5 to 10 gram. of extract, and the solution is boiled. The strips have merely to be immersed for two or three minutes, then removed and dried. They are then compared with standard colours.

PART II.

TANNING.

CHAPTER I.

THE INSTALLATION OF A TANNERY.

THE way in which a tannery is installed is, economically, of the highest importance. It ought to be arranged in such a manner that skins can be passed in the minimum time through the series of operations which they must undergo before they are marketable products. This must be managed with the least possible expenditure of fuel and labour. To avoid loss of power and to insure the production of the best possible article, all the apparatus whether engines or machinery, should be of the most improved type and in good working order.

The plans of a perfect tannery cannot be drawn up without a complete study of the class of goods which are to be produced, and the processes which are to be used. Thus it is impossible to give any general rules for the installation. We give, however, in Fig. 10, a plan which has proved itself very efficient.

The building is made in two storeys, the ground floor being given up entirely to tanning operations, whilst the first floor is occupied by drying rooms, bark stores, and various machines, used in the preparation of the skin.

When currying and tanning operations are carried on together, the arrangements are much the same, excepting that the building is two or three storeys high, to allow room for the currying work, and a special drying loft.

The first thing to be considered is the motive power. Horses

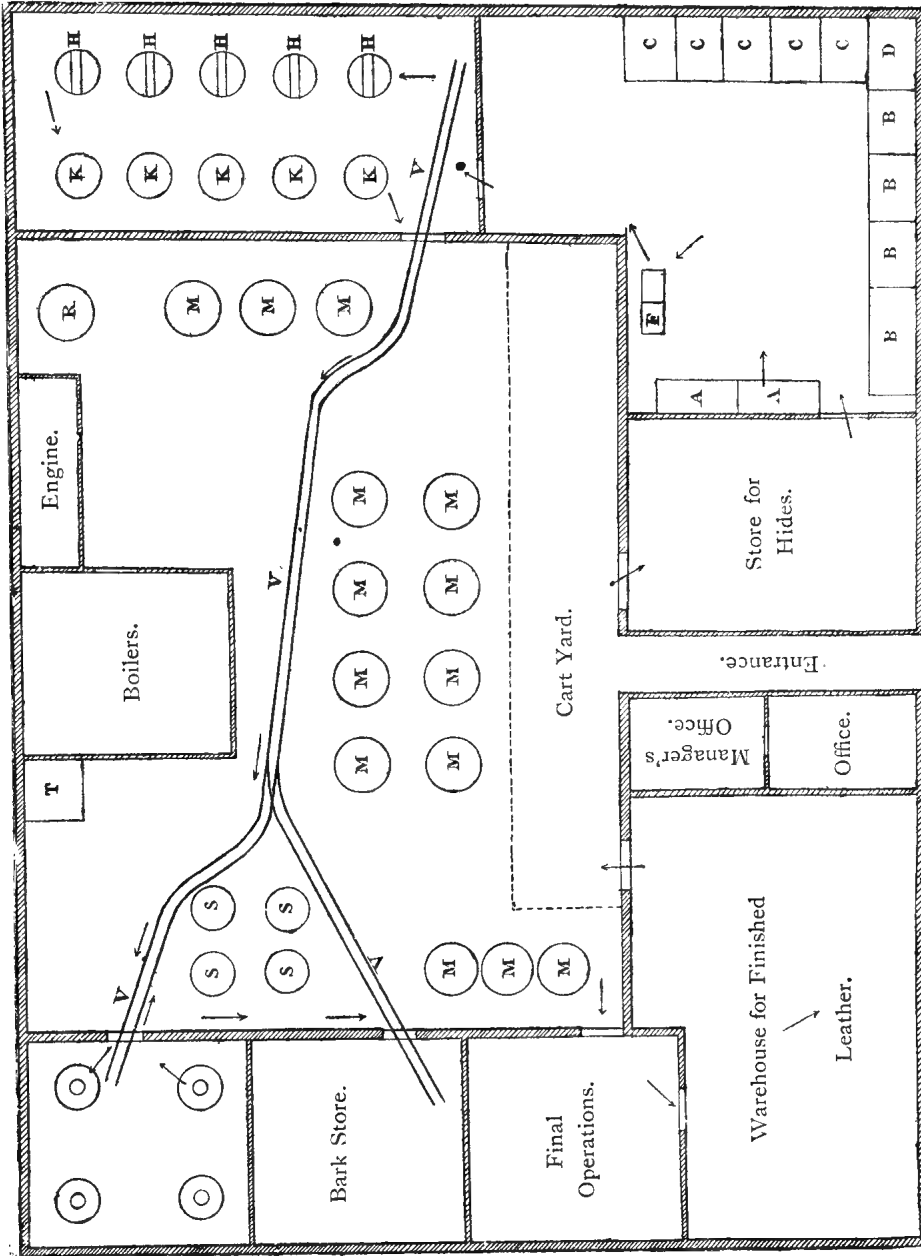

FIG. 10.

Plan of a Tannery.

- A and B. Soaking and softening vats.
- C. Lime.
- D. Pit for slacking lime.
- E. Tumbler.
- F. Handlers.
- G. Suspenders.
- H. Layers.
- I. Preliminary tanning.
- J. Water tank.
- K. Ooze tanks.
- L. Tan press.
- V. Tramway.

The arrows indicate the direction in which the hides are moved as they pass from one process to the next.

are frequently used in small tanyards to work the pumps, bark mills, etc., but their work is costly and is gradually disappearing.

Hydraulic motors, water wheels and turbines are occasionally used when the establishment is set up close to rapidly running water or near a fall.

Steam engines are more employed every day. This appears natural when it is remembered that the tanner has free fuel in the tan and exhausted wood. Seeing that tan requires special furnaces, etc., we shall start by giving some practical details on this subject. The question of steam engines will therefore be discussed under three heads: Furnaces for tan burning, boilers and engines.

I.—TAN FURNACES.

Tan, as it comes from the pit, contains from 65 to 75 per cent. of water. In this state of course it will not burn. It must be dried, or at least exposed to the air until the greater part of the water has evaporated, before it can be of any use in the furnace.

The best method of getting rid of the water is by using the Bréval press, of which elevation and section are shown in Fig. 11. The description given under the figures will be sufficient explanation of its various parts.

This press requires the attention of one man, and dries 15 cubic metres (about 20 cubic yards) of tan in ten hours, at an expenditure of one horse power.

In 1886 M. Albert Huguet (Bréval's successor) improved this press so that it would not only dry the tan for fuel but recover the expressed liquor. This new press has only two rollers, which greatly simplifies the arrangement.

Extracted wood, such as chestnut and oak, cannot be pressed, as they lose very little of their water by this treatment. It must be dried in the air, or burned directly in special regenerative furnaces.

In industrial physics, fuel containing large quantities of water is burned by means of inverted flame furnaces, in which the fuel is allowed to fall through a hopper on to a grating where combustion takes place.

“It should be possible, when necessary, to pass a draught of

PURIFICATION OF TANNERY
WASTEWATER

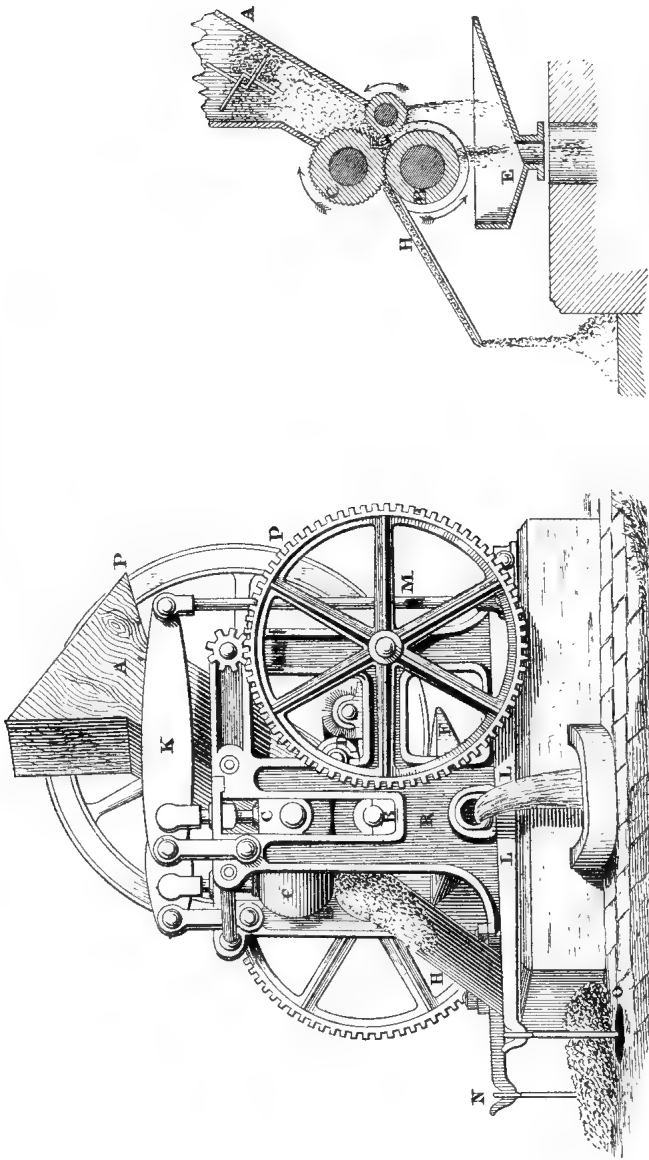

FIG. 11. - The Brevet Press: A, hopper; B, smooth roller; C, channelled roller; D, feeding roller; E, receiver for water; F, agitator in the hopper; H, inclined plane to receive dry tan; K, pressure lever; L, lower pressure lever; M, connecting rod between levers; O, counterpoise pit.

air through the grating. I ought to say, however, that furnaces of this class have not yet been tried for peat, so that nothing can be positively affirmed with regard to their efficiency, though it is probable that they would succeed with peat as well as with wood" (Pécelet, *Traité de la chaleur*, vol. i., p. 300).

In 1838 Passenger took out a patent for "certain improvements in furnaces for steam production". The apparatus consisted of a large hopper above, into which the fuel is thrown. It falls into a retort or barrel, whence it is dropped on a hearth which keeps more or less incandescent according to the supply of fuel.

The front part of the retort, which is open and projecting above the furnace, is kept at a red heat so that the gas which escapes catches fire immediately and, mixing with the flame from the hearth, burns the smoke completely. The door through which the fuel is introduced is horizontal and keeps closed by its own weight. The descent of the fuel is regulated by the friction of the wall.

In 1845, Dupérier and David took out a patent for a hearth, continuously fed from an upper chamber, into which a certain quantity of the fuel is loosely thrown from time to time. From this chamber it falls continuously on to the incandescent hearth as required.

The inventors of this apparatus, in the long specification of the patent, seem to attach great importance to the rapid transmission of heat from the furnace to the water in the boiler. With this end in view they have multiplied metallic surfaces in the furnace.

As the fuel falls it is regulated by friction against water tubes.

Later, in 1863, we find a serious patent (Varillat) which describes a furnace with a hopper above from which the fuel falls constantly on to an incandescent hearth, the rate of feeding being governed by combustion and distillation.

Here we have the beginnings of the idea of continuous feeding of a furnace through a passage filled with fuel which descends by its own weight as the falling mass burns below; the descent of the fuel being checked by friction. The Varillat furnace was designed especially for burning extracted dye-woods.

In 1865, Ruelle invented an arrangement consisting of three

furnaces side by side, the middle one for coal and the side ones for wood refuse.

Ruelle, at the time of applying for his patent, had already, as a contractor, built several tan furnaces. He wished to have his new hearth different from those which he had constructed already, and which he knew to be patented. Hence his arrangement of three furnaces.

This furnace has three gratings, all in the same plane, arranged so that the flames from all three come together under one boiler. They are fed with fuel by two lateral chambers at a higher level than the furnaces, into which the tan, etc., is thrown from time to time. This fuel falls on to the hearth as the combustion and distillation make room for it.

Later, in 1868, Bréval took out patents for various systems of smoke-consuming furnaces, made to burn all kinds of fuel.

The author describes two furnaces. The first is very similar to the one just explained. It has two grates in the same horizontal plane, which direct their flames together under one boiler. They are fed with fuel from two chambers at a higher level into which the fuel is thrown, and from which it descends on the hot hearth.

The second furnace which he describes has only one chamber for the fuel.

The inventor explains that the hopper, above the furnace, is divided by pieces of cast iron, triangular in section, so that the fuel falling between these pieces on to the hearth forms a series of heaps, which exposes a larger surface to the action of the air and is thus kept incandescent. He explains that the falling in of the fuel is proportionate to the rate of combustion. Air is introduced through the triangular castings, where it first gets hot, and then, bearing downwards on to the hearth, causes very complete combustion.

The furnaces which we are now about to examine do not require the help of the press, which is costly; they use fuel charged with water.

Krafft is the first who, in his furnace for burning poor fuels,

employs the idea of forming air spaces in the mass of fuel by causing it to fall in heaps.

His furnace is built of masonry in a peculiar shape. A valve at the top closes the hopper when it is not in use. It is raised whilst the furnace is working. As the fuel falls it comes to a sudden widening, produced by a recess in each wall. There is no grating, but the bottom of the chamber forms a receptacle for ashes which are drawn out through side doors. In case of need air may be allowed to enter through these doors.

The inventor explains that should the fuel by any chance become jammed and stay for some time without falling, combustion will take place on the lower surface of the suspended mass. When the block of fuel gives way, the fire will not be choked because of the lateral recesses in the masonry, which always keep open triangular spaces for the passage of the air and the flames. The air gains access to these recesses by means of a special perforated conduit. All the walls of the furnace become very hot and distil the fuel as it falls against them. This distillate, coming into contact with the air, catches fire.

Air comes in from above as well as in the ways already mentioned. For Krafft takes care to point out that the cover should be raised whilst the furnace is in action, and replaced when the fire is damped down.

He imagined that the fuel would remain suspended for a certain time, and that the falls would come at fairly regular intervals. In practice, however, and especially in the earlier furnaces, this is not so. The descent often takes place in such an irregular fashion, that if it does not completely extinguish the fire, it needs great skill on the part of the stoker to keep the heat at all constant.

Another engineer, M. Müller, noticing that in the Krafft furnace it was only the surface of the fuel in the recesses that was in a state of incandescence, thought that the power of the apparatus might be greatly increased if the fuel could have two spaces in its mass. Krafft had also thought of this, but considered the practical difficulties too great. Müller tried to divide up the fuel as it fell through the hopper, by means of partitions running from one side

to the other at a certain height above the grating. We find in this patent for the first time the principle of dividing up that part of the furnace which is above the hearth.

To encourage the formation of cavities, he made the partitions (*culées*) hollow and triangular in section.

Air is driven in, which first becomes hot, then forces its way down through openings to help the combustion below. Besides this improvement, he uses a grating instead of the simple mass of masonry used by Krafft.

In comparing the Krafft and Müller furnaces we come across striking differences ; but there is a great similarity in essential points.

Krafft, fearing that the fire might be extinguished if the fuel descended in a mass, had made certain, by means of the recesses in the walls, that there would be a heap formed whose surface would be in contact with the air, thus preventing extinction and at the same time providing a passage for the air and flames.

Müller, seeing that the Krafft furnaces only burned on the surface of the heap or in accidental cavities, set to work to split up the heap, thus increasing the surface exposed, and encouraging the formation of cavities by shaping the partitions so as to restrict the fall of the fuel.

Experience soon showed that it was better to widen the hoppers a little, which allowed the fuel to fall regularly instead of hanging it in blocks ; the progress of combustion becoming more even. The Müller furnaces were found more efficient than those of Krafft, because of the better arrangement of the heaps and the better management of the air.

For fear of having too little air, Müller caused it to come in from all sides, from the partitions above, from the grating below, and through the sides of the furnaces. He soon recognised the inconvenience of a large excess of air, and modified the apparatus so as to make it regenerative, thus improving the original arrangement.

Having recognised the advantages of forming small heaps beneath the partitions, Müller arranged his grating at such an elevation that it was always covered with a fairly thick layer of fuel ; and going from one extreme to the other, he cut off all air

from above and from the sides, and only admitted it through the ash doors. Afterwards he thickened the layer of fuel, and reduced the air admitted from below to such a point as to render combustion incomplete.

He placed the partitions higher up and at the same time made them narrower at the base, so that the fuel might not get jammed but would fall with the greatest regularity.

The air which came in through the ash pit was allowed to go through the grating and penetrate the fuel. Air was no longer admitted by the partitions, and not coming in sufficient quantities, the combustion is accompanied by destructive distillation.

The gaseous products are led to a chamber near the hearth, where more air is introduced and combustion completed. In the original drawings, the air is introduced through perforated bricks.

We recognise here the principle of the regenerative furnace, *i.e.*, the production of combustible gases in a hearth, and the burning of them in a separate chamber, having a special air supply.

In 1862, by a special arrangement with Müller, who had left Alsace, Krafft made an addition to his furnaces by using the Müller patents.

In his later specifications he describes a number of partitions running across in every direction, arranged in ranks one above the other ; in fact, dividing the mass of fuel in every conceivable way.

Since that time, "improvements" have multiplied rapidly. Some make the partitions higher or narrower, sometimes solid and sometimes hollow, sometimes in one piece, sometimes in several pieces. Others have recognised that the shape of the partition is of secondary importance. They have been narrowed a little when either the wood refuse, tan or sawdust has been mixed with lumps of wood or twigs so as to make wider openings. Their number and their distance above the grate depends entirely on the size of the furnace and the degree of fineness of the fuel, which will render it more or less permeable by the air.

In a prospectus of the old-established firm of Bouillon & Müller, describing a series of installations carried out by Müller during the years 1858-62, a furnace is recommended for the consumption

of tan and fine materials containing water. In this, which was erected for M. Placide Peltreau, at Châteaurenault, the partitions are hollow and very high up, and the recesses are lateral, as in the Krafft furnaces.

M. Koch, well known to the tanning world, took out a patent on the 9th of March, 1871, for a furnace using as fuel dye-wood refuse, sawdust, tan or other dry and wet substances.

This invention, which was contested in a famous law-suit, makes a great speciality of the arrangement of firebrick partitions, which divide up that portion of the furnace above the grating. These partitions diminish the charge of fuel and facilitate combustion. They also store up a certain quantity of heat, which accelerates the drying of the wood and heats the air, thus helping on the combustion.

In fact, the Koch patent is only an improvement on the Müller furnace, without any change in principle, but with considerable change in the nature of the means employed.

The Serrière Furnace.—Wood refuse, impregnated with a large quantity of water, can only be burned with great difficulty and with considerable disadvantages. The object of the Serrière furnace is to use such a fuel with more advantage than if the fuel were dried or even roasted.

The great difficulties are: (1) that such substances have a habit of caking on the grates and forming compact masses which the air cannot enter, and (2) that the large quantity of water given off as steam lowers the temperature of the furnace, making combustion difficult.

To diminish the caking of the incandescent mass above the grating, and to facilitate the circulation of the gas, M. Serrière has followed in the track of his predecessors, notably Krafft and Müller, and has adopted the system of feeding through a hopper from above. He has, like them, made a constriction at a certain height above the grate, both by lateral recesses and by partitions which divide up the falling fuel, so as to make it fall through openings equal in breadth to the thickness of the partitions. Below these the fuel, falling on to the hearth, forms a series of heaps between

which are channels allowing the passage of gases. The size and number of the partitions depends on the class of fuel to be used.

Originally fire-brick was used to divide up the part of the furnace above the grate. It was built in arches, with vertical conduits above, down which the fuel fell regularly. Afterwards, instead of bricks, large earthenware blocks of a special shape were used having a similar triangular section to the upper partitions.

In small furnaces they were made in one piece, but in larger ones two or three pieces were needed. They were made solid and hollow, with or without circulation of air. They were placed lengthways or across the furnace. Finally they were cast in metal.

The author of this book has seen a great number of these furnaces at work. They have the following drawbacks :—

When bricks are used for the partition, it has not sufficient solidity, and the movements of the masonry caused by the expansion of the hearth dislocates the arches and the conduits. When large pieces are used, their lower portion, exposed directly to the fire, rises to a high temperature, whilst the upper part is constantly cooled by the descent of moist fuel. The unequal contractions and expansions caused in this way soon break the partition to pieces, and the fire has frequently to be stopped for repairs. When metal partitions are used, their lower part, being constantly heated by radiation from the fire, is rapidly burned away.

M. Serrière uses the following method of construction: Thin wedges of fire-clay of small dimensions are set in metal coverings which protect them from bending and hinders lateral pressure. These wedges being very small easily resist the action of the heat, and as they protect the castings into which they fit against the action of the flames, these are not likely to burn. The castings are not fixed into the masonry. Any one piece is readily replaced without cooling the furnace.

To clean the hearth, plates movable from outside, which are arranged between the partitions, are placed so as to stop the fall of fuel. That portion of the hearth is then cleaned without the fire being allowed to die out. When the ash has been removed the plates are turned and the furnace returns to its normal condition.

Usually two furnaces are used together for one large boiler, and the waste gases after having heated the boiler are led back by a tube through the hoppers. The draught of the chimney causes the gas and water vapour to move through the perforation of the walls. Here there is one circulation for both hoppers, but a separate circulation for each could easily be obtained by arranging collecting pipes before and behind which communicate by means of the passages through the hoppers. In the same way each hopper might be isolated temporarily from the general system by valves, and thus allow of repairs being made without interfering with the continuity of the work.

The following are results which have been obtained by using these economising furnaces:—

Serrière's Nos. 1 and 2 boilers, having 12 tubes when worked together expose a heating surface of 300 sq. metres (3,333 sq. ft.). Boiler No. 3, with an internal furnace, has a heating surface of 164 sq. metres (1,824 sq. ft.).

Together the three boilers expose a surface of 464 metres (5,157 sq. ft.). In twenty-four hours, the three boilers have used:—

	Francs.
12,500 kilos. coal at 2 fr. per 100 kilos.	50
40 cubic metres tan at 2 fr. per metre	80
	130

These boilers will make 8,500 kilos. (8½ tons) of chestnut extract in twelve hours or boil 34,000 litres (34 tons) of water for six hours and evaporate these 34 tons to a seventh of their bulk, or vaporise 27,500 litres (27½ tons) of water.

If this work had been performed by furnaces using coal alone, it would have cost 500 francs (£20).

The cost of fuel in producing 100 kilos (220 lb.) of chestnut extract (20° Baumé) is reduced by the Serrière hearth to a franc.

Many other arrangements might be designed by which the same end would be reached, *viz.*, the drying of moist fuel by means of hot

12½ tons coal	£2 0 0
55 cubic yds. tan	3 4 0
	£5 4 0

waste gases, so that it may come to the hearth free from the greater part of the water which is so annoying in ordinary furnaces. The Criner furnace consists of a series of vertical columns arranged in quincunx behind the hearth. These columns are arranged on a floor of bone-earth in such a manner that the ashes cannot accumulate in the corners. To manage this, prismatic triangular bricks are arranged between the columns, forming a slope down which the ashes slide into the openings in the floor.

II.—CHIMNEYS, BOILERS ETC.

Chimneys are intended to carry away the waste gases after their passage through tubes. These last should be arranged so that the gases may come out as cool and yet as clean as possible. Under ordinary circumstances, the heat which is lost up the chimney is 25 per cent. of that developed in the furnace.

The draught is proportional to the sectional area of the chimney, and increases in the ratio of the square root of the height. It increases with the temperature of the gas up to 200° C. (392° F.). From 200° C. to 400° C. (752° F.) it remains nearly constant, above 400° C. it decreases; the maximum being at about 300° (572° F.).

The sectional area which a chimney should possess may be calculated in various ways: (1) from the quantity of coal burned per hour, which gives the following section for each 100 kilos. (220 lb.) :—

35.5 sq. ft. for a chimney	33 ft. high.
27.7 " "	67 "
22.2 " "	100 "

(2) by calculating from the superficial area of grate dependent on the chimney :—

$\frac{1}{2}$ the grate area for a chimney	33 ft. high.
$\frac{7}{4}$ " " "	67 "
$\frac{1}{4}$ " " "	100 " and above.

A tubular boiler is the best for tanneries. It ought to have a length six times its diameter. Thus a boiler 3 ft. in diameter ought to be 36 ft. long with 1 ft. 6 in. tubes. It ought to be made of strong

sheet iron from $\frac{2}{8}$ to $\frac{4}{8}$ in. thick, fastened together by rivets $\frac{4}{8}$ to 1 in. in diameter.

Flaws are chiefly caused in three ways: (*a*) unequal expansion, (*b*) faults of construction, (*c*) bending backwards and forwards of the plates. Flaws between the rivets and along the lines of junction are very dangerous. They are most commonly caused by working at too high a pressure.

Boilers should weigh from 210 to 220 kilos. per square metre (42 to 45 lb. per square foot) of heating surface. A square foot of total heating surface will evaporate 5 to 6 lb. per hour. The total surface of a tubular boiler is made up of four-fifths of the tube surface, and half the surface of the boiler. Twenty-six square feet heating surface should develop one horse power. One pound of coal will vaporise 7.5 to 8 lb. of water, and 10 lb. of tan will produce the same effect.

The boiler should be fed with water into which is placed a little oak bark, the best of all disincrustators.

III.—STEAM ENGINES.

Engines which give a rotatory motion to a shaft are called rotatory engines. They may be divided into oscillating engines, vertical engines and horizontal engines.

Oscillating engines are the oldest. Nowadays they are never used for developing less than 25 or 30 horse power; any weaker ones are of an old type. They are excellent as condensing engines, but are costly.

Vertical engines have the advantage of occupying a small space but on the other hand they are difficult to keep in repair. They are used greatly in connection with vertical boilers where the power required is small.

Horizontal engines are by far the best motors for a tannery. They are not well adapted for low pressures, and expansion working, though it economises fuel, should not be used in a tannery. They may be used for developing all powers and at all speeds.

We give the dimensions of a good horizontal engine, the Corliss engine :—

Length of cylinder	3 ft. 6 in.
Diameter of cylinder	1 " 6 "
Thickness	0·84 "
Height of the piston	7 "
Piston rod diameter	3·2 "
Stroke	3 ft. 4 "
Diameter of shaft	0·8 "
Diameter of fly wheel	11 ft. 6 "
Revolutions per minute	70
Maximum horse power	120

Here are a few practical notes on the working of a good engine :—

Effective horse power	82
Indicated " "	90
Efficiency	93 per cent.
Number of revolutions per minute	60
Steam consumed per effective horse power per hour	165 lb.
" " indicated " "	150 "
Total steam used in twenty-four hours	1½ tons.
Condensed water for 100 parts steam	10 parts.
Temperature of condensed water	90° C. (197° F.)
Coal consumed per effective horse power per hour	17½ lb.
" " indicated " "	16½ "
Coal consumed in twenty-four hours	1½ tons.
Temperature of water in condenser	40° C. (104° F.)
Vacuum in cylinder in millimetres of mercury	650

CHAPTER II.

GRINDING AND TRITURATION OF TANNING SUBSTANCES.

BARK, wood, or fruit, must be reduced to a more or less fine state of division before they are used for tanning. The machines for the three classes of substance are different.

I.—CUTTING UP OAK BARK.

The grinding of oak bark and its reduction to tan takes place in two operations, cutting or chopping into chips and the grinding properly so called.

1. **Scraping or "Rossing".**—Ordinary bark is ready for chopping.

Old bark which contains much tannin, but which is covered with a reddish layer, must be scraped or "rossed" before being cut up. This work is carried out by women and children with pruning knives. Tresse has devised a machine to replace this manual labour, which was made by Damourette. It is a circular plane made up of a travelling drum armed with horizontal steel knives, and two feeders, one to lead the bark, the other to catch it and prevent it from slipping under the action of the knives. The pieces of cork, moistened and flat, are placed on the receiving plate with the incrustated side above. This very simple and efficient machine is only used in large factories.

2. **Chopping.**—In this operation the bark is cut into pieces of $\frac{1}{2}$ to $1\frac{1}{2}$ in. in length. All bark cutters consist essentially of a drum carrying tempered steel blades fixed on a shaft and turning in front of a table. The bark is laid between two rollers and pressed forward by springs or weights. Springs give a more even result. The length of the chip depends on various circumstances. It may be calculated from the following formula:—

$$L = \frac{C}{R \times p},$$

where L is the length of the chip, c the circumference of the feeding cylinders, *i.e.*, the diameter $\times 3.14$; p = the number of knives on the drum and R = the ratio of the number of teeth on the two cogged wheels.

Supposing that the diameter of the feeding cylinders of bark be 15 centimetres, the circumference will be $15 \times 3.14 = 47$ cc.

The number of knives is 4, and the ratio of the wheels is 4.2 : 1; then the length of the chips will be:—

$$L = \frac{470}{4 \times 4.2} = \frac{470}{16.8} = 28 \text{ mm.}$$

To find the ratio between the wheels necessary to obtain pieces of a certain length, the formula

$$R = \frac{c}{L \times p}$$

must be used.

If it be desired to make them 20 mm. long, and the rolls are 120 mm. diameter, and the number of knives 6, then we shall have:—

$$R = \frac{.377}{.02 \times 6} = \frac{.377}{.120} = 3.14.$$

To find the diameters of the wheel and pinion we may use the formula:—

$$D = \frac{2E \times R}{R + 1} \quad d = 2E - D,$$

where D is the diameter of the wheel, d is the diameter of the pinion, and E the distance between their centres.

Fig. 12 shows the details of a cutter with the following dimensions:—

	Inches.
Diameter of the feeding cylinders	8½
Circumference of the feeding cylinders	26½
Diameter of the toothed wheel	34
Diameter of the pinion	6¾
Diameter of the knife drum	17
Length of the knife drum	20

Fifty-six feet of bark pass through the rollers per minute. The drum makes 130 revolutions per minute, and being furnished with 4 knives, it follows that the 56 ft. of bark are cut into $130 \times 4 = 520$ pieces 1½ in. long. Worked by a man, this machine can cut up a ton of bark in a day.

The Bérendorf cutter No. 1 cuts $1\frac{3}{4}$ tons per hour, requiring 3 horse power. No. 2 produces a ton of cut bark per hour with 2 horse power.

II.—GRINDING BARK.

1. Stamping Mills.—Stamping mills consist of a longitudinal wooden trough in which the bark is placed and beaten with a series of wooden stamps whose lower ends are furnished with knives. These stamps are alternately raised and lowered by cams fixed on a horizontal shaft. A rake constantly stirs up the contents of the trough and exposes it thoroughly to the action of the stamps. Stamping mills give 30 kilos (65 lb.) per horse power per hour.

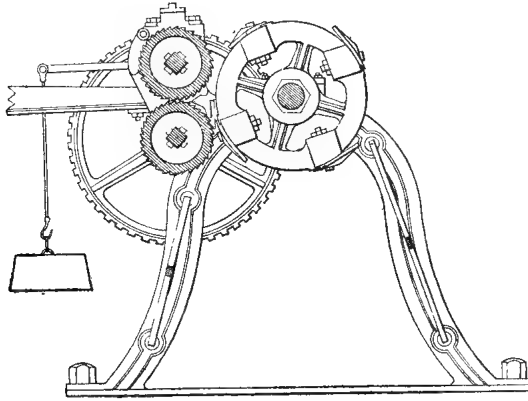

FIG 12.—Bark Cutter.

The tan produced by the stamps is fine, but granular. Stamps work irregularly, the tan being nearly always mixed with lumps which have escaped the action of the knives.

Messrs. Allard construct a mill with eight stamps producing 60 kilos. (130 lb.) per hour.

2. Mills with Horizontal Stones.—These mills are arranged just like flour mills, excepting that the feeding hole and the grooves are a little larger. The tan produced is very fine, and in some factories it is used in preference to all others. Their drawbacks are that they heat the tan, give a very small output, and are easily choked, especially when the bark is damp.

3. Mills with Vertical Stones.—Those machines are largely used for grinding green oak. They consist of one or two vertical

stones, 7 ft. in diameter by 18 in. thick, running round in a cast iron trough perforated so that the tan powder may escape as it is formed. These stones turn freely on a horizontal shaft, to which a circular movement is given by a vertical axle. A rake keeps the bark constantly moving beneath the wheels.

4. Saw-mills.—These mills reduce the bark to chips and to powder. There are two varieties, alternating and continuous. The first consist of a series of inclined saws, separated from one another by a space of half an inch, which may be moved rapidly backwards and forwards by means of a crank. The bark is submitted to the action of this multiple saw in the same way as in the chopper; that is, by feeding rollers.

They give an excellent product, but very little of it.

These mills have been replaced by the continuous or circular saws.

Molard and Copeau arrange their saws in a helix by cutting them radially.

Jarlat of Nantes simply places the saws obliquely on the shaft.

The product of these mills is very similar to that of the alternating saws, but it is no more abundant because of the great expense of obtaining large saws. M. Damourette has made a mill with segments of circular saws, to replace the true circular saws, which he calls the travelling saw.

It consists, says M. Damourette: (1) of a drum fixed to a shaft which can be rotated at a high speed by means of a wheel and pulleys; (2) feeding apparatus similar to that of the choppers, made up of two grooved cylinders. The lower one is connected with the shaft by toothed wheels, and is in its turn connected with upper one by wheels with very long teeth which do not lose grip when the rollers are forced apart by thick bark. A strong steel spring keeps the bark pressed constantly against the saw. A cutting table of cast iron is placed in front of the feeding apparatus, and whilst travelling along this table the bark is acted on by the saws.

The working drum consists of the following parts:—

A cast iron pulley fixed to a shaft carries at each end a disc of

sheet iron which projects about an inch beyond the edge of the pulley. The rims so formed are pierced with holes through which strong bolts are passed. On the pulley several rows of segmental saws are placed, separated from one another by blocks of wood or metal about half an inch thick. Each row is fixed on two of the bolts. The segmental saws are held in an inclined direction by having the interstitial blocks wedge-shaped, so that each row is inclined differently. With this apparatus a good and plentiful supply of tan may be obtained.

Fontsauvage has modified this system by fixing the segments to the drum with strips and screws. The produce is shorter but coarser.

Billeter and Klunzt, in 1877, constructed another apparatus consisting of an iron drum on the periphery of which was placed

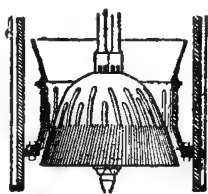

FIG 13.—Nut Mill.

a helical saw made up of separate segments. The drum was made in such a way that any segment could easily be let out a little as it wore away and was re-set, thus enabling the blades to be used for a very long time.

5. Nut Mills.—Nut mills are very much like ordinary coffee grinders. They consist (see Fig. 13) of basin *a, a*, and a bell or nut fixed on a vertical shaft. The bell and bush are of soft steel. They have large teeth on their upper portion of various lengths, and finer ones below. Those of the bell are inclined in one direction, those of the bush in the other. The bell being conical, the teeth come nearer and nearer together until at the lower edge they nearly touch.

The chips are thrown into the basin at *c*; they become caught between the two portions of the apparatus, broken up by the large teeth, and powdered by the small ones.

These mills are usually kept under the first floor beside the bark store. On the first floor is the chopper and the chips. As they come out of this chopping apparatus they fall into the nut mill. The tan falls either down a spout into sacks or into a tan store. The shaft which drives the bell should be very solidly fixed. It ought to run right through the ground and first floors. Below, it is supported by a socket on a stone bed. Under the floor it is guided by bearings fixed to the bush, and at the top by a head.

The toothed wheel connection is fixed on the second floor so as to be out of the way.

By means of this apparatus a tan may be obtained as fine or coarse as desired, by raising or lowering the bell.

These mills are generally used. They give a good yield, do not readily get out of order, and, when the teeth are well cut, do not wear away.

III.—THE GRINDING OF TAN WOODS.

Dye-woods are usually ground in special machines of great strength, consisting of a cast iron disc armed with knives and turning at a high speed.

M. Berendorf constructed a machine of this class with 15 blades which could, with four horse power, produce 6,800 kilos. of cuttings in ten hours or 3,000 kilos. of powder. It made 400 revolutions per minute.

The Arbey is of the same class.

Another more advantageous arrangement consists of a group of knives arranged so as to form a cylinder, or better a truncated cone. These are fixed together as in the bark cutter, but much more strongly. The wood is brought up to this apparatus by means of a slide.

With a machine having the following dimensions :—

	In.
Diameter of driving wheel	20
„ „ fly wheel	67
Length of knives	8½
Larger diameter of cone	23½
Smaller diameter	20

IV.—POWDERING OF FRUIT, GALLS AND GRAINS.

Ordinarily this is done in the nut mill or in the stamp, but much improved machines have been specially designed, such as the grinders of Carr, Vapart, Hall, etc.

1. **The Carr Disintegrator.**—This consists of two vertical discs from 2 ft. to 4 ft. 6 in. diameter, fitted with two rows of steel bars set perpendicularly to the plane of the discs. A very strong iron blade is fixed parallel to and beneath the axle, so as to break up large pieces. The nuts, etc., are led by a hopper towards the centre of the plates, where they are thrown by centrifugal force against the bars and pulverised. Bark may also be powdered by this machine. The author has experimented with chestnut wood, but has found no practical advantage.

2. **Vapart Disintegrator.**—This machine consists of three wedge-shaped plates on a vertical shaft turning in different directions. These plates contain very fine grooves. The substance undergoes grinding on the first plate, then falls to the one below it, and afterwards to the third. Thus a series of mills are formed whose power increases with the velocity of rotation.

3. **Hall Disintegrator.**—In this apparatus disintegration is brought about by a cage of bars arranged in pairs and revolving at a high speed inside a circular trough furnished with stationary bars. These last are armed with pyramidal projections against which the different tanning materials are thrown violently, falling back constantly into the action of the centrifuge until they can pass through the sieve which is below. Each mill is furnished with different sieves so that it may produce powders of varying coarseness.

Machines of this class are only useful for fruits or very hard substances. Their extreme speed, 1,500 to 2,500 revolutions, prevents their general adoption, hence they have been described here very briefly.

4. **The Anduze Disintegrator**, which is by far the best for this work, is described farther on. It is greatly used for grinding leather which is to be used as manure.

In the following table is a *résumé* of the output of the principal machines used for grinding tan :—

Name of Machine.	Horse power required.	Revolutions per minute.	Yield per hour.	
Battery of {	two stamps	1	30	56 lb.
	five heavy stamps	3	30	2 cwt.
	eight " "	6	30	4 cwt.
	ten " "	8	30	5½ cwt.
Oscillating saws {	small	1	600	90 lb.
	large	3	1200	300 lb.
Choppers for bark {	small	1	200	880 lb.
	large	4	175	2640 lb.
Bark cleaner	1½	250	1 ton	
Horizontal mills	4	60	550 lb.	
Vertical mills	2	10	110 lb.	
Nut mills {	small	3	25	660 lb.
	large	6	25	1320 lb.
Large wood cutter	15	350	6 tons	
Carr disintegrator	5	2500	5 tons	
Vapart disintegrator	4	2000	3½ tons	
Hall disintegrator	6	3000	4½ tons	
Anduze disintegrator	4	500	6 cwt.	

V.—NOTES ON THE GRINDING OF BARK.

Bark is usually very dry when it is ground, and produces large quantities of fine tan dust which is objectionable in many ways. It gets into the throats of the workmen, increases the chances of fire, and causes considerable loss of tannin.

To overcome this, one method is to cover the choppers, nut mills or cutters with sheets which retain most of the dust particles, but the working of the machines is hindered greatly by such arrangements.

Another method is to use a ventilator, and, when this is conveniently placed, it produces a good effect. The dusty air is aspirated through wide wooden tubes into chambers where it is allowed to settle.

We should like to see the general adoption of dust collectors, such as are used in corn mills.

The first apparatus of this kind was invented by Prinz. It sifted the dust-laden air through a flannel filter, which is made up of 80 pieces stretched in the form of a fan. The Howarth, Van Gelder and Beantz collectors are based on the same principle. These

arrangements are perhaps a little too complicated for a tannery, but the "Cyclone" collectors might be used with advantage.

The Cyclone collector consists essentially of an inverted hollow cone surmounted by a cylindrical chamber. At the upper end of the chamber is a wide opening. The point of the cone, slightly truncated, is also open. The upper opening is connected with an inner cylinder which dips down to the level of the base of the cone. Another opening placed laterally is connected with the covers of the grinding apparatus, and it is through this opening that the dust is drawn off. The ventilating fan which is attached to this machine produces a current of air which forces the dust downwards against the inner walls of the cone. Since all dust particles travel in a straight line, they instantly collect on the partition, then they are swept by the current of air through the cone and out of the lower opening, whence they fall into some convenient receptacle.

The Vortex, Smith and Climax collectors are based on the same principle.

CHAPTER III.

MANUFACTURE OF SOLE LEATHER.

THE preparatory processes consist of various operations which bring the pelts into a fit state for tanning. The chief of these operations are: washing, cleaning, soaking, "breaking over," sweating, un-hairing, fleshing and plumping.

I.—PREPARATION FOR TANNING.

1. **Fresh or Green Hides.**—The skin is freed from useless parts, such as the horns, hoofs, skull, and then soaked in clear fresh water to remove the blood, dirt, and other foreign substances. An hour or two is sufficient for the hides ordinarily provided by a good butcher. When they are laden with dirt they require four to six hours. Many tanners put them into the tank overnight and remove them next morning. This is an exceedingly good method, as the skins swell considerably and become thoroughly clean.

The tank is a reservoir built of brick and lined with Portland cement, 10 to 13 ft. square by 3 ft. to 3 ft. 6 in. deep. It is sunk in the earth, and is only raised an inch or two above the paved or cemented platform on which the workman stands. Square tanks are not to be recommended, because of the dirt which accumulates in the corners. It is better to round off all the angles by quarter circles of about 2 ft. 6 in. diameter. Water is run into the tank from above, and finds its way out by a conical hole drilled through a block of wood cemented into one corner of the floor. This may be closed by a wooden plug.

The water supplied to the tank should always be at one even temperature, or as nearly so as possible. Changes of temperature which expand and contract the tissue of the skins at short intervals weaken them considerably, and cause them to give a less solid and

compact leather. A fault frequently met with is to throw the hides at any time into currents of water more or less muddy. This ought never to happen. The water running into the tanks may be either warm or cold, provided that the temperature remains constant. The author prefers a temperature between 15° and 20° C. (59°-68° F.).

In some large works three tanks are arranged so that the water may run from one to the other. The fresh skins are placed in the third tank, then removed to the purer water of the second, and finally cleaned in the pure water of the first.

The cleaning is carried out on the beam by means of a semi-circular knife with a blunted edge.

The hides are soaked again for an hour, then drained for six hours.

2. Softening Dry Hides.—Dried or flint hides have to soak for a long time before they regain their former state, and acquire the necessary elasticity.

They are allowed to soak for several days (three on the average) in tanks, then withdrawn and well worked on the beam.

The scraping is done with a blunt knife. The workman stretches the skin on a beam, the hair beneath, then gripping the knife with both hands he works it from the upper to the lower part, taking care to press more or less heavily according to whether the parts are hard or soft. This operation is named "breaking over". One or several scrapings are given according to circumstances. The skins are next plunged into a tank of water maintained at about 20° C. (70 F.) by means of steam. Every other day the water is changed to prevent putrefaction. Fifteen or sixteen days are sufficient to bring back the elasticity to medium-sized skins, though eighteen to twenty days are required for the larger ones. At first the skins are washed each day and worked several times during the soak. The drawback to this system is that the scraping is apt to impair the texture of the skin.

It is the same with all mechanical means for restoring elasticity to dry skins. The stocks ruin the tissue, bruise it and break the fibre. The peg tumbler weakens the leather and is apt to pierce it.

The tissue is broken and loses its strength and elasticity so much that skins prepared in this way have no body, and after tanning give a thin flat leather.

Softening by means of putrid soaks is very objectionable.

Skins left in a putrid soak quickly soften, because of the rapidity with which fermentation, or rather putrefaction, takes place. This is readily accounted for by the presence of septic organisms. The skins, however, generally become spotted by the action of this dirty water, and they cannot be soaked in it without losing their texture and having the grain totally altered. Further, the putrid smell given off by the tanks is very harmful to the health of the workmen. Stocking in closed tumblers has the same objections.

Piling the skins after scraping, with occasional soakings, takes too long and requires such careful watching that it has been almost discarded.

The best of all methods is to let the hide soften in fresh water renewed every other day, and kept at a temperature of from 20° to 25° C. (68° to 76° F.). We strongly recommend the addition of some antiseptic to the water to stop putrefaction. Good results are obtained by using 10 gram. of mercuric iodide per cubic metre of water (about 7 grains per 10 gallons). Fifteen or twenty days suffice for this operation.

Another good process which we have seen, consists in letting the skins soak for twenty-four hours in water at 30° C. (86° F.), draining them for several hours, then soaking again in fresh water for another twenty-four hours. After the second soaking they are placed for twenty minutes in warm water 60° C. (140° F.),¹ and finally soaked in water at 30° C. (86° F.). At the end of four days the hides are ready for liming.

Natural Sweating is used to a great extent in softening large hides. This is carried out by leaving the hides to soak for twenty-four hours in cold water, washing the flesh and rinsing the hair side, then leaving them to drain in a heap for four or five hours. In making the heaps the skins are folded in two with the hair out-

¹ It is usually considered unsafe to treat raw skins at a higher temperature than 120° F.

side. They are next placed in the sweating chamber (see p. 118) in which they are hung up and left until they begin to sweat. They are watered with clean water from an ordinary watering-can fitted with a rose, allowed to heat again and the operation repeated until the heating has taken place three times. They are then returned to a bath of fresh water. The harder parts are scraped if necessary, and then the sweating is allowed to continue until the hair falls.

Many different methods have been proposed for hastening the softening, which we only notice here in order that we may put tanners on their guard against the fatal results which are brought about by such hastening.

Rubbing the flesh side with lime disorganises the tissue and makes the skin empty or hollow.

Caustic alkalies and alkaline carbonates act in the same way.

The use of blood, although it gives good results, is very dangerous to the workmen.

We have recommended, in various tanneries, the addition of 3 per cent. sodium sulphide to the water to help softening.

3. Softening Salted Hides.—Hides simply salted and put to soak in tanks in the same way as fresh skins, renewing the water from time to time so that the salt may be thoroughly washed out. They return to the state of green hides in about forty-eight hours, and afterwards they are treated in the same manner as the latter.

Hides which have been salted and dried undergo several soakings. First of all they are washed in many changes of water, squeezing out the water between each washing; when they are free from salt they are treated in the same manner as dried skins.

It is after this operation that the tanner is able to judge of the good or bad salting of the hides which he has bought. After soaking, softening and draining, a well-salted skin weighing 88 lb. ought to increase in weight to the extent of from 13 to 15 lb. The skin reabsorbs the water which the salt had removed. When the salting has been done in a pit, a hide similar in all respects will only increase by about 5 lb.

As a rule, a hide ought to gain about 3 per cent. of its weight,

when the salting has been good. A pit-salted hide, sometimes called "brined" hides or brine-salted hides, will only gain $\frac{1}{2}$ per cent.

Weighted hides, that is to say, hides charged with heavy substance, will lose as much as 2 per cent. of their original weight.

Hides in hair, charged during salting with sulphate of barium or spalt powder, should be cleaned with larger quantities of water in a tank, then drained and weighed.

II.—SWEATING AND UNHAIRING.

1. Natural Sweating.—Natural sweating is brought about by first folding the hides lengthways, or lengthways and across, with the hair inside, and then piling them one on the other. As soon as fermentation starts, the heat developed is sufficient to make unhairing easy. The hides must be carefully watched so that fermentation may be stopped exactly at the right moment, that is, when the hair slips on pulling it. If fermentation be carried too far, the skins will be spotted and the grain altered.

To prevent too rapid fermentation, a handful of salt is spread over half the hide before it is folded. In Germany, some tanners use wood vinegar, sprinkling it thinly over the hides.

Those hides which heat up rapidly must be taken out from time to time, replacing the ones which have not fermented sufficiently. The author has found that the best results are obtained with temperatures of from 25° to 30° C. (77° to 86° F.), whilst very defective work is done when the temperature runs from 35° to 40° C. (95° to 104° F.).

Two days are sufficient to swell the hide and deprive it of its hair.

Hides are sometimes suspended from beams in a sealed chamber, as at Givet (where it is called the *pendoir*), until fermentation takes place.

Natural sweating is being slowly abandoned. Besides the deterioration of the tissue, it is not thoroughly effective in removing the hair from large foreign hides.

2. Stove Sweating.—This system is similar to that of the "*pendoir*". The heating is hastened by lighting a fire of dried tan

in the centre of the floor. This burns very slowly and fills the chamber with smoke. Hence a chamber of this kind is sometimes called a smoke chamber. Two days are required for the operation.

3. Steam Sweating.—This process was first described in 1838 by Delbut, a tanner of Saint-Germain-en-Laye. It was used for a long time at Montbéliard.

The hides are suspended in a chamber known as the *échauffe* which is arched, and measures about 10 ft. high by 10 ft. wide and 12 ft. long. It has two floors: the lower one is of stone, continuous with the masonry of the walls, and slopes towards one corner where there is an outlet for any liquid which may fall on the floor; the second floor is of wood, and stands about 8 in. above the lower one. It is pierced by a number of circular holes. The skins are arranged above this upper floor. Steam is admitted between the two floors by means of a pipe, and rises through the holes in the wood, whilst the condensed water runs away by the outlet below.

The temperature of the chamber is maintained at from 20° to 25° C. (68° to 77° F.). It must be regulated with the utmost care, since the joint action of heat and moisture will readily change the substance of the skin to gelatin, whilst spots and punctures are also formed by the rapid development of the foreign organisms which are so fatal in natural sweating. The operation is complete in eighteen hours.

The hides are hung across horizontal beams arranged at such a height that neither end touches the wooden floor, and sufficiently far apart to allow the air to circulate freely around them.

4. American Sweating Process.—The hides are placed in a cellar 13 ft. 6 in. long, 12 ft. wide and 13 ft. 6 in. high, which is entered by a passage 7 ft. long, closed by a door at each end. The inner door is double, the cavity being filled with tan, to prevent changes of temperature in the cellar. A wooden conduit 10 or 12 in. square is arranged, so as to run at least 4 ft. below the surface of the ground. One end enters the cellar by the middle of the floor, which slopes from all sides towards this point, whilst the other communicates with a drain.

The roof of the cellar is on a level with the ground; on the roof

are arranged two rows of boards placed on end, leaving a space between them of about 2 in. All the roof is covered with soil to the depth of at least 3 ft. 6 in. excepting the space which separates the boards and which forms a tall narrow chimney. Water enters through pipes and runs along gutters fixed to the top of the walls. From the gutters it falls either in a fine spray or runs in a film down the walls.

The cellar is thus kept cool and at a constant temperature, so that the skins may be unhaired without heating and without fermentation. The water used should not exceed 10° C. (50° F.); it is intended to saturate the atmosphere, to absorb the heat which the hides give off, and to maintain a uniform temperature in the cellar.

The skins, fresh from the soaking tank, are hung up in this cellar. They are fixed by the head to one of three bars which run close beneath the roof, furnished with iron hooks 2 or 3 in. apart. The doors of the cellar are shut and the water is turned on. A current of air ascends across the cave, entering by the end of the wooden conduit, having been first cooled down by running for 70 ft. under the earth, and escaping by means of the longitudinal opening above. The water flows in the opposite direction. Falling from above, it absorbs the vapours of the chamber and runs away from the floor by the wooden conduit.

The temperature ought not to be below 7° C. (45° F.), nor above 12° C. (54° F.). When the temperature falls below 7° C., the current of air is checked by partly closing the chimney, and when it rises above 12° C., either more cold air or more cold water is used.

At the end of three days, when the hair begins to fall from the upper parts of the skins, they are turned and hung by the tails until the hair comes off evenly.

Skins require six or eight days for complete unhairing.

It is a good process, and one in which little risk is run of spoiling the hides.

5. The Warm Water Method.—In America, warm water is also used for unhairing. This is similar to the use of steam, excepting

that the current of steam is replaced by a current of warm water. The two methods have the same drawbacks, and require excessive care.

6. Cold Sweating, also called American sweating. The hides are placed in pits, built of masonry and lined with cement, and provided with a wooden channel by which the water can flow away. The water is kept at a temperature of from 6° to 12° C. (43° to 54° F.). The hides are allowed to soak in this water for twenty-four hours, then they are piled for another twenty-four hours, watering them every six with a watering can. The whole series of operations is repeated three times, and the hides are ready.

For unhairing, many new processes, are used under the name of "chemical" methods. We shall speak of them when dealing with fine leathers, in the manufacture of which they are principally used.¹

7. Unhairing.—After sweating, the hides are plunged into a tank of water for an hour and then the hair is sprinkled with fine sand. Some tanners prefer to use sifted ashes, which do not fray the surface like sand.

The workman starts by making a cushion on his beam, by covering it with several skins, folded in two, to obtain the elasticity necessary for his work. He then places the skin to be unhaired on the cushion, hair above, and proceeding from below upwards, he removes the hair with the working knife. If the hair does not come off easily, the workman adds a little more sand or ashes. Scratches may be avoided by taking care that no foreign matter comes between the knife and the skin. Special care must be taken with the edges.

The working knife is sometimes replaced by the "slate," a kind of stone or slate in the shape of a knife blade and set in a handle.

The hides are left in water for two or three hours to clean them.

8. Trimming.—The hide is trimmed with a knife. The navel is cut off level with the hide. The teats are cut off, and the tail and vent are cut round. The ears, feet and all useless parts are

¹ For use of lime, see page 154.

removed. This waste matter, known as offal, is used for the extraction of fat and the manufacture of glue. A highly skilled workman should be entrusted with this operation, so that no more skin may be removed than is absolutely necessary.

9. Fleshing.—This operation has for its object the removal of all particles of flesh adhering to the hide.

Large pieces are removed gently with the knife. The other pieces are taken off with the fleshing knife, which only differs from the unhairing knife in being sharp instead of blunt. The work is carried out on the bare beam, working the knife from above downwards, so as to remove all flesh and thickenings of the skin.

10. Slating.—This is a method of softening the skin and giving it an even texture. It is effected by means of the slate. If, however, the slat has been used in removing the hair, this operation is suppressed.

Between each of these operations, care is taken to rinse the skin in clean water. Finally, it is thoroughly washed on both sides, until the water runs away quite clear. Nowadays this last washing is carried out in the dash wheel, which we shall speak of when describing fine leather manufacture.

11. Unhairing Machines.—Although great progress has been made in the invention of these machines, the work is usually carried out by hand, and, excepting for the dash wheel, tanners still cling to the rough and fatiguing work of hand dressing.

Lepelley, a Parisian tanner, is the inventor of a slating machine, which is similar in principle to all which have followed it. It consists of a cylinder cut into a double screw over which the skins are passed, and a table armed with scraping stones. The skin is scraped by the helix and rubbed against the slates.

This machine has been modified by Allard of Château-dun, Jonquet of Paris, Alder, and lastly by Beaudoin and Damourette in 1866.

The chief parts of the Damourette machine are: A working double screw cylinder, and a keyboard with movable keys, both having an elastic table opposite; a scraping table with an opposing table of cork, and lastly, a roller to collect the skins.

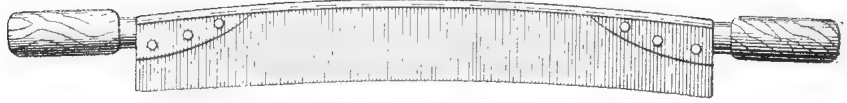

FIG. 15.—Knife, Château Renault Pattern.

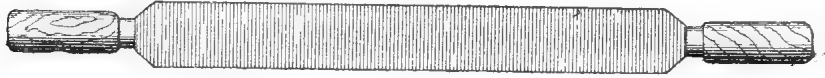

FIG. 16.—Two-edged Flexible Knife.

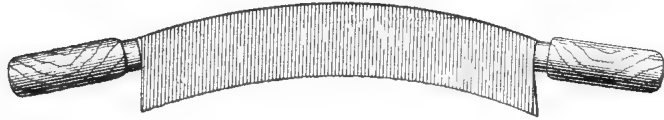

FIG. 17.—Unhairing Knife.

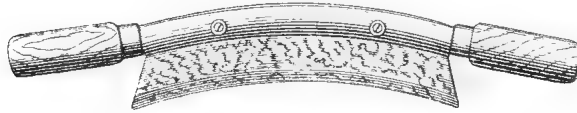

FIG. 18.—Slate.

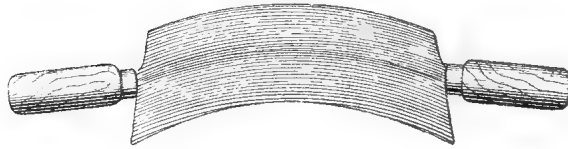

FIG. 19.—Fleshing Knife, Millau Pattern.

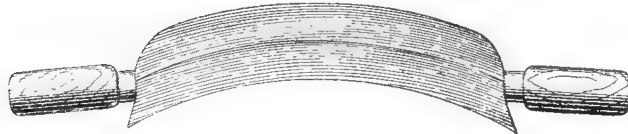

FIG. 20.—Ordinary Fleshing Knife.

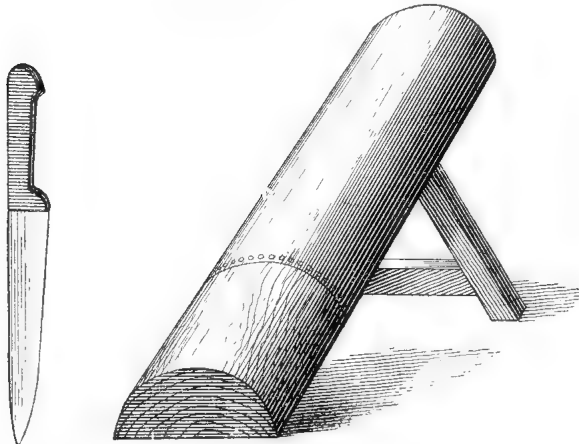

FIG. 21.—Trimming Knife.

FIG. 22.—Tanner's Beam.

The working cylinder, the table of slates and the keyboard are fixed in the machine one above the other, whilst the roller, the cork table, and the elastic table are on a large carriage which enables them to slide in and out of their places.

The cylinder carries a helical thread whose pitch increases from the centre outwards. These threads are either cast with the cylinder, or are cut from sheets and screwed into place. Various metals are used for these pieces, according to the work which is to be undertaken: for cleaning or fulling, soft iron or steel; for fleshing, tempered steel.

The table facing the cylinder ought to be elastic and flexible, that is to say, hinged and covered with cork, rubber, or felt. Springs placed at the back of the table press it against the hide whilst working, and so keep the hide close against the cylinder.

The keyboard is a long iron casting in which are arranged side by side little keys of copper, which may be moved independently to a slight extent. Behind each key is a spiral spring, held in position by a guiding rod. The keys, when working, press the hide against a hard flat table, so that they complete the work of the cylinder and remove the slightest inequalities of the skin.

The scraping table is arranged in such a manner that the edges of the slates form a projecting horizontal line parallel with the cylinder. On this edge rests a curved table faced with cork. This heavy table can be raised at will by means of hand levers.

The cork table being raised, a hide is stretched on the slates, the cylinder and the roller. The table is replaced and the roller bar fixed firmly. The machine is then started. The hide rolls up on to the roller. It is scraped by the cylinder and submitted to the action of the slates on which it is pressed by the cork table. The roller consists either of a grooved roller with a gripping bar, or of a solid wooden roller with hooks and straps to hold the skin. In the latter case, the hooks are sunk in little circular pits so that they do not project beyond the surface of the roller.

The different parts are arranged one above the other in the following order, beginning from below: the cylinder, the key-

board, the slates, and the drawing wheel. Below the cylinder an inclined board may be placed to facilitate the stretching.

The hide is passed through several times so as to treat each face once or twice. It is stretched on the travelling carriage and attached to the roller. The carriage is then run back into its place. During the operation the hide is kept wet by means of a longitudinal tube pierced throughout its length with holes. The water squirting through these holes washes away the hair, skin and dirt which are removed by the various working parts of the machine.

12. Soaking.—After fleshing, the hides are thrown into a tank of clean water and allowed to soak for four or five hours, changing the water if necessary two or three times. A soaking of twenty-four hours in clear cold water increases the yield, because it opens the tissue of the skin, softens it and renders it more amenable to the later operations. A good soaking gives 4 per cent. increase in weight.

A good tannery water should be soft, clean, and of even temperature, or nearly so, during all operations. It ought not to exceed 15° of hardness.

Water contains chiefly, carbonate of lime, sulphate of lime, carbonate of magnesia, and carbonic acid. In soaking, it is only the bicarbonates of lime and magnesia that affect the skin; sulphate of lime scarcely acts at all. Carbonic acid is desirable, and well-aerated waters are preferable to others. To soften tannery water many methods are used; the best are as follows:—

(a) Commercial silicate of potash or soda at the rate of 10 gram. per cubic metre (7 grains per 10 gallons) per degree of hardness.

(b) Chloride of barium in the same proportion.

(c) Alum, used twice as strong.

(d) Oxalic acid, oxalates, boracic acid, borates.

The chemical should be added to the water in a large tank, well mixed with a paddle, and allowed to stand all night. The water should then be pumped into a reservoir, taking care that the end of the pump is at least 4 in. from the bottom, so that the sediment

is left behind. When the tank is empty, the sediment is allowed to run away by a separate opening.

These processes, although excellent, are too complicated for practical use. The manipulation, however simple it may seem, presents great difficulties.

What is really necessary? The removal of the carbonate of magnesia and lime. In place of precipitating them they may be caused to enter into some combination which will form soluble substances. The water will remain clear, unchanged in appearance, and the manipulation will be greatly simplified.

The author has done this in several tanneries with excellent results, using either hydrochloric or acetic acid.

Twenty gram. of commercial hydrochloric acid (20° Baumé), or 20 gram. commercial nitric acid (36° Baumé), or 25 gram. of acetic acid (9° Baumé), are used per cubic metre,¹ per degree of hardness. All that is necessary is to add the acid to the water in a wooden or cemented tank, stir it with a pole, and it is then ready for use.

Finally, tannery waters should fulfil the following conditions:—

(a) To be soft, or softened as described above.

(b) To be at a constant temperature, either cold or warm, so that it be not liable to change by remaining some time in the tannery.

(c) To be well ærated, which can be assured by causing it to fall some distance in a cascade.

13. Loss in Soaking, etc.—A hide weighing 100 lb. when it leaves the slaughter-house will weigh, after the removal of the horns, etc., 91 lb., or a loss of 9 per cent. The treatment in the tanks before removing the hair brings back the weight to 108 lb., or 17 per cent. (really 18·5 per cent. on the 91 lb.), so that the hide altogether increases by 8 per cent.

After unhairing, the same skin weighs 100 lb.—the weight after slaughter. After fleshing, the hide only weighs 92 lb., or 8 per cent. loss.

The hide thus sustains a definite loss of 9 per cent. for horns,

¹ A cubic metre is 220 gallons, and a gram. is about 15 grains.

etc., 8 per cent. for unhairing, 8 per cent. for glue, etc., or a total of 25 per cent.

The hide ought then to weigh $100 - 25 = 75$ lb. As it really weighs 92 lb., there is a difference of 17 per cent. entirely due to absorbed water.

If this hide were dried absolutely, it would give 25 lb. of dry skin; it contains, therefore, $92 - 25 = 67$ per cent. of water. Indeed, hides fresh from the slaughter-house contain 50 per cent. of water.

A good soaking will bring back our 92 lb. to 96 lb.

A 100 lb. skin will contain:—

50 lb.	of water	as it leaves the slaughter-house.
67	„	after the first soaking.
72	„	„ „ fleshing.
76	„	„ second soaking.

This is calculated from the true dry matter of the skin, but it should be remembered that skin which is to all appearance quite dry, still retains with great avidity some 15 per cent. of water, which can only be expelled by submitting it to a temperature of 100° C. for several days.

III.—PLUMPING AND COLOURING.

After depilation, the hides must be swelled or plumped, to be ready for the reception of the tannin. This is a delicate operation, which determines to a great extent the quantity and quality of leather produced. The skin when it has been prepared for tanning is like a new-born child. It must be treated with the greatest care, especially in its earlier stages, like the delicate care of a mother for her child. The more this idea can be impressed upon the mind of the workman, the more likely he is to produce good leather.

This operation is carried out either by means of ooze or of acids:—

1. **Ooze.**—This is water in which either tan or exhausted tan has been soaked. As we shall have occasion to notice later, the tan is never quite exhausted in the pits. There always remains at least 1 per cent. of tannin, which is not dissolved by the cold

water of the tan pits. By leaching this waste bark we can obtain weak extracts, which become quickly acid in contact with the air, from fermentation, which gives rise to various organic acids.

This leaching is carried out in a very simple manner. Water is poured over the exhausted tan in a vat, and the whole is allowed to stand for six or seven hours. At the end of that time the liquor is drawn off and pumped back over the tan. Three macerations usually complete the exhaustion.

In certain factories a pit is dug in the earth and a square wooden pipe made of four pieces of wood, 6 in. wide, is fixed upright in it, with one end close to the bottom. The pit is filled with the exhausted tan, and water poured over its surface. The liquid runs down through the layer of tan and into the pipe, from which it may be pumped back over the tan until all the tannin has been extracted.

This work may be managed more methodically as follows :—

A position is chosen in the tanyard for the installation, close to the tan pits. The vats should be made either of wood or cemented brickwork, about 10 ft. 6 in. in diameter, and the same height. They must have a false bottom about 4 in. above their floor, pierced with holes (100 per sq. metre = 9 per sq. ft.). In the true bottom of the vat is a conical hole which is closed by a wooden plug fixed to a pole about 10 ft. long. This pole is enclosed in a 4-in. square wooden tube, pierced below by holes. Fig. 23 shows the details of the vat.

Four of these vats A B C D (Fig. 23) are arranged around a well E, sunk in the earth, into which the effluent liquor is led by the tubes *a b c d*. The bottom of the vat A communicates by means of a tap-tube L with the upper part of B. The lower part of B with the top of D by M. The tube N fulfils the same office between D and C, and O communicates in the same way between C and A. These tubes are made of copper and are 4 in. in diameter. One end of each opens into the vats, between the true and the false bottom, and the other from 8 in. to a foot below the top of the vat.

The vats being filled with tan, the extraction is started as follows :—

A is filled with water by means of a flexible tube K (Fig. 23), care being taken that the tap in O is closed. The water traversing the layer of tan extracts the tannin. When it is full it is allowed to stand soaking for two hours. The water is then turned on again at K, and this forces out the old liquor through L into B. The fresh water is allowed to work for two hours, whilst the liquor which has passed on to B, takes up a fresh lot of tannin. After this second soaking, the water is turned on again, and B discharges into D, and A into B, whilst fresh water comes again into A. After

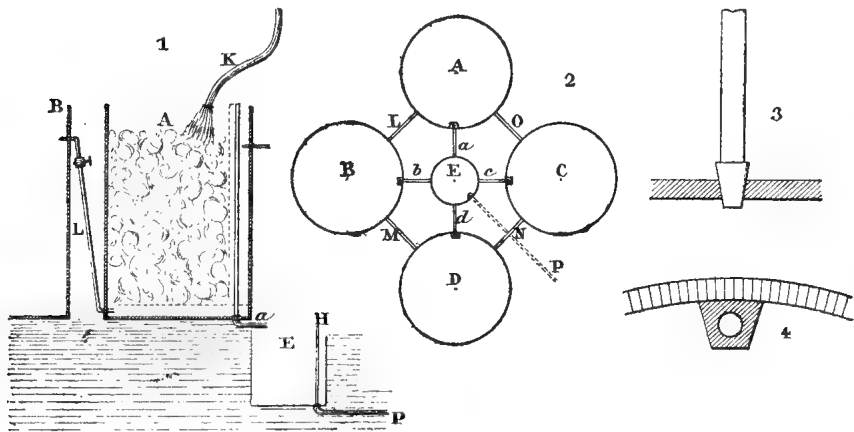

FIG. 23.—Leachers on Spender Pits.

two more hours, further water is added to A, which forces the liquor from D to C, from B to D, and from A to B. At the end of an hour, the liquor in C, which is now sufficiently strong, is run off into the well E by drawing up the pole which closes the opening. From the well it may be run off by an underground pipe as required in the works.

In A the tan is now completely exhausted ; it is emptied and charged afresh, and instead of being the first vat, it becomes the last.

Fresh water is then run into B, so that the liquor passes to C, and later from C to A. It is then run off into the well, and the tan in B is exhausted. The clear water which B contains is run off and

carried back by a special tube into the next vat. Fresh tan is added and B becomes the last vat.

This arrangement may be modified and simplified. Instead of having their effluent tubes *a b c d* below, they are placed just above the level of the upper openings of L M N O. Thus the rods are got rid of and the vats may be sunk in the ground with the well only slightly below them.

Charging and discharging is more easy, and the manipulation becomes simpler. The water flows continuously in a fine jet from K into A, at such a rate that it is filled in two hours. B will then fill in the next two hours so that each change will occupy a like time.

After eight hours, C will be full and the tan in A exhausted. The flow into is then stopped and the jet removed to B. The tap communicating between A and B is closed. The water running into B drives the clean water out of A down the drains. It is then charged with fresh tan. The tap in O is opened, and that in L closed, and clean water is run into D. The contents of C run into A, those of D into C, and of B into D. During the two hours of the operation, B is discharging, and it is then refilled with tan.

The work is continuous. Water is constantly entering by K, and the liquor is constantly running from one of the vats. This system, however, is best carried out with six vats, but is worked in exactly the same way as has been described for four.

The liquor so obtained is clear, more or less reddish in colour according to its strength, and contains a certain quantity of organic acids, principally acetic, formed by fermentation. It is known as sour ooze.

2. Colouring.—The colouring pits should be constructed deep in the ground so that they may keep at a uniform temperature. Quick changes of temperature should be avoided at all costs, as they have the effect of causing the hides to fall. In winter, when it is very cold, a few handfuls of tan are burned in the middle of them. The smoke so formed has a good effect. In the heat of summer, the yard should be watered three times a day and currents of air established through the building. The sultry heats of

August and September are especially difficult to deal with. The temperature of the shed should be 12° C. (54° F.).

Wooden vats or pits having a diameter of 4 ft. and a depth of 6 ft. or 7 ft. are arranged in two, four or even six rows. Nowadays it is found more economical to build them of cement in the form of a hemisphere, 7 ft. across, and buried nearly 2 ft. in the ground.

Brick pits, which are the best of all and the most convenient, have the drawback that they blacken the leather and produce disagreeable marks; but this is merely temporary, for at the end of a certain time the vats become crusted on the inside with a precipitate of tannate of lime which protects the tannic liquor from the action of the lime. Nevertheless, various processes are in use which do away with the inconvenience altogether.

When the pit has been built and is sufficiently dry a charcoal fire is lit at the bottom to thoroughly dry the mortar and cement to a depth of at least $\frac{1}{2}$ an in. It is then painted with one of the following compositions:—

(a) Sulphuric acid diluted with ten times its volume of water. This converts the lime into sulphate of lime or plaster. It fulfils its object of preserving the skins from stain; but a vat so prepared disintegrates very quickly. We cannot recommend the process, although it is very widely used.

(b) A layer of hot boiled linseed oil, spread with a brush and allowed to dry, forms a very durable protective layer.

(c) Commercial silicate of potash or soda.

(d) Lastly, a soap varnish which gives most excellent results and which may be prepared as follows: Heat together 50 parts of soda, 100 parts of water and 100 parts of powdered resin, until the solution is complete, adding water from time to time to make up for loss by evaporation. Next add 100 parts of water in which has been dissolved 15 parts of glue. The whole is boiled together and forms a varnish which dries very quickly.

A series of eight pits is arranged for eight workings. Each pit contains seven to ten hides. The series is divided into four sets named respectively first, second, third and fourth suspenders, the fourth being the strongest. Each of these vats contains a

solution of tannin or ooze of a certain strength which increases gradually. The liquor brought from the well by a subterranean tube runs into a cistern from which it is pumped into the vats. The first one receives 2 parts of strong liquor and 8 parts of water; the second receives 3 parts of liquor to 8 parts of water; the third, 3 parts of liquor to 7 parts of water; the fourth, 3 parts of liquor to 6 parts of water; the fifth, 3 parts of liquor to 5 parts of water; the sixth, 3 parts of liquor to 4 parts of water; the seventh, 3 parts of liquor to 2 parts of water, and the last pure liquor.

The hides are placed in the first pit and allowed to remain there twenty-four hours. It is faintly acid and shows a strength of half a degree on the barkometer. The hides are removed two or three times during the day, and placed on a board beside the pit where they are allowed to drain for an hour at a time. They are then put through the process of scouring, which completely removes the hair and scudd left from former processes and which it has been impossible to remove before. This process is carried out as soon as the hides begin to swell, with a special knife (*Raclette*).

On the second day the hides are removed from the first pit, allowed to drain for an hour or two, and put into the next pit where the liquor is a little stronger. The same operation is repeated each day until the skins have arrived at the sixth or head pit.

The skins then pass into the pits which consist of fresh liquor, which ought to show three- or four-tenths on the barkometer. After twenty-four hours in this bath, the hides have attained their maximum development and they are taken to the handlers.

Mechanical pits are being introduced for the treatment of heavy leather, but many still prefer to leave the skins at rest in the pits. These appliances will be described under the head of dressing leather, for which they are more generally used. We may say that their use favours swelling but is apt to bruise the hides. It is best simply to move them with the tanner's hook.

In this process the hides ought not to fall—that is to say, they should not be placed in a pit with less strength in acid or tannin than that from which they have last been taken, nor to remain too

long in the same pit, or else they shrink and it is difficult to bring them back to their normal state. Falling may be remedied by the use of fresh liquor, which must, however, be used with great care or it will stiffen the hides, in which case the remedy is worse than the disease.

The hides ought not to be treated with over strong liquor, nor placed in pits in which the strength of tannin and acid is sensibly different. In swelling too much the skins are apt to acquire a hard grain, and give a harsh brittle leather.

3. Estimation of Acidity in Tan Liquor.—The use of the tannometer (barkometer) for estimating the strength of the liquor is quite misleading. To obtain a true idea of its strength two things are necessary: (1) an estimation of the tannin by one of the methods given in Pt. i., Chap. ii., Sec. 11; (2) an estimation of the free acid in the liquor. This last we will now proceed to describe.

The acids formed by the fermentation of tan liquors are acetic, butyric and lactic. The estimation which at first sight appears easy becomes difficult in practice on account of the colour of the liquor, and the presence of foreign substances which mask the alkalimetric reactions.

(a) *Exact Method.*—100 cubic centimetres¹ of liquor are distilled until 70 cc. have come over. The remaining 30 cc. are cooled and made up again to 100. They are again distilled and made up in in the same way. This process is carried out four times so as to collect about 300 cc. of distillate. This distillate is then titrated with decinormal soda and the acidity calculated as acetic acid.

For the total acidity, about 80 cc. is allowed to digest in the cold with 3 or 4 gram. of freshly-calcined magnesia, shaking from time to time. The liquid should be entirely decolourised. It is then filtered and 20 cc. are evaporated to dryness. The residue is strongly heated to change organic magnesium salts into magnesium carbonate. The residue when cool is moistened with water charged with carbonic acid, dried, taken up with boiling water, filtered and washed well. The carbonate of magnesia on the filter, when weighed

¹ The metric system of weights and measures has been retained here and elsewhere when laboratory operations are described on account of its convenience.—TRANS.

in the usual manner, corresponds to the total quantity of organic acids.

The total acids are calculated as acetic acid, and the percentage of true acetic acid found by distillation is subtracted. The remainder gives the non-volatile acids, which should be calculated as lactic acid.

(b) *Rapid Method.*—The exact process just described cannot be used daily on account of its length and tediousness. The author has therefore devised another method, less exact but more rapid, and better adapted to the ordinary needs of the tanner.

Ten gram. of freshly-precipitated lead oxide are added to 200 cc. of the liquor. The acids when treated with an excess of this oxide give soluble basic salts; tannin, colouring matter and sulphuric acid being precipitated. A clear liquid is thus obtained which may be decanted or filtered. To 100 cc. of the filtered liquid decinormal sulphuric acid is added until the white sulphate of lead is no longer precipitated. The acidity is given as sulphuric acid, and may be calculated as found most convenient.

4. Swelling by Acids.—It is customary to add some acid to the ooze to increase the plumping and to hasten the work.

The method most commonly used is to pass the hides successively through the six first pits described above and then to prepare special pits for the final work.

The new pit is made up of fresh ooze into which a thousandth part of sulphuric acid (66° Baumé) is poured little by little, stirring continually with the paddle. The hides are placed in this pit and removed twice during the first day, allowing them to drain for two hours at each removal. The next day they are removed once. The third day they are placed in the next pit, which contains the same quantity of sulphuric acid, and left all day. In the evening they are taken out and drained for two hours, then put back for the night. In the morning they are ready for the next process.

Some tanners object to sulphuric acid because of its disorganising effect, but the strength of 1 part per 1,000 when used in the last pit has no objectionable effects. On the contrary, sulphuric

acid allows the use of very weak liquors in the first pit, which makes the work slow and progressive.

We prefer the use of 50° Baumé acid at the rate of 1½ parts per 1,000.

Hydrochloric acid (5 parts per 1,000) has been suggested. It is not to be recommended, because when used at a strength of 10 parts per 1,000 it does not act so well as sulphuric. Further, it contains many impurities, including iron. Nitric and phosphoric acids have only one-fifth the effect of sulphuric acid and are five times as dear.

Acetic and lactic acids, which occur in the liquor, both work well, giving a good plumping. Commercial lactic acid of 26° Baumé contains 71 per cent. of the acid. Acetic acid of 9° Baumé contains 40 per cent. of acid. Oxalic acid is still much used. For every thousand parts of raw hide one part of oxalic acid is required with a liquor containing 1 per cent. of tannin.

Boric, tartaric, citric and saccharic acids are too dear to be used profitably.

Taking the "swelling power" of sulphuric acid as 100, then acids of an equal strength will have the following relative swelling effects:—

Sulphuric	100
Acetic	80
Lactic	60
Tartaric	45
Oxalic	45
Citric	40
Nitric	30
Phosphoric	25
Hydrochloric	12
Boracic	10

The use of organic acids demands that the liquors shall be used gradually, beginning with a very weak acid and increasing to a stronger one. Three only of these acids are to be recommended—acetic, lactic and oxalic.

Supposing that we wished to use oxalic acid, we see from the table that for equal weights it has about half the effect of sulphuric acid. We should therefore put into the seventh and eighth pits 2½

parts per 1,000 of liquor, in the fifth and sixth $1\frac{1}{2}$ parts per 1,000, in the third and fourth 1 per 1,000, and in the first and second 1 per 2,000. Thus we should have a natural gradation. Lactic and acetic acids should be used in the same way, taking a smaller quantity according to proportion calculated from the table.

It is of the greatest importance that the ratio of acidity to tannin should remain constant in all the swelling pits. In other words, the tannin must be increased in proportion to the increase in acidity. If the percentage of tannin remains constant and the acidity is increased, the hides become soft, flaccid, flat, and tend to break. If, on the other hand, the percentage of tannin increases more rapidly than the acidity, the skins not being sufficiently swelled, the tannin hardens them, even burns them, and defective leather is produced. It is necessary then to maintain a correct medium and so increase the acidity, whether natural or artificial, and the tannin in exact proportion. It must be remembered, however, that the barkometer is entirely fallacious as a guide in this work.

Certain tanning substances contain the materials necessary for producing a fermentation acid. Such are the false fir, the pine and the larch. The addition of acid when these are used is unnecessary—at any rate until the end.

Other substances do not contain a sufficient quantity of these materials, as oak-bark, dividivi, valonia and sumach. To these either glucose is added, which is transformed into lactic and acetic acids, or else acids are added to each of the pits.

Substances such as chestnut, which do not contain any acid producers, receive the correct dose of acid in each pit.

We shall finish this chapter by mentioning the methods proposed by Liautaud in 1872, by which carbonic acid is used in swelling skins. The original method consisted in injecting carbonic acid under pressure into the pits by means of a worm pierced with holes. Swelling is considerably hastened.

For several years the author has used carbonic acid under pressure in hermetically sealed pits containing the liquor and the hides. In his hands a pressure of four atmospheres has given excellent results; as good in fact as those obtained with sulphuric acid. He

has only used it in the two final pits. The carbonic acid was produced in a coke furnace, washed with water and compressed by a pump into the water of the pit through a perforated worm. The pressure was left on for six hours.

IV.—HANDLING.

After remaining twenty-four hours in the last pit, the hides are lifted out, 165 lb. of coarsely-ground bark are added, and the hides are put back for five days. They are again taken out, a basketful of tan is added, and they are re-dipped for two hours, then allowed to stand for four days, and finally taken to the layer-pit.

This method has a grave fault. The hides are damaged in these movements; they shrink because they do not find sufficient nourishment to keep up their body, and cannot support the weight which comes on them in the layer-pit. The tanned skins are hungry and baggy.

The process has been abandoned in modern works, and is only used by rule-of-thumb tanners. The process at present used is as follows:—

The hides are placed in pits, placing tan between any folds which are made, and separating them from one another with coarse bark. Thirty hides arranged in this manner will fill a pit. They are totally covered with tan, and fresh liquor from the liquor-well is pumped in on them. After they have remained in this state for a month, they are taken out and placed in the layer-pit.

1. Handling.—The skins are laid with care in shallow pits, wide enough for the skin to be stretched out to its full extent. They are separated by coarse bark and tan. Fifty or sixty hides are thus piled up. The pits are filled with fresh liquor and covered with tan. The hides are allowed to remain for a fortnight, at the end of which time they are treated again in the same manner in a fresh pit, the hides which were at the top before being below now. A third tanning is given at the end of another fortnight. These tannings ought to be stronger each time, lasting altogether six weeks. Sometimes a fourth tanning is given.

The hides on coming out of these pits ought to be firm, free from harshness, and full in all parts. The first ooze should have a strength of 6° of the barkometer, the second and the third 12°, and the fourth 16°.

2. The Object of Handling.—The object of handling is to give body to the plumped skin, so that it may be able to support the weight which will press on it in the layer-pit, and to prepare it for the reception of the tannin without losing any of the swelling which it has received in the swelling pits.

Besides this, the weak liquors used up to this point have, so to speak, accustomed the skin to the absorption of tannin, which will be carried out finally in the pit.

V.—TANNING, OR LAYING AWAY.

1. Pits.—Tan-pits or lay-away pits are large vats, sometimes round, and made of oak, bound with iron. These are 10 ft. high by 8 or 9 ft. in diameter, and sunk in the ground until their tops are level with the soil. Sometimes they are square, and built of masonry and hydraulic cement. Round pits are also made with either flat or wedge-shaped bricks.

Wooden pits, which are nearly always used, have the drawback of being relatively costly, and requiring frequent repair. They may be preserved to some extent by coating them on the outside with tar before placing them in the ground.

Cemented pits are made, using bricks placed on end all round a pit which has been dug in the earth. The following precautions should be taken:—

The hole dug in the first place should be 10 ft. deep by 10 ft. in diameter.

The bottom should be well stamped, sand spread over it to make it quite level, and hydraulic cement spread to a thickness of 1½ in. In very damp soil a third part of sand should be mixed with the cement.

The next day the bottom is covered with bricks laid on the flat, and then the cylindrical wall is built.

The whole interior is covered with a good layer of cement.

We have already pointed out that cement is apt to stain the hides, and have suggested various remedies. For lay-away pits we strongly recommend the following, which is very simple and easily made in the tannery:—

This cement is a Chinese invention, and bears the name of *schia-lio*. Five parts of blood are mixed with 1,500 parts of slaked lime, to form a paste which must be spread immediately on the dried cement. Two coats are sufficient. This coating will not keep, and must be used at most within two days of its preparation.

Finally, it has been suggested to try double arched bricks thicker than those ordinarily in use, having a tenon at one end and a mortise at the other, so that they may be fitted together perfectly in a circle. On the upper and lower surfaces are grooves which, when the bricks are placed together, form cylindrical channels. These are filled with mortar so that the bricks may be cemented together. By this method the liquor comes in contact only with the bricks and not with the mortar.

Nevertheless, we recommend the impermeable lining of blood which does away with the need for precautions. For it must be remembered that bricks always contain oxides of iron which are quite capable of producing stains on any leather with which they come in contact.

2. Arranging the Hides in the Pits.—The bottom of the pit is covered with a layer of old tan about 8 in. thick and above this is spread about 4 in. of new tan in fine powder. A wooden chimney made of three boards 6 in. across is placed against the side of the pit. A first hide is then stretched so that the head is against the wall and the flesh side below. A layer of tan is spread on the grain side, giving rather more to the thicker portions than elsewhere. The tan is carried in a basket, and is slightly moistened to keep down the dust which is so harmful to the workmen. Certain manufacturers will not allow the tan to be moistened, and in these "dust" pits the workmen have to cover their noses and mouths with a wet cloth. The use of wet powder is preferable from every point of view.

The workman arranges the skins around the pit going from left to right, the tail of the last hide pointing to the right side of the one which has preceded it. The pit is gradually filled in this manner until within a couple of feet of the upper edge. It is finished by a layer of tan a foot thick named a "cap".

Care must be taken that there are no folds in the hides and that there is a layer of fine tan separating them in all parts. Pockets, that is to say, the folds which are nearly always formed at the extremities, ought to be cut off if they cannot conveniently be stretched. When it is necessary to fold any parts, care must be taken to put powder between every fold. A pit contains fifty or sixty skins.

The pits are watered with tan liquor coming from the well already described. This is poured down the wooden chimney in a fine stream until the pit is full. This is a better method than running the liquor into a hollow made in the cap, which takes too long and cannot be done all at once, as it is always found necessary to add another lot of liquor the next day. The cap is covered with boards and stones.

3. Time required for Laying Away.—The hides are removed from the pit and put back again three times so that the tan may be renewed, as it is exhausted by the absorption of tannin by the skin. Technically this is known as three powders or three barks.¹

The first bark is given on the grain side with fine tan from the stamps or the mill at the rate of 110 lb. of bark for each hide of 66 lb. It lasts three months.

The second bark is placed on the flesh side with coarser powder at the rate of 77 lb. for the same weight of hide, and lasts five months.

The third bark is on the grain side with better quality bark, a little coarser, at the rate of 66 lb., and lasts six months.

A fourth bark is given to large hides similar to the third, but only for three months.

A hide weighing 66 lb. thus requires 250 lb. of bark, or one of

¹ The English equivalent of the expression powder or bark would be "layer".

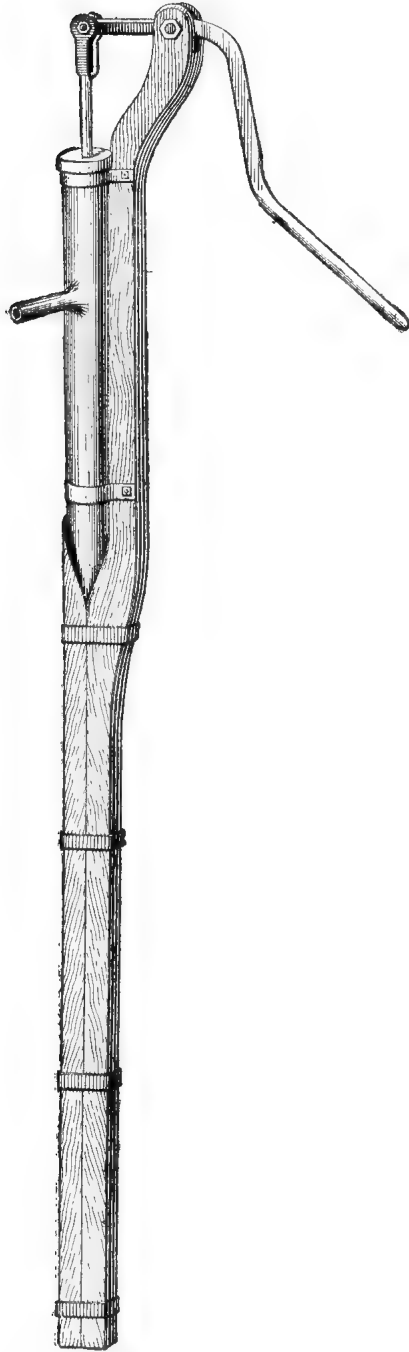

FIG. 24.—Pump.

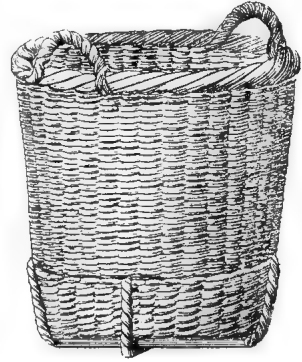

FIG. 25.—Tan Basket.



FIG. 26.—Tan Spade.

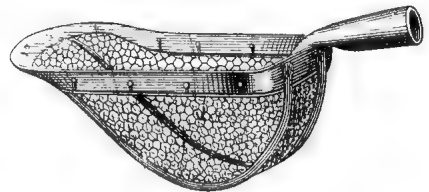

FIG. 27.—Tan Scoop.

110 lb. requires 300 lb. when the pits have been watered with tan liquor. A hide uses up 3 lb. of bark for every lb. of skin fresh from the slaughter.

When the hides are to be changed, a neighbouring pit is prepared and in it the skins are placed after being beaten to remove adherent tan.

The hides which are at the top of the first pit are placed at the bottom of the second. The liquor which has been pumped out of the first pit is now allowed to flow down the chimney of the second.

The conditions which must be fulfilled to obtain a good result are :—

(a) The pits should not be too deep or the bottom hide will be crushed.

(b) An even temperature must be maintained, sharp changes being avoided.

(c) Fermentation (acidification) of the liquor must be avoided, by exposing it as little as possible to the air. If possible a centrifugal pump and tubes of waterproofed cloth should be used.

(d) Fresh water must not be used in the second or third layer, especially when tan liquor has been used in the earlier one.

(e) The poorest bark should be used in the first pit and the richest and finest saved for the last pit.

(f) From the first to the last the liquor should be used stronger and stronger.

The time necessary for transforming a large la Plata hide in hair into finished leather is as follows :—

	Days.
Softening	15
Depilation	15
Swelling	15
Handling	45
First layer	90
Second layer	150
Third layer	180
Fourth layer	90

600 = 20 months.

4. Cost of Tanning in Francs per Hundred :—¹

	Oxen.	Cows.
Preparation in hair	30	20
Depilation	45	35
Fleshing	50	40
Dressing	70	60

VI.—TANNING ELEPHANTS' HIDES.

As an example of the tannage of large hides, we give the following account of the tanning of an elephant's hide which weighed 900 lb. and was rather over $1\frac{1}{2}$ in. thick.

The hide was soaked in a tank of clean water to soften it. Each day it was worked for an hour on the stocks and every other day it was scudded. After ten days' soaking in pure water, it was steeped for ten days in 4 per cent. salt solution, and finally for twenty days in pure water. The soaking had thus lasted forty days, but the hide was only just softened.

The head and feet, weighing together 100 lb., were removed.

The hide was sweated for a day and afterwards placed in a depilatory of lime with caustic soda and a little sodium sulphide in the following proportions:—

	Parts.
Water	1,000
Slaked lime	25
Caustic soda	3
Sulphide of sodium	2

After two days in this bath it was rinsed with water at 20° C. (68° F.), then sweated for another day, and replaced in the depilatory. After this double operation had taken place three times it was ready for unhairing.

The workman took nearly a day in removing the hair, which weighed 26 lb.

Another day was taken up with fleshing and piecing.

After all these operations the hide had lost 30 per cent. of its weight.

Plumping lasted two months and was carried out in exactly

¹Seeing that the cost of French labour is different from English, and therefore not of practical value to the English tanner, it has been left in francs exactly as given by the author.—TRANS.

the same way as for an ox, excepting that it was left three times as long in each pit.

Handling lasted altogether two months.

Tanning in the pit was carried out together with ox hides, the elephant skin being placed in the middle of the pit. Six layers were given, two first, two second and two third.

Altogether the work took the following time:—

	Days
Softening	40
Depilation	16
Swelling	50
Handling	60
First layer (double)	200
Second layer „	300
Third layer „	400

1,066 = 3 years.

TIME REQUIRED FOR TANNING HEAVY LEATHER.

Nature of the Skin.	Approximate weight (lb.)	Softening (days).	Depilation (days).	Plumping	Handling.	First tanning.	Second tanning.	Third tanning.
Ox	120	15	15	20	45	90	150	180
Bison	150	20	15	25	45	120	180	210
Buffalo	145	20	15	25	50	120	180	210
Kangaroo	155	25	15	25	50	120	180	210
Camel	200	25	15	30	50	120	180	210
Dromedary	190	30	15	30	50	120	180	210
Rhinoceros	280	30	15	40	60	180	270	300
Hippopotamus	310	45	15	50	80	210	330	390
Seal	225	30	15	35	50	150	180	210
Whale	300	25	15	35	45	120	180	210
Horse	65	15	15	30+30	45	120	180	210
Cow (large)	75	15	15	15	40	90	180	180

VII.—DRYING.

On coming out of the pit the hides are taken to the drying loft. They are here cleaned by stretching them on wooden tables and scrubbing with a stiff brush.

A mechanical cleaner has been invented by Henry. It consists of a long hollow rotating cylinder open at both ends and made up of longitudinal strips of wood two inches wide and two inches apart. The cylinder is conical and turns on a horizontal

axis. The leather is thrown in at the smaller end. It rolls down towards the larger one and comes out clear.

Another machine consists of a cylindrical brush rotating above a horizontal table. The hides have merely to be passed over the table.

1. **Drying in the Sun.**—We only mention this system to point out its danger. In certain places the hides are spread out over wooden poles in a field, to dry under the action of the sun. Direct sunlight marbles the leather, hardens it and makes it brittle. Sunlight should be avoided, even in the drying lofts.

2. **Elementary Principles of Drying.**—To carry out the operations of drying in a rational manner, the following principles must be applied :—

(a) Air and gases have the power of absorbing moisture.

(b) Air and gases absorb more moisture when hot than when cold.

(c) Air and gases become more difficult to saturate with moisture as their temperature rises.

(d) Cold causes air and gases which are charged with moisture to give up the moisture, which then condenses as water or dew.

The following table gives all the necessary information on this subject :—

Temperature of the Air in Degrees.		Tension of Vapour in Millimetres.	Weight of Water in Gram. per 1 Cubic metre Saturated Air.
Centigrade.	Fahrenheit.		
0	32	4.60	4.892
2.5	36.5	5.49	5.796
5	41	6.53	6.788
7.5	45.5	7.75	7.969
10	50	9.16	9.335
12.5	54.5	10.80	10.372
15	59	12.69	11.812
17.5	63.5	14.88	14.790
20	68	17.39	17.240
22.5	72.5	20.26	19.943
25	77	23.35	22.290
27.5	81.5	27.30	26.371
30	86	31.54	30.273

4. Drying in the Open Air.—Usually long narrow sheds are used, built in a north and south direction so that the interior never receives the direct rays of the sun which, as we have already mentioned, are highly objectionable. The sheds are furnished with wide openings or windows guarded with blinds and wooden shutters.

In large tanneries the building is arranged in two or three storeys on the top of some other workshop. In smaller works the loft of the tannery is arranged in a manner to be described later. The drying loft ought to be as high up as possible and sheltered from the wind. Sometimes the drying is carried out on planks held in stakes just above the ground.

The hides are hung on cords or rods fixed to hooks in the joists of the roof.

Drying requires great care even in the most minute details. When the hides have been submitted for some time to the action of the air they tend to curl up. They are taken down, stretched out one over the other, and put into a press for about two days to bring them back to their normal shape. This operation is repeated whenever they curl. The drying is continued until the surface is quite dry; that is, when it becomes white. As the deeper parts of the hides still contain moisture, they are "piled"; this consists in heaping them one on the other so that only the edges are exposed to the air.

The skins are then rubbed, brushed, straightened and piled again taking care that the edges lie across one another alternately head to head and tail to tail. The larger skins are piled together and the smaller ones in a separate pile.

The drying of leather is not so easy as this description would seem to indicate. In carrying it out the following facts must always be remembered:—

(a) The degree of moisture influences the drying greatly. The wetter the leather, the slower the drying should be. Rapid drying is only allowable after the hides have lost from a third to half their moisture.

(b) The "humidity" of the air is an important factor; the drier the air, the quicker will the hides dry.

(*c*) Temperature influences drying. The warmer the air, the greater will be its capacity for taking up water, and consequently the greater will be the rate of drying.

(*d*) Movement of the air. The greater the velocity of the current of air, the more rapid the drying.

(*e*) Drying is more rapid in the day-time than at night, and more rapid in the middle of the day than in the morning or evening.

(*f*) Moist heat, especially that of August or September, is objectionable. It encourages the development of ferments and cryptogamic organisms which produce black stains very difficult to remove. Under these conditions all the openings of the drying loft should be closed, even the shutters. In spite of these precautions, the fog, as tanners call it, comes just the same, but with less intensity. We have endeavoured to protect the hides from these microscopic enemies by sponging an antiseptic (1 per cent. solution of corrosive sublimate) over the leather.

(*g*) Sudden changes of temperature and storms are to be watched for. At such times the same precautions should be taken as for moist heat.

(*h*) Frost breaks the skin. As the water freezes, the crystals of ice cut through the fibres of the skin. It must be avoided by entirely closing the loft.

Drying should be carried out regularly and intelligently, and may be regulated by the use of Venetian blinds.

5. Drying by Artificial Currents of Air.—The circulation of the air may be increased by using a ventilator placed high up at one end of the loft. By causing three times the natural quantity of air to pass through the loft, the moisture-absorbing power is multiplied by three, and the drying is quickened proportionally.

Lumpp has invented a mechanical fan which produces an excellent effect by displacing the air vertically and continuously. It consists of three blades (Fig. 28) and is placed in the ridge of the roof. The apparatus is moved either by toothed wheels or by a strap, the power required being from 1 to 2 horse power. One fan is sufficient for a loft whose length is not more than $1\frac{1}{2}$ times its width. The loft is provided with one or more chimneys,

ventilators or other openings in its upper part, and louvers or other inlets in its lower part, all of which should be easily closed.

At a temperature of 25° C. (77° F.) large hides fresh from the pit will dry in twenty-four hours with the fan working for ten hours.

6. Drying in Warm Air.—We know that the air has a greater avidity for moisture at high than at low temperatures. Warm drying is rational, and may be used under all circumstances. The air may be warmed either inside or outside the loft.

Let us consider the latter case. It would be wasteful to heat the air directly when we have at our disposal the waste heat from the furnaces. This is used by passing the air through cast iron tubes which come in contact with the flames as they pass out from the furnace, or else are inserted in the base of the chimney. The

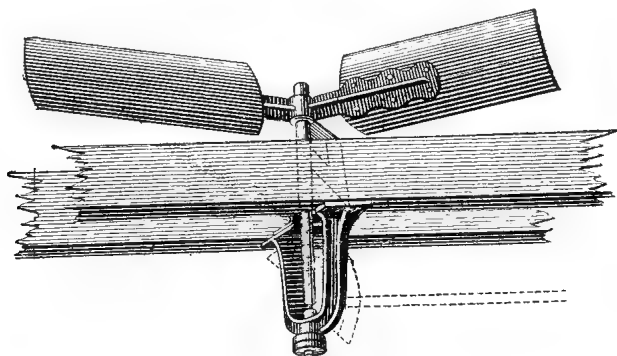

FIG. 28.—Mechanical Fan (Lumpp).

air enters by the lower end of the tubes, becomes warm, and rises to the upper end where it is received in a wooden tube which leads to the drying loft.

More commonly the waste steam from the engine is used. The best apparatus for this work is Fouché's aero-condenser. It consists of a set of vertical tubes arranged between two plates of sheet iron on which are fixed castings, to form chambers into which all the tubes open. A fan causes a violent draught of air to play on the outside of the tubes. The steam comes into the upper chamber, and is condensed in the tubes by the current of air. Steam which has done its work in the cylinders of an engine has only lost a small part of its heat. It still contains sufficient to considerably raise the temperature of the air passing between the tubes. An

aero-condenser receiving steam from a 15 horse power engine working normally will supply in an hour:—

20,000 cubic metres	(700,000 cub. ft.)	at 20° C.	(68° F.)
13,000 „ „	(455,000 „)	„ 30° C.	(86° F.)
10,000 „ „	(350,000 „)	„ 40° C.	(104° F.)

The drying loft must be more carefully arranged than when ordinary air is used. The best arrangement, which should be adhered to as closely as possible, is: length 70 ft., breadth 14 ft., height 35 ft. The height should be divided into four equal parts, by three double wooden floors. The double floors have a space of about 2 in. between them filled with spent tan. In this way four chambers are formed; 1, 2, 3, 4, (Fig. 29) each having a height of 8 ft. 9 in. The hides are hung in these chambers in the same way as in the loft. The top floor A B has a square opening at M

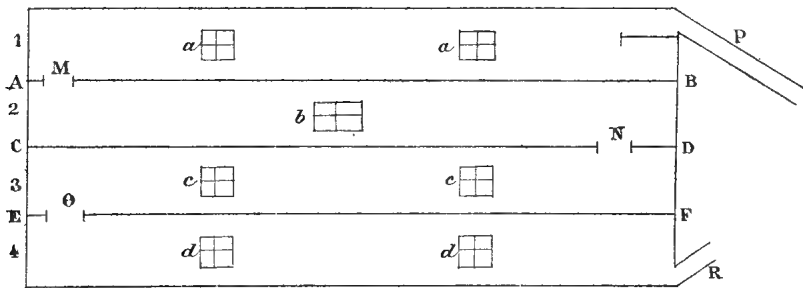

FIG. 29.—Arrangement of Drying Loft.

about 1 ft. 9 in. across. C D has its opening at N, and E F at O. The glazed windows at *a b c d* give sufficient light for working and inspection. A staircase or lift on the outside of the building forms a means of communication with each floor. The doors should of course be always kept closed.

In this arrangement drying is carried out methodically, that is, the moist skins are treated with colder air and those nearly dry are suspended in warm dry air.

The warm air comes in at the top and fills the first chamber. It passes by the opening M into the second, thence into the third and fourth, finally it goes out by the exit R.

The skins are first put to dry in four, then taken up to three, thence to two, and finally to one, from which they come quite dry.

Warm air thus comes in contact with the drier hides, and takes out the last traces of moisture, arriving at the fourth chamber charged with moisture.

The temperatures of the chambers should be :—

No. 1	...	25° C.	...	(77° F.)
2	...	22° C.	...	(72° F.)
3	...	19° C.	...	(66° F.)
4	...	15° or 16° C.	...	(59° or 61° F.)

A hide should remain for eight hours in each chamber.

The hides thus undergo a steady progression of temperature and rate of drying which gives them a fine appearance and a good colour. At the same time the drying is most economical.

7. Drying in the American Tower.—This is a methodical system of drying, similar to the one just described, with the difference that the air is heated inside the drying chamber. Instead of being long, the chamber is very high. It is built in five storeys and is about 14 ft. square. The floors are of open lattice work, to allow the air to pass freely from below upwards, and the tower terminates above in a chimney. At the bottom are openings to admit the necessary quantity of air.

Heat is supplied by steam which comes directly from the boilers or else from the exhaust of the engine. This steam circulates through wrought-iron tubes $2\frac{1}{4}$ in. in diameter arranged as a grating inclined slightly (1 in 100) to allow the condensed water to run away. These gratings are arranged either along the walls or in the centre of the lower chamber, or on the first or second floor. The air is warmed as it passes upwards, and naturally rises, becoming saturated with moisture before it passes out by the chimney. Thus a steady current which may be easily regulated is set up. The wet hides are placed at the top and the drier ones below. A lift outside the tower enables the workmen to remove the skins rapidly.

A system has also been invented in which the floors are movable, so that the skins need not be touched during the process of drying.

VIII.—STRIKING OR PINNING.

Striking the leather increases its firmness and consolidates its fibre, thus forming a more impermeable substance, and at the same time equalising its thickness.

It was formerly done with a hard wooden mallet, the leather being stretched on a table of wood, marble or stone or cast iron. Afterwards a power hammer worked by a cam was used, similar to those used in iron works. These are still employed to some extent. The table on which the leather is spread may be heated by means of an envelope of sheet iron in which spent tan is burned. With this hammer four hides can be prepared in an hour.

In 1839, Sterlingue invented a better method. The leather was hammered by a thick disc of brass weighing about 6 cwt., attached to the end of a shaft moved by a lever, which received its movement from a cam-wheel. Unfortunately, this arrangement shakes the whole building in which it works. In 1842, Flottard and Delbut improved this apparatus by adding a spring to increase the number of blows and a curb to diminish the intensity of each blow.

In 1842, Bérendorf invented a press, which is both more effective and more economical, and in spite of the great number of machines which have been invented since that time, it is still the one most used everywhere.

It consists essentially of: -

(a) A hammer (A) (Fig. 30) of wrought iron capped at its lower end with a bronze head (B). The cylindrical shaft is fitted into a vertical socket in a strong cast iron girder (C), resting at its two ends on the cast-iron columns (D D). The whole is firmly fixed together to resist the pressure of the hammer.

(b) A stationary hammer *o* carrying a bronze head similar to the upper one. It is between these two bronzes that the leather is held during the pressing, its edges resting on the horizontal table (T T), part of which is cut away to allow the workman to come close up to the anvil (*o*). This table is 7 ft. long by 20 in. deep.

(c) A lever (M) which works the hammer by pressing on its

upper end which is furnished with a steel ball working in a socket. It is put in motion by the pulley wheel (P) and the rod (R).

The bronzes are generally 4 in. in diameter, and, in order that their edges may not cut the leather, they are slightly rounded so that the actual pressure only falls on a disc of about 2 in. diameter. It is the business of the workman to see that the blows overlap one another. The lower bronze or anvil may be raised or lowered

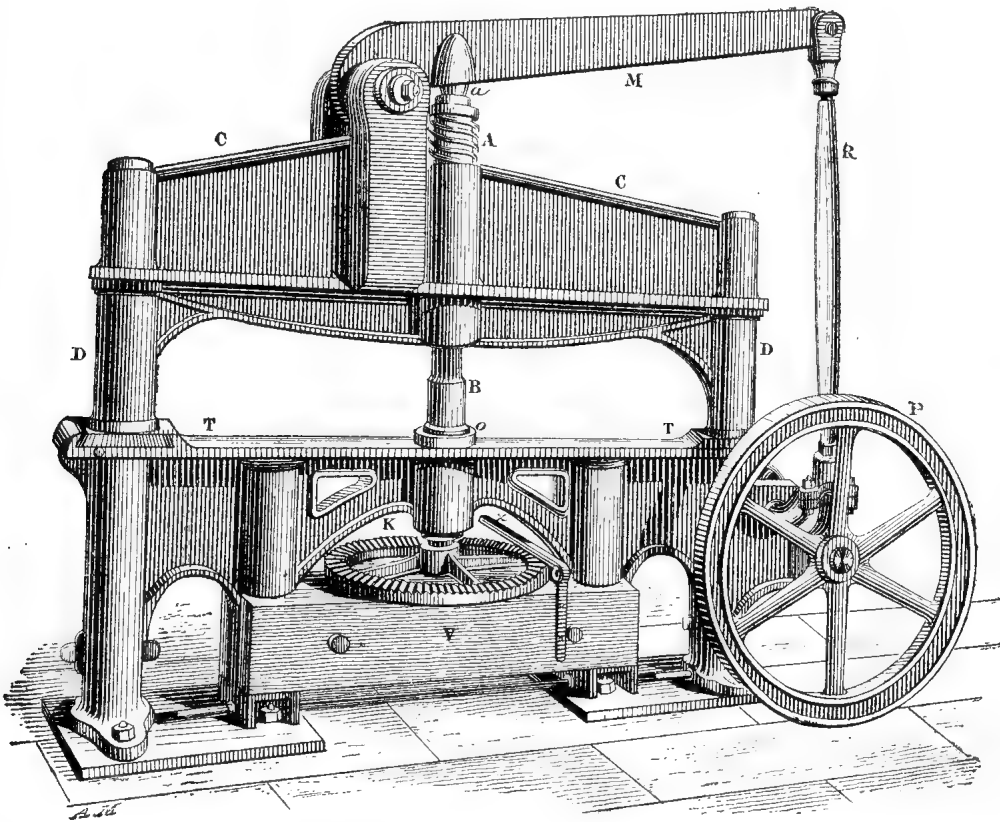

FIG. 30.—Bérendorf Press.

through a distance of about 4 in. It ends in a large screw fitting into an iron collar sunk in a block of oak (V). As the leather is not always of a constant thickness, it is necessary that the workman shall be able to move the anvil up and down easily whilst working. This is accomplished by turning the wheel (K) in one direction or the other. On the upper part of this wheel are teeth, by means of which a lever (Z) holds the wheel in position. The machine requires about $1\frac{1}{2}$ horse power and brings a pressure of about 13,000 lb.

to bear on the leather. The number of blows per minute varies from 180 to 200, according to the skill of the workman. It will work twenty coarse hides or twenty-five fine ones in a ten hours' working day.

Chapelle and Scellos have applied the steam hammer to striking hides. The shaft of the hammer is worked directly by the piston rod of a vertical cylinder.

The Komgen hammer is only a steam hammer composed of a heavy beam raised by a cam. In rising, the hammer compresses a spring of caoutchouc, and this spring throws the hammer down with increased force. The two last are little used.

Leopold Saint-Andrieu's leather-beating machine works on the balance principle. Attached on one side to an eccentric rod which gives it the necessary movement, and at the other to a hammer, it gives 160 blows per minute and produces four pelts per hour.

CHAPTER IV.

THE MANUFACTURE OF DRESSING LEATHER.

DRESSING leather, whose particular property is its great flexibility, is prepared from the skins of cows, calves and horses. It is used in shoemaking, saddlery, harness-making, coach-building, military equipment, etc. It is also called belt leather, upper leather, etc.

The operations of tanning vary more or less according to the kind of skin used. We shall take as a general example of the tannage of this class of leather, the process generally used for calf skins, which are the most delicate, and require most operations. Afterwards we shall give the modifications used in the preparation of other skins.

I.—SOAKING.

1. **Soaking.**—Calf skins fresh from the slaughter-house are thrown into a tank to free them from blood and clean them. The tank should contain 1 cubic metre (35 cubic ft.) for every 2 cwt. of skins. The same precautions should be observed as for sole leather.

The softening of dry and salted skins is performed in the manner described for heavy skins. Here the hide mill or stocks must be used to hasten the softening. It must be turned slowly so that the grain of the skin may not be broken. Those who are afraid to use the stocks work it several times on the beam either with the iron or better with the slate.

Softening may be hastened by putting the skins in a 3 per cent. solution of sodium sulphide or a mixture of realgar and lime (1 per cent.).

Natural softening requires ten days. The above chemicals will do it in five or six days.

II.—DEPILATION.

1. **Lime Pits.**—These are round wooden vats bound with iron, or else quadrangular vats of masonry containing the milk of lime used in unhairing. Usually the pits are built of brick work and sunk in the earth. They are about 7 ft. square and 7 ft. deep, and they are three in number. The old or dead lime (*plain mort*), the middle lime (*plain gris*) and the new lime (*plain vif*). The first is the weakest and the last the strongest. When a large number of pits are used they are arranged in *series* of three.

The sheds in which liming is carried on should be well protected against outside agencies by good windows and doors. They ought to be well lighted and not, as is commonly the case, dull and dark. Light is hygienic. Its action is explained later on in the chapter on the theory of tanning. The sheds should be kept warm and moist, best by steam heating. Steam is brought from the boiler or the exhaust of the engine by means of a pipe 6 in. in diameter curved backwards and forwards so as to expose a large heating surface. The following statistics should be considered in steam heating:—

(a) The temperature should be between 15° and 20° C. (59° and 68° F.).

(b) There must be 1 sq. decimetre of heating surface for every cubic metre of air (1 sq. ft. for every 315 cubic ft. of air).

(c) One metre (40 in.) of tubing of 15 centimetres (6 in.) diameter is equal to 50 sq. centimetres (5½ sq. ft.) of heating surface.

Thus a room 20 metres (70 ft.) long, 5 metres (17 ft. 6 in.) wide and 3 metres (10 ft. 6 in.) high requires a tube 6 metres (21 ft.) long, calculated thus:—

$20 \times 5 \times 3 = 300$ cubic metres, which will require 300 sq. decimetres of heating surface, or, at the rate of 1 metre to 50 sq. centimetres of surface, a length of 6 metres.

Towards the middle of the room, at the highest part of the tube, is a little opening by which the steam can escape into the air, to keep the atmosphere moist.

2. **Lime.**—Lime is a white, caustic substance formed by the union of 40 parts of the metal calcium with 16 parts of oxygen.

Its chemical formula is CaO . It is infusible and soluble in 500 times its weight of cold water, or rather more than 1,200 times its weight of hot water. The solution is called lime water. When exposed to the air it absorbs carbonic acid and the surface of the liquid becomes covered with a pellicle of carbonate of lime, which breaks up on shaking and falls to the bottom of the liquid. A new layer is soon produced, and so on until all the lime is turned into carbonate. The density of lime is 2.3.

If water be poured on it, a small quantity at a time, the liquid is instantly absorbed. Further additions disappear less and less quickly until "slaking" is complete, and shortly afterwards the temperature rises, a large quantity of heat is developed, and the water is turned to steam with considerable hissing. It breaks, falls to pieces, and increases its volume considerably. This is called "slacking" or slaking. The hydrate of lime is a fine powder known as slaked lime. With water it forms a thick paste known as "milk of lime". In the air lime quickly absorbs moisture, becoming hydrated and afterwards carbonated. The tanner only uses good "fat" lime of the finest quality.

As it is used as milk of lime, the first operation is slaking the quick lime. This may be done in three different ways: (*a*) by throwing water over it (ordinary slaking); (*b*) by immersion, and (*c*) spontaneously, by the action of the air.

Ordinary slaking is done in water-tight tanks, 7 ft. diameter by 16 in. deep, built of bricks or stone. The lime is spread to a depth of 10 in., and water is poured over it so as to wet the whole thoroughly and rapidly. One hundred parts of lime require 30 to 35 parts of water. Fat lime of good quality increases to three times its original volume.

Slaking by immersion is carried out as follows: The lime is broken up into pieces about the size of an apple and placed in baskets. The baskets are plunged into water and held there until the surface of the water begins to boil. They are then brought out, allowed to drain for a moment, and their contents turned out in a heap and left to fall. In this way the lime increases to 1.5 or 1.7 times its original volume.

3. **Liming.**—The lime pits are made up by putting 60 litres (about 2 cubic ft.) of slaked lime into the first lime, 120 litres in the second lime and 200 litres in the third. It is stirred well with the paddle to form an even milk. The drained skins are put into the weakest lime, sinking them one at a time so that each may become thoroughly impregnated. The pit will take 120 calf skins. They are left in this state forty-eight hours, then withdrawn and placed at once in the medium pit, which has just been well stirred. They are left here another forty-eight hours and then transferred to the strong lime and left until the hair comes off easily. This is generally at the end of three days.

Whilst these later limings are going on, fresh skins are placed in the first and second lime. After three lots have been treated, the first lime will be exhausted and may be run off to the drains. Two hundred litres (about 7 cubic ft.) of lime are thrown in and it

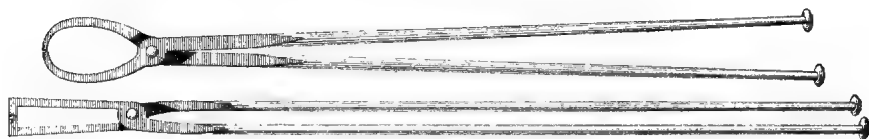

FIG. 31.—Liming Tongs.

is filled with water. It is now used as strong lime. The second becomes weak lime and the third medium lime. It is now worked methodically, each pit being made up as strong lime and becoming, as the lime is exhausted, firstly medium and then weak lime.

The quantity of lime used should be 20 litres of slaked lime per 100 kilos of green skin or 7 litres of quicklime.¹

The skins are worked with tongs (Fig. 31).

Sometimes five limes are used of more graduated strength. This is more applicable in large works.

Good liming requires the following precautions:—

(a) The milk of lime must be sufficient in bulk to cover the hides entirely, leaving at least 2 or 3 in. of liquid over the topmost hide.

¹ About 16½ lb. quick lime or 22 lb. slaked lime per 100 lb. of green skin.

(b) A steady temperature of 20° C. (68° F.) must be maintained. Below 6° C. (43° F.), the action of the lime becomes very feeble, and below freezing point it stops altogether.

(c) The surface of the lime ought to be disturbed as little as possible. A crust of chalk will form over the top which, if left unbroken, will prevent the carbonic acid from penetrating more deeply into the liquid. Carbonate of lime is very objectionable, especially when it forms on the skins, from which it is very hard to remove, and later on, under the influence of the tannic acid, it forms deep brown stains.

(d) In moving the skins from one lime to the next, do not expose them to the air more than is absolutely necessary. This for two reasons. The first is that the lime which impregnates the skins will tend to become carbonated, with the results detailed in the last paragraph, and secondly, that lime in contact with the oxygen of the air burns the tissue of the skin.

(e) Never use quick lime in making up the limes. It seldom slakes completely, some granules are always left, which burn the skin wherever they touch it. Only slaked lime which has been riddled should be used.

(f) Do not leave the skins in contact with the lime any longer than is necessary for unhairing, and disregard the old saying, *Qui pelane tanne*.

4. Unhairing.—When they come out of the lime, the hides are placed in a tank of water, then unhaird on the beam with a knife as described elsewhere. A good workman will unhair ten or twelve hides per day. Afterwards they are soaked for six hours, fleshed by hand or in the machine, pieced and scudded.

5. Washing.—The hides are impregnated with lime, which must be removed at all costs, otherwise, under the action of tannin, the leather will become hard, brittle, and covered with reddish-brown stains. Formerly the skins were worked over and over again on the beam with a slate, soaking between each operation, until the liquor ran off clear. This method is slow and laborious, and only gives imperfect results.

Nowadays a “tumbler” is used. This apparatus consists of

an oak drum bound with iron, and turning on a horizontal axle supported by two standards.

It is usually 7 ft. in diameter by 3 ft. 6 in. wide for small skins and 3 ft. 9 in. in diameter, by 4 ft. 6 in. wide for large ones. Its speed varies from 13 to 20 revolutions per minute.

The drum bears on the inside horizontal hard-wood bars, carrying large pegs, and on one side has a wide door.

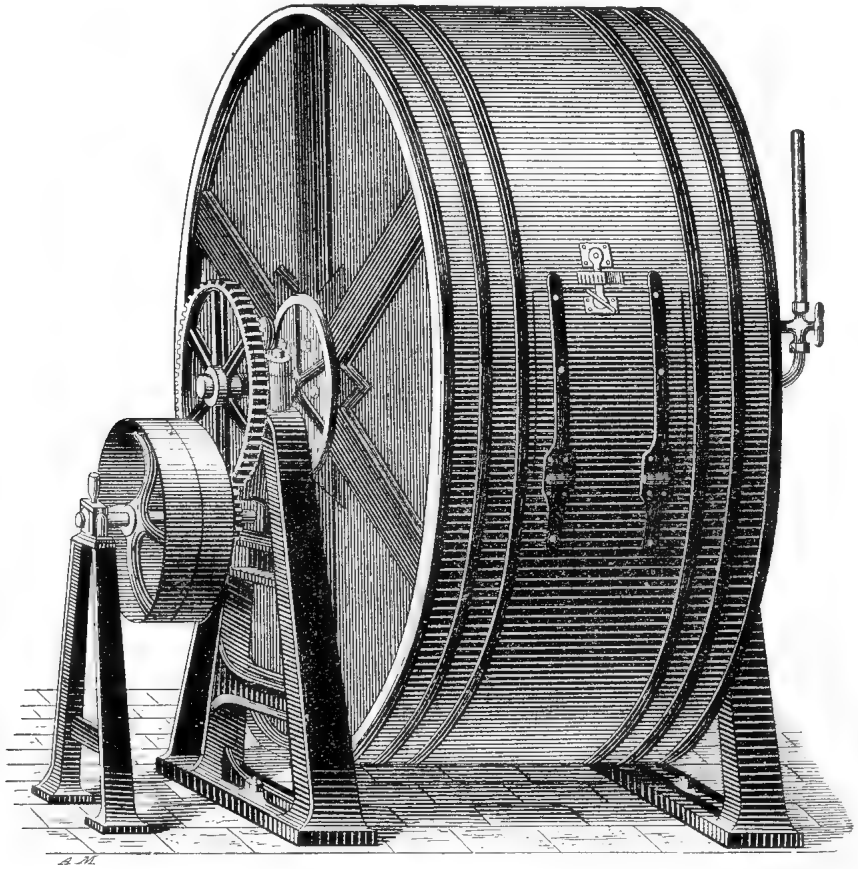

FIG. 32.—“Tumbler”.

To remove the lime, six skins are thrown into the drum. A fine stream of water is turned on through a tube which runs into the drum by the axle. The machine is then set in motion until the water runs off clear.

The movement carries the skins to the top of the drum and lets them fall again with each revolution. This continuous agitation,

together with the kneading action of the pegs, washes the skins thoroughly. In this way the greater part of the lime is removed.

We may note in passing, that a similar drum has been used for unhairing (Arthus' patent, 1851). The skins are thrown in just as they come from the lime. The drum is turned, dry, for fifteen minutes to remove the hair, then the water is turned on. The objection to this process is that the hair becomes matted into balls which are then useless excepting for manure.

For the removal of lime, from forty-five to sixty minutes are needed.

It is urged against this system that it breaks the skin by handling it too roughly.

M. Baudin advises the employment of a "tumbler" which cleans the skin without damage. Here are his specifications: Diameter, 1·6 metres (5 ft. 4 in.); width, 2·5 to 3 metres (8 ft. 9 in. to 10 ft. 6 in.); speed, ten revolutions per minute. It is made entirely of iron. Round standards carry the axle, and a sheet of iron encloses the cylinder. It is pierced by holes for the efflux of the water. On the inside are bars of brass, bronze, or oftener steel. The water is led in through the axle, the jet is directed upwards and falls back in a spray.

Baudin's washing drum acts in the same way as the "tumbler". The skins are struck by the bars and bent in every direction, without stocks.

6. Mechanical Liming.—To hasten the action of the lime, and to facilitate the work, mechanical liming has been suggested. The skins are hung vertically on a horizontal wooden frame which just fits the lime pit, and moved by a pulley fixed to the ceiling. The immersion or removal of the skins is thus carried out all at once. This process has serious drawbacks. The lime, which is only in suspension in the water tends to settle, so that the lower part of the skins becomes depilated and even burned, whilst the upper part is intact. This is overcome by placing a screw agitator at the bottom.

Another process is to suspend the skins on the spokes of a circular frame and rotate the frame in a round pit.

Finally, the paddle or wheel is used. This is described in the next chapter.

None of these methods give the best results, because the fact of the fresh tender skin being hung up stretches it and elongates the fibres, and later on causes difficulties in the taking up of tannin, the loss due to this being from 3 to 4 per cent.

7. Mechanical Processes for Removing Lime from Depilated Skins.—Various machines have been invented for removing the lime which are, however, only used in special cases.

Iwaskiewicz's agitator is a cubical drum turning about an axle passing diagonally from one solid angle to another, so that in rotating all the faces are sloping. The skins, instead of falling from a height, roll down the interior faces of the chamber.

The Hannequand-Parmentier horizontal cleaner is based on the same principle as the mangling machine of the laundries. It consists of two horizontal wooden cylinders, one above the other, turning in opposite ways, and one having ridges fitting into grooves on the other. The lower cylinder is fixed, and the higher one has a certain amount of play. These rollers are immersed in water. The skins, fixed together in an endless chain, two abreast, are passed over and over again between the rollers.

Dumas's rubbing belt consists essentially of a large horizontal roller, large enough for a skin to be stretched on it without going right round it, and a horizontal belt parallel with the cylinder mounted on two rotating drums. The cylinder turns slowly, and the belt moves quickly, and as it moves longitudinally the skin travels over it and is rubbed in all parts. The belt is furnished with slates, brushes, knives, etc.

The slating or unhairing machines of Lepelley, Allard-Ferré, Jonquet, Adler, Baudoin, Damourette, Richard, Duplex, and the slicking machines of Bérendorf and Fitz-Henry may be used for the same purpose.

8. Chemical Methods of Removing Lime from Depilated Skins.—These methods all depend on the formation of some soluble salt of lime by the action of acids or sugar.

Acids.—The acids usually employed are hydrochloric, which

forms the very soluble chloride of calcium, or acetic, which forms the soluble calcium acetate; 100 lb. of commercial hydrochloric acid (20° Baumé) will dissolve 30 lb. of lime or 60 lb. of carbonate; 100 lb. of acetic acid (9° Baumé) will dissolve 20 lb. of lime or 40 lb. of carbonate.

The acids are made up in solutions never exceeding 1 per cent. These solutions are placed in wooden vats, and the skins are soaked with continual stirring. The use of the graining wheels give excellent results. A drum pierced with holes on all its faces, and turning in a vat of acid, is to be recommended. Iron should be entirely avoided. An hour's soaking in the acidulated water is sufficient. The acid skins are rinsed in clean water.

The Use of Carbonic Acid.—We have already stated that 500 parts of water are required for the solution of 1 part of lime. To dissolve 1 part of carbonate, 100,000 parts of water are needed, but 1,000 parts of water charged with carbonic acid will dissolve 7 parts of carbonate of lime or .35 parts of lime. This solubility increases under pressure. In submitting skins to the action of carbonic acid gas, all the lime is changed to carbonate, then, on continuing the action, the soluble bicarbonate is formed. The action of carbonic acid on the skin is not in the least objectionable; on the contrary, it advantageously modifies the texture of the skin.

C. P. Nesbit has made the process practicable (1887). The carbonic acid gas is prepared by the action of hydrochloric acid on chalk. It is washed and stored in a gas-holder, and carried thence to the vats containing the water and skins. Thirty skins can be purified in one hour. The cost of cleaning 500 skins need not exceed 2 francs (1s. 8d.).

Carbonic acid gas may be more easily prepared from wood charcoal (*vide infra*).

Use of Sugar.—Lime forms two compounds with sugar. The first is formed in the presence of an excess of sugar (formula $C_{12}H_{22}O_{11}, CaO$); it is very soluble in cold water, 100 parts of sugar taking up 18 parts of lime. It is important to note that the quantity of lime soluble in a solution of sugar varies with the density and percentage of sugar. A solution containing 20 parts

of sugar in 100 of water will dissolve 21 parts of lime for every 100 parts of sugar ; 10 parts of sugar in 100 parts of water will dissolve 20 parts of lime for every 100 parts of sugar ; 5 parts in 100 of water dissolves 10 parts of lime per 100 of sugar, and 2 parts in 100 of water only dissolves 15 parts per 100 of sugar.

A solution containing 2 per cent. of sugar is made, and the skins are kept moving in it for an hour ; they are allowed to soak for an hour, and then stirred for another hour. Finally, they are washed with clean water. The sugar solution should be in such quantity that it never becomes saturated with lime, in which case an insoluble sucrate is formed.

The lime does not change the sugar, so it may be revived very economically. To do this, carbonic acid gas coming from a coke or charcoal fire is passed through the liquid. The lime is precipitated as carbonate, which is allowed to settle. It is then decanted or filtered through a tan filter. Only about 10 per cent. of the sugar is lost in each operation.

Glucose does not work in the same way as cane or beet sugar. It does not combine so readily with lime, and when combined it undergoes so great an alteration that it cannot be recovered.

Molasses, which contains 50 per cent. of sugar, may be used.

The sugar method has the great drawback that it only removes free lime, leaving the carbonate intact.

This difficulty is overcome by adding caustic soda to the solution in the ratio of 20 per cent of the sugar. This displaces the carbonic acid of the carbonate.

Marris works in the following manner : He places in a vat 300 gallons of water, $\frac{1}{2}$ lb. of sugar and $\frac{1}{2}$ lb. of flowers of sulphur. He soaks the skins in the mixture and passes a current of sulphuretted hydrogen, made from dilute sulphuric acid and sulphide of iron, through the liquid for an hour. He removes the skins, washes and drains them. A complex reaction takes place. The lime dissolves in the sugar, the sulphuretted hydrogen changes it to sulphide which, combining with the sulphur, forms a polysulphide which combines with more lime, returning to the state of sulphide and so on. This process, like the plain sugar method, only removes the lime.

III.—NEW PROCESSES FOR THE DEPILATION OF SKINS.

The working of skins in lime has many inconveniences. Lime always alters the tissue more or less. It penetrates the pores and remains there most obstinately in the form of carbonate of lime, or lime soap, formed by the fatty matters of the skin. In spite of the washings and the numerous different processes to which the skin is submitted, the lime is never totally removed. Its presence is objectionable in many ways. It prevents the entrance of the tannin, and the compounds which it forms with tannin are an enormous drawback to currying. The following methods have been suggested to replace it:—

1. **Depilation with Soda.**—Proposed in 1833 by Felix Boudet.

Under the action of the alkali, the skins swell rapidly and may be unhaired in two or three days. On the beam they give up their hair more easily and have a softer grain.

The depilatory is made up of 20 lb. of crystallised carbonate of soda, 15 lb. of slaked lime and 50 gallons of water. The mixture is well stirred with the paddle, and 1,000 lb. of green hides are placed in it. Three baths are used exactly in the same way as if it were lime. The skin is left for a day in the first bath, a day in the second and a day in the third. In this process the soda is very slowly causticised, which prevents the too rapid action of the caustic alkali. On the other hand, the skins are always covered with carbonate of lime.

It is better to causticise the soda before use by placing in a cast-iron boiler 12 or 15 gallons of water, 40 lb. of soda crystals and 40 lb. of slaked lime. This should be boiled for two hours, replacing evaporated water. It is allowed to cool, and the clear liquid decanted off. The liquid is poured into the vat, which should contain 120 gallons of water, and in which are placed 2,500 lb. weight of skins.

In practice, seeing the low price of caustic soda, it is better to buy it than to make it. Ten lb. are placed in 100 gallons of water to treat 2,000 lb. weight of skins. As the manipulation is not very easy, it is best to dissolve the soda in the water in a wooden or

metallic tub until it is of a strength of about 35° Baumé. Four gallons of this are required with 100 gallons of water in the fresh vat.

The special precaution to be taken when using this process is to unhair the skin immediately on withdrawing it from the soda.

Many tanners consider that this process swells the leather with a surplus of water which is lost on storage.

We consider it in every way superior to the lime process. Many tanneries use it, and find that it gives excellent results.

2. Aluminate of Soda.—Many inventors have tried to reduce the causticity of the soda or potash by combining it with feeble acids or metallic oxides. Townsend uses aluminate of soda, prepared by treating 1 part of sodium carbonate (soda crystals) with 2 parts of the mineral bauxite (aluminium hydrate). This aluminate is very soluble in water. One lb. is dissolved in a gallon of water for soaking the skins. After a longer or shorter soaking, the skins are washed with water and passed through a 3 per cent. solution of boracic acid.

3. Zincate of Soda.—This is prepared by heating together a gallon of water, 3 lb. of soda and 1 lb. of zinc oxide. A solution is obtained, which is poured into 10 gallons of water. This will depilate 200 lb. of fresh skin. Like the last process, this is scarcely ever employed.

4. Silicate of Soda.—This process consists of leaving the skins for four or five days in a 12 per cent. solution of commercial silicate. We have tried this process in studying depilation, but have never succeeded in obtaining good results. It is always necessary to add a little caustic soda, whose effect it moderates. Thus, 50 gallons of water, 2 gallons of 35° (Baumé) soda, and 1 gallon of commercial silicate are required for 1,000 lb. of skin.

5. Ammonia.—Depilation by ammonia is one of the best, but the method of its employment is complex, and it is exceedingly objectionable to the workmen. The author was the first to apply it successfully. It is only possible in large installations. Without referring to earlier attempts, the following is the final method used:—

Round wooden vats are built 4 ft. 9 in. diameter, and the same depth, and fitted with a cast-iron lid 2 in. thick and movable by means of a chain and counterpoise. These vats, numbering four or five according to the size of the works, communicate by an upper tube with the horizontal pipe, which runs past them. Each tube carries a tap. At the bottom of the vats is an effluent tube closed by a plug. Inside the vats are three brackets 8 in. high, to hold a strong iron frame furnished with chains, the other ends of which are all attached to one link. On the frame, when it is drawn out, the skins are placed. They are kept apart by bars of wood, 2 in. thick and 4 in. wide, which are simply placed on the hides, so as to leave a space between them. A pile of 100 to 150 skins is thus made. By means of a pulley attached to the top of the chains the frame is lowered into the vat and rested on the brackets. Fresh water is run in until it is 4 in. above the highest skin, the cover is then fixed in position, on a washer of caoutchouc by means of screws. A whole series of vats is prepared in this manner.

At the end of the upper horizontal tube with which the vats are connected is a dome-shaped cast iron boiler of about 10 gallons capacity, heated by a worm through which steam may be passed. The ammonia is prepared here.

Supposing that we were commencing the process and that we had two vats, each containing 750 kilos. (1,650 lb.) of skin or 1,500 kilos. (3,000 lb.) altogether, we should charge the boiler with 50 kilos. (110 lb.) of commercial sulphate of ammonia, 100 litres (22 gallons) of water, and 20 kilos. (44 lb.) of slaked lime. We should next warm the boiler very gently and carefully. The ammonia would come off slowly and be absorbed by the water in the vats. As ammonia solution is lighter than water, it remains at the top. Underneath the brackets in each vat is a mechanical stirrer, which may be worked from the outside by hand. This is kept going during the first few minutes to make absorption regular. In this way 10 kilos. (22 lb.) of ammonia gas will be injected into the two vats, or 665 grammes per 100 kilos. of skin (about $\frac{3}{4}$ lb. per cwt.).

This operation lasts an hour. The taps are then turned off, and the liquid stirred night and morning. At the end of two days,

depilation will be complete. Communication is cut off between the boiler and the horizontal tube. The vats are placed in communication with the latter, which is connected with an air pump. This draws off the ammonia, and compresses it into the boiler, which is now filled with a concentrated solution of bicarbonate of ammonia. This solution absorbs ammonia in proportion as it is compressed by the pump. In half an hour the water in the vats will have given up all its ammonia. The pump is then stopped; the vats are opened, and the liquid, which is merely water charged with organic matter, is run off. The vats are closed again and the air pump worked for another ten minutes to remove the last traces of ammonia. The skins are then washed and unhaired.

Another operation is started, but this time the air pump simply aspirates the ammonia from the boiler into the vats, the boiler being kept at a temperature of 50° C. (122° F.). The ammonia is thus used over and over again, well-made installations only losing about 5 per cent. per operation.

The cost of providing for this loss is only about a franc (10d.) for 1,500 kilos. (3,300 lb.) or less than one-twentieth of a penny per calf skin. This method has all the advantages of the soda process without any of its drawbacks. It gives clean skins, from which the hair is easily removed, with a scarcely altered tissue and glossy grain, easy to tan and to curry.

6. Sodium Sulphide.—Suggested by Boudet in 1838 (patented 17th August). This is a very soluble compound met with commercially as a bye-product from the Leblanc soda process. It contains: sodium 58.97 per cent., and sulphur 41.03 per cent. The commercial substance has the formula $\text{Na}_2\text{S} \cdot 9\text{H}_2\text{O}$, thus containing 67.5 per cent. water.

In this condition both the alkali and the sulphur act as depilatories. The action of the two substances is infinitely better than the action of free alkali. Usually sulphides are used more highly charged with sulphur and known as polysulphides.

The following are the best preparations:—

(a) One hundred lb. of dry commercial carbonate of sodium is heated in a cast-iron boiler with 90 lb. of sulphur. The reaction

takes place at the melting point of sulphur. The mass is run on to iron plates and then dissolved.

(*b*) One hundred lb. of water is boiled with 30 lb. of caustic soda and 25 lb. of sulphur until solution is complete.

The product may be used like caustic soda, but usually the work is carried out thus: The greatly softened skins are stretched on a table with the hair above. The sulphide is applied to all the parts, then the skins are piled flesh to flesh, and covered with boards weighted down by stones. The hair may be removed in a very short time, but is destroyed by the process.

In 1872, Watteau recommended the use of the double sulphide of calcium and sodium, which is prepared by boiling together 4,800 parts of water, 630 parts of lime, 400 parts of caustic soda and 140 parts of sulphur for six hours. The skin is rubbed over with this liquid, and in two days the hair comes off. Sulphide of barium is also occasionally used.

7. Calcium Sulphhydrate.—This sulphhydrate is prepared by boiling equal parts of slaked lime and sulphur with water and filtering. The use of this substance has been described by Bœtger in Germany, and Darvault in France.

The skin is stretched on a wooden or stone table, the grain above. The hair is covered thinly with the paste, by means of a wooden trowel, which causes the substance to penetrate to the roots of the hair. Other skins are prepared in the same way.

They are piled up, hair to hair, and covered with boards weighted down by stones. At the end of two hours the hair may be easily removed.

Lindner has suggested the use of gas lime, which contains sulphide of lime. In the use of sharpened lime (a mixture of lime with realgar), it is the sulphide of lime which acts, or rather the sulpharsenite of lime.

8. Sulpharsenite of Lime.—This has been used from time immemorial by certain eastern religious sects for the preparation of depilatory pomades.

Orpiment or realgar (sulphides of arsenic or thioarsenious acid), contains 61 parts by weight of arsenic to 39 parts of sulphur. It is

yellow, fusible and volatile. It may be prepared by heating $3\frac{1}{2}$ parts of crude arsenious acid with half a part of sulphur. This commercial orpiment contains quantities of free arsenious acid. It combines with sulphides and with alkalies. With lime it gives sulpharsenite of lime, which is a powerful depilatory. It is applied like sulphide of sodium, but is scarcely used excepting in tawing.

Sulpharsenite of sodium acts in the same manner.

All these compounds form the basis of the depilatory compounds sold in commerce, which are usually simple mixtures more or less useful in the unhairing of skins.

9. Depilation by Wood Charcoal.—Discovered by Anderson in 1874. Powdered wood charcoal at the rate of 2 lb. per calf skin is suspended in water, and the skins are plunged into the liquid and stirred frequently. The temperature is kept at 25° C. (77° F.), and the skins are taken out and piled each day. At the end of five days the skins may be unhairied. The hair comes off without any swelling of the skin, leaving a very fine grain.

The action of the charcoal in this case is much disputed. Probably it is some kind of fermentation regulated by the absorbent action of the charcoal (*see* "Theory").

IV.—TANNING.

Plumping and the preparation to receive the tannin which is made in handling is carried out in the same way as for heavy leather, but more slowly, and gradually so as not to hurry the grain, which is extremely delicate. Stirring, which calls for great care on the part of the workman, is generally performed by mechanical stirrers which bring the action of the liquor to bear on all parts of the skin. Tanning in the pit is performed just as for sole leather but requires a longer time.

1. Paddles or Graining Wheels.—The wooden or masonry pits are furnished above with mechanical handlers. This apparatus consists of a horizontal axle carrying at its ends two vertical oak discs. The two discs are united by six, eight, or ten thwarts (Fig. 33). The paddle so formed is at such a height that only $\frac{1}{3}$ of it is

immersed at one time. When working it gives a gyratory motion to the liquor and thence to the skins. To facilitate this motion, the pits are built in a semi-cylindrical form having their axes parallel to the axle of the paddles. Such pits are most readily built of masonry.

Choureau suggests that the thwarts of the paddle should be inclined so as to make them act after the manner of a screw and produce a horizontal as well as a vertical motion.

Lastly, elliptical pits are sometimes used. They are fitted with two small paddles parallel to the smaller axis and turning in opposite directions so as to keep up a continual circulation.

These handlers are turned either by hand, or by steam power. In the latter case it is best to place several pits in a line so that all the paddles may rotate on one shaft.

2. Graining.—The calf skins are placed in a colouring vat,

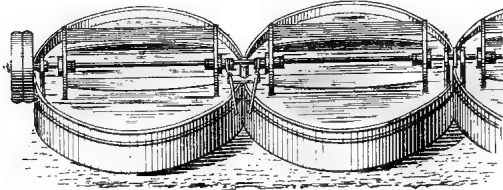

FIG. 33.—Paddles, or Graining Wheels.

having a strength of one or two degrees on the barkometer. They are stirred for an hour, allowed to lie still for two hours, and stirred again for half an hour. They are next placed in the first handler pit, containing weak liquor coming from the liquor well, having a strength of 4° C. They are stirred for half an hour, and allowed to soak for two hours. Next a kilo. ($2\frac{1}{2}$ lb.) of tan is added for every ten skins, the liquor is stirred for half an hour, a fresh kilo. of tan per ten skins is added, followed by half an hour's further stirring. The grain now begins to rise. A fresh dose of tan is added and a fresh stirring for half an hour given. The grain shows up well. The skins are hung over the side of the pits to drain; meanwhile another kilo. of tan per ten skins is placed in the pit. After a quarter of an hour, the skins are put back one by one into the liquor.

The work is carried out in this way so that the grain may be

developed very slowly and gradually. If developed more quickly it will be over-mature. This first part of the operation lasts four hours.

After two hours the skins are removed from the pit, and folded in two, grain inside. Two kilos. of tan ($4\frac{1}{2}$ lb.) are added for every ten skins. In about a quarter of an hour the skins are placed in the vat, stirred for half an hour, and left for three hours. They are then removed as before, and two more kilos. of tan added per ten skins. After half an hour they are returned, stirred for a quarter of an hour, and left to soak for three hours. The whole operation is then repeated. This work lasts from morning until evening. The skins are left in the pit all night. Next morning they are taken out, two kilos. of tan per ten skins added, the skins returned, stirred for half an hour, and left to soak for the day. In the evening, and again in the morning and evening of the third day, the operation is repeated. Afterwards they are left to soak for four days.

The first handling thus lasts nine days and requires 20 kilos. (44 lb.) of tan for every ten skins.

They are passed on to the second handler pit, where the same precautions are observed. This pit contains stronger liquors. Four kilos. (9 lb.) of tan are added for every ten skins. They are removed for an hour, followed by half an hour's stirring with a fresh addition of tan (9 lb. per ten skins), every morning for four days, and then left to soak for four days.

The second handling takes eight days and uses 16 kilos. ($35\frac{1}{2}$ lb.) of tan per ten skins.

The skins go to the third pit, whence they are taken out every morning for two hours, and 4 kilos. of tan placed in the pit for every ten skins. They are replaced and stirred for half an hour, and left at rest for the day. This goes on for four days, after which they are allowed to soak for a day.

The third handling lasts five days and uses 16 kilos. ($35\frac{1}{2}$ lb.) for every ten skins. The time required for handling is thus twenty-four days, and the tan used is about the same weight as the skins treated.

3. First Tanning.—After coming from the handler pits the skins are drained for three hours, then spread out, grain side up, at

the bottom of a pit into which ooze (4° by the barkometer) has been poured to a depth of 15 to 20 centimetres (6 to 8 in.) The skins are piled up, separating them by some handfuls of moistened tan. When the liquor is absorbed, another lot is poured in and so on until it is full. One hundred skins are placed thus with 200 kilos. (440 lb.) of tan. The vat is then covered with a layer of exhausted tan 6 in. thick. It is left in this state for a fortnight.

It is then repeated. Six in. of fine tan are spread on the floor of a pit and the skins stretched out flat, grain side above, and a few handfuls of tan thrown over them, rather more thickly on the throat than on the other parts. The pit is filled up exactly as though it were a layer-pit. The last skin is placed grain side down, a 6-in. covering of exhausted tan is given, and the pit is filled with strong liquor (5° C.). Two hundred kilos. (440 lb.) of tan are used for every 100 skins. The pit is left undisturbed for a month.

4. Laying Away.—We need say nothing of the final tanning, which is carried out exactly as though it were sole leather. It receives two pits, each lasting two months.

Altogether calf skins require :—

Days.
15 liming, etc.
30 in the handler pits.
45 first tanning.
60 in the first lay away.
60 in the second lay away.

Total 210 days or 7 months.

The skins are dried carefully and piled up to remove folds. They are then known as crust calf.

A calf skin weighing 16½ lb. when fresh from the slaughter-house should weigh after tanning about 10 lb.

5. Charges.—The following is the cost of working up calf skin :—

	Francs per 100.
Liming, etc.	5
Unhairing	5
Unhairing dried skins	8
Fleshing	15
„ dried skins	20
First tanning	10
Laying away	5

V.—COW HIDES.

Soaking, liming and unhairing are performed in the same way as is done with calf skins.

Handling is done thus: In the first pit they are stirred for an hour, allowed to soak for the next hour, then stirred afresh with an addition of 15 lb. of tan for every 100 lb. of skin. During the first day they are stirred every two hours. In the evening 15 lb. of tan per 100 lb. skin are added and they are allowed to soak for the night. During the next day they are stirred every two hours for a quarter of an hour. After four hours they are taken out and placed in the second pit. This first pit is called the colouring pit.

The second pit is made up with stronger liquor than the first. Ten lb. of tan per 100 lb. of skin are thrown in and the skins put to soak with half an hour's stirring. On the second day the skins are taken out and drained for half an hour, then put back with 10 lb. of tan per 100 lb. of skin. On the third day the operation is repeated and then they are left to soak for five days.

After removing from this pit and draining for an hour they are placed in the third pit containing stronger liquor with 10 lb. of tan per 100 of skin and stirred for half an hour. The next day they are removed for half an hour and put back with 15 lb. of tan per 100 lb. skin and stirred for half an hour. On the third day the operation is repeated using 25 lb. of tan. They are then left to soak for eight or ten days.

They are next given two tannings of twenty days each similar to those given to calf skins.

They are afterwards placed in the lay away (twice) the first time for three months and the second time for four months.

The time required is thus:—

15 days liming, unhairing, etc.
 25 days in handler pits.
 40 days first tanning.
 90 days first lay away.
 120 days second lay away.

Total 290 days or 9 months.

The cost is distributed thus:—

	Francs per 100.
Liming	20
Unhairing	35
Fleshing	40
Tanning	60

A cow hide weighing 77 lb. gives $17\frac{1}{2}$ lb. offal and $48\frac{1}{2}$ lb. of finished leather.

The drying and piling are carried out as for ox skins.

VI.—HORSE HIDES.

Horse hides are left to soak for a night. They are depilated in three limes, allowing a day in each. For 140 skins the fresh lime receives $8\frac{1}{2}$ bushels of lime. The skins are washed in running water and unhaired on a wide beam with an unhairing knife. In fleshing, a considerable thickness is removed; in large works this is done with a splitting machine. Afterwards the hides are cut across to cut off the butt so as to use for tanning only the crup. The butt is used for sole leather. The crup is bated with dogs', pigeons', or hens' dung (*see* "Tawing").

They are then placed in the handler pits. There are four of these pits graduated as follows: The first 6° , the second 9° , the third 12° , and the fourth 20° by the barkometer. They remain eight days in the first, being taken out to drain eight times during the first day, six times during the second, four times during the third and twice during each of the others. In the second pit they remain for ten days and are only removed once a day. In the third they remain twelve days, being removed once a day, and in the fourth they lie for fifteen days. During the last soaking a basket of fresh tan (55 lb.) is thrown in twice a day until it has received seven baskets.

After the fourth handler pit the leather is tanned. It is then stretched on a marble table and partially dried, being handed over to the currier before dessication is complete. This is tanning in liquors.

A horse hide weighing 22 lb. loses $6\frac{1}{2}$ lb. in unhairing, and gains 9 lb. in tanning, thus reaching $25\frac{1}{2}$ lb. when finished.

VII.—GOAT SKINS.

These skins are softened in the stocks and depilated with three linings or better with realgar or sulphides. Goat skins require considerable preparation. They are put into the colouring and handler pits like calf, but with a much shorter exposure to the latter operation. They are finished by placing in a layer-pit for a month.

Many tanners only tan goat skins in liquor like horse hides. They mix catechu with the oak bark to increase the percentage of tannin.

Sheep skins are got up in exactly the same way as goat skins.

MANUFACTURE OF SPLIT HIDES.

Split hides are made by splitting ox hides, that is to say, cutting them into two layers. The best portion, *i.e.*, the one containing the grain, is called cow-hide, and is used for patent leather. The other portion is the waste part of the skin and is used for making coarse leather for the uppers of boots.

This division of the leather is made before tanning by means of a splitting machine.

I.—SPLITTING MACHINES.

Splitting machines were introduced from England and America. They have been improved in France by Lepelley, Martin, Giraudon, Cauvain, Varin and Millet, Baudoin and Damourette.

One of the first patented in France was that of Duport (21st February, 1848) in which atmospheric pressure was used for splitting and fleshing skins, but it has never been much used.

In 1854 The Flanders and Marsden machine appeared (10th October). It consists principally of an endless ribbon of steel acting like a band-saw.

The Lepelley machine (1856) is based on the same principle.

The Baudoin and Damourette machine, however, was the first to give homogeneous results. In this machine the shaving is performed by a knife which is longer than the width of the skin,

and is moved rapidly backwards and forwards. This knife ought to remain always perfectly straight, with a perfectly straight, sharp, well-set edge. There must be no folds in the skin when it passes under the knife, as each fold will mean a hole in the grain. To avoid these folds a keyboard with movable keys presses the skin on to a leather table over which the knife moves. On each side the skin is stretched by a double screw cylinder whose threads, made of copper, are inclined at 45° and strike right and left from the centre. The knife moves backwards and forwards 400 or 500 times per minute.

To split the hide, the knife is carefully set, then fixed at the desired distance from the cutting table. The knife carriage is pushed back about 10 in., and the skin thrown over the table and fixed to the roller by hooks. The creases are removed on an inclined wooden table covered with zinc placed beneath the flexible table. The cylinders are started, leaving the knife still. The carriage is brought up until it touches the end of the skin and is fixed in this position. The skin begins to roll up on the cylinders, since its controlling wheel is put in action by the bringing up of the carriage. After running an inch or two, the skin reaches the edge of the cutting table. The knife is set in motion and the splitting proceeds.

In the Martin splitting machine there are no helical cylinders. The workmen draw the skins through by means of tongs. Neither is there a carriage, so the machine has to be completely stopped and the knife and keyboard removed before placing each skin in position.

The machine of Messrs. Cauvain, Varin and Millet is similar to that of Martin. The cylinder is replaced by the Damourette table.

In the Giraudon machine the skin is placed on the outer surface of a cast-iron drum. A sharp steel knife with an undulating edge like a saw with rounded teeth is set at a slight inclination with its edge tangential to the drum.

The cylinder has a diameter of 53 in. so that its circumference is 14 ft. This cylinder only turns $\frac{1}{284}$ of the rate of the driving

shaft. The knife gives 100 cuts per minute and cuts each time through a centimetre ($\frac{2}{5}$ in.). In a minute it will cut through 8 in. A skin 7 ft. 4 in. long will thus be split in eleven minutes.

When the Giraudon machine only makes 75 cuts, the cutting of a skin of the same length will take fifteen minutes. In a twelve hours' day thirty-six skins may be split, allowing time for stretching them on the machine.

II.—TANNING.

The grain split is tanned like calf.

The flesh split is tanned in the same way as hides. As it requires great care it is usually tanned in liquor. In England exotic tans, such as gambier, kino, etc., are kept specially for this work.

CHAPTER V.

ON VARIOUS METHODS OF TANNING.

FROM the descriptions of the ordinary operations of tanning which we have given, it will be seen that the process is exceedingly long, and the capital required is very large. For the last half century attempts have been made to modify this purely empirical process, by methods based on the scientific theories which have thrown light on so many industries, and brought about so much industrial progress. Unfortunately, tanning has only been improved in a slight degree. Tanners have been able to discover little concerning the tanning matters which they use, their methods of preservation, and the manner in which they act. The number of processes invented for hastening and improving tannage is incalculable. An attempt to review them all would only lead to confusion, especially as most of them give anything but good results. We will therefore study the chief ones under three heads: mechanical, physical and chemical.

I.—MECHANICAL METHODS.

1. **Arrangement of Pits.**—It will be at once seen that when hides are piled one upon the other in the tan-pit, the lower ones have to bear a pressure proportional to the number and weight of the skins lying above them. This pressure squeezes them together and prevents the tannic liquor from penetrating them. This great inconvenience is obviated: (1) by diminishing the depth of the pits; (2) by using wide pits (20 in. deep by 17 ft. 6 in. in diameter); (3) by laying the hides in an ordinary pit, but fixing them all by the tail to a bar of copper. When the pit is full the bar is brought round to a horizontal position at the top. The skins

all retain their relative positions but are no longer subjected to pressure—this method has given good results (Villon); (4) by separating the skin with wooden hurdles so as to allow the tannic liquid to get at them all around (Nossiter)—this process unfortunately marks the leather with the impression of the hurdles; (5) by dividing the pit into three or four compartments by false bottoms pierced with holes—this diminishes the pressure on the lower hides to a third or a fourth of that sustained in ordinary pits.

Royer System.—We give this process, which appears to us very rational, in detail. It is described by the inventor thus:—

Four little wheels support a wooden frame to which are nailed two parallel boards dipping down into the pit. In these boards are grooves for receiving the bands to which the skins are attached.

Let us suppose that we are working to the description given in the last chapter of the tanning of calf skins weighing about $16\frac{1}{2}$ lb. when green and with heads. Each of the pits will contain 100 skins. It will measure 8 ft. 9 in. long, 8 ft. wide by 3 ft. 6 in. deep. On each of the long sides are fastened two little joists of the same length, carrying a strip of iron $1\frac{1}{2}$ in. wide to serve as a rail.

The wooden frame is made of four pieces, fixed together in a rectangle, 8 ft. 9 in. long and 7 ft. 11 in. wide. It is furnished with four cast-iron wheels bearing on the rails so that, when in position, the frame will be 2 in. above the pit. Across each of two planks, 7 ft. long by 1 ft. wide, are made fifty grooves, $\frac{4}{5}$ in. wide, 4 in. long and $\frac{4}{5}$ in. apart. These two planks are nailed to the frame near the wheels, the uncut part below and dipping 4 in. into the pit. The apparatus is completed by placing fifty strips of hide in the grooves so that they descend to the bottom of the pit.

The pit is filled three parts full of water or weak liquor. One hundred calf skins, which have been stirred in the handler pits with 220 lb. of bark, are hung on the strips in the following manner: The middle of the skin is on the strip, and head and tail are on the bottom of the pit, the grain above. Every skin being fixed to its strip by little copper hooks, 220 lb. of the partly exhausted bark and 110 lb. of fresh bark are thrown into the pit. The next day

110 lb. are thrown in, morning and evening. On the third day this is repeated until 660 lb. have been added. Three times each day the skins are moved by rolling the frame backwards and forwards for two minutes. Once a week the hides are removed, and the pit stirred with a paddle or the Massoutier agitator. This latter consists of a rotating paddle-wheel, whose thwarts reach nearly to the bottom of the pit.

After fourteen days the first lot of tan is exhausted. The skins are removed, and the exhausted bark taken out with a net. Three hundred and thirty lb. of fresh bark are added and the skins returned. Next day 110 lb. are added morning and evening. On the third day 110 lb. more are added. After twenty days, the spent tan is again removed, and a third lot of tan is given similar to the second. This third tanning lasts twenty days.

2. Agitation of the Liquor in the Pit.—When the skins are in the pit, the liquid in which they are bathed is rapidly deprived of its tannin, and the absorption of that which surrounds it only takes place by diffusion, and very slowly. This difficulty is overcome by suspending the skins from the spokes of a round horizontal frame. The frame is placed in the pit so that the ends of the skins reach within 10 in. of the bottom. On the bottom is a screw agitator. The liquid is thus kept in motion, and the layer in contact with each skin is constantly renewed without moving the skin. It gives good results.

3. Circulation of the Liquor.—To renew the liquid surfaces in contact with the skin two methods have been used:—

(a) A pit is used with a false bottom, on which the skins are placed in the usual way, until the pit is three-quarters full. Every day the liquid which has collected beneath the false bottom is pumped up on to the top, thus causing a circulation. For hides or kips three tannings are given, each lasting a month. For calf skins two tannings of twenty-five days each are required (Ogerau and Vos).

(b) A more scientific method is to pass the liquor from a later pit into an earlier one, and so on. Let us suppose that we are using a set of eight double-bottomed pits, each having a 6-in. covering

at the top, whilst a tube leads from the bottom of one to the top of the next. The first pit is filled, and fifteen days afterwards the next is filled also. Into the first pit is poured a stronger liquor than the one which it originally contained. This being poured in at the top forces out the old liquor into the next pit. Fifteen days later the third pit is filled, and so on until all are full, always pouring a stronger liquor into the first pit. Each pit receives, together with the skins, three times their weight of bark. At the end of 120 days the liquor will have run from the eighth back into the first pit. It will then be exhausted. It is emptied and recharged, becoming the eighth pit. The addition of the strong liquor then takes place in the second pit, which has now become first, and so on (Bérenger and Sterlingue).

4. Agitating the Skins in the Liquor.—These methods do not, as a rule, give such good results as the ones just described. They are said to bruise the skins. The chief arrangements are:—

(a) The skins are sewn together head to tail so as to form an endless band and placed over a cylinder fixed above the vats, which turns at such a rate that four skins are immersed per minute (Lowersidge).

(b) The skins are sewn together as before, and passed between two rollers similar to those on a wringing machine. The rollers move so as to carry the skins along at the rate of seven feet per minute. As they go between the rollers the exhausted liquor is squeezed out of them, and they are ready to absorb a fresh lot. The expressed liquor is not returned to the pit but taken to a feebler one (Herepath).

(c) The skins are placed in a large fixed drum through which passes a revolving shaft, bearing long stirring-arms. (Vauquelin.)

(d) The skins are run through a washing machine such as is used for cloth (Vauquelin), but this breaks the skin and destroys the texture.

(e) An ordinary cleaner such as is figured in Fig. 32 may be used. The hides are placed in the drum together with the tan liquor and the machine turned at the rate of five revolutions per minute. The strength of the liquor is increased from time to time (Knoderer).

(*f*) The skins may be fixed on the spokes of a circular frame placed in the fulling machine and the drum turned at the rate of one revolution per minute. This makes the skins concave on one side and convex on the other, closing the pores on the concave and opening them on the convex face. It gives broken leather.

(*g*) The skins are placed in a perforated barrel turning about a horizontal axle, and half-immersed in a pit of liquor which is strengthened from time to time (Squire).

(*h*) A horizontal cleaner and a stirrer may be used.

(*i*) Horizontal drums turning in specially-constructed liquor troughs are filled with skins. The edges of the drums have teeth fitting into similar teeth at the bottom of the trough so that as they revolve they run round the troughs so that the skins are constantly being turned (Chailly).

(*j*) Paddles are used, as in the handler pits. They bruise the skins.

(*k*) A stirring apparatus consisting of a vertical screw carrying a travelling disc. On the outer surface of this disc are pegs from which the skins are hung by the head so that they may dip vertically into the liquor. The disc may be fixed in any position on the screw by means of a key. When the key is in position, the revolving screw axle will drag the skins round at the rate of six revolutions per minute for some minutes. Then by an automatic arrangement the direction of rotation is reversed. In this way the motion of the skins is altered ten or twelve times per hour.

When it is wished to remove the skins the key is taken out and the movement of the skins stops. The disc runs up the screw and lifts its charge. They all rise together and may be left out in the air just so long as is required. Lowering them back is done just as easily as bringing them out. An indefinite number of such pits may be worked together, each containing from twenty to twenty-four skins, and it is not necessary to bring them out one by one for draining. The movement produced in the liquor by this apparatus stirs up the tanning substances, which tend to settle to the bottom, and thus keeps the whole of the liquor at the same strength.

The two faces of the leather being at the same time in contact

with liquor of the same density it follows that the weak parts receive as much as the strong ones (Tourin).

(*l*) The arrangement last described may be altered so as to work horizontally instead of vertically, with the skins stretched on rectangular frames. They get badly torn.

5. Filtration of Liquor through the Skins :—

(*a*) The skins are sewn together, grain to grain, so as to form a bag. The bags are hung up by cords sewn to their edges. An opening is left at the top of each bag to introduce a funnel by which cold tan liquor is poured in. At the end of several days, the outer surface becomes damp, and drops begin to collect at the bottom. These are allowed to drip into a collecting vessel and are poured back continually so as to keep the bag always full.

Sometimes a tube is fitted tightly in the opening of the bag by which liquor runs in from a cistern to make up for the loss on filtering. In this case the bags are hung up in a row with a pipe running above them, and connected with each by a small tube.

The temperature of the workshop is kept between 20° and 60° C. (68° to 140° F.) until the skins are tanned, which is recognised by the slackening of the filtration and the blackening of the skins. The bags are then emptied, unsewn, and the skins spread out to dry (Cox, Drake).

Alterlerg of Stockholm fixes the skins on boards, leaving two openings: one receives the liquid from a reservoir, the other allows it to run off (1887).

(*b*) Danish tanning consists of sewing the skins together two and two, with an opening 10 or 12 in. wide, filling the bags so formed with water and tan, sewing up the opening, heating the skins thoroughly and placing them in special pits named *nauffe*. These pits are filled with liquor sufficient to cover the skins, then they are covered with boards weighted by stones. Tanning takes two months. The leather has no solidity.

(*c*) The skins are stretched on wooden frames clamped together so as to form a box, of which the skins form the walls. Liquor is run in between the frames whilst the air is allowed to escape by a vent, which is closed as soon as the box is full. The pressure of

the liquor forces it slowly through the pores of the skin (Spilsbury).

(*d*) Filtration may be brought about by pressure. The skins are arranged on frames which are put together and worked like a filter press (Valery Hannoie).

(*e*) Lastly, filtration may be brought about by centrifugal force. The skins are fixed around the periphery of a perforated drum. The tan liquor is led down into the drum from a reservoir, by means of a hollow shaft. The outside of the drum, which is made of metallic gauze or perforated metal, is covered with felt on which the skins are fixed by an outer covering of gauze (Solminihac).

II.—PHYSICAL METHODS.

1. Heat.—Heat is a powerful help in hastening tannage, but, unfortunately, hot tanning only gives spongy leather, with no strength, and, worst of all, a brittle grain. The temperature of tanning ought never to be above 25° or 30° C. (77° to 86° F.). All processes in which the pits are heated give inferior leather.

2. Vacuum.—The use of vacua for the hastening of tanning has been the foundation of an immense number of processes. None of them are of any value, because vacuum has no effect either on the skin or the tannin or the absorption of one by the other. The processes are all much the same. The skins are placed in a hermetically sealed vat made either of wood or metal and containing some apparatus for stirring the contents. The air is pumped out and liquor allowed to run in from below and remain in contact with the skin for a while; then air is admitted and the liquor run off again, to ærate the skin. The operation is repeated once or twice each day, using stronger liquor each time, until tanning is complete.

This description will serve equally well for the processes invented by Poole, Knowlis, Dnesbury, Knoderer, Eason, Hamer, Macrum, Lanvin, Schraen, etc.

A vacuum has been used for the purpose of hastening filtration of tan liquor through skins (Sautelet). This is very complicated and unpractical and gives defective leather.

3. Evaporation.—In this method, tannin is caused to penetrate

the skins by moistening one side with tan liquor and heating the other artificially to cause evaporation so that the liquid rapidly passes through the leather. A skin is tanned thus in ten days (Rotch).

4. Electricity.—Electricity which has revolutionised the world by its industrial applications has had much less success in the operations of tanning than elsewhere. It is well known that the electric current decomposes water into its elementary constituents, oxygen and hydrogen, which in the nascent state will destroy tannin. It is quite possible that the current may in some way help the combination of skin and tannin, but up to the present no method has been discovered for using it.

The first inventor who proposed the use of electricity was Ward of Auburn (Cayoga County), New York, who took out a patent on 10th December, 1859.

In 1883 Gaulard published details of a process. He suspended the skins in a tanning bath through which a current was passing. The hydrogen formed, according to the author, acted on the leather, destroying nitrogenous matter (!) After eight days' soaking a more concentrated solution was applied and the current reversed. The oxygen now came into action, oxidising the tannin and precipitating it in the pores of the skin.

In 1887 two Swedes, Aborn and Lanclin, described a process at Stockholm based on the use of electric currents.

The authors state that electricity intensifies the capillary and osmotic action by means of which the tannin finds its way into a skin. The hide to be treated is placed in a tannin solution between two plates of copper which act as electrodes, or else it may be placed in a metallic vessel which is then used as one of the electrodes. An alternating current is then passed. Continuous currents give off gases which cause a loss of tannin by oxidation.

5. Spraying.—The author had occasion to use Bandsept's method of impregnating tissue by a spray, with great success. He applied it to the tanning of small skins, goat, dog, sheep, etc. The skins were stretched on a wooden frame and fixed by copper hooks. The frame was placed so that the skin was vertical and a spray of tan

liquor was allowed to play on the skin at an angle of 20° with its surface.

During the first hour the liquid used had a strength of 5° (barkometer); during the second hour 10° ; during the third 15° ; during the fourth 20° ; during the fifth 26° ; and during the sixth 30° .

On the large scale the process would be carried out as follows:—

Goat skins are sewn, two abreast, in a long endless band of forty skins and fixed over two rollers. The upper one is fixed and the lower one is sufficiently movable to allow the operator to stretch the skins tightly. The rollers are rotated at the rate of one revolution per minute, causing the skin to move forwards ten inches at each revolution. The spray is set from 4 to 5 ft. above the level of the ground, and directs a jet horizontally across the skins. In two hours the whole band will be impregnated. Two complete turns of the band are given in each of the liquors, which are graduated as explained above. Tanning requires twenty-four hours for the forty skins.

Calf skins may be tanned in five days, cow skins in seven days, and ox hides in fifteen days.

6. Light.—If ever an eccentric process was devised, it is that of Coccolhk, who hastens the work and fixes the tannin (!) by using light vats. This idea cannot be taken seriously, and we only mention it here to point out its absurdity.

III.—CHEMICAL METHODS.

1. Substances Added to the Liquor to Facilitate the Absorption of Tannin.—All kinds of chemicals have been used to facilitate the combination of the tannin with the skin. It may be noted that the object of all such additions has been to swell the fibres of the skin and so make its texture more open.

Sulphuric acid, which was used in 1778 by Macbride, and on a large scale by Séguin in 1795, only gave defective results. It ought never to be used except in the colouring pits for heavy leathers, and then in moderation, as has been already pointed out. It should

be altogether excluded from the working of small skins and dressing leather.

Many processes have been based on the use of sulphuric acid, whose action is well known. Jones in 1810; Lawrance in 1804; Leprieur in 1833; Desmond in 1850; Derruys in 1854; all suggested an addition of $\frac{1}{1000}$ part of sulphuric acid to their colouring liquors.

Any acids may be used, more particularly those mentioned *à propos* of plumping. Warrington used oxalic acid in 1841; Nickerson suggested in 1878 the use of the acid obtained by distilling sour tan liquor; Ador proposed phosphoric acid in 1879.

In 1853, Lapeyrouse introduced metallic chlorides, especially zinc chloride.

In 1857, Kennedy used sulphate of soda, sulphate of magnesia, sulphate of alumina, carbonate of sodium, borax, or boracic acid. Lowsidge in 1867 added ammonia and ammonium carbonate to the list. Other substances intended to help the absorption of the tannin are alum, aluminium acetate, sugar (Turnbull), urea (Blet), hyposulphite of soda, etc., all of which have been used either separately or in mixtures.

None of these substances, with the exception of sulphuric acid, oxalic acid and magnesium sulphate, have given respectable results, as they all form spongy or hygroscopic leathers.

2. Tanning with Carbonic Acid Gas.—We have already mentioned the use of this gas in purging skins of lime and plumping. In tanning it produces a most pronounced effect and gives leather of a high quality. All that is required is to pass a current of gas through a vat, in which the skins are hung up vertically. This is best managed by means of a perforated metallic worm. The best results are obtained when the tanning is carried out in hermetically sealed vats filled in the ordinary manner, the vats being charged with carbonic acid gas at a pressure of $2\frac{1}{2}$ atmospheres. The gas is prepared by aspirating air by means of a pump, through a hearth where charcoal or coke is burning brightly. Carbonic acid mixed with carbonic oxide (which has no action on the skins) comes off and must be first washed and cooled in a cask of water,

then forced into the vat. The pressure may be gauged by a manometer.

3. Tanning with Ox Brains.—This method has come to us from savages, who tan their hides by macerating them in large earthenware pots with brains, at a temperature of about 35° C. (95° F.). The method was patented by Klemm in 1849, who sold it to Preller, by whom it was much improved and repatented in 1852. The first hides thus prepared came from the Southwark tannery, and the product was called crown leather.

The details of the preparation are as follows: The unhaired skins, after being soaked and partly dried, are stretched on large tables where they are painted over on the flesh side with a paste made up of—

	Parts.
Barley flour	25
Ox brains	25
Milk	12½
Salt	5
Animal fat (horse or neatsfoot oil)	35

When coated with this mixture they are placed in large drums similar to those used for washing out lime, 10 ft. 6 in. diameter and 4 ft. 9 in. wide, and rolled until they have absorbed the dressing. This is often hastened by the introduction of steam. After some time, which varies with the thickness of the skin, they are examined to see whether the absorption and partial drying has gone on uniformly and whether the skins have become saturated. They are then dressed afresh with the paste and rolled again. When the second dressing is absorbed, the operation is repeated.

Calf skins are thus prepared in sixteen hours, and heavy ox hides in two days and a half. This method gives 75 per cent. less weight than oak-bark tanning; but it is supple and 35 per cent. stronger than tan leather. It is much used in the manufacture of boot soles.

4. Tanning with Albuminous Substances.—This process was described by Putz of Passau (Bavaria) in 1879. The skin is swelled with a solution of salt and alum, coloured with oak bark and then impregnated with a solution made from hoofs, horn, hair, and other nitrogenous refuse. These substances, together with one-fifth their

weight of fish oil, are dissolved in caustic soda, and the excess of alkali exactly neutralised with dilute sulphuric acid. The solution thus prepared is introduced by the fulling machine. The leather is then dipped into the tanning liquor (salt, alum and bark) and the fulling with the albuminous liquid repeated until the leather is saturated. In this way a stiff leather is obtained very much like cardboard.

5. Transparent Leather.—Patented by Starck of Mayence. It is prepared as follows:—

The skins are depilated, cleaned, and stretched on a frame and rubbed with a mixture of—

	Parts.
Glycerin (26° Baumé)	1,000
Salicylic acid	2
Picric acid	2
Boracic acid	25

Before the skins are quite dry they are taken into a room from which daylight is excluded, and saturated with a solution of potassium bichromate and then dried. They are next covered with an alcoholic solution of ordinary shellac, and the transparent leather is complete.

This leather is very waterproof and makes excellent belting.

6. Tanning with "Pyrofuchsin".—Discovered by Professor Reinsch of Erlanger.

The "pyrofuchsin" is extracted from bituminous coal. The coal is powdered and boiled with a solution of caustic soda; the solution is then allowed to settle and decanted. The clear solution is saturated with carbonic acid, giving a liquid having a specific gravity of 1.025 to 1.030 and containing 10 to 15 gram. per litre of "pyrofuchsin". It is an odourless insipid substance, insoluble in water, non-poisonous, pasty, soluble in alkalies, giving a deep brown solution. It possesses peculiar antiseptic properties, and in contact with epidermic and muscular tissues gives waterproof compounds. It is on this last property that its usefulness in tanning depends. It is only necessary to soak the skin in the alkaline solution. The time required is about a quarter of that required by ordinary tanning. It gives black swollen leather.

7. Iron Tannage.—In 1842, Darcet tanned hides by plunging them into a solution of ferric sulphate, but the sulphuric acid which is always set free in the skins gradually and completely destroys them. In 1856 Friedel tanned hides with the same salt mixed with oxides of zinc and aluminium. In 1858, Knapp described the method of using salts of iron with soap, and three years after the beginning of Knapp's work, Bellfond made the first attempts at mineral tanning.

Two baths are prepared: One of soap solution containing from 3 to 5 per cent. of soap, and the other of iron (ferric chloride 10 per cent.). The skins are first placed in the metallic solution and stirred for forty-eight hours. They are then drained and thrown into the soap solution, which is kept at a temperature of 35° C. (95° F.). When the reaction is complete they are washed and dried.

In 1877, Paesi proposed the use of ferric chloride and salt (water 100, ferric chloride 10, salt 5) at 20° C. (68° F.).

The leather obtained by any of these processes has a bad colour, and is very stiff. The same may be said of the next method, *viz.* :—

8.—Chromium Tannage.—The unhaired skins are placed in vats filled with a solution of bichromate of potassium, and a current of air blown through to keep them moving. Tanning is complete in a week. They are then made to absorb a certain quantity of paraffin and handed over to the currier. This process, suggested by M. C. Heinzerling in 1877, had a certain vogue which it has not retained. The leather produced is reddish-brown, will not keep out water, and is hard and unprofitable. Its manufacture costs 25 per cent. less than that of bark leather.

Vanderstraeten impregnates leather tanned in the ordinary way with bichromate and soaks it in a warm gelatin bath. When this is placed in an acid bath a deposit of insoluble gelatin is formed in the pores of the material.

Balastschano and Trenk waterproof the leather in the same way.

9. Aluminium Tannage.—We shall only speak here of those processes which form insoluble precipitates inside the skin of alumina-tannin compounds. Balastschano and Trenk tan skins with two solutions :—

(a) 20 to 30 parts of aluminium chromate dissolved in 1,000 parts of water by means of 20 to 30 parts of pyroligneous acid.

(b) A solution of cream of tartar containing a little nickel-ammonium-chloride.

Two parts of *a* are mixed with one part of *b*, and the skins are soaked in the mixture for twenty days at a temperature of 25° C. (77° F.).

Another process consists of soaking the skins for two or three days at 40° C. (104° F.) in a solution of 10 parts of water, 3 parts of aluminium sulphate, and 1 part of salt; then placing them in a solution of borax, 1 part, and glycerin (28° Baumé), 2 parts, at the same temperature. Borate of aluminium is formed. The skins are washed and curried.

Aluminium soap is also used for tanning.

No mineral process has ever given products which can in any way be compared with tanned leather. Much research will be required before good results are obtained.

IV.—TANNING WITH EXTRACTS.

1. **Extracts.**—Extracts, as has been explained already, are tannin-containing substances from which the wood has been removed. The true use of extracts is only apparent when the materials originally contain less than 10 per cent. of tannin, though certain manufacturers who deal in exotic substances make extracts from much richer substances.

Commercial extracts come into the market in three forms: 20° Baumé, 30° Baumé and solid. We object entirely to the use of solid extracts, as they offer no advantages, and give overmuch colour to the leather. We only recommend the use of 30° extracts in special cases, and thus can only advise tanners to use extracts of from 20° to 25° strength, which are much less coloured, and less liable to adulteration.

Further, extracts are of three main qualities: Ordinary extracts, which are made without any special manipulation, and which give an abundant precipitate when diluted in the cold; clarified extracts from which all substances precipitated in the cold have been re-

moved ; and decolourised extracts, which do not give the result which one would expect. We should, therefore, advise the use of ordinary extracts which have been well made, and evaporated in a good vacuum so as to avoid too much colouration.

2. Solution.—Commercial extracts are dissolved in, or diluted with, water at a temperature of 30° C. (86° F.) in a large vat heated by steam. The liquid is pumped up, and allowed to run on to a layer of fresh tan, placed on the false bottom of a vat. This acts as a filter ; the clear liquor, which should have a strength of 10° Baumé, is led into a reservoir.

The deposit which is formed after a while should be removed, as it is completely inert unless in solution, and seeing that the pits are never at a higher temperature than 25° C. (77° F.), they cannot utilise substances which are only soluble at temperatures above 30° C. (86° F.).

In dissolving solid extracts, boiling water must be used, but, as we have remarked before, it should never be used for good work.

3. Tanning.—Tanning with extracts is a kind of liquid tanning which is used in England and America for upper leather and calf, etc. It is scarcely used at all in France.

The extract is pumped into a reservoir placed seven feet above the level of the ground, from the bottom of which a tube leads downwards, then bends at right angles and runs horizontally in front of all the tan-pits. Branch pipes with taps lead the extract into each pit.

The pits are ordinary handler pits with mechanical stirrers, and are best built of stone.

(a) Tanning is carried out in a single vat. Old ooze, if any be obtainable, or else pure water sufficient to cover 500 kilos. (about 10 cwt.) of hides, is poured into the vat. The skins are stirred, 1 per cent. of oxalic acid added to swell them, and they are allowed to soak for a day. Supposing that we had 500 litres (110 gallons) of water for 500 kilos. (10 cwt.) of hides, we should add 5 litres (a gallon) of extract (10° Baumé) from the reservoir, stir ten minutes, and leave at rest for an hour. Another 5 litres would then be added, fifteen minutes' stirring would be given, and another hour's soaking

allowed. This is repeated regularly for twelve hours, so that at the end of the day 50 kilos. (11 gallons) of 10° extract will have been added, or a gallon for every 100 lb. of skins. They are left to soak for the night. This slow treatment prevents the too sudden development of the grain, which rises imperceptibly.

On the following day 10 kilos. ($2\frac{1}{3}$ gallons) of extract are added in the morning, 10 kilos. at noon, and 10 in the evening, stirring for half an hour after each addition. This is continued for a month. An overflow allows the exhausted liquor to run into a neighbouring pit, where it is used either for starting fresh pits or for dissolving extracts. In this month the skin will have absorbed the tan from 900 litres (198 gallons) of 10° extract. During the next month they are stirred morning and evening, adding each time 15 litres ($3\frac{1}{3}$ gallons) of extract. The leather is then tanned.

(b) The method just given has the drawback of requiring large quantities of liquid. It is much better to use twelve vats, each containing the same quantity of liquid. The vats should be set in a row with a supply pipe alongside, and having side tubes connecting the bottom of one with the top of the next. The skins are placed in pit No. 1; fifteen days afterwards a fresh lot is placed in pit No. 2, and so on, filling them up at equal intervals. Pit No. 1 is filled with pure water, to which extract is added, night and morning, 10 litres at a time, or better still, allowed to run in slowly through a regulating tap which will discharge exactly 20 litres ($4\frac{2}{3}$ gallons) per day. The liquor flows into the second vat, which has already received 200 litres (44 gallons) of water. In fifteen days there will accumulate $15 \times 20 = 300$ litres, so that the vat will be fully charged; the skins are then placed in it, and so on for the rest. Each vat thus is gradually filled, and the liquor runs from 1 to 12, becoming more exhausted in each vat. When the twelfth pit is full, *i.e.*, in $11 \times 15 = 165$ days, the first will contain finished leather. They are removed, and the strong liquor pumped into a special vat. Fresh skins are placed in the pit with 200 litres of water, and the liquor of the twelfth allowed to run in, the strong liquor being run into No. 2.

Every day 500 kilos. (1,100 lb.) of leather is taken out, and 500 kilos. of fresh skins. added. Large hides may be tanned in this way

in six months. Calf skins are tanned in two months, emptying a pit every five days. The liquor in the special vat is used for making fresh extract.

(c) A series of pits may be kept, each at a certain strength, and the skins soaked in one pit after the other. The series consists of twelve pits. Each has an areometric density of $\cdot 2^\circ$ greater or less than the one next it. Each is automatically supplied with the necessary quantity of extract to keep up its strength. The first $\cdot 2^\circ$, the next $\cdot 4^\circ$. . . the twelfth $2\cdot 5^\circ$ Baumé.

The skins are placed in the first, which contains 1 per cent. of oxalic acid, and after one or two days passed on to the second, where it remains for eight days, then into the third, where it remains for a like period, and so on. They are thus always carried from a weaker to a stronger liquor, whilst fresh skins are being placed in the acid and then brought forward.

When all the pits are full, the skins are removed every eight days from the twelfth and replaced by those in the eleventh, and so on, always placing fresh skins in the first and removing tanned leather from the last. Between the operations the skins are spread on the edges of the pits to drain.

Since the addition of strong extract causes the volume of liquid to increase, each pit has an overflow which leads into the next weaker pit, the weakest of all overflowing into the drains. After a time each pit will be charged with extractive matters, and the liquor must be changed. When this is considered necessary, the supply of extract is cut off for a day or two, leaving the skins in the pits. At the end of this time they are taken out and allowed to drain. Whilst the skins are draining the two last pits are emptied through the series (so that the liquor from 1 and 2 runs down the drains) and fresh extract of the correct strength is put into them. The skins are then returned and the work continued.

(d) In all these operations pits are used which have some means of keeping the skins moving. No means gives such good results as that of hanging the skins vertically and stirring the liquid with a screw agitator.

4. Mixed Tanning with Bark and Extracts.—The skins are

prepared as for tanning with oak bark. When they come from the colour pits, the skins are placed in lay-aways in the ordinary way, and watered with liquor of 2° Baumé for the first pit, 3° for the second, and 4° for the third.

Those who wish to keep the handler pits use liquor of 1.5° for the first and 2° for the second pit.

This is the method most generally used in France, and gives both quantity and quality.

5. Mixed Tanning with Extracts and Bark.—The skins are prepared in the colour pits with extract, forcing it in the last pit. The handler pits are suppressed, and one or two tannings are given. Thus liquid tanning is used to begin with and dry tanning to finish. This process is used both in France and Belgium.

6. General Remarks on the use of Extracts.—Extracts have only given good results in the tanning of large skins. With calf skins they do not work well, giving a brittle grain and a less durable leather than when worked with bark. Still, good calf of a fine colour has been prepared for some time with oak-bark extract. This is a distinct step in the right direction.

Extracts give a red colour to leather which can only be altered by using mixtures. Quebracho extract especially cannot be used alone.

To obtain good results, a combination of extracts must be used, in which the tanner has to take into consideration the colour, the yield, the price, etc., of each.

The use of extracts, as we shall have an opportunity of explaining in the next chapter, is the only means of reducing the net cost of the leather. At the same time it permits the use of all the tannin contained in any vegetable substance, which is never done in the use of bark, etc. The cost of tanning with extracts is, moreover, less than the cost of working with the tanning substances themselves.

CHAPTER VI.

QUANTITY AND QUALITY.

I.—QUANTITY.

WE have already pointed out that 100 lb. of hide fresh from the slaughter-house, when it has been fleshed, unhaired, and completely prepared for tanning, will give 25 lb. of dry matter. Skins from fat beasts give 22 lb., whilst thin ones from young and vigorous animals yield 26 lb.

The weight of tannin absorbed is approximately equal to the weight of dry skin. Thus 100 lb. of hide fresh from the slaughter-house giving 25 lb. of dry matter, will weigh after tanning 50 lb. Its yield will be 50 per cent.

The average yield of leather from fresh skins is practically 47 per cent.

The average yield of leather from salted skins is 52 per cent.

The average yield from dried skins is 125 per cent.

Skins from young and vigorous animals give above the average yield. Skins with hollow flanks and flat backs yield badly, whilst those with full flanks and round backs yield well.

The yield also varies with the nature of the tannin used. We all know that pure tannin is of no use for changing a skin into leather. It is the foreign matter which is found in bark and vegetable tans which gives quality, hardness, suppleness or quantity to leather. In this way, extracts give a large yield because of the large quantity of available foreign substances which they contain.

Each variation in the method of tanning alters the quantity of leather obtained. Thus the manufacture of black leather gives higher results than does "satin". Each tanner works to his own yield.

The yield is increased by the movement of the liquors or the skins, by the use of heat, by excessive swelling with acids, etc.

But the yield cannot be increased indefinitely, as the buyer indirectly fixes a limit, beyond which it is unprofitable to go. For instance, a shoemaker will cut out a fixed number of soles from an ox hide which has given a 47 per cent. yield. If the tanner sells him one which has yielded 50 per cent. of leather, he will only cut the same number of soles, and the skin will weigh ever so much more. The buyer is thus the regulator. This, however, does not prevent certain manufacturers from neglecting certain operations and making up by the addition of weighting substances.

II.—NET COST.

Theoretically 100 kilos. of fresh skin will use up 23 kilos. of tannin. Oak bark contains 7·5 per cent. ; we shall have, therefore, to use 300 kilos. of bark which at 10 francs per 100 = 30 francs, so that 1 kilo. of oak-bark tannin costs 1·3 francs.

The net cost of tanning 100 kilos. (220 lb.) with oak bark is therefore :—

	Francs.
100 kilos. of fresh skins	100
300 „ pure bark	30
Labour and expenses	20
Interest (12 months at 5 per cent.)	7½
	157½ = £6 6s.

Yield 48 per cent., net cost 3·3 francs per kilo.¹ This is, of course, under the most favourable conditions.

We have already stated that the addition of extracts is a method of increasing the yield and diminishing the cost. As an example in support of this statement we give the following :—

	Francs.
100 kilos. of fresh skin	100
250 kilos. of pure bark	25
35 kilos. of extract at 25s. per 100	9
Labour and expenses	20
Interest (8 months at 5 per cent.)	5·1
	159·1 = £6 7s. 2d.

¹ 14·4 pence per lb.

Yield 52 per cent, net cost 3·05 francs¹ per kilo. When using extracts alone :—

	Francs.
100 kilos. fresh hide	100
110 kilos. extract	27·50
Labour and expenses	15
Interest (7 months at 5 per cent.)	5
	147·50 = £5 18s.

Yield 55 per cent., net cost 2·67 francs per kilo.² The cost may be lowered by a judicious use of tanning substances, of which a long list will be found at the beginning of this volume. We have not given the price of each substance or mixture, because such a list would be useless. The state of the market and the cost of transport must be always studied when buying tan.

III.—QUALITY OF LEATHER.

The quality of leather depends on its degree of tannage ; that is, as to whether it has been tanned completely or only superficially. A sample of leather is of better quality according to the completeness of penetration and to the evenness and slowness with which the tannin has entered into combination with the fibres of the skin. The surface of a section is the best indication of the degree of tanning. In well-tanned leather the section is homogeneous and lustrous, with a compact texture. It should have an appearance similar to that of a nutmeg, and should show no darker bands excepting in the grain. Leather is said to be “green” when it is marbled, and shows a white line along the middle of the section which is called the “corne”. Sole leather cut across in any direction should give a homogeneous appearance. The rump, the back and the throat, being the thickest parts, are the ones which are cut for testing. On the other hand, a badly-tanned hide has a dull section with loose tissue and a spongy open texture, whilst a white or black line is found in the middle.

When boiled with water good leather does not swell. It remains quite opaque everywhere and does not get sticky. The water in which it is boiled becomes reddish-brown and limpid, and on evaporation does not form a jelly. If the leather has been incom-

¹ 13·33 pence per lb.

² 11·64 pence per lb.

pletely tanned it swells up, becoming transparent and sticky, leaving the tanned portions opaque and coffee coloured. The liquid in which it is boiled is turbid, yellow, and sets to a jelly on cooling.

Another test for the degree of tanning of leather is to cut off a piece about $\frac{1}{2}$ in. thick and place it in vinegar. If the leather be perfectly tanned and of good quality, it will not change except for a slight darkening in colour, even when left in the vinegar for several months. If, on the other hand, the tannin has not penetrated the skin, the fibres will swell quickly and in a very short time the leather will be changed into a gelatinous mass.

In the chemical laboratory of the *section technique d'artillerie*, a 12 per cent. solution of crystallisable acetic acid in water is used.

Tanners test for spongy leather by placing a drop of water on the section. If the drop keeps its shape and does not spread it is considered to be well tanned. If the leather absorbs the water, it is spongy and ill prepared. The quality of leather increases with its impermeability, or in inverse ratio to the quantity of water which it will absorb in a given time.

We have noticed that after twenty-four hours' contact with water, leather has absorbed as much as it can hold. This makes the estimation of the absorbent power of leather very easy.

One hundred gram. of leather placed in water gave the following increase :—

24 gram.	in 35 minutes.
37 "	16 hours.
37 "	4 days.

To carry out this operation easily the author has devised an apparatus consisting of a graduated cylinder (Fig. 34) having the zero of its graduations at about two-thirds of its height from which they are numbered in either direction. A piece of leather 10 cc. long by 6 cc. wide is rolled up into a cylinder and tied with two pieces of thread or wire, water is poured in up to the zero mark, and then the roll of leather introduced. The increase of volume gives the volume of the leather, this is noted, and the apparatus allowed to stand for twenty-four hours. The leather is then removed, allowed

to drain for a few seconds, and the decrease in volume read off. The ratio of the volume of leather to the volume of water absorbed is called the degree of permeability of the leather.

A good leather has given :—

Volume of leather	100
„ water absorbed	30
Degree of permeability	$\frac{30}{100} = 0.3$

The greater this degree the more impermeable the leather.

The permeability may also be measured by the increase in thickness of leather which has been soaked in water.

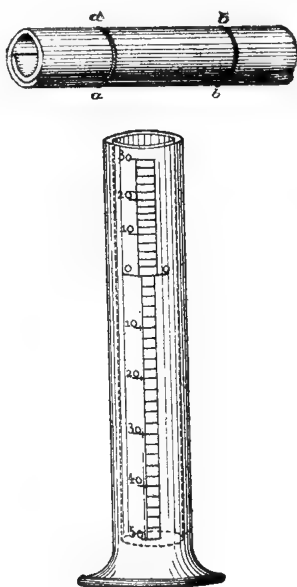

FIG. 34.—Absorption Estimating Apparatus.

Thus the above sample gave an increase in thickness of 23 per cent. in thirty-five minutes, 33 per cent. in sixteen hours, and 33 per cent. in four days.

Leather tanned with metallic salts (Heinzerling) is much less permeable than leather prepared with tan. This is caused by the large quantity of paraffin wax which it contains. One hundred parts of this leather placed in water absorbed 1 of water in thirty-five minutes, 8 in sixteen hours and 20 in four days. Treated with the author's apparatus it gave :—

Volume of leather	100
„ water absorbed	10
Degree	$\frac{10}{100} = 0.10$

The following conditions should be also fulfilled by good class leather :—

It should have a good colour, free from redness ; should not have any cuts on the flesh side nor scratches on the grain side. It should be free from bot-fly punctures, scratches, callosities, packets, or thin places.

The grain should not be brittle, as is the case when burned with lime or strong acid. Burning is recognised by little cracks which show when the leather is folded backwards.

Horny leather has faulty structure and has been tanned badly so that some parts are hard and dry and have never been tanned. These inferior leathers may be recognised by the line seen in the middle of the section, which has a horny appearance.

Leather should not be hollow nor too open, and it should not be too hard or firm. These faults are caused by the use of over energetic mechanical appliances in tanning, by artificial heat or by frost.

It is the same with heated skins ; that is, skins which have been piled too long. These have no grain, and sometimes show traces of rotteness.

Sour leather is full of invisible holes due to acidity. They are spongy and very absorbent.

Finally, leather should not contain more than 15 per cent. of water.

CHAPTER VII.

VARIOUS MANIPULATIONS OF TANNED LEATHER.

I.—SECOND TANNING.

A SECOND tanning is sometimes given for two reasons: (1) to surcharge the leather with tannin so that it will give a higher yield; (2) to give a better colour to leather tanned with certain substances which do not give the colour required in commerce.

1. Strong Extracts.—Skin will absorb very large quantities of tannin. The 40 per cent. which is fixed by combination in the leather is insoluble, but the excess which fills up the pores and spaces between the fibres is not in any way combined, and is consequently soluble. The second tanning may be carried out in two ways:—

(a) The tanned hides are soaked for a month in chestnut or oak extract (20° Baumé), taking care to let them drain two or three times for two days at a time. They are washed quickly in weak tan liquor and dried. In this way they will add 10 per cent. to their weight.

(b) The leather is stretched on a table, and successive layers of 20° extract are passed over it with a pad. When the grain side of several hides has been treated in this way, they are piled up flesh to flesh and allowed to stand several days for the tannin to penetrate them. The process is then repeated until the desired weight is obtained.

2. Bark and Acid.—The tanned hides are placed in a tan-pit with fine tan, and the pit is filled with ooze containing 1 or 2 per cent. of acetic acid. The leather is thus caused to swell and at the same time to absorb an excess of tannin.

3. Revivification of Defective Skins.—Skins which have a greenish-yellow colour, and a dull section like English croûtes and other foreign leather made with inferior tan, are often improved by soaking them in concentrated bark ooze. This acts very imperfectly. We have known curriers use the following rather empirical method :—

They make an infusion of fresh vine-shoots in cold water, add chestnut extract to make a strong liquor, and soak the skin in the mixture. The result is perfect.

As we cannot always have vine-shoots on hand, the author has examined the decoction and discovered that the active principles are oxalic and tartaric acids. This has led to the use of the following mixture :—

	Per Cent.
Chestnut extract	50
Valonia extract	50
Oxalic acid	0.5
Water	100

Leather soaked in this solution comes out completely transformed, and looking exactly as though it had been tanned with oak bark.

II.—GREASE STAINS.

Stains which come to the surface of ox or cow-hide arise from the fat adhering to the flesh side, which has not been completely removed in fleshing before being placed in the lime. This fat is transformed by the lime into a lime soap which, being insoluble, remains fixed in the interior of the skin. Later, in the operations of tanning, this soap is decomposed, and fatty acids set at liberty, forming the stains in question.

Several means are used for removing them :—

(a) The use of potassium or sodium carbonate, which, when applied to the white, untanned patches cause it to take up both tannin and colouring matter.

The white spot is sponged with a solution and immediately appears dark, but little by little it returns to the general colour of the skin.

(b) The use of a weak solution of sodium sulphide applied in the same way.

(c) The use of vegetable soap.

III.—BLEACHING LEATHER.

When leather has been tanned with any substance other than bark, the colour is more or less dark. When extracts have been used, the disagreeable red-brown colour is particularly marked. When the hides have been burned in the lime or tanned too rapidly, they have an abnormal colour. Many ways of restoring the true tan colour have been suggested. The following give good results:—

1. Hypochlorite of Aluminium.—To prepare this body two solutions are made up: one of 150 parts of aluminium sulphate in 500 parts of water, and the other of 100 of parts chloride of lime (bleaching powder) in 1,500 parts of water. These are mixed, and the precipitated sulphate of lime is allowed to settle. The clear solution may be sponged over the skin. Good results are thus obtained. The process was originally used by Orioli in 1859 for bleaching paper pulp.

2. Peroxide of Hydrogen.—Commercial peroxide, containing 3 per cent. or 10 volumes, readily decolourises leather if the following precautions be taken: Three per cent. of ammonia is added to the peroxide, and the leather saturated with the liquid. It is dried in a current of air which must not be warmer than 20° C. (68° F.). Bleaching goes on rapidly as the water evaporates and the solution becomes more concentrated. If the decolourisation be insufficient the operation may be repeated.

3. Permanganate of Potash.—The hides are treated with a 2 per cent. solution of permanganate, which is well rubbed in with a sponge. Then they are washed with clear water, and finally sponged over with a solution of sulphurous acid, which causes an almost instantaneous bleaching (Barreswill).

4. Hydrosulphite of Soda.—This substance is prepared by treating a solution of bisulphite of sodium in a closed vessel with granulated zinc or zinc turnings, or more rapidly with zinc dust.

It is most convenient to use a small cask holding about $4\frac{1}{2}$ gallons, fitted with a wooden tap. The zinc is placed inside, and then the bisulphite poured in so as to fill the cask completely. It is closed with a cork through which is cut a small hole. The cask is placed in a cool place, and at the end of three or four hours the hydro-sulphite is ready. It is passed rapidly over the skin with a sponge. It should be prepared freshly just before using, as it will not keep overnight.

5. Chlorozone.—This substance, discovered by Dienheim-Brochowski, is a powerful decolouriser. It is an oxidised hypochlorite of sodium, obtained by saturating caustic soda solution with hypochlorous acid in a current of air. The hypochlorous acid is prepared by the action of hydrochloric acid on bleaching powder. This substance is neutralised with a few drops of sulphuric acid and passed over the skin.

6. Tin Salts.—Many tanners use tin salts (stannous chloride) to give a good appearance to their leather.

IV.—WATERPROOFING LEATHER.

Impermeability is one of the properties of good leather and various means have been devised for giving this property to such leather as is without it. The substances so employed should be colourless, free from fat, and should not in any way spoil the appearance of the leather. The following give good results:—

Soap.—(a) A solution of: soap, 62 parts; glue, 124 parts; water, 2,000 parts; is poured over the leather, then after the solution has thoroughly penetrated the hide a second solution is used, containing alum, 400 parts; salt, 460 parts; water, 2,000 parts. The leather must soak for two hours in each solution (Lowry).

(b) To a boiling solution of 100 parts of caustic soda in 2,000 parts of water is added: tallow, 300 parts; resin, 180 parts; and the whole boiled until solution is complete. Next 100 parts of glue and 100 parts of linseed oil are added. It is again boiled and made up with water to 10,000 parts. This liquid is used in the same way as the last, being fixed by a bath of aluminium acetate prepared by dissolving 400 parts of aluminium sulphate and 200 parts of lead

acetate in 5,000 parts of water. This method is due to Paut, who prepares waterproofs in this way.

(c) To a solution of 100 parts of tallow soap in 1,000 parts of boiling water, a boiling solution of alum is added. The precipitate is allowed to settle, and the liquid decanted off. After being washed with boiling water the precipitate (aluminium soap) is dried and dissolved in benzene or coal naphtha. This solution is spread thinly over the surface of the leather, where it sets to a hard elastic impermeable cement.

(d) Two hundred parts of resin soap are dissolved in 350 of water. To this is added a solution of 15 parts of glue in 100 of water and finally 20 parts of glycerin. It is used in the same way as the last.

V.—WEIGHTING TANNED LEATHER.

Weighting leather, although much practised, is a fraud which cannot be too strongly condemned. We only speak of it to put manufacturers on their guard against such dishonest practices.

1. Weighting with Oil.—Some tanners, especially manufacturers of upper leather, are in the habit of weighting their leather, as soon as it is tanned, with whale or cod oil, by passing 5, 10 or 20 kilos. (11, 22, 44 lb.) of oil over the skins and drying them. The yield is thus increased 5 per cent or more.

2. Weighting with Glucose.—A hot syrupy solution of glucose is applied to the flesh side of the skins. They are piled flesh to flesh for twenty-four hours, at the end of which time the glucose will have entirely entered the leather. They are then either treated again with glucose or dried and finished. Drying should be as rapid as possible to avoid fermentation. Usually this is done at 50° C. (122 F.) and requires from six to eight hours. The leather thus gains in weight from 10 to 15 per cent. Leather treated in this way attracts moisture and is always damp; moreover, it attracts flies unless a strong solution of *quassia amara* has been mixed with the original syrup.

3. Weighting with Sulphate of Magnesia.—This salt is specially adapted to serve the ends of adulterators, both on account of

its cheapness and its lack of deliquescence. Skins are soaked in a strong solution and dried in the ordinary way. They do not soften like those charged with sugar.

Sometimes the two methods are combined and the leather is impregnated with a mixture of equal parts of glucose and magnesium sulphate. It is first dried in the air and then at 50° C. (122° F.). In this way a hide may have 25 per cent. added to its weight.

4. Weighting with Barium Chloride.—This is a very common adulterant, because it is cheap, heavy, readily soluble in water, colourless, and does not harm the leather. The skins are placed in large vats of the solution, and allowed to soak for twenty-four hours. They are next washed, then allowed to dry slowly. If a white efflorescence forms on the surface of the leather it is washed on both sides with a slightly damp sponge.

5. Weighting with Barium Sulphate.—The leather is steeped, as before, in a solution of barium chloride and then plunged into a vat of sulphate of soda. A double decomposition takes place, a fine heavy insoluble precipitate being formed, which adheres strongly to the fibres of the skin.

6. Various Substances.—The following substances are used either alone or mixed: sulphate of zinc, succrates of barium and lead, saccharate of lead, sulphosaccharate of lead, sulpholeate of barium, sulpholeate of lead, sulpho-ricinolate of sodium, barium and magnesium, etc.

VI.—PRESERVATION OF LEATHER.

Leather left in a damp place becomes moist and covered with fungi *aspergillus*, etc. This may be prevented by brushing a 1 per cent. solution of mercuric chloride (corrosive sublimate) or mercuric iodide over the surface of the tanned leather.

Leather warehouses are often infested with insects which do enormous damage. These chief ones are *Attagenius pellio*, whose larvæ devour the tissue, making subcutaneous galleries, and the *Dermestes vulpinus*, living chiefly in sole leather, the interior of which becomes filled with larvæ, so much so that if the leather be pressed it breaks open.

These two insects are the scourge of tanneries and leather warehouses and it is very difficult to destroy them. Carbon bisulphide, benzene and petroleum vapour or carbolic acid, are the only things that will affect them. When a warehouse or store is attacked they should be got rid of at once. The walls and corners should be covered with the liquids and the doors and windows closed all day to keep in the smell. Next day they must be aired and the operation repeated. After three or four such treatments the skins may be returned after having been beaten and powdered with an insecticide (*see* "Furs").

CHAPTER VIII.

TANNING VARIOUS SKINS.

IN this chapter we enumerate the peculiarities of various skins which are used for tanning. Many of them are only used for fancy goods.

Dog skins, buck skins, wolf skins, deer skins, ass skins, etc., all those which are as large as or larger than calf skins are treated in the same way as the latter.

The skins of the cod, lota and eel, are tanned in liquor.

Small skins undergo more delicate treatment.

1. **Frog Skins.**—African and Brazilian frogs and those from equatorial America are the most commonly used. In France three manufactories are devoted to this singular work.

The skins are soaked for two days in cold water to soften them, then placed in a drench of sour bran, they are scraped, fleshed, trimmed and tanned with gall nuts, sumach and a little alum. We know of one house which tans them with decolourised sumach and glycerine.

Lastly, we have seen frog skins tanned as transparent leather without any alteration of their original colour or appearance.

The skins of large toads are treated in the same way, but as the skin of the back is very much harder than that of the belly, the two parts are separated by cutting around the sides of the animal. The lower skin gives a wonderfully supple leather.

Frog skins are used to make card cases and other little fancy articles.

2. **Rat Skins.**—Rats, field mice and even moles are used extensively by tanners. They are tanned in sumach or valonia liquor, or sometimes with oak-bark extract, after being depilated with sulphides.

3. Bird Skins.—Amongst birds the ostrich, the agami (trumpeter), and the barn-door fowl, supply skins for tanning.

They are first softened by soaking in salt and fresh water. The down is removed by sulphides, and they are soaked for a long time in water containing corrosive sublimate, or better white arsenic. They are swelled with sour brain, although we should prefer the use of oxalic or tartaric acids.

The skins are so fragile that they can only be acted on very slowly by tan, using sumach or gall nuts. As we have seen gall nuts used, our description applies specially to this substance. When sumach is used, three times the quantity is required.

Two hundred and twenty lb. of skin and 44 gallons of water are placed in a vat 3 ft. 6 in. diameter by 4 ft. 9 in. deep. A pound ($\frac{1}{2}$ kilo.) of powdered gall nuts is added and stirred in for fifteen minutes. The vat is then left at rest for an hour. Another fifteen minutes' stirring and another hour's soaking are given, then another lb. of tan is added and the complete operation repeated. The whole is then gone through for a third time. This brings us to the end of the first day. Two and a quarter lb. of powdered gall nuts are stirred in and the skins are left to soak for the night. On the following days $2\frac{1}{4}$ lb. (1 kilo.) of tan is added night and morning, stirring after each addition and at midday for fifteen minutes. This treatment is continued for eighteen days, when the tanning will be complete.

4. Snake Skins.—Snake skins are prepared so as to retain their natural appearance. Bark tanning is not often used, and most of the methods are secret. Here, however, is a process concerning which we have received special information.

The skins are soaked for a long time in water containing sulphate of zinc to prevent putrefaction. This requires at least ten days. They are fleshed, scraped, washed by hand, and placed in a first bath made up as follows:—

	Parts.
Water	1,000
Borax	10
Boracic acid	100
Precipitated alumina	as much as the liquid will dissolve.
Tartaric acid	25

They are left in this for a day, then transferred to bath No. 2 containing :—

	Parts.
Water	1,000
Phosphate of zinc	25
Benzoate of aluminium	25
Glycerin	50
Alcohol	20

They are left for a day, then put back into No. 1 for a day, then back to No. 2 for another day. In four or six days tanning is complete, and they are stretched on frames to dry.

PART III.

CURRYING.

CHAPTER I.

WAXED CALF.

THE currier carries out that series of operations by which tanned leather acquires the properties which are required by boot and shoemakers, saddlers, harness-makers, trunk-makers, case-makers, bookbinders, military outfitters, engineers, etc., etc. These results are obtained by softening and equalising the leather and finally dressing, polishing, enamelling, sleeking, waxing, colouring, etc., etc.

Each of these preparations requires various processes, though the preliminary operations are common to all, such as fulling, shaving, brushing, striking out and paring.

We will take the preparation of black calf, which is one of the most important industries in France, as an example, and describe all the operations used in its currying. Afterwards we shall explain the modifications necessary for the preparation of other qualities of leather.

I.—PREPARATION.

1. Drying.—When the tannery joins the curriery the calf skins are taken from the pits, beaten to remove the tan which adheres to the flesh side, taken to the open drying loft and partly dried. They must be watched to see that all parts are drying at the same rate. They are stretched, brushed on both sides, and piled.

In large completely equipped factories, 100 to 150 skins are placed together under a hydraulic press, which dries them sufficiently, and thus economises time. The pressure is increased very slowly, if too sudden there is a risk of staining the skins.

2. Soaking.—When tanning and currying are carried on separately, the leather received by the currier is hard and dry. It is known as crust leather, and must be soaked. This is done in a large vat of water, where the skins are left for some hours. Afterwards they are stretched on a stone table to render them amenable to the later operations.

Often the soaking is carried out in a “tumbler” similar to that which has been described for the removal of lime. It is started dry so as to break off any foreign substance adhering to the skins, then continued with an abundant supply of water for twenty minutes. It should be continued until the water runs off clear. When the leather has been weighted with glucose, magnesium sulphate, barium chloride, etc., the fulling should be continued until these substances, so objectionable in later processes, are completely removed. This will be a dead loss to the buyer, but he will be more careful another time.

II.—SHAVING.

Shaving with a special knife removes any flesh from the skin and equalises its thickness.

The first operation is to scrape the skin with a special instrument having a solid blade with a blunt edge; this is worked over the skin, stretched on a beam, to remove the tan. It may be done mechanically.

1. Currier's Knife.—This knife (Fig. 35) is a foot long by 6 or 7 in. wide. Its blade is two-edged. The sharp edge is set at right angles with the blade, first on a grind-stone, then on an emery-stone, and finally with a steel so that, in order to make it cut, the blade must be held perpendicular to the skin. It requires much practice before a workman can keep this instrument in order.

When it requires sharpening, it is taken out from its handle and held, whilst wet, against the middle of the grindstone, moving it backwards and forwards the while, and finished with an oil-stone. It is put back in its handle, then, holding it between his chest and the beam, the workman strops the edge with the hone,

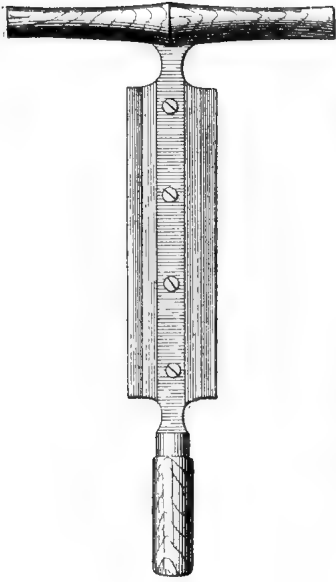

FIG. 35.—Shaving Knife.



FIG. 36.—Moon Knife.



FIG. 37.—Carrier's Steel.

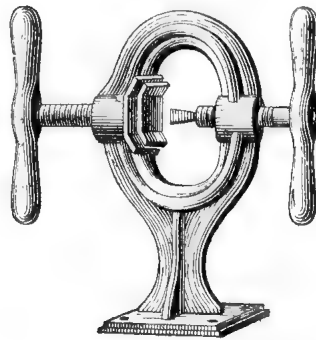
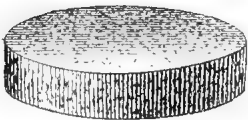
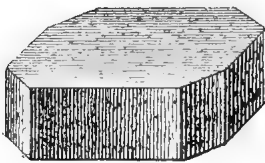
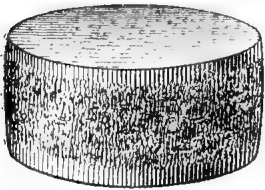

FIG. 39.—Vice for Extracting Knife.



FIG. 38.—Turning Steel.



FIGS. 40-42.—Stones for Sharpening Knives.

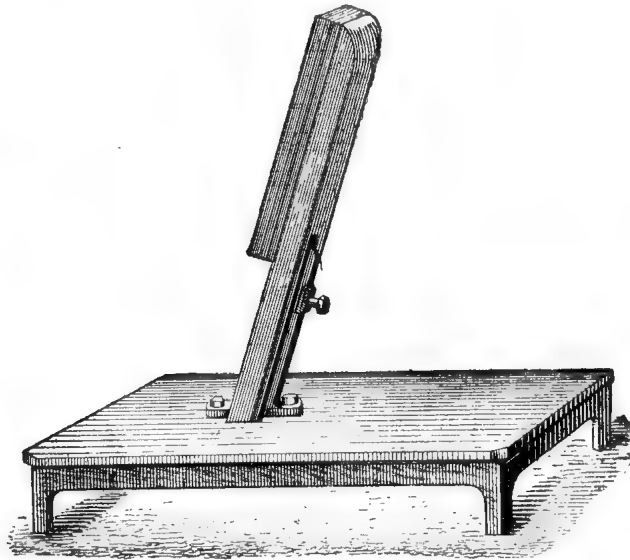

FIG. 43.—Shaving Beam.

keeping it absolutely perpendicular to the blade. Some curriers give a curve to the blade.

Sometimes the knife is replaced by the lunette, a ring-shaped implement (Fig. 36) with a blade $2\frac{1}{2}$ to 3 in. wide; it is slightly curved, and the workman uses the back on the skin, passing his hand through the central hole, the skin being stretched on a frame.

2. Shaving.—The workman places the skin on the beam, turning the edges down so as to fix it on the flat part of the beam, and holding it in position with his knees, he then works over it with his knife from the top to the bottom, removing all the rough parts. He pares off shavings as fine as paper, going over the thicker parts several times to make the skin perfectly even. A good workman can shave four dozen calf skins in a day.

Good workmen are scarce because of the great skill and care necessary to avoid streaks, cuts and scratches, and to economise the skin as much as possible. Long strokes of the knife should be avoided, for although time is thus saved leather is lost to the extent of 5 per cent.

3. Mechanical Shaving.—This operation has never been managed by machinery. The Ott (*see* "Morocco") and Jesson machines do not work either evenly or quickly. Baudoin and Damourette have invented a machine which comes much nearer to our requirements. It consists of a concave wheel fixed on the head of a rapidly-turning shaft. The skin is fixed to a beam which may be controlled by the workman's foot. The upper surface of this beam, which is made of copper, is moved up or down according to the thickness of leather required. The skins are drawn through by feeding rollers.

These machines have been improved by an English engineer named Pitt.¹

III.—SLICKING OR STRIKING OUT.

1. Fulling.—The skins are placed in troughs containing either water or ooze, and stamped in the stocks until they are completely softened, or more often they are rolled up and placed in the fulling

¹ There is now on the market a very good shaving machine invented by Rood, manufactured in America by the Vaughan Machine Co. This machine, in most cases, does away with hand shaving.

mill and worked until they are completely softened. They are then allowed to soak for several hours in clean water.

2. Tools.—The *table* is 12 ft. long by 5 ft. wide, and supported by three strong trestles about 26 in. high. This height varies according to the height of the workman, as it is necessary that he should be able to use his strength to the best advantage. The top is made either of marble or slate $1\frac{1}{2}$ to 2 in. thick and slightly inclined away from the workman.

The *slate* is a slab of slate mounted in a handle (Fig. 47); a stronger instrument being used for large than for small skins. The edge of the slate should be sharp, but with only a small bevel so that it may not wear away too rapidly. Its corners should be rounded, and it must be kept well ground so as to avoid scratches.



FIG. 44.

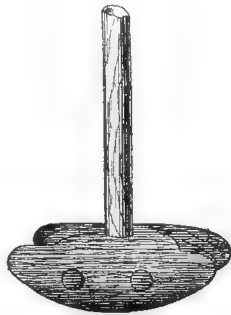

FIG. 45.

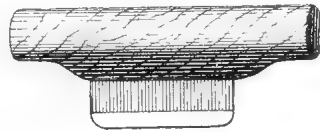

FIG. 46.

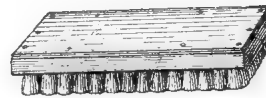

FIG. 48.

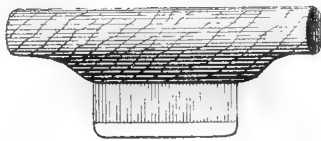

FIG. 47.

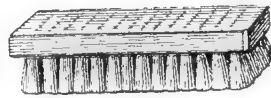

FIG. 49.

TOOLS USED FOR SLICKING.

The *slicker* (Fig. 46) is a plate of iron or copper ($\frac{1}{12}$ in. thick by 4 in. wide and 6 in. long), fixed firmly in a wooden handle. The blade has a slightly-curved edge and rounded angles. It is sharpened on a soft stone, avoiding any roughness in the edge. A stiff brush and a wooden pail completes the list of tools.

3. Slicking.—The workman takes one of the calf skins which has been soaking, places it on his table with the flesh side above and the neck to the left, the median line of the skin being about 4 in. from the working side of the table. Then he starts working

the thick part of the back with a slicker, stroking it in lines parallel with the edge of the table, and moving from the shoulders to the tail and in the next stroke working back again. The throat is stretched by working the iron radially across the skin (see Fig. 50) taking in 1 to 2 in. of the skin with each stroke. After reaching the navel all the strokes are made parallel with the last one. When the rump is reached the strokes must be strong and oblique, and from right to left.

In Fig. 50 the direction of the stroke is shown diagrammatically. Finally the brush is dipped in the bucket and the skin is washed with abundance of water.

It is now turned round and the other half treated in exactly the same way, then it is folded in four and placed on the edge of the table or in clear water. This operation breaks down the body of

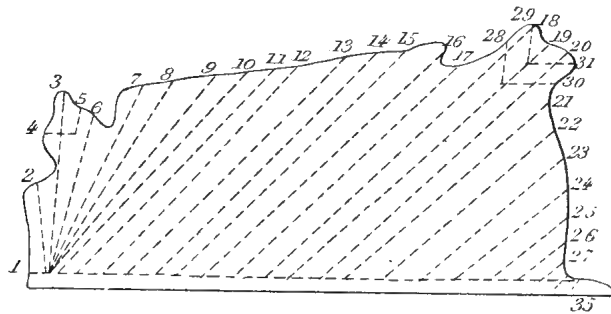

FIG. 50.

the skin, scraping the thickest parts and removing the last traces of flesh adhering to it, shrinking the stronger parts and preparing the skin for the next operation.

The reason for using the particular method of stretching shown in the figure is that it avoids folds, renders the working of the softer part more easy, and displaces the excess of leather from the neck and throat towards the other parts.

4. Stretching the Grain Side.—The skin is stretched on the table and stroked as before, but using the slate instead of the slicker. The skin is scrubbed and the stretching repeated, working the slate in the opposite direction. The slate makes a peculiar noise on the grain from which the density can be guessed. All texture disappears excepting the lines of the blood vessels, which rise to the

epidermis. When this happens the slating is finished. The skin is washed afresh and gone over with the iron. The other half is then treated in the same way.

A workman can prepare three dozen skins in a day.

Badly tanned, badly limed or over-swelled skins are very difficult to manage.

These operations are always done by hand for calf, though machines are used to make "satin" and black leather.

5. Second Slicking.—The skins are dried by hanging in the loft or by hydraulic pressure. In summer they need not be dried but are passed over the stretching iron. This operation is intended to develop the fore leg pieces, to remove roughnesses, to polish the skin and prepare it for the next operation.

IV.—OILING THE GRAIN.

1. Dubbing.—This is made by mixing equal parts of light whale oil and melted tallow. The tallow is first melted in an iron vessel, and whilst it is as cool as possible the whale oil is poured in and stirred until it sets to a slimy, homogeneous mass. To avoid any granulation, some carriers add 10 to 100 parts of degreas or sod oil. Either cod liver oil or any other animal oil may be used, but vegetable and mineral oils must be avoided.

2. Oiling.—A thin coat of the dubbing is brushed on to the grain side of the skin, which is then folded in two and left in a pile for three days. Under the action of the composition, the grain regains all its softness and fineness. The oil penetrates the skin, whilst the tallow remains on the surface and preserves it in the next operations.

The grain should show a pretty nut colour without any marbling. This result cannot be brought about unless the grain has been uniformly tanned.

V.—OILING THE FLESH SIDE.

1. Moëllon.—Moëllon is a fatty material extracted from chamoyed skins (*see* "Chamoying"). It readily forms an emulsion with water, probably on account of the resinoid substances formed during the operations of chamoying. The oil extracted from moëllon

has a higher specific gravity than fish oil, which is '928 as against '950 of the resinified oil. Moëllon contains a quantity of fibre detached from the skins, which are accounted for in analyses under the name of organic matter. The fluidity of the sample depends on the proportion of this fibre.

Pure moëllon as it comes off from the skins has the following composition :—

	Per Cent.
Water	12
Fish oil	75
Organic matter	5
Resinoid matter	8
	100

The pure substance is seldom employed. It is used in the manufacture of *degras*, which is usually made up by the *chamoisiers* or by the *curriers* themselves, who prefer not to run the risk of buying an adulterated product.

2. Degras.—*Degras* is a mixture of animal fats with moëllon. The chief of these fats are *sod oil*,¹ obtained by the washing of skins in alkaline baths, fish oil and tallow. In moëllon *degras* the moëllon is mixed to the extent of 20 per cent., in ordinary *degras* only 5 per cent. is used. *Degras* is sometimes known in France as *bôte à encre*, because it contains any substances which imagination can devise to reduce its cost and increase its usefulness. When we describe *chamoying* we shall speak of its preparation.

3. Analysis of Degras.—The analysis of *degras* is necessary in every *curriery*. Its neglect leads to great difficulties and serious loss. We should add, however, that these analyses are carried out very badly in most chemical laboratories, especially where the chemists are ignorant of the various manipulations of skin, and of the object of the *degras*. Only special chemists should be employed, or else the *currier* should insist on its being carried out by the following method, due to Ferdinand Jean :—

(a) *Estimation of Water.*—Twenty gram. of the sample are weighed out in a tared dish and mixed with sufficient washed and ignited sand to form a solid dry mass. It is weighed again to obtain.

¹ *Sod oil* is now invariably obtained by pressing the leather in a hydraulic press.

the total weight and the weight of silica added. It is then dried in an oven at 120° C. The loss of weight is reckoned as water. Some authorities advise evaporation in *vacuo* over sulphuric acid, but this is unnecessary.

(b) *Estimation of Fat.*—Twenty gram. are weighed out, dissolved in petroleum ether and filtered through a small filter-funnel which has been weighed together with its plug of dried cotton wool. The petroleum ether which runs off is evaporated in a weighed capsule, dried at 120° C., and weighed as fatty matter.

(c) *Estimation of Insoluble Substances.*—The filter used in the last estimation is dried at 120° C., and weighed, the increase in weight being insoluble matter. The cotton wool and the substances remaining on the filter are placed in a platinum dish and ignited. If the insoluble substances are of organic origin, practically no ash will be left. If a considerable residue be left, it is weighed and analysed to detect clay, chalk, sulphate of lime or barytes, alum oxide of lead, etc.

(d) *Estimation of the Ash.*—Five to ten gram. are weighed out in a tared platinum dish, carefully burned, and the ash weighed. If the original sample has an alkaline reaction, the ash must be dissolved in distilled water and titrated for alkaline carbonates. If it be acid 25 gram. are weighed out and boiled with 200 cc. of distilled water. The mixture is allowed to cool in a separator, and the water drawn off. After discovering the nature of the acid, which is usually sulphuric, 50 cc. are titrated with standard alkali.

(e) *Estimation of Resinoid Matter.*—One hundred and fifty to two hundred gram. of the sample are heated over the flame until no more gaseous bubbles are formed and then filtered through linen. Twenty gram. of this fatty matter are weighed out and exhausted in alcohol kept at 40° C. on the water bath, shaken well and allowed to cool. Fish oil and neutral fats are very slightly soluble in cold alcohol, whilst resin dissolves readily. On evaporating the alcohol, a residue is obtained in which resinoid substances may be recognised; by treating the residue with petroleum ether, the pure resin is dissolved and the resinoids are left. Both portions are weighed.

(f) *Estimation of Mineral Oil.*—Twenty-five gram. of the

sample are weighed into a capsule, heated to 200° C. for some time, then cooled and saponified with 15 cc. of caustic soda (40° Baumé) and 15 cc. alcohol. The soap is dissolved in distilled water, boiled, and after cooling shaken up with ether. The ether, which removes the unsaponifiable matter, is run off and the soap is shaken up again with ether to remove the last traces. The ether is then evaporated, and the weight and nature of the residue determined.

(g) *Estimation of Free Fatty Acid.*—Five gram. of the fat obtained as in the estimation of resinoid matter are weighed out and boiled with 100 cc. alcohol. Several drops of phenol-phthalen are added, and the liquid is titrated with standard potash (·159 gram. of potash, K_2O , corresponds to 1 gram. of the fatty acids from whale oil).

(h) *Estimation of Glue.*—Degras often contains gelatin, formed by the action of warm water on the skins or their refuse, or sometimes added fraudulently to increase the consistency of the substance.

Twenty gram. of the sample are boiled with 100 cc. of water for ten minutes. Fifty cc. of the watery solution are measured out with a pipette and mixed with 20 cc. of 20 per cent. alum solution, and the gelatin determined with a 1 per cent. tannin solution. The two substances combine in equal weights.

Good degreas should have the following composition :—

	Per Cent.
Neutral fat	70
Fatty acids	12
Organic substances (skin fibre)	1
Resinoids	5
Water	12
Ash	'25
	100'25

It should contain neither free alkali, free acid, vegetable oil, mineral oil, iron, nor gelatin.

4. **Artificial Degras.**—As degreas, sod oil or moëllon owe their peculiar properties to the presence of resinoid substances formed by the oxidation of the oil used in chamoising, various methods have been suggested for preparing it in a cheaper way. Some of

these are successfully carried out on a large scale. The following are the chief processes :—

(a) *Livache's Process*.—This consists in agitating the oil with a mixture of finely-divided lead (precipitated from solution by zinc) and nitrate of manganese. This latter salt is remarkably soluble in oils. After decanting, the oil is shaken up with lead oxide to decompose the excess of manganese nitrate whose deliquescence would be inconvenient. Cod or whale oil when treated in this way gives a thick viscous oil, which has increased in weight 8 per cent., and which readily forms an emulsion with water and easily penetrates leather.

(b) *Schill and Seilacher Process*.—Either oil, or a mixture of oil, 100 parts, water, 15 parts, and caustic soda, 0.5 parts, is heated to 90° C. (194 F.), and a current of air passed through it.

In another process used by the same inventors, hydrogen peroxide is mixed mechanically with the oil at 30° C. (86° F.). The temperature rises a little and the substance sets. Two per cent. of the commercial peroxide is required.

(c) *Nitric Acid Process*.—The oil is heated to 80° C. (176° F.) and mixed with 3 per cent. of nitric acid (36° Baumé). After the reaction is over the excess of acid is neutralised with a little ammonia. This gives a deeply-coloured oil, which is never used in France. In certain German towns no other is used.

(d) *The Oxidising Tower*.—The author has constructed an apparatus for making artificial moëllon from cod-liver and whale oils. It consists of a sheet-iron tower 17 ft. 6 in. high by 1 ft. 9 in. diameter. At the top of this tower is a reservoir for the oil which is allowed to run on to a platform pierced with very small holes. Through each of these holes passes a piece of cotton ending in a knot which acts as a stopper to the hole. Each thread is 17 ft. long and is stretched perpendicularly, there being 200 threads altogether. The oil after reaching the platform runs slowly by capillarity along the threads to the bottom of the tower and is received on a second platform whence it runs into another reservoir. A current of air warmed to 50° C. (122° F.) rises through the tower, escaping by a chimney which passes through the upper platform. The

oil is oxidised sufficiently after running down the tower three times.

(e) Oil may be oxidised by adding phosphate of ammonia, and thus encouraging the growth of certain moulds, especially *Oleorum microcladus* (Villon) or by passing a strong current of electricity through the oil in the presence of oxidising gases (Müthel and Lükke).

Oils prepared in any of these ways are mixed with 5 or 10 per cent. of tallow to give the necessary consistency.

The analysis of artificial degreas gives the same results as for moëllon; they are, however, rather purer.

5. Oils Used in the Dressing of Skins.—The currier has his choice of some 120 animal oils. He ought to be guided in his choice by his geographical position, the climate, the class of skin, and the price and peculiar properties of each oil. He will get the best and most economical results by an intelligent mixture.

We give below some of the most important properties of each of the principal oils and fats used in dressing skins.

Cod-liver Oil.—Three varieties of oil are extracted from cods' livers: white, or pale oil, of a golden yellow colour, sp. gr. 0·923; brown oil, similar in colour to Malaga wine, sp. gr. 0·924; and black oil, dark brown, appearing greenish-black by reflected light, sp. gr. 0·930. Cod-liver oil contains 12 per cent. free fatty acids and 2 per cent. resinoid matter.

True cod-liver oil is extracted from *Gadus morrhua*; other varieties are obtained from *Gadus aeglefinus*, *Gadus carbonarius*, and *Squalus glacialis*. To distinguish between these oils, 10 parts of the oil are placed in a stoppered bottle with 1 part of a mixture of strong nitric and strong sulphuric acid in equal proportions, and vigorously shaken. The oil of *Gadus morrhua* at once becomes a bright rose colour, which quickly changes to lemon yellow; the oils of *Gadus aeglefinus* and *carbonarius* first become bright rose, but the yellow which follows is not so pure; the oil from *Squalus glacialis* becomes rosy red, and changes to brownish-violet.

Cod-liver oil is adulterated with seal oil, which may be detected by adding *aqua regia* (2 parts hydrochloric and 1 part nitric acid).

Cod oil becomes deep greenish-yellow, which turns brown in half an hour, whilst seal oil gives a very clear yellow (Rossler).

To recognise ray-liver oil, it is treated with a current of chlorine. Cod-liver oil turns brown, whilst shark oil remains yellow even after half an hour's action.

To recognise fish oils, fuming nitric acid is added. Pure oil gives a fine rose colour which does not appear in mixtures (Boudard).

Cod oils are mixed with olive or colza oils, which are very prejudicial to the skins. To detect these the iodine, of which the oil contains 0.02 per cent. to 0.03 per cent., is determined. All oil containing less is suspicious. The iodine or iodide occurring naturally in the oil cannot be extracted by shaking with water or alcohol, whilst any of these substances which may have been added artificially is easily removed in this way. Lastly, colophony resin is added to cod oil. This is the cause of many troubles in currying. It thickens under the oxidising action of the air, and exudes from the leather in sticky drops. To detect this fraud, 1 cc. of the oil is dissolved in 12 cc. acetic ether (density 0.890) in a graduated cylinder 30 cm. long by 15 mm. diameter. The tube is closed and shaken vigorously. It is allowed to stand for a minute, keeping it as near 17° C. as possible. If, after this time, the liquid is not turbid it most certainly contains resin. To obtain a limpid liquid, with pure oil 15 volumes of acetic ether are required; the less ether required the more resin is present. Each volume less than 15 represents 5 per cent. resin.

Fish Oils.—Colour, yellowish-brown; sp. gr. 0.930. They do not solidify at 0° C. One hundred parts of alcohol (95°) dissolve 122 parts of oil; the solution does not become turbid until 63°. It is not acid. Other properties similar to those of cod oil.

Whale Oil.—Usually white; sp. gr. 0.930. It freezes at 0° C. and deposits a white fat. It is soluble in its own volume of alcohol at 75° C. (167° F.).

Sperm Oil.—Clear, transparent yellow; sp. gr. 0.884. Solidifies at 8° C. (46.5° F.).

Dolphin Oil.—Lemon yellow; sp. gr. 0.920. Solidifies at 3° C.

(37° F.). One hundred parts of 81° alcohol dissolves 110 parts; 70° dissolves 100 parts; absolute alcohol dissolves 123 parts at 20° C. (68° F.). The alcoholic solution becomes turbid at 52° C. (126° F.). It has no action on litmus.

Porpoise Oil.—Pale yellow; sp. gr. 0·938. One hundred parts of boiling alcohol ·81 dissolves 20 parts of this oil. It does not redden litmus.

Tunny Oil.—Reddish-yellow; sp. gr. 0·927. Thickens at 5° C. (41° F.).

Alligator Oil.—Reddish-yellow, semi-fluid, unctuous; sp. gr. 0·928. Solidifies at 5° C. (41° F.).

Crocodile Oil.—Reddish, more fluid than the last; sp. gr. 0·900. Solidifies at 2° C. (36° F.).

Shark Oil.—Reddish, thick; sp. gr. 0·891. Solidifies at 2° C. (36° F.).

Seal Oil.—Yellow; sp. gr. 0·925. Freezes at 5° C. (41° F.).

Salmon Oil.—Pale yellow; sp. gr. 0·920. Freezes at 0° C. (32° F.).

Sardine Oil.—Pale. Solidifies at 20° C. (68° F.). Reddens litmus.

Sturgeon Oil.—Pale to reddish-yellow; sp. gr. 0·910. Reddens litmus.

Menhaden Oil.—Brown, sp; gr. 0·923. Solidifies at 4° C. (39° F.).

6. Tallows and Fats.—Certain fats are mixed with the oils to increase their consistency and render them better fitted for dressing skins. The most common is tallow, but other fats may be used. Below are given the chief ones:—

Tallows.—Tallow such as is extracted from animals is enclosed in cellular tissue; it is called leaf tallow or suet.

The fat is separated from the membrane either by melting over a fire, or by the action of acids. Preference should be given to that which has been melted out. One hundred parts of leaf tallow give 80 parts of melted tallow.

Mutton Tallow includes the tallow from rams, sheep and goats. It is a hard, pinkish-white substance, melting at 39° C. (102° F.).

Beef Tallow, from cows and bulls. White, hard, non-opalescent; melting at 37° C. (99° F.).

Lard, or pig fat. White, odourless, melting at 28° C. (82° F.); sp. gr. 0.938.

Marrow Fat.—Yellowish-white, melting at 26° C. (79° F.).

Ox Fat.—White or yellowish, melts at 45° C. (113° F.).

Bone Tallow.—Yellowish-white, melts at 36° C. (97° F.).

Suint.—This substance, which is extracted from wool washings, is nowadays largely used in currying. It is easily absorbed by leather. We shall give several formulæ for degreas in which it is used. Suint is treated in various ways to produce suintine, suint stearin, suint olein, etc.

7. Composition of Dubbing for Skins.—The currier makes the dressings for his skins himself, preparing them differently according to the season, the quality of the skins, and many other conditions, the correct understanding of which is the outcome of experience.

The dressing is usually prepared in the following manner: The currier places 70 kilos. (154 lb.) of degreas in a tub, and pours into it 30 kilos. (66 lb.) of melted tallow, heated until a finger cannot be held in it. The degreas melts, and the whole forms a homogeneous liquid which sets on cooling. Whilst cooling it must be well stirred, so as to form a soft, unctuous, semi-fluid mass without any trace of granulation. In summer it takes a long time to solidify, even a day sometimes, unless a stream of cold water be circulated outside the tub. Under these circumstances the stirring must be more thorough, to prevent the substances from separating, and the tallow need not be heated so much. In winter, on the other hand, the tallow is heated more strongly and less is used (80 parts of degreas to 20 parts of tallow). It is stirred vigorously to prevent the rapid separation of solid matter.

We recommend the following method both for large and small currieries: Melt the tallow at a temperature of 45° C. (113° F.) in a cast-iron boiler. Melt the degreas at 30° C. (86° F.) in a similar vessel. If steam be at hand the operation can be carried out in two wooden vats, heated by a worm, and placed 4 ft. above the ground. Each of these vats must be furnished with an effluent

tube fixed near the bottom through which the melted fats may be run out into a vat standing on the floor. This vat must be long and rectangular, like a dyer's vat, and large enough to hold the contents of both melting vats. Before allowing the degreas and tallow to run together they should be filtered through a copper or galvanised iron sieve to remove the foreign matters which these substances always contain, and which have a serious action on the cutting edges of tools used in later operations. The idea of using a long vat is to facilitate mixing, which is done lengthways. We cannot see any advantage in mechanical stirring. Hand labour is cheaper, because when the mixture thickens a mechanical stirrer would require considerable power; besides this, mechanical stirring has the disadvantage of complicating operations because the agitator must be removed before taking the mixture from the vat and all its parts must be scraped to remove adherent grease.

8. Artificial Dubbing.—Although degreas gives excellent results when made from pure substances, considerations of economy has driven manufacturers to seek some other mixtures of animal fats. We give some of these mixtures which we have seen used in France and abroad. They may be prepared either in a cast iron boiler or in wooden steam-heated vats. The best way is to melt the more solid substances first, then add those which melt more easily, finishing with the liquids.

1.		2.	
	Parts.		Parts.
Moëllon	30	Moëllon	25
Cod-liver oil	40	Suint oil	45
Tallow	30	Tallow	25
		Water	5
3.		4.	
Artificial degreas	30	Artificial degreas	25
Cod-liver oil	30	Cod-liver oil	15
Tallow	30	Suint	25
Water	10	Tallow	25
		Water	10
5.		6.	
Suint	40	Neatsfoot oil	25
Neatsfoot oil	20	Hog's lard	25
Whale oil	10	Whale oil	25
Cod-liver oil	10	Tallow	10
Tallow	10	Water	10
Water	10	Vaseline oil	5

It is unnecessary to add that the cod oil may be replaced in these recipes by any of the fish oils which have been enumerated.

9. Greasing.—The skin is spread out on the marble up to the shoulders and carefully examined to see which parts are thick and which weak. The degreas is taken up from the corners of the slab, where it has been placed beforehand, with a fairly soft brush. The first stroke is given on the left buttock, the next on the right, leaving plenty of grease on each. It is then spread gently across the rump and over the whole width of the skin from the buttocks to the shoulders. A second coat is given to the hind feet, the rump, the flanks and the belly-pieces, each according to its thickness. Male calves receive a nearly even layer of grease. Females should receive less on the rump and flanks, which are thin, and more on the back.

The greased part is then half-lifted and gently folded back so as to bring the neck on to the table. The grease is placed on the strong part and spread over in the same way as on the buttocks. The stronger parts such as the fore feet, the neck, and the shoulders then receive another coat, care being taken that the sides of the neck are not left dry.

The skin thus receives grease to the extent of 25 to 30 per cent. of its weight, about 5 per cent. of its weight being applied to the grain.

This done, a slit $1\frac{1}{2}$ in. long is made in each of its hind by-pieces and a dog-berry wand is passed through. It is then taken to dry.

The grease should be applied to the skin whilst still damp so that the oil may only penetrate slowly and as the skin dries. Degreas which requires 10 per cent. of water to make an emulsion penetrates in a much more even manner. The object of using the degreas or moëllon is to preserve the homogeneity of the grease.

When degreas is badly made, when it is granular, or badly emulsified, the fibre of the skin has a selective action, the tallow remaining outside and the oil rapidly filtering through to the grain. It is not properly absorbed and will afterwards sweat out the oil. A good degreas should melt at 24° C. (75° F.). Six dozen skins can be greased in a day.

10. Greasing in the "Tumbler".—Sometimes calf skins are

greased ("stuffed") in the "tumbler". They are placed in the drum with about half their weight of grease, and turned at the rate of three revolutions per minute. The temperature rises slightly from the friction and the grease becomes liquefied, and is, so to speak, forced into the skin. We have occasionally known the contents of the machine rise to a temperature of 50° C. (122° F.). The degrease used for this process should be hardened by the addition of 25 per cent. more tallow. For instance, 60 parts of ordinary grease may be mixed with 40 parts of tallow. The operation takes two hours.

In this way the skins are more heavily charged, and both manual labour and grease are economised; but on the other hand the work is not carried out with such care as can be done by hand. The strong parts are not sufficiently charged, whilst the weak parts are over nourished, and the grain is not so fine.

One hundred lb. of skin use 35 to 40 lb. of grease.

11. Drying.—The rods which have been threaded through the holes in the skins are hung on rings in a drying loft similar to that described for the drying of leather, and kept at a temperature of from 16° to 20° C. (64° to 68° F.). Drying should occupy six or eight days. If the skins are left longer, they are apt to grow mouldy. If they are dried too quickly, the grease runs and the skins are marbled.

When dry, they are taken down, folded in two, grain inside, and piled in heaps of twelve dozen. Planks are laid on top and weighted down by stones. They are left in this state for at least eight days. In some large factories they remain for a month. The grease gets absorbed and the calf increases in weight and acquires a finer colour.

The excess of dubbing is removed with a well-sharpened knife. The skin is placed lengthways along the table. The slightly inclined knife is drawn over the skin, pressing strongly; all grease which has not been absorbed is thus scraped off and is put on one side to sell.

12. Yield.—One hundred lb. of dubbing applied by hand gives the skin an increase of 42 lb. If 300 lb. of dry skin are charged

with 100 lb. of grease it will return on drying to 342 lb.; this loss is made up as follows :—

	Per Cent.
Loss of dubbing during manipulation	5
Dubbing removed with the knife	12
Loss of water in the dubbing	12
Loss of water displaced by fat	30
	59

On an average 100 lb. of skin gain 18 lb. after greasing. Some houses obtain 25 lb. increase; but they charge with a large excess of oil and this depends on the method of tanning.

One hundred lb. of grease applied in the “tumbler” give an increase of 80 lb. to the skins. If 200 lb. of skin have been placed with 100 lb. of degreas, 280 lb. of skin will be obtained after drying. The loss is made up thus :—

	Per Cent.
Loss of dubbing	2
Dubbing removed by the knife	4
Loss of water in the dubbing	9
Loss of water displaced by fat	5
	20

On the average 100 lb. of skin increases in weight by 35 lb. after the mechanical process.

VI.—WHITENING AND GRAINING.

1. **Whitening** is the next process. It was formerly done with a round iron but nowadays it is generally done with a paring knife. The work requires great accuracy and can only be done by skilful and intelligent workmen. The knife is first sharpened on the grindstone and then on the oilstone until it has a razor edge. This is felt with the thumb nail to make sure that it has no dents. The bevel is then greased with tallow and bent back with the steel.

The skin is worked first lengthways then across with delicate strokes. This is done on a wooden table similar to the marble one and covered with a plate of polished zinc which must be carefully cleaned before each skin is stretched on it. The least piece of grit which raises the skin will damage both the skin and the edge of the knife.

The finest possible shaving must be removed from the surface of the skin, the skill of the workman consisting in giving the best possible appearance to the skin with the smallest loss.

The grain side is next slicked in the same way as the flesh side, to remove the dubbing.

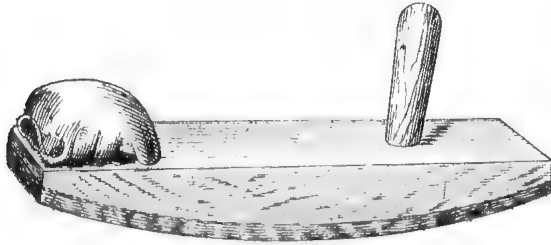

FIG. 51.—Crippling Board.

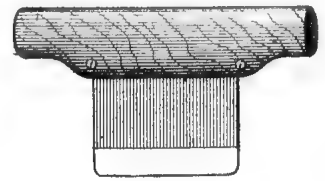

FIG. 52.—Whitening Sleeker.

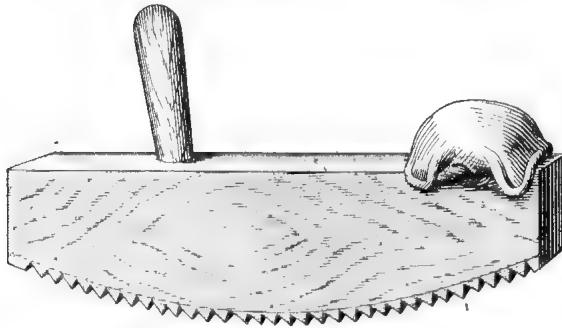

FIG. 53.—Crippling Board for Calf.



FIG. 54.—Waxing Brush.

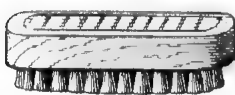

FIG. 55.—Waxing Brush.

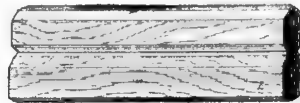

FIG. 56.—Tool for straightening necks.

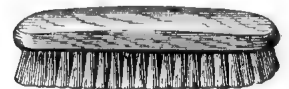

FIG. 58.—Cleaning Brush.

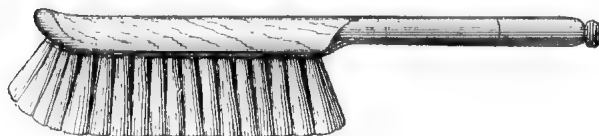

FIG. 57. Cleaning Brush.



FIG. 59.—“Glass.”

CURRYING TOOLS.

2. Graining. -The object of this process is to give a certain texture to the skin which varies according to the fancy of the maker, barley grain, multiple grain, etc. The work is done with a soft pummel. This consists of a curved piece of wood 12 in. long

by 6 wide. The upper part is flat and furnished with a leather handle, the lower portion is covered with cork. A wooden table is used.

The skin is held by the hind shank which is rolled up as far as the navel with the left hand. Then holding the cork firmly in the right hand and pressing firmly, the skin is worked backward to form a grain, beginning at the navel and working from left to right and moving through a quarter of the width of the cork ($1\frac{1}{2}$ in.) between each stroke. Thus the right flank is slowly passed over until the right hind shank is reached. The process is then repeated on the other three quarters. A workman can grain eight dozen per day.

VI.—WAXING.

1. **Making the Wax.**—The blacking or wax used for skins is essentially fat, being composed of lamp black, linseed oil, cod-liver oil, and some black dye. The currier prepares his own mixture, as the article sold by makers is far from perfect; moreover, it does not keep well.

The lamp black must be of the highest quality, made by burning Burgundy peas, terebinthine or oil. It is calcined three times to destroy all impurities. As it is sold ready for use and well made, I shall not trouble here to go into the details of its manufacture. It ought to be free from grit and very light. It must be kept in a warm, dry place, as it easily absorbs water and then does not give a good polish.

Here is the recipe for ordinary wax :—

	Per Cent.
Cod liver oil	45
Linseed oil	20
Tallow	25
Light lamp black	4
Ox gall	2
Yellow wax	1
Alcohol	2
Pyrolignite of iron	1
Aniline black	0'05
Indigo carmine	0'2

100'25

The linseed oil is placed in a vessel and the lamp black poured over it. They are left together without any stirring for twelve hours. That is to say, they are put together in the evening and left to stand for the night. When the black is of good quality it sinks into the oil and forms a fine homogeneous paste. This is placed, a little at a time, on a zinc plate and rubbed by hand by a workman who breaks up any rough parts with his fingers. It is then placed in another vessel and the cod oil stirred well into the mixture. Next the tallow is melted together with the wax, heated to 50° C. (122 F.) and poured in. A fine, even, black liquid is thus obtained. The other substances are added in the following order, with constant stirring: ox gall, alcohol, pyrolignite.

The aniline black is dissolved together with the indigo in 200 parts of water and added to the mass. It is then stirred until perfectly cold. In winter rather less tallow is used and the cod-liver oil is gently heated before mixing with the black.

The ox gall helps the wax to run over the surface of the leather, the alcohol enables it to dry quickly, and the pyrolignite acts as a mordant to fix the aniline black and indigo carmine on the surface of the leather.

In place of pyrolignite black beer may be used.

The black is sometimes mixed by machinery, but the work is best done by hand. The usual form of machine consists of three rubber-covered cylinders working together.

2. Extra Wax.—For the finest quality of calf, and to give a high finish, we give a formula used by a house of the foremost rank which has kept it secret. Its only fault is its cost.

	Per Cent.
Linseed oil	20
Olive oil	40
Tallow	15
Lamp black	4
Eggs	8
Alcohol	2
Ammonium vanadate	0.01

The black is made up as usual with the linseed oil, and the olive oil and melted tallow added. Then the eggs are beaten up with a little ammonia and poured in. Finally the vanadate is dissolved in the alcohol and stirred well into the mixture.

3. English Wax.—A caustic polish, which, when well made, gives excellent results is:—

A.		B.	
	Parts.		Parts.
Water	25	Cod-liver oil	50
Gum-arabic	6	Yellow wax	6
Soap powder	6	Prussian blue	2
Aniline black	2	Lamp black	6
		Glycerin	2

To prepare A, the water is boiled and the gum is dissolved, next the soap and lastly the aniline black. For B, the wax is melted and mixed with the oil and glycerin; then the black is stirred in, a little at a time, and finally the Prussian blue. The two compositions are mixed hot, stirring until cold, and rubbed together either by hand on a zinc plate, or between rubber rollers.

We have replaced the gum-arabic by linseed mucilage of which we shall give the preparation later.

The drawback possessed by this polish is that it drags a little under the brush, but this is easily remedied by the addition of a little soft soap.

4. Waxing.—A dozen skins are arranged on the table with the larger ones underneath (flesh side up) and the butts at the upper part of the table. The blacking is in a vessel with one side higher than the other. It is spread with a special brush, which is round, 5 in. in diameter, and has very short hairs, less than $\frac{1}{2}$ in. long (see Fig. 54). This is dipped in the polish and struck against the higher side of the pot to spread it evenly over the brush, and remove excess, then it is placed on the rump end of the skin and worked round and round until the whole of the flesh side is well dressed. During this operation the workman holds the skin in position with his knees and presses as strongly as possible on the brush, which he holds with both hands. From the rump he works down to the neck and along the flanks. Any clots are immediately removed with a knife.

The skin should be quite black and not show any reddish parts in strong daylight.

The waxed skin is brushed when dry, rubbed by hand, and then cleaned with a horse-hair brush.

This being done, the neck is blackened. The blacking must not be put on too thickly and must not be allowed to penetrate to the grain. Should the skins be highly charged with dubbing the blacking must be used very cautiously.

A workman can wax six dozen skins per day.

Waxed skins are folded in two, grain side within, piled on the beam and left thus for at least a day. In good works, they are left two days. During this time the blacking sets, and becomes even and fixed in the skin.

VIII.—FINISHING.

We now come to the most delicate operation in the manufacture of calf, the final touch, which gives it the appearance and finish demanded by the buyer.

Finishing is the most difficult of all a currier's work, and good finishers are rare; they are more difficult to find than good curriers, though both are absolutely necessary for the production of a first class article.

It is surrounded by such conditions and influences that a currier who is excellent in all other work may be a very second-rate finisher. We shall enter into all the necessary explanations of this important question.

1. Preparation of the Size.—Glove skin is boiled with water. Kid clippings give the best results. The Grenoble glovers carefully collect all their waste to sell to curriers. It ought to be carefully selected, and no trace of paper, cloth, or chamois leather should be left in it. The latter especially should be avoided, as it gives a fatty size. The best Grenoble glove kid leaves an insoluble residue of 15 per cent. The choice glove kid is placed in a cylindrical basket, 3 ft. 6 in. long by 1 ft. 9 in. diameter, which turns on a horizontal shaft so that its lower half may be always immersed in the water of a vat. In this way the kid is washed free from dust and all foreign matter. It is then taken out and left to soak over night in clear water, 44 lb. of cleaned kid is placed in a cast-iron boiler with 22 gallons of water and 440 lb. of white soap, and boiled gently for six consecutive hours, renewing the water from time to time, to com-

pensate for loss by evaporation. The soap is added to neutralise the effect of the alum and other mordants which have been used in dyeing the kid. We have many times noticed that the kid is reduced to gelatin in four hours, but it is not sufficiently strong. If heated for more than six hours it becomes too brittle thus, from five to six hours is the best length of time for boiling, and gives the highest yield.

Next the glue is filtered. Three filters of different coarseness are used. The top one retains large pieces of skin, the next retains coarse fibre, and the last removes all fine dust. They are simply wooden frames 18 to 20 in. high with metal gauze stretched below them and fitting one inside the other.

These filters are placed in the middle of the vat which is to receive the gelatin. It is 24 in. high by 20 in. wide and has two parallel wooden bars fixed across it, to support the filters. Such vats will just hold the liquid from the boiling described above. If larger quantities are prepared it is better to use several vats of this size rather than a larger one, as the cooling goes on better and the layers of glue separate out more evenly.

The vats are carried to a cool place, such as a clean cellar, and allowed to set. To prevent any putrefaction, half a per cent. of zinc sulphate or mercuric chloride is added. Whilst filtering, the filters should never be disturbed, as this will cause particles of dust to come through. Should the filters get stopped up, no more liquid must be poured in, the filters must be allowed to drain, then removed and cleaned with boiling water and a metallic brush. In many works, a jet of steam is allowed to play on the lower surface of the filter. This arrangement has always given good results in the author's hands. The residue is boiled for an hour with fresh water to exhaust it, and then for five hours with a fresh lot of skin.

In winter the size takes twelve hours to set, and in summer twenty-four hours.

One lb. of kid gives 5 lb. of size.

When setting, the size separates into three layers. The first, brilliant, with an equally brilliant fracture, constitutes the upper half. Three-quarters of the rest is pasty and granular; whilst the

bottom layer is dirty and should be reboiled with the residue from the filters. One-third of the upper layer is set on one side for the final operation, and the remaining two-thirds used to make up the sizing paste.

2. Preparation of the Size.—The size is an intimate mixture of tallow and gelatin, with which all the unevennesses of the skin can be filled up, so as to leave a perfectly smooth surface. It is the preparation of this size which presents the greatest difficulties to the finisher.

The gelatin is cut up into little cubes, and about a pound placed in a clean white cloth. The cloth is folded over it so as to make a round ball, then squeezed to force the substance through it. A fine thread of gelatin will run through each pore of the cloth. A second filtering of this kind will give a very soft mass.

A cake of mutton tallow about 10 in. high, by 29 in. diameter, is carefully scraped to remove all impurities from its surface, then placed on a table and pared into thin shavings with a knife. When enough of these shavings have been cut off, they are rubbed together by hand on the zinc table until they form a pasty mass, the warmth of the workman's hands softening the tallow sufficiently.

Equal volumes of tallow and gelatin are then taken and worked together with the fingers, so as to make a fairly intimate mixture. If it be worked too long, the gelatin will be melted and run out from the mass. Some workmen use a piece of hard wood, 8 in. long, 3 high and 2 wide, curved on its lower surface, with which to heat up the mixture, but good finishers usually prefer to use their hands. We have noticed that when a man uses his fingers, he works a considerable quantity of air into the mass which softens the tallow and facilitates the mixing. This air plays a considerable part in the work of the size. It gives a softer and better-looking mass. The wooden beater does not give such an emulsive preparation.

This paste, which the workmen call first size, ought to answer to various tests and fulfil certain conditions.

(a) It should be made from glove skin, chiefly kid; no other gelatin answers the purpose.

(*b*) The glue should not be putrid nor liquefied in the least. This is assured by the use of antiseptics as described above.

(*c*) The tallow should be rubbed by hand so as to introduce a quantity of air. It should be free from the smallest particle of grit.

(*d*) The gelatin should be very finely divided by passing it several times through a cloth.

(*e*) An even temperature of 20° C. (68° F.) is absolutely necessary. This is the temperature at which the paste should be kept whilst in the process of manufacture, and the temperature at which it should remain whilst being used. In good workshops this condition is fulfilled at all costs. When the temperature is higher, the mass loses its firmness and is constantly running. To overcome the difficulties of working on a hot summer day, the workmen often make up their size very early in the morning, after having cooled down the tallow in cold water. When the temperature falls below 68° F., the tallow becomes too hard and will not mix with the gelatin. The mass becomes granular and useless.

(*f*) No violence should be used in the preparation. The two substances should mix naturally and easily. They should be slowly spread out together, and the edges of the mass folded over to the centre, spread out again and refolded, until the mass is homogeneous.

(*g*) The workman's fingers are the best implements for mixing, but his blood must not be overheated; he must not have been making merry the night before, as his fellow-workmen would suggest, and he must not be too active. However ridiculous these remarks may seem, they are nevertheless true, and will be best appreciated by those who have attempted this work. The author can make up size fairly well, as he possesses a quiet temperament and considerable patience.

Workmen who cannot make the material with their hands sometimes use a comb.

(*h*) The tallow and gelatin should be mixed in equal volumes (3 parts by weight of gelatin to 2 of tallow). An excess of tallow gives a paste that will not spread, or if by dint of great care it

should be placed on the skins, it will come off on the glass (*vide infra*) and the skin will stain. Too much gelatin will give a paste which refuses to polish.

(i) Skins which have been over-greased, should have a special paste made up, containing an excess of gelatin, or they will work as though too much tallow were present. On the other hand, under-greased skins should be dressed with a paste rich in tallow.

(j) The paste must be used on the day that it is made, especially in summer. Paste should never be made up the night before using.

(k) It ought to spread easily under the brush. The more one rubs, the more liquid it should become (without separating). When it is badly made it catches, forms lumps on the skin, or even separates, the tallow remaining on the brush, and the gelatin running on to the skin. The brush should not harden after use.

To find out whether the mixing has been well done, and whether the paste will run easily on the skin, the following test may be applied. Take about 2 gram. on the end of a finger, and rub it in the palm of the other hand. After four or five turns it should liquefy, and should remain liquid as long as the rubbing is continued. If the tallow sticks to the skin and the gelatin shows up in liquid spots, or if any resistance is felt to the motion of the finger, the probability is that the paste will be difficult to apply to the skin.

(l) The size should readily combine with the blacking which is already on the skin. It should not wash over it nor come away from it.

(m) Size, after being applied to the skin, should not be dried too rapidly, *i.e.*, not in less time than twenty minutes, and however it may be, it should remain flexible and easy to work with the glass. Large excess of gelatin makes it hard. Too much tallow makes it soft.

In glazing, the paste should not dry. If it rolls up under the glass, too much tallow has been used.

3. Mechanical Preparation of the Size. — In large factories, where as much as 500 lb. of size is used in a day, machinery has been devised to do away with the inconvenience of bad mixing.

The gelatin is placed in a cast-iron cylinder, the bottom of which, is made of copper gauze, through which it may be forced by an accurately fitting piston. In the side of the cylinder is an opening through which the gelatin is introduced. The opening

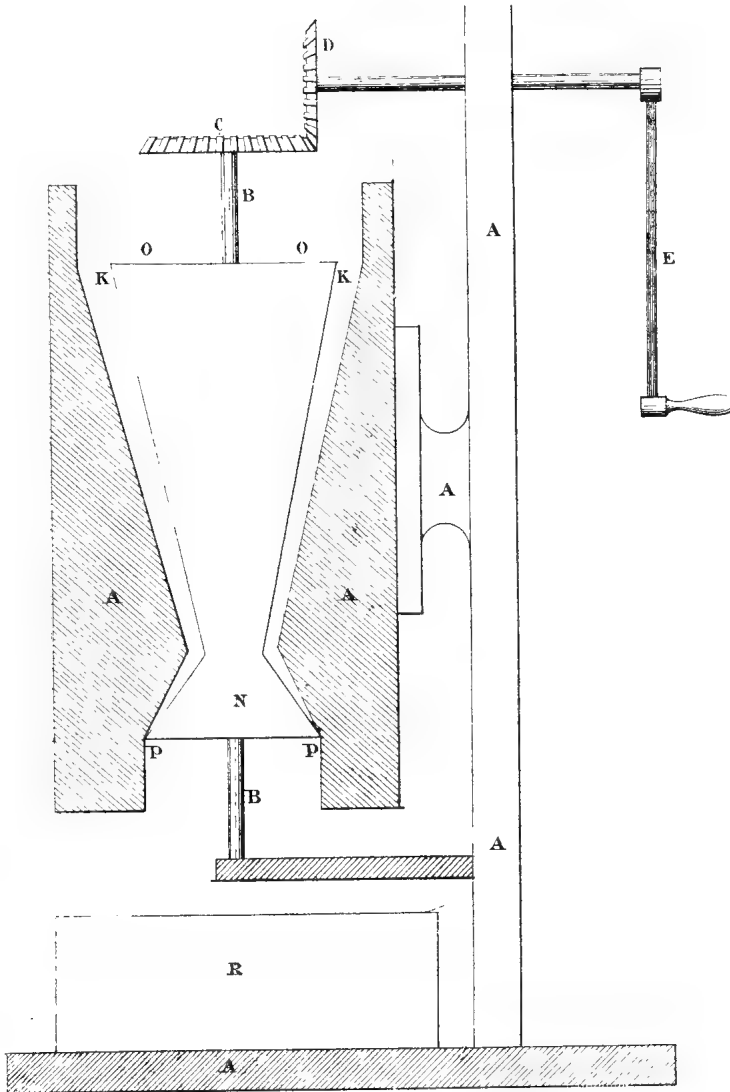

FIG. 60.—Tallow Grinding Mill.

being closed afterwards by a door whose interior is flush with the inner surface of the cylinder. With this arrangement the gelatin is broken up and is forced through the gauze two or three times.

The tallow is ground in a mill very similar to an ordinary coffee

grinder (see Fig. 60). The apparatus consists of a strong cast iron erection A A A, in the middle of which is a shaft B, which may be rotated by means of the handle E. On this shaft is a double cone O O N, made of hard wood and carrying a helical groove, which at the end O is 2 cm. (nearly an inch) wide and the same depth. As the groove approaches the end P, it gets finer and finer, until it is only $\frac{1}{50}$ in. wide. This double cone does not fit accurately into A, but leaves a space 2 in. wide (K) at the upper end, which grows narrower until it is only $\frac{1}{100}$ in. at P. The edges of A and the upper surface of the cone form a sort of vat O O, into which the tallow is thrown. As the cone revolves, the substance is dragged down, broken up and discharged into the receptacle R, where it may be examined, and, if necessary, returned to O.

The mixture of the tallow and gelatin is made in a shallow cylindrical vat. An agitator turns in this vat, consisting of two horizontal arms, each bearing teeth, so as to form a sort of rake or comb. The teeth reach the bottom of the vessel. The mixture is made by turning these arms for about ten revolutions in one direction, then the same number in the opposite way, and so on until the mixture is complete.

4. Black Sizing.—The skin is placed on a table and brushed to remove all dust and nodules of black. Next the paste is smeared on several places at one end of the skin and vigorously rubbed in with a fairly hard brush. The workman holds the brush with both hands and spreads the paste across the skin, causing sufficient friction to liquefy the paste. More dressing is used for males than for females, and more on the flanks and throat than on the back. The brush is moved over the skin in a series of figures of 8, and afterwards the paste is made even by strokes across its breadth. The skin is then turned, and the operation repeated on its other side. Finally, it receives a brushing lengthways.

The skin is hung up on a horizontal iron bar by means of a hook which passes through a hole punched in the throat.

In summer each skin is only allowed to hang whilst three or four more are being dressed (from twelve to fifteen minutes). In winter each is allowed to hang whilst six are being dressed (or

twenty-five minutes). They are then taken down, folded in two, grains within, and piled on the beam and left for at least five or six hours.

5. Glassing.—Large skins are glassed on a marble table, medium sized ones on a walnut table, sometimes covered with zinc, and small ones on a leather sheet. In the last case, the leather is powdered with talc to prevent the skin from sticking. The skins are stretched on the table and worked over with an instrument exactly like a slate, excepting that the blade is made of glass about half an inch thick and with a rounded edge. Starting at the neck, strokes are given diagonally or directly across the skin as required, working slowly to the other end.

6. Sizing.—A quantity of the brilliant clear gelatin which has been prepared as described in paragraph 1 of this section is melted, diluted with a quarter of its volume of water, and mixed with 10 or 12 per cent. of lard. The skin is spread on a table with the neck at the top and sponged evenly with the size, drawing the sponge across in straight lines. It is then hung up to dry for at least twelve hours in some place free from dust.

The finished calf should have a brilliant deep black surface which will not be permanently marked by pressing a finger on it.

7. Mechanical Finishing.—In England, calf is finished by machinery. An arrangement very similar to a printing machine is used. It is dragged through a system of rollers which expose every portion of it to the action of brushes which cover it with blacking. Thence it runs over a table where it receives a warm paste of tallow. Glazing takes place between two indiarubber cylinders, and it is finally finished with a sponge. Unfortunately, skins treated in this way, in spite of their good appearance, have not the solidity of those prepared by the French method.

8. Yield.—Average sized skins receive :—

	Gram.	Lb.
Black	400	·88
Paste	200	·44
Gelatin	100	·22
	<hr/>	<hr/>
	700	1·54

This $1\frac{1}{2}$ lb. of material leaves in the finished skin about $1\frac{1}{10}$ lb., or 70 per cent. In the finishing, therefore, the skins gain about 5 per cent. in weight.

Some carriers add weighting matter to the blacking or the paste to obtain a greater yield. This gives a tarnished leather.

IX.—DRY FINISHING.

This method is a much quicker one than that just described, and does not present anything like the same difficulties. It gives just as good an appearance, but the finish is not so lasting. It is mostly used where the calf is to be made up into boots or shoes at once.

The substance used is very fine talc which has been sifted through flannel. Since this powder is white, a good precaution is to dye it black. This is done by first soaking it in a bath of tannin, then in one of pyrolignite of iron and verdigris. It is then filtered through flannel, dried and re-powdered.

The calf is blacked very heavily. English wax gives good results ($1\frac{1}{3}$ lb. per skin). It is left for a day and then powdered. The powder is lightly rubbed in by hand, then well brushed to make it adhere strongly to the polish. The skin is next folded and left for a day.

At the end of the day it is brushed again with a paste-brush, glazed and sized, using a size containing 20 per cent. of lard.

By using powdered soap instead of talc, a very beautiful finish is obtained. The manipulation is exactly the same as when using talc.

X.—FINISHING IN COLOUR.

Finishing in colour, of which the author has been the promoter, is quite a new industry. Spain, which is always fond of bright colours, has been the first to use coloured calf. The first attempts to produce it on a large scale were made in 1887. The East will, doubtless, soon buy large quantities of shoes in coloured waxed kid.

Here are the details of manufacture, which is even more difficult than finishing in black:—

1. **Colours.**—Only mineral colours or lakes are used; vegetable and artificial colours do not possess the necessary body. The colour is ground in pure linseed oil, as colourless as possible, and the other substances rubbed in with the precautions already given.

The composition is as follows:—

	Parts.
White or pale whale oil	45
Linseed oil	30
Tallow	20
Colouring matter	3.5
White wax	2
Alcohol	2

Red.—For this colour Florentine lake, Venetian red, mineral red, Mars red and vermilion are used. The last is expensive, but gives a very fine colour. It is only used on the finest skins. For coarse skins red ochre may be used.

Blue.—Mineral blue, Orient blue, Prussian blue, Brema blue, ultramarine.

Yellow.—Chrome yellow, Naples yellow, Mars yellow, Washington yellow. For coarse work, washed yellow ochre, etc.

Green.—Green ultramarine, terra-vert, green cinnabar, and Rinnmann's green.

Violet.—Ultramarine violet.

White.—Oxide of zinc and white lead.

By mixing these colours any desired tint may be obtained.

2. **Size.**—The size should be made up with white gelatin usually coloured with a little of the wax. The top sizing is done with the pure gelatin.

3. **Finishing in Colours.**—The skin is first dyed the required colour (*see* "Dyeing Leather"). The dyed skin is dried, polished exactly as for black, then pasted and sized, taking the same precautions as for ordinary calf.

XI.—COST PER DOZEN.

	Francs.	Cents..
Shaving 1	75
Striking out 1	80
Final setting out 0	60
Stuffing 1	0
Sleeking off (flesh side) 0	30
Sleeking off (grain side) 0	40
Whitening 1	0
Flatting 0	40
Rounding 0	30
Graining 0	60
Waxing 1	70
Sizing 0	40
Glassing 0	40
Top-Sizing 0	30

CHAPTER II.

WHITE CALF.

WHEN it is intended to preserve the natural colour of the skins, only the best ones are used, especially selecting those free from stains. The operations described in the last chapter are carried out in exactly the same order, but with especial care in every part of the work that the skins shall not be tarnished.

A special operation is carried out on the flesh side, known as finishing white.

FINISHING IN WHITE.

1. **White Size.**—This size is a mixture of glue and fat which sizes the flesh side of the skin, and gives it evenness, weight and a good appearance. Without stopping to notice the more or less extravagant formulæ used with much mystery in different workshops, we give here one of the best, which is used by the best manufacturers. Later, we shall give certain modifications.

	Parts.
Water	200
Linseed	20
Vegetable wax	10
Stearine	10
Tallow	15
White soap	30
Carbonate of potash	3
Oxide of zinc	5
Yellow catechu	1

Selected linseed is boiled for two hours with water to dissolve out the mucilage, of which the seed contains 15 per cent. The liquid is filtered, whilst boiling, through a sieve to separate the grains. On cooling, a thick, gluey, stringy liquid is left which is called linseed mucilage.

This gum has all the properties of gum-arabic, but is neither so transparent nor so brittle. It gives a very flexible dry glue, much used for sizing leather.

When the linseed is boiled and filtered, the broken-up wax, the stearine, the tallow, the soap broken up into little pieces, and the potash are added. The mixture is boiled for two hours. If a perfectly white paste is required the oxide of zinc is used. If, on the other hand, the true colour of the leather is to be produced, the catechu is used. The paste should be continually stirred whilst cooling, when it sets to a jelly.

2. Sizing.—The skin is stretched on a table and the size spread all over its surface with a brush in the manner already described. We ought to add, however, that the preparation and sizing are by no means difficult. The skins are hung up on a rod to dry for about an hour, or two or three times as long as for waxed calf. They are taken down, stretched on a table and glassed, which should present no difficulties. It is next powdered with fine talc, brushed over with a soft brush, removing all excess of talc. They are then put on one side to allow the powder to sink in, glassed a second time and finally rubbed with a woollen rag.

3. New Compositions.—The linseed gum is replaced by other mucilages obtained from different plants, such as quince seeds, various algæ, especially chondrus, the urvillæa, the confervæ, lichens, and Chinese moss. Another composition which may be used in the same manner, but without powder, is as follows:—

	Parts.
Water	300
Soap	12
Carbonate of potash	6
Virgin wax	40
Sugar candy	15
Gum-arabic	6
Tallow	10
Cod-liver oil	20

First, the gum is dissolved in boiling water, then the carbonate of potash is added, next the soap, wax, sugar, the tallow, and finally the oil. It is boiled until it forms a perfectly even paste, which

requires from an hour to an hour and a half. This composition gives a brilliant polish to the skin.

4. Blackening over White Finish.—When the skins have been finished in white they are often blackened ; indeed, in certain houses the calf is never blacked until it has received this treatment. In this way a much finer and more even finish is obtained, but one which easily peels off.

Blackening over the white finish is done in the ordinary way, but is much more difficult. A very clear blacking must be used, containing an excess of linseed oil. Sometimes an extra 1 per cent. of pyrolignite of iron is added.

When the skins have been finished in white with starch, it is almost impossible to blacken them. The blacking will not bite ; and red places are always left which produce a most disagreeable effect. The same thing happens when calf is being finished with a gelatin paste. The best thing to do in this case is to sponge over the surface of the skin with linseed oil, fold it in four, pile it up for a day and finish in the ordinary way.

CHAPTER III.

COW HIDE FOR UPPER LEATHERS.

COW hides for the upper leathers of boots are waxed and finished in white, black and red. The distinctive character of this kind of leather is its softness. Only perfect cow hides which have been well tanned should be used. The hides are cut up into crups or bends 5 ft. long by 3 ft. 6 in. wide, by rounding off the bellies and heads and dividing the skin from head to tail. Crust splits, that is to say, hides which have been split in the splitting machine, are treated in the same way as cow hides.

I.—BLACK COW HIDE.

The leather is soaked down, set out and shaved in exactly the same manner as calf.

It is stuffed either with a brush or in a "tumbler," always using the same percentage of dubbing. For a hide weighing $17\frac{1}{2}$ lb., $5\frac{1}{2}$ lb. of dubbing are used; the same degreas being used both for the grain and the flesh side of the skin. After drying, the excess of fat is removed. The skins are bleached, grained, blackened, sized and top-sized. Occasionally they are finished with powder. As cow hides are never as fine as calf skins, it is customary in some houses, directly after graining, to treat them like white calf, either with white paste or powder, and glasse them. After drying they are blacked and finished. The idea of this double operation is to give them a finer grain and to increase their weight. The author has found this increase to be about 3 per cent.

II.—WHITE COW HIDE.

The leather is soaked down, set out, shaved, struck out, stuffed and "tumbled" to soften them, then trimmed, pressed, brushed and grained with the cork. They are set out with a rather sharp slicker on the flesh side.

A thin coating of an infusion of Avignon grains and saffron in beer is brushed over the grain of the skin. When it is dry the colour is brought out by rubbing with a piece of white linen. This infusion is sometimes replaced by a colouring matter consisting of Brazil wood, Avignon grains and Flanders glue boiled together. Instead of these dyes special coloured gelatins are used which give very fine results. They are prepared as follows: 200 parts of grated white soap are dissolved in 1,000 parts of soft water, and as much canauba wax as the soap will take up. It is allowed to cool and mixed with 1,000 parts of colourless glove kid gelatin, warmed, and a solution of some yellow colouring matter added (*see* "Leather Dyeing"). It is left in a cool place until it sets, and then sponged on to the grain side of the skin.

Brilliantine.—We have found that in some houses a liquid named brilliantine is used for this purpose. It consists of:—

	Parts.
Water	1,000
Sugar	200
Alcohol	500
Glycerin	1,000

These skins are finished in white on the flesh side in the same way as calf.

III.—BLACK COW HIDE.

When the hide has been dried after stuffing, the excess of dubbing is removed in the "tumbler" and it is then restuffed with more oil than degreas. It is fulled a second time and all the dubbing removed from the grain by brushing with a 2 per cent. potash solution. It is then blacked. This operation is carried out as will be described later, *à propos* of black leather. After the first blacking, the leather is well rubbed, blacked again, and dried. When it is dry, it is fulled again, broken down with a wooden graining tool, the edges removed, the hide shaved, corked over, and finally a thin layer of oil rubbed over it to bring out the black colour.

IV.—COLOURED COW HIDE.

The usual colours are yellow and red. The hides are soaked down, shaved, cleaned with water, and struck out. A mixture of equal parts of oil and degreas is spread on the flesh side,

using 18 parts of the dubbing to 100 of the skin. After drying, it is brushed over with a 5 per cent. solution of alum as a mordant. (We prefer the use of aluminium acetate.) They are broken down, dried and corked lightly. Whilst the hides are still lying on the table, a solution of colouring matter is rubbed over with a hard brush. They are allowed to dry partially, then another coat of colour is given, and finally they are dried completely. After drying, they are corked lengthways and across, reddened for a third time, dried, smoothed with a glass, and rubbed with a piece of linen, soaked in barberry juice, to brighten the colour, and glassed.

Red.—The red is prepared by boiling together 250 parts of water, 40 parts of Brazil wood, and 2 parts of lime. When half of this liquid has evaporated, 1 part of cochineal is added and the liquid allowed to settle. A clear solution is used for dyeing. The dyeing may be carried out in two operations. First a 10 per cent. solution of alum is rubbed on the skin with a piece of flannel, then a decoction of 10 parts of Brazil wood, 150 parts of water and 1 part of lime are rubbed over. This double operation is repeated three times.

Yellow.—Yellow dyeing is effected with barberry juice, Avignon grains, or aniline colours. We shall give a description of the method when describing leather dyeing.

Graining.—Usually red cow hide receives a grain, which is given before dyeing either by hand or mechanically.

Hand graining is scarcely ever used. It is done with a toothed tool which is dragged over the skin on the grain side. The strokes are crossed at right angles if a square grain is required, and obliquely to give lozenge-shaped marks. It is also occasionally done with a roller.

The graining machine consists of a pair of rollers placed one above the other, so that the leather can pass between them. The lower one is smooth, and the upper or larger one has a raised pattern on its surface. It may be heated by steam so as to give a better impression on the leather. The rollers are set in motion by a handle fixed to the axle of the lower cylinder which is coupled to the upper one with cogged wheels.

CHAPTER IV.

SMOOTH COW HIDE.

Cutting.—On coming out of the layer-pit, cow hides are cut into two equal parts. They are stretched on a table, grain upwards; two men hold them in position whilst a third cuts them with a long knife.

A special beam has been invented for cutting hides, but it is very little used. Its upper part is made of two soles, leaving a space between them for the insertion of the knife. Each of the soles carries a platform, forming a table which gives stability to the skin and facilitates the operation. After their separation, the two sides are marked by a small figure near the tail so that they may be readily recognised.

2. Drying.—The drying of smooth leather requires careful watching. The same care should be given as in the drying of freshly-tanned leather. In this case, however, more than any other, a sharp look out should be kept for blackening or mould.

3. Graining or Corking.—The leather, conveniently dry, is fixed to the currying table on which it is to be corked. The object of this is to clean the skin from the tan and flesh which impregnate it, and to soften the grain and compress the tissues which have been swelled during tanning.

The currying table is made of beechwood, 3 to 4 in. thick. It is 11 ft. 4 in. long, 4 ft. 8 in. wide by 2 ft. high. To keep this table free from damp, it is coated with hot linseed oil.

The grain side of the skin is thoroughly brushed to remove the tan. Graining consists in working the skin very strongly with the graining tool, grain to grain. It is an operation which soon wears

out the strongest man. Only the most vigorous can do it at all, and then only during seven or eight years.

The tool used is known as a "marguerite," in England called a "crippler". It is a large pummel about 18 in. long. On the top are a handle and a strap to hold and direct it, and at one end a pad which supports and protects the workman's elbow.

The lower part of the "crippler" is set with copper blades which project about $\frac{1}{2}$ in. with $\frac{1}{2}$ in. space between them.

The tool is used like a graining board. The teeth grip the

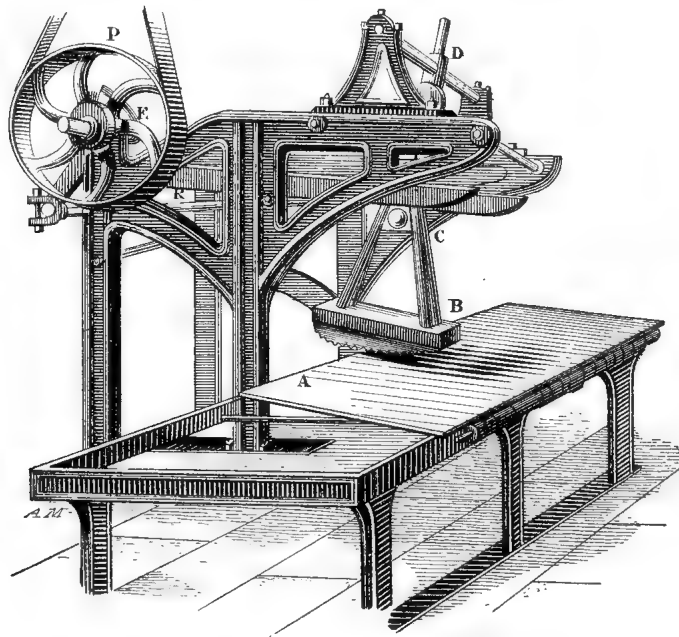

FIG. 61.

grain and spread it. The skin stretches considerably; the grain becomes even; the fibre is broken down and the leather becomes quite soft. Folds, pockets and roughnesses having no body will completely disappear.

4. Graining Machines.—Several machines have been constructed to do away with the terribly heavy work which this inflicts on the labourers. The first were those of Messrs. Placide Peltreau & Delpech, in which the "crippers" are given a double movement, one backwards and forwards, and the other lateral. These

complicated machines have been improved by Fleury, Allard-Ferré, Cattois, Dezeau-Lacour, Allégatière.

The Fleury machine built by M. Bérendorf (Fig. 61), consists of a cast-iron erection, having a projection below which supports a travelling table (A). This table holds a folded hide which is fixed by an eccentric roller. Sometimes the table is set on springs to give it elasticity.

The "crippler" (B) is made of hard wood and is fixed at the lower end of a wooden vibrator (C) which swings about (D). A shaft (E) with its driving wheel (P) gives a backward and forward movement to the horizontal bar (R) and so works the tool. The workman guides the hide under the tool and, after each journey of the table, removes it and folds it anew.

This machine uses about $1\frac{1}{2}$ horse power.

5. Striking.—After graining, the workman goes over the flesh side with a blunt knife, without biting into the leather, so as to completely remove any tan or flesh which may still remain. The operation is carried out in the same way as striking out, or it may be done by machinery.

6. Polishing.—The hide is stretched on the table, grain side up, and well brushed with a stiff brush, which opens up the leather and prepares it to receive the stiffening.

The flesh side is rubbed over with a wet bundle of hemp cloth to wash out all excess of tannin. This brings up a white scum, which is brushed off with a scrubbing brush, using plenty of water. Afterwards, the following mixture is rubbed over the skin with the hemp cloth pad.

	Parts.
Water	200
Rye flour	20
China clay	20
Chinese moss	1
Tannin	2

The Chinese moss is boiled in the water, giving a strong mucilage (gelose). It is allowed to cool, then the rye flour and the clay added, and finally, sufficient chestnut extract, or other tannin, to give it the required colour.

Chinese moss is not much used. We have only come across it

in works of the highest class. Usually the paste only contains water, clay and flour.

Another composition widely used is:—

Water	Parts.
	200
Dextrine	5
Zinc white	5
Indigo carmine	0·1

These compositions glue the fibres of the flesh side together, hence they should be thoroughly incorporated with the skin.

The hide is turned over, taking care that the table is absolutely clean, and the next operation proceeded with.

7. Striking Out or Stoneing.—This is done with a slate, if the grain be well developed and with a slicker if the development be not good.

A good workman should moisten the leather as little as possible. Large quantities of water decrease both the weight and firmness of the leather.

After the last working with the slicker, the grain is sprinkled with a little water and dried with a clean, dry, linen cloth and the hide is hung up on the joists of the workshop or in some place where it will dry slowly. Whilst drying it should be continually watched to prevent its moulding. It is as well to use a little mercuric chloride or iodide in the sprinkling water.

8. Machines for Stoneing.—These machines have, to a large extent, done away with the rough work which we have described. One of the first was invented by Fitz Henry. It consists essentially of a carriage, which moves rapidly backwards and forwards, furnished with two arms in front and two behind. A rod communicates its movement to the carriage at the rate of 120 strokes per minute. The carriage runs on two horizontal slides, supported by brackets fixed to the beams of the ceiling.

Underneath the carriage is a large horizontal table on which the skin is stretched. It runs on rollers so that any portion of the skin may be submitted to the action of the tools attached to the carriage. The tool is generally made up of four irons, two in front, and two behind.

The Bérendorf machine is almost the same.

The Tourin machine has its irons or slates fixed to a belt, which runs over two parallel horizontal rollers. The skin is stretched on a movable table underneath the belt so that the tools may travel over its surface.

In the Peltreau machine the skin is placed on a table over which swings a beam, carrying at its lower end a roller, either smooth or channelled. The roller works backwards and forwards over the surface of the skin.

The Dorge-Heuzé machine is just like a smoothing machine.

The Lockwood machine has a fixed table and tools which travel over the whole of its surface.

9. Smoothing Machines.—The above machines may be used for polishing the skin, by using glass or hard wood rollers instead of the irons or slates. Sometimes the calendering machine is used for the same purpose.

CHAPTER V.

BLACK LEATHER.

BLACK or tallowed leather is made chiefly from cow hides or calf skins. These are first of all milled to soften them. This operation was formerly carried out in the stocks. Nowadays it is done in the drum or in the Poisson horizontal fulling mill (Fig. 62) which consists of two cast-iron cylinders armed with a large number of iron pegs with rounded ends, which bite together sufficiently to turn the upper roller when the lower one is set in motion. These rollers and their pegs are galvanised. After passing the skins once or twice between these rollers they are sufficiently softened.

Shaving and graining are carried out, either by hand or by machinery, as described in the preceding chapters.

1. Tallowing.—After the various currying operations the leather is slightly heated before a bright fire so that the greasy mixture which is to be placed on it may remain liquid for a little while. This is sometimes done with a gas stove (*see* “Hungary Leather”). The skin is stretched on a table and impregnated with the hot tallow by means of a large brush made of wool (Fig. 65). Both sides of the skin are dressed in this way, putting the greater quantity on the flesh side. The temperature of the tallow should be 90° C. (194° F.), and about 33 per cent. of the weight of the skin should be used.

Some curriers do not use tallow; they make up mysterious mixtures which are special secrets of their works. These mixtures contain resin, pitch, wax, etc., which should never be used if the

best results are to be obtained. The best composition we have met with is :—

	Parts.
Beef tallow	30
Pure bone tallow	30
Paraffin	25
Resin	15

2. **The Tallowing Drum.**—M. Delpech has invented a machine in which leather may be rapidly and evenly greased.

It consists of a large drum with two envelopes, the outer of sheet iron and the inner of copper, arranged in the same way as

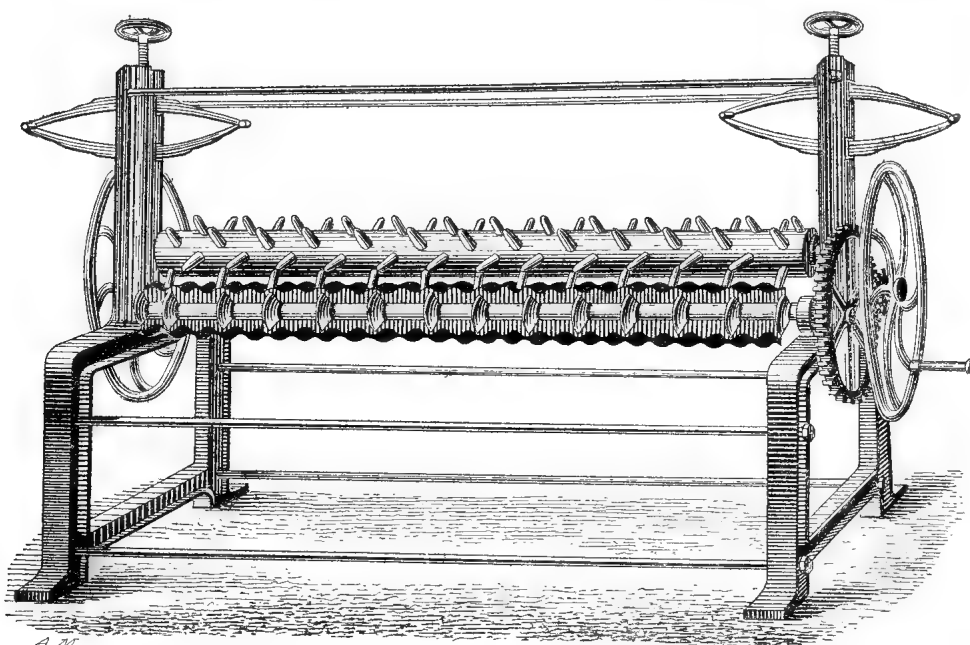

FIG. 62.

the machine for washing out lime, but in place of water, tallow, which has been melted in a steam-jacketed reservoir, is run in through one axle, whilst through the other steam is admitted between the two walls, the leather is thrown in through a door at the side, and the tallow and steam admitted, and the machine set in motion for an hour, when the skins are again withdrawn. The dimensions of these drums vary considerably. We have seen them 9 ft. in diameter by 26 in. wide and capable of holding twenty-five hides at a time.

3. **Blacking.**—After the tallowing they are allowed to dry for twenty-four or forty-eight hours, corked on the flesh side and

scraped on the grain. They are then stretched on a table and made even by working with the slicker. The grain is wiped with a bundle of leather waste to remove excess of fat, and slicked again. Whilst the leather is still moist, it is blacked with a pad of wool or better with a horse-hair brush. The skin is folded in four and left to allow the black to penetrate. When it is half-dry it receives a second coat, is refolded in two and left until half-dry again, and then gets a third coat, which is allowed to dry completely by hanging the skin on hooks in the joists of the workshop. Usually the black is formed by saturating the skin with some mordant, rubbing it well in at the hard parts.

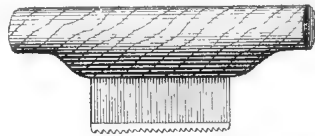

FIG. 63.—Dicing Slicker.

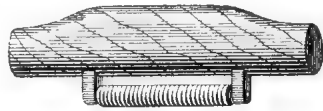

FIG. 64.—Hand-dicing Roller.

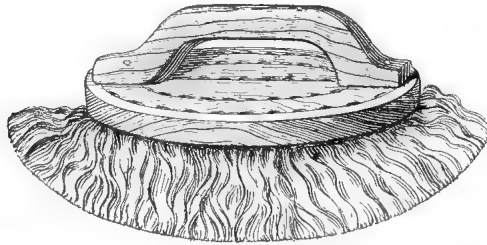

FIG. 65.—Tallowing Brush.



FIG. 66. Scouring Brush.

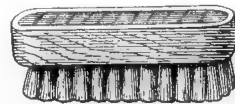

FIG. 67.—Blacking Brush.

CURRYING TOOLS.

4. Composition of the Blacking.—The commonest blacking is a solution of some salt of iron with a weak acid. Various compositions have been invented, each with some more or less real advantage.

(a) *Beer Black.*—This is made by the curriers themselves. They let beer go sour by exposing it to the air for some weeks and then throw iron filings into it. Some use very acid tan liquor. We have seen a method employed for making this blacking which is

so ingenious that it is well worth describing. An ordinary barrel—a petroleum cask of 200 litres (44 gallons) capacity by preference—is divided into two equal parts by a partition running from end to end. This partition is perforated so that liquor may pass freely through it. Each end of the barrel has an opening 2 in. in diameter so that air may have access to the interior. The iron turnings are placed in one chamber through the bung hole. The barrel is placed on its side with the iron turnings beneath and enough beer or tan liquor poured in to nearly half-fill the barrel. At night the barrel is left so that the iron is soaking in the liquor. In the daytime it is rolled half-way over so that the liquor remains in the lower compartment whilst the iron is exposed to the air in the upper half. By this simple arrangement the liquid gets thoroughly aerated and therefore acidifies rapidly. At the same time the iron oxidises and acetate of iron is produced. Beer, however, is rather too costly, and is not always obtainable (the beer referred to is of course the bottoms of casks and such refuse), and is therefore often replaced by a solution of glucose, mixed with beer yeast. Alcohol is formed by fermentation, and this afterwards oxidises to acetic acid. It gives a purer and less rusty black. Twelve lb. of glucose are dissolved in 20 gallons of water and 1 lb. of yeast is added. When it begins to ferment it is poured over the iron, preferably in the apparatus described above.

Honey is sometimes used, giving a beautiful black.

(b) *Vegetable Black*.—This name is given to the product obtained by digesting certain sugar-containing plants in water with iron filings. Acetate of iron is thus produced by the fermentation and oxidation of the sugar of the plant. It is merely an extra complication of no advantage, at any rate in France. Glucose black is much more economical. It is different however in some foreign currieries, where the only economical substance is that produced by the soil.

In France we have seen the following used: Sorghum, carrots, water melons, mountain ash, beet-root and figs.

Abroad the choice is far greater: The refuse of the sugar cane and the fruits of the banana, the date and the fig, the Indian and

Barbary figs, on which the cochineal insects live. The fruit of the guava, the aguacate, the pitanga, the jabutica, the mango, the Senegal cherry, the safu, the jamrose, the letchi, the tamarind and many others, especially those which contain sufficient tannin to intensify the black colour.

(c) *Acetate of Iron*.—Commercial pyrolignite of iron having a strength of 15° to 20° Baumé has been used for making black by simply diluting it with its own volume of water, but as this substance usually contains tar, which stains the skin and makes it sticky, no pyrolignite should be used except that which is made from distilled acid. Ferrous acetate is the best. It may be prepared by heating together iron filings and either acetic acid or distilled pyroligneous acid at 75° C. (167° F.) When the mixture is cool it is drawn off and put into bottles so that the air cannot get to it.

(d) *Vanadate of Ammonia*.—This costly material, which is always bought ready made, is dissolved in water so as to make a 1 per cent. solution. The precipitate which it forms with fannin is really blue, but so intense that it looks black. This is the finest black known at the present day.

(e) *Compound Black*.—The following substances are boiled together for an hour:—

	Parts.
Vinegar or acetic acid diluted ten times	20
Logwood	5
Gall nuts	4
Water	5
Iron filings	1

After boiling, the mixture is poured into a vat and allowed to oxidise. Sometimes oxidation is helped by the addition of 1 per cent. of oxalic acid.

(f) *Paris Dye*.—This consists of:—

	Parts.
Logwood extract (10° Baumé)	10
Pyrolignite of iron (11° Baumé)	5
Acetic acid	1

Before using, this should be diluted with two or three times its volume of warm water.

(g) *Lyons Black*.—The following are boiled together :—

	Parts.
Dry logwood extract	100
Water	800
Lime (to develop the black)	10

To this the following mixture is added :—

	Parts.
Carbolic acid	3
Hydrochloric acid	25
Pyrolignite	100
Gum-arabic	30
Bichromate	3

(h) *Caustic Black*.—Two solutions are prepared :—

A.

	Parts.
Washing soda	50
Water	500
Resin (colophony)	12
Yellow wax	40

These are boiled together until entirely dissolved :—

B.

	Parts.
Water	500
Solution A.	30
Shellac	30
Gelatin	25
Salt	15
Sugar	20

About 50 parts of well-powdered lamp-black are stirred into the mixture. It will be noticed that this composition contains no mordant or iron salt.

(i) *German Black* :—

	Parts.
Lime water	2,000
Logwood extract	250
Alum	30
Sulphate of iron	10
Sulphate of copper	10
Sugar	20
Bichromate	5
Indigo carmine	30
Glycerin	30

(j) *Chrome Black*.—Ten lb. of logwood are boiled in 10 gallons of water, and the liquor evaporated until it weighs 100 lb. Nitrate of chromium is thrown into the boiling liquor, a little at a time, until the bronze-coloured precipitate, which is formed at first,

ing. It is quite different with the iron salts, which only give the black when they have combined with the tannin; and seeing that the tannin is an integral part of the leather it cannot be washed out. These iron salts are divisible into two groups: (1) those which form the black at once, that is to say, ferric salts; and (2) those which only develop the black on exposure to the air (ferrous salts). In the first group the action is instantaneous, and if the solutions, happen to be too concentrated, the precipitation may be so rapid that the black is brittle and breaks away from the rest of the leather, giving an irregular appearance. This difficulty is entirely done away with by the use of ferrous salts. These give no colour with the tannin, but soak well into the fibre before the air has time to develop the black.

In all these reactions the iron salt is decomposed, its oxide remains fixed in the tannin and its acid is set free. If this should be a strong acid like sulphuric, hydrochloric, or even acetic, it will destroy the texture of the skin, that is why we have replaced these by the weak citric and saccharic acids which have no action on tanned leather. In any case the skin should be carefully washed after the application of the black, first with water and then with very dilute ammonia.

Vanadate of ammonia is free from all the above inconveniences, but it is far too expensive to be much used.

Recapitulating, the following conditions should be observed:—

- (a) Always use ferrous salts combined with weak acids.
- (b) Always use dilute solutions.
- (c) Carefully wash the skins after dyeing.

6. Finishing.—After blacking the skin it is submitted to a series of operations to improve its appearance. They are generally as follows:—

It is seasoned with sour beer, then corked from the four shanks to give it a grain, wiped with a soft flannel, and washed again with the beer to remove the last traces of grease. It is corked again, polished with the smooth slicker, wiped with the flannel, and finally well rubbed with "rinette."

The strength of the barberry juice is 5° Baumé; sometimes

redissolves to form a deep blue $\frac{1}{2}$ solution. This liquid gives a very fine black. The chromium nitrate is prepared by first precipitating a hot solution of chrome alum with sodium carbonate, and after washing the precipitate, dissolving it in pure dilute nitric acid.

(k) *Aniline Black*.—Commercial aniline black, nigrosine, etc., is of two kinds, one soluble in water and the other soluble in alcohol. Both kinds are used. The following is a good formula:—

Aniline black	20
Hydrochloric acid	20
Alcohol (90°)	100
Water	500
Gum-arabic	30

(l) *Villon's Black*.—This consists of compounds of iron with very weak organic acids. These have the advantage of not altering the grain of a skin. Usually ferrous salts are used, preferably the citrate or the saccharate. The citrate is prepared by dissolving metallic iron in a solution of citric acid. It is neutral and very soluble. To prepare the saccharate sugar is treated with three times its weight of nitric acid (sp. gr. 1.25) in a large enamelled boiler. It is kept at 50° C. (122° F.) until it gives off nitrous fumes. When the reaction is over it is diluted with its own volume of water, the excess of nitric acid neutralised with litharge, and as much iron dissolved in it as it will take.

5. General Remarks.—The recipes which we have just given are simply typical ones selected from the innumerable formulæ used at the present time. They may be divided into two classes: (1) those which only consist of a mordant and therefore only give the black colour when they have entered into combination with the tannin of the leather, (2) those in which the black is already formed.

Seeing that this blacking of leather is in reality a dyeing process, it is necessary that a compound should be formed of the black, the mordant, and the fibre of the skin. Blacks in which the colour is already formed cannot do this; moreover, they are not so fine as the others. They merely act by depositing the solid dye in the pores and on the fibres of the leather. They are, therefore, not properly fixed and can be removed by a sufficiently long wash-

sumach (2° Baumé) weak spirits of wine, sour beer or decoctions of sour fruits are used instead of barberry.

I.—BLACK LEATHER.

This material is prepared in exactly the same way as the last, but after receiving the three coats of black it is put into a press for ten days, then taken out, rearranged, and pressed for another ten days. It is then laid out flat on a table with the grain below, and well wiped to remove any grease or moisture. Next it is rubbed with barberry juice or sour beer, and polished with a glass until perfectly even. Finally, it is rubbed over with a cloth containing a little of the juice and dried in the shade.

II.—COW HIDES.

These are prepared like ordinary greased cow hides, but with more care and more tallow. They are dressed with 45 per cent. of their weight of tallow, and after partially drying are rubbed on both sides with oil and degreas, using $1\frac{1}{2}$ lb. of degreas for each hide.

This leather is left in its natural colour and is very supple.

III.—WAXED COW HIDE.

This is prepared by mixing 25 per cent. of yellow wax with the tallow. Nowadays paraffin or ceresine is used instead of the more expensive bees wax. In this case either 30 per cent. of ceresine or 38 per cent. of paraffin is used.

CHAPTER VI.

MISCELLANEOUS HIDES.

I.—HORSE.

WE have already pointed out that horse skins are cut in two, and the front used for shoemaking. We proceed to describe the currying process.

First it is fulled and shaved to remove the flesh, corked on both sides and set out in the ordinary way. It is stuffed with a mixture of equal parts of fish oil and degreas, applied to the flesh side. This is best done by using an excess of dubbing in the fulling drum. It is next dried, the excess of fat removed, scraped and blacked on the grain side. Before blacking, the leather should be washed with dilute potash, to make the black liquor run easily on the surface. After the first coat of black it is partially dried, then given another rubbing with degreas on the grain side, and after drying treated first with potash and then with a second black.

When the skin has completely dried it is again treated with 15 per cent. degreas, piled so that the grease shall have time to penetrate, whitened, struck out, waxed and finished like waxed calf.

The finishing is not so fine in the case of waxed calf. The size is made by boiling together 1 kilo. ($2\frac{1}{2}$ lb.) of fine gelatin with 800 gram. ($1\frac{3}{4}$ lb.) of fish oil for three hours, replacing the water as it evaporates. If the resulting size be too soft, it is mixed with 10, 15 or 20 per cent. of tallow and the same quantity of fresh gelatin. The final sizing should be richer in fat than the size used for calf. Rather more lard is used, together with the yolks of one or two eggs.

The back part of the hide is treated rather differently. After

fulling, striking out and setting, the flesh side is treated with degreas and cod oil, and the grain side with pure cod oil. It is dried, corked on both sides, and oiled again. The hides are piled together for fifteen days, corked again, trimmed and finished.

II.—GOAT.

The skins are first softened by soaking for twenty-four hours, and fulled and scraped on the beam. They are partially dried, either in the air or by hydraulic pressure, then greased with 3 or 4 lb. of degreas to every 10 lb. of skin.

The degreas used for goat skins is light coloured, and some manufacturers mix it with vegetable oil as in the four following compositions :—

	1.	2.	3.	4.
Degras	80
Tallow	4	10	5	10
Cotton oil	16
Moellon oil	50	...	15
Colza oil	30	...	50
Cod oil	10
Artificial degreas	90	...
Suint	5	...
Linseed oil	15
Whale oil	10

The skins are fulled, sleeked out, corked, washed with dilute potash, then well worked with the graining tool to bring up the grain. They are wrung out, wiped, blacked, piled for an hour, blacked again, piled in sets of six, well rubbed with a cloth, stretched out until three parts dry, blacked for a third time, then wiped and dried thoroughly.

The grain is corked up from the four shanks, a coat of beer is run over the grain side, and the surface well worked with a roller. The skin is then trimmed, shaved, corked again and rubbed with barberry. This stain is worked in with a piece of woollen cloth, starting from head to tail, then back again, and finally across, rubbing until the cloth is nearly dry and the skin begins to polish. It is then rubbed with a roll of flannel, corked and dressed with the best linseed oil at the rate of $3\frac{1}{4}$ lb. to the dozen hides.

III.—WAXED GOAT SKIN.

This is blacked like waxed calf and gives excellent leather for boot and shoemaking.

Only large and perfect skins can be used for this work, and the black size used is made up of:—

	Parts.
Glove kid gelatin	10
Tallow	10
Calf paste	1
Degras	2

The size consists of—

	Parts.
Glove kid gelatin	10
Egg albumin	2
Lard	3

IV.—MATT GOAT SKINS.

Goat skins may either be made up as shagreen or with a smooth dull surface. The former process is described later.

For a matt surface, the skins are carefully pared, then fullled. Two dozen skins are generally rolled up loosely and turned in the fulling machine for a quarter of an hour, then with a fresh lot of water for five minutes.

The skins are struck out lengthways and crossways, reset on the grain on a table which has previously been rubbed with a little dubbing. The butt is first sized or waxed, then the rest of the skin. A light coat of fish oil is then given on the grain. The skins are then horsed up with the flesh side uppermost till the lot is finished. They are then dried.

As soon as the skins are dry they are blacked. A solution of logwood (1° Baumé) is painted on with a long-haired brush, and rubbed in strongly with a hard brush until it has penetrated the grain; then a coat of beer black, vegetable black, or acetate of iron is applied in the same way.

The logwood is usually made by boiling together:—

	Parts.
Water	200
Logwood	20
Sumach	5
Yellow wood (fustic)	3
Lime	½

The best black for use with this logwood is:—

Water	Parts.
	200
Acetate of iron	5
Bichromate of potash	6
Alum	1

After blacking, the grain is rubbed with a mixture of fish oil containing 15 to 20 per cent. of tallow or lard. When greased, the skins are piled for twenty-four hours, grain to grain, turned, and left in pile for twelve more hours. Degras is then rubbed into the flesh side, either using pure degreas or an emulsion containing 10 per cent. of water. The skins are hung up to dry and piled for at least twenty-four hours.

The skins are corked from butt to neck and slightly whitened on the flesh side, then dressed and glassed. The grain side is worked with a glass then finished with a very thin coat of size.

When the skin is imperfect or contains punctures, finishing is not so easy. After rubbing on the paste the skin is dried, then sized either like waxed calf or with one of the following compositions:—

1.		2.	
	Parts.		Parts.
Melted butter	1,000	Weak gelatin	1,000
Eggs (whole)	100	Soap	200
Gelatin	700	Tallow	400
Blacking	50	Blacking	50
3.		4.	
	Parts.		Parts.
Water	1,000	Water	1,000
Soda	20	Borax	50
Shellac	120	Casein	200
Lard	500	Glue	100
Aniline black	50	Lard	600

CHAPTER VII.

RUSSIA LEATHER.

IN Russia a leather is prepared called *youfte*, which possesses remarkable properties, notably an agreeable aromatic smell and the double advantage of never growing mouldy in moist places and never being attacked by insects. Moreover, no insects will come into its neighbourhood.

Bookbinders and makers of fancy goods use large quantities of it.

1. **Tanning.**—The skins used in this manufacture are generally cow and ox hides and large calf skins. The skins are soaked for two or three days to soften them. They are unhaired with lime, fleshed, and prepared in the ordinary way. They are swelled by leaving them for forty-eight hours in a bath containing :—

	Parts.
Water	2000
Rye flour	20
Oat flour	10
Yeast	1
Salt	2

The skins are next placed in small handler pits containing weak ooze made from willow, pine, or birch bark, and left there for fifteen days, lifting them out to drain twice every day. Afterwards they are put in a pit filled with a decoction of willow bark or a mixture of oak, willow, pine and birch bark. The willows used are: *Salix inerea*, *S. caprea*, *S. arenaria*, *S. russeliana*, *S. capraca*, and *S. pentendra*. The skins are left in this pit for eight days, draining them twice a day, and then placed for eight days in a stronger liquor, draining them as before. The leather is now sufficiently tanned. It is rinsed, drained and allowed to partially dry.

2. **Dubbing.**—The skins are stretched on a table, flesh side up,

and impregnated with a mixture of seal oil and birch bark oil, two-thirds of birch oil to one-third of seal oil, or, if the leather be very thin, equal parts. The mixture is spread either with a rag or by hand. A thin coat of birch bark oil is passed over the surface.

The leather is stocked to soften it.

3. Birch Bark Oil.—This empyreumatic oil, which gives Russia leather its peculiar odour, is prepared by the distillation of birch bark mixed with *Ledun palustre* or *Andromeda polifolia*.

Birch bark is resinous and never decays. In the old forests of the Carpathians and Russia, trees are found quite dead from old age, the bark standing as a hollow tube with its lower part filled with the remains of wood destroyed by insects. *Andromeda* is a plant of the family *Tricaceæ* a near relative of the brooms growing in the North of Europe and in Russia, where it is used in silk dyeing. The leaves contain as much as 24 per cent. of tannin.

The distillation is carried out in various ways.

First Method.—The mixture of birch bark and andromeda is placed in a boiler and the lid fixed in position. The lid is dome-shaped and has a hole at the top through which passes an iron tube passing to the bottom of another boiler of the same size. All the openings are carefully luted. The empty boiler is completely buried in the earth and the one containing the bark, which should stand on the level of the soil, is covered with sand and clay. A wooden fire is lit all around it and kept burning for some time. It is then allowed to slowly cool and is broken open. In the lower vessel is found a strongly smelling oil mixed with tan and a little acetic acid.

Second Method.—The white scale or epidermis, which is shed by the birch bark during the flow of the sap, is collected and piled up in the forest. By only using the white part, a much more colourless oil is obtained. This material is placed in rectangular sheet-iron boxes connected together in series of fifteen to twenty. The boxes are heated up very slowly over a naked fire, and the products of distillation carried through a tube into a series of vessels where the tar is condensed. The operation lasts twenty-four hours.

Third Method.—Considerable improvements have been made in

the apparatus used for preparing this oil nowadays, especially in Russia, where the Swedish still is chiefly used. This apparatus (see Fig. 68) consists of a strong iron boiler (A), of thirteen cubic yards capacity, built into a firebrick hearth. The hearth is lateral, and the flames circulate through the channels *b b* before finding their way to the chimney. The boiler has two dome-shaped ends. In the upper one is a manhole (*g*), by which the boiler is charged, and a swan's neck tube leading to the spherical receptacle (B). This receptacle is connected by a vertical tube (*h*) with a similar one also marked (B), into which any condensed tar will run. The lower end of the boiler is connected directly by a tube (*c*) with this lower

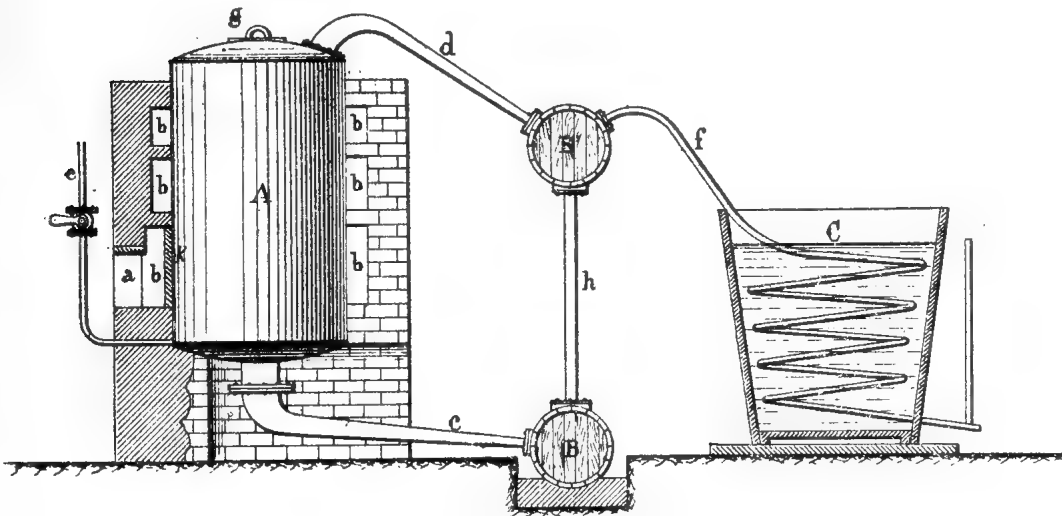

FIG. 68.

receptacle, to which it carries the tarry liquor which runs from the bark during distillation.

The volatile products which do not condense in the upper receptacle, are carried by a tube (*f*) to a condensing worm (C).

1,000 lb. of bark will give :—

	Lb.
Birch bark oil	500
Pyroligneous acid	200
Charcoal	200

1,000 lb. of birch wood gives :—

	Lb.
Charcoal	254
Pyroligneous acid	533
Tar	25

To obtain the pure oil the tar and the crude oil are fractionally distilled.

4. Dyeing.—The skin is stretched on the table grain side up, and it is mordanted three times with a 5 per cent. solution of alum. Next it is dyed with either a decoction of santal wood and Pernambuco wood (1° Baumé) or a mixture of cochineal and Brazil wood spread either with a brush or by hand. At least four coats should be given to obtain a good red. After each coat the dye should be allowed to sink into the skin and dry before the next coat is put on.

Sometimes the leather is dyed black instead of red, which is managed in the manner described for black leather.

After dyeing, the skins are piled up for two days until the creases have gone. They are then stretched, the flesh side redressed with seal and birch bark oil, and well rubbed on the grain side with a piece of flannel which has been dipped in the same mixture.

5. Graining.—Russia leather is made up in several varieties: (1) Malia leather, grained in parallelograms; (2) shaved hide, grained in squares; (3) verhock leather with a lozenge-shaped grain; and (4) smooth leather. The graining is done in the same way as for red cow hide. The leather is brushed with a coarse brush, dried, and put in the press.

ARTIFICIAL RUSSIA LEATHER.

Russia leather acquires its peculiar properties from the method of tanning and the use of birch bark oil. Leather which has been tanned with willow bark has a smell which varies according to the season and the temperature. Attempts have been made to give the Russia leather smell to leather which has been tanned with oak bark. By the use of specially prepared birch bark oil a perfect imitation has been made excepting for one thing. It slowly but surely loses its smell. In real Russia leather the willow or birch bark causes the scent to become a constitutional part of the skin.

1. Birch Oil.—Messrs. Grouvelle & Duval, who were the first manufacturers to treat French leather in the Russian fashion, prepared their birch oil by distilling the bark in a copper retort attached

to a condenser. One hundred lb. of bark gave them 60 lb. of odorous oil. Payen has improved this process by arranging a spherical receiver (M, Fig. 69) at the bottom of a furnace. The neck of the receiver passes through the floor of the furnace into a similar vessel N, which receives the products of distillation. The furnace stands on the two bricks (*b b*) which lie on a plank supported by two trestles (*c c*). Having filled the flask (M) with the epidermis of birch bark, its neck is luted in position with a little clay, and the furnace filled up to *f* with sand. A covering of sheet iron or earthenware is placed over it and covered with burning charcoal. The

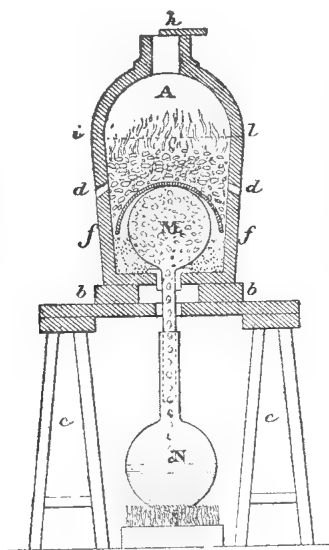

FIG. 69. Furnace with Payen's Receiver.

two openings (*d d*), supply the air required for combustion. Under the action of the heat the oil quickly distils downwards into the receptacle (N). It is at first clear but becomes darker as the distillation proceeds. All the oil distils over in about forty minutes. The oil may be also prepared in the apparatus used in Russia for the preparation of the coarse oil.

2. Dyeing.—For the manufacture of imitation Russia leather the best skins, which have been well tanned, and have a fine grain, are selected. They are dyed with some red vegetable colour, chiefly Brazil wood, though any of the compositions described in the chapter on leather dyeing may be used.

Wagmeister of Poggstall uses a tin compound as mordant and Pernambuco wood mixed with cream of tartar as a dye. The skins are oiled on the flesh side only, then fulled, dried with woollen rags, and the grain whilst still half wet beaten carefully. When the skins are perfectly dry they are corked up, coated three times with the mordant, and dyed two or three times with the warm dye. This gives a very solid and permanent red colour to the skin. The flesh side is dyed. The skins are sprinkled, struck out, beaten, dried, and finally a coat of gelatin applied to the grain. Any of the other methods described in the chapter on dyeing may be used equally well.

All the other operations are performed in the manner already explained. On the average, a cow hide requires about 2 lb. of birch oil, which ought to be mixed with a little whale oil.

PART IV.

ENAMELLED LEATHER.

HUNGARY LEATHER—TAWED LEATHER—CHAMOIS LEATHER—
MOROCCO—PARCHMENT—FURS—ARTIFICIAL LEATHERS.

CHAPTER I.

ENAMELLED LEATHER.

LEATHER is enamelled to make it waterproof and brilliant and give it the appearance and properties required for fancy shoe-making, harness-making and saddlery.

This industry originated in England in 1780. It was introduced into France by Plummer of Pont-Audemer in 1801, and improved by Nys and Longagne in 1835, since which time the industry has continually increased. In 1870, there were thirty enamelled leather works in Paris alone. French enamelled leather is in every way superior to that of other countries.

I.—VARNISH MANUFACTURE.

The varnishes which are used for leather are mixtures of boiled linseed oil, Prussian blue, lamp-black and shellac. Their composition is exceedingly variable, as each manufacturer has his own special recipe, and all of them are difficult to prepare. A first-class varnish should be supple, elastic, and waterproof when dry. It should not become sticky, and should give a fine bright black, which does not crack either in the cold or after long use. There should be perfect adhesion between the leather and the varnish, and it

For the manufacture of varnishes, the oil should be one or two years old, yellow, and very transparent. New oil is easily recognised, as it is usually turbid and greenish. Old oil is purer and contains much less water than new. The drying of all these oils is simply an oxidation which transforms them into hard transparent bodies rather like india-rubber. This drying is much more rapid when the oil has absorbed a certain amount of oxygen beforehand. To bring this about, it was formerly boiled until it thickened, nowadays the operation is hastened by adding substances which readily give up oxygen and form metallic soaps. The principal substances used are manganese dioxide, lead oxide, zinc oxide, zinc borate, manganese borate, and finely divided lead. For bright-coloured varnishes the oil must be kept as colourless as possible.

2. Purification of Linseed Oil.—If the linseed oil is not perfectly clear, or if it should contain mucilage or vegetable albumen or water, it is treated with strong sulphuric acid before submitting it to the ordinary operations. About 3 per cent. of acid (66° Baumé) is poured little by little into the oil, stirring rapidly all the time. The acid will get more and more green until it is nearly black. At this point the mucilage is precipitated from the oil in fine dark-coloured particles which soon fall to the bottom of the vessel. After standing for twenty minutes the oil is decanted off and washed with a 2 per cent. solution of potash to neutralise the acid. Warm water is then added and the oil allowed to separate. At first it is turbid, but after a while becomes perfectly clear. There is a loss of about 3 per cent.

It is better to use a concentrated solution of ferrous sulphate instead of the sulphuric acid. One part of the saturated solution is mixed with ten parts of the oil in shallow vessels, and left exposed to the light for one or two weeks, stirring frequently. Loss 1·2 per cent.

Nearly all drying oils contain besides their own special fats a non-drying substance named palmitin. This substance hinders the drying and destroys the fine polish which patent leather should always possess. Ordinary oil varnishes often have a coarse appearance, due to the presence of palmitin. It is therefore necessary,

should be so elastic that it will adapt itself to all the movements of the leather without splitting or coming off.

It is difficult to make a varnish having all these properties, but allowance being made for the quality of the materials and the conditions of drying, the difficulty often depends on the lack of knowledge of the reactions and transformations of the oil and the products formed by its decomposition, which are as yet imperfectly understood. We shall therefore consider the composition and manufacture of black and coloured varnishes at some length.

1. Linseed Oil.—When extracted in the cold, linseed oil is of a pale yellow colour. When extracted hot it is brownish yellow. At 20° below zero C. (4° below zero F.) it becomes very light coloured without freezing. It does not solidify until 27° below zero C. (15° below zero F.), at which temperature it sets to a clear yellow mass. Its specific gravity is:—

0.9395	at 12° C. (54° F.)
0.9300	at 25° C. (77° F.)
0.9125	at 50° C. (122° F.)
0.8815	at 94° C. (201° F.)
0.8500	at 110° C. (130° F.)

It is soluble in five times its volume of boiling alcohol, forty times its volume of cold alcohol, and 1.6 times its volume of ether. Chemically it is a glyceride of linoleic acid. On saponification it gives glycerine together with oleic, palmitic, myristic, and linoleic acids, the latter having the formula $C_{16}H_{28}O_2$. If the oil is boiled for some time it loses weight, thickens, and readily dries to a transparent varnish, to which the name linoxyn has been given, having the formula $C_{22}H_{35}O_{11}$. Heated to 323° C. (613° F.) it takes fire and burns, leaving a residue of tar and charcoal; but if it is extinguished by covering up the receptacle, a brown substance is left very like glue. Between the temperatures of 50° and 80° C. (122° to 176° F.) it combines with bromine and chlorine to form dark brown liquids known as brominated and chlorinated linseed oil corresponding to the formula $C_{16}H_{22}Cl_2O_2$. When exposed to the air it absorbs oxygen and forms a resinous mass called oxylinoleic acid having the formula $C_{16}H_{25}O_5$. This oxidation takes place much more rapidly if the oil is heated.

if we wish to produce a high quality of varnish, to remove it from the linseed oil. This is most easily done with nitric acid. Nitric acid, especially the fuming acid, when brought into contact with various organic substances forms a little nitrous acid, and this, together with the remaining nitric and hyponitrous acids, acts in various ways on the mixture of fats contained in the linseed oil. Palmitin is decomposed into palmitic acid and glycerin, and may thus be readily separated from the oil as the insoluble palmitate of lead or manganese by adding the oxide of one of these metals.

The purified and perfectly clear oil is treated with nitric acid in glass vessels, or better still in large stone troughs of six and a half gallons capacity, furnished on one side with a series of holes. About an oz. of fuming nitric acid is placed at the bottom of each trough, and six or seven gallons of oil, which has been heated to between 50° and 60° C. (122° to 140° F.) in a copper boiler, is poured in, stirring briskly all the time. On the following day the acid and oil are again well stirred, and the stirring repeated each day. After the fourth day the oil is allowed to stand until clear, which takes about three days. The clear portion is drawn off through the holes in the side, and the turbid portion is again well stirred. After a few days it is warmed and filtered through a layer of animal charcoal, sawdust, or wool.

In England linseed oil is purified by heating gradually during two hours up to 300° C (572° F.) allowing it to remain at this temperature for three hours and boiling for an hour with 2 per cent. of calcined magnesia, then decanting off and allowing to stand for three months.

3. The Boiling of Linseed Oil.—For the preparation of varnish, linseed oil should be submitted to the action of some agent which causes it to absorb oxygen and thicken, and thus to acquire good drying properties. The substance so prepared is known as boiled oil.

(a) *Heat.*—About 10 gallons of purified oil are placed in a cast-iron boiler of 15 gallons capacity, and heated slowly up to 180° C. (356° F.). After remaining three hours at this temperature all the water which it may have contained will have evaporated. When this is the case, the oil will become lighter in colour. Its surface

should remain perfectly even. The temperature is next increased to 300°C . (540°F .) and a white froth will form on its surface. When the froth rises to the edge of the boiler it is subdued by pouring on cold oil. Meanwhile the temperature is increased to 315°C . (567°F .), at which temperature it is kept for three hours, keeping down the effervescence with cold oil. When the froth begins to dry on the edges, a lid is placed on the boiler, the fire is put out, and the boiler swathed in cloth to prevent it cooling too quickly. On the next day the oil, which should be still warm, is poured into tall cylinders, which have taps let in about two inches from the bottom through which the oil may be decanted after a few days.

Heating by superheated steam is more regular and easier to manage. It is used in many important works.

(*b*) *Litharge*.—Purified linseed oil is heated to 150°C . (302°F .) in an iron boiler for an hour, then 3 per cent. of litharge added and well stirred in. The boiler should be large enough to hold twice as much oil as is actually used, so that it may not easily froth over. The temperature is taken up to 250°C . (482°F .), and kept so for twelve hours, during which time the oil is constantly stirred to prevent any solid matter sticking to the bottom of the boiler. At the end of the two hours the temperature should not be above 275°C . (527°F .). It is left to stand all night and next day very slowly heated, so that it takes twelve hours for the temperature to reach 300°C . (540°F .). The fire is then put out and the oil run into the tall cylinders, where it is left to clarify for a fortnight.

To test the varnish it is placed on a plate of glass and left all night. In the morning it should be dry, free from white spots and stickiness. If it is sticky 5 per cent. of spirits of turpentine is added to the warm oil.

Sometimes 5 per cent. of umber or of white lead is added with the litharge.

The following are recipes for varnish :—

	I.	II.	III.	IV.	V.
Linseed oil	100	100	100	100	100
Litharge	3	8	5	5	4
Umbre	—	—	5	—	3
White lead	—	—	—	5	3

(c) *Manganese Compounds*.—Half a per cent. of manganese hydrate when mixed with linseed oil gives it a greenish colour and good drying properties.

Manganese dioxide in the proportion of 5 per cent. is heated with the oil for twenty-four hours at 300° C. (540° F.). This gives a very thick varnish, which should be diluted with a little raw linseed oil or turpentine.

To prepare varnish with manganese borate, 4 parts of the dry, finely-powdered salt are well mixed with 25 parts of linseed oil and the paste poured into 2,000 parts of raw oil, which is then heated for half an hour at 250° C. (482° F.), or for a quarter of an hour at 316° C. (601° F.). The varnish obtained in this manner is very light coloured.

(d) *Lead*.—Livache thickens oil by means of finely-divided lead prepared by precipitation. This process gives the colourless varnish from which the coloured enamels are made of which we shall speak later.

Twenty-five petroleum casks are each divided into two equal parts, lengthways, by perforated wooden partitions. Circular holes 2 in. in diameter are drilled in both ends of each cask to allow the air to enter freely. One of the compartments of each barrel is filled with zinc turnings which have been soaked in a dilute lead solution so as to give them a coating of lead. The casks are then half filled with oil and laid side by side on two long beams. During the night-time they are turned so that the oil is in the same compartment as the zinc. In the day-time they are rolled over so that the oil runs into the other compartment. This change of position is generally effected by means of a long ratchet which fits into a toothed wheel on each cask.

Before putting the oil into this apparatus 0.2 per cent. of manganese nitrate has been added to the oil.

When the oil is sufficiently thickened, *i.e.*, at the end of about ten days, it is shaken up with 0.5 per cent. of oxide of lead.

4. Lacs and Resins.—Resins are very widely distributed throughout the vegetable kingdom. They are produced by the action of atmospheric oxygen on the essential oils secreted by plants.

General Properties.—Resins are amorphous bodies insoluble in water, but soluble in alcohol, ether, essential oils, hot fatty oils, nitrous ether, etc. They are fusible but not volatile, and are decomposed by heating strongly. They will not combine with acids, the stronger of which decompose them when warmed. Alkalies dissolve resins, forming soluble salts known as resinates. The density of resins varies from 0.92 to 1.2.

Shellac.—This substance is produced by an insect (*Coccus lacca*), which looks like a red louse and which punctures the young branches of fig trees (*Ficus indica* and *religiosa*) *Aleurites laccifera*, *Rhammus jujuba*, and *indica*, *Butea frondosa*, etc., etc. The sap which runs from this puncture forms a sort of thick crust all over the epidermis of the branch. The branches and twigs covered with this resin are gathered just before the last change of the insect, so that it remains imprisoned in the lac. It is exported either as stick lac, that is to say, still adhering to its native branches, as grain lac, *i.e.*, fragments which have fallen from the branches, or as shellac, prepared in scales. The preparation is carried out as follows: The sticks are passed between two rollers to get rid of the wood, bark, and other coarse impurities, and then placed in vats of water. In these vats coolies wash it by trampling it with their feet until the water runs away perfectly clear.

This washed lac contains 10 per cent. of colouring matter which is removed by boiling with an alkaline water. The lac melts, floats to the top, and is skimmed off and placed in clean cotton bags. Two coolies expose a bag to a bright fire over a trough. The resin melts and filters through the bag into the trough. Melted resin is spread on copper rollers and allowed to set, when it is broken off in irregular brittle scales.

The alkaline solution contains the colouring matter known as lac dye, a very fine red which is used for dyeing morocco.

Thread lac is exactly the same, but drawn out into threads instead of scales.

All the lac consumed comes from India *viâ* Calcutta, or from the French establishments of Cochin-China.

Commercially there are three varieties: brown, red and white.

The Ceylon croton furnishes a lac very similar to shellac. Japanese lac is produced from the sumach (*Rhus Vernicifera*). When a cut is made in the tree a weak, milky juice runs out, having a density of 1.002 at 22° C. (72° F.). It turns brown in the air and dries to a bright transparent lac. Yoshino produces the finest material. The juice of this tree contains urushic acid to the extent of 3 per cent., to which it owes its drying properties. A thousand trees only furnish 10 kilos. (22 lb.) of sap. The tree which furnishes this substance is known as Ourousi-no-ko and the varnish is called Yangtsi. In China the lacquer tree is called Tsi (probably the Kouangtsi lacquer). Cochin-China wax, known as cay-dau, is gathered in the province of Bien-Hoâ.

Shellac consists of:—

	Per Cent.
Resin partly soluble in alcohol	66.65
Laccine	16.75
Colouring matter	3.75
Extractives	4.00
Wax	1.67
Sand, insect refuse, and salts	4.00

It is translucent, brittle, totally soluble in absolute alcohol, and partly soluble in ether and essential oils, soluble in hydrochloric and acetic acids and in aqueous solutions of potash, soda, or borax. Its density is 1.34.

Bleaching the Lac.—For the preparation of coloured varnishes the lac must be bleached, so that it may not alter the colour of the mixture.

It is dissolved in alcohol or dilute carbonate of soda and *eau de javelle* added. After a quarter of an hour a little hydrochloric acid is added, but not sufficient to cause a precipitate, and the mixture is left exposed for a little while to the sunlight.

It is then filtered, a little sulphite of soda added, and finally the lac is precipitated by exactly neutralising the alkali with acid. This method, proposed by Kressler and improved by Sauerwein, is the one usually employed.

Eder operates as follows:—

Ten kilos. (22 lb.) of crusted lac are dissolved together with 4 kilos. (9 lb.) crystallised soda in 150 litres (33 gallons) of warm

water in a copper vessel, and the violet solution filtered through a cloth into a wooden trough. Meanwhile another solution containing 10 kilos. (22 lb.) of crystallised soda, 10 kilos. (22 lb.) chloride of lime (30 per cent. chlorine) in 200 litres (44 gallons) of water is prepared and filtered into the lac. The mixture is cooled down, and hydrochloric acid diluted with three times its volume of water is carefully added until the lac begins to precipitate. Usually a very small quantity is sufficient. After standing for three days the bleaching is finished and the lac may be precipitated with strong hydrochloric acid. It is left for two hours in the acid liquid so that the liberated chlorine may act on the finely-divided lac. It is then filtered through a coarse cloth, well washed, and melted down under boiling water.

Hyposulphite of soda is sometimes used for bleaching (*see* "Leather Bleaching").

Copal.—Two varieties of copal are known—soft or gum enemi and hard copal.

Soft copal, obtained from *Hymenæa Courbaril*, comes from India and South America in white or pale yellow globular masses, with a vitreous fracture melting at 100° C. (212° F.). The copal from cayenne is partly soluble in cold alcohol and totally in hot alcohol. Indian copal is very slightly soluble in alcohol. Both are soluble in turpentine. When they have been broken up and sweated for a month they become very soluble in alcohol and ether.

Hard copal comes from Bombay, Calcutta and Madagascar. The most important is Calcutta or amber copal, which is extracted from *Hymenæa Verrucosa*. It is found in drops or hard yellow plates with a vitreous fracture, very smooth and with a density of 1.045. It is nearly insoluble in alcohol and other solvents. Before it can be used in varnish it must be exposed to a temperature of 360° C. (680° F.) until it has lost a quarter of its weight, when it becomes soluble in alcohol, ether, turpentine, benzine, petroleum and vegetable oils. Copal heated in a closed vessel to 350° or 400° C. (662° or 752° F.) with any one of these solvents will dissolve without any loss of weight.

Elemi Resin is partially soluble in cold, totally in hot alcohol.

Gamboge.—Two varieties are known. The best comes from Ceylon and Cambodia, where it is extracted from *Stalagnites Cambodioides*. The other variety comes from Malabar, where it is extracted from Cambodia gutta. It is exported in large cylindrical pieces, reddish-brown on the outside and reddish-yellow on the inside. Its powder is yellow. It is partly soluble in water, giving a fine yellow emulsion. Alcohol dissolves it entirely, and alkalis turn it red. Its composition is as follows:—

	Pipe Gamboge.	Coke Gamboge.	Ceylon Resin.
Resin (insoluble in water)	72·9	64·65	68·8
Gum (soluble in water)	22·9	20·20	20·7
Starchy matter	—	5·60	—
Wood	—	5·30	6·8
Water	4·8	4·10	4·6

Mastic.—Extracted from *Pistacia lenticus*: it is sold in grains or yellowish drops; soluble in alcohol and ether.

Sandarach.—This is extracted *Juniperus communis* or the African juniper and *Thuja articulata*: easily fusible; light yellow drops; sp. gr. 1·85; completely soluble in alcohol.

Pine Resin.—This resin exudes from cuts made in different kinds of pine which give various qualities. Those best known commercially are:—

Bordeaux resin obtained from <i>pinus maritima</i> .	
Venice " " " " " "	picra.
Alsace " " " " " "	picra.
Vosges " " " " " "	larix.
Boston " " " " " "	australis.
American " " " " " "	strobis.
Hungary " " " " " "	mughos.
Carpathian " " " " " "	cimbra.
Canadian " " " " " "	balsamea.
English " " " " " "	tæda.
Chios " " " " " "	<i>pistacia terebinthus</i> .

Barrus is produced by the solidification of turpentine in the air.

Gallipot Resin is the gum which has run down to the foot of the tree.

Virgin Resin is that which exudes naturally from the twigs and branches.

Yellow Resin is obtained by melting gallipot resin in a boiler.

Sun-dried Resin is made by fusing gallipot which has been spread out on straw mats.

Colophony is the residue obtained when turpentine is distilled. It is soluble in fixed and volatile oils, in alcohol, and in alkalies. Its density is 1.071.

5. Preparation of the Varnish.—The best method of preparing the varnish is as follows: After having boiled the linseed oil and allowed it to stand in the cylinders from fifteen to twenty days, it is run back into the boiler, heated up to 100° C. (212° F.), and 1 lb. of finely-divided bichromate of potash added in five portions. It is kept for a quarter of an hour at this temperature, then heated up, and kept at 160° C. (320° F.) for an hour. Prussian blue (1 lb. for every 10 lb. of oil) is powdered very finely and sifted through silk, then sifted on to the oil through an iron sieve. The temperature is steadily increased until at the end of three hours it reaches 250° or 300° C. (482° or 572° F.). During this time it will give off large quantities of inflammable disagreeable-smelling vapour, so that the boiler should be covered up with a still-head to carry away these vapours. A mechanical stirrer keeps the mass constantly moving.

Whilst this is going on another mixture is being prepared by boiling together in an autoclave:—

	Parts.
Linseed oil	100
Copal	100
Shellac	100
Turpentine	300
Cerisine	25

This is kept at 350° C. (662° F.) for half an hour; 30 per cent. of this varnish is mixed with the hot oil.

A sample of the substance when spread on a glass plate and cooled should form a deep brown shining coat without any stringiness or oily edge.

The temperature of the mass is now allowed to fall until it reaches 100° C. (212° F.) and 10 per cent. of spirits of turpentine are thoroughly stirred in.

It is run off into vertical cylinders and left to stand for twenty days in a room kept at 25° C. (77° F.) where it slowly clarifies.

Enamel made in this way is very viscous at the ordinary temperature, but becomes fluid on warming. Seen by transmitted light it is brownish-black, but by reflected light it is intensely black.

This is the composition most generally used for black patent leather. Sometimes the quantities of shellac and resin are altered, or the Prussian blue and bichromate replaced by bitumen of Judea. Some makers increase the amount of turpentine or cerisine, or colour it with lamp-black.

6. Other Compositions.—We give next some typical formulæ of leather enamels of an entirely different nature :—

I.—HEIN ENAMEL.

	Parts.
Mineral wax	90
Spermaceti	30
Spirits of turpentine	350
Asphaltum	20
Borax	10
Lamp-black	20
Prussian blue	10
Nitro-benzine	5

2.—NICOLET ENAMEL.

A.

Wax	150
Tallow	15
Linseed oil	200
Litharge	20
Treacle	100
Lamp-black	103

B.

Alcohol	1,000
White lac	333
Pine resin	80
Prussian blue	20

or

Turpentine	280
Shellac	5
Aniline violet	2
Alcohol	35

3.—GUNTHER ENAMEL.

Shellac	80
Alcohol	15
Wax	3
Castor oil	2

4.—ANILINE ENAMEL.

A.		Parts.
Aniline black		400
Hydrochloric acid		400
Alcohol		2,400
B.		
Shellac		2,400
Alcohol		10,000

5.—

A.		
Lamp-black		1,500
Animal charcoal		190
Glycerin		1,865
Glucose		1,865
B.		
Gutta-percha		75
Stearine		300
C.		
Senegal gum		155
Water		560
Lavender oil		155

It should be noticed that these somewhat original recipes contain several highly objectionable substances. Enamel should never contain either tallow or non-drying oils, which should be replaced by mineral fats, as they are apt to produce stains and unevenness. Glucose makes the varnish crack. The following are the formulæ of an enamel which we have made for very small and delicate skins :—

A.		Per Cent.
Boiled linseed oil		33'3
Copal		33'3
Spirits of turpentine		33'3
B.		
Alcohol		75
Shellac		25
Aniline violet		1
C.		
Linseed oil boiled with Prussian blue		60
Mineral wax		25
Vaselin		5
Spirits of turpentine		10
D.		
Gutta-percha		20
Spirits of turpentine		40
Boiled linseed oil and blue		40

7. Soap Varnishes.—When solutions of soap are treated with metallic salts precipitates are formed of metallic soaps. These substances, of which the chief are aluminium, zinc and iron soaps, are insoluble in either water or oil.

In their preparation palm-oil soap is generally used. The commercial article has the following composition :—

	Per cent.
Fatty acids	65
Soda	10
Water	20
Foreign salts	5

Ten parts of this soap are dissolved in ninety parts of boiling water. In another vessel a hot strong solution of alum is prepared. The alum is poured into the boiling soap until no further precipitation takes place. The mixture is filtered whilst still boiling through a clean cloth and the palmitate of aluminium so formed is well

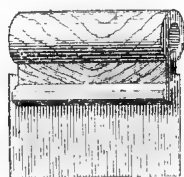

FIG. 70.

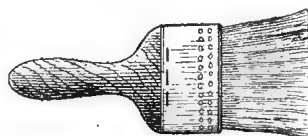

FIG. 71.

VARNISHING TOOLS.

washed with boiling water. After draining it is dried and dissolved in boiling turpentine. In this way a hard elastic varnish is prepared, which, however, is not very brilliant. This difficulty is overcome by using a little shellac.

Iron soap is made in the same way and is soluble in benzene, but being a coloured substance it can only be used for black varnishes whereas the aluminium soap may be used for varnishing in colour.

II.—APPLICATION OF THE ENAMEL.

1. Preliminary Operations.—Skins used for the preparation of patent leather should be very well tanned. They are usually split in the lime or occasionally after tanning.

They are passed through the ordinary currying processes, but special precautions are required in greasing. The degreas should contain no tallow and should be used very sparingly; 20 per cent.

will be quite sufficient. Too much degreas prevents the first coat of enamel from drying well and leaves greasy stains.

2. Dressing.—The object of dressing is to close up the pores of the skin and render it perfectly even by polishing.

The first operation is sizing. The skin is stretched on the table, flesh side up, and a thin coat of glove-kid gelatin passed over it. This gelatin is prepared as has already been described excepting that one part of kid is used for every ten of water. The sized skins are dried in an oven at 25° C. (77° F.), then rubbed with a very fine soft pumice stone.

Next the skin is coloured by sponging it with an alcoholic solution of aniline blue or better still an aqueous solution of aniline violet. Afterwards it is dried first in the air, then in an oven.

The dressing is next given. It consists of:—

	Parts.
Boiled linseed oil	100
White lead	2
Whitening	2
Lamp-black	4

The skins are stretched on frames, and the dressing applied with a steel scraper. They are dried in a room kept at 18° C. (66° F.). After drying for two days they are dressed again and dried for three days. A third dressing is then given and a final drying for four days.

The skins are well rubbed with a pumice stone to make the surface perfectly smooth, two more coats of dressing are given, then another stoning, then a single coat of dressing, and lastly they are rubbed with a very fine stone. The oily layer ought not to get too far into the skin, otherwise the enormous number of little capillary tubes so formed will become brittle when dry and completely spoil it for receiving the enamel. The layer of dressing should be very thin.

A second dressing is given with the following mixture:—

	Parts.
Boiled linseed oil	100
Fine lamp-black	8
Aniline violet	1
Alcohol	3
Turpentine	50

The linseed oil and the alcoholic solution of aniline violet are mixed at a temperature of about 60° C. (140° F.), then the black is thoroughly rubbed in, and finally the turpentine is added to render it more liquid.

Three successive coats of this dressing are given with a soft, long-haired brush. This gives a bright smooth surface of a very deep black.

3. Mechanical Stoning.—Stoning is generally done by hand, but in large works mechanical stones are used with excellent results. The best known machines are those of Sénat, Jesson, Sueur, Soyer, etc.

They consist of a round stone fixed at the lower end of a hollow vertical shaft which turns in the centre of a large arched standard. Between the ends of the standard is a large table on which the workmen spread the skins. Underneath the stone is a metal disc, which may be raised or lowered by a pedal so as to press the skin against the stone. The stone may be replaced by a smooth metal disc, in which case the skin is sprinkled with pumice powder.

4. Enamelling.—After the last stoning the skins are rubbed with the finest pumice powder spread on a woollen rag.

The skin is then nailed on a horizontal table covered with a thick woollen cloth and the enamel spread with a soft brush. After receiving three layers the skins are dried at 50° C. (122° F.).

During enamelling the utmost precautions should be taken to avoid all particles of dust. Drying is complete in from twenty-four to thirty-six hours.

III.—ENAMELLING IN COLOUR.

Coloured enamels are prepared and applied in the same way as black enamel. All the linseed oil and resin used for this purpose should be colourless.

The skin is first dyed the same colour as the enamel (*see* "Dyeing").

The following are the most commonly used formulæ:—

1. White Enamel.

	Parts.
Boiled linseed oil	100
Copal varnish	100
Spirits of turpentine	50
White lead	20

The white lead should be first spread on the muller and ground into the linseed oil, and afterwards mixed with the other substances.

The white lead (basic carbonate of lead) may be replaced by zinc white (oxide of zinc) or mineral white (sulphate of barium).

2. Red Enamel.—The chief colours used are : (1) vermilion (sulphide of mercury), also called Chinese red, patent red, Paris red and cinnabar ; (2) English red (peroxide of iron), also called ruddle, Nuremberg red or Naples red ; (3) the lakes, which are pigments obtained by mixing decoctions of certain colouring matters with carbonate of soda and alum. The colours principally used for the preparation of lakes are cochineal, lac-dye, madder and logwood. They are known as Vienna lake, Florentine lake, Venetian lake and crimson lake.

The colour is mixed up with a varnish consisting of:—

	Parts.
Copal	1
Spirits of turpentine	2
Boiled linseed oil	2

3. Blue Enamel.—The colours used are ultramarine (sulphide of sodium and silicate of alumina), sometimes called azure blue ; smalt (chiefly cobalt oxide) known as Saxony blue, royal blue, cobalt blue ; Prussian blue (ferrocyanide of iron) ; mineral blue (basic carbonate of copper).

All these blues may be lightened by the addition of white lead or mineral white.

4. Yellow Enamel.—The colours employed are chrome yellow, (chromate of lead), sometimes named Paris, Leipzig, Gotha, Hamburg, Cologne, Zwickau, imperial and lemon yellow ; mineral yellow (oxychloride of lead), also called Cassel, Montpellier, Paris, Verona, Turner's, and chemical yellow ; Naples yellow (antimoniate of lead) ; orpiment (sulphide of arsenic), sometimes called royal, Persian, Chinese and Spanish yellow ; raw Sienna (clay), also called

yellow ochre and lemnos' earth ; yellow ultramarine (chromate of barium) gamboge and Indian yellow.

5. Green Enamel.—The colours used are green ultramarine, Rinnmann's green, Brema green, mineral or Scheele's green (arsenite of copper), English green (arsenite and acetate of copper), which goes by a large number of names ; Terra vate (double silicate of iron and potassium) ; oil green, a mixture of Prussian blue and chrome yellow, also called chrome or Naples yellow ; Guignet's green (borate of copper).

6. Mixed Enamels.—By mixing different colours various tints may be obtained. These should be determined by experiments on a small scale.

The preparation of all these varnishes is carried out in the manner explained under the heading of black, white and yellow enamels.

7. Transparent Enamelling.—This consists of dyeing the skin the required colour, and then colouring it with colourless copal or lac varnish.

8. Gilt Enamelling.—This is sometimes done with enamel mixed with Muscovite gold (sulphide of tin), or zinc, silver, or gold dust ; or else by passing copal varnish over gilt or silvered leather (*see* "Morocco").

CHAPTER II.

HUNGARY LEATHER.¹

THE manufacture of Hungary leather was originated, as its name implies, in Hungary. Its introduction into France is due to the enterprise of Sully, a minister of Henry IV. For this class of leather, the tan or tannin is replaced by chloride of aluminium. It is a kind of mineral tanning. In this case there is no combination of the skin with the mineral matter, but simply a deposition between the fibres, which stiffens them and preserves them, seeing that chloride of aluminium is a powerful antiseptic. The aluminium salt is prepared by the action of common salt (chloride of sodium) on alum (double sulphate of aluminium and potassium).

Hungary leather is made from large hides, especially those of Limousin oxen. It is manufactured very rapidly, only two months being required to change the skin into leather.

I.—PRELIMINARY.

1. Alum.—Alum is a double sulphate of aluminium and potassium, having the formula $K_2Al_2(SO_4)_4 \cdot 24H_2O$.

It occurs commercially as large colourless crystals with a sweet astringent taste. It has an acid reaction and a density of 1.71. It is much more soluble in hot than in cold water. A hundred parts of water dissolve 3.3 parts at 0° C. (32° F.), 9.5 at 10° C. (50° F.), 22 at 30° C. (86° F.), 31 at 60° C. (140° F.), 90 at 70° C. (158° F.) and 350 at 100° C. (212° F.). When heated to 72° C. (162° F.) it melts in its own water of crystallisation; if it be allowed to cool down in this state, it becomes solid and vitreous, and is known as rock alum. Solutions of alum are precipitated by potash, soda and

¹This process is not carried on in England and is included in tawing in usual descriptions of the manufacture.

ammonia, or their carbonates or by lime. Alum contains 44 per cent. by weight of water.

Soda and ammonia alums are also known.

Sulphate of aluminium, which is the essential part of alum, has the formula $Al_2(SO_4)_3$. It crystallises with difficulty, has a strong astringent taste and a marked acid reaction. The commercial article contains from 48 to 60 per cent. of water. It is extremely soluble in water.

2. Common Salt.—We need say nothing about this salt, as its properties are well known. Thirty-seven parts will dissolve in 100 parts of water. It is nearly as soluble in cold water as in hot.

3. Aluminium Chloride.—This is formed by the reaction of common salt on alum, according to the equation:—

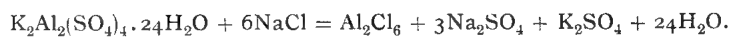

A hundred parts of alum should be used for every 40 of common salt.

Chloride of aluminium is white and very soluble in water.

4. Action of these Bodies on Skin.—Skin dipped into a dilute solution of alum will absorb 8 per cent. of its weight without any decomposition of the alum. From a dilute solution of sulphate of aluminium it will absorb 25 per cent. of its weight without decomposition, and from a solution of chloride of aluminium 25 per cent.

It was formerly supposed that basic salts were formed in the skin, and acids set free in the solution; but this is not so, as the salts are absorbed without any decomposition.

As to the common salt, it not only transforms the aluminium sulphate into chloride, but also has an action of its own, since chloride of aluminium by itself will not give such good leather as a solution of alum and salt. Moreover, in practice, an excess of salt is always used. We have already mentioned that 40 parts of salt will transform 100 parts of alum; practically at least 60 parts of salt are used. Common salt has the property of removing moisture from the skin until the fibres no longer stick together. In the preparation of Hungary leather it exercises great influence either by favouring endosmosis or otherwise facilitating the work of tanning.

II.—WET WORK OR PREPARATION.

1. **Washing.**—The skins usually arrive fresh or green; the horns are removed and the skins are cut in two by machinery. They are cleaned on the beam with a blunt knife, and fleshed lightly, only removing the fat and useless pieces of flesh. They are soaked to remove the greater part of the blood, rinsed and passed on to the process of shaving.

2. **Shaving.**—A bed is made on the beam with several thicknesses of skins. The workman then shaves them with a very sharp knife. As the hair accumulates he brushes it on to the floor with the back of his knife. The legs when left on the skin take a relatively long time to shave. A workman can scarcely shave more than twelve or fifteen skins a day.

The skins are soaked for twenty-four or thirty-six hours to remove all blood and then drained for two or three hours on the beam, observing the same precautions as in soaking skins for tanned leather.

III.—ALUMING.

1. **Solution of the Salts.**—A batch of skins worked together, usually consists of nine skins or eighteen "sides" but is of course variable. The work is carried out by two workmen, the presser and the fuller.

The salt and alum are dissolved in a cylindrical boiler, placed over a fire. It should be about 16 in. deep in the centre, by 2 ft. in diameter, its capacity thus being about 60 gallons, which is sufficiently large to contain the liquid required by nine skins. When working with larger numbers, larger boilers should be used, keeping the same proportion between the size of the boiler and the number of skins.

For every skin weighing from 77 to 88 lb., $6\frac{1}{2}$ lb. of alum, 4 lb. of salt and $6\frac{1}{2}$ gallons of water should be used. We should prefer, however, to give the quantities for every 100 parts of skin as has been done hitherto. This would not leave the proportions so vague as in an ordinary trade recipe. Thus 100 lb. of skin will require 10 gallons of water, 9 lb. of alum and 5 lb. of common salt.

On commencing the work, fresh water is always used with double the quantity of salts; as soon as the operations have been started, old liquors are used, which still contain a certain quantity of the salts. In this case it is only necessary to replace that which has been removed by the skins.

The solution is carried out with constant stirring at a temperature of 50° C. (122° F.).

2. Vatting.—Whilst the alum is dissolving, the presser has placed the skins in vats 5 ft. 8 in. long, 3 ft. 4 in. wide, and 2 ft. 8 in. deep. For a batch of nine skins, three of these vats are used. In each is placed six strips (three skins) folded with the grain outside. Three buckets full of warm water are thrown over them. The fuller with soaked feet tramples the leather with his heels, pushing the skins before him from one end of the vat to the other. We should here remark that the skins are placed in the vat so that the head of the first lies over the tail of the second and so on. After going backwards and forwards three times, the fuller does the same work on the skins which the presser has placed in the next vat, and so on to the third. Each three workings is called a wash, and four washings complete the vatting.

When all three vats have had one wash, the second is given with warm water, the third with water still warmer and the fourth with hot water, which is not poured directly on to the skins.

A complete set of four washings can be given by a workman in a day.

3. Mechanical Vats.—The work which has just been described is very fatiguing, so that manufacturers have to a great extent replaced human labour by machinery. Delpech suggested a large vat turning slowly about a vertical axis. Two stamps work the skins as they pass round. With this machine the washing is never regular.

Lepelley has arranged oscillating vats, each vat being furnished with a horizontal axle fixed beneath it. The oscillatory movement is given by a vertical rod attached to a crank on an overhead shafting.

The hides are arranged in each vat in the ordinary way and

rollers of wood placed on them. The rollers run backwards and forwards, effectually working the skins, whilst at the same time the liquid is strongly agitated.

The use of this apparatus is now very general.

4. Turning (Culbutage).—After the fourth wash the sides are folded in four and placed in vats 2 ft. 8 in. deep and 2 ft. 8 in. in diameter, and old alum water is poured in until they are covered. They are left thus for twenty-four hours and then turned.

This is done by removing the pile of skins, turning it upside down and placing it in a fresh vat. It is left in this alum water for eight days to finish tanning. Some manufacturers prefer to turn them again and give them another eight days in alum.

5. Second Fulling.—After the alum the leather is fulled a second time, shaking it a little more violently. Four washings are given, using a solution of salt and alum or of alum alone. They are then put back into the vats for eight days, turned, and left in the alum for eight days more.

6. Drying.—The hides are allowed to drain for one or two hours, so that the liquor drains back into the vats. Then four holes are made in the tail end of each side; a rod is passed through the holes and the skins are taken to the drying chamber. They are allowed to become three parts dry and then redressed.

7. Stretching.—The strip is folded in two with the grain inside. The workman places his knees on the fold, and stretches the strip by pressing it with a rod so as to remove all creases. The rod is 22 in. long by $\frac{3}{4}$ in. in diameter and is worked over the skin, starting from the middle of the back towards the tail, then starting again from the same place and working up to the throat. When the first strip is stretched the next is placed on top of it and treated in the same way, and so on until the first strip has remained in position for a day.

They are stretched a second time and allowed to dry.

In large works the leather is stretched between two heavy wooden rollers. It is passed through twice in such a way that each side in turn is submitted to the action of the roller.

wheels so that they may all turn together at the same speed. A cloth band is folded between the rollers in the direction indicated by the arrows. This guides the skins in the right direction between the rollers. The skins are led in one after another, eighteen being fixed together and also fastened to the two ends of the cloth so as form an endless chain. The rollers are turned slowly and the skins run through all the twists between the rollers, so that they first work the grain and then the flesh. After once running through, the rollers are moved at twice the pace, then a third working is given at three times the original pace. The system of rollers is then turned so that only the cloth remains between them, the hides are

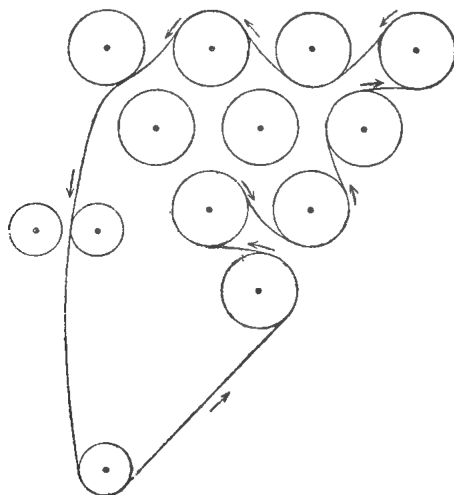

FIG. 72.—Dressing by Machinery (roller system).

then unfastened and another set started. A hundred and fifty skins can be worked in one day.

Tourin has invented a machine for drawing a rod over Hungary leather, which works ten sides per hour, and uses a half horse-power.

V.—TALLOWING.

1. **The Chamber.**—Tallowing is carried out in a "stove" 5 ft. high, 13 ft. long, and 10 ft. wide, having all its apertures well closed so that no heat may escape from it. It contains a cast-iron boiler set in a brickwork fireplace, capable of holding 175 lb. of tallow. The chamber is heated either by an ordinary currier's

IV.—DRESSING OR LOFT WORK.

1. **First Dressing.**—The hide is folded in two, grain within, tail above and head below, and placed on an inclined table 40 sq. ft. in area. The table consists of planks fixed across joists which are set 12 in. apart. The hide is placed with the back turned towards the lower part of the table. A perfectly even round rod, 2 ft. long and $\frac{3}{4}$ in. in diameter, is placed between the folds. The workman, who is shod with large shoes without heels, stands on the hide, then supporting himself by holding a bar placed in front of him, he rolls the rod with his feet from one end to the other. In this way the rod comes to the edge of the skin; the work is then restarted, but with the head above the tail. About a foot of the tail end is folded over, the rod is slid into the fold and rolled right along as far as the back. Next it is folded so that the hind leg comes over the back, the rod is inserted as before and rolled across. The tail is thrown on to the head and rolled. A fold is made across the leg, throwing the hip as far as the navel, and rolled. The tail is placed on the head and the full length of the belly rolled. The folded skin is then turned over, so that the half which has hitherto been above is now pressed on the table and the whole set of operations is repeated.

The skin is refolded with the grain outside, and the whole double series of operations is gone through again.

This work is extremely fatiguing. A workman can only get through forty sides per day.

2. **Final Dressing.**—The hides are piled for twelve days, then the pressing is carried out in exactly the same way as for the first pressing.

3. **Dressing by Machinery.**—Having noticed the fatigue of the workmen after this difficult and painful work, the object of which is to soften the leather and open it so that it may receive the tallow, the author has invented a simple machine for the purpose. It consists of ten hard wooden cylinders (Fig. 72), 5 in. in diameter and 3 ft. 4 in. high. They are placed vertically in a frame and turned from below. They are fixed together above by toothed

stove or some other arrangement. The Aurusse stove is specially adapted for economically heating with coal. It has a hearth 3 ft. 4 in. long by 2 ft. high, above which is a smoke-pipe 2 ft. long by 6 in. in diameter. This ends in a vertical column 3 ft. 4 in. high and 10 in. in diameter. Two small tubes lead the heat and smoke from this to two other columns 3 ft. high by 10 in. in diameter, placed at the side of the first column. These two lead into a horizontal tube which in its turn communicates with the chimney.

Inside the chamber is a brickwork erection supporting a grid 3 ft. square.

Lastly the chamber contains two large tables, and a set of poles for hanging up the hides.

2. Heating the Leather.—A basketful of charcoal (22 in. high by the same diameter) is lit on the grating. When it is well alight the poles are arranged in the form of a pyramid above the grating and from twenty-four to thirty-eight sides are stretched over them. In spreading out the skins they are folded head to tail and hung over the poles so that they are really folded in four. The head is placed so as to hang next the fire and the whole set is arranged so that the thickest are in the hottest, and the thinnest in the cooler part of the chamber. When all the hides are placed on the poles the workmen go out and close the door, leaving the hides to sweat.

During this sweating the leather loses its moisture in the form of a thick evil-smelling vapour. After a quarter of an hour the door is opened to let out the smoke. If too much salt has been used with the alum the skins will contain an excess of moisture and will drip and give off much more vapour, the sweating taking a long time.

When a strip has been sufficiently heated it becomes white, commencing by the leg pieces.

After heating is finished the workmen go into the chamber with no other clothing than a short apron. They take the skins off the poles and stretch them on a table placed near the tallow boiler. The thin skins are laid down first and the thicker ones last so as to form a pile all flesh side up and tail end nearest the boiler.

3. Tallowing.—When the pile has been made, the first strip is

folded in two bringing the tail up towards the head, flesh side out. The tallowing cloth, made of strips of flannel 1 ft. long fixed to a 6-in. wooden handle, is dipped into the melted tallow (120° to 140° F.) and the requisite quantity of tallow transferred to the skin. A half hide requires 3½ lb. of tallow. The grease is first placed on the head and worked downwards carefully until the whole flesh side is covered. It is then turned over and a thin layer of fat given to the grain side, without dipping the cloth into the tallow, and thus using only what is left on the cloth. This operation is carried out by two workmen.

The side thus greased is carried to another table, where it is laid, folded lengthways, flesh side out. As the other skins are greased they are piled on top of the first one, placing the back of the second over the belly of the first and so on.

Thirty sides can be greased in an hour.

4. Tallowing with the Fulling Machine.—The tallowing of Hungary leather is not only very exhausting, but also unhealthy. The workmen breathe vitiated air, containing large quantities of water vapour, and various organic matters derived from the skin, carbonic oxide and carbonic acid from the combustion of the charcoal, and acrid fumes from the tallow boiler; moreover the heat is excessive. They are obliged to take great precautions, and they cannot stay in the chamber longer than six minutes at a time. When they enter the chamber they must not have had anything to eat for at least two hours, or they will be liable to violent vomiting. Lastly, they are exposed to what is known as chamber sickness, which is a ringing in the ears with absolute deafness, which lasts as long as they stay in the chamber.

Plenty of means have been invented for the remedying of these difficulties, such as steam heating and the use of the fulling machine, but the older method is still most used.

Lepelley's tallowing machine (1849) is too complicated to be generally adopted, and the same may be said of Moret's machine (1872). At present the machine most commonly used in high-class works is Delpesch's stuffing drum, which has been already described. The hides, together with the tallow, are placed in this

machine after they have been sweated in the chamber. Results are excellent and the health of the workmen is not impaired. The author has done away with all these inconveniences, and at the same time obtained the best class of leather by the use of steam.

5. Tallowing by Steam.—When the hides come from the machine shown in Fig. 72, they are exposed to a temperature of 50° C. (122° F.) in a steam dryer arranged in the same way as the American drying tower.

Immediately on coming out of the dryer the hides are hung on rods of wood or iron which are placed in line in a square vat 32 in. high, 10 ft. long, and 7 or 8 ft. wide. The hides are set about half an inch apart so that ninety may go into the vat at once. Before introducing the hides, the necessary quantity of tallow has been placed in the vat and melted by steam which maintains it at a constant temperature of 122° F. The hides are soaked for an hour in the warm tallow which will penetrate the skin more or less according to its dryness. This method gets over the great inconvenience shown by the fulling machine, which breaks the fibre of the skin. Further, it allows the tallow to enter the hide by capillary attraction, so that it only takes up the requisite amount.

This method of tallowing is far superior to the old one. The products obtained are at least as good and the work does not cause any suffering to the workmen.

6. Fats used for Hungary Leather.—White tallow is too expensive, consequently the refuse of beef and bone fat is generally used.

Of late paraffin, ozokerit and vaselin have been used either alone or mixed with tallow. These substances, which are very dangerous to use with dressing leathers, give excellent results with Hungary leather.

Paraffin is a colourless, translucent, odourless solid. It melts, according to quality, between 45° and 65° C. (131° to 149° F.)

Boghead paraffin	melts at	45° C. (131° F.).
Ozokerit	„ „	63° C. (145° F.).
Petroleum	„ „	61° C. (142° F.).
Pitch	„ „	46° C. (133° F.).

Its boiling point is 300° C. (572° F.). Its density is 0·870. It is not affected either by the air or by acids or alkalies.

The paraffin should be mixed with the tallow to the extent of 30 per cent.

As this substance is a little stiff in the leather it should be softened as follows: It is heated to 150° C. (300° F.) in an iron boiler and a current of warm air blown through it for an hour, when it will become yellowish-brown; 30 per cent. of tallow is then mixed with it, and it is ready for use.

7. Singeing.—The hides are left piled on the table for about an hour to absorb the fat. Meanwhile a basket of charcoal is placed on the grate and lit, the pile of leather being covered with a sheet to protect it from the heat. Afterwards the hides are passed over the fire, exposing the flesh side, then they are piled on the empty table, grain below. The pile is covered with cloths and left for half an hour. The object of this operation is to drive the fat into the fibres of the skin.

8. Stoving.—Singeing is often replaced by heating for half an hour or an hour in an oven. We recommend an oven heated by steam to 50° C. (122° F.). The penetration is more regular and the labour very much less.

9. Cooling.—On coming out of the oven the hides are piled for half an hour. Afterwards they are rubbed on both sides with a dry cloth, hung over poles, grain below, and exposed to the air to dry for a day. Strong sunlight is to be avoided.

10. Piling.—The skins are piled for four days, then they are weighed and their weights marked on the tail. They are piled again for five days and are then ready for use.

VI.—HUNGARY LEATHER FROM VARIOUS HIDES.

1. Oxen.—Ox hides are prepared in the manner just described. A hide weighing 100 lb. as it leaves the slaughter-house gives 40 lb. of Hungary leather. The finished leather contains 3 per cent. of alum, 2 per cent. of salt and 10 per cent. of tallow.

2. Cows.—Cow hides are not shaved, but unhaired with lime.

They give a yield of 38 per cent., and absorb 4 per cent. of alum, 2·5 per cent. of salt, and 12 per cent. of tallow.

3. Calf.—These skins are treated like cow hides, but use less tanning material. For a large calf skin 1 lb. of alum, $\frac{1}{2}$ lb. of salt, and 1 lb. of tallow is used. The yield is 42 per cent. and they absorb 2·9 per cent. of alum, 2 per cent. of salt, and 8 per cent. of tallow.

4. Horse Hides.—Hungary leather made from horse hides is called German leather. The hides are treated immediately on removing from the animal. They are scraped carefully so as not to injure the thin parts, and they are shaved or unhaired with lime. In the latter case they must be exceedingly well washed. In aluming, $5\frac{1}{2}$ lb. of alum and $3\frac{1}{3}$ lb. of salt are used for a large horse hide, or half these quantities for a medium-sized one. After being turned twice they are hung up in a drying room; 3 lb. of tallow is used for each skin. The yield is 35 per cent., the skin absorbing 2·9 per cent. of alum, 1·75 per cent. of salt, and 8 per cent. of tallow.

5. Defects of Hungary Leather.—Besides the defects inherent in the skin, such as cuts and punctures, Hungary leathers occasionally have the following faults:—

(a) *Horny Leather* is that which has horny places resulting from imperfect washing. It has neither strength, suppleness, nor durability.

(b) *Stiff Hides* are those which have not been sufficiently opened in the loft work. They have not been able to take up sufficient tallow and consequently are not supple.

(c) *Brittle Leather* has had its grain tallowed at too high a temperature.

(d) *Black Leather* has been badly tallowed.

6. Coloured Hungary Leather.—Hungary leather is sometimes blackened by the method already explained. This was first practised by Kresse in 1836.

They may be dyed red or yellow (*see* "Dyeing").

CHAPTER III.

TAWING.

IN tawing, or the preparation of leather for gloves or ladies' shoes, only very small skins are used, especially those of young animals such as the kid and the lamb. Next come young calves, does and sheep for strong gloves. More rarely the skins of the goat, the foal, the rabbit, the deer, and the dog are used. The tawer also prepares skins, without removing the hair, for the manufacture of rugs, etc.

The goat is found nearly all over the world, though it is very scarce in North America and Australia. It lives chiefly in the mountainous districts of Europe : Switzerland, Savoy, Styria, Tyrol, Austria, Dalmatia, Bulgaria, Umbria, the Sicilys, and the kingdom of Naples, all the coast of the Mediterranean and Spain. Large numbers also come from South Africa, Algeria, India and Mexico.

Calf skins come chiefly from Bohemia, Saxony, Switzerland and Bavaria, where they grow very large and strong. Large ones also come from Zeeland, but they are much lighter than the first named. Medium-sized ones come from Norway, Galicia and Transylvania, and small ones come from Russia and Servia.

Tawing is an eminently French industry. The greatest centre of glove kid manufacture is Annonay. Other important centres are Paris, Lyons, Grenoble and Chaumont.

I.—PREPARATORY OPERATIONS.

1. **Softening.**—The skins are usually dry and are therefore soaked for twenty-four hours more or less, according to their dryness and thickness. They are then scudded to remove the dirt.

2. Unhairing.—The skins are stretched one after the other on a table, flesh upwards, and painted with a paste of realgar and lime, or lime and sulphide of sodium, or any other alkaline sulphhydrate. A workman can prepare eighty-five skins in an hour.

The skins are then folded in two, flesh to flesh, and piled up for from six to twelve hours, according to the temperature and the quality of the skins. Afterwards the hair or wool comes off quite easily.

They are next rinsed in running water or in vats furnished with paddles.

The unhairing is done on a beam standing on four legs. It is about 4 ft. long, the front part standing 40 in. above the ground and the back part about a foot high. The skin is placed on the beam with the head pointing upwards, and stretched tightly. It is unhaired in the ordinary way with a round knife or a slate. The skins are then thrown into a basin of clear water and left there for a day.

When the skins are covered with down they are soaked in weak milk of lime, or better still, gas lime, then rinsed and fleshed in the ordinary way.

Unhairing has been performed by machinery. The best known ones are those of Adler, Jonquet, Baudoin and Damourette, all of which have already been described.

When the tawer receives unshered sheep skins, he should cut off the wool and send it to the wool merchant, and before unhairing should carefully wash away the suint. Afterwards sheep skins are split by a special machine.

3. Washing.—After unhairing, the skins are placed in clear water. Formerly they were kept in motion by stirring them with rods, or else by soaking in a vat containing a paddle wheel.

Iwaskiewicz's square tumbler is almost always used nowadays. It consists of a cubical vat which turns about one of its diagonals in such a way that all its faces are inclined. This is shown in Fig. 73.

4. Bating.—In this operation the skins are submitted to the

action of a putrefying liquid which opens its pores and prepares it for subsequent operations.

The skins are placed in a large vat filled with water and dogs' dung. For 1,000 skins two pailfuls of the latter which has been allowed to soak in four pailfuls of water are used. The skins are left soaking from six to twelve hours, during which time a fermentation sets in, destroying the stiffness and swelling the skin. It is generally supposed that this disgusting method has been abandoned, but this is not true. Out of twenty manufactories visited by the author fourteen used dogs' dung.

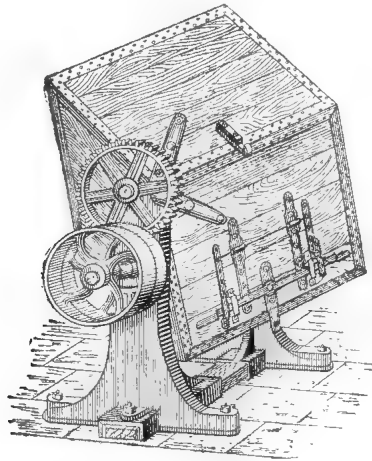

FIG. 73.—Iwaskiewicz's square "tumbler."

The excrement of the dog gives the following analysis:—

Organic matter	17.46
Lime	64.00
Phosphoric acid	0.50
Chlorides	0.50
Potash	0.43
Soda	0.50
Carbonic acid	0.12

Sometimes the droppings of pigeons and fowls are used and occasionally guano. This latter has the following composition:—

Organic matter and ammonium salts	52.52
Phosphate of lime	19.52
Phosphoric acid	3.12
Alkaline salts	7.56
Sand	1.46
Water	15.82
	<hr/>
	100.00

passed in under a pressure of about half an atmosphere. It is left to stand thus for about half an hour, and the pressure increased by half an atmosphere every half-hour until the operation has lasted six hours. The carbonic acid which comes from a charcoal fire has an average temperature of about 75° C. (167° F.), which gives to the skins a temperature of from 25° to 28° C. (77° to 82° F.). This method is easy to regulate, and does not give the leather a chance of putrefying.

II.—DRESSING.

Dressing is the tanning of tawed skins. A mixture of salt, alum, yolk of egg and flour is used instead of tannin. We shall proceed to study the last two bodies.

1. **Yolk of Egg.**—An egg consists of sixty parts of white and forty parts of yolk. One thousand six hundred and sixty-four eggs are required to produce 40 lb. of yolk. The white contains 16 per cent. of dry albumen. The yolk consists of—

	Per Cent.
Water	51.486
Vitelline	15.760
Margarine and olein	21.304
Oleic and margaric acids	7.226
Phosphoglyceric acid	1.200
Cholesterin	0.438
Cereberic matter	0.300
Extracted matter (like extract of meat)	0.400
Phosphates and chlorides of potash, soda, ammonia, lime and magnesia	1.333
Colouring matter, lactic acid and iron	0.533
	<hr/>
	99.980

Yolk of egg is viscous, thick, opaque, and varying in colour from lemon to orange yellow. When mixed with water it forms an almost white emulsion with an alkaline reaction, which sets on boiling to a brittle mass. Glycerin dissolves it completely. In tawing, yolk of egg acts by virtue of the oil and the albuminoid matter which it contains.

The oil of egg yolk is a semi-fluid liquid of a deep yellow colour. It freezes at 10° C. (50° F.). It goes rancid very easily.

Vitelline is an albuminoid very similar to the albumen of the

These excreta are replaced sometimes by fermented gelatin. The author has attempted to use linseed mucilage. We append two other formulæ more rational and less disgusting:—

A.		Parts.
Water		100
Phosphate of potash		1
Sulphate of magnesia		1
Phosphate of lime		1
Citrate of ammonia		2
B.		Parts.
Water		100
Sulphate of magnesia		1
Nitrate of lime		1
Phosphate of potash		1
Calcium chloride		1

Either of these two, after being allowed to ferment, is used in the same way as the dogs' dung.

Another substance, known commercially as phosphobutyroline, is prepared by the lactic and butyric fermentation of glucose to which phosphate of lime has been added. All these new materials act like dogs' dung in that they form lactic and butyric acids and give off gases.

Afterwards the skins are placed in a drench of bran kept at a temperature of 30° to 35° C. (86° to 95° F.). About half a pound of bran is used with each skin. They are laid flat in the vat, each skin being separated from the next by a handful of bran. They are left there three days, taking them out and washing them once each day.

On coming out of the drench the skins are rinsed and scudded on the beam to remove any flesh and bran adhering to them.

5. Gassing.—With the idea that bating and drenching merely cause a slight swelling and softening of the skin, the author has, after many experiments, invented the following method, which is fully appreciated by at least two houses where it is used. The apparatus consists of an octagonal vessel of strong galvanised iron, mounted as shown in Fig. 73. The axle is hollow. The skins are placed in this vessel with $\frac{1}{2}$ per cent. solution of carbonate of ammonia. The door is then hermetically sealed and carbonic acid

egg. It coagulates at 76° C. (170° F.) and ferments very easily, giving off a disgusting smell.

To avoid this rapid decomposition of the yolk antiseptics are mixed with the mass, but all of them have a more or less pronounced action. The best results are obtained at present with sodium glyceroborate. This is prepared by heating together 150 parts of glycerine and 100 parts of borax, and heating to 160° C. (310° F.) for half an hour. It is then run on to plates of copper and allowed to set. It is very soluble in water and alcohol and is strongly antiseptic.

Analysis of Yolk of Egg.—As this substance is very much adulterated, it should be always analysed and compared with the proportions already given.

(a) To make certain that it has not been coloured with turmeric, a few drops of caustic soda are added which will turn the turmeric brown immediately. This test is best made in a small porcelain basin.

(b) A portion should be treated with glycerin to see that it dissolves entirely.

(c) The water is estimated in the manner which has already been described for degreas (p. 218). It ought never to be more than 52 per cent.

(d) The oil is estimated as follows: 10 gram. of yolk are weighed out in a stoppered flask and mixed with 25 cc. of water. Fifteen gram. of ether are added and left in contact with the liquid for eight hours, shaking every half-hour. It is then left to stand over night. The ether charged with oil will rise to the surface. It may then be separated and distilled. The residue is weighed. The remainder of the yolk is again shaken with boiling alcohol and the alcohol separated and evaporated. The sum of the two residues gives the weight of fat. This should always be 25 per cent.

(e) The solidifying point of the oil should be determined. This should always commence at 9° C. (48° F.). The author has found that the solidifying point is lowered 1° C. by 5 per cent. of animal

oil. This gives an approximate method of determining the amount of foreign oil present.

(*f*) To determine the vitelline a weighed quantity of fresh yolk is dissolved in twenty times its weight of water and allowed to settle. The supernatant liquid is decanted and replaced by fresh water and the operation repeated. After a third washing has been given the washings are mixed and the vitelline estimated with a standard solution of tannin. A gram. of tannin will precipitate 95 gram. of vitelline.

(*g*) The ash is estimated as in *degras*. The quantity should be neither more nor less than 1.4 per cent. and should contain two-thirds of metaphosphoric acid and a quarter of chlorides.

2. Wheat Flour.—Flour is composed of:—

	Parts.
Starch	75
Gluten	13
Yellow resin	1
Extractives	11

In wheat flour only the gluten acts. This is a substance insoluble in water or ether but soluble in boiling alcohol, acids, or caustic alkalis. It is precipitated by tannin.

3. Dressing.—The skins, having been dried after fulling, are resoftened in water. A mixture is then prepared by dissolving salt and alum in warm water and mixing the solution with flour and yolk of egg so as to form a thin cream. The best proportions to use are:—

	Parts.
Water	15
Alum	9
Salt	2
Flour	6
Yolk of egg	$\frac{1}{2}$

The skins are laid out flat in a vat with this mixture and five or six men work them with their feet. They have been worked sufficiently when, on holding up to the light, they appear perfectly even. They are allowed to soak over night and the next day placed in the apparatus shown on Fig. 73, together with the dressing, and turned for an hour. Afterwards they are allowed to stand in the mixture for four hours. Every 300 lb. of skin requires 100 lb. of the dressing mixture.

As egg yolks are very expensive, various substances have been suggested to replace them. The following is a composition which we have found to work well :—

A.		Parts.
Water		500
Albumen		180
Glycerin		50
Neatsfoot oil		200
Ammonia		50
Lard		30

B.		
Water		30
Alum		18
Salt		4
Flour		12

4. Drying.—The skins are folded in two flesh to flesh and hung up in a drying loft. They are dried as rapidly as possible, then made up into packages, and kept in the warehouse until they are ready for softening.

5. Staking.—As the drying has hardened the skins they are soaked in clear water. This is done with the tawing stocks, which consists of two stamps made of a squared rod of wood 7 ft. long, terminated by a sole 16 in. across. We prefer, however, the use of the fulling machine (Fig. 73).

The skins are next “staked”. The instrument known as a “stake” is a wide semicircular blade of steel mounted on a foot 32 in. high by 10 in. across (see Fig. 80). The skin is held with both hands flesh below and pressed on the blade, moving it to and fro, or sometimes sliding it slowly from top to bottom with the knee. Under this action the skin stretches, the fibres open, the skins become white and increase by about one-third their breadth. Further, this operation softens the skin and removes the dressing still adhering to it. The skins are dried, fullled and softened again.

Instead of a knee stake the Germans use a “hard”. It is a half ring of iron fixed in a wall over which the skins are passed.

6. “Fluffing” or Wheeling.—Skins were formerly pared with a knife but nowadays “fluffing” machines are always used.

These machines consist of wooden wheels 32 in. in diameter by 8 in. wide, covered with emery (Fig. 82).

The workmen hold the skins with both hands and press their flesh side gently against the wheel, the thicker parts being held longer in contact than the thin ones. The dust is carried away by a ventilator and allowed to settle in a special chamber.

“Fluffed” skins should be of even thickness and smooth. If they are to be left white they are now made up into boxes of 3 dozen.

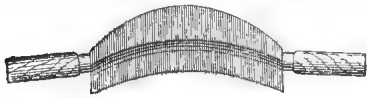

FIG. 74.—Fleshing knife for glove leather.

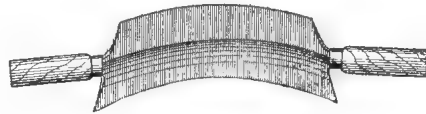

FIG. 75.—Fleshing knife for sheep and goat.

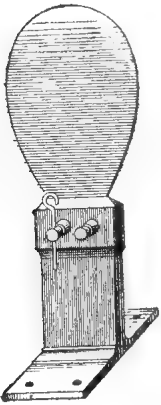

FIG. 80.—Knee stake.



FIG. 76.—Wool shears.

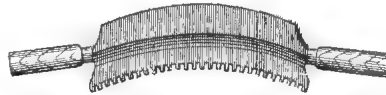

FIG. 77.—Unhairing knife.



FIG. 78.—Scudding knife.



FIG. 79.—Tongs.

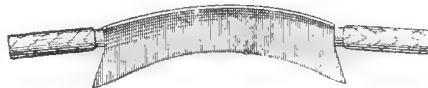

FIG. 81.—French frizing knife.

III.—DYEING TAWED SKINS.

1. Preliminary Operations.—After “fluffing” the skins are re-softened with water and left soaking until all the adhering flour is removed. They are then struck out to prepare them for receiving the dye.

2. Dyeing with a Brush.—The skins are placed on a thick wooden table, surrounded by a ledge to prevent the liquor running off. One corner is pierced by a hole so that the excess of dye may run into a bucket placed underneath. The table is slightly raised in the centre and covered with zinc. It stands about 32 in. from the ground. The skins are placed on this table flesh below and the back on the raised centre. They are stretched by stroking out the

Glacé skins are polished with the glass like morocco. They receive a dressing consisting of:—

	Parts.
Water	2,000
Gum senegal	100
Gum tragacanth	50
Soap	100
Yolk of egg	200
Paraffin wax	100

Other compositions are described under the heading of "Morocco".

IV.—RUGS.

Skins for rugs must be prepared without removing the hair. The operations are soaking, fleshing, passing through a bath of soap, combing, bating, in which the skin must be watched carefully to avoid fermentation, which may remove the hair. The carbonic acid method is here very useful. After bating it is rinsed, and lastly dressed. A much clearer dressing is used than that which has been described. The skins are folded in two with the hair inside and the dressing spread on the flesh. They are piled for twenty-four hours, rinsed, pressed and dried. They are worked on the stake, and the hair moistened with a mixture of Spanish white and water. This is allowed to dry and removed by beating (*see* "Furs").

folds with a piece of hard india-rubber. The mordant and the dye are then brushed over in the required number of coats.

3. Kristen's Method.—Kristen fixes the skin on a rotating horizontal disc. The colour is led by a tube to the centre of the skin, and the rotating motion spreads it out evenly over the surface of the leather. These discs turn in a trough so that the excess colour may be caught and used over again. A skin may be thus coloured in ten or twelve minutes. Several of these discs may be placed side by side in the trough. One workman can manage five machines and can dye 150 skins in twelve hours.

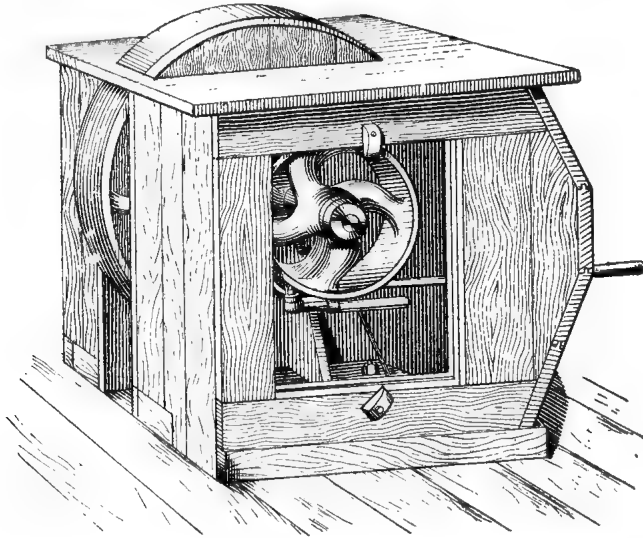

FIG. 82.—“Fluffing” machine.

4. Dyeing by Dipping.—The skins are placed in the square “tumbler” (Fig. 73) together with the dye at a temperature of 35° to 40° C. (95° to 104° F.).

The details of these operations and the colours used are described under “Morocco” (page 320).

5. Finishing.—The skins are partially dried, then dressed with an emulsion of yolk of egg in water, in which they are left to soak for three hours, or else they are dressed on the flesh side with neatsfoot oil. They are then nailed on to planks and left to dry. They are “staked” and finally “fluffed” on the machine.

Calf skins are polished with a hot iron just as linen is ironed.

CHAPTER IV.

CHAMOY LEATHER.

THIS class of leather, as its name indicates, is prepared chiefly from the skin of the chamois, a kind of antelope. It is tanned with fish oil without either alum, salt, or tannin. Other skins are treated in the same way, such as those of the goat, sheep, calf, deer, kid, elk, doe and reindeer. The object of chamoying is to give the skins a suppleness and pliability equal to that of textile fabrics, and at the same time to preserve their solidity and most of their impermeability.

1. Preliminary Operations.—The skins as received by the tanner are generally without hair, and are called pelts, or if split, linings.

The preparatory operations are similar to those of tawing, including drenching with bran.

A special operation is known as “skiving” or “frizing,” which consists of removing the epidermis or grain with a sharp knife. It is carried out in the preparation of all skins used for chamoy leather, with the exception of calf and sheep skins which are to be used for dyeing or washing. The skins are soaked three or four hours, rinsed, and the water carefully squeezed out of them. Three skins are hung up together over a wooden beam, and wrung out by twisting them with an iron rod until apparently dry.

2. Oiling.—The skins are stretched on a table and thoroughly oiled by rubbing it in with the fingers. It is then folded into four and taken to the fulling mill.

3. Oils used.—The oils used are chiefly whale, cod-liver and sardine oil, but all readily oxidisable animal oils may be employed.

We have given a list of them under manufacture of French calf. To test the value of an oil for chamoy leather the following operation should be carried out: Lead freshly precipitated by zinc which has been well washed with water, alcohol, and ether, and completely dried is weighed out into a watch-glass. Two or three drops of oil are placed on the lead, in such a manner that they do not run into each other, and the watch-glass is weighed again. It is then placed in a dessicator containing strong sulphuric acid and exposed to the sunlight for four days. It is weighed again and the increase in weight gives the amount of oxygen absorbed.

The following results have been obtained from various oils:—

	Per Cent.
Whale oil increases	8·266 (Jean)
Japanese oil „	8·194 (Jean)
Alligator oil „	7·211 (Villon)
Cod-liver oil „	6·383 (Jean)
Cod-liver oil „	6·500 (Villon)
Menhaden oil „	5·454 (Jean)
Sardine oil „	4·131 (Villon)
Salmon oil „	3·190 (Villon)
Sperm oil „	1·629 (Jean)
Neatsfoot oil „	1·003 (Villon)

The greater this increase and the better will be both the leather and the degreas.

4. Fulling or “Stocking”.—The fulling machine consists of an inclined trough, fixed in a wooden frame (Fig. 83). The stamps do not work perpendicularly, but move in the arc of a circle through an angle of about 45°. The head of the stamp is cut into teeth as shown in the figure so that it may get a better grip of the skin. The general action is readily seen by examining the figure, which, however, only shows two stamps. Some machines have four, six, or even eight.

Skins placed in the trough are worked from two to three hours, the time varying according to the class of skin and the oil used. The skins are next exposed to the air on cords for a day or two according to the weather, then oiled, fullled and aired again. The smallest skins have this series of operations repeated three times; the medium ones six times, and the largest ones ten times. The oiling is not necessarily repeated every time.

6. Scraping.—Any portions of the epidermis which may not have been removed before oiling are now scraped off with the blunt knife used in paring, great care being taken to avoid damaging the skin. Each workman puts his own private mark upon the skin so that he may recognise it in case of deterioration.

7. Pressing.—The skins are thrown into a boiler of hot water and stirred with an iron rod, then they are placed in a hydraulic press. The liquid which runs away, after the water has been separated from it, is moellon oil.

8. Scouring.—On coming out of the press the skins are placed in a warm bath of potash (2° Baumé), where they are kept constantly stirred for an hour at 35° C. (95° F.).

The oil is separated from the alkaline solution by slowly adding dilute sulphuric acid until the alkali is neutralised. The supernatant oil is skimmed off and dried in a boiler heated either over the fire or by high pressure steam. The fat thus obtained is called *degras*. The skins give up 50 per cent. of their fat.

9. Staking.—The skins are dried; and since they harden on drying they are worked on a stake as has already been described.

The work must be conducted very carefully and evenly, to prevent transparent places appearing on the skin. The sole idea of the operation is to make the oil penetrate in a regular fashion.

5. **Stoving.**—The skins are stretched on rods in a chamber similar to the drying loft of a tannery, kept at a temperature of 25° C.,

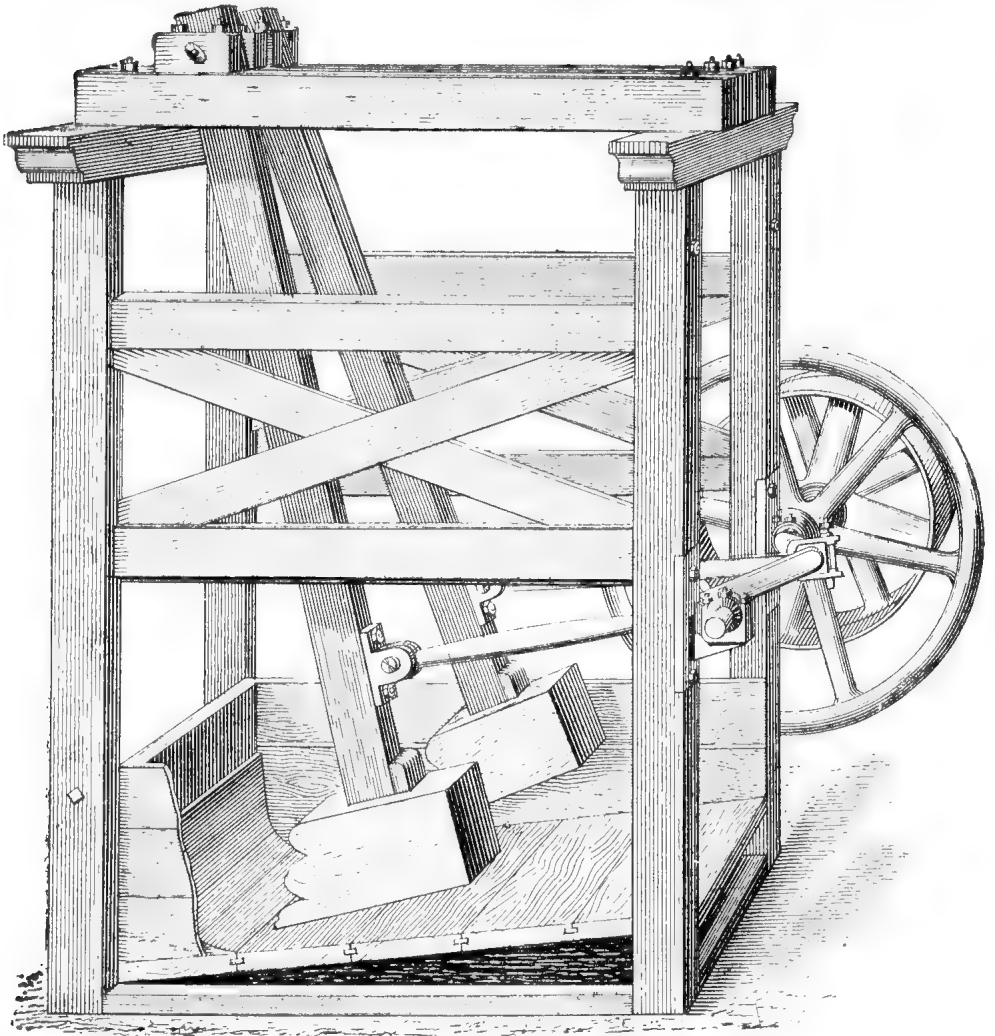

FIG. 83.—“Stocking” machine.

(77° F.) or else arranged in conical heaps in a closed chamber and allowed to heat naturally. In the last case, as soon as the skins are warm, the heap is taken to pieces and a fresh heap made. This is continued until the skins become yellow. Great care must be taken to prevent the skins burning.

CHAPTER V.

MOROCCO.

THE manufacture of morocco is that part of the tanning industry devoted to the preparation of dyed leather. It is at the same time one of the most interesting and one of the most difficult of manufactures. It demands on the part of the manufacturer a thorough knowledge of tanning and a wide knowledge of chemistry.

Morocco is made from goat and buck skins; an imitation morocco is also made from sheep skins.

I.—PRELIMINARY OPERATIONS.

1. Soaking.—Whether the skins be fresh or dried they are soaked for two days in clear water to soften them. The use of the stocks hastens the operation. They are next roughly fleshed on the beam and soaked again for an hour.

2. Unhairing.—This operation is either done with lime, sulphides, or lime sharpened with realgar, as has already been explained. Afterwards the hair is removed on the beam. The lime is washed out in the “tumbler”. This must be done with the utmost care, since lime is more objectionable in morocco than in any other kind of leather. When the water runs away clear the skins are soaked for half an hour in a bath containing 2 parts per 1,000 of hydrochloric acid. They are then taken back to the dash-wheel, and washed for a quarter of an hour with large quantities of water.

3. Fleshing.—Fleshing was formerly carried out on the beam with a slate. Nowadays the Ott machine or mechanical beam is generally used. It consists of a smooth table of sheet iron, over which a threaded cylinder works. This machine acts with very

slight modifications in the same way as the Damourette machine, which has already been described (page 214).

The skins are then "tumbled" for five minutes.

II.—MOROCCO TANNING.

1. Drenching.—The skins are placed for a day in a warm drench of bran containing 7 oz. of bran per skin. Some people use dogs' dung, but we again repeat that lactic or carbonic acid will swell the skin more easily.

After drenching, the skins are classified, the finer ones being selected for bright colours.

2. Red Dyeing.—Formerly red leather was always dyed before tanning, but this method is being abandoned more and more as solid dyes are being introduced.

The skins are folded in two, flesh to flesh, and the edges sewn up as tightly as possible. They are soaked for a quarter of an hour in a warm dilute solution of chloride of tin, then drained, wrung out, and thrown over a beam. A bath is next prepared by boiling together alum, cream of tartar, and 1 lb. of cochineal for every twelve skins. This is filtered through linen and the bath divided into two equal parts. The skins are placed in one bath for half an hour, then transferred to the other for a second half-hour, after which they are rinsed and tanned.

3. Tanning.—When the skins are to be dyed a light colour they are tanned with sumach or gall-nut extract. For deeper colours catechu or some other rich but cheap substance is used.

Sheep and goat skins are sewn together, flesh to flesh, in pairs of as nearly as possible the same size. In this way sacks are formed, having a very small opening through which sumach is introduced and air blown in. The opening is then closed and the inflated sacks so prepared are thrown into a conical vat, 10 ft. in diameter at the top, 3 ft. 6 in. at the base, and 5 ft. high. The vat contains water and sumach. After being stirred in this vat for six hours, the water is run off and fresh water and sumach added. In thirty-six hours the skins are tanned.

In Paris, where the stirring is done mechanically, the vats

are cylindrical, 8 ft. 6 in. long, by 3 ft. 4 in. in diameter, and the liquor and skins are kept in motion by means of a paddle-wheel. Nowadays it is becoming more and more the fashion to do the tanning by placing the skins with sumach and water in a tumbler. The machine turns slowly during the first day, stops for the night, and starts again next morning. In the evening, or the morning afterwards, the skins will be tanned.

Two hundred and twenty lb. of sumach are used for 100 skins.

As this is quite an ordinary method of tanning, all the directions given in other parts of the book may be followed out. The special peculiarity of morocco tanning is that every care should be directed towards keeping the leather colourless. This is done by using colourless tans such as sumach, gall nuts, valonia, etc. After tanning is complete, the skins are rinsed to remove adherent sumach, and cleaned in the machine. They are then softened with a softening iron.

4. Dipping.—Morocco manufacturers do not always tan their own hides. When they are bought ready tanned they are thoroughly washed in the fulling machine, worked on the beam, replaced in the fulling machine, and turned in the dry state for a quarter of an hour, then with water for ten minutes. Skins so dipped are partially dried, either in the drying loft or by placing in a hydraulic press.

III.—MORDANTS USED IN MOROCCO MANUFACTURE.

1. Object of Dyeing.—The object of dyeing is to fix the colours in the skin, leather, or textile fabric in such a manner that it becomes a part of the fibre and resists the action of those agents to which it is commonly exposed. Dyeing may be divided into two classes: direct and indirect. In direct dyeing colours combine directly with the skin without any outside help. There are three kinds of direct dyeing: (*a*) where the dye is developed in the fibre; (*b*) where it is simply absorbed; (*c*) where it combines chemically with the tissue.

Indirect dyeing is brought about by means of an intermediary

called the mordant, which fixes the colour. Dyeing of this class always requires two operations, mordanting and dyeing.

Indirectly fixed colours are of two kinds: (*a*) those which are fixed by the presence of the mordant; (*b*) those which are formed by double decomposition.

2. Aluminium Mordants.—These are the most important of all mordants. They have no objectionable action and are easily absorbed by the skin.

Alum.—The chief of these mordants are potash and ammonia alum. Skin will absorb 5 per cent. of them. Both have already been described on page 293. The alum mordant bath contains 5 per cent.

Aluminium Acetate.—For red dyes the mordant is prepared as follows: 25 lb. of alum are dissolved in 10 gallons of boiling water, 2½ lb. of sodium carbonate and 25 lb. of acetate of lead are then added, and the liquid is filtered. The filtrate should have a strength of 40° Baumé, becoming turbid at 70° C. (158° F.). For yellow the mordant is made in the same way, but only 1½ lb. of soda is used.

The ordinary mordant is prepared with 2 gallons of water, 15 lb. of alum, and 15 lb. of acetate of lead. It has a strength of 14° Baumé, and only goes turbid on boiling. It can be more cheaply made by dissolving 25 lb. of alum in 10 gallons of water and adding 37 lb. pyrolignite of lime. After filtering, the strength is 12° Baumé. Skin absorbs 20 per cent of aluminium acetate.

Aluminium Hyposulphite— $\text{Al}_2(\text{S}_2\text{O}_3)_3\text{H}_2\text{O}$ —is prepared by dissolving 5 lb. of alum, and 5 lb. of sodium hyposulphite in 10 gallons of water.

Sodium Aluminate— $\text{Na}_2\text{Al}_2\text{O}_4\cdot 2\text{H}_2\text{O}$ —and a solution of gelatinous alumina in methylamine have been used in special cases.

3. Tin Mordants.—The salts of tin are largely employed in red dyeing and also in the preparation of Russia leather.

Stannous Chloride.—This salt (SnCl_2) is found in commerce under the name of salts of tin.

Stannic Chloride (SnCl_4).—Under this name we classify all

those solutions and compounds of tin which the dyer prepares for himself and uses for reds and scarlets. The solutions are prepared in many different ways, of which the following is one of the most common: 700 parts of hydrochloric acid (22° Baumé) is mixed with 300 parts of nitric acid (36° Baumé) in a stoneware vessel. The mixture is well stirred with a glass rod, placed in a draught cupboard, and 130 parts of granulated tin added little by little. It is allowed to cool down, 20 parts of tin are added to saturate the acids, and the whole is allowed to stand over night.

Tin compound is prepared by dissolving 1 part of sal-ammoniac in 8 parts of nitric acid (25° Baumé) heating slightly and adding 1 part of granulated tin. When solution is complete 2 parts of water are added.

Tin solutions are made up in the following proportions:—

I.		Parts.
Nitric acid, 30° Baumé		8
Sal-ammoniac		1
Tin		1
Water		2½

II.		Parts.
Water		8
Common salt		¼
Nitric acid, 34° Baumé		8
Tin		1

III.		Parts.
Water		10
Alum		22
Cream of tartar		11
Salts of tin		5

IV.		Parts.
Hydrochloric acid		12
Nitric acid		1
Tin		1½

V.		Parts.
Salts of tin		4
Nitric acid, 36° Baumé		1¼
Hydrochloric acid		1

VI.

	Parts.
Water	8
Common salt	$\frac{1}{2}$
Sal-ammoniac	$\frac{1}{2}$
Nitric acid	1
Hydrochloric acid	1
Tin	3

Under certain circumstances sulphocyanide of tin, stannate of ammonia and stannate of soda are used.

4. Iron Mordants.—The most commonly used is ferrous sulphate or green copperas. Other salts are ferric sulphate, ferric chloride and nitrate of iron.

We have already given a list of the organic iron salts which are used in dyeing leather black.

5. Copper Mordants.—The most important are copper sulphate, or blue vitriol, verdigris, and cuprous chloride, which is prepared by dissolving copper turnings in hydrochloric acid. These are not of much importance in leather dyeing.

6. Chromium Mordants.—Either bichromate of potash is used or a neutral chromate prepared by adding soda to the bichromate.

IV.—NATURAL COLOURS USED IN MOROCCO DYEING.

1. Logwood.—Logwood comes from the trunk of *Hematoxylon campestrianum*, which grows in Mexico and the Antilles.

Five varieties are found in commerce: (*a*) Spanish, (*b*) Jamaica, (*c*) San Domingo and Hayti, (*d*) Honduras, (*e*) Martinique and Guadeloupe. It arrives in Europe in large logs, which are ground into chips.

The dyer buys the wood ready ground up. Before boiling, it should be subjected to fermentation to develop its colour. For this purpose it is heaped up in a room to a depth of a yard and watered with urine, or better a solution containing 1 per cent. each of phosphate of ammonia, glucose and glue. The heap is turned from time to time and a good draught kept up in the room to prevent overheating. This fermentation lasts four days.

Two hundred parts of water are boiled with 20 parts of logwood and 1 part of chalk. After boiling for an hour the liquid

is drawn off and a fresh lot of water added. The two boilings are mixed together. In this way 1 part of wood gives 20 parts of logwood extract. This is the solution which is used for morocco-dyeing. A little chloride or iodide of mercury is added as an antiseptic.

Logwood extracts are sold with a strength of 10°, 20° or 30° Baumé, or sometimes dry. We cannot recommend the use of these extracts, as they are almost always badly adulterated. Here, for instance, is an analysis of a so-called pure No. 1 Havre extract :—

	Per Cent.
Pure extract	90
Treacle	4
Salt	2
Chestnut	3'5
Chalk	'5

Another sample, which did not pretend to be pure, contained—

	Per Cent.
Extract	50
Treacle	25
Dextrin	10
Chestnut	12
Salt	3

A substance which deserves more notice from dyers is hæmatin, which is the colouring matter of logwood more or less carefully purified. The following is its composition :—

	American.	French.
Hæmatoxylin	53	54
Hæmatin	10	20
Insoluble substances	17	6
Water	20	20
	100	100

English hæmatin contains 95 per cent. of colouring matter.

The normal colouring matter of logwood is hæmatin (Chevreul, 1810) or hæmatoxylin. By oxidation in the air or by the action of alkalis it changes to hæmateine. The following are the properties of logwood solution :—

Weak acids turn it yellow; strong acids turn it red; sulphurous and carbonic acids turn it yellow; alkalis give red or violet; lime baryta, magnesia, and oxide of zinc, give blue precipitates; aluminate of soda and tin salt give violet-blue

precipitate; stannic chloride gives a violet-red precipitate; zinc salts give a deep purple.

It is chiefly used for black dyes.

2. Brazil Wood.—Brazil wood is obtained from *Cæsalpinia crista*, growing in the East Indies, Central America and the Antilles. The different kinds are: (a) Pernambuco—this is the most valuable and comes from Paraibo; it colours water a beautiful red; (b) Brazil wood (*Cæsalpinia brasiliensis*), only half as rich as the former; (c) St. Martha wood (*C. echinatos*), which comes from Santa Martha and the Sierra Nevadas, is richer than (b); (d) Nicaragua wood, very much like the last; (e) Japan wood (*C. sappan*) comes from China, Japan, India, the Antilles and Brazil; (f) Lima wood, which is a variety of the last. Other varieties are Manilla, California, Columbia and Bahia wood. We might also mention cam-wood and bar-wood.

This is ground up and made into extracts like logwood, after first being fermented. The decoction is made with 20 parts of water to 1 of wood. The colouring matter is brasilin, which on oxidation gives brasileine.

3. Sandal Wood, also called bar-wood, is obtained from *Pterocarpus santalinus* or *indicus*, growing in the East Indies, Ceylon and Timour. It is shipped from Calcutta. The wood is treated like the former ones, but the colouring matter, santalin, is insoluble in cold water and soluble in alcohol, alkalies and acetic acid. The decoction is prepared in a solution of carbonate of soda. One part of wood gives 15 parts of liquor.

4. Yellow Wood (called dyer's mulberry, yellow Brazil wood, old fustic, Cuba wood), is obtained from *Morus tinctoria*, which grows in the East Indies and South America. There are five chief varieties. Cuba wood, which is the best, Tampico wood, lighter coloured, San Domingo wood, Tuspan wood and Maracaibo. It is treated like logwood, but without fermentation. Yellow wood contains two principal substances, a special tannin called maclurin and a yellow colour called morin.

5. Fustic is obtained from *Rhus cotinus*, which grows in the

centre of France, the Antilles and Jamaica. The yellow colour it contains is called fustin.

6. **Quercitron** is the bark of an oak, *Quercus nigra* or *tinctoria*, which grows in North America. It gives a fine pure yellow. The colouring matter which it contains is quercitrin or quercitric acid.

Quercetin is obtained by acidulating the solution of quercitrin with sulphuric acid. It is precipitated in lemon yellow flocks, insoluble in water, but soluble in alcohol and warm acetic acid.

Flavin is the same as quercetin. It has sixty times the colouring power of quercitron.

Chrysein is only a pasty modification of flavin, with a quarter of its colouring power.

7. **Barberry**.—This is very largely used in dyeing to give a yellow polish to skins. It is one of the family *berberides*, thorny trees which grow in the temperate zones. *Berberis vulgaris* or common barberry has a root which contains a yellow principle called berberin. It occurs commercially as an extract of 5° Baumé strength.

8. **Anotta** is obtained from *Bix orellana* which grows in Guiana and Guadeloupe. It is exported from Cayenne. It comes ready prepared in cakes from 2 lb. to 4 lb. weight. It loses its colour on keeping.

Its colouring matter, bixin, is scarcely soluble in water, but soluble in alcohol and caustic alkalis. For use it is dissolved up in 2 per cent. carbonate of potash.

9. **Avignon Grains**, or Persian berries, are the berries of a shrub known as the dyer's buckthorn (*Rhamnus infectorius*) growing in Central France and Europe. Avignon grains come from Venice, Persian berries from the East. The latter are the most valuable. The colouring matter of this berry is chrysothamin which is polymerised by the action of water forming xanthorhammine.

10. **Indian Yellow**.—This substance comes from India and China. It is made by a secret process and contains cuxanthic acid, soluble in alkalis.

11. **Carthamum**, obtained from the flowers of *Carthamus tinc-*

torius, growing in India, Egypt and Central Europe. These flowers contain two colouring matters, a very fine rose, carthamine or saffron, the other one is yellow. This latter is much more abundant, but is valueless. It is removed by maceration in cold water, which completely dissolves it. To extract the carthamine the washed flowers are treated with a solution of sodium carbonate. This dissolves out the colouring matter, which may be precipitated with an acid.

This precipitate is called vegetable rose.

12. Cochineal (*Coccus cacti*).—This is a little insect which lives on a cactus specially cultivated in Mexico, San Domingo, Port au Prince, the Canaries and Algeria. The insects are gathered by scraping them off the leaves with a blunt knife. They are killed with boiling water and dried in the sun. There are two chief commercial varieties: (a) fine cochineal or *Grana fina*, obtained from the cultivated cactus, the best being mēstique from Honduras, and zaccatilla from the Canaries; (b) *Grana sylvestris*, obtained from wild cactus.

The colouring matter is carmine or carminic acid. Cochineal carmine is cochineal freed from inactive substances.

Ammoniacal cochineal is obtained by soaking the insects in ammonia. The colouring matter combines with the alkali, forming a new substance, carminamide, which is reddish-violet and remains unchanged by mordants.

13. Kermes is an insect similar to cochineal. It is the *Coccus illicis*, and lives on *Quercus coccifera*. Kermes red is almost the same as cochineal red, but not quite so brilliant.

14. Lac Dye.—This substance has already been mentioned when speaking of shellac, from which the colour is extracted by dilute alkalies. The alkaline solution is precipitated with alum, and the precipitate is compressed into square cakes of about 1 lb. weight. The colouring matter is not easy to dissolve without the use of alkalies. Many dyers use the following process: 4 parts of dye are soaked in 8 parts of water and 3 parts of sulphuric acid (66° Baumé) for two days. It is then diluted with 150 parts

of boiling water and allowed to settle for twenty-four hours. The supernatant liquid is decanted, and powdered lime added until the acid is neutralised. The precipitated calcium sulphate is filtered off and the liquid used for dyeing. Two parts of lac dye will do the work of one part of cochineal.

15. Alkanet is the root of *Anchus tinctoria* or *Litho spermum tinctorium*, cultivated in the neighbourhood of Montpellier. The colouring matter of this root is anchusine. It is insoluble in water but soluble in alcohol, acetic acid and alkalies.

16. Archil.—This colouring matter is obtained from lichens growing in the Pyrenees, the Alps, Auvergne and Sweden, and various seaweeds. The following occur commercially—Canary weed, Cape Verde weed, Madeira weed, Mogador, Réunion and Mozambique.

It is generally sold ready made.

(a) Ordinary archil in paste (1 part of weed gives 4 parts of paste).

(b) Cudbear, which is archil paste dried and powdered.

(c) Archil extract, richer in colouring matter than the two last.

(d) Archil purple, which is the lime lake. This may be dissolved by treating with oxalic acid, which separates it from the lime.

The colouring matter of archil is orcin, which on oxidation gives orceine. This last is the chief constituent of commercial archil.

17. Indigo Carmine.—This is sold ready prepared. It is made by treating indigo with strong sulphuric acid, saturating it with sodium carbonate and purifying the body so obtained. This is sulphindigotate of soda.

18. General Remarks on Vegetable Colouring Matters.—The substances give characteristic reactions with various chemical agents. The chief of these are given in the appended table.

We may add to these the general reactions that they are destroyed by the action of chlorine, hypochlorous acid, sulphurous acid, sulphuretted hydrogen and nascent hydrogen. Animal charcoal absorbs them.

COLOURS PRODUCED BY THE ACTION OF MORDANTS ON VEGETABLE COLOURS.

Colouring Matter.	Acid.	Alkalies.	Stannous Chloride.	Stannic Chloride.	Alum.	Acetate of Copper.	Iron Salts.	Chromate of Potash.	Special Reactions.
Logwood	Yellow.	Red purple.	Blue purple.	Red.	Violet Red.	Blue.	Blue black.	Blue black.	NaHCO ₃ = red purple.
Brazil wood	Yellow.	Crimson.	Red violet.	Red.	Red.	Deep red.	Brown.	Yellow red.	Lead salts = violet.
Sandal wood	Red.	Red.	Red purple.	Red.	Red.	Yellow brown.	Brown.	Orange.	
Yellow wood	Lighter.	Deeper.	Yellow.	Yellow.	Lighter.	Greenish brown.	Olive green.	Yellow brown.	
Fustic	Yellower.	Red.	Orange.	Greenish yellow.	Orange.	Brown.	Green black.	Yellow brown.	
Barberry	No change.	Orange.	Yellow.	Greenish yellow.	Yellow.	Green yellow.	Deep brown.	Yellow brown.	
Anotta	Light yellow.	Orange red.	Orange yellow.	Deep orange.	Yellow.	Green yellow.	Deep chamois.	Yellow brown.	H ₂ SO ₄ (strong) = indigo blue.
Quercitron	Dirty yellow.	Light yellow.	Yellow.	Light yellow.	Lighter yellow.	Greenish yellow.	Green black.	No change.	
Avignon Grains	Yellower.	Yellow red.	Gold yellow.	Gold yellow.	Orange yellow.	Green brown.	Green black.	Deep yellow red.	
Catechu	Dirty yellow.	Brown red.	Light yellow.	Yellowish blue.	No change.	Light brown.	Olive green.	Deep orange.	
Indian yellow	Pale yellow.	Deep red.	Light red.	Greenish yellow.	Yellow.	Yellow brown.	Yellow brown.	Red brown.	
Carthamus	Orange.	Crimson.	Red.	Rose.	No change.	Deep blue.	Yellow brown.	Orange yellow.	Ammonia = crimson.
Cochineal	Bright red.	Crimson.	Violet red.	Rose.	Crimson.	Violet.	Yellow brown.	Orange yellow.	HCN = crimson.
Ammoniacal cochineal	Lighter.	Violet.	Blue.		Crimson.		Red brown.	Brown.	NH ₃ = violet red.
Archil purple	Decolouration.	Decolouration.	Violet blue.	Greenish yellow.	Red brown.		Yellow.	Brown.	NH ₃ = decolouration.
Archil extract	Red.	Violet.	Red.	Cherry red.	Red.	Violet.	Orange brown.	Orange red.	NH ₃ = violet.
Archil red	Red.	Blue.	Red.	Cherry red.	Red.	Violet blue.	Orange brown.	Orange red.	NH ₃ = blue.
Archil blue	Red.	Violet.	Crimson.	Crimson.	Violet.		Violet grey.		Lead salts = blue.
Alkanet	Orange yellow.	Crimson.	Red.	Red.	Crimson Red.				
Kermes	Red.	Red.	Red.	Scarlet.	No change.				
Lac dye	Lighter.	Green yellow.	Decolouration.	Light blue.	No change.				
Indigo carmine	Lighter.	Brown red.	Yellow.	Yellow.	Yellow.				
Turmeric	Lighter.	Deeper.	Yellow.	Canary yellow.	Yellow.				
Weld	Lighter.	Deeper.	Yellow.	Canary yellow.	Yellow.				Boric acid brown.

V. ARTIFICIAL COLOURS.

The discovery of the aniline colours has brought about a revolution in leather dyeing. Thanks to the facility with which they combine with tanned leather and skins, giving solid and delicate colours, they have rapidly replaced the older vegetable dyes. It is otherwise, however, with oiled and chamoy leathers, whose grease prevents the absorption of the colour, but by special methods of removing the grease and tanning with 5 per cent. gall-nut extract it can be made to take them up.

It is impossible to give a description or even a summary of these beautiful colours, on account of their immense number and the complexity of their composition. The reader is referred to special text-books on the subject.

The properties most interesting to the leather dyer have been summarised as far as possible in the following tables, which contain a list of the chief artificial colours used for leather with their principal properties. The tables have been drawn up from experiments carried out by the author on whole skins.

VI.—DIFFERENT METHODS OF DYEING.

Leather dyeing is carried out in two entirely different ways: with the brush (English method) or by dipping (French method). Brushing may be done either by hand or mechanically, and dipping may be done either in a trough or in a vat. We shall examine each of these processes and its modifications.

1. **Brushing.**—The table used has already been described under tawed leather. Long-haired brushes are used. The temperature of the colouring matter should be between 30° and 60° C. (86° to 140° F.). The skin should be uniformly wet and well pressed down on the zinc of the table so as to be perfectly smooth. In this process only one side of the leather is dyed, the other remaining white. The brush should be well filled with the colour and passed rapidly over the skin so as to dye as much as possible of it. The dyeing of the edges and the rubbing in of the colour may be attended to later.

In spite of all precautions the brush method gives inferior and less uniform results than the dipping method. It should only be used for dark colours. Blacks are usually prepared in this way.

2. Mechanical Brushing.—In this method the skin is stretched on the table in the ordinary way, and a revolving brush is moved backwards and forwards over its surface. The dye is run in through the axle of the brush. As soon as the dye is turned on, the brush is started. Its motion prevents the dye from settling in patches and drives the colour into the skin throughout the epidermis. Skins treated in this way are evenly dyed.

A machine has been invented consisting of two rollers which draw the skin under a cylindrical brush. The results have not been satisfactory.

3. Kristen Process.—This has been described on page 314. The system is not so applicable to morocco as to tawed skins. The dyeing is uniform but not deep, and only from a third to a half of the grain is saturated.

4. Spraying.—In this process the dye is sprayed on to the surface of the skin in very fine particles and penetrates very well. The grain is thoroughly dyed. If the flesh side be treated, it is better to direct the jet obliquely. With a little skill a skin may be perfectly and regularly dyed in five minutes.

From personal experiments, we have found that a deeper colour may be obtained by the use of carbonic acid gas instead of air.

5. Dyeing in the Trough.—The trough process, which is scarcely ever employed, is carried out in the following way: Sufficient water is placed in a vat to enable the skins to be worked easily. The necessary quantity of dye is added and a skin is worked about until it is all absorbed. A new quantity of dye is then added, and a second skin dyed and so on. When the set of skins under treatment have all been in the trough they are dyed afresh, and if the colour be uneven they are treated a third time.

6. Dyeing in the Vat.—This process when properly applied is the most rational and gives a more even tint than any other which has been suggested.

TABLE OF ARTIFICIAL

Commercial Name.	Inventor and Date.	Appearance.
1. Fuchsin (Magenta)	Verguin de Lyon, 1859.	Green metallic crystals.
2. Cerise IV.		Green yellow metallic grains.
3. Rubin N.	Badische.	Yellowish red powder.
4. Magdala red	Durand & Huguenin.	Brown red grains.
5. Safranin	Rocquencourt & Dourot, 1858.	Brown powder.
6. Eosine		Red brown grains (fluorescent).
7. Rosolic acid	Runge, 1834. Persoz, 1859.	Deep green grains (fluorescent).
8. Corallin red	Persoz, 1859.	Violet powder.
9. Corallin yellow		Red brown granules.
10. Cochineal scarlet	Gaesz, 1883.	Red powder.
11. Cochineal scarlet 2 R.	Gaesz, 1883.	Red powder.
12. Cochineal scarlet 4 R.	Gaesz, 1883.	Bright red powder.
13. Wool scarlet R.	Meusching, 1884.	Brown red powder.
14. Scarlet G. R.	Levinstein, 1879.	Red powder.
15. Scarlet G.	Meister Lucius & Co.	Red brown powder.
16. Safranin scarlet G.	Badische.	Reddish yellow powder.
17. Fuchsin scarlet B.	Badische.	Red brown powder.
18. Poppy 4 G. B.	Griesz, 1878.	Brilliant red powder.
19. Poppy G.	Meister Lucius & Co.	
20. Poppy 2 R. (xylidine red)	Meister Lucius & Co., 1878.	Red brown powder.
21. Poppy 3 R. (cumidine red)	Baum, 1878.	Deep red powder.
22. Bordeaux red G.	Meister Lucius & Co.	Red brown metallic crystals.
23. Bordeaux red B.	Meister Lucius & Co.	Brown red powder.
24. Rhodamine	Badische.	
25. Bengal rose N. T.	Badische.	
26. Phloxine B. B. N.	Badische.	
27. Phloxine H.	Badische.	
28. Erythrosine I. N.		
29. Rocelline	Poirier.	
30. Coccinine (phenetol red).	Baum, Meister Lucius, 1878.	Deep red powder.
31. Coccinine B.	Baum, Meister Lucius, 1878.	Deep red powder.
32. Buffalo rubin.	Meusching & Co., 1884.	Brown powder.
33. Croceine B.	Meusching & Co., 1884.	Brown red powder.
34. Brilliant croceine G.		Bright red powder.
35. Grenadine	Meister Lucius & Co.	Green metallic granules.
36. Geranosine carmine		Red powder.
37. Russia red G. and 2 G.	Badische.	Red brown powder.
38. Solid red A. and E.		
39. Naphthylamine red	Badische.	
40. Archil red		Brown paste.
41. Ethyl violet		Greenish metallic granules.
42. Methyl violet	Meister Lucius & Co.	Greenish metallic granules.
43. Paris violet	Poirier & Chappat.	Greenish metallic granules.
44. Benzylmethylrosaniline.		Greenish metallic granules.
45. Alexandra violet		Grey brown powder.

COLOURS (VILLON).

Solubility in Water, with Colour.	Action of Acids.	Action of Alkalies.	Colour given to Leather.
Soluble, fine red.	Becomes yellow.	Decolouration.	Red violet.
Soluble, red.	Becomes yellow.	Decolouration.	Red violet and red brown.
Soluble, reddish yellow.	None.	Yellowish.	Deep red.
Soluble, fluorescent.	None.	Red violet.	Wine red.
Soluble, red.	Redder.	More intense.	Rose red.
Soluble, red fluorescent.	Yellow.	Rose.	Rose red.
Insoluble.	None.	Rose.	Rose.
Soluble red.	Yellow.	Brighter.	Rose red.
Soluble, orange.	None.	Rose.	Reddish yellow.
Soluble, yellowish red.	Orange yellow.	Red.	Red brown.
Slightly soluble when hot.	Red.	Orange.	Red less brown than 10.
Slightly soluble.	Brown red.	Yellowish red.	Like 10.
Soluble, reddish yellow.	Blue red.	Yellowish red.	Brighter than 10.
Soluble, reddish yellow.	Brown red.	None.	Like 12.
Soluble, reddish yellow.	Red.	None.	Like 13.
Soluble, reddish yellow.	None.	Yellow.	Deep red.
Soluble, reddish brown.	Yellowish red.	Reddish yellow.	Very brown red.
Soluble, orange yellow.	Yellow brown.	Brown yellow.	Light brown red.
Soluble.			Orange red.
Soluble, brown red.	None.	None.	Deep orange red.
Soluble, cherry red.	None.	Yellow.	Deep orange red.
Soluble, poppy red.	Deeper.	Pale brown.	Light red.
Soluble, deep red.	Deeper.	Pale brown.	Light red.
			Red violet rose.
			Red rose.
			Paler than 25.
			Like 25.
			Like 26.
			Deep rose red.
Soluble, cherry red.	Deeper.	Red brown.	Deep red.
Soluble, cherry red.	None.	Red brown.	Deep red.
Soluble, magenta.	None.	None.	Bright deep red.
Slightly soluble, magenta.	Violet.	Violet.	Red violet.
Soluble, cherry red.	Brown.	Brown.	Very brown red.
Soluble, purple red.	Orange yellow.	Red brown.	Grenat.
Soluble, yellowish red.	None.	Rose.	Rose red.
Soluble, red brown.			Chestnut red.
			Red.
			Red to violet.
Soluble, red brown.	Red brown.	Red brown.	Wine red.
Soluble, violet.	Greenish yellow.	Violet blue.	Violet.
Soluble, violet.	Green.	Violet brown.	Violet.
Soluble, violet.	Green.	Deep violet.	Fine violet.
Soluble, violet.	Steel blue.	Red violet.	Violet.
Violet red (alcohol).	Green blue.	Unstable red.	Violet.

LIST OF ARTIFICIAL

Commercial Name.	Inventor and Date.	Appearance.
46. Primulin	Meister Lucius & Co.	Green powder.
47. Mauve	Kestner.	Green metallic granules.
48. Lumière blue		Blue grains.
49. Alkali blue	Nicholson, 1862.	Grey blue granules.
50. Blue B. S.	Monnet & Co.	Metallic granules.
51. Diphenylamine blue	Bindschadler.	Metallic granules.
52. Metadiphenylamine blue	Geigy.	Metallic granules.
53. Iodine green	Vanklyn & Paraff, 1866.	Green powder.
54. Aldehyde green	Cherpin, Usèbe, 1862.	Green powder.
55. Methyl green		Metallic granules.
56. Solid green	Fitz, 1862.	Brown grey powder.
57. Naphthol green B.	Hofmann, 1885.	Deep green powder.
58. Induline		Violet grey powder.
59. Picric acid	Laurent, 1842.	Yellow crystals.
60. Victoria yellow	Mittenzwey, 1869.	Red yellow powder.
61. Flavaurine	Post, 1874.	Red yellow powder.
62. Phenicienne	Roth, 1863.	Brown yellow powder.
63. Salicyl yellow A. B.	Schering, 1880.	Yellowish white powder.
64. Salicyl orange	Schering, 1880.	
65. Palatinate orange	Caro, 1869.	Orange brown powder.
66. Mars or gold yellow	Martius, 1864.	Yellow crystals.
67. Sun yellow	Mertz & Weith.	Orange powder.
68. Naphthol yellow S.	Caro, 1879.	Yellow powder.
69. Brilliant yellow	Meusching, 1884.	Yellow powder.
70. Citronine	Brooke, Simpson & Spiller, 1877.	
71. Emperor yellow	Kopp, 1873.	Orange crystals.
72. Curcumine	Walter, 1883.	Brown powder.
73. Aniline yellow	Mène, 1861.	Steely crystals.
74. Solid yellow G.	Graessler, 1878.	Yellow powder.
75. Cream yellow	Griesz, 1877.	Yellow spangles.
76. Phosphine		Orange red powder.
77. Lancaster yellow	Griesz, 1876.	Brown black crystals.
78. Quinoline yellow	Badische.	
79. Tropeoline	Witt, 1878.	Brown powder.
80. Orange G.	Baum, 1878.	Red brown powder.
81. Chrysoidine	Caro, 1875.	Crystalline red brown powder.
82. Orange III.	Poirier, 1878.	Brown paste.
83. Bismarck brown	Martius, 1875.	Brown black powder.
84. Havannah brown		Violet brown powder.
85. Vesuvine		Brown black powder.
86. Soluble brown	Durand & Huguenin.	Brown black powder.
87. Soudan G.	Baeyer & Jager, 1875.	Brown black powder.
88. Acid brown G.		Brown powder.
89. Nigrosine		Blue black powder.
90. Resorcin brown	Wallach, 1881.	Blue black powder.

COLOURS (*continued*).

Solubility in Water, with Colour.	Action of Acids.	Action of Alkalies.	Colour given to Leather.
Soluble, red violet.	Dirty green.	Violet brown.	Bright violet.
Soluble, red violet.	None.	Violet blue.	Violet.
Soluble, blue.	Brighter.	Violet blue.	Blue.
Soluble, bright blue.	None.	Reddish.	Bright blue.
Soluble, blue.	Blue.	Blue violet.	Blue violet.
Soluble, blue.	Blue.	Blue violet.	Blue violet.
Blue (alcohol).	Brighter.	Deep blue.	Fine blue.
Soluble, blue.	Yellow green.	Bright green.	Green blue.
Soluble, green.	Discolouration.	Discolouration.	Bright green.
Soluble, green blue.	Deeper.	Discolouration.	Deep green.
Soluble in alkalies.		Deeper.	Fine green.
Soluble, yellow green.	None.	Deeper.	Green.
Soluble, violet blue.	Bluer.	Violet.	Deep violet blue.
Soluble yellow.	None.	A little yellower.	Deep yellow.
Soluble, orange.	Bleaches.	None.	Yellow.
Soluble, yellow.	Red.	Deeper.	
Soluble in alkalies and acids.	None.	None.	
Soluble in alkalies.	None.	None.	Deep yellow.
			Deep orange.
Soluble, orange.	Yellowish white.	Deeper.	Deep orange.
Soluble, yellow.	Bright yellow.	Orange.	Straw yellow.
Soluble, orange.	Bright yellow.	None.	Straw yellow.
Soluble, yellow.	Deeper.	None.	Bright yellow.
Soluble, brown yellow.	Bright yellow.	Deep yellow.	Fine yellow.
			Reddish yellow.
Soluble, orange.	Yellow.	None.	Yellow.
Soluble, yellow brown.	None.	None.	Deep yellow.
Soluble, yellow.	Yellow.	Orange.	Yellow brown.
Soluble, yellow.	Orange.	None.	Fine yellow.
Soluble in hydrochloric.	None.	Yellow.	Orange yellow.
Soluble, orange.	Yellower.	Yellow.	Orange yellow.
Soluble, yellow.	None.	Red yellow.	Orange yellow.
			Bright greenish yellow.
Soluble, red yellow.	Red.	Yellow.	Orange yellow.
Soluble, orange yellow.	None.	Red yellow.	Orange.
Soluble, brown.	None.	None.	Deep orange.
Soluble, red brown.	Red brown.	Red brown.	Orange.
Soluble, brown.	None.	Brown.	Deep brown yellow.
Soluble, brown yellow.	Yellow.	Yellow brown.	Deep brown yellow.
Soluble, brown yellow.	Yellow.	Yellow brown.	Deep brown yellow.
Soluble, brown red.	None.	Yellow brown.	Deep brown yellow.
Soluble, brown red.	Bright brown.	Brown.	Deep chestnut.
Soluble, brown red.	None.	Red brown.	Deep chestnut.
Soluble, blue black.	None.	None.	Blue black.
Soluble, brown.	None.	None.	Black chestnut.

(1) A dozen skins are dipped in a dyeing bath containing a quarter of the necessary colour, and are moved about until the colour is exhausted. They are taken out and spread over the beam to dry. Another quarter of the colour is added and the process is repeated. The second draining should last for an hour, at the end of which time the remaining half of the colour is placed in the bath and the skins soaked until they acquire the necessary tint.

(2) Three baths are prepared, one weak, one medium, and one strong. The skins are placed in the first for a certain time, drained for a quarter of an hour, worked energetically in the second, exposed to the air for half an hour, then dyed to the necessary depth in the strong bath. After using this series once the strong bath becomes a medium one, and the medium a weak one. This method of working allows all the colouring matter to be used up in a rational way.

7. Paddle Dyeing.—This process is only a modification of the last. Five vats are used in which the colour gets stronger and stronger. The vats are about 40 in. deep by the same diameter, and are kept at a temperature of 35° C. (95° F.) by means of a steam coil, and contain a paddle wheel to keep it stirred. Twenty-five skins are placed in vat No. 1, which contains one-tenth of the necessary colour. The skins are turned for twenty minutes, drained for five minutes, and placed in vat No. 2, which contains two-tenths of colour, and in which they remain for a quarter of an hour. After draining for ten minutes, they are placed successively in No. 3 (four-tenths), No. 4 (eight-tenths), and No. 5 (ten-tenths). Vat No. 1 being now exhausted, is refilled with water containing ten-tenths of colour and becomes vat No. 5; the second becomes No. 1, and so on.

8. Tumbler Dyeing.—This apparatus has given excellent results. It should be used systematically in series of four.

VII.—DYEING WITH NATURAL COLOURS.

1. Black.—This colour is generally obtained by forming tannate of iron in the skin. As leather already contains tannin, it is only

necessary to treat it with an iron salt. This has already been described (page 258). In this section we shall only describe double dyeing ; that is, dyeing with logwood and either iron or some other mordant. All blacks are put on with a brush.

(a) The simplest method is to pass over the skin a solution of logwood containing 1 or 2 per cent. of ammonia, and, when the skin is quite red, brushing on a layer of pyrolignite of iron or copperas. This gives a blue black.

(b) The skin is treated first with a 10 per cent. solution of bichromate of potash containing 2 per cent. of alkali, next with a decoction of logwood, and finally with a mixture of blue and green vitriol. The skin is dead black.

(c) The skin is treated successively with red compound and black compound made up as follows :—

Red Compound.		Black Compound.	
	Parts.		Parts.
Logwood	100	Water	100
Yellow wood	10	Bichromate	5
Sumach	10	Pyrolignite	50
Ammonia	2		

(d) The same logwood is used as in (c.), but one of the two following mordants is substituted for the black compound :—

1.		2.	
	Parts.		Parts.
Sulphate of iron	37·2	Sulphate of iron	40
Sulphate copper	27·9	Sulphate of copper	40
Oxalate of potash	31·0	Tartar	3
Tartar	2·0	Alum	1
Chloride of copper	1·9	Oxalic acid	3
Water	1,000·0	Water	1,000

(e) We have already stated that compounds of iron with strong acids should be avoided as much as possible. The following are the formulæ of the two compounds used by several good houses :—

	Parts.		Parts.
Logwood	100	Acetate of iron	8·0
Yellow wood	5	Cream of tartar	1·5
Gall nuts	5	Alum	0·5
Ammonia	2	Chloride of copper	1·5
		Sugar	0·5
		Water	100·0

Dressing for Black.—All the blacks just described are bluish.

They should be well washed in clear cold water, partially dried, and brushed over with the following dressing :—

	Parts.
Water	100
Borax	5
Shellac	7.5
Nigrosine	7.5

The object of this dressing is to give a deep tone to the black and to varnish the grain, so that it shall resist moisture and never acquire a disagreeable grey appearance.

2. Fawn.—The fawn or tan colours are very numerous, varying from light hazel to chocolate. They are obtained with catechu.

Amarillis.—The skin is treated first with catechu (100 of water, 5 of catechu, 2 of sulphuric acid), then with Brazil wood, and finally with chromate (water 100, alum 3, chromate $\frac{1}{2}$). Another method is to use catechu (5 per cent.), chromate (2 per cent.), and sandal (5 per cent).

Carob is obtained by treating first with catechu, then with Brazil wood 1, Indian wood 1, alum 2, water 100.

Cinnamon.—First bath : catechu 3, alum $1\frac{1}{2}$, sulphate of copper $1\frac{1}{2}$, water 100. Second bath : chromate 2, soda crystals 1, water 100.

Aventurine.—Alum bath (5 per cent.) and yellow bath (water 100, anotta 1, quercitron 1, potash 1).

Bronze.—(a) catechu bath (water 100, catechu 4, chromate $\frac{1}{2}$, blue vitriol 2) ; (b) pyrolignite bath ($\frac{1}{2}$ per cent.) (c) ; yellow bath (water 100, quercitron 2, alum 1).

Grenat.—(a) catechu bath as for bronze ; (b) tin compound (10 per cent.) ; (c) wood bath (Brazil 10, logwood 2, tin compound 0.1).

Flesh.—Water 1,000, catechu 1 to 2, quercitron 1, alum 1, chromate 0.2.

Chamois.—Water 1,000, catechu 2, Brazil 2, alum 2.

Brown.—Water 100, catechu 5, chromate 0.5, sulphate of copper 1.5.

Deep Brown.—The same plus 0.6 sulphate of iron.

Chestnut.—(a) catechu bath (water 100, catechu 2, alum 2.50, sulphate of copper 0.75) ; (b) chromate bath ($\frac{1}{2}$ per cent.) ; (c) tin bath

(1 per cent. salts of tin); (*d*) wood bath (logwood 2, Brazil 1.5, quercitron 0.5). These compounds are extremely variable and depend on the tannin used in preparing the leather and the natural colour of the leather. The dyer is always obliged to test a small portion if he wishes to obtain any exact tint. All we can do here is to give a general idea of the dyes used in obtaining the different shades of tan. The use of artificial colours has been a great help in this, which is the most important class of leather dyeing.

The following are two new English formulæ:—

Chamois.		Cinnamon.	
	Per Cent.		Per Cent.
Water	100	Water	100
Cream of tartar	1	Yellow wood	5
Yellow wood	0.5	Alum	1.5
Cochineal	0.06	Tartar	1.5
Tin salts	0.35	Sandal.	2
		Madder	1
		Sulphuric acid	1.5
		Indigo carmine	0.25

3. Blue.—Blue leather is always obtained by dyeing with indigo carmine. The skin is first mordanted with—

	Parts.
Water	100
Cream of tartar	2
Alum	2

It is then soaked in the colour made up of—

	Parts.
Water	100
Indigo carmine	2
Cream of tartar	2

If a reddish blue is required 0.2 parts of ammoniacal cochineal are added.

4. Red.—Dyeing with red is very important. There is a great variety of dyes.

Scarlet.—

Mordant.		Dye	
	Parts.		Parts.
Water	1,000	Water	1,000
Cream of tartar	5	Cream of tartar	3
Cochineal	0.5	Powdered cochineal	100
Tin solution	5	Tin solution	15

Different shades of scarlet may be obtained by varying the proportions of cochineal and tin.

For kermes scarlet the leather is mordanted with—

	Parts.
Water	100
Alum	5
Tartar	2'5

and dyed with a neutral solution of kermes mixed with half its volume of the mordant. It is scarcely ever used.

Lac dye gives a very fine colour to skin. The mordant used is water 100, tartar 2, tin solution 2. After mordanting, it is dyed in a bath made up by adding lac dye 1'5, and tin solution 1'5, to the mordant bath. The colour is further brought out by dipping in water 100, tartar 2, tin solution 4, lac dye 2. Sometimes 10 per cent. of cochineal lake is added to brighten the colour.

Crimson.—This is dyed in one bath consisting of water 100, alum 5, cream of tartar 2, cochineal 2, tin solution 0'5.

Brazil wood crimson is made by passing the leather first through a mordant of tin solution and colouring with 30 parts of Brazil and 1 part of logwood. Afterwards it is brightened in a dye containing 0'5 of tin.

Poppy.—The leather is treated first with water 8, tin solution 8, cochineal 0'2, turmeric 0'2; secondly with water 8, tin solution 2, cochineal 1, tartar 0'5. The poppy colour is obtained with lac dye by using first a bath containing 5 per cent. of tartar and 1 per cent. of tin, and afterwards a 5 per cent. solution of lac dye.

Claret.—The bath used is water 100, cream of tartar 2, alum 1, ammoniacal cochineal 1.

Rose.—We may either use water 100, tartar 2, alum 0'5, cochineal 0'25, or mordant the leather with water 100, alum 1, sulphuric acid 1, tin salts 1, and dye with Pernambuco 20 per cent., potash $\frac{1}{2}$ per cent.

Corn Poppy Red.—First bath: water 100, anotta 5, potash 0'5; second bath: tin 5° Baumé; third bath: Brazil wood; fourth bath: alum.

Wood Red.—First bath: water 100, anotta 5, potash 0'5; second bath: alum; third bath: Brazil wood; fourth bath: tin 3° Baumé.

5. Yellow.—The leather should be mordanted with water 100, alum 5, cream of tartar 1, and then dyed with one of the following

colours: barberry, which gives the best results, and may be used without a mordant; dyer's weed, 10 per cent.; fustic, 10 per cent.; quercitron, 10 per cent.

6. Green.—The leather is first dyed with indigo and afterwards with one of the yellows just described. Various tints may be obtained by using either the blue or yellow in excess. For bronze greens different fawn-coloured leathers are dipped in indigo.

7. Violet and Lilac.—These are obtained by dyeing first red and then blue.

8. Orange is dyed by combining yellow and red.

VIII.—DYEING WITH ANILINE COLOURS.

1. General Remarks.—The artificial or aniline colours are rapidly replacing the natural ones, as they are cleaner, more brilliant, and easier to use. They require no mordant, as the tannin of the leather fixes them perfectly. Only those colours should be used which are soluble in water, as acids or alcoholic solvents are always harmful to the leather. A slightly alkaline bath is often desirable.

The solubility of the colours is often increased by boiling Panama wood or Egyptian soap-wort in the water before adding the colour. About 50 gram. ($1\frac{3}{4}$ oz.) of colour is required for each skin. It is boiled with water for about twenty minutes to thoroughly dissolve it. Sometimes the colour may be brought out, as in the case of corallin, by adding a little borax.

Each colour should be used separately, and when two are to be combined the leather should be dyed in two weak baths.

When the colour does not take well the skins must be removed from the dye and mordanted with 5 per cent. gall nuts or 10 per cent. sumach. The dyeing should then be recommenced.

In the table of artificial colours on page 334 we have given a list of the dyes used and the colours which they give to leather. We need not repeat them here. For intermediate colours experiments should be carried out on small pieces of skin.

2. Fixing Colours.—Artificial colours are faster on leather than

silk, nevertheless, to prevent any change they are tanned or passed through a fixing solution (5 per cent. bichromate is commonly used), but it should be remembered that reds and yellows are turned more brown by its use. Sometimes either nitrate of iron or chloride of copper is mixed with the bichromate. The fixing bath should be used after every colour bath.

3. Mixed Natural and Artificial Dyes.—Dyeing is often commenced by applying some natural dye to the leather, which afterwards receives a bath of artificial dye to brighten the colour.

Artificial colours take very well over natural colours but the contrary is not the case.

4. Dyeing of Curried Leather.—This presents several difficulties. Let us take, for example, red dyeing, which is the most common with Russia leather: (1) the skin is cleaned with a 5 per cent. solution of ammonia, or better carbonate of ammonia. It is thoroughly rubbed, well sprinkled with the alkaline solution, left for a few minutes, washed with very soft water, rubbed again with the alkali, and finally well rinsed; (2) it is dyed red in the manner already described (*see* "Logwood") and washed; (3) it is dipped into gall-nut solution; (4) it is dyed in aniline red, mixed with borax and soap-wort; (5) it is fixed with chloride of copper; (6) it is dyed with strong aniline red; (7) it is dipped in dilute chloride of copper.

Other colours are dyed in much the same way.

IX.—DYEING WITH METALLIC SALTS.

Several houses use metallic salts exclusively because of their fastness and economy.

The process is based on the combination of two salts producing an insoluble coloured compound. To obtain good results the following method should be adopted:—

Place the leather in a very dilute cold solution ($\frac{1}{2}$ to 1 per cent.) of the mordant salt and leave it for a quarter of an hour. Take it out, allow it to drain for an hour, then plunge it three times into cold water without letting it have time to soak. Next place it in

exactly the same way in a dilute solution of the colouring salt, then wash it thoroughly. If the colour be not strong enough a second and third dyeing may be given in the same way. When various colours are to be combined it must be washed very carefully between each dyeing.

The following table gives a list of the commonest metallic colours and the salts used to form them:—

Colour obtained on the Leather.	Salts used.	
	Mordant Salt.	Colouring Salt.
Yellow	Lead acetate.	Potassium bichromate.
Orange	Lead sub-acetate.	Potassium bichromate.
Green	Copper acetate.	Arsenious acid.
Fawn	Manganese chloride.	Caustic soda.
Chestnut	Potassium permanganate.	None.
Golden yellow	Cadmium chloride.	Sodium sulphide.
Pale yellow	Stannous chloride.	Sodium sulphide.
Brown	Bismuth nitrate.	Sodium sulphide.
Red	Mercurous nitrate.	Potassium iodide.
Red	Antimony chloride.	Sodium sulphide.
Black	Copper acetate.	Sodium sulphide,
Blue	Cobalt nitrate.	Ammonia.

X.—LEATHER PRINTING.

1. **Resists (Réserves).**—These are certain preparations which when applied to the leather prevent it from dyeing. If a pattern be printed on the leather with a resist before placing it in the dye the pattern will remain leather-coloured while the rest of the skin is dyed. The following is the composition of two resists, one thin and the other thick, both of very good quality:—

	Thin.	Thick.
Resin	80	80
Yellow wax	4	4
Spermaceti	5	6
Tallow	4	4
Spirits of turpentine	150	60
Alcohol	20	10

The fatty substances are melted together, removed from the fire, and the turpentine stirred in. When the mass has cooled down to 60° C. (140° F.) the alcohol is added.

The pattern is drawn on the leather with the resist, in some

cases using two or three coats, and then powdered over with fuller's earth to prevent the parts from sticking together. It is next dried in an oven. Dyeing is always done cold and usually with aniline colours. After the leather is dyed and dry the resist is removed by means of a sponge soaked in equal volumes of benzene and petroleum ether. This operation is sometimes carried out centrifugally. The solvent is recovered by distillation, but there is always a loss of from 15 per cent. to 20 per cent.

In this manner leather-coloured designs are printed on various backgrounds. If, however, the leather has first received a dye of, say, rose colour and after drawing the pattern it is dyed blue a rose pattern will be formed on a blue ground. These combinations may be varied indefinitely.

Two resists in different colours may be made on the same skin. Supposing, for instance, that red roses with green leaves are to be printed on a black ground. The skin will be dyed rose colour; resists are applied in the shape of roses. The leather may then be dyed green. The leaves are then drawn in and it is dyed black. On washing off the resists roses will be found with their leaves. We have seen as many as six resists in different colours on one piece of leather.

These processes are not without their difficulties, and demand on the part of the designer a considerable knowledge of dyeing. Lighter tints must always be used first and dark ones last. Often colours are entirely altered by superposition, in which case modifying baths or bleaching agents must be used.

2.—Coloured Resists.—In this case the resist is mixed with a colour which will become fixed in the skin after the wax is removed. A coloured resist is composed as follows:—

	Parts.
Resin	40
Yellow wax	4
Spermaceti	5
Tallow	5
Albumen	5

This is mixed with a concentrated alcoholic solution of some dye insoluble in water. The following are most commonly used:

Mars yellow, coralline yellow, phosphine, Hoffmann's violet, magenta, saffranine, alcohol blue, methyl green, alcohol black, etc.

It is removed with benzene as described in the last paragraph.

3. Direct Printing on Leather.—The use of artificial colours makes printing very easy, as these are all fixed immediately by the tannin. The liquid containing the dye is thickened by adding 5 per cent. of gum senegal or 2 per cent. of starch, or better still with glove skin gelatin. Some printers use gelose (lichen extract).

The design is applied to the leather by means of a block of pear tree or sycamore wood from which it is cut in relief. The leather is placed on a table with a very smooth surface. Close to the table, on the right hand of it, is a wooden bucket half filled with false colour (a strong solution of gum). The false colour is placed on a waxed cloth stretched on a frame and covered with a damp cloth, also stretched on a frame. The colour is spread on this second cloth as evenly as possible. In this manner a pad is formed with which the block is inked. After printing the leather is dried for three days at 25° C. (77° F.).

4. Pigments.—These are colours simply painted on to the leather. They usually consist of lakes or powdered vegetable or mineral colours insoluble in water.

The paint is made up by mixing 25 parts of glycerin with 100 parts of water and 10 parts of the lake are stirred in; 35 parts of gum are then added, together with 100 parts of a 50 per cent. solution of dry albumen.

This mixture is applied with the block, and dried slowly. The skins are then soaked in a solution of pale sumach for four hours.

XI.—FINISHING MOROCCO.

1. Drying:—When the skins come out of the dyeing vat they are saturated with the liquor. To remove this and recover it, the leather is passed between rollers so arranged that the liquid squeezed out of the skins runs back into the vat. The skins are put into the fulling machine and washed to remove the last traces of free colour. When the liquid runs away clear they are turned dry for ten

minutes, removed from the machine, passed through rollers and hung up to dry.

2. Oiling.—The skins are treated with a coat of linseed oil (about 5 per cent. of the weight of the skin). They are laid on a table in heaps of a dozen, grain side up, with the larger ones below, and the smaller ones above. They are oiled with a sponge, placed grain to grain and piled for two hours, after which time they are hung up again to dry.

The linseed oil should be well clarified and absolutely free from mucilage, which would remain on the surface of the skin and spoil its colour. Oil which has been kept for a year is to be preferred. It is customary in good houses to keep the oil for at least a month in a cellar. The barrel is tapped some distance from its lowest part so that the oil may be always drawn off clear.

Vaselin oil obtained from petroleum is being gradually introduced for this work. It gives body and weight to the skin.

3. Dressing or Seasoning.—The leather is first shaved to make it even and then dressed with some composition to soften the grain, to increase the lustre and to facilitate polishing. We give six recipes for these compositions :—

A.	
1.	2.
Parts.	Parts.
Water	Water
4,000	1,000
Potash	Carbonate of ammonia
250	100
B.	
Wax	Stearin
1,500	100
Egg	Mineral wax
100	200
Resin Soap	Egg
100	50
Water	Glycerin
2,000	50
3.	4.
Water	Water
1,000	1,000
Cotton oil	Ammonia
200	50
Ammonia	Castor oil
50	300
Yolk of egg	Alcohol
50	50
5.	6.
Water	Water
1,000	1,000
Ammonia	Sugar
20	100
Glycerin	Glycerin
100	100
Yolk of egg	Yolk of egg
300	50

Brilliant gelatin or any of the compositions given on page

378 may be used. We also recommend shellac dissolved in borax mixed with a little of the colour; sugar and linseed mucilage; sugar and albumen, etc.

4. **Dressing the Flesh.**—The flesh side is dressed with linseed mucilage and glycerin. Hat leathers are stiffened by dressing them on the flesh side with the following composition:—

	Parts
Water	40,000
Alum	125
Glycerin	500
Dextrin	200

Soft gelatin is also used, which is made by mixing gelatin with glycerin and alcoholic castor oil.

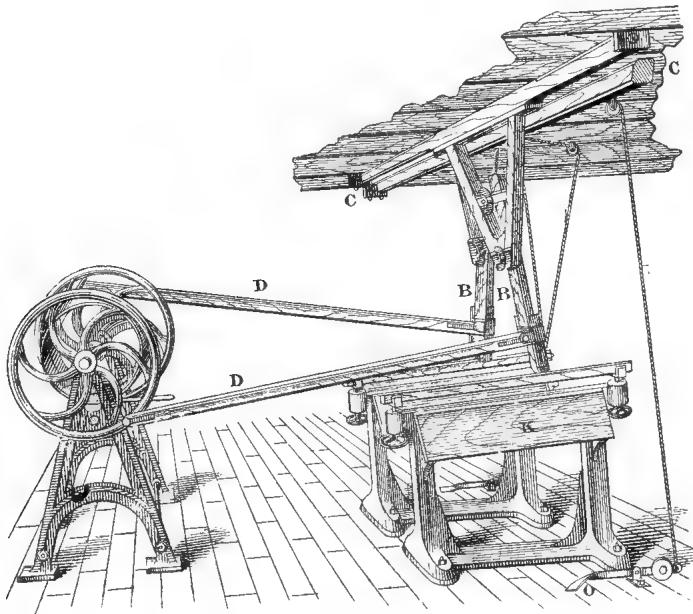

FIG. 84.—Glazing Machines.

5. **Glazing.**—This operation, besides polishing the skin, makes it more even and solid. The glazing machine is shown in Fig. 84. A little glass roller is fixed at the lower end of the wooden beams (B B), which are hinged above to the wooden shaft (C C.) The beams are set in motion by the rods (D.) The workman stretches the skin on the table beneath the glass cylinders and moves it backwards and forwards, until the whole surface is polished. He can vary the pressure by means of the pedal (O).

6. Graining.—The skins which are made up to imitate shagreen are grained in the usual way. The tool used for this work is known as a cork or graining board. Various grains are given, known as barley, lozenge, etc. Instead of the pummel a polishing machine may be used in which the glass rollers have been replaced by bronze or steel ones on which the pattern has been carved. In some places a special machine consisting of two rollers is used, the upper roller being engraved with the pattern. Hand graining is always considered superior to machine work.

XII.—SHAGREEN.

1.—Shagreen is lightly tanned leather covered with small round lumps. It is made in the East from horse, ass and mule skins. The processes of manufacture are very simple. The skin is un-haired and tanned either with tannin, or alum, or both together. To form the grain the skin is covered on the flesh side with mustard seeds and exposed to the sun. The grain is sometimes forced by trampling the leather under foot or piling it for a certain time before drying. When dry the seeds are beaten out. It is then dyed either red or green with kermes or lac.

The best shagreen is grey and comes from Constantinople; white shagreen is very inferior.

2. Galuchat.—This is manufactured from the skin of the dog-fish, which is covered with granular markings. It is very hard and strong, and is made principally in the neighbourhood of Biarritz. The manufacture is very simple. The skin is filed to remove the roughness, and polished with pumice stone. It is bright and transparent, and may be dyed green or red. Only the fine-grained leather is made from dog-fish skin. The rarer coarse-grained leather is made by the English from the Red Sea shark.

3. Shagreened Morocco.—Until about 1860 all shagreen came from the Levant, but since that time the manufacture of shagreened morocco has been so much improved that the Oriental leather is scarcely ever used. It is for this reason that we have only touched slightly on the details of the Oriental industry.

XIII.—BRONZED LEATHER.

This leather has an agreeable metallic appearance. Its colour may be yellow, green, bronze, steel, etc., and is produced by the formation of a metallic sulphide on the surface of the leather.

The skin is first dyed the necessary colour, and then dipped into a metallic solution.

For iron grey, nitrate of lead.

For golden yellow, cadmium sulphate.

For black, copper acetate.

It is allowed to become nearly dry and hung in a cubical chamber containing a vessel full of sodium sulphide. A leaden tub leads from the outside of the chamber into this vessel. Through this tube hydrochloric or sulphuric acid is poured down on to the sulphide, setting free sulphuretted hydrogen, which combines with the salts in the leather. The sulphides so formed have a metallic lustre.

The skins are next polished, and then sized with egg albumen or a varnish made of shellac, and boric and picric acids.

This process has a great drawback, as the smell of the sulphuretted hydrogen is very disagreeable. It may be replaced by a solution of thiourea.

Sometimes metallic powders are mixed with a solution of albumen and applied to the skin. After drying, the metallic lustre is developed by burnishing.

CHAPTER VI.

GILDING AND SILVERING.

MOROCCO can be gilded, silvered, platinised or nickeled either by sponging or electrically. In either case the first process is to metallise it. This is done by covering the leather with a solution of acetate of lead or copper and exposing it to sulphuretted hydrogen in the manner explained in the last chapter. Dilute solutions (1 per cent.) are used, and the operation is performed twice over, after which the leather is washed and dried.

I.—GILDING.

1. **Sponging.**—The moistened leather is spread on a table similar to that used in dyeing and the gilding liquid spread with a fine sponge. The liquid should be used immediately after it has been mixed. It consists of 2,000 parts of a solution containing 15 parts of chloride of gold, 500 parts of a solution containing 20 parts of silver, 15 parts of glycerin diluted with its own volume of water.

The gold is deposited at once. At the end of a quarter of an hour the leather is washed and the washings collected to recover the gold. It is then dried, polished and sized with a solution of albumen or a flexible copal varnish.

Another recipe is :—

	Parts.
Water	2,500
Chloride of gold	15
Caustic soda	20
Alcohol	15
Glucose	15

2. **Electro Gilding.**—The apparatus consists of a vat 6 ft. long, by 3 ft. broad, by 2 ft. 6 in. deep. Two rods of copper run along

the upper edges of the vat. These are put in connection with the negative pole of a battery of Daniell's cells, whilst the positive pole is connected with a sheet of gold placed at the bottom of the vat. The vat is filled with a liquid consisting of:—

	Parts.
Water	100,000
Cyanide of potassium	3,000
Chloride of gold	500

The skins are sewn two and two with the flesh inside and hung with copper hooks from the rods in such a manner as to lie vertically in the liquid. Fifty skins are placed in each vat. The different shades of gilding are obtained by having the gold electrode alloyed with silver or copper, or both. If a platinum wire be fixed to the positive pole and just dipped into the liquid, the gilding will be very pale. By dipping it more deeply the gilding becomes yellow, and by immersing it altogether the gilding becomes red.

These results are more striking if the bath be kept at 50° C. (122° F.). The mean temperature for leather gilding is 30° to 35° C. (86° to 95° F.). After six hours the skins are turned so that the parts formerly at the top are now at the bottom. The total time of immersion is very variable, and can only be determined by practice. On an average three-quarters of a grain of gold is deposited on an ordinary goat skin.

The skins are dried, unsewn and rubbed with a roll of cloth dipped in barberry liquor. They are finally polished.

The two following baths are sometimes used:—

	Parts.		Parts.
Water	1,000	Water	1,000
Sodium phosphate	60	Borax	50
Sodium bisulphite	10	Potassium cyanide	5
Potassium cyanide	1	Gold chloride	1
Gold chloride	2	Glycerin	10

3. Direct Gilding.—Sometimes metallic gold is applied directly to the leather. It is prepared by sizing with parchment glue, or if the leather be brown with white starch. This is allowed to dry and covered with two or three coats of white of egg.

While the last coat is still moist it is slightly greased with tallow, and the gold leaf applied. If any pattern is required, it is

worked on with hot copper dies. Dutch metal is sometimes used instead of gold leaf.

II.—SILVERING.

1. **Sponging.**—This is done in exactly the same way as gilding with one of the following solutions :—

Water	Parts. 10,000	Water	Parts. 10,000
Silver nitrate	100	Glucose	100
Ammonia	65	Quick lime	40
Tartaric acid	15	Silver nitrate	10

2. **Electro Silvering** is exactly like electro gilding with a bath consisting of :—

Water	Parts. 100,000
Cyanide of potassium	2,500
Nitrate of silver	500

3. **Direct Silvering.**—Exactly like direct gilding.

III.—NICKEL AND COBALT.

Nickel is deposited electrolytically from a bath consisting of :—

Water	Parts. 15,000
Sodium sulphate	5,000
Nickel nitrate	400
Ammonia	400

Cobalt is deposited from :—

Water	Parts. 1,000
Cobalt ammonia sulphate	100

CHAPTER VII.

PARCHMENT.

1. **Skins Used.**—The skins usually employed are those of the ram, the sheep and the lamb. Vellum, which is very fine parchment, is made from the skins of young calves, more especially of those which have been still-born. Virgin parchment is made from the skins of lambs which have been taken from sheep that have been killed accidentally. It is also made from still-born kids. It is nearly equal to vellum, but not so strong. Goat skins give ordinary parchment.

All these kinds of parchment are used for writing.

Pig skins are used for covering boxes. The skin of the ass, the calf, and more rarely of the wolf give parchment for drums.

2. **Unhairing.**—The skins are soaked, treated with lime and unhaired as in tawing. Great care should be taken in the liming; only skins of uniform size being treated together. Long contact with the lime takes the strength out of the parchment and de-segregates the fibres. On coming out of the lime the skins should be washed free from lime in a square “tumbler.” A fulling machine is apt to destroy the texture of the skin.

After being well washed the skins are stretched on a wooden frame 5 ft. long by 4 ft. 6 in. wide, each side of which is furnished with pegs.

Eighteen or twenty skewers are fixed around the edges of the skin by threading each skewer through four holes; the skewers are next fastened by string to the pegs on the edge of the frame so that the skin is stretched out flat. It is usual to have a longer skewer fixed into the head, passing through six or eight holes

instead of four, and to strain this on to the pegs by means of two strings, one at each end.

When the skin is in position, the edges of the frame are twisted with an iron key, so that they exert a powerful tension on all parts of the hide.

3. Fleshing.—This operation is performed with a fleshing knife which is curved, sharp on one side, and rounded on the other. This utensil is held with both hands, and worked over the stretched skin so as to remove, first, the adherent flesh and fat, and, secondly, fine shavings of skin. This must be done with great care, especially for vellum.

4. Backing.—The knife is reversed so as to use the rounded edge, and the grain or back of the skin is rubbed thoroughly to render it even, and to remove any lime water that may remain in the skin.

Coarse parchment is now finished and only has to dry, but other operations are necessary for writing parchment.

5. Drying.—The two sides of the skin are sprinkled with finely-divided slaked lime, and set to dry, still stretched, in the shade. It is difficult to make parchment in the winter as drying is too slow. Damp deteriorates the product, and frost completely destroys it. The use of the drying loft is much preferable. The idea of using lime is that it rapidly absorbs the moisture from the skin and prevents it from becoming discoloured, but on the other hand, it always destroys much of the strength of the skin.

Of late, lime has been replaced by Kiesselguhr the absorbent infusorial earth used in the manufacture of dynamite. Some manufacturers also use kaolin.

When the skin is dry, it is beaten to remove the dust, and the edges are cut away.

6. Pumicing.—Slaked lime is sprinkled on the flesh side, and the skin is polished with a smooth pumice stone. The grain side is pumiced without lime; an improvement on this method is to substitute finely-ground pumice powder for lime.

7. Shaving.—After pumicing, the skin is thoroughly dried, wiped clean, and passed on to the shaving.

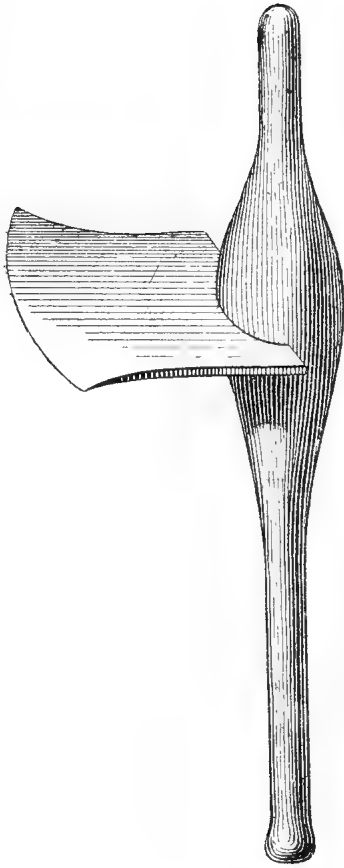

FIG. 85.—Fleshing knife (parchment maker's.)

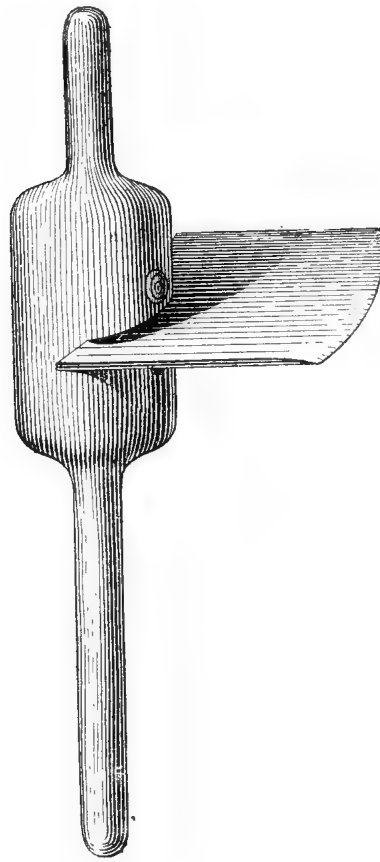

FIG. 86.—Paring knife, for skins slack in the frame.

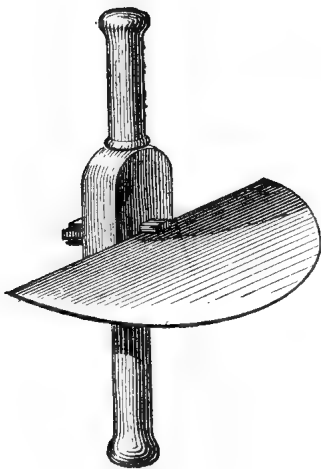

FIG. 87.—Paring knife for skins stretched in the frame.

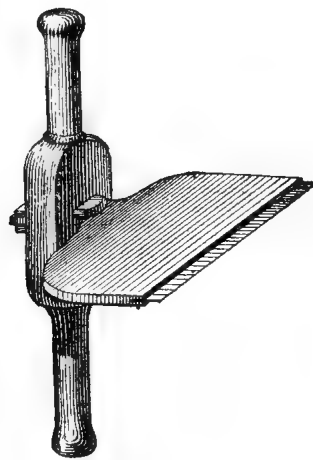

FIG. 88.—Polishing tool for vellum.



FIG. 89.—Steel.

For this purpose a special frame is used, on which a calf skin, with the hair on, is stretched in the way described in paragraph 2. The skin to be shaved is fixed to the upper portion of this frame. It is then carefully shaved with the shaving knife (fig. 87) to remove all superficial stains, unevennesses, fat, etc., which may be found on either face of the parchment.

Afterwards it is stretched on the pumicing saddle and the grain is pumiced until all marks of the scraping iron are removed. This pumicing which has great influence in the beauty of the skin may be performed rapidly and evenly by the machine described on page 349.

8. Finishing.—The parchment is finished by sizing on the grain side with fine gelatin and starch. It is then dried and pressed.

Parchment may be stained green or red by any of the dyeing processes already described.

9. Patching.—Skins which contain holes or scratches may be repaired in such a manner that the patches are invisible. Lamb skin in very fine shavings is sometimes glued over the bad places. Sometimes little pieces of parchment are cut, a little larger than the hole which is to be hidden. The edges are then carefully bevelled, and the edges of the whole trimmed in the same way. The patch is fixed in position with gum water, and is then dried, pumiced and sized.

Parchment should be dense, transparent, white, free from roughness, unevenness, stains, or holes. Vellum should be elastic, even and firm.

CHAPTER VIII.

FURS AND FURRIERY.

I.—PRELIMINARY REMARKS.

PELTS¹ are skins from which the hair has not been removed.

Furs are pelts which have undergone certain processes which increase their beauty and protect them from decay.

The hair is therefore the ornamental part of a fur. It is divided into the following classes.

Spines.—Large, hard and sharp, as on the hedgehog or porcupine.

Bristles.—Finer, but still hard excepting at the tips, as on the hog or wild boar.

Hair.—Finer still, long, and supple throughout their length, as on the horse.

Wool.—Very long, soft and tangled, as the sheep.

Fine Hair.—Long, fine, but coarser than wool, as the rabbit.

Down.—Very fine, short, soft and supple.

Most furs are obtained from mammalian animals, whose skin is covered with an under layer of down, through which in most cases grows the coarser hair. The colour of pelts is very various. They may be black, white, yellow or a mixture. Again, the distribution of the colour over the surface of the body is very various. It may be uniform, marbled, striped, rayed, spotted, etc.

Hairs are not of the same colour throughout their length, being darker at the tips than near the skin.

Hair does not remain the same throughout the year. At certain times it falls off to make room for a new crop growing beneath.

¹ The word "Pelt" is also used in England for sheep skins from which the wool has been removed.

This takes place once or twice in the year, occurring in spring or autumn, or both. At such times there is no alteration in the quality of the hair, but its colour may be altered.

Cold has a great effect on the qualities of furs. The finest skins come from cold countries, indeed, the value of furs is greater the colder the country of origin. The furs of animals killed in winter are the finest. The hair is more uniform in colour and length, it is light, soft and supple, and evenly distributed over the skin.

Even in winter, the exact time, beginning or end of the season, will have an influence on the fur. In the first cold days, the down is not yet formed. The skin has a greenish tint and the hair is hard and long. In the last frosts the skin is open and reddish, and the hair is not so strongly fixed in the skin. In mid-winter the skin is white, dense and fine, the down is well formed, and the hair is long, solid, soft and lustrous.

A good pelt is judged by touch and appearance.

Good furs of the highest quality are thick, well covered with hair, and their skins are thin and supple.

We may divide furs into two classes—indigenous and foreign.

Indigenous furs are those produced in this country (France) and are said to be common when produced by domestic or farm animals, and wild when from wild animals. Foreign furs are divided into two classes, according to whether they come from hot countries, as the tiger, or cold ones, as the ermine.

II.—INDIGENOUS FURS.

1. **Lamb Skins.**—The lamb is a sheep of less than a year old. Hoggs are lambs which have been weaned; their skin is inferior. The best varieties are Turin skins, black and lustrous, from Lombardy, Tuscany and Piedmont. Pyrenees lambs from Bearn or Spain have either black (the best) or white skins; they are used by the German peasantry for trimming their coats. Arles skins, larger than the preceding varieties, come from Provence, and are divided into three classes: strong lambs, with long wool; crisp lambs, with short frizzy wool; and common lambs of inferior quality.

Auvergne, Limousin, Perigord and Guyenne lambs are the poorest of any value. German and Scotch lambs are of very little worth.

Astrakhan (a town on the Volga) and Orenburg skins are taken from still-born lambs; they have a smooth, black, lustrous appearance. A higher class are clouded. Lambs which are intended to give Astrakhan are cared for in a peculiar manner. The bodies are sewn up in a linen garment, which is replaced by a larger one as the animal grows. The fleece, thus compressed, sets in curls. The animal is killed as soon as the appearance of the skin is perfect. Other countries produce skins similar to Astrakhan. Persian skins are dense, curly and grey. Crimean skins are grey or black, curly and longer in the wool than Persians. Ukranian skins are black, very fine and curled. Skins from the Kalmucks and Bachkirs are also very fine.

2. Goat Skins.—Domestic goats are of three kinds—European, Asiatic and African. European and African goats are not used for furs.

The Asiatic goat is found in the Himalayas to the north of Hindustan, in Southern Thibet and in the Punjab. It is smaller than the European goat (2 ft. to 2 ft. 4 in. high), has abundant long wavy hair, which is black or white, bluish or yellowish. There are three kinds of Asiatic goats :—

Angora goats have long, fine, silky hair, sometimes as long as 2 ft. 6 in. Each goat gives $4\frac{1}{2}$ lb. of hair. The hair is very durable, and does not stain easily. It is sometimes made into carpets. They bear two kids per year whose fleece is fine and very curly.

Cashmere goats have long grey or white hair with an extremely fine down beneath.

Thibetian and Kirghiz goats have a finer appearance than the last.

3. Cat Skins.—The wild cat is much larger than the domestic cat. Its colour is greyish-brown with faint black bands, one along the back and others down the flanks. The belly, the inner parts of the thighs, and sometimes the breast are fawn.

Domestic cats have skins of very various colours. Black cats

are most prized, and are sold in large quantities to London and Leipzig. The tiger cat is very similar in appearance to the wild cat, but its stripes are more defined.

The Persian cat is of an ashy grey, almost slate. The Spanish cat is usually of three colours—white, black and ruddy, or white, grey and ruddy, or black, white and yellow. In France the males have only two colours.

The Angora cat has very long, silky hair, usually white, but they may be grey, fawn or mottled.

Foreign cats are very numerous. In Africa there are the tiger cat, fawn-coloured with black stripes; the Egyptian gloved cat, greyish-fawn with a black stripe down the back and on the head; the dark cat, ruddy black with black-bands; the Kaffir cat, grey with black stripes.

In Asia there are the Bengal cat, grey-fawn above, white beneath, stained brown on its back with four black marks on its forehead, two black stripes on the cheeks, and two bands round its neck; the rusty cat, which is a rusty-grey above and white beneath, has three reddish-yellow stripes along the back with cross stripes on the flanks. The Tobolsk cat has a red colour. That of the Cape of Good Hope is bluish. In America are found the panther cat or margay, ruddy above, white below, with dark brown and black stains, and the elegant cat, which has a thick coat, bright reddish above, black or white below, with brown markings.

4. Dog Skins.—Many kinds of dogs exist in the wild state. The Indian dhole is very similar to our terrier, and inhabits the jungles on the eastern border of Bengal. The dingo of Australia is another wild dog. These are the two chief ones, and both give greyish-fawn fur.

The fawn-coloured Turkish dog is half wild.

The appearance of dogs is too well known to need description here. We may mention, however, as the chief fur producers, the collie, the Thibetian dog, the mastiff, the Dane, the Newfoundland, the spaniel, and the Maltese terrier.

5. Rabbit Skins.—The wild rabbit is grey mixed with fawn and black. It has a white belly and throat.

Domestic rabbits are of all colours, the most common being the grey whose hair is used in felting.

Those used for furs are either the French "lapin argenté" or the white Chinese rabbit. The "argentés" are slaty-grey with long silky hair. The finest are produced by unsexed males. France produces the best of these rabbits, and of all French animals those from Normandy are the finest. The skins are divided into three qualities according to quality and sold in boxes of 104. Warren rabbits are sold in couples. After Normandy come the Ardennes and Brittany, whilst all cool mountainous countries can produce them. In France the skin is always well covered with down which gives them their value, whilst in warmer countries they are covered with valueless coarse hair.

In Australia rabbits are the commonest of vermin, they are mostly grey and very small. A larger variety is silvered.

The white Chinese rabbit has fine, brilliant, soft, white hair.

The Angora rabbit has wavy silken hair, sometimes a little curled, and pearly grey.

6. Hare Skins.—The common European hare is grey-fawn with brown marks; it is very rarely used in furriery. One rabbit skin is worth two hare skins. The fur hare which is found in Sweden, Norway, Siberia, Lapland and the Pyrenees, has a white coat in winter and a ruddy one in spring and autumn. The Russian hare, which does not alter, is black, and of great value; this is partly due to its rarity.

7. Wolf Skins.—The common wolf which inhabits Northern Europe is about 4 ft. long by 2 ft. 4 in. high. Its coat is tarnished grey-fawn in colour with a black stripe down the back. Its hair is harsh. The Siberian wolf has long thick soft hair, and is the finest for furriery. Sometimes it is silvered. Next to the Siberian come the Russian skins; they are not so white nor so rich. The Polish wolves are yellow, sometimes marked brown or black.

The black wolf, wrongly called black fox by furriers, chiefly inhabits North America. Its skin is intensely black (sometimes grey) with a white stain on the muzzle and the breast.

The red wolf is met with in La Plata. It is reddish, with a black mane.

White skins are the most valuable.

8. Lynx Skins.—Lynx fur is highly prized. It is grey, inclined to red, mixed with brighter colours, and marked deeply on the head, back and neck. The body is white beneath, and two whitish tufts surround a bright fawn-coloured face giving the effect of a long beard. It has three black stripes on each cheek and a collar of long hair. Its average length is 2 ft. 8 in.

The lynx is found in Sweden, Russia, Poland, Germany, the Alps, the Pyrenees, etc. It is sometimes called the deer-wolf. Lesser animals are named deer-cats. The finest skins come from Siberia, where they are known as *rys*, the Swedes call them *wargelue* and the Danes *los*. The hair is short in summer and long in winter.

The following kinds of lynx are known :—

The *Pard Lynx*, smaller than the common lynx, has a bright lustrous ruddy skin spotted with black. It is met with in Central Europe.

The *Caracal* (kara-kalack of the Turks, anah-el-ared of the Arabs) is very small (2 ft. 6 in.), fawn on the back, yellowish-white on the belly and inside the thighs. A black stripe runs from the eye to the tip of the nose. It inhabits Northern Africa, Arabia and Persia.

The *Red* or *Canadian Lynx* is of the same size as the caracal, and gives fine skins of a fawn or deep grey colour. It inhabits Sweden, Lapland, Russia and America.

The *Marsh* or *Booted Lynx* or cat lynx is 2 ft. long, deep fawn on the back, pale grey underneath, with black feet. It is found in Egypt and Eastern and Central Asia.

The *Muscovy Lynx* is 3 ft. 6 in. long and gives a fine fur.

The *Manoul* or *Siberian Lynx* is 3 ft. long with a ruddy colour and two black marks on the head.

The *Pajeros* is 2 ft. 6 in. long, light brown marked with black. It inhabits South America, especially Patagonia.

9. Ferret Skins.—This fur is of little value: it is usually yellowish, but sometimes white, yellow and black.

10. **Guinea Pig skins** are white with black or ruddy markings.

11. **Alpaca Skins.**—This is a kind of llama 3 ft. 4 in. long. Its colour is brown. The head and belly are white. The hair or wool is long (14 in.), extremely fine, straight, brilliant, soft and elastic. One animal will yield 9 to 11 lb. of wool. The finest development is towards the neck, shoulders, back and flanks.

12. **Deer Skins.**—The common or European deer have fawn skins of various shades. The fawns or young ones are darker but touched with white. Old ones grow ruddy or red, paler on the belly. The Canadian deer has a thicker coat and a finer colour; it has received various names, wapiti, newwashish, American deer, red deer, horned deer, red elk, etc. The Virginian deer is pale fawn. The Indian or Bengal deer is fawn touched with white. The hair of a deer is thick, long, greyish-brown in winter, red-brown in summer. The down hidden by the hair is grey with red tips.

13. **Elk Skins.**—These animals have a deep grey coat nearly black on the withers and nape. They occur in Europe and America. In Canada is found the original elk or moose. The hair is longer in the elk than in the deer and the skin is larger.

14. **Fallow Deer Skins.**—This animal is very similar to the deer. Its coat is fawn marked with white in summer and brown in winter. It has two white stripes, one along the flanks, the other down the thigh. The fawns are marked with white. White, black and spotted fallow deer are known.

15. **Roebuck Skins.**—The roebuck is fawn grey with white buttocks. It also occurs white with black, red or grey spots; it is 4 ft. 6 in. long.

16. **Reindeer Skins.**—The reindeer is deep brown in spring and greyish-white in summer. The hair is long and silky or woolly. It is met with in Arctic regions: Lapland, Siberia and Greenland. In Canada it is known as the caribou.

17. **Civet Skins.**—The Spanish cat is 20 to 24 in. long, its colour is grey marked with brown or black. Its hair is soft and brilliant and mixed with very soft down. A black band of very long hair runs from head to tail. It is found in Spain and the

Levant. Other kinds of civet are the Barbary civet, the Senegal or panther civet and the Madagascar civet.

18. Cheetah Skins.—The hunting tiger or maned leopard is found in Asia, Kordofan, Senegal and the Cape. It is nearly 4 ft. long. Its coat is bright fawn above and white below and covered with black spots. The tail has black and white rings.

19. Antelope Skins.—The common or African antelope or gazelle is of the same size as the roebuck, light fawn above, white below, with a brown band on the flanks. The springbok of South Africa is a little larger, but of the same colour.

20. Chamois Skins.—The chamois is the European antelope. It lives in the Alps and Pyrenees. It is grey in spring and reddish-fawn in summer.

21. Squirrel Skins.—There are many varieties of squirrels, of which the following are the chief:—

(a) *The Common Squirrel*, 9 in. long, reddish in summer, with white belly, throat and thighs. In winter it becomes grey. It inhabits the forests of Europe. In the Alps and Pyrenees its body is deep brown, its belly grey and its tail black. It is little used in furriery, but its hair is used for fine artist's brushes.

(b) *The Grey Squirrel* of Russia and Siberia is bright red in summer, and in winter a very fine grey. The more even this grey tint the more valuable the skin. The best come from the shores of the sea of Okotsk; they are known as saccamina. The largest come from Nertschinsk. Next come the Yakutsk skins which have a bluish lustre. Lena skins are of four qualities, amongst which those from the Obi are very light and those of the Yenesei are the poorest. In Russia the great markets for these skins are Archangel and Kazan. The great centre of manufacture is at Weissenfels on the Saal.

Commercially there are four classes of grey squirrels. They are known as white, in which grey dominates; common, which only have grey flanks; blue-grey from Russia and Siberia, and black, which are really dark grey.

(c) The following foreign varieties are of a much lower value:

The Mexican, which is yellowish with white-tipped hair. The fox-tailed squirrel, larger than the Siberian, has a reddish skin mixed with grey. Its hair is harsh. It inhabits Central America. The Mexican squirrel or coquallin is reddish-grey striped with white. The Brazilian squirrel is brown mixed with yellow with white marks on its sides. The grey squirrel of Carolina is grey with a white belly. The Carolina mark squirrel is iron grey with black head and white muzzle, belly and ears. The striped American squirrel is streaked with black, brown or fawn. It has one brown streak on the back and two lighter ones on each side. The Hudson Bay squirrel has a bluish back and ashy belly. The African or Barbary squirrel is brown marked with four white stripes running from the shoulders to the buttocks. The Sumatra squirrel or toupai is brown marked with one white and one dark brown stripe on each side. The flying squirrel of Canada is rusty grey on the back and white on the belly. The Malabar squirrel is the largest of all (16 in.), it is black on the back, fawn on the belly, and reddish on the flanks. The prairie dog is reddish mixed with grey.

22. Bear Skins.—This is one of the most useful skins known to furriery.

The following are the chief varieties :—

(a) The *White* or *Polar Bear* inhabits the polar regions and has a dense, smooth white coat; it is 6 to 7 ft. long. The Siberian white bear gives a fur of much lower quality, sometimes quite brown.

(b) *The Grizzly Bear*, 8 ft. long, has brown hair with grey tips. The head is quite grey. It is a native of the rocky mountains of North America.

(c) The *North American Brown Bear* gives a fine fawn coloured fur.

(d) *The Brown* or *European Bear* is very widely distributed. Its chief varieties are the completely brown bear of the Alps and Pyrenees; the Siberian bear, which has black marks and a white band across its shoulders; the Thibetian bear, which is very dark and carries a white Y on its breast; and the Syrian bear, grey-brown with a sort of mane all along its back.

(e) The *North American Black Bear* is black with a fawn-coloured breast.

(f) The following varieties give good furs: The Chilian bear, black with fawn snout; the Cordillera bear, black with white round the eyes and white marks on the breast; the Malay bear, black with red muzzle and eyes, and a white mark on the breast; the labiated bear of Thibet, black, marked with fawn, with a V on the breast.

23. Fox Skins.—(a) The common *European Fox* is nearly 2 ft. long. It is brown on the back, whitish on the belly. This quality is scarcely ever used in furriery, but certain varieties give excellent furs; for instance, the black fox, which is fawn-coloured, with patches of black on the back, breast and feet; the cross fox, with a black cross on its back; the white fox and the noble fox.

(b) The *Blue Fox* inhabits the Arctic portions of Europe and Asia, and gives a most valuable skin. It has a white coat, often inclined to grey, with slaty tints. The bluer its appearance, the more high its value. The hair is long, thick and soft. Small foxes about five months old have a black cross on their backs and are known as krestowiki. This cross disappears entirely before they reach the age of eight months. The blue fox is very rare.

(c) The *Siberian Black Fox* has a brownish-black coat, touched with white on the back and the belly. It comes next in value to the blue fox. Its hair is very fine and soft.

(d) The tri-coloured or *Grey Canadian Fox* is white, grey and black. The sides, breast and throat are white. The feet are often fawn-coloured on the outside. Inside the legs is a black or white stripe.

(e) The *Zerda* or fennec of Africa is very small (14 in.) and has fawn woolly hair.

(f) The *Cape Megalotis* is greyish-yellow above and whitish below.

(g) The *Red Fox* of Florida and the Carolines has fine ruddy hair.

(h) The *Virginian Fox* has coarse silver-grey hair.

(i) The *Egyptian Fox* is ruddy on the back, grey on the belly and black on the ears.

(j) The *Bengal Fox* is brown on the back, with two black stripes.

24. Weasel Skins.—The weasel inhabits Europe. Its body is $6\frac{1}{2}$ in. long. Its coat is ruddy brown above and white beneath, with soft, thick hair. In temperate climates it is of little value, but Siberian skins are used as sable.

25. Badger Skins.—The European badger is 30 in. long. Its colour is greyish above and black below, with longitudinal bands on the head, alternately black and white. Its hair is very long.

The Asiatic badger is more brilliant in colour, and the Indian badger or mydaus is smaller.

The American badger or wolverine, found in Hudson Bay territory, is black in summer, and brown shading to red in winter. Its skin is highly prized.

26. Mole Skins.—This is not much used; its coat is fine, soft and velvety, brown in colour, with a bluish lustre.

27. Hamster Skins.—The common hamster is about 1 foot in length including the tail which is 2 inches. It is a kind of rat found in Germany. Its coat is rusty-grey on the back, black on the belly, with three white marks on each side, and two on the throat. Young hamsters have white skins with black bellies. They are sometimes found black with white breasts, and occasionally white foreheads. Others are fawn with grey bellies.

Other varieties are found in Asia and Russia.

28. Marmot Skins.—The marmot of the Alps and Pyrenees is about the same size as a rabbit. It has yellowish-grey fur with ashy tints about the head.

The *Babax* of the Carpathians is very similar.

The *Sousik* or *Zizel* of Siberia is greyish-brown, grey or whitish. The Kamtschatka marmots are mottled.

29. Sable Skins.—The sable is ordinarily about 20 in. long. Its coat is thick, soft and lustrous, with silky hair and fine down. Its colour is black, reddish-brown or yellow. The browner the colour the more highly it is valued. It is finer in cold countries, but is found in Europe, Asia and America.

30. Mink Skins.—The mink gives a bright fawn fur, white about the head. It is met with in Europe, Asia and America. Its fur is as soft as that of the sable.

31. Polecat Skins.—The common polecat is 20 in. long. Its coat is brown on the back, yellow on the flanks, with white marks on the eyes and snout.

The Alpine polecat is yellow above, paler below, with a white patch on the snout. The polecat of Poland is white and brown. The Northern polecat is smaller (12 in.) and has a chestnut-black colour with a white head. Its fur is known as skunk.

32. Marten Skins.—The marten is brown with white throat. Its hair is coarser than that of the weasel. It is found in Europe and Asia.

33. Glutton Skins.—The fur of the glutton is deep chestnut with a large brown mark on the back. It is warm, light and brilliant. The yellowish furs from Kamtschatka are most valued. In Russia it is called rossomak.

III.—FOREIGN FURS FROM HOT COUNTRIES.

1. Lion Skins.—The lion measures from 4 ft. 6 in. to 10 ft. long, and up to 4 ft. 4 in. high. It is of a tawny colour. The cub has a woolly skin with brown cross-stripes on the flanks, which disappear as it grows older. On its neck, the lion has a thick mane which is absent in the female.

The chief varieties are :—

(a) The *Barbary* or *Algerian Lion* has a brown coat and long thick, black mane. Other varieties have fawn-coloured or grizzly manes.

(b) The *Senegal Lion* has a sleek, yellow coat and a smaller mane.

(c) The *Persian* or *Arabian Lion* has a pale fawn colour and thick mane with brown patches.

(d) The *Cape Lion* is yellow or brown.

2. Puma Skins.—The American lion or puma is, like the lioness, maneless, and measures 4 ft. 6 in. long. Its coat is pale

fawn touched with white and its hair is thick. It is found in Central America.

3. Tiger Skins.—The royal tiger is as big as a lion. Its coat is light fawn above and white beneath, striped with transverse black lines from back to belly. Its tail has 15 black rings. The tiger is met with in India, China and Tonkin.

4. Jaguar Skins.—The American, Brazilian or Guianian tiger is not so large as the true tiger. Its colour is bright fawn to reddish on the body and white below. Its hair is supple, bright and short, and instead of being striped like the tiger it has four rows of black marks, each mark being a ring with a spot in the centre. Furriers call it the great panther.

5. Ocelot Skins.—The ocelot is 3 ft. 6 in. long. Its coat is grey fawn, white beneath with a black line on the back, and oblique ruddy marks on the sides. It is found in Paraguay and throughout South America.

6. Leopard Skins.—The leopard is from 3 ft. 6 in. to 5 ft. long by 2 ft. 6 in. high. Its coat is bright fawn covered with ten ranks of black spots. It inhabits Africa and equatorial Asia.

The black panther is only a variety of leopard. Its coat is brown-black covered with black spots which can only be seen by viewing the skin obliquely.

7. Panther Skins measure 6 ft. 6 in. long, and closely resemble leopard skins. The coat is well covered with lustrous hair. It is fawn above and white beneath, beautifully marked with black discs $1\frac{1}{2}$ in. across. The legs are spotted and ringed. The panther inhabits Asia, India and Africa.

8. Ounce Skins.—These are 3 ft. 8 in. long. Their colour is grey marked with small irregular black spots. A black line runs along the back and is continued along the tail. The fur is thick and long, very much resembling that of the leopard. It is found in China, Siberia, and generally throughout Asia.

9. Giraffe Skins.—Their coat is grey with very short hair.

10. Quagga Skins.—The Cape horse is as large as a horse. Its skin is brown striped with greyish-white on the neck and shoulders, red on the rump, and white on the legs.

11. **Bison Skins.**—These measure 6 ft. 8 in. long. They are deep brown in colour, bright in summer and dull in winter. The forehead, the throat and shoulders are furnished with more or less wavy hair. Two species are recognised: (*a*) the European bison, which is still to be found in the forest of Bialowicza in Lithuania, and in the forest of Atzikhou in the Caucasus; (*b*) the American bison, which is found in herds in Louisiana, whence its flesh is exported as Illinois beef.

12. **Zebra Skins.**—A kind of African horse. It is white, striped on the back, the flanks and the breast with black.

13. **Vicuna Skins.**—Bright brown, reddish-brown, deep brown, ruddy grey or even white in colour, with long silky hair like alpaca.

14. **Monkey Skins.**—The only monkey skins used in furriery are those of the grey and black sapajous of Brazil. The hair is long and silky. The black ones are lustrous. The grey are slaty with a reddish band.

15. **Chinchilla Skins.**—This animal gives a very valuable fur. It is 16 in. long, its hair is of medium length, silky, very soft and fine grey in colour. It inhabits Central America and is caught at Coquimbo or Copiaco, being exported from Valparaiso and Buenos Ayres.

The ordinary chinchilla is silver grey with deep reflections. The back is bluish-grey, the belly and feet are white. The grey hairs are of three colours, deep grey at the tips, white at the centre and pale grey at the roots. The woolly chinchilla or woolly mouse is smaller (10 in.), ashy grey with dark specks. The belly is yellowish grey. The hair is very fine and very soft. It is the most highly valued.

16. **Viscaya Skins.**—Similar to chinchilla; nearly 2 ft. long. Its coat is brownish-grey, darker above. It is found in the pampas of South America.

17. **Lagotis Skins.**—This animal is intermediate between the chinchilla and the Viscaya. It inhabits Peru and gives a valuable but thin skin.

18. **Civet Skins.**—The common or African civet, also known

as the civet cat or musk cat, is 2 ft. 6 in. long. Its colour is ashy with black uneven stripes; two black bands run round the neck, and one around the face. Its fur is dense with long hairs which hide a silky down. A mane runs along the back.

The Indian civet is slightly larger. Its coat is ashy with black marks, and four black marks around the neck. The mane is absent. It is found in the Indian Archipelago and the Philippines.

19. Kangaroo Skins.—The giant kangaroo is 4 ft. long and 6 ft. high. Its coat is soft, thick, short, ruddy-brown above, rusty below. The woolly kangaroo is 4 ft. 6 in. long. Its coat is rust-coloured. It inhabits New Holland. The striped kangaroo is 3 ft. long. Its colour is grey with white stripes. It is found in the island of St. Peter.

20. Opossum Skins.—The opossum is about the size of a cat. Its coat is white spotted with black. The head is white. It inhabits North America. Another variety is smaller with chestnut-coloured back and white belly. It has a white mark on each eye.

The gamba is white stained with black on the head. The great opossum is brownish-yellow with a brown line on the nose. They are found in Brazil, Paraguay, Guiana, etc.

21. Skunk Skins.—The American skunk, about the size of a cat, has a black coat with a white line on each flank. It is thick, silky, with a striped bushy tail. The Chilian skunk, smaller than the American, has no striped tail. The same may be said of the South American skunk.

22. Nutria Skins.—Its coat is chestnut above, paler beneath. It is found in South America.

23. Dormouse Skins.—The dormouse is white on the throat and belly and chestnut-grey on the back. The tail is covered with very long hair.

The garden dormouse has two black marks near its eyes. Its tail has shorter hair.

The glis is distinguished by the fawn colour of its hair. It is the size of a mouse.

24. Rat Skins.—Common rats are blackish, but there are brown, grey and white rats.

25. Field Mouse Skins.—The common short-tailed field mouse is like a rat ; its coat is always darker on the back than the belly.

The amphibious field mouse, or water rat, with a thick tail, is browner. The white rat is nearly white. It comes from Siberia.

The lemming has a multi-coloured skin, a mixture of brown, red, white, grey and black.

26. Musk Rat Skins.—The musk rat of the United States and Canada is 20 in. long. Its coat is rusty brown on the back and ashy beneath. There are many peculiar exceptions. They are sometimes found quite black, quite white, or piebald. Its fur, thick and soft, is very like beaver, but not so fine. The Russian musk rat has a fur brown on the back, white on the belly, lustrous and soft.

27. Raccoon Skins.—The racoon is 2 ft. long. It is greyish-black with white ears and snout. The hair is soft and silky. The crab-eating racoon is of a uniform grey. Both inhabit South America, Guiana, etc.

28. Tapir Skins.—The American tapir is brown-grey on the throat and head. The Indian tapir is brownish-black with grey back.

29. Canadian Marten Skins.—Brown, with long silky hair.

IV.—FOREIGN FURS FROM COLD COUNTRIES.

1. Ermine Skins.—The ermine is 14 in. long. In summer its coat is rusty above and yellowish below. In winter it is brilliantly white. When the animal is ill its hair is rusty grey. The ermine is found in Russia, Siberia and Norway. It is one of the most beautiful of all furs.

2. Otter Skins.—The coat of the otter consists of hair and down. The hair is long, firm and silky. The down is fine, thick and soft. The colour is always more or less dark brown with a whitish place beneath the throat. The common European otter is 2 ft. 2 in. long. The Canadian or American otter is browner than the common one.

The sea otter or Kamtschatka otter inhabits the Arctic Ocean,

and is very highly prized. It is 5 ft. 8 in. long with a soft brilliant rusty-brown coat. The adult males are named bobry, the females matka, and the young hoschloki. This is a very beautiful and costly fur.

3. Sable Skins.—The sable has a lustrous brown coat which darkens in winter and becomes lighter in summer. The deeper the brown the more it is valued. The fur is made up of long soft hair and fine thick soft down. It is finest between November and March, and is found in Northern Europe and Asia between the Lena and Kamtschatka. The neighbourhoods of Jakarzk, Nertchinsk, Magoscisk and Baikal give the darkest and finest furs.

In Russia the long hair is named "osé" and the short "podosé". Skins with black "osé" are the most valuable, whilst "podosé" skins are least valuable. The mixture of the two is known as "motchka" and down "podsada." A fine fur should not contain too much "podsada," because it makes the hair stand out.

The bellies of sables called *puppli-souvoli* are cut into strips 1 to 1½ in. wide.

White sables are also very valuable.

4. Berweski or Siberian Mouse Skins.—This animal is found in cold European countries. Its coat is whitish-grey, striped or spotted, and with short hair.

5. Beaver Skins.—The American beaver is 40 in. long by 1 ft. high. It lives in the cold parts of Asia and America. Its fur is silky, long, lustrous, and from brown to deep chestnut, though it is occasionally white. Under the hair is a silver-grey down. Black beavers are the most valuable.

Fresh beaver is trapped in winter, and dry beaver in summer, that is, when it is casting its coat. Fat beaver is sold by the natives after they have used it.

The French beaver is very rare nowadays. Occasional specimens are seen on the banks of the Rhone, the Weser and the Danube. Its coat is harsh.

6. Mink or Vison Skins, Putorius.—Brown to fawn colour. It is found in the colder parts of America and Europe.

7. Seal Skins.—The common seal is 4 ft. 6 in. long, and is yellowish-grey marked with brown, lighter below. The white-bellied seal is 8 ft. 6 in. long, black above, white below. The sea lion or sea elephant is 26 ft. long by 16 ft. round, and of the same colour. The attarsak is greyish-white with a black cross on its back. The otaries consist of: (*a*) the mane seal, 20 ft. long, with a fawn-coloured coat. It has a mane on its neck. (*b*) The sea bear, 8 ft. 4 in. long; it is brown above and white beneath. These two are called fur seals. The best come from the Cape. Young animals are the most valued, as they have a fine skin and soft hair. The fur of the seal is very similar to that of the otter.

V.—FURS FROM BIRDS' SKINS.

1. Swan Skins.—The common or red-beaked swan is most valuable. It is found in the wild state in the lakes of Europe, and domesticated in various countries. The plumage of a two-year-old swan is brilliantly white.

The black swan is totally black excepting for its red beak, and it is a native of Australia.

The American swan has white plumage with a jet-black beak. Sometimes it has an orange-yellow mark on the top of its head. Young American swans are slaty grey, and the red mark on the head is more pronounced. The Berwick swan is of the same colour.

The trumpeter swan is 6 ft. 8 in. long, and perfectly white, with black beak and feet.

The down found under the swan's feathers is exceedingly fine.

2. Goose Skins.—The common or domestic goose is covered beneath the feathers with a fine down similar to that of the swan, from which an excellent fur may be manufactured. A gosling's skin contains 15 gram. ($\frac{1}{2}$ oz.) of down. A goose's skin has 20 gram. ($\frac{2}{3}$ oz.).

3. Grebe Skins.—The tufted grebe, 3 ft. 6 in. long, has a black

back and a silver-white belly with a white stripe on the wing. Its breast is covered with fine silvery down, and it is this part which is used for fur. It nests in France twice a year. It lives in the north of Europe and America, and is common on Lake Geneva.

The eared grebe is smaller (14 in.), and the lesser grebe is still smaller (10 in.), but both are of the same colour as the crested grebe.

4. Ostrich Skins.—The ostrich, which is generally killed for its plumes, has its body covered with hairy down. Its skin makes very fine fur. It is essentially an African bird, and is nowadays reared on special farms. It is from 6 ft. to 7 ft. high.

5. Toucan Skins.—This bird is found throughout America. The toco is black with a rust-coloured belly and a white throat and crop. The cochichat or collared toucan is black with a red collar and a green belly. The tocard is black with a white neck and a red collar. Occasionally toucans are found with white or yellow throats. Only the belly and the throat are used for fur.

6. Moonal Pheasant Skins.—These birds have brilliant metallic feathers which show iridescent colours. They live in Hindustan.

7. Trumpeter Skins.—This bird is found in the wild state in South America. The trumpeter is 2 ft. 4 in. high. Its plumage is black with metallic lustre on the breast. The head and neck have only a weak down. Another species is the white-winged trumpeter.

VI.—PREPARATION OF FURS.

The skins sent to the furrier have simply been dried in the sun. In the drying, care must be taken to keep the skins stretched to avoid the formation of creases.

Large skins like those of the lion and tiger, etc., are tawed or chamoised in the manner already explained. Other skins are treated by the furrier, *i.e.*, dressed, dyed and combed to give the fur lustre. We will now describe these operations in detail.

VII.—DRESSING.

1. Soaking.—The skins are softened in 5 per cent. salt solution. For the first two days they are merely allowed to soak. Afterwards they are trampled every morning and evening. After three days the water is run off and a 2½ per cent. salt solution used. Three days later this is replaced by pure water. Altogether ten days are required for a thorough softening of the skins.

The use of a square “tumbler” gives good results.

2. Fleshing.—The flesh and fat adhering to the skin are removed on a special beam 2 ft. 6 in. long, 10 in. wide, and 1 ft. 8 in. high, at the end of which a tool is mounted similar to a fleshing knife. The workman sits astride the beam, and holding one end of the skin in each hand, he scrapes the flesh aside backwards and forwards over the tool until the refuse has been removed from every part of it.

3. Sewing.—The skins are sewn up so as to form pouches with the hair inside. Closed skins, that is to say, those like the sable, which have been skinned by merely opening a slit in the belly, need only have the opening sewn up.

4. Oiling. Certain skins have their hair covered with a glutinous substance which cements the hairs to one another. Before sewing up these skins the hair is treated with olive oil to remove this material. Some furriers use olive oil on all their skins.

5. Dubbing.—The flesh side of the skin is rubbed over with either pork fat, butter or olive oil. We have seen the following compositions used :—

(a) Olive oil 50, cotton oil 30, colza oil 20.

(b) Cotton oil 80, vaselin oil 20.

(c) Cocoa butter 30, castor oil 30, whale oil 10, beaver fat 20, vaseline 10.

Five parts of fat are used for every one hundred parts of skin.

6. Stocking.—The object of this operation is to drive the fat into the skin and to make it more supple. In most works this is done with the feet. The skins are placed in an empty tank ten or so at a time, according to their size. The workman, naked to his waist,

enters the tank, and works the skins backwards and forwards with his feet for about three hours. From time to time he examines the skins so that he may find the harder parts and gives them extra working. After each examination he puts on one side those skins which are finished and gives a fresh coat of oil to any that may need it.

The work is finished when the fibres of the skin are swollen sufficiently to give it a whitish colour.

Two precautions are necessary in this operation. The first is to avoid overheating the skins, which may cause the hair to fall off, and the second is to avoid over-much working, which is apt

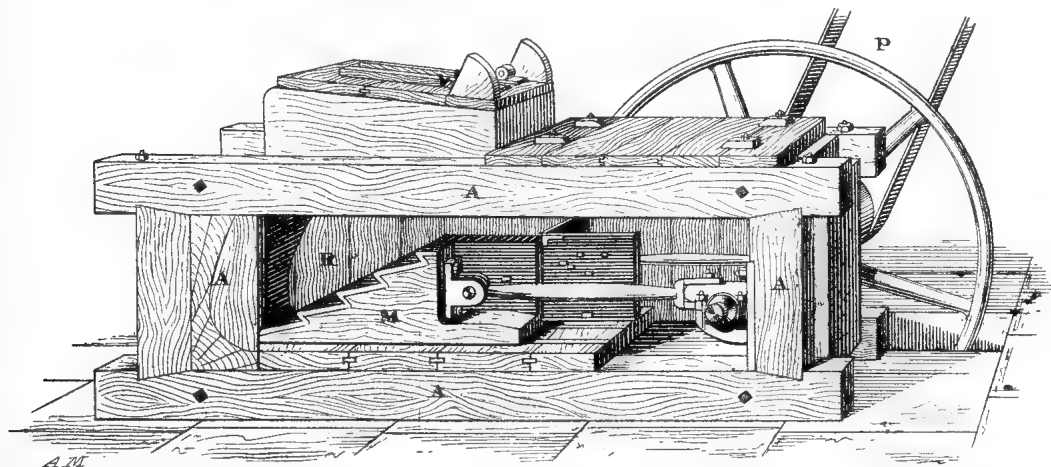

FIG 90.—Furrier's "Stocking" Machine.

to entangle the fur. The best work is done at a temperature of 20° C. (68°F.).

Nowadays in large furrieries this laborious work is replaced by the use of stocks, which give much more even results.

The machine generally used is the one already described on page 318, though it is more often arranged horizontally as shown in Fig 90. It consists of a rectangular frame of strong wooden beams (A) 8 ft. 6 in. long by 3 ft. 6 in. high. At one end of this frame is fixed a horizontal rod (B) which is set in motion by a pulley. This rod works a stamp (M) which stocks the skins placed in the trough (R).

Thiron of Paris has invented stocks in which the skins are

placed in a trough and worked by stamps which are moved by a cam action. When the square "tumbler" is used round shot about $4\frac{1}{2}$ lb. each are placed in the machine along with the skins.

7. Softening.—The skins are unsewn, or if they were closed skins in the first place, they are slit open with a sharp knife. They are stretched out to dry and then softened in one of three ways:—

(a) Two skins are held in one hand flesh to flesh and thoroughly beaten all over with a rod.

(b) The skins are drawn backwards and forwards over a tightly-stretched cord.

(c) The best method is that already described for tawed skins on page 312 viz., staking.

8. Removal of the Grease.—That part of the oil which has not penetrated the skin is removed by turning the skins in a special vat with some material which absorbs grease. Various substances are used, such as chalk, fine sand, plaster, infusorial earth or kaolin. For very fine furs the best absorbents are sawdust or bran. Whichever substance may be selected is heated to about 50° C. (122° F.) before being placed in the tank.

Occasionally the grease is removed in the cold, the only difference being that the operation is very much longer.

9. Beating.—When the skins are taken out of the machine used in the last operation they are beaten with rods to remove the chalk or other powder adhering to them.

10. Trimming.—The skin is stretched out horizontally on a table and the rough edges cut off. The last traces of the powder are carefully beaten out and the hair is combed by hand. This finishes the dressing.

VIII.—COLOURING.

The object of colouring is either to hide defects in the skin, to change the colour of the hair, or to make the appearance more brilliant. Some of the methods have been practised from time immemorial; others are modern scientific introductions.

1. Bleaching.—White furs which are soiled or yellowish or

spotted lose very considerably in value. They may be bleached and cleaned by the following processes :—

(a) *Sulphur*.—The skins are hung across horizontal wooden beams in a cubical chamber about 7 ft. high. The door is closed and a crucible of sulphur is lit inside through a small hole made for the purpose. The fumes of sulphurous acid produced in this manner readily bleach slightly-coloured skins. Before placing in the chamber, the skins should be slightly damp. The operation lasts twelve hours more or less.

(b) *Hyposulphite of Soda*.—The hair is thoroughly moistened with a dilute solution of this substance spread with a fine sponge and then hung up in a chamber exactly like the one just described. Carbonic acid gas is introduced into the chamber, where it slowly decomposes the hyposulphite. This gives a more even bleaching.

(c) *Essential Oils*.—The hair is rubbed with a sponge soaked in warm lavender oil or thyme oil and exposed to the sun. The chief defect of this process is that it takes at least a fortnight.

(d) *Hydrogen Peroxide*.—The fur is stretched on a table and the oil washed out of the hair with a 5 per cent. solution of sal-volatile (ammonium carbonate) which takes about a quarter of an hour. It is next washed with clear water, then with warm soap solution and finally rubbed with hydrogen peroxide (eight volumes) to which $\frac{1}{2}$ per cent. of ammonia has been added. It is then allowed to dry in the air. This gives excellent results.

Another process consists of rubbing the hair with a pasty mixture of water, barium peroxide, and silicate of potash in equal parts.

After bleaching, the white colour is made more effective by blueing in water containing a little indigo carmine.

2. Finishing in White.—This operation gives a gloss to the fur, renders it soft to the touch and softens the hair. It is performed by rubbing the hair with the following varnish :—

	Parts.
Alcohol	1,000
Sandarach	80
Cerasin	80
Glycerin	50
Yolk of egg	80

When it is merely wished to give a gloss to fur it is rubbed

with brilliant gelatin or white of egg mixed with half its weight of glycerin.

3. Black.—(*Ancient Method.*) The following eccentric formula was given by Roland in 1790:—

	Parts.
Lime water	1,117
Gall nuts	1,500
Litharge	500
Sal-ammoniac	65
Alum	128
Verdigris	64
Antimony	64
Minium	32
Iron filings	128
Green copperas	384

All these substances, with the exception of the gall nuts and half the lime water, are boiled in a cauldron, stirring constantly. The copperas is placed in a bucket with the gall nuts and the contents of the cauldron poured over them. The rest of the lime water is then added and the mixture is well stirred. It is allowed to settle for an hour and is then ready for use.

In spite of the empirical nature of this recipe we give it here because it is used and maintained as a secret by many furriers.

The skin being stretched on a table is brushed over with a hog's hair brush dipped in the mixture, working from the head to the tail. A second coat is given and rubbed in thoroughly with the brush, and a third coat painted on smoothly. Lastly a few drops are allowed to fall from the brush, to see whether the liquid runs evenly amongst the hair. When the skins are dry, the flesh side is well rubbed with lard and the excess removed with hot sand. The skins are then beaten and trimmed.

Sable Dyeing, that is, dyeing the whole length of the hair. This is done as in ordinary dyeing, using the following composition:—

	Parts.
Lime water	50,000
Burnt gall nuts	5874
Litharge	489
Sal-ammoniac	489
Green copperas	979
English red	367
Alum	979
Sumach, boiled with lime water	958
Verdigris	245

A modification of these recipes is used in which the useless substances are omitted. First two coats are given of the following mordant :—

	Parts.
Lime	1,500
Sal-ammoniac	500
Alum	500
Water	10,000

Next two coats of a second mordant :—

	Parts.
Green copperas	2,000
Blue vitriol	50
Water	10,000

Lastly the fur is dyed in the following bath :—

	Parts.
Gall nuts	1,200
Green copperas	200
Alum	200
Verdigris	200
Salt	200
Lime water	10,000

4. Modern Processes for Black.—It is easy to understand that the recipes just given although fairly effective are of no scientific value. Thanks to the great progress of the art of dyeing the same results may be arrived at in a far simpler way.

(a) *Cougny's Process.*—The mordant consists of :—

	Parts.
Water	10,000
Lime	1,000
Sal-ammoniac	250
Alum	250

The solution should not have a greater density than 5° Baumé. This is applied to the hair with a soft brush, taking care not to touch the skin. It is left thus moist for twelve hours, or twenty-four hours in winter, then taken to dry in a stove. The excess of grease is removed with acacia sawdust mixed with French chalk, and the powder is afterwards beaten out. The second mordant is a 10 per cent. solution of green copperas. This is applied like the first and a fresh treatment with sawdust given as before.

The whole series of operations, that is to say, the double mordanting, is repeated.

The tips of the hair are then dyed with the following liquid:—

	Parts.
Water	10,000
Green copperas	100
Gall nuts	800
Alum	100
Verdigris	100
Logwood extract (10° Baumé)	1,500

This dye is brushed on without touching the skin, then the fur is treated with sawdust and beaten as before.

If it be required to dye the whole length of the hair, two and a half times the amount of water is used. The skins are sewn together, flesh to flesh, and soaked in the dye.

(b) *The Author's Process.*—Furs to be dyed are prepared in the ordinary way, that is to say, they are softened with water in a square “tumbler,” partially dried and sewn up as described on page 378.

The suint is then removed by agitating in the “tumbler” with a 5 per cent. solution of carbonate of ammonia, and washing.

A weak bath of sumach is then used at a strength of $\frac{1}{2}$ ° Baumé. Next the skins are agitated in $\frac{1}{2}$ per cent. bichromate solution and afterwards placed in a warm bath 40° C. (104° F.) of the following mixture:—

	Parts.
Water	1,000
Yellow wood	5
Logwood	500
Sumach	5

After this bath the skins are turned in the “tumbler” for a quarter of an hour, allowed to stand for a quarter of an hour, turned again for five minutes, and hung on rods to drain and dry. Afterwards they are treated with a solution of ferrous acetate, and stretched on beams to allow the acetate to oxidise. If the colour is not deep enough the process is repeated, after which the skins are thoroughly washed.

The skins are next unsewn and put through the ordinary processes of the furrier.

If it should be desired to dye only the tips of the hair the

various baths are applied with a brush, and in this case it is not necessary to sew up the skins.

(c) *Another Process of the Author's*.—Six baths are given in succession: (1) a bath of manganous acetate; (2) weak soda; (3) a washing with plenty of water; (4) calcium chloride; (5) aniline hydrochloride, obtained by dissolving 1 part by weight of aniline in 2 parts by weight of hydrochloric acid and diluting with 20 parts of water; (6) a 2 per cent. solution of bichromate of potash.

(d) *Various Processes*.—Any of the black dyes which have been described under the heading of “Morocco Dyeing” may be used. We especially recommend the vanadate of ammonia black.

5. Chestnut.—(a) *Ancient Method*. Roland describes the following mixture, which is used in exactly the same way as his black:—

	Parts.
Burnt gall nuts	980
Raw gall nuts	245
Red lead	1,469
Sumach	960
Litharge	490
Alum	490
Green copperas	490
Sal-ammoniac	245
Verdigris	490
Antimony	125
White lead	980
Water	3,000

(b) *Coungny's Process*.—The four mordants are used which have been described for Coungny's black, excepting that the strength is reduced by half.

For dyeing the tips of the hair the dye is:—

	Parts.
Gall nuts	400
Verdigris	100
Alum	100
Green copperas	50
Brazil wood extract (10° Baumé)	3,000
Water	10,000

This is passed five or six times over the hair, in fact, until the required colour is obtained.

When the whole length of the hair is to be dyed, only one half of the Brazil wood is to be used.

Gilding and silvering are done in the same way as for morocco.

8. Marking and Spotting.—There are three ways in which furs may be treated to produce imitations of peculiarly marked animals.

(a) To make white marks on a coloured skin hyposulphite is used. The white marks are painted with this substance and the fur afterwards hung up in the carbonic acid chamber (see page 381).

(b) To make black marks on a white skin, any ordinary black dye is painted on with a brush.

(c) To make black marks on a fawn-coloured ground, the spots are first painted in in black and the whole fur is afterwards dyed to a required depth of fawn.

It should be remarked the success of these operations depends almost entirely on the skill of the workman.

9. Glossing.—To give a gloss to the hair and to make it feel smoother it is rubbed with the following composition :—

A.		Parts.
Alcohol		1,000
White lac		80
B.		
Glycerin		100
Yolk of egg		80
Cerisin		50
Cotton seed oil		50

This is rubbed into the hair, first with the hands and afterwards with a brush.

IX.—PREPARATION OF BIRD SKINS.

There are certain skins, such as those of the swan or the goose from which the feathers must be removed one by one, so as to leave only the down; in other cases certain feathers are left for ornamental purposes; sometimes all the feathers are left, *e.g.*, the golden-breasted pheasant, the toucan and the grebe. If the feathers are to be dyed at all they must be done before any further operations are performed.

A paste is next rubbed over the flesh side of the skin consisting of water, maize flour, alum, salt and yolk of egg, mixed in the proportions used for tawing. The skins are either folded in two

(c) *Author's Process*.—The dyeing is carried out before the work of the furrier. Six operations are performed: (1) the fat is removed with carbonate of ammonia; (2) the skin is placed in a bath of alum (water 100, alum 4, cream of tartar 2); (3) a bath of catechu (water 100, catechu 2, alum $\frac{1}{2}$, sulphate of copper $\frac{3}{4}$); (4) a $\frac{1}{2}$ per cent. bath of chromate of potash; (5) a 1 per cent. bath of tin salts; and (6) a bath of Brazil wood (Brazil wood 2, quercitron 1, logwood 500, water 40). After each bath the fur is allowed to dry in the air. In this way the dyeing is very gradual, but very strongly fixed.

(d) *Various*.—Any of the colours used for morocco dyeing give good results with fur, but they should be diluted with an equal quantity of water.

6. **Fawn Colour**.—(a) *Ancient Method*. Roland gives this recipe:—

	Parts.
Lime water	10,000
Litharge	500
Alum	250
White vitriol	250
Sal-ammoniac	128
Verdigris	96
Gall nuts	1,500

(b) *The Author's Processes*.—The following three processes give excellent results:—

The grease is removed; next a bath is given of water 1,000, catechu 2, Brazil wood 2, alum 2, after which the fur is exposed to the air for half an hour. This process is repeated again and again until the requisite colour is obtained. Or:—

The grease is removed and the fur is dyed with water 1,000, cream of tartar 3, yellow wood 4, cochineal $\frac{1}{2}$, tin solution 3. Or:—

The grease is removed, and the fur is dyed with water 1,000, yellow wood 20, alum 12, cream of tartar 12, sandal 10, madder 5, indigo carmine $\frac{1}{2}$.

(c) *Various*.—Any of the methods used in morocco dyeing.

7. **Bronzed Furs**.—A most brilliant metallic lustre may be given to fur by coating the hair with metallic sulphides as described on page 351.

or simply piled one on top of another, always placing them flesh to flesh. In summer time they are left four hours; in winter for a day.

They are next dried and carefully ironed. They are given a second dressing and ironing and the grease is removed in the usual way.

If the feathers are to be bronzed, silvered or gilded, they are treated by the methods already described. Down or feathers give a much more brilliant metallic lustre than morocco.

X.—PRESERVATION OF FURS.

All furs are liable to be attacked by various insects which sometimes puncture the leather and generally loosen the hair. The dermestids do considerable harm. The fox *Dermestes* is the scourge of fur warehouses. It has a larva which feeds on feathers and fur. The grubs of various moths are also very harmful. *Tinea pellionella* cuts the hair off the fur. *Tinea sarcitella* destroys woollen cloths and also attacks fur. These insects will generally fall out when the fur is exposed to the air in a strong light. Various methods have been suggested for removing insects from furs, of which the following are the most effective:—

1. **Beating.**—The furs are kept closely packed together in drawers, boxes, etc., which are made as air-tight as possible. From time to time they are removed and examined. Before returning to their cases they are beaten in a strong light. The insects, none of which can bear the light, will at once drop out whilst their eggs will probably be removed at the same time.

2. **Fur Chamber.**—The skins should be hung across horizontal rods with the hair above, in a room 7 ft. high, 16 ft. long, 10 ft. wide, with two windows on each of the long sides and one on each of the short sides. The top is glazed and the floor is made of polished corrugated iron so as to reflect as much light as possible. Light has an enormous effect in checking the insects, and furs hung up in this way very seldom go wrong.

3. **Vetiver.**—The methods just described may be made more certain by the use of certain odorous substances whose smell removes

insects. Those most commonly used are vetiver and pyrethrum. Vetiver is andropogon, a plant of the order *graminæ* of which various species are known.

Andropogon muricatus, commonly known as Indian dog's tooth, is the most important. In India it bears the name of wetti-vayr, wetti-ver cus-cus. Its roots are from 6 in. to a foot long and have a peculiar penetrating odour due to an essential oil, which is extracted in the country under the name of khuss, which is worth more than a sovereign per oz. *Andropogon ischæmun* and *Andropogon squarrosus* have odoriferous roots.

It is only necessary to place the roots into the drawers containing the fur to prevent insect attacks.

4. Insecticide Plants.—The following plants have the property of driving insects out of furs and woollen cloth, though not to the same extent as those mentioned in the last paragraph. Odoriferous centaury, musk centaury, rock apium or Macedonian parsley (leaves only), acorus root or sweet rush, aloes, pepper, tobacco, snuff, etc.

5. Insecticides.—The following recipes are given by various authorities :—

(a) Sprinkle the fur with a solution of 5 parts mercuric chloride and 10 parts of camphor in 100 parts of strong alcohol.

(b) Sprinkle with powdered camphor. This is perhaps the most widely used of preservatives.

(c) Sprinkle with 10 parts of pyrethrum to 1 part of camphor.

(d) Mix the following substances in equal quantities: cloves, caraway seeds, nutmeg, mace, cinnamon, tonga bean, and add the mixture to an equal quantity of iris root.

(e) Put saucers containing carbolic acid in the drawers containing the fur.

(f) Naphthalene is largely used, but unfortunately its smell is very objectionable.

(g) Pine oil is occasionally used.

(h) An alcoholic solution of iodine gives excellent results.

6. Villon's Compressed Air Process.—The author has noticed that when furs are placed in a chamber containing air under a

pressure of five atmospheres, they keep perfectly. This process is cheap and easy to manage. The author would especially recommend a chamber with plenty of light.

7. Cleaning Fur.—Ermine is cleaned by rubbing the hair with a soft flannel, then rubbing in barley flour, then beating thoroughly, and finally rubbing with a perfectly clean piece of flannel.

Chinchilla, skunk and sable are rubbed with warm bran and well brushed.

White furs are easily cleaned by first moistening with warm water, drying with bran, then rubbing with hot bran, finally rubbing with magnesia and wiping with a piece of muslin.

CHAPTER IX.

ARTIFICIAL LEATHER.

I.—LEATHER MADE FROM SCRAPS.

THIS is a very simple process and consists of only a few operations.

1. **Picking.**—The little pieces of leather cut off by curriers and the scraps left from bootmaking are divided into three qualities. First, large ; second, medium ; and third, useless scraps, which last are treated chemically and used for manure.

2. **Glueing.**—The pieces are soaked with a waterproof glue consisting principally of gelatin. The workmen spread the pieces on a board, heaping them up to a depth of six or eight layers, all very close together.

3. **Pressing.**—As soon as the mass of leather is sufficiently thick, fifteen or twenty boards are heaped one on top of the other in a hydraulic press for about a quarter of an hour. The slabs thus obtained are carefully dried and used for making cheap shoes.

4. **Another Method** consists of boiling the leather in an autoclave with its own weight of water under a pressure of three atmospheres. In this way a sort of magna is produced which is submitted to hydraulic pressure and passed between steam rollers. Leather produced in this way is very dark brown and structureless.

II.—COMPRESSED LEATHER.

1. **Pulping.**—Leather is torn up by machines similar to those used for paper-making. Threads of leather are thus obtained which are carefully screened to remove dust and large pieces.

2. **Agglutination.**—The fibrous mass is placed in a vat containing strong glue and oil varnish. It is thoroughly stirred, allowed to

drain, and pressed slightly between rollers to remove any excess of liquid.

3. Compressing.—The substance thus prepared is either spread out between sheets of iron or placed in moulds and submitted to hydraulic pressure. The sheets or masses thus obtained are dried.

This is only a general outline of the process, which is always the same in principle, but varies in details according to the materials used and the class of product required.

III. —AMERICAN CLOTH.

American cloth is a strong supple material having the appearance of leather. It is manufactured nowadays in large quantities, and used for upholstery, book-binding, etc.

The original fabric is a strong, flexible cloth. As this material arrives in the rough state it is first calendered by machinery.

The pieces next go to the sizing shop, which consists of two compartments; in one, it receives the sizing, and in the other it is dried. Both these operations are going on at the same time, the cloth running over a series of rollers so that as soon as one portion has received the sizing, it runs on into the drying compartment. Thus, an endless band of cloth may continuously receive seven or eight coats of the sizing composition and dry between each two coats.

The composition is made as follows:—

Boil together—

	Parts.
Boiled linseed oil	100
Linseed oil boiled with sulphur	25
Glove skin gelatin	50
Meudon white	2
Tannin	5

and when they form a homogeneous paste, add 25 parts of spirits of turpentine.

The cloth, after being treated in this manner, is calendered, greased and grained by machinery similar to that used in performing the same operation on leather. Sometimes it is varnished with copal varnish.

Each piece is 120 yards long, and is cut up into pieces about 12 yards each. Its ordinary width is about a yard and a half.

IV.—PAPIER MACHÉ.

Papier Maché is made like ordinary cardboard, by glueing together sheets of paper until a board of the necessary thickness has been made. The only difference is, that an impermeable glue is used.

The two best known are the following:—

(a) *Bichromate Glue*.—A 2 per cent. solution of bichromate of potash is added to strong, fine glue. This will become insoluble on exposure to light.

(b) *Impermeable Gelatin*.—Ordinary glue is boiled for six hours with 7 per cent. of linseed oil. Three per cent. of meudon white is added, and the mixture boiled for another hour.

Various kinds of *papier maché* are made, of which the following are the chief:—

(a) The cardboard is made in the ordinary way, but submitted to hydraulic pressure. It is used for roofing instead of tiles.

(b) Pieces of cloth are placed between sheets of paper. This material is used for the inside of boot soles.

(c) Rough pieces of leather are interposed between the paper. This is used for soles, heels, etc.

(d) American counterboard is made by interposing manilla fibre or jute between the paper. It is used largely for making the heels of boots and shoes.

V.—LINOLEUM.

Linoleum, which is so much used nowadays, is a compound of oxidised linseed oil and powdered cork.

The oxidation of the oil is carried out in a high building which is maintained at a temperature of 60° C. (140° F.) or thereabouts, by means of steam. In the interior of the building, large pieces of coarse cloth are suspended vertically. The linseed oil runs down from a cistern at the top of the building, so that a very fine layer trickles down on each surface of the cloth. This oil oxidises under

the influence of the hot air, and when it has sufficiently hardened, a fresh coat of oil is allowed to run down. This is continued until the cloth is covered with a coat an inch thick, which takes about twelve weeks to form. The skin is stripped off and the operation started afresh.

Oxidised oil has a gelatinous appearance, similar to that of glue or india-rubber. It is mixed in a masticator, exactly similar to that used for india-rubber, adding 1 per cent or 2 per cent. of yellow ochre towards the end of the operation. It is then melted in a revolving boiler heated by steam. Various gums are mixed with it, and it is run off into a large, square mould, where it solidifies and is cut into bars like soap.

The cork dust is obtained by grinding cork between millstones and carefully sifting the product.

The mixture of cork dust is made in a sort of kneading trough which is furnished with an apparatus like a chaff cutter. This cuts up the mixture as it leaves the kneading trough into extremely fine slices which fall down between very powerful rollers. These rollers compress it into a broad, even sheet, which runs out on to a jute cloth. Thus, a convenient quantity of linoleum is fixed to a textile base. The thickness of the composition varies from 3 to 12 millimetres ($\frac{1}{10}$ to $\frac{1}{2}$ in.). Its width is from 6 ft. to 12 ft.

Linoleum is next printed. It is first coloured by rollers. The printing is done by hand or by Wright's machine. This consists of two large drums 30 ft. in diameter, placed side by side, and moving independently, on each of which is rolled a piece of linoleum. Parallel to the axles are frames containing small printing rollers on which the pattern is engraved. As the linoleum runs under these, the pattern is repeated.

As soon as the printing is finished, it is taken to the drying rooms, where it remains for at least three months.

VI.—ARTIFICIAL LEATHER.

Pollak, of Vienna, prepares artificial leather as follows:—

A small quantity of a 2 per cent. solution of gum-arabic and a

20 per cent. solution of alum are added to a boiling solution of starch. When this is cool, rags are plunged into it, removed, placed in rectangular moulds and beaten with a mallet. The blocks thus obtained are soaked in a solution of 1 part of hard soap in 2 parts of water and then submitted to hydraulic pressure.

These pieces are soaked for half an hour in water 95 parts, silicate of potash (38° Baumé) 5 parts, then for a further half hour in a 5 per cent. solution of sulphate of zinc; finally rolled, pressed and dried.

Another artificial leather is made of:—

	Parts.
Strong glue	16
Rape oil	4
Water	16
Glycerin	8
Boiled linseed oil	18

This mixture is submitted to the action of a current of air so as to form tough sheets. These are treated with tannin, pressed and dried.

PART V.
LEATHER TESTING AND THE THEORY OF
TANNING.

CHAPTER I.

TESTING AND ANALYSIS OF LEATHER.

1. **Dry Hides.**—Dry hides, in hair, are adulterated, firstly, with earthy powders, secondly, with heavy metallic salts, and thirdly, with substances which retain water.

A hide in hair ought not to contain more than 8 per cent. of water at the ordinary temperature. To estimate the moisture, 100 gram. of skin are cut up with scissors, weighed carefully and placed in a tared basin. This is then heated for four hours at a temperature of 85° C.,¹ and two hours in an air bath at 110° C. The different hides of commerce when submitted to this treatment lose the following percentages of moisture :—

	Per Cent.
Fat oxen (1 cwt.)	8·527
Medium oxen (88 lb.)	8·465
Small oxen (72 lb.)	8·121
La Plata and Rio Grande dry	7·894
Heavy cows (66 lb.)	8·612
Heavy	8·413
Light	8·129
Bullocks	8·520
Large calves (15½ lb.)	8·200
Small calves (13⅓ lb.)	7·920
Goat	6·800
Elephant	9·700

¹ In this chapter, the decimal system is retained, as it is used in most English laboratories.

The quantity of water which a skin in hair should contain after it has been properly dried is, therefore, from 8 to 8.5 per cent.

The ash is determined by calcining 25 gram. of skin in a muffle furnace: 100 grammes of skin give .80 gram. of ash. All excess should be considered as fraudulent addition.

A dry skin in hair should increase in weight 45 per cent. when soaked in water until it has absorbed as much as possible.

Many skins are actually adulterated by placing them in blood or else in a solution of hair in water heated under pressure. To recognise this adulteration it is only necessary to leave the skin to soak in water for two days. In time these substances will dissolve in the water; the skin may then be dried and reweighed. Since all skins lose a certain part of their substance (coriin) under this treatment a comparative test should be made with dry skin which has not been adulterated in this manner.

The following are the most common adulterants:—

Twelve to 15 per cent. of water; 15 per cent. of chloride of barium; 5 per cent. of nitre, and salt, which enable the skins to retain 5 per cent. of water; 4 per cent. of sulphate of magnesium.

2. Salted Skins.—For salted skins the determinations are made in the same way, taking especial note of the ratio which the salt bears to the water, which last is, of course, present in large quantities. The ordinary processes of tanning will show whether the salting has been done in vats. This has already been explained (see page 116)

I.—PHYSICAL TESTING OF TANNED LEATHER.

1. Appearance.—As we have already given a special chapter to the description of the defects in tanned leather we need not repeat it here.

Sole leather tanned in liquor ought to be fawn-coloured with a hard tough tissue and a grey fracture. It should be sold in skins or half skins from $\frac{1}{6}$ to $\frac{1}{5}$ in. thick at the chine, without heads, feet or tails; that is to say, the legs should be cut off at the hocks or knees and the heads 4 in. behind the ears. The weight of each hide should

be at least 44 lb. and the minimum length should be 6 ft. 8 in. from the insertion of the tail to the section made 4 in. behind the ears. For a minimum of 53 lb. and maximum of 60 lb. the length should be 7 ft. 8 in. to 8 ft. from the root of the tail to the horns, by from 3 ft. 2 in. to 3 ft. 6 in. across from back to belly measured at the widest part.

Square hides are 8 ft. long by 4 ft. 8 in. and $\frac{1}{8}$ in. thick.

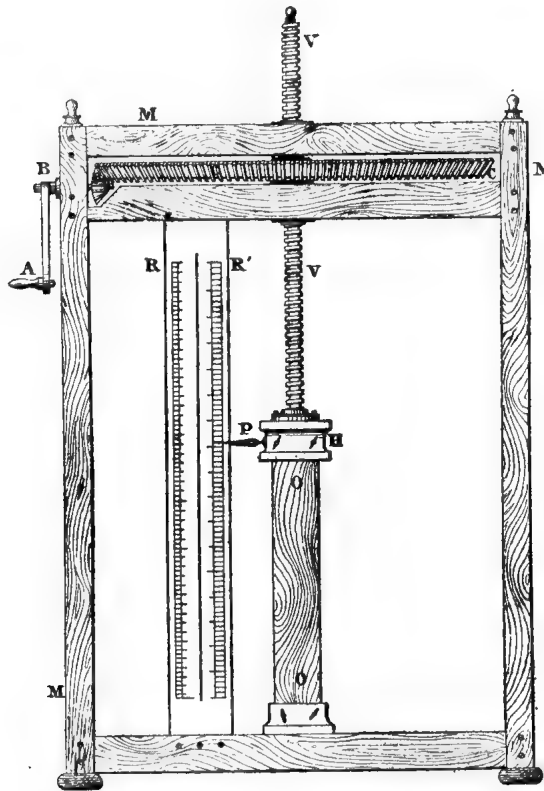

FIG. 91.—Machine for testing breaking strain.

Soft cow skins are 5 ft. to 5 ft. 4 in. long by 5 ft. wide, $\frac{1}{12}$ in. thick and weigh from 9 to 11 lb.

The bellies of country cows weigh 7 to 9 lb. the pair ; are 5 ft. 10 in. to 6 ft. 2 in. long by 16 in. across at the middle.

Selected black calf, one third female, weigh $17\frac{1}{2}$ lb. per dozen ; grained calf skins weigh 33 to 48 lb. per dozen.

Sheep skins are 3 ft. long by 2 ft. 8 in. across the middle and weigh 13 lb. per dozen.

2. **Breaking Strain.**—The higher the strain needed to break

leather the better its quality, hence ox and cow hides are usually submitted to a dynamometric test. A good ox hide offers a resistance of 3 kilos. (6.6 lb.) per square millimeter ($\frac{1}{28}$ in.) section. Cow skin has a breaking strain of 2.5 kilos. (5.5 lb.) and calf 2 kilos. (4.4 lb.). This resistance to strains is of great importance when the leather is to be manufactured into machine belts. The great railway companies require all leather to have a breaking strain of over 2.5 kilos.

Various machines have been invented for making this test.

The one used by the author is shown in Fig. 91.

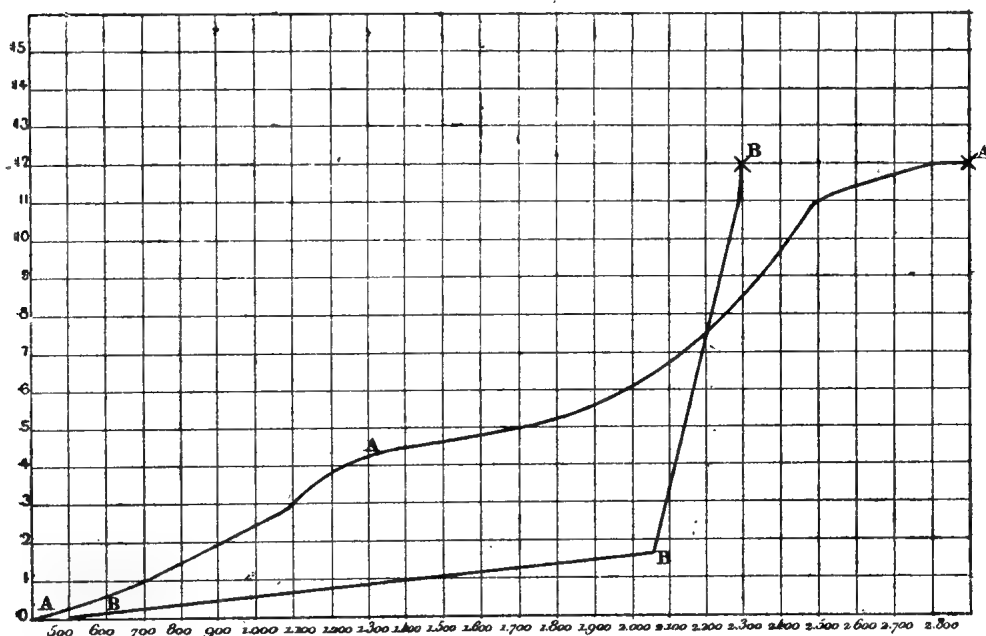

FIG. 92.—Curves showing good (A) and bad leather (B).

It consists of a pinion (B) moved by a handle (A) which turns a toothed wheel (C) whose diameter is ten times as great as that of the smaller wheel. This large wheel is fixed to a screw (V) at the end of which is the carriage (H). The pitch of the screw is very small and consequently the straining force is very great. By means of this machine the force applied to the handle is increased a thousand times at the carriage, and on the other hand, the carriage only moves one-thousandth as fast as the handle. The leather is thus submitted to a progressive strain and a slow lengthening which gives the true coefficient of resistance. The strip of leather, 20 cm. long by 5

cm. wide, which is to be tested is fixed at one end to a clip in the frame, and at the other to another clip in the carriage. The carriage bears a pointer (P), which runs up and down a scale (R), which cates the percentage increase in length, and a spiral spring which acts as a dynamometer and measures the force used.

The testing is very simple. It is only necessary to turn the handle until the leather breaks and to make the two readings.

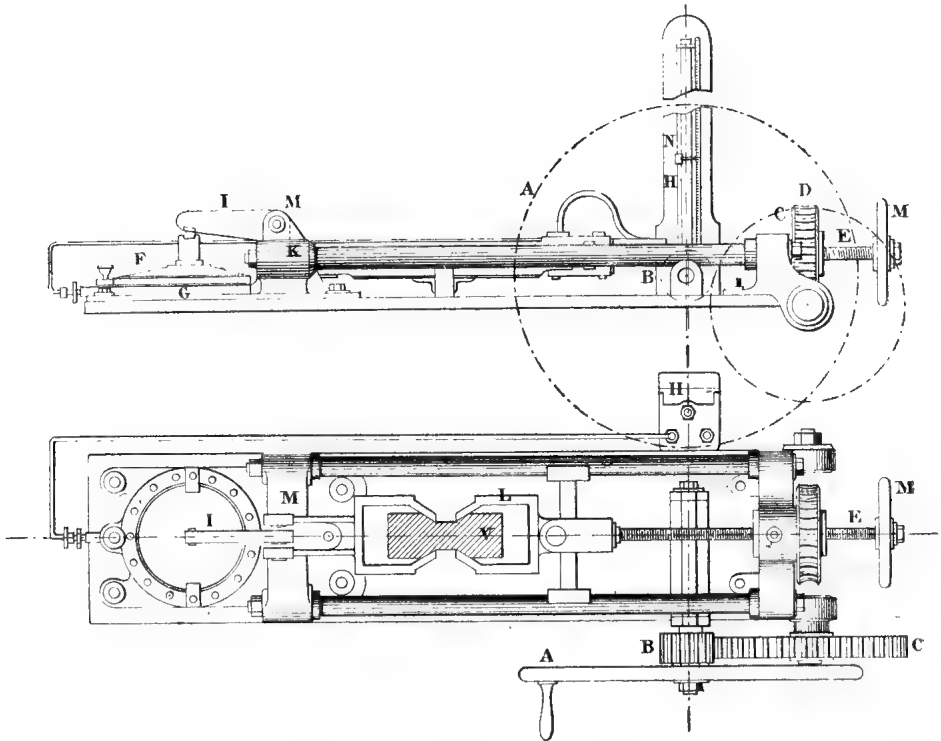

FIG. 93.—Thomasset Machine.

This machine has the advantage of allowing the operator to construct a curve showing the relation of elongation to strain.

For a given force, the greater the lengthening the better the leather. The lengthening of a good leather is regular, or nearly so, until the breaking point. The less the leather stretches, or the more suddenly it breaks, the poorer its quality.

Fig. 92 shows two curves, one of good (A) and one of bad leather (B).

The Thomasset machine is well adapted for making this test.

It consists of two distinct parts (Fig. 93); one part exerts the force and the other measures it.

The first part consists of a wheel (A) turning a screw by means of the toothed wheels (B) and (C). This screw works in the wheel (D), which is fixed to the screw (E), which in its turn bears the clip (L).

The measuring part of the apparatus consists of a bent lever (I) fixed by its shorter arm to the second clip (H). The other arm presses on the centre of a piston (F) lying on an india-rubber diaphragm. This diaphragm is fixed at its edges by the joint (G), and compresses a thin layer of water communicating with a mercury manometer (H). The two arms of the lever have relative lengths

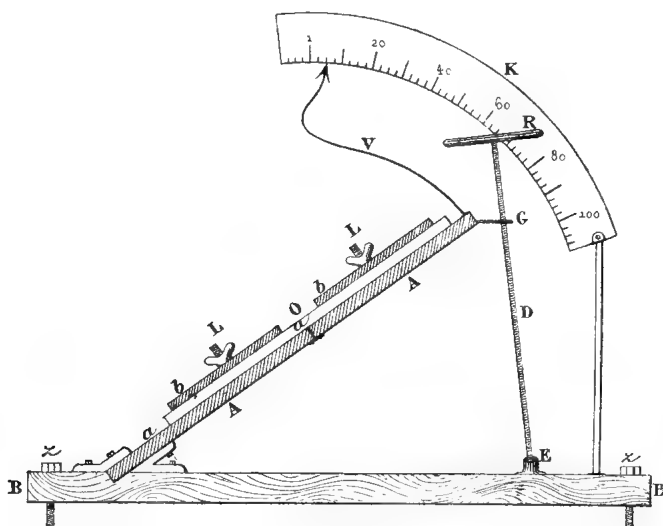

FIG. 94.—Apparatus for measuring brittleness.

of one and five respectively. The tension is exerted by the screw (E). The arm (I) turns round the axis (M), and presses on the diaphragm. The pressure on the water is thus one-fifth of the tension on the leather strips. This pressure is registered on a mercury manometer placed close to the operator. It is graduated in kilos. of effective force acting on the leather strips. An index (N), sliding along the column, is used to mark the point where the leather breaks.

3. Fracture.—One of the chief defects of leather is brittleness which may be roughly determined by folding a piece of leather in two. To measure the degree of brittleness, the author has invented the above apparatus (Fig. 94).

A hinged steel plate (A A), $\frac{1}{2}$ in. thick, is fixed at an angle in the bed-plate (B B), which can be fastened to a support by the bolts (*xx*). The lower portion of the steel plate is held rigid, whilst the upper portion may be bent downwards by means of the screw (D). G is a steel plate in which the screw runs, and by means of which the upper plate (A) may be depressed to the required extent. V is a needle which runs along the scale (K), so that the angle of depression may be easily read off. The head (R) of the screw is also graduated so that a fraction of revolution may be measured.

To test a piece of leather, it is placed in the position marked *a* in the figure, and fixed down by the plates L L. The wheel R is then turned so that the upper plate is slowly depressed. When the leather breaks, the angle through which the indicating needle has moved is read off. The most brittle leather will break when bent through one division of the scale, whilst chamois leather will bend over to the 100 mark. It need hardly be said that, for comparative tests, the same thickness of leather should always be used. The determinations made by this instrument are of no absolute value excepting as comparisons.

II.—CHEMICAL ANALYSIS.

In this section is given a description of the methods used in the author's laboratory for discovering the state of leather and the quantities of material which have been added, either in the legitimate process of tanning, or for purposes of adulteration. The estimations usually made are: Water, substances soluble in water, skin, fat, lime, ash and tannin (by difference).

1. **Estimation of Water.**—This estimation presents no special difficulty. A weighed quantity of leather is heated in an air bath at 90° C. (194° F) until it ceases to lose weight. Leather strongly tanned with oak bark contains 14 to 15 per cent. of water. Valonia-tanned leather contains 12 to 13 per cent. Damp skins contain 15 per cent., and tallowed leather contains 12 per cent.

2. **Estimation of Soluble Substances.**—It is a well-known fact that tanners often increase the weight of tanned leather by saturating them with tannin to a greater extent than is necessary. Indeed

this is carried out to such an extent that the quality of the leather is greatly deteriorated. It is also well known that dishonest manufacturers add various weighting matters, which have already been enumerated (page 21). To estimate the nature and quantity of these foreign substances, a weighed quantity of the leather is soaked for six hours in a beaker of distilled water. The water is decanted off into a measuring flask, and fresh water added. It is left to stand for a further six hours, and the operation repeated until four soakings have been given. The liquor is then submitted to qualitative and quantitative analysis.

Good leather tanned with oak bark gives 7 per cent. of soluble matter, calculated from the dry leather, or 8 per cent. of ordinary leather. Leather tanned with other substances gives 10 per cent. of extractives. All leather giving more than this amount may be considered as surcharged.

3. Estimation of Skin.—We have already seen that a skin does not lose any perceptible quantity of nitrogen during the operations of tanning. The estimation of nitrogen is therefore one of the best methods of discovering the actual quantity of skin in the leather. The following is a simple method for performing this estimation:—

A gram. of dry leather (the portion used for the estimation of water will serve) is weighed out into a long-necked, round-bottomed flask. Twenty gram. of pure, strong sulphuric acid are added, and the mixture gently heated until the leather is dissolved, care being taken not to let the liquid boil. This is best done in a calcium chloride bath (100 parts water, 200 parts CaCl_2), which boils at a constant temperature of 160°C . It is left for two hours in this bath.

The flask is removed and allowed to cool down a little, then powdered potassium permanganate is added little by little, until the liquid becomes green. It is cooled, 400 cc. of water is cautiously added, and allowed to stand until all has dissolved. The liquid is then introduced into a distilling apparatus of about 75 litres capacity, and 40 cc. of caustic soda solution (sp. gr. 1.3) added. A few pieces of zinc are placed in the liquid, and it is distilled for twenty minutes, collecting the distillate in a flask of

water, and titrating the ammonia with standard sulphuric acid. From the ammonia the quantity of nitrogen is readily determined.

If exactly 1 gram. be used, then every $\cdot 001816$ of nitrogen represents 1 per cent. of skin on the dry leather.

4. Estimation of Fat.—The most convenient method for estimating the fat is the following: 10 gram. of leather are cut up into thin shavings and boiled for one hour with 100 cc. of 10 per cent. caustic potash and 100 cc. of water replacing the water as it evaporates. The liquid is then decanted, and the residue washed with 1 per cent. caustic potash. The alkaline solution of soap is decomposed by boiling with an excess of hydrochloric acid (15° Baumé). The fatty acids are washed and separated (in a Cassal's butter flask), dried and weighed. Their melting point is then taken, and the quantity of fat which they represent calculated from Chevreuil's or Dalican's tables.

Tallowed leather contains 16 to 18 per cent., and leathers curried with degreas contain 15 to 18 per cent.

5. Estimation of Lime.—A weighed quantity of leather is burned, the ash dissolved in hydrochloric acid, the liquor saturated with potash, and an excess of ammonium oxalate added. The precipitate is filtered, washed, redissolved in nitric acid, and the quantity of oxalic acid estimated by standard permanganate; from this the amount of lime may be calculated. Unhaired skin contains $\cdot 1736$ per cent. of lime in the state of calcium sulphate. After the action of the acid liquor, it only contains $0\cdot 1386$ per cent. During tanning, the skin gains $0\cdot 1113$ per cent. of lime. When the leather contains more, it has been badly washed on coming from the lime.

6. Estimation of Ash.—Five gram. of leather are placed in a platinum vessel together with 5 gram. of ammonium nitrate, and burned until the ash is white: 100 parts of fresh skins give $\cdot 6693$ parts of ash, and after tanning 1 part. If a higher percentage of ash be found, we may conclude that the leather has been charged with mineral matter. In this case, the ash is analysed in the ordinary way.

Leather tanned with iron or chrome alum is treated in the same way.

7. Tannin Estimation.—If we add together the percentage of all the substances estimated, as described above, and subtract them from 100, we shall have the percentage of tannin.

8. Résumé.—A good sample of leather on being submitted to analysis gives the following results :—

	Parts.
Water	12
Skin	45
Tannin	35
Soluble substances	6
Lime	0'30
Ash	1
Fat	0'70
	<hr/>
	100'00

Here are two analysis of curried leather :—

	Tallow.	Degras.
Water	12	12
Skin	37	36
Tannin	29	28
Fat	16	18
Soluble substances	5'17	5'09
Lime	'22	'23
Ash	'61	.68
	<hr/>	<hr/>
	100'00	100'00

It is precipitated by basic lead acetate, tannin or heat.

The process of softening has for its object the soaking of this coriin so as to make it swell or take it into solution.

From the above facts, we see that the following conditions should be rigidly observed if we wish to soften the skins in the best manner.

(a) They must be soaked in cold water; any heat is a drawback to the softening. If under the action of heat, the softening proceeds more rapidly, it is at the expense of the quality of the skin. For under these conditions the fibres are being superficially converted into gelatin which gives the appearance of softening.

(b) Softening is hastened by the addition of 10 per cent. of common salt.

(c) Softening is accelerated by the use of alkalies or acids, but their use at this point of the work is prejudicial to later operations.

(d) The use of mechanical means of softening destroys and breaks the fibre.

II.—THEORY OF UNHAIRING.

It has already been pointed out (page 5) that each hair terminates in a bulb containing albuminous matter named *pilline* which has the general characteristics of albuminoids. It differs from most of them, however, in its great solubility in alkalies, alkaline sulphides, and soluble basic salts.

The author has determined its composition, which corresponds to the formula $C_{25}H_{45}N_4O_{12}$.

The object of unhairing is to destroy or remove this substance and set the hair free. This is done either by fermentation or with alkalies or sulphides.

1. Unhairing by Sweating.—The hides are submitted to the action of moist air at a temperature of from 20° to 25° C. (68° to 77° F.) until the hair falls off.

The author has isolated the bacterium which is chiefly concerned in this fermentation. It is aerobic (lives in the presence of air), and lives on pilline. It transforms this into leucin, tyrosin, butyric and margaric acids, and sets free ammonia. This last dissolves

CHAPTER II.

THE THEORY OF TANNING AND OTHER OPERATIONS IN THE LEATHER AND SKIN INDUSTRY.

THE operations examined in this chapter may be divided into three sets: Preliminary operations or wet work, tanning and currying.

I.—THEORY OF SOAKING.

We have seen that skin is made up of bundles of fibres matted together, but separated by an albuminous substance (the coriin of Reimer). On drying, these fibres adhere firmly together so as to form a hard substance.

This may be illustrated by soaking a mass of silk fibre in a solution of albumen. As long as the threads of silk remain moist, they will be supple and soft, but as soon as they are dry they become glued together into a hard mass which cannot be bent without injuring the silk.

The coriin of the skin has properties very similar to this albumen. It is insoluble in water, but will emulsify and remain in suspension like starch; when shaken up with water, it swells up like gum tragacanth, and finally gives a white liquid which, when allowed to stand, deposits coriin in white flocks. A little salt in the water increases the swelling. A moderate quantity dissolves the substance, but a saturated solution of salt precipitates it.

Alcohol and ether prevent the swelling of coriin and precipitate it from its solutions. Heat also prevents the swelling.

Solutions of the salts of the alkalies and alkaline earths, acids and alkalies dissolve it.

It is not precipitated by potassium ferrocyanide, ferric chloride, copper sulphate, neutral lead acetate nor mercuric chloride.

in the water impregnating the hide, and the alkaline liquid so formed dissolves the coriin, thus swelling the skin. It lives in the presence of various other putrefying organisms which have already been mentioned. These live on the substance of the skin. They should therefore be kept down as much as possible, which necessitates the greatest possible watchfulness and care.

The special micro-organism, which attacks pilline is shown in Fig. 95. The author has given it the name of *bacterium pilline*. This bacterium lives in the hair, and is scarcely to be found in the liquid which drops from the skins. The author has shown that there is a constant ratio between the rate at which this organism multiplies on the surface of the skin, the quantity of ammonia pro-

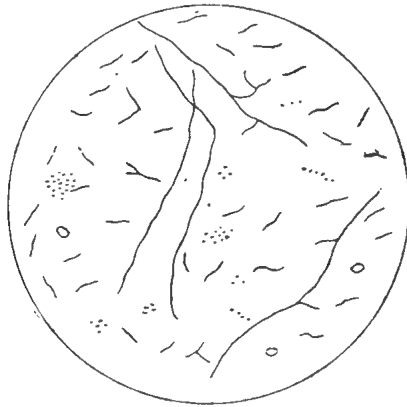

FIG. 95.—Micro-organism which attacks pilline.

duced, and the coefficient of resistance of the hair. By watching the process of sweating carefully, and making daily observations, he has endeavoured to solve various questions.

(a) What is the number of bacteria on a square millimeter of the skin? It would be impossible here to enter into all the details of this research, and it would take us rather too far from the domain of commercial work.

(b) What is the percentage of ammonia in the air of the sweating room and in the skin?

(c) What resistance do the hairs oppose to their removal? This was determined by a special form of screw clip by means of which 100 hairs were gripped. This was attached to the short end of a lever, to the other end of which was fixed a vessel into which

water could be poured. From the weight of water needed to tear out the hair it was easy to calculate the actual force bearing on the hair.

This force was named the "coefficient of resistance".

The sweating was carried out by workmen in the ordinary way, the tests being made on two skins. In the natural sweating, one skin was placed at the top of the heap, and another in the middle. In the artificial sweating, one was placed near the wall, and the other in the centre of the chamber.

Four tests were made with each skin, two on the thick and two on the thin parts.

The average results of five series of experiments are shown in the following table:—

Duration of Sweating in hours.	Natural.				Artificial.			
	Bacteria per sq. mm.	Ammonia per cent.		Coefficient of Resistance in gram.	Bacteria per sq. mm.	Ammonia per cent.		Coefficient of Resistance in gram.
		In Air.	In Skin.			In Air.	In Skin.	
6	0	0	0	5.460	2	0	0.003	5.090
12	4	0.001	0.008	4.389	10	0.009	0.011	4.000
18	90	0.005	0.014	4.120	18	0.011	0.021	3.400
24	270	0.011	0.048	3.820	200	0.020	0.080	2.040
30	200	0.030	0.098	3.500	200	0.030	0.120	1.000
36	250	0.030	0.118	2.800	208	0.040	0.128	1.100
42	190	0.030	0.120	1.500
48	230	0.025	0.140	1.000
54	310	0.020	0.140	0.080
60

The tests showed that the sweating should be carried out at an even temperature, without any sharp changes, and as rapidly as possible, so that noxious bacteria may not have a chance of attacking the skin. When the skins are left to sweat after the pilline has disappeared, the pilline bacteria will themselves attack the skin. It is therefore necessary to judge the exact moment for stopping.

To make sure that the pilline bacterium is the real cause of depilatory fermentation, the following experiments were carried out in the laboratory.

(a) The bacterium was cultivated in ammoniacal gelatin, and a pure culture prepared by Pasteur's method.

(b) Some dried skin in hair was sealed up in a flask, and sterilised by keeping for a day at a temperature of 50° C. (122° F.), and then raising for ten minutes to 110° C. (224° F.). Sterilised cold water was then introduced, and a week allowed for the skin to soften.

Next the skin was allowed to sweat at 20° C. (68° F.) for a month, at the end of which time the flask was broken, and the skin was found to be quite unaltered, the hair adhering firmly to the skin. The liquor in the flask contained no ammonia, and the coefficient of resistance of the hair was 4.82 gram.

(c) To make sure that the skin used in the last experiment had not been affected by the heat of sterilisation, the experiment was repeated, allowing the skin to soften in ordinary distilled water with access of air. It softened in eight days, and four days after the hair came off. The liquid contained ammonia, and pilline bacteria were found on the skin.

(d) A portion of skin was enclosed in a flask and sterilised as before. After softening in sterilised water for a fortnight, a cubic centimeter of a pure culture of pilline bacteria was added. On the twentieth day the flask was broken. It contained ammonia, and hair came away from the skin.

(e) This fermentation was found to need air for its working.

From these experiments it may be concluded that sweating is a special fermentation caused by a specific micro-organism.

2. Unhairing with Lime. Unhairing with lime is caused by the same fermentation, excepting that the lime prevents any other kind of fermentation. The pilline bacterium alone can develop in the lime solution.

The author has determined the same constants for lime unhairing as for sweating.

Duration of Unhairing.	Bacteria per sq. mm.	Ammonia per cent. in Liquid.	Co-efficient of Resistance.
1 day	0	0	5.200
2 days	0	0	5.200
3 "	2	0.004	4.900
4 "	30	0.012	4.800
5 "	70	0.041	4.400
6 "	100	0.041	3.800
7 "	90	0.088	3.500
8 "	100	0.100	2.000
9 "	120	0.131	1.000
10 "	150	0.142	.085

He has further shown :—

(a) That the fermentation is due to the pilline bacterium, which may be cultivated in lime-water and gelatin.

(b) That depilation does not take place in sterilised lime.

(c) That the fermentation requires the presence of air.

(d) That sterilised skin is 'unhaired' when introduced into a liquid culture of the bacteria.

He has also traced depilation by means of charcoal, baryta, strontia, zinc oxide and magnesia to the same source.

3. Unhairing with Alkalies.—Alkalies, as we have already stated, act as solvents of pilline. The following table records a series of experiments showing the number of hours required by alkaline solutions to remove the hair from a skin of medium thickness :—

Name of Alkali.	Weight of Alkali in 1,000 of water.					
	1.	2.	5.	10.	20.	25.
	Hours.	Hours.	Hours.	Hours.	Hours.	Hours.
Caustic potash	40	35	28	22	18	15
Caustic soda	50	45	37	30	27	22
Ammonia	58	53	48	29	24	20
Methylamine	60	60	50	41	35	30
Aluminate of soda	75	70	63	54	42	42
Zincate of soda	75	75	67	55	50	45
Stannate of soda	80	80	75	68	60	60
Antimonate of soda	100	90	79	72	70	70

These figures prove that :—

(a) Depilation is not proportional to the quantity of alkali used.

(b) It is more rapid with strong alkalis than with weak ones.

(c) Alkalis combined with metallic oxides act less energetically than free alkalis.

Further, it was shown that the rate of depilation is proportional to the temperature.

4. **Unhairing with Sulphides.**—Sulphides act like alkalis but more rapidly. They act at rates varying with their composition as shown in the following table:—

Name of Sulphide.	Composition.		Time Required by a 1 per cent. Solution.
	Sulphur.	Alkali.	
Potassium monosulphide	29.1	70.9	23 hours.
Potassium disulphide	45.1	54.9	18 "
Potassium trisulphide	55.2	44.8	18 "
Potassium tetrasulphide	62.16	37.84	23 "
Potassium pentasulphide	67.25	33.75	28 "
Sodium monosulphide	41.03	58.97	20 "
Sodium disulphide	58.19	41.81	19 "
Sodium trisulphide	67.61	32.39	23 "
Sodium tetrasulphide	73.57	26.43	25 "
Sodium pentasulphide	77.67	22.33	28 "
Ammonium monosulphide	46.98	53.01	17 "
Ammonium disulphide	63.93	36.06	23 "
Ammonium pentasulphide	81.60	18.40	30 "
Ammonium heptasulphide	86.12	13.88	30 "
Barium sulphide	18.82	81.18	28 "
Strontium sulphide	26.87	73.13	34 "
Calcium monosulphide	44.45	55.55	15 "
Calcium disulphide	62.97	37.30	18 "
Calcium pentasulphide	79.97	20.30	25 "
Magnesium sulphide	56	44	28 "
Sulpharsenious acid ¹	39.02	60.98	23 "
Sulpharsenic acid ¹	51.70	48.30	16 "
Arsenic persulphide	79.39	20.61	33 "
Potassium thiocarbonate	51	...	20 "
Zinc sulphide ¹	33.3	66.7	39 "

These experiments show that:—

(a) Sulphides act most energetically when the sulphur and alkali are in nearly equal proportions.

(b) Polysulphides are not so active as mono- or disulphides.

A piece of skin submitted to the action of sulphuretted hydrogen did not lose its hair, showing that sulphides do not act, as has been suggested, by means of the sulphuretted hydrogen which they liberate.

¹ These were dissolved in potash or soda.

5. **Conclusions.**—Artificial and natural sweating develop a special fermentation. Lime, magnesia, etc., do the same but without allowing putrefaction. The effect of this special fermentation is to destroy the pilline.

Alkalies and sulphides dissolve the pilline.

III.—THEORY OF SWELLING.

Swelling has already been partially produced by the alkalies used in unhairing. These wholly or partially dissolve the coriin, which is washed away by the water used in fulling. The skin thus loses 3 per cent. of its weight, which loss was formerly believed to be gelatin. It is however only the coriin or cementing matter of the skin. The removal of this material allows free play to the fibres. When the action of the alkali is continued after the disappearance of the coriin the fibre is attacked. It swells up and dissolves, thus causing a loss in the form of gelatin.

The acids used in plumping are intended to neutralise the alkalies (which would turn the tannin brown) and to continue the swelling without attacking the fibre. The skin expands in all directions, especially in thickness. The reason of this action is that under the influence of the acid the tissue absorbs water. This property is not peculiar to skin, being shared by other animal membranes, as well as albumen, gum, etc. The absorption is due to the formation of high gelatinous hydrates, for it attains its maximum when the skin has lost its structure, and has been transformed into a transparent gelatinous mass.

The following table shows progress of plumping by acids, the percentage of water absorbed and thickness in millimetres having been determined under various conditions.

Acid Used.	Time in the Acid.	Proportion of Acid Added.					
		2 per 1000.		5 per 1000.		10 per 1000.	
		Thickness, Millim.	Water, per cent.	Thickness, Millim.	Water, per cent.	Thickness, Millim.	Water, per cent.
Acetic . . .	1 day	16.3	54	17.8	59	18.5	61
Acetic . . .	2 days	17.1	57	18.8	66	19.9	69
Acetic . . .	3 days	18.9	68	19.9	75	21.8	79
Lactic . . .	1 day	15.1	53	16.3	57	17.4	60
Lactic . . .	2 days	16.4	58	17.2	63	18.6	68
Lactic . . .	3 days	16.9	65	18.1	69	19.7	74
Oxalic . . .	1 day	14.9	53	15.7	58	16.8	60
Oxalic . . .	2 days	15.8	58	16.5	67	17.9	69
Oxalic . . .	3 days	16.2	64	17.3	72	18.6	76
Butyric . . .	1 day	14.7	54	15.1	58	16.1	57
Butyric . . .	2 days	15.2	59	15.9	64	17.2	63
Butyric . . .	3 days	15.9	61	16.8	70	17.9	71
Sulphuric . . .	1 day	17.2	57	18.5	59	19.7	65
Sulphuric . . .	2 days	18.8	64	19.7	69	21.1	75
Sulphuric . . .	3 days	19.9	73	20.9	77	22.9	85
Before treatment .	—	14	52	14	52	14	52

The skin gains in thickness from a quarter to a third under the influence of acids and gains in weight to about the same extent.

The swelling stops when the skin is washed in water, and it begins to shrink if left in pure water. The swelling is destroyed by neutralising the liquid or by adding astringents.

The action of tannin is interesting. When it is added in small quantities to the acid liquid the swelling is slightly diminished. When the skin is placed in water containing equal parts of acid and tannin the swelling stops and the skin does not vary in thickness any further. If, lastly, the tannin be in excess the skin will shrink. During plumping by means of acids a portion of the tissue of the skin is attacked and dissolved, but in an acid liquor containing some astringent a slow plumping takes place without any loss of tissue.

If small quantities of tannin solution be added at intervals to the acid liquor so that each accession of strength may find its way into the swelled skin, the plumping action will slowly cease. On continuing the addition until the opposite actions of tannin and acid are equal, we obtain the same result as if the acid had been neutralised by a base. In both cases, at the neutral point, the fibres which before swelling were solidly cemented together, are

separated and form much looser bundles. The result is that a very much larger surface is offered to the action of the tan. The interstices are more regular and of larger volume.

Each fibre of the skin has swelled, imbibed water, and opened its pores for the reception of the tannin.

The object of plumping is thus to dilate the tissue :—

- (a) By separating the bundles of fibres from one another.
- (b) By separating the fibres in the bundles.
- (c) By swelling each fibre and opening up its tissue throughout.

IV.—THEORY OF HANDLING.

If a hide which has been swelled by long soaking in a strong acid is plunged into a bath rich in tannin, a rapid absorption takes place. The fibres, which were still under the influence of the acid, have not had time to return slowly to their original state, for the tissue combines directly and rapidly with the tannin, and the compound so formed is interposed between the fibres. The skin will return to its original condition, the fibres remain hard, distended and brittle, only their surface is tanned and their interior remains untouched.

The skin must therefore be prepared to receive the tannin by slowly neutralising the effect of the swelling. This is done by the use of acid tan liquors, which keep up the swelling of the skin whilst the tannin is being thoroughly absorbed by the whole mass of the fibres.

At first the fibres become a little more compact and less sensitive to the acid, their substance becomes slightly modified and their shape becomes more definite. In the next phase a liquor is used in which the effect of the acid is exactly counterbalanced by the tannin. The fibres become more compact and acquire solidity, their pores remain open and they no longer have the power of contracting or closing, they are insensible to the action of acids and their shape is well defined. The general swelling of the skin ceases.

In the third phase, the liquor is only slightly acid : tannin dominates ; the fibres fortify themselves without any contraction taking

place. The general thickness of the leather decreases because the fibres come closer together. The skin sets at a thickness about half-way between its original state and the full plumpness which it acquired in the acid. This setting is brought about by the alteration of the substance of the fibres which lose their power of expansion and contraction.

The objects of handling are therefore :—

(*a*) To keep open the fibres of the skin by forming an insoluble compound which permanently retains its size and shape.

(*b*) To bring the fibres and bundles back into their original positions by means of the astringent.

This operation is the most important in the art of the tanner. On its skilful management depends the quantity and quality of the leather. By neglecting any part of it, the leather becomes defective. Above all, it is necessary to use acid weaker and weaker whilst the tannin becomes stronger and stronger.

Perhaps this is best shown by citing three cases.

(1) The acidity increases with the tannin. In this case the fibre is well prepared, but neither the fibres nor their bundles become united, so that a spongy leather is the result.

(2) The acidity is suddenly removed. The substance of the fibres contracts, its pores close up, the bundles of fibres contract and become united too strongly, and the tannin can neither penetrate into the interior of the fibres nor the inner parts of the skin. The result is a dry, hard, brittle leather. The same result is obtained either by increasing the strength of the tannin or by decreasing the acidity too rapidly.

(3) A happy medium between these two cases. After a great number of experiments, both in the laboratory and the tanyard, the author has prepared the following table which shows the proportions of tannin and acid most suitable to each period of handling. This table represents an ideal which should be approached as nearly as possible by the intelligent use of acids and extracts :—

Period of Handling.		Composition of Liquor in parts per thousand.		State of the Skin. ²	
		Acid. ¹	Tannin.	Thickness in millimetres.	Water, per cent.
First phase.	1st day	2'000	'500	24	78
	2nd "	1'930	1'000	23'9	77
	3rd "	1'860	1'500	23'7	76
	4th "	1'790	2'000	23'6	75
	5th "	1'720	2'500	23'4	74
	6th "	1'650	3'000	23'3	73
	7th "	1'500	3'500	23'1	72
	8th "	1'510	4'000	23'0	71
	9th "	1'440	4'500	22'8	70
Second phase.	10th "	1'370	5'000	22'7	69
	11th "	1'300	5'500	22'5	68
	12th "	1'230	6'000	22'4	67
	13th "	1'160	6'500	22'2	66
	14th "	1'090	7'000	22'1	65
	15th "	1'020	7'500	20'9	64
	16th "	'950	8'000	20'8	63
	17th "	'880	8'500	20'6	62
	18th "	'810	9'000	20'5	61
Third phase.	19th "	'740	9'500	20'3	60
	20th "	'670	10'000	20'2	59
	21st "	'600	10'500	19'9	58
	22nd "	'530	11'000	19'8	57
	23rd "	'460	11'500	19'7	56
	24th "	'390	12'000	19'6	55
	25th "	'320	12'500	19'5	54
	26th "	'250	13'000	19'5	53
	27th "	'180	13'500	19'5	50
	28th "	'110	14'000	19'5	45

V.—THEORY OF TANNING.

The object of tanning is to saturate the fibres of the skin with the tanning substance. This operation should be conducted slowly enough to allow the tannin to penetrate the whole thickness of the fibre. Capillarity plays no part in tanning. It is only the porosity of the fibre which does the important work. These pores, opened by plumping and maintained in this state by handling, allow the tanning liquor to penetrate to the centre of each fibre by diffusion. The saturation with tannin commences at the circumference, and as the rate of diffusion of tannin is very slow, thirty-three times less than that of salt, tanning becomes a very lengthy operation.

The chemical composition of the skin also plays its part, as it determines the affinity of the fibres for the tanning matters.

¹ The acidity is calculated as sulphuric acid.

² The skin was originally 17 mm. thick, and contained 51 per cent. of water.

With the exception of the porosity of the fibres, the physical structure of the skin has nothing to do with the tanning.

The tanning matter which is deposited between the fibres does not tan the skin but adds to its solidity, hardness and weight.

We have already seen that the tanning liquors in the layers should not be acid or they will dilate the fibres and give a spongy leather. Fermentation in the pits should be therefore avoided, as it always leads to the production of organic acids.

The strength of the tanning liquor should always increase as tanning proceeds. A hide should never be left in exhausted liquor or it will lose its nature. Neither should hides be transferred from very weak to very strong tans, as the astringency of the liquor will contract the fibres so greatly that the pores will close and prevent the tannin from reaching the interior. The work should thus never stop, and the strength of the liquor should be ever on the increase.

To show in a systematic way the possibilities of defective tanning in the pits, the following table has been prepared. It shows the average of the methods of several high-class tanners. The percentage composition of the skin is given for the greater part without decimal places, as the method of analysis was not sufficiently exact to warrant their use.

VI.—THEORY OF THE ACTION OF TANNIN ON THE SKIN.

It is impossible, in such a work as this, to enter into a full discussion of the various theories which have been proposed. We therefore merely give a description of the generally accepted notions of the method in which tannin acts on skin.

(1) Tanning is the action of tannin on skin, and the product is leather. No substance which is used to replace tannin, such as alum, iron and chromium salts, etc., produces true leather, and their action cannot be considered as tanning. With alum for instance, the result is an alumed skin, with salt a salted skin, etc.

(2) The effect of tanning, as defined above, is to combine skin— which, be it remembered, is not gelatin, but a substance which may be transformed into gelatine by boiling with water—with tannin, and to produce a special compound. This compound is insoluble,

and only slightly penetrable by cold water. Its animal matter and tannin cannot be separated by solvents, and boiling water does not transform, it into gelatin.

Salt, alum and chromium or iron salts do not combine with skin, for skins thus prepared will yield up their astringent or antiseptic charges to solvents, and are altered to gelatin on boiling.¹

Period of Tanning.	Composition of the Skin.			Composition of the Liquor.		Tannin per cent. in the Bark.	
	Skin.	Tannin.	Water.	Tannin.	Acid.		
Original materials	50	...	50	1.2	0.04	7.45	
After	50	5	45	
4 Handlers. {	10 days	49	6	45	1.4	0.21	3.5
	12 "	48	8	44	1.5	0.19	2.1
	12 "	45	10	45	1.4	0.29	3.1
	15 "	48	12	40	1.3	0.23	1.99
	10 "	51	14	35	1.9	0.04	7.0
	15 "	50.5	14.5	55	2.0	0.12	6.5
	20 "	50	15	35	1.0	0.12	4.2
	30 "	47	14.5	38.5	1.5	0.15	4.1
	35 "	48	16	36	1.4	0.18	3.5
	40 "	45	18	37	1.1	0.20	2.90
First layer. {	45 "	45	18	37	0.3	0.49	2.50
	50 "	45	18	37	0.3	0.49	1.20
	60 "	40	20	40	2.2	0.04	7.44
	70 "	43	21	36	2.1	0.04	7.00
	89 "	44	22	34	1.8	0.16	6.57
	90 "	46	24	30	1.6	0.20	5.92
	100 "	46	24	30	1.4	0.21	5.20
	120 "	45	25	30	1.0	0.31	4.91
	130 "	43	26	31	0.8	0.35	3.11
	140 "	43	26	31	0.2	0.40	2.10
Second layer. {	150 "	40	30	30	3.3	0.03	7.50
	160 "	39	32	29	3.3	0.03	7.40
	170 "	39	32	29	2.9	0.04	7.12
	180 "	40	33	27	2.2	0.22	6.60
	190 "	40	33	27	1.8	0.25	6.00
	200 "	41	34	28	1.5	0.30	5.40
	210 "	41	34	25	1.5	0.30	4.90
250 "	41	34	25	1.4	0.32	3.12	

(3) During tannage, the skin retains its fibrous structure. The fibres themselves change their nature and appearance. After tanning they are arranged exactly as before the operation.

(4) Tannin is not the only substance taking part in the tanning reaction. Various extractives, which always accompany tannin in nature, are also absorbed. Some of these act chemically along with the tannin and help to bring about the alteration in the composition of the fibre, others are simply deposited between the

¹ Chrome leather as prepared at the present day resists boiling.

fibres and give weight to the leather. The first set, which we may call assimilable, are those which give leather its peculiar colour and odour, and make it supple or stiff, flexible or brittle, etc. These substances are not removed by solvents.

The second, which we may call interposed substances, set around the fibres and cement them together. They fill up the interstices and render the leather more or less impermeable to water.

(5) The proportion of tanning substance taken up by the skin depends on :—

(a) The nature of the skin. The skin provided by one kind of animal will vary according to its sex, state of health, method of feeding, the climate, age, etc. The skin of a single animal will vary in different parts.

(b) The state of the skin—fresh, dry, salted or boraxed—length of time it has been kept, etc.

(c) The softening of the skin.

(d) The plumping, and the class of acid used.

(e) The manner in which the handling has been carried out.

(f) The nature of the tannin.

(g) The nature of the extractives accompanying the tannin.

(h) The proportion of tannin to extractives.

(i) The rate at which tanning is carried out, and the strength of the solutions used.

(j) The temperature.

(k) The liability of the tannin and extractives to ferment, and the nature of the acids so formed.

In the presence of these twelve variables it is impossible to give any precise statement as to the quantities which are absorbed.

(6) The tannin combines directly with the skin. In practice, a certain amount of oxidation always takes place, but it is so small as to be negligible.

According to Müntz, the composition of the matter fixed during tannage is :—

	Absorbed from Liquor.	Absorbed from layers.	Tannin.
Carbon	54'56	54'72	52'42
Hydrogen	4'71	4'41	3'56
Oxygen	40'73	40'07	44'02

(7) The skin does not change its composition during tanning. Müntz has found a trifling loss of nitrogen.

100 parts of fresh skin contains 52.68 carbon, 5.65 hydrogen, 9.07 nitrogen, 31.67 oxygen.

100 parts of fresh skin give 54.67 of leather, which contains 28.12 carbon, 3.63 hydrogen, 9.93 nitrogen, 12.60 oxygen.

About 4.73 per cent. of the skin entered into solution in the tanning liquor, which will account for any loss of nitrogen which takes place. The substance which disappears is the coriin, and when it is carefully removed with cold water before tanning, no loss is found either experimentally or practically.

The author has obtained the following results:—

Elements.	Composition of Skin.		Composition of Tannin.	
	Before Tanning.	After Tanning.	Calculated.	Absorbed.
Carbon	51.25	51.28	52.42	52.40
Hydrogen	6.70	6.67	3.56	3.56
Oxygen	23.09	23.12	44.02	44.04
Nitrogen	18.20	18.15
Ash	0.76	0.79

The two bodies, tannin and skin, simply combine together.

The composition of skin and leather is as follows:—

Elements.	Composition.		
	Skin.	After Handling.	Leather.
Carbon	51.43	52.10	52.68
Hydrogen	6.64	6.30	5.65
Nitrogen	18.16	15.31	9.07
Oxygen	23.06	25.99	31.67
Ash	0.71	0.30	0.93

(8) The composition of the ash undergoes a change which has been studied by Müntz.

The large quantity of tannin absorbed by the skin (54 per cent.), when no antiseptic is used, is caused by the production of organic acids by fermentation. These have opened the pores of the skin and enabled it to take up this quantity of tannin. In the table, all the substances absorbed by the skin are reckoned as tannin, the estimation having been made by difference.

(10) Heat greatly helps the absorption of tannin. The following table gives the results of experiments on this subject:—

Temperature.		Duration of Tanning.	Tannin Absorbed by 100 parts Dry Skin.
Centigrade.	Fahrenheit.		
-10	14	Not tanned	18
-5	23	12 months	29
0	32	12 "	33
5	41	11 "	40
10	50	10 "	43
15	59	8 "	48
20	68	6 "	51
25	77	6 "	54
30	86	5 "	55
35	95	4 "	55
40	104	4 "	56
45	113	4 "	56
50	122	3 "	59
55	131	3 "	59
60	140	2½ "	62
65	149	2½ "	63
70	158	2½ "	63
75	167	2 "	66

In the last three of these experiments, the tannin was only added a little at a time, to prevent too rapid absorption, but the leather formed was spongy and brittle when dry.

(11) Leather could not be formed but for the fibrous structure of the skin. If plates of gelatin, albumen, or compressed skin be treated with tannin, their outer surfaces combine with it to form impermeable coatings, so that leather is never formed.

(12) A skin of any single kind, placed under the same conditions of temperature, pressure, acidity, strength of tannin solution, etc., will always absorb the same quantity of pure tannin.

The author has carried out a series of experiments with the following solutions:—

(a) Pure oak bark tannin prepared as described in the chapter on tannin.

(b) Dividivi, valonia, chestnut and sumach tannin, prepared pure by the ammoniacal acetate of zinc method.

(c) Pure extractives, *i.e.*, the substances accompanying tannin in nature. This solution was prepared by precipitating the tannin from extracts of the above-named substances by means of gelatin added very gradually until precipitation ceased.

The pieces of skin weighed about 1 kilo. (2½ lb.). They were prepared by cleaning thoroughly from the lime, soaking with frequent scrapings in fresh water at 8° C. (43° F.), and in distilled water containing a little sodium fluoride as an antiseptic.

The pure tannin baths were standardised by estimating the tannin by the Barbieri process, and the extractive baths by simple evaporation at 75° C. (167° F.).

Sodium fluoride was used in all cases, and in each mixed bath the tannin was mixed with the extractives coming from the same source.

The results are summed up in the appended table:—

Tanning Bath.	Composition of Bath.		Matters Absorbed.		
	Tannin.	Extractive.	Total.	Tannin.	Extractive.
Pure oak tannin	2	0	43'528	43'528	0
" "	2	0	43'531	43'531	0
" "	2	0	43'540	43'540	0
" "	3	0	43'540	43'540	0
" "	5	0	43'550	43'550	0
" "	10	0	43'500	43'500	0
Tannin and extractives	2	2	49'623	44'400	5'223
" "	2	2	49'628	44'400	5'228
" "	2	2	49'612	44'400	5'212
" "	4	4	50'702	43'693	6'009
" "	4	4	50'700	43'550	6'150
" "	5	5	51'122	44'902	6'220
" "	2	4	52'120	44'960	7'160
" "	2	8	55'200	45'080	10'120
" "	4	2	52'194	44'861	7'333
" "	8	2	52'220	44'920	7'300
Pure tannin, with 1 p. c. acid	3	0	44'440	44'440	0
" " " "	6	0	44'450	44'450	0
Tannin and extractives	3	3	55'900	44'201	11'699
" " " "	3	6	56'822	44'411	12'411
" " " 2 p. c. acid	3	3	57'522	44'029	13'493
" " " "	3	6	60'000	44'500	15'500
" " " 3 p. c. acid	3	6	62'020	45'301	16'619
" " " "	3	8	63'000	45'878	17'122
" " " "	3	9	64'522	45'322	19'200
Tannin at 30° C. (86° F.)	3	0	44'020	44'020	0
Tannin and extract at 30° C.	3	3	55'080	43'880	11'200

It will be seen from the table that the tannin combines in a definite proportion (44 per cent.) with the skin, and that the variation shown either in practice or in the laboratory, are due to the extractives.

It is the absorption of these substances which is influenced by external causes.

(13) The theory of the action of the skin on tannin, based on capillary attraction, *i.e.*, the interposition of tannin between the fibres, cannot be supported by facts.

VII.—THEORY OF HUNGARY LEATHER MAKING.

1. **Action of Common Salt.**—If skin be left in a solution of salt the cohesion between the elements of the skin is relaxed; the coriin swells, and even dissolves to a slight extent, but this is very slight, especially when the solution is strong.

When the solution is neutral, it does not become fixed in the skin, but simply extracts the coriin. When, on the other hand, it is acid, the coriin swells up, precipitates and becomes fixed in the skin. It can absorb 4 per cent. of salt, which is interposed between the fibres, and acts as an astringent. Water removes it readily. The skin has the appearance of tawed leather badly made. It will keep a long time. It does not set, because the coriin is in an inert, precipitated state.

2. **The Action of Alum.**—According to Knapp, skin absorbs alum without decomposition. To be more exact, the skin absorbs aluminium sulphate without decomposition, for the alkaline sulphate which enters into the constitution of alum is not absorbed.

Reimer, who has made numerous experiments on the subject, has obtained the following results:—

Weight of Skin in Grams.	Composition of Solution.				Absorption of SO ₃ .		Absorption of Al ₂ O ₃ .		Ratio.	
	Before Reaction.		After Reaction.		Grams.	Per cent.	Grams.	Per cent.	Al ₂ O ₃ .	SO ₃ .
	SO ₃ .	Al ₂ O ₃ .	SO ₃ .	Al ₂ O ₃ .						
15.365	3.8128	1.2280	3.1724	0.9950	0.6404	4.168	0.2330	1.516	100	275
14.330	3.6163	1.1615	3.1383	0.9281	0.4780	3.338	0.2344	1.630	100	205
17.910	3.6163	1.1615	4.1766	1.2649	0.5404	3.012	0.2501	1.396	100	216

Reimer considers that, when the alum penetrates the skin, part of the solution is decomposed into sulphate of alumina and sulphate of potash. The sulphate of alumina remains in the skin and is fixed in the fibre, whilst the sulphate of potash slowly diffuses into the external liquid.

Alum tanned skin becomes leather of a medium quality. After drying, it differs very little from mere dried skin. Water will remove all the sulphate of alumina, and boiling water will reduce the whole mass to gelatin.

The alum is deposited in the skin but not combined.

When skin is treated with a solution of alum, coriin is not precipitated. As the skin dries, the coriin which remains in solution dries in the same way as it would have done if no alum had been used, forming a hard, horny substance, which pervades the whole skin, making the leather brittle. Alum acts as a weak acid, but it does not swell the skin, as its astringent properties predominate over its action as an acid.

3. Action of Salt and Alum Mixed in Equivalent Quantities.—

Reimer has obtained the following results :—

RESULTS OF ONE HOUR'S TREATMENT.

Nature of Solution.	Alumina Absorbed.		Excess of SO_3 .	Sodium Chloride Absorbed.	
	Grams.	Per cent.		Grams.	Per cent.
Pure alum	0.0089	0.16	0.0885	0	0
Alum and salt in equivalent quantities	0.0354	0.58	0.1698	0.0447	0.73
Alum and salt in equal quantities	0.0304	0.52	0.0951	0.0313	0.53

RESULTS OF TWELVE HOURS' TREATMENT.

Nature of Solution.	Weight of Skin in Grams.	Substances Fixed by the Skin.						Ratio of Al_2O_3 to SO_3 .
		SO_3		Al_2O_3		NaCl.		
		Grams.	Per cent.	Grams.	Per cent.	Grams.	Per cent.	
Alum	5.802	0.2009	3.462	0.1175	2.024	100 : 71
Equivalent quantities alum and salt	6.541	0.0721	1.102	0.1440	2.201	0.095	1.452	100 : 50
Equal quantities alum and salt	7.562	0.1460	1.930	0.1351	1.787	...

The sulphate of alumina absorbed is hydrated. The author's experiments bear out Reimer's conclusion, the following results having been obtained:—

Weight of Skin.	Weight of Substances Fixed.				Total Absorption.		Ratio between Al ₂ O ₃ and SO ₃
	SO ₃ .		Al ₂ O ₃ .		Dry Method.	Wet Method.	
	Grams.	Per Cent.	Grams.	Per Cent.			
1. 6.239	0.203	3.25	0.145	2.32	0.383	0.348	100 : 140
2. 6.500	0.209	3.21	0.160	2.46	0.428	0.431	100 : 131
3. 7.718	0.288	2.73	0.184	2.88	0.526	0.472	100 : 156
4. 7.212	0.378	5.21	0.171	2.45	0.424	0.613	100 : 213
5. 6.343	0.318	5.01	0.141	2.27	0.359	0.593	100 : 225
6. 16.550	0.645	3.82	0.296	1.78	0.848	0.987	100 : 218

In the first three experiments, alum and salt were used in equal quantities; in the last three in equivalent quantities.

Reimer's explanation may be summed up thus: The action of alum is of several kinds. It acts chemically as an acid, it acts as a tanning agent, precipitating an aluminium compound in the skin, and it acts as an astringent and antiseptic.

Its acidity only acts chemically, because any physical action such as swelling is counteracted by its astringency.

The aluminium compound fixed in the skin varies under varying conditions. It is a neutral sulphate of alumina in the entire absence of lime, in the presence of an organic acid, and with a slight excess of salt. Under the same conditions, but with a large excess of salt a basic sulphate is formed. The same result is arrived at when the lime has been so thoroughly removed from the skin as to leave it with an acid reaction, and a solution of alum is used containing its exact equivalent of salt.

The basicity of the compound increases with the amount of lime left in the skin, and with the excess of salt.

With the increase of basicity of the deposited substance, a corresponding increase goes on of the acidity of the liquor.

The salt actively promotes endosmosis. It removes from the skin those substances which have no part in the tanning action, such as sulphate of potash, sulphuric acid, and sulphate of lime,

and prevents any objectionable results which would follow from their presence. It acts as a tanning agent by precipitating the coriin, and bringing back the swollen fibres to their natural state. Lastly it stops the action of the acid which is set free during the reaction.

4. Action of Aluminium Sulphate.—Aluminium sulphate used either alone or with salt gives the following results:—

Weight of Skin.	Substances Fixed in the Skin.						Ratio of Al_2O_3 to SO_3 .
	SO_3 .		Al_2O_3 .		NaCl.		
	Grams.	Per Cent.	Grams.	Per Cent.	Grams.	Per Cent.	
6.948	0.158	2.274	0.069	1.052	100 : 239
6.580	0.254	3.313	0.104	1.580	100 : 244
7.029	0.097	1.380	0.103	1.465	0.100	1.42	100 : 75

5. Action of Aluminium Acetate. We strongly recommend this salt. It has all the advantages of alum without the inconvenience of setting free sulphuric acid. Its action is shown in the following table:

Nature of the Experiment.	Weight of Skin.	Substances fixed by the Skin.					
		Alumina.		Acetic Acid.		Salt.	
		Grams.	PerCent.	Grams.	PerCent.	Grams.	Per Ct.
Dilute acetate	22.150	0.108	0.478	0.322	1.462
Acetate and salt	23.190	0.529	0.28	1.572	6.780	0.944	4.07
Strong acetate	16.212	0.109	0.67	0.221	1.360
Strong acetate and salt	24.400	0.775	3.17	1.437	5.890	0.787	4.04

VIII.—THEORY OF TAWING.

The action of salt and alum is exactly the same as in Hungary leather making. In this section we shall examine the action of flour and yolk of egg.

1. Action of Flour. The only active part of the flour is gluten, which is absorbed by the skin. The presence of the starch is useful, as it helps to form a flocculent and finely-divided precipitate, which

RESULTS OF TAWING EXPERIMENTS.

Nature of the Experiment.	Substances Used.						Substances Absorbed.						Albuminoids.				
	Weight of Skin in Grams.	Proportions Used.			Composition.			Starch.		Fat.		Salt.		Alum.		In Grams.	Per cent. of Skin.
		Flour.	Egg.	Alum.	Salt.	Flour.		Albuminoid.	In Grams.	Per cent. of Skin.	In Grams.	Per cent. of Skin.	In Grams.	Per cent. of Skin.			
						Sarch.	Gluten.								Oil.		
1. Salts and alum alone	300	...	200	100	4'500	1'500	16'650	5'560
2. Salts and starch alone	300	...	200	100	...	100	4'500	1'500	16'650	5'560	0'290	0'090	...
3. Salts and gluten alone	300	...	200	100	...	100	...	0	4'500	1'500	16'650	5'560
4. Salts, gluten and starch	300	200	200	100	2	198	...	0	4'500	1'500	16'650	5'560	2'130	0'709	...
5. Salts, gluten and starch	300	200	200	100	175	25	...	0'920	0'306	...	4'500	1'500	16'650	5'560	4'139	1'376	...
6. Salts, gluten and starch	300	200	200	100	175	25	...	0'316	0'105	...	4'500	1'500	16'650	5'560	8'212	2'704	...
7. Salts, gluten and starch	300	200	50	100	175	25	12	12	0'211	0'070	12'600	4'200	16'650	5'560	10'211	3'403	...
8. Salts, gluten and egg	300	200	100	100	175	25	24	24	0'211	0'070	15'900	5'300	16'650	5'560	12'800	4'266	...
9. Salts, gluten and egg	300	200	200	100	175	25	48	48	0'233	0'077	20'990	6'996	16'650	5'560	15'990	5'330	...
10. Casein	300	...	100	200	100	175	25	24	0'222	0'074	14'220	4'740	17'900	5'966	11'200	3'733	...
11. Fibrin	300	...	100	200	100	175	25	24	0'249	0'083	13'190	4'396	18'822	5'274	9'431	3'143	...
12. Albumin	300	...	100	200	100	175	25	24	0'118	0'039	12'960	4'320	19'700	6'566	11'320	3'740	...
13. Legumin	300	...	100	200	100	175	25	24	0'301	0'100	16'300	5'433	15'999	5'333	4'900	1'633	...
14. Whale oil	300	200	...	200	100	175	25	...	0'211	0'070	11'326	3'442	18'300	6'100	11'891	3'963	...
15. Olive oil	300	200	...	200	100	175	25	...	0'211	0'070	14'130	3'710	18'300	6'100	13'141	4'380	...
16. Whale oil and lard	300	200	...	200	100	175	25	...	0'229	0'076	10'900	3'633	18'300	6'100	10'130	3'376	...
17. Alum, salt and flour	500	200	...	200	100	175	25	...	0'413	0'082	24'109	4'821	18'440	3'690	...
18. Alum, salt, flour and egg	500	200	100	200	100	175	25	24	0'516	0'103	18'690	3'740	25'800	5'160	21'220	4'244	...

is readily absorbed by the skin. Other substances analogous to gluten, such as casein, fibrin, albumen and legumin, when emulsified with starch are able to replace gluten perfectly.

Experiments on this subject will be found in the table on page 429.

2. Action of Yolk of Egg.—The active parts of yolk of egg are albumen and fat. These two substances are in a finely emulsified state. Other albuminoids and other oils act in the same way when substituted for egg yolk.

The table on page 429 gives a *résumé* of the author's experiments and shows the part played by each element in this class of tanning. Each experiment was made on a whole sheep skin.

Experiments 1-9 show the parts played by the various substances. Experiments 10-13 show that gluten may be replaced by other albuminoids. Experiments 14-16 show that yolk of egg may be replaced by emulsified oils, and, lastly, experiments 17-18 have been made with the idea of discovering the part played by starch or egg in the absorption of alum and salt.

In the first three sets of experiments, tawing took place in two parts: Firstly, soaking in alum and salt; secondly, soaking in the mixture. In the last set of experiments the whole work was performed in one operation.

IX.—THEORY OF CHAMOY LEATHER MAKING.

Chamoy leather making is oil tanning, that is, each swelled fibre is surrounded with a fatty coating which becomes adhesive by oxidation. This oxidation produces a resinoid material which has the property of fixing the fat uniformly to the fibres of the skin.

It is evident that this form of tanning is merely an interposition. The fat may be removed by the ordinary solvents. Boiling with water gives gelatin and oxidised fat.

The two important points in making chamoy leather are (*a*) good mechanical penetration of the fat into all parts of the skin, and (*b*) good, even and progressive oxidation of the fat.

It is with the latter point that we are concerned here.

The oxidation of oils is a special form of fermentation caused by *microcladus oleorum*. This is easily studied by exposing a drop of linseed oil to the air under a microscope. For several minutes no change is noticeable. At the end of a quarter of an hour sickle-shaped objects appear which rapidly increase in length. At a certain point in their development they throw out little tubes which increase without ever reaching the size of the parent form. The two bodies have the appearance of two leaves attached to their stem. Sometimes a third smaller member is formed at the junction of the other two. These branches are the mycelia of the plant. The spores are formed at the wide part of the branches.

When the drop of oil has been exposed to the air for twenty-four hours, all the different phases of development are visible, from the spores to the complete threads. The mycelium is white, transparent and motionless. The spores are egg-shaped, $2\frac{1}{2}$ micro-millimeters by 1 micro-millimeter (μ).

When animal, non-drying oils are examined, the same phenomena are observed, but the plant is mobile.

This plant lives at the expense of the nitrogenous substances contained in the oil. It uses these in preference to nitrogenous substances artificially added. Manganese borate, and benzoate favour its development. Copper and lead do no harm to the growth, but combine with the fatty acids set free during the oxidation, forming poisonous salts which stop the oily fermentation. Phenol, arsenious acid, copper sulphate, and antiseptics generally stop the action.

Microcladus oleorum transfers oxygen from the air to the olein, margarine, etc., setting free the acids, and almost entirely oxidising the glycerin with which they are combined. Like all other fermentations it is promoted by warmth.

The following table shows the composition of the oil extracted from a chamoyed skin at different periods of its preparation :—

Operations.	Increase in Weight of Fat per cent.	Composition of Fat.		
		Fat.	Acids.	Resin.
Composition of whale oil	0	90·820	7·040	2·140
After 1 airing	0·50	89·972	7·500	2·528
" 2	0·70	89·271	8·009	2·712
" 3	1·10	88·160	8·612	3·228
" 4	2·29	86·560	9·320	4·120
" 5	3·31	82·060	10·712	7·228
" 6	6·50	77·623	12·928	9·449
After stoving	9·68	70·092	15·728	14·180

X.—THEORY OF MINERAL TANNING.

In this class of tanning the fibres of the leather are prevented from sticking together by the interposition of some antiseptic metallic salt. These bodies are always absorbed without decomposition. They form no chemical combination with the substance of the skin, and may be removed by suitable solvents.

This kind of tanning, as we have already had occasion to remark, is of no great practical importance, and since the action of different salts is similar to that of alum, we only need give a list of the quantities of various materials absorbed by skin.

	Per Cent.	
Alum	8·5	Knapp.
Aluminium sulphate	27·9	"
Aluminium chloride	27·3	"
Aluminium acetate	23·3	"
Ferric chloride	23·3	"
Chrome alum and salt (equal parts)	6·13	Reimer.
Iron alum and salt (equal parts)	8·89	"
Manganese alum and salt (equal parts)	7·77	Villon.
Zinc alum and salt (equal parts)	8·16	"
Basic sulphate of iron	11·40	Reimer.
Aluminium benzoate	14·23	Villon.
Aluminium tartarate	12·16	"
Zinc acetate	7·22	"
Lead acetate	5·31	"
Zinc fluoride	19·52	"
Stearic acid	1	Knapp.
Oleic acid	1	"
Cod-liver oil	0·5	"
Colophony	0·5	"
Picric acid (aqueous solution)	22·75	"
Picric acid (alcoholic solution)	8·5	"

PART VI.

USES OF LEATHER.

CHAPTER I.

MACHINE BELTS.

BELTS communicate the motion from one piece of machinery to another when the axles are some distance apart and the resistance is not great. They form a valuable means of transmission which is very durable and economical of force. Their use is general in all kinds of industry, and the old idea that they could not be used for heavy machinery is now known to be quite unfounded on fact. There is a belt in Loth near Brussels 50 metres (about 56 yards) long by 1·9 metres (6 ft.) wide which transmits 600 horse power.

We proceed to give details of the manufacture of leather belting, and afterwards to give hints as to its use and maintenance.

I.—MANUFACTURE OF BELTING.

1. Skins Used.—The leather principally used is tallowed but unblackened. In half hides or sides the stronger parts are kept for making heavy belts, whilst the thinner parts are used for lighter ones.

Belts are made of Hungary leather, parchmented skin, transparent leather and skins tanned with iron and chrome.

2. Stretching.—Carefully-chosen butts are stretched to remove creases. One edge of the skin is fixed to a post by means of a rod clamped on, and the other is fixed in the same way to the drum of a windlass. In this manner they are kept stretched out until they are perfectly flat. This is merely one of a large number of methods for flattening the leather.

3. Cutting.—The butts are cut either by hand or by machinery into strips of various uniform breadths. These strips are selected and carefully dressed. All defective parts are removed so that the strength of the piece shall be perfectly even throughout. The length of the strips should not exceed 5 ft.

In hand cutting the butt is stretched on a table. A steel rule is laid on the top and a special knife run along its edge.

The cutting machine consists of two iron frames facing one another at a distance of 8 ft. apart, with cross-beams below, which support a cutting table. They are connected above by triangular guides.

A carriage runs on the guides bearing the knives which may be adjusted by a side screw. The carriage is driven by a screw.

The butt is clamped on the table. The knife is adjusted to run close to one side of the leather, and the driving screw set in motion. When it has run the entire length of the skin the knife is readjusted so as to form a parallel cut at the required distance from the first. This work is continued until the butt is entirely cut up.

4. Equalising the Strips.—The strips when freshly cut are not of the same thickness throughout. The thicker parts are removed roughly with a knife. Sometimes the whole is done in the splitting machine which has already been described. Afterwards they are run through copper calendering rollers.

5. Splicing the Strips.—The ends of the strips are bevelled either by hand or by machinery, and united either by cement, stitches or rivets.

6. Cementing.—The two bevelled ends are covered with a very powerful cement and submitted to hydraulic pressure between hot plates, which makes a perfect union.

The cements used are very numerous, but there are very few which perfectly fulfil the necessary requirements of strength and flexibility. The following recipes are all excellent, and the manufacturer should choose that one best suited to the class of leather which he uses.

(a) Dissolve 100 parts of unvulcanised india-rubber in 4,000 parts of naphtha by cutting the rubber and shaking it from time to time.

In the cold, solution will be complete in ten days. Mix two parts of shellac with one part of this solution, allow the mixture to stand for a day in the cold, then heat in an iron vessel, stirring constantly until a homogeneous substance is obtained. This composition is known as marine glue.

The bevelled edges of the leather are covered with this glue at a temperature of 70°C . (158°F). If it is too thick it is diluted with turpentine. A pound of the glue will cover $14\frac{1}{2}$ sq. ft. of surface.

(b) Gutta-percha dissolved in thirty times its volume of benzene or petroleum ether.

(c) Fish glue 100, bichromate of potash 3, water 100, glycerin 3.

(d) One hundred parts of fine glue and 100 parts of fish glue are soaked for 10 hours in just sufficient water to cover them, the mass is then heated to boiling point and tannin added until it gets a stringy consistency.

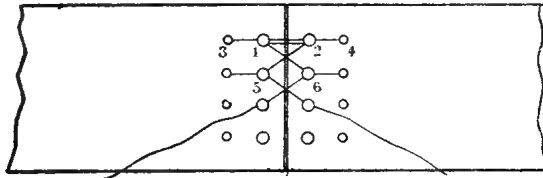

FIG. 96.—Stitch 1.

7. Stitching.—Belts are stitched with leather laces or strong waxed thread. The manufacture of laces will be described later (page 45). Shoemaker's waxed thread is made from hemp. Three, four, five or six threads are measured off, each about two yards long, and twisted together, then rubbed over with cobbler's wax, and a hog's bristle placed at the end of the thread so formed.

Parallel series of holes are driven through the leather with an awl and the waxed thread or leather lacing is sewn through the holes.

In Figs. 96 to 99 we give several methods of stitching belts.

Stitch 1 (Fig. 96). First, two rows of holes are punched in the ends of the strips, the first row 1 in. from the edge, the second $1\frac{1}{4}$ in. from the first. For a belt $8\frac{1}{2}$ in. wide 7 sets of holes will be required; for one $6\frac{1}{2}$ in. wide, 5 holes, for 5 in. 4 holes, etc.

The first set of holes are punched large enough to take three thicknesses of thread, and are preferably oval. In the second rank, the holes are made just large enough for one thread. The advantage of this method of stitching is that the thread does not pull directly on the hole, but, in virtue of the two ranks has, so to speak, an anchor in the solid part of the belt.

The stitches are made thus: A thread of the necessary strength

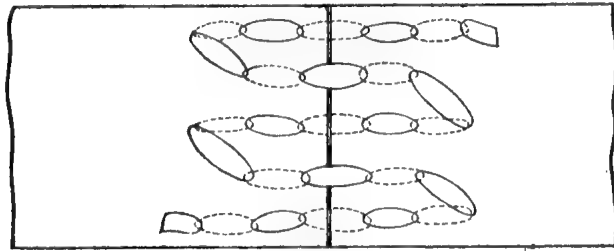

FIG. 97.—Stitch 2.

is passed through hole 1, leaving the upper length 4 in. longer than the lower one. The two ends are threaded through 2 and the one which is now below is threaded upwards through 1. The left-hand end is then passed down through 3, and up again through 1, and the right-hand end down through 4 and up through 2. Both ends now being above, they are crossed from 1 to 6 and up again

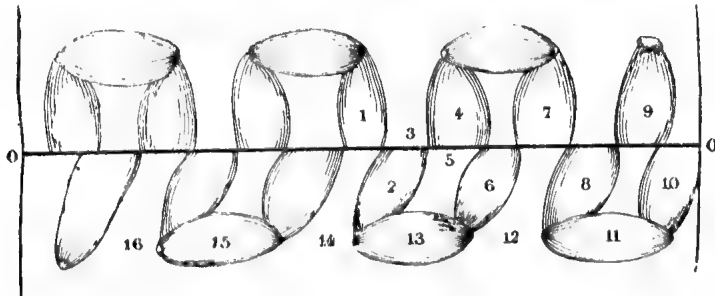

FIG. 98.—Stitch 3 (American splice).

through 5, and from 2 to 5 and up again through 6, and so on. After each stitch the thread will be crossed above and in straight lines below.

Stitch 2 (Fig. 97). The stitch shown in this figure is an ordinary one passing alternately above and below. Its special recommendation is that it passes very easily over the pulley wheel, and is especially useful when the diameter of the wheel is small. The

tension on the thread tends to draw the stitches into the leather and bring them flush with the surface of the belt. Further, the length of the bevels may be indefinitely increased by this method of stitching.

Belts sewn on this system are specially adapted for cases in which both sides of the belt come into contact with pulleys.

Stitch 3. The American splice (Fig. 98) is used in uniting the ends of rather narrower belts in which it is wished to have as few holes as possible. The holes are punched $\frac{3}{8}$ in. from one another and from the edges. The lacing is started in the middle (hole 1) and the flat lace is passed between the bevels of the leather to hole 2, and so to 3 and 4 on to 10. The lace is doubled in 9 and 10, then threaded transversely over 11 and under 12 and so on to 16. The second half of the seam is then laced in the same way.

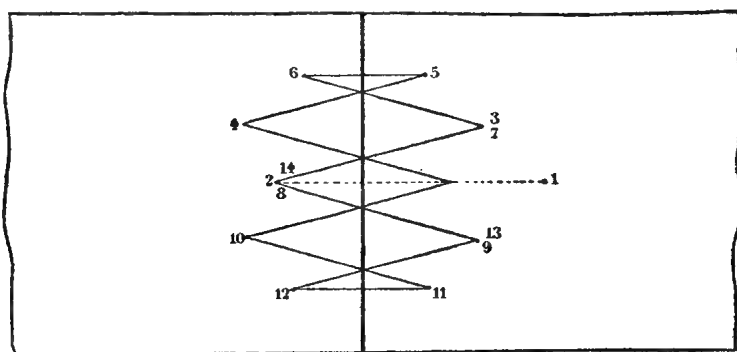

FIG. 99.—Stitch 4 (W stitch).

Stitch 4 (Fig. 99). The W stitch is very much used. The one shown in Fig. 99 is perhaps the commonest. The lace, with a knot at its end is threaded into hole 1 passed underneath to 2, then over to 3, under to 4, over to 5, under to 6, over to 3 (7), and so on to 15 where it stops.

Sewing with shoemaker's thread is either done by hand (stitches 2 and 4) or by a machine exactly like an ordinary sewing machine, but stronger.

After sewing, the stitches are beaten in either with a hammer or between rollers.

8. Riveting.—This is done with ordinary rivets. The belt is first pierced with a punch, making the holes of the exact size to fit the rivets. These are then inserted and the heads screwed or

hammered. The rivets and screws which are made of copper are of various patterns (Figs. 100 to 104).

9. Stretching Belts.—After splicing, belts are stretched by powerful stretching machines, consisting of two clamps, one fixed and the other movable; each clamp holds one end of the belt, and the movable clamp is moved slowly by a fine screw, thus gradually increasing the tension. Very long belts are passed backwards and forwards over rollers fixed on strong beams. Our leather testing apparatus gives a fair idea of the principle of these machines.

In the old machines the belts were stretched by means of a lever, which acted too rapidly, and weakened the leather.

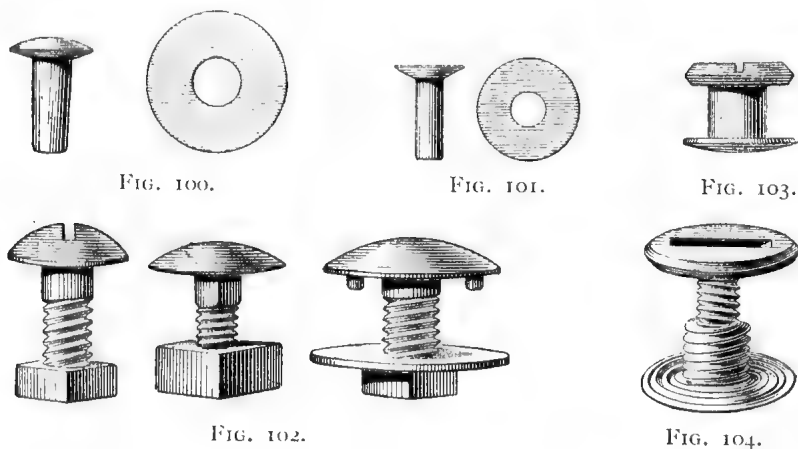

SOME RIVETS AND SCREWS USED IN BELT-MAKING.

II.—LEATHER CHAIN BELTS.

It is generally supposed that these belts are quite a recent invention, but as a matter of fact they date back to the early sixties. At this time Roullier of Paris experimented with a belt made up of pieces of leather $1\frac{1}{2}$ in. long and $\frac{1}{2}$ in. broad, fixed together with rods of iron, riveted at each end. M. Roullier's object was purely economical, as he wished to use up leather scraps. He improved his methods, and went to America, where he patented his belting in 1862. Many experiments were made, but he eventually recognised that this class of belt would not do for American high-speed machinery. The inventor next came to England where he obtained some success, as the belts were better adapted for the class of machinery which he tried there. To-day they are used

throughout the United Kingdom. Many improvements have been made on the original design, and they are manufactured in all parts of the world.

In 1882, Hall patented, in America, a new chain belt, in which



FIG. 105.

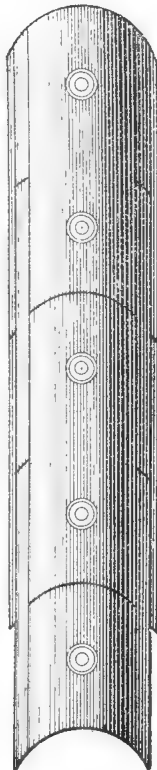

FIG. 106.

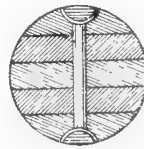

FIG. 107.—Section.

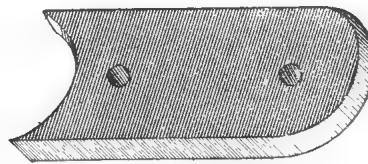

FIG. 108.—Link.

ROUND BELT.

some links were leather and others steel, one of the latter to three or four of the former, with the idea of strengthening the whole belt.

The practical defects of this system were soon recognised. In a very short time the leather lengthened and the whole tension was borne by the steel. The steel links then cut the bars and the belt broke into pieces.

In 1884, a Chicago company patented a belt, in which the holes through the leather links were guarded with metal eyes. An effect was produced very similar to that in Hall's belt. The eyes soon destroyed the pins and the belt quickly broke down.

Lastly, in 1887, the problem was solved by a committee appointed by the New York Society of Engineers. Their belt has been adopted almost universally.

Roullier made the mistake of using refuse scraps of leather; and as a belt of this class is merely a chain, its strength is the strength of its weakest link. It is therefore necessary that the best leather should be used. Further, the leather must be very flexible, but solid and tough, or it will stretch and break. These

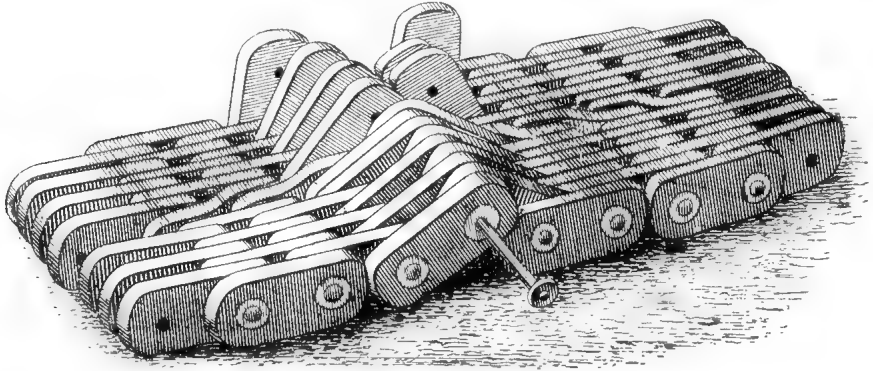

FIG. 109.—Showing how broad belts are built up.

conditions are most important. Roullier's leather was hard and coarse. He believed, in fact, that the harder the link the less liable the belt would be to stretch. Experiment has shown this to be untrue.

Nowadays the leather is saturated with a compound of tallow, neatsfoot oil and other fats, which make it pliable and tough.

The arrangement of the links is also of great importance. They should be perfectly even, and the rivets should be counter sunk. Figs. 105 to 112 show the way in which they are pieced together. Figs. 105 and 106 show a round belt, and 107 shows a section. Fig. 108 is one of the links. These links are cut out by a machine similar to that used in cutting boot soles. The sizes of the links vary with the strength required in the belt.

Fig. 109 shows the manner in which broad belts are built up, where two pins are used instead of one to traverse the whole breadth. These belts are well adapted for transmitting motion from one shaft to another at right angles to it as the wheels are better gripped.

They can be adapted to any form of pulley, and since they are endless they run more smoothly than spliced belts.

To lengthen or shorten them it is only necessary to add or remove the required number of rows of links.

In England they are used for dynamos at speeds up to 700 revolutions per minute.

III.—VARIOUS BELTS.

Domange's belt is made up of a large number of strips $\frac{4}{5}$ in. wide placed edgeways, side by side, and sewn together tightly with a twisted cord. A belt 40 yards long by 20 inches wide is made up of 102 strips. These belts are apt to slip, on account of the air forced in between the belt and the wheel. An Englishman has suggested piercing the belt with holes an inch apart to allow a passage for the air, which makes it act more evenly. The great strength and thickness of these belts makes them very costly.

IV.—USE OF BELTS.

Experience has shown that the flesh side of the leather should be placed next the pulley.

If a strip of leather be carefully examined, it will be seen that the fibres, which are more entangled on the flesh side, change their appearance as they approach the grain, where the mass becomes dense and compact. This compact mass is covered with little cracks. This explains the results of the following experiment :—

If a strip of leather be hung over some round object representing a pulley, and weights attached to its ends until it breaks, it will be found that the weight required is greater when the flesh side is applied to the pulley than when the grain is next it. Experiments

in the author's laboratory have given comparative results of 2·8 kilos. for the flesh side and 2·4 for the grain side.

When the grain touches the wheel, the tension at the point of contact crumples up the grain and splits it, moisture penetrates, and cracks are formed. On the other hand, when the flesh side receives the pressure, its solidity is increased.

1. Joining Belts.—The belts are put in position and stretched, the two ends are brought together and either laced, riveted or screwed as described in the last section.

After a little use the belts stretch, and they have to be unsewn and shortened. To render this easier, various clasps have been invented.

The Valot and Lacroix clip consists of a plate of soft iron

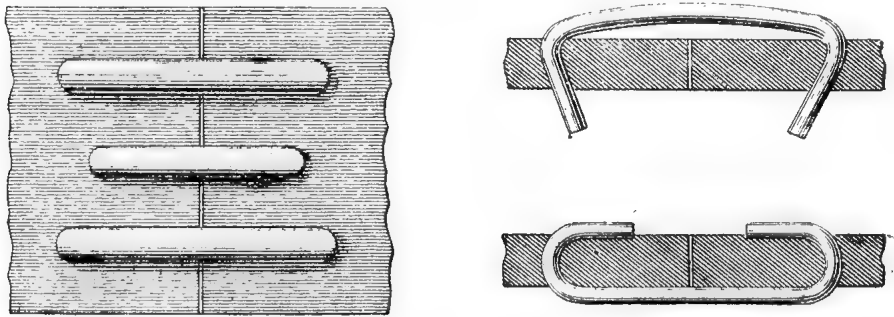

FIG. 110.—Simple belt clasp.

furnished with screws. The ends of the belt are strained into position and squared accurately. The screws are removed and the plate placed in position and struck sharply with a mallet. This leaves a mark wherever a screw hole has to be punched. After making the holes, the plate is replaced and screwed on, countersinking the screw heads flush with the leather.

Fig. 11c, No. 1, represents a very simple belt clasp. To use it, the requisite number of holes are punched in the ends of the belt, and the clips inserted and hammered down into position.

The Riemen clip (Fig. 111) is fixed as follows: The clip B is placed in a slightly concave block of hard wood, A, with its points turned upwards. The ends of the belt are brought together over the clip, a block of wood placed over them, and hammered down.

A new clip is represented on Fig. 112.

2. Slipping.—The greatest drawback to the use of belts is their tendency to slip over the pulley.

This slipping is usually caused by degreas, and lack of pliability in the leather. It is prevented in the following ways:—

(a) By powdering the belt with resin, but this has a destructive action on the leather.

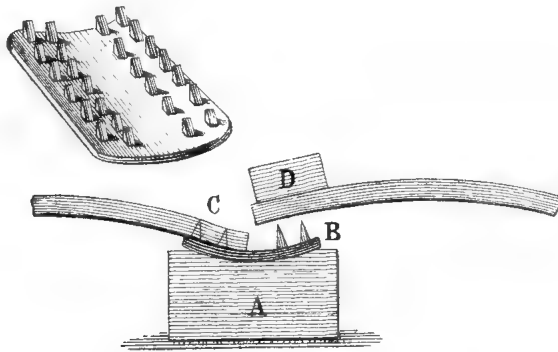

FIG. 111. Riemen Clip.

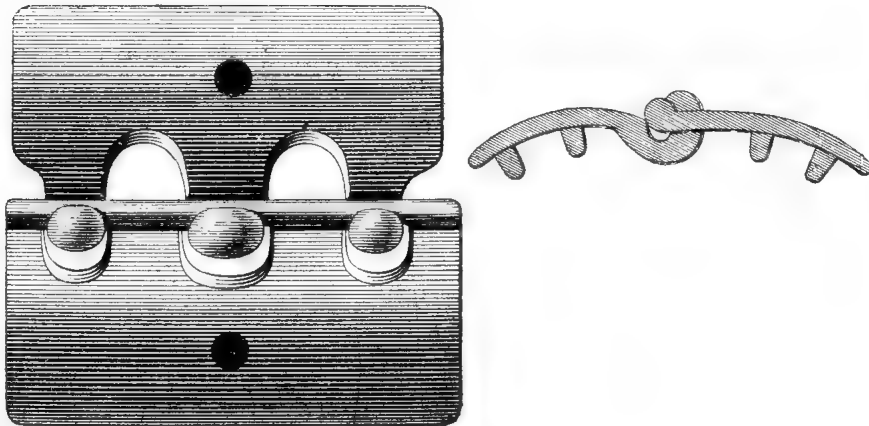

FIG. 112.—Another Clip.

(b) By applying one of the following resinous compositions:—

A.		Parts.	B.		Parts.
Caoutchouc		300	Tallow		400
Turpentine		300	Resin		500
Fish oil		1,500	Resin oil		200
Resin		400	Mineral wax		400
Yellow wax		500	Castor oil		200
Tallow		500	Sugar		100

These gradually harden the leather.

(c) A slightly better method, but still not to be recommended, is the application of tallow to the inside of the belt. It swells the leather and makes its adhesion more perfect.

(d) Whale oil applied to the outside gives better results, but forms clots on both belts and pulleys.

(e) A mixture of equal parts of castor oil and tallow has the same advantages and drawbacks as whale oil.

(f) The best application is undoubtedly mineral oil. The outer surface of the belt is stretched more than the inner, and is more likely to crack; it is therefore oiled whilst running. It is as well to remove the belt from time to time so that it may be washed with warm water. When clean it is wiped dry and mineral oil well rubbed in. It is then placed in a warm room until all the oil has been absorbed, and a second coat rubbed in.

Mineral oil gives a better grip than other oils and fats, as is seen from the following relative results:—

Friction of a belt on a wooden pulley	0·50
„ „ moist belt on iron	0·38
„ „ belt greased with mineral oil	0·38
„ „ „ slightly greased (tallow)	0·28
„ „ „ well „ „	0·22

3. Arrangement of Belts.—Let us suppose that it is required to connect together two pulleys, whose axles are at right angles to one another. When the belt is working, the advancing side of the belt must always be in the same mean plane as the drawing pulley. To understand the method trace the line A B (Fig. 113) and touching it on each side, describe two circles, H and G representing the pulleys. By folding the plan about the line, it will be seen that, whilst lying flat, a belt would run steadily over the two whilst when folded the belt would slip.

Consider G as the power pulley, then by turning H through a right angle we can make it run in either direction as shown in Figs. 114 and 115.

For other angles the only thing necessary is to be careful that the angular rotation takes place about the line A B.

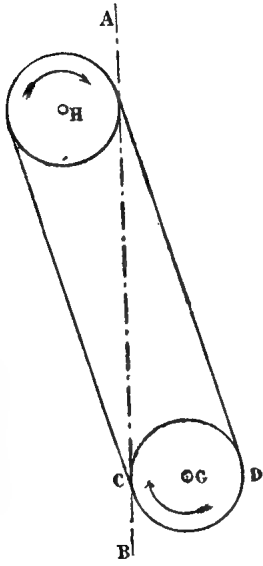

FIG. 113.

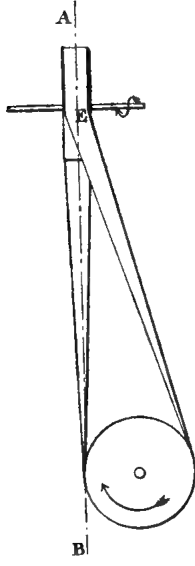

FIG. 114.

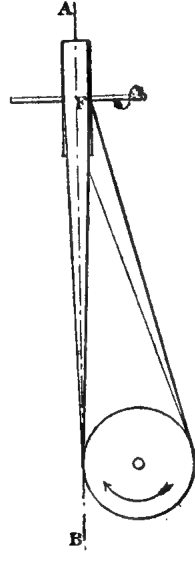

FIG. 115.

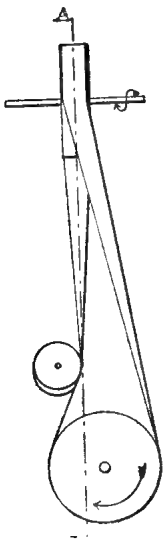

FIG. 116.



FIG. 117.

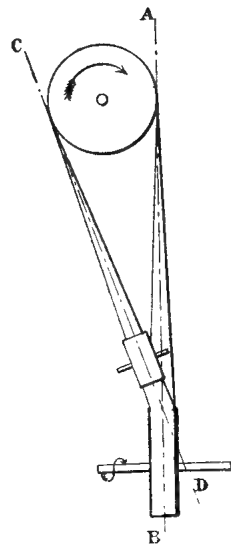

FIG. 118.

ARRANGEMENT OF BELTS.

When a roller or hanger is used it must be set so that the face touching the belt is tangential to A B. (Figs. 116, 117.)

Fig. 118 is another view of Figs. 116 and 117. The pulley is on the slack side of the belt, *i.e.*, the side leaving the power pulley. The roller should touch the belt between 11 and 15 centimetres ($4\frac{1}{2}$ to 6 in.) from the power wheel (*American Miller*).

CHAPTER II.

BOOT AND SHOEMAKING.

I.—BOOTS AND SHOES.

ORDINARY boots consist of three parts, the sole, the upper and the heel.

1. **Soles.**—Sole leather is thick hide, well tanned and hammered. It is usually hammered a second time to increase its hardness and solidity.

Hammering.—The shoemaker soaks his leather in a vessel of stagnant water and beats it with a hammer on a smooth stone.

In large factories a machine is used, similar to the one shown in Fig. 61 but more powerful. The hammer and anvil are of smaller diameter.

Cutting.—The shoemaker cuts the sole roughly with a sharp knife on a board which he supports on his knees.

This work is carried out more conveniently with a large punch or die.

Stamping.—In the stamping machine the soles are given the required curvature. The machine is simply a stamp, fitted with iron, steel or paper dies, and is used not only for stamping the soles but also for stamping fancy work on shoe leather. Sometimes machines are used which do the cutting and stamping in one operation.

2. **Uppers.**—The uppers are cut on shapes. The skill of the workman is shown by the way in which he uses up his material whilst avoiding weak places. He first marks out the leather, then cuts out the shapes; using up the leather to the best advantage. The fore shanks go to make cheap lined boots and the neck for buskins.

Sometimes the uppers are cut from uncurried skin, just as it comes from the tanyard. In this case it is curried after cutting,

and undergoes all the operations described in the chapter on black calf.

Bordeaux uppers are not oiled, because Bordeaux calf has already received oil in tanning, but it is put through all the other currying operations.

Bending to the Last.—The uppers are sorted into strong, medium and fine. In small works the leather is bent on a wooden last, but in large manufactories it is done by machinery. Bending stretches certain parts of the leather, especially those parts about the instep,

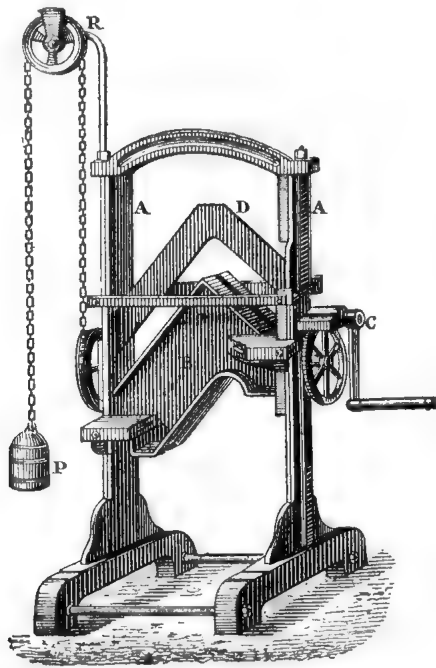

FIG. 119.—Bending Machine.

and bends them in such manner that they retain their shape after the pressure is removed.

When a wooden last is used, the interior of the upper is moistened with a wet sponge and stretched tightly over the form, fixing it in position with carpenter's nails. It is then made to take the exact shape of the last by means of a rasp.

In the bending machine the leather is placed on a copper shape and forced into a hollow iron box containing striated copper moulds. This machine is shown in Fig. 119. The two columns

(A A) support the box B, the cover of which (D), is raised or lowered by the handle C. The width of the box may be regulated by screws.

3. Mounting.—This operation adjusts the upper and sole together ready for sewing.

The shoemaker first fixes the first sole in position at three points one in front, one in the middle, and one at the heel. The stiffener is sewn on with long stitches from the front to the centre of the heel. The last is then introduced and the edges of the upper are bent round and nailed on at various points underneath.

This is the most delicate operation in shoemaking and is sometimes done by machinery. Duméry's machine is thus described by Damourette:—

The cast-iron frame has the shape of a swan's neck and is two metres (6 ft. 8 in.) high. It terminates below in a bed plate, and carries in a groove a large ellipse pivoted vertically about its major axis, which may be fixed by a catch in two corresponding positions. A second smaller ellipse is pivoted about its horizontal minor axis inside the larger ellipse, and is able to catch in the two vertical positions.

This inner ellipse carries the cast-iron shape and the clips, which can either stretch the upper or compress it. These clips are worked by cat-gut cords passing over little hooks fixed on two small parallel rods perpendicular to the plan of the ellipse. These little hooks are furnished with jaws to which the cords may be attached.

To press the upper on the sole the clips are worked horizontally by gut cords passing over the hooks and attached to pedals fixed to the bed plate.

The sole and upper are placed on the form and the latter is fixed by the clips and thus stretched into position.

Another machine (Lemercier's) is based on the same principle.

4. Sewing.—The way in which a shoemaker sews on a sole with waxed thread is well known. When machines are used they are similar to ordinary sewing machines but stronger. The Blake

machine will sew 300 pairs a day when worked by the foot, or 500 pairs when steam power is used.

The welt is a thin strip of leather sewn between the sole and the upper, sometimes a second and third sole of imitation leather is cemented on to the first sole. This is done with one of the cements described in the last chapter.

5. Riveting.—The false sole is fixed to the true sole and upper by means of little iron or brass pegs. This is done by hand or machinery.

Machines are of two kinds :—

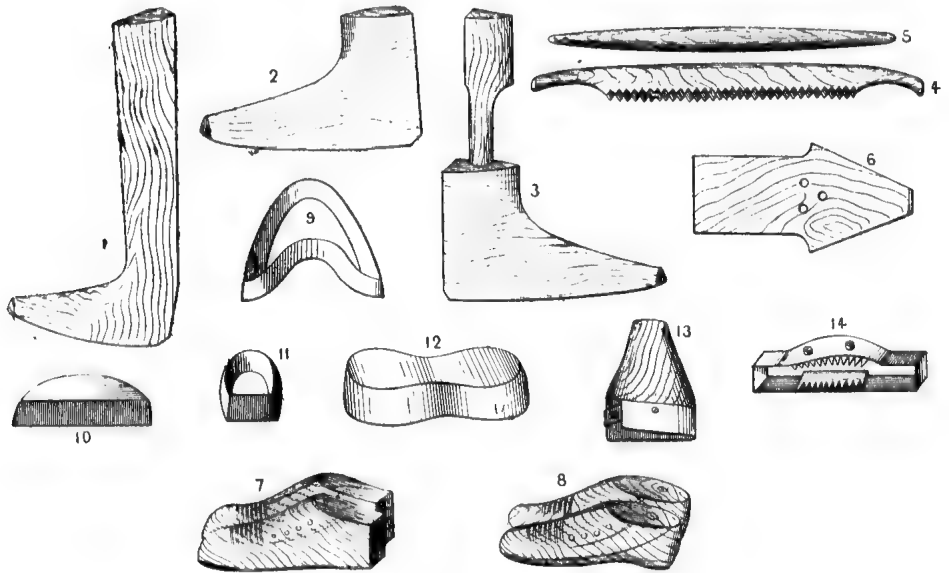

FIG. 120.—Shoemaker's Tools.

(a) Those which make their own pegs as the Lemerrier, the Cabourg and the Duméry machines.

(b) Those which use ready-made pegs like the Mangin machine.

6. The Heel.—The heel is made by sewing a first piece of leather on the sole and piling up on this a series of pieces cut to shape. The whole is fixed in position by two long iron nails. Holes are then made and wooden pegs are hammered in. Finally a good piece of sole leather is nailed on the top.

7. Finishing.—The edges of the sole and heel are finished off with the knife, the rasp and the file. They are smoothed with a

smoothing stick and sand or emery paper and polished with a hot iron.

These operations may be carried out mechanically.

(a) With a "fraise" turning at 3,000 revolutions per minute, which shapes the soles and heels and replaces the knife and rasp ; or,

(b) With a polishing wheel 10 in. in diameter by 2½ in. in width turning at a speed of 2,000 revolutions per minute.

8. Polishing.—During all these operations the upper has gradually become soiled and its finish impaired. It is therefore pasted and polished just as described in the manufacture of French calf.

As this requires several operations the author has invented a new polish which is simply passed over the finished shoes, and gives them at once a good appearance.

	Parts.
Water	1,000
Soap	120
American potash	80
Vegetable wax	120
Sugar	150
Linseed oil	200
Lamp black	200
Alcohol	50
Glove kid gelatin	1,000

II.—MANUFACTURE OF LACES.

Laces are made out of scraps with a punch. This is done in three ways.

(a) The punch (Fig. 121) consists of a steel ribbon rolled into a spiral, one edge of which is sharpened to a cutting edge. The scrap of leather is placed on a wooden block and the punch hammered down so as to cut out a spiral piece. The distance between the successive layers of the punch is adjusted so as to be of the same thickness as the leather.

(b) When long strips of leather are obtainable the laces are cut out with a knife having several parallel blades.

When using a fixed knife of twelve blades, the end of the strip is fixed to a little roller worked by hand, the knife is then lowered

on to the leather and the piece dragged through so that it is split into eleven equal strips.

(c) A hole about $\frac{2}{3}$ in. diameter is punched in a piece of leather, which is then stretched on a table so that the hole fits tightly on a pivot fixed to its centre. On this pivot is fixed a horizontal arm which, by means of an arrangement of screws, lengthens as it

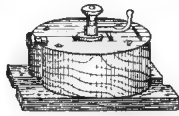

FIG. 121.—Lace-making Punch.



FIG. 122.—Plate (for polishing laces).

revolves. The end of this variable arm carries a knife which is brought down on to the leather. As the knife revolves the arm elongates, thus causing a spiral to be cut out.

Laces are afterwards slightly rounded, and then pointed.

They are rounded and polished by drawing through the plate shown in Fig. 122.

Sometimes they are bleached or coloured.

CHAPTER III.

SADDLERY.

I.—COMPOSITION OF A SADDLE.

THE framework of a saddle is made up of two bows, the hinder one corresponding in shape to the loins, and the forward one corresponding to the withers. These are bound together by strips, the whole being made of beech wood. Under the bows and strips a pad is fixed to protect the back of the horse. Above the framework are placed in succession a pad, a false seat of cloth and a leather seat. Fixed to the wooden strips are flaps of cloth or leather, which hang down so as to prevent the rider's knees from rubbing against the flanks of the horse, and to the same strips are affixed the stirrup leathers. Lastly, the saddle is maintained in position on the horse's back by means of girths, breast-piece and crupper. The breast-piece is sometimes connected with the girths by a martingale, a strap which runs on from the breast-piece to the bridle, and prevents the horse from throwing up its head.

To make this more clear we give the description of the French army saddle (modified 1874 model).

The leather used is either smooth or grained dun cow hide, or smooth yellow calf. The flaps are of fawn ox leather, from 4 to 4½ millimetres¹ thick fixed to the strips by 10 wooden pegs in front, by a screw passing through the cantle on the right side, and on the left by a hole in the flap. Six small pieces sewn on to the upper part of the flaps are fixed to the strips by pegs. The false flaps which are made of smooth cow hide 3½ to 4 millimetres thick are sewn throughout their width to the external border of each panel.

¹ A millimetre is about $\frac{1}{25}$ of an inch.

The panels are movable and are put on at the front end, and buckled at the back to the cantle. They consist of an upper part of smooth yellow calf 2 millimetres thick, strengthened with another piece of the same leather glued to the inside of the panel and of the same size as the false flap, and a lower portion of net work.

Strips of yellow calf are stitched so as to unite the upper with the lower.

An opening is made in the upper part of the panels to insert the hair which forms the stuffing.

The stirrup and girth leathers are made of smooth cow hide $3\frac{1}{2}$ to 4 mm. thick.

The quantity of cloth and grey hair required by the panels are :—

For reserve and line	{	cloth	0.50 metres (20 in.).
		hair	1.00 kilos. (2½ lb.).
For light cavalry	{	cloth	0.45 metres (18 in.).
		hair	1.00 kilos. (2½ lb.).

The mortices in the leather allow a certain amount of play to the stirrup leathers, and facilitate the arrangement of accessories. The cloth is hemp or pure linen. The breast-piece of smooth fawn cow hide $3\frac{1}{2}$ to 4 mm. thick is made up of (a cross-piece) two straps, which are fixed on each side of the bow by a wooden peg with a large head. The shoe pockets are made of smooth fawn cow hide $3\frac{1}{2}$ to 4 mm. thick with the exception of the nail pouch and the flaps which are made of grained cow hide 2 to $2\frac{1}{2}$ mm. thick. Each pocket can hold two shoes.

The two saddle bags are mounted on two straps of smooth cow hide $3\frac{1}{2}$ to 4 mm. thick.

The right saddle bag contains a case of hide 3 to $3\frac{1}{2}$ mm. thick intended to hold a dynamite cartridge. This cartridge, made of a single piece, is fixed in a mandril to give it shape. In the covering of this bag and close to the strap, is an opening through which the handle of a hatchet is fixed. The flap is prolonged over the handle of the hatchet.

In the right bag is a pouch made of leather strips which can hold four packets of cartridges.

These bags consist of grained cow hide 2 to $2\frac{1}{2}$ mm. thick.

The pommel strap, the saddle bag straps and the reins are made of smooth cow hides $3\frac{1}{2}$ to 4 mm. thick.

The girths are smooth buff ox hide 5 mm. thick. They are fixed to the bow by strong Hungary leather laces 9 mm. wide. The stirrup leathers are of 9 mm. ox hide. The sword belt is ox hide 4 to $4\frac{1}{2}$ mm. thick. The bridle and the halter are smooth cow hide $3\frac{1}{2}$ to 4 mm. thick.

The stitches are made with saddler's thread No. 8. This is used triple or quadruple, twisted and waxed with white pitch, the stitches being first marked with a special instrument giving 8 or 10 punctures to the inch. The awl used is 2 mm. diameter for 3 threads or 2.5 for 4. All the holes are made by hand. Those of the false flaps, the breast-piece, the saddle bags, the straps, the stirrup leathers and the belt are marked out with a stamp of 8 per in., and sewn with quadruple thread. The panels and the borders of the saddle bags with triple thread (8 stitches to the inch), and the shoe pockets, bridle and collars with triple thread, 10 stitches per inch.

II.—CONSTRUCTION OF A SADDLE.

1. Construction of the Tree.—The dimensions of the bows are either taken from model tables or from actual measurements of the horse for which the saddle is intended. These measurements are made with a pair of compasses, which have curved legs, and with a tape.

The wood is first cut with a saw into the bow shape, dressed with a hatchet and finished with a rasp. The pieces which are 7, 9, or even 12 in number are united by means of glue.

The finished bows are now united temporarily by nailing on three false strips. The true strips are then prepared, adjusted and glued into position. When the glue has set, the temporary strips are removed, and the framework is complete.

The framework is bound with strips of leather, or sized thread, then the cloth, which has been cut out to shape, is stretched over the frame and glued in position.

The iron work is fixed, then the straps and the false seat.

The straps consist of two bands running from one bow to the other, above and below, and two crossed straps. The false seat is made by nailing on cloth.

2. Quilting.—The seat is cut from leather according to the required pattern, folded, stuffed with hair and compressed flocks or flannel, and sewn up. The seat is placed on the false seat between the bows, and sewn first at the back, then at the front to the cantle, leaving openings for the insertion of the stuffing.

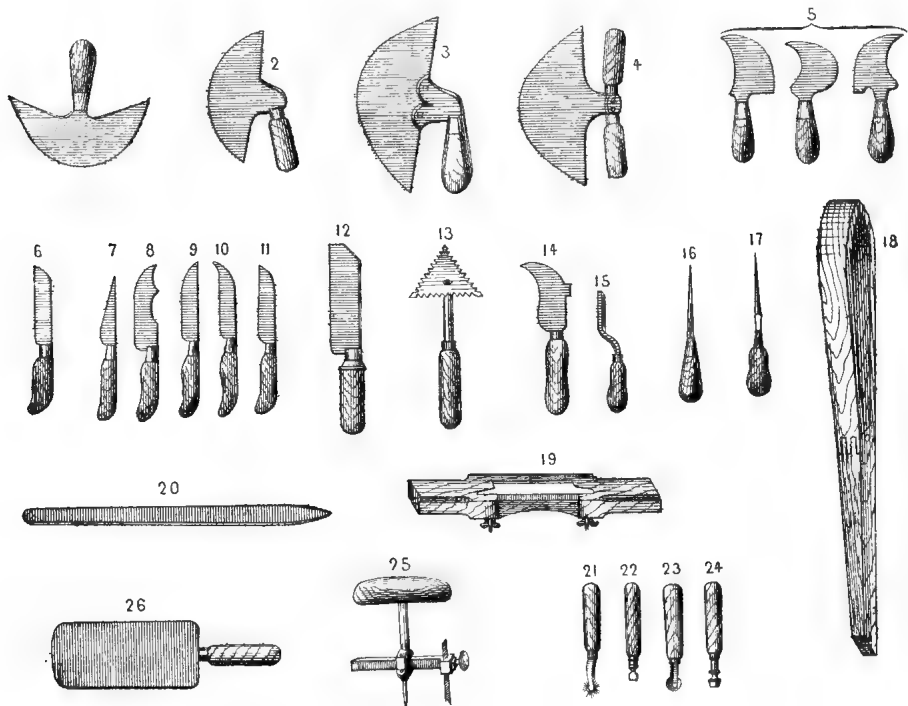

FIG. 123.—Various tools for working leather.

3. The Flaps.—A tanned sheep skin (basil) is stretched on a table, and a piece of cloth of the same size glued on to it. When dry it is unstretched and the flaps cut to the required shape. A sheep skin ordinarily makes two flaps. When fancy cloths, velvet, or Russia leather are to be glued on, they are fixed in the same way.

Sometimes the flaps are curved as in hunting and English saddles. This is accomplished by stamping them before they are quite dry. The hollow is filled with hair, kept in position by a strip of cloth glued at the edges.

The linings of the flaps are called false flaps. They are made of cloth or soft leather of the same shape as the flaps. They are really panels stuffed with wool to protect the flanks of the horse.

The panels under the bows are made of the same materials as by the false flaps.

4. Ornaments.—Designs are made either by fancy stitching or by embossing the leather.

The design is first stencilled on the leather with a perforated paper design, through which chalk is rubbed. The chalk marks are then gone over with a special instrument, which is pressed into the leather so as to leave a furrow.

For little designs like flowers and leaves, small stamps known as rosettes are used.

CHAPTER IV.

HARNESS.

I.—THE PACK SADDLE.

This is a saddle placed on beasts of burden, chiefly asses and mules, to enable them to carry bulky packages. It consists of a wooden stock or bow, made up of two curves, two boards and a panel. It is usually kept in position on the beast's back by four different straps. Firstly, a belly-band, secondly, a crupper with a tail-piece, thirdly a breast-strap, and fourthly a breech leather.

The details of manufacture are as follows :—

The saddler receives the stock roughly cut out, and finishes it with a hatchet and a rasp. He puts it together, fixing the lobes and the curves with four nails, two in front and two behind. The panel is then fixed on. It is made from a sheep skin which is moistened, stretched and folded lengthwise, grain side out, then cut to fit the stock. This is lined and bound with cloth, and stuffed with straw, which is held in position by waxed threads which run through it after the fashion of a mattress.

The panel is then fixed on the stock by a long leather strap which passes through holes in the panels, and on through holes specially drilled in the bows. The two ends of the strap are sewn together. Little straps are then passed from each corner of the panel through a hole in the middle of the lower part of each lobe, where they cross and are taken on and nailed to the point of the bows.

The pack-saddles are ornamented in various ways.

The simplest form of a pack-saddle is simply a long cloth cushion, stuffed with straw, which is strapped on the back of the animal and held in position by a crupper.

II.—HARNESS.

1. **Shaft Harness.**—When carts or drays are drawn, as is mostly the case in France, by teams of horses, the shaft horse is the one which bears the greater part of the harness.

2. **Bridles.**—The halter, which is the simplest form of bridle, consists of a set of straps which are fixed together to form a head-piece, a nose-band, two cheek-straps, a throat-band and a long leading-rein.

A bridle consists of a head-stall, cheek-pieces, with or without blinkers, a nose-piece, bit and reins.

The cheek-straps consist of two strips of leather fixed to the rings of the bit, the left cheek-strap passing upwards over the head to form the head-stall, and joining the right cheek-strap, to which it is firmly sewn. This forms the foundation to which the straps are fixed. It is usual to place buckles wherever necessary, so that any part may be lengthened or shortened at will.

The blinkers are coverings for the eyes which limit the vision of the horse and concentrate its attention on that which is immediately before it.

3. **The Collar.**—A basil is soaked in water until thoroughly softened, then stretched on a table and folded down the middle, grain side within. The fold is firmly pressed so as to become permanent. It is unfolded and cut up into the different parts which, when pieced together, forms the case whose shape is so well known, and which is eventually stuffed with straw. The pieces are sewn together with triple-waxed thread. A strip of cloth is sewn on the back of the leather near the front edge, the leather is then bent back to form a hem, and sewn close up to the edge of the cloth. The hem is stuffed with barley straw so as to be hard and round. The collar is then stuffed with a central stuffing of straw, surrounded by horse hair, then ox hair, and finally, outside with calf hair, and well beaten to compress the stuffing.

The collar is now merely a long, straight cushion. It is bent round into the required shape, and the ends sewn up with unwaxed thread. Afterwards, the various ornaments and accessories are added.

The collar consists of the head, or point of union, which is the thickest part, the body, the opening, the cap, a piece of leather over the head, the belly, which is the widest part of the back and the hames.

After shaping the collar the cap is sewn on, and two rods of beech wood, fitting exactly to the shape of the collar, are fixed on by straps running through specially made holes. Straps are fixed on each side of the collar for the attachment of the traces or chains.

The donkey collar, which opens below, was adopted for the artillery in 1856.

4. The Saddle.—This is the piece of harness lying across a horse's back to support the shafts. Two wooden bows are united by two lobes on which are placed two crossed straps. A cloth lining is nailed on over the bows; the framework is covered with leather, and stuffed with straw or hair. The panel is fixed as in a pack-saddle, and a buckle is sewn on top for the bridle rein.

5. Ridge-band.—This is a strip of leather 20 centimetres (8 in.) wide, folded upon itself. Through the fold is passed a strap 8 cm. ($3\frac{1}{2}$ in.) wide, sewn to the lower part of the leather. To the end of these straps are fixed little iron rods which are as long as the strap is broad, and which are prevented from slipping out by round heads at each end. A hole is cut in the straps, close up to the iron rods, so that the central part of the rods is left bare.

The band is placed over the saddle and the two ends receive the hooks on the shafts.

6. The Belly-band.—This is a wide belt, nailed under the right lobe of the saddle, and passing under the belly of the horse and buckling on the right lobe.

The belly-band is made of thick leather, 6 or 7 centimetres wide (2 to 3 in.). The shaft-band is a little wider and runs from shaft to shaft, just in front of the belly-band.

7. The Breech-piece.—A piece of harness fixed around the rump of the horse and attached to the shafts by means of which, the cart can be held back during a descent. It consists of a double strap along the back and another running horizontally round the

rump. These are united by three straps down each side, all the top joints being made by rings which are padded underneath to prevent injury to the horse. The breech-piece is fixed in front to the saddle.

8. The Crupper.—This keeps the harness in position on the horse's back ; it is a stuffed tube of leather, bent round in half oval, which passes under the horse's tail and is attached in front to the two branches of a forking piece of leather. It is attached to the upper strap of the breech-piece.

9. The Harness of a Leader.—This consists of the following parts :—

The Pilcher, a piece of cloth with a leather flap to which the crupper is attached

The Back-band is a strap 5 centimetres (2 in.) wide, which passes over the pitcher and holds up the chain sheaths on each side.

The Sheaths are made of tanned leather 35 centimetres (14 in.) long, by 15 centimetres (6 in.) wide, rolled up and sewn together at the edges.

The Traces are cords or chains, with a ring at each end. The front ring is fixed to the collar, and the back one to the shafts of the cart.

The False Back-band is a little strap with an iron ring at one end, and fixed by the other end to the saddle. The reins pass through the ring.

A cord passes the left flap of the collar of the shaft horse. The shorter end is fixed to the reins of the shaft horse, and the longer to the reins of the leader, so that the waggoner may drive both horses with the same rein.

10. Pole Harness.—In some carriages the horses are harnessed one on each side of a pole.

The saddle is made of two straps with a sheep skin between them. The lower strap is 15 centimetres (6 in.) wide, and the upper 9 centimetres (4 in.). The whole is sewn together, and an iron ring fixed on each side ; this is placed behind the collar. A thong is fixed to one ring, passed through the rings at the head of

the pole and brought back to the other ring of the saddle. Another thong is fixed to each ring, passed backwards and attached to the breech-piece.

The breech-strap is a strong strap which passes through one of the trace rings, round in front of the breast of the horse and through the other ring. The two ends are buckled to the larger ring of the breech-piece. An iron hook is fixed to that part in front of the horse's breast, and to this hook are fastened the chains of the pole. This enables the horse to hold back the carriage when descending a hill.

11. Carriage and Fancy Harness.—This only differs from the harness already described in its smallness, finish and ornamentation. The collar is small, opening below, and the hames are made of steel rods, covered with leather and scarcely visible. The saddle is replaced by a panel of calf lined with cloth and stuffed with hair. The breast-pieces are made of ox hides bent round into tubes. All the other pieces are made small and elegant, and ornamented with nickel silver, silver and silver gilt.

CHAPTER V.

MILITARY EQUIPMENT.

1. **Hats and Caps.**—The shako used by the cavalry consists of body, cap, shade, pompom, gusset, the straps and lining.

The body is made of cow hide, stretched, pared and calendered to 2 mm. thickness, and stitched with waxed thread. The edges are bevelled carefully at the lower edge so that there may be no projecting parts likely to bruise the head of the wearer.

The cap consists of strong black grained cow hide. The shade or peak is of strong cow hide 4 mm. thick, enamelled on the flesh side and bound with copper.

The gusset is of cow hide 2 mm. thick. The chin-strap is black enamelled cow hide. The lining is basil (tanned sheep skin). The Chasseurs d'Afrique and the reserve cavalry have cardboard helmets with shades, chin-straps and lining similar to the same parts of the light cavalry shako.

2. **Belts.**—Belts are made of blackened, half-curried cow hide. The strip of leather is from 3 to 3·5 mm. thick. The D-shaped ring is fixed on to the thickest end. Belts are made in three sizes: 1·15 metres (3 ft. 10 in.), 1·05 (3 ft. 6 in.), and ·90 metres (3 ft.).

3. **Slings.**—Rifle, carbine, or musket straps are 2·5 to 3 mm. thick. The button hole should be of the same size as the stem of the button.

4. **Holster.**—The revolver case and belt are made of brown leather. For cavalry it consists of stiff half-curried leather. The trigger guard and the sights fit into enlargements which prevent any chance of rubbing. The lid is roughened by stitches so that it is

readily opened. The joints must be stitched and not simply cemented.

The belts are made of half-curried leather of even thickness.

For infantry the black case and belt is exactly the same excepting that, after it is finished, it is painted black.

5. Water Bottle Slings.—The slings for the litre water bottle are made from simple strips of lightly-curried cow hide, blackened on the flesh side, from 2 to 2·5 mm. thick. The thinner end is folded back around a copper buckle and sewn up with waxed thread.

The other end is rounded and pierced by two copper bound holes 22 mm. in diameter. The first hole is 15 mm. from the end and the second about 50 mm. from the first. The total length is 1·46 metres (4 ft. 10½ in.) and the width 0·02 metres (nearly an inch).

The cavalry sling is made of blackened cow hide 2½ mm. thick. One of the ends is pierced by two button holes 20 mm. diameter. The first hole is 350 mm. (14 in.) from the sheath and the second 100 mm. (4 in.) from the first.

The strap is folded so that both button holes may be fixed on one button, and in the loop so formed is placed a little buckle whose tongue runs into a hole half-way between the two button holes. This buckle is fixed also to the other end of the strap, which has 12 holes punched in it at intervals of 20 mm.; a sheath is sewn on this belt, made of black leather in the form of a truncated cone. This sling is usually made of two strips of leather which are joined together at the point where the bottle case is sewn on. The total length is 1·9 metres (7 ft. 6 in.).

6. Cartridge Pouch.—This is made entirely of leather and consists of back, front and bottom.

The back is made of cow hide blackened on the grain side, and curried with tallow, about 2·5 millimetres thick. The lower part is cut in a rectangle, but the upper part, which is to form a top, is rounded to the arc of a circle. A flap is sewn on to this semi-circular lid and a button hole stamped in its centre about 35 mm. from the seam.

A flap of black leather 2·5 mm. thick is sewn on to the middle of the back of the cartridge case, and at the end of the flap is fixed a ring of galvanised iron by which it may be suspended from the belt.

The front, made of the same leather as the back, is nearly a rectangle, the top being hollowed so that the height at the centre is 8 mm. less than at the edge; 27 mm. from the lower edge is the copper button to which the upper flap is fixed. The rivet of the button is covered on the inside of the pouch by a disc of leather.

The bottom, which is continued around the sides, is of cow hide, blacked on the grain, clean on the flesh, 2 mm. thick. This is sewn on to unite front and back, and a flap is left projecting at the top of each side which may be folded in under the main flap of the pouch. Two threads of iron wire are run through, one 30 mm. and the other 60 mm. from the bottom, fixed at the ends to two flat strips of tinned iron. Between the wire stitches are sewn strips of leather which reach to within 25 mm. of the bottom.

7. Shoes.—The Neapolitan boot consists of the upper, the hind quarter, the external or strong sole, known as the second sole, the interior or first sole, the welt, the spur and the different parts of the heel.

The upper and hind quarter are of split cow hide well curried; each part is made out of one piece. It should be perfectly tanned, without a trace of greenness, and also well curried. The leather should be about 2 mm. thick, varying a little according to the length of the boot. The upper hind parts are placed grain side within.

The outer sole (external) is of tanned sole leather. Its thickness is at least 5 mm.

In cutting out soles the very ends of the skin are to be avoided, as they are apt to be insufficiently tanned. Before using, the sole is well beaten to consolidate it and make it more durable.

The interior sole is of ordinary smooth cow hide 2 to 3 mm. thick.

The welt is made like the first sole, of one piece of smooth cow hide 2·5 mm. thick.

The spur straps are cut from the poorer part of the hide.

Boots are made like Neapolitan boots, and the kinds of leather used are the same. The uppers are in two pieces of curried cow hide. The front piece is bent cold. The other, forming the back, is strengthened below by an extra strip. The heel should consist of seven strips of cheap leather and one of good sole leather.

Shoes are made in the same way. In Germany each regiment is expected to make its own shoes. Each battalion has ten shoemakers, and each regiment eighteen. There are altogether 375 military workshops, each managed by an officer who has been a shoemaker up to the time when he entered the army. All the details of regimental shoemaking are under the direction of a committee of officers presided over by the colonel.

A regiment in peace time uses 150 pairs of boots and 100 pairs of shoes, or for an army corps 2,000 pairs of boots and 1,100 pairs of shoes.

8. Haversacks.—The haversack consists of a wooden frame covered entirely with cloth and with a supple leather. The accessories, such as straps, etc., are sewn on with triple-waxed thread. The lid when closed overlaps the sides 10 mm. and the bottom 20 mm.

CHAPTER VI.

GLOVE MAKING.

THE best gloves are made from kid, and ordinary ones from sheep and lamb skin. Glacé and suède gloves are made from tawed skin, and deer skin and beaver gloves from chamoyed skins.

The first operation is paring, which is done either with the lunette or glover's paring knife (Fig. 123). The skins are then moistened and folded grain to grain, and placed in a press. Next they are stretched and softened by drawing them backwards and forwards over the marble edge of the table.

The skins are cut up into rectangles which are stretched out on the marble table, flesh side up, and pared with a wide-bladed smoothing knife (Fig. 123) to thin down the stouter parts of the skin and make it more supple.

Two pieces of skin are placed together, grain to grain, slightly moistened, so that they stick together, and the back and front of the glove are cut out by a stamp which marks out the holes for the stitches at the same time. The Jouvin machine cuts the thumb out together with the fingers. The strips which run down the sides of the fingers are next cut out from the remnants of the skin and the whole sewn into position.

The fingers of the glove are stretched with glove stretchers covered with soap powder, and the rest of the hand and thumb stretched on a wooden hand.

After stretching, the gloves are wrapped up in a moist linen and beaten, then folded and pressed.

The finished gloves are perfumed. In the Provençal method they are placed in layers in a box with intermediate layers of flowers.

Every twenty-four hours the gloves are hung out to air for an hour, and put back with fresh flowers. The process is repeated seven or eight times. The ordinary method is to rub gloves with perfumed oil.

France manufactures gloves of all sorts. Austria and Germany make kid specially for this work. Vienna and Prague are the chief centres. The United States also produces large quantities of gloves. It is the chief manufacture of many towns: Gloversville, Johnstown, Hamilton, Saratoga and Montgomery have 300 factories, employing 25,000 people and producing 10,000,000 pairs of gloves.

Under the administration of General Farre, on the 22nd of July, 1881, French soldiers were ordered to carry kid gloves; this was done at the suggestion of M. Antonin Proust, deputy for Deux-Sèvres. The order was rescinded on 28th October, 1882.

FANS.

We need not speak of fans such as are made of lace, tulle, gauze, feathers, satin, etc., but we should point out that sometimes they are made from swan, grebe, and golden pheasant skins.

Others are made of folded paper lined with kid.

CHAPTER VII.

CARRIAGE BUILDING.

CARRIAGES, landaus, coupés, phaetons, victorias, etc., are generally upholstered and fitted with leather, and it is from this point of view that we shall treat the subject of coach-building.

1. **Closed Carriages.**—The fitter receives the frame-work of the carriage from the builders. He takes it to pieces as far as possible, and starts by upholstering the interior. The first thing is lining, by glueing strips of cloth cut to the requisite shape on the inside. The vehicle is turned over so that whichever part is being upholstered becomes horizontal. A layer of hair is carefully spread over the lining, and a second cloth nailed on top. The material which is to form the final covering is sewn on to the upper cloth.

Double upholstering consists of placing another layer of hair over the second cloth, and covering the whole with a third cloth. The sides of the carriage are always stuffed in this way.

The cloth or leather is edged with some kind of braid which is nailed on with round-headed nails around the doors and windows.

The seat is composed of two boards, one horizontal, and the other, which is narrower, vertical. A basil is cut to the exact shape of the seat, and a long strip of the same material is also cut out and sewn all round the edge of the former piece, so that it stands up vertically and forms the frame-work of the cushion.

A layer of hair is placed in this frame-work, then a piece of cloth, and then a thick layer of feathers. The whole is covered with a piece of cloth which is sewn on to the leather by means of a piece of braid or an edging of leather.

Spring cushions are sometimes used which contain spiral springs

of copper. The top of the carriage is usually made of black ox or cow hide, whilst the outer panels are painted or varnished. The coachman's seat is covered with a cushion stuffed with hair. The bottom is strong leather, the edges, basil, and the top cloth are covered with strips of calf at the places where the straps run, which fix it to the seat.

The mud-guards and splash-boards are cow hide stretched on iron frames.

2. Open Carriages.—The general details are the same as for closed carriages with the exception of the hood.

This is cut according to pattern out of cow hide, and softened by soaking in water. It is then stretched on a frame to remove creases, and allowed to dry, rubbing it from time to time. When dry it is removed from the frame and the lining, usually of cloth, glued on. It is now ready to be stretched on the iron frame-work of the hood.

CHAPTER VIII.

MECHANICAL USES.

1. **Bellows.**—Leather bellows consist of two kite-shaped pieces of wood joined by leather hinges to a smaller piece of wood at their narrow end. Through this smaller piece passes the blast tube. The two pieces are joined all round by a strip of pleated leather nailed on to their edges. The lower board has a leather valve. When the two boards are drawn apart, the air rushes in through the valve, but when pressed together it is forced through the blast pipe. In forge bellows, however strong the leather may be, it is apt to fold badly, so that it is generally arranged on a series of frames.

Some bellows are divided into two compartments which communicate by means of a hole through the partition. The lower compartment fills with air in the ordinary way, but instead of forcing it directly into the blast pipe, it passes it on through the valve in the partition to the upper chamber. The upper chamber has a weight above so that it forms a sort of spring reservoir, which emits a continuous blast.

Rabier's triple bellows consists of three compartments one above the other. The two lower compartments take in the air through four valves and force them through three others into the upper chamber. The lower board of the middle chamber and the upper board of the lower are fixed, whilst the diaphragm between them is movable. As this rises the lower chamber fills, as it falls this discharges into the middle, and on rising again the same lot of air is forced into the upper chamber, which is merely a weighted reservoir. This gives a very steady blast.

Another triple apparatus has been invented by Jeffries and Halley. It consists of a single leather bellows contained in an iron case which forms a cistern in which the air is compressed. From the iron reservoir the air passes into a large horizontal leather bellows to which is fixed the blast pipe.

2. Leather Tubes.—For fire-engines and street-watering leather hose-pipes are used which are sufficiently supple to carry the water through all sorts of sinuous passages. These hose-pipes need no special description; we need only mention that they are sometimes sewn with waxed thread or brass wire, but are better riveted. When they are used for aspirating air they are fitted inside with rings of copper to prevent collapsing.

3. Pistons.—Pump pistons are cylindrical pieces of metal furnished with valves. Usually these flap-valves are fixed above, and close by their own weight. They are shod with leather whenever practicable.

4. Various.—The use of leather in mechanics is very widespread: washers, polishing wheels and many other parts of machinery consisting of leather.

APPENDIX.

THE WORLD'S COMMERCE IN LEATHER.

I.—EUROPE.

1. **France.** — Area, 204,090 sq. miles; population, 37,321,000. The leather and skin industry is one of the most important in France. It is carried out all over the country and employs a large number of workmen.

The beast population of France is: —

Cattle	81,647,795
Horses	2,845,143
Sheep	21,634,706
Goats	1,497,114
Pigs	36,500,000
Mules and donkeys	750,000

In France 1,540,000,000 lb. of meat are consumed, which represents 137,500,000 of lb. of skin. Here, for instance, are the statistics of the Paris slaughter-houses for the year 1885: Bullocks, 185,611; bulls, 15,970; cows, 48,871; calves, 227,476; sheep, 1,776,210. France imports 212,000,000 lb. of large raw hides which come from the following countries: England, 2,026,132; Belgium, 243,827; Germany, 2,388,000; Holland, 1,371,000; Switzerland, 608,010; Uruguay, 6,604,626; Brazil, 8,164,129; Argentine Republic, 4,122,722; other countries, 8,235,193; representing a total value of £2,375,060.

Of small raw skins (rams, sheep, etc.) France imports 58,700,000 lb. which are made up as follows: Uruguay, 1,580,000 lb.; Argentine Republic, 52,900,000 lb.; Algeria, 292,000 lb.; other countries, 6,220,000 lb., having a value of £2,547,627. The total imports of lamb skins are 1,325,000 lb., having a value of £76,054; kid skins, 3,770,000 lb., having a value of £540,496.

Altogether France produces £24,800,000 worth of skins for tanning and receives £6,400,000 worth from abroad, giving a total

of £31,200,000 worth, from which must be subtracted the value of the exports, that is, £2,560,000, leaving £28,640,000 worth of skins of all kinds which are used for leather making in France.

Tanning materials.—In France there are 22,600,000 acres of woods and forests, of which 2,380,000 acres belong to the state; 5,150,000 belong to public establishments; 15,100,000 to private individuals. The principal forests are—in the North: Fontainebleau, Compiègne, Rambouillet, Mormalet and Villers-Cotterets; in the East: la Haye, the Vosges mountains, Jura mountains, Chaud, Grande-Chartreuse; in the West: Lyons, Bercé-Percoigne and d'Ecouves; in the South: Quillau, Soule, Lannes; in the centre: Orleans, Tronçais, Vierzon, Châteauroux and Bertranges-Guérigny.

The greater part of the bark from French forests comes from the rouvre and pedunculate oak which produce 110,000,000 lb. The yeuse oak produces 11,000,000 lb., and the kermes oak produces 11,000 lb. The Aleppo pine produces 550,000 lb. and the picea 1,606,000 lb.

France imports about 26,500,000 lb. of bark and exports 88,000,000 lb. The imports are chiefly from Belgium and Algeria, and the exports to Belgium, Germany and Switzerland.

Leather.—Paris is the most important centre of leather manufacture of all kinds. The following are the centres where different kinds of leather are manufactured:—

Sole Leather.—Château-Renault, Givet, Saint-Saens, Pont-Audemer, Coulom-miers, Saint-Avoid, Saint-Hyppolite, Montbéliard, Magny, Vernon, Rennes, Sierk, Alençon, Abbeville, Argenton-sur-Creuse, Semur, Montargis, and Fécamp.

Glacé—Château-Renault, Magny, Avallon, Longjumeau, Moulins, Ville-neuve-sur-Yonne, Nogent-le-Rotrou, Gironde, Montfaucon-sur-Moine and Ferté-Bernard.

Hood Leather.—Paris, Port-Launey, and la-Suze.

Black and White Calf.—Paris, Millau, Lyons, Nantes, Bordeaux, Roanne, Montpellier, Vitré, Aubusson, Rouen, Guise (Aisne), Garron, Moulins, Valence, Bazas, Graulhet and Carcassonne.

Tawed Skins.—Paris, Chaumont, Annonay, Grenoble, Montpellier, Lyons, etc.

Chamois Leather.—Niort, Amiens, Givors, Beauserré, Enencourt, Leage, Tyre-le-Château.

Parchment.—Issoudun, Villedieu, Paris.

Kid and Morocco.—Marseilles, Paris, Lyons.

France imports 3,115,000 lb. of tanned hides, worth £826,733;

221,000 lb. of curried hides, worth £34,238; 69,800 lb. of tawed skins, worth £38,033; 260,600 lb. of morocco and fancy leather, worth £100,000.

The exports are: tanned hides, 7,050,000 lb., worth £644,819; curried skins, 14,400,000 lb., worth £2,595,214; tawed skins, 244,000 lb., worth £147,139; dyed leather, 570,000 lb., worth £152,927; other leather, 1,450,000 lb., worth £417,881.

Manufactured Articles.—France annually imports £280,000 worth of manufactured leather goods, and exports £5,350,000 worth. The exports of boots and shoes alone are worth £3,000,000.

2. Belgium.—Area, 14,533 sq. miles; population, 5,536,185.

The beast population is proportionally larger in Belgium than in any other country of Europe.

Horses	283,660
Asses and mules	11,849
Cattle	1,242,445
Sheep	586,097
Goats	197,138
Pigs	632,301

Belgium has an enormous trade in raw hides (57,821 tons). Antwerp has the largest trade on the continent. The transit of skins through Belgium is very great. While the exports are only 1,907 tons the quantity which passes through Belgium is 3,025 tons, which has a value of £750,225.

In 1886 Antwerp imported 1,194,965 hides, exported 899,723, whilst 280,437 passed through the port. Belgium exports 2,500 tons of raw hides to France.

Tan.—The Belgian forests cover more than a million acres, and produce 4,500 tons of bark; 1,500 tons are annually imported from the French Ardennes. Belgium further imports 4,000 tons of quebracho, 2,000 tons of African bark, 60 tons of myrobolans, 1,000 tons of valonia, 3,000 tons of hemlock extract.

Leather.—All kinds of leather are manufactured in Belgium, sole leather being the principal. Liège, Stavelat, Verviers, Hey and Herve are the chief centres of the manufacture and commerce.

Stavelot, Louvaine, Soignies, Namur, Tournai, Houffalize, Brussels, manufacture sole leather. Stavelot alone has thirty tan-yards.

Liège, Tournai and Verviers manufacture glacé leather. The number of hides worked at Liège amounts to 50,000.

Alost, Ghent, Mimes, Tournai and Brussels manufacture waxed calf.

Patent leather is manufactured at Anderlecht-les-Bruxelles.

Herve is *par excellence* the town of shoemakers. Out of 4,600 inhabitants nearly 3,000 are employed in this industry.

Belgium exports 808 tons of tanned leather to France, 360 tons to Germany, 115 tons to Switzerland, 112 tons to Holland, and 103 tons to England, whilst 8,000 tons annually pass through the country.

Belgium imports £72,720 worth of made-up leather articles, such as boots, belts and harness and exports £69,455 worth. On the other hand, £204,840 worth of these articles passes through the country.

3. Germany.—Area, 208,437 sq. miles ; population, 45,234,000.

Hides.—The beast population of Germany is :—

Cattle	16,000,000
Sheep	25,000,000
Goats	2,750,000
Horses	3,500,000
Pigs	7,000,000

The rearing of cattle is carried out on a very large scale in Southern Germany. The exports in living animals are worth £50,280. The imports and exports of hides have been taken from the statistics of the Zollverein, which does not comprise the ports of Hamburg, Altona, Bremen, Bremerhaven, Gesterunde and Bracke, nor certain towns in the grand duchy of Baden. On the other hand, it includes the grand duchy of Luxemburg and the town of Jungholy in Austria.

Imports : 1,715 tons of green ox hides ; 37,675 tons of salted ox hides ; 7,775 tons of green calf skins ; 8,286 tons sheep skins ; 6,538 tons horse skins ; and 2,157 tons of undressed furs.

Exports : 842 tons of green ox hides ; 7,480 tons salted ox hides ; 5,025 tons of green calf skins ; 2,499 tons of sheep skins ; 520 tons of horse hides, and 1,681 tons of undressed furs.

Tan.—The most woody parts of Germany are the great duchies of Hesse and Baden, next comes Bavaria. The percentages of forest land to total area of the various parts of Germany are as follows :—

	Parts.
Prussia	23
Bavaria	32
Saxony	30·5
Wurtemberg	30·6
Baden	33·4
Hesse	32·7
Mecklenburg	13·3
Other parts	19·7

Germany imports 15,800 tons of bark from France and about the same quantity from Hungary.

Leather.—Tanning is practised in all parts of Germany. German leather usually has a good appearance, but is of poor quality.

Prüm, Trèves, Cologne, Ehrenbreitstein and Hanover make sole leather.

Hamburg, Altona, Wickrath, Odenkirchen, Potsdam, Breslau, Schandorf, Brunn, Neumünster and Schleswig manufacture horse leather.

Bensheim, Endigen, Kunzelsau, Stuttgart, Ulm, Dresden, Munich, and the Palatinate are famous for curriery and waxed calf. Glacé leather is manufactured at Eberstadt, Frankfort.

Worms and Bopfigen make patent leather.

Munich and Bavaria make tawed skins.

Finished goat skins are manufactured in large quantities in Germany, as many as 40,000,000 skins being used. The centre of this manufacture is Kirn a/d Nahe. Mayence manufactures shagreen and morocco. Altogether Germany imports 2,373 tons of leather and exports 3,655 tons.

Finished Goods.—Germany imports 395 tons of coarse boots and shoes and exports 1,728 tons. Of fine goods the exports are 4,815 and imports 445. Of gloves the exports are 250 tons and imports 60 tons.

4. England. Area, 58,311 sq. miles; inhabitants, 33,000,000.

The beast population is:

	England.	Wales.
Horses	1,094,103	137,167
Cattle	4,160,085	655,345
Sheep	15,382,856	2,466,945
Pigs	1,733,280	191,792

Large numbers of these animals are also reared in the Isle of Man, Jersey and Guernsey.

England imports £5,760,000 worth, or 80,000 tons of green hides, foreign hides forming 70 per cent. of the material used in the tanneries.

English sole leather is not of very high quality. It is manufactured at Bristol and Avonside. Saddlery leather is made in Edinburgh, morocco in London and Leeds, hat leathers in the neighbourhood of Manchester, and fancy goods in Kendal.

England exports £3,363,074 worth of leather and hides, £1,877,444 worth of boots and shoes, and £1,270,887 worth of various made-up articles.

English imports are £9,296,663 worth of leather, and £351,525 worth of boots and shoes.

The total annual consumption of leather in England is 99,450 tons. The production in 1890 was 5·4 lb. per head of the population as against 2·7 lb. per head in 1840.

London carries on a large trade in raw goat skins. In 1883, it imported 4,749,895 skins.

5. Austria.—Area, 116,000 sq. miles ; population, 22,144,000. The beast population is :—

Horses	1,456,000
Asses and mules	43,000
Cattle	7,500,000
Sheep	5,200,000
Goats	1,000,000
Pigs	2,600,000

Eighty-five thousand cattle and 200,000 sheep are exported alive.

The imports of raw hides are : 528 tons of calf skins ; 2,863 tons of sheep and goat skins ; 2,969 tons of lamb and kid skins ; 5,100 tons of ox hides ; and 12,794 tons of other skins.

The exports are : ox hides, 400 tons ; calf skins, 1,912 tons ; sheep and goat skins, 855 tons ; lamb and kid skins, 651 tons ; rabbits and hares, 198 tons ; and other skins, 3,137 tons.

Austria possesses 3,860,000 acres of forest, or 31·67 per cent. of its total area, and the products of this forest land are very important. Half belongs to private individuals, a quarter to the clergy, and a quarter to the crown.

The forests annually yield 39,000 tons of tan, and from 3,000 to 4,000 tons of sumach.

Austria imports 1,000 tons of knoppers ; 300 tons of gall nuts ; 12,960 tons of valonia ; 4,500 tons of sumach ; 1,256 tons of catechu and gambier ; 15 tons of chestnut extract ; 72 tons of hemlock and quebracho extract ; 320 tons of dividivi ; and 6,110 tons of other tans.

It exports 1,000 tons of knoppers ; 128 tons of gall nuts ; 1,578 tons of valonia ; 2,472 tons of sumach ; 62 tons of catechu and gambier ; 4,153 tons of wood extracts ; and 32,054 tons of other tans.

Tanning is practised in all parts of Austria, more especially around Vienna, in Bohemia, Styria, Moravia and Galicia. In 1870 there were 3,800 tanyards, of which 160 alone employed 7,700 workmen.

Siariano is famous for sole leather, Vienna for currying, Lebersdorf for calf, and Marbour and Trieste for dyed leather.

All qualities of leather are manufactured in Austria with the exception of a few, such as patent leather, kid and morocco, which are imported from Germany.

The imports are: common leather, 497 tons; sheep and goat leather, 2215 tons; saddle leather, 710 tons; black leather, 319 tons; glove kid, 100 tons; patent leather, 145 tons; and other kinds, 254 tons.

The exports are: common leather, 610 tons; sheep and goat leather, 610 tons; saddle leather, 248 tons; black leather, 116 tons; glove kid, 10 tons; patent leather, 17 tons; other kinds, 158 tons.

The consumption of shagreened goat skins amounts to between £500,000 and £600,000 worth.

The most important centres for tawing and chamoising are Vienna and Prague.

6. Hungary.—Area, 125,000 sq. miles; population, 15,509,455.

The beast population is:—

Horses	2,200,000
Asses and mules	34,000
Cattle	5,300,000
Sheep	15,000,000
Goats	600,000
Pigs	4,500,000

Hungary produces 2,300 tons of raw hides, including those of horned beasts, horses, pigs and dogs.

The area of the forests is 36,000 sq. miles, or 28·79 per cent. of the total area. They produce 30,000 tons of tan, of which 20,000 tons are exported. At Lipto-Uvar in the Carpathians, there is an enormous factory, where 2,500 tons of extract are prepared annually. The chief tans used are pine-bark and knop-perns.

Hungary produces most of the leather consumed in the country, but imports all the high quality leather used by saddlers and upholsterers, and exports lower class sole leather, and good quality tawed sheep and goat skins.

Of ordinary leather, Hungary produces 895 tons, and of fine materials, such as dyed and patent leather, about 75 tons.

The value of the sumach-prepared calf which Hungary exports is £5,000. Black leather is made at Debrecksen, Kekskeinet and Sabadka.

Hungary has only one glove manufactory, employing 25 workmen, and turning out annually 25,000 pairs of gloves.

7. Turkey in Europe.—Area, 125,556 sq. miles ; population, 8,500,000.

The beast population is :—

Cattle	3,000,000
Sheep	14,000,000
Goats	6,000,000
Pigs	1,250,000
Horses	700,000
Asses and mules	350,000

In Constantinople each year there are slaughtered 1,000,000 sheep, 70,000 oxen, 150,000 lambs and kids, and 120,000 goats, of which about half are mohairs.

The sheep are used for a material known as Rassabachis. Part of the woollen furs are sent to Marseilles together with the goat skins. The lamb skins go to London, the kid to Paris, and the large hides are tanned in Turkey.

Every year 200,000 hare skins are imported from Asia.

The value of the exports are : ox and buffalo skins, £4,000 ; goat and sheep skins, £32,000 ; and various, £4,832.

The country produces 1,000 tons of tan, half of which is consumed at home, and the other half exported *via* Trieste.

The port of Salonica exports £53,776 worth of leather and imports £57,693 worth.

£44,000 worth of made up articles are imported.

8. Russia.—Area, 2,063,529 sq. miles ; population, 83,600,000.

The beast population is :—

Horses	20,000,000
Cattle	30,000,000
Sheep	65,000,000
Goats	1,000,000
Pigs	12,000,000

This huge country has 3,179 large leather factories, employing 19,685 workmen and producing 38,000,000 roubles worth of leather (a rouble is about 2s.). Besides these there are 1,115 smaller tanneries producing at least 1,000 roubles worth each.

In Russia are 32 manufactories of leather articles, employing 1,700 workmen and 400 furriers.

Each year the Russian tanyards tan 10,264,218 skins.

Southern Russia produces green hides of horses, oxen, cows and calves, of which the larger part is used in the country, though

some are exported to Bulgaria, Roumelia and Constantinople. From La Plata some 1,200 skins are imported and tanned in Odessa and Sebastopol and consumed in the country; 700,000 shagreened goat skins are imported, of which 200,000 are sold in Moscow.

The exports of Odessa are 53,928 raw hides and 1,649 pairs of boots.

9. Italy.—Area, 114,205 sq. miles; population, 28,453,000.

The beast population is:—

Cattle	3,500,000
Sheep	7,000,000
Goats	1,750,000
Pigs	1,500,000
Horses	500,000

Italy produces large quantities of sole leather, saddlery leather, black and white calf, patent leather, sheep skins, glove kid, dyed lamb and kid, and belting leather.

The chief factories are at Milan, Bologna, Turin, Naples, Pescia, Modena, Varesa, Brescia and Venice.

10. Spain.—Area, 192,967 sq. miles; population, 16,551,647.

The beast population is:—

Cattle	3,000,000
Sheep	22,000,000
Goats	4,500,000
Pigs	4,500,000
Horses	700,000
Asses and mules	2,250,000

Spain annually imports 300,000 hides.

Barcelona makes sole leather, Madrid makes morocco, Valencia and Lugo black and white calf, Barcelona glacé kid, whilst Salamanca is renowned for its curriery.

There are no official returns of the Spanish leather industry, so that it is almost impossible to form an idea of its amount or value.

11. Portugal.—Area, 34,500 sq. miles; population, 4,000,000.

Portugal has 642,000 acres of forest land, chiefly pine and cork-bearing oak. It has ninety-three tanneries employing 823 workmen and producing £324,000 worth of leather. Green and dried hides are imported from Brazil (1,586 tons); the Portuguese colonies (180 tons); Germany (55 tons); and England (47 tons).

The imports of curried, dyed, patent leather, etc., are: from France, 46 tons; from Germany, 36 tons; and from England, about 3 tons.

Portugal exports 554,952 pairs of boots and shoes.

12. Bulgaria.—Area, 24,659 sq. miles; population, 2,000,000.

This country exports poor qualities of sole leather, morocco and black calf which are manufactured at Tirnova, Lovtcha, Serlievo, Gabrovo and Samokof.

Saddlers use the native leather, but better class saddles are imported from France.

Trunks and bags are all imported with the exception of the Kerbé, a little valise which is hung from a saddle. The total imports in leather goods amount to 410½ tons worth £70,368, and the exports are practically *nil*.

13. Servia.—Area, 18,786 sq. miles; population, 1,700,000.

This country only manufactures small quantities of leather, but imports all kinds.

Of sole leather the imports are: 444 tons of dyed leather; 55½ tons of dyed leather, 10,000 prepared goat skins and 100,000 sheep skins are brought into the country annually, whilst of boots and shoes the imports are worth £21,254.

The raw materials exported from Servia are: 600,000 sheep skins; 1,000,000 lamb skins; 180,000 goat skins; and about 3,000 tons of valonia.

14. Switzerland.—Area, 16,190 sq. miles; population, 2,846,000.

French Switzerland has few tanneries, and the curriery trade is not nearly so important as in German Switzerland. The materials manufactured in the country are boot leather, sole leather, cow hide, black calf, etc., whilst leather for fine saddlery, patent leather, morocco and kid is imported from France, Germany, Italy and Belgium. France sends £480,000 worth of leather, and takes back £324,000 worth.

15. Holland.—Area, 12,731 sq. miles; population, 4,060,000.

Tanneries and currieries are numerous in the country, the principal centres being Waalwyk, Tilbourg, Schoterland, Amersfoort, Eindhoven, Utrecht, Oosterhout. The last of these places has thirty-two factories.

Boots and shoes are made in Waalwyk. The Neederlandsche-fabrik van Leder-artikelen at Baarwyk makes all kinds of leather articles, and the Paardenleder-fabrik in the same place prepares only horse leather.

There are no returns published of the quantities of Dutch trade.

16. Denmark.—Area, 14,553 sq. miles; population, 1,969,000.

Denmark makes all kinds of boot and shoe leather. It imports

hemlock, valonia, dividivi, and horse leather from Hamburg. It also imports 5,238,043 lb. of raw hides ; 138,720 lb. of dyed and black leather ; and 905,752 lb. of sole leather.

The exports are 7,109,882 lb. of raw hides ; 4,600 lb. of dyed and black leather ; and 538,101 lb. of sole leather.

About 20,000 shagreened goat skins are received annually from Brussels and Paris.

17. Sweden.—Area, 12,850 sq. miles ; population, 4,565,000.

The home manufacturer of leather is of little importance, and there are no exports. On the other hand, all kinds of leather are imported. Strong leather comes from America ; shoe leather comes from Germany and Austria.

The imports of sole leather and tawed and chamoised skins are 2,500 tons, and those of other classes 2,000 tons.

II.—AMERICA.

1. United States.—Area, 3,580,000 sq. miles ; population, 50,442,066.

The beast population is :—

Cattle	29,500,000
Sheep	36,000,000
Horses	10,500,000
Asses and mules	1,500,000

The United States grows twenty-one species of oak, besides hemlock and rich tans.

All kinds of leather are made in the United States. The total imports are worth £1,300,000, whilst the exports are worth £1,940,400, nearly the whole of which arrives *via* New York.

The United States has 7,000 tanneries, 20,000 shoe factories, and 8,000 saddlery and harness works.

2. Dominion of Canada.—Area, 3,205,000, of which only 33,800 are under cultivation.

The beast population is :—

Horses	225,000
Colts and fillies	488,000
Yoke oxen	49,200
Milch cows	490,000
Other cattle	490,000
Sheep	880,000
Pigs	329,200

The tanning industry is concentrated in old Canada. There are 32

tanneries in Ontario province, 271 in the province of Quebec, 1 in Manitoba, 8 in Nova Scotia, 6 in British Columbia, 59 in New Brunswick, and 10 in Prince Edward's Island.

It imports £308,339 worth of manufactured leather, £84,320 worth of rough furs, and £353,862 worth of raw hides. It exports £72,811 worth of bark and £120,580 worth of skins and furs.

3. Mexico.—Area, 741,825 sq. miles; population, 9,500,000.

This country possesses some 3,000,000 horned beasts, and leather manufacture is practised more or less all over the country. It is almost entirely limited to sole leather. The town of Leon has thirty tanneries which employ 15,000 persons.

In Mexico very elaborate saddles are made, ornamented with silver and worth £100 to £200. There are two belting factories. Another special article is heavy riding boots.

The exports of tanned leather are worth £4,600.

France sends into Mexico 4,157 tons of ox hides, 1,691½ tons of goat skins, and 204 tons of kid.

4. Guatemala.—Area, 4,100 sq. miles; population, 1,191,000.

In this country leather is made for soles and belting. The imports are black and glacé kid, imitation morocco saddlery, etc., most of which come from England, France and Germany. Their value is about £11,372.

5. Central America.—The Republic of San Salvador exports £22,482 worth of ox hides and £1,035 worth of kid.

Venezuela manufacture all kinds of leather excepting patent leather. It exports sole leather. Its imports come from France and Germany.

Costa Rica produces a small quantity of inferior leather, which is entirely used in the country. San José has six tanneries.

The imports are: £11,266 worth of shoes; £187 worth of calf; £5,094 worth of saddlery; £10 worth of patent leather; £157 worth of imitation buffalo hide. Hayti exports 350,000 lb. of skins and imports 300,000 lb. of boots, shoes, and other manufactured goods.

6. Chili.—Area, 124,121 sq. miles; population, 2,400,000.

Chili manufactures sole leather, black cow hide and calf, goat leather and belting. It imports black and bronzed kid, glacé kid, tawed sheep skins, patent leather, black calf, tawed and chamoised calf, and exports raw hides and sole leather.

7. Brazil.—Area, 3,219,135 sq. miles; population, 11,108,290.

At Rio de Janiero are five tanneries, of which the largest employs

100 workmen. This town practically supplies the country with sole leather.

8. Argentine Republic.—Area, 1,178,310 sq. miles ; population, 2,400,000.

The mass of this country is devoted to stock raising. It possesses 15,000,000 head of cattle ; 80,000,000 sheep ; and 4,000,000 horses.

The exports are : dried ox hides, 18,000 tons ; salted ox hides, 7,100 tons ; sheep skins, 257,000 tons. The total value of these skins is more than £12,000,000. The imports are : black kid, 5,000 to 6,000 dozen ; glacé kid, 7,000 dozen ; patent leather, 4,000 dozen ; kid, 8,000 dozen ; cow hide, 7,000 pieces.

9. Uruguay.—Area, 72,000 sq. miles ; population, 447,000.

The beast population is :—

Sheep	15,000,000
Cattle	7,200,000
Horses	880,000
Mules	18,800
Goats and pigs	25,000

The chief exports are 427,371 salted and 842,008 dried skins.

III.—ASIA.

1. Turkey in Asia.—Area, 730,000 sq. miles ; population, 16,132,900.

Leather manufacture is little practised in Asia Minor. It is with difficulty that Smyrna procures the necessary bark, as the Ottoman government forbids its removal from the forests. France sends annually £60,000 worth of goods out of a total import of £100,000 worth.

The exports from Palestine are £720 worth of raw hides and about the same value of finished leather.

2. India.—Area, 3,170,000 sq. miles ; population, 313,043,560.

In the Punjab £1,440,000 worth of leather is tanned ; 1,332,000 heavy and 16,000,000 small skins are exported.

It is estimated that there are in India 30,000,000 cattle and 14,000,000 sheep and goats.

Madras exports 9,600 tons of tanned leather to America, England and Austria.

India imports from England 20,361 tons of hides and 11,000 tons of tanned leather. Other countries send 10,000 tons of raw hides and 11,400 tons of tanned leather.

The exports are 7,350,000 raw ox and cow hides and 3,780,000 smaller hides ; 60 per cent. goes to England, 10 per cent. to America, 15 per cent. to Italy, 6 per cent. to Austria, 4 per cent. to France, and 5 per cent. to other countries.

3. China.—Area, 4,561,500 sq. miles ; population, 433,694,000.

The Chinese scarcely ever use leather tanned with oak bark ; they generally prepare skins by smoking them. The soles of their shoes are chiefly made of wood or straw. There are neither exports nor imports of tanned leather.

In 1884, Shanghai sent 100,000 goat skins to New York.

4. Japan.—Area, 146,613 sq. miles ; population, 35,925,000.

The Japanese leather trade has started quite recently, and develops more every year.

Its imports are about 430 tons of all classes of leather and 805 tons of fur, the latter coming chiefly from Corea.

The exports are 703 tons, worth £26,731.

IV.—AFRICA.

1. Algeria.—Area, 257,600 sq. miles ; population, 2,867,000.

The beast population is :—

Horses	159,058
Mules	131,367
Asses	171,778
Camels	185,843
Cattle	1,500,000
Sheep	9,500,000
Goats	3,600,000
Pigs	60,000

There are many tanneries in Algeria ; Constantine alone has forty. The chief manufactures are calf, red or white sheep skins, light oiled skins and black calf.

The imports are boot leather, glacé, black goat and calf.

The exports are raw goat and sheep skins.

2. Morocco.—This country only manufactures leather for its own consumption. It imports a few hides when required and at other times exports a few. The imports and exports of tanned leather into and from Morocco are small, most of the exports going to Algeria.

3. Tunis.—Tunisia manufactures sole leather specially prepared for the Mussulmans, and dyed sheep skins for shoemaking ; these specialties are not imported. Tunis imports various classes of

leather from France to the value of £4,800, and shoes to the value of £160,000.

4. **Egypt.**—There are in this country 300,000 cattle, 200,000 sheep and 23,000 goats, whose skins are tanned at Alexandria or in Algeria. In Alexandria is a tannery where 40,000 hides are prepared yearly.

V.—AUSTRALASIA.

Area, 3,457,000 sq. miles ; population, 4,167,000.

The beast population is:—

Horses	1,067,000
Cattle	7,526,400
Sheep	63,169,000

In Victoria there are 156 tanneries, employing 1,754 workmen, with 3,614 pits, which annually tan 384,000 large and 1,433,000 small hides. The exports of tanned leather are worth over £3,000,000 ; raw hides worth £4,000 ; and boots and shoes to the value of £640,000. The imports are £1,200,000 worth of hides and about the same value in boots and shoes.

In New South Wales there are 156 tanneries which import about 4½ tons of mimosa bark from Tasmania. This colony exports £154,000 worth of tanned leather and £240,000 worth of raw hides.

In Queensland there are 28 tanneries. The colony exports £160,000 worth of hides. New Zealand imports £168,000 worth of boots and shoes.

PUB. C. O.



INDEX.

A.

- Abies canadensis*, 59.
 — *excelsa*, 59.
 — *pectina*, 59.
Acacia, 61, 76.
 — *adansonii*, 71.
 — *arabica*, 71, 73.
 — *catechu*, 71.
 — *curupy*, 64.
 — *farnesiana*, 72.
 — *indica*, 71.
 — *mollissima*, 60.
 — *nicolata*, 71.
 — *vestita*, 67.
 Acetate of iron, 260.
 Acidity of extracts, 85.
 — of tan liquor, 132.
 Acids, for removing lime, 149.
 — relative swelling power, 134.
 — swelling action, 133.
 Action of tannin on skin, 418.
 Adder skins, 25.
 Adler's unhairing machine, 306.
 Adulteration of hides, 396.
 — of salt, 19.
 Aero-condenser, 147.
 African kino, 74.
 — oak, 56.
 Agami skins, 25.
 Agitation of liquor in pit, 179.
 — of skins in liquor, 180.
 Aguacate, 76.
 Albanian valonia, 70.
 Albuminous substances in tanning, 187.
 Alder, 71.
 — bark, 60.
 — catkins, 75.
 Aleppo pine extract, 77.
Aleurites loccifera, 281.
Algarobas, 71.
Algarobillas, 71.
 Algeria leather trade, 486.
 Alkalies, unhairing with, 411.
 Alkanet, 330.
 Allard-Ferré graining machine, 253.
 Allégatière graining machine, 253.
 Alligator oil, 224, 317.
 — skins, 25.
Alnus campestris, 61.
 — *firma*, 60.
 — *glutinosa*, 60, 71.
 Alpaca skins, 365.
Alternaria, 42.
 Alum, 8, 323.
 — action on skin, 425.
 — in salt, 19.
 — in tanning, 186.
 — properties of, 293, 309.
 Aluming, 295.
 Aluminium acetate, 323.
 — — action on skin, 428.
 — — in tanning, 186.
 — chloride, 293.
 — — action on skin, 294.
 — hypochlorite, 293.
 — hyposulphite, 323.
 — mordants, 323.
 — sulphate, action on skin, 428.
 — tannage, 189.
Amarillis dyeing, 340.
 American cloth, 392.
 — drying tower, 149.
 — kino, 75.
 — sumach, 66.
 — sweating, 118.
 Ammonia in tanning, 186.
 Ammonium carbonate in tanning, 186.
 Analysis of degreas, 218.
 — of extracts, 78, 85.
 — of leather, 402.
 — of tannin, 80.
 — of yolk of egg, 310.
 Anchusine, 330.
Anchus tinctoria, 330.
Andromeda, 65, 67.
 — *arborea*, 67.
 — *polifolia*, 270.
Andropogon muricatus, 389.
 — *ischæmun*, 389.
 — *squarrosus*, 389.
 Anduze's disintegrator, 110.
 Angelina, 65.
 Angora goats, 361.
 Aniline black, 262.
 — colours, use of, 343.
 Animal tannin, 30.
 Anotta, 328.
 Antelope skins, 366.
 Antilles oak, 59.
 Antiseptics, relative power of, 42.
 — use in tanning, 422.
Aphis chinensis, 69.
 — *pistachiæ*, 69.

- Appearance of good leather, 200.
 Application of enamel, 288.
 Archil, 330.
 extract, 330.
 purple, 330.
 Arcotaphylos, 67.
 Areca, 75.
 catechu, 72.
 nuts, 72.
 Argentine Republic leather trade, 485.
 Army saddle, French, 453.
 Arna, 76.
 Artificial degreas, 220.
 dubbing, 225.
 dyes, 332.
 leather, 391.
 Pollak's, 394.
 Russia leather, 272.
 Asagai hout, 76.
 Ash, alterations in tanning, 122.
 estimation in degreas, 219.
 in leather, 404.
 Aspergillus niger, 40.
 Aspidospermum churmeum, 64.
 peroba, 64.
 quebracho, 63.
 sessiflora, 64.
 Asses' skins, uses of, 24.
 Astrakhan, 361.
 Atropos divinatoria, 207.
 Attagenius pellio, 206.
 Aurusse stove, 300.
 Australasia, leather trade, 487.
 Australian sumach, 67.
 Austria, leather trade, 478.
 Aventurine dyeing, 340.
 Avignon grains, 328.
- B.**
- Babax, 369.
 Bablah, 71, 75.
 Bacillus septicus, 7.
 subtilis, 7.
 ulna, 7.
 Bacteria, action on skin, 7.
 Bacterium pilline, 407.
 termo, 7.
 Badger skins, 369.
 Baloghia pancheri, 75.
 Balsamocarpum brevifolium, 71.
 Bamboo, 75.
 Banana, 75.
 "Bandes de Villon," 86.
 Barberry, 328.
 Barium chloride in salt, 20.
 weighting leather with, 206.
 sulphate, weighting leather with,
 206.
 Bark, 45.
 African oak, 56.
 alder, 60.
 black, 52.
 composition of, 57.
 cutting, 103.
 dog berry, 61.
 drying, 50.
 elm, 61.
 fir, 59.
 hemlock, 59.
 larch, 59.
 mangoe, 76.
 mills, 105.
 mimosa, 60.
 mountain ash, 61.
 oak, 51.
 packing, 51.
 pine, 59.
 pistachio, 61.
 pomegranate, 61.
 poplar, 61.
 quantity of, 52.
 red, 52.
 silver birch, 61.
 Sologne oak, 56.
 stacking, 51.
 steam stripping, 53.
 storage, 56.
 stripping, 47.
 Tjaarna, 72.
 white, 52.
 wild cherry, 61.
 willow, 60.
 yellow, 52.
 yield of, 32.
 Barkometer, 81.
 Barrus, 284.
 Bating, 173, 306.
 Baudoin unhairing machine, 306.
 Beam, mechanical, 320.
 — tanner's, 122.
 Bear skins, 367.
 Beasts, butchered, 9.
 Beaver skins, 375.
 Beef tallow, 225.
 Beer, black, 258.
 Bèrendorf press, 150.
 — striking out machine, 254.
 Belgium leather trade, 478.
 Bellows, 471.
 — Halley's, 471.
 — Jeffries', 472.
 — Rabier's, 471.
 Belting, 433.
 Belts, Domange's, 441.
 Hall's, 439.
 — military, 463.
 Rouillier's, 438, 440.
 use of, 441.
 Bending uppers, 448.
 Bengal catechu, 73.
 kino, 74.
 fox skins, 369.
 Benjoin, 75.
 Berweski skins, 375.
 Betel nut, 75.
 Betula alba, 61.
 Berberin, 328.
 Berberis vulgaris, 328.
 Birch bark oil, 270.
 — oil, 272.

- Bird skins, 25.
 Bird furs, 376.
 — — preparing, 387.
 — — tanning, 209.
 Bison skins, 21, 23, 372.
 Bixin, 328.
 Bix orellana, 328.
 Black, aniline, 262.
 — bear skins, 367.
 — beer, 258.
 — caustic, 261.
 — chrome, 261.
 — compound, 260.
 — cowhide, 248.
 — dyeing, 338.
 — — fur, 381.
 — fox skins, 368.
 — German, 261.
 — leather, 256, 304.
 — Lyons, 260.
 — sizing, 240.
 — sorghum, 75.
 — vegetable, 259.
 — Villon's, 262.
 Bleaching calf over white finish, 245.
 — composition of, 258.
 — for calf, 231.
 — for leather, 257.
 Bleaching furs, 380.
 — lac, 282.
 — leather, 203.
 Blood vessels in skin, 3.
 Blue dyeing, 341.
 — enamel, 291.
 — for skins, 368.
 Boghead paraffin, 302.
 Boilers, 100.
 Boiling linseed oil, 278.
 Bokhara nuts, 69.
 Bone tallow, 225.
 Boot making, 447.
 — polish, 454.
 Boracic acid in tanning, 186.
 Borax in salt, 20.
 — in tanning, 186.
 Bos Americanus, 22.
 — moschatus, 22.
 — taurus, 9.
 Botany Bay kino, 74.
 Bot fly, 13.
 Botoncillo, 76.
 Boxwood, 65.
 Bran, 308.
 Branding, 14, 21.
 Brazil kino, 75.
 — leather trade, 484.
 — wood, 327.
 Breaking over, 114.
 — strain of leather, 398.
 Breech piece, 460.
 Breeds of cattle, 10.
 Bréval press, 91.
 Bridles, 459.
 Brilliantine, 249.
 Brion's knife, 12.
 Brittle leather, 304.
 Bronze dyeing, 340.
 Bronzed fur, 386.
 — leather, 351.
 Brown bear skins, 367.
 — catechu, 73.
 — dyeing, 340.
 — gambier, 74.
 Bucida, 75.
 Buffaloes, 21.
 Bulbs, tan-bearing, 72.
 Bulgaria leather trade, 482.
 Butchered beasts, 9.
 Butchers' hides, defects in, 12.
 Butea frondosa, 74, 281.
 Byrsonima spicata, 75.
- C.**
- Cæsalpinia brasiliensis, 327.
 — crista, 327.
 — echinatos, 327.
 — sappan, 327.
 Calf, finishing, 234.
 — skins, 11, 23.
 — waxed, currying of, 210.
 — — shaving of, 212.
 — waxing, 231.
 — white, 245.
 Cambium, 47.
 Canada leather trade, 483.
 Canella, 75.
 Caps, 463.
 Caracal skins, 364.
 Carapa, 65.
 Caratonia siliqua, 71.
 Carbolic acid in salt, 20.
 Carbonate of ammonia, bating, 308.
 — of sodium in tanning, 186.
 Carbonic acid from skin, 2.
 — — in bating, 308.
 — — in tanning, 186.
 — — vats, 136.
 Carminamide, 329.
 Carminic acid, 329.
 Carob dyeing, 340.
 Carriage building, 469.
 — harness, 462.
 Carriages, closed, 469.
 — open, 470.
 Carr's disintegrator, 110.
 Carthamine, 329.
 Carthamum, 328.
 Carthamus tinctorius, 328.
 Cartridge pouch, 464.
 Cashmere goat skins, 361.
 Castanea pumila, 63.
 — vesca, 61.
 Catalapa longissima, 59.
 Catechu, 72.
 Catkins, alder, 75.
 Cat skins, 361.
 Cattle, breeds of, 10.
 Cattois' graining machine, 253.
 Caustic black, 261.
 Cayman, 25.

- Cebil, 76.
 Celtis australis, 65.
 Cement, 130.
 Cementing belts, 434.
 Cements for belts, 434.
 Central America leather trade, 484.
 Chaully method of tanning, 181.
 Chan belts, 438.
 Chamada, 70.
 Chamois skins, 366.
 uses of, 24.
 Chamoying, experiments on, 132.
 theory of, 430.
 Chamoy leather, 8, 416.
 Charcala, 70.
 Chertah skins, 366.
 Chemical composition of skin, 6.
 methods of removing lime, 160.
 of tanning, 185.
 Chemistry of tannin, 33.
 Chestnut, 61.
 dye for fur, 385.
 dyeing, 340.
 extract, 77.
 oak, 76.
 Chih leather trade, 484.
 Chikan bean, 368.
 Chimneys, 100.
 China leather trade, 486.
 Chinchilla skins, 472.
 Chinese galls, 68.
 Chlorozone, 204.
 Chopping bark, 103.
 Chorion, 3.
 Chrome black, 261.
 Chromium mordants, 425.
 tannage, 189.
 Chrysanthic acid, 428.
 Chrysem, 428.
 Chrysorhamm, 428.
 Cinnamon dyeing, 340.
 Circulation of liquor in pit, 179.
 Civet skins, 365, 472.
 Claret dye, 242.
 Clarifying extracts, 77.
 Classification of hides, 14.
 Cleaning from lime, 156.
 fur, 390.
 leather, 143.
 Closed carriages, 469.
 Cobalt on leather, 454.
 Cobra skins, 25.
 Coccus cacti, 329.
 lacca, 281.
 illicis, 329.
 Cochineal, 329.
 Cocoa palm, 76.
 Cod liver oil, 222, 317.
 Coefficient of resistance, 409.
 Cold countries, fur from, 474.
 sweating, 120.
 Collars, horse, 459.
 donkey, 460.
 Collectors, dust, 111.
 Colophony, 285.
 Coloured cowhide, 249.
 Coloured Hungarian leather, 303.
 resists, 345.
 Colour finish for calf, 242.
 Colouring, 126, 129.
 furs, 380.
 power of tans, 86.
 Colours, mineral, 243.
 Columbian kino, 75.
 Commerce in leather. *See* Statistics.
 Composition of bark, 56.
 of degrass, 224.
 of dubbing, 225.
 of leather, 305.
 Compound black, 260.
 Compressed leather, 391.
 Cones, pine, 71.
 Conocarpus, 75.
 Constitution of tannin, 33.
 Copal, 283.
 Copper mordants, 325.
 Corliss engine, 102.
 Coriindines, 7.
 Coriine, 6, 406.
 Corn poppy red, 342.
 Cornus masculata, 61.
 Corrosive sublimate, 8.
 Corticle, 4.
 Cost of tanning, 196.
 Cougny's black for fur, 383.
 chestnut for fur, 385.
 Coury, 73.
 Cow hides, 9, 11, 23.
 black, 264.
 currying, 248.
 smooth, 251.
 tanning, 172.
 waxed, 264.
 Cows, Indian, 23.
 Cresote in salt, 20.
 Crimson dye, 342.
 Crocodile oil, 224.
 Crupper, 461.
 Cudbear, 330.
 Culbutage, 297.
 Curried leather, dyeing of, 344.
 Carrier's knife, 212.
 Currying, 211.
 cow hide, 248.
 Curupai, 75.
 Cuticle, 3.
 Cutting up bark, 103.
 Cyclone collector, 112.
 Cynips calicis, 69.

D.

- Damourette saw mill, 106.
 unhairing machine, 121, 306.
 Danish tanning, 182.
 Darso knife, 13.
 Deep brown, 340.
 Deer skins, 365.
 Defective skins, 202.
 Defects in butchers' hides, 12.
 in Hungary leather, 304.

- Degras, 218.
 — analysis of, 218.
 — artificial, 220.
 — composition of, 220.
 Delpech's stuffing drum, 301.
 — vats, 296.
 Denmark leather trade, 482.
 De Nomaison stripping, 53.
 Density of bark, 53.
 Depilation, 154.
 — by ammonia, 164.
 — by aluminate of soda, 164.
 — by calcium sulphhydrate, 167.
 — by charcoal, 168.
 — by lime, 156.
 — by silicate of soda, 164.
 — by soda, 163.
 — by sodium sulphide, 166.
 — by sulpharsenite of lime, 167.
 Dermestes, 388.
 vulpinus, 206.
 Dermis, 21, 23.
 Determination. *See* Estimation.
 Dezeau-Lacour graining machine, 253.
 Dingo skins, 362.
 Dipping, 314.
 Direct gilding, 353.
 Dirt in skins, 17.
 Diseases of skin, 13.
 Disintegrators, 110.
 Dividivi, 42, 70, 76.
 — extract, 77.
 Doe skin, 316.
 Dog-fish skin, 26.
 Dogs' dung, 307.
 Dog skin, 362.
 — — uses of, 24.
 Dole skins, 362.
 Dolphin oil, 223.
 Domange's belts, 441.
 Doornboom, 76.
 Doornspoor, 76.
 Dormouse skins, 373.
 Double salting, 23.
 Drench, 308.
 Drenching morocco, 321.
 Dressing, composition of, 312.
 — for tawing 31.
 — furs, 378.
 — Hungary leather, 298.
 — leather, laying away, 169.
 — manufacture, 153.
 — — skins for, 153.
 — morocco, 348.
 — tanning, 169.
 — tawed skins, 309.
 Driemmi, 72.
 Drum stuffing, 301.
 Dry finish for calf, 242.
 — hides, adulteration of, 396.
 Drying bark, 50.
 — Hungary leather, 297.
 — leather, 143.
 — loft, 143.
 — tower, American, 149.
 — sun, 22.
 Dubbing, 217.
 — artificial, 225.
 — composition of, 225.
 — furs, 378.
 — Russia leather, 269.
 Dumas' rubbing belt, 160.
 Dung, dogs', 307.
 — fowls', 307.
 — pigeons', 307.
 Dyeing, 313.
 — black, 338.
 — blue, 341.
 — fawn, 340.
 — fur, 380.
 — green, 343.
 — in trough, 333.
 — in tumbler, 338.
 — Kristen process, 314, 333.
 — morocco, 321.
 — orange, 343.
 — paddle, 328.
 — red, 341.
 — Russia leather, 272.
 — violet, 343.
 — with brush, 332.
 — with metallic salts, 344.
 — yellow, 342.
 Dyes, artificial, 325.
 — — table of, 334.
 — natural, 325.
 Dyospira ebum, 68.
 Dystilium racemosum, 68.

E.

- Ebony, 75, 76.
 Egg, 309.
 — yolk of, 309.
 Egyptian fox skins, 369.
 — pine, 73.
 Egypt, leather trade, 487.
 Elasticity of skin, 1.
 Electricity, effect on tanning, 184.
 Electric knife, 13.
 Electro gilding leather, 352.
 Elemi resin, 284.
 Elephant hides, tanning of, 142.
 — uses of, 23.
 Elk, 24.
 Ellagic acid, 44.
 Enamel, application of, 288.
 — coloured, 290.
 — formulæ, 286.
 — gilt, 292.
 — preparation of, 286.
 — transparent, 292.
 Enamelled leather, 275.
 Engines, steam, 101.
 England, leather trade, 477.
 English wax for calf, 233.
 Epidermis, 2, 3.
 Epsom salts, 20.
 Equipment, military, 463.
 Ermine skins, 374.
 Essential oils for fur, 381.

- Estimation of acidity in tan, 132.
 — of ash in degreas, 219.
 — of ash in leather, 404.
 — of fat in degreas, 219.
 — of fat in leather, 404.
 — of free fatty acid in degreas, 220.
 — of glue in degreas, 220.
 — of insoluble substances in degreas, 219.
 — of lime in leather, 404.
 — of mineral oil in degreas, 219.
 — of nitrogen in leather, 403.
 — of resinoid matter in degreas, 219.
 — of skin in leather, 403.
 — of soluble substances in leather, 402.
 — of tannin, exact method, 82.
 — of tannin in leather, 404.
 — of water in degreas, 218.
 — of water in leather, 402.
 Eucalyptus, 67, 74, 76.
 Evaporation, effect on tanning, 183.
 Excreta, 307.
 Experiments on chamoying, 414.
 — on liming, 411.
 — on plumping, 414.
 — on sweating, 409.
 — on tawing, 414.
 — on unhairing with alkalis, 411.
 — on unhairing with sulphides, 412.
 Extracts, 190.
 — acidity of, 85.
 — analysis of, 77, 85.
 — archil, 330.
 — logwood, 326.
 — manufacture of, 76.
 — mixed, 78.
 — strong, 201.
 — tanning with, 190.
 Extractives, action on skin, 419, 424.
 Extromètre, 85.
- F.**
- Fairbank Canning Company, 13.
 Fallow deer skins, 365.
 False gambier, 75.
 Fans, 468.
 Fat, estimation in degreas, 219.
 — — in leather, 404.
 Fatty acids, estimation in degreas, 220.
 Fawn dye for fur, 386.
 — dyeing, 240.
 Fermentation, butyric, 308.
 — lactic, 308.
 — of tannin, 32, 39.
 Ferret skins, 364.
 Fever bark, 64.
 Fibres of skin, 6.
 Ficus indica, 281.
 — religiosa, 281.
 Field mouse skins, 374.
 Filao, 75.
 Filtration of tan liquor through skins, 182.
 Finishing black leather, 263.
 — calf in colour, 242.
 Finishing furs, 381.
 — morocco, 347.
 — tawed skins, 314.
 — waxed calf, 234.
 Fir bark, 59.
 — — extract, 74.
 Fisheries Exhibition, 27.
 Fish, flat, 27.
 — oil, 223.
 — — in salt, 20.
 — skins, 25.
 Fitz Henry's stoning machine, 254.
 Flat fish, 27.
 Flavin, 328.
 Flaying, 21.
 Flesh colour dyeing, 340.
 Fleshing, 120, 320.
 — furs, 378.
 Fleury's graining machine, 253.
 Flour, 311.
 — action on skin, 428.
 "Fluffing," 312.
 Follicle, 4.
 Foreign skins, 21.
 Fowls' dung, 307.
 Fox fly, 388.
 Fox skins, 368.
 Fracture of leather, 401.
 France, leather trade, 473.
 Frauds in sale of skins, 16.
 French galls, 68.
 — sumach, 66.
 Fresh hides, 113.
 "Frizing," 316.
 Frog skins, 208.
 Fruits, grinding of, 110.
 — tan-bearing, 70.
 Fuller for Hungary leather, 296.
 Fulling, 297, 317.
 — calf, 214.
 Fungi on leather, 206.
 Furnace, Bouillon & Müller, 96.
 — Duperier & David, 92.
 — Krafft, 93.
 — Koch, 97.
 — Müller, 94.
 — Passenger, 92.
 — Ruelle, 92.
 — Serrière, 97.
 — tan-burning, 90.
 — Varillat, 92.
 Furriery, 359.
 Furs, 359.
 — bleaching, 380.
 — bronzed, 386.
 — chamber, 388.
 — cleaning, 390.
 — colouring, 380.
 — dressing, 378.
 — finishing, 381.
 — from bird skins, 376.
 — from cold countries, 374.
 — from hot countries, 370.
 — glossing, 387.
 — indigenous, 360.
 — preparation of, 377.

Furs, preservation of, 388.
 — removal of grease, 380.
 — spotting, 381.
 Fustic, 327.
 Fustin, 328.

G.

Gadus *æglefinus*, 222.
 — *carbonarius*, 222.
 — *morrhua*, 222.
 Gallate of tannin, 44.
 Gallerythronic acid, 43.
 Gallic acid, 43.
 Gallipot resin, 284.
 Gallons, 69.
 Galls, 75.
 — Aleppo, 68.
 — Chinese, 68.
 — French, 68.
 — German, 68.
 — grinding, 110.
 — Istrian, 68.
 — Marmora, 68.
 — Moreau, 68.
 — nut extract, 77.
 — nuts, 67.
 — pouille, 68.
 — pistachio, 68.
 — royal, 68.
 — Smyrna, 68.
 — tamarisk, 68.
 Galuchat, 350.
 Gambier, 73.
 — false, 75.
 Gamboge, 284.
 Garabic, 75.
 Gassing, 306.
 Gateodo, 76.
 Gelatine, 6.
 — preparation of, 234.
 Genubata, 75.
 German black, 261.
 — galls, 66.
 — leather, 364.
 Germany, leather trade, 476.
 Gilding, direct, 353.
 — leather, 352.
 Gilt enamel, 292.
 Giraffe skins, 371.
 Girths, 460.
 Glace skins, 315.
 Glands, perspiratory, 1, 3.
 — sebaceous, 2, 3.
 Glazing morocco, 349.
 — waxed calf, 241.
 Glis skins, 273.
 Glossing fur, 387.
 Gloves, 305.
 — manufacture, 467.
 — perfuming, 467.
 Glucose, weighting leather with, 205.
 Glue, estimation of, in degrass, 220.
 Gluten, 311.
 Glutton, 370.
 Goat skins, 12, 361.

Goat skins, currying, 264.
 — — matt, 267.
 — tanning, 174.
 — uses of, 24.
 — — waxed, 267.
 Goose skins, 375.
 Gonakia, 75.
 Goyacan, 76.
 Graining, 251.
 — calf, 230.
 — cowhide, 250.
 — machines, 252.
 — morocco, 350.
 Grains, grinding of, 110.
 Grannaniumba, 75.
 Grease stains, 202.
 — removal from furs, 380.
 Greasing calf, 227.
 Grebe skins, 375.
 Green dye, 343.
 — enamel, 292.
 — hides, 12, 113.
 Grenat dye, 340.
 Grey fox skins, 368.
 Grinding bark, 104.
 — machine, 103.
 — tan, 103.
 Grizzly bear skins, 367.
 Guabari, 75.
 Guano, 307.
 Guatemala, leather trade, 484.
 Guibourt's preparation of tannin, 35.
 Guinea pig skins, 365.

H.

Hæmatin, 326.
 Hæmatoxylin, 326.
 Hæmatoxyton campestrinum, 326.
 Hair, 5.
 — classes of, 359.
 Halley's bellows, 472.
 Hall's belts, 439.
 Hall's disintegrator, 110.
 Hamster skins, 369.
 Handlers, 131.
 — mechanical, 169.
 Handling, 136.
 — object of, 137, 416.
 — theory of, 415.
 Hannequand-Parmentier cleaning machine, 160.
 Har, 75.
 Hare skins, 362.
 Hard, 312.
 Harness, 457.
 — carriage, 462.
 — pole, 461.
 Hatos, 23.
 Hats, 463.
 Haversack, 466.
 Heat, effect on tanning, 183.
 Heating Hungary leather, 300.
 Heels for boots, 450.
 Hemlock, 76.

Hemlock bark, 59.
 extract, 77.
 Henry's mechanical cleaner, 143.
 Herapat's method of tanning, 180.
 Hide powder, 81.
 Hides, arrangement in layers, 138.
 classification of, 14.
 cow, 11.
 for sole leather, 143.
 fresh, 113.
 green, 112, 113.
 oaking, 113.
 softening, 114.
 split, 171.
 Hippopotamus hides, use of, 23.
 Henderspool, 76.
 Holland, leather trade, 183.
 Hobster, 164.
 Horny leather, 394.
 Horse, as motive power, 90.
 collars, 139.
 hides, 11.
 currying, 264.
 tanning, 173.
 Horses, 21, 23.
 Hot countries, fur from, 170.
 Human skin, 27.
 Hungarian leather, 8, 293.
 coloured, 304.
 theory of, 125.
 Hydrogen peroxide, 203, 381.
 Hydrosulphite of soda, 203.
 Hymenaea comboid, 283.
 verucosa, 283.
 Hypolephus sephen, 27.
 Hyposulphite of soda, 181.
 in tanning, 186.

L

Lazu, 60.
 Limos ox, 23.
 India leather trade, 183.
 Indian cows, 23.
 kimo, 74.
 yellow, 328.
 Indigenous furs, 360.
 Indigo camme, 339.
 Insecticide plants, 380.
 Insecticides, 380.
 Insects on leather, 206.
 Insoluble substances, estimation in degtas,
 219.
 Inspection of skins, 14.
 slaughter houses, 14.
 Installation of a tannery, 88.
 Iron acetate, 260.
 mordants, 362.
 salts, action on tannin, 17.
 tannage, 180.
 Italian galls, 68.
 Italian sumach, 66.
 Italy, leather trade, 183.
 Iwaki, 60.
 Iwaskiewicz's square tumbler, 306.

J

Jacaranda, 76.
 Jaguar skins, 371.
 Jannosa, 75.
 Japanese oil, 317.
 Japan, leather trade, 186.
 Jeffries' bellows, 472.
 John Zuka, 27.
 Joining belts, 442.
 Jonquet's unhairing machine, 306.
 Juices, tanning, 72.
 Jujube, 76.
 Juniperus communis, 284.

K

Kai, 60.
 Kangaroo skins, 373.
 uses of, 24.
 Karath, 71.
 Kassa catechu, 73.
 Kermes, 329.
 Khaki, 71, 75.
 Khaya, 75.
 Khen, 72.
 Kid, uses of, 24.
 Kimo, 74.
 Knee stake, 312.
 Knife, Bruon's, 12.
 corner's, 212.
 Darsø, 13.
 electric, 13.
 Newglass, 13.
 Knoderer's method of tanning, 180.
 Knoppers, 69.
 Koumao, 75.
 Kresse, 304.
 Kristen dyeing process, 314, 333.

L

Lac dye, 281, 329.
 Laces, manufacture of, 451.
 Laces, 280.
 Lagotis skins, 372.
 Lamb skins, 360.
 Lambert's preparation of tannin, 35.
 Lamellar layer, 3.
 Larch, 76.
 bark, 59.
 Lard, 225.
 Lary Europe, 59.
 Lasso, 22.
 Laurel oak, 76.
 Lay away pits, 137.
 Layers, 137.
 Laying away dressing leather, 171.
 Leaching bark, 127.
 Lead in boiled oil, 280.
 Leather, appearance of good, 200.
 artificial, 391.
 Russia, 272.
 black, 250.

- Leather, bleaching, 203.
 — bronzed, 351.
 — chains, 438.
 — chamois, 8.
 — cleaning, 143.
 — coloured Hungary, 304.
 — composition of, 405.
 — compressed, 391.
 — drying, 143.
 — fracture of, 401.
 — fungi in, 206.
 — German, 304.
 — gilding, 352.
 — Hungary, 8, 293.
 — insects in, 206.
 — made from scraps, 391.
 — mechanical uses of, 471
 — physical testing of, 397.
 — preservation of, 206.
 — printing, 345.
 — Russia, 269.
 — silvering, 352.
 — sole, manufacture of, 113.
 — spongy, 197.
 — testing, 197, 396.
 — trade. *See* Statistics.
 — tubes, 472.
 — uses of, 433.
 — various manipulations, 201.
 — waterproofing, 204.
 — weighting, 205.
 — world's commerce. *See* Statistics.
- Leaves, tannin-bearing, 65.
 Ledun palustre, 276.
 Leopard skins, 371.
 Lepellet's tallowing machine, 301.
 — vats, 296.
 Libi-dibi, 70.
 Light, effect on tanning, 186.
 Lignite in salt, 20.
 Lignum vitæ, 76.
 Lilac dye, 343.
 Lime, 154, 306, 320.
 — estimation in leather, 404.
 — milk of, 306.
 — water, 8.
 Liming, 156.
 — experiments on, 411.
 — hooks, 156.
 — mechanical, 159.
 — theory of, 411.
 Linings, 316.
 Linoleum, 393.
 Linseed mucilage, 245.
 — oil, 276.
 — — boiling, 278.
 — — purification of, 277.
 Lion skins, 370.
 Liquor, agitation in pits, 179.
 — circulation in pits, 179.
 List of artificial dyes, 332.
 — of mineral colours, 243.
 — of natural dyes, 331.
 Litharge in boiled oil, 279.
 Lithospermum tinctorium, 325.
 Livache's degreas, 220.
 Llama skins, uses of, 24.
 Lockwood's stretching machine, 255.
 Loft work, 298.
 Lofts, ventilation of, 146.
 Logwood, 325.
 — extract, 326.
 Loss in soaking, 125.
 Lota maculata, 27.
 Louvers, 147.
 Lowe and Schiff on tanning, 33.
 Lowsidge's method of tanning, 180.
 Lynx skins, 364.
 Lyons black, 260.
- M.**
- Machine belts, 417
 Machines, unhairing, 121.
 Maclurin, 327.
 Magnesium sulphate in salt, 20.
 — — in tanning, 186.
 — — weighting leather with, 205.
 Malaga sumach, 65.
 Malay bear skins, 368.
 Malpighian layer, 2, 3.
 Mammals, skins of, 23.
 Manatee, 26.
 Manganese compounds in boiled oil, 280.
 Mangifera indica, 67.
 Mango bark, 76.
 Mangrove, 75.
 — leaves, 67.
 Manipulation of leather, 201.
 Manos, 23.
 Manoul skins, 364.
 Marking fur, 387.
 — weights on skins, 15.
 Marmora galls, 68.
 Marmot skins, 369.
 Marrow fat, 225.
 Marten skins, 370, 374.
 Massoutier's agitator, 179.
 Mastic, 67, 284.
 Matt goat skins, 267.
 Mechanical beam, 320.
 — tanning, 177.
 — uses of leather, 471.
 — vats, 131, 296.
 Medullary substance of hair, 5.
 Megalotis skins, 368.
 Menhaden oil, 317.
 Mercuric iodide, 8.
 Metallic chlorides in tanning, 186.
 — colours, list of, 345.
 — salts, dyeing with, 344.
 Mexico, leather trade, 484.
 Micromillimetre, 7.
 Military equipment, 463
 Milk of lime, 156, 306.
 Mills, nut, 107.
 — stone, for bark, 105.
 Mimosa, 76.
 — bark, 60.
 — extract, 77.
 Mimusops, 75.
 Mineral colours, 243.
 — oil, estimation in degreas, 219.

- Mineral quantities absorbed by skin, 432.
 — tanning, 293.
 — tanning, theory of, 432.
 Mink skins, 370, 375.
 Mixed extracts, 78.
 — tanning with bark and extracts,
 193.
 Moëllon oil, 217.
 Moisture in dry hides, 396.
 — in skins, 16.
 Mole skins, 369.
 Monesia, 75.
 Monkey skins, 372.
 Moonal pheasant skins, 377.
 Mordants, 322.
 — aluminium, 323.
 — chromium, 325.
 — copper, 325.
 — effect on natural dyes, 331.
 — iron, 325.
 — tin, 323.
 Moreau galls, 68.
 Moret's tallowing machine, 301.
 Morin, 327.
 Morocco dyeing, 322.
 — finishing, 347.
 — leather, 320.
 — leather trade, 486.
 Morus tinctoria, 327.
 Mounting boot soles, 449.
 Mucilage linseed, 245.
 Mulhouse strips, 86.
 Müntz and Ramspacher tannin estimation,
 81.
 — on penicillum, 42.
 — on steamed bark, 56.
 — on tan absorption, 420.
 Mutton tallow, 224.
 Myrobolans, 71, 77.
- N.**
- Nandipa, 75.
 Naphthalin in salt, 19.
 Natural colours, 325.
 — sweating, 115, 117.
 Neatsfoot oil, 317.
 Nebsnebs, 71.
 Nerves, 3.
 Nervous papillæ, 4.
 Newgass knife, 12.
 Nickel on leather, 354.
 Nitrate of soda in salt, 19.
 Nitric acid for making degreas, 221.
 Nitrogen, estimation in leather, 403.
 Nut mills, 107.
 Nutria skins, 373.
 Nuts, gall, 67.
 Nys, 275.
- O.**
- Oak, African, 56.
 — Antilles, 59.
 Oak apples, 71.
 — bark, 45.
 — bark extract, 77.
 — chestnut, 76.
 — extract, 77.
 — laurel, 76.
 — red, 76.
 — varieties of, 57.
 — West Indian, 75.
 — white, 76.
 — wood, 64.
 Object of handling, 416.
 — of tanning, 8.
 Ocelot skins, 371.
 Offal, 16.
 Ogerau and Vos pits, 179.
 Oil, alligator, 224, 317.
 — birch, 272.
 — — bark, 270.
 — cod-liver, 222, 317.
 — crocodile, 224.
 — dolphin, 223.
 — fish, 223.
 — for dressing skins, 222.
 — Japanese, 317.
 — Menhaden, 224, 317.
 — mineral, estimation in degreas, 219.
 — moëllon, 217.
 — of eggs, 309.
 — oxidation of, 394.
 — porpoise, 224.
 — salmon, 224, 317.
 — sardine, 224, 317.
 — seal, 224.
 — shark, 224.
 — sod, 220.
 — solidifying point of, 310.
 — sperm, 223, 317.
 — sturgeon, 224.
 — tunny, 224.
 — weighting leather with, 205.
 — whale, 223, 317.
 Oiling calf, 217.
 — chamoy leather, 316.
 — furs, 378.
 — morocco, 348.
 Oleorum microcladus, 222.
 Ooze, 126.
 Open air drying, 144.
 — carriages, 470.
 Opossum skins, 373.
 Orange dye, 343.
 Ossein for tannin estimation, 81.
 Ostrich skins, 376.
 Osyris compressa, 67.
 Otter skins, 374.
 Ott shaving machine, 214, 320.
 Ounce skins, 371.
 Outeniqua geelhout, 76.
 Oxalic acid in tanning, 186.
 Ox brain tanning, 187.
 — fat, 225.
 — hides, 9, 23.
 — Illinois, 16.
 Oxidation of oil, 394.
 Oxidising oil, 317.

Oxidising tower for degreas, 221.
Ozokerit, 306.

P.

Packing bark, 51.
Paddle dyeing, 338.
Pajeros skins, 364.
Palmetto root, 72.
Pandanus, 75.
Panther skins, 371.
Papier maché, 393.
Papillæ, 3.
— nervous, 4.
Paraffin, 302.
Parchment, 355.
— patching, 358.
Paris dye, 260.
Passenger's furnace, 91.
Patching parchment, 358.
Pathological tannin, 32.
Payen's still, 273.
Peeling iron, 48, 50.
Pegging boots, 450.
Pelouza's preparation of tannin, 35.
Peltreau's striking out machine, 255.
Pelts, 316, 359.
Pendoir, 117.
Penicillium glaucum, 41.
Perfuming gloves, 467.
Permanganate of potash, 203.
Persea lingua, 75.
Persian berries, 328.
Perspiratory glands, 1, 3.
Petroleum, 302.
— in salt, 20.
Phosphobutyroline, 308.
Phosphoric acid in tanning, 186.
Physical constitution of skin, 5.
— methods of tanning, 182.
— testing of leather, 397.
Physiological tannin, 32.
Physiology of skin, 1.
Picea alba, 59.
Pigeons' dung, 307.
Pigmented layer, 3.
Pigments for printing, 347.
Pilcher, 461.
Piling Hungary leather, 303.
Pilline, 4, 407.
Pimento, 75.
Pine, 75, 76.
— bark, 59.
— cones, 71.
— Egyptian, 73.
— oil in salt, 20.
— resin, 284.
— varieties of, 284.
Pinning, 156.
Pinus cembra, 59.
— halepensis, 59.
Pistachio, 67.
— galls, 69.
Pistacia lentiscus, 61, 67, 284.
Pistons, 472.
Pitch, 302.

Pits for tanning, 137.
Plaster of Paris, 19.
Plumping, 126.
— experiments on, 413.
— theory of, 413.
Pockets in leather, 139.
Polar bear skins, 367.
Polecat skins, 370.
Pole, harness, 461.
Polishing cowhide, 253.
Pollak's artificial leather, 393.
Pomegranate, 71.
Poppy dye, 342.
Populus fastigata, 61.
Pores, 2.
Porpoise, 26.
— oil, 224.
Portugal, leather trade, 481.
Portuguese sumach, 66.
Pouille galls, 68.
Pranzini, skin of, 28.
Preparation of furs, 377.
— of pure tannin, 35.
Preservation of furs, 388.
— of leather, 206.
Presser for Hungary leather, 296.
Pressing chamoy leather, 319.
Principles of drying, 144.
Printing leather, 245.
Properties of tannin, 36.
Prosopis dulcis, 71.
— pallida, 71.
Protective varnish for vats, 130.
Prunus avium, 61.
— sphærocarpa, 67.
Pterocarpus erinocœus, 74.
— indicus, 327.
— marsupium, 74.
— santalinus, 327.
Puma skins, 470.
Pump, 140.
Purification of linseed oil, 277.
Putorius skins, 375.
Pyrofuchsin tanning, 188.
Pyroligneous acid in salt, 20.

Q.

Quagga skins, 371.
— — uses of, 24.
Qualie, 74.
Quality of bark, 52.
Quantities of leather obtained in various processes, 195.
— of minerals absorbed by skin, 432.
Quebracho, 63, 76.
— blanco, 64.
— Colorado, 64.
— extract, 77.
Quercitric acid, 328.
Quercitron, 328.
Quercus ægilops, 45, 70.
— alba, 58.
— ballota, 45.
— banisteri, 58.

- Quercus castanæfolia*, 45, 58.
 — *cerris*, 45.
 — *coccifera*, 45, 58, 70, 329.
 — *dentala*, 59.
 — *fontanesii*, 45.
 — *græca*, 70.
 — *ilex*, 45, 58, 68.
 — *infectoria*, 67.
 — *mongolica*, 59.
 — *nigra*, 328.
 — *obovata*, 59, 68.
 — *oophora*, 70.
 — *pedunculata*, 45, 57, 69.
 — *phellos*, 58.
 — *pubescens*, 69.
 — *robur*, 68.
 — *rubra*, 58.
 — *sessiflora*, 45, 57, 69.
 — *stagnosa*, 69.
 — *suber*, 45.
 — *tauzzin*, 45, 58, 68.
 — *tinctoria*, 45, 58, 328.
 — *ungeri*, 70.
 — *valonea*, 70.

R.

- Rabbit skins, 362.
 Rabier's triple bellows, 471.
 Raccoon skins, 374.
 Ram skins, uses of, 24.
 Rat skins, 373.
 — tanning, 208.
 Ray, 26.
 Realgar, 306, 320.
 Recipes for enamel, 286.
 Red bark, 59.
 — enamel, 291.
 — fox skins, 368.
 — oak, 76.
 Reimer's coriin, 406.
 — experiments on alum, 425.
 Reindeer skins, 365.
 Removal of stains, 202.
 Reserves, 345.
 Resin, 280.
 — gallipot, 284.
 — pine, 284.
 — virgin, 284.
 — yellow, 284.
 Resinoid matter, estimation in degrass, 219.
 Resistance of hair, 419.
 Resists, 345.
 — coloured, 345.
 Revivification of defective skins, 202.
 Rhabdista, 70.
Rhamnus indica, 281.
 — *infectorius*, 328.
 — *jujuba*, 281.
 Rhinoceros hides, 23.
Rhizophora mangle, 67, 74.
 Rhus, 65.
 — *aromatica*, 66.
 — *coriaria*, 65.
 — *cotinoides*, 66.

- Rhus, *cotinus*, 327.
 — *glabra*, 66.
 — *javanica*, 68.
 — *metopium*, 66.
 — *myrtifolia*, 65.
 — *osbecky*, 68.
 — *oxyacantoides*, 67.
 — *pumila*, 66.
 — *semialata*, 68.
 — *smiliata*, 32.
 — *tomentosa*, 67.
 — *typhina*, 67.
 — *vernificera*, 282.
 Ridge band, 460.
 Riveting belts, 437.
 Roebuck skins, 365.
 — — uses of, 24.
 Roots, tan-bearing, 72.
 Rose dye, 342.
 Rouillier's belts, 438, 440.
 Royal galls, 68.
 Royer system of tanning, 178.
 Rufigallic acid, 44.
 Rugs, 305, 315.
Rumex hymenoseplum, 72.
 Russia, leather trade, 480.

S.

- Sabal serrulata*, 72.
 Sable dye for fur, 381.
 — skins, 369, 375.
 Saddle, construction of, 455.
 — French army, 453.
 Saddlery, 453.
 Sakum, 69.
 Sal, 75.
 Saladeros, 23.
 Salix, 60.
 — *arenaria*, 269.
 — *capraca*, 269.
 — *caprea*, 269.
 — *inerea*, 269.
 — *pentendra*, 269.
 — *russeliana*, 269.
 Salmon oil, 224, 317.
 Salt, 8.
 — action on skin, 425.
 — adulteration of, 19.
 — sea, 19.
 — tax, 19.
 Salted hides, softening, 116.
 Salting, double, 21.
 — skins, 17.
 Salts of tin, 323.
 Sandal wood, 327.
 Sandarach, 284.
 Santalin, 327.
 Santarita, 75.
 Santh, 71.
 Sardine oil, 224, 317.
 Saw mills, 106.
 Schia-lio cement, 138.
 Schill and Seilacher's degrass, 221.
Schinus mollis, 75.

- Schweitzer's reagent, 7.
 Scilla maritima, 72.
 Scouring chamois leather, 319.
 Scraping bark, 103.
 — chamois leather, 319.
 Scraps, leather from, 391.
 Scudding, 305.
 Seal oil, 224.
 — skins, 26.
 Seals, 26.
 Sea onion, 72.
 — salt, 19.
 Seasoning morocco, 348.
 Septomena, 42.
 Servia, leather trade, 482.
 Sewing boots, 449.
 — furs, 378.
 Shagreen, 350.
 Shako, 463.
 Shark oil, 224.
 — skins, 26.
 Shaving waxed calf, 210.
 Sheep skins, 12, 23.
 Shellac, 281.
 Shibuki, 75.
 Shoes, ladies', 305.
 — making, 447.
 — military, 465.
 Siami, 72.
 Sicilian sumach, 65.
 Silurus, 27.
 Silverboom, 76.
 Silvering leather, 354.
 Simaruba, 76.
 Singapore gambier, 74.
 Singeing, 303.
 Size for calf, 234.
 Skin, 1.
 — action of bacteria on, 7.
 — anatomy of, 3.
 — blood vessels of, 3.
 — chemical composition of, 6.
 — diseases of, 13.
 — estimation of, in leather, 403.
 — fibres of, 6.
 — human, 26.
 — nerves of, 3.
 — physical constitution of, 5.
 — physiology of, 1.
 — section of, 2.
 Skinning, 9.
 Skins, adder, 25.
 — agami, 25.
 — agitation in liquor, 180.
 — alligator, 25.
 — alpaca, 365.
 — antelope, 366.
 — asses', uses of, 24.
 — badger, 369.
 — bear, 367.
 — beaver, 375.
 — berweski, 375.
 — bird, 25.
 — — tanning, 209.
 — bison, 372.
 — calf, 11, 231.
 — caracal, 364.
 — cat, 361.
 — chamois, 366.
 — — uses of, 24.
 — cheetah, 366.
 — chinchilla, 372.
 — civet, 365, 372.
 — cobra, 25.
 — deer, 365.
 — dingo, 362.
 — dirt in, 17.
 — dog, 362.
 — — uses of, 24.
 — fish, 26.
 — dole, 362.
 — dormouse, 372.
 — elk, 365.
 — ermine, 374.
 — fallow deer, 365.
 — ferret, 364.
 — field mouse, 374.
 — fish, 25.
 — for belting, 433.
 — foreign, 21.
 — for parchment, 355.
 — for tanning, 9.
 — for tawing, 305.
 — fox, 368.
 — frog, tanning, 208.
 — giraffe, 371.
 — glutton, 370.
 — goat, 12, 24, 361.
 — goose, 376.
 — grebe, 376.
 — guinea pig, 365.
 — hajeros, 364.
 — hamster, 369.
 — hare, 363.
 — inspection of, 14.
 — jaguar, 371.
 — kangaroo, 373.
 — — uses of, 24.
 — lagotis, 372.
 — leopard, 371.
 — lion, 370.
 — llama, uses of, 24.
 — lote, 27.
 — lynx, 364.
 — manatee, 26.
 — manoul, 364.
 — marmot, 369.
 — marten, 370, 374.
 — mink, 370, 375.
 — moisture in, 16.
 — mole, 369.
 — monkey, 372.
 — moonal pheasant, 372.
 — mule, 23.
 — musk rat, 374.
 — nutria, 373.
 — ocelot, 371.
 — of mammals, 23.
 — opossum, 373.
 — ostrich, 377.
 — otter, 374.
 — ounce, 371.

- Skins, panther, 371.
 — pole cat, 370.
 — porpoise, 26.
 — puma, 370.
 — putorius, 375.
 — quagga, 371.
 — — uses of, 24.
 — rabbit, 363.
 — racoon, 374.
 — ram, uses of, 24.
 — rat, 373.
 — — tanning, 208.
 — ray, 26.
 — reindeer, 365.
 — roebuck, 365.
 — — uses of, 24.
 — sable, 369, 375.
 — salting, 17.
 — seal, 26.
 — shark, 26.
 — sheep, 12, 23.
 — skunk, 373.
 — snake, 25, 209.
 — squirrel, 366.
 — staining of, 19.
 — swan, 25, 376.
 — tapir, 374.
 — tiger, 371.
 — toucan, 377.
 — trumpeter, 25, 377.
 — vicuna, 372.
 — viper, 25.
 — viscaya, 372.
 — vison, 375.
 — walrus, uses of, 24, 26.
 — weasel, 369.
 — weighting of, 21.
 — weight of, 15.
 — whale, 27.
 — wild boar, uses of, 24.
 — wolf, 363.
 — zebra, 372.
 Slacking lime, 154.
 Slate, currier's, 215.
 — in salt, 19.
 Slating, 120.
 Slaughter houses, inspection of, 14.
 Slicker, 215.
 Slicking, 215.
 Slings for water bottle, 464.
 Slipping of belts, 443.
 Smooth cowhide, 251.
 Smoothing machines, 256.
 Smyrna galls, 68.
 Snake skins, 28.
 — — tanning of, 209.
 Soaking, 8, 124.
 — dressing leather, 153.
 — furs, 378.
 — theory of, 406.
 Soap powder in salt, 19.
 — varnishes, 288.
 Sodium aluminate, 323.
 — sulphide, 306.
 Sod oil, 220.
 Softening, 153.
 — Softening furs, 380.
 — water, 124.
 Soils for growing bark, 46.
 Sole leather manufacture, 113.
 Soles for boots, 447.
 Solidifying point, 310.
 Sologne oak, 56.
 Soluble substances in leather, 402.
 Solution of extracts, 191.
 Sorbis acuparia, 61.
 Soubar, 76.
 Souski, 369.
 Spain, leather trade, 481.
 Spanish sumach, 66.
 Spender pits, 128.
 Sperm oil, 223, 317.
 Splicing belts, 434.
 Split hides, 174.
 Splitting cow hide, 251.
 Spongy leather, 197.
 Spotting fur, 387.
 Spraying dyes, 333.
 — tan liquor, 184.
 Squalus glacialis, 222.
 Square "tumbler," 306, 314.
 Squill, 72.
 Squire's method of tanning, 181.
 Squirrel skins, 366.
 Stacking bark, 51.
 Stagbarm sumach, 66.
 Staining of skins, 19.
 Stake, 312.
 Staking chamoy leather, 319.
 Stamping mills for bark, 103.
 Stannic chloride, 323.
 Stannous chloride, 323.
 Statistics of trade in Algeria, 486.
 — Argentine Republic, 485.
 — Australasia, 487.
 — Austria, 478.
 — Belgium, 478.
 — Brazil, 484.
 — Bulgaria, 482.
 — Canada, 483.
 — Central America, 484.
 — Chili, 484.
 — China, 486.
 — Costa Rica, 484.
 — Denmark, 482.
 — Egypt, 487.
 — England, 477.
 — Germany, 476.
 — Guatemala, 484.
 — Holland, 482.
 — Hungary, 479.
 — Italy, 481.
 — Japan, 486.
 — Mexico, 484.
 — Morocco, 486.
 — Portugal, 481.
 — Servia, 482.
 — Spain, 481.
 — Sweden, 483.
 — Switzerland, 482.
 — Tunis, 486.
 — Turkey in Asia, 485.

- Statistics of trade in Turkey in Europe, 480.
 — United States, 483.
 — Uruguay, 485.
 — Venezuela, 484.
 Steam engines, 101.
 — stripping, 53.
 — sweating, 118.
 — tallowing, 302.
 Stiff hides, 304.
 Still for birch oil, 271.
 Stitching belts, 435.
 "Stocking," 317, 378.
 Stocks, Thiron's, 379.
 Stoning, 289.
 — mechanical, 290.
 Storage of bark, 56.
 Stove, sweating, 117.
 — tallowing, 299.
 Stoving Hungary leather, 303.
 Stretching belts, 433.
 — calf, 214.
 — Hungary leather, 297.
 — machines, 254.
 Striking, 150.
 Stripping bark, 47.
 — — by steam, 53.
 Strong extracts, 201.
 Structure of skin, 1.
 Stuffing drum, 301.
 Surgeon oil, 224.
 Substances which help the absorption of
 tan, 185.
 Suède gloves, 467.
 Sugar, use in tanning, 186.
 Suint, 225.
 Sulphate of ammonia in salt, 20.
 — of soda in salt, 20.
 Sulphides, unhairing with, 412.
 Sulphindigotate of soda, 330.
 Sulphur bleaching, 381.
 Sulphuric acid in tanning, 185.
 Sumach, 76.
 — American, 66.
 — Australian, 67.
 — extract, 77.
 — French, 66.
 — Malaga, 66.
 — Portuguese, 66.
 — Sicilian, 66.
 — Spanish, 66.
 — staghorn, 66.
 Sun drying skins, 22, 144.
 Suspenders, 130.
 Sweat, 1.
 Sweating, 117.
 — American, 118.
 — cold, 120.
 — experiments on, 409.
 — Hungary leather, 300.
 — natural, 115, 117.
 — steam, 118.
 — stove, 117.
 — theory of, 407.
 — warm water, 119.
 Sweet pea, 75.
 Sweden, leather trade, 483.
 Swelling by acids, 133.
 — power of acids, 134.
 — theory of, 413.
 Switzerland, leather trade, 482.
- T.**
- Tabarca, 76.
 Table of artificial dyes, 334.
 Tallow, 224.
 Tallowing Hungary leather, 299, 300.
 — machines, 301.
 — stove, 299.
 Tamarind, 76.
 Tamarix indica, 68.
 Tan basket, 140.
 — bearing bulbs, 72.
 — — fruits, 70.
 — — leaves, 65.
 — — roots, 72.
 — colouring power of, 86.
 — furnaces, 90.
 — liquor, acidity of, 132.
 — scoop, 140.
 — spade, 140.
 — woods, grinding, 108.
 Tannates, 42.
 Tannic acid, 30.
 — acids, list of, 31.
 Tannin, 8, 30.
 — bearing leaves, 65.
 — chemistry of, 33.
 — constitution of, 33.
 — estimation of, 80, 405.
 — extracts, manufacture of, 76.
 — fermentation of, 32, 39.
 — in chestnut wood, 61.
 — pathological, 32.
 — physiological, 32.
 — properties of, 36.
 — pure, 35.
 — reactions of, 38.
 — synthesis of, 34.
 Tanning bird skins, 209.
 — by carbonic acid gas, 185.
 — by electricity, 184.
 — by evaporation, 183.
 — by heat, 183.
 — by light, 185.
 — by spraying, 184.
 Chailly method, 181.
 chemical methods, 185.
 — cost of, 196.
 — cow hide, 172.
 — Danish, 182.
 — dressing leather, 169.
 — experiments on, 417, 419, 421.
 — frog skins, 208.
 — Herepath's method, 180.
 — horse hide, 173.
 — in vacuo, 183.
 — juices, 72.
 — Knoderer's method, 180.
 — Lowersidge's method, 180.

- Tanning, mechanical methods, 177.
 -- mineral, 293.
 -- morocco, 321.
 -- object of, 8.
 -- physical methods, 183.
 -- rat skins, 208.
 -- Royer system, 178.
 -- second, 201.
 -- snake skins, 209.
 -- Squire's method, 181.
 -- theory of, 396, 406, 417.
 -- time required for, 138.
 -- Tourin's method, 182.
 -- Vauquelin's method, 180.
 -- with albuminous substances, 187.
 -- with aluminium, 189.
 -- with bark and extracts, 193.
 -- with chromium, 189.
 -- with extracts, 190.
 -- with iron, 189.
 -- with ox brains, 187.
 -- with pyrofuchsin, 188.
 -- woods, 61.
- Tannins, classification of, 32.
 -- list of, 31.
- Tannomelanic acid, 44.
- Tannoxylic acid, 44.
- Tapir skins, 375.
- Tarare, 1.
- Tar in salt, 19.
- Tawing, 293, 305.
 -- experiments, 429.
- Tension of vapour, 144.
- Terminalia, 71.
- Testing machine, Thomasset, 400.
 -- leather, 197, 396.
- Theory of action of tannin on skin, 418.
 -- chamoying, 430.
 -- handling, 415.
 -- Hungary leather making, 425.
 -- liming, 410.
 -- mineral tanning, 432.
 -- soaking, 406.
 -- sweating, 407.
 -- swelling, 413.
 -- tanning, 396, 406, 417.
 -- tawing, 429.
 -- unhairing, 407.
 -- -- with alkalis, 411.
 -- -- with sulphides, 412.
- Thibet bear skins, 368.
- Thiron's stocks, 379.
- Thomasset's testing machine, 400.
- Thread lac, 281.
- Thuya articulata, 284.
- Tiger skins, 371.
- Timbo, 76.
- Time required for tanning, 138.
- Tinea pellionella, 388.
 -- sarcitella, 388.
- Tin mordants, 323.
 -- salts for bleaching, 204.
 -- solution, 324.
- Tjaarna bark, 72.
- Totomi, 60.
- Toucan skins, 377.
- Tourin's machine for Hungary leather, 299.
 -- method for tawing, 182.
- Traces, 461.
- Trade. *See* Statistics.
- Transparent enamel, 292.
 -- leather, 188.
- Transpiration, 2.
- Trimmatostroma, 42.
- Trimming, 120.
- Trumpeter skins, 25, 377.
- Trumpet wood, 75.
- Trussing, 9.
- Tsi, 282.
- Tubes, leather, 472.
- "Tumbler," 158.
 -- dyeing, 338.
- Tunis leather trade, 486.
- Tunny oil, 224.
- Turkey in Asia, leather trade, 485.
 -- Europe, leather trade, 480.

U.

- Uncaria gambir, 72.
- Unhairing, 117, 120, 154, 320.
 -- machines, 121.
 -- theory of, 407.
 -- with alkalis, experiments on, 411.
 -- -- theory of, 411.
 -- with sulphides, experiments on, 412.
 -- -- theory of, 412.

United States, leather trade, 483.

Uppers for boots, 447.

Urape, 76.

Urea, 186.

Uruguay leather trade, 485.

Urushic acid, 282.

Uses of belts, 441.

-- leather, 433.

V.

Vacuum in tanning, 183.

Vaingra, 75.

Valonea, 70.

-- extract, 77.

Van Tieghem on tannin, 39.

Vapart's disintegrator, 110.

Vapour tension, 144.

Varnish manufacture, 277, 285.

-- soap, 288.

Vaseline, 302.

Vats, Delpech's, 296.

-- Lepelley's, 296.

-- mechanical, 131, 296.

-- salting in, 20.

Vauquelin's method of tanning, 180.

Vegetable rose, 329.

Vellum, 355.

Venezuela leather trade, 484.

Ventilation of drying lofts, 146.

Vetiver, 388.

Vicuna skins, 372.

Villon's black for fur, 384, 385.

Villon's chestnut for fur, 385.
 — fawn for fur, 386.
 — process for preserving fur, 389.
 Vinegar, action on leather, 197.
 Violet dye, 343.
 Virgin parchment, 355.
 — resin, 284.
 Virginian fox skins, 368.
 Viscaya skins, 372.
 Vison skins, 375.

W.

Wallaby, 25.
 Walrus, 26.
 — skin, uses of, 24, 26.
 Warm air drying, 147.
 Warm water sweating, 119.
 Water estimation in degreas, 218.
 — in leather, 402.
 — for tanneries, 124.
 — softening, 124.
 Waterproofing, 204.
 Wattle tree, 65.
 Wax, extra, 231.
 — for calf, 231.
 Waxed calf, 230.
 Waxing calf, 231.
 Weasel skins, 369.
 Weighting skins, 21, 205.
 Weight marks, 15.
 — of skins, 15.
 West Indian oak, 75.
 Whale oil, 223.
 — skins, 27.
 White enamel, 291.
 — oak, 76.
 Whitening calf, 229.
 Whortleberry, 67.

Wild boar skins, 24.
 Willow bark, 60.
 Woof on bark, 46.
 Wolverine skins, 369.
 Wood, Brazil, 327.
 — citron, 76.
 — Cuba, 327.
 — grinding, 108.
 — jujube, 76.
 — mulberry, 76.
 — oak, 76.
 — orange, 76.
 — red, 342.
 — sandal, 327.
 — vine, 76.
 — yellow, 327.
 Woods, tanning, 61.
 Wouta-pana, 70.

Y.

Yagrumo, 76.
 Yayamados, 75.
 Yellow dye, 342.
 — enamel, 291.
 — gambier, 74.
 — resin, 285.
 — wood, 327.
 Yerva mathe, 67.
 — tea, 75.
 Yolk of egg, action on skin, 430.

Z.

Zebra skins, 372.
 Zerda skins, 368.
 Zinc chloride in tanning, 186.
 — sulphate in salt, 20.
 Zizal skins, 369.

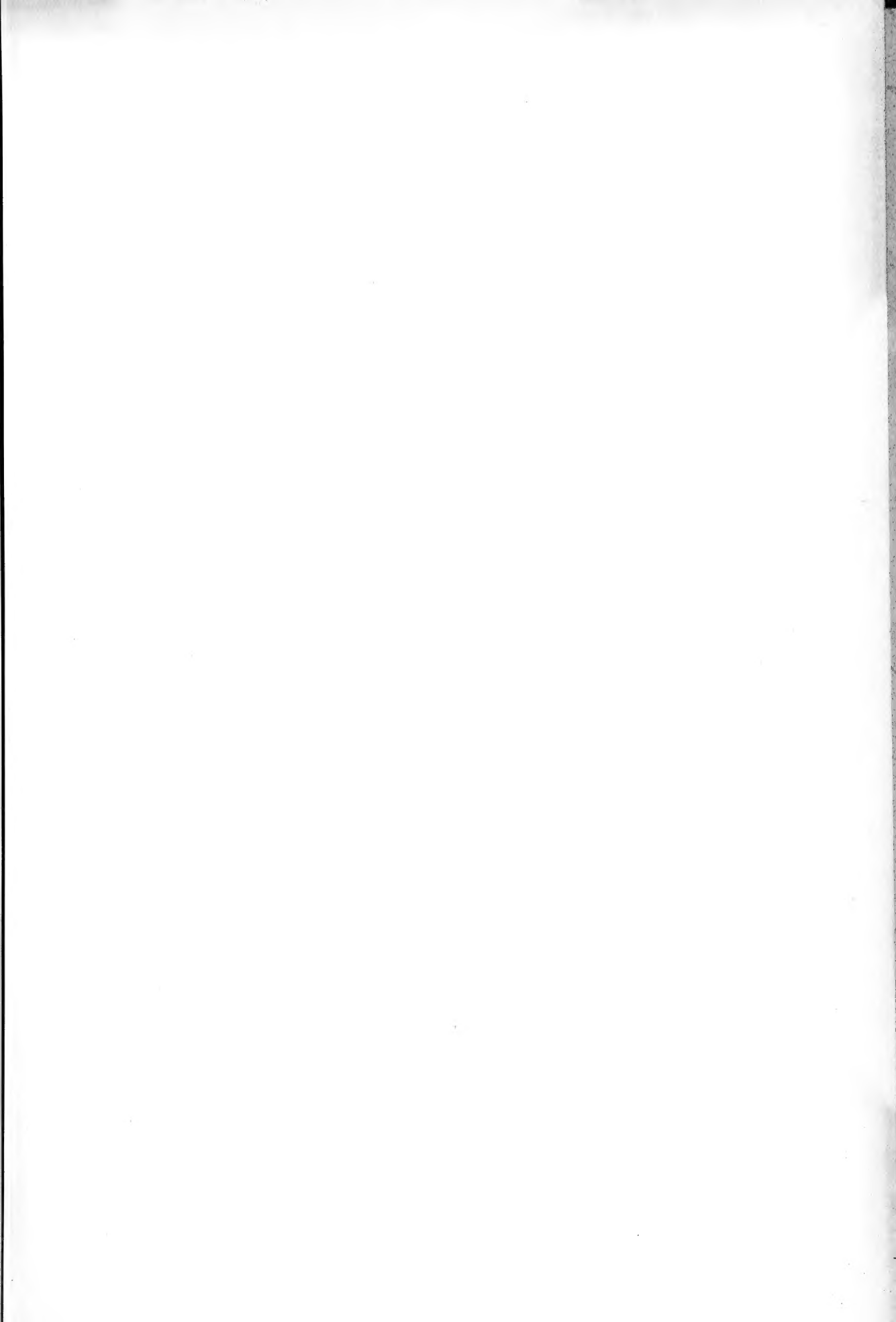

SCIENCE

695.2

V759

INSTITUTE OF SCIENCE VICTORIA

THE PUBLIC LENDING LIBRARY OF VICTORIA.

NOTICE TO BORROWERS.

1. Borrowers are required to make themselves familiar with the Lending Library Rules.
2. A Fine of **THREEPENCE** a day, or portion of a day, is incurred by borrowers who detain books longer than a Fortnight.
3. Borrowers are cautioned against writing upon, marking, or otherwise injuring Books; and their attention is specially directed to Lending Library Rules numbered 11 and 12.
4. Lending Library Books must be immediately returned in the event of the outbreak of any infectious disease in the house in which a borrower is dwelling.
5. Change of residence by a borrower must be notified to the Librarian without delay.

By order of the Trustees,

E. LA T. ARMSTRONG, Librarian.

