

11 Predictive Mycology

Philippe Dantigny

CONTENTS

- 11.1 Introduction
- 11.2 Concerns
 - 11.2.1 Mycotoxins Production
 - 11.2.2 Economic Losses
- 11.3 Mold Specificities
- 11.4 Models
 - 11.4.1 Primary Models
 - 11.4.2 Secondary Models
- 11.5 Perspectives
- References

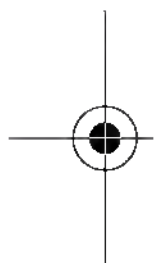

11.1 INTRODUCTION

For over 20 years, predictive microbiology has focused on bacterial food-borne pathogens, and some spoilage bacteria. Few studies have been concerned with modeling fungal development. Predictive modeling is a versatile tool that should not be limited to bacteria, but should be extended to molds. Mathematical modeling of fungal growth was reviewed earlier (Gibson and Hocking, 1997), but at that time very few models were available. The concerns were growth and toxin production, but germination was not examined. On one hand, most of food mycologists are not familiar with modeling techniques, and they tend to use existing models that were developed for describing bacterial growth in foods. On the other hand, people involved in modeling may not be aware of mold specificities. Predictive mycology aims at developing specific tools for describing fungal development.

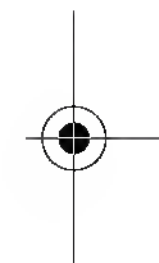

11.2 CONCERNS

The occurrence of food-borne fungi was described extensively by Northolt et al. (1995). Food raw material and products can be contaminated with spores or conidia and mycelium fragments from the environment. Under favorable conditions, fungal growth occurs. A large number of metabolites are formed during the breakdown of carbohydrates, some of which can accumulate under certain conditions. The main concern is production of mycotoxins, which cannot simply be destroyed by heat.

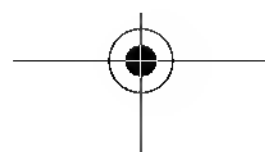
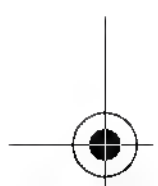

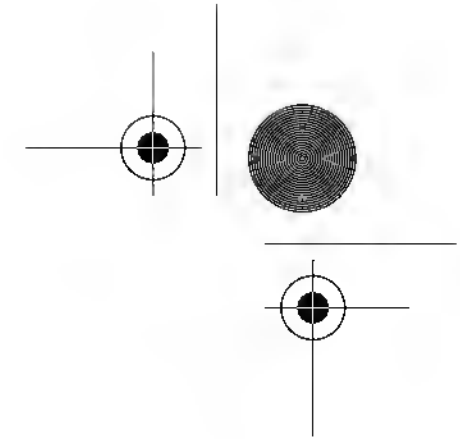
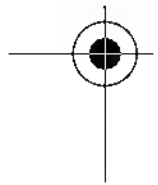

11.2.1 MYCOTOXINS PRODUCTION

It has been reported that 25% of agriculture products are contaminated with mycotoxins (Mannon and Johnson, 1985). Mycotoxin ingestion by humans, which occurs mainly through plant-based foods and the residues and metabolites present in animal-derived foods, can lead to deterioration of liver or kidney function (Sweeney and Dobson, 1998) and therefore constitutes a risk for human health. The main genera responsible for toxins production are *Fusarium*, *Aspergillus*, and *Penicillium*. While *Fusarium* species are destructive plant pathogens producing mycotoxins before or immediately post harvesting, *Penicillium* and *Aspergillus* species are more commonly found as contaminants of commodities and foods during drying and subsequent storage (Sweeney and Dobson, 1998). Plant contamination by molds such as *Fusarium* cannot be avoided at the field level because it depends largely on climatic conditions. Predictive mycology would be useful for making predictions on the extent of contamination, growth, and toxin production by these pathogens; however, there are no models currently available. In contrast, controlling the environmental factors during storage of raw materials can prevent the development of *Penicillium* and *Aspergillus*. The prevalence of one species as compared to the other one is related to temperature, *Penicillium* being capable of developing at lower temperatures than is *Aspergillus*.

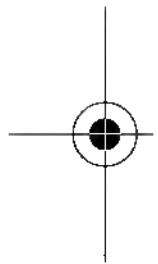

11.2.2 ECONOMIC LOSSES

Because of the appearance of visible hyphae and production of unpleasant odors, fungal spoilage of food causes economic losses. For example, in the baking industry, these losses vary between 1 and 3% of products, depending on season, type of product, and method of processing (Mälkki and Rauha, 1978). The most widespread and probably most important molds in terms of biodeterioration of bakery products are species of *Eurotium*, *Aspergillus*, and *Penicillium* (Abellana et al., 1997). But there are many other species responsible for food spoilage. The reason why a particular species dominates in a product is certainly correlated with the species characteristics and the properties of the product (Northolt et al., 1995). Therefore, predictive mycology can well be applied to control fungal development through product formulation, food processing, type of packaging, and conditions of storage.

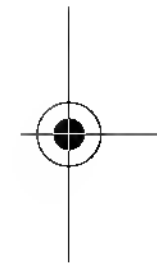

11.3 MOLD SPECIFICITIES

Fungal growth involves germination and hyphal extension, eventually forming mycelium. Spores are widely disseminated in the environment, and they are principally responsible for spoilage. Under favorable conditions, spores will swell. Thereafter, when the length of the germ tube is between one half and twice the spore diameter (depending on the source), the spore is considered to have germinated. Germination can be considered as the main step to be focused on, because a product is spoiled as soon as visible hyphae can be observed. However, few studies have concerned germination kinetics. This limitation can be explained in part by the difficulties of acquiring sufficient, reproducible data. In fact, this kind of study requires microscopic

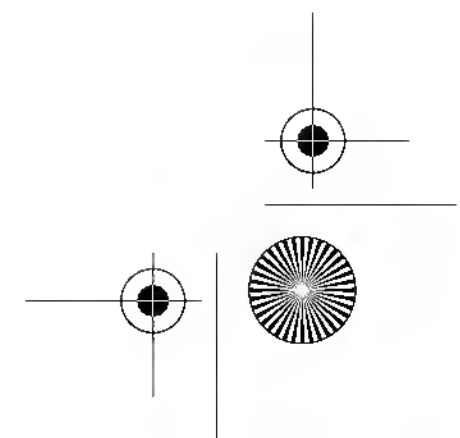
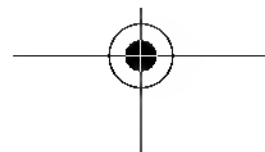
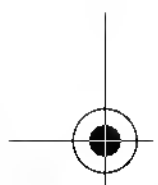

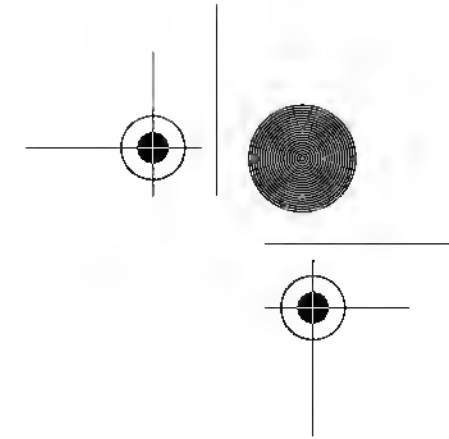
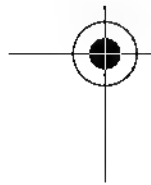

observation for evaluating the length of the germ tube. Moreover, observations and measurements should be carried out without opening the dishes (Magan and Lacey, 1984) and experimental devices should be developed for this purpose (Sautour et al., 2001a, 2001c). In contrast, more work was dedicated to the measurement of hyphal extension rate, which is usually reported as radial growth rate (mm d^{-1}).

Because of their ability of dividing, bacteria form single cells and they can be easily enumerated, especially in liquid broth. In such a case, and at high cellular densities, bacterial growth can be estimated automatically, for example, by using the Bioscreen[®] device, which is based on turbidity measurements. At lower cellular densities and in solid media, colony-forming units per gram (CFU/g) or CFU/ml can be determined.

In contrast, molds form mycelium, and the weight, except at the early stage of growth, does not increase exponentially (Koch, 1975). It is therefore useless to determine the weight of the mycelium for estimating a growth rate parameter. In addition, it is impossible to split the mycelium into individual cells. However, the CFU method can be applied to the enumeration of spores (Vindeløv and Arneborg, 2002).

Temperature (T) is the main factor for controlling bacterial growth, but the effect of water activity (a_w) on mold growth is more important than T (Holmquist et al., 1983). Oxygen is necessary for the growth of food spoilage fungi. Therefore, the use of modified atmospheres to prevent fungal growth and mycotoxin production has been evaluated to extend the shelf life of some kinds of food (El Halouat and Debevere, 1997; Taniwaki et al., 2001).

11.4 MODELS

11.4.1 PRIMARY MODELS

Two aspects of fungal growth can be modeled using primary models: spore germination and radial growth of colonies. The germination of spores of *Fusarium moniliforme* as a function of time was first studied at different a_w (Marín et al., 1996). The percentage of germination vs. time was modeled with the modified Gompertz equation (see Chapter 2) at different water activities (Figure 11.1). In contrast to the case with bacteria where the initial bacterial load (N_0) is a critical parameter to be estimated, the initial percentage of germination was always equal to 0. The asymptotic value where the percentage of germination becomes constant was 100 in most cases. But under harsh environmental conditions some spores are unable to initiate a germ tube, thus leading to a maximum percentage of germination less than 100 (Figure 11.1).

There are two different ways of looking at spore germination: (1) the percentage of germination at a certain time, and (2) the time to obtain a certain germination percentage, or germination time. In the present example, the percent germination after 24 h does not discriminate water activity levels very well (vertical dotted line in Figure 11.1). The response was 100% for a_w in the range 0.94 to 0.98, and 0% in the range 0.88 and 0.92. In contrast, germination time (defined here as half the maximum percent germination) is clearly dependent upon a_w (horizontal dotted line in Figure 11.1). It should be noted, however, that an accurate determination of the germination time requires modeling of the whole germination curve.

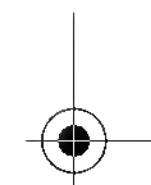
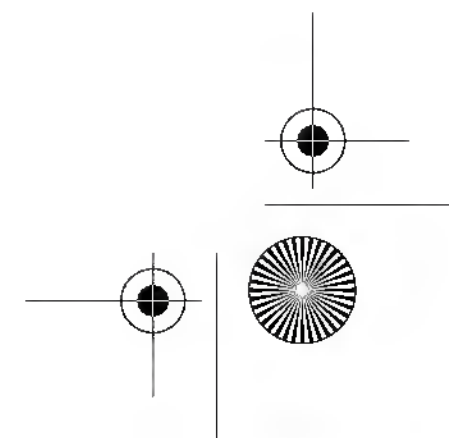
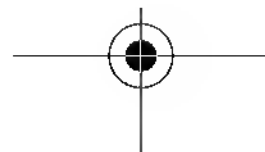
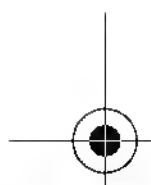
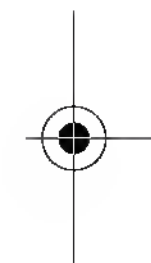
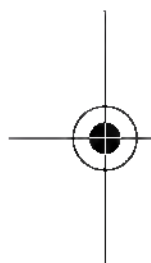

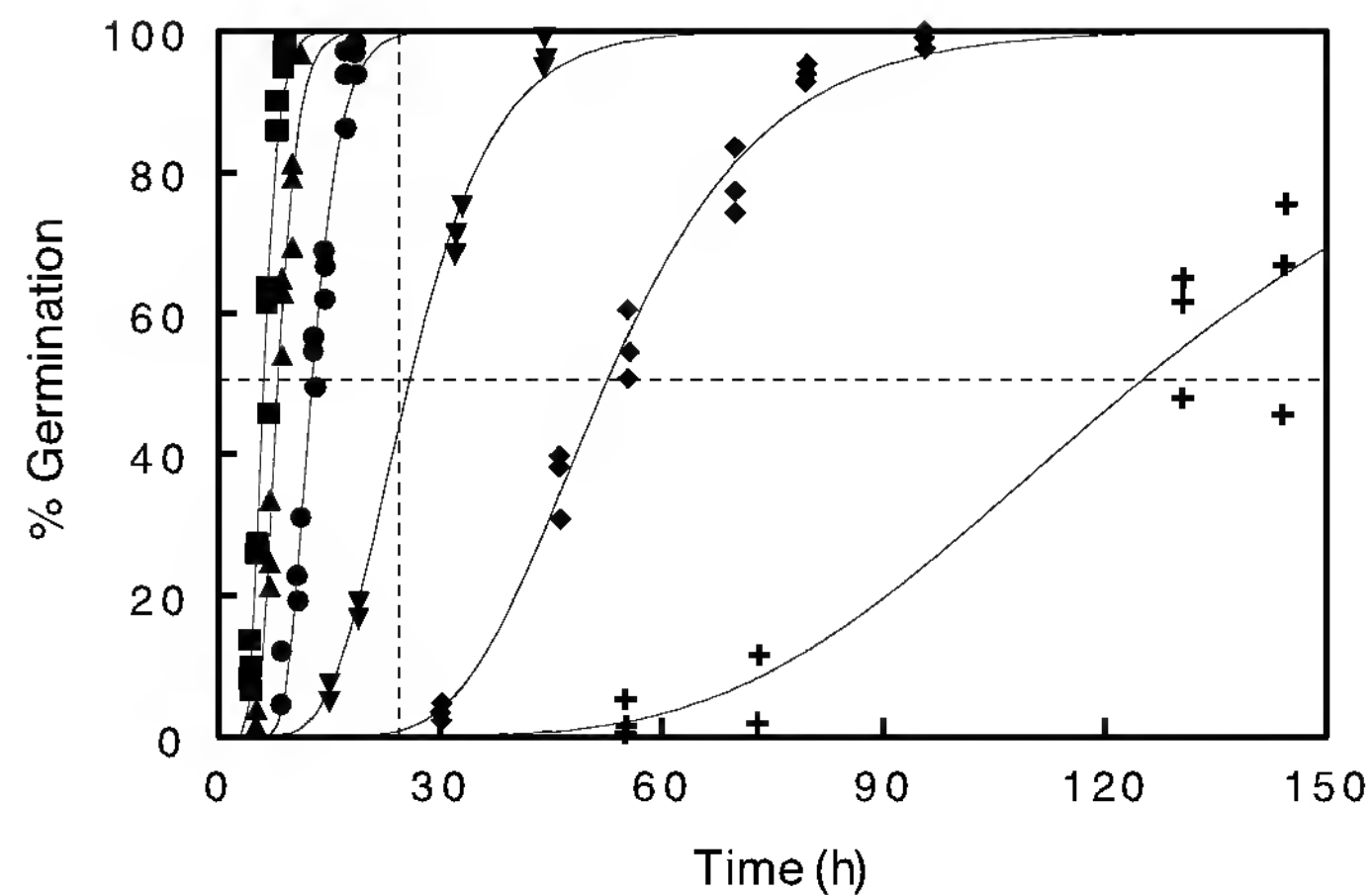
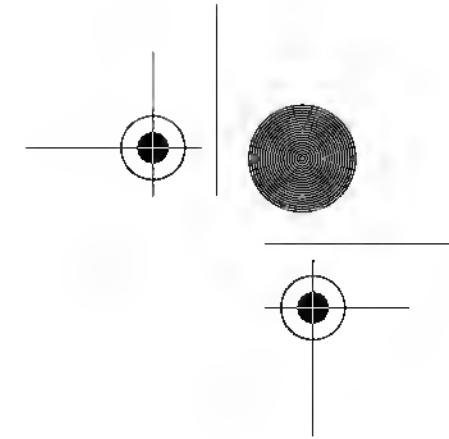
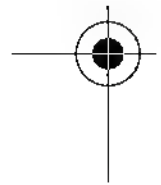

FIGURE 11.1 Effect of water activity and time on germination (%) of spores of *Fusarium moniliforme* (isolate 25N) on MMEA (maize meal extract agar) at 25°C. Water activity levels were 0.98 (■), 0.96 (▲), 0.94 (●), 0.92 (▼), 0.90 (◆), and 0.88 (+). (Redrawn from Marín, S., Sanchis, V., Teixido, A., Saenz, R., Ramos, A.J., Vinas, I., Magan, N. 1996. *Can. J. Microbiol.* 42, 1045–1050.) The vertical dotted line indicates the percent germination at 24 h, and the horizontal dotted line shows the time required for 50% germination at each water activity.

The germination time can also be considered as the probability of a single spore germinating. Accordingly, the logistic function that is usually dedicated to probabilistic models:

$$P = \frac{P_{\max}}{(1 - e^{(k[\tau-t])})} \quad (11.1)$$

was used for describing the germination kinetics of *Mucor racemosus* (Dantigny et al., 2002). The parameter P_{\max} was substituted with 100% because all spores were capable of germinating. With the objective of designing a secondary model, the parameters of the logistic function were expressed as a function of environmental factors. The rate factor k was constant whatever the temperature, whereas τ (time where $P = P_{\max}/2$) was more discriminative.

Shortly after the completion of germination, the mycelium is visible to the naked eye (when the colony diameter reaches approximately 3 mm). Therefore fungal growth can be easily estimated from macroscopic measurements of the radius of the colony. The primary model developed by Baranyi (see Chapter 2) has been adapted to fit colony diameter growth curves of *Penicillium roqueforti* (Valík et al., 1999), *Aspergillus flavus* (Gibson et al., 1994), and *Penicillium brevicompactum* (Membré and Kubaczka, 2000). In our laboratory we have had considerable success with a simple linear model with breakpoint:

$$r = \mu \cdot (t - \lambda) \quad (11.2)$$

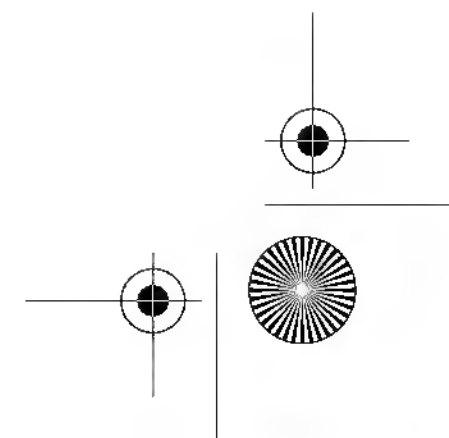
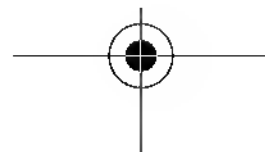
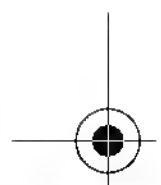

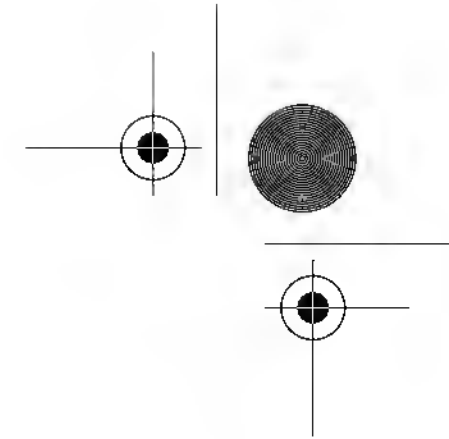
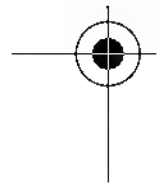

where r is the colony radius (mm), μ is the radial growth rate (mm d⁻¹), and λ is the lag time (d). The linear section of the graph (with growth rate of μ) is extrapolated to a zero increase in diameter, and the intercept on the time axis is defined as the lag prior to growth (λ). In most cases, the fits are excellent, with the regression coefficients being greater than 0.995. Therefore, under these conditions, it is unlikely that other models such as those of Baranyi or Gompertz would demonstrate superiority over the linear approach. In addition, the parameters μ and λ , can be obtained even when the petri dish is not entirely covered with mycelium. It should also be mentioned that early measurements of diameter of the colony improve the accuracy of the lag period because this parameter is obtained by extrapolation of the straight line.

11.4.2 SECONDARY MODELS

pH, which is usually associated with other environmental factors to prevent bacterial growth, has no marked influence on mold germination or growth. Water activity has a greater effect on mold development than does temperature, whereas an interactive effect between T and a_w is noticed. The effects of temperature and water activity on growth rate of food spoilage molds were compared using normalized variables μ_{dim} , T_{dim} , and $a_{w\ dim}$ within Bělehrádek-type equations : $\mu_{dim} = [T_{dim}]^\alpha$ and $\mu_{dim} = [a_{w\ dim}]^\beta$ (Sautour et al., 2002). It can be observed that for $\alpha = 2$, the equation is equivalent to the square-root model that was originally described by Ratkowsky et al. (1982).

It was reported that the molds studied were characterized by α -values ranging from 0.81 to 1.54 and β -values from 1.50 to 2.44. Because of the lack of specific models for molds there is a tendency to apply models that have been developed for bacteria. For example, the square-root model was used to describe the effect of T on the growth of *Rhizopus microsporus* (Han and Nout, 2000). It is clear that the effect of temperature on molds cannot be modeled by the square-root model because of α -values close to 1. It has been demonstrated that the use of the square-root model when α is less than 2 leads to underestimation of T_{min} (Dantigny and Molin, 2000). Similarly, some doubt can be raised with the use of the cardinal model with inflexion (CMI) described by Rosso et al. (1993) for describing the effect of T on fungal growth rate. For example, a T_{min} value as low as -12°C has been reported for *P. rocqueforti* using the CMI model (Cuppers et al., 1997). In contrast, the CMI model was used satisfactorily for describing the effect of a_w on fungal growth rate (Rosso and Robinson, 2001; Sautour et al., 2001b) as suggested by the β -values close to 2. It should also be noted that, in contrast to the square-root model proposed by Gibson et al. (1994) to describe fungal growth, the CMI model allows an estimation of $a_{w\ min}$, which is not easily determinable because fungal growth can well occur after several months of incubation.

11.5 PERSPECTIVES

For the objective of modeling fungal kinetics, the tools that were developed for bacteria can be used, but mold specificities should be taken into account. As a primary step in modeling fungal development, attention should be focused on spore

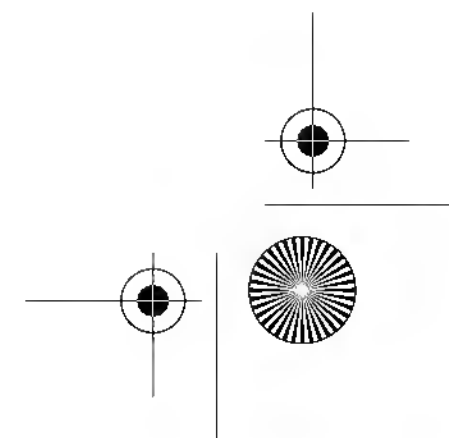
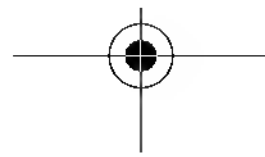
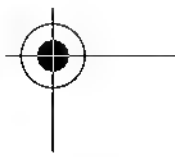
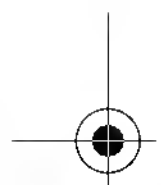

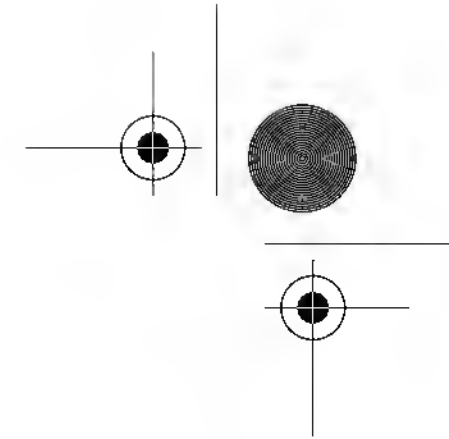
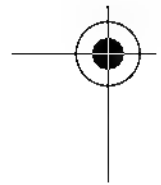

germination. Although there is no widely accepted definition of germination time, this variable provides a pertinent insight into how fast spores are germinating. To determine this variable accurately, spore germination kinetics should be monitored using regular microscopic observations and by developing a specific experimental setup. A significant breakthrough in predictive mycology would be the automation of spore observations. Some attempts were made using image analysis (Paul et al., 1993), but clumping of spores should be avoided. In addition, culture media should be clear enough to allow microscopic observations. Therefore, any model describing germination kinetics could be hardly validated on food products by this technique.

Fungal growth, which is usually reported as radial growth rate, can be easily determined by macroscopic observations. In order to substitute a microscopic observation for a macroscopic one, a relationship between the lag for growth and the germination time was established (Dantigny et al., 2002). However, it was shown that the lag time is very much dependent on the number of spores inoculated at the same spot (Sautour et al., in press). This could be explained, because a large inoculum will form a visible colony more rapidly than a small one, thus decreasing the lag. Some more studies should be conducted to determine the relationship between the lag and the number of spores inoculated. It should also be verified that such a relationship is independent from the environmental factors.

Secondary models concern mainly the influence of environmental factors on fungal growth rate. At present, very few models aimed at assessing the influence of these factors on spore germination have been elucidated. Unfortunately, existing models are polynomial, and cannot be extrapolated to other molds. Secondary models based on parameters with biological significance (e.g., cardinal values) to determine the influence of environmental factors on spore germination and mycotoxins production should be developed. Eventually, other parameters such as preservatives should be included in the list of environmental factors.

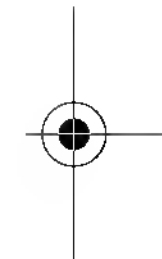
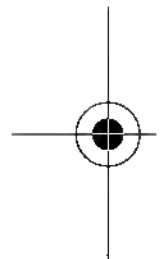

REFERENCES

- Abellana, M., Torres, L., Sanchis, V., Ramos, A.J. 1997. Caracterización de diferentes productos de bollería industrial. II. Estudio de la microflora. *Alimentaria* 287, 51–56.
- Cuppers, H.G.A.M., Oomes, S., Brul, S. 1997. A model combined effects of temperature and salt concentration on growth rate of food spoilage molds. *Appl. Environ. Microbiol.* 63, 3764–3769.
- Dantigny, P., Molin, P. 2000. Influence of the modelling approach on the estimation of the minimum temperature for growth in Bělehrádek-type models. *Food Microbiol.* 17, 597–604.
- Dantigny, P., Soares Mansur, C., Sautour, M., Tchobanov, I., Bensoussan, M. 2002. Relationship between spore germination kinetics and lag time during growth of *Mucor racemosus*. *Lett. Appl. Microbiol.* 35, 395–398.
- El Halouat, A., Debevere, J.M. 1997. Effect of water activity, modified atmosphere packaging and storage temperature on spore germination of moulds isolated from prunes. *Int. J. Food Microbiol.* 35, 41–48.
- Gibson, A.M., Baranyi, J., Pitt, J.I., Eyles, M.J., Roberts, T.A. 1994. Predicting fungal growth: the effect of water activity on *Aspergillus flavus* and related species. *Int. J. Food Microbiol.* 23, 419–431.

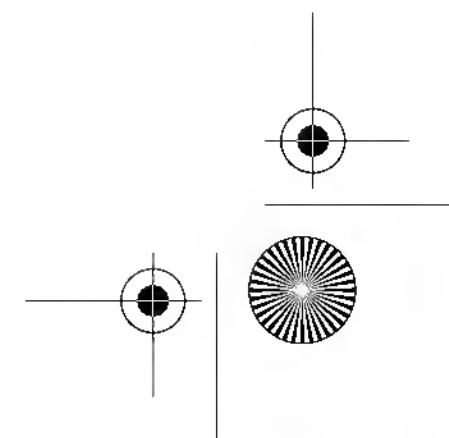
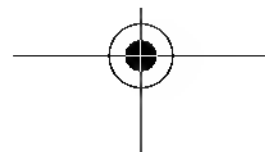
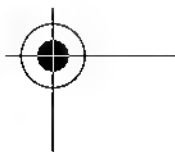
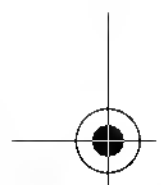

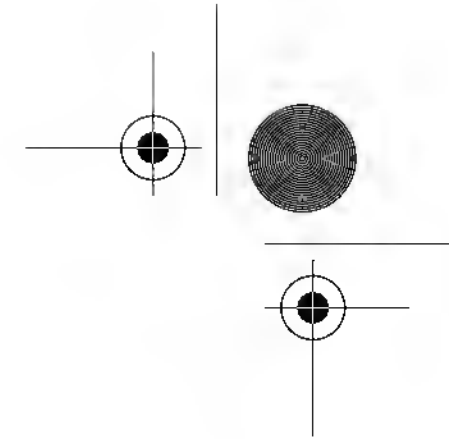
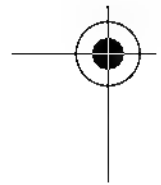

- Gibson, A.M., Hocking, A.D. 1997. Advances in the predictive modelling of fungal growth in food. *Trends Food Sci. Technol.* 8, 353–358.
- Han, B.-Z., Nout, M.J. 2000. Effects of temperature, water activity and gas atmosphere on mycelial growth of temperate fungi *Rhizopus microsporus* var *microsporus* and *R. microsporus* var *oligosporus*. *World J. Microbiol. Biotechnol.* 16, 853–858.
- Holmquist, G.U., Walker, H.W., Stahr, H.M. 1983. Influence of temperature, pH, water activity and antifungal agents on growth of *Aspergillus flavus* and *A. parasiticus*. *J. Food Sci.* 48, 778–782.
- Koch A.L. 1975. The kinetics of mycelial growth. *J. Gen. Microbiol.* 89, 209–216.
- Magan, N., Lacey, J. 1984. Effect of temperature and pH on water relations of field and storage fungi. *Trans. Br. Mycol. Soc.* 82, 71–81.
- Mälkki, Y., Rauha, O. 1978. Mold inhibition by aerosols. *Baker's Digest.* 52, 47–50.
- Mannon, J., Johnson, E. 1985. Fungi down on the farm. *New Scientist.* 195, 12–16.
- Marín, S., Sanchis, V., Teixido, A., Saenz, R., Ramos, A.J., Vinas, I., Magan, N. 1996. Water and temperature relations and microconidial germination of *Fusarium moniliforme* and *Fusarium proliferatum* from maize. *Can. J. Microbiol.* 42, 1045–1050.
- Membré, J.-M., Kubaczka M., 2000. Predictive modelling approach applied to spoilage fungi: growth of *Penicillium brevicompactum* on solid media. *Lett. Appl. Microbiol.* 31, 247–250.
- Northolt, M.D., Frisvad, J.C., Samson, R.A. 1995. Occurrence of food-borne fungi and factors for growth. In *Introduction to Food-Borne Fungi*, 4th ed. Samson, R.A., Hoekstra, E.S., Frisvad, J.C., Filtenborg, O. (Eds.), Centraal Bureau voor Schimmelcultures, Delft, The Netherlands, pp. 243–250.
- Paul, G.C., Kent, C.A., Thomas, C.R. 1993. Viability testing and characterization of germination of fungal spores by automatic image analysis. *Biotechnol. Bioeng.* 42, 11–23.
- Ratkowsky, D.A., Olley, J., McMeekin, T.A., Ball, A. 1982. Relationship between temperature and growth rate of bacterial cultures. *J. Bacteriol.* 149, 1–5.
- Rosso, L., Lobry, J.R., Bajard, S., Flandrois, J.P. 1993. An unexpected correlation between cardinal temperatures of microbial growth highlighted by a new model. *J. Theor. Biol.* 162, 447–463.
- Rosso, L., Robinson, T.P. 2001. A cardinal model to describe the effect of water activity on the growth of moulds. *Int. J. Food Microbiol.* 63, 265–273.
- Sautour, M., Dantigny, P., Divies, C., Bensoussan, M. 2001a. Application of Doehlert design to determine the combined effects of temperature, water activity and pH on conidial germination of *Penicillium chrysogenum*. *J. Appl. Microbiol.* 91, 900–906.
- Sautour, M., Dantigny, P., Divies, C., Bensoussan, M. 2001b. A temperature-type model for describing the relationship between fungal growth and water activity. *Int. J. Food Microbiol.* 67, 63–69.
- Sautour, M., Dantigny, P., Guilhem, M.-C. Bensoussan, M. In press. Influence of inoculum preparation on the growth of *Penicillium chrysogenum*. *J. Appl. Microbiol.*
- Sautour, M., Rouget, A., Dantigny, P., Divies, C., Bensoussan, M. 2001c. Prediction of conidial germination of *Penicillium chrysogenum* as influenced by temperature, water activity and pH. *Lett. Appl. Microbiol.* 32, 131–134.
- Sautour, M., Soares Mansur, C., Divies, C., Bensoussan, M., Dantigny, P. 2002. Comparison between the effects of temperature and water activity on growth rate of food spoilage molds. *J. Ind. Microbiol. Biotechnol.* 28, 311–315.
- Sweeney, M.J., Dobson, A.D.W. 1998. Mycotoxin production by *Aspergillus*, *Fusarium* and *Penicillium* species. *Int. J. Food Microbiol.* 43, 141–158.
- Taniwaki, M.H., Hocking, A.D., Pitt, J.I., Fleet, G.H. 2001. Growth of fungi and mycotoxin production on cheese under modified atmospheres. *Int. J. Food Microbiol.* 68, 125–133.

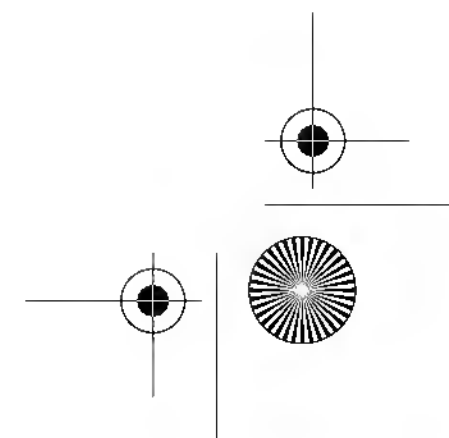
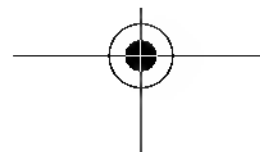
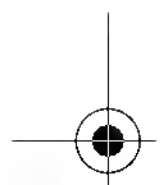
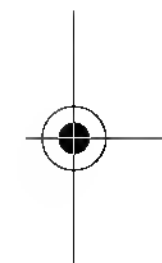
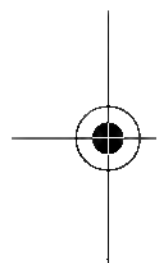

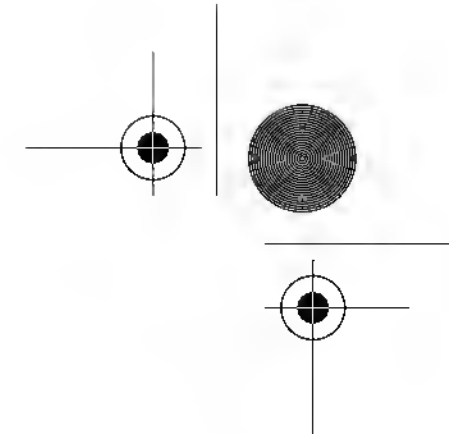
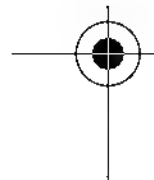

- Valík, L., Baranyi, J., Görner, F. 1999. Predicting fungal growth: the effect of water activity on *Penicillium roqueforti*. *Int. J. Food. Microbiol.* 47, 141–146.
- Vindeløv, J., Arneborg, N. 2002. Effects of temperature, water activity, and syrup film composition on the growth of *Wallemia sebi*: development and assessment of model predicting growth lags in syrup agar and crystalline sugar. *Appl. Environ. Microbiol.* 68, 1652–1657.

