

P. G. NUERNBERGER & G. RETTIG, JR.  
TYPE CASTING MOLD.

APPLICATION FILED DEC. 30, 1905.

2 SHEETS—SHEET 1.

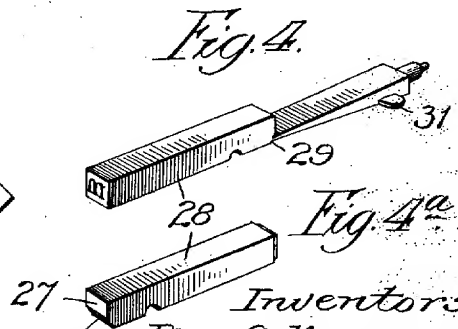
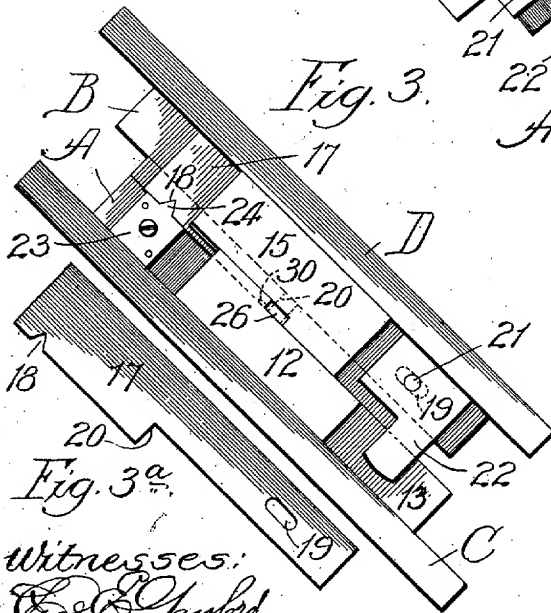
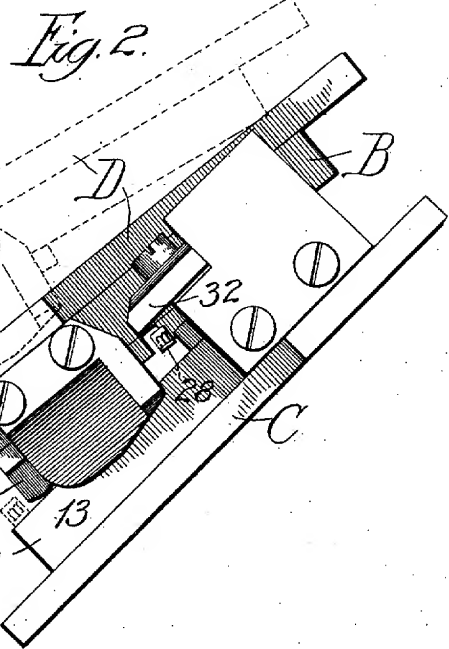
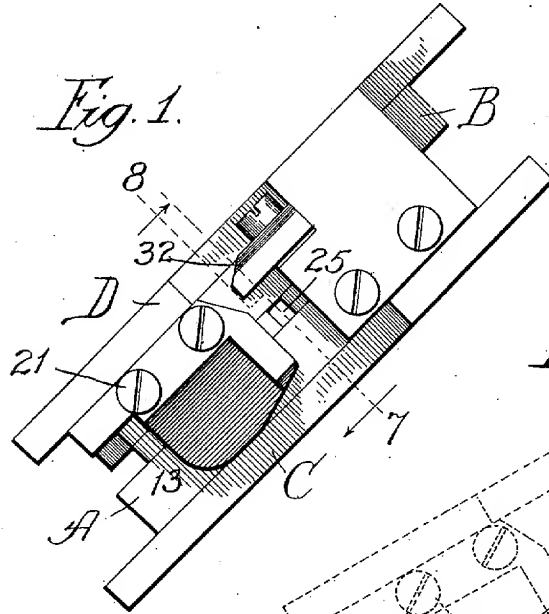

Witnesses:  
*Edw. B. Clifford.*  
*John Enders.*

Inventors:  
 29 *Philip G. Nuernberger &*  
*George Rettig Jr.*  
 By *G. B. Coupland.*  
*Att'y*

P. G. NUERNBERGER & G. RETTIG, JR.  
TYPE CASTING MOLD.

APPLICATION FILED DEC. 30, 1905.

2 SHEETS—SHEET 2.

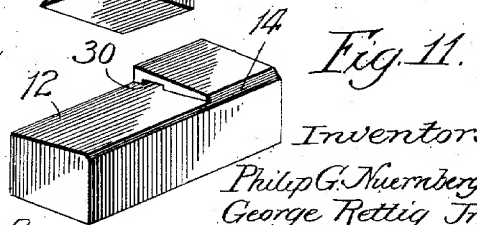
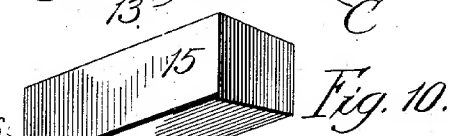
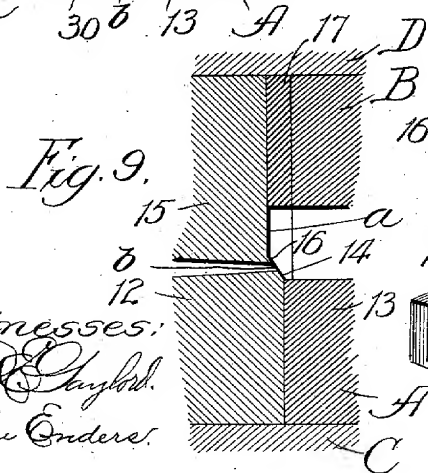
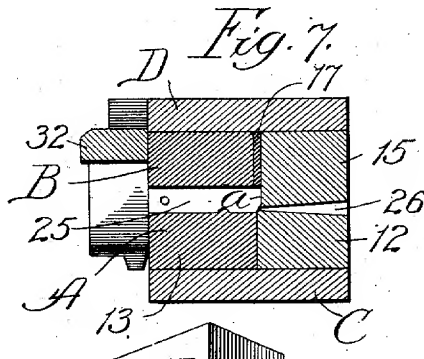
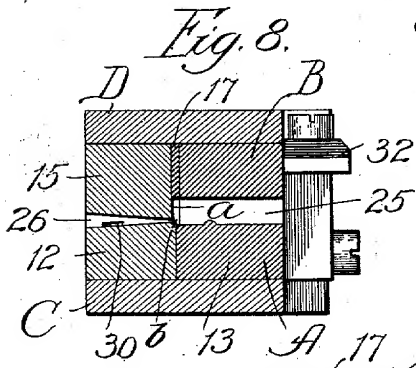
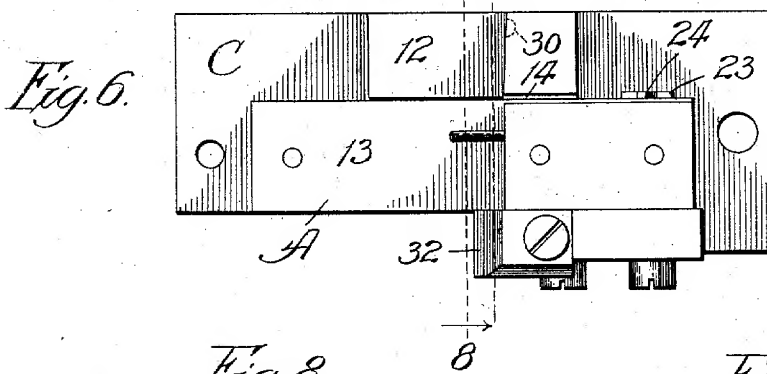
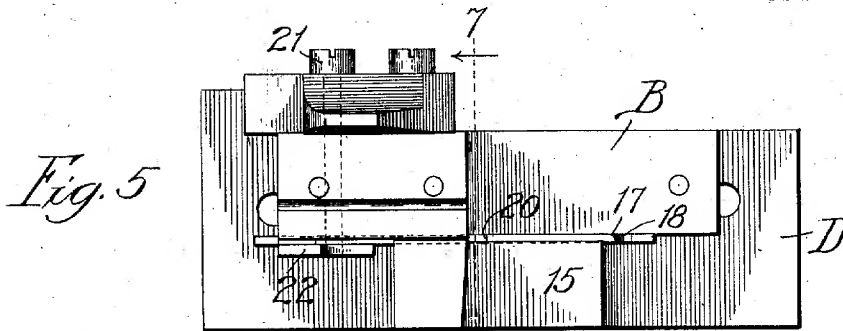

Witnesses:  
*John Enders.*

Inventors:  
 Philip G. Nuernberger &  
 George Rettig Jr.  
 By *L. B. Coupland,*  
 Attorney

# UNITED STATES PATENT OFFICE.

PHILIP G. NUERNBERGER AND GEORGE RETTIG, JR., OF CHICAGO, ILLINOIS, ASSIGNORS TO UNIVERSAL AUTOMATIC TYPECASTING MACHINE COMPANY, OF CHICAGO, ILLINOIS, A CORPORATION OF ILLINOIS.

## TYPE-CASTING MOLD.

No. 884,754.

Specification of Letters Patent.

Patented April 14, 1908.

Application filed December 30, 1905. Serial No. 294,016.

*To all whom it may concern:*

Be it known that we, PHILIP G. NUERNBERGER and GEORGE RETTIG, Jr., citizens of the United States, residing at Chicago, in the county of Cook and State of Illinois, have invented new and useful Improvements in Type-Casting Molds, of which the following is a specification.

This invention relates to improvements in molds for casting type and has for its object to provide a mold of this character embracing features providing for the casting of finished type ready for practical use when dropped from the molds.

The object is the same as that set forth in pending applications Nos. 256,930 and 260,581, but differentiates with reference to the location of the breaking-off junction of the type and jet in the operation of casting. In the applications referred to, the type-body is provided in the base with a groove or depression in the operation of casting and the junction of the type and jet located in the bottom of such groove. In this instance the location of the junction of the type and jet is at one side or edge of the type-body so that when the jet is broken away a smooth level base or foot is provided for the type to stand on.

In the drawing, Figure 1 is a front elevation showing the mold members in their closed position. Fig. 2 is a similar view partly open, the dotted lines indicating the wide open position. Fig. 3 is a rear side elevation of the mold closed. Fig. 3<sup>a</sup> is a side elevation of a detached detail. Fig. 4 is a view in perspective of a type-body the jet or sprue being shown attached thereto. Fig. 4<sup>a</sup> is a view in perspective of a type-body, the jet being removed. Fig. 5 is an opened out view of the upper movable mold-member looking at the inside. Fig. 6 is a similar view of the lower stationary member. Fig. 7 is a transverse section on line 7 Figs. 1, 5 and 6, looking in the direction indicated by the arrow. Fig. 8 is a transverse section on line 8, Figs. 1, 5 and 6. Fig. 9 is an exaggerated transverse section of a portion of the mold parts. Fig. 10 is a view in perspective of the upper jet-part or member. Fig. 11 is a similar view of the lower jet-part.

In the pending applications herein referred

to the jet-parts or members have a movable action in breaking off the jet. In this instance the jet-parts are stationary, the jet being broken off in the usual manner common to the operation of type-casting machines.

A represents the lower mold-member, B the upper mold-member, C the bottom mold-plate and D the top mold-plate, to which the respective mold-members are secured.

The lower jet-part 12 is rigidly secured to the corresponding mold plate C. The inner upper corner of this jet part extends above the level of the adjacent wall of the lower mold carriage-part 13 and is provided with a beveled edge 14, as shown in Figs. 7, 8, 9, 10 and 11. The upper jet-part 15 is rigidly secured to the top mold-plate D and is of a less width than the lower jet-part 12 and forms an off-set *a* that is, bringing the vertical line of the inside wall of the upper jet-part back of the vertical line of the lower jet-part, as best shown in Fig. 9. The lower inner corner of the upper jet-part 15, is provided with a projected lip-edge 16 which comes on a diagonal line with the beveled edge 14 of the lower jet-part and forms a tight joint between the adjacent joining surfaces, as best shown in Figs. 7, 8 and 9.

A compensating or division plate 17 is inserted between the upper jet-part and the corresponding body and carriage parts in the upper half of the mold. This plate is of the contour shown in Fig. 3<sup>a</sup>, and is provided in the lower edge adjacent to one end with a notch 18, and in the opposite end with a slot 19. A part of the plate starting in from the lower edge and one end, is cut away and provides a shoulder 20 on the junction line of the carriage and body parts of the mold. The screw 21 extends through far enough to loosely engage the slot 19 in the plate, as shown in Fig. 3 and indicated by dotted lines in Fig. 5. The inner end of screw 21 also threads in the guide 22. This permits of the usual adjustment of the upper mold-member without imparting a corresponding endwise movement to the plate 17. A plate 23 is rigidly secured to the lower mold member and is provided with a beveled lug 24 corresponding in shape to and loosely engaging the V-shaped notch 18 in the lower edge of the plate 17 when the mold is in its closed

position, as best shown in Fig. 3. By this arrangement the plate will always close with the mold to its proper casting position after each opening movement of the mold in discharging the type. That is, when the mold closes the notch 18 in the plate engages the beveled lug 24 with a drawing action so that when the mold is closed the shoulder edge 20 on the plate always comes even on a vertical line with the corresponding wall of the type-casting chamber 25. The plate 17 is beveled or sharpened on the lower edge as at *b*, to conform to the beveled edge 14 of the lower jet-part for the purpose of forming a tight joint and prevent leakage of the molten metal in the operation of casting. The difference between the inner wall edges of the jet-parts on a straight vertical line is approximately less than that of the thickness of the plate 17. This difference provides the off-set *a* of the type casting chamber. The ingate passage 26 through which the molten metal is injected gradually contracts to a small slit and opens into the type-chamber just below the off-set so that the metal will flow in back and form the foot or base 27 on the type 28, above the contracted orifice 26, the area of which is approximately equal to that of the beveled edge 29 formed on the foot of the type at one side and in line with the injecting orifice or passage 26; the beveled edge 29 corresponding to the beveled edge 14 on the lower jet-part. By this arrangement the junction of the type and sprue is on the beveled edge 29 and the line of separation above or away from the foot of the type and provides the same with a smooth finished base to stand on when discharged from the mold.

The lower mold-member is provided in the ingate passage with a recess 30 into which a portion of the metal charge will flow and forms a tongue 31 (Fig. 4) on the sprue and provides the means for breaking off the same from the type as the mold opens. The type

is dislodged from the upper mold-member by coming in contact with the stool 32.

Having thus described our invention, what we claim is:

1. In a type casting-mold, the mold-members, the jet-parts having their inner edges in different planes, and means inserted between the upper jet-part and mold to prevent leakage in the operation of casting.

2. In a type casting-mold, the jet-parts having their inner edges in different planes, one of the said jet-parts being provided with a beveled corner edge and the other part with an inclined lip-edge adapted to overlap said beveled corner edge when the mold is closed, and a plate inserted between the upper jet-part and the carriage part of the mold having its lower edge beveled, and means for retaining said plate in its proper working position.

3. In a type casting-mold, the lower jet-part having its inner wall edge extending above that of the adjacent carriage-part, the upper jet-part having the vertical line of its inner edge back of the inner edge of the lower jet-part, and means inserted between the upper jet-part and the corresponding carriage-part in compensating for the relative different widths of the jet-parts.

4. In a type casting-mold, a lower jet-part an upper jet-part having its inner wall edge on a line back of the corresponding wall of the lower jet-part, a division plate inserted between the upper jet-part and the adjacent carriage-part and means for retaining said plate in its working position.

In testimony whereof we affix our signatures, in presence of two subscribing witnesses.

PHILIP G. NUERNBERGER.  
GEORGE RETTIG, JR.

Witnesses:

L. B. COUPLAND,  
J. B. DONALSON.