

J. S. THOMPSON.
 TYPE CASTING MACHINE.
 APPLICATION FILED JAN. 6, 1906.

1,119,733.

Patented Dec. 1, 1914.

4 SHEETS—SHEET 1.

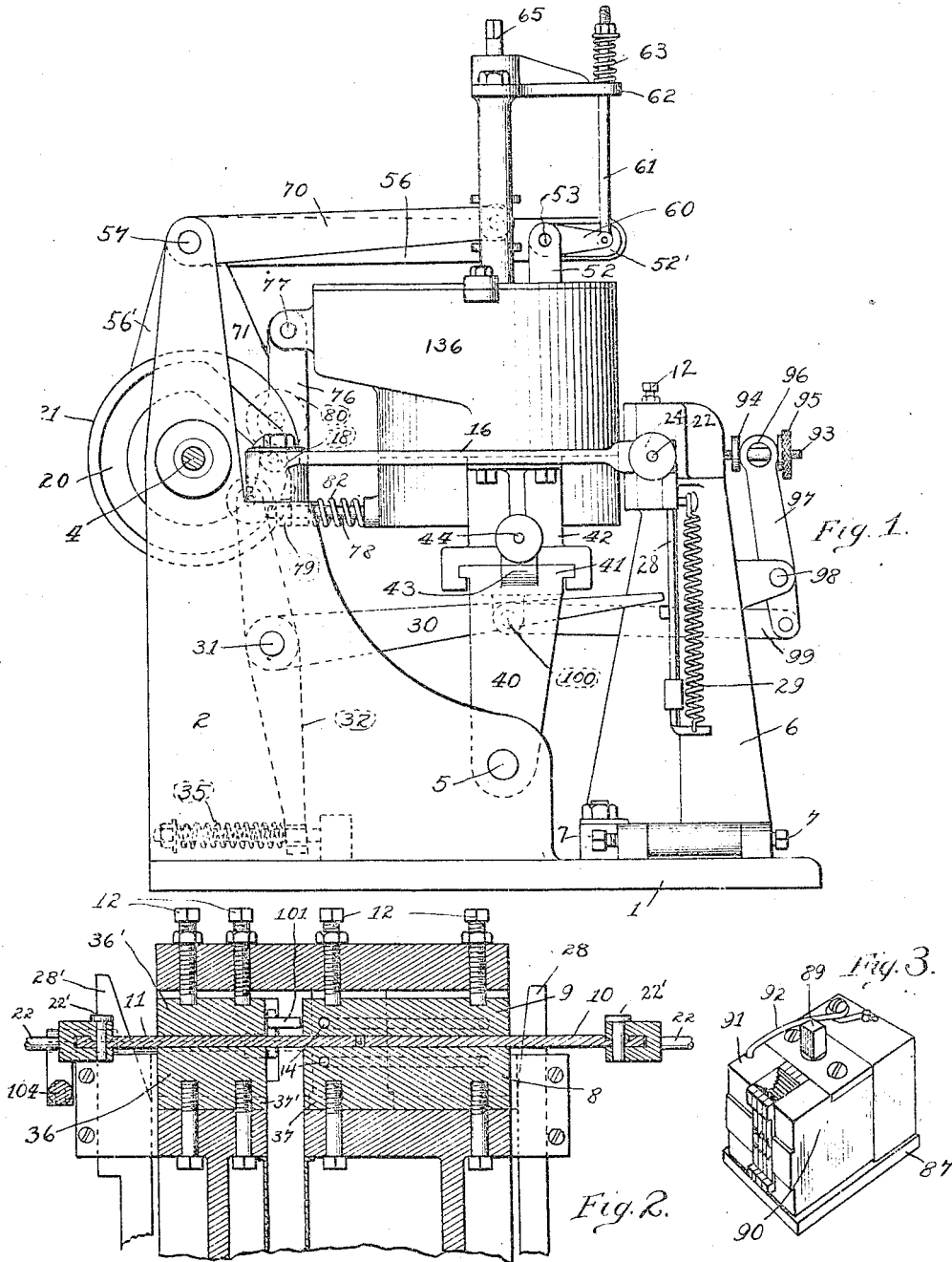

Witnesses:
 John Braunwalder
 R. B. Mac Intosh

Inventor:
 John S. Thompson
 By Hill & Hill
 Att'ys.

J. S. THOMPSON.
 TYPE CASTING MACHINE.
 APPLICATION FILED JAN. 6, 1906.

1,119,733.

Patented Dec. 1, 1914.

4 SHEETS-SHEET 2.

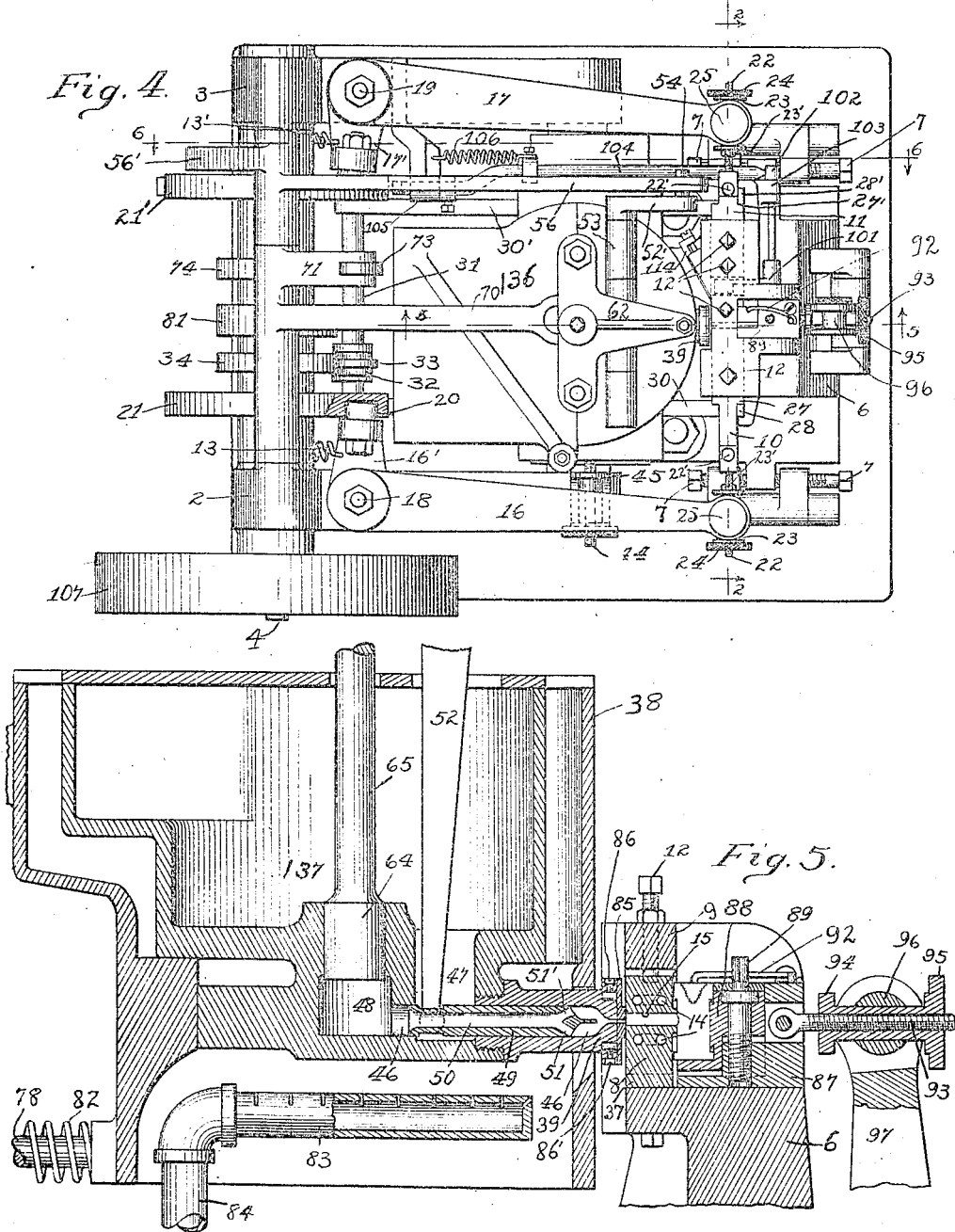

Witnesses
 John Braunwalder
 R. B. Mac Intosh

Inventor:
 John S. Thompson
 By Hill & Hill
 Att'ys:

J. S. THOMPSON.
 TYPE CASTING MACHINE.
 APPLICATION FILED JAN. 6, 1906.

L,119,733.

Patented Dec. 1, 1914.
 4 SHEETS—SHEET 3.

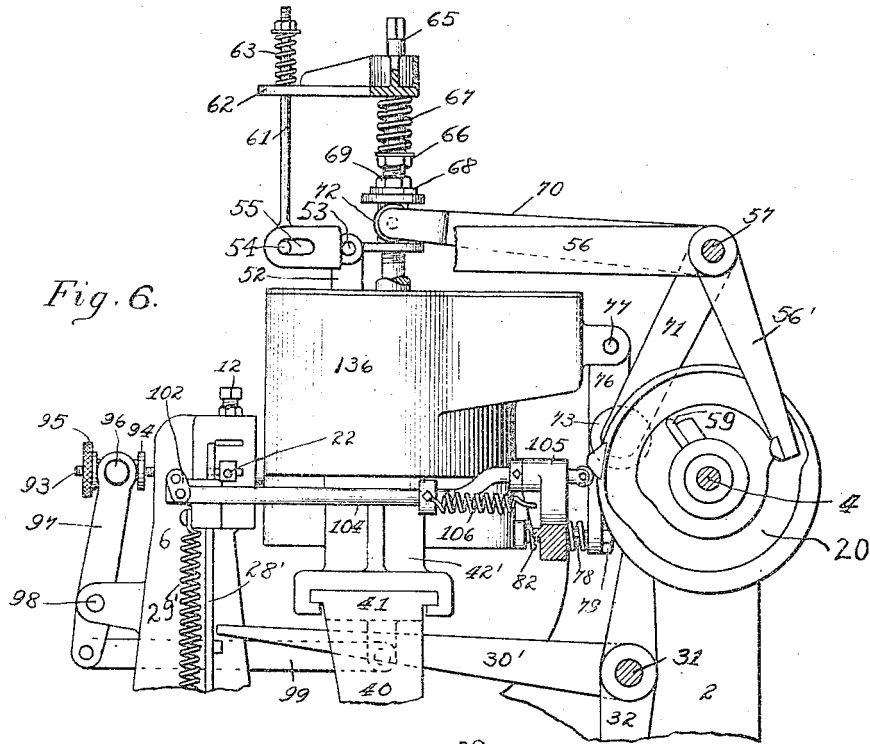

Fig. 6.

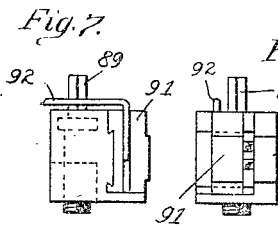

Fig. 7.

Fig. 8.

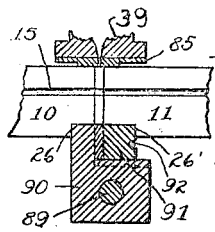

Fig. 12.

Fig. 9.

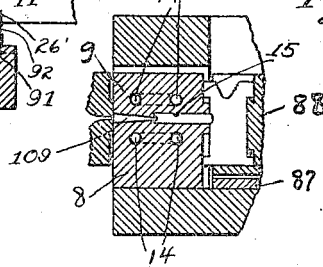

Fig. 10.

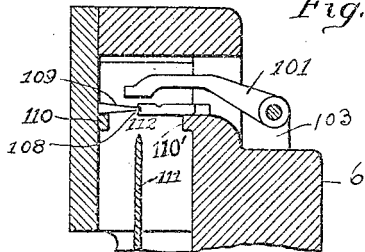
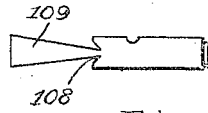

Fig. 11.



Witnesses:
 John Braunwalder
 R. B. Mac Intosh.

Inventor:
 John S. Thompson
 By [Signature] Hill
 Att'ys

J. S. THOMPSON.
 TYPE CASTING MACHINE.
 APPLICATION FILED JAN. 6, 1906.

1,119,733.

Patented Dec. 1, 1914
 4 SHEETS—SHEET 4.

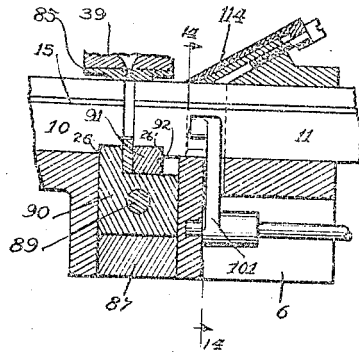

Fig. 13.

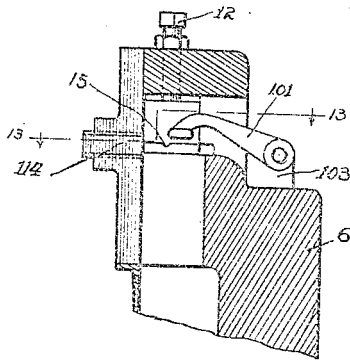

Fig. 14.

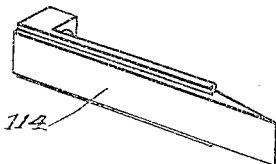

Fig. 15

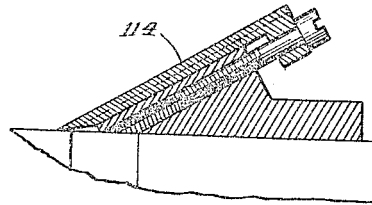

Fig. 16

Witnesses:
 John Braumwalder
 Charles J. Cobb

Inventor:
 John S. Thompson
 By Hill & Hill
 Atty's

UNITED STATES PATENT OFFICE.

JOHN S. THOMPSON, OF CHICAGO, ILLINOIS, ASSIGNOR TO THOMPSON TYPE MACHINE COMPANY, OF CHICAGO, ILLINOIS, A CORPORATION OF ILLINOIS.

TYPE-CASTING MACHINE.

1,119,733.

Specification of Letters Patent.

Patented Dec. 1, 1914.

Application filed January 6, 1906. Serial No. 294,958.

To all whom it may concern:

Be it known that I, JOHN S. THOMPSON, a citizen of the United States, residing at Chicago, county of Cook, and State of Illinois, have invented a new and Improved Type-Casting Machine, of which the following is a description.

My invention relates to that class of devices employed for casting the various forms of type used in the art of printing.

The object of my invention is to produce a simple, compact, and easily adjusted device of the kind described, wherein the various adjustments incident to the operation of the machine are so conveniently provided for that the services of an especially trained and skilled operator may be dispensed with.

To this end my improvement consists in the novel construction, arrangement, and combination of parts, herein shown and described and more particularly pointed out in the claims.

In the accompanying drawings wherein like or similar reference characters indicate like or corresponding parts; Figure 1 is an elevation of my device. Fig. 2 is a partial section taken substantially on line 2-2 of Fig. 4. Fig. 3 is a perspective detail of the matrix holder. Fig. 4 is a plan view of my device. Fig. 5 is a partial section taken substantially on line 5-5 of Fig. 4. Fig. 6 is a partial section taken substantially on line 6-6 of Fig. 4. Figs. 7 and 8 are detail views of a portion of the matrix holder. Figs. 9 and 10 are sectional views showing slight modifications which may be made in my device when it is desired to form each type with a jet and remove the same as the type is discharged from the machine. Fig. 11 is an enlarged view of a type as formed with a jet. Fig. 12 is a detail showing the relative cooperating portions of the liners, matrix holder, etc. Fig. 13 is a section taken substantially on line 13-13 of Fig. 14. Fig. 14 is a section taken substantially on line 14-14 of Fig. 13. Fig. 15 is an enlarged perspective detail of the type base trimming knife, and Fig. 16 is an enlarged sectional detail of the base trimming knife and associated parts.

My device consists essentially of a suitable metal pot, a mold for forming the body of the type and a matrix holder arranged to

periodically present a matrix to one end of said mold, and mechanism for simultaneously operating the several parts. Any suitable form of support or frame may be provided for maintaining the several parts of my device in proper cooperating relation. As shown, a base 1, consisting of a substantially flat plate, is provided with brackets 2 and 3 positioned at its opposite edges near the rear. In the drawings, the brackets 2 and 3 are shown formed integral with the plate 1 and each provided with suitable bearings for the driving shaft 4 and the metal pot shaft 5 and other cooperating portions of my device.

Near the front of the base 1 an upright 6 is shown, provided near its upper end with the fixed member of the type mold, the movable matrix holder and other cooperating parts directly associated with the matrix holder and mold. Set-screws 7 or equivalent means are preferably provided for accurately adjusting the position of the upright 6 upon the base 1, also to enable the same to be returned to the position previously occupied when for any purpose it is removed from the plate.

Any suitable form of type mold may be employed, that shown in the drawings consisting of a base 8, cap 9 and two movable liners 10 and 11 positioned between the cap and base, their adjacent faces being straight and parallel and slightly separated to form a mold cell.

The base 8 is preferably rigidly attached to the upright 6, while the cap is arranged substantially parallel to the base and adjustably secured in place by means of set-screws 12 or equivalent means, the points of the set-screws being shown positioned in suitable recesses formed in the cap to prevent its lateral displacement. A channel 14 is shown both in the base 8 and cap 9 through which water may be circulated to reduce the temperature of the mold when in operation. Any desired number of longitudinal ridges 15 may be provided upon the adjacent faces of the base or cap to form nicks in the edges of the type cast in the mold cell, and also may be made to serve as guides to prevent the lateral movement of the liners.

The liners 10 and 11 are flat pieces formed

105

to accurately fit upon and fill the space between the base and cap, the thickness of the liners determining the size or body of the type cast in the mold, and the distance between the adjacent faces of the liners controlling the width or set of the type, and are preferably adjusted before each type is cast. As soon as a type is formed in the mold, one of the liners is retracted while the other is advanced and forces the cast type longitudinally between the base and cap.

Any suitable means may be employed to control the position and movements of the liners. As shown two bell crank levers 16' and 17' are provided and mounted respectively upon the brackets 2 and 3 at 18 and 19 with their arms 16 and 17 adjustably attached to the liners 10 and 11 respectively, while the arms 16' and 17' are each preferably provided with a roller positioned in suitable grooves 20 formed respectively in the cams 21 and 21' mounted upon the shaft 4.

The arms 16 and 17 may be attached to the liners in any desired manner. As shown, a screw or stud 22 is rigidly attached to the end of each liner by pins 22' and provided with a spool or double flanged nut 23 preferably having a milled head 24 or other convenient means for adjusting its position and a jam nut 23' or other suitable means to secure the same in its adjusted position, a suitable pin 25 being provided to engage each of said spool nuts and pivotally attach the same to the arms 16 and 17 respectively near their extremities. If the above described mechanism, however, controlled the position of the liners constantly, it is evident that the distance between the faces of the liners when in casting position would always be substantially the same and consequently only one width of type could be cast in my device without changing the adjustment between the arms and liners. To avoid this difficulty and provide automatic adjustment of the liners for the various widths of type faces, projections 26 26' are provided, in the form shown (see Figs. 12 and 13) upon the edges of the liners 10 and 11 respectively, to engage with any matrix, or with parts whose position is controlled by the matrix positioned at the mold, to accurately determine the width of the mold cell when the liners are forced toward each other as far as possible. The grooves 20 in the cams 21 21' are preferably so formed that after moving the liners substantially to the above described position they are left free to be moved toward each other until stopped by the engagement of their respective projections 26 26', after which both liners are firmly held in that position while molten metal is forced into the mold cell to form a type. Any suitable means may be employed for finally bringing the liners into

casting position and preventing their movement while the cast is being made. As shown, the final movements of the liners are produced by springs 13 and 13' extending respectively from suitable parts of the brackets 2 and 3 to the arms 16' and 17', and the locking of the liners in casting position is accomplished by means of a shoulder 27 27' or equivalent means provided upon each liner and a pair of movable wedges 28 and 28' mounted upon the upright 6, each arranged to move vertically and engage the shoulders 27 27' upon the liners. As shown, these wedges are each resiliently forced toward the upper limit of their travel by springs 29 29' or equivalent means, and are each withdrawn from and held out of engagement with the liners between the casting operations by means of arms 30 and 30' each rigidly mounted upon a shaft 31 rotatably mounted in suitable bearings upon the brackets 2 and 3. An arm 32 is also shown mounted upon the shaft 31, having a roller 33 at one end in position to engage a cam 34 upon the shaft 4, and at the opposite end provided with a spring 35 arranged to resiliently force the roller 34 against the face of the cam and maintain the arms 30 30' out of engagement with the wedges 28 28'. In the form shown, in which both liners 10 and 11 move longitudinally of the base and cap to discharge the cast type at the end of the base, it is evident that one liner is periodically entirely removed from between the base and cap, and in Fig. 2 the parts 36 and 36' are provided to serve as a continuation of the base and cap respectively and support the liner while so removed. In Figs. 2 and 5 also distance pieces 37 and 37' are shown under the base 8 and part 36, which may be removed when desired, and thus by lowering the base when very large type are to be cast avoid introducing the metal in the same relation to the bottom of the mold as when small type are formed.

The metal pot may be of the usual or any preferred construction for storing a quantity of molten metal and maintaining the same at a suitable temperature, and may be arranged in any desired manner so that its nozzle may periodically register with the mold cell for introducing molten metal into the mold. As shown, the metal pot 136 comprises a reservoir or crucible 137 provided with a jacket or housing 38 and a nipple or nozzle 39 projecting preferably from the lower front side of the jacket, the whole being pivotally mounted in suitable manner upon the shaft 5. In the form shown, the shaft 5 is rotatably mounted on the brackets 2 and 3, and a support 40 is rigidly mounted on the shaft and provided with a suitable guide or way 41 at its upper side substantially parallel with the shaft 5. Arms 42 and 42' are provided upon the

pot 136 with their lower ends suitably formed to engage the way 41, thus providing a rigid support for the pot with longitudinal adjustment between the pot and shaft.

Any suitable means may be provided to control the position of the pot upon the support. As shown, a lug 43 is provided upon the support at one end of the way 41 and a screw 44 having a spool nut 45 is rigidly attached to the arm 42 with the nut positioned in a suitable engaging recess in the lug 43, a milled head or other convenient means being provided to operate the nut. The nipple 39, as above explained, projects from the side of the jacket near the bottom of the reservoir 137, and is connected thereto by passages 46 and 47 and a well or cylinder 48, a valve or choker 49 being positioned in the passage 46, controlling the passage therethrough and the discharge of metal from the reservoir.

The cylinder 48 is preferably circular, uniform in section, and positioned vertically in the bottom of the reservoir with its upper end opening thereto. The passage 46 extends from the nipple to the cylinder and is also preferably circular in section, the passage 47 extending upward therefrom at a point near the cylinder. The valve or choker 49 is formed to snugly fit within the passage 46, and is provided with a suitably formed point to fit in and close the nipple, and a duct 50 extending longitudinally of the choker and terminating at the front in the openings 51 and 51'. The choker 49 is preferably so formed that when in position closing the nipple, the tip of the choker will extend slightly beyond the face of the nipple, leaving the passage 46 open to the passage 47 and metal free to pass from the reservoir by way of the passages 46 and 47 into the lower portion of the cylinder 48; but when the choker is retracted to open the nipple, communication between the passages 46 and 47 is cut off.

The movements of the choker 49 are preferably controlled by a bell crank 52 52', pivotally mounted at the top of the pot at 53. The arm 52 extends downward through the reservoir into the passage 47, where it is suitably formed to engage an annular recess or equivalent means upon the choker. The arm 52' extending forward and provided with a pin 54 positioned in a slot 55 in the arm 56 of a bell crank 56 56', rotatably mounted upon a shaft 57 mounted upon the brackets 2 and 3, the arm 56' of which extends downward and is periodically engaged by a cam 59 upon the shaft 4. An arm 60 is also shown upon the bell crank 52 52', extending forward and pivotally attached to a rod 61 extending upward through an elevated plate or guide 62, above which a spring 63 is provided upon the

rod, and means for controlling the pressure of the spring, thus drawing the arm 60 upward and the choker 49 into position to close the nipple with any desired pressure.

The cylinder 48 is fitted with a plunger 64 provided with a shank 65 extending upward through the top of the pot and above the elevated plate 62, where it is preferably squared so that a wrench may be employed to rotate the plunger if desired. A nut 66 is provided upon the shank 65 and a spring 67 positioned between the nut and plate 62 to resiliently force the plunger downward in the cylinder.

As shown, a spool nut 68 is also mounted upon the shank 65 with a cooperating jam-nut or equivalent means 69 to lock the spool nut in position. A bell crank lever 70, 71, is loosely mounted upon the shaft 57 with the free end of its arm 70, preferably forked and provided with a roller 72 for each fork, engaged between the flanges of the spool nut. The arm 71 extends downward and is provided with a roller 73 arranged to bear upon the face of a cam 74 upon the shaft 4, suitably formed to normally hold the spring 67 compressed and the plunger 64 elevated, but provided with a depression in its face so that the plunger 64 may be periodically forced downward to force a portion of the metal in the cylinder into the mold.

Any suitable means may be provided to control the position and movements of the metal pot. As shown, the shaft 5 is so positioned that the weight of the metal pot tends to withdraw the pot and nipple from the mold, the movements of the pot to and from the mold being controlled by a lever 76 pivotally mounted upon the pot at 77 with its opposite end engaging a fixed guide pin 78 provided with a nut 79 at its outer end to limit the movement of the lever. A roller 80 is mounted upon the lever 76 to bear upon the face of a cam 81 upon the shaft 4, and a spring 82 is provided at the lower end of the lever to resiliently force the end against the nut 79 and provide sufficient flexibility in the movements of the pot to avoid straining the various parts of the mechanism. Suitable means are also provided for heating the metal in the pot to the desired temperature. As shown, a gas or oil burner 83 is provided for this purpose and attached by means of a pipe 84 to a suitable source of fuel supply (not shown).

In Figs. 5 and 12 a detachable face 85 is shown upon the nipple 39 secured in position by screws 86, 86', to provide a smooth casting surface for the foot of the type and a convenient arrangement for renewing the face of the nipple, in case it becomes worn or damaged from any cause.

Any preferred form of matrix holder may be employed to periodically present a matrix or a plurality of matrices to the mold to

hold them firmly in position while a type is cast in the mold. As shown, the holder consists of a carriage 87 arranged to move longitudinally of the mold upon a suitable guide-way or track at the upper end of the upright 6, a matrix seat 88 adjustably mounted upon the carriage 87 and provided with an adjusting screw 89 or equivalent means for controlling its position, a fixed side 90, and a movable side 91 arranged to clamp the matrices positioned upon the seat 88 between them, the movable side being preferably actuated by a spring 92 or equivalent means for this purpose.

Any suitable means may be provided to control the movements of the matrix holder. As shown, a threaded rod 93 is pivotally attached to the carriage 87, provided with a spool nut 94, having a milled head 95 or other means for conveniently rotating the same, and attached by means of a pivotal connection 96 to one end of a lever 97, pivotally mounted upon the upright 6 at 98, its opposite end being connected by means of a link 99 to the metal pot support 40 at 100. By this arrangement, the metal pot and matrix holder simultaneously move toward each other, and grip the mold firmly between them, closing both its ends, one end with a matrix in proper casting position and the other by the nipple of the metal pot. Before these parts are brought entirely into position, the liners 10 and 11 are moved toward each other by the springs 13 and 13' until the projections 26 and 26' upon the liners engage the sides 90 and 91 of the matrix holder, and thus gage the distance between the faces of the liners to the matrix in the holder. The wedges 28 and 28' are then forced into place by the springs 29 29' after which the ends of the mold are securely closed as above explained. When so positioned, the choker 49 is moved into the position shown in Fig. 5 and the plunger descends, forcing metal from the pot into the mold to form a type, after which the choker closes the nipple, the metal pot and matrix holder are retracted, the wedges 28 and 28' withdrawn, and the liners moved to the right until the type just cast is entirely clear of the base and cap.

When this position is reached, the free end of an arm 101 of a bell crank 101, 102, pivotally mounted upon the upright 6 at 103, is moved downward, forcing the type from between the liners, where it falls by gravity from the machine. The movements of the bell crank 101, 102, are preferably controlled by a rod 104, attached to the free end of the arm 102 and extending through a guide 105 to a cam face upon the periphery of the cam 21'. A spring 106 holds the end of the rod in contact with the cam face and the free end of the arm 101 elevated. Any desired means may be employed for rotating the

shaft 4. As shown, a belt pulley 107 is provided upon which a belt from any desired source of power may be operated.

As described, the type are cast with a finished base and of the desired length or height. It is obvious however, that, if preferred a trimming knife or scraper 114 may be positioned at the foot end of the mold as shown in Figs. 4 and 13 and provided with suitable means for adjusting and securing the same in position so that each type in passing from the mold passes the knife 114 and in so doing its base is trimmed to bring the type to the exact height desired; also if preferred, a jet of any desired shape may be formed upon the type and removed as the type are delivered from the machine.

In Fig. 9 a mold section is shown for producing a type formed as shown in Fig. 11 in which the bottom or foot of the type is recessed as at 108 and the jet 109 considerably reduced in section is attached to the type at the bottom of the recess.

In Fig. 10 convenient means are shown for breaking the jet from the type and insuring a separate discharge of each from the machine. As shown, projections 110 110' are provided to support each type at its extremities after it is discharged from the mold. A partition 111 is provided in the discharge opening 112 of the machine, so positioned that when the type and jet are broken apart by the operation of the ejector 101, the jet falls from the machine upon one side of the partition and the type upon the other.

Any preferred form of matrix may be employed, as shown, the character is stamped into the edge of a rectangular plate, preferably reduced in thickness to a size corresponding with the width of the character, thus providing for a ready and automatic adjustment of the mold to the width of the type to be cast. This form of matrix also permits two or more matrices being used conjointly to produce word types, etc.

What I claim as new, and desire to secure by Letters Patent is:

1. In a type casting machine, a pivotally mounted metal pot, a slidably mounted matrix holder, a link connecting said metal pot and matrix holder whereby a movement of one will produce a corresponding movement of the other.

2. In a type casting machine, a movable metal pot, and a slidably mounted matrix holder, in combination with a link connecting said metal pot and matrix holder whereby a movement of one will produce a corresponding movement of the other in the opposite direction.

3. In a type casting machine, a mold comprising a base, a cap and movable liners arranged to form the side walls of said mold, in combination with a matrix holder, one or

more removable matrices positioned in said holder and adapted to cooperate with said type mold and means upon said mold for engaging said matrix holder and centering the mold upon the matrices therein.

4. A type casting machine, comprising a type mold, a metal pot and a matrix holder arranged to move to and from opposite sides of said mold, means upon the mold adapted to cooperate with said matrix holder to control the width of type cast in the mold, means for casting type in said mold, and means for transferring the cast type transversely within the mold and ejecting it therefrom.

5. In a type casting machine, a matrix holder, and a metal pot connected to and cooperating with said matrix holder, in combination with a mold having a mold cell the width of which is controlled by the engagement of the mold with said matrix carrier.

6. In a type casting machine, an adjustable mold, in combination with a reciprocating matrix holder adapted to hold a plurality of matrices in position to cooperate with said mold to form a single type with a plurality of characters upon its face in position for printing, and means upon the mold adapted to engage both sides of said matrix holder to control the adjustment of the mold.

7. In a type casting machine, a type mold comprising two stationary parts and a pair of movable liners adapted to form the sides of the mold, in combination with means for engaging each liner and locking the same against movement in any direction during the casting operation.

8. In a type casting machine, a type mold comprising two stationary parts and a pair of movable liners adapted to form the sides of the mold, in combination with means for engaging said liners and locking the same against longitudinal movement during the casting operation.

9. In a type casting machine, a type mold comprising two stationary parts, a pair of movable liners adapted to form the sides of the mold, and resilient means tending to force said liners toward each other, in combination with means engaged by said liners when in casting position to gage the distance between them, and locking means arranged to engage said liners when in casting position to prevent their movement during the casting operation.

10. In a type casting machine, a type mold comprising two stationary parts, a pair of movable liners adapted to form the sides of the mold, and means tending to force said liners toward each other, in combination with means engaged by said liners when in casting position to gage the distance between them, and a bar for each liner positioned transversely thereof when in casting

position to lock said liner in position during the casting operation.

11. In a type casting machine, a type mold comprising two stationary parts, a pair of movable liners adapted to form sides of said mold, and resilient means tending to force said liners toward each other, in combination with variable means engaged by said liners when in casting position to gage the distance between said liners and control the width of the mold, and a tapering bar for each liner positioned transversely thereof when in casting position to lock said liners in position during the casting operation.

12. In a type casting machine, a type mold comprising two stationary parts, a pair of movable liners adapted to form the sides of the mold, and resilient means tending to force said liners toward each other, in combination with means engaged by said liners when in casting position to gage the distance between them and a longitudinally movable tapering bar for each liner positioned transversely of said liner when in casting position to lock the same in position during the casting operation.

13. In a type casting machine, a type mold comprising two stationary parts, a pair of movable liners positioned between said parts adapted to form the sides of said mold, and means tending to force said liners toward each other, in combination with means engaged by said liners when in casting position to gage the distance between them, a longitudinally movable bar for each liner positioned transversely of the liner when in casting position to lock the same in position during the casting operation, and means for automatically controlling the position of the several parts.

14. In a type casting machine, a type mold comprising two stationary parts, a pair of movable liners adapted to form the sides of said mold, and means tending to force said liners toward each other, in combination with a movable matrix holder engaged by said liners when in casting position to gage the distance between the liners and a bar for each liner arranged to engage the same and lock said liners in position during the casting operation.

15. In a type casting machine, a vertically adjustable type mold comprising two stationary parts and a pair of movable liners adapted to form the sides of said mold, in combination with means for locking said liners against longitudinal movement during the casting operation.

16. In a type casting machine, a type mold comprising two stationary parts, and a pair of movable liners adapted to form the sides of said mold, means for engaging and positively locking said liners in position during the casting operation, means

for releasing said liners, and means for retracting one liner and advancing the other to eject the cast type from the mold.

17. In a type casting machine, a type mold comprising two stationary parts, means for independently adjusting each of said parts vertically, and a pair of movable liners adapted to form the sides of said mold.

18. In a type casting machine, a matrix holder adapted to receive a plurality of matrices, and an alining plate upon said matrix holder arranged to maintain the vertical alinement.

19. In a type casting machine, a matrix holder comprising a carriage having a portion vertically movable in relation to other portions thereof, means for controlling the adjustment of said vertically movable part, and an alining plate upon said vertically movable part adapted to engage the projecting ears of matrices in said holder.

20. In a type casting machine, a matrix holder provided with an alining plate adapted to engage the projecting ears of one or more matrices and maintain the alinement, and means for adjusting the vertical position of the matrices.

21. A type casting machine, comprising a type mold, a matrix holder, a plurality of matrices and a metal pot, in combination with means upon the mold parts adapted to cooperate with the matrix holder to control the width of type, means for casting the type, and means for retracting one of said mold parts and advancing another to eject the type from the mold.

22. In a type casting machine, a matrix holder comprising a horizontally movable carriage, a matrix seat for one or more matrices, each provided with projecting shoulders, means for engaging the shoulders of each matrix, means for holding said matrices in position upon the seat, and means for controlling the position of said matrix seat upon said carriage.

23. In a type casting machine, a matrix holder comprising a carriage, a relatively adjustable block upon said carriage provided with an alining plate adapted to engage the projecting ears of a matrix, and means for adjusting the block vertically of the carriage.

24. In a type casting machine, a type mold comprising a cap and a base and a pair of longitudinally movable liners cooperating therewith, in combination with means for retracting one of said liners and advancing the other to transfer the type from the casting position.

25. A type casting machine, comprising a type mold, a metal pot and a matrix holder arranged on opposite sides of said mold, means upon the mold adapted to cooperate with said matrix holder to control

the width of type cast in the mold, means for casting type in said mold and means for transferring said type transversely within the mold.

26. In a type casting machine, a type mold provided with two movable side walls, in combination with a matrix holder having one fixed and one movable side wall, the relative position of said matrix holder walls controlling the adjustment of said mold walls when the parts are in casting position.

27. In a type casting machine, a type mold comprising two stationary parts and two movable parts, in combination with means engaged by said movable parts when in casting position to gage the distance between them, and means for casting type in said mold.

28. In a type casting machine, a type mold comprising two stationary parts and two movable parts, and resilient means tending to force said movable parts toward each other, in combination with adjustable means engaged by said movable parts when in casting position to gage the distance between them and control the width of the mold, and means for casting type in said mold.

29. In a type casting machine, a type mold comprising a cap, a base, and a pair of movable liners controlling the height or body of type cast in said mold, in combination with means for raising or lowering said mold to conform to changes in type body.

30. In a type casting machine, a type mold, a matrix holder comprising a carriage, a matrix seat adjustably mounted upon said carriage and provided with one stationary and one movable side wall, adapted to inclose a matrix whose thickness controls the thickness of the type cast in the mold.

31. In a type casting machine, a matrix holder comprising a carriage a matrix seat mounted upon said carriage and provided with one stationary and one spring actuated movable side wall, and means for controlling the adjustment of the mold by the relative positions of the two matrix holder walls.

32. A typecasting machine, comprising a matrix holder having side walls adapted to engage both sides of one or more matrices and form an extension flush with the casting faces thereof, a type mold adapted to cooperate with said matrix holder, and means for casting type.

33. In a type casting machine, a type mold, a matrix holder having the inclosing side walls flush with the casting face of the matrix, the relative positions of said side walls controlling the adjustment of the mold.

34. A typecasting machine, comprising a

type mold, a metal pot and a matrix carrier, means for dimensioning the mold by the engagement of the mold with the matrix carrier, and means for casting type.

5 35. A typecasting machine comprising an adjustable mold, a reciprocating matrix holder adapted to hold a matrix in position to cooperate with said mold to form a type, means upon the mold adapted to engage
10 both sides of said matrix holder to control the adjustment of the mold, a metal pot, and means for casting type.

36. A typecasting machine comprising a type mold, a matrix carrier provided with a vertically adjustable matrix seat, and also provided with a stationary and a relatively adjustable side wall, means for controlling the adjustment of the mold by the relative positions of the two matrix holder walls,
20 and means for casting type.

37. A type casting machine comprising a metal pump a matrix carrier and a type mold, means upon the mold adapted to cooperate with the matrix carrier to determine the set-wise dimensions of the mold, means
25 for casting type in said mold, an ejector, and means for removing the type from said ejector.

38. In a type casting machine a matrix carrier comprising a block, a stationary side wall and a movable side wall mounted upon said block between which one or more matrices may be positioned and an alining plate upon the block for engaging the projecting ears of said matrices, said side walls having faces flush with the face of the matrices.

39. In a type casting machine, a matrix carrier provided with side walls adapted to grip a matrix between them, said side walls each having a face in the same vertical plane as the working face of the matrix between them and mold parts having shoulders adapted to engage the opposite sides of the matrix carrier to dimension the mold,
45 and means for alining the matrix with the mold.

40. In a type casting machine, a matrix holder adapted to receive one or more matrices and an alining plate upon said matrix holder adapted to engage the matrices upon the holder to maintain the horizontal alignment of the matrices.

41. A type casting machine comprising a

type mold a matrix carrier and a metal pot, means upon the mold parts adapted to cooperate with the matrix carrier to control the width of the type, means for casting type in said mold and means for retracting one of said mold parts and advancing another to eject the type from the mold.

42. In a type casting machine, a type mold comprising two stationary parts and two movable parts, in combination with a matrix carrier adapted to be engaged by said movable parts when in casting position to gage the distance between them, and means for casting type in said mold.

43. In a type casting machine, a mold and a reciprocating matrix holder adapted to hold a matrix in position to cooperate with said mold to form a type, and means upon the mold adapted to engage both sides of said matrix holder to determine the set-wise dimension of the type.

44. A typecasting machine comprising a matrix holder having side walls adapted to engage both sides of one or more matrices and form an extension flush with the casting faces thereof, a type-mold adapted to cooperate with said matrix-holder to determine the set-wise dimensions of the mold and means for casting a type in said mold.

45. In a type casting machine, a matrix carrier provided with side walls adapted to grip a matrix between them, the faces of said side walls being in the same vertical plane as the working face of the matrix.

46. In a type casting machine, matrices having casting faces on one edge thereof, the thickness of the matrices corresponding to the width of the faces thereon, and a matrix block having side walls forming an extension on both sides of said matrices flush with said casting faces.

47. In a type casting machine, a matrix carrier having side walls adapted to engage both sides of one or more matrices and form an extension flush with the casting faces thereof, and means for holding the matrices on the carrier.

In testimony whereof, I have hereunto signed my name in the presence of two subscribing witnesses.

JOHN S. THOMPSON.

Witnesses:

BURTON U. HILLS,
CHARLES I. COBB.