

R. W. MITCHEL.

MACHINE FOR PARING AND CORING APPLES, &c.

No. 686.

Patented Apr. 13, 1838

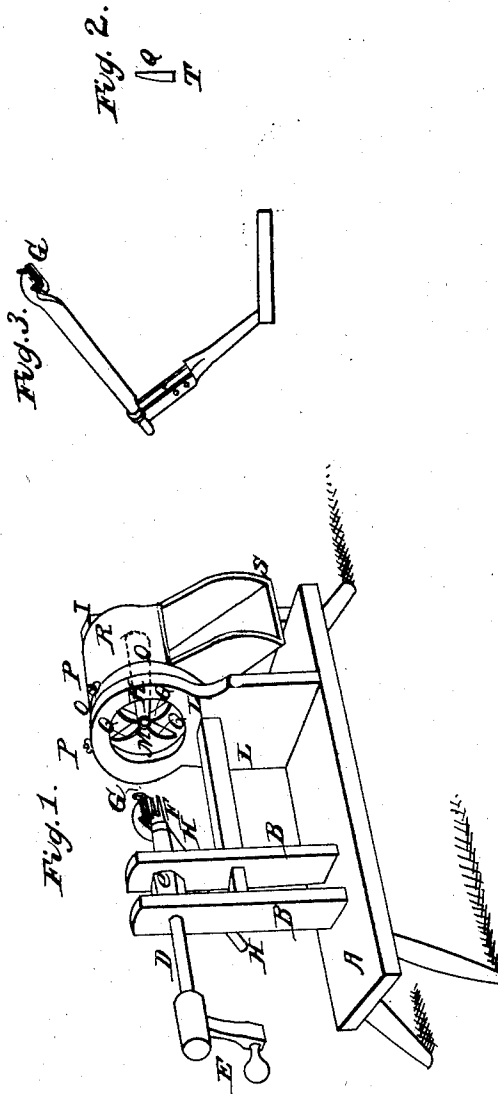

# UNITED STATES PATENT OFFICE.

ROBERT W. MITCHELL, OF SPRINGFIELD TOWNSHIP, RICHLAND COUNTY, OHIO.

## MACHINE FOR PARING, CORING, AND DIVIDING APPLES.

Specification of Letters Patent No. 686, dated April 13, 1838.

*To all whom it may concern:*

Be it known that I, ROBERT W. MITCHELL, of Springfield township, Richland county, State of Ohio, have invented a Machine for  
5 Paring, Coring, and Quartering Apples, which is described as follows, reference being had to the annexed drawings of the same, making part of this specification.

The nature of my invention consists in  
10 placing the apple on a fork inserted into the end of a shaft, which shaft is turned by a crank by hand while the operator holds with his other hand a paring knife to the surface of the apple, said knife being turned  
15 and accommodated to the shape of the apple as it is advanced by the crank shaft, and when pared forcing it between knives which core and quarter it, the center one for taking out the core being circular and  
20 the others which quarter it being straight and radiating from the surface of the circular knife, and when quartered the pieces of apple falling upon an inclined board by which they are conducted to a receiver while  
25 the core is driven out at the end of the machine.

A, Fig. 1, represents a bench of suitable length, breadth, and height to support the several parts of the machine.

30 B, B represent two upright pieces of timber mortised and tenoned into the bench in a vertical position about 3 inches apart, between which, near the top, is placed a hub, or round piece of wood *c* perforated  
35 through the center with a circular aperture, through which the shaft D passes. The shaft D is made a little less in diameter than the aperture in the hub through which it passes, except at the end where the handle  
40 is inserted, where it is enlarged.

E represents the crank handle for turning the shaft. F, the fork in the smaller end of the shaft upon which the apple is stuck.

The knife G, for paring the apple is made  
45 something like the cooper's draw-knife and is fastened on the end of a stick H, which is attached to the edge of the bench by a universal joint to allow of its being turned about in any direction required.

50 About six inches from the upright B, B, is a vertical piece of timber L mortised and tenoned into the bench, in which, near the top of the same is made a round aperture M larger than the apple to be pared and which

passes through said aperture. To this piece 55 of timber and around the aperture inside is fastened a circular curb. Around the curb is placed a circular ring O through which pass screws P for securing and setting the knives. At the end of the bench is a post I 60 through which passes the center circular cutter or tube K for cutting out the core, made funnel shaped, and projecting horizontally from said post to the face of the vertical piece of timber L the larger or dis- 65 charging end being next to the post. In the surface of the circular cutter or tube at the smaller end are small cavities or depressions to admit small projections or points at the ends of the knives Q by which they are held 70 securely, the other ends of said knives containing cavities to admit the ends of the thumb screws P passing through the ring O for securing and regulating the knives. For quartering the apples the four knives Q 75 described are all that will be necessary but should it be required to cut the apples in smaller pieces more knives and screws will be required.

The knives are made in the manner represented at Fig. 2 having ribs or points T for entering the cavities in the surface of the circular cutter or tube before described. The other end containing a cavity or depression for the point of the thumb screw 85 P used for securing and setting the knife. The knives radiate from the outer surface of the circular knife or tube K to the inner surface of the curb at equal distances apart.

Between the vertical piece of timber L 90 and post I is a curved casing R to catch the pieces of apple and conduct them to an inclined spout S below which conducts them to a receiver.

*Operation:* Put the apple on the fork, 95 take the stick containing the paring knife in the left hand, the crank handle in the right. The shaft being drawn back apply the knife to the end of the apple near the core, turn the crank and the shaft and 100 apple. At the same time manage the knife so as to conform to the shape of the apple until it is pared from one end to the other in a continuous paring. The apple is then pushed against the cutters and divided into 105 parts which fall upon the inclined board and are conducted to the receiver. The core is forced through the tube or circular cutter.

Fig. 3 represents the paring knife detached from the bench.

What I claim as my invention and which I desire to secure by Letters Patent consists

5 in—

The combination of the before described

machine for paring with the knife for dividing, and coring apples.

ROBERT W. MITCHELL.

Witnesses:

WM. P. ELLIOT,

WM. BISHOP.