



HARVARD
COLLEGE
LIBRARY

ACTIVITIES OF KU KLUX KLAN ORGANIZATIONS
IN THE UNITED STATES
PART 1

HEARINGS
BEFORE THE
COMMITTEE ON UN-AMERICAN ACTIVITIES
HOUSE OF REPRESENTATIVES
EIGHTY-NINTH CONGRESS
FIRST SESSION

—————
OCTOBER 19, 20, 21, 22, AND 25, 1965
(INDEX IN SEPARATE VOLUME)
—————

Printed for the use of the
Committee on Un-American Activities





CONTENTS

	Page
October 19, 1965: Testimony of—	
Donald T. Appell.....	1528
Philip R. Manuel.....	1545
Donald T. Appell (resumed).....	1596
Afternoon session:	
Robert Marvin Shelton.....	1600
Carol Long.....	1623
Betty L. Shelton.....	1627
Philip L. Schmitz.....	1629
October 20, 1965: Testimony of—	
Robert Marvin Shelton (resumed).....	1639
Afternoon session:	
Philip R. Manuel (resumed).....	1692
James Robertson Jones.....	1700
October 21, 1965: Testimony of—	
James Robertson Jones (resumed).....	1731
Afternoon session:	
James Robertson Jones (resumed).....	1764
Marshall Robert Kornegay.....	1790
October 22, 1965: Testimony of—	
John (Jack) Hammond Crum.....	1819
Joseph G. DuBois.....	1829
Afternoon session:	
Joseph G. DuBois (resumed).....	1838
Roy Woodle.....	1844
Boyd Lee Hamby, Sr.....	1864
James Huey (Sonny) Fisher.....	1869
William Richard Walston.....	1877
Wayne Dayvault.....	1883
Donald Edmund Leazer.....	1888
October 25, 1965: Testimony of—	
Arthur C. Leonard.....	1898
Richard Joseph Constantineau.....	1915
Afternoon session:	
Fred L. Wilson.....	1925
Grady Burdell Mars.....	1945
Index in separate volume	

PUBLIC LAW 601, 79TH CONGRESS

The legislation under which the House Committee on Un-American Activities operates is Public Law 601, 79th Congress [1946]; 60 Stat. 812, which provides:

*Be it enacted by the Senate and House of Representatives of the United States of America in Congress assembled, * * **

PART 2—RULES OF THE HOUSE OF REPRESENTATIVES

RULE X

SEC. 121. STANDING COMMITTEES

* * * * *

17. Committee on Un-American Activities, to consist of nine Members.

RULE XI

POWERS AND DUTIES OF COMMITTEES

* * * * *

(q) (1) Committee on Un-American Activities.

(A) Un-American activities.

(2) The Committee on Un-American Activities, as a whole or by subcommittee, is authorized to make from time to time investigations of (i) the extent, character, and objects of un-American propaganda activities in the United States, (ii) the diffusion within the United States of subversive and un-American propaganda that is instigated from foreign countries or of a domestic origin and attacks the principle of the form of government as guaranteed by our Constitution, and (iii) all other questions in relation thereto that would aid Congress in any necessary remedial legislation.

The Committee on Un-American Activities shall report to the House (or to the Clerk of the House if the House is not in session) the results of any such investigation, together with such recommendations as it deems advisable.

For the purpose of any such investigation, the Committee on Un-American Activities, or any subcommittee thereof, is authorized to sit and act at such times and places within the United States, whether or not the House is sitting, has recessed, or has adjourned, to hold such hearings, to require the attendance of such witnesses and the production of such books, papers, and documents, and to take such testimony, as it deems necessary. Subpenas may be issued under the signature of the chairman of the committee or any subcommittee, or by any member designated by any such chairman, and may be served by any person designated by any such chairman or member.

* * * * *

RULE XII

LEGISLATIVE OVERSIGHT BY STANDING COMMITTEES

SEC. 136. To assist the Congress in appraising the administration of the laws and in developing such amendments or related legislation as it may deem necessary, each standing committee of the Senate and the House of Representatives shall exercise continuous watchfulness of the execution by the administrative agencies concerned of any laws, the subject matter of which is within the jurisdiction of such committee; and, for that purpose, shall study all pertinent reports and data submitted to the Congress by the agencies in the executive branch of the Government.

ACTIVITIES OF KU KLUX KLAN ORGANIZATIONS IN THE UNITED STATES

Part 1

TUESDAY, OCTOBER 19, 1965

UNITED STATES HOUSE OF REPRESENTATIVES,
SUBCOMMITTEE OF THE
COMMITTEE ON UN-AMERICAN ACTIVITIES,
Washington, D.C.

PUBLIC HEARINGS

A subcommittee of the Committee on Un-American Activities met, pursuant to call, at 10 a.m. in the Caucus Room, Cannon House Office Building, Washington, D.C., Hon. Edwin E. Willis (chairman) presiding.

(Subcommittee members: Representatives Edwin E. Willis, of Louisiana, chairman; Joe R. Pool, of Texas; Charles L. Weltner, of Georgia; John M. Ashbrook, of Ohio; and John H. Buchanan, Jr., of Alabama.)

Subcommittee members present: Representatives Willis, Pool, Weltner, Ashbrook, and Buchanan.

Committee member also present: Representative George F. Senner, Jr., of Arizona.

Staff members present: Francis J. McNamara, director; William Hitz, general counsel; Alfred M. Nittle, counsel; Donald T. Appell, chief investigator; and Philip R. Manuel, investigator.

The CHAIRMAN. The subcommittee will come to order.

Under the rules of the House, the Chair is required to make an opening statement, and I now proceed to make it.

The regular members of the subcommittee are myself, as chairman, Mr. Pool of Texas, Mr. Weltner of Georgia, the ranking minority or Republican member, Mr. Ashbrook of Ohio, and Mr. Buchanan of Alabama.

We are very pleased, however, to have with us a member of the full committee, Mr. Senner. I would hope as we go along that other members of the full committee might be able to attend for as long as they desire.

Now for the opening statement.

This subcommittee of the House Committee on Un-American Activities is convened to hold hearings pursuant to a resolution unanimously adopted by the full committee on March 30, 1965. That resolution reads as follows:

WHEREAS, at the commencement of the 89th Congress the Chairman instructed the staff to commence a preliminary inquiry into the activities of the

Ku Klux Klan organizations in the United States to assist the Committee in determining whether it should authorize an investigation of the Klan organizations; and

WHEREAS, the Committee on February 2, 1965, by resolution, unanimously directed the Chairman to continue the preliminary inquiry; and

WHEREAS, the Chairman has today made a report to the Committee on the results of this preliminary inquiry, which report clearly indicates that the nature and scope of the Klan organizations' activities are such that the Committee should authorize an investigation; and

WHEREAS, the President's recent public appeal also demonstrates that such an investigation is justified and necessary; and

WHEREAS, the President has offered the full cooperation of the Executive Branch of the Government in such an investigation; now therefore,

BE IT RESOLVED, that the Committee undertake an investigation of the various Klan organizations and their activities with the view of holding hearings for the purpose of aiding Congress in any necessary remedial legislation; and

BE IT FURTHER RESOLVED, that inasmuch as the appropriation for the Committee's work for this session is not sufficient to enable it to undertake this investigation in addition to other investigations already approved and under way, the Chairman is directed to request a supplemental appropriation of \$50,000 to conduct an investigation of Ku Klux Klan organizations; and

BE IT FURTHER RESOLVED, that the Chairman is directed to continue the preliminary inquiry into the activities of the Black Muslims, the Minutemen and the American Nazi Party previously authorized by the Committee, for the purpose of determining whether an investigation of these groups is called for.

As this resolution indicates, the committee's decision to undertake an investigation of Ku Klux Klan organizations in this country was made only after careful consideration and on the basis of certain information concerning Klan activities then in its possession. Late last year, the committee discussed the growing activities of the Ku Klux Klans and a suggestion was made by Mr. Pool that an investigation be considered.

Before any formal investigation is authorized by the committee, it is usual to make a preliminary inquiry. The staff was, therefore, directed to do so in this instance. Other Members of Congress subsequently expressed themselves on the subject, particularly Mr. Weltner, who called the matter to the attention of our colleagues on the floor of the House.

At its organizational meeting on February 2 of this year, the committee unanimously authorized the continuance of this preliminary inquiry. Thereafter, the staff reported to the committee from time to time and, on March 30, the committee voted unanimously that a formal investigation be undertaken for the purpose of holding hearings which would assist the Congress in drafting such remedial legislation as it deemed appropriate and necessary to deal with the problems created by Klan activities.

On April 14 of this year, the House of Representatives, by a vote of 312 to 43, adopted House Resolution 310, authorizing the expenditure of \$50,000 for the committee's investigation of Ku Klux Klan organizations.

What must Congress know to determine whether legislation is called for in this area and, if so, what type legislation will be effective?

It must know the objectives and purposes of the Ku Klux Klans, their structure and organizations, their affiliated organizations, and groups created or controlled by them or organized to support, defend, and assist them. The Congress must know their constitutions and bylaws, the type of activities in which they engage, how they are controlled, who their key officers are, how Klan groups are financed, and what their funds are used for. It must know whether the Klans sub-

scribe to—and use—illegal means to achieve either declared or concealed objectives. The Congress must know whether the operations and actions directed and carried out by Klan leaders and certain members are in accord with the wishes of the membership as a whole, or whether certain activities are engaged in without the knowledge and approval of the membership. It must know whether Klan recruits are informed of the true nature and purposes of the Klans—or whether they are hoodwinked into joining them. It must also know, of course, something of the size, strength, and scope of the Klan movement. These are the matters which are the subject of this inquiry.

At the time the committee decision to conduct this inquiry was announced, certain Klan leaders stated publicly that they welcomed the investigation. Those statements were encouraging, if true. It is the committee's hope that they really meant them.

The investigative work done by the committee preparatory to these hearings, in my belief, has been thorough. It is my intention that these hearings will be fair in every respect. For this reason, Klan leaders and members will have nothing to fear or lose by cooperating fully with the committee by telling all, and everything, they know about Klan operations. They have nothing to fear or lose, that is, if they have nothing to hide—nothing to hide from the Congress, nothing to hide from the American people, and nothing to hide from the rank-and-file Klan membership.

I would point out to all witnesses summoned to testify in this inquiry that it is being conducted by a duly and lawfully constituted committee of the House of Representatives of the United States Congress, the lawmaking branch of our Government, and that the courts have held, over and over again, that every American citizen has a duty to answer all pertinent questions asked him in such an inquiry.

The Supreme Court in a 1957 decision growing out of another inquiry by this committee reiterated a fundamental principle of our Government when it stated:

The power of Congress to conduct investigations is inherent in the legislative process.

It then went on to say:

It is unquestionably the *duty* of all citizens to cooperate with the Congress in its efforts to obtain the facts needed for intelligent legislative action. It is their *unremitting obligation* to respond to subpoenas, to respect the dignity of the Congress and its committees and to testify fully with respect to matters within the province of proper investigation. (*U.S. v. Watkins*, 354 U.S. 178.) [Emphasis added.]

That this was not a new or novel holding by the Court is indicated by many much earlier rulings of similar nature and, for example, by a relatively recent report of a special committee of the American Bar Association which in 1953—without evoking any protest—stated that:

Every citizen, when called as a witness, has the duty to disclose any facts within his knowledge sought by a court or by a duly constituted legislative committee.

Generally, the committee recognizes only one valid reason for a witness' refusal to answer pertinent questions—the invocation of the fifth amendment, a statement by the witness that it is his belief that an honest answer to the question might lead to his being prosecuted for a criminal act.

The various Klan organizations operating in this country today proclaim that they are patriotic, 100 percent Americans, Christian, moral, and law abiding. I hope, therefore, that we will not, in these hearings, experience what we have so often seen in practically all of our investigations in other areas of the committee's jurisdiction—witness after witness finding it necessary, or feeling the need, to invoke the fifth amendment, again and again, when asked, not about his beliefs, but about his actions.

All witnesses, as I have said—and I stress this—will have the right to make proper invocation of the fifth amendment in this inquiry. The American people, however, are not likely to look with favor on such recourse by persons who proclaim from the rooftops that they are saviors of America and patriots second to none. The public cannot be expected to approve such action in these hearings any more than it has in other inquiries in which witnesses have taken refuge in constitutional provisions even while conspiring to destroy the Constitution.

And talking about conspiracy, I would add this point: There are various kinds of conspiracy, in addition to that which is aimed at the destruction of our Government, and all kinds are outlawed. As Justice Robert H. Jackson stated in his concurring opinion in the case of *Dennis versus United States*: "The Constitution does not make conspiracy a civil right."

In his concurring opinion in another case, that of *American Communications Association versus Douds*. Justice Jackson pointed out that:

The conspiracy principle has traditionally been employed to protect society against all "ganging up" or concerted action in violation of its laws. No term passes that this Court does not sustain convictions based on that doctrine for violations of the antitrust laws or other statutes. * * * (*A.C.A. v. Douds*, 339 U.S. 382.)

Conspiracy to take a man's life, to injure him, or to deny certain groups of people their rights is no more protected by the Constitution than is conspiracy to destroy our Government. Conspiracy, in and of itself, is so inimical to ordered society that there is a broad Federal statute which makes it a crime to conspire to commit any offense against the United States. (Title 18, U.S.C., sec. 371.)

And there is a third, specific kind of conspiracy I must mention here—the secret ganging up of any group to punish or harm a person in any way because that person has, in line with his duties as a citizen, testified before a congressional committee, giving the committee the kind of information the Congress must have to enact laws for the general welfare.

That kind of conspiracy, like all other forms, is outlawed. In fact, influencing or injuring witnesses is so destructive of the American way of life, eating away at its legislative foundation, that it is a criminal act even when there is no conspiracy involved in it. The very act of harming, or of attempting to harm, influence, or intimidate, a subpoenaed witness to keep him from talking or of injuring or threatening a witness because he has cooperated with the Congress by giving testimony is punishable by 5 years in prison and/or a fine of \$5,000.

And I want to state for the record, here and now, that no one had better attempt to violate this law in regard to any witness under subpoena to testify in this inquiry. If anyone does, then just as cer-

tainly as I am sitting here today, I will do all in my power to see that the guilty party, or parties, are punished according to the law, and I know that all other members of the committee feel the same way about it because we have discussed it many times.

Being informed, as they are, of the facts developed to date in this investigation, the subcommittee members have quite naturally formed certain tentative opinions of some Klan groups and their leaders. However, we are not going to prejudge the issue. These facts have raised questions in our minds, but in any human undertaking there can be error, and it is also possible that there might be some explanation for certain of the facts we have uncovered. That is one reason why this public hearing is being held—to test the accuracy of our investigative effort and to give the persons concerned an opportunity to answer the questions that have been raised in our minds—to deny, to qualify, to confirm, to explain.

This is as it should be. Congress cannot legislate on the basis of investigation alone. It should, and must, test the results of its investigations, except when national security precludes it, in public hearings. This is what we have done in the past; it is what we will do in the future. This is in conformity with the rules of the House and with court decisions. We are engaged in the business of the people of the United States, and they have a right to be able to see and judge for themselves how that business is being conducted.

Let me remind all that this is an inquiry, not a prosecution. We are an investigating committee. We are charged with the duty of developing facts about the Klans and making them a part of a public record, not to convict anyone of anything, but for the purpose of assisting the Congress in the performance of its legislative function.

In conclusion, let me urge all witnesses summoned to testify in these hearings to testify fully and honestly, without evasion or subterfuge and without fear. This is your duty. If you truly have the national interest at heart, this is what you will do. By way of both encouragement and warning, I want to say that this is a country of law, that it is strong and secure; and that no individuals, groups, or conspiracies within its borders can, or will, prevail against its laws.

I now offer for inclusion in the record the July 19, 1965, order of appointment of the subcommittee to conduct these hearings.

That order reads as follows, that order of mine as chairman, addressed to Mr. McNamara, the director of the committee:

Pursuant to the provisions of the law and the Rules of this Committee, I hereby appoint a subcommittee of the Committee on Un-American Activities, consisting of Honorable Joe R. Pool, Honorable Charles L. Weltner, Honorable John M. Ashbrook, and Honorable John H. Buchanan, Jr., as associate members, and myself, as Chairman, to conduct hearings in Washington, D.C., commencing on or about Tuesday, July 20, 1965, and/or at such other times thereafter and places as said subcommittee shall determine, as contemplated by the resolution adopted by the Committee on the 30th day of March, 1965, authorizing hearings concerning the activities of the various Ku Klux Klan organizations in the United States.

Please make this action a matter of Committee record.

If any member indicates his inability to serve, please notify me.

Given under my hand this 19th day of July, 1965.

/s/ Edwin E. Willis
EDWIN E. WILLIS

Chairman, Committee on Un-American Activities.

(At this point Representative Ichord entered the hearing room.)

The CHAIRMAN. I am pleased to announce that another member of the full committee, Mr. Ichord, of Missouri, has arrived.

If there are any members of the House present, and I recognize at least one, Mrs. Kelly of New York, it would be a pleasure to have them take a seat with us. Come on, Edna.

I don't expect any, but there cannot be demonstrations in the audience, either in approval or disapproval of the conduct of these hearings. We must maintain decorum, and that is consistent with the rules of the House.

I have already announced that under the rules of the House, even the radio and TV people are under certain limitations. They respect that. They would like to be inside, but that is the rule of the House that I am carrying out.

I will read another rule of the House after a while concerning the functions of attorneys appearing for witnesses before the committee. That is another rule of the House that will be observed and enforced.

I would like to say this preliminary to calling our first witness: In the course of these hearings, it will be necessary, because of the nature of the groups we are investigating, to make frequent use of terms which, although familiar to the witnesses, will be completely foreign to Members of Congress, the public, and the press, on which the public must rely for information about these hearings. The subcommittee has, therefore, decided that before the first Klan witness is called, in order to assist in better understanding of the matters that will be developed and referred to in this inquiry, certain background information concerning the Klans, their structure, titles, and terminology should be placed in the record. For that purpose, I ask that Mr. Donald T. Appell be sworn.

Do you solemnly swear that the testimony you are about to give will be the truth, the whole truth, and nothing but the truth, so help you God?

Mr. APPELL. I do, sir.

TESTIMONY OF DONALD T. APPELL

The CHAIRMAN. Mr. Appell, you are the chief investigator of this committee; are you not?

Mr. APPELL. I am, sir.

The CHAIRMAN. How long have you been employed in this investigative work for the committee?

Mr. APPELL. I have been with the committee since January of 1947.

The CHAIRMAN. And your duties stretch as far back as the Alger Hiss-Whittaker Chambers episode?

Mr. APPELL. That is correct.

The CHAIRMAN. Mr. Appell, you were assigned, were you not, to supervise the investigative phase of the committee's inquiry into the Klans?

Mr. APPELL. Yes, sir; from the preliminary stage starting the end of last year, and from an active investigative phase from March of this year, sir.

The CHAIRMAN. Would you give us a brief history of the Klan movement in the United States, just enough, Mr. Appell, to provide the essential background for the hearings, the type of information that, although there are many books and treatises written on the subject, the type of background that there appears to be no dispute about?

Mr. APPELL. Yes.

The CHAIRMAN. Will you proceed to do that?

Mr. APPELL. As you said, Mr. Chairman, many books have been written on the history of the Klan movement; but, briefly, we would like to point out that the first Ku Klux Klan was formed in Pulaski, Tennessee, in December of 1865. It grew rapidly and its "dens," as the local clubs were then called, spread throughout and beyond the borders of Tennessee. In 1867 a conference attended by representatives of these dens collected together in a convention that was held in Nashville, Tennessee. A constitution was formally adopted and Confederate General Nathan Bedford Forrest was chosen the Grand Wizard, or leader, of the Ku Klux Klan.

Whatever may have been the original purpose in the formation of the first Ku Klux Klan, the organization was soon engaging in acts of violence. General Forrest officially disbanded his Ku Klux Klan in January 1869. Klan groups, however, continued to operate, and their lawlessness grew to such proportions that on March 23, 1871, President Grant sent the following message to the Congress:

A condition of affairs now exists in some of the States of the Union rendering life and property insecure, and the carrying of the mails and the collection of the revenue dangerous. The proof that such a condition of affairs exists in some localities is now before the Senate. That the power to correct these evils is beyond the control of State authorities, I do not doubt; that the power of the Executive of the United States, acting within the limits of existing laws, is sufficient for present emergencies is not clear. * * *

He also recommended that legislation be enacted, and a joint congressional committee was formed. From April to September of 1871, hearings were held relating to the lawless conduct of "The Ku-Klux [Klan] Conspiracy" in North Carolina, South Carolina, Georgia, Alabama, and Mississippi. On April 20, 1871, the President approved, and I shall quote, "An act to enforce the provisions of the fourteenth amendment to the Constitution of the United States, and for other purposes."

It has been estimated that the post-Civil War Klan attained a peak membership of about a half-million members.

The Klan was revived in 1915 by William Joseph Simmons, of Atlanta, Georgia, and in the mid-1920's achieved its all-time membership peak which has been variously estimated as between 3 million and 5 million members.

Exposés of the Knights of the Ku Klux Klan, Inc., as the first 20th century Klan was termed, were published by many newspapers in the early 1920's, and the House Rules Committee held brief hearings on it in 1921. In 1924, following widely publicized murder cases in which Klansmen were involved, the membership again began to decline.

On August 18, 1940, not long before this country's entry into World War II, Klansmen took part in a rally at the German-American Bund's Camp Nordland, in the State of New Jersey. This led to an investigation by the Special Committee on Un-American Activities, which held hearings on the Klan in 1940 and 1942.

The Klan became dormant after America's entry into World War II and was formally dissolved in 1944, when the Internal Revenue Bureau sued the Knights of the Ku Klux Klan for \$685,000 in back taxes.

Following World War II there was limited revival of the Klan, led by the formation of Dr. Samuel Green's Association of Georgia Klans in 1946. Other localized Klans sprang up in the late 1940's and early 1950's. Klan strength has definitely been on the upswing in the last few years, with some leaders talking about operations on a nationwide scale.

The CHAIRMAN. Now, Mr. Appell, during the course of the last few months you have informed the committee on a number of occasions of the fear of the Klan which you and other investigators found in certain areas while interviewing various persons in relation to this inquiry.

Would you now summarize for the record what the investigative staff observed in relation to this matter?

Mr. APPELL. This will be a very brief summary, Mr. Chairman.

The CHAIRMAN. The committee wants it that way. We are just laying the foundation for a proper understanding of the conduct of this inquiry.

Mr. APPELL. In certain areas of the South, investigators found a very real fear of the Klan existing among Klansmen themselves, ex-Klansmen, victims of the Klan, and the general public. The investigative staff encountered this fear time after time in interrogating, and trying to interrogate, sources of information. It was a major obstacle to the development of all the information we hoped to obtain—a very real bar to cracking wide open the veil of secrecy that surrounds many of the operations of the "Invisible Empire," as it is called, of the Ku Klux Klans.

These people fear Klan harassment in the form of threatening letters and telephone calls. They fear economic reprisals, cross-burnings on their property, beatings, bombings, and, yes, even death. Rightly or wrongly, they blame much of the violence of this type that has taken place in the South in recent years on the Klans.

The oath taken by all Klan members, which we hope shortly to make a part of the hearing record, contains a section on secrecy which reads as follows, and this is Section II of the oath called Secrecy:

I most solemnly swear—that I will forever—keep sacredly secret—the signs, words and grip—and any and all other—matters and knowledge—of the * * * *—and here the particular Klan is supposed to be mentioned—

regarding which a most rigid secrecy—must be maintained—which may at any time—be communicated to me—and will never—divulge same nor even cause same to be divulged—to any person in the whole world—unless I know positively—that such person is a member of this Order—in good and regular standing—and not even then—unless it be—for the best interest of this Order.

In continuation:

I most sacredly vow—and most positively swear—that I will never yield to bribe—flattery—threats—passion—punishment—persecution—persuasion—nor any enticements whatever—coming from or offered by—any person or persons—male or female—for the purpose of—obtaining from me—a secret or secret information—of the * * * *—

and the particular Klan is to be named—

I will die rather than divulge same—so help me God—

Also, Mr. Chairman, under a series of oaths taken, with the title of "Ishness," we find this additional oath of secrecy:

I swear that I will keep secure to myself—a secret of a [Klan]*sman—when same is committed to me—in the sacred bond of [Klan]*smanship—the crime of violating THIS solemn oath—treason against the United States of America—rape—and malicious murder—alone excepted.

Any member or former member of the Klan who reveals information about Klan activities violates this oath, except for the saving clause.

For this reason, persons who are or have been members of the Klans fear reprisals if they reveal information about Klan activities—reprisals not only against themselves, but much more, in many cases, against their families—against their wives, their children, their sisters, their brothers, even their parents and close relatives.

Some have said that they feel that they can take care of themselves, or at least are willing to risk trying to do so, but they are naturally concerned about others in their families. They have also pointed out that, after revealing what they know about the Klans, they could move to another area or State where they would be safely out of the Klans' reach. The problem, however, is that other close relatives and members of their families are not all in a position to do this, and they fear Klan vengeance on them, even though they themselves would be safe.

It is difficult for a person who has never lived in an area where certain Klans have been active to appreciate how strong and widespread this fear is.

This fear, and in some cases actual terror, which the Klans have succeeded in creating, not only makes it difficult to develop full information about the Klans, but is also a serious impediment to law enforcement and, of course, a source of Klan strength and influence.

The CHAIRMAN. Now, Mr. Appell, quite a bit has been written on the subject of Klan infiltration of law enforcement agencies. What have you and other investigators found relative to this subject?

MR. APPELL. There is and has been some infiltration of law enforcement agencies by the Klans. The experience of the committee's investigative staff during the past 6 months, however, indicates that without question the overwhelming majority of police and law enforcement officers in the South are neither Klan members nor sympathetic to the Klans. On the whole, the committee investigators received excellent cooperation from both State and local law enforcement agencies. In most cases they did everything they could to assist us.

There have been a few instances, however, in which we deliberately avoided contacting law enforcement officers because our preliminary investigation indicated either Klan sympathy or even, in some cases, Klan membership. Mr. Chairman, I would like to point out one experience I had which, I think, illustrates this point.

Some months ago I covered a Klan rally that was held on the outskirts of a Southern town. I drove out on various roads leading from the town without being able to locate the site of the rally. I returned to the town and saw a policeman standing on the sidewalk talking to the proprietor of a local store. I stopped my car, walked over to the officer, and asked him if he could direct me to the site of the Klan rally.

He at first appeared uncertain, but then recalled the location and gave me directions. I thanked him and returned to my car. No

sooner had I shut the door than a hand came through the open window on the driver's side. Following the arm to the body, I discovered it belonged to the policeman I had left on the sidewalk and who must have run to catch up to me. I grasped his hand, thinking he wanted to introduce himself. Instead, he rotated my hand clockwise until it was in a horizontal position. Fortunately, I had done a little research and I recognized this as one of the official Klan handshakes, and I rotated his hand in the opposite direction until it was parallel to the ground.

Frankly, Mr. Chairman, I didn't know what to do next, but he took me off the spot by stating that he sure would like to attend the rally, but he was on duty and it was outside of his patrol area.

This experience, however, was an exception to the rule. I have already read into the record the secrecy section of the Klan oath. The wording of this oath indicates that if a law enforcement officer should join the Klan and become a dedicated member of it, placing this oath above all others, he would place himself in the position of not being able to fully discharge his duties as a law enforcement officer.

Finally, I would make these points relative to the accusation made by some that law enforcement agencies in the South have deliberately failed to solve crimes of violence which, rightly or wrongly, have been attributed to the Klans. First, Klansmen make use of citizens band radios for communication among themselves. In addition, they have equipment which enables them to intercept police radio calls. With quick means of communication, hot rods, and being in a position to know where police patrol cars are at a given time, they can judge pretty well when and where they can commit an act of violence and have time to make a getaway.

Second, of course, there is the fear that I have already referred to. Because of this fear, a considerable period of time often elapses before the police learn that an act of violence has been committed. We have seen evidence of this—records which show that hours pass before local police or sheriffs' departments receive word of the commission of a crime. This is, of course, a very real obstacle to the apprehension of guilty parties.

The CHAIRMAN. While on the subject of law enforcement and investigative agencies and their efforts to apprehend those guilty of crimes of violence, I want, at this point, to take the opportunity to pay tribute to an organization recognized by the overwhelming majority of Americans as a truly fine one. I am referring, of course, to the FBI. During the past 6 months, the committee's investigators have been reporting to me and to the committee regularly on what they have found on their field trips.

On the basis of what they have told us—and we all know they have spoken the truth—agents of the FBI are doing outstanding work in areas where the Klans are operating. It is my conviction that if it weren't for the dedication, the outstanding and hard work of these men, there would have been much more Klan violence in the South than we have seen in the last few years.

In this respect, as in others, the FBI on all levels merits the respect and gratitude of the American public, and I express the gratitude of this committee to the FBI. In my opinion, it is the finest investigative agency in the world.

Finally, Mr. Appell, I believe you have a number of exhibits to submit for the record concerning the Klan organizations operating in

the United States, their structures and organization, terminology and related matters, including, I think, an exhibit which names key officers of the largest of the Klan groups, most of them self-identified and self-proclaimed, and all of whose identities, of course, have been confirmed by committee investigation.

The committee would be pleased to have you proceed with the introduction and identification of these exhibits,¹ in which effort I think you might want to be joined by Mr. Manuel, who has been so helpful in this investigation, and perhaps by Mr. Hitz, and Mr. Nittle, another counsel of the committee. I will have something else to say about that soon.

Mr. APPELL. Mr. Chairman, we have projected this that I am going to present on slides. The first one that we will deal with is Ku Klux Klan terminology.

(A slide of the following was shown:)

[Committee Exhibit No. 1]

Ku Klux Klan Terminology

Term	Definition
Invisible Empire.....	The overall territorial jurisdiction of a Ku Klux Klan.
Kloran.....	The official ritual book of a Ku Klux Klan organization.
Klankraft.....	Ku Klux Klan spirit and knowledge of all matters pertaining to the Ku Klux Klan.
Klectokon.....	The Klan initiation fee.
Kalendar.....	The special Klan terminology to designate days, months, and years.
Imperial Klonvokation.....	A national convention of a Ku Klux Klan organization.
Imperial Kloncilium.....	The supreme advisory and governing board of a Ku Klux Klan organization.
Realm.....	A territorial subdivision of the Invisible Empire, embracing a State.
Province.....	A territorial subdivision of a realm, embracing a congressional district.
Klorero.....	A realm (State) convention; also the realm governing and advisory board.
Klonverse.....	A convention of a province.
Klan, Klavern.....	The smallest unit (local club) of a Ku Klux Klan organization.
Klanton.....	The territorial jurisdiction of a Klan or Klavern.
Klonklave.....	Secret convention or meeting of a Klan.
Aliens.....	All persons who are not members of a Ku Klux Klan organization.
KLORANIC ORDERS	
K-UNO.....	Order of Probationary Citizenship in the Invisible Empire.
K-DUO.....	Knights of Kamellia—Primary Order of Knighthood.
K-TRIO.....	Knights of the Great Forest—Order of American Chivalry.
K-QUAD.....	Knights of the Mid-night Mystery—Superior Order of Knighthood and Spiritual Philosophies.

¹ Documents designated committee exhibits and numbered consecutively.

Mr. APPELL. We come to the Invisible Empire, which we have referred to already, which is the overall territorial jurisdiction of a Ku Klux Klan; the Kloran, the official ritual book of the Ku Klux Klan; Klankraft, Ku Klux Klan spirit and knowledge of all matters pertaining to the Ku Klux Klan; the Klectokon, the Klan initiation fee; the Kalendar, the special Klan terminology to designate days, months, and years; the Imperial Klonvokation, a national convention of a Ku Klux Klan organization; the Imperial Kloncilium, the supreme advisory and governing board of a Ku Klux Klan organization; the Realm, a territorial subdivision of the Invisible Empire embracing a State; the Province, a territorial subdivision of a realm, embracing a congressional district, with a realm having as many provinces as there are congressional districts within the State boundaries; the Klorero, a realm or State convention; also the realm governing and advisory board; the Klonverse, a convention of the province leaders.

Continuing with the terminology, Mr. Chairman, we have a Klan or Klavern. This is the smallest unit and would compare with a local club of any other national organization. The reason that we show it as a Klan or Klavern is that technically, within the constitution of a Klan organization, the unit is a Klan, but because there are so many different Klans, it is popularly referred to as a Klavern.

The Klanton is the territorial jurisdiction of a Klan or Klavern.

A Klonklave is a secret convention or meeting of a Klan.

Aliens are all of us who are not members of a Ku Klux Klan.

Like other orders, they have Kloranic degrees. K-UNO is the Order of Probationary Citizenship in the Invisible Empire. K-DUO, Knights of Kamellia, Primary Order of Knighthood. K-TRIO, Knights of the Great Forest—Order of American Chivalry. K-QUAD, Knights of the Midnight Mystery—Superior Order of Knighthood and Spiritual Philosophies.

With respect to the fourth order, Mr. Chairman, we have had testimony from a man who has been in the Klan many years that no one has ever had to take the fourth order because it hasn't even been written yet, and if it were completed, and it is now being worked on, it would take 16 hours to confer and it would require \$40,000 worth of equipment.

We now, Mr. Chairman, will deal with the model Klan organization chart.

(Model Klan Organization Chart shown on slide. See Committee Exhibit No. 2, p. 1535.)

Mr. APPELL. We go from the Imperial Office. You will note footnote designations. This compares with national offices of a normal organization. Positions are filled by vote of delegates to Imperial Klonvokation or national convention.

From the Imperial Office we flow to the Realm Office. As you can see from the footnote designation, this compares with the State division of a national office and is not an autonomous body. Offices are filled by vote of delegates to a klorero or State convention. Before a State has a sufficient number of Klaverns or members to hold elections, the offices are filled by appointments of the Imperial Wizard.

The next is the Province Office. And, as we note, the provinces conform to the boundaries of a congressional district and are as many as there are congressional districts in a State. Offices are filled by vote of delegates to a klonverse or district convention.

[COMMITTEE EXHIBIT No. 2]

MODEL KLAN ORGANIZATION CHART

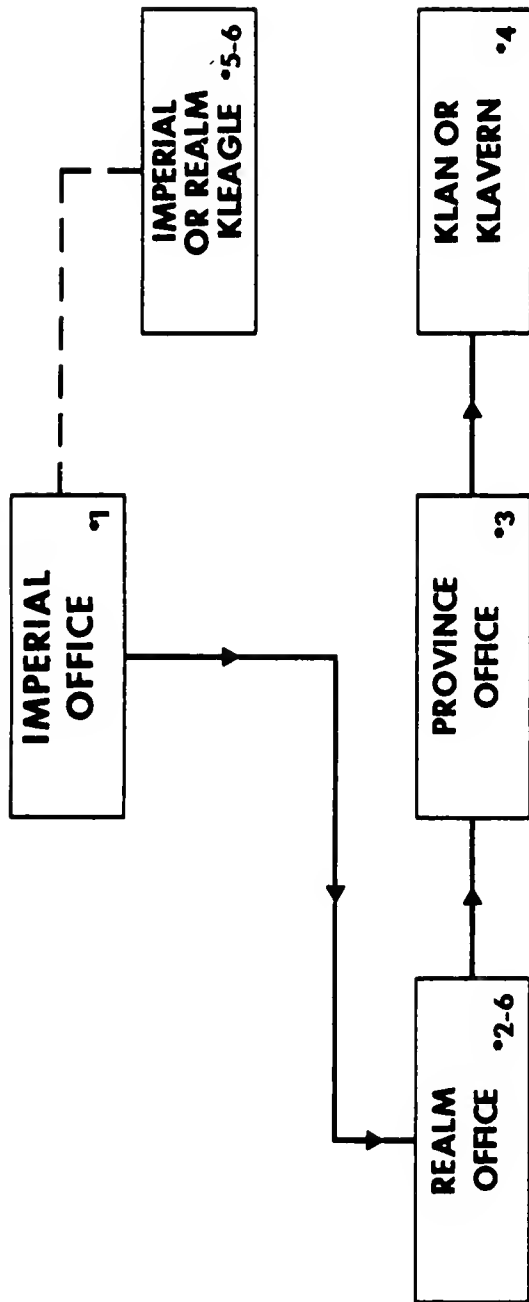

- *1 Compares with National Offices - positions filled by vote of delegates, to Imperial Klonvokation or National Convention.
- *2 Compares with State division of National Office - is not autonomous body. Offices filled by vote of delegates to a Klorero or State Convention.
- *3 Provinces conform to the boundaries of a Congressional District. Provinces are as many as Congressional Districts assigned a given state. Offices filled by vote of delegates to Klonverse or District Convention.
- *4 Compares with a club of a National or State organization. Offices filled by election of club membership.
- *5 Organizer appointed by Imperial Wizard or Grand Dragon - receives portion of Kledokon or initiation fee paid by new member until Klavern has 25 members.
- *6 Realm officers and Kleagles are appointed by the Imperial Wizard until membership has grown to strength sufficient to hold elections.

Then we come to the smallest order of the Klan or Klavern, which is in footnote 4, which compares with a club of a national or state organization, with offices filled by election of club membership. As a service function out of the office of the Imperial Wizard, and sometimes out of the office of the realm leader or Grand Dragon, these men are appointed by either the Imperial Wizard, who also is the Supreme Kleagle or organizer for the organization.

We now deal with the Imperial (National) Offices, and the number and titles given to these.

We have attempted to make an analogy between the office as it would relate to a national organization that we all might be familiar with.

(Chart of Imperial (National) Offices shown on slide. See Committee Exhibit No. 3, p. 1537.)

Mr. APPELL. The Imperial Wizard is the national president, the supreme chief executive officer, the Supreme Kleagle or organizer.

Then we have the Imperial Klaliff, who would compare with a national vice president; the Imperial Klokard, the national director of propaganda; the Imperial Kludd, the national chaplain; the Imperial Kligrapp, the national secretary; the Imperial Klabee, the national treasurer; the Imperial Kladd, the national secretary to the president; the Imperial Klarogo, the national inner guard of conventions or national executive board meetings; the Imperial Klexer, the national outer guard of conventions or national executive board meetings; the Imperial Klonsel, the national legal adviser; the Imperial Night-Hawk, the national auditor and chairman of a 3- to 5-member audit and advisory committee.

All of these together are known as the Imperial Wizard and his Genii.

We next pass to the realm, Mr. Chairman.

(Chart of Realm (State) Offices shown on slide. See Committee Exhibit No. 4, p. 1538.)

Mr. APPELL. Here we find that these men, after they are of sufficient strength, are elected at a State klorero, or convention, by delegates from Klans or Klaverns. I will point out in this that the top man of a realm is known by the title of Grand Dragon.

I will remove this in order to show that the other offices are the same, but preceding the office on a State level they are referred to as Grand Klaliff, grand klokard, grand et cetera.

I wish to point out that this body of men is known as the Grand Dragon and his Hydras.

We next go to the subdivision within the State, or the province, the district offices.

(Chart of Province (District) Offices shown on slide. See Committee Exhibit No. 5, p. 1539.)

Mr. APPELL. The great titan is the highest officer of a province and could be considered its president.

There are three great klaliffs that operate as an advisory board; the great kligrapp or secretary, the great klabee or treasurer, the

[COMMITTEE EXHIBIT No. 3]

IMPERIAL (NATIONAL) OFFICES

IMPERIAL WIZARD——NATIONAL PRESIDENT
 SUPREME CHIEF EXECUTIVE OFFICER
 SUPREME KLEAGLE OR ORGANIZER

IMPERIAL KLALIFF——NATIONAL VICE PRESIDENT

IMPERIAL KLOKARD——NATIONAL DIRECTOR OF PROPAGANDA

IMPERIAL KLUDD——NATIONAL CHAPLAIN

IMPERIAL KLIGRAPP——NATIONAL SECRETARY

IMPERIAL KLABEE——NATIONAL TREASURER

IMPERIAL KLADD——NATIONAL SECRETARY TO THE PRESIDENT

IMPERIAL KLAROGO——NATIONAL INNER GUARD OF CONVENTIONS
 OR NATIONAL EXECUTIVE BOARD MEETINGS

IMPERIAL KLEXTER——NATIONAL OUTER GUARD OF CONVENTIONS
 OR NATIONAL EXECUTIVE BOARD MEETINGS

IMPERIAL KLONSEL——NATIONAL LEGAL ADVISOR

IMPERIAL NIGHT-HAWK——NATIONAL AUDITOR AND CHAIRMAN OF
 3-5 MEMBERS OF AUDIT AND ADVISORY
 COMMITTEE

IMPERIAL
 WIZARD
 AND HIS GENII

[COMMITTEE EXHIBIT No. 4]

REALM (STATE) OFFICES

ELECTED AT STATE KLOREO OR CONVENTION BY
DELEGATES FROM KLANS OR KLAVERNS (CLUBS)

GRAND DRAGON PRESIDENT OF KLOREO

GRAND KLALIFF VICE PRESIDENT

GRAND KLOKARD LECTURER

GRAND KLUDD CHAPLAIN

GRAND KLIGRAPP SECRETARY

GRAND KLABEE TREASURER

GRAND KLADD CONDUCTOR OF CEREMONIES

GRAND KLAROGO INNER GUARD

GRAND KLEXTER OUTER GUARD

GRAND NIGHT-HAWK . . AUDITOR

GRAND
DRAGON
AND HIS
HYDRAS

PROVINCE (DISTRICT) OFFICES

GREAT TITAN _____ HIGHEST OFFICER OF A
PROVINCE AND PRESIDENT
OF THE KLONVERSE

3 GREAT KLALIFFS _____ ADVISORY BOARD

GREAT KLIGRAPP _____ SECRETARY

GREAT KLABEE _____ TREASURER

GREAT KLUDD _____ CHAPLAIN

GREAT NIGHT-HAWK _____ AUDITOR

GREAT TITAN
AND
HIS FURIES



great kludd or chaplain; and this body is known as the great titan and his furies.

Here we come to the Klan or Klavern, the club offices.

(Chart of the Klan-Klavern (Club) Offices shown on slide. See Committee Exhibit No. 6, p. 1541.)

Mr. APPELL. Here the top man is the exalted cyclops. The men under him hold the same titles. However, as you will note, they are not preceded by the word of either "Grand" or "Imperial" and this body is known as the exalted cyclops and his terrors.

Mr. Chairman, I would like to deal with a graph of the United Klans of America.

(Chart of United Klans of America, Inc., shown on slide. See Committee Exhibit No. 7, p. 1542.)

Mr. APPELL. I would like to, with your permission, state that basically this organization grows out of an organization formed in 1955 known as the U.S. Klans. Following the death of its leader, Eldon Edwards, in 1960, it split with a great bulk of its leadership creating an organization which is known as the Invisible Empire, United Klans, Knights Ku Klux Klan of America, Inc.

This organization was formed in February of 1961. Joining with this organization was the Alabama Knights of the Ku Klux Klan, which was formed in part by Robert M. Shelton after he had been replaced by Edwards as Grand Dragon of the U.S. Klans for the State of Alabama.

Sometime, in May or June of 1961, these bodies came together; and in July of 1961, Mr. Shelton was elected its Imperial Wizard and has held that office since.

Starting off with what could be grabbed away from the membership of the U.S. Klans, the organization has grown to what we picture here today.

We have set this graph up, Mr. Chairman, so that realms are displayed as a realm because, according to our investigation, there is sufficient Klan strength to hold elections. We will, as we go down this chart, list States without a prefix of "realm" because the Klan does not have, according to our investigation, sufficient strength to form or elect bodies within themselves, so we have listed them merely as a State and have designated persons who, according to our investigation, and also which is confirmed by public press sources, are people Mr. Shelton has appointed as Grand Dragons in these various areas.

These are not in the order in which they were formed as the United Klans came into being in 1961, but are set forth to show how the United Klans looks today according to our investigation.

There is the Realm of Tennessee, headed by Grand Dragon Anderson; the Realm of Louisiana headed by Grand Dragon Dr. Edwards; the Realm of Mississippi headed by Grand Dragon McDaniel; the Realm of Alabama headed by Grand Dragon Creel; the Realm of Florida, headed by Grand Dragon Cothran; the Realm of Georgia

[COMMITTEE EXHIBIT No. 6]

KLAN - KLAVERN (CLUB) OFFICES

- EXALTED CYCLOPS..... PRESIDENT
- KLALIFF..... VICE PRESIDENT
- KLOKARD..... LECTURER
- KLUDD..... CHAPLAIN
- KLIGRAPP..... SECRETARY
- KLABEE..... TREASURER
- KLADD..... CONDUCTOR
- KLAROGO..... INNER GUARD
- KLEXTER..... OUTER GUARD
- NIGHT - HAWK..... IN CHARGE OF CANDIDATES
- KLOKANN BOARD..... THREE-MEMBERS WHO ACT AS BOARD OF ADVISORS, INVESTIGATORS, AND AUDITORS.

**EXALTED
CYCLOPS
AND HIS
TERRORS**

[COMMITTEE EXHIBIT No. 7]

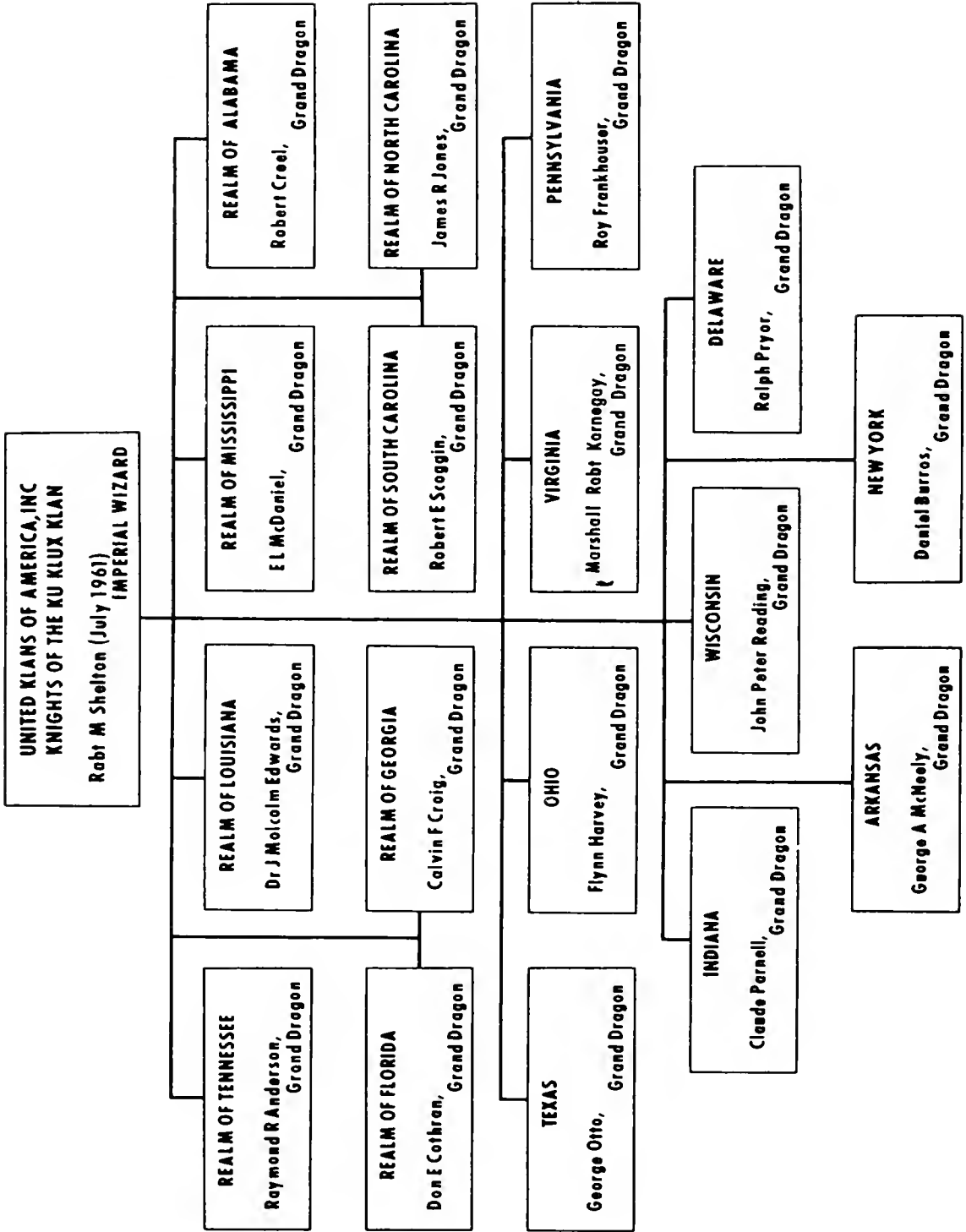

headed by Grand Dragon Craig; the Realm of South Carolina headed by Grand Dragon Scoggin; the Realm of North Carolina headed by Grand Dragon Jones.

In Ohio we have designated the leader in the State, Mr. Harvey; in Texas it is Mr. Otto; in Virginia, Mr. Kornegay, who, until being designated Grand Dragon of Virginia, was a paid employee of the Klan in North Carolina; in Pennsylvania, Mr. Frankhouser; in Indiana, Claude Parnell; in Wisconsin, John Peter Reading; in Delaware, Ralph Pryor; in Arkansas, George A. McNeely; and in New York, Daniel Burros.

Mr. Chairman, for investigative purposes, we have divided the Klan organizations into basically three divisions, the United Klans of America and a group of autonomous Klans formed within an association, and then a few Klan organizations which sit outside of either Mr. Shelton's Klan or the association.

I would now like to show those Klans within the National Association.

(Chart of National Association of the Knights of the Ku Klux Klans shown on slide. See Committee Exhibit No. 8, p. 1544.)

Mr. APPELL. This National Association is, as I said, an informal sort of arrangement under the chairmanship of James R. Venable, of Georgia. They meet roughly three times a year. Their purpose in meeting is to discuss common problems among the Klans within the association.

There is the Dixie Klans, Inc., Knights of the Ku Klux Klan. We have Mr. Jack W. Brown heading it. It is our investigative understanding that he has died within the past several days.

The Improved Order of U.S. Klans, with Earl E. George; the Original Knights of the Ku Klux Klan, with Murry H. Martin.

You will note that the Dixie Klans, Inc., has Klaverns in Tennessee, Georgia, and Alabama. The Improved Order of U.S. Klans has Klaverns in Alabama and Florida.

Then we deal with the National Knights of the Ku Klux Klan, Inc., which is an autonomous Klan group, and also under the leadership of Mr. Venable. This organization has Klaverns in Louisiana, Georgia, North Carolina, and Alabama.

Then there is the Association of South Carolina Klans, comprised solely within the jurisdiction of South Carolina.

Then the U.S. Klans, Knights of the Ku Klux Klan, Inc., out of which the big Klan of Mr. Shelton's grew, and it is under the leadership of Mr. H. J. Jones; the Association of Georgia Klans, under Charles Maddox; and the United Florida Ku Klux Klan under Jason E. Kersey.

The next, Mr. Chairman, are Klan groups which we establish as independent Klan organizations.

[COMMITTEE EXHIBIT No. 8]

**NATIONAL ASSOCIATION
KNIGHTS OF THE KU KLUX KLANS
JAMES R. VENABLE, CHAIRMAN**

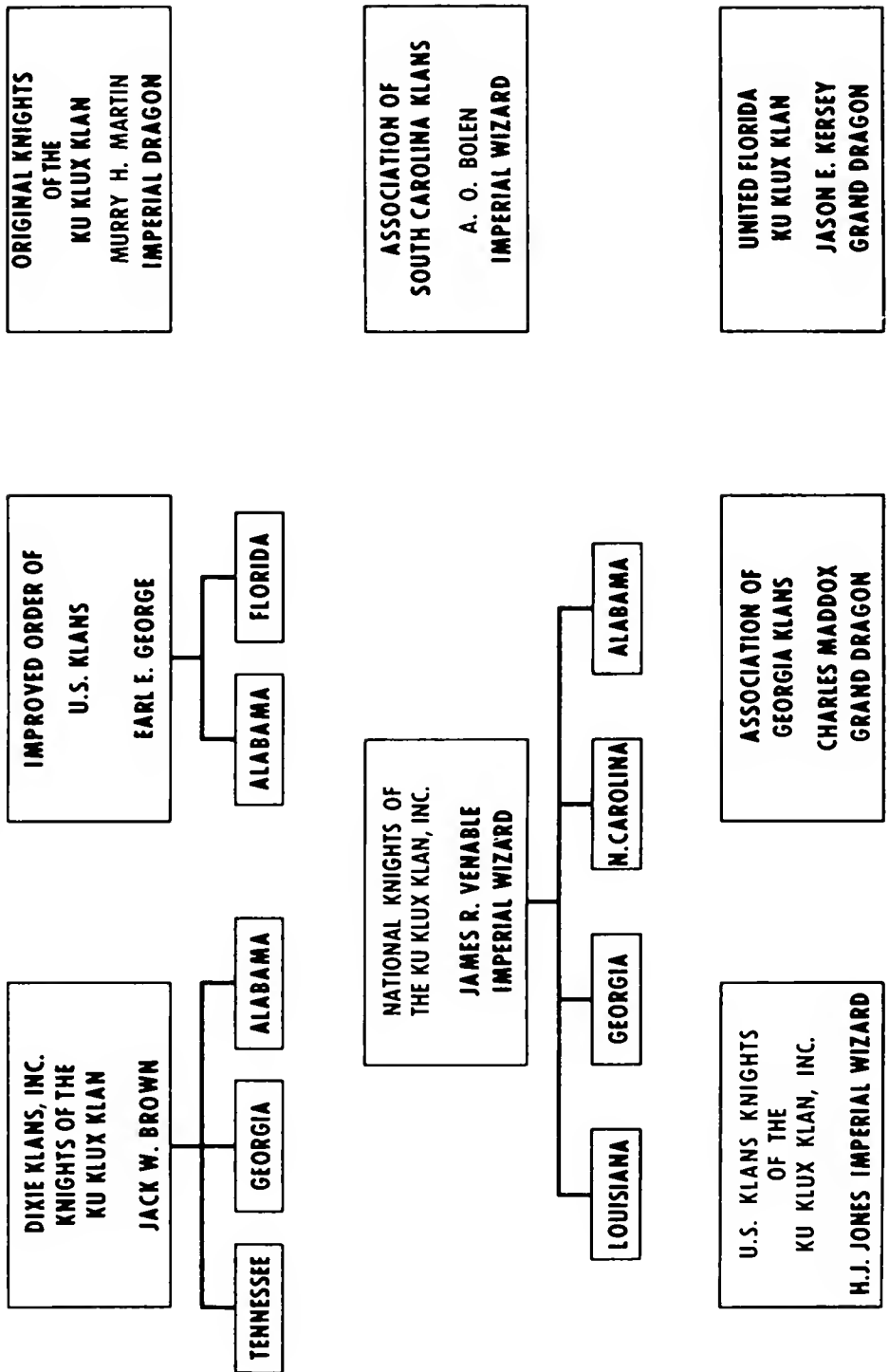

(A slide of the following was shown:)

[Committee Exhibit No. 9]

Independent Klan Organizations

1. White Knights of the Ku Klux Klan (Mississippi).
2. Anti-Communist Christian Association (Louisiana) formerly the Original Knights of the Ku Klux Klan.
3. Association of Arkansas Klans.
4. Militant Knights of the Ku Klux Klan (Florida).
5. Mississippi Knights of the Ku Klux Klan.

Mr. APPELL. Membershipwise, they range from a very important Klan in Mississippi known as the White Knights of the Ku Klux Klan of Mississippi, down to a one-man Klan organization that I will point out as we uncover this list.

In the order of their importance, the White Knights of the Ku Klux Klan of Mississippi; the Anti-Communist Christian Association is next. This was formerly a part of the Original Knights of the Ku Klux Klan. They are confined mainly within the Sixth Congressional District of Louisiana, which is the Bogalusa area as the predominant point.

The third is the Association of Arkansas Klans, very small.

Fourth is the Militant Knights of the Ku Klux Klan, a Florida group which has started an organization effort within the last 3 months; and the Mississippi Knights of the Ku Klux Klan, which, according to the best of our information, is comprised solely of its top officer.

Mr. Chairman, this concludes my part of the presentation, and I would like to have you call as the next witness Mr. Philip Manuel, a member of the investigative staff, who will deal with a breakdown of these Klans by States in order to show the location and what our investigation established as far as Klaverns or clubs are concerned.

The CHAIRMAN. That will be done.

Will you raise your right hand?

You do solemnly swear that the testimony you are about to give will be the truth, the whole truth, and nothing but the truth, so help you God?

Mr. MANUEL. Yes, sir.

TESTIMONY OF PHILIP R. MANUEL

Mr. MANUEL. Mr. Chairman, the exhibits which I am about to show are a compilation of all Klaverns which the committee investigation has determined were in existence in the years 1964 and 1965 to the present time.

I want to emphasize that, in some cases, some Klaverns which existed for part or all of 1964 may not be in existence today. The committee investigation has shown that, by the nature of the various Klan organizations, Klaverns are both established and dissolved in a relatively short time and the secrecy under which the Klan groups operate makes their detection very difficult.

Therefore, these exhibits are intended to show the concentration by county of Klaverns of the various Klan groups which are known to have been in existence for the period January 1964 to the present time.

I wish to emphasize that the investigative staff is not claiming that these are the only Klaverns which exist, or have existed, for the period January 1964 to the present. There is a possibility that other Klaverns exist, or have existed, of which the staff has no knowledge.

I also wish to point out that additional information is still being collected which may possibly enlarge the committee's knowledge in this matter. An additional exhibit I will display after the State maps will give a listing of the county, city, or town in which the particular Klavern is located, plus the cover name by which the Klavern is known.

The committee investigation has revealed that some Klan groups, and in particular the United Klans of America, Inc., make extensive use of cover names when establishing bank accounts, for example, or post office boxes or making group reservations at some hotel or other business establishment.

Now, Mr. Chairman, I will proceed to show each individual State exhibit, starting with the State of Virginia.

The CHAIRMAN. Mr. Manuel, for the record, please describe your background as an investigator and how long you have been with the committee.

Your name, of course, is Philip Manuel.

Mr. MANUEL. Philip R. Manuel. I have been employed by the Committee on Un-American Activities since the 1st of January 1964. Prior to that date I was a special agent of the Counterintelligence Corps of the Department of the Army, in which capacity I served from 1960 until the date that I joined the staff of the committee.

The CHAIRMAN. Were you not in the CIA?

Mr. MANUEL. No, sir. It is commonly known as CIC, the Counterintelligence Corps of the United States Army, the Department of Defense.

Now I will proceed with the State of Virginia.

(Map of Virginia shown on the slide. See Committee Exhibit No. 10, p. 1547.)

Mr. MANUEL. You will see shown the State map of Virginia. The red dots on this map, Mr. Chairman, represent the Klaverns which the committee investigation has shown to exist in this State at the present time. I want to point out that until June of 1965 the State's Grand Dragon and principal offices were located in the area of Chesapeake, Virginia. Since June of 1965, a new Grand Dragon has been appointed whom Mr. Appell identified as Marshall Kornegay, and he has been active, the committee investigation shows, in this particular area, and the committee investigation has shown that three additional Klaverns have been established since he took over.

The identities of these Klaverns are as follows, as far as the county, city, and, where known, the Klavern name and designation.

[COMMITTEE EXHIBIT No. 10]

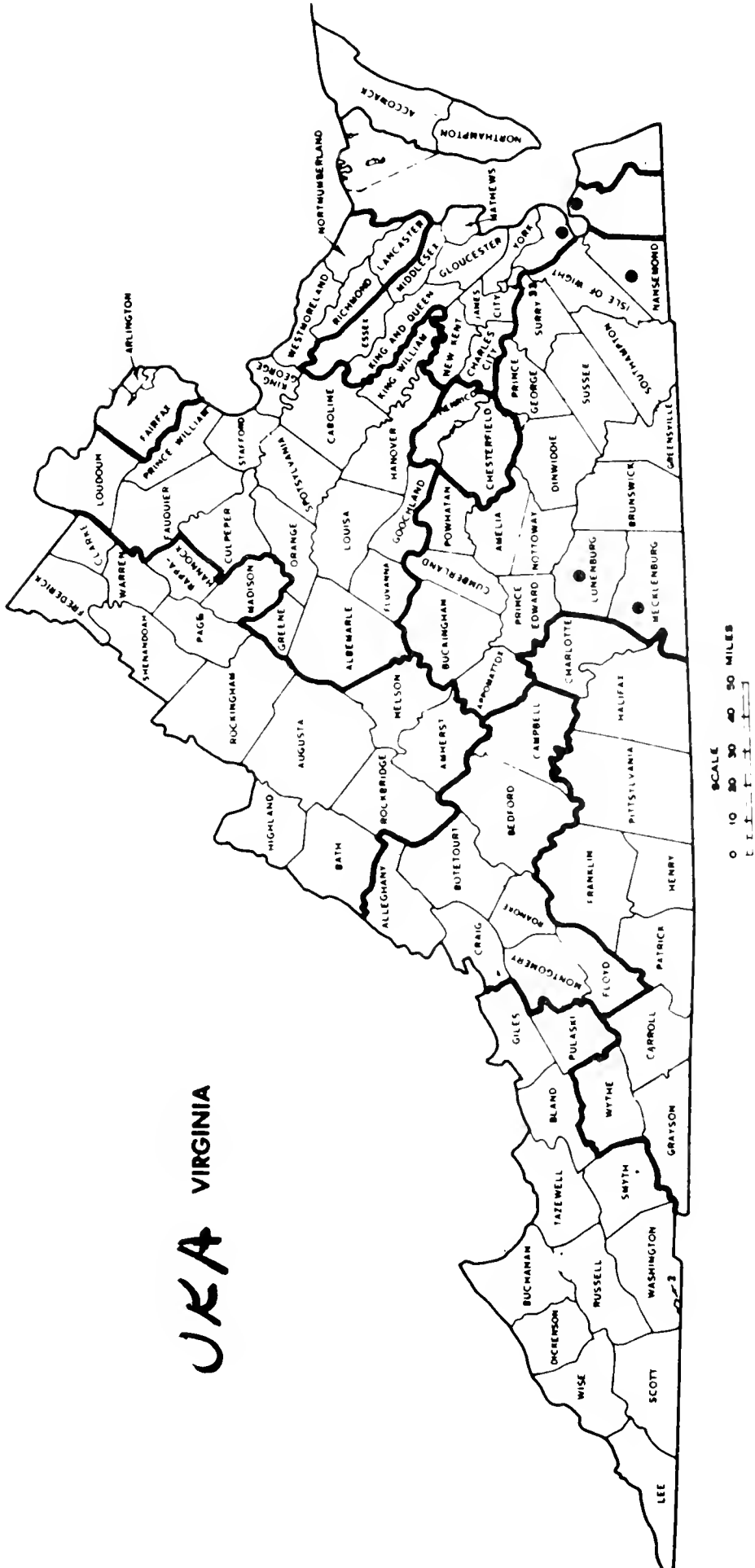

UKA VIRGINIA

I want to do this very briefly and as quickly as possible as each of these, Mr. Chairman, the staff hopes to enter into the record as exhibits.

The CHAIRMAN. We will do that after you finish. Proceed.

Let me say at this point that the exhibits identified by Mr. Appell will be received in evidence in the order in which they were presented by him, and the exhibits now being identified by Mr. Manuel will be received in evidence in the record in the order and at the points identified by Mr. Manuel.

(Chart of the Virginia Klaverns shown on slide. A list of these Klaverns follows:)

[Committee Exhibit No. 11]

State of Virginia—Klaverns of the United Klans of America, Inc.

County	City or Town	Klavern Name and Designation
Lunenburg.....	Victoria.....	
Mecklenburg.....	Chase City.....	Chase City Fellowship Club.
Nansemond.....	Holland.....	
Norfolk.....	Portsmouth.....	
Warwick.....	Newport News.....	Warwick Mens Club.

Mr. MANUEL. Next the committee staff would like to present its results of investigation as far as North Carolina is concerned.

Maps of North Carolina shown on slides. See Committee Exhibits Nos. 12 and 13, pp. 1549, 1550.)

Mr. MANUEL. I would like to point out that the dark black lines that you see on each of these maps are taken from the exact congressional districts at the start of the present Congress. That would be current as of January 1964. The significance of this is that, as Mr. Appell has stated—

The CHAIRMAN. 1965.

Mr. MANUEL. 1965. I am sorry.

As Mr. Appell has stated, the congressional districts are synonymous with the province breakdowns of the various Klan groups.

I will first represent by the red dots, which you will see on this overlay, the locations which the committee investigation has shown to exist at the present time covering the years 1964 and 1965 in the State of North Carolina.

The committee investigation has shown that we have a total of 112 Klaverns which the investigation has uncovered of the UKA in North Carolina (Exhibit No. 12). There is one additional Klavern located in Wilson County, North Carolina, represented by the green dot, and that signifies a Klavern of the National Knights of the Ku Klux Klan (Exhibit No. 13).

As an additional exhibit, I would like to display briefly the county, city and town, and Klavern name or designation, where known, for each of the Klaverns which were plotted on the map.

[COMMITTEE EXHIBIT No. 12]

NORTH CAROLINA

U/K A

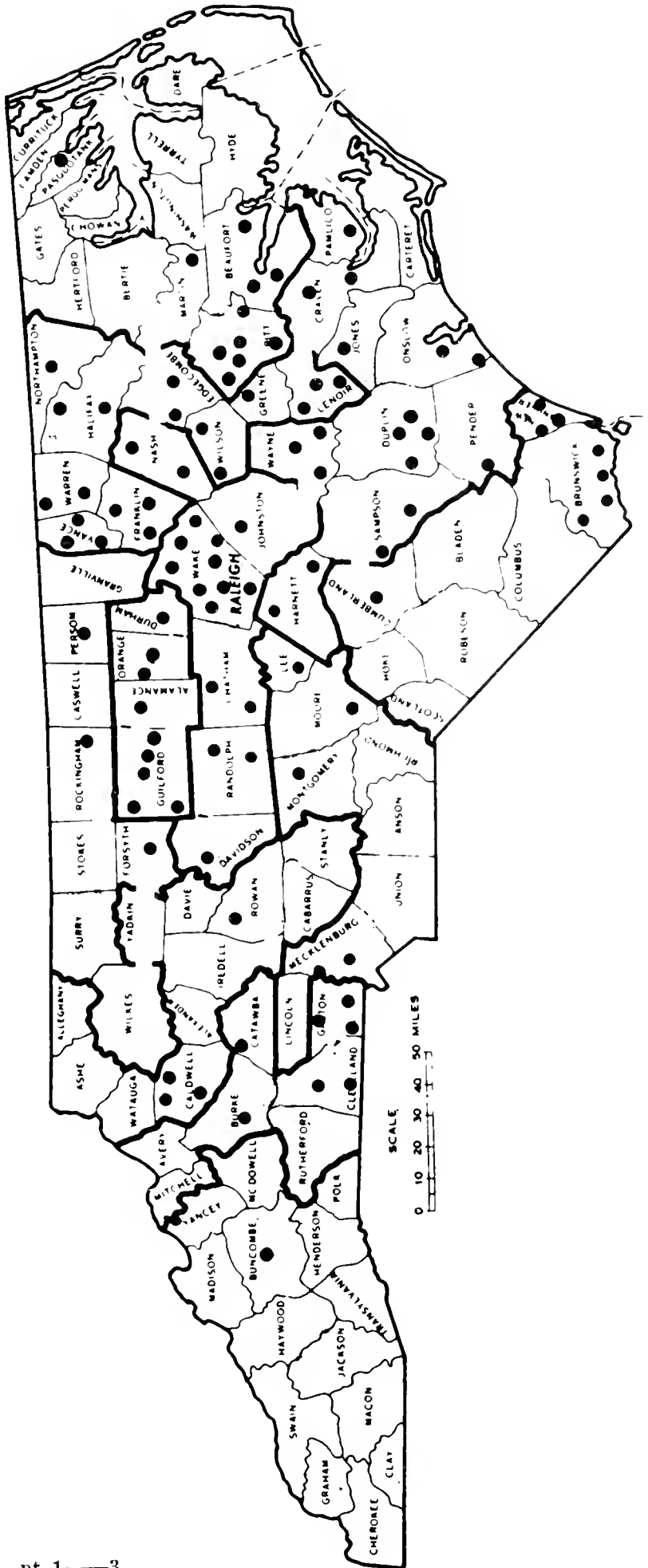

[COMMITTEE EXHIBIT No. 13]

NAT KNIGHT NORTH CAROLINA

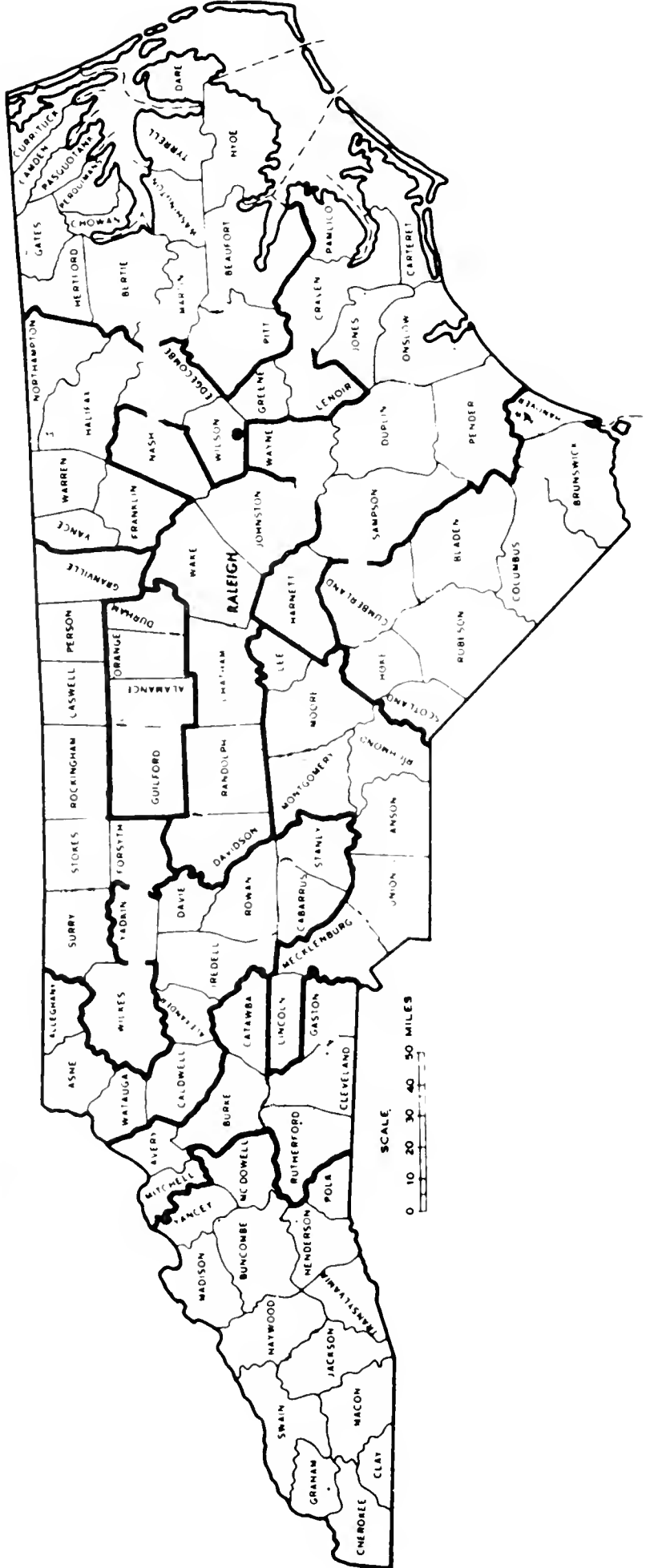

And the cover names that I spoke of previously you can see listed. (Charts of North Carolina Klaverns of United Klans of America, Inc., shown on slides. A list of these Klaverns follows:)

[Committee Exhibit No. 14]

State of North Carolina—Klaverns of the United Klans of America, Inc.

County	City or Town	Klavern Name and Designation
Alamance.....	Burlington.....	Unit No. 18, Ladies' Auxiliary of the KKK.
Beaufort.....	Washington.....	
	Blounts Creek.....	
Bladen.....	Pantego.....	Unit No. 81.
Brunswick.....	Supply.....	Klavern No. 28.
	Freeland.....	
	Shalotte.....	
	Bolivia.....	
Burke.....	Morganton.....	Burke County Improvement Society.
Caldwell.....	Lenoir.....	Chatham Citizens Club.
	Whitnel.....	
	Gamewell.....	
Chatham.....	Bynum.....	Chatham Citizens Club No. 19.
	Pittsboro.....	Central Carolina Ladies' League.
Cleveland.....	Goldston.....	Hunters Club.
	Shelby.....	Red Wood Lodge.
Columbus.....	Kings Mountain.....	Craven County Improvement Association; Craven County Ladies' Auxiliary No. 33.
	New Bern.....	
Craven.....	Vanceboro.....	Craven Fellowship Club.
Cumberland.....	Fayetteville.....	Cumberland County Patriots.
Catawba.....	Hickory.....	Catawba County Improvement Association.
Davidson.....	Lexington.....	Davidson County Sportsman Club.
Duplin.....	Rose Hill.....	Sportsman Club.
	Beulaville (2).....	Limestone Fishing Club No. 48.
	Wallace.....	Cape Fear Fishing Club.
Durham.....	Durham.....	Town and Country Sportsman Club No. 9; Friendly Circle No. 9.
Edgecombe.....	Rocky Mount.....	Tri-County Sportsman Club No. 24.
	Tarboro.....	Tarboro Klavern No. 43.
Franklin.....	Louisburg.....	Louisburg Klavern No. 29.
	Centerville.....	Bunn Saddle Club.
Forsyth.....	Bunn.....	
	Winston-Salem.....	Gaston County Sportsman Club No. 34.
Cherryville.....		
Gaston.....	Mount Holly.....	Greene County Improvement Association.
Granville.....	Bessemer City.....	
Greene.....	Snow Hill.....	Pinedale Saddle Club No. 10; Traveler's Club No. 10; Traveler's Auxiliary No. 10.
Guilford.....	Greensboro (3).....	
	High Point (2).....	Sophia Rebels Club No. 11; High Point Brotherhood Club No. 11.
Halifax.....	Roanoke Rapids.....	Roanoke Rapids Klavern No. 40.
	Enfield.....	Halifax County Ladies Club.
Harnett.....	Dunn.....	Harnett County Improvement Association No. 22.
	Angier.....	Black River Improvement Club.

State of North Carolina—Klaverns of the United Klans of America, Inc.—Con.

County	City or Town	Klavern Name and Designation
Iredell		
Johnston	Clayton	Ranch Gun Club.
Jones	Trenton	
Lee	Sanford	Lee County Improvement Association No. 23.
Lenoir	La Grange	Neuse Hunting Club; Trent Community Club; Lenoir Fellowship Club.
	Deep Run	
	Kinston (3)	
Martin	Williamston	Martin County Sportsman Club No. 4.
Mecklenburg	Charlotte	
Montgomery	Biscoe	Little River Club No. 27.
Moore	Southern Pines	211 Pointers Club.
New Hanover	Wilmington (2)	Ladies of Knights Circle; Pender County Improvement Association.
	East Wilmington	
Nash	Wrightsville Beach	Ladies of Knights Circle.
	Nashville	Nashville Klavern No. 51.
	Middlesex	
Northampton	Pleasant Hill	
Onslow	Holly Ridge	LaRose Fishing ACC Club.
Orange	Hillsboro	The Sportsman's Lakeside Lodge.
Pamlico	Stonewall	
Pasquotank	Elizabeth City	
Pender	Atkinson	Atkinson Klavern No. 26.
Person	Roxboro	Roxboro Fishing Club.
	Greenville (2)	Benevolent Association No. 53; Ogden Christian Fellowship Club No. 53.
	Winterville	Benevolent Association.
Pitt	Farmville	Pitt County Improvement Association No. 37.
	Ayden	Ayden Christian Fellowship Club.
	Fountain	
	Grifton	Grifton Christian Society.
Randolph	Sophia	Sophia Rebels Club.
	Asheboro	White Citizens of Randolph.
Robeson		
Rockingham	Reidsville	Fine Fellows Club.
Rowan	Salisbury	Rowan Sportsman's Club No. 1.
	Spencer	Rowan Sportsman's Club.
	Salemburg	Little Coharie Improvement Association.
Sampson	Clinton	The Enterprise Club No. 46.
Stanly		
Vance	Henderson (3)	Keystone Club No. 47; Family Improvement Club No. 47; Franklin County Improvement Association No. 47.
	Raleigh (3)	Capital City Restoration Association No. 41; Eastern Triangle Ladies League No. 6; Neuse Rescue Service No. 41.
	Wendell	Black River Improvement Club.
Wake	Apex	Apex Restoration Association.
	Knightdale	
	Zebulon	
	Neuse	
	Fuquay Springs	Willow Springs Restoration Service.

State of North Carolina—Klaverns of the United Klans of America, Inc.—Con.

County	City or Town	Klavern Name and Designation
Warren	Norlina (2)	Warren County Improvement Association No. 30; Warren Women's Improvement Association.
	Warrenton (2)	
Wayne	Goldsboro	Wayne County Improvement Association No. 38.
	Seven Springs	
	Mount Olive	
Wilson	Wilson	Wilson County Improvement Association No. 31.
	Lucama	Wilson County Improvement Association.

Mr. MANUEL. As I say, there were 112 Klaverns of the UKA which the committee found in the State of North Carolina, which is by far the most active State in terms of Klaverns and membership of the UKA.

The CHAIRMAN. This is still North Carolina?

Mr. MANUEL. Still North Carolina, Mr. Chairman.

The last one is the Klavern of the National Knights which was established very recently in Wilson County, North Carolina.

(Chart of North Carolina Klavern of National Knights of Ku Klux Klan, Inc., shown on slide. It is as follows:)

[Committee Exhibit No. 15]

State of North Carolina—Continued—National Knights of the Ku Klux Klan, Inc.

County	City or Town	Klavern Name and Designation
Wilson	Wilson	

Mr. MANUEL. The next State that I will cover is the State of Tennessee, where the committee investigation, first reviewing the Klaverns of the United Klans, has established some five Klaverns indicated on the map with the red dots.

In the State of Tennessee, located at Chattanooga, Tennessee, is the headquarters of a Klan organization identified previously by Mr. Appell. This is the headquarters of the Dixie Klans, Inc., Knights of the Ku Klux Klan.

(Maps of Tennessee shown on slides. See Committee Exhibits Nos. 16 and 17, pp. 1554, 1555.)

Mr. MANUEL. Here the Klaverns of the United Klans of America are listed by county, city, Klavern name as well as the Dixie Klans located in Hamilton County, in the city of Chattanooga, using the cover name sometime as the Old Hickory Club.

[COMMITTEE EXHIBIT No. 16]

TENNESSEE

U.K.A.

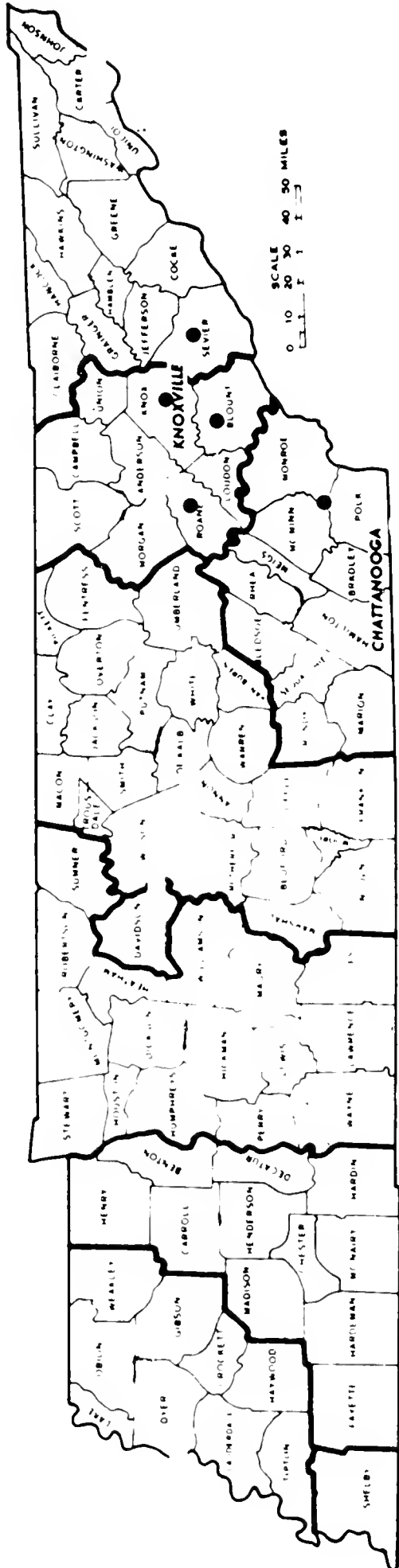

[COMMITTEE EXHIBIT No. 17]

Dixie TENNESSEE

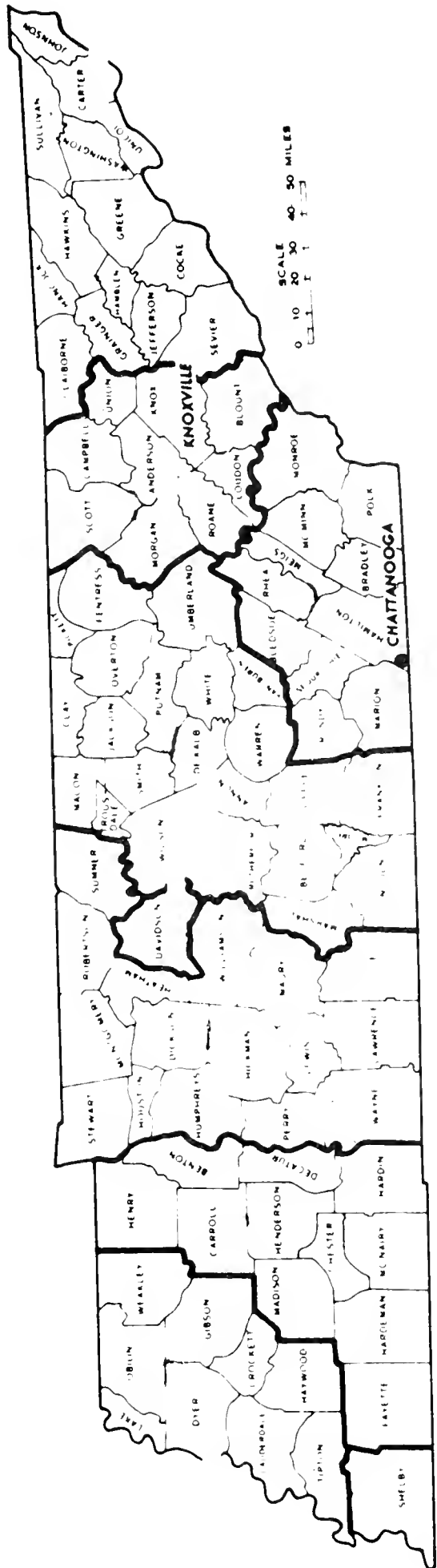

(Chart of the Tennessee Klaverns shown on slide. A list of these Klaverns follows:)

[Committee Exhibit No. 18]

State of Tennessee—Klaverns of the United Klans of America, Inc.

County	City or Town	Klavern Name and Designation
Blount.....	Maryville.....	Maryville Klavern No. 1.
Knox.....	Knoxville.....	Knoxville Klavern No. 3.
McMinn.....	Etowah.....	Etowah Klavern No. 4.
Roane.....	Harriman.....	Harriman Klavern No. 2.
Sevier.....	Sevierville.....	Sevierville Klavern No. 5.

State of Tennessee—Continued—Disc Klans, Inc.—Knights of the Ku Klux Klan

Hamilton.....	Chattanooga.....	Chattanooga Klavern No. 1; Also Known as Old Hickory Club.
---------------	------------------	--

MR. MANUEL. The next State is the State of South Carolina shown on the screen by this map.

(Maps of South Carolina shown on slides. See Committee Exhibits Nos. 19 and 20, pp. 1557, 1558.)

MR. MANUEL. First, the red dots will indicate the location and number of the Klaverns of the United Klans of America (Exhibit No. 19). And in the State of South Carolina there is another Klan organization in existence known as the Association of South Carolina Klans, whose Klaverns are shown by means of the purple dots (Exhibit No. 20), and their headquarters are located in West Columbia, South Carolina.

Again, here is the listing of the Klaverns of the United Klans of America in South Carolina, listed by county, city, or town. And where we know the identity, also is listed the cover name of the organization.

[COMMITTEE EXHIBIT No. 19]

UKA SOUTH CAROLINA

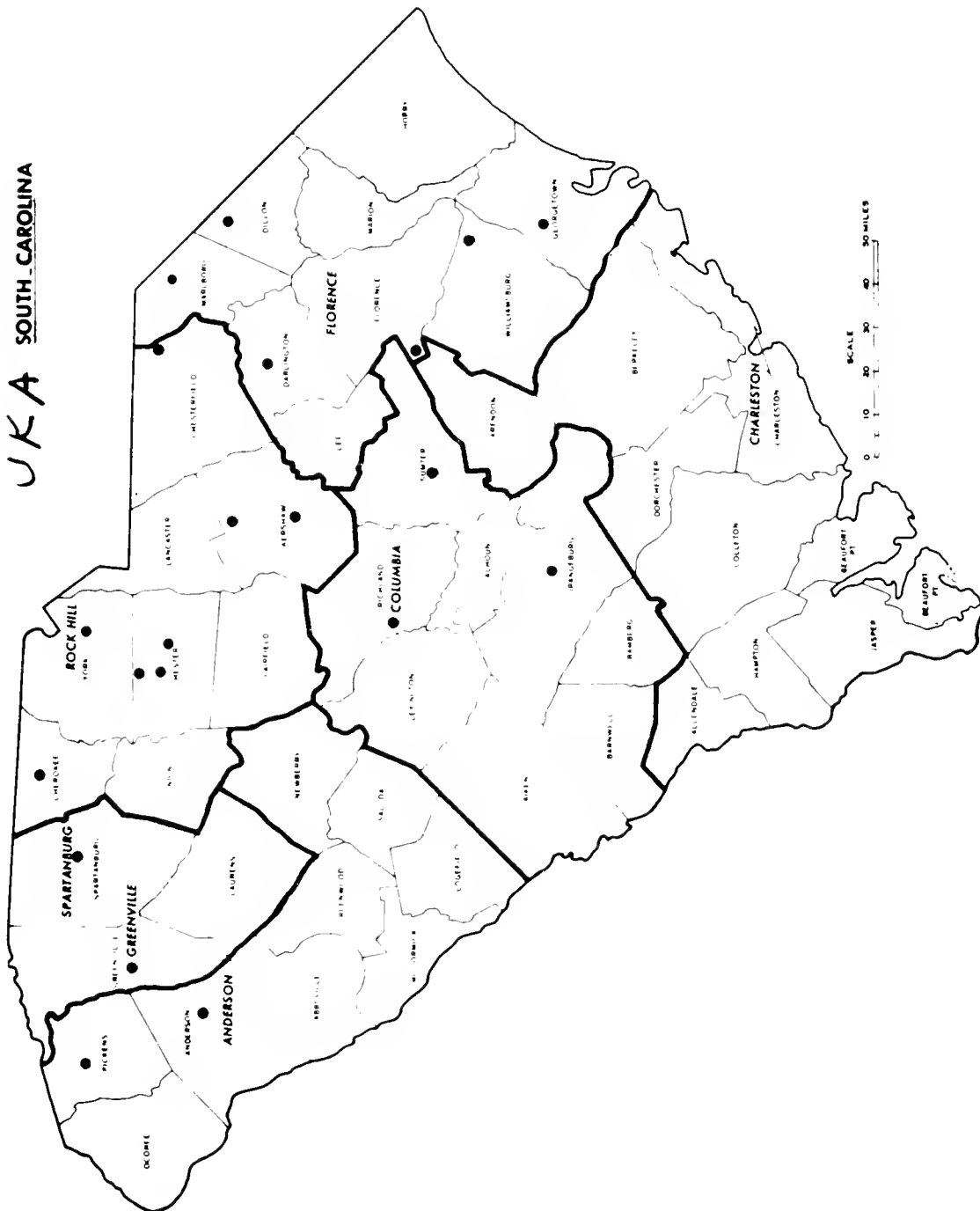

[COMMITTEE EXHIBIT No. 20]

ASSOC SOUTH-CAROLINA KLANs

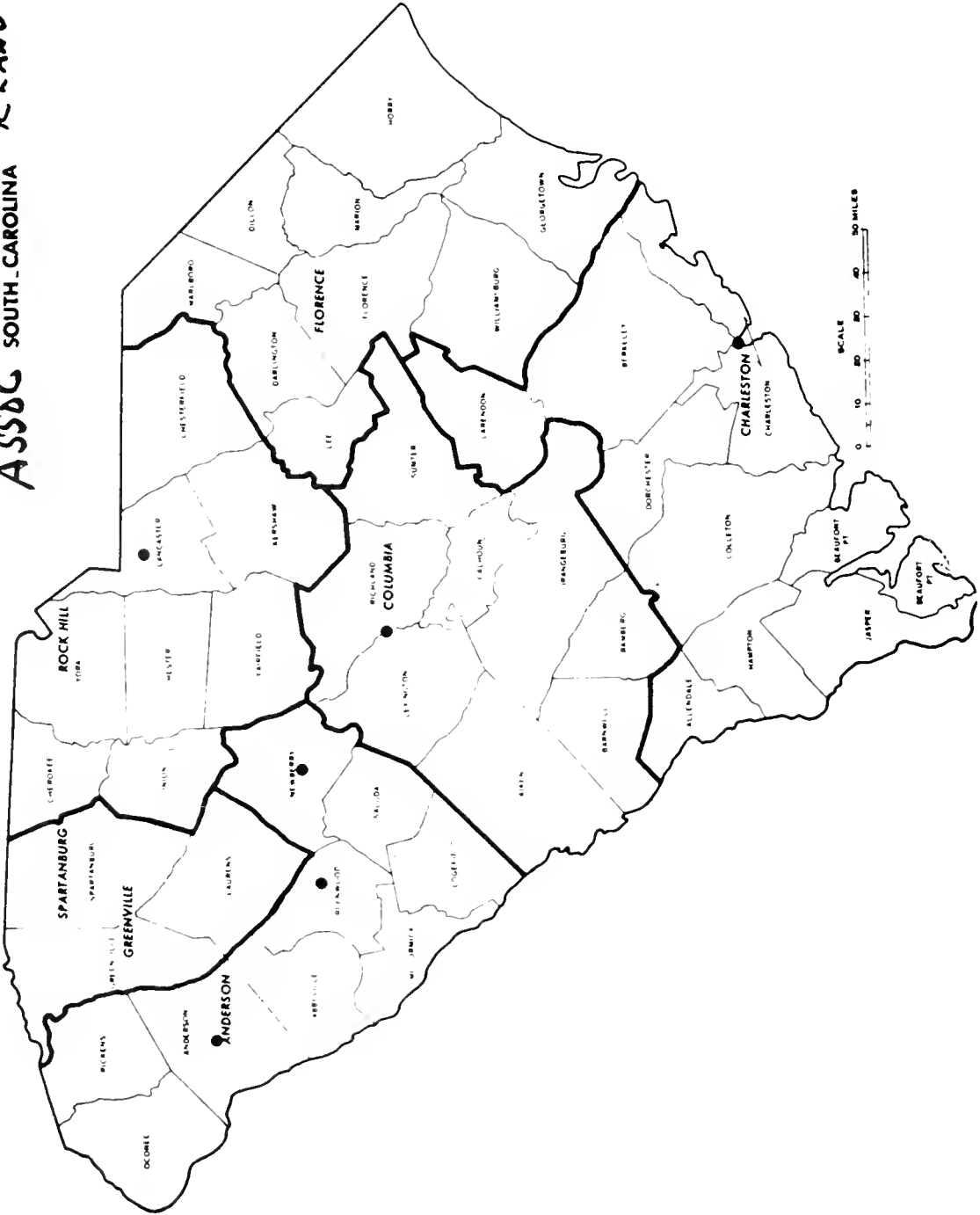

(Chart of South Carolina Klaverns of UKA shown on slide. A list of these Klaverns follows:)

[Committee Exhibit No. 21]

State of South Carolina—Klaverns of the United Klans of America, Inc.

County	City or Town	Klavern Name and Designation
Spartanburg	Spartanburg	Spartanburg Klavern No. 21.
Greenville	Greenville	Wade Hampton Kalvern No. 1.
Anderson	Anderson	
Pickens	Pickens	Sportsmans Club No. 4.
Cherokee	Gaffney	Cherokee Sportsmans Club.
Sumter	Sumter	Sumter Sportsmans Club No. 10.
Richland	Columbia	Capital City Sportsmans Club.
Orangeburg	Orangeburg	Garden City Club.
Georgetown	Andrews	Santee Sportsmans Club.
Williamsburg	Hemingway	Hemingway Sportsmans Club.
Dillon	Dillon	Odd Brothers Club.
Marlboro	Bennettsville	Red River Club No. 19.
Chesterfield	Cheraw	Chesterfield County Sportsmans Club.
Darlington	Hartsville	Hartsville Sportsmans Club No. 24.
York	Rock Hill	
Kershaw	{ Camden	Friendship Club.
	{ Kershaw	
Chester	{ Lowrys	
	{ Fort Lawn	
	{ Chester	

MR. MANUEL. Here listed is the location by county, city, and cover name of the Association of South Carolina Klans, whose headquarters are in West Columbia, South Carolina.

(Chart of Klaverns of Association of South Carolina Klans shown on slide. The list follows:)

[Committee Exhibit No. 22]

State of South Carolina—Continued—Association of South Carolina Klans

County	City or Town	Klavern Name and Designation
Charleston	Charleston	Charleston Klavern No. 794.
Lexington	West Columbia	West Columbia Klavern No. 335; Also Known as West Columbia Club; Also Known as Majority Citizens League.
Lancaster	Lancaster (2)	Lancaster Klavern No. 252; Camp Creek Club.
Newberry	Newberry	Newberry Klavern No. 790
Greenwood	Ninety Six	Klavern No. 96.
Anderson	{ Anderson	Anderson Klavern No. 694.
	{ Williamston	AKIA Club No. 14.

MR. MANUEL. The next State I will cover is the State of Georgia. (Maps of Georgia shown on slides. See Committee Exhibits Nos. 23 through 28, pp. 1560-1565.)

[COMMITTEE EXHIBIT No. 23]

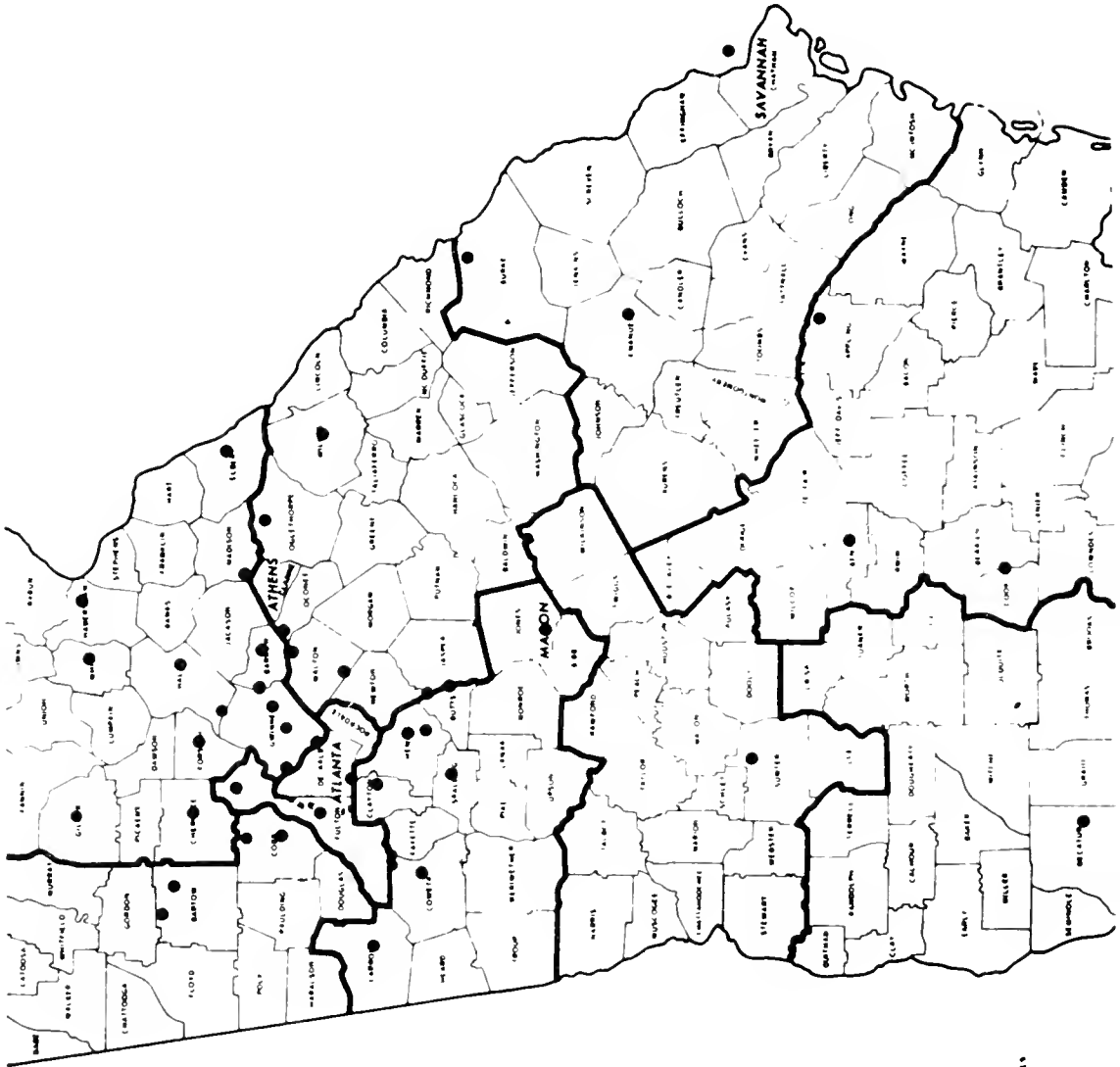

UKA
GEORGIA

SCALE
0 10 20 30 MILES

[COMMITTEE EXHIBIT No. 24]

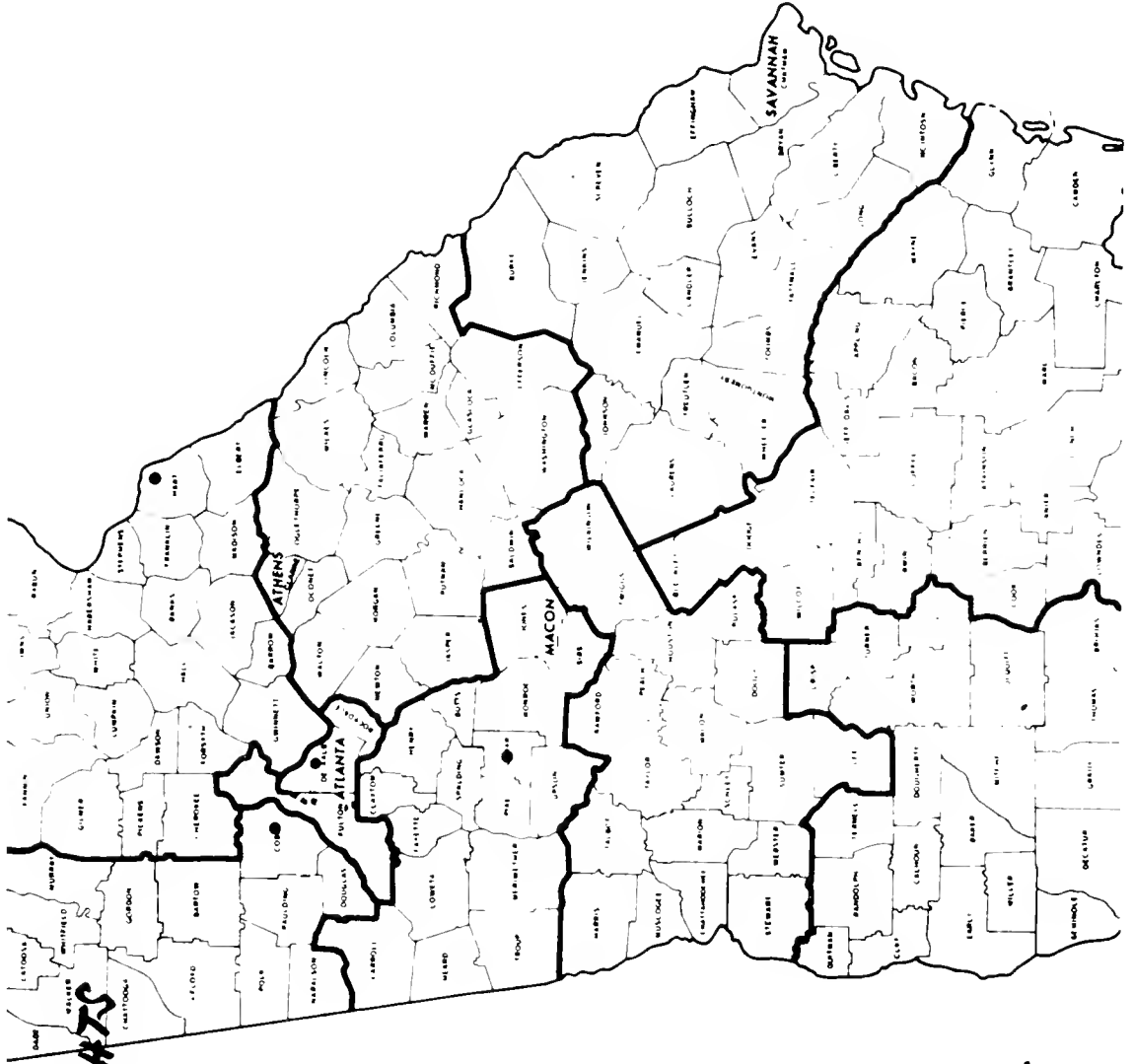

NAT. KNIGHTS
GEORGIA

SCALE 0 10 20 MILES

[COMMITTEE EXHIBIT No. 25]

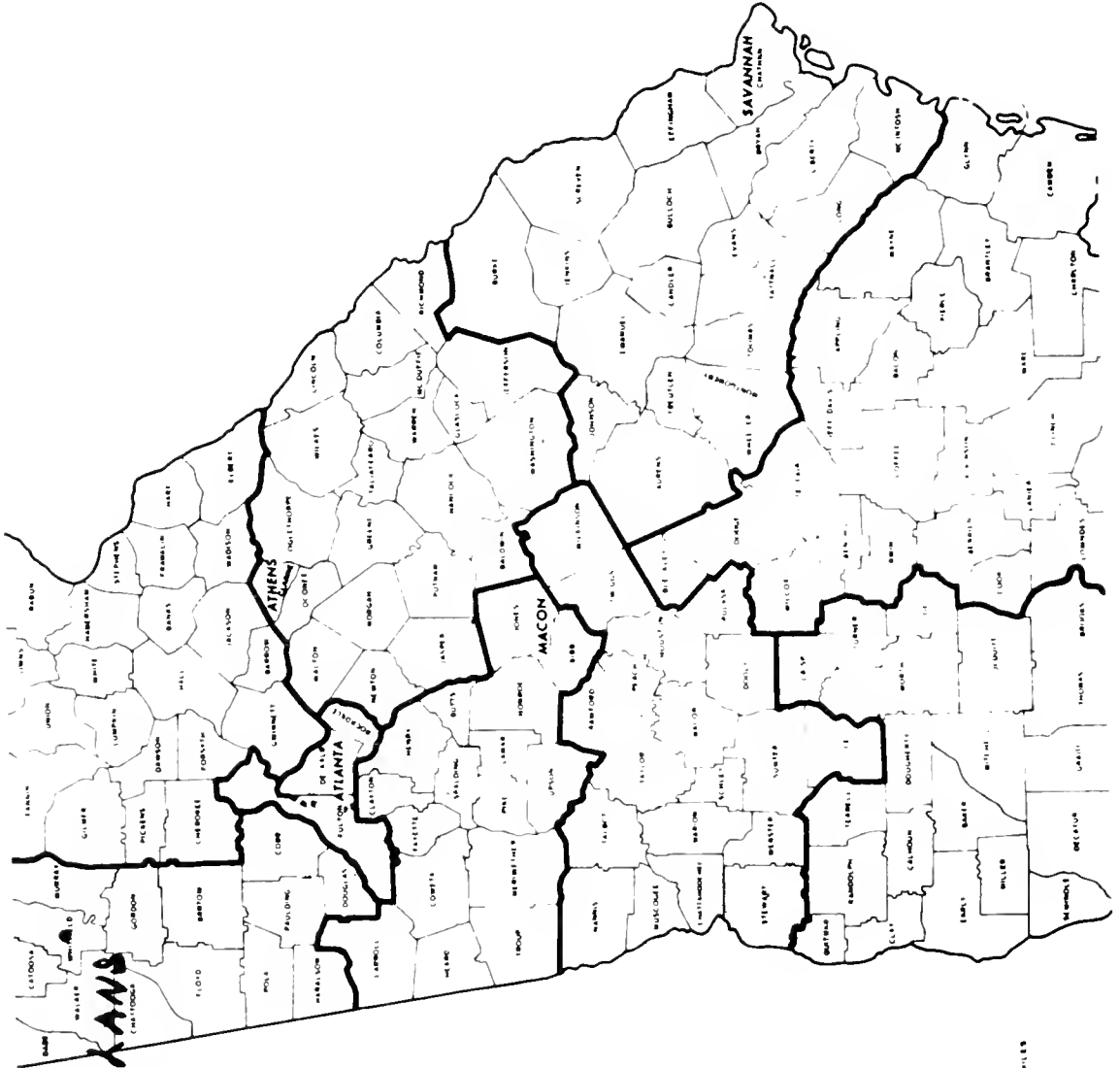

DIXIE
KANSAS
GEORGIA

SCALE 0 1 2 3 4 5 6 7 8 9 10 MILES

[COMMITTEE EXHIBIT No. 26]

IMP. ORDER
GEORGIA

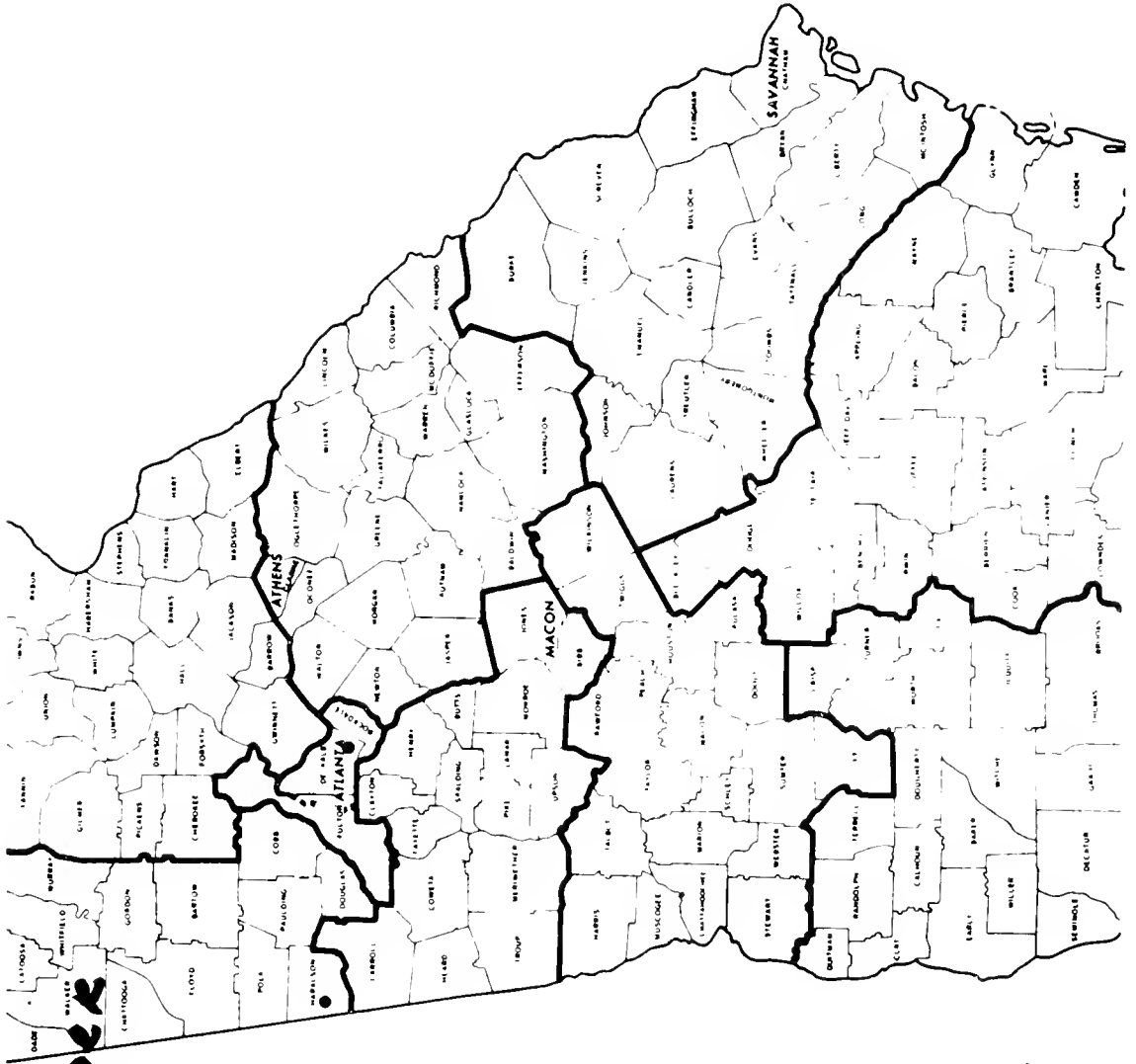

SCALE
0 10 20 30 40 50 MILES

[COMMITTEE EXHIBIT No. 27]

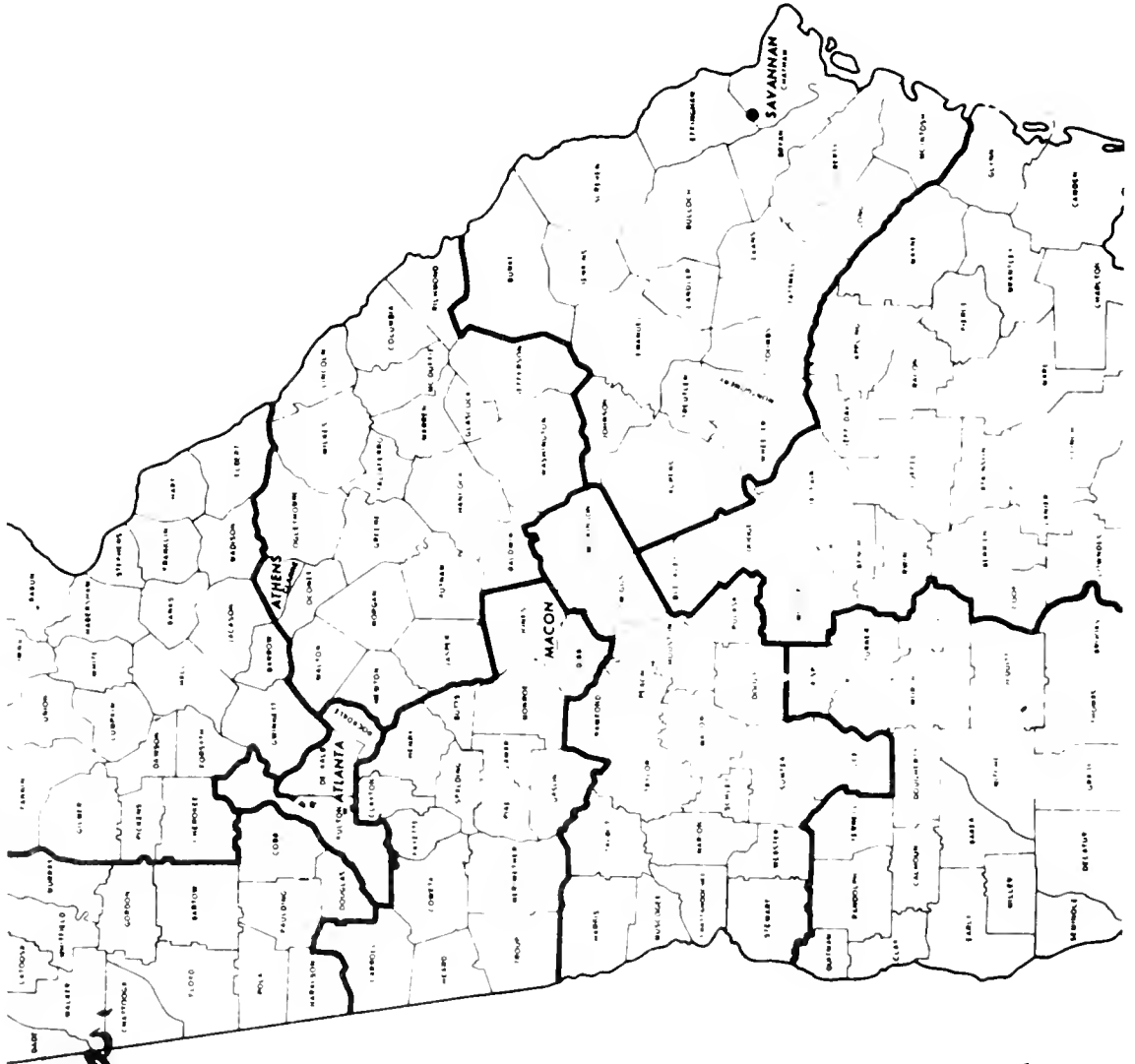

ASSOC
GA
GEORGIA

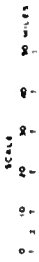

[COMMITTEE EXHIBIT No. 28]

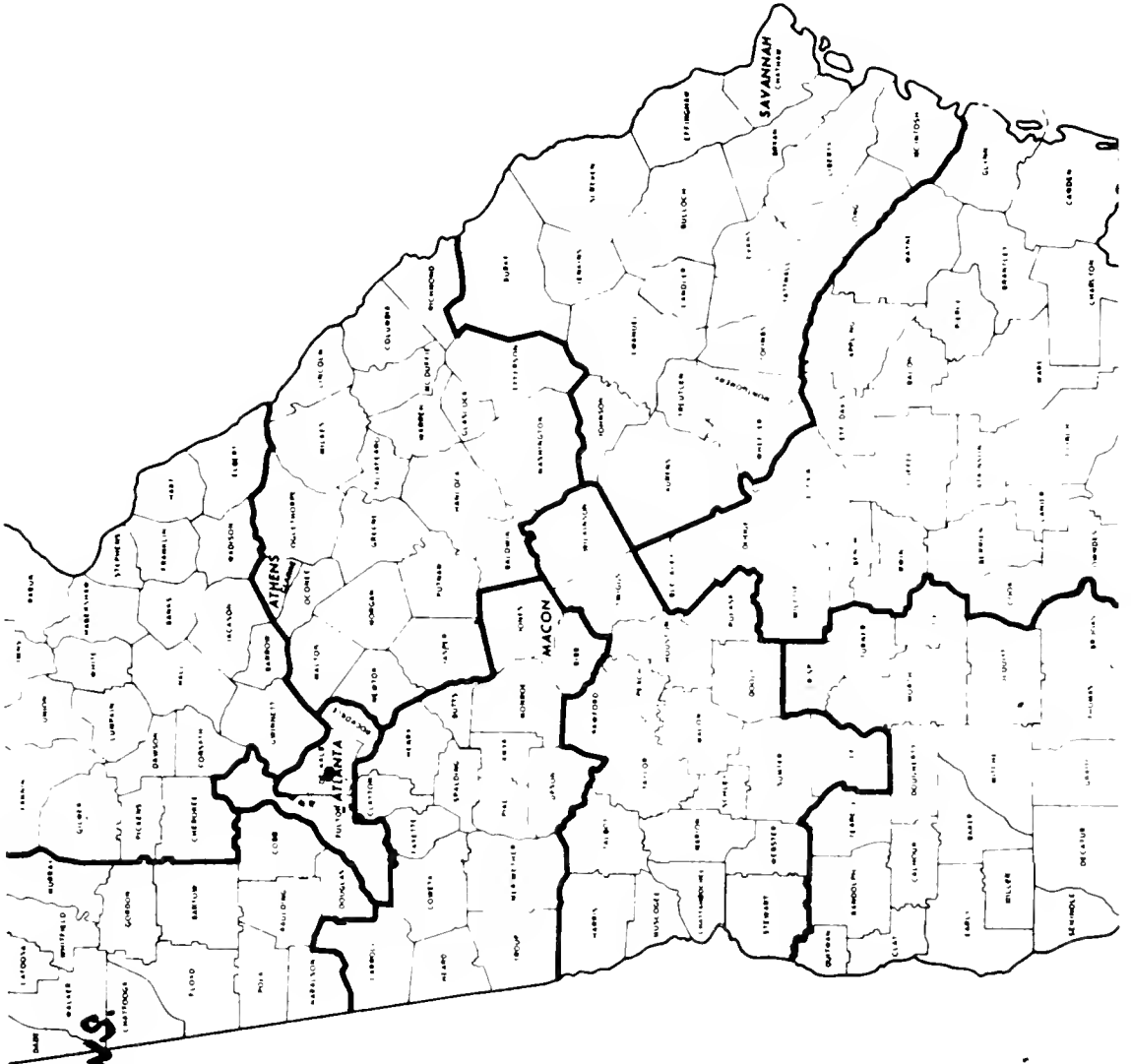

U. S. KLANNS.
GEORGIA

SCALE
0 10 20 30 40 50 MILES

MR. MANUEL. You will see on the screen a map of the State of Georgia. The first Klan group we will cover, again, is the United Klans of America (Exhibit No. 23). Each Klavern is shown by means of the red dots in the respective county in which the committee investigation has shown that these Klaverns exist.

Another Klan group in the State of Georgia is the National Knights of the Ku Klux Klan (Exhibit No. 24) headed by James Venable, whom Mr. Appell previously identified. Their headquarters are located in Tucker, Georgia, in DeKalb County.

The Dixie Klans (Exhibit No. 25), previously identified, has two Klaverns in the State of Georgia, and they exist as shown in these respective counties.

Another Klan group located in the State of Georgia is the Improved Order of U.S. Klans (Exhibit No. 26), whose headquarters is shown in Lithonia, Georgia, in DeKalb County.

Another Klan group in Georgia is located in Chatham County, outside of the city of Savannah, in a town called Bloomingdale, Georgia, and its name is the Association of Georgia Klans (Exhibit No. 27).

Also in Georgia, in Fulton County, in a city called College Park, there is a headquarters of a Klan group known as the U.S. Klans (Exhibit No. 28).

The listing of each Klan shown on the map is as follows.

First for the Klaverns of the United Klans of America, the county, city or town, and, where known, the cover name of each Klavern.

(Charts of Klaverns of the UKA of Georgia shown on slides. A list of these Klaverns follows:)

[Committee Exhibit No. 29]

State of Georgia—Klaverns of the United Klans of America, Inc.

County	City or Town	Klavern Name and Designation
Appling	Baxley	Altamaha Men's Club No. 72.
Decatur	Bainbridge	Flint River Men's Group No. 30.
Cook	Adel	
Ben Hill	Fitzgerald	Fitzgerald Klavern.
Sumter	Americus	
Chatham	Savannah	Savannah Klavern No. 41.
Emanuel	Swainsboro	Swainsboro Klavern No. 314.
Burke	Waynesboro	Waynesboro Klavern No. 310.
Bibb	Macon	Ghost Klavern No. 115.
Wilkes	Washington	Washington Klavern No. 301.
Oglethorpe	Crawford	Oglethorpe Klavern No. 244.
Elbert	Elberton	
Clarke	Athens	Clarke County Klavern No. 244.
Walton	{ Monroe	Douglas Klavern No. 714.
	{ Bold Spring	Vinegar Hill Klavern No. 53.
Butts	{ Jackson	Impala No. 42.
	{ Indian Springs	
Spalding	Griffin	Spalding County Klavern No. 25.
Henry	{ McDonough	Henry County Klavern No. 60.
	{ Locust Grove	Lakeview Men's Club.
Coweta	Newnan	
Newton	Covington	Rocky Plains Klavern No. 38.
Carroll	Carrollton	

State of Georgia—Klaverns of the United Klans of America, Inc.—Continued

County	City or Town	Klavern Name and Designation
Bartow	{ Adairsville	Wolf Den Klavern No. 411. Canton Klavern No. 70. Yukon Klavern No. 5. Straight Arrow No. 17.
Cherokee	{ White	
Gilmer	{ Canton	
Forsyth	{ Ellijay	
White	{ Cumming	
Habersham	{ Cleveland	
Hall	{ Clarkesville	
	{ Gainesville	
Gwinnett	{ Lawrenceville	
	{ Dacula	
	{ Lilburn	Lilburn Klavern No. 229.
De Kalb	{ Doraville	Fiery Cross Klavern No. 113.
	{ Lithonia	Kelly Haines Klavern No. 9.
	{ Atlanta	Confederate Klavern No. 2.
Clayton	{ Forest Park	Clayton Klavern No. 52.
	{ Jonesboro	Clayton Civic Club.
Cobb	{ Marietta	Joseph E. Johnston Club No. 61.
	{ Mableton	Old No. 66.
Fulton	{ Atlanta	Nathan Bedford Forrest Klavern No. 1.
	{ Roswell	Cherokee Klavern No. 92.

Mr. MANUEL. Here is a listing of the Klaverns in Georgia, by county and city, of the National Knights and of the Association of Georgia Klans, organizations I have previously identified.

(Chart of Georgia Klaverns of National Knights of KKK and Association of Georgia Klans shown on slide. A list of these Klaverns follows:)

[Committee Exhibit No. 30]

State of Georgia—Continued—National Knights of the Ku Klux Klan, Inc.

County	City or Town	Klavern Name and Designation
De Kalb	Tucker	
Cobb	Smyrna	
Lamar	Barnesville	
Hart	Hartwell	

Association of Georgia Klans

Chatham	Bloomington	
---------	-------------	--

Mr. MANUEL. Just recently, I might add, and these were included in the map which I have shown on the State of Georgia, there were some new additions of Klaverns that have been just recently established in that State—in Early, Oglethorpe, Seminole, Floyd, Thomas, and Bibb Counties, in the towns shown, with their Klavern name being shown.

(Chart of additional Klaverns of the UKA of Georgia shown on slide. A list of these Klaverns follows:)

[Committee Exhibit No. 31]

State of Georgia—Continued—New Additions—Klaverns of the United Klans of America, Inc.

County	City or Town	Klavern Name and Designation
Early.....	Blakely.....	Early Lodge No. 35.
Oglethorpe.....	(Rural Area).....	Tri-County Klavern No. 65.
Seminole.....	Seminole City.....	Donaldsville Klavern No. 3.
Floyd.....	Rome.....	
Thomas.....	Coolidge.....	
Bibb.....	Macon.....	Bibb County Klavern No. 115.

Mr. MANUEL. As previously identified, we have other Klan groups in the State of Georgia identified as the Improved Order of U.S. Klans, with headquarters in Lithonia; we have additional Klaverns of the Dixie Klans in the State of Georgia; and in the State of Georgia we have the headquarters of the U.S. Klans, Knights of the Ku Klux Klan, located in Fulton County, in College Park.

(Chart of Klaverns of other Klan groups in Georgia shown on slide. A list of these follows:)

[Committee Exhibit No. 32]

State of Georgia—Continued—Improved Order of U.S. Klans

County	City or Town	Klavern Name and Designation
De Kalb.....	Lithonia.....	
Haralson.....	Tallapoosa.....	

Dixie Klans, Inc.—Knights of the Ku Klux Klan

Whitfield.....	Dalton.....	
Murray.....	Chatsworth.....	

U.S. Klans, Knights of the Ku Klux Klan, Inc.

Fulton.....	College Park.....	
-------------	-------------------	--

Mr. MANUEL. The next State I would like to cover is the State of Florida. This is shown on the following maps.

(Maps of Florida shown on slides. See Committee Exhibits Nos. 33 through 36, pp. 1569-1572.)

[COMMITTEE EXHIBIT No. 33]

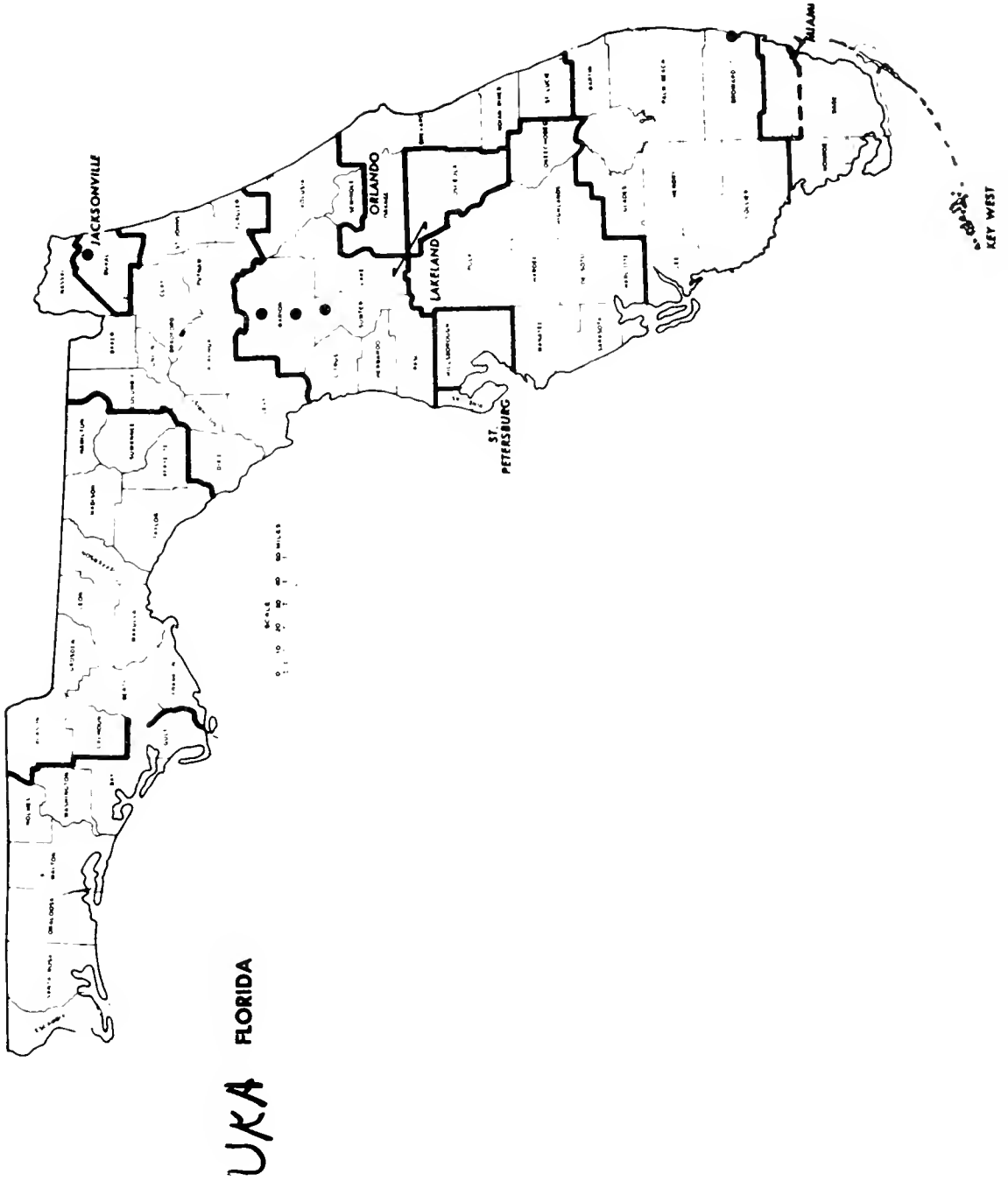

[COMMITTEE EXHIBIT No. 34]

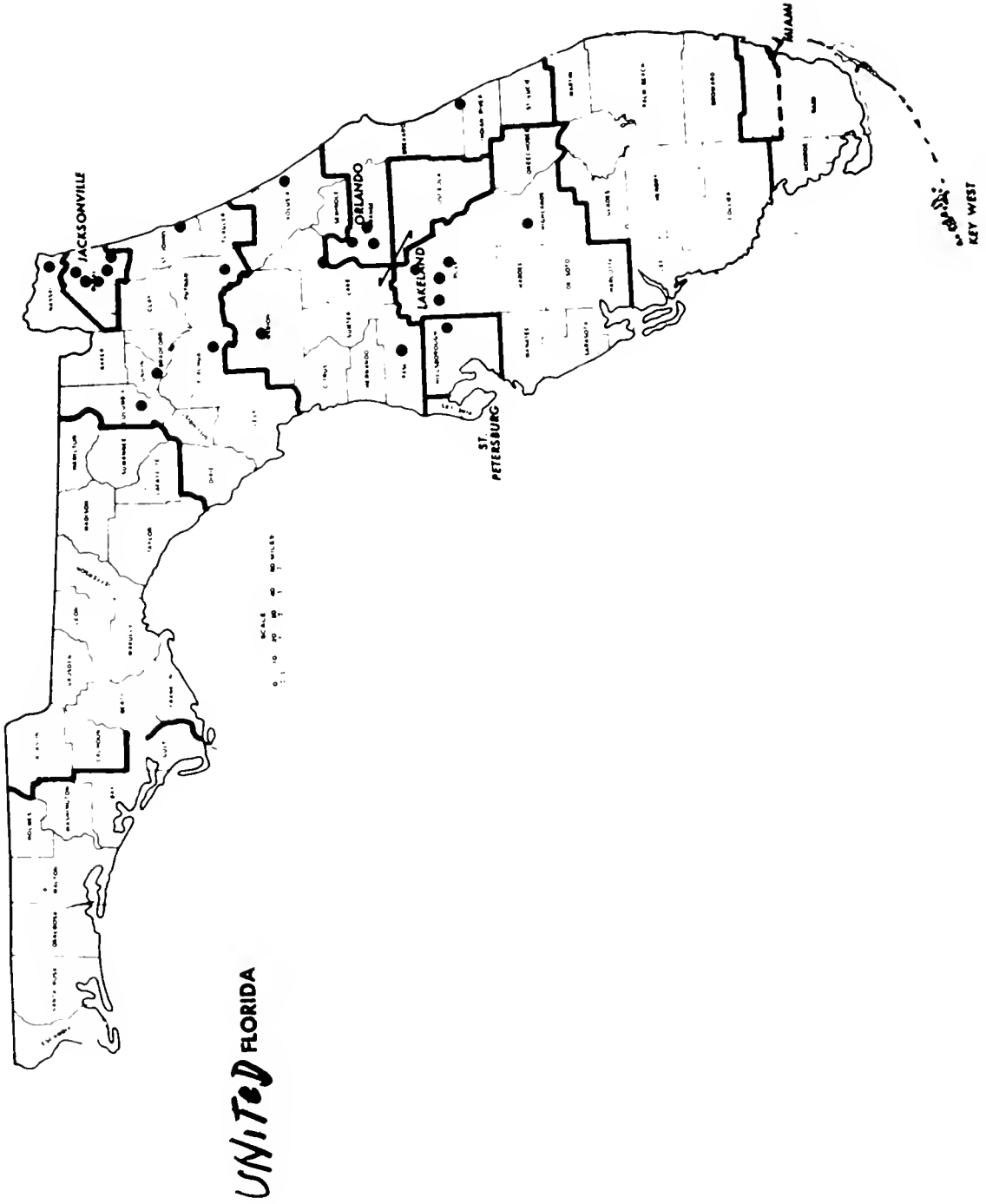

[COMMITTEE EXHIBIT No. 35]

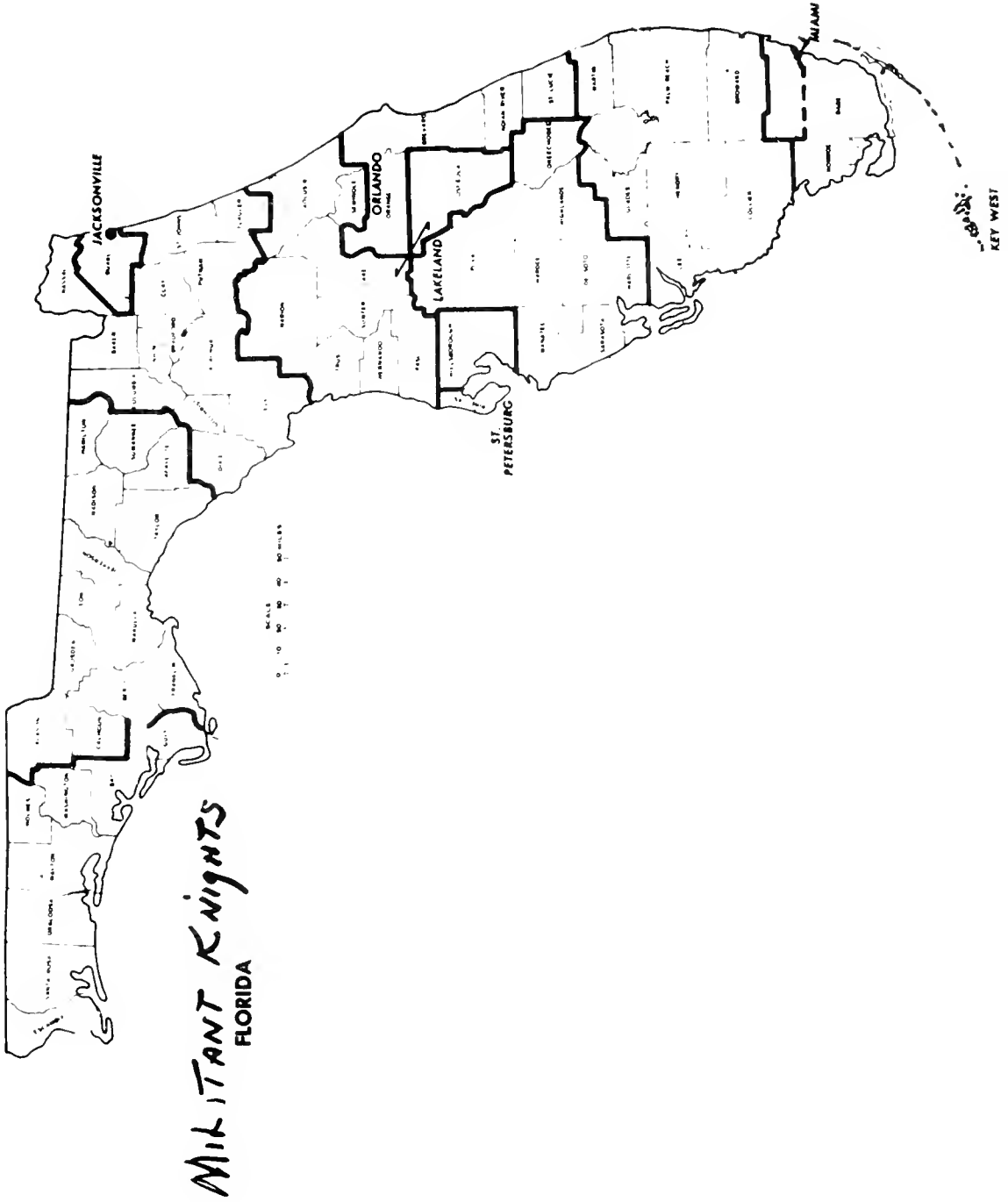

MILITANT KNIGHTS
FLORIDA

[COMMITTEE EXHIBIT No. 36]

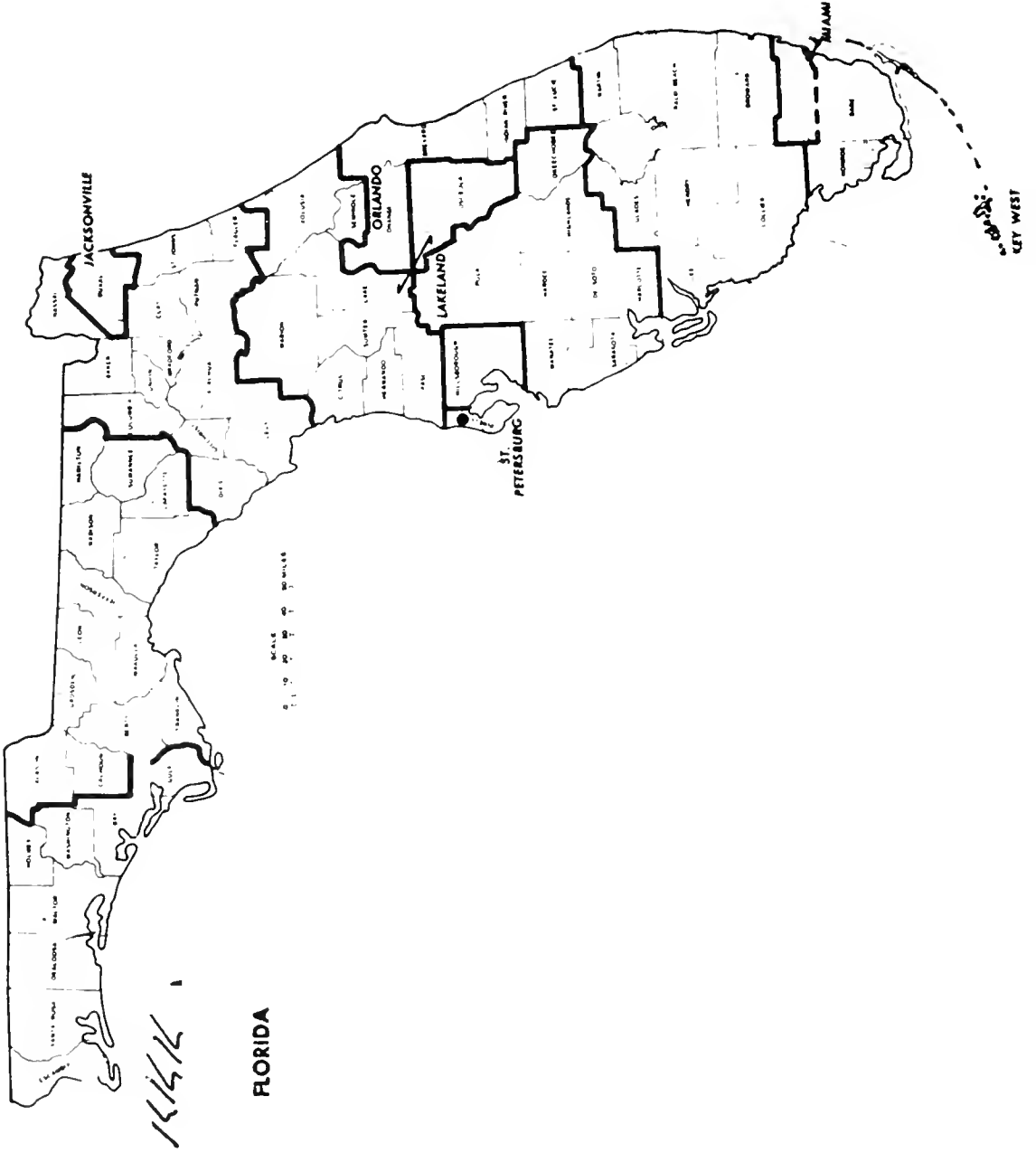

Mr. MANUEL. The committee investigation has revealed that the following Klaverns of the United Klans of America are in existence in the State of Florida. They are designated, again, by the red dots on the map inside the limits of the counties in which they are located (Exhibit No. 33).

In the State of Florida, in addition to the United Klans of America, there is a separate Klan group, previously identified by Mr. Appell, which is known as the United Florida Klans, a relatively active group. Its Klaverns are listed by county as you see on this particular map (Exhibit No. 34).

Also in the State of Florida, previously identified by Mr. Appell, is a separate Klan organization known as the Militant Knights of the Ku Klux Klan whose headquarters are in Jacksonville, Florida (Exhibit No. 35).

Also in the State of Florida, a separate and very small Klan group, which meets on an irregular basis, according to committee information, is located in the town of Oldsmar, Florida, in Pinellas County, and it is known as the Knights of the Ku Klux Klan (Exhibit No. 36).

A listing of each Klavern of the United Klans is as follows, showing the county in which it is located, the city or town, and the cover name or Klavern designation which it uses.

(Chart of Klaverns of the United Klans of America, Inc., of Florida shown on slide. A list of these Klaverns follows:)

[Committee Exhibit No. 37]

State of Florida—Klaverns of the United Klans of America, Inc.

County	City or Town	Klavern Name and Designation
Duval.....	Jacksonville.....	Jacksonville Klavern No. 2.
Marion.....	{ Belleview.....	Summerfield Fellowship Club.
	{ Ocala.....	
Sumter.....	Wildwood.....	Wildwood Sportsmans Club.
Broward.....	Fort Lauderdale.....	Broward Fellowship Club.
Dade.....	Miami.....	Dade County Klavern No. 6.

Mr. MANUEL. Following is a list of the Klaverns by county, city or town, et cetera, of the United Florida Klans, which were shown with the blue dots on the map.

As you can see, there are five separate Klaverns of this group in the area of Jacksonville, Florida.

(Chart of Klaverns of United Florida KKK shown on slide. A list of these Klaverns follows:)

[Committee Exhibit No. 38]

State of Florida—Continued—United Florida Ku Klux Klan

County	City or Town	Klavern Name and Designation
Nassau	Yulee	Nassau County Klavern No. 501.
Duval	Jacksonville (5)	Jacksonville Klavern No. 502; Also Known as Paul Revere Historical Society; Also Known as Duval Fellowship Club; Robert E. Lee Klavern No. 506; Robert E. Lee Klavern No. 508; Robert E. Lee Klavern No. 513; Robert E. Lee Klavern No. 520.
St. Johns	St. Augustine	St. Augustine Klavern No. 519; Also Known as Ancient City Gun Club.
Columbia	Lake City	Lake City Klavern.
Union	Lake Butler	
Alachua	Gainesville	Patriot Klavern.
Putnam	Palatka	
Marion	Ocala	Marion Klavern.
Volusia	Samsula	DeLand Sportsmans Club No. 8-1.
Lake	Mount Dora	
	Lakeland	Forrest Club No. 11, United Gun Club.
Polk	Auburndale	Auburndale Fisherman's Club.
	Haines City	Central Sportsmans Club No. 101.
	Lake Wales	Lake Wales Pioneer Club No. 5-4.

Mr. MANUEL. This is a continuation of the previous group, the United Florida Klans; the separate Klan group previously identified in Pinellas County; and the separate group of the Militant Knights located in Duval County, Florida.

(Chart of additional Klaverns of United Florida KKK and Klaverns of Knights of the KKK and Militant Knights of the KKK in Florida shown on slide. A list of these Klaverns follows:)

[Committee Exhibit No. 39]

State of Florida—Continued—United Florida Ku Klux Klan—Continued

County	City or Town	Klavern Name and Designation
Orange	Apopka	West Orange Sportsman's Lodge No. 7-3.
	Ocoee	Sherwood Club No. 7-2.
	Orlando	The 7-1 Club.
Hillsborough	Plant City	East Hillsborough Sportsman's Club.
Highlands	Sebring	Imperial Club No. 27-1.
Brevard	Melbourne	Melbourne Klavern.
Pasco	Dade City	Confederate Club No. 38.

Knights of the Ku Klux Klan

Pinellas	Oldsmar	
----------	---------	--

Militant Knights of the Ku Klux Klan

Duval	Jacksonville	Unit No. 1.
-------	--------------	-------------

Mr. MANUEL. That completes the listing of the Klaverns in the State of Florida.

The next State the committee staff would like to cover is that of Alabama.

(Maps of Alabama shown on slides. See Committee Exhibits Nos. 40 through 43, pp. 1576-1579.)

Mr. MANUEL. Again starting out with the United Klans of America, the committee investigation has revealed these Klaverns exist as shown on the map in the counties indicated.

Calling your attention to the city of Tuscaloosa, Alabama, this is the headquarters of the United Klans of America (Exhibit No. 40).

In Alabama also is a Klavern of the National Knights of the Ku Klux Klan (Exhibit No. 41).

The CHAIRMAN. That is not affiliated with the United Klans of America?

Mr. MANUEL. No, sir. It is a separate Klan group. This is a Klavern of the Improved Order of U.S. Klans, which the committee investigation has revealed was in existence in the period 1964 to the present, and they also have two other Klaverns in Bullock County (Exhibit No. 42).

Also in the State of Alabama, in Anniston, is a Klavern of the Dixie Klans, which I have previously identified as having its headquarters in Chattanooga, Tennessee (Exhibit No. 43).

This is a listing of the Klaverns of the United Klans of America, with county, city, and cover name.

[COMMITTEE EXHIBIT NO. 41]

NAT K. ALABAMA

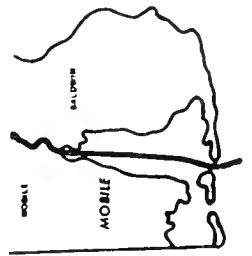
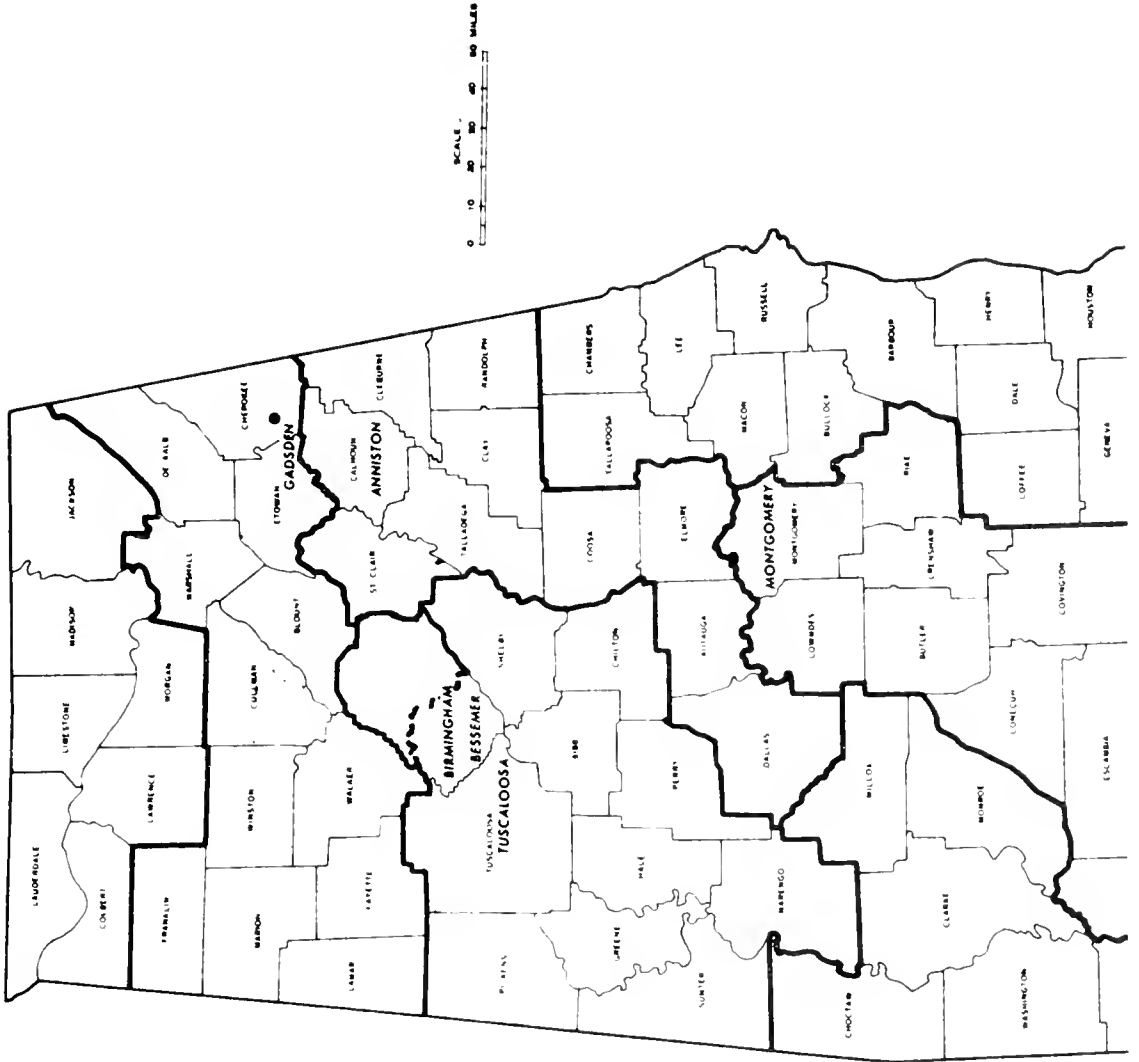

[COMMITTEE EXHIBIT No. 43]

DIXIE ALABAMA

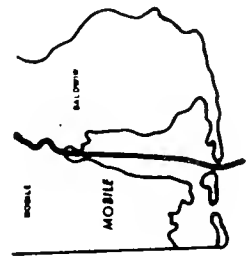
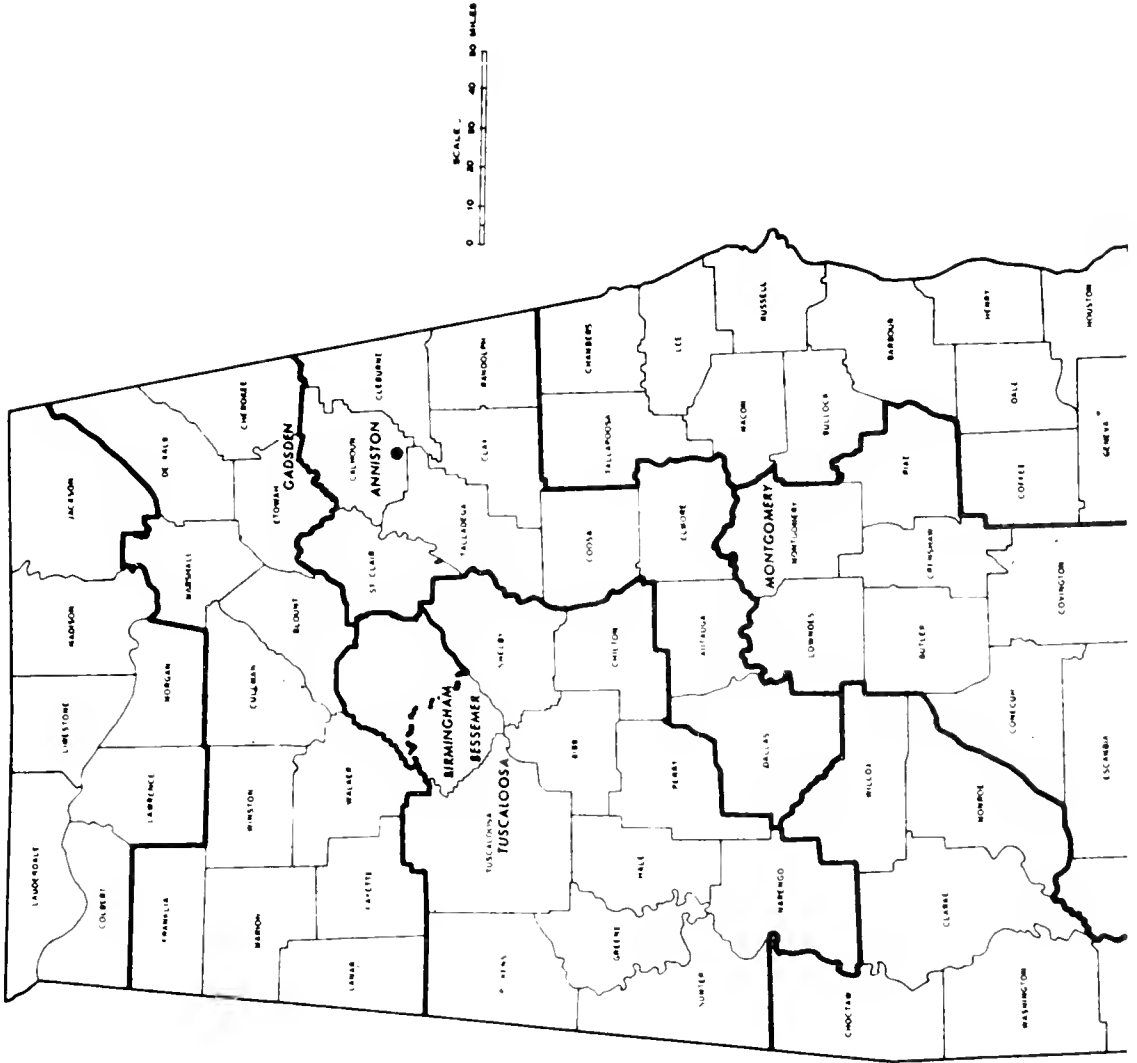

(Chart of UKA Klaverns in Alabama shown on slide. A list of the Klaverns follows:)

[Committee Exhibit No. 44]

State of Alabama—Klaverns of the United Klans of America, Inc.

County	City or Town	Klavern Name and Designation
Lawrence.....	Moulton.....	Fort Payne Klavern.
Morgan.....	Decatur.....	
De Kalb.....	Fort Payne.....	
Jefferson.....	{Warrior.....	Eastview Klavern No. 13. Bessemer Klavern No. 20; Also Known as Young Men's Social Club.
	{Birmingham.....	
	{Bessemer.....	
Tuscaloosa.....	Tuscaloosa.....	Tuscaloosa Klavern No. 5.
Marengo.....	{Linden.....	Clarke-Washington Hunting & Fish- ing Club.
	{Demopolis.....	
Butler.....	Greenville.....	
Clarke.....	Jackson.....	
Etowah.....	Gadsden.....	Lawrence Lodge No. 610; Confeder- ate Den No. 11.
Montgomery.....	Montgomery (2).....	

Mr. MANUEL. And the other Klan groups which are located in the State, the Improved Order, the county, city, and its cover name; the Dixie Klans; and the National Knights of the Ku Klux Klan.

(Chart of Klaverns of other Alabama Klan groups shown on slide. A list of these Klaverns follows:)

[Committee Exhibit No. 45]

State of Alabama—Continued—Improved Order of U.S. Klans

County	City or Town	Klavern Name and Designation
Perry.....	Heiberger.....	U.S. Klavern No. 33.
Bullock.....	Union Springs (2).....	

Dixie Klans, Inc.—Knights of the Ku Klux Klan

Calhoun.....	Anniston.....	
--------------	---------------	--

National Knights of the Ku Klux Klan, Inc.

Cherokee.....	Centre.....	
---------------	-------------	--

Mr. MANUEL. The next State the staff would like to cover is the State of Mississippi, shown as follows on these maps.

(Maps of Mississippi shown on slides. See Committee Exhibits Nos. 46 and 47, pp. 1581, 1582.)

[COMMITTEE EXHIBIT No. 47]

WHITE KNIGHTS
MISSISSIPPI

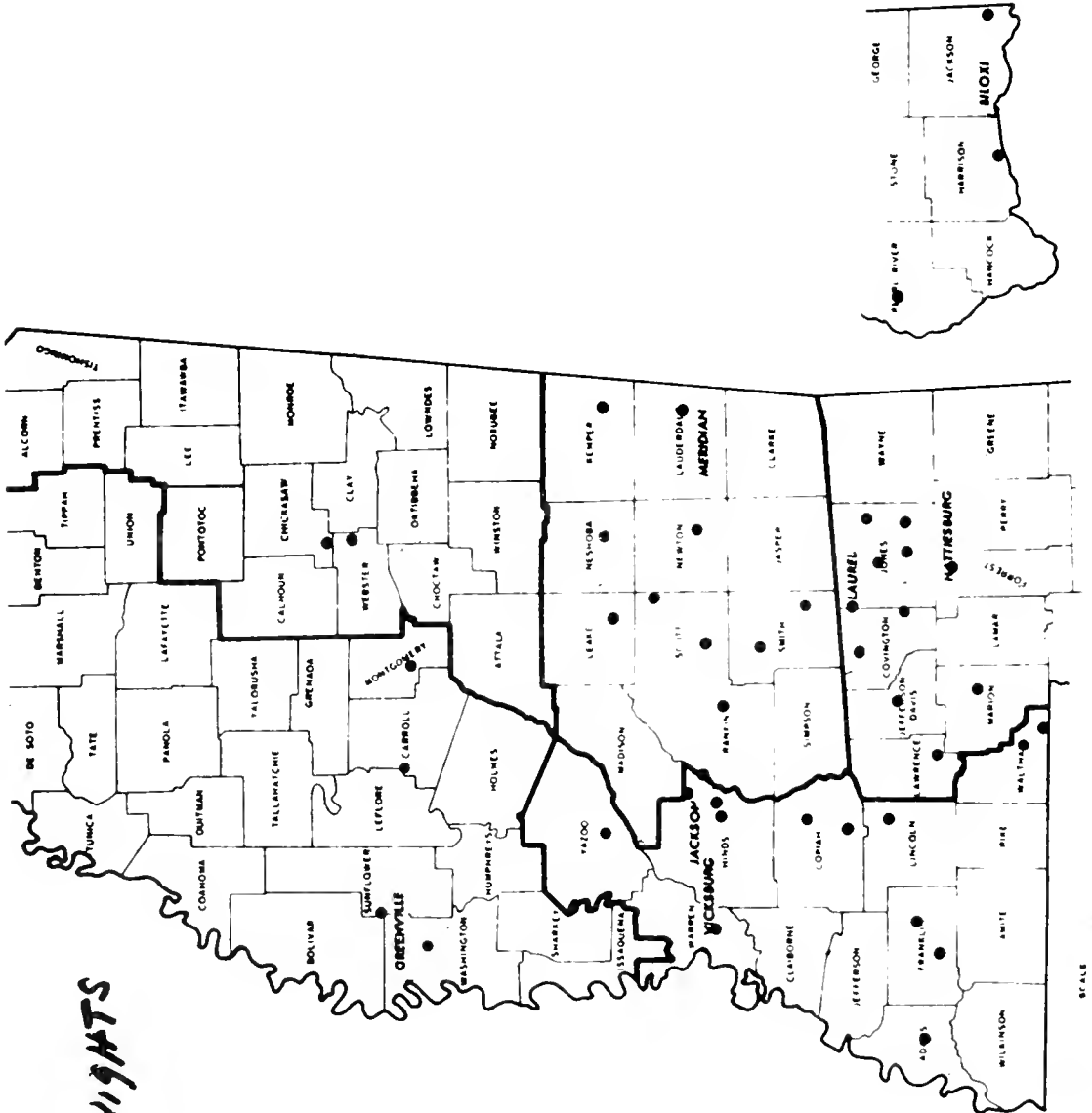

SCALE 0 10 20 40 60 MILE

MR. MANUEL. In Mississippi there are two main groups, two main Klan organizations in existence at this time.

The red dots show the locations of Klaverns of the United Klans of America in the limits of the respective counties in which they are located (Exhibit No. 46).

The next Klan group, previously identified by Mr. Appell as an independent Klan group, operating solely in the State of Mississippi, is the White Knights of the Ku Klux Klan and their Klavern locations, the committee investigation has shown, are as follows in the counties in which they are located (Exhibit No. 47).

Here is a separate listing of the United Klans of America Klaverns, showing county, city or town, and designation.

(Charts of UKA Klaverns in Mississippi shown on slides. A list of these Klaverns follows:)

[Committee Exhibit No. 48]

State of Mississippi—Klaverns of the United Klans of America, Inc.

County	City or Town	Klavern Name and Designation
Adams	Natchez	Adams County Civic & Betterment Association No. 719.
Pike	McComb	McComb Klavern No. 700; Also Known as South Pike Marksman-ship Association.
Lincoln	Brookhaven	Brookhaven Klavern No. 701.
Walthall	Improve	
Lawrence	Jayess	
Jones	Laurel	
Wayne		Wayne County Unit.
Pearl River	{ McNeill	
	{ Picayune	Pearl River County Unit No. 702.
Clarke	{ Quitman	
Rankin	{ Puckett	Rankin County Klavern No. 703
	{ Brandon	Rankin County Unit No. 726.
Madison	Canton	
Yazoo	Yazoo City	
Sharkey	{ Rolling Fork	
	{ Delta City	
Washington	Greenville	
Holmes	Durant	
Leake	Carthage	
Neshoba	Philadelphia	
Kemper	De Kalb	
Lauderdale	Meridian	Meridian Unit No. 720.
Lowndes	Columbus	
Lee	Tupelo	
Tippah	Ripley	
Webster	{ Mathiston	
	{ Eupora	

MR. MANUEL. And following is a listing of the White Knights of the Ku Klux Klan, which exists only in the State of Mississippi. That is as follows.

(Charts of Klaverns of the White Knights of the KKK, Mississippi, shown on slides. A list of these Klaverns follows:)

[Committee Exhibit No. 49]

State of Mississippi—Continued—White Knights of the Ku Klux Klan of Mississippi

County	City or Town	Klavern Name and Designation	
Adams	Natchez	Bogue Chitto Unit. Copiah Rod & Gun Club Klavern.	
Franklin	Meadville		
Lincoln	Bunkley Community		
Lincoln	Brookhaven		
Copiah	Crystal Springs		
Copiah	Wesson		
Lawrence	Monticello		
Walthall	Salem		
Marion	Columbia		
Jefferson Davis	Prentiss		
Covington	Mount Olive		
Covington	Collins		
Covington	Hot Coffee		
Jones	Laurel		The Bogue Homa Hunting & Fishing Club.
Jones	Ellisville (2)	The Wolf Pack Unit.	
Jones	Soso		
Forrest	Hattiesburg	Pearl River Gun & Rod Club.	
Pearl River	Crossroads		
Harrison	Gulfport		
Jackson	Pascagoula		
Smith	Polkville		
Smith	Raleigh		
Rankin	Brandon		
Hinds	Forest Hill		
Hinds	Jackson (3)		
Warren	Vicksburg		
Scott	Sebastopol		
Scott	Morton		
Newton			Newton County Unit.
Lauderdale	Meridian		Meridian Klavern.
Neshoba	Philadelphia		
Leake	Carthage		
Yazoo	Yazoo City		
Sharkey	Rolling Fork		
Washington	Greenville		
Leflore	Greenwood		
Bolivar	Shaw		
Montgomery	Winona		
Webster	Mantec		
Chickasaw	Woodland		

MR. MANUEL. The next State the staff would like to cover is the State of Louisiana.

(Maps of Louisiana shown on slides. See Committee Exhibits Nos. 50 through 52, pp. 1585-1587.)

MR. MANUEL. The first Klan group we would like to introduce by means of the red dots is the United Klans of America, who, up until recently, confined their activities to the north central portion of the State of Louisiana (Exhibit No. 50).

[COMMITTEE EXHIBIT No. 50]

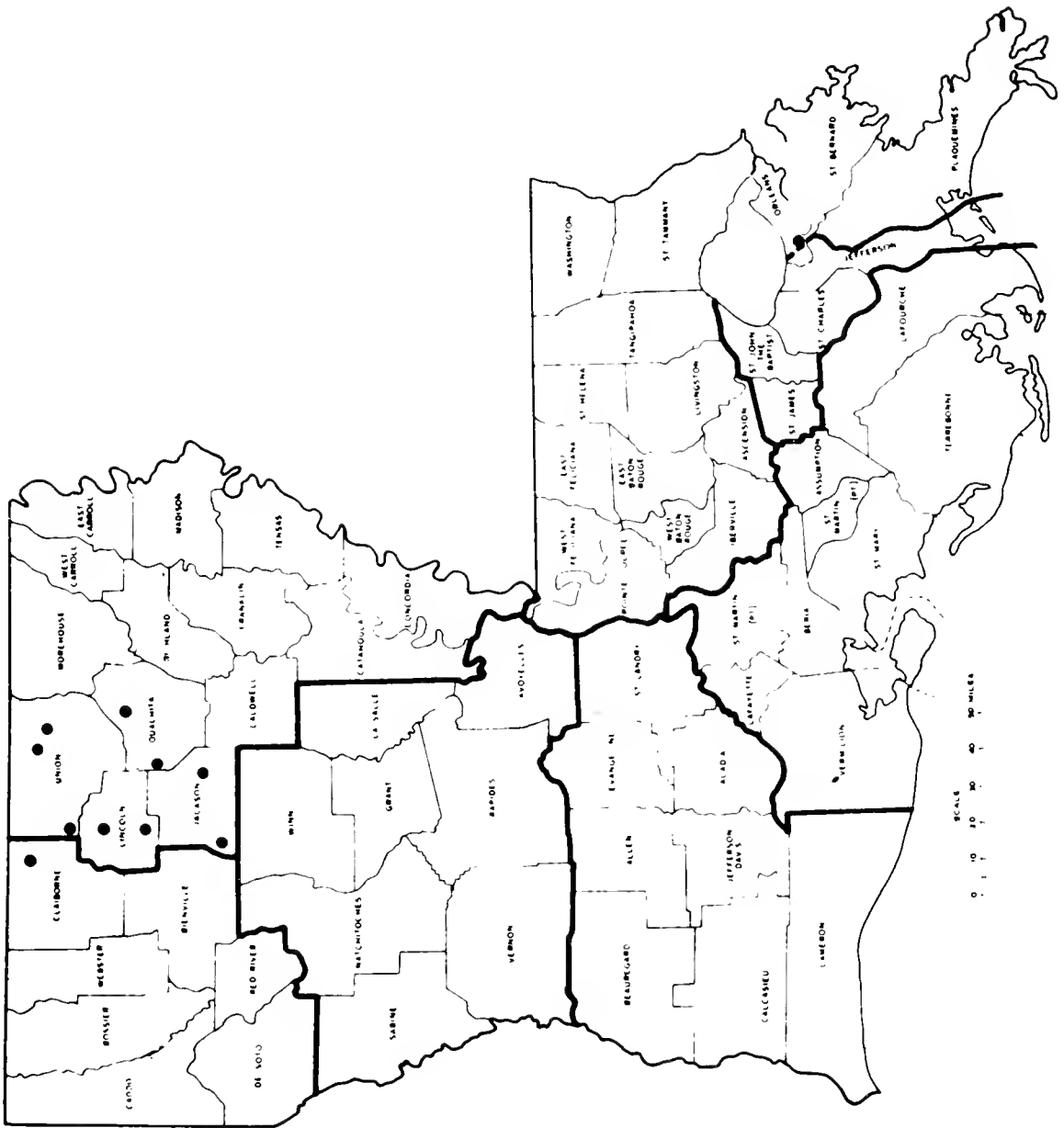

UKA
LOUISIANA

[COMMITTEE EXHIBIT No. 52]

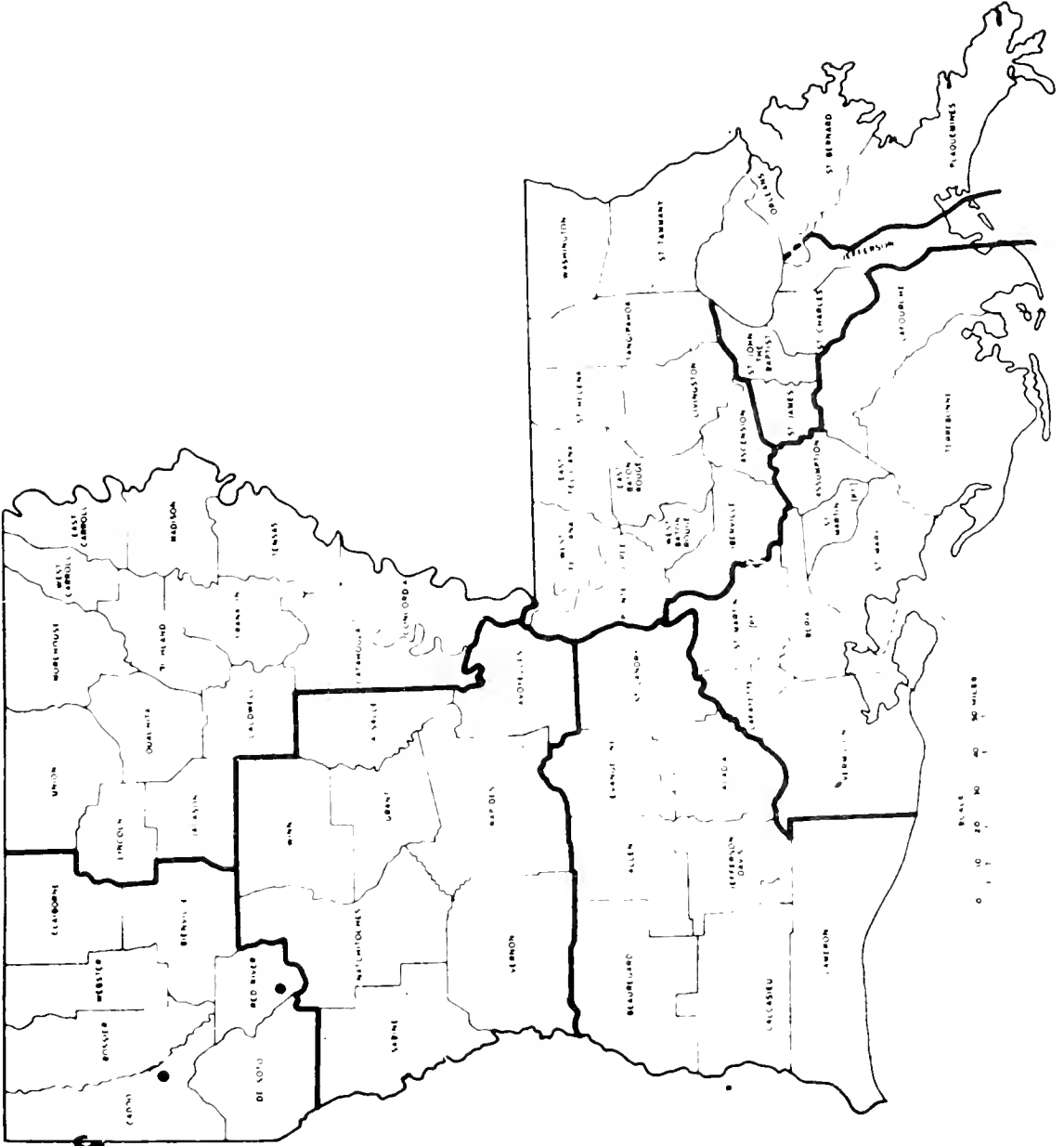

NAT. KNIGHTS
 LOUISIANA

As previously identified by Mr. Appell, another organization exists, mainly in the State of Louisiana, known as the Original Knights of the Ku Klux Klan, and the locations of their Klaverns, as far as the committee investigation has determined, is shown on the map by means of these purple dots (Exhibit No. 51).

The committee investigation has shown that as far as the Original Knights of the Ku Klux Klan are concerned, there are three factions within this group, which will later be brought out, and the group whose name is the Anti-Communist Christian Association, as previously identified by Mr. Appell, is located mostly in the Sixth Congressional District of the State of Louisiana.

Another fact I wish to bring out is that recently the portion of the Original Knights which operated in the area of Monroe, Louisiana, and included most of this group, has recently, according to committee investigation, gone over to the United Klans of America.

If you want to superimpose this, we can establish that most of these now are Klans of the United Klans of America.

The CHAIRMAN. I notice you don't have any dots in the Third Congressional District, which is mine.

Mr. MANUEL. We didn't find any dots [Klaverns] in the Third Congressional District, Mr. Chairman.

The CHAIRMAN. Nor any individuals.

Mr. MANUEL. And to finish off the State of Louisiana, there are two Klaverns of the National Knights previously identified at Ouachita and Shreveport, shown on the map (Exhibit No. 52).

Again, here is an individual listing that the committee investigation has determined. It is shown with the parish, the city or town, the Klavern name, and designation of the United Klans.

(Chart of UKA Klaverns in Louisiana shown on slide. A list of these Klaverns follows:)

[Committee Exhibit No. 53]

State of Louisiana—Klaverns of the United Klans of America, Inc.

Parish	City or Town	Klavern Name and Designation
Claiborne.....	Junction City.....	Junction City Sportsmans Club.
Lincoln.....	{ Dubach.....	
	{ Ruston.....	
Jackson.....	{ Jonesboro.....	Chatham Hunting & Fishing Club.
	{ Chatham.....	
Ouachita.....	{ Calhoun.....	Monroe Hunting & Fishing Club.
	{ Monroe.....	
Union.....	{ Farmerville.....	Marion Hunting & Fishing Club.
	{ Berniee.....	Berniee Sportsmans Club.
Orleans.....	New Orleans.....	New Orleans Klavern.

Mr. MANUEL. Going to the organization known as the Original Knights, of which there are three factions, and consolidating them under one heading, we have the identities by parish, city and town, and Klavern designation.

(Chart of Klaverns in Louisiana of Original Knights shown on slide. A list of these Klaverns follows:)

[Committee Exhibit No. 54]

State of Louisiana—Continued—Original Knights of the Ku Klux Klan

Parish	City or Town	Klavern Name and Designation
Concordia	Vidalia	Bush Hunting & Fishing Club No. 1055.
	Morville	
Washington	Franklinton	
	Bogalusa	
	Varnado	
	Bush	Pearl River Hunting & Fishing Lodge No. 1028.
St. Tammany	Covington	
	Pearl River	
	Folsom	Christian Constitutional Crusaders.
Tangipahoa	Amite	
Jefferson	Kenner	
East Baton Rouge.	Baton Rouge	
Calcasieu	Lakes Charles	
Rapides	Alexandria	
Grant	Pollock	
La Salle	Jena	
Franklin	Winnsboro	
Madison	Tallulah	
Ouachita	Swartz	
	Ouachita	
Livingston	Denham Springs	
Bossier	Bossier City	

Mr. MANUEL. And the third group in Louisiana, the National Knights of the Ku Klux Klan, is located as follows on this chart.

(Chart of National Knights Klaverns in Louisiana shown on slide. A list of these Klaverns follows:)

[Committee Exhibit No. 55]

State of Louisiana—Continued—National Knights of the Ku Klux Klan, Inc.

Parish	City or Town	Klavern Name and Designation
Caddo	Shreveport	
Red River	Coushatta	

Mr. MANUEL. The next State which will be covered by this presentation is the State of Arkansas.

(Maps of Arkansas shown on slides. See Committee Exhibits Nos. 56 and 57, pp. 1590, 1591.)

[COMMITTEE EXHIBIT No. 56]

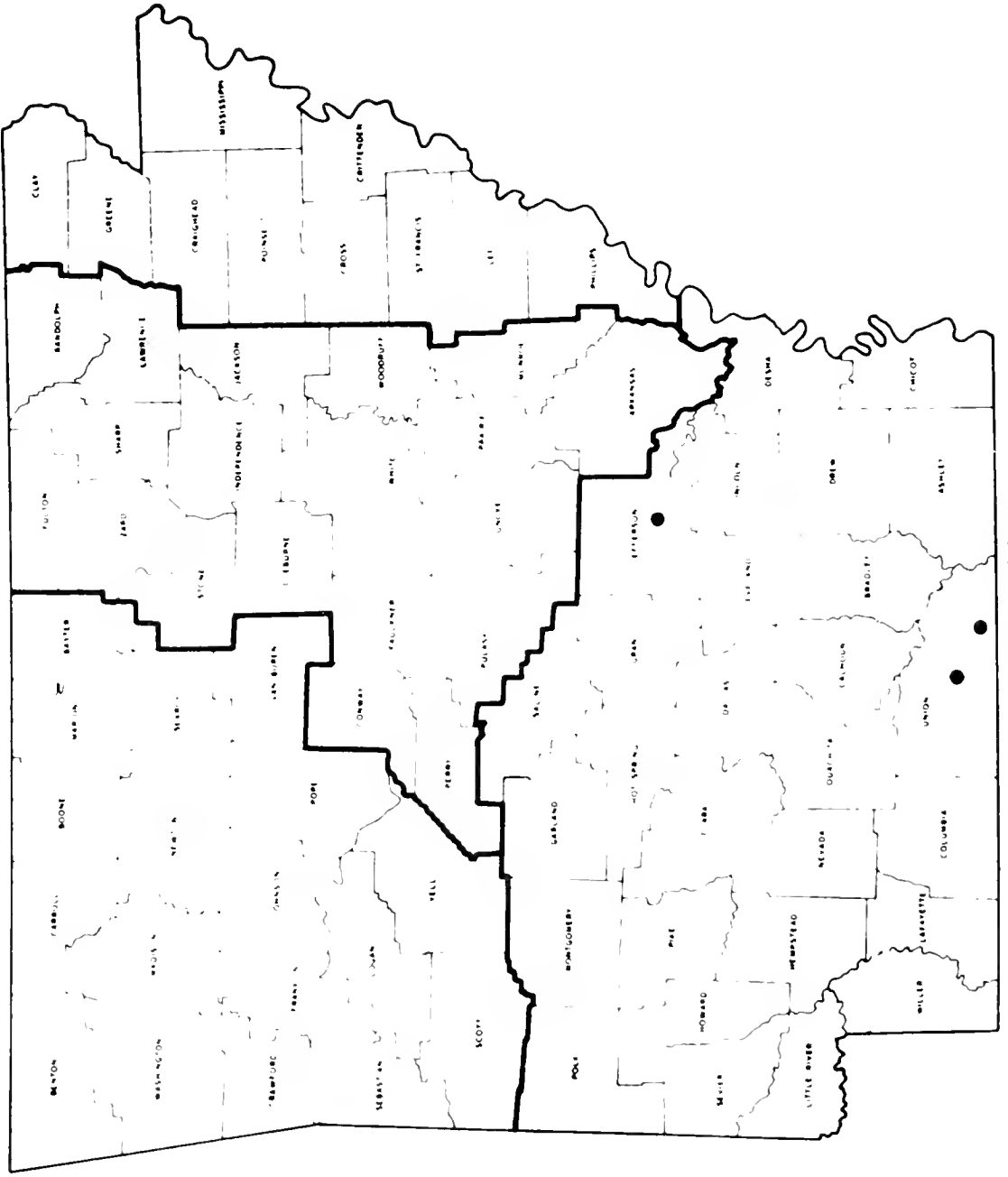

SCALE
 0 10 20 30 MILES
 0 10 20 30 KILOMETERS

UKA
 ARKANSAS

[COMMITTEE EXHIBIT No. 57]

**ASSOC. OF
ARKK.
ARKANSAS**

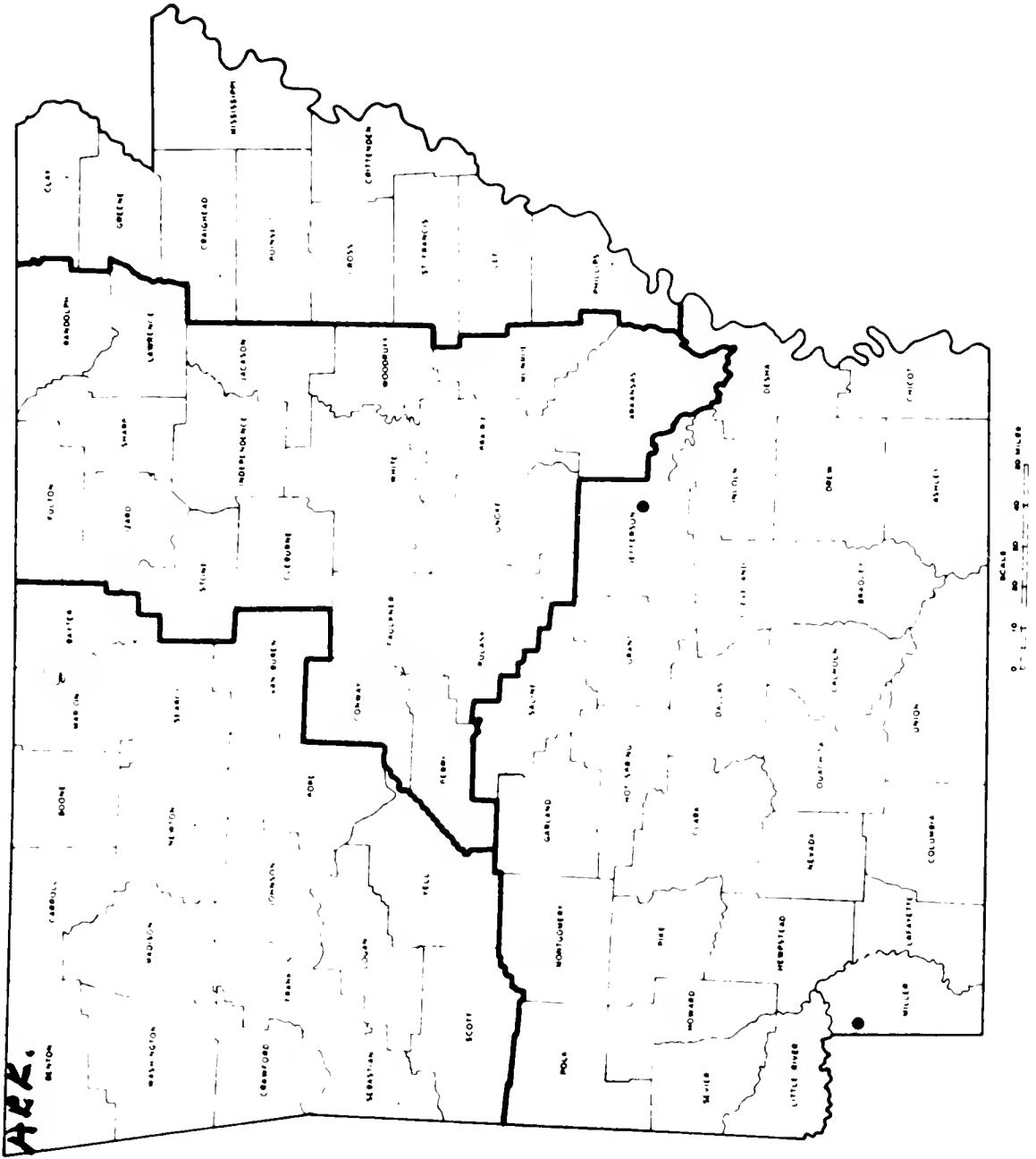

Mr. MANUEL. Committee investigation has revealed that recently the United Klans of America has appointed a Grand Dragon for the State of Arkansas who operates in the vicinity of Strong, Arkansas. And committee investigation has revealed that three Klaverns of the United Klans of America exist in the State of Arkansas in the areas designated on the map (Exhibit No. 56).

Also in the State of Arkansas, previously identified by Mr. Appell, is an organization known as the Association of Arkansas Klans. Committee investigation has found that they have two Klaverns in the State, one located at Pine Bluff, Arkansas, and the other at Texarkana (Exhibit No. 57).

A separate listing of the Klaverns of Arkansas is as follows in the cities listed. The one at Strong, Arkansas, is the State headquarters of the UKA in that State.

(Chart of Klaverns in two Klan groups in Arkansas shown on slide. A list of these Klaverns follows:)

[Committee Exhibit No. 58]

State of Arkansas—Klaverns of the United Klans of America, Inc.

County	City or Town	Klavern Name and Designation
Jefferson.....	Pine Bluff.....	
Union.....	{ El Dorado.....	
	{ Strong.....	

Association of Arkansas Klans

Jefferson.....	Pine Bluff.....	
Miller.....	Texarkana.....	

Mr. MANUEL. The next State the committee staff would like to cover is the State of Texas, where committee investigation has found that recently there has been some activity on the part of the United Klans of America, having established a State headquarters in the area of Houston, Texas, with two separate Klaverns being noted in this area and one also in Dallas, Texas.

(Map of Texas shown on slide. See Exhibit No. 59, p. 1593.)

[COMMITTEE EXHIBIT No. 59]

U K. K. TEXAS

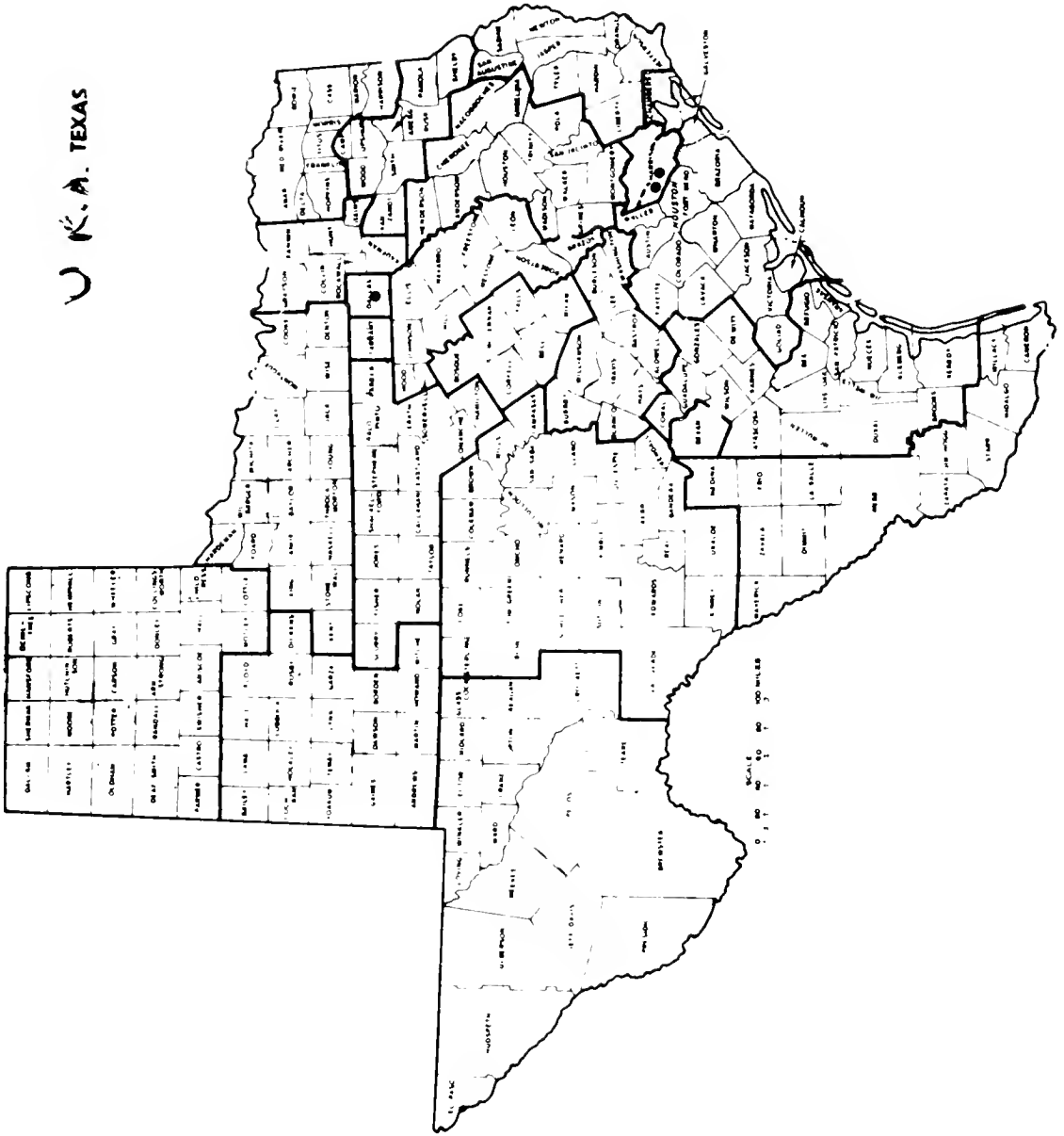

Mr. MANUEL. A listing of these Klaverns is as follows for the State of Texas.

(Chart of UKA Klaverns in Texas shown on slide. A list of these follows:)

[Committee Exhibit No. 60]

State of Texas—Klaverns of the United Klans of America, Inc.

County	City or Town	Klavern Name and Designation
Dallas.....	Dallas.....	
Harris.....	Houston.....	

Mr. MANUEL. Mr. Chairman, with the conclusion of the map and the other exhibits on the State of Texas, this concludes the presentation of the individual States.

However, there is one final exhibit which I would like to show to the committee showing the areas of influence. There are other States which were not shown on the maps in which committee investigation has revealed some activity on the part of the United Klans.

I would like to explain this, if I may.

(Map delineating KKK's area of influence shown on slide. See Committee Exhibit No. 61, p. 1595.)

Mr. MANUEL. On the Vu-graph you see a map of the eastern half of the United States, and although Mr. Appell has gone over this in some detail, I would like to point out that the United Klans of America has established headquarters in each of the following States, in addition to the States that I have gone over separately with the maps.

They have now headquarters in the State of Pennsylvania, one in Delaware, a headquarters in New York, a headquarters in the State of Ohio, one in Indiana, and one in Wisconsin.

The identity and headquarters of these State realm divisions are shown as follows:

For the State of Alabama, it has its headquarters in Bessemer, Alabama, the Grand Dragon previously identified as Robert Creel; Georgia, headquarters in Atlanta, the Grand Dragon, Calvin Craig; Mississippi, headquarters located in Natchez, Mississippi, the Grand Dragon, Edward McDaniel; Louisiana, headquarters in Jonesboro, of the UKA, the Grand Dragon being James Edwards; in Florida, the headquarters is Jacksonville and the Grand Dragon is Donald Cothran; South Carolina has its UKA headquarters in Spartanburg and its Grand Dragon is Robert Scoggin; North Carolina, headquarters in Granite Quarry, and its Grand Dragon is J. R. Jones; in the State of Virginia, to the best of the committee's information, at this time they have not established a definite State headquarters. However, its Grand Dragon is Marshall R. Kornegay. The Realm of Tennessee has its headquarters in Maryville, Tennessee, and its Grand Dragon is Raymond Anderson. The State of Arkansas has its headquarters in Strong, Arkansas, and its Grand Dragon is George McNeely. The State of Texas has its headquarters in Houston and its Grand Dragon is George Otto. The State of Ohio has its headquarters in Columbus, Ohio, and its Grand Dragon is Flynn Harvey. The

[COMMITTEE EXHIBIT No. 61]

UNITED KLANS OF AMERICA - KNIGHTS OF THE KU KLUX KLAN, INC.
 Imperial Wizard: Robert M. Shelton
 Headquarters: Tuscaloosa, Alabama

<u>REALM</u>	<u>HEADQUARTERS</u>	<u>GRAND DRAGON</u>
Alabama	Bessemer	Robert Creel
Georgia	Atlanta	Calvin F. Craig
Mississippi	Natchez	Edward McDaniel
Louisiana	Jonesboro	James M. Edwards
Florida	Jacksonville	Donald Cothran
So. Carolina	Spartanburg	Robert Scoggin
No. Carolina	Granite Quarry	J. R. Jones
Virginia		Marshall Kornegay
Tennessee	Maryville	Raymond Anderson
Arkansas	Strong	George A. McNeely
Texas	Houston	George Otto
Ohio	Columbus	Flynn Harvey
Delaware	So. Wilmington	Ralph Pryor
New York	Queens	Daniel Burros
Wisconsin	Madison	John P. Reading
Pennsylvania	Reading	Roy Frankhouser
Indiana	Greenfield	Claude Parnell

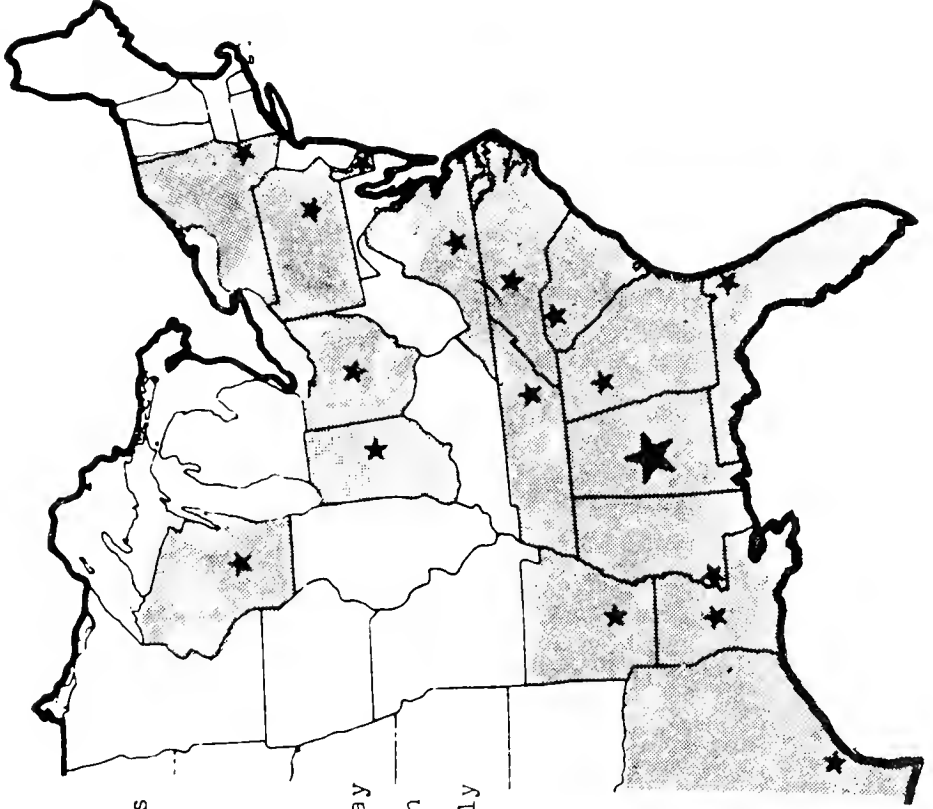

State of Delaware has its headquarters in south Wilmington and its Grand Dragon, at this time, is Ralph Pryor. The State of New York has its headquarters in Queens, and its Grand Dragon is Daniel Burros. The State of Wisconsin has its headquarters in Madison, and John P. Reading is the Grand Dragon of that realm. The State of Pennsylvania is headquartered in Reading, Pennsylvania, and its Grand Dragon is Roy Frankhouser. Finally, the Realm of Indiana, located at Greenfield, Indiana, with its Grand Dragon being an individual named Claude Parnell.

This final sheet will indicate an area of influence of the United Klans of America ranging through the Southeastern States. I want to make this point clear, that the organizations in the Northeastern States whose maps I did not show individually, committee investigation has shown, are recent attempts on the part of the UKA to establish headquarters and gain membership in momentum in these northeastern areas.

To the committee's knowledge, there is not sufficient membership at this time, in some cases, to establish what would be an organization compared to other parts of the country.

That, Mr. Chairman, concludes the presentation of these particular exhibits.

The CHAIRMAN. Mr. Appell, would you resume the stand, please?

TESTIMONY OF DONALD T. APPELL—Resumed

The CHAIRMAN. Would you flash back the slide on the Independent Klan Organizations?

Mr. APPELL. Mr. Chairman, I will cover all of them, but there is one thing I think of interest to the committee that I should point out. The White Knights of the Ku Klux Klan in Mississippi grew out of a split within the Original Knights of the Ku Klux Klan of Louisiana, which, in 1963, formed a realm in the State of Mississippi.

There was a leadership struggle or a disagreement with leadership, as happens so often in the Klan, and this realm membership, which was about 200 in Mississippi, broke away from the Original Knights and they formed the White Knights of the Ku Klux Klan. This was the only Ku Klux Klan organization in Mississippi until around July of 1964, when one of the leaders of the White Knights was appointed Grand Dragon of the UKA. And since that time there have been numerous defections from the White Knights into the UKA.

This Anti-Communist Christian Association—this group was also a part of the Original Knights of the Ku Klux Klan, which was basically a Louisiana organization. After the split in leadership—this group split once—it split again, and with the second split the group in the Sixth Congressional District went independent.

The group which was located up around Monroe and the Shreveport areas chartered themselves as what was known as the Original Knights of the Ku Klux Klan of America, Inc. Their purpose was to try to get all of these Klan groups together under their head. But they failed, and within the last several weeks the Knights of the Ku Klux Klan of America, Inc., went, almost en masse, into the UKA.

Then there is the Association of Arkansas Klans, which Mr. Manuel has dealt with, the Militant Knights of the Ku Klux Klan of Florida,

origin of just a few months ago, and finally the one-man Klan, the Mississippi Knights of the Ku Klux Klan, located down in Biloxi.

Is this clear, Mr. Chairman?

The CHAIRMAN. Yes.

Mr. APPELL. Thank you, sir.

The CHAIRMAN. Mr. Manuel, I think you wanted to address yourself to this other map?

Mr. MANUEL. Yes, Mr. Chairman, I wanted to call your attention and that of the committee to the map on the wall in back of the committee.

On this map has been compiled all of the Klaverns and their locations in specific cities which I have shown in this series of exhibits.

The CHAIRMAN. It is a composite map?

Mr. MANUEL. Yes, sir; showing all the Klan groups and their locations in the area in which the committee has worked.

On that composite map is listed all of the Klaverns which I have shown on the screen.

The CHAIRMAN. Thank you very much.

I would like to take this occasion to express the appreciation of the committee to the Tecnifax Corporation for being so helpful to our staff members in the preparation of these maps and slides which have been exhibited. They have done, in my opinion—and this is the first time I have seen them—a very magnificent job and we certainly want to thank the Tecnifax Corporation for their great contribution to these hearings.

After consulting with the members, I intend to adjourn for lunch.

Mr. Pool, would you care to say anything?

Mr. POOL. Thank you, Mr. Chairman.

I think in the very short time that the committee staff had to work on this, in their investigative work, and I had a lot of experience in that during World War II—you usually need a long time to really get into the facts—I think in the very short time that this committee staff has had to work on this that they have done an excellent job. They have made a very thorough investigation.

I think the hearings to come will show that the background and history they have given here this morning are very excellent.

I want to make one other comment, that some people have said that you shouldn't have an investigation because you might even increase the membership of the Klan by having it, by giving them publicity. But in view of the maps that we have seen here and the widespread membership, I think certainly that this thing has been increasing in membership and that we certainly should look into it and Congress should be informed of this.

That is the work of this committee, to get the facts. And then if legislation is needed, we will see about that, too.

Thank you.

The CHAIRMAN. Mr. Weltner?

Mr. WELTNER. Thank you, Mr. Chairman.

I have been very interested in this investigation and I am convinced that the matters to come forth as a result of this will be of great interest to the South and to the people of the South.

I join my colleague, Mr. Pool, in commending our staff. I think they have done a particularly outstanding duty. It has not been easy; it

has not been pleasant. But they have given it their entire time and attention.

I simply wish to say that these hearings will fully justify the decision made by the House Committee on Un-American Activities on March 30 to proceed with this most important inquiry.

The CHAIRMAN. Mr. Ashbrook?

Mr. ASHBROOK. Thank you, Mr. Chairman. I will associate myself with what has been said. But I would like to make one additional point. The House Committee on Un-American Activities, of course, is a different committee, dealing with hostile subjects. It may seem that this was a little tedious, a little drawn out. But those of us who have been associated with this for about 10 months now realize that we have merely scratched the surface.

Our committee has but one real means of determining the facts and deducing information. Because we deal with hostile subjects—whether they be communism, travel to Cuba, or the Ku Klux Klan—we have to develop, through thorough investigation, the information for our committee. This is done by firsthand reports. It is done by conferring with other agencies of the Government, such as the FBI.

In the case of the Ku Klux Klan, as in previous investigations, it will be based on bit-by-bit piecing-together of all the parts as we gather them. This requires a lot of work.

There has been 10 months of hard work that has already gone into this investigation, and only those of us who have been intimately connected with it have any realization of the thousands of hours of work which have gone into the staff preparation to this point. Actually, the chairman has stated there are 20,000 man-hours which have gone into this work. As in the past, we will develop the record bit by bit, piece by piece, on the basis of concrete, provable information.

I point this out because sometimes it has been alleged that we were dragging our feet. It took 10 full months before we could reach this point. I certainly commend the staff. There is no question in my mind on the basis of the information that I have seen to date that we are going to be able to present this in a proper perspective, and we are going to be able to show the need for remedial legislation.

I hope that as the months drag out—and I am afraid this will run into months—we will recognize that in bringing forth testimony sometimes it will seem tedious, sometimes it will seem trivial.

This committee has been very successful in the past in developing information, developing the whole picture on a piece-by-piece, bit-by-bit technique. As a matter of fact, again dealing with the hostile subject, this is the only way we have been able to do it.

Thank you, Mr. Chairman.

The CHAIRMAN. Mr. Buchanan?

Mr. BUCHANAN. Thank you, Mr. Chairman.

I want to join with the others in saying how much I appreciate this thorough and excellent job done by the investigative staff.

My interest in this investigation is that of one who loves the South and its people and who understands that, while the South is not inhabited by angels, it is inhabited by people who are law-abiding Americans and who, in overwhelming majority, deplore acts of violence or terrorism. The people who have been guilty of the commis-

sion of such acts are, in fact, the greatest enemies to the people of the South.

I want to underline, therefore, Mr. Chairman, both as a Southerner and as a member of this committee, something you said a few moments ago when you were introducing this hearing or beginning it—that he who has nothing to hide has nothing to fear.

We are not here to convict or prosecute people. We are here to get the truth and to follow the truth wherever it may lead us and to draw conclusions from that truth. Therefore, unless a man has something to hide from the Congress or the American people or from even the rank-and-file members of the Klan organization, he has nothing to fear or no reason to hesitate in giving testimony before this committee. Only those who have something to hide or to fear stand hesitant to let the full light of truth be cast upon their activities. This is true of the members of the Klans as of any other outfit.

So, as a Southerner and as a member of this committee, I am glad to be a part of this investigation and feel we are doing something not only for the Nation but for the South in conducting it.

The CHAIRMAN. Though not a member of the subcommittee yet equally interested, Mr. Ichord, from Missouri.

We appoint subcommittees for convenience, because of the necessity for a quorum at all times. But the full committee members are all interested in this work.

Mr. Ichord.

Mr. ICHORD. Mr. Chairman, I would like to take this opportunity to commend the staff and the subcommittee for the very obvious extensive and thorough work which the staff and the subcommittee have done in bringing about these public hearings.

I know that the subcommittee has spent many hours in executive hearings, which is required by the rules of the House and by the rules of this committee before public hearings can be held.

I compliment the staff and the committee for the work that you have done. I am very interested in seeing just what these public hearings develop.

The CHAIRMAN. And from the West, Mr. Senner, of Arizona.

Mr. SENNER. Mr. Chairman, the hour is late. I will not add too much to the record, other than to say that I join my colleagues in their remarks today.

The CHAIRMAN. The committee will stand in recess until 1:30.

(Members present at time of recess: Representatives Willis, Pool, Weltner, Ashbrook, and Buchanan, of the subcommittee, and also Representatives Ichord and Senner.)

(Whereupon, at 12 noon, Tuesday, October 19, 1965, the subcommittee recessed, to reconvene at 1:30 p.m. the same day.)

AFTERNOON SESSION—TUESDAY, OCTOBER 19, 1965

(The subcommittee reconvened at 1:30 p.m., Hon. Edwin E. Willis, chairman, presiding.)

(Members present: Representatives Willis, Pool, Weltner, and Buchanan, of the subcommittee, and also Representative Senner.)

The CHAIRMAN. The subcommittee will please come to order.

Let me say that the subcommittee appreciates the attitude and decorum of the audience, our guests. We welcome you here and we are glad to have you.

I wish to state that the general counsel of this committee is Mr. William Hitz, who, for some 30 years before he became attached to the committee some time ago, was connected with the Department of Justice here in Washington. Mr. Hitz is an outstanding attorney, and it had been anticipated that he would conduct the interrogation, or most of it, anyway. But a couple of weeks ago he was told by his physician to take it easy for a couple of weeks.

He is with us, immediately to my left and in front of me, and will be with us during the hearings, but will not take the burden, the chief burden, of examining the witnesses. Instead, the witnesses, for the most part, will be interrogated by Mr. Appell and Mr. Manuel.

As a matter of fact, Mr. Appell is an old hand at that—at interrogating witnesses. Furthermore, up until some years ago it was the custom of this committee, as it is with many others, to have a lay member of the staff do the interrogation. Mr. Appell has done that innumerable times in the last few years in executive sessions and very frequently in open sessions prior to that.

So with that, Mr. Appell, will you please call your first witness?

Mr. APPELL. Mr. Chairman, I would like to call Mr. Robert M. Shelton.

The CHAIRMAN. The news media will please desist.

Please raise your right hand, sir.

Do you solemnly swear that the testimony you are about to give will be the truth, the whole truth, and nothing but the truth, so help you God?

Mr. SHELTON. I will affirm. I won't swear, but I will affirm.

The CHAIRMAN. What is that?

Mr. SHELTON. I said not swear, but to affirm.

The CHAIRMAN. You do not swear, but you do affirm. I have to propose a different oath.

Do you affirm, having declined to swear, that you will tell the truth, the whole truth, and nothing but the truth in these hearings?

Mr. SHELTON. I do.

TESTIMONY OF ROBERT MARVIN SHELTON, ACCOMPANIED BY COUNSEL, LESTER V. CHALMERS, JR.

Mr. APPELL. Mr. Shelton, will you state your full name for the record, please?

Mr. CHALMERS. Mr. Chairman, I am Lester V.—

The CHAIRMAN. We will develop that. That is introductory.

Mr. APPELL. Mr. Shelton, will you state your full name for the record, please?

Mr. SHELTON. Robert Marvin Shelton.

Mr. APPELL. Are you represented by counsel?

Mr. SHELTON. I am, sir.

Mr. APPELL. Will counsel please identify himself for the record?

Mr. CHALMERS. Lester V. Chalmers, Jr., from North Carolina, a member of the North Carolina Bar.

Mr. APPELL. Mr. Shelton, when and where were you born?

Mr. SHELTON. Tuscaloosa, Alabama, in June of 1929.

Mr. APPELL. Mr. Shelton—

The CHAIRMAN. At this point, I wish to do what I did this morning. It is customary. You heard me say this morning that under the

rules of the House the function of the news media, specifically the TV and radio, and photograph-taking, was limited, under the rules of the House, and that under the rules of the House the audience, of course, was required to keep good order and decorum.

(At this point Representative Ashbrook entered the hearing room.)

The CHAIRMAN. I want to read the rules of the committee which, of course, carries out the rules of the House, with respect to the function of counsel before this committee.

[A] At every hearing, public or executive, every witness shall be accorded the privilege of having counsel of his own choosing.

[B] The participation of counsel during the course of any hearing and while the witness is testifying shall be limited to advising said witness as to his legal rights. Counsel shall not be permitted to engage in oral argument with the Committee, but shall confine his activity to the area of legal advice to his client.

Sir, I read that to you not with any thought that I expect or suppose or have a notion that you will do otherwise, but we must proceed according to the rules of the House, and I am carrying them out.

Thank you very much.

By the way, we now have another member of our full committee here, Mr. Del—Congressman Del Clawson.

We are glad to have you, Del.

Mr. APPELL. Mr. Shelton, are you appearing before the committee this afternoon in accordance with a subpoena served upon you by a United States marshal on October 11, 1965?

Mr. SHELTON. Yes, somewhere in the neighborhood of that date.

Mr. APPELL. Mr. Shelton, I hand you a document, a copy of a document, which the committee obtained from the secretary of state's office of the State of Georgia. It is entitled "Certified Statement for Annual Registration of a Corporation." It is dated September 15, 1964. The name of the corporation is set forth on the registration statement and is the "Invisible Empire United Klans Knights Ku Klux Klan of America, Inc.," signed "Robert M. Shelton," president, dated September 10, 1964.

I ask you to look at this document, sir, and to answer whether or not this is a copy of a document filed by you?

Mr. SHELTON. Sir, is this question directed to me as an individual or is it directed to me as an officer of a corporation?

Mr. APPELL. It is directed to you, as the document implies, as president of that corporation.

Mr. SHELTON. Could I talk to my counsel, please?

Mr. APPELL. Surely.

(Witness confers with counsel.)

Mr. SHELTON. Sir, I respectfully decline to deliver to this committee any and all records as requested by this committee under subpoena dated October 7, 1965—

Mr. APPELL. Mr. Shelton—

Mr. SHELTON. —for that information is not relevant and germane to the subject under investigation, and the same will not aid the Congress in the consideration of any valid remedial legislation, nor is such inquiry within the scope of that authorized to be investigated by Rule XI of the Rules Committee, adopted by the 89th Congress, or House Resolution 8, adopted January 4, 1965.

(Document marked "Robert Shelton Exhibit No. 1" follows:)

ROBERT SHELTON EXHIBIT No. 1

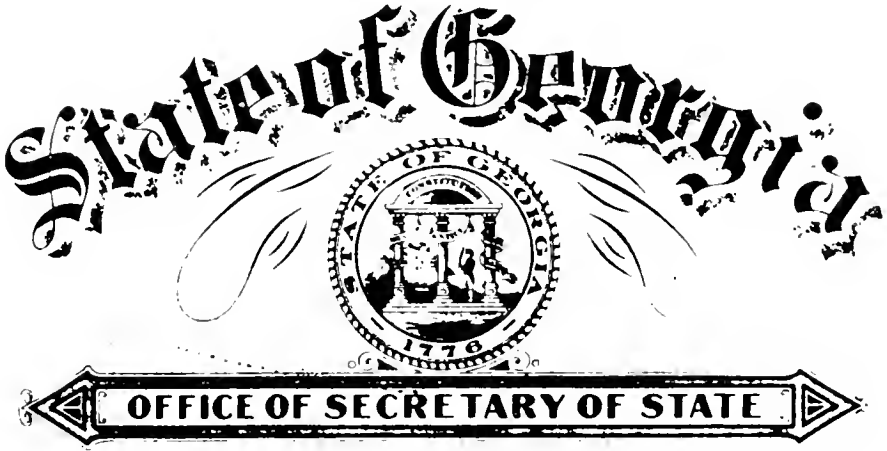

I, Ben W. Fortson, Jr., Secretary of State of the State of Georgia, do hereby certify, that

the one page of photographed printed matter hereto attached is a true and correct copy of the last statement for annual registration filed in this office by INVISIBLE EMPIRE UNITED KLANS KNIGHTS KU KLUX KLAN OF AMERICA, INC. on the 15th day of September, 1964, as the same appears of file and record in this office.

IN TESTIMONY WHEREOF, I have hereunto set my hand and affixed the seal of office, at the Capitol, in the City of Atlanta, this 23rd day of April, in the year of our Lord One Thousand Nine Hundred and Sixty Five and of the Independence of the United States of America the One Hundred and Eighty-ninth.

Ben W. Fortson

SECRETARY OF STATE, EX-OFFICIO CORPORATION
COMMISSIONER OF THE STATE OF GEORGIA.

ROBERT SHELTON EXHIBIT No. 1—Continued

Form F-39

STATE OF GEORGIA

SEPT 15 1961

CERTIFIED STATEMENT FOR ANNUAL REGISTRATION OF A CORPORATION

NAME OF CORPORATION: Invisible Empire United Klans Knights Ku Klux Klan of America, Inc
Robert L. Shelton

PRESIDENT: Robert L. Shelton
GENERAL MANAGER: Tuscaloosa Ala.

PRINCIPAL OFFICE: (Street and No.) Suite 401 Alston Bldg. CITY Tuscaloosa STATE Ala.

TRINCIPAL OFFICE IN GA.: (St. and No.) 772 Pearce Street CITY Atlanta, Georgia

AUTHORIZED AGENT IN GA. (If foreign): Calvin F. Craig
CITY Atlanta, Georgia

AGENT'S ADDRESS (If foreign): 772 Pearce Street
CITY Atlanta, Georgia

NATURE OF BUSINESS Fraternal, Patriotism, Benevolent Society

WHEN INCORPORATED (Date) Feb. 21, 1961 BEGAN BUSINESS IN GA. (Date) Feb. 21, 1961 Ga.

WHERE INCORPORATED (CITY) FULTON COUNTY STATE Ga.

BY WHAT AUTHORITY Judge of the Superior Court, Atlanta Judicial Circuit

TO THE HONORABLE BEN W. FORTSON, JR., Atlanta, Ga.

I hereby certify that the above statement furnished the Secretary of State of Georgia for record, as required by law, is correct.

Signed by: *Robert L. Shelton* DATE: *Sept 15 1961* TITLE: *President*

(OVER)

The CHAIRMAN. This document, as I understand, was not ordered to be produced here under subpoena. Is that right, Mr. Appell?

Mr. APPELL. I have only asked him whether this was a document, a copy of a document, which he filed with the secretary of state of Georgia. I have not asked for the production of any documents called for by his subpoena, sir.

The CHAIRMAN. Thus far.

Mr. APPELL. Thus far; yes, sir.

(Witness confers with counsel.)

Mr. SHELTON. I would like to call your attention to the scope of the investigation, as declining to deliver to the committee any records, documentations or otherwise, material requested by this committee under subpoena dated October 7, 1965, for that information is not relevant or germane to the subject under investigation, and the same would not aid the Congress in the consideration of any valid legislation, nor is such inquiry within the scope of that authorized to be investigated by Rule XI of the rules adopted by the 89th Congress or by House Resolution 8, adopted January 4, 1965.

Mr. APPELL. Mr. Chairman, I ask that the witness be directed to answer the question.

The CHAIRMAN. Yes.

This document, the production and identification of this document, is completely germane and proper to the subject under inquiry and is part of the necessary material required to perform our duties in this investigation.

I, therefore, order and direct you to answer the question.

Let me tell you why I do that, why I use those words, so you can understand. You have counsel and you may take his advice. The decisions of the Supreme Court of the United States indicate and hold that when this committee concludes or determines that an answer to a question is proper that, to be perfectly frank about it, if the subject may result in a citation for contempt, that the witness must be directed to answer the question.

In other words, it is, in effect, a warning.

Mr. Witness, you are on thin ice. Your refusal to answer that question may lead to contempt citation. I will not have to repeat that over and over again, that there may be further implications.

Therefore, I order and direct you to answer that question.

Mr. SHELTON. Sir, I respectfully decline to answer that question for the reason that I honestly feel that my answer might tend to incriminate me in violation of my rights as guaranteed to me under the amendments 5, 1, 4, and 14 of the Constitution of the United States of America.

The CHAIRMAN. Are you now specifically invoking the privileges of the fifth amendment?

Mr. SHELTON. Sir, I am invoking the privileges of the 5th amendment, the 1st amendment, the 4th amendment, and the 14th amendment of the Constitution of the United States of America.

The CHAIRMAN. Why?

Mr. SHELTON. I decline to answer that question for the reason that I honestly feel that it might tend to incriminate me in violation of my rights, as is so stipulated and guaranteed to me in amendments 5, 1, 4, and 14 of the Constitution of the United States of America.

The CHAIRMAN. Do you honestly believe that to answer this simple question as to whether, in effect, you certified to the secretary of state or some other official in Georgia that you were president of a corporation would subject you to criminal prosecution, would tend to incriminate you?

Mr. SHELTON. Again I respectfully decline to answer that question for the reasons previously stated, because it is my honest and sincere feeling that my answer might tend to incriminate me in violation of my rights as guaranteed to me under the amendments 5, 1, 4, and 14th of the Constitution of the United States of America.

The CHAIRMAN. In view of the invocation of the fifth amendment, and your repeating it after I asked you if you honestly felt that it might tend to incriminate you, you, of course, are on solid ground. That is to say with respect to the invocation.

Mr. APPELL. Mr. Shelton, I hand you—

The CHAIRMAN. That does not mean that you are not going to be questioned on all the things you were going to be questioned on, even with that answer.

Go on.

Mr. APPELL. Mr. Shelton, I hand you a copy of a document obtained from the Office of Secretary of State, which is a charter application executed the 21st day of February 1961, with the incorporators listed in the document as Robert Day, George Sligh, William A. Daniel, Sr., and M. Wesley Morgan, Sr.

I ask you if this is the original incorporation paper of the organization with which you are now affiliated?

Mr. SHELTON. Sir, again, is this question directed to me as an individual, or is it directed to me as an officer of a corporation?

Mr. APPELL. It is directed to you as the president of the corporation. (Witness confers with counsel.)

Mr. SHELTON. May I further confer with my counsel, please?

The CHAIRMAN. You may.

(Witness confers with counsel.)

Mr. SHELTON. Sir, I respectfully decline to answer that question for the reasons that I honestly feel that any answer might tend to incriminate me in violation of my rights as guaranteed to me under amendments 5, 1, 4, and 14 of the Constitution of the United States of America.

(Document marked "Robert Shelton Exhibit No. 2." This exhibit will be reproduced in a forthcoming report on Klan organizations.)

The CHAIRMAN. Now ask him the question as an individual.

Mr. APPELL. Mr. Shelton, with respect to the first document, you asked whether I asked you as an individual or in your corporate capacity, and also with respect to the second document, and I specifically directed it to your position as a corporate officer.

Now let me ask you again with respect to you as an individual and the document filed with the secretary of state, the annual registration certificate.

Did you as an individual file it?

Mr. SHELTON. Sir, I respectfully decline to answer that question for the reasons that I honestly feel that any answer might tend to incriminate me in violation of my rights as guaranteed to me by

amendments 5, 1, 4, and 14 of the Constitution of the United States of America.

Mr. APPELL. Now with respect to the second document I handed you, I ask you whether or not that is the charter of an organization which you, as an individual, now head?

Mr. SHELTON. Sir, I respectfully decline to answer that question for the reasons that I honestly feel that any answer that I might give would tend to incriminate me in violation of my rights as guaranteed to me under amendments 5, 1, 4, and 14 of the Constitution of the United States of America.

Mr. APPELL. Mr. Shelton, I now hand you a document, which is headed "Constitution And Laws Of The United Klans Of America, Inc., Knights Of The Ku Klux Klan."

I ask whether or not this is the constitution of an organization which you now head?

Mr. SHELTON. Could I refer to my counsel, please?

(Witness confers with counsel.)

(At this point Representative Ichord entered the hearing room.)

The CHAIRMAN. What is the pending question?

Mr. APPELL. Whether or not that is the Constitution and Laws of the order, sir.

The CHAIRMAN. That is a very simple question, Mr. Shelton. You have been fiddling with that book for a long time. I order and direct you to answer that question.

(Witness confers with counsel.)

Mr. SHELTON. Sir, I respectfully decline to answer that question for the reasons that I honestly feel that any answer might tend to incriminate me in violation of my rights as guaranteed to me by amendments 5, 1, 4, and 14 of the Constitution of the United States of America.

(Document marked "Robert Shelton Exhibit No. 3." This exhibit will be reproduced in a forthcoming report on Klan organizations.)

The CHAIRMAN. Proceed.

Mr. APPELL. May I have the document?

The CHAIRMAN. Proceed. Ask the next question.

Mr. APPELL. Mr. Shelton, this document states on its face "As amended, ratified and approved by the Imperial Klonecilium at Birmingham, Alabama, September, 1964."

The inside face of the back cover is imprinted, "By Proclamation of The Imperial Wizard, Robert M. Shelton," signed with a reproduced signature of Robert M. Shelton, "Imperial Wizard."

I would like to ask you, sir, whether or not that is your signature?

(Document handed to witness.)

Mr. SHELTON. Sir, is this question directed to me as an individual or is it directed to me as an officer of a corporation?

Mr. APPELL. In both capacities.

The CHAIRMAN. Both.

Mr. SHELTON. I respectfully decline to answer that question for the reasons that I honestly feel that my answer might tend to incriminate me in violation of my rights as guaranteed to me by amendments 5, 1, 4, and 14 of the Constitution of the United States of America.

The CHAIRMAN. Do you feel that a proclamation signed by yourself as the Imperial Wizard incriminates you?

Mr. SHELTON. Sir, I respectfully decline to answer that question for the reason that I honestly feel that my answer might tend to incriminate me in violation of my rights as is guaranteed to me by the amendments 5, 1, 4, and 14 of the Constitution of the United States of America.

The CHAIRMAN. You are invoking your constitutional privileges, but I feel, and I suppose the committee does, too, that this is incredible. Proceed.

Mr. APPELL. Mr. Shelton, did this document supersede a constitution and laws or manual put into effect when the organization was formed in July of 1961?

Mr. SHELTON. Sir, is this question directed to me as an individual or is it directed to me as an officer of the corporation?

The CHAIRMAN. Let me ask you—maybe you have some kind of distinction that I don't catch—why do you ask that question?

Mr. SHELTON. Sir, I respectfully decline to answer that question for the reason my answer might tend to incriminate me in violation of my rights as guaranteed to me under the amendments No. 5, 1, 4, and 14 of the Constitution of the United States of America.

The CHAIRMAN. The committee cannot tolerate applauses or demonstrations, pro or con, in these hearings.

Let me say this is serious with me. I was trying to be fair with you. I have been a lawyer for 39 years. Maybe I miss the point.

Are you drawing a distinction? You are asking us to explain in what capacity we are questioning you. I thought I had missed the point.

Mr. APPELL. The subpoena served upon you by a United States marshal on October 11, 1965, called upon you to produce, and I will quote from the subpoena attachment:

All books, records, documents, correspondence and memoranda relating to the organization of and the conduct of business and affairs of the Invisible Empire, United Klans, Knights of the Ku Klux Klan of America, Inc., also known as the United Klans of America, Inc., Knights of the Ku Klux Klan, and affiliated organizations, namely the Alabama Rescue Service, United Klansmen of America, Whiteman's Defense Fund, Christian News Service, in your possession, custody control, or maintained by or available to you as Imperial Wizard of the Invisible Empire, United Klans, Knights of the Ku Klux Klan of America, Inc., also known as the United Klans of America, Inc., Knights of the Ku Klux Klan.

That is part 1, Mr. Chairman, and I would like to ask for a production of those documents at this time, sir.

(Witness confers with counsel.)

Mr. SHELTON. I respectfully decline to deliver to this committee any and all records as requested by this committee under subpoena dated October 7, 1965, for that information is not relevant nor germane to the subject under investigation, and the same would not aid the Congress in the consideration of any valid legislation or in any such inquiry within the scope of that authorized to be investigated by Rule XI of the rules adopted by the 89th Congress, by House Resolution 8, adopted January 4, 1965.

The CHAIRMAN. I order and direct you to answer that question. Let me say, before the order, that the position of this committee is that these documents called for are very relevant, very pertinent, very appropriate and essential in connection with this investigation and, therefore, I overrule your refusal to respond to the subpoena.

So I order and direct you to answer that question.

Mr. SHELTON. Sir, I respectfully decline to turn over to this committee any records under subpoena for the reason that I honestly feel that any material that I might turn over would tend to incriminate me in violation of my rights as guaranteed to me under the amendments No. 5, 1, 4, and 14 of the Constitution of the United States of America.

Mr. APPELL. Mr. Shelton, do you refuse——

The CHAIRMAN. Wait a second.

As I understand, Mr. Appell, these documents that are being ordered to be produced by that subpoena, are being ordered to be produced by him as president of the corporation and as Imperial Wizard of that organization; is that correct?

Mr. APPELL. Yes, sir.

The CHAIRMAN. Mr. Appell, your answer to my question is in the affirmative; is that correct?

Mr. APPELL. Yes, sir.

The CHAIRMAN. All right.

Now, Mr. Shelton, this subpoena is an order for you to produce documents in your possession in the capacity of president, as well as Imperial Wizard, of your organization. This has nothing to do with your refusal to answer a question. This is an order to produce documents pursuant to a subpoena duces tecum. Of course, the fifth amendment invocation is improper under these circumstances.

Furthermore, and for other reasons, why the invocation is improper is when documents are ordered to be produced before a court or before a committee, the court or the committee has a right to inspect those documents and find out more about their contents, their pertinency, their scope and nature and so forth.

Therefore, your invocation of the fifth amendment the Chair rules improper, and you are now ordered and directed to produce the documents requested and demanded by the subpoena in the capacity I have described.

(Witness confers with counsel.)

Mr. APPELL. There is a direction to you, Mr. Shelton.

Mr. SHELTON. Sir, I respectfully decline to turn over any records, books, or materials so subpoenaed for the reason that I honestly feel that any material turned over might tend to incriminate me in violation of my rights as guaranteed to me by amendments 5, 1, 4, and 14 of the Constitution of the United States of America.

Mr. APPELL. Mr. Shelton, at the hour of 1:25 o'clock p.m. on the 11th day of October 1965, when you were served, were you the Imperial Wizard of the United Klans of America, Inc., Knights of the Ku Klux Klan?

Mr. SHELTON. Sir, I respectfully decline to answer that question for the reasons that I honestly feel that my answer might tend to incriminate me in violation of my rights as guaranteed to me by amendments 5, 1, 4, and 14 of the Constitution of the United States of America.

Mr. APPELL. Mr. Shelton, part 2 of your subpoena called for you to produce:

All books, records, documents, correspondence, and memoranda in your possession, custody or control, or maintained by or available to you, in your

capacity as Imperial Wizard of the United Klans of America, Inc., Knights of the Ku Klux Klan, which the "Constitution and Laws" of said organization authorize and require to be maintained by you and any other officer of said organization, the same being in your possession, custody or control.

Are you prepared to submit the documents called for by your Constitution and Laws?

Mr. SHELTON. Sir, I respectfully decline to turn over any documents under the listing of the subpoena dated October 7, 1965, for the reason that I honestly feel that any such material might tend to incriminate me in violation of my rights as guaranteed to me under amendments 5, 1, 4, and 14 of the Constitution of the United States of America.

Mr. APPELL. Mr. Chairman, I ask that the witness be directed to produce the documents called for by the Constitution and Laws.

The CHAIRMAN. I direct you to produce those documents.

Mr. SHELTON. Sir, I decline to turn over any documents as listed by the subpoena of October 7, 1965, for I personally and honestly feel that any material that I might turn over to the committee would tend to incriminate me in violation of my rights as guaranteed to me by the amendments No. 5, 1, 4, and 14 of the Constitution of the United States of America.

The CHAIRMAN. The last question referred to documents requested and ordered to be produced under part 2 of the subpoena. You understand that, do you, and my demand for production has to do with the documents referred to in part 2 of the subpoena?

Mr. SHELTON. Sir, I respectfully decline to answer that question for the reasons that I honestly feel that any answer might tend to incriminate me in violation of my rights as guaranteed to me by amendments 5, 1, 4, and 14 of the Constitution of the United States of America.

Mr. ASHBROOK. Mr. Chairman, I am sure that the witness is very proud to have committed such a long passage to memory. But to facilitate the hearings I suggest we inform him of his ability to invoke this by just referring to the grounds previously stated.

The CHAIRMAN. Yes, I might explain that to counsel.

It is usual, or not unusual, let's put it, in cases of repeated invocation of the fifth amendment, instead of literally repeating all the words, to say that he declines to answer on the grounds previously stated, if he wants to. It is up to him.

(Witness confers with counsel.)

The CHAIRMAN. I just made a suggestion. You can act the way you want. I want to make it clear that the documents just referred to, required to be produced under part 2 of the subpoena which has been served upon you, and you are being asked to produce them both as president of the corporation and as Imperial Wizard of the United Klans of America.

I just want to make the record clear. The subpoena was directed to you in that capacity, as president and Imperial Wizard.

If you understand that, you don't have to repeat the invocation, but you may do it if you wish.

Do you understand that?

Mr. SHELTON. Sir, I decline to answer that question for the reason that I honestly feel that the answer might tend to incriminate me in violation of my rights as guaranteed to me under the amendments 5, 1, 4, and 14 of the Constitution of the United States of America.

The CHAIRMAN. Now, let me ask you this question: If the previous questions that were posed to you before we reached the subpoena had been addressed to you not only as an individual and an official, but also as an Imperial Wizard, would your answers have been the same?

Mr. SHELTON. Sir, I respectfully decline to answer that question for the reason that I honestly feel that the answer might tend to incriminate me in violation of my rights as guaranteed to me by amendments 5, 1, 4, and 14 of the Constitution of the United States of America.

The CHAIRMAN. And I take it that the suggestion made a while ago, that instead of going through this ritual of reading the paper you have in front of you, that you might simply say that you decline to answer for reasons previously stated, is declined by you; is that correct?

Mr. SHELTON. I respectfully decline to answer that question for the reason that I honestly feel that my answer might tend to incriminate me in violation of my rights as guaranteed to me under amendments 5, 1, 4, and 14 of the Constitution of the United States of America.

The CHAIRMAN. Am I to understand that your reason for not following my suggestion is that in addition to your refusing to answer by invoking repeatedly your privileges under the fifth amendment also involves an attitude of delaying the proceedings?

Mr. SHELTON. I respectfully decline to answer that question for the reason that I honestly feel that my answer might tend to incriminate me in violation of my rights as guaranteed to me under amendments 5, 1, 4, and 14 of the Constitution of the United States of America.

Mr. POOL. Mr. Chairman——

The CHAIRMAN. Mr. Pool?

Mr. POOL. Have you advised other Klansmen throughout the country that they should not take the fifth amendment?

Mr. SHELTON. I respectfully decline to answer that question for the reasons that I honestly feel that my answer might tend to incriminate me in violation of my rights——

Mr. POOL. It is all right for you to take the fifth——

Mr. SHELTON. —as guaranteed to me by amendments 5, 1, 4, and 14 of the Constitution of the United States of America.

Mr. POOL. In other words, it is all right for you to take the fifth amendment, but they shouldn't take it; they should come up and testify?

Mr. SHELTON. I respectfully decline to answer that question for the reason that I honestly feel that the answer might tend to incriminate me in violation of my rights as guaranteed to me by amendments 5, 1, 4, and 14 of the Constitution of the United States of America.

Mr. POOL. Well, is membership in the Ku Klux Klan considered by you to be a membership that will incriminate you?

Mr. SHELTON. I respectfully decline to answer that question for the reasons that I honestly feel that the answer might tend to incriminate me in violation of my rights as guaranteed to me by amendments 5, 1, 4, and 14 of the Constitution of the United States of America.

Mr. POOL. All right, answer this question, if you will: Are you ashamed to be a member of the Ku Klux Klan?

Mr. SHELTON. I respectfully decline to answer that question for the reason that I honestly feel that my answer might tend to incriminate

me in violation of my rights as guaranteed to me by amendments 5, 1, 4, and 14 of the Constitution of the United States of America.

Mr. POOL. And to that question—this is not a question but a statement—to that question, then, you took the fifth amendment.

The CHAIRMAN. All right, proceed.

Mr. APPELL. Mr. Shelton, part 3 of your subpoena called for you to produce:

Copies of unexecuted forms relating to applications for membership, applications and issuance of charters; copies of Constitutions and By-Laws; manuals; and unexecuted forms and documents used by Kligrapps (Imperial, Realm and Klan or Klavern), and Klabees (Imperial, Realm and Klan or Klavern), Grand Dragons (Realm), Kleagles (Imperial, Realm, Province, and Klan, or Klavern); all of which are in your possession, custody or control, or available to you as Imperial Wizard of the Invisible Empire, United Klans, Knights of the Ku Klux Klan of America, Inc., also known as the United Klans of America, Inc., Knights of the Ku Klux Klan, and its affiliated organizations, the Alabama Rescue Service and United Klansmen of America, and which are used in connection with the business and affairs of said organizations.

I ask you to produce—I direct you to produce those documents. (Witness confers with counsel.)

Mr. SHELTON. Sir, I respectfully decline to produce these documents called for under this subpoena for the reason that I honestly feel that these documents might tend to incriminate me in violation of my rights as guaranteed to me by amendments 5, 1, 4, and 14 of the Constitution of the United States of America.

(At this point Mr. Ashbrook left the hearing room.)

Mr. APPELL. Mr. Chairman, I ask for a direction for the witness to produce the documents.

The CHAIRMAN. I order and direct you to produce those documents for the reasons I have already indicated.

Mr. SHELTON. Sir, I respectfully decline to produce these documents under question for the reason that I honestly feel that the answer might tend to incriminate me in violation of my rights as guaranteed to me by amendments 5, 1, 4, and 14 of the Constitution of the United States of America.

Mr. APPELL. Mr. Shelton, part 4 of your subpoena called upon you to produce:

Copies of U.S. Treasury Department, Internal Revenue Service, Form 1120, [which is titled] "U.S. Corporation Income Tax Return", for the fiscal years 1961 through June 30, 1965, filed by you as President and/or Imperial Wizard, United Klans of America, Knights of the Ku Klux Klan, Inc., with the U.S. Treasury Department, Internal Revenue Service.

I direct you to produce those documents.

Mr. SHELTON. Sir, I respectfully decline to turn over these documents under subpoena for the reason that I honestly feel that these documents might tend to incriminate me in violation of my rights as guaranteed to me by amendments 5, 1, 4, and 14 of the Constitution of the United States of America.

(At this point Mr. Ashbrook returned to the hearing room.)

The CHAIRMAN. That demand is made upon you as president of the corporation, and as Imperial Wizard of the Klan. I order and direct you to produce those documents pursuant to that subpoena in that capacity.

Mr. SHELTON. Sir, I respectfully decline to produce these documents in question for the reason that I honestly feel they might tend to incriminate me in violation of my rights as guaranteed to me by amendments, 5, 1, 4, and 14 of the Constitution of the United States of America.

The CHAIRMAN. Supplemental to the reasons on which I ruled that your invocation is improper, I call to your attention, and to that of your counsel, decisions of the courts holding that if pertinent to the investigation, and this is pertinent, it is proper to subpoena from the taxpayer involved, or the president of the corporation, a copy of Federal income tax returns. I wanted to make that clear.

That case is *U.S. versus O'Mara*, 122 Fed. Supp. 399, and incidentally, it was a contempt citation case, contempt before a committee of Congress.

Proceed.

Mr. APPELL. Mr. Shelton, part 5 of your subpoena attachment called for you to produce:

Copies of U.S. Treasury Department, Internal Revenue Service, Form 1040 [which is titled] "U.S. Individual Income Tax Return", for the calendar years 1958 through 1964, filed by you as an individual taxpayer with the U.S. Treasury Department, Internal Revenue Service.

I direct that you produce the documents at this time.

Mr. SHELTON. Sir, I respectfully decline to turn over this document in question for the reason that I honestly feel that my answer might tend to incriminate me in violation of my rights as guaranteed to me by amendments 5, 1, 4, and 14 of the Constitution of the United States of America.

The CHAIRMAN. I order and direct you to produce the documents.

Mr. SHELTON. Sir, I respectfully decline to produce these documents in question for the reason that I honestly feel that my answer might tend to incriminate me in violation of my rights as guaranteed to me by amendments 5, 1, 4, and 14 of the Constitution of the United States of America.

The CHAIRMAN. Did you not, on October 14, 1965, in Hotel Stafford, Tuscaloosa, tell our investigator, Mr. Louis Russell, that you would not invoke the fifth amendment?

Mr. SHELTON. Sir, I respectfully decline to answer that question for the reason that I honestly feel that it might tend to incriminate me in violation of my rights as guaranteed to me by amendments 5, 1, 4, and 14 of the Constitution of the United States of America.

The CHAIRMAN. Did you not, as late as yesterday, in the company of the attorney next to you, call on the director of this committee, Mr. Francis McNamara, and then and there tell him—both you and your lawyer—that you would cooperate in every way possible with this committee?

Mr. SHELTON. Sir, I respectfully decline to answer that question for the reason that I honestly feel that my answer might tend to incriminate me in violation of my rights as guaranteed to me by amendments 5, 1, 4, and 14 of the Constitution of the United States of America.

The CHAIRMAN. And may I say that I am not in the least reproaching your legal counsel's advice. I am seeking facts. I just want to say that. I know it was just told to me that counsel had said

that he would, of course, have to protect the rights of his client, or words to that effect.

Mr. CHALMERS. Yes.

Mr. APPELL. Mr. Chairman, with the indulgence of the committee, I would like to refer to the Constitution and Laws of the order and those sections of the Constitution and Laws that places the responsibility upon the Imperial Wizard to do certain things and to carry out certain functions of his office.

Section 3, under the "Duties, Prerogatives and Powers of the Imperial Wizard," reads:

He shall issue charters for Klans, specify conditions on which charters shall be issued, and shall have the power to open and close charters of Klans at his discretion or upon request of a Klan. He shall have full authority and power to suspend or revoke charters of Klans, for cause.

Mr. Shelton, do you have communications relating, and documents relating, to the issue of charters?

Mr. SHELTON. Sir, I respectfully decline to answer that question for the reason that I honestly feel that my answer might tend to incriminate me in violation of my rights as guaranteed to me by the amendments 5, 1, 4, and 14 of the Constitution of the United States of America.

Mr. APPELL. Section 6 provides "he," referring to the Imperial Wizard, or as the Constitution and Laws say, the president—and "he" is used in the context of both president and Imperial Wizard:

He shall have full authority to issue decrees, edicts, mandates, rulings and instructions covering any matter not specifically set forth in this Constitution, or emphasizing any matter of this Constitution, and all such decrees, edicts, mandates, ruling and instructions must be respected and obeyed promptly and faithfully by all members of this Order on penalty of Suspension upon approval of the Imperial Board.

Do you have in your possession any decrees, edicts, mandates, rulings, or instructions issued by you?

Mr. SHELTON. Sir, I respectfully decline to answer that question for the reason that I honestly feel that my answer might tend to incriminate me in violation of my rights as guaranteed to me by amendments 5, 1, 4, and 14 of the Constitution of the United States of America.

Mr. APPELL. Section 9 says "he," referring to the Imperial Wizard or president—

shall have full power and authority to suspend from office at any time any officer of this Order, or any rank or station or capacity, or any employee whomsoever, on the ground of incompetency, disloyalty, neglect of duty, or for unbecoming conduct.

Do you have in your possession any documents relating to the suspension of any officer, member, or employee?

Mr. SHELTON. Sir, I respectfully decline to produce any such documents in question for the reason that I honestly feel that my presentation of documents might tend to incriminate me in violation of my rights as guaranteed to me by amendments 5, 1, 4, and 14 of the Constitution of the United States of America.

Mr. APPELL. Section 10 provides "he," referring to the Imperial Wizard and president—

shall have and hold full and original authority and power, office and title of "Supreme Kleagle."

As this Constitution and Laws describes the Supreme Kleagle as the Supreme Organizer, do you have any documents in your possession with respect to the organization or organizational activities of organizers or the establishment of realms?

Mr. SHELTON. May I speak with my counsel!?

The CHAIRMAN. Yes.

(Witness confers with counsel.)

Mr. SHELTON. Sir, I respectfully decline to answer that question for the reasons that I honestly feel that the answer might tend to incriminate me in violation of my rights as guaranteed to me by amendments 5, 1, 4, and 14 of the Constitution of the United States of America.

The CHAIRMAN. In that connection, with reference to this series of questions, isn't it a fact that you have said many times that you didn't believe in violence, and if people engaged in violence that you had means of suspending or rejecting those members? And also is it not a fact that that is just a sham and you never have expelled any member because of violence even though you knew they had committed violence, and that is what the provisions in this document are talking about?

Mr. SHELTON. Sir, I respectfully decline to answer that question for the reason that I honestly feel that my answer might tend to incriminate me in violation of my rights as guaranteed to me by amendments 5, 1, 4, and 14 of the Constitution of the United States of America.

Mr. APPELL. Section 11 provides "he," the Imperial Wizard or president—

shall issue and sign all commissions or other credentials of this Order in promulgating same, and affix the Imperial Seal thereto; and he shall contract, in the name of this Order, with other members for its extension, financing, management, operation and business interests.

Do you have in your possession any documents related to and within Section 11?

Mr. SHELTON. Sir, I respectfully decline to answer that question for the reason that I honestly feel that the answer might tend to incriminate me in violation of my rights as guaranteed to me by amendments 5, 1, 4, and 14 of the Constitution of the United States of America.

Mr. APPELL. Mr. Chairman, there are many other sections of the constitution which relate to the documents, decrees, and edicts issued by the Imperial Wizard or president. However, I shall now pass to that portion of the constitution which relates itself to financial documents.

Under Article XIII, which deals with paraphernalia, regalia, emblems, ensigns, and insignia, Section 3:

All articles, designs and things referred to or implied in Sections 1 and 2, above, and Article X, Section 7, of this Constitution, and all property, real and personal, shall ever be and remain the property of this Order and such supplies can only be procured from the Imperial Wizard by the required requisition therefor, and this also shall apply to all supplies used by any subordinate jurisdiction and any and all jewelry or other articles used by a member upon the approval of the Imperial Board.

Mr. Shelton, do you maintain records of receipts of money for sales of supplies to realms or to Klans or Klaverns within the realms?

Mr. SHELTON. Sir, I respectfully decline to answer that question for the reason that I honestly feel that my answer might tend to incriminate me in violation of my rights as guaranteed to me by amendments 5, 1, 4, and 14 of the Constitution of the United States of America.

Mr. ASHBROOK. Mr. Chairman, could I ask a question at that point?

The CHAIRMAN. Yes.

Mr. ASHBROOK. Mr. Shelton, in your invitation to men to join your organization, which bears your picture and has your name, you make the following statement, which appears most interesting at this point. You say:

We will never cower before any master or bend to any threat. It is our heritage to stand erect, proud, and unafraid; to think and act for ourself; enjoy the benefits of our creation, and to face the world boldly and say: . . . This I have done!

It is your feeling that this is what you are doing at the present time, standing and facing the world boldly and saying, "This I have done!" or is this invitation for people to join the Klan, like most of what we have seen, just somewhat of a ruse?

Mr. SHELTON. Sir, I respectfully decline to answer that question for the reasons that I honestly feel that my answer might tend to incriminate me in violation of my rights as guaranteed to me by amendments 5, 1, 4, and 14 of the Constitution of the United States of America.

The CHAIRMAN. The question before the one you declined to answer had to do with your maintenance of financial records, and to that you invoked the fifth amendment. Is fear of answer involving possible incrimination because of financial irregularities and failure properly to report your income to the Federal Government or the State of Alabama in your income tax returns?

Mr. SHELTON. Sir, I respectfully decline to answer that question for the reasons that I honestly feel that my answer might tend to incriminate me in violation of my rights as guaranteed to me by amendments 5, 1, 4, and 14 of the Constitution of the United States of America.

(At this point Mr. Ichord left the hearing room.)

The CHAIRMAN. Have you, in fact, faithfully used and expended and utilized all funds coming to you as president of your corporation and as Imperial Wizard and spent it for purposes received, or have you, in fact, misappropriated any of those funds?

Mr. SHELTON. Sir, I respectfully decline to answer that question for the reason that I honestly feel that my answer might tend to incriminate me in violation of my rights as guaranteed to me by amendments 5, 1, 4, and 14 of the Constitution of the United States of America.

Mr. APPELL. Mr. Chairman, Article XV, Section 1, says on revenues:

The revenues of this Order shall consist of: First, a per capita tax, which shall be known as the Imperial Tax, which shall be a sum of fifty cents (\$.50)

per month. Second, all profits realized from the placing of paraphernalia, regalia, supplies, jewelry, uniforms, costumes, stationery, and any and all other articles used in the work of this Order, or by any member. Third, all interest accruing [sic] on investments made by this Order.

Mr. Shelton, do you maintain financial records covered by Section 1, Article XV?

Mr. SHELTON. Sir, I respectfully decline to answer that question for the reason that I honestly feel that my answer might tend to incriminate me in violation of my rights as guaranteed to me by amendments 5, 1, 4, and 14 of the Constitution of the United States of America.

The CHAIRMAN. Mr. Shelton, I assure you this question has no religious connotations. I respect your rights in full under the Constitution, including your religious persuasion. But as a proper question in my opinion, under this investigation, I am compelled to ask you this question, as it is in my opinion perfectly proper:

You have, as part of your ritual an oath of allegiance which was quoted in part this morning and I will repeat part of it here:

"I, in the presence of God and Man—most solemnly pledge, promise and swear" that I will do thus and so, and it finally winds up, "I will die rather than divulge same—so help me God."

Yet in appearing before this committee you refused to take an oath and chose to affirm. I respected that right. In fact, I posed the proper opening form of oath. The question that comes to my mind is this:

It appears that you are willing to swear and cause all your members to swear—and I will put the word "swear" in quotes—with reference to Klan matters; yet you only affirmed here today. Is the reason that you consider an oath only with respect to the Klan, and thereby hold that oath above an oath in appearance before a congressional committee?

Mr. SHELTON. Sir, I respectfully decline to answer that question for the reason that I honestly feel that my answer might tend to incriminate me in violation of my rights as guaranteed to me under amendments 5, 1, 4, and 14 of the Constitution of the United States of America.

The CHAIRMAN. Isn't it a fact that according to the tenets of your Klan organization, that your primary obligation, your true allegiance, is to the Klan, above allegiance to your Government or anything else?

Mr. SHELTON. Sir, I respectfully decline to answer that question for the reason that I honestly feel that my answer might tend to incriminate me in violation of my rights as guaranteed to me under the amendments of 5, 1, 4, and 14 of the Constitution of the United States of America.

The CHAIRMAN. Proceed.

Mr. APPELL. Mr. Shelton, I hand you a series of oaths: Section I.—Obedience; Section II.—Secrecy; Section III.—Fidelity; Section IV.—[Klan]*ishness.

I ask you if these are the series of oaths administered to members of the United Klans of America.

The CHAIRMAN. I hope you will not invoke the fifth amendment on the ground of possible self-incrimination in referring to an oath.

Mr. SHELTON. Sir, I respectfully decline to answer that question for the reason that I honestly feel that my answer might tend to incriminate me in violation of my rights as guaranteed to me by amendments 5, 1, 4, and 14 of the Constitution of the United States of America.

(Document marked "Robert Shelton Exhibit No. 4." This exhibit will be reproduced in a forthcoming report on Klan organizations.)

The CHAIRMAN. I think I am going to direct you, and I hereby direct you, to answer that question.

Mr. SHELTON. Sir, I respectfully decline to answer that question for the reason that I honestly feel that my answer might tend to incriminate me in violation of my rights as guaranteed to me by amendments 5, 1, 4, and 14 of the Constitution of the United States of America.

(At this point Mr. Buchanan left the hearing room.)

The CHAIRMAN. Now, I renew the suggestion I made a while ago that instead of going through that ritual—which by now you are reading faster, incidentally—instead of doing that, I offer again that you simply say that you decline to answer for reasons previously stated.

(At this point Mr. Weltner left the hearing room.)

The CHAIRMAN. Do you accept that suggestion?

Mr. SHELTON. Sir, I respectfully decline to answer that question for the reason that I honestly feel that my answer might tend to incriminate me in violation of my rights as guaranteed to me by amendments 5, 1, 4, and 14 of the Constitution of the United States of America.

(At this point Mr. Weltner returned to the hearing room.)

Mr. APPELL. Mr. Shelton, the series of oaths that I handed to you, did you, as an individual, ever take them? Were they ever administered to you as an individual?

Mr. SHELTON. I respectfully decline to answer that question for the reason that I honestly feel that my answer might tend to incriminate me in violation of my rights as guaranteed to me by amendments 5, 1, 4, and 14 of the Constitution of the United States of America.

Mr. APPELL. Mr. Shelton, you were asked about the receipt of money provided for by Section 1 of Article XV. Does the United Klans of America, Inc., as an organization, or yourself as an individual, maintain a bank account under the name of the Alabama Rescue Service at "The First National Bank of Tuscaloosa," Tuscaloosa, Alabama?

Mr. SHELTON. Sir, I respectfully decline to answer that question on the grounds of the previous statement.

The CHAIRMAN. Oh? You decline to answer for reasons previously stated?

Mr. SHELTON. Heretofore stated.

(At this point Mr. Buchanan returned to the hearing room.)

The CHAIRMAN. That is fine.

Mr. SHELTON. That is, in my previous answer.

Mr. APPELL. Mr. Chairman, the Committee on Un-American Activities has served subpoenas upon The First National Bank of Tuscaloosa for the production of certain books and records maintained under the name of Alabama Rescue Service.

The CHAIRMAN. Before you go into that, let me ask this question: Isn't the Alabama Rescue Service a plain front organization?

Mr. SHELTON. Sir, I respectfully decline to answer that question on the grounds previously stated and included thereof.

The CHAIRMAN. And does not your organization and its various ramifications throughout the several States have several front organizations, such as clubs, gun clubs, and any number of others?

Mr. SHELTON. Sir, I respectfully decline to answer that question on the previous grounds stated thereof.

Mr. APPELL. Mr. Shelton, again before we get to the subpoena, were you interviewed by an agent of the Internal Revenue Service on 1 of 3 days, August 6, 7, or 8, 1963,¹ by Internal Revenue Service Agent Roy Heddy when you were accompanied by Mr. James R. Jones?

Mr. SHELTON. Sir, I respectfully decline to answer that question on the grounds as previously stated and included thereof.

Mr. APPELL. Mr. Chairman, I would like to read into the record a report furnished us by the Internal Revenue Service in respect to a request made of the President of the United States for permission to review certain tax records which the committee has the authority to do under Executive order. This memorandum, prepared by Albert B. Niemann, revenue officer, High Point, contains this paragraph:

Revenue Officer Heddy called me this morning stating he had conferred with Mr. Shelton and with Mr. Jones, and had received the following information. The Realm of North Carolina is simply a geographical subdivision of the National Chapter and is used only to identify a given area, i.e., the State of North Carolina. It is not an organization and has no funds, income or expense, therefore no returns are due. The North Carolina Rescue Service does not exist. Mr. Shelton stated that there is an Alabama Rescue Service which is simply a book-keeping function, wherein funds are placed in that name in the bank and disbursements made from that checking account—in the state of Alabama. No such checking account exists in the state of North Carolina, according to Mr. Shelton and Mr. Jones, therefore, no returns are due.

Mr. Shelton, is that a truthful reporting of an interview conducted of you and Grand Dragon Jones by Internal Revenue Agent Heddy?

Mr. SHELTON. Sir, I respectfully decline to answer that question based on the grounds heretofore stated.

Mr. APPELL. As it was reported to us, is it correct?

Mr. SHELTON. Sir, I respectfully decline to answer that question based on the grounds heretofore stated.

(Document marked "Robert Shelton Exhibit No. 5" and retained in committee files.)

Mr. APPELL. Mr. Chairman, in accordance with the subpoena served upon The First National Bank of Tuscaloosa, the committee has received records of the Alabama Rescue Service going back to May 13, 1963. Together with the production of documents called for, there were copies of signature cards.

Mr. Shelton, I hand you the first signature card containing the names of Fredrick G. Smith and Alvin B. Sisk and ask you whether or

¹ This should read "1965".

not they were officers of the United Klans of America using a book-keeping function known as the Alabama Rescue Service.

Mr. SHELTON. Sir, I respectively decline to answer that question based on the grounds heretofore stated.

(Document marked "Robert Shelton Exhibit No. 6" follows:)

ROBERT SHELTON EXHIBIT NO. 6

<i>First National Bank</i>																										
INDIVIDUAL																										
FIRST NATIONAL BANK, TUSKALOOSA, ALABAMA																										
<p>The bank is hereby authorized to recognize the signature executed herewith in payment of funds or transaction of any other business of said party. In receiving items for deposit or collection, this bank acts only as depositor's collecting agent and assumes no responsibility beyond the exercise of due care. All items are credited subject to final payment in cash or solvent credit. This bank will not be liable for default or negligence of its duly selected correspondents nor for losses in transit, and each correspondent so selected shall not be liable except for its own negligence. This bank or its correspondents may send items, directly or indirectly, to any bank including the payor, and accept its draft or credit as conditional payment in lieu of cash; it may charge back any item at any time before final payment, whether returned or not, also any item drawn on this bank not good at close of business on day deposited. Service charges will be made in accordance with rules and regulations, effective as of date of this deposit, prescribed by the Tuscaloosa County Clearing House Association.</p>																										
SIGNATURE ALABAMA RESCUE SERVICE																										
OCCUPATION OR BUSINESS <i>x Frederick H. Smith</i>										STATEMENT TO BE MAILED HELD																
BUSINESS ADDRESS <i>x Alvin B. Sisk</i>										DATE OPENED <i>8-25-61</i>																
RESIDENCE ADDRESS <i>401-Alston Bldg. City</i>										INITIAL DEPOSIT SEP 24 1961																
INTRODUCED BY				PREVIOUS BANKING CONNECTION <i>Personal Acct.</i>				ACCOUNT ACCEPTED BY <i>Mrs.</i>																		
<table border="1"> <tr> <td>New</td> <td>Slg.</td> <td>Req.</td> <td>1</td> <td>2</td> <td>3</td> <td>4</td> <td>5</td> <td>6</td> <td>7</td> <td>8</td> <td>9</td> <td>10</td> <td>11</td> <td>12</td> </tr> </table>												New	Slg.	Req.	1	2	3	4	5	6	7	8	9	10	11	12
New	Slg.	Req.	1	2	3	4	5	6	7	8	9	10	11	12												
ALABAMA RESCUE SERVICE																										

Mr. APPELL. Mr. Shelton, isn't it a fact that Mr. Alvin B. Sisk was killed as a result of a plane crash in South Carolina in which you were a passenger in the plane?

Mr. SHELTON. Sir, I respectively decline to answer that question based on the grounds heretofore stated.

Mr. APPELL. Following the death of Mr. Sisk, I assume that it was necessary to file new signature cards. The bank failed to note the exact date that this signature card went into effect, but I would like to show it to you. It is Alabama Rescue Service, Robert M. Shelton, T. M. Montgomery, 401 Alston Building.

I ask you when you filed that signature card with The First National Bank of Tuscaloosa, Tuscaloosa, Alabama.

(Document handed to witness.)

Mr. SHELTON. Sir, I respectively decline to answer that question based on the grounds heretofore stated.

(Document marked "Robert Shelton Exhibit No. 7" appears on p. 1620.)

Mr. APPELL. Mr. Shelton, was T. M. Montgomery an elected official of the United Klans of America using the bookkeeping designation Alabama Rescue Service?

Mr. SHELTON. Sir, I respectively decline to answer that question for the reason that I honestly feel that any answer that I give might tend to incriminate me in violation of my rights as guaranteed to me

ROBERT SHELTON EXHIBIT No. 7

INDIVIDUAL									
FIRST NATIONAL BANK, TUSCALOOSA, ALABAMA									
<p>The bank is hereby authorized to recognize the signature executed herewith in payment of funds or transaction of any other business of said party in receiving items for deposit or collection, this bank acts only as depositor's collecting agent and assumes no responsibility beyond the exercise of due care. All items are credited subject to final payment in cash or solvent credit. This bank will not be liable for default or negligence of its duly selected correspondents nor for losses in transit, and each correspondent so selected shall not be liable except for its own negligence. This bank or its correspondents may send items, directly or indirectly, to any bank including the payor, and accept its draft or credit as conditional payment in lieu of cash; it may charge back any item at any time before final payment, whether returned or not, also any item drawn on this bank not good of close of business on day deposited. Service charges will be made in accordance with rules and regulations, effective as of date of this deposit, prescribed by the Tuscaloosa County Clearing House Association.</p>									
SIGNATURE	Alabama Rescue Service								
OCCUPATION OR BUSINESS	STATEMENT TO BE MAILED FIELD								
By: <i>Robert M. Shelton</i>									
BUSINESS ADDRESS	DATE OPENED								
By: <i>T. M. Montgomery</i>									
RESIDENCE ADDRESS	INITIAL DEPOSIT								
<i>461 Alston Bldg.</i>									
INTRODUCED BY	PREVIOUS BANKING CONNECTION								
	ACCOUNT ACCEPTED BY								
<table border="1"> <thead> <tr> <th colspan="2">TITLE</th> <th colspan="2">PER BANK</th> </tr> </thead> <tbody> <tr> <td>Nov</td> <td>12</td> <td>15</td> <td>15</td> </tr> </tbody> </table>		TITLE		PER BANK		Nov	12	15	15
TITLE		PER BANK							
Nov	12	15	15						
ALABAMA RESCUE SERVICE									

by amendments 5, 1, 4, and 14 of the Constitution of the United States of America.

Mr. APPELL. Mr. Shelton, Section 5 of Article X of the Constitution and Laws of the United Klans of America in dealing with the Imperial Klabee, or as the Constitution and Laws provide, the treasurer, the normal designation of a Klabee, or treasurer, does it not read this way:

Imperial Klabee: Is the Supreme Treasurer of this Order and is, therefore, the custodian of its funds, and he shall countersign all checks with the Imperial Wizard, and he shall make a full and complete report of his office to the regular Klonvokation each and every year.

Was Mr. Montgomery, T. M. Montgomery, the Klabee?

Mr. SHELTON. Sir, I respectfully decline to answer that question based on the grounds of the statement expressed heretofore.

The CHAIRMAN. Was Mr. T. M. Montgomery a member of the Klan?

Mr. SHELTON. Sir, I respectfully decline to answer that question for the reason based on the grounds that have been heretofore stated.

The CHAIRMAN. Where does he live?

Mr. SHELTON. Sir, I respectfully decline to answer that question based on the grounds as heretofore stated.

The CHAIRMAN. Who is he?

Mr. SHELTON. Sir, I respectfully decline to answer that question based on the grounds heretofore stated.

The CHAIRMAN. Did you not, on October 14, 1965, at the Hotel Stafford, in Tuscaloosa, ask our investigator, Mr. Louis Russell, whom you called upon rather than he calling upon you, if—

T. M. Montgomery was also to be subpoenaed since he had been questioned regarding this person by the F.B.I. He claimed to have told them that "this is

for me to know and you to find out." He [Shelton] claimed that no one would ever know who T. M. Montgomery is.

Did you make that statement to our investigator, Louis Russell, in that hotel in Tuscaloosa on October 14?

Mr. SHELTON. Sir, I respectfully decline to answer that question based on the grounds as heretofore stated.

Mr. APPELL. Mr. Shelton, is it not a fact that T. M. Montgomery is not a man, but a woman?

Mr. SHELTON. Sir, I respectfully decline to answer that question based on the grounds as heretofore stated.

Mr. APPELL. Mr. Shelton, according to the bank records—

The CHAIRMAN. Wait a moment.

Mr. APPELL. Mr. Shelton, is it not a fact that the signature "T. M. Montgomery" was executed by a woman, Mrs. Carol Long?

Mr. SHELTON. Sir, I respectfully decline to answer that question based on the grounds heretofore stated.

Mr. APPELL. Mr. Shelton, I now hand you—Mr. Shelton, was Mrs. Carol Long ever an employee in your office at 401 Alston Building, Tuscaloosa, Alabama?

Mr. SHELTON. Sir, I respectfully decline to answer that question based on the grounds heretofore stated.

Mr. APPELL. Mr. Shelton, I hand you—

The CHAIRMAN. Mr. Shelton, I must tell you that these questions are not a fishing expedition, that we have information that we expect to produce—full proof—that the T. M. Montgomery is not a man; that she is a woman, and she is the lady just identified by Mr. Appell. I want you to think about that.

Is your answer still the invocation of the fifth amendment?

Mr. SHELTON. Sir, I respectfully decline to answer that question for the reason that I honestly think that my answer might tend to incriminate me in violation of my rights as guaranteed to me by amendments 5, 1, 4, and 14 of the Constitution of the United States of America.

Mr. APPELL. Mr. Shelton, on May 14, 1964, a third signature card was filed with The First National Bank of Tuscaloosa, Tuscaloosa, Alabama, and this signature card contains the signatures of Robert M. Shelton and James J. Hendrix, with the designation following the name Hendrix, "Treas.," which I presume is the abbreviation of treasurer, with the address of "401 Alston Bldg., City."

The CHAIRMAN. And that is with reference to what bank?

Mr. APPELL. This is the bank account at The First National Bank, Tuscaloosa, Alabama, in the name of the Alabama Rescue Service, the same account we have been discussing with the two previous signature cards.

(Document handed to witness.)

(Witness confers with counsel.)

Mr. SHELTON. Sir, I respectfully decline to answer that question for the reason that I honestly feel that my answer might tend to incriminate me in violation of my rights as guaranteed to me by amendments 5, 1, 4, and 14 of the Constitution of the United States of America.

(Document marked "Robert Shelton Exhibit No. 8" follows:)

ROBERT SHELTON EXHIBIT NO. 8

INDIVIDUAL

FIRST NATIONAL BANK, TUSKALOOSA, ALABAMA

The bank is hereby authorized to recognize the signature attached herewith in payment of funds or transaction of any other business of said party. In receiving moneys for deposit or collection, this bank acts only as depository's collecting agent and assumes no responsibility beyond the exercise of due care. All items are credited subject to final payment in cash or solvent credit. This bank will not be liable for default or negligence of its duly selected correspondents due to losses in transit, and such correspondents or parties shall not be liable to the bank for its own negligence. This bank or its correspondents may send moneys directly or indirectly to any bank including the payor, and accept its draft or credit as conditional payment in lieu of cash; it may charge back any item at any time before final payment, whether returned or not, also any loss drawn on this bank not good of close of business on any deposited service charges will be made in accordance with rules and regulations, effective as of date of this deposit.

ALABAMA RESCUE SERVICE

SIGNATURE _____

OCCUPATION OR BUSINESS _____

BY: *Robert M. Shelton* STATE - TO BE MAILED - X

BUSINESS ADDRESS _____ DATE OPENED _____

BY: *James J. Hendrix* *Treas*

RESIDENCE ADDRESS _____ INITIAL DEPOSIT _____

X 401 - Adista Bedy. City

INTRODUCED BY _____ PREVIOUS BANKING CONNECTION _____ ACCOUNT ACCEPTED BY *Chas. J. ...*

TITAN *Chas. J. ...* **MAY 14 1924**

ALABAMA RESCUE SERVICE

The CHAIRMAN. Is the name James J. Hendricks or Hendrick?

Mr. APPELL. H-e-n-d-r-i-x.

The CHAIRMAN. Mr. Appell read to you a while ago the provision of your own Constitution and Laws to the effect that the treasurer or the individual required to countersign checks with you, or having the authority independently to draw checks, must be the treasurer of the United Klans of America.

Was James J. Hendrix the treasurer of your Klan organization?

Mr. SHELTON. Sir, I respectfully decline to answer that question based on the grounds heretofore stated.

The CHAIRMAN. Was James J. Hendrix a member of the Klan?

Mr. SHELTON. Sir, I respectfully decline to answer that question based on the grounds as heretofore stated.

The CHAIRMAN. Where does James J. Hendrix live?

Mr. SHELTON. Sir, I respectfully decline to answer that question based on the grounds heretofore stated.

The CHAIRMAN. Is there such a person as James J. Hendrix?

Mr. SHELTON. Sir, I respectfully decline to answer that question based on the grounds heretofore stated.

The CHAIRMAN. Isn't it true that James J. Hendrix is not a male, but a female—a lady?

Mr. SHELTON. Sir, I respectfully decline to answer that question based on the grounds as heretofore stated.

The CHAIRMAN. I give you the privilege—I am not going to ask you—I give you the privilege of naming that lady.

Mr. SHELTON. Sir, I—

The CHAIRMAN. And tell you before you answer that we have definite proof of who that lady is.

Mr. SHELTON. Sir, I respectfully decline to answer that question for the reasons that I honestly feel that my answer might tend to incriminate me in violation of my rights as guaranteed to me by amendments 5, 1, 4, and 14 of the Constitution of the United States of America.

(Witness confers with counsel.)

The CHAIRMAN. Mr. Shelton, you will be excused for a moment, but you are ordered not to leave this room.

Mr. SHELTON. Yes, sir.

The CHAIRMAN. Call your next witness, Mr. Appell.

Mr. APPELL. Mr. Chairman, I should like to call as the next witness Mrs. Carol Long.

The CHAIRMAN. Do you solemnly swear that the testimony you are about to give will be the truth, the whole truth, and nothing but the truth, so help you God?

Mrs. LONG. No, sir; I do not swear; I affirm.

The CHAIRMAN. Do you affirm?

Mrs. LONG. I certainly do.

The CHAIRMAN. Do you affirm that the testimony you are about to give will be the truth, the whole truth, so help you God?

Mrs. LONG. I certainly do.

**TESTIMONY OF CAROL LONG, ACCOMPANIED BY COUNSEL,
LESTER V. CHALMERS, JR.**

Mr. APPELL. Will you state your full name for the record?

Mrs. LONG. Mrs. Carol Long.

Mr. APPELL. Are you represented by counsel?

Mr. CHALMERS. She is.

Mr. APPELL. Will you please identify yourself for the record?

Mr. CHALMERS. Lester V. Chalmers, Jr., attorney at law, 501 First Federal Building, Raleigh, North Carolina.

Mr. APPELL. Are you appearing before the committee this morning in accordance with a subpoena served upon you by a United States marshal at 11:55 o'clock a.m., the 11th day of October 1965?

Mrs. LONG. Yes, sir. I am not sure about the correct time.

Mr. APPELL. Mrs. Long, were you ever employed or did you ever receive income from the United Klans of America or Alabama Rescue Service?

Mrs. LONG. Sir, I respectfully decline to answer that question for the reason that I honestly feel my answer might tend to incriminate me in violation of my rights that are guaranteed to me by amendments 5, 1, 4, and 14 of the Constitution of the United States of America.

Mr. APPELL. Mrs. Long, I hand you a Recordak copy of a check drawn on the Alabama Rescue Service, Suite 401 Alston Building, Tuscaloosa, Alabama, drawn on The First National Bank of Tuscaloosa, Tuscaloosa, Alabama, dated 8-2-63, made payable to cash in the amount of \$50 signed "Robert M. Shelton, T. M. Montgomery," and endorsed on the reverse thereof "Carol Long."

Would you examine that check and answer as to whether or not the endorsement on the reverse of the check, the name "Carol Long," was signed by you?

Mrs. LONG. I would like to consult my counsel.

(Witness confers with counsel.)

Mrs. LONG. Sir, I respectfully decline to answer that question for the reason that I honestly feel my answer might tend to incriminate me in violation of my rights as guaranteed to me by amendments 5, 1, 4, and 14 of the Constitution of the United States of America.
 (Document marked "Carol Long Exhibit No. 1" follows:)

CAROL LONG EXHIBIT NO. 1

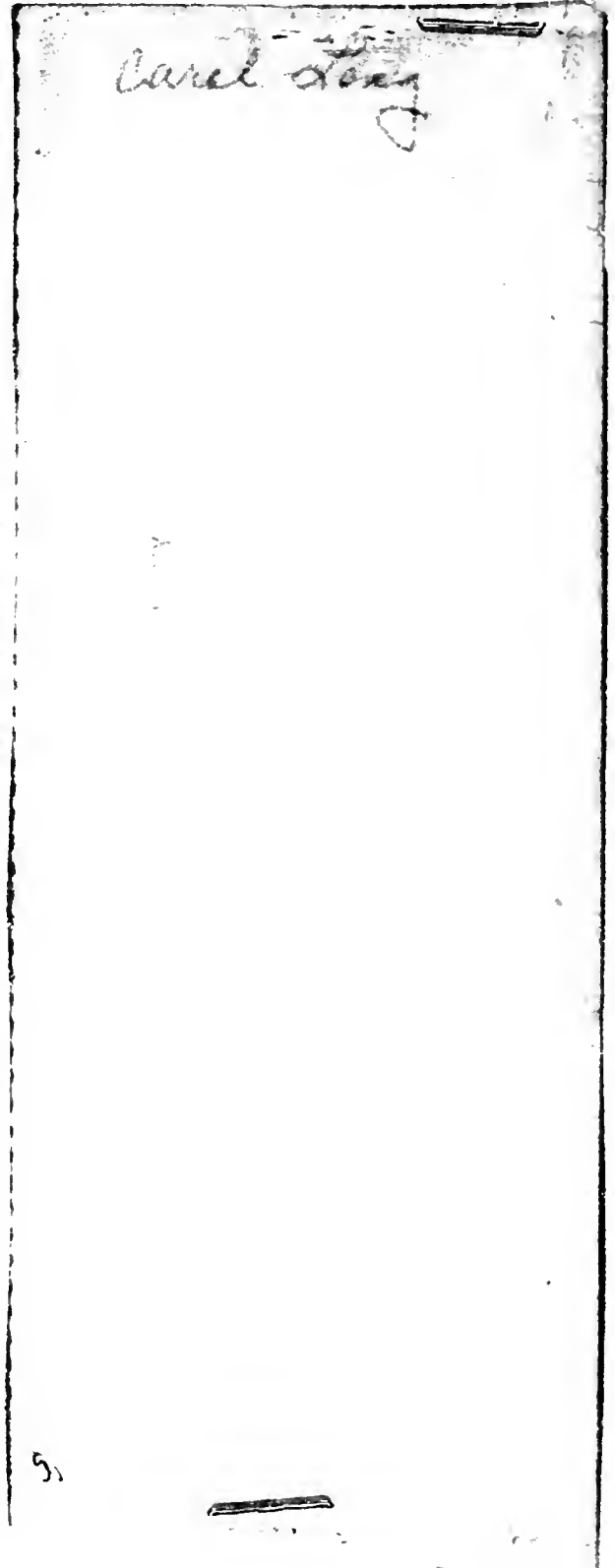
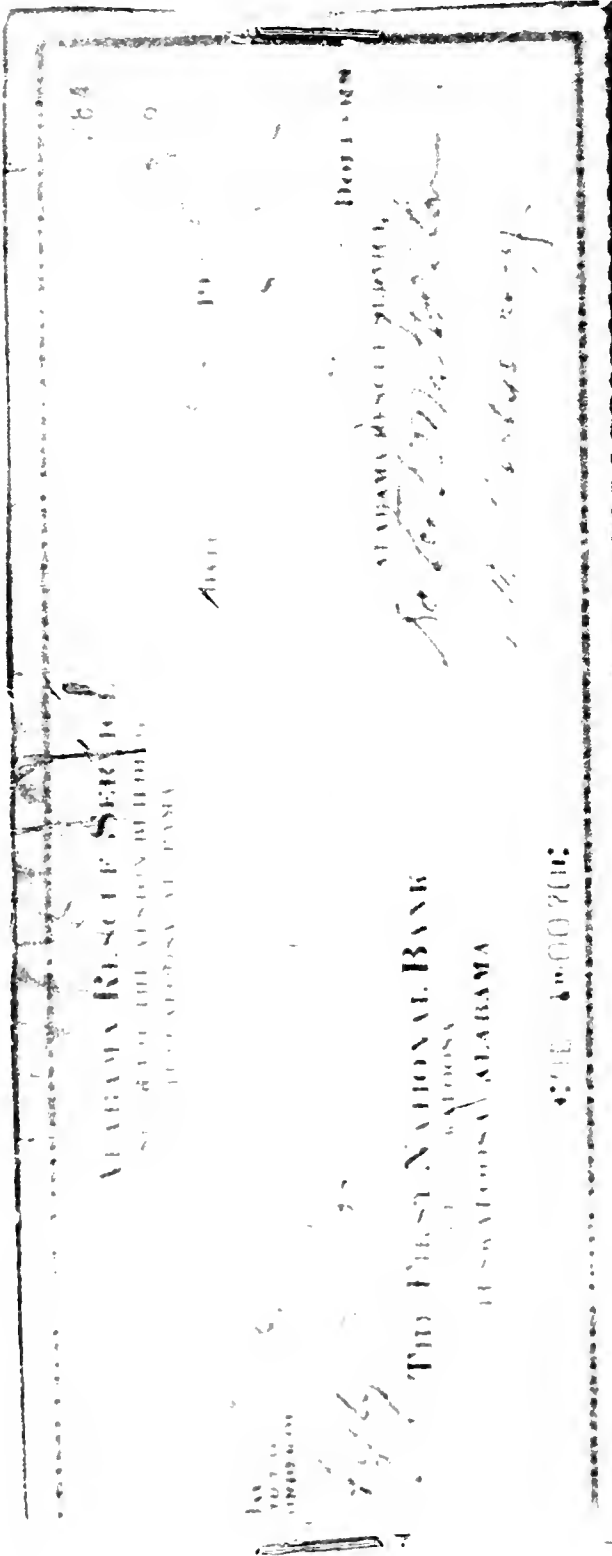

The CHAIRMAN. Mrs. Long, is it not a fact, an honest fact, that the signature "T. M. Montgomery," as a maker of the check, and the signature "Carol Long," as the endorser of the check, are one and the same handwriting?

Mrs. LONG. Sir, I respectfully decline to answer that question for the reason that I honestly feel my answer might tend to incriminate me in violation of my rights that are guaranteed to me by amendments 5, 1, 4, and 14 of the Constitution of the United States of America.

The CHAIRMAN. I think I ought to tell you, because this may lead to just such things as you are talking about, that we will adduce in a few moments proof that it is the same handwriting.

Mrs. LONG. Sir, I respectfully decline to answer that question for the reason that I honestly feel my answer might tend to incriminate me in violation of my rights that are guaranteed to me by amendments 5, 1, 4, and 14 of the Constitution of the United States of America.

Mr. APPELL. Mrs. Long, were you ever employed by the Park Street Furniture Company?

Mrs. LONG. I respectfully decline to answer that question for the reason that I honestly feel my answer might tend to incriminate me in violation of my rights as guaranteed to me by amendments 5, 1, 4, and 14 of the Constitution of the United States of America, sir.

Mr. APPELL. Mrs. Long, I hand to you two documents, which are contracts for the purchases of appliances by customers of the "Park Street Furniture Co.," one dated 11-27-64, which shows that it was executed by Carol Long; the other dated 11-28-64 for a Philco washer which was purchased by Mr. Fred Montgomery. I ask you whether these contracts were executed by you in your hand.

Mrs. LONG. Sir, I respectfully decline to answer that question for the reason that I honestly feel my answer might tend to incriminate me in violation of my rights that are guaranteed me by amendments 5, 1, 4, and 14 of the Constitution of the United States of America, sir.

(Documents marked "Carol Long Exhibits Nos. 2-A and 2-B," respectively, follow:)

CAROL LONG EXHIBIT No. 2-A

Cash

PARK STREET FURNITURE CO.

Charge

COMPLETE LINE HOME FURNITURE

1230 PARK STREET

No. 1939

NORTHPORT, ALA., 11/27 1964

This Agreement Certifies, That I, Annie Cleveland
Address 55 East Circle Northport

Terms: Have This Day Purchased of PARK STREET FURNITURE CO., Northport, Alabama, the Following Property, to-Wit:

QUANTITY	NUMBER	ARTICLES	PRICE	TOTAL
1	1491160	Sylvania Portable TV Serial # 563101-11-4052 Bunt.		

As a part of the consideration of this contract, I expressly agree that any payments made by me to Park Street Furniture Company, whether under the provisions of this or any prior or subsequent contract, shall be applied as a credit to my general account as a whole and not towards the payment of any particular contract or contracts, item or items. I further agree that the loss, injury or destruction of said property shall not release me from the payments as provided herein, and I agree and acknowledge that this contract contains the entire agreement between the parties hereto, their agents or employees, either verbal or written. I further agree that the waiver or indulgence of any default or breach of this contract shall not operate as a waiver of any subsequent default or breach and wherever used the singular shall include the plural and the plural the singular.

In Witness Whereof, I hereto set my hand and seal this, the 27 day of November, 1964.
Witness: Ray Bigham by Carol Long
Delivered by
Received all of the above in good condition.
Signed by

WEATHERFORD PRINTING CO. TUSCALOOSA

CAROL LONG EXHIBIT No. 2-B

Cash

PARK STREET FURNITURE CO.

Charge

COMPLETE LINE HOME FURNITURE

1230 PARK STREET

No. 1375

NORTHPORT, ALA., 11/28 1964

This Agreement Certifies, That I, Fred Montgomery
Address (Crested Rd.)

Terms: Have This Day Purchased of PARK STREET FURNITURE CO., Northport, Alabama, the Following Property, to-Wit:

QUANTITY	NUMBER	ARTICLES	PRICE	TOTAL
1	W231U	Phifer Washer Serial # 3AK 13372		169.95
				8.50
				178.45

As a part of the consideration of this contract, I expressly agree that any payments made by me to Park Street Furniture Company, whether under the provisions of this or any prior or subsequent contract, shall be applied as a credit to my general account as a whole and not towards the payment of any particular contract or contracts, item or items. I further agree that the loss, injury or destruction of said property shall not release me from the payments as provided herein, and I agree and acknowledge that this contract contains the entire agreement between the parties hereto, their agents or employees, either verbal or written. I further agree that the waiver or indulgence of any default or breach of this contract shall not operate as a waiver of any subsequent default or breach and wherever used the singular shall include the plural and the plural the singular.

In Witness Whereof, I hereto set my hand and seal this, the 28 day of November, 1964.
Witness:
Delivered by
Received all of the above in good condition.
Signed by

WEATHERFORD PRINTING CO. TUSCALOOSA

Mr. APPELL. I hand you a signature card which was received through subpoena from The First National Bank of Tuscaloosa, Tuscaloosa, Alabama, for the Alabama Rescue Service, signed "Robert M. Shelton" and "T. M. Montgomery," 401 Alston Building, and I ask you if you signed the "T. M. Montgomery" that appears on this copy of the signature card.

Mrs. LONG. Sir, I respectfully decline to answer that question for the reason that I honestly feel my answer might tend to incriminate me in violation of my rights that are guaranteed to me by the amendments 5, 1, 4, and 14 of the Constitution of the United States of America, sir.

(Document previously marked "Robert Shelton Exhibit No. 7." See p. 1620.)

Mr. APPELL. Mr. Chairman, I would like to ask that the witness step aside.

The CHAIRMAN. The witness will be excused for a moment, but is ordered to remain in the room.

Mrs. LONG. Yes, sir.

The CHAIRMAN. Call your next witness.

Mr. APPELL. I should like to call Mrs. Betty L. Shelton.

The CHAIRMAN. Please raise your right hand.

Do you solemnly swear the testimony you are about to give will be the truth, the whole truth, and nothing but the truth, so help you God?

Mrs. SHELTON. I affirm.

The CHAIRMAN. Do you solemnly affirm that the testimony you are about to give will be the truth, the whole truth, and nothing but the truth, so help you God?

Mrs. SHELTON. I affirm.

TESTIMONY OF BETTY L. SHELTON, ACCOMPANIED BY COUNSEL, LESTER V. CHALMERS, JR.

Mr. APPELL. Mrs. Shelton, would you state your full name for the record, please?

Mrs. SHELTON. Mrs. Betty L. Shelton.

The CHAIRMAN. You are the wife of Robert M. Shelton; are you not?

Mrs. SHELTON. Yes.

Mr. CHALMERS. Mr. Chairman, may I at this time ask the chairman to entertain my motion under Rule XII?

Mr. APPELL. Can we identify you on the record first?

Mr. CHALMERS. Yes.

Mr. APPELL. Are you represented by counsel, Mrs. Shelton?

Mrs. SHELTON. Yes.

Mr. APPELL. Will counsel identify himself for the record?

The CHAIRMAN. And please speak into the microphone. You have sworn that you are Mrs. Robert M. Shelton.

What is the second question?

Mr. APPELL. I asked the counsel to identify himself for the record.

Mr. CHALMERS. Lester V. Chalmers, Jr., attorney at law, 501 First Federal Building, Raleigh, North Carolina.

The CHAIRMAN. And you represent the witness?

Mr. CHALMERS. Yes, sir.

The CHAIRMAN. Now, you wanted to——

Mr. CHALMERS. Mr. Chairman, I would like to call Rule XII to the attention of the chairman and to the other members of the committee and asked respectfully that Mrs. Shelton be accorded the provisions under Rule XII.

The CHAIRMAN. I will read the rule aloud:

The confidential relationship between husband and wife shall be respected and, for reasons of public policy, one spouse shall not be questioned concerning the activities of the other, except when a majority of the Committee or Subcommittee shall determine otherwise.

That is all right. We could have called a meeting with reference to Mrs. Shelton. We could have done it. We are not going to do it in this instance. We are not going to question her about activities of her husband. We are going to question her about her activities.

Mr. APPELL. Mrs. Shelton, are you appearing before the committee today in accordance with the subpoena served upon you at 11:20 a.m. on the 11th day of October 1965?

Mrs. SHELTON. About that time.

Mr. APPELL. Mrs. Shelton, have you ever been employed or worked in the offices of the United Klans of America, also known as the Alabama Rescue Service, Room 401, Alston Building, in Tuscaloosa?

Mrs. SHELTON. I respectfully decline to answer that question for the reason that I honestly feel my answer might tend to incriminate me in violation of my rights as guaranteed to me by amendments 5, 1, 4, and 14 of the Constitution of the United States of America.

Mr. APPELL. As a matter of fact, Mrs. Shelton, it was in that office that you and I first met; was it not?

Mrs. SHELTON. I respectfully decline to answer that question for the reason that I honestly feel my answer might tend to incriminate me in violation of my rights guaranteed to me by amendments 5, 1, 4, and 14 of the Constitution of the United States of America.

Mr. APPELL. Mrs. Shelton, did you ever hear of, and know the identity of, T. M. Montgomery?

Mrs. SHELTON. I respectfully decline to answer that question for the reason that I honestly feel my answer might tend to incriminate me in violation of my rights as guaranteed to me by amendments 5, 1, 4, and 14 of the Constitution of the United States of America.

MR. APPELL. Mrs. Shelton, I hand to you a copy of a signature card which the committee obtained through a subpoena from The First National Bank of Tuscaloosa, Alabama, showing that this signature card was made effective on May 14, 1964, for the Alabama Rescue Service, with signatures of "Robert M. Shelton; James J. Hendrix, Treas., 401 Alston Bldg., City."

I ask you if you signed the name "James J. Hendrix."

(Witness confers with counsel.)

MRS. SHELTON. I respectfully decline to answer that question for the reason that I honestly feel my answer might tend to incriminate me in violation of my rights as guaranteed to me by amendments 5, 1, 4, and 14 of the Constitution of the United States of America.

(Document previously marked "Robert Shelton Exhibit No. 8." See p. 1622.)

MR. APPELL. Mrs. Shelton, is it a fact that you did sign the name "James J. Hendrix"?

MRS. SHELTON. I respectfully decline to answer that question for the reason that I honestly feel my answer might tend to incriminate me in violation of my rights as guaranteed to me by amendments 5, 1, 4, and 14 of the Constitution of the United States of America.

THE CHAIRMAN. Isn't it a fact that there is no such person as James J. Hendrix?

MRS. SHELTON. I respectfully decline to answer that question for the reason that I honestly feel my answer might tend to incriminate me in violation of my rights as guaranteed to me by amendments 5, 1, 4, and 14 of the Constitution of the United States of America.

THE CHAIRMAN. Mrs. Shelton, you will be excused for a moment, but you are ordered to remain in the room.

Call your next witness.

MR. APPELL. Mr. Chairman, I would like to call Mr. Philip Schmitz.

THE CHAIRMAN. Please raise your right hand.

Do you solemnly swear the testimony you are about to give will be the truth, the whole truth, and nothing but the truth, so help you God?

MR. SCHMITZ. I do.

TESTIMONY OF PHILIP L. SCHMITZ

MR. APPELL. What is your name, sir?

MR. SCHMITZ. Philip L. Schmitz.

MR. APPELL. What is your business or occupation?

MR. SCHMITZ. I am a documents analyst, sometimes referred to as a handwriting expert, for the U.S. Veterans' Administration in Washington, D.C.

MR. APPELL. What are your duties as a documents analyst?

MR. SCHMITZ. My duties involve the examination and comparison of handwriting, handprinting, typewriting, indented, obliterated writing, alterations, erasures, ink studies, and related material that concern the establishment of whether or not a document is genuine or fraudulent.

MR. APPELL. What educational training and background have you received?

Mr. SCHMITZ. I have a bachelor of science degree from St. Thomas College, St. Paul, Minnesota, and have conducted studies and researches in this field of document examination for a period of over 20 years.

Mr. APPELL. What did you do in a special way to prepare yourself for the work you are now doing?

Mr. SCHMITZ. After graduation from college, I received an appointment with the Federal Bureau of Investigation in Washington, D.C. Shortly after entering the FBI, I was assigned to the Document Section of the FBI Laboratory, where I worked under the direct supervision of qualified document analysts.

During this time, I received the course of instruction, attended lectures and conferences, and conducted researches and studies on the subject, working on actual cases under the direct supervision of experienced document examiners.

After reaching a satisfactory degree of proficiency, I was appointed special agent for the FBI as a senior document identification specialist and was granted the right to testify as an expert witness in documents identification matters, representing the FBI and the U.S. Government.

I spent approximately 3 years in the U.S. Army as an investigator and later as an investigating officer. Since January of 1947, I have been with the Identification and Detection Division of the U.S. Veterans' Administration, doing the same type of work I did with the FBI. I have conducted lectures and prepared papers on this subject.

Mr. APPELL. As a matter of fact, Mr. Schmitz, did you not do much of the documents work for this committee in the Alger Hiss-Whittaker Chambers matter?

Mr. SCHMITZ. Yes, I did.

Mr. APPELL. Have you ever testified as an expert witness?

Mr. SCHMITZ. Yes; on many occasions I have been called to testify as an expert witness in this field. I have testified before the Federal district courts, both criminal and civil, in Washington, D.C. I testified in Massachusetts, New York, Alabama, Florida, California. I have testified before Veterans' Administration hearing boards in central office in Washington, D.C.; in Chicago, Illinois; Memphis, Tennessee. And on a number of occasions I have been called to testify, but defendant has entered a plea of guilty prior to my having the opportunity to actually take the stand.

Mr. APPELL. Are you a member of any recognized scientific society?

Mr. SCHMITZ. Yes; I am a fellow member of the American Academy of Forensic Sciences and was elected to the chairmanship of the Questioned Documents Section of that organization, which I considered a very high honor.

Only recently I was elected to regular membership in the American Society of Questioned Document Examiners, which is a very select group of well-qualified document examiners. This is an international society with a very limited membership. I believe it is about 37. I consider my election to this organization as one of the highest honors I have ever received.

Mr. APPELL. Have you assisted in training document analysts for foreign countries?

COMPARISON CHART

KNOWN WRITING

Mrs. Betty S. Shelton 2-14-63
AND WIFE MUST SIGN (Wife's signature and date)

Betty S. Shelton
(Wife's signature and date)

Betty S. Shelton Jan 1962
(If other return, wife's signature) (Date)

Robert M. Shelton
 576 S.E.
 April 27, 1962

Robert M. Shelton
 1708-15th St. East, City
 Jan 29 1962

QUESTIONED WRITING

James J. Hendrix Trace

James J. Hendrix

James J. Hendrix

James J. Hendrix
 One Hundred Thirtyfourth and

Mr. SCHMITZ. Yes. Our laboratory has assisted the AID, the Agency for International Development, in training document examiners from a number of foreign countries, including the Philippine Islands, Lebanon, Libya, Turkey, Thailand, Tunisia, Ethiopia, and Brazil. I believe there are about eight countries so far.

Mr. APPELL. Mr. Schmitz, in connection with the committee's investigation into this matter, were numerous documents submitted to you for your examination for the purpose of attempting to identify the person who wrote the names "T. M. Montgomery" and "James J. Hendrix"?

Mr. SCHMITZ. That is true.

Mr. APPELL. From these documents, have you been able to establish the authorship of T. M. Montgomery and James J. Hendrix?

Mr. SCHMITZ. Yes, I have.

Mr. APPELL. Have you prepared certain documents and exhibits which you would like at this time to present for the consideration of the committee?

Mr. SCHMITZ. Yes.

Mr. APPELL. Mr. Chairman, I would like to ask that the witness be given permission to proceed with his own slides and with his own explanation of those documents.

The CHAIRMAN. The witness will proceed.

Mr. SCHMITZ. Prior to the demonstration, I would just like to make one or two points. Handwriting identification is based on the principle that no two individuals write exactly alike. In order to actually make an identification, there must be a strong combination of similarities in handwriting and no unexplained major differences.

One person might ask the question: "How is handwriting identified?" It is not by general qualities, but by small, inconspicuous writing characteristics that each of us has in our own writing and as we write we are unaware that they exist.

If differences do occur, the question that must be answered by the examiner is: "Are they natural variations or are they wide divergencies which actually point to different writers?"

Natural variations are desirable, that is, desirable for an identification. Wide divergencies would point to a different writer.

I have prepared a chart which I would like to exhibit at his time.

(Comparison Chart "A" as shown on slide appears opposite this page.)

Mr. SCHMITZ. In explaining this chart, this particular signature refers to an income tax form dated February 14, 1963 [indicating], a joint return submitted by Robert M. Shelton and Mrs. Betty L. Shelton. It has her known signature.

This signature [indicating] refers to an income tax form dated April 18, 1960, a joint return submitted by Betty L. Shelton and Robert M. Shelton.

This signature [indicating] refers or is contained on income tax form dated April 16, 1962. It is of the same variety.

The fourth item is a bank deposit slip at the First National Bank, Tuscaloosa, Alabama, and as you can see is dated April 27, 1964.

The fifth item is a bank deposit slip which is dated January 29, 1965. These are all listed under known writing. There is a separation in here.

On this side we have questioned writing. Beneath that we have the signature of "James J. Hendrix" as it appears on a bank signature card dated May 14, 1964, which was previously identified by Mr. Appell.

This signature of James J. Hendrix [indicating] appears on a check of the Alabama Rescue Service, check No. 640, dated April 2, 1965.

This signature [indicating] refers to a similar check of the Alabama Rescue Service, No. 502, dated August 25, 1964.

This final entry appears also on the same check, No. 502, in the body of the check, dated August 25, 1964.

In summarizing this chart, the three signatures at the top left were considered known since they appeared on the income tax forms of Betty L. Shelton. The bottom two signatures appear on bank deposit slips.

The writing on the top three signatures was compared with the writing on the bank deposit slips.

Then after identifying these two together [indicating], all of this writing was in turn compared with the questioned writing.

I would like to point out just a few points that are brought out in the identification of this writing.

The capital "M" in "Mrs." the center stroke, lower down, does not come down to meet the line as do the two outside strokes.

This similar type "M" appears also on the bank deposit slip, as you will notice, and also appears—

The CHAIRMAN. Pardon me, but isn't that "Robert M. Shelton"?

Mr. SCHMITZ. Robert M. Shelton; yes, sir.

The CHAIRMAN. We are talking about Betty.

Mr. SCHMITZ. This is a bank deposit slip. That is correct, sir. I am showing that Betty Lou Shelton made the deposit in the name of Robert M. Shelton.

The CHAIRMAN. In other words, what you are saying is that the name "Robert M. Shelton" was written by Mrs. Shelton?

Mr. SCHMITZ. This is what I am demonstrating; yes, sir.

So that "M" is comparable to the "M" in Robert M. Shelton, and the "M" in the latter signature of Robert M. Shelton.

Next I would like to point out the entire name "Shelton" as it appears in the first line, in the second line, in the third line, and especially compare this name "Shelton" with this name "Shelton" down here [indicating], and it is not very difficult to see the extreme similarity in the capital "S," the formation of the "h," especially the one down here [indicating], and the "e," the "l," and going across to the "ton." Take the "h," for example, as it appears in the first signature, and you see a high approach to the "h," forming this loop which stops at the lower right side.

A similar "h" appears in the second signature and also in the third signature, and a similar type "h" also appears down here in the fifth signature.

If we drop across over here to the word "Thirty," you will find a similar approach stroke, with the same type "h."

I would also like to point out that we have a variation in this "h," what we refer to as a natural variation, with it being just a little bit

lower. But similar characteristics throughout the signature prove it is a natural variation.

Bringing to your attention the small "e" as it appears in Betty and in Shelton, and Betty in the second signature and in Shelton in the second signature, and Betty in the third signature and Shelton in the third signature.

Also in the fourth signature, we find the "e" in Robert, and we find in the fifth signature a small "e," especially in Shelton, and in Shelton in the fourth signature also.

Going over to this die, the "e" in Hendrix, the first entry on the right side; the "e" in Hendrix and the "e" in James, and the "e" in Hendrix and the "e" in James, and also the "e" in the word "hundred" [indicating].

The point I am trying to emphasize is that the "e's" are extremely small and extremely consistent throughout all of the writing.

Note next the "lt" combination, which, if the "t" cross were eliminated, would be a double "l." You can see the loop in the "t." It is very consistent as it goes to the second signature and the third signature "Shelton."

It also appears in the fourth signature and also in the fifth signature.

It appears over on this side [indicating] in the word "Thirty." You will note the loop in the "T" in Thirty.

And the small "o" in the word "Shelton," you will notice the loop on this is not a common type loop, but is a loop which is extremely on the right side and is quite wide.

It also appears down here in this name "Shelton," showing that the person who wrote the first one also wrote the fourth one. And it is in the fifth name "Shelton."

Now if you will take a look at the one on the right side, you will see it has the same identification, of the loop on the right.

And the small "n" as it appears in the second signature of Shelton also appears on the third signature, appears in the fourth signature, appears in the fifth signature and when we get to the sixth signature we have "Hendrix" where the same type of "n" is formed.

Down in this entry, you find the "n" appearing three times, once in "One," "Hundred," and the word "and," all three of them tying in with the same type.

Note the "Apr"—short for April—as it appears in the fourth entry and also appears in the third entry. It is not very difficult to see the extreme similarity in the formation of somewhat of a backhand formation.

Next take a look, if you will, at the capital "J" in January, and also note the initial "J" in James J. Hendrix. It is almost a retrace, a backhand retrace.

Then, if you will, note that it also occurs in this third signature of Hendrix on two occasions. It comes to a definite point.

Now let's take a look at the same "J" with the "a" combination, "Ja," and this is an extremely high identifying characteristic as the motion goes from the bottom of the "J," looping high into the top, into the "a."

You will notice that same type of approach going high into the top into the "a." It appears in this James J. Hendrix signature [indicating], in this one, and in this James J. Hendrix signature.

Another point is the capital "C" in City, as it appears in the fifth one on the left side, and also in the letters "GMAC." Incidentally, if I didn't mention before, this capital "M" appeared on this side in the first, and on this side, in the fifth one, and also in the GMAC.

Another point is the capital "H," which is quite consistent throughout. You will notice in the "H's" the loop on the "H" is very small and hugs in very tightly.

I ask you to note with that the similar type of approach to the capital "M," a small, hugging motion, and right in here [indicating] the same type of thing and also here, showing a very strong similarity.

Also you have the loop in "Mrs." in the name "Mrs. Betty L. Shelton."

Another point is the small "d" as in Hendrix. You can see the "d" that appears there [indicating], and it also appears here in very similar formation, it appears here in very similar formation [indicating], and then down here you find the same type of "d" on three occasions, in "Hundred," twice, and at the end of the word "and."

Finally, one little note is the "y" in "Betty," compared with the "y" in "Thirty," a crossover mark, not a rounded loop, but a crossover mark.

Without going into further characteristics, I concluded as a result of this study that all of the writing on the documents that are depicted here was written by one person, namely, Betty Lou Shelton, whose known handwriting specimens appear on the income tax forms.

I have prepared a second chart comparable to the first one in most respects.

(Comparison Chart "B" as shown on slide appears opposite this page.)

Mr. SCHMITZ. I would like to explain the source of the signatures on this chart. The first signature—

The CHAIRMAN. This has reference to Carol H. Long?

Mr. SCHMITZ. That is correct; yes, sir.

The first signature was obtained from the Park Street Furniture Company, slip No. 1375, which is dated 11-28-64.

The second signature appears on the income tax form of Carol H. Long, dated April 14, 1965.

The third entry was taken from the furniture slip No. 1375, the same as the first signature was.

The fourth entry, this "TV" was taken from furniture slip No. 1939, dated November 27, 1964.

The fifth entry, "by Carol Long," also appeared on furniture slip No. 1939. These are all listed under known writing of Carol Long.

Under questioned writing, we have the signature "T. M. Montgomery" which appears on the bank signature card of The First National Bank of Tuscaloosa, Alabama, previously identified.

The second entry "T. M. Montgomery" and the date on the right, 8-2-63, were taken from a check of the Alabama Rescue Service, Tuscaloosa, Alabama. The third entry is taken from check No. 344, dated 12-5-63, of the Alabama Rescue Service, Tuscaloosa, Alabama.

The next entry is from check No. 353, dated 12-19-63, of the Alabama Rescue Service, Tuscaloosa, Alabama.

The first entry on the last line of the right side is from check No. 344, which is the same as the third line, which is dated 12-5-63. This

COMPARISON CHART

KNOWN WRITING

Fred Montgomery

Carol N Long ^{plus 7} _{plus 011} 4/14/65
DATE FOR IF ONLY ONE HAD INCOME DATE

N^o 1375

11/28 1964

TV

by Carol Long

QUESTIONED WRITING

~~T.M. Montgomery~~

T.M. Montgomery DATE 9/2 1968

T.M. Montgomery 12/16/68

T.M. Montgomery DATE 1/1 1968

T.M. Fifty DATE 1/1 1968

entry next to it of "Fifty" was taken from check No. 284, the same as the second one, the second line.

And the final entry on the last line was taken from check No. 346, dated 12-6-63, of the Alabama Rescue Service.

Now that they have been identified, I would like to point out first of all what I imagine people are able to observe as handwriting characteristics and draw their own conclusions.

However, I would like to point out those similarities in handwriting characteristics.

First, I would like to point out, comparing this known signature of Fred Montgomery which was written by Carol Long with the questioned signature of T. M. Montgomery as it appeared on the bank signature card, and running a cross comparison, first note the capital "M," the approach to the capital "M," and the formation of the letter there, and as it appears over here on questioned, the similarity is tremendous, the loop, the center part, where it doesn't extend to the bottom, the third loop, the rounded portions at the top, and the rounded portions at the lower right side. That also appears in this approach to the "M" in the second line. You have a similar approach to "Montgomery" in the third line, you have a similar approach to "Montgomery" in the signature on the fourth line.

The small "o," which, as you will recall, in the previous chart looped off to the right, this individual has a different handwriting characteristic, namely, it is a large loop and loops at the top of the "o." It is quite evident here in Montgomery, twice on the first line of known writing, and is evident in the second line, in Carol.

It is evident on the fourth line in the word "Carol," where it is very heavy.

It is also evident up here twice in this "o" in Montgomery and this "o" in Montgomery [indicating], and in the second line it is evident in this "o" and this "o" [indicating].

The next point to bring out would be the small letter "n" as it appears in the second line on the known side, in the name "Long," and in the fourth line in the name "Long."

It appears over here in Montgomery in the first line. You will notice the same type of an "n," a large loop and then a second loop. You will also notice it on the second line in Montgomery.

May I also point out that we have variations. And this is what we look for in document identification, natural variation.

There is the small "n" as it appears in signature number one, which also appears in signature number seven and also in number eight, somewhat of a variation. However, they are consistent.

Next note, if you will, the small "t." The cross of the "t" is extremely low in comparison to where the average individual does, and it also appears the same over on the right side. It is present in this "t" in Montgomery, in this "t," and in this "t" in Montgomery [indicating].

The "g" is very long, and the "y" in Montgomery. You will notice a similar formation at bottom, a looping stroke, very large. Not a straight stroke and back up again, but a large looping stroke.

It appears here in Long and in the "g" and in the "y" in Montgomery. It also appears down here in the name of Long.

Over here in questioned, it appears once here [indicating], once here, and once here, in the sixth, seventh, and eighth [indicating].

There is also variation in the "y," if you will see here the word "By," where it is a little elongated. But you have a similar type "y" over here as it appears in the word "Fifty." It shows it is consistent in both the known and the questioned writing.

Next is something that some people don't stop to think about, the formation of the lower part of the "g" in comparison to the lower part of the "y." If you were to put a line there you would see a downhill motion, a downhill trend.

In other words, the "y" end is lower than the "g." If you will take a look at all of the Montgomery signatures the "y" is lower than the "g," the "y" is lower than the "g," the "y" is lower than the "g," the "y" is lower than the "g" [indicating], consistently.

A point or two more to make: A capital "F" in Fred compares with the capital "F" in the word "Fifty."

The capital "T" in TV, a printed "T," which gives a sheltered or umbrella-type effect over the "V" which is beneath it, and then notice the "T" in T. M. Montgomery, which gives the same sheltered effect [indicating], and also the "T" in the word "Twelve," the same type of effect.

Other "T's" I would like you to note also where you have a somewhat similar effect, which is an angle. It is not a horizontal line, but it is on an angle, a lower left and going up to the right, higher, with the crossbar with the same features. Also, you will notice that they are off center. Actually, the right side of the "T" cross is longer than the left side.

Finally, one other point I would like to emphasize is this particular habit of this individual in preparing a diagonal for the date. If you will notice, it looks more like a reverse motion "P" than anything else, but it is a very consistent habit, and it goes right along with the habit of making a capital "L," the first stroke of the capital "L" and the first stroke of the diagonal. You will notice that it occurs here and here [indicating] on her income tax form, and it also occurs on the Park Furniture Company form and in the name "Long." It occurs twice on the income tax form.

And it occurs over here on the right side, if you will notice, the date of 8-2, 12-5, and down here [indicating] and down here [indicating], the diagonals.

So there are sufficient handwriting characteristics present, and I think it is only right to conclude that all of the writing on the documents under the questioned area was written by the same person, namely, Carol H. Long, who prepared the writing on the opposite side of the document.

MR. APPELL. Mr. Schmitz, can you summarize that which you have detailed as a conclusion, an expert conclusion, which you have arrived at with respect to the signature of James J. Hendrix?

MR. SCHMITZ. Yes, I believe so. I reached the conclusion that the signatures "James J. Hendrix" appearing on the signature card which was stamp-dated May 14, 1964, of the First National Bank, Tuscaloosa, Alabama, and also appearing on Alabama Rescue Service check number 502, dated 8-25-64, and on Alabama Rescue Service

check number 640, dated April 2, 1965, were all written by Betty Lou Shelton, whose known handwriting appears on income tax forms dated April 18, 1960, April 16, 1962, and February 14, 1963.

I reached a further conclusion that Betty Lou Shelton also prepared handwritten entries on deposit slips dated April 27, 1964, January 29, 1965, as well as handwritten entries and signatures of James J. Hendrix on numerous other checks of the Alabama Rescue Service.

Mr. APPELL. Have you arrived at a conclusion which may summarize your detailed explanation with respect to the signature "T. M. Montgomery"?

Mr. SCHMITZ. Yes. I reached the conclusion that the signatures "T. M. Montgomery" on the signature card of The First National Bank of Tuscaloosa, Alabama, for the Alabama Rescue Service, which card was undated, and the signatures "T. M. Montgomery" on check number 284, dated 8-2-63, check number 344, dated 12-5-63, and check number 353, dated 12-19-63, all of the Alabama Rescue Service, were written by Carol H. Long, whose known writing appears on income tax form of April 14, 1965, as well as on Park Street Furniture Company agreement form number 1939, which is dated November 27, 1964, and on 1375, which was dated November 28, 1964.

I reached the additional conclusion that Carol Long wrote the signatures "T. M. Montgomery" on numerous other checks of the Alabama Rescue Service and also prepared handwritten entries on many of these checks.

Mr. APPELL. Mr. Chairman, I have no further questions to ask of Mr. Schmitz.

Mr. WELTNER. I have a question or two.

The CHAIRMAN. Proceed.

Mr. WELTNER. Mr. Schmitz, is there any doubt in your mind whatsoever concerning the conclusions you have just stated?

Mr. SCHMITZ. None whatsoever.

Mr. WELTNER. You have stated, then, as an expert, that there is no room for any erroneous interpretation or conclusion on your part, and you are stating as a fact that these signatures, as you mentioned, were affixed to documents by the same persons?

Mr. SCHMITZ. This is my reasoned judgment.

Mr. WELTNER. Thank you, sir.

The CHAIRMAN. Thank you very much.

I want to again thank Tecnifax Corporation for providing their facilities to make these exhibits possible.

Mr. APPELL. Mr. Chairman, I would like that these exhibits of Mr. Schmitz be made a part of the record.

The CHAIRMAN. That will be done.

The committee will now stand in recess for a few minutes.

(A brief recess was taken from 4:10 p.m. to 4:15 p.m. All subcommittee members were present at time of recess and when hearings resumed. Representative Senner was also present when hearings resumed.)

The CHAIRMAN. The committee will please come to order.

It is now well past 4 o'clock, and inasmuch as we will be going into other areas of inquiry and evidence, the committee, during the recess, has voted to recess at this time until 10 o'clock tomorrow morning.

Mr. Shelton, you will return here tomorrow morning at 10 o'clock.

Mrs. Shelton and Mrs. Long, if you desire to go back to Alabama, you are excused, if you want to be excused. You can come tomorrow or not come, as you wish, but Mr. Shelton will return at 10 o'clock and he is still under subpena.

The committee is in recess until 10 o'clock tomorrow morning.

(Members present at time of recess: Representatives Willis, Pool, Weltner, Ashbrook, and Buchanan, of the subcommittee, and also Representative Senner.)

(Whereupon, at 4:16 p.m., Tuesday, October 19, 1965, the subcommittee recessed, to reconvene at 10 a.m., Wednesday, October 20, 1965.)

ACTIVITIES OF KU KLUX KLAN ORGANIZATIONS IN THE UNITED STATES

Part 1

WEDNESDAY, OCTOBER 20, 1965

UNITED STATES HOUSE OF REPRESENTATIVES,
SUBCOMMITTEE OF THE
COMMITTEE ON UN-AMERICAN ACTIVITIES,
Washington, D.C.

PUBLIC HEARINGS

The subcommittee of the Committee on Un-American Activities met, pursuant to recess, at 10 a.m. in the Caucus Room, Cannon House Office Building, Washington, D.C., Hon. Edwin E. Willis (chairman) presiding.

(Subcommittee members: Representatives Edwin E. Willis, of Louisiana, chairman; Joe R. Pool, of Texas; Charles L. Weltner, of Georgia; John M. Ashbrook, of Ohio; and John H. Buchanan, Jr., of Alabama.)

Subcommittee members present: Representatives Willis, Pool, Weltner, Ashbrook, and Buchanan.

Committee members also present: Representatives George F. Senner, Jr., of Arizona, and Richard H. Ichord, of Missouri.

Staff members present: Francis J. McNamara, director; William Hitz, general counsel; Alfred M. Nittle, counsel; Donald T. Appell, chief investigator; and Philip R. Manuel, investigator.

The CHAIRMAN. The subcommittee will please come to order.

Mr. Appell, call your next witness.

Mr. APPELL. Mr. Chairman, I would like to recall to the stand Mr. Robert M. Shelton.

The CHAIRMAN. Let the record show that the witness, Mr. Shelton, has already affirmed, and his attorney has already been identified.

Be seated, Mr. Shelton.

The photographers will desist.

Proceed.

TESTIMONY OF ROBERT MARVIN SHELTON, ACCOMPANIED BY COUNSEL, LESTER V. CHALMERS, JR.—Resumed

Mr. APPELL. Mr. Shelton, would you give the committee a brief résumé of your educational background?

Mr. SHELTON. Sir, I respectfully decline to answer that question for the reasons that I honestly feel that my answer might tend to

incriminate me in violation of my rights as guaranteed to me by amendments 5, 1, 4, and 14 of the Constitution of the United States of America.

The CHAIRMAN. This is just preliminary and background information. I order and direct you to answer that question.

Mr. SHELTON. Sir, I respectfully decline to answer that question for the reasons that I honestly feel that my answer might tend to incriminate me in violation of my rights as guaranteed to me by amendments 5, 1, 4, and 14 of the Constitution of the United States of America.

Mr. APPELL. Mr. Shelton, would you give the committee a brief résumé of your employment background?

Mr. SHELTON. Sir, I respectfully decline to answer that question for the reason that I honestly feel that my answer might tend to incriminate me in violation of my rights as guaranteed to me by amendments 5, 1, 4, and 14 of the Constitution of the United States of America.

Mr. APPELL. Mr. Shelton, as the Imperial Wizard or president of the United Klans of America, Inc., the Knights of the Ku Klux Klan, by a vote of a kloncilium or by a vote of a klonvokation, were you given a guaranteed salary for the office that you held?

Mr. SHELTON. Sir, I respectfully decline to answer that question for the reason that I honestly feel that my answer might tend to incriminate me in violation of my rights as guaranteed to me by amendments 5, 1, 4, and 14 of the Constitution of the United States of America.

Mr. APPELL. Mr. Shelton, the money that came to you in the form of the imperial tax paid by Klans or Klaverns within your jurisdiction, and placed into a bank account known in the name of the Alabama Rescue Service, was this account yours to do with as you pleased, or were you under any supervision and control with respect to the disbursement of that money by either the Kloncilium or the klonvokation?

Mr. SHELTON. Sir, I respectfully decline to answer that question for the reasons that I honestly feel that my answer might tend to incriminate me in violation of my rights as guaranteed to me by amendments 5, 1, 4, and 14 of the Constitution of the United States of America.

Mr. APPELL. Mr. Shelton, the *Washington Post* of October 17, 1965, contained a story by Paul Good, datelined Atlanta, Georgia, which related to a rally held there, I assume last weekend. This article quotes Calvin F. Craig, whom we believe to be the Grand Dragon of the State of Georgia—I will ask you, Is he your Grand Dragon for the State of Georgia?

Mr. SHELTON. Sir, I respectfully decline to answer that question for the reason that I honestly feel my answer might tend to incriminate

me in violation of my rights as guaranteed to me by amendments 5, 1, 4, and 14 of the Constitution of the United States of America.

Mr. APPELL. Mr. Shelton, the *Washington Post* quoted Mr. Craig as saying that he drives a Falcon and says that a Cadillac driven by Imperial Wizard Shelton is Klan property.

May I ask you, Is that car registered in the name of the Klan?

Mr. SHELTON. Sir, I respectfully decline to answer that question for the reason that I honestly feel my answer might tend to incriminate me in violation of my rights as guaranteed to me by amendments 5, 1, 4, and 14 of the Constitution of the United States of America.

(Document marked "Robert Shelton Exhibit No. 9" and retained in committee files.)

Mr. APPELL. Mr. Shelton, the committee's investigation uncovered the fact that in December of 1962 you purchased a 1963 Grand Prix Pontiac from Stansell Pontiac-Cadillac, Inc.; that the cost of this car was \$4,728 and that you paid \$986 cash, leaving a balance of \$3,742; that you financed this car with GMAC with insurance and finance charges making a total indebtedness to GMAC of \$4,900 payable in 36 equal installments of \$136.33; and that the present outstanding balance is \$681.65.

On the 14th of November 1964, a 1961 Cadillac sedan was substituted for the Pontiac.

Were the checks, payments on the Pontiac, and the Cadillac when it was substituted for the Pontiac, paid for from the funds of the United Klans of America in the name of the Alabama Rescue Service and drawn by checks against that account?

Mr. SHELTON. Sir, I respectfully decline to answer that question based on the grounds heretofore stated.

Mr. APPELL. Isn't it a fact that the automobile is not registered in the name of the United Klans of America?

Mr. SHELTON. Sir, I respectfully decline to answer that question based on the grounds heretofore stated.

Mr. APPELL. Mr. Shelton, an analysis of the account shows that hundreds of dollars were disbursed from this fund to a company known as the Lorch's Diamond Shop. Can you tell me what that money purchased?

Mr. SHELTON. Sir, I respectfully decline to answer that question for the reasons that I honestly feel that my answer might tend to incriminate me in violation of my rights as guaranteed to me by amendments 5, 1, 4, and 14 of the Constitution of the United States of America.

(Analysis of Alabama Rescue Service bank account marked "Robert Shelton Exhibit No. 10" and retained in committee files. Records from Lorch's Diamond Shop introduced in record on Oct. 25, 1965, marked "Robert Shelton Exhibit 10-A" follow:)

ROBERT SHELTON EXHIBIT No. 10-A

H. T. - 27536

NAME	Shelton, Mr. Robert M (Betty)	ACCT. NO.	16783
ADDRESS	1708 E 15th St	TERMS	
ADDRESS		TERMS	30.00 10th
ADDRESS	Office 200 (11/18/62)	TERMS	(6/11/62)
ADDRESS	95221	TERMS	6/62

LINE NO.	DATE	DEBIT	CREDIT	BALANCE	ACCOUNT NUMBER	DATE # TO MAIL
1	JUN11-62	* 40.00		40.00	CROPB • 16783	10/19 T.P.
3	JUN11-62	* 339.60		299.60	CHB • 16783	10/28 FF4
4	JUL18-62	* 30.00		269.60	RAB • 16783	11/4 FF6
5	AUG18-62	* 30.00		239.60	RAB • 16783	11/7 FF6
6	AUG18-62	* 211.16			CH16783	11/7 FF6
7	AUG18-62	* 30.06		415.00	PPA	
8	SEP17-62	* 30.00	30.00	385.00	RAA • 16783	
9	OCT18-62	* 30.00		355.00	RAA • 16783	
10	NOV16-62	* 30.00		325.00	RAA • 16783	
11	JAN18-63	* 30.00		295.00	DCA • 16783	
12	JAN28-63	* 30.06		265.00	RAA • 16783	
- 6/11/62 C667 Gts Dia Cluster 289.00						
Office 200 - 66640 Systems Output & Screen 179.95						
13	FEB27-63	* 20.00		245.00	RAA • 16783	
14	MAR18-63	* 30.00		215.00	RAA • 16783	
15	MAR22-63	* 30.00		185.00	RAA • 16783	
16	MAR22-63	* 30.00		155.00	RAB • 16783	
17	AUG19-63	* 00.00		155.00	RAB • 16783	
18	OCT15-63	* 30.00		125.00	RAA • 16783	
19	NOV-8-63	* 25.00		100.00	RAA • 16733	
20	DEC18-63	* 73.00		27.00	CH A • 16733	
21	JAN18-64	* 20.00		7.00	PPA	
22	MAR18-64	* 167.00			CH A • 16733	
23	MAY18-64		200.00	200.00	PPA	
24	5/18/64			recorder 59.95 St 3.00		

OCCUPATION Asst. Transportation Sc10.05

EMPLOYER P. O. 80 US, Ga. Offices: in Montgomery

EMPLOYER Prev. D. S. C. ADDRESS Americus, Ga, Ocala, FL

RELATIVE Mr. H. M. Shelton Shelton Gro 15th St

NAME: H. M. McDaniels or Holt ADDRESS Alabama

NAME: J. R. Mc... ADDRESS

OFFICE: 401 (11/18/62) Bldg - City

Ref: J. R. Mc... - Buiter Newton

ROBERT SHELTON EXHIBIT No. 10-A—Continued

NAME Shelton, Mr. Robert M. (Batty)	ACCT. NO. 16783
ADDRESS 1708 E 15th St.	TERMS 30/17th 66/17/64
ADDRESS	TERMS 35- 11/ 3/11-11
ADDRESS Office: 402 Alton 9-5221	TERMS
ADDRESS	TERMS

LINE NO.	DATE	DEBIT	CREDIT	BALANCE	ACCOUNT NUMBER	DATE #	TO	MAIL
1	MAY 18-64	* 62.95		* (200.00)	CSA 16733	7/31		
2	JUL-8-64	6-17 * 30.00		* 170.00	RAA 16733	7/12		
3	JUL 23-64	7-15 * 30.00		* 140.00	RAA 16733	7/25		
4	AUG 19-64	8-15 * 30.00		* 110.00	RAB 16733			
5	SEP-9-64	* 21.33	131.33	* 21.33	CHA 19556	6/30		
6	SEP 18-64	9/17 * 30.00		* 101.33	RAA 16733	7/31		
7	OCT 16-64	10/17 * 30.00		* 71.33	RAA 16733			
8	NOV 19-64	11-17 * 30.00		* 41.33	RAA 16733			
9	DEC 21-64	* 138.00		* 179.33	CHB 16733			
10	DEC 22-64	12-17 * 30.00		* 149.33	RAA 16733			
11	JAN 15-65	1-17 * 30.00		* 119.33	RAA 16733			
<p>APR 21/64; 5/18/64; 5/18/64; 9-13-64 78.50 100.00 10.00 23.00</p> <p>5/18/64 Webcor Recorder 94-1-78869 139.00 st 7.00 sc 21.00</p> <p>9/9/64 53-1-71272 West Iron 16.88 sb .85 sc 3.60</p>								
12	JUL 18-65	* 47.65		* 166.98	CHB 16733			
13	AUG 18-65	* 30.00		* 136.98	RAA 16733			
14	MAR 17-65	* 35.00		* 101.98	RAA 16733			
15	APR 17-65	* 3.97		* 101.98	CSA 29846			
16	APR 19-65	* 35.00		* 66.98	RAA 16733			
17	MAY 17-65	* 35.00		* 31.98	RAA 16733			
18	JUN 18-65	* 31.98		* 0.00	RAA 16783			
19	JUL 15-65	* 10.50		* 0.00	CSA 32317			
20								
21								
22								
23								
24	2/18/65	54-9-72257 Rem. Tok.		37.95	st 1.90	sch 7.80		
25	7/15/65	47-35-71260 Record Player		10.00	st .50			

REMARKS

~~Kandian Loan Co 19.68 90.00~~ I do hereby constitute and appoint my wife as my attorney in fact, for me and my steed, to hereinafter purchase such merchandise as she may see fit from Lorch's Diamond Shop, and to execute for me and in my name a sales contract similar to this one covering such purchase.

~~Sat Loan: 57.60 very Sat~~

~~Furn: 321.00-0- Sat City Nat~~

OK Goodaact

Fur - Paid out ahead with

Signed _____

10/11/63

ROBERT SHELTON EXHIBIT NO. 10-A—Continued

NAME	Shelton, Mrs. Betty (Robert)	ACCT. NO.	247-27
ADDRESS	1708 15th Street E, City	TERMS	7.00 10th 10/10
ADDRESS		TERMS	
ADDRESS		TERMS	
ADDRESS		TERMS	
DP:gl		9/65	\$15

LINE	DATE	DEBIT	CREDIT	BALANCE	ACCOUNT	DATE #	TO	MAIL
SP	SEP 10-65	* 20.08			ChB •24727			
1	SEP 10-65	* 5.00		* 15.08	DPB			
2								
SP	SEP 22-65	* 9.80			ChB •24727			
4	SEP 22-65	* 2.00		* 22.88	DPB			
10/9	OCT-5-65	* 5.00		* 17.88	BAB •24727	OCT-5-65		
6								
7								
8								
9								
10								
11								
12	9/10/65 45-16-71545 RCA Trans 15.88 st .80 sc 3.40							
	9/22/65 53-20-7530 Fosboria st iron 8.88 st .45 sc .47 10/5/65 all							
13								
21								
24								

OCCUPATION	United Klans of America	B. T.
EMPLOYER	ADDRESS	
EMPLOYER	ADDRESS	
RELATIVE		
NAME	ADDRESS	
HOLDER	ADDRESS	
CUSTOMER		

21								
22								
23								
24								

REMARKS

I do hereby constitute and appoint my wife as my attorney in fact, for me and my stead, to hereinafter purchase such merchandise as she may see fit from Lorch's Diamond Shop, and to execute for me and in my name a sales contract similar to this one covering such purchase.

Signed Mrs. Betty Shelton

Mr. APPELL. Mr. Shelton, this analysis of the checks drawn against that account shows that a sum in excess of \$5,600 was drawn to cash, and endorsements on the reverse of those checks show that they were cashed at Piggly-Wiggly Stores, cashed at service stations, and cashed at other places. Can you explain to us the number of checks for cash and why they were all drawn for cash?

Mr. SHELTON. Sir, I respectfully decline to answer that question for the reason that I honestly feel that my answer might tend to incriminate me in violation of my rights as guaranteed to me by amendments 5, 1, 4, and 14 of the Constitution of the United States of America.

Mr. APPELL. Mr. Shelton, it is the committee's—

The CHAIRMAN. Mr. Shelton, why is it, in answer to one or two previous questions you invoked the privilege of the fifth amendment by saying that you relied on the grounds previously stated, and as we now go along you are repeating from the piece of paper you are reading from?

Mr. SHELTON. Sir, I respectfully decline to answer that question for the reason that I honestly feel that my answer might tend to incriminate me in violation of my rights as guaranteed to me by amendments 5, 1, 4, and 14 of the Constitution of the United States of America.

The CHAIRMAN. I might say that there are reasons for me to ask that question. I deliberately noticed when you did it.

Proceed.

Mr. APPELL. Mr. Shelton, it is the committee's information that the United Klans of America, Inc., files with the Internal Revenue Service a corporate tax return on a fiscal year basis from July 1 of one year to June 30th of the following year.

It is a fact that on July 29, 1965, you, signing as "President" of the United Klans of America, filed the corporate tax return?

Mr. SHELTON. May I counsel, please?

(Witness confers with counsel.)

Mr. SHELTON. Sir, I respectfully decline to answer that question for the reasons that I honestly feel my answer might tend to incriminate me in violation of my rights as guaranteed to me by amendments 5, 1, 4, and 14 of the Constitution of the United States of America.

Mr. APPELL. Mr. Shelton, isn't it a fact that on this corporate return you showed income from all sources of \$18,487.60?

Mr. SHELTON. Sir, I respectfully decline to answer that question for the reason that I honestly feel that my answer might tend to incriminate me in violation of my rights as guaranteed to me by amendments 5, 1, 4, and 14 of the Constitution of the United States of America.

(Document marked "Robert Shelton Exhibit No. 11" and retained in committee files.)

Mr. APPELL. Mr. Shelton, an analysis of the United Klan bank account at The First National Bank of Tuscaloosa, which is carried under the name of the Alabama Rescue Service, shows that there were checks written against that account in the amount of \$18,036.95.

Do you mean to tell me that the difference of that, which is approximately \$450, is all of the income that the Klan received in all of its realms? As you told the Internal Revenue agent, as I quoted to

you yesterday, these are just geographical subdivisions, so that any income they had it was your responsibility to report. Do you mean to tell me that their income was only what you report here, the difference of \$450?

Mr. SHELTON. May I counsel?

(Witness confers with counsel.)

Mr. SHELTON. Sir, I respectfully decline to answer that question for the reasons that I honestly feel that my answer might tend to incriminate me in violation of my rights as guaranteed to me by amendments 5, 1, 4, and 14 of the Constitution of the United States of America.

Mr. APPELL. Mr. Shelton, are you acquainted with an organization known as Heritage Enterprises, Inc?

Mr. SHELTON. Sir, I respectfully decline to answer that question for the reasons that I honestly feel my answer might tend to incriminate me in violation of my rights as guaranteed to me by amendments 5, 1, 4, and 14 of the Constitution of the United States of America.

Mr. APPELL. Mr. Chairman, I would like to have entered into the record at this point a certified copy of the Certificate of Incorporation of Heritage Enterprises, Inc.

The CHAIRMAN. It will be admitted into the record at this point.

(Document marked "Robert Shelton Exhibit No. 12" and retained in committee files.)

Mr. APPELL. This document, Mr. Chairman, is dated December 5, 1963, and it shows as the officers and directors of the corporation—and I would like to quote from the page that contains this information:

The names and post office addresses of the directors chosen for the first year are as follows:

Name	Address
Robert M. Shelton	1708 East 15th Street, Tuscaloosa, Alabama
William Otto Perkins	Route # 1, Northport, Alabama
Donald E. Luna	4315—51 Avenue North, Birmingham, Alabama
R. J. W. Kimble, Jr.	1309 Panorama Drive Vestavia Hills, Birmingham, Alabama
Calvin Fred Craig	772 Pearce Street S.W., Atlanta, Georgia

Mr. Shelton, isn't it a fact that all of the men whose names I have read to you, with the exception of Mr. Kimble, are members of the Ku Klux Klan?

Mr. SHELTON. Sir, I respectfully decline to answer that question for the reason that I honestly feel that my answer might tend to incriminate me in violation of my rights as guaranteed to me by amendments 5, 1, 4, and 14 of the Constitution of the United States of America.

Mr. APPELL. Mr. Shelton, under the subscription list of capital stocks of the Heritage Enterprises, Inc., I find the following: Donald E. Luna, 115 shares, \$1,150; R. J. W. Kimble, Jr., 55 shares, \$550; William Otto Perkins, 25 shares, \$250.

I wish to ask you, Is not this a false accounting of shares recorded by the corporation?

Mr. SHELTON. Sir, I respectfully decline to answer that question for the reason that I honestly feel that my answer might tend to incriminate me in violation of my rights as guaranteed to me by

amendments 5, 1, 4, and 14 of the Constitution of the United States of America.

Mr. APPELL. Did you receive a \$150 advance from Mr. Kimble after the advancement of the idea of the Heritage Enterprises, Inc.?

Mr. SHELTON. Sir, I respectfully decline to answer that question for the reason that I honestly feel that my answer might tend to incriminate me in violation of my rights as guaranteed to me by amendments 5, 1, 4, and 14 of the Constitution of the United States of America.

Mr. APPELL. As a matter of fact, Mr. Shelton, in order to kick off this Heritage Enterprises, Inc., did you not call a klonvokation to be held at the Dinkler-Tutwiler Hotel in Birmingham, Alabama, in February 1964?

Mr. SHELTON. Sir, I respectfully decline to answer that question for the reason that I honestly feel that my answer might tend to incriminate me in violation of my rights as guaranteed to me by amendments 5, 1, 4, and 14 of the Constitution of the United States of America.

Mr. APPELL. Mr. Chairman, I would like to enter into the record at this point copies of three letters, one dated December 31, 1963, addressed to Mr. Don Luna, Suite 401, Alston Building, Tuscaloosa, Alabama; another dated January 3, 1964, to Mr. Luna, at the same address; and a letter dated January 29, 1964, addressed to Mr. Robert [Bob] Shelton at the same address.

These letters are from the Catering Manager of the Dinkler-Tutwiler Hotel in Birmingham, Alabama.

I would like to just quote for the record the first paragraph to the letter to Mr. Shelton dated January 29, 1964:

We are pleased to confirm our Grand Ballroom for your Banquet on February 8th, and your meeting on February 9th.

The CHAIRMAN. The letters will be admitted into the record at this point.

(Documents marked "Robert Shelton Exhibits Nos. 13-A through 13-C," respectively, and retained in committee files.)

Mr. APPELL. Mr. Shelton, as a part of the 2-day meeting, part of which was social and part of which was official Klan business, did you not present to the people assembled, Mr. Kimble, who operated an insurance agency in Bessemer, Alabama, and a man by the name of Harry Richardson, who was representing the Continental Assurance Company, for them to give sales pitches to your assembled delegates in the interest of this policy?

Mr. SHELTON. Sir, I respectfully decline to answer that question for the reason that I honestly feel that my answer might tend to incriminate me in violation of my rights as guaranteed to me by amendments 5, 1, 4, and 14 of the Constitution of the United States of America.

Mr. APPELL. In connection with your arrangements with Mr. Richardson and the Continental Assurance Company, didn't you sort of become the adviser to him on representatives in each State to handle the health-life policies which were going to be underwritten by the Continental Assurance Company?

Mr. SHELTON. Sir, I respectfully decline to answer that question for the reason that I honestly feel that my answer might tend to incriminate me in violation of my rights as guaranteed to me by amendments 5, 1, 4, and 14 of the Constitution of the United States of America.

Mr. APPELL. Mr. Chairman, I would like to enter into the record at this point a letter dated March 15, 1964, addressed to Mr. Robert Shelton, at 401 Alston Building, Tuscaloosa, Alabama, which, in turn, was forwarded to Mr. Harry Richardson and which contains the following note at the bottom of the original letter: "Write this man a [sic] make Arrangements for meeting with Dr. Edwards to set up Insurance Program for La.," Signed "Bob."

I would like to ask you, sir, is that your signature and your handwriting?

(Document handed to witness.)

(Witness confers with counsel.)

Mr. SHELTON. Sir, I respectfully decline to answer that question for the reason that I honestly feel my answer might tend to incriminate me in violation of my rights as guaranteed to me by amendments 5, 1, 4, and 14 of the Constitution of the United States of America.

(Document marked "Robert Shelton Exhibit No. 14" appears on p. 1649.)

The CHAIRMAN. Mr. Shelton, I notice that you are wearing a button in your lapel. I would like to give you the privilege of explaining that, if you want to.

Mr. SHELTON. Sir, I respectfully decline to answer that question for the reason that I honestly feel my answer might tend to incriminate me in violation of my rights as guaranteed to me by amendments 5, 1, 4, and 14 of the Constitution of the United States of America.

Mr. APPELL. Mr. Shelton, at the February meeting at the Dinkler-Tutwiler Hotel, did you assemble your Grand Dragons from various areas and other delegates to a klonvokation?

Mr. SHELTON. Sir, I respectfully decline to answer that question for the reason that I honestly feel my answer might tend to incriminate me in violation of my rights as guaranteed to me by amendments 5, 1, 4, and 14 of the Constitution of the United States of America.

Mr. APPELL. Mr. Shelton, as a matter of fact, because you made the arrangements for the banquet facilities, was your suite of rooms gratis?

Mr. SHELTON. Sir, I decline to answer that question for the reason that I honestly feel my answer might tend to incriminate me in violation of my rights as guaranteed to me by amendments 5, 1, 4, and 14 of the Constitution of the United States of America.

Mr. APPELL. Mr. Chairman, the committee subpoenaed from the Dinkler-Tutwiler Hotel all records in their possession with respect to registration of guests. And I have, and would like to enter into the record at this point, the original registration cards of Robert M. Shelton and Raymond R. Anderson—and I ask you, Mr. Shelton, at that time whether he was your Grand Dragon from Tennessee.

Mr. SHELTON. Sir, I respectfully decline to answer that question for the reason that I honestly feel that my answer might tend to incriminate me in violation of my rights as guaranteed to me by amendments 5, 1, 4, and 14 of the Constitution of the United States of America.

Mr. APPELL. I note, Mr. Chairman, that Mr. Anderson's registration includes Mrs., also.

ROBERT SHELTON EXHIBIT No. 14

Jonesboro, Louisiana

March 15, 1964

Mr. Robert Shelton
401 Alston Building
Tuscaloosa, Alabama

Dear Bob,

John Bates and Leamon Hodnett advised me to write to you concerning the possibility of establishing the general agency for the Heritage Insurance Company.

I have been interested in this concern since you mentioned the operation on one of your recent trips to Louisiana. At the present time I am licensed to sell Pan-American and Vulcan lines of ordinary life insurance. I have had some experience in the fire and casualty business when I worked for my father's agency during high school and college.

My regular employment is the Assistant Cashier at the Jackson Parish Bank and I handle the credit life insurance department in addition to other bank duties. The Pan American and Vulcan is my own personal line of insurance.

If it is possible to do so I would like to get together with a representative of the Heritage Insurance Company and see if there is something we can work out in the way of a general agency. I am not experienced in the way of getting state charters and such but I am willing to learn both for the organization and my own benefit.

John tells me that you plan a trip to Louisiana in a couple of weeks or so and if it is possible I would like to see you in connection with this business.

If you should come to Jonesboro and don't find John or Leamon right away call me at the bank phone 3394 or my house 3959.

Sincerely,

David F. Stinson
David F. Stinson

*Want the man a make arrangements
for meeting with Mr. Edwards
next up Louisiana Program for
the*

Zot

Mr. and Mrs. C. F. Craig—was C. F. Craig your Grand Dragon for the State of Georgia at that time?

Mr. SHELTON. Sir, I respectfully decline to answer that question for the reason that I honestly feel that my answer might tend to incriminate me in violation of my rights as guaranteed to me by amendments 5, 1, 4, and 14 of the Constitution of the United States of America.

Mr. APPELL. Another original registration at the hotel is J. R. Jones. Is James R. Jones your Grand Dragon from the State of North Carolina?

Mr. SHELTON. Sir, I respectfully decline to answer that question for the reason that I honestly feel that my answer might tend to incriminate me in violation of my rights as guaranteed to me by amendments 5, 1, 4, and 14 of the Constitution of the United States of America.

Mr. APPELL. Another registration for the same dates in February is Mr. and Mrs. R. E. Scoggin. Was R. E. Scoggin your Grand Dragon for South Carolina at that time?

Mr. SHELTON. Sir, I respectfully decline to answer that question for the reason that I honestly feel that my answer might tend to incriminate me in violation of my rights as guaranteed to me by amendments 5, 1, 4, and 14 of the Constitution of the United States of America.

(Documents marked "Robert Shelton Exhibits Nos. 15-A through 15-E," respectively, appear on pp. 1651-53.)

Mr. APPELL. On February 11, 1964, did you give to the Dinkler-Tutwiler Hotel a check on the Alabama Rescue Service, No. 379, in the amount of \$996, signed by Robert M. Shelton and cosigned by T. M. Montgomery?

Mr. SHELTON. Sir, I respectfully decline to answer that question for the reason that I honestly feel my answer might tend to incriminate me in violation of my rights as guaranteed to me by amendments 5, 1, 4, and 14 of the Constitution of the United States of America.

(Document marked "Robert Shelton Exhibit No. 16" appears on p. 1653.)

Mr. APPELL. At the klonvokation that was held there, were not elections held for certain offices on the imperial staff?

Mr. SHELTON. Sir, I respectfully decline to answer that question for the reason that I honestly feel that my answer might tend to incriminate me in violation of my rights as guaranteed to me by amendments 5, 1, 4, and 14 of the Constitution of the United States of America.

Mr. APPELL. Was Mr. Robert Thompson, of Georgia, elected Imperial Klaliff, or vice president, at that meeting?

Mr. SHELTON. Sir, I respectfully decline to answer that question for the reason that I feel my answer might tend to incriminate me in violation of my rights as guaranteed to me by amendments 5, 1, 4, and 14 of the Constitution of the United States of America.

Mr. APPELL. Was Mr. W. O. Perkins, whom we have just mentioned in connection with the Heritage Enterprises, Inc., papers elected as Kligrapp, or imperial secretary, at that meeting?

Mr. SHELTON. Sir, I respectfully decline to answer that question for the reason that I honestly feel that my answer might tend to incriminate me in violation of my rights as guaranteed to me by amendments 5, 1, 4, and 14 of the Constitution of the United States of America.

ROBERT SHELTON EXHIBIT No. 15-A

1126 SHELTON ROBERT M 8-34 47825

H 47825

M-W 2/7 TUSC ALA

PLEASE CHECK YOUR BAGGAGE OR SEND SAME TO YOUR ROOM; OTHERWISE THE HOTEL COMPANY WILL NOT BE RESPONSIBLE FOR LOSS

Dinkler-Tutwiler

DIRECTION
DINKLER HOTEL CORPORATION
"DISPENSERS OF TRUE SOUTHERN HOSPITALITY"

GUESTS ARE HEREBY NOTIFIED THAT THE COMPANY WILL NOT BE RESPONSIBLE FOR VALUABLES, MONEY, JEWELRY, CLOTHING ETC. UNLESS THE SAME ARE DEPOSITED IN SAFE

Name Robert M. Shelton
 Street Route 204 Abiston Rd. One State Ala.
 Firm Cell - Rescue City Sumner State _____
 Room No. 1126 Rate 8.80 Clerk _____
 SMTWTFS

ROBERT SHELTON EXHIBIT No. 15-B

952 ANDERSON RAYMOND R 15-60 47940
& WF

H 47940

F-DA 2/8 MARYVILLE TENN

PLEASE CHECK YOUR BAGGAGE OR SEND SAME TO YOUR ROOM; OTHERWISE THE HOTEL COMPANY WILL NOT BE RESPONSIBLE FOR LOSS.

Dinkler-Tutwiler

DIRECTION
DINKLER HOTEL CORPORATION
"DISPENSERS OF TRUE SOUTHERN HOSPITALITY"

GUESTS ARE HEREBY NOTIFIED THAT THE COMPANY WILL NOT BE RESPONSIBLE FOR VALUABLES, MONEY, JEWELRY, CLOTHING ETC. UNLESS THE SAME ARE DEPOSITED IN SAFE

Name Raymond Anderson
 Street Box 1066 City Maryville State Tenn
 Firm _____ City _____ State _____
 Room No. 952 Rate 15.60 Clerk _____
 SMTWTFS

ROBERT SHELTON EXHIBIT No. 15-C

857 CRAIG C F & WF 9-88 47828

H 47828

M-W 2/7 ATL GA

PLEASE CHECK YOUR BAGGAGE OR SEND SAME TO YOUR ROOM: OTHERWISE THE HOTEL COMPANY WILL NOT BE RESPONSIBLE FOR LOSS.

Dinkler-Tutwiler

DIRECTION
DINKLER HOTEL CORPORATION
"DISPENSERS OF TRUE SOUTHERN HOSPITALITY"

GUESTS ARE HEREBY NOTIFIED THAT THE COMPANY WILL NOT BE RESPONSIBLE FOR VALUABLES. MONEY. JEWELRY. CLOTHING ETC. UNLESS THE SAME ARE DEPOSITED IN SAFE

Name *Mr + Mrs C F Craig*

Street *774 Peach St* City *Atl* State *Ga*

Firm _____ City _____ State _____

Room No. *857* Rate *9.88* Clerk _____

SMTWTFS

ROBERT SHELTON EXHIBIT No. 15-D

1104 JONES J R 5-72 47758

H 47758

F-DA 2/7 GRANITE QUARRY N C

PLEASE CHECK YOUR BAGGAGE OR SEND SAME TO YOUR ROOM: OTHERWISE THE HOTEL COMPANY WILL NOT BE RESPONSIBLE FOR LOSS.

Dinkler-Tutwiler

DIRECTION
DINKLER HOTEL CORPORATION
"DISPENSERS OF TRUE SOUTHERN HOSPITALITY"

GUESTS ARE HEREBY NOTIFIED THAT THE COMPANY WILL NOT BE RESPONSIBLE FOR VALUABLES. MONEY. JEWELRY. CLOTHING ETC. UNLESS THE SAME ARE DEPOSITED IN SAFE

Name *J R Jones*

Street *Box 221* City *Granite Quarry* State *NC*

Firm _____ City _____ State _____

Room No. *1104* Rate *7.00* Clerk _____

SMTWTFS

ROBERT SHELTON EXHIBIT NO. 15-E

1057 SCOGGINS R E & MF 9-36
SPARTNABURG S C 47843
2/8 RS

H 47843

T

PLEASE CHECK YOUR BAGGAGE OR SEND SAME TO YOUR ROOM: OTHERWISE THE HOTEL COMPANY WILL NOT BE RESPONSIBLE FOR LOSS.

Dinkler-Tutwiler

DIRECTION
DINKLER HOTEL CORPORATION
"DISPENSERS OF TRUE SOUTHERN HOSPITALITY"

f

GUESTS ARE HEREBY NOTIFIED THAT THE COMPANY WILL NOT BE RESPONSIBLE FOR VALUABLES MONEY, JEWELRY CLOTHING ETC UNLESS THE SAME ARE DEPOSITED IN SAFE

Name Mr James R. E. Scoggin

Street 818 SAYON AVE City SPARTANBURG State SC

Firm ALABAMA RENE SOURCE State _____

Room No. 1057 Rate 9.88 Cl. SMTWTFS

ROBERT SHELTON EXHIBIT NO. 16

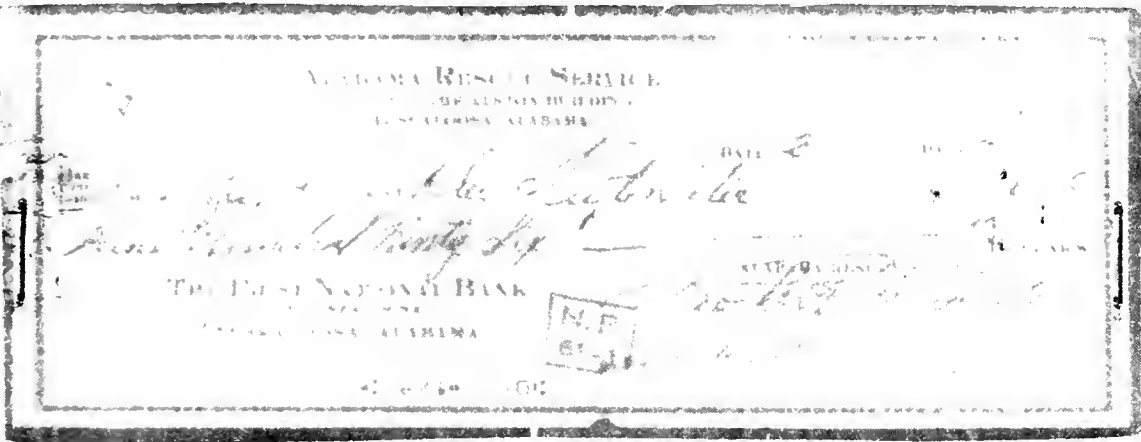

Mr. APPELL. Was Mr. Fredrick Smith elected Imperial Klabeer or imperial treasurer at that meeting?

Mr. SHELTON. Sir, I respectfully decline to answer that question for the reason I honestly feel my answer might tend to incriminate me in violation of my rights as guaranteed to me by amendments 5, 1, 4, and 14 of the Constitution of the United States of America.

Mr. APPELL. Mr. Shelton, at the same hotel in September of 1964 did you hold another klonvokation?

Mr. SHELTON. Sir, I respectfully decline to answer that question for the reason that I honestly feel that my answer might tend to incriminate me in violation of my rights as guaranteed to me by amendments 5, 1, 4, and 14 of the Constitution of the United States of America.

Mr. APPELL. Mr. Chairman, I would like to enter into the record at this point a letter dated June 23, 1964, on the letterhead of the United Klans of America, Inc., Suite 401, The Alston Building, Tuscaloosa, Alabama, Office of the Imperial Wizard. [Reads full text of letter.]
The CHAIRMAN. The letter will be received in evidence.
(Letter marked "Robert Shelton Exhibit No. 17" follows:)

ROBERT SHELTON EXHIBIT NO. 17

UNITED KLANS OF AMERICA
INCORPORATED
SUITE 401 - THE ALSTON BUILDING
TUSCALOOSA, ALABAMA

OFFICE OF THE IMPERIAL WIZARD

JUNE 23, 1964

Mr. T. Marcel
Catering Manager
Dinkler-Tutwiler
Birmingham, Alabama

Dear Mr. Marcel:

We would like to have a confirmation on the date we previously agreed on February 9th about September 5th and 6th for our banquet and convention.

Please give us a date when we may come and talk to you about the arrangements.

Let us hear from you as soon as possible.

Sincerely,



Robert M. Shelton

R.S:bs

Mr. APPELL. Under the same subpoena of the Dinkler-Tutwiler Hotel we received original copies of hotel registrations and, in the case of this meeting, cards which were printed by the Dinkler-Tutwiler Hotel which were distributed to the United Klans of America for them to make advance reservations.

I would like to enter at this point the original registration of Mr. Robert M. Shelton, which shows the stamped date of September 4, 1964; Mr. Raymond R. Anderson, who, according to the registration form, was accompanied by Mr. Claude L. Abbott, dated September 5, 1964; the original request for a reservation, and I would like, Mr. Chairman, to read this. It is a printed form, printed, as I said earlier, by the Dinkler-Tutwiler Hotel. It states on the top:

"Make Your Hotel Reservations Now!" and there is printed:

"I will be attending the convention of" followed by a blank space, which this card has filled in as the Alabama Rescue Service.

"I will arrive Friday, the 4th [approximately] 11 p.m. I will depart Sunday the 6th [approximately] 5 p.m. Reserve for me the following accommodations: double bedroom," with the typed signature, "J. M. Edwards, 424 6th St., Jonesboro, Louisiana."

I also attach to this as part of the same exhibit the original registration card of Dr. and Mrs. James M. Edwards.

(Documents marked "Robert Shelton Exhibits Nos. 18-A through 18-D," respectively, appear on pp. 1656, 1657.)

Mr. APPELL. I ask if Dr. Edwards is your Grand Dragon for Louisiana.

Mr. SHELTON. Sir, I respectfully decline to answer that question for the reason that I feel my answer may tend to incriminate me in violation of my rights as guaranteed to me by amendments 5, 1, 4, and 14 of the Constitution of the United States of America.

Mr. APPELL. Mr. Chairman, I would like to enter into evidence a request for—

The CHAIRMAN. Have you already placed the last documents into the record?

Mr. APPELL. Yes, sir.

The CHAIRMAN. Very well.

Mr. APPELL. I would like to enter into evidence at this point, Mr. Chairman, a request for hotel accommodations for the purpose of attending the Alabama Rescue Service, with the indication that the party intended to arrive on August 2 and claims to leave August 5. It is signed by James R. Jones, P. O. Box 321, Granite Quarry, North Carolina.

I have attached as part of the exhibit the original registration of Mr. Jones, which shows that he checked in at 10:28 on September 2, 1964.

Was Mr. Jones in September your Grand Dragon for the State of North Carolina?

Mr. SHELTON. Sir, I respectfully decline to answer that question for the reason that I honestly feel my answer might tend to incriminate me in violation of my rights as guaranteed to me by amendments 5, 1, 4, and 14 of the Constitution of the United States of America.

(Documents marked "Robert Shelton Exhibits Nos. 19-A and 19-B," respectively, appear on p. 1658.)

Mr. APPELL. I would like to enter into the record at this point, Mr. Chairman, a request for hotel accommodations for the purpose of attending the Alabama Rescue Service convention, signed E. L. McDaniel, 2156 Second Street, Natchez, Mississippi, and the original registration card is stamped September 5, 1964.

Was E. L. McDaniel your Grand Dragon for the State of Mississippi at the time he registered in the hotel on September 5?

Mr. SHELTON. Sir, I respectfully decline to answer that question for the reason that I honestly feel my answer right tend to incriminate me in violation of my rights as guaranteed to me by amendments 5, 1, 4, and 14 of the Constitution of the United States of America.

(Documents marked "Robert Shelton Exhibits Nos. 20-A and 20-B," respectively, appear on p. 1659:)

ROBERT SHELTON EXHIBIT No. 18-A

522-4-6 SHELTON ROBERT M COMP 65600

H 65600

M-W 9/4 TUSC ALA

PLEASE CHECK YOUR BAGGAGE OR SEND SAME TO YOUR ROOM: OTHERWISE THE HOTEL COMPANY WILL NOT BE RESPONSIBLE FOR LOSS

Dinkler-Tutwiler

DIRECTION
DINKLER HOTEL CORPORATION
"DISPENSERS OF TRUE SOUTHERN HOSPITALITY"

*also
Res
Service*

GUESTS ARE HEREBY NOTIFIED THAT THE COMPANY WILL NOT BE RESPONSIBLE FOR VALUABLES, MONEY, JEWELRY, CLOTHING ETC. UNLESS THE SAME ARE DEPOSITED IN SAFE

Name *Robert M. Shelton*

Street *Suite 401* City *Tusculum* State *ALA*

Firm *Alston Bldg* City *Tusculum* State *ALA*

Room No. *522-4-6* Rate *COMP* Clerk *SMTWTFSS*

ROBERT SHELTON EXHIBIT No. 18-B

1261 ANDERSON RAYMOND R 18-72 65886
ABBOTT CLAUDE

H 65886

E-R 9-5 MARYVILLE TENN

PLEASE CHECK YOUR BAGGAGE OR SEND SAME TO YOUR ROOM: OTHERWISE THE HOTEL COMPANY WILL NOT BE RESPONSIBLE FOR LOSS

Dinkler-Tutwiler

DIRECTION
DINKLER HOTEL CORPORATION
"DISPENSERS OF TRUE SOUTHERN HOSPITALITY"

GUESTS ARE HEREBY NOTIFIED THAT THE COMPANY WILL NOT BE RESPONSIBLE FOR VALUABLES, MONEY, JEWELRY, CLOTHING ETC. UNLESS THE SAME ARE DEPOSITED IN SAFE

Name *Raymond R Anderson* *Claude L Abbott*

Street *Bldg 1066* City *Maryville* State *Tenn*

Firm City State

Room No. *1261* Rate *187* Clerk *SMTWTFSS*

ROBERT SHELTON EXHIBIT No. 18-C



MAKE YOUR HOTEL RESERVATIONS NOW!

I will be attending the convention of the . . .

ALABAMA RESCUE SERVICE
(name of group or association)
Fri.

I will arrive (day) 4th (date) (hour) 11 p. m.

I will depart (day) Sun. (date) 6th (hour) 5 p. m.

Reserve for me the following accommodations . . .

(check one) single double bedroom
 twin bedroom suite

YOUR NAME J. M. Edwards

ADDRESS 424 6th St.

CITY Jonesboro, Louisiana

ROBERT SHELTON EXHIBIT No. 18-D

553 EDWARDS DR J M & WF 9-38
JONESBORO LA 65606 1

H 65606

9-4 RS

PLEASE CHECK YOUR BAGGAGE OR SEND SAME TO YOUR ROOM; OTHERWISE THE HOTEL COMPANY WILL NOT BE RESPONSIBLE FOR LOSS

Dinkler-Tutwiler

DIRECTION
DINKLER HOTEL CORPORATION
"DISPENSERS OF TRUE SOUTHERN HOSPITALITY"

GUESTS ARE HEREBY NOTIFIED THAT THE COMPANY WILL NOT BE RESPONSIBLE FOR VALUABLES, MONEY, JEWELRY, CLOTHING ETC. UNLESS THE SAME ARE DEPOSITED IN SAFE

Name J M Edwards Dr + Mrs.

Street 424 6th City Jonesboro State La.

Firm _____ City _____ State _____

Room No. 653 Rate 9.88 Clerk _____

XVI I WTFS

ROBERT SHELTON EXHIBIT No. 19-A



MAKE YOUR HOTEL RESERVATIONS NOW!

I will be attending the convention of the . . .

ALABAMA Rescue Service
(name of group or association)

I will arrive (day) Wed. (date) Aug. 2 (hour) . . . m.

I will depart (day) SUN. (date) AUG. 5 (hour) . . . m.

Reserve for me the following accommodations . . .

(check one) single double bedroom
 twin bedroom suite

YOUR NAME JAMES B. JONES

ADDRESS P.O. Box 321

CITY GRANITE QUARRY, N.C.

ROBERT SHELTON EXHIBIT No. 19-B

440-42 JONES J R & MRS 10-40 65402

H 65402

M-T 9/2 GRANITE QUARRY N C

PLEASE CHECK YOUR BAGGAGE OR SEND SAME TO YOUR ROOM; OTHERWISE THE HOTEL COMPANY WILL NOT BE RESPONSIBLE FOR LOSS

Dinkler-Tutwiler

DIRECTION
DINKLER HOTEL CORPORATION
"DISPENSERS OF TRUE SOUTHERN HOSPITALITY"

GUESTS ARE HEREBY NOTIFIED THAT THE COMPANY WILL NOT BE RESPONSIBLE FOR VALUABLES, MONEY, JEWELRY, CLOTHING ETC. UNLESS THE SAME ARE DEPOSITED IN SAFE

Name Mr & Mrs J R Jones
 Street Box 321 City Granite Quarry State N.C.
 Firm _____ City _____ State _____
 Room No. 440-42 Rate 10.40 Clerk _____

8MTWTF8

ROBERT SHELTON EXHIBIT NO. 20-A



MAKE YOUR HOTEL RESERVATIONS NOW!

I will be attending the convention of the . . .

Alabama Rescue Service
(name of group or association)

I will arrive (day) SAT (date) SEPT 5 (hour) 9 A. m.

I will depart (day) SUN (date) SEPT 6 (hour) 9 A. m.

Reserve for me the following accommodations . . .

(check one) single double bedroom
 twin bedroom *with water* suite

YOUR NAME E. L. M Daniel

ADDRESS 2156 Second St

CITY Natchez, Miss

ROBERT SHELTON EXHIBIT NO. 20-B

NOV 10 DANIEL E L 7-54 65656

H 65656

NAF MISS
9-4 R3

PLEASE CHECK YOUR BAGGAGE OR SEND SAME TO YOUR ROOM; OTHERWISE THE HOTEL COMPANY WILL NOT BE RESPONSIBLE FOR LOSS

Dinkler-Tutwiler

DIRECTION
DINKLER HOTEL CORPORATION
"DISPENSERS OF TRUE SOUTHERN HOSPITALITY"

GUESTS ARE HEREBY NOTIFIED THAT THE COMPANY WILL NOT BE RESPONSIBLE FOR VALUABLES, MONEY, JEWELRY, CLOTHING ETC. UNLESS THE SAME ARE DEPOSITED IN SAFE

Name E. L. M Daniel

Street 2156 Second City Natchez State Miss

Firm Alabama Rescue Service City _____ State _____

Room No. 956 Rate 7.00 Clerk _____

SMTWTFS

Mr. APPELL. During the business part of this convention, Mr. Shelton, were there additional elections to imperial office of the organization which you call the United Klans of America, Inc., Knights of the Ku Klux Klan, but which is chartered the "Invisible Empire, United Klans, Knights Ku Klux Klan of America, Inc.," additional elections to the imperial staff, imperial offices?

Mr. SHELTON. Sir, I respectfully decline to answer that question for the reason that I honestly feel that my answer might tend to incriminate me in violation of my rights as guaranteed to me by amendments 5, 1, 4, and 14 of the Constitution of the United States of America.

Mr. APPELL. As a matter of fact, Mr. Shelton, weren't you re-elected at this klonvokation unopposed?

Mr. SHELTON. Sir, I respectfully decline to answer that question for the reason that I honestly feel my answer might tend to incriminate me in violation of my rights as guaranteed to me under amendments 5, 1, 4, and 14 of the Constitution of the United States of America.

Mr. APPELL. Was there also elected to the imperial level at this klonvokation as the Klokard Mr. Robert Collins of Birmingham, Alabama?

Mr. SHELTON. May I counsel?

(Witness confers with counsel.)

Mr. SHELTON. Would you repeat the question?

Mr. APPELL. Was Mr. Robert Collins, of Birmingham, Alabama, elected as Klokard?

Mr. SHELTON. Sir, I respectfully decline to answer that question for the reason that I honestly feel my answer might tend to incriminate me in violation of my rights as guaranteed to me by amendments 5, 1, 4, and 14 of the Constitution of the United States of America.

Mr. APPELL. Mr. Shelton, it is the committee's information, based on its investigation, that also elected to the imperial staff at that time, and I shall name all of the officers before I ask you the question:

As the Imperial Kludd or chaplain, the Reverend George Dorsett, from North Carolina; as the Imperial Kladd, Mr. Robert Hudgins, of Raleigh, North Carolina; as the Imperial Klarogo or inner guard, Mr. Walter Brown, of Sumter, South Carolina; as the Imperial Klaxter, Mr. Robert Korman, of Miami, Florida; as the Imperial Night-Hawk, Dr. Amos Pedigo.

Were those men elected at that klonvokation?

Mr. SHELTON. Sir, I respectfully decline to answer that question for the reason that I honestly feel my answer might tend to incriminate me in violation of my rights as guaranteed to me by amendments 5, 1, 4, and 14 of the Constitution of the United States of America.

Mr. APPELL. Mr. Shelton, as a result of a demand by the secretary of state of North Carolina, did you execute on July 2 and file with the secretary of state of North Carolina on July 7 an Application for Certificate of Authority for a foreign corporation to do business in the State of North Carolina?

Mr. SHELTON. May I counsel, please?

(Witness confers with counsel.)

Mr. SHELTON. Sir, I respectfully decline to answer that question for the reason that I honestly feel my answer might tend to incriminate me in violation of my rights as guaranteed to me by amendments 5, 1, 4, and 14 of the Constitution of the United States of America.

Mr. APPELL. The form required by the State of North Carolina under section 7 calls for the names and addresses of all of the directors and officers of the corporation.

This application, Mr. Chairman, was filed in the name of the "Invisible Empire, United Klans, Knights Ku Klux Klan of America, Inc.," setting forth that it was a Georgia corporation.

The CHAIRMAN. Are the officers named?

Mr. APPELL. Yes, they are named.

The CHAIRMAN. Name them and ask the question.

Mr. APPELL. The names listed are "Robert M. Shelton, President; Mr. Melvin Sexton, Secretary; Mr. Robert Thompson, Vice-President; Mr. W. O. Perkin,¹ Treasurer."

I would like to ask, due to the fact that your constitution calls for 16 officers, why you did not fully comply with the North Carolina law and set forth all of the officers and directors as this document called for?

Mr. SHELTON. Sir, I respectfully decline to answer that question for the reason that I honestly feel my answer might tend to incriminate me in violation of my rights as guaranteed to me by amendments 5, 1, 4, and 14 of the Constitution of the United States of America.

Mr. APPELL. Mr. Chairman, I would like to ask that a copy of this certification be made a part of the record at this point.

The CHAIRMAN. The document is admitted, but before its admission, the reservations and all previous documents, if they have not already been offered, will be received in evidence as they were respectively referred to.

(Document marked "Robert Shelton Exhibit No. 21" appears on pp. 1662-64.)

Mr. APPELL. Mr. Shelton, I note here that Mr. Melvin Sexton is listed as secretary, and I also note in the corporate return filed in July of 1965 with the Internal Revenue Service that Melvin Sexton signs as secretary.

When and under what circumstances did he replace Mr. W. O. Perkins as the Kligrapp or secretary of the organization?

Mr. SHELTON. May I counsel?

(Witness confers with counsel.)

Mr. SHELTON. Sir, would you repeat the question, please?

Mr. APPELL. Yes, sir. I said that Mr. Melvin Sexton is shown on this document and is also shown on the corporate return filed in July 1965 as secretary.

I would like to know when he replaced Mr. W. O. Perkins as secretary, imperial secretary, or Imperial Kligrapp.

Mr. SHELTON. Sir, I respectfully decline to answer that question for the reason that I honestly feel my answer might tend to incriminate me in violation of my rights as guaranteed to me by amendments 5, 1, 4, and 14 of the Constitution of the United States of America.

Mr. APPELL. Did this action happen at the same time Mr. Perkins replaced Mr. Smith as treasurer?

Mr. SHELTON. Sir, I respectfully decline to answer that question for the reason that I honestly feel my answer might tend to incriminate me in violation of my rights as guaranteed to me by amendments 5, 1, 4, and 14 of the Constitution of the United States of America.

¹ Correct name W. O. Perkins.

ROBERT SHELTON EXHIBIT No. 21

RECEIVED
 1965
 STATE OF NORTH CAROLINA

APPLICATION FOR CERTIFICATE OF AUTHORITY

FOREIGN CORPORATION

INVISIBLE EMPIRE, UNITED KLANS, KNIGHTS KU KLUX KLAN OF AMERICA, INC.
 (Name of Corporation)

organized and existing under the laws of the State of Georgia, hereby makes application for authority to transact business in the State of North Carolina, and in compliance with the provisions of Section 55-135 of the General Statutes of North Carolina, makes the following statement:

- The name of the corporation is INVISIBLE EMPIRE, UNITED KLANS, KNIGHTS KU KLUX KLAN OF AMERICA, INC.
- The corporation was incorporated under the laws of the State of Georgia on the 20 day of February 1961, and is in good standing in its home state. The period of duration of the corporation is Thirty-Five Years
- The name the corporation elects to use in the State of North Carolina is* INVISIBLE EMPIRE, UNITED KLANS, KNIGHTS KU KLUX KLAN OF AMERICA, INC.
- The address (including street and number, if any) of the home or principal office of the corporation in the state of incorporation is Suite 401 Alston Bldg., Tuscaloosa, Alabama
- The address (including street and number, if any) of the proposed registered office of the corporation in the State of North Carolina is P.O. Box 321, Granite Quarry, North Carolina, Rowan County and the name of the proposed registered agent at such address upon whom process may be served is J.R. Jones
- The purpose or purposes which the corporation proposes to pursue in the transaction of business in the State of North Carolina are:
 The general purpose of the corporation shall be to teach patriotism, to support the Constitution and Laws of the United States and the several States wherein said corporation may be established, and to maintain the liberty bequeathed to us by our forefathers, and to preserve the American way of life.

* If the name of the corporation does not contain the word "corporation", "company", "incorporated", or "limited", or an abbreviation of one of such words, insert the name of the corporation with the word or abbreviation which it elects to add thereto for use in the State of North Carolina.

ROBERT SHELTON EXHIBIT No. 21—Continued

7. The names and addresses (including street and number, if any) of all of the directors and officers of the corporation are

Directors	Address
Mr. Robert M. Shelton	Suite 401 Alston Bldg., Tuscaloosa, Ala.
Mr. Melvin Sexton	Suite 401 Alston Bldg., Tuscaloosa, Ala.
Mr. Robert Thompson	Marbleton, Georgia
Mr. W. O. Perkin	17 Lake Sherwood, North Port, Ala.

Officers	Title	Address
Mr. Robert M. Shelton	President	Suite 401 Alston Bldg., Tuscaloosa, Ala.
Mr. Melvin Sexton	Secretary	Suite 401 Alston Bldg., Tuscaloosa, Ala.
Mr. Robert Thompson	Vice-President	Marbleton, Georgia
Mr. W. O. Perkin	Treasurer	17 Lake Sherwood, North Port, Ala.

8. The number of shares which the corporation has authority to issue, itemized by classes, par value of shares, shares without par value, and series, if any, within a class, is as follows:

Number of Shares	Class	Series	Par Value, or Statement that Shares are without par value
------------------	-------	--------	---

N O N E

9. The number of shares actually issued by the corporation, itemized by classes, par value of shares, shares without par value, and series, if any, within a class, is as follows:

Number of Shares	Class	Series	Par Value, or Statement that Shares are without par value
------------------	-------	--------	---

N O N E

10. In consideration of the issuance of a Certificate of Authority to transact business in the State of North Carolina, the corporation hereby appoints the Secretary of State of North Carolina as its agent to receive service of process, notice or demand whenever the corporation fails to appoint or maintain a registered agent in the State of North Carolina, or whenever any such registered agent cannot with reasonable diligence be found at the registered office of the corporation.

ROBERT SHELTON EXHIBIT NO. 21—Continued

11. Attached hereto is a copy of the Articles of Incorporation and all amendments thereto, or a copy of the restated, integrated or consolidated charter of the corporation, duly authenticated by the proper officer of the state or country wherein incorporated.

IN TESTIMONY WHEREOF, this statement is signed by the _____ president and _____ Secretary,

this 2nd day of July, A.D. 19 65.

INVISIBLE EMPIRE UNITED KLANS, KNIGHTS KU KLUX KLAN OF AMERICA, INC.

Robert N. Shelton
President

By: _____
President

Melvin Sexton
Secretary

STATE OF Alabama
COUNTY OF TUSCALOOSA

Robert N. Shelton and Melvin Sexton, each

being duly sworn, deposes and says that he signed the foregoing "Application for Certificate of Authority" in the capacity indicated, and that the statements therein contained are true and correct.

Sworn to and subscribed before me this 2nd day of July, A.D. 19 65.

Sue M. Clary
Notary Public

State of Alabama at Large.

Mr. APPELL. Mr. Shelton, have you ever had service in the military of the United States?

(Witness confers with counsel.)

Mr. SHELTON. Sir, I respectfully decline to answer that question for the reason that I honestly feel my answer might tend to incriminate me in violation of my rights as guaranteed to me by amendments 5, 1, 4, and 14 of the Constitution of the United States of America.

The CHAIRMAN. I cannot conceive that disclosure as to service to your country can incriminate you. I direct you to answer the question.

Mr. SHELTON. Sir, I respectfully decline to answer that question for the reason that I honestly feel my answer might tend to incriminate me in violation of my rights as guaranteed to me by amendments 5, 1, 4, and 14 of the Constitution of the United States of America.

Mr. APPELL. Mr. Shelton, you, according to the military records—Mr. Shelton, after your term of enlistment expired, because of the Korean emergency, all men were frozen in service. Did you request of the Air Force a hardship discharge on the grounds that you had to assist your mother and father in the operation of a grocery store?

Mr. SHELTON. Sir, I respectfully decline to answer that question for the reason that I honestly feel that my answer might tend to incriminate me in violation of my rights as guaranteed to me under the—

under the amendments 5, 1, 4, and 14 of the Constitution of the United States of America.

Mr. APPELL. Isn't it a fact that you were discharged after this plea on July 9, 1951, and returned to your employment with Goodrich Service—or Tire & Rubber Company on August 7?

Mr. SHELTON. Sir, would you repeat that question, please?

Mr. APPELL. Yes. Isn't it true that you were separated from service because of your request for a hardship discharge because of the need to help your parents operate a grocery store on July 9, 1951, and isn't it a further fact that you returned to your employment as a tirebuilder or tireworker at the Goodrich Tire & Rubber Company, Tuscaloosa, Alabama, on August 7, less than 30 days after your discharge?

Mr. SHELTON. Sir, I respectfully decline to answer that question for the reason that I honestly feel that my answer might tend to incriminate me in violation of my rights as guaranteed to me by amendments 5, 1, 4, and 14 of the Constitution of the United States of America.

Mr. APPELL. And this was when a lot of our boys were losing—

The CHAIRMAN. Proceed with the next question.

Mr. APPELL. Mr. Shelton, are you the holder of a citizens band radio license?

Mr. SHELTON. Sir, I respectfully decline to answer that question for the reason that I honestly feel that my answer might tend to incriminate me in violation of my rights as guaranteed to me by amendments 5, 1, 4, and 14 of the Constitution of the United States of America.

Mr. APPELL. Mr. Chairman, I would like to enter into the record at this point an application for a citizens band license, Class D, signed by Robert M. Shelton, notarized by Alvin B. Sisk, whose name we discussed yesterday in connection with the first signature card of the Alabama Rescue Service.

I would like to read from this form: "How is radio to be used in connection with applicant's business or personal activities?" And there is stated thereunder: "To be used in connection with Emergency rescue activities."

Item 9 is an addendum to the original form. It is amended to read as follows:

This radio equipment is to be used in connection with my personal activities and business. I am in the business of selling two-way radio equipment to customers in this area. I conduct my business under my own name.

There was requested permission to operate six mobile units.

Is that a truthful application, Mr. Shelton?

Mr. SHELTON. Sir, would you repeat that question?

Mr. APPELL. Is that a truthful application?

Mr. SHELTON. Would you repeat the question concerned?

Mr. APPELL. I will show you the document and ask you to look at the entries on it, and answer if the application was truthfully executed.

(Document handed to witness.)

(Witness confers with counsel.)

Mr. SHELTON. Sir, I respectfully decline to answer that question for the reason that I honestly feel my answer might tend to incriminate me in violation of my rights as guaranteed to me by amendments 5, 1, 4, and 14 of the Constitution of the United States of America.

(Document marked "Robert Shelton Exhibit No. 22" follows:)

ROBERT SHELTON EXHIBIT No. 22

FCC Form 505
September 1958

Form Approved
Budget Bureau No. 52-R123 8

CITIZENS RADIO LICENSE

This authorization permits the use only of transmitters which: (1) Are listed under Special Conditions below, (2) appear in the Commission's "Radio Equipment List, Part C", or (3) in the case of Class C or Class D stations, are crystal controlled.

1. Class of station (Check one)
 A
 B
 C
 D

2. COMMISSION FILE COPY
 FOR COMMISSION USE ONLY
 6 Q 4311
 CALL SIGN

1(a) FREQUENCIES	1(b) EMISSION	BASE	2(b) NO. OF TRANSMITTERS	FIXED
Class D	Class D		6	

3. Location of transmitter(s) at a fixed location
 Number of street (or other indication of location)
 DNA

City DNA County State

4. Location of control point(s)
 DNA

5. If mobile units, or other class of station at temporary locations, are included in this authorization, show area of operation
 Alabama, Georgia, Tennessee, Florida
 Mississippi, North Car. & South Car.

6. Name (see instructions)
 Robert M. Shelton

7. Mailing address (number, street, city, zone, county, state)
 1708 E. 15th Street
 Tuscaloosa, Alabama (Tuscaloosa Co)

8. Location of transmitter(s) at a fixed location
 Number of street (or other indication of location)
 DNA

City DNA County State

9. Mailing address (number, street, city, zone, county, state)
 DNA

10. Term of authorization. This authorization is effective August 11, 1961 and will expire 3:00 A. M. EST. August 11, 1963 and is subject to further conditions as set forth on reverse side.
 By direction of the FEDERAL COMMUNICATIONS COMMISSION
 Acting SECRETARY

7. State whether applicant is (Check one)
 Individual Partnership Association Corporation
 Governmental Entity

8. If applicant is a corporation or an unincorporated association, item 15 or item 16 whichever is applicable, on the reverse side of this form must be filled out.

9. (a) Will applicant own the radio equipment? YES NO
 If answer is "No", give name of owner

(b) If not the owner of the radio equipment, is applicant a party to a lease or other agreement under which control will be exercised in the same manner as if the equipment were owned by the applicant? YES NO

(c) Will applicant have unlimited access to the premises/station and will effective measures be taken to prevent use of the radio equipment by unauthorized persons? YES NO

10. Will this radio be used in connection with applicant's business or personal activities? (Use space on the reverse of this page or attach additional sheet, if necessary.)
 To be used in connection with
 Emergency rescue activities

11. If for Class C or Class D stations, are transmitters crystal controlled? YES NO

12. If antenna will extend more than 20 feet above ground or more than 20 feet above an existing non-radio structure on which it will be mounted, give the following:
 (a) Construction of antenna _____ feet. (b) Elevation of ground above mean sea level at antenna site _____ feet.

13. If antenna structure is a tower, attach a profile sketch showing structure height and antenna height.

14. If applicant is authorized to operate the station, attach a diagram showing the locations of all the other stations in the system (space or fixed) in the system and the area of operations of the system.

15. If applicant is authorized to use a transmitter which does not appear on the Commission's "Radio Equipment List," or a crystal-controlled transmitter in a Class C or D station, describe such transmitter in proper perspective on this or attach additional sheets.

All the statements made in the application and attached exhibits are considered material representations, and all the exhibits are a material part hereof and are incorporated herein as if set out in full in the application.

I certify that I have a current copy of Part 19 of the Commission's Rules governing the Citizens Radio Service, and eighteen or more years of age (or twelve or more years of age if for Class C). I also certify that I am not for a partnership, corporation, or association of the applicant, that each partner, the corporation, or the association is not the representative of any alien or any foreign government, that I waive any claim to the use of any particular frequency or of the ether as against the regulatory power of the United States because of previous use of the same, and that I accept full responsibility for the operation of, and will retain control of, any Citizens Radio Station licensed to me pursuant to this application, in compliance with the law and the Rules of the Federal Communications Commission. I further certify that said station will not be used for any purpose contrary to federal, state or local laws.

Subscribed and sworn to before me this 16 day of April 1961

Notary Public (FOR NAME AND TITLE OF OTHER PERSON COMPELLED TO ADMINISTER OATHS)

My commission expires 15 August 1962

Signature of Applicant: Robert M. Shelton
 SIGNATURE OF APPLICANT (MUST AGREE WITH NAME AS SHOWN IN ITEM 7(a))

By: Individual Applicant
 Member of Applicant Partnership
 Officer of Applicant Corporation or Association
 Official of Governmental Entity

ROBERT SHELTON EXHIBIT No. 22—Continued

FCC Form 730
April 1960

UNITED STATES OF AMERICA
FEDERAL COMMUNICATIONS COMMISSION
WASHINGTON 25, D. C.

Form Approved.
Budget Bureau No. 52-R169

ATTACHMENT TO RESUBMITTED APPLICATION

INSTRUCTIONS TO APPLICANT: According to law all applications must be signed under oath or affirmation before a Notary Public or other official authorized to administer oaths. If you supply any additional information, or make any changes in the application form, you must again swear to it before a Notary Public or other official. This form is for your convenience. After you have made the corrections in the attached returned application, or if you wish, after you have supplied the information called for on any additional sheets of paper you may attach to the returned application form, sign this and check the proper block below before a Notary who will fill in the remaining blanks.

The space below or the reverse side of this sheet may be used for any additional information required to correct the application.

Item 9: is amended to read as follows:

This radio equipment is to be used in connection with my personal activities and business. I am in the business of selling two-way radio equipment to customers in this area. I conduct my business under my own name.

Item 11, is amended to read as follows:

The transmitters that will be used under this license are crystal controlled.

I hereby certify that the information supplied on the attached form or on this and on any additional sheets attached thereto is true and correct to the best of my knowledge and belief.

Robert M. Shelton

APPLICANT (Must agree with name as shown on the application.)

By Robert M. Shelton
(Designate appropriate classification below)

- Individual Applicant
- Member of Applicant Partnership
- Officer of Applicant Corporation or Association
- Official of Governmental Entity

Signed, under oath (or affirmation),

before me this 4 day of August, 1961.

Notary Public: William D. Bisk (SEAL)
(or name and title of other person competent to administer oaths)

My commission expires 15 August 1962

The CHAIRMAN. Mr. Shelton, did you ever engage in individual rescue service?

Mr. SHELTON. Sir, I respectfully decline to answer that question for the reason that I honestly feel my answer might tend to incriminate me in violation of my rights as guaranteed to me by amendments 5, 1, 4, and 14 of the Constitution of the United States of America.

The CHAIRMAN. Isn't it a fact that you misstated—to use a harsh word—the purpose of the application just referred to, to your Government, but that this application was to be used, and has in fact been used, in connection with that phony front outfit, the Alabama Rescue Service, which is part of your so-called Invisible Empire operations?

Mr. SHELTON. Sir, I respectfully decline to answer that question for the reason that I honestly feel that my answer might tend to incriminate me in violation of my rights as guaranteed to me by amendments 5, 1, 4, and 14 of the Constitution of the United States of America.

Mr. ASHBROOK. Mr. Chairman?

The CHAIRMAN. Yes.

Mr. ASHBROOK. Many rescue services specialize in pets and animals. Possibly your rescue service directed their attention towards this species. Would that be correct?

Mr. CHALMERS. Mr. Chairman, may I state that I don't see any legislative purpose in answering a question like that.

The CHAIRMAN. That is a proper question. We are probing into whether there was any validity attached to the application in connection with any kind of rescue. I mentioned the human kind, and Mr. Ashbrook referred to other kinds. I think it is a proper question. But we will not prolong it.

Mr. SHELTON. Sir, I respectfully decline to answer that question for the reason that I honestly feel my answer might tend to incriminate me in violation of my rights guaranteed to me by amendments 5, 1, 4, and 14 of the Constitution of the United States of America.

Mr. APPELL. Mr. Shelton, have you and other members of the Klan in the Tuscaloosa, Alabama, area, used these citizens band radios which you have in your possession for the purpose of conducting Klan activities?

Mr. SHELTON. Sir, I respectfully decline to answer that question for the reason that I honestly feel my answer might tend to incriminate me, in violation of my rights as guaranteed to me by amendments 5, 1, 4, and 14 of the Constitution of the United States of America.

Mr. APPELL. Have you used the citizens band radios for the purpose of intimidating any citizens in the Tuscaloosa, Alabama, area?

Mr. SHELTON. Sir, I respectfully decline to answer that question for the reason that I honestly feel my answer might tend to incriminate me in violation of my rights as guaranteed to me by amendments 5, 1, 4, and 14 of the Constitution of the United States of America.

Mr. APPELL. Mr. Shelton, I show you a photograph of yourself seated in front of a typewriter, talking over a piece of radio equipment.

I ask you to examine the photograph, the three pieces of radio equipment shown in the photograph, and I ask you whether or not any of this equipment can be used to monitor police channels.

(Photograph handed to witness.)

Mr. SHELTON. Sir, I respectfully decline to answer that question for the reason that I honestly feel my answer might tend to incriminate me in violation of my rights as guaranteed to me by amendments 5, 1, 4, and 14 of the Constitution of the United States of America.

(Photograph marked "Robert Shelton Exhibit No. 23" follows:)

ROBERT SHELTON EXHIBIT NO. 23



Robert M. Shelton using short wave radio.

Mr. APPELL. Mr. Shelton, were you ever employed by the Dixie Engineering Corporation of Mobile, Alabama?

Mr. SHELTON. Sir, I respectfully decline to answer that question for the reason that I honestly feel my answer might tend to incriminate me in violation of my rights as guaranteed to me by amendments 5, 1, 4, and 14 of the Constitution of the United States of America.

The CHAIRMAN. Isn't it a fact that you received at least \$4,000 from that employment and performed no services?

Mr. SHELTON. Sir, I respectfully decline to answer that question for the reason that I honestly feel my answer might tend to incriminate me in violation of my rights as guaranteed to me by amendments 5, 1, 4, and 14 of the Constitution of the United States of America.

The CHAIRMAN. I think I should rephrase the question to come within the exact information of the committee. Isn't it a fact that you received at least \$4,000 from the company named because you knew your way around in Montgomery and because of your ability to exercise political influence?

Mr. SHELTON. Sir, I respectfully decline to answer that question for the reason that I honestly feel my answer might tend to incriminate me in violation of my rights as guaranteed to me by amendments 5, 1, 4, and 14 of the Constitution of the United States of America.

The CHAIRMAN. And again in fairness, which is not a question but which conforms to the information of the committee, it is my impression, anyway, that the payments were made by a rather unwilling victim of yours.

Mr. SHELTON. May I confer with counsel?

The CHAIRMAN. I didn't ask a question, but if you want to I will put it in the shape of a question.

(Witness confers with counsel.)

Mr. APPELL. Mr. Chairman, I would like to enter into the record at this point original checks payable—some to Robert M. Shelton, some to Robert Shelton, some to R. C. Shelton, and we have testimony that these are all one and the same man, which represent payments to him by the Dixie Engineering Company.

I would like them to be entered into the record at this point.

(Documents marked "Robert Shelton Exhibits Nos. 24-A through 24-H," respectively, appear on pp. 1671-1673.)

Mr. APPELL. I would like to ask you whether or not it is a fact that you failed to report much of this income on your personal income tax return.

Mr. SHELTON. Sir, I respectfully decline to answer that question for the reason that I feel my answer might tend to incriminate me in violation of my rights as guaranteed to me by amendments 5, 1, 4, and 14 of the Constitution of the United States of America.

The CHAIRMAN. The checks have been received in evidence at the point where they were referred to.

Mr. APPELL. Mr. Shelton, have you an employee in the office by the name of Lewis E. Perkins?

Mr. SHELTON. Sir, I respectfully decline to answer that question for the reason that I honestly feel my answer might tend to incriminate me in violation of my rights as guaranteed to me by amendments 5, 1, 4, and 14 of the Constitution of the United States of America.

Mr. APPELL. Mr. Chairman, I would like to have entered into the record at this point telephone toll slips which we subpoenaed by a subpoena duces tecum from the telephone company, which shows that the telephone bills to the Alabama Rescue Service are sent care of

ROBERT SHELTON EXHIBIT No. 24-A

61-342
621

PINE APPLE, ALA., July 14 19 63 No. 00

BANK OF PINE APPLE
 PINE APPLE, ALABAMA

PAY TO THE ORDER OF Robert M. Shelton \$ 500
Five Hundred & 00/100 DOLLARS

Disc Engineering Corporation of Montgomery
 By C. A. Murrell

July

⑆0621⑆0342⑆

ROBERT SHELTON EXHIBIT No. 24-B

SELMA, ALABAMA Sept 24 1963 No. 127
61-617
621

CITIZENS BANK & TRUST COMPANY

PAY TO THE ORDER OF Robert Shelton \$ 500
Five Hundred & 00/100 DOLLARS

PAYABLE AT PAR
 Through Federal Reserve System

Disc Engineering Corporation of Montgomery
 By C. A. Murrell

⑆0621⑆0617⑆

ROBERT SHELTON EXHIBIT No. 24-C

61-46
621

No. 7

MONTGOMERY, ALA. November 6 1963

PAY TO THE ORDER OF R. C. Shelton \$ 500.00

Five hundred dollars and no cents DOLLARS

PAYABLE AT PAR THROUGH FEDERAL RESERVE SYSTEM

Peoples BANK AND TRUST CO.
 MONTGOMERY, ALA.

Disc Engineering Corporation
 By C. A. Murrell

ROBERT SHELTON EXHIBIT No. 24-D

Worshipful Bank & Trust Co
~~THE STATE BANK OF MONTGOMERY~~
 MONTGOMERY, ALA. *Jan 13 1963* No. 00
 Pay to the order of *Robert Shelton* \$ 500
Five Hundred → *4/100* DOLLARS
Dixie Engineering Corporation
Pay to U. Umwith
00235-6
 205 235 0355

ROBERT SHELTON EXHIBIT No. 24-E

Mobile, Ala. *Jan 8 1964* No. 1406
THE MERCHANTS NATIONAL BANK 61-29
 OF MOBILE 651
 Pay to the order of *R.C. Shelton* \$ 500⁰⁰
Five Hundred Dollars
 JAN 2 1964
 DIXIE ENGINEERING CORPORATION
Pay to U. Umwith
 00 676 11 "0000050000"

ROBERT SHELTON EXHIBIT No. 24-F

MERCHANTS NATIONAL BANK No. 1620
 OF MOBILE 61-29
 Mobile, Alabama *Feb 13 1964* 651
 Pay to the order of *Robert Shelton* \$ 500⁰⁰
Five Hundred → *4/100* DOLLARS
 MAR 5 1964
 DIXIE ENGINEERING CORP.
Pay to U. Umwith
 00651-00291 02 618 51" 4991 0000050000"

ROBERT SHELTON EXHIBIT No. 24-G

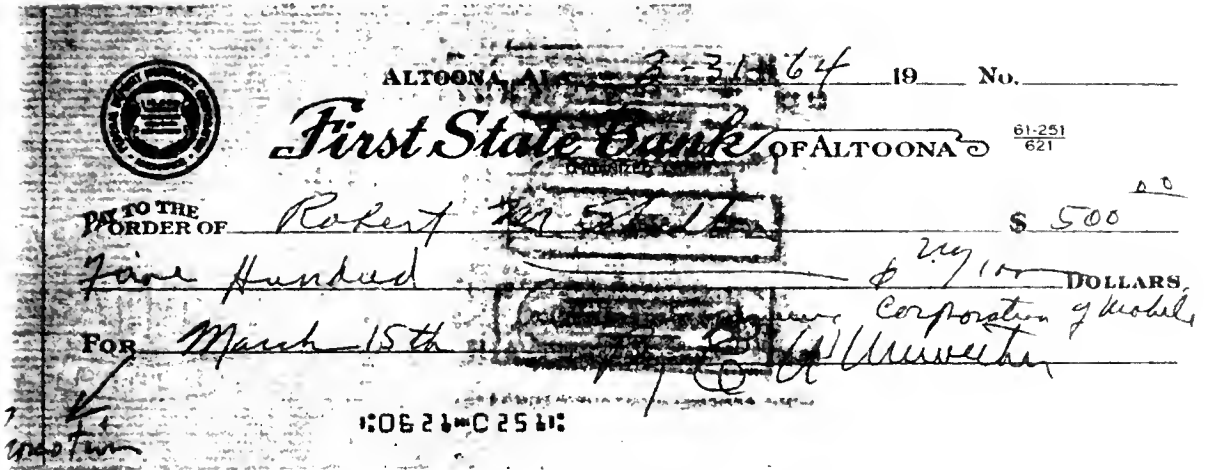

ROBERT SHELTON EXHIBIT No. 24-H

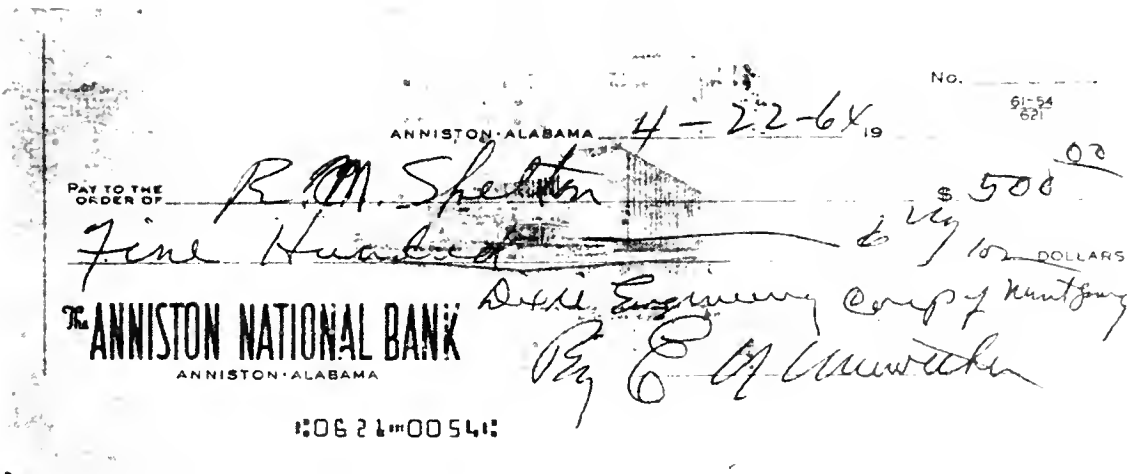

Lewis E. Perkins, Alston Building, Room 401, Tuscaloosa, Alabama.

The CHAIRMAN. The documents will be received in evidence at this point.

(Documents marked "Robert Shelton Exhibit No. 25." One of said toll slips appears on p. 1674; balance retained in committee files.)

Mr. APPELL. Mr. Shelton, when did you first become a member of the Ku Klux Klan?

Mr. SHELTON. Sir, I respectfully decline to answer that question for the reason that I honestly feel my answer might tend to incriminate me in violation of my rights as guaranteed to me by amendments 5, 1, 4, and 14 of the Constitution of the United States of America.

The CHAIRMAN. Is it your position that joining the Klan is something which may result in criminal prosecution?

Mr. SHELTON. Sir, I respectfully decline to answer that question for the reason that I honestly feel my answer might tend to incriminate me in violation of my rights as guaranteed to me by amendments 5, 1, 4, and 14 of the Constitution of the United States of America.

Mr. APPELL. Mr. Chairman, from the official court records of the secretary of state, probate courts, the State of Alabama, the com-

ROBERT SHELTON EXHIBIT No. 25

PA	CALL	DEN
DN	PD	REST
CLAIMS	CALL	N P
& MISC		DISC

ALA RESCUE SERVICE
 C/O LEWIS & PERKINS
 ALSTON BLDG RM 401
 TUSCALOOSA AL 35401

205 759 5221
 683
 MAY 19 1965
 TUSC 054

LOC TAX OF	1 20
DATE	COOK
BALANCE	
CALLS	
ADV	13 20
OCC	28 88
BAL	
TOT	42 08
BAL	

0607 C -2

FORM 918A
(9-64)

T - SEE REVERSE FOR EXPLANATION

LIST OF CALLS

DATE	PLACE CALLED	T AMOUNT	BILLING NUMBER	CONN TIME	MINS	C S
0419	MONTGOMERY ALA	263 2494	759 5221		002	B
0421	BIRMINGHAM ALA	324 4506			002	B
0421	TUSCALOOSA ALA FROM MONTGY ALA	90			004	B
0422	MONTGOMERY ALA	263 3182			001	B
0422	MONTGOMERY ALA	263 3182			003	B
0427	MONTGOMERY ALA	263 6853			003	B
0429	JONESBORO LA	300			009	B
0430	BIRMINGHAM ALA	324 4506			011	B
0323	TUSCALOOSA ALA FROM TEXARKAARKA	345			009	B
0511	MONTGOMERY ALA	263 6853			002	B
0511	MONTGOMERY ALA	263 3182			004	B
0512	BIRMINGHAM ALA	322 7056			003	B
0514	BESSEMER ALA	428 4739			005	B
0514	MONTGOMERY ALA	263 6853			005	B
0518	MONTGOMERY ALA	263 3182			005	B
TOTAL EXCL TAX						
FED TAX						
TOTAL INCL TAX						

(Broad)

mittee has received certain documents about which I would now like to question Mr. Shelton.

Mr. Shelton, I have a document dated the 10th day of June 1957, signed by "E. L. Edwards As President (Imperial Wizard), Wm. A. Daniel, Sr., As Secretary (Kligrapp)," which notification says that Robert M. Shelton is the agent of the U.S. Klans, Knights of the Ku Klux Klan, Inc., for the State of Alabama.

Is that a factual document, sir?

(Document handed to witness.)

(Witness confers with counsel.)

Mr. SHELTON. Sir, I respectfully decline to answer that question for the reason I honestly feel my answer might tend to incriminate me in violation of my rights as guaranteed to me by amendments 5, 1, 4, and 14 of the Constitution of the United States of America.

Mr. APPELL. On November 4, 1959, were you removed from your office of Grand Dragon by Imperial Wizard E. L. Edwards?

Mr. SHELTON. Sir, I respectfully decline to answer that question for the reason that I honestly feel my answer might tend to incriminate me in violation of my rights as guaranteed to me by amendments 5, 1, 4, and 14 of the Constitution of the United States of America.

Mr. APPELL. Mr. Chairman, I would like to have entered into the record at this point the document designating Mr. Shelton as agent for the U.S. Klans.

The CHAIRMAN. The document will be received in evidence at this point.

(Document marked "Robert Shelton Exhibit No. 26" appears on p. 1676.)

Mr. APPELL. I would like to introduce in evidence at this point a document of the U.S. Klans, with the heading at the top "E. L. Edwards, Imperial Wizard, P.O. Box 21, College Park, Georgia," addressed to the Secretary of State, State of Alabama, Montgomery, Alabama:

DEAR SIR,

Please be informed that on November 4th, 1959 by orders of the Imperial Wizard (President) that one (Robert M. Shelton, 1708 E, 15th, St. Tuscaloosa, Ala. Was removed from the Office of and as the Agent of the U.S. Klans, Knights of the Ku Klux Klans, Inc. in and for the State of Alabama.

Will you Please remove the above Name from your Files as the Agent of and for the U.S. Klans, Knights of the Ku Klux Klans, Inc,

A replacement will be forthcoming.

Signed "E. L. Edwards, Imperial Wizard."

The CHAIRMAN. The document will be received in evidence.

(Document marked "Robert Shelton Exhibit No. 27.")

Mr. APPELL. I would like to introduce the next document on the same letterhead, also signed by E. L. Edwards, addressed to the Secretary of State, dated November 25, 1959:

Dear Sir,

Please be informed that after careful consideration, we are now re-instating [sic] Robert M. Shelton, 1708 E. 15th, St. Tuscaloosa, Alabama, as the *Agent* for the U.S. Klans, Knights of the Ku Klux Klans, Inc. in the State of Alabama.

The CHAIRMAN. That will be received in evidence.

(Document marked "Robert Shelton Exhibit No. 28.")

ROBERT SHELTON EXHIBIT No. 26

"Office of U. S. Klans, Knight Of The Ku Klux Klan, Inc."

Located at Atlanta, Fulton County, Georgia.

In compliance with the provisions of Title 10, Section 192, et sequ. of the 1940 Code of Alabama, and Section 232 of the Constitution of Alabama, 1901, U. S. Klans, Knights of the Ku Klux Klan, a corporation or association organized under the laws of the State of Georgia, and having its principal place of business, in the City of Atlanta, State of Georgia, herewith files a certified copy of its Articles of Incorporation or Association under the laws of said State of Georgia and designates as its known place of business in the State of Alabama 1708 East 15th Street, in the City of Tuscaloosa, County of Tuscaloosa, and as its authorized agent thereat, Robert M. Shelton, on whom, as such agent, service of process may be made and all legal notices served for all the purposes contemplated by the laws of the State of Alabama.

IN WITNESS WHEREOF, the said corporation has caused these presents to be signed by its President and Secretary, and attested by its corporate seal, at its office in Atlanta, Georgia, this the 10 day of June, 1957.

E. L. Edwards As President (IMPERIAL WIZZARD

Wm. A. Gurnel As Secretary (KLIGRAPP



RECEIVED

JUN 14 1957

SECRETARY OF
STATE

Mr. APPELL. I would like to enter into evidence at this point, Mr. Chairman, an additional document, a form dated the 25th day of November 1959, a certificate designating agent, place of business in Alabama, which reads as follows:

In compliance with provisions of Section 192, Title 10, of the Code of Alabama 1940, and Section 232 of the Constitution of Alabama 1901, U.S. Klans, Knights of the Ku Klux Klan, Inc. a corporation or association organized under the laws of the State of Georgia and having its principal place of business at 508 Anderson Street, in the City of College Park, State of Georgia * * * designates as its known place of business in the State of Alabama, 1708 15th Street in the city of Tuscaloosa, County of ———, and as its authorized agent thereat, Robert M. Shelton * * *.

Signed "E. L. Edwards," 25 November 1959.

The CHAIRMAN. The document will be received in evidence at this point.

(Document marked "Robert Shelton Exhibit No. 29.")

Mr. APPELL. The next document, Mr. Chairman, is a change of designation of agent and it replaces Mr. Robert M. Shelton as Grand Dragon by Mr. Alvin "Horne."

The CHAIRMAN. That will be received in evidence.

(Document marked "Robert Shelton Exhibit No. 30." Exhibits Nos. 27-30 appear on pp. 1678-1681.)

Mr. APPELL. The date of that document, Mr. Chairman, is April 11, 1960.

Mr. Shelton, what brought about this removal of you as Grand Dragon for the U.S. Klans in the State of Alabama?

Mr. SHELTON. Sir, I respectfully decline to answer that question for the reason that I honestly feel my answer might tend to incriminate me in violation of my rights as guaranteed to me by amendments 5, 1, 4, and 14 of the Constitution of the United States of America.

Mr. APPELL. Mr. Shelton, the press of that day, the *Montgomery Advertiser* of May 30, 1960, says "Robert M. Shelton, Tuscaloosa"——

The CHAIRMAN. You are referring to a period before the creation of the United Klans of America; are you not?

Mr. APPELL. Yes, sir.

I will have to start againn, Mr. Chairman. [Continues reading:]

Robert M. (Bobby) Shelton of Tuscaloosa has been ousted as Grand Dragon of the Alabama Ku Klux Klan and replaced by a former Dragon, Alvin Horn of Rt. 4, Talladega.

The story goes on to quote Mr. Shelton as follows:

"Edwards has replaced me (with Horn) as Grand Dragon." He said he was notified of the change "about a week ago."

The ousted Klan leader said he and Edwards "had some differences of opinion about policies and procedure."

"I am organizing an independent group here in Alabama," he said——

The CHAIRMAN. Those are the words of Shelton?

Mr. APPELL. This is a quote of Shelton; yes, sir. [Continues reading.]

"I would say about 70 per cent of the members of the old group have already joined the new Klan."

As to the reasons that you were replaced as quoted in this article, Mr. Shelton, are they factual?

ROBERT SHELTON EXHIBIT No. 27

E. L. Edwards
Imperial Wizard

P. O. BOX 21
College Park, Georgia

In God We Trust



"We fight not for glory nor for
wealth nor for honor, but only
and alone for freedom, which no
good man surrenders but with
his life.—SCOTTISH CLANS, 1320

U. S. KLANS INC.

"Through these portals do mem-
bership pass the future guar-
dians of American Liberty and
Security."

NOV, 5, 1959

SECRETARY OF STATE
STATE OF ALABAMA
MONTGOMERY ALABAMA.

DEAR SIR,

Please be informed that on November 4th, 1959 by orders
of the Imperial Wizard (President) that one (Robert M. Shelton
1703 E, 15th, ST.
Tuscaloosa Ala.
Was removed from the Office of and as the Agent of the U.S.

Klans, Knights of the Ku Klux Klans Inc. in and for the
State of Alabama,

Will you Please remove the above Name from your Files
as the Agent of and for the U.S. Klans, Knights of the
Ku Klux Klans Inc,

A replacment will be forth coming.

E. L. Edwards
E. L. EDWARDS, IMPERIAL WIZARD.
(PRESIDENT) U. S. KLANS,
KNIGHTS OF THE KU KLUX KLANS INC.

SEAL

RECEIVED

NOV 6 1959

SECRETARY OF
STATE

ROBERT SHELTON EXHIBIT No. 28

E. L. Edwards
Imperial Wizard

P. O. BOX 21
College Park, Georgia

In God We Trust



U. S. KLANS, INC.

*"We fight not for glory nor for
wealth nor for honor, but only
and alone for freedom, which no
good man surrenders but with
his life.—SCOTTISH CLANS, 1320*

NOV, 25 1959

*"Through these portals do mem-
bership pass the future guar-
dians of American Liberty and
Security."*

Secretary of State
State of Alabama.

Dear Sir,

Please be informed that after careful consideration, we are now re-instating Robert M. Shelton, 1708, E, 15th, St. Trucalooosa Alabama. as the Agent for the U.S. Klans, Knights of the Ku Klux Klans Inc. in the State of Alabama.

RECEIVED

NOV 30 1959

SECRETARY OF
STATE

E. L. Edwards
E. L. EDWARDS, IMPERIAL WIZARD
U. S. KLANS, KNIGHTS of the
KU KLUX KLANS, INC.

SEAL

ROBERT SHELTON EXHIBIT No. 29

CERTIFICATE DESIGNATING AGENT AND PLACE OF BUSINESS IN ALABAMA FOR FILING IN OFFICE OF SECRETARY OF STATE OF ALABAMA

OFFICE OF U. S. Klans, Knights of the Ku Klux Klan, Inc
LOCATED AT 1708 15th Street
Tuscaloosa, Alabama

In compliance with provisions of Section 192, Title 10, of the Code of Alabama 1940, and Section 232 of the Constitution of Alabama, 1901,

U. S. Klans, Knights of the Ku Klux Klan, Inc
a corporation or association organized under the laws of the State of Georgia
and having its principal place of business at 508 Anderson Street.
in the City of College Park State of Georgia
herewith files a certified copy of its articles of incorporation or association under the laws of said
State of and designates as its known place of business in the State
of Alabama, 1708 15th Street in the city of Tuscaloosa.
County of , and as its authorized agent thereat, Robert M. Shelton

on whom, as said agent, service of process may be made and all legal notices served, for all the purposes contemplated by the laws of the State of Alabama.

IN WITNESS WHEREOF, the said corporation or association has caused these presents to be signed by its President and Secretary, and attested by its corporate seal, at its office in Atlanta, Georgia

this 25 day of November, 1959

[Signature] President.
[Signature] Secretary.

NOTE.—The fee for filing above certificate is \$10.00, as provided in Section 192 of Title 10 of the Code.

RECEIVED

NOV 30 1959

SECRETARY OF STATE

ROBERT SHELTON EXHIBIT No. 30

CERTIFICATE DESIGNATING AGENT AND PLACE OF BUSINESS IN ALABAMA FOR FILING IN OFFICE OF SECRETARY OF STATE OF ALABAMA

OFFICE OF U. S. SLAND, INT. OF INT. ...

LOCATED AT ATLANTA, GEORGIA

In compliance with provisions of Section 192, Title 10, of the Code of Alabama 1940, and Section 232 of the Constitution of Alabama, 1901,

a corporation or association organized under the laws of the State of GEORGIA and having its principal place of business at ATLANTA, GEORGIA ... herewith files a certified copy of its articles of incorporation or association under the laws of said State of ALABAMA and designates as its known place of business in the State of Alabama, ROUTE 4 in the city of TALLADEGA County of TALLADEGA, and as its authorized agent thereat, ALVIN HORNE on whom, as said agent, service of process may be made and all legal notices served, for all the purposes contemplated by the laws of the State of Alabama.

IN WITNESS WHEREOF, the said corporation or association has caused these

signed by its President and Secretary, and attested by its corporate seal, at its office in ATLANTA, GEORGIA

this 11 day of APRIL 1960

E. H. Edwards President. Wm. C. Daniel Sr. Secretary.

NOTE.—The fee for filing above certificate is \$10.00, as provided in Section 192 of Title 10 of the Code.

PLEASE REMOVE THE NAME OF ROBERT M. SHELTON 1708 EAST 15th St. Tuscaloosa, Alabama

CHANGED TO: ALVIN HORNE ROUTE 4 TALLADEGA, ALABAMA

RECEIVED APR 12 1960 SECRETARY OF STATE

Mr. SHELTON. Sir, I respectfully decline to answer that question for the reason that I honestly feel my answer might tend to incriminate me in violation of my rights as guaranteed to me by amendments 5, 1, 4, and 14 of the Constitution of the United States of America.

(Document marked "Shelton Exhibit No. 31," follows:)

ROBERT SHELTON EXHIBIT NO. 31

[Montgomery Advertiser, May 30, 1960]

Page 6A.)

133rd Year—No. 104

Klan Names

Horn Chief, Shelton Out

Ex-Grand Dragon

Claims 70 Per Cent

Switch To New Group

Robert M. (Bobby) Shelton of Tuscaloosa has been ousted as Grand Dragon of the Alabama Ku Klux Klan and replaced by a former Dragon, Alvin Horn of Rt. 4, Talladega.

Shelton has begun organizing an "Independent" Klan group as a result and claims about 70 per cent membership switchover to his camp.

These developments came to light Friday through records of the secretary of state where official papers of the KKK incorporation are on file.

NEW AGENT

Secretary of State Betty Frink was notified April 11 that Horn had been appointed the new "authorized agent" of the Klan for Alabama. The change was announced in a letter from E. L. Edwards, Atlanta, Ga., Imperial Wizard of the U.S. Klans, Knights of the Ku Klux Klan, Inc. State law requires the listing of "authorized agents" for foreign corporations doing business in Alabama.

Although Edwards' letter did not state that Shelton had been removed as Grand Dragon, it said he was removed as authorized agent.

Shelton, contacted in Tuscaloosa, said:

"Edwards has replaced me (with Horn) as Grand Dragon." He said he was notified of the change "about a week ago."

INDEPENDENT GROUP

The ousted Klan leader said he and Edwards "had some differences of opinion about policies and procedure."

"I am organizing an Independent group here in Alabama," he said. "I would say about 70 per cent of the members of the old group have already joined the new Klan."

Although the Shelton Klan group hasn't been named formally, he said it would be "the Ku Klux Klan — we can use that name; it's not copyrighted."

As to the difference between the two Klans, Shelton said of his group, "The leader won't have so much dictatorial powers — that's how Edwards rips his."

Asked if he thought he had been removed for personal reasons, Shelton replied, "I wouldn't want to comment on that."

NO SUBSTITUTE

Edwards was not available for comment in Atlanta.

The Secretary of State received a letter dated Nov. 4, 1959, from Edwards instructing that Shelton's name be removed as "authorized agent" for the U.S. Klans. No substitute was named then.

Later, Edwards wrote Mrs. Frink that Shelton was to be reinstated. Then on April 11, he wrote a third letter authorizing Horn as agent in place of Shelton.

Horn, a 48-year-old Baptist minister, could not be located through Talladega and Clay Counties.

(See KLAN, Page 6A)

Klan

(Continued From Page 1)

sources. It was reported he recently had moved but his whereabouts were not known by relatives.

UNFAVORABLE PUBLICITY

Horn had served as Grand Dragon of the KKK in Alabama but resigned in 1957 after unfavorable publicity stemming from his marriage to a 15-year-old girl. Shelton was his successor.

The clergyman was indicted on a murder charge in 1950 following the nightrider slaying of Charlie Hurst, Pell City. Hurst was shot down shortly after telling his son he thought the Klan was after him. The charge against Horn was dismissed in October, 1952.

Shelton's active role in the 1958 gubernatorial campaign in behalf of John Patterson won him considerable statewide attention. More recently he charged that his KKK activities had cost him his long-time job with the B. F. Goodrich Tire and Rubber Co.

Mr. APPELL. Mr. Shelton, the committee's investigation established that in the days of the U.S. Klans, that the Klans and Klaverns forwarded their money to the Grand Dragon, who took out of the entire package his share and then forwarded to the imperial office, the imperial office share.

Is it a fact that you were removed because you weren't making a proper accounting of funds to the imperial staff?

Mr. SHELTON. Sir, I respectfully decline to answer that question for the reason that I honestly feel my answer might tend to incriminate me in violation of my rights as guaranteed to me by amendments 5, 1, 4, and 14 of the Constitution of the United States of America.

The CHAIRMAN. Mr. Appell, you asked him, "Is it a fact?" The form of the question might be misconstrued. I think you can phrase it this way, that it is the committee's information that it is a fact, and does he wish to affirm or deny it.

Mr. APPELL. Will you answer the question?

Mr. SHELTON. Sir, will you rephrase the question or repeat it?

The CHAIRMAN. It is the committee's information that you were replaced because of financial reasons. Is that true or not? Is our information true or not?

Mr. SHELTON. Sir, I respectfully decline to answer that question for the reason that I honestly feel my answer might tend to incriminate me in violation of my rights as guaranteed to me by amendments 5, 1, 4, and 14 of the Constitution of the United States of America.

Mr. APPELL. It is the committee's further information, Mr. Shelton, that you were ordered to appear before an Imperial Klouncilium and to produce the books and records of your realm and that you failed to do so.

Is this information that the committee has obtained true or false?

Mr. SHELTON. Sir, I respectfully decline to answer that question for the reason that I honestly feel my answer might tend to incriminate me in violation of my rights as guaranteed to me by amendments 5, 1, 4, and 14 of the Constitution of the United States of America.

Mr. APPELL. Mr. Chairman, the staff has no further questions of Mr. Shelton—pardon me, sir, I do have.

Mr. Shelton, the committee has obtained from the State of Alabama a Certificate of Incorporation dated May 17, 1960—16 days after the notice of Imperial Wizard Edwards that he had removed you—of the incorporation of the Alabama Knights, Knights of the Ku Klux Klan, Inc.

This document shows that the incorporators, trustees, and addresses are as follows: Robert M. Shelton, 1708 East 15th Street, Tuscaloosa, Alabama; H. M. Shelton, 1700 East 15th Street, Tuscaloosa, Alabama; and James Elmore, 2920 Birmingham Highway, Tuscaloosa, Alabama.

Did you participate in the incorporation of the Alabama Knights of the Ku Klux Klan, Inc.?

Mr. SHELTON. Sir, could I counsel?

The CHAIRMAN. Yes.

Mr. SHELTON. Sir, could I ask that the document you are referring to be read, in order to determine?

The CHAIRMAN. Hand it to him.

(Document handed to witness.)

The CHAIRMAN. You understand that we will then question you. If you want to read it, read it. You may read it out loud, and then we will question you.

(Witness confers with counsel.)

Mr. SHELTON [returning document]. Thank you, sir.

(Document marked "Robert Shelton Exhibit No. 32" and retained in committee files.)

Mr. APPELL. Mr. Chairman, there is a great deal more material that the staff intends to interrogate Mr. Shelton about. However, from this phase of the inquiry I ask that Mr. Shelton be excused as a witness, to return on November 15.

The CHAIRMAN. Before ruling on that, the Chair wishes to say this: I invite your attention, Mr. Shelton, to what I am about to say.

Yesterday you refused to produce documents called for by a subpoena duces tecum served on you on October 11 of this year. You were in the hearing room for the greater part of my opening statement as I read it. You did come in a few minutes late.

A copy of the opening statement was handed to you and your attorney.

That is true, is it not?

Mr. CHALMERS. Yes, sir.

The CHAIRMAN. Counsel, I am directing my question to you. That is true, is it not?

Mr. CHALMERS. Yes, sir; for the record.

The CHAIRMAN. You were observed reading the statement, and it is my understanding that both you and your counsel not only read the statement but, I assume, but that you carried it with you.

My opening statement spelled out with indisputable clarity, I believe, the things the subcommittee desires to know, the information that it wishes to place on this record to assist the Congress in the enactment of remedial legislation. Those things were specified in paragraph 4, page 2, of my opening statement, describing the purposes of these hearings, and so on.

I don't see, and the committee members do not see, how anyone could argue, after reading the committee resolution of March 30, contained on page 1 of the statement, and House Resolution 310 specifically authorizing this investigation, copies of which, by the way, were given you and your attorney by the staff the day before yesterday, and my opening statement—we say no one could argue, after reading the documents and the records, that papers and documents pertaining to the structure and organization, incorporation, finances, corporate tax returns, and so forth, of each and every Klan organization are not pertinent to this inquiry.

I am saying I don't see how anyone can so argue, that these things are not pertinent to this inquiry. The first full paragraph of the attachment to the subpoena served upon you called on you to produce certain records and documents as an official and representative of the United Klans of America, Inc., Knights of the Ku Klux Klan, the Invisible Empire, United Klans, Knights of the Ku Klux Klan of America, Inc., the Alabama Rescue Service, the Whiteman's Defense Fund, and the United Klansmen of America.

I want to clarify just this one point: Did you and your attorney know the contents of my opening statement at the time you were on the witness stand and refused to produce these documents?

I further want to warn you that unless your answer to this question is that you did not know the contents of this opening statement, your course of action yesterday is completely without legal justification and may result in a contempt citation.

So I again ask: Did you and your attorney know the contents of my opening statement at the time you were on the stand and refused to produce those documents?

Mr. SHELTON. Sir, could I counsel?

The CHAIRMAN. Yes. This is a legal question. I think you ought to.

Mr. CHALMERS. May I state this to the chairman and to the other members of the committee: At the time answers were given yesterday afternoon I myself had not fully read the opening statement of the chairman of the committee.

I, of course, cannot answer for my client. But it is my information, if I may state it, that I doubt very seriously if he read the statement fully.

The CHAIRMAN. The question is not did you read it, necessarily. Did you know, from hearing me read the statement, the contents of my opening statement, before he took the witness stand?

Mr. CHALMERS. No, sir; not fully and completely, I did not.

The CHAIRMAN. Then I will give the benefit of the doubt to your client.

Do you wish 5 minutes' or 10 minutes' recess to read it now?

Mr. CHALMERS. I would like about a 10-minute recess to confer with my client, if it would be permissible.

The CHAIRMAN. That request is granted.

I now hand each of you a copy of my opening statement.

Mr. CHALMERS. May I state to the chairman I have a copy in my files.

The CHAIRMAN. All right.

The committee is now in recess for 10 minutes. I wish that order be maintained during the recess.

(Whereupon, at 11:40 a.m. the subcommittee recessed. All subcommittee members present at time of recess.)

(The subcommittee reconvened at 11:47 a.m. with all subcommittee members present.)

The CHAIRMAN. The subcommittee will come to order.

The equipment of the press, TV, and radio will be removed.

Let the record show that the committee stood in recess for approximately 10 minutes to give Mr. Shelton and his counsel the opportunity to read and familiarize themselves in greater detail concerning my opening statement, particularly the part I referred to a moment ago, paragraph 4 on page 2.

I take it, Mr. Chalmers, that you have had that opportunity?

Mr. CHALMERS. That is correct; yes.

The CHAIRMAN. By the way, Mr. Chalmers, I want to compliment you for your demeanor before this committee. I think you deserve it.

Mr. CHALMERS. Thank you, sir.

The CHAIRMAN. In view of that, namely, that both counsel and his client now concede, admit for clarity, that they are familiar with my opening statement, which spells out the purposes of these hearings, and on the basis of which I ruled on the pertinency of the documents referred to in the subpoena, I wish, nevertheless, Mr. Shelton, to ask you four questions, or make four directions.

I now order and direct you to produce the documents referred to in the first paragraph of the attachment to the subpoena dated October 7, 1965, and according to the marshal's return served on you on October 11.

Mr. SHELTON. May I counsel?

(Witness confers with counsel.)

Mr. SHELTON. Sir, is this question directed to me as an individual or directed to me as an officer of a corporation?

The CHAIRMAN. I covered that in my statement of a while ago, but I will repeat it.

The subpoena which was served on you called on you to produce certain documents as an official and representative of the United Klans of America, Inc., Knights of the Ku Klux Klan, the Invisible Empire, United Klans, Knights of the Ku Klux Klans of America, Inc., the Alabama Rescue Service, the Whiteman's Defense Fund, and the United Klansmen of America.

So that is the capacity, as an officer and as an Imperial Wizard and as a representative of these organizations.

(Witness confers with counsel.)

Mr. SHELTON. Sir, I respectfully decline to deliver to this committee any and all records as requested by this committee under subpoena dated October 7, 1965, for that information is not relevant and germane to the subject under investigation and the same would not aid the Congress in the consideration of any valid remedial legislation, nor is such inquiry within the scope of that authorized to be investigated by Rule IV of the rules adopted by the 89th Congress, of House Resolution 8, adopted January 4, 1965.

I respectfully decline to turn over these documents in question for the reason that I honestly feel that by doing so it might tend to incriminate me in violation of my rights as guaranteed to me by amendments 5, 1, 4, and 14 of the Constitution of the United States of America.

The CHAIRMAN. I now order and direct you to produce the documents called for in paragraph 2 of the attachment to the same subpoena.

Mr. SHELTON. Sir, I respectfully decline to deliver to the committee any and all records as requested by this committee under subpoena dated October 7, 1965, for that information is not relevant and germane to the subject under investigation and the same will not aid the Congress in the consideration of any valid remedial legislation, nor is such inquiry within the scope of that authorized to be investigated by Rule IV of the rules adopted by the 89th Congress, by House Resolution 8, adopted January 4, 1965.

I respectfully decline to turn over these documents for the reason that I honestly feel that by doing so it might tend to incriminate me in violation of my rights as guaranteed to me by amendments 5, 1, 4, and 14 of the Constitution of the United States of America.

The CHAIRMAN. I now order and direct you to produce the documents referred to in paragraph 3 of the attachment to that subpoena.

Mr. SHELTON. Sir, I respectfully decline to deliver to this committee any and all records as requested by this committee under subpoena dated October 7, 1965, for that information is not relevant—
(Witness confers with counsel.)

Mr. SHELTON. —is not relevant and germane to the subject under investigation and the same would not aid the Congress in the consideration of any valid remedial legislation, nor is such inquiry within the scope of that authorized to be investigated by Rule IV of the rules adopted by the 89th Congress, by House Resolution 8, adopted January 4, 1965.

I respectfully decline to turn over these documents in question for the reason that I honestly feel my answer might tend to incriminate me—the documents might tend to incriminate me in violation of my rights as guaranteed to me by amendments 5, 1, 4, and 14 of the Constitution of the United States of America.

The CHAIRMAN. I order and direct you to produce the documents referred to in paragraph 4 of the attachment to the subpoena referred to.

Mr. SHELTON. Sir, I respectfully decline to deliver to this committee any and all records as requested by this committee under subpoena dated October 7, 1965, for that information is not relevant or germane to the subject under investigation and the same will not aid the Congress in the consideration of any valid remedial legislation, nor is such inquiry within the scope of that authorized to be investigated by Rule IV of the rules adopted by the 89th Congress, by House Resolution 8, adopted January 4, 1965.

I respectfully decline to turn any records over to this committee for the reason that I honestly feel that by doing so it might tend to incriminate me in violation of my rights as guaranteed to me by amendments 5, 1, 4, and 14 of the Constitution of the United States of America.

The CHAIRMAN. Do you understand that the orders I made on you to produce all these documents, including those in paragraph 4, were addressed to you in your representative capacities as I indicated?

Mr. SHELTON. Sir, I respectfully decline to answer that question for the reason that I honestly feel my answer might tend to incriminate me in violation of my rights as guaranteed to me by amendments 5, 1, 4, and 14 of the Constitution of the United States of America.

The CHAIRMAN. I wish to say, and I assume counsel agrees, that the committee rejects your reasons for not producing these documents.

Mr. CHALMERS. Yes, sir.

The CHAIRMAN. Mr. Shelton, yesterday I referred to a memorandum dated October 14, 1965, made by our investigator, Mr. Louis Russell, and I referred to and asked you about certain things you said to him on that day in the Hotel Stafford in Tuscaloosa.

Now I ask you this: Our investigator, Mr. Louis Russell, said that on that day, in that hotel, you said this:

He [Shelton] said that he would bring about the defeat of Chairman Willis in Louisiana, and that the Chairman would be besieged by telephone calls before the hearing began.

Mr. Russell further stated:

He [Shelton] claimed to have a book on every member of the Committee and said that Congressman Weltner was tied in with the Communists and that President Johnson got his first political job from Aubrey Williams.

Did he tell the truth or did he falsify?

Mr. SHELTON. Sir, I respectfully decline to answer that question for the reason that I honestly feel my answer might tend to incriminate me in violation of my rights as guaranteed to me by amendments 5, 1, 4, and 14 of the Constitution of the United States of America.

The CHAIRMAN. Let me say that, so far as I am concerned, I not only welcome, but challenge and dare you to come in my congressional district and fight me politically.

Mr. WELTNER. Mr. Chairman—

The CHAIRMAN. Mr. Weltner.

Mr. WELTNER. Mr. Shelton, I have not asked you any questions thus far. I had hoped that you would cooperate with this committee, and I am disappointed that you have not done so. I do not criticize you for claiming any right that you have under the Constitution. That is your right as an American citizen, and I have no quarrel with you or any other American citizen for exercising any right guaranteed by the Constitution.

I don't have any questions, but I do have this comment: It seems to me that you obviously have the ability to organize and that you have proved some qualities of leadership and you have shown energy in your tasks.

I submit that it is unfortunate for our section of the country, yours and mine, that your leadership and ability and energy have been given over to dividing Southern people rather than uniting them.

Mr. Chairman, I have no further comment and no questions.

The CHAIRMAN. Mr. Buchanan.

Mr. BUCHANAN. Mr. Chairman, unless my eyes deceived me during the recess, the witness was speaking very freely to the press. And unless the reports are inaccurate, I understand he has spoken rather freely in various places concerning the fact that he would welcome this investigation. I wonder, therefore, if we might have better results if we conducted this investigation in a cornfield and let the press interrogate him.

However, I would say what you said at the outset, Mr. Chairman, and I would ask the chairman and counsel to correct me if I am in error on this point:

I think your counsel has advised you well and I will not argue with your right, of course, to invoke the fifth amendment. I would say, however, that evidence has been offered here before this committee concerning your use of certain funds, the alleged signing of checks to some \$5,600 cash, the manner in which they were countersigned, the purchase of an automobile, diamonds purchased, and this sort of thing, evidence of an ouster from the U.S. Klans with financial questions surrounding it, evidence concerning your military record and circumstances and time at which it came to an end.

I would say that, as I said before this hearing began, he that has nothing to hide has nothing to fear. We are not in the business of prosecuting or convicting, but we are here to get the facts and know

the truth. We are, I think you can see, with or without your cooperation, producing evidence in this hearing. We are going to continue this investigation and this hearing. Evidence will be produced.

While I am not going to make any inferences from the numerous times that you have invoked the fifth amendment, I will simply say this: that for those who have eyes to see and ears to hear, it may well prove that the record in your case will speak very clearly for itself, Mr. Shelton.

Mr. SHELTON. Thank you sir.

The CHAIRMAN. I understand that Mr. Appell has another question he overlooked asking.

Mr. APPELL. Mr. Chairman, I have two very short and simple questions.

Mr. Shelton, in connection with your being on the payroll of the Dixie Engineering Company, it is the committee's understanding that during an investigation by the Federal Public Roads Administration or Bureau, you were questioned by agents of the United States Government with respect to your being on the payroll of the Dixie Engineering Corporation and that you refused to answer the Federal Bureau's agent's questions. Is this true, sir?

Mr. SHELTON. Sir, I respectfully decline to answer that question for the reason that I honestly feel my answer might tend to incriminate me in violation of my rights as guaranteed to me by amendments 5, 1, 4, and 14 of the Constitution of the United States of America.

Mr. APPELL. Mr. Shelton, the committee, during its many months attending Klan rallies and other things, has noted with great interest the ability of the Klan to collect large sums of money in cash at these rallies.

What percentage of the take of the rallies that you have attended has come into your hands in the form of cash?

Mr. SHELTON. Sir, would you repeat that question, please?

Mr. APPELL. Yes, sir. We have observed at numerous rallies that collections are taken up in the form of cash collections and that these collections, at different times and at different rallies, have reached considerable sums, in the hundreds of dollars.

I am asking you what part of this money collected at these rallies has been turned over to you.

Mr. SHELTON. Sir, I respectfully decline to answer that question for the reason that I honestly feel my answer might tend to incriminate me in violation of my rights as guaranteed to me by amendments 5, 1, 4, and 14 of the Constitution of the United States of America.

Mr. APPELL. Mr. Shelton, the committee also subpoenaed from The First National Bank of Tuscaloosa, Alabama, your personal bank account. And the ledger sheet of this account, together with a deposit slip dated November 2, 1964, shows that there was deposited in the form of checks, although the checks are not enumerated—it could be one or it could be more—\$2,125.

Was that money, money which you had received in the form of an imperial tax from Klans throughout the United States?

Mr. SHELTON. Sir, would you repeat that question, please?

Mr. APPELL. Yes, sir. Was this deposit of \$2,125 deposited to your personal account on November 2, 1964, money which was received by

you as imperial tax from the Klans or Klaverns located throughout the United States?

Mr. SHELTON. Sir, I respectfully decline to answer that question for the reason that I honestly feel my answer might tend to incriminate me in violation of my rights as guaranteed to me by amendments 5, 1, 4, and 14 of the Constitution of the United States of America.

(Bank account records marked "Robert Shelton Exhibit No. 33" and retained in committee files.)

Mr. APPELL. Mr. Chairman, the staff has no further questions, and I ask that Mr. Shelton—

The CHAIRMAN. Wait a moment.

I wish to reiterate and to stress what I said two or three times in my opening statement: that whatever has been said here by anyone about your right, Mr. Shelton, to invoke the privileges of the fifth amendment should not be considered as relating to the rulings I have made as chairman, and on this I also reiterate and stress that the committee here is in unanimous agreement.

Mr. ASHBROOK. Mr. Chairman, I would like the record to show specifically that this is the understanding of the committee. By no statements made has there been any waiver. As one member of the committee, I confirm what you have said and what the record will so show.

Mr. CHAIRMAN. I am sure that all the members would feel the same.

Mr. WELTNER. Subject to the reservation of personal satisfaction as to the application of the law.

Mr. BUCHANAN. Mr. Chairman, I confirm without reservation what you have said, sir.

The CHAIRMAN. Mr. Ichord?

Mr. ICHORD. Mr. Chairman, in that connection I would like to state that I have attended most of these proceedings as an interested member of the full committee and of the Congress. Of course, the purpose of these hearings is to develop information concerning the activities of the Klan and to develop information that would serve as a basis for the Congress making a decision as to whether legislation is needed to curb the activities of the Klan, or what kind of legislation is needed.

This, Mr. Chairman, is the first time during my service on the committee that we have had witnesses before the committee to be questioned about their activities with organizations other than Communist organizations, Communist fronts and similar extremist organizations.

I wanted to make note of the fact, Mr. Chairman, that the attorney for Mr. Shelton has carried out his duties in a very commendable way. I have observed that he has fully advised his client as to his constitutional rights.

You have done it in a way that is commendable and in a way that contrasts pleasantly with the way that some of the lawyers have advised witnesses in Communist investigations conducted by this committee. Unfortunately, Mr. Shelton has not chosen to give us any information concerning the activities of the Klan except his name, his birth place, and his age. I regret that fact, but that is his constitutional right.

Sir, I do commend you on the way you carried out your duties as his attorney.

Mr. WELTNER. Mr. Chairman, may I also, following Mr. Ichord's comments, point out that this hearing has been conducted without the

protests and demonstrations that have occurred within and without hearings of this committee in the past. I recall quite well the difficult task that befell our distinguished chairman in Chicago in the effort to maintain order and dignity in the proceedings.

Perhaps the absence of protests or demonstrators to this proceeding casts some light on the validity and sincerity of those protests when they do occur.

Mr. POOL. Mr. Chairman, I want to add my support to the chairman on the rulings he has made, and I want to point that out for the record.

The CHAIRMAN. Thank you very much.

I simply express the hope that as we go along we will proceed with equal decorum and dignity.

Mr. Shelton, your subpoena is continued. That is, you remain under subpoena until November 15. We will be calling you again and will be questioning you on a variety of areas of your and your organization's activities.¹

The committee will stand in recess until 1:45.

(Subcommittee members present at time of recess: Representatives Willis, Pool, Weltner, Ashbrook, and Buchanan.)

(Whereupon, at 12:15 p.m., Wednesday, October 20, 1965, the subcommittee recessed, to reconvene at 1:45 p.m. the same day.)

AFTERNOON SESSION—WEDNESDAY, OCTOBER 20, 1965

(The subcommittee reconvened at 2 p.m., Hon. Edwin E. Willis, chairman, presiding.)

(Subcommittee members present at time of reconvening: Representatives Willis, Pool, and Ashbrook.)

The CHAIRMAN. The subcommittee will please come to order.

Mr. Appell, call your next witness.

Mr. APPELL. Mr. James R. Jones.

I am sorry. Pardon me, Mr. Chairman.

Mr. Jones, you are not going to be called at this time.

Mr. Chairman, I would like to call Mr. Philip R. Manuel, a member of the investigative staff of the committee.

The CHAIRMAN. Let the Chair say this: that Mr. Shelton was questioned at some length concerning certain financial transactions and he chose to invoke the fifth amendment. All witnesses may as well know that this procedure is not going to deter us from putting the facts on the line.

Most of the questions asked of Mr. Shelton were supported by introduction of documentary evidence, checks and other documents. And, of course, there can be no stronger evidence than written documents which really speak even more accurately than words. But in certain phases of Mr. Shelton's testimony we will bring out affirmative evidence because he forces us to do it.

Proceed.

Mr. Manuel has been sworn, but this will be a new phase.

Do you solemnly swear that the testimony you are about to give will be the truth, the whole truth, and nothing but the truth, so help you God?

Mr. MANUEL. I do.

¹ Mr. Shelton was not recalled, and on January 6, 1966, was discharged from further appearance under his subpoena.

TESTIMONY OF PHILIP R. MANUEL—Resumed

Mr. APPELL. For the record, state your full name, sir.

Mr. MANUEL. Philip R. Manuel.

Mr. APPELL. And you are a member of the investigative staff of the Committee on Un-American Activities?

Mr. MANUEL. That is correct.

Mr. APPELL. In the course of the current investigation, did the staff establish that tax and dues payable to United Klans of America from its Klans or Klaverns located throughout the United States were deposited into the account known as the Alabama Rescue Service?

Mr. MANUEL. Yes; that is correct.

Mr. APPELL. What documentation establishes this as a fact?

Mr. MANUEL. Well, the committee has established that most of the checks drawn by Klans or Klaverns of the United Klans are made payable to the Alabama Rescue Service and, further, the Alabama Rescue Service account at The First National Bank in Tuscaloosa, Alabama.

For documentation of this, I wish to present several checks, out of many, which the committee has in its possession, all properly obtained by committee subpoena.

The CHAIRMAN. On the banks?

Mr. MANUEL. Yes, sir. These records reflect the individual organizations which made payments to the Alabama Rescue Service. In addition to having checks made payable to the Alabama Rescue Service, I wish to show that some checks were made payable to the United Klans of America, which later were found in the account of the Alabama Rescue Service at The First National Bank in Tuscaloosa, Alabama.

As my first example of this, I wish to introduce a check of the Rowan Sportsmen's Club, dated March 2, 1965, in the amount of \$46, drawn on the Security Bank & Trust Co. of Spencer, North Carolina, signed by Fred L. Wilson and Wayne Dayvault, and the notation on the check says it is for dues.

The endorsement on the reverse side of this check has the notation "For deposit in Alabama Rescue Service Account Only."

(Check marked "Philip Manuel Exhibit No. 1" appears on p. 1693.)

Mr. APPELL. Mr. Manuel, while we are discussing this question of dues, on the basis of our investigation have we established, or has the committee established, the staff established, the division of dues to the imperial level?

Mr. MANUEL. Yes, sir; it has.

Mr. APPELL. Could you state for the record what this amount is?

Mr. MANUEL. As of September 1964, the amount is 50 cents per month per member for imperial tax, which is supposed to be paid to the headquarters of the United Klans of America.

Mr. APPELL. Do you have additional documentation which shows deposits of checks made payable to the United Klans of America deposited into the Alabama Rescue account?

Mr. MANUEL. Yes, sir. In addition to the one just mentioned of the Rowan Sportsmen's Club which illustrates the point, I further wish to add a check dated August 27, 1965, made payable to the United Klans of America in the amount of \$30. The notation is for payment

PHILIP MANUEL EXHIBIT NO. 1

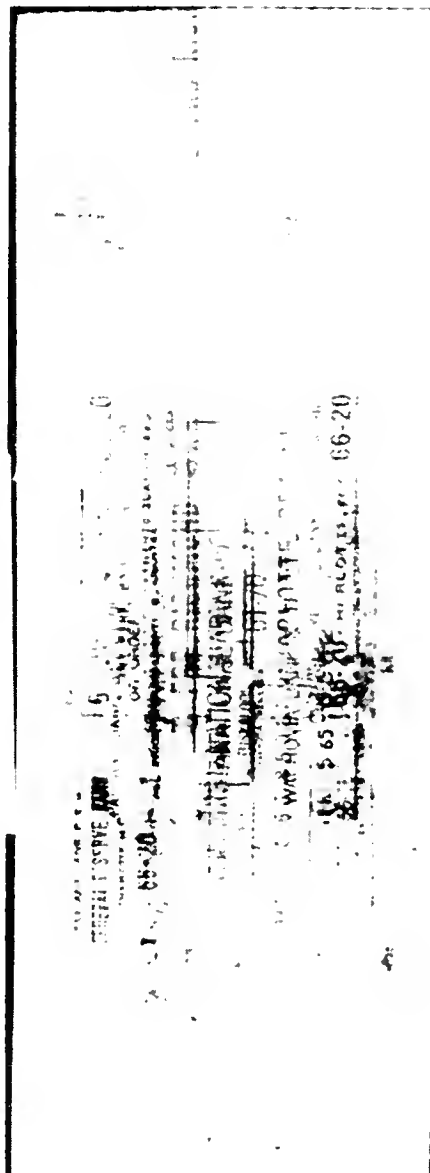
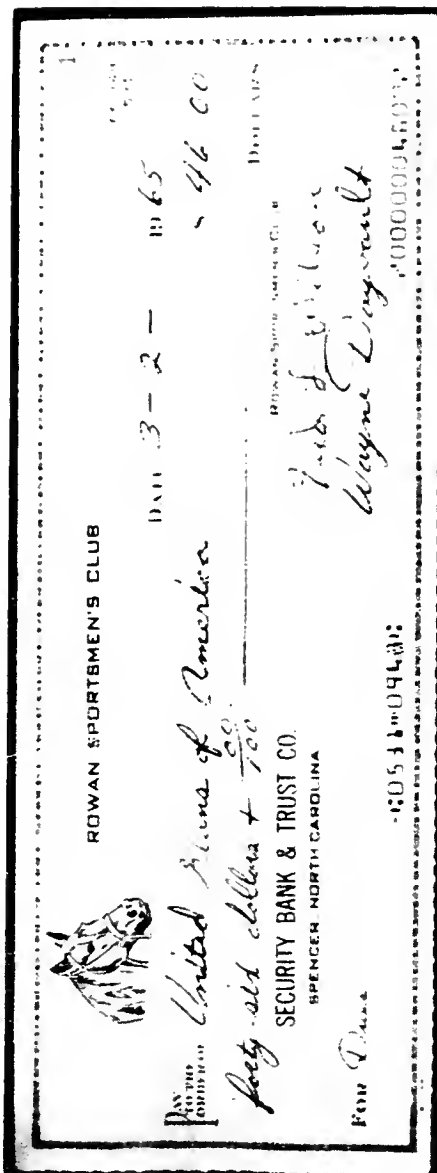

of the publication the *Fiery Cross*, which is the official publication of the United Klans of America.

This check is drawn on the Merchants Trust and Savings Bank of Kenner, Louisiana. It is signed by Charles L. Miller of 2512 Airline Highway in Kenner, Louisiana. This check shows up as a deposit in the account of the Alabama Rescue Service on September 9, 1965, as a \$30 deposit of the Merchants Trust and Savings Bank and is endorsed to the account of the Alabama Rescue Service on its reverse side.

(Check marked "Philip Manuel Exhibit No. 2" appears on p. 1964.)

The CHAIRMAN. Who was the maker of the first check you referred to?

Mr. MANUEL. That was the Rowan Sportsmen's Club.

The CHAIRMAN. What is the Rowan Sportsmen's Club? Is that a front organization?

Mr. MANUEL. The Rowan Sportsmen's Club is a cover name for a Klavern located in Spencer, North Carolina.

The CHAIRMAN. It is a front or a coverup.

PHILIP MANUEL EXHIBIT No. 2

MERCHANTS TRUST AND SAVINGS BANK
 KENNER, LOUISIANA *Aug 27 1965* No 153447

PAY TO THE ORDER OF *United Klans of America*

MERCHANTS TRUST AND SAVINGS BANK *100 AND 86 CTS*

NOT VALID OVER \$250.00

Charles L. Miller
 SIGNATURE

2512 Airline Highway
 ADDRESS

711 *May 1965*
 :065200469: #90 059 711

Mr. MANUEL. It is a cover name for a Klavern in Rowan County, North Carolina.

The CHAIRMAN. What about the second check? Who is the maker of that check and what is that outfit?

Mr. MANUEL. This is made payable to the United Klans of America.

The CHAIRMAN. No. The maker?

Mr. MANUEL. The maker is Charles L. Miller, 2512 Airline Highway, in Kenner, Louisiana.

Mr. ASHBROOK. For whom?

Mr. APPELL. Is it not a fact that, according to the staff investigation, many Klaverns and Klans do not maintain bank accounts, but that they maintain and transmit money through personal accounts and also in the form of U.S. postal money orders?

Mr. MANUEL. That is correct, sir, and I have some illustrations of that in the form of a personal check. The last example was also a personal check.

I have another personal check made by Mr. George A. Otto, dated September 8, 1965, payable to the order of the United Klans of America in the amount of \$50, drawn on the Bank of the Southwest, in Houston, Texas.

(Check marked "Philip Manuel Exhibit No. 3" follows:)

PHILIP MANUEL EXHIBIT No. 3

GEORGE A. OR MARTHA O. OTTO 711
 7187 APPLETON, BOX 1-1631
 HOUSTON, TEXAS 77022

711
 92-6
 7700

1965

PAY TO THE ORDER OF *United Klans of America* \$50.00

DOLLARS

GEORGE A. OR MARTHA O. OTTO

George A. Otto
 SIGNATURE

500 9541

Mr. APPELL. And that, according to your investigation, is remittance by a Klavern, perhaps under a cover name, to the United Klans or sometimes to the Alabama Rescue Service as that cut on dues collected locally?

Mr. MANUEL. That is correct.

Mr. APPELL. Would you further identify Mr. Otto?

Mr. MANUEL. Committee investigation has established that Mr. George Otto is the Grand Dragon, recently appointed, in the State of Texas of the United Klans of America.

The CHAIRMAN. And your testimony is that in many cases remittance for Shelton's outfit, the United Klans of America, is sometimes made by individuals, individual checks, and not in the name of a Klavern by name or any front by name?

Mr. MANUEL. That is correct. We picked examples of both things.

The CHAIRMAN. So we will have a general understanding of what this is about, you do have many cases, however, of local Klaverns dealing with banks also?

Mr. MANUEL. That is correct.

Mr. POOL. On the signature on the check of Mr. Otto, read the whole signature, will you?

Mr. MANUEL. It is signed "George A. Otto," and it is on a personal check which is stamped "George A. or Martha O. Otto," of 7702 Appleton, Houston, Texas.

Mr. POOL. The word "trust" is not there? It is not a trust account at all?

Mr. MANUEL. No, sir.

Mr. POOL. Thank you.

The CHAIRMAN. Proceed.

Mr. APPELL. Mr. Manuel, through an analysis of the account of the Alabama Rescue Service, are there checks endorsed by Carol Long?

Mr. MANUEL. Yes, sir. Out of the material received by the committee, we have a total of 14 checks endorsed by Carol Long made out to cash. They are signed on the check headed "Alabama Rescue Service," drawn on "The First National Bank of Tuskaloosa, Tuskaloosa, Alabama," signed by Robert M. Shelton, T. M. Montgomery. The endorsement on the reverse side is made with the signature of Carol Long.

The CHAIRMAN. And we have established that T. M. Montgomery is Carol Long.

Mr. MANUEL. That is correct, sir. The total amount of these 14 checks is \$705.

(Checks marked "Philip Manuel Exhibit No. 4." One of said checks appear on p. 1696; balance retained in committee files.)

Mr. POOL. What dates do they cover, or about what period of time?

Mr. MANUEL. They cover from the 2d of August 1963 until the 11th day of February 1964.

The CHAIRMAN. August 1963 to what?

Mr. MANUEL. August 1963 to February of 1964.

The CHAIRMAN. That is a period of 6 months.

Mr. POOL. That is a similar time to the \$500 checks that questions were asked about earlier in the hearing room when Mr. Shelton was on the stand. I believe those \$500 checks, and I think they totaled

PHILIP MANUEL EXHIBIT NO. 4

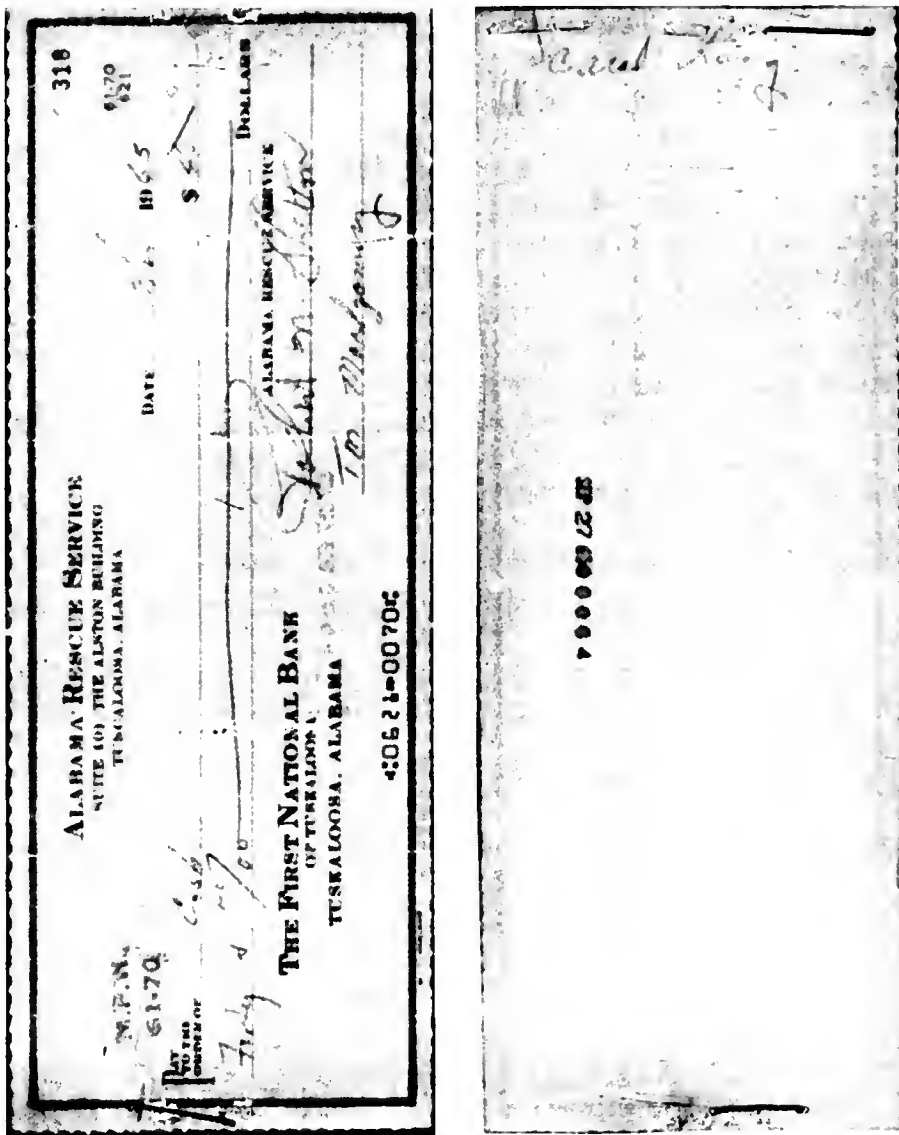

\$3,000, on them the period of time is a similar time. In that case it was July 1963 to February 1964, as I recall the testimony.

Mr. APPELL. Mr. Manuel, from an examination of the canceled checks received from The First National Bank, do these canceled checks reflect payments to Lorch's Diamond Shop, Tuscaloosa, Alabama?

Mr. MANUEL. The committee has in its possession 14 canceled checks made payable to Lorch's or Lorch's Diamond Shop of Tuscaloosa, Alabama, in the total amount of \$469.93. They were made in 14 separate payments starting in May of 1964, and the last check was dated June 18, 1965.

These checks are drawn on "The First National Bank of Tuscaloosa, Tuscaloosa, Alabama," on checks labeled "Alabama Rescue Service, Suite 401, The Alston Building, Tuscaloosa, Alabama," which the committee investigation has established is the headquarters of United Klans of America. These checks are signed by Robert M. Shelton and James J. Hendrix.

(Checks marked "Philip Manuel Exhibit No. 5." One of said checks follows; balance retained in committee files.)

PHILIP MANUEL EXHIBIT NO. 5

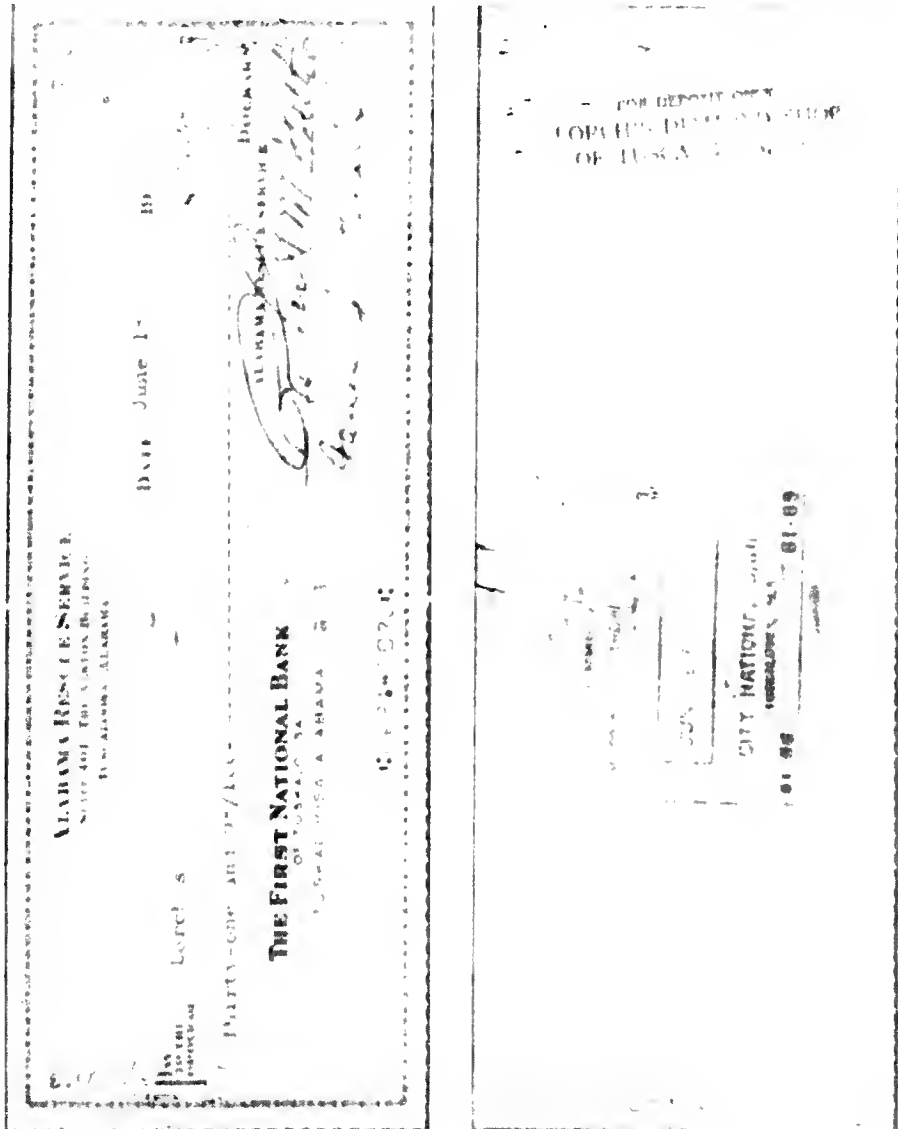

Mr. POOL. To whom were the checks made payable?

Mr. MANUEL. They were made payable in some cases to Lorch's Diamond Shop and in other cases to Lorch's. However, the endorsement on the reverse side is always "For deposit only, Lorch's Diamond Shop of Tuscaloosa, Inc."

Mr. POOL. What is the total amount?

Mr. MANUEL. The total amount of these checks is \$469.93.

Mr. POOL. Do you know what they were given for? Do you have any information on that?

Mr. MANUEL. No, sir.

Mr. POOL. They couldn't be for that diamond ring that the Imperial Wizard Shelton has been wearing here in this hearing room; could they? Do you know anything about that?

Mr. MANUEL. I have no knowledge of that, sir.

Mr. POOL. Did you notice the ring he was wearing?

Mr. MANUEL. Yes, sir.

Mr. POOL. Have you any idea how many carats that ring is?

Mr. MANUEL. I do not.

Mr. POOL. It looked like it was worth more than \$400. There must have been some other checks somewhere.

Mr. APPELL. Do the canceled checks received from The First National Bank, Tuscaloosa, Alabama, reflect payments to GMAC, General Motors Acceptance Corporation?

Mr. MANUEL. Yes, sir. The committee has in its possession 14 canceled checks made payable to GMAC, in most instances in the amount of \$136.33, which was payment for a car.

Mr. ASHBROOK. All checks are in the same amount?

Mr. MANUEL. There was one check that includes two payments in the amount \$272.66. However, these 14 checks total \$2,044.95. In some cases, these checks were made payable to cash and signed by Robert M. Shelton and James J. Hendrix. However, on the reverse side they are endorsed by the General Motors Acceptance Corporation of Tuscaloosa, Alabama.

(Checks marked "Philip Manuel Exhibit No. 6." One of said checks follows; balance retained in committee files.)

PHILIP MANUEL EXHIBIT No. 6

755
61-70
621

ALABAMA RESCUE SERVICE
SUITE 401, THE ALSTON BUILDING
TUSCALOOSA, ALABAMA

DATE: August 5 1965

TO THE ORDER OF GMAC

One-hundred & Thirty-six and 33/100

ALABAMA RESCUE SERVICE
DOLLARS

Robert M. Shelton
James J. Hendrix

THE FIRST NATIONAL BANK
OF TUSCALOOSA
TUSCALOOSA, ALABAMA

⑆062⑆0070⑆

PAY ANY BANK, BANKER OR
TRUST COMPANY

AUG - 6 1965

GENERAL MOTORS ACCEPTANCE
CORPORATION
TUSCALOOSA, ALABAMA

AUG 6 1965

The CHAIRMAN. We have established that James J. Hendrix is none other than Mrs. Shelton.

Mr. MANUEL. According to expert testimony.

Mr. APPELL. Mr. Manuel, from an analysis of the canceled checks, what is the total amount written by checks in which the payee is "Cash"?

Mr. MANUEL. For the fiscal year 1964, the total amount of checks made payable to cash was \$5,581.50.

The CHAIRMAN. And they were all drawn by, or signed as maker, by whom?

Mr. MANUEL. Robert M. Shelton and James J. Hendrix.

The CHAIRMAN. Mr. and Mrs. Shelton.

Mr. MANUEL. According to expert testimony.

Mr. POOL. Have you finished all your checks?

Mr. MANUEL. No.

Mr. POOL. You have some more?

Mr. MANUEL. Yes.

Mr. APPELL. Mr. Manuel, as a result of an analysis of the canceled checks which we received from the bank, how many and over what period—how many checks were signed by Robert M. Shelton and T. M. Montgomery, and how many checks were signed as the maker of the check by Robert M. Shelton and James J. Hendrix?

Mr. MANUEL. From the period July 1, 1963, to August 13, 1965, committee investigation has established that the total number of checks signed by both Robert M. Shelton and James J. Hendrix is 301. The checks signed by both Robert M. Shelton and T. M. Montgomery is 131. Total checks signed by Robert Shelton is 432.

The CHAIRMAN. And they were variously used for such items as, you said, a diamond ring—

Mr. ASHBROOK. He didn't say that.

The CHAIRMAN. Well, a jewelry shop, GMAC, and cash. Any other categories?

Mr. MANUEL. There are some checks made payable to grocery stores.

(At this point Mr. Buchanan entered the hearing room.)

Mr. POOL. So he was using this money he took in for traveling-around money, you might call it, cash, for diamonds, cars, and now he is getting his groceries out of it. Is that your testimony?

Mr. MANUEL. There are some checks made payable to grocery stores; yes, sir.

The CHAIRMAN. And that came out of the account—

Mr. MANUEL. Of the Alabama Rescue Service.

The CHAIRMAN. —of the Alabama Rescue Service, which is a front, the cover name for the United Klans of America, and representing dues collected from these poor members here and there in the States we have described.

Mr. MANUEL. From the membership of the Klaverns; that is correct, Mr. Chairman.

(At this point Mr. Weltner entered the hearing room.)

Mr. APPELL. Mr. Chairman, I have no further questions of this witness.

The CHAIRMAN. All right. Call your next witness.

Mr. APPELL. Now, Mr. Chairman, I would like to call Mr. James R. Jones.

The CHAIRMAN. The photographers will have to desist. Please raise your right hand.

Do you solemnly swear that the testimony you are about to give will be the truth, the whole truth, and nothing but the truth, so help you God?

Mr. JONES. I do.

**TESTIMONY OF JAMES ROBERTSON JONES, ACCOMPANIED BY
COUNSEL, LESTER V. CHALMERS, JR.**

Mr. APPELL. Mr. Jones, will you state your full name for the record, please, sir?

Mr. JONES. James Robertson Jones.

Mr. APPELL. Are you appearing here this afternoon in response to a subpoena served upon you by a deputy United States marshal at 10:20 o'clock a.m., on the 11th day of October 1965?

Mr. JONES. Yes, sir.

Mr. APPELL. Are you represented by counsel?

Mr. JONES. Yes, sir.

Mr. APPELL. Will counsel please identify himself?

Mr. CHALMERS. My name is Lester V. Chalmers, Jr. I am an attorney at law, Raleigh, North Carolina, 501 First Federal Building.

Mr. APPELL. Mr. Jones, when and where were you born?

Mr. JONES. Rowan County.

(Witness confers with counsel.)

The CHAIRMAN. Will you speak into the microphone?

Mr. JONES. I respectfully decline to answer to that question for reasons that I honestly feel my answer might tend to incriminate me in violation of my rights as guaranteed to me by amendments 5, 1, 4, and 14 of the Constitution of the United States of America.

The CHAIRMAN. These are what we call identifying and preliminary questions, and I can't conceive your constitutional rights being impaired by answering this question, and perhaps others along the same line.

I therefore order and direct you to answer the question.

Mr. JONES. I respectfully decline to answer that question for reasons that I honestly feel my answer might tend to incriminate me in violation of my rights as guaranteed to me by amendments 5, 1, 4, and 14 of the Constitution of the United States of America.

Mr. APPELL. Mr. Jones, would you give to the committee a brief résumé of your educational background?

Mr. JONES. I respectfully decline to answer that question for reasons that I honestly feel my answer might tend to incriminate me in violation of my rights as guaranteed to me by amendments 5, 1, 4, and 14 of the Constitution of the United States of America.

The CHAIRMAN. I order and direct you to answer that question.

Mr. JONES. I respectfully decline to answer that question for reasons that I honestly feel my answer might tend to incriminate me in violation of my rights as guaranteed to me by amendments 5, 1, 4, and 14 of the Constitution of the United States of America.

The CHAIRMAN. Of course, we respect your invocation of the rights if you honestly believe, as you just read there. But do you honestly believe that if you answer that simple question as to your educational background it could possibly involve you in anything?

Mr. JONES. I respectfully decline to answer that question for reasons that I honestly feel my answer might tend to incriminate me in violation of my rights as guaranteed to me by amendments 5, 1, 4, and 14 of the Constitution of the United States of America.

The CHAIRMAN. I notice you are reading your answers. I am not being technical about a witness' right to invoke constitutional privileges. But if you know, can you tell me upon what basis you are invoking the first amendment?

Mr. JONES. I respectfully decline to answer that question for reasons that I honestly feel my answer might tend to incriminate me in violation of my rights as guaranteed me by amendments 5, 1, 4, and 14 of the Constitution of the United States of America.

The CHAIRMAN. The 14th amendment talks about equal protection of the law and things of that kind. On what basis are you possibly invoking the 14th amendment?

Mr. JONES. I respectfully decline to answer to that question for reasons that I honestly feel my answer might tend to incriminate me in violation of my rights as guaranteed to me by amendments 5, 1, 4, and 14 of the Constitution of the United States of America.

The CHAIRMAN. What about the fourth amendment? On what basis are you invoking that?

Mr. JONES. I respectfully decline to answer that question for reasons that I honestly feel my answer might tend to incriminate me in violation of my rights as guaranteed to me by amendments 5, 1, 4, and 14 of the Constitution of the United States of America.

The CHAIRMAN. I invite you in all seriousness and in the interest of orderly procedure, if you wish on advice of your counsel, to simply say, if you intend from here on to have some more invocations, that you decline to answer the questions on the grounds previously stated.

I make that suggestion, and I invite you to follow that course if you want to.

Ask the next question.

Mr. APPELL. Mr. Jones, would you briefly outline for the committee your employment background?

Mr. JONES. I respectfully decline to answer that question for reasons that I honestly feel my answer might tend to incriminate me in violation of my rights as guaranteed me by amendments 5, 1, 4, and 14 of the Constitution of the United States of America.

Mr. APPELL. Mr. Jones, your subpoena served upon you on October 11, 1965, called for you to produce certain documents. Were you present in the hearing room yesterday when the chairman read his opening statement? Did you receive a copy of the opening statement and do you understand its contents prior to my asking for a demand for those documents?

Mr. JONES. I respectfully decline to deliver—

(Witness confers with counsel.)

Mr. JONES. I respectfully decline to answer that question based on the grounds previously stated.

Mr. CHALMERS. Mr. Chairman, may I state to the committee—

The CHAIRMAN. What is the pending question?

Mr. APPELL. I asked him if he was present when your opening statement was made, whether he received a copy of the opening statement, and whether or not he understood the content of the opening statement.

Mr. CHALMERS. Mr. Chairman, may I state to the committee, and to you, sir, that my client has been informed of the opening statement and is well aware of the contents thereof, and has been informed by me also of that fact and what the opening statement contains.

The CHAIRMAN. That is correct, is it not? You can answer that. Well, you speak for your client?

Mr. CHALMERS. I am speaking for my client, sir.

The CHAIRMAN. Thank you for that expeditious way of proceeding.

Mr. APPELL. Mr. Jones, part 1 of the attachment to your subpoena, which was made a part of the subpoena, called upon you to produce:

All books, records, documents, correspondence, and memoranda relating to the organization of and the conduct of business and affairs of the Invisible Empire, United Klans, Knights of the Ku Klux Klan of America, Inc., also known as the United Klans of America, Inc., Knights of Ku Klux Klan, and affiliated organizations, namely, the Alabama Rescue Service, New Bern and Blounts Creek Fund, in your possession, custody or control, or maintained by you or available to you as Grand Dragon, Realm (State) of North Carolina, of the Invisible Empire, United Klans, Knights of the Ku Klux Klan of America, Inc., also known as the United Klans of America, Inc., Knights of the Ku Klux Klan.

I now ask you to produce those documents, sir.

Mr. JONES. I respectfully decline to deliver to the committee any and all records as requested by this committee under subpoena dated October 8, 1965, for that information is not relevant and germane to the subject under investigation, and the same would not aid the Congress in consideration of any valid remedial legislation, nor is such required within the scope of that authorized by Rule IV of the House rules adopted by the 89th Congress, by House Resolution 8, adopted January 4, 1965.

(At this point Mr. Buchanan left the hearing room.)

The CHAIRMAN. Mr. Jones, the committee does not accept your reasons for refusal to answer. It does not accept any of your constitutional invocations, and is of the opinion that your failure to produce the documents enumerated may well result in a contempt citation, in a recommendation by this subcommittee to the full committee, and by the full committee to the House of Representatives, for a contempt citation.

(At this point Mr. Buchanan returned to the hearing room.)

The CHAIRMAN. I hope it won't be necessary for me to repeat the reasons why the committee does not accept your reasons for refusal to produce these documents.

Is that understood, Mr. Counsel?

Mr. CHALMERS. Yes, sir.

The CHAIRMAN. In this instance I therefore order and direct you, Mr. Jones, to produce those documents called for by part 1 of the attachment to your subpoena.

May I have the privilege from here on to say for the reasons previously given the committee rejects the refusal to produce the documents.

Mr. CHALMERS. Yes, sir; and may I state to the chairman and to the committee my client is well aware of the implications.

The CHAIRMAN. I don't know if you answered the question, Mr. Jones.

Did he?

I now order and direct you to produce those documents enumerated in part 1 of the attachment to your subpoena.

(Witness confers with counsel.)

Mr. JONES. I respectfully decline to deliver to the committee any and all records as requested by this committee under subpoena dated October 8, 1965, for that information is not relevant and germane to the subject under investigation, and the same would not aid the Congress in the consideration of any valid remedial legislation, nor is such inquiry within the scope of that authorized to be investigated by Rule IV of the rules adopted by the 89th Congress, by House Resolution 8, adopted January 4, 1965.

(Witness confers with counsel.)

The CHAIRMAN. Mr. Counselor, would you listen to me now?

My own general counsel suggests that I ask you if it is understood that, first, he heard my questioning of Mr. Shelton along these lines, and second, are you still satisfied that you well understand the purposes and objectives and pertinency of evidence now being presented as described in my opening statement, and with all of that knowledge he still persists in refusing to produce the documents? That is understood?

Mr. CHALMERS. Let me speak to my client.

(Counsel confers with witness.)

Mr. CHALMERS. Mr. Chairman, I think, sir, I am not fully familiar how we can stipulate to something in this hearing, but we certainly do not desire to extend it out. My client, sir, heard what the chairman told Mr. Shelton this morning.

The CHAIRMAN. And that includes the fact that I told Mr. Shelton, and it applies to him, too, that this order is for him to respond to the subpoena by producing these documents on the basis of his representative capacity as Grand Dragon?

Mr. CHALMERS. I can't go that far, sir. I am sorry, I can't go that far. I can stipulate, sir, to this, that the subpoena reads to James R. Jones, and that based on that, the original subpoena which we have here, I imagine, he was ordered to produce the items listed in number 1, that he heard your statements with respect to what Mr. Shelton said, that Mr. Shelton was told this morning, that he heard and is familiar with the opening statement made by the chairman yesterday, and that he realizes the possibility of a contempt citation based on the subpoena served upon him dated October 8, 1964.

I don't know what date it was served on him.

The CHAIRMAN. Look at paragraph 1.

Mr. CHALMERS. I see that. Let me say this—

The CHAIRMAN. I call to your attention, Mr. Chalmers, that paragraph 1 of the attachment to the subpoena calls for certain records for him, of course, to produce, but it reads "or maintained by you"—

documents * * * in your possession, custody or control, or maintained by you or available to you as Grand Dragon, Realm (State) of North Carolina, of the

Invisible Empire, United Klans, Knights of the Ku Klux Klan of America, Inc., also known as the United Klans of America, Inc., Knights of the Ku Klux Klan.

So the capacity is there.

Mr. CHALMERS. I am certain, sir, that the wording of a subpoena speaks for itself, and certainly whatever is there we will certainly stipulate on that this subpoena was served on him based upon what was said in the subpoena itself.

The CHAIRMAN. If you have any objection, you are a good lawyer, and I will recess and serve another one on him.

Mr. CHALMERS. No, sir; I do not.

The CHAIRMAN. Is it agreed to the understanding that he is being directed to produce these documents in his possession, control, custody or control, or maintained by him, or available to him as Grand Dragon?

In other words, as an official of the organizations technically enumerated in that subpoena? We can agree to that. I think it is self-evident that it speaks for itself and that is what it means. But if you have any technical reasons, let's recess and I will serve another one on him.

Mr. CHALMERS. We expressly state, sir, that we will stipulate that the subpoena says what it means.

The CHAIRMAN. What is it you can't stipulate, then?

Mr. CHALMERS. I can stipulate, sir, that he heard your opening statement.

The CHAIRMAN. I understand that.

Mr. CHALMERS. I can stipulate that this subpoena was served on him asking him to produce these records.

The CHAIRMAN. In his capacity enumerated?

Mr. CHALMERS. As whatever the capacity is in there, sir. I wish I could approach the bench.

The CHAIRMAN. Come up here.

(Discussion off the record.)

The CHAIRMAN. May I suggest that perhaps what good counsel has in mind is that he can't stipulate and agree that his client is the Grand Dragon of this order, but that he does stipulate that he is directed to produce these documents as Grand Dragon.

Mr. CHALMERS. Yes, sir.

The CHAIRMAN. In other words, we will have to establish that he is Grand Dragon.

Mr. CHALMERS., Yes, sir.

The CHAIRMAN. We will ask him that question right away.

Mr. CHALMERS. All right, sir. Thank you, sir.

The CHAIRMAN. By the way, we have evidence under oath in the record that he is, seriously.

The bells have rung and while this committee under the rules of the House is authorized to sit continuously there is an important vote going on.

The committee will stand in recess in order to respond to that roll-call. We will resume at 3:15.

But before that, may I ask you while this thing is on our minds, what you said in response to my colloquy and technical discussion we had with reference to this witness, Mr. Jones, that is your same position with respect to Mr. Shelton?

Mr. CHALMERS. Yes, sir; that is correct.

The CHAIRMAN. The committee will stand in recess until 3:15.

(Whereupon, at 2:50 p.m. the subcommittee recessed. All subcommittee members present at time of recess.)

(The subcommittee reconvened at 3:35 p.m. Subcommittee members present: Representatives Willis, Pool, Ashbrook, and Buchanan.)

The CHAIRMAN. The subcommittee will be in order.

The photographers will remove their equipment.

Proceed, Mr. Appell.

Mr. APPELL. Mr. Jones, under the attachment to the subpoena, section 2, you are called upon to produce:

All books, records, documents, correspondence, and memoranda in your possession, custody or control, or maintained by or available to you, in your capacity as Grand Dragon, Realm (State) of North Carolina, of the United Klans of America, Inc., Knights of the Ku Klux Klan, which the "Constitution and Laws" of said organization authorize and require to be maintained by you and any other officer of said organization, the same being in your possession, custody or control.

I now ask you to produce those documents.

The CHAIRMAN. Now let me say this: It is understood, I take it, so we won't have to cover it any more, that under the first paragraph of this attachment, and under this one, and under others to follow, that the subpoena duces tecum directs him to produce those documents in his capacity recited in that paragraph.

Mr. CHALMERS. Yes, sir; that is stipulated, sir.

Mr. APPELL. Please answer the question.

Mr. JONES. I respectfully decline to deliver to the committee any and all records requested by this committee under the subpoena dated October 8, 1965, for that information is not relevant and germane to the subject under investigation, and the same would not aid the Congress in consideration of any valid remedial legislation, nor is such inquiry within the scope of that authorized by the Rule IV of the rules adopted by the 89th Congress, by House Resolution 8, adopted January 4, 1965.

(Witness confers with counsel.)

Mr. JONES. I respectfully decline to deliver records or documents for I honestly feel they might tend to incriminate me and be a violation of my rights as guaranteed by amendments 5, 1, 4, and 14 of the Constitution of the United States of America.

Mr. APPELL. Mr. Chairman, I ask for a direction.

The CHAIRMAN. I will do that.

Mr. Jones, I now order and direct you for the reasons previously indicated, which your counsel has stipulated need not be repeated, to produce those documents.

Mr. JONES. I respectfully decline to deliver to the committee any and all records as required by this committee under subpoena dated October 8, 1965, for that information is not relevant and germane to the subject under investigation, and the same would not aid the Congress in the consideration of any valid remedial legislation, nor is such inquiry within the scope of that authorized by the investigation, by Rule IV of the House rules adopted by the 89th Congress, by House Resolution 8, adopted January 4, 1965.

I respectfully decline to deliver to the committee such records or documents for the reason that I honestly feel they might tend to incriminate me and be a violation of my rights guaranteed to me by amendments 5, 1, 4, and 14 of the Constitution of the United States of America.

Mr. APPELL. Mr. Jones, part 3 of the subpoena calls for you to produce:

Copies of U.S. Treasury Department, Internal Revenue Service, Form 1120, [titled] "U.S. Corporation Income Tax Return," for the fiscal years 1961 through June 30, 1965, filed by you as Grand Dragon, Realm (State) of North Carolina, United Klans of America, Inc., Knights of the Ku Klux Klan.

I now ask you to produce those documents in your possession.

Mr. JONES. I respectfully decline to deliver to the committee any and all records as required by this committee—as requested by this committee under subpoena dated October 8, 1965, for that information is not relevant and germane to the subject under investigation, and the same would not aid the Congress in the consideration of any valid remedial legislation, nor is such inquiry within the scope of that authorized to be investigated by Rule IV of the rules adopted by the 89th Congress, by House Resolution 8, adopted January 4, 1965.

I respectfully decline to deliver to the committee any such records as requested as they might tend to incriminate me and violate my rights as guaranteed me by amendments 5, 1, 4, and 14 of the Constitution of the United States of America.

(At this point Mr. Weltner entered the hearing room.)

Mr. APPELL. Mr. Jones, is it not a fact that you filed no corporate tax return?

Mr. JONES. I respectfully decline to answer that question for the reason that I honestly feel my answer might tend to incriminate me in violation of my rights as guaranteed me by amendments 5, 1, 4, and 14 of the Constitution of the United States of America.

Mr. APPELL. Mr. Jones, is it not a fact that during the 3 days of August 6, 7, and 8, 1965, the North Carolina Klan was holding rallies in the Wilson, North Carolina, area?

Mr. JONES. I respectfully decline to answer that question for the reason that I honestly feel my answer might tend to incriminate me in violation of my rights as guaranteed to me by amendments 5, 1, 4, and 14 of the Constitution of the United States of America.

Mr. APPELL. And isn't it a further fact that Internal Revenue Agent Roy Heddy conferred with Mr. Shelton and yourself and received the following information, and I quote from a report supplied to the committee:

The Realm of North Carolina is simply a geographical subdivision of the National Chapter and is used only to identify a given area, i.e. [that is], the State of North Carolina. It is not an organization and has no funds, income or expense, therefore no returns are due. * * *

Wasn't that statement made to the Internal Revenue Service agent by you and Mr. Shelton as reported by the agent?

Mr. JONES. May I consult counsel?

(Witness confers with counsel.)

Mr. JONES. I respectfully decline to answer that question for reasons that I honestly feel my answer might tend to incriminate me in viola-

tion of my rights as guaranteed to me by amendments 5, 1, 4, and 14 of the Constitution of the United States of America.

(Document previously marked "Robert Shelton Exhibit No. 5.")

Mr. APPELL. Mr. Jones, under paragraph 4—section 4—of the attachment which was made a part of the subpoena, you were ordered to produce:

All books, records, documents, correspondence, and memoranda of the Invisible Empire, United Klans, Knights of the Ku Klux Klan of America, Inc., also known as the United Klans of America, Inc., Knights of the Ku Klux Klan, and affiliated organizations, namely, the Alabama Rescue Service, and the Realm (State) of North Carolina and the Capital City Restoration Association, in your possession, custody or control, or maintained by you or available to you as Grand Dragon, Realm (State) of North Carolina of the Invisible Empire, United Klans, Knights of the Ku Klux Klan of America, Inc., also known as the United Klans of America, Inc., Knights of the Ku Klux Klan, which relate to insurance contracts between the Capital City Restoration Association and the International Life and Accident Insurance Company.

I now ask you to produce those documents in your possession.

Mr. JONES. I respectfully decline to deliver to this committee any and all records as requested by this committee under subpoena dated October 8, 1965, for that information is not relevant and germane to the subject under investigation, and the same would not aid the Congress in the consideration of any valid remedial legislation, nor is such inquiry within the scope of that authorized to be investigated by Rule IV of the House rules adopted by the 89th Congress, by House Resolution 8, adopted January 4, 1965.

I respectfully decline to deliver to this committee those documents as requested as I honestly feel they might tend to incriminate me in violation of my rights as guaranteed to me by amendments 5, 1, 4, and 14 of the Constitution of the United States of America.

The CHAIRMAN. For reasons previously stated, and which it has been stipulated I need not repeat, you are hereby ordered and directed to produce those documents.

Mr. JONES. I respectfully decline to deliver to this committee any and all records as requested by this committee under subpoena dated October 8, 1965, for that information is not relevant and germane to the subject under investigation, and the same would not aid the Congress in the consideration of any valid remedial legislation, nor is such inquiry within the scope of that authorized to be investigated by Rule IV of the House rules adopted by the 89th Congress, by House Resolution 8, adopted January 4, 1965.

Mr. APPELL. Mr. Jones—

(Witness confers with counsel.)

Mr. JONES. I respectfully decline to deliver those records requested by this committee for I honestly feel they might tend to incriminate me in violation of my rights as guaranteed to me by amendments 5, 1, 4, and 14 of the Constitution of the United States of America.

Mr. APPELL. Mr. Jones, section 5 of the attachment which was made a part of the subpoena calls for:

Copies of U.S. Treasury Department, Internal Revenue Service, Form 1040, [titled] "U.S. Individual Income Tax Return," for the calendar years 1958 through 1964, filed by you as an individual taxpayer with the U.S. Treasury Department, Internal Revenue Service.

(At this point Mr. Buchanan left the hearing room.)

Mr. APPELL. Mr. Jones, I ask you to produce the documents called for in section 5.

Mr. JONES. I respectfully decline to deliver to this committee any and all records as requested by this committee under subpoena dated October 8, 1965, for that information is not relevant and germane to the subject under investigation, and the same would not aid the Congress in the consideration of any valid remedial legislation, nor is such inquiry within the scope of that authorized to be investigated by Rule IV of the rules adopted by the 89th Congress, by House Resolution 8, adopted January 4, 1965.

I respectfully decline to deliver to this committee these records for the reason I honestly feel to do so might tend to incriminate me in violation of my rights as guaranteed to me by amendments 5, 1, 4, and 14 of the Constitution of the United States of America.

The CHAIRMAN. Is that all concerning the production of documents?

Mr. APPELL. Yes, sir.

The CHAIRMAN. Let me say this: As previously indicated, you were ordered for the reasons I stated, and you refused to produce the documents referred to in paragraphs 1, 2, and 4 for reasons you indicated, which I did not accept, and I further point out that this could lead to an ultimate citation for contempt.

It is noted that I did not order you to produce, right now, the documents referred to in paragraphs 3 and 5, namely corporation tax returns.

I did not do that because, according to the information supplied to us by the Internal Revenue Service you did not file, so it is unnecessary for me to direct you to produce them, therefore.

Incidentally, if my information is correct, you are in worse trouble than a citation for contempt.

Proceed.

Mr. APPELL. Mr. Jones, I hand you an application for a Post Office Box, No. 321, dated 6-28-65, signed James R. Jones, with the name of the firm or corporation being "Ku Klux Klan—District Manager."

I ask you if you executed that application for a post office box?

Mr. JONES. I respectfully decline to answer that question for the reason that I honestly feel my answer might tend to incriminate me in violation of my rights as guaranteed to me by amendments 5, 1, 4, and 14 of the Constitution of the United States of America.

(Document marked "James Jones Exhibit No. 1" appears on p. 1709.)

Mr. APPELL. Mr. Jones, I hand you a document, North Carolina Domestic Corporation Franchise Tax Report, due July 31, 1965, with an affirmation of the taxpayer dated July 20, 1965, signed James R. Jones, Grand Dragon, North Carolina.

I ask you if you signed this document and formally filed it with the State of North Carolina?

Mr. JONES. I respectfully decline to answer that question for the reason I honestly feel my answer might tend to incriminate me in

JAMES JONES EXHIBIT NO. 1

FOR POST OFFICE USE ONLY	POSTMASTER J.M. Poeler	DATE BOX OPENED 6/25/65	DATE BOX CLOSED	BOX NO. 321
APPLICANT PLEASE NOTE: Completion of this application signifies your willingness to comply with all postal rules relative to the renting and use of Post Office boxes.				
NAME OF APPLICANT (Print or type) James H. Jones			TYPE OF IDENTIFICATION	
NAME OF FIRM OR CORPORATION (If box is rented for use of either) KLU KLUX KLAN - DISTRICT MANAGER				
KIND OF BUSINESS K.K.K.				
BUSINESS ADDRESS (No., street, and ZIP code) GRANITE QUARRY, N.C. ROWAN ST.			TELEPHONE NO.	
HOME ADDRESS (No., street, and ZIP code) Rowan St. Granite Quarry, N.C.			TELEPHONE NO.	
SIGNATURE OF APPLICANT X James R. Jones			DATE OF APPLICATION 6/28/65	
ADDRESS VERIFIED BY Postmaster			TELEPHONE NUMBERS VERIFIED BY	

For Post Office Use Only ENTERED IN DIRECTORY	INITIALS OF CLERK C.M. P	INITIALS OF CARRIER	BOX NO. 321
--	-----------------------------	---------------------	----------------

THE FOLLOWING MUST BE COMPLETED AND SIGNED BEFORE P.O. BOX IS ASSIGNED

DELIVER MAIL IN ACCORDANCE WITH INSTRUCTIONS CHECKED BELOW

ALL EXCEPT SPECIAL DELIVERY IN BOX ALL INCLUDING SPECIAL DELIVERY IN BOX ONLY MAIL ADDRESSED TO BOX IS TO BE PLACED IN IT ALL OTHER MAIL TO BE DELIVERED AS ADDRESSED.

OTHER INSTRUCTIONS (Specify)

SPECIAL DELIVERY MAIL ONLY (Deliver as checked below)

DELIVER TO LOCAL RESIDENCE AT DELIVER TO LOCAL BUSINESS ADDRESS AT

(No., street, and ZIP code) (No., street, and ZIP code)

NAME OF PERSONS ENTITLED TO RECEIVE MAIL THROUGH BOX (If box is rented to a firm, include the full name of each of its members whom mail is to be placed in box.)

James R. Jones
Mrs. Sybil Jones
Sanford Bryan
Mrs. Sanford Bryan
David Bryant

HAVE READ ITEMS 1 THROUGH 5 ABOVE AND WILL COMPLY WITH THEM. X *[Signature]*

PSD FORM 1093
Dec 1962

APPLICATION FOR POST OFFICE BOX

U.S. GOVERNMENT PRINTING OFFICE: 1962-O-714-708

Box 321, Granite Quarry, North Carolina (1964-1965)

violation of my rights as guaranteed me by amendments 5, 1, 4, and 14 of the Constitution of the United States of America.

(Document marked "James Jones Exhibit No. 2." Pages 1 and 4 of said exhibit follow :)

JAMES JONES EXHIBIT NO. 2

JOHN M. LINGLIF, JR.
FORM C 300
N. C. Dept. of Revenue
Raleigh, N. C.

1964
~~1964~~
1965

NORTH CAROLINA
DOMESTIC CORPORATION FRANCHISE TAX REPORT
DUE JULY 31, 1965

This report must be filed by every North Carolina corporation regardless of whether it is actually carrying on business in the State. Report covers the fiscal year July 1, 1965 through June 30, 1966.

ATTACH REMITTANCE AND MAKE PAYABLE TO N. C. DEPARTMENT OF REVENUE

Name of reporting corporation *Invisible Empire United Klans, Knights*
KU KLUX KLAN OF AMERICA, INC.
Street address *P.O. Box 321* County _____
City and State *Greene County, N.C.*
Date incorporated *July 7, 1965* Kind of business *NON-PROFIT*
Fraternal Organization
Indicate if connected with another corporation as: Parent Subsidiary Affiliate
Furnish name, address and business of each (Attach Schedule) _____

A	BASIS AND COMPUTATION OF TAX	AMOUNT
1.	Capital Stock outstanding, Surplus, Undivided Profits (Brought from page 2, item 23)	\$
2.	Affiliated Indebtedness (Brought from page 2, item 27)	
3.	Total of items 1 and 2 (See note on page 4)	
4.	Total investment in tangible properties in North Carolina (Brought from page 2, item 35)	
5.	Total assessed value of all properties located in North Carolina including total valuation of intangible personal property (From page 2, item 41)	
6.	TOTAL TAXABLE AMOUNT (Item 3, 4, or 5, whichever is greatest)	
7.	Amount of tax computed at \$1.50 per \$1,000 of item 6 (Minimum Tax \$10.00)	
8.	Less: Intangible tax on bank deposits (1964)	
9.	TOTAL AMOUNT OF TAX (MINIMUM TAX \$10.00)	52.77
10. (a)	Add: Penalty of 5% per month of delinquency period up to a maximum of 26% of item 9, not less than \$5.00, for failure to file on date due	10.00
(b)	Add: Interest at 6% per annum	
11.	TOTAL TAX, PENALTY AND INTEREST DUE	62.77

AFFIRMATION OF TAXPAYER

I hereby affirm that this report, including the accompanying schedules and statements (if any), has been examined by me and to the best of my knowledge and belief, is true and complete and is made in good faith covering the taxable period stated, pursuant to the Revenue Act of 1937 as amended, and the regulations issued under authority thereof, and that this affirmation is made under the penalties prescribed by law

James Jones
Signature of Officer and Title
James Jones
Address of Officer other than taxpayer

THIS SPACE FOR DEPARTMENTAL USE ONLY

a. Corrected Taxable Amount	\$
b. Tax @ \$1.50 per \$1,000	\$
c. Less: Remittance (if any)	\$
d. Additional Franchise Tax	\$
e. Interest at % per annum to	\$
f. Penalty for Late Filing or Payment	\$
g. Additional Charge Billed	\$
Additional Amount Paid	
\$	

JULY 20, 1965
OFFICE
ADDIT
100
DIVISION

JAMES JONES EXHIBIT No. 2—Continued

PAGE 4

1	OFFICERS NAMES AND ADDRESSES	
President:	James R. Jones	GARDNER STATION, N.C.
Vice-president:	G. R. MERRILL	WARREN, N.C.
Vice-president:		
Secretary:	A. E. Leazer	SHELBY, N.C.
Treasurer:	F. L. WILSON	SHELBY, N.C.

(NOTE. Every domestic corporation owning real estate and tangible property located outside North Carolina and also carrying on, conducting or engaging in business outside North Carolina should apply to the Department of Revenue, Corporate Income and Franchise Tax Division, for Form C-300-A and file as part of this report.)

Franchise tax liability accrues each year on July 1 and all of the tax due becomes payable with the filing of report which is due on or before July 31. Failure to file the report before July 31 will subject the corporation to a penalty amounting to 5% of the tax due for each month's delinquency. (Maximum penalty in absence of fraud 25%, minimum penalty \$5.00.) Interest at the rate of $\frac{1}{2}$ of 1% per month is charged on all delinquent tax payments from August 1 to the date of payment. The same rate of interest is also charged on all extended tax payments.

No partial or installment franchise tax payments are permitted by the Statute. The total tax due must accompany this report.

REPORT AND TAX DUE BY JULY 31, 1965 — N. C. DEPARTMENT OF REVENUE, RALEIGH, N. C.

The CHAIRMAN. Mr. Jones, you were questioned about your education and you invoked the fifth amendment. I thereupon directed you to answer that question. Again you refused.

Mr. JONES. I respectfully decline—

The CHAIRMAN. Wait a second. I haven't asked the question yet.

Mr. JONES. I thought you did.

The CHAIRMAN. No. I am very serious in this respect. I don't mean anything by the question. I think perhaps counsel himself might concede that his client has had very little education. I think it is obvious from the way he has been reading the documents.

Will counsel concede that? I am not going to hold it against him.

Mr. CHALMERS. May I have a conference?

The CHAIRMAN. Yes.

(Counsel confers with witness.)

Mr. CHALMERS. May I state to the Chairman and to the committee that my client did not graduate from high school.

Mr. APPELL. Mr. Jones, the "Constitution And Laws Of The United Klans of America, Inc., Knights Of The Ku Klux Klan," under Article XV, "Revenues and Property Titles," Section 3, reads:

The revenues of a Realm shall consist of: First, such portion of the Imperial revenue received from that Realm as may be fixed by proclamation of the National Klonvokation. Second, a per capita tax, to be known as a Realm Tax, in such amount as the Klorero may determine, in no case to be less than 25 cents per month.

Do you maintain financial records for reporting the receipt of money from Klaverns in the form of a State tax?

Mr. JONES. I respectfully decline to answer that question based on the grounds previously stated.

(Document previously marked "Robert Shelton Exhibit No. 3.")

The CHAIRMAN. I think you are doing fine now.

Mr. APPELL. I show you a copy of an advertisement which appeared in the Dunn, North Carolina, daily *Record*, on January 5, 1965, which seeks additional membership in the Ku Klux Klan, which invites people to make inquiry if they are interested in membership in North Carolina, Box 321, Granite Quarry, North Carolina, the box to which I just handed you the application, and I ask you if you have any correspondence or applications in your possession with respect to membership.

(Document handed to witness.)

(Witness confers with counsel.)

Mr. JONES. I respectfully decline to answer that question based on the grounds previously stated.

(Document marked "James Jones Exhibit No. 3 and retained in committee files.)

Mr. APPELL. Mr. Jones, I will hand you a document dated July 19, 1965, addressed "Esteemed Klansmen" and it is signed "Yours for God and Country, James R. Jones, Grand Dragon."

It is signed "James R. Jones, Grand Dragon."

In handing you the document, I want to ask you if you are the author of the document, and I wish to call your attention to paragraph 2 which reads:

Enclosed you will find a 3 x 5 card, in the top left corner, I want your unit number and mailing address, Under that I want your E.C.'s name, home address and telephone number; under that, your Secretary, address and telephone number.

The CHAIRMAN. And EC stands for exalted cyclops?

Mr. APPELL. That is correct, sir.

I ask you, Mr. Shelton, whether or not you sent that letter, whether that is your signature.

(Witness confers with counsel.)

Mr. CHALMERS. May I ask you to see if you did not call him Mr. Shelton rather than Mr. Jones?

Mr. APPELL. Please correct the record. I did not mean to call Mr. Jones Mr. Shelton, if I did.

Mr. Jones?

Mr. JONES. I respectfully decline to answer that question based on the grounds previously stated.

(Document marked "James Jones Exhibit No. 4" follows:)

JAMES JONES EXHIBIT NO. 4

July 19, 1965

Esteemed Klansmen,

It has been brought to my attention that some towns and counties while putting out posters and circulars, put these in mail boxes. This as you know and have been told is illegal. The postmaster general says I am going to pay for each poster and circular and in turn, each county and town responsible is also going to pay. From now on please do not mess with anything belonging to the federal government.

Enclosed you will find a 3 X 5 card, in the top left corner, I want your unit number and mailing address, Under that I want your E. C.'s name, home address and telephone number; under that, your Secretary, address and telephone number.

For you Kleagles and people starting new units, first get in touch with your Titan to let him know so we can organize our efforts, in a given town or county.

September 4th and 5th is National Meeting in Tuscaloosa, Alabama. This is the 100th year of the Klan and we expect to have a parade in robes, horses and all, a full Klan parade. Everyone should start making arrangements, so North Carolina can be well represented.

There has been a lot of unnecessary talking and confusion behind the ropes at Rallys. This distracts the speakers and the audience, so please refrain from this as much as possible.

At the Tennessee State Meeting, Mr. Shelton said in no uncertain terms, any man in leadership capacity of United Klans of America found under the influence of alcohol, will be replaced without fear or favor. The next 90 days the leadership of this organization will be under fire from all sides. Your petty politicians are getting scared, so not drinking in public is a small sacrifice to pay for the freedom of our country, Your help and cooperation is expected and will be appreciated.

The upcoming Rallys will be a strain on everyone so if your Rally is on a given day, you are expected to have a representative at the Rally before your Rally to help tear down platform and drive truck back to your town.

Please leave electrical equipment on the truck alone. You are also expected to have all needed equipment for your Rally at the Rally site at least by noon on the Rally date.

Yours for God and Country,

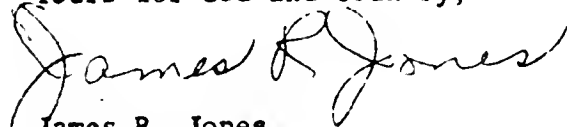
James R. Jones,
Grand Dragon

Mr. APPELL. In response to the request made of Klans within the State of North Carolina, did you, in response to your demand of July 19, 1965, receive 3 by 5 cards containing the information called for?

Mr. JONES. I respectfully decline to answer that question based on the grounds previously stated.

Mr. APPELL. Are those cards still in your possession?

Mr. JONES. I respectfully decline to answer that question based on the grounds previously stated.

Mr. APPELL. Have they been destroyed?

Mr. JONES. I respectfully decline to answer that question based on grounds previously stated.

Mr. APPELL. Mr. Jones, the committee, by subpoena dated—

The CHAIRMAN. May I ask a question of you, Mr. Appell?

These cards you just referred to—by the way, you better offer them and all of the documents for the record.

All documents previously referred to are now made a part of the record in the respective orders identified.

Now, Mr. Appell, these cards you just referred to sent by, according to you, Mr. Jones to other people, do they indicate a listing of membership by name, by number, or both, in this instance? What would be your interpretation?

Mr. APPELL. What Mr. Jones asked for was the full identity—the name, address, and telephone number of the exalted cyclops and the name, address, and telephone number of the secretary or kligrapp of each of the Klaverns within his jurisdiction.

The CHAIRMAN. But with respect to membership. I now ask you concerning the testimony on it whether it is not a fact established by the investigation that ordinary members are given numbers, or usually referred to by numbers rather than by names, except that somewhere down the line someone has a list of names with numbers but usually the members are known by numbers.

Is that not a fact? If I haven't stated it correctly, please correct me.

Mr. APPELL. Mr. Chairman, during the investigation we were advised, and we have received testimony, that in many cases an application is destroyed immediately upon its being executed and that, within the Klavern itself, a man is known by a number rather than a name and that when a roster is passed during a Klavern meeting, in order to determine who is there, the man indicates his presence by putting down a number which is assigned to him.

The CHAIRMAN. And these numbers do not necessarily always start from number 1 and go on, but might start with number 400 and go on; is that correct?

Mr. APPELL. That is true, sir, and do not necessarily run in a numerical sequence even within the Klavern itself.

The CHAIRMAN. And that is for security reasons?

Mr. APPELL. Yes, sir.

The CHAIRMAN. Proceed.

Mr. APPELL. Mr. Jones, we received, as a result of the subpoena served on August 17, 1965, upon the manager of Mill Fabrics, Inc., 126 States-

ville Boulevard, Salisbury, North Carolina, invoices covering the purchase of material, one invoice of 2-20-65, 1,064½ yards of acetate satin, 69 cents a yard, 10 percent discount, sales tax, total invoice: \$680.89; May 14, 1965, 211 yards of Princeton satin, 69 cents a yard with the discount plus a sales tax, a total invoice of \$134.96; May 18, 1965, 60 yards of 38-inch buckram, 69 cents a yard with discount added to sales tax, \$38.38; on May 20, 1965, 1,029 yards of Princeton satin, 69 cents a yard, \$710.01, less discount, plus sales tax, a total invoice of \$658.18; May 26, 1965, 107 yards of carded cotton broadcloth, 39 cents a yard, \$41.73, less discount, plus sales tax, a total invoice of \$38.69; July 13, 1965, 1,453 yards of Princeton acetate satin, 69 cents a yard, or \$1,002.57, less discount, plus sales tax, \$929.38; 90 yards of unicorn buckram, 69 cents a yard, \$62.10, less discount, plus sales tax, \$57.57, or a total of 3,757½ yards of satin.

The CHAIRMAN. Who got the business?

Mr. APPELL. The invoices are all billed to Mr. James R. Jones, Box 321, Granite Quarry, North Carolina.

The CHAIRMAN. I don't understand that. Whose invoices?

Mr. APPELL. These are the invoices of Mill Fabrics, Inc., upon whom we served a subpoena.

The CHAIRMAN. Let's be frank. Are those the people who make the sheets? I am serious.

Mr. APPELL. This is just for the bulk material, sir. I wanted to ask of Mr. Jones after he purchased this satin material what he did with it.

The CHAIRMAN. It is not all satin.

Mr. APPELL. Satin and then there is buckram, which is the stiffening material that holds the peak up, and then, of course, broadcloth, which is a little cheaper grade material.

The CHAIRMAN. So all the boys don't wear the same outfits?

Mr. APPELL. No, sir; and the boys don't pay the same price, whether it is broadcloth or satin.

The CHAIRMAN. Ask your question.

Mr. APPELL. Mr. Jones, did you purchase this material as I have set forth in these invoices?

Mr. JONES. I respectfully decline to answer that question based on the grounds previously stated.

Mr. APPELL. Mr. Chairman, the staff, in figuring up these invoices, shows that the average cost of satin is 64 cents a yard, and that it takes approximately 5 yards to make a small robe.

Mr. JONES, it is the committee's information that you sell the satin robes for \$15. Is that information correct as far as the cost of the robe?

Mr. JONES. I respectfully decline to answer that question based on the grounds previously stated.

Mr. APPELL. After you purchase the material, who do you get to manufacture the robes for you?

Mr. JONES. I respectfully decline to answer that question based on the grounds previously stated.

The CHAIRMAN. Before the next question, Mr. Manuel testified that Shelton's order, United Klans of America, got a cut of 50 cents on the

dues. Can you state right now at this point, so we can follow you, what our information is, if any, as to the cut the Imperial Wizard's outfit receives from the apparel?

Mr. APPELL. \$15 for the satin robe, sir, and 25 cents per man per capita dues per month.

The CHAIRMAN. Who gets the \$15?

Mr. APPELL. This is a good question. This is a question which Mr. Jones can answer because he purchased the material and we want to know who makes the profit, the enormous profit off of these robes.

The CHAIRMAN. All right.

Mr. JONES. I respectfully decline to answer that question based on grounds previously stated.

The CHAIRMAN. I ask you again, Mr. Appell, what is your best information as to who gets what part or the whole of this \$15 item?

Mr. APPELL. Mr. Chairman, after whatever Mr. Jones pays to have the material made into the robe, the profit goes to Mr. Jones.

Mr. Chairman, I would like to ask that the invoices to which I have just referred be entered as exhibits at this point in the order in which they were referred to.

The CHAIRMAN. The documents will be accepted in the record at this point.

(Documents marked "James Jones Exhibits Nos. 5-A through 5-G," respectively, and retained in committee files.)

The CHAIRMAN. Mr. Reporter, I will repeat again that all documents previously identified will be inserted in the record at the respective points where they were identified.

Mr. APPELL. Mr. Jones, did the United Klans of America, in North Carolina, hold a rally at Dunn, North Carolina, approximately May 25, 1965?

Mr. JONES. I respectfully decline to answer that question based on the grounds previously stated.

Mr. APPELL. It is the committee's knowledge that at these rallies there is always a pitch made for money for the purpose of either putting people on the road as paid, salaried people, or for some other appeal. In working this appeal, do you operate what would be commonly known as a shill game, in that when you start asking for money you have your people come up and make presentations of \$100 or \$50 in order to try to sucker other people into donating the same large sums of money?

(Witness confers with counsel.)

Mr. JONES. I respectfully decline to answer that question for the reason that I honestly feel my answer might tend to incriminate me in violation of my rights as guaranteed to me by amendments 5, 1, 4, and 14 of the Constitution of the United States.

The CHAIRMAN. Here we go again. Maybe I am dumb, but why go back to the long form of invocation?

Mr. APPELL. Mr. Jones, I hand you a photograph in which there is a man dressed in what appears to be a Klan robe counting money. I want to ask you, first, if you know the identity of that man.

Mr. JONES. I respectfully decline to answer that question based on grounds previously stated.

(Photograph marked "James Jones Exhibit No. 6" follows:)

JAMES JONES EXHIBIT NO. 6

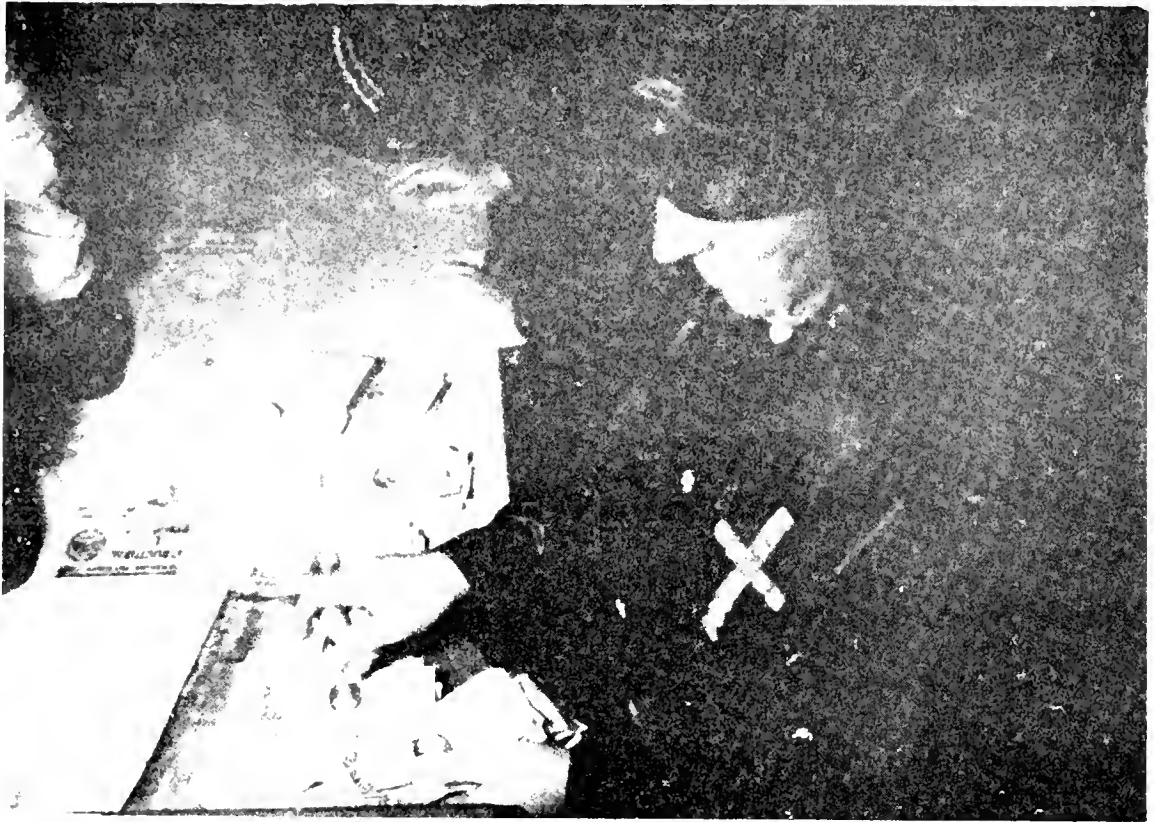

REV. GEORGE DORSETT, KU KLUX KLAN CHAPLAIN

The CHAIRMAN. Before the next question, Mr. Appell, you asked Mr. Jones whether it was not a fact that the old shill or come-see game was employed at these rallies, where a basket or a hat is passed around in a fashion whereby confederates or chosen people put in rather unusual sums as a pitch for others to kick in more than what they would normally do or can afford.

Does the investigation establish that to be a fairly common practice?

MR. APPELL. Yes, sir.

Mr. Jones, what happens to this money after it is collected at these rallies, as this man is counting it out here?

MR. JONES. I respectfully decline to answer that question based on grounds previously stated.

MR. APPELL. Do you maintain an account in the name of the United Klans of America, care of James R. Jones, at the Wachovia Bank and Trust Company, Salisbury, North Carolina?

MR. JONES. I respectfully decline to answer that question based on grounds previously stated.

The CHAIRMAN. By the way, Mr. Appell, I must caution you that the questions I propounded to you assume that the oath you took yesterday still obtains. You understand that, do you?

MR. APPELL. Yes, sir; I do, very well, sir.

Mr. Jones, the committee has obtained through subpoena an account from the Wachovia Bank and Trust Company in the name of the

United Klans of America, Inc., care of James R. Jones, Post Office Box 321, Granite Quarry, North Carolina, which, according to the ledger cards of the account, was opened on May 13, 1965, with a deposit in the form of currency of \$759, a check of \$25, or a total deposit of \$784, and that from that starting date of May 13, 1965, through September 19, 1965, from May through September, there has been deposited to that account \$16,903.37.

Where did that money come from, Mr. Jones?

Mr. JONES. I respectfully decline to answer that question based on the grounds previously stated.

The CHAIRMAN. How many months would that be?

Mr. APPELL. May 13th to September 19th is 4 months.

The CHAIRMAN. Mr. Jones, Mr. Appell asked you where this money came from, and you invoked your privilege. Now I ask you, did you deposit in this bank or other accounts all the funds you received from dues, apparel, drives, basket-passing, and all other sources?

Mr. JONES. I respectfully decline to answer that question based on grounds previously stated.

(Bank records marked "James Jones Exhibit No. 7-A" and retained in committee files.)

Mr. APPELL. Is the Reverend George Dorsett a paid employee of the United Klans of America, North Carolina?

Mr. JONES. I respectfully decline to answer that question based on grounds previously stated.

The CHAIRMAN. I wish you could give the committee a very accurate response to this question of mathematics. What portion of these deposits such as have been made, and I hope it is all that you received, would be for these various items—apparel, dues, collections, drives, so-called defense fund, and so on? Could you break that down for us?

Mr. JONES. I respectfully decline to answer that question based on grounds previously stated.

(At this point Mr. Buchanan returned to the hearing room.)

The CHAIRMAN. You see, that would aid the committee, if this is the only bank account, in knowing what the dues are, and knowing what you keep, in fixing the numbers of your organization. As to the United Klans of America, our information is that their bank deposits, mostly if not all, are receipts from dues, so it will be fairly easy later on to figure that out. I suppose Mr. Appell will cover that subject in due time.

Mr. APPELL. Mr. Chairman, with respect—

The CHAIRMAN. I was just asking if you want to go into it at this time. I don't want to break your continuity of thought.

Mr. APPELL. This account does not deal with dues.

Mr. Jones, is it not a fact that from this account you made payments to the Reverend George Dorsett on July 23, 1965, August 6, August 14, August 20, August 28, September 3, September 10, September 17, one payment of \$100 and seven payments of \$150 or a total of \$1,150?

Mr. JONES. I respectfully decline to answer that question based on the grounds previously stated.

(Checks marked "James Jones Exhibit No. 7-B.")

Mr. ASHBROOK. Did you say "Reverend"?

Mr. APPELL. Yes, sir.

The CHAIRMAN. Will you establish who he is? Who is Dorsett?

Mr. JONES. I respectfully decline to answer that question based on grounds previously stated.

The CHAIRMAN. Why was he given that money?

Mr. JONES. I respectfully decline to answer that question based on grounds previously stated.

Mr. APPELL. From this account, did you make 13 payments at \$150 each which, according to the regularity of the payments, appear to be weekly payments of \$150 a week to Boyd Hamby for a total of \$1950?

Mr. JONES. I respectfully decline to answer that question based on grounds previously stated.

(Checks marked "James Jones Exhibit No. 7-C.")

Mr. APPELL. Did you make payments from this account to Grady B. Mars, 16 checks at \$150 each for a total of \$2,400?

Mr. JONES. I respectfully decline to answer that question based on grounds previously stated.

(Checks marked "James Jones Exhibit No. 7-D.")

Mr. APPELL. Did you make payments from this account to Marshall R. Kornegay, 8 payments at \$150 each, for a total to him of \$1200?

Mr. JONES. I respectfully decline to answer that question based on grounds previously stated.

(Checks marked "James Jones Exhibit No. 7-E.")

Mr. APPELL. Did you make 12 payments for \$150 to Donald E. Leazer?

Mr. JONES. I respectfully decline to answer that question based on grounds previously stated.

(Checks marked "James Jones Exhibit No. 7-F." One check from each of said exhibits 7-B through 7-F appears on pp. 1720, 1721; balance retained in committee files.)

Mr. APPELL. Isn't it a fact that each of these gentlemen, in addition to holding some type of official capacity within the United Klans of North Carolina, were known within the Klan circles as paid organizers?

Mr. JONES. I respectfully decline to answer that question based on grounds previously stated.

Mr. APPELL. Mr. Jones, did you maintain in the name of the United Klans of America an account at the Farmers & Merchants Bank at Granite Quarry, North Carolina?

Mr. JONES. I respectfully decline to answer that question based on grounds previously stated.

Mr. APPELL. Mr. Chairman, an analysis of this account shows that starting with a deposit on 9-11-63, in the amount of \$31, that there has been deposited into that account, in addition to that which we dealt with in the first account, through September 4, 1965, \$7,659.25.

The CHAIRMAN. That is a period of slightly less than a year?

Mr. APPELL. No, sir. September 1963 through 8-16-65.

Mr. ASHBROOK. September 1964?

Mr. APPELL. 1963, sir.

The CHAIRMAN. September 1963 through August?

JAMES JONES EXHIBIT No. 7-B

2062 - 4/15/57

56

66.92
531

UNITED KLANS OF AMERICA, INC.
P. O. Box 321
GRANITE QUARRY, N. C. 28072

DATE 9-17 1965

PAY TO THE ORDER OF Dr. George L. Smith \$ 150.00

One Hundred Fifty DOLLARS

FOR Salary & Expense

WACHOVIA BANK AND TRUST COMPANY
SALISBURY, NORTH CAROLINA

POSTED
SEP 23 1965
WACHOVIA BANK AND TRUST COMPANY

UNITED KLANS OF AMERICA, INC.
Fred S. Wilson
James R. Jones

⑆0531⑆0992⑆⑆19⑆607⑆ ⑆00000⑆5000⑆

JAMES JONES EXHIBIT No. 7-C

55

66.92
531

UNITED KLANS OF AMERICA, INC.
P. O. Box 321
GRANITE QUARRY, N. C. 28072

DATE 9-17 1965

PAY TO THE ORDER OF Fred S. Wilson \$ 150.00

One Hundred Fifty DOLLARS

FOR Salary & Expense

WACHOVIA BANK AND TRUST COMPANY
SALISBURY, NORTH CAROLINA

POSTED
SEP 23 1965
WACHOVIA BANK AND TRUST COMPANY

UNITED KLANS OF AMERICA, INC.
Fred S. Wilson
James R. Jones

⑆0531⑆0992⑆⑆19⑆607⑆ ⑆00000⑆5000⑆

JAMES JONES EXHIBIT No. 7-D

57

66.92
531

UNITED KLANS OF AMERICA, INC.
P. O. Box 321
GRANITE QUARRY, N. C. 28072

DATE 9-17 1965

PAY TO THE ORDER OF George L. Smith \$ 150.00

One Hundred Fifty DOLLARS

FOR Salary & Expense

WACHOVIA BANK AND TRUST COMPANY
SALISBURY, NORTH CAROLINA

POSTED
SEP 23 1965
WACHOVIA BANK AND TRUST COMPANY

UNITED KLANS OF AMERICA, INC.
Fred S. Wilson
James R. Jones

⑆0531⑆0992⑆⑆19⑆607⑆ ⑆00000⑆5000⑆

JAMES JONES EXHIBIT NO. 7-E

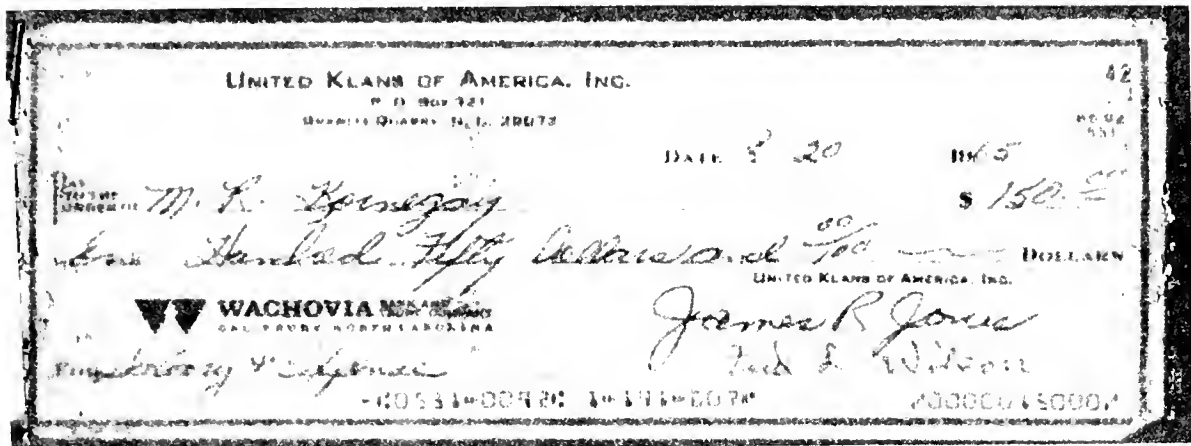

JAMES JONES EXHIBIT NO. 7-F

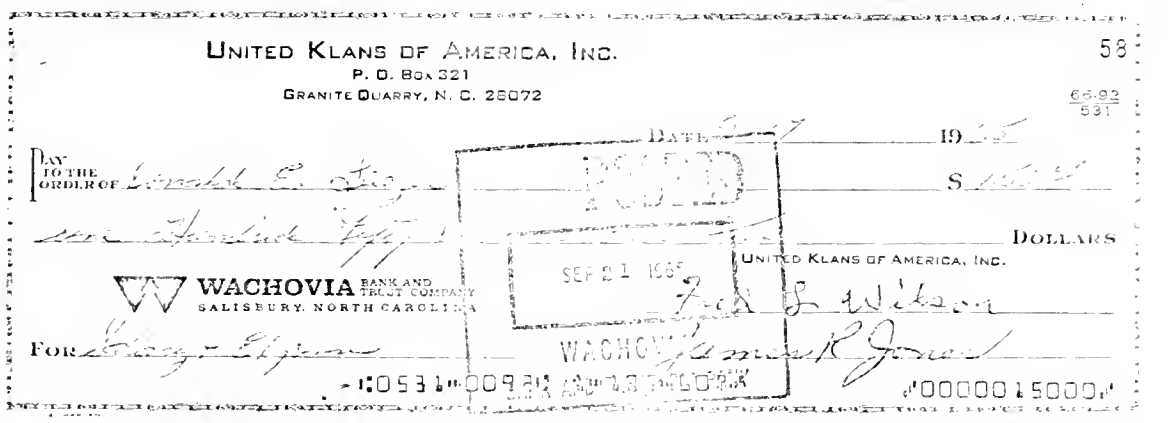

Mr. APPELL. August 16, 1965.

The CHAIRMAN. It is a period of slightly less than 2 years; is that right?

Mr. APPELL. Yes, sir.

Mr. JONES, from what source was money placed into this account?

Mr. JONES. I respectfully decline to answer that question based on grounds previously stated.

Mr. APPELL. Did you write checks against this account for printing in the amount of \$3,677?

Mr. JONES. I respectfully decline to answer that question based on grounds previously stated.

Mr. APPELL. Did you write checks to yourself in the amount of \$1,525?

Mr. JONES. I respectfully decline to answer that question based on grounds previously stated.

(Checks marked "James Jones Exhibit No. 8-A" follow:)

JAMES JONES EXHIBIT No. 8-A

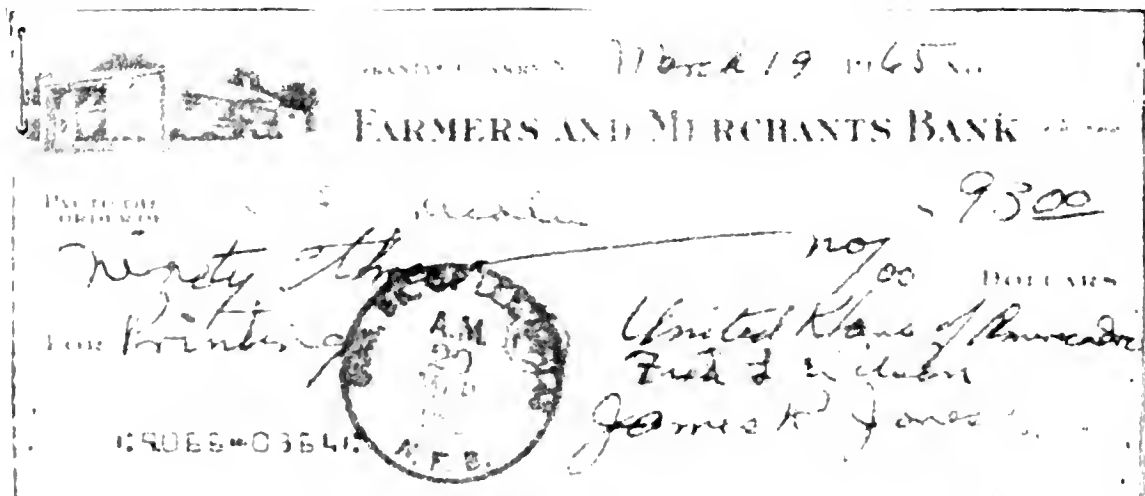
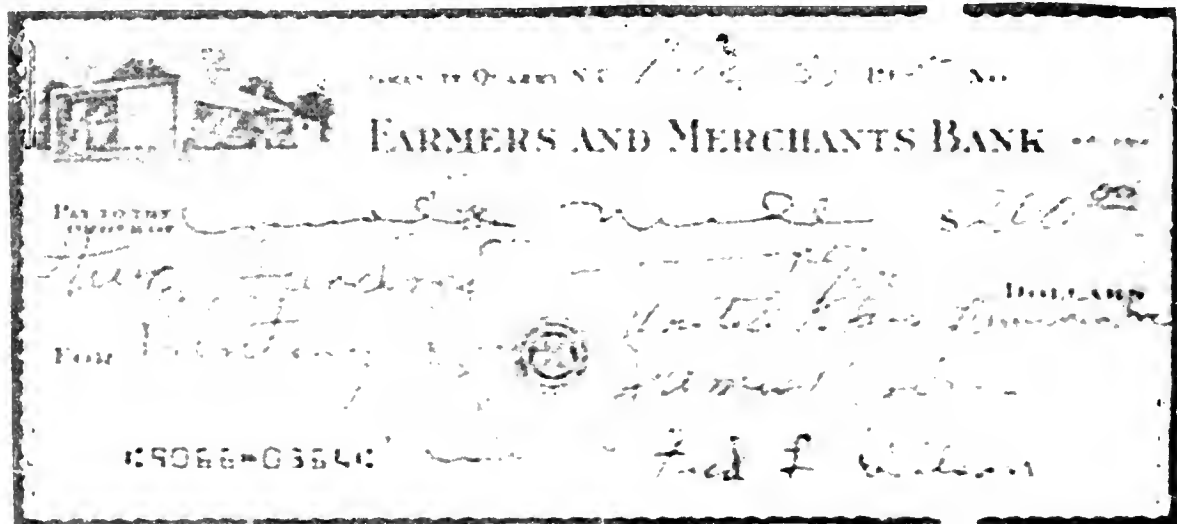
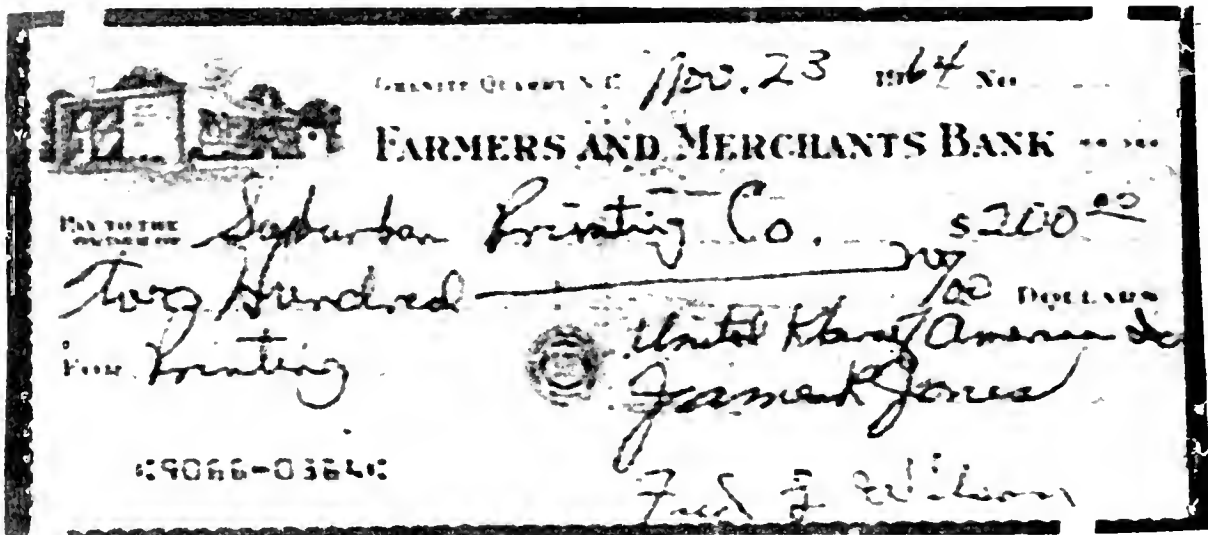

JAMES JONES EXHIBIT No. 8-A—Continued

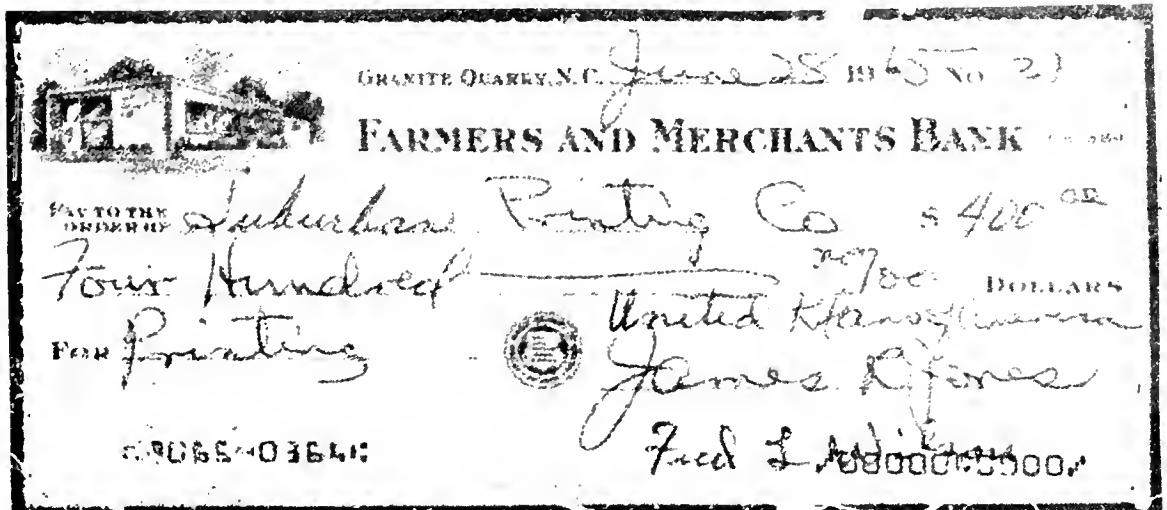
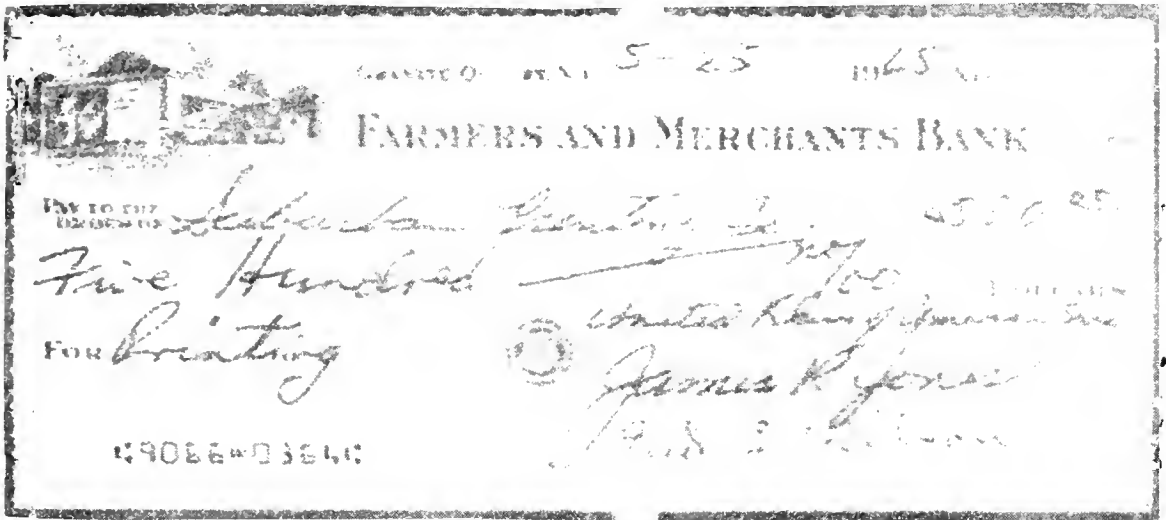
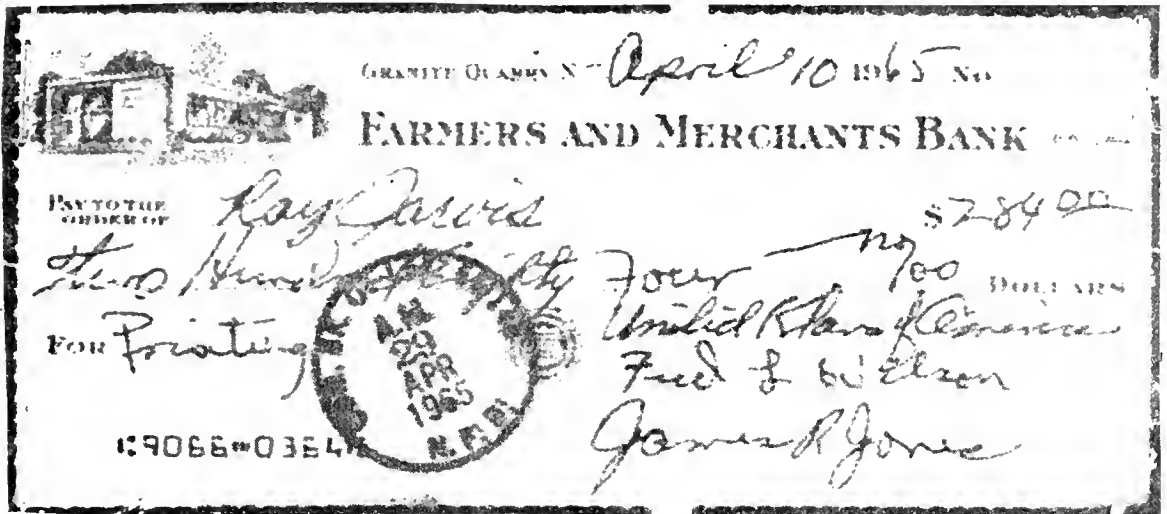

JAMES JONES EXHIBIT No. 8-A—Continued

GRANITE QUARRY, N.C. *Aug 4 1965* No. *1*

FARMERS AND MERCHANTS BANK

Pay to the order of *Suburban Building Co.* \$1000.00

One Thousand Dollars

FOR *United States of America*
Fred L Wilson
James R Jones

⑆9066⑉0364⑆ ⑆0000100000⑆

GRANITE QUARRY, N.C. *Aug 1965* No. *1*

FARMERS AND MERCHANTS BANK

Pay to the order of *Suburban Building Co.* \$1000.00

One Thousand Dollars + 00/100

FOR *United States of America*
James R Jones

⑆9066⑉0364⑆ ⑆0000100000⑆

GRANITE QUARRY, N.C. *March 14 1967* No. *3*

FARMERS AND MERCHANTS BANK

Pay to the order of *J. R Jones* \$90.00

Ninety

FOR *Travel* *United States of America*
James R Jones
Fred L Wilson

⑆9066⑉0364⑆

JAMES JONES EXHIBIT NO. 8-A—Continued

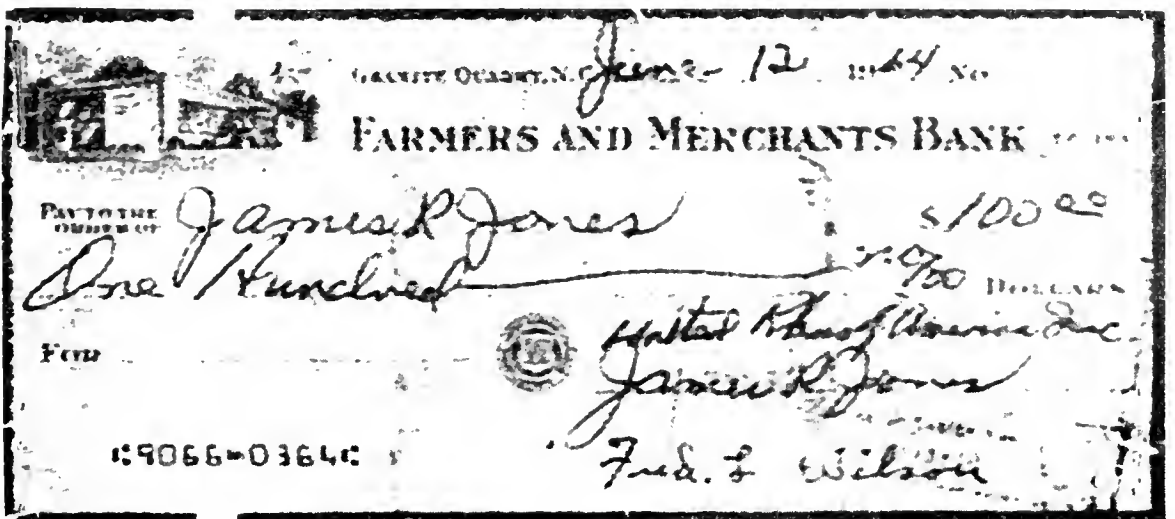
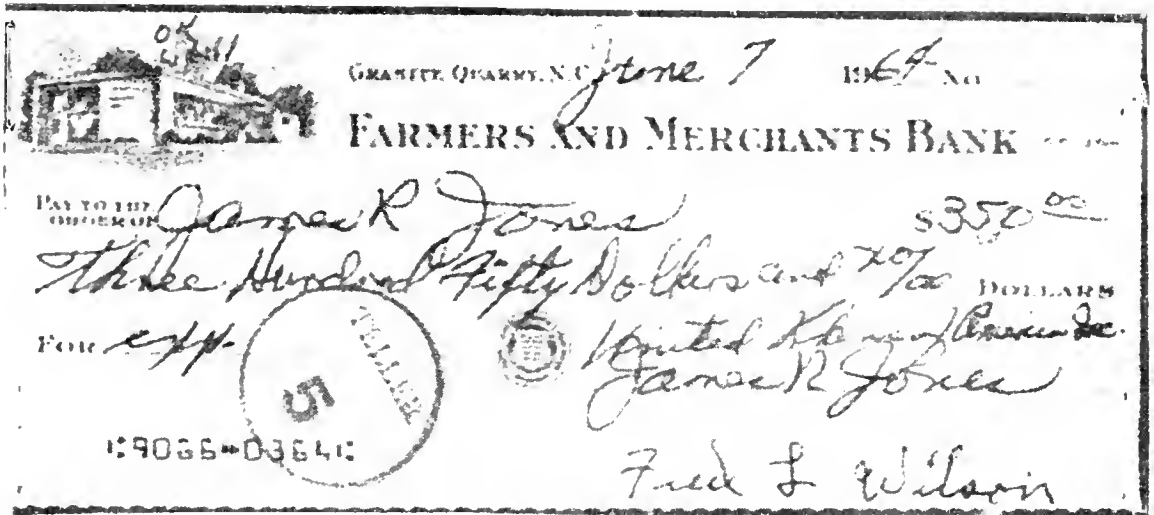
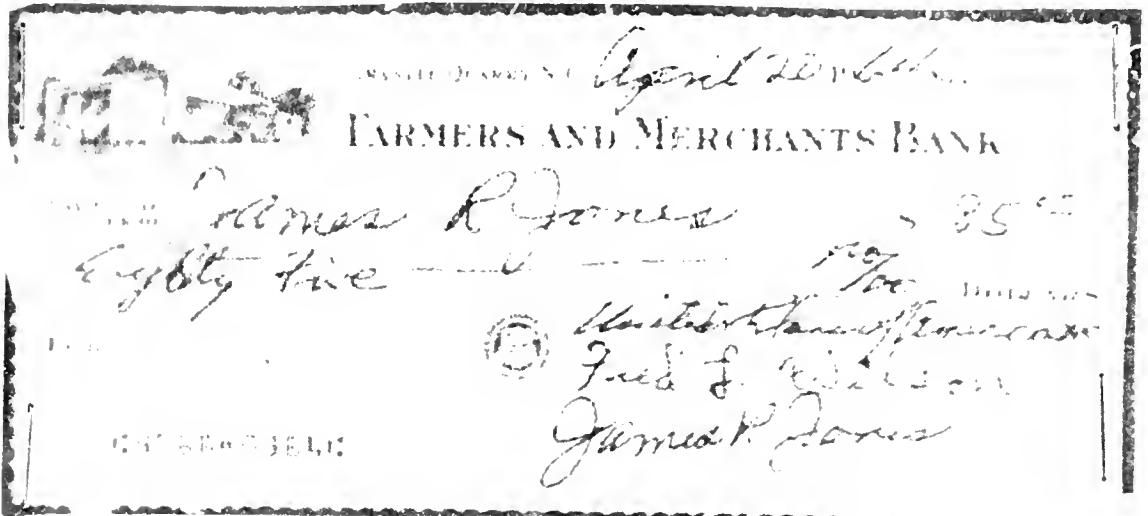

JAMES JONES EXHIBIT NO. 8-A—Continued

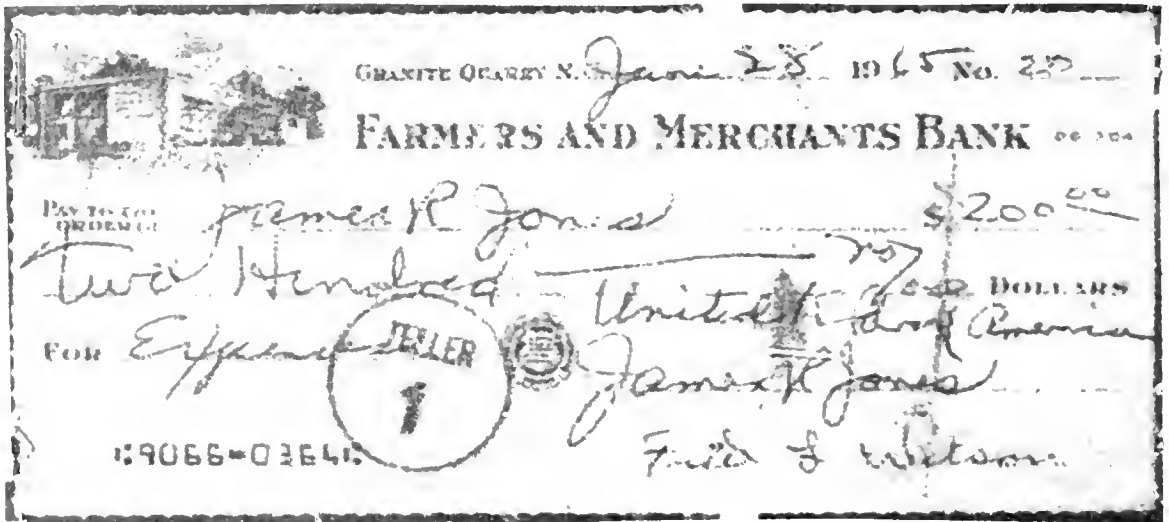
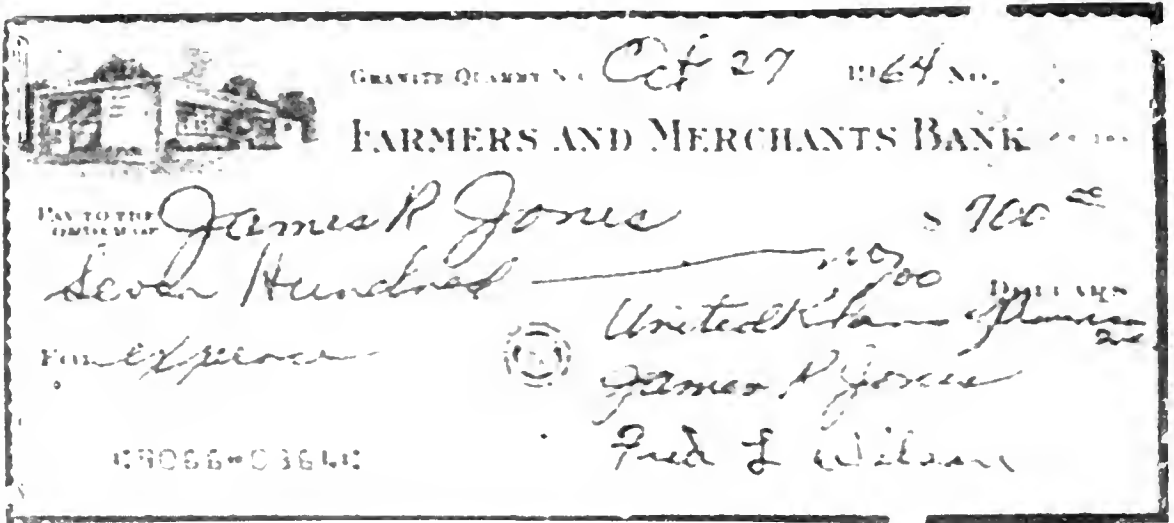

Mr. APPELL. In view of the fact that this is a check by yourself to yourself, I will hand you one and give you an opportunity to see the document, because I would like to ask you who the cosigner on that account is, Fred L. Wilson.

Mr. JONES. I respectfully decline to answer that question based on grounds previously stated.

Mr. APPELL. Isn't it a fact that at the time that check was drawn Fred L. Wilson was treasurer of the Realm of North Carolina, United Klans of America?

Mr. JONES. I respectfully decline to answer that questions based on grounds previously stated.

Mr. APPELL. Isn't it a further fact that he is a member of the same Klavern that you are?

Mr. JONES. I respectfully decline to answer that question based on grounds previously stated.

The CHAIRMAN. Does our investigation answer that question in the affirmative?

Mr. APPELL. Yes, sir.

The CHAIRMAN. The two questions?

Mr. APPELL. Yes, sir.

Mr. JONES, do you know Roy Woodle?

Mr. JONES. I respectfully decline to answer that question based on grounds previously stated.

Mr. APPELL. I saw him on a CBS-TV show, and he talked about how money went to different places that no one knew where it went to. Did you ever pay him any money?

Mr. JONES. I respectfully decline to answer that question based on grounds previously stated.

Mr. APPELL. On June 4, 1965, didn't you make a payment to Roy Woodle out of the account at the Farmers & Merchants Bank for \$20?

Mr. JONES. I respectfully decline to answer that question based on grounds previously stated.

Mr. APPELL. I note in this account, Mr. Jones, that there is a check dated August 4, 1965, payable to "M. R. Korneagay" in the amount of \$200. This check reads, "Mistake In Acc[ount]. Washington # 57, Blounts Creek # 25."

Can you tell us what that refers to, sir?

Mr. JONES. I respectfully decline to answer that question based on grounds previously stated.

Mr. APPELL. Mr. Shelton, the account shows that there were two checks drawn against this account, one on September 19, 1964, in the amount of \$30; another on October 27, 1964, in the amount of \$1,530. The purpose for which the check was drawn was to purchase a truck. Is that truck titled in the name of the United Klans of America or in your own personal name?

Mr. JONES. I respectfully decline to answer that question based on grounds previously stated.

(Checks marked "James Jones Exhibits Nos. 8-B through 8-E," respectively, and retained in committee files.)

Mr. APPELL. Mr. Jones, do you maintain a bank account at the Security Bank and Trust Company in Salisbury, North Carolina, in the name of Mr. and Mrs. James R. Jones?

Mr. JONES. I respectfully decline to answer that question based on grounds previously stated.

Mr. APPELL. Is it not a fact—I place it to you as a fact—that money received from Klaverns in the form of dues are deposited to you, by you, into that account rather than in the accounts in the name of the United Klans of America?

Mr. JONES. I respectfully decline to answer that question based on grounds previously stated.

The CHAIRMAN. Mr. Appell, you placed that question as a fact?

Mr. APPELL. Yes, sir.

The CHAIRMAN. And repeat it, please. I didn't catch it.

Mr. APPELL. I asked Mr. Jones if it was not a fact that he deposited to the personal account in the name of Mr. and Mrs. Jones, money which he receives from Klaverns in the form of tax.

Mr. Jones, are you acquainted with the Craven County Improvement Association?

Mr. JONES. I respectfully decline to answer that question based on grounds previously stated.

Mr. APPELL. I show you a check subpoenaed from the First-Citizens Bank & Trust Company, the account of the Craven County Improvement Association. The check is dated 6-12-1964. It is in the amount of \$5. It says on its face "Tax," and I note that it was deposited, according to the check itself, at the Security Bank & Trust Co. after being endorsed by James R. Jones, and the deposit slips accompanying the committee subpoena from the bank reflect the deposit of this check.

(Document handed to witness.)

The CHAIRMAN. Are you referring now to the account in the name of Mr. and Mrs. Jones?

Mr. APPELL. Yes; I am, sir.

Mr. JONES. I respectfully decline to answer that question based on grounds previously stated.

(Check marked "James Jones Exhibit No. 9" follows:)

JAMES JONES EXHIBIT No. 9

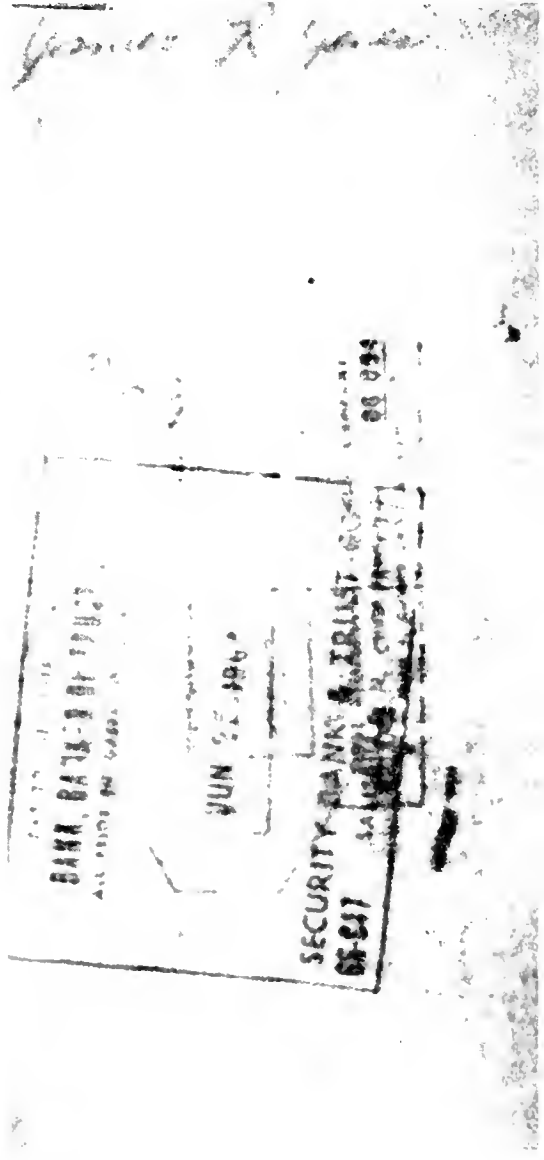
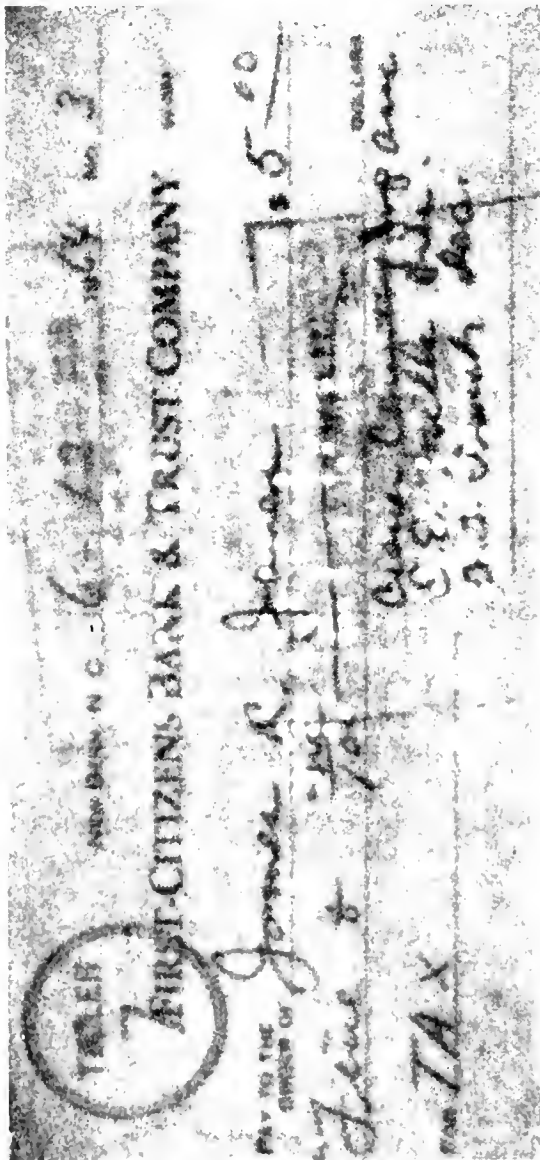

Mr. APPELL. Mr. Chairman, we have many accounts of the Klans in North Carolina, all of which consistently reflect that the money paid to Mr. Jones in tax either goes into the account of Mr. and Mrs. Jones or else they are cashed by Mr. Jones in various and sundry places, and I would assume that no bookkeeping record is kept.

Mr. Chairman, with respect to the account of Mr. and Mrs. Jones, an analysis of this account shows that the account was opened in—

The CHAIRMAN. Do you have the analysis?

Mr. APPELL. Yes, sir; I have the analysis, and I am going to deal with it right now.

Mr. Chairman, the analysis of the account of Mr. and Mrs. Jones, as reflected by the ledger cards submitted to the committee in response—

The CHAIRMAN. That is in just one account?

Mr. APPELL. Just one account, sir, shows that the account was opened on January 1, 1961, and that there was deposited to this account during the entire year of 1-1-61 to 10-31-61 a total of \$87.50.

The CHAIRMAN. How much?

Mr. APPELL. \$87.50. During the year 1-1-62 to 12-31-62 there was deposited into that account during the entire year a total of \$98.

Checks written against that account in that year totaled \$97.39, and the balance at the end of the year 1962 was \$6.53.

During the year January 1, 1963, to 12-31-1963 there was deposited to that account a total of \$162. There was disbursed or checks written against the account for \$165.83, leaving a balance at the end of 1963 of \$2.70.

It is the committee's information that Mr. Jones became Grand Dragon in August of 1963 and that during the year 1964 there was deposited to that account \$1,745.85. During the year 1965, from January 8, 1965, through September 3, 1965, there has been deposited to that account \$4,216.20.

The CHAIRMAN. That makes a total of what? Do you have the ready figure? If not, the record will speak for itself.

Mr. APPELL. Of all three accounts, sir?

The CHAIRMAN. Are you talking about three accounts or 3 or 4 years?

Mr. APPELL. We have only totaled the years from January 1, 1964, through 12-31-64, and January 1, 1965, through 8-14-65. The figure shows that the total deposits in 1964 were \$1,745.85; total deposits in 1965 were \$4,216.20. That, roughly, Mr. Chairman, is \$5,962.05 over that 2-year period.

The CHAIRMAN. I suppose you will develop it, but let me ask you this general question, counsel:

Let me ask it of you first, Mr. Jones.

Mr. Jones, you heard these deposits in the joint account of you and your wife. My question is: Is it correct that these funds came from Klan sources?

Mr. JONES. I respectfully decline to answer that question based on the grounds previously stated.

(Bank records marked "James Jones Exhibit No. 10" and retained in committee files.)

The CHAIRMAN. What were they disbursed for? Were they disbursed for Klan purposes or for your individual use?

Mr. JONES. I respectfully decline to answer that question based on the grounds previously stated.

The CHAIRMAN. I wish you would consider that, Mr. Appell, but we have to leave because there is a record vote going on a very important bill. You can make an observation, but we will have to recess until tomorrow.

Mr. APPELL. The observation that I would like to make, Mr. Chairman, is that if we took the money that the committee found to have been deposited during the fiscal year 1965, and we deal only with the fiscal year 1965, deposited into the Alabama Rescue Service account—

The CHAIRMAN. Are you talking about another account now?

Mr. APPELL. I want to tie that of Mr. Shelton's account in the Alabama Rescue Service into what we have found in the fiscal year deposited in Mr. Jones' account, Mr. Shelton—

The CHAIRMAN. This is Mr. Jones.

Mr. APPELL. Yes, but Mr. Shelton, if he had reported all income from all Klan sources and if he had just included the income into North Carolina with the income that went into his organization in Tuscaloosa, he would have reported on the basis of what we have discovered, and only on the Imperial and State level, \$32,845.20.

The CHAIRMAN. That is Mr. Shelton?

Mr. APPELL. Who claims he was reporting income from all sources in his corporate return filed with the Treasury Department.

The CHAIRMAN. And I suppose you will have much more to say about other bank accounts.

Mr. APPELL. Yes, sir, as this hearing proceeds, we will.

The CHAIRMAN. The committee will have to stand in recess until 10 o'clock tomorrow morning.

(Subcommittee members present at time of recess: Representatives Willis, Pool, Weltner, Ashbrook, and Buchanan.)

(Whereupon, at 4:24 p.m., Wednesday, October 20, 1965, the subcommittee recessed, to reconvene at 10 a.m., Thursday, October 21, 1965.)

ACTIVITIES OF KU KLUX KLAN ORGANIZATIONS IN THE UNITED STATES

Part 1

THURSDAY, OCTOBER 21, 1965

UNITED STATES HOUSE OF REPRESENTATIVES,
SUBCOMMITTEE OF THE
COMMITTEE ON UN-AMERICAN ACTIVITIES,
Washington, D.C.

PUBLIC HEARINGS

The subcommittee of the Committee on Un-American Activities met, pursuant to recess, at 10:15 a.m. in the Caucus Room, Cannon House Office Building, Washington, D.C., Hon. Edwin E. Willis (chairman) presiding.

(Subcommittee members: Representatives Edwin E. Willis, of Louisiana, chairman; Joe R. Pool, of Texas; Charles L. Weltner, of Georgia; John M. Ashbrook, of Ohio; and John H. Buchanan, Jr., of Alabama.)

Subcommittee members present: Representatives Willis, Weltner, and Buchanan.

Committee members also present: Representatives Richard H. Ichord, of Missouri, and George F. Senner, Jr., of Arizona.

Staff members present: Francis J. McNamara, director; William Hitz, general counsel; Alfred M. Nittle, counsel; Donald T. Appell, chief investigator; and Philip R. Manuel, investigator.

The CHAIRMAN. The subcommittee will please come to order.

There are enough seats for everybody. Please be seated. We welcome you. I again thank the audience for their fine cooperation.

Call your first witness, Mr. Appell.

Mr. APPELL. Mr. Chairman, I would like to recall to the stand Mr. James R. Jones.

The CHAIRMAN. The photographers will desist.

Proceed.

TESTIMONY OF JAMES ROBERTSON JONES, ACCOMPANIED BY COUNSEL, LESTER V. CHALMERS, JR.—Resumed

Mr. APPELL. Mr. Jones, yesterday you were asked to give the committee the benefit of your employment background. Is it not a fact that since 1960 you have not had what could be considered regular employment with any employer?

Mr. JONES. I respectfully decline to answer that question for the reason that I honestly feel my answer might tend to incriminate me

in violation of my rights as guaranteed me by amendments 5, 1, 4, and 14 of the Constitution of the United States of America.

Mr. APPELL. Isn't it a fact that your gross income for 1960 was \$3,872.98?

Mr. JONES. I respectfully decline to answer that question for the reason that I honestly feel my answer might tend to incriminate me in violation of my rights as guaranteed me by amendments 5, 1, 4, and 14 of the Constitution of the United States of America.

Mr. APPELL. Isn't it a fact that your gross income in 1961 was \$1,630.75?

Mr. JONES. I respectfully decline to answer that question for the reason that I honestly feel my answer might tend to incriminate me in violation of my rights as guaranteed me by amendments 5, 1, 4, and 14 of the Constitution of the United States of America.

Mr. APPELL. Isn't it a fact that your gross income for 1962 was \$3,579?

Mr. JONES. I respectfully decline to answer that question based on the grounds previously stated.

Mr. APPELL. Isn't it a fact that your gross income for 1963 was \$2,766.35?

Mr. JONES. I respectfully decline to answer that question based on grounds previously stated.

Mr. APPELL. Mr. Jones, in reporting a gross income in 1963 of \$2,766.35—

The CHAIRMAN. Do you mean on his income tax return?

Mr. APPELL. Yes, sir. —you reduced that income so that you came out on your tax return losing \$113.65 for the year. You deducted as an item of expense 30,000 miles of travel in your automobile at 9 cents a mile, or \$2,700. How much of that 30,000 miles was traveled by you as an official of the United Klans of America?

Mr. JONES. I respectfully decline to answer that question based on grounds previously stated.

Mr. APPELL. Isn't it a fact that in your 1964 income tax you reported a gross income from only one employer, the United Klans of America, in the amount of \$8,923.05?

Mr. JONES. I respectfully decline to answer that question based on grounds previously stated.

The CHAIRMAN. What year was that?

Mr. APPELL. 1964, Mr. Chairman.

(At this point Representative Ashbrook entered the hearing room.)

Mr. APPELL. The gross income was \$8,923.05, Mr. Chairman.

Mr. Jones, as deductions from that gross income, did you not deduct items which you were paid for from the bank accounts of the United Klans of America?

Mr. JONES. I respectfully decline to answer that question based on grounds previously stated.

(At this point Representative Pool entered the hearing room.)

The CHAIRMAN. Was the reported income of \$8,923 a true and correct gross income you received for 1964 from all sources?

Mr. JONES. I respectfully decline to answer that question based on grounds previously stated.

Mr. APPELL. Mr. Chairman, the staff would like to introduce as exhibits at this time—and, Mr. Chairman, with your permission, I would like to ask that all documents exhibited during the testimony of Mr. Jones be admitted in evidence in the sequence in which they are offered in order that I not ask on each individual occasion.

The CHAIRMAN. That leaves a loophole as to the order in which they are offered. Offer them in each instance. Why don't you say "as referred to"?

Mr. APPELL. As referred to, sir.

Mr. ASHBROOK. Mr. Chairman, could I ask a question?

The CHAIRMAN. Mr. Ashbrook?

Mr. ASHBROOK. The question up to now, Mr. Jones, was in regard to your return. The legislative pertinence and purpose deals with whether, in fact, you have received any money, expense money, as a Klan leader or a member of a Klan.

Have you, in fact, received expense money for the duties that you have as a Klan leader in your State?

Mr. JONES. I respectfully decline to answer that question based on grounds previously stated.

The CHAIRMAN. I might point out that the income tax return itself indicates that the total earnings or income reported was derived from the United Klans of America.

Did you not say that, Mr. Appell?

Mr. APPELL. The form itself Mr. Chairman, is an attachment to the return. It is entitled "Profit (Or Loss) From Business Or Profession." The first line states "James R. Jones." The second line, "A," states: "Principal business activity: United Klans of America; product, Service." Gross income, \$8,923.05.

Mr. Jones reduces this in order to pay tax on a net income of \$1,991.55 as follows: Robes, \$531.51; Interest, \$112.31; Telephone (toll calls), \$484.05; Electronic Repairs, \$314.98; Printing Literature, \$2,941.77; Auto Expense, Gas, Oil, Repairs et cetera, \$1,851.28; Depreciation, a 1964 truck which, incidentally, Mr. Chairman, we showed yesterday was paid from the United Klans of America bank account at Granite Quarry, North Carolina, depreciation, 1964 International truck, purchased 9-1-64, cost \$2,030, 3 years expectancy, \$215.60; Expense, Lodging Away From Home, \$480, or a total expense, the great bulk of which is paid from accounts in the name of the United Klans of America, in the amount of \$6,931.50.

The CHAIRMAN. The question now, Mr. Jones, is this, and it may be repetitious but it will be final: Is it not a fact that some, most, and practically all of these deductions that you claimed from your reported income you had already received from the United Klans of America or from some of your Klaverns?

Mr. JONES. I respectfully decline to answer that question based on grounds previously stated.

(Income Tax Returns for Years 1960-1964, inclusive, marked "James Jones Exhibits Nos. 11-A through 11-E," respectively, and retained in committee files.)

Mr. CHALMERS. Mr. Chairman, may I state to you, sir, and to the committee, that that is exactly the reason we did not bring any income tax returns up here, because we were well aware that those income tax

returns were available to the committee from another source and we knew that those income tax returns——

The CHAIRMAN. I am surprised at that coming from you, sir. Let me see that subpoena.

That is for the birds and that is for the press.

I ask your client or you. Do you say that we had the information called for in any more items that you know of?

Mr. CHALMERS. No, sir. Mr. Chairman: I am not saying that. No, sir.

The CHAIRMAN. And you refuse, or your client refused, to produce all of the items listed in the attachment to the subpoena based on alleged self-incrimination, which were rejected. Do you contend that all of the items called for would be self-incriminating?

Mr. CHALMERS. I cannot stipulate to that, sir.

The CHAIRMAN. I will ask him.

Is it your contention that you refuse to produce the items, the page of them, called for by the attachment to the subpoena because it would incriminate you if you produced them?

Mr. JONES. I respectfully decline to answer that question on the grounds previously stated.

The CHAIRMAN. Of course, if you wish to be selective about it, you may not.

Proceed.

Mr. APPELL. Mr. Jones, yesterday we went into your account or the account in the name of the United Klans of America maintained by the Wachovia Bank which showed considerable deposits starting with May 13, 1965.

In July, or toward the end of July of 1965, did you say to the Klansmen throughout North Carolina in a communication by you, and I quote:

Money coming in for people on the road is slow. The payroll for the Klan employees is \$600.00 per week, so in order to keep these people at work, we are going to have to have more support.

Please make payroll checks sent in, payable to United Klans of America, Wachovia Account or special account.

Isn't it a fact that between May 13th and June 28th you had placed into that account \$5,046.55, had paid out only \$750, and you are telling your membership that money is coming in slow?

Mr. JONES. I respectfully decline to answer that question based on grounds previously stated.

(Document marked "James Jones Exhibit No. 12" and retained in committee files.)

Mr. APPELL. Mr. Jones, I have in my hand a document, on the stationery of the United Klans of America——

Mr. POOL. On that last question you asked, what was your authority for that last statement?

Mr. APPELL. A statement by Mr. Jones sent out to Klaverns throughout the State of North Carolina.

Mr. POOL. Was that mailed to them?

Mr. APPELL. Yes, sir.

Mr. POOL. Do you have copies of it?

Mr. APPELL. We have excerpts, sir.

The CHAIRMAN. I suppose that will be offered in evidence.

Mr. APPELL. Yes, sir.

Mr. Jones, we have a document on the letterhead of the "United Klans of America, Inc., Knights of the Klu Klux Klan, P.O. Box 84, Whitnel, N.C." This is a form letter addressed "Dear Sir":

It has been brought to our attention that you are a sound believer in the "RIGHTS FOR THE WHITES".

We know that you would like to become a member of your local Klan, but due to your business or other reasons you cannot afford to. This is why we are writing you this letter of top secret.

We would like you to know that you can help fight for the freedom of all whites just as hundreds of others are doing, by making a donation to your local Klu Klux Klan unit. Your donation will be used to help make our community a better place to live.

Your donation will be of top secret and will not be revealed to anyone.

So whether making a donation or not, please place this letter in the enclosed self-addressed stamped envelope and mail today.

Thanking you for your donation and cooperation.

Please make your check payable [as this one says] to: Caldwell Improvement Assn. Thank you.

K K K K

Mr. Jones, were form letters similar to this sent to businessmen and other people throughout the State of North Carolina?

Mr. JONES. I respectfully decline to answer that question based on grounds previously stated.

(Document marked "James Jones Exhibit No. 13." See p. 1736.)

The CHAIRMAN. Mr. Appell, I happen to have in my office, and I don't know if you have it, a circular by, I think, the United Klans, although I will have to verify it, or perhaps it is Shelton's, indicating in plain print on the circular a similar appeal to this one, to the effect that donations would be income tax deductible. I notice in this particular one that is not included.

Mr. APPELL. No, sir; it is not. It is the committee's information that back in 1961 Calvin Craig, the Grand Dragon—

The CHAIRMAN. That is the one I am talking about.

Mr. APPELL. —Calvin Craig, the Grand Dragon of North Carolina, put out a circular in which he put on the bottom that it was tax exempt. He was advised by the Internal Revenue that it was not a tax exempt organization.

Mr. Shelton, through counsel, requested the Internal Revenue Service to forward him copies of the necessary forms in which an organization could be declared tax exempt, and he never executed the forms and the United Klans of America, Knights of the Ku Klux Klan, or under the name of the Invisible Empire, United Klans, Knights of the Ku Klux Klan of America, Inc., have never been granted tax exempt status by the United States Government.

Mr. WELTNER. Mr. Chairman, the record ought to show that Calvin Craig is the Grand Dragon of Georgia, not of North Carolina.

Mr. APPELL. I am sorry, sir.

The CHAIRMAN. That is the document I have reference to.

As I say, though, to make the record straight, this letter, at least, does not make that claim.

Mr. APPELL. It does not, Mr. Chairman.

JAMES JONES EXHIBIT No. 13

United Klans of America, Inc.
Knights of the Klu Klux Klan

P. O. BOX 84

WHITNEY, N. C.

Dear Sir:

It has been brought to our attention that you are a sound believer in the "RIGHTS FOR THE WHITES".

We know that you would like to become a member of your local Klan, but due to your business or other reasons you cannot afford to. This is why we are writing you this letter of top secret.

We would like you to know that you can help fight for the freedom of all whites just as hundreds of others are doing, by making a donation to your local Klu Klux Klan unit. Your donation will be used to help make our community a better place to live.

Your donation will be of top secret and will not be revealed to anyone.

So whether making a donation or not, please place this letter in the enclosed self-addressed stamped envelope and mail today.

Thanking you for your donation and cooperation.

Please make your check payable to:

Caldwell Improvement Assn. *f. S.*

Thank you.
K K K K

Mr. Chairman, I would like to have received in the record at this point, and I do not intend to go into the items, these documents. The staff has throwaways or leaflets announcing Klan rallies in the State of North Carolina starting Sunday, April 4, 1965, and running through one they expect to have this Saturday, October 23, at Supply, North Carolina.

The CHAIRMAN. Let me see one.

Mr. APPELL. Yes, sir. There is a total of 67 of these, all of which, of course, except the ones they haven't held, they have passed the plate at, they have sought donations of money. I would like to ask that these circulators be accepted into the record at this point in the order of their date.

The CHAIRMAN. It will be so ordered, and the document previously referred to, specifically, the letter just read, will be inserted into the record at the point where Mr. Appell described it.

(Documents marked "James Jones Exhibits Nos. 14-1 through 14-67," respectively, and retained in committee files.)

Mr. APPELL. The committee subpoenaed from the Suburban Printing Company, Lexington, North Carolina, invoices of printing work done by them during the years 1964 and 1965.

The CHAIRMAN. It is a fact, is it not, Mr. Jones, that these throwaways or leaflets were widely distributed in large numbers, in thousands?

Mr. JONES. I respectfully decline to answer that question based on grounds previously stated.

Mr. APPELL. One of the invoices submitted to the committee in accordance with this subpoena is an invoice—

The CHAIRMAN. What subpoena?

Mr. APPELL. A subpoena on the Suburban Printing Company of Lexington, North Carolina. — is dated October 8, 1965, billed to James R. Jones, Box 321, Granite Quarry, North Carolina. It shows that the order number was No. 527.

The CHAIRMAN. You don't have to describe it in great detail.

Mr. APPELL. It calls for 10,000 copies of "Widows Benevolent Fund Applications" at a cost of \$115.36.

Mr. Jones, who is the custodian of the Widows Benevolent Fund?

Mr. JONES. I respectfully decline to answer that question based on grounds previously stated.

(Document marked "James Jones Exhibit No. 15-A.")

Mr. APPELL. Mr. Chairman, I would like to ask that this form of application printed for Mr. Jones by the Suburban Printing Company be entered into the record at this point, and I would like to read from it. It is to be signed by the applicant. It says:

I, hereby, agree that to benefit from this plan I must stay in good standing within my own unit and must pay promptly the \$1.00 assessment fee in case of death of any member. I, hereby, agree that in case of my leaving the unit for any reason that I will forfeit any and all benefits and monies I may have paid in.

Under the "NAME of UNIT," there is an amount of \$999.95.

Is that the amount that would be paid to the widow or beneficiaries of a deceased Klansman in case of death out of this fund?

Mr. JONES. I respectfully decline to answer that question based on grounds previously stated.

(Document marked "James Jones Exhibit No. 15-B." Exhibits 15-A and 15-B follow:)



DATE **October 8, 1965**

**James R. Jones
Box 321
Granite Quarry, N. C.**

YOUR ORDER NO.

NO. 527

Net 30 Days

10,000	Widows Benevolent Fund Applications	Tax			
		<table border="0"> <tr> <td>\$112.00</td> </tr> <tr> <td><u>3.26</u></td> </tr> <tr> <td>\$115.26</td> </tr> </table>	\$112.00	<u>3.26</u>	\$115.26
\$112.00					
<u>3.26</u>					
\$115.26					
Large Enough To Serve You ... Small Enough To Appreciate Your Business					

JAMES JONES EXHIBIT NO. 15-B

APPLICATION TO **Widows Benevolent Fund**

NAME _____ DATE of BIRTH _____

ADDRESS _____

NAME of UNIT _____

AMOUNT \$999.95

Beneficiary _____ Relationship _____

I, hereby, agree that to benefit from this plan I must stay in good standing within my own unit and must pay promptly the \$1.00 assessment fee in case of death of any member. I, hereby, agree that in case of my leaving the unit for any reason that I will forfeit any and all benefits and monies I may have paid in.

OK BY _____

AGENT

SIGNATURE of APPLICANT

DATE of APPLICATION _____ UNIT NO. _____

The CHAIRMAN. That, I take it, is sort of an insurance policy for the widow of a Klansman who dies?

Mr. APPELL. Yes, sir.

The CHAIRMAN. And this monthly dues of \$1.00 is strictly an insurance payment and not, of course, the regular dues as a Klansman or for other paraphernalia they have to buy?

Mr. APPELL. Mr. Chairman, it is not a dollar a month as I read the application. In the case of the death of a Klansman, every member of the Klan who signs up in the Widows Benevolent Fund will be assessed a dollar, and a sum will then be paid to the widow or beneficiary.

I do not know the significance of the amount of \$999.95 that appears on this application. I was in hopes that Mr. Jones who ordered this printing and who is apparently the author of the plan would advise the committee of it and advise the committee as to whether or not he

had discussed this matter under the North Carolina State insurance laws.

The CHAIRMAN. Let me ask you this question: I happen to know from personal knowledge of a plan somewhat, I gather, along these lines, that the people who pay in and subsequently no longer belong to the organization must forfeit what was previously paid. That is number one.

Number two, I accept this statement that in case of death the widow, if her husband was still in good standing and had not forfeited, would receive \$999.95. But the hitch is that there are usually many more members than are needed to get \$999.95, so there is a huge profit on the side and the net result is that the more who die the more money they make.

I am not saying that is the plan, but I will ask you if that is substantially the plan, Mr. Jones.

Mr. JONES. I respectfully decline to answer that question based on grounds previously stated.

Mr. APPELL. Mr. Jones, did a—

The CHAIRMAN. Wait a moment. What is the name? Is that a corporate entity?

Mr. APPELL. Mr. Chairman, our only knowledge of this comes from the subpoena on the Suburban Printing Company.

The CHAIRMAN. What is the name of it?

Mr. APPELL. Widows Benevolent Fund.

The CHAIRMAN. Is there a corporation by that name, Mr. Jones?

Mr. JONES. I respectfully decline to answer that question based on grounds previously stated.

The CHAIRMAN. Whether it is a corporation or an entity in the form of a partnership, in which case a memorandum return would have to be made, a return by that Widows Benevolent Fund—an income tax return—I would judge would have to be filed. Do you know whether an income tax return has been regularly filed by the Widows Benevolent Fund?

Mr. JONES. I respectfully decline to answer that question based on grounds previously stated.

Mr. APPELL. Mr. Jones, in December of 1964, or late November 1964, did you, together with a few of your top leaders, decide that it would be a good idea to coerce the Klan leadership into presenting you with a 1964 Cadillac?

Mr. JONES. I respectfully decline to answer that question based on grounds previously stated.

The CHAIRMAN. Did you receive and accept that Cadillac?

Mr. JONES. I respectfully decline to answer that question based on the grounds previously stated.

Mr. APPELL. Mr. Chairman, with respect to the Cadillac, I would like to enter into the record at this point a document obtained through subpoena from the Farmers & Merchants Bank, which is a note signed by James Robertson Jones in the amount of \$5,868, calling for payment at the rate of \$163 a month for a 1964 Cadillac, serial number 64G074473, including radio, heater, spare tire, wheel, and all other accessories. "Witness my hand * * * the 15 day of December, 1964, James Robertson Jones."

The CHAIRMAN. Ask him if he signed it.

Mr. APPELL. I show you this document, Mr. Jones, and ask you if you did sign that note?

(Document handed to witness.)

Mr. JONES. I respectfully decline to answer that question based on the grounds previously stated.

(Document marked "James Jones Exhibit No. 16.")

Mr. APPELL. Mr. Jones, after the decision was made by your leadership to buy you this 1964 Cadillac, were Klans assessed sums of money for the purpose of paying off the note which you signed?

Mr. JONES. I respectfully decline to answer that question based on grounds previously stated.

Mr. APPELL. Mr. Chairman, the ledger sheet supplied by the Granite Quarry Bank [Farmers & Merchants Bank], showing the payments made, shows that between January 26, 1965, and September 29, 1965, there had been paid off on this automobile—well, the balance owed had been reduced to \$898.10.

The CHAIRMAN. Have any payments been made since September?

Mr. JONES. I respectfully decline to answer that question based on grounds previously stated.

(Document marked "James Jones Exhibit No. 17." Exhibits Nos. 16 and 17 appear on pp. 1742, 1743-1744.)

Mr. POOL. What was that total?

Mr. APPELL. The balance on September 29 owed on the car was \$898.10.

Mr. Jones, isn't it a fact that Mr. Kornegay made a report to the membership as the chairman of the car committee in which he claimed that:

Listed below are the latest amounts paid on Cadillac:

Norlina 185.00, Raleigh 175.00, Clinton 175.00, Enfield 175.00, Farmville 175.00, New Bern 175.00, Henderson 175.00, Dunn 175.00, Louisburg 175.00, Goldsboro 172.35, Jones County 150.00, Seven Springs 150.00, Blounts Creek 150.00, Washington 150.00, Wilson 150.00, Kinston 150.00, Ayden 150.00, La Grange 150.00, Deep Run 150.00, Pleasant Hill 150.00, Beulaville 150.00, Durham 128.00, Williamston 125.00, Tarboro 100.00, Rocky Mt. 100.00, Cherryville 90.00, Biscoe 60.00, Greensboro 59.00, Lexington 50.00, Sophia 50.00, Nashville 50.00—

The CHAIRMAN. Nashville, North Carolina?

Mr. APPELL. Yes, sir. [Continues reading:]

Burlington 45.00, Salisbury 42.00, Pittsboro 40.00, Sanford 26.00, Greenville 25.00, High Point 25.00, Atkinson 25.24, Roanoke Rapids 20.00, Wilmington 18.00, LADIES UNITS Wilmington 25.00, Salisbury 20.00, Raleigh 17.00, and Louisburg 15.00.

Total sent in \$4,522.59, total paid out \$4,522.59. Balance owed on car \$1,286.62.

This is signed "M. R. Kornegay, Chairman Car Committee."

"P.S. Please do not send the balance of your obligation on car to me, but to above party," referred to in the first paragraph as "Mrs. James R. Jones, P.O. Box 321, Granite Quarry."

I show you this document addressed to "Esteemed Klansmen" and ask you if this is a factual copy of a document sent out by Mr. Kornegay?

(Document handed to witness.)

Mr. JONES. I respectfully decline to answer that question based on grounds previously stated.

(Document marked "James Jones Exhibit No. 18-A" appears on p. 1746.)

The CHAIRMAN. Mr. Jones, I take it that these payments were re-

JAMES JONES EXHIBIT No. 16

NOTE

No

FARMERS & MERCHANTS BANK

\$ 5868.00 Granite Quarry, N. C., December 15, 1964

I, (We), James Robertson Jones of the County of Rowan

State of North Carolina am (are) jointly and severally, as principal(s), indebted to and promise to pay to the FARMERS & MERCHANTS BANK Granite Quarry, N. C., or order, the sum of FIVE THOUSAND EIGHT HUNDRED SIXTY EIGHT & NO/100-----

Dollars, payable in 36 installments of \$ 163.00 Dollars, the first payment to be on the 15th day of January, 1965, and a similar payment of \$ 163.00 to each month

Granite Quarry, N. C.

In the event the maker(s) hereof shall fail to pay any installment hereof, either of principal or interest, when the same shall become due and payable then and in that event, the full amount thereof shall immediately become due and payable.

This note is secured by a Chattel Mortgage of even date herewith upon the following described personal property to wit

1964 Cadillac, S#64G074473 including radio, heater, spare tire, wheel, and all other accessories.

No transfer, release, extension or Assignment of this note or any interest thereunder, or loss, injury or destruction of said property shall release the maker(s) hereof from his (their) obligation hereunder.

In the event maker(s) default(s) on any payment due on this note or fail(s) to comply with any condition of this contract or a proceeding in bankruptcy, receivership, insolvency, reorganization or liquidation of the maker(s) or his (their) property, or if payee deems the property in danger of misuse or confiscation, the full amount shall be immediately due and payable to the payee's option after the full amount may have become immediately due and payable as herebefore provided, of any installment or payment that is due or becomes due to affect the maker's obligation and/or the payee's rights hereunder with respect to any subsequent payments or default thereon.

Maker(s) shall keep said property free of all taxes, liens and encumbrances, shall not use same illegally, injure, or in any way shall not remove same from the state without the consent of the payee of this note, shall not transfer any interest in this note or said property. Any sum of money paid by the payee in payment or discharge of taxes, liens and encumbrances on said property shall be secured by and under this note. The proceeds of any insurance, whether paid by reason of loss, injury, theft, fire or otherwise shall be applied toward the replacement of the property or payment of this obligation, at the option of payee. Payee may insure said property against fire and theft or any accidental physical damage to the extent of the maker, payee or payee's assignee. Maker(s) agree(s) to pay the premium on insurance and that the due payment of said premiums shall be secured by this note.

Time and of the essence of this note, and if maker(s) default(s) in complying with the terms hereof, payee or any assignee or other officers of the law may take immediate possession of said property without demand or process (after default being unlawful), including any equipment, fixtures, contents, and for this purpose payee may enter up on the premises where said property may be and remove same. Such possession shall not affect payee's right to foreclose on the real estate payments made prior thereto. Payee may sell said property, so retained, at public or private sale, with or without notice to the maker, and the proceeds therefrom shall be applied to the payment of the balance hereof, with interest, but the payee shall be entitled to a lien for making, repairing and selling such property, including a reasonable attorney's fee. The balance hereof shall be applied to amount due, any such balance to be paid over to maker(s), in case of deficiency maker(s) shall pay the same with interest. Payee may take possession of any other property in the above described mortgageable of time of repossession, wherever such other property may be thereon and hold same temporarily for maker(s) without liability on the part of payee.

Payee shall have the right to enforce one or more remedies hereunder, successively or concurrently. Maker(s) hereby waive(s) the right to remove any legal action from the court of the state having jurisdiction and waive(s) all homestead and other insurable by exemption laws. Any provision of this note prohibited by law of any state shall as if said state be ineffective to the extent of such prohibition without invalidating the remaining provisions of this note.

Witness my (our) hand(s) and seal(s), this the 15 day of December, 1964

James Robertson Jones (SEAL) Address

(Street) (Town) (State)

(SEAL) Address

(Street) (Town) (State)

Witness

JAMES JONES EXHIBIT No. 17

MAKER
James Robertson Jones

DEALER ENDORSEMENT
 ENDORSEMENT PLAN

CODE
 DLR NO. 5575
 DATE OF NOTE 12-15-64
 AMOUNT OF NOTE \$5868.00

MAKER'S NAME AND ADDRESS
Box 221, Granite Quarry, N. C.

MATURITY
 12-15-67

MAKE AND MODEL
'64 Cadillac

DATE PURCHASED
 YR. MONTH

AMOUNT TO DEALER
 RATE
 DISC. REC.
 RESERVE

REMARKS
 3-26-2
 3412.00 (10-21-65)
 138.14 int
 2352.108
 2248.52
 261.00
 867.96 DC

PAYMENT SCHEDULE			BAL. AFTER PAYMENT	PAYMENTS MADE			NO.
DATE	AMOUNT DUE		DATE	AMOUNT	LATE CHGE.		
JAN 15 '65 Feb 1-65	163.00	5.705.00	JAN 26 '65	5,575 163.00		1	
FEB 15 '65	163.00	5.542.00	MAR 1 '65	5,575 163.00		2	
MAR 15 '65	163.00	5.379.00	MAR 30 '65	5,575 163.00		3	
APR 15 '65	163.00	5.216.00	APR 27 '65	5,575 163.00		4	
MAY 15 '65	163.00	5.053.00	JUN 1 '65	5,575 163.00		5	
JUN 15 '65	163.00	4.890.00	JUN 18 '65	5,575 163.00		6	
JUL 15 '65	163.00	4.727.00	JUL 15 '65	5,575 163.00		7	
AUG 15 '65	163.00	4.564.00	JUL 21 '65	5,575 163.00		8	
SEP 15 '65	163.00	4.401.00	JUL 21 '65	5,575 163.00		9	
OCT 15 '65	163.00	4.238.00	JUL 21 '65	5,575 163.00		10	
NOV 15 '65	163.00	4.075.00	JUL 21 '65	5,575 163.00		11	
DEC 15 '65	163.00	3.912.00	JUL 21 '65	5,575 163.00		12	
JAN 15 '66	163.00	3.749.00				13	
FEB 15 '66	163.00	3.586.00				14	
MAR 15 '66	163.00	3.423.00				15	
APR 15 '66	163.00	3.260.00				16	
MAY 15 '66	163.00	3.097.00				17	
JUN 15 '66	163.00	2.934.00					



JAMES JONES EXHIBIT No. 17—Continued

REMARKS

B

James Robertson Jones

PAYMENT SCHEDULE			BAL. AFTER PAYMENT	PAYMENTS MADE				NO.
DATE DUE	MEMO	AMOUNT DUE		DATE	ACCT. NO.	AMOUNT	DATE DUE	
JUL 15 '66		163.00	2,251.00					
AUG 15 '66		163.00	2,088.00					20
SEP 15 '66		163.00	1,925.00					21
OCT 15 '66		163.00	1,762.00					22
NOV 15 '66		163.00	1,599.00					23
DEC 15 '66		163.00	1,436.00	1,953.10	SEP 1 '67	5,5751,958.90		24
JAN 15 '67		163.00	1,273.00					25
FEB 15 '67		163.00	1,110.00					26
MAR 15 '67		163.00	947.00					27
APR 15 '67		163.00	784.00					28
MAY 15 '67		163.00	621.00					29
JUN 15 '67		163.00	458.00	899.10	SEP 29 '67	5,5751,055.00		30
JUL 15 '67		163.00	295.00					31
AUG 15 '67		163.00	132.00					32
SEP 15 '67		163.00	(31.00)					33
OCT 15 '67		163.00	(194.00)					34
NOV 15 '67		163.00	(357.00)					35
DEC 15 '67		163.00	(520.00)					36

mitted by the exalted cyclops, the heads of these various Klaverns; am I correct?

Mr. JONES. I respectfully decline to answer that question based on grounds previously stated.

The CHAIRMAN. It is my understanding that all of the Klaverns have, just like your higher unit, some sort of rules, constitution, and bylaws, requiring that expenditures be approved by someone.

Do you know whether these exalted cyclops just took it upon themselves, with your committee group, to make these payments, or whether they were approved by the general membership of these various Klaverns?

Mr. JONES. I respectfully decline to answer that question based on grounds previously stated.

The CHAIRMAN. Do you know whether the general membership has ever known anything about this transaction?

Mr. JONES. I respectfully decline to answer that question based on grounds previously stated.

Mr. APPELL. Mr. Chairman, this letter from which I have just read, addressed to the "Esteemed Klansmen," accompanied a letter addressed to the "Esteemed Klansmen" signed by Mr. James R. Jones as the Grand Dragon, North Carolina.

He says, and I quote from just one or two paragraphs, although I ask that the entire document and the one previous be placed in the record at this point, "Mr. M. R. Kornegay"—

The CHAIRMAN. Mr. Appell, you will have to have a general pattern. It will be confusing if you offer some. All those you talk about will be received in evidence as you describe them. Either that or you will have to offer each one.

Mr. APPELL. I prefer your previous suggestion.

I will quote from two paragraphs of the letter which accompanied the Kornegay letter which I just read. This is signed by James R. Jones, Grand Dragon, North Carolina:

Mr. M. R. Kornegay is no longer with us. He is now Grand Dragon of Virginia, being Grand Dragon of Virginis [sic] he has all the problems he can handle.

It was a pleasure having him in the State of North Carolina but please refrain from bothering him with North Carolina problems.

Money on the car from now on will be made out to Mrs. James R. Jones and sent to the State Office. Enclosed you will find a letter showing the amount each unit has sent in, if this is not right please let me know.

As soon as time permits I will send out the letter on the State meeting. If I can be of any help don't hesitate to call.

Yours for God & Country.

/s/ James R. Jones.

And following this is a note: "P.S. Syble"—and this is the name of Mr. Jones' wife—

The CHAIRMAN. I don't think you ought to question him about her.

Mr. APPELL. Following the "P.S." which I will not go into on your instruction, Mr. Chairman, there is a listing of dates to remember: September 8, Henderson, and there is an additional listing of locations and dates where rallies are to be held.

Mr. Chairman, these "Esteemed Klansmen" letters are not dated.

(Document marked "James Jones Exhibit No. 18-B" appears on p. 1747.)

JAMES JONES EXHIBIT No. 18-A

Esteemed Klansmen:

I would like to convey to you my sincere appreciation for the work and money put into this endeavor for your Grand Dragon. Please look at your unit and the amount paid and if it is not up to what you know is your fair share, please send in the balance. Send all money for Cadillac to: Mrs. James R. Jones, P. O. Box 321, Granite Quarry.

Also, I would like to take this opportunity to say that I have truly enjoyed meeting with you and being a part of this fine organization. I know that with the type of Klanspeople we have here that North Carolina will certainly go forward on this hard road back to a great America. May you forever give your leaders your unwavering loyalty and full support, so they may do a better job.

HANG TOGETHER OR HANG ALONE.

A stage driver passed o'er a trail one day
 Past meadow and woodland he took his way
 His long whip snapping with unerring aim,
 whether standing or moving, 'twas just the same.
 A horsefly fell to his snaky lash
 Shot out as sure as the lightning's flash;
 A grasshopper here, a butterfly there,
 Fell to his aim, as they winged the air.
 A hornet's nest hung on a limb nearby,-
 But the driver passed that carefully by.
 "How come?" the passengers cried surprised.
 "Why", answered he, "they're organized!"
 Horsefly, butterfly, grasshopper, too
 Their fate is a lesson and warning to you,
 You will flutter and fall like the hoppers and flies,
 Unless, like the hornets, you're organized!

Listed below are the latest amounts paid on Cadillac:

Norlina 185.00, Raleigh 175.00, Giltton 175.00, Enfield 175.00, Farmville 175.00, New Bern 175.00, Henderson 175.00, Dunn 175.00, Louisburg 175.00, Goldsboro 172.35, Jones Co. 150.00, Seven Springs 150.00, Blounts Creek 150.00, Washington 150.00, Wilson 150.00, Kinston 150.00, Ayden 150.00, LaGrange 150.00, Deep Run 150.00, Pleasant Hill 150.00, Beulaville 130.00, Durham 128.00, Williamston 125.00, Tarboro 100.00, Rocky Mt. 100.00, Cherryville 90.00, Biscoe 60.00, Greensboro 59.00, Lexington 50.00, Sophia 50.00, Nashville 50.00, Burlington 45.00, Salisbury 42.00, Pittsboro 40.00, Sanford 26.00, Greenville 25.00, High Point 25.00, Atkinson 25.24, Roanoke Rapids 20.00, Wilmington 18.00, (LADIES UNITS) Wilmington 25.00, Salisbury 20.00, Raleigh 17.00, and Louisburg 15.00.

Total sent in \$ 4,522.59, total paid out \$ 4,522.59. Balance owed on car \$ 1,286.62.

M. R. Kornegay
 Chairman Car Committee

P. S. Please do not send the balance of your obligation on car to me, but to above party.

JAMES JONES EXHIBIT NO. 18-B

Esteemed Klansmen,

I would like to take this opportunity to thank you for the fine cooperation we have had in July and August and hope to get the same cooperation at the rallies in September and October. The next 90 days in North Carolina may prove to be rough, so let me ask you to conduct yourself as the fine people I know you are.

The first Sunday in October for the people in the Second Congressional District at 3 P. M. in Enfield, N. C. over the Fire Department there will be a Province meeting to elect new Province officers in the Second Congressional District. All units are expected to have (10) ten men from each unit present as voting delegates.

The second Sunday in October, 3rd Congressional District will be expected to have the same amount of delegates at the Klavern Hall in Dunn to elect new Province Officers and Titan widows benevolent fund application forms. If you need them write the State office. We want to get them in as soon as possible. They must be in by October 15th or it will not be able to be put in effect.

Mr. M. R. Kornegay is no longer with us. He is now Grand Dragon of Virginia, being Grand Dragon of Virginia he has all the problems he can handle.

It was a pleasure having him in the State of North Carolina but please refrain from bothering him with North Carolina problems.

Money on the car from now on will be made out to Mrs. James R. Jones and sent to the State Office. Enclosed you will find a letter showing the amount each unit has sent in, if this is not right please let me know.

As soon as time permits I will send out the letter on the State meeting. If I can be of any help don't hesitate to call.

Yours for God & Country

James R. Jones

James R. Jones
Grand Dragon
North Carolina

P. S. Syble said to ask each of you to get on the ball and send in the stamps. We have about 400 books at present. This is still a long way from 2,000. Thanks.

DATES TO REMEMBER:

September 8 - Henderson	9 - Franklin County
10 - Washington	11 - Williamston
12 - Pamlico County	13 - Plymouth
14 - Cove City	15 - Aurora
16 - Swan Quarter	17 - Durham
18 - Winston	19 - Boiling Springs
20 - Hemstead	21 - Whiteville
22 - Supply	23 - Wilmington
24 - Apex	25 - Clayton
26 - Raleigh	

September 27, 28, 29 and 30 and October 1 - Mountains

Rally dates to follow.

The CHAIRMAN. Does this letter purport to have been sent to the general membership or to the exalted cyclops of the Klaverns? I want the record to be straight on that. I didn't mean to be putting words in his mouth when I asked a question. I want information.

Mr. APPELL. Mr. Chairman, only Mr. Jones can answer to the full extent of the distribution of the "Esteemed Klansmen" letter.

The CHAIRMAN. I asked him. Well, the document will speak for itself.

Mr. APPELL. Yes, sir. The point I wish to make is that giving notice to the membership of a rally to be held on September 8th, this document had to be mailed prior to September 8th and, therefore, Mr. Kornegay's report that \$4,522.59 had been sent in and the total paid out was \$4,522.59 does not jibe with the statement of payments as received by us from the bank.

If we total up the amounts paid and the dates upon which they were paid, there was only \$3,914.90 paid into this fund prior to September 1 of 1965.

The CHAIRMAN. I will ask this direct question: Mr. Jones, did you pocket or keep or use personally these car payments, which obviously had been agreed upon, instead of applying them all to your note?

Mr. JONES. I respectfully decline to answer that question based on grounds previously stated.

(At this point Mr. Buchanan left the hearing room.)

Mr. APPELL. Mr. Jones, I ask you as a fact if you also own a 1964 Dodge station wagon?

Mr. JONES. I respectfully decline to answer that question based on grounds previously stated.

Mr. APPELL. Mr. Chairman, the Department of Motor Vehicles of the State of North Carolina, Raleigh, North Carolina, in response to an inquiry made of them, has sent us a letter.

I would like to read two paragraphs:

License DR-6195 was issued to James Robertson Jones, Granite Quarry, North Carolina covering 1964 Dodge Station Wagon, serial 7542584426. Mr. Jones purchased this vehicle new from Ray Bandy, Inc., of Rocky Mount, North Carolina. North Carolina title 6413226 was mailed to lien holder, Farmers and Merchants Bank, Granite Quarry as they hold \$2150.00 chattel mortgage dated April 22, 1964. Date of purchase from Ray Bandy, Inc. by Mr. Jones is April 23, 1964.

License DR-6196 was issued to James Robertson Jones, Box 321, Granite Quarry, North Carolina covering 1964 Cadillac Tudor, serial 64G074473. Mr. Jones purchased this vehicle used from Charles Lindbergh Martin of Raleigh, North Carolina on December 17, 1964. North Carolina title 6551686A was mailed to lien holder, Farmers and Merchants Bank, Granite Quarry as they hold \$5868.00 chattel mortgage dated December 17, 1964.

Mr. Jones, the ledger card—

The CHAIRMAN. Let's ask him about that.

Mr. Jones, I noticed when Mr. Appell was reading this letter from the most reliable authority we know to inquire from, namely the Motor Vehicle Bureau of North Carolina, you leaned to your counsel and smiled.

I ask you whether this letter is correct? I want to ask you another question after that.

Mr. JONES. I respectfully decline to answer that question based on the grounds previously stated.

(Document marked "James Jones Exhibit No. 19-A" and retained in committee files.)

(At this point Mr. Buchanan returned to the hearing room.)

The CHAIRMAN. We are giving you an opportunity to affirm or deny documentary evidence obtained in good faith and from most reliable sources. We did the same thing to Mr. Shelton yesterday and then he blabbered something to the press and TV about we were wrong in one instance or something.

Do you intend after leaving the stand, since you are smiling to your counsel, to say you caught us in one instance?

Mr. JONES. I respectfully decline to answer that question based on grounds previously stated.

The CHAIRMAN. By the way, Mr. Appell now tells me and refreshes my memory with reference to an item of \$2,135 which Mr. Shelton talked about outside the room, saying that our counsel knew all along that that was from an insurance policy from which he collected accident benefits, that nothing of the kind is in the record.

What Mr. Appell questioned Mr. Shelton about was very proper. In effect, Mr. Appell said to Mr. Shelton "I notice that there is an item, a deposit in your account, of \$2,135. What is the source of that money?"

Mr. Appell didn't say it was from any evil source. He just asked him a question.

Mr. APPELL. Mr. Jones, according to the ledger card maintained by the Farmers & Merchants Bank, Granite Quarry, North Carolina, relative to the 1964 Dodge, it shows that the first payment on this car in the amount of \$73.75 was made in May 1964.

The CHAIRMAN. You are talking about the Dodge?

Mr. APPELL. Yes, sir; the Dodge.

We asked you yesterday whether or not the tax which you received from Klaverns, and we exhibited to you at least one document to show that tax from Klaverns was placed into the bank account in the name of Mr. and Mrs. James R. Jones. Was not payments for this 1964 Dodge made from this account into which tax from Klaverns was received?

Mr. JONES. I respectfully decline to answer that question based on grounds previously stated.

(Ledger sheet marked "James Jones Exhibit No. 19-B" appear on pp. 1750, 1751.)

(At this point Mr. Weltner left the hearing room.)

Mr. APPELL. I hand you six checks totaling \$442.50.

Mr. Jones, an analysis of the account shows—

The CHAIRMAN. You showed him six checks. Ask him a question.

Mr. APPELL. Do these checks properly reflect, as they state on their face, payments from your account to the Farmers & Merchants Bank in the amount of \$73.75? That is from the account to which the Klan tax is deposited.

The CHAIRMAN. It is a Klan account?

Mr. APPELL. But it is in the name of Mr. and Mrs. James R. Jones.

Mr. JONES. I respectfully decline to answer that question based on grounds previously stated.

JAMES JONES EXHIBIT No. 19-B

MAKER
James Robertson Jones

DATE OF ISSUE: 4-24-64
 DUE DATE: 10-20-66
 AMOUNT OF NOTE: \$2212.50

Box 321, Granite Quarry, N. C.
 1964 Dodge

DATE	BALANCE	PAYMENT	PAYMENTS MADE			NO
			PERCENTAGE	AMOUNT	DATE CHG	
	2212.50					
MAY 20'64	73.75	2138.75	MAY 19'64	5,033	73.75	1
JUN 20'64	73.75	2065.00	JUN 15'64	5,033	73.75	2
JUL 20'64	73.75	1,991.25	JUL 17'64	5,033	73.75	3
AUG 20'64	73.75	1,917.50	AUG 17'64	5,033	73.75	4
SEP 20'64	73.75	1,843.75	SEP 22'64	5,033	73.75	5
OCT 20'64	73.75	1,770.00	OCT 28'64	5,033	73.75	6
NOV 20'64	73.75	1,696.25	NOV 31'64	5,033	73.75	7
DEC 20'64	73.75	1,622.50	NOV 31'64	5,033	73.75	8
JAN 20'65	73.75	1,548.75				9
FEB 20'65	73.75	1,475.00	JAN 16'65	5,033	147.50	10
MAR 20'65	73.75	1,401.25	MAR 13'65	5,033	73.75	11
APR 20'65	73.75	1,327.50	APR 22'65	5,033	73.75	12
MAY 20'65	73.75	1,253.75	MAY 26'65	5,033	73.75	13
JUN 20'65	73.75	1,180.00	JUN 26'65	5,033	73.75	14
JUL 20'65	73.75	1,106.25	JUL 20'65	5,033	73.75	15
AUG 20'65	73.75	1,032.50	AUG 25'65	5,033	73.75	16
SEP 20'65	73.75	958.75	SEP 30'65	5,033	73.75	17
OCT 20'65	73.75	885.00				18



73.75 811.25

INSTALLMENT
 LOAN LEDGER

(Documents marked "James Jones Exhibit No. 20." One of said checks follows; balance retained in committee files.)

JAMES JONES EXHIBIT NO. 20

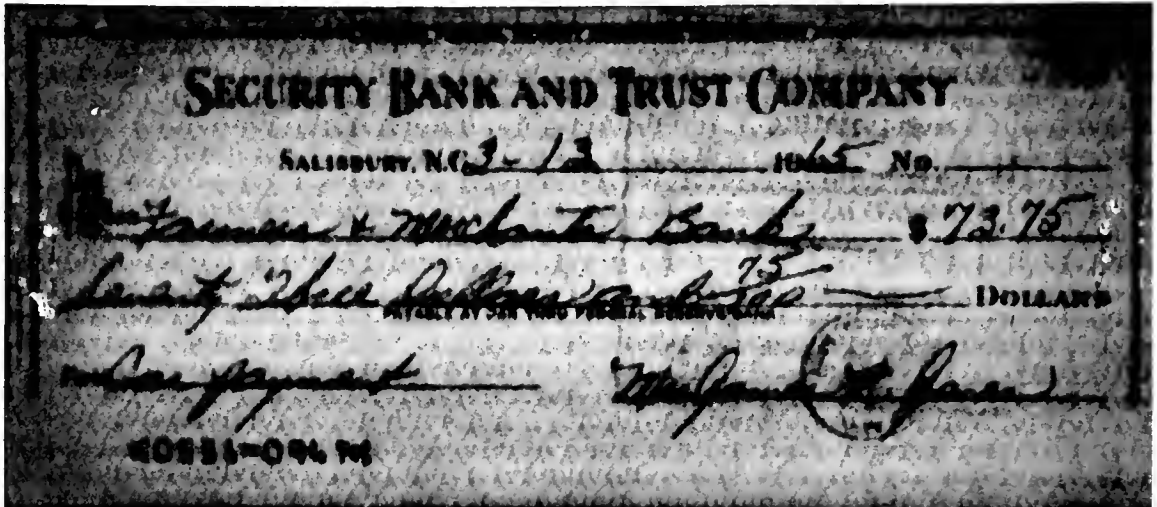

The CHAIRMAN. In other words, as I follow the questioning, the point is that Klan dues money was used to pay on the account of that Dodge?

Mr. APPELL. Yes, sir.

The CHAIRMAN. Is that correct, Mr. Jones?

Mr. JONES. I respectfully decline to answer that question based on grounds previously stated.

The CHAIRMAN. If you used Klan money to pay that, that would be just as much income to you as anything else, reportable on your income tax return. That is why I asked the question.

Mr. JONES. I respectfully—

The CHAIRMAN. I didn't ask another question.

Mr. APPELL. Mr. Jones, an analysis of the account of Mr. and Mrs. James R. Jones, together with the UKA account at the Farmers & Merchants Bank and the Wachovia Bank in Salisbury, failed to reflect payments by check, many payments by check, made on this automobile.

Did you on any occasion use cash which you received in your position as Grand Dragon to make some of these payments?

Mr. JONES. I respectfully decline to answer that question based on grounds previously stated.

Mr. APPELL. Mr. Jones, are you—

The CHAIRMAN. I should have asked and I now ask about the checks exhibited, having been proved to come from Klan sources, did the membership authorize you to use that Klan money?

Mr. JONES. I respectfully decline to answer the question based on grounds previously stated.

Mr. APPELL. Mr. Jones, has the governing body of the State of North Carolina ever fixed for you a salary in your position as Grand Dragon?

Mr. JONES. I respectfully decline to answer that question based on grounds previously stated.

The CHAIRMAN. Now, Mr. Jones, I might as well ask you this question: Do you honestly believe that your answer to this last question and to all other questions previously asked might tend to incriminate you?

Mr. JONES. I respectfully decline to answer that question for the reason that I honestly feel my answer might tend to incriminate me in violation of my rights as guaranteed to me by amendments 5, 1, 4, and 14 of the Constitution of the United States of America.

The CHAIRMAN. The right to invoke the privilege of the fifth amendment is based on an honest fear of self-incrimination or criminal prosecution.

Now I think also in fairness to you I should point out this, but first I will ask a question.

Do you intend, after you leave this stand, to issue a statement explaining and answering some of these very questions we are talking about, that we have asked you?

Mr. JONES. I respectfully decline to answer that question for the reason that I honestly feel my answer might tend to incriminate me in violation of my rights as guaranteed me by amendments 5, 1, 4, and 14 of the Constitution of the United States of America.

The CHAIRMAN. I do hope you honestly so believe because, having invoked the fifth amendment on all of these questions, if you do speak out and answer some of them, or perhaps question the veracity or integrity of some of these questions, that would pretty well destroy your honesty in the invocation and might result, and will result, I think, as we consider it, in our questioning Mr. Shelton when he returns about what he did say outside, after he had the opportunity to answer questions.

I am not in the least questioning your right to make any statement you want to make. I am talking about evidence before this committee. I am testing your honesty in the invocation. That is all.

Any statement you wish to make outside this room, go to it. But I do admonish you of the situation it places you in.

Proceed.

Mr. APPELL. Mr. Jones, section 4 of the attachment to your subpoena which was made a part of the subpoena, called upon you to produce certain books and records relating to an insurance contract between the Capital City Restoration Association and the International Life and Accident Insurance Company.

What is the Capital City Restoration Association?

Mr. JONES. I respectfully decline to answer that question based on grounds previously stated.

Mr. APPELL. Isn't it a fact that it is a cover name of a Klavern of the United Klans of America?

Mr. JONES. I respectfully decline to answer that question based on grounds previously stated.

Mr. APPELL. Mr. Jones, I hand you a series of checks, some made payable to cash, some made payable to the United Klans of America, and some made payable to James R. Jones, and I ask you if it isn't a fact that these checks reflect that the payments were for the stated

purpose for which drawn, tax, and if the imprint of the check doesn't show the Capital City Restoration Association and if this does not establish the fact that it is a cover for a Klan unit?

(Witness confers with counsel.)

Mr. JONES. I respectfully decline to answer that question based on grounds previously stated.

(Documents marked "James Jones Exhibit No. 21" and retained in committee files.)

Mr. APPELL. I show you another group of checks written by the Capital City Restoration Association, and invite your specific attention to the first one, dated October 26, 1964, in the amount of \$16.75, made payable to the Alabama Rescue Service, and invite your attention to the purpose for which drawn, which is set forth on this check as "Imperial Tax."

I ask you if this does not establish that this is a cover for a Klan unit?

(Documents handed to witness.)

(Witness confers with counsel.)

The CHAIRMAN. What do you mean by cover? A front?

Mr. APPELL. A front.

The CHAIRMAN. In other words, the invisibility beyond the invisible.

Mr. JONES. I respectfully decline to answer that question based on grounds previously stated.

(Documents marked "James Jones Exhibit No. 22." Check of October 26, 1964, follows; balance retained in committee files.)

JAMES JONES EXHIBIT NO. 22

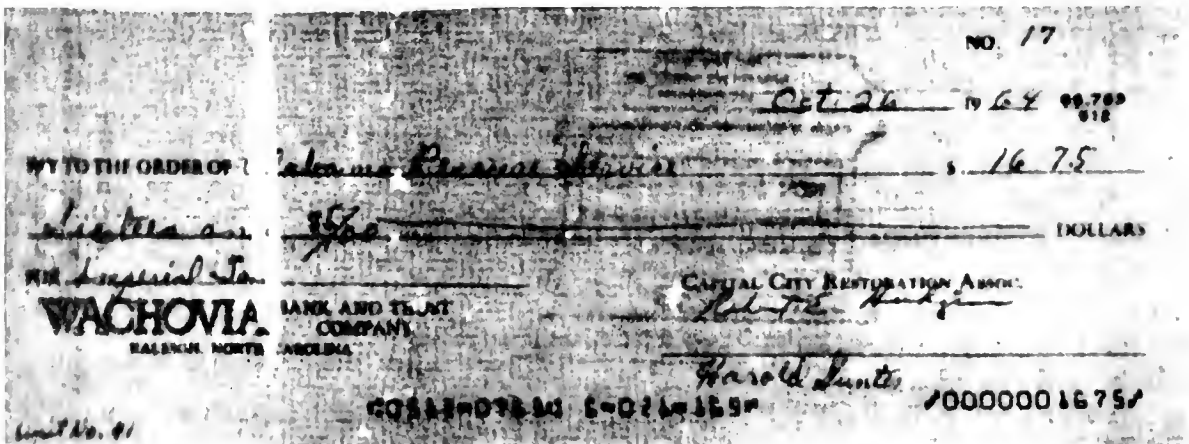

Mr. APPELL. Dealing further with the Capital City Restoration Association, did the Klan, using the Capital City Restoration Association, enter into a contract with the International Life and Accident Insurance Company to write medical policies, hospital and medical policies, for Klansmen throughout the State of North Carolina?

(At this point Mr. Weltner returned to the hearing room.)

Mr. JONES. I respectfully decline to answer that question based on grounds previously stated.

The CHAIRMAN. Mr. Jones, I don't want the question to imply the illegality, per se, of an insurance plan within an organization.

We simply want the facts and what the insurance plan is, whether it is an entity, who is deriving the profits and so on. That is the purpose of the question.

Mr. APPELL. Mr. Jones, at the time this plan was being sold to the Klansmen throughout North Carolina, was it held out by you and others that the premium paid on the first, the first month's premium, would be used in part to pay your expenses traveling throughout the State, and that a portion of this would be returned to the Klavern for its expenses?

Mr. JONES. I respectfully decline to answer that question based on grounds previously stated.

Mr. APPELL. Mr. Chairman, I have a letter which says at the top, "TO BE READ ON ALL KLAVERN HALL FLOORS":

TO ALL KLANSMEN:

As you know we have a group hospital plan for Klansmen of North Carolina. This is a first, for it is practically impossible to get a company to recognize our group and give us this VAST coverage at the price we are paying. On April 6, 1965 (for one week) we paid out a total of \$1,400.25 for claims to our Brother Klansmen.

I would like to interrupt the reading right here, Mr. Jones, and ask you isn't it a fact that you did not pay out that amount of money during that week, and that you knew it?

Mr. JONES. I respectfully decline to answer that question based on grounds previously stated.

Mr. APPELL. [Continues reading:]

The total paid out so far, since the beginning of this Group Policy, is a tremendous sum. This money has gone to help our Klansmen who, if they did NOT have this plan, would have had to pay the hospital bills themselves. In order to keep this program as it is, we must hold it in line with claims. Therefore we must have immediately 400 NEW applicants to add to this group in the next two weeks. We must also keep the ones that have already participated in this plan, so be sure to keep yours paid.

We are sorry to say we have only about 250 in this plan out of our whole North Carolina Group. Of the original 250, only 111 are paying.

Mr. Chairman, I will skip rather than read the whole thing and conclude with:

Enclosed is information sheets.

Kligrapp: Get the names from your unit and send to me of the ones that do not have it now, but will take it now.

Send reply on Hospital Insurance to: P.O. Box 9183, Raleigh, North Carolina.
Yours for God and Country.

/s/ James R. Jones,
JAMES R. JONES, *Grand Dragon*
North Carolina U.K.A.

P.S. We must build this group to 500 paying members. Help us save this plan.

The CHAIRMAN. Mr. Jones, at this point I ask you this question: A number of documents have been offered in evidence, signed by yourself, calling yourself the Grand Dragon of North Carolina. Are you the Grand Dragon of North Carolina?

Mr. JONES. I respectfully decline to answer that question based on grounds previously stated.

Mr. APPELL. The accompanying document, Mr. Chairman, is headed "An Insurance Program Designed For Capital City Restoration Association And Affiliated Groups In North Carolina."

I hand you these, Mr. Jones, to ask whether this is a copy of a document that you sent out, together with the enclosure?

(Witness confers with counsel.)

Mr. JONES. I respectfully decline to answer that question based on grounds previously stated.

(Documents marked "James Jones Exhibit No. 23" follow:)

JAMES JONES EXHIBIT No. 23

TO BE READ ON ALL KLAVERN HALL FLOORS

TO ALL KLANSMEN:

As you know we have a group hospital plan for Klansmen of North Carolina.

This is a first, for it is practically impossible to get a company to recognize our group and give us this VAST coverage at the price we are paying. On April 6, 1965 (for one week) we paid out a total of \$1,400.25 for claims to our Brother Klansmen. The total paid out so far, since the beginning of this Group Policy, is a tremendous sum. This money has gone to help our Klansmen who, if they did NOT have this plan, would have had to pay the hospital bills themselves. In order to keep this program as it is, we must hold it in line with claims. Therefore we must have immediately 400 NEW applicants to add to this group in the next two weeks. We must also keep the ones that have already participated in this plan, so be sure to keep yours paid.

We are sorry to say we have only about 250 in this plan out of our whole North Carolina Group. Of the original 250, only 111 are paying.

Since we pay in to a Company LESS than we receive, you can readily see the position we find ourselves in.

I could not get any hospital insurance before we got this through and so were a lot of other Klansmen in the same boat with me. Now that we have this, and see the benefit it has already been to our local units, are we going to continue to support people that do not support us or are we going to join this hospital plan and HELP people that helps us.

Our North Carolina Group is growing by leaps and bounds and with it we must help keep the ONE COMPANY that is on our side to stay with us.

Some few of our units have joined with a majority of the unit and some DO NOT have a SINGLE ONE from their unit in this Hospital Plan.

It is most urgent and important, that we take this under advisement and support this group plan NOW by getting your unit covered.

I went out on a limb from the first by promising this company 1000 members and this certainly would not be but a small percentage of our number of Klansmen. As you can see NO ONE will support us unless we support them.

Klansmen, are we going to lose this group plan or are we going to support and keep a White Man's Company behind us?

This plan will pay even if you have another plan that pays also.

Enclosed is information sheets.

Kligrapp: Get the names from your unit and send to me of the ones that do not have it now, but will take it now.

Send reply on Hospital Insurance to: P.O. Box 9183, Raleigh, North Carolina.

Yours for God and Country

James R. Jones

JAMES R. JONES, *Grand Dragon,*

North Carolina U.K.A.

P.S.—We must build this group to 500 paying members. Help us save this plan.

AN INSURANCE PROGRAM

DESIGNED FOR

CAPITAL CITY RESTORATION ASSOCIATION AND AFFILIATED GROUPS IN
NORTH CAROLINAMEMBERSHIP IN ANY OF THESE ORGANIZATIONS ENTITLES YOU TO THE FOLLOWING
ADVANTAGES UNDER THIS SPECIAL HEALTH INSURANCE PROGRAM

1. Reduced premium rates.
2. Pre-existing health conditions covered immediately 30 days from issue date.
3. No waiting periods (except maternity—10 months).
4. No reduction in benefits if you have other insurance.
5. Good anywhere in the world.
6. Mental and nervous disorders are covered.
7. A grace period of 31 days allowed for paying renewal premiums.
8. Surgical benefits paid in or out of hospital.
9. First aid benefit paid when treatment is rendered in hospital or at the doctor's office.
10. Any member leaving group will be allowed to continue same policy by paying future premiums quarterly, semiannually, or annually.
11. Dependent children will be deleted as a result of marriage or attaining the age of 18 years, but at such time they will be permitted to convert to an individual plan with the same rates as the group and by paying premiums as outlined in number 10.

BENEFITS PROVIDED UNDER THIS PLAN ARE AS FOLLOWS

Hospital room & board.—\$12.00 per day up to 9 days for each accident or sickness. No Limit to Number of Times Used Each Year.

Hospital extras.—Up to \$120.00 for each sickness or accident—includes charges for operating room, drugs, dressings, laboratory, X-rays, etc.

Surgical fees.—\$250.00 schedule of allowances included in policy.

Maternity.—\$120.00 hospital charges allowance—plus \$50.00 delivery fee for normal birth; \$100.00 caesarean section; \$25.00 miscarriage.

First aid benefit.—Up to \$36.00 for treatment of injuries within 24 hours, after accident, if not covered under any other part of policy. Treatment can be rendered in hospital or doctor's office.

MONTHLY PREMIUM RATES, AGE GROUPS 16 TO 59

Family.—\$14.50 (includes all unmarried children under eighteen years of age).

Husband and wife only.—\$9.65.

Male only.—\$3.55.

Female only.—\$5.25 (excludes maternity).

Male or female ages 60 to 69.—6.10.

Proposal Prepared and Submitted by M. R. Kornegay.

The CHAIRMAN. Mr. Jones, I said awhile ago that insurance programs, benefits, by many organizations are duly recorded as completely legal and certainly in vogue and certainly exercised. Most of them, so far as I know, have very noble causes. Here is an opportunity really to talk about this program. Especially, you have an opportunity to say that, as the document you sign states, you are making no profits.

Didn't that passage in there say that no profits were made, Mr. Appell?

Mr. APPELL. I didn't read that part.

The CHAIRMAN. I misunderstood you, then. There was a general statement at the very beginning.

Is it in there?

Mr. APPELL. I don't see it, sir.

The CHAIRMAN. I thought you indicated that it said something about "We don't take in more than we disburse" or something.

Mr. APPELL. What it said was "we must hold it in line with the claims. Therefore we must have immediately 400 NEW applicants * * *."

The CHAIRMAN. Before that.

Mr. APPELL. "This money has gone to help our Klansmen who, if they did NOT have this plan, would have had to pay the hospital bills themselves."

The CHAIRMAN. Before that.

Mr. APPELL. I will start from the first:

This is a first, for it is practically impossible to get a company to recognize our group and give us this VAST coverage at the price we are paying. On April 6, 1965 (for one week) we paid out a total of \$1,400.25 for claims to our Brother Klansmen. The total paid out so far—

The CHAIRMAN. Let's see the document.

Mr. APPELL. Yes, sir.

The CHAIRMAN. [Reading:]

This is a first, for it is practically impossible to get a company to recognize our group and give us this VAST coverage at the price we are paying.

Well, it didn't say what I thought it said.

But there is an opportunity, nevertheless, Mr. Jones, for you to say is this insurance plan self-sustaining only, or are profits made from it?

Mr. JONES. I respectfully decline to answer that question based on grounds previously stated.

The CHAIRMAN. Proceed.

I was wrong. It did not say what I thought it said. I am glad I caught it.

Mr. APPELL. Mr. Jones, the committee has obtained from the Insurance Department of the State of North Carolina all of the applications executed by Klansmen under this program, and while the insurance coverage called for Capital City Restoration Association and affiliated groups, we have pulled from the entire number of applications some which relate to affiliated groups.

I wish to ask you as I name the affiliated group whether you, as the Grand Dragon of North Carolina, knew this affiliated group to be, like the Capital City Restoration Association, a unit of the Klan.

Harnett County Improvement Association, P.O. Box 48, Dunn, North Carolina?

Mr. JONES. I respectfully decline to answer that question based on grounds previously stated.

(Document marked "James Jones Exhibit No. 24-A." See p. 1780.)

The CHAIRMAN. Isn't it a fact, Mr. Jones, that you have in the State of North Carolina as in all the States that I know of, large numbers of cover groups, front groups, such as gun clubs and others of that type, that are actually high-sounding names to use to camouflage, or as a matter of security, in the use of these names, when, in fact, they are Klan groups and Klaverns. Isn't that true?

Mr. JONES. I respectfully decline to answer that question based on the grounds previously stated.

The CHAIRMAN. And I say our investigative work indicates that that is definitely true. Isn't it true?

Mr. JONES. I respectfully decline to answer that question based on grounds previously stated.

Mr. APPELL. Another of the affiliated groups listed on one of the applications for hospital-surgical coverage is the New Hanover Improvement Association, Inc., P.O. Box 1104, Wilmington, North Carolina.

Is this Improvement Association one of your Klan units?

Mr. JONES. I respectfully decline to answer that question based on the grounds previously stated.

(Document marked "James Jones Exhibit No. 24-B." See p. 1781.)

Mr. APPELL. Within the New Hanover County Improvement Association, do you possess any knowledge as to whether or not, within its membership, there are law enforcement officers?

Mr. JONES. I respectfully decline to answer that question based on ground previously stated.

Mr. APPELL. A hospital-surgical coverage application also designates as an affiliated unit the Town & Country Sportsman Club, P.O. Box 244, Durham, North Carolina.

Is this Town & Country Sportsman Club a Klan unit?

Mr. JONES. I respectfully decline to answer that question based on grounds previously stated.

(Document marked "James Jones Exhibit No. 24-C." See p. 1782.)

Mr. APPELL. An additional application shows an affiliated group, Warrenton Improvement Association, Norlina, P.O. Box 156, North Carolina.

Do you know the Warrenton Improvement Association to be a Klan group unit?

Mr. JONES. I respectfully decline to answer that question based on grounds previously stated.

(Document marked "James Jones Exhibit No. 24-D." See p. 1783.)

Mr. APPELL. Another of the affiliated units, according to an application, is the Halifax County Sportsman Club, Box 611, Enfield, North Carolina.

Do you know it to be a Klan unit?

Mr. JONES. I respectfully decline to answer that question based on the grounds previously stated.

(Document marked "James Jones Exhibit No. 24-E." See p. 1784.)

Mr. APPELL. Another application which lists an affiliated unit shows Kings Mountain, North Carolina, No. 55, P.O. Box 681, Kings Mountain, North Carolina.

Do you know Kings Mountain, North Carolina, No. 55, to be the numerical designation of a Klan unit in North Carolina?

Mr. JONES. I respectfully decline to answer that question based on grounds previously stated.

(Document marked "James Jones Exhibit No. 24-F." See p. 1785.)

Mr. APPELL. Mr. Jones, this applicant is James D. Carter. Was James D. Carter a province titan within the Klan in North Carolina?

Mr. JONES. I respectfully decline to answer that question based on grounds previously stated.

Mr. APPELL. As a matter of fact, at a rally, didn't he come up to you and push his robes into your gut and tear up his membership card in front of your face?

Mr. JONES. I respectfully decline to answer that question based on grounds previously stated.

Mr. APPELL. Another affiliated unit is listed merely as Number 23.

I read it, Mr. Chairman, as Sanford, without the designation of the State, although the applicant lists his residence as Sanford, North Carolina.

Do you have a unit in North Carolina known as Unit Number 23?

Mr. JONES. I respectfully decline to answer that question based on grounds previously stated.

(Document marked "James Jones Exhibit No. 24-G." See p. 1786.)

Mr. APPELL. Another affiliated unit, Mr. Jones, is shown as Number 38, Goldsboro, North Carolina. Do you have a unit known as Number 38 in Goldsboro, North Carolina?

Mr. JONES. I respectfully decline to answer that question based on grounds previously stated.

(Document marked "James Jones Exhibit No. 24-H." See p. 1787.)

Mr. APPELL. Another of the affiliated groups, according to the application, is the Limestone Fishing Club, P.O. Box 313, Beulaville, North Carolina. Is the Limestone Fishing Club a unit of the Klan in North Carolina?

Mr. JONES. I respectfully decline to answer that question based on grounds previously stated.

(Document marked "James Jones Exhibit No. 24-I." See p. 1788.)

Mr. APPELL. The last of the affiliated units that we could find within the applications is the Keystone Club, 1069 Henderson, North Carolina. Is the Keystone Club known to you as an affiliated, as a Klan within the State of North Carolina?

Mr. JONES. I respectfully decline to answer that question based on grounds previously stated.

(Document marked "James Jones Exhibit No. 24-J." See p. 1789.)

Mr. APPELL. Mr. Jones, was there an important meeting of the Klan held in Rockwell, North Carolina, on August 22, 1965?

Mr. JONES. I respectfully decline to answer that question based on grounds previously stated.

Mr. APPELL. Did you at this meeting make a financial report to the membership?

Mr. JONES. I respectfully decline to answer that question based on grounds previously stated.

Mr. APPELL. Did you report that the total taken in was approximately \$14,125 to date, and that you had paid out \$11,000, had a balance of \$3,125.18, and that some bills were outstanding and that the balance in the bank as of this date, which is August 22, 1965, was \$1,625.18?

Mr. JONES. I respectfully decline to answer that question based on grounds previously stated.

(Document marked "James Jones Exhibit No. 25" and retained in committee files.)

Mr. APPELL. Isn't it a fact, Mr. Jones, that during the period of time from the first of 1965 to the date of your report that you had

taken in \$21,974.22, disbursed \$15,111.77, and had a balance in the bank at that time of \$6,862.45?

Mr. JONES. I respectfully decline to answer that question based on grounds previously stated.

The CHAIRMAN. Mr. Appell, are you asking the question as a fact which has been verified?

Mr. APPELL. Yes, sir.

The CHAIRMAN. And all of these questions have been verified by investigation?

Mr. APPELL. Yes, sir, by an analysis of the bank accounts. I would like to point out, Mr. Chairman, that the staff does not know whether this is all the money that has come in.

The CHAIRMAN. That was the question I was about to ask him.

Mr. Jones, Mr. Appell, following good and honest investigative practice, is questioning you from material subpoenaed from or received from the bank, a bank, which could be erroneous. You are being given an opportunity to verify or dispute these figures. I will ask you this question.

As of the date when, according to verifiable bank records, you had—

Mr. APPELL. He had received during the period from the first of 1965 to the period of his report \$21,974.22.

The CHAIRMAN. This is according to material received from the bank. In fact, as of that date, had you or had you not—I will put it two ways this time because I am talking about the facts developed—had you or had you not received more funds that you either had not put into the bank or kept for yourself? Is that all you had received and did you deposit it all in the bank?

Mr. JONES. I respectfully decline to answer that question based on grounds previously stated.

The CHAIRMAN. Is it, or is it not, a fact that you have other accounts in other banks besides the one we are now talking about?

Mr. JONES. I respectfully decline to answer that question based on grounds previously stated.

Mr. WELTNER. Mr. Chairman, can Mr. Appell repeat the figures as contained in the report submitted?

Mr. APPELL. His report to the membership was the total taken in to date approximately \$14,125, and paid out approximately \$11,000.

Mr. WELTNER. That is all.

Mr. APPELL. Mr. Chairman, I would like to observe that the figure of \$21,974 brought in does not include \$4,969.90 which was paid toward the automobile, and I wish to also point out that an analysis of accounts of Klans or Klaverns shows that many checks payable to Mr. Jones, made payable to J. R. Jones, are never deposited in any bank account because the endorsements on the reverse thereof show that Mr. Jones has cashed these checks at places other than at his bank.

The CHAIRMAN. Proceed.

Mr. APPELL. Mr. Jones, at approximately March 1st, or in the period within the first few days of March, was a State meeting of the Klan of North Carolina held?

Mr. JONES. I respectfully decline to answer that question based on grounds previously stated.

Mr. APPELL. At this meeting—

The CHAIRMAN. What was the date of that?

Mr. APPELL. In the first few days of March 1965, sir.

At this meeting, were you nominated and elected—

The CHAIRMAN. "Were you or were you not?"

Mr. APPELL. Were you or were you not elected—

The CHAIRMAN. If you know it to be a fact—

Mr. APPELL. Isn't it a fact that you were nominated and elected to your office of Grand Dragon without opposition?

Mr. JONES. I respectfully decline to answer that question based on grounds previously stated.

Mr. APPELL. Isn't it a fact that George Dorsett and Grady Mars were nominated to the office of treasurer and that Grady Mars was elected?

Mr. JONES. I respectfully decline to answer that question based on the grounds previously stated.

Mr. APPELL. Isn't it a fact that Jim Hackney, M. R. Kornegay, Reverend Woodle, were nominated for the office of klokard and that Mr. M. R. Kornegay was elected?

Mr. JONES. I respectfully decline to answer that question based on grounds previously stated.

Mr. APPELL. Isn't it a fact that there were nominated for the position of kludd or chaplain the Reverend Roy Woodle and Bill McCubbins and ——— Morgan ¹ and that Reverend Woodle was elected?

Mr. JONES. I respectfully decline to answer that question based on grounds previously stated.

Mr. APPELL. Isn't it a fact that when it came to the nomination for the office of grand kligrapp or secretary, that a motion was made, seconded, and carried to let you, as the Grand Dragon, appoint your own secretary?

Mr. JONES. I respectfully decline to answer that question on grounds previously stated.

The CHAIRMAN. Did you appoint your own secretary and, if so, who is the person?

Mr. JONES. I respectfully decline to answer that question based on grounds previously stated.

Mr. APPELL. Isn't it a fact that Fred Wilson was elected without opposition to the position of grand klabee?

Mr. JONES. I respectfully decline to answer that question based on grounds previously stated.

Mr. APPELL. Isn't it a fact that Bill Brown, Robert Reaves, and Jack Murray, Jr., were nominated to the position of grand kladd and that Robert Reaves was elected?

Mr. JONES. I respectfully decline to answer that question based on grounds previously stated.

Mr. APPELL. Isn't it a fact that Albert Outlaw, Wayne Rivers, and J. T. Shepard were nominated for the position of klarogo, with Albert Outlaw being elected?

Mr. JONES. I respectfully decline to answer that question based on grounds previously stated.

Mr. APPELL. Isn't it a fact that Joe Norman, Clarence Brindle, and Ray Tripp were nominated for the position of klexter, with Clarence Brindle elected?

¹ First name unknown.

Mr. JONES. I respectfully decline to answer that question based on grounds previously stated.

Mr. APPELL. Isn't a fact that Boyd Hamby was elected without opposition to the position of grand night-hawk?

Mr. JONES. I respectfully decline to answer that question based on grounds previously stated.

Mr. APPELL. Isn't it a fact that it was announced at that meeting that the constitution and bylaws of the United Klans of America, Inc., were being changed so that they would provide that all imperial and grand officers are elected for a period of 2 years?

Mr. JONES. I respectfully decline to answer that question based on grounds previously stated.

The CHAIRMAN. What was it before?

Mr. APPELL. It staggered, Mr. Chairman, with the Imperial Wizard being 3 years, with the Imperial Klabee being 2 years, the Imperial Kligrapp being 2 years, and certain other officers only for a period of 1 year.

The CHAIRMAN. All right.

Mr. APPELL. Mr. Jones, preceding this election, I ask you if it is a fact if at one time Woody Goodwin, of Wilmington, North Carolina, was your Klaliff or vice president?

Mr. JONES. I respectfully decline to answer that question based on grounds previously stated.

Mr. APPELL. I ask you if it is a fact that Arthur C. Leonard, of Salisbury, North Carolina, was the grand klokard.

Mr. JONES. I respectfully decline to answer that question based on the grounds previously stated.

The CHAIRMAN. Did you ask if it was a fact?

Mr. APPELL. Yes, sir.

Is it or is it not a fact that Arthur C. Leonard was the grand klokard?

Mr. JONES. I respectfully decline to answer that question based on grounds previous stated.

Mr. APPELL. Is it not a fact that W. R. McCubbins, M-c-C-u-b-b-i-n-s, was grand kludd?

Mr. JONES. I respectfully decline to answer that question based on grounds previously stated.

Mr. APPELL. Prior to the election that I previously discussed with you, was it a fact that Charles Deese of Salisbury, North Carolina, was grand kligrapp or secretary?

Mr. JONES. I respectfully decline to answer that question based on grounds previously stated.

Mr. APPELL. Is it not a fact that Ray Terry, of Durham, North Carolina, prior to the election that we have discussed, was the grand kladd?

Mr. JONES. I respectfully decline to answer that question based on grounds previously stated.

Mr. APPELL. Is it not a fact that Buck Hoarse,¹ of Lexington, was at one time the grand inner guard?

Mr. JONES. I respectfully decline to answer that question based on grounds previously stated.

¹ Correct name Buck House.

Mr. APPELL. Is it not a fact that he was replaced on August 6, 1964, by M. R. Kornegay?

Mr. JONES. I respectfully decline to answer that question based on grounds previously stated.

Mr. APPELL. Is it not a fact that at one time Jim McLamb of Wilmington, North Carolina, was the grand outer guard under you as Grand Dragon?

Mr. JONES. I respectfully decline to answer that question based on grounds previously stated.

The CHAIRMAN. Mr. Appell tells me that he cannot conclude with this witness before lunch, so the committee will stand in recess until 1:30.

(Subcommittee members present at time of recess: Representatives Willis, Pool, Weltner, Ashbrook, and Buchanan.)

(Whereupon, at 12 noon, Thursday, October 21, 1965, the subcommittee recessed, to reconvene at 1:30 p.m. the same day.)

AFTERNOON SESSION—THURSDAY, OCTOBER 21, 1965

(The subcommittee reconvened at 1:45 p.m., Hon. Edwin E. Willis, chairman, presiding.)

(Subcommittee members present: Representatives Willis, Weltner, Ashbrook, and Buchanan.)

The CHAIRMAN. The subcommittee will come to order.

Call your witness, Mr. Appell.

Mr. APPELL. Mr. Chairman, I would like to recall to the stand Mr. James R. Jones.

The CHAIRMAN. Please proceed.

TESTIMONY OF JAMES ROBERTSON JONES—Resumed

Mr. APPELL. Mr. Jones, within the United Klans of America, is it the practice to issue official charters to Klans under cover names, such as improvement associations?

Mr. JONES. I respectfully decline to answer that question for reasons that I honestly feel my answer might tend to incriminate me, in violation of my rights as guaranteed me by amendments 5, 1, 4, and 14 of the Constitution of the United States of America.

Mr. APPELL. Mr. Jones, I put it to you as a fact, and ask you to affirm or deny the fact, that the United Klans of America did issue a formal charter in the name of the Craven County Improvement Association, New Bern, North Carolina, Klan No. 33.

Mr. JONES. I respectfully decline to answer that question based on grounds previously stated.

Mr. APPELL. I hand you a copy of that charter and ask you if it is not a fact, and ask you to affirm or deny it, if it is not a fact that your name appears as the Grand Dragon, and Mr. Robert M. Shelton's name appears, Mr. W. O. Perkins' name appears there, but appears to have been signed for him by someone having the initials "C L" and that it was accepted for that Klavern by Raymond D. Mills.

Mr. JONES. I respectfully decline to answer that question based on grounds previously stated.

(Document marked "James Jones Exhibit No. 26" follows:)

Mr. JONES. I respectfully decline to answer that question based on grounds previously stated.

(Document marked "James Jones Exhibit No. 27" and retained in committee files.)

Mr. APPELL. Mr. Jones, I put it to you as a fact, and ask you to affirm or deny it, that there was created the New Bern and Blounts Creek Fund, Grady B. Mars or James R. Jones, Arcola Rural Station, Warrenton, North Carolina, for the purpose of raising funds for the defense of Raymond Mills.

Mr. JONES. I respectfully decline to answer that question based on grounds previously stated.

The CHAIRMAN. I will ask Mr. Appell, as I am not sure, but did you establish that Mr. Mills pleaded guilty? Did you ask him that? Did you put that to him as a fact and ask him to affirm or deny that fact?

Mr. APPELL. I do not remember, sir, so I will.

Did Raymond Mills, in the course of the trial, change his plea from not guilty to guilty of the crimes for which he was indicted?

Mr. JONES. I respectfully decline to answer that question based on grounds previously stated.

The CHAIRMAN. It is more than that. I put it to you as a fact that the court records show that he did plead guilty. I ask you to affirm or deny that fact.

Mr. JONES. I respectfully decline to answer that question based on grounds previously stated.

Mr. APPELL. I put it to you as a fact, Mr. Jones, and ask you to affirm or deny the fact, that the total amount deposited into that account was \$645.16.

Mr. JONES. I respectfully decline to answer that question based on grounds previously stated.

Mr. APPELL. I put it to you as a fact, and ask you to affirm or deny that fact, that as far as loans or advances of money in behalf of Mills, that on May 3, 1965, a check was drawn against this account in the amount of \$260, signed by Grady B. Mars, which check contained a notation "90 day note, Lonnie R. Mills, Rt. 2, Vanceboro, N.C."

Mr. JONES. I respectfully decline to answer that question based on grounds previously stated.

(Document marked "James Jones Exhibit No. 28" follows:)

JAMES JONES EXHIBIT NO. 28



The CHAIRMAN. What was the total amount collected for that defense fund, Mr. Appell?

Mr. APPELL. \$645.16.

The CHAIRMAN. Understand the situation, Mr. Jones. As I understand it, the campaign went on to collect this amount of money to defend Mr. Mills, and the account shows, I believe—what?

Mr. APPELL. There was deposited \$645.16. As for withdrawals from the account, Mr. Chairman, there was a check in the amount of \$57 which was a debit to the account because the check submitted was "insufficient funds." There was a check written, as I described in the record, and the third check that was written against the account was a cashier's check which was used to close the account, and the maker of that check was Grady B. Mars.

Mr. WELTNER. Would counsel identify Grady Mars from the trial records that have been offered into evidence?

Mr. APPELL. Grady B. Mars, according to the record, Mr. Weltner, is the Klaliff or vice president, of the Realm of North Carolina. Incidentally, he is a paid worker or organizer at the rate of \$150 per week.

The CHAIRMAN. How much was there deposited, Mr. Appell?

Mr. APPELL. There was a total deposit of \$645.16.

The CHAIRMAN. Give me the items of withdrawal.

Mr. APPELL. There was a debit of \$57 which constituted a check which bounced because of insufficient funds, and there were two withdrawals.

The CHAIRMAN. \$57 NSF?

Mr. APPELL. Yes. And a \$260 withdrawal which was marked as a 90-day loan to Lonnie Mills, and a check in the amount of \$328.16 which was used to close the account and to purchase a cashier's check, the disposition of which we have no knowledge.

The CHAIRMAN. Now, Mr. Jones, I am asking you—I am not putting it to you as a fact, because I don't know the fact—whether this cashier's check was used by Grady Mars to remit to Mr. Mills, as part of his legal defense.

Mr. JONES. I respectfully decline to answer that question based on grounds previously stated.

The CHAIRMAN. Now, I do put it to you as a fact, and I ask you to deny or affirm that fact, that instead of giving the \$260 to Mr. Mills for his defense, you loaned him the money.

Mr. JONES. I respectfully decline to answer that question based on grounds previously stated.

The CHAIRMAN. I put it to you as a fact, and ask you to affirm or deny the fact, coming to us from our investigation, that many fund-raising campaigns for legal defense, in many areas—I am not sure about the particular areas within your jurisdiction—while the funds were raised for defense, the poor defendants never got a nickel out of them. Has that occurred within your realm?

Mr. JONES. I respectfully decline to answer that question based on grounds previously stated.

The CHAIRMAN. Proceed.

Mr. APPELL. Mr. Jones, after the arrest of Raymond Mills, what investigation did your organization conduct for the purpose of deter-

mining the guilt or innocence of Mr. Mills as it involved membership in your organization?

Mr. JONES. I respectfully decline to answer that question based on grounds previously stated.

Mr. APPELL. On March 1, 1965, at the same meeting at which you made a report on finances, did you make a report that Mr. Raymond Mills had been suspended for his own protection and state further, "Let me make it clear 'he has not been banished' and all units are asked to help financially."

Mr. JONES. I respectfully decline to answer that question based on grounds previously stated.

The CHAIRMAN. I put it to you as a fact, and ask you to affirm or deny the fact, that while your organization and others generally pretend to have rules and regulations and procedures to expel members who commit violence, and you pretend to be against violence, you have never expelled a member known to you to have committed acts of violence.

Mr. JONES. I respectfully decline to answer that question based on grounds previously stated.

Mr. APPELL. Mr. Chairman, I should like the record to show that the charter document which was exhibited to Mr. Jones was presented to the committee as a result of a subpoena duces tecum served upon Raymond Mills, who appeared before the committee in executive session on August 24, 1965.

The CHAIRMAN. And a transcript of that charter will appear in the record at the point it was commented on.

Mr. APPELL. Yes, sir.

Mr. JONES. Mr. Mills also submitted to us, in accordance with the subpoena, rough notes of minutes of Klavern meetings, the Craven County Improvement Association.

The CHAIRMAN. And that was done pursuant to a subpoena?

Mr. APPELL. Yes, sir.

There is an entry of a meeting in August which reports that 20 members were present. The "opening ceremony [sic] was carried out. The first business was to naturalize 3 new members, #100 #75 #77. It was an impressive ceremony [sic]," read the notes.

"The E.C. gave first part of Oath The Vice President gave the second and third parts. #15 explained"—it looks like it should read, Mr. Chairman, "that the" but it reads "the the"—

The CHAIRMAN. Start the sentence again.

Mr. APPELL. [Reading:]

The E.C. gave first part of Oath The Vice President gave the second and third parts. #15 explained the [sic] the person who owned the building was pressing for us to buy it.

The Kloman brought up new members We also decide to burn 3 cross [sic] one at Oscar Funerl [sic] Home, one on Brices Creek Road, and one in Pamlico County. The meeting was then adjourind [sic]. The Klaxter built the cross for us.

Mr. Jones, I put it to you as a fact, and ask you to affirm or deny the fact, that there was a cross burned in front of the Oscar Funeral Home on either October 17 or 18, 1964.

Mr. JONES. I respectfully decline to answer that question based on grounds previously stated.

Mr. APPELL. I ask for a correction of the record, Mr. Chairman. The date should be August 17th or August 18th.

Does that change your answer in any way, Mr. Jones?

Mr. JONES. I respectfully decline to answer that question based on grounds previously stated.

(Document marked "James Jones Exhibit No. 29" follows:)

JAMES JONES EXHIBIT NO. 29

July 17 64 20 members present
Opening Ceremony was carried out. The first business was to notarize 3 new members. # 100 # 75 # 77. It was an impressive ceremony.

The E.C. gave first part of oath. The Vice President gave the second and third parts. # 15 explained that the person who owned the building was pressing for us to buy it.

The Klaxon brought up new members. We also made to burn 3 crosses one at Owen Funeral Home, one on Brice Creek Road, and one in Lambie County. The meeting was then adjourned. The Klaxon built the cross for use.

Mr. APPELL. Mr. Jones, what investigation do you make when there are crosses burned to determine whether or not your Klansmen burn these crosses?

Mr. JONES. I respectfully decline to answer that question based on grounds previously stated.

Mr. APPELL. I put it to you as a fact, and ask you to affirm or deny the fact, that at 10 p.m. on 28 May 1965 a cross was burned at the

Elizabethtown, North Carolina, Courthouse which is located in Bladen County; that on May 28, 1965, a cross was burned at Southport Courthouse, North Carolina, Brunswick County; in the same county, at Supply, 200 yards in front of the Jessie A. Bryant home on 24 May 1964; at Holden Beach, in front of a Negro revival tent, on the 19th or 20th of November 1964; in Burke County, North Carolina, at Valdese, in front of the yard of the Valdesian Presbyterian Church on 9 December 1964; in Columbus County, North Carolina, on the lawn of the Whiteville Courthouse on 28 May 1964.

Then in Craven County, one at the Oscar Funeral Home to which I have just referred.

The CHAIRMAN. What is the date?

Mr. APPELL. The date is August 17 or 18, Mr. Chairman.

In Edgecombe County, North Carolina, at Tarboro Post Office, on 28 May 1965; in Franklin County, North Carolina, on August 20, 1964, at Epsom, on dirt road in front of H. T. Rodwell residence, Rodwell being a member of the Franklin County NAACP Chapter; in Granville County on May 28, 1965, on the lawn of the courthouse in Granville; in Greene County, North Carolina, in June 1964, at Snow Hill, on Highway 258 bypass; in Halifax County, on September 3, 1964, in Enfield, two crosses burned in the Negro area of town; in Iredell County, North Carolina, on May 28, 1965, in front of the Statesville Senior High School; in Jones County, North Carolina, on May 6, 1965, one at Pollocksville and three at Trenton on the same date; also in May 1965; six crosses burned at Wise Fork and Haskins Crossroads communities; in Lenoir County, North Carolina, on April 20, 1965, in La Grange, at the home of Paul A. Barwick, a newspaper publisher; in New Hanover County, North Carolina, in Wilmington, on the 28th of May 1965, at the courthouse; in Pender County, North Carolina, on the 28th of May at Currie; also on May 28th at Wards Corner; also on May 28th at Burgaw; in Person County, at Roxboro City Hall, also on May 28th; in Robeson County, North Carolina, on February 24, 1965, outside of Lumberton, Highway 41, at the home of Carl Leaker, a retired barber; in Rowan County, North Carolina, on May 28, 1965, at the health center in Salisbury; in Stanly County on May 28th at Albemarle, Highway 52, inside the city limits; in Vance County, on May 28th, the lawn of the courthouse building; in Wake County, on August 14, 1965, on the lawn of the Governor's Mansion, then Governor Terry Sanford; on the 23rd of February 1965 in front of the Reverend Frank Hutchins' home, 1913 South East Street, Raleigh; in Wayne County, North Carolina, on October 16, 1964, on the front lawn of James Davis home, 905 North Virginia Street, Goldsboro; on January 8, 1965, on the front lawn of Geneva Hamilton, at 510 Bunch Drive, Goldsboro.

That concludes the listing, Mr. Jones, and I put it to you as a fact, and ask you to affirm or deny the fact, that these cross burnings did take place.

Mr. JONES. I respectfully decline to answer that question based on grounds previously stated.

Mr. APPELL. What action did you take as Grand Dragon to determine how many of these cross burnings, if not all of them, were carried out by members of your organization, the United Klans of America?

Mr. JONES. I respectfully decline to answer that question based on grounds previously stated.

Mr. APPELL. Were any of your members suspended for engaging in any of the cross burnings in which these Klansmen participated?

Mr. JONES. I respectfully decline to answer that question based on grounds previously stated.

Mr. APPELL. Mr. Jones, in connection with a subpoena served upon the Suburban Printing Company, we received a copy of an invoice dated June 11, 1965, billed to the Ku Klux Klan, Box 321, see exhibit No. 31, Granite Quarry, North Carolina, Order No. 394, 200,000 copies of Negro Pepsi handbills, printed two sides, \$350.

I put it to you as a fact, and ask you to affirm or deny the fact, that you placed that order, sir.

(Document handed to witness.)

(Witness confers with counsel.)

Mr. JONES. I respectfully decline to answer that question based on grounds previously stated.

(Document marked "James Jones Exhibit No. 30" and retained in committee files.)

Mr. APPELL. I hand you a reproduction of a handbill which reads at the top "Below Picture of Negro Vice President Of Pepsi-Cola, At Left, And His White Wife, In Center. Let The Pepsi People Know What You Think Of Their Vice President And His White Wife."

Isn't this a copy of that which was printed by the Suburban Printing Company?

I put it to you as a fact, and ask you to affirm or deny the fact, that it is a copy.

Mr. JONES. I respectfully decline to answer that question based on grounds previously stated.

(Document marked "James Jones Exhibit No. 31" appears on p. 1772.)

Mr. APPELL. Before issuing that document, did you make an investigation to determine who the wife of the Negro vice president of Pepsi-Cola, Harvey Russell, was?

Mr. JONES. I respectfully decline to answer that question based on grounds previously stated.

Mr. APPELL. I put it to you as a fact, and ask you to affirm or deny the fact, that she was the daughter of Colonel Franklin A. Dennison, who was the first Negro raised to field grade rank in World War I, and who died in the early 1920's holding the rank of a brigadier general in the United States Army.

Mr. JONES. I respectfully decline to answer that question based on grounds previously stated.

The CHAIRMAN. Who was he?

Mr. APPELL. The first Negro field grade officer in the United States Army.

I put it to you as a fact, and ask you to affirm or deny the fact, that the Pepsi-Cola Company came to you personally and advised you of the fact, and that you did nothing to stop the circulation of that leaflet.

Mr. JONES. I respectfully decline to answer that question based on grounds previously stated.

The CHAIRMAN. I put it to you as a fact, and ask you to affirm or deny the fact, that the wife of Harvey Russell, who is a Negro, did

**Below Picture of Negro Vice
President Of Pepsi-Cola,
At Left, And His White Wife,
In Center**



Pepsi Cola vice president negro Harvey Russell and wife Jackie give citation to one of company's salesmen, Bob Logan (right).

**Let The Pepsi People Know What
You Think Of Their Vice President
And His White Wife**

not pretend to be anything but what she is, the daughter of a Negro general.

Mr. JONES. I respectfully decline to answer that question based on grounds previously stated.

Mr. APPELL. Mr. Jones, I hand you a copy of application for citizens band radio license, executed by James R. Jones, applied for in

JAMES JONES EXHIBIT No. 32—Continued

UNITED STATES OF AMERICA
FEDERAL COMMUNICATIONS COMMISSION
WASHINGTON, D. C.

Form Approved
Hudger Bureau No. 52-R169

ATTACHMENT TO RESUBMITTED APPLICATION

INSTRUCTIONS TO APPLICANT: All information on this application must be signed under oath or affirmation by a Notary Public or other official authorized to administer oaths. If you supply any additional information, or make any changes to the application form, you must have it signed by a Notary Public or other official. This form is for your convenience. After you have completed the information on the attached returned application, or if you wish, after you have supplied the information called for in any additional sheets of paper you may attach to the returned application form, sign your name in the proper blank below before a Notary who will fill in the remaining blanks.

The space below or the reverse side of this sheet may be used for any additional information required to correct the application.

I am an outside salesperson for home improvement materials. I would like the use of a telephone in order that my wife might receive calls at home to take care of my office and customers and relay same to me.

I hereby certify that the information supplied on the attached form or on this and on any additional sheets attached thereto is true and correct to the best of my knowledge and belief.

James R. Jones
APPLICANT (Must agree with name as shown on the application.)

- By _____
(Designate appropriate classification below)
- Individual Applicant
 - Member of Applicant Partnership
 - Officer of Applicant Corporation or Association
 - Official of Governmental Entity

Signature of applicant (or affirmation),
on this _____ day of _____, 196_____.

Witnessed by Laurella M. Lindeman (SEAL)
(or name and title of other person competent to administer oaths)

My transmission expires November 25, 1962

Mr. APPELL. I show you the reproduction of a sticker which the committee investigation found posted around throughout several Southern States, which says "THE KNIGHTS OF THE KU KLUX KLAN IS WATCHING YOU."

Has that been issued in your jurisdiction and, if so, for the purpose of intimidating people with whom you disagree?

(Document handed to witness.)

Mr. JONES. I respectfully decline to answer that question based on grounds previously stated.

(Document marked "James Jones Exhibit No. 33" and retained in committee files.)

Mr. APPELL. Mr. Jones, I put it to you as a fact, and ask you to affirm or deny the fact, that when you travel around North Carolina in your position as Grand Dragon, that you carry on your person, concealed in a shoulder holster, a .38 caliber snub-nose revolver, that you have a carbine strapped to the inside of the driver's door, and that you carry a .30-06 rifle in your trunk with a large supply of ammunition.

Mr. JONES. I respectfully decline to answer that question based on grounds previously stated.

Mr. APPELL. Mr. Chairman, the staff has no further questions of Mr. Jones.

The CHAIRMAN. Mr. Jones, the committee has established that in certain Klaverns, and I am not putting it to you as a fact that it is true in yours, but I am going to ask you if this or similar kinds of activities are engaged in—and the document I have is entitled "HARRASMENT" [sic]. And I can't read it all because it is very long, but I will come to pertinent activities of harassment.

It starts with this sentence "An Enemy's Army which has been harassed for a long time may be easily defeated," and that is a quotation from an old Sanskrit proverb. It says:

Each local unit must make a thorough study of the technique of harassing the enemy at little or no cost to themselves. All members should tax their minds to devise new means and methods of accomplishing this important work.

In general, harassing should always have a humorous twist to it and should be in the nature of Halloween Pranks. This does not mean that it should be executed in a careless or haphazard manner. It must be done seriously and soberly and with a definite aim in mind. The purpose of preserving the humorous twist to the work is to obscure the deadly seriousness behind the work—

and so on.

Besides asking the members to devise acts of harassment of their own, there is a list of 16 suggested:

1. [Using] Roofing nails
2. Sugar and Molasses [in tanks]
3. Firecrackers
4. Snakes and Lizards
5. Mad Dogs
6. Itching Powder
7. Stink Bombs
8. Tear Gas
9. Paint
10. Lacquer Thinner
11. Slingshots, Marbles, BB guns, Air Rifles, Bow and Arrow, cross bows
12. Blank cartridges and pistols
13. Roman Candles

14. Skyrockets
15. Salt and pepper
16. Noismakers [sic]

And then the document goes on to talk about other much more serious acts. But those are suggested acts of harassment, in addition to which there is the use of telephone calls, and so on.

I am asking you in all seriousness, and I give you the opportunity to affirm or deny, whether within your realm such acts of harassment leading to worse involvement—and we will come to that in these hearings—are employed within your realm?

Mr. JONES. I respectfully decline to answer that question based on grounds previously stated.

(Document marked "James Jones Exhibit No. 34." This exhibit will be reproduced in a forthcoming report on the Ku Klux Klan organizations.)

Mr. APPELL. Mr. Chairman, I have one more question.

Mr. Jones, at the public rallies that are held within North Carolina by the Klan, do you have a security detail or a security patrol which operates there, as well as a security patrol within the Realm of North Carolina?

Mr. JONES. I respectfully decline to answer that question based on grounds previously stated.

Mr. APPELL. At these rallies, do you deliberately harass the press and other people whom you invite to attend because of something—that their appearance might not look good or they might have a camera at a public rally that you invite them to, and you don't want them to take photographs?

Mr. JONES. I respectfully decline to answer that question based on grounds previously stated.

Mr. APPELL. Don't you even go so far as to shake these people down, search their cars, and do all the other things that law enforcement authorities could never do under the Constitution?

Mr. JONES. I respectfully decline to answer that question based on grounds previously stated.

Mr. APPELL. I have no further questions, Mr. Chairman.

The CHAIRMAN. I think I only have one question, a general one.

Mr. Jones, it appears that you only have had a grammar school education, and for which I don't reproach you in the least, and from the evidence have had barely any employment at all for the past few years.

Then all of a sudden it would appear you became a Grand Dragon and have the use of a Cadillac, another vehicle, and frankly—if I am wrong, you can correct it—seem to be living rather high on the hog.

My question is this, and it is an important question in the inquiry, I assure you: Are you typical of the type of people in leadership, such as Grand Dragons, in Shelton's United Klans of America, Inc.?

Mr. JONES. I respectfully decline to answer that question based on grounds previously stated.

The CHAIRMAN. That is all I have.

Mr. WELTNER. Mr. Chairman, I have one matter that I should like to present and that is the following: We have heard of the indications presented by Mr. Appell as to the Klan's abhorrence of acts of violence and the efforts the Klan employs to prevent members from engaging

in acts of violence. As portion of that posture on the part of the Klan we learn of the supposed ejection, banishment, or suspension of Raymond D. Mills who pleaded guilty to bombing cars in New Bern, North Carolina, Mills being the then exalted cyclops of the Craven County Improvement Association, I believe that Klavern was called.

I know that Mr. Mills on June 3, 1965, pleaded guilty to that offense, and I further know that that should be fairly plain evidence of an act of violence on the part of a Klan member. If that were the case, then surely if the North Carolina Realm undertook to banish members who committed acts of violence, then he would be banished.

Bear in mind, that is June 3, 1965. On August 24, 1965, several months later, in executive testimony before our committee—

The CHAIRMAN. May I say that that executive testimony has, by a vote of the committee, been released for our use. Under our rules, executive evidence must remain so except by a vote of the committee. Because of the necessity to use this evidence, the committee, by formal action, did release it.

Mr. WELTNER. Thank you, Mr. Chairman.

Mr. Mills stated at that executive session, reading from the transcript at page 340:

Let me say this to clarify one thing, Mr. Willis. I don't know of any FBI being into the organization. They may have men into our organization, but let me say this: We have men in organizations, also.

The entire statement plainly indicates and affirms that Mr. Mills, notwithstanding his conviction several months prior to August 24, still under oath acknowledged his membership in the Realm of North Carolina, United Klans of America.

I should like to pose this question to the witness, to ask whether or not Mr. Mills has been banished, or whether or not his membership in the Realm of North Carolina, or in the United Klans of America has been terminated?

Mr. JONES. I respectfully decline to answer that question based on grounds previously stated.

Mr. WELTNER. I have no further questions, Mr. Chairman.

The CHAIRMAN. Mr. Buchanan.

Mr. BUCHANAN. Thank you, Mr. Chairman.

Mr. Jones, I assume, if I understand the structure of your organization, that Mr. Robert M. Shelton, the Imperial Wizard, is your leader. Consequently, I wonder, given the very interesting evidence presented at this hearing as to the financial activities of Mr. Shelton, given the evidence presented yesterday and today about your handling of the funds of your North Carolina organization—I wonder if you received any instructions in the handling of funds of your organization from the Inferior Lizard—I mean the Imperial Wizard—Mr. Robert M. Shelton.

Mr. JONES. I respectfully decline to answer that question based on grounds previously stated.

Mr. BUCHANAN. No further questions, Mr. Chairman.

Mr. SENNER. Mr. Jones, is the corporation the United Klans of America, Inc., Knights of the Ku Klux Klan, authorized to do business in the State of North Carolina?

Mr. JONES. I respectfully decline to answer that question based on grounds previously indicated.

Mr. SENNER. Is it a foreign corporation?

Mr. JONES. I respectfully decline to answer that question based on grounds previously stated.

Mr. SENNER. I noticed in your 1965 North Carolina Initiation Franchise Tax Report, you are a foreign corporation, the name of the corporation being Invisible Empire, United Klans, Knights of the Ku Klux Klan of America, Inc., and you are listed as president, signed James R. Jones, Grand Dragon, North Carolina.

You list your assets as none, capital stock as none, your total receipts as none, the total tangible property in North Carolina as none, your net worth none, and your liabilities none. Apparently you pay a minimum of tax to do business in that State of \$10. Is this correct?

Mr. JONES. I respectfully decline to answer that question based on grounds previously stated.

Mr. SENNER. Isn't it a fact that you are violating the laws of the State of North Carolina in the conducting of business in that State in the manner in which Mr. Appell has related these events?

Mr. JONES. I respectfully decline to answer that question based on grounds previously stated.

Mr. SENNER. Mr. Chairman, I have no further questions.

Mr. POOL. I have a question, Mr. Chairman.

The CHAIRMAN. Mr. Pool.

Mr. POOL. During the testimony, I believe we had some testimony about the purchase of white satin cloth. Do you have a cloak that you have made out of this white satin cloth?

Mr. JONES. I respectfully decline to answer that question based on grounds previously stated.

Mr. POOL. In other words, you prefer to be swathed in the fifth amendment; is that it?

Mr. JONES. I respectfully decline to answer that question based on grounds previously stated.

The CHAIRMAN. Mr. Jones, a moment ago I read a list of suggested forms of harassments with an appeal to members to devise some of their own.

I didn't say, because I don't know, honestly, whether those are the types of harassments that you approve and tolerate. Obviously, you tolerate and approve burning crosses. But you declined to answer.

I might say that the committee investigation discloses that in addition to the list of suggested acts of harassment, some of them devised by the members, there are such things as throwing dead rats in front of homes and in mail boxes, chickens with their necks cut off, and dead bugs.

I am not saying you engage in that, but I am asking you whether you engage in that type of harassment within your realm, in addition to cross-burnings, which have been established?

Mr. JONES. I respectfully decline to answer that question based on grounds previously stated.

The CHAIRMAN. Finally, and this will be my last question, Mr. Shelton is Imperial Wizard of the United Klans of America, and you are one of his Dragons, according to our established evidence. I take it that the Grand Dragons under Shelton in the various realms in various States constitute some sort of a board of directors or board of advisors to the Imperial Wizard.

I want to ask you this question, because it is very important: Did you know, did Shelton advise you, and did he obtain the consent of the Grand Dragons throughout his whole larger realm, that checks were being signed against the imperial account by a person allegedly known, a man allegedly known, as James J. Hendrix who turned out to be Mrs. Shelton and by a man allegedly known as T. M. Montgomery, who turned out to be Carol Long?

It is important to know the policy or who is advising with whom in these financial transactions. Did you know about that? Were you consulted? Did you give your consent?

Mr. JONES. I respectfully decline to answer that question based on grounds previously stated.

The CHAIRMAN. Mr. Ashbrook.

Mr. ASHBROOK. Mr. Chairman, I would like to ask the witness one question. The Goldsboro, North Carolina, *News-Argus*, of Sunday, August 15, 1965, carries a front page story with the caption headed "Klan Can Rule, [Dragon Declares]." Reporter John Rains, Mr. Jones, quotes you as, among other things, lashing out at "Negroes, jews, communists and 'white niggers,'" whatever that is, and that you said that, "the only way to fight communists and integrationists is by swinging election or 'with bullets.'"

This is a direct quote that is attributed to you by John Rains, reporter for this newspaper. I am wondering if you would, in light of your protestations of playing down violence, answer for this committee whether or not this is factual reporting of what you said at the Klan meeting in Goldsboro, North Carolina, on that date?

Mr. JONES. I respectfully decline to answer that question based on grounds previously stated.

Mr. ASHBROOK. No further questions, Mr. Chairman.

The CHAIRMAN. Mr. Appell, is that all?

Mr. APPELL. Yes, Mr. Chairman.

The CHAIRMAN. Mr. Jones, you are excused for the day, but you will be continued under subpoena until November 14.¹

Mr. ASHBROOK. Mr. Chairman, I would like to have this article made a part of the record, the one that I referred to.

The CHAIRMAN. Without objection, that will be done.

(Document marked "James Jones Exhibit No. 35" and retained in committee files.)

(James Jones Exhibit Nos. 24-A through 24-J, introduced on pp. 1758-1760, follow:)

¹Mr. Jones was not recalled, and on December 29, 1965, was discharged from further appearance under his subpoena.

JAMES JONES EXHIBIT NO. 24-A

HOSPITAL SURGICAL COVERAGE

INTERNATIONAL LIFE & ACCIDENT INSURANCE CO.

- 1. Name C. B. Hedson Sex M Birth July 1912 Age 42
- 2. Address Rte #1 City Coner State D.C.
- 3. Height 5 Ft 10 1/2 Ins. Weight 155 Lbs. Martial Status Married
- 4. Occupation Carpenter 5. Employer Self

5. List Included family members.
- | Name | Birth | Age | Wt. Ht. | Relation |
|-----------|-------|-----|---------|----------|
| (a) _____ | | | | |
| (b) _____ | | | | |
| (c) _____ | | | | |
| (d) _____ | | | | |
| (e) _____ | | | | |
| (f) _____ | | | | |
| (g) _____ | | | | |

Signature of Applicant C. B. Hedson Date March 19, 1965

Licensed Representative M. B. Kerney

Carolina Insurance Agency Inc. Amount Prem. Paid \$ 3.55

Unit Name Harris County Improvement Assoc

Unit Address P.O. Box 48 - Dunny, D.C.

Benefits: Daily Rate 12.00 Surgical 250.00 Prem. 3.55 **AMB**

Mode of Payment: (M) J SA A Circle One POL. NO. FR-110-1264

479-079-197

EFF. DATE 4-10-65

JAMES JONES EXHIBIT NO. 24-B

HOSPITAL SURGICAL COVERAGE

INTERNATIONAL LIFE & ACCIDENT INSURANCE CO.

1. Name Hubert Osmond Elkins Sex M Birth 1911 Age 53
 2. Address 309 Breekenridge dr City Wilmington State Ne
 3. Height 5 Ft. 10 1/2 Ins. Weight 146 Lbs. Martial Status M.
 4. Occupation Salesman 5. Employer Harris Pontiac

5. List Included family members.

	Name	Birth	Age	Wt.	Ht.	Relation
(a)						
(b)						
(c)						
(d)						
(e)						
(f)						
(g)						

Signature of Applicant H.O. Elkins Date 3-11-65

Licensed Representative M. R. Kormogay

Carolina Insurance Agency Inc. Amount Prem. Paid \$10.65

Unit Name New Hanover Improvement Association Inc.

Unit Address P.O. 1104 Wilmington, N.C.

Benefits: Daily Rate 12.00 Surgical 250.00 Prem. 10.65 NMB

Mode of Payment: M SA A Circle O POL. NO. FR-110-1263
479-079-197 EFF. DATE 4-10-65

JAMES JONES EXHIBIT No. 24-C

HOSPITAL SURGICAL COVERAGE

INTERNATIONAL LIFE & ACCIDENT INSURANCE CO.

- 1. Name James Woodrow Kernodle Sex M Birth Oct. 2 Age 27
- 2. Address Rt. # 2, Box 416 City Durham State N.C.
- 3. Height 5 Ft. 11 Ins. Weight 180 Lbs. Martial Status M
- 4. Occupation clerk 5. Employer Golden Belt Mfg. Co.

5. List Included family members.
- | | Name | Birth | Age | Wt. | Ht. | Relation |
|-----|-------|-------|-------|-------|-------|----------|
| (a) | _____ | _____ | _____ | _____ | _____ | _____ |
| (b) | _____ | _____ | _____ | _____ | _____ | _____ |
| (c) | _____ | _____ | _____ | _____ | _____ | _____ |
| (d) | _____ | _____ | _____ | _____ | _____ | _____ |
| (e) | _____ | _____ | _____ | _____ | _____ | _____ |
| (f) | _____ | _____ | _____ | _____ | _____ | _____ |
| (g) | _____ | _____ | _____ | _____ | _____ | _____ |

Signature of Applicant James W. Kernodle Date 7-16-65

Licensed Representative M. L. Kernegay

Carolina Insurance Agency Inc. Amount Prem. Paid \$3.55

Unit Name Town & Country Sportsman Club

Unit Address P.O. Box 244, Durham, N.C.

Benefits: Daily Rate \$12.00 Surgical \$250.00 Prem. \$3.55 NMB

Mode of Payment: (M) J SA A Circle O POL. NO. EP-110-1243
479-079-199 EFF. DATE MAR 10 1965

JAMES JONES EXHIBIT No. 24-D

HOSPITAL SURGICAL COVERAGE

INTERNATIONAL LIFE & ACCIDENT INSURANCE CO.

- 1. Name Linwood Earl Massey Sex M Birth Jan 7 31 1941 Age 23
- 2. Address Rt # 1-53 City WARRENTON State N.C.
- 3. Height 5 Ft. 10 Ins. Weight 165 Lbs. Marital Status ROD
- 4. Occupation SURVONY 5. Employer STATE
- 5. List Included family members.

	Name	Birth	Age	Wt.	Ht.	Relation
(a)						
(b)						
(c)						
(d)						
(e)						
(f)						
(g)						

Signature of Applicant Linwood Earl Massey Date 1/15/65

Licensed Representative John A. Clark, Jr.

Carolina Insurance Agency Inc. Amount Prem. Paid 355

Unit Name Warrenton Improvement Association

Unit Address NORLINA P.O. Box 156 N.C.

Benefits: Daily Rate 1200 Surgical 250⁰⁰ Prem. 355

Mode of Payment: (M) J SA A Circle One NMB

479-079-~~153~~²⁹⁰

EFF: JAN 10 1965

FR-110-1142

JAMES JONES EXHIBIT NO. 24-E

HOSPITAL SURGICAL COVERAGE

INTERNATIONAL LIFE & ACCIDENT INSURANCE CO.

- 1. Name James Jones Sex M Birth 1-28-39 Age 25
- 2. Address 413 St. ... City Englewood State N.C.
- 3. Height 5 Ft. 10 Ins. Weight 170 Lbs. Martial Status Single
- 4. Occupation Student 5. Employer Self

5. List Included Family members.

	Name	Birth	Age	Wt. Ht.	Relation
(a)	<u>None</u>				
(b)					
(c)					
(d)					
(e)					
(f)					
(g)					

Signature of Applicant James Jones Date 10-8-64

Licensed Representative J. R. Kennedy

Carolina Insurance Agency Inc. Amount Prem. Paid 13.55

Unit Name

Unit Address N.C.

Benefits: Daily Rate \$1.00 Surgical \$250.00 Prem. 3.55

Mode of Payment: J SA A Circle One

499-094-199

FR-110-1042

Handwritten mark resembling a stylized 'S' or '5'.

JAMES JONES EXHIBIT NO. 24-F

HOSPITAL SURGICAL COVERAGE

INTERNATIONAL LIFE & ACCIDENT INSURANCE CO.

- 1. Name James D. Carter Sex M Birth 12-19-27 Age 37
- 2. Address P.O. Box 681 City Kings Mtn State NC
- 3. Height 5 Ft. 11 Ins. Weight 206 Lbs. Marital Status Married
- 4. Occupation Field Representative 5. Employer COMMERCIAL MORTGAGE AND Finance Corp.

5. List Included family members.

Name	Birth	Age	Wt.	Ht.	Relation
(a) <u>Thelma E. Carter</u>	<u>12-22-30</u>	<u>34</u>	<u>140</u>	<u>5'8 1/2 in.</u>	<u>Wife</u>
(b) <u>Jesse G. Carter</u>	<u>9-18-48</u>	<u>16</u>	<u>125</u>	<u>5'6 in.</u>	<u>Son</u>
(c) <u>Donna Kay Carter</u>	<u>12-22-49</u>	<u>15</u>	<u>110</u>	<u>5" Ht.</u>	<u>Daughter</u>
(d) <u>Eliz. Carol Carter</u>	<u>3-4-51</u>	<u>13</u>	<u>115</u>	<u>5" 2 in.</u>	<u>"</u>
(e)					
(f)					
(g)					

Signature of Applicant James D. Carter Date 2-7-1965

Licensed Representative M. R. Komegany

Carolina Insurance Agency Inc. Amount Prem. Paid 14.50

Unit Name Kings Mountain, N.C. # 55

Unit Address P.O. Box 681 Kings Mountain, N.C.

Benefits: Daily Rate 12.00 Surgical 250.00 Prem. 14.50 1216

Mode of Payment: M O SA A Circle POL. NO. FR-110-1715

478-038-197 I T DATE 2-10-65

JAMES JONES EXHIBIT No. 24-G

HOSPITAL SURGICAL COVERAGE

INTERNATIONAL LIFE & ACCIDENT INSURANCE CO.

- 1. Name Walter Lee Freeman ^{FREEMAN} Sex M Birth 2-4-29 Age 35
- 2. Address P#5 City Sanford State N.C.
- 3. Height 5 Ft. 9 Ins. Weight 185 Lbs. Marital Status married
- 4. Occupation Bus. - Manager 5. Employer Self
- 5. List Included Family members.

	Name	Birth	Age	Wt.	Ht.	Relation
(a)	<u>Jessie</u>	<u>6-20-24</u>	<u>40</u>	<u>135</u>	<u>5'5"</u>	<u>wife</u>
(b)	<u>Sharon Lee</u>	<u>8-31-48</u>	<u>16</u>	<u>115</u>	<u>5'5"</u>	<u>Daughter</u>
(c)	<u>Shirley Ann</u>	<u>12-19-49</u>	<u>14</u>	<u>115</u>	<u>5'5"</u>	<u>Daughter</u>
(d)						
(e)						
(f)						
(g)						

Signature of Applicant Walter Lee Freeman Date 12-14-64

Licensed Representative C. A. O. I.

Carolina Insurance Agency Inc. Amount Prem. Paid 14.50

Unit Name #23

Unit Address Sanford

Benefits: Daily Rate 12.00 Surgical 250.00 Prem. 14.50

Mode of Payment: M U SA A Circle One

479-079-197

EFF JAN 10 1965

FR-110-1125

JAMES JONES EXHIBIT No. 24-H

HOSPITAL SURGICAL COVERAGE

INTERNATIONAL LIFE & ACCIDENT INSURANCE CO.

1. Name Connie M. Clough Sex W Birth 6-23-35 Age 35

2. Address 2744 Rav. 11-5 City Haldobrook State N.C.

3. Height 6 Ft. ___ Ins. Weight 170 Lbs. Marital Status married

4. Occupation Depart 5. Employer _____

5. List Included Family members.

	Name	Birth	Age	Wt.	Ht.	Relation
(a)	<u>Rose E.</u>	<u>2-11-32</u>	<u>33</u>	<u>125</u>	<u>5'4"</u>	<u>Wife</u>
(b)	_____	_____	_____	_____	_____	_____
(c)	_____	_____	_____	_____	_____	_____
(d)	_____	_____	_____	_____	_____	_____
(e)	_____	_____	_____	_____	_____	_____
(f)	_____	_____	_____	_____	_____	_____
(g)	_____	_____	_____	_____	_____	_____

Signature of Applicant [Signature] Date 12-9-64

Licensed Representative Wm A. Outlaw

Carolina Insurance Agency Inc. Amount Prem. Paid 9.65

Unit Name #38

Unit Address Haldobrook N.C.

Benefits: Daily Rate 12.00 Surgical 250.00 Prem. 9.65

Mode of Payment: (M) J SA A Circle One

478-074-197

EFF 12-10-64

FR-110-1061

JAMES JONES EXHIBIT NO. 24-I

HOSPITAL SURGICAL COVERAGE

INTERNATIONAL LIFE & ACCIDENT INSURANCE CO.

- 1. Name TOM HOUSTON Sex M Birth 1942 Age 22
- 2. Address RT 2 City PICK HILL State N.C.
- 3. Height 5 Ft. 9 Ins. Weight 178 Lbs. Martial Status M
- 4. Occupation Landscaping 5. Employer SELF

5. List Included family members.

	Name	Birth	Age	Wt.	Ht.	Relation
(a)	<u>Marie Houston</u>	<u>1913</u>	<u>21</u>	<u>100</u>	<u>5-4</u>	<u>WIFE</u>
(b)	_____	_____	_____	_____	_____	_____
(c)	_____	_____	_____	_____	_____	_____
(d)	_____	_____	_____	_____	_____	_____
(e)	_____	_____	_____	_____	_____	_____
(f)	_____	_____	_____	_____	_____	_____
(g)	_____	_____	_____	_____	_____	_____

Signature of Applicant Tom Houston Date 5-11-65

Licensed Representative M R Komegay

Carolina Insurance Agency Inc. Amount Prem. Paid 9.65

Unit Name LIMESTONE FISHING CLUB

Unit Address P.O. BOX 313 BEULAVILLE, N.C.

Benefits: Daily Rate 12.00 Surgical 250.00 Prem. 9.65

Mode of Payment: (1) J SA A Circle POL. NO. FR-110-1287
479-079-197 EFF. DATE 6-10-65

JAMES JONES EXHIBIT No. 24-J

I. SPITAL SURGICAL COVERAGE

INTERNATIONAL LIFE & ACCIDENT INSURANCE CO.

- 1. Name Willard W. Jones Sex M Birth 4/21/31 ¹⁹¹³ Age 41
- 2. Address 116 Parker St. City Henderson State NC.
- 3. Height 5 Ft. 8 In. Weight 172 Lbs. Marital Status Married
- 4. Occupation Minister 5. Employer First Tr. Bank

5. List included family members.
- | (a) | Name | Birth | Age | Wt. Ht. | Relation |
|-----|------|-------|-----|---------|----------|
| (a) | | | | | |
| (b) | | | | | |
| (c) | | | | | |
| (d) | | | | | |
| (e) | | | | | |
| (f) | | | | | |
| (g) | | | | | |

Signature of Applicant Willard W. Jones Date 6-21-65

Licensed Representative [Signature]

Carolina Insurance Agency Inc. Amount Prem. Paid 4/065

Unit Name Penitence Club

Unit Address 1069 Henderson NC.

Benefits: Daily Rate 12.00 Surgical 250.00 Prem. 10.65

Mode of Payment: M SA A Circle ONE POL. NO. 32-40-1171
EFF. DATE 2-10-65

479-074-197

The CHAIRMAN. The committee will stand in recess for 10 minutes. (Whereupon, at 2:45 p.m. a brief recess was taken. All subcommittee members were present at time of recess and when hearings resumed.)

The CHAIRMAN. The subcommittee will be in order. Call your next witness, Mr. Appell.

Mr. APPELL. Marshall R. Kornegay.

The CHAIRMAN. Please raise your right hand.

Do you solemnly swear that the testimony you are about to give will be the truth, the whole truth, and nothing but the truth, so help you God?

Mr. APPELL. Mr. Chairman, I think maybe the witness nodded in taking the oath. The record could not record his nod.

The CHAIRMAN. The reporter didn't get your response.

You do solemnly swear that the testimony you are about to give will be the truth, the whole truth, and nothing but the truth, so help you God?

Mr. KORNEGAY. Yes, sir.

**TESTIMONY OF MARSHALL ROBERT KORNEGAY, ACCOMPANIED
BY COUNSEL, LESTER V. CHALMERS, JR.**

Mr. APPELL. Would you please state your full name for the record, sir?

Mr. KORNEGAY. Marshall Robert Kornegay.

Mr. APPELL. Mr. Kornegay, are you appearing here today in accordance with a subpoena served upon you at 6:20 o'clock p.m., on the 10th day of October 1965, by an investigator of this committee, Mr. Neil E. Wetterman?

Mr. KORNEGAY. Somewhere about that.

Mr. POOL. Somewhere about that.

Mr. KORNEGAY. Somewhere about that date.

The CHAIRMAN. But you were served, and you are appearing pursuant to that subpoena?

Mr. KORNEGAY. Yes, sir.

Mr. APPELL. Are you represented by counsel?

Mr. KORNEGAY. Yes, sir.

Mr. APPELL. Would the counsel please identify himself for the record, please?

Mr. CHALMERS. My name is Lester V. Chalmers, Jr., attorney at law, Room 501, First Federal Building, Raleigh, North Carolina.

Mr. APPELL. Mr. Kornegay, when you answered my question as to where you were served, you said sometime about that date. I would like to ask you exactly when and where you were served with the subpoena.

(Witness confers with counsel.)

Mr. KORNEGAY. I respectfully decline to answer that question for the reason that I honestly feel my answer might tend to incriminate me in violation of my rights as guaranteed to me by amendments 5, 1, 4, and 14 of the Constitution of the United States of America.

The CHAIRMAN. Counsel, do you understand the question?

Mr. CHALMERS. Yes, sir. I am certain we can enter into a stipulation. I have Mr. Kornegay's subpoena before me right now.

The CHAIRMAN. Will you stipulate the time of service and place?

Mr. CHALMERS. Whatever the record shows, I will certainly stipulate to that.

The CHAIRMAN. State the time and place shown by the return.

Mr. APPELL. 6:20 p.m., Mr. Chairman, the subpoena shows on the reverse thereof that Investigator Wetterman, according to his return on the reverse of the subpoena, served Mr. Kornegay on a farm located on the south side of Route 58, 8 miles east of Danville, Virginia, at the location of a Klan rally at 6:20 p.m. on the 10th day of October 1965.

The CHAIRMAN. And Counsel, you do have authority to make that stipulation?

(Counsel confers with witness.)

Mr. CHALMERS. Yes, sir; I do.

The CHAIRMAN. Because this is technical. As sure as I am talking to you, [I] wouldn't take advantage of it, if anything comes out of this, but I must ask you this. I noticed that you consulted with your client. He agrees that you have that authority to make this stipulation?

Mr. CHALMERS. Yes, sir.

Mr. APPELL. Mr. Kornegay, when and where were you born?

Mr. KORNEGAY. I respectfully decline to answer that question for the reason that I honestly feel my answer might tend to incriminate me in violation of my rights as guaranteed to me by amendments 5, 1, 4, and 14 of the Constitution of the United States of America.

Mr. POOL. Are you an American citizen?

Mr. KORNEGAY. I respectfully decline to answer that question for the reason that I honestly feel——

The CHAIRMAN. We will not have any demonstrations.

Mr. KORNEGAY. —feel my answer might tend to incriminate me in violation of my rights as guaranteed to me by the constitutional amendments 5, 1, 4, and 14 of the Constitution of the United States of America.

The CHAIRMAN. I now order and direct you to answer the question before last, which is simply laying the foundation, which is preliminary in identifying you, namely when and where were you born?

Mr. KORNEGAY. I respectfully decline to answer that question for the reason that I honestly feel my answer might tend to incriminate me in violation of my rights as guaranteed to me by amendments 5, 1, 4, and 14 of the Constitution of the United States of America.

Mr. POOL. Mr. Chairman?

The CHAIRMAN. Mr. Pool.

Mr. POOL. Do you honestly feel that it would incriminate you to admit that you are an American citizen?

Mr. KORNEGAY. I respectfully decline to answer that question for the reason that I honestly feel my answer might tend to incriminate me in violation of my rights as guaranteed to me by amendments 5, 1, 4, and 14 of the Constitution of the United States of America.

The CHAIRMAN. The question is such that the Chair feels obligated to direct you to answer it. I can't see how anything incriminating is involved in admission or denial of American citizenship.

Mr. KORNEGAY. I respectfully decline to answer that question based on the grounds previously stated.

Mr. APPELL. Mr. Kornegay, I state it to you as a fact, and ask you to affirm or deny the fact, that you were born on September 10, 1928, in Sampson County, North Carolina.

Mr. KORNEGAY. I respectfully decline to answer that question based on the grounds previously stated.

Mr. APPELL. I put it to you as a fact, and ask you to affirm or deny the fact, that you are a graduate of Pine Grove, North Carolina, high school.

Mr. KORNEGAY. I respectfully decline to answer that question based on the grounds previously stated.

Mr. APPELL. Mr. Kornegay, under the terms of the subpoena served upon you, and an attachment thereto which was made a part of the subpoena, you were ordered and directed to produce items called for in five paragraphs.

I will now read to you paragraph No. 1:

All books, records, documents, correspondence, and memoranda relating to the organization of and the conduct of business and affairs of the Invisible Empire, United Klans, Knights of the Ku Klux Klan of America, Inc., also known as the United Klans of America, Inc., Knights of the Ku Klux Klan, and affiliated organizations, namely, the Alabama Rescue Service, in your possession, custody or control, or maintained by you or available to you as Grand Dragon, Realm (State) of Virginia of the Invisible Empire, United Klans, Knights of the Ku Klux Klan of America, Inc., also known as the United Klans of America, Inc., Knights of the Ku Klux Klan.

I now demand the production of those documents in accordance with the terms of the subpoena.

Mr. KORNEGAY. I respectfully decline to deliver to the committee any and all records as requested by this committee under subpoena dated October 4, 1965, for that information is not relevant and germane to the subject under investigation, and the same would not aid the Congress in the consideration of any valid remedial legislation, nor is such inquiry within the scope of that authorized to be investigated by Rule IV of the rules adopted by the 89th Congress, by House Resolution 8, adopted January 4, 1965.

(Witness confers with counsel.)

Mr. KORNEGAY. I respectfully decline to deliver to this committee the documents requested for I honestly feel that to do so might tend to incriminate me in violation of my rights as guaranteed to me by amendments 5, 1, 4, and 14 of the Constitution of the United States of America.

The CHAIRMAN. We have been through this before, but we have to establish a record in each instance.

Mr. Chalmers, I take it that you admit and speak for your client that he has been in the room and that he is familiar with the opening statement I made regarding the relevancy and pertinency, from our point of view, of the documents sought to be produced.

Mr. CHALMERS. Yes, sir; that is so stipulated.

The CHAIRMAN. And I take it that, speaking for your client, you stipulate that for the reasons indicated in other instances of appearance before this committee, that the committee takes the position that his reasons for refusing to produce them are not well founded. Is that correct?

Mr. CHALMERS. If they are not well founded?

The CHAIRMAN. I mean from our point of view.

Mr. CHALMERS. Yes, sir.

The CHAIRMAN. And I think you also would stipulate, as you did in previous instances, that the subpoena was served on him and ordered him to produce those documents mentioned in paragraph 1 of the attachment to the subpoena in his capacity as Grand Dragon, Realm (State) of Virginia of the Invisible Empire, United Klans, Knights of the Ku Klux Klan of America, Inc., also known as the United Klans of America, Inc., Knights of the Ku Klux Klan.

Mr. CHALMERS. Sir, if you recall what I said yesterday afternoon—

The CHAIRMAN. Well, you state it.

Mr. CHALMERS. I will stipulate what the subpoena shows, that it was served.

The CHAIRMAN. In other words, since your client does not admit that he is Grand Dragon, you don't wish to testify for him in that respect, but you admit that the subpoena calls for him to do that in that capacity.

Mr. CHALMERS. In that capacity; yes, sir.

The CHAIRMAN. And I understand the stipulations we have just entered into, you on behalf of your client, and me as chairman speaking for the committee, will apply to all pertinent paragraphs in this attachment relative to the production of other documents without the necessity of our having to repeat the stipulation in each instance.

Mr. CHALMERS. Yes, sir.

The CHAIRMAN. And I will be accorded the privilege of saying for the reasons already indicated, he will be directed to produce them.

Mr. CHALMERS. Yes, sir.

May I suggest this to the chairman in the interest of time? I don't know whether it can be done. But in the interest of time and saving a lengthy record, could we also stipulate, you for the committee and me for my client, that his answers to your direction with respect to the other paragraphs in the subpoena will be the same.

The CHAIRMAN. That is satisfactory.

Mr. CHALMERS. Thank you, sir.

The CHAIRMAN. Now, Mr. Kornegay, I order and direct you to produce all the documents called for by the subpoena duces tecum in paragraph 1.

(Witness confers with counsel.)

Mr. KORNEGAY. Sir, I respectfully decline to deliver to this committee any and all records as requested by this committee under subpoena dated October 4, 1965, for that information is not relevant and germane to the subject under investigation, and the same would not aid the Congress in the consideration of any valid remedial legislation, nor is such inquiry within the scope of that authorized to be investigated by Rule IV of the rules adopted by the 89th Congress, by House Resolution 8, adopted January 4, 1965.

I respectfully decline to deliver to this committee those documents called for and requested in the subpoena for I honestly feel that the delivery of these documents might tend to incriminate me in violation of my rights as guaranteed to me by the amendments 5, 1, 4, and 14 of the Constitution of the United States of America.

The CHAIRMAN. Mr. Chalmers, I think to be perfectly clear I must ask you to stipulate that you understand that the reason for this direction is pursuant to our understanding of the jurisprudence, and that that indicates we don't agree with his refusal, and that his refusal to produce these documents pursuant to the subpoena may lead to a citation by the House for contempt.

Mr. CHALMERS. Yes, sir; I discussed that with my client and he is thoroughly familiar with it.

I was just wondering, Mr. Chairman, for the record, with respect to the other items, 2, 3, 4, and 5, is there any further need for any stipulation in connection therewith?

The CHAIRMAN. I personally think, and I am asking our counsel to look them over, that it would be sufficient to have one more direction to produce the documents called for by the other paragraphs. I don't know how many there are.

Mr. CHALMERS. Whatever the chairman thinks is best.

Mr. APPELL. Mr. Kornegay, under the terms of the subpoena, you were ordered to bring with you and produce items called for in an attachment which was made part of the subpoena, part 2:

All books, records, documents, correspondence, and memoranda relating to the organization of and the conduct of business and affairs of the Invisible Empire, United Klans, Knights of the Ku Klux Klan of America, Inc., also known as the United Klans of America, Inc., Knights of the Ku Klux Klan, and affiliated organizations, namely, the Alabama Rescue Service, the Realm (State) of North Carolina and Capital City Restoration Association, in your possession, custody or control, or maintained by or available to you as an officer or employee of the Realm (State) of North Carolina, of the Invisible Empire, United Klans, Knights of the Ku Klux Klan of America, also known as the United Klans of America, Inc., Knights of the Ku Klux Klan.

The CHAIRMAN. We have stipulated that you would read them all.

Mr. APPELL. All right, sir.

(3) All books, records, documents, correspondence, and memoranda in your possession, custody or control, or maintained by or available to you, in your capacity as Grand Dragon, Realm (State) of Virginia, United Klans of America, Inc, Knights of the Ku Klux Klan, which the "Constitution and Laws" of said organization authorize and require to be maintained by you and any other officer of said organization, the same being in your possession, custody or control.

(4) All books, records, documents, correspondence, and memoranda relating to any insurance contracts between the Capital City Restoration Association and the International Life and Accident Insurance Company.

(5) Copies of U.S. Treasury Department, Internal Revenue Service, Form 1040, [titled] "U.S. Individual Income Tax Return," for the calendar years 1958 through 1964, filed by you as an individual taxpayer with the U.S. Treasury Department, Internal Revenue Service.

Mr. Kornegay, I call for you to produce the documents called for by paragraphs 2, 3, 4, and 5.

Mr. Chairman, I have been advised by counsel that I should demand each separately.

I now call for the production of those called for in paragraph 2. (Witness confers with counsel.)

The CHAIRMAN. His answer should be with respect to each one. He will have to answer to each of the demands.

Mr. KORNEGAY. I respectfully decline to deliver to this committee any and all records as requested by this committee under subpoena dated October 4, 1965, for that information is not relevant and germane to the subject under investigation, and the same would not aid the Congress in the consideration of any valid, remedial legislation, nor is such inquiry within the scope of that authorized to be investigated by Rule IV, of the House rules adopted by the 89th Congress, by House Resolution 8, adopted January 4, 1965.

I respectfully decline to deliver to this committee any documents as requested for the reason that I honestly feel that to do so might tend to incriminate me in violation of my rights as guaranteed to me by amendments 5, 1, 4, and 14 of the Constitution of the United States of America.

The CHAIRMAN. For the reasons previously indicated, to which a stipulation has been made by your counsel, Mr. Kornegay, I order and direct you to produce the documents you were ordered to produce by the subpoena served upon you.

(Witness confers with counsel.)

MR. KORNEGAY. I respectfully decline to deliver to this committee any and all records as requested by this committee under subpoena dated October 4, 1965, for that information is not relevant and germane to the subject under investigation, and the same would not aid the Congress in the consideration of any valid, remedial legislation, nor is such inquiry within the scope of that authorized to be investigated by Rule IV of the rules adopted by the 89th Congress, by House Resolution 8, adopted January 4, 1965.

I respectfully decline to deliver to this committee any records or documents as requested, for the reason that I honestly feel to do so might tend to incriminate me in violation of my rights as guaranteed to me by amendments 5, 1, 4, and 14 of the Constitution of the United States of America.

(At this point Mr. Ashbrook left the hearing room.)

MR. APPELL. Mr. Kornegay, I now ask you, under the conditions and terms of the subpoena, to produce those documents which I read to you which are called for in paragraph 3.

(Witness confers with counsel.)

MR. KORNEGAY. I respectfully decline to deliver to the committee any and all records as requested by this committee under subpoena dated October 4, 1965, for that information is not relevant and germane to the subject under investigation, and the same would not aid the Congress in consideration of any valid, remedial legislation, nor is such inquiry within the scope of that authorized to be investigated by Rule IV of the rules adopted by the 89th Congress, by House Resolution 8, adopted January 4, 1965.

I respectfully decline to deliver to this committee any and all documents as requested for to do so I honestly feel might tend to incriminate me in violation of my rights as guaranteed by amendments 5, 1, 4, and 14 of the Constitution of the United States of America.

MR. APPELL. Mr. Chairman, I now ask for a direction for the production of those documents called for in paragraph 3.

THE CHAIRMAN. For reasons previously stated, and as to which a stipulation has been made, Mr. Kornegay, I order and direct you to produce those documents thus called for in paragraph 3 of the attachment to the subpoena served upon you.

MR. KORNEGAY. Sir, I respectfully decline to deliver to this committee any and all records as requested by this committee under subpoena dated October 4, 1965, for that information is not relevant and germane to the subject under investigation, and the same would not aid the Congress in the consideration of any valid, remedial legislation, nor is such inquiry within the scope of that authorized to be investigated by Rule IV of the rules adopted by the 89th Congress, by House Resolution 8, adopted January 4, 1965.

I respectfully decline to deliver to this committee any and all documents as requested by the subpoena for to do so I honestly feel might tend to incriminate me in violation of my rights as guaranteed to me by amendments, 5, 1, 4, and 14 of the Constitution of the United States of America.

MR. APPELL. Mr. Kornegay, under the conditions of the subpoena which called upon you to bring with you and to produce, I now demand the production of those documents called for in paragraph 4.

MR. KORNEGAY. I respectfully decline to deliver to the committee any and all records as requested by this committee under subpoena dated October 4, 1965, for that information is not relevant and germane to the subject under investigation, and the same would not aid the Congress in the consideration of any valid, remedial legislation, nor is such inquiry within the scope of that authorized to be investigated by Rule IV of the rules adopted by the 89th Congress, by House Resolution 8, adopted January 4, 1965.

I respectfully decline to deliver to this committee any and all records as requested by the subpoena for I honestly feel that to do so might tend to incriminate me in violation of my rights as guaranteed to me by amendments 5, 1, 4, and 14 of the Constitution of the United States of America.

MR. APPELL. Mr. Chairman, may I ask for a demand from the Chair, sir?

THE CHAIRMAN. For the reasons previously indicated, and as to which a stipulation has been made with your counsel speaking for you, Mr. Kornegay, I order and direct you to produce the documents called for by paragraph 4 of the attachment to the subpoena duces tecum served upon you.

MR. KORNEGAY. I respectfully decline to deliver to this committee any and all records as requested by this committee under subpoena dated October 4, 1965, for that information is not relevant and germane to the subject under investigation, and the same would not aid the Congress in the consideration of any valid, remedial legislation, nor is such inquiry within the scope of that authorized to be investigated by Rule IV of the rules adopted by the 89th Congress, by House Resolution 8, adopted January 4, 1965.

I respectfully decline to deliver to this committee any and all records as requested by the subpoena for to do so I honestly feel might tend to incriminate me in violation of my rights as guaranteed to me by amendments 5, 1, 4, and 14 of the Constitution of the United States of America.

MR. APPELL. Mr. Kornegay, under the terms of the subpoena served upon you, which called for you to bring with you and to produce documents, I now demand the production of those documents called for in paragraph 5.

MR. KORNEGAY. I respectfully decline to deliver to this committee any and all records as requested by this committee under subpoena dated October 4, 1965, for that information is not relevant and germane to the subject under investigation, and the same would not aid the Congress in the consideration of any valid, remedial legislation, nor is such inquiry within the scope of that authorized to be investigated by Rule IV of the rules adopted by the 89th Congress, by House Resolution 8, adopted January 4, 1965.

I respectfully decline to deliver to this committee any and all documents as requested by the subpoena for to do so I honestly feel might tend to incriminate me in violation of my rights as guaranteed to me by amendments 5, 1, 4, and 14 of the Constitution of the United States of America.

THE CHAIRMAN. Mr. Kornegay, paragraph 5, unlike paragraphs 1, 2, 3, and 4, calls for the production of your individual income tax

returns. You have invoked the fifth amendment, the provisions of the fifth amendment, against self-incrimination to that demand.

I now order you to produce the documents called for in paragraph 5.

Mr. KORNEGAY. I respectfully decline—

The CHAIRMAN. No, I am not demanding.

In other words, I accept his invocation on paragraph 5.

Mr. CHALMERS. I am sorry.

Mr. APPELL. Mr. Kornegay, would you give the committee a brief resume of your employment background?

Mr. KORNEGAY. I respectfully decline to answer that question for the reason that I honestly feel my answer might tend to incriminate me in violation of my rights as guaranteed to me by amendments 5, 1, 4, and 14 of the Constitution of the United States of America.

(At this point Mr. Weltner left the hearing room.)

Mr. APPELL. Mr. Chairman, I ask that the subpoena be made a part of the record at this point, and I ask that all additional documents be offered in evidence in the order in which they are presented.

The CHAIRMAN. That course will be followed, Mr. Reporter.

In preparing the record you will follow the rules previously announced, namely, that each document exhibited will be received in sequence, in the order in which they have been referred to and exhibited.

(Document marked "Marshall Kornegay Exhibit No. 1" and retained in committee files.)

Mr. APPELL. Mr. Kornegay, do you presently hold a license to engage in the sale of insurance in the State of North Carolina?

Mr. KORNEGAY. I respectfully decline to answer that question for the reason that I honestly feel my answer might tend to incriminate me in violation of my rights as guaranteed to me by amendments 5, 1, 4, and 14 of the Constitution of the United States of America.

Mr. APPELL. In 1957, did you lose your insurance license?

I put it to you as a fact, and ask you to affirm or deny the fact, that in 1957 you lost your insurance license in the State of North Carolina.

Mr. KORNEGAY. I respectfully decline to answer that question for the reason that I honestly feel my answer might tend to incriminate me in violation of my rights as guaranteed to me by amendments 5, 1, 4, and 14 of the Constitution of the United States of America.

Mr. APPELL. I would like to read into the record documents obtained from the Insurance Department of the State of North Carolina with respect to the insurance license held by Mr. Kornegay prior to February of 1957.

The first letter is from the Southland Life Insurance Company, addressed to Mr. Cecil Duncan, North Carolina Department of Insurance, Raleigh, North Carolina:

Re: Marshall Robert Kornegay.

Dear Cecil:

We advised your department Monday, February 25, 1957, to cancel the insurance license for the above named.

Mr. Kornegay left us at the close of business Friday, February 22, 1957, without showing up his account. We have already this week found approximately \$100.00 shortage in two cases and we anticipate further shortage on this debit.

We will advise you further as to the amount of the shortage and to what action has been taken regarding same.

The CHAIRMAN. That is addressed to whom?

Mr. APPELL. That is addressed to Mr. Cecil Duncan of the North Carolina Department of Insurance, signed by T. E. Williamson, District Manager, Southland Life Insurance Company.

I would now like to read a letter dated April 3, 1957, addressed to Mr. M. R. Kornegay, Route 1, Turkey, North Carolina:

DEAR MR. KORNEGAY:

We have completed the inspection of debit number 12, and we have found a total shortage on this debit of \$342.71. You have a credit in our office of \$48.95, deducting this amount from the total shortage would leave a balance of \$293.76

As required by law under general statutes 14-96.1 this is being turned over to the North Carolina Insurance Department as of today. I know you will want to contact the Insurance Department immediately regarding this.

Sincerely yours,

/s/ T. E. Williamson,
T. E. WILLIAMSON,
District Manager.

I hand you this, Mr. Kornegay, and ask if you received the original of this copy?

Mr. KORNEGAY. I respectfully decline to answer that question based on the grounds previously stated.

Mr. APPELL. Mr. Kornegay, I read to you a letter dated April 4, 1957:

Mr. M. R. KORNEGAY,
Route 1,
Turkey, N.C.

DEAR SIR:

In accordance with G.S. 14-96.1 the Southland Life Insurance Company has reported a shortage of \$342.71 less \$48.75 credits, leaving a net balance due at this time of \$293.76.

It is a violation of the criminal laws of this State to not properly account for premiums collected while acting as a licensed agent and unless full restitution is made immediately it will be necessary for this Department to take appropriate action. Your license has been cancelled and tagged.

Very truly yours,

C. C. DUNCAN,
Deputy Commissioner.

I put it to you as a fact, and ask you to affirm or deny the fact, that you did receive the original of the copy that I am now showing you.
(Document handed to witness.)

Mr. KORNEGAY. I respectfully decline to answer that question based on the grounds previously stated.

Mr. APPELL. I would like to now read, Mr. Chairman, a letter dated April 17, 1957, on the letterhead of the Southland Life Insurance Company, from T. E. Williamson, District Manager, addressed to Mr. C. C. Duncan, Deputy Commissioner of Insurance, North Carolina Department of Insurance, Labor Building, Raleigh, North Carolina:

Re: M. R. Kornegay

Dear Mr. Duncan:

As you will recall Mrs. Kornegay contacted you on April 8, 1957, and arranged with you to make full settlement with us on Monday, April 15, 1957. As of this

date we have heard nothing from these folks, and would appreciate if you would take what further action you see fit in this case.

Sincerely,

/s/ T. E. Williamson,
T. E. WILLIAMSON,
District Manager.

A letter on the letterhead of the Southland Life Insurance Company, dated April 26, 1957, on the stationery of T. E. Williamson, District Manager, to Mr. C. C. Duncan, Deputy Commissioner, North Carolina Department of Insurance, Labor Building, Raleigh, North Carolina:

Re: M. R. Kornegay

Dear Cecil:

I am glad to advise that a friend of Mr. Kornegay's came by our office yesterday and paid the shortage of \$293.76 which was due by him. This gives us a complete settlement with this man.

Sincerely,

/s/ Tom
T. E. WILLIAMSON,
District Manager.

Mr. Kornegay, I put it to you as a fact, and ask you to affirm or deny the fact, that you refused to repay the person from whom you borrowed the money or who came in and paid off the indebtedness which was reported by this firm.

(Witness confers with counsel.)

Mr. KORNEGAY. I respectfully decline to answer that question based on the grounds previously stated.

(Documents marked "Marshall Kornegay Exhibits Nos. 2-A through 2-E," respectively, and retained in committee files.)

The CHAIRMAN. Mr. Kornegay, I notice that you have been talking to your counsel, which is absolutely proper. I want the record to show that you are at perfect liberty to say that you did repay those funds. I am saying that our information is as stated. I do not want you to say later on that we knew all along this, thus, and the other thing, so this is an opportunity to speak up at this time.

Mr. KORNEGAY. I respectfully decline to answer that question based on the grounds previously stated.

Mr. APPELL. Mr. Kornegay, I put it to you as a fact, and ask you to affirm or deny the fact, that you became a member of the United Klans of America on July 3, 1964.

Mr. KORNEGAY. I respectfully decline to answer that question based on the grounds previously stated.

Mr. APPELL. I hand you a copy of the oaths of allegiance issued to Klansmen. I ask you to examine this document and to answer as to whether or not this is the series of oaths which you took.

Mr. KORNEGAY. I respectfully decline to answer that question based on the grounds previously stated.

(Document previously marked "Robert Shelton Exhibit No. 4.")

Mr. APPELL. Mr. Kornegay, did you speak at a public rally of the United Klans on April 3, 1965, near China Grove, North Carolina?

Mr. KORNEGAY. I respectfully decline to answer that question based on the grounds previously stated.

Mr. APPELL. I put it to you as a fact, and ask you to affirm or deny the fact that during the speech you stated that, during your speech you advised the assembled people that you had been interviewed by the FBI recently and that the agents advised you it was a violation of law to carry a concealed weapon.

Mr. KORNEGAY. I respectfully decline to answer that question based on the grounds previously stated.

Mr. APPELL. I put it to you as a fact, and ask you to affirm or deny the fact, if you did not then, there and then, pull back your robe and coat and display a holster and gun to the crowd and stated that you always intended to wear this gun in the future.

Mr. KORNEGAY. I respectfully decline to answer that question based on the grounds previously stated.

Mr. APPELL. I put it to you as a fact that you generally carry a .25 caliber automatic pistol.

The CHAIRMAN. And he asked you whether you affirm or deny that fact.

Mr. KORNEGAY. I respectfully decline to answer that question based on the grounds previously stated.

Mr. APPELL. I put it to you as a fact, and ask you to affirm or deny the fact, that you own two .303 British rifles and one 7.65 Argentine Mauser.

Mr. KORNEGAY. I respectfully decline to answer that question based on the grounds previously stated.

Mr. APPELL. I put it to you as a fact, and ask you to affirm or deny the fact, that on December 13, 1964, you demonstrated incendiary devices for several Klansmen at a meeting at your home.

Mr. KORNEGAY. I respectfully decline to answer that question based on the grounds previously stated.

Mr. APPELL. I put it to you as a fact, and ask you to affirm or deny the fact, that one of the incendiary devices was a capsule containing powder which was dropped into a container of acid which, in turn, was suspended in a container of gasoline. When the acid ate through the capsule, the powder was ignited which set off a minor explosion and ignited the gasoline.

Mr. KORNEGAY. I respectfully decline to answer that question based on grounds previously stated.

Mr. APPELL. Was this demonstration, to your knowledge, known by the Grand Dragon, Mr. James R. Jones?

Mr. KORNEGAY. I respectfully decline to answer that question based on the grounds previously stated.

Mr. APPELL. What was the purpose of this demonstration conducted by you?

Mr. KORNEGAY. I respectfully decline to answer that question based on the grounds previously stated.

Mr. APPELL. Mr. Kornegay, prior to your becoming a paid employee of the Klan, and a Grand Dragon for the State of Virginia, you had not held steady employment; is that not a fact?

Mr. KORNEGAY. I respectfully decline to answer that question based on the grounds previously stated.

Mr. APPELL. In 1960, were you employed by the Capital Sewing Center, the Morse Sewing Center, and the Atlas Sewing Center, all of Raleigh, North Carolina?

Mr. KORNEGAY. I respectfully decline to answer that question based on the grounds previously stated.

Mr. APPELL. During the year 1961, did you have any employment other than that with the Atlas Sewing Center?

Mr. KORNEGAY. I respectfully decline to answer that question based on the grounds previously stated.

Mr. APPELL. Wasn't your total income for the year 1961 from the Atlas Sewing Center \$2,486?

Mr. KORNEGAY. I respectfully decline to answer that question based on the grounds previously stated.

The CHAIRMAN. I think that figure is being read from a copy of the income tax return; is it not, Mr. Appell?

Mr. APPELL. It is, sir.

The CHAIRMAN. Ask him if it is correct as reported.

Mr. APPELL. I ask you if it is not a fact, I state to you that it is a fact, and ask you to affirm or deny the fact, that that is what you reported on your individual tax return for the year 1961.

Mr. KORNEGAY. I respectfully decline to answer that question based on the grounds previously stated.

Mr. APPELL. For the year 1962, I put it to you as a fact, and ask you to affirm or deny the fact, that you were employed by Carolina Model Homes, and received total income from that firm of \$809.

Mr. KORNEGAY. I respectfully decline to answer that question based on the grounds previously stated.

Mr. APPELL. I put it to you as a fact, and ask you to affirm or deny the fact, that in the same year you were employed by Capitol Homes, Inc., and received total income of \$1,853.76.

Mr. KORNEGAY. I respectfully decline to answer that question based on the grounds previously stated.

Mr. APPELL. I put it to you as a fact, and ask you to affirm or deny the fact, that the total income which you reported in 1962 was \$2,262.76.

Mr. KORNEGAY. I respectfully decline to answer that question based on the grounds previously stated.

Mr. APPELL. I put it to you as a fact, and ask you to affirm or deny the fact, that in 1963 you were employed by Summit Insurance Company of Raleigh, North Carolina, and received commissions and wages totaling \$2,379.15.

The CHAIRMAN. As reported on your income tax return.

Mr. KORNEGAY. I respectfully decline to answer that question based on the grounds previously stated.

Mr. APPELL. I ask you if also in the year 1963 you were employed by the Carolina Insurance Agency and received total income of \$1,343.30, and I put it to you as a fact, and ask you to affirm or deny it.

Mr. KORNEGAY. I respectfully decline to answer that question based on the grounds previously stated.

Mr. APPELL. I put it to you as a fact, and ask you to affirm or deny the fact, that you reported total income for the year 1963 of \$3,722.45.

Mr. KORNEGAY. I respectfully decline to answer that question based on the grounds previously stated.

(Income tax returns for years 1961–1963 marked “Marshall Kornegay Exhibits Nos. 3–A through 3–C,” respectively, and retained in committee files.)

Mr. APPELL. I put it to you as a fact, and ask you to affirm or deny the fact, that in 1965 you became a paid employee of the United Klans of America, Knights of the Ku Klux Klan, and received salary from an account maintained in the name of the United Klans of America, care of James R. Jones, P.O. Box 321, Granite Quarry, North Carolina, maintained at the Wachovia Bank and Trust Company, Salisbury, North Carolina.

Mr. KORNEGAY. I respectfully decline to answer that question based on the grounds previously stated.

Mr. APPELL. Mr. Kornegay, I am now going to hand to you checks dated July 5, 1965; July 10, 1965; July 16, 1965; July 23, 1965; August 1, 1965; August 6, 1965; August 14, 1965; August 20, 1965.

These checks are on a check which has imprinted on the top “United Klans of America, Inc., P.O. Box 321, Granite Quarry, N.C.” The dates that I have mentioned appear on the checks. They say, “Pay to the order of M. R. Kornegay \$150.00,” drawn on the Wachovia Bank and Trust Company, Salisbury, North Carolina. Purpose for which drawn: “Salary & Expense.”

There is then imprinted over two signatures “United Klans of America, Inc., James R. Jones, Donald E. Leazer,” or “Fred L. Wilson.”

The CHAIRMAN. And the checks are in what amounts?

Mr. APPELL. \$150 each, eight checks totaling \$1200. I put it to you as a fact, and ask you to affirm or deny the fact, that these checks were issued to you and that these checks contain your endorsement on the reverse thereof, as the person who cashed them or deposited them, these checks.

(Witness confers with counsel.)

(At this point Mr. Weltner returned to the hearing room.)

Mr. KORNEGAY. I respectfully decline to answer that question based on the grounds previously stated.

(Documents previously marked “James Jones Exhibit No. 7–E.” See p. 1721.)

Mr. APPELL. Mr. Kornegay, did the membership of the United Klans in the State of North Carolina know that you were receiving \$150 a week salary from them, from their money?

Mr. KORNEGAY. I respectfully decline to answer that question based on the grounds previously stated.

Mr. APPELL. Mr. Kornegay, I hand you a document which is an undated document, prepared earlier than the document to which I referred this morning in interrogating Mr. Jones. This document is signed “Marshall Robert Kornegay, Grand Klokar of N.C., Chairman—Car Committee.”

I put it to you as a fact, and ask you to affirm or deny the fact, at the time this document was distributed to all Klans in the North Carolina area that you held the position set forth on that document.

Mr. KORNEGAY. I respectfully decline to answer that question based on the grounds previously stated.

(Document marked “Marshall Kornegay Exhibit No. 4” follows:)

MARSHALL KORNEGAY EXHIBIT NO. 4

TO ALL UNITS:

Listed below is the amount each unit has paid on the Cadillac up to this date.

Unit number:		Unit number:	
22 -- Dana	\$175.00	23 -- Sanford	\$25.00
37 -- Farmville	100.00	26 -- Atkinson	25.24
48 -- Beulaville	65.00	53 -- Greenville	25.00
10 -- Greensboro	59.00	47 -- Henderson	25.00
9 -- Durham	58.00	11 -- High Point	25.00
4 -- Williamston	50.00	46 -- Olinston	25.00
24 -- Rocky Mount	50.00	38 -- Goldsboro	22.35
29 -- Louisburg	50.00	39 -- Enfield	20.00
41 -- Raleigh	50.00	40 -- Roanoke Rapids	20.00
35 -- Blounts Creek	50.00	27 -- Biscoe	20.00
33 -- New Bern	50.00	Salisbury Ladies	20.00
51 -- Nashville	50.00	15 -- Pittsboro	19.00
43 -- Tarboro	50.00	6 -- Raleigh Ladies	17.00
30 -- Hertina	50.00	31 -- Wilson	16.00
34 -- Cherryville	45.00	9 -- Louisburg Ladies	15.00
1 -- Salisbury	42.00		

This is a combined total of \$1,314.59.

Fellow Klansmen, the time for our pay off on this auto is rapidly coming around. We have only \$402.29 left in the car fund at this time. As you can see by the figures, we must have a substantial amount sent in to pay off this obligation.

We have received some money from 31 units (including 3 Ladies units) which only gives us 28 men's units cooperating.

According to the ones that have helped, we must get approximately \$175.00 per unit to pay the amount off.

If your unit hasn't contributed any money, please send me a check as soon as possible. If you have sent a small amount please make up the difference to the full amount of \$175.00 if at all possible.

I would like to thank personally each and every Klansman that has helped the car committee in this tremendous undertaking. I would also like to say that our Grand Dragon has appreciated the Honor bestowed upon him, by all of us, more than words could ever convey.

This beautiful auto has been one of the shining examples of white men getting together in great show of Klansmanship.

As you know the words of our oath unite us in a strong common bond of fellowship each man for each other and the group for each man.

Let us continue to be brothers and to stand up for what we know is right.

The God given right to be white and the God given right to be free.

Send money to: Mr. M. R. Kornegay, P. O. Box 9183, Raleigh, N. C.

Thank you Brother Klansmen!

Marshall Robert Kornegay
Grand Klodard of N. C.
Chairman - Car Committee

Mr. APPELL. Mr. Chairman, I would like the record to show—and I am not going to deal with the dollar signs of the money that had been paid into the Cadillac fund because I have referred to that and it is in the record of this morning—

The CHAIRMAN. Give a résumé of the document.

Mr. APPELL. The thing I wanted to do, Mr. Chairman, is that the document this morning says that from, let's say, Sanford, there was so much money received. I would like to show in the record at this time that the unit number of the Klavern is shown on this document. Therefore, the unit in Dunn is Unit 22; the unit in Farmville is Unit No. 37; the unit in Beulaville is No. 48—

The CHAIRMAN. By unit, do you mean Klavern?

Mr. APPELL. Yes, sir. That is the number assigned to the Klavern.

The unit in Greensboro is Unit 10; the unit in Durham is No. 9; the unit in Williamston is No. 4; the unit in Rocky Mount is No. 24; the unit in Louisburg is No. 29; the unit in Raleigh is No. 41; the unit in Blounts Creek is No. 35; the unit at New Bern is No. 33; the unit at Nashville is No. 51; the unit at Tarboro is No. 43; the unit at Norlina is No. 30; the unit at Cherryville is No. 34; the unit at Salisbury is No. 1.

Incidentally, Mr. Chairman, the committee's investigation established that even under the days of the old U.S. Klan, the unit in Salisbury was also No. 1.

The unit at Sanford is No. 23; the unit at Atkinson, No. 26; the unit at Greenville is 53; the unit at Henderson is 47; the unit at High Point is 11; the unit at Clinton is No. 46; the unit at Goldsboro is 38; the unit at Enfield is No. 39; the unit at Roanoke Rapids is 40; the unit at Biscoe is 27; the Salisbury ladies receive no unit number; the unit at Pittsboro is 19; the Raleigh ladies are given a unit designation of 6. The Wilson unit is No. 31 and the Louisburg ladies unit is No. 9.

Mr. Kornegay, there was put into the record this morning through Mr. Jones a report sent out as a compliment to a letter signed by him, a report on the car from the car committee and yourself as chairman showing that \$4,522.59 had been sent in and that there had been paid out \$4,522.59. There is a typed signature of "M. R. Kornegay, Chairman Car Committee." The enclosure announced that you were then at that time Grand Dragon of Virginia.

Did you prepare this document which I now hand you?

Mr. KORNEGAY. I respectfully decline to answer that question based on the grounds previously stated.

(Documents previously marked "James Jones Exhibits Nos. 18-A and 18-B," respectively. See pp. 1746, 1747.)

Mr. APPELL. Mr. Kornegay, in a State meeting in March 1965, were you elected to the position of klokard, or reelected to the position of klokard?

Mr. KORNEGAY. I respectfully decline to answer that question based on the grounds previously stated.

Mr. APPELL. I put it to you as a fact, and ask you to affirm or deny the fact, that you were present at that State meeting.

Mr. KORNEGAY. I respectfully decline to answer that question based on the grounds previously stated.

Mr. APPELL. I put it to you as a fact, and ask you to affirm or deny the fact, that at that State meeting, James R. Jones was elected Grand Dragon, Grady Mars was elected Grand Klaliff; that you, yourself, were elected grand klokard; that Reverend Roy Woodle was elected grand kludd; that Fred Wilson was elected grand klabee; that Robert Reaves was elected grand kladd; that Mr. Albert Outlaw was elected

grand klarogo; that Mr. Clarence Brindle was elected grand klexter; and that Boyd Hamby was elected grand night-hawk.

Mr. KORNEGAY. I respectfully decline to answer that question based on the grounds previously stated.

Mr. APPELL. Mr. Kornegay, were you the originator of the formation of a hospital-surgical insurance plan underwritten by the International Life—

Mr. KORNEGAY. I respectfully decline—

Mr. APPELL. I haven't finished yet.—the International Life and Accident Insurance Company with the Capital City Restoration Association?

Mr. KORNEGAY. I respectfully decline to answer that question based on the grounds previously stated.

(Documents marked "Marshall Kornegay Exhibit No. 5" and retained in committee files. A list of applicants for such group hospitalization policies appears on pp. 1814-1818.)

Mr. APPELL. Were you a member of the Capital City Restoration Association?

Mr. KORNEGAY. I respectfully decline to answer that question based on the grounds previously stated.

Mr. APPELL. I put it to you as a fact, and ask you to affirm or deny the fact, that you were a member of the Capital City Restoration Association.

Mr. KORNEGAY. I respectfully decline to answer that question based on the grounds previously stated.

Mr. APPELL. I put it to you as a fact that in the adoption of this insurance program—and I ask you to affirm or deny the fact—the Klans within the State, the Klaverns within the State of North Carolina, were told that the first month's premiums would be used to pay the expenses of Grand Dragon Jones and that a portion thereof would revert to the Klaverns.

Mr. KORNEGAY. I respectfully decline to answer that question based on the grounds previously stated.

Mr. APPELL. I put it to you as a fact, and ask you to affirm or deny the fact, that there was paid to you in the form of commissions from November of 1964 through May of 1965, in the form of new commissions and renewal commissions, the total of \$3,562.74.

Mr. KORNEGAY. I respectfully decline to answer that question based on the grounds previously stated.

Mr. APPELL. Mr. Kornegay, it is the committee's information that International Life and Accident Insurance Company sold out in early June or July of 1965 to the Life Insurance Company of Florida and that, following this transaction the Life Insurance Company of Florida determined that what was being written was not insurance for what they considered to be a legitimate fraternal organization, but that of the Ku Klux Klan, and that the new owners of the insurance company ordered that the policies be canceled and that refunds be made on all premiums paid covering periods that had not lapsed.

Mr. KORNEGAY. I respectfully decline to answer that question based on the grounds previously stated.

Mr. WELTNER. What was the date of that action by the owners of the company?

Mr. APPELL. Mr. Weltner, we have a letter here—

The CHAIRMAN. Just give the date.

Mr. APPELL. June 3, 1965. The pro rata refund of unearned premiums and adjustments of commissions would be made on or before June 20, 1965.

Mr. WELTNER. What was the initial date of the coverage?

Mr. APPELL. The initial date of the coverage?

Mr. WELTNER. How long had the plan been in effect?

Mr. APPELL. According to the documents which we subpoenaed and received from Mr. R. B. Royal, a former owner of the International Life and Accident Insurance Company, Mr. Kornegay received premiums or commissions on this from November—and the exact date in November is not stated—1964 through May of 1965.

Mr. WELTNER. Thank you.

Mr. APPELL. November through May of 1965, and total commissions paid to Mr. Kornegay were \$3,562.74.

Mr. Kornegay, did this cause a great deal of dissension among the Klansmen in North Carolina, the fact that some of them had paid premiums for 4 or 5 months, had had no illnesses, and all of a sudden their policies were cancelled on them?

Mr. KORNEGAY. I respectfully decline to answer that question based on the grounds previously stated.

(Documents marked "Marshall Kornegay Exhibit No. 6" and retained in committee files.)

The CHAIRMAN. Isn't it a fact that there was a considerable ruckus and dissatisfaction among the membership in view of the cancellation of their policies and the small refunds made to them compared to the full amount they had paid?

Mr. KORNEGAY. I respectfully decline to answer that question based on the grounds previously stated.

Mr. APPELL. Mr. Kornegay, according to the files that we received, you had a contract with Mr. R. B. Royal in which you signed a contract to operate in Raleigh, North Carolina, a branch office of the Carolina Insurance Agency.

I put it to you as a fact, and ask you to affirm or deny the fact, that Mr. Royal found it necessary to terminate his contract with you.

Mr. KORNEGAY. I respectfully decline to answer that question based on the grounds previously stated.

Mr. APPELL. Mr. Chairman, I would like to read into the record a letter dated June 21, 1965, addressed to Mr. M. R. Kornegay, P.O. Box 9183, Raleigh, North Carolina:

Dear Bob:

Shortly after our last visit I took a vacation which lasted for almost two weeks. I arrived in the office again this date and upon examining the reports I find you have not submitted any new business nor have you remitted any renewal premiums. I checked the lapses for April and May and found you had a total of \$159.60 in monthly premium. Some of these were advance pay cases, but I broke it down to show our monthly premium losses.

During our last visit we both discussed our future careers and as I told you mine is in the insurance business. I realize you are interested in another cause and I further realize [sic.] a person has to devote their talents to any endeavor they are most interested in. I feel as though you have lost interest in the insurance business, but due to my investment I am going to have to continue to stay in this field. You know the history behind the Raleigh office and I am

sure you relize [sic.] this has been a very costly operation from the date of orgin [sic.]. I feel that you can only say that I have treated you fairly and I would like to also feel that we are going to continue to be friends in the future. I am going to either close the office or appoint another person in Raleigh who will devote their full time to my business. If you desire to keep the office you are in I will make arrangements to move the furniture on or before July 1, 1965. Please advise the landlord of your intentions upon receipt of this letter.

Regards,
R. B. ROYAL

Did you receive the original of this letter, Mr. Kornegay?

(Document handed to witness.)

Mr. KORNEGAY. I respectfully decline to answer that question based on the grounds previously stated.

(Document marked "Marshall Kornegay Exhibit No. 7" and retained in committee files.)

Mr. APPELL. That letter, Mr. Kornegay, was dated June 21, 1965.

I read a letter dated Carolina Insurance Agency, Post Office Box 9183, Raleigh, North Carolina, June 25, 1965. "Mr. R. B. Royal, President, Carolina Insurance Agency Ins., Greensboro, North Carolina":

Dear Mr. Royal:

Since receiving your letter of dismissal dated June 21, 1965, I have given a lot of thought to this matter and contacted an attorney and I do not propose to go along with some of the things in said letter.

I this date ask for a conference between your attorney and you, my attorney and me as soon as possible.

Let's try to work this meeting within the next few days and then you can move the furniture.

Very truly yours,
/s/ M. R. Kornegay
M. R. KORNEGAY

(At this point Mr. Weltner left the hearing room.)

Mr. APPELL. I put it to you as a fact, and ask you to affirm or deny the fact, that this is a copy of the original letter which you wrote to Mr. R. B. Royal.

(Document handed to witness.)

Mr. KORNEGAY. I respectfully decline to answer that question based on the grounds previously stated.

(Document marked "Marshall Kornegay Exhibit No. 8" and retained in committee files.)

Mr. APPELL. Mr. Kornegay, I put it to you as a fact, and ask you to affirm or deny the fact, that Mr. Royal paid off for you promissory notes, made good on checks which bounced for insufficient funds, paid for telephone calls that were not insurance business, and that when you left his employment you owed him the sum of \$1,435.22.

(Witness confers with counsel.)

Mr. KORNEGAY. I respectfully decline to answer that question based on the grounds previously stated.

Mr. APPELL. Mr. Kornegay, I would like to ask you whether you possess any knowledge of how, why, and who had anything to do with the burning of a cross on the lawn of the Governor's Mansion, former Governor Terry Sanford, on August 14, 1964.

Mr. KORNEGAY. I respectfully decline to answer that question based on the grounds previously stated.

Mr. APPELL. I ask you if you possess any knowledge with respect to the placing and setting off of a cross, the burning of a cross, on February 23, 1965, in front of the Reverend Frank Hutchinson's home, 913 South West Street, Raleigh?

Mr. KORNEGAY. I respectfully decline to answer that question based on the grounds previously stated.

Mr. APPELL. Mr. Chairman, I have no further questions to ask this witness at this point.

I do have another item, Mr. Chairman.

Mr. Kornegay, I would like to ask you if it is a fact, from the information that the staff has gathered during its investigation, that the reason you were appointed Grand Dragon in Virginia was because of the resentment within the Klan against you in the State of North Carolina?

Mr. KORNEGAY. I respectfully decline to answer that question based on the grounds previously stated.

Mr. APPELL. I ask you if it is a fact, as our investigation established, that several members of the Klan, because of your conduct, had threatened you personally prior to your going to Virginia?

Mr. KORNEGAY. I respectfully decline to answer that question based on the grounds previously stated.

Mr. APPELL. Mr. Kornegay, I put it to you as a fact, and ask you to affirm or deny the fact, that at a meeting of the Rocky Mount Klavern on March 13, 1965, you addressed the group and spoke concerning Selma, Alabama, racial demonstrations, and that in the course of your presentation, and I will summarize this, you indicated that there was a definite need for mass killing in Selma, Alabama, before things could get back to normal.

I ask you to affirm or deny that.

Mr. KORNEGAY. I respectfully decline to answer that question based on the grounds previously stated.

Mr. APPELL. I have no further questions.

The CHAIRMAN. Mr. Pool.

Mr. POOL. Mr. Chairman, in listening to the testimony here, especially the testimony on the actions of the witness in regards to bringing the records before the committee, I don't intend to advise him as counsel. He has a lawyer with him and I respect the lawyer's counseling. But I want to point out that in *Arthur McPhaul* versus the *United States of America*, which was decided by the Supreme Court on November 14, 1960, Mr. Justice Whitaker delivered this opinion, and I will just cite the reference to the question we have had before us today.

It was a similar case where the witness had been subpoenaed to bring records and correspondence and things like that pertaining to the organization to a certain committee. This was before the House Committee on Un-American Activities. Mr. Justice Whitaker in his opinion, and the opinion was upheld by the Supreme Court, or, rather, speaking for the court, said this in his opinion:

The Fifth Amendment did not excuse petitioner from producing the records of the Civil Rights Congress, for it is well settled that "[b]ooks and records kept 'in a representative rather than in a personal capacity cannot be the subject of the personal privilege against self-incrimination, even though production of the papers might tend to incriminate [their keeper] personally.' * * *."

Here is another part of his opinion—

“ * * * a decent respect for the House of Representatives, by whose authority the subpoenas issued, would have required that [he] state [his] reasons for non-compliance upon the return of the writ.” * * *

In view of that, I will ask both the witness before us and also his attorney if they care to produce the records?

Mr. CHALMERS. Mr. Pool, may I state that I am thoroughly familiar with that opinion you have just read from, and we have been ordered by the Chairman to deliver the records. He has directed us to do it. We have declined to do it.

Mr. POOL. And you are going to stand on the record as made by you and your client?

Mr. CHALMERS. Yes, sir.

The CHAIRMAN. Have you anything else, Mr. Appell?

Mr. APPELL. No, Mr. Chairman.

The CHAIRMAN. Mr. Buchanan.

Mr. BUCHANAN. Mr. Chairman, I have no questions of this witness but I would like to make one statement. This committee is engaged in a solemn legislative purpose. As I understand it, it is our job, and we have had a mandate to do this, to look into an organization or a group of organizations to determine their nature of activities, to see whether there is a need for a legislative action or remedy. This is our purpose as a committee of the Congress.

In line with that purpose, one of the ways in which you understand an organization and come to evaluate that organization is by looking at its leadership and at the character and caliber of its leadership.

It seems to me that we have been doing a good bit of this in the hearings today. I just want to point out that this is a way to evaluate and to come to understand an organization, by taking a look at its leadership. In this connection, Mr. Chairman, I said this in order to say this, that I rather regret personally my earlier slip of the tongue in which I referred to the Imperial Wizard as the “Inferior Lizard,” not particularly because my opinion of Mr. Shelton has changed in the last hour, but because seriously this is not a place, of course, for name-calling or for personal opinion, so much as for developing evidence and hearing testimony to understand an organization.

I think we could say, and I think anyone who has attended these hearings would admit and testify, we have shed light on the nature of the leadership, the character and caliber of the leadership in this organization in the hearings to date.

Thank you, Mr. Chairman.

The CHAIRMAN. I understand you overlooked one point, Mr. Appell.

Mr. APPELL. Yes, Mr. Chairman, I overlooked one point.

Mr. Kornegay, the committee subpoenaed from the Branch Bank & Trust Company of Wilson, North Carolina, the checking account of M. R. Kornegay and the Carolina Insurance Agency. An analysis of this account shows that there was paid by check, stamped to identify it as “Carolina Insurance Agency, Inc.,” and “P.O. Box 9001,” it looks like, “Raleigh, North Carolina,” eight checks totaling \$415 to J. R. Jones, all signed M. R. Kornegay.

I put it to you as a fact, and ask you to affirm or deny the fact, that there are these eight checks totaling \$415 with you as the maker and with the payee as Mr. Jones.

(Documents handed to witness.)

Mr. KORNEGAY. I respectfully decline to answer that question based on the grounds previously stated.

(Documents marked "Marshall Kornegay Exhibit No. 9." One of said checks follows; balance retained in committee files.)

MARSHALL KORNEGAY EXHIBIT NO. 9



Mr. APPELL. Were these payments in the form of commissions to Mr. Jones on insurance written under the contract between the Capital City Restoration Association and International Life and Accident Insurance Company?

Mr. KORNEGAY. I respectfully decline to answer that question based on the grounds previously stated.

Mr. APPELL. I wish to point out, Mr. Chairman, that, as we observed in other parts of the record, two of these checks payable to Mr. Jones, one dated October 23, 1964, and one dated 11-6-64, did not go into any bank account of Mr. Jones, but went to show a further endorsement of the Mill Fabrics, Inc., and as these are 1964 this is additional material purchased by Mr. Jones, of which we do not have a record.

The president of Mill Fabrics explained the discrepancy to us by saying that when a person comes into the store and pays cash he has no invoice and, therefore, he did not have knowledge of additional purchases by Mr. Jones.

Mr. KORNEGAY, I show you a series of checks, all but one on the imprinted check of Carolina Insurance Agency, Inc., all with the maker being M. R. Kornegay, checks dated 11-12-64, 11-25-64, 12-14-64, 12-16-64, 2-2-65, 7-8-65—there are six checks totaling \$529, payable to Al or Albert Outlaw, who has been identified in this record as an official of the United Klans of America, Realm of North Carolina.

I put it to you as a fact, and ask you to affirm or deny the fact, that you are the maker of those checks and that Albert or Al Outlaw is the recipient of the money.

(Documents handed to witness.)

Mr. KORNEGAY. I respectfully decline to answer that question based on the grounds previously stated.

(Documents marked "Marshall Kornegay Exhibit No. 10." One of said checks follows; balance retained in committee files.)

MARSHALL KORNEGAY EXHIBIT NO. 10

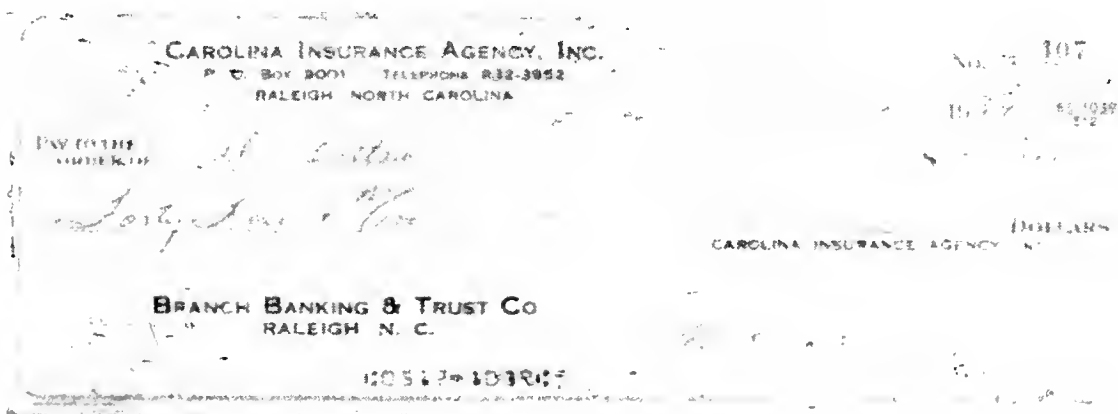

Mr. APPELL. I put it to you as a fact, and ask you to affirm or deny the fact, that instead of this money going to the Klaverns, that it was really announced as a plan at the start of the program that this money was paid to an official of the Klan, Albert or Al Outlaw as premiums for insurance that he sold.

Mr. KORNEGAY. I respectfully decline to answer that question based on the grounds previously stated.

Mr. APPELL. In examining your bank account, Mr. Kornegay, we could only find checks payable to the Farmers & Merchants Bank

towards the automobile, the Cadillac, given or donated to Mr. Jones in the amount of \$1956.

How was the balance of this money collected by you handled, and what was its depository?

MR. KORNEGAY. I respectfully decline to answer that question based on the grounds previously stated.

(Documents marked "Kornegay Exhibit No. 11." One check follows; balance retained in committee files.)

MARSHALL KORNEGAY EXHIBIT NO. 11

CAROLINA INSURANCE AGENCY, INC.
 101 N. BOYD ST. RALEIGH, N. C. 27602
 NA 1881 (N. C. 101) CAROLINA

No. 502
 23 10 65
 \$ 163 ⁰⁰/₁₀₀

Pay to the order of *Tarmon & Merchants Bank*
 One Hundred Sixty Three & ⁰⁰/₁₀₀ Dollars

BRANCH BANKING & TRUST CO.
 RALEIGH N. C.

M R Kornegay

CAROLINA INSURANCE AGENCY, INC.

MR. APPELL. Mr. Kornegay, did any part of the money submitted to you by Klaverns—

(Witness confers with counsel.)

THE CHAIRMAN. I see there is a whisper between counsel and his client. Let the record note that it is now exactly 5 o'clock, and when that last question was asked, whatever time that was, perhaps a minute or so ago, one of the members was on the telephone, and if the whisper between client and attorney had to do with a lack of a quorum, I ask you to repeat the last question.

MR. CHALMERS. No, sir; it did not, Mr. Chairman. And may I state to you, sir, that we are not concerned about that.

THE CHAIRMAN. On our own, I would adjourn right now if he had not been in the room.

MR. CHALMERS. We will make no point of it anywhere along the line.

MR. APPELL. Mr. Kornegay, as my last question, I must ask you did any part of the money turned over to you by Klans, Klaverns or individuals in payment of the automobile given to James R. Jones—was any of that money appropriated by you for your own purpose?

MR. KORNEGAY. I respectfully decline to answer that question based on the grounds previously stated.

MR. APPELL. I have no further questions.

THE CHAIRMAN. Mr. Kornegay, what is the Capital City Restoration Association? Honestly, what does it restore? What is the business of it?

MR. KORNEGAY. I respectfully decline to answer that question based on the grounds previously stated.

The CHAIRMAN. I am told by an investigator that our investigation reveals that this is one more front of a Klan organization. It is just a Klavern.

One final question, the same I put to the previous witness: The evidence established that you are the Grand Dragon of the United Klans of America, Inc., for the State of Virginia. Under the constitution and bylaws of the United Klans of America, checks drawn on their account or accounts of the United Klans of America are required to be authorized formally and specifically, as I recall, by the constitution and bylaws of the United Klans of America, requiring that the check be countersigned, with one signer required to be the treasurer, whatever the nomenclature is in the organization, and, as I understand it—and please correct me if I am wrong—as a Grand Dragon you collaborated with, advised with, or sort of acted in some broad form or other capacity with Mr. Shelton.

I ask you, were you aware of the fact that two people in fact signing the checks against the account of the United Klans of America, of which Shelton is the Imperial Wizard, were allegedly a male named James J. Hendrix, who turned out to be Mrs. Shelton, and another man named T. M. Montgomery, who turned out to be Carol Long, and that apparently to me, anyway, this was a ruse and a blind, deliberately or purposely designed to hide?

Were you aware of the fact that these two supposedly men were the ladies I named?

MR. KORNEGAY. I respectfully decline to answer that question based on the grounds previously stated.

MR. POOL. I have no further question, Mr. Chairman, in view of the fact that we have a reluctant Dragon here before us.

The CHAIRMAN. The committee will stand in recess until 10 o'clock tomorrow morning.

Before Mr. Kornegay leaves, I want to tell you, Mr. Kornegay, that you will remain under subpoena until November 15.¹

We will now stand in recess until 10 o'clock tomorrow morning.

(Subcommittee members present at time of recess: Representatives Willis, Pool, and Buchanan.)

(Whereupon, at 5:05 p.m., Thursday, October 21, 1965, the subcommittee recessed, to reconvene at 10 a.m., Friday, October 22, 1965.)

[On the following pages is a list of applicants for group hospitalization policies referred to on pp. 1805 and 1898.]

¹ Mr. Kornegay was not recalled, and on December 29, 1965, was discharged from further appearance under his subpoena.

[The following are applicants for group hospitalization policies sponsored by the United Klans of America, Inc., Realm of North Carolina, using cover name of Capital City Restoration Association. Kornegay Exhibit No. 5, p. 1805.]

Name and address of applicant	Name and address of unit	Name and address of applicant	Name and address of unit
Addison, Elmore L., 3002 E. Greer St., Durham, N.C.	Capital City Restoration Assn., P.O. Box 10484, Raleigh, N.C.	Brown, Wade H., Route 1, Box 260, Chinquapin, N.C.	Capital City Restoration Assn., P.O. Box 10484, Raleigh, N.C.
Adkins, Berkley H., Route 7, Burlington, N.C.	Do.	Bryan, Charles Sanford, P.O. Box 321, Granite Quarry, N.C.	Do.
Albertson, John E., Route 1, Beulaville, N.C.	Do.	Bryant, Joseph C., 1917 Wood Dale Terrace, Charlotte, N.C.	Do.
Allen, Cushion Biggs, Route 3, Williamston, N.C.	Do.	Bullock, James Robert, Box 363, Chocowinity, N.C.	Do.
Anderson, George F., Box 455, Bridgeton, N.C.	Do.	Bunting, Jessie M., Route 2, Box 503A, Greenville, N.C.	Do.
Anderson, Hilton D., Box 283, Chocowinity, N.C.	Do.	Bushhousen, L. M., Route 1, Blounts Creek, N.C.	Do.
Anderson, John, Jr., Genl. Del., Bridgeton, N.C.	Do.	Butler, Marian Franklin, Route 3, Dunn, N.C.	Do.
Anderson, Joseph R., Box 113, Bridgeton, N.C.	Do.	Butler, Shelton Richardson, Route 3, Dunn, N.C.	Do.
Anderson, Larry, Route 1, Farnville, N.C.	Do.	Byerly, Willis A., 414 Hodgkin St., High Point, N.C.	Do.
Anderson, Pete, Route 1, Box 134, New Bern, N.C.	Do.	Carter, Luther, 827 Argo St., Goldsboro, N.C.	Do.
Askew, Lonnie E., 803 Champion St., Henderson, N.C.	Do.	Carter, Raeford W., Route 1, Blounts Creek, N.C.	Do.
Ayscue, John Scott, Route 1, Henderson, N.C.	Do.	Champion, Charlie S., Jr., 321 Ranos Dr., Henderson, N.C.	Do.
Barber, Wilbert J., 503 Herring St., Clinton, N.C.	Do.	Clark, A. E., Clark's Bird Game Farm, P.O. Box 241, Beulaville, N.C.	Do.
Barbour, Lue Esther, Route 1, Coats, N.C.	Do.	Clark, Douglas A., P.O. Box 241, Beulaville, N.C.	Do.
Barbour, Thomas E., Route 1, Coats, N.C.	Do.	Clark, Joe H., 432 Cedar St., Henderson, N.C.	Do.
Barefoot, James Dewey, Route 5, Dunn, N.C.	Do.	Clark, John Archie, Jr., Box 555, Zebulon, N.C.	Do.
Barefoot, R. E., Route 2, Benson, N.C.	Do.	Coats, Joseph Sherrill, Route 3, Dunn, N.C.	Do.
Barnhill, Donald M., Genl. Del., Atkinson, N.C.	Do.	Coker, Joe, Route 1, Whitakers, N.C.	Do.
Barringer, Melvin L., 305 Union Hgts. Blvd., Salisbury, N.C.	Do.	Comer, William Thomas, P.O. Box 255, Norlina, N.C.	Do.
Bass, Jerry Dawson, 500 N. Wilson Ave., Dunn, N.C.	Do.	Cooley, Ervin, Route 3, Box 35, Elm City, N.C.	Do.
Bass, Sherrill F., 500 N. Wilson Ave., Dunn, N.C.	Do.	Corbett, F. M., Route 1, Box 113, Fountain, N.C.	Do.
Bates, David, Route 2, Box 291, China Grove, N.C.	Do.	Corriher, Carrie M., Route 4, Box 544, Salisbury, N.C.	Do.
Beasley, Elmer, Route 7, Raleigh, N.C.	Do.	Council, Jessie A., Route 3, Box 508, Williamston, N.C.	Do.
Blalock, Jack H., Box 602, Apex, N.C.	Do.	Cox, Robert A., Box 136, Blounts Creek, N.C.	Do.
Boggs, Garland Gene, Route 3, Williamston, N.C.	Do.	Cox, Walter T., R.F.D. 5, Lexington, N.C.	Do.
Bowen, Allen T., Route 1, Box 516, Ayden, N.C.	Do.	Cox, Zennie, Box 93, Apex, N.C.	Do.
Brantley, Cornelius F., Box 13, Bunn, N.C.	Do.	Crowder, John W., 403 Penny Street, Garner, N.C.	Do.
Brantley, David P., Route 2, Zebulon, N.C.	Do.	Crowell, Arthur Lee, 121 N. Clay Street, Salisbury, N.C.	Do.
Brantley, Frances C., P.O. Box 13, Bunn, N.C.	Do.	Crowell, Mary Ann, 121 N. Clay Street, Salisbury, N.C.	Do.
Brigman, Nancy B., 304 Mendeta Ave., Lexington, N.C.	Do.		
Brown, Robert H., 2223 Rumson Rd., Raleigh, N.C.	Do.		

Name and address of applicant	Name and address of unit	Name and address of applicant	Name and address of unit
Curlings, John W., 1412 W. Gold Street, Wilson, N.C.	Capital City Restoration Assn., P.O. Box 10484, Raleigh, N.C.	Hicks, James R., 218 Gary Street, Henderson, N.C.	Capital City Restoration Assn., P.O. Box 10484, Raleigh, N.C.
Davis, Alonzo Redd, Route 3, Raleigh, N.C.	Do.	Hilburn, James H., Route 7, Raleigh, N.C.	Do.
Davis, Kenneth W., 2202 S. William, Goldsboro, N.C.	Do.	Hinkle, Clyde V., 28 W. Green Street, Thomasville, N.C.	Do.
Dayvault, Frank, Route 1, Box 409, Kannapolis, N.C.	Do.	Hinton, James D., Route 1, Zebulon, N.C.	Do.
Deese, Robert W., Route 7, Box 237, Salisbury, N.C.	Do.	Hinton, James D., Jr., Route 1, Zebulon, N.C.	Do.
Dewery, Joseph T., Jr., Route 3, Box 327, Tarboro, N.C.	Do.	Hoffman, David E., 1006 Lawrence Street, Sanford, N.C.	Do.
Duke, Anna G., Route 4, Box 1, Salisbury, N.C.	Do.	Holton, W.A., Route 1, Box 352, New Bern, N.C.	Do.
Dunn, Wilbur, Route 1, Box 327, Fountain, N.C.	Do.	Hope, Ruby Ray, 710 W. James Street, Raleigh, N.C.	Do.
Eason, Lester L., Route 3, Box 204, Tarboro, N.C.	Do.	Hudgins, G. M., 1001 S. Glenburnie Road, New Bern, N.C.	Do.
Edwards, Charlie, Box 74, Grimesland, N.C.	Do.	Hudgins, Robert E., 411 Dorothy Drive, Cary, N.C.	Do.
Emory, Ernest C., 824 Greenwich Street, Raleigh, N.C.	Do.	Humphrey, Stanley, 401 S. East R.R., Wallace, N.C.	Do.
Evans, Cullum N., 408 Montgomery St., Henderson, N.C.	Do.	Hunt, Andrew Jackson, 508 E. Franklin Street, Raleigh, N.C.	Do.
Fearrington, Paul E., Chapel Hill, N.C.	Do.	Hunt, B. R., South Church St. Ext., Rocky Mt., N.C.	Do.
Fields, John T., P.O. Box 1639, Durham, N.C.	Do.	Hurley, Euyless Grant, Route 5, Sanford, N.C.	Do.
Fisher, James, P.O. Box 321, Farmville, N.C.	Do.	Hurt, Paul T., Route 1, Box 139, Grantsboro, N.C.	Do.
Fisher, Sonny Jay, P.O. Box 321, Farmville, N.C.	Do.	Jackson, Henry, Route 3 (c/o A. C. Fowler), Dunn, N.C.	Do.
Flowers, Paul W., Route 4, Zebulon, N.C.	Do.	Jacobs, Dollie, 1010 Chester St., Durham, N.C.	Do.
Forsythe, Luther, Jr., Route 1, Knightdale, N.C.	Do.	Jernigan, George Alton, Route 5, Dunn, N.C.	Do.
Foshee, Alfred, Route 2, Bear Creek, N.C.	Do.	Jernigan, Robert H., Route 5, Dunn, N.C.	Do.
Foskey, Arnie, Route 4, Box 60B, Greenville, N.C.	Do.	Johnson, Arthur E., Route 2, Wake Forest, N.C.	Do.
Fowler, Willie, Route 1, Box 35, Clinton, N.C.	Do.	Johnson, David P., Route 2, Wake Forest, N.C.	Do.
Freeman, Velton Lee, Route 5, Sanford, N.C.	Do.	Johnson, Jesse, Route 2, Box 5A, Greenville, N.C.	Do.
Fulcher, David, Route 1, Ernul, N.C.	Do.	Johnson, Ned R., 615 Monroe Dr., Raleigh, N.C.	Do.
Garner, Preston N., Route 6, Sanford, N.C.	Do.	Jones, Charles E., P.O. Box 194, Bridgeton, N.C.	Do.
Gaskins, Luther Earl, Route 5, Box 300, New Bern, N.C.	Do.	Jones, Clara I., P.O. Box 194, Bridgeton, N.C.	Do.
Gaskins, Vernal, 1313 S. Washington, Greenville, N.C.	Do.	Jones, Edwin, Route 1, Mt. Olive, N.C.	Do.
Gladden, Samuel Leon, Route 3, Sanford, N.C.	Do.	Jones, James R., Box 321, Granite Quarry, N.C.	Do.
Godwin, Kenneth Wayne, Route 5, Dunn, N.C.	Do.	Joyner, Wiley G., Raleigh Rd. Ext., Box 557, Rocky Mt., N.C.	Do.
Griffin, Bobby A., Route 8, Box 99, Raleigh, N.C.	Do.	Kersey, Belvin, 419 Bizzell St., Clinton, N.C.	Do.
Halloman, Levi, 109 Parkview, Wilson, N.C.	Do.	Kidd, Eddie L., 918 Jackson St., Roanoke Rapids, N.C.	Do.
Halloman, Patsy Rose, 109 Parkview, Wilson, N.C.	Do.	Kinton, Jerry S., Route 3, Sanford, N.C.	Do.
Hardee, Linwood, Route 2, Box 34, Farmville, N.C.	Do.	Kornegay, Herbert, Route 6, Gainey Dr., Goldsboro, N.C.	Do.
Harding, Berble, Route 1, Chocowinity, N.C.	Do.	Kornegay, Marshall R., 4312 Wedgewood Dr., Raleigh, N.C.	Do.
Hardison, William E., Route 3, Dunn, N.C.	Do.	Lambert, Robert R., Route 6, Box 248(?), Goldsboro, N.C.	Do.
Harris, Amos M., Route 8, Box 345, Salisbury, N.C.	Do.	Lancaster, Lester R., 1103 Albemarle Avenue, Tarboro, N.C.	Do.
Hearn, Cleveland F., Box 6, Colon, N.C.	Do.		
Hefner, D. C., Sr., Route 2, Bear Creek, N.C.	Do.		
Herrin, John C., Parkers Drug Store, Henderson, N.C.	Do.		

Name and address of applicant	Name and address of unit	Name and address of applicant	Name and address of unit
Lassiter, Earl, Box 103, Snow Hill, N.C.	Capital City Restoration Assn., P.O. Box 10484, Raleigh, N.C.	Newton, Robert A., Route 1 Henderson, N.C.	Capital City Restoration Assn., P.O. Box 10484, Raleigh, N.C.
Leazer, Donald E., Route 3, Box 608, Salisbury, N.C.	Do.	Norris Willie Earl, Route 1, Box 118A, Garner, N.C.	Do.
Leonard, Arthur C., 517 E. Bank St., Salisbury, N.C.	Do.	Norville, Betty L., Box 63, Falkland, N.C.	Do.
Lewis, Henry, Route 1-70, Blounts Creek, N.C.	Do.	Norville O. L., Box 63, Falkland, N.C.	Do.
Lewis, Joseph, Jr., Route 1, Blounts Creek, N.C.	Do.	Nyberg, John H., 1423 Spencer Ave., New Bern, N.C.	Do.
Lewis, L. W., Route 1, Blounts Creek, N.C.	Do.	O'Dell, Cannon R., Route 1, Rockwell, N.C.	Do.
Lewis, Robert, Genl. Del. Elm City, N.C.	Do.	O'Neal, Linwood Earl, Route 2-P, Bailey, N.C.	Do.
Linton, Robert, 1901 B. Maple St., Goldsboro, N.C.	Do.	Outlaw, Oza Albert, 3153 Stanhope Ave., Raleigh, N.C.	Do.
Lockamy, Robert Dwight, 4312 Wedgewood Dr., Raleigh, N.C.	Do.	Overcash, David, 306 Union Hgts. Blvd, Salisbury, N.C.	Do.
Lovie, Lynn, 108 N. Waverly St., Farmville, N.C.	Do.	Parker, Chester, Route 5, Dunn, N.C.	Do.
Lowery, William T., 108 Hekory St., Lexington, N.C.	Do.	Partin, C. Allen, Box 47, Siler City, N.C.	Do.
Lucas, Willie Harold, Route 3, Dunn, N.C.	Do.	Peaks, Rannie, Route 2, Box 249, Williamston, N.C.	Do.
Lynch, Jimmy W., 478 E. Main St., Clayton, N.C.	Do.	Perry, Herbert M., Route 3, Zebulon, N.C.	Do.
Manning, Carl, 407 Perkins Ave., Greenville, N.C.	Do.	Perry, James L., 315 E. Whitaker Mill Rd., Raleigh, N.C.	Do.
Marks, Gordon A., 620 Bureh Ave., Durham, N.C.	Do.	Pike, Nathan R., 1505 Aycock St., Wilson, N.C.	Do.
Mars, Grady B., Arcola Rural Sta., Warrenton, N.C.	Do.	Pippin, Marion Ray, Route 2, Box 618, Washington, N.C.	Do.
Marshburn, J. E., 2 Logan Court, Raleigh, N.C.	Do.	Pittman, Ernest, Route 1, Box 206, Enfield, N.C.	Do.
Martin, James K., R.F.D. 9-122B, Lexington, N.C.	Do.	Pittman, Vernon Ray, Route 1, Box 206, Enfield, N.C.	Do.
Mauney, Bessie M., Route 2 (28021), Cherryville, N.C.	Do.	Pollock, Donald R., 820 N. William St., Goldsboro, N.C.	Do.
Mauney, Everette F., Route 2 (28021) Cherryville, N.C.	Do.	Poole, George R., P.O. Box 562, Thomasville, N.C.	Do.
McCracken, Francis O., 702 Grace St., High Point, N.C.	Do.	Powell, Eva Adkin, Route 2, Lucoma, N.C.	Do.
McCracken, Verlon, 710 Paramount St., High Point, N.C.	Do.	Powell, Lee, Route 2, Lucoma, N.C.	Do.
McCubbins, William R., 709 7th St., Spencer, N.C.	Do.	Powell, Walter Lee, Route 2, Lucoma, N.C.	Do.
McDuffie, William Douglas, Route 1, Biscoe, N.C.	Do.	Poythress, Forest, 110 N. Main Street, Laurinburg, N.C.	Do.
Memory, George A., 413 Denny St., High Point, N.C.	Do.	Price, Johnnie A., 305 Murray St., Goldsboro, N.C.	Do.
Moore, Cecil E., Route 2, Dover, N.C.	Do.	Proctor, Charlie R., Route 2, Zebulon, N.C.	Do.
Morris, David F., P.O. Box 172, Knightdale, N.C.	Do.	Raper, Richard, 3815 Burt Dr., Raleigh, N.C.	Do.
Morris, Herbert Bolt, Route 2, Box 12, Halifax, N.C.	Do.	Reaves, Robert L., 114 Falkner St., Henderson, N.C.	Do.
Morris, John F., Ernul, N.C.	Do.	Rich, Edward F., Route 3, Kinston, N.C.	Do.
Moses, Jerry, Route 3, Pittsboro, N.C.	Do.	Richardson, Flora L., 510 E. Maple Ave., Gastonia, N.C.	Do.
Murchison, William Harold, Jr., Box 71, Goldston, N.C.	Do.	Richardson, Lonie L., 510 E. Maple Ave., Gastonia, N.C.	Do.
Murray, Jack C., 3012 E. Geer St., Durham, N.C.	Do.	Ritter, Norwood, Route 1, Pikeville, N.C.	Do.
Murray, Jack C., Jr., 306 S. Benjamin St., Durham, N.C.	Do.	Rivers, Wayne, 529 Rowland St., Henderson, N.C.	Do.
Murray, Jesse W., 829 Argo St., Goldsboro, N.C.	Do.	Robbins, William Edward, Jr., P.O. Box 57, Wilson, N.C.	Do.
Narron, Ishmael W., Box 242, Knightdale, N.C.	Do.	Rogers, Gerald V., 2938 N. Blvd., Raleigh, N.C.	Do.
		Ruffin, Herman, 1207 Herring Ave., Wilson, N.C.	Do.

Name and address of applicant	Name and address of unit	Name and address of applicant	Name and address of unit
Russ, James O., Route 3, Sanford, N.C.	Capital City Restoration Assn., P.O. Box 10484, Raleigh, N.C.	Turnage, J. H., Route 3, Wilson, N.C.	Capital City Restoration Assn., P.O. Box 10484, Raleigh, N.C.
Sandlin, Fred, Route 2, Beulaville, N.C.	Do.	Tutor, Bobby R., 702 Hamiton [sic] Rd., Raleigh, N.C.	Do.
Saulter, J. E., 2705 Jefferson Dr., Greenville, N.C.	Do.	Wagner, Donald E., 23 West Green St., Thomasville, N.C.	Do.
Seehrest, James L., 303 Kindberry, Lexington, N.C.	Do.	Wainwright, Jim W., Route 1, Box 172A, Fountain, N.C.	Do.
Seymour, Earl E., 221 Grand Ave., Raleigh, N.C.	Do.	Watkins, Wade C., 517 Holloway St., Durham, N.C.	Do.
Shaekelford, James, Route 2, Box 61, Farmville, N.C.	Do.	Watson, Shelby R., 105 Olive Ave., Lenoir, N.C.	Do.
Sharpe, Reno C., Route 2, Box 103, Bear Creek, N.C.	Do.	Webber, Cooper, Jr., Apt. 6, St. Andrews St., Tarboro, N.C.	Do.
Sherriek, Myrtle A., P.O. Box 244, Tarboro, N.C.	Do.	Webber, Phillip J., 1004 Poplar St., Tarboro, N.C.	Do.
Sherron, James, 511 Oakwood Ave., Raleigh, N.C.	Do.	Wells, Redmond, Route 4, Box 322, Wilson, N.C.	Do.
Skol, Walter L., Route 3, China Grove, N.C.	Do.	Weston, Durwood S., Route 2, Box 207, Blounts Creek, N.C.	Do.
Smith, Joseph T., Route 1, 61A, Farmville, N.C.	Do.	Whitley, Charlie B., 478 E. Main St., Clayton, N.C.	Do.
Smith, Matthew C., Route 5, Lexington, N.C.	Do.	Wileox, James P., P.O. Box 51, New Bern, N.C.	Do.
Smith, Ronald C., Route 1, Farmville, N.C.	Do.	Williams, Ernest, Route 4, Dunn, N.C.	Do.
Smith, William E., Box 86, Wendell, N.C.	Do.	Williams, Robert H., 307 Jackson St., Roanoke Rapids, N.C.	Do.
Stamey, William Harold, Route 1, Knightdale, N.C.	Do.	Williamson, Earl C., Route 2, Box 89, Williamston, N.C.	Do.
Stephenson, E. H., Route 1, Enfield, N.C.	Do.	Wilson, Alex Cullom, P.O. Box 311, Apex, N.C.	Do.
Stirewalt, John F., Route 2, China Grove, N.C.	Do.	Wilson, Fred L., 610 Little St., Salisbury, N.C.	Do.
Strickland, Leroy, P.O. Box 65, Saratoga, N.C.	Do.	Winecoff, Barrett A., Route 7, Box 498, Salisbury, N.C.	Do.
Surles, Alfred T., Box 182, Micro, N.C.	Do.	Winstead, Henry C., S. Goldsboro St., Wilson, N.C.	Do.
Sutton, Edward E., Route 2, Box 14, Newton Grove, N.C.	Do.	Woods, Darrell A., 805 Park St. Smyre, Gastonia, N.C.	Do.
Tart, Garland D., Route 2, Benson, N.C.	Do.	Barnhill, Reginald Renno, 115 N. Dennis Street, Enfield, N.C.	Halifax County Sportsman Club, Box 611, Enfield, N.C.
Tart, Lehmon, Route 2, Dunn, N.C.	Do.	Cuthrell, Ralph Donald, Jr., 413 Sherrod Heights, Enfield, N.C.	Do.
Taylor, C. P., Route 5, Kinston, N.C.	Do.	Johnson, J. Ryford, P.O. Box 166, Whitakers, N.C.	Do.
Taylor, Clifton E., Route 4, Box 197, Goldsboro, N.C.	Do.	Lucas, Herman Loyd, Enfield, N.C.	Do.
Taylor, Colonel B., Box 336, Pikeville, N.C.	Do.	Hudson, C. B., Route 1, Coats, N.C.	Hartnett County Improvement Association, P.O. Box 48, Dunn, N.C.
Taylor, James E., Route 1, Farmville, N.C.	Do.	Ranes, Ballard M., 116 Parker Street, Henderson, N.C.	Keystone Club, 1069 Henderson, N.C.
Taylor, John William, Route 3, Box 35, Elm City, N.C.	Do.	Carter, James D., P.O. Box 681, Kings Mountain, N.C.	Kings Mountain, N.C., No. 55, P.O. Box 681, Kings Mountain, N.C.
Teague, Edgar R., Route 2, Robbins, N.C.	Do.	Houston, Tom, Route 2, Pink Hill, N.C.	Limestone Fishing Club, P.O. Box 313, Beulaville, N.C.
Tilton, Edward L., Route 4, Raleigh, N.C.	Do.	Jones, A. V., Route 2, Pink Hill, N.C.	Do.
Todd, Brenda Gail, 203 Charlotte [sic] Ave., Sanford, N.C.	Do.	Kennedy, James D., Route 2, Pink Hill, N.C.	Do.
Todd, H. B., 203 Charlotte Ave., Sanford, N.C.	Do.		
Tolar, Nannie I., Route 1, Blounts Creek, N.C.	Do.		
Toler, Bill, Route 5, Box 166, New Bern, N.C.	Do.		
Tolson, Nellie P., 321 W. Main St., Thomasville, N.C.	Do.		
Tolson, Troy L., 321 W. Main St., Thomasville, N.C.	Do.		
Tripp, Troy L., 807 E. 6th St., Washington, N.C.	Do.		
Tucker, Melvin W., 200 No. Salisbury, Lexington, N.C.	Do.		

Name and address of applicant	Name and address of unit	Name and address of applicant	Name and address of unit
Biddle, Herbert McClammy, Sr., Box 124 Stokley Rd., Wilmington, N.C.	New Hanover Improvement Association, P.O. Box 1104, Wilmington, N.C.	Champlin, Connie M., Route 4, Box 169, Goldsboro, N.C.	No. 38, Goldsboro, N.C.
Cook, Jack Charles, 4208 Cedar Avenue, Wilmington, N.C.	Do.	Head, Ed Douglas, Route 6, Box 710, Goldsboro, N.C.	Do.
Elkins, Hubert Osmond, 309 Breckenridge Drive, Wilmington, N.C.	Do.	Marlow, Howard, 204 Westwood Drive, Goldsboro, N.C.	Do.
Shepard, J. T., 4112 Franklin Ave., Wilmington, N.C.	Do.	Sutton, Ross B., 1905 A E-Holly, Goldsboro, N.C.	Do.
Taylor, Lee M., Box 543, Wilmington, N.C.	Do.	Kernodle, James Woodrow, Route 2, Box 416, Durham, N.C.	Town and Country Sportsman Club, P.O. Box 244, Durham, N.C.
Freeman, Velton Lee, Route 5, Sanford, N.C.	No. 23, Sanford, N.C.	Ray, Floyd M., Box 858, Hillsboro, N.C.	Do.
Gains, Ernest Charles, Route 1, Sanford, N.C.	Do.	Robinson, Johnny Calvin, Route 2, Durham, N.C.	Do.
Rasser, Julian T., Route 1, Sanford, N.C.	Do.	Moseley, Linwood Earl, Route 1, Warrenton, N.C.	Warrenton Improvement Assotian, Norlina, P.O. Box 156, N.C.
Smith, Samuel P., P.O. Box 832, Sanford, N.C.	Do.		
Williams, Alton Leroy, 310 Hawkins Ave., Sanford, N.C.	Do.		

ACTIVITIES OF KU KLUX KLAN ORGANIZATIONS IN THE UNITED STATES

Part I

FRIDAY, OCTOBER 22, 1965

UNITED STATES HOUSE OF REPRESENTATIVES,
SUBCOMMITTEE OF THE
COMMITTEE ON UN-AMERICAN ACTIVITIES,
Washington, D.C.

PUBLIC HEARINGS

The subcommittee of the Committee on Un-American Activities met, pursuant to recess, at 10:15 a.m. in the Caucus Room, Cannon House Office Building, Washington, D.C., Hon. Edwin E. Willis (chairman) presiding.

(Subcommittee members: Representatives Edwin E. Willis, of Louisiana, chairman; Joe R. Pool, of Texas; Charles L. Weltner, of Georgia; John M. Ashbrook, of Ohio; and John H. Buchanan, Jr., of Alabama.)

Subcommittee members present: Representatives Willis, Pool, and Weltner.

Committee members also present: Representatives Richard H. Ichord, of Missouri, and George F. Senner, Jr., of Arizona.

Staff members present: Francis J. McNamara, director; William Hitz, general counsel; Alfred M. Nittle, counsel; Donald T. Appell, chief investigator; and Philip R. Manuel, investigator.

The CHAIRMAN. The subcommittee will please come to order, and our guests in the audience will please be seated.

Call your first witness.

Mr. APPELL. Mr. Chairman, I would like to call the Reverend Jack Crum.

The CHAIRMAN. The photographers will have to retire from the room.

Please stand.

Do you solemnly swear that the testimony you are about to give will be the truth, the whole truth, and nothing but the truth, so help you God?

Mr. CRUM. I do.

TESTIMONY OF JOHN (JACK) HAMMOND CRUM

Mr. APPELL. Reverend Crum, will you state your full name for the record, please, sir?

Mr. CRUM. John Hammond Crum. I am known as Jack.

The CHAIRMAN. Now, Mr. Appell. Mr. Crum, we are aware of the fact that you are a minister of the gospel. I think the Chair ought to say this.

We are not interested or concerned with your or anyone else's religious, theological, philosophical, or political beliefs. We are not really concerned with your opinions or anybody else's opinions, likes, or dislikes.

You are here under subpoena as an individual, to give your first-hand knowledge concerning the facts which we regard as pertinent to the subject matter of this inquiry.

I think I ought to make that plain, because that is our standard procedure and policy.

Mr. CRUM. Yes, I understand that, Mr. Chairman.

The CHAIRMAN. All right, proceed.

Mr. APPELL. For the record, Reverend Crum, you are appearing this morning in response to a subpoena served upon you?

Mr. CRUM. Yes, sir.

Mr. APPELL. Are you represented by counsel?

Mr. CRUM. I am not.

Mr. APPELL. Do you desire counsel?

Mr. CRUM. No.

Mr. APPELL. Would you please give to the committee—

The CHAIRMAN. Would you speak a little louder, Reverend?

Mr. CRUM. Yes.

Mr. APPELL. Would you please give to the committee your educational background?

Mr. CRUM. I graduated from Emory University in Atlanta, Georgia, in 1951. I graduated from Duke University Divinity School in 1955. I believe that is right.

Mr. APPELL. What is your denomination, Reverend Crum?

Mr. CRUM. I am a Methodist.

Mr. APPELL. Were you in Farmville, North Carolina, on September the 26th of 1964?

Mr. CRUM. Yes, I was.

Mr. APPELL. Reverend, did you attend an open public meeting of the Ku Klux Klan in Farmville, North Carolina, on September 26, 1964?

Mr. CRUM. Yes, I did.

The CHAIRMAN. Now, as I understand, that was a public meeting. That was a public meeting?

Mr. CRUM. Yes, it was, Mr. Chairman.

The CHAIRMAN. And information was disseminated to that effect?

Mr. CRUM. Yes. A friend of mine in Farmville picked up—I don't have with me, but he picked up a piece of the information which said it was a public rally, and the white public was invited.

The CHAIRMAN. All right.

Mr. APPELL. And you attended that rally?

Mr. CRUM. Yes, I did.

Mr. APPELL. Would you relate your experiences at that rally, sir?

Mr. CRUM. May I refer to my notes?

Mr. APPELL. Yes, sir.

Mr. CRUM. All right.

I went, sir, with my wife and with the Reverend W. S. Taylor, Jr., and with Father Gordon Kendall. We drove out to the site of the rally, just outside Farmville, at the intersection of Highway 264-A and Highway 264.

Later, although we didn't realize it at the time, we found that this was just beyond the Pitt County line, and in Greene County, and I—perhaps this contributed to the policing problem, because the Farmville police could not come. We had expected them to be there.

As we drove up to the rally, what we thought, or what we wondered, what looked like National Guardsmen, directed us to drive off the highway into a field. I thought of staying on the highway, but they were motioning, and so I parked by car off the highway, in the field, as they directed.

Later, Patrolman McCullum of the Highway Patrol said that he also at first thought that these Klans' security guards were National Guardsmen, and they were dressed with military uniforms; with helmets, boots, and insignia, and Mr. Taylor, who accompanied me, said that he saw rifles and billy clubs, also, that some of the security guard possessed.

(At this point Representative Buchanan entered the hearing room.)

Mr. CRUM. We parked the car, and then walked around. I was dressed in a suit and a hat, and I think a raincoat that I have over here, a white raincoat. My wife had on a red topcoat, and I carried a camera, which was outside of my raincoat in full view. We went without pretense. I dressed as I normally do, as I dressed to come here, because the Klans' invitation was a public invitation.

We went to see, by experience, what the Klan meeting was like, for we had read about it in the press.

On one side was the speaker's stand, and on the left of the stand was an American Flag. On the right was the Confederate flag, and in the center was a large picture of Senator Goldwater. To one side of the stand was a large, roped-off field in which stood a telephone pole-sized cross. Robed Klansmen and Klanswomen, the helmeted security guards, and spectators were walking around the field.

Mr. Taylor, who became separated from me, saw a man surrounded by guards, that he saw his films taken from him, and that he was escorted off the field. I did not know about this until later, but apparently this was a newspaperman.

A Klansman also challenged me. This was before the rally actually began. He said, "Is that a camera?" I thought it looked like a camera. I said, "Yes." He said, "We don't allow pictures."

Well, I told him I would be glad to put the camera away. Then a green-robed Klansman—

The CHAIRMAN. When you say "he," do you know who he was?

Mr. CRUM. No, I do not know who this man was. He was robed.

Mr. POOL. Can you further identify him?

Mr. CRUM. Not this particular man.

Mr. APPELL. Was he dressed in a white robe?

Mr. CRUM. He was; yes. But at this particular time, when this other man was questioning me, a green-robed man said it would be all right for me to take a picture of the cross, if I had a security guard with me who monitored the pictures that I took.

As I recall, he said, "If anybody questions you, tell them Bob said it was okay." I didn't know who this was, but I later found out that this man was Grand Dragon J. R. Jones, from Granite Quarry.

Now, I told the security guard who had been assigned to me, apparently, because he followed me everywhere I went, that I thought it

would be better if I put the camera back in the car, as I hadn't come to cause trouble at the Klan rally. He wouldn't reply to me. He wouldn't smile; he would only follow and look at me. But I decided that I would put the camera back in my car.

After all, my wife was present. I had come to a public rally. I hadn't come to get in a fight. So I went back to my Volkswagen and raised the hood and put the camera in the trunk.

One robed Klansman walked along beside me and said, "If you do"—that is, if you do take pictures—"that camera won't be here, and you are liable to be beaten up, too."

I do not know the name of this man.

The CHAIRMAN. Was he robed?

Mr. CRUM. Yes, he was.

I rejoined my wife and Father Gordon Kendall, at that time. The rally was opened with an invocation, and in the prayer, there was an appeal, the Lord's Prayer.

The CHAIRMAN. Reverend—

Mr. CRUM. Yes?

The CHAIRMAN. I would prefer that you don't indulge in descriptions of religious expressions. In fact, you used the name of one man; I am sorry you did.

Mr. CRUM. I am sorry.

The CHAIRMAN. I know, you were describing the platform.

Mr. CRUM. Yes.

The CHAIRMAN. All right.

Mr. CRUM. Can I delete that part of the testimony, or what is the procedure?

The CHAIRMAN. Well, we have given it too much prominence at that. That's all.

Mr. CRUM. I will try to be careful.

Now let me ask, Mr. Chairman, about another matter. At this time, as I said—

The CHAIRMAN. There was an invocation?

Mr. CRUM. Yes.

The CHAIRMAN. All right; that's proper.

Mr. CRUM. Then a man, a young man, who said he was from Wilson, spoke. Now, would you like for me to tell anything at all about what he said? I want to cooperate with the committee here. I have a very little bit, but it might be—

The CHAIRMAN. Will you desist for a moment?

(The subcommittee conferred off the record.)

The CHAIRMAN. I think it would be appropriate, if that is the case. I don't know what you are about to say.

Mr. CRUM. Yes.

The CHAIRMAN. Wait a minute. Let me put it this way—

Mr. CRUM. Yes, sir.

The CHAIRMAN. If it is true, or if you had in mind saying it, that there were exhortations to violence, fine, but I would prefer for you not to go into a description of racial or political or current issues. If there were exhortations to violence, give a general description in that sense, but I prefer that you not go into political issues, racial issues, because I am interested in what happened to you.

Mr. CRUM. Yes, right.

Well, what I was about to say, perhaps, might include names of people that were ridiculed.

The CHAIRMAN. Well——

Mr. CRUM. It might be past issues now. This was a year ago.

The CHAIRMAN. Well——

Mr. POOL. Mr. Chairman, I don't think that he ought to just have a carte blanche to name off people that were at this rally. The investigator might question him. Would that be better?

The CHAIRMAN. Suppose you respond to questions directed at you.

Mr. CRUM. Yes.

Mr. APPELL. Reverend Crum, after the speeches were made, what was the next course of action that was followed at the rally?

Mr. CRUM. Well, things happened during the rally which, after a couple of speeches were made, the security guard had been following me, apparently was displeased with something my wife was carrying. It was a small telescope. I brought it with me, so we said, well, we didn't want to cause trouble. We went and put it in the car.

But then one of the men dressed as a security guard came up to us, while we were at the car, and we were surrounded by, I guess, I don't know an exact number, I would say 15 of these security guards, and this man said, "We will have to have the film in that camera," referring to the camera that I had previously put in the trunk of the car.

I told him that I hadn't taken any pictures, and that I had put the camera up.

The CHAIRMAN. And you declare under oath that you had not taken any pictures?

Mr. CRUM. Yes, I did.

Mr. POOL. You do. You do declare under oath that you did not take any pictures.

Mr. CRUM. Yes, I do—at this rally. That is what you mean.

The CHAIRMAN. I understand.

Mr. CRUM. Yes. I told him that the pictures that were in the camera were vacation pictures, and, of course, I would like to keep those pictures for their sentimental value.

He replied—and I understood him to be, although I do not know his name—the chief or head security guard at that particular rally—he said, "We want that film." Now they were very positive. I took them to be menacing.

About that time, my two friends, Father Gordon Kendall and Mr. Taylor, came up. Father Kendall demanded, "Where is your warrant?" which I thought was an appropriate question. They did not reply to his question, however. I told them that I would cooperate in opening the trunk of the car, and that I would give them the film. After all, under those circumstances, with my wife beside me, I did not want to get into a fight, and as I said, I came to observe.

I asked if they would send the film back to me. I told them I was here as an open person, would be glad to give them my name and my address, which I did.

While I was doing that, one man——

The CHAIRMAN. Well, now, wait a minute. Did you say—I misunderstood you. Did you say that you offered to surrender, or you did not offer to surrender the film?

Mr. CRUM. Yes. I realize this is an important point. Let me try to get it clear.

The CHAIRMAN. Yes, I missed that.

Mr. CRUM. They demanded of me the film out of that camera. Well, I had the choice, it looked to me like, of opening the trunk voluntarily, and either giving them the camera or keeping my camera and taking the film out of it, and giving it to them, or of having it forced in some way, so I regarded this as force. But I submitted to them. I said, "I will cooperate and give you the film,"—

The CHAIRMAN. All right.

Mr. CRUM. —which I took out of the camera myself and handed to the head security guard. I asked him if he would return the film, which he said he would, when they had ascertained that it was not of the Klan rally, but I have never received it.

The CHAIRMAN. All right.

Mr. CRUM. Are there further questions?

Mr. APPELL. Did they just accept the film from you, and then leave you alone, and let you proceed upon your way?

Mr. CRUM. No, sir.

Mr. APPELL. What action, then, was taken by them?

Mr. CRUM. Well, they wanted to search the trunk of the car, but apparently, Mr. Chairman, they did not want to put their hands into the trunk of the car. This may be a technical legal point. So they stood outside the trunk, and they pointed, and they said, "What is that?"

No, first they said, "What was that other thing you put in the trunk of the car?" They were referring to the telescope.

The CHAIRMAN. Yes.

Mr. CRUM. And so my wife leaned in the trunk and took it out and gave it to them. They opened it up and pulled it out of the case and saw that it was only a telescope, put it back in, and gave it back to us.

Would you want me to tell a humorous bit?

Mr. APPELL. Yes, go right ahead.

Mr. CRUM. My wife was pretty peeved by this time. She leaned in the trunk of the car where she had an extra pair of shoes and stuck out a shoe and said, "Here, you want to search this, too."

The CHAIRMAN. Proceed.

Mr. APPELL. After this, did you leave or did you return to the rally for the purpose of hearing additional speeches?

Mr. CRUM. Well, we observed the attitude which we had tried to observe the whole time, sir, that we had come to a public rally, that we had every right to be there, by their invitation, and that we wanted to observe, and to see, and so we stayed. We stayed until about the end of the rally.

Mr. APPELL. After the speeches, and you were attempting to leave—

The CHAIRMAN. Well, about the speeches, let me ask you the direct question, in a general way: Were there exhortations to violence and reference to racial issues? Just answer the question.

Mr. CRUM. There was certainly reference to racial issues, and by "violence," this I would take to be more implied.

The CHAIRMAN. All right. That is enough. That is fine.

Mr. APPELL. As you returned to your car, were you again approached by the Klan's security guard?

Mr. CRUM. Yes. Mr. Chairman, we were approached at the end of the rally by people who were giving out literature, which I will be glad to submit to the committee, if you would desire.

The CHAIRMAN. Well, we will receive it and take a look at it.

(Documents marked "Jack Crum Exhibit No. 1" and retained in committee files.)

Mr. POOL. You say after the rally?

Mr. CRUM. Well, no, toward the close of the rally this was given out. About the time it was about to adjourn, but it hadn't formally adjourned.

The CHAIRMAN. All right.

Mr. CRUM. We did proceed to the car, or we started to proceed to the car, Mr. Chairman. I think one of us said, "Well, let's go" to the others, and we turned around to go. We saw behind us the security guard that had been with me—I think it was the same one—ever since we had been there. He said, "You are not going anywhere."

The CHAIRMAN. Was that the same individual who had been following you, or was it someone else?

Mr. CRUM. Well, I could not definitely say, but I think so. It was a security guard, dressed in one of the uniforms.

Mr. POOL. Did he have a mask on?

Mr. CRUM. No, sir; North Carolina law does not prohibit masks.

Mr. WELTNER. North Carolina law what?

Mr. CRUM. As I understand it, North Carolina law does not—does prohibit masks. I am very sorry. Thank you for that correction. Does not allow masks, is what I should have said.

Mr. POOL. You couldn't identify the faces. It was too hard, and you saw too many of them. Is that the idea?

Mr. CRUM. Of these particular men; that is true.

The CHAIRMAN. Proceed, Mr. Appell.

Mr. CRUM. Well, we were, of course, upset. The crowd was beginning to leave, and naturally, we did not want to stay. Father Gordon Kendall, as I recall, I think, said, "This is a free land, and we are going," and he started off, and we all started walking, despite what the security guard had said. At this, the security guard blew his whistle, and we were very quickly surrounded by a good number of the security guards, and we were stopped.

We did not know, we were not told, why we were being detained against our wills, upon this property.

Mr. POOL. How did they stop you?

Mr. CRUM. They surrounded us, as a group, from all sides. If we had proceeded, we would have had to push them out of the way.

The CHAIRMAN. All right.

Mr. CRUM. In a few minutes, a man who was called Bob, dressed in a brown sweater, appeared.

Mr. POOL. I didn't get the last word.

Mr. CRUM. A man who was called Bob, dressed in a brown sweater, without a robe, appeared. I recognized him as Grand Dragon J. R. Jones.

He asked about the camera, and we told him what had happened. He said that we were not being threatened. I replied, "One man threatened to beat me up." He asked "Was it a robed Klansman?"

"Yes," I answered. "A man"——

The CHAIRMAN. Now who is "he" in this instance?

Mr. CRUM. Grand Dragon J. R. Jones.

"Yes," I answered, "a man in a white robe." He replied, "If a Klansman said he would beat you up, you had better watch out, for he will do it."

Mr. APPELL. Did Jones then leave, and did the security guard disperse itself, or did they continue to harass you?

Mr. CRUM. Jones left for a few minutes, I do not know why, but then he returned, and we were kept there until he returned. When he came back, he asked Mr. Taylor, the Reverend Mr. Taylor, if he would allow him to search him. Well, again, I don't know the legal terms of the matters here. I am a layman. But with the security guards all around us, and with the crowd leaving the field, Mr. Taylor felt that he was forced to consent by saying "Yes, you can search me," rather than by resisting. He felt he was forced.

He emptied his pockets, at the Grand Dragon's direction. When he refilled them, he also put his glasses in his pocket, which my wife noticed, but I didn't, for he felt like we might be in real trouble, and might have a fight.

Jones then ran his hands down the sides of the Reverend Mr. Taylor, feeling his pockets.

Mr. APPELL. Is this the normal way that you would, like, shake a man down, if you were looking to see if he had any concealed arms or weapons or other instruments on him?

Mr. CRUM. I don't know much about this kind of thing, but I assume so; yes, sir.

The CHAIRMAN. It is what they call "frisking."

Mr. CRUM. Yes, sir.

Mr. APPELL. And this man was the Reverend Mr. Taylor?

Mr. CRUM. Yes, sir.

Mr. APPELL. Yes.

Mr. CRUM. He did not find anything, and Jones told the guards to get us off the field, and at that, we went back to the car.

Mr. APPELL. Now, were you immediately able to drive away, or did you find that you had some additional harassment to you which was unknown to you? Before that, did they require you to empty your pockets, and did they frisk you?

Mr. CRUM. No, they did not.

The CHAIRMAN. How about the third man who was with you?

Mr. CRUM. Father Kendall? No.

Mr. POOL. Father Kendall was not searched.

Mr. CRUM. No, he was not.

Mr. APPELL. But, of course, as I understand, Father Kendall was dressed in slacks.

The CHAIRMAN. Well, it wouldn't make any difference. He wasn't frisked. Proceed.

Mr. APPELL. What did you discover when you returned to your car?

Mr. CRUM. Well, we got in the car, and started driving off, and

then it looked like the car was not going along very well, so we got out and looked, and two of the tires had been partially deflated. At that, Father Kendall and Mr. Taylor stayed outside the car, and ran along beside it until we got the car to the highway, where there was a highway patrolman and sheriff's deputies who stayed with us until we had changed one of the tires.

Mr. APPELL. These acts were carried out against you and your companions as you have testified under oath with apparently no provocation on your part, or the part of your companions?

Mr. CRUM. There was no provocation except that they didn't know who I was, recognized me as someone they did not know, I suppose.

Mr. APPELL. Did you have other experiences in your life of which you made a comparison between your treatment at the Klan rally and your treatment that you had experienced previously?

Mr. CRUM. Well—

The CHAIRMAN. Mr. Appell, I don't know what that opens up. We don't want any generalities.

Wait a second.

(The subcommittee conferred off the record.)

The CHAIRMAN. Withdraw that question.

Mr. APPELL. I withdraw the question.

Did you make a tour of the Soviet Union?

The CHAIRMAN. Withdraw that question.

Mr. APPELL. I have no further questions, Mr. Chairman.

Mr. POOL. I have no questions.

Mr. WELTNER. Mr. Crum, how long were you detained at the Klan rally at Farmville, North Carolina?

Mr. CRUM. Not a long time, sir. I would say 10 to 15 minutes, but I know—I didn't keep a record.

Mr. WELTNER. How many security guards surrounded you on the first instance, when you were trying to move to your car?

Mr. CRUM. I have estimated it as being about 15.

Mr. WELTNER. Thank you.

Mr. CRUM. I am not sure. There were, as I recall, someone counted over 30—30 to 40 security guards on the field.

The CHAIRMAN. Could you estimate or did you try to estimate the numbers of people at the rally?

Mr. CRUM. I can give one accurate figure. Yes, the accurate figure—

The CHAIRMAN. Well, your best estimate, within your knowledge.

Mr. CRUM. There were about 85 robed Klansmen at the time they put on their robes and circled the cross, and then there were other people, of course, who were unrobed. I would have said—I hesitate, but not too many. I hesitate to give a figure. I am not very good at estimating, but not very many. Say a couple of hundred more.

The CHAIRMAN. That is the kind of figure that a witness is expected to give, an honest estimate. That is all right.

Any questions?

Mr. BUCHANAN. No.

The CHAIRMAN. Are there any facts relating to yourself, within your knowledge, occurrences affecting you or your group other than those you have related in general terms?

Mr. CRUM. I am not——

The CHAIRMAN. I mean, were there other, if there were things such as further threats, if there were threats, and further detention or further details along that line, within the framework of what we have been talking about?

Mr. CRUM. Well, there have been telephone calls to me and to friends of mine, and to some of those who went to this particular rally with me——

The CHAIRMAN. That is pertinent.

Mr. CRUM. —of a threatening nature.

The CHAIRMAN. That is pertinent. After the rally?

Mr. CRUM. Yes. Not a great many to me personally, let me say, but to others.

The CHAIRMAN. Let's say to you. You did receive phone calls?

Mr. CRUM. Yes, but not many.

The CHAIRMAN. Well, was there one?

Mr. CRUM. Yes, we will say one.

The CHAIRMAN. Or two or five?

Mr. CRUM. Yes. Right.

The CHAIRMAN. What was the general tenor of the phone calls? Were they in the nature of admonitions or threats or things of that kind?

Mr. CRUM. Generally, they were "You better not do this kind of thing again. You had better not say the things you have been saying about the Klan."

Mr. POOL. This was after the rally?

Mr. CRUM. Yes. But I wouldn't put a lot of importance on this.

The CHAIRMAN. And it is within your personal knowledge that others of your acquaintance received others and more telephone calls of that nature?

Mr. CRUM. I can refer to a man that was referred to in the testimony yesterday, in Raleigh, Frank Hutchinson.

The CHAIRMAN. His name was brought up?

Mr. CRUM. Yesterday, and he has received many more calls than I have.

The CHAIRMAN. And they were along the lines you have indicated.

Mr. CRUM. Yes.

The CHAIRMAN. We do sincerely appreciate your coming here, and we regard your experience, your first-hand knowledge, as being pertinent to the inquiry into the subject matter of this investigation. We appreciate your appearing.

Mr. CRUM. Yes, sir; you are welcome.

The CHAIRMAN. Call your next witness.

Mr. APPELL. Mr. Chairman, I would like to call Joseph G. DuBois.

Mr. DuBois, will you remain standing while the chairman administers an oath, please?

The CHAIRMAN. Please raise your right hand.

Do you solemnly swear that the testimony you are about to give will be the truth, the whole truth, and nothing but the truth, so help you God?

Mr. DuBois. I do, sir.

TESTIMONY OF JOSEPH G. DuBOIS

Mr. APPELL. Mr. DuBois, will you bring the mike in to you?

Mr. DuBois, are you appearing before the subcommittee today in accordance with a subpoena served upon you by a United States marshal at 10:55 a.m. on the 12th day of October 1965?

Mr. DuBois. Yes, sir.

Mr. APPELL. Mr. DuBois, are you represented by counsel?

Mr. DuBois. No, sir.

Mr. APPELL. Did you desire counsel?

Mr. DuBois. No, sir.

Mr. APPELL. Mr. DuBois, what is your educational background, sir?

Mr. DuBois. May I have a drink of water, please? I haven't been this nervous since just before going into action on Guadalcanal.

The CHAIRMAN. That is all right. Take your time.

Mr. DuBois. Repeat the question, sir.

Mr. APPELL. Would you give us your educational background, please, sir?

Mr. DuBois. Yes, sir.

At an early age, in my teens, my mother and father were separated: they separated. At the age of 15—I have a younger sister—I had to take over support of the family. I had to quit school. I went into CC Camps—most of you gentlemen know what that is—to support my mother and my sister. I had no one to turn to.

After that, while I was in the CC Camp, a Marine recruiter came through; I saw my 16th birthday.

The CHAIRMAN. What grade did you go to? The fact that you have little education is unimportant. We want it for the record. I might say that I have some folks who are uneducated.

Mr. DuBois. If you would let me continue, sir, I think I will answer all your questions.

The CHAIRMAN. All right.

Mr. DuBois. I went into the Marine Corps at the age of 16, after I saw my 16th birthday. I was—a Marine recruiter came through the CC Camp, recruiting Marines. He told me that I could finish my education in the Marine Corps, and learn a trade, so I immediately joined the Marine Corps. I took my training, sir—

Mr. APPELL. May I interrupt you, sir? At what year is that?

Mr. DuBois. This is approximately March 28, 1941. I have documented proof on that, sir.

Mr. APPELL. All right. Now, while you were in the Marine Corps, did you earn what we would call a high school equivalent certificate?

Mr. DuBois. No, sir. Soon after I joined the Marine Corps I was—the war broke out, approximately 9 months. I was with the Fleet Marine Force, which is the fighting unit of the Marine Corps ground units.

Mr. APPELL. We will get to that under your occupational—

The CHAIRMAN. Just answer the question. It will be easier for you. He has notes.

Mr. DuBois. All right, fine.

My 2 years, after I was—in 1948, I went back to night school and completed my high school education, sir.

Mr. APPELL. Thank you very much.

Now, would you please outline for the committee briefly your occupational background?

Mr. DuBois. Yes, sir. After going back to night—after finishing, going to night school to finish my education, I was offered a position with a B. F. Goodrich Company tire company. They had checked my records in the school, and they wanted to help me, and I went to Charlotte, North Carolina, with the B. F. Goodrich Company and took training in budget management.

The CHAIRMAN. That was when?

Mr. DuBois. Approximately '49, '48 and '49, somewhere in that neighborhood.

The CHAIRMAN. Let's go back a little bit, Don. Let's go back to his period of service, in the Armed Forces.

Mr. APPELL. Yes, sir. What year did you join the CC Corps?

Mr. DuBois. I don't know the exact date, sir, because I never did receive a discharge, since I went to the Marines, in the forties.

Mr. APPELL. Approximately how long?

Mr. DuBois. Approximately 9 months. We had 6 months' service, and I was starting on my second hitch, and the reason I did that, I sent all my money home to my mother and my sister to live off of—

Mr. APPELL. And then you joined the Marine Corps.

Mr. DuBois. The Marine Corps; yes, sir.

Mr. APPELL. All right. Now, what period of time were you in the Marine Corps?

Mr. DuBois. I was in the Marine Corps, sir, from March 28, 1941. I was discharged January 26th of 1944, by reason, upon report of a medical survey for disability, with character excellent.

Mr. APPELL. Now, I want to give you the opportunity to put into the record as a part of your employment what service you contributed to your country as a member of the Marine Corps.

Mr. DuBois. Sir, my record speaks for itself. On the bottom of this discharge is listed battles, engagements, skirmishes, and expeditions, and half a page are filled, here. You may inspect it.

Pass it to the chairman, sir.

The CHAIRMAN. Wait a second.

Well, this lists very many engagements. I see you were in the Samoan Islands, May 8th to September 4, 1942; the Solomon Islands, September 18, 1942 to January 5, 1943; Australia, January 12 to July 31, 1943; and you were under Japanese naval bombardment, vicinity of the mouth of the Lunga River, Guadalcanal, for a stated period of time here.

Skirmishes with the Japanese armed forces, vicinity of Pioneer Bridge, Lunga River, Guadalcanal, another period of service, 1942, battle of the Japanese Army Forces, vicinity of Mbalo, Guadalcanal area, and vicinity of Point Cruz, Guadalcanal, another engagement, and First Marine Division, operations against the Japanese Army, Unit A. Guadalcanal area, under enemy naval bombardment in October 1942, on Guadalcanal.

Participated in defense of Sector No. 3 in that area, action against Japanese forces in other areas of Guadalcanal engagements, and so on.

It is quite an impressive service. I will tell you that.

Mr. POOL. Is that the First Marine Division?

Mr. DuBois. Yes, sir.

Mr. POOL. I had a nephew.

Mr. DuBois. Here is the hometown paper that was put out while I was overseas.

Mr. POOL. I had a nephew in that same outfit.

Mr. DuBois. Thank you, sir. I would like for that to be——

The CHAIRMAN. By the way, this is not theatrics. The audience should understand that.

Here is a picture apparently on the front page called "Goldsboro Boy Gets Nine Japs At One Whack."

Mr. DuBois. Yes, sir.

The CHAIRMAN. Congratulations.

Mr. DuBois. Gentlemen, here is a writeup after I came back from Guadalcanal. I participated while I was in the hospital in California, some movie stars and other people were entertaining troops, came by the hospital, and they requested that I be able to go with them on the Third War Bond Drive. At that time it was the Third War Bond Drive. In that bottom, you will read it, sir, they gave me credit for selling \$500,000 worth of war bonds. That is in the bottom part of that writeup, sir.

The CHAIRMAN. Well, here are some of the headings of the papers. "Corporal Joseph DuBois Found Guadalcanal Hot Spot." Another one headed "Corporal DuBois Had 10 Attacks Through Flak," and many others.

Mr. DuBois. Gentlemen, I am not bragging. I didn't bring this information up here to be bragging. I would like to—I feel that my integrity and loyalty has been questioned.

The CHAIRMAN. All right, we will come to that.

Mr. APPELL. Mr. DuBois, we will give you an opportunity.

The CHAIRMAN. Just respond to his questions.

Mr. DuBois. All right.

Mr. APPELL. We will give you an opportunity to say whatever you would like to say for the record, sir.

Mr. DuBois. Do you have my discharge, sir?

Mr. ICHORD. Right here.

Mr. APPELL. Mr. DuBois, I wondered if when you return if you would have a copy of that discharge made and forwarded to us for the record, please.

Mr. DuBois. I will, sir.

(Document marked "Joseph DuBois Exhibit No. 1" and retained in committee files.)

Mr. APPELL. Mr. DuBois, then, after you got out of the Marine Corps you went to night school and then you had further employment.

Mr. DuBois. Pardon me. I would like to make one statement, please.

All during this time, while I was overseas fighting, I was sending home money to my mother and sister to live on. They had no welfare help, no help whatsoever, except what I sent them. I would like that part of the record, sir.

The CHAIRMAN. I commend you. He will develop the facts.

Mr. DuBois. Thank you, sir.

The CHAIRMAN. He interviewed you, and he will develop the facts.

Mr. DuBois. Thank you, sir. All right.

Mr. APPELL. Now, in order that the record follow a chronology, after discharge you said that you went to night school for education, so I assume that you took some kind of employment immediately after discharge.

Mr. DuBois. Yes, sir. With the B. F. Goodrich. Pardon me. Immediately after discharge, the mayor of our town, Mr. Scott Berkeley, who is deceased now, escorted me personally to the local air base to apply for a job, not a position. My first starting salary was \$1500, as a mechanic's helper.

Mr. APPELL. And then——

Mr. DuBois. I worked there until 1946.

Mr. APPELL. And then is it 1946 when you joined the B. F. Goodrich Company?

Mr. DuBois. Yes, sir; approximately. Sorry.

No. Well, '46, '7—there is a small length of time in there I worked with Sears, Roebuck in the Budget Department.

Mr. APPELL. Then how long did you remain employed with B. F. Goodrich Company?

Mr. DuBois. I am not sure, sir.

Mr. APPELL. But just your best estimate.

Mr. DuBois. Approximately 6 or 7 months. Under the circumstances, I wasn't being promoted as I felt I should be, through the local store, and I resigned.

Mr. APPELL. What was your next employment, sir?

Mr. DuBois. I operated a Firestone store in Smithfield as manager.

Mr. APPELL. How long did you operate that store, sir?

Mr. DuBois. Until it was sold. Approximately a year or better, until it was sold to an individual.

Mr. APPELL. What was your next employment, sir?

Mr. DuBois. Let's see. My next employment, sir, was with the Dixie Finance Corporation, which was a loan company.

Mr. APPELL. How long did you remain employed by them, sir?

Mr. DuBois. Until I went in business for myself, sir, in 1951.

Mr. APPELL. What business did you enter, sir?

Mr. DuBois. I went into the used car business, buying and selling used cars.

Mr. APPELL. Are you still engaged in that business?

Mr. DuBois. Yes, sir.

The CHAIRMAN. At what town is that?

Mr. DuBois. That is Goldsboro, North Carolina.

The CHAIRMAN. All right.

Mr. APPELL. Now, Mr. DuBois, the subpoena served upon you calls for you to produce:

All books, records, documents, correspondence, and memoranda relating to the organization of and the conduct of business and affairs of the Invisible Empire, United Klans, Knights of the Ku Klux Klan of America, Inc., also known as the United Klans of America, Inc., Knights of the Ku Klux Klan, and affiliated organizations, namely, the Alabama Rescue Service and Wayne County Improvement Association, in your possession, custody or control, or maintained by you or available to you as an officer or employee of the Wayne County Improvement Association of the Invisible Empire, United Klans, Knights of the Ku Klux

Klan of America, Inc., also known as the United Klans of America, Inc., Knights of the Ku Klux Klan.

Part 2 calls for you to produce :

All books, records, documents, correspondence, and memoranda in your possession, custody or control, or maintained by or available to you, in your capacity as an officer or employee of the Wayne County Improvement Association of the United Klans of America, Inc., Knights of the Ku Klux Klan, which the "Constitution and Laws" of said organization authorize and require to be maintained by you and any other officer of said organization, the same being in your possession, custody or control.

Under the terms of that subpoena, Mr. DuBois, I ask you if you have brought with you the documents called for.

Mr. DuBois. May I make a statement first, sir?

The CHAIRMAN. Surely.

Mr. DuBois. I have been informed by some members of the Klan I should stand on the fifth amendment. I think this is—will not help my record any. At this time, any vows that I took in this organization are secondary to the loyalty to my integrity and loyalty to this Nation. To God is first. Nation is second. Anything after that, I figure is secondary.

I have no intentions of taking the fifth amendment, no matter what happens. I have been informed that possibly I would be held in contempt. I hope and pray that you don't do that. I have come up here to speak the truth. I figure that if the Klan had nothing to hide, the reason I joined it, I thought it was an organization that was according to what I knew about it and what I read, the literature I had read, had been to the betterment of this country.

At this time, under the circumstances of the fifth amendment that the people have been taking on this, I would like to resign as a Klan member, and as treasurer of my local unit, and I have the people—I have nothing against my people of the unit. They are garden variety Americans. As far as I know, there is nothing subversive in it. I have found nothing subversive in it, and if it is found to be subversive, I have already resigned, but I hope that is no reflection on it as being subversive, because I have seen nothing.

The CHAIRMAN. We appreciate your attitude. I don't know who told you what about what you should do or not do, on what issues you should invoke the fifth amendment or not, or whether we would hold you for contempt or not.

We are the judges of that, and I congratulate you for voluntarily saying what you said, and I have no notion of what you are going to say or what you are about to say, and to what you said, I say amen.

Mr. DuBois. Thank you.

The CHAIRMAN. Now perhaps, Don, before he produces the document, don't you want to ask him when he joined, and lead up to it?

Mr. Appell. I will, Mr. Chairman. I was going to ask. However, preliminary to that, with respect to two statements that he just made, one with respect to him being urged to take the fifth amendment, as to the identity of those people who urged him to take the fifth amendment.

Mr. DuBois. Sir, the people that mentioned this to me, I have never seen before. I do not know their names. If I did, I would hate to divulge it.

The CHAIRMAN. But you honestly don't?

Mr. DuBois. I honestly don't, sir.

The CHAIRMAN. Was that in the nature of a telephone conversation, or personal appearance?

Mr. DuBois. Yes, sir; in difference ways.

The CHAIRMAN. I wish you would describe that.

Mr. DuBois. Well, sir, some of these people are not Klansmen. They are people that are back in my hometown, that know my background, respect me, and they said that "You think you are going to be in trouble, or get in trouble, take the fifth amendment."

The CHAIRMAN. Nobody gets in trouble anywhere in America by telling the truth.

Mr. DuBois. That is the reason I am up here, sir, and that is the reason I am up here without counsel.

The CHAIRMAN. We appreciate it.

Mr. Appell. Who gave you the advice that the committee might hold you in contempt?

Mr. DuBois. This was also over the phone, and I do not—I personally do not know the people.

The CHAIRMAN. Well, perhaps—

Mr. DuBois. I am a Baptist by faith, and I am a Christian, and I intend to tell the truth. I hope that I am not hurting anybody. I am not out here to blacken anyone's reputation; I don't want mine blackened. I don't want my children—back when I was fighting, I didn't know what I was fighting for. I was 17 years old, and I didn't know then, but now I have a wife and three children. I know what I am fighting for.

There are things that I do not approve of in the government, and being handed down by the government, but I am not hiding to tell it. I imagine that is the reason I am up here. I don't feel that I have anything to hide. There is bound to be some conflict in this country, and there is uprisings and the riots and everything, and I think that these people should come back and make this country as great as it has been, and I think this greatness of this country is not only because of the Government, but in spite of the Government. Individuals.

The CHAIRMAN. Well, I appreciate your views, and if there is one thing sacred in America, it is the right to speak out. Congratulations.

Mr. DuBois. Thank you, sir. I may be persecuted. I haven't been threatened.

The CHAIRMAN. Let me tell you this: I said in my opening statement and I now reiterate, if I have any influence—and the members feel that I do—in this town, if anything occurs to you in the way of threats or anything else, as the result of your appearance here, you just let us know.

(At this point Mr. Weltner left the hearing room.)

Mr. DuBois. Thank you, sir.

The CHAIRMAN. And as I said, knowing of our Government and judicial system, I will let the fur fly.

Mr. Appell. Mr. DuBois, before I ask for the production of the documents called for in the subpoena, when did you join the Ku Klux Klan?

Mr. DuBois. To give you the exact date, sir, I could not.

The CHAIRMAN. Just about.

Mr. DuBois. Approximately 18 months ago. Approximately. I wouldn't—it could be 12.

Mr. APPELL. To what unit of the Klan were you assigned as a new member?

Mr. DuBois. Sir, I would like to answer this—

The CHAIRMAN. Well, in what town?

Mr. DuBois. —in an honest way. Goldsboro, North Carolina.

The CHAIRMAN. The Klavern located in Goldsboro, North Carolina.

Mr. DuBois. Yes, sir.

Mr. APPELL. Now, the reason, Mr. DuBois—and I will tell you this—that you were subpoenaed is because the committee, in the course of its investigation, obtained the bank account of the Wayne County Improvement Association, and it found in an examination of these records that you were a signator to this account.

Mr. DuBois. Yes, sir, up until several months ago, when I resigned. They refused my resignation, but my name was withdrawn as a signator. I still have been keeping the books. I also am finance chairman of my church.

The CHAIRMAN. Finance chairman of your church?

Mr. DuBois. Yes, sir; of my local church.

The CHAIRMAN. Well, as a matter of fact, you indicated that part of your schooling was some course in finance.

Mr. DuBois. Yes, sir.

Mr. APPELL. Do you know whether or not they did file a new signature card with the bank after you told them of your resignation?

Mr. DuBois. I am sure they did, sir, because there have been checks going out since then.

Mr. APPELL. Well, the original signature card contained three names, any two of which were authorized to sign checks.

Mr. DuBois. That is correct, sir.

(Document marked "Joseph DuBois Exhibit No. 2" follows:)

JOSEPH DuBOIS EXHIBIT No. 2

ACCOUNT NAME	DATE	SAVINGS
Wayne County Improvement Association		CHECKING
		SPECIAL
ACCOUNT NUMBER	S. S. No.	
6-750-852		
SIGNATURES		
J. A. [Signature]		
W. H. Barrow		
[Signature]		
MAIL ADDRESS		
BUSINESS AND ADDRESS	STREET AND NUMBER	CITY STATE
FORMER BANK REFERENCES		

THIS ACCOUNT IS ACCEPTED BY WACHOVIA BANK AND TRUST COMPANY SUBJECT TO THE PROVISIONS STATED ON THE REVERSE SIDE OF THIS CARD ABOVE ARE THE DULY AUTHORIZED SIGNATURES WHICH THE BANK WILL RECOGNIZE IN THE PAYMENT OF FUNDS OR THE TRANSACTION OF OTHER BUSINESS

Mr. APPELL. I am not going to ask you who they are. I am going to state for the record, and if I am wrong I ask you to correct me, that it was J. A. Price, A. H. Barrow, and yourself, Joseph G. DuBois.

Mr. DuBois. I think that is correct, sir.

Mr. APPELL. Now, the name of this account is in the name of the Wayne County Improvement Association.

Mr. DuBois. Yes, sir.

Mr. APPELL. Did you know the Wayne County Improvement Association to be the designation of a Klan unit to which Klansmen were assigned?

Mr. DuBois. Yes, sir.

Mr. APPELL. Now, I now ask you, Mr. DuBois, to produce for the committee the documents in your possession or control called for by the subpoenas.

Mr. DuBois. May I make a statement also, sir, before doing this? It will concern it, and after that I will.

The CHAIRMAN. And you will produce them?

Mr. DuBois. Yes.

The CHAIRMAN. Yes, go ahead.

Mr. DuBois. On Monday night, the last meeting that we had, I asked, I explained to the people that I represent that I had been subpoenaed, and what had been subpoenaed, and what was in my custody, and I asked that they give me a 100 percent showing to bring that, and every man raised his hand to give me permission to bring this.

I want that known. I don't know these other gentlemen, the higher-ups in the Klan. Mr. Jones I have met on one or two occasions. I have been to two rallies in my home area. I do not have time to attend the rallies, because I have my—still have my mother to support, and my family, and my business to look after, and I can't be running all over the country. And since the—

The CHAIRMAN. Well, I congratulate you and your members on willingness to produce the documents that you are now about to hand in.

Mr. DuBois. And I had the full cooperation of my local unit, and I think that—that is the reason I am producing these documents.

The CHAIRMAN. All right.

Well, let me ask you this question: I understand, therefore, that, and you said as much, because you said you were contacted by phone and by people you don't know—those who suggested that you invoke the fifth amendment are not members of your Klavern?

Mr. DuBois. No, sir.

May I ask—pardon me, sir. May I ask that these be returned to me to return them to my unit at a date—

The CHAIRMAN. They will have to be studied, and excerpts, I suppose excerpts will do for our purposes, but I don't want to—we are not in the business of keeping documents for the sake of keeping documents. We may have to hold them, and scrutinize them a little.

(Documents marked "Joseph DuBois Exhibit No. 3," and retained in committee files.)¹

Mr. DuBois. They were put in my custody, sir, and the people had trust in me that put them in mine, and I would like to see them returned to them.

(At this point Mr. Weltner returned to the hearing room.)

¹ Copies were made of those documents of interest to the committee, and all originals were returned to witness.

The CHAIRMAN. Well, under those circumstances, I am not going to violate trust. We will reproduce them, but, of course, we are not going to ask you to violate trust, and you are tendering them to us with the condition that they be returned, at least for us to make excerpts of such parts of them as we consider pertinent. That will be understood.

Order. We are still in session.

(The subcommittee conferred off the record.)

The CHAIRMAN. Mr. DuBois, I will tell you the way we will proceed: You hand the documents to Mr. Appell and in your presence he will give a very general designation of each; we won't have time to study them, and then so you know what you handed us, and if there is any misunderstanding about it, because it will be in your presence, it will be itemized.

Then, if agreeable, we will adjourn until 1:30 so we can examine them more closely and then return them to you after 1:30. Will that be agreeable?

Mr. DuBois. Yes, sir.

Gentlemen, if there is any way possible, I would like to get out as soon as possible and get back home to my family and business. I have been up here 2 days.

Mr. Pool. Mr. Chairman, I don't think we will have time to make excerpts before 1:30.

Have the investigator read off what they are.

The CHAIRMAN. All right. To the reporter, make a general description of each document, and set them aside, one by one.

All right, I understand you told our general counsel that you are willing to leave them with us for several days.

Mr. DuBois. Yes, sir.

The CHAIRMAN. Well, we will return them to you. We will make a list right now.

Mr. DuBois. Fine. Thank you, sir.

The CHAIRMAN. But I think it would not—could you, Mr. Appell, enumerate them, one by one, a checkbook, in very general terms, of what appears to be such-and-such?

Mr. DuBois. The only thing you have, sir, is a checkbook and a few receipts, and some deposit slips, which we have been—

The CHAIRMAN. Well, you are entirely familiar with them.

Mr. DuBois. Yes, sir.

The CHAIRMAN. And you are not going to demand that we make an inventory of them right now, and you will trust us.

Mr. DuBois. Yes, sir. It is time for someone to trust somebody, sir.

The CHAIRMAN. Time for someone to trust somebody. You are so right.

You might give a very general description.

Mr. Appell. Yes, sir.

The CHAIRMAN. Say it is a checkbook, receipts.

Mr. Appell. There are two checkbooks, imprinted checkbooks.

The CHAIRMAN. All right, that is enough.

Mr. Appell. One envelope which contains check stubs.

Mr. DuBois. No check stubs, sir, in there. I haven't had any check stubs. No check stubs returned. That is the checkbook. I am sorry. Same thing. That is the old one.

Mr. Appell. Some individual small checkbooks, and looks like bills which were paid from this account, together with copies of deposit slips, and a zipper case which contains—

Mr. DuBois. There is a quarter in there that was an overage from the last deposit. It is under your checkbook there, sir.

Mr. APPELL. Plus 25 cents, but I will give you back the 25 cents, so that doesn't get lost in the process.

And some blank deposit forms together with deposit books.

These are the items contained in the material produced.

Mr. DuBois. This is items that were in the deposit. After I explained that I had those.

The CHAIRMAN. That is a correct description of this document; is it not?

Mr. DuBois. Yes, sir.

The CHAIRMAN. Now the committee will stand in recess until 1:30.

The subcommittee will come to order.

Mr. DuBois, we would like you to confer with our investigator about these documents between now and 1:30. Will you do that?

Mr. DuBois. Yes, sir.

The CHAIRMAN. The subcommittee is recessed.

(Subcommittee members present at time of recess: Representatives Willis, Pool, Weltner, and Buchanan.)

(Whereupon, at 11:38 a.m., Friday, October 22, 1965, the subcommittee recessed, to reconvene at 1:30 p.m. the same day.)

AFTERNOON SESSION—FRIDAY, OCTOBER 22, 1965

(The subcommittee reconvened at 1:45 p.m., Hon. Edwin E. Willis, chairman, presiding.)

(Subcommittee members present: Representatives Willis, Pool, Weltner, and Buchanan.)

The CHAIRMAN. The subcommittee will please come to order.

I understand you have recalled Mr. DuBois.

Mr. APPELL. Yes, sir; we have recalled Mr. DuBois.

TESTIMONY OF JOSEPH G. DuBOIS—Resumed

Mr. APPELL. Mr. DuBois, would you briefly outline to the committee the duties and responsibilities—or let me ask you this. I don't know for sure whether I put it on the record this morning. Within the Wayne County Improvement Association, which you identified to be a club to which members of the Ku Klux Klan were assigned, what specific position did you hold?

Mr. DuBois. Treasurer, sir.

Mr. APPELL. And within the Klan the treasurer is known as the klabee?

Mr. DuBois. Yes, sir.

Mr. APPELL. What are the duties and responsibilities of a treasurer?

Mr. DuBois. Well, the only responsibility and duties I had was to make the deposits and write the checks and then pass them on to everywhere they were to be sent.

Mr. APPELL. Is it true that under the procedures the secretary is the man who receives money, and makes all the written reports, and turns the money over to the treasurer for the treasurer to deposit?

Mr. DuBois. Yes, sir. Of course I don't know whether he gets all the money or what the deal is as far as collecting or something. Of course all the money is supposed to be turned into me to make deposits with and then entered on my record, the check stub, so we will know at all times what our balance is.

Mr. APPELL. Let me ask you this. Within the group that you belonged, what was the initiation fee paid?

Mr. DuBois. Well, the membership, my membership fee was \$10.00.

Mr. APPELL. What are the monthly dues?

Mr. DuBois. We have no monthly dues, sir. It is quarterly.

Mr. APPELL. Quarterly within your organization, and what were the quarterly dues?

Mr. DuBois. Four and a quarter.

Mr. APPELL. \$4.25?

Mr. DuBois. Yes, sir.

Mr. APPELL. Now, it is the committee's understanding that the secretary—

The CHAIRMAN. Wait a minute. I wonder if he understood you. \$4.25 per quarter?

Mr. DuBois. Yes, sir.

The CHAIRMAN. Per quarter.

Mr. DuBois. Yes, sir.

Mr. APPELL. The committee's investigation disclosed that the secretary makes up either on a monthly or a quarterly basis that which is known as a kligrapp's report which is forwarded to the state or realm level and also to the imperial level.

This report contains the number of members, and the number initiated, and losses and minuses. The money that is to be transmitted, is this merely the amount requested of you as the treasurer, or are you given a breakdown of membership upon which you write the check?

Mr. DuBois. No, sir; I am not given anything but make a check out for this amount to a certain area.

Mr. APPELL. I hand you a series of checks, some endorsed—or showing you as the maker, as a comaker, others without your signature as a comaker. All of these are made payable to the Alabama Rescue Service.

Can you tell the committee what the Alabama Rescue Service is?

Mr. DuBois. Well, sir, I don't know exactly what the Alabama Rescue Service is, but I know that is where we are supposed to send our checks or where we are supposed to answer to.

(Documents marked "Joseph DuBois Exhibit No. 4." One check follows; balance retained in committee files.)

JOSEPH DuBOIS EXHIBIT NO. 4

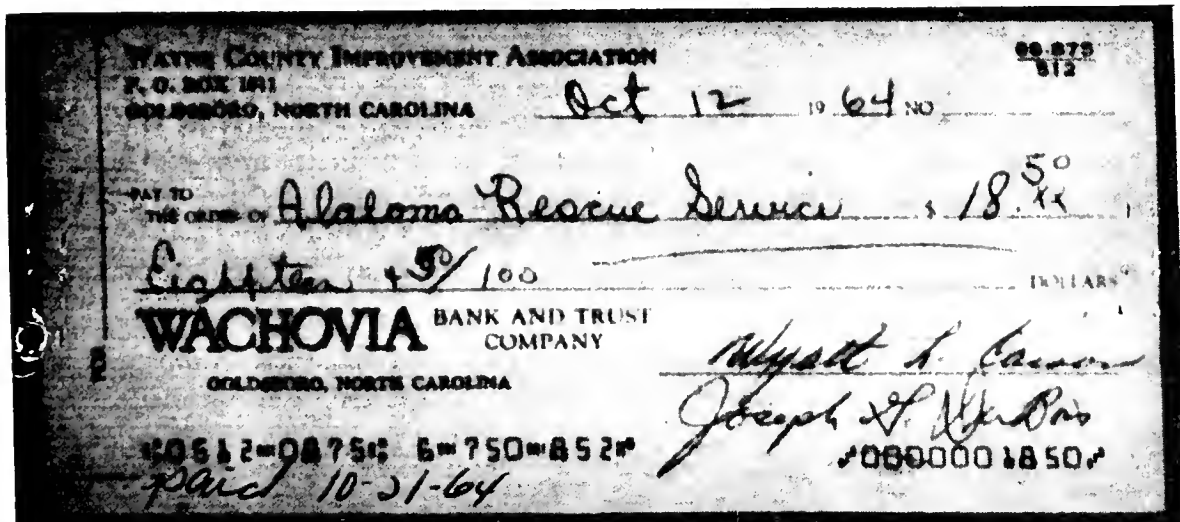

The CHAIRMAN. I might inform you that the Alabama Rescue Service is a front or cover name that Mr. Shelton uses and his organization uses in connection with the operations of the United Klans of America.

Mr. APPELL. And these checks that were sent or made payable to the Alabama Rescue Service were for what is known as imperial tax?

Mr. DuBois. I don't know how they were classified, sir, under the circumstances. I mean I was just keeping the books for the checks, of course for the unit.

Mr. APPELL. But this was a portion of the dues money collected from the membership?

Mr. DuBois. I guess so; yes, sir.

Mr. APPELL. There were a number of checks in this account drawn to the order of J. R. Jones. Can you tell us what checks payable to J. R. Jones, as a general rule the purpose for which this money was drawn?

Mr. DuBois. I think that—of course, as I said, again I don't know the amount or anything about it, but it is just like the same thing that—it is a local or statewide—

Mr. APPELL. State tax?

Mr. DuBois. I don't know whether you call it tax or what you would call it. I mean it is to help operate, I guess, for expenses, Mr. Jones and his duties.

Mr. APPELL. You are familiar with this document called Constitution and Laws of the United Klans of America, Incorporated, Knights of Ku Klux Klan?

Mr. DuBois. No, sir; I have never seen one before.

Mr. APPELL. According to that document, 25 cents is supposed to go to the state or realm and 50 cents to the imperial. Therefore, checks made payable to Mr. Jones would be the state share and checks to the Alabama Rescue Service would be the imperial share.

Is that your understanding, sir?

Mr. DuBois. As I said before, sir, I don't know what amount. The only thing I know we did send checks to them. I don't know what the amount was or what it was used for. I have tried to keep the books where they keep the money straight for them. That is all I have done.

The CHAIRMAN. I am satisfied thus far, and I know it will be true throughout the testimony; it would seem that you are handling your funds all right, but I am asking you this: Do you know what Jones and Shelton do with the money that is received from you?

Mr. DuBois. No, sir; I have no way of knowing except it is supposed to be to offset expenses incurred in their operation or in the operation of the Klan.

The CHAIRMAN. Did you know, for example, that under the setup at the Imperial Wizard level, Robert M. Shelton himself, as to monies that are received from you, deposits those funds in a bank in California; that checks he draws against that account are signed by himself and supposedly by a man by the name of James J. Hendrix or a man by the name of T. M. Montgomery, but that in fact there are no

such males, and that those persons are thieves, that Hendrix is the wife of Shelton and Montgomery is someone who works for Shelton?

Did you know that before?

Mr. DuBois. No sir; I did not.

Mr. Pool. From what the chairman has told you, what do you suppose would be the reaction of your Klan members back in your Klavern? What would they think of this revelation?

Mr. DuBois. Gentlemen, as I said once before, I don't want to break any sacred trust the people put in me, but I feel that my country, God and my country, comes first and anything else is secondary.

I went to my people at the last meeting and asked them, told them I had my subpoena and what it required me, and asked them permission to bring this checkbook up here and present to you gentlemen.

I said, "As far as I know, we have nothing to hide. We have never, of my knowledge, we have never done anything subversive or destructible or otherwise. We have a common cause, there was some things we don't approve of, and I think the only way that you will get representation is by a majority," and I asked them if I could bring these books up here, and I had a hundred percent in my unit raise their hand and give me their confidence.

Mr. Pool. What I am getting at is this. Well, I don't want to make this statement. The Imperial Wizard is wearing a big diamond ring and driving the car the Klan bought him, and the same way with some of the Dragons.

These revelations should shake up the membership back home when they find these things out. I don't think they have known about it.

Mr. DuBois. Well, in some cases some of the things possibly they do know about. Others they don't know about.

The Chairman. What you are trying to say is that you run your affairs straight?

Mr. DuBois. Yes, sir.

The Chairman. You don't know what Jones and others are doing?

Mr. DuBois. Right. I feel about the Klan and the unit I belong to just like I do about my church, or my country, or my income tax. Once I do my part and sent the money in I have done my part and what happens to it is someone else's worry.

Mr. Pool. I understand.

Mr. DuBois. The same way with my church and my tithes to my church. What they do with it, if it is misused or otherwise, my conscience is clear.

The Chairman. It then becomes between them and their God?

Mr. DuBois. Yes, sir. I still think I have nothing to hide.

The Chairman. We appreciate that.

Mr. DuBois. And people in my local unit as far as I know, has nothing to hide.

The Chairman. You are not going to be the loser and nothing is going to happen to you for your frank, open way of expressing yourself.

Mr. APPELL. Let me ask you this: Who possessed the records with respect to membership? The treasurer, or secretary?

Mr. DuBois. Well, I can answer this much: The treasurer does not.

Mr. APPELL. You have no records which reflect the membership of your unit?

Mr. DuBois. No, sir.

Mr. APPELL. As a matter of fact, all of the records which were in your possession you presented to the committee this morning?

Mr. DuBois. Yes, sir.

Mr. APPELL. And only as to the financial transactions which are reflected by these records do you have knowledge?

Mr. DuBois. No, sir; only what you see and that what I brought up here is the only thing I have any knowledge of. Of course, we have never been able to hold a regular meeting as far as I am concerned, like it should be held according to the Klan, because public opinion and newspapers and all have been mighty biased on us and have been pushing us from one area to the other, and it has been rather hard to keep an organization together. You are roaming around.

The CHAIRMAN. In other words, the records that you brought are the only records that you have control of?

Mr. DuBois. Yes, sir.

Mr. APPELL. Do you have an estimate of the size of your membership?

Mr. DuBois. No, sir.

Mr. APPELL. Mr. Chairman, due to the fact that the records submitted by the witness, together with the documents subpoenaed by the committee, tell the financial story of this unit and due to the fact that this is the only knowledge possessed by this witness, the staff has no further questions to ask of this witness.

The CHAIRMAN. I just want to tell you this: The committee is very grateful to you. You have displayed a great deal of courage and gumption by coming over here and telling us what you know within your knowledge freely and openly, and I assure you that, whatever information has been given to you to the contrary, this committee is interested only in the facts, not interested in subjecting you or anyone else to harassment or ill treatment for coming over here and voluntarily and under oath saying all they know.

Mr. DuBois. Thank you, sir.

The CHAIRMAN. You have a very wonderful record that you have displayed here in service to your country and your allegiance to God and country first, and the feeling that this is superior to any allegiance to the Klan or anything else, and I admire you for coming here in view of the things that have transpired, that you talked about in this committee room, something no one knew about or expected of you, what you did recite right then and there in public session before a congressional committee.

Now listen carefully. You are under subpoena here.

Mr. DuBois. Yes, sir.

The CHAIRMAN. In addition to compelling a person to appear in response to a subpoena, a subpoena issued by a court, grand jury, by a congressional committee, and the like, carries with it the protection

of Federal law, meaning that under that law if anyone appears before a court or grand jury or petit jury or congressional committee and testifies under oath, then anyone who threatens that person or who molests him, intimidates him, does anything else, is violating that Federal law.

I am going to continue the subpoena until January 1, 1966. That means two things. That if developments require, you are under compulsion to report back and, number two, it is for your further protection as a voluntary witness before a congressional committee.

If there are any threats, intimidations, recriminations, any acts, verbal or physical, that occur to you or members of your family, so far as I am concerned, as a result of your appearance, you please just let me know.

Mr. DuBois. Yes, sir. Thank you.

Mr. BUCHANAN. Mr. DuBois, I want to congratulate you for your military record. We tend to forget that there is freedom in the world today because of what you and other men like you did in World War II, and in my opinion freedom will continue to survive in this world because of what men are doing now to resist tyranny in the same way.

I believe you stated that your reason for testifying before this committee is because you put God first, country second, and other things fall below that.

Mr. DuBois. Yes, sir.

Mr. BUCHANAN. And that your loyalty to your country is greater than your loyalty to any such organization as the Ku Klux Klan.

Mr. DuBois. Yes, sir.

Mr. BUCHANAN. Is that correct? And that since a law, based firmly on the Constitution of this country, requires you to testify as you have testified and because of loyalty to your country you felt impelled to testify, that you held this to be a higher loyalty and therefore testified before this committee. Is that correct?

Mr. DuBois. Yes, sir.

Mr. BUCHANAN. I noticed when you took the oath as a Christian you swore to tell the whole truth, nothing but the truth, so help you God.

Mr. DuBois. Yes, sir.

Mr. BUCHANAN. You swore rather than affirming.

Mr. DuBois. Yes, sir.

Mr. BUCHANAN. I noted that also. Then, finally, I just want to confirm this fact: That you have testified twice, I think, you joined this organization with no idea of wrongdoing as did other members of your local unit, so far as you are concerned?

Mr. DuBois. That is correct, sir.

Mr. BUCHANAN. You, this day, have resigned from this organization about which certain questions have been raised in this hearing, and not your unit I mean, but you did this day resign?

Mr. DuBois. Yes, sir.

Mr. BUCHANAN. From that organization?

Mr. DuBois. Yes, sir.

Mr. BUCHANAN. I want to congratulate you, Mr. DuBois, for your service to the country in the past and the service you have rendered in your testimony today.

Mr. DuBois. Thank you, sir.

The CHAIRMAN. Any more questions?

Mr. APPELL. No, Mr. Chairman, the staff has no further questions.

The CHAIRMAN. Thank you very much.

Mr. APPELL. Thank you.

The CHAIRMAN. Call your next witness.

Mr. APPELL. Mr. Chairman, I would like to call as our next witness

Mr. Roy Woodle and I would like to request permission for Mr. Philip Manuel, investigator for the committee, to interrogate the witness.

The CHAIRMAN. Raise your right hand.

Mr. Woodle, do you solemnly swear to tell the truth, the whole truth, and nothing but the truth, so help you God?

Mr. WOODLE. I do.

The CHAIRMAN. Mr. Manuel, proceed.

TESTIMONY OF ROY WOODLE

Mr. MANUEL. Mr. Woodle, would you please give your full name to the committee, please?

Mr. WOODLE. Roy Woodle.

Mr. MANUEL. And how do you spell that last name?

Mr. WOODLE. W-o-o-d-l-e.

Mr. MANUEL. When and where were you born?

Mr. WOODLE. In Davidson County, Lexington, North Carolina.

Mr. MANUEL. What is your current occupation?

Mr. WOODLE. Bricklayer.

Mr. MANUEL. Are you appearing here today, sir, in response to a subpoena served upon you on the 6th of October 1965, served upon you by an investigator of this committee, Mr. Raymond McConnon?

Mr. WOODLE. That is right, sir.

Mr. MANUEL. Mr. Woodle, have you ever been a member of the North Carolina Realm of the United Klans of America?

Mr. WOODLE. Yes, sir; I have.

Mr. MANUEL. When did you become a member of that organization?

Mr. WOODLE. Roughly 8 or 9 months ago. I couldn't recall the date that I became a member of it, but roughly 9 or 10 months ago.

Mr. MANUEL. Would that be approximately December of 1964?

Mr. WOODLE. Somewhere in that area; yes.

Mr. MANUEL. Under what circumstances did you join the UKA or the United Klans of America?

Mr. WOODLE. Why did I join the organization?

Mr. MANUEL. Yes, sir.

Mr. WOODLE. I joined the organization because I was approached that it was an organization to present a program against integration, which I didn't believe in integration, and that it was a Christian organization, and that is what caused me to join the organization.

Mr. MANUEL. Reverend Woodle, do you have a background as a preacher or a reverend for a church?

Mr. WOODLE. Well, I have been preaching for some 3 years now.

Mr. MANUEL. Where do you preach, sir?

Mr. WOODLE. I don't preach nowhere in particular now, just anywhere opportunity, and I preached on the radio for 3 years till recently, about 3 or 4 months ago.

Mr. MANUEL. In what city in North Carolina did you preach?

Mr. WOODLE. The vicinity of Lexington and different churches that call you to speak for them.

Mr. MANUEL. When you became a member of the United Klans of America to what Klavern or unit were you assigned?

Mr. WOODLE. In Lexington.

Mr. MANUEL. To your certain knowledge, do you remember what number or designation that Klavern had?

Mr. WOODLE. No, to the number, and whatever it went by, I never went into that and don't know. I saw in the news one night last week it showed so many different Klaverns and it give the number and I believe this one was No. 9 or some kind of a No. 9—let me think just a minute; some kind of a club or something under that name.

Mr. MANUEL. Upon becoming a member of this Klavern and becoming a member of the United Klans of America, did you take an oath of allegiance—

Mr. WOODLE. I absolutely did.

Mr. MANUEL. To that organization. I would like to at this point hand you a copy of that oath and ask you to the best of your memory to identify it for the committee.

Mr. WOODLE. Well, now, the way the oath was taken—you know, when you get a thing and going down and a man asks a question and you repeat after him, I can't recall just word for word what was said or how it was said.

Mr. MANUEL. Is that an oath similar to the one that you subscribed to?

Mr. WOODLE. It looks like it would be about the same thing, but as far as how it was worded and not worded, I couldn't say because I didn't know. I have never had one. I have never had an oath or never been entrusted to me or nothing. I wouldn't know.

(Document previously marked "Robert Shelton Exhibit No. 4.")

Mr. MANUEL. Upon your subscription to that oath, did it mention God?

Mr. WOODLE. Yes, it did, in some place it did whenever it was given, something to that effect, yes.

Mr. MANUEL. Reverend Woodle, when you joined this organization what kind of an organization did you believe it to be?

Mr. WOODLE. Well, I was told it was a religious organization. They stood for the truth and right and honesty for all, and that is the reason I finally joined.

Mr. MANUEL. During the course of your membership in this organization did you change your original opinion as you have just outlined it?

Mr. WOODLE. Well, let's put it this way: In my way of saying, I was approached that this organization was a very religious organization, it stood for the truth and what was right, and it stood against integration. Now, I stayed in the organization some 8 or 9 months myself and I done what I thought I was supposed to do, try to carry out my duty as a member and what was asked them, everything that was asked reasonable and right, and the whole time I was in I don't find it stood for religion or against integration. If it did I don't know where the

program was or where it performed that. Not in the State of North Carolina as I know there was an active program against it, and those was the two main reasons I joined the organization.

The CHAIRMAN. Did they say it was a Christian organization?

Mr. WOODLE. Definitely. When the man comes to me to ask me to join I told him I was afraid it would go against my conviction, and having been a preacher I was afraid it would hurt me, and he told me, "No, sir; we stand for the truth," and what was right, and I believed in that and I believed we ought to have had a program against integration, which every man has a right to believe what he wants to believe, and that was my motive for joining it, and I believe that 98 percent of the rest of the Klan joined for that reason. If they did or didn't, I know not. It is just a personal opinion.

Mr. MANUEL. Reverend Woodle, while a member of this organization did you hold any office or elected position?

Mr. WOODLE. I was elected State chaplain or the State kludd or kludd, or whatever they call it.

Mr. MANUEL. The grand kludd of the Realm of North Carolina; is that correct, sir?

Mr. WOODLE. Yes, sir.

Mr. MANUEL. Approximately when were you elected to this position?

Mr. WOODLE. January, February, somewhere along there.

Mr. MANUEL. What year, sir?

Mr. WOODLE. This year.

The CHAIRMAN. Let me say this at this point, along the lines of what I said this morning, we are not concerned with religious beliefs, theological, or philosophical, or political beliefs or opinions.

I am permitting you to testify here because you are relating personal experiences as a Klansman and that is competent testimony because you are an official Klansman and official chaplain or kludd of the Realm of North Carolina, and that is important because you are relating an experience.

Proceed.

Mr. MANUEL. Now, Reverend Woodle, at the time you were elected to the position of grand kludd, was Mr. J. R. Jones elected to the position of Grand Dragon for the Realm of North Carolina?

Mr. WOODLE. Yes, sir; that is right.

Mr. MANUEL. What were your main activities while a member of the Realm of North Carolina, United Klans of America?

Mr. WOODLE. I would go around from rally to rally and speak at the rallies.

Mr. MANUEL. Where and how were your speaking engagements arranged?

Mr. WOODLE. Well, we just went to the rallies, and they would invite me up to the—to speak.

Mr. MANUEL. Approximately how many rallies were there at which you were the speaker?

Mr. WOODLE. Well, I spoke at several rallies. I couldn't tell you how many.

I missed the first one they had in the spring, and then I attended them all, up until I resigned.

The CHAIRMAN. You did resign?

Mr. WOODLE. I did resign.

The CHAIRMAN. When was that?

Mr. WOODLE. About 5 weeks ago.

The CHAIRMAN. You might question him more.

Mr. MANUEL. While you were preaching at the Klan rallies, what fund-raising activities were engaged in by the United Klans of America, while the rallies were going on, or immediately upon their conclusion?

Mr. WOODLE. Well, they would just go ahead and take up the offering, like they do, I mean, out in the field, just go ahead and take up their offering, just like ordinarily, I reckon. I don't know what procedure you would call it, but—

Mr. MANUEL. Now, what method did they employ to collect funds?

Mr. WOODLE. Well, they just told the people they needed the money, needed some help, and set out to get it.

Mr. MANUEL. To your knowledge—

The CHAIRMAN. Who would make that plea? Would Jones be one of them?

Not putting words in your mouth.

Mr. WOODLE. I don't recall who made the plea, but in my knowledge I believe that Mr. Dorsett done the most of that out in the field.

Now, I wouldn't say, but if others did or not, I don't know. I don't know who done it. I didn't take notice to keep a record. I didn't dream of such a thing acoming to pass. If I did, why, there might have been different arrangements, earlier.

Mr. MANUEL. Now, would you please further identify Mr. Dorsett, whom you just mentioned?

Mr. WOODLE. Mr. Reverend Dorsett, out in Greensboro, North Carolina, I believe, I can't say. He was most of the time one of the main speakers.

Mr. MANUEL. Did you know him to be an official of the Realm of North Carolina?

Mr. WOODLE. What if he was an official or not, I don't know.

Mr. MANUEL. In collecting funds at rallies, to your direct knowledge, did the Klan employ persons or use persons within the audience who would come to the speakers' stand and donate an unusually large amount of money, in order that other members and other attendees at the rally would then contribute some money?

Mr. WOODLE. A fellow come to me was a Klansman and said he had been planted with \$50 to bring it forth, that it might bring others to come forth, but he would get his \$50 back.

Now, who he was, I don't know, didn't identify himself, and he come to me, and said he was troubled over it, after what he had done, and he hated he had done it.

Now, who he was, I don't know. He was a Klansman. He approached me later on that stage, and said he felt bad for doing such a thing.

Mr. MANUEL. Are there any other examples of that type of activity on the part of the United Klans, to your direct knowledge, Rev. Woodle?

Mr. WOODLE. No, the man come to me with that, and as far as any more of it, I know not.

The CHAIRMAN. Well, of course, as a churchman, I take it that you don't believe in poker or gambling, but some people like that are called come-see boys, or shills. You wouldn't know about that. The names of them. He didn't tell you.

Mr. WOODLE. No, sir, I don't think no man ought to bow his head and pray, and then try to deceive a man. I believe in just being, if you are going to deceive a man, don't pray and ask God to bless it, and then the man come up and shake his hand say, "May God bless you," and going to get around the corner. Personally, I don't believe in that. The other people can believe what they want to.

Mr. MANUEL. Now, Reverend Woodle, did there come a time when Mr. Bob Jones, the Grand Dragon of the Realm of North Carolina, offered you a job with the United Klans of America?

Mr. WOODLE. Yes, sir, I was offered a job with the United Klans of America.

Mr. MANUEL. And what position, exactly, was that?

Mr. WOODLE. I think it was supposed to be organizer, or something to that effect.

Mr. MANUEL. And did Mr. Jones mention an amount of money or a salary to you at that time?

Mr. WOODLE. \$150 a week.

Mr. MANUEL. Did you take that position?

Mr. WOODLE. No, I didn't take it. I was about to take it, but after I come to the conclusion that a man couldn't go under dictatorship without a reason, why, to stand up with principle, a fellow couldn't afford to, and I had to withdraw from it.

I was almost persuaded to do it, but after giving it thought for 2 or 3 days, I couldn't accept it.

The CHAIRMAN. You would say that Mr. Jones and the head people in the Klan have pretty good power of persuasion?

Mr. WOODLE. Anybody who is paying you, most of the time, you have to listen to them. And I don't think a Christian, or any man with any self-responsibility, should have to go under a man that cusses the name of the Lord and a man tries to do halfway right, and I mean, that is just my conviction of people do what they want to do.

In my position, I didn't feel like—I was obligated to God, and my friend to go under dictatorship to no man.

The CHAIRMAN. What do you mean by dictatorship? Do you regard Klan or Klan leaders in such kind of fashion?

Mr. WOODLE. I wouldn't know how to say that.

The CHAIRMAN. Well, say it in your own words, and don't go beyond what—

Mr. WOODLE. I think every man ought to have a right to speak his piece without trouble. Regardless of circumstances. And whenever a man has to live under fear the rest of his life because he had to sleep with hisself at night against his conviction, I don't believe he should go under that. If you have to die, don't go under it. That's my conviction.

Mr. MANUEL. Did Mr. Jones try to persuade you to act other than in accordance with your convictions?

Mr. WOODLE. I don't quite understand your question, sir.

Mr. MANUEL. Well, did Mr. Jones or any other leader in the Klan organization try to make you act one way, in disagreement with what you thought was right?

Mr. WOODLE. No, not while I was there. Nobody approached me on that, under no—

The CHAIRMAN. Well, except for tempting you with a salary as an organizer. You didn't think that was right.

Mr. WOODLE. Oh, it would have been all right, if I had wanted to do it, but I didn't feel like that that condition, under the conditions that I would have to go under, have to give an account to certain people at certain times, at their call, I don't believe in.

Mr. MANUEL. Would you describe that more for the committee, Mr. Woodle?

Mr. WOODLE. Well, say, if a man had called me at midnight, I have got to get up and go under all conditions, why I don't—I mean, I just felt like I couldn't be at liberty with that job.

The CHAIRMAN. Let me ask you: Did you understand that, if you accepted that position, that you would be subject to—

Mr. WOODLE. I was chargeable to Mr. Jones. I would have felt like I would have been chargeable to Mr. Jones, if I had of took the job.

The CHAIRMAN. Then you think you would be under his influence, and would have to respond to whatever he called on you to do?

Mr. WOODLE. That would have been my belief, but the reason I couldn't accept it, yes.

Mr. MANUEL. Now—

Mr. POOL. Just a minute.

And you had some reservations about what Mr. Jones might ask you to do?

Mr. WOODLE. Yes. In a broad statement, that would be—you have to consider what could—what it could lead to.

Mr. MANUEL. Now, Reverend Woodle, how did you tell Mr. Jones that you would not accept this job?

Mr. WOODLE. After I was exposed, was going to accept the job, and then I guess I was talking somewhere that I wasn't going to accept it, and the word got back to him through—I don't know what you would call it. I never was approached or mentioned no more about it.

Mr. MANUEL. What happened to you, very briefly, as a result of your refusing to accept this job as organizer for the Realm of North Carolina?

Mr. WOODLE. Nothing. That was just the last of it.

Mr. MANUEL. Yes. Now, are you still a member of the Realm of North Carolina, United Klans of America?

Mr. WOODLE. No, sir.

Mr. MANUEL. Would you please inform the committee as to why you left that organization?

Mr. WOODLE. Just why I got out of the organization?

Mr. MANUEL. Yes, sir.

Mr. WOODLE. Well, when I was in the organization, I joined it, as I told you a while ago, for the principle they told me it was standing for. And I joined, of course, those was two things I didn't see no action on whatsoever. And I got a telephone call.

I went to a 3-day rally, and I got a telephone call the next week. I had been talking about resigning several weeks before, on different occasions, about different things, but I was asked to stay on, and stay on, and I felt obligated to the people, to the job I hold.

I did preach the truth to the people, and the Klansmen will verify that, I believe, and so I got a telephone call that I was to be set down, it was my friend acalling me, to "Get set, it's coming," and I just took it for what it's worth, and about 2 days later it come, that I was supposed to not be allowed back on the platform no more, and so you know when something is coming on you, you don't know what it is all about, you get inquisitive, and I tried to ask a few questions why, and some of them said I said something against Mr. Shelton, and I have never said a word against Mr. Shelton. Said I got on the platform at Trenton, Trenton, North Carolina, and talked against Mr. Shelton, therefore I had to go down.

I never got on the platform and said nothing against Mr. Shelton or no other Klansmen, and so I just decided, well, that looks pretty bad, a man—

So I asked for a reason why, and what did I say?

So I called the man, Mr. Jones, and asked him, "What did I say?"

And he said I got on the platform and said something.

I asked them, "What did I say?" and, "We don't know, you just said something."

But then when I figure a man is accusing a man and can't tell him what he is accusing of, a leader of a great religious organization, then it is time to stand for something.

Mr. MANUEL. Did you subsequently find out why they wanted you removed from the platform as a speaker at their rallies?

Mr. WOODLE. Personally, I knew no man's motive, and I don't know why, but I had my opinion, my opinion why, but as far as their motive, why they done it, I don't know. I don't know no man's motive.

Mr. MANUEL. What was the date of your leaving the Klan organization, Reverend Woodle?

Mr. WOODLE. I would say 5, 6 weeks ago.

The CHAIRMAN. Well, if you thought about it, and if what you thought the reasons were, behind the move to stop you from taking the stand, and so on, and you are convinced of that, I would like for you to explain what motivated you, what opinion motivated you.

Mr. WOODLE. When I got in the Klan, people was nice to me, and I found 98 percent of the Klansmen is, I believe to be, honest and sincere people, and they was very nice to me, and my opinion, that was the reason I had to go down, because people was a little too nice to me.

Popularity didn't speak at the right place, in my opinion, and I just felt like that I was being mistreated, and—

The CHAIRMAN. Mistreated, or perhaps—

Mr. WOODLE. Just pushed out without a cause, and I told Mr. Jones, "If I have done anything wrong, you tell me what I have done, and I am subject to a mistake, and I apologize, but if I haven't done wrong, I would like to have a reason for it," and I got the answer, "We don't have to give reasons."

It suited me fine.

Mr. MANUEL. Reverend Woodle, were you actually challenging Mr. Jones for leadership in the Realm of North Carolina?

Mr. WOODLE. I never challenged—I didn't never ask to get on the speakers' platform, I never asked to do nothing. I just tried to do kind of like I was told to do, as a citizen, and was going to have an organization to stand for decency and what was right.

Mr. MANUEL. Now, Reverend Woodle, at the time that you described, and you fell in disfavor with Jones and the other leaders of the Realm of North Carolina—

The CHAIRMAN. Well, let me ask you this question: During this period of time when you were trying to find out why it was that you would not be permitted to take the stand more, and that Mr. Jones told you that he didn't have to tell you why, did you detect that the leaders kind of shunned you, and ignored you, or any attitude like that?

Mr. WOODLE. Well, you see, I got calls from different people, and was telling me to look out, "Get set, it's coming," see, from people was friends of mine, and I figured it must have been a friend, or he wouldn't have told me, so I just took it for granted, and I set guard, and what they said was going to happen did happen, so I figured it must have been the truth.

The CHAIRMAN. Did they indicate what might happen, or—

Mr. WOODLE. What do you mean?

The CHAIRMAN. You said people called you and told you certain things.

Mr. WOODLE. To get set, things was coming, they was going to do away with me.

The CHAIRMAN. Well, that's what I mean. And they were friends of yours?

Mr. WOODLE. Well, they said they was, I mean, a man just calls you on the phone and don't tell you who it is, you consider that.

The CHAIRMAN. And you treated them as friends? You thought they were your friends?

Mr. WOODLE. Definitely.

The CHAIRMAN. And they said that you had better watch out, something would happen to you, or words to that effect?

Mr. WOODLE. They didn't say something was going to happen, but, "Get set, they are taking out against you."

The CHAIRMAN. Did they say anything more about what they meant by that?

Mr. WOODLE. No, not at that time, no.

The CHAIRMAN. Later on?

Mr. WOODLE. Later on, people told me different things, And this story that I had said something against Mr. Shelton didn't go over too good, the people was at the really realized that I didn't get on the platform and say nothing against Mr. Shelton or no other Klansman, and anybody was at that rally can verify that.

Then the story come out that the Government bought me a home, to come in the outfit to break it up, to get my friends against me, see, and that my boy, when he finished school, the Government bought him a car for me to rat on them.

The CHAIRMAN. That was not true?

Mr. WOODLE. The story of my boy's car, he bought him a 1963 Mercury, and we took out an insurance policy when the boy was borned,

and when he finished school—it was paid up when he was 10 years old, and he cashed it in and got \$300—some on the policy, and to make a down payment on the car, and he is paying People's Finance Company in Lexington, North Carolina, \$70 a month for the 30 months to pay for the car.

The CHAIRMAN. And yet they were saying what about your boy?

Mr. WOODLE. About the car and stuff, that I was planted in the outfit to tear it up, and I never did speak to a Government man, no law enforcement officer, under no conditions, till I got this subpoena.

The CHAIRMAN. In other words, they were in effect saying that you were telling things, telling tales, and spying on them, or something?

Mr. WOODLE. That's what my friends that was in the Klans tell me.

This was from rally hall to rally hall. Different people would call me. I would meet with different people, that would tell me that was what was happening.

The CHAIRMAN. What about the home?

Mr. WOODLE. And I just built me a home, and I went to Perpetual Savings and Loan Association and borrowed \$15,500 to purchase the home, and that the Government's buying me that to get in the Klan to tear it up, such as that, to try to tear my influence down with the people, because they was nice to me.

That's that great Christian organization I am talking about.

The CHAIRMAN. You think they were planting those things on you?

Mr. WOODLE. To turn the people against me. That's what I believe.

I don't know what the motive was. That was my opinion.

The CHAIRMAN. All right.

Mr. MANUEL. Reverend Woodle, at the time that you—after you left the Klan, did you receive a phone call, from a person whom you know to be a Klansman, threatening you to bodily harm?

Mr. WOODLE. I don't know what if you would call it bodily harm or not. Said he had the authority to do away with me. [Laughter.]

The CHAIRMAN. Well, I would say you could classify it that. [Laughter.]

Mr. MANUEL. To your certain knowledge—

The CHAIRMAN. He wants to say something.

Mr. MANUEL. Go ahead.

The CHAIRMAN. If you want to.

Mr. WOODLE. No, go ahead, sir.

Mr. MANUEL. To your certain knowledge, do you know the identity of the person who so telephoned you?

Mr. WOODLE. Well, the fellow called me and told me a certain man was going to call me, and about an hour later, he did call me.

Mr. MANUEL. And who was that?

Mr. WOODLE. Mr. Hamby, Boyd Hamby.

Mr. MANUEL. Mr. Boyd Hamby?

Mr. WOODLE. Yes, sir.

Mr. MANUEL. Did you know at that time that Boyd Hamby was an official of the Realm of North Carolina for the United Klans of America?

Mr. WOODLE. I didn't know that he was. I still don't know that he is. I had heard that he was.

The CHAIRMAN. You heard that he was what? What officer?

Mr. WOODLE. That he was official in the Klan. A full-time man, but what if he was or not, it is just hearsay. I don't know nothing about it.

The CHAIRMAN. Someone phoned you before and said this man would phone you, and he did?

Mr. WOODLE. And said he was going home and call me.

The CHAIRMAN. And he did?

Mr. WOODLE. And about an hour later, I got a call, and he identified himself as that.

Who it was, I don't know, over the phone. I just took it for granted the fellow told me he was going to call, he did call, and I figured that was it.

The CHAIRMAN. Well, the first one who called you to tell you that that second one would call you is a friend of yours?

Mr. WOODLE. He didn't identify himself, but I took him as a friend. I appreciated the man calling me. I was set for it when he called me.

Mr. MANUEL. Reverend Woodle, do you know Mr. Boyd Hamby when you see him?

Mr. WOODLE. Yes, sir.

Mr. MANUEL. Have you seen him in this hearing room today?

Mr. WOODLE. Yes, sir, he is here.

Mr. MANUEL. Would you stand up and identify Mr. Boyd Hamby?

Mr. WOODLE. The fellow sitting right back there, with the mustache.

Mr. MANUEL. In the front row?

Mr. WOODLE. Yes, sir.

Mr. MANUEL. Fourth seat?

Mr. WOODLE. Yes, sir.

Mr. MANUEL. And that man threatened your life?

Mr. WOODLE. No.

The CHAIRMAN. He said——

Mr. WOODLE. He had the authority——

Mr. MANUEL. To do you in?

The CHAIRMAN. To do away with you?

Mr. WOODLE. Now, I took it for granted. I didn't—for what it said. I didn't—he didn't say he was going to kill me or hurt me, or nothing, but I just kind of tried to get on guard.

Mr. MANUEL. Subsequent to that telephone call, were any other acts of intimidation made upon you?

Mr. WOODLE. Nothing, only a cross was burned in my yard. That's the only other thing.

The CHAIRMAN. When was that about, after that telephone call? If you remember.

Mr. WOODLE. The night after the CBS news report on the Klan, it was burned.

The CHAIRMAN. The night after you appeared on CBS News, they burned the cross?

Mr. WOODLE. Yes, on my lawn.

The CHAIRMAN. On your lawn?

Mr. WOODLE. Yes, sir.

That was some of the money they prayed over to build that cross.

[Laughter.]

The CHAIRMAN. What?

Mr. WOODLE. That money where they used——

The CHAIRMAN. What?

Mr. WOODLE. This money that they prayed over and asked God to bless, they burnt it up in kerosene and cross and burlap bags.

Mr. WELTNER. Mr. Woodle, did you say that was the night following the CBS report?

Mr. WOODLE. Yes, sir, I believe that's correct.

Mr. WELTNER. Now, that would be the 22d day of September; would it not?

Mr. WOODLE. I believe that is right, now.

Mr. WELTNER. And tell me, if you will, Mr. Woodle, when you saw the cross burning in your front yard, what did you take that for? You considered that to be a message of some kind? [Laughter.]

Mr. WOODLE. What do you mean, sir, by "message of some kind"?

Mr. WELTNER. What did you interpret that burning cross on your front yard to mean?

Mr. WOODLE. Stupidity. [Laughter.]

Mr. CHAIRMAN. No, the act was stupidity, but do you—I am sorry.

Mr. WELTNER. Mr. Woodle, my question is this: When you saw the cross burning on your front yard, did you interpret that as a sign of displeasure, possibly, from whoever erected that cross and set it on fire?

Mr. WOODLE. Undoubtedly, apparently I felt like somebody must have been displeased or something, dissatisfied.

Mr. WELTNER. Well, did that raise any fears in your mind about any possible acts against you or your family?

Mr. WOODLE. No, that didn't bring the worries on, that has been on a few days before that, already, but the reason I didn't even get in the act, a fellow had me on the telephone while the act was going on. That was the onliest reason. I would have saw the act, if it hadn't been for that. Caught me off guard on the telephone.

Mr. WELTNER. Well, what does it mean to an ordinary person who has a cross burned on his front yard?

Mr. WOODLE. I couldn't speak for nobody but myself. I don't know what it would mean to you or some other fellow.

Mr. WELTNER. Thank you.

Mr. POOL. Did the cross-burning on your front yard, did that represent a threat to you or your family?

Mr. WOODLE. I had already had the threat, and when I got this little telephone call, I was—I mean, as far as the cross-burning, it was just—and it was just another thing, as far as its worrying me any more, worry didn't come on to me account of that.

Mr. POOL. You didn't consider that an additional threat, then, or did you?

Mr. WOODLE. No.

The CHAIRMAN. Proceed.

Mr. MANUEL. Reverend Woodle, with further reference to the telephone call which you described, from the person whom you identified as Boyd Hamby, would you tell the committee what else, if anything, was said in that conversation?

Mr. WOODLE. Let me first clarify that I don't know it was Mr. Hamby on the phone. Because he was on the other end of the line, I wouldn't see him.

I just took for granted he was, and he identified himself as that, and I have heard so many times and so many different lies, I don't know what to believe sometimes, so I took it for granted it was him, but I couldn't swear on an oath that it was him.

The CHAIRMAN. He said he was?

Mr. WOODLE. Yes.

Mr. MANUEL. The person on the phone identified himself?

Mr. WOODLE. As Mr. Hamby.

It might not have been. It might have been somebody else.

Mr. POOL. You haven't ever talked to Mr. Hamby on the phone before? You had no way to recognize his voice?

Mr. WOODLE. Yes, I have talked to him before on the phone. It sounded like his voice. Personally, I believe it was, but I have got no way of swearing to it.

Mr. MANUEL. But the person did identify himself as Boyd Hamby?

Mr. WOODLE. Yes.

Mr. MANUEL. Did anything else transpire in that telephone—

Mr. WOODLE. Well, there was a pretty good little conversation going on.

It amounted to several words.

Mr. MANUEL. Would you briefly tell the committee what was said?

Mr. WOODLE. Well, he said that I was ordered to get out and leave us alone, and I asked him who "us" was, and he never told me who "us" was, and I told him we will play the game any way you want to play.

I told him, "My dues is paid, yourn is, and I don't think nobody has got a right to throw a man out without reason."

I told him, "We will play the game any way you want to play it. You name it. We'll play it."

When you get pushed around and pushed around, you know, you can rub a sore too much, and you just take too much.

After I had went out and put my life in an effort to try to be a man of honesty, and I got enough, in that great religious organization.

Mr. MANUEL. Reverend Woodle, when you appeared on the CBS program on the Ku Klux Klan, you were asked, "Do some of the Klan leaders misuse the people's money?"

Will you now please answer that question for the committee?

Mr. WOODLE. It is according to what you call misusing money. I guess they just take it to do what they please with it.

I mean, it's theirs, after they get it, and I don't figure—I guess it is theirs to do what they please. I mean, I don't hardly know how to answer that, but—

Mr. MANUEL. Well, do you have any knowledge of where the money goes, and what it is used for, after it is taken in by the leadership?

Mr. WOODLE. Personally, I got a \$20 check one time from Mr. Jones on a 3-day trip for about 250 miles, and for myself, I bought gas on credit to go to ralliēs, and go to ralliēs, and go back and forwards, to try to support, and what they do with it, outside of that \$20, I don't know what they do with it.

Mr. MANUEL. Well, does the leadership of the Klan keep their membership informed of their activities? Regularly? To your certain knowledge?

Mr. WOODLE. If they keep the members informed, in their activities? Now, what you mean, I don't quite get it.

The CHAIRMAN. He is talking about finances, I take it.

We are now talking about finances. Is the membership kept informed as to what is done with the money? Do they get a monthly report, or every 6 months, which indicates the realm receives so much money, and here is what they spend it for?

That is what he means, I think.

Mr. WOODLE. Not to my knowledge, there is no way, none of that is—

The CHAIRMAN. And that is why you say from all you know, they do what they please with the money?

Mr. WOODLE. That's right. As far as I know, nothing to that effect. I have no records of nothing, never heard nothing to that effect, that they ever report on nothing, or nothing of the kind.

Mr. POOL. They never do have the treasurer get up and read a treasurer's report, or any thing like that?

Mr. WOODLE. Not to my knowledge, no.

The CHAIRMAN. And you attended many rallies, but besides your own Klavern?

Mr. WOODLE. Yes. I would go to about all the rallies. I felt like that I was wanted, and after I got in the Klan and saw the good people in the Klan, I tried to preach the truth to them, be truthful to them, and honest with the people.

I don't think a Klansman can say I wasn't honest to him, and tried to be truthful with him at all times. I took an oath to be honest, but I didn't take no oath for people to call me up and cuss me and lie on me.

I didn't take no oath for people out taking poor people for their money. I didn't take no oath to that effect, and just go out and lie on people, and accuse them of being in the Government, the Government paying them, I didn't take no oath to stand for nothing like that.

I took an oath to stand like a man, and I think that's what a man ought to stand like—a man.

The CHAIRMAN. And you are standing like a man here today under oath.

Mr. WOODLE. Trying to, doing my best.

The CHAIRMAN. Well, at these rallies, in the field, as you call them, now away from your own Klan, where you had speakers, and where money was raised, and where on one occasion at least a man told you he was given a \$50 bill to put in the kitty to—

Mr. WOODLE. Try to lure others.

The CHAIRMAN. Lure others—

Mr. WOODLE. In other words, I say, deceiving them, bewitching them.

The CHAIRMAN. That is right, to deceive them, to bewitch them.

Now, at those rallies, after they picked the money, did they say, well, in all the rallies together, we received so many dollars, and we want to tell you what we did with those dollars? Did they tell you that kind of thing?

Mr. WOODLE. Yes, a couple of occasions, they did. Two or three times, they done that, how much they had received. They sure did.

The CHAIRMAN. Did they put that on a piece of paper, or did they just say it?

Mr. WOODLE. Just said it, or now what they had on the piece of paper, I don't know.

The CHAIRMAN. They didn't give you a statement?

Mr. WOODLE. No.

The CHAIRMAN. Written out, and said, "We received so much money in North Carolina, or in the Klavern, or this month, and here is what we did with the money," and put that in writing?

Mr. WOODLE. Not to my ability.

The CHAIRMAN. Go on.

Mr. MANUEL. Now, Reverend Woodle, as a person who has traveled with other Klan leaders to rallies, and so forth, could you tell the committee how these leaders live when they are on the road, traveling?

Mr. WOODLE. What do you mean in "how they live"?

Mr. MANUEL. What kind of—

Mr. WOODLE. Of condition they live?

Mr. MANUEL. That is right.

Mr. WOODLE. First class. Rib eye steaks. Cadillacs.

In my opinion, that's what it is. I mean, it might be different. They might not have it, but in all indications, that's what I seen.

The CHAIRMAN. They lived "high on the hog."

Mr. WOODLE. And then on other occasions, I saw poor men out on the side, can't hardly pay their bills, supporting it, and promising you, "We are going to give you the victory. We are going to stand. We are going to stand," but ain't nobody found out what they are going to stand for.

Burning a cross, I know that. I don't know what else, and I don't appreciate it.

Mr. POOL. Most of them drive Cadillacs?

Mr. WOODLE. And eat rib eye steaks, and live in first class motels. In what I saw.

Mr. POOL. Do very many of them wear diamonds?

Mr. WOODLE. Pretty good-sized ones, yes, and I don't imagine they had to buy theirs on credit, like I did.

Mr. POOL. How about their clothes? Did they go in the best clothes, I guess?

Mr. WOODLE. It looks very good.

But don't misunderstand me. A man's worth is his heart, but don't tell me you are standing against integration and for the Christian religion, and that's two things you never touch. If they do, I don't know—not in North Carolina—know of it.

In my honest opinion, the way I see it, come into town this month, have a rally, get all the money you can get, and get out, and say, "Now, you folks work hard, get all the members you can. We will be back next year for another rally."

And it's not because people really want it that way. People is deceived. It is just like a man that is drowning. They see this thing come along. They grab the first limb coming along.

I am afraid there—there are a lot of good, honest people. If I knowed what I know today, I would have been somewhere else.

I was misled, and I hate that I influenced people to be misled, and a lot of them have come and told me I influenced them to join it, and I hate I done it, and I have saw my mistake, and I hate it.

Not that I don't say we don't need a program. I am for the program, but let's don't say we are doing one thing, and doing something else.

That is where I oppose it at. I think a bricklayer ought to lay brick, and if a man's got a program to oppose something, I think it ought to come forth. I don't think it ought to be rode out in Cadillacs.

Mr. MANUEL. Now, Reverend Woodle, are you, and since the time that you left this organization, are you in fear of your life?

Mr. WOODLE. Well, I am expecting—at any time, anything happens won't surprise me. And I am looking for it.

But I believe the Lord will take care of me. If He's not able, I am ready to go, anyhow. If God will let a God-cusser run over me, I am ready to go.

I believe God will protect me. I believe He will cause the man to stumble, that I can see him first, or something, and with God as my helper, I will have something around.

Mr. MANUEL. Do you have any reason or indication to believe that certain specific individuals would do you bodily harm, either you or your family?

Mr. WOODLE. I believe if a man will deceive a poor man that can't hardly pay his bills, look out for anything.

Mr. MANUEL. Do you feel threatened by any specific individual whom you have known within the Realm of North Carolina or within the whole organization of the United Klans of America?

Mr. WOODLE. I am real suspicious of several people.

Mr. MANUEL. Reverend Woodle, what is the extent of your actual fear, and who is it that you do fear, within the Klan?

Mr. WOODLE. I don't actually fear no man that's openly and that I have been put wise to, that's certain, but you can look for it to come from out of town, or most anywhere.

In my opinion, look for it anywhere. When I go out the door of a morning, I am looking in the bushes to see what might be there. And I am expecting to live that way the rest of my life, but I am ready to stand that way.

The CHAIRMAN. Why are you suspicious?

What?

Mr. WOODLE. Well, when you get a telephone call that people's hired to do away with you, and a cross is being burnt in your yard, and people don't have no respect for children, women, dogs, or people's children with nothing to eat, you have to beware of that.

That's Castro's policy—Communists.

Mr. POOL. Do you know of any acts of violence that these people have committed on other people?

Mr. WOODLE. No, sir.

Mr. POOL. That's not why you are afraid of them? You are afraid of them for these other things?

Mr. WOODLE. On general principles. On just general principles, just take everything and put it in a pot, and that's what you have got.

But don't misunderstand me, now. I believe .98 percent of the people is honest and sincere. I believe the most of them was.

A man kept coming to me and persuading me, "This is the organization. We need you. You will stand; we want you."

And everything he told me about the organization before I got in it, not one thing he told me proved out to be true. Not one item. That the man had gotten me to join the Klan proved to be what he said it was.

Mr. POOL. So you were speaking of some of the leaders in the Klan when you mentioned these things?

Mr. WOODLE. In other words, a leader leads his men to victory. A dictator drives them to captivity, in my opinion. A lot of difference in a leader and a driver.

The CHAIRMAN. Go on.

Mr. MANUEL. Reverend Woodle, while you were a member of the Lexington Klavern, did you buy a robe?

Mr. WOODLE. No, sir.

Mr. MANUEL. Was any attempt made to get you to buy a robe?

Mr. WOODLE. Some fellow said they would pay for me a robe, but I told them I didn't want one, but it never did come through.

I told them I didn't do nothing I was ashamed of; about 4 years ago, I quit doing what I was ashamed of, that's the reason I used to hide when I would do something I didn't want nobody to know, and I quit that.

Mr. MANUEL. Now, other than your speaking activities, to rallies and the like would you please inform the committee of your other activities as a member of the Realm of North Carolina UKA?

Mr. WOODLE. Didn't have no other activities.

Mr. MANUEL. That is all you did, was speak?

Mr. WOODLE. At the rallies.

Mr. MANUEL. At the rallies?

Mr. WOODLE. Yes.

Mr. MANUEL. Why were you selected to speak at rallies?

Mr. WOODLE. Well, the fellow just called on me, and I would get up and open the Book and preach.

Mr. MANUEL. And who was it who requested you to speak?

Mr. WOODLE. Well, whoever was taking care of it—

Mr. MANUEL. At each rally?

Mr. WOODLE. Whoever was calling the speakers to the platform. It would be different ones at times.

(Discussion off the record.)

Mr. WELTNER. Mr. Woodle, you stated a few moments ago that your only activities with the Realm of North Carolina were to attend rallies, and you have also stated that at the rallies there was an effort made to collect funds from the audience.

Do you know whether any of the money collected at those rallies was ever turned over to the local Klavern, that is, the local unit of the Realm of North Carolina in the vicinity where the rally was held?

Mr. WOODLE. As far as I know, and in the reports, you know, what you hear while you are traveling, you know, it all went one way.

Mr. WELTNER. Which way was that?

Mr. WOODLE. However Mr. Jones—I don't have no knowledge of any local outfit keeping any of the money that is took up at a rally.

You see, in this, I believe that when you get a pearl, then you get a phony; when you get the real Klan, then you get a phony Klan.

That's someone trying to imitate and deceive the people, and they all don't work alike, in my opinion.

Mr. WELTNER. As far as you know, all of the money collected went to the state office, and none of it stayed to promote Klan activities in the area?

Mr. WOODLE. As far as I know, that's right.

Mr. WELTNER. Now, these rallies were held to generate new members and to expand the membership of the local Klans; were they not?

Mr. WOODLE. I believe the rally was. It seemed to be that way, but my opinion, the rallies was held to agitate the people.

Mr. WELTNER. Was there any—to your knowledge, was there any—action taken by the state officers at the rallies to organize locally, or did they just move on to somewhere else?

Mr. WOODLE. In my opinion, just to move on out. Get what you can, and go back, "I'll see you in a few more months, if you can get enough people together to have another rally."

That is my opinion. I don't know. That's how I take it.

Mr. SENNER. Mr. Chairman, I have one question.

Reverend Woodle, at any of these rallies that you attended, did any of the speakers advocate violence against integration or the use of violence by the Klan against integration?

Mr. WOODLE. I believe that's what has got the most of the people deceived. They are using that as a screen. Making the people think they are going to do something about integration. While they are doing the work the other way.

That is my opinion.

Mr. SENNER. I take it, then, your answer is that violence was preached?

Mr. WOODLE. No, not as I know of. That violence, never no indication of it. It is deceit, not violence.

Mr. SENNER. What did they preach? I mean, what did they lecture or talk about, these other speakers, relative to integration?

Mr. WOODLE. Sir?

Mr. SENNER. What did these speakers talk about, as a preventive measure against integration, at these rallies?

Mr. WOODLE. That's what has got the organization caught. Nothing against that, but using that to get their white people to rally behind them.

In other words—

The CHAIRMAN. Mostly for fund-raising?

Mr. WOODLE. In my opinion, just to get what we can out of the people, and you go to—and we are going home.

That's my opinion. I don't know the other man's motive. I don't know your motive, or his, but in my opinion, it's to draw, to agitate the white people, to get them to think we are standing against integration, we are going to stand for right, we are going to give you the victory, we are going to take care of your schools, your churches, they are not going to integrate, join our organizations; but at the end, no plan, nothing to do, for that. Nothing whatsoever, to my ability.

If there is anything in the State of North Carolina to stand against integration, by this United Klans of America, Incorporated, the reason I joined the organization, we have no word of where that takes place.

Mr. SENNER. Well, I take it that apparently the organization in and of itself is using the money, in your opinion, not to carry out the purposes in which they are telling the people at the rally. Is that correct?

Mr. WOODLE. Well, if anywhere they had a plan against integration, I don't know where it's at. You fellows might know, but I don't.

Mr. SENNER. Well, to raise money, do speakers at these rallies, on behalf of the United Klans of America, Incorporated, specifically or generally, outline methods in which they are going to take care of the integration problem in the schools, the hospitals, and other places?

Mr. WOODLE. You will have to ask that again. I didn't catch that.

Mr. SENNER. Do the speakers at these rallies advocate any plan in which they are going to take care of the problem of integration?

Mr. WOODLE. That's where the secret is.

If the poor people that's in it could wake up and see they don't have no plan, that would change the course, they would go join an organization that had a plan to do something.

That's my interpretation.

Mr. SENNER. I understand your opinion, that the United Klans has no plan.

Mr. WOODLE. Not to my ability. Under no condition.

Mr. SENNER. Now, at these local rallies, are there speakers on behalf of the Klan that are advocating some plan?

Mr. WOODLE. Oh, they say, "We are the organization. We are going to do it."

Mr. SENNER. Do they tell how they are going to do it?

Mr. WOODLE. That's where the lack of leadership comes.

You need a platform to go forth, a program. That's the reason. We don't have it, see, and the poor people, just like a man said a while ago, a man drowning, he will be grabbing anything that comes along. and that's what the people is doing, in my opinion, because there is some fine people in that organization, and there is some good Christian people in it, and a lot of people have been misled, like I have, I am afraid.

Mr. SENNER. Well, have you heard any speaker at a Klan meeting or rally advocate violence against integration?

Mr. WOODLE. No.

Mr. SENNER. Have they advocated any type of plan to stop integration?

Mr. WOODLE. Nothing as I know of.

You people know more about it than I do. I know nothing about whether—that's the reason I say, society's wrong somewhere.

A bricklayer ought to—I go out to lay brick, if I never lay none, people will say, "He's a phony." And I believe if the United Klans of America was standing against integration, they ought to have some kind of a program.

People run out here 2 or 3 years, and nothing done. I don't understand it. I mean, it gets me confused.

The CHAIRMAN. Will you yield to me?

Mr. SENNER. Yes.

The CHAIRMAN. What you are saying, as I understand, is that whereas that was your purpose in joining, and that was what was told you was the plan——

Mr. WOODLE. Yes.

The CHAIRMAN. —that instead of putting that plan into effect, they are using the poor members to get more money, and to highball.

Mr. WOODLE. Now, that is my opinion. I don't know the other man's motive. I don't know your motive, or no Klan member's motive, but I had a motive, and I know what my motive was.

It don't work that way. It worked different. I have spent more grief, more sorrow, more aches and pains, since I have been in that organization than I have in the 41 years of my life.

Mr. SENNER. Reverend Woodle, if they burned any crosses at these rallies that you attended——

Mr. WOODLE. Oh, yes.

Mr. SENNER. What was the purpose of burning a cross at the rally? What was the symbolic purpose?

Mr. WOODLE. I guess to kind of excite the people, to bring on excitement, enthusiasm, or whatever.

I mean, I don't know the purpose. That was just my opinion, as far as it taking care of our school situation, or anything, I don't know what good it done.

It might have done somebody some good, but I don't know. Just a little more of that Christian religion, tow sacks and kerosene and crosses.

I don't know the motive. Maybe this could——somebody else, because I don't know.

Mr. SENNER. At these rallies that you attended, did you estimate what the crowds were? They varied from, say, a hundred to more than a hundred?

Mr. WOODLE. No, sir. I have no—I never considered that. The crowds, or—I couldn't estimate it, to start with. Sometimes bigger crowds, smaller crowds, and different crowds.

Mr. SENNER. But it would be—What was the smallest crowd? Fifty or less?

Mr. WOODLE. Wouldn't have the slightest idea.

Mr. SENNER. The largest crowd, would you have an idea?

Mr. WOODLE. No, sir, I wouldn't.

Mr. SENNER. How many of these rallies did you attend?

Mr. WOODLE. Sir?

Mr. SENNER. How many rallies did you attend?

Mr. WOODLE. Well, I attended them all, until about 6 or 8 weeks ago, this year, but the first one, I didn't attend the first one.

Mr. SENNER. All but one, and how many would that be?

Mr. WOODLE. Then I attended the rest until I got out.

Mr. SENNER. Well, could you make an estimate of how many rallies you attended?

Mr. WOODLE. Oh, say, 12, 15.

Mr. SENNER. Thank you very much.

That's all the questions I have, Mr. Chairman.

The CHAIRMAN. Thank you very much. We appreciate your appearance.

And you were in the room a while ago when I talked about the meaning of a subpoena? In other words, you were served with a subpoena?

Mr. WOODLE. Yes, sir.

The CHAIRMAN. To come here. You did, and you testified under oath.

Mr. WOODLE. Yes, sir.

The CHAIRMAN. Now, I want to continue that subpoena, till January 1, in case something develops where we might have to call you back.

Mr. WOODLE. Yes, sir.

The CHAIRMAN. Anybody who would threaten you, or who would do any acts to you or your family, because you came here and testified, they would be violating a Federal law, and if that should happen to you, let me know, and we will handle it.

At least we will take the proper steps to protect you. That is a violation of Federal law, to try to intimidate or to coerce or threaten a person who comes forward and testifies before a court or a jury, or a congressional committee. And I want to see that that law is respected.

With that, thank you. We deeply appreciate your coming here, and your courage, and your contribution to these hearings, by reciting your individual experiences, and we are very grateful to you.

Thank you very much.

Call your next witness.

Mr. APPELL. Mr. Chairman, I would like to call to the stand Boyd Hamby.

The CHAIRMAN. Mr. Buchanan?

Mr. BUCHANAN. Before this witness is called, Mr. Chairman, I would like to read a portion of a telegram I have just received:

Would appreciate your help in making clear the Alabama Rescue Service mentioned in the KKK hearing is not recognized or known by the Alabama Association of Rescue Squads. The selfless and heroic members of local rescue squads have been somewhat embarrassed by association in the public mind with the KKK front. We fully support hearings.

and so forth.

And that is signed Brandt Ayers, B-r-a-n-d-t A-y-e-r-s, who is managing editor of the *Anniston Star*, and may I say, Mr. Chairman, that these rescue squads, in many of the smaller communities, especially, render a great public service, and they have no connection whatsoever with the Alabama Rescue Service identified in this hearing.

The CHAIRMAN. Well, you may inform your constituent, the good editor, that the Alabama Rescue Service is a cover name for the United Klans of America.

I appreciate your contribution, and we also appreciate very much the interest and support of that newspaper.

Please raise your right hand.

Do you solemnly swear that the testimony you are about to give will be the truth, the whole truth, and nothing but the truth, so help you God?

Mr. HAMBY. I do.

The CHAIRMAN. Proceed.

Identify both the witness and his counsel.

**TESTIMONY OF BOYD LEE HAMBY, SR., ACCOMPANIED BY COUNSEL,
LESTER V. CHALMERS, JR.**

Mr. APPELL. Would you state your full name for the record, please, sir?

Mr. HAMBY. Boyd Lee Hamby, Sr., sir.

The CHAIRMAN. Henry?

Mr. CHALMERS. H-a-m-b-y.

Mr. APPELL. Are you here in accordance with a subpoena served upon you by a United States marshal at 10:45 o'clock a.m. on the 11th day of October 1965?

Mr. HAMBY. Thereabouts, sir.

Mr. APPELL. Are you represented by counsel?

Mr. HAMBY. Yes, sir; I am.

Mr. APPELL. Will your counsel please identify himself for the record?

Mr. CHAMBERS. Yes, sir. I am Lester V. Chambers, Room 501, First Federal Building, Raleigh, North Carolina.

Mr. APPELL. Mr. Hamby, when and where were you born?

Mr. HAMBY. Sir, I respectfully decline to answer that question for the reason that I honestly feel that my answer might tend to incriminate me in the violation of my rights as guaranteed to me by the amendments 5, 1, 4, and 14 of the Constitution of the United States of America.

The CHAIRMAN. This is preliminary, a foundation question. I order and direct you to answer it.

Mr. HAMBY. Sir, I respectfully decline to answer that question for the reason that I honestly feel my answer might tend to incriminate me in violation of my rights as guaranteed to me by amendments 5, 1, 4, and 14 of the Constitution of the United States of America.

Mr. APPELL. Mr. Hamby, did you know the gentleman who preceded you on the witness stand?

(Witness confers with counsel.)

Mr. HAMBY. Sir, I respectfully decline to answer that question for the reason that I honestly feel my answer might tend to incriminate me in violation of my rights as guaranteed to me by amendments 5, 1, 4, and 14 of the Constitution of the United States of America.

Mr. APPELL. Mr. Hamby, you were, as I noted, seated here when he said that—

The CHAIRMAN. Well, name him. When "he."

Mr. APPELL. When Mr. Roy Woodle testified that he received a call from a person whom he identified as Boyd Hamby, and that he was advised by Boyd Hamby that Boyd Hamby had the authority to "do you in."

Did you make such a telephone call to Mr. Roy Woodle?

Mr. HAMBY. Sir, I respectfully decline to answer that question for the reason that I honestly feel my answer might tend to incriminate me in violation of my rights as guaranteed to me by the amendments 5, 1, 4, and 14 of the Constitution of the United States of America.

The CHAIRMAN. I think the actual words of the previous witness were that the gentleman, Mr. Hamby, "had authority to do away with" him. So recast the question. Those words actually are the words.

Mr. APPELL. Did you make a telephone call to Mr. Roy Woodle advising him that you had the authority to do away with him?

Mr. HAMBY. Sir, I respectfully decline to answer that question for the reason that I honestly feel my answer might tend to incriminate me in violation of my rights as guaranteed to me by the amendments 5, 1, 4, and 14 of the Constitution of the United States of America.

The CHAIRMAN. Let me make it perfectly clear, Mr. Hamby, that Mr. Woodle, when he made that statement, in your presence, with you in the room, was under oath.

Now, you have the opportunity to deny that statement under oath. And so far as this committee is concerned, it wants the truth, and if you would decide to deny that statement, then obviously we would have two directly contradictory statements under oath and one would be false, and then one of the two would be subject to the pains and penalties of perjury. And let me advise you that I would not hesitate to send the record to the Department of Justice for investigation, and to take appropriate perjury action.

With that statement, I give you the opportunity to deny Mr. Woodle's statement under oath, just made a moment ago.

He doesn't avail himself.

Go on.

Mr. APPELL. Mr. Hamby, I put it to you as a fact, and ask you to affirm or deny the fact, that you are currently the grand night-hawk of the Realm of North Carolina.

Mr. HAMBY. Sir, I respectfully decline to answer that question for the reason that I honestly feel my answer might tend to incriminate me in violation of my rights as guaranteed to me by amendments 5, 1, 4, and 14 of the amendments of the Constitution of the United States of America.

Mr. APPELL. Mr. Hamby, I put it to you as a fact, and ask you to affirm or deny the fact, that in the position of grand night-hawk, that you have a responsibility with respect to investigations conducted by the Klan in North Carolina, a leadership responsibility in that area.

Mr. HAMBY. Sir, I respectfully decline to answer that question, based on the grounds previously stated.

Mr. APPELL. I put it to you as a fact, and ask you to affirm or deny the fact, that heading an advisory committee in your position of grand night-hawk, that such things as the burning of crosses and other things come under your direct responsibility.

Mr. HAMBY. Sir, I respectfully decline to answer that question, based on the grounds previously stated.

Mr. APPELL. Mr. Hamby, I particularly noticed that you were in the room yesterday when I read a list by counties of crosses burned in

the State of North Carolina, and in your position of grand night-hawk, I ask you whether you played any role in any of the cross-burnings mentioned in the testimony yesterday.

Mr. HAMBY. Sir, I respectfully decline to answer that question, based on the grounds previously stated.

The CHAIRMAN. Did you play any part in connection with the burning of a cross on the property of the previous witness, on or about September 22?

Mr. HAMBY. Sir, I respectfully decline to answer that question, based on the grounds previously stated.

Mr. APPELL. Mr. Hamby, I hand you a signature card of the Davidson County Sportsman Club, received from the Lexington State Bank, Lexington, North Carolina, in compliance on the part of the bank with the subpoena duces tecum, which shows the signatures, authorized signatures to this account, Boyd L. Hamby, Charles R. Smith, Mack Grant.

I hand you this card and put it to you as a fact, and ask you to affirm or deny the fact, that that is your signature.

Mr. HAMBY. Sir, I respectfully decline to answer that question, based on the grounds previously stated.

(Document marked "Boyd Hamby Exhibit No. 1" follows:)

BOYD HAMBY EXHIBIT NO. 1

NAME	Davidson County Sportsman Club		Number of Signatures Required	
	FIRM	375-607	Checks	Notes
			(2)	
<small>Below are duly authorized signatures, which you will recognize in the payment of funds or the transaction of other business for our account. Depositor agrees to the rules and regulations governing commercial accounts as set out on the reverse side hereof.</small>				
Signature	<i>Boyd L. Hamby</i>			
Signature	<i>Charles R. Smith</i>			
Signature	<i>Mack Grant</i>			
Signature				
Address	60 Brown St.		Phone	CH 32322
Line of business				
Other Bank Accounts	<i>Has personal account</i>			
References				
REMARKS	<i>Send Bank Statement to P O Box 481</i>			
Date Account Opened	<i>1-13-04</i>		Initial Deposit	<i>7.00</i>
Date Account Closed	<i>in withdrawal 2-25-64</i>			<i>4</i>

Mr. APPELL. The signature card to this account was changed through an authorization dated 2-25-64.

I hand you that card, and ask you if it is not a fact that the change of the authorized signatures to the account of the Davidson County Sportsman Club became Wayne Tucker, William L. Lowery, and Matthew Smith.

(Witness confers with counsel.)

Mr. HAMBY. Sir, I respectfully decline to answer that question, based on the grounds previously stated.

(Document marked "Boyd Hamby Exhibit No. 2" follows:)

BOYD HAMBY EXHIBIT NO. 2

NAME	Number of Signatures Required	
	Checks	Notes
Davidson County Sportsman Club <small>FIRM</small>		
Below are duly authorized signatures, which you will recognize in the payment of funds or the transaction of other business for our account. Depositor agrees to the rules and regulations governing commercial accounts as set out on the reverse side hereof.		
Signature	<u>Wayne Tucker</u>	
Signature	<u>William L. Lowery</u>	
Signature	<u>Matthew Smith</u>	
Signature		
Address	<u>200 N. Salisbury St</u>	
Phone		
Line of business		
Other Bank Accounts		
References		
REMARKS	<u>New Authorization 2/25/64</u>	
Date Account Opened		
Initial Deposit		
Date Account Closed		

Mr. APPELL. I show you a check imprinted "Davidson County Sportsman Club, P.O. Box 481, Lexington, N.C.," check "No. 5," made payable to the Alabama Rescue Service, in the amount of \$3.75.

I can't read the one signature, Mr. Chairman, but the second signature on this check is shown as Boyd L. Hamby.

I put it to you as a fact, and ask you to affirm or deny the fact, that this was a check payable for imperial tax by the Davidson County Sportsman Club to the United Klans of America, in the name of the Alabama Rescue Service.

Mr. HAMBY. Sir, I respectfully decline to answer that question, based on the grounds previously stated.

(Document marked "Boyd Hamby Exhibit No. 3" follows:)

BOYD HAMBY EXHIBIT NO. 3

No. 5

DAVIDSON COUNTY SPORTSMAN CLUB
P. O. BOX 151

66-987
531

LEXINGTON, N.C. Feb. 24 1964

PAY TO THE ORDER OF Alabama Home Service

53.00

DOLLARS

Lexington State ^{of}
BANK
LEXINGTON, N.C.

Thomas D. Hamby Jr.
Boyd Hamby

⑆0531⑉0987⑆ 325⑉07⑆ ⑈0000000425⑈

Mr. APPELL. Mr. Hamby, I show you a series of checks made payable to J. R. Jones, on the account of the Davidson County Sportsman Club, and I ask you, I put it to you as a fact, and ask you to affirm or deny the fact, that many of these checks, containing your signature as a cosigner, were payable to J. R. Jones as state taxes based on the membership of the Davidson County Sportsman Club.

Mr. HAMBY. Sir, I respectfully decline to answer that question, based on the grounds previously stated.

(Documents marked "Boyd Hamby Exhibit No. 4" and retained in committee files.)

The CHAIRMAN. Wait a minute.
All right.

Mr. APPELL. Mr. Chairman, I would like to ask that the checks obtained from the Lexington State Bank, Lexington, North Carolina, relating to the account of the Davidson County Sportsman Club, be entered in evidence at this point.

The CHAIRMAN. That will be done, and let the reporter record that all documents now being described and those that have previously been referred to throughout the hearings be inserted in the record at the respective places where they were commented on and exhibited.

Mr. APPELL. Mr. Hamby, I put it to you as a fact, and ask you to affirm or deny the fact, that at the time you were elected grand night-hawk, that J. R. Jones was elected Grand Dragon, Mr. Grady Mars elected Klaliff, Mr. M. R. Kornegay elected klokard, the Reverend Roy Woodle, who just left the stand, elected grand kludd, that Fred Wilson was elected grand klabee, that Robert Reaves was elected grand kladd, that Albert Outlaw was elected grand klarogo, and that C. J. Brindell was elected as grand klexter.

Mr. HAMBY. Sir, I respectfully decline to answer that question, based on the grounds previously stated.

Mr. APPELL. Did you succeed C. J. Brindell as grand night-hawk?

Mr. HAMBY. Sir, I respectfully decline to answer that question, based on the grounds previously stated.

Mr. APPELL. Mr. Hamby, are you what is now known within the Klan Realm of North Carolina as a paid worker?

Mr. HAMBY. Sir, I respectfully decline to answer that question, based on the grounds previously stated.

Mr. APPELL. Mr. Hamby, I show you a series of checks, 13 in all, each in the amount of \$150, starting with date of June 26, 1965, and concluding with the date of September 17, 1965, each in the amount of \$150, or 13 checks totaling \$1,950, and I put it to you as a fact, and ask you to affirm or deny the fact, that these checks were given to you as designated on the checks for salary and expenses as a paid worker of the Realm of North Carolina.

(Checks handed to witness.)

Mr. HAMBY. Sir, I respectfully decline to answer that question, based on the grounds previously stated.

(Checks previously marked "James Jones Exhibit No. 7-C." See p. 1720.)

Mr. APPELL. Mr. Hamby, did you know as a member of the Klan Joseph DuBois, who was on the stand before Roy Woodlee?

Mr. HAMBY. Sir, I respectfully decline to answer that question, based on the grounds previously stated.

Mr. APPELL. Mr. Chairman, I have no further questions to ask of this witness.

(At this point Mr. Buchanan left the hearing room.)

(Discussion off the record.)

The CHAIRMAN. The witness is excused.

Mr. CHALMERS. Mr. Chairman, may I ask, sir, if it will be permissible for him to return to his home?

The CHAIRMAN. It is.

Mr. CHALMERS. Would the chairman desire to have him continue under subpoena?

The CHAIRMAN. No.

Mr. CHALMERS. All right, sir. Fine.

Thank you, sir.

The CHAIRMAN. Off the record.

(Discussion off the record.)

The CHAIRMAN. Call your next witness.

Mr. APPELL. I will call Sonny Fisher.

The CHAIRMAN. The committee will stand in recess for 10 minutes. (Brief recess.)

The CHAIRMAN. The subcommittee will please come to order. Call your next witness.

Mr. APPELL. Mr. Chairman, I would like to call Sonny Fisher.

The CHAIRMAN. Please raise your right hand.

Do you solemnly swear that the testimony you are about to give shall be truth, the whole truth, and nothing but the truth, so help you God?

Mr. FISHER. Yes, sir.

TESTIMONY OF JAMES HUEY (SONNY) FISHER, ACCOMPANIED BY COUNSEL, LESTER V. CHALMERS, JR.

Mr. APPELL. State your name for the record.

Mr. FISHER. James Huey Fisher.

Mr. APPELL. Are you popularly know as "Sonny" Fisher?

Mr. FISHER. Sir, I respectfully decline to answer that question for the reason that I honestly feel my answer may tend to incriminate me in the violation of my rights as guaranteed to me by amendments 5, 1, 4, and 14 of the Constitution of the United States of America.

The CHAIRMAN. Of course this answer doesn't hold up. If you admit that you are James, you ought to be able to admit that you are "Sonny." But I won't belabor it, because I will get the same reply, meaning I won't order you to answer.

Mr. APPELL. Are you represented by counsel?

Mr. FISHER. Yes, sir.

Mr. APPELL. Will counsel please identify himself for the record?

Mr. CHALMERS. I am Lester V. Chalmers, Jr., attorney at law, Room 501, First Federal Building, Raleigh, North Carolina.

Mr. APPELL. Mr. Fisher, your subpoena called upon you to produce:

All books, records, documents, correspondence, and memoranda relating to the organization of and the conduct of business and affairs of the Invisible Empire, United Klans, Knights of the Ku Klux Klan of America, Inc., also known as the United Klans of America, Inc., Knights of the Ku Klux Klan, and affiliated organizations, namely, the Alabama Rescue Service and the Pitt County Improvement Association, in your possession, custody or control, or maintained by you or available to you as an officer or employee of the Invisible Empire, United Klans, Knights of the Ku Klux Klan of America, Inc., also known as the United Klans of America, Inc., Knights of the Ku Klux Klan, and Pitt County Improvement Association.

The subpoena called for you to bring with you and produce said documents, and I now demand their production.

Mr. FISHER. Sir, I respectfully decline to deliver to the committee any and all records as requested by this committee under subpoena dated October 21, 1963, for that information is not relevant and germane to the subject under investigation and the same would not aid the Congress in the consideration of any valid remedial legislation, nor is such inquiry within the scope of that authorized to be investigated by Rule IV of the rules adopted by the 89th Congress, by House Resolution 8, adopted January 4, 1965.

I respectfully decline to deliver to the committee any and all documents and records as demanded by the committee in a subpoena dated October 21, 1965, for the reason that I honestly feel that to do so, the same might tend to incriminate me in violation of my right as guaranteed to me by amendments 5, 1, 4, and 14 of the Constitution of the United States of America.

Mr. APPELL. Mr. Chairman, before I ask for a direction, I would like to ask whether or not Mr. Fisher was here when our opening statement was read.

The CHAIRMAN. Counsel, I understand that our previous stipulations will obtain in this case, namely, that you stipulate that your client was in the hearing room and/or is familiar with my opening statement disclosing the pertinency of these records, and you further stipulate that for reasons previously indicated, the committee does not accept his objection or reasons for refusing to produce those documents, and that we do not in fact accept the refusal. Therefore, the position of the committee is that he subjects himself to a citation for refusing.

Mr. CHALMERS. Yes, sir, it is so stipulated for my client. I conferred with him with respect to that matter and he understands it and we certainly will apply the same stipulation to this.

The CHAIRMAN. And included in the stipulation as previously entered into between counsel and the chairman, is the fact that he is familiar with my opening statement setting forth, also, besides pertinency, the legislative purpose of this hearing, as well as the fact that he is being asked to produce these documents in the representative capacity stated in the subpoena.

Mr. CHALMERS. In the subpoena, yes, sir, and let me say that he is familiar with the opening statement.

The CHAIRMAN. In full?

Mr. CHALMERS. Yes, sir.

The CHAIRMAN. Counsel, I understand that there is one more document.

Mr. APPELL. We only demand as to paragraph 1.

The CHAIRMAN. Sir, I order and direct you to produce the documents described by Mr. Appell, and order them to be produced pursuant to the subpoena served upon you in the capacity indicated.

Mr. FISHER. Sir, I respectfully decline to deliver to this committee any and all records as requested by this committee under subpoena dated October 21, 1965, for that information is not relevant nor germane to the subject under investigation and the same would not aid the Congress in the consideration of any valid remedial legislation, nor is such inquiry within the scope of that authorized to be investigated by Rule IV of the rules adopted by the 89th Congress, by House Resolution No. 8, adopted January 4, 1965.

I respectfully decline to deliver to the committee any and all documents and records as demanded by the committee in a subpoena dated October 21, 1965, for the reason that I honestly feel that to do so, the same might tend to incriminate me in violations of my rights as guaranteed to me by amendments 5, 1, 4, and 14 of the Constitution of the United States of America.

Mr. APPELL. Mr. Fisher, under section 2 of the attachment which is made a part of the subpoena, you are ordered to produce:

All books, records, documents, correspondence, and memoranda in your possession, custody or control, or maintained by or available to you, in your capacity as an officer or employee of the United Klans of America, Inc., Knights of the Ku Klux Klan, which the "Constitution and Laws" of said organization authorize and require to be maintained by you and any other officer of said organization, and the Pitt County Improvement Association, the same being in your possession, custody or control.

I now demand that you produce under the terms of the subpoena the documents called for in part 2.

Mr. FISHER. Sir, I respectfully decline to deliver to the committee any and all records as requested by this committee under subpoena dated October 21, 1965, for that information is not relevant nor germane to the subject under investigation and the same would not aid the Congress in the consideration of any valid remedial legislation, nor is such inquiry within the scope of that authorized to be investigated by Rule IV of the rules adopted by the 89th Congress, by House Resolution 8, adopted January 4, 1965.

I respectfully decline to deliver to the committee any and all documents and records as demanded by the committee in a subpoena dated October 21, 1966, for the reason that I honestly feel that to do so, the same may tend to incriminate me in violation of my rights as guaranteed to me by amendments 5, 1, 4, and 14 of the Constitution of the United States of America.

The CHAIRMAN. Counsel, it is understood that we make the same stipulation relating to this paragraph as we did to paragraph 1?

Mr. CHALMERS. It certainly is; yes, sir.

The CHAIRMAN. I order you, sir, and direct you to produce the records called for by paragraph 2 in the attachment to subpoena, directing you to produce those records.

Mr. FISHER. Sir, I respectfully decline to deliver to the committee any and all records as requested by this committee under subpoena dated October 21, 1965, for that information is not relevant nor germane to the subject under investigation and the same would not aid the Congress in the consideration of any valid remedial legislation, nor is such inquiry within the scope of that authorized to be investigated by Rule IV of the rules adopted by the 89th Congress, by House Resolution No. 8, adopted January 4, 1965.

I respectfully decline to deliver to the committee any and all documents and records as demanded by the committee in a subpoena dated October 21, 1965, for the reason that I honestly feel that to do so, the same may tend to incriminate me in violation of my rights as guaranteed to me by amendments 5, 1, 4, and 14 of the Constitution of the United States of America.

The CHAIRMAN. Proceed.

Mr. APPELL. Mr. Fisher, in accordance with the subpoena duces tecum on the Edgecomb Bank and Trust Company of Tarboro, North Carolina, there was produced certain checks and other records, ledgers and signature cards in connection with an account in the name of the Pitt County Improvement Association. Upon receipt of the documents from the bank, we noted that the first signature card was not included in the documents and had apparently been destroyed. I would like to read to you three paragraphs from a letter addressed to the committee of September 17, 1965:

1. At the inception of this account we honored signatures drawn against this account by two people, both signatures being required, namely R. O. Bryan [B-r-y-a-n] and Sonny Fisher (Exhibit A—check dated 10-20-64 in the amount of \$56.00 is an example).

2. Under date of February 24, 1965 a new signature card was executed bearing three names, with the authority to honor any two of the three (Per Exhibit B attached). I believe we mailed you a copy of this signature card. The names appearing on the signature card of 2-24-65 are R. O. Bryan, Sonny Fisher and A. T. Bowen [B-o-w-e-n].

3. The signature card of 2-24-65 is current and still in effect.

I ask you, Mr. Fisher, if the statement reported to the committee by the bank is factual.

Mr. FISHER. Sir, I respectfully decline to answer that question for the reason that I honestly feel my answer might tend to incriminate me in violation of my rights as guaranteed to me by amendments 5, 1, 4, and 14 of the Constitution of the United States of America.

(Documents marked "James Fisher Exhibit No. 1." The signature card follows:)

JAMES FISHER EXHIBIT No. 1

AUTHORIZED SIGNATURE OF

PITT COUNTY IMPROVEMENT ASSN. FARMVILLE, N.C.

For the Transaction of Business with

EDGECOMBE BANK & TRUST COMPANY

FOUNTAIN, N. C.

TARBORO, N. C.

OAK CITY, N. C.

In receiving items for deposit or collection, this Bank acts only as depositor's collecting agent and assumes no responsibility beyond the exercise of due care. All items are credited subject to final payment in cash or solvent credits. This Bank will not be liable for default or negligence of its duly selected correspondents nor for losses in transit, and each correspondent so selected shall not be liable except for its own negligence. This Bank or its correspondents may send items, directly or indirectly, to any Bank including the payor and accept its draft or credit as conditional payment in lieu of cash; it may charge back any item at any time before final payment whether returned or not, also any item drawn on this Bank not good at close of business on day of deposit.

SIGNATURE _____

SIGNATURE _____

ADDRESS _____

BUSINESS _____

DATE Feb. 24, 1965

Introduced By _____

We hereby certify that this is an exact duplicate taken from the records of Edgecombe Bank & Trust Company, Fountain, N. C.- Branch Office, of Edgecombe Bank & Trust Company, Tarboro, N.C.

8-23-65

EDGECOMBE BANK & TRUST COMPANY

By: [Signature]
President

JOINT ACCOUNT—PAYABLE TO EITHER OR SURVIVOR

We agree and declare that all funds now, or hereafter deposited in this account are, and shall be our joint property and owned by us as joint tenants with right of survivorship, and not as tenants in common; and upon the death of either of us any balance in said account shall become the absolute property of the survivor. The entire account or any part thereof may be withdrawn by, or upon the order of, either of us or the survivor. It is especially agreed that withdrawals of funds by the survivor shall be binding upon us and upon our heirs, next of kin, legatees, assigns and personal representatives.

Witness our hands and seals this 23 day of FEB - 1965

WITNESS:

(SEAL)

(SEAL)

JOINT ACCOUNT—TWO OR MORE SIGNATURES REQUIRED

All moneys now or at any time deposited by us, with this bank to the credit of this account, are and shall be so deposited by us and received by the bank upon the following terms and conditions of repayment, namely, that the amount thereof shall be paid by the bank to us, or upon the written order of any _____ such persons so entitled to payment; and without reference to the original ownership of the moneys deposited, all withdrawals must contain _____ of the following signatures:

[Signature]
[Signature]
[Signature]

Mr. APPELL. Mr. Fisher, I show you four checks, all printed checks of the Pitt County Improvement Association, made payable to the Alabama Rescue Service, the first one with the cosignatures R. O. Bryan and Sonny Fisher in the amount of \$23.

The second is Alabama Rescue Service, \$92.50, countersigned by the same persons, the purpose for which drawn is imperial tax. And the third check, dated 6/30/65 to Alabama Rescue Service, \$152.00, tax, the same signatures, and I put it to you as a fact, and ask you to affirm or deny the fact, that this money was forwarded by the Pitt County Improvement Association, of which you are one of the cosigners, as the imperial tax payable to the United Klans of America, Incorporated, under the cover name of Alabama Rescue Service.

The CHAIRMAN. And Pitt County Improvement Association has been identified as a cover name for a local Klavern.

Mr. APPELL. Yes, sir.

(Documents handed to witness.)

Mr. FISHER. Sir, I respectfully decline to answer that question based upon the ground previously stated.

(Documents marked "James Fisher Exhibits Nos. 2-A through 2-D," respectively. Exhibit No. 2-A follows; 2-B, C, and D retained in committee files.)

JAMES FISHER EXHIBIT NO. 2-A

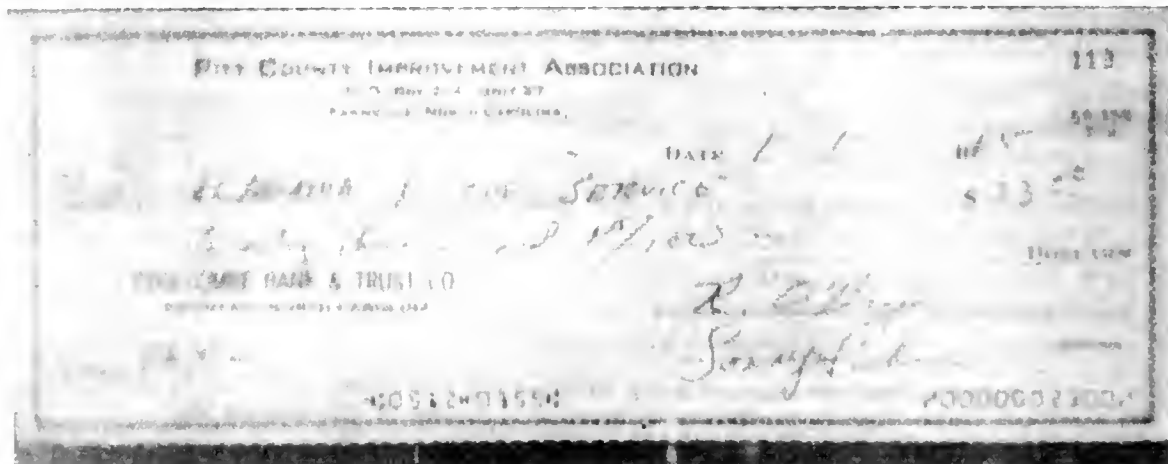

Mr. APPELL. Mr. Fisher, I now hand you a check, or a copy of an imprinted check, Pitt County Improvement Association, dated 3/31/65, which reads on the line "Pay To Order Of State tax J. R. Jones, \$12.75," cosigned, and as one of the cosigners, Sonny Fisher, and I put it to you as a fact, and ask you to affirm or deny the fact, that this was a payment to the Realm of North Carolina, as a per capita tax from the Pitt County Improvement Association.

Mr. FISHER. Sir, I respectfully decline to answer that question based upon the grounds previously stated.

(Document marked "James Fisher Exhibit No. 3" follows:)

JAMES FISHER EXHIBIT No. 3

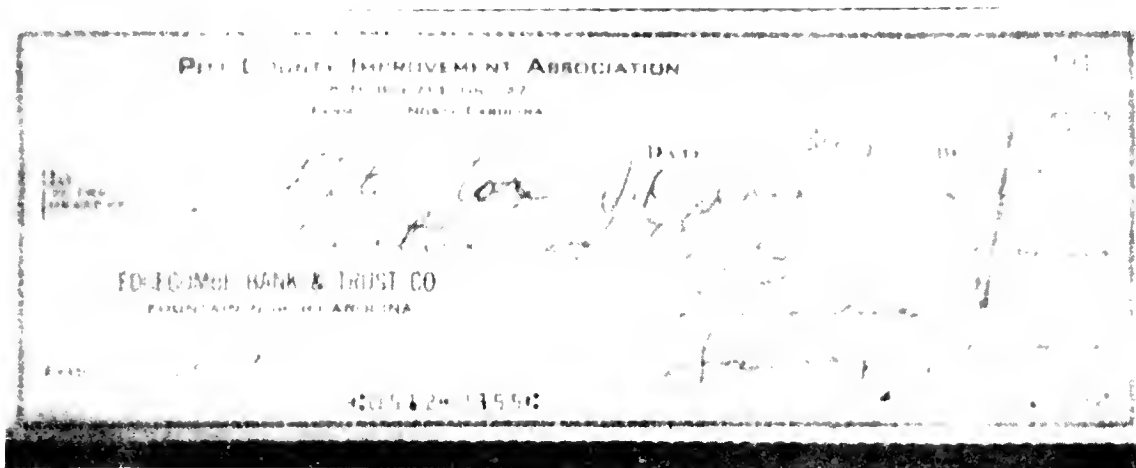

Mr. APPELL. I hand you a copy of a check dated 12/17/64, imprinted Pitt County Improvement Association, pay to the order of M. R. Kornegay, in the amount of \$100.00, the purpose for which drawn is, "Christmas Gift To James R. Jones."

I put it to you as a fact, and ask you to affirm or deny the fact, that you are one of the cosigners to this check.

Mr. FISHER. Sir, I respectfully decline to answer that question based upon the grounds previously stated.

(Document marked "James Fisher Exhibit No. 4" follows:)

JAMES FISHER EXHIBIT No. 4

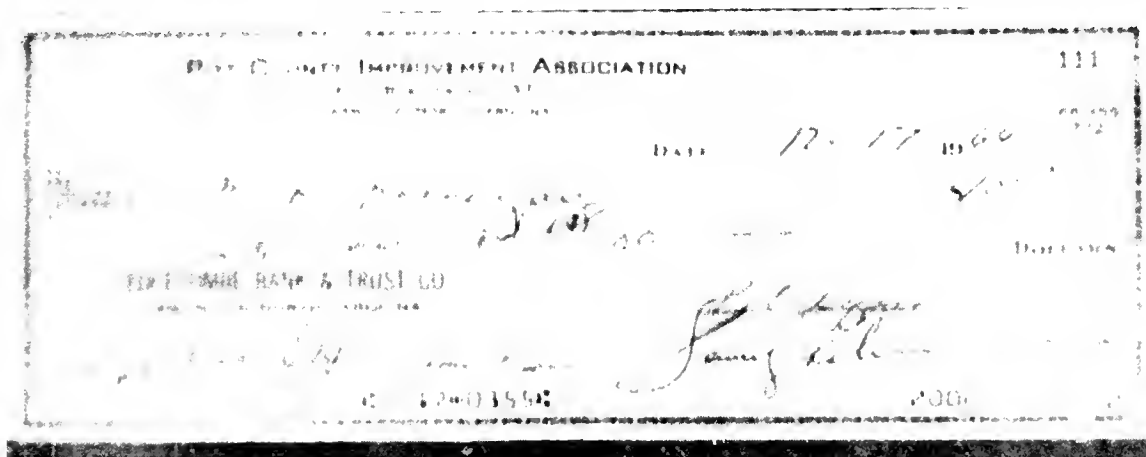

Mr. APPELL. Mr. Fisher, I hand you an additional check, copy of imprinted check of the Pitt County Improvement Association, dated 4/21/65, pay to the order of "New Bern & Blounts Creek Fund," \$42.11. The name of Sonny Fisher appearing as a cosigner. And I put it to you as a fact, and ask you to affirm or deny the fact, that this money was forwarded to this account for the purpose of helping to defray expenses of Klansmen involved in the New Bern bombing.

Mr. FISHER. Sir, I respectfully decline to answer that question based upon the grounds previously stated.

(Document marked "James Fisher Exhibit No. 5" follows:)

JAMES FISHER EXHIBIT NO. 5

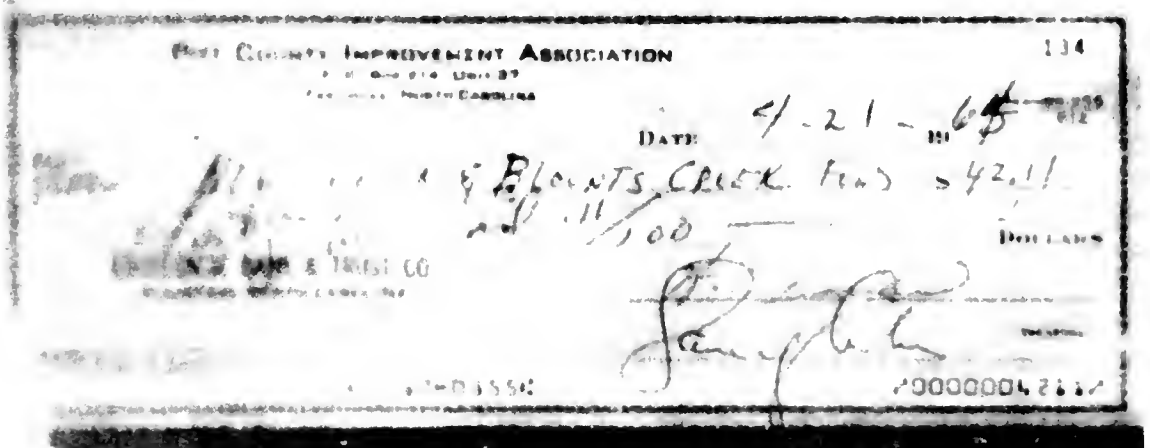

Mr. APPELL. Mr. Chairman, as a result of subpena duces tecum we served a subpena upon the Barrett Printing House, Wilson, North Carolina, for invoices and copies of material printed for the United Klans of America, Pitt County Improvement Association.

I would like permission to enter this material in the record at this point, and I wish to bring to the attention of the committee that the top secret solicitation of funds is one of the documents contained in this group of material which the Pitt County Improvement Association ordered printed by the Barrett Printing Company.

Also there are copies of the lotteries for certain prizes, for which they sold tickets at the rate of \$1.00 per ticket.

The CHAIRMAN. The documents will be received at this point. As a matter of fact, I will reiterate to the reporter since I don't want to override the generality of what I already said, that these and all other documents previously exhibited and referred to, and those to come, without the necessity of saying it each time, will be printed in the record at the point they were exhibited and commented on.

(Documents marked "James Fisher Exhibit No. 6" and retained in committee files.)

Mr. APPELL. The staff has no further questions for this witness, Mr. Chairman.

The CHAIRMAN. The witness is excused.

Mr. CHALMERS. I take it he may be excused to return to North Carolina?

The CHAIRMAN. Yes.

Mr. FISHER. Thank you, sir.

Mr. APPELL. The next witness is William R. Walston.

The CHAIRMAN. Do you solemnly swear that the testimony you are about to give shall be the truth, the whole truth, and nothing but the truth, so help you God?

Mr. WALSTON. I do.

**TESTIMONY OF WILLIAM RICHARD WALSTON, ACCOMPANIED BY
COUNSEL, LESTER V. CHALMERS, JR.**

Mr. APPELL. Will you please state your name for the record.

Mr. WALSTON. William Richard Walston.

Mr. APPELL. Are you appearing before the committee today in accordance with the subpoena served upon you at 1:20 o'clock p.m. on the 12th day of October 1965?

Mr. WALSTON. Yes, I am.

Mr. APPELL. Are you represented by counsel?

Mr. WALSTON. Yes, sir.

Mr. APPELL. Will counsel please identify himself for the record.

Mr. CHALMERS. Lester Chalmers, Jr., attorney at law, Room 501 First Federal Building, Raleigh, North Carolina.

Mr. APPELL. Mr. Walston, under the terms of the subpoena served upon you, you are demanded to bring with you and to produce documents described on an attachment which is made a part of the subpoena, reading:

(1) All books, records, documents, correspondence, and memoranda relating to the organization of and the conduct of business and affairs of the Invisible Empire, United Klans, Knights of the Ku Klux Klan of America, Inc., also known as the United Klans of America, Inc., Knights of the Ku Klux Klan, and affiliated organizations, namely, the Alabama Rescue Service, and Wilson County Improvement Association, in your possession, custody or control, or maintained by you or available to you as an officer or employee of the Invisible Empire, United Klans, Knights of the Ku Klux Klan of America, Inc., also known as the United Klans of America, Inc., Knights of the Ku Klux Klan, and the Wilson County Improvement Association.

I demand production of these records at this time, sir.

Mr. WALSTON. Sir, I respectfully decline to deliver to the committee any and all records as requested by this committee under subpoena dated October 21, 1965, for that information is not relevant and germane to the subject under investigation and the same would not aid the Congress in the consideration of any valid remedial legislation, nor is such inquiry within the scope of that authorized to be investigated by Rule IV of the rules adopted by the 89th Congress, by House Resolution 8, adopted January 4, 1965.

I respectfully decline to deliver to the committee any and all documents and records as demanded by the committee in a subpoena dated October 21, 1965, for the reason that I honestly feel that to do so, the same would tend to incriminate me in violation of my rights as guaranteed to me by amendments 5, 1, 4, and 14 of the Constitution of the United States of America.

The CHAIRMAN. Now, Mr. Chalmers, I take it that the several stipulations we have previously made to the effect that your client is familiar with my opening statement, particularly those portions dealing with the pertinency of these documents and the legislative purpose for their requirements and the fact that they are being requested of him in the capacity indicated in the attachment to the subpoena served upon him, are now renewed?

Mr. CHALMERS. Yes, sir, my client is familiar with the opening statement and the other statements and stipulations, yes, sir.

The CHAIRMAN. Sir, I order and direct you to produce those documents.

Mr. WALSTON. Sir, I respectfully decline to deliver to the committee any and all records as requested by this committee under subpoena dated October 21, 1965, for that information is not relevant and germane to the subject under investigation and the same would not aid the Congress in the consideration of any valid remedial legislation, nor is such inquiry within the scope of that authorized to be investigated by Rule IV of the rules adopted by the 89th Congress, by House Resolution 8, adopted January 4, 1965.

I respectfully decline to deliver to the committee any and all documents and records as demanded by the committee in the subpoena dated October 21, 1965, for the reason that I honestly feel that to do so might tend to incriminate me in violation of my rights as guaranteed to me by amendments 5, 1, 4, and 14 of the Constitution of the United States of America.

Mr. APPELL. Mr. Walston, under part 2 of the subpoena, an attachment which was made a part of the subpoena, requires that you bring with you and produce:

(2) All books, records, documents, correspondence, and memoranda in your possession, custody or control, or maintained by or available to you, in your capacity as an officer or employee of the United Klans of America, Inc., Knights of the Ku Klux Klan, which the "Constitution and Laws" of said organization authorize and require to be maintained by you and any other officers of said organization, and the Wilson County Improvement Association, the same being in your possession, custody or control.

I demand that you produce the documents called for in section 2.

The CHAIRMAN. Mr. Chalmers, I take it that the stipulations we just made relating to paragraph 1 of the attachment to the subpoena duces tecum apply to this paragraph, too.

Mr. CHALMERS. It is so stipulated.

The CHAIRMAN. Sir, I order and direct you to produce the documents called for by paragraph 2 of the attachment to the subpoena duces tecum served upon you.

Mr. WALSTON. I respectfully decline to deliver to the committee any and all records as requested by this committee under subpoena dated October 21, 1965, for that information is not relevant and germane to the subject under investigation and the same would not aid the Congress in the consideration of any valid remedial legislation, nor is such inquiry within the scope of that authorized to be investigated by Rule IV of the rules adopted by the 89th Congress, by House Resolution 8, adopted January 4, 1965.

I respectfully decline to deliver to the committee any and all documents and records as demanded by the committee in the subpoena dated October 21, 1965, for the reason that I honestly feel that to do so might tend to incriminate me in violation of my rights as guaranteed to me by amendments 5, 1, 4, and 14 of the Constitution of the United States of America.

The CHAIRMAN. The committee will stand in recess for 5 minutes. (A brief recess was taken.)

The CHAIRMAN. The subcommittee will come to order.

Resume your examination, Mr. Appell.

Mr. APPELL. Mr. Walston, I hand you two signature cards supplied to the committee by the First-Citizens Bank & Trust Company of Wilson, North Carolina, in the account of the Wilson County Improvement Association, William R. Walston, W-a-l-s-t-o-n, Troy Walker,

W-a-l-k-e-r, M. E. P-o-y-t-h-r-e-s-s, G. E. Smiley, S-m-i-l-e-y, and Hoyt L. Waller.

I hand you these cards and put it to you as a fact, and ask you to affirm or deny the fact, that these are the signature cards of Wilson County Improvement Association, which is known within the United Klans of America, Realm of North Carolina, as Unit 31.

Mr. WALSTON. Sir, I respectfully decline to answer that question for the reason that I honestly feel my answer might tend to incriminate me in violation of my rights as guaranteed to me by amendments 5, 1, 4, and 14 of the Constitution of the United States of America.

(Documents marked "William Walston Exhibit No. 1" follow:)

WILLIAM WALSTON EXHIBIT NO. 1

NAME Wilson Improvement Association No. of Signatures Required Assent

To FIRST-CITIZENS BANK & TRUST COMPANY

You are hereby authorized to recognize the signature below in the payment of funds and the transaction of other business in connection with my account. Said account is and shall be subject to your By-Laws, Rules and/or Regulations as they now or may hereafter exist, and you are expressly authorized to charge the account, without notice, for any service, collection, or other charges provided therein.

It is hereby stipulated and agreed that any and all items deposited by the person, firm or corporation whose signature appears below are received by this Bank for deposit or collection and in so doing this Bank acts only as depositor's collecting agent and assumes no responsibility beyond the exercise of due care. All items are credited subject to final payment in cash or solvent credits. This Bank will not be liable for default or negligence of its duly selected correspondents nor for losses in transit, and each correspondent so selected shall not be liable except for its own negligence. This Bank or its correspondents may send items, directly or indirectly, to any bank including payor, and accept its draft or credit as conditional payment in lieu of cash; it may charge back any item at any time before final payment, whether returned or not.

It is also understood and agreed that any items, deposited or otherwise acquired in due course, drawn on this Bank that are not good, may be charged back at any time, whether returned or not.

It is further agreed that this bank is authorized to charge this account with a service charge in accordance with its rules. This is your authority to make an annual, semi-annual or monthly maintenance charge against the account, regardless of the amount on deposit and without regard to the activity or inactivity of said account.

Authorized Signature William P. Walston

Authorized Signature Hoyt L. Waller

Address 766 W. Walnut St. Wilson
Newton Park P.O. Box 366

NAME Wilson County Improvement Association, Unit 31 No. of Signatures Required Assent

To FIRST-CITIZENS BANK & TRUST COMPANY

You are hereby authorized to recognize the signature below in the payment of funds and the transaction of other business in connection with my account. Said account is and shall be subject to your By-Laws, Rules and/or Regulations as they now or may hereafter exist, and you are expressly authorized to charge the account, without notice, for any service, collection, or other charges provided therein.

It is hereby stipulated and agreed that any and all items deposited by the person, firm or corporation whose signature appears below are received by this Bank for deposit or collection and in so doing this Bank acts only as depositor's collecting agent and assumes no responsibility beyond the exercise of due care. All items are credited subject to final payment in cash or solvent credits. This Bank will not be liable for default or negligence of its duly selected correspondents nor for losses in transit, and each correspondent so selected shall not be liable except for its own negligence. This Bank or its correspondents may send items, directly or indirectly, to any bank including payor, and accept its draft or credit as conditional payment in lieu of cash; it may charge back any item at any time before final payment, whether returned or not.

It is also understood and agreed that any items, deposited or otherwise acquired in due course, drawn on this Bank that are not good, may be charged back at any time, whether returned or not.

It is further agreed that this bank is authorized to charge this account with a service charge in accordance with its rules. This is your authority to make an annual, semi-annual or monthly maintenance charge against the account, regardless of the amount on deposit and without regard to the activity or inactivity of said account.

Authorized Signature M. E. Poythress

Authorized Signature G. E. Smiley

Address Hoyt L. Waller Rt 2

Mr. APPELL. Mr. Chairman, I would like to have entered into the record all of the checks made payable to James R. Jones, Wilson County Improvement Association. In order to save time, I am going to show the witness a copy of the imprinted check, Wilson County Improvement Association, Wilson, North Carolina, August 29, 1964, James R. Jones, \$205, signed Troy Walker and William R. Walston, something "on July," and I cannot read what that is, sir.

I show you this check, Mr. Walston, and put it to you as a fact, and ask you to affirm or deny the fact, that this check was drawn, countersigned, and made payable to James R. Jones.

The CHAIRMAN. Are they all on the same bank and payable to the same people?

Mr. APPELL. Yes.

The CHAIRMAN. Mr. Appell hands you the following checks with the same bank and the same payee, respectively, dated as follows, and in the following amounts:

Mr. APPELL. I am having difficulty on some of these checks, Mr. Chairman, with the dates, trying to read them. The date in May of 1964, \$4.50.

June 7, 1964, \$9.75.

June 17, 1964, \$50.00.

July 1, 1964, \$360.

August 14, 1964, \$49.

August 19, 1964, \$100.00.

August 29, 1964, \$205.

September 10, 1964, \$46.75.

September 16, 1964, \$50.00.

October 9, 1964, \$193.75.

The CHAIRMAN. He puts it to you as fact, and asks you to affirm or deny the fact, that all of these checks had your signature.

Mr. APPELL. No, they were all payable to J. R. Jones. The check dated May 1964 in the amount of \$4.50, and the check dated June 7, \$9.75 and June 17, '64, in the amount of \$50.00 and the check dated July 1, 1964, in the amount of \$360 do not contain the signature of Mr. Walston; the remainder do. They are all payable to Mr. James R. Jones.

The CHAIRMAN. They contain the signature required by the signature card previously identified.

Mr. APPELL. Yes, sir.

The CHAIRMAN. I think that I have previously directed these to the witness.

Mr. WALSTON. I respectfully decline to answer that question for the reason that I honestly feel that my answer might tend to incriminate me in violation of my rights as guaranteed to me by amendments 5, 1, 4, and 14 of the Constitution of the United States of America.

(Documents marked "William Walston Exhibits Nos. 2-A through 2-J," respectively; 2-J appears on p. 1881; balance retained in committee files.)

Mr. APPELL. Mr. Walston, I hand you a series of checks all made payable to the Alabama Rescue Service, on the imprinted checks of the Wilson County Improvement Association:

August 21, 1964, \$14.50.

June 9, 1964, \$9.95.

WILLIAM WALSTON EXHIBIT No. 2-J

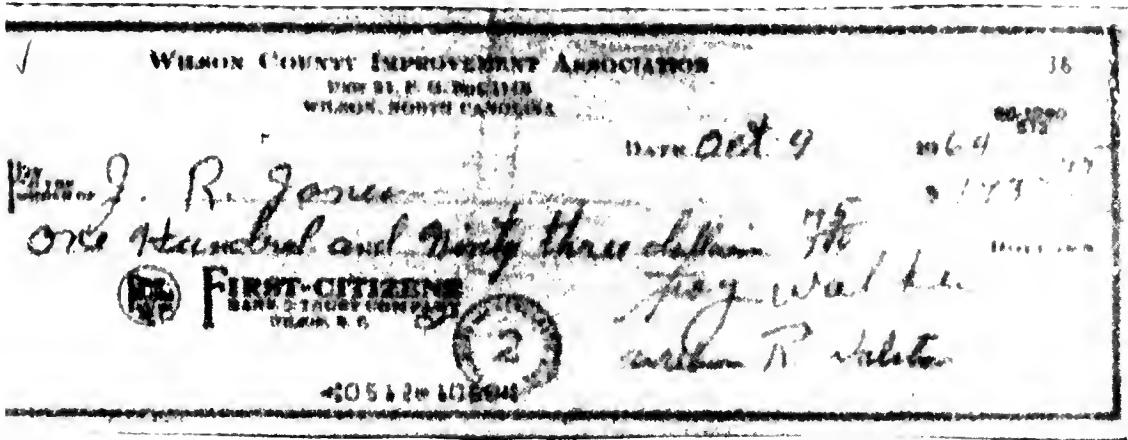

July 18, 1964, \$25.75.

August 14, 1964, \$49.00.

August 19, 1964, \$40.00.

September 10, 1964, \$46.75.

October 9, 1964, \$35.25.

All made payable to the Alabama Rescue Service.

I hand you these checks and ask you—and put to to you as a fact, and ask you to affirm or deny the fact, that these checks are made payable from the Wilson County Improvement Association to the Alabama Rescue Service, and the funds represented here constitute a per capita tax to the imperial office of the United Klans of America.

Mr. WALSTON. Sir, I respectfully decline to answer that question based upon the grounds previously stated.

(Documents marked "William Walston Exhibits Nos. 3-A through 3-G," respectively; 3-G follows, balance retained in committee files.)

WILLIAM WALSTON EXHIBIT No. 3-G

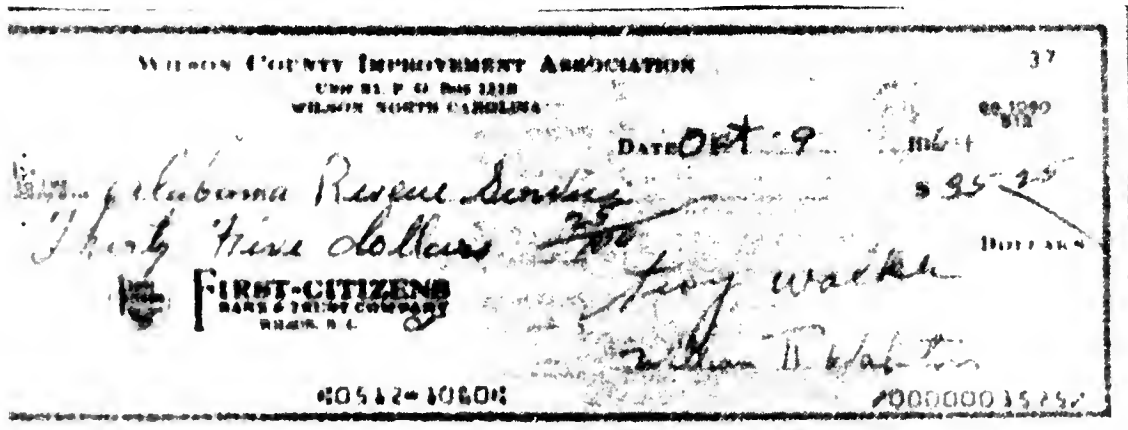

Mr. APPELL. Mr. Walston, I hand you a check dated September 2, 1964, an imprinted check of the Wilson County Improvement Association, countersigned by Troy Walker and William R. Walston, made payable to Dick Walston in the amount of \$951.00. I hand you the

check and put it to you as a fact, and ask you to affirm or deny the fact, that that check was issued.

Mr. WALSTON. Sir, I respectfully decline to answer that question based upon the grounds previously stated.

Mr. APPELL. For what purpose was that check in the amount of \$951 drawn?

Mr. WALSTON. Sir, I respectfully decline to answer that question based upon the grounds previously stated.

(Document marked "William Walston Exhibit No. 4" follows:)

WILLIAM WALSTON EXHIBIT NO. 4

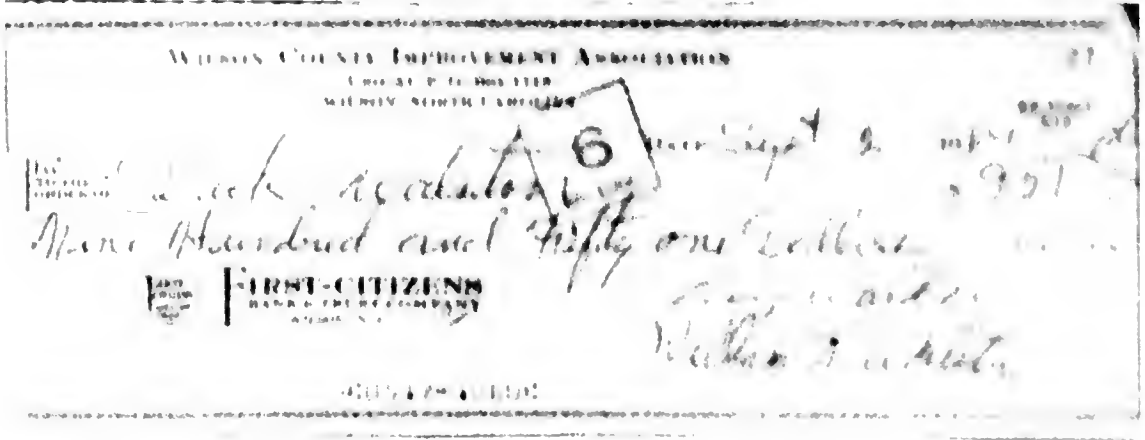

Mr. APPELL. Mr. Walston, I show you a check dated November 19, 1964, in the amount of \$187.84, made payable to cash, which was written for the purpose of closing out this account, and I ask you where the funds of the Wilson County Improvement Association were transferred after November of 1964.

Mr. WALSTON. Sir, I respectfully decline to answer that question based upon the grounds previously stated.

(Document marked "William Walston Exhibit No. 5" follows:)

WILLIAM WALSTON EXHIBIT NO. 5

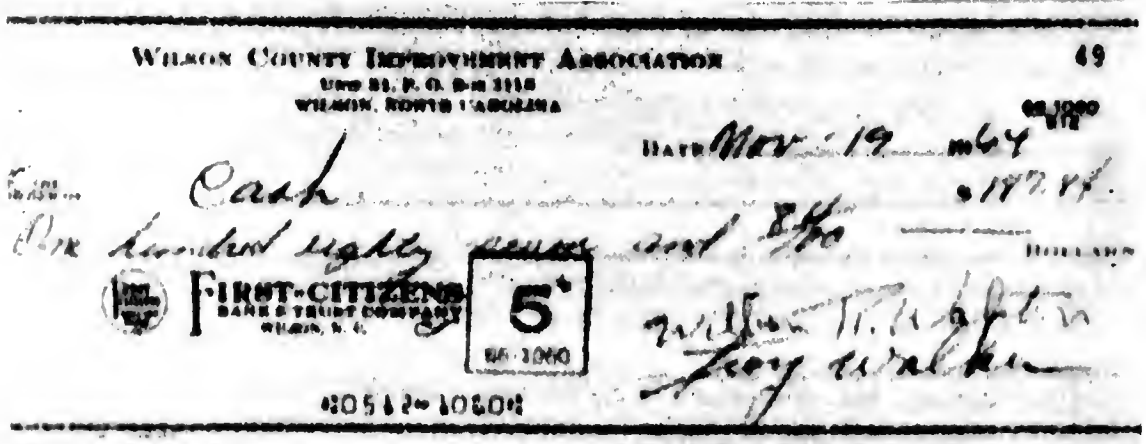

Mr. APPELL. Do you know James R. Jones to be Grand Dragon of the State of North Carolina?

Mr. WALSTON. I respectfully decline to answer that question based upon the grounds previously stated.

Mr. APPELL. Do you know Robert M. Shelton to be the Imperial Wizard of United Klans of America, and using as a bookkeeping cover name the Alabama Rescue Service?

Mr. WALSTON. I respectfully decline to answer that question based upon the grounds previously stated.

Mr. APPELL. Mr. Walston, the *Charlotte Observer* of September 4, 1964, reporting on Klan activities in the North Carolina area reported that at a Klan rally near Salisbury, on August 8, William R. Walston of Wilson, "demonstrated the same talent" with respect to "going two ways at once," with respect to violence and nonviolence. They quote you as saying:

"We are opposed to violence to the man," he shouted, and then quickly added the qualifier: "But if violence must come, we are ready to a man."

Did you make that statement, sir?

Mr. WALSTON. Sir, I respectfully decline to answer that question based upon the grounds previously stated.

(Document marked "William Walston Exhibit No. 6" and retained in committee files.)

Mr. APPELL. I have no further questions to ask of this witness, Mr. Chairman.

The CHAIRMAN. The witness is excused and discharged from his subpena.

Mr. CHALMERS. Thank you.

The CHAIRMAN. Call your next witness.

Mr. APPELL. I call Mr. Wayne Dayvault.

The CHAIRMAN. Raise your right hand.

Do you solemnly swear that the testimony you are about to give will be the truth, the whole truth, and nothing but the truth, so help you God?

Mr. DAYVAULT. I do.

TESTIMONY OF WAYNE DAYVAULT, ACCOMPANIED BY COUNSEL, LESTER V. CHALMERS, JR.

Mr. APPELL. Would you state your full name for the record?

Mr. DAYVAULT. Wayne Dayvault.

Mr. APPELL. Are you appearing before the committee this afternoon in accordance with subpena served upon you at 12:30 o'clock p.m., on the 11th day of October 1965?

Mr. DAYVAULT. Yes, sir.

Mr. APPELL. You are represented by counsel?

Mr. DAYVAULT. Yes, sir.

Mr. APPELL. Would counsel please identify himself for the record?

Mr. CHALMERS. I am Lester V. Chalmers, attorney at law, room 501, First Federal Building, Raleigh, North Carolina.

Mr. APPELL. Mr. Dayvault, the subpena served upon you called upon you to bring with you documents described on an attachment which was made a part of the subpena, which reads, as part 1, as follows:

All books, records, documents, correspondence, and memoranda relating to the organization of and the conduct of business and affairs of the Invisible Empire, United Klans, Knights of the Ku Klux Klan of America, Inc., also known as the United Klans of America, Inc., Knights of the Ku Klux Klan, and affiliated organizations, namely, the Alabama Rescue Service, Realm (State) of North Carolina, and Rowan Sportsmen's Club in your possession, custody or control, or maintained by you or available to you as Grand Kligrapp (Secretary), Realm (State) of North Carolina, and as an officer of the Rowan Sportsmen's Club of the Invisible Empire, United Klans, Knights of the Ku Klux Klan of America, Inc., also known as the United Klans of America, Inc., Knights of the Ku Klux Klan.

I demand the production of those documents under part 1 of your subpoena, Mr. Dayvault.

Mr. DAYVAULT. I respectfully decline to give to the committee any and all records as requested by the committee under subpoena dated October 21, 1965, for that information is not relevant and germane to the subject under investigation and the same would not aid the Congress in the consideration of any valid remedial legislation, nor is such within the scope of that authorized to be investigated by Rule IV of the rules adopted by the 89th Congress, by House Resolution 8, adopted January 4, 1965.

I respectfully decline to deliver to the committee any and all documents and records as demanded by the committee in a subpoena dated October 21, 1965, for the reason that I honestly feel that to do so, the same might tend to incriminate me in violation of my rights as guaranteed to me by amendments 5, 1, 4, and 14 of the Constitution of the United States of America.

The CHAIRMAN. Counsel?

Mr. CHALMERS. The same stipulations.

The CHAIRMAN. It is stipulated that this subpoena was served on the witness?

Mr. CHALMERS. Yes, sir.

The CHAIRMAN. I take it that we now stipulate with you, on behalf of your client, and I, on behalf of the committee, that he is familiar with the contents of my opening statement, pointing out the pertinency of these documents sought by this subpoena, as well as the legislative purpose to be served, and that this subpoena has been served on him in the capacity indicated in the subpoena.

Mr. CHALMERS. It is so stipulated.

The CHAIRMAN. Sir, I now order and direct you to produce the documents demanded by the subpoena in paragraph 1 of the attachment thereto.

Mr. DAYVAULT. I respectfully decline to deliver to the committee any and all records as requested by this committee under subpoena dated October 21, 1965, for that information is not relevant or germane to the subject under investigation and the same would not aid the Congress in the consideration of any remedial legislation, nor is such within the scope of that authorized to be investigated by Rule IV of the rules adopted by the 89th Congress, of the House Resolution 8, adopted January 4, 1965.

I respectfully decline to deliver to the committee any and all documents and records as demanded by the committee in a subpoena dated October 21, 1965, for the reason that I honestly feel that to do so, the same might tend to incriminate me in the violation of my rights as guaranteed to me by amendments 5, 1, 4, and 14 of the Constitution of the United States of America.

MR. APPELL. Mr. Dayvault, the subpoena called for you to bring with you and to produce items contained in the attachment which was made a part of the subpoena, part 2:

All books, records, documents, correspondence, and memoranda in your possession, custody or control, or maintained by or available to you, in your capacity as Grand Kligrapp (Secretary), Realm (State) of North Carolina, and as an officer of the Rowan Sportsmen's Club of the United Klans of America, Inc., Knights of the Ku Klux Klan, which the "Constitution and Laws" of said organization authorize and require to be maintained by you and any other officer of said organization, the same being in your possession, custody or control.

I now demand the production of the documents called for in paragraph 2.

THE CHAIRMAN. It is understood that the stipulations made with reference to paragraph 1 apply to paragraph 2?

MR. CHALMERS. Yes, sir.

THE CHAIRMAN. Sir, I order and direct you to produce the documents referred to and ordered by the subpoena served upon you.

MR. CHALMERS. Mr. Chairman, if I may, and correct me, sir, there was a demand made but there was no reply to the demand. There was no refusal yet.

MR. DAYVAULT. Sir, I respectfully decline to deliver to the committee any and all records as requested by the committee under subpoena dated October 21, 1965, for that information is not relevant and germane to the subject under investigation and the same would not aid the Congress in the consideration of any valid remedial legislation, nor is such within the scope of that authorized to be investigated by Rule IV of the rules adopted by the 89th Congress, House Resolution 8, adopted January 4, 1965.

I respectfully decline to deliver to the committee any and all documents and records as demanded by the committee in a subpoena dated October 21, 1965, for the reason that I honestly feel that to do so, the same might tend to incriminate me in violation of my rights as guaranteed to me by amendments 5, 1, 4, and 14 of the Constitution of the United States of America.

THE CHAIRMAN. Sir, I order and direct you to produce the documents just called for.

MR. DAYVAULT. I respectfully decline to deliver to the committee any and all records as requested by the committee under subpoena dated October 21, 1965, for that information is not relevant and germane to the subject under investigation and the same would not aid the Congress in the consideration of any valid remedial legislation, nor is such within the scope of that authorized to be investigated by Rule IV of the rules adopted by the 89th Congress, by House Resolution 8, adopted January 4, 1965.

I respectfully decline to deliver to the committee any and all documents and records as demanded by the committee in a subpoena dated October 21, 1965, for the reason that I honestly feel that to do so, the same might tend to incriminate me in violation of my rights as guaranteed to me by amendments 5, 1, 4, and 14 of the Constitution of the United States of America.

MR. APPELL. Mr. Dayvault, when and where were you born?

MR. DAYVAULT. I respectfully decline to answer that question for the reason that I honestly feel my answer might tend to incriminate me in violation of my rights as guaranteed to me by amendments 5, 1, 4, and 14 of the Constitution of the United States of America.

The CHAIRMAN. I order and direct you to answer this question, and I might say that if a contempt citation results from the failure to produce documents in response to a subpoena served upon you, this refusal will be included in the citation.

Mr. DAYVAULT. I respectfully decline to answer that question for the reason that I honestly feel my answer might tend to incriminate me in the violation of my rights as guaranteed to me by amendments 5, 1, 4, and 14 of the Constitution of the United States of America.

Mr. APPELL. Mr. Dayvault, I hand you a copy of the original hotel registration, Dinkler-Tutwiler Hotel, Birmingham, Alabama, for September 4, 1964, and put it to you as a fact, and ask you to affirm or deny the fact, that you registered at that hotel for the purpose of attending a klonvokation in September of 1964.

Mr. DAYVAULT. I respectfully decline to answer that question based upon the grounds previously stated.

(Document marked "Wayne Dayvault Exhibit No. 1" follows:)

WAYNE DAYVAULT EXHIBIT No. 1

1140-2 DAYVAULT WAYNE 5-20 65591

H 65591

M-W 9/4 N C

PLEASE CHECK YOUR BAGGAGE OR SEND SAME TO YOUR ROOM. OTHERWISE THE HOTEL COMPANY WILL NOT BE RESPONSIBLE FOR LOSS

Dinkler-Tutwiler

DIRECTION
DINKLER HOTEL CORPORATION
"DISPENSERS OF TRUE SOUTHERN HOSPITALITY"

GUESTS ARE HEREBY NOTIFIED THAT THE COMPANY WILL NOT BE RESPONSIBLE FOR VALUABLES, MONEY, JEWELRY, CLOTHING ETC. UNLESS THE SAME ARE DEPOSITED IN SAFE

Cabarrus

Name Wayne Dayvault

Street 1402 North Central Blvd City Charlotte N.C. State _____

Firm _____ City _____ State _____

Room No. 1140-2 Rate 5.20 Clerk SMTWTFSS

Mr. APPELL. I put it to you as a fact, and ask you to deny or affirm the fact, that at that klonvokation there was elected to the imperial staff of the United Klans of America, known by the cover name of the Alabama Rescue Service, Robert Shelton as Imperial Wizard, Robert Collins as Imperial Klokard, and Reverend George Dorsett as Imperial Kludd, Robert Hudgins as Imperial Kladd, Walter Brown as Imperial Klarogo, and Robert Korman as Imperial Klexter.

Mr. DAYVAULT. Sir, I respectfully decline to answer that question based upon the grounds previously stated.

Mr. APPELL. Mr. Dayvault, I put it to you as a fact that you were secretary or grand kligrapp of the Realm of North Carolina.

The CHAIRMAN. The committee will stand in recess for a few minutes.

(A brief recess was taken.)

The CHAIRMAN. The subcommittee will please come to order.

Mr. DAYVAULT. Sir, I respectfully decline to answer that question based upon the grounds previously stated.

Mr. APPELL. I put it to you as a fact, and ask you to affirm or deny the fact, that you succeeded Charles Guest of Salisbury, North Carolina, as kligrapp or secretary of the Realm of North Carolina.

Mr. DAYVAULT. Sir, I respectfully decline to answer that question based upon the grounds previously stated.

Mr. APPELL. I put it to you as a fact, and ask you to affirm or deny the fact, that you were replaced as the grand kligrapp or secretary by D. E. Leazer.

Mr. DAYVAULT. Sir, I respectfully decline to answer that question based upon the grounds previously stated.

Mr. APPELL. I put it to you as a fact, and ask you to affirm or deny the fact, that you were as of May 25, 1965, an officer of the Rowan Sportsmen's Club, a Klan or Klavern of the United Klans of America.

Mr. DAYVAULT. I respectfully decline to answer that question based upon the grounds previously stated.

Mr. APPELL. Mr. Chairman, there will be several witnesses who hold membership in the Rowan Sportsmen's Club. I intend to exhibit to this witness only one check for the purpose of establishing his connection with the Rowan Sportsmen's Club. It is a check dated May 25, 1965, on the imprinted check of the Rowan Sportsmen's Club, with the head of a horse here, so maybe the impression is left that it relates to a riding club of some kind. "Pay to the order of Bob Jones, \$97.25," drawn on the Security Bank & Trust Co., Spencer, North Carolina, cosigned Fred L. Wilson, Wayne Dayvault.

(Document handed to witness.)

Mr. APPELL. I put it to you as a fact, and ask you to affirm or deny the fact, that that check is as I stated it and that you are a cosigner.

Mr. DAYVAULT. I respectfully decline to answer that question based upon the grounds previously stated.

(Document marked "Wayne Dayvault Exhibit No. 2" follows:)

WAYNE DAYVAULT EXHIBIT NO. 2

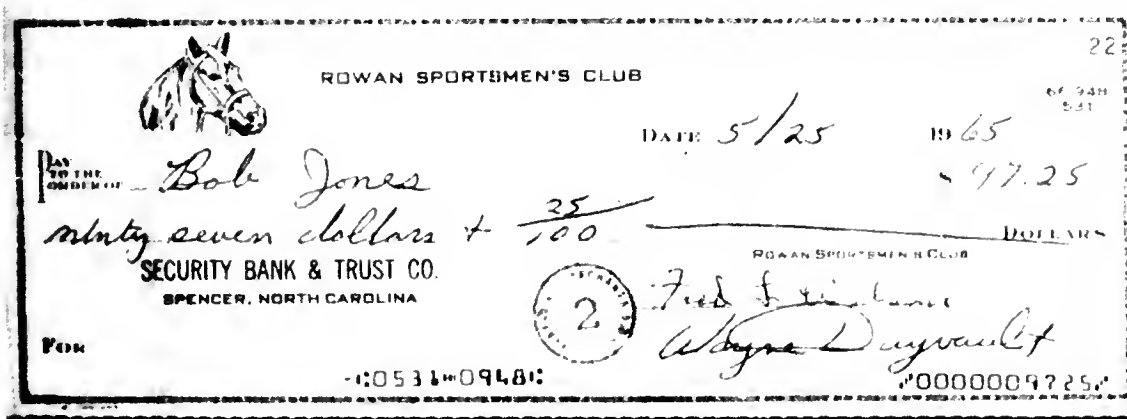

Mr. APPELL. I put it to you as a fact, and ask you to affirm or deny the fact, that Fred L. Wilson, in addition to being an official of the Rowan Sportsmen's Club, is the realm or state treasurer for the Realm of North Carolina.

Mr. DAYVAULT. I respectfully decline to answer that question based upon the grounds previously stated.

Mr. APPELL. I put it to you as a fact, and ask you to affirm or deny the fact, that the Rowan Sportsmen's Club is a Klavern to which Grand Dragon J. Robertson Jones is assigned as far as being a member of the organization.

Mr. DAYVAULT. I respectfully decline to answer that question based upon the grounds previously stated.

Mr. APPELL. Mr. Chairman, I have no further questions to ask of this witness.

The CHAIRMAN. The witness is excused and discharged from his subpoena.

Before the witness leaves, I don't know that this is necessary, as I understood what happened, Mr. Appell, I notice you have quite a number of checks which will later be put in the record, but you questioned him relative to one check to prove his official capacity.

Mr. APPELL. That is right, and that is all that is being presented in evidence at this time, sir.

The CHAIRMAN. All right.

Mr. APPELL. Mr. Chairman, I would like to call as my next witness, D. E. Leazer.

The CHAIRMAN. Raise your right hand.

Do you solemnly swear that the testimony you are about to give will be the truth, the whole truth, and nothing but the truth, so help you God?

Mr. LEAZER. Yes, sir.

TESTIMONY OF DONALD EDMUND LEAZER, ACCOMPANIED BY COUNSEL, LESTER V. CHALMERS, JR.

Mr. APPELL. Would you state your full name for the record?

Mr. LEAZER. Don Edmund Leazer.

Mr. APPELL. Are you appearing here this afternoon in accordance with a subpoena served upon you at 11 o'clock a.m., the 11th day of October 1965?

Mr. LEAZER. Yes, sir.

Mr. APPELL. Are you represented by counsel?

Mr. LEAZER. Yes, sir.

Mr. APPELL. Will counsel identify himself for the record?

Mr. CHALMERS. Lester V. Chalmers, attorney at law, 501 First Federal Building, Raleigh, North Carolina.

Mr. APPELL. Mr. Leazer, under the terms of the subpoena served upon you, you were to bring with you and to produce certain documents called for in the attachment which was made a part of the subpoena, and part 1 reads:

All books, records, documents, correspondence, and memoranda relating to the organization of and the conduct of business and affairs of the Invisible Empire, United Klans, Knights of the Ku Klux Klan of America, Inc., also known

as the United Klans of America, Inc., Knights of the Ku Klux Klan, and affiliated organizations, namely, the Alabama Rescue Service, Realm (State) of North Carolina, and Rowan Sportsmen's Club, in your possession, custody or control, or maintained by you or available to you as Grand Kligrapp (Secretary) and employee of the Realm (State) of North Carolina, of the Ku Klux Klan of America, Inc., also known as the United Klans of America, Inc., Knights of the Ku Klux Klan.

I demand that you produce those documents in accordance with the provisions of the subpoena.

Mr. LEAZER. I respectfully decline to deliver to the committee any and all records as requested by this committee under subpoena dated October 22, 1965, for that information is not relevant or germane to the subject under investigation and the same would not aid the Congress in the consideration of any valid remedial legislation, nor is inquiry within the scope of that authorized to be investigated by Rule IV of the rules adopted by the 89th Congress, by House Resolution 8, adopted January 4, 1965.

I respectfully decline to deliver to the committee any and all documents and records as demanded by the committee in a subpoena dated October 4, October 22, 1965, for the reason that I honestly feel that to do so, the same might tend to incriminate me in violation of my rights as guaranteed to me by amendments 5, 1, 4, and 14 of the Constitution of the United States of America.

The CHAIRMAN. Counsel, I take it that you stipulate that your client is familiar with my opening statement in all of its particulars, intents and purposes and coverage?

Mr. CHALMERS. That is correct.

The CHAIRMAN. And that your client has been ordered to produce these documents in the capacity described by the subpoena?

Mr. CHALMERS. Yes, sir.

The CHAIRMAN. It is further stipulated that the documents called for which are directed to be produced are in the capacities indicated in the subpoena. We are not quibbling about any details, I take it?

Mr. CHALMERS. You and myself, we are not, Mr. Willis, no, sir.

The CHAIRMAN. Therefore, sir, I order and direct you to produce the documents just read by Mr. Appell and order you to produce these in the capacity indicated.

Mr. LEAZER. I respectfully decline to deliver to the committee any and all records as requested by this committee under subpoena dated October 22, 1965, for that information is not relevant and germane to the subject under investigation and the same would not aid the Congress in the consideration of any valid remedial legislation, nor is such inquiry within the scope of that authorized to be investigated by Rule IV of the rules adopted by the 89th Congress, by House Resolution 8, adopted January 4, 1965.

I respectfully decline to deliver to the committee any and all documents and records as demanded by the committee in the subpoena dated October 22, 1965, for the reason that I honestly feel that to do so, the same might tend to incriminate me in violation of my rights as guaranteed me by amendments 5, 1, 4, and 14 of the Constitution of the United States of America.

Mr. APPELL. Mr. Leazer, under the terms and conditions of the

subpena you are also ordered to bring with you and produce that described in part 2:

All books, records, documents, correspondence, and memoranda in your possession, custody or control, or maintained by or available to you, in your capacity as Grand Kligrapp (Secretary) and employee of the Realm (State) of North Carolina of the United Klans of America, Inc., Knights of the Ku Klux Klan, which the "Constitution and Laws" of said organization authorize and require to be maintained by you and any other officer of said organization, the same being in your possession, custody or control.

Mr. LEAZER. I respectfully decline to deliver to the committee any and all records as requested by this committee under subpena dated October 22, 1965, for that information is not relevant and germane to the subject under investigation and the same would not aid the Congress in the consideration of any valid remedial legislation, nor is such inquiry within the scope of that authorized to be investigated by Rule IV of the rules adopted by the 89th Congress, by House Resolution 8, adopted January 4, 1965.

I respectfully decline to deliver to the committee any and all documents and records as demanded by the committee in a subpena dated October 22, 1965, for the reason that I honestly feel that to do so, the same might tend to incriminate me in violation of my rights as guaranteed to me by amendments 5, 1, 4, and 14 of the Constitution of the United States of America.

The CHAIRMAN. The same stipulation with reference to my opening statement is agreed to and the same stipulation with reference to the fact that the subpena was served on him in his representative capacity is agreed to?

Mr. CHALMERS. Yes, sir.

The CHAIRMAN. Sir, I order and direct you pursuant to the subpena duces tecum, served upon you, in a representative capacity as indicated, I order and direct you to produce the documents just referred to by Mr. Appell.

Mr. LEAZER. I respectfully decline to deliver to the committee any and all records as requested by this committee under subpena dated October 22, 1965, for that information is not relevant and germane to the subject under investigation and the same would not aid the Congress in a consideration of any valid remedial legislation, nor is such inquiry within the scope of that authorized to be investigated by Rule IV of the rules adopted by the 89th Congress, by House Resolution 8, adopted January 4, 1965.

I respectfully decline to deliver to the committee any and all documents and records as demanded by the committee in a subpena dated October 22, 1965, for the reason I honestly feel that to do so, the same might tend to incriminate me in violation of my rights as guaranteed to me by amendments 5, 1, 4, and 14 of the Constitution of the United States of America.

Mr. APPELL. Mr. Leazer, I hand you a document, Foreign Corporations Franchise Tax Report of the State of North Carolina, signed by James R. Jones, Grand Dragon of North Carolina, dated July 20, 1965, and I put it to you as a fact, and ask you to affirm or deny the fact, that Grand Dragon Jones in filing this document on July 20, 1965, listed himself as the president, G. B. Mars, as vice president,

and yourself, D. E. Leazer, as secretary, and F. L. Wilson as treasurer.

Mr. LEAZER. I respectfully decline to answer that question for the reason that I honestly feel my answer might tend to incriminate me in violation of my rights as guaranteed to me by amendments 5, 1, 4, and 14 of the Constitution of the United States of America.

(Document marked "Donald Leazer Exhibit No. 1." Pages 1 and 4 of said exhibit follow:)

DONALD LEAZER EXHIBIT NO. 1

JOHN M. LINGLE, JR.
FORM C 303

-1965-
**NORTH CAROLINA
INITIAL FRANCHISE TAX REPORT
FOREIGN CORPORATIONS**

This form is to be used for the initial report of corporations pursuant to the provisions of G. S. 105-123, and said report should be filed with the Department of Revenue within sixty days of domestication or the beginning of its business in North Carolina, whichever occurs first, with remittance to cover tax reported from this date to June 30 next (minimum tax \$10.00). This does not take the place of the annual franchise report required to be filed on July 31 of each year by foreign and domestic corporations.

Name of Corporation Invincible Empire United Klans, Knights
KU KLUX KLAN OF AMERICA, INC.
 Street Address P.O. Box 321
 Post Office Address Route 2, Wray, N.C. Incorporated Under laws of _____
 Principal office or place of business in North Carolina Route 2, Wray, N.C.
 Date domesticated in N. C. JUL 7 1965 Kind of Business Non-Profit
franchise organization
 Indicate if connected with another corporation as: Parent Subsidiary Affiliate
 Furnish name, address and business of each (Attach Schedule) _____

A	BASIS AND COMPUTATION OF TAX	AMOUNT	
1.	Capital stock outstanding, Surplus, Undivided Profits, and allocations thereof. (Brought from page 2, item 22)	\$	
2.	Add: Indebtedness to or guaranteed by parent or affiliated corporation, (Brought from page 2, item 26)		
3.	Total (Sum of items 1 and 2)		
4.	Total amount allocated to North Carolina (..... % of item 3)		
5.	Total assessed value of all properties located in North Carolina including total valuation of intangible personal property (From page 2, item 40)		
6.	Total investment in tangible properties in North Carolina (Brought from page 2, item 34)		
7.	TOTAL TAXABLE AMOUNT (Item 4, 5, or 6, whichever is greatest)		
8.	Amount of tax computed at \$1.50 per \$1,000.00 of item 7 (MINIMUM \$10.00)	5276	10 00
9.	(a) Add: Penalty of 5% per month of delinquency period up to a maximum of 25% of item 9, not less than \$5.00, for failure to file on date due. (b) Add: Interest at 6% per annum		
10.	TOTAL TAX, PENALTY AND INTEREST DUE (MINIMUM \$10.00)	\$	10 00

ATTACH REMITTANCE AND MAKE PAYABLE TO N. C. DEPARTMENT OF REVENUE

AFFIRMATION OF TAXPAYER

I hereby affirm that this report, including the accompanying schedules and statements (if any) has been examined by me and, to the best of my knowledge and belief, is true and complete and is made in good faith covering the taxable period above, pursuant to the Revenue Act of 1959, as amended, and the regulations issued under authority thereof, and that this affirmation is made under the penalties prescribed by law.

Date July 20, 1965
 Date July 20, 1965
 Signature of Officer and Title James G. Jones, Pres. Wray, N.C.
 Signature of preparer other than taxpayer John Leazer
 Signature of preparer other than taxpayer

THIS SPACE FOR DEPARTMENTAL USE ONLY		CHECKED IN
a. Corrected Taxable Amount	\$	IIII 23 65
b. Tax @ \$1.50 per \$1,000	\$	
c. Add: Remittance	\$	
d. Additional Tax	\$	
e. Interest at 6% per annum to	\$	
f. Penalty for Filing or Payment	\$	
g. Additional Charge Billed	\$	
h. Status of Prior Years	\$	
Additional Amount Paid		\$

DONALD LEAZER EXHIBIT No. 1—Continued

Page 4

I ALLOCATION PERCENTAGE RATIO			
To be used when corporation's principal business is either manufacturing, producing, selling, or dealing in tangible personal property.			
Property—(Tangible property used in Trade or Business)	In North Carolina	Total	Ratio
102. Realty: Land	\$	\$	
Buildings			
Rentals (See Instructions Below)			
103. Personal: Machinery and Equipment			
Inventories (Averaged)			
Other Property			
Rentals (See Instructions Below)			
104. Total Cost and Rental Value	\$	\$	
105. Less: Depreciation Reserve			
106. Total Statutory Value	\$	\$	
107. RATIO OF PROPERTY	XXXXXXXXXX	XXXXXXXXXX	%
108. Payrolls—Total	\$	\$	
109. Less: Compensation to officers having company-wide authority			
110. Payrolls—Net	\$	\$	
111. RATIO OF PAYROLLS	XXXXXXXXXX	XXXXXXXXXX	%
112. RATIO OF SALES	\$	\$	%
113. TOTAL OF THREE RATIOS	XXXXXXXXXX	XXXXXXXXXX	%
114. ARITHMETICAL AVERAGE—RATIO— (To page 1, line 4)	XXXXXXXXXX	XXXXXXXXXX	%
To be used when corporation's principle business is other than as described above or other than the operation of a public service corporation.			
	In North Carolina	Total	Ratio
115. RATIO OF GROSS RECEIPTS (Attach Schedule) (To page 1, line 4)	\$	\$	%

VALUE OF RENTAL PROPERTY

Assign values of rental property for allocation purposes by multiplying the annual net rent paid for each class of property by the applicable multiple. (Net rent means gross rent paid less rent received from subrentals)

	Multiple
Real Property	8
Machinery & Equipment used in Manufacturing	3
Delivery and Mobile Equipment	1
Furniture & Fixtures	3
Office Machinery & Equipment	2

J OFFICERS NAMES AND ADDRESSES	
President:	James R. AONES Granite Quarry N.C.
Vice-president:	G. R. MARSH WARRENTON, N.C.
Vice-president:	
Secretary:	D. E. LEAZER Salisbury, N.C.
Treasurer:	F. L. WILSON Salisbury, N.C.
Name and address of process agent in North Carolina	James R. AONES Granite Quarry, N.C.

Failure to file this report within sixty days of the corporation's domestication or the beginning of its business in North Carolina, whichever occurs first, will subject the corporation to a penalty of 5% per month of delinquency period (maximum of 25%) of the amount of tax and not less than \$5.00. All necessary questions must be answered or an amended report will be required. Remittance of amount due must accompany this report.

CORPORATE INCOME AND FRANCHISE TAX DIVISION
N. C. DEPARTMENT OF REVENUE, RALEIGH, N. C.

Mr. APPELL. Mr. Chairman, the committee's investigation establishes that the Rowan Sportsmen's Club with which we have just previously dealt with the preceding witness is known as Klavern Number 1, and was known as Klavern Number 1 during the days of the U.S. Klans under the leadership of Eldon Edwards, and prior to becoming formally known as the Rowan Sportsmen's Club at least as far as its checking account was concerned was known merely as the

United Klans of America, Incorporated, Knights of the Ku Klux Klan.

The CHAIRMAN. Is that the same Edwards referred to before?

Mr. APPELL. He was head of the U.S. Klans prior to 1960.

The CHAIRMAN. He called Shelton on the carpet for financial manipulations?

Mr. APPELL. The same man.

The CHAIRMAN. As a result of which Shelton thereupon created his own organization.

Mr. APPELL. After being removed from the position of Grand Dragon, U.S. Klans, by Imperial Wizard Edwards; yes, sir.

Mr. Leazer, I put it to you as a fact that you were a member of a Klan unit now known as the Rowan Sportsmen's Club, and I exhibit to you a check dated 11-10-1964, imprinted "United Klans of America, Inc., Knights of K.K.K.," Don Leazer, \$5.15.

(Document handed to witness.)

Mr. APPELL. I ask you to affirm or deny that fact.

Mr. LEAZER. I respectfully decline to answer that question based upon the grounds previously stated.

(Document marked "Donald Leazer Exhibit No. 2" follows:)

DONALD LEAZER EXHIBIT NO. 2

UNITED KLANS OF AMERICA, INC. KNIGHTS OF K. K. K.		379
DATE 11-10	NO. 64	65-948 531
Pay TO THE ORDER OF <i>Don Leazer</i>		\$ 5.15
<i>five dollars & 15/100</i>		
FOR	UNITED KLANS OF AMERICA, INC. <i>Fred L. Wilson</i> <i>W. R. McCubbins</i>	
SECURITY BANK & TRUST CO. SPENCER, NORTH CAROLINA	⑆053⑆⑉0948⑆	

Mr. APPELL. I ask you to affirm or deny the fact that Fred L. Wilson, who is a cosigner on this check, you knew to be treasurer of the Klavern as well as presently the State treasurer.

Mr. LEAZER. I respectfully decline to answer that question based upon the grounds previously stated.

Mr. APPELL. I put it to you as a fact, and ask you to affirm or deny the fact, that while this gentleman has held many offices within the Klavern, you knew him at one time to be the exalted cyclops, W. R. McCubbins.

Mr. LEAZER. I respectfully decline to answer that question based upon the grounds previously stated.

Mr. APPELL. Mr. Leazer, I put it to you as a fact, and ask you to affirm or deny the fact, that this is the signature card to which there is affixed your signature, together with James R. Jones, and Fred L. Wilson, the account maintained at Wachovia Bank and Trust Company, in Salisbury, North Carolina.

I ask you to affirm or deny that fact.

(Document handed to the witness.)

The CHAIRMAN. What is the name of that account?

Mr. APPELL. United Klans of America, Incorporated.

Mr. LEAZER. I respectfully decline to answer that question based upon the grounds previously stated.

(Document marked "Donald Leazer Exhibit No. 3" follows:)

DONALD LEAZER EXHIBIT NO. 3

NAME	DATE 5-13-65
UNITED KLANS OF AMERICA, INC	CORPORATION
<i>James R. Jones</i>	PRESIDENT
<i>Donald E. Leazer</i>	VICE-PRESIDENT
<i>Fred L. ...</i>	TREASURER
/s/ JAMES R. JONES	
MAIL ADDRESS	P.O. BOX 321 GRANITE QUARRY, N.C.
STREET AND NUMBER	CITY STATE
<p>This account is accepted by Wachovia Bank and Trust Company subject to the provisions stated on the reverse side of this card. Above are the duly authorized signatures which the Bank will recognize in the payment of funds or the transaction of other business.</p>	
764 REV 6-61	1 191 607 <i>tw</i>

Mr. APPELL. I hand you a series of checks, Mr. Leazer, dated July 2, July 10, July 16, July 23, August 2, August 6, August 14, August 20, August 28, September 3, September 10, September 17, all of 1965, a total of 12 checks, each in the amount of \$150.00, salary and expense, payable to Donald E. Leazer, and ask you to affirm or deny the fact that you are the Donald Leazer, the payee, on these checks.

Mr. LEAZER. I respectfully decline to answer that question based upon the grounds previously stated.

(Documents previously marked "James Jones Exhibit No. 7-F." See p. 1721.)

The CHAIRMAN. And those checks are drawn on the account you just referred to?

Mr. APPELL. Yes, sir.

Mr. Leazer, I ask you from what source the money is derived which is placed into this account in the name of the United Klans of America, Incorporated, care of James R. Jones, with the Wachovia Bank and Trust Company, of which there has been deposited from May 13, 1965, through September 19, 1965, \$16,903.37. I ask you the source of that?

Mr. LEAZER. I respectfully decline to answer that question based upon the grounds previously stated.

(Documents previously marked "James Jones Exhibit No. 7-A.")

Mr. APPELL. Mr. Leazer, as a Klansman, do you carry a concealed weapon?

Mr. LEAZER. I respectfully decline to answer that question based upon the grounds previously stated.

Mr. APPELL. Were you tried for the crime of carrying a concealed weapon on August 27, 1965?

Mr. LEAZER. I respectfully decline to answer that question based upon the grounds previously stated.

Mr. APPELL. Mr. Chairman, I would like to read into the record from a certified copy of a court record, signed by the assistant clerk of the superior court, Rowan Superior Court, Rowan County, North Carolina, Case 166642:

State vs. Donald E. Leazer ; Carrying Concealed Weapon ; State Witnesses C. L. Wilhelm, C. M. Grant, J. G. Overcash, 8-27-65.

The Defendant Pleads Not Guilty. The Defendant is Adjudged Guilty. Let the Defendant be confined in the Common Jail of Rowan County for a period of 60 days and be assigned to work under the supervision of the State Prison Department. This sentence is suspended, by and with consent of defendant in open court, on the following conditions: Defendant is to pay a fine of \$50.00 plus costs; Defendant is to be and remain of general good behavior for two years; let the weapon be confiscated and destroyed.

Is that a factual record as certified to by the assistant clerk of the superior court?

Mr. LEAZER. I respectfully decline to answer that question based upon the grounds previously stated.

Mr. WELTNER. What is the date of the sentence?

Mr. APPELL. 8-27-65.

Mr. WELTNER. Do you have any checks that are dated subsequent to that date?

Mr. APPELL. Yes, sir. We have one dated August 28, the day following, and one September 3, and one September 10, and one September 17.

Mr. WELTNER. Those are following a pattern of a weekly payment; is that correct?

Mr. APPELL. \$150, the purpose for which drawn is salary and expense.

Mr. WELTNER. Thank you.

The CHAIRMAN. What was the concealed weapon? Does the judgment show?

Mr. APPELL. No, it says, "Let the weapon be confiscated and destroyed."

On the same date, Mr. Chairman, I would like to read another entry certified by the assistant clerk of the superior court:

Case 166647 State vs. Donald E. Leazer Possession of Tear Gas 8-27-65 The Defendant Pleads Not Guilty. The Defendant Is Adjudged Guilty. Let the Defendant be confined in the Common Jail of Rowan County for a period of 60 days and be assigned to work under the supervision of the State Prison Department. This sentence is suspended, by and with consent of defendant in open court, on the following conditions: Defendant is to pay a fine of \$40.00 plus costs; Let the tear gas be confiscated and destroyed.

Is that a factual recitation of the facts, Mr. Leazer?

Mr. LEAZER. I respectfully decline to answer that question based upon the grounds previously stated.

(Document marked "Donald Leazer Exhibit No. 4" and retained in committee files.)

Mr. APPELL. Were these fines and costs adjudged against you paid by the United Klans of America?

Mr. LEAZER. I respectfully decline to answer that question based upon the grounds previously stated.

Mr. APPELL. Was this tear gas obtained by you for possible use in connection with your membership in the United Klans of America?

Mr. LEAZER. I respectfully decline to answer that question based upon the grounds previously stated.

Mr. APPELL. Mr. Chairman, I have no further questions of this witness.

The CHAIRMAN. Mr. Leazer, you are hereby continued under that subpoena until November 15.

The committee will resume hearings next Monday at 10 o'clock.

(Whereupon, at 5:45 p.m., Friday, October 22, 1965, the subcommittee recessed, to reconvene at 10 a.m., Monday, October 25, 1965.)

ACTIVITIES OF KU KLUX KLAN ORGANIZATIONS IN THE UNITED STATES

Part 1

MONDAY, OCTOBER 25, 1965

UNITED STATES HOUSE OF REPRESENTATIVES,
SUBCOMMITTEE OF THE
COMMITTEE ON UN-AMERICAN ACTIVITIES,
Washington, D.C.

PUBLIC HEARINGS

The subcommittee of the Committee on Un-American Activities met, pursuant to recess, at 10:15 a.m. in the Caucus Room, Cannon House Office Building, Washington, D.C., Hon. Edwin E. Willis (chairman) presiding.

(Subcommittee members: Representatives Edwin E. Willis, of Louisiana, chairman; Joe R. Pool, of Texas; Charles L. Weltner, of Georgia; John M. Ashbrook, of Ohio; and John H. Buchanan, Jr., of Alabama.)

Subcommittee members present: Representatives Willis, Pool, Weltner, and Buchanan.

Committee member also present: Representative George F. Senner, Jr., of Arizona.

Staff members present: Francis J. McNamara, director; William Hitz, general counsel; Alfred M. Nittle, counsel; Donald T. Appell, chief investigator; and Philip R. Manuel, investigator.

The CHAIRMAN. The subcommittee will come to order, please.

Will you please call your first witness?

Mr. APPELL. Mr. Chairman, before I call my first witness, I would like to ask permission of the Chair to place into the record at the appropriate point in the testimony of Mr. Robert Shelton the documents which we have now received in response to a subpoena duces tecum which related to purchases from the Lorch's Diamond Shop in Tuscaloosa, Alabama.

I would like to bring to the committee's attention that one of these documents appears to be a personal account of Mrs. Robert Shelton, which reflects on its face that her employer, or her occupation, is United Klans of America, and this credit card is signed by Mrs. Betty Shelton.

The CHAIRMAN. The documents will be received and inserted at that point in the record.

In other words, Mr. Appell, you received these documents subsequent to the appearance of Mr. Shelton and his testimony?

Mr. APPELL. They were received on last Friday, sir, after Mr. Shelton's testimony; yes, sir.

Mr. Chairman, I would also like to ask permission that there be placed in the record at the conclusion of the testimony of Mr. Kornegay the applications for insurance under the Klan program of insurance between the Capital City Restoration Association and the International Life and Accident Insurance Company, those applications of Klansmen signed up under that program.

The CHAIRMAN. The documents will be received in evidence and inserted at the point indicated.

Mr. APPELL. Mr. Chairman, I would like to call as the first witness this morning Arthur C. Leonard.

The CHAIRMAN. Please raise your right hand.

You do solemnly swear that the testimony you are about to give will be the truth, the whole truth, and nothing but the truth, so help you God?

Mr. LEONARD. I do.

The CHAIRMAN. Proceed.

TESTIMONY OF ARTHUR C. LEONARD, ACCOMPANIED BY COUNSEL, LESTER V. CHALMERS, JR.

Mr. APPELL. Would you state your full name for the record, sir?

Mr. LEONARD. Arthur C. Leonard.

Mr. APPELL. Are you appearing here this morning in response to a subpoena served upon you by an investigator of the committee, Mr. Ray McConnon, at 9 o'clock a.m. on the 13th day of October 1965?

Mr. LEONARD. I am.

Mr. APPELL. Are you represented by counsel?

Mr. LEONARD. I am.

Mr. APPELL. Will counsel please identify himself for the record, please?

Mr. CHALMERS. Lester V. Chalmers, Jr., attorney at law, Room 501, First Federal Building, Raleigh, North Carolina.

Mr. APPELL. Mr. Leonard, would you set forth for the committee when and where you were born?

Mr. LEONARD. I respectfully decline to answer that question for the reason that I honestly feel my answer might tend to incriminate me in violation of my rights as guaranteed to me by amendments 5, 1, 4, and 14 of the Constitution of the United States of America.

The CHAIRMAN. That question is preliminary and is simply laying the foundation. We do not accept your reasons for refusal to answer and I direct you to answer.

Mr. LEONARD. I respectfully decline to answer that question for the reason that I honestly feel my answer might tend to incriminate me in violation of my rights as guaranteed me by amendments 5, 1, 4, and 14 of the Constitution of the United States of America.

Mr. APPELL. I put it to you as a fact, and ask you to affirm or deny the fact, that you advised Investigator McConnon at the time he served you with a subpoena that you were born in 1904 at Rowan, North Carolina, Rowan County, North Carolina.

Mr. LEONARD. I respectfully decline to answer that question for the reasons that I honestly feel my answer might tend to incriminate me

in violation of my rights as guaranteed to me by amendments 5, 1, 4, and 14 of the Constitution of the United States of America.

Mr. APPELL. Mr. Leonard, would you set forth your educational background?

Mr. LEONARD. I respectfully decline to answer that question for the reason that I honestly feel my answer might tend to incriminate me in violation of my rights as guaranteed to me by amendments 5, 1, 4, and 14 of the Constitution of the United States of America.

Mr. APPELL. I put it to you as a fact, and ask you to affirm or deny the fact, that you advised the committee investigator, McConnon, that you had completed the first 10 years of school.

Mr. LEONARD. I respectfully decline to answer that question for the reason that I honestly feel my answer might tend to incriminate me in violation of my rights as guaranteed to me by amendments 5, 1, 4, and 14 of the Constitution of the United States of America.

Mr. APPELL. I ask you, Mr. Leonard, to set forth your employment background.

Mr. LEONARD. I respectfully decline to answer that question for the reason that I honestly feel my answer might tend to incriminate me in violation of my rights as guaranteed to me by amendments 5, 1, 4, and 14 of the Constitution of the United States of America.

Mr. APPELL. I put it to you as a fact, and ask you to affirm or deny the fact, that you advised Investigator McConnon that you were in the home improvement business and have been since 1948, presently owner of the Southern Awning Manufacture Company, Lexington Road, Spencer, North Carolina, where it has been located for the last 4 years.

Mr. LEONARD. I respectfully decline to answer that question for the reason that I honestly feel my answer might tend to incriminate me in violation of my rights as guaranteed to me by amendments 5, 1, 4, and 14 of the Constitution of the United States of America.

Mr. APPELL. Mr. Leonard, under the terms of the subpoena, you were directed to, or commanded to bring with you, and produce before said committee, documents which were called for on an attachment which was made a part of the subpoena. This attachment, consisting of one paragraph, reads:

All books, records, documents, correspondence and memoranda relating to the organization of and the conduct of business and affairs of the Invisible Empire, United Klans, Knights of the Ku Klux Klan of America, Inc., also known as the United Klans of America, Inc., Knights of the Ku Klux Klan, and affiliated organizations, namely, the Alabama Rescue Service, Rowan Sportsmens Club, Realm (state) of North Carolina, in your possession, custody or control or maintained by you or available to you as the former Grand Dragon, Realm (state) of North Carolina, and as a present or former officer Rowan Sportsmens Club, Realm (state) of North Carolina, of the Invisible Empire, United Klans, Knights of the Ku Klux Klan of America, Inc., also known as the United Klans of America, Inc., Knights of the Ku Klux Klan.

Mr. LEONARD. I respectfully decline to deliver to the committee any and all records as requested by this committee upon subpoena dated October 4, 1965, for that information is not relevant and germane to the subject under investigation and the same would not aid the Congress in the consideration of any valid remedial legislation, nor is such inquiry within the scope of that authorized to be investigated by Rule XI of the rules adopted by the 89th Congress, by House Resolution 8, adopted January 4, 1965.

I respectfully decline to deliver to the committee any and all documents and records as demanded by the committee in its subpoena dated October 4, 1965, for the reason that I honestly feel that to do so, the same might tend to incriminate me in violation of my rights as guaranteed to me by amendments 5, 1, 4, and 14 of the Constitution of the United States of America.

The CHAIRMAN. Mr. Chalmers, do you agree to the following stipulation: (1) That the witness has been furnished a copy of the chairman's opening statement of October 19, 1965, and that he is familiar with its contents; (2) that the directions of the subpoena to produce the documents called for are made to the witness in the official representative capacity described in the subpoena.

Mr. CHALMERS. Yes, sir.

Mr. Chairman, may I state, sir, I conferred with counsel for the committee earlier this morning, and there was some mistake which he and myself have worked out. Rather than it being Rule IV of the rules adopted by the 89th Congress and House Resolution 8, it is actually Rule XI. I think counsel and myself understand the difference there.

The CHAIRMAN. It appears on page iv?

Mr. CHALMERS. It appears on page vi, actually.

The CHAIRMAN. We understand.

Mr. CHALMERS. I wanted to call it to your attention.

The CHAIRMAN. But the stipulation is entered into?

Mr. CHALMERS. Yes, sir; that is correct, sir.

The CHAIRMAN. Now, Mr. Leonard, the Chair does not accept your reasons for failing to produce the documents called for in the subpoena, for you to produce them in the capacity indicated, and I now order and direct you to produce them.

Mr. LEONARD. I respectfully decline to deliver to the committee any and all records as requested by this committee under subpoena dated October 4, 1965, for that information is not relevant and germane to the subject under investigation and the same would not aid the Congress in the consideration of any valid remedial legislation, nor is such inquiry within the scope of that authorized to be investigated by Rule XI of the rules adopted by the 89th Congress, by House Resolution 8, adopted January 4, 1965.

I respectfully decline to deliver to the committee any and all documents and records as demanded by the committee in a subpoena dated October 4, 1965, for the reason that I honestly feel that to do so, the same might tend to incriminate me in violation of my rights as guaranteed to me by amendments 5, 1, 4, and 14 of the Constitution of the United States of America.

The CHAIRMAN. Proceed.

Mr. APPELL. Mr. Leonard, are you currently the holder of the position of klokar for the Rowan County Klavern or the Rowan Sportsmen's Club?

Mr. LEONARD. I respectfully decline to answer that question for the reason that I honestly feel my answer might tend to incriminate me in violation of my rights as guaranteed to me by amendments 5, 1, 4, and 14 of the Constitution of the United States of America.

Mr. APPELL. I put it to you as a fact, and ask you to affirm or deny the fact, that you advised committee investigator McCommon on the 13th day of October 1965, at the time he served you with the subpoena, that you did hold the position of klo kard within your Klavern.

Mr. LEONARD. I respectfully decline to answer that question based upon the grounds previously stated.

Mr. APPELL. Mr. Chairman, the committee subpoenaed from the Security Bank & Trust Co., Spencer, North Carolina, bank accounts relating to the Rowan Sportsmen's Club and accounts under the name of the United Klans of America. The bank forwarded to the committee in compliance with this subpoena duces tecum canceled checks, ledger cards, signature cards, that relate to this.

These cards reflect that the account which was subpoenaed was opened on December 10, 1958, and it was opened in the name of the U.S. Knights of the Ku Klux Klan, Box 666, China Grove, North Carolina.

I desire, Mr. Chairman, to read from the signature card of December 10, 1958, and then ask certain questions of the witness.

It appears on top: "2 sig[nature]s required, Dec. 10, 1958. Name U.S. Knights of K K Klan [Address] Box 666 China Grove NC. The following two signatures will both be necessary to withdraw funds."

This is written out in longhand. "A. C. Leonard, Act. Treasurer; W. R. McCubbins, E.C.; C. B. Gobble, Treasure [sic]."

Typed onto this document is that "We prefer to sign cks without using titles."

"*g/c* opened by Mr. Leonard & Mr. McCubbins" with a deposit of \$121.29.

I hand you this card, Mr. Leonard, and put it to you as a fact, and ask you to affirm or deny the fact, that you are the A. C. Leonard listed on the signature card.

(Witness made no reply.)

(Document marked "Arthur Leonard Exhibit No. 1-A" appears on p. 1902.)

Mr. APPELL. I put it to you as a fact, and ask you to affirm or deny the fact, that the bank properly reported that this account was opened by yourself and Mr. McCubbins.

Mr. LEONARD. I respectfully decline to answer that question based upon the grounds previously stated.

Mr. APPELL. Mr. Chairman, the bank records reflect that that signature card remained in effect until 10-11-63.

I am sorry, Mr. Chairman. Until 2-8-60.

This card, which I would like to read into the record, shows: "U.S. Knights of K. K. Klan, J. L. Corriher, Treas., Rt. #4, Box 544, Salisbury, N.C." Two signatures required: "J. L. Corriher, Treas.; W. R. McCubbins, Secr.; F. L. Wilson, V.P."

The card contains the notation that on August 27, 1963, Mr. F. L.—I cannot make out the name clearly enough, Mr. Chairman, to put it into the record—succeeds Mr. O. C. Snider as vice president as of this date, and this contains, as the authority, the signature "Arthur C. Leonard."

I hand you this card, Mr. Leonard, and ask you whether or not the facts that I have just recited to you from this card are facts.

ARTHUR LEONARD EXHIBIT No. 1-A

Dec 10 - 1958

2 Sigs required

NAME U.S. Knights of K. K. Klan

ADDRESS Box 666 China Grove NC

The following two signatures will both be

AUTHORIZED SIGNATURES necessary to withdraw funds Continued from front side

either two signatures will (TYPEWRITE NAME HERE) SIGN

(SIGNATURE IN THIS COLUMN)

TITLE

<i>A.C. Leonard</i>	<i>Asst. Treasurer</i>
<i>V.R. McCubbs</i>	<i>Treasurer</i>
<i>C.B. Bohler</i>	

WE PREFER TO SIGN CKS WITHOUT USING TITLES

operated by Mr Leonard & Mr McCubbs
A.O.L. E.C. 10/12/58
\$121.91

Partnership Corporation Account of Address

U. S. KNIGHTS OF K. K. KLAN Box 666, China Grove, N.C. Business

Phone

In consideration of the opening of this account by the SECURITY BANK & TRUST CO., the undersigned agree that all notes, drafts, checks, or other papers purchased by the bank from the undersigned or received by it for credit or collection from or through the undersigned, are purchased or received subject to the actual receipt in cash or proceeds thereof by the bank and until such receipt said paper or proceeds shall be held at the risk of the undersigned, and the bank shall not be liable for the loss thereof or for the default, negligence or failure of its agents, or of any correspondents or others to whom the paper may be sent for collection. The bank and any collecting agents of the bank or of the undersigned may present such paper direct to the bank on which it is drawn or at which it is payable or to its discretion may forward such paper to a collecting agent with authority to present such paper for payment, and this bank and/or any collecting agent may accept in return the check, draft or credit of any other bank or banks. Any papers not actually realized on, any item lost in transit, and any bank check, draft or credit on which this bank fails to realize the full amount in cash may be charged by the bank in whole or in part to the undersigned's account. Each collecting agent shall be the agent of the undersigned and not of the bank, but neither this bank nor any such agent shall be liable for any loss growing out of the neglect, default or failure of another agent.

The undersigned agrees that the bank may refuse payment of and return as unpaid to the party presenting same, any checks presented when the undersigned does not have a sufficient balance of collected funds in his account at the opening of business on the day such checks are presented to pay the same.

The undersigned hereby agrees that the bank may waive demand, notice and protest on all checks, drafts, and other papers purchased by the bank or received by it for credit or collection by, from or through the undersigned.

Checks will be presented for payment through our Clearing Bank and if dishonored will be charged to depositor's account or presented to him for payment. Checks, drafts, and other items drawn on this bank not paid for any reason at the close of business on its business day next following the day deposited may be charged back to the undersigned.

Liability of endorsers on checks certified at the bank's request shall not be released until such items are paid.

It is agreed that a service charge may be made by the bank each month for handling this account in accordance with the rules from time to time prescribed by this bank and the amount thereof shall be charged to customer's account.

It is also agreed that a charge of 50c for each check drawn against this account and returned for insufficient funds shall be made against this account.

It is also agreed that the statement of my account furnished by the bank will be examined promptly upon the receipt of same and that if no error is reported to the bank within ten days, the bank will consider statements as correct.

The signature of persons authorized to draw checks which the bank will recognize in payment of funds or for the transaction of other business on account of the undersigned are hereby given below.

The undersigned hereby certifies that he has read and agrees to the above contract.

DEC 10 1958

This.....day of.....19.....

By..... (Continued on Reverse Side)

Mr. LEONARD. I respectfully decline to answer that question based upon the grounds previously stated.

(Document marked "Arthur Leonard Exhibit No. 1-B" follows:)

ARTHUR LEONARD EXHIBIT NO. 1-B

U. S. Knights of K. K. Klan 2 sigs. required

J. L. Corriher, Treas

NAME Rt. # 4, Box 544

ADDRESS Salisbury, N. C.

AUTHORIZED SIGNATURES Effective date 2-8-60

Continued from front side

(TYPEWRITE NAME HERE)	WILL SIGN	(SIGNATURE IN THIS COLUMN)	TITLE
J. L. Corriher	"	<i>J. L. Corriher</i>	Treas
W. R. McCubbins	"	<i>W. R. McCubbins</i>	Secr.
C. O. Snider	"	<i>C. O. Snider</i>	V.P.
F. L. Wilson	AUG 27 1963	<i>F. L. Wilson</i>	V.P.
	"		
	"		
<i>Aug 27th Mr F. L. Wilson succeeds Mr C. O. Snider as vice pres as of this date Arthur C. Leonard</i>			

Mr. APPELL. I put it to you as a fact, and ask you to affirm or deny the fact, that the change that went into effect on August 27, 1963, was merely to replace Mr. C. O. Snider as vice president to F. L. Wilson as vice president.

Mr. LEONARD. I respectfully decline to answer that question based upon the grounds previously stated.

Mr. APPELL. I put it to you as a fact, and ask you to affirm or deny the fact, that at that time you were an officer of the Realm of North Carolina, United Klans of America.

Mr. LEONARD. I respectfully decline to answer that question based upon the grounds previously stated.

Mr. APPELL. I hand you a card, a new card, 1-2-64, now changed to the United Klans of America, Inc., Knights of the Ku Klux Klan—

The CHAIRMAN. What is the date?

Mr. APPELL. January 2, 1964—which shows Mr. F. L. Wilson as treasurer and that the other signatures contained on the account under the U.S. Klan were still in effect at the time of the new card on January 2, 1964.

Mr. LEONARD. I respectfully decline to answer that question based upon the grounds previously stated.

(Document marked "Arthur Leonard Exhibit No. 1-C" follows:)

ARTHUR LEONARD EXHIBIT No. 1-C

NAME UNITED KLANS OF AMERICA, INC
KNIGHTS OF K. K. K.

ADDRESS ~~610 Little St~~
72 Wilson Treas

AUTHORIZED SIGNATURES new cards 1-2 to 4 Continued from side

(TYPEWRITE NAME HERE)	WILL SIGN	(SIGNATURE IN THIS COLUMN)	TITLE
	✓	<i>F L Wilson</i>	TREAS
	✓		
		<i>See attached card for other sig</i>	

Mr. APPELL. Mr. Chairman, an analysis of the account reflects that on February 24, 1965, the account in the name of the United Klans of America, Inc., was closed out with a check in the amount of \$134.99, and that this check was used to open a new account, in the name of the Rowan Sportsmen's Club, Fred L. Wilson, Treasurer, 610 Little Street, Salisbury, North Carolina.

The CHAIRMAN. What is that date?

Mr. APPELL. This is February 24, 1965.

That this account contains the signatures of Fred L. Wilson as treasurer; W. R. McCubbins, who has been previously referred to on other signature cards; and Wayne Dayvault, a witness before this committee last week.

I hand you this card and put it to you as a fact, and ask you to affirm or deny the fact, that this signature card was authorized by the membership of the Rowan Sportsmen's Club.

Mr. LEONARD. I respectfully decline to answer that question based upon the grounds previously stated.

(Document marked "Arthur Leonard Exhibit No. 1-D" appears on p. 1905.)

The CHAIRMAN. As I heard the question, he could properly say no to this question.

Well, all right.

Mr. APPELL. Mr. Leonard, when did you become a member of any Ku Klux Klan organization?

Mr. LEONARD. I respectfully decline to answer that question based upon the grounds previously stated.

Mr. APPELL. I put it to you as a fact, and ask you to affirm or deny the fact, when interviewed by Investigator McConnon on October 13, 1965, that you advised him that you joined the Klan in 1953.

ARTHUR LEONARD EXHIBIT NO. 1-D

ROWAN SPORTSMEN'S CLUB

NAME Fred L. Wilson, Treas.
 ADDRESS 610 Little Street
 Salisbury, NC

TWO SIGNATURES NECESSARY FOR WITHDRAWAL

AUTHORIZED SIGNATURES

Continued from front side

(TYPEWRITE NAME HERE)	WILL SIGN	(SIGNATURE IN THIS COLUMN)	TITLE
	✓	<i>Fred L. Wilson</i>	TREAS
	✓	<i>W. R. McElberris</i>	
	✓	<i>Wayne Dayvault</i>	
	"		
	"		
	"		
	"		

FEB 24 1965
W. R. McElberris
~~134/99~~

Mr. LEONARD. I respectfully decline to answer that question based upon the grounds previously stated.

Mr. APPELL. Mr. Leonard, I put it to you as a fact, and ask you to affirm or deny the fact, that this Klavern to which we have established official affiliation on your part was, prior to becoming affiliated with the U.S. Klans, under the leadership of the Imperial Wizard Eldon Edwards; that you were affiliated as a Klavern of the North Carolina Knights of the Ku Klux Klan, which was under the leadership of Grand Wizard James W. "Catfish" Cole.

Mr. LEONARD. I respectfully decline to answer that question based upon the grounds previously stated.

Mr. APPELL. Mr. Chairman, in order that the record may properly understand questions that are going to be asked of the witness, I would like to read into the record a statement on the basis of the committee's investigation to the effect that in the winter of 1955 there was formed an independent Klan group which started out merely by the title of the Knights of the Ku Klux Klan, but then became known as the North Carolina Knights of the Ku Klux Klan; that this organization was started in Charlotte, North Carolina, and after the leadership of several temporary Grand Wizards, its leadership was taken over by a former carnival pitchman, self-styled Baptist "Free Will" Minister, from Marion, South Carolina, James W. "Catfish" Cole.

Cole's influence until January 1958 when this Klan burned a cross on the outskirts of St. Pauls, North Carolina, in front of the home of an Indian woman who the Klan implied was involved with a white man. They also burned crosses at the residence of Indians who had recently moved into a formerly all-white neighborhood.

On January 18, 1958, Cole's Klan scheduled a rally near Maxton, North Carolina, in spite of warnings by the local sheriff that he lacked the manpower to put down a riot should one occur. On the night of

the proposed rally, an estimated 50 to 75 Klansmen gathered around Cole at the rally site carrying shotguns, rifles, and pistols.

Before the rally started, an estimated 1000 armed Indians of the Lumbee Indians gathered along the edge of the highway and charged the unrobed Klansmen and the rally turned into a riot. Cole escaped, leaving his wife and children to be protected by other Klansmen.

On April 8, 1959, Cole was committed to jail in Lumberton, North Carolina, to begin serving an 18-24 month term for inciting the riot at Maxton Klan rally.

I put it to you as a fact, Mr. Leonard, and ask you to affirm or deny the fact, that it was following this that your Klavern and other Klaverns in the State of North Carolina began negotiations with representatives of Eldon Edwards for the purpose of becoming affiliated with his organization as a realm of the U.S. Klan in the State of North Carolina.

Mr. LEONARD. I respectfully decline to answer that question based upon the grounds previously stated.

Mr. APPELL. I put it to you as a fact, and ask you to affirm or deny the fact, that George Dorsett, now an official of the United Klans of America, who was the grand kludd, or chaplain, under James W. "Catfish" Cole, became the Grand Wizard of this organization after Cole was committed to serve his term.

Mr. POOL. Was that a Grand Wizard or Imperial Wizard?

Mr. APPELL. This is on a State level, sir; it is the Grand Wizard.

Mr. LEONARD. I respectfully decline to answer that question based upon the grounds previously stated.

Mr. APPELL. Mr. Leonard, do you know Fred L. Wilson in addition to being treasurer of your Klavern, klabee, to be klabee or treasurer of the Realm of North Carolina?

Mr. LEONARD. I respectfully decline to answer that question based upon the grounds previously stated.

Mr. APPELL. Did you know Wayne Dayvault and Don Leazer to be members of your Klavern?

Mr. LEONARD. I respectfully decline to answer that question based upon the grounds previously stated.

Mr. APPELL. I put it to you as a fact, and ask you to affirm or deny the fact, that when Investigator McConnon interviewed you on October 13, 1965, that after first refusing to discuss these individuals that you identified Fred L. Wilson, Wayne Dayvault, and Don Leazer as members of your Klavern, and that you later admitted to him in the course of the interview the positions which they held within the Klan.

Mr. LEONARD. I respectfully decline to answer that question based upon the grounds previously stated.

Mr. APPELL. I put it to you as a fact, and ask you to affirm or deny the fact, that you identified Leazer as one of Jones' full-time organizers; Wilson to be klabee of the Klavern; and Dayvault to be the kligrapp or secretary.

Mr. LEONARD. I respectfully decline to answer that question based upon the grounds previously stated.

Mr. APPELL. Mr. Leonard, during the time that your Klan was known as a Klan or Klavern within the U.S. Klan, Unit Number 1,

at the time Mr. W. R. McCubbins was the kludd, I put it to you as a fact, and ask you to affirm or deny the fact, that James R. Jones, now Grand Dragon of North Carolina, was the klokann chief of the Klavern.

Mr. LEONARD. I respectfully decline to answer that question based upon the grounds previously stated.

Mr. APPELL. I put it to you as a fact, and ask you to affirm or deny the fact, that toward the end of 1958 or early 1959, that now Grand Dragon Jones, now Realm Treasurer Wilson, and now Grand Kligrapp or Secretary Leazer were expelled from your Klavern for nonpayment of dues.

Mr. LEONARD. I respectfully decline to answer that question based upon the grounds previously stated.

Mr. APPELL. I put it to you as a fact, and ask you to affirm or deny the fact, that prior to that time, that now Grand Dragon James R. Jones was disciplined by your Klavern on many occasions for his radical conduct.

Mr. LEONARD. I respectfully decline to answer that question based upon the grounds previously stated.

Mr. APPELL. Did you possess knowledge of an organization known as the Black Shirts or Chessmen?

Mr. LEONARD. I respectfully decline to answer that question based upon the grounds previously stated.

Mr. APPELL. Mr. Leonard, it is the committee's information that following—

The CHAIRMAN. One second, Mr. Appell.

Who did you say was dismissed or expelled for nonpayment of dues?

Mr. APPELL. The present Grand Dragon, James R. Jones. This was in late 1958 or early 1959.

The CHAIRMAN. Now, Mr. Leonard, having expelled or dismissed Mr. Jones for nonpayment of dues, did you expel or did anyone to your knowledge ever expel anyone for acts of violence?

(Witness confers with counsel.)

Mr. LEONARD. I respectfully decline to answer that question based upon the grounds previously stated.

Mr. APPELL. Mr. Leonard, in order to obtain the context of the next question, I would like to make a statement for the record that in the spring of 1959, August W., properly known as "Gus" Holman, the former Imperial Klabee of the U.S. Klan, under the Imperial Wizard Eldon Edwards, formed in Columbia, South Carolina, a Klan-type organization which became known as the Chessmen. The Chessmen quickly moved into North Carolina and merged with an organization called the Black Shirts, which, like the Chessmen, was comprised of former Klansmen who had been expelled from the U.S. Klans for various reasons.

A group of Chessmen damaged a sawmill in Richfield, North Carolina, on April 3, 1959, and thereafter the Chessmen began to disintegrate.

I ask you if you know James R. Jones to have been a member of that organization.

Mr. LEONARD. I respectfully decline to answer that question based upon the grounds previously stated.

Mr. APPELL. Mr. Leonard, I am going to read you a paragraph from Investigator McConnon's report of interview with you, and after I have read it I desire you to deny it, confirm it, or to give any comment on it that you care to.

"Shelton visited Jones 2 weeks ago, according to subject [referring to yourself] and both welcome the investigation of the Klan by the committee, believing it will bring to light a lot of false thinking about the Klan. Neither Jones or Shelton were worried about the Klan end of the investigation, he related, but Jones was worried about what might be brought out about him in a personal way. Subject clarified this statement by stating that Jones at one time, just after reenlisting in the Army in California, went AWOL due to family problems back home. Subject stated he himself had gone to Washington with Jones in an effort to get Jones his discharge changed from undesirable to honorable. He said the AWOL charge caused Jones to receive this undesirable discharge. They lost out in Washington, however, and Jones was not granted a change in wordage of his discharge. Subject [referring to you] also alluded to Jones being concerned about something that happened in his youth as well, or at least when he was a young man. Subject declined [meaning you] to go any further on that point, however."

Mr. Leonard, I ask you to affirm it, deny it, or make whatever comment you want upon this quoted paragraph from Investigator McConnon's report of interview with you.

Mr. LEONARD. I respectfully decline to answer that question based upon the grounds previously stated.

Mr. APPELL. Mr. Leonard, over a number of years you were an employer of Mr. Jones; were you not?

Mr. LEONARD. I respectfully decline to answer that question based upon grounds previously stated.

Mr. APPELL. I put it to you as a fact, and ask you to affirm or deny the fact, that you told Investigator McConnon that you were his employer over a period of many years.

Mr. LEONARD. I respectfully decline to answer that question based upon the grounds previously stated.

Mr. APPELL. I put it to you as a fact, and ask you to affirm or deny the fact, that you advised Investigator McConnon that you were the Grand Dragon immediately preceding the appointment of Mr. Jones to be Grand Dragon for the Realm of North Carolina.

Mr. LEONARD. I respectfully decline to answer that question based upon grounds previous stated.

Mr. APPELL. With that knowledge, Mr. Leonard, can you in any way explain to the committee an interview given by Mr. Jones to the *Winston-Salem Journal* on September 6 which appeared in an issue of September 16, 1964, in which Mr. Jones is quoted as advising the reporter that:

Early in the summer of 1963, he called a meeting of some men he thought might be interested in reviving the Klan. After some discussion, they decided to unite with Imperial Wizard Robert M. Shelton of Tuscaloosa, Ala.

Shelton sent Grand Dragon Scoggin up from Spartauburg, and he and Jones went to work.

On Aug. 18, a small nucleus of men met in the Klan's old state headquarters in southern Union County, and Jones was elected to a four-year term as Dragon

Can you explain this in light of your knowledge that you immediately preceded—your statement to the investigator that you immediately preceded Jones as the Grand Dragon of the United Klans of America, Realm of North Carolina?

Mr. LEONARD. I respectfully decline to answer that question based upon the grounds previously stated.

Mr. APPELL. I put it to you as a fact, and ask you to affirm or deny the fact, that prior to the summer of 1963, and for some time prior to the summer of 1963, that Grand Dragon Jones was a member of the United Klans of America and assigned to the same Klavern that you were a member of.

Mr. LEONARD. I respectfully decline to answer that question based upon the grounds previously stated.

Mr. APPELL. I had earlier asked you about the expulsion of Mr. Jones from the Klan in 1958, and I asked you about any comment that appears in this interview, where Mr. Jones says or the reporter reports:

He didn't talk much about his early days in the Klan. He said he joined "about 1954" and "got out about 1958." He said he quit because the Grand Dragon in those day was guilty of "a multitude of sins."

As a member of the Klan in 1958 and as an officer of the Klavern, what multitude of sins was now Grand Dragon Jones referring to at that period of time?

Mr. LEONARD. I respectfully decline to answer that question based upon the grounds previously stated.

Mr. APPELL. As a former employer of Jones over many years, I ask you to comment upon this paragraph which is a direct quote:

Thus far I haven't been paid anything for my work. I've gotten a majority of my expenses paid ever since I was Grand Dragon. In the past 10 years I would think I've got \$25,000 tied up in the Klan. I have worn out tires and automobiles going all over the country, and I missed money I'd have made if I had been working.

Mr. Leonard, on the basis of the work and the money reported by Jones as gross income or net income over the years, he could not possibly have made \$25,000 in 10 years; could he?

Mr. LEONARD. I respectfully decline to answer that question based upon the grounds previously stated.

Mr. APPELL. Mr. Jones also said in this interview, and I quote—and this, I might add, relates to the image of the Klan and the acceptance of the Klan:

The main reason is that people don't understand the Klan People are trying to crucify me because the old Klan did things. I do not and never have belonged to the Ku Klux Klan. I belong to the Knights of the Ku Klux Klan. The Ku Klux Klan is on the attorney general's subversive list. This one is not and never has been.

Was Mr. Jones ever a member of a Klan which appeared on the Attorney General's list?

Mr. LEONARD. I respectfully decline to answer that question based upon the grounds previously stated.

(At this point Mr. Weltner left the hearing room.)

(Document marked "Arthur Leonard Exhibit No. 2" and retained in committee files.)

Mr. APPELL. Mr. Leonard, I show you a blank form of a "Klipgrapp's Quarterly Report" used in the days of the U.S. Klan under the Imperial Wizard Eldon L. Edwards. You will note—well, let me have you examine it.

(Document handed to witness.)

Mr. APPELL. According to this form, under the leadership of Imperial Wizard Edwards, Klans or Klaverns made reports not part to the realm and part to the imperial, but they made their checks payable to the Grand Dragon of the realm, and he took off his slice and forwarded what the imperial was supposed to get directly to the imperial.

I put it to you as a fact, and ask you to affirm or deny the fact, that today, under the United Klans of America, this procedure no longer follows, and that your Klavern sends part of the money due the realm directly to the realm, and to the imperial directly to the imperial. I ask you to affirm or deny that.

Mr. LEONARD. I respectfully decline to answer that question based upon the grounds previously stated.

(Document marked "Arthur Leonard Exhibit No. 3" appears on p. 1911.)

Mr. APPELL. Mr. Leonard, after Mr. Jones replaced you as Grand Dragon, in January 1964 were you elected to the office of Grand Klaliff, or vice president?

Mr. LEONARD. I respectfully decline to answer that question based upon the grounds previously stated.

Mr. APPELL. I put it to you as a fact, and ask you to affirm or deny the fact, that at that election held on January 26, 1964, at Granite Quarry, North Carolina, that Jones was elected the Grand Dragon; that Leonard, Arthur C. Leonard, was elected Grand Klaliff; that W. R. McCubbins, who has been identified as a member, whose name appeared on the same signature card that your name appeared on, was elected the grand kludd; that Charles Bud Deese, of Salisbury, North Carolina, was elected grand kilgrapp, or secretary; that Ray Terry, of Durham, North Carolina, was elected the conductor; that Buck House, of Lexington, North Carolina, was elected the inner guard; that Jim McLamb, of Wilmington, North Carolina, was elected outer guard; and that Red Biddle, of Wilmington, North Carolina, was elected as chief of the klokann committee; and that C. J. Brindle—Clarence J. Brindle, was elected grand night-hawk.

I put it to you as a fact, and ask you to affirm or deny the fact.

Mr. LEONARD. I respectfully decline to answer that question based upon the grounds previously stated.

Mr. APPELL. I put it to you as a fact, and ask you to affirm or deny the fact, that you also held on the grand level the position of grand klokard.

Mr. LEONARD. I respectfully decline to answer that question based upon the grounds previously stated.

Mr. APPELL. Do you know George Dorsett?

Mr. LEONARD. I respectfully decline to answer that question based upon the grounds previously stated.

Mr. APPELL. I put it to you as a fact, and ask you to affirm or deny the fact, that you advised Investigator McConnon that you had heard that George Dorsett was one of the full-time organizers under Jones today.

ARTHUR LEONARD EXHIBIT No. 3

FORM K-105

READ INSTRUCTIONS ON BACK BEFORE PREPARING THIS REPORT

KLIPGRAPP'S QUARTERLY REPORT

Klan No. _____ Realm of _____ Quarter, 19____

This report must be accurately made out in duplicate by the Kilgrapp and sent to proper headquarters NOT LATER THAN THE TENTH of the month immediately following the last month of the QUARTER. Klans in Organized Realms send one copy to State Office. Remittances must be made by check, cash, Post Office Order or Express money order.

To His Majesty, the Imperial Wizard, Knights of the Ku Klux Klan:

The following is my report for the _____ Quarter, 19____

- 1. Klan located at _____, State of _____
- 2. Number Klonslaves held _____
- 3. Average attendance _____
- 4. Number of members in good standing last report _____
(If new Klan, number when chartered _____)
- 5. Number members naturalized this quarter Carry down to line 11b, 11c or 11d) _____
- 6. Number ministers naturalized this quarter (Tax due—No Klectokon) _____
- 7. Number members reinstated this quarter (carry down to line 11f) _____
- 8. Number members received by transfer this quarter (carry down to line 11e) _____
- Gross membership _____
- 9. Deductions: a—Suspended (for non-payment of dues) _____
b—Transferred (Tax to be paid by Klan issuing transfer) _____
c—Died _____
- Total Deductions _____
- Net Membership Good Standing This Report _____

- 10. KLECTOKEN ON _____ MEMBERS AT \$5.00 EACH _____ \$ _____
- 11. A—TAX ON _____ AT 70¢(THREE MONTHS) _____ \$ _____
- B—TAX ON _____ AT 47¢(TWO MONTHS) _____ \$ _____
- C—TAX ON _____ AT 24¢(ONE MONTH) _____ \$ _____
- D—TAX ON _____ (CURRENT MONTH NEW MEMBERS) _____ \$ _____
- E—TRANSFERS _____ (PAID BY KLANS USING TRANSFER)
- F—TAX ON _____ REINSTATED MEMBERS AT \$2.00 _____ \$ _____

Total Amount Due Imperial Headquarters This Report _____ \$ _____

MAKE CHECKS PAYABLE TO GRAND DRAGON IN YOUR REALM

Remarks: In organized Realms Reports will be sent to Grand Dragon's officer for certification.

Date _____, A. D. 19____, A. K. _____

Signed _____
Kilgrapp.

(KLAN SEAL)

No. _____ Realm of _____
P. O. Address _____
Certified by _____

E. C.

(SEE OTHER SIDE FOR INSTRUCTIONS)

Mr. LEONARD. I respectfully decline to answer that question based upon the grounds previously stated.

Mr. APPELL. Do you know Boyd Hamby?

Mr. LEONARD. I respectfully decline to answer that question based upon the grounds previously stated.

Mr. APPELL. I put it to you as a fact, and ask you to affirm or deny the fact, that you advised Investigator McConnon that you had heard that Hamby was a full-time organizer for the Klan.

Mr. LEONARD. I respectfully decline to answer that question based upon the grounds previously stated.

Mr. APPELL. Do you know Grady Mars?

Mr. LEONARD. I respectfully decline to answer that question based upon the grounds previously stated.

Mr. APPELL. I put it to you as a fact, and ask you to affirm or deny the fact, that while stating that you had only met Grady Mars on two or three occasions, that you stated that you would not be surprised, however, if Grady Mars was another full-time organizer for Bob Jones in the UKA.

Mr. LEONARD. I respectfully decline to answer that question based upon the grounds previously stated.

Mr. APPELL. Did you purchase a policy under the Klan hospital-surgical policies which were written under the affiliated group, the Capital City Restoration Association?

Mr. LEONARD. I respectfully decline to answer that question based upon the grounds previously stated.

Mr. APPELL. I put it to you as a fact, and ask you to affirm or deny the fact, that you advised Investigator McConnon that you did buy an insurance policy under that plan.

Mr. LEONARD. I respectfully decline to answer that question based upon the grounds previously stated.

Mr. APPELL. Did you discuss with Investigator McConnon, Calvin Craig, the Grand Dragon of Georgia?

Mr. LEONARD. I respectfully decline to answer that question based upon the grounds previously stated.

(At this point Mr. Weltner returned to the hearing room.)

Mr. APPELL. I put it to you as a fact, and ask you to affirm or deny the fact, that you stated you had met Calvin Craig on four or five occasions; that you described him as being a bit hotheaded, but has worked hard for the Klan.

Mr. LEONARD. I respectfully decline to answer that question based upon the grounds previously stated.

Mr. APPELL. Did you discuss with Investigator McConnon Robert Scoggin, the Grand Dragon for the State of South Carolina?

Mr. LEONARD. I respectfully decline to answer that question based upon the grounds previously stated.

Mr. APPELL. I put it to you as a fact, and ask you to affirm or deny the fact, that you stated to Investigator McConnon that you had known Robert Scoggin for a period of 10 years, considered him to have good intentions, but to be a man who lacks the ability to represent the Klan in the best light.

Mr. LEONARD. I respectfully decline to answer that question based upon the grounds previously stated.

Mr. APPELL. As a matter of fact, Mr. Leonard, you knew Mr. Scoggin to also be a Grand Dragon for the Realm of South Carolina under the U.S. Klans during its existence under the leadership of Imperial Wizard Edwards; is that not a fact?

Mr. LEONARD. I respectfully decline to answer that question based upon the grounds previously stated.

Mr. APPELL. Mr. Leonard, I hand you, although they are not prepared in the form in which the document is being handed to you, a series of oaths (Robert Shelton Exhibit No. 4) which are taken by Klansmen. I ask you to examine this series of oaths to advise the committee whether or not these are the oaths administered to members entering the United Klans of America today.

Mr. LEONARD. I respectfully decline to answer that question based upon the grounds previously stated.

Mr. APPELL. According to Investigator McConnon's report, you have studied the work of the Klan to such a point that you were able to recite to him the provisions of these oaths verbatim. I put it to you as a fact, and ask you to affirm or deny the fact, that you did quote to him verbatim sections from these oaths.

Mr. LEONARD. I respectfully decline to answer that question based upon the grounds previously stated.

Mr. APPELL. Did you advise Investigator McConnon that in appearing before the committee, you possibly would not be able to testify to the things that you told him about because they would violate your Klan oath?

Mr. LEONARD. I respectfully decline to answer that question based upon the grounds previously stated.

Mr. APPELL. Is your invocation of grounds upon which you refuse to testify in any way related to the oath of secrecy that you have taken as a Klansman?

Mr. LEONARD. I respectfully decline to answer that question based upon the grounds previously stated.

Mr. APPELL. Mr. Chairman, I have no further questions to ask of this witness.

The CHAIRMAN. Mr. Pool?

Mr. POOL. Mr. Leonard, when you were an official of the U.S. Knights of the Ku Klux Klan and had charge of their records for the money received, did you file an income tax return? That is, for the U.S. Knights of the Ku Klux Klan?

Mr. LEONARD. I respectfully decline to answer that question based upon the grounds previously stated.

Mr. POOL. You kept the records for the U.S. Knights of the Ku Klux Klan?

Mr. LEONARD. I respectfully decline to answer that question based upon the grounds previously stated.

Mr. POOL. Were you not the treasurer of the U.S. Knights of the Ku Klux Klan?

Mr. LEONARD. I respectfully decline to answer that question based upon the grounds previously stated.

Mr. POOL. And you refuse to answer as to whether or not you filed an income tax return for the U.S. Knights of the Ku Klux Klan?

Mr. LEONARD. I respectfully decline to answer that question based upon the grounds previously stated.

Mr. POOL. That is all, Mr. Chairman.

The CHAIRMAN. Mr. Weltner?

Mr. WELTNER. Mr. Chairman, I don't have any questions of this witness, but I think for the purpose of clarity it might be well to ask Mr. Appell to briefly relate the transition from the date of the North Carolina Knights under "Catfish" Cole to the present Realm of North Carolina under J. R. Jones.

Mr. APPELL. The North Carolina Knights of the Ku Klux Klan started to disintegrate after the conviction of "Catfish" Cole and the riot that grew out of the attack upon the rally by the Lumbee Indians. However, it did not completely disintegrate as an organization, and they still retained some Klaverns, but the bulk of the Klaverns that were in that organization went into the U.S. Klans, some before the Lumbee Indians incident, and others after.

With respect to the Klavern to which Mr. Leonard is a member, it continued in the U.S. Klans until the death of Eldon Edwards, at which time the bulk of the U.S. Klan membership in North Carolina, including the Rowan County Klavern, went into the United Klans of America and were represented at the convention in July of 1961 at which Mr. Robert M. Shelton was elected Imperial Wizard for the United Klans of America.

In a period there, the leadership of the "Cole Klan," the North Carolina Knights of the Ku Klux Klan, attempted to get together with the U.S. Klan elements in order to try to get together and merge into one big organization. They even scheduled a meeting with "Catfish" Cole in the penitentiary to carry this out.

Mr. WELTNER. Was the Rowan Sportsmen's Club then successor Klavern to the North Carolina Knights, the U.S. Knights, and presently in the UKA?

Mr. APPELL. Yes, sir.

Mr. WELTNER. That is all, Mr. Chairman.

The CHAIRMAN. Mr. Buchanan?

Mr. BUCHANAN. I have no questions, Mr. Chairman.

The CHAIRMAN. The documents Mr. Appell questioned the witness on will be received in evidence at the respective points where they were exhibited and discussed.

The witness is excused and discharged from his subpoena.

Mr. CHALMERS. Thank you, sir.

The CHAIRMAN. The committee will stand in recess for 3 minutes.

(Whereupon, at 11:25 a.m., the subcommittee recessed, Representatives Willis, Pool, Weltner, and Buchanan being present, and reconvened at 11:30 a.m. with Representatives Willis, Weltner, and Buchanan present.)

The CHAIRMAN. The subcommittee will please come to order.

Call your next witness, Mr. Appell.

Mr. APPELL. Mr. Chairman, I would like to call Mr. Richard Joseph Constantineau.

The CHAIRMAN. Please raise your right hand.

Do you solemnly swear that the testimony you are about to give will be the truth, the whole truth, and nothing but the truth, so help you God?

Mr. CONSTANTINEAU. I do.

TESTIMONY OF RICHARD JOSEPH CONSTANTINEAU

Mr. APPELL. Would you state your full name for the record, sir?

Mr. CONSTANTINEAU. Richard Joseph Constantineau.

Mr. APPELL. For the stenographer, would you spell your last name?

Mr. CONSTANTINEAU. C-o-n-s-t-a-n-t-i-n-e-a-u.

The CHAIRMAN. C-o-n-s-t-a-n-t-i-n-e-a-u.

Mr. APPELL. Mr. Constantineau, are you appearing here in accordance with a subpoena served upon you at 6:15 o'clock p.m. on the 14th day October 1965, by Investigator McConnon, a member of the staff of this committee?

Mr. CONSTANTINEAU. Yes, sir.

Mr. APPELL. Are you represented by counsel?

Mr. CONSTANTINEAU. No, sir.

Mr. APPELL. Do you require counsel?

Mr. CONSTANTINEAU. No, sir.

Mr. APPELL. Mr. Constantineau, the subpoena served upon you called for you to produce documents described in two sections which were made a part of the subpoena. One is:

All books, records, documents, correspondence, and memoranda relating to the organization of and the conduct of business and affairs of the Invisible Empire, United Klans, Knights of the Ku Klux Klan of America, Inc., also known as the United Klans of America, Inc., Knights of the Ku Klux Klan and affiliated organizations, namely, the Alabama Rescue Service, New Hanover Improvement Association, New Hanover Improvement League, Realm (state) of North Carolina, in your possession, custody or control, or maintained by you or available to you as a member or officer of New Hanover Improvement Association, New Hanover Improvement League, Realm (state) of North Carolina, of the Invisible Empire, United Klans, Knights of the Ku Klux Klan of America, Inc., also known as the United Klans of America, Inc., Knights of the Ku Klux Klan.

Do you have any of these documents in your possession and are you now prepared to submit them in accordance with the terms of the subpoena?

Mr. CONSTANTINEAU. I do not have any in my possession as I have never had any in my possession.

Mr. APPELL. Part 2 of the subpoena calls for:

All books, records, registers, accounts, papers and correspondence of the Beacon Gun Works (an unincorporated business in Wilmington, North Carolina, of which you are owner or co-owner), in your possession, custody, or control, including but not limited to such records as are required to be maintained in accordance with the Federal Firearms Act, relating to the purchase and sale of firearms and ammunition, both in local or intra-state commerce and in interstate or foreign commerce, for the period from August 1962 to date.

Mr. Chairman, before asking for a production of the documents—

The CHAIRMAN. And you say those are documents required to be maintained by him? Say that again.

Mr. APPELL. Required to be maintained in accordance with the Federal Firearms Act relating to the purchase and sale of firearms and ammunition.

Prior to making a demand for the production, Mr. Chairman, Mr. Constantineau brought with him all books, records, et cetera, not knowing specifically the interest of the committee. I advised Mr. Constantineau that we are interested in the records of the sale of guns because under the regulations the sale of ammunition can be invoiced only

to cash, where the purchase of guns and others must be registered in the name of the individual purchasing.

Therefore, I asked Mr. Constantineau to produce only those documents which relate to the sale of firearms.

Are you prepared to produce those documents, Mr. Constantineau?

Mr. CONSTANTINEAU. I am.

The CHAIRMAN. Let the record show that the witness has handed to Mr. Appell a bound book, a volume.

Mr. APPELL. Mr. Chairman, I would like to state for the record that after copies of these records can be made, that the originals of these records shall be returned to Mr. Constantineau.

The CHAIRMAN. As an illustration of the pamphlets within that volume, I refer to the first one, which apparently is in compliance with regulations of the Government. It is entitled "Firearms Record From" this one reads "8-25-62 to"; this one reads "5-6-63, 121 Entries. Dealer's name: Beacon Gun Works; address, 5811 Oleander Drive; city, Wilmington; State, North Carolina" for North Carolina.

"License number 56-2776, issued" blank; "expires" with the word "renewable" and at the bottom in print "Courtesy of Remington Arms Company, Inc., sales promotion, Bridgeport, 2, Connecticut."

(Documents marked "Richard Constantineau Exhibit No. 1" and retained in committee files.)

Mr. APPELL. Mr. Constantineau, I hand you a certified copy of a document obtained from the secretary of state's office of the State of North Carolina which is certified to be true copies of the articles of incorporation of the New Hanover County Improvement Association, Inc.

I hand you this document and ask you if you have ever heard of the organization?

Mr. CONSTANTINEAU. Yes, sir.

(Document marked "Richard Constantineau Exhibit No. 2." This exhibit will be reproduced in a forth coming report on Ku Klux Klan organizations.)

Mr. APPELL. Mr. Constantineau, have you ever been a member of the United Klans of America?

Mr. CONSTANTINEAU. Yes.

Mr. APPELL. When did you join the United Klans of America?

Mr. CONSTANTINEAU. The date is not clear. It was either late April or early May of 1964.

Mr. APPELL. How did you happen to become interested in joining? What process did you follow in order to become a member of the United Klans of America?

Mr. CONSTANTINEAU. I received some literature and an application blank which I filled out and returned to the address indicated.

Mr. APPELL. And after returning it, what advice did you receive from the Klan?

Mr. CONSTANTINEAU. I was told when and where to go.

Mr. APPELL. And where were you told you should go? Or just where. You earlier stated you could not remember when.

Mr. CONSTANTINEAU. It was a room over a theater on Second Street.

Mr. APPELL. Do you possess knowledge as to the long-term lessee of the premises?

Mr. CONSTANTINEAU. No, sir; I have no knowledge of that.

Mr. APPELL. I hand you, but not in the form that it is handed out, a series of oaths (Robert Shelton Exhibit No. 4) and asked you if in review of these, these appear to be a series of oaths which you took at the time you became a member of the Klan?

Mr. CONSTANTINEAU. It is similar. I cannot truthfully say it is word for word because I cannot remember that far back.

The CHAIRMAN. But in substance that is the form of the oaths?

Mr. CONSTANTINEAU. Yes, sir.

Mr. APPELL. When you arrived at this building which you were invited to attend in response to your application or interest in application, were you then and there explained what the Klan stood for as far as attempting to interest you in a formal membership?

Mr. CONSTANTINEAU. Yes, sir.

Mr. APPELL. Do you know the identity of the man who gave you the lecture on the Klan prior to the administering of any oaths?

Mr. CONSTANTINEAU. Did I know him before the oath?

Mr. APPELL. Do you know the identity of the man—

The CHAIRMAN. Did you know before?

Mr. APPELL. —the man who gave you the lecture before you took any of the oaths?

Mr. CONSTANTINEAU. I did not know him before I took the oath, no.

The CHAIRMAN. Did you learn who he was afterwards?

Mr. CONSTANTINEAU. Yes, sir.

Mr. APPELL. You now know his identity?

Mr. CONSTANTINEAU. Yes, sir.

Mr. APPELL. Who is he?

Mr. CONSTANTINEAU. The man that gave the oath I don't know.

Mr. APPELL. The man who lectured to you on the principles of the Klan?

Mr. CONSTANTINEAU. Mr. Chadwick, Warren Chadwick.

Mr. APPELL. Is that Warren J. Chadwick?

Mr. CONSTANTINEAU. I don't know his middle initial.

Mr. APPELL. Were you at that time after the purposes of the Klan were explained to you given a formal application?

Mr. CONSTANTINEAU. Yes, sir.

Mr. APPELL. This is not a reproduction of that formal application in the size, but can you look at this and tell us whether this is similar to the application that you signed?

(Document handed to witness.)

Mr. CONSTANTINEAU. This is not the same. The one I signed was postcard size.

Mr. APPELL. I am sorry, I didn't hear you.

Mr. CONSTANTINEAU. I said this is not the same. The one I signed was about the size of a postcard.

The CHAIRMAN. He did say it was not the same size, he indicated that. It was not the same size. You say the one you looked at, or the one exhibited to you was in card form. But the point is, is this in the form?

Mr. CONSTANTINEAU. It is similar. I don't remember exactly what it looked like.

(Document marked "Richard Constantineau Exhibit No. 3" and retained in committee files.)

Mr. APPELL. But other than the card which you signed which you had received in the mail and forwarded in, you were not given a formal application of this format to sign?

Mr. CONSTANTINEAU. No, sir.

Mr. APPELL. After you agreed to become a member, were you then administered this series of oaths?

Mr. CONSTANTINEAU. Yes, sir.

Mr. APPELL. In the administering of this series of oaths, were certain sections, such as the oath of allegiance, Section I, Obedience; Section II, Secrecy; and Section III, Fidelity, read to you, and subscribed to by you, before you were taken into what we shall call, for the want of a better term, the inner chambers of the Klavern?

Mr. CONSTANTINEAU. Yes, sir.

Mr. APPELL. And the section of oaths which deals with the Klanishness, they were administered to you as a part of the ceremony within the Klavern chamber itself?

Mr. CONSTANTINEAU. Yes, sir.

Mr. APPELL. Did the Klavern to which you were assigned meet normally in the same building where you presented yourself on the first night as a candidate for membership?

Mr. CONSTANTINEAU. Yes, sir; normally they met there.

Mr. APPELL. Wasn't this some kind of a labor hall?

Mr. CONSTANTINEAU. I heard later that it was a union hall. I had never been there before that night.

Mr. APPELL. But later you knew that it was a hall used by one of the local labor unions?

Mr. CONSTANTINEAU. Yes, sir.

The CHAIRMAN. Let me ask you this question.

Let me see the lease. You exhibited to him a lease and he said something about he wasn't familiar with it. You said something about a long-term lease. Didn't you question him about a long-term lease? I thought you had.

What I wanted you to establish, if you had, is that it was my impression you mentioned the words "long-term lease," and he said he didn't know anything about the lease. That is my impression.

I want to ask him, though, not knowing anything about the lease, if that is the case, would the lease be at the same address that he attended meetings at?

Mr. APPELL. Mr. Chairman, if I might correct the record, I used the reference to a lease in order to try to establish from the witness at that time that the premises used were in fact those of a labor union organization.

The CHAIRMAN. I am now catching on to that.

Mr. APPELL. And I do not have the lease.

The CHAIRMAN. You don't?

Mr. APPELL. No, sir.

The CHAIRMAN. I am wondering if the address given of the leased premises is the place where he attended meetings. Is that true? Is that your understanding?

Mr. APPELL. Yes, sir.

The CHAIRMAN. In other words, the lease did cover the union hall, as you say.

Mr. APPELL. Yes, sir.

The CHAIRMAN. And that is the place he now says he did attend meetings at.

Mr. APPELL. Yes, sir.

The CHAIRMAN. Proceed.

Mr. APPELL. Did the Klan or Klavern to which you were assigned carry a designation other than Knights of the Ku Klux Klan?

Mr. CONSTANTINEAU. Yes, sir.

Mr. APPELL. And what cover or what designation did it have other than Knights of the Ku Klux Klan?

Mr. CONSTANTINEAU. New Hanover Improvement Association.

Mr. APPELL. Mr. Constantineau, before we leave the place of the meeting, the labor hall, did the Klavern move its place of meeting from there to some other location?

Mr. CONSTANTINEAU. Yes, sir.

Mr. APPELL. And where did it move its meeting place to?

Mr. CONSTANTINEAU. To a motel, a motel meeting room.

Mr. APPELL. And was this the Elberta Motel in Wilmington?

Mr. CONSTANTINEAU. Yes, sir.

Mr. APPELL. The committee's investigation establishes that the reason for the moving was that when the trade union body found that this was in fact a Klan group that was meeting there under the name of the New Hanover County Improvement Association, that they refused to permit the group to continue to use its facilities.

Do you know that this was the reason why they moved from that point to the Elberta Motel?

Mr. CONSTANTINEAU. No, sir; I do not know the reason for the move.

Mr. APPELL. Mr. Constantineau, in the articles of incorporation which I show you for the New Hanover County Improvement Association, Inc., the registered agent of the corporation is listed as James H. McLamb.

Did you know McLamb to be a member of the Klan and a member of the New Hanover County Improvement Association?

Mr. CONSTANTINEAU. Yes, sir.

Mr. APPELL. The incorporation says that the name and addresses of persons who are to serve as initial directors are, and the first name listed is Warren Chadwick, 212 North Channel Drive, Wrightsville Beach, North Carolina.

Is this the same Warren Chadwick to whom you referred as lecturing you on the advantages of the Klan prior to your taking your first series of oaths?

Mr. CONSTANTINEAU. Yes, sir.

Mr. APPELL. The other officer is James H. McLamb, 3850 Peachtree Avenue, Wilmington, North Carolina, and this is the same gentleman who was designated as the agent of the corporation and whom you have identified as a person you knew?

Mr. CONSTANTINEAU. Yes, sir.

Mr. APPELL. The third name is Carey Strickland, 232 Lake Forest Parkway, Wilmington, North Carolina.

Did you likewise know Carey Strickland?

Mr. CONSTANTINEAU. No, sir; I do not know Carey Strickland.

Mr. APPELL. Mr. Constantineau, at the time you joined the United Klans of America and were assigned to its Klavern which used the name of the New Hanover County Improvement Association, what was the initiation fee which you paid?

Mr. CONSTANTINEAU. I believe, though I am not sure, it was \$10.00.

Mr. APPELL. Do you possess any knowledge of the distribution of that \$10.00 once you turned it over to someone?

Mr. CONSTANTINEAU. No, sir; I do not.

Mr. APPELL. Do you recall to whom you turned over the \$10.00?

Mr. CONSTANTINEAU. Mr. Chadwick.

Mr. APPELL. To Mr. Chadwick.

Within your particular Klavern, that known as the New Hanover County Improvement Association, what was your rate of dues?

Mr. CONSTANTINEAU. It was either 50 cents or \$1.00 a month. I can't remember that far back. I paid 6 months in advance, anyway.

Mr. APPELL. After becoming a formal member of this Klan Klavern, were you required to purchase a robe?

Mr. CONSTANTINEAU. It was not required.

Mr. APPELL. Did you purchase a robe?

Mr. CONSTANTINEAU. Yes, I did.

Mr. APPELL. From whom did you purchase your robe?

Mr. CONSTANTINEAU. I purchased it from Mr. Chadwick. It was ordered somehow.

Mr. APPELL. And how much did you pay for the robe?

Mr. CONSTANTINEAU. I believe it was \$10.00.

Mr. APPELL. Did you have a satin robe or a broadcloth robe?

Mr. CONSTANTINEAU. A satin robe.

Mr. APPELL. At \$10.00?

Mr. CONSTANTINEAU. I believe that is correct.

Mr. APPELL. Not \$15.00?

Mr. CONSTANTINEAU. I believe it was \$10.00.

Mr. APPELL. After you became a member of this Klan group, how active were you as a member?

Mr. CONSTANTINEAU. I attended approximately one meeting monthly, and during the course of my membership I attended approximately 8 or maybe 10 rallies.

Mr. APPELL. And when did you terminate your membership?

Mr. CONSTANTINEAU. In the latter part of August 1964.

Mr. APPELL. During the course of your membership, did you ever attend any State meetings?

Mr. CONSTANTINEAU. Yes, sir.

Mr. APPELL. Did you attend any State meetings at which elections of officers were held?

Mr. CONSTANTINEAU. Yes, sir.

Mr. APPELL. Were you elected to any State office?

Mr. CONSTANTINEAU. Yes, sir.

Mr. APPELL. To what State office were you elected?

Mr. CONSTANTINEAU. State klokann.

Mr. APPELL. And what advice did you receive as to the duties and responsibilities of the State klokann?

Mr. CONSTANTINEAU. I was to investigate new applications for membership and clear them for entry into the organization.

Mr. APPELL. Can you recall the identity of any other man elected at that same election for any office within the State of North Carolina?

Mr. CONSTANTINEAU. Mr. Red Biddle, I believe, was elected. I don't know what office he was elected to. And Mr. Hamby, I believe, was elected night-hawk.

Mr. APPELL. This is Mr. Boyd Hamby?

Mr. CONSTANTINEAU. Yes, sir. The others I do not know.

Mr. APPELL. You say that you were unfamiliar with the organization so that you do not know the identity of the other people elected at that time?

Mr. CONSTANTINEAU. Yes, sir.

Mr. APPELL. Within the Realm of North Carolina, there are titans which, according to the Constitution and Laws, have the overriding jurisdiction within provinces or which conform to congressional districts.

Do you know the identity of the titan in the district to which the Wilmington Klavern was a part?

Mr. CONSTANTINEAU. No, sir; I do not.

The CHAIRMAN. Have you asked him when and where the State meeting was?

Mr. APPELL. I failed to.

When and where was that State meeting?

Mr. CONSTANTINEAU. It was on the outskirts of Salisbury. I don't know the exact location. It is the first time I had ever been there. I don't know the exact date. It was in August 1964.

Mr. APPELL. How long did you carry out the functions as a member of the State klokann committee?

Mr. CONSTANTINEAU. I resigned the following week.

The CHAIRMAN. The following week? The week following what?

Mr. APPELL. The State meeting, sir.

The CHAIRMAN. Does he know when he resigned? Try to establish the date.

Mr. APPELL. Yes, sir.

Prior to your resignation, who do you recall as having held offices within the unit of the Klan to which you were assigned known as the New Hanover County Improvement Association?

Mr. CONSTANTINEAU. Mr. McLamb and Mr. Biddle were the only two I knew that held any office.

Mr. APPELL. Did Mr. Warren Chadwick hold any office at that period of time?

Mr. CONSTANTINEAU. I heard that he did, but I don't know what it was other than being a local leader.

The CHAIRMAN. A local what?

Mr. CONSTANTINEAU. The head of the local unit.

Mr. APPELL. Do you recall the identify of any other members of the Klavern to which you were assigned?

Mr. CONSTANTINEAU. Mr. Chadwick, Mr. Biddle, Mr. McLamb are the only ones that I can remember the names of.

Mr. APPELL. Mr. Constantineau, W. J. Chadwick, to whom you referred, made a complaint at the sheriff's office that he had purchased a tear gas gun from Milton Finkelstein Music Company. Had you also been charged with the sale of Penguin type tear gas kits?

Mr. CONSTANTINEAU. Yes, sir.

Mr. APPELL. What knowledge did you possess at that time with respect to the illegality of the sale of such weapons?

Mr. CONSTANTINEAU. I had no knowledge whatsoever that they were illegal. They were being sold throughout the State.

Mr. APPELL. Did Warren Chadwick make the complaint against the store that I mentioned following your arrest because no action had been taken against them?

Mr. CONSTANTINEAU. I believe that is correct.

Mr. APPELL. Do you know that this was a discussion within the Klan, yourself and others, that this is what he should properly do?

Mr. CONSTANTINEAU. No, sir; I did not know anything about that until after he had done it.

Mr. APPELL. What understanding did you later obtain?

Mr. CONSTANTINEAU. He just told me that he had bought one and turned it over to the sheriff's department.

Mr. APPELL. You stated that you attended the State meeting in July or August—

The CHAIRMAN. He said he attended a meeting about a week before he resigned.

Mr. CONSTANTINEAU. It was the last week in August.

The CHAIRMAN. It was what?

Mr. CONSTANTINEAU. The last week in August 1964.

The CHAIRMAN. And you resigned when?

Mr. CONSTANTINEAU. The week following that State meeting.

Mr. APPELL. So that puts your resignation somewhere around the 1st of September?

Mr. CONSTANTINEAU. Of last year; yes, sir.

Mr. APPELL. Yes, sir; of 1964.

Why did you resign from the Klan?

Mr. CONSTANTINEAU. My wife was in very bad health and my business—I was neglecting my business, so to speak, so I felt that I had better stay with my business. My wife was on the verge of a nervous breakdown. That was my reasons for resigning.

Mr. APPELL. Your wife's condition had some relationship to your membership?

Mr. CONSTANTINEAU. Yes, sir. She was worried of my activities.

Mr. APPELL. Would you, having been in the Klan and out of the Klan, again sign a Klan membership card?

Mr. CONSTANTINEAU. I don't believe I would at the present time.

Mr. APPELL. Do you care to state any reasons for this?

Mr. CONSTANTINEAU. Well, I don't think that they have a program that satisfies me.

The CHAIRMAN. Do you care to say what you mean by that?

Mr. CONSTANTINEAU. Well, what I mean by that is I don't see where they have anything lined up. I don't know how to express what I mean.

The CHAIRMAN. Were you familiar with how the funds were handled? Did that have anything to do with your dissatisfaction, or an important thing to do with your dissatisfaction?

Mr. CONSTANTINEAU. No, sir; that had nothing to do with it, and I don't know what the funds were used for, or dues, whatever you call them.

Mr. APPELL. Within the New Hanover County area, there were, over a period of time, during the time of your membership, crosses burned, either at the New Hanover County Courthouse and other places.

Do you possess any knowledge of this?

Mr. CONSTANTINEAU. No, sir; I do not.

Mr. APPELL. Did you ever participate in any act of violence as a member of the Klan?

Mr. CONSTANTINEAU. No, sir; I did not.

Mr. APPELL. Mr. Chairman, the staff has no further questions of the witness.

The CHAIRMAN. Mr. Constantineau, we appreciate your appearance, as we will have any others who want to cooperate with this committee to testify to individual, firsthand knowledge. This is the first time I knew the substance of what you were to testify to. The investigator interviewed you, and I am sure that, as usual, he questioned you very carefully as to your testimony, the extent of it. We do appreciate your appearance very much.

Mr. CONSTANTINEAU. Thank you.

The CHAIRMAN. Mr. Weltner.

Mr. WELTNER. Mr. Constantineau, would you kindly examine the documents that you have submitted today in response to the subpoena?

I would like to question you about a couple of entries in there.

On the folder that refers to the date of June 13, 1964, which, as I understand, is 2 or 3 months after you became a member of the Wilmington Klan, there is an entry for W. J. Chadwick purchasing a .38 caliber S & W revolver.

I take it that is a Smith & Wesson revolver.

Mr. CONSTANTINEAU. Yes.

Mr. WELTNER. Is that the W. J. Chadwick you referred to as the exalted cyclops of the Klavern of which you were a member?

Mr. CONSTANTINEAU. Yes, sir.

Mr. WELTNER. Then if you would follow on to September 17, 1964, which, as I understand, is maybe 2 or 3 weeks following your resignation from the Klan, there is another entry that a W. J. Chadwick purchased a .32 caliber S & W revolver, which I take to be a Smith & Wesson revolver. Is that the same W. J. Chadwick?

Mr. CONSTANTINEAU. Yes, sir.

Mr. WELTNER. Are there any other entries in there to persons whom you know to be members of the Klan?

Mr. CONSTANTINEAU. Mr. Biddle and Mr. McLamb.

Mr. WELTNER. And I believe you testified that those are the only three persons whom you recall to have been members during the time that you were a member?

Mr. CONSTANTINEAU. Yes, sir.

Mr. WELTNER. Mr. Constantineau, you began that record on the 25th day of August 1962.

Mr. CONSTANTINEAU. Yes, sir.

Mr. WELTNER. And there are 11 books there. The last one is not yet completed, it having some blank space in it. I note there are about 120 entries in each one of those volumes. I would like to point out this brief analysis and ask for your comment on it, whatever relevance you think it might have.

The first volume runs from August 25, 1962, to May 6, 1963, a period of a little less than 9 months, with about 121 entries in it.

Mr. CONSTANTINEAU. Yes, sir.

Mr. WELTNER. Entries meaning sales of guns, with a few exceptions, I note, where you purchased a firearm.

The second volume runs from May 6, 1963, to October 14, 1963, about 5 months. The third volume runs from October 15, 1963, to December 27, 1963, a little over 2 months. The fourth volume runs from March 11, 1964, to July 1, 1964, about 4 months.

It was during this period of time that you became a member of the Klan.

Mr. CONSTANTINEAU. Yes, sir.

Mr. WELTNER. The fifth volume of about 120 entries runs from July 1, 1964, to August 22, 1964, 1 month. The sixth volume runs from August 22, 1964, to September 23, 1964, and that also is just about 1 month.

Then it was in this period that you resigned as a member of the Klan. Am I correct?

Mr. CONSTANTINEAU. Yes, sir.

Mr. WELTNER. Then the following volume runs from September 23, 1964, to December 1, 1964, a little less than 2 to 3 months; the next volume from December 1, 1964, to April 17, 1965, 4 months; the next volume from April 17, 1965, to August 28, 1965, about 4 months; and then the following one, which is not yet completed, August 28, 1965, to the present.

It seems to me like during that period of time in which you were a member of the Klan there was a marked increase in the sale of firearms. I am wondering if I am correct in my interpretation of the chronology here and whether or not your membership in the Ku Klux Klan had any reference to or relation to the volume of your business as a dealer in firearms.

Mr. CONSTANTINEAU. That is possible. In the gun business it usually is that business starts increasing about July and carries on through to about mid-September and then tapers off until the following year.

Mr. WELTNER. So there is a seasonal upswing in sales at any rate?

Mr. CONSTANTINEAU. Yes, sir.

Mr. WELTNER. Whether or not there is any specific connection with any organization?

Mr. CONSTANTINEAU. That is correct.

Mr. WELTNER. Thank you, Mr. Constantineau.

The CHAIRMAN. Mr. Constantineau, thanks again for your appearance. You are discharged.

In other words, you have satisfied the terms of your subpoena.

I am sorry.

Let me say that we appreciate your response to the subpoena. As I indicated yesterday, though you may not have been in the hearing room, there is Federal law which states that if a witness appears before a court, grand jury, petit jury, or a committee of the Congress, he is entitled to protection.

If anybody threatens him, coerces him, molests him, or does anything to him, that person may be punished. It is a criminal offense.

I am going to continue this subpoena; we may require your re-attendance upon further inquiry into your activities in this.

If anyone, and I don't care who he is, in high place, middle place, location—anyone—should, because of your appearance here, do anything to you, threaten you, or your family, I invite you to let me know.

MR. CONSTANTINEAU. All right, sir.

The CHAIRMAN. We are not going to stand for that.

Therefore, the witness is continued under subpoena until January 2, 1966.

The committee will stand in recess until 2:15.

(Subcommittee members present at time of recess: Representatives Willis, Weltner, and Buchanan.)

(Whereupon, at 12:25 p.m., Monday, October 25, 1965, the subcommittee recessed, to reconvene at 2:15 p.m. the same day.)

AFTERNOON SESSION—MONDAY, OCTOBER 25, 1965

(The subcommittee reconvened at 2:25 p.m., Hon. Edwin E. Willis, chairman, presiding.)

(Subcommittee members present: Representatives Willis, Pool, and Weltner.)

The CHAIRMAN. The subcommittee will please come to order.

Mr. Appell, call your first witness for this afternoon.

Mr. APPELL. Mr. Chairman, I would like to call Fred L. Wilson.

The CHAIRMAN. Please raise your right hand, Mr. Wilson.

Do you solemnly swear that the testimony you are about to give will be the truth, the whole truth and nothing but the truth, so help you God?

Did you answer?

Mr. WILSON. Yes, sir.

The CHAIRMAN. Proceed.

TESTIMONY OF FRED L. WILSON, ACCOMPANIED BY COUNSEL, LESTER V. CHALMERS, JR.

Mr. APPELL. State your name for the record.

Mr. WILSON. Fred L. Wilson.

Mr. APPELL. Are you here today in accordance with a subpoena served upon you at 10:30 o'clock a.m. on the 11th day of October 1965 by a deputy United States marshal?

Mr. WILSON. Yes, sir.

Mr. APPELL. Are you represented by counsel?

Mr. WILSON. Yes, sir.

Mr. APPELL. Will counsel please identify himself for the record?

Mr. CHALMERS. I am Lester V. Chalmers, Jr., attorney at law, Room 501, First Federal Building, Raleigh, North Carolina.

(At this point Mr. Buchanan entered the hearing room.)

Mr. APPELL. Mr. Wilson, will you state for the record when and where you were born?

Mr. WILSON. I respectfully decline to answer that question for the reason that I honestly feel my answer might tend to incriminate me in violation of my rights as guaranteed to me by amendments 5, 1, 4, and 14 of the Constitution of the United States of America.

The CHAIRMAN. I direct you to answer that question.

Mr. WILSON. I respectfully decline to answer that question for the reason that I honestly feel my answer might tend to incriminate me in

violation of my rights as guaranteed to me by amendments 5, 1, 4, and 14 of the Constitution of the United States of America.

Mr. POOL. Were you born outside the United States?

(Witness confers with counsel.)

Mr. WILSON. I respectfully decline to answer that question for the reason that I honestly feel my answer might tend to incriminate me in violation of my rights as guaranteed to me by amendments 5, 1, 4, and 14 of the Constitution of the United States of America.

Mr. POOL. I can't see where American citizenship would incriminate you in any way.

(Witness confers with counsel.)

Mr. POOL. That is, unless you were born outside the United States. That might have some bearing on it.

Mr. APPELL. Mr. Wilson, I put it to you as a fact, and ask you to affirm or deny the fact, that you were born on April 27, 1898, in Rowan County, North Carolina.

Mr. WILSON. I respectfully decline to answer that question for the reason that I honestly feel my answer might tend to incriminate me in violation of my rights as guaranteed to me by amendments 5, 1, 4, and 14 of the Constitution of the United States of America.

Mr. APPELL. Mr. Wilson, do you operate a business in Salisbury, North Carolina, known as the Council Street Market?

Mr. WILSON. I respectfully decline to answer that question for the reason that I honestly feel my answer might tend to incriminate me in violation of my rights as guaranteed to me by amendments 5, 1, 4, and 14 of the Constitution of the United States of America.

Mr. APPELL. Mr. Wilson, under the terms of the subpoena served upon you, you were demanded to bring with you and to produce before the committee certain items called for in an attachment to the subpoena, which was made a part of the subpoena. Part 1 reads:

All books, records, documents, correspondence, and memoranda relating to the organization of and the conduct of business and affairs of the Invisible Empire, United Klans, Knights of the Ku Klux Klan of America, Inc., also known as the United Klans of America, Inc., Knights of the Ku Klux Klan, and affiliated organizations, namely, the Alabama Rescue Service, Realm (state) of North Carolina, and Rowan Sportsmen's Club in your possession, custody or control, or maintained by you or available to you as Grand Klabee (Treasurer) Realm (state) of North Carolina, and Klabee (Treasurer) Rowan Sportmen's Club, of the Invisible Empire, United Klans, Knights of the Ku Klux Klan of America, Inc., also known as the United Klans of America, Inc., Knights of the Ku Klux Klan.

I demand that you produce the records called for in part 1 of your subpoena.

(Witness confers with counsel.)

Mr. WILSON. I respectfully decline to deliver to the committee any and all records requested by this subpoena under subpoena dated October 11, 1965, for that information is not relevant and germane to the subject under investigation and the same will not aid the Congress in the consideration of any valid remedial legislation, nor is such inquiry within the scope of that authorized to be investigated by Rule XI of the rules adopted by the 89th Congress, by House Resolution 8, adopted January 4, 1965.

I respectfully decline to deliver to the committee any and all documents and records as demanded by the committee in its subpoena dated

October 11, 1965, for the reason that I honestly feel that to do so, the same might tend to incriminate me in violation of my rights as guaranteed to me by amendments 5, 1, 4, and 14 of the Constitution of the United States of America.

The CHAIRMAN. Mr. Chalmers, as we have all along, let's say it is agreed, I take it, that we hereby enter into the following stipulations: (1) That the witness has been furnished a copy of the chairman's opening statement of October 19, 1965, and that he is familiar with its contents; (2) that the directions of the subpoena to produce the documents called for are made to the witness in the official representative capacity described in the subpoena.

Is that understood?

Mr. CHALMERS. It is so stipulated, Mr. Chairman.

The CHAIRMAN. I therefore order and direct you, Mr. Wilson, to produce the documents called for by the subpoena duces tecum just described.

Mr. WILSON. I respectfully decline to deliver to the committee any and all records requested by this committee under subpoena dated October 11, 1965, for that information is not relevant and germane to the subject under investigation and the same would not aid the Congress in the consideration of any valid remedial legislation, nor is such inquiry within the scope of that authorized to be investigated by Rule XI of the rules adopted by the 89th Congress, by House Resolution 8, adopted January 4, 1965.

The CHAIRMAN. And I take it, Mr. Chalmers, so that there won't be any question about it on your part, or on my part, that wherever in the past stipulations identical to this or in substance like this, meaning the same, wherever you refer to Rule IV you mean what?

Mr. CHALMERS. Rule XI.

The CHAIRMAN. Wherever you refer to what?

Mr. CHALMERS. Wherever I referred to Rule IV previously, it was Rule XI.

Thank you, sir.

Mr. WILSON. I respectfully decline to deliver to the committee any and all documents and records as demanded by this committee in the subpoena dated October 11, 1965, for the reason that I honestly feel that to do so, the same might tend to incriminate me in violation of my rights as guaranteed to me by amendments 5, 1, 4, and 14 of the Constitution of the United States of America.

Mr. APPELL. Mr. Wilson, under part 2 of the subpoena, you are ordered to bring with you and to produce:

All books, records, documents, correspondence, and memoranda in your possession, custody or control, or maintained by or available to you, in your capacity as Grand Klabee (Treasurer) Realm (state) of North Carolina, and Klabee (Treasurer) Rowan Sportmen's Club of the United Klans of America, Inc., Knights of the Ku Klux Klan, which the "Constitution and Laws" of said organization authorize and require to be maintained by you and any officer of said organization, the same being in your possession, custody or control.

I now ask that you produce those documents.

Mr. WILSON. I respectfully decline to deliver the committee any and all records requested by this committee under subpoena dated October 11, 1965, for that information is not relevant and germane to the subject under investigation and the same would not aid the

Congress in the consideration of any valid remedial legislation, nor is such inquiry within the scope of that authorized to be investigated by Rule XI of the rules adopted by the 89th Congress, by House Resolution 8, adopted January 4, 1965.

I respectfully decline to deliver to the committee any and all documents and records as demanded by the committee in the subpoena dated October 11, 1965, for the reason that I honestly feel that to do so, the same might tend to incriminate me in violation of my rights as guaranteed to me by amendments 5, 1, 4, and 14 of the Constitution of the United States of America.

The CHAIRMAN. Mr. Chalmers, without the necessity of repetition, it is agreed that the same stipulation in two parts we just entered into would apply to this paragraph of the subpoena?

MR. CHALMERS. Yes, sir.

The CHAIRMAN. Mr. Wilson, I therefore order and direct you to produce those documents.

MR. WILSON. I respectfully decline to deliver to the committee any and all records requested by this committee under subpoena dated October 11, 1965, for that information is not relevant and germane to the subject under investigation and the same would not aid the Congress in the consideration of any valid remedial legislation, nor is such inquiry within the scope of that authorized to be investigated by Rule XI of the rules adopted by the 89th Congress, by House Resolution 8, adopted January 4, 1965.

MR. POOL. Mr. Wilson—

MR. CHALMERS. He has not completed his answer.

MR. WILSON. I respectfully decline to deliver to the committee any and all documents and records as demanded by the committee in the subpoena dated October 11, 1965, for the reason that I honestly feel that to do so, the same might tend to incriminate me in violation of my rights as guaranteed to me by amendments 5, 1, 4, and 14 of the Constitution of the United States of America.

MR. POOL. Mr. Wilson, as you have heard previously, your counsel and our chairman have set up stipulations that show we are in disagreement as to whether or not you should bring these documents and produce them to this committee.

I want to tell you, as a member of this committee, speaking only for myself, that your action by refusing to produce these documents here under a valid subpoena, and under that I consider the case law in our favor, that I am going to vote in committee to cite you for contempt of Congress. I am speaking for myself. I don't know what the rest of the committee will do. But that is the way I feel about it.

You can go ahead and answer if you want to or say anything you want to right now. But that is what you are up against. That is a statement. I did not ask for an answer. If you want to answer, I will be glad to hear it. But this is dead serious business and I am trying to be fair with you by stating it that way.

The other day I read some case law to one of the other witnesses. Your lawyer disagrees with the effect of that decision. But in my mind I am convinced that it applies to you and it applies to your action here today in refusing to bring these records in here to this

committee and let the people of America as well as Congress know what is in those records.

I think the Congress has a right to know it. I think you are in contempt of Congress if you do not produce them. I am telling you I am trying to be fair to you.

The CHAIRMAN. All right, Mr. Appell.

Mr. APPELL. Under part 3 of your subpoena, Mr. Wilson, you were ordered to bring with you and to produce:

Copies of U.S. Treasury Department, Internal Revenue Service, Form 1040 [which is titled], "U.S. Individual Tax Return," for the calendar years 1958 through 1964, filed by you as an individual taxpayer with the U.S. Treasury Department, Internal Revenue Service.

I ask that you produce these documents.

Mr. WILSON. I respectfully decline to deliver to the committee any and all records as requested by this committee under subpoena dated October 11, 1965, for that information is not relevant and germane to the subject under investigation and the same would not aid Congress in the consideration of any valid remedial legislation, nor is such inquiry within the scope of that authorized to be investigated by Rule XI of the rules adopted by the 89th Congress, by House Resolution 8, adopted January 4, 1965.

I respectfully decline to deliver to the committee any and all documents and records as demanded by the committee in its subpoena dated October 11, 1965, for the reason that I honestly feel that to do so, the same might tend to incriminate me in violation of my rights as guaranteed to me by amendments 5, 1, 4, and 14 of the Constitution of the United States of America.

The CHAIRMAN. Proceed.

Mr. APPELL. Mr. Wilson, the committee made certain inquiries of the U.S. Treasury Department with respect to application by one Fred Lee Wilson, of Salisbury, North Carolina, for the purchase of wagering tax stamps. The Treasury Department advised the committee that their records show that Fred Lee Wilson purchased stamps for the fiscal years ended June 30, 1964, and June 30, 1965.

Is that information factual?

Mr. WILSON. I respectfully decline to answer that question for the reason that I honestly feel my answer might tend to incriminate me in violation of my rights as guaranteed to me by amendments 5, 1, 4, and 14 of the Constitution of the United States of America.

(Witness confers with counsel.)

Mr. APPELL. Mr. Wilson, were you ever convicted for violating North Carolina lottery laws?

Mr. WILSON. I respectfully decline to answer that question based upon the grounds previously stated.

Mr. APPELL. Mr. Wilson, I put it to you as a fact, and ask you to affirm or deny the fact, that on June 27, 1960, you were convicted for violating the lottery laws in the sale and distribution of tip boards; that you were sentenced to 6 months in the Rowan County Jail, which sentence was suspended upon the payment of a \$200 fine, and that you be on your good behavior and not violate lottery laws of North Carolina for 2 years.

I ask you to affirm or deny the fact as I have read it to you.

Mr. WILSON. I respectfully decline to answer that question based upon the grounds previously stated.

The CHAIRMAN. Wait a moment, unless this question be misunderstood.

Is it not a fact, Mr. Wilson, that according to the tenets of the Klans which, in the open, they proclaim, they are against gambling, drinking, and the like?

Mr. WILSON. I respectfully decline to answer that question based upon the grounds previously stated.

The CHAIRMAN. This is a chance to speak out, Mr. Wilson, because this involves your veracity under oath. I am not directing you to answer. I am describing at least two grounds of pertinency in the question.

Proceed.

Mr. APPELL. Mr. Wilson, Investigator McConnon, of our staff, in reporting an interview with Mr. Arthur C. Leonard, reported that Mr. Arthur C. Leonard advised him that you were the State treasurer as of October 12, 1965.

Is this information reported by the investigatory staff factual?

Mr. WILSON. I respectfully decline to answer that question based upon the grounds previously stated.

Mr. APPELL. Mr. Wilson, I hand you a signature card drawn on the Wachovia Bank and Trust Company, Salisbury, North Carolina, dated May 13, 1965, in the name of the United Klans of America, Inc., containing three signatures with the notation "2 sig's required," the three names being James R. Jones, Donald E. Leazer, and Fred L. Wilson, care of James R. Jones, mail address: P.O. Box 321, Granite Quarry, North Carolina.

In handing you this I put it to you as a fact, and ask you to affirm or deny the fact, that this is the official signature card covering a United Klans of America bank account at the Wachovia Bank and Trust Company, Salisbury, North Carolina.

(Witness confers with counsel.)

Mr. WILSON. I respectfully decline to answer that question based upon the grounds previously stated.

(Document previously marked "Donald Leazer Exhibit No. 3." See p. 1894.)

Mr. POOL. Are you through with this trying to establish the fact he is treasurer?

Mr. APPELL. Yes, sir.

Mr. POOL. Mr. Wilson, did you file income tax returns for yourself individually or in your representative capacity as treasurer of this Klavern? No, you were grand klabee of the Realm of North Carolina, UKA. Did you file income tax returns for that organization?

Mr. WILSON. I respectfully decline to answer that question based upon the grounds previously stated.

Mr. POOL. Did you file individual income tax returns?

Mr. WILSON. I respectfully decline to answer that question based upon the grounds previously stated.

Mr. APPELL. Mr. Wilson, the bank account to which we are referring shows that starting with the deposit of May 13, 1965, and con-

cluding with the deposit of September 19, 1965, there was deposited to this account in the form of cash——

The CHAIRMAN. And the account is in the name of what?

Mr. APPELL. The United Klans of America, Inc., care of James R. Jones.

—there was deposited to this account in the form of coins and currency \$15,404.45. There was deposited to this account in the form of checks \$1,498.92, making a total deposit of \$16,903.37.

Would you tell the committee the source from which these funds were derived?

Mr. WILSON. I respectfully decline to answer that question based on the grounds previously stated.

(Bank records previously marked "James Jones Exhibit No. 7-A.")

The CHAIRMAN. You have been questioned and it has been established that you were the treasurer, the man handling the money for the Realm of North Carolina. I ask you this question: Did you deposit to this account or any other bank account all the funds handled by you in connection with the activities of the United Klans of America, Realm of North Carolina?

Mr. WILSON. I respectfully decline to answer that question based upon the grounds previously stated.

Mr. APPELL. Mr. Wilson, I hand you an envelope containing 12 checks of \$150 each for a total of \$1,800, made payable to Donald E. Leazer, who Mr. Leonard identified as being the realm secretary.

The CHAIRMAN. I don't think he identified him.

Mr. APPELL. To our investigator.

I ask you if these checks were countersigned by you as payment to Mr. Leazer of a salary from the Realm of North Carolina.

The CHAIRMAN. And those checks are weekly checks or monthly checks?

Mr. APPELL. Approximately weekly, Mr. Chairman. I can read the exact dates of them if you want me to.

Mr. POOL. The will be going into the record anyway.

Mr. WILSON. I respectfully decline to answer that question based upon the grounds previously stated.

(Checks previously marked "James Jones Exhibit No. 7-F." See p. 1721.)

Mr. APPELL. I show you a series of checks drawn on the United Klans of America, Wachovia Bank and Trust, made payable to M. R. Kornegay. These checks are July 5, July 10, July 16, July 23, August 1, August 6, August 14, and August 20.

The CHAIRMAN. 1965?

Mr. APPELL. 1965.

And all of these checks are countersigned James R. Jones and Donald E. Leazer, except the last one of August 20, 1965, countersigned James R. Jones and Fred L. Wilson.

Were those checks issued in payment to Mr. Leazer as a paid employee of the United Klans of America—I mean to Mr. Kornegay?

(Documents handed to witness.)

Mr. WILSON. I decline to answer that question based on the grounds previously stated.

(Checks previously marked "James Jones Exhibit No. 7-E." See p. 1721.)

The CHAIRMAN. Is that the same Kornegay who appeared here last week?

Mr. APPELL. Yes, sir.

Mr. POOL. What is the amount?

Mr. APPELL. Eight checks at \$150 each, for a total of \$1,200.

The CHAIRMAN. Let the reporter note a thing which I have repeated from time to time, that all documents exhibited to and discussed with this witness, as well as others this morning, will be received in evidence at the respective points where they were exhibited or discussed.

Mr. APPELL. Mr. Wilson, I note that in reviewing checks payable to Mr. Kornegay, that I have exhibited to you, and checks payable to Donald E. Leazer, that there are seven checks in the amount of \$150 each and one in the amount of \$100, payable to George Dorsett. There are 16 checks of \$150, totaling \$2,400—

The CHAIRMAN. For what period? That is, from the first to the last.

Mr. APPELL. The earliest in the case of Grady Mars, who received 16 checks, the first check was June 4, and the last was September 17 (James Jones Exhibit No. 7-D, p. 1720). In the case of George Dorsett, the first check was 7-23-65 and the last was 9-17 (James Jones Exhibit No. 7-B, p. 1720). In the case of Donald Leazer, the first check was July 2 and the last was September 17 (James Jones Exhibit No. 7-F, p. 1721). In the case of Kornegay (James Jones Exhibit No. 7-E, p. 1721), who, Mr. Chairman, the record discloses became Grand Dragon for the Realm of Virginia, it was July 5 through August 20, all of the year 1965.

I notice in reviewing these checks, Mr. Wilson, that some are signed by you as the comaker on the bottom line; some on the top line. Do you sign checks in blank and turn them over to Mr. Jones?

Mr. WILSON. I respectfully decline to answer that question based on the grounds previously stated.

The CHAIRMAN. Mr. Wilson, without implying that it would violate your charter and bylaws as to which I am uninformed, I ask you this question: Are the officials, including yourself, of the United Klans of America, appearing before this committee, receiving expenses for your attendance here, as distinguished from the others who have not as high a title in the organization?

Mr. WILSON. I respectfully decline to answer that question based upon the grounds previously stated.

Mr. APPELL. Mr. Wilson, the committee's investigation established that in December 1958, or early January 1959, that you were expelled from the Salisbury Klavern for the nonpayment of dues. Is this information factual, sir?

Mr. WILSON. I respectfully decline to answer that question based on the grounds previously stated.

Mr. APPELL. Mr. Wilson, I hand you a form of membership card used by the U.S. Klans. I ask you if you held a membership card similar to that while you were a member?

(Witness confers with counsel.)

Mr. WILSON. I respectfully decline to answer that question based on the grounds previously stated.

(Document marked "Fred Wilson Exhibit No. 1" follows:)

FRED WILSON EXHIBIT NO. 1

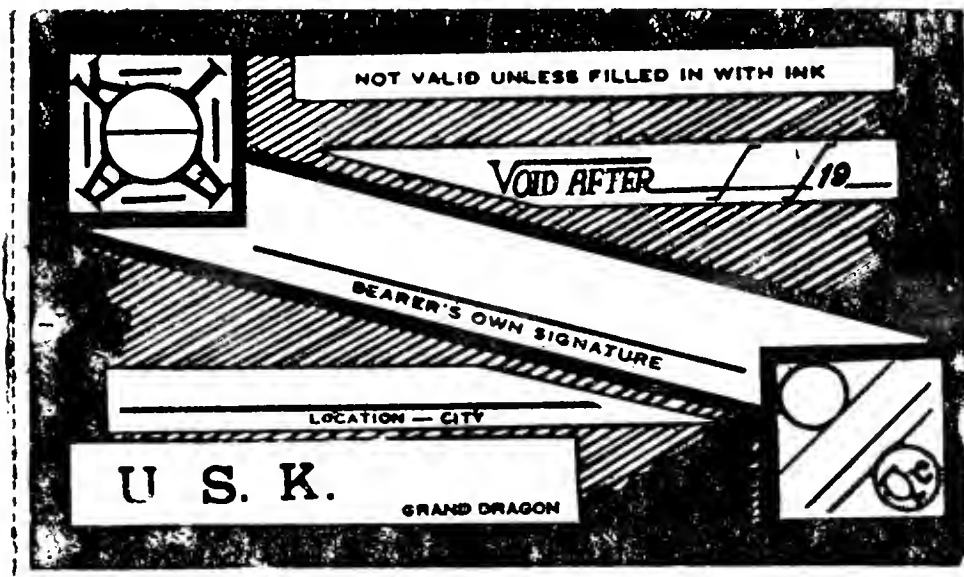

Mr. APPELL. The committee's investigation determined that even back in the days of the U.S. Klans a man's membership card and a man was known within his Klavern by a number and by a name, and that within the Realm of North Carolina under the U.S. Klans the number assigned to a Klan member was a 200-series dash, and then a third set of numerals. I ask you if your number was 200-001?

Mr. WILSON. I respectfully decline to answer that question based upon the grounds previously stated.

Mr. APPELL. I ask you if the card that you now carry as a member of the United Klans of America, distinguished from an officer of the realm, is identical to this card except adapted to apply to the United Klans of America rather than the U.S. Klans.

Mr. WILSON. I respectfully decline to answer that question based upon the grounds previously stated.

Mr. APPELL. Do you still carry the number 1?

Mr. WILSON. I respectfully decline to answer that question based upon the grounds previously stated.

The CHAIRMAN. Is it not a fact, Mr. Wilson, that when Mr. Shelton and his group formed the United Klans of America and broke away from the U.S. Klans, that there was quite some competition for the old membership of the U.S. Klans, and at the prodding or persuasion of Mr. Shelton and his entourage, a great number, including yourself, belonging to the old organization, then shifted to the Shelton organization?

Mr. WILSON. I respectfully decline to answer that question based upon the grounds previously stated.

Mr. POOL. Mr. Wilson, I have been sitting here watching your appearance. You impress me as a man who is not afraid to say anything. I want to ask you this: Have you been threatened in any manner about your testimony here before this committee today?

Mr. WILSON. I respectfully decline to answer that question based upon the grounds previously stated.

Mr. POOL. This is your chance, if that has happened to you, this would be your chance to lay it on the line. The committee would take appropriate action to see to it that these threats would not be carried out. I am just trying to give you a chance. That has been the impression you have given me since you sat down at the table there.

Mr. APPELL. Mr. Wilson, were you again this year elected to the position of klabee or treasurer of the Realm of North Carolina, United Klans of America?

Mr. WILSON. I respectfully decline to answer that question based upon the grounds previously stated.

Mr. APPELL. I hand you a franchise tax report filed with the State of North Carolina, signed by James R. Jones, Grand Dragon, North Carolina, dated July 20, 1965. I ask you if you are the F. L. Wilson, Salisbury, North Carolina, listed by Mr. Jones as the organization's treasurer.

Mr. WILSON. I respectfully decline to answer that question based upon the grounds previously stated.

(Document previously marked "Donald Leazer Exhibit No. 1." See pp. 1891, 1982.)

Mr. APPELL. Mr. Jones sets forth in this document that the officers of the Invisible Empire, United Klans, Knights of the Ku Klux Klan of America, Inc., in North Carolina, having a Post Office Box of 321, Granite Quarry, were himself as president, with an address at Granite Quarry, North Carolina; G. B. Mars, with an address of Warrenton, North Carolina, vice president; with D. E. Leazer, of Salisbury, North Carolina, as secretary; and F. L. Wilson, Salisbury, North Carolina, as treasurer.

I put it to you as a fact, and ask you to affirm or deny the fact, that these are are current officers of the Realm of North Carolina.

Mr. WILSON. I respectfully decline to answer that question based upon the grounds previously stated.

Mr. APPELL. Mr. Wilson, the committee's investigation established that during the month of February and in the month of September 1964 the United Klans of America, under the cover name of Alabama Rescue Service, held two klonvokations or conventions at the Dinkler-Tutwiler Hotel in Birmingham, Alabama.

I hand you copies of two registration cards, one of February 8, signed Fred L. Wilson, 610 Little, Salisbury, one of September 2, 1964, Mr. and Mrs. Fred Wilson, 610 Little, Salisbury, North Carolina.

I put it to you as a fact, and ask you to affirm or deny the fact, that these are true copies of your signature as applied to the registration card when you registered at the Dinkler-Tutwiler Hotel in Birmingham, Alabama, on the dates indicated.

Mr. WILSON. I respectfully decline to answer that question based upon the grounds previously stated.

(Documents marked "Fred Wilson Exhibits Nos. 2-A and 2-B," respective, follow:)

FRED WILSON EXHIBIT No. 2-A

440-42 WILSON FRED & MRS 10-40 65403

H 65403

N-W 9/2 SALISBY N C

PLEASE CHECK YOUR BAGGAGE OR SEND SAME TO YOUR ROOM: OTHERWISE THE HOTEL COMPANY WILL NOT BE RESPONSIBLE FOR LOSS

2 41 PM
SEP

Dinkler-Tutwiler

DIRECTION
DINKLER HOTEL CORPORATION
"DISPENSERS OF TRUE SOUTHERN HOSPITALITY"

GUESTS ARE HEREBY NOTIFIED THAT THE COMPANY WILL NOT BE RESPONSIBLE FOR VALUABLES, MONEY, JEWELRY, CLOTHING ETC. UNLESS THE SAME ARE DEPOSITED IN SAFE

Name Mr & Mrs Fred Wilson
 Street 610 Little Salisbury State N.C.
 City Salisbury State N.C.
 Room No. 440-42 Rate 10.40 Clerk

BMTWTFS

FRED WILSON EXHIBIT No. 2-B

1232 WILSON FRED L 7-28 47923

H 47923

F-BA2//8 SALISBURY N C

PLEASE CHECK YOUR BAGGAGE OR SEND SAME TO YOUR ROOM: OTHERWISE THE HOTEL COMPANY WILL NOT BE RESPONSIBLE FOR LOSS.

Dinkler-Tutwiler

DIRECTION
DINKLER HOTEL CORPORATION
"DISPENSERS OF TRUE SOUTHERN HOSPITALITY"

GUESTS ARE HEREBY NOTIFIED THAT THE COMPANY WILL NOT BE RESPONSIBLE FOR VALUABLES, MONEY, JEWELRY, CLOTHING ETC. UNLESS THE SAME ARE DEPOSITED IN SAFE

Name Fred L Wilson N.C.
 Street 610 Little City Salisbury State N.C.
 City Salisbury State N.C.
 Room No. 1232 Rate 7.00 Clerk

BMTWTFS

Mr. APPELL. I put it to you as a fact, and ask you to affirm or deny the fact, that at the February klonvokation Robert Thompson from Georgia was elected Imperial Klaliff, or vice president; W. L. Perkins, Tuscaloosa, Alabama, was elected Imperial Kligrapp or secretary; and that Fredrick Smith of Tuscaloosa, Alabama, was elected Imperial Klabee or treasurer. I ask you to affirm or deny that.

Mr. WILSON. I respectfully decline to answer that question upon the grounds previously stated.

Mr. APPELL. I put it to you as a fact that, at the September klonvokation, Robert Shelton was unopposed in reelection for the office of Imperial Wizard; that Robert Collins, of Birmingham, was elected Imperial Klokard; that George Dorsett of Greensboro, North Carolina, was elected Imperial Kludd; that R. Hudgins, of Raleigh, North Carolina, was elected Imperial Kladd; that Walter Brown, of Sumter, South Carolina, was elected Imperial Klarogo; and that Robert Korman, of Florida, was elected Imperial Klexter.

I ask you to affirm or deny that.

Mr. WILSON. I respectfully decline to answer that question based upon the grounds previously stated.

Mr. APPELL. Mr. Wilson, the committee obtained through subpoena duces tecum the bank account of the United Klans of America from the Security Bank and Trust Company in Salisbury, North Carolina. Included in these documents were documents that are signature cards which were introduced into the record this morning during the appearance of Mr. Arthur C. Leonard.

I hand you each of these cards and put it to you as a fact, and ask you to affirm or deny the fact, that these signature cards were authorized by the Klavern and that the current signature card lists Fred L. Wilson as treasurer, with the two other authorized signatures as W. R. McCubbins and Wayne Dayvault. I ask you to affirm or deny it.

Mr. WILSON. I respectfully decline to answer that question based upon the grounds previously stated.

(Documents previously marked "Arthur Leonard Exhibits Nos. 1-A through 1-D." See pp. 1902-1905.)

Mr. APPELL. Mr. Wilson, I hand you checks drawn against this account, all payable to the United Klans of America or James R. Jones or J. R. Jones, all containing your signatures as one of the co-signers, and I put it to you as a fact, and ask you to affirm or deny the fact, that these checks were drawn in the official capacity of the organization as an affiliate of the United Klans of America, Inc.

The CHAIRMAN. How many checks are you handing him?

Mr. APPELL. Ten, sir.

The CHAIRMAN. What is the date of the first and the last?

Mr. APPELL. The first is September 18, 1963, and the last that is in this group is August 24, 1964.

Mr. WILSON. I respectfully decline to answer that question based upon the grounds previously stated.

Mr. APPELL. Mr. Chairman, I would like for the record to show that the check—well, I will not worry about the sequence, Mr. Chairman.

A check dated February 13, 1964, made payable to the United Klans of America, is endorsed United Klans of America, and reendorsed James R. Jones, in the amount of \$15; check of February 13, 1964, in the amount of \$16, the purpose for which drawn is State dues, made payable to James R. Jones, endorsed James R. Jones, with a further endorsement, "For deposit only" at the Rowan Telephone Co., Inc.

The CHAIRMAN. What?

Mr. APPELL. A telephone company, incorporated, of Granite Quarry, but I cannot tell what the official and full name of the telephone company is.

The CHAIRMAN. For deposit to whose account?

Mr. APPELL. The telephone company account.

A check dated March 5, 1964, in the amount of \$17.25, marked "Feb. Dues," deposited as a payment of a loan which Mr. and Mrs. Jones had at the Wachovia Bank and Trust Company, Salisbury, North Carolina; a check in the amount of \$14.50 made payable to J. R. Jones for State dues, endorsed J. R. Jones, reendorsed for deposit to the account of the Suburban Printing Company; a check of August 24, 1964, to J. R. Jones, in the amount of \$22, endorsed J. R. Jones, reendorsed for deposit in Suburban Printing Company; a check dated January 7, 1964, to James R. Jones, \$16, N.C. tax.

I can make it clearer now, Mr. Chairman, the telephone company. It is endorsed James R. Jones, for deposit only to the account of the Eastern Rowan Telephone Company.

A check in the amount of \$15 to J. R. Jones, dated December 11, 1963, the purpose for which drawn being State tax, endorsed J. R. Jones, with the further endorsement "Deposit Only Food Town #4, Salisbury, N.C."

A check dated November 6, 1963, in the amount of \$15, endorsement of James R. Jones, and the second endorsement of an individual whose name cannot be read, but it shows it was not deposited into either of Mr. Jones' many bank accounts; a check dated October 9, 1963, payable to J. R. Jones, \$13.50, State tax, endorsed J. R. Jones and further with the second endorsement of Jesse L. Corriher, who is an official of the Klavern to which Mr. Wilson belongs; a check dated September 18, 1963, to J. R. Jones, \$12.50, N.C. tax endorsed J. R. Jones, reendorsed by Mrs. Melvin Barringer, and deposited to the account of Stillers & Son, General Store.

The CHAIRMAN. And the point you are making is what?

Mr. APPELL. The point I am making, Mr. Chairman, is that while we have three bank accounts of the United Klans of America, one of which includes the personal account of Mr. and Mrs. Jones, to whom we have established that tax money from Klaverns is deposited, that a detailed examination of those accounts does not reflect all of the money paid to Mr. Jones because, as is evident from this, some checks are cashed at other places for other purposes.

The CHAIRMAN. And do not go either to the Jones' personal account or the Klan account?

Mr. APPELL. Right, sir.

The CHAIRMAN. Those, of course, would constitute income.

Mr. APPELL. Yes, sir.

The CHAIRMAN. That is, if what you say is correct.

Mr. APPELL. Yes, sir.

(Checks marked "Fred Wilson Exhibits Nos. 3-A through 3-J," respectively. Exhibit 3-A follows; balance retained in committee files:)

FRED WILSON EXHIBIT NO. 3-A

355
66 928
951

UNITED KLANS OF AMERICA, INC.
KNIGHTS OF K. K. K.

DATE Feb 13, 1964

Pay to the order of *United Klans of America, Inc.*

10000

UNITED KLANS OF AMERICA, INC.

Fred Wilson

POB McCallens (S.C.)

DOLLARS

SECURITY BANK & TRUST CO
SPRINGERS, NORTH CAROLINA

⑆053⑆0948⑆

United Klans of America, Inc.
James R. Jones

BANK OF AMERICA

SECURITY BANK & TRUST CO

FEB 27 1964

SECURITY BANK & TRUST CO

Mr. APPELL. Mr. Wilson, I now show you a check dated February 23, 1965, United Klans of America, in the amount of \$57.99, with the purpose for which drawn not shown—

The CHAIRMAN. Before that, some of these checks, 16, I think, in number, were any or all or part of them signed by Mr. Wilson?

Mr. APPELL. Every one, Mr. Chairman, contained Mr. Wilson as one of the signators.

The CHAIRMAN. All right, Mr. Wilson, I ask you: Did you know that the checks which you signed and which are now exhibited and being offered for the record were used by Mr. Jones for purposes not connected with Klan activities?

Mr. WILSON. I respectfully decline to answer that question based upon the grounds previously stated.

Mr. APPELL. Mr. Wilson, I hand you this check dated February 23, 1965, United Klans of America being the organization listed on the line of "Pay to the Order of" and it is cosigned by Fred L. Wilson and W. R. McCubbins. I invite your attention to the reverse thereof where you find the endorsement "United Klans of America, Rowan Sportsmen's Club, Fred L. Wilson, Treasurer."

Wasn't this check a part of the deposit which closed out the old account in the name of the United Klans of America and used to start the new account in the name by which the Klavern is now known, namely, Rowan Sportsmen's Club?

(Check marked "Fred Wilson Exhibit No. 4" and retained in committee files.)

Mr. WILSON. I respectfully decline to answer that question based upon the grounds previously stated.

Mr. APPELL. Mr. Wilson, I hand you a total of seven checks—let me take them one at a time.

I hand you a check dated September 19, 1964, made payable to the order of Fred Wilson in the amount of \$225, with the purpose for which drawn being reimbursement.

Can you advise the committee in what way you were reimbursed?

Mr. WILSON. I respectfully decline to answer that question based upon the grounds previously stated.

Mr. APPELL. I show you a check dated April 20, 1964, payable to Fred L. Wilson in the amount of \$95.85, with the purpose for which drawn being "Building Fund." Was the \$225 to you and this \$95.85 a means whereby the Klavern reimbursed you for money which you advanced to permit them to buy a place in which the Klavern would hold its meetings?

Mr. WILSON. I respectfully decline to answer that question based upon the grounds previously stated.

Mr. APPELL. There are five more checks, Mr. Wilson, payable to you either prior to the change of the name to the Rowan Sportsmen's Club and since the change. Would you examine these checks and advise the committee the purpose for which these checks were drawn payable to you?

(Documents handed to witness.)

Mr. WILSON. I respectfully decline to answer that question based upon the grounds previously stated.

(Checks marked "Fred Wilson Exhibits Nos. 5-A through 5-G," respectively. Exhibits 5-A and 5-G follow; balance retained in committee files:)

FRED WILSON EXHIBIT NO. 5-A

UNITED KLANS OF AMERICA, INC.
KNIGHTS OF K K K

373

DATE *Sept 19 1964*

Pay to the order of *Fred Wilson*

Two Hundred Twenty Five ————— *00*

For *Reimbursement*

SECURITY BANK & TRUST CO.
SPENCER, NORTH CAROLINA

UNITED KLANS OF AMERICA, INC.
Fred S. Wilson

10531-09481

FRED WILSON EXHIBIT NO. 5-G

ROWAN SPORTSMEN'S CLUB

28

DATE *7/20 1965*

Fred S. Wilson

Eighteen ————— *00*

SECURITY BANK & TRUST CO.
SPENCER, NORTH CAROLINA

ROWAN SPORTSMEN'S CLUB
Fred S. Wilson

10531-09481

The CHAIRMAN. Were these checks made payable to you and did you cash them for personal use or for Klan activities duly authorized?

Mr. WILSON. I respectfully decline to answer that question based upon the grounds previously stated.

Mr. APPELL. Mr. Wilson, early in the year 1965 a State meeting was held in North Carolina at which the officers, including yourself, were elected. It is the committee's information that Grand Dragon Jones, in the course of a discussion, brought up Raymond Mills, and the fact that he had been arrested in the bombings in New Bern.

I ask you if it is a fact, I put it to you as a fact, and ask you to affirm or deny the fact, that he reported that Mills had not been banished, and asked all units to help financially.

Mr. WILSON. I respectfully decline to answer that question based upon the grounds previously stated.

Mr. APPELL. Did he request at that same time that all moneys for the defense of Raymond Mills be sent to Mr. Grady Mars, General Delivery, Warrenton, North Carolina?

Mr. WILSON. I respectfully decline to answer that question based upon the grounds previously stated.

Mr. APPELL. Did you, on the date of April 20, 1965, on an imprinted check of the Rowan Sportsmen's Club, countersign the check along with Wayne Dayvault, in the amount of \$26.60, made payable to Grady B. Mars, and the purpose for which paid marked as "Defence Fund"?

(Document handed to witness.)

Mr. WILSON. I respectfully decline to answer that question based upon the grounds previously stated.

(Check marked "Fred Wilson Exhibit No. 6" follows:)

FRED WILSON EXHIBIT NO. 6

		ROWAN SPORTSMEN'S CLUB	19
		DATE 4/21/65	66949 511
Pay to the order of Grady B. Mars		\$ 26 60	
Twenty six Dollars & $\frac{60}{100}$			DOLLARS
SECURITY BANK & TRUST CO. SPENCER, NORTH CAROLINA		Rowan Sportsmen's Club	
For Defense Fund		Fred Wilson	
		Wayne Dayvault	0000002660

Mr. WELTNER. What was the date of that check?

Mr. APPELL. April 20, 1965.

The CHAIRMAN. Do you know whether Grady Mars did, in fact, remit that amount to Mr. Mills for his defense to the incident he was involved in?

Mr. WILSON. I respectfully decline to answer that question based upon the grounds previously stated.

Mr. WELTNER. What was the date in 1965 when he was arrested?

Mr. APPELL. He was arrested on January 22, 1965, and I think the change of his plea in the trial to guilty was June 3.

Mr. Wilson, I read into the record this morning—

The CHAIRMAN. Wait a moment.

There will appear in the record, I know, that the check made payable to Grady B. Mars was simply endorsed "Grady B. Mars." It bears no other endorsement.

I am not informed as to what it was used for. Here is an opportunity, if you know, to say that Grady B. Mars used the money for the purposes intended. I might tell you, Mr. Wilson, that the committee has information that in certain instances, quite a few, so-called drives for defense funds were made and the funds not given to those accused.

If this is not such a situation, I welcome you to clarify it, if you wish to.

Do you wish to clarify it?

Mr. WILSON. I respectfully decline to answer that question based upon the grounds previously stated.

Mr. APPELL. Mr. Wilson, in the course of this morning's presentation there was an allusion made to the creation of an organization in the spring of 1959 known as the Black Shirts which later joined an organization headed by August W. Holman of Columbia, South Carolina, known as the Chessmen.

Were you a member of that organization, sir?

Mr. WILSON. I respectfully decline to answer that question based upon the grounds previously stated.

Mr. APPELL. Mr. Wilson, on the 28th day of May 1965, a cross was burned, as were many burned throughout the State of North Carolina on that day, at the Health Center in Salisbury. Do you possess any knowledge with respect to this cross-burning?

Mr. WILSON. I respectfully decline to answer that question based upon the grounds previously stated.

Mr. APPELL. As a State officer, do you possess knowledge of any of the cross-burnings carried out on May 28, 1965?

Mr. WILSON. I respectfully decline to answer that question based upon the grounds previously stated.

Mr. APPELL. Are you acquainted with the Grand Dragon of South Carolina, Robert Scoggin?

Mr. WILSON. I respectfully decline to answer that question based upon the grounds previously stated.

Mr. APPELL. Isn't it a fact that you knew him to be the Grand Dragon for the Realm of South Carolina of the U.S. Klans under Imperial Wizard Eldon Edwards?

Mr. WILSON. I respectfully decline to answer that question based upon the grounds previously stated.

Mr. APPELL. Isn't it a fact that you now know him to be Grand Dragon of the Realm of South Carolina under Robert M. Shelton?

Mr. WILSON. I respectfully decline to answer that question based upon the grounds previously stated.

Mr. APPELL. I show you a photograph, the glossy print of one, which appeared in the *Charlotte Observer* of August 30, 1964, and I put it to you as a fact and ask you to affirm or deny the fact that the three men shown, excluding the man on the white horse or the robed horse, are James Robertson Jones, the Grand Dragon of the State of North Carolina; yourself, the treasurer or klabee of the Realm of North Carolina; and Robert Scoggin, although it is here with an s, S-c-o-g-g-i-n-s, the Grand Dragon for the Realm of South Carolina.

Mr. WILSON. I respectfully decline to answer that question based upon the grounds previously stated.

(Photograph marked "Fred Wilson Exhibit No. 7." This exhibit will be reproduced in a forth coming report on Ku Klux Klan organizations.)

Mr. APPELL. Mr. Wilson, without going over this again for the record, because it is already in the record, I wish to show you a report of funds made by Robert Marshall Kornegay relating to the Cadillac which the Klaverns financed and which Mr. Jones is now driving. I ask you to give me the identity of the secretary who transmitted the funds from each of the Klaverns enumerated on this list.

(Document handed to witness.)

Mr. WILSON. I respectfully decline to answer that question based upon the grounds previously stated.

(Document previously marked "James Jones Exhibit No. 18-A." See p. 1746.)

Mr. APPELL. Mr. Chairman, I would like the record to show that there appeared on the check stub of the records turned over to us last week by Joseph DuBois, of the Wayne County Improvement Association, that a check was written from that account on September 14, 1964, in the amount of \$120, the purpose for which drawn being membership fees through 9-14-64.

I show you the check, Mr. Wilson, and ask you whether that represents a remittance to the State from the membership fees—to the realm—or the portion of member initiation fees which is reportable to the realm.

(Document handed to witness.)

Mr. WILSON. I respectfully decline to answer that question based upon the grounds previously stated.

(Check marked "Fred Wilson Exhibit No. 8" follows:)

FRED WILSON EXHIBIT NO. 8

WAYNE COUNTY IMPROVEMENT ASSOCIATION
P. O. BOX 1011
GOLDSBORO, NORTH CAROLINA

9-14-64

86.075
312

PAY TO THE ORDER OF *J. R. Jones* \$120.00

One Hundred Twenty Dollars

WACHOVIA BANK AND TRUST COMPANY
GOLDSBORO, NORTH CAROLINA

Wayne Co. Imp. Assn.
Relat. Beg. 9/14/64
10000087000

⑆0512⑆0875⑆ 6⑆750⑆852⑆

Printed 9-55-64

Mr. APPELL. Mr. Chairman, I wish to point out for the record that also in the records from the Wayne County Improvement Association there is a check dated August 2, 1965, in the amount of \$66.50 to the Alabama Rescue Service marked "Dues" and on the same date a check to J. R. Jones in the amount of \$33.25 marked "Dues."

If, Mr. Chairman, we take the 25 cents per member which at that time was paid to the State, and 50 cents per member which was due as the imperial share of the dues, the Wayne County Improvement Association as of that date had 133 members.

(Documents marked "Fred Wilson Exhibits Nos. 9-A and 9-B," respectively, and retained in committee files.)

The CHAIRMAN. Is that Mr. DuBois' unit?

Mr. APPELL. Yes, sir.

Mr. POOL. Go over that again. Mr. Jones got how much?

Mr. APPELL. Mr. Jones got \$33.25. To the Alabama Rescue Service you double that amount, \$66.50, and at the rate of 25 cents per member on the realm level, or 50 cents per member on the imperial level, the membership of the Klavern as of the period that this covers was 133.

Mr. POOL. He wasn't trying to cheat the imperial realm; was he? Did he turn in the exact amount he should have, according to their rules?

Mr. APPELL. Mr. Pool, the treasurer of the Klavern has nothing to do with membership records and he draws the check payable on the basis of what the secretary, who maintains the membership records, advises him is due on the basis of membership.

Mr. POOL. There is no discrepancy at this point between the imperial and the state.

Mr. APPELL. Mr. Wilson, are you also treasurer for the United Klans of America on a bank account maintained at the Farmers & Merchants Bank in the name of the United Klans of America, care of J. R. Jones?

Mr. WILSON. I respectfully decline to answer that question based upon the grounds previously stated.

Mr. APPELL. When, as the record pointed out last week, there were two checks drawn against that account in payment for a truck, do you possess knowledge as to whether or not that truck was titled in the name of the United Klans of America, or in the name of J. R. Jones?

Mr. WILSON. I respectfully decline to answer that question based on the grounds previously stated.

Mr. APPELL. Mr. Wilson, in light of the fact that you are the State treasurer, I give you an opportunity to comment upon a statement made to Roy Heddy, an agent of the Internal Revenue Service, who interviewed Mr. Shelton and Mr. Jones in August of 1965, wherein he was advised by them that the Realm of North Carolina is simply a geographical subdivision of the national charter and is used only to identify a given area, that is, the State of North Carolina. It is not an organization and has no funds, income, or expense; therefore, no returns are due.

Mr. WILSON. I respectfully decline to answer that question based upon the grounds previously stated.

Mr. APPELL. Mr. Chairman, the staff has no further questions of this witness.

The CHAIRMAN. Would you step aside for a moment, Mr. Wilson, but remain in the room? We may call you back.

Mr. CHALMERS. Mr. Chairman, may I just state that my client informed me that he has a severe heart condition and has an appointment with a physician tomorrow with respect thereto. I would like to call that to the chairman's attention. I am certain that the chairman would want to accommodate him in any way possible.

The CHAIRMAN. I made that suggestion at the suggestion of Mr. Weltner, who said he may have some further interrogation.

Do you have further interrogation?

Mr. WELTNER. No, sir; I don't.

The CHAIRMAN. Then the witness will be excused and discharged from his subpoena.

Mr. CHALMERS. Thank you, sir.

The CHAIRMAN. I want to point out, however, Mr. Chalmers, that this is the first knowledge that the Chair or members of the staff have

had concerning Mr. Wilson's condition. It has never been called to our attention before. I don't reproach you or anybody else. I am just stating that as a fact.

Mr. CHALMERS. That is correct, and I am certain that the Chair and no members of the committee had any knowledge of it, sir.

The CHAIRMAN. Call your next witness, Mr. Appell.

Mr. APPELL. Mr. Chairman, I would like to call Grady B. Mars.

The CHAIRMAN. Please raise your right hand.

You do solemnly swear that the testimony you are about to give will be the truth, the whole truth, and nothing but the truth, so help you God?

Mr. MARS. I do.

The CHAIRMAN. And his name is what?

Mr. APPELL. Mr. Mars.

The CHAIRMAN. Grady B. Mars.

Proceed.

TESTIMONY OF GRADY BURDELL MARS,¹ ACCOMPANIED BY COUNSEL, LESTER V. CHALMERS, JR.

Mr. APPELL. Mr. Mars, will you state your full name for the record, please, sir?

Mr. MARS. Grady Burdell Mars.

Mr. APPELL. Would you spell your middle name?

Mr. MARS. B-u-r-d-e-l-l.

Mr. APPELL. As to the other two parts of your name, Grady and Mars, I spelled them properly, G-r-a-d-y, M-a-r-s?

Mr. MARS. That is correct, sir.

Mr. APPELL. Mr. Mars, are you appearing before the committee this afternoon in connection with a subpoena served upon you at 11:40 o'clock a.m. on the 11th day of October 1965?

Mr. MARS. Yes, sir.

Mr. APPELL. Are you represented by counsel?

Mr. MARS. Yes, sir.

Mr. APPELL. Will counsel identify himself for the record?

Mr. CHALMERS. I am Lester V. Chalmers, Jr., attorney at law, Room 501, First Federal Building, Raleigh, North Carolina.

Mr. APPELL. Mr. Mars, when and where were you born?

Mr. MARS. I respectfully decline to answer that question for the reason that I honestly feel my answer might tend to incriminate me in violation of my rights as guaranteed to me by amendments 5, 1, 4, and 14 of the Constitution of the United States of America.

The CHAIRMAN. I order and direct you to answer that question.

Mr. MARS. I respectfully decline to answer that question for the reason that I honestly feel my answer might tend to incriminate me in violation of my rights as guaranteed to me by amendments 5, 1, 4, and 14 of the Constitution of the United States of America.

Mr. APPELL. Mr. Mars, do you receive a monthly income from the Government of the United States?

¹ According to the *Washington Star* of Dec. 15, 1965. Grady Mars committed suicide on Dec. 11 at his home in Granite Quarry, N.C.

Mr. MARS. I respectfully decline to answer that question for the reason that I honestly feel my answer might tend to incriminate me in violation of my rights as guaranteed to me by amendments 5, 1, 4, and 14 of the Constitution of the United States of America.

Mr. APPELL. Are you a retired member of the Armed Forces of the United States?

Mr. MARS. I respectfully decline to answer that question for the reason that I honestly feel my answer might tend to incriminate me in violation of my rights as guaranteed to me by amendments 5, 1, 4, and 14 of the Constitution of the United States of America.

Mr. APPELL. Mr. Mars, I ask you the source of the income reported on numerous deposit slips. I will refer to one of April 1, 1964, which shows a deposit in the amount of \$144.55, and the source of the check being the Treasury.

Mr. MARS. I respectfully decline to answer that question based upon the grounds previously stated.

Document marked "Grady Mars Exhibit No. 1" follows:)

GRADY MARS EXHIBIT NO. 1

DEPOSITED IN
THE CITIZENS BANK
 WARRENTON, N. C.

By Grady B. Mars

April 1, 1964

CURRENCY	Dollars	Cents
Checks on follows:		
<u>Treas.</u>	<u>144</u>	<u>55</u>

Mr. APPELL. Mr. Mars, under the conditions of the subpoena served upon you on October 11, 1964, you were commanded to bring with you and to produce for the committee documents which were set forth on an attachment which was made a part of the subpoena. Part 1 reads:

All books, records, documents, correspondence, and memoranda relating to the organization of and the conduct of business and affairs of the Invisible Empire, United Klans, Knights of the Ku Klux Klan of America, Inc., also known as the United Klans of America, Inc., Knights of the Ku Klux Klan, and affiliated organizations, namely, the Alabama Rescue Service, Realm (State) of North Carolina and New Bern and Blounts Creek Fund, in your possession, custody or control, or maintained by you or available to you as Grand Klaliff (Vice President), and employee Realm (State) of North Carolina and as an officer of the New Bern and Blounts Creek Fund of the Invisible Empire, United Klans, Knights of the Ku Klux Klan of America, Inc., also known as the United Klans of America, Inc., Knights of the Ku Klux Klan.

Mr. MARS. I respectfully decline to deliver to the committee any and all records as requested by this committee under subpoena dated October 11, 1965, for that information is not relevant and germane to the subject under investigation and the same would not aid the Congress in the consideration of any valid remedial legislation, nor is such inquiry within the scope of that authorized to be investigated by Rule XI of the rules adopted by the 89th Congress, by House Resolution 8, adopted January 4, 1965.

I respectfully decline to deliver to the committee any and all documents as demanded by the committee in a subpoena dated October 11, 1965, for the reason that I honestly feel that to do so, the same might tend to incriminate me in violation of my rights as guaranteed to me by amendments 5, 1, 4, and 14 of the Constitution of the United States of America.

The CHAIRMAN. Mr. Chalmers, I take it that the stipulation which we have been entering into all along, namely (1) that the witness has been furnished a copy of the chairman's opening statement of October 19, 1965, and that he is familiar with its contents, and (2) that the direction of the subpoena to produce the documents called for was made to the witness in the official representative capacity described in the subpoena obtains and applies in this case and is hereby entered into between you and me?

Mr. CHALMERS. Yes, sir.

The CHAIRMAN. You, for your client, and me for the committee.

Mr. Mars, I order and direct you to produce the documents testified to, those contained in the subpoena.

Mr. MARS. I respectfully decline to deliver to the committee any and all records as requested by this committee under the subpoena dated October 11, 1965, for that information is not relevant and germane to the subject under investigation and the same would not aid the Congress in the consideration of any valid remedial legislation, nor is such inquiry within the scope of that authorized to be investigated by Rule XI of the rules adopted by the 89th Congress, by House Resolution 8, adopted January 4, 1965.

I respectfully decline to deliver to the committee any and all documents as demanded by this committee in the subpoena dated October 11, 1965, for the reason that I honestly feel that to do so, the same might tend to incriminate me in violation of my rights as guaranteed to me

by amendments 5, 1, 4, and 14 of the Constitution of the United States of America.

Mr. APPELL. Mr. Mars, under part 2 of the subpoena which under the conditions of the subpoena you were to bring with you and produce there are set forth:

All books, records, documents, correspondence, and memoranda in your possession, custody or control, or maintained by or available to you, in your capacity as Grand Klaliff (Vice President) and employee Realm (State) of North Carolina of the United Klans of America, Inc., Knights of the Ku Klux Klan, which the "Constitution and Laws" of said organization authorize and require to be maintained by you and any other officer of said organization, the same being in your possession, custody or control.

I now ask that you produce those documents.

Mr. MARS. I respectfully decline to deliver to the committee any and all records as requested by this committee under subpoena dated October 11, 1965, for that information is not relevant and germane to the subject under investigation, and the same would not aid the Congress in the consideration of any valid remedial legislation, nor is such inquiry within the scope of that authorized to be investigated by Rule XI of the rules adopted by the 89th Congress, by House Resolution 8, adopted January 4, 1965.

I respectfully decline to deliver to the committee any and all documents as demanded by the committee in the subpoena dated October 11, 1965, for the reason that I honestly feel that to do so, the same might tend to incriminate me in violation of my rights as guaranteed to me by amendments 5, 1, 4, and 14 of the Constitution of the United States of America.

The CHAIRMAN. Mr. Chalmers, is it understood that the stipulation we made a moment ago in two parts applies to this part of the demands of the subpoena?

Mr. CHALMERS. It certainly is; yes, sir.

The CHAIRMAN. I order and direct you to produce those documents.

Mr. MARS. I respectfully decline to deliver to the committee any and all records as requested by this committee under subpoena dated October 11, 1965, for that information is not relevant and germane to the subject under investigation and the same would not aid the Congress in the consideration of any valid remedial legislation, nor is such inquiry within the scope of that authorized to be investigated by Rule XI of the rules adopted by the 89th Congress, by House Resolution 8, adopted January 4, 1965.

I respectfully decline to deliver to the committee any and all documents as demanded by the committee in a subpoena dated October 11, 1965, for the reason that I honestly feel that to do so, the same might tend to incriminate me in violation of my rights as guaranteed to me by amendments 5, 1, 4, and 14 of the Constitution of the United States of America.

Mr. APPELL. Mr. Mars, on July 20, 1965, James R. Jones, signing himself Grand Dragon, North Carolina, filed a domestic corporation franchise tax for the Invisible Empire, United Klans, Knights of the Ku Klux Klan of America, Inc.

This document requires a listing of officers and there is listed by Mr. Jones, in Mr. Jones' hand, James R. Jones, Granite Quarry; G. B.

Mars, Warrenton, North Carolina; D. E. Leazer, Salisbury, North Carolina; F. L. Wilson, Salisbury, North Carolina.

I put it to you as a fact, and ask you to affirm or deny the fact, that these are current officers of the United Klans of America, Realm of North Carolina.

(Document handed to witness.)

Mr. MARS. I respectfully decline to answer that question for the reason that I honestly feel my answer might tend to incriminate me in violation of my rights as guaranteed to me by amendments 5, 1, 4, and 14 of the Constitution of the United States of America.

(Document previously marked "James Jones Exhibit No. 2." See pp. 1710-1711.)

Mr. APPELL. Mr. Mars, I hand you checks imprinted with United Klans of America, Inc., P.O. Box 321, Granite Quarry, North Carolina, each in the amount of \$150, dated June 4, June 14, 18, 26; July 5, 10, 16, 23; August 2, 6, 14, 20, 28; September 3, 10, 17; 16 checks at \$150 each marked salary and expenses, a total of \$2400.

These are payable to Grady B. Mars. I put it to you as a fact, and ask you to affirm or deny the fact, that these checks were payable to you as a paid employee of the Realm of North Carolina.

Mr. MARS. I respectfully decline to answer that question based upon the grounds previously stated.

The CHAIRMAN. I take it that you reported these checks on your individual income tax.

Mr. MARS. I respectfully decline to answer that question based upon the grounds previously stated.

Mr. APPELL. Mr. Mars, I hand you back two of these checks and ask you if you can explain to the committee why—

The CHAIRMAN. I am sorry, but it has been called to my attention that these checks were dated in 1965 and are not reportable, therefore, until next year. But take my advice and report them next year.

Mr. APPELL. Mr. Mars, I shall hand you back two of these checks, one dated July 5, 1965, which contains as the first endorsement "Grady B. Mars" and the second endorsement "Syble Jones," and the check of August 2, 1965, payable to Grady Mars, containing the first endorsement "Grady B. Mars" and the second endorsement "J. R. Jones."

I ask you if you can explain to the committee why those checks are so endorsed.

(Documents handed to witness.)

Mr. MARS. I respectfully decline to answer that question based upon the grounds previously stated.

(Check previously marked "James Jones Exhibit No. 7-D." See p. 1720.)

Mr. APPELL. I hand you a check dated April 24, 1965, drawn on the Davidson County Sportsman Club, Lexington, North Carolina, made payable to cash in the amount of \$25.00, endorsed "Grady B. Mars, New Bern & Blounts Creek Fund."

Mr. MARS. I respectfully decline to answer that question based upon the grounds previously stated.

(Check marked "Grady Mars Exhibit No. 2" appears on p. 1951.)

Mr. APPELL. I show you a check drawn, according to the face of the check, by the Harnett County Improvement Association, dated

April 6, 1965, made payable to Grady B. Mars, \$100, with the endorsement "Grady B. Mars."

I ask you whether that was a contribution to the Mills Defense Fund and if it was in fact deposited to that account.

Mr. MARS. I respectfully decline to answer that question based upon the grounds previously stated.

(Check marked "Grady Mars Exhibit No. 3" appears on p. 1952.)

The CHAIRMAN. Mr. Mars, I notice that this check made payable to you was endorsed "Grady B. Mars." You could have cashed it, deposited it to cash, in the Defense Fund, or you could have cashed it and handed the cash to Mr. Mills.

Did you do either or did you keep the money?

Mr. MARS. I respectfully decline to answer that question based upon the grounds previously stated.

Mr. APPELL. Mr. Chairman, we subpoenaed from the First National Bank in Henderson, North Carolina, the records which appeared in an account known only by the name of the Keystone Club, with the co-signers to the account James R. Ranes and Robert L. Reaves.

The Henderson Bank did not have available to it the equipment necessary to reproduce the checks by the Recordak system. They therefore made an individual search and presented us with a series of checks drawn against this account which they certify to be accurate.

One of the checks is dated April 15, 1965, and it is payable to Grady B. Mars, according to the bank, in the amount of \$20.00, and contains only the endorsement "Grady B. Mars." I ask you what disposition was made of that \$20.00, Mr. Mars?

(Document handed to witness.)

Mr. MARS. I respectfully decline to answer that question based upon the grounds previously stated.

(Check marked "Grady Mars Exhibit No. 4" appears on p. 1953.)

Mr. WELTNER. Mr. Appell, that check has no bank stamp on it?

Mr. APPELL. As an individual certification?

Mr. WELTNER. No; bank stamp.

Mr. APPELL. Do you mean the stamp by which the check was deposited, how it got through the system?

Mr. WELTNER. How did that happen to have apparently no bank stamp on the reverse side of the check?

Mr. APPELL. On most of the checks we have received, the bank has taken a film on which the canceled check appears, and has reproduced copies from the film, from the Recordak film.

The Henderson bank was not equipped to do this. Therefore, they made an individual examination of all the items, the debit items, in the account of the Keystone and made up copies which they in transmittal certify to be the copies of the checks drawn against that account.

Mr. WELTNER. So what you have here is simply a conforming copy of the check that cleared through.

Mr. APPELL. That is correct, sir.

Mr. Mars, did you in fact open an account with The Citizens Bank, Warrenton, North Carolina, their branch at the Arcola Rural Station in the name of the New Bern and Blounts Creek Fund?

GRADY MARS EXHIBIT NO. 2

DAVIDSON COUNTY SPORTSMAN CLUB
P. O. BOX 151

NO 3
66 987
597

LEWINGTON N.C.

\$ 25.00

Twenty Five and No/100
DOLLARS

Lewington N.C.
BANK
LEWINGTON N.C.

William T. Young

⑆053⑆⑉0987⑆ 335⑉67⑆ ⑆000000⑆500⑆

John J. ...
...
THE BANK OF COMMERCE
JUN 3 - '65
66-805

66-20
FEDERAL RESERVE BANK
JUN 3 '65
PAY TO THE ORDER OF
FEDERAL RESERVE BANK

GRADY MARS EXHIBIT No. 4

HENDERSON, N.C. 4-15 1945 No.

FIRST NATIONAL BANK

66 142
512

IN HENDERSON

PAY TO THE
ORDER OF

Grady B. Mars

DOLLARS

\$ *26 62*

FOR

*Business Club -
200 1/2 S. 1st St.
Henderson, N.C.*

⑆2770⑆⑆2750⑆⑆

Grady B. Mars

*Virginia Bank - Washington, D.C. April 26
Federal Reserve Bank - Richmond, Va. - April 27
First Nat'l Bank - Henderson, N.C. - April 28*

Mr. MARS. I respectfully decline to answer that question based upon the grounds previously stated.

Mr. APPELL. While this account contained both the names of Grady B. Mars and James R. Jones, I put it to you as a fact, and ask you to affirm or deny the fact, that the signature of Mr. Jones was never added to the signature card.

Mr. MARS. I respectfully decline to answer that question based upon the grounds previously stated.

Mr. APPELL. Mr. Chairman, the records subpoenaed from the bank show that the account was opened with a deposit—

The CHAIRMAN. What is the name of the account?

Mr. APPELL. The New Bern and Blounts Creek Fund.

The CHAIRMAN. What do you make that to be? Do you know? In other words, to be frank about it, do you assume this to be, perhaps, the Mills Defense Fund?

Mr. APPELL. Yes, sir; because as we put into the record last week, a check was drawn against this account in the amount of \$260 which, according to the bank, contains a notation "90 day note, Lonnie R. Mills."

The CHAIRMAN. All right.

Mr. APPELL. The deposit slip furnished us reflects that with the initial deposit of April 26, 1965, there was deposited cash in the amount of \$57.45; a check of \$20.00 designated "Henderson"; \$25.00, Beulaville; \$25.00, Dunn; \$100, Dunn; \$42.11, Fountain, North Carolina; \$26.60, Spencer, North Carolina; \$25.00, Williamston, North Carolina; making a total deposit of \$321.16.

The CHAIRMAN. And what withdrawals?

Mr. APPELL. May I deal with all the deposits first?

The CHAIRMAN. All right.

Mr. APPELL. On May 3 there was deposited the amount of \$137.00, consisting of three checks. I am sorry I cannot read the first location in North Carolina, \$50.00; Durham, North Carolina, \$57.00; Wilmington, North Carolina, \$30.00.

A deposit of May 11, consisting of one or more checks—it is impossible to tell from the deposit slip—totaling \$50.00.

A deposit of May 13, 1965, currency in the amount of \$62.00, and a deposit on June 1, 1965, three checks, each in the amount of \$25.00.

According to the bank records, the check in the amount of \$57.00 which was deposited on May 3, 1965, bounced for insufficient funds.

I hand you again this check, Mr. Mars (Grady Mars Exhibit No. 3), and ask you if this \$100.00 which you received from the Harnett County Improvement Association is the item contained on the initial deposit of April 26 from Dunn marked \$100?

Mr. MARS. I respectfully decline to answer that question based on the grounds previously stated.

(Bank records marked "Grady Mars Exhibit No. 5" and retained in committee files.)

Mr. APPELL. Mr. Chairman, the bank records show, and these records are in the process of being filmed so that we will have the actual item for the record, that as far as withdrawals from this account there were only two. One was a check dated May 3, 1965, which appears to have been made payable to "Wachovia Bank & Trust," signed

by Grady B. Mars, with a notation thereon "90 day note, Lonnie R. Mills, Rt. 2, Vanceboro, N.C." (James Jones Exhibit No. 28, p. 1766.)

There was no other withdrawal from that account until September 9, 1965, when a check was drawn by Mr. Grady B. Mars, and, as the notation from the bank shows, a cashier's check was drawn in the amount of \$328.16, and the purpose for which the check was drawn was to close out the account.

The CHAIRMAN. Mr. Mars, here is an opportunity to explain all that. We have no tricks up our sleeves. Did all that money go to Mills?

Mr. MARS. I respectfully decline to answer that question based upon the grounds previously stated.

The CHAIRMAN. On the face of it all, it looks like at least—how much?

Mr. APPELL. \$260, Mr. Chairman.

The CHAIRMAN. At least one check for \$260 drawn against that account appears, instead of having been given to Mr. Mills for his defense, to have been given to him in exchange for his note.

It looks very bad, unless you explain it. Can you explain that?

Mr. MARS. I respectfully decline to answer that question based upon the grounds previously stated.

Mr. APPELL. Mr. Chairman, Lonnie R. Mills is not the defendant but a relative of the defendant.

The CHAIRMAN. The Mills indicated there is not the defendant?

Mr. APPELL. He is a relative of the defendant, Mr. Chairman.

Mr. WELTNER. The defendant's name is Raymond D. Mills.

The CHAIRMAN. That seems to make it worse.

Go on.

Mr. APPELL. Mr. Mars, by September 5, 1965, Mr. Mills had changed his original not guilty plea to guilty, and had been sentenced by the court. Was the \$328 which, according to the bank records, a cashier's check was drawn for, was that \$328 refunded to the Klaverns that had advanced the money?

Mr. MARS. I respectfully decline to answer that question based upon the grounds previously stated.

Mr. APPELL. What disposition was made of the \$328.16?

Mr. MARS. I respectfully decline to answer that question based upon the grounds previously stated.

The CHAIRMAN. Mr. Mars, I think you better assume we will find out the whole truth about this thing. Here is another opportunity for you to explain, if you want to. Do you want to avail yourself of my new offer for you to explain these transactions?

Mr. MARS. I respectfully decline to answer that question based upon the grounds previously stated.

Mr. APPELL. According to a joint bank account maintained in the names of Grady B. and Mary J. Mars, maintained by The Citizens Bank of Warrenton, North Carolina, we find that on May 8, 1964, a

check was drawn against this private account to Bob Jones in the amount of \$48.00.

Will you advise the committee as to the purpose for which that check was drawn?

Mr. MARS. I respectfully decline to answer that question based upon the grounds previously stated.

(Check marked "Grady Mars Exhibit No. 6" follows:)

GRADY MARS EXHIBIT NO. 6

WARRENTON, NC. 5-8-		1964	NO. 80
THE CITIZENS BANK			
PAY TO THE ORDER OF <u>Bob Jones</u>		\$ 48.00	
<u>Forty Eight Dollars</u>		DOLLARS	
FOR		<u>Grady Mars</u>	
⑆9066-0275⑆			

Mr. APPELL. On June 5, 1964, a check was made payable to James R. Jones for \$16.00. Would you advise the committee the purpose for which that check was drawn?

Mr. MARS. I respectfully decline to answer that question based upon the grounds previously stated.

(Check marked "Grady Mars Exhibit No. 7" and retained in committee files.)

The CHAIRMAN. Mr. Appell, I take it from your analysis of the deposits made in the account, before we move away from it, the account furnished to us by the bank is not in such a shape that you can identify the checks that went into it, and that is why you questioned him about these checks payable to him and simply endorsed? There is no way of checking where the checks that went into that account came from and who deposited them; is that correct?

Mr. APPELL. That is right, Mr. Chairman. We do not have the information.

The CHAIRMAN. All right.

Mr. APPELL. On August 25 there was a check written to James R. Jones in the amount of \$16.00. For what purpose was that check drawn?

Mr. MARS. I respectfully decline to answer that question based upon the grounds previously stated.

(Check marked "Grady Mars Exhibit No. 8" and retained in committee files.)

Mr. APPELL. On January 11, 1965, there was a check payable to Carolina Insurance Agency in the amount of \$14.50. Did you take out an insurance policy under the affiliated group of the Capital City Restoration Association?

Mr. MARS. I respectfully decline to answer that question based upon the grounds previously stated.

(Check marked "Grady Mars Exhibit No. 9" follows:)

GRADY MARS EXHIBIT NO. 9

WARRENTON, NC / - 11 - 1963 NC 67

THE CITIZENS BANK

Carolina Ins Agency S. H. 56

Warrenton - Keelard + 3480

FOR (4874)

Grady Mars Exhibit No. 9

1:9066002751:

M. R. KORNEGAY
 CAROLINA INS AGENCY INC.
 P. O. BOX 9183 - PHONE 332 3952
 RALEIGH, N. C. 27603

M. R. Kornegay

THE CITIZENS BANK

68-1039

WARRENTON, NC

PAID TO ORDER

Mr. APPELL. Mr. Mars, were you, prior to becoming a paid employee of the Realm of North Carolina, the exalted cyclops of a Klavern known as the Warren County Improvement Association?

Mr. MARS. I respectfully decline to answer that question based upon the grounds previously stated.

Mr. APPELL. Mr. Chairman, the Warren County Improvement Association maintains its account at The Peoples Bank in Norlina, North Carolina.

According to vice president of this bank it was impossible for them to even look, to make searches of their records, and they submitted us only those items which they had on hand. They consist of a check payable to J. R. Jones in the amount of \$12.00, dated July 24, 1965, signed by Andrew F. Collins and David A. Hight.

Do you know those gentlemen to be officers of the Harnett County Improvement Association?

Mr. MARS. I respectfully decline to answer that question based upon the grounds previously stated.

(Document marked "Grady Mars Exhibit No. 10" and retained in committee files.)

Mr. APPELL. I ask that the record be corrected to the Warren County Improvement Association.

Mr. Mars, during the course of the committee's investigation it was indicated that you had in your possession or available to you incendiary material. Is this information obtained during our investigation true or false?

Mr. MARS. I respectfully decline to answer that question based upon the grounds previously stated.

The CHAIRMAN. I think I ought to state for the record that according to what the investigator tells me, and Mr. Appell used the term "incendiary material," that that is the information that came to us, from the information received from the State Bureau of Investigation of North Carolina.

Mr. APPELL. Mr. Chairman, the staff has no further questions to ask of this witness.

The CHAIRMAN. The witness is excused and is discharged from his subpoena.

Mr. CHALMERS. Thank you.

Mr. WELTNER. Mr. Chairman, I have one question to pose to Mr. Appell, if I might, to somewhat recap this.

Mr. Appell, as I understand, you have placed documents into the record indicating a total of \$588.16 which was deposited in the New Bern account, and \$260 of that was withdrawn indicating a 90-day loan to Lonnie R. Mills, and \$328.16 was withdrawn in September 1965. We have no indication of what disposition was made of a cashier's check when that was withdrawn?

Mr. APPELL. As of this time we do not have any information.

Mr. WELTNER. So far as you have been able to determine, the check is still outstanding?

Mr. APPELL. No, sir; the check drawn against the account was used to purchase the cashier's check.

Mr. WELTNER. Is the cashier's check still outstanding?

Mr. APPELL. We do not possess the knowledge. We have requested the information but it is not forthcoming as yet, sir.

Mr. WELTNER. Thank you.

The CHAIRMAN. The committee will stand in recess for 5 minutes.

(Whereupon, at 4:30 p.m. the subcommittee recessed and reconvened at 4:35 p.m. Present at time of recess and when hearings resumed: Representatives Willis, Pool, Weltner, and Buchanan.)

The CHAIRMAN. The committee will stand in recess until 10 o'clock tomorrow morning.

(Subcommittee members present at time of recess: Representatives Willis, Pool, Weltner, and Buchanan.)

(Whereupon, at 4:35 p.m., Monday, October 25, 1965, the subcommittee recessed. to reconvene at 10 a.m., Tuesday, October 26, 1965.)

BOSTON PUBLIC LIBRARY



3 9999 05706 3065

338

