

UC-NRLF

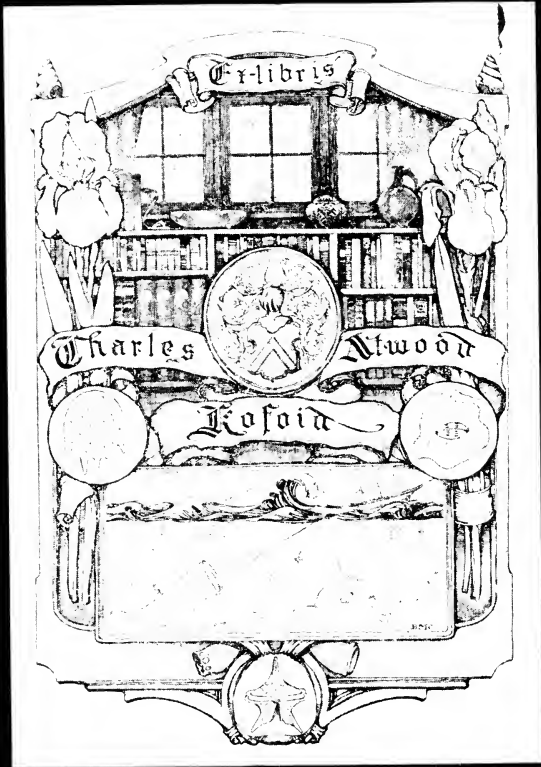

58 76 706

YC 67109





THE LIBRARY  
OF  
THE UNIVERSITY  
OF CALIFORNIA

PRESENTED BY  
PROF. CHARLES A. KOFOID AND  
MRS. PRUDENCE W. KOFOID

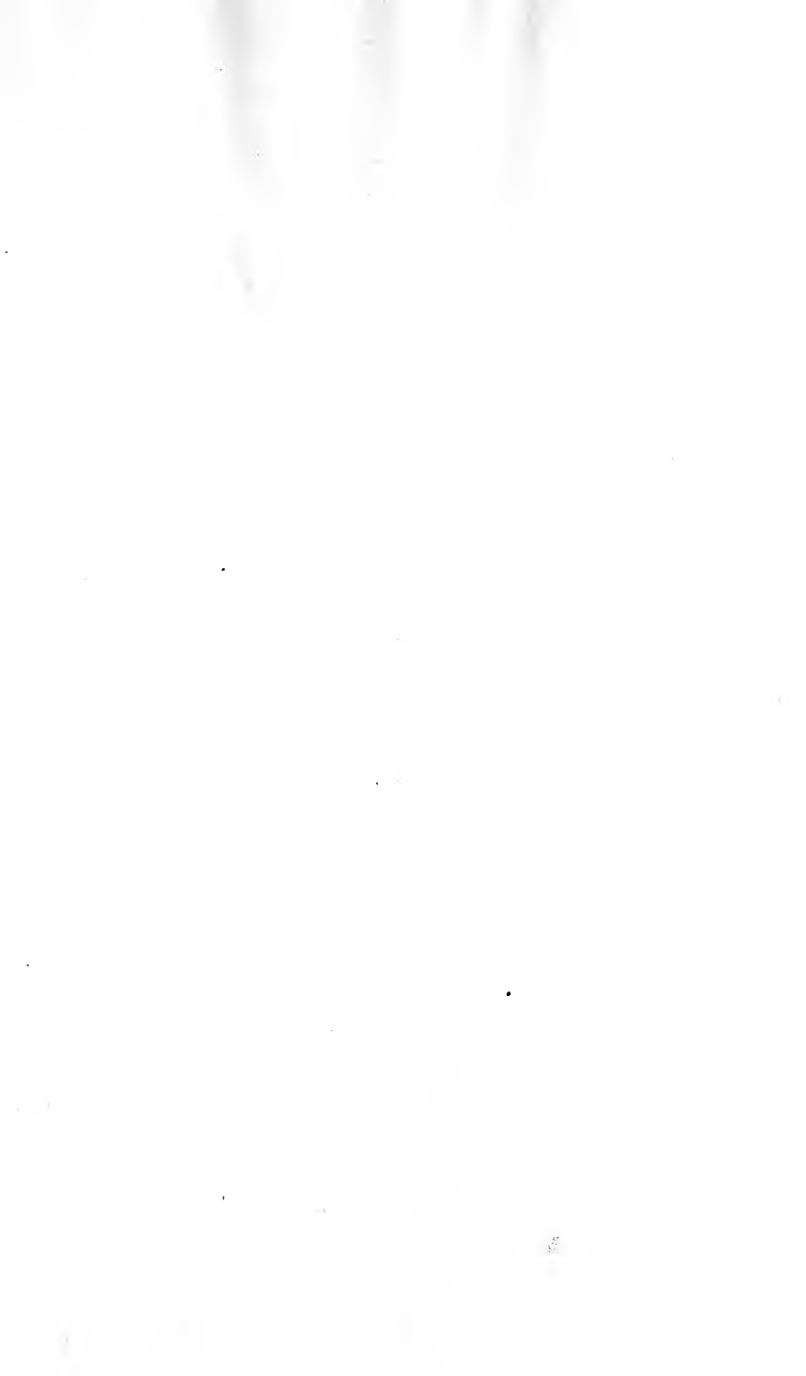





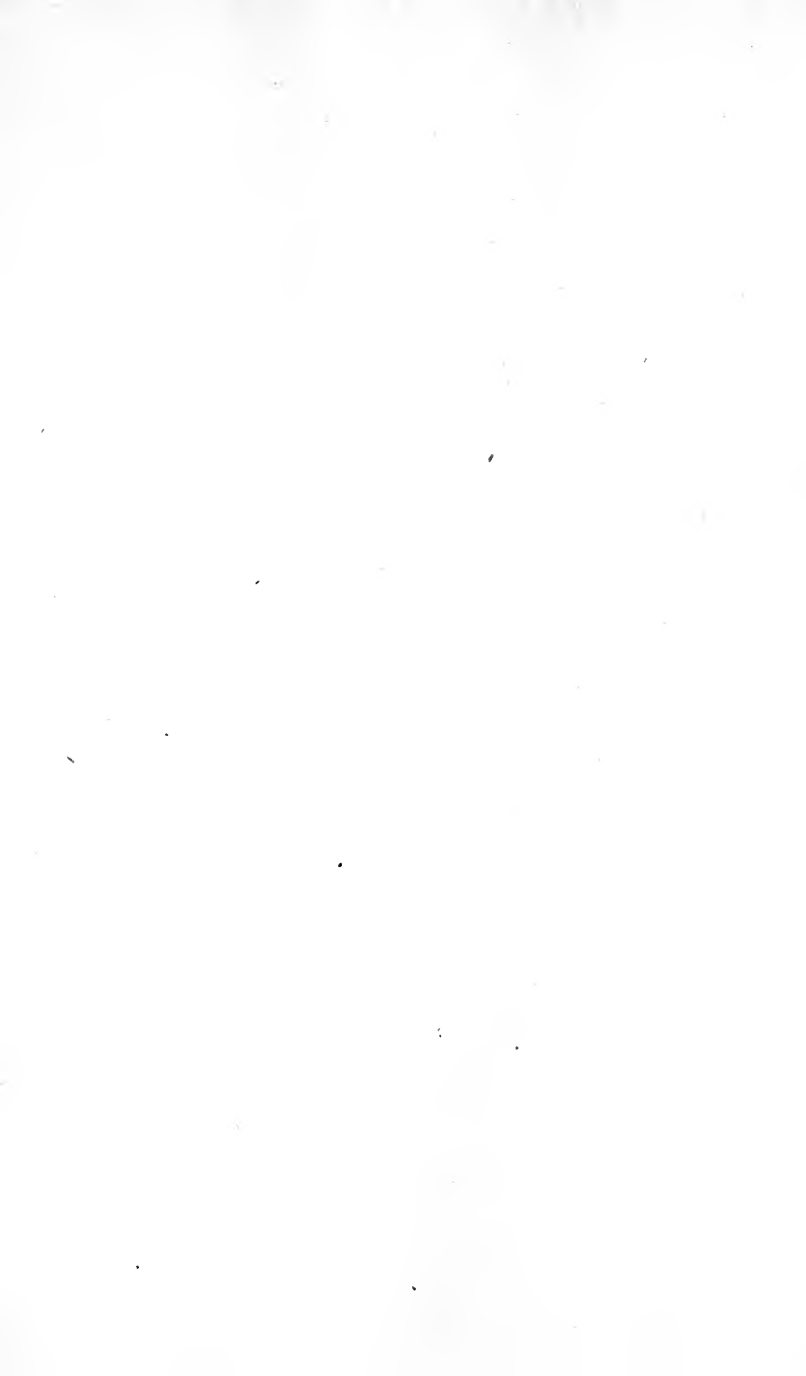

THE

ADVANCED

MACHINIST.



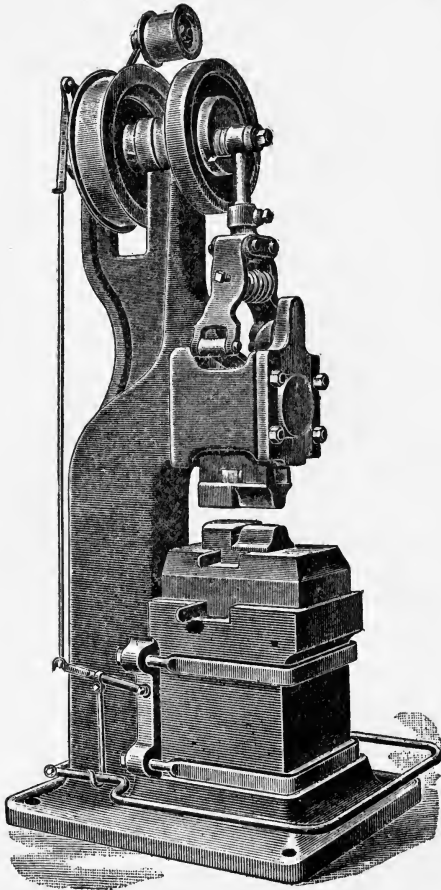

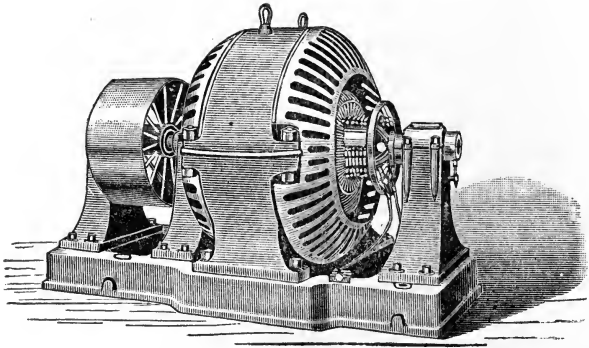

THE  
ADVANCED  
MACHINIST

A PRACTICAL AND EDUCATIONAL  
TREATISE, WITH ILLUSTRATIONS

BY  
WILLIAM ROGERS



THEO. AUDEL & COMPANY

63 FIFTH AVENUE. NEW YORK CITY.

COPYRIGHTED, 1902, 1903,  
BY  
THEO. AUDEL & CO., NEW YORK.



PLAN  
OF THE  
WORK

*The difference between an engineer and a machinist is one of degree only—hence a book written for the benefit of engineers is of service to machinists; and, again, a book devoted to the interests of machinists is of the utmost value to engineers.*

*Why? Because the machinery which the engineer operates is made in the shop.*

# GENERAL CONTENTS.

---

INTRODUCTORY .....	1- 18
SUMMARY OF ARITHMETIC .....	19- 56
USEFUL MEASUREMENTS .....	57- 81
PARTS OF A CIRCLE.....	82- 83
MEASURING MACHINES .....	84-100
SCREW CUTTING IN THE LATHE.....	101-137
BORING MACHINES AND OPERATIONS....	138-150
PLANING MACHINES AND OPERATIONS...	151-174
MILLING MACHINES AND OPERATIONS...	175-198
DRILLING MACHINES AND OPERATIONS..	199-212
GRINDING OPERATIONS.....	213-226
PUNCHING AND SHEARING MACHINES AND OPERATIONS.....	227-233
BOLT CUTTING MACHINE AND OPERATION	234-242
AUXILIARY MACHINES.....	243-262
UTILITIES AND ACCESSORIES.....	263-274
SHOP MANAGEMENT.....	275-286
USEFUL WORKSHOP RECIPES .....	287-296
AID TO THE INJURED IN ACCIDENTS.....	297-316
TABLES AND INDEX.....	317-334

---

*For special index, alphabetically arranged, see page 325.*

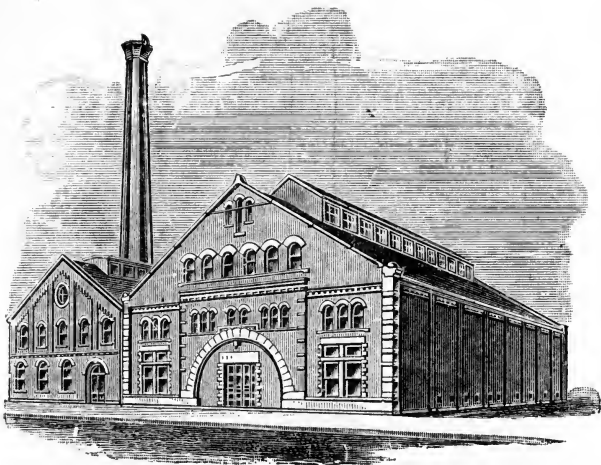

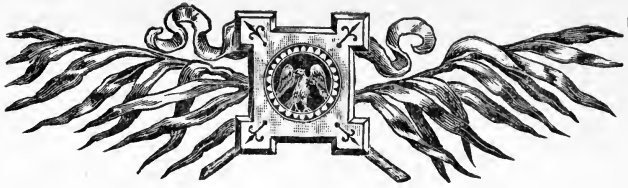

## PREFACE.

---

In a certain high-class journal of a recent date, devoted to the interests of the class for whom this book of instruction is designed, there appeared under the heading "Help Wanted," thirty-two paid advertisements in a single issue.

Not a single one of these called for any except those possessing qualifications expressed as follows :

"Sober," "first-class," "good," "competent," "accurate," "experienced," "undoubted ability," "ambitious," "able to handle men," "skilled," "with shop experience," "executive ability," "all-around," "able to design," "able to supervise construction," "satisfactory men."

The closest scrutiny fails to discover a wish for the opposite of those thus described, nor in the eleven paid advertisements under the heading of "Situations Wanted," in the same paper, does there appear even one saying "I am a second-class man—hire me," as that would be money thrown away. Hence, the only call is for the kind of men classified as in the foregoing quoted words.

Now, examining the list again, we find what these men are specially desired to perform—the range of service needed is wide, but interesting enough to study. All are described under the letters “ Help Wanted ”:

“ A good die-maker on round work.”—“ Accurate machinist for marine-engine work.”—“ Draftsman experienced on steam pumps.”—“ First-class designer on cotton machinery.”—“ First-class machinists for heavy floor and machine work.”—“ First-class toolmakers, experienced on jigs, punch and die work.”—“ Experienced mechanical draftsman for detail work on engines.”—“ Four first class machinists, those familiar with oil-well tool work.”—“ A machine-tool inspector, of undoubted ability.”—“ Mechanical draftsman having experience on large vertical Corliss-engine work.”—“ A large Chicago factory desires to employ a man experienced at fixing differential piece-work rates.”—“ A number of mechanical draftsmen on iron-and-steel-work machinery.”—“ Mechanic wanted, one accustomed to rolling mill work.”—“ Foreman to take charge of machine shop employing about fifteen men.”—“ We invite application from pattern-makers, molders and machinists.”—“ Wanted, superintendent for small shop in Brooklyn, N. Y.”—“ Man experienced in light machinery, able to design, draft and supervise construction of special tools, jigs, etc., with shop experience, executive ability and some knowledge of cost and piece work accounts.”—“ A New York factory contemplating additions to their drafting force desires applications from experienced draftsmen and tracers for electrical switchboard and instrument work.”—“ A thoroughly competent mechanical engineer, to take charge of drafting-room of a concern manufacturing a full line of mining machinery, except steam engines and boilers.”—“ Foreman for a brass department containing 50 hands, in a large electrical factory ; must be familiar with parts of electrical apparatus and with modern methods of production, and know the entire details of the workings of such a department.”—“ Three first-class floor men, as gang foremen, to take charge of machine shop operating several hundred men. Steady employment for competent men.”

Men possessing the qualifications described above may well be classed as “ advanced ” machinists, designers, draughtsmen and engineers ; it is the glory of the age that there are many such to be found ; these descriptions are

---

quoted to plainly tell what kind of talent is desired, and—

This is the call for men in but a single issue of one periodical; there are many other journals containing similar "wants"; again, scores of mighty war ships are "lying in port" because competent machinists and engineers cannot be found to man them; and, still again, every great engine and every intricate machine makes place for a good man to operate it; in fact, the openings for clever, ingenious, trusty men, are world-wide.

It will be noted that the demand is for men possessing certain qualities most difficult to define and hard indeed to acquire; there must, perforce, be second-class men, to fill the ranks, for all cannot be "Captains of Industry"; but this book is not for them, unless it be to inspire thought and ambition to do better.

A few quotations may be helpful, indicating the path of advancement:

"Just do a thing and don't talk about it. This is the great secret in all enterprises."—"Modest confidence in his own abilities is one of the most pleasing traits a man can possess, and it is often his best business capital. I know many a young man with the right kind of stuff in him, who has watched the operations of other people and has said, 'I can do it *if they can.*' Then, with all the judgment he possessed, he made the effort successfully."—"It is easy to do what one is absolute master of. Indeed, this absolute mastery commands the fighting-deck of any trade, profession or labor, and to be best in anything honorable is to be secure of continual success."—"The man who undertakes to learn his business from books will never make a practical mechanic, but, on the other hand, the mechanic who refuses to read whatever he finds of interest on the subject can hardly expect to be successful."—"There are two ways of doing work. One may go about

it with a clouded brow, a lagging step, and a general expression of disgust and weariness; or it is possible to be alert, energetic, bright of countenance and elastic of step, as if the labor were really enjoyable. The work is done in either case, of course, but there is something in the latter manner that inspires confidence in the worker and assures him of a reward that would not crown his efforts were they put forth in the other way."—"The best rule for success in life that I have ever found is to do a little more than is expected of you. Whatever your position in life may be, whether in an office, store, or workshop, do a little more than is expected of you, and you will never be overlooked, be the establishment large or small."—"The word 'tact' is equivalent to the word 'touch'; tact is that nice perception which comprehends everything of the order, formation, location and disposition of aught which bears upon the successful issue of the enterprise at issue. The man of tact who has that presence of mind which can bring him on the instant all he knows, is worth for action a dozen men who know as much, but can only bring it to light slowly."—"The young fellow who will distance his competitors is he who masters his business; who preserves his integrity, who lives cleanly and purely, who never gets into debt, who gains friends by deserving them, and puts his money into the savings bank. There are some roads to fortune that look shorter than this old dusty highway. But the staunch men of the community, the men who achieve something really worth having, good fortune, good name and a serene old age, all go this road."—"Our present generation of coming men, youths of from fifteen to eighteen, can have not the least ground for fearing the temper and promise of the times into which their lives are going. Never before in the world's history has there been such a call from the near future to a rising army of eager workers. Science has probed the secrets of things, and the practical application of knowledge to all the lines of labor has lifted even menial services to a place of dignity, provided always that the operator is master of what he takes into hand."

In short, the preparation and issue of this work is aimed to point the way of advancement to those who must become fitted to assume the obligations, as well as to receive the rewards of those who, in the order of things, must give place to the coming-man.



But! this is not all—

The trade of the machinist is peculiar in that it is a preparation for so many positions outside of it. It takes a man of good natural ability and of considerable education—not always from books—to make a first-class machinist, and more of the same to make a competent foreman or a superintendent; so that when he is well qualified for these positions he is also well prepared for so many other openings with which the machine shop apparently has little to do; and many of these keep calling him, and many respond to the call, hence in consequence it is said that skill is dying out, that skilled workers are becoming scarce, that soon, as things are going, we will be left behind, in the world's markets, by the lack of both competent operatives and of the higher skill and reliability that are to exercise supervision and direction.

It is with a full knowledge of this fact, that in "The Plan of the Work" some subject matter has been introduced which the author is confident will be of the utmost value in the shop and afterwards as well, when the student "makes a change;" for in the fluctuation of business there come times when everybody is busy and then times that are slack and not so booming, when foremen and superintendents have that toughest of all jobs, the telling of good men that there is nothing for them to do; this being incident, also, to the kind of country we live in.

There is a bit of a necessary warning, too, in a little fable the author has seen, from *Æsops Fables* (Revised)—

"A man had a Glass in which he looked at himself every day. And he did not perceive that he grew older. But at length he perceived that the Glass had grown old.

So he threw it away and got another that was new. Then he saw that he had grown old with his Glass.”

Every man looks in a glass at times and afterwards does some rather serious thinking; it is to aid the friendly reader and student in such moments to right thoughts that some things, too, have been put in the book in odd spaces, with the hope that the good will with which it has been done will not be taken amiss.

The path of advancement, how uncertain is it and at times so difficult to discern amid the shadows. The mere mention of this allows the quotation of a wise leader of men, that may well be the author's closing words for the volume.

“Look up and press forward and the way will become clear step by step, day by day; the space between is the way thither.”

# SUMMARY OF ARITHMETIC.

---

The following abridgment of several of the rules of arithmetic, often referred to in elementary books on mechanical science, are here inserted for the convenience of reference. These rules and examples are given merely to refresh the memory, it being taken for granted that the reader has already acquainted himself with the principles of common arithmetic. They will, however, be found serviceable, both as a convenience of reference and to give some insight to the subjects on which they treat.

Arithmetic is the science of numbers, and numbers treat of magnitude or quantity. Whatever is capable of increase or diminution is a magnitude or quantity.

The processes of arithmetic are merely expedients for making easier the discovery of results which every man of ordinary ingenuity would find a means for discovering himself. Roger Bacon lived eight centuries ago ; in the great roll of modern scientists, his name stands first ; these are his

---

NOTE.—Calculation is the art, practice or manner of computing by numbers : the use of numbers by addition, subtraction, multiplication or division, for the purpose of arriving at a certain result.

Upon this art—of calculation—rest not only the mechanical arts, but the whole structure of modern civilization. Consider the solar system, a time-piece, a well-equipped modern factory—the characteristic of each is its “calculability.” Everything comes at last to correct figuring for assured success.

## SUMMARY OF ARITHMETIC.

words: "For he who knows not mathematics cannot know any other sciences; and, what is more, he cannot discover his own ignorance or find its proper remedies."

In every branch of science, our knowledge increases as the power of measurement becomes improved; it is very generally true that the one ignorant of useful numbers is the one who serves, while the leader in all departments is the one who calculates.

A glossary is a collection of words not in general use, especially of an art or science; the ordinary use of a glossary is to explain in some detail many of the more difficult words used in the text, hence the following—

## SYMBOLS, ABBREVIATIONS AND DEFINITIONS.

— *Equal to.* The sign of equality; as 100 cts. = \$1, signifies that one hundred cents are equal to one dollar.

— *Minus or Less.* The sign of subtraction; as  $8 - 2 = 6$ ; that is, 8 less 2, is equal to 6.

+ *Plus or More.* The sign of addition; as  $6 + 8 = 14$ ; that is, 6 added to 8 is equal to 14.

× *Multiplied by.* The sign of multiplication; as  $7 \times 7 = 49$ ; that is, 7 multiplied by 7 is equal to 49.

÷ *Divided by.* The sign of division; as  $16 \div 4 = 4$ ; that is, 16 divided by 4 is equal to 4.

## SYMBOLS, ABBREVIATIONS AND DEFINITIONS.

$\therefore$ . Signifies then or therefore.

$\because$ . Since or because.

$d^2$  = diameter squared, or is a number multiplied by itself, thus  $2 \times 2 = 4$ .

$d^3$  = diameter cubed, or is a number multiplied by itself twice, thus  $2 \times 2 \times 2 = 8$ .

$d^4$  = diameter to the fourth power, or is a number multiplied by itself thrice, thus  $2 \times 2 \times 2 \times 2 = 16$ .

*A single accent* (') signifies feet; *a double accent* (") inches; thus  $3' 6'' = 3$  feet 6 inches.

*Dia.* = diameter.  $^{\circ}$  Degrees.

*Revs. per min.* = revolutions per minute.

*Lbs. per sq. in.* = pounds per square inch.

*Brackets* ( ) or [ ] are employed to denote that several numbers are to be taken collectively. Thus  $4(a + b)$  signifies that the number represented by  $a + b$  is to be multiplied by 4; again  $(a + b) \times (c - d)$  denotes that the number represented by  $a + b$  is to be multiplied by the number which is the result of subtracting  $d$  from  $c$ .

*The Greek Letter  $\pi$*  denotes the ratio of the circumference of a circle to its diameter. In the English alphabet, this letter stands in place of  $p$ , and is called *pi*; it is very frequently met with in mechanical literature.

*The Decimal Point.*—In both France and Germany, one-fourth ( $\frac{1}{4}$ ) reduced to a decimal is always written as 0,25; in England it is written 0.25, and in the United States in this way, 0.25.

## SYMBOLS, ABBREVIATIONS AND DEFINITIONS.

A *formula* is an arithmetical rule in which all words are omitted, all the quantities represented by letters and figures, and all the operations indicated by signs, and by the position of the different characters; the word "formula" is another name for "form."

The following 10 formulas include the elementary operations of arithmetic and follow from the succeeding illustrations.

1. *The Sum* = all the parts added.
2. *The Difference* = the Minuend — the Subtrahend.
3. *The Minuend* = the Subtrahend + the Difference.
4. *The Subtrahend* = the Minuend — the Difference.
5. *The Product* = the Multiplicand  $\times$  the Multiplier.
6. *The Multiplicand* = the Product  $\div$  the Multiplier.
7. *The Multiplier* = the Product  $\div$  the Multiplicand.
8. *The Quotient* = the Dividend  $\div$  the Divisor.
9. *The Dividend* = the Quotient  $\times$  the Divisor.
10. *The Divisor* = the Dividend  $\div$  the Quotient.

A number is exactly divisible by—2, when the number ends in an even number or in 0; 3, when the sum of the digits is exactly divisible by 3; 4, when the number formed by the last two digits is exactly divisible by 4; 5, when the number ends in 5 or 0.

*Ratio* is the relation of one number to another, as obtained by dividing one by the other; hence, ratio means the same as the word quotient.

## SYMBOLS, ABBREVIATIONS AND DEFINITIONS.

*Log.* This is the abbreviation of the term *logarithm*; these are auxiliary numbers, by means of which the simple operations of addition and subtraction may be substituted for the more cumbrous operations of multiplication and division, and easy cases of multiplication and division for involution and evolution.

*The use of logarithms* reduces multiplication to addition, division to subtraction; raising powers or extracting roots to multiplication and division, respectively.

*Logarithms of numbers* are arranged in tables, running to four and six figures, beginning with one and going to so high as to fill entire books with the columns.

*Algebra* is that science which deals with formulas; it is a mathematical science which teaches the art of making calculations by letters and signs instead of figures. The name comes from two Arabic words, *al gabron*, reduction of parts to a whole. The letters and signs are called *Symbols*. *Quantities* in Algebra are expressed by *letters*, or by a combination of *letters* and *figures*; as  $a$ ,  $b$ ,  $c$ ,  $2x$ ,  $3y$ ,  $5z$ , etc. The first letters of the alphabet are used to express *known* quantities; the last letters, those which are *unknown*.

The operations to be performed are expressed by the same signs as in Arithmetic; thus  $+$  means Addition,  $-$  expresses Subtraction, and  $\times$  stands for Multiplication.

---

NOTE.—A machinist has little or no use for algebra in his everyday work; but if he wants to find out more about the how and why of things and study into general principles, it is the most important subject that he can take up, next to arithmetic and mechanical drawing.

## SYMBOLS, ABBREVIATIONS AND DEFINITIONS.

A NUMBER is a unit or collection of units; as two, five, six feet, etc.

An INTEGER is a number that represents whole things.

An ABSTRACT NUMBER is one which does not refer to any particular object.

A CONCRETE NUMBER is a number used to designate objects or quantities.

An ODD NUMBER is a number which cannot be divided by two.

An EVEN NUMBER can be exactly divided by two.

FACTORS of a number are those numbers which, when multiplied together, make that number.

A PRIME NUMBER is a number exactly divisible by one.

A COMPOSITE NUMBER is a number which can be divided by other integers besides itself and one.

An EXACT DIVISOR of a number is a whole number that will divide that number without a remainder.

The GREATEST COMMON DIVISOR of two or more numbers is the greatest number that will divide each of them exactly.

A MULTIPLE of a number is any number exactly divisible by that number.

The LEAST COMMON MULTIPLE of two or more numbers is the least number that is exactly divisible by each of them.

A PRIME FACTOR is any prime number used as a factor.

---

NOTE.—*Quantity* is the amount of anything considered, or of any commodity bought, or sold. *Price* is the value in money of one, or of a given unit of any commodity. *Cost* is the value in money of the entire quantity bought, or sold.



## NOTATION AND NUMERATION.

---

NOTATION is a system of representing numbers by symbols. There are two methods of notation in use, the *Roman* and the *Arabic*. NUMERATION is a system of naming or reading numbers.

THE ARABIC METHOD OF NOTATION employs ten characters or figures, viz :

<i>1</i>	<i>2</i>	<i>3</i>	<i>4</i>	<i>5</i>	<i>6</i>	<i>7</i>	<i>8</i>	<i>9</i>	<i>0</i>
<i>One,</i>	<i>Two,</i>	<i>Three,</i>	<i>Four,</i>	<i>Five,</i>	<i>Six,</i>	<i>Seven,</i>	<i>Eight,</i>	<i>Nine,</i>	<i>Zero.</i>

The nine figures are called *digits* or significant figures. The character 0 has no value when standing alone.

The nine digits have each a *simple* and a *local value*. The simple value of a figure is the one expressed by it when standing alone or in the units place. The local value of a figure is that which depends upon the place which the figure occupies in a number.

There must be three figures in every period, except the one at the left, which may have one, two or three. Every order of a number not occupied by a significant figure must be filled with a cipher, or 0.

---

NOTE.—By means of these ten figures or characters we can represent any number. When one of the figures stands by itself, it is called a unit; but if two of them stand together, the right-hand figure is still called a unit, but the left-hand figure is called tens; thus, 79 is a collection of 9 units and 7 sets of ten units each, or of 9 units and 70 units, or of 79 units, and is read as seventy-nine. If three of them stand together, then the left-hand figure is called hundreds; thus, 279 is read two hundred and seventy-nine.

## NOTATION AND NUMERATION.

RULE FOR NOTATION.—*Beginning at the left, write the hundreds, tens and units of each successive period in their proper order, filling all vacant orders and periods with ciphers.*

## NUMERATION TABLE.

Names of periods :	Billions.	Millions.	Thousands.	Units.
Order of Units :	8 Hundred-billions	5 Hundred-millions	2 Hundred-thousands	
	7 Ten-billions	4 Ten-millions	0 Ten-thousands	
	6 Billions	3 Millions	1 Thousands	
				2 Hundreds
				8 Tens
				2 Units
				. Decimal point
				4 Tenths
				8 Hundredths
				9 Thousandths

The number in the table is read “eight hundred and seventy-six billion, five hundred and forty-three million, two hundred and one thousand, two hundred and eighty-two, decimal point, four, eight, nine.”

In the table given, it will be observed that the long row of figures is divided into groups of three figures, called periods. This is to aid in their ready reading. The first set is called *units*, the second *thousands*, the third *millions*, etc.

Beginning at units place, the orders on the right of the decimal point express tenths, hundredths, thousandths, etc.

THE READING OF DECIMALS.—In reading decimals, it is well to omit, even in thought, the idea of a denominator, and to say, thus—example, .25 ; to read, say “point, 2, 5”; in reading .48437, say “point, 4, 8, 4, 3, 7.”

EXAMPLE.—Write sixty-four thousandths in decimals.

Since there are only two figures in the numerator 64, and the right-hand figure of the decimal must occupy the

NOTATION AND NUMERATION.

third decimal place to express thousandths, it is necessary to prefix a cipher to bring the right-hand figure into its proper place. Therefore write *point, oh, six, four* (.064), in the order named.

It is well also to say "oh" (this is the letter O).

THE ROMAN NOTATION is the method of notation by letters, and is illustrated as follows:

I,	V,	X,	L,	C,	D,	M,
1,	5,	10,	50	100,	500,	1,000.

Repeating a letter repeats its value; thus: I = 1, II = 2.

Placing a letter of less value before one of greater value diminishes the value of the greater by the less; thus, IV = 4, IX = 9, XL = 40.

Placing the less after the greater increases the value of the greater by that of the less; thus, VI = 6, XI = 11, LX = 60.

Placing a horizontal line over a letter increases its value a thousand times; thus,  $\overline{IV}$  = 4,000  $\overline{M}$  = 1,000,000.

ROMAN TABLE.

I denotes One.	XVII denotes Seventeen.
II " Two.	XVIII " Eighteen.
III " Three.	XIX " Nineteen.
IV " Four.	XX " Twenty.
V " Five.	XXX " Thirty.
VI " Six.	XL " Forty.
VII " Seven.	L " Fifty.
VIII " Eight.	LX " Sixty.
IX " Nine.	LXX " Seventy.
X " Ten.	LXXX " Eighty.
XI " Eleven.	LXXX " Eighty.
XII " Twelve.	XC " Ninety.
XIII " Thirteen.	C " One hundred.
XIV " Fourteen.	D " Five hundred.
XV " Fifteen.	M " One thousand.
XVI " Sixteen.	$\overline{X}$ " Ten thousand.
	$\overline{M}$ " One million.

## ADDITION.

---

Addition is uniting two or more numbers into one. The result of the addition is called the Sum or Amount. In addition, the only thing to be careful about except the correct doing of the sum, is to place the unit figures under the unit figure above it, the tens under the tens, etc.

### RULE.

After writing the figures down so that units are under units, tens under tens, etc.:

1. *Begin at the right hand, up and down row, add the column and write the sum underneath if less than ten.*

2. *If, however, the sum is ten or more, write the right-hand figure underneath, and add the number expressed by the other figure or figures with the numbers of the next column.*

3. *Write the whole of the last column.*

### EXAMPLES FOR PRACTICE.

7,060	248,124	13,579,802
9,420	4,321	83
1,743	889,876	478,652
4,004	457,902	87,547,289
22,227	Ans.	

Use care in placing the numbers in vertical lines; irregularity in writing them down is the cause of mistakes.

**RULE FOR PROVING THE CORRECTNESS OF THE SUMS.**—*Add the columns from the top downward, and if the sum is the same as when added up, the answer is right.*

Add and prove the following numbers:

684 32 257 20. Ans. 993.

## SUBTRACTION.

---

Subtraction is taking a lesser sum from a greater one.

As in addition, care must be used in placing the units under the units, the tens under the tens, etc.

The answer is called the remainder or the difference.

The sign of subtraction is (—) Example:  $98 - 22 = 76$ .

Subtraction is the opposite of addition: one "takes from," while the other "adds to."

### RULE.

1. *Write down the greater number first, and then under it the lesser number, so that the units stand under the units, the tens under the tens, etc., etc.*

2. *Begin with the units, and take the under from the upper figure, and put the remainder beneath the line.*

3. *But if the lower figure is the larger, add ten to the upper figure, and then subtract and put the remainder down: this borrowed ten must be deducted from the next column of figures where it is represented by 1.*

### EXAMPLES FOR PRACTICE.

892	89,672	89,642,706
46	46,379	48,765,421
<hr style="width: 100%;"/>	<hr style="width: 100%;"/>	<hr style="width: 100%;"/>

846 remainder.

---

NOTE.—In the first example,  $892 - 46$ , the 6 is larger than 2; borrow 10, which makes it 12, and then deduct the 6; the answer is 6. The borrowed 10 reduces the 9 to 8, so the next deduction is 4 from  $8 = 4$  is the answer.

## SUBTRACTION.

RULE FOR PROVING THE CORRECTNESS OF SUBTRACTION.—*Add the remainder, or difference, to the smaller amount of the two sums, and if the two are equal to the larger, then the subtraction has been correctly done.*

EXAMPLE.	898		246
	246	Now then,	652
	652		898 Ans.

## MULTIPLICATION.

MULTIPLICATION is finding the amount of one number increased as many times as there are units in another.

The number to be multiplied or increased is called the MULTIPLICAND.

The MULTIPLIER is the number by which we multiply. It shows how many times the multiplicand is to be increased.

The answer is called the PRODUCT.

The multiplier and multiplicand which produce the product are called its FACTORS. This is a word frequently used in mathematical works, and its meaning should be remembered.

The sign of multiplication is  $\times$  and is read "times," or multiplied by; thus,  $6 \times 8$  is read, 6 times 8 is 48, or, 6 multiplied by 8 is 48.

The principle of multiplication is the same as addition; thus,  $3 \times 8 = 24$  is the same as  $8 + 8 + 8 = 24$ .

MULTIPLICATION.

RULE FOR MULTIPLYING.

1. Place the unit figure of the multiplier under the unit figure of the multiplicand, and proceed as in the following :

EXAMPLES. Multiply 846 by 8, and 487,692 by 143.  
Arrange them thus :

846	487,692
8	143
———	———
6,768	1463076
	1950768
	487692
	———
	69,739,956

2. But if the multiplier has ciphers at its end, then place it as in the following :

Multiply 83,567 by 50, and 898 by 2,800.

83567	898
50	2800
———	———
4,178,350	718400
	1796
	———
	2,514,400

The product and the multiplicand must be in like numbers. Thus, 10 times 8 gallons of *oil* must be 80 gallons of *oil*; 4 times 5 *dollars* must be 20 *dollars*; hence, the multiplier must be the *number* and not the *thing* to be multiplied.

In finding the cost of 6 tons of coal at 7 dollars per ton, the 7 *dollars* are taken 6 times, and not multiplied by 6 tons.

## MULTIPLICATION.

When the multiplier is 10, 100, 1000, etc., the product may be obtained at once by annexing to the multiplicand as many ciphers as there are in the multiplier.

## EXAMPLE.

1. Multiply 486 by 100. Now 486 with 00 added = 48,600.

2.  $6,842 \times 10,000 =$  how many? Ans. 68,420,000.

## TO PROVE THE RESULT IN MULTIPLICATION.

RULE.—*Multiply the multiplier by the multiplicand, and if the product is the same in both cases, then the answer is right.*

## DIVISION.

Division is a word derived from the Latin, *divido* meaning to separate into parts. In arithmetic, it may be defined as the dividing of a number or quantity into any number of parts assigned.

When one number has to be divided by another number, the first one is called the DIVIDEND, and the second one the DIVISOR, and the result is the QUOTIENT.

## 1. TO DIVIDE BY ANY NUMBER UP TO 12.

RULE.—*Put the dividend down with the divisor to the left of it, with a small curved line separating it, as in the following*

EXAMPLE.—Divide 7,865,432 by 6.

$$\begin{array}{r} 6 \overline{)7,865,432} \\ \underline{1,310,905} \quad 2 \end{array}$$



DIVISION.

Here at the last we have to say, "6 into 32 goes 5 times and 2 over"; always place the number that is over as above, separated from the quotient by a small line, or else put it as a fraction, thus,  $\frac{2}{6}$ , the top figure being the remainder, and the bottom figure the divisor, when it should be put close to the quotient; thus, 1,310,905 $\frac{2}{6}$ .

2. TO DIVIDE BY ANY NUMBER UP TO 12, WITH A CIPHER OR CIPHERS AFTER IT, as 20, 70, 90, 500, 7,000, etc.

RULE.—Place the sum down as in the last example, then mark off from the right of the dividend as many figures as there are ciphers in the divisor; also mark off the ciphers in the divisor; then divide the remaining figures by the number remaining in the divisor; thus:—

EXAMPLE.—Divide 9,876,804 by 40.

$$\begin{array}{r} 40 \overline{) 9,876,804} \\ \underline{246,920} \phantom{4} \end{array}$$

The 4 cut off from the dividend is put down as a remainder, or it might have been put down as  $\frac{4}{40}$  or  $\frac{1}{10}$ .

3. TO DIVIDE BY ANY NUMBER NOT INCLUDED IN THE LAST TWO CASES.

RULE.—Write the divisor at the left of the dividend and proceed as in the following

EXAMPLE.

Divide 726,981 by 7,645.

$$\begin{array}{r} 7,645 \overline{) 726981} \phantom{95} \\ \underline{68805} \\ 38931 \\ \underline{38225} \\ 706 \end{array}$$

Ans. 95 $\frac{706}{7645}$ .

## DIVISION.

## EXAMPLES FOR PRACTICE.

- 1.—Divide 76,298,764,833 by 9.  
 2.— “ 120,047,629,817 “ 20.  
 3.— “ 9,876,548,210 “ 48.  
 4.— “ 3,247,617,219 “ 63.

*Multiplying the dividend, or dividing the divisor by any number, multiplies the quotient by the same number.*

*Dividing the dividend, or multiplying the divisor by any number, divides the quotient by the same number.*

*Dividing or multiplying both the dividend and divisor by the same number does not change the quotient.*

## RULE FOR PROVING DIVISION.

*Division may be proved by multiplying the quotient by the integral part of the Divisor, and adding to the product the remainder, if there is any. The result will be equal to the dividend if the work is correct.*

EXAMPLE. 12)48679

$$\begin{array}{r} \hline 4056-7 \\ 12 \\ \hline \end{array}$$

48679 Proof.

QUOTATION.—“As long ago as the days of ancient Greece, Aristotle said: ‘I find the young men who study mathematics quick and intelligent at other studies.’ But, apart from the value of mathematical studies as a mental training, the modern engineer, whatever branch of the science he may pursue, will find mathematics one of the necessary tools of his profession.”

---

## REDUCTION.

---

A DENOMINATE NUMBER is a number applied to an object; thus, 40 inches and 3 feet 5 inches are denominate numbers; the first is a *simple* and the latter a *compound denominate number*.

REDUCTION is changing these numbers from one denomination to another without altering their values. It is of two kinds, DESCENDING and ASCENDING.

Reduction Descending is changing higher denominations to lower, as tons to pounds. Reduction Ascending is changing lower to higher denominations, as cents to dollars.

Reduction of Denominate Numbers is the process of changing the denomination of a number without changing the value. Thus, 3 yards may be expressed as 9 feet, or 108 inches.

TO CHANGE DENOMINATE NUMBERS TO LOWER DENOMINATIONS is done by multiplication and by the following

RULE.—1. *Multiply the number of the highest denomination given by the number of units of the next lower denomination required to make one of that higher, and to the product add the given number of the lower denomination, if any.*

2. *Proceed in like manner with this result and each successive denomination obtained, until the given number is reduced to units of the required denomination.*

---

NOTE.—A *simple number* is one which expresses one or more units of the same denomination. A *compound number* expresses units of two or more denominations of the same kind, as 5 yards, 1 foot, 4 inches—or example, page 36, 6 T., 8 cwt., 3 qrs.—these are compound numbers; but *ten oxen*, or *five dollars*, are simple numbers.

## REDUCTION.

## EXAMPLE.

Reduce six tons, eight hundred weight, three quarters, to lbs.

$$\begin{array}{r}
 6 \text{ T. } 8 \text{ cwt. } 3 \text{ qrs.} \\
 20 \\
 \hline
 120 \\
 8 \text{ add above.} \\
 \hline
 128 \\
 4 \\
 \hline
 512 \\
 3 \text{ add above.} \\
 \hline
 515 \text{ qrs.} \\
 25 \\
 \hline
 2575 \\
 1030 \\
 \hline
 12875 \text{ lbs. Answer.}
 \end{array}$$

TO REDUCE LOWER DEMOMINATIONS TO HIGHER IS DONE BY DIVISION.

RULE.—1. *Divide the given number by the number of units of the given denomination required to make a unit of the next higher denomination.*

2. *In the same manner, divide this and each successive quotient until the required denomination is reached. The last quotient, with the remainders annexed, will be the required result.*

Ex.—Bring 98,704,623 lbs. to tons and lbs.

$$\begin{array}{r}
 2000 \overline{)98704623} \\
 \hline
 49352 \text{ Tons, } 623 \text{ lbs.}
 \end{array}$$

REDUCTION.

EX.—76,245 gills to gallons, etc.

$$\begin{array}{r} 4 \overline{)76245} \end{array}$$

$$\begin{array}{r} 2 \overline{)19061} \text{—1 gill} \end{array}$$

$$\begin{array}{r} 4 \overline{)9530} \text{—1 pint.} \end{array}$$

$$2382 \text{—2 quarts.}$$

Ans., 2382 gallons, 2 quarts, 1 pint and 1 gill.

PROOF.—Reduction Ascending and Descending *prove* each other; for one is the reverse of the other.

FRACTIONS.

A fraction means a part of anything. A vulgar fraction is always represented by two numbers (at least), one over the other and separated by a small horizontal line. The one above the line is always called the NUMERATOR, and the one below the line the DENOMINATOR.

The denominator tells us how many parts the whole thing has been divided into, and the numerator tells us how many of those parts we have. Thus, in the fraction  $\frac{3}{8}$  the eight is the denominator, and shows that the object has been divided into eight equal parts; and three is the numerator, and shows that we have three of those pieces or parts of the object.

A PROPER FRACTION is one whose numerator is less than the denominator, as  $\frac{3}{8}$  or  $\frac{2}{5}$ .

AN IMPROPER FRACTION is one whose numerator is more than its denominator,  $\frac{8}{3}$  or  $\frac{5}{2}$ .

NOTE.— $\frac{8}{3}$  means more than a whole one, because  $\frac{3}{3}$  must be a whole one. Thus  $\frac{8}{3}$  will be three-thirds + three-thirds + two-thirds, or  $2\frac{2}{3}$ , and this form of fraction is called a *mixed number*.

## REDUCTION OF FRACTIONS.

TO REDUCE AN IMPROPER FRACTION TO A MIXED NUMBER.

RULE.—*Divide the numerator by the denominator ; the quotient is the whole number part, and the remainder is the numerator of the fractional part.*

EXAMPLES:  $\frac{16}{7} = 2\frac{2}{7}$ .       $\frac{15}{3} = 5$ .       $\frac{27}{8} = 3\frac{3}{8}$ .

TO REDUCE A MIXED NUMBER TO AN IMPROPER FRACTION.

RULE.—*Multiply the whole number part by the denominator, and add on the numerator ; the result is the numerator of the improper fraction.*

EXAMPLES:  $2\frac{2}{7} = \frac{16}{7}$ .       $5\frac{1}{3} = \frac{16}{3}$ .       $3\frac{3}{8} = \frac{27}{8}$ .

TO REDUCE A FRACTION TO ITS LOWEST TERMS.

RULE.—*Divide both numerator and denominator by the same number ; if by so doing there is no remainder.*

EXAMPLE.—Reduce  $\frac{8}{12}$ . Here 4 will divide both top and bottom without a remainder. Divide by 4.

$$4 \overline{) \frac{8}{12}} = \frac{2}{3}.$$

The meaning of this is, that if you divide a thing into 12 equal parts, and take 8 of them, you will have the same as if the thing had been divided into 3 equal parts and you had two of them.

TO REVERSE THE LAST RULE ; TO BRING A FRACTION OF ANY DENOMINATOR TO A FRACTION HAVING A GREATER DENOMINATOR.

RULE.—*See how often the less will go into the greater denominator and multiply both numerator and denominator by it. The result is the required fraction.*

## REDUCTION OF FRACTIONS.

## EXAMPLES.

Bring  $\frac{1}{2}$  to a fraction whose denominator is 8.

Here 2 goes in 8 four times; then multiply the numerator and denominator of  $\frac{1}{2}$  by 4 =  $\frac{4}{8}$ , which is the required fraction.

Bring  $\frac{2}{3}$  to a fraction whose denominator is 15.

Here 3 goes into 15 five times; then  $\frac{2}{3}$  becomes  $\frac{10}{15}$ .

In case of a fraction of a fraction, as  $\frac{1}{2}$  of  $\frac{1}{4}$ , it is called a compound fraction, and should always be reduced to a simple fraction *by multiplying all the numerators together for a new numerator, and all the denominators together for a new denominator; then, if necessary, reduce this fraction to its lowest terms.*

EXAMPLE.— $\frac{3}{4}$  of  $\frac{2}{3}$  of  $\frac{4}{9}$ . Reduce to a single fraction:  $3 \times 2 \times 4 = 24$ ; and  $4 \times 3 \times 9 = 108$ .

Thus,  $\frac{24}{108}$  is the fraction. Reduce this  $12 \frac{24}{108} = \frac{2}{9}$ .

TO REDUCE TWO OR MORE FRACTIONS TO EQUIVALENT FRACTIONS HAVING THEIR LEAST COMMON DENOMINATOR.

RULE.—*Find the least common multiple of the given denominators for the least common denominator, and reduce the given fractions to this denominator.*

## EXAMPLE.

Reduce  $\frac{2}{3}$ ,  $\frac{3}{4}$ ,  $\frac{5}{6}$  and  $\frac{9}{10}$  to equivalent fractions having their least common denominator; then  $\frac{2}{3} = \frac{40}{60}$ ,  $\frac{3}{4} = \frac{45}{60}$ ,  $\frac{5}{6} = \frac{50}{60}$ ,  $\frac{9}{10} = \frac{54}{60}$ .

## CANCELLATION.

This is a method of shortening problems by rejecting equal factors from the divisor and dividend.

The sign of cancellation is an oblique mark drawn across the face of a figure, as *A*, *6*, *2*.

Cancellation means to leave out; if there are the same numbers in the numerator and the denominator they are to be left out.

Ex.— $\frac{3}{4}$  of  $\frac{2}{3}$  of  $\frac{4}{9}$ . Here the 3 in the first numerator and the 3 in the second denominator are left out; also 4 of the first denominator and the last numerator, thus:

$$\text{Ans. } \frac{\cancel{3}}{4} \times \frac{2}{\cancel{3}} \times \frac{\cancel{4}}{9} = \frac{2}{9}$$

Ex.— $\frac{2}{9}$  of  $\frac{3}{8}$  of  $\frac{14}{18}$  of  $\frac{90}{170}$ —by cancellation thus:

$$\frac{\cancel{2}}{9} \text{ of } \frac{\cancel{3}}{8} \text{ of } \frac{\cancel{14}}{18} \text{ of } \frac{\cancel{90}}{170} = \frac{7}{3 \times 2 \times 34} = \frac{7}{204}$$

$\begin{array}{cccc} 7 & 5 & & \\ \cancel{2} & \cancel{3} & \cancel{14} & \cancel{90} \\ 3 & \cancel{4} & & 34 \end{array}$

See note.

NOTE.—The process is as follows: The first numerator, 2, will go into 8, the denominator of the second fraction, 4 times; the denominator of the third fraction, 18, will go into 90, the numerator of the last quantity, 5 times. The numerator of the second fraction, 3, will go into the denominator of the first fraction 3 times; 5 will go into 170, 34 times; 2 will go into 4 twice, and 2 into 14, 7 times, and as we cannot find any more figures that can be divided without leaving a remainder, we are at the end, and the quantities left must be collected into one expression. On examination, we have 7 left on the top row; this is put down at the end as the final numerator; on the bottom we have 3, 2 and 34; these multiplied together give us 204, which is the final denominator.



USEFUL DEFINITIONS.

RULES FOR CANCELLING.

1. Any numerator may be divided into any denominator, provided no remainder is left, and vice versa, thus:

$$\frac{\cancel{3}}{5} \text{ of } \frac{\cancel{4}}{\cancel{9}} = \frac{4}{15} \quad \left| \quad \frac{\cancel{3}}{5} \text{ of } \frac{\cancel{15}}{\cancel{18}} = \frac{1}{2}$$

2. Any numerator and denominator may be divided by the same number, provided no remainder is left, and the decreased value of such numerator and denominator be inserted in the place of those cancelled.

$$\frac{\cancel{5}}{\cancel{8}} \text{ of } \frac{\cancel{20}}{\cancel{31}}$$

Here 8 is divided by 4, and 20 can also be divided by the same number without leaving any remainder. Answer,  $\frac{15}{8}$ .

Ex.—

$$\frac{\cancel{8}}{\cancel{15}} \text{ of } \frac{\cancel{5}}{\cancel{32}} \text{ of } \frac{\cancel{14}}{\cancel{17}} = \frac{7}{3 \times 2 \times 17} = \frac{7}{102}$$

DEFS.—A COMMON DENOMINATOR of two or more fractions is a denominator to which they can all be reduced, and is the common multiple of their denominators.

THE LEAST COMMON DENOMINATOR of two or more fractions is the least denominator to which they can be reduced, and is the least common multiple of their denominators.

A MULTIPLE of a number is a number that is exactly divisible by it; or it is any product of which the given number is a factor.

Thus, 12 is a multiple of 6; 15 of 5, etc.

A COMMON MULTIPLE of two or more numbers is a number that is exactly divisible by each of them.

Thus, 12, 24, 36 and 48 are multiples of 4 and 6.

THE LEAST COMMON MULTIPLE of two or more numbers is the least number that is exactly divisible by each of them.

Thus, 12 is the least common multiple of 4 and 6.

## ADDITION OF FRACTIONS.

Addition of fractions is the process of finding the sum of two or more fractions. In order that fractions may be added, they must have like denominators and be parts of like units.

*RULE.*—Bring all the fractions to the same common denominator, add their numerators together for the new numerator, and reduce the resulting fraction to its simplest form.

### EXAMPLES.

What is the sum of  $\frac{1}{4} + \frac{1}{2} = \frac{1}{4} + \frac{2}{4} = \frac{3}{4}$ . Ans.

What is the sum of  $\frac{3}{4} + \frac{1}{2} + \frac{3}{8} + \frac{6}{8} = \frac{19}{8} = 2\frac{3}{8}$ . Ans.

## SUBTRACTION OF FRACTIONS.

Bring the fractions to others having a common denominator, as in addition, and subtract their numerators.

### EXAMPLES.

From  $\frac{7}{8}$  subtract  $\frac{3}{8} = \frac{4}{8} = \frac{1}{2}$ .

From  $\frac{1}{2}$  take  $\frac{1}{6}$ .  $\frac{3-1}{6} = \frac{2}{6} = \frac{1}{3}$ .

$\frac{7}{16} - \frac{3}{8} = \frac{7-6}{16} = \frac{1}{16}$ .

What is the difference between  $\frac{1}{2}$  of  $\frac{3}{4}$  and  $\frac{1}{4}$  of  $1\frac{1}{2}$ ?

$\frac{1}{2}$  of  $\frac{3}{4} = \frac{3}{8}$ ; and  $\frac{1}{4}$  of  $1\frac{1}{2} = \frac{1}{4}$  of  $\frac{3}{2} = \frac{3}{8}$ .

Therefore, it is  $\frac{3}{8} - \frac{3}{8} = 0$ .

## MULTIPLICATION OF FRACTIONS.

First bring each fraction to its simplest form; then multiply the numerators together for the new numerator, and the denominators together for the new denominator. Reduce the fraction to its simplest form.

MULTIPLICATION OF FRACTIONS.

EXAMPLES.

1. Multiply  $\frac{4}{7} \times 1\frac{6}{16}$ ; that is,  $\frac{4}{7} \times \frac{21}{16} = \frac{84}{112} = \frac{21}{28} = \frac{3}{4}$ , or by canceling

$$\begin{array}{r} 1 \\ \cancel{4} \\ 7 \\ 1 \end{array} \times \begin{array}{r} 3 \\ 21 \\ \cancel{16} \\ 4 \end{array} = \frac{3}{4}$$

The 4 cancels into the 16 four times, and the 7 into the 21 three times. Thus  $1 \times 3 = 3$ , and  $1 \times 4 = 4$ . Answer  $\frac{3}{4}$ .

2.  $2\frac{1}{10}$  of  $3\frac{4}{7} \times 6\frac{1}{8}$  of  $\frac{8}{21}$ .

$$\begin{array}{r} 3 \\ 21 \\ 2 \end{array} \text{ of } \begin{array}{r} 5 \\ 25 \\ 7 \\ 1 \end{array} \times \begin{array}{r} 7 \\ 49 \\ 8 \\ 1 \end{array} \text{ of } \begin{array}{r} 1 \\ 8 \\ 21 \\ 3 \end{array}$$

$$\begin{array}{r} 5 \\ 15 \\ 2 \end{array} \times \frac{7}{3} = \frac{35}{2} = 17\frac{1}{2} \text{ Answer.}$$

DIVISION OF FRACTIONS.

Reverse the divisor and proceed as in multiplication.

The object of inverting the divisor is convenience in multiplying.

After inverting the divisor, cancel the common factors.

EXAMPLES.

$\frac{3}{4} \div 1\frac{1}{8}$ , that is,  $\frac{3}{4} \div \frac{9}{8}$ , reverse the  $\frac{9}{8}$  and it becomes  $\frac{8}{9}$ ; then the question is  $\frac{3}{4} \times \frac{8}{9} = \frac{24}{36} = \frac{2}{3}$  Ans.

$4\frac{2}{7}$  of  $\frac{14}{15} \div 3\frac{2}{3}$  of  $3\frac{1}{5}$ , that is,  $\frac{30}{7}$  of  $\frac{14}{15} \div \frac{15}{4}$  of  $\frac{16}{5}$ ; canceling reduces the dividend to  $\frac{4}{1}$  and the divisor to  $\frac{1}{12}$  and we have  $\frac{4}{1} \div \frac{1}{12}$ , that is,  $\frac{4}{1} \times \frac{12}{1} = \frac{48}{1} = 48$  Ans.

## DECIMALS.

A decimal fraction derives its name from the Latin *decem*, "ten," which denotes the nature of its numbers. It has for its denominator a UNIT, or whole thing, as a pound, a yard, etc., and is supposed to be divided into ten equal parts, called tenths; those tenths into ten equal parts, called hundredths, and so on.

The denominator of a decimal being always known to consist of a unit, with as many ciphers annexed as the numerator has places, is never expressed, being understood to be 10, 100, 1000, etc., according as the numerator consists of 1, 2, 3 or more figures. Thus:  $\frac{2}{10}$ ,  $\frac{24}{100}$ ,  $\frac{125}{1000}$ , etc., the numerators only are written with a dot or comma before them, thus: .2, .24, .125.

The use of the dot (.) is to separate the decimal from the whole numbers.

The first figure on the right of the decimal point is in the place of tenths, the second in the place of hundredths, the third in the place of thousandths, etc., always decreasing from the left towards the right in a tenfold ratio, as in the following

TABLE.

Etc., Etc.	5	Tens of Millions.
5	5	Millions.
5	5	Hundreds of Thousands.
5	5	Tens of Thousands.
5	5	Thousands.
5	5	Hundreds.
5	5	Tens.
5	5	Units.
•	5	Decimal point.
5	5	Tenths.
5	5	Hundredths.
5	5	Thousandths.
5	5	Ten Thousandths.
5	5	Hundred Thousandths.
5	5	Millionths.
5	5	Ten Millionths.
Etc., Etc.		

Ascending.

Descending.

## DECIMALS.

A cipher placed on the left hand of a decimal decreases its value in a tenfold ratio by removing it farther from the decimal point. But annexing a cipher to any decimal does not alter its value at all. Thus 0.4 is ten times the value of 0.04, and a hundred times 0.004. But  $0.7=0.70=0.700=0.7000$ , etc., as above remarked.

0.2 is equal to two-tenths.

0.25 " " " twenty-five hundredths.

0.1876 " " " one thousand eight hundred and seventy-six ten thousandths, and so on.

Mixed numbers consist of a whole number and a decimal, as 4.25 and 3.875.

## TO REDUCE A FRACTION TO A DECIMAL.

RULE.—*Annex decimal ciphers to the numerator, and divide by the denominator, pointing off as many decimal places in the quotient as there are ciphers annexed.*

EX.—Reduce  $\frac{3}{4}$  to a decimal.

$$\text{EX.—} 4 \overline{) 3.00} \\ \underline{.75}$$

## TO REDUCE A DECIMAL TO A FRACTION.

RULES.—1, *Omit the decimal point*; 2, *Supply the proper denominator*; 3, *Reduce the fraction to its lowest terms.*

EX.—Reduce .075 to an equivalent fraction.

$$.075 = \frac{75}{1000} = \frac{3}{40}.$$

---

NOTE.—“It is not merely the ability to calculate that constitutes the utility of mathematical knowledge to the engineer; it is also the increased capacity for understanding the natural phenomena on which the engineering practice is based.”

## ADDITION OF DECIMALS.

*RULE.*—Place the quantities down in such a manner that the decimal point of one line shall be exactly under that of every other line; then add up as in simple addition.

### EXAMPLE.

Thus:—Add together 36.74, 2.98046, 176.4, 31.0071 and .08647.

$$\begin{array}{r}
 36.74 \\
 2.98046 \\
 176.4 \\
 31.0071 \\
 .08647 \\
 \hline
 247.21403
 \end{array}$$

## SUBTRACTION OF DECIMALS.

*RULE.*—Place the lines with decimal point under decimal point, as in addition. If one line has more decimal figures than another, put naughts under the one that is deficient till they are equal, then subtract as in simple subtraction.

### EXAMPLES.

From 146.2004 take 98.9876.

$$\begin{array}{r}
 146.2004 \\
 98.9876 \\
 \hline
 \end{array}$$

47.2128 Answer.

From 4.17 take 1.984625.

$$\begin{array}{r}
 4.170000 \\
 1.984625 \\
 \hline
 \end{array}$$

2.185375 Ans.

## MULTIPLICATION OF DECIMALS.

RULE.—Place the factors under each other, and multiply them together as in whole numbers; then point off as many figures from the right hand of the product as there are decimal places in both factors, observing, if there be not enough, to annex as many ciphers to the left hand of the product as will supply the deficiency.

EXAMPLE.—Multiply 3.625 by 2.75.

$$3.625 \times 2.75 = 9.96875 \text{ Ans.}$$

## DIVISION OF DECIMALS.

RULE.—Prepare the decimal as directed for multiplication; divide as in whole numbers; cut off as many figures for decimals in the quotient as the number of decimals in the dividend exceeds the number in the divisor; and if the places in the quotient be not so many as the rule requires, supply the deficiency by annexing ciphers to the left hand of the quotient.

EXAMPLE.—Divide 173.5425 by 3.75.

$$\begin{array}{r}
 3.75 \overline{)173.5425} (46.27+ \\
 \underline{1500} \\
 2354 \\
 \underline{2250} \\
 1042 \\
 \underline{750} \\
 2925 \\
 \underline{2625} \\
 300
 \end{array}$$

## RATIO, PROPORTION, RULE OF THREE.

THE RULE OF THREE, so called because there are always *three* numbers to find a fourth.

The solving of this problem, *i. e.*, having three numbers, to find the fourth, is the most important part of proportion. On account of its great utility and extensive application, it has been called *the golden rule*.

RATIO is the relation of two numbers as expressed by the quotient of the first divided by the second. Thus, the ratio of 6 to 3 is  $6 \div 3$ , or 2.

THE RATIO BETWEEN TWO NUMBERS *is expressed by placing a colon between them; thus, the ratio of 8 to 4 is expressed 8 : 4.*

A SIMPE RATIO IS A RATIO BETWEEN TWO NUMBERS, as 4 : 5.

A COMPOUND RATIO is a ratio formed by the combination of two or more simple ratios.

Thus,  $\frac{4}{3} : \frac{5}{2}$  is a compound ratio, and is equivalent to  $4 \times 3 : 5 \times 2$ , or 12 : 10.

The numbers whose ratio is expressed are *the terms of the ratio*. The two terms of a ratio form *a couplet*, the first of which is *the antecedent* and the second *the consequent*.

PROPORTION IS AN EQUALITY OF RATIOS. The first and fourth terms of a proportion are called *the extremes*, and the second and third *the means*.

*The product of the means is equal to the product of the extremes.*



## RATIO AND PROPORTION.

*A missing mean may be found by dividing the product of the extremes by the given mean.*

*A missing extreme may be found by dividing the product of the means by the given extreme.*

SIMPLE PROPORTION is an equality of two simple ratios, as,

$$9 \text{ lb.} : 18 \text{ lb.} :: 27 \text{ cents} : 54 \text{ cents.}$$

Ex.—If 24 wrenches cost \$27, what will 32 wrenches cost?

ANS.—36 dollars. See note.

RULE.—*For convenience, take for the third term the number that may form a ratio with, or is of the same denomination as, the answer. If, from the nature of the example, the answer is to be greater than the third term, make the greater of the two remaining terms (which must be of the same denomination) the second term; when not, make the smaller the second term. Then multiply the means (the second and third) together, and divide their product by the given extreme (the first term).*

Exs.—The missing term,  $x$ , in the examples below, can be found by applying the principles given on page 48).

$$16 : x :: 24 : 18. \text{ Ans. } 12.$$

$$x : 27 :: 18 : 54. \text{ Ans. } 9.$$

$$32 : 27 :: x : 135. \text{ Ans. } 160.$$

$$16 : 12 :: 24 : x. \text{ Ans. } 18.$$

NOTE.—For convenience in working this example make the fourth term the missing term, or the required answer. Since the third and fourth terms must be of the same denomination and the denomination of the answer will be dollars, take \$27 as the third term. From the nature of the example the answer will be more than \$27, the third term; therefore, make 32 wrenches the second term and 24 wrenches the first term. The proportion will then be stated as follows: 24 wrenches : 32 wrenches :: \$27 :  $x$  (Let  $x$  represent the unknown term). Multiplying 32 by 27, and dividing the product by 24, the fourth or missing term will be \$36.

## EVOLUTION OR SQUARE ROOT.

The SQUARE ROOT of a number is one of the two equal factors of a number. Thus, the square root of 25 is 5.  $5 \times 5 = 25$ .

TO FIND THE SQUARE ROOT OF A NUMBER.

RULE.—*Beginning at units' place, separate the given number into periods of two figures each.*

*Find the greatest square in the left-hand period, and write its root at the right in the form of a quotient in division. Subtract this square from the left-hand period, and to the remainder annex the next period to form a dividend.*

*Double the part of the root already found for a trial divisor. Find how many times this divisor is contained in the dividend, exclusive of the right-hand figure, and write the quotient as the next figure of the root. Annex this quotient to the right of the trial divisor to form the complete divisor. Multiply the complete divisor by the last figure of the root, and subtract the product from the dividend.*

*To the remainder annex the next period, and proceed as before.*

*When the given number is a decimal, separate the number into periods of two figures each, by proceeding in both directions from the decimal point.*

EXAMPLE.

Find the square root of 186624.

$$\begin{array}{r}
 18,66,24(432 \\
 16 \\
 83 \overline{) 266} \\
 \underline{249} \\
 862 \overline{) 1724} \\
 \underline{1724}
 \end{array}$$

Proof

$$\begin{array}{r}
 432 \\
 \underline{432} \\
 864 \\
 1296 \\
 1728 \\
 \hline
 186624
 \end{array}$$

EXAMPLE.

Find the square root of 735.

	7,35(27.11 etc.		Proof 2711
	4		2711
47	335		2711
	329		2711
541	600		2711
	541		18977
5421	5900		5422
	5421		734.9521
	etc.		

We proceed as before till we get the remainder 6, and we see it is not a perfect square; we wish the root to be taken to two or three places of decimals; there are no more figures to bring down, therefore bring down two ciphers and proceed as in the first example; to the remainder attach two more ciphers and proceed as before, and by attaching two ciphers to the remainder you may carry it to any number of decimal places you please. In the above example the answer is 27.11, etc.

The following important note is to be studied in connection with example at the bottom of the opposite page.

NOTE.—Begin at the last figure 4, count two figures, and mark the second as shown in the example; count two more, and mark the figure, and so on till there are no more figures; take the figures to the left of the last dot, 18, and find what number multiplied by itself will give 18. There is no number that will do so, for  $4 \times 4 = 16$ , is too small, and  $5 \times 5 = 25$ , is too large; we take the one that is too small, viz., 4, and place it in the quotient, and place its square, 16, under the 18, subtract and bring down the next two figures, 66. To get the divisor, multiply the quotient 4 by 2=8. place the 8 in the divisor, and say 8 into 26 goes 3 times, place the 3 after the 4 in the quotient and also after the 8 in the divisor; multiply the 83 by the 3 in the quotient, and place the product under the 266 and subtract, then bring down the next two figures, 24. To get the next divisor, multiply the quotient 43 by 2=86; see how often 8 goes into 17, twice; place the 2 after the 43 of the quotient, and also after the 86 of the divisor; multiply the 862 by the 2, and put it under the 1724, then subtract. Answer, 432.

## EVOLUTION.

In expressing the square root it is customary to use simply the mark ( $\sqrt{\quad}$ ), the 2 being understood.

All roots as well as powers of *one* are 1, as  $\sqrt{1}=1$ .

## EXAMPLE.

Find the square root of 588.0625.

$$\begin{array}{r}
 5,88.06,25(24.25 \\
 \underline{4} \\
 44 \mid 188 \\
 \underline{176} \\
 482 \mid 1206 \\
 \underline{964} \\
 4845 \mid 24225 \\
 \underline{24225}
 \end{array}$$

In a decimal quantity like the above, the marking off differs from the former examples. Instead of counting twos from right to left, we begin at the decimal point and count twos toward the left and toward the right. The rest of the work is similar to the other examples.

Notice, that when the .06 is brought down, the figure for a quotient is a decimal.

To familiarize oneself with the extracting of the square root, it is well first to square a number and then work backward according to the examples here given, and by long and frequent practice become expert in the calculation. But in first working square root, it is undoubtedly better to secure the services of a teacher.

## INVOLUTION

Is the raising a number (called the root) to any power. The powers of a number are its square, cube, 4th power, 5th power, etc.

$2 \times 2 = 4$	4 is the square or 2nd power of 2.
$2 \times 2 \times 2 = 8$	8 is the cube or 3d power of 2.
$2 \times 2 \times 2 \times 2 = 16$	16 is the 4th power of 2.
Etc.	Etc.

RULE.—*To square a number multiply it by itself.*

EXAMPLE.

What is the square of 27 (written  $27^2$ )?

$$\begin{array}{r} 27 \\ 27 \\ \hline 189 \\ 54 \\ \hline \end{array}$$

729 Answer.

RULE.—*To cube a number, multiply the square of the number by the number again.*

EXAMPLE.—What is the cube of 50 (written  $50^3$ )?

$$\begin{array}{r} 50 \\ 50 \\ \hline 2500 \text{ the square} \\ 50 \\ \hline \end{array}$$

125000 the cube.

A *power* of a quantity, is the product arising from multiplying the quantity by itself one or more times. When the quantity is taken *twice* as a factor, the product is called the *second* power; when taken *three* times, the *third* power, and so on.

## INVOLUTION.

## SIGNS THAT REPRESENT THE ROOTS OF NUMBERS.

The sign common to all roots is  $\sqrt{\quad}$  or  $\sqrt{\quad}$  and is known as the Radical Sign. If we require to express the square root of a number we simply put this sign before it, as  $\sqrt{16}$ , but if the number is made up of two or more terms, then we express the square root by the same in front, but with a line as far as the square root extends, as  $\sqrt{9+7}$  or  $\sqrt{4(19+6)}$ .

The cube root is expressed by the same sign, with a 3 in the elbow, as  $\sqrt[3]{8}$  or  $\sqrt[3]{7(100-51)}$ .

All other roots in the same manner, the number of the root being put instead of the 3. As fifth root  $\sqrt[5]{\quad}$ , and sixth root  $\sqrt[6]{\quad}$ , etc.

In the above examples,  $9+7=16$ , and the square root of 16 is 4.

The  $4(19+6)=4 \times 25=100$ , and the square root of 100 is 10.

The other way of expressing that the root is required, is by putting a fraction after and above the quantity, as  $16^{\frac{1}{2}}$ , which means the square root of 16,  $(19+17)^{\frac{1}{2}}$ , or  $\{4(19+6)\}^{\frac{1}{2}}$  all of which means the square root of the quantities to which they are attached.

The cube root, 4th root, 5th root, etc., are written in the same way, as  $729^{\frac{1}{3}}=9$ ;  $256^{\frac{1}{4}}=4$ ;  $3125^{\frac{1}{5}}=5$ , etc.

THE POWERS OF NUMBERS.

SIGNS REPRESENTING THE POWER OF NUMBERS.

$6^2$  is equal to  $6 \times 6 = 36$ ; that is, 36 is the square of 6.

$5^3$  is equal to  $5 \times 5 \times 5 = 125$ ; that is, 125 is the cube of 5.

$4^4$  is equal to  $4 \times 4 \times 4 \times 4 = 256$ ; that is, 256 is the fourth power of 4.

The power and the root are often combined, as  $4^{\frac{3}{2}}$ ; this is read as the square root of 4 cubed. So the numerator figure represents the power, and the denominator figure represents the root. In this case the square root of 4 is 2, and the cube of 2 is  $2 \times 2 \times 2 = 8$  Answer.

Perhaps the most common form that the student will meet with this sign is in the following:

$8^{\frac{2}{3}}$ , which is read the cube root of 8 squared. Now, 8 squared = 64, and the cube root of 64 is 4 Answer.

Find the value of  $20^{\frac{3}{2}}$ .

20 cubed = 8000, and square root of 8000 = 89.4, etc.

EXAMPLE.

What is the value of  $\frac{8^{\frac{2}{3}} + 81}{3^{\frac{3}{2}}}$ ?

$$8^{\frac{2}{3}} = \sqrt[3]{8^2} = \sqrt[3]{64} = 4; 81^{\frac{1}{2}} = 9; 3^{\frac{3}{2}} = \sqrt{3^3} = \sqrt{27} = 5.2 \text{ nearly.}$$

Hence,  $\frac{4+9}{5.2} = \frac{13}{5.2} = 2.5$  or  $2\frac{1}{2}$  Answer.

( ) are called *brackets*, and mean that all the quantities within them are to be put together first; thus,  $7(8-6+4 \times 3)$  means that 6 must be subtracted from  $8=2$ , and 4 times  $3=12$  added to this  $2=14$ ; and then this 14 is to be multiplied by  $7=98$ .

## THE METRIC SYSTEM.

In the Metric or French system of weights and measures, the *Meter* is the basis of all the units which it employs. The *Meter* is the unit of length, and is equal to one ten-millionth part of the distance measured on a meridian of the earth from the equator to the pole, and equals about 39.37 inches, or  $39\frac{1}{8}$  inches nearly.

The standard meter is a bar of platinum carefully preserved at Paris. Exact copies of the meter and the other units have been procured by the several nations (including the United States) that have legalized the system.

In this system, weights and measures are increased or decreased by the following words prefixed to them:

Milli	expresses the	1,000th	part.
Centi	“	“	100th “
Deci	“	“	10th “
Deka	“	10	times the value.
Hecto	“	100	“ “ “
Kilo	“	1,000	“ “ “

### TABLE.

	1 Millimeter.....( $\frac{1}{1000}$ of a meter)	= .03937 <i>in.</i>
10 <i>mm.</i>	= 1 Centimeter.....( $\frac{1}{100}$ of a meter)	= .3937 <i>in.</i>
10 <i>cm.</i>	= 1 Decimeter.....( $\frac{1}{10}$ of a meter)	= 3.937 <i>in.</i>
10 <i>dm.</i>	= 1 METER.....(1 meter)	= 39.37 <i>in.</i>
10 <i>m.</i>	= 1 Dekameter.....(10 meters)	= 32.8 <i>ft.</i>
10 <i>Dm.</i>	= 1 Hectometer.....(100 meters)	= 328.09 <i>ft.</i>
10 <i>Hm.</i>	= 1 Kilometer.....(1000 meters)	= .62137 <i>mile.</i>

---

NOTE.—A gramme is the weight of a cubic centimeter of distilled water; a decigramme contains  $\frac{1}{10}$  of a gramme; a dekagramme contains 10 grammes.





**MENSURATION**



---

## USEFUL MEASUREMENTS.

---

*A measurement* is an ascertained dimension, as the length, breadth, thickness, depth, extent, quantity, capacity, etc., of a thing as determined by measuring.

*Mensuration is the art of measuring things which occupy space*; the art is partly mechanical and partly mathematical.

*There are three kinds of quantity in space, viz., length, surface and solidity*; and there are three distinct modes of measurement, viz., *mechanical measurement, geometrical construction and algebraical calculations*. The last two modes are done by calculations, while in mechanical measurements they are made by the direct application of rules and special measuring instruments.

*Lengths are measured on lines, and the measure of a length of a line is the ratio or relation which the line bears to a recognized unit of length*—the inch, foot or mile determined by reference to brass rods kept by the United States Government at Washington as a standard. The use of the “rules” is called *direct measurement*.

*The second kind of quantity to be measured is surface*. This sort of measurement is never done directly or mechanically, but always by the measurement of lines, as will be seen both under this division and under the sections relating to geometry.

*The third species of quantity is solidity*. Direct measurement of solid quantities consists simply in filling a vessel

## USEFUL MEASUREMENTS.

of known capacity, like a bushel or gallon measure, until all is measured. The geometrical mode of computing solids is the one hereafter shown by examples and illustrations.

## SURFACES.

*A surface* is the exterior part of anything that has length and breadth, as the surface of a cylinder. *The area* of any figure is the measure of its surface or the space contained within the bounds of that surface, without any regard to the thickness.

## TO FIND THE AREA OF A TRIANGLE.

A Triangle is a figure bounded by three sides, and is half a parallelogram; hence the

RULE.—*Multiply the base by half the perpendicular height.*

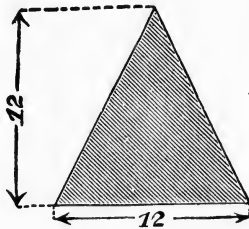

Fig. 6.

EXAMPLE.—The base of the triangle is 12 feet, and it is also 12 feet high; what is its area?

Half the height=6 feet; and  $12 \times 6 = 72$  square feet area.

## SURFACES.

## TO FIND THE AREA OF A TRAPEZIUM.

A Trapezium is any four-sided figure that is neither a rectangle, like a square or oblong, nor a parallelogram.

RULE.—1. *Join two of its opposite angles, and thus divide it into two triangles.*

2. *Measure this line and call it the base of each triangle.*

3. *Measure the perpendicular height of each triangle above the base line.*

4. *Then find the area of each triangle by the previous rule; their sum is the area of the whole figure.*

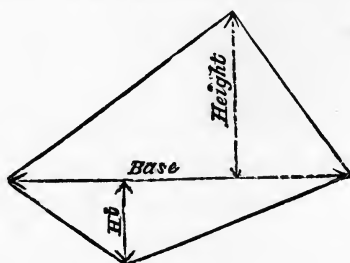

Fig. 7.

## TO FIND THE AREA OF A TRAPEZOID.

A Trapezoid is a trapezium having two of its sides parallel.

RULE.—*Multiply half the sum of the two parallel sides by the perpendicular distance between them.*

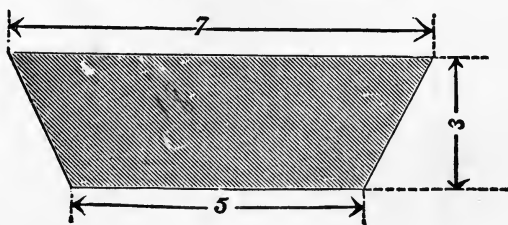

Fig. 8.

## USEFUL MEASUREMENTS.

Let the figure be the trapezoid, the sides 7 and 5 being parallel; and 3 the perpendicular distance between them.

EXAMPLE.—Find the area of the above trapezoid, the parallels being 7 feet and 5 feet, and the perpendicular height being 3 feet.

$$\begin{array}{r} 7 \\ 5 \\ \hline 2)12 \\ \hline \end{array}$$

6 And  $6 \times 3 = 18$  square feet.

## TO FIND THE AREA OF A SQUARE.

A Square is a figure having all its angles right angles and all its sides equal.

RULE.—*Multiply the base by the height; that is, multiply the length by the breadth.*

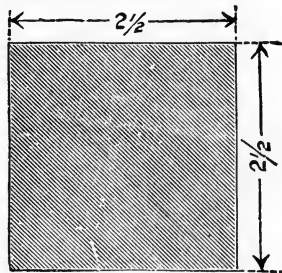

Fig. 9.

EXAMPLE.—What is the area of a square whose side is  $2\frac{1}{2}$  feet?

$$\begin{array}{r} 2.5 \\ 2.5 \\ \hline 125 \\ 50 \\ \hline \end{array}$$

Answer, 6.25 square feet.

## SURFACES.

## TO FIND THE AREA OF A RECTANGLE.

A rectangle is a figure whose angles are all right angles, but whose sides are not equal; only the opposite sides are equal.

RULE.—*Multiply the length by the breadth.*

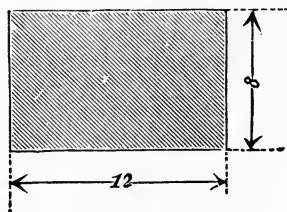

Fig. 10.

EXAMPLE.—What is the area of a rectangular figure whose base is 12 feet and height 8 feet?

12

8

—

Answer, 96 square feet.

## TO FIND THE AREA OF A PARALLELOGRAM.

A Parallelogram is a figure whose opposite sides are parallel, the square and oblong are parallelograms; so also are other four-sided figures whose angles are *not* right angles. It is these latter whose area we now want to find.

RULE.—*Multiply the base by the perpendicular height.*

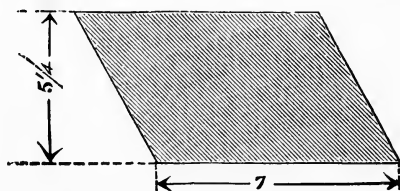

Fig. 11.

## USEFUL MEASUREMENTS.

EXAMPLE.—Find the area of a parallelogram whose base is 7 feet and height  $5\frac{1}{4}$  feet?

$$\begin{array}{r} 5.25 \\ 7 \\ \hline \end{array}$$

Answer, 36.75 square feet.

TO FIND THE AREA OF A POLYGON.

RULE.—*Multiply the sum of the sides, or perimeter of the polygon, by the perpendicular dropped from its center to one of its sides, and half the product will be the area.* This rule applies to all regular polygons.

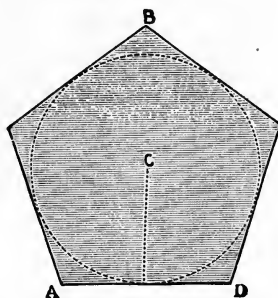

Fig. 12.

EXAMPLE.—What is the area of a regular pentagon, or five-sided figure,  $BAD$  whose side  $AD$  is 9 feet and the perpendicular  $CE$  is 6 feet?

$$\begin{array}{r} 9 \\ 5 \\ \hline 45 \text{ the perimeter.} \\ 6 \\ \hline 270 \\ 2 \overline{) 270} \\ \hline \end{array}$$

Answer, 135 feet.



## THE CIRCLE.

The circle is a plane figure, comprehended by a single curve line, called its *circumference*, every part of which is equally distant from a point called the *center*. Of course, all lines drawn from the center to the circumference are equal to each other.

### .7854

“Why is the decimal .7854 used to ascertain the area of a circle or round opening?” is a question frequently asked. Now, if you will divide a square inch into 10,000 parts, then describe a circle one inch in diameter and divide that into ten thousandths of an inch, you will find that you have 7854 of such squares, each one-thousandth of an inch, hence the decimal .7854 is used as a “constant” or multiplier, after squaring the diameter, and the result is the area of the circle.

### 3.1416

The Greek letter  $\pi$ , called pi, is used to represent 3.1416, the circumference of a circle whose diameter is 1. The circumference of a circle equals the diameter multiplied by 3.1416, nearly. Another approximate proportion is  $\frac{22}{7}$ , and another still nearer is  $\frac{355}{113}$ .

This decimal has been worked out to 36 places, as follows :

3.141592653589793238462643383279502884+

and called the Ludolphian number, because calculated by Ludolph Van Ceulen, a long time ago.

## USEFUL MEASUREMENTS.

TO FIND THE LENGTH OF THE CURVE LINE, CALLED THE CIRCLE; THAT IS, TO FIND THE CIRCUMFERENCE OF A CIRCLE.

RULE.—*Multiply 3.1416 by the diameter.*

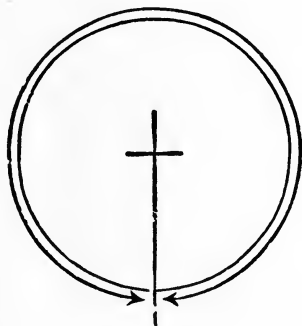

Fig. 13.

EXAMPLE.—What is the circumference of a circle whose diameter is 3 inches?

$$\begin{array}{r} 3.1416 \\ 3 \\ \hline \end{array}$$

Answer, 9.4248 inches.

TO FIND THE DIAMETER OF A CIRCLE.

RULE.—(1) *Multiply the circumference by 7 and divide by 22*; or, (2) *Divide the circumference by 3.1416.*

EXAMPLE.

A pulley has a circumference of 50.30'', find its diameter?

$$\frac{50.30 \times 7}{22} = 16'' \text{ diameter. Answer.}$$

THE CIRCLE.

TO FIND THE AREA OF A CIRCLE.

RULE.—Multiply the square of the diameter by .7854.

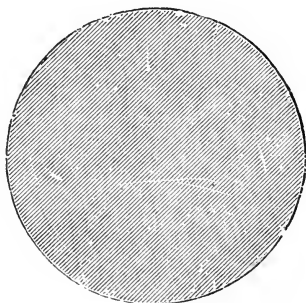

Fig. 14.

EXAMPLE.—The diameter of a circle is 3 inches, find its area.

$$\begin{array}{r} 3 \\ 3 \\ \hline 9 \end{array}$$

$$\begin{array}{r} .7854 \\ \hline 9 \end{array}$$

Answer, 7.0686 square inches.

EXAMPLE.—The diameter of a circle is 3.5 inches, find the area.

$$\begin{array}{r} 3.5 \\ 3.5 \\ \hline 175 \\ 105 \\ \hline 12.25 \end{array}$$

$$\begin{array}{r} .7854 \\ 12.25 \\ \hline 39270 \\ 15708 \\ 15708 \\ 7854 \\ \hline \end{array}$$

Answer, 9.621150 square inches.

NOTE.—“In every branch of science our knowledge increases as the power of measurement becomes improved.”

## USEFUL MEASUREMENTS.

TO FIND THE SECTIONAL AREA OF A RING OR PIPE.

RULE.—From the area of the greater circle subtract that of the lesser.

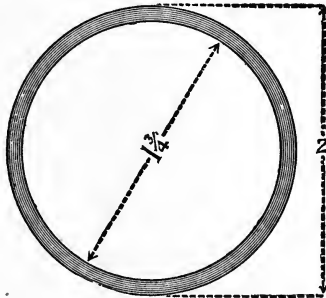

Fig. 15.

EXAMPLE.—A pipe has an external diameter of 2" and an internal diameter of 1 1/4", find its sectional area in square inches.

$$\begin{array}{l} \text{Thus area of } 2'' = 2^2 \times .7854 = 3.1416 \\ \text{“ } 1\frac{1}{4}'' = 1\frac{1}{4}^2 \times .7854 = 2.4053 \end{array}$$

Answer, .7363 square inches.

TO FIND THE AREA OF AN ELLIPSE.

RULE.—Multiply .7854 by the product of the diameters.

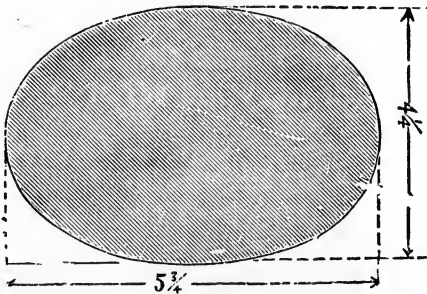

Fig. 16.

THE CIRCLE.

EXAMPLE.

What is the area of an ellipse whose diameters are  $5\frac{3}{4}$  and  $4\frac{1}{4}$ ?

5.75	24.4375
4.25	.7854
2875	977500
1150	1221875
2300	1955000
24.4375	1710625
	19.19321250

TO FIND THE SURFACE OR ENVELOPE OF A CYLINDER.

RULE.—Multiply 3.1416 by the diameter, to find the circumference, and then by the height.

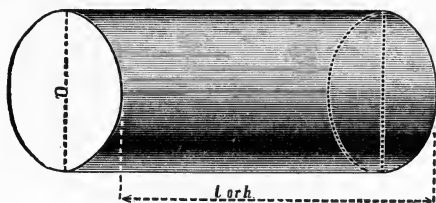

Fig. 17.

EXAMPLE.

What is the surface of a cylinder whose diameter is 9 inches and height 15 inches.

3.1416	
9	
28.2744	= circumference.
15	
1413720	
282744	
424.1160	area of surface in square inches,

## USEFUL MEASUREMENTS.

TO FIND THE SURFACE OR ENVELOPE OF A SPHERE.

The surface of a sphere is equal to the convex surface of the circumscribing cylinder; hence the

RULE.—*Multiply 3.1416 by the diameter of the sphere, and this again by the diameter; because in this case the diameter is the height of the cylinder;*

*Or multiply 3.1416 by the square of the diameter of the sphere.*

## EXAMPLE.

What is the surface of a sphere whose diameter is 3 feet? See figure page 73.

$$\begin{array}{r} 3.1416 \\ \quad 9=3^2 \\ \hline 28.2744 \text{ area of surface in square feet.} \end{array}$$

QUOTATION.—“Observe any of the best-known mechanics’ pocket reference books after it has been used a few years, and there is always indisputable evidence that the arithmetical tables are used oftener than any other part of the contents. Though it may be well preserved in all other parts, the tables are worn to a useless condition.”

## SOLIDS.

---

A *solid* is a body or magnitude which has three dimensions—length, breadth and thickness—being thus distinguished from a *surface*, which has but two dimensions, and from a *line*, which has but one ; the boundaries of solids are surfaces.

The measurement of a solid is called its solidity, capacity or content.

TO FIND THE SOLIDITY OR CAPACITY OF ANY FIGURE IN THE CUBICAL FORM.

RULE.—*Multiply the length by the breadth and by the depth.*

### EXAMPLES.

A tank is 10 feet long, 6 feet broad and 3 feet deep ; how many cubic feet of water will it hold ?

$$10 \times 6 \times 3 = \text{Ans. } 180 \text{ cubic feet.}$$

A bar of iron is 24" long, 6½" broad, and 2¼" thick ; how many cubic inches does it contain ?

$$24 \times 6.5 \times 2.25 = \text{Ans. } 351 \text{ cubic ins.}$$

Find the cubical contents in inches of a shaft 3" diameter and 15' 0" long ?

$$3^2 \times .7854 = 7.0686 \times 15 \times 12 = \text{Ans. } 1272.348 \text{ cubic ins.}$$

## MEASUREMENTS OF SOLIDS.

A CUBE is a solid having six equal square sides. TO FIND THE CONTENTS—

RULE.—*Multiply the area of the base by the perpendicular height.*

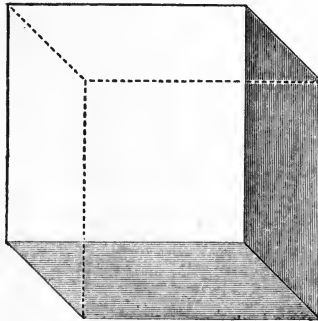

Fig. 18.

EX.—What is the contents of a cistern whose sides and depth are 3 feet 6 inches?

$$3' 6'' \times 3' 6'' \times 3' 6'' = 42' 10'' \text{ nearly (42.875 cubic feet).}$$

TO FIND THE CONTENTS OF A RECTANGULAR SOLID.

RULE.—*Multiply the length, breadth and height together.*

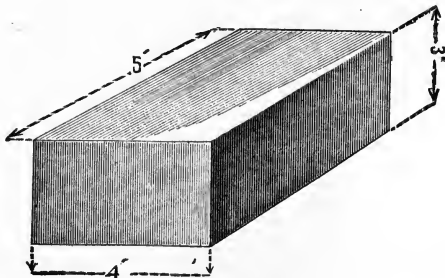

Fig. 19.



EXAMPLE.

What is the contents of a rectangular solid whose length is 5 feet, breadth 4 feet and height 3 feet?

$$\begin{array}{r}
 5 \text{ feet} \\
 4 \text{ feet} \\
 \hline
 20 \text{ square feet of base} \\
 3 \text{ feet} \\
 \hline
 60 \text{ cubic feet}
 \end{array}$$

TO FIND THE CUBIC CONTENTS OF A SPHERE.

RULE.—Multiply .7854 by the cube of the diameter, and then take  $\frac{2}{3}$  of the product.

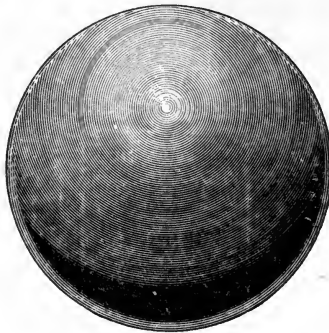

Fig. 20.

EX.—Find the cubic contents of a sphere whose diameter is 5 feet.

$$\begin{array}{r}
 5 \\
 5 \\
 \hline
 25 \\
 5 \\
 \hline
 125 = 5^3
 \end{array}
 \qquad
 \begin{array}{r}
 .7854 \\
 125 \\
 \hline
 39270 \\
 15708 \\
 7854 \\
 \hline
 98.1750 \\
 2 \\
 \hline
 3)196.3500
 \end{array}$$

Answer, 65.4500 cubic feet.

## USEFUL MEASUREMENTS.

The rule is only approximate, owing to the "repeating decimal" used in the calculations. Another rule is as follows:

*Multiply the cube of the diameter by .5236, or the cube of the circumference by .016887, and the product will be the solidity.*

## TO FIND THE SOLIDITY OF A HEMISPHERE.

**RULE.**—*Multiply the square of the diameter by the radius, and multiply the product by .5236, which is the ratio between the solidity of a cube and that of a sphere, whose diameter is equal to one side of the cube.*

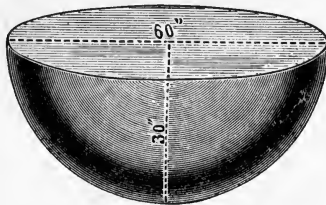

Fig. 21.

**EXAMPLE.**—How many cubic inches in a hemisphere whose diameter is 60 inches?

$$60 \times 60 \times 30 \times .5236 = 56548.8 \text{ cubic inches. Answer.}$$

**NOTE.**—The convex surface of a sphere may be found by multiplying the circumference by the diameter. Or, multiply the square of the diameter by 3.1416, and the product will be the convex surface.

The solidity of a sphere is equal to two-thirds of the solidity of its circumscribing cylinder.

The surface of a sphere is equal to 4 times the area of a circle of the same diameter as the sphere; or to the area of a circle whose diameter is double that of the sphere; or to the convex surface of the circumscribing cylinder.

SOLIDITY OF A HEMISPHERE.

TO FIND THE SOLIDITY OF A SEGMENT OF A SPHERE.

RULE 1.—To three times the square of the radius of the segment's base, add the square of the depth or height; then multiply this sum by the depth, and the product by .5236.

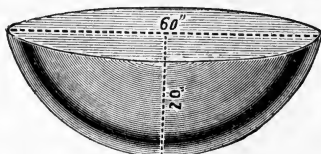

Fig. 22.

EXAMPLE.—How many cubic inches in a spherical segment which has a diameter of 60 inches and a depth of 20 inches?

$60 \div 2 = 30$  inches radius.  $30 \times 30 \times 3 = 2700$ ;  $2700 + (20 \times 20) = 3100$ ;  $3100 \times 20 \times .5236 = 32463.2$ , which is the number of cubic inches.

RULE 2.—From three times the diameter of the sphere subtract twice the height of the segment; multiply the remainder by the square of the height, and that product by .52361 for the solidity.

EXAMPLE.—If the diameter of a sphere be 3 feet 6 inches, what is the solidity of a segment whose height is 1 foot 3 inches? Ans. 6.545 feet.

$$\begin{array}{r} \text{Now, } 3.5 \times 3 = 10.5 \\ 1.25 \times 2 = 2.5 \\ \hline 8 \end{array}$$

$$1.25 \times 1.25 = 1.5625 \times 8 = 12.5 \text{ Product.}$$

$$\text{Then, } 12.5 \times .52361 = 6.545 \text{ cubic feet.}$$

NOTE.—When the segment is greater than a hemisphere, find the solidity of the lesser segment and subtract the same from the solidity of the entire sphere.

## USEFUL MEASUREMENTS.

TO FIND THE CUBIC CONTENTS OF A SOLID CYLINDER.

RULE.—*Find the area of the base, and multiply this by the height or length.*

## EXAMPLE.

What is the cubic contents of a cylinder whose diameter is 4 feet, and height or length  $7\frac{1}{2}$  feet?

$$\begin{array}{r} 4 \\ 4 \\ \hline 16 \end{array} \quad \begin{array}{r} .7854 \\ 16 \\ \hline 47124 \\ 7854 \\ \hline \end{array}$$

12.5664 = area of base in square feet  
7.5 = height or length in feet

$$\begin{array}{r} 628320 \\ 879648 \\ \hline \end{array}$$

Answer, 94.24800 cubic feet.

TO FIND THE SOLIDITY OF A CYLINDRICAL RING.

RULE.—*To the thickness of the ring, add the inner diameter; and this sum being multiplied by the square of the thickness, and the product again by 2.4674, will give the solidity.*

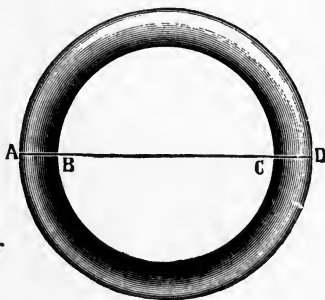

Fig. 23.

NOTE.—The surface of a cylindrical ring may be found by the following rule: To the thickness of the ring, add the inner diameter; and this sum being multiplied by the thickness, and the product again by 9.8696, will give the surface required.

SOLIDITY OF A CYLINDRICAL RING.

EXAMPLE.—What is the solidity of a cylindrical ring whose thickness  $A B$  or  $C D$  is 6, and the inner diameter  $B C$  20 inches?

Here  $(20+6) \times 6^2 \times 2.4674 = 26 \times 36 \times 2.4674 = 936 \times 2.4674 = 2309.4864$  inches, the solidity required.

TO FIND THE SOLIDITY OF A CONE.

RULE.—Multiply the area of the base by the perpendicular height, and  $\frac{1}{3}$  of the product will be the solidity.

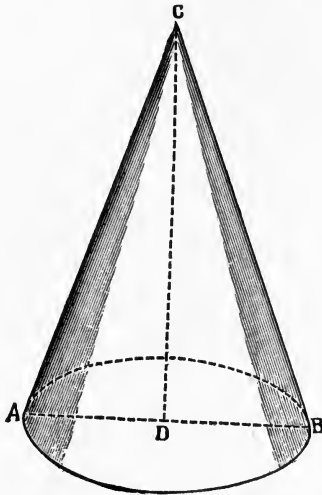

Fig. 24.

EXAMPLE.

1. Required, the solidity of the cone  $A B C$ ; the diameter,  $A B$ , of the base being 12 feet, and the perpendicular altitude,  $D C$ , 18 feet 6 inches.

Here  $.7854 \times 12^2 = .7854 \times 144 = 113.0976$ , the area of the base; and  $(113.0976 \times 18.5) \div 3 = 2092.3056 \div 3 = 697.4352$  feet, the solidity required.

## USEFUL MEASUREMENTS.

TO FIND THE CUBIC CONTENTS OF A FRUSTRUM OF A CONE.

A frustrum of a cone is the lower portion of a cone left after the top piece is cut away.

RULE.—*Find the sum of the squares of the two diameters ( $d$ ,  $D$ ), add on to this the product of the two diameters multiplied by .7854, and by one-third the height ( $h$ ).*

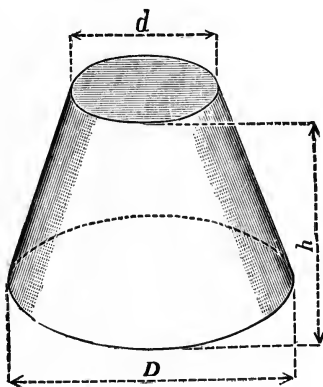

Fig. 25.

EXAMPLE.—Find the cubic contents of a safety-valve weight of the following dimensions: 12" large diameter, 6" small diameter, 4" thick. Now:

$$144 + 36 + 72 \times .7854 \times 1.33 \\ 252 \times .7854 \times 1.33 = 263.23, \text{ etc., cubic inches.}$$

TO FIND THE SOLIDITY OF A PYRAMID.

Pyramids may be trilateral, quadrilateral, pentagonal, hexagonal, heptagonal, octagonal, etc., having three, four, five, six, seven, eight triangular sides, respectively.

## SOLIDITY OF A PYRAMID.

The trilateral pyramid has three triangles. The quadrilateral pyramid has four triangles, and the pentagonal pyramid has five triangles, and so on.

RULE.—*Multiply the area of the base by one-third of the perpendicular height, and the product will be the solidity.*

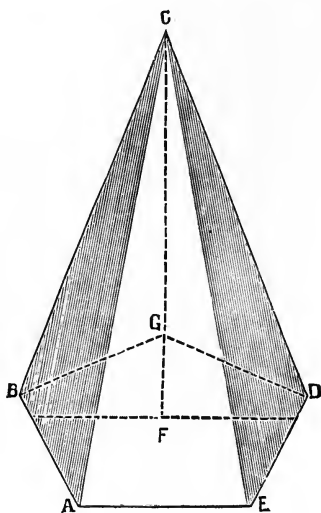

Fig. 26.

EXAMPLE.—What is the solidity of the regular pentagon pyramid  $A B C D E$ , each side of the base being 9 feet, and the perpendicular altitude,  $F C$ , 24 feet?

The area of the base, see page 64, is

$$\frac{135}{8} \text{ feet} \times \frac{1}{3} \text{ of } 24 = 8$$

Answer, 1080 feet, the solid contents.

## USEFUL MEASUREMENTS.

**TO FIND THE SOLIDITY OF AN IRREGULAR SOLID.**

## RULE.

*Divide the irregular solid into different figures; and the sum of their solidities, found by the preceding problems, will be the solidity required.*

*If the figure be a compound solid, whose two ends are equal plane figures, the solidity may be found by multiplying the area of one end by the length.*

*To find the solidity of a piece of wood or stone that is craggy or uneven, put it into a tub or cistern, and pour in as much water as will just cover it; then take it out and find the contents of that part of the vessel through which the water has descended, and it will be the solidity required.*

If a solid be large and very irregular, so that it cannot be measured by any of the above rules, the general way is to take lengths, in two or three different places; and their sum divided by their number, is considered as a mean length. A mean breadth and a mean depth are found by similar processes. Sometimes the length, breadth and depth taken in the middle are considered mean dimensions.

There are five regular solids which are shown in Figs. below. A regular solid is bounded by similar and regular plane figures. Regular solids may be circumscribed by spheres, and spheres may be inscribed in regular solids.

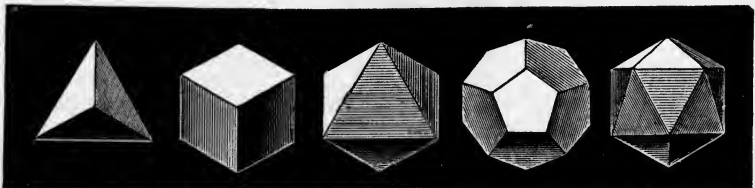

Fig. 27.

Fig. 28.

Fig. 29.

Fig. 30.

Fig. 31.



THE FIVE REGULAR SOLIDS.

The *Tetrahedron* (fig. 27) is bounded by four equilateral triangles.

The *Hexahedron*, or cube (fig. 28), is bounded by six squares.

The *Octahedron* (fig. 29) is bounded by eight equilateral triangles.

The *Dodecahedron* (fig. 30) is bounded by twelve pentagons.

The *Icosahedron* (fig. 31) is bounded by twenty equilateral triangles.

TO FIND THE SURFACE AND THE CUBIC CONTENTS OF ANY OF THE FIVE REGULAR SOLIDS.

RULE.—For the surface, multiply the tabular area below, by the square of the edge of the solid.

For the contents, multiply the tabular contents below, by the cube of the given edge.

TABLE OF CONSTANTS.

SURFACES AND CUBIC CONTENTS OF REGULAR SOLIDS.

Number of Sides	NAME	Area. Edge = 1	Contents. Edge = 1
4	.....Tetrahedron.....	1.7320	0.1178
6	.....Hexahedron.....	6.0000	1.0000
8	.....Octahedron.....	3.4641	0.4714
12	.....Dodecahedron.....	20.6458	7.6631
20	.....Icosahedron.....	8.6603	2.1817

A constant is a quantity or multiplier which is assumed to be invariable.

## PARTS OF A CIRCLE.

The circumference of a circle is supposed to be divided into 360 degrees or divisions, and as the total angularity about the center is equal to four right angles, each right angle contains 90 degrees or  $90^\circ$ , and half a right angle contains  $45^\circ$ . Each degree is divided into 60 minutes, or  $60'$ ; and, for the sake of still further minuteness of measurement, each minute is divided into 60 seconds, or  $60''$ . In a circle there are, therefore,  $360 \times 60 \times 60 = 1,296,000$  seconds.

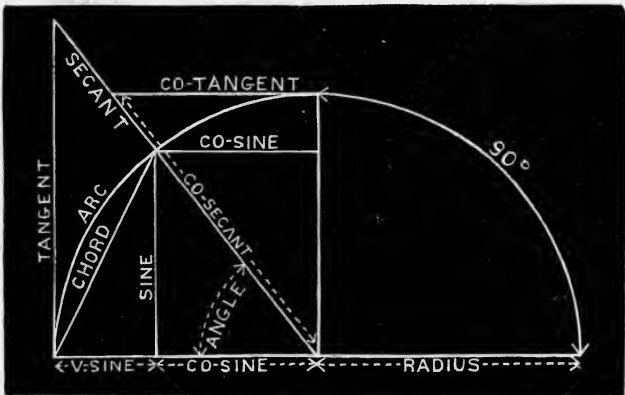

Fig. 32.

The above diagram exemplifies the relative positions of the

Sine,

Tangent,

Cosine,

Cotangent,

Versed sine,

Secant, and

Cosecant

of an angle.

---

**NOTE.**—The circumferences of all circles contain the same number of degrees, but the greater the radius, the greater the absolute measures of a degree. The circumference of a fly-wheel or the circumference of the earth have the same number of degrees; yet the same number of degrees in each and every circumference is the measure of precisely the same angle.

## DEFINITIONS OF PARTS OF A CIRCLE.

1. The *Complement* of an arc is  $90^\circ$  minus the arc.
2. The *Supplement* of an arc is  $180^\circ$  minus the arc.
3. The *Sine* of an angle, or of an arc, is a line drawn from one end of an arc, perpendicular to a diameter drawn through the other end.
4. The *Cosine* of an arc is the perpendicular distance from the center of the circle to the sine of the arc; or it is the same in magnitude as the sine of the complement of the arc
5. The *Tangent* of an arc is a line touching the circle in one extremity of the arc, and continued from thence to meet a line drawn through the center and the other extremity.
6. The *Cotangent* of an arc is the tangent of the complement of the arc. The *Co* is but a contraction of the word complement.
7. The *Secant* of an arc is a line drawn from the center of the circle to the extremity of the tangent.
8. The *Cosecant* of an arc is the secant of the complement.
9. The *Versed Sine* of an arc is the distance from the extremity of the arc to the foot of the sine.

For the sake of brevity these technical terms are contracted thus: for sine  $AB$ , we write *sin. AB*; for cosine  $AB$ , we write *cos. AB*; for tangent  $AB$ , we write *tan. AB*, etc.

---

NOTE.—*Trigonometry* is that portion of geometry which has for its object the measurement of triangles. When it treats of plane triangles it is called *Plane Trigonometry*, and as the engineer will continually meet in his studies of higher mathematics the terms used in plane trigonometry, it is advantageous for him to become familiar with some of the principles and definitions relating to this branch of mathematics.

## MEASURING MACHINES, TOOLS AND DEVICES.

---

The accuracy of a man's workmanship can usually be determined from knowing the kind of measuring instruments he employs. It is an old saying among mechanics that a blacksmith's "hair's-breadth" is anything less than a quarter of an inch. There used to be good ground for this statement, the reason being that the blacksmith measured with a square, the graduations of which were  $\frac{1}{4}$  inch.

When a man begins to use a scale graduated to hundredths he finds, as soon as he learns to distinguish the marks, that there is considerable space included in  $\frac{1}{100}$  of an inch.

When a man has used a micrometer caliper for a short time he learns to determine  $\frac{1}{2}$  of  $\frac{1}{1000}$  of an inch quite readily, and then begins to appreciate the value of fine measurements and close fits. In considering modern methods and comparing them with older practice, we are at once struck by the definiteness with which the sizes of parts are now fixed. The fitting of one part to another is no longer a question of working to gauges of which the absolute sizes are unknown, but of working to sizes which

---

NOTE.—In a device consisting of a short steel rod fitting into a hollow cylinder, the rod being three-quarters of an inch in diameter, it was found that the fit was so perfect that it would slide freely in and out, but if the rod was taken out and held in the hand for a few seconds, the slight expansion caused by the warmth of the hand was enough to render it impossible to insert the rod until it had been allowed by gradual cooling to regain its normal size.

## MEASURING MACHINES AND TOOLS.

are definitely fixed and stated, and which are at any time capable of reproduction. To carry out this system means the general provision of instruments for accurate measurement which were formerly only to be found in a very few special establishments; it means the possession of skill in the use of such measuring appliances, and a cultivation of an appreciation of the value of small units.

Fig. 33 shows a side view of a standard End-Measuring Rod; these are formed of steel, hardened on the ends and accurately ground, so that the ends form sections of true spheres whose diameters are equal to those of the length of the rods. They are suitable for making internal measure-



Fig. 33.

ments, as rings, cylinders, etc.; and, as reference tools, are particularly well adapted for setting calipers, comparing gauges, and work of a similar character. They are also suitable for measuring parallel surfaces, as the spherical ends will pass such surfaces without cramping, the same as spheres of like diameters.

Figs. 34 to 39 exhibit Inside Micrometer Gauges. These are adjustable, and designed for making internal measurements, and work of a similar character, and are also adapted for measuring parallel surfaces.

The device consists of a holder provided with a micrometer screw and thimble. The screw has a movement of  $\frac{1}{2}$ " ; and, by the use of the extension rods fur-

## MEASURING TOOLS AND DEVICES.

nished, measurements from 3" to 6" can be made by the thousandths of an inch.

The extension rods vary by  $\frac{1}{2}$ ", and each rod is provided with an adjusting nut and check-nut, which are set

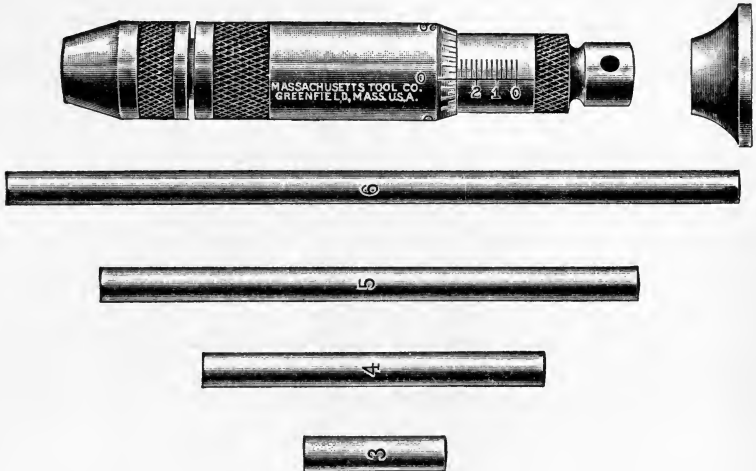

Figs. 34 to 39.

to obtain the proper measurement of the given rod, and should be adjusted only when the point of that rod has become worn.

This instrument is provided with a micrometer screw and nut, and is graduated to read by half-thousandths.

Provision is made for adjustment to compensate for wear of the screw and measuring surfaces.

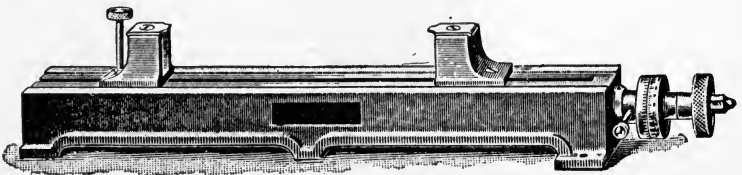

Fig. 40.

## MEASURING MACHINES.

Fig. 40 shows a standard form of measuring machine for use in the tool room in preparing templates, reamers, mandrels, etc. It will measure differences of the  $\frac{1}{10000}$  of an inch. Adjustments in the machine provide for the wear of measuring points.

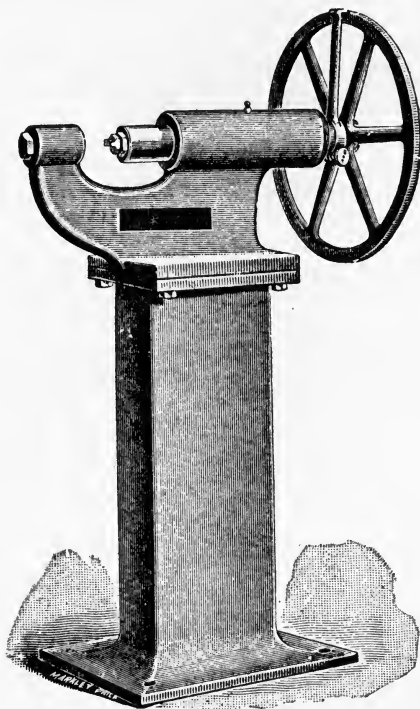

Fig. 41.

Calipering Machines are used to transmit sizes, and differ from fixed calipers in that they record as the size is approached, and show how much a piece is to be reduced.

Machines of this type are used in connection with standard sizes as an accurate pair of calipers, and have the features of a measuring machine, as they will measure

## MEASURING DEVICES.

accurately *above and below a certain size* after having been adjusted and the index, which is on the edge of the wheel, set for a standard size. The machine shown in fig. 41

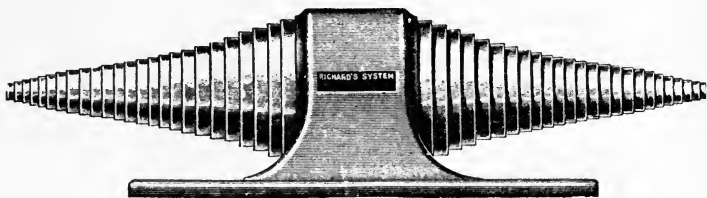

Fig. 42.

will caliper to 6 inches. The index wheel is divided to read to ten-thousandths of an inch.

Fig. 42 shows corrective gauge standards. These discs are employed for testing and correcting fixed gauges, for setting calipers, and also as a reference to prove dimensions within their range. Each disc is separate and is ground independently to size.

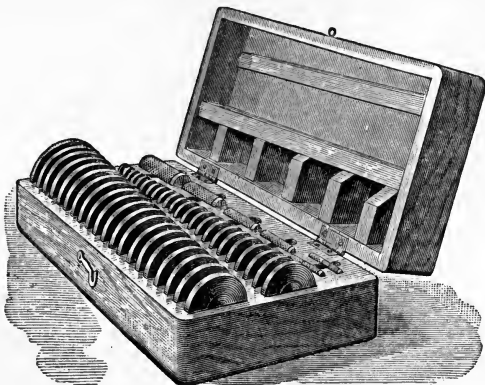

Fig. 43.

The introduction of accurate scientific methods into manufacturing and commercial processes involves the use



MEASURING TOOLS.

of a great variety of standards of far greater accuracy than formerly required. Fig. 42 is but one of very many measuring devices introduced to secure the essential accuracy.

Standard reference discs are shown in fig. 43. These are employed for testing and correcting fixed caliper gauges, for setting calipers, and also as a reference to

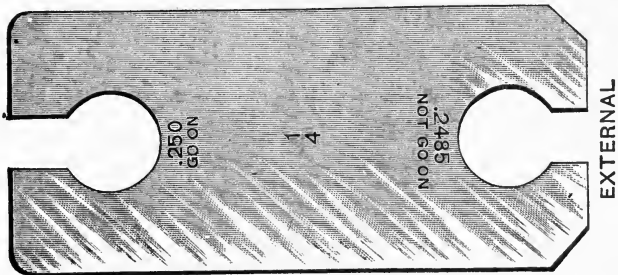

Fig. 44.

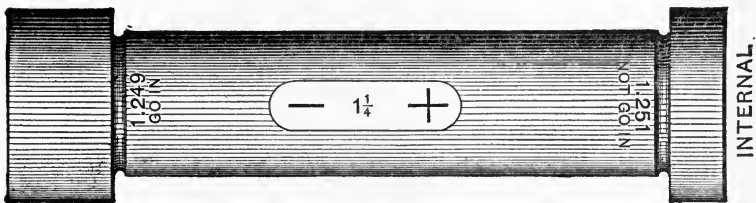

Fig. 45.

prove dimensions within their range. They are intended to serve principally as originals, not as working gauges.

The illustration represents "a set" of forty-five discs, ranging in size from  $\frac{1}{4}$ " to 3", inclusive, by 16ths, and four handles. The discs vary in width from  $\frac{1}{4}$ " to  $\frac{1}{2}$ ", according to the diameter, and afford ample contact surface.

The figures 44 and 45 represent the common form of internal and external limit gauges. Gauges of this type

## MEASURING DEVICES.

are stamped with the words "go on" and "not go on," for the external, and "go in" and "not go in" for the internal; and, as the two ends are of different shape, the workman is enabled to easily and quickly distinguish the large from the small end without looking at the sizes stamped upon the gauge.

These gauges are not only used as references for finishing operations, but are of advantage in roughing work for finishing. When used in this way the same amount of stock is left on each piece, thus enabling the operator who finishes the pieces to work to better advantage than if they were of various sizes.

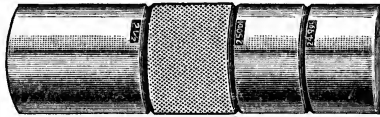

Fig. 46.

The fig. 46 shows a limit gauge as used in shop practice. It is stamped  $2\frac{1}{2}$ , 2.500, 2.4995; the end marked  $2\frac{1}{2}$  is ground accurately to size, and is not used except as a reference standard, the calipers or measuring instruments being set by the ends marked 2.500, 2.4995. The difference between these is a limit of .0005, or the  $\frac{1}{2000}$  part of an inch.

The advantages derived from the use of the limit gauges are being appreciated more and more; as, by their use the time consumed in testing and gauging is reduced to a minimum, and the duplication of parts is insured.

## MEASURING DEVICES.

Fig. 47 shows an adjustable parallel measuring gauge. It measures from  $\frac{1}{4}$  inch to 4 inches, and measurements over the above are got by placing a base beneath. The slide is tightened by the right-hand thumb nut and the scriber by the the left-hand one, by which both work inde-

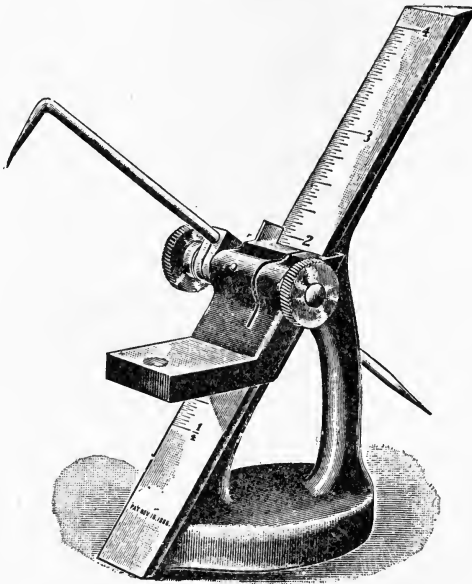

Fig. 47.

pendently of each other. It is graduated into 64 parts to the inch. The graduation on the tool is wider than the ordinary scale, it being on an incline, but the operator should read them just the same as a scale of 64ths, matching the line of the slide to the graduation on the incline.

## GAUGES.

English or Birmingham gauges, for sheet and plate steel and iron, are shown in figs. 48 and 49. The former indicates sizes from 1 to 32; the latter from 000 to 25. The illustrations are about two-thirds the real size.

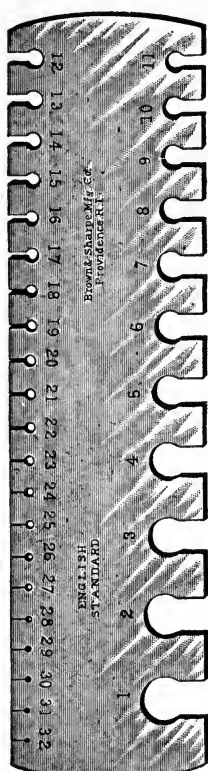

Fig. 48.

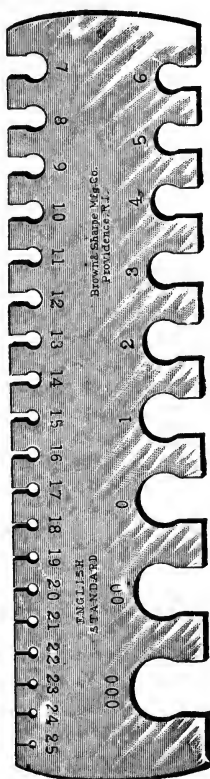

Fig. 49.

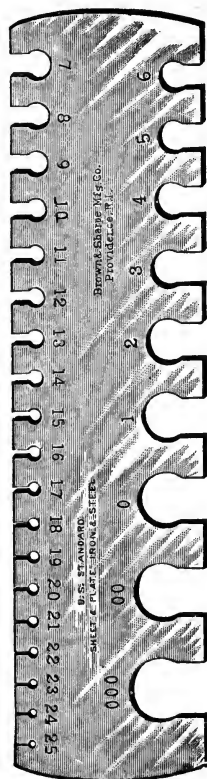

Fig. 50.

Fig. 50 represents, two-thirds actual size, the United States Standard Gauge for sheet and plate steel and iron, adopted by Congress March 3, 1893.

GAUGES.

Figs. 51 and 52 are gauges for use in measuring twist drills and steel drill rods.

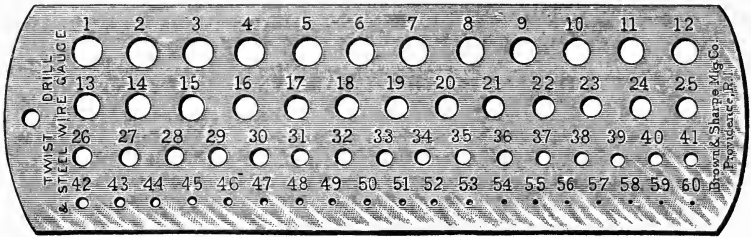

Fig. 51.

Gauge No. 51 is about  $\frac{1}{16}$ " thick,  $1\frac{5}{8}$ " wide,  $5\frac{1}{4}$ " long, and contains gauge numbers from 1 to 60 inclusive.



Fig. 52.

Gauge No. 52 is about  $\frac{1}{16}$ " thick,  $\frac{3}{4}$ " wide, 2" long, and contains gauge numbers from 61 to 80 inclusive.

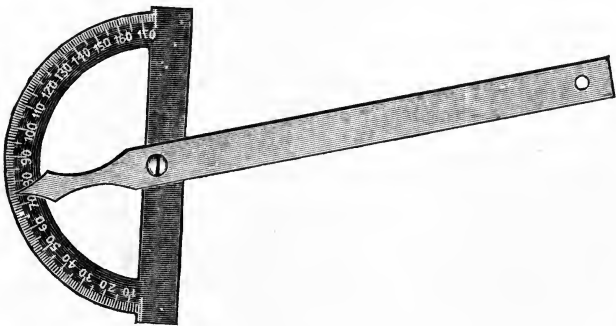

Fig. 53.

Fig. 53 shows an angle gauge, with the addition of a protractor and registering dial. It is a very useful tool for testing planed and finished parts.

## ANGLE-GAUGES.

Fig. 54 shows a simple form of bevel protractor operated on the same principles as that shown in the preceding illustration.

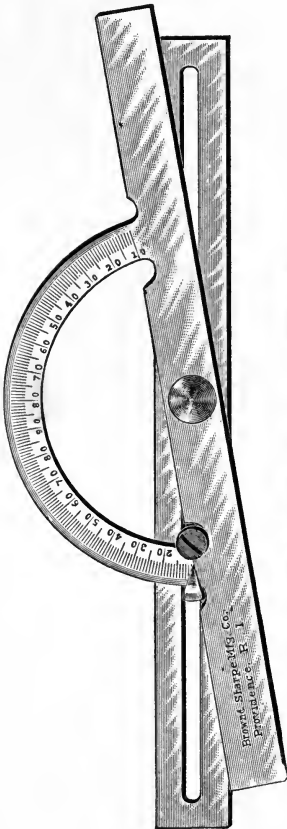

Fig. 54.

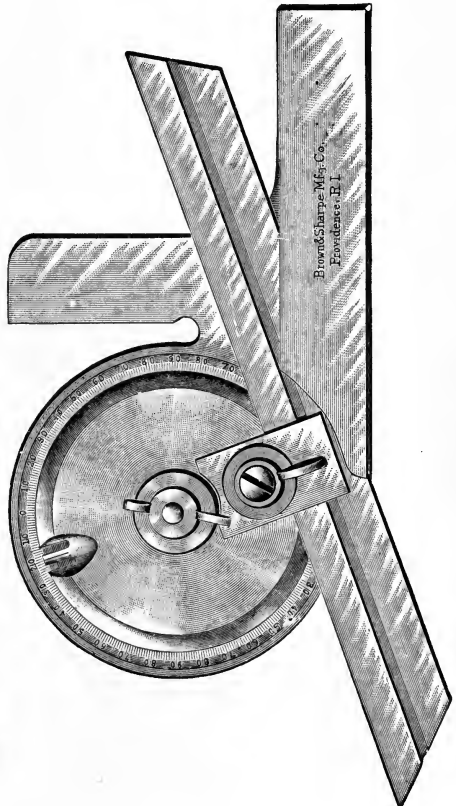

Fig. 55.

Fig. 55 shows still another form of the same device. In each of the above instruments the circles, or parts thereof, are divided into degrees.

## USEFUL MEASUREMENTS.

This tool is well adapted for all classes of work where angles are to be laid out or established; one side of the stock is flat, thus permitting its being laid upon the paper or work. The dial is accurately graduated in degrees the entire circle. It turns on a large central stud, which is hardened and ground, and can be rigidly clamped by the thumb nut shown in cut.

The line of graduations is below the surface, thus protecting them from wear. The blade is about one-eighth inch thick, can be moved back and forth its entire length, and clamped independently of the dial, thus adapting the protractor for work where others cannot be used.

## THE VERNIER AND ITS USE.

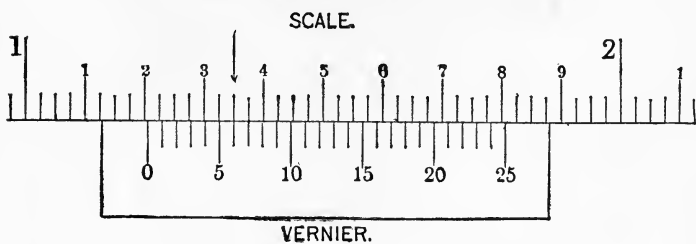

Fig. 56.

The Vernier is a small *movable scale* invented by Pierre Vernier in 1631, and used for measuring a fractional part of one of the equal divisions on the graduated *fixed scale*.

The Vernier consists, in its simplest form, of a small sliding scale, the divisions of which differ from those of the fixed or primary scale; the ingenuity of the invention has given a lasting and world-wide fame to the discoverer of its useful application.

## THE VERNIER AND ITS USE.

On the scale of the tool is a line of graduations divided into inches and numbered 0, 1, 2, etc., each inch being divided into ten parts, and each tenth into four parts, making forty divisions to the inch.

On the sliding jaw is a line of divisions of twenty-five parts, numbered 0, 5, 10, 15, 20, 25. The twenty-five divisions on the Vernier correspond, in extreme length, to twenty-four divisions, or  $\frac{24}{40}$  of an inch, on the scale; each

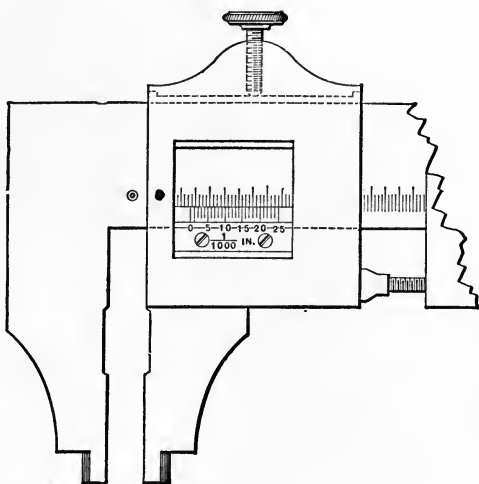

Fig. 57.

division on the Vernier is, therefore,  $\frac{1}{25}$  of  $\frac{1}{40}$ , or  $\frac{1}{1000}$  of an inch shorter than the corresponding division on the scale.

If the Vernier is moved until the line marked 0 on the Vernier coincides with that marked on the scale, then the next two lines to the right will differ from each other by  $\frac{1}{1000}$  of an inch; and the difference will continue to increase  $\frac{1}{1000}$  of an inch for each division, until the line 25 on the Vernier coincides with a line on the scale.



## USEFUL MEASUREMENTS.

Fig. 56 represents a Vernier caliper, showing the two scales, and in the note is an admirable explanation of its use, for which credit is due to Brown & Sharpe Manufacturing Co.

NOTE.—On the bar of the instrument is a line of inches, numbered 0, 1, 2, etc., each inch being divided into ten parts, and each tenth into four parts, making forty divisions to the inch. On the sliding jaw is a line of divisions of twenty-five parts, numbered 0, 5, 10, 15, 20, 25. The twenty-five parts on the Vernier correspond, in extreme length, with 24 parts, or twenty-four fortieths of the bar; consequently, each division on the Vernier is smaller than each division on the bar by .001 part of an inch. If the sliding jaw of the caliper is pushed up to the other, so that the line marked 0 on the Vernier corresponds with that marked 0 on the bar, then the two next lines to the right will differ from each other by .001 of an inch, and so the difference will continue to increase, .001 of an inch for each division, till they again correspond at the line marked 25 on the Vernier. To read the distance the caliper may be open, commence by noticing how many inches, tenths and parts of tenths the zero point on the Vernier has been moved from the zero point on the bar.

Now, count upon the Vernier the number of divisions, until one is found which coincides with one on the bar, which will be the number of thousandths to be added to the distance read off on the bar. The best way of expressing the value of the divisions on the bar is to call the tenths one hundred thousandths (.100), and the fourths of tenths, or fortieths, twenty-five thousandths (.025). Referring to the cut shown above, it will be seen that the jaw is open two-tenths and three-quarters, which is equal to two hundred and seventy-five thousandths (.275). Now, suppose the Vernier was moved to the right, so that the tenth division would coincide with the next one on the scale, which will make ten thousandths (.010) more to be added to two hundred and seventy-five thousandths (.275), making the jaws to be open two hundred and eighty-five thousandths (.285).

## USEFUL, MEASUREMENTS.

Figs. 58 and 59 represent the entire calipers of which the head only is shown in fig. 57.

These instruments are graduated on the front side to

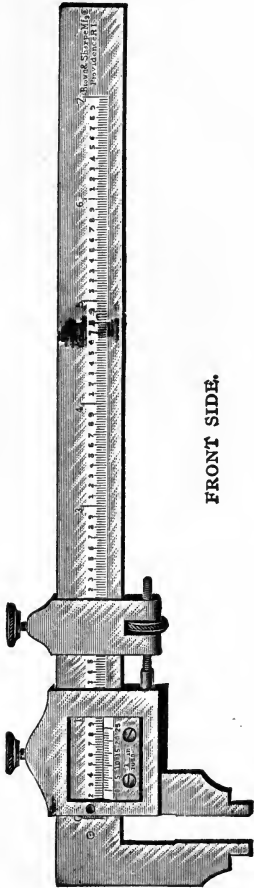

Fig. 58.

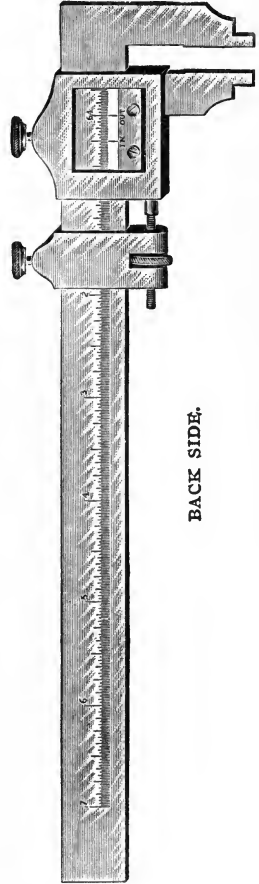

Fig. 59.

read, by means of the Vernier, to thousandths of an inch, and on the back to sixty-fourths of an inch; the jaws can be used for either outside or inside measurements; points

THE VERNIER AND ITS USE.

are placed on the bars and slide, so that dividers can be used to transfer distances. Verniers are applied to minute measuring instruments, as the sextant, barometer, etc.

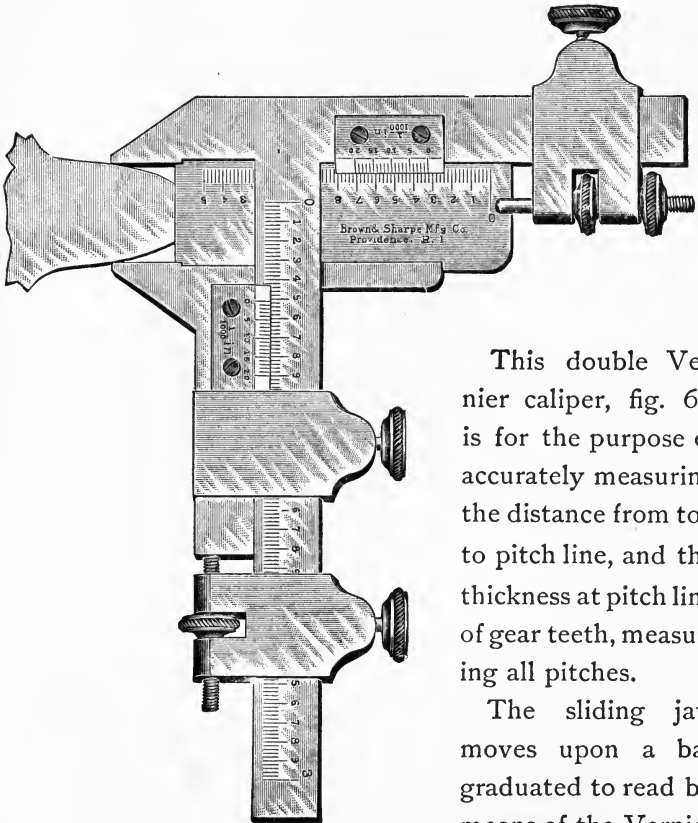

Fig. 60.

This double Vernier caliper, fig. 60, is for the purpose of accurately measuring the distance from top to pitch line, and the thickness at pitch line of gear teeth, measuring all pitches.

The sliding jaw moves upon a bar graduated to read by means of the Vernier to thousandths of an

inch. A tongue, moving at right angles with the jaws, is graduated in the same manner. Both the sliding jaw and tongue are provided with adjusting screws.

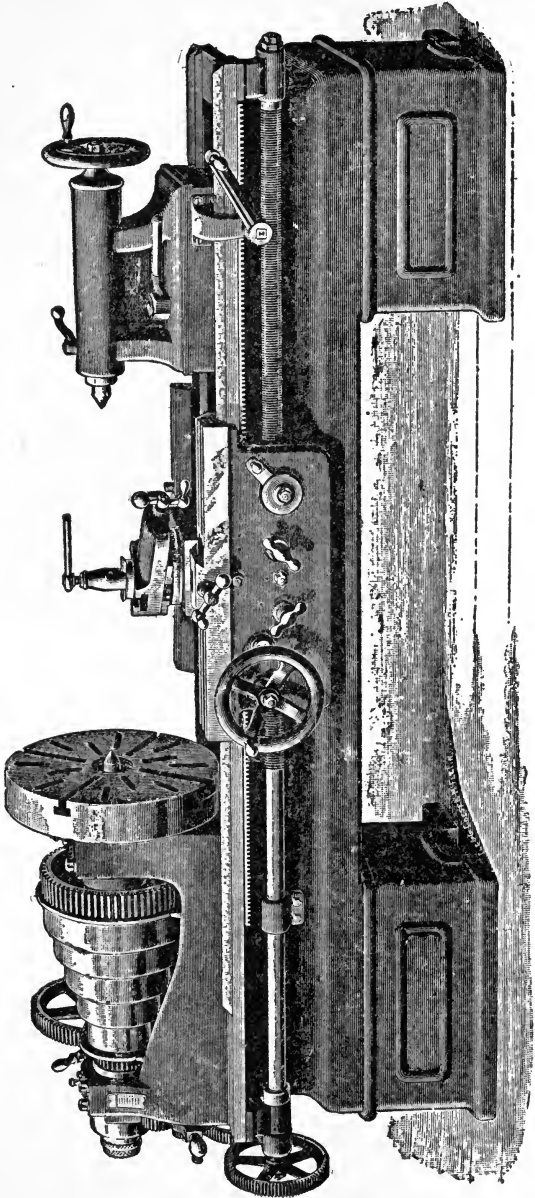



Fig. 61.



**TURNING**  
**AND**  
**BORING**

“There is a difference between ‘cut’ and ‘wear’; tightening a *cut* journal will ruin it; steady, uniform, rotary *wear* upon a journal will outlast the lifetime of almost any machine.”

“No man of any pretensions has any right to mix up the terms journal and bearing; a *journal* is that part of a shaft or axle that rests in the bearings; a *bearing* is the part, the contact with which, a journal moves, or the part of any piece where it is supported or the part of another piece where it is supported; a bearing is a guide to steady a shaft or rod and maintain it in position.”

## SCREW-CUTTING IN THE LATHE.

---

The operations of turning and boring are performed in the lathe, screw machine, boring mill, etc.; in these the work is usually made to rotate to a cutting tool, which, except for "the feeds," is stationary.

The movement of the work and the cutting of the tools, produce curved or circular, external or internal, and plane surfaces.

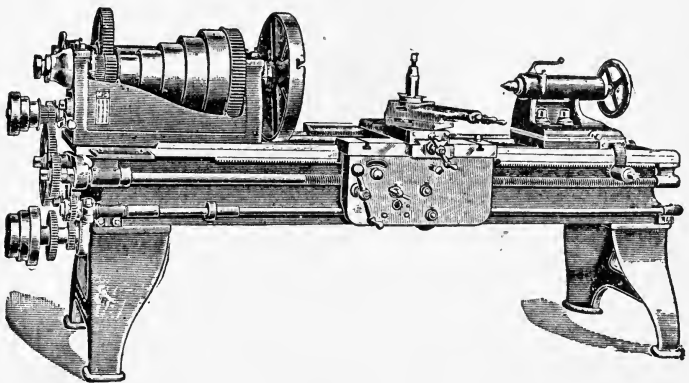

Fig. 62.

The lathe, with its two headstocks, is admirably adapted for all kinds of work supported by the two heads directly, or supplemented by supports or steady rests.

When boring and facing have to be done on the headstock, disadvantages and defects are encountered; the work must of necessity overhang when fixed on the hori-

## TURNING AND BORING.

zontal spindle, causing vibration, etc. Another defect of the horizontal lathe, when used for boring, is the difficulty of setting and securing the overhang work to the face-plate.

The illustration, page 100, is a lathe designed for screw-cutting by the means of the lead-screw shown on the front.

Fig. 62 shows a lathe for turning, boring and screw-cutting; it has self-acting longitudinal and cross feeds, actuated by the spline feed spindle in front, on which is a sliding worm geared into a worm wheel on the carriage; the screw-cutting mechanism is actuated by the long leading screw shown in front, under the rack which is fixed to the shears or slides of the lathe.

Fig.  
63.Fig.  
64.

There are two ways of cutting a screw-thread in a lathe: 1, *by tools manipulated by the hand, called chasers*; 2, *by cutting tools fixed in the lathe rest, which slides automatically.*

Chasers are of two kinds, the outside and the inside chaser; fig. 63 shows the outside or male chaser; it is the one which cuts the male thread, on a pipe, etc.; fig. 64 shows the inside, or female chaser; this cuts the interior thread on a pipe, etc.

The teeth of chasers are made to correspond to the number of threads per inch which they are intended to cut, and each size chaser can only be used to cut its own



## SCREW-CUTTING IN THE LATHE.

number of threads, although the same chaser is equally suitable for different diameters of work; thus, an eight-thread-to-the-inch chaser would cut a thread of this pitch equally as well on a piece of work  $\frac{3}{4}$  inch diameter as on a piece 1 inch diameter.

The mode of applying a chaser to cut an external thread is shown in fig. 65. Here *A* is the work between centers, *B* the tool rest, and *C* the chaser. If the tool rest, *B*, is placed with its upper surface level with the center of the work, then the chaser, *C*, must be tilted slightly, as shown in fig. 65, in order to bring the cutting angles of

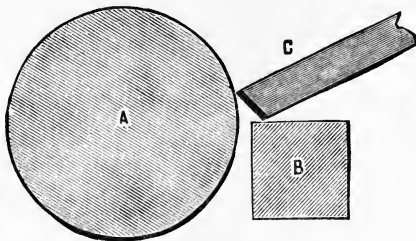

Fig. 65.

NOTE.—These hand tools or chasers would appear, at first acquaintance to many, to be old-fashioned, and not up-to-date devices for performing the very beautiful process of producing a perfectly uniform thread; nevertheless, chasers cannot be entirely superseded, even by the very perfect modern lathe, as a good workman can produce, with their aid and with ease and certainty, screws of the greatest cleanness and delicacy—the pressure required being very slight—threads can be cut by this method on the thinnest and the most fragile materials, which would be quite unable to resist the more violent treatment to which they would be subjected by any other process of screw-cutting; this system is used by manufacturers of brass fittings for telescopes and exceedingly light work, the thickness of the tube employed frequently exceeding only to a very small extent the depth of the screw thread which is cut upon them; it is not unusual to give the finishing touch to the threads of machine and engine work with the hand chaser when accurate and perfect threads are required.

## TURNING AND BORING.

the tool into the right position. To start a thread, the end of the work should first be beveled off, as shown in fig. 66, and the points of the chaser teeth applied lightly to the work: if the chaser is held still in the one place, it is evident the teeth will simply cut a series of rings or circles on the surface of the work instead of a spiral thread; at the same time, therefore, as the teeth are applied to the work, a sliding motion towards the left hand must be given to the chaser; the exact rate at which the

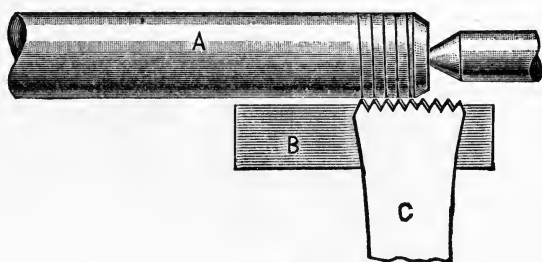

Fig. 66.

chaser is moved depends on the pitch of the screw to be cut, and also the speed at which the work is revolved in the lathe.

To cut a true thread, the chaser should move through a distance of one tooth for each revolution of the work, and this motion should be perfectly uniform; the speed of the lathe also should be constant and regular; if this operation be correctly performed the teeth of the chaser will produce one continuous spiral line, which should run quite true as the work revolves; the chaser is then brought back to the right-hand end of the work, and another cut taken, so as to deepen the line already made.

## SCREW-CUTTING IN THE LATHE.

Great care is necessary for the first few cuts, to insure that the chaser-teeth engage in the same cuts each time, and that they do not start fresh threads; the line or groove is thus cut deeper and deeper, until it becomes a V-shaped groove, with, of course, the V-shaped ridge, or thread, between.

Fig. 67 shows a hand-chaser being used for cutting an internal thread. In this case the tool-rest, *B*, is placed across the mouth of the hole, and the chaser is inserted and gradually advanced, with its teeth against the interior surface, as shown.

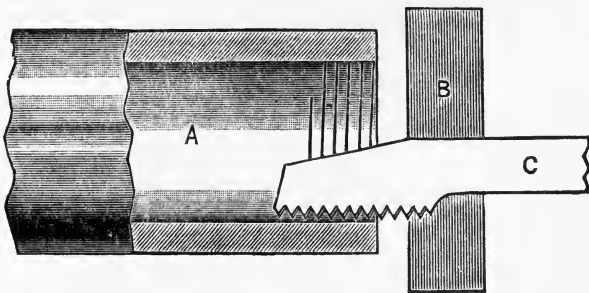

Fig. 67.

In chasing wrought iron or steel, plenty of soap and water or oil, preferably the former, should be used as a lubricant. If the chaser be moved along unevenly, or if the speed of the lathe fluctuate, an irregular thread will be produced, and this will be readily recognized by the "wobbling" appearance it has when running. A thread of this description is caused by incorrect speed of travel.

If the chaser-teeth be inserted in a true thread, without any cutting taking place, the screw will carry the chaser along at the proper speed. By trying this plan with the lathe

## TURNING AND BORING.

running at various speeds, the reader will readily see how the speed at which the work revolves necessitates a faster or slower sliding motion of the chaser accordingly to produce a screw of the desired pitch.

When it is desired to cut a screw of, say, two or three inches, with a hand-chaser, the first inch or so should be well started before following up to the remaining portion of the screw; this, if correctly done, will then form a guide to lead the chaser up to the part as yet uncut.

*The second method of screw-cutting in the lathe is performed by cutting-tools fixed in the lathe rest.*

For cutting screws of any pitch by a tool fixed in the lathe rest, the lathe requires to be specially fitted with, 1, a leading or guide screw; 2, a quadrant fitted with one or more studs for carrying the change wheels; 3, a saddle or carriage upon which is fixed the slide rest carrying the cutting tools; 4, a nut attached so that it can be readily put into or out of gear with the leading screw.

The following illustration, fig. 68, shows the general arrangement of lathe for cutting a screw. *A* is the leading screw; the round metal bar, *B*, on which the screw is to be cut, is placed between the steel centers of the fast and movable headstocks of the lathe; a "carrier," or dog, *C*, is secured to the bar at the end next to the fast headstock, which engage with a driving stud, *D*, attached to the face-plate.

The cutting of a screw in a lathe, whether V-shape or a square thread, is an operation, the most important part

## SCREW-CUTTING IN THE LATHE.

of which is the selection of the proper change wheels. Every turn or revolution of the leading screw moves the carriage and cutting tool through a distance equal to the pitch of the leading screw. If the iron bar, *B*, fig. 68, revolves at the same rate as the leading screw, *A*, the pitch of the screw cut upon the bar will be

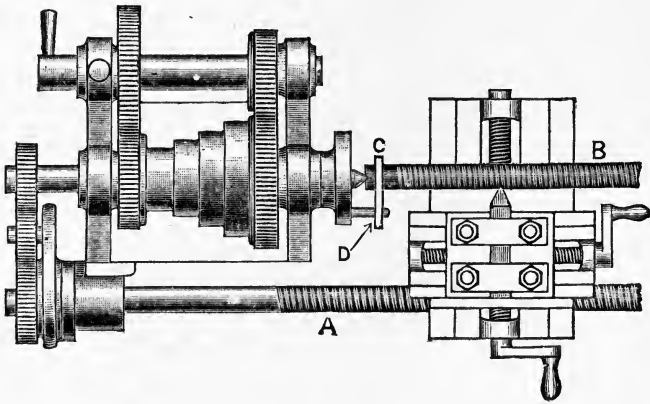

Fig. 68.

the same pitch as that of the leading screw; to cut the same thread as the leading screw, therefore, the driving wheel on the lathe mandrel must be the same size as the follower or driven wheel on the leading screw.

If the bar revolve faster than the leading screw, then the pitch of thread cut on the bar will be less than that on the leading screw; if the bar revolve slower than the leading screw, the thread cut upon the bar will be of greater pitch than that of the leading screw.

Fig. 68 shows the general arrangement *looking down on the work of a lathe* arranged for cutting screw threads,

## SCREW-CUTTING IN THE LATHE.

with a cutting tool fixed in the tool-holder, which slides or travels automatically.

When V-threads are cut in a screw-cutting lathe by tools sliding automatically, a single-pointed tool is generally used.

Fig. 69 shows the front tool for cutting the male or outside thread; fig. 70 shows the inside tool for cutting the interior thread.



Fig. 69.

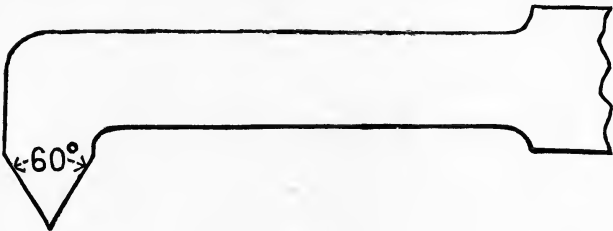

Fig. 70.

It will be noticed that the tools are very similar to the ordinary turning and boring tools, but with the points ground to a V-shape, the angle of the V corresponding exactly with the correct angle for the screw to be cut.

**NOTE.**—When cutting internal screw-threads it is important to remember that the diameter of the hole should be equal to the diameter at the *bottom* of the male screw-thread, which is to fit into it; thus the hole intended for an inch bolt, having eight threads per inch on it, would be bored out to just under seven-eighths inch diameter.

## SCREW-CUTTING IN THE LATHE.

There is one important difference, however, between the shape of a turning tool and a screw-cutting tool; *i. e.*, that the tool point is canted or sloped over at an angle; this is necessary in the screw-cutting tool to prevent it rubbing against the sides of the thread, owing to the slope or "rake" of the latter; the rake of a thread depends on the pitch of the screw and the diameter of the work on which it is cut; thus, a screw of one-eighth pitch cut on a bolt of one-inch diameter, will have greater rake or slope than that of a thread of same pitch cut on a bolt of two inches diameter.

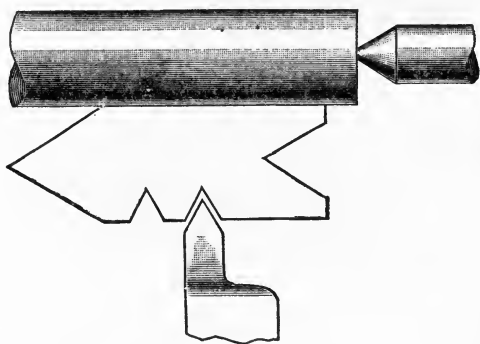

Fig 71.

It may be said, however, that in actual practice it is not necessary to make a separate tool for each pitch of thread when cutting V-threads of reasonably small pitch and diameter, the clearance angle given to the cutting edges of the tool usually being sufficient to allow for slight variations in the rake of the thread.

It is necessary to have some gauge to which the tool can be ground to the correct shape; one way is to grind it to fit between the threads of an ordinary plug-tap, but a

## TURNING AND BORING.

special screw-cutting gauge is more satisfactory; the one shown in fig. 71 is a useful form; the V-openings are cut out to the standard angle,  $60^\circ$ , and as it is made of light sheet steel, it can be readily applied to the tool when grinding, to test it.

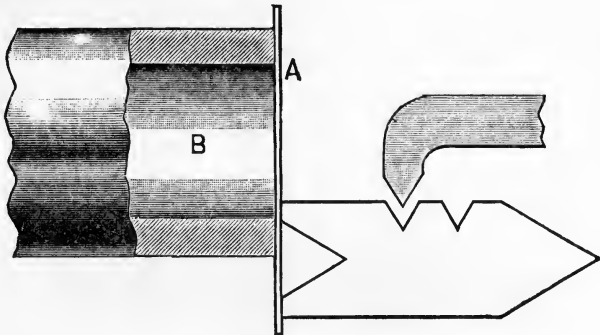

Fig. 72.

The method of setting an outside screw-cutting tool in correct position with regard to the work is shown in fig. 71, and fig. 72 shows how the gauge may be used for setting an inside screw-cutting tool. It will be noticed that a steel rule or other flat strip of metal, *A*, is laid across the end of the work, *B*, to form a surface for the end of the gauge to rest against.

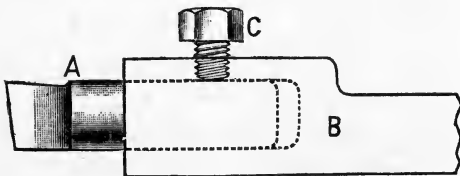

Fig. 73.

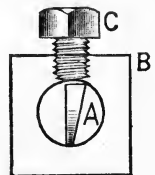

Fig. 74.

The form of tool used for cutting square threads is very similar to a parting tool, only that canting, or rake,



## SCREW-CUTTING IN THE LATHE.

must be provided for in the portion that enters the work, to prevent side rubbing.

A tool holder of the kind shown in fig. 73 simplifies the making of square-thread tools very much. The tool itself is filed up out of a small round piece of tool-steel, *A*, which is then fixed in the holder, *B*, by means of the set-screw, *C*. The tool-steel being circular in section, can be turned round in the holder before the set-screw is tightened, so as to give any desired degree of rake.

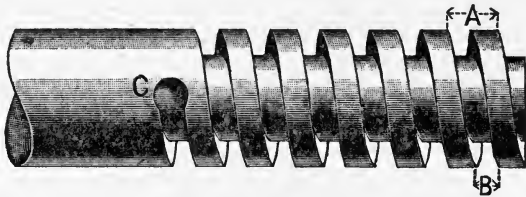

Fig. 75.

Fig. 74 shows the end view of the tool and its holder.

The width of a tool for cutting a single square thread must be equal to half the pitch of the thread. This will be seen from fig. 75, where *A* shows the pitch of the thread, which is equal to the thickness of a thread and a space. *B* shows the width the cutting tool should be, *i. e.*, exactly half of *A*. In cutting a double or triple thread the case is different, as will be seen from fig. 76, which represents a double thread. Here the pitch, *A*, is equal to

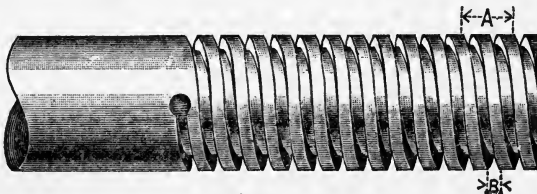

Fig. 76.

## TURNING AND BORING.

the thickness of two threads and two spaces, so that the width of the cutting tool,  $B$ , must be exactly one-quarter of the pitch,  $A$ .

Fig. 77 shows a double-threaded screw with only the first groove cut. When the second groove is cut in the center of the intervening portions of the work, it leaves the double thread.

A neat way of finishing off a square thread is to drill a small hole into the work at the end of the thread for the tool to run into, as shown at  $C$ , in fig. 75. The diameter of the hole should be slightly larger than the thickness of the tool, and the depth a little greater than the depth of the thread. The lathe must be stopped just before the

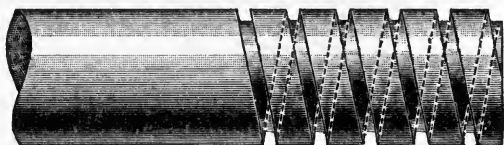

Fig. 77.

tool reaches the hole, and pulled round by hand for the last half turn or so. As soon as the tool finishes its cut, it is withdrawn and run back again in readiness for taking a fresh cut.

The process of cutting a screw in the lathe is comparatively simple. The work being mounted between centers, the tool fastened in the slide-rest, and the proper screw-cutting change wheels placed in gear, the lathe is started and a preliminary cut taken along the work; the tool is then withdrawn, the clasp-nut disengaged from the leading screw, the carriage is run back to the starting

## SCREW-CUTTING IN THE LATHE.

point, and the tool is set in a little deeper than before; the clasp being dropped into gear with the leading screw again, a second cut is taken along.

This series of operations is repeated until the screw is cut to a sufficient depth. There are, however, one or two precautions which must be observed; in the first place, a screw-cutting tool, by reason of its shape, is weak at the point, and is therefore easily broken; consequently, the depth of cut taken should not be greater than the tool can easily stand, and this should be regulated in a systematic manner. A simple plan is to mark, with a piece of chalk, the position of the cross-slide handle with which the tool is fed to the work, when the tool is withdrawn after a cut has been taken; it is wound in again before taking the next cut, so that the chalk mark is in exactly the same position as before; this shows the position of the tool during the previous cut, so that the operator can now readily judge how much further to turn the handle round to advance the tool sufficiently for the next cut.

This done, the old chalk mark is wiped out, and a fresh one substituted, the marking being repeated as each successive cut is taken.

The same guidance can be obtained in a neater way by placing a brass ring or clip over the handle of the slide rest, with a line marked across it, as shown in fig. 78; the ring is slipped back after each cut has been set in, so as to bring its mark again opposite to the arrow mark on the boss on the slide-rest, in readiness for the adjustment of the following cut.

Some lathes are provided with a small graduated disk

## TURNING AND BORING.

on the handle which winds the tool in, a fixed pointer being attached to the lathe saddle; in this case, of course, the simpler expedients already described are not required.

There is another important precaution to be taken, viz., that the tool shall follow in the same path at each successive cut. There will be no trouble on this point when cutting any thread which is an exact multiple of the thread on the leading screw, or guide screw, of the lathe. If, for example, the guide screw has four threads per inch,

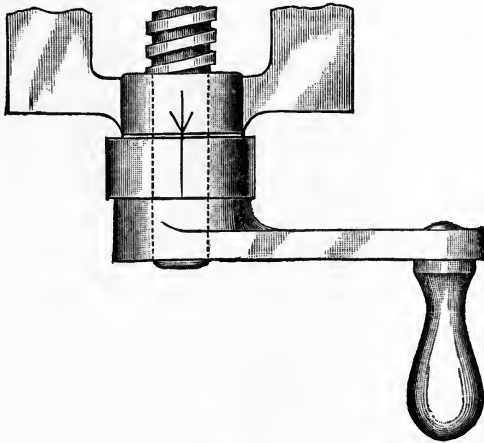

Fig. 78.

and the screw to be cut has twelve threads per inch, the work will always be in the right position for the tool to follow in the thread when the clasp-nut engages with the leading screw.

The same will be true if the screw to be cut has eight, sixteen, twenty or any number of threads per inch which is divisible by four.

The reason for this is that the change-wheel on the

## SCREW-CUTTING IN THE LATHE.

spindle and the change-wheel on the leading screw are in exactly the same proportion to each other as the threads on the leading screw and the screw being cut; and, since the number of teeth in one wheel is an exact multiple of the teeth in the other wheel, the smaller wheel of the two will always make an exact number of complete revolutions for each revolution of the larger.

To cut twelve threads per inch, as in the case mentioned above, a wheel with forty teeth would be placed on the spindle, and a wheel with 120 teeth on the leading screw; the spindle would therefore make three complete revolutions for each revolution of the leading screw, and the commencement of the screw-thread on the work would accordingly be brought to exactly the same position in relation to the tool each time the clasp-nut became engaged with the leading screw.

If, instead of twelve threads to the inch, a screw of ten threads to the inch is to be cut, the wheels required would be forty on the spindle and 100 on the leading screw; it will be apparent that for each turn of the leading screw the spindle will now make only  $2\frac{1}{2}$  revolutions, and the work will therefore be half a revolution behind its proper position, thus causing the point of the tool to come on top of the thread instead of in the groove between the threads, if the clasp-nut be engaged with the leading screw.

If the leading screw be allowed to make another complete revolution before engaging with the clasp-nut, the work will make another two and a half revolutions, which will bring it into the right position again for starting the tool in the proper groove. The work is therefore

## TURNING AND BORING.

only in the correct position for starting a cut once during every two revolutions of the leading screw. Similarly, with other threads which are not exact multiples of the thread of the leading screw, it will be found that to bring the tool to the right position the clasp-nut must only be dropped in at certain intermediate positions of the change-wheels.

To prevent any mistake arising, the usual plan is to stop the lathe before the tool commences its first cut along the work, and chalk a tooth on the spindle wheel and a tooth on the leading screw wheel, placing another chalk mark on the headstock opposite the former and a chalk mark on the lathe bed opposite the latter, the clasp-nut being then engaged with the leading screw.

The saddle is run back to the starting point after each cut, and as soon as both chalk marks on the wheels come opposite to the stationary marks again at the same instant, the clasp-nut may be engaged with the leading screw, and another cut taken.

When cutting a double thread, a wheel with an even number of teeth should be selected for the spindle, and a chalk mark should be made on each of two exactly opposite teeth. The space into which one of these teeth falls in the wheel with which it gears should also be marked; when the first thread has been cut, the mandrel wheel should be disengaged and turned through half a revolution, so that the other marked tooth comes opposite the marked space; the wheels are then geared together again, and the second thread can be cut.

## SCREW-CUTTING IN THE LATHE.

For a triple thread the spindle wheel should be divided into three, and for a quadruple thread into four, and so on.

*For cutting a right-hand thread, the tool traverses from right to left, and for a left-hand thread it traverses from left to right.*

In the latter case the necessary reversal in the direction of rotation of the leading screw is obtained by inserting an extra wheel in the train of gear wheels between the spindle and the leading screw; this extra wheel does not in any way affect the *speed* of rotation of the leading screw; it simply alters the *direction* in which it revolves.

A square thread must be finished to exact size with the tool. A V-thread can be finished off with a hand chaser.

All that is necessary to cut any pitch desired is to arrange gearing to revolve the screw as many times as it has threads to the inch, while the feed stud, or spindle, is making as many revolutions as the desired pitch.

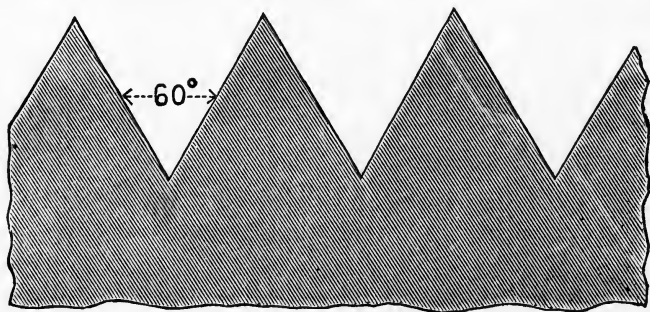

Fig. 79.

Fig. 79 shows an ordinary V-thread, of which the angle is  $60^\circ$ .

## TURNING AND BORING.

Fig. 80 shows the American Standard thread ; it is the V-thread, with one-eighth of its depth cut off the top and bottom, the angle being  $60^{\circ}$ .

Fig. 81 shows the Whitworth, or English Standard thread ; it is a V-thread, with one-sixth of its depth rounded off the top and bottom the angle being  $55^{\circ}$ .

The following quotation from Low and Bevis' "Manual of Machine Drawing and Design" presents the relative merits of screw-threads shaped according to the Whit-

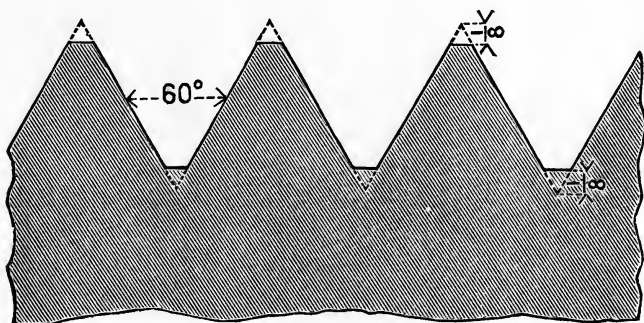

Fig. 80.

worth and Sellers system respectively, as seen through English eyes. The comparison, however, seems to be fair. Without underrating the good points of the Sellers thread, we believe that the Whitworth thread has its good points also, and that they are not as fully appreciated in this country as they might be:

"Comparing the 'Whitworth' and 'Sellers' screw-threads, the former is stronger than the latter because of the rounding at the root. The point of the Whitworth thread is also less liable to injury than the Sellers. The



## SCREW-CUTTING IN THE LATHE.

form of the Sellers thread is, however, one which is more easily produced with accuracy, in the first place, because it is easier to get with certainty an angle of 60 degrees than an angle of 55 degrees, and, in the second place, because it is easier to make the point and root perfectly parallel to the axis than to ensure a truly circular point and root. The Sellers thread has also a slight advantage in that the normal pressure, and therefore the friction, at every point of the acting surface is the same; while in the Whitworth thread the normal pressure, and therefore the friction, is greater at the rounded parts. The surface of the Sellers thread will, therefore, wear more uniformly than the surface of the Whitworth thread. The total friction, and also the

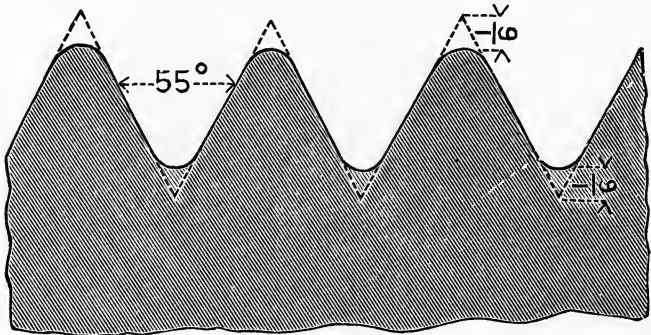

Fig. 81.

bursting action on the nut, are slightly greater in the Sellers thread than in the Whitworth, because of the greater angle of the V; it will be seen that for a given diameter of screw the diameter at the bottom of the thread is greater in the case of the Whitworth than in the Sellers. A bolt with a Sellers thread is, therefore, weaker than the same size of bolt with a Whitworth thread. The strength of the Sellers screw is still further reduced on account of the sudden change of the cross-section of the bolt at the bottom of the thread."

## CHANGE-WHEELS.

Cutting a screw in the lathe is a mechanical operation, of which the most important part is the selection of the proper change-wheels. Change-wheels, or change-gears, are the gear-wheels employed to change the revolutions of a lead-screw, or feed motion.

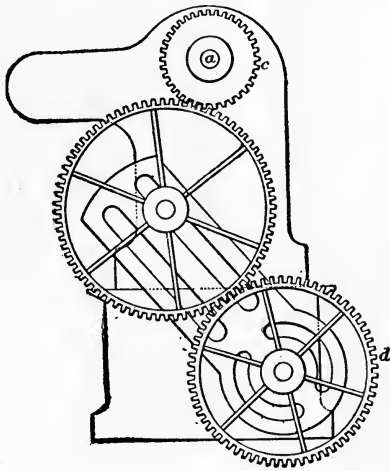

Fig. 82.

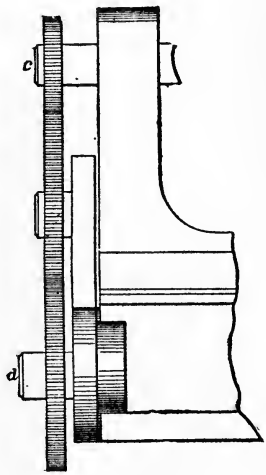

Fig. 83.

There are two ways of arranging the wheels: 1st, with two change-wheels; 2d, with four change-wheels.

Fig. 82 shows the two change-wheels, *c* and *d*; the middle wheel serves only to connect the two; *c* is the wheel on the spindle *a*; *d* is that on the leading screw.

Fig. 83 is a side view of this two-change-wheel.

The distance between the spindle and the leading screw of a lathe does not generally admit of cutting a

SCREW-CUTTING IN THE LATHE.

screw of more than ten threads to the inch, with *two* wheels, as the wheel on the leading screw would be too large, and that on the spindle too small.

In the same way, for cutting coarse-pitched screws, such as half a turn to the inch, the second method is generally used, or else the wheel on the leading screw would

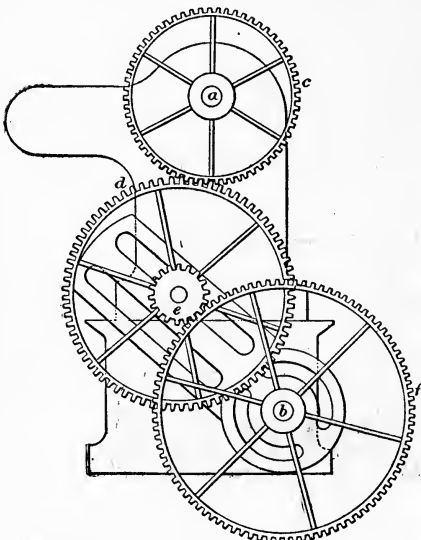

Fig. 84.

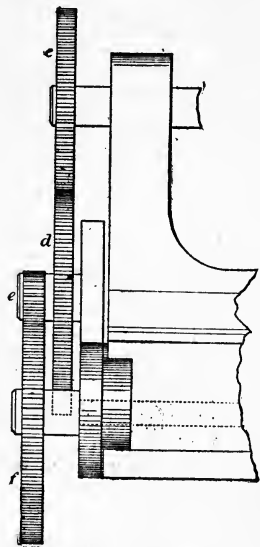

Fig. 85.

be too small, and that on the spindle too large. Thus the second method is employed for cutting screws of coarser pitch than one-half a thread, and finer than ten threads to the inch, and the first method for screws of a pitch intermediate between one-half a thread and ten threads to the inch.

Fig. 84 shows the second arrangement with four change-wheels, *c, d, e, f*; *c* is the wheel on the spindle, *d*

## CHANGE-WHEELS.

and  $e$  are the wheels on the stud,  $f$  is the wheel on the leading screw  $b$ .

Fig. 85 is a side view of the arrangement with four change-wheels.

The rule for calculating the size of the change-wheels to cut threads of different pitches is really a very simple one, though frequently a source of difficulty to the student. It may be expressed as a simple proportion sum, thus :

*As the pitch of the leading screw is to the pitch of the screw to be cut, so is the number of teeth in the wheel on the spindle to the number of teeth in the wheel on the leading screw.*

Putting this in fractional form, we have :

$$\frac{\text{Pitch of leading screw}}{\text{Pitch of screw to be cut}} = \frac{\text{Wheel on spindle}}{\text{Wheel on leading screw.}}$$



Fig. 86.

EXAMPLE 1.—Suppose that the lathe has a leading screw,  $a$ , with four threads to the inch ; what wheels will be required to cut a screw,  $b$ , having eight threads per inch ?



Fig. 87.

NOTE.—It simplifies matters by using the number of threads per inch in the two screws instead of the pitch, as in most cases it enables us to use whole numbers instead of fractions for figures.

## SCREW-CUTTING IN THE LATHE.

Now, substituting these figures in the above fractions, we get

$$\frac{4}{8} = \frac{\text{Wheel on spindle}}{\text{Wheel on leading screw,}}$$

therefore, any two wheels in the proportions of four to eight will answer the purpose; if we multiply both these figures by the same number we do not alter the proportions at all; therefore, by multiplying both by five we get twenty and forty, as two suitable wheels, or multiplying by ten we get forty and eighty, or multiplying by fifteen we get sixty and one hundred and twenty, any of which pair will give the desired result.

Selecting the last pair, put the sixty wheel on the spindle and the one hundred and twenty wheel on the leading screw, and gear the two together by inserting an intermediate wheel, which may be whatever size will fit it best.

EXAMPLE 2.—Suppose a screw of eleven threads per inch is to be cut in the same lathe, the leading screw has four threads to the inch, as before, then the proportion required between the wheels is  $\frac{4}{11}$ , so that (multiplying by ten), a forty and a one hundred and ten wheel will be correct, or (multiplying by five), a twenty and a fifty-five wheel, or any wheels having the same ratio.

If a fractional number of threads is to be cut, such as  $9\frac{1}{2}$  threads per inch, exactly the same plan is adopted. The proportion is  $4 : 9\frac{1}{2}$ ; multiplying both by ten, we get forty and ninety-five as suitable wheels.

Similarly, if the leading screw have two threads per inch, and it is desired to cut twelve threads per inch, the

## CHANGE-WHEELS.

proportion is 2:12. Multiplying both by ten, we get twenty and one hundred and twenty as being suitable wheels.

It is sometimes difficult to measure the exact number of threads per inch in places where there is a fractional part of a thread included, as, for instance, five and a quarter threads per inch. It is then better to measure such a length of the screw as contains an exact number of threads, and compare it with the number of threads in a similar length of the leading screw. A screw with five and a quarter threads per inch will have twenty-one complete threads in a distance of four inches. If the leading screw has four threads to the inch, it will clearly have sixteen complete threads in four inches. Therefore the relation between the two screws is 16:21. Multiplying both of these by five, we get eighty and one hundred and five as the wheels necessary to cut such a thread.

The calculations so far refer to a simple train of wheels. Cases frequently arise, however, especially with fine pitches, in which the wheels calculated in this way are not available. If the leading screw has four threads to the inch, and it is required to cut a screw of forty threads to the inch, the proportion is 4:40. Multiplying both by five, we get twenty and two hundred as the necessary wheels, but in all probability the lathe to be operated is not fitted with a two hundred wheel. A compound train of wheels, that is, four change-wheels, as shown in fig. 84, must therefore be selected.

To calculate these, proceed as follows: The proportion, as already stated is  $\frac{4}{40}$ . Split each number up into

SCREW-CUTTING IN THE LATHE.

two separate numbers, which, if multiplied together, will produce the original number, thus  $\frac{4}{40} = \frac{2}{5} \times \frac{2}{8}$ . Multiplying each of these numbers by 10, we get  $\frac{20}{50} \times \frac{20}{80}$ . This means that a wheel on the spindle, gearing into a 50 wheel on the intermediate stud, and another 20 wheel on the intermediate stud, gearing into an 80 wheel on the leading screw, will give the desired result.

It will be more easily understood if the student considers the fact that the first 20 wheel, *c*, gearing into the 50 wheel, *d*, reduces the speed in the proportion of  $2\frac{1}{2}$  to 1, and the second 20 wheel, *e*, gearing into the 80 wheel, *f*, on the leading screw again reduces this speed in the proportion of 4 to 1, making a total reduction in speed of 10 to 1, which is the proportion between the thread to be cut and the thread on the leading screw, *i. e.*, 4 to 40.

A few other examples are worked out to assist the reader to thoroughly grasp the rule.

EXAMPLE 1.—Leading screw two threads per inch, required the wheels to cut twenty-five threads per inch.

$$\frac{2}{25} = \frac{2 \times 1}{5 \times 5}$$

Multiplying each pair of numbers by the same figure, we get  $\frac{20 \times 10}{50 \times 50}$  as one set of wheels, or using different multipliers we get  $\frac{30 \times 25}{75 \times 125}$  as another set of wheels, either of which will cut the desired threads. The respective wheels may be identified by comparing the above fractions with the following :

$$\frac{\text{Driving wheel on spindle} \times \text{driving wheel on stud} :}{\text{driven wheel on stud} \times \text{driven wheel on leading screw.}}$$

## CHANGE WHEELS.

The figures in the fractions of all the examples correspond to the wheel here indicated in the same position.

EXAMPLE 2.—Leading screw two threads per inch, required the wheels to cut nineteen threads per inch.

$$\frac{2}{19} = \frac{2 \times 1}{9\frac{1}{2} \times 2} = \frac{20 \times 40}{95 \times 80}$$

as one set of wheels, or  $\frac{20 \times 35}{95 \times 70}$  as another set of wheels.

EXAMPLE 3.—Leading screw four threads per inch, required the wheels to cut thirty-three threads per inch.

$$\frac{4}{33} = \frac{2 \times 2}{3 \times 11} = \frac{40 \times 20}{60 \times 110}$$

as one set of wheels, or  $\frac{30 \times 20}{45 \times 110}$  as another set of wheels,

either of which would do.

EX. 4.—Leading screw four threads per inch, required the wheels to cut seventeen and a half threads per inch.

If there are seventeen and a half threads in one inch of the screw to be cut, there are thirty-five threads in two inches. In two inches of the leading screw there are eight

threads, so that the proportion is  $\frac{8}{35}$

$$\frac{8}{35} = \frac{2 \times 4}{5 \times 7} = \frac{20 \times 40}{50 \times 70}$$

as one set of wheels, or  $\frac{40 \times 60}{100 \times 105}$  as another set, which will

cut the desired pitch.

If any doubts exist as to the correctness of the calculations for a set of wheels, the result may easily be tested by multiplying the number of teeth in the driving wheels together and the number of teeth in the driven wheels



SCREW-CUTTING IN THE LATHE.

together, and placing these totals one above the other, in the form of a fraction. Then reduce this fraction to its lowest terms, and the figures obtained should correspond with the ratio of the leading screw to the screw to be cut, expressed in its lowest terms. Thus, to prove the second

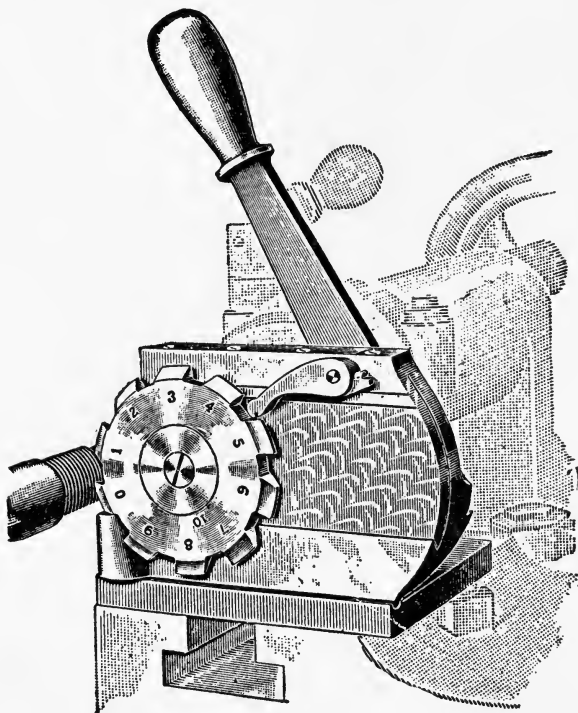

Fig. 88.

wheels obtained in example (1), we have thirty and twenty-five as drivers, and 75 and 125 as the driven wheels.

$30 \times 25 = 750$ , and  $75 \times 125 = 9,375$ .  $\frac{750}{9375}$  reduced to its low-

est term  $\frac{2}{25}$ , which represents the ratio of the leading

## CHANGE-WHEELS.

screw (two threads per inch) to the screw to be cut (twenty-five threads per inch).

It should be remembered that the "drivers" are those wheels which impart motion, and the "driven"

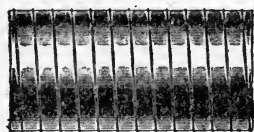

Cuts.  
No. 1.

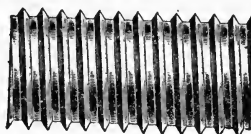

No. 6.

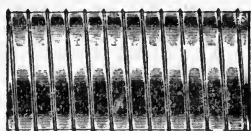

No. 2.

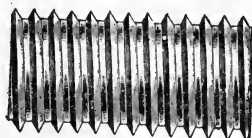

No. 7.

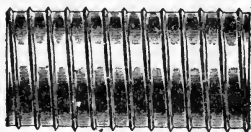

No. 3.

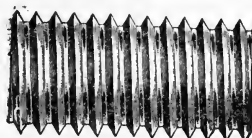

No. 8.

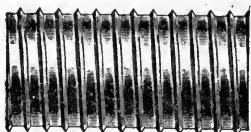

No. 4.

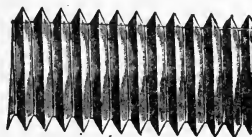

No. 9.



No. 5.

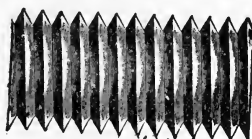

No. 10.

Figs. 89-98.

wheels are those which receive motion. The wheel on the spindle is a "driver," while the wheel on the leading screw is a "driven" wheel; the wheel on the intermediate stud, which gears with the spindle wheel, is a "driven" wheel, and the other wheel, on the intermediate stud,

## SCREW-CUTTING IN THE LATHE.

which imparts motion to the wheel on the leading screw, is a "driver."

Fig. 88 shows a specially devised tool in operation, cutting a screw-thread on the lathe; the tool consists, as will be seen, of a disc of steel having ten distinct teeth on its rim, these teeth are graded for cutting the thread in distinct operations of the tool.

The cutter is mounted on a hand-sliding rest, which is bolted to the ordinary lathe carriage, and the tool is adjusted to each cut by the hand lever. Fig. 99 shows a separate view of the cutter.

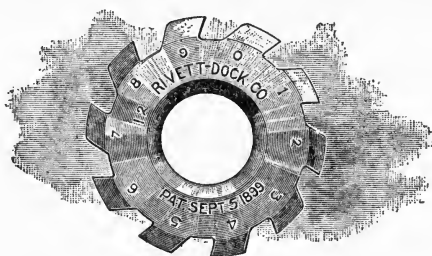

Fig. 99.

Figs. 89-98 show a screw as it would appear after each cut has been performed. Commencing at No. 1, the thread is finished in ten trips, each of which removes an exact depth of stock. The first tooth, No. 1, makes a shallow cut the full width of the thread; each following tooth cuts deeper (as well as narrower), until the last one (No. 10), with its cutting point, does the finishing.

When fine work, such as for taps, etc., is required, the pawl is thrown back out of action, the micrometer adjustment used, and another trip taken across the thread. Advancing the lever one hole in the micrometer adjustment

## CHANGE-WHEELS.

brings the cutting point a fraction of a thousandth of an inch forward. Successive trips with advance of lever will give the finest finish possible to a thread.

The heel of the tooth in action rests upon a stop, so that it can be ground until but an eighth of an inch in thickness, and still retain the full strength and power to do the work; a square is employed against the face of the cutting disc, and the thread angles are ground from this face.

When once set, neither tool nor cross-slide adjustment need to be changed in cutting the screw or any number of screws in exact duplication.

This form of tool requires very little grinding, as the point of the tool is reserved and only used in the finishing or last cut.

Ingenuity on the part of the lathe builders has resulted in the design of a simple contrivance by which the gears which are mounted under the head can be instantly set to cut any required thread at the will of the operator, without delay of calculating or of changing the gears. The mechanism consists of a set of gear wheels, usually ten, mounted on a shaft called the "change gear shaft," which is placed in the bed under the headstock of the lathe.

By an arrangement consisting of a sliding or tumbling gear, any of these ten fixed gears can be brought into operation; these combine with a set of intermediate gears located outside of the head, also varied in their arrangement by a lever mechanism, to vary the speed of the lead

SCREW-CUTTING IN THE LATHE.

screw to cut any of the following forty threads or feeds per inch.

Fig. 100 shows an index plate for the "change gear shaft"; this is usually attached to the front of the lathe, "handy" to the two levers to which reference is made.

THDS	KNOB	THDS	KNOB	THDS	KNOB	THDS	KNOB
18	2	9	2	4½	2	2	1
19	3	9½	3	4¾	3	2¼	2
20	4	10	4	5	4	2½	4
22	5	11	5	5½	5	2¾	5
23	6	11½	6	5¾	6	2⅞	6
24	7	12	7	6	7	3	7
26	8	13	8	6½	8	3¼	8
28	9	14	9	7	9	3½	9
30	10	15	10	7½	10	3¾	10
32	11	16	11	8	11	4	11
<b>F E E D S</b>							
80 To 40		40 To 20		20 To 10		10 To 5	

18-Inch Index Plate.

Fig. 100.

EXAMPLE.—Should the operator desire to cut 12 threads per inch, he engages the sliding gear on the lead screw intermediates, opposite the table showing 20 to 10 threads per inch, and then places the lever in front of the lathe head, which carries the sliding or tumbling gear into the hole marked "7," as indicated in the index plate opposite 12, the number of required threads; the tool is then ready for operation.

The gears required are obtained by moving two levers only; one being on the intermediate gear of the lead screw, the other being outside the headstock.

## CHANGE-WHEELS.

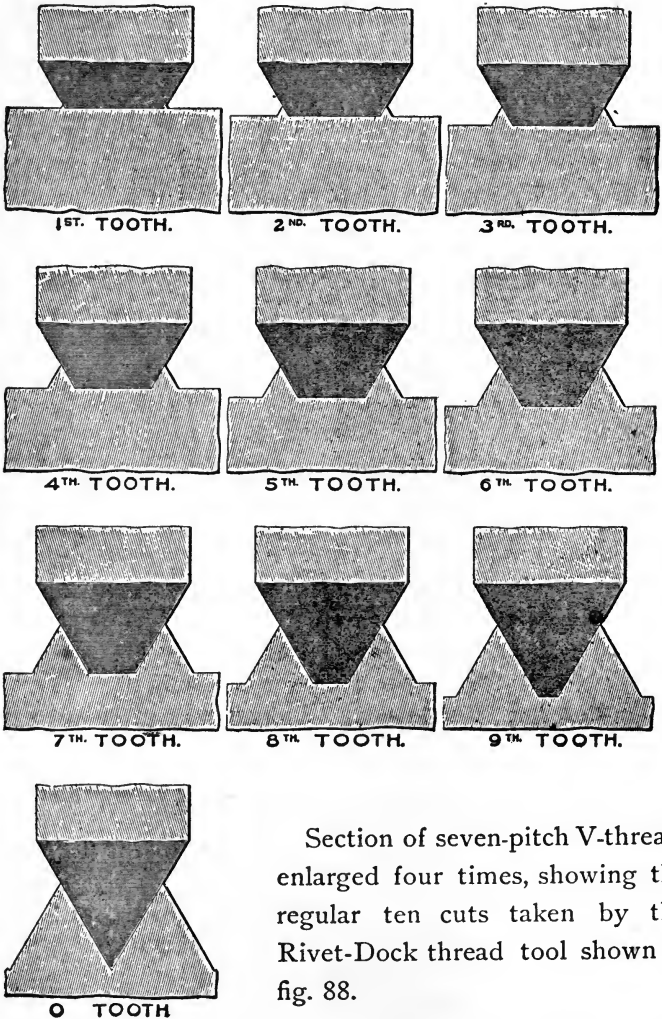

Section of seven-pitch V-thread, enlarged four times, showing the regular ten cuts taken by the Rivet-Dock thread tool shown in fig. 88.

Figs. 101-110.

SCREW-CUTTING IN THE LATHE.

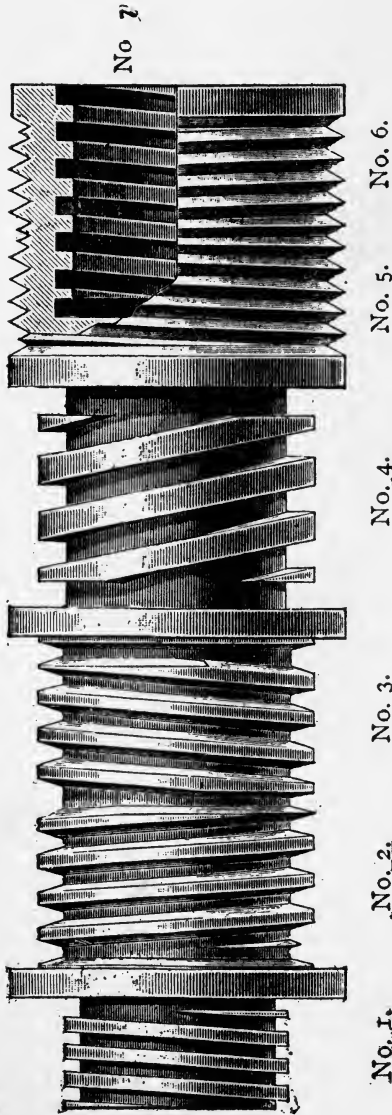

Fig. III.

The above figure represents an external screw cut in a lathe without "change-wheels," and with the work constantly in motion and effected through the use of an automatic-stop on the carriage. No. 7 in the figure shows an internal thread cut to the shoulder by the same contrivance.

## CHANGE-WHEELS.

The gauge, fig. 112, is used as a standard for grinding tools to cut threads according to the United States Standard.

The angles are 60 degrees, and the flat surfaces at top and bottom of threads are equal to one eighth of the pitch.

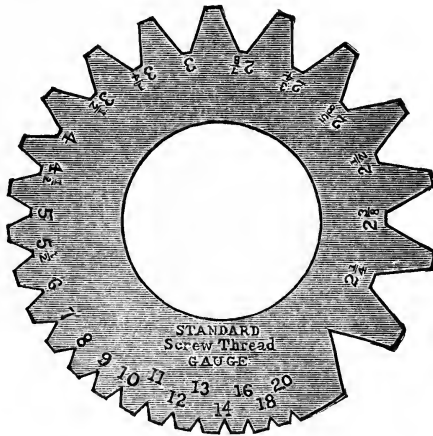

Fig. 112.

Fig. 113 shows a center gauge of United States Standard, 60 degrees; the method of setting a screw cutting tool by its use is shown in illustrations, figs. 114-116, on page 137.

This gauge is also used for a guide in grinding screw cutting-tools. The table on the gauge (see full size cut) is used for determining the sizes of tap drills for V-threads

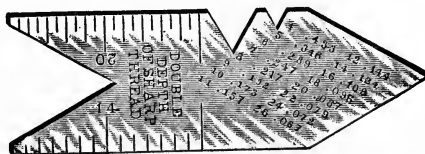
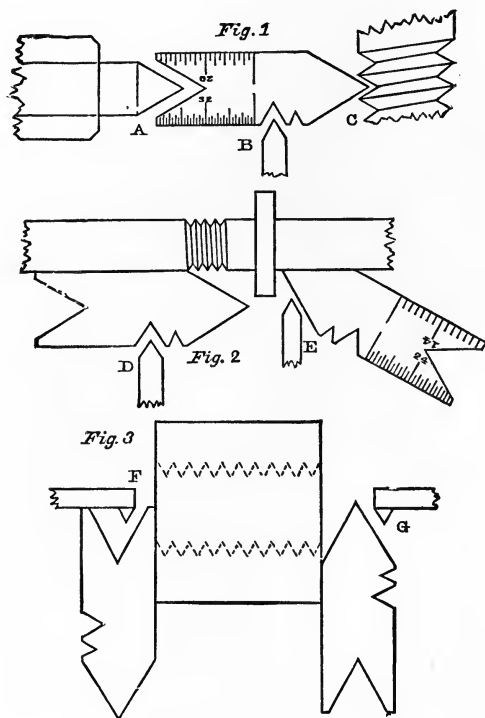

Fig. 113.



## SCREW-CUTTING IN THE LATHE.

and shows in thousandths of an inch the double depth of thread of taps and screws of the pitches most commonly used.



Figs. 114-116.

NOTE.—In *Fig. 1*, at *A*, is shown the manner of gauging the angle to which a lathe centre should be turned; at *B*, the angle to which a screw thread cutting tool should be ground; and at *C*, the correctness of the angle of a screw thread already cut.

In *Fig. 2* the shaft with a screw thread is supposed to be held between the centres of a lathe. By applying the gauge as shown at *D*, or *E*, the thread tool can be set at right angles to the shaft and then fastened in place by the screw in tool post, thereby avoiding imperfect or leaning threads.

In *Fig. 3*, at *F* and *G*, the manner of setting the tool for cutting inside threads is illustrated.

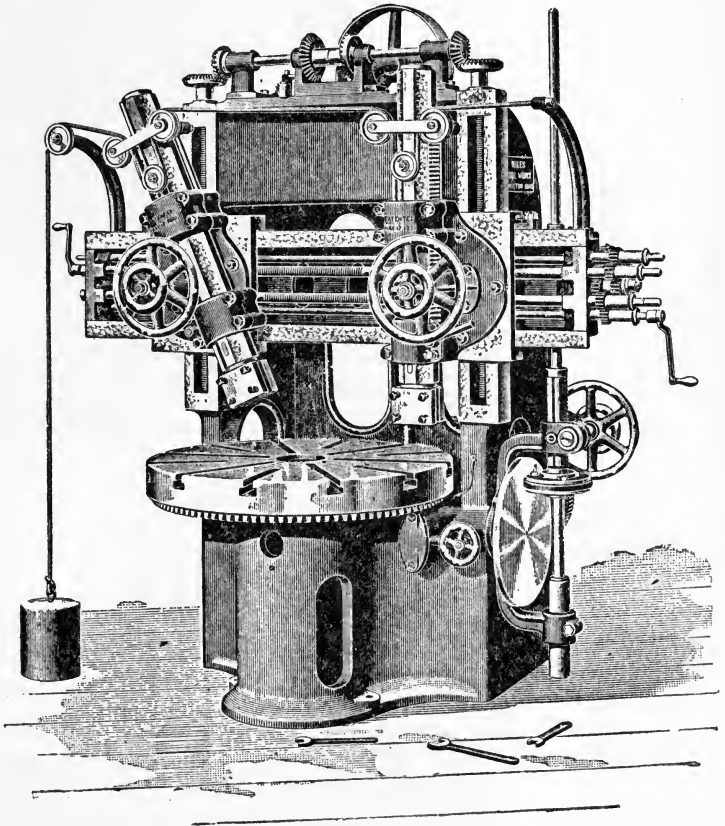

Fig. 117.

## BORING OPERATIONS.

---

The operation of *boring* is the enlarging and trueing of holes already formed, and differs from *drilling*, which applies to making holes in solid stock.

Boring can be divided into two classes: 1, horizontal; 2, vertical. Horizontal boring is done in a lathe in two ways: 1, the work rotates and the cutting tool is stationary; 2, the work is stationary and the cutting tool rotates.

Vertical boring is generally performed in special machines; in light work, *the cutting tool revolves*, as in drilling, the work being stationary; in heavy boring, *the work is revolved*, and the cutting tool is stationary except for feed motions.

Vertical boring machines having suitable automatic traverse for the cutting tool are largely used for turning and surfacing work which rotates; these machines are known as boring and turning mills, and may be described as revolving planing machines.

The most simple form of boring in a lathe is done on the chuck or face-plate, to which the work is fixed and rotated to a stationary tool in the saddle or carriage. When the hole is deep and the tool has to project beyond the holder, it is liable to spring, and the work itself, being overhung on the headstock, is liable to jar; in such cases, the work is more advantageously attached to the carriage of the lathe, and a bar used, as shown in fig. 118. This is designed to pass through the work and revolve between

## BORING OPERATIONS.

the lathe centers, as shown in figs. 120 and 122, the carriage feeding the work to the rotating cutter.

In some cases, it is found needful to fix the work without any motion, the boring bar having both rotary and feed motion combined; such a boring bar is shown in fig. 119. *K* is a stout, strong bar, usually of cast-iron, because it does not "spring" as readily as wrought-iron; the cutting tool *L* is fixed to a sleeve *H* sliding on bar *K* by

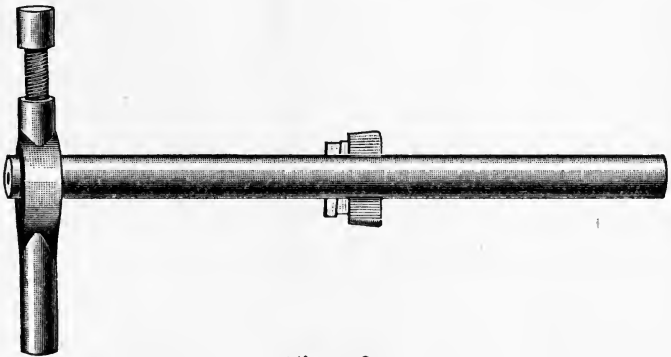

Fig. 118.

means of the feed screw actuated by the handle *G*, or automatically by the provision *I* at the other end, as shown; the work to be operated on is securely fixed between the clamps or bearings *F* and *J*, the splined boring-bar *K* is rotated by the worm-wheel *E*, which is operated by the worm *D* connected to the driving-pulley or sheave *A*.

This is a portable tool, useful for boring cylinders, etc., without removing them from their beds, as it can be fixed at any angle or position; it may also be used between the centers of the lathe instead of the plain boring bar shown in fig. 118.

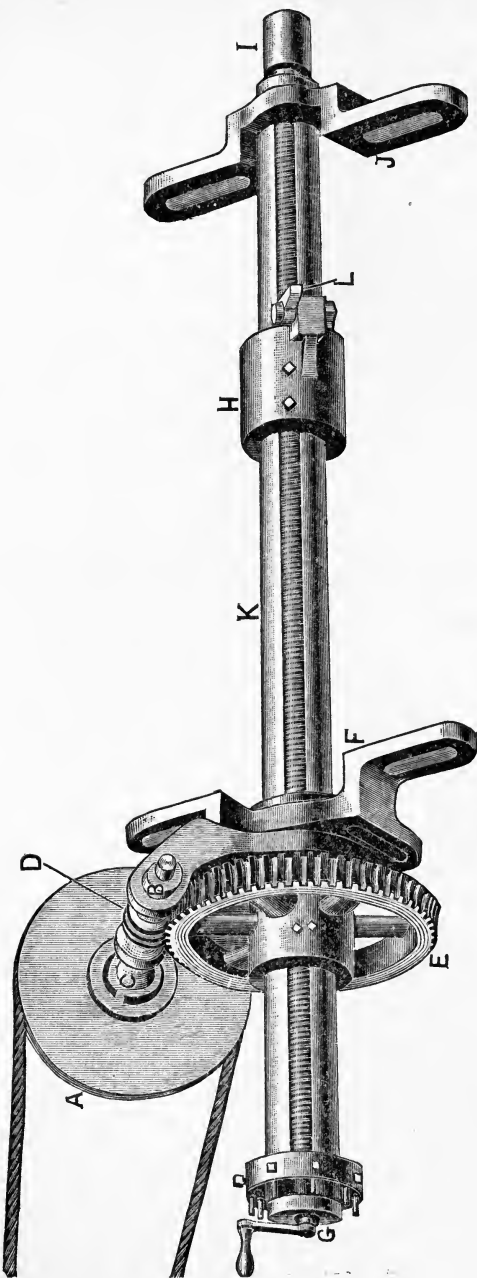

Fig. 119.

## TURNING AND BORING.

Special horizontal boring machines are made which differ from the ordinary lathe in that the work-table is constructed with three movements, one being in a vertical and two in the horizontal plane; when the work has been set vertically, the work-table is moved crosswise and lengthwise

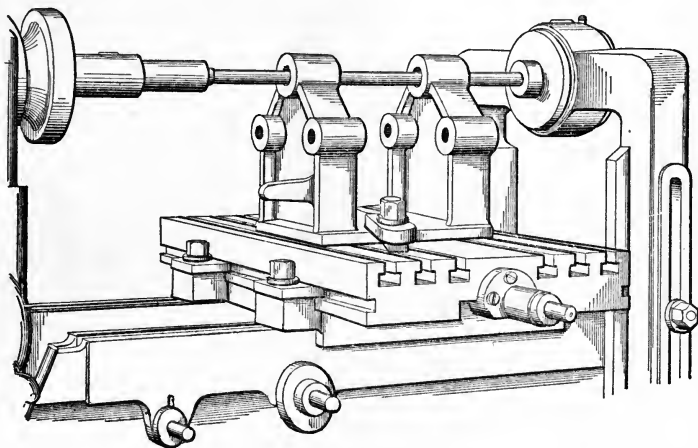

Fig. 120.

until the horizontal setting has been found; no blocking of any kind is needed; such an arrangement is shown in fig. 120.

Boring of taper holes in a lathe is illustrated by the arrangement shown in fig. 122; this is used when neither attachment, compound rest nor reamers are available; *A* is the headstock of the lathe, and *W W* the piece of work mounted on the face-plate.

Now, set over the tail-stock *B* the same as if turning, an outside taper the same as the hole to be bored. Fit up a boring-bar *F*, of as large diameter as practicable, with a

BORING OPERATIONS.

key-way *G*, and a traveling-head *D* carrying a cutter. Connect this traveling-head to the cross-carriage of the lathe *C* by the link *E*. Set a lathe-dog (see figs. 123 and 124) on

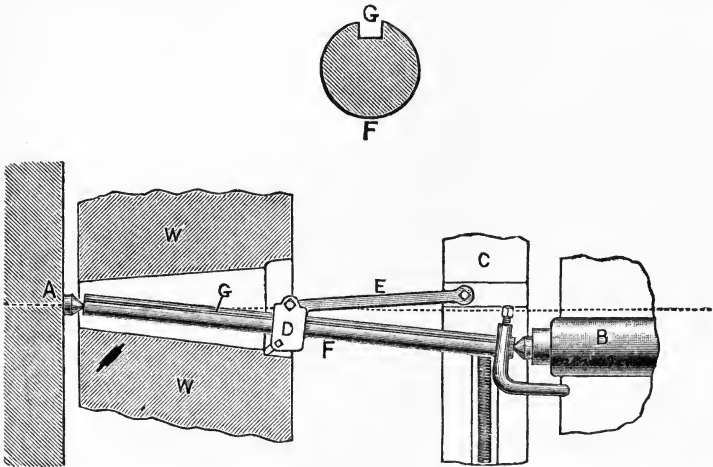

Figs. 121 and 122.

the outer end of the bar to prevent the bar from turning. Use the usual power longitudinal feed of the lathe, and adjust the cutter in the traveling-head for size the same as

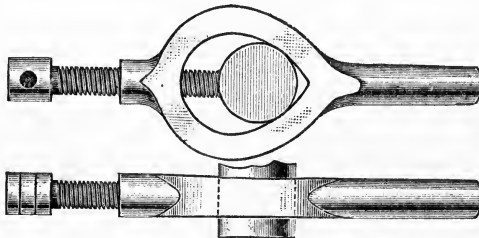

Figs. 123 and 124.

for cylinder boring. This is a satisfactory way of taper boring where the conditions are suitable for the method.

## THE BORING MILL.

The boring mill is essentially a vertical face-plate lathe, without the defects of the horizontal construction, *i. e.*, the

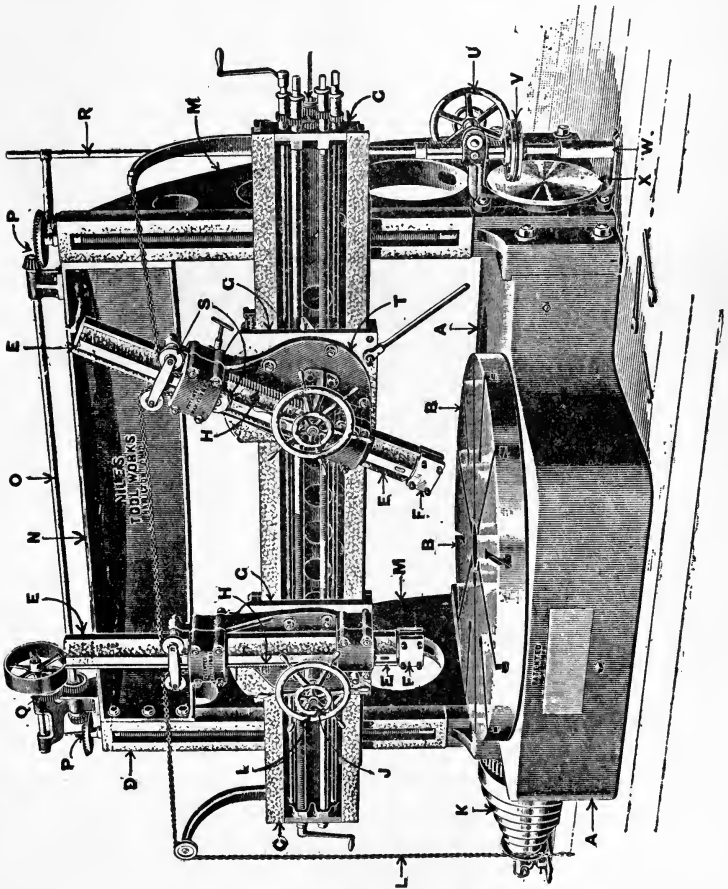

Fig. 125.

difficulty of setting and securing the work, and the necessity of heavy overhanging parts, etc.



## BORING OPERATIONS.

Fig. 125 shows a boring mill, in which the horizontal table *B* is driven by internal bevel-gearing from a belt-cone *K*, the power being increased by external spur-gearing. The bed *A* is cast in one piece and well ribbed and braced for all stresses; the " housings " *M* are of hollow section, having wide palms where connected to the bed, to which they are fixed by bolts passing through reamed holes; a cross-brace *N*, at the top, stiffens the whole structure; the cross-rails *c, c*, are of box-girder form, having wide slide surfaces for the saddles *b, b*, and for the " housings;" power gears *Q* are used for elevating the cross-rails; the saddles *b, b*, are made " right " and " left," to permit the tool-bars *E, E*, to come close together; these tool-bars are octagonal in section, held in adjustable capped bearings, and will swing to any angle, being counter-weighted in all positions, and having convenient adjustment by racks *H, H*, and hand pinion wheel *I*, which have a power feed at all angles by friction nut *J, J*.

*P, P*, are the gears for elevating the cross-rails; the friction disc *X* communicates motion to rod *R* through the friction wheel *V*, which gives the quickest possible adjustment by handwheel *U* while running; a system of double gears at the end of the cross-rail gives vertical and horizontal traverse feeds to the tool; these are instantly reversible by sliding any one of the four slip gears shown in sketch.

The tool holders *F, F*, fig. 125, are solid steel forgings, held in the tool-bars by steel shanks and keys; these tool

---

NOTE.—The names of the parts and the above description are furnished by the makers of this admirable tool.

## BORING MILL.

holders will grip tools in any position, and are easily removable for the insertion of cutter-bars or special tools, for which purpose the right-hand bar is set exactly central with the table; the counterweight acts at all angles through the wide bearing surface; in addition, the table has an annular, angular bearing which increases the bearing surface and

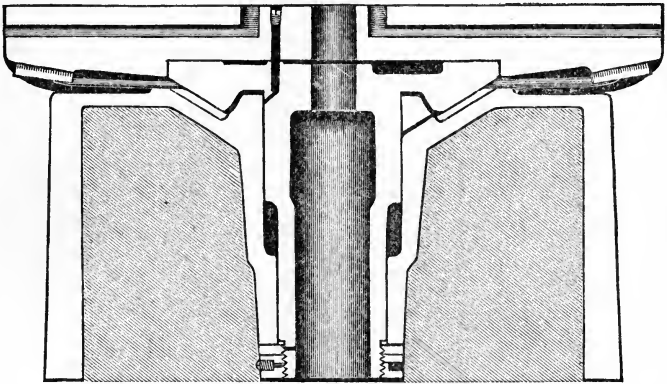

Fig. 126.

gives steadiness of motion; it has also a self-centering tendency, so that the combined weight of the table and spindle, as well as that of the work upon the table, tends to preserve and not destroy the alignment.

The advantages in the boring mill are that the work lies upon the horizontal table, and the total weight of the table and the work is distributed on a large angular bearing provided for that purpose, as shown in section, fig. 126, which gives rigidity and smooth cutting qualities, thus avoiding all jar or trembling, which occur in overhung lathes.

## BORING MILLS.

Vertical boring machines are largely taking the place of planing machines for doing "surface" work. The continuous motion of the boring mill gives economy in time saved; an additional advantage is that a cutting-tool on a circular surface, when once it commences the cut, is continuous, whereas, in the planing machine, the tool gets into

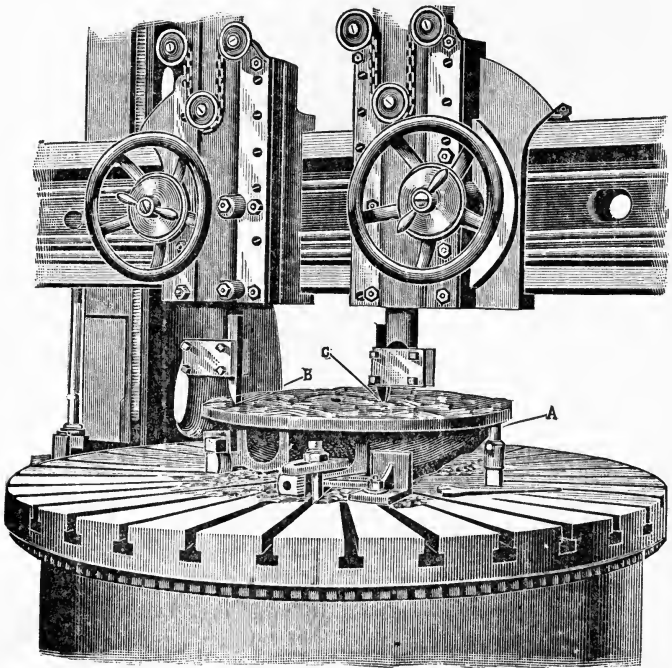

Fig. 127.

and out of the work at each stroke, often causing a ridge at the commencement, or a break-off at the termination, of the cut.

Fig. 127 shows a valve, held by angle-plates on the table, being faced or operated by two tools.

## TURNING AND BORING.

Fig. 117 shows a boring mill driven by an external bevel-ring attached to the table. In many boring mills, an internal worm-wheel, geared into a worm on the cone spindle, is used, instead of chain *L* and the sheaves *S*, *S*, and does not pull the swinging tool-bar over, nor does it interfere with the moving saddles.

A section through the center of the revolving table is shown in fig. 126, the center spindle being of large diameter giving toothed gear the advantages claimed for the worm gearing, *i. e.*, steadiness in motion, and the table is closer to the floor level, thus being more convenient for handling heavy work.

When worm gearing is adopted, it is necessary that it and the thrust-bearing should run in a flood of oil, which reduces the friction to a minimum.

On page 149 are shown a set of turning tools for general use in a boring mill.

Fig. 128 being "a skiveing tool."

Fig. 129 is "a round-nose tool."

Fig. 130 is "a boring tool."

Fig. 131 is "a hog-nose roughing tool."

Fig. 132 is "a side tool."

Fig. 133 is "a broad finishing tool."

On page 150 are shown a set of boring tools for finishing cored-holes. Fig. 134 is an adjustable reamer with floating shank, the arrangement of which is shown in section in fig. 135. Fig. 136 is a boring bar with an adjustable cutter. Fig. 137 is a four-lipped roughing drill.

BORING-MACHINE TOOLS.

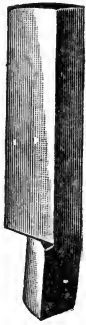

Fig. 128.



Fig. 129.



Fig. 130.



Fig. 131.



Fig. 132.



Fig. 133.

## BORING MACHINE TOOLS.

A boring mill is practically an endless or continuous planer, that is, a planer without reversing. The convenience and facility with which work can be set on the vertical table, and the ease with which pieces can be secured, are apparent, the weight of the piece being on the machine and not on the securing device.

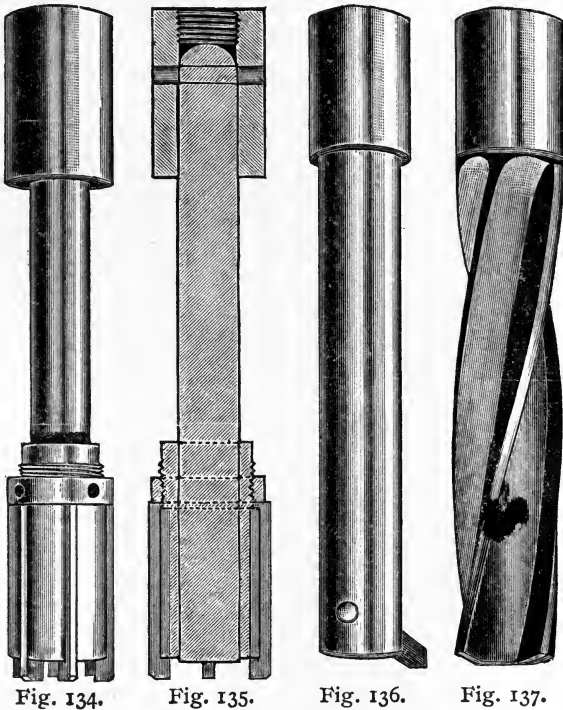

Fig. 134.

Fig. 135.

Fig. 136.

Fig. 137.

Irregular shapes, such as eccentric discs, offset valves, brackets, etc., require no counterbalance in the boring mill, thus saving the time adjusting counterweights, which are seldom satisfactory on the overhung lathe, even when specially designed.

A rectangular metal plate with rounded corners, featuring four circular fasteners (one in each corner) with diagonal lines through them. The text "PLANING MACHINES" is embossed in the center in a bold, blocky font.

**PLANING  
MACHINES**

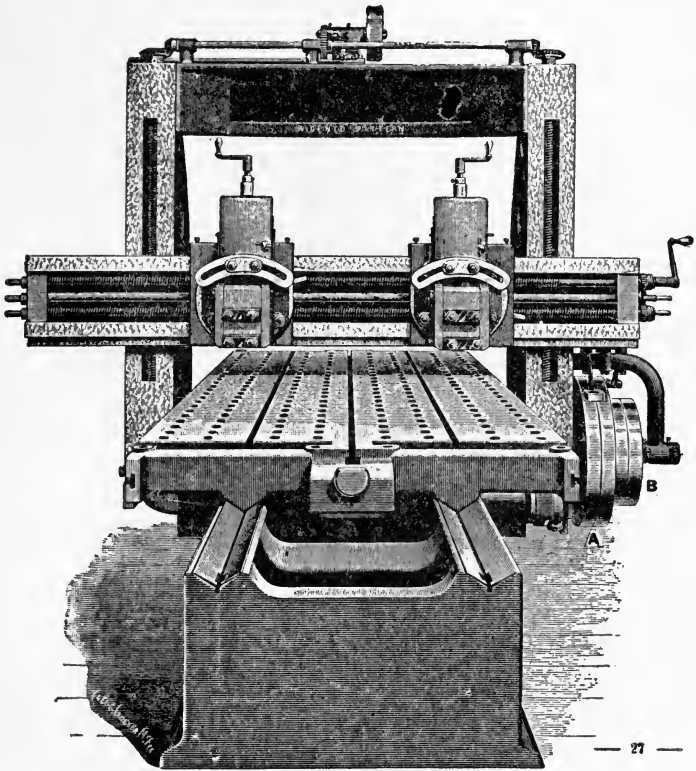

Fig. 138.



## PLANING OPERATIONS.

---

The operation of planing constitutes straight-line cutting by means of a planer, a shaper, a slotting machine or a key-way cutter, with a steel cutting tool. In the planer, the piece to be planed is given a straight-line motion to a stationary tool; while in the shaper and slotting machine, the work is stationary and the cutting tool is given a straight-line motion over the surface of the former. The planer is a very important tool to the engine-builder, as well as others, being instrumental in the production of engine and lathe beds, slides, parallel pieces, etc.

The work to be planed is securely fixed to the table of the machine, and is moved backwards and forwards by means of suitable gear, the cutting tool being held in the tool box, mounted upon the cross-slide.

The devices feeding the cutting tool, and regulating the traverse of the table in planing machines, are of different forms; the general practice is 1, the employment of two driving belts, one for the forward and the other for the backward movement of the table; 2, the feeds are actuated by independent frictional devices, the tappets on the carriage being employed only to shift the belts; 3, narrow driving belts moving at a high speed to facilitate shifting on the pulleys.

Also, the rack and pinion movement is employed in nearly all planers to give the traverse to the table.

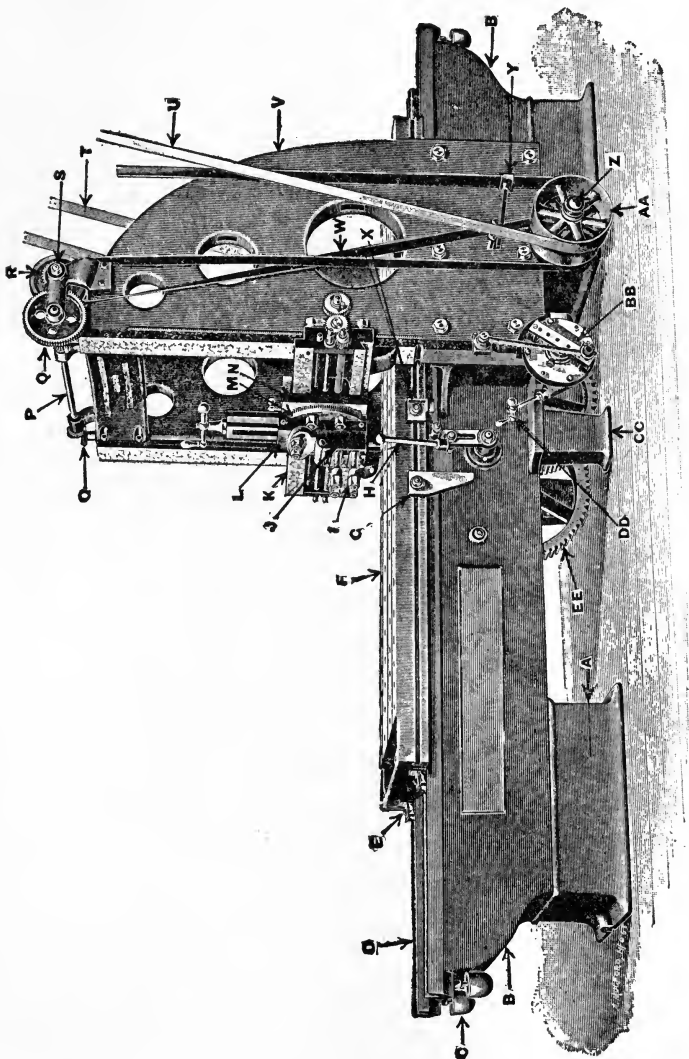

Fig. 139.

## PLANING OPERATIONS.

Fig. 139 shows a heavy planer designed to plane 10 feet long, 34 inches high and 34 inches wide. The cabinets *A* support the bed *B*, which has parallel, V-shaped grooves *D*, on its upper side. Drip cups, to receive the overflow oil from these grooves, are shown at *C*. The table *F* is moved by rack and gear; on its under side are parallel V-shaped strips, which are fitted to slide smoothly in the similarly-shaped grooves *D*, on the bed; the wipers *E* contain felt to filter the oil entering the grooves, and also tend to keep them clean.

The long dog *G* strikes the rocker arm *H*, which has a removable arm for hand use; this rocker arm, through a system of mechanism, shifts the driving belts, reversing the motion of the table; *X* is the back or short dog; the cutter-head is on the cross-bar and consists of the tool-post *I*, where the cutting tool is clamped; *J* is the clapper or tool box, fastened to the vertical slide, or feed regulator, *L*, and swivels to any angle, being attached to the shoe *N*, which slides on the cross-bar *K*, thus giving the cross-feed or "advance" of the tool.

The down-feed or depth of cut is regulated by the handle shown over slide *L*. The head-lift bevel pinion *O* raises or lowers the cross-bar *K*, being geared to head-lift shaft *P*, on which is the spur-wheel *Q*, geared into pinion *S*, operated by the pulley *R* and belt *W*, driven from the pulley shaft *Z*.

The front post, or housings, *V*, are of box-form in section, and are bolted to the sides of the bed, being connected at the top by a substantial box-shaped cross-girt. The pulley-shaft *Z* is driven by two driving belts; the

## PLANING MACHINES.

forward, or cutting belt, *T*, and the backward, or return belt, *U*; the belts being moved on the fast and loose pulleys by belt shifter *Y*. The backing pulleys *A A* are shown in the illustration; the forward, or cutting motion pulleys, are on the other side of the bed.

The friction box *B B* revolves through an angle which is varied by turning the worm shaft *D D*, which moves a segment having stop-lugs, so placed that the lugs on the back of the friction box strike them, thereby actuating the cross-feed. *E E* is the center gear which meshes with the table-rack.

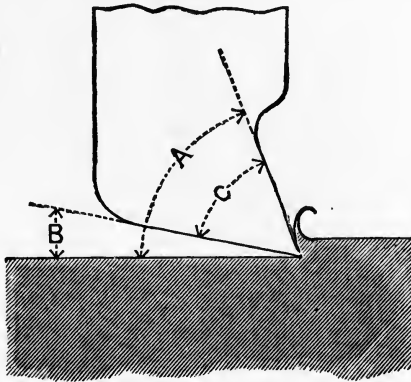

Fig. 140.

Planing machines run at a linear velocity of 15 to 20 feet per minute. The depth of cut depends on the material. The average cutting speeds for the various metals are as follows: Brass, 30 feet; gun metal, 25; cast iron, 15 to 20; wrought iron, 16; steel, 12. For general work the cross-feed, or advance of the tool should be from 12 to 14 cuts per inch for roughing cuts. The finishing cuts should be done with a broad tool, advancing from one-fourth to three-eighths of an inch with each cut.

## PLANING OPERATIONS.

The tools used in planing are very similar in form to lathe-turning tools—a front tool used for roughing, a side tool for edge work, and a spring tool for flat work or surfacing. In fig. 140, *A* is the cutting angle, *B* the angle of relief or clearance, and *C* the tool angle.

The “cutting angle” for cast iron is  $70^\circ$ , for wrought iron,  $65^\circ$ , for brass,  $80^\circ$ , according to the table below.

TABLE.

	Cast Iron.	Wrought Iron.	Brass.
Cutting angle.....	$70^\circ$	$65^\circ$	$80^\circ$
Clearance.....	$3^\circ$	$4^\circ$	$3^\circ$
Tool angle.....	$67^\circ$	$61^\circ$	$77^\circ$

One cutter head is shown in fig. 139, but it is quite common to have two cutter heads or clapper boxes, as shown in front view fig. 138, on the cross-bar, and in large machines there are, in addition, “side-heads,” one on each housing, making four. All these heads will swivel to any angle.

Fig. 141 shows the arrangement of the cutter or cross-bar head which moves on the cross-bar parallel with the work table or platen.\*

*A* is the tool-post-apron, sometimes called the clapper-box, being hinged so that the tool can lift upon the return or backward stroke; this prevents the tool edge rubbing on the work; *B* is the swivel apron; *C* the “slider” which carries the apron; *D* is the swing frame or swivel head; *E* is the saddle which slides on the cross-bar.

\* *Platen* is a very old word meaning a covering plate; the more modern definition for this is “table.”

## PLANING MACHINES.

The cross-bar heads are operated by self-acting mechanisms both in the cross and angular feeding, the side-heads being fitted with vertical self-acting feed motions.

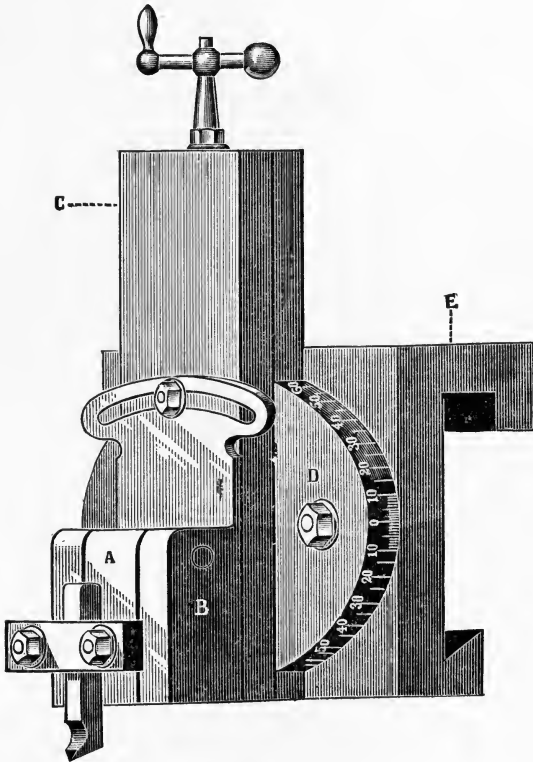

Fig. 141.

Planing machine tables are provided with bolt-holes and T-slots or grooves on the surface for fixing the work, which is usually bolted direct to the table. This cannot always be done, on account of the shape of the work.

## PLANING OPERATIONS.

Fig. 142 shows an open-side planer; this tool is adapted to accommodate work when bolted to the table, of a greater width than the ordinary planer; the cross-vail or beam is a right-angle casting having a vertical leg with

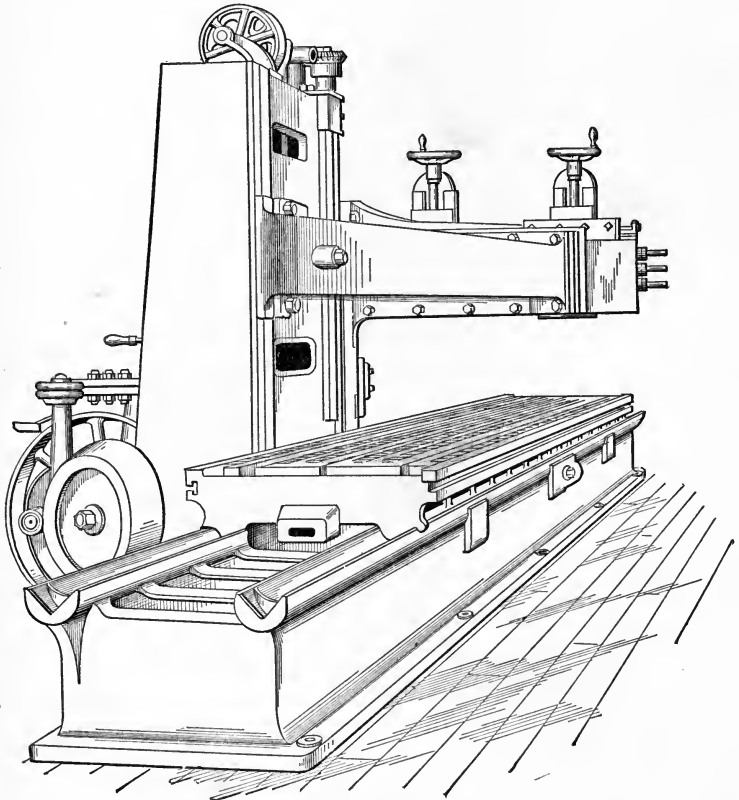

Fig. 142.

a very long bearing on the front face of the post; the horizontal arm is supported at the back by a heavy brace bolted securely to it, this arrangement insuring stiffness and stability; the brace has a sliding bearing on the side

## CHUCKS.

and at the rear of the post, being rigidly clamped to it when set in position for planing. The beam and brace are raised and lowered by power.

Fig. 143 shows a swivel chuck which is sometimes

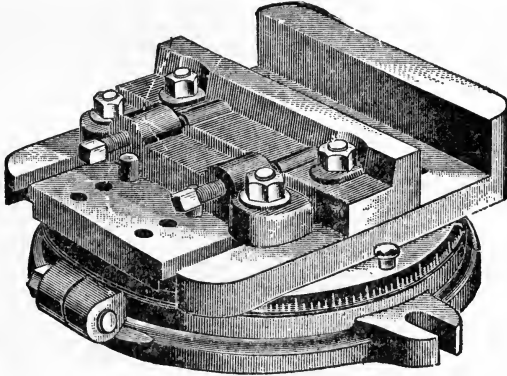

Fig. 143.

used ; it is bolted on the table and travels with it, the work being held between the jaws as in a vise. Frequently work has to be held as on a lathe ; for this purpose two

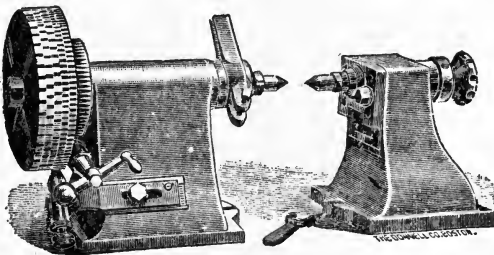

Fig. 144.

“planer centers” are used, as shown in fig. 144. These are bolted on the table ; one of these is shown with a “dividing index.”



PLANING MACHINE TOOLS.

The following illustrations show the tools in general use in planing machines. The name of each tool is given below in Note.

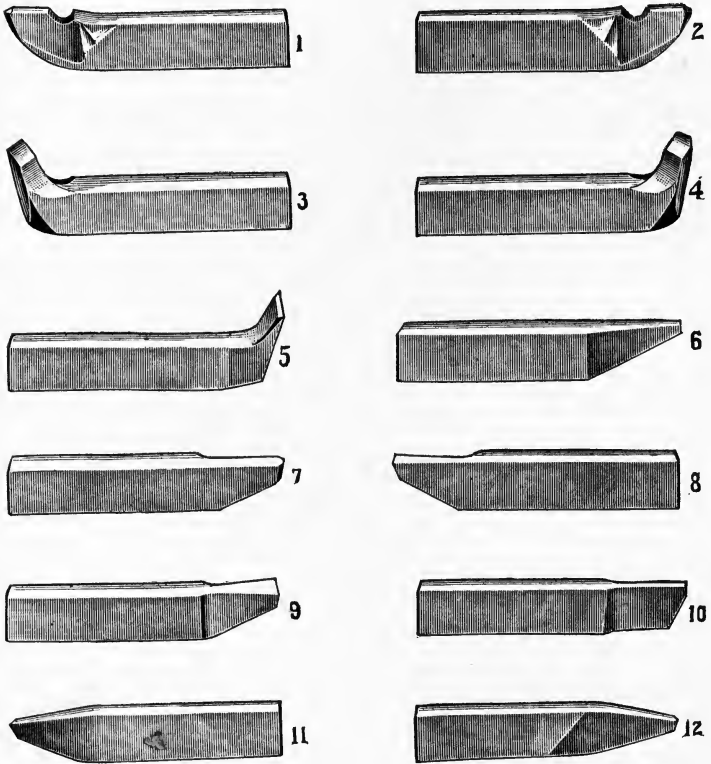

Figs. 145-156.

NOTE.—No. 1, Left-hand Side Tool; No. 2, Right-hand Side Tool; No. 3, Left-hand Diamond-point Tool; No. 4, Right-hand Diamond-point Tool; No. 5, Broad-nose, or Stocking Tool; No. 6, Scaling Tool; No. 7, Right-hand Siding Tool; No. 8, Left-hand Siding Tool; No. 9, Finishing Tool, for corners; No. 10, Cutting-off Tool; No. 11, Left-hand Bevel Tool; No. 12, Right-hand Bevel Tool.

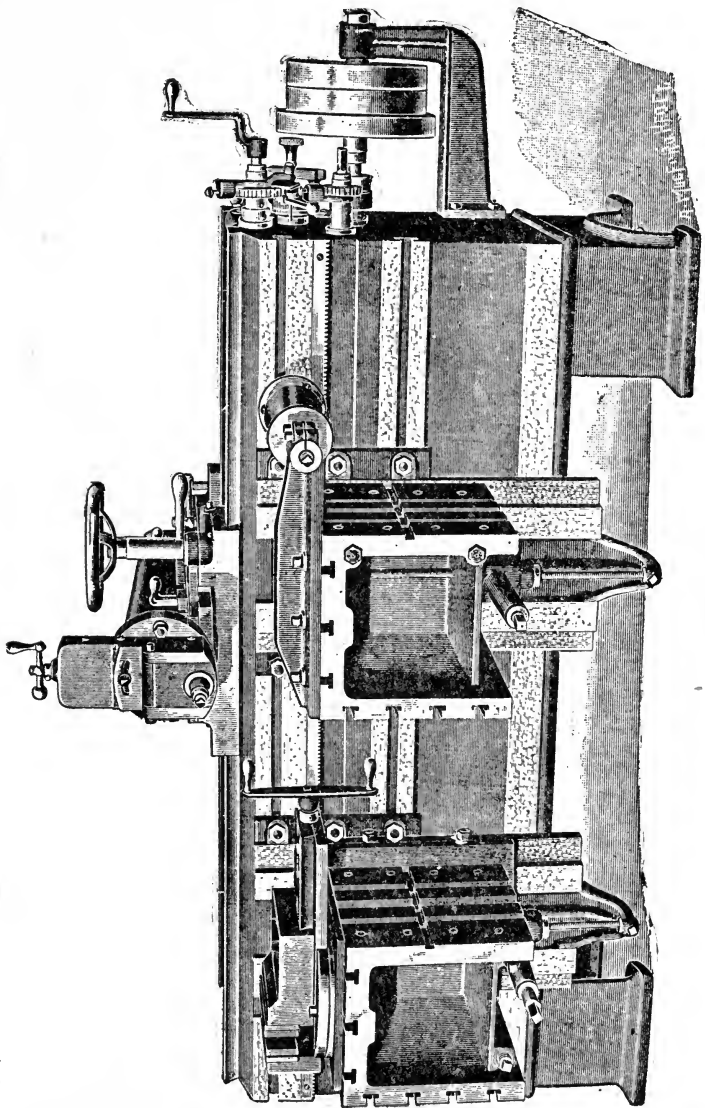

Fig. 157.

---

## SHAPING MACHINES.

---

The shaper, or shaping machine, is a straight-line cutter of the planer class; they perform a large variety of operations formerly executed by hand-chipping and filing.

In this machine the work is held stationary, the tool being given a reciprocating cutting motion.

The feed-motion of shaping machines may be communicated either to the cutting-tool or to the work; when the feed is given to the cutting-tool the machine is described as a *traveling-head* shaper; such an arrangement is shown in fig. 157.

More generally—and in all small shapers—the feed is communicated to the work-table, as shown in fig. 158, the ram or tool-head having no side travel, the feed motion being given to the table carrying the work.

The shaper is a useful and handy tool, and is made in a variety of forms for special purposes, the work ranging from key grooves in shafting to planing valves and steam ports in engine cylinders.

Fig. 157 shows a usual type of traveling-head shaper; the tool-head is carried in a saddle having variable self-acting feed in either direction; it has also a rapid movement along the bed by hand through a rack and pinion, or in some cases it is operated by a powerful square-cut screw; the tool has ratchet down-feed motion; it can be swiveled and will act at an angle; two tables are provided,

---

NOTE—Shaping machines are generally run at a tool speed of 12 to 20 feet per minute.

## PLANING OPERATIONS.

each having a hand movement along the bed, and also a vertical adjustment by screws; one table has, generally, a horizontal surface for clamping work, the other being provided with horizontal and vertical slotted surfaces for clamping the work in any desired position.

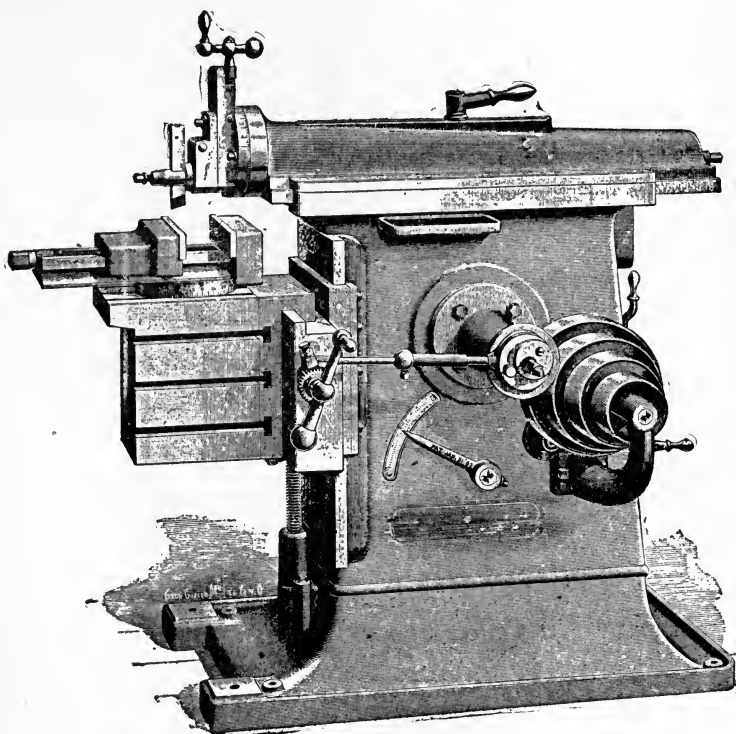

Fig. 158.

For forming teeth in spur-wheels cut out of solid blanks, shapers of special design are made, of which an example is given in fig. 159—it is the “Fellows’ Gear Shaper.”

SHAPING MACHINES.

*A, B, C*, are change gears; *D*, the "module" or pitch gear, the number of teeth of which must have a fixed ratio with the teeth of the cutter; *E*, feed trip; *F*, lower index; *G*, apron; *H*, chip pan; *I*, work arbor; *J*, cutter; *K*, cutter

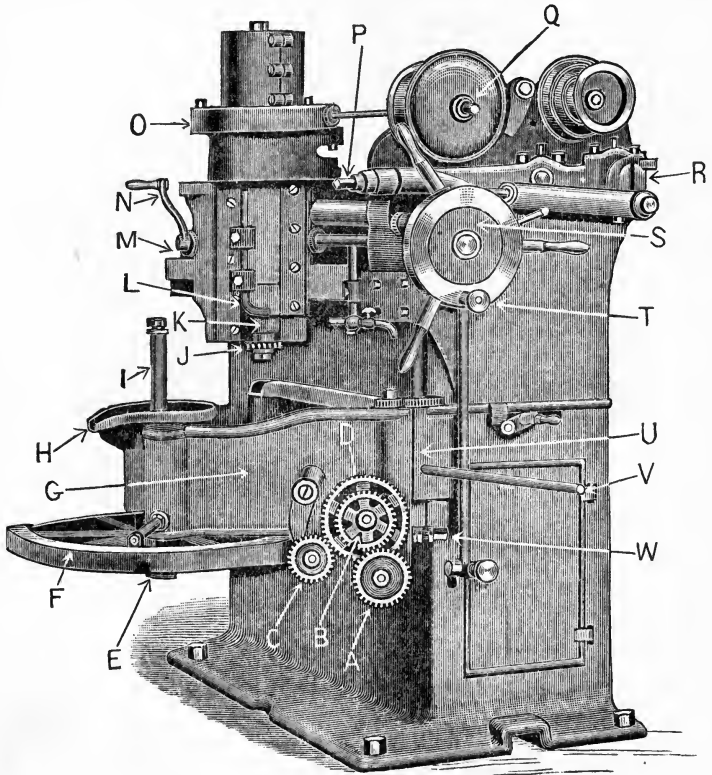

Fig. 159.

slide; *L*, work support; *M*, saddle binder; *N*, saddle adjustment; *O*, upper index; *P*, adjustment for the position of cutter; *Q*, to rotate cutter; *R*, driving crank; *S*, pilot wheel; *T*, locking pin; *U*, apron lever; *V*, detachable lever; *W*, worm adjustment.

## PLANING OPERATIONS.

The Fellows Gear Shaper goes back to first principles and generates its tooth form from flat and circular surfaces which can be made absolutely true and can be proven to be so.

The work is done automatically, by a circular cutter of the correct pitch.

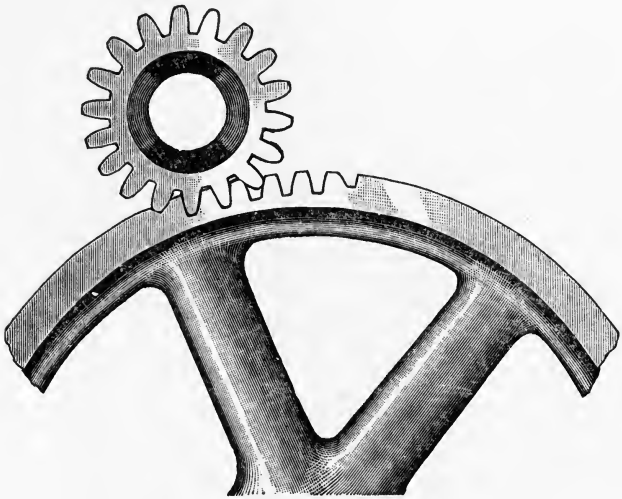

Fig. 160.

An example of the work produced is shown in fig. 160. This is effected as follows: The blank to be cut is securely fixed on the work arbor and the machine being started, the cutter reciprocating vertically on its center line is fed towards the blank, and cuts its way to the proper depth; at this point both cutter and blank begin to revolve, the cutter maintaining its reciprocating motion; this revolution of the cutter and blank is obtained by external mechanism, which insures that the movement

## SHAPING MACHINES.

shall be as though the cutter and blank were two complete gears in correct mesh; fig. 161 shows a section through the centers of blank and cutter which will explain the process of cutting an external-toothed gear wheel; internal gears can be cut with equal ease and regularity.

Fig. 161 shows the action of the gear cutter, also each cut and the wedge form of the gear shaper chips.

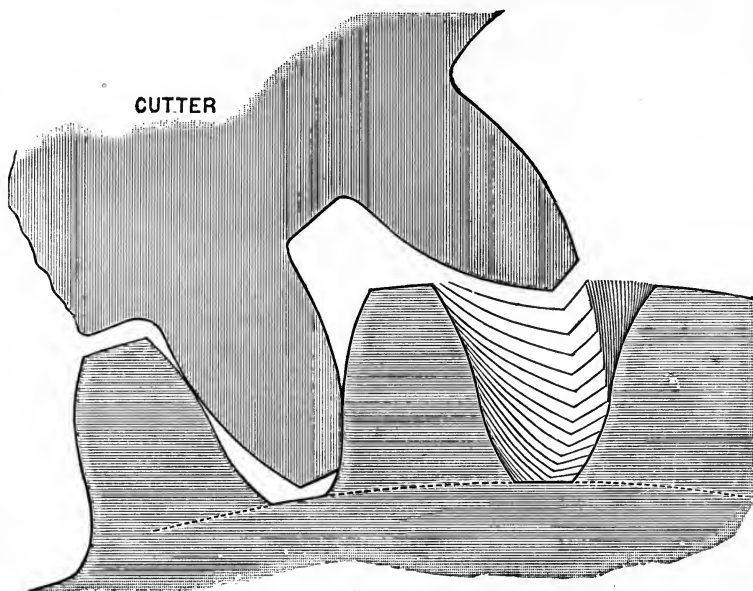

Fig. 161.

The combined result of rotary and reciprocatory motions is that the cutter teeth generate conjugate teeth in the blanks which mesh correctly with the cutter teeth and with each other.

Fig. 162 illustrates a device for setting planing or shaper tools; it consists of a body containing a spirit level, the bubble of which appears through an elongated opening

## DEVICE FOR SETTING TOOLS.

formed in the top plate, attached to the body and provided at its side with linear graduations having their zero points coinciding with the zero point of the bubble. The body is provided with a downwardly extending web terminating in

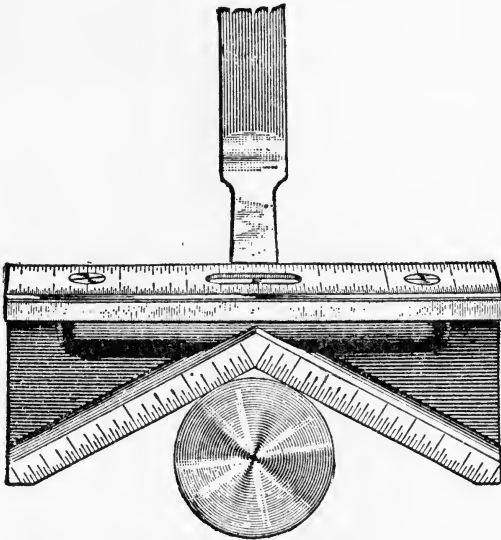

Fig. 162.

legs, extending at an angle of 150 degrees and having their apex in vertical alignment with the bubble of the spirit level. The outer faces of the legs are provided with linear graduations, reading from the apex outwardly.

NOTE.—The figure shows the instrument on the shaft and the tool in position in the tool post ready to cut a keyseat. For setting a square-nose tool in the shaper or planer, to cut a keyseat or groove, the operator places the instrument upon the shaft with the legs touching the sides of the shaft and turns the instrument until the bubble of the spirit level is at zero. The planer tool is then brought to the correct position by aid of the graduations and is set with its edge parallel with the top surface of the instrument.



## THE SLOTTING MACHINE.

---

The slotting machine may be classed as a *vertical shaper*, or planing machine; it performs straight line cutting; the tool, as in the shaper, receives the motion, the bed or table being stationary, except for feed adjustment.

There are many varieties of slotters, both light and heavy; the small machines are usually crank-driven, the larger ones have steel racks and pinions driven by a train of spur gears, with shifting belts; for slotting heavy forge work, especially cutting propeller shaft cranks out of the solid, they are built of great cutting power.

The principal features aimed at in all, are smooth running and convenient handling of the work.

The advantageous features of the slotter are, first, that the lay-out of the work is always visible, the line to be worked to being on top where the tool begins to cut, instead of where it finishes the cut as in the case of the shaper; and secondly, that there are three feeds—longitudinal, cross and circular—all with a wide range.

For the slotting of interior surfaces, and the planing of such exterior surfaces as for one reason or another cannot be done advantageously on the planer or turned in the lathe, and where the pieces are of medium or large size, the slotter is a necessity.

For cutting keyways in wheels, etc., the slotting machine has no equal and in addition nearly all descriptions of broaching work can be accomplished with it.

## PLANING OPERATIONS.

Fig. 163 shows a well known form of the tool in common use for machine-shop purposes; the tool-bar can be adjusted to suit the height of the work, or any length

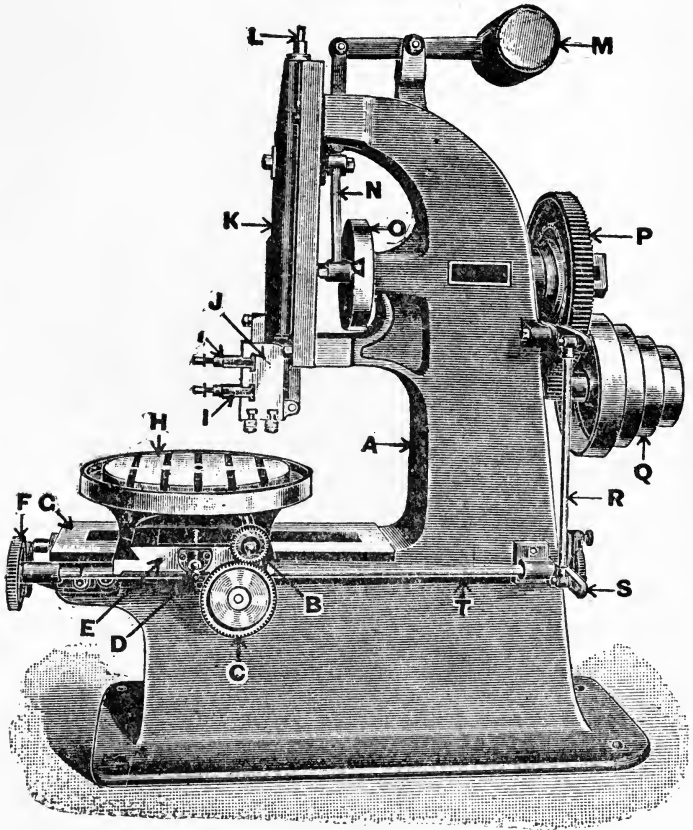

Fig. 163.

of tool used; the work-table has power feed for the longitudinal, cross and circular movement; all the feeds are moved at the top of the stroke, when the tool is clear of the work.

## THE SLOTTING MACHINE.

The ram, or tool-bar, as shown in the illustration, is counter-weighted and easily regulated; the hand cranks and levers for all adjustments are placed within easy reach of the operator.

The cutting tools in slotting machines are gripped in a relief tool block, *J*, carried by the ram, *K*, moving vertically in the slides of the upright frame, *A*; the work being operated on is fixed on the work table, *H*, which lies horizontal beneath the ram; the work table is carried on a compound slide, having two horizontal motions: the lower slide or carriageway, *G*, is operated by the rod or feed-shaft, *T*, and the end main feed gear, *F*; the upper slide or saddleway, *E*, is operated in a similar manner by the main intermediate gear, *C*. *D* is the transverse adjusting screw; the small wheel, *B*, operates a worm, which engages with a worm wheel on the periphery of the circular table, *H*, to rotate it; the tool-posts, *I, I*, are carried in the relief tool block or apron, *J*; the ram, *K*, may be varied according to the thickness of the work on the table by the adjusting screw, *L*, on the ram; *M* is the counterweight which balances the ram and prevents "jump" when the tool is entering or leaving the work; *N* is the connecting rod attached to the crank-plate, *O*, which gives motion to the ram; the gear, *P*, on the crank-plate shaft is driven by a pinion on the driving-cone pulley, *Q*; the feed-rod, *R*, gives motion to the feed-shaft, *T*, by means of the bell-crank, *S*.

The cutting-bar slide is made adjustable on the outside of frame, and by making the slide very heavy, no matter at what point the cutting-bar is set, it will be very rigid. To adjust the cutting-bar slide, it is only necessary

## PLANING OPERATIONS.

to tighten up one of the gib screws and loosen the clamping bolts, and by revolving the driving cone the slide can be adjusted in any desired position to bring it down close to the work.

The accompanying drawings (fig. 174 being a side view and fig. 175 a front view) will show the detail of the relief tool-block on all these machines.

*A* is the adjustable slide attached to the main frame by the bolts *C*; *B* is the ram having slides *H, H*; *D* is the

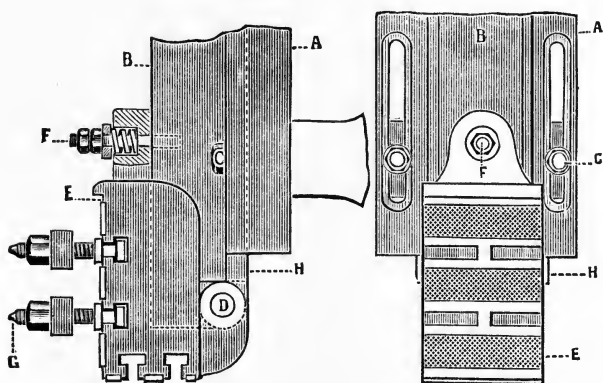

Fig. 174.

Fig. 175.

pivot or pin on which the apron or tool-box *E* hinges; *F* is the relief spring which presses the apron *E* against the ram *B* on the downward or cutting stroke of the tool, as illustrated in fig. 176; on the return or idle stroke, the relief spring yields and takes the pressure off the cutting point of the tool, which is carried in the tool posts *G*.

Fig. 177 shows a form of machine used largely in machine shops for cutting keyways up to one inch wide; it is constructed on the principle of a broacher or drift cutter,

## THE SLOTTING MACHINE.

the work being fixed to the adjustable table, *A*, by the heavy clamping, *D*. The cutter-bar, *G*, which has coarse teeth, as shown, is drawn through the work: there is a provision for automatic relief on the return stroke, which prevents the breaking of the cutter-teeth; *B* is the supporting bracket used when cutting sleeves or hubs; it has an adjusting screw, *C*, for holding the work; the clamp, *D*, is used for holding all large work such as pulleys, spur and

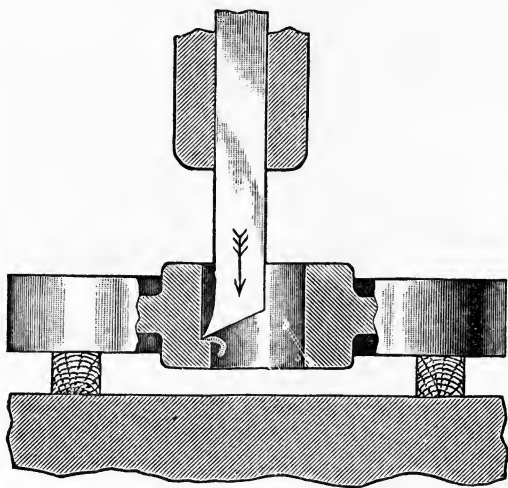

Fig. 176.

bevel gears, etc., being fixed by the screwed studs, *E*, which compress springs *Q*.

An adjustable chuck, *F*, is used for centering small work; the vertical cutter bar, *G*, is connected to the cross-head, *V*, which reciprocates in vertical guides under the table; a scale, *H*, is provided for graduating the depth of the key seat; collars or packing, *I*, regulate the height of

## PLANING OPERATIONS.

the clamp, *D*; an adjustable clamp arm, *J*, is used for holding small work; it has hand feed screw; an adjusting post, *N*, and clamp screw, *M*, for attachment to the table.

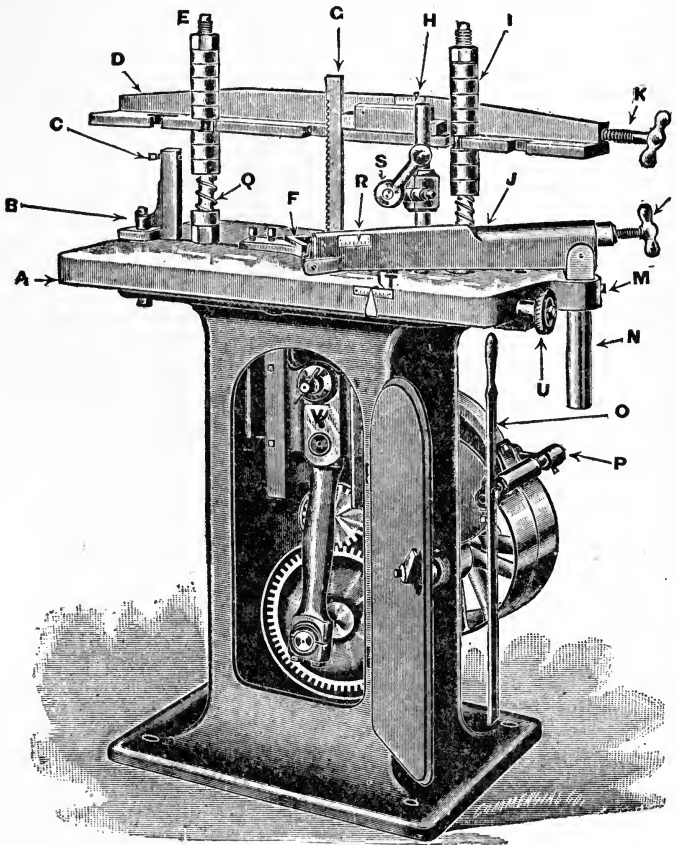
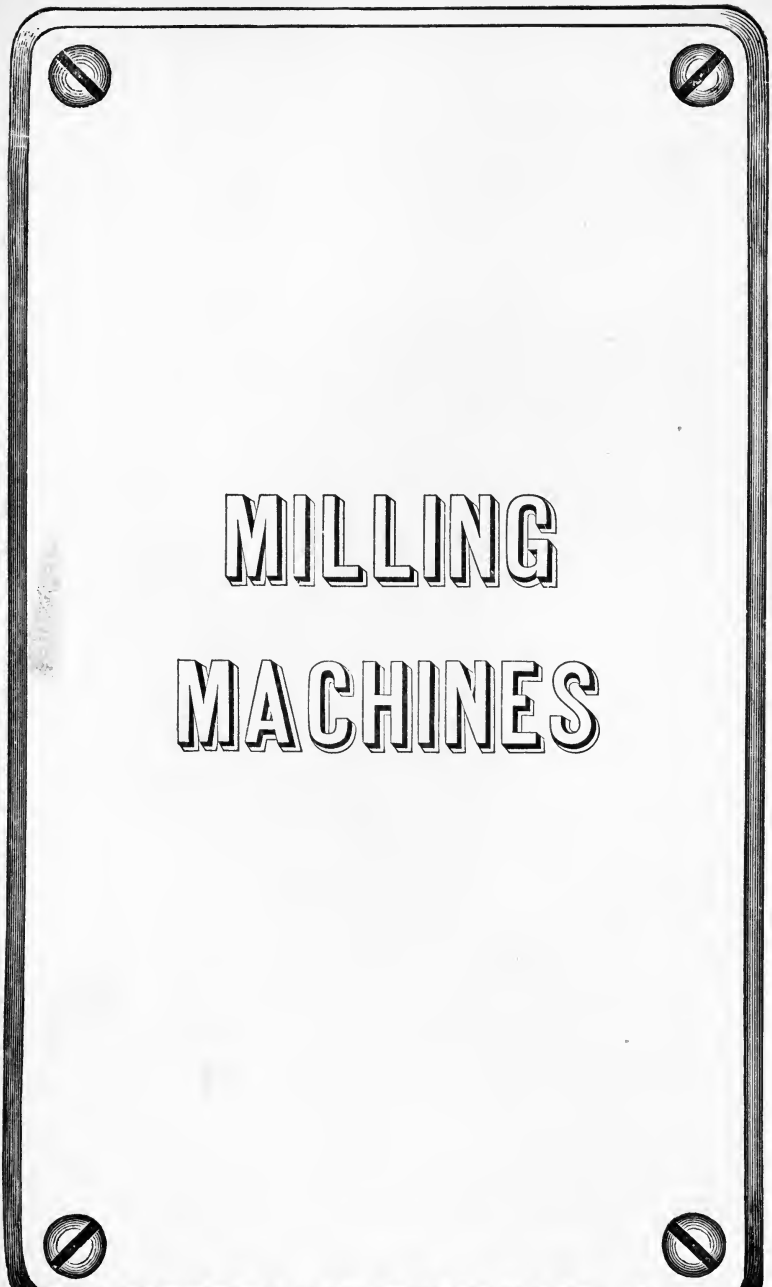

Fig. 177.

The spur gear enclosed in case, *O*, are driven by the tight and loose pulleys revolving at 175 revolutions per minute; in this machine the work is chucked by the hole or bore.



**MILLING  
MACHINES**

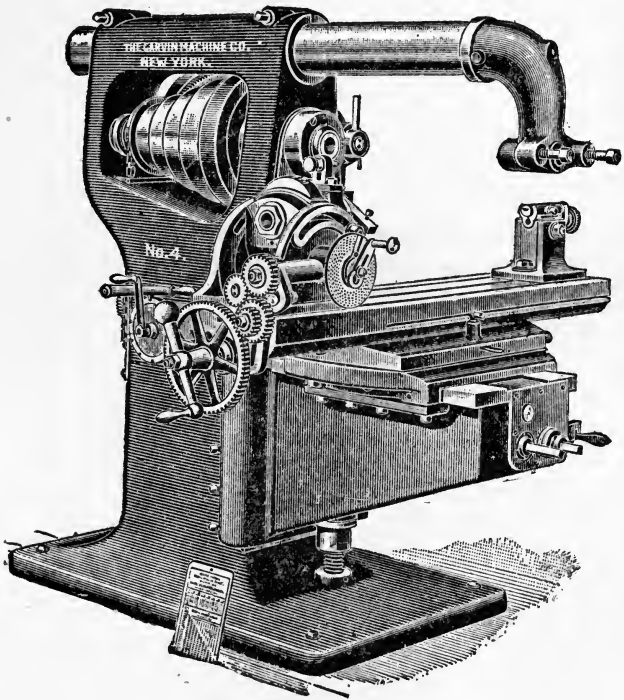

Fig. 178.



## MILLING MACHINES.

---

A milling machine is a power machine-tool for shaping metal by means of a cylindrical cutter or serrated spindle.

No special tool has come more rapidly to the front in recent years than the milling machine; by its use a large variety of work which was formerly done by the planer, shaper, and by hand, is now performed on various types of these tools.

A milling machine has been defined as "a whole machine shop in itself"; it has a movable table, to which the work is fixed and on which it is brought to the cutter; it is fitted with index-plates and other appliances for securing accuracy in the work executed.

Milling is nearly identical with grinding; the former is a cutting and the latter an abrading process; the milling machine resembles in its action a high type of emery-grinder; the rotating cutter in the grinder being, however, of emery, while in the milling machine it is a steel cutter, the latter producing plain, curved or special formed surfaces on the material operated upon.

Metal may be cut away by a rotary milling cutter at from four to ten times the speed at which it can be cut in a shaping or planing machine.

A "universal milling machine" is shown in fig. 178; this is capable of cutting spirals on either taper or parallel work, being provided with an index head arranged with suitable gearing or feed motion to rotate the work while it

## MILLING MACHINES.

is travelling beneath the cutter; hence, when these two feed motions act simultaneously, the path of the work beneath the cutter is a spiral, and the action of the revolving cutter in the work is therefore similarly spiral; grooves may be cut or spiral projections left on the work according to the shape of the cutter employed.

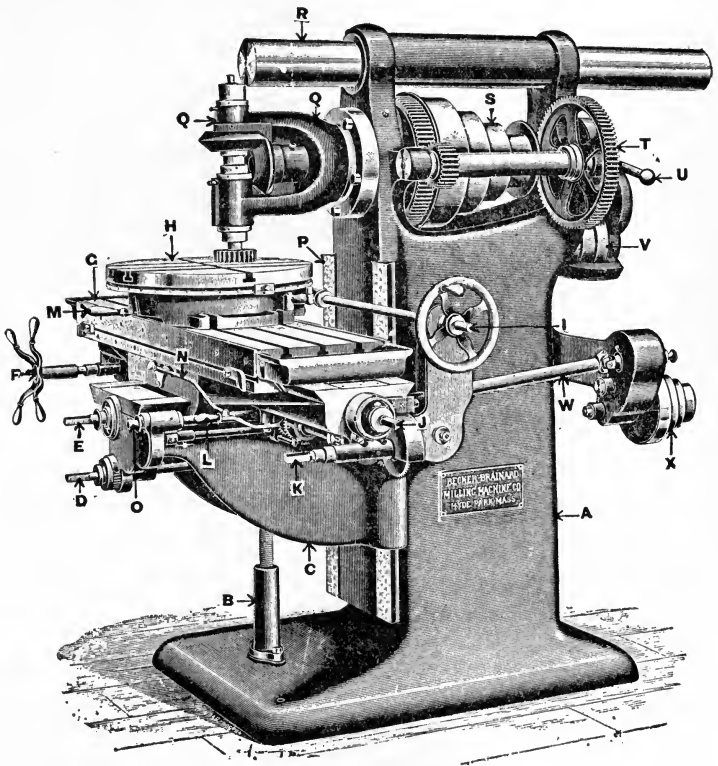

Fig. 179.

Fig. 179 shows a plain horizontal milling machine, fitted with a vertical head and rotary cutter.

## PARTS OF MILLING MACHINE.

Following is a description of the principal parts of this machine tool and their use:

*A* is the standard on which is attached all the main parts of the machine.

*B* is called the horn, and contains the elevating screw for raising the knee, *C*, which is adjustable vertically on the slide, *P*.

*D* is the spindle with micrometer attachment for operating the elevating screw of the knee, *C*. This is also connected with the power feed spindle, *W*, through connecting spindle *O*.

*E* is the horizontal adjustment for the saddle, which, in turn, supports the table, *G*. This is also connected in the same manner as *D*.

*F* is the hand-wheel shown connected with the quick-return longitudinal movement of the table. This handle can also be used on the spindle, *K*, which also operates a quick-return movement connected with the table.

*G* is the table, which is shown with oil grooves on each side and oil pockets on each end. On each end of the table on the side, and shown connected by the T-slot running longitudinally with the table, is a dog, which, by engaging with the locking lever, *R*, in the center of the saddle, this, in turn, being connected by the rod, *N*, with the lever, *L*, throws the power feed off when the machine is in motion. This power feed is connected to the longitudinal and transverse motions of the table.

*H* is the rotary table which is shown bolted to the regular platen of the machine and connected with the power feed by the spindle, *I*. This, in turn, is connected by gearing, which is shown encased, with the spindle, *J*, which, in turn, is connected with power-feed spindle, *W*.

*M* is the lever connected with the interior mechanism of the rotary table for tightening the same when the table is to remain in a fixed position.

*O* is a spindle on which is the pull gear for connecting the cross or vertical feed with the power-feed spindle, *W*.

*Q* is the vertical attachment.

*R* is the overhanging arm, on which is used, at times, the out-

board bearing for supporting the end of horizontal spindle. *S* is the driving cone on main spindle of machine.

*T* is the back-gearred sleeve, and gears which are thrown in connection with the spindle by the lever, *U*.

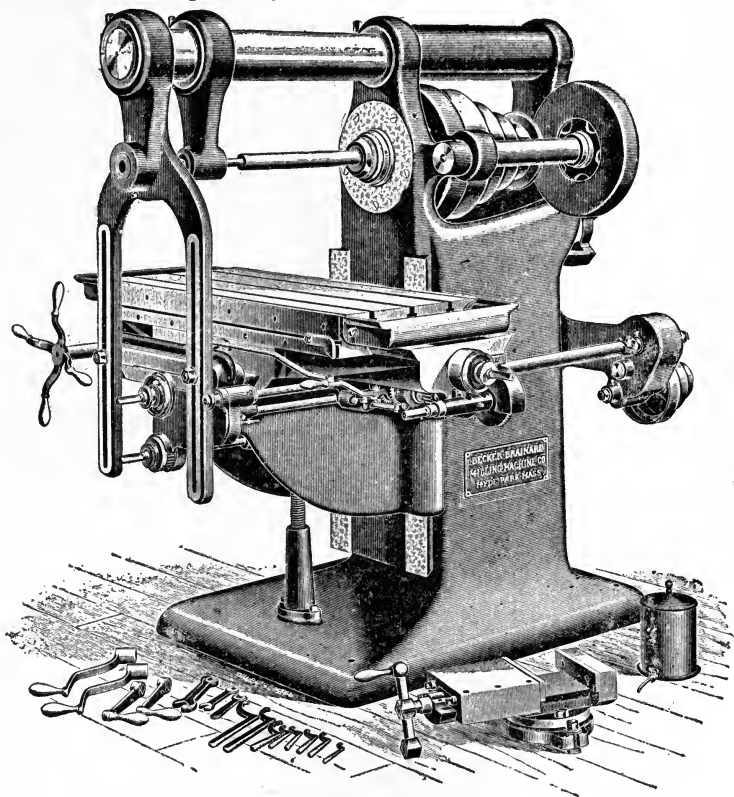

Fig. 180.

*V* is the feed cone connected by gearing with the end of the main spindle.

*X* is the feed-driving cone, which is connected by a belt with cone *V*. This cone drives the complete feed mechanism of the machine.

Fig. 180 shows a milling machine of the simplest design, with horizontal cutter; it is a similar machine to the one illustrated in fig. 179, without the vertical head.

Fig. 181 shows a dividing head and tail stock for a milling machine; the index plate has five rows of

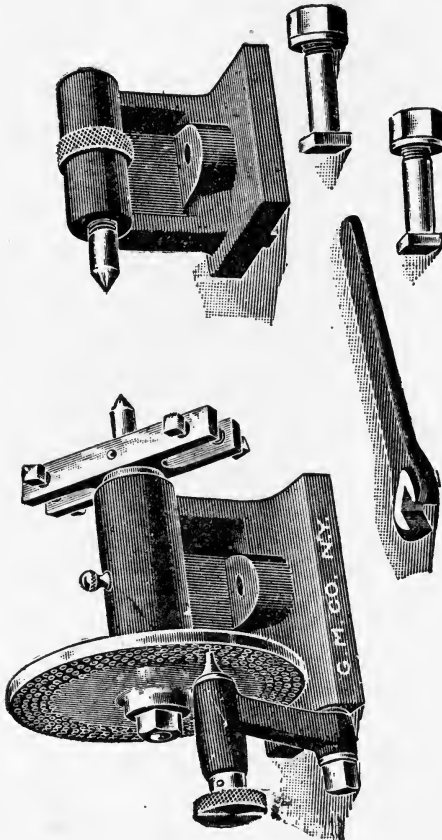

Fig. 181.

holes drilled in circles of 48, 56, 60, 66 and 72; the spindle can be solidly bound for taking heavy cuts, thus relieving the index pin from strain.

Fig. 182 shows a dividing head and tail stock. In this example the dial is moved by a worm and gear which turns and at the same time holds the head-stock spindle, thus relieving the index pin and the dial of strain, and

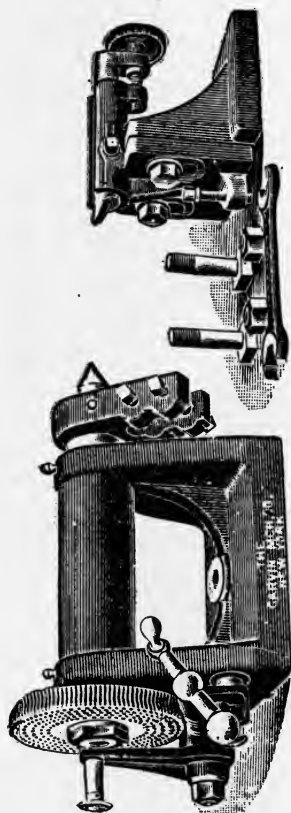

Fig. 182.

also the attendant wear and loss of accuracy; the worm can be dropped out of gear when it is desirable to turn the dial by hand; the tail-stock spindle has a vertical adjustment for taper work, as shown in the illustration.

Fig. 183 shows a regular vise, mounted on a graduated base, and held by a beveled friction disk and bound at any angle.

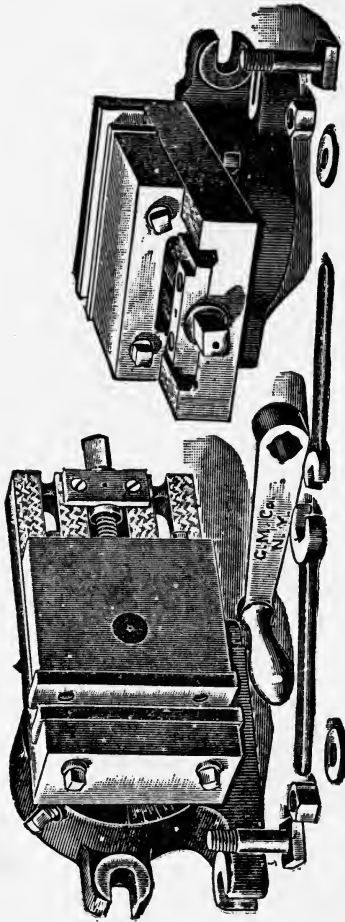

Fig. 186.

The base is provided with two clamping surfaces, so that the vise can be mounted horizontally or vertically, and clamped at any angle in either position.

The Feed Mechanism is a special feature of the Garvin Milling Machine

As shown by the illustration, fig. 184, the Change-Gear Box is set into the column and driven by a chain from the spindle. The Feed-Box is movable vertically and provided with an adjusting-screw, so that any slack in the chain can be taken up at once. A slip-friction

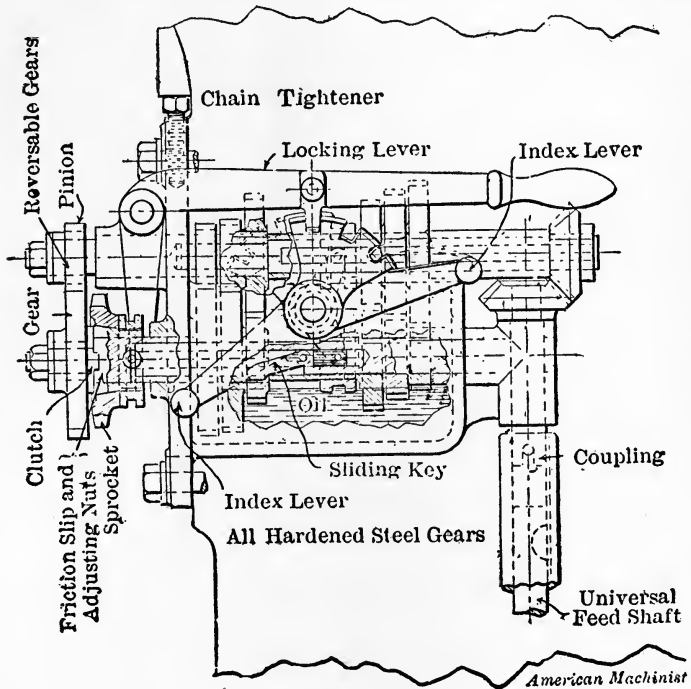

Fig. 184.

device is set in the feed-box sprocket, so that if any unusual strain is put on the machine, the frictional resistance will be overcome and prevent breakage.

Two double cones of gears are employed, which arrangement gives a larger number, and greater range, of feeds than is possible with a single cone. Nine direct changes are obtained, and by reversing the two outside gears, eighteen changes are obtained, ranging from  $\frac{1}{270}''$  to  $\frac{1}{4}''$  per revolution of spindle.



The change-gears in the box are all hardened steel and run in a bath of oil. Gears are connected to the shaft by means of two sliding spring-keys, as shown, which require no waiting for keyways to come in line. Each index lever is connected to a sliding key, and when each lever is moved the key is changed from one set of gears to another.

The numbers on the index table represent numbers of revolutions of spindle per inch travel of table. Feeds marked "pinion" mean that the outside pinion must be attached to the upper shaft, and feeds marked "gear" mean that the large outside gear should be attached to the upper shaft to obtain the indicated feed-speed. Supposing that a feed of  $\frac{1}{100}$ " is required; examine table and see that combination 2—5 gives this feed; first lift the locking lever, and then bring No. 2 on the outside lever around to the setting point; then No. 5 on the inside lever is brought to the setting point. The locking-lever is now pushed down into place, thereby locking the index levers in place, when the connection will be made for this feed. These feeds are all positive.

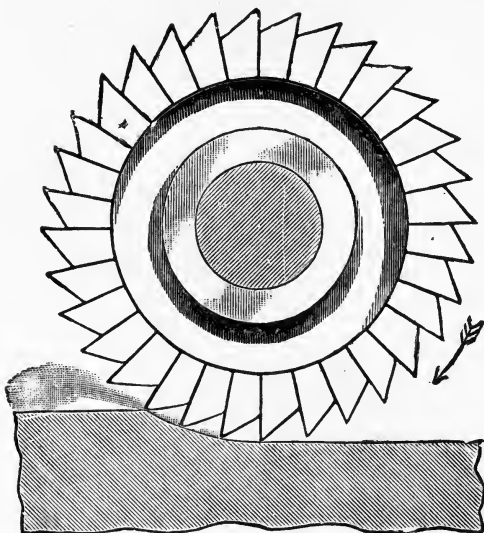

Fig. 185.

Fig. 185 represents a side view of a face or straddle mill in operation; the direction of the motion of the tool is shown by the arrow—the movement of the work being from the left hand to the tool.

MILLING OPERATIONS.

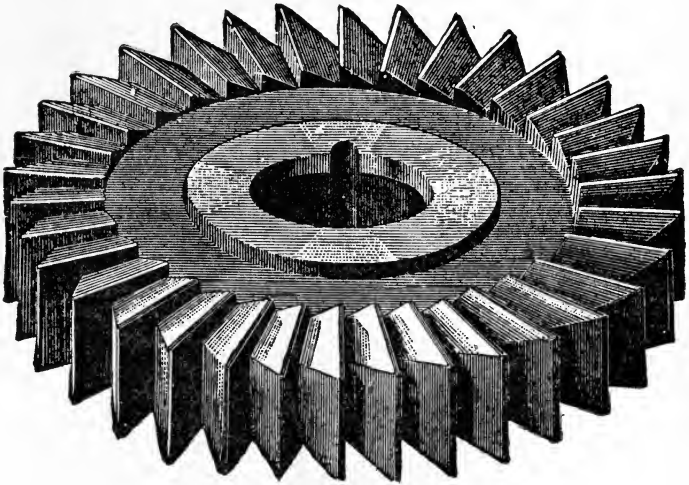

Fig. 186.

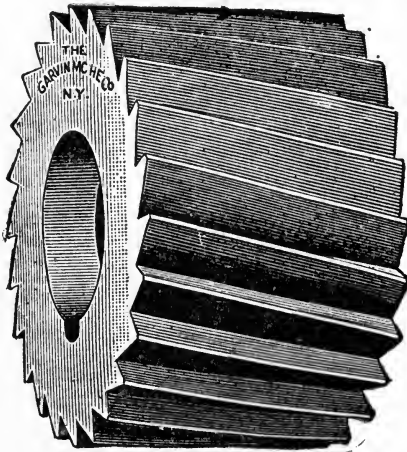

Fig. 187.

## SPEED FOR MILLING CUTTERS.

The face mill shown in fig. 185 is a form in general use; it has straight teeth arranged at equal distances on its "face," parallel to its axis, and radial teeth on one side, as shown in fig. 186. When two of these mills are arranged in pairs, or when a single mill has teeth on its face and on two sides, it is called a "straddle" mill.

Should a mill have a wide "face," the teeth are cut spirally, as shown in fig. 187; wide, straight teeth would not maintain a uniform cut on entering or leaving the work; with spiral teeth the cut begins at one end of the tooth; the cut being started, the cutting is uniform, producing smooth work, also avoiding a sudden shock when entering or leaving the cut.

The face-mill cutter is provided with a center hole, which fits on an arbor, and is provided with a keyway, shown in the illustration; the end of the arbor fitting into a conical seat, is securely held in the machine spindle, permitting the arbor to revolve in either direction, without becoming released; the mill can be reversed on the arbor, and the feed of the work can be changed, which, it is plain, could not be done if the mill was on an arbor that screwed upon the driving spindle of the machine.

The proper rotating speed of the cutters is essential to the economical production of work done by milling machines. The following rules and table will be found of value.

*RULE.—Divide the required speed per minute in inches, by the circumference of the cutter in inches, and the result is the number of revolutions per minute of the cutter.*

MILLING OPERATIONS.

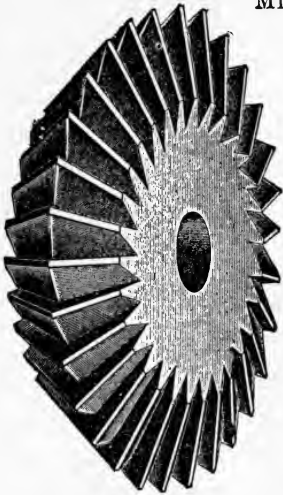

Fig. 188.  
Angle or Spiral Cutter.

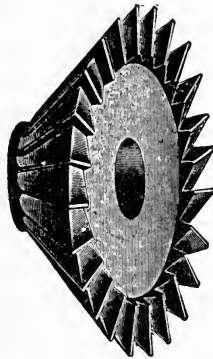

Fig. 189.  
Angle or Spiral Cutter.

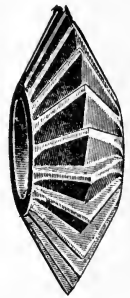

Fig. 190.  
Double Angle  
Cutter.

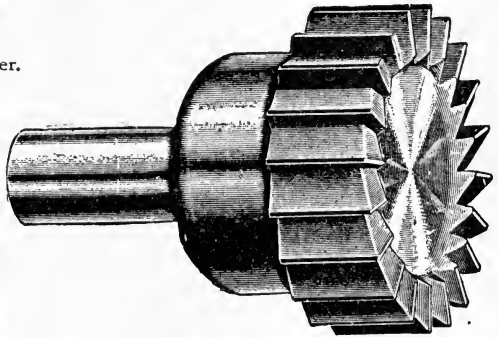

Fig. 191.  
Face Milling Cutter.

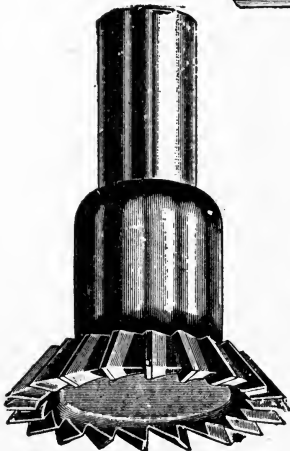

Fig. 192.  
Angle or Spiral Cutter.

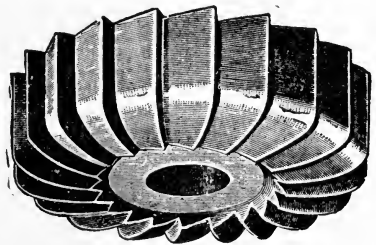

Fig. 193.  
Face Milling Cutter.

## SPEEDS FOR MILLING CUTTERS.

EXAMPLE FOR FIGURING CUTTER SPEEDS.—If a milling cutter is 3 inches in diameter, and it is required to cut wrought iron at a peripheral speed of 40 feet per minute, how many revolutions per minute must the cutter make? Now,

$$\frac{40 \times 12''}{3'' \times 3.1416} = \frac{480 \text{ inches}}{9.4248'' \text{ circum.}} = 51 \text{ revols., nearly. Ans.}$$

RULE.—*Multiply the circumference of the cutter in inches by the number of revolutions of the cutter per minute, divide by 12, the result is the cutting speed per minute in feet.*

If a milling cutter of 4 inches diameter makes 60 revolutions per minute, what is its peripheral cutting speed in feet per minute?

$$\frac{4 \times 3.1416 \times 60}{12} = 63 \text{ feet per minute, nearly. Ans.}$$

## SPEEDS FOR MILLING CUTTERS

	Brass	Cast Iron	Machine Steel	Tool Steel Annealed
Ft. per min...	80 to 120	40 to 60	35 to 45	25 to 35

*The speed of the cutters varies considerably with the kind of material to be operated upon, and is another case where the workman will be called upon to use his own judgment. The table shown above may be taken as a guide.*

MILLING OPERATIONS.

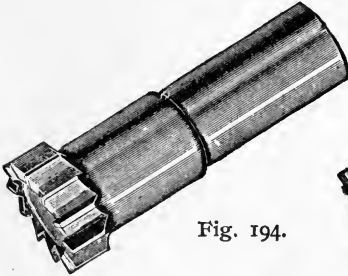

Fig. 194.

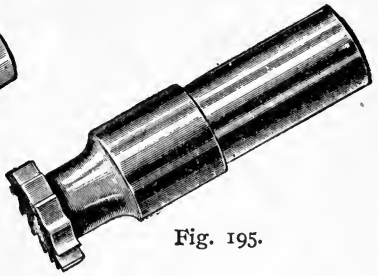

Fig. 195.

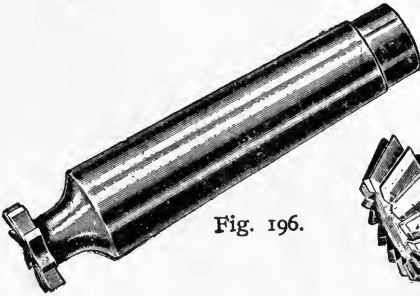

Fig. 196.

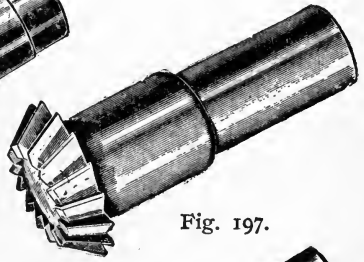

Fig. 197.

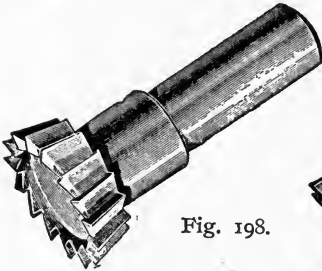

Fig. 198.

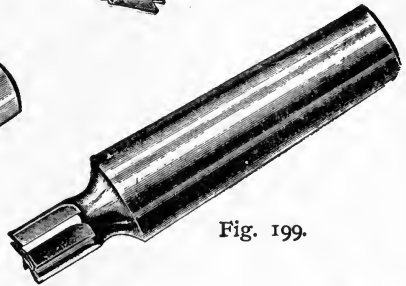

Fig. 199.

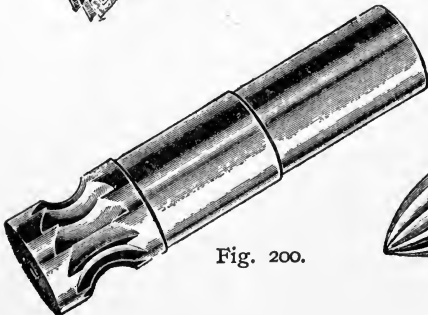

Fig. 200.

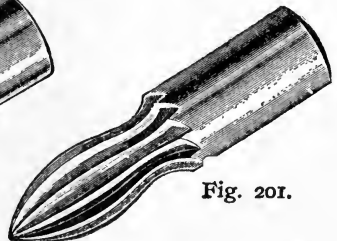

Fig. 201.

SPEEDS FOR MILLING CUTTERS.

It is more satisfactory to run milling cutters up to nearly the maximum speed, with comparatively light feed, than to reduce the speed of cutter, and overfeed the work.

A second table is added to the one printed on page 189; this gives the speeds for roughing and finishing, and also the traverse feed.

TABLE SHOWING AVERAGE MILLING SPEEDS, VIZ., THE PERIPHERY SPEED OF CUTTER (IN FEET) PER MINUTE.

	Steel	Wrought Iron	Cast Iron	Gun Metal	Brass
Roughing cut.....	30	40	60	80	120
Finishing Cut.....	40	55	75	100	140
Feed per min., ins..	$\frac{1}{4}''$ to $\frac{1}{2}''$	$\frac{3}{4}''$ to $2''$	$\frac{1}{2}''$ to $1\frac{1}{2}''$	$1\frac{1}{4}''$ to $2''$	$2\frac{1}{2}$

Where there is no great depth of material to cut away, these feeds may be taken as the maximum figures.

On page 188 are illustrated a variety of milling cutters or "mills."

Figs. 188 and 189 are angle mills used in cutting spiral grooves.

Fig. 190 is a double angle cutter.

Figs. 191 and 193 are face milling cutters.

Fig. 192 is an angle or spiral cutter.

On page 190: figs. 194-196 are T-slot cutters, figs. 197 and 198 are bevel mills, fig. 199 is an end mill or shank cutter, figs. 200 and 201 are surface mills or form cutters.

MILLING OPERATIONS.



Fig. 202.

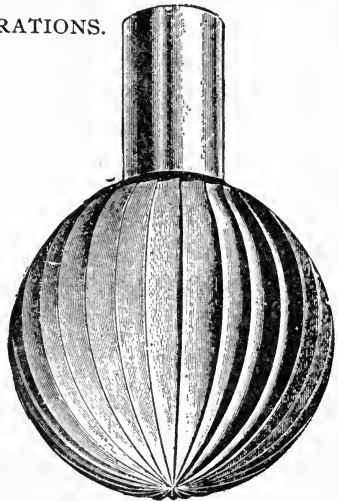

Fig. 203.

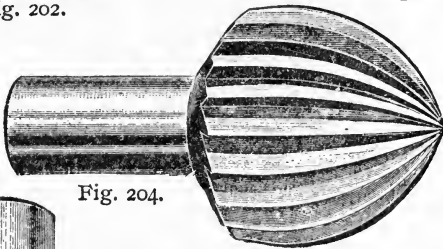

Fig. 204.

Rose or Groove Cutters.

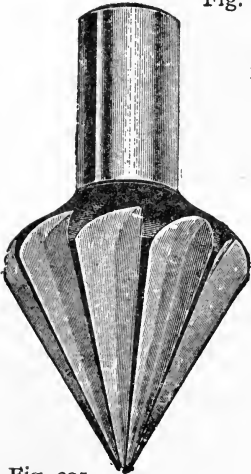

Fig. 205.

Counter Bore Mills.

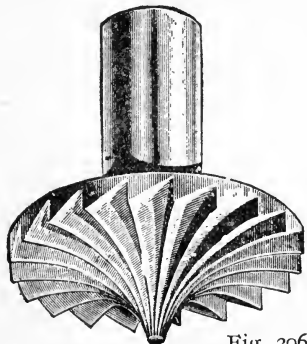

Fig. 206.



MILLS AND CUTTERS.

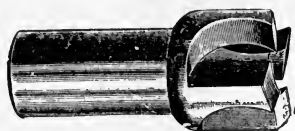

Fig. 207.



Fig. 208.



Fig. 209



Fig. 210.



Fig. 211.



Fig. 212.



Fig. 213.

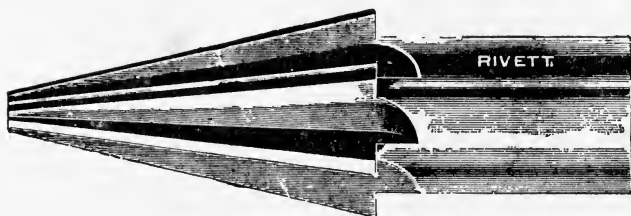

Fig. 214.

## MILLING OPERATIONS.

Figs. 202–204 are rose mills or groove cutters.

Figs. 205 and 206 are counter-bore mills, or irregular cutters.

On page 193: fig. 207 is a special surface cutter, fig. 208 is a hollow end mill.

Fig. 209 is a center reamer.

Fig. 210 is a counter-bore mill.

Fig. 211 is a parallel reamer.

Figs. 212–214 are taper reamers.

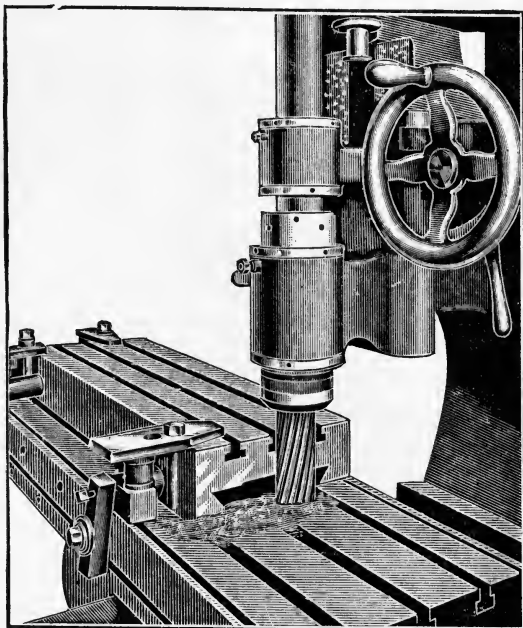

Fig. 215.

Fig. 215 exhibits a side cutter in operation, finishing the end of a milling machine table; formerly this work was done in a planing machine, which required to be very large, in order to permit the casting to pass between the housings.

## MILLING OPERATIONS.

Fig. 216 illustrates a rose mill (see fig. 203) operating on the periphery of a circular casting, cutting a groove; this class of work can be done very much faster on a mill-

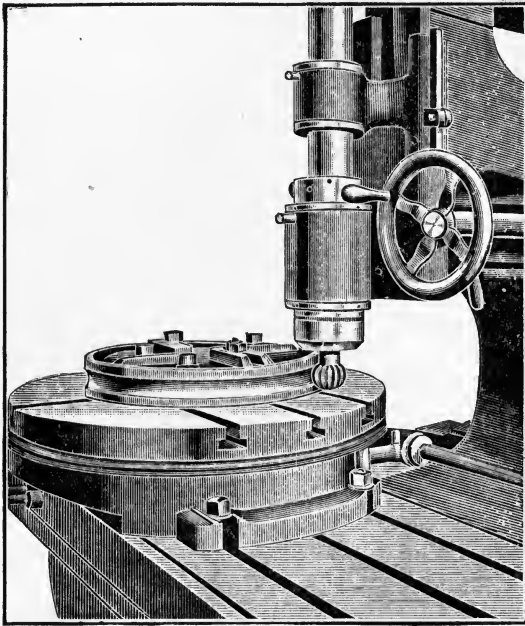

Fig. 216.

ing machine than it could be accomplished in a lathe; in addition, the shape of the recess is secured without a possibility of an error on the part of the operator, by the use of the rose mill.

## MILLING OPERATIONS.

Fig. 217 illustrates a bevel or angle mill in operation, finishing a cone or bevel surface on a circular casting; this cutter bevels the internal face of a corresponding ring, in-

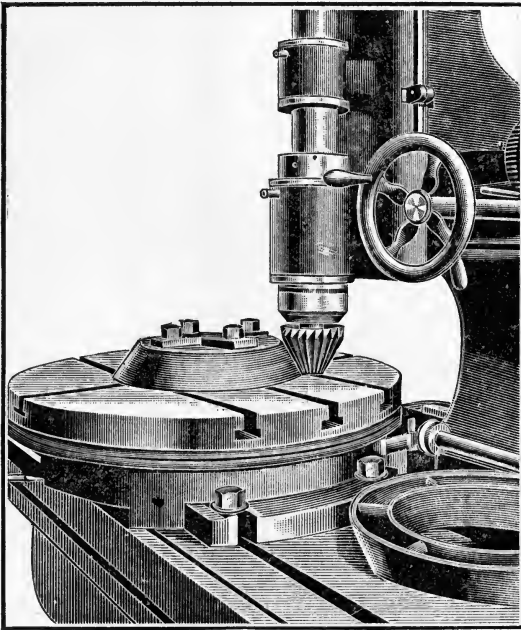

Fig. 217.

surrounding accuracy of fit between the two faces; this mill is largely used for economically finishing valves and many forms of similar work,

## MILLING OPERATIONS.

Fig. 218 shows an angle mill in operation, finishing the parallel vees on the inside of a sliding-head casting; both the vees can be finished at one setting; the slides can

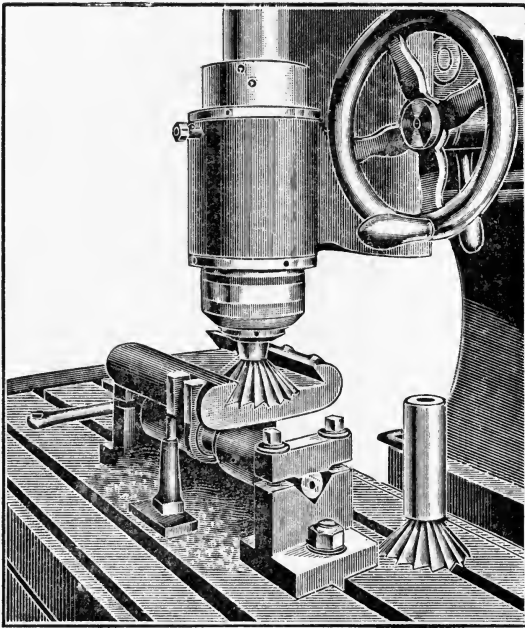

Fig. 218.

be made to match in duplication, or duplicate work, in less time in the milling machine than the same work could be done in a planer. For the four last illustrations credit is due to the Becker-Brainard Milling Machine Co.

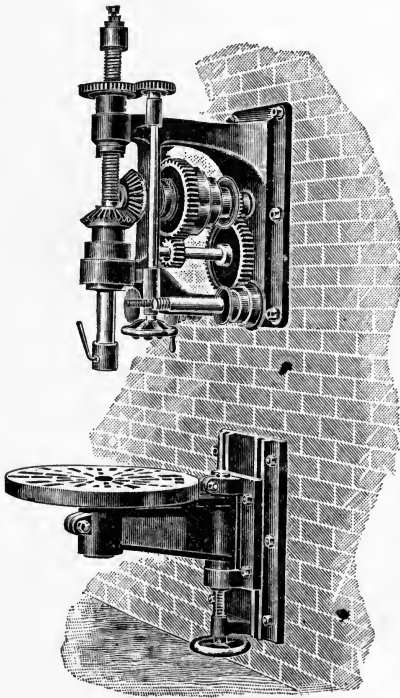

Fig. 219.



**DRILLING  
MACHINES**

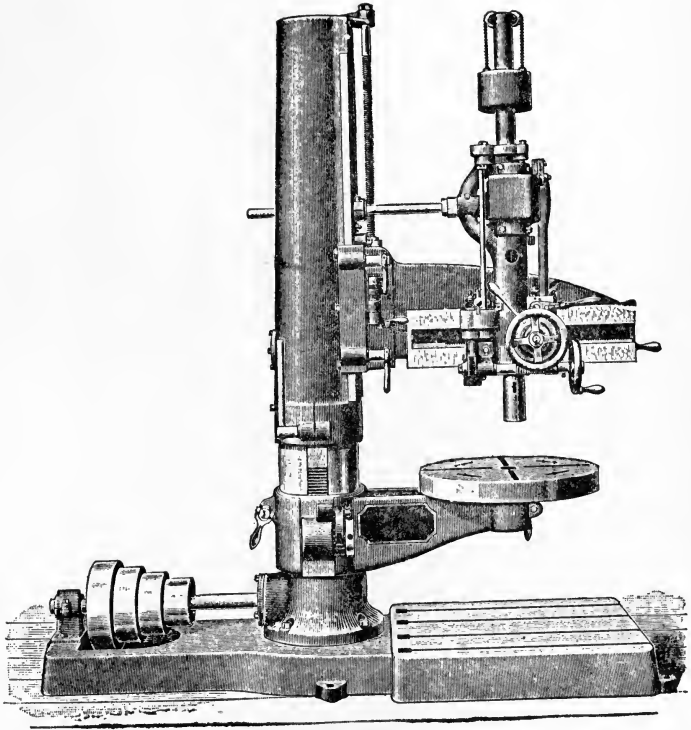

Fig. 220.



## DRILLING OPERATIONS.

---

The word "drill" has a history; it is formed from the word "rille," now called *rill*, meaning "a channel," hence the root signification of the word is "to turn, wind, or twist," a trickling stream wearing its own channel.

A drill is a tool to pierce holes; a drilling machine is adapted for drilling holes in metal; boring and drilling are nearly the same, the former term being applied to very large and the latter word to smaller operations; drilling, too, differs from boring in that the latter term applies specially to the enlarging and "truing" of a hole already formed.

The operation called drilling is the perforation of solid metal with revolving tools; these are made pointed and adapted to suit the work. The tool receives the "feed," the work being stationary.

Two classes of stress are imposed upon drilling machines; this is owing to the fact, never to be forgotten, that a revolving drill does not cut at its central point, while its outermost circumference may have excellent cutting effect; hence, the two strains, one of direct pressure and the other of twisting or torsion, are to be always reckoned with in designing a drilling machine.

The torsion is easily met by a spindle of high carbon steel, accurately cut gearing, and stiff driving shafts; to reach large work the drill must overhang, and therefore needs a very strong frame to stand the end pressure.

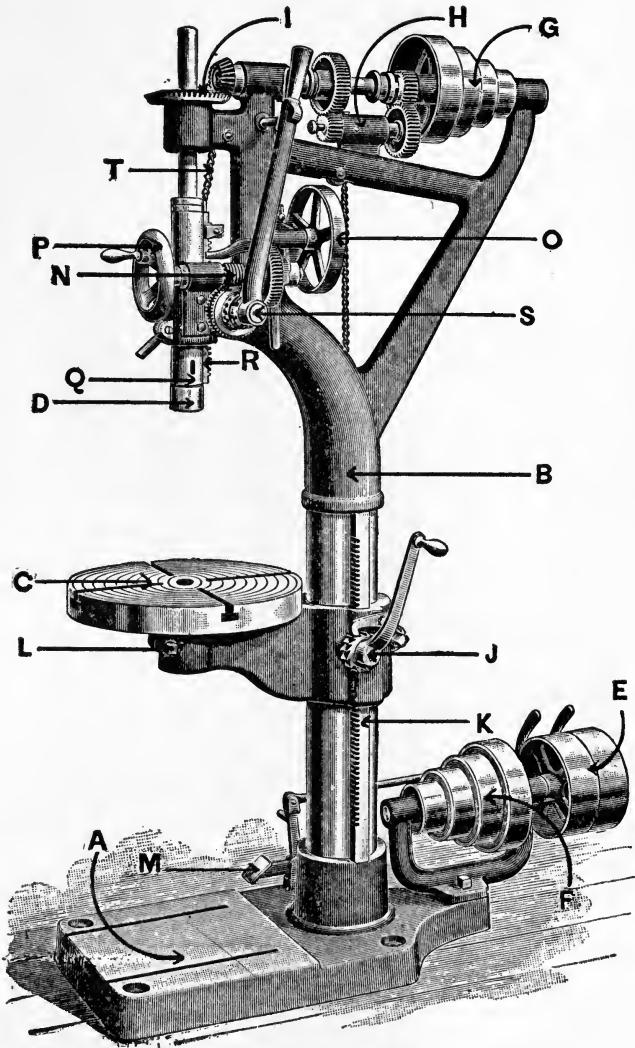

Fig. 221.

## DRILLING OPERATIONS.

Drilling machines are made in many forms and sizes, suitable for fixing to the floor, the bench or the wall, according to requirements.

Drilling machines are described by some special feature which they possess, as a "single cutting," "multiple drilling," "direct," "double-gearred," "rigid," "radial," "self-acting," "friction feed," etc.

Fig. 221 shows a vertical drilling machine, double-gearred, with hand and self-acting feed, and adjustable table, with the parts lettered, to aid in the description following:

*A* is a substantial base plate, having planed upper face having bolt-holes for fixing to foundations, and also provided with T-slots for bolts used to fix large or special work, which, on account of size or shape, cannot be operated on the ordinary table, *C*.

*B* is the upright pillar frame, or standard, which carries the drill spindle and its driving and feed motion.

*C* is a circular table, or face-plate, provided with slot-grooves for sliding clamping bolts; it has a cylindrical box on the under side which fits into a recess in its supporting bracket.

*D* is the vertical drill spindle or arbor which has recess and provision for fixing drills and boring tools.

*E* shows the power—fast and loose—pulleys for shifting belt.

*F* is the speed cone fixed on pulley spindle.

*G* is the speed cone which receives motion from Cone *F*.

*H* is the spur gear, to reduce speed of cone and thereby increase the power of cutter.

*I* shows a pair of bevel wheels which transmit the motion and power from the horizontal spindle to the vertical drill spindle, *D*; the bevel wheel slides on spindle *D*, and rotates it by means of a key or feather sliding in a groove running the length of spindle.

*J* exhibits the hand-ratchet motion for raising and lowering table by a spur pinion, or ratchet spindle, geared into rack *K*.

## DRILLING OPERATIONS.

*K* is the rack fitted into a groove in the bracket ; this rack slides loose with bracket round the pillar, and is used to raise and lower the table, the rack being confined between the collars of the pillar.

*L* is the bracket supporting the table ; this slides every way on pillar according to adjustment.

*M* shows a foot-lever actuating belt fork or guide on fast and loose pulleys for starting or stopping the drill.

*N* is a self-acting feed for vertical spindle *D* ; it receives its motion from horizontal shaft through pulley *O*, which communicates it through a pair of spur wheels and a pair of worm wheels to a spur pinion gearing into rack *R* on sleeve *Q*.

*O* is a pulley for self-acting feed motion.

*P* is a hand wheel for hand-feed attachment fixed on worm spindle ; when using the hand feed the self-acting feed can be disconnected by cam attachment.

*Q* is a sleeve for raising or lowering drill spindle *D*, which revolves in it.

*R* is a rack on sleeve.

*S* is a hand lever for quickly adjusting spindle *D*, used for hand feed.

*T* is a balance weight and chain to counterbalance weight of spindle *D*, drill, etc.

On page 198 is shown a wall drilling-machine ; it is double geared, with self-acting feed motion, as shown in the upper portion of the illustration ; the lower part shown is the table, with an elevating screw beneath to regulate the height ; these portions shown are bolted to a wall, hence the name.

The advantage of the machine consists in its portability, allowing its use in rough and temporary situations, aside from its extreme lightness.

## DRILLING MACHINES.

Fig. 220 shows one form of the approved "radial" drill; the name is derived from "radius"—from a center.

The base of this machine has traverse slots for facilitating the clamping of the work; the column extends to the top of the sleeve, which is a feature affording stiffness to the machine, which is so essential to true work; the radial arm is raised and lowered by power under the control of a lever located within convenient reach of the operator; the arm describes a free circle about the column, which is desirable for many classes of work; the back gears are fitted with friction clutches; the feed is automatic.

Drills used in machines vary in size according to the nature of the work; in ordinary shop practice  $\frac{3}{8}$ -inch to 3-inch diameter is the range of holes drilled. Therefore, tools are made in sets; with each set is a steel socket which fits the drill spindle at one end, and at the other end the recess fits all the drills in the set; they are, therefore, interchangeable.

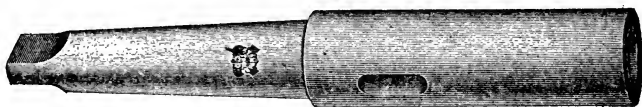

Fig. 222.

A socket or collet is shown in above illustration.

To enable the drill to be easily extracted from the socket, the latter is provided with a slot, as shown in the figure; this slot passes through it; the drill end protrudes

---

NOTE.—Usually the sockets are in sizes from  $\frac{1}{4}$  to  $\frac{13}{32}$  inch;  $\frac{5}{8}$  to  $\frac{23}{32}$  inch;  $\frac{15}{16}$  to  $1\frac{1}{4}$  inches;  $1\frac{9}{16}$  to 2 inches, and  $2\frac{1}{8}$  to 3 inches diameter.

## DRILL, CHUCKS.

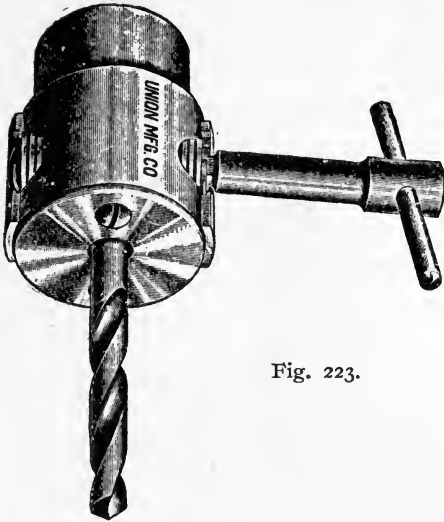

Fig. 223.

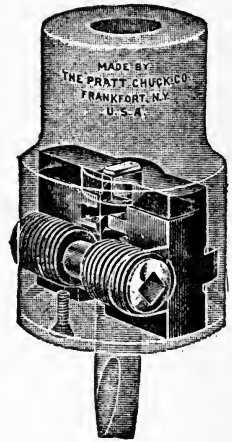

Fig. 224.

into the stop, so that a key driven into the aperture will force the drill out.

Fig. 223 shows one of many forms of drill chucks ; it



Fig. 225.

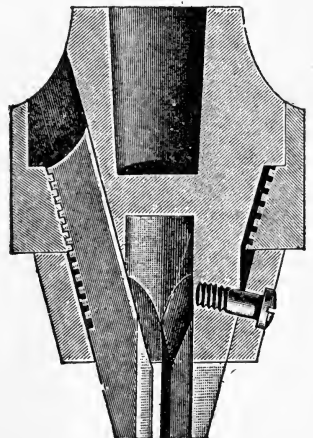

Fig. 226.

## DRILLING OPERATIONS.

consists of two movable jaws operated by a spindle, on which are formed a right-hand and a left-hand thread; the spindle is operated by a key, as shown; the jaws which grip the drill move simultaneously towards or recede from one another, closing or opening as required.

Fig. 224 shows a similar chuck in section.

Fig. 225 is a patent drill chuck; the jaws are operated by the action of a nut or collar as shown in section in fig. 226.

Twist drills are illustrated in figs. 228 and 229. These are fast superseding all other forms of drills used in machine work.

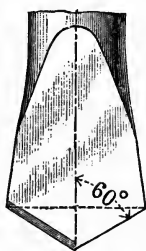

Fig. 227.

Care must be exercised in grinding and sharpening both the ordinary "flat drill" and the "twist drill," to get a proper cutting angle. Authorities differ on the question of the angle, but one found excellent in actual practice is to grind each cutting lip to an angle of  $60^{\circ}$ , with a line taken through the central axis of the drill, as shown in fig. 227.

NOTE.—The flat drill must be forged in order to keep it up to the required size and to keep its point thin enough for cutting; on account of this forging it is difficult to get a flat drill to run true; the sides of the drill form a very indifferent guide in the hole; the diameter of the hole made by the drill depends on the accuracy of the grinding of the cutting edge; should one edge be longer than the other, as soon as the end pressure is applied, the flat drill will endeavor to revolve on its point, and the tendency of the drill will be to cut eccentric, the greatest cutting radius making a larger hole than the diameter of the drill.

## TWIST DRILLS.



Fig. 228.



Fig. 229.

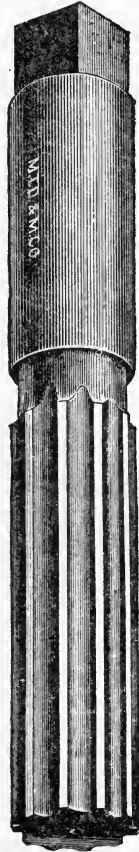

Fig. 230.



Fig. 231.

Fig. 228 is a roughing drill, having two cutting edges; fig. 229 is an enlarging drill, having three cutting edges, and fig. 230 is a finishing reamer; fig. 231 is an adjustable reamer; fig. 232 is an adjustable shell reamer; fig. 233 and fig. 234 are fluted shell reamers.



DRILLING OPERATIONS.

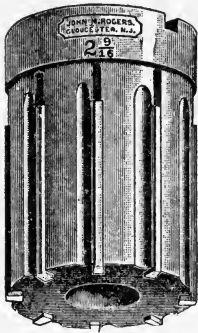

Fig. 232.

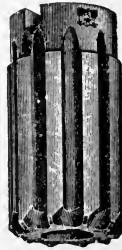

Fig. 233.

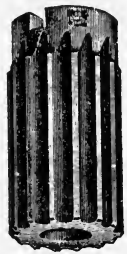

Fig. 234.

Fig. 235 shows a device designed for use on a twist drill. To grind twist drills to the proper angle, place the drill parallel and against the left-hand leg, to bring the cutting edge parallel with the other leg. Note the length of one cutting edge by the graduations, then turn the drill half

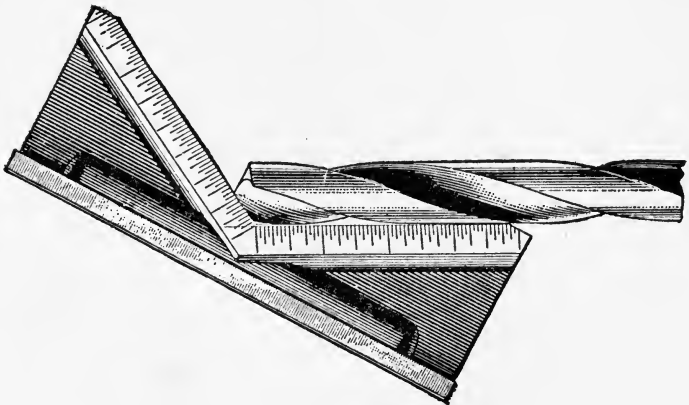

Fig. 235.

way round to get the length of the other cutting edge, and continue turning the drill and grinding the edges until they are the same length.

TABLE OF SPEEDS.

The table below gives the revolutions per minute for drills from  $\frac{1}{16}$  inch to 2 inch diameter, as usually applied; the table shows the drill speeds recommended by the Morse Twist Drill and Machine Co. for cutting steel, iron and brass.

TABLE OF SPEEDS FOR TWIST DRILLS.

Diameter of Drill in inches.	Revolutions per Minute			Diameter of Drill in inches.	Revolutions per Minute.		
	For Steel.	For Iron.	For Brass.		For Steel.	For Iron.	For Brass.
$\frac{1}{16}$	940	1280	1560	$\frac{3}{4}$	75	105	130
$\frac{1}{8}$	460	660	785	$\frac{7}{8}$	65	90	115
$\frac{3}{16}$	310	420	540	1	58	80	100
$\frac{1}{4}$	230	320	400	$1\frac{1}{8}$	52	70	90
$\frac{5}{16}$	190	260	320	$1\frac{1}{4}$	46	62	80
$\frac{3}{8}$	150	220	260	$1\frac{3}{8}$	42	58	72
$\frac{7}{16}$	130	185	230	$1\frac{1}{2}$	39	54	66
$\frac{1}{2}$	115	160	200	$1\frac{5}{8}$	36	49	60
$\frac{9}{16}$	100	140	180	$1\frac{3}{4}$	33	45	56
$\frac{5}{8}$	95	130	160	$1\frac{7}{8}$	31	41	52
				2	29	39	49

To drill 1 inch in soft cast iron will usually require for  $\frac{1}{4}$ -inch drill, 125 revolutions; for  $\frac{1}{2}$ -inch drill, 120 revolutions; for  $\frac{3}{4}$ -inch drill, 100 revolutions, and for 1-inch drill, 95 revolutions.

NOTE.—The advantages of a twist drill over a flat drill are chiefly :—The cuttings can find free egress in the twist drill; in the flat drill the cuttings jamb between the hole and the wedge-shape sides of the drill, causing frequent removal of the drill to extract the cuttings. In deep holes more time is occupied in this manner than in the actual cutting operation. The twist drill always runs true, and requires no retooling or tempering, and, by reason of its shape, fits closely and produces a straight, parallel hole, provided the point is ground true.

SPEED OF DRILLS.

The following is a table given by the Standard Tool Co. and recommended by them.

SPEED OF DRILLS.

Diameter of Drill.	Revolutions per Minute.			Diameter of Drill.	Revolutions per Minute.		
	Steel.	Iron.	Brass.		Steel.	Iron.	Brass.
$\frac{1}{16}$	890	1220	1550	$1\frac{1}{2}$	37	52	63
$\frac{1}{8}$	445	630	775	$1\frac{9}{16}$	35	50	60
$\frac{3}{16}$	291	405	525	$1\frac{1}{8}$	34	48	58
$\frac{1}{4}$	223	305	395	$1\frac{1}{16}$	33	46	55
$\frac{5}{16}$	178	245	315	$1\frac{3}{4}$	32	44	53
$\frac{3}{8}$	148	205	260	$1\frac{1}{8}$	31	42	50
$\frac{7}{16}$	122	175	225	$1\frac{7}{8}$	30	40	49
$\frac{1}{2}$	111	150	195	$1\frac{5}{16}$	29	39	46
$\frac{9}{16}$	98	135	175	2	28	38	45
$\frac{5}{8}$	89	125	155	$2\frac{1}{16}$	28	37	44
$\frac{11}{16}$	81	110	140	$2\frac{1}{8}$	27	35	43
$\frac{3}{4}$	74	100	125	$2\frac{3}{16}$	27	34	42
$\frac{13}{16}$	69	95	115	$2\frac{1}{4}$	26	33	41
$\frac{7}{8}$	63	85	110	$2\frac{5}{16}$	25	33	40
$\frac{15}{16}$	59	80	105	$2\frac{3}{8}$	25	32	39
1	55	75	100	$2\frac{7}{16}$	24	31	38
$1\frac{1}{16}$	52	70	95	$2\frac{1}{2}$	23	30	37
$1\frac{1}{8}$	49	68	90	$2\frac{9}{16}$	22	30	36
$1\frac{3}{16}$	46	65	80	$2\frac{5}{8}$	22	29	35
$1\frac{1}{4}$	44	60	75	$2\frac{3}{4}$	21	28	34
$1\frac{5}{16}$	42	58	70	$2\frac{7}{8}$	20	27	33
$1\frac{3}{8}$	40	56	68	3	19	26	32
$1\frac{7}{16}$	38	54	65				

The above table gives a suitable speed for drills, for general use, but it can be increased from 50 to 75 per cent. to suit special conditions.

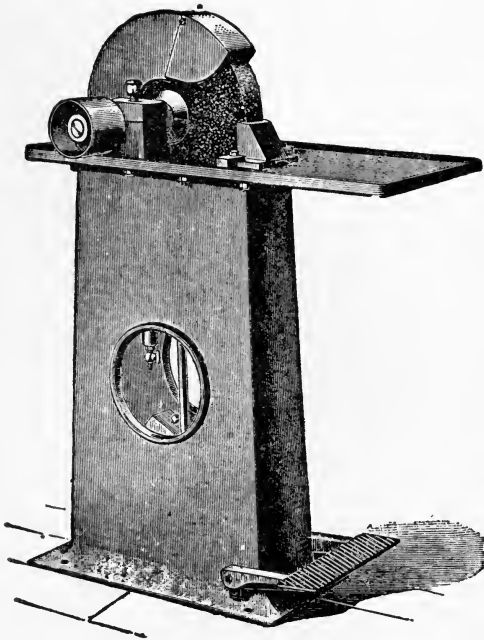

Fig. 236.



**GRINDING  
OPERATIONS**

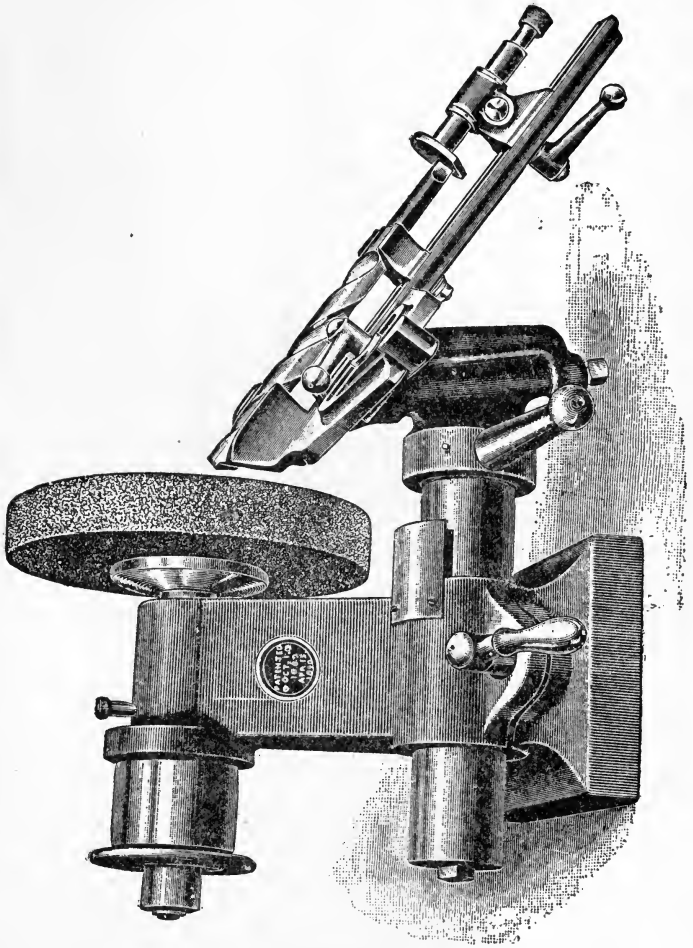

Fig. 237.

## GRINDING OPERATIONS.

---

*To grind* is to wear down, smooth or sharpen by friction, as by friction of a wheel or revolving stone to give a smooth surface, edge or point to an object.

*To abrade* is the act of wearing or rubbing off or away by friction or attrition. *An abrasive* is a material used for grinding, such as emery, sand, powdered glass, etc. The

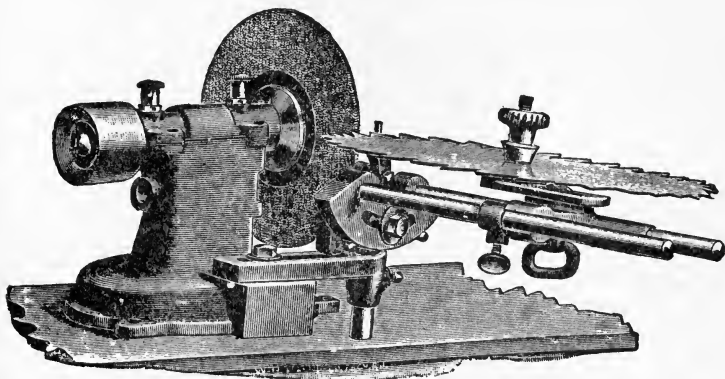

Fig. 238.

operation of grinding is an abrasive process, the material being ground away rather than cut; grinding makes possible the accurate finish of the hardest metals.

In modern machine-shop practice the grinding machine has become recognized as an indispensable tool, and no shop equipment is considered complete without it. The use of hardened spindles in lathes, milling machines, drilling machines, etc., also hardened crank pins and cross-head pins in steam engines, is made possible by its use; with it can be ground milling cutters of all shapes, taps, reamers,

GRINDING OPERATIONS.

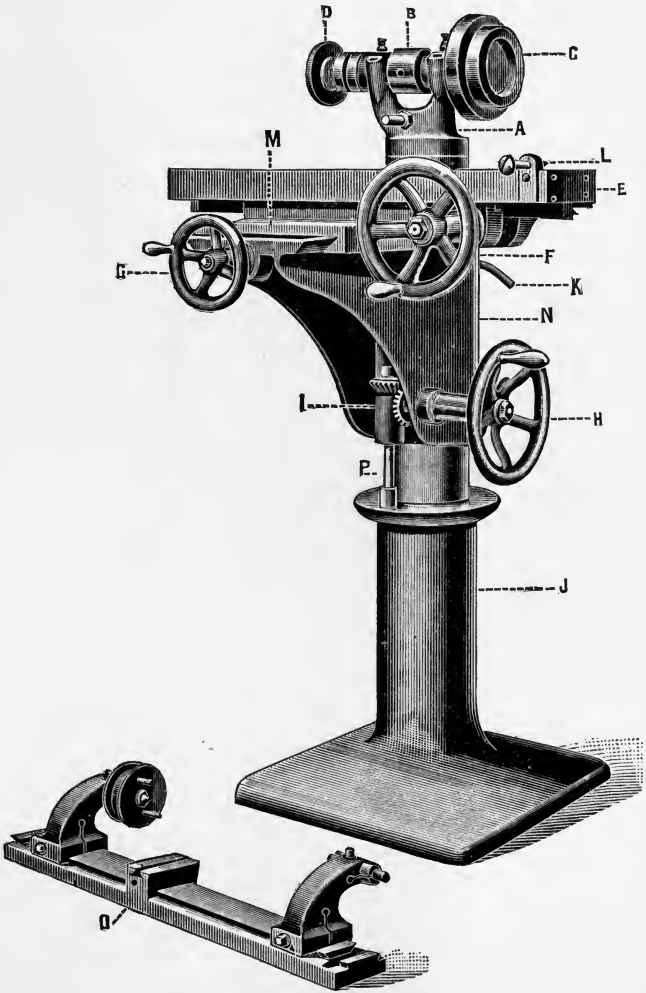

Fig. 239.



## GRINDING OPERATIONS.

arbors, keys, gauges, holes in cutters or other articles, edges, sides and ends of flat, square, hexagon or octagon objects, leaving the ends square with the sides or edges, and also many other kinds of work.

Grinding machines are of various designs, and range from the simple rotating emery or corundum wheel to a perfectly automatic, self-acting universal and surface-grinding machine. One of the former is shown in fig. 236. On page 218, fig. 240, is shown a machine of the latter description.

Fig. 236 shows a simple Wet Tool Grinder; the emery wheel being mounted on a spindle, running in broad bearings, is driven by the pulley; the emery wheel is covered with a shield, to prevent the water splashing; it has no pump; the water trough is raised to the wheel by pressing on the footpedal shown in front of the machine.

Fig. 237 shows an emery grinder sharpening a twist drill; a rest is provided for the shank of the drill, also an adjustable end stop, for any length of drill.

Fig. 238 shows an emery grinder sharpening a circular saw; a self-centering device holds the saw in position; the attachment can be "tilted" to give any desired bevel to the saw.

Fig. 239 is a Grinder, on which a variety of work can be done; the arbor is arranged for two wheels, one on each end; *A* is the "head" of the machine, mounted upon the "standard" *J*; the head contains a spindle driven by the "pulley" *B*, and having emery wheel *D* on left-hand end,

## GRINDING OPERATIONS.

and cup emery wheel *C* on right-hand end; *H* is the hand-wheel which operates the bevel gears *I*, and gives the vertical adjustment to the knee *N*, by the screw *P*; *G* is the hand-wheel fastened to the cross-feed screw, which moves the cross-carriage *M* forward or back; *K* is the binder-screw, which clamps the knee *N* when in the required position; *F* is the hand-wheel fixed on pinion, which operates the long slide *E*; *L* is the adjusting screw, which swivels the pair of centers, *O*, which can be fixed on long slide *E*, when grinding reamers, taps, etc.

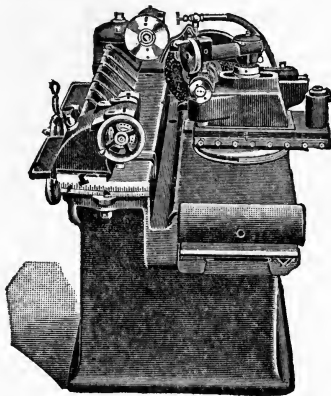

Fig. 240.

Fig. 240 exhibits a front view of a grinding machine, for straight and taper work, that revolves on two dead centers. To obtain the best results, a great variety of table work and wheel speeds are necessary; all speed changes are adaptation of the belt and cone, easily understood by operators.

Provision is made for the amount of power and water demanded by the rapid rate at which the machine is designed to work.

GRINDING OPERATIONS.

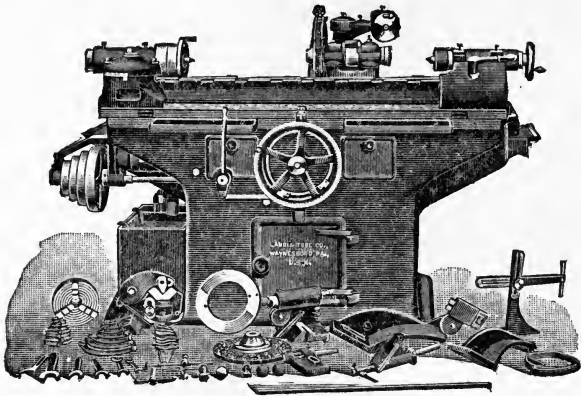

Fig. 241.

Fig. 241 is a front view and fig. 242 is a back view of the machine shown in fig. 240. From these views the arrangement of the machine can be easily understood.

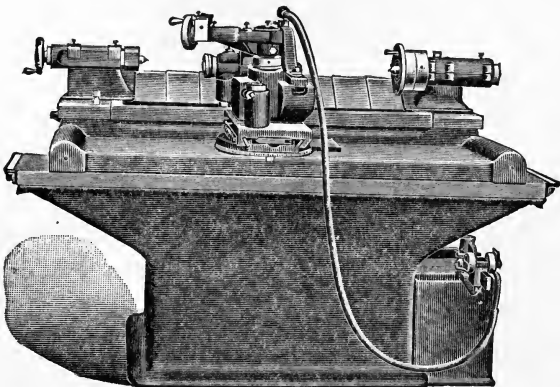

Fig. 242.

## GRINDING OPERATIONS.

The following illustrations show several of the many kinds of accurate work, for which the universal grinding machines shown in fig. 178 are adapted.

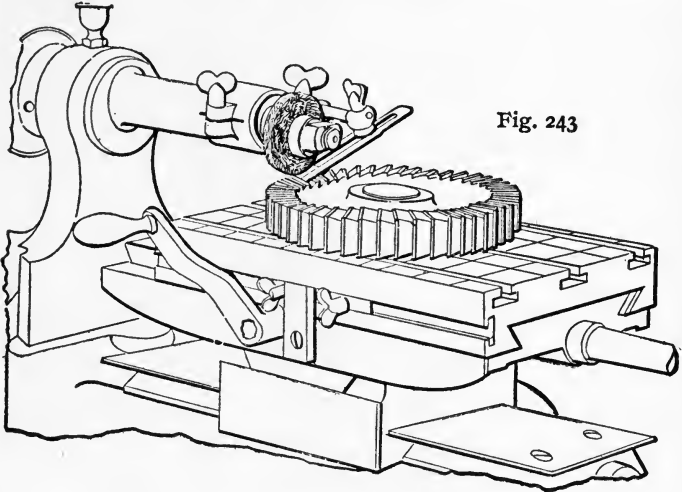

Fig. 243

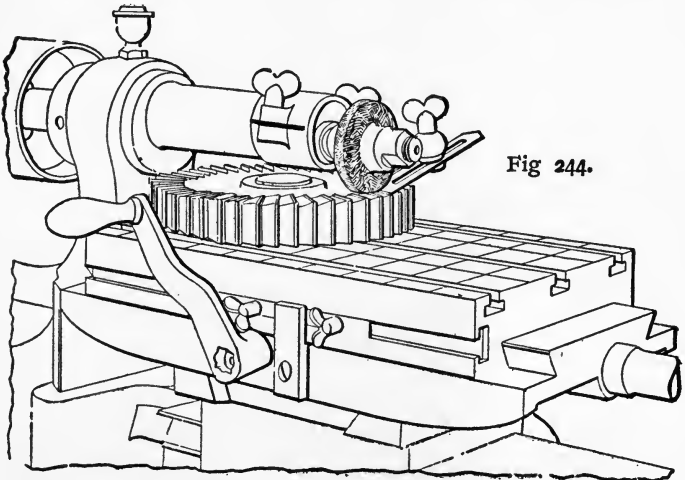
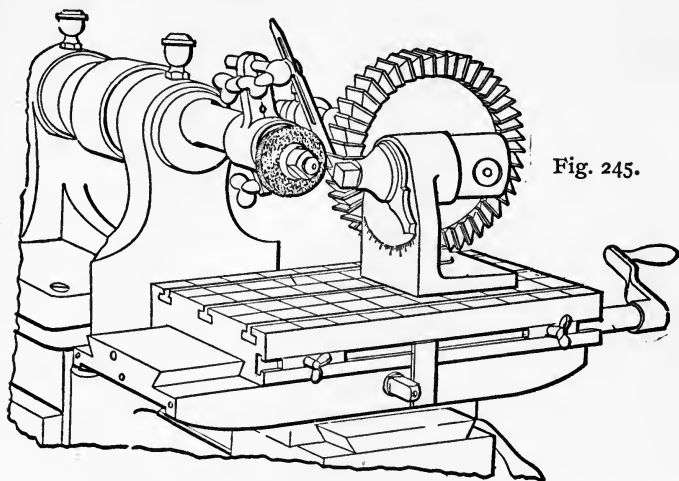

Fig 244.

Fig. 243 and fig. 244 exhibit the method of grinding the sides of a face, or straddle mill, by means of the

GRINDING OPERATIONS.



emery wheel. The straddle mill is placed upon the table of the grinding machine, and is revolved on a stud, so as to bring each tooth in turn under the action of the revolving emery wheel.

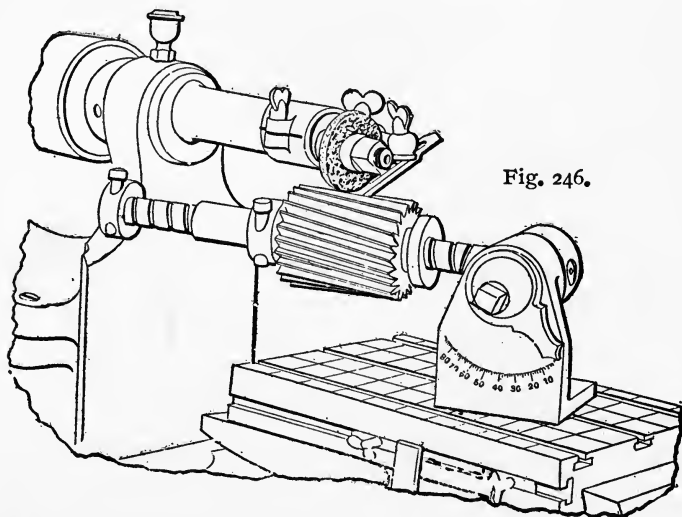

## GRINDING OPERATIONS.

Fig. 245 shows the grinding of the same object, the emery wheel acting upon the face of the mill, which is carried on a stud in the universal cutter-head.

Fig. 246 illustrates the grinding of a spiral tooth cutter, carried on a sleeve, sliding on the arbor, between the head and the adjustable collar.

Fig. 247 shows the sharpening of a tap held in reamer centers, which are fitted in the universal cutter-head.

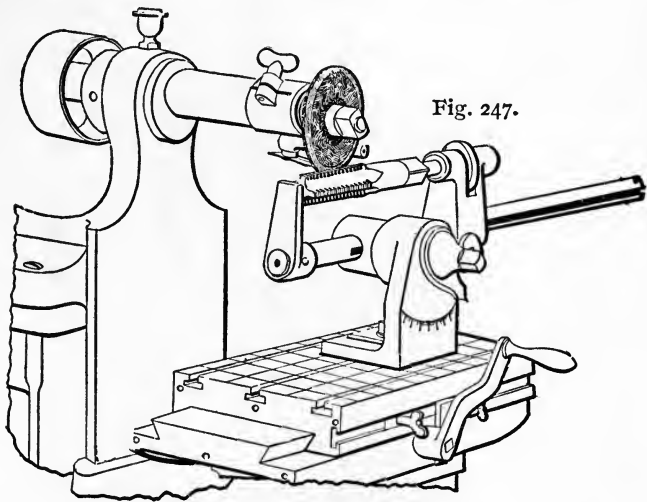

## “POINTS” RELATING TO GRINDING OPERATIONS.

It is considered good engineering practice to push the work of a grinding machine to the utmost limit, get all that can be got out of it in work and get it out quick. This does not imply wasting the tool; it is intended to save the time of workmen. At the same time, where grinding is to

## GRINDING OPERATIONS.

be done rapidly and well, a machine to do it must be heavy and powerful.

The durability and usefulness of all machines depend largely upon proper care, which if not given will in a short time cause them to become unreliable, even though the machines are well constructed. The grinding machine being a tool upon which great accuracy is required, becomes, therefore, most susceptible to bad results through such lack of care.

The machine should be kept clean and the bearings well lubricated, using the best oil only, to prevent gumming.

In order to produce correct work it is important that the spindle boxes be kept in proper adjustment, so that there may be no lost motion. This is true of the head-stock, foot-stock and emery wheel spindles and also the wheel spindle boxes, which, to do accurate work, should be adjusted closely, even though they warm up slightly.

The adjustment of the emery wheel slide is equally important; it should be close and yet not tight enough to move hard; the slide should be well oiled.

Wheels for internal grinding should be softer than for external, as the surface in contact is greater; therefore the wheel will not let go the dulled particles so readily. It should be very keen cutting and of coarser grade than for external grinding. As the surface speed of the wheel is not as great as that for external grinding, the work cannot therefore be done as rapidly, and more time must be given to remove the stock, and the work must be revolved slower.

Too great a variety of work should not be expected of one grade of wheel, and when the amount of grinding will

## GRINDING OPERATIONS.

warrant it, several grades of wheels can be profitably employed, each carefully selected for its particular purpose.

All machines should be securely fastened to a solid floor or foundation where there is no vibration.

To grind tools without drawing the temper requires a soft grade of wheel, which would not be suitable for rough work; moreover, much depends upon the nature of the material to be ground as to whether a hard or soft, coarse or fine wheel should be used.

A wheel should be kept perfectly true and in balance to obtain the best results, both as regards rapidity and accuracy in grinding. For the sake of economy it is necessary that a dresser be kept constantly at hand to dress up the wheels a little and not allow them to become out of true.

It should be remembered, the contact between an emery wheel and the work is entirely different from that of the lathe or planer tool in operation. In the latter case some extra pressure is always required to counteract spring between work and tool; but in the former condition, some material is removed at the slightest contact.

The speed of work should be in proportion to the amount of stock removed at each revolution, as the wheel must always have sufficient time to do its work; if the

---

NOTE.—There can be no hard and fast rules for the speed of emery and polishing wheels, since there is so great a variety in the nature of the work to be done, but a peripheral speed of a mile—5,280 feet—a minute for ordinary emery wheels is commonly regarded as good practice. For water tool-grinders the speed is usually about two-thirds that of dry grinders, while on the other hand, polishing wheels are generally run at about one and one-half, and buff wheels at twice the speed of dry grinders. Emery wheels are classed as water grinders and dry grinders; the former run at about one-third less than the dry grinders, that is, about two-thirds of a mile per minute on the surface.



## GRINDING OPERATIONS.

work is revolved too rapidly the wheel is liable to crowd, chatter and waste, and make an unsatisfactory job. There is no fixed rule as to speed, but by a little experience the operator will soon learn what is best.

These numbers represent the grades of emery, and the degree of smoothness of surface may be compared to that left by files as follows:

8 and	10	represent	the	cut	of	a	wood	rasp.
16	"	20	"	"	"	"	"	" a coarse rough file.
24	"	30	"	"	"	"	"	" an ordinary rough file.
36	"	40	"	"	"	"	"	" a bastard file.
46	"	60	"	"	"	"	"	" a second-cut file.
70	"	80	"	"	"	"	"	" a smooth file.
90	"	100	"	"	"	"	"	" a superfine file.
120 F	and	FF	"	"	"	"	"	" a dead-smooth file.

Nearly all emery wheel makers use a letter to designate the grade of hardness of wheels, grade M being the medium between the hardest and the softest. All letters before M are softer, as L, K, J, I, in the order given; while all letters after M are harder, as N, O, P, in their order.

Wheels are numbered from coarse to fine; that is, a wheel made of No. 60 emery is coarser than one made of No. 100. Within certain limits, and other things being equal, a coarse wheel is less liable to change the temperature of the work and less liable to glaze than a fine wheel. As a rule, the harder the stock the coarser the wheel required to produce a given finish. For example, coarser wheels are required to produce a given surface upon hardened steel than upon soft steel, while finer wheels are required to produce this surface upon brass or copper than upon either hardened or soft steel.

Wheels are graded from soft to hard, and the grade is denoted by the letters of the alphabet, A denoting the softest grade. A wheel is soft or hard chiefly on account of the amount and character of the material combined in its manufacture with emery or corundum. But

## GRINDING OPERATIONS.

other characteristics being equal, a wheel that is composed of fine emery is more compact and harder than one made of coarser emery. For instance, a wheel of No. 100 emery, grade B, will be harder than one of No. 60 emery, same grade.

The softness of a wheel is generally its most important characteristic. A soft wheel is less apt to cause a change of temperature in the work, or to become glazed, than a harder one. It is best for grinding hardened steel, cast-iron, brass, copper and rubber, while a harder or more compact wheel is better for grinding soft steel and wrought iron. As a rule, other things being equal, the harder the stock the softer the wheel required to produce a given finish.

Generally speaking, a wheel should be softer as the surface in contact with the work is increased. For example, a wheel 1/16-inch face should be harder than one 1/2-inch face. If a wheel is hard and heats or chatters, it can often be made somewhat more effective by turning off a part of its cutting surface; but it should be clearly understood that while this will sometimes prevent a hard wheel from heating or chattering the work, such a wheel will not prove as economical as one of the full width and proper grade, for it should be borne in mind that the grade should always bear the proper relation to the width.

Pieces intended to be ground can frequently be profitably turned in the lathe to near the finished size before being tempered. *After hardening*, the pieces can then be accurately finished in the grinding machine, thus securing the utmost accuracy united with great durability. Many pieces of work require but one cut to prepare them for the grinding machine; if the tool has dulled or the work has sprung in hardening or in turning, it causes no trouble when being ground.

---

**NOTE.**—Emery is a granular mineral substance and belongs to the species corundum, but is not pure, being mixed with magnetic or hematite ores. Corundum is a mineral substance found in a crystalline form. Its hardness is next to the diamond. Emery is granular corundum more or less impure. As an abrasive, corundum cannot be excelled, its diamond-like hardness, brittleness and sharpness giving it lasting qualities.



**PUNCHING**  
**AND**  
**SHEARING**

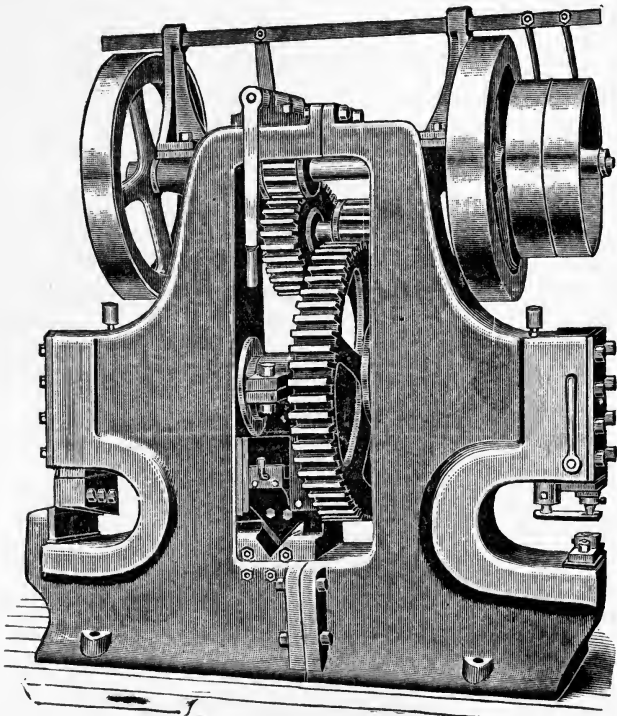

Fig. 248.

# PUNCHING AND SHEARING.

---

*To punch* is to pierce, to perforate or indent a solid material.

*To shear* is to clip or cut with a sharp instrument; the act or operation of cutting by means of two edges of sharpened steel, as on the principle upon which shears are operated.

A *punch* is a tool, the working end of which is pointed or blunt, and which acts either by pressure or percussion—applied in the direction of its length—to drive out or in, or to make a hole or holes, as in sheet or plate iron and steel.

*Shears* consist of two blades with beveled edges facing each other and used for cutting. There are innumerable forms of these two implements—punches and shears—but this volume has to do only with those actuated by power, hence called “power-punching machines” or “power-cutting machines,” etc.

Punching machines are very commonly combined with shearing machines, the work of both being essentially the same. In some cases the construction is such as to allow of the removal of the shear-blades and substitution of the punch, and *vice versa*, as desired. More usually, however, the two contrivances are separate, though arranged in the same supporting frame. Fig. 248 represents a punching and shearing machine. The reason the two are combined in one machine is that it is very usual for both shearing and punching to be needed on the same plate.

Presses used for stamping or forming purposes are properly punches; the term punch includes two very different kinds of instruments; 1, tools whose duty is to indent

## PUNCHING AND SHEARING.

the material without absolutely separating or dividing it, 2, tools which, in conjunction with a bolster placed underneath the work, cut or divide it similarly to the action of a pair of shear blades.

Punching machines, as is evident from the flat or obtuse angle of the edge of the punch, do not effect the division of the material by cutting, but by a tearing apart

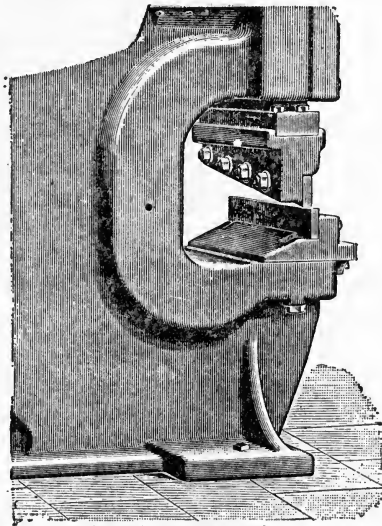

View of throat, showing tools in position.

Fig. 249.

of the fibre of the material; this is equally true of the upper and lower blades of a shearing machine, as shown in fig. 249; the blades are not cutting edges, but are flat or nearly so.

The operations of both punching and shearing may be regarded as similar, one being done with circular or curved and the other with straight tools. The blades of a shear-

## PUNCHING AND SHEARING.

ing machine will pass through a plate an inch and a half in thickness with a rapidity and appearance of ease which give little idea of the power actually used.

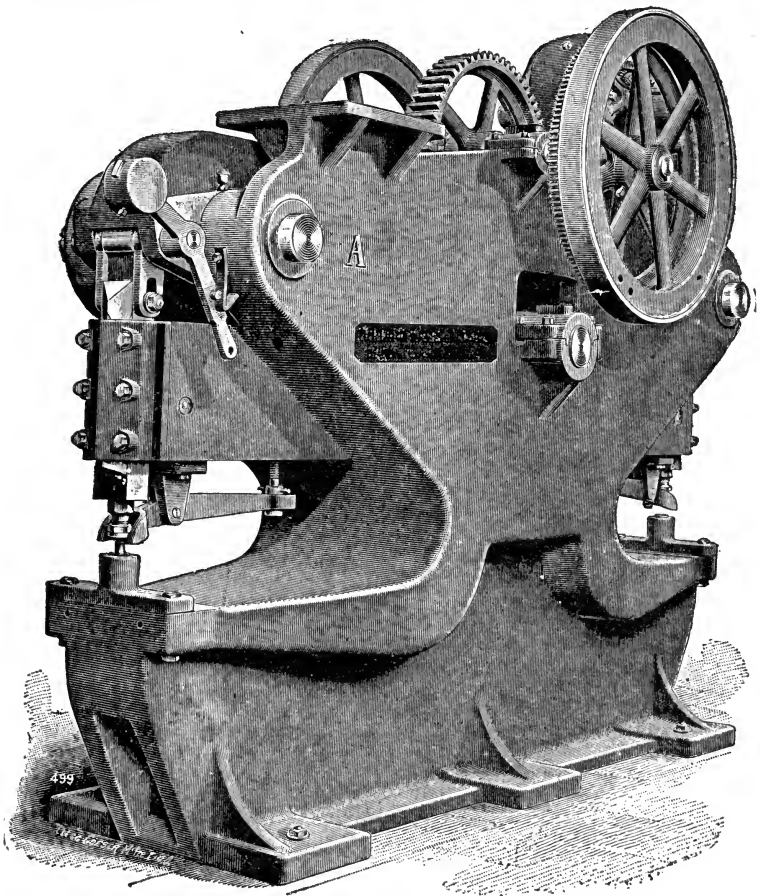

Fig. 250.

Fig. 251 shows an enlarged view of the arrangement of the punch end of the machine illustrated in fig. 248; the operation is that of perforating a hole in a heavy plate;

## PUNCHING AND SHEARING.

each portion is named, to more readily convey the idea of the work and the several parts of the machine.

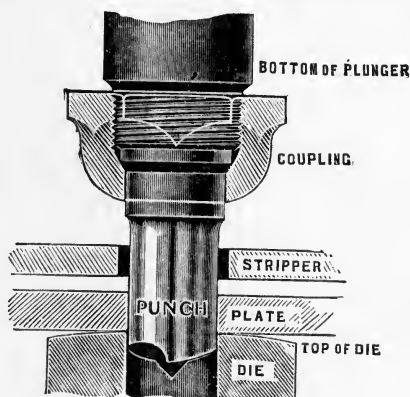

Fig. 251.

The above cut shows the positions of punch, plunger and die; also the positions of the stock, punch and coupling, and the correct position of the stripper relative to the punch and plate, in use, to prevent the plate from binding when the punch is drawn.

In punching and shearing machines the power is applied in many ways: 1, by screw pressure; 2, by hydraulic pressure; 3, by a lever; or, 4, by eccentrics—the latter is the usual method.

A complete set of punching tools includes 1 punch, 1 die, 1 die block, 1 die holder, 1 socket, 1 stripper or pull-off, 1 edge gauge and wrenches. The die block bolts on to the lower jaw to receive the die holder or the die, and the die holder is made to fit in the die block and is bored to receive the various sizes of small dies. The edge-gauge bolts to the frame of the machine, and its edges serve as a gauge



## PUNCHING AND SHEARING.

for the edge of the piece being punched. The stripper or pull-off is a pivoted lever whose forward end straddles the punch and strips the sheet as the punch rises; it is adjustable up and down by means of a pin at the rear end of the lever, so as to accommodate different thicknesses of metal.

The capacities of the different machines vary according to the size, and the throats in the same size vary in depth. The distance from the edge of the sheet at which punching or shearing can be done, is governed by the depth of the throat; by the depth of the throat is meant the distance from the center of the punch to the back wall of the throat.

Fig. 248 shows a double-ended eccentric, punching and shearing machine.

This machine is double-gearred, the frame cast in halves securely bolted and dowelled together. The driving and eccentric shafts are of steel, and the latter drives the slides through short connecting rods. The slides have large rectangular bearing surfaces, those for the punch and the shears being fitted with stop motions.

Fig. 250 shows a double-ended lever punch of approved design.

This machine is double-gearred, and the punch and shear slides are worked by levers which allow the slides to remain at the top of the stroke during half a revolution of the main shaft, thus affording time for adjustment of the plate.

In single-ended machines the punching and shearing are both operated from one slide, the shears being placed at the top.

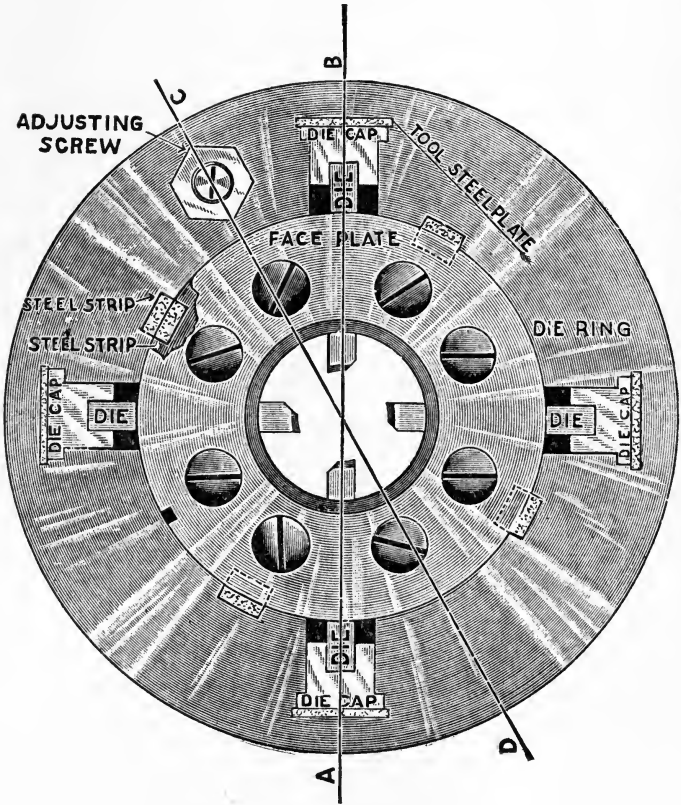

Fig. 252.

# MACHINE BOLT CUTTING.

---

This subject also properly includes nut tapping and bolt-heading. Bolt-cutters, like most other machines, require additional tools and devices, according to their complication and general construction; an example of this is the special cutting-off tool designed to reduce round rolled iron to the exact length necessary for heading in the heading machine, which is in itself an accessory of the bolt-cutter; another example is the power feed-attachment, designed to be applied to the main machine, to produce coarse bastard threads true to the pitch.

Fig. 254 shows an improved bolt-thread cutter, arranged with gear for screwing large diameters of bolts.

The cutters, four in number, are arranged in a revolving die head; fig. 252 is a front view of same; the carriage is moved to and from the die head by a rack and pinion operated by hand wheel; the lubrication for the dies is supplied by an oil pump of plain plunger type, placed within the column of the machine, and is driven from the cone pulley—the throw of the crank pin can be adjusted to and from the center, thereby decreasing and increasing the stroke of the plunger, and regulating the supply of oil to the cutters.

A substantial metal box frame *A*, provides an oil tank in the base, the top forms the bed and the slides for the carriage; the headstock *B* carries the live spindle *C*, to which is bolted the die head *D*; the hand wheel *F* opens and closes the vise *E*, which slides with carriage *G*, and is operated by hand wheel *H* and the rack and pinion shown;

## MACHINE BOLT CUTTING.

the hand lever *I* operates the clutch ring, opening and closing the dies, which is also automatically accomplished

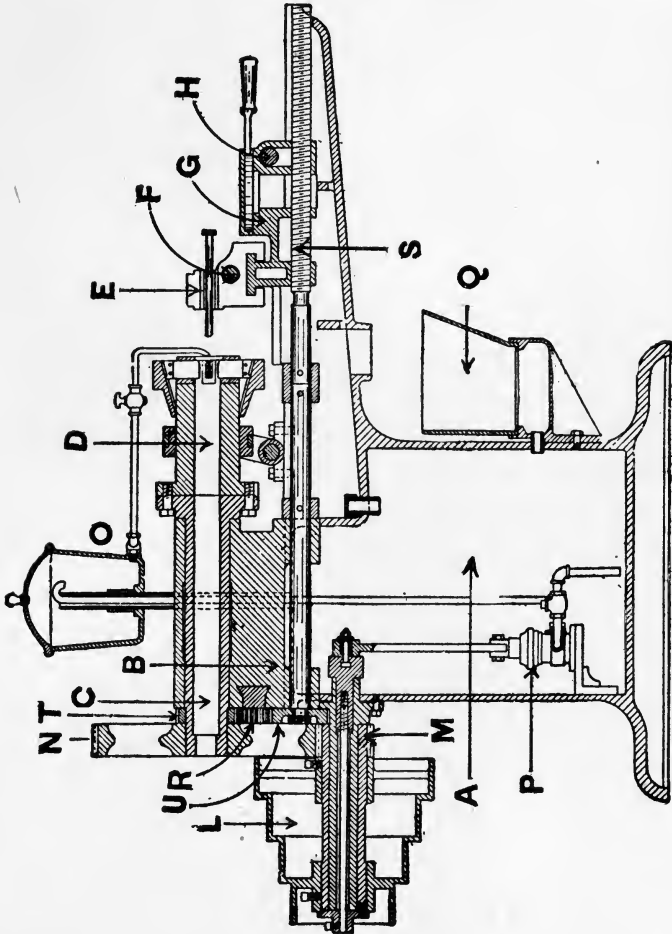

Fig. 253.

by the stop rod *J*, which slides through the vise block, and the stops *K K*, being set to the length of the screw to be cut, are operated by contact with the vise.

MACHINE BOLT CUTTING.

The driving cone *L*, with pinion *M*, gear into wheel *N* on the live spindle; the oil supply *O* is fed by the pump *P*, in the metal box frame, through the center of the overflow pipe; the discharge end is curved downwards slightly below the top of the overflow pipe, which prevents splashing of the oil.

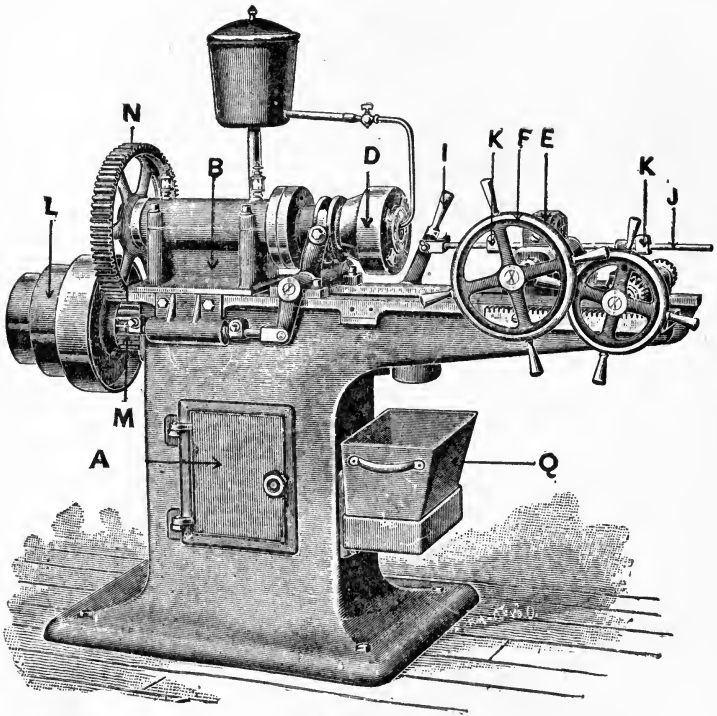

Fig. 254.

The pump is of ample size, so that when running on the slow speed a sufficient supply of oil is discharged into the oil-pot to keep a constant stream on the dies when cutting threads; the removable chip-pan will hold the chips of a day's work.

## MACHINE BOLT CUTTING.

Fig. 253 is a section side view of the machine, showing the interior arrangement of the parts and the plunger pump *P*; it also shows a device, a substitute for the rack and pinion motion for travelling carriage, which is not shown in fig. 254, viz., a self-acting lead screw *S*, which is driven from the live spindle by two spur gears, *T* and *U*, and idle or carrier wheels *R*, which reverse the motion for right or left-hand screw cutting.



Fig. 255.



Fig. 256.



Fig. 257.



Fig. 258.

The die ring is made of cast iron; this ring controls the movement of the dies radially to and from the center, by means of recesses at an angle to its face; the clutch ring has a phosphor-bronze ring working in a groove and attached to the automatic spring and closing device; the movement of the clutch ring is transmitted to the die ring through the rocking lever and toggle.

The cutters are four in number; fig. 255 is a side view, fig. 256 an end view, of the cutter with cast-steel head attached; figs. 257 and 258 show the tool-steel caps; the upper one is for a full-size die. When recut several times, it is needful to use the deeper steel cap, to make up for the shortening of the cutter by recutting.

MACHINE BOLT CUTTING.

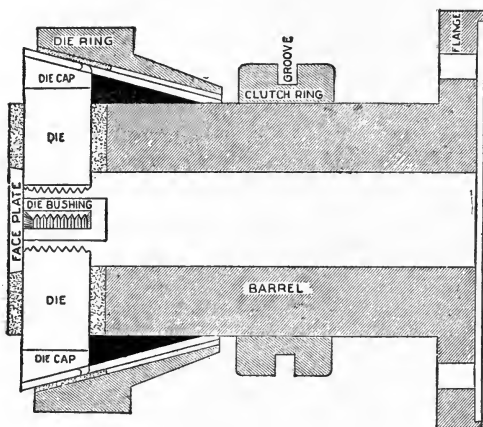

Fig. 259.

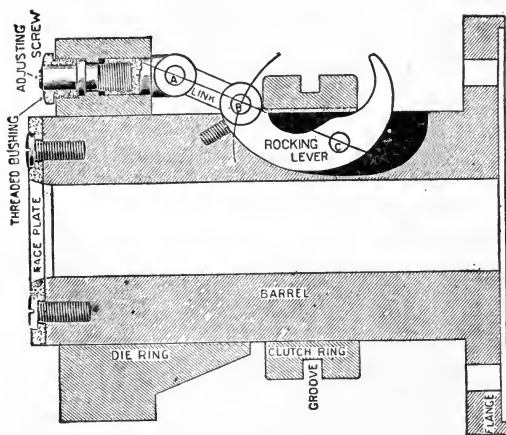

Fig. 260.

## MACHINE BOLT CUTTING.

Fig. 261 shows the side view of the die head, which is made of cast iron, turned, milled and bored. To the post end is fastened a face plate, which serves to hold the dies and die bushings in place—see fig. 252; in the outer surface of the barrel, there are four longitudinal grooves milled to within a short distance of the flange, and in these grooves are fitted steel strips, hardened and ground to resist the wear of the sliding die ring.

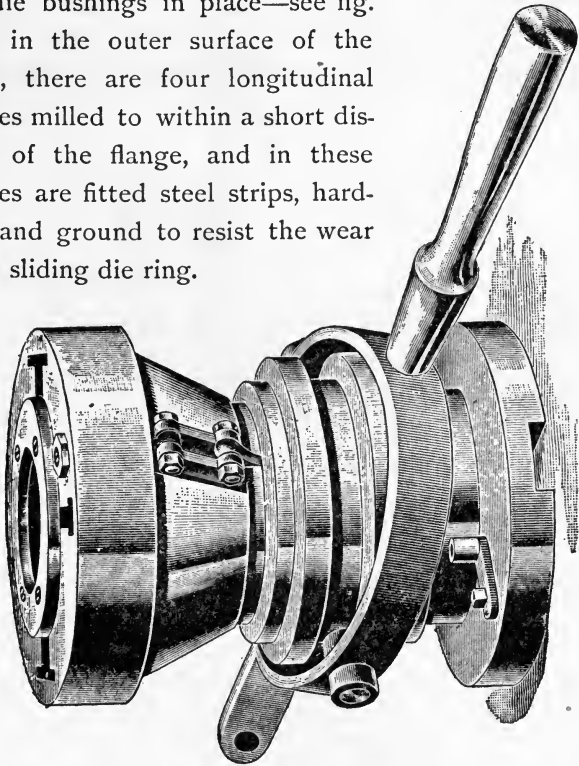

Fig. 261.

A section on line *AB* of revolving die head; figure 252 shows the dies and die caps, etc., fig. 259; a section on line *CD* of the die head—see fig. 260—shows the opening and closing device operated by the clutch ring and the rocking lever and toggle.

Fig. 262 shows a lead screw, and fig. 263 a split-nut; these are required for each pitch cut; the lead screws



MACHINE BOLT CUTTING.

are made short and they can be changed from one pitch to another; the bronze split-nut fits in the carriage and is opened and closed by means of a cam disc and lever operated by hand.



Fig. 262.



Fig. 263.

The cutting speeds for dies in bolt cutting are as follows:

TABLE.

Diameter of Bolt.	Revolution of Dies.	Diameter of Bolt.	Revolution of Dies.
$\frac{1}{8}$	460	$1\frac{1}{8}$	50
$\frac{1}{4}$	230	$1\frac{1}{4}$	45
$\frac{5}{16}$	188	$1\frac{3}{8}$	40
$\frac{3}{8}$	153	$1\frac{1}{2}$	38
$\frac{7}{16}$	131	$1\frac{5}{8}$	35
$\frac{1}{2}$	115	$1\frac{3}{4}$	32
$\frac{9}{16}$	102	$1\frac{7}{8}$	30
$\frac{5}{8}$	93	2	28
$\frac{3}{4}$	75	$2\frac{1}{4}$	25
$\frac{7}{8}$	65	$2\frac{1}{2}$	22
1	55	$2\frac{3}{4}$	20
		3	18

The usual cutting speed for bolts in machine-shop practice is fifteen lineal feet per minute; the above table is based upon that capacity of work. In tapping nuts, the same number of revolutions of the taps are required.

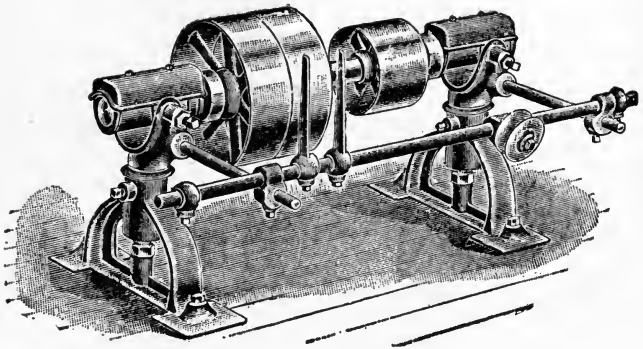

Fig. 264.



**AUXILIARY  
MACHINES**

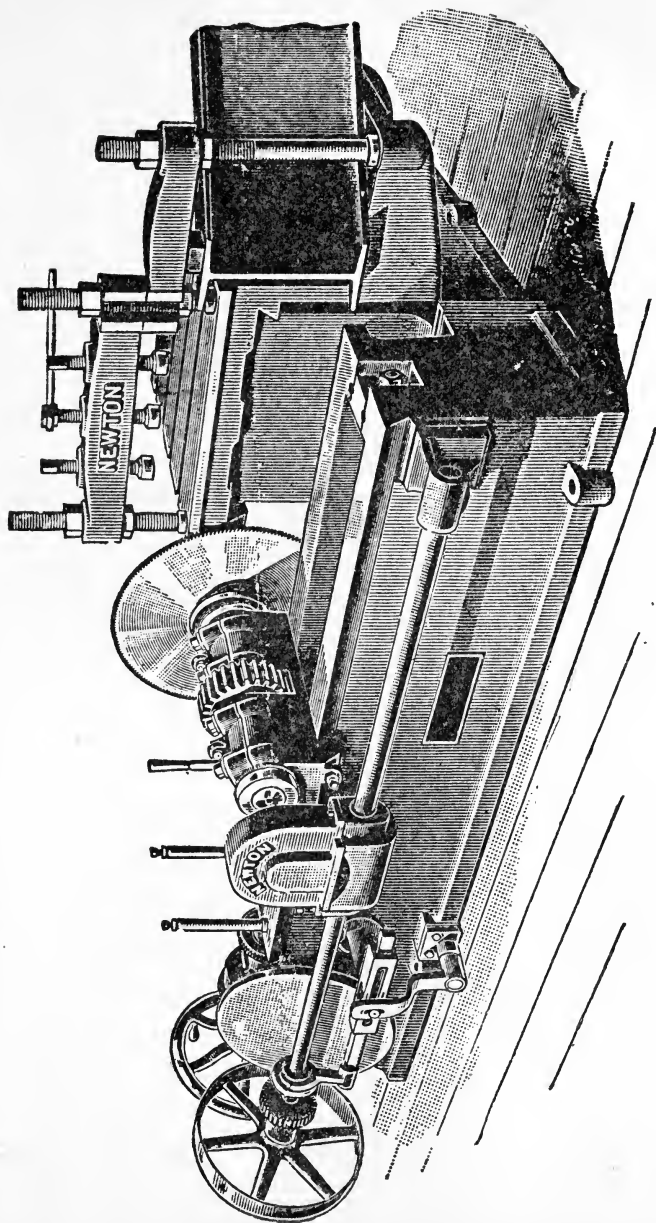

Fig. 265.

## AUXILIARY MACHINES.

---

The introduction of a new machine or device implies the immediate employment of a whole series of auxiliary and dependent appliances.

Some of these are seemingly of more importance than the parent machine, and frequently are much more complicated and expensive to build; they are named, frequently, by their use, and largely aid in the practical success of the new machine which they are designed especially to operate with.

Thus a "cutting-off" machine is used to cut off stock to the required length before it can be operated on by the lathe, etc.; one of these machines is shown on the opposite page and described below.

---

## CUTTING-OFF MACHINES.

---

When rods, etc., are required to be cut to a certain length, the operation is performed in several ways; 1, either by a special lathe designed for the purpose, or, 2, by a power saw; when executed in a lathe, the revolving spindle in the headstock is constructed hollow, the rods pass through the hole and are then cut to exact length

## AUXILIARY MACHINES.

by an ordinary "parting" or cutting-off tool fixed in the rest or carriage of the lathe.

A special cutting-off tool for the purpose is shown in fig. 266; it consists of a substantial drop-forged steel

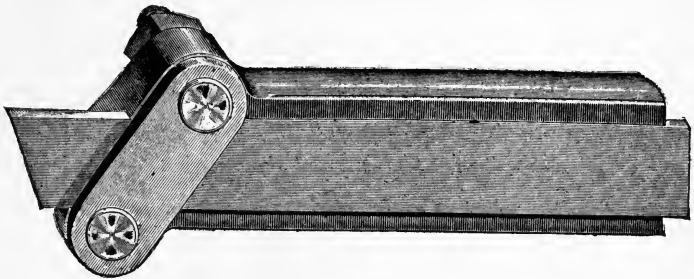

Fig. 266.

holder; the under edge is extended, giving a firm support to the blade directly under the cut; the blades are six inches long, seven-eighths inch wide, milled and ground on both sides to give proper clearance. The top, or cut-

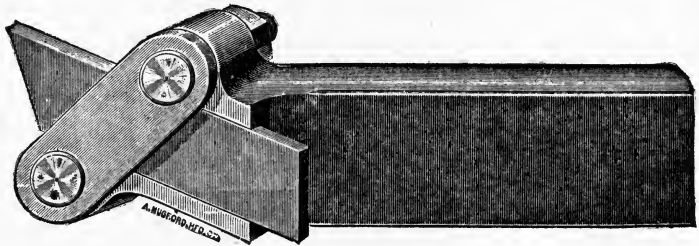

Fig. 267.

ting edge, and bottom are ground square, to gauge of slot in holder. Hence the blades used in this style of holder require grinding on the end only. In use, the blade should be set to project beyond the supporting lip of holder, or under side, a sufficient distance to cut to center of stock; on heavy stock the blade can be advanced after

## CUTTING-OFF MACHINES.

making a cut of one inch or so on the outside. The blade is held in position by a substantial strap, bolts and case-hardened nuts.

Fig. 267 is a similar cutting-off tool, but fitted with an offset holder for particular work which could not be executed by the straight tool holder shown in fig. 266.

A "cutting-off" saw is a machine designed for "cropping" the ends of work and cutting it to length; in the ordinary machine shop practice, a power-driven hack-saw is used, but when cutting large work, a circular, revolving saw is used to cut the work cold; this is commonly styled a cold saw cutting-off machine; the latter is shown in fig. 265.

The power hack-saw illustrated in fig. 268 is especially designed to meet all the requirements of a machine for sawing metal. The upper arm of the frame can be extended so that large work can be cut; the jaws holding the work are planed and can be set so that work on any required angle, as well as straight sawing, can be done. The machine has an 8-inch stroke with quick return; by loosening the set screw in the stud holding the connecting rod, the frame can be swung to either side; by this adjustment the saw can be made to cut perfectly straight; the lower arm of the frame passes through a hole in the sliding thimble with a projecting stud, to which the connecting rod is attached, and on which friction nuts are placed; a set screw runs through this stud and holds the frame in

---

NOTE.—It has been the custom, when cutting a piece of iron or steel, especially hard tool-steel, to send it to the blacksmith to heat the metal in the forge and cut it to the required length; this method has the disadvantage of deteriorating the steel in quality consequent on the heating, and the rod is returned in a rough shape.

## AUXILIARY MACHINES.

any set position; a piece of steel with concaved end is placed under the set screw to prevent the point from coming in contact with the arm. The slide in which the thimble runs is split so that any wear can readily be taken up by tightening the screws at each end. There is no drag on the saw during the backward movement.

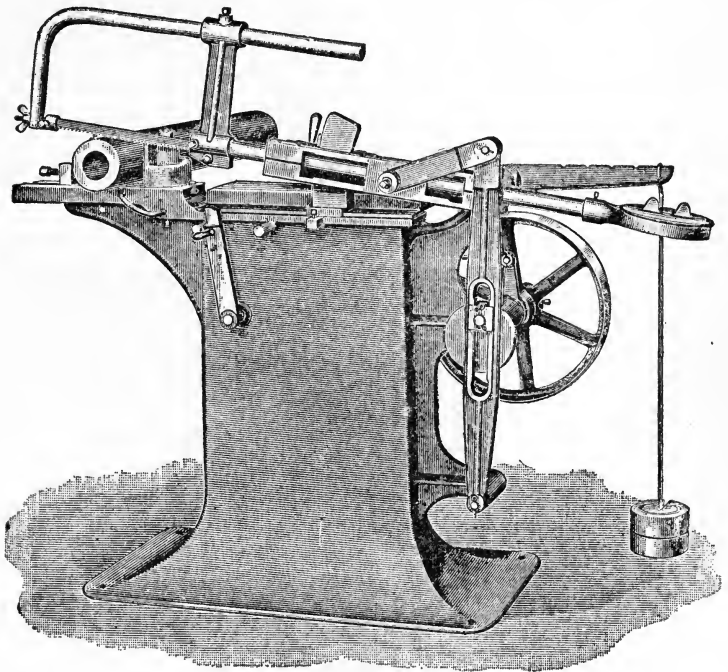

Fig. 268.

By adjusting the friction on the connecting rod the saw can be made to lift gently from the work when going backward, and the pressure on the forward stroke can be increased or diminished by the same means. A coil containing twenty-five feet of saws is placed in the magazine on the rear end of the arm, and can be drawn through the



## CUTTING-OFF MACHINES.

proper distance for the work being sawed. By using the magazine coil principle the saws can be used their entire length. This feature alone reduces the cost of saws fully one-half, and as the saw is firmly clamped at both ends instead of being held by pins, the danger of the holes being pulled out of the ends of blades is entirely obviated. The usual speed of the blade is 40 strokes per minute. After a cut is finished, the clutch is automatically thrown out and the machine is stopped.

With flexible hack-saw blades the teeth only are hardened, the back remaining untempered; thus the blade will

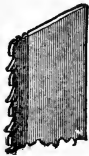

Fig. 269.

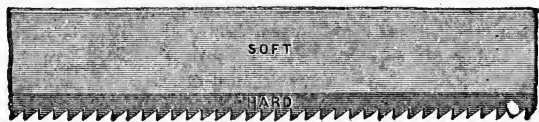

Fig. 270.

neither snap nor break, assuring full efficiency until the teeth are worn dull. Fig. 270 shows the construction of the flexible back blade; fig. 269 shows the set of the teeth. These blades for cutting iron, steel, brass, etc., are made from 23-gauge stock, and have 15 teeth to the inch; for cutting tubing and sheet metals the teeth are finer, being made 24 teeth to the inch.

Fig. 264 shows the countershaft used with the power hack-saw shown in fig. 268; the motion is stopped by shifting the driving belt from the fast on to the loose pulley; these are the pair shown in the cut, the small pulley being the driving pulley connected to the pulley on the machine.

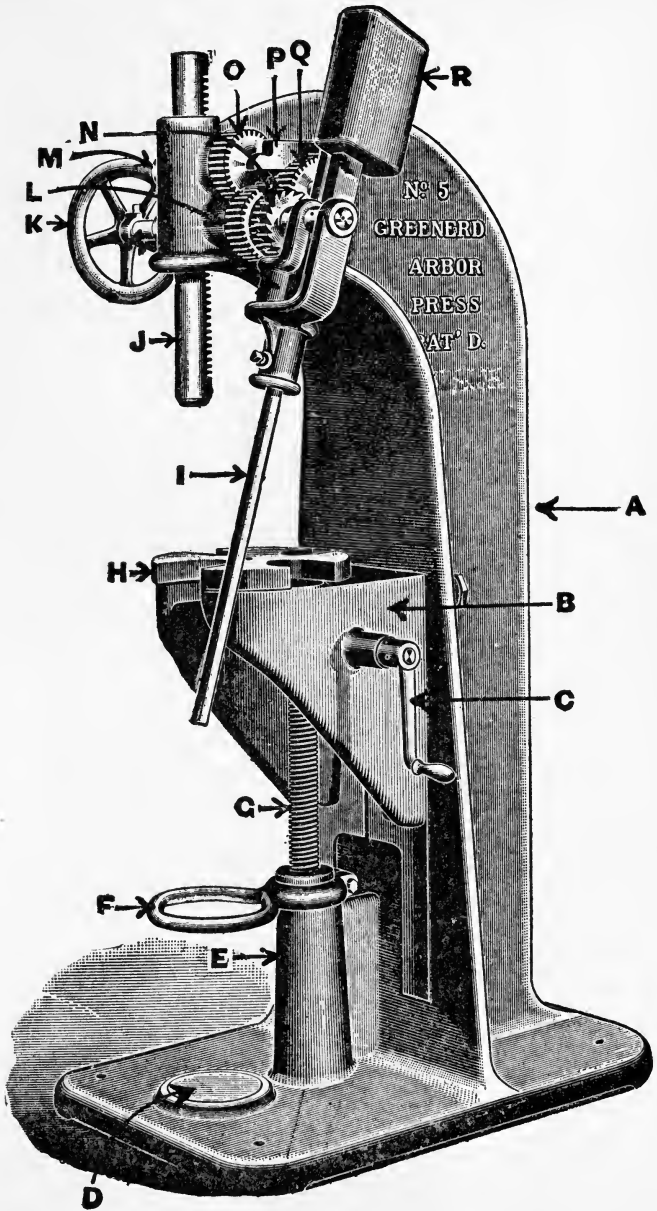

Fig. 271.

## THE ARBOR PRESS.

---

The arbor press is a machine devised for accomplishing the work described in the note, which is ordinarily done by hand, by means of a hammer, etc. The arbor or mandrel is a spindle which is forced or driven into a bored hole in the work, such as a pulley or wheel, to enable it to revolve between the centers of a lathe, milling cutter, etc.

Fig. 271 shows such a machine, which is a very useful device, being quick in action, and which can be bolted on the end of the lathe-bed or on a separate bench, and which is always ready for use. Operated by a hand lever, a pressure of seven and a-half tons can be obtained by an ordinary man by means of the gear-wheels shown in the engraving; it is exceedingly simple in action, and consists of a massive standard *A*, which carries a sliding or adjustable knee *B*, which can be regulated to the height of the work by a square-thread screw *G*, which acts in a nut in the top of standard *E*; the handle *C* operates the screw *G*; the plate *H* is free to revolve on the knee *B*, and is provided with lateral openings of graduated sizes for various-dimensioned mandrels; when released from the work, the arbor or mandrel drops on the soft babbitted cushion *D*, and is caught or retained in the large steel ring *F*; the plunger or ram *J* has a rack cut on one side; this rack is engaged with two pinions, one on spindle *M* and one on

---

NOTE.—Very generally the mandrel is driven into the work with a lead-headed hammer, or an ordinary sledge is used; as a precaution, a piece of sheet-brass, copper or hard-wood is placed against the end of the mandrel to receive the force of the blow of the sledge and thus prevent the "center" in the mandrel being damaged or destroyed, as the brass strips will spread and become thin from repeated use, soon rendering it unfit for the purpose.

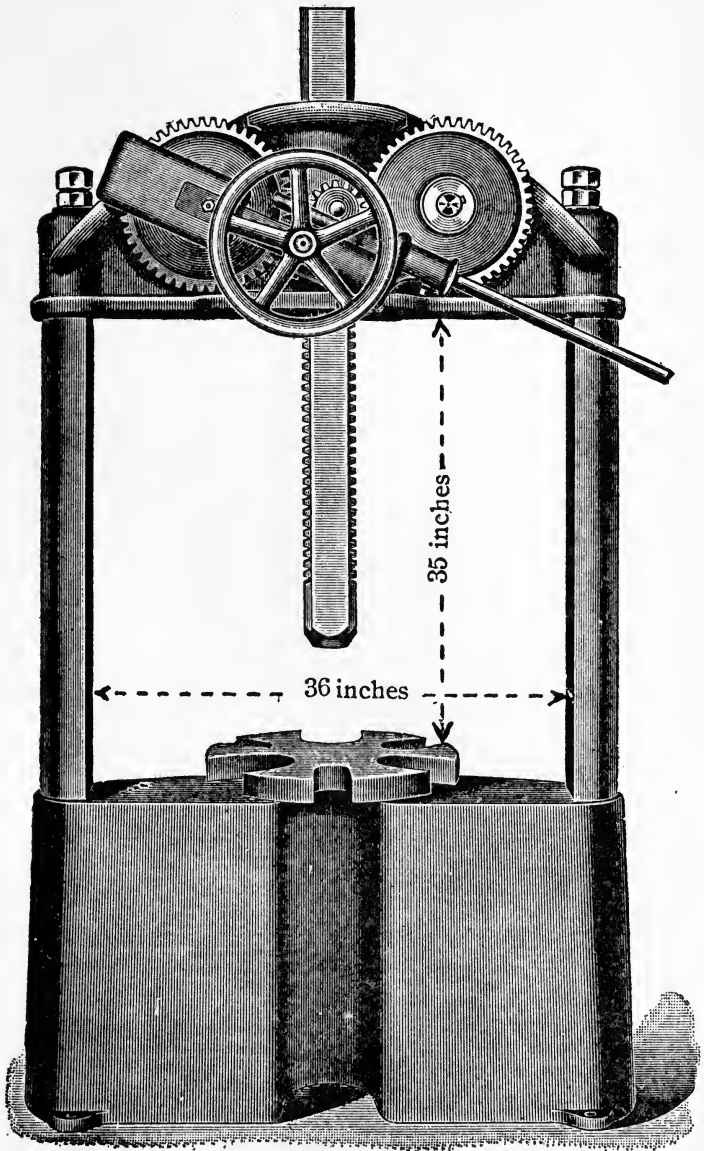

Fig. 272.

## THE ARBOR PRESS.

the lever spindle, and they are geared together by the spur wheels *L* and *O*; the leverage is obtained by means of wheel *Q* and a pinion hidden in the drawing by the ratchet *N*; a pawl fits into the casting, into which the lever *I* is fixed; a leverage of 135 to 1 is thus obtained. The counterweight *R* balances the lever and keeps it in an upright position when not in use; a pin projects from one side of the pawl, so that when the lever casting is upright,

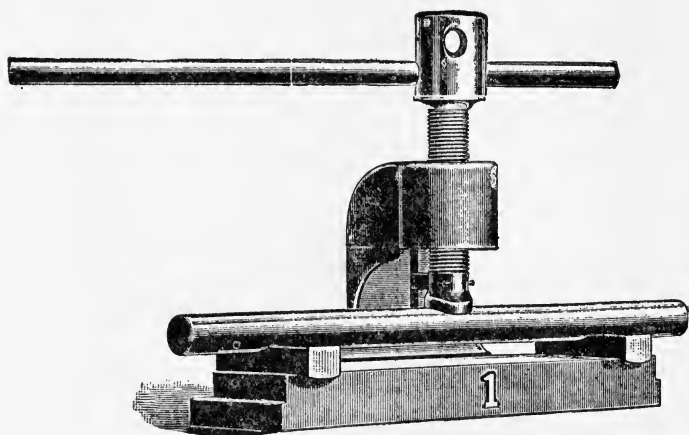

Fig. 273.

the pawl rides the “shedder” *P*, disengaging the pawl from the ratchet, thus leaving the ram *J* free to be moved up or brought down to the work by means of the hand-wheel *K*.

Fig. 272 shows a very powerful press, designed for mandrels up to 7 inches diameter; the ram is made of four-inch steel and has a rack cut on two opposite sides; the gears are steel, have a leverage of 250 to 1 and exert a pressure of about sixteen tons at the end of the ram, with a man of ordinary strength at the lever.

## SHAFT-STRAIGHTENING MACHINES.

---

Fig. 271 shows a hand-power shaft-straightening machine intended for bench use; it has a powerful screw made of steel; the bed is planed true and has two steel blocks or vees fitted to slide upon it; these can be adjusted to suit the bend or twist in the shaft, and will accommodate work of any length.

This is but one of many devices of this nature; some of these are much more complicated and costly and operated by pneumatic and other powers; one of the most common is a machine used in railroad shops in straightening car and locomotive engine axles.

---

## TURRET MACHINES.

---

These were originally named from their resemblance to the *turrets* or "little towers rising from or otherwise connected with a larger building;" the word turret was in very frequent use in the middle ages as defining *movable towers* used in military operations; at the present date turrets, in engineering practice, are always understood to mean a revolving mechanism, as the turret-gun, designed for use in "a revolving turret," and the turret lathe, which has a revolving tool-holder.

---

NOTE.—*The monitor, or turret lathe*, derives its name from the Ericsson's Monitor, designed and built in 1862; this carries on its deck one or more *revolving turrets*, each containing one or more great guns, which can be successively brought into range by revolving the steel-clad turret, thus combining the maximum of gun power with the minimum of exposure. Ericsson named his newly-invented ship *The Monitor*, from its use as a caution or warning to the enemies of his adopted country.

## AUXILIARY MACHINES.

In modern machine shops a turret is known as a revolving tool holder; that is, a tool holder which contains a number of cutting tools, any one of which may be used by revolving the holder, which brings the cutting tool successively into position to operate on the work; while the turret is principally used on lathes, screwing and drilling machines, it is applied to many other machines, such as the planer, and shaper, and also in wood-working machines.

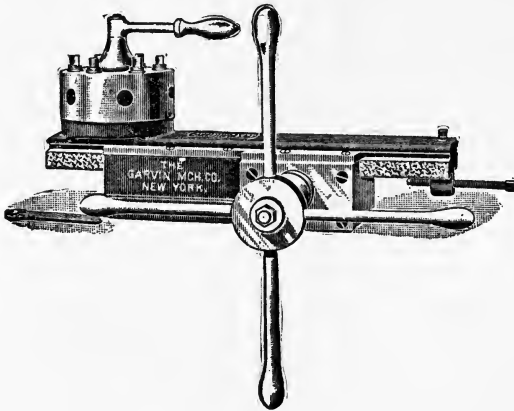

Fig. 272.

Fig. 272 shows a turret fitted on the shears or bed of a lathe; the turret is bored with holes for the reception of six tools; it has hand longitudinal and cross feeds, the turret being revolved by hand; it has at its base, a steel index ring of large diameter, hardened and ground; the locking bolts are hardened and ground, and provided with a taper gib for taking up the wear; a spiral spring forces the locking bolts into the slots, and is adjusted by a screw at the back end of the turret slide. The turret slides move in flat bearings with adjustable taper gibs to maintain correct alignment.

## THE TURRET LATHE.

Fig. 273 exhibits a turret fitted on the carriage of an engine lathe, similar to that illustrated in fig. 61; it shows the hexagonal turret mounted on the carriage, being interchangeable with the compound rest shown in fig. 61, enabling the lathe to be used either as an engine lathe or a turret lathe.

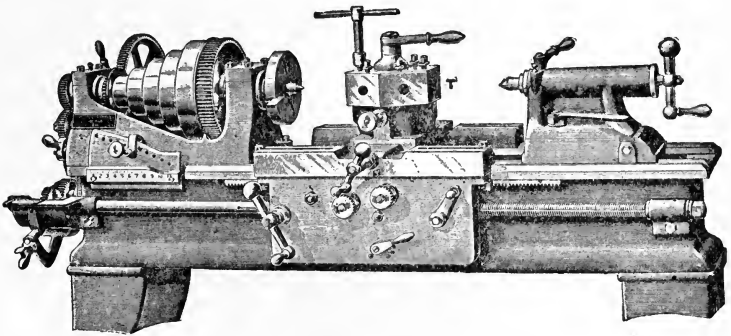

Fig. 273.

The advantages of this turret are that it has power, longitudinal and cross feeds, and is screw cutting; it has all the changes of feed that the lathe has; it may be used in connection with the half-nuts, and therefore chase a thread; it permits running in such taps as conform with the threads cut by the lathe at their proper pitch and bringing them out without danger of stripping any of the threads; it may be "set over" either way from the center and is provided with centre stops.

---

**NOTE.**—In practice, all pieces made from the continuous bar are machined as follows: A long bar of the rough iron or steel is pushed through the spindle, until the piece projects beyond the chuck long enough to make the piece desired. The various tools on the turret are set for the different diameters and cuts, and after each performs its operation, it is turned out of the way to admit the next tool. Since a number of tools are set for the various diameters, it gives this machine a great advantage over the lathe where there is but one tool.



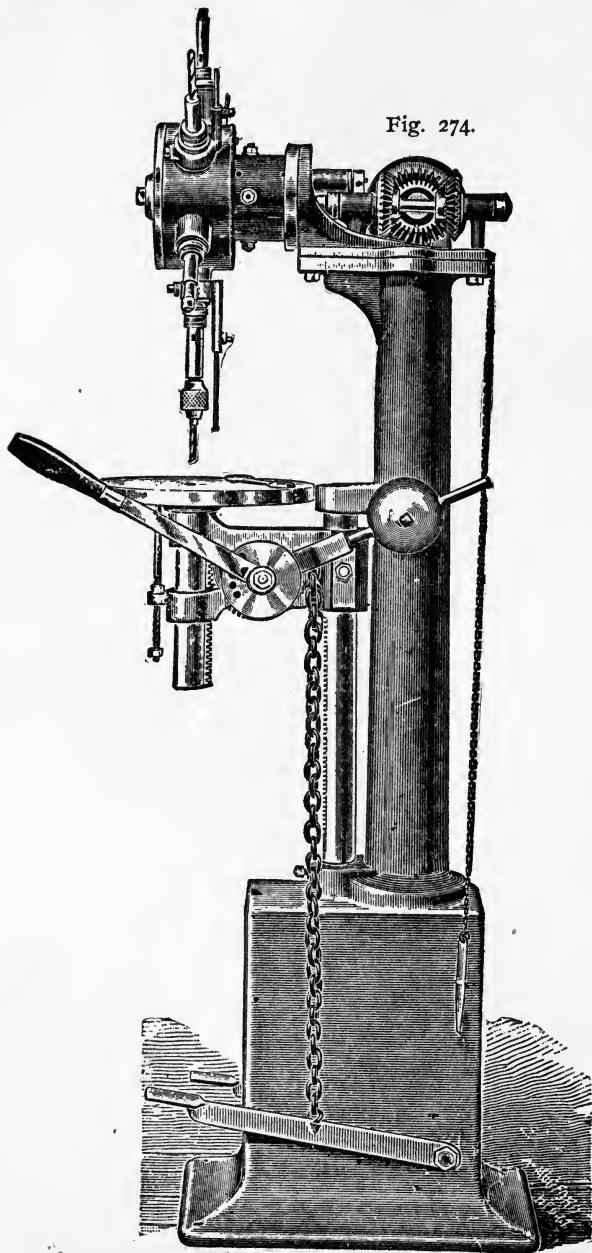

Fig. 274.

## THE TURRET DRILL.

Fig. 274 shows a turret head fitted to a drilling machine described as a turret drill. On the trunnion of the frame is mounted the turret head with any number of projecting bearings; six are shown in the illustration fig. 275, which is a front view of the turret head. These projecting bearings support and guide the drill spindles; through the frame passes the driving shaft, on the end of which, inside of the turret, is fastened a bevel gear in mesh

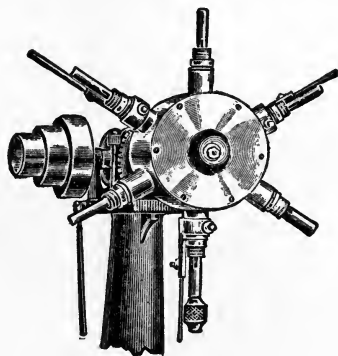

Fig. 275.

NOTE.—Pivoted on the front of the gear-case, fig. 275, in the interior of the turret head is a bell crank lever, one end of which is forked and loosely connected to the driving spindle; the other arm of this lever is connected to the locking bolt that holds the turret head in position. Fastened to the locking bolt is a rod connected to the foot-treadle shown on left-hand side of the base. When the treadle is pressed downward it moves the locking bolt outward; at the same time the driving spindle moves upward and is unlocked from the drill spindle before the locking bolt leaves its socket, thus making it impossible for the turret to be moved while the driving spindle is in contact with the drill spindle. When the turret is revolved to the tool wanted, the bolt will automatically drop in its socket, and the driving spindle moves downward and engages the drill spindle.

The feed is by hand and foot lever. The table is balanced and has a vertical feed motion. The knee that supports the table is fastened to the face of the column and balanced by a weight inside of the column. The drill spindles are of steel, hardened and ground, and reamed to fit the Morse taper; the spindles have an independent drill stop.

## AUXILIARY MACHINES.

with another bevel gear, loosely splined to the driving spindle, which has on its lower end a clutch that engages, when in operation, with a corresponding clutch on the inner end of the drill spindle.

Fig. 276 shows a screw-cutting die-head which is self-opening and adjustable; it is designed for use on screwing machines, lathes and in turrets, being provided with an internal adjustable gauge for varying the length of the threads. It has few parts, yet admits of the finest adjust-

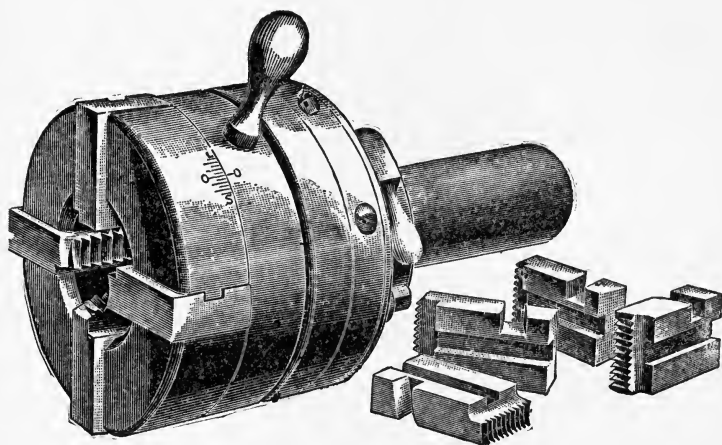

Fig. 276.

ments; being graduated upon one side of the shell and provided with an index by which quick and accurate variations in the diameter of threads may be made, and as the index is controlled by one screw, both dies are adjusted simultaneously. It is provided with four single-point dies, and also with a roughing and finishing attachment, by means of which two cuts may be taken in making a thread, and insures a more perfect quality of work than is possible to produce with one passage of dies.

## SCREW-CUTTING DIE HEAD.

The roughing and finishing attachment is operated by a small handle located at one side and back of the head proper, and as shown in the illustration, so arranged that by moving it to a forward position the dies are opened slightly for the roughing cut, and when the handle is returned to its original or backward position, the dies are closed and locked at a predetermined point for the finishing cut; this handle is easily and quickly manipulated by the left hand of the operator. In regular practice the tripping of the dies is effected by the stock as it passes through the dies and comes in contact with the end of the gauge, but they may be tripped at any point on the cut by moving the handle which operates the roughing and finishing attachment to a central position, which unlocks the dies and causes them to open.

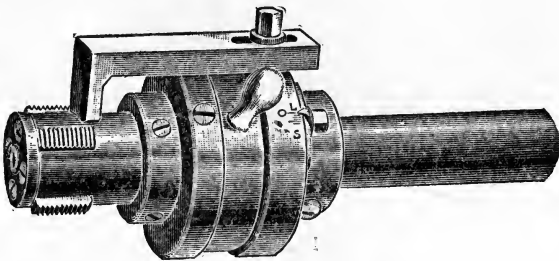

Fig. 277.

Adjustable collapsing taps, as shown in fig. 277, are designed for use in screwing machines and lathes and are held either in the turret, or in the rotary or live spindle. By reason of not requiring to be reversed, these taps retain their cutting edges longer and will cut smoother and cleaner than a solid tap; the standard size of thread can be maintained by adjusting the chasers or cutters in a similar manner to the adjustable dies described on page 259.

## KEYSEATING MACHINE.

Fig. 278 shows a machine which will cut keyseats on any portion of a shaft, without removing it from its bearings; the machine being firmly fastened to the shaft by two clamps, the cutter-head is fed along the shaft and will mill a keyseat 12 inches long without resetting, and as it has a sliding support under the cutter at all times, it cuts without jar and produces keyseats with straight sides and

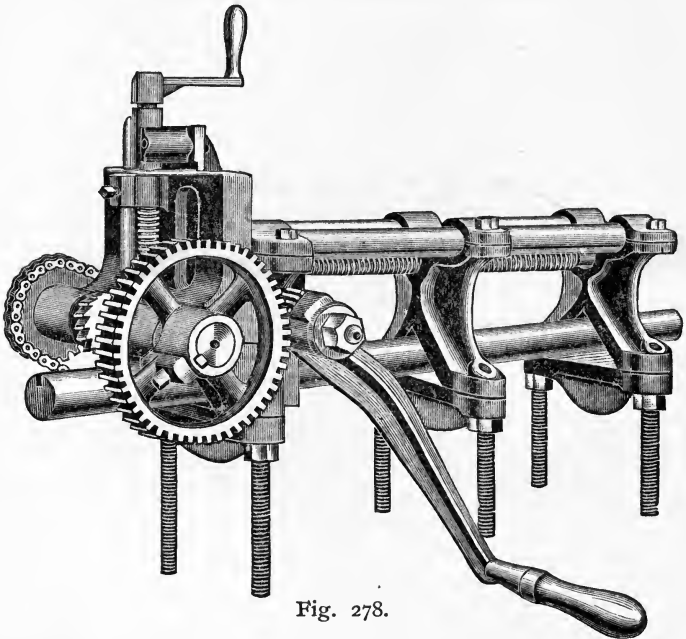

Fig. 278.

smooth bottoms. The machine is provided with an automatic feed while cutting, but this feed may be disengaged if desired, and the cutter-head fed by hand.

Five milling cutters are used with each machine; by employing one or more of which on spindle, keyseats of any of the following sizes may be milled full width at one operation :

$\frac{1}{4}$ ,  $\frac{5}{16}$ ,  $\frac{3}{8}$ ,  $\frac{7}{16}$ ,  $\frac{1}{2}$ ,  $\frac{9}{16}$ ,  $\frac{5}{8}$ ,  $\frac{11}{16}$ ,  $\frac{3}{4}$ ,  $\frac{13}{16}$ ,  $\frac{7}{8}$ ,  $\frac{15}{16}$ , 1,  $1\frac{1}{16}$ ,  $1\frac{1}{8}$  in.

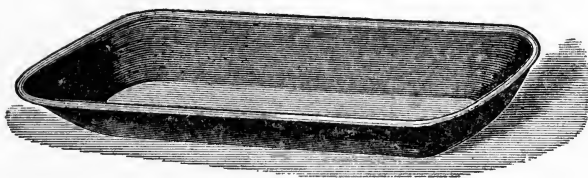

Fig. 279.

A rectangular metal plate with a double-line border. Four screws are visible at the corners, each with a diagonal line through the head. The word "UTILITIES" is centered in a bold, outlined, sans-serif font.

UTILITIES

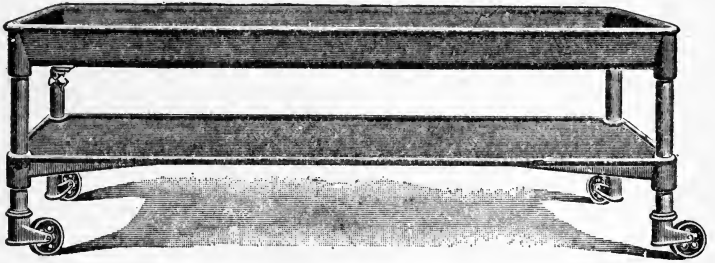

Fig. 280.

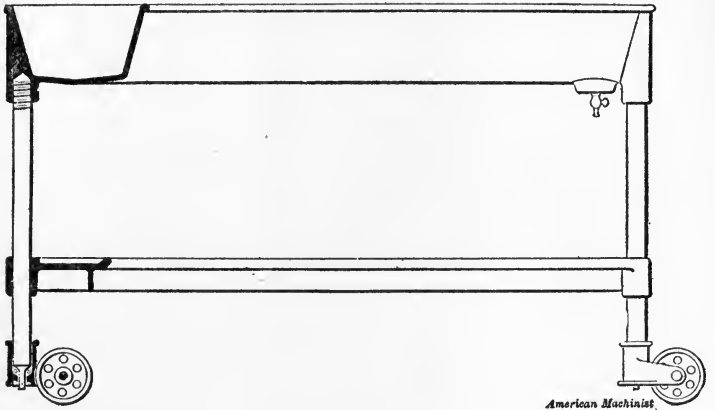

Fig. 281.

*American Machinist.*



# UTILITIES AND ACCESSORIES.

---

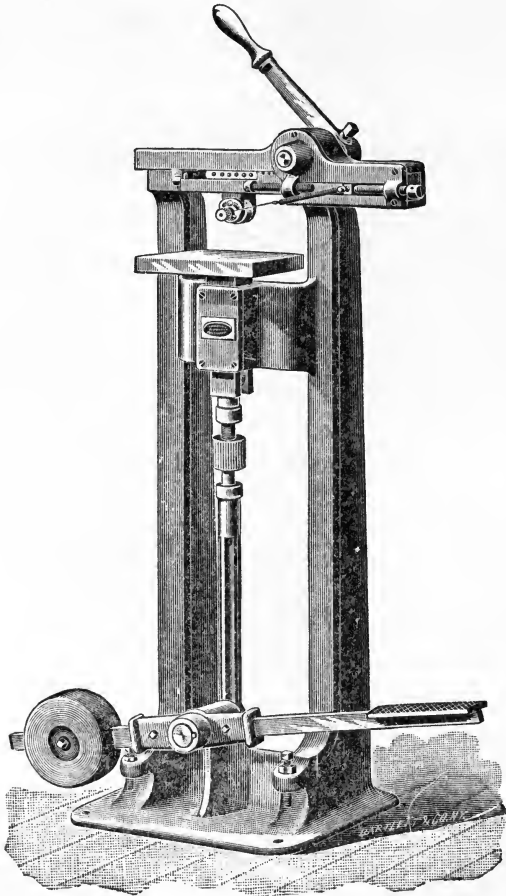

Fig. 282.

*A utility* is defined as a useful thing; a machine shop utility is a tool or device adapted for use among machines of larger and more pretentious reputation; each shop has

---

 JIGS, SHOP KINKS AND WRINKLES.
 

---

its own utilities, and upon their proper application depends largely the success of the whole organization.

*An accessory* machine or tool is one contributing to a general effect and belonging to something else as a principal; a "jig," defined below, is properly an accessory machine or device.

*A jig* is defined as any subordinate mechanical con-



Fig. 283.



Fig. 284.

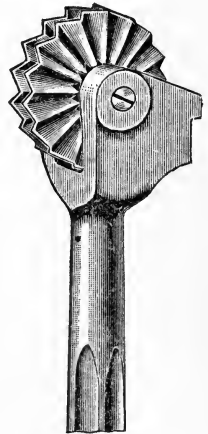

Fig. 285.

trivance or convenience to which no definite name is attached; a jig is a small special tool or otherwise a "wrinkle" or shop "kink."

---

NOTE.—In repetition work, where hundreds, thousands or even millions of similar pieces are to be worked upon, the profitableness of these special devices is most apparent. Jigs to the number of many thousands have been devised and used, although not always to advantage; they have often "cost more than they come to" in economical results.

The few examples shown on the following pages are rather as suggestions than an attempt to fully explain all the useful contrivances known under the names of utilities, jigs, etc.

## UTILITIES AND ACCESSORIES.

Fig. 279 shows a pressed-steel shop pan used for handling bolts, rivets, nails, screws, nuts, washers, castings and other substances; they are also used under lathes and drilling machines, to catch the turnings, trimmings, oil drippings, etc. The pressed steel pans are found, in practice, more durable than riveted ones, and are lighter and more easily cleansed.

Fig. 280 shows a lathe pan; the lower pan or "shelf" is intended for the usual lathe extras, the upper pan is for the chips or cuttings. The top tray, which catches the chips and oil, is sometimes provided with a strainer and draw-off cock, as shown in section in fig. 281; by using this, the lubricant can be separated and used again.

When emery wheels wear out of true or glaze on the surface, it becomes necessary to true them. For this purpose a hand tool is used, which consists of a pure carbon or black diamond set firmly in the end of a steel rod provided with a suitable wooden handle; with this tool any desired shape, round or bevel, can be given to face of the wheel; the diamond produces true and smooth work, but the cutting qualities of the emery are slightly impaired by its action.

The above device is designed to be operated by hand; it is not illustrated; a similar tool is used, which can be fixed in the tool-post, the diamond being set in a solid steel shank.

Emery wheel dressing tools usually held in a sliding holder, are shown in three figures on the opposite page.

---

NOTE.—The chips are made at or near the headstock end and, of course, drop in one end of the pan; when brass and iron work alternate, to keep the chips separate, simply turn the pan end for end—for this purpose the wheels of the casters are large and swivel readily.

## EMERY-WHEEL DRESSING TOOLS.

For the purpose of removing the smoothness from emery wheels which have become glazed, emery-wheel dressers, as shown, are used; they are serrated or grooved discs which are pressed against the wheel and traversed back and forth across the face; the tool shown in fig. 283 is specially intended for large, thick wheels, say from 8 inches diameter and 2 inches thick or

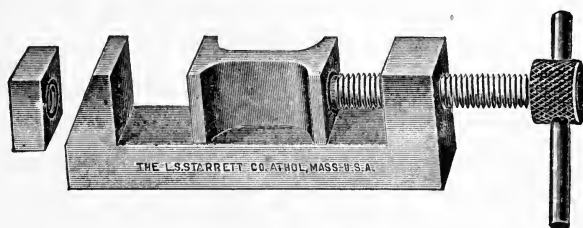

Fig. 286.

more, but are not practical for use on small, thin wheels; while the dressers shown in fig. 284 and fig. 285 are generally used on smaller and thin wheels, but can likewise be used on the large wheels.

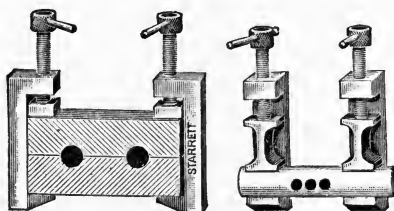

Fig. 287.

Fig. 288.

Figs. 286 to 288 are steel clamps made from drop forgings, case-hardened, and have take-up blocks to slip on and off the end of the screw. They will hold work square and parallel for laying out on surface plates, drilling, etc. A round piece may be rigidly held in two of the clamps and drilled, as shown in the illustration, fig. 288.

## UTILITIES AND ACCESSORIES.

Various devices are used for stamping on metal surfaces impressions of trademarks, etc.; the machine shown in fig. 282 is designed for this purpose ; it will mark, by means of steel dies, letters, numbers, etc., on either flat or round metal surfaces, such as twist drills, taps, dies, reamers, etc.

The piece of work to be marked is held on the table by a suitable fixture. For marking flat surfaces a cylindrical die is used, carried in a yoke or holder, which is attached to the slide bar or rack, and which is moved by the lever and pinion shown. By using a round die only a single point on its circumference is in contact with the work at one time. Many kinds of material that would be distorted by the use of a punch press can readily be stamped

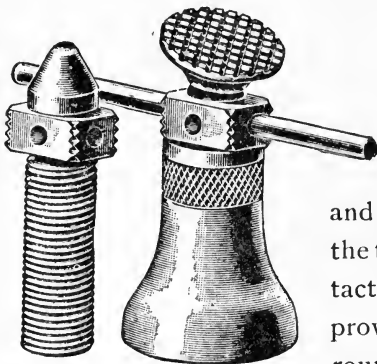

Fig. 289.

by this machine. When marking round surfaces, as the shanks of drills and reamers, a flat die is attached to the rack or slide, and the work allowed to roll on the table as the die comes in contact with it. Adjustments are provided when using flat or round dies, so that the proper character on the die shall come in contact with the work at a stated point ; the amount of travel, after contact is made, is governed by screw stops ; the round die, after use, is relieved of pressure and returned by spring tension to its original position.

Fig. 289 shows a screw jack, which is useful for lifting heavy castings into position on the planer, etc. The illustration explains itself, the cap being self-adjusting

## MACHINE SHOP UTILITIES.

Fig. 290 exhibits a pair of "two and two" sheave rope blocks, fitted with an "automatic lock" or self-sustaining brake, which holds the load in any desired position; this lock can be released only by a pull on the rope, hence it is a safety block; for many purposes, rope blocks are superior to chain blocks.

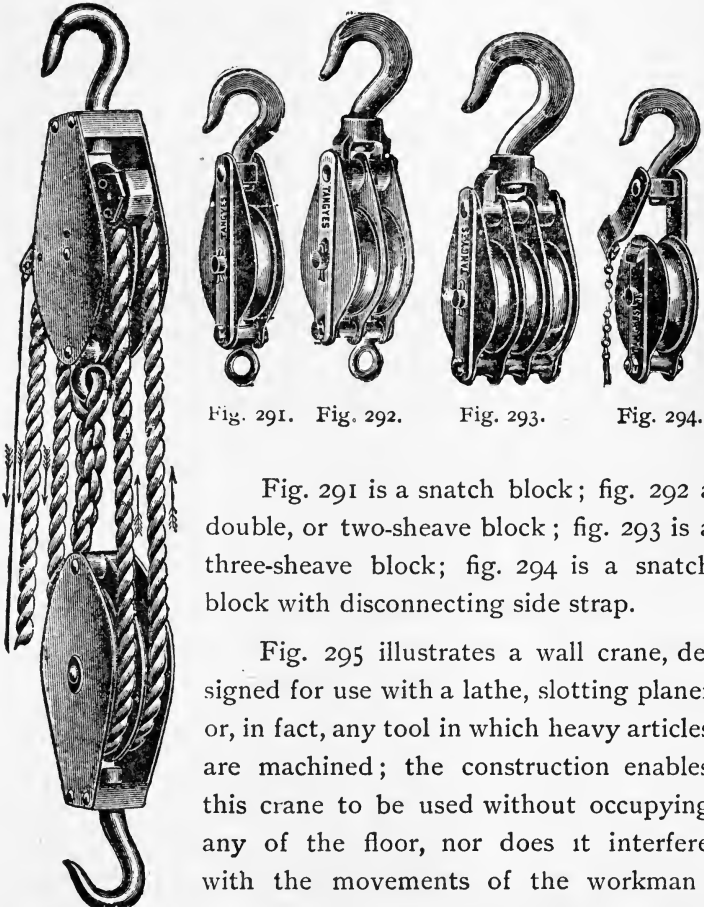

Fig. 291. Fig. 292. Fig. 293. Fig. 294.

Fig. 291 is a snatch block; fig. 292 a double, or two-sheave block; fig. 293 is a three-sheave block; fig. 294 is a snatch block with disconnecting side strap.

Fig. 295 illustrates a wall crane, designed for use with a lathe, slotting planer or, in fact, any tool in which heavy articles are machined; the construction enables this crane to be used without occupying any of the floor, nor does it interfere with the movements of the workman; with this description of crane, pulley

Fig. 290.

## SNATCH AND SHEAVE BLOCKS.

blocks are generally used to raise the work, to a trolley which slides on the top of the crane arm, as shown in fig. 295.

Fig. 296 shows a simple and convenient method of supplying a grindstone with water, an essential feature being to provide a supply of water for the wheel while in operation, and to keep the wheel dry when not in use. The wheel, as illustrated, is mounted on a wooden frame, and the trough for the water is made of galvanized iron, the

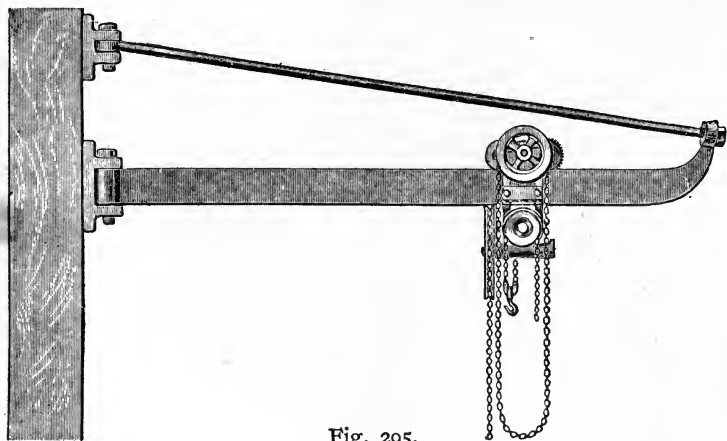

Fig. 295.

trough being high enough to enter the top of the frame, which serves as a guide, thus returning all the water to the trough again. When down, the water is below the bottom of the stone; the treadle, made of a piece of pine  $1 \times 5$  inches, is connected to the trough by a couple of kettle ears and fulcrumed about the center of its length to the floor. The weight of the water keeps the trough down, and a pressure of the foot quickly brings the water in contact with the stone.

## MACHINE SHOP UTILITIES.

Fig. 297 shows a "buff" or polishing machine. The stand or pedestal is hollow, and the wheel guard is of such shape that the draught, caused by the rapid movement of the wheel, carries the larger part of the dust produced by polishing, from the operator to the bottom of the stand; this may be connected with a blower, and the dust almost completely removed.

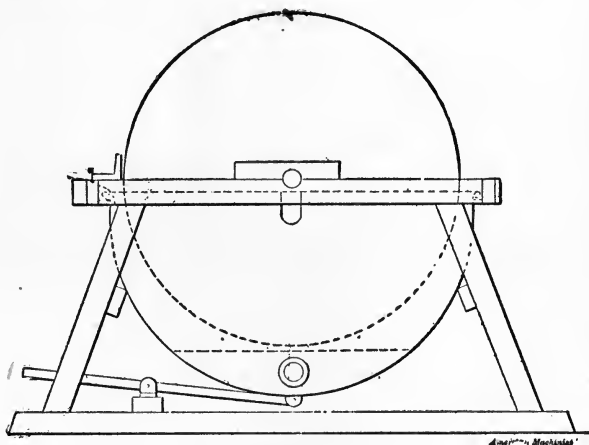

Fig. 296.

Polishing wheels are made of different materials, such as wood covered with leather, canvas clamped between iron plates, felt, unbleached muslin, etc.; the best wheels are

**NOTE.**—While most shops are provided with special tool grinders and sharpeners, the old grindstone still seems to have a place of its own among them, and most machinists prefer the grindstone when it is kept in good shape and well supplied with water. The chief objections to grindstones are that they do not hold their form any great length of time, and that the means usually employed to keep them well supplied with water are unsatisfactory. If the stone is kept submerged in water when not running, soft spots will result, and these will wear much faster than the rest of the stone.



## THE GRINDSTONE.

solid leather and are made in three grades: soft, medium and hard; and they are well adapted to all kinds of polishing. These wheels are made of discs of oak-tanned leather, held together with elastic water-proof cement, and compressed under a hydraulic pressure of from 75 to 100 tons. They have advantages over other wheels, being more pliable and elastic, can be turned to any shape face, saving the

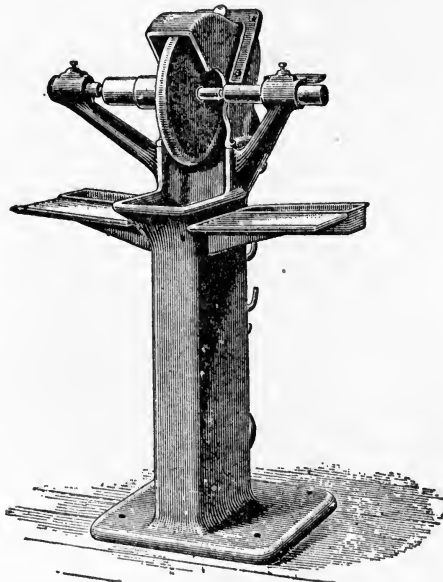

Fig. 297.

expense of re-covering, as a coat of emery is all that is needed to make them ready for service. Being water-proof, they can be washed like a leather-covered wood wheel when a new coat of emery is needed, and they can be run at any speed with perfect safety.

A tool chest is shown in fig. 298. This is preferably made of hardwood and furnished with locks and handles.

“The user of the machine tool, wiser in his generation than the agitator, refuses to make sudden and radical changes in methods which have proved successful. To him machines are but a means to an end. He does not purchase them because they make watches, or engines, or ships. For these things he does not care. He wants them to make money, and

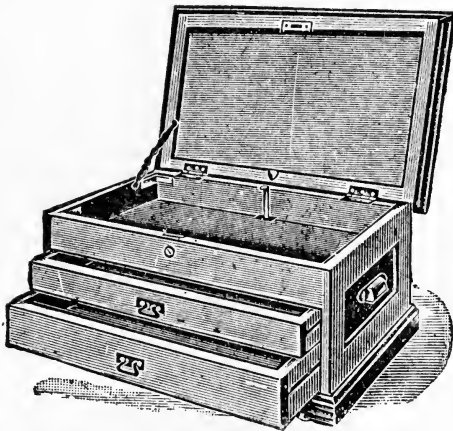

Fig. 298.

if he finds that a new machine can turn out more of it in an hour than an old machine, he tries the new. But it is labor lost, explaining the beauties of its construction, the excellence of its work, and the rapidity of its output, if it cannot be shown that it makes more money than a tool his grandfathers found good.”



**SHOP  
MANAGEMENT**

“The most successful managers are those who manage men, not things. By selecting the right heads of departments, encouraging them to do their best, by showing in a substantial manner their work is appreciated, the manager or superintendent can suggest improvements to the various departments that far out-weigh the whole cost of some of the details. It is well to know the details, so as to be able to examine them occasionally, but to attempt to follow them continually prevents attention to features of more importance.”

“The shop manager must educate his foremen; must train them to his methods; must teach them concentration along the line of their particular work. Imbued with this spirit the shop foreman will train the gang boss, and he in turn the workmen under him. All must understand, that the greatest output of perfect, finished product, with the least delay and waste, is the sole object in view.”

## SHOP MANAGEMENT.

---

The advanced machinist, in common with other trades and professions, has, in very recent times, learned the value of co-operation between man and man, and between man and machines; at last he is working on the principles he has found to underlie good results in any trade—division of labor and organization.

When the modern machinist undertakes a problem of construction, or a special line of manufacture, he looks it squarely in the face, and if the equipment is not equal to the demands of the situation, supplies the need with the most approved machines or he invents new and improved devices and tools, and guarantees successful and definite results even before the work is begun. He does this by what is broadly named shop management.

The subject suggests two things—a shop and a manager; or, to enlarge a little, shops with machinery in operation and a foreman; again, to widen the view still further, shop management may properly include as its field of operations, a vast establishment with thousands of skilled and unskilled workmen, with their gang-bosses, foremen, and superintendents of departments, the whole animated and directed as a single whole by a general manager, who in turn is responsible to a board of directors, representing the capital employed.

For its most effective use, the shop may be considered a machine, sometimes large and sometimes small, of which the equipment and men are the moving parts. These are so placed as to work one with another, so that the product,

## SHOP MANAGEMENT.

passing through the shop, reaches the finished condition with the least expense, in the desired state of finish and accuracy, thus effecting the combination of superiority and low price.

Be the "plant" large or small, the first thing that enters into its successful management is a "system" adapted to its size, condition and location. The word system explains the idea: A plan or scheme according to which ideas or things are connected together as a whole; a union of parts forming a whole; whatever savors of system, savors of accuracy, speed, ease and comfort.

Let it not be forgotten, that of thousands of machine-shops now in existence, the exceptions are few in number but what they had their beginnings in the days of small things, as to men and equipment; they have simply grown with passing years, but with all, the fact has been, that success and continuance has depended upon a proper system, which has been classified as

1. Organization;
2. Management;
3. Equipment.

---

NOTE.—"System is not work, but is simply a law of action for reducing work; it does not require special executors, but permits few to accomplish much. It loads no man with labor but lightens the labor of each by rigidly defining it. Hard work begins when system relaxes.

System never under any circumstances, interferes with variations in human action, but includes them; elasticity is not a quality of system, but comprehensiveness is. System is the result of two rigid laws: 1, a place for everything and everything in its place, and, 2, specific lines of duty for every man. The laws being written, understood and executed, lighten the responsibility of every man."—*Chordal's Letters.*

**ORGANIZATION.**

The term organization refers to the arrangement of departments and the positions they occupy, but in this book, the term does not include the commercial organization, of account keeping, financing or business management.

**EQUIPMENT.**

The term equipment may be said to include all machinery, tools, gauges, auxiliary plant, means of transportation and shop fittings; this is nearly a definition of a power-plant.

**MANAGEMENT.**

The above enter into the operation of every shop and "plant," and so the problems of to-day in shop and factory management, *are not so much problems of machinery as of men*; the question of men is, and always will be a difficult one; men are, as a rule, willing to do a good, fair day's work for a fair day's pay. They do not have to be driven to this. It is only necessary that the foreman let them know, in manly, inoffensive ways, what is expected of them.

Many schemes of co-operation have been attempted in the various trades and factories, with varying success. Many schemes have been too complicated, and many have a serious drawback in the length of time necessary before the workman knows to what extent he has participated in the profits. Many schemes are too visionary, and some good ones may have been failures on account of the methods taken to introduce them. Any plan, to succeed, must be practical and simple enough to introduce without

---

**NOTE.**—The Century Dictionary defines a "plant" as "the fixtures, machinery, tools, apparatus, etc., necessary to carry on any trade or mechanical business, or any mechanical process or operation."

## SHOP MANAGEMENT.

displacing entirely the old. The most practical schemes seem to be those in which the workman is able to participate in the profit on a given piece. That is, he is given opportunity to reduce cost of production and is allowed an increase of wage for so doing.

## PIECE-WORK PLAN.

The piece-work is the most widely introduced of any system in which the machinist shares in his increased productiveness. It consists in paying a fixed price for a certain piece of work. Although it was originally intended to benefit the manufacturer, in its first result it most directly benefited the workman, as he received an increase of wage, while the price per piece remained constant to the manufacturer, who, however, gains something by the greater output of his plant.

## THE DIFFERENTIAL PLAN.

The differential plan consists of paying a man a high price per piece in consideration of his reaching a certain high-water mark of production per day, and a lower price per piece provided he falls below this rate of production. This plan congregates the ablest of workmen, but leaves the medium men considerably in the shade. It necessi-

---

NOTE.—“A tour of the machine shops of the United States and the newer works of Europe gives few impressions more striking than the one created by the widespread evidence of growing thought for the comfort of the workman. Humanitarian considerations aside, *it pays*—pays in quality and lower cost of output—when the worker is kept well nourished and in good hygienic surroundings. It is not, of course, possible for all works to go so far as some others, but the general principles are everywhere applicable.”—*The Editors of the Engineering Magazine.*



## PIECE-WORK AND PREMIUM PLANS.

tates a radical change from the method of paying by the hour, but perhaps conforms more closely than any other plan to the true theory of having the wage proportionate to the production.

## THE PREMIUM PLAN.

The premium plan consists of setting a "time limit" upon the piece, within which limit the piece is expected to be completed. The man is paid his hourly wage for every hour he works upon the piece, and a specified premium for every hour he saves or does not work upon the piece inside the "time limit" set. The "time limits" and premium rates are not changed or cut. The advantages of this plan are: First, adaptability to ordinary work fitting in alongside of regular day work; second, its self-regulating feature, whereby the cost per piece is reduced to the employer and the wage per hour increased to the workman every time any improvement is made in production; third, its flexibility, due to the opportunity at the start of fixing a premium rate adapted to the conditions or business in hand, and the opportunity thereafter of setting either a liberal or close "time limit" to regulate cost per piece. It does not crowd out the medium machinist, but gives him encouragement to become better.

It also serves the foreman as the best indicator possible for setting the rates of men per hour, by affording him an opportunity to note the amount of product turned out in a given time.

Of these three plans of co-operation, the piece work plan requires the least knowledge in fixing prices; the differential plan requires a most extensive, minute and

## SHOP MANAGEMENT.

complete knowledge of the exact maximum rate of production. The premium plan requires a fair knowledge and judgment of machine-shop operations, in order to set a reasonable "time limit," but with proper premium rates the "time limits" may vary considerably, without varying the actual cost to a dangerous extent.

## AN EQUITABLE METHOD.

An equitable method of scaling the rates for machine labor would tend to clear the atmosphere for those who are in doubt. An even rate for all machinists greatly handicaps the most skilled labor and benefits most the incompetent.

## PLANNING A SHOP.

In planning a shop, however small, the possibility of its steady growth for many years to come, should be kept constantly in mind. No building should be erected that does not conform with part of the whole scheme of what the plant might be in the remote future. Another consideration is to provide for the unity of the plant, even though it trebles or quadruples in size.

---

NOTE.—A notable example of forethought in guarding against this possibility is the new Allis-Chalmers shop at Milwaukee. Provision has been made not only for its doubling, but for its expansion indefinitely, without loss of its integrity. The foundry and pattern shop run parallel to each other. At right angles and abutting the foundry are three machine shop bays, and at the other end of these bays, running out at right angles to them, is the erecting shop, so that the castings from the foundry go through the various machine shop bays and into the erecting shop by the most direct routes. But the finest feature of this whole plant is that more bays may be added and the foundry, pattern shop and erecting shop lengthened without damaging the correct proportions of these departments relatively to each other, and without their growing apart.

## DEPARTMENTS.

As an army is divided into divisions, brigades and companies, so are the large shops of the present day divided into departments, each of which has its official head.

A description of one will be sufficient to indicate the management of many. It is that of a well ordered pattern shop, which constituted a department in an extensive establishment.

The closing paragraphs of the article are especially worthy of attention :

“ The shop was on the second floor of a separate building, having windows on all sides. Benches were around the outer walls, each having a window over it. Windows had shades to roll from both top and bottom, thus getting all possible light without the glare of the sun. Each bench had a tool rack at back of same for tools most commonly used, and drawers built in the bench for workmen’s supplies and such tools as were only occasionally used. A small clothes closet with towel, rack and mirror over each bench completed the individual equipment. Each workman was required to leave his bench clean and in order at night.

“ The shop floor was swept every night, and the refuse taken out, thereby lessening fire dangers. The lumber was kept in racks on edge, one size above another, the heavier pieces near the floor. In this way any piece could be taken out without moving any other. There was but one scrap pile in the shop. Instead of being thrown on the floor in a heap, pieces of lumber were properly sorted in a rack next the band-saw, shelves being provided for the smaller pieces and cross-bars for longer ones. But little time was lost getting nearly the right piece. No scrap was allowed under the benches. All pieces left had to be put in the rack or thrown in the waste. The floor under the benches was kept as clean as the rest of the shop.

“ The machines were in groups in the center of the shop at one end, leaving a large floor space at the other end. This made the machines accessible from all sides. All machines were belted from below, thus avoiding belts across the shops. All face-plates, centers, wrenches, calipers, etc., were kept on shelves under the lathe, and back of same to be easily accessible. Each workman was required to leave machines clean and in order.

## SHOP MANAGEMENT.

"A great deal of work was only sandpapered after sawing. Some was only sawed. Saws were kept in order by the foreman and hung alongside the machine. The buzz planer was kept in the best possible condition. The 30-inch grindstone ran 450 revolutions per minute, taking water on its side, centrifugal force carrying it out. The stone was properly hooded, had tight and loose pulleys and iron frame. This machine had the fast cutting qualities of an emery grinder without its heating disadvantages. There was a small bench drill taking small twist drills and the ordinary wood bits up to one inch. There was one large trimmer and two smaller ones conveniently arranged about the shop. Round, concave and convex sandpapering blocks of standard sizes and curves were kept in a rack for that purpose.

"Time slips and approximate amount of material used were turned in to the foreman every night. The aim in this shop seemed to be to waste nothing; to do work at as low cost as possible; to do good work; to be considerate of the comforts and conveniences of the men, and to have good order and cleanliness everywhere."

Mr. Sibley, in the same journal, tells of a new foreman who reformed a shop noted for its untidiness:

"Shortly after his appearance on the scene, he started a crusade against dirt and rubbish; he had the carpenter build a bin in one corner of the yard, which was roofed over and fitted with a door, made in sections which could be successively inserted as the bin filled, after which he sawed in two a half dozen empty oil barrels, which were painted a bright red and on which were inscribed in large white letters the legend "Refuse;" these were located in convenient places. A laborer was selected and given an outfit consisting of broom, rake, shovel and wheelbarrow, and to him was assigned the task of raking up and wheeling away all litter from the yard; also once a day cleaning out the chips and scraps from the various boxes around the machine tools and depositing them in the bin.

"It is an axiom that 'Like begets like,' and the result of such surroundings was to make the men more careful and painstaking in their work, reducing the loss from waste and spoiled jobs, and also having the effect of drawing and holding a much better and more intelligent class of workmen than could otherwise be obtained for the same wages."

## THE FOREMAN.

The man upon whom the success, comfort, character, and continuance of a "works" depends in the ultimate is the model foreman; he has been described as follows:

## THE FOREMAN.

“A foreman is a chief or leading man, with those whom he is appointed to manage and direct; a successful foreman must be two-sided. He must not only keep the machinery under his charge in proper order, but he must discipline, direct and control the animated human machine that operates the inanimate tools. He should be a good mechanic as well as a good leader of men.

“To be a leader of men, he should cultivate perfect patience, forbearance and self-control, remembering that no man has controlled others who did not start by controlling himself. He should be even-tempered, or, if not born so, should not let anyone discover it. He should be strictly just, granting cheerfully everything due his employees, while jealously guarding his employer's interests, curbing his generosity in spending funds intrusted to him. A man so qualified should make a successful master mechanic, but will not long remain one in the present day of keen competition in all branches, calling for competent men for advancement.”

The shop manager should be keen to remove and keep removed from the foreman such tasks as do not bear directly upon the production. The foreman must turn out the maximum of good products. To do this he must have his materials supplied to him without effort on his part. He must be left time to pick and choose the men best suited to the various classes of work. He must train them into rapid and skillful workmen. He must keep the machine tools in good order and see that they are worked to their full capacity, and the organization of which he is a

## SHOP MANAGEMENT.

part must make it possible for him to do all this, and must not distract his attention with anything else.

## GANG BOSSES.

Gang bosses are now common on the erecting floors of even small shops, and there is no reason why gang bosses should not be appointed to oversee work on tools also. For example, the best lathe hand in a group of three or four is paid a trifle more and put in authority over them. The foreman instructs this man in regard to the work laid out ahead for these lathes, while the man in turn sees that it is carried out in detail. He is still a producer, but at the same time he is relieving the foreman of a considerable burden. In this way the foreman is left freer to plan out the more important details of his work.

A quotation expresses a strongly-felt need for information: "There are a great many problems for the small shop to solve, and the methods of the big shops furnish no solution. I mean the small shop that is just big enough to have troubles, but not big enough to have a fine organization—where one man has to do many things—where the question of *commercial* expediency turns up daily. I mean the shop employing from twenty-five to fifty hands and doing a variety of small work—sometimes a quantity of pieces, sometimes a limited number of special machines. Something a little beyond the jobbing machinists, but away behind the great sewing machine companies and small arms companies and type-writer concerns. *I sometimes think the manager of such a shop has a tougher job than a man with one ten times as large.*"



**USEFUL  
RECIPES**

“A machinist must love the tools he uses. They are his work-day companions during life ; he learns to handle them with skillful gentleness ; he learns to regard them with that sort of warmth of feeling which, during the long years of association with them, unfolds itself into a genuine love for those that have stood by him—have remained ‘good to the last.’ They are his ‘never fail me’s,’ and with certain ones he would not part for ten times their cost to him.”



## WORKSHOP RECIPES.

---

*A recipe*, in popular usage, is a receipt for making almost any mixture or preparation.

Shop recipes pertain to the shop, and embrace a thousand processes, receipts, kinks and formulas, in common report among mechanics; these are passed along from man to man and frequently are printed and thus pass into literature.

Each establishment has its own particular collection of recipes, and many of them are applicable only in their own home-land, where necessity has given them birth. In the same way, each machinist, engineer and artisan should possess, as a part of his private equipment, a good store of these useful and most helpful items of knowledge.

Each one is advised to keep a memorandum-book in which he may record, from time to time, such recipes as, in his line of activity, may be considered valuable, eliminating and omitting—like old lumber—all such as belong to outside affairs and hence of no service to the compiler of what may be properly called a “list of useful recipes.”

A few only, of many of such in current use, are here presented, more as a guide for such collections which each one can make for himself, rather than as a complete exhibit of recipes and formulas.

**BABBITT METAL.**—Babbitt metal is an alloy, composed of tin 45.5, copper 1.5, antimony 13, lead 40 parts.

Formerly the alloy, originated by Isaac Babbitt, was used for all purposes, but there is no one composition that will bring equally good results in all kinds of machinery, hence are given the following :

## WORKSHOP RECIPES.

Babbitt metal for light duty is composed of 89.3 parts of copper, 1.8 parts of antimony, 8.9 parts of lead.

Babbitt metal for heavy bearings is composed of 88.9 parts of copper, 3.7 parts of antimony, 7.4 parts of lead.

SOLDERS.—Alloys employed for joining metals together are termed "solders," and they are commonly divided into two classes: hard and soft solders. The former fuse only at a red heat, but soft solders fuse at comparatively low temperatures. Common solders are composed of equal parts of tin and lead; fine solder, two parts of tin to one of lead; cheap solder, one of tin and two of lead; common pewter contains four lead to one of tin; German silver solder is composed of copper 38, zinc 54, nickel 8 parts=100.

HOW TO SOLDER ALUMINIUM.—In soldering aluminium, it is necessary to bear in mind that upon exposure to the air a slight film of oxide forms over the surface of aluminium, and afterwards protects the metal. The oxide is the same color as the metal, so that it cannot easily be distinguished. The idea in soldering is to get underneath this oxide while the surface is covered with the molten solder. With the following procedure quick manipulation is necessary: 1, clean off all dirt and grease from the surface of the metal with a little benzine; 2, apply the solder with a copper bit, and when the molten solder is

---

NOTE.—The best treatment for wrought steel, which has a knack of growing gray and lustreless, is to first wash it very clean with a stiff brush and ammonia soapsuds, rinse well, dry by heat if possible, then oil plentifully with sweet oil, and dust thickly with powdered quick lime. Let the lime stay on two days, then brush it off with a clean very stiff brush. Polish with a softer brush, and rub with cloths until the lustre comes out. By leaving the lime on, iron and steel may be kept from rust almost indefinitely.

---

**HOW TO SOLDER ALUMINIUM.**

covering the surface of the metal, scratch through the solder with a little wire scratch-brush. By this means you break up the oxide on the surface of the metal underneath the soldering, and the solder, containing its own flux, takes up the oxide and enables you, so to speak, to tin the surface of the aluminium.

**TO TIN A SOLDERING IRON.**—File the bolt clean over the part to which the tinning is to be applied. Wet this part with soldering fluid. Heat the bolt till it is hot enough for use and rub it into solder placed upon a piece of tin. If this does not secure an even coating, heat the bolt again and attend to the bare spots in the same manner as before. If you use a soldering pot, you can keep sal-ammoniac on top of the solder, and dip the iron into the solder through the liquid.

**BRAZING CAST IRON.**—The reason that cast iron cannot be brazed with spelter as wrought iron can, is that the graphitic carbon in the former prevents the adhesion of the spelter, as a layer of dust prevents the adhesion of cement to stone or brick. A process to remove this graphite has been patented in Germany, consisting essentially in applying to the surfaces to be united an oxide of copper and protecting them against the influence of the air with borax or silicate of soda. When the joint is heated the oxide of copper gives up its oxygen to the graphite, converting it into carbonic oxide gas, which escapes in bubbles, while particles of metallic copper are deposited on the iron.

---

**NOTE.**—For removing rust from iron the following is given: Iron may be quickly and easily cleaned by dipping in or washing with nitric acid one part, muriatic acid one part and water twelve parts. After using wash with clean water.

## WORKSHOP RECIPES.

Any oxide of iron which may be formed is dissolved by the borax, and the surfaces of the iron, thus freed from graphite, unite readily with the spelter which is run into the joint before it cools, the copper already deposited on the iron assisting the process. The inventor claims that cast iron can in this way be readily brazed in an ordinary blacksmith's forge.

## A CHEAP LUBRICANT FOR MILLING AND DRILLING.

—Dissolve separately in water, 10 pounds of whale-oil soap and 15 pounds of sal-soda. Mix this in 40 gallons of clean water. Add two gallons of best lard oil, stir thoroughly, and the solution is ready for use.

SODA WATER FOR DRILLING.—Dissolve three-fourths to one pound of sal-soda in one pailful of water.

## FUSING POINTS OF TIN-LEAD ALLOYS.

Tin 1 to lead 10, . . .	558° F.	Tin 1½ to lead 1, . . .	334° F.
" 1 " " 5, . . .	511° F.	" 2 " " 1, . . .	340° F.
" 1 " " 3, . . .	482° F.	" 3 " " 1, . . .	356° F.
" 1 " " 2, . . .	441° F.	" 4 " " 1, . . .	365° F.
" 1 " " 1, . . .	370° F.	" 5 " " 1, . . .	378° F.

USE OF LIME TO KEEP SHOP FLOORS CLEAN.—In the Elevated Railroad shops of Chicago it has been found that the use of lime aids in cleaning up the shop floors and in keeping them in good condition. This lime is simply swept over the floor every day, in addition to the regular cleaning. Very little remains on the floor after the sweeping, but it is sufficient to counteract the effect of the oil

NOTE.—Among all the soft metals in use there are none that possess greater anti-friction properties than pure lead; but lead alone is impracticable, for it is so soft that it cannot be retained in the recess of a bearing. In most of the best and most popular anti-friction metals in use, sold under the name "Babbitt," the basis is lead.

## MARKING SOLUTION.

and grease, and to make it easy at the beginning of each day to clean up what has fallen the previous day, as well as to improve the appearance of the floor.

NICKEL-PLATING SOLUTION.—To a solution of 5 to 10 per cent. of chloride of zinc (5 grains, drams or ounces, to 95 of water, or 10 parts to 90 of water) add enough sulphate of nickel to produce a strong green color, and bring to boiling point in a porcelain or stoneware vessel. The piece, or article, to be plated must be free from grease (by dipping in dilute acid); it is introduced by hanging on wire by a stick across the vessel, so that it touches the sides as little as possible. Boiling is continued from 30 to 60 minutes, water being added to supply that lost by evaporation. During boiling, the nickel is deposited as a white and brilliant coating. Boiling for two or three hours does not increase the thickness of the coating. As soon as the object appears to be plated, wash in water having a little chalk in suspension, and then carefully dry. Polish the article with chalk. The chloride of zinc and nickel sulphate must be free from metals precipitable by iron. If, during the precipitation of the nickel on the articles, the solution becomes colorless, more nickel sulphate should be added. The liquid spent may be used again by exposing it to the air until the contained iron (from the articles) is precipitated, filtering and adding the salts as above.—W. B. BURROW in *Power*.

MARKING SOLUTION.—Dissolve one ounce of sulphate of copper (blue vitriol) in four ounces of water and half a teaspoonful of nitric acid. When this solution is applied on bright steel or iron, the surface immediately turns cop-

## WORKSHOP RECIPES.

per color, and marks made by a sharp scratch will be seen very distinctly.

FOR BLUING BRASS.—Dissolve one ounce (or any other unit in the same proportions will do) of antimony chloride in twenty ounces of water and add three ounces of pure hydrochloric acid. Place the warmed brass article into this solution until it has turned blue. Then wash it and dry in sawdust.

TO PROTECT BRIGHT WORK FROM RUST.—Use: 1, a mixture of one pound of lard, one ounce of gum camphor melted together, with a little lamp-black; or, 2, a mixture of lard oil and kerosene, in equal parts; or, 3, a mixture of tallow and white lead; or, 4, of tallow and lime.

VARNISH FOR COPPER.—To protect copper from oxidation a varnish may be employed which is composed of carbon disulphide 1 part, benzine 1 part, turpentine oil 1 part, methyl alcohol 2 parts and hard copal 1 part. The varnish is very resisting; it is well to apply several coats of it to the copper.—*Die Werkstatt.*

TO REMOVE THE SAND AND SCALE FROM IRON CASTINGS.—Immerse the parts in a mixture composed of one part of oil of vitriol to three parts of water; in six to ten hours remove the objects, and wash them thoroughly with clean water; this is called "pickling." A weaker solution can be used by allowing a longer time for the action of the solution.

---

NOTE.—A common sewing needle held in a suitable handle makes an excellent scribe for accurate work. It is so cheap that grinding is unnecessary, as, when dull, it can be simply replaced by a new one. The point on a needle is ground by an expert, and is far superior to anything possible by the ordinary machinist.

## EXTRACTING BROKEN TOOLS.

**RUST JOINT COMPOSITION.**—This is a cement made of sal-ammoniac 1 lb., sulphur  $\frac{1}{2}$  lb., cast-iron turnings 100 lbs.; the whole should be thoroughly mixed and moistened with a little water; if the joint is required to set very quick, add  $\frac{1}{4}$  lb. more sal-ammoniac. Care should be taken not to use too much sal-ammoniac, or the mixture will become rotten.

**RUST JOINT (slow setting)**—Two parts sal-ammoniac, 1 flour of sulphur, 200 iron borings. This composition is the best, if joint is not required for immediate use.

**CEMENT FOR FASTENING PAPER OR LEATHER TO IRON.**—The following ingredients are required: 1 pound best flour,  $\frac{1}{4}$  pound best glue,  $\frac{1}{2}$  pound granulated sugar,  $\frac{1}{2}$  ounce powdered borax,  $\frac{1}{2}$  ounce sal-ammoniac,  $\frac{1}{4}$  ounce alum. Soak the glue in three pints of soft water for 12 hours, or if you have glue already melted, pour in the quantity. Mix the flour in one quart of soft water, mix all together, and boil over a slow fire, or cook with a steam jet. When cool it is ready for use. The face of the pulley or surface where the leather is to be applied must be thoroughly clean and free from grease.

**EXTRACTING BROKEN TOOLS.**—To extract the fragment of a drill, punch or steel tool, which has broken off while working any metal but iron or steel. The object containing the broken-off piece is immersed in a boiling solution composed of 1 part common alum to 4 or 5 parts of water. This solution may be held in a vessel of stoneware, porcelain, copper, etc., but not of iron. The object should be so placed that the gaseous bubbles that form as the alum attacks the metal are easily disengaged. At the end of a short time the fragment of the tool is entirely dis-

## WORKSHOP RECIPES.

solved. A piece of steel spring, one-sixteenth of an inch thick, dissolved in a concentrated solution of alum in three-quarters of an hour.—*Herr Bornhauser, Prussia.*

LUBRICANTS FOR USE IN CUTTING BOLTS AND TAPPING NUTS.—Dissolve  $1\frac{1}{2}$  pounds of sal-soda in three gallons of warm water, then add one gallon of pure lard oil. This is called a soda solution. Pure lard oil is the best for fine, true work. Never use mineral oil.—*Acme Machinery Co.*

SOLDERING FLUIDS.—Add pieces of zinc to muriatic acid until the bubbles cease to rise, and the acid may be used for soldering with soft solder.

Mix one pint of grain alcohol with two tablespoonfuls of chloride of zinc. Shake well. This solution does not rust the joint as acids are liable to do.

When soldering lead, use tallow or resin as a flux, and use a solder consisting of one part tin and  $1\frac{1}{2}$  parts lead.

PREVENTING RUST ON TOOLS.—To prevent rust on tools, use vaseline, to which a small amount of gum camphor has been added; heat together over a slow fire.

IN LAYING OUT WORK—on planed surfaces of steel or iron, use blue vitriol and water on the surface. This will copper-plate the surface nicely, so that all lines will show plainly. If on oily surfaces, add a little oil of vitriol; this will eat the oil off and leave a nicely coppered surface.

A METAL THAT WILL EXPAND IN COOLING—is made of 9 parts lead, 2 parts antimony, and 1 part bismuth. This metal will be found very valuable in filling holes in castings.



---

**AID TO THE INJURED.**

**TO COPPER THE SURFACE OF IRON OR STEEL WIRE.**—Have the wire perfectly clean, then wash with the following solution, when it will present at once a coppered surface: Rain water, three pounds; sulphate of copper, 1 pound.

**TO KEEP WATER FROM FREEZING.**—Common salt is the best material, and by using common (agricultural) salt the expense is the least.

**AN OIL THAT WILL NOT GUM.**—Take good Florence olive oil and put it in a bottle with some strips of zinc and shavings of lead, which should be clean. Expose the bottle to sunlight until the curdy matter ceases to be deposited; this will require considerable time, but the oil when decanted will be of very fine quality and will not gum.

---

**AID TO THE INJURED IN ACCIDENTS.**

A noted surgical writer has said that the fate of an injured person depends upon the acts of the one into whose hands he first falls. In the time of an accident, the presence of a person with a knowledge of what to do and the presence of mind to carry such knowledge into effect, is invaluable.

---

**NOTE.**—Few subjects can more usefully employ attention and study than the proper treatment and first remedies made necessary by the peculiar and distressing accidents to which persons are liable who are employed in or around machinery; under the title of "First Aid," etc., there are most helpful instructions printed and distributed, well worth the study of the advanced machinist; where enough in number of the trade are together, it would be worthy of praise, for owners to provide each year, a short course of lectures, illustrated, for the benefit of those unfortunately injured, as they are sure to be from time to time, and in a greater or less degree.

## USEFUL RECIPES.

A clear head, a steady hand and some practical knowledge of what is to be done, are what are needed in the first moments of sudden disaster of any kind; an experienced machinist or engineer is nearly always found, in the confusion incident to such a time, to be the one most competent to advise and direct the efforts made to avert the danger to life, limb or property, and to remedy the worst after-effects.

To fulfill this responsibility is worth much previous preparation, so that the best things under the circumstances may be done quickly and efficiently. To this end the following advice is given relating to the most common accidents which are likely to happen, in spite of the utmost care and prudence.

1, Keep cool. 2, Summon a surgeon at once. 3, Send a written message, describing the accident and injury if possible, in order that the surgeon may know what instruments and remedies to bring. 4, Remove the patient to a quiet, airy place where the temperature is comfortable. 5, Keep bystanders at a distance. 6, Handle the patient gently and quietly.

## IN CASE OF WOUNDS.

Arrange the injured person's body in a comfortable position; injuries to the head require that the head be raised higher than the level of the body; when practical

---

NOTE.—An entire chapter on "*Accidents and how to avoid them,*" would be useful; the first advice might be this: To resolve firmly to be constantly careful, and determine, with all the solemnity of an oath, neither to be injured oneself, nor to cause injury to another. This has been the author's rule and it has resulted well; again: *always to look in the direction in which one is moving.*

## AID TO THE INJURED.

lay the patient on his back with the limbs straightened out in their usual natural position. Unless the head be injured, have the head on the same level as the body. Loosen the collar, waist-band and belts. If the patient should be faint, have his head rather lower than his feet. If the arm or leg be injured, it may be slightly raised and laid on a cushion or pillow.

Watch carefully if unconscious.

If vomiting occurs, turn the patient's body on one side, with the head low, so that the matters vomited may not go into the lungs.

If a wound be discovered in a part covered by the clothing, cut the clothing in the seam. Remove only sufficient clothing to uncover and inspect the wound.

All wounds should be covered and dressed as quickly as possible. If a severe bleeding should occur, see that this is stopped, if possible, before the wound is finally dressed.

Bleeding is of three kinds: 1, from the arteries which lead from the heart; 2, that which comes from the veins which take the blood back to the heart; 3, that from the small veins which carry the blood to the surface of the body. In the first, the blood is bright scarlet and escapes as though it were being pumped. In the second, the blood is dark red and flows away in an uninterrupted stream. In the third, the blood oozes out. In some wounds all three kinds of bleeding occur at the same time.

The simplest and best remedy to stop the bleeding is to apply direct pressure on the external wound by the fingers. Should the wound be long and gaping, a compress

## USEFUL RECIPES.

of some soft material large enough to fill the cavity may be pressed into it; but this should always be avoided, if possible, as it prevents the natural closing of the wound.

Pressure with the hands will not suffice to restrain bleeding in severe cases for a great length of time, and recourse must be had to a ligature, this can best be made with a pocket handkerchief or other article of apparel, long enough and strong enough to bind the limb. Fold the article neck-tie fashion, then place a smooth stone, or anything serving for a firm pad, on the artery, tie the handkerchief loosely, insert any available stick in the loop and proceed to twist it, as if wringing a towel, until just tight enough to stop the flow.

Examine the wound from time to time, lessen the compression if it becomes very cold or purple, or tighten up the handkerchief if it commences bleeding.

Some knowledge of anatomy is necessary to guide the operator where to press. Bleeding from the head and neck requires pressure to be placed on the large artery which passes up beside the windpipe and just above the collar bone. The artery supplying the arm and hand runs down the inside of the upper arm, almost in line with the coat seam, and should be pressed with the finger or thumb.

The artery feeding the leg and foot can be felt in the crease of the groin, just where the flesh of the thigh seems to meet the flesh of the abdomen, and this is the best place to apply the ligature. In arterial bleeding, the pressure must be put between the heart and the wound, while in *venous* bleeding it must be beyond the wound, to stop the flow as it goes toward the heart.

---

**AID TO THE INJURED.**

In any case of bleeding, the person may become weak and faint; unless the blood is flowing actively, this is not a serious sign, and the quiet condition of the faint often assists nature in staying the bleeding, by allowing the blood to clot and so block up any wound in a blood vessel.

Unless the faint is prolonged or the patient is losing much blood, it is better not to hasten to relieve the faint condition; when in this state anything like excitement should be avoided, external warmth should be applied, the person covered with blankets, and bottles of hot water or hot bricks to the feet and arm-pits.

**IN CASE OF CUTS.**

The chief points to be attended to are: 1, arrest the bleeding; 2, remove from the wound all foreign bodies as soon as possible; 3, bring the wounded parts opposite to each other and keep them so; this is best done by means of strips of adhesive plaster, first applied to one side of the wound and then secured to the other; these strips should not be too broad, and space must be left between the strips to allow any matter to escape. Wounds too extensive to be held together by plaster must be stitched by a surgeon, who should always be sent for in severe cases.

For washing a wound, to every pint of water add 2½ teaspoonfuls of carbolic acid and 2 tablespoonfuls of glycerine—if these are not obtainable, add 4 tablespoonfuls of borax to the pint of water—wash the wound, close it, and

---

NOTE.—Severe bleeding is not usual after machinery and railroad accidents, as the wounds inflicted are such that the blood vessels are generally closed, because they are torn and twisted off. This is not the case with cuts.

## USEFUL RECIPES.

apply a compress of a folded square of cotton or linen ; wet it in the solution used for washing the wound and bandage down quickly and firmly.

If the bleeding is profuse, a sponge dipped in very hot water and wrung out in a cloth should be applied as quickly as possible—if this is not to be had, use ice, or cloth wrung out in ice water.

Wounds heal in two ways: 1, rapidly by primary union, without suppuration, and leaving only a very fine scar; 2, slowly by suppuration and the formation of granulations and leaving a large red scar.

Do not touch the wounds with the hands either during examination, or while applying dressings, unless they have been previously made clean.

After dressing a wound, do no more to the patient unless necessary to restore him to consciousness or relieve faintness.

If suffering from shock, place him in a comfortable position and await the arrival of the surgeon.

## IN CASE OF BROKEN BONES.

The treatment consists of: 1, carefully removing or cutting away, if more convenient, any of the clothes which

---

NOTE.—“Bones do not break directly across ; they break zig-zag and one bone overlaps the other, sometimes with many sharp points, and if you pick up a patient and do not pay special attention to how you carry him, the first thing you know, one sharp end of the bone will be sticking out. This is a great element of danger to the case. If he is to be conveyed some distance, and no one is on hand to attend to him, the best thing to do is to apply a splint and bandage. Take a piece of board about four inches wide and two and one-half feet long and put it on the back side of the leg, then put two or three turns of the bandage around it. This will answer well enough to convey the patient some distance.”—J. EMMON BRIGGS, M.D.

**AID TO THE INJURED.**

are compressing or hurting the injured parts ; 2, very gently replacing the bones in the natural position and shape, as nearly as possible, and putting the part in a position which gives most ease to the patient ; 3, applying some temporary splint or appliance, which will keep the broken bones from moving about and tearing the flesh ; for this purpose, pieces of wood, pasteboard, straw, or firmly folded cloth may be used, taking care to pad the splints with some soft material and not to apply too tightly, while the splints may be tied by loops of rope, string or strips of cloth ; 4, conveying the patient home or to an hospital.

To get at a broken limb or rib, the clothing must be removed, and it is essential that this be done without injury to the patient ; the simplest plan is to rip up the seams of such garments as are in the way. Boots must be cut off. It is not imperatively necessary to do anything to a broken limb before the arrival of a doctor, except to keep it perfectly at rest.

**HOW TO CARRY AN INJURED PERSON.**

In case of an injury where walking is impossible, and lying down is not absolutely necessary, the injured person may be seated in a chair, and carried ; or he may sit upon a board, the ends of which are carried by two men, around whose necks they should place his arms so as to steady himself.

Where an injured person can walk he will get much help by putting his arms over the shoulders and round the necks of two others.

A seat may be made with four hands and the person

## USEFUL RECIPES.

may be thus carried and steadied by clasping his arms around the necks of his bearers.

If only one person is available and the patient can stand up, let him place one arm round the neck of the bearer, bringing his hand on and in front of the opposite shoulder of the bearer. The bearer then places his arm behind the back of the patient and grasps his opposite hip, at the same time catching firmly hold of the hand of the patient resting on his shoulder, with his other hand; then by putting his hip behind near the hip of the patient, much support is given, and if necessary, the bearer can lift him off the ground and as it were, carry him along.

To carry an injured person by a stretcher (which can be made of a door, shutter or settee—with blankets or shawls or coats for pillows), three persons are necessary. In lifting the patient on the stretcher *it should be laid with its foot to his head*, so that both are in the same straight line; then one or two persons should stand on each side of him, raise him from the ground and slip him on the stretcher;

---

NOTE.—A broad board or shutter may be employed as a stretcher; but if either of them be used, some straw, hay, or clothing should be placed on it, and then a piece of stout cloth or sacking; the sacking is useful in taking the patient off the stretcher when he arrives at the bedside.

Always test a stretcher before placing the patient on it. Place an uninjured bystander upon it and let the bearers carry him a short distance, practicing placing him upon it, laying down, raising up, turning around, etc.

Never allow stretchers to be carried on the bearers' shoulders.

Always carry patient feet-foremost, except when going up a hill. In cases of fractured thigh or fractured leg, if the patient has to be carried down hill, carry the stretcher head-first.

In carrying a patient on a stretcher, care should be taken to avoid lifting the stretcher over walls or ditches.—*Johnson's First Aid Manual.*



## AID TO THE INJURED.

this to avoid the necessity of any one stepping over the stretcher, and the liability of stumbling.

If a limb is crushed or broken, it may be laid upon a pillow with bandages tied around the whole (*i. e.*, pillow and limb) to keep it from slipping about. In carrying the stretcher the bearers should "break step" with short paces; hurrying and jolting should be avoided and the stretcher should be carried so that the patient may be in plain sight of the bearers.

## IN CASE OF BURNS AND SCALDS.

*Burns* are produced by heated solids or by flames of some combustible substance; *scalds* are produced by steam or a heated liquid. The severity of the accident depends mainly, 1, on the intensity of the heat of the burning body, together with, 2, the extent of surface, and, 3, the vitality of the parts involved in the injury; thus, a person may have a finger burned off with less danger to life than an extensive scald of his back.

In severe cases of burns or scalds the clothes should be

---

NOTE.—The immediate effect of scalds is generally less violent than that of burns; fluids not being capable of acquiring so high a temperature as some solids, but flowing about with great facility, their effects become most serious by extending to a large surface of the body. A burn which instantly destroys the part which it touches may be free from dangerous complication, if the injured part is confined within a small compass; this is owing to the peculiar formation of the skin.

The skin is made up of two layers; the outer one has neither blood vessels nor nerves, and is called the scarf-skin or cuticle; the lower layer is called the true skin, or cutis. The latter is richly supplied with nerves and blood vessels, and is so highly sensitive we could not endure life unless protected by the cuticle. The skin, while soft and thin, is yet strong enough to enable us to come in contact with objects without pain or inconvenience.

## USEFUL RECIPES.

removed *with the greatest care*—they should be carefully cut, at the seams, and not pulled off.

In scalding by burning water or steam, cold water should be plentifully poured over the person and clothes, and the patient then carried to a warm room and laid on the floor or a table, but not put to bed as there it becomes difficult to attend further to the injuries.

The secret of the treatment is to avoid chafing, *and to keep out the air*. Save the skin unbroken, if possible, taking care not to break the blisters; after removal of the clothing, an application to the injured surface, of a mixture of *soot and lard*, is, according to practical experience, an excellent and efficient remedy. The two or three following methods of treatment also are recommended according to convenience in obtaining the remedies.

Take ice well crushed or scraped, as dry as possible, then mix it with fresh lard until a broken paste is formed; the mass should be put in a thin cambric bag, laid upon the burn or scald and replaced as required. So long as the

---

NOTE.—A method in use in the New York City Hospital known as the “glue burn mixture,” is composed as follows: “ $7\frac{1}{2}$  Troy oz. white glue, 16 fluid oz. water, 1 fluid oz. glycerine, 2 fluid drachms carbolic acid. Soak the glue in the water until it is soft, then heat on a water bath until melted; add the glycerine and carbolic acid and continue heating until, in the intervals of stirring, a glossy, strong skin begins to form over the surface. Pour the mass into small jars, cover with paraffine papers and tin foil before the lid of the jar is put on and afterwards protect by paper pasted round the edge of the lid. In this manner the mixture may be preserved indefinitely. When wanted for use, heat in a water bath and apply with a flat brush over the burned part.”

## AID TO THE INJURED.

ice and lard are melting, there is no pain from the burn; return of pain calls for a repetition of the remedy.

In burns with lime, soap, lye or *any caustic alkali*, wash abundantly with water (do not rub), and then with weak vinegar or water containing a little sulphuric acid; finally apply oil, paste or mixture as in ordinary burns.

## INSENSIBILITY FROM SMOKE.

To recover a person from this, dash cold water in the face, or cold and hot water alternately. Should this fail, turn the patient on his face with the arms folded under his forehead; apply pressure along the back and ribs and turn the body gradually on the side; then again slowly on the face, repeating the pressure on the back; continue the alternate rolling movements about sixteen times a minute until breathing is restored. A warm bath will complete the cure.

## HEAT-STROKE OR SUN-STROKE.

The worst cases occur where the sun's rays never penetrate and are caused by the extreme heat of close and confined rooms, overheated workshops, boiler-rooms, etc. The symptoms are: 1, a sudden loss of consciousness; 2, heavy breathing; 3, great heat of the skin, and 4, a marked absence of sweat.

*Treatment.*—The main thing is to lower the temperature. To do this, strip off the clothing, apply chopped ice wrapped in flannel to the head; rub ice over the chest, and place pieces under the armpits and at the side. If no ice can be had use sheets or cloth wet with cold water, or the body can be stripped and sprinkled with cold water from a common watering pot.

## USEFUL RECIPES.

## FROST BITE.

No warm air, warm water, or fire should be allowed near the frozen parts until the natural temperature is nearly restored; rub the affected parts gently with snow or snow water in a cold room; the circulation should be restored very slowly; and great care must be taken in the after-treatment.

## TO REMOVE FOREIGN BODIES IN THE EYE.

Take hold of the upper lid and turn it up so that you can look on the inside of the upper lid. Have the patient make several movements with the eye; first up, then down, to the right side and to the left. Then take a tooth-pick with a little piece of absorbent cotton wound around the end and moistened in cold water, and swab it out. The foreign body will adhere to the swab and you will get the object out of the eye without any trouble.

## DEATH SIGNS.

The note following is added with some doubt as to its useful application, but this whole subject relates to very serious occurrences, and it may be well, considering all things, to print it.

---

NOTE.—Hold the hand of the person apparently dead before a candle or other light, the fingers stretched, one touching the other, and look through the space between the fingers toward the light. If the person is living, a scarlet red color will be seen where the fingers touch each other, due to the still circulating fluid blood as it stows itself between the transparent, but yet congested tissues. When life is extinct this phenomenon ceases. Another method is to take a cold piece of polished steel, for instance a razor blade or table knife, hold this under the nose and before the mouth; if no moisture condenses upon it, it is safe to say that there is no breathing.

In cases of severe shock, etc., it is not sufficient to test the cessation of the heart-beat by feeling of the pulse at the wrist. An acute ear can generally detect the movement of the heart by the sound when the ear is applied to the chest or back. The electric battery may be used under the advice of a physician in doubtful cases,

## AID TO THE INJURED.

## THE D'ARSONVILLE METHOD OF RESUSCITATION FROM ELECTRIC SHOCK.

The proof of the efficacy of this method is now so complete that no one following pursuits in which there is danger from electric shocks, is justified in neglecting to make himself familiar with it.

First, it must be appreciated that accidental shocks seldom result in absolute death unless the victim is left unaided for too long a time, or efforts at resuscitation are suspended too early.

In the majority of instances the shock is only sufficient to suspend animation temporarily, owing to the momentary and imperfect contact of the conductors, and also on account of the indifferent parts of the body submitted to the influence of the current. It must be appreciated also that the body under the conditions of accidental shocks seldom receives the full force of the current in the circuit, but only a shunt current, which may represent a very insignificant part of it.

When an accident of this nature occurs, the following rules should be promptly adopted and executed with due care and deliberation :

1.—Remove the body at once from the circuit by breaking contact with the conductors. This may be

---

NOTE.—The introduction of electricity as an industrial and useful agent has been attended with many distressing accidents, causing great suffering and frequently loss of life; while happily these accidents are becoming less frequent, none the less it is important to both know and observe the rules for safety so constantly repeated.

Currents of electricity passed through the limbs affect the nerves with certain painful sensations, and cause the muscles to undergo involuntary contractions. The effect experienced by the discharge with high potential difference is that of a sharp and painful *shock*.

## RESUSCITATION FROM ELECTRIC SHOCK.

accomplished by using a dry stick of wood, which is a non-conductor, to roll the body over to one side, or to brush aside a wire, if that is conveying the current. When a stick is not at hand, any dry piece of clothing may be util-



Fig. 299.

ized to protect the hand in seizing the body of the victim, unless rubber gloves are convenient. If the body is in contact with the earth, the coat-tails of the victim, or any loose or detached piece of clothing, may be seized with impunity to draw it away from the conductor. When this has been accomplished, observe Rule 2.



Fig. 300.

2.—Turn the body upon the back, loosen the collar and clothing about the neck, roll up a coat and place it under the shoulders, so as to throw the head back. and then make efforts to establish artificial respiration (in other words,

## AID TO THE INJURED.

make him breathe), just as would be done in case of drowning. To accomplish this, kneel at the subject's head, facing him, and seizing both arms draw them forcibly to their full length over the head (as shown in fig. 299), so as to bring them almost together above it, and hold them there for two or three seconds only. (This is to expand the chest and favor the entrance of air into the lungs.)

Then carry the arms down to the sides and front of the chest, firmly compressing the chest walls, and expel the air from the lungs (as shown in fig. 300). Repeat this manœuvre at least sixteen times per minute. These efforts should be continued unremittingly for at least an hour, or until natural respiration is established.

3.—At the same time that this is being done, some one should grasp the tongue of the subject with a handkerchief or piece of cloth to prevent it slipping, and draw it forcibly out when the arms are extended above the head, and allow it to recede when the chest is compressed.

This manœuvre should be repeated at least sixteen times per minute. This serves the double purpose of freeing the throat so as to permit air to enter the lungs, and also, by exciting a reflex irritation from forcible contact of the under part of the tongue against the lower teeth, frequently stimulates an involuntary effort at respiration. If the teeth are clenched and the mouth cannot be opened

NOTE.—Linemen's rubber gloves are designed to prevent the frequent and often fatal accidents occurring to linemen from shock while handling electric light wires or other wires in contact with the same, and also the dangers of line work from lightning in stormy weather. The gloves are also useful in handling the strong acids of batteries, being impervious to the same.

## USEFUL RECIPES.

readily to secure the tongue, force it open with a stick, a piece of wood, or the handle of a pocket-knife.

Commence always with pulling the tongue, but the method of artificial respiration should be applied at the same time if possible.

Concurrent efforts should be made to bring back the circulation by rubbing the surface of the body, smartly striking it with the hands or wet towels, throwing from time to time water on the face, and causing the victim to inhale ammonia and vinegar.

The dashing of cold water into the face will sometimes produce a gasp and start breathing which should then be continued as directed above. If this is not successful the spine may be rubbed vigorously with a piece of ice. Alternate applications of heat and cold over the region of the heart will accomplish the same object in some instances. It is both useless and unwise to attempt to administer stimulants to the victim in the usual manner by pouring it down his throat.

While this is being done, a physician should be summoned.

## COLIC.

Apply heat in the form of hot water bags, or bottles, hot plates, and mustard plaster over the seat of pain. Hot baths are sometimes useful.

## VOMITING.

Give large amounts of hot water, as hot as can be taken. Patient should always lie down. Small bits of ice held in the mouth or swallowed, will relieve vomiting caused by indigestion. A lump of ice held against the pit



## AID TO THE INJURED.

of the stomach will sometimes bring relief. When other means fail, apply a mustard plaster to the pit of the stomach.

## BANDAGES.

These are frequently made by cutting a piece of linen or calico forty inches square into two pieces crosswise, and may be used either as a "broad" or "narrow" bandage. The broad is made by spreading the bandage out, then bringing the point down to the lower border, and then folding into two folds. The narrow is made by drawing the point down to the lower border, and then folding into three; a bandage should always be fastened either by a pin or by being tied with a reef-knot.

When rolled into strips, the following sizes have been found advantageous; for hand, fingers, and toes, one inch wide, one to two yards in length; for arms, legs, and extremities, two and a half inches wide, seven yards in length; for thigh, groin, and trunk, three inches wide and eight to ten yards in length.

## POULTICES.

These outward applications are useful to relieve sudden cramps and pains due to severe injuries, sprains and colds. The secret of applying a mustard poultice is to apply it hot and keep it so by frequent changes—if it gets cold and clammy it will do more harm than good. A poultice to be of any service and hold its heat should be from one-half to one inch thick. To make it, take flaxseed, oatmeal, rye meal, bread, or ground slippery elm; stir the meal slowly into a bowl of boiling water, until a thin and smooth dough is formed. To apply it take a piece of old linen of the right size, fold it in the middle, spread the

---

 RESPONSIBILITY OF EMPLOYERS.

dough evenly on one-half of the cloth and cover it with the other.

To make a "mustard paste" as it is called, mix one or two tablespoonfuls of mustard and the same of fine flour, with enough water to make the mixture an even paste; spread it neatly with a table knife on a piece of old linen, or even cotton cloth. Cover the face of the paste with a piece of thin muslin.

## CARE OF SELF.

Want of care is the cause of more injuries than want of knowledge; hence care and knowledge should be well commingled. It is easier to form a habit than to break one off, therefore we should strive to form correct habits in relation to avoiding accidents.

## PRINCIPLES INVOLVING THE RESPONSIBILITY OF EMPLOYERS FOR THE SAFETY OF THEIR WORKMEN.

The following are abstracts chiefly from recent decisions in the higher courts of various states. In general they are indicative of the law throughout the country:

The risks and dangers assumed by an employee are such as are incident to his employment, such as are known to him, and such as are obvious and patent. (*Pa. 9 Dist. Rep. 291.*)

To show that an employee assumed the risks connected with the operation of a machine it must appear, not only that a defect was patent, but that he knew the danger of operating it in its defective condition. (*Minn. 92 N. W. Rep. 981.*)

---

NOTE. — The portions of the above abstracts printed *in italics* are the Law References to cases which have established and confirmed verdicts in test cases. *The American Machinist* is entitled to the credit for this list of cases.

## RESPONSIBILITY OF EMPLOYERS.

A minor cannot recover for an injury received while working a machine when the danger of the machine is such as can readily be seen, and he was duly instructed in its use, and the machine was in good condition. (*Pa. 17 L. L. Rep. 247.*)

Where an employee is injured while obeying the orders of his employer to perform work in a dangerous manner, the employer is liable, unless the danger is so imminent that a man of ordinary prudence would not incur it. (*88 Ill. App. Ct. Rep. 169.*)

In order to recover for defects in the appliances of the business, the employee must establish by proof three propositions: First, that the appliance was defective; second, that the employer had notice or knowledge of such defect, or should have had; third, that the employee did not know of the defect, and had not equal means of knowing with the employer. (*87 Ill. App. Ct. Rep. 551.*)

It is incumbent on an employer to exercise ordinary care to provide and maintain a reasonably safe place and reasonably safe machinery and appliances in which and by means whereof an employee is to perform his service. (*U. S. Ct. App. 163 Fed. Rep. 265.*)

It is not only the duty of an employer to warn his employee against the danger that lies in the unskillful or careless operation of machinery, involved in his employment or task, but he should also give suitable instructions as to the manner of using the same so as to avoid danger. (*13 Pa. Sup. Ct. Rep. 219.*)

While it is settled law that an employee assumes the ordinary and apparent risks of his employment, he does

**RESPONSIBILITY OF EMPLOYERS.**



not assume the risk from defects in the plant itself, which the employer is bound to make and keep in a reasonably safe condition. (*Me. 46 Atl. Rep. 804.*)

An experienced workman of mature years cannot continue to operate a machine, which he knows is dangerous, without assuming the risk, simply because the employer has assured him that it is safe, when the workman has just as much knowledge of the danger arising from its use as the employer. (*Mich. 82 N. W. Rep. 797.*)



The burden of proving that an accident arose out of and in the course of the workman's employment lies on the employee; but the burden of proving serious and willful misconduct lies on the employer. (*Eng. 80 L. T. 317.*)

If the negligence of the employer operates as a concurring and efficient cause of an injury to an employee, his liability will not be relieved by the negligence of fellow-employees also concurring. (*88 Ill. App. Ct. Rep. 162.*)

To constitute fellow-servants they must either directly co-operate in the particular business so that they may exercise an influence on one another promotive of proper caution, or their duties must be such as to bring them into habitual association so that they may exercise such influence on each other. (*88 Ill. App. Ct. Rep. 169.*)



**TABLES**  
AND  
**INDEX**



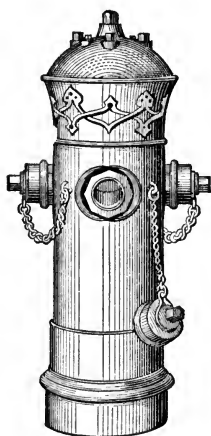

# TABLES USEFUL FOR MACHINISTS.

---

The speeds required for machining advantageously the different materials, according to the different diameters, may be termed "surface speeds." Roughly speaking, the surface speeds for the different materials vary in comparatively narrow limits. We may assume the following speeds for the following:

## TABLE OF SURFACE SPEEDS.

Cast iron.....30 to 45 feet per minute.

Steel.....20 to 25 feet per minute.

Wrought iron....30 feet per minute.

Brass.....40 to 60 feet per minute.

For cast iron as found in Europe, we may assume 20 to 35 feet per minute. This is owing to the fact that European iron is considerably harder.

## SPEED OF SAWS, ETC.

Band saws for hot iron and steel run at about 200 to 300 feet per minute. Plain soft iron discs run at a rim velocity of 12,000 feet per minute, and are sometimes used to cut off ends of steel rails, jets of water playing on the circumference of the saw.

## AVERAGE CUTTING SPEED FOR DRILLS.

The following table represents the most approved practice in rate of cutting speed for drills ranging from  $\frac{1}{16}$  inch to 2 inches in diameter.

Diameter of Drills	Speed on Steel	Speed on Cast Iron	Speed on Brass	Diameter of Drills	Speed on Steel	Speed on Cast Iron	Speed on Brass
$\frac{1}{16}$	1,712	2,383	3,544	$1\frac{1}{8}$	72	106	180
$\frac{1}{8}$	855	1,191	1,772	$1\frac{1}{4}$	68	102	170
$\frac{3}{16}$	571	794	1,181	$1\frac{3}{8}$	64	97	161
$\frac{1}{4}$	397	565	855	$1\frac{1}{2}$	58	89	150
$\frac{5}{16}$	318	452	684	$1\frac{5}{8}$	55	84	143
$\frac{3}{8}$	265	377	570	$1\frac{3}{4}$	53	81	136
$\frac{7}{16}$	227	323	489	$1\frac{7}{8}$	50	77	130
$\frac{1}{2}$	183	267	412	$1\frac{1}{2}$	46	74	122
$\frac{9}{16}$	163	238	367	$1\frac{9}{8}$	44	71	117
$\frac{5}{8}$	147	214	330	$1\frac{3}{4}$	40	66	113
$1\frac{1}{8}$	133	194	300	$1\frac{1}{2}$	38	63	109
$\frac{3}{4}$	112	168	265	$1\frac{3}{4}$	37	61	105
$1\frac{1}{8}$	103	155	244	$1\frac{7}{8}$	36	59	101
$1\frac{1}{4}$	96	144	227	$1\frac{1}{2}$	33	55	98
$1\frac{3}{8}$	89	134	212	$1\frac{1}{8}$	32	53	95
$1\frac{1}{2}$	76	115	191	2	31	51	92

## SIZE OF DRILLS FOR U. S. STANDARD TAPS.

Diam. of Tap	Threads per inch	Diam. of Drill	Diam. of Tap	Threads per inch	Diam. of Drill	Diam. of Tap	Threads per inch	Diam. of Drill
$\frac{1}{4}$	20	$1\frac{1}{8}$	$\frac{7}{8}$	9	$\frac{3}{4}$	$1\frac{3}{4}$	5	$1\frac{1}{2}$
$\frac{5}{16}$	18	$\frac{1}{4}$	1	8	$\frac{27}{32}$	$1\frac{7}{8}$	5	$1\frac{3}{8}$
$\frac{3}{8}$	16	$\frac{5}{16}$	$1\frac{1}{8}$	7	$\frac{11}{16}$	2	$4\frac{1}{2}$	$1\frac{1}{4}$
$\frac{7}{16}$	14	$\frac{3}{8}$	$1\frac{1}{4}$	7	$\frac{1}{8}$	$2\frac{1}{4}$	$4\frac{1}{2}$	$1\frac{1}{8}$
$\frac{1}{2}$	13	$\frac{1}{2}$	$1\frac{3}{8}$	6	$1\frac{1}{8}$	$2\frac{1}{2}$	4	$2\frac{1}{8}$
$\frac{5}{8}$	11	$\frac{3}{4}$	$1\frac{1}{2}$	6	$\frac{9}{16}$	$2\frac{3}{4}$	4	$2\frac{7}{16}$
$\frac{3}{4}$	10	$\frac{7}{8}$	$1\frac{5}{8}$	$5\frac{1}{2}$	$1\frac{1}{8}$	3	$3\frac{1}{2}$	$2\frac{3}{8}$



TABLE OF EMERY WHEEL SPEEDS.

Diam. Wheel.	Rev. per Minute for Surface Speed of 4,000 ft.	Rev. per Minute for Surface Speed of 5,000 ft.	Rev. per Minute for Surface Speed of 6,000 ft.
1 in.	15,279	19,090	22,918
2 "	7,639	9,549	11,459
3 "	5,093	6,366	7,639
4 "	3,820	4,775	5,370
5 "	3,056	3,820	4,584
6 "	2,546	3,183	3,820
7 "	2,183	2,728	3,274
8 "	1,910	2,387	2,865
10 "	1,528	1,910	2,292
12 "	1,273	1,592	1,910
14 "	1,091	1,364	1,637
16 "	955	1,194	1,432
18 "	849	1,061	1,273
20 "	764	955	1,146
22 "	694	868	1,042
24 "	637	796	955
30 "	509	637	764
36 "	424	531	637

The above table designates the number of revolutions per minute for specific diameters of emery wheels to cause them to run at the respective periphery rates of 4,000, 5,600 and 6,000 feet per minute.

The medium of 5,000 feet is usually employed in ordinary work, but in special cases it is sometimes desirable to run them at a lower or higher rate, according to requirements.

The stress on the wheel at 4,000 feet periphery speed per minute is 48 lbs. per square inch; at 5,000 feet, 75 lbs.; at 6,000 feet, 108 lbs.

U. S. STANDARD SCREW THREADS.

Nominal Diameter of Screw.		Number of Threads per inch.	Diameter of Tap at Root of Thread.		Size of Tap Drill, giving a Clearance of $\frac{1}{8}$ the Height of the Original Thread Triangle.		Area at Root of Thread.	Safe Load on Threaded Bolt on basis of 6,000 lbs. Stress per sq. in. of Section at Root of Thread.
Inches	Inches		Inches	Nearest 64ths	Inches	Nearest 64ths		
							Sq. In.	Pounds
$\frac{1}{4}$	.250	20	.185	$\frac{3}{16}$	.196	$\frac{1}{8}$	.027	162
$\frac{1}{8}$	.312	18	.240	$\frac{15}{64}$ +	.252	$\frac{1}{4}$ +	.045	270
$\frac{3}{8}$	.375	16	.294	$\frac{19}{64}$	.307	$\frac{5}{16}$	.068	408
$\frac{7}{16}$	.437	14	.345	$\frac{6}{16}$ +	.360	$\frac{3}{8}$ +	.093	558
$\frac{1}{2}$	.500	13	.400	$\frac{13}{32}$	.417	$\frac{7}{16}$	.126	756
$\frac{9}{16}$	.562	12	.454	$\frac{29}{64}$ +	.472	$\frac{1}{2}$	.162	997
$\frac{5}{8}$	.625	11	.507	$\frac{1}{2}$ +	.527	$\frac{9}{16}$	.202	1210
$\frac{11}{16}$	.687	11	.569	$\frac{9}{16}$ +	.589	$\frac{1}{2}$	.254	1520
$\frac{3}{4}$	.750	10	.620	$\frac{5}{8}$	.642	$\frac{11}{16}$	.302	1810
$\frac{13}{16}$	.812	10	.683	$\frac{11}{16}$	.704	$\frac{3}{4}$	.366	2190
$\frac{7}{8}$	.875	9	.731	$\frac{47}{64}$	.755	$\frac{7}{8}$	.420	2520
$\frac{15}{16}$	.937	9	.793	$\frac{65}{64}$	.817	$\frac{15}{16}$	.494	2960
I	1.000	8	.838	$\frac{47}{56}$	.865	$\frac{15}{16}$	.551	3300
$I\frac{1}{8}$	1.062	8	.900	$\frac{23}{32}$	.927	$\frac{15}{16}$	.636	3810
$I\frac{1}{8}$	1.125	7	.939	$\frac{15}{16}$ +	.970	$\frac{15}{16}$	.694	4160
$I\frac{3}{8}$	1.187	7	I.002	I +	I.032	$I\frac{1}{8}$	.788	4720
$I\frac{1}{4}$	1.250	7	I.064	$I\frac{1}{8}$ +	I.095	$I\frac{3}{8}$	.893	5350
$I\frac{3}{8}$	1.375	6	I.158	$I\frac{5}{8}$ +	I.215	$I\frac{7}{8}$	I.057	6340
$I\frac{1}{2}$	1.500	6	I.283	$I\frac{9}{8}$ +	I.345	$I\frac{15}{8}$	I.295	7770
$I\frac{5}{8}$	1.625	5 $\frac{1}{2}$	I.389	$I\frac{25}{16}$	I.428	$I\frac{15}{8}$	I.515	9090
$I\frac{3}{4}$	1.750	5	I.490	$I\frac{63}{64}$ +	I.534	$I\frac{31}{32}$ +	I.746	10470
$I\frac{7}{8}$	1.875	5	I.615	$I\frac{99}{64}$ +	I.659	$I\frac{23}{16}$ +	2.051	12300
2	2.000	4 $\frac{1}{2}$	I.711	$I\frac{23}{16}$ +	I.760	$I\frac{23}{16}$	2.302	13800
2 $\frac{1}{4}$	2.250	4 $\frac{1}{2}$	I.961	$I\frac{61}{32}$ +	2.010	2 $\frac{1}{4}$	3.023	18100
2 $\frac{1}{2}$	2.500	4	2.175	2 $\frac{1}{4}$ +	2.230	2 $\frac{1}{2}$	3.719	22300
2 $\frac{3}{4}$	2.750	4	2.425	2 $\frac{3}{4}$ +	2.480	2 $\frac{3}{4}$	4.620	27700
3	3.000	3 $\frac{1}{2}$	2.629	2 $\frac{5}{8}$ +	2.691	3	5.428	32500
3 $\frac{1}{4}$	3.250	3 $\frac{1}{2}$	2.879	2 $\frac{7}{8}$ +	2.941	3 $\frac{1}{4}$	6.510	39000
3 $\frac{1}{2}$	3.500	3 $\frac{1}{4}$	3.100	3 $\frac{1}{8}$ +	3.167	3 $\frac{1}{2}$	7.548	45300
3 $\frac{3}{4}$	3.750	3	3.317	3 $\frac{1}{8}$ +	3.389	3 $\frac{3}{4}$	8.641	51800
4	4.000	3	3.567	3 $\frac{9}{16}$ +	3.639	4	9.063	59700

STANDARD SIZES OF WROUGHT IRON WELDED PIPE.

Inside diameter, nom.	Actual outside Diameter.	Thick-ness.	Actual inside Diameter.	External circum-ference.	Internal circum-ference.	Length of pipe per square foot of outside surface.	Length of pipe per square foot of inside surface.	External area.	Actual internal area.	Length of pipe containing one cubic foot.	Weight per foot of length.	No. of threads per inch of screw.	Length perfect screw.
1/8	.405	.068	0.269	1.272	0.848	9.440	14.15	.129	.0572	2500.	.243	27	0.19
1/4	.54	.088	0.364	1.696	1.144	7.075	10.50	.229	.1041	1385.	.422	18	0.29
3/8	.675	.091	0.493	2.121	1.552	5.657	7.67	.358	.1916	751.5	.561	18	0.30
1/2	.840	.109	0.622	2.652	1.957	4.502	6.13	.554	.3048	472.4	.845	14	0.39
3/4	1.050	.113	0.824	3.299	2.589	3.637	4.635	.866	.5333	270.0	1.126	14	0.40
1	1.315	.134	1.047	4.134	3.292	2.903	3.679	1.357	.8627	166.9	1.670	11 1/2	0.51
1 1/4	1.660	.140	1.38	5.215	4.335	2.301	2.768	2.164	1.496	96.25	2.258	11 1/2	0.54
1 1/2	1.90	.145	1.61	5.969	5.061	2.010	2.371	2.835	2.038	70.65	2.694	11 1/2	0.55
2	2.375	.154	2.067	7.461	6.494	1.611	1.848	4.430	3.355	42.36	3.667	8	0.58
2 1/2	2.875	.204	2.467	9.032	7.754	1.328	1.547	6.491	4.783	30.11	5.773	8	0.89
3	3.50	.217	3.066	10.996	9.636	1.091	1.245	9.621	7.388	19.40	7.547	8	0.95
3 1/2	4.0	.226	3.548	12.566	11.146	.955	1.077	12.566	9.837	14.56	9.055	8	1.00
4	4.50	.237	4.026	14.137	12.648	.849	0.949	15.904	12.730	11.31	10.728	8	1.05
4 1/2	5.0	.247	4.506	15.708	14.153	.765	0.848	19.635	15.939	9.03	12.492	8	1.10
5	5.563	.259	5.045	17.475	15.849	.629	0.757	24.299	19.990	7.20	14.564	8	1.16
6	6.625	.280	6.065	20.813	19.054	.577	0.630	34.471	28.889	4.98	18.767	8	1.26
7	7.625	.301	7.023	23.954	22.063	.505	0.544	45.663	38.737	3.72	23.410	8	1.36
8	8.625	.322	7.981	27.096	25.076	.444	0.478	58.426	50.039	2.88	28.348	8	1.46
9	9.688	.344	9.000	30.433	28.277	.394	0.425	73.715	63.633	2.26	34.677	8	1.57
10	10.750	.366	10.018	33.772	31.475	.355	0.381	90.762	78.838	1.80	40.641	8	1.68

“Any shop which makes it a fixed rule to discharge any man for any act, not distinctly malicious or revealing incurable habits of carelessness or negligence, will soon lose its best men, and the average of skill and reliability in its force cannot fail to deteriorate.

“It is just the same the other way, too. A man shouldn't be in too much of a hurry about discharging his boss. His job calls for skill as much as any other, and the skill that is required to do a first-class job of bossing is just as rare, and takes as much sifting and training to produce, as any other.

“To retain an employer it is necessary sometimes to overlook some of his shortcomings. As he learns by experience that it will not do to discharge every man whenever he proves that he is not quite perfect, so it is well to remember, on the other side, that you can't run things very well or very long without a boss, even if he may not be the most satisfactory boss in the world. It is a rather poor boss who is not generally better than none at all.”

TECUMSEH SWIFT.

# INDEX

FOR THE ADVANCED MACHINIST.

---

## A

- ABRASIVE**, definition, 215.  
**ACCESSORY**, definition, 266.  
**ACCIDENTS AND HOW TO AVOID THEM**, note, 298.  
**ADDITION**, 28.  
Of decimals, 46.  
Of fractions, 42.  
**AID TO THE INJURED**, 297-316.  
Note on the importance of the subject, 297.  
**ALGEBRA**, definition, 23.  
**ALUMINIUM**, how to solder, 290.  
**AMERICAN STANDARD THREAD**, 120.
- ANGLE OR SPIRAL CUTTERS** for milling machines, illustrations, 188.  
**ARBOR PRESS**, description and illustrations, 251-253.  
**ARC**, complement of the, definition, 83.  
**ARISTOTLE**, quotation from, 34.  
**ARITHMETIC**, formulas, 22.  
Note, 19  
Summary of, 19-56.  
**AUTOMATIC SCREW CUTTING DIES**, 238.  
Illustrations, 234, 238, 239, 240, 241.  
**AUXILIARY MACHINES**, 243-262.

## B

- BABBITT METAL**, recipe for, 289.  
**BANDAGES**, how to make, 313.  
**BAND-SAWS**, speed for cutting hot iron, 319.  
**BEVEL PLANING TOOL**, 161.  
**BIRMINGHAM GAUGES**, illustrations, 92.  
**BLADES**, flexible for hack-saws, 249.  
**BLEEDING**, how to stop, 299, 300, 301.  
Of three kinds, 299.  
**BLOCK**, rope sheave, illustration, 270.  
Snatch, illustration, 270.  
**BLUING BRASS**, recipe, 294.  
**BOLT-CUTTING**, speed for, 241.  
Thread cutter, 235.  
**BONES**, broken, how to treat in case of accident, 302.  
**BORING-BAR**, illustrations, 140, 141.  
With adjustable cutter, description, 148, illustration, 150.
- BORING MACHINES**, horizontal, 142.  
Taper holes in the lathe, illustration, 143.  
Vertical, 147.  
**BORING MILL**, advantages of, 140.  
Description, 144-150.  
Facing a valve in a, illustration, 147.  
Illustrations, 138, 144, 146.  
Tools used in a, illustrations, 149, 150.  
**BORING-OPERATIONS**, 139-150.  
**BOSSES**, gang, 286.  
**BRACKETS**, definition, 21, 55.  
**BRASS**, recipe for bluing, 294.  
**BRAZING CAST IRON**, recipe, 291.  
**BROAD FINISHING TOOLS**, description, 148; illustration, 149.  
Nose planing tool, 161.  
**BROKEN BONES**, the treatment for, in case of accident, 302.  
**BUFF MACHINE**, illustration, 273.  
**BURN MIXTURE**, recipe, 306.  
**BURNS**, treatment of, 305, 306.

## C

**CALCULATION**, definition, 19.  
**CANCELLATION**, 40.  
**CALIPERING MACHINES**, illustrations, 87, 88.  
**CARE OF SELF**, 314.  
**CASTINGS**, recipe for "pickling," 294.  
**CAST IRON**, cutting angle for, 157.  
 Recipe for filling holes in, 296.  
 Surface speed for machining, 319.  
**CEMENT**, for fastening paper or leather to iron, 295.  
**CHANGE-WHEELS**, illustration and description, 122-123.  
**CHASERS**, illustrations, 104, 105, 106, 107.  
 Operation of, 104-108.  
 Note, 105.  
**CHUCKS FOR DRILLS**, 206, 207.  
 The swivel, illustration and description, 159.  
**CIRCLE**, circumference and area of a, 65-67.  
 Definitions, 65.  
 Degrees of a, note, 82.  
 Parts of a, 82.  
 Radius of a, definition and illustration, 82.  
 Rule for finding diameter of a, 66.  
**"CLAMPS,"** illustration and description, 268.  
**CLAPPER-BOX**, illustration, 158.  
**CO**, definition, 83.

**DECIMAL POINT**, location of, 21.  
**DECIMALS**, 44.  
 Reading of, 26.  
**DEFINITIONS**, arithmetical, 20.  
**DEGREES OF A CIRCLE**, note, 82.  
**DENOMINATE NUMBERS**, 35.  
**DEPARTMENTS IN SHOPS**, 283.  
**DEVICE**, for setting planer and shaper tools, 168.  
 Use on twist drills, illustration, 209.  
**DIAMOND-POINT PLANING TOOL**, 161.

**COLLET**, description and illustration, 25.  
**COMPLEMENT OF AN ARC**, definition, 83.  
**CONSTANT**, a, definition, 81.  
**COPPER**, varnish for, recipe, 294.  
 To, iron or steel wire, recipe, 297.  
**COSECANI OF AN ANGLE**, definition, 82.  
**COSINE**, definition and illustration, 82.  
**COTANGENT OF A CIRCLE**, definition and illustration, 82.  
**COUNTERSHAFT**, illustration, 249.  
**CRANE**, wall, illustration, 271.  
**CUBE**, definition, 72.  
**CUTS**, how to treat, 301.  
**CUTTERS**, for milling machines, 188, 190, 192, 193.  
 Side and other, in operation, illustration, 194.  
**CUTTER-SPEEDS**, explanation for figuring, description, 189.  
**CUTTING ANGLES**, for cast and wrought iron and brass, 157.  
**CUTTING-OFF MACHINES**, description, 245.  
 Planer tool, 161.  
 Saw, description, 247, illustration, 247.  
 Tools, illustrated, 246.  
**CYLINDER**, rule for finding the surface of a, 69.

## D

**DIE HEAD**, screw-cutting, description and illustration, 259.  
**DIE OF POWER PUNCH**, illustration, 232.  
**DIES**, automatic bolt-cutting, illustrations, 234, 238, 239, 240, 241.  
 Lubrication of, 235.  
 Revolutions of, 241.  
**DIFFERENTIAL PLAN OF PAYMENT**, 280.  
**DISCS**, plain iron, speed for cutting off ends of steel rails, 319.  
 Standard reference, illustration, 87.

## D

- DIVIDING HEAD AND TAIL STOCK**, 181.  
Illustrations, 181, 182.
- DIVISION**, 32.  
Of decimals, 47.  
Of fractions, 43.
- DODECAHEDRON**, the, definition, 81.
- DRESSING-TOOLS FOR EMERY WHEELS**, 268.
- DRILL CHUCKS**, description and illustrations, 206, 207.  
Turret, illustrations, 257, 258.
- DRILLING MACHINE**, adjustable reamer for, illustration, 203.  
Description of parts, 203.  
Drill chucks, illustration, 206.  
Radial, 206.  
Recipe for a cheap lubricant for, 292.
- DRILLING MACHINE**, shell reamer, illustration, 209.  
Socket or drill collet, description and illustration, 205.  
Speeds for twist drills, 210, 211.  
Special forms of, 203.  
Twist drill, grinding gauge, 209.  
Vertical, illustration, 202.
- DRILLING OPERATIONS**, 201-211.
- DRILLS**, how to grind flat, 207.  
Table of average cutting' speeds for, 320.  
Table of sizes for U. S. standard taps, 320.  
Table of speeds, 211.  
Twist, illustration, 208.  
Variations of, 205.
- DRIVER AND DRIVEN WHEELS**, 130.

## E

- ELECTRIC SHOCK**, how to resuscitate from, 309-312.
- ELLIPSE**, rule for finding area of, 68.
- EMERY**, description, in note, 226.  
Grinders, illustrations, 212, 214, 215, 216, 218, 219; in operation, illustrations, 220, 221, 222.
- EMERY WHEEL DRESSING TOOLS**, illustration, 266.  
Speeds, table, 321.  
Grade of, by numbers, 225.  
"Points" relating to, 226.
- EMERY WHEEL DRESSING TOOLS**, stress per square inch when running, 321.
- EMPLOYERS'** responsibility to workmen in case of accident, 314, 316.
- ENLARGING DRILL**, illustration, 208.
- "EQUIPMENT" IN SHOPS**, 279.
- EVOLUTION**, 50.
- EXPANSION OF A STEEL ROD**, 84.
- EXTRACTING BROKEN TOOLS**, recipe, 295.
- EYE**, treatment for removing foreign bodies, 308.

## F

- FACE OR STRADDLE MILL IN OPERATION**, 185.
- FACTORS**, definitions, 24, 30.
- FEED MECHANISM**, milling machine, 184.  
Illustration, 184.
- FELLOWS' GEAR SHAPER**, illustration, 165.
- FILES**, equivalent grades of emery, 225.
- FIVE REGULAR SOLIDS**, illustration, 80.
- FOREMAN**, who reformed shop, 284.  
Model, 284, 285, 286.
- FORMULA**, definition, 22.
- FRACTIONS**, 37.  
Addition of, 42.  
Division of, 43.  
Subtraction of, 42.
- FRENCH SYSTEM OF MEASURES AND WEIGHTS**, 56.
- FROST BITE**, treatment for, 308.
- FUSING POINTS OF TIN-LEAD ALLOYS**, 292.

## G

- GANG BOSSES**, 286.
- GAUGE**, U. S. standard, illustrations, 92, 136.
- GAUGE FOR MEASURING ANGLES**, illustration, 93.
- GAUGES**, adjustable parallel measuring, illustration, 91.
- Corrective standards, illustration, 87.
- English or Birmingham, illustration, 92.
- Inside micrometer, illustrations, 85, 86.
- Internal and external limit, illustrations, 89, 90.
- GAUGING ANGLE OF LATHE CENTRES**, 137.
- GEAR SHAPER**, Fellows', illustration, 165.
- Example of work, 160.
- GENERAL MANAGER**, 277.
- GLOSSARY**, definition, 20.
- GREEK LETTER  $\gamma$** , definition, 21.
- GRINDING**, a face or straddle mill, illustrations, 220, 221.
- A spiral tooth cutter, illustration, 221.
- Cutting tools, 224.
- GRINDING MACHINES**, definition, 215.
- Description of parts, 217.
- Self-acting, universal and surface, 217; illustrations, 218, 219.
- GRINDING OPERATIONS**, 214-226.
- Hardening, 226.
- Sharpening a circular saw, illustration, 215.
- Sharpening a twist drill, illustration, 214.
- Sharpening a tap, illustration, 222.
- GRINDSTONE TROUGH**, illustration, 271.
- Note relating to, 272.

## H

- HACK SAW BLADES**, flexible, illustration, 249.
- Magazine coil, description, 248.
- Power, illustration, 248.
- HEXAHEDRON**, the, definition, 81.
- HOG-NOSE ROUGHING TOOL**, description, 148.
- Illustration, 149.

## I

- ICOSAHEDRON**, the, definition, 81.
- INDEX - PLATE FOR CHANGE-GEAR SHAFT**, 133.
- INVOLUTION**, 53.
- IRON**, cast, recipe for brazing, 291.
- Cutting angle for cast and wrought, 157.
- IRON PIPE**, table of sizes, 323.

## J

- "**JACK-SCREW**," illustration, 269.
- "**JIG**," definition, 266.
- Note, 266.

## K

- KEYSEATING MACHINE**, illustration, 261.
- KEYWAY CUTTING MACHINE**, 172-174.
- Illustration of, 174.
- "**KINK**," shop, definition, 266.



L

- LATHE**, arrangement of, for cutting screws, 108.  
Centers, manner of gauging angle of, 137.  
Pan, illustration, 264.  
Screw cutting in the, 103-137.
- LAYING OUT WORK**, recipe for marking surface on steel or iron, 296.
- LEAD**, as an anti-friction metal, 292.
- LEFT-HAND "SIDE" PLANING TOOL**, 161.
- LIME**, use of, to keep shop floors clean, recipe, 292.
- LIMIT-GAUGES**, illustrations, 89, 90.
- LOGARITHM**, definition, 23.
- LUBRICANT**, recipe for milling and drilling, 292.  
For use in cutting bolts and tapping nuts, 296.

M

- MACHINE**, bolt cutting, 235-241.  
Cutting-off, description, 245.  
For buffing, illustration, 273.  
For shaft straightening, illustration, 254.  
Keyseating, illustration, 261.  
Screwing, illustration, 235.
- MACHINES**, auxiliary, 243-262.
- MANAGER**, works or general, 277.
- MANDREL**, how driven into work, 25.
- MARKING SOLUTION**, recipe, 293.  
Presses, illustration, 265.
- MATHEMATICAL STUDIES**, value of, 34.
- MEASURING-MACHINE**, standard form, illustration, 87.  
End rod, illustration, 85.
- MEASURING MACHINES, TOOLS AND DEVICES**, 84.
- MECHANICS' POCKET REFERENCE BOOKS**, note, 70.
- MENSURATION**, 58.
- METAL**, a, that will expand in cooling, recipe, 296.
- METER**, definition, 56.
- METRIC SYSTEM OF WEIGHTS AND MEASURES**, 56.
- MILLING MACHINES**, a cheap lubricant for, 292.  
Bevel or angle, in operation, illustration, 196.
- MILLING MACHINES**, cutters, illustrations, 185, 186, 188, 190, 192, 193.  
Cutter in operation, illustration, 185.  
Descriptions, 177-197.  
Illustrations, 176, 178, 180.
- MILLING CUTTERS**, dividing head and tail stock, description, 181; illustrations, 181, 182.  
Feed mechanism, description and illustration, 184.  
Horizontal, plain, illustration, 180.  
Horizontal with vertical head, illustration, 178.  
Operation of, 177-197.  
Rose cutter in operation, illustration, 195.  
Rule for finding the speed of cutters, 187.  
Side cutter in operation, illustration, 194.  
Traverse feed, 191.  
Used with keyseating machines, sizes of, 261.
- MILLING MACHINE**, "universal," 177; illustration, 176.  
Vise, description and illustration, 183.
- MONITOR LATHES**, why so named, 254.
- MULTIPLICATION**, 30.  
Of decimals, 46.  
Of fractions, 42.

- NEEDLE FOR "SCRIBER,"** 294.
- NICKEL-PLATING,** solution, recipe, 293.
- NOTATION,** 25.  
Arabic, method of, 25.  
Roman, 27.
- NUMBER,** a compound, 35.  
A simple, 35.
- OCTAHEDRON,** the, definition, 81.
- OIL-PUMPS,** described, 235, 237.
- PAN,** shop, illustration, 262.
- PARALLELOGRAM,** definition, 63.
- PARTS OF A CIRCLE,** 82.
- PATTERN SHOP,** a model, 283, 284.
- PENTAGON,** definition, 64.
- PERSON,** an injured, how to carry, 303, 304.
- "PICKLING" CASTINGS,** recipe, 294.
- "PIECE-WORK,"** definition, 280.
- PIPE,** rule for finding sectional area of a, 68.  
Wrought iron, table of sizes, 323.
- PLANER,** the open side, illustration and description, 159.
- PLANER CENTERS,** illustration, 160.
- PLANER OPERATION,** centers, 160.
- PLANER TOOLS,** device for setting, 168.
- PLANING,** tools used in, 157.
- PLANING MACHINE TOOLS,** description and illustration, 161.  
Illustrations, 152, 154, 159.
- PLANING OPERATIONS,** 153-174.  
Cutter or cross-bar head, illustration, 158.  
Cutting tool, illustration, 156.  
Cutting tool, speed of, 156.  
Device for setting tools, 167; illustration, 168.  
Tool post and clapper head, the, 157.
- PLANNING A SHOP,** 282.
- PLANS OF PAYMENT,** piece work, differential and premium, 280, 281.
- "PLANT,"** definition, 279.
- N**
- NUMBERS,** definition, 24.  
Denominate, 35.  
Powers of, 54.  
Roots of, 54.
- NUMERATION,** 25.  
Table, 26.
- O**
- "ORGANIZATION,"** in shop management, 279.
- P**
- PLATE STEEL AND IRON GAUGES,** illustration, 92.
- PLATEN,** definition, 157.
- "POINTS,"** relating to emery wheels, 226.  
Relating to grinding operations, 222.
- POLISH FOR WROUGHT STEEL,** 290.
- POLISHING MACHINE,** illustration, 273.
- POLYGON,** definition, 64.
- POWERS OF NUMBERS,** 55.
- PREMIUM PLAN OF PAYMENT,** 281.
- PRESS,** arbor, description and illustrations, 251-253.
- PRESSES,** properly punches, 229.
- PROPORTION,** or rule of three, 48.
- PROTRACTOR,** bevel, illustration, 94.
- PUMP,** for lubricating with oil, 235, 237.
- PUNCH END OF MACHINE,** illustration, 231.
- PUNCHING AND SHEARING,** similar operations, 230.
- PUNCHING AND SHEARING MACHINE,** eccentric driven, illustration, 231.  
Illustrations, 228, 231.  
Lever punching, description, 233; illustration, 231.  
Presses for stamping, 229.  
Why combined, 229.
- PUNCHING AND SHEARING OPERATIONS,** 229-234.  
Action of the punch, 230; illustrations, 231, 232.
- PUNCHING TOOLS,** set of, description, 232.

**Q**

**QUANTITY**, definition of, 24.

**QUOTATIONS**, 274, 276, 288.

**R**

**RADIAL DRILL**, description, 205; illustration, 200.

**RATIO**, definition, 22, 48.

**REAMER**. adjustable, description, 148; illustration, 150.

Adjustable shell, 209.

Finishing, illustration, 208.

Fluted shell, 209.

For milling machines, illustration, 194.

**RECIPES**, useful, 287-316.

**RECTANGLE**, definition, 63.

**REDUCTION**, 35.

Of decimals, 45.

Of fractions, 38.

**RESPONSIBILITY OF EMPLOYERS**, to workmen in case of accident, 314-316.

**RIGHT HAND SIDE PLANING TOOLS**, 161.

**ROMAN NOTATION**, 27.

**ROOT**, square, 50.

**ROOTS OF NUMBERS**, 54.

**ROPE SHEAVE BLOCKS**, illustrations, 270.

**ROSE CUTTER FOR MILLING MACHINE**, 192.

**ROUGHING DRILL**, illustration, 208.

Tools, description, 148; illustration, 149.

**ROUND-NOSE TOOL**, description, 148; illustration, 149.

**RULE**, addition, 29.

Addition of decimals, 41.

Addition of fractions, 42.

Adjusting change wheels, 122-130.

Cancellation, 41.

Division, 32, 33.

Division of decimals, 47.

Division of fractions, 43.

Extracting square root, 50, 51.

For notation, 26.

**RULE**, Multiplication, 30.

Multiplication of fractions, 42.

Reduction of fractions, 38.

Subtraction, 29.

Subtraction of decimals, 46.

Subtraction of fractions, 42.

**RULE FOR FINDING**, the diameter of a circle, 65, 66.

The length of a circle, 65, 66.

The solidity of a cone, 77.

The solidity of a cylindrical ring, 76.

The solidity of a pyramid, 78, 79.

The solidity of a segment of a sphere, 75.

The solidity of an irregular solid, 80.

The solidity or capacity of any figure in the cubical form, 71, 72.

The speed for milling cutters, 187.

The surface and contents of the five regular solids, 81.

The surface of a cylinder, 69.

The surface of a sphere, 70.

**RULE FOR FINDING THE AREA**, of a circle, 67.

Of an ellipse, 68.

Of a parallelogram, 63.

Of a pentagon, 64.

Of a polygon, 64.

Of a rectangle, 63.

Of a square, 62.

Of a trapezium, 61.

Of a triangle, 60.

**RULE FOR FINDING THE CONTENTS**,

Of a hemisphere, 74.

Of a rectangular solid, 72.

Of a frustrum of a cone (cubic), 78.

Of a solid cylinder (cubic), 76.

Of a sphere (cubic), 73.

**RULE FOR PROVING**, division, 34.

Multiplication, 30.

Multiplication of decimals, 46.

## R

- RULE FOR PROVING**, the correctness of addition, 28.
- RULE OF THREE**, 48.
- RULE FOR USING THE VERNIER**, B. & S., 97.
- RUST**, to protect bright work from, recipe, 294.
- Iron, recipe for removing, 291.
- On tools, to prevent, recipe, 296.
- RUST-JOINT COMPOSITION**, 295.

## S

- SADDLE**, illustration, 158.
- SAWS**, speed of, 319.
- SCALDS**, treatment of, 305, 306.
- Important note, 305.
- SCREW-CUTTING DIE-HEAD**, description and illustration, 259.
- Example showing use of index plate, 133.
- Machine, 235.
- Section of seven pitch V-thread, 129-134.
- SCREW-CUTTING IN THE LATHE**, 103-137.
- American standard thread, illustration, 120.
- Change wheels, 122-130.
- Cutting a double square thread, 118; illustration, 113.
- Cutting a single square thread, illustration, 113.
- Gauge for setting in tool, illustrations, 111, 112.
- Hand tools, illustrations, 104, 105, 106, 107.
- Head screw, the, 124.
- Illustrations, 104-138.
- Pitch of screw, 124.
- The cross-slide feed screw, illustration, 116.
- V-thread, illustration, 119.
- With automatic cutting tools, 108-137; illustrations, 109, 110, 111, 112.
- Without changing the wheels, 132-135.
- SCREW-JACK**, illustration, 269.
- SCREW THREADS**, U. S. Standard, table, 322.
- "**SCRIBER**," sewing needle for, 294.
- SELF**, care of, 314.
- SET OF PUNCHING TOOLS**, description, 232.
- SHAFT-STRAIGHTENING MACHINES**, illustration, 254.
- SHANK CUTTER FOR MILLING MACHINE**, 191.
- SHAPING MACHINE**, description, 163-168; illustrations, 162, 164.
- Fellow's gear, 164; illustrations, 165, 166, 167.
- Fellow's gear, operation of, 166.
- Setting tools in, device for, 167 illustration, 168.
- Speed of Tool for, 163.
- Travelling head, 163.
- SHEET METAL GAUGE**, U. S., illustration, 92.
- SHEARS**, definition, 229.
- SHOCK**, electric, how to resuscitate from, 309-312.
- SHOP**, planning a, 282; note, 282.
- SHOP FLOORS**, use of lime to keep clean, 292.
- "**SHOP-KINKS**," definition, 266.
- SHOP MANAGEMENT**, 275-286.
- SHOP-PANS**, illustrations, 262-264.
- SIDE PLANING TOOL**, 161.
- And other cutters in operation, illustrations, 194-197.
- SIGNS**, arithmetical, 20.
- SINE**, definition, 82.
- SKIVING TOOL**, description, 148; illustration, 149.
- SLOT**, provided for drill, 205.
- SLOTING MACHINE**, description, 169-174; illustration, 170.
- For cutting keyways, 172; illustration, 174.

## S

- SLOTING MACHINE**, Operation, 169; illustration, 173.  
Relief-tool block, 172; illustration, 172.
- SNATCH-BLOCK**, illustration, 270.
- SOCKET FOR DRILL**, description and illustration, 205.
- SOCKETS**, size of, 205.
- SODA WATER FOR DRILLING**, 292.
- SOLDERING FLUIDS**, recipe, 296.
- SOLDERING IRON**, how to tin, 291.
- SOLDERS**, recipes for, 290.
- SOLIDS**, definition, 71.  
Five regular illustration, 80.
- SPEED**, for bolt cutting, 241.  
Of emery saws, 319.  
Of emery wheels, table, 321; note, 224.
- SPHERE**, rule to find the surface of a, 70.
- SQUARE ROOT**, 50.
- STOCKING PLANING TOOL**, 161.
- STRIPPER, OR PULL-OFF, OF POWER PUNCH**, illustration, 232.
- SUBTRACTION**, 29.  
Of decimals, 46.  
Of fractions, 42.
- SUN OR HEAT STROKE**, treatment for, 307.
- SUPERINTENDENTS**, 277.
- SURFACE FOR LAYING OUT WORK**, recipe, 296.
- SURFACE SPEEDS OF IRON, STEEL AND BRASS**, table, 319.
- SURFACES**, definition, 60.
- SWING FRAME OR SWIVEL-HEAD**, illustration, 158.
- SWIVEL APRON**, illustration, 158.
- SYMBOLS, ABBREVIATIONS AND DEFINITIONS**, 20-24.
- "SYSTEM" IN SHOP MANAGEMENT**, quotation from Chordal's letters, 278.

## T

- TABLE**, of average cutting speeds for drills, 320.  
Of cutting angles, 157.  
Of cutting speeds for dies, 241.  
Of fusing points of tin-lead alloys, 292.  
Of the grades of emery, 225.  
Of Roman notation, 27.  
Of speeds for emery wheels, 321.  
Of speeds for milling cutters, 189.  
Of speeds for twist drills, 210, 211.  
Of standard sizes of wrought iron pipe, 323.  
Of surface speeds, 319.  
Showing the periphery speed of milling cutters, 191.
- TABLES USEFUL FOR MACHINISTS**, 319-323.  
U. S. Standard screw-thread, 322.
- TANGENT OF AN ANGLE**, definition and illustration, 82.
- TAP**, sharpening a, illustration, 222.
- TAPPING NUTS**, lubricant for, 296.  
Speed table for, 241.
- TAPS**, adjustable collapsing, description and illustration, 259.
- TETRAHEDRON**, the, definition, 81.
- TIN**, to, a soldering iron, 291.
- TIN-LEAD ALLOYS**, fusing points of, 292.
- TOOL**, angle for planer, table, 157.  
Broad finishing, description, 148; illustration, 149.  
Four-lipped roughing drill, 150.  
Hog-nose roughing, description, 148; illustration, 149.  
Round-nose, description, 148; illustration, 149.  
Side, description, 148; illustration, 149.  
Skiving, description, 148; illustration, 149.

- T**
- TOOL CHEST**, illustration, 273.
- TOOL-GRINDER**, wet, illustration, 212.
- TOOL-POST**, description, 157; illustration, 158.
- TOOL-POST APRON**, illustration, 158.
- TOOLS**, broken, how to extract, 295.  
Cutting off, illustration, 246.  
To prevent rust on, recipe, 296.
- TRAVELING-HEAD SHAPER**, 163; illustration, 162.
- TRAPEZIUM**, definition, 61.
- TRIANGLE**, definition, 60.
- TRIGONOMETRY**, definition, 83.
- TURNING AND BORING**, operation of, 103.
- TURRET**, fitted on the bed of a lathe, illustration, 255.
- TURRET-DRILL**, illustrations, 257, 258.
- TURRET LATHE**, advantages of, 256; illustration, 256.
- TURRET LATHES**, description in note, 254.
- TURRET MACHINES**, description, 254.
- TWIST DRILLS**, illustration, 208.  
Note, 210.  
Sharpening, illustration, 214.  
Table of speeds for, 210.
- U**
- UNIVERSAL MILLING MACHINE**, description, 177; illustration, 176.
- USEFUL RECIPES**, 287-316.
- UTILITIES AND ACCESSORIES**, 263, 274.
- UTILITY**, definition, 265.
- V**
- VARNISH FOR COPPER**, recipe, 294.
- VERNIER**, the, and its use, 95-99; illustrations, 95, 96, 98, 99.
- VERTICAL DRILLING MACHINE**, 203.
- VERSED SINE**, definition and illustration, 82.
- WISE FOR MILLING MACHINE**, description and illustration, 183.
- W**
- WALL CRANE**, illustration, 271.  
Drilling machine, description, 204; illustration, 198.
- WATER**, to keep from freezing, recipe, 297.
- WET TOOL GRINDER**, 217; illustration, 212.
- WHITWORTH THREAD**, illustration, 120.
- WORKS MANAGER**, 277.
- WOUNDS**, how to treat, 298, 299.  
Recipe for solution for washing, 301, 302.  
Two ways of healing, 302.
- "WRINKLE,"** definition, 266.
- WROUGHT STEEL**, polish for, 290.



MECHANICAL LIST

**EDUCATIONAL**  
**MANUALS . . .**

—ON—

ENGINEERING, ELECTRICITY,  
MECHANICAL DRAWING,  
MACHINE SHOP PRACTICE,  
MILLWRIGHTING, APPLIED  
MECHANICS, ETC. . .



**THEO. AUDEL & COMPANY**

— PUBLISHERS —

**63 FIFTH AVE., NEW YORK**

ERECTING AND OPERATING \$3  
JUST ISSUED



**A** PRACTICAL HANDBOOK on Excavations, Foundations, Structures, Millwrighting, Shafting, Belting, Piping, Boilers, Engines, Installing Machinery, etc.

In order to become an expert at the erection and operation of modern machinery and appliances, judgment must be added to execution; now as judgment cannot be taught in writing, further than in laying down certain principles of procedure, therefore the book is largely personal.

The method of instruction followed is to deal with the various subjects mentioned, each consisting of nearly the same number of pages and illustrations, indicating the course of study.

Working Drawings, Foundations, Excavating, Piling and Grillage, Brick Work, Concrete, Reinforced Concrete, Millwright's Tools, Steel Square and its uses, Bridge Work, Structures, Scaffolding and Staggering, Rigging Knots, Hitches and Splices, Chains and Tackle, Steel Structure Work, Roofing, Blacksmithing, Tool Dressing, Belting and Pulleys, Shafting Lining, Speeds, Piping and Joints, Plumbing, Steam Boilers and Accessories, Chimneys, Drafts, Steam Engine Operation, Engine Foundations, Valve Setting, Water Power Installations, Steam Turbines, Pumping Machinery, Electrical Installations, Motors, Wiring, etc., Refrigerating Systems, Rules, Receipts, Metallic Compositions, Useful Tables, Ready Reference Index.

By following this plan, and with the aid of the ready refer-

ence index to be found at the end of the volume, the work becomes a reference book, as well as a course of systematic study in Mill Engineering.

This volume is convenient in size, handsomely and durably bound in black cloth, having gold edges and titles; containing 600 pages, illustrated by over 500 drawings and illustrations of practical work. It is in every way a generously good book both in contents and manufacture.

**PRICE \$3** to any address.



# DRAWING AND DESIGN \$3

THIS volume is arranged for a comprehensive, self-instruction course for both shop and drawing room.

## PLAN OF INSTRUCTION

Useful Terms and Definitions; Drawing Board, T-Square and Triangles; Lettering; Shade Lines; Section Lining; Ge-

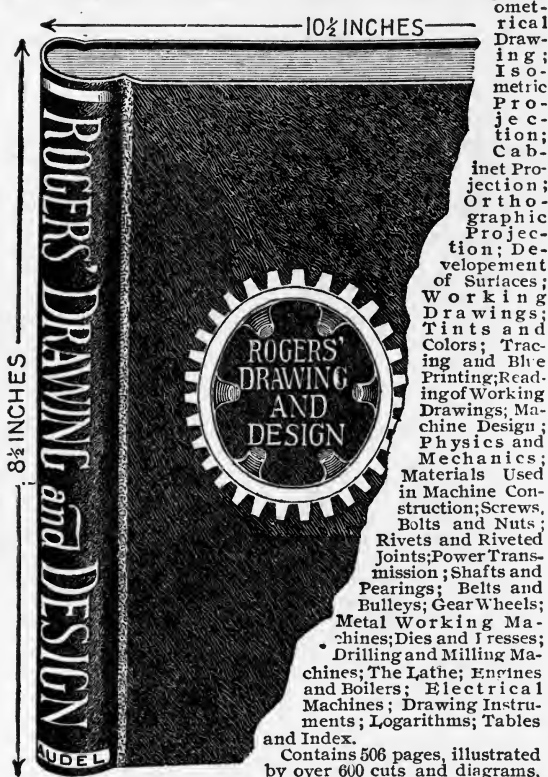

Contains 506 pages, illustrated by over 600 cuts and diagrams, very many of them full page drawings; the book is printed on a very fine grade of paper; it measures 8½ x 10½ inches and weighs over 3 pounds; the binding is in black cloth with gold edges and titles; the volume is made to open freely and is in every way a most complete up-to-date book.

**PRICE, \$3 to any address.**

## ADVANCED MACHINIST \$2

---



THE trade of the machinist is peculiar in that it is a preparation for so many positions outside of it.

It takes a man of good natural ability and of considerable education—not always from books—to make a first-class machinist; so that when one is well qualified he is also prepared for many other openings.

The aim of this work is to point the way of advancement to those who become fitted to assume these responsibilities and rewards.

The advanced machinist is a work of sterling merit, a few of the hundreds of subjects are here named, but they in no way show the scope of this work, which must be seen to be appreciated:

A Course in Machine Shop Mathematics; Various Measuring Instruments and Their Uses; Screw Cutting; Boring; Milling; Drilling; Grinding; Punching and Shearing; Bolt Cutting Machinery; Special and Auxiliary Machines; Shop Management; Work Shop Receipts and Devices, etc., etc.

The personal character of the book appeals to all in any way associated in the machinery and allied trades.

This book is a companion volume to Progressive Machinist and is uniform in binding and style, but more advanced in the subject of Machine Shop Practice, containing about the same number of pages, illustrations, etc.

---

PRICE, \$2, Postpaid

---

THEO. AUDEL & CO.,

63 FIFTH AVENUE, NEW YORK

## PROGRESSIVE MACHINIST \$2

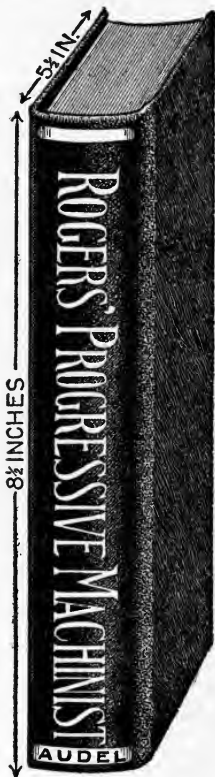

**T**HIS is a valuable volume for all Metal Workers;—the following are a few of the many subjects treated:

**Materials.**—Definitions; Qualities of Matter; Iron, Steel; Various Metals, Alloys, etc.; Gravity and Tables; Three Laws of Motion; Strength of Materials; Fatigue of Metals; Table of Melting Points of Solids; Useful Weights and Measures.

**Shop Drawing.**—Free-hand Drawing; Instruments; Pencil-ing; Inking; Lettering Drawings; Dimensioning; Shading; Section-Lining; Reading Working Drawings; Problems in Geometrical Drawing—Points Relating to Drawing.

**Gearing.**—Cog Wheels, Spur and Bevel Wheels; Mitre Wheel; Mortise Wheel; Worm Gearing; Helical Wheel; Designing Gears; Speed of Gear Wheels.

**Bench and Vice.**—Tempering and Hardening Metals; Grades of Steel; Cementation Process; Bessemer and Siemen-Martin Process; Case-Hardening; Annealing; Hand Tools; Machine Tools; Work Benches; Sledge and Anvil; Surfacing; Red Marking; Hand Drilling; Broaching; Screw Cutting by Hand; Pipe Cutting.

**Tools and Machines.**—Machine and Hand Tools; Portable Tools; Action of Machines; Classification of Machine Work; Turning and Boring; Planing; Milling; Drilling; Grinding; Punching and Shearing.

**Lathe Work.**—Forms and use of Foot Lathes; Hand Lathes; Chuck or Surfacing Lathe; Engine Lathe; Parts of the Lathe; Cutting Tools Used in the Lathe; Tempering of Lathe Tools Rule; Lathe Practice; Measuring Instruments; Mandrels; Lathe-Dogs; Driving Work Between Centers; Turning Work Between Centers; Lathe Speed; Chuck and Face-plate Work; Drilling and Boring in the Lathe; Proportion of Parts of a Lathe; Useful References; Tables and Index.

**Description of Binding.**—The book is handsomely bound in black cloth, with gold edges and titles, printed on fine paper, illustrated with 330 diagrams and drawings of practical work, containing over 360 pages of valuable information, and 1031 ready reference index for quick information. This volume will be mailed to any address postpaid upon receipt of 2 dollars.

## AUDELS GAS ENGINE MANUAL \$2

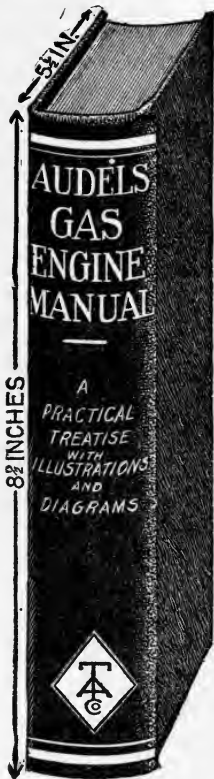

**T**HIS volume just published gives the latest and most helpful information respecting the construction, care and management of Gas, Gasoline and Oil Engines, Marine Motors and Automobile Engines, including chapters on Producer Gas Plants and the Alcohol Motor.

The work is divided into 27 Chapters as follows:— Historical Development — Laws of Permanent Gases — Theoretical Working Principles — Actual Working Cycles — Graphics of the Action of Gases — Indicator Diagrams of Engine Cycles — Indicator Diagrams of Gas Engines — Fuels and Explosive Mixtures — Gas Producer Systems — Compression, Ignition and Combustion — Design and Construction — Governing and Governors — Ignition and Igniters — Installation and Operation — Four-Cycle Horizontal Engines — Four-Cycle Vertical Engines — Four-Cycle Double-Acting Engines — Two-Cycle Engines — Foreign Engines — Oil Engines — Marine Engines — Testing — Instruments Used in Testing — Nature and Use of Lubricants — Hints on Management and Suggestions for Emergencies — The Automobile Motor — Useful Rules and Tables.

Each chapter is illustrated by diagrams which make it a thoroughly helpful volume, containing 512 pages, 156 drawings, printed in large clear type on fine paper, handsomely bound in rich red cloth, with gold top and title, measuring  $5\frac{1}{2} \times 8\frac{1}{2}$  inches and weighing over two pounds.

The book is a practical educator from cover to cover and is worth many times the price to any one using a gas engine of any type or size.

**PRICE \$2.00 POSTPAID.**

**THEO. AUDEL & CO.,**

**63 FIFTH AVENUE, NEW YORK, N. Y.**

## MOTOR CAR PRACTICE \$2

---

A Good Book for Owners, Operators, Repairmen and Intending Purchasers.

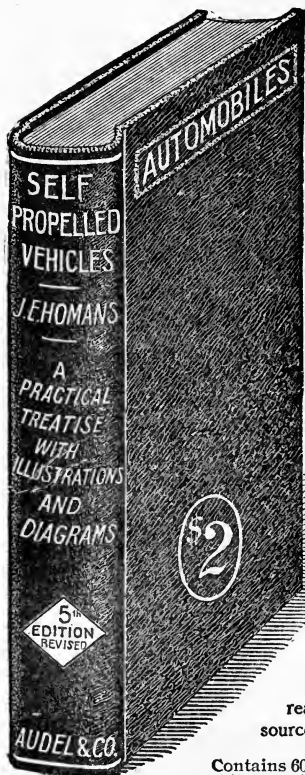

**T**HIS work is now the accepted standard on the practical care and management of motor cars—explaining the principles of construction and operation in a clear and helpful way, and fully illustrated with many diagrams and drawings, making it of value to the intending purchaser, driver and repair man.

The subjects treat of the needs of the man behind the wheel, and are presented clearly, concisely and in a manner easy to understand by the reader, be he a beginner or an expert.

The treatise on the gasoline engine cannot fail to prove valuable to anyone interested in explosive motors, which are daily coming to the front as the readiest and most convenient source of power.

Contains 608 pages, over 400 diagrams and illustrations, printed on fine paper, size  $5\frac{3}{4}$  by  $8\frac{1}{4}$  inches, with generously good binding. Highly endorsed. This book will be sent to any address in the world, postpaid, upon receipt of **\$2.**

---

THEO. AUDEL & CO.

63 FIFTH AVENUE, NEW YORK

# PUMPS AND HYDRAULICS \$4

---

## 2 PARTS

---

**I**T is with pleasure we call your attention to the recent publication on pumping machinery. This work, issued under the title of "ROGERS' PUMPS AND HYDRAULICS," is a complete and practical handbook, treating on the construction, operation, care and management of pumping machinery; the principles of hydraulics being also thoroughly explained. The work is illustrated with cuts, diagrams and drawings of work actually constructed and in operation; the rules and explanations of the examples shown are taken from everyday practice. No expense has been spared in the endeavor to make

this a most helpful instructor on the subject, useful to all pump attendants, engineers, machinists and superintendents.

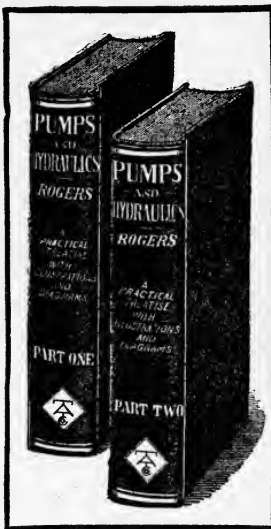

### Subjects Treated

The Air Pump; Air and Vacuum Pumps. Air Compressors; The Air Lift Pump; The Steam Fire Engine; Miscellaneous Pumps; Mining Pumps; Marine Pumps; "Sugar-house" Pumps; Circulating Pumps; Atmospheric Pumps; Ammonia or Acid Pumps; The Screw Pump; Aermotor Pumps; Rotary and Centrifugal Pumps; Turbine Pumps; Injectors and Ejectors; Pulsometer-Aqua-Thruster; Pump Speed Governors; Condensing Apparatus; Utilities and Attachments, Tools, Valves and Piping, Pipes, Joints and Fittings, Useful Notes; Tables and Data; Glossary of Pump and Hydraulic Terms; Elementary Hydraulics; Flow of water Under Pressure; Water Pressure Machines, Water Wheels; Turbine Water Wheels; Turbine Pumps; Water Pressure En-

gines; Hydraulic Motors; Hydraulic Apparatus; Hydraulic Jack; Hydraulic Press; Hydraulic Accumulator; Hydraulic Ram; Pumps as Hydraulic Apparatus; Classification of Pumps; Hand Pumps; Power Pumps; Belted Pumps; The Electric Pump; The Steam Pump; The Duplex Pump; Underwriter Fire Pump; Specifications of the National Board of Fire Underwriters Relating to Duplex Fire Pumps.

These two volumes of nearly nine hundred pages, illustrated with about seven hundred wood cuts, are admirable specimens of bookmaking; they are printed on fine white paper in large clear text, with ample margins, and bound in black vellum cloth with titles and tops in gold. In size they are six by nine inches.

---

**PRICE, \$4, DELIVERED**

---

## MARINE ENGINEERING \$2

---

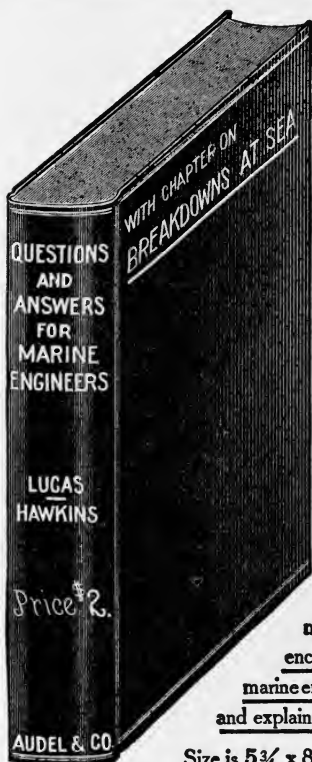

**T**HIS treatise is the most complete published for the practical engineer, covering as it does a course in mathematics, the management of marine engines, boilers, pumps, and all auxiliary apparatus, the accepted rules for figuring the safety-valve.

The book is divided into two parts: Part I, Construction; Part II, Operation; it contains 700 pages.

The volume is illustrated with plate drawings, diagrams and cuts, having an Index with more than 1,000 ready references, 807 Questions on practical marine engineering are fully answered and explained.

Size is  $5\frac{3}{4} \times 8\frac{1}{2}$  inches,  $1\frac{1}{2}$  inches thick, and weighs nearly three pounds, strongly and durably bound in rich green cloth, with full gilt edges, and is the accepted standard on Marine Engineering.

---

Price \$2, sent free to any address in the world. Money will be refunded if not entirely satisfactory.

---

THEO. AUDEL & CO.,

63 FIFTH AVENUE, NEW YORK

## MECHANICAL DRAWING \$2

**T**HE work has been carefully arranged according to the fundamental principles of the art of drawing, each theme being clearly illustrated. A list of the subjects are given below:

Chalk Work; Preliminary Terms and Definitions; Freehand Drawing; Geometrical Drawing; Drawing

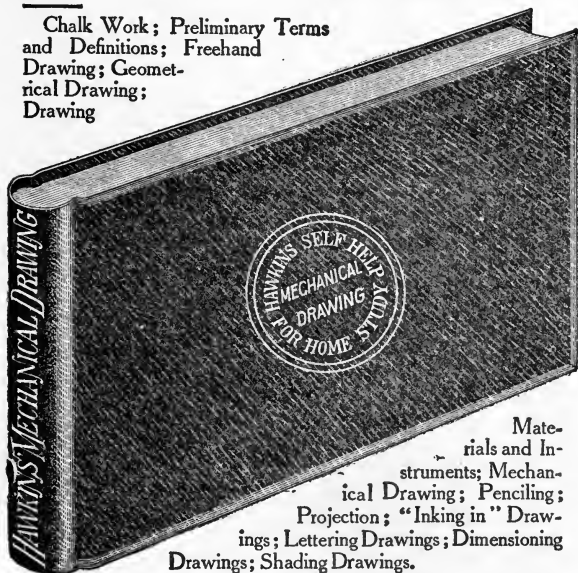

Materials and Instruments; Mechanical Drawing; Penciling; Projection; "Inking in" Drawings; Lettering Drawings; Dimensioning Drawings; Shading Drawings.

Section Lining and Colors; Reproducing Drawings; Drawing Office Rules; Gearing; Designing Gears; Working Drawings; Reading Working Drawings; Patent Office Rules for Drawings; Useful Hints and Points; Linear Perspective; Useful Tables; Personal, by the Editor.

The book contains 320 pages and 300 illustrations, consisting largely of diagrams and suggestive drawings for practice. It is bound in dark green cloth with full gold edges and titles; it is printed on fine paper, size 7x10 inches; it weighs 33 oz., and will fit into any engineer's or mechanic's library to good advantage.

**PRICE, \$2, Postpaid**

**THEO. AUDEL & CO.,**

**63 FIFTH AVENUE, NEW YORK**



## ELECTRICITY FOR ENGINEERS \$2

---

**T**HE introduction of electrical machinery in almost every power plant has created a great demand for competent engineers and others having a knowledge of electricity and capable of operating or supervising the running of electrical machinery. To such persons this pocket-book will be found a great benefactor, since it contains just the information that is required, *explained in a practical manner.*

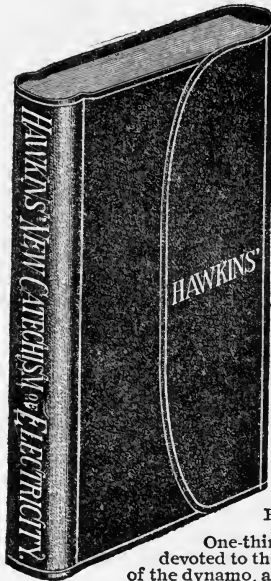

### Plan of Study

The following is a partial list of the topics discussed and illustrated:

Conductors and Non-Conductors; Symbols, abbreviations and definitions relating to electricity; The Motor; The Care and Management of the Dynamo and Motor.

Electric Lighting; Wiring; The rules and requirements of the National Board of Underwriters in full; Electrical Measurements.

The Electric Railway; Line Work: Instruction and Cautions for Linemen and the Dynamo Room; Storage Batteries; Care and Management of the Street-Car Motor; Electro Plating.

The Telephone and Telegraph; The Electric Elevator; Accidents and Emergencies, etc., etc.

One-third of the whole book has been devoted to the explanation and illustrations of the dynamo, and particular directions relating to its care and management;—all directions being given in the simplest and kindly way to assist rather than confuse the learner.

---

It contains 550 pages with 300 illustrations of electrical appliances; it is bound in heavy red leather, (size  $4\frac{1}{2} \times 6\frac{1}{4}$  for the pocket), with full gold edges and is a most attractive handbook for Electricians and Engineers.

**PRICE, \$2, Postpaid**

---

**THEO. AUDEL & CO.**

**63 FIFTH AVENUE, NEW YORK**

## ENGINEERS' EXAMINATIONS \$2

---

**T**HIS work is an important aid to engineers of all grades, and is undoubtedly the most helpful ever issued relating to a safe and sure preparation for examination. It presents in a condensed form the most approved practice in the care and management of Steam Boilers, Engines, Pumps, Electrical and Refrigerating Machines, also a few plain rules

of arithmetic with examples of how to work the problems relating to the safety valve, strength of boilers and horse power of the Steam Engine and Steam Boiler.

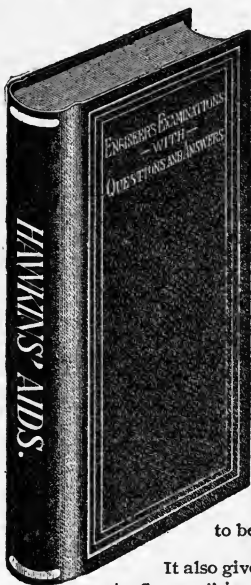

It contains various rules, regulations and laws of large cities for the examination of boilers and the licensing of engineers. It contains the laws and regulations of the United States for the examination and grading of all marine engineers.

The book gives the underlying principles of steam engineering in plain language, with very many sample questions and answers likely to be asked by the examiner.

It also gives a short chapter on the "Key to Success" in obtaining knowledge necessary for advancement in engineering.

---

This helpful volume contains 200 pages of valuable information not elsewhere obtainable; it is bound in rich red leather with full gold edges and titles; it measures  $5 \times 7\frac{1}{2}$  inches and weighs twenty-two ounces.

**PRICE, \$2, Postpaid**

---

**THEO. AUDEL & CO.,**

**63 FIFTH AVENUE, NEW YORK**

## STEAM BOILER PRACTICE \$2

---

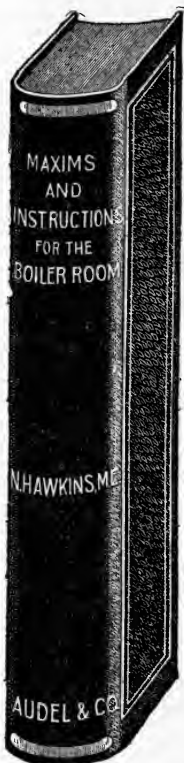

**T**HIS book of instruction on boiler-room practice will be of great help to firemen, engineers and all others who wish to learn about this important branch of Steam Engineering.

It treats on materials, coals, wood, coke, and oil and gas, fuels, etc., their composition, properties, combusive value, also on combustion and evaporation.

Giving the practical rules to be observed in firing with various fuels, management of steam boilers, prevention of foaming; tools and fire irons; covering stationary, marine and locomotive boilers.

It enumerates sixty important points of cautions to be observed in the proper management of boilers.

It contains a description of and full treatise on stationary, marine and locomotive boilers, and the historical development of boilers; specifications for boilers; riveting; bracing; rules for finding pressure or strain on bolts.

It gives inspectors rules relating to braces in steam boilers. Also rules and tables for calculating areas and steam and water space of boilers.

It treats on boiler tubes, construction and drawing of boiler sections; defects and necessary repairs; inspection of steam boilers; mechanical stokers' corrosion and scale, boiler compounds, feed water heaters, injectors, pumps, boiler settings; pipes and piping; steam heating, chemistry of the furnace; boiler making; plumbing, and hundreds of other useful subjects.

It states several plain rules for the calculation of safety valve problems and those sanctioned by the U. S. inspectors.

---

The volume has 330 pages and 185 illustrations and diagrams. It is 6 x 8½ in. in size and weighs 28 ounces. The binding is uniform with that of the "Calculations" and "Catechism of the Steam Engine," being bound in heavy green cloth, with ornamental titles and edges in gold.

**PRICE, \$2, Postpaid**

---

THEO. AUDEL & CO.,

63 FIFTH AVENUE, NEW YORK

## CALCULATIONS FOR ENGINEERS \$2

---

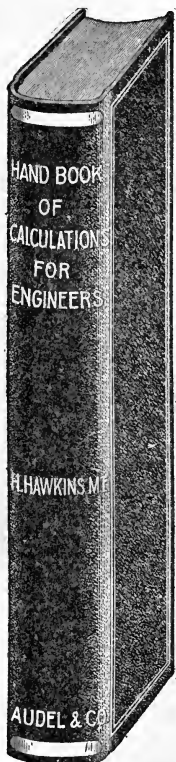

**T**HE Hand Book of Calculations is a work of instruction and reference relating to the steam engine, the steam boiler, etc., and has been said to contain every calculation, rule and table necessary to be known by the Engineer, Fireman and a steam user.

Giving a complete course in Mathematics for the Engineer and steam user; all calculations are in plain arithmetical figures, so that the average man need not be confused by the insertion of the terms, symbols and characters to be found in works of so-called "higher mathematics."

Mechanical Powers; Natural or Mechanical Philosophy; Strength of Materials; Mensuration; Arithmetic; Description of Algebra and Geometry.

Tables of Weights, Measures, Strength of Rope and Chains, Pressures of Water, Diameter of Pipes, etc.; The Indicator, How to Compute; The Safety Valve, How to Figure; The Steam Boiler; The Steam Pump; Horse Powers, How to Figure for Engines and Boilers; Steam, What It Is, etc.

Index and Useful Definitions.

---

This work contains 330 pages and 150 illustrations; it is durably and handsomely bound, uniform in style and size with the "Instructions for the Boiler Room" and the "Catechism of the Steam Engine;" it has gold edges and titles, and weighs over 28 ounces.

**PRICE, \$2, Postpaid**

---

THEO. AUDEL & CO.,

63 FIFTH AVENUE, NEW YORK

## STEAM ENGINE PRACTICE \$2

---



“It has been well said that engineers are born, not made; those in demand to fill the positions created by the great installations of power-producing machinery now so common, are men who are familiar with the contents of good books, and as well, are the product of a hard bought practical experience.”

**T**HIS work is gotten up to fill a long-felt need for a practical book. It gives directions for running the various types of steam engines that are to-day in the market.

A list of subjects, which are fully yet concisely discussed, are as follows:

Introduction; The Steam Engine; Historical Facts Relating to the Steam Engine; Engine Foundations; The Steam Piston; Connecting Rods; Eccentric; Governor; Materials; Workmanship; Care and Management; Lining up a Horizontal or Vertical Engine; Lining Shafting; Valve Setting; Condensers; Steam Separators; Air, Gas, and Compressing Engines; Compounding; Arithmetic of the Steam Engine; Theory of the Steam Engine; Construction.

There also is a description of numerous types of the engines now in operation, such as the Corliss, Westinghouse, and many others.

The book also treats generously upon the Marine, Locomotive and Gas Engines.

---

This is a rarely fine book, handsomely bound in green silk cloth, with full gold edges and titles; it contains 440 pages, 325 illustrations; in size it is 6x8 $\frac{1}{4}$  inches, and weighs 2 pounds.

**PRICE, \$2, Postpaid**

---

THEO. AUDEL & CO.,

63 FIFTH AVENUE, NEW YORK

## STEAM ENGINE INDICATOR \$1

---

**T**HE work is designed for the use of erecting and operating engineers, superintendents, and students of steam engineering, relating; as it does, to the economical use of steam.

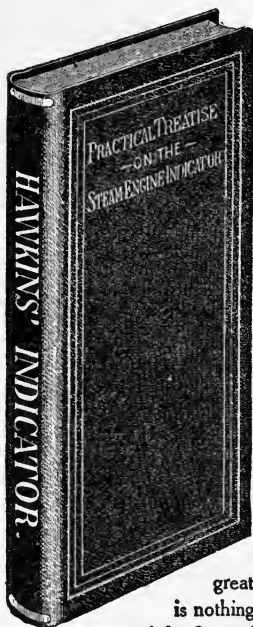

The following is a general outline of the subjects defined, illustrated and presented most helpfully in the book.

Preparing the Indicator for use; Reducing Motions; Piping up Indicator; Taking Indicator Cards; The Diagram; Figuring Steam consumption by the diagram; Revolution Counters; Examples of Diagrams; Description of Indicators; Measuring Diagram by Ordinates; Planimeters; Pantographs, Tables, etc.

He who studies this work thoughtfully will reap great benefit and will find that there is nothing difficult or mysterious about the use of the Steam Engine Indicator. This knowledge is necessary to every well-informed engineer and will undoubtedly be highly appreciated and a stepping-stone toward promotion and better things.

---

The work is fully illustrated, handsomely bound, and is in every way a high grade publication.

---

**PRICE, \$1.00**

---

THEO. AUDEL & CO.,

63 FIFTH AVENUE, NEW YORK

# TELEPHONE ENGINEERING \$1

THE "A B C of the Telephone" is a book valuable to all persons interested in this ever-increasing industry. No expense has been spared by the publishers, or pains by the author, in making this the most comprehensive handbook ever brought out relating to the telephone.

## TABLE OF CONTENTS

### 29 CHAPTERS

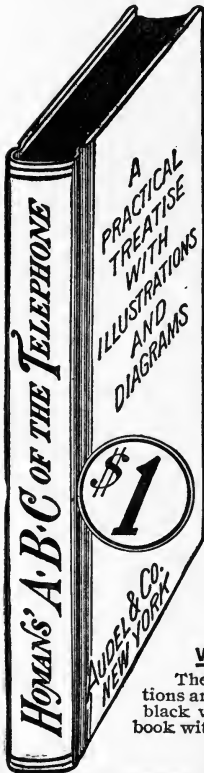

The Telephone Apparatus and its Operation; A Brief Survey of the Theory of Sound, Necessary to an Understanding of the Telephone; A Brief Survey of the Principles of Electricity; Electrical Quantities; History of the Speaking Telephone; Later Modifications of the Magnet Telephone; The Carbon Microphone Transmitter; The Circuits of a Telephone Apparatus; The Switch Hook and its Function in Telephone Apparatus; The Switchboard and the Appliances of the Central Station; The Operator's Switch Keys and Telephone Set; Improved Switchboard Attachments; Switchboard Lamp Signals and Circuits; The Multiple Switchboard; Locally Interconnected or Multiple Transfer Switchboard; Exchange Battery Systems; Party Lines and Selective Signals; Private Telephone Lines and Intercommunicating Systems; Common Return Circuits; Private Telephone Lines and Intercommunicating Systems; Full Metallic Circuits; Large Private Systems and Automatic Exchanges; Devices for Protecting Telephone Apparatus from Electrical Disturbances; The General Conditions of Telephone Line Construction; Telephone Pole Lines; Wire Transportations on a Pole Line. Telephone Cables and their Use in Underground and Pole Lines; Circuit Balancing Devices; The Microtelephone; Wireless Telephony; Useful Definitions and Hints on Telephone Management.

### WITH READY REFERENCE INDEX

The volume contains 375 pages, 268 illustrations and diagrams; it is handsomely bound in black vellum cloth, and is a generously good book without reference to cost.

**PRICE, \$1, Postpaid**

THEO. AUDEL & CO.

63 FIFTH AVENUE, NEW YORK

# Hawkins' Dictionary, \$3.50

---

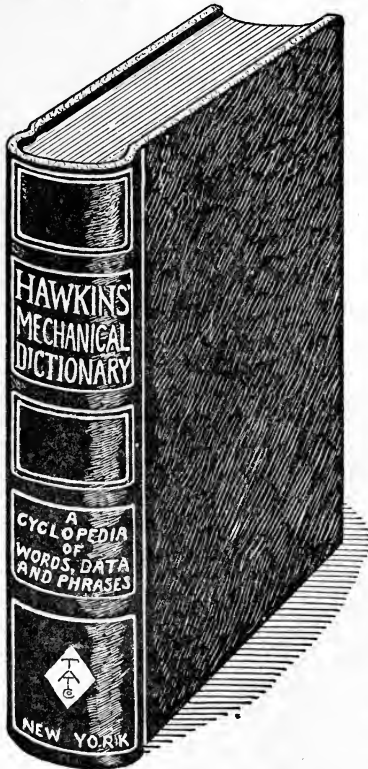

**T** THIS volume  
is the most  
useful book  
in Mechanical  
Literature.

If constantly referred to will enable the student to acquire a correct knowledge of the words, terms and phrases in use in Mechanical Engineering and its various branches  
Its greatest  
value lies in this:

that no man representing the mechanical profession can find excuse for not knowing the use and meaning of the terms used in his work.

## HAWKINS' MECHANICAL DICTIONARY

explains and defines in plain language the use of all words and terms now used or heretofore used in the Mechanic Arts, Trades and Sciences.

It is an unequalled reference work, and is the one book of permanent value no student or expert should dispense with. Complete from A to Z. Highly endorsed.

---

**Contains 704 pages, handsomely bound, price \$3.50 postpaid. Satisfaction guaranteed.**

---









RETURN TO the circulation desk of any  
University of California Library

or to the

NORTHERN REGIONAL LIBRARY FACILITY  
Bldg. 400, Richmond Field Station  
University of California  
Richmond, CA 94804-4698

ALL BOOKS MAY BE RECALLED AFTER 7 DAYS

- 2-month loans may be renewed by calling  
(510)642-6753
- 1-year loans may be recharged by bringing  
books to NRLF
- Renewals and recharges may be made  
4 days prior to due date

DUE AS STAMPED BELOW

**JUL 26 2003**

DD20 15M 4-02

UNIVERSITY OF CALIFORNIA, BERKELEY  
FORM NO. DD6, 40m, 3/78 BERKELEY, CA 94720

GENERAL LIBRARY - U.C. BERKELEY



8000986472

YC 67109

