

UC-NRLF

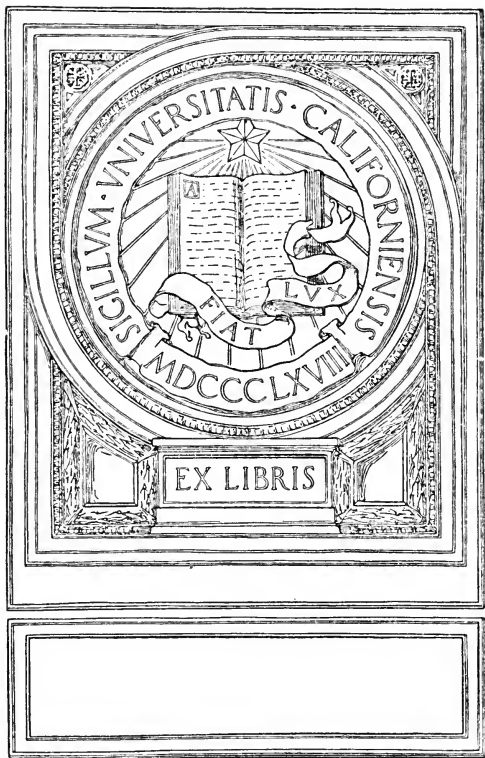

5B 33 046



EX LIBRIS







AEROPLANE PATENTS



green

AEROPLANE PATENTS

BY

ROBERT M. NEILSON

WHITWORTH EXHIBITIONER, MEMBER OF THE INSTITUTION OF MECHANICAL ENGINEERS

MEMBER OF THE INSTITUTION OF ENGINEERS AND SHIPBUILDERS IN SCOTLAND

CONSULTING ENGINEER
CHARTERED PATENT AGENT



NEW YORK

D. VAN NOSTRAND COMPANY

23 MURRAY AND 27 WARREN STREETS

1910

TL513
N4

LEAF 200 F100

act

PREFACE

THIS book is intended neither as a treatise on Patent Law nor as a rival to the volumes of Abridgments of Specifications of Patents published by the British Patent Office. Its purpose may be expressed briefly as being to give useful hints and data relating to patents, to inventors and manufacturers interested in heavier-than-air flying machines.

From eleven years experience of patent agency work the author believes that he is familiar with many of the questions which occur to inventors and manufacturers, and he attempts to deal with these questions in language as simple as possible.

The difficulty which manufacturers and users experience in connection with a rapidly developing industry in ascertaining what devices can be made or used without infringement of patents is sought to be met by the section in which many of the important flying machine patents are reviewed; and it is hoped that this section will also prove to be of considerable service to inventors.

R. M. N.

ATLANTIC CHAMBERS,
45, HOPE STREET,
GLASGOW.

September, 1910.

CONTENTS

SECTION.	PAGE
I. ADVICE TO INVENTORS	1
II. REVIEW OF BRITISH PATENTS	14
III. BRITISH PATENTS AND APPLICATIONS FOR PATENTS FROM 1860 TO 1910, ARRANGED IN ORDER OF APPLICATION	70
IV. BRITISH PATENTEES, ARRANGED ALPHABETICALLY	81
V. UNITED STATES PATENTS FROM 1896 TO 1909, ARRANGED IN ORDER OF ISSUE	87
VI. UNITED STATES PATENTEES, ARRANGED ALPHABETICALLY	89

LIST OF ILLUSTRATIONS

FIG.	PAGE
1 and 2. PHILLIPS' PLANES	16
3. MAXIM'S ALTITUDE CONTROL	17
4. MAXIM'S WING TIP	18
5. MAXIM'S PROPELLER	19
6 and 7. PENNINGTON'S AUTOMATIC RUDDER CONTROL	20
8 and 9. LANCHESTER'S FLYING MACHINE	21
10. LANCHESTER'S PROPELLER	22
11. LANCHESTER'S SECTION OF WING	22
12. CHANUTE'S GLIDER. SIDE ELEVATION	23
13. CHANUTE'S GLIDER. PLAN	24
14. CHANUTE AND HERRING'S FLYING MACHINE	25
15, 16 and 17. CHANUTE AND HERRING'S SECTIONS OF PLANES	26
18. CHANUTE AND HERRING'S SECTION OF STRUT	26
19, 20 and 21. WRIGHT FLYING MACHINE, WITH WING-WARPING AND RUDDER ACTION	28
22. HANSEN-ELLEHAMMER'S STABILISATION DEVICE	29
23. HARPER'S ENGINE, WITH ROTATING CYLINDERS	30
24. VALVE GEAR OF HARPER'S ENGINE	30
25. ROE'S STEERING DEVICE	31
26. ROE'S STEERING DEVICE	32
27. MURRAY'S PROPELLER DRIVE	33
28. DAVIDSON'S FISH-TAIL	34
29. DAVIDSON'S MECHANISM FOR ACTUATING TAIL	34
30. LANCHESTER'S FLYING MACHINE	35
31. LANCHESTER'S AEROPLANE GIRDER	35
32. LANCHESTER'S TANDEM PROPELLER DRIVE	36
33. HENNEBIQUE'S STABILISATION DEVICE	38
34. HENNEBIQUE'S PROPELLER DRIVE	38
35. STRAKA'S TANDEM PROPELLER DRIVE	38
36. ESNAULT-PELTERIE'S STEERING AND EQUILIBRIUM MECHANISM	39
37. ESNAULT-PELTERIE'S FLYING MACHINE	40
38 and 39. ESNAULT - PELTERIE'S STEERING AND EQUILIBRIUM MECHANISM	41
40, 41 and 42. ESNAULT-PELTERIE'S RUDDER	42
43. HEEREN'S STABILISATION DEVICE	43
44. BLÉRIOT'S RUDDER MECHANISM	43
45. ESNAULT-PELTERIE'S WING BEAM	44
46. ESNAULT-PELTERIE'S WING BEAM	45

FIG.	PAGE
47. SHADBOLT'S RUDDER	45
48. BLÉRIOT'S STEERING MECHANISM	46
49. ESNAULT-PELTERIE'S AUTOMATIC WING-WARPING ARRANGEMENT	47
50. Garsed's STABILISATION DEVICE	48
51. CLARKE'S FLYING MACHINE	49
52. HARE'S AEROPLANE	49
53 and 54. MAXIM'S FLYING MACHINE	50
55. TRIBELHORN'S BOX RUDDER	51
56. BLÉRIOT'S STEERING LEVERS	51
57. BLÉRIOT'S STEERING MECHANISM	52
58. J. M. WRIGHT'S PROPELLER DRIVE	53
59. WRIGHTS' FLYING MACHINE	55
60. WRIGHTS' VERTICAL RUDDERS	56
61. ESNAULT-PELTERIE'S SPRING BUFFER	57
62. BLÉRIOT'S WHEEL SUPPORT	58
63. ROE'S FLYING MACHINE	58
64. WRIGHTS' STABILISATION DEVICE	59
65, 66 and 67. ESNAULT-PELTERIE'S MOVABLE BLADE PROPELLER .	61
68. LANCHESTER'S STEERING DEVICE	62
69. LANCHESTER'S BOX RUDDER	62
70 and 71. GNOME MOTOR	63
72. HERRING'S GYROSCOPICALLY-CONTROLLED PROPELLERS . .	64
73. WRIGHTS' CAMBERED RUDDER	65
74. SHORT'S CAMBERED RUDDER	67
75. SHORT'S CAMBERED PLANE OR RUDDER	68
76 and 77. GRACE'S CLAMPING DEVICE	69



AEROPLANE PATENTS

SECTION I

ADVICE TO INVENTORS

What can be Patented.—A valid British patent can be obtained only for what is new, useful and constitutes invention. Novelty alone is not sufficient, nor yet novelty combined with usefulness. The discovery of a new physical law, say, for example, a new law relating to the deflection of stream lines in moving air, could not be patented even although the discovery might be, not only of academic interest, but also of practical value. The invention, however, of a new form of aerofoil adapted to take advantage of the new discovery might be good subject-matter for a patent. Moreover, novelty and invention are not sufficient without usefulness; and a patent may be upset for absence of utility. A patent for a useless invention may be a hindrance to industry, and can only be of profit to the patentee through intentional or unintentional deception.

Novelty according to British law means novelty within the United Kingdom. Prior knowledge of the invention abroad, even in a British Colony, is no bar to the obtaining of a valid British patent; so that a British aviator might invent and patent, say, a new form of attachment of propeller blades which had previously been invented by an American and employed on a flying machine publicly exhibited in America, but not described in any printed publication in circulation, or in a public library, in the United Kingdom prior to the Britisher's date of application for the patent.

Moreover, an inventor is not debarred from obtaining a valid patent for an invention by reason of the invention having previously been invented by another party and tried in secret within the United Kingdom. It frequently happens that two persons independently invent the same invention. Priority is then accorded to the first of the two who applies

for the patent, even although the other party was the first to invent.*

What constitutes "Invention."—It has been said that invention is essential in order to obtain a valid patent. Whether a certain change in design does or does not comprise invention has been the subject of many a lawsuit, and the subject cannot be treated exhaustively in the present volume. Only a single piece of advice will be given which will be illustrated by an example. Suppose that the improvement lies in a new construction of transverse rib for supporting the fabric of an aeroplane wing. The inventor or designer should put to himself the question: Is the improvement so natural and so obvious that an intelligent workman engaged in the manufacture of aeroplane wings and having a knowledge of all that has already been done of a relevant nature would in nine cases out of ten think of it? If the answer to the question is in the affirmative, there is probably no invention; if in the negative, there probably is. In many cases the inventor or improver will not be able to answer the question with confidence, and in such cases he should consult a patent agent who has sufficient knowledge of aeroplane construction to be able to give a reliable opinion.

Patents and Designs.—Certain novel and useful improvements can be protected by registering the design. It is cheaper to register a design than to obtain protection by means of a patent; and the question often arises as to which means should be chosen to obtain protection. In debating this question it is important to note that, in considering whether a new design is sufficiently novel and distinctive to be registrable, and also in considering whether a registered design is infringed by a somewhat similar design, the reason for adopting the design, and the utility of the design, must be put in the background. Designs should be compared by the eye alone. An engine builder might conceive, say, a new design of a crank-shaft bearing which possessed decided advantages but which might be of such a nature that it could be imitated, and the same effect obtained, by many other designs which, judged by the eye alone, were all considerably different from the original. Registration of design would in such a case afford little protection; but, if the purpose of the innovation were new, a patent could be obtained. It

* See, however, remarks on International Convention on p. 9.

sometimes happens on the other hand that, even as regards a part of a machine which is not exposed to public view and in which appearance is no consideration, the virtue of a particular configuration lies in the precise design adopted; and in such a case registration of design affords all the protection possible and is easier and cheaper to obtain, and more quickly obtained, than a patent.

The term of a patent is fourteen years. A design is registered in the first instance for five years: an extension of term for another five years can afterwards be obtained; and, with the Comptroller's consent, a second extension for five years more may be obtained. The full term of registration for a design may thus be fifteen years.

Who can apply for a Patent?—A single applicant for a British Patent must be the inventor. Where there are two or more applicants, these must include the inventor or inventors; but one or more non-inventors may also be included. What really amounts to an exception to this rule (although it may be argued in legal language not to constitute an exception) lies in the fact that, if an invention previously unknown in the United Kingdom is communicated to a party in the United Kingdom from a party abroad, the communicatee can apply for a patent. There is a further exception to the rule in certain cases in which an application for a British patent is made by a party or parties who have previously applied for a patent abroad. This exception is of little interest to the British inventor and need not be discussed.

Joint Patentees.—As it is common for two or more persons to combine to apply for a patent, the respective rights of the two parties are of interest. It should be noted in the first place that, if one of the applicants is the inventor and the other is not, the law makes no distinction between the two: each has the same rights as the other. Moreover, whether one or more of the patentees are inventors, any one of them has, in the absence of an agreement, the right to work the invention without the consent of his colleague or colleagues; but no one of them can grant a licence without the consent of the others. In the case of the death of one of the patentees, his interest in the patent devolves on his personal representatives. Joint applicants for a patent should, as a rule, have an agreement in writing, no matter how intimate or friendly be their relationship to each other.

Employees and Patents.—In the absence of an agreement to the contrary, it is quite in order for an employee to apply for a patent for his own invention, even if the subject-matter of the invention is relevant to the work on which he is employed and for which he is paid. It would be fraud, however, for an employee to apply for a patent for an invention which originated with his employer and which he had simply developed on his employer's instructions. An employer is quite entitled to use his employees to assist him in working out his ideas and in improving them, and he can then, quite rightly, apply for a patent in his own name alone. Moreover, an employer may ask his employees to sign an agreement to the effect that they will not apply for any patents without first obtaining his consent; and, without any specific statement on the subject, the terms on which an employee is engaged or employed may render a particular invention the property of his employer.

When an employee gives up his rights with regard to his own invention to his employer, it is not allowable for the latter to apply for a patent in his own name alone: the inventor must be the applicant or a joint applicant. In all cases where an employer wishes to have the patent rights of inventions of his employee, a written and stamped agreement is desirable.

Steps to take to apply for a Patent.—As soon as a would-be patentee has decided on a patent, or when he is in doubt as to whether or not to apply for a patent, he should consult a patent agent; and the writer would here put in a word of warning against certain individuals and firms who are not, and do not include among their principals, persons who are qualified to call themselves patent agents but who in advertisements or circulars term themselves "Patent Experts" or "Patent Bureau," or otherwise try to evade the law which forbids a man to represent that he is a patent agent unless he is on the official register prepared in accordance with Act of Parliament.*

The application for the patent should be made before the public is allowed to see the invention; but the invention may be worked in secret or shown or described in confidence to one or

* A copy of this register, containing the names and addresses of all patent agents, can be obtained, either directly or through any bookseller, from Messrs. Eyre and Spottiswoode, Limited, East Harding Street, London, E.C. Price, 1s. Postage, 1d.

more individuals or firms before the date of application. It is desirable to take all reasonable precautions to prevent the invention being known to the public before the date of application; but any disclosure through breach of faith will not be a bar to the grant of a valid patent if the applicant lodges his application without undue delay after hearing of the disclosure of the invention. The patent agent will give the applicant the necessary information about Patent Office requirements with regard to an application for patent.

Provisional Protection.—An application for patent can be lodged accompanied either by a provisional or by a complete specification of the invention. When the former alternative is chosen, a complete specification must be subsequently filed in order to obtain a patent. The invention does not require to be described in such detail in a provisional as in a complete specification, and, with the former, drawings are not as a rule required. Moreover, in a provisional specification the applicant's claims do not require to be particularly formulated.

In the majority of cases it is the better course to file a provisional specification in the first instance, because the trials of the invention under service conditions often suggest small (and occasionally large) improvements which can be incorporated in the complete specification; and it is usually not safe to put the invention into service until a patent has been applied for. Suppose for example, that the invention consists in a shock-absorbing or shock-reducing device for use on alighting. The invention may have been well thought out, and a model tried and found to work satisfactorily, and the device may even have been fitted to a flying machine and proved to act as intended during one or two descents; but it cannot be expected that the machine and aviator will be intentionally exposed to risk of severe injury in order to test the limit of its usefulness. If, however, provisional protection is obtained, it may happen that a prolonged experience or an accident may suggest valuable improvements.

Moreover, the filing of a provisional specification in the first instance puts the applicant to less initial expense; and, before it is necessary to file a complete specification, he may, if not a manufacturer himself, have come to an arrangement with a manufacturer. Moreover, he may, during the interval, acquire experience or knowledge which shows him that it will be

advisable to abandon the application, or to frame his claims in a way which he would not have done had he filed a complete specification in the first instance. Six months—or, on payment of a late fee, seven months—can elapse from the filing of a provisional, to the filing of a complete, specification.

One complete specification can embody the subject-matter of two or more provisional specifications which in the opinion of the examiner are sufficiently allied to each other. In this case one patent only is granted, a saving in fees thus being effected.

When a person files an application for a patent accompanied by a provisional specification, he is said to apply for “provisional protection”; and provisional protection dates from the date of application.

Complete Specification in first instance.—In many cases, however, it is desirable to file a complete specification in the first instance in order to get the full advantage of a patent at as early a date as possible. An action for infringement cannot be commenced until a patent has actually been granted, which is not until the complete specification has been received, examined, accepted and published by the Patent Office, and, although retrospective damages may be obtained, this applies only to the period subsequent to the publication of the complete specification.

Search as to Novelty.—The inventor is always more or less in doubt as to the novelty of his invention, and the question often arises as to whether he should have a search made through the patent records with the object of reducing the uncertainty to a minimum. An invention may, of course, be anticipated by some publication not to be found in the patent records; but a thorough search made by a competent person familiar with the official method of abridging the specifications and having the necessary technical knowledge will, as a rule, leave only a small chance that anything which would anticipate the invention exists and has not been found.

As the British Patent Office makes a search, it is often best for the inventor to save expense by applying for a patent without previously making any search, and this is the course which is usually adopted. When, however, it is proposed to spend much money on the invention before the result of the British Patent Office search is made known, it is generally to

be recommended that a patent agent be instructed to make a search. Of course a patent agent may, without making a search, be able to inform the inventor of some prior patent which will affect him, but he cannot be expected to be familiar with all that is contained in the patent records. A search, if decided on, should be done well.

What to Claim.—An inventor must be largely influenced by the advice of his patent agent on the matter of his patent claims; but a few words of advice may be useful. If too little is claimed, the patent does not give adequate protection; if too much is claimed, the patent is invalid. It may be thought at first that only reasonable care is required to avoid claiming too much or too little, but this is not the case. The inventor must remember that there are other persons who are as clever—or let us say almost as clever—as himself, and that it is usually easier to modify an invention than to originate it. A rival may, by a suitable modification, avoid a claim and effect as good, or nearly as good, a result; and if, to guard against such an event, the claim is made very wide, it may read so as to include some device other than the inventor's but already known, which would render the patent invalid.

The inventor, in consultation with his patent agent, must try to decide as to what really constitutes the invention—what, as the Germans express it, is the new technical effect. A knowledge by the patent agent of the principles of the subject to which the invention relates is of the utmost use in enabling him to distinguish between essential and non-essential differences in design.

The inventor should inform his patent agent of all that he knows has been previously done which will affect his patent. Some inventors are inclined to hold back information which might minimise their invention. Sometimes this is done intentionally, and at other times unconsciously. It is a practice to be avoided. In the belief that the applicant is entitled to broader claims than he really is, the patent agent may insert claims which may be objected to by the examiner and so cause unnecessary trouble, or the examiner may pass the claims and the patent may be invalid.

Moreover, the withholding of information may mislead the patent agent as to the real gist of the invention, and cause the whole specification to be drawn up according to a wrong scheme,

which cannot be satisfactorily put right by amendment after the specification has once reached the Patent Office.

It cannot be too much emphasised that, in order to obtain the utmost protection for an important invention, it is necessary that the patent agent should combine with a knowledge of patent law and procedure, not only a mind's-eye view of the physical aspect of the invention, but an appreciation of the characteristic idea which is its distinguishing feature.

Opposition to Patent.—After a complete specification has been accepted, *i.e.*, passed as in order by the Patent Office examiner, it is published, and any interested party can oppose the grant of a patent. Some firms directly, or through their patent agents, watch for applications for patents which, if granted, would adversely affect them. It involves much less expense to oppose the grant of a patent than to afterwards bring an action to have it revoked. The question of opposition cannot be discussed at length here, and it must suffice to say that two months are allowed from the advertisement of acceptance of a complete specification in the Official Journal in which to lodge opposition.

Duration of Patent.—The normal term of a British patent is fourteen years, but, in order to keep the patent in force for this period, it is necessary to pay renewal fees commencing at the end of the fourth year of the term. The applicant for a patent does not incur any liability to pay these fees, but, if they are not paid, the patent lapses. The term of the patent is reckoned from the date of application in Great Britain except that, when an earlier date is claimed in virtue of an earlier application in another convention country,* the term is reckoned from this earlier date. An extension of the term of a patent beyond fourteen years can sometimes be obtained, if it can be proved that the patentee has been inadequately remunerated, taking into account the nature and merits of the invention. It is not worth while incurring the expense of an application for extension of term unless a very good case can be put forward, and it may here be mentioned that the Court may be greatly concerned with the remuneration of the original patentee and show little or no concern with the remuneration of any individual or company who may have acquired or be working the patent.

* The term "convention country" is explained on p. 9.

Colonial and Foreign Patents: International Convention.—Patents for inventions can be obtained in most civilised countries; and in certain countries where patents are not granted protection can be obtained of a nature which is nearly equivalent to that given by a patent. It would be impossible in this volume to give even a summary of the laws in the various British possessions and foreign countries; but a few remarks may be made about applying for patents abroad. A large number of the more important foreign states, together with Great Britain and certain British Colonies, are signatories to an International Convention, and, by one of the clauses of the Convention, a British inventor can file applications for patents in the other convention countries any time within twelve months from the date of his application in Great Britain, and can secure for these applications the benefit of the British date. An inventor has, therefore, ten or eleven months from the date of filing his application in Great Britain in which to ascertain how his invention is likely to turn out in service, and in which to obtain if necessary financial assistance or to assign his rights, or grant, or arrange to grant, licences.

Moreover, a person who has filed an application for a patent for any invention in a convention country other than Great Britain, prior to his British application, can obtain for his British patent the date of his application in this other country. Speaking generally, the date of the first application in any convention country can be obtained for all subsequent applications for the same invention in other convention countries up to the twelve-month limit.

It is not of course every invention which it is worth while to patent abroad, even if the inventor has money to devote to this purpose; but in many cases it is advisable to apply for patents in a greater or less number of colonial or foreign countries; and it is not always wise to delay till near the end of the twelve months allowed by the International Convention. In Germany especially it is advisable to file an application as soon as it is decided to apply for a patent in that country; and in the case of the United States of America the *pros* and *cons* of early and late application should be discussed for every invention.

German Gebrauchsmuster.—In a case where a patent cannot be obtained in Germany for a modification in design which, although important and useful, would not be considered by the

German Patent Office as suitable subject-matter for a patent, protection can be obtained by means of a "Gebrauchsmuster." A Gebrauchsmuster, moreover, costs less than a patent. A new section of frame member, or a new design for connecting longitudinal with cross members, might be covered by a Gebrauchsmuster, where a patent would almost certainly be refused. In some cases it is advisable to lodge applications at the same time both for a patent and a Gebrauchsmuster and only rely on the latter if the former is refused.

Delaying Acceptance or Sealing of British Patent.—

In the case of certain British possessions and certain foreign countries the period during which an application for a patent can be filed terminates a certain time after the date of sealing of the British patent for the same invention; and in the case of other countries the publication of the British specification prior to the application for a patent in these countries is a bar to the grant of a patent. It is, therefore, in many cases advisable to delay the publication of the British specification or the sealing of the British patent. Publication, in the normal course of events, follows immediately after the complete specification is passed by the examiner as satisfactory; and the patent is sealed, if unopposed, after the opposition period has elapsed and the sealing fee has been paid. Publication and sealing may, however, be delayed if desired by the applicant; and it is frequently expedient to effect delay. Each case must be considered independently.

Patents for Supplementary Inventions.—When an invention is supplementary to that for which a previous patent has been applied for or granted—if it is, for example, an improvement in, or modification of, the device or apparatus forming the subject-matter of the prior patent—the applicant may apply for a "patent of addition" instead of for an ordinary patent. The advantage of a patent of addition lies in the fact that no renewal fees have to be paid to keep it in force except those that are required to keep the primary patent in force. That is, the one set of renewal fees serves both for the primary patent and the patent of addition. The disadvantage of a patent of addition is that it terminates with the primary patent instead of running fourteen years. It rests with the Patent Office examiner to decide what constitutes good subject-matter for a patent of addition;

and the examiner's views in this respect may differ from the applicant's.

If the examiner decides that the invention is not what he considers good subject-matter for a patent of addition, and if this constitutes his only objection, he will allow the application to be amended, and an ordinary patent to be applied for, without loss of date or of stamp fees.

There is no limit to the number of patents of addition which can be dependent on the one primary or principal patent; but a patent of addition cannot be dependent on another patent of addition.

Exploiting an Invention.—When an inventor is not in a position to directly make money from his invention by putting it into practice himself, it is of course necessary to come to an arrangement with a manufacturer. It is usually of advantage for the inventor to approach the manufacturer directly if this is possible; but sometimes another party can better secure an interview with the manufacturer or is in a position to negotiate better terms. In this connection it may be well to advise the inventor not to pay fees, except on the basis of commission, to any individual or firm who offers to arrange terms with manufacturers but whom he knows only through advertisement or circular. In that case, if no real service is rendered, no expense is incurred.

In putting an invention before a party whom it is hoped will take it up, it is desirable to have an example or model, if this will help the explanation; and the article exhibited should be as nearly as possible the exact likeness of what will be adopted in practice. A bad model lowers the apparent value of the invention in spite of explanation as to how it can be improved.

It is important to show the manufacturer what he will gain by taking up the invention. It is not sufficient for the inventor to show that his invention is on more scientific lines than what it is intended to replace, or even to show that it will be better for the user. The manufacturer naturally does not want to go to expense unless he can recover his outlay and, moreover, he wants some substantial gain to compensate him for the risk and trouble which he subjects himself to.

Assignment of Patents.—A patentee's rights can be assigned or transferred to any party, who then in reality becomes the patentee, except that the assignee's rights may be limited to

a portion or district of the United Kingdom. A patentee may assign his patent to several independent parties, in each case the assignment being applicable to a different portion of the kingdom. Assignment is performed by deed which is usually drawn up by a solicitor. There are many points to be watched in drawing up the deed of assignment which, however, cannot be discussed in this volume; the patent agent should as a rule be consulted.

Licences.—A patentee may grant a licence to use, vend or manufacture his invention; and the said licence may be unlimited geographically, or may be limited to a particular portion of the United Kingdom. Moreover, it may give the licensee the exclusive right to manufacture, use or sell the invention in the United Kingdom or in a district; or other manufacturers may also be licensed for the same territory. A licence is usually granted in consideration of a royalty, and other conditions are attached; an agreement is therefore involved, and this agreement conferring the licence should be in writing and be stamped. A licence, or more properly an agreement for a licence, may be made for a prospective patent for an invention for which only provisional protection has as yet been obtained.

Royalties.—It is common practice for a manufacturer, who holds a licence, to pay the patentee a certain sum of money for each article made according to the invention, or to pay a certain percentage of the list price of each article sold, or a certain percentage of the actual receipts obtained from the sale of the articles. Sometimes a clause in the licence agreement provides that the annual total of royalties shall not be less than a certain amount. Such a clause is necessary in the interests of the licensor if the licence is exclusive and if it cannot be determined at will by the licensor, as otherwise the licensee might pursue a dog-in-the-manger policy which in many cases it would be in his interest to pursue.

Working of Patented Inventions.—It is not intended by the Patent Law that a person shall take advantage of his patent to prevent the public from benefiting by his invention. He is expected to work his invention, or allow it to be worked by others, if the public will benefit thereby; and moreover it is expected that the invention be worked in the United Kingdom. The subject will be explained by examples.

Suppose that a manufacturer has a slow-rotation (relatively speaking) engine which is very suitable for the direct drive of aerial propellers, and is in fact so advantageous for this purpose that the manufacturer has practically a monopoly of the supply of engines for direct driving, but that he has to compete with high speed engines and geared propellers supplied by other makers which obtain a considerable sale. This manufacturer invents, let us suppose, an improved system of gearing which is of no use with his engine but would be of great use to his opponents; and he applies for and obtains a patent for this gearing. He would like, no doubt, to prevent this invention being employed, but he has not a right to refuse to work it and also refuse to grant licences to others to work it. If he does so refuse, one of his opponents may apply for, and obtain, a compulsory licence on terms fixed by the Court, or the patent may even be revoked by order of the Court.

Suppose now that the same manufacturer invents some improved detail in connection with his own engine, and that this detail requires special and expensive plant for its economical manufacture. The manufacturer may wish to make this detail in one factory only, and it may be preferable for him to have this factory in, say, France, and supply the British market by importation. Unless, however, he manufactures in Great Britain within four years from the date of his patent he is liable, if he is manufacturing abroad, to have his British patent revoked. It does not follow that revocation will in every case follow working abroad with non-working in Great Britain; but the question cannot be discussed at length in this volume, and the warning given above must suffice.

SECTION II

REVIEW OF BRITISH PATENTS

EVERY British patent relating to heavier-than-air flying machines is not reviewed in this section. In the official abridgments prepared at and published by the Patent Office an abridgment is given of the specification of every British Patent granted at least since 1855. Ten volumes of these abridgments are devoted to aeronautics. To read through these volumes is, however, tedious; and, unless each abridgment is carefully read, something of interest may be missed.

The official abridgments are, in general, very carefully prepared and, as regards recently published volumes, fulfil their purpose very well; but the official abridger is always handicapped in so far that he must be absolutely impartial; and therefore the space which he devotes to a particular specification may be out of all relationship to its interest or value. Moreover, he must not express his opinion as to the bearing of one patent on another.

The author's object has been to pick out only those patents which are of outstanding interest or which disclose some construction which, from its nature or its date of disclosure, is of particular interest. Probably there have been errors of omission. Moreover, the author's object has been to pick out the important point or points in every specification reviewed, and to make these as clear as possible without regard to the language of the specification which is often laborious.

In cases where much the same device has been described in several successive specifications of different inventors, the first, or one prior to 1896, has been selected, with the idea of giving light to the manufacturer on the question of infringement of a later patent now in force.

Patents for flying machines which do not appear to be of a practical design, or of a design which is at present in use or is likely to be adopted in the future, but which contain some proposal of interest, have, as a rule, been reviewed without an

illustration; but it does not follow that the absence of an illustration necessarily puts the patent into this category.

In many cases the mechanism described and illustrated is not of a nature which could be recommended for adoption in actual service; but the idea is suggestive, or the disclosure of a nature to affect the obtaining of patents for contrivances having similar objects in view.

The patentee's claims are usually not given. The claims in a modern aeroplane patent should be studied with the assistance of a patent agent. The claims in many cases appear to give the patentee much broader protection than he is entitled to.

The date in the reviews given below which immediately follows the number of each patent is the date of application. When, previous to this date, a patent for the same invention has been applied for by the same inventor or with his consent in one or more other countries signatory to the International Convention, the date of the first application in a convention country is given in parenthesis. The term of the British patent counts from this date. See Section I., p. 8.

5251 of Nov. 3, 1882.—P. Jensen (G. Koch).

This patent relates to a dirigible balloon, and in the specification it is stated that air, instead of water, may be employed as the cooling agent for a gas engine employed to propel the vessel, and that a pipe may be provided to convey the air from the front of the machine to the cylinders and thence to the rear of the machine. The pipe may be in the shape of an Archimedean screw worked by the engine in order to assist the cooling effect.

4245 of Sept. 3, 1883.—J. H. Johnson (E. J. Delaurier).

It is proposed by the inventor to employ the reaction of a steam jet to propel an aerial machine, and he suggests pivoting the discharge nozzle so as to allow for altering the angle of the jet.

13768 of Oct. 17, 1884, and 13311 of Aug. 6, 1891.—

H. F. Phillips.

In the specifications of these two patents the idea of employing multi-planes with camber is set forth. The inventor had apparently some idea of the best form and arrangement of planes to give maximum supporting effort. He advocates a series of planes arranged at a suitable distance apart so that the air may act independently on each without disturbance by the others.

The planes are to be long relatively to their width and are to be moved through the air in the direction of their width or shorter dimension. The upper surface of each plane is to be convex. The general design and arrangement of the planes is, therefore, that adopted in present-day multi-plane flying machines. Figs. 1 and 2 are fore-and-aft vertical sections of two of the designs of plane proposed. Phillips' ideas as to the advantage of camber were either not quite correct or else not

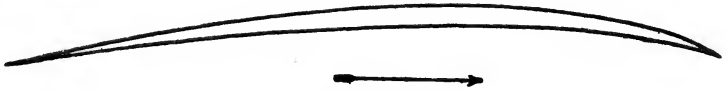

Fig. 1.—Phillips' Planes.

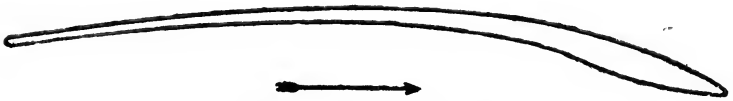

Fig. 2.—Phillips' Planes.

correctly expressed, but a careful perusal of the specifications tends to bring one to the conclusion that his ideas were in the main sound.

10068 of Aug. 25, 1885.—T. Griffiths.

It is proposed to propel a balloon by the reaction of steam and furnace gases ejected together through nozzles.

10359 of June 25, 1889.—Hiram S. Maxim.

This patent covers the construction of a steam generator and steam engine intended for use on flying machines. Both engine and generator are very skilfully and ingeniously designed in order to secure extreme lightness. As it appears unlikely that steam engines will again be employed for aerial propulsion, and as a short abridgment of the specification would not do justice to the invention with its many important details, no description will be here given. Those interested had better obtain the complete specification.

16883 of Oct. 25, 1889.—Hiram S. Maxim.

When application was made for this patent Sir Hiram Maxim was working hard with the object of evolving, what had not up to that date been obtained, a practical heavier-than-air flying machine. The specification includes a description of a

device intended for keeping constant the altitude at which the flying machine travels.

In Fig. 3, A is a hollow lever which is oscillated in order to drive, for example, the fuel pump of the motor. B is a ratchet wheel which is fixed on a spindle C, and which is engaged by one or other of the pawls D, E, carried by the lever F, which is fulcrumed at G. The continuous oscillation of the lever A, which occurs when the motor is running, causes the ratchet wheel B to be intermittently rotated in one or the other direction, according as the pawl D or the pawl E engages with the teeth of

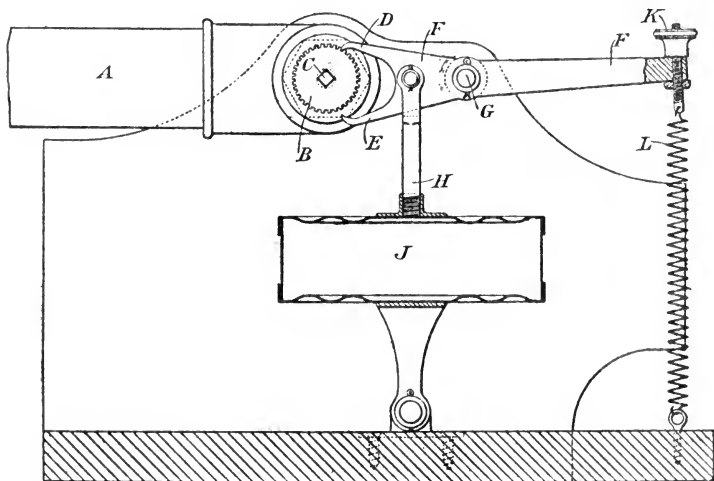

Fig. 3.—Maxim's Altitude Control.

the wheel; and mechanism is provided whereby the length of stroke of the fuel pump is lengthened or shortened by the rotation of the wheel B in one or the other direction respectively. The lever F is connected by means of the link H with the centre of the circular corrugated top of the closed box J, of which the centre of the opposite and similar end is anchored to a fixed part of the machine. As the flying machine rises or falls in the air, the change in the atmospheric pressure on the outside of the box will produce a movement in the link H, and by this means one or other or neither of the pawls D, E is put into engagement with the teeth of the wheel B, so regulating the stroke of the fuel pump. The speed of the machine is thus affected and, as the rising effort is proportional to the speed, the altitude of the

machine is thus kept constant. Positive regulation can be effected by means of the thumb nut K which controls the tension of the spring L. Although this device has probably never been employed, it may be of interest as affecting Letters Patents of later date relating to automatic means for controlling the altitude of aeroplanes.

Another device described in the same specification has reference to the auxiliary planes N, N, Fig. 4, which are attached to the sides (that is, the tips) of the main plane and which can be adjusted by hand. Moreover, by means of the cords O, O, these planes are rapidly and automatically pulled down whenever the

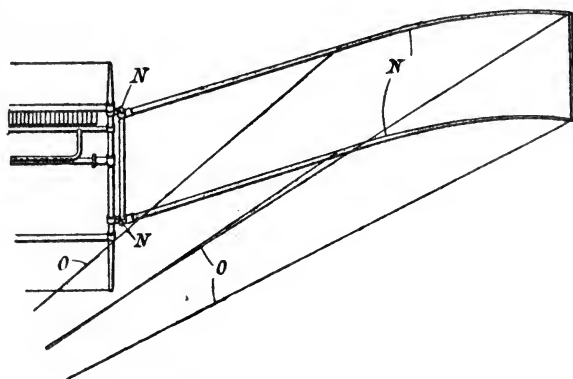

Fig. 4.—Maxim's Wing Tip.

wheels of the machine touch the ground on alighting, thereby diminishing the shock of landing.

Fig. 5 shows the construction of the blades of the propeller. Each blade consists of spokes S, S, covered with suitable fabric F—which does not extend to the propeller boss—and inserted in sockets T which are passed through a tubular boss R provided with flange P. It is proposed to stiffen the blades by means of stay ropes or the like.

**12349 of Aug. 7, 1890.—T. Griffiths and
H. W. Beddoes.**

The inventors propose to propel an aerial machine by the reaction produced by the discharge of the products of combustion of an explosive mixture (*e.g.*, a combustible gas and air) compressed by a pump before ignition.

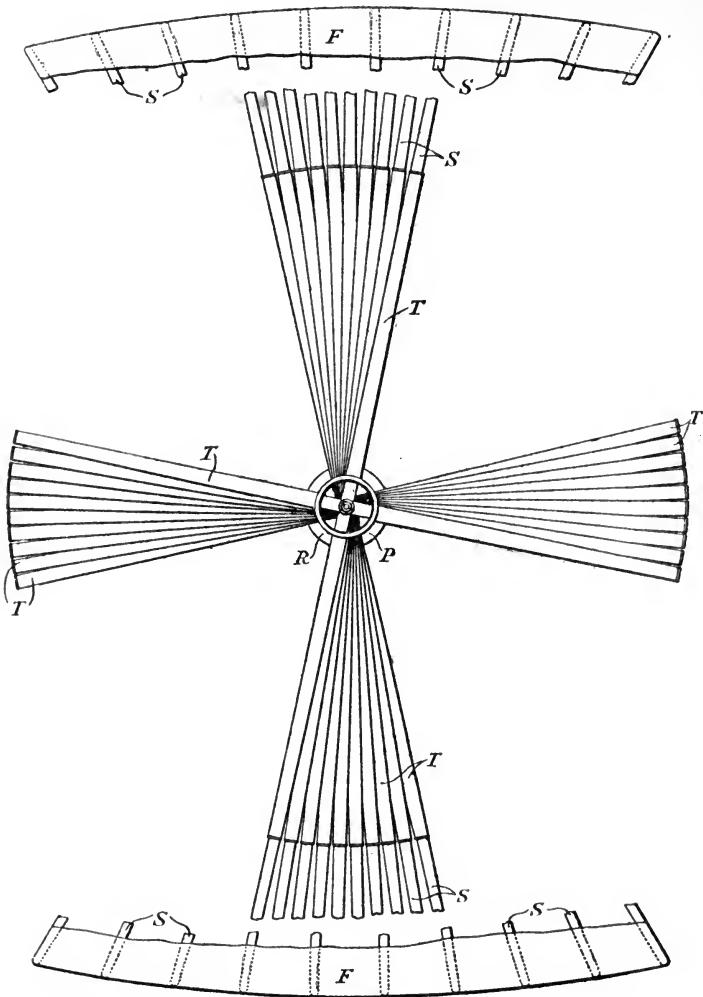

Fig. 5.—Maxim's Propeller.

**2557 of Feb. 6, 1893.—H. T. Barnett and
30932 of Dec. 31, 1897.—W. T. Carter.**

Both inventors propose to arrange two propellers co-axially and adjacent to each other, one behind the other, the forward propeller being mounted on a hollow shaft through the interior of which passes the shaft of the aft propeller. The two shafts are rotated in opposite directions by direct connection to the two elements of a rotary motor of which both parts rotate.

25050 of Dec. 31, 1895.—E. J. Pennington.

Figs. 6 and 7 show the means proposed for actuating the vertical and horizontal rudders employed to steer an aerial vessel. A, Fig. 6, is the shaft of the vertical rudder, and B, Fig. 7, is the beaded end of the horizontal rudder. Each rudder is deflected by means of a toothed segment and worm, the latter being actuated by an electromotor C energised by current from storage batteries.

The motor for the vertical rudder is controlled by a compass needle which, by means of electric contacts, causes the motor to rotate in one or other direction so as to keep the vessel on a steady course. The motor of the vertical rudder is similarly controlled by means of the index finger of a barometer so as to maintain the vessel at a pre-determined altitude.

Fig. 6.

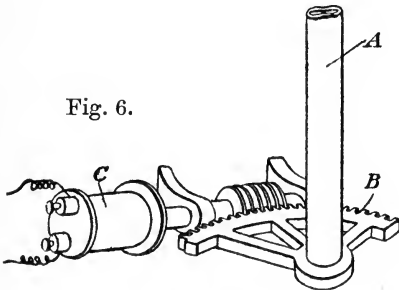
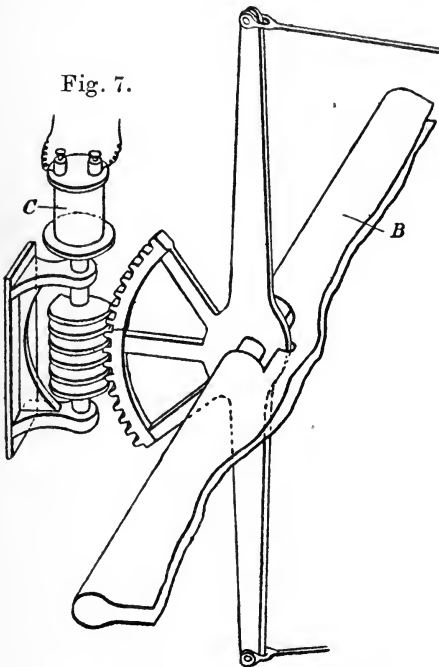

Fig. 7.



Figs. 6 and 7.—Pennington's Automatic Rudder Control.

3608 of Feb. 10, 1897.— F. W. Lanchester.

Figs. 8 and 9 show in elevation and plan respectively a flying machine described in the specification of this patent. A is the main supporting surface which may either be shaped at the tips as shown at B, or may have a "capping plane" C. Vertical fins D, D, E, E, are provided for stabilisation purposes; and the fins E, E may be used as rudders for steering the machine in a

horizontal plane. F, F are the screw propellers which act also as flywheels, and are formed, each as shown in Fig. 10, with a rim

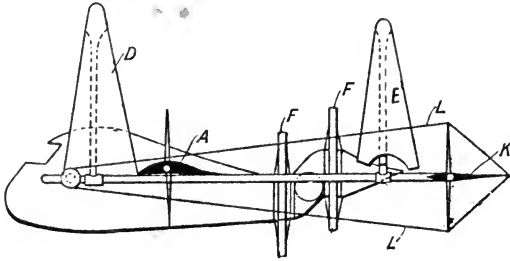

Fig. 8.

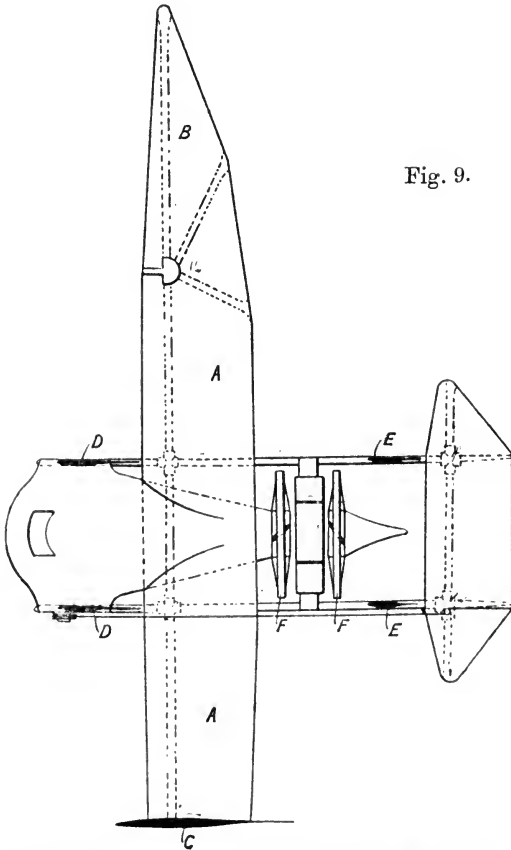

Fig. 9.

Figs. 8 and 9.—Lanchester's Flying Machine.

G stayed to a boss H, and with the blades J, J formed of fabric or wood. In Fig. 11 are given sections of the main supporting surface by planes at varying distances from the centre line of the machine; and it will be seen that the camber decreases towards

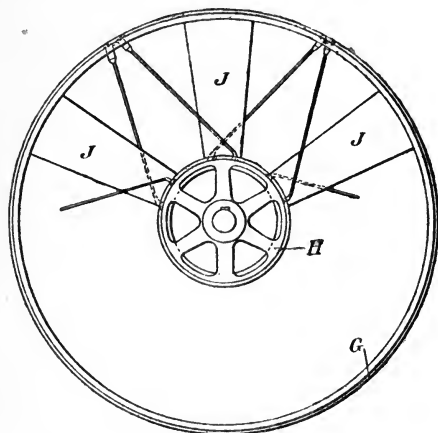

Fig. 10.—Lanchester's Propeller.

the wing tips. The tail plane K, Fig. 8, may be swivelled by the cords L L for vertical steering.

The inventor further states (and this is important as bearing on the Wright wing-warping patent, see p. 27) that "an alteration in the angle of the two wings relatively to one another or parts of them will by giving a list sideways to the machine affect an alteration in its course."

No means are, however, described for performing this action.

10620 of April 28, 1897.—H. S. Maxim.

The machine described in the specification of this patent is of a type which has not come into use, and therefore need not be illustrated. No patent of Sir Hiram Maxim's is, however, without interest.

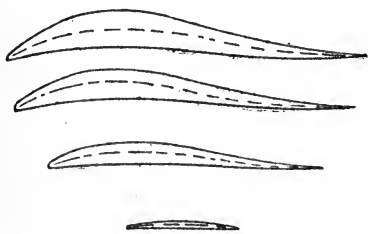

Fig. 11.—Lanchester's Section of Wing.

In the present case the inventor describes a pendulum stability device according to which the tilting of the machine controls the power of the engines which drive the screw propellers so that the machine is automatically righted. Lifting and

driving screws are described in which the forward edge of each blade is rigid while the rear edge is flexible, and controlled by a spring which can yield if the propeller is subjected to undue stress. It is stated that the tension of the springs controlling the flexible edges of the blades may be increased or diminished

at the will of the aviator, "so that if, for instance, one side of the machine have a tendency to lift before the other, it will then be possible to increase the tension of the springs on one side and so bring the machine to an even keel." The adjustment of the angle of incidence of the blades—which constitute supporting planes—for purposes of stability is important on account of its bearing on the Wright wing-warping patent (p. 27), although the machine described in this specification of Sir Hiram's is very different from the Wright machine.

13372 of May 31, 1897.—O. Chanute.

The machine described in the specification of this patent is a glider, and has no motive power. The patent is nevertheless of

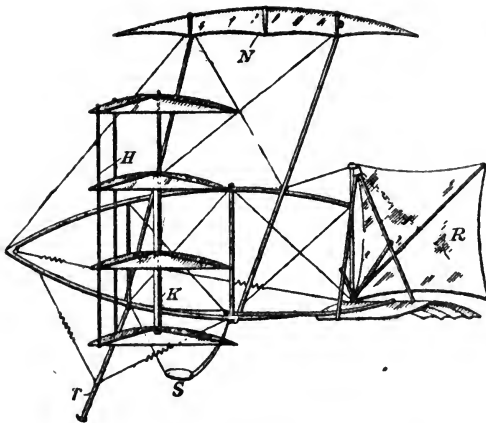

Fig. 12.—Chanute's Glider. Side Elevation.

great interest on account of its early date. The glider is shown in side elevation in Fig. 12, and in front elevation in Fig. 13. It has two wings—each built up of four superposed cambered planes—an auxiliary supporting surface N, and a tail. The superposed planes forming each wing are rigidly connected together by rods H, but each wing can swivel about the vertical shaft K which supports it in such a manner that the angle of incidence of all its planes is increased or diminished. The aviator sits on the seat S with his feet on pedals on the ends of the levers T. Cords attached to these levers are connected to the wings, so that the aviator can at will swivel either or both

wings and alter the angle of incidence, and thus steer the machine in a vertical or horizontal direction.

The vertical tail surface R may be hand-actuated and used as a horizontal rudder; but the inventor states that in practice it is found more useful as a tail, as the steering can be more easily accomplished by pedal action on one or the other wing.

The provision of means whereby the angle of incidence of the one wing can be altered relatively to the other is important on

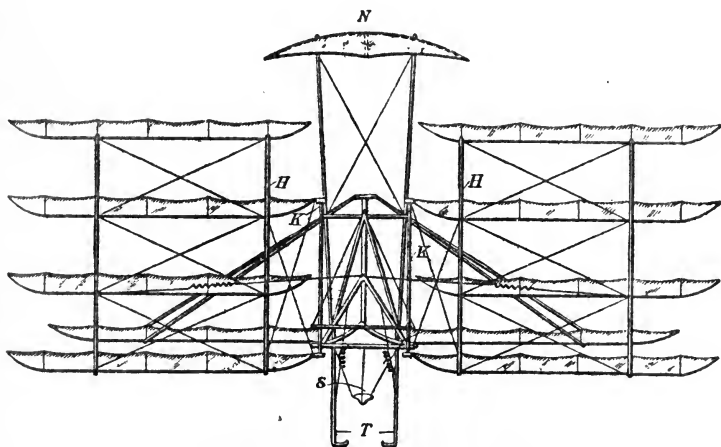

Fig. 13.—Chanute's Glider. Plan.

account of its bearing on the Wright wing-warping patent (p. 27).

15221 of June 25, 1897.—T. Moy (O. Chanute and A. M. Herring).

The flying machine described in the specification of this patent is shown in perspective in Fig. 14. There are two or more supporting surfaces (three in the machine illustrated), and two screw-propellers. One of the propellers A is at the front of the machine, and is seen in full in the figure; the other B is at the rear, and is only partly visible. The propellers are driven by independent engines C, C, and rotate in opposite directions.

A tail provided with vertical and horizontal surfaces D, E, and with a runner F, is connected to the body of the machine by means of a rod H and universal joint K, and can be deflected in both a vertical and a horizontal plane by wind pressure or at the

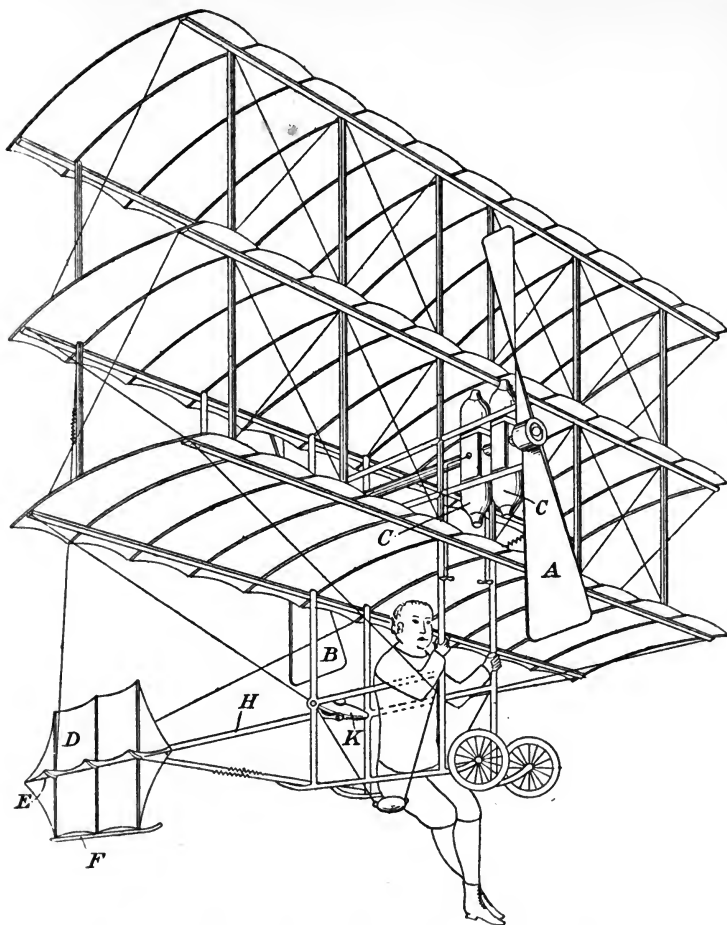

Fig. 14.—Chanute and Herring's Flying Machine.

will of the aviator. Figs. 15, 16 and 17 are sections of proposed forms of planes, and Fig. 18 a cross-section of the framework struts.

27212 of Dec. 11, 1903.—L. Brennan.

25395 of Dec. 6, 1905, and 15796 of July 9, 1907.

—**F. R. Simms.**

In the specifications of these patents are described devices for maintaining the stability of flying machines by means of gyroscopes. Brennan's device is not described with special reference to flying machines, but, as there is no apparent reason why it could not be applied to such machines, and as the device

is that of a man who has carefully considered the problem of gyroscopic stabilisation, it is of considerable importance to aviators. Brennan proposes to employ two equal gyroscopes mounted on parallel axes and geared so as to rotate with equal and opposite angular velocities. The employment of twin oppositely-rotating gyroscopes allows of the machine being turned,

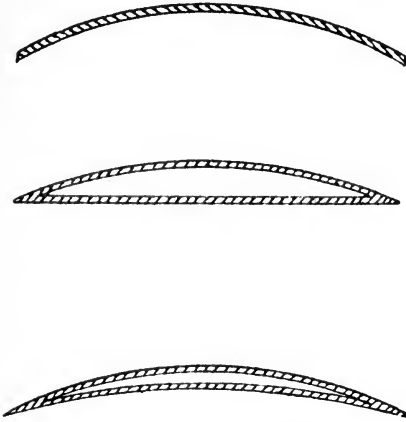

Figs. 15, 16 and 17.—Chanute and Herring's Sections of Planes.

say, in a horizontal plane while automatically correcting any tendency to tilt in a vertical plane at right angles to the line of motion. Means are provided whereby the precession of the gyroscopes caused by the tilting of the machine can be accelerated by hand, or is automatically accelerated by a pendulum, so as to restore the balance of the machine.

Simms' devices are described with special reference to airships and involve the employment of a gyroscope consisting of one, or of two, discs mounted on vertical axes. In the earlier specification it is proposed to change by hand the plane of rotation of the gyroscope; and in the later specification the inventor proposes to automatically increase the speed of rotation of the gyroscope should any tilting of the machine take place, acceleration in speed being brought about by means of a pendulum acting on the throttle valve of the engine which drives the gyroscope.

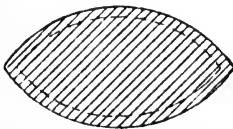

Fig. 18.—Chanute and Herring's Section of Strut.

**4901 of Feb. 27, 1904.—
H. Adams.**

The propeller shaft is driven through a Hooke's coupling and bevel pinions. The propeller is turned in the required direction for rising, falling or steering, by means of ropes or otherwise. The propeller blades are of sheet metal stiffened and stayed. The propeller thrust is taken by a ball bearing.

6732 of March 19, 1904.—O. and W. Wright.

This is the famous wing-warping patent. The application for patent was filed in Great Britain, on March 19, 1904, but the date claimed for the British patent, under the terms of the International Convention, is that of the date of filing of the application for the corresponding patent in the United States of America. This date is March 23, 1903, although—and it is interesting to note this fact—the patent was not granted in America till May 22, 1906.

Referring to the British patent the objects of the invention are said to be “first, to provide a structure combining lightness, strength, convenience of construction, and the least possible edge resistance; second, to provide means for maintaining or restoring the equilibrium of the apparatus; and third, to provide efficient means of guiding the machine in both vertical and horizontal directions.” Three figures are given which are here reproduced, Fig. 19, is a perspective view of the machine, Fig. 20 is a side elevation, and Fig. 21 is a plan.

The supporting planes A, B are so constructed and connected together by the standards C that they can yield to a twisting action, both planes working together. Referring to Fig. 19 in which the machine is viewed from the front, and referring particularly to the ends of the planes seen to the left in this figure, it will be obvious that, if a tension is put on the rope D while at the same time the rope E is slackened, the forward corner of the lower plane, and the aft corner of the upper plane, will be drawn together. The angles of incidence of both planes will therefore be increased at this end. The twisting or warping action is performed by means of a movement to the right or left given to the cradle H to which are attached the wing-warping ropes; and these ropes are so arranged that, when the planes have their angles increased at one end, the angles at the other end are reduced. Each plane is twisted into the form of a two-bladed propeller. Moreover, the rudder K is so connected with the wing-warping ropes that it is always deflected to the side at which the angle of incidence is least.

When the machine in flight tilts so as to, say, rise at the right and fall at the left, the aviator moves the cradle so as to reduce the angle of incidence at the right and increase this angle at the left. This action will tend to right the machine, but, as the resistance to motion will be greatest where the angle of incidence

is greatest, the machine will tend to rotate about a vertical axis. Such a rotation is, however, prevented by the rudder which, by the same movement of the cradle, is deflected to the right and keeps the machine square to the line of motion.

Fig. 19.

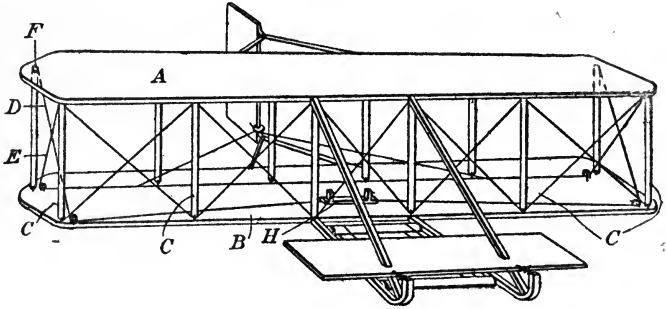

Fig. 20.

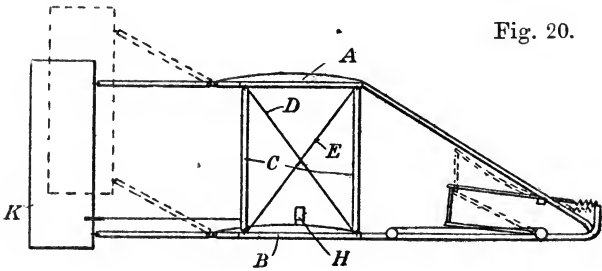
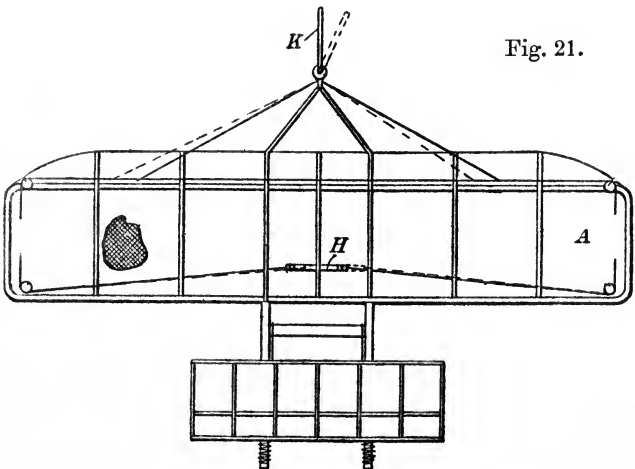

Fig. 21.



Figs. 19, 20 and 21.—Wright Flying Machine, with Wing-Warping and Rudder Action.

The inventors state that, although at the date of applying for the patent, they prefer to use ropes for twisting the planes, they do not restrict themselves to any particular method of imparting this twist to a structure formed in the manner specified in their specification. They state, moreover: "We do not confine ourselves to the particular construction and attachment of the rear rudder hereinbefore described, nor to this particular construction of surfaces or wings, but may employ this combination in the use of any movable vertical rear rudder operated in conjunction with any wings capable of being presented to the wind at respectively differing angles at their opposite tips for the purpose of restoring the lateral balance of a flying machine and guiding the machine to right or left."

Fourteen claims are made of which the most important, in the author's opinion, are the 3rd, 6th and 7th which are as follows:—

3. In a flying machine, the combination of one or more supporting surfaces or wings with a device for imparting a twist to the said surfaces or wings for the purpose stated.

6. In a flying machine, the combination of wings having their right and left tips capable of being adjusted so as to be presented to the wind at respectively differing angles, with a vertical adjustable rear rudder operating in conjunction therewith in the manner and for the purpose specified.

7. In a flying machine having wings capable of being twisted by actuating ropes, the combination therewith of a movable vertical rear rudder having tiller cords attached to said actuating ropes, substantially as described.

The corresponding U.S. patent contains eighteen claims aggregating about 1800 words—not an unusually great verbage for an American patent. The drawings are somewhat clearer than the British, and contain two additional figures which illustrate the pivotal connection of the planes with the standards which connect them together.

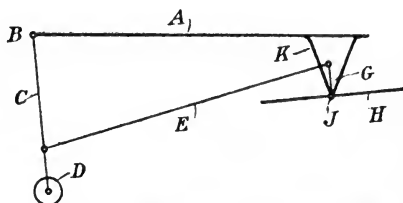

Fig. 22.—Hansen-Ellehammer's Stabilisation Device.

7377 of March 27, 1906.—J. C. Hansen-Ellehammer.

Referring to Fig. 22, A is the supporting surface of a flying machine to which is pivoted at B a rod C supporting a pendulum weight D. The rod C is connected, by means of a link E, with

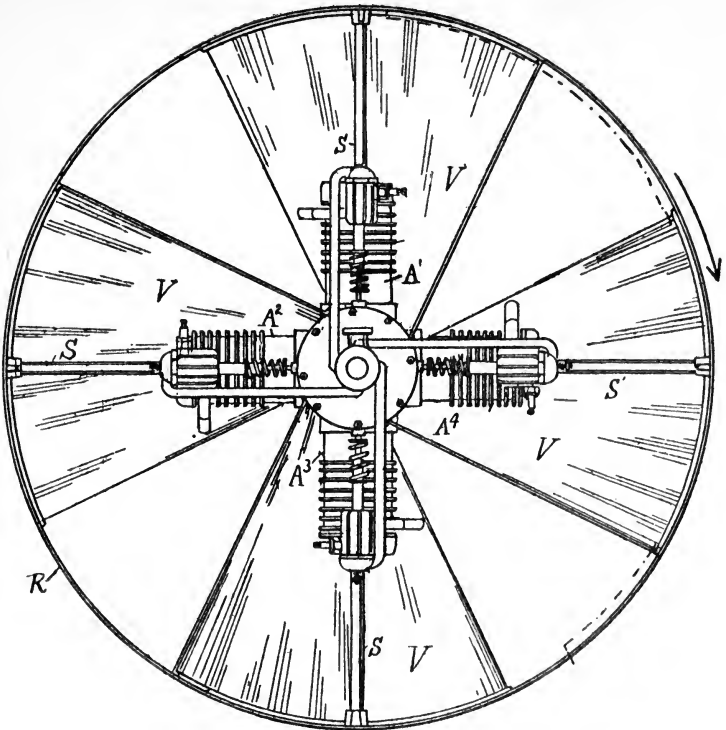

Fig. 23.—Harper's Engine, with Rotating Cylinders.

the lever G, which operates the horizontal rudder H, which is pivoted at J, to the bracket K. The length of the link E, or its point of connection to the rod C, may be adjusted.

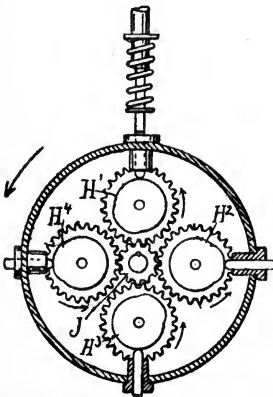

Fig. 24.—Valve Gear of Harper's Engine.

16626 of July 23, 1906.—
W. Harper.

The internal combustion engine cylinders A^1 , A^2 , A^3 , A^4 , Fig. 23, are rigidly connected to the crank case and (by struts S) to a ring R , the whole structure being adapted to rotate and to act as a flywheel. Moreover, the blades V , V , stretching from the ring R to the crank case, act as propeller blades, the necessity of providing a separate propeller being thus obviated. The pistons

of the engines A^1 and A^4 drive on to one crank pin, and those of the engines A^2 and A^3 on to another crank pin, at 180 degrees from the first. Fig. 24 shows the exhaust valve mechanism. J is a stationary pinion which gears with four planet pinions which carry cams H^1, H^2, H^3, H^4 , which respectively actuate the exhaust valves of the four cylinders.

Lubricating oil is contained in a chamber formed in one with the crank case and is fed to the cylinder by centrifugal force.

26099 of Nov. 19, 1906.—A. V. Roe.

The inventor proposes to steer a flying machine in a horizontal plane without the employment of a vertical rudder by the deflec-

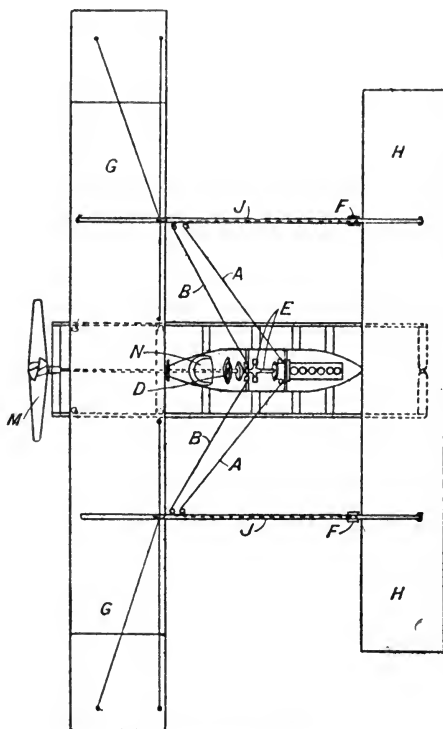

Fig. 25.—Roe's Steering Device.

tion of an auxiliary plane situated in front of the main supporting surfaces. Fig. 25 is a plan of the machine. G is the upper

main plane, and there is a lower main plane parallel to it. H is the auxiliary plane, and M is the screw propeller at the rear of the machine. N is the aviator's seat, and D the wheel by which he steers the machine, by acting on the plane H by means of the cords A, B.

Fig. 26 shows the plane H in side elevation with the means for supporting and deflecting it. It is pivoted at C, C to the frame bars J (see both figures), which also carry brackets F, F in which the aft end of the plane is guided. The steering wheel spindle is pivoted at E, so that, if the wheel is pressed bodily down, the ropes B are tensioned while the ropes A are slackened, and the aft end of the plane H is raised, thus causing the path of the machine to deflect downwards. Raising the steering wheel produces an opposite effect, while turning the wheel in one or the

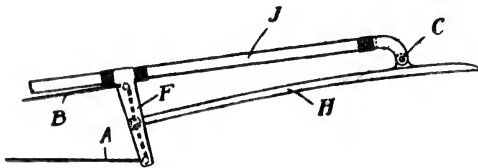

Fig. 26.—Roe's Steering Device.

other direction twists the plane, depressing the aft end at the one side and raising the aft end at the other, and so deflecting the path of the machine in a horizontal plane. The movements given to the steering wheel are in the same direction as the movements desired to be given to the machine, thus reducing to a minimum the chance of the aviator giving the wrong movement.

29308 of Dec. 22, 1906.—W. E. Murray.

It is proposed to drive an aerial machine by means of propellers, which, as shown in Fig. 27, are driven by the engine through the agency of bevel pinions and the shafts P, P¹. The latter rotate within tubes Q, Q¹, which carry at their ends bracket bearings V, V¹ for the propeller shafts. These tubes Q, Q¹ can be rotated by means of worms which are actuated by the hand wheel Z, and which engage with the worm wheels W, W¹ attached to the tubes Q, Q¹, so that the planes of rotation of the propellers can be altered at will.

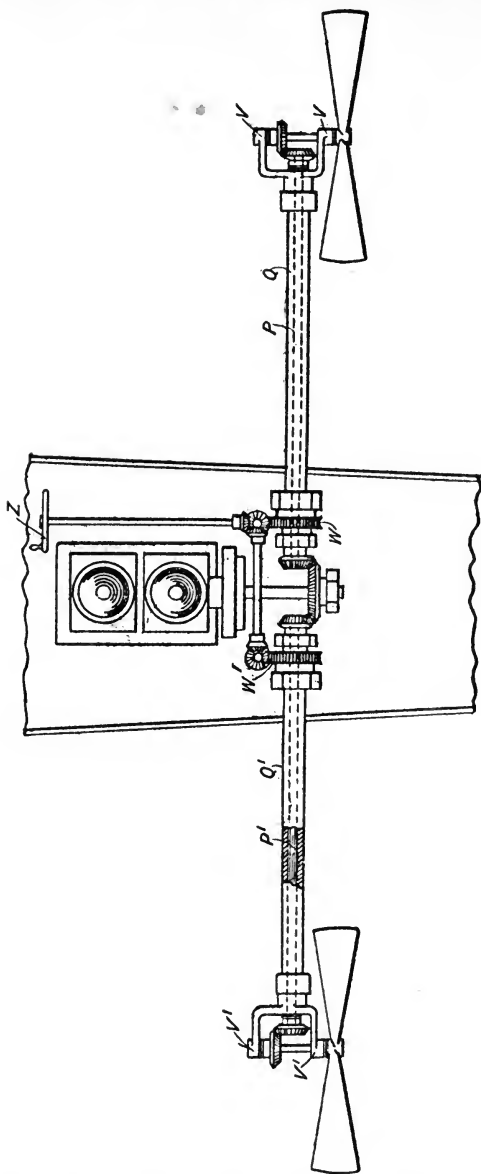

Fig. 27.—Murray's Propeller Drive.

1960 of Jan. 25, 1907.—G. L. O. Davidson.

In the specification of this patent is described mechanism for automatically affecting stabilisation by means of a moving weight.

The tail of the machine is actuated by engines controlled by the moving weight, but the disposition of the latter and its mode of acting on the engines are not described. The only item of

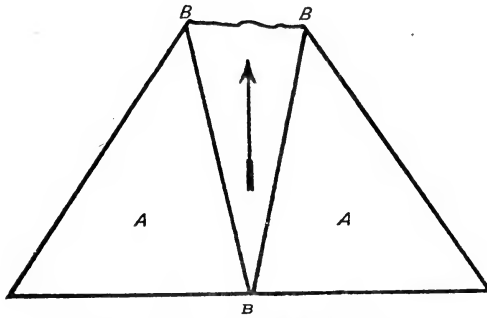

Fig. 28.—Davidson's Fish-Tail.

interest in the specification, in the author's opinion, is the proposal to make the tail somewhat like that of a fish or as shown diagrammatically in Fig. 28, the arrow indicating the direction of

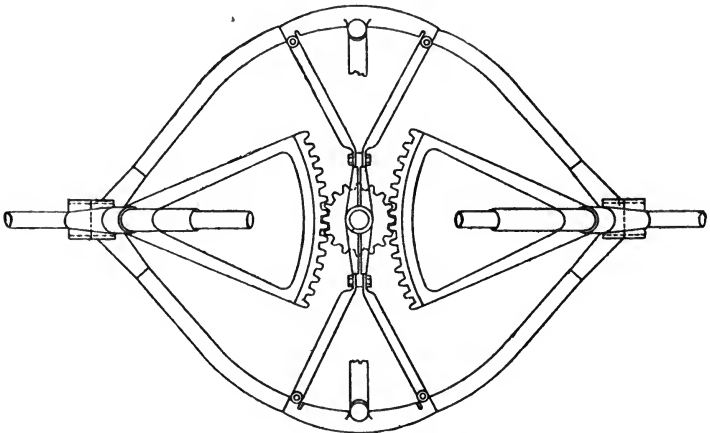

Fig. 29.—Davidson's Mechanism for Actuating Tail.

motion of the machine. The fins or wings A, A are movable about the lines B, B as axes, and one can be tilted up, while the other is tilted down, for stabilisation purposes. The mechanism proposed for effecting this tilting action is shown in Fig. 29.

9413 and 9413A of April 23, 1907.—F. W. Lanchester.

Fig. 30 shows the flying machine in side elevation, partly in section. The supporting surface A is a structural part of the

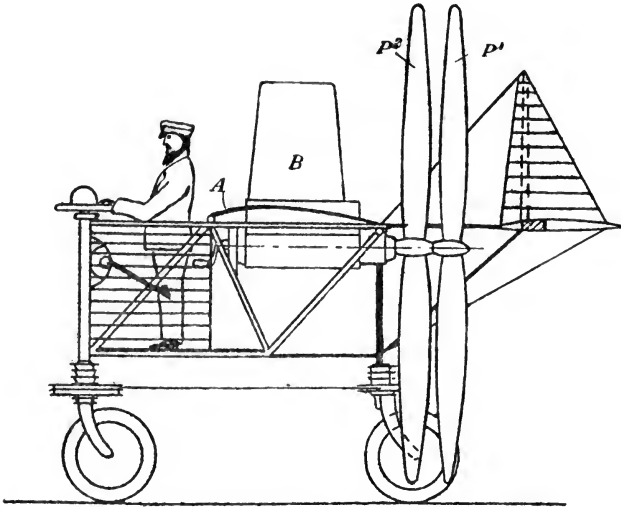

Fig. 30.—Lanchester's Flying Machine.

frame of the machine which in the main consists of a triangular lattice girder of which a detail is shown in Fig. 31. B is the

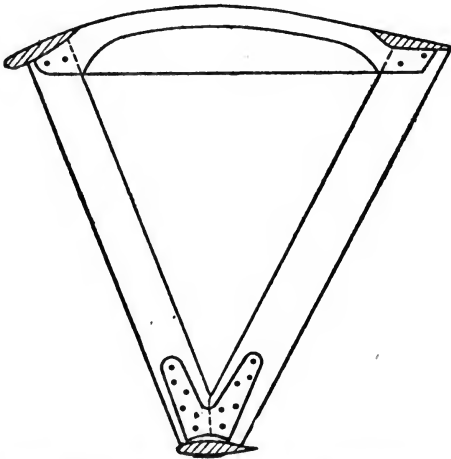

Fig. 31.—Lanchester's Aeroplane Girder.

engine, and P^1, P^2 the propellers. The propellers are of opposite hand, and, as shown in Fig. 32, are fixed respectively on shafts P^3 and P^4 which are keyed to, or form part of, the planet elements M^1

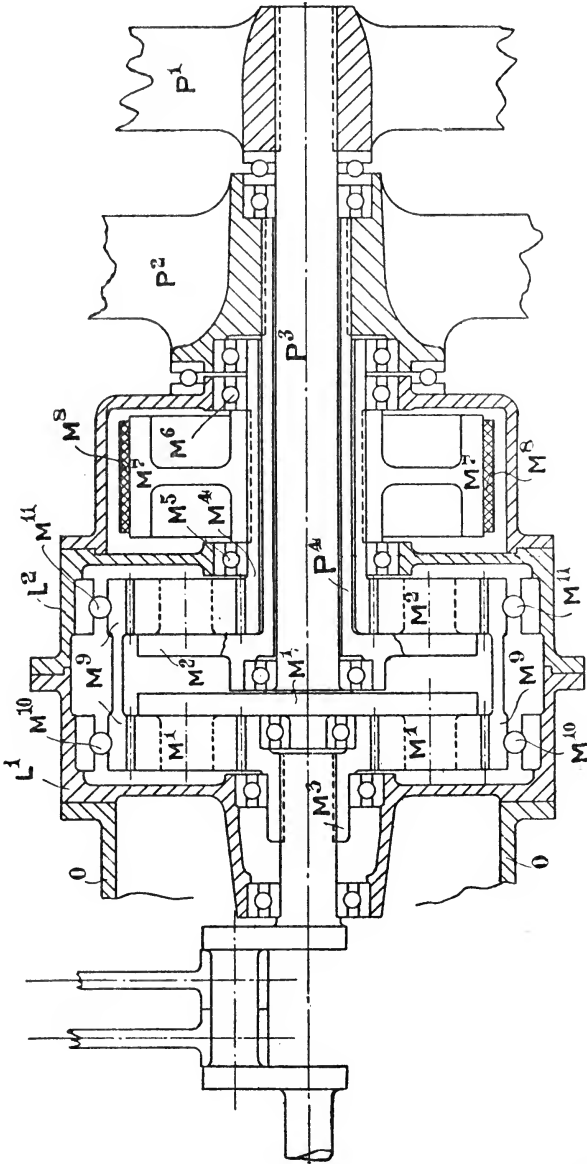

Fig. 32.—Lanchester's Tandem Propeller Drive.

and M^2 of the two trains of epicyclic gear contained within the casing L^1, L^2 , which is bolted on to the extremity of the crank chamber O . One of the "sun" elements M^3 is coupled direct to the motor shaft, and the other "sun" M^4 is mounted revolvably in bearings M^5 and M^6 , and carries a brake drum M^7 acted on by a brake, shown as a band brake M^8 . The ring element of the two trains of gear M^9 is common to both and is mounted in bearings in the casing M^{10}, M^{11} , and is quite unrestrained as regards rotation except by its engagement with the planet pinions of the two trains.

When the "sun" element M^4 is free to rotate, there is no driving effort exerted on either propeller, and the planet elements can both stand still while both "suns" rotate in one direction, and the common ring element rotates in the opposite direction.

When the "sun" M^4 is brought to rest by means of the brake M^7, M^8 , the planet elements are constrained to revolve; but the relative rate of rotation depends on the relative retarding torque.

17366 of July 29, 1907.—J. A. Colquhoun.

According to this invention, when the machine becomes tilted, a pendulum, owing to its inertia, makes contact with one or two of four insulated plates which are electrically connected respectively to the driving mechanisms of four propellers, so that the tilting of the machine causes less power to be transmitted to one or two of the propellers. The propellers rotate about vertical axes and are so disposed that the reduction in speed of rotation of any one propeller, or any two adjacent propellers, will tend to right the machine.

26000 of Nov. 23, 1907.—F. Hennebique.

The boss B of the tractor screw A , Fig. 33, is connected to the driving shaft E by means of a universal joint which may be of the type which is drawn to a larger scale in Fig. 34. The balls C, C , which transfer the torque from the shaft to the boss, are located in spheroidal recesses cut half in the spherical end of the shaft and half in the enclosing surface of the boss. The weight D , suspended from the boss, serves to maintain the propeller in a vertical plane in spite of fore-and-aft tilting of the flying machine.

27408 of Dec. 11, 1907.—J. Straka.

The drawing here given, Fig. 35, is not a reproduction of that shown in the patent specification, but is a diagrammatic representation of the proposed propeller drive. The propellers are arranged at the rear of the airship. The shaft A has a bearing in the bracket B, which is rigid with the frame of the machine. This shaft carries a bevel pinion C, which gears with the pinion D, which rides loose

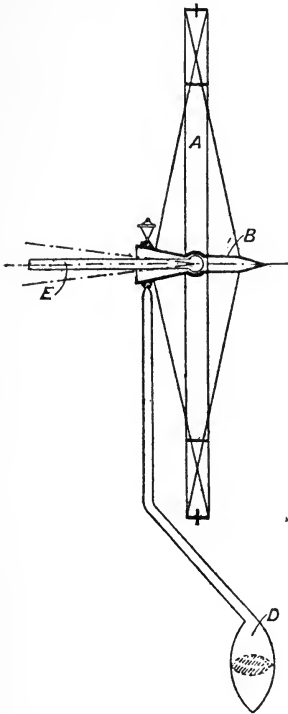

Fig. 33.—Hennebique's Stabilisation Device.

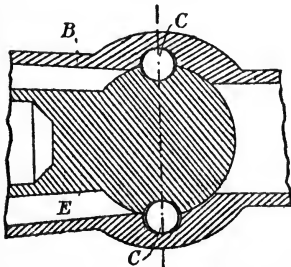

Fig. 34.—Hennebique's Propeller Drive.

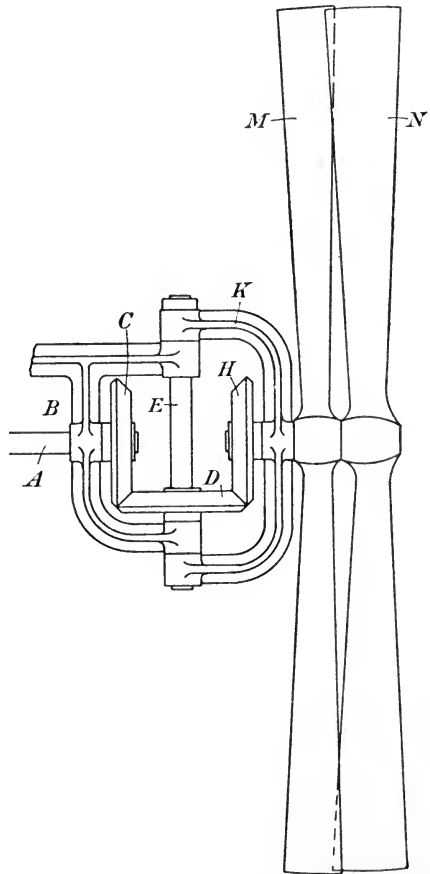

Fig. 35.—Straka's Tandem Propeller Drive.

on the spindle E, and gears with the pinion H, which is keyed on the propeller shaft.

The latter carries both propellers M, N, which rotate in the same direction, the aft propeller N having the greater pitch. The propeller shaft has a bearing in the bracket K, which can pivot about the spindle E, so that the angle of the propeller shaft can be altered in a horizontal plane to steer the machine.

28034 of Dec. 19, 1907. (Dec. 19, 1906.)—R. Esnault-Pelterie.

In this specification is described the combined steering and equilibrium mechanism illustrated diagrammatically in Fig. 36.

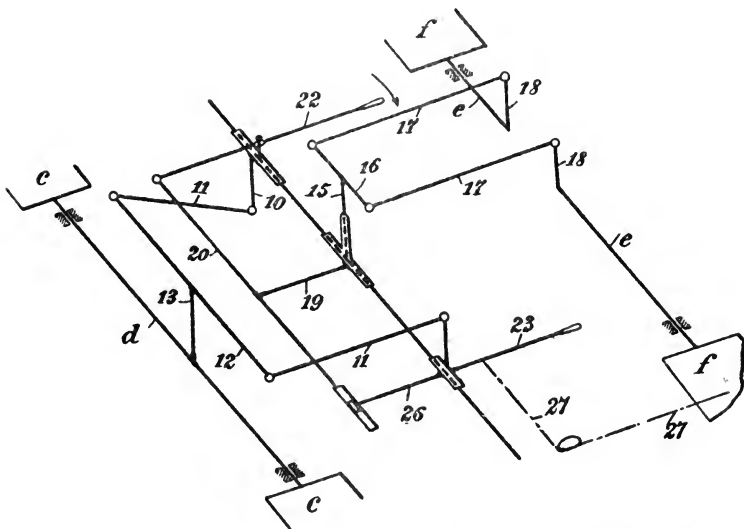

Fig. 36.—Esnault-Pelterie's Steering and Equilibrium Mechanism.

There are two pairs of supporting planes of which the forward pair is represented by *c, c*, and the aft pair by *f, f*. 22 is the stability, and 23 the steering, handle. When 22 is raised, the planes *c, c* are tilted up (*i.e.*, up at the forward edge so as to increase the angle of incidence) through the agency of the levers 10, the link 11, shaft 12, lever 13, and axle *d*; and at the same time the planes *f, f* are tilted down through the agency of the shaft 20, bell-crank lever 19, 15, rod 16, links 17, 17, levers 18, 18, and axles *e, e*. The result is, therefore, to raise the machine

at the head and lower it at the tail. An opposite movement given to the handle 22 produces an opposite effect, while a movement to the right or left has no effect on the forward planes, but, as regards the rear planes, by acting on the rod 20 and thus rotating the lever 19, 15, about the axis of 15, it gives opposite tilts to the two rear planes and therefore tends to rotate the machine about an axis parallel to the direction of travel.

An upward movement given to the handle 23 tilts both pairs of

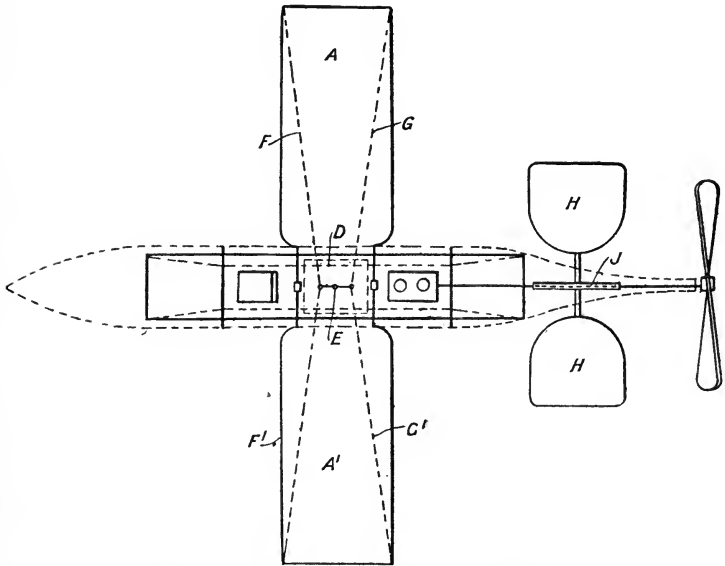

Fig. 37.—Esnault-Pelterie's Flying Machine.

planes downwards, and a downward movement tilts both planes upwards, while a right or left hand movement given to this handle has no effect on the planes (owing to the end of the lever 26 working in a slot in the shaft 20), but actuates the rudder (not shown) by means of the cord 27. The handle 23 can therefore be used for steering the machine both vertically and horizontally.

The device is ingenious, but has the defect that, whereas the handle 22 is raised to raise the head of the machine, the handle 23 has to be lowered to raise the machine—an arrangement apt to prove confusing.

221 of Jan. 3, 1908. (Jan. 19, 1907.)—R. Esnault-Pelterie.

In this specification is described and claimed another steering and equilibrium arrangement. In Fig. 37, which is a plan of the flying machine, the main wings A, A' are rigidly connected to the frame of the machine, and are adapted to be warped for transverse stabilisation. The warping action is accomplished by means of the stays F, F', G, G' , which extend downwards from the front and rear of the wing tips to the lower part of the body of the machine, where they are connected to the end of a

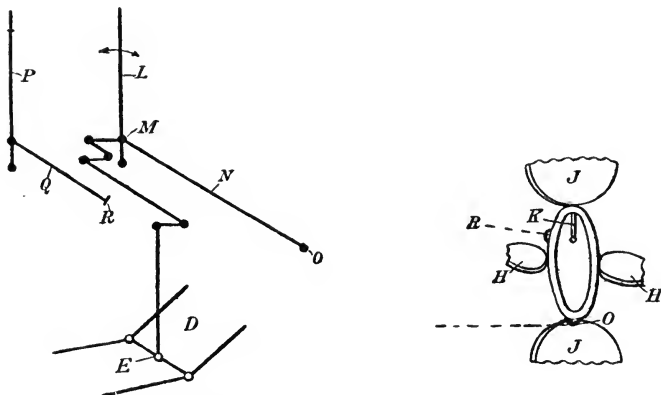

Figs. 38 and 39.—Esnault-Pelterie's Steering and Equilibrium Mechanism.

rod D (see also Fig. 38), pivoted at E . It will be evident that, by swivelling the rod D in a horizontal plane about the point E in a counter-clockwise direction, tension will be put on the stays F and G' , and the one wing tip will be bent down at the front while the other is bent down at the rear.

H, H are blades forming a horizontal rudder at the rear of the machine; and similar blades, of which one, J , is seen in Fig. 37, constitute a vertical rudder. The blades are attached to a ring as shown in Fig. 39, which ring is rigidly attached to a stud K , which is pivoted at its free end to a support by a universal joint.

Fig. 38 shows the mechanism by which the wings are warped and the rudder actuated. When the aviator's lever L , pivoted at M , is moved in the plane which contains the link N , this link,

which is pivoted at O (Figs. 38 and 39) to the rudder ring, deflects the horizontal rudder. A movement of the lever L in a vertical plane, at right angles to the link N, swivels the rod D about the point E, and so warps the wings. The vertical rudder is operated by a separate lever P, which actuates the link Q, pivoted to the rudder ring at R. This arrangement differs from the Wright device in this respect, that the vertical rudder is not actuated by the same movement as is employed to warp the wings.

1258 of Jan. 18, 1908. (Jan. 22, 1907.)—

R. Esnault-Pelterie.

In this specification is described a further steering and stabilisation arrangement. Mechanism is described and illustrated whereby

Fig. 41.



X

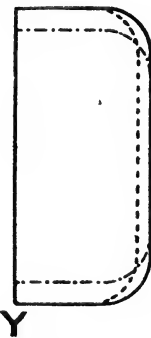

Fig. 40.

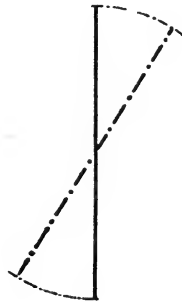

Fig. 42.

Figs. 40, 41 and 42.—Esnault-Pelterie's Rudder.

wing-warping and rudder control is effected. The chief difference between the arrangement described in this specification and that described in 221, 1908, is that, in place of the combined vertical and horizontal rudder described in the latter, a single horizontal rudder with a single surface is employed. This rudder is illustrated diagrammatically in Figs. 40, 41 and 42, which are plan, side elevation and end elevation respectively. (The diagrams are the author's, not the patentee's.) A lever corresponding to L, in Fig. 38, is employed as before to warp the wings by one motion and to deflect

the rudder by another motion ; but in the present case the rudder swings about the axis $X Y$ into a position such as that shown by dotted lines in Figs. 40 and 41. A lever corresponding to P in Fig. 38 is also employed, and this lever tilts the rudder into a position such as that shown by chain lines in Figs. 40 and 42. The rudder need not be a flat surface, but may be cambered. A tractor screw is employed for propulsion.

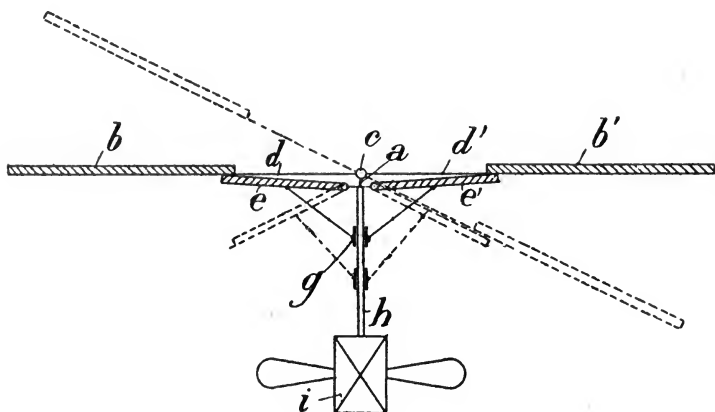

Fig. 43.—Heeren's Stabilisation Device.

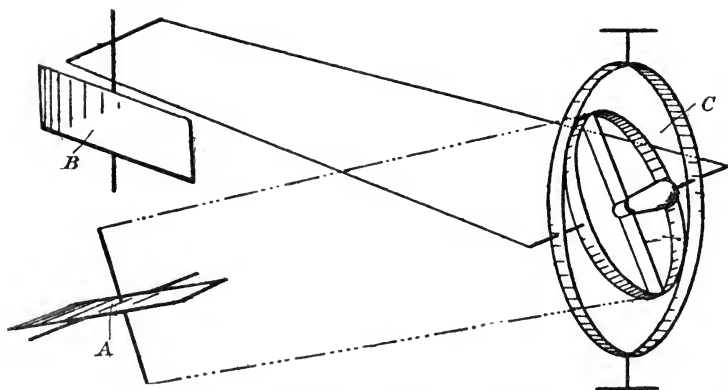

Fig. 44.—Blériot's Rudder Mechanism.

1683 of Jan. 24, 1908.—O. Heeren.

The wings b, b , Fig. 43, are hinged at c , so that, moving together, they can occupy an inclined position such as that

indicated by dotted lines. The auxiliary supporting surfaces e, e' occupy the gap between the wings and are independently hinged at a ; they are linked, as shown, to the collar g which can slide on the rod h , which supports the car or weight i . When the wings become tilted to the position shown by dotted lines, the surface e' is pressed down by the wing b' to the position shown, and, by virtue of the links and collar, it carries the surface e into a similar position.

The inventor's idea is that by this means there is a diminished pressure or supporting power on the left side of the machine, which will therefore tend to right itself, and, moreover, that the inclination of the surface e to the other supporting surfaces will tend to prevent the machine sliding down to the right. It is not, however, clear to the author that the device will act as effectively as the inventor believes.

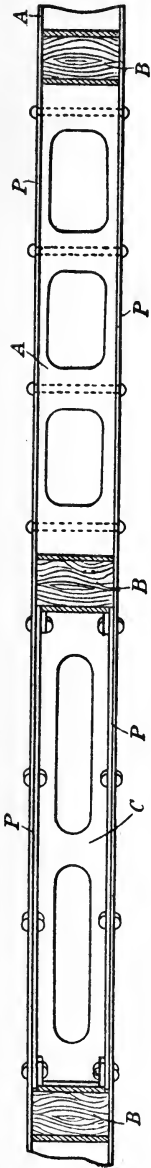

Fig. 45.—Esnault-Pelterie's Wing Beam.

**2588 of Feb. 5, 1908. (Feb. 9, 1907.)—
L. Blériot.**

A Cardan controlling system C , which is illustrated diagrammatically in Fig. 44, is employed to actuate a horizontal rudder A and a vertical rudder B . A practical mechanism for putting the device into practice is also described and illustrated, but the claims are not confined to this mechanism.

5471 of March 11, 1908.—G. Kerwat.

A stabilisation device is described in the specification of this patent, which is of a somewhat similar nature to that described in 17366, 1907. In the present case, however, it is proposed that mercury, or other suitable liquid adapted to flow to one or other end of a horizontal tube, shall take the place of the pendulum.

8643 of April 18, 1908. (May 4, 1907.)—R. Esnault-Pelterie.

A construction of transverse beam for the wings of flying machines is described and claimed. The beam is built up of lengths of wood A, Fig. 45, cut away as shown for lightness, and connected to each other by continuous metal plates P. Spaces are left between the ends of the lengths of wood for the cross-pieces B. It is stated that at places "where the curvature changes" lengths C of steel or aluminium, as shown in Figs. 45 and 46, may be substituted for the wood.

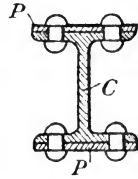

Fig. 46. — Esnault-Pelterie's Wing Beam.

8842 of April 23, 1908.—L. P. Shadbolt.

The vertical rudder A, Fig. 47, of a flying machine consists of canvas or other flexible material stretched between an upper

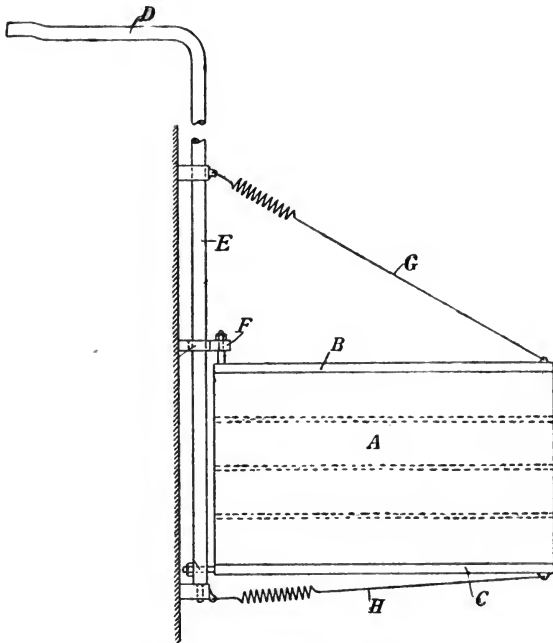

Fig. 47.—Shadbolt's Rudder.

arm B and a lower arm C, which are stayed by cords G, H. The lower arm can be swivelled by means of a tiller D and post E

(or by means of ropes), but the upper arm is not positively controlled, but is pivoted to the fixed bracket F, through which the post E passes freely. Consequently, when the tiller is actuated, the lower portion of the rudder is deflected more than the upper portion, and the rudder assumes a helical form. The object of the arrangement is to prevent the momentary drop of the aeroplane at the instant of changing its course in a horizontal plane.

9069 of Feb. 5, 1908. (April 26, 1907.)—L. Blériot.

The two rudders or half-tails A and B (Fig. 48) are pivoted about the same horizontal spindle C, which is situated at right angles to the line of travel of an aeroplane. The rudders, when

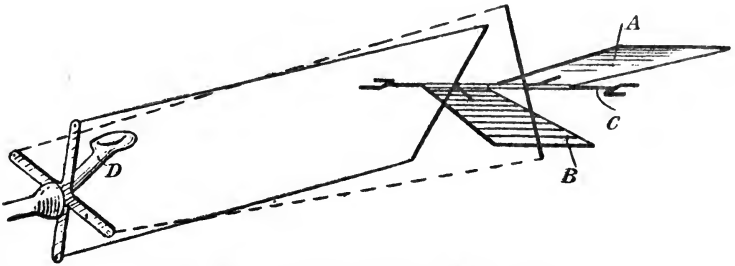

Fig. 48.—Blériot's Steering Mechanism.

in their central or normal positions, are in the same plane, and either rudder can, by means of the handle D, be deflected either up or down or be maintained stationary. A careful study of the diagram will be necessary to appreciate the movements, and explanation in addition to this will be superfluous.

10528 of May 14, 1908. (May 22, 1907.)—R. Esnault-Pelterie.

The object of this invention is to provide a system of surfaces in an aeroplane arranged in a manner to allow of rapid and automatic deformation, so as to compensate for wind influences tending to disturb the stability or course of the machine. The main supporting surface A, Fig. 49, is stayed by the two sets of ropes, of which the set B, B¹ extends from the forward edge of the plane to the bottom of the rod C, and prevents any movement

of the front of the plane relatively to the body of the machine. The remaining rope *D* extends from two points on the rear edge of the plane and passes over a pulley *E*, so that the wings can be automatically warped by inequalities in wind pressure.

The tail plane *T*, which is pivoted about the horizontal axis *MN*, can rise or fall automatically, the movement being controlled by a spring. Moreover, the tail can be automatically

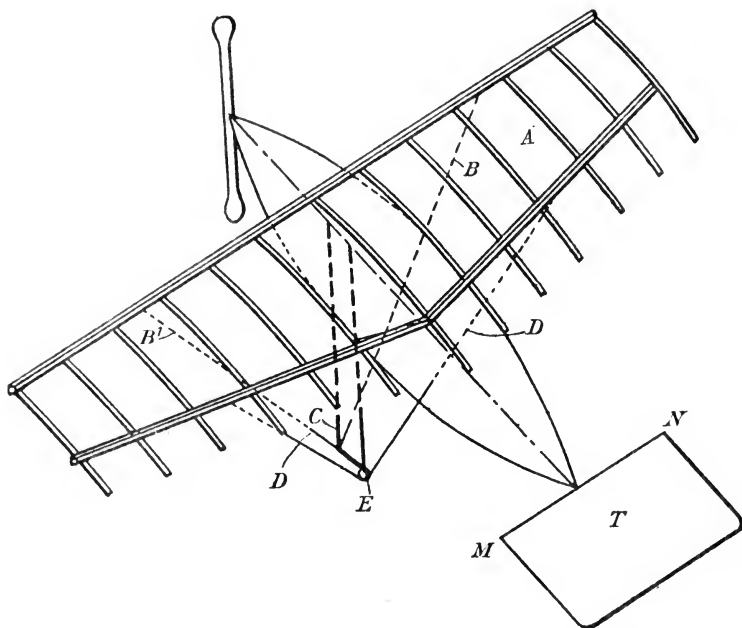

Fig. 49.—Esnault-Pelterie's Automatic Wing-Warping Arrangement.

warped by a side wind, one rear corner rising while the other is depressed.

11905 of June 1, 1908. (June 13, 1907.)—P. Skousès.

Propulsion is proposed to be effected by the reaction caused by the discharge of gases obtained by the explosion of producer gas with air. The gas is made in a gas producer and is thereafter compressed. The air is also compressed, and the explosion takes place in a plurality of exploding chambers. It is proposed to regulate the discharge of the combustion gases so as to effect steering as well as propulsion.

12013 of June 3, 1908.—J. L. Garsed.

The disc 4, Fig. 50, pivotally mounted in the frame of a flying machine, is connected to the supporting or directing surfaces or rudders, so that the steering or stability of the machine can be controlled by rotation of the disc in one or the other direction.

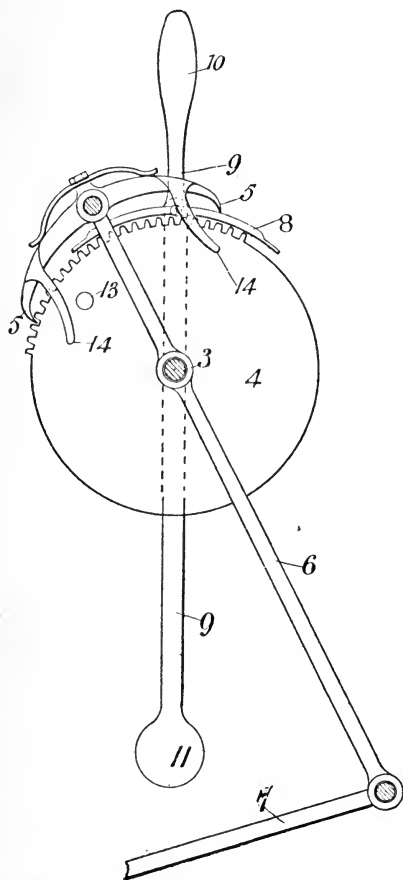

Fig. 50.—Garsed's Stabilisation Device.

The surface *a* is capable of being swivelled in a vertical plane about the axis f^1 , by means of the steering shaft *f*, and steering wheel f^2 . The surface *a* may also, if desired, be arranged to be swivelled in a horizontal plane about the axis a^1 . Moreover, by rotating the wheel f^2 , the wheel *g* can be made to act on the cords g^1 , so as to tilt the plane *a*, raising one wing tip and depressing the other.

controlled by rotation of the disc in one or the other direction. The connecting rod 7 is reciprocated by any motive power, and oscillates the lever 6 which is pivoted at 3 and carries the pawls 5, 5. These pawls are normally kept out of action by a shield 8, which is mounted on a lever 9, which carries a pendulum weight 11. On the machine becoming tilted, one or other of the pawls comes into action so as to perform a righting action. Positive control can be effected by the handle 10, on the lever 9, but such positive control is limited by the pin 13, making contact with one or other of the projections 14, 14, which would force the operating pawl out of action.

15924 of July 27, 1908.—
T. W. K. Clarke.

Referring to Fig. 51, *a* is the forward supporting and steering surface, and *b* is the

rearward main supporting surface of a flying machine. The surface *a* is capable of being swivelled in a vertical plane about the axis f^1 , by means of the steering shaft *f*, and steering wheel f^2 . The surface *a* may also, if desired, be arranged to be swivelled in a horizontal plane about the axis a^1 . Moreover, by rotating the wheel f^2 , the wheel *g* can be made to act on the cords g^1 , so as to tilt the plane *a*, raising one wing tip and depressing the other.

The forward edge of the rear plane abuts against the stop *h*. The rearward portion of this plane is held down by means of the bridle *h*¹, which extends from the front to near the rear edge of the plane and is provided with a resilient tie *h*². *k*, not described, is presumably a skid, one being provided at each side of the

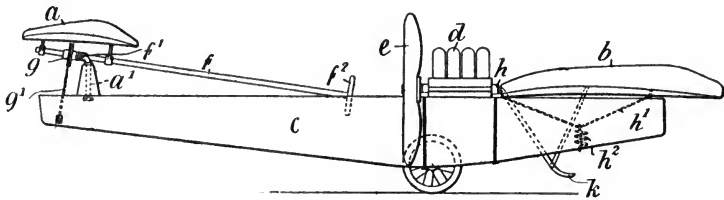

Fig. 51.—Clarke's Flying Machine.

plane *b*. The arrangement allows either wing tip to yield should it strike the ground on the descent of the machine. *c* is the frame of the machine, *d* is the motor, and *e* a propeller.

17150 of Aug. 14, 1908.—J. Weiss.

In an aeroplane according to this invention the curvature of longitudinal section of the supporting plane is greatest at the centre and decreases towards the sides. Moreover, the rigidity of the plane decreases from the front outwards and rearwards.

19805 of April 21, 1908.—E. H. Hare.

The aeroplane *A*, Fig. 52, is provided with hinged corners *B*, which can be operated by levers so as to steer the machine or

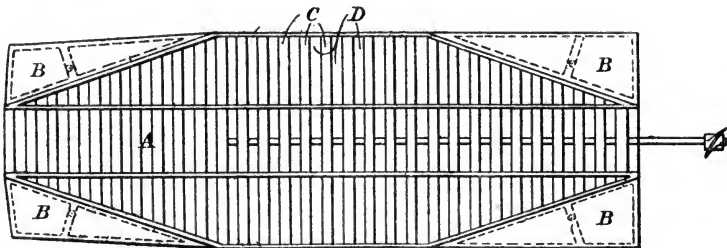

Fig. 52.—Hare's Aeroplane.

control its altitude. The main supporting surface is, moreover, composed of slats *C*, the distance *D* between the slats being equal

to the width of a slat. A suitable width for a slat is said to be 6 inches. The machine is propelled by a rear propeller, driven by a motor mounted on a framework which is not shown.

20038 of Sept. 23, 1908.—H. S. Maxim.

In a flying machine, of which Fig. 53 is a vertical section and Fig. 54 a partial plan, the steering handle *b* is pivoted at *m* so that

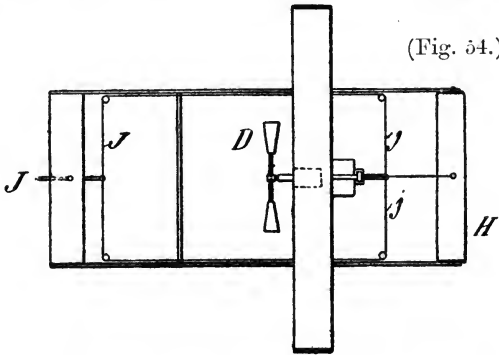
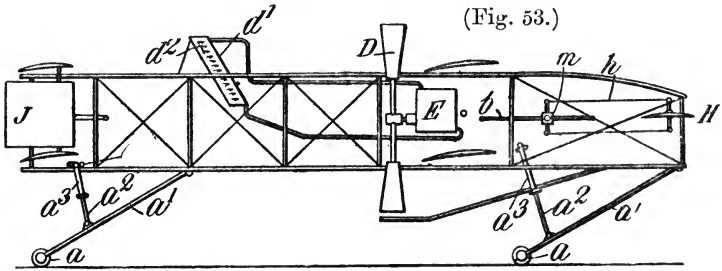

Figs. 53 and 54.—Maxim's Flying Machine.

it can be moved either in a vertical or in a horizontal plane. When moved vertically it actuates the forward horizontal rudder *H* by means of the wires *h* and, when moved horizontally, it operates the rear vertical rudder *J* by means of the wires *j*.

A shock-absorbing device comprises wheels *a*, levers *a*¹ which are preferably flat (for spring), and rods *a*² which can be driven into compressed air cylinders *a*³. India-rubber bulbs are provided which cover small apertures at the tops of the cylinders, which bulbs will burst under a pressure of about 300 pounds per square inch and allow the air to escape, thus cushioning the landing of the machine.

E is the engine and D the propeller, and means are described whereby the pitch of the propeller blades can be readily adjusted.

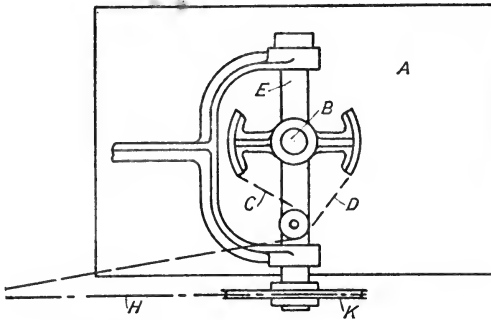

Fig. 55.—Tribelhorn's Box Rudder.

The engine jacket water is cooled by passing it through tubes d^1 provided with blades d^2 adapted to act as auxiliary supporting surfaces.

20785 of Oct. 2, 1908. (Oct. 4, 1907.)—L. Blériot.

This invention relates to means for starting aeroplanes from a standing position by directing a current of air against the wings or planes by means of the propellers. The inventor hopes by this means to obviate the necessity of providing wheels and to allow of the alighting devices being simplified. The positions in which the propellers require to be placed do not, however, appear to be very desirable ones.

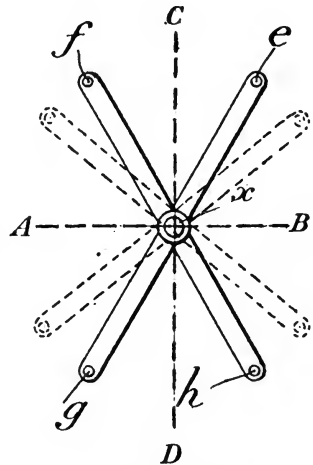

Fig. 56.—Blériot's Steering Levers.

21092 of Oct. 6, 1908.—

A. Tribelhorn.

The box rudder A, Fig. 55, can be employed for both vertical and horizontal steering. The rudder is mounted on the horizontal spindle B, which can be rotated by the cords C, D. The spindle B is mounted in a crosshead carried by the vertical spindle E, which can be rotated by the cord H, which passes over the pulley K.

21497 of Feb. 5, 1908. (Oct. 15, 1907.)—L. Blériot.

In the device described in the specification of Blériot's

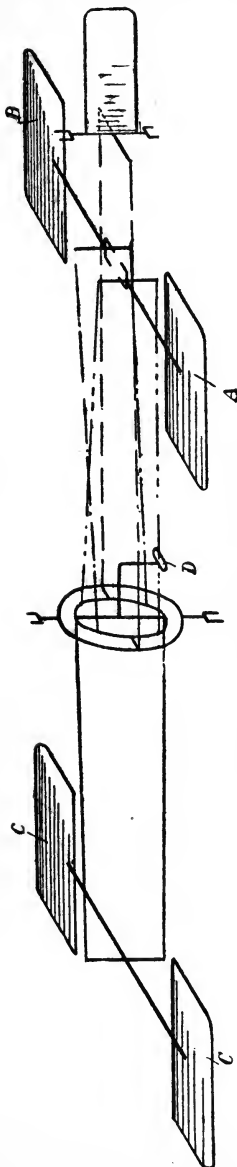

Fig. 57.—Blériot's Steering Mechanism.

previous patent, 9069 of 1908, the four arms attached to the handle D are said to be equally spaced, that is, to be arranged at 90° to each other. In the present patent the device is claimed of allowing the four arms to be adjusted relatively to each other as, for example, by constructing them in pairs of opposite arms, *f, h*, and *e, g* (Fig. 56), and making them rotatable about the pin *x*. From a study of Fig. 48, of patent 9069 of 1908, it will be seen that, the relative leverage being thus affected, the relative sensitiveness of the several movements can be controlled. For example, when the arms are placed as shown in full lines in Fig. 56, a given angular movement about the (imaginary) axis *A B* would give a greater movement to the steering ropes than the same angular movement about the axis *C D*. It would, therefore, be possible to get, for example, greater sensitiveness as regards similar, than as regards divergent, movements of the two rudders, and it would appear from the description that this is what Blériot was aiming at. The claim, however, refers to the object of the device as being "to permit the modification of the relative sensitiveness of the two rudders," an expression which, if construed literally, means a very different thing.

The arrangement illustrated in Fig. 57 is also claimed in this patent. By carefully examining the mechanism and connections shown in this figure it

will be seen that, by raising the actuating handle D, the rear planes A, B, as well as the forward planes C, C, will be tilted

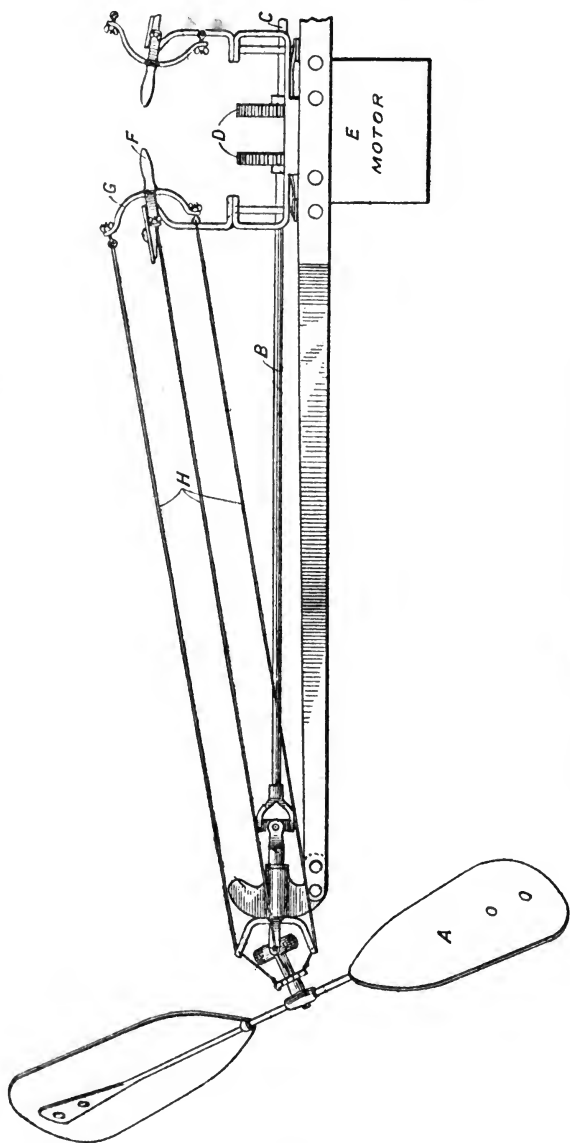

Fig. 58.—J. M. Wright's Propeller Drive.

down (*i.e.*, down at the front), and a downward movement of the handle will have an opposite effect. A movement of the handle

to the right or left will have no effect on the forward planes but will tilt one rear plane down and the other up, and at the same time actuate the vertical rudder.

22258 of Oct. 20, 1908.—J. M. Wright.

The propeller A, Fig. 58, is driven by a shaft B to which it is connected by a universal joint. A similar propeller is provided on the end of the shaft C, and the two shafts are driven by means of toothed wheels D by the motor E. A handle F, connected to a four-armed spider G, is employed to deflect the propeller in any desired direction by means of four cords H. A similar arrangement is provided for deflecting the other propeller.

23595 of Nov. 4, 1908.—W. Friese-Greene.

This invention consists in providing as propelling machinery a main motor which may be, for example, a petrol engine, a dynamo adapted to work as a motor, and storage batteries. During normal running the petrol engine drives the propellers, and any surplus power is employed in generating current by means of the dynamo, which current is stored in the storage cells. Should the petrol engine fail, the dynamo, working as a motor, obtains current from the storage batteries and drives the propellers. In the drawings the dynamo is shown as direct coupled to the engine, and the propellers are driven by chains.

24076 of Nov. 10, 1908. (Nov. 18, 1907.)—W. and O. Wright.

This invention relates to modifications of, or improvements in, the wing-warping and rudder devices described in the Wrights' prior patent, namely, 6732 of 1904. Referring to Fig. 59, the cords A at the front of the machine are fixed at their ends, so that the front edges of the two planes are rigidly braced together and are incapable of any movement relatively to each other. The rear edges only of the planes are moved, and this is accomplished by means of cords B, C and D, E which are connected respectively to the upper and lower ends of the two outer standards which at each end connect together the rear edges of the planes. The two centre standards at the rear of the machine are immovably braced together and are also rigidly braced to the two front standards, so that the whole of the central portion of the machine

and the whole of the front face of the machine together form a rigid structure. In addition to a rear vertical rudder M, a front

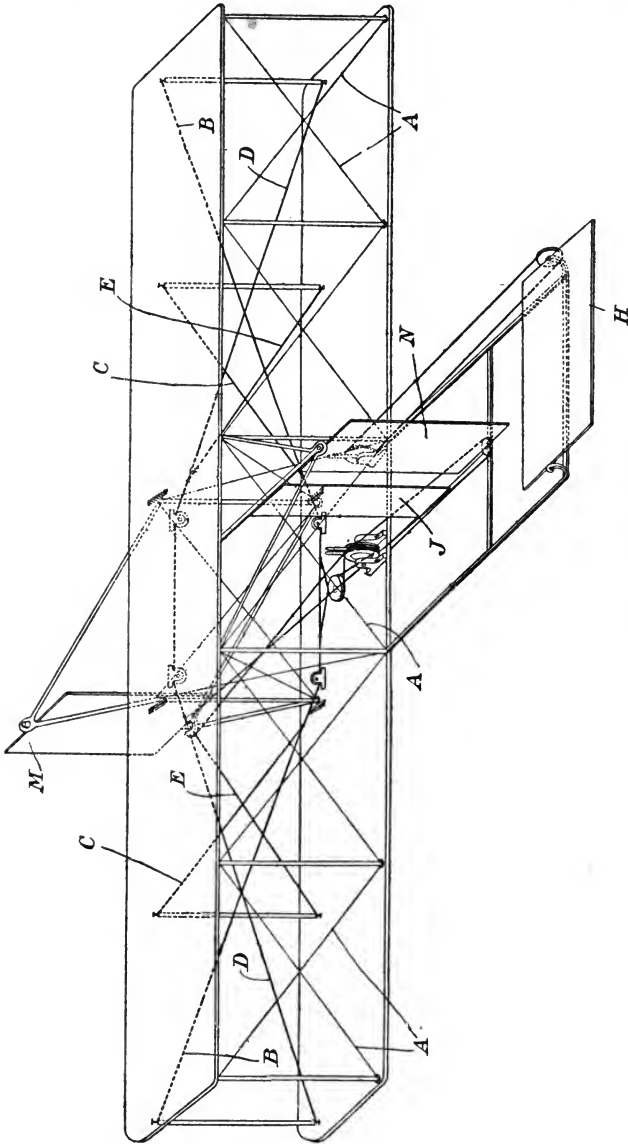

Fig. 59.—Wrights' Flying Machine.

vertical rudder N may also be employed, and the two rudders may be connected together so as to be actuated by the one

mechanism. A vertical stationary vane *J* is, or may be, also employed to assist the vertical rudder or rudders. *H* is a horizontal front rudder.

Claims are made for the means of warping the wings applicable to the new construction, but, in the author's opinion, the most important claims in the specification are the 1st and 2nd, which are as follows:—

1. In a flying machine, the combination with a single or multiple aeroplane having lateral portions capable of being adjusted while in flight to different angles of incidence on the right and left sides of the machine, of a vertical adjustable front rudder and a vertical adjustable rear rudder.

2. In a flying machine, the combination with a single or multiple aeroplane having lateral portions capable of being adjusted while in flight to different angles of incidence, of a vertical adjustable rudder and a fixed vertical vane co-operating therewith to form a turning couple.

24077 of Nov. 10, 1908. (Nov. 18, 1907.)—W. and O. Wright.

In order to compensate for the unequal resistance to advance of the two sides of a flying machine, when the angle of incidence at the two sides is different, vertical vanes or rudders *A*, *A* are arranged one at each wing tip as shown in Fig. 60, which is a

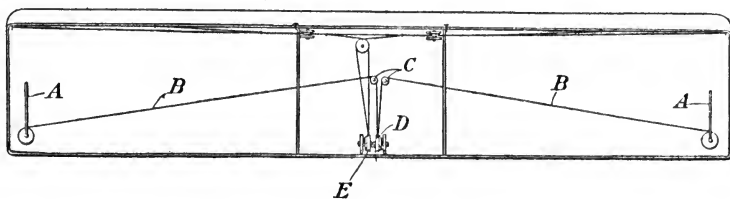

Fig. 60.—Wrights' Vertical Rudders.

plan of a bi-plane machine with the top plane removed. The vanes or rudders *A* are actuated by cords *B* which pass over pulleys *C* and can be tensioned by means of a lever which actuates the drum *D*. A corresponding and adjacent lever arranged to actuate a co-axial drum *E* is employed to operate the cords which control the warping of the wings.

The specification contains the following noteworthy paragraph:—

The lateral rudders may likewise be replaced by surfaces movable about axes normal to the line of flight, kept normally flattened down upon the planes of support and raised on the side of the machine which is presented at the smaller angle of incidence when a modification is made in the angles

of incidence of the wings ; for the same purpose there might likewise be employed longitudinal vertical surfaces arranged for example along the small sides of the aeroplanes, drawn at pleasure and brought forward by a return square on the extreme vertical rods connecting the horizontal superposed planes.

28026 of Dec. 23, 1908. (Dec. 26, 1907.)—R. Esnault-Pelterie.

The invention herein described and claimed consists in a hydro-pneumatic spring buffer intended to reduce the shock of landing of an aeroplane. The plunger 1, Fig. 61, is attached to the wheel of the machine, and is adapted to work within the cylinder 6 which contains oil 19 up to the level indicated. The cylinder is provided with diaphragms 9 and 12. The former contains a single opening 17 which can be very nearly closed by a disc 10 mounted on a spindle 18 which is guided in the upper diaphragm and is normally pressed down by a spring until the stop 11 makes contact with the boss of the diaphragm 12. A key 2 attached to the plunger 1 works in a double slot 8 formed in the cylinder. The shock of landing gives the plunger 1 a relative upward movement which compresses the spring 4 which is situated between the collars 3 and 5 carried respectively by the key and by the cylinder. The oil at first escapes rapidly through the hole 17 in the lower diaphragm and the hole 13 in the upper diaphragm, but the disc 10 is immediately forced upwards so as to nearly close the hole 17 and thus restrict the area of outflow. The shock of landing is thus cushioned, and the accumulated energy in great part absorbed. The upper space in the cylinder 16 is filled with air which also serves as a cushion. This air cushion is of use when the machine is running on its wheels before taking flight.

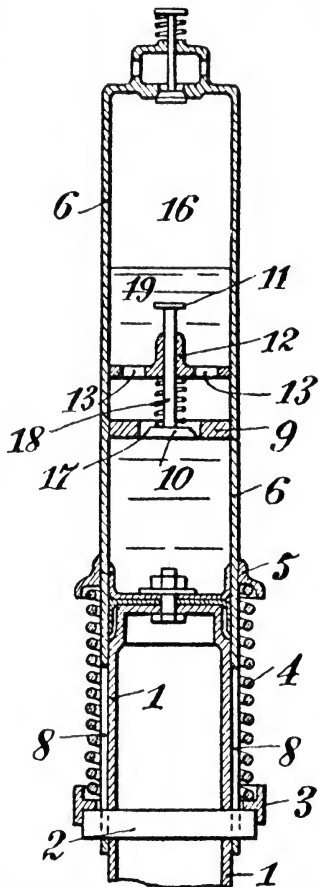

Fig. 61.—Esnault-Pelterie's Spring Buffer.

463 of Jan. 7, 1909. (Jan. 15, 1908.)—
L. Blériot.

The support *a*, Fig. 62, for the wheel of a flying machine is rigidly connected to the frame *b* of the machine so that it can be employed for other purposes than the support of the wheel. The wheel *d* is placed to the rear of the rod *a* and is carried by rods *f* and *h* which are pivotally connected to collars *g* and *i* carried by the rod so that the wheel can have an angular horizontal movement relative to the frame of the machine, and will act like a castor in always tending to place its plane in the line of motion of the vehicle. Moreover, the collar *i* can slide upwards on the rod *a*, being held down only by a spring *j*, so that the shock of landing is reduced.

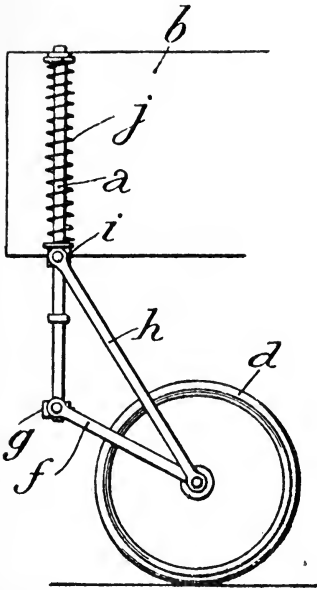

Fig. 62.—Blériot's Wheel Support.

750 of Jan. 12, 1909.—
A. V. Roe.

A flying machine, shown in side elevation in Fig. 63, is described in which three superimposed

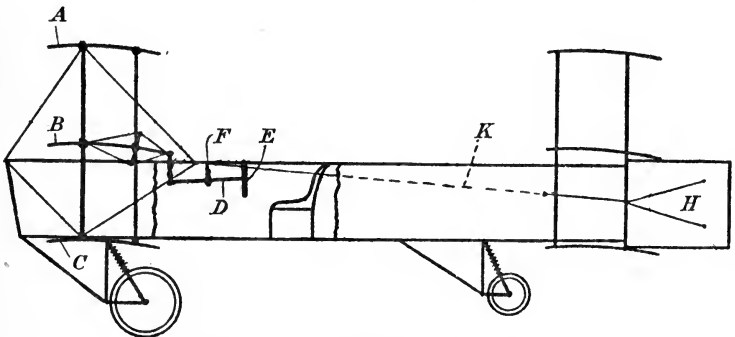

Fig. 63.—Roe's Flying Machine.

main planes A, B, C (two, or more than three, might however be employed) are connected together by a rigid front frame and

a flexible rear plane. The system of bracing which is employed is interesting, but cannot be described in this abridgment.

The steering rod *D* carrying the steering wheel *E* is pivoted at *F* so that, when the wheel is raised or lowered, the rear edges of all the planes are raised or lowered and, when the wheel is rotated one way or the other, the planes are raised at one side and lowered at the other, while the vertical rudder *H* is at the same time actuated by cords *K*.

2913 of Feb. 6, 1909. (Feb. 10, 1908.)—W. and O. Wright.

Wright.

This invention consists principally in a device for automatically maintaining the equilibrium of a flying machine. The horizontal

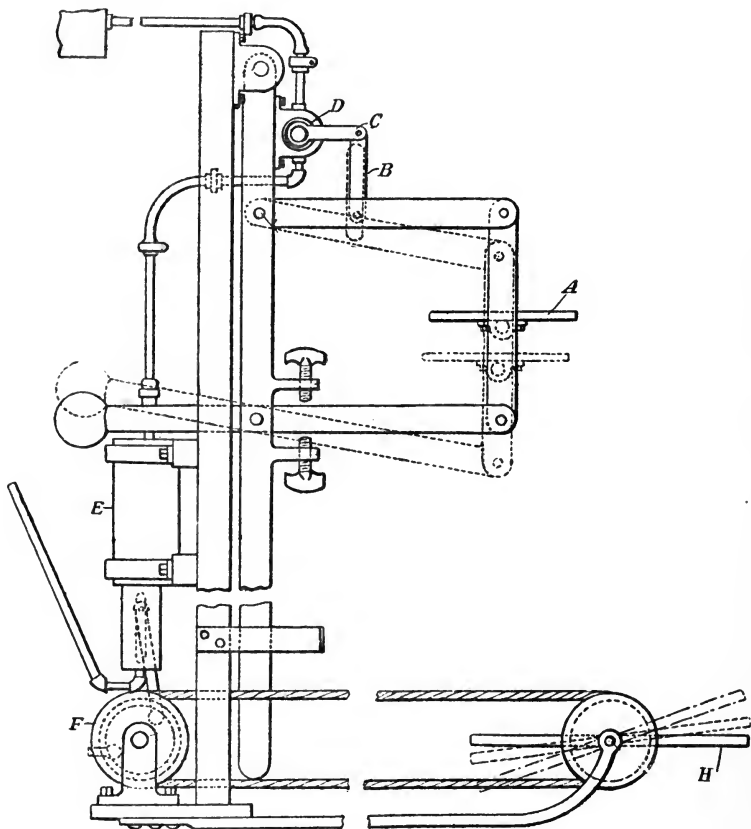

Fig. 64.—Wrights' Stabilisation Device.

vane A, Fig. 64, is supported in a framework which can be adjusted so that the vane makes such an angle with the main supporting surfaces as it is desired that this surface should maintain with the relative wind. If the relative wind at any time strikes the main planes at an angle of incidence greater than the angle between these planes and the vane A it will strike the latter vane on the underside and force it upwards. The vane will thus, by means of the link B and lever C, actuate a valve D which controls the admission of compressed air to a cylinder E. This cylinder actuates the drum F which operates the horizontal rudder H. The action of the vane A is therefore to right the machine.

A device is also described whereby, if the machine tilts laterally, a pendulum actuates a valve which controls the admission of compressed air to an engine which operates cords so as to warp the wings and deflect a vertical rudder.

The devices are described in great detail together with positive control arrangements.

**8118 of April 5, 1909, and 11021 of May 10, 1909.—
J. W. Dunne.**

The specifications of these patents are of interest, but cannot be satisfactorily abridged in the space here available.

The inventor proposes, with the object of obtaining automatic stability and freedom from oscillation, to construct the supporting planes as one or two pairs of rearwardly projecting rigid wings, a line joining the tips of any pair of wings passing behind the centre of gravity of the machine. (The machine in plan is like a broad arrow.) The angle of incidence of each wing decreases from the body of the machine to the wing tip.

**10098 of April 28, 1909. (May 22, 1908.)—
R. Esnault-Pelterie.**

This invention relates to air propellers, the blades of which are pivoted to the boss in such a manner that automatic adjustment can take place. Figs. 65 and 66 are exact reproductions of the drawings. The description and explanation given in the specification with reference to these figures are not as full as they might with advantage have been, and it would not be safe to attempt an abridgment. Fig. 66 is said to be a section on the line XX, of Fig. 65, and v is said to represent the direction

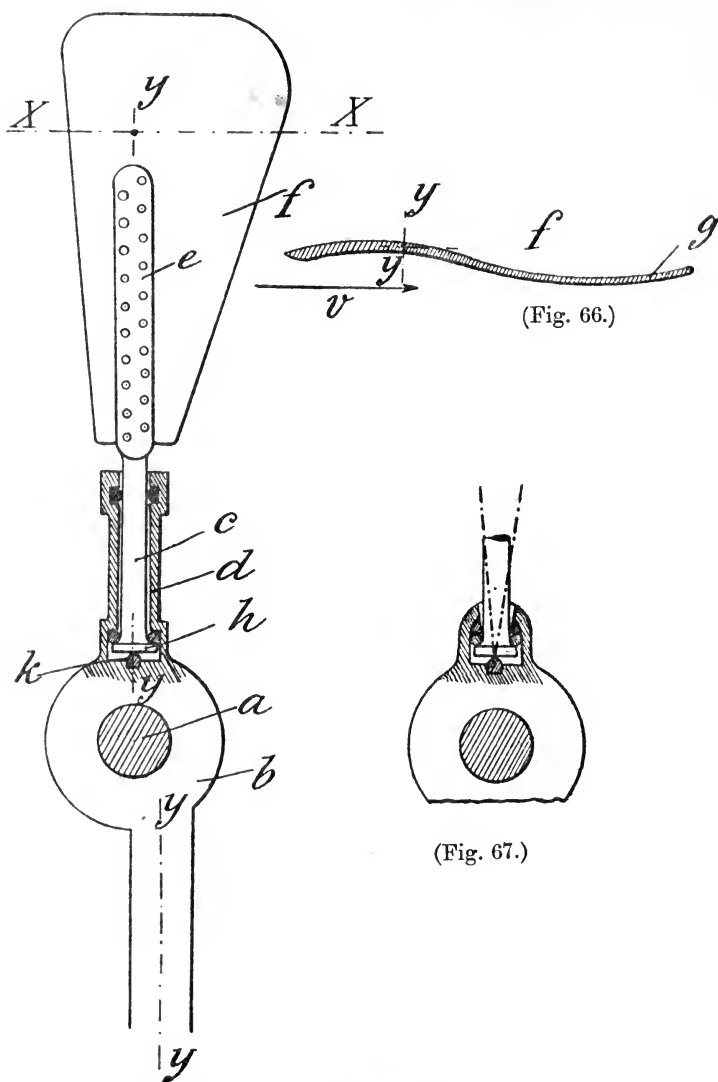

Fig. 65.—Esnault-Pelterie's Movable Blade Propeller.

of flow of the air encountered by the sectional element of the blade under consideration. The first claim of the patent is important: it reads as follows:—

A helical propeller whereof the blades, which are mounted on arms adapted in known manner to rotate on their axes, are made with a concave

surface and a convex surface such that the blades are automatically and correctly turned into the position suitable for the speed of travel, substantially as described.

Fig. 67 shows a modified connection for the propeller arm, a spherical socket being employed so that not only can the arm turn on its axis, but it can, as indicated by the dotted lines, assume different inclinations.

10422 of May 3, 1909.—F. W. Lanchester.

In the flying machine, shown in Fig. 68, A, A are the main

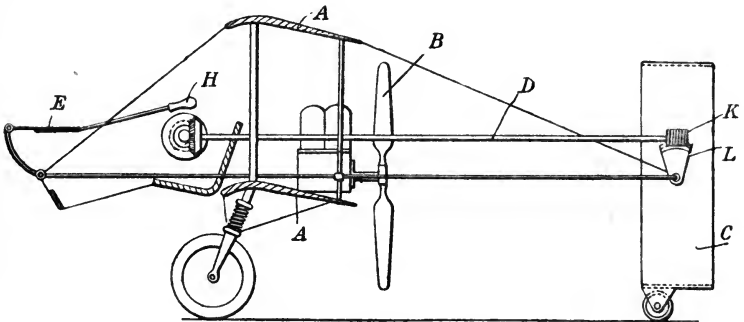

Fig. 68.—Lanchester's Steering Device.

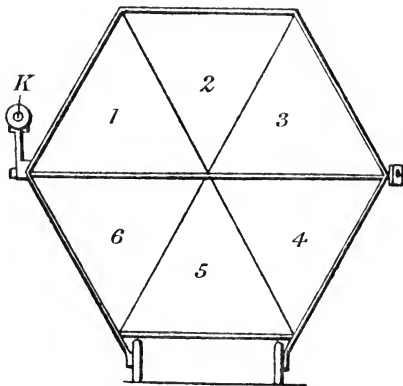
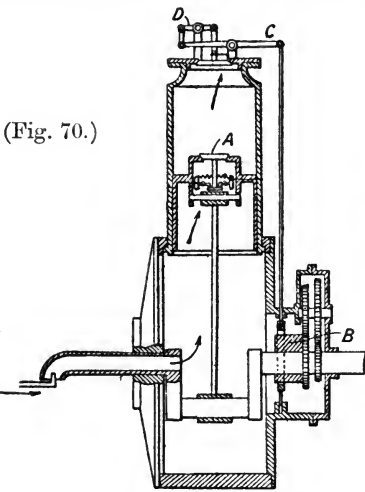

Fig. 69.—Lanchester's Box Rudder.

supporting planes and B is the propeller. The box rudder C is of multicellular form and may be constructed, as shown in end elevation in Fig. 69, to consist of six cells, 1, 2, 3, 4, 5, 6. The

rotary motion given to the air by the propeller acts to a certain extent on the surfaces forming the rudder, and so helps to neutralise the re-active torque of the propeller which tends to turn the flying machine about an axis parallel to the axis of rotation of the propeller.



(Fig. 70.)

The angular position of the rudder C can be altered by hand by means of the spindle D, worm K, and toothed segment L. E is a forward rudder pivotally supported at its forward edge and free to take up any angular position in a vertical plane unless controlled by the handle H.

**12036 of May 21,
1909.**

**(July 6, 1908.)—
Soc. des Moteurs
Gnome.**

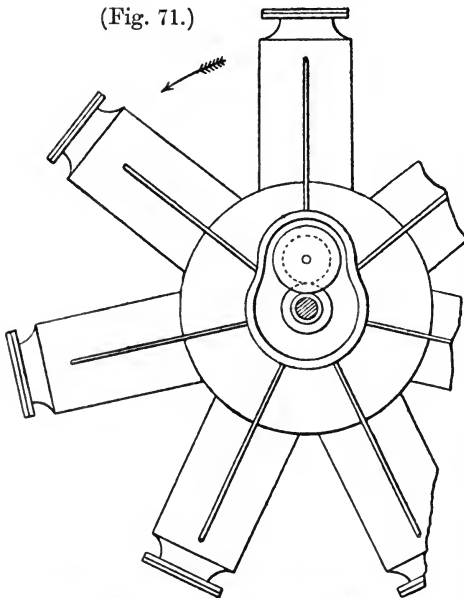

(Fig. 71.)

This patent relates to explosion motors of the type in which the cylinders rotate about a fixed axle or crank shaft. Figs. 70 and 71 are reproduced from the specification. The claims are as follows:—

1. An explosion motor with radial cylinders rotating round a fixed axle in which the explosive mixture is introduced into the casing by the hollow shaft, and is admitted into the explosion chamber by an admission valve mounted on the piston, characterised by the exhaust valve of each cylinder being

Figs. 70 and 71.—Gnome Motor.

arranged on the bottom of said cylinder so as to allow the burnt gases to escape radially from the interior to the exterior, their evacuation being assisted by centrifugal force, substantially as described.

2. Motor as in Claim 1, wherein the admission valves mounted on the pistons are automatic and balanced so as to be able to open under the effect of the suction produced in the explosion chambers by the evacuation of the burnt gases, thus producing an automatic clearance of these gases.

3. The improved rotary motor, substantially as herein described and illustrated in the annexed drawing.

In Fig. 70 the admission valve is shown at A. It is balanced by two weights which are controlled by a spring so that it is uninfluenced by the centrifugal force caused by the rotation of the cylinder. The spring is adjusted to be of sufficient strength to allow the valve to open when, during the suction stroke of the engine, the pressure on the side of the valve adjacent to the crank shaft is greater than the pressure on the other side of the valve. The exhaust valve is controlled by a cam B, which is caused to rotate at the speed requisite to open the exhaust valve of each cylinder once in every two revolutions. One cam serves to actuate the valves of all the cylinders, levers C and D being provided for each cylinder. The levers are balanced so as to be unaffected by centrifugal force as regards their action on the valve.

12256 of May 24, 1909.—A. M. Herring.

A and B, Fig. 72, represent the two main supporting

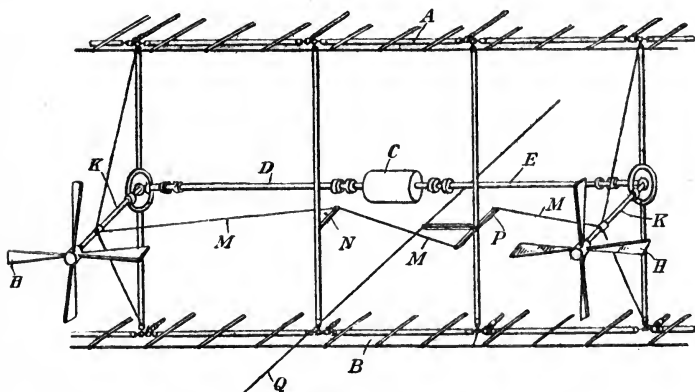

Fig. 72.—Herring's Gyroscopically-Controlled Propellers.

surfaces of a flying machine, and C diagrammatically represents the motor which drives the shafts D, E. H, H are the propellers

which are rotated in opposite directions. The propeller shafts K, K are so supported and so driven from the motor shafts that they can swing in horizontal planes but are prevented from swinging in vertical planes. When the machine in flight tilts up or down, considered longitudinally, the propeller shafts, due to gyroscopic action, will either swing towards each other or away from each other. In either case, by means of the cords M, M, lever N, and T-shaped lever P, they will actuate the cord Q, which is arranged to control the inclination of fore and aft rudders or auxiliary supporting surfaces, so as to effect the righting of the machine.

Other devices involving the employment of independent gyroscopes are also described in connection with the fore-and-aft and transverse stability of flying machines.

16068 of July 9, 1909. (July 15, 1908.)—W. and O. Wright.

A flying machine double rudder, shown in Fig. 73, consists of

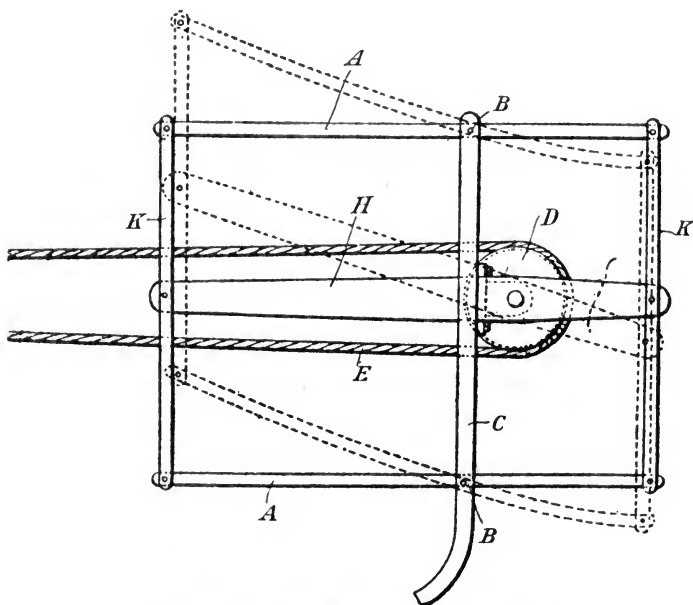

Fig. 73.—Wrights' Cambered Rudder.

two planes A, A, pivoted at B, B to the frame C of the machine. A pulley D, also pivoted to the frame, is adapted to be actuated by a rope E, and is rigidly connected by means of its shaft to levers H of which one only is seen. The levers are connected by links K, K to the ends of the rudder surfaces. The ratio of the two arms of the levers is not the same as the ratio of the two portions of the rudder surfaces, so that the rudder surfaces, besides being swivelled with the lever, are bent into the curved forms indicated by the dotted lines, that is, the rudder surfaces are cambered, the concave side being presented to the relative wind. The longitudinal bars of the rudders may, if desired, be formed in two portions pivotally connected at B, and the links K may also be made in two portions pivotally jointed at the points where they are connected to the end of the levers. The device may be applied to other than horizontal rudders.

**23166 of Oct. 11, 1909.—H. L. Short, A. E. Short,
and H. O. Short.**

This invention also relates to means for altering the angle of a rudder and at the same time flexing or cambering it so that it will receive the air pressure on its concave side. The desired camber is obtained by proportioning the ribs of the rudder.

The frame 10, Fig. 74, carries the uprights 3, 7. The ribs 5 of the double rudder are made of diminishing thickness towards the forward end at which they are connected to a transverse member 1 hinged at 2 to the uprights 3. The ribs 5, at an intermediate portion of their length, are fastened to transverse members 4 which are anchored by links 8 to brackets 14 which are rigidly connected to the uprights 7. The shaft 16, supported in bearings carried by the frame 10, is operated by the crank 19 and the connecting rod 20, and actuates levers 17 which, by means of links 18 and rods 15, give the desired movement to the rudders. The dotted lines give the curve of the rudders when the rear ends are deflected upwards. It will be noted that the deflecting force is applied to the rudders at one (the rear) edge only.

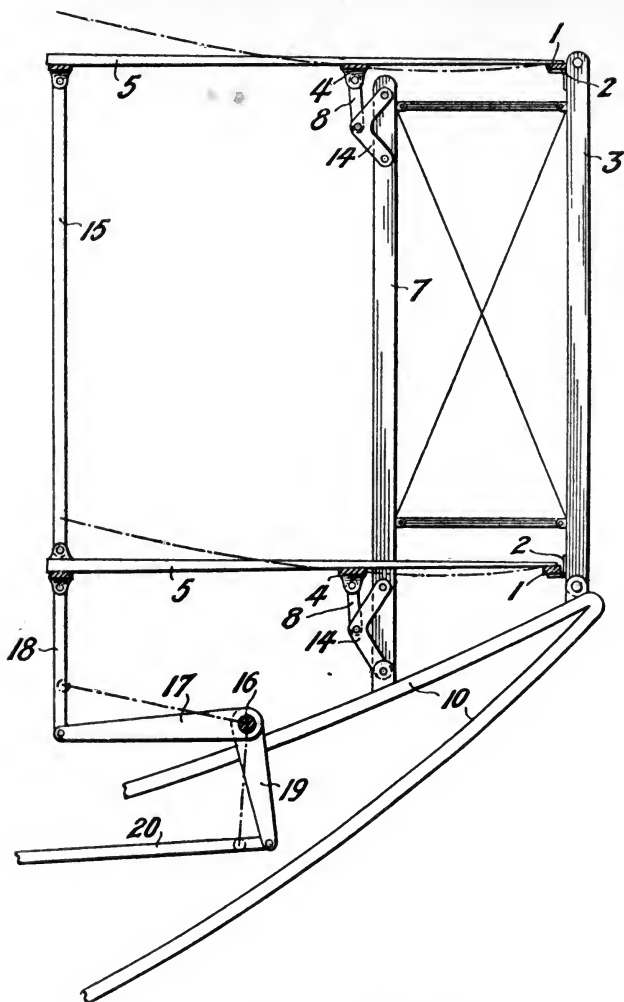

Fig. 74.—Shorts' Cambered Rudder.

2611 of Feb. 2, 1910.—H. L. Short, A. E. Short, and
H. O. Short.

This patent, granted to the same parties as the last reviewed, relates to another device for giving camber to a rudder, but the device in the present instance is said to be also suitable for the main supporting surfaces. Referring to Fig. 75, a fabric 4 is

directly connected, say at its forward edge, to a frame 1, 2, 3, 3, while the rear edge of the fabric is connected to the frame by a device comprising the use of a spring or springs. Different spring arrangements are described. In the device shown in the figure, spiral springs 6 are interposed between the frame and a

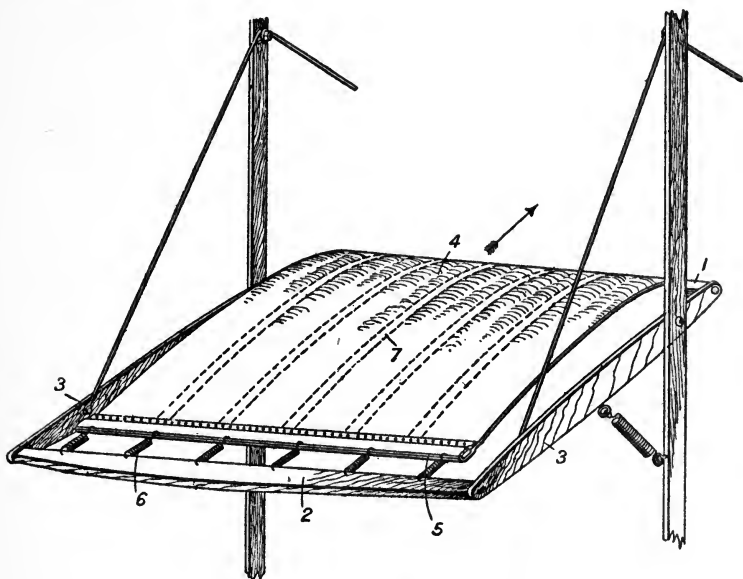

Fig. 75.—Shorts' Cambered Plane or Rudder.

bar 5 to which the fabric is attached. Laths or other flexible members 7 may be placed in longitudinal pockets provided in the fabric, and these laths are preferably constructed, as shown at 5 in Fig. 74, with the forward end of less depth or thickness, and therefore more flexibility, than the rear end.

4515 of Feb. 23, 1910.—P. R. Grace.

This invention relates to a device for tensioning the flexible or wire ties employed in the construction of aeroplanes, etc. As shown in Figs. 76 and 77, the device consists of two annular plates 6, 6, held together by four screws 7. The wires 4, 5 at their point of crossing pass between the two plates and are secured in tension by tightening the screws 7. If one of the

wires should become slack from any cause, the clamping device is loosened and moved a small distance along the other wire (which is still in proper tension), so altering the point of crossing and bringing the slack wire to the requisite degree of tension as shown by the dotted lines in Fig. 76. The screws are then tightened

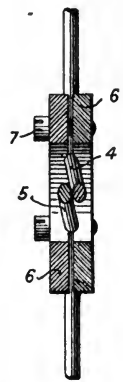
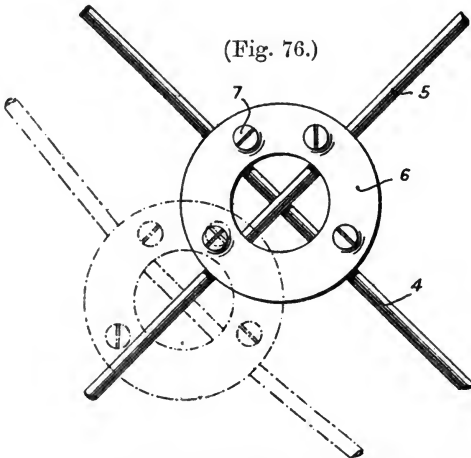

Figs. 76 and 77.—Grace's Clamping Device.

to again secure the wires together. If, however, both wires should become slack, the device is loosened and moved down vertically until the wires again have the proper tension: the screws are then tightened.

14760 of June 18, 1910. (July 1, 1909.)—Société Antoinette.

This relates to a device for procuring a helicoidal deformation of the wings by means of ropes which pass over upper and lower pulleys and are attached to the front or rear edges of the wings, the two wings being warped in opposite directions.

SECTION III

BRITISH PATENTS RELATING TO HEAVIER-THAN-AIR FLYING MACHINES
FROM THE BEGINNING OF 1860 TO THE END OF 1908
ALSO APPLICATIONS FOR PATENTS FROM JANUARY 1, 1909, TO
JUNE 30, 1910

ACCORDING to the classification adopted by the British Patent Office nearly all the patents enumerated below are included in the class entitled "Aeronautics." This class, however, includes many inventions which are not of interest in connection with heavier-than-air machines, and which have consequently been excluded by the author from the lists given below. Patents for balloons and the like have, as a rule, been omitted; but, where a propeller, rudder, or other device, is described or claimed which was considered by the author as of interest to inventors or manufacturers of heavier-than-air machines, the patent has been included. The Patent Office classification, although of great use for the purpose for which it is intended, could not be, and has not been, relied upon for the present purpose, but an independent selection has been made.

As the specifications of a large number of applications for patents dated as of 1909 have not yet been published, this year, along with the first eight months of 1910, has been treated differently from the previous years. It has been impossible to make a selection of the patents applied for during this period of twenty months, and all the applications considered by the Patent Office to be comprised in the class "aeronautics" have been included, with an additional few which were considered relevant. Some of these applications may not be of interest in connection with heavier-than-air machines, and others may be subsequently abandoned and no patent granted.

In many cases inventions are communicated from a party abroad to a party (usually a patent agent) resident in this country. In such cases the name of the communicatee is placed first, and the name of the communicator is printed immediately afterwards within parentheses.

1860.

- 561 Smythies, J. K.
1598 Stevens, C. (Rabbat, C. F.).

1861.

- 1929 Ponton d'Amecourt, G. L. M.,
Viscount de.
2420 Phillips, J. S.

1862.

None.

1863.

None.

1864.

- 2030 Brooman, R. A. (Couturier,
C. E. F.).
2464 Fontaine-Moreau, P. A.,
Comte de (Nesmond, P. C.).

1865.

None.

1866.

- 1143 Butler, J. W.
1571 Wenham, F. H.
2489 Boulton, M. P. W.
3262 Boyman, R. B.

1867.

- 473 Kaufmann, J. M.
696 Boulton, M. P. W.
1392 Smyth, W.
1525 Kaufmann, J. M.
1982 Craddock, T.
2115 Butler, J. W., and Edwards,
E.
2229 Nelson, J. E.
2504 Smythies, J. K.

1868.

- 392 Boulton, M. P. W.
412 Masey, P. E.
568 Hullett, J.
1005 Boulton, M. P. W., and
Imray, J.
1178 Spencer, C. G.
1988 Boulton, M. P. W.
2680 Hunter, J. M.

1869.

- 1124 Abel, C. D. (Jombart, E.).
1769 Michel, M.
2827 Noble, W. H. (Marriott, F.).

1870.

- 440 Villeneuve, A. H. de.
1469 Harte, R.
2040 Ross, W. M.

1871.

- 728 Osselin, A. F.
3067 Wilson, G.
3238 Moy, T., and Shil, R. E.

1872.

- 411 Brown, D. S.
821 Soul, M. A. (Haenlein, P.).

1873.

- 2346 Brown, D. S.
2396 Gedge, W. E. (Fréville, E.).
3194 Wirth, F. (Beins, H.).
3309 Fleury, A.

1874.

- 81 Vogt, H. C. de.
265 Monckton, E. H. C.
777 Ridley, J. D.
2808 Moy, T.

1875.

- 140 Cave, J. O. C.
574 Boulton, M. P. W.
4151 Smythies, J. K.

1876.

None.

1877.

- 3974 Brannon, P.

1878.

- 3346 Brewer, E. G. (Bastien, J. B.).

1879.

- 2376 Brearey, F. W.

1880.

- 4871 Stevenson, R.

1881.

- 430 Capel, T. J., and la Pauze,
A. de.
3561 Kerkhove, A. H. van de, and
Snyers, T.

1882.

- 34 Smythies, J. K.
1229 Lake, A. W. (Hyatt, T.).
4585 Maughan, B. W., and Waddy,
S. D.
5251 Jensen, P. (Koch, G.).

1883.

- 1552 Maughan, B. W., and Waddy,
S. D.
2264 Sjöström, P.
4245 Johnson, J. H. (Delaurier,
E. J.).

1884.

- 7 Smythies, J. K.
2339 Quartermain, W.
2589 Cornelius, W.
5942 Kosztovits, O. I.
12503 Smart, G. E.
13768 Phillips, H. F.
14038 Armour, J.

1885.

- 5118 Henderson, A. C. (Bontems,
B.).
9193 Owen, R. G.
10068 Griffiths, T.

1886.

- 1830 Waelde, J.
7015 Redfern, G. T. (Foster, J. S.).

1887.

None.

1888.

- 9725 Middleton, H.

1889.

- 3360 Craig, J.
5199 Millet, F. T.
10359 Maxim, H. S.
14737 Otto, E. C. F., and E. C. F.
16883 Maxim, H. S.

1890.

- 12349 Griffiths, T., and Beddoes,
H. W.
13311 Moore, R. F.
20435 Phillips, H. F.

1891.

- 13311 Phillips, H. F.
19228 Maxim, H. S.
20032 Hutchinson, W. N.
21885 Middleton, H.

1892.

- 634 Walker, J. C.
3872 Quentin, A. A. H., and
Guattari, A., and C.
9106 Crease, J. F.
15977 Battey, S. B.

1893.

- 1064 Stark, T. A., and Ortlepp,
J. C.
9775 Middleton, H.
10852 Maxim, H. S.
16269 Thompson, W. P. (Koch, G.).
17859 Decazes, Vicomte.

1894.

- 3128 Mills, F. E., and Deming,
H. A.
7919 Hofmann, J.
9347 Booth, H. S.
10034 Haddan, H. J. (Piquet & Co.).
10819 Golby, F. W. (Oetling, C.).
11941 Hofmann, J.
13996 Thompson, W. P. (Palacios,
R. de, and Goetjes, W.).
15128 Lautenschläger, P. E.
19264 May, R. E.
22597 Birnbaum, E. J. W. P.
23564 Borgfeldt, N. H.

1895.

- 6 Moore, R. F.
4125 Macdonald, T.
5938 Barbé, P. E. S.
7271 Los Olivos, E. C. de.
9390 Roeper, C. H. O.
10239 Marshall, J.
22011 Hofmann, J.
25050 Pennington, E. J.

1896.

- 3657 Roots, J.
 9108 Waelde, J., and Abelspies,
 J. F. C.
 9144 Pilcher, P. S.
 12469 Davidson, G. L. O.
 17119 Pennington, E. J.
 25716 Simms, F. R.

1897.

- 2351 White, J. D.
 3608 Lanchester, F. W.
 5739 Molesworth-Hepworth, E. N.
 6320 Simms, F. R.
 7012 Diesel, R.
 9734 Marshall, J.
 9864 Beenen, B. R.
 10620 Maxim, H. S.
 13372 Chanute, O.
 14334 Dufferin, H. J.
 15221 Moy, T. (Chanute, O., and
 Herring, A. M.).
 15987 Adams, A.
 18663 Krauss, R.
 18935 Hardacre, G.
 26391 Wolf, Carl, Baron von.
 30932 Carter, W. T.

1898.

- 10968 Le Rond, L. J. J. B.

1899.

- 3637 Blunt, A. H. P.
 7442 Bowyer-Smyth, D. M.
 8019 Blunt, A. H. P.
 17611 Brown, B.
 17913 Baumann, A.
 17977 Walker, W. G.
 20739 Armitage, C.
 21329 Placet, P. E.

1900.

- 12514 Kalisch, E.
 13241 Groombridge, C., and South,
 W. A.
 17367 Gathmann, L.
 17371 Lehmann, E.
 18287 Vergara, A.
 19199 Filippi, A. P., and Macler, C.

1900—continued.

- 19424 Tarbe, J.
 20115 Blunt, A. H. P.
 20368 Simms, F. R.

1901.

- 346 Blunt, A. H. P.
 883 Flynn, P. J.
 1066 Nicholl, G.
 2389 Brüncker, E.
 3691 Léger, M.
 8320 Tarczal, V., Roheim, E., and
 Simko, J.
 15960 Porak, W.
 16100 Griffiths, W. J.
 16856 Moy, T.
 18862 Tuckfield, C.
 19995 Swingle, E. L.

1902.

- 8681 Haas, T.
 9251 Murray, T. B., and Fulton,
 F. O.
 9706 Blunt, A. H. P.
 10267 Fraser, J.
 11616 Lipkowski, J. de.
 11982 Seiberi, J.
 13499 Krakow, A. K. R. A.
 14145 Le Rond, L. J. J. B.
 15110 Bausset, A. de.
 15403 Nemethy, E.
 16698 Sampson, D.
 21680 Middleton, H.
 23161 Manker, C. A.
 24587 Mott, S. D.
 25723 Groombridge, C., and South,
 W. A.
 27027 Cochrane, W.

1903.

- 878 Lebaudy, P., and P.
 1943 Graham, C. K.
 2688 Baumann, A.
 2826 Wellner, G.
 7179 Winsch, J., and Lazarowicz,
 J.
 7763 Haylock, D., and R. A.
 11719 Roux, E.
 12149 Booth, H. S.

1903—*continued.*

- 15748 Maxim, Sir H. S.
 18768 Bourcart, M.
 19347 Green, W. A.
 20169 Bratschie, A.
 20702 Stewart, J.
 23380 Long, L.
 24701 Howell, T. J.
 25378 Barclay, J.
 25444 Blunt, A. H. P.
 26821 Powell, B. F. S. Baden-.
 27212 Brennan, L.

1904.

- 1446 Avery, A. H.
 1543 Hawkins, E. C.
 1763 Macleod, M. C.
 1778 Hutchinson, F. W. H.
 1788 McMullen, G.
 3120 Maxim, Sir H. S.
 3307 Vojácek, L.
 3336 Visoly, S. H. de.
 3929 Crawford, R. L.
 4901 Adams, H.
 5787 Hückel, H.
 6732 Wright, O., and W.
 8418 Hoernes, H.
 9506 Parker, T.
 13502 Delprat, A.
 13747 Benston, E.
 14327 Winegarden, A. van, and
 Crawford, G. M.
 14367 Mutti, A.
 15798 Thompson, W. P.
 21477 Marinakis, A.
 23833 Jones, J. M.
 24807 Knäpper, G.
 26891 Preidel, W.
 28264 Westlake, A. J.

1905.

- 3186 Morgan, F. S.
 3214 Mumford, E. R.
 3456 Bennett, J. F., Mastin, J.,
 and Platts, W.
 3990 Dufaus, A., and H.
 7603 Forlanini, E.
 7802 Shanks, J., and Taylor, A. G.
 9767 Becht, L. A.

1905—*continued.*

- 11748 Blunt, A. H. P.
 15613 Booth, H. S.
 15698 Mumford, E. R.
 16838 Wondra, F.
 17935 Lanchester, F. W.
 25395 Simms, F. R.

1906.

- 620 Gambin, A.
 1436 Middleton, H. M.
 1747 Montgolfier, P. de.
 2803 Renner, E., M., L., and A.
 4204 Fauber, W. H.
 6443 Powell, B. F. S. Baden-.
 6502 Rebikoff, W.
 7377 Ellehammer, J. C. Hansen.
 8316 Gilbert, W. V.
 8868 Turnbull, W. R.
 9804 Brandl, A.
 10757 Boulton, A. J. (Maul, A.).
 11699 Dippel, C.
 13959 Lentz, H., and Bellens, C.
 14003 Gibon, T.
 16626 Harper, W.
 18581 Armitage, C.
 19259 Cornu, J., and P.
 19488 Hardie, A.
 20952 Garsed, J. L.
 21514 Homola, J.
 26099 Roe, A. V.
 26414 Taaffe, R.
 26764 Vaniman, M.
 27312 Thompson, W. P.
 27817 Deixler, J.
 28710 Clarke, T. W. K.
 29061 Wynne, W. R.
 29308 Murray, W. E.

1907.

- 16 Kay, M.
 1004 Wallace, G.
 1391 Wallin, B. H.
 1831 Eder, J.
 1960 Davidson, G. L. O.
 2084 Burgess, W. E.
 2353 Lucas, E.
 2479 Dalton, P.
 4033 Tasker, E. E.

1907—*continued.*

- 4043 Laitte, L. B. de.
 4245 Porter, J. R.
 4659 Hewitt, S. R.
 4835 Hammond, E. V.
 6946 Bliven, A. P.
 7059 Nial, M.
 7156 Roots, J. D.
 7491 Hutchinson, F. W. H.
 7887 Hutchinson, F. W. H.
 7894 Thomas, F. W.
 8435 Saward, J.
 8966 McCurd, W. A.
 9119 Reden, U. von.
 9413 Lanchester, F. W.
 9413a Lanchester, F. W.
 9594 Garsed, J. L.
 9691 Powell, B. F. S. Baden-.
 10004 Bode, E.
 10961 Schülke, J.
 11188 Buch, M.
 11590 Hardie, A.
 12848 Peugeot, A., and Huber, T.
 (trading as Soc. A. Peugeot;
 T. Huber & Co.), and
 Lostalot, H. de.
 13905 Zizke, E.
 15438 Buckwalter, C. L.
 15457 Wallin, B. H.
 15590 Porter, J. R.
 15796 Simms, F. R.
 15890 Addis, F. H.
 16484 Lindkvist, E. E.
 17156 Forlanini, E.
 17366 Colquhoun, J. A.
 17725 Webb, H. B.
 18158 Frossard, J.
 18559 Gathmann, L.
 19822 Pomianowski, R. A.
 21290 Clarke, T. W. K.
 21923 Chappell, C. A.
 22273 Davies, C. J.
 23307 Day, S. A.
 23459 Raggett, J. J.
 23553 Watson, P. A.
 24247 Scott, B. D., and W. E.
 25295 Taaffe, R.
 25518 Antoni, G., and U.
 26000 Hennebique, F.

1907—*continued.*

- 26069 Bedell, B. H.
 26884 Bjelovucic, M. S.
 27221 Fadda, A. S., Lorenzo, J. di,
 and Aeroplane Co.
 27408 Straka, J.
 27552 Cloud, J. W.
 27805 Connolly, B.
 28034 Pelterie, R. Esnault-.
 28590 Capone, F.

1908.

- 84 Neyen, E.
 221 Pelterie, R. Esnault-.
 1035 Garsed, J. L.
 1258 Pelterie, R. Esnault-.
 1307 Winderlich, A.
 1445 Fronz, F.
 1593 Ferrero, M.
 1683 Heeren, O.
 2216 Larkin, G. F., and Bowden's
 Patents Syndicate, E. M.
 2493 Wilson, E. F.
 2588 Blériot, L.
 2651 Thompson, W. P.
 2808 Dunne, J. W., and Hunting-
 ton, A. K.
 4519 Edwards, A. H.
 4788 Motorluftschiff-Studienges.
 4842 Bernd, E. von.
 5220 Lester, E. J., and Best, W. G.
 5310 Chantraine, J.
 5312 Beach, S. Y., and White-
 head, G.
 5471 Kerwat, G.
 5949 Mutti, A., and Mond, R. L.
 5977 Cervelli, J., Molinari, J., and
 Bernasconi, J.
 7129 Capone, F.
 7205 Kay, M.
 7370 Saward, J.
 7632 Mielcarek, W. S.
 8118 Solon, M. F., and Tellwright,
 W.
 8591 Warswick, A.
 8627 Hart, G. W.
 8628 Demoulin, A.
 8643 Pelterie, R. Esnault-.
 8842 Shadbolt, L. P.

1908—*continued.*

9069 Blériot, L.
 9898 Brown, C. R. B.
 9970 Humbert, V.
 10528 Pelterie, R. Esnault-.
 11155 Piffhard, H. H.
 11763 Fairweather, W. (Lake, S.).
 11905 Skousès, P.
 11948 Wisniewski, V.
 12013 Garsed, J. L.
 13315 McLean, R.
 13809 Lorenzen, C.
 14327 Deixler, J.
 15924 Clarke, T. W. K.
 16030 Campa, P.
 16153 Wood, F.
 16300 Tzimbalist, I. O.
 16606 Greene, W. Friese-, and
 Friese-Greene Patents.
 16941 Lindkvist, E. E.
 17014 Gaunt, J.
 17131 Bartelt, F. L.
 17150 Weiss, J.
 17370 Montjustin, R. d'Equivilley-.
 17855 Schroeder, F. W.
 17877 Dufwa, F. W.
 18877 Kober, M.
 19677 Fredrikson, A. J.
 19805 Hare, E. H.
 19825 Klupathy, E., and Berger, C.
 19982 Fraser, J. E.
 20038 Maxim, Sir H. S.
 20433 Silverston, A. R.
 20694 Dontre, A. F. J.
 20785 Blériot, L.
 20822 Schmid, E., and Bauer, H.
 20916 Humphreys, J. E.
 21074 Humphreys, J. E.
 21092 Tribelhorn, A.
 21261 Porter, J. R.
 21363 Evans, W. E.
 21445 Degn, P. F.
 21497 Blériot, L.

1908—*continued.*

21498 Penkala, R., and E.
 21618 Danovan, J.
 21656 Thayer, R.
 21668 Howard, W. F.
 21754 Grosclaude, D. A. L.
 21952 Britain, W.
 22209 Mark, W.
 22238 Humphreys, J. E.
 22258 Wright, J. M.
 22384 Baron, F. E., and M.
 22809 Perks, E.
 22943 Geest, K. L. W.
 23104 Garsed, J. L.
 23129 Hammant, W.
 23208 Taylor, F. W. T.
 23316 Garsed, J. L.
 23347 Holle, A. A.
 23595 Greene, W. Friese-.
 23618 Schütz, S.
 23798 Mercer, I. E.
 24076 Wright, W., and O.
 24077 Wright, W., and O.
 24148 Degn, P. F.
 24344 Fauber, W. H.
 24441 Cloud, J. W.
 24617 Peache, G. A.
 24682 Garsed, J. L.
 24928 Tacquin, A.
 25315 Thompson, W. P.
 26617 Beilharz, G.
 26827 Forbes, Sir C. S.
 26924 Sturgess, G., and C.
 27771 Babillot, G.
 27812 Smith, G. P. B.
 28015 Steinhaus, E. E.
 28026 Pelterie, R. Esnault-.
 28027 Pelterie, R. Esnault-.
 28028 Pelterie, R. Esnault-.
 28119 Phillips, A.
 28273 Forbes, Sir C. S.
 28321 Fawcett, J.
 28558 Boulton, A. J.

1909.

47	2932	6154	8602	10468	12269	14638	16623
101	3144	6310	8687	10479	12305	14645	16677
123	3202	6366	8828	10495	12369	14666	16707
205	3412	6378	8849	10540	12446	14668	16747
217	3455	6414	8866	10761	12536	14682	16785
307	3503	6500	9006	10764	12556	14685	16786
463	3535	6568	9060	10869	12670	14921	16829
600	3616	6598	9068	10875	12728	14922	16868
704	3645	6647	9074	10990	12775	14927	16971
750	3697	6648	9181	11021	12814	14958	17053
753	3728	6745	9235	11069	12846	14990	17131
755	3837	6869	9239	11090	12856	15013	17173
771	3908	6966	9295	11100	12907	15022	17291
863	3932	6989	9303	11141	12925	15109	17295
962	3962	7057	9321	11153	13054	15110	17307
1051	3965	7061	9388	11197	13108	15195	17310
1303	4006	7084	9500	11279	13133	15233	17343
1351	4097	7105	9512	11299	13270	15271	17456
1402	4217	7209	9519	11367	13293	15291	17552
1497	4348	7237	9525	11395	13319	15402	17569
1514	4473	7349	9608	11448	13417	15415	17613
1528	4525	7395	9609	11498	13418	15422	17668
1556	4607	7501	9610	11501	13477	15510	17678
1632	4624	7503	9611	11504	13608	15542	17811
1639	4642	7524	9616	11523	13618	15564	17857
1640	4803	7548	9635	11534	13651	15577	17986
1656	4812	7666	9687	11536	13670	15587	17993
1709	4945	7667	9805	11638	13706	15637	18008
1803	4954	7774	9843	11814	13726	15675	18033
1909	5133	7792	9846	11819	13774	15677	18040
1999	5221	7987	9857	11934	13791	15801	18041
2111	5391	7998	9983	11960	13818	15831	18055
2131	5550	8011	9989	11961	13853	15885	18068
2165	5628	8086	9990	11962	13965	15940	18095
2166	5649	8118	10006	11963	14031	15951	18096
2304	5662	8179	10098	12003	14077	15963	18097
2397	5699	8192	10131	12036	14188	16010	18116
2446	5716	8282	10142	12042	14355	16011	18138
2467	5720	8285	10154	12044	14373	16045	18174
2540	5910	8350	10193	12080	14414	16068	18204
2572	5915	8363	10245	12081	14434	16077	18205
2575	6017	8407	10299	12163	14437	16085	18212
2593	6021	8432	10304	12172	14438	16107	18234
2606	6038	8441	10306	12186	14476	16274	18237
2741	6072	8462	10347	12231	14494	16303	18303
2744	6092	8463	10359	12256	14519	16367	18318
2913	6119	8501	10422	12263	14520	16430	18327
2926	6125	8531	10467	12268	14583	16494	18344

1909—*continued.*

18374	19627	20520	22162	23309	24685	26165	28092
18375	19641	20530	22167	23362	24722	26185	28109
18384	19666	20555	22176	23386	24728	26321	28123
18459	19700	20575	22203	23454	24732	26329	28134
18486	19731	20577	22206	23492	24774	26390	28149
18525	19760	20594	22251	23498	24791	26394	28168
18546	19765	20609	22264	23589	24808	26441	28195
18620	19807	20630	22265	23626	24830	26488	28198
18634	19808	20675	22268	23656	24888	26549	28203
18639	19810	20723	22286	23666	24902	26567	28236
18651	19822	20753	22295	23713	24985	26568	28243
18688	19823	20846	22304	23740	25017	26599	28253
18710	19824	20854	22350	23754	25116	26601	28316
18722	19830	20877	22379	23757	25163	26626	28382
18751	19874	20887	22386	23776	25168	26637	28403
18766	19896	20897	22439	23779	25183	26638	28461
18767	19934	20925	22447	23843	25295	26674	28464
18768	19952	20954	22470	23844	25319	26703	28503
18777	19976	20962	22475	23845	25320	26710	28517
18796	19977	21040	22477	23915	25327	26716	28568
18829	19988	21045	22521	23931	25394	26916	28576
18892	20024	21052	22528	23967	25406	27082	28602
18899	20078	21059	22547	24038	25453	27140	28626
18909	20082	21132	22576	24088	25480	27183	28831
18972	20108	21189	22684	24089	25508	27271	28837
18976	20145	21200	22706	24090	25535	27298	28852
18982	20164	21210	22727	24104	25555	27316	28920
19005	20173	21220	22737	24107	25575	27375	28962
19006	20180	21360	22814	24162	25603	27476	28979
19046	20208	21373	22821	24221	25619	27490	28995
19163	20232	21384	22829	24315	25632	27535	28999
19198	20249	21413	22836	24339	25662	27545	29012
19208	20250	21465	22852	24381	25663	27672	29024
19216	20256	21485	22860	24385	25669	27673	29036
19240	20267	21486	22883	24386	25726	27690	29037
19265	20268	21724	22985	24399	25744	27760	29066
19266	20283	21732	23003	24410	25754	27779	29067
19303	20295	21785	23015	24424	25780	27804	29150
19315	20296	21813	23020	24427	25787	27838	29195
19327	20349	21903	23143	24433	25805	27851	29268
19345	20350	21922	23145	24484	25849	27856	29338
19405	20351	21927	23152	24499	25864	27892	29372
19415	20357	21956	23153	24519	25873	27903	29440
19473	20422	22012	23158	24535	25968	27974	29443
19493	20448	22021	23159	24570	26059	27988	29478
19540	20463	22042	23166	24606	26074	28009	29481
19548	20477	22069	23186	24655	26097	28034	29492
19619	20491	22124	23270	24658	26138	28040	29513

1909—*continued.*

29545	29724	29855	30105	30194	30414	30521	30588
29595	29792	29856	30143	30282	30454	30533	30595
29655	29793	29996	30183	30344	30490	30573	30604
29716	29834	30083					

1910 (*eight months only.*)

27	1924	3566	5676	6959	8663	10924	12182
171	1972	3678	5703	6971	8750	10947	12195
193	2065	3728	5726	7020	8778	10952	12208
210	2095	3732	5737	7023	8808	10986	12228
217	2118	3766	5836	7037	8822	10993	12239
223	2142	3861	5843	7053	8901	11009	12306
236	2203	4029	5857	7067	9016	11039	12374
237	2231	4042	5908	7101	9047	11040	12502
356	2241	4048	6004	7130	9163	11101	12514
386	2247	4095	6029	7131	9306	11193	12516
473	2280	4229	6037	7145	9329	11205	12519
515	2294	4297	6048	7244	9485	11319	12578
600	2302	4344	6050	7265	9495	11328	12698
630	2450	4377	6051	7289	9503	11332	12746
635	2479	4433	6074	7333	9544	11334	12769
712	2481	4510	6098	7349	9666	11348	12819
716	2555	4515	6100	7372	9709	11355	12833
762	2611	4516	6131	7381	9800	11396	12866
785	2612	4560	6150	7409	9950	11398	12892
885	2613	4663	6174	7443	10059	11420	12905
935	2614	4674	6180	7508	10064	11467	12934
996	2615	4708	6187	7530	10184	11504	12957
1017	2626	4764	6217	7582	10235	11654	12965
1114	2631	4779	6264	7668	10253	11666	13005
1125	2664	4791	6287	7678	10364	11701	13013
1258	2751	4822	6314	7680	10376	11754	13044
1297	2800	4891	6316	7780	10415	11757	13068
1318	2827	4965	6323	7814	10424	11779	13119
1344	3014	5164	6359	7950	10453	11786	13202
1388	3045	5218	6360	8013	10457	11793	13240
1429	3079	5327	6388	8066	10575	11808	13290
1443	3303	5403	6401	8083	10699	11828	13298
1545	3305	5439	6416	8092	10702	11847	13324
1624	3374	5473	6605	8204	10713	11882	13331
1640	3432	5499	6642	8212	10787	11894	13375
1694	3438	5564	6647	8290	10816	11984	13376
1873	3458	5573	6657	8569	10877	12039	13434
1887	3506	5629	6689	8606	10896	12092	13441
1922	3533	5646	6775	8619	10902	12164	13484

AEROPLANE PATENTS

1910—*continued.*

13486	14560	15231	16705	17460	18064	19013	19616
13573	14610	15278	16773	17510	18104	19017	19700
13587	14649	15308	16790	17527	18117	19029	19718
13607	14653	15502	16802	17552	18158	19086	19759
13658	14654	15566	16886	17591	18207	19180	19779
13710	14656	15576	16888	17634	18283	19204	19798
13955	14673	15602	16946	17638	18284	19221	19852
13980	14688	15633	16970	17653	18478	19261	19857
14073	14724	15761	16976	17668	18481	19318	19906
14114	14727	15779	16982	17672	18482	19321	19925
14178	14760	15849	17036	17720	18604	19349	19946
14204	14846	15918	17062	17735	18661	19370	20070
14205	14868	16130	17135	17776	18675	19388	20080
14207	14979	16138	17145	17844	18683	19426	20105
14248	15045	16276	17185	17969	18701	19427	20125
14351	15048	16405	17186	18020	18839	19430	20145
14402	15049	16463	17264	18023	18863	19440	20184
14413	15064	16464	17286	18055	18881	19526	20285
14455	15115	16581	17362	18056	18994	19550	20312
14460							

SECTION IV

ALPHABETICAL LIST OF BRITISH PATENTEES, 1860—1908

PATENTS enumerated in Section III. (1860—1908) alone are considered. It is impossible to make a complete list of 1909 patentees at the time of writing.

The number and year of each patent are given after the name. The year, as well as the number, is required to identify a British Patent.

Abel, C. D.	1124/69	Beins, H.	3194/73
Abelspies, J. F. C.	9108/96	Bellens, C.	13959/06
Adams, A.	15987/97	Bennett, J.	3456/05
Adams, H.	4901/04	Benston, E.	13747/04
Addis, F. H.	15890/07	Berger, C.	19825/08
Aeroplane Co.	27221/07	Bernasconi, J.	5977/08
Antoni, G., and U.	25518/07	Bernd, E. von	4842/08
Armitage, C.	20739/99	Best, W. G.	5220/08
"	18581/06	Birnbaum, E. J. W. P.	22597/94
Armour, J.	14038/84	Bjelovucic, M. S.	26884/07
Avery, A. H.	1446/04	Blériot, L.	2588/08
		"	9069/08
Babillot, G.	27771/08	"	20785/08
Baden-Powell, B. F. S.	26821/03	"	21497/08
"	6443/06	Bliven, A. P.	6946/07
"	9691/07	Blunt, A. H. P.	3637/99
Barbé, P. E. S.	5938/95	"	8019/99
Barclay, J.	25378/03	"	20115/00
Baron, F. E., and M.	22384/08	"	346/01
Bartelt, F. L.	17131/08	"	9706/02
Bastien, J. B.	3346/78	"	25444/03
Batthey, S. B.	15977/92	"	11748/05
Bauer, H.	20822/08	Bode, E.	10004/07
Baumann, A.	17913/99	Bontems, B.	5118/85
"	2688/03	Booth, H. S.	9346/94
Bausset, A. de	15110/02	"	12149/03
Beach, S. Y.	5312/08	"	15613/05
Becht, L. A.	9767/05	"	23564/94
Bedell, B. H.	26069/07	Borgfeldt, N. H.	10757/06
Beenen, B. R.	9864/97	Boult, A. J.	28558/08
Beilharz, G.	26617/08	"	2489/66
		Boulton, M. P. W.	

Boulton, M. P. W.	696/67	Cornu, J., and P.	19259/06
"	392/68	Couturier, C. E. F.	2030/64
"	1005/68	Craddock, T.	1982/67
"	1988/68	Craig, J.	3360/89
"	574/75	Crawford, G. M.	14327/04
Bourcart, M.	18768/03	Crawford, R. L.	3929/04
Bowdens Patents Syndi- cate, E. M.	2216/08	Crease, J. F.	9106/92
Bowyer-Smyth, D. M.	7442/99	Dalton, P.	2479/07
Boyman, R. B.	3262/66	Davidson, G. L. O.	12469/96
Brandl, A.	9804/06	"	1960/07
Brannon, P.	3974/77	Davies, C. J.	22273/07
Bratschie, A.	20169/03	Day, S. A.	23307/07
Brearey, F. W.	2376/79	Decazes, Vicomte	17859/93
Brennan, L.	27212/03	Degn, P. F.	21445/08
Brewer, E. G.	3346/78	"	24148/08
Britain, W.	21952/08	Deixler, J.	27817/06
Brooman, R. A.	2030/64	"	14327/08
Brown, B.	17611/99	Delaurier, E. J.	4245/83
Brown, C. R. B.	9898/08	Delprat, A.	13502/04
Brown, D. S.	411/72	Deming, H. A.	3128/94
"	2346/73	Demoulin, A.	8628/08
Brüncker, E.	2389/01	Diesel, R.	7012/97
Buch, M.	11188/07	Dippel, C.	11699/06
Buckwalter, C. L.	15438/07	Donovan, J.	21618/08
Burgess, W. E.	2084/07	Dontre, A. F. J.	20694/08
Butler, J. W.	1143/66	Dufaux, A., and H.	3990/05
"	2115/67	Dufferin, H. J.	14334/97
Campa, P.	16030/08	Dufwa, F. W.	17877/08
Capel, T. J.	430/81	Dunne, J. W.	2808/08
Capone, F.	28590/07	Eder, J.	1831/07
"	7129/08	Edwards, A. H.	4519/08
Carter, W. T.	30932/97	Edwards, E.	2115/67
Cave, J. O'C.	140/75	Ellehammer, J. C. Hansen- Esnault-Pelterie, R.	7377/06 28034/07
Cervelli, J.	5977/08	"	221/08
Chantraine, J.	5310/08	"	1258/08
Chanute, O.	13372/97	"	8643/08
"	15221/97	"	10528/08
Chappell, C. A.	21923/07	"	28026/08
Clarke, T. W. K.	28710/06	"	28027/08
"	21290/07	"	28028/08
"	15924/08	Evans, W. E.	21363/08
Cloud, J. W.	27552/07	Fadda, A. S.	27221/07
"	24441/08	Fairweather, W.	11763/08
Cochrane, W.	27027/02	Fauber, W. H.	4204/06
Colquhoun, J. A.	17366/07	"	24344/08
Connolly, B.	27805/07	Fawcett, J.	28321/08
Cornelius, W.	2589/84		

ALPHABETICAL LIST OF BRITISH PATENTEES 83

Ferrero, M.	1593/08	Haddan, H. J.	10034/94
Filippi, A. P.	19199/00	Haenlein, P.	821/72
Fleury, A.	3309/73	Hammant, W.	23129/08
Flynn, P. J.	883/01	Hammond, E. V.	4835/07
Fontaine-Moreau, P. A.,		Hansen-Ellehammer, J. C.	7377/06
Comte de	2464/64	Hardacre, G.	18935/97
Forbes, Sir C. S.	26827/08	Hardie, A.	19488/06
"	28273/08	"	11590/07
Forlanini, E.	7603/05	Hare, E. H.	19805/08
"	17156/07	Harper, W.	16626/06
Foster, J. S.	7015/86	Hart, G. W.	8627/08
Fraser, J.	10267/02	Harte, R.	1469/70
Fraser, J. E.	19982/08	Hawkins, E. C.	1543/04
Fredrikson, A. J.	19677/08	Haylock, D., and R. A.	7783/03
Fréville, E.	2396/73	Heeren, O.	1683/08
Friese-Greene Patents	16606/08	Henderson, A. C.	5118/85
Fronz, F.	1445/08	Hennebique, F.	26000/07
Frossard, J.	18158/07	Hepworth, E. N. Moles-	
Fulton, F. O.	9251/02	worth-	5739/97
Gambin, A.	620/06	Herring, A. M.	15221/97
Garsed, J. L.	20952/06	Hewitt, S. R.	4659/07
"	9594/07	Hoernes, H.	8418/04
"	1035/08	Hofmann, J.	7919/94
"	12013/08	"	11941/94
"	23104/08	"	22011/95
"	23316/08	Holle, A. A.	23347/08
"	24682/08	Homola, J.	21514/06
Gathmann, L.	17367/00	Howard, W. F.	21668/08
"	18559/07	Howell, T. J.	24701/03
Gaunt, J.	17014/08	Huber, T.	12848/07
Gedge, W. E.	2396/73	Hüchel, H.	5787/04
Geest, K. L. W.	22943/08	Hullett, J.	568/68
Gibon, T.	14003/06	Humbert, V.	9970/08
Gilbert, W. V.	8316/06	Humphreys, J. E.	20916/08
Goetjes, W.	13996/94	"	21074/08
Golby, F. W.	10819/94	"	22238/08
Graham, C. K.	1943/03	Hunter, J. M.	2680/08
Green, W. A.	19347/03	Huntington, A. K.	2808/08
Greene, W. Friese-	16606/08	Hutchinson, F. W. H.	1778/04
"	23595/08	"	7491/07
Griffiths, T.	10068/85	"	7887/07
"	12349/90	Hutchinson, W. N.	20032/91
Griffiths, W. J.	16100/01	Hyatt, T.	1229/82
Groombridge, C.	13241/00	Imray, J.	1005/68
"	25723/02	Jensen, P.	5251/82
Grosclaude, D. A. L.	21754/08	Johnson, J. H.	4245/83
Guattari, A., and C.	3872/92	Jombart, E.	1124/69
Haas, T.	8681/02	Jones, J. M.	23833/04

Kalisch, E.	12514/00	McMullen, G.	1788/04
Kaufmann, J. M.	473/67	Manker, C. A.	23161/02
„	1525/67	Marinakis, A.	21477/04
Kay, M.	16/07	Mark, W.	22209/08
„	7205/08	Marriott, F.	2827/69
Kerkhove, A. H. van de	3561/81	Marshall, J.	10239/95
Kerwat, G.	5471/08	„	9734/97
Klupathy, E.	19825/08	Masey, P. E.	412/68
Knäpper, G.	24807/04	Mastin, J.	3456/05
Kober, M.	18877/08	Maughan, B. W.	4585/82
Koch, G.	5251/82	„	1552/83
„	16269/93	Maul, A.	10757/06
Kosztovits, O. I.	5942/84	Maxim, H. S.	10359/89
Krakow, A. K. R. A.	13499/02	„	16883/89
Krauss, R.	18663/97	„	19228/91
„		„	10852/93
Laitte, L. B. de	4043/07	„	10620/97
Lake, A. W.	1229/82	„	15748/03
Lake, S.	11763/08	„	3120/04
Lanchester, F. W.	3608/97	„	20038/08
„	17935/05	May, R. E.	19264/94
„	9413/07	Mercer, I. E.	23798/08
„	9413a/07	Michel, M.	1769/69
La Pauze, A. de	430/81	Middleton, H.	9725/88
Larkin, G. F.	2216/08	„	21885/91
Lautenschläger, P. E.	15128/94	„	9775/93
Lazarowicz, J.	7179/03	„	21680/02
Lebaudy, P., and P.	878/03	„	1436/06
Léger, M.	3691/01	Mielcarek, W. S.	7632/08
Lehmann, E.	17371/00	Millet, F. T.	5199/89
Lentz, H.	13959/06	Mills, F. E.	3128/94
Le Rond, L. J. J. B.	10968/98	Mockton, E. H. C.	265/74
„	14145/02	Molesworth-Hepworth, E. N.	5739/97
Lester, E. J.	5220/08	Molinari, J.	5977/08
Lindkvist, E. E.	16484/07	Mond, R. L.	5949/08
„	16941/08	Montgolfier, P. de	1747/06
Lipkowski, J. de	11616/02	Montjustin, R. d'Equé- villey	17370/08
Long, L.	23380/03	Moore, R. F.	13311/90
Lorenzen, C.	13809/08	„	6/95
Lorenzo, J. di	27221/07	Morgan, F. S.	3186/05
Los Olivos, E. C. de	7271/95	Motorluftschiff-Studienges	4788/08
Lostalot, H. de	12848/07	Mott, S. D.	24587/02
Lucas, E.	2353/07	Moy, T.	3238/71
„		„	2808/74
McCurd, W. A.	8966/07	„	15221/97
Macdonald, T.	4125/95	„	16856/01
McLean, R.	13315/08	Mumford, E. R.	3214/05
Macleod, M. C.	1763/04	„	15698/05
Macler, C.	19199/00		

ALPHABETICAL LIST OF BRITISH PATENTEES 85

Murray, T. B.	9251/02	Porter, J. R.	4245/07
Murray, W. E.	29308/06	„	15590/07
Mutti, A.	14367/04	„	21261/08
„	5949/08	Powell, B. F. S. Baden-	26821/03
		„	6443/06
Nelson, J. E.	2229/67	„	9691/07
Némethy, E.	15403/02	Preidél, W.	26891/04
Nesmond, P. C.	2464/64		
Neyen, E.	84/08	Quartermain, W.	2339/84
Nial, M.	7059/07	Quentin, A. A. H.	3872/92
Nicholl, G.	1066/01		
Noble, W. H.	2827/69		
		Rabbat, C. F.	1598/60
Oetling, C.	10819/94	Raggett, J. J.	23459/07
Ortlepp, J. C.	1064/93	Rebikoff, W.	6502/06
Osselin, A. F.	728/71	Reden, U. von	9119/07
Otto, E. C. F., and E. C. F.	14737/89	Redfern, G. F.	7015/86
Owen, R. G.	9193/85	Renner, E., M., L., and A.	2803/06
		Ridley, J. D.	777/74
		Roe, A. V.	26099/06
Palacios, R. de.	13996/94	Roeper, C. H. O.	9390/95
Parker, T.	9506/04	Roheim, E.	8320/01
Peache, G. A.	24617/08	Roots, J.	3657/96
Pelterie, R. Esnault-	28034/07	„ J. D.	7156/07
„	221/08	Ross, W. M.	2040/70
„	1258/08	Roux, E.	11719/03
„	8643/08		
„	10528/08	Sampson, D.	16698/02
„	28026/08	Saward, J.	8435/07
„	28027/08	„	7370/08
„	28028/08	Schmid, E.	20822/08
Penkala, R., and E.	21498/08	Schroeder, F. W.	17855/08
Pennington, E. J.	25050/95	Schülke, J.	10961/07
„	17119/96	Schütz, S.	23618/08
Perks, E.	22809/08	Scott, B. D., and W. E.	24247/07
Peugot, A.	12848/07	Seiberi, J.	11982/02
Phillips, A.	28119/08	Shadbolt, L. P.	8842/08
Phillips, H. F.	13768/84	Shanks, J.	7802/05
„	20435/90	Shil, R. E.	3238/71
„	13311/91	Silverston, A. R.	20433/08
Phillips, J. S.	2420/61	Simko, J.	8320/01
Piffhard, H. H.	11155/08	Simms, F. R.	25716/96
Piguet & Co.	10034/94	„	6320/97
Pilcher, P. S.	9144/96	„	20368/00
Placet, P. E.	21329/99	„	25395/05
Platts, W.	3456/05	„	15796/07
Pomianowski, R. A.	19822/07	Sjöstrom, P.	2264/83
Ponton d'Amecourt, G. L.		Skousès, P.	11905/08
M., Viscount de	1929/61	Smart, G. E.	12503/84
Porak, W.	15960/01	Smith, G. P. B.	27812/08

Smyth, D. M. Bowyer-	7442/99	Tzimbalist, I. O.	16300/08
" W.	1392/67	Vaniman, M.	26764/06
Smythies, J. K.	561/60	Vergara, A.	18287/00
"	2504/67	Villeneuve, A. H. de	440/70
"	4151/75	Visoly, S. H. de	3336/04
"	34/82	Vogt, H. C. de	81/74
"	7/84	Vojáček, L.	3307/04
Snyers, T.	3561/81	Waddy, S. D.	4585/82
Soc. A. Peugeot, T. Huber & Co.	12848/07	"	1552/83
Solon, M. F.	8118/08	Waelde, J.	1830/86
Soul, M. A.	821/72	"	9108/96
South, W. A.	13241/00	Walker, J. C.	634/92
"	25723/02	Walker, W. G.	17977/99
Spencer, C. G.	1178/68	Wallace, G.	1004/07
Stark, T. A.	1064/93	Wallin, B. H.	1391/07
Steinhaus, E. E.	28015/08	"	15457/07
Stevens, C.	1598/60	Watson, P. A.	23553/07
Stevenson, R.	4871/80	Webb, H. B.	17725/07
Stewart, J.	20702/03	Weiss, J.	17150/08
Straka, J.	27408/07	Wellner, G.	2826/03
Sturgess, G., and C.	26924/08	Wenham, F. H.	1571/66
Swingle, E. L.	19995/01	Westlake, A. J.	28264/04
Taaffe, R.	26414/06	White, J. D.	2351/97
"	25295/07	Whitehead, G.	5312/08
Tacquin, A.	24928/08	Wilson, E. F.	2493/08
Tarbe, J.	19424/00	Wilson, G.	3067/71
Tarczal, C.	8320/01	Winegarden, A. van	14327/04
Tasker, E. E.	4033/07	Winsch, J.	7179/03
Taylor, A. G.	7802/05	Wirth, F.	3194/73
" F. W. T.	23208/08	Wisniewski, V.	11948/08
Tellwright, W.	8118/08	Wolf, Carl, Baron von	26391/97
Thayer, R.	21656/08	Wondra, F.	16838/05
Thomass, F. W.	7894/07	Wood, F.	16153/08
Thompson, W. P.	16269/93	Worswick, A.	8591/08
"	13996/94	Wright, J. M.	22258/08
"	15798/04	Wright, W., and O.	6732/04
"	27312/06	"	24076/08
"	2651/08	"	24077/08
"	25315/08	Wunderlich, A.	1307/08
Tribelhorn, A.	21092/08	Wynne, W. R.	29061/06
Tuckfield, C.	18862/01	Zizka, E.	13905/07
Turnbull, W. R.	8868/06		

SECTION V

PATENTS GRANTED IN THE U.S.A. RELATING TO FLYING MACHINES FROM THE BEGINNING OF 1896 TO THE END OF 1909

THE date following the number of the patent is that on which the patent was issued.

M. V. Coutinho	556,621 : Mar. 17/96	B. O'Kane	820,938 : May 15/06
L. P. Mouillard	582,757 : May 18/97	O. and W. Wright	821,393 : May 22/06
J. D. Graybill	592,704 : Oct. 26/97	J. Hofmann	827,017 : July 24/06
T. Leibbrand	600,878 : Mar. 22/98	J. B. Kramer	827,157 : July 31/06
F. A. Jone	605,579 : June 14/98	O. Chanute	834,658 : Oct. 30/06
J. T. Rice	606,942 : July 5/98	G. M. West	838,673 : Dec. 18/06
T. J. Brown	610,843 : Sept. 13/98	G. G. Schroeder	841,581 : Jan. 15/07
S. Otis	641,793 : Jan. 23/00	W. Morgan	843,476 : Feb. 5/07
G. T. Woglom	648,544 : May 1/00	A. McCarthy	844,172 : Feb. 12/07
L. E. Roze	648,634 : May 1/00	H. M. Bellows	844,771 : Feb. 19/07
S. Cairncross	653,615 : July 10/00	A. and H. Dufaux	846,830 : Mar. 12/07
J. H. Dillon-Greg.	666,266 : Jan. 22/01	A. Brandl	849,971 : Apr. 9/07
E. M. Farr	678,114 : July 9/01	A. P. Bliven	850,616 : Apr. 16/07
W. J. Bell	693,943 : Feb. 25/02	B. F. Mickley	851,683 : Apr. 30/07
S. J. Conyne	698,634 : Apr. 29/02	M. Nial	851,895 : Apr. 30/07
J. T. Rice	704,375 : July 8/02	B. Connolly	852,221 : Apr. 30/07
I. Lancaster	706,832 : Aug. 12/02	T. Orgren	852,292 : Apr. 30/07
T. Gibon	710,266 : Sept. 30/02	I. Gruber	855,945 : June 4/07
O. A. Kaehler	727,377 : May 5/03	R. Lewitz	856,073 : June 4/07
G. D. Shultz	729,800 : June 2/03	A. G. Bell and H.P.	
T. Gibon	730,107 : June 2/03	McNeil	856,838 : June 11/07
I. I. Morris	737,947 : Sept. 1/03	L. D. Merrich	856,895 : June 11/07
C. E. van Deventer	741,568 : Oct. 13/03	W. Phillips	856,910 : June 11/07
A. G. Bell	757,012 : Apr. 12/04	F. E. Felts	857,166 : June 18/07
C. F. Morrison	761,053 : May 24/04	J. H. Wilson	859,274 : July 9/07
S. M. Craig	766,021 : July 26/04	W. H. Cook	860,447 : July 16/07
H. de Walden and		F. M. Mahan	861,133 : July 23/07
H. Knudsen	769,034 : Aug. 30/04	E. M. La Penotiere	861,740 : July 30/07
G. W. Thompson	769,721 : Sept. 13/04	D. L. Moorhead	865,419 : Sept. 10/07
A. G. Bell	770,626 : Sept. 20/04	A. O'Brate	866,672 : Sept. 24/07
A. P. Criswell	785,717 : Mar. 28/05	„	866,673 : Sept. 24/07
I. Lancaster	785,740 : Mar. 28/05	„	867,525 : Oct. 1/07
G. McMullen	792,154 : June 13/05	J. U. de Uherkócz	868,038 : Oct. 15/07
A. H. Friedel	804,593 : Nov. 14/05	„	868,039 : Oct. 15/07
A. L. Platt	813,519 : Feb. 27/06	J. W. Roshon	868,488 : Oct. 15/07

J. D. Pursell	869,019 : Oct. 22/07	M. G. Adams	917,513 : Apr. 6/09
B. Connolly	870,936 : Nov. 12/07	C. J. Lake	918,336 : Apr. 13/09
L. Gathmann	871,926 : Nov. 26/07	R. G. Dressler	919,834 : Apr. 27/09
F. B. Ashley	872,778 : Dec. 3/07	W. S. Romme	920,085 : Apr. 27/09
G. Halliday	873,542 : Dec. 10/07	A. P. Filippi	920,554 : May 4/09
F. Wondra	876,125 : Jan. 7/08	C. R. Culver	922,264 : May 18/09
G. H. Benedict	879,848 : Feb. 25/08	J. Means	922,710 : May 25/09
W. Halle	881,184 : Mar. 10/08	„	922,711 : May 25/09
E. E. Warner	881,836 : Mar. 10/08	„	922,712 : May 25/09
G. Whitehead	881,837 : Mar. 10/08	„	922,713 : May 25/09
E. L. Drake	882,189 : Mar. 17/08	P. F. Degn	922,756 : May 25/09
T. J. Whalem	882,435 : Mar. 17/08	J. J. Rekar	922,952 : May 25/09
E. R. Ernst	882,457 : Mar. 17/08	G. W. Thompson	922,972 : May 25/09
H. J. Cragun	883,090 : Mar. 24/08	J. Potts	923,075 : May 25/09
W. Pars	883,565 : Mar. 31/08	A. Beriozze	923,936 : June 8/09
M. Vaniman	884,432 : Apr. 14/08	W. A. McCurd	924,813 : June 15/09
B. Guthrie	886,122 : Apr. 28/08	J. H. Rogers	924,833 : June 15/09
M. B. Sellers	886,159 : Apr. 28/08	J. H. Wilson	926,159 : June 29/09
C. J. A. Fiesse	887,931 : May 19/08	H. A. Orme	926,593 : June 29/09
F. I. Judson	888,618 : May 26/08	L. J. Brown	926,804 : July 6/09
F. R. Sweeny	889,062 : May 26/08	P. V. Wadleigh	926,913 : July 6/09
D. D. Beatty	889,502 : June 2/08	M. B. Sellers	927,289 : July 6/09
O. K. Chance	890,215 : June 9/08	J. Seiler	927,605 : July 13/09
S. von Wiszewsky	890,483 : June 9/08	L. Ruppin	927,815 : July 13/09
E. R. Mumford	892,380 : June 30/08	A. A. Zalondek	929,362 : July 27/09
C. A. Moore and		C. R. Bannihir	931,026 : Aug. 17/09
E. Barrow	892,606 : July 7/08	W. Sinclair	931,966 : Aug. 24/09
E. J. Pennington	893,647 : July 21/08	S. H. Gilson	933,548 : Sept. 7/09
E. E. Warner	893,887 : July 21/08	P. F. Degn	934,394 : Sept. 14/09
A. V. Wilson	897,504 : Sept. 1/08	D. C. Dorman	934,717 : Sept. 21/09
W. Gordon	897,738 : Sept. 1/08	W. R. Turnbull	934,771 : Sept. 21/09
D. L. Wolf	898,081 : Sept. 8/08	A. R. Malasomma	935,039 : Sept. 28/09
E. E. Steinhaus	899,350 : Sept. 22/08	W. H. Martin	935,384 : Sept. 28/09
A. H. Friedel	900,844 : Oct. 13/08	J. Means	935,766 : Oct. 5/09
H. B. Schiller	901,486 : Oct. 20/08	A. W. Reinoehl	935,862 : Oct. 5/09
J. and P. Cornu	902,859 : Nov. 3/08	C. W. Cheney	936,303 : Oct. 12/09
J. B. Macduff	905,547 : Dec. 1/08	J. S. Letts	937,250 : Oct. 19/09
T. H. Gignilliat	906,406 : Dec. 8/08	A. E. Mueller	937,381 : Oct. 19/09
H. S. Booth	907,120 : Dec. 22/08	D. S. Foster	937,587 : Oct. 19/09
„	907,310 : Dec. 22/08	S. W. Applegate	939,651 : Nov. 9/09
G. A. Metcalf	908,734 : Jan. 5/09	A. H. Friedel	940,866 : Nov. 23/09
O. and W. Wright	908,929 : Jan. 5/09	J. Suter	941,896 : Nov. 30/09
J. Bernard	910,488 : Jan. 26/09	L. Felker	942,629 : Dec. 7/09
H. Bea	910,773 : Jan. 26/09	S. S. Williams	942,691 : Dec. 7/09
W. D. Valentine	911,784 : Feb. 9/09	J. Means	943,120 : Dec. 14/09
C. J. Lake	913,517 : Feb. 23/09	A. W. H. War-	
H. Mueller	914,969 : Mar. 9/09	shawsky	944,301 : Dec. 28/09
M. Strzelecki	916,626 : Mar. 30/09		

SECTION VI

ALPHABETICAL LIST OF U.S. PATENTEES, 1896—1909

THE numeral following the name is the number of the patent.
An American patent can be identified by the number alone.

Adams, M. G.	917,513	Criswell, A. P.	785,717
Applegate, S. W.	939,651	Culver, C. R.	922,264
Ashley, F. B.	872,778		
		Degn, P. F.	922,756
Bannih, C. R.	931,026	"	934,394
Barrow, E.	892,606	Deventer, C. E. Van	741,568
Bea, H.	910,773	Dillon-Greg, J. H.	666,266
Beatty, D. D.	889,502	Dorman, D. C.	934,717
Bell, A. G.	757,012	Drake, E. L.	882,189
"	770,626	Dressler, R. G.	919,834
"	856,838	Dufaux, A., and H.	846,830
Bell, W. J.	693,943		
Bellows, H. M.	844,771	Ernst, E. R.	882,457
Benedict, G. H.	879,848		
Beriozze, A.	923,936	Farr, E. M.	678,114
Bernard, J.	910,488	Felker, L.	942,629
Bliven, A. P.	850,616	Felts, F. E.	857,166
Booth, H. S.	907,120	Fiesse, C. J. A.	887,931
"	907,310	Filippi, A. P.	920,554
Brandl, A.	849,971	Foster, D. S.	937,587
Brown, L. J.	926,804	Friedel, A. H.	804,593
Brown, T. J.	610,843	"	900,844
		"	940,866
Cairncross, S.	653,615		
Chance, O. K.	890,215	Gathmann, L.	871,926
Chanute, O.	834,658	Gibon, T.	710,266
Cheney, C. W.	936,303	"	730,107
Connolly, B.	852,221	Gignilliat, T. H.	906,406
"	870,936	Gilson, S. H.	933,548
Conyne, S. J.	698,634	Gordon, W.	897,738
Cook, W. H.	860,447	Graybill, J. D.	592,704
Cornu, J., and P.	902,859	Greg, J. H. Dillon-	666,266
Coutinho, M. V.	556,621	Gruber, I.	855,945
Cragun, H. J.	883,090	Guthrie, B.	886,122
Craig, S. M.	766,021		





RETURN
TO →

CIRCULATION DEPARTMENT
202 Main Library

642-3403

LOAN PERIOD 1

2

3

4

5

6

LIBRARY USE

This book is due before closing time on the last date stamped below

DUE AS STAMPED BELOW

LIBRARY USE OCT 18 1977

REC. CIR. OCT 18 77

LIBRARY USE JAN 17 '80

REC. CIR. JAN 17 '80

FORM NO. DD 6A, 12m, 6'76

UNIVERSITY OF CALIFORNIA, BERKELEY
BERKELEY, CA 94720

© 1

LD 21-100m-7,'89(402s)

YC 19418

217-305

T
113
39

THE UNIVERSITY OF CALIFORNIA LIBRARY

