

THE

MINU OF JAPAN



3 1761 06143951 9



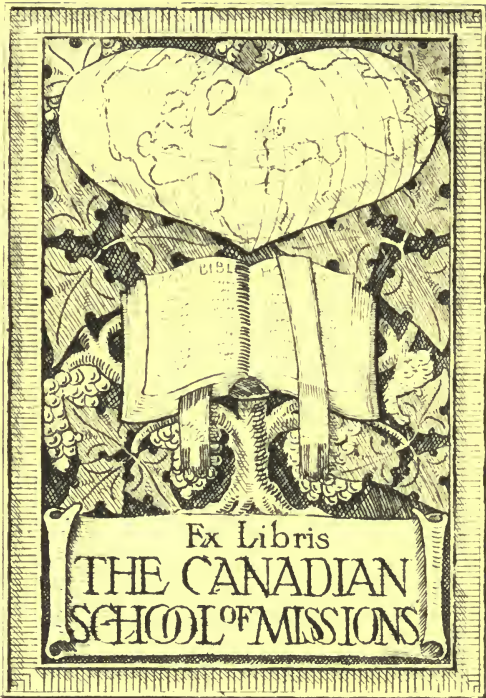

157330

6
Minniebaha Memorial
Library -

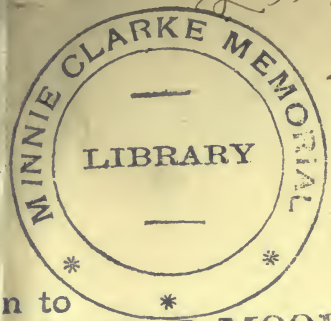

~~294 Drummond~~
Montreal

n to
S. H. E. MOODIE
66 Hutchison Street
MONTREAL
THE

AINU OF JAPAN

to ~~185~~ ~~Drummond Street~~
66 Hutchison Street



PRINTED BY
SPOTTISWOODE AND CO., NEW-STREET SQUARE
LONDON





AN AINU

THE
AINU OF JAPAN

THE RELIGION, SUPERSTITIONS, AND GENERAL HISTORY
OF THE HAIRY ABORIGINES OF JAPAN

BY THE
REV. JOHN BATCHELOR

C.M.S. MISSIONARY TO THE AINU

COMPILER OF 'AN AINU-ENGLISH-JAPANESE DICTIONARY' AUTHOR OF
'AN AINU GRAMMAR' TRANSLITERATOR OF THE 'NIPPON SEI
KŌKAI KITŌ BUN' AUTHOR OF 'SPECIMENS OF AINU
FOLK-LORE' 'NOTES ON THE AINU' ETC.

WITH EIGHTY ILLUSTRATIONS

LONDON
THE RELIGIOUS TRACT SOCIETY

56 PATERNOSTER ROW, 65 ST PAUL'S CHURCHYARD
AND 164 PICCADILLY

1892



Digitized by the Internet Archive
in 2007 with funding from
Microsoft Corporation

N
B
Ref.

PREFACE



THE major portion of the chapters contained in this volume were not originally intended for publication, but were written as letters to relatives, who naturally take a great interest in Mission work, especially in Japan. But, before I had finished the series, it was thought by my friends that what I was writing for private perusal might perhaps prove interesting to the public if put into book form. Hence the appearance of this work. Moreover, having received many letters inquiring about the Ainu—some asking questions concerning their manners and customs, others about their religion, and some, again, of their special superstitions—I have the more readily fallen in with the suggestion.

Some of the chapters contained in this book comprise short articles and legends which I have published elsewhere, but which are not easily obtainable. The greater part of the volume, however, is entirely new.

Many of the illustrations which enrich the volume

are from photographs; but my best thanks are due to my wife and helper for the great assistance she has rendered me in the matter of drawing the large number reproduced from her sketches.

No doubt a very great deal more might be said about the Ainu, and I feel that only the outside of the subject has been touched in this book. The subsequent chapters are merely notes by the way. They have been set down at odd times, and collected as the writer has had cause to inquire into things whilst prosecuting his special work amongst the Ainu. But his object will be attained if it leads his readers to appreciate the good points of this strange race; and, above all, if it leads them to feel renewed interest in the efforts that are being made to bring them under the civilising influence and the saving grace of the Gospel of Jesus Christ.

CONTENTS



CHAPTER	PAGE
I. THE AINU	13
II. AINU WOMEN	34
III. CLOTHING AND ORNAMENTS	45
IV. HUT-BUILDING AND HOUSE-WARMING	54
V. FURNITURE	72
VI. INAO, OR RELIGIOUS SYMBOLS	86
VII. ETIQUETTE	101
VIII. EDUCATION	109
IX. THE ARTS AND PLEASURES OF LIFE	123
X. JUSTICE AND MARRIAGE	135
XI. DEER-HUNTING AND FISHING	143
XII. BEAR-HUNTING	158
XIII. AINU FATHERLAND AND GOVERNMENT	179
XIV. FEAR OF ANGRY WOMEN AND TREATMENT OF THE SICK	191
XV. DEATH AND BURIAL	203
XVI. GHOSTS AND THE FUTURE LIFE	219
XVII. AINU POLYTHEISM	239
XVIII. INCIDENTS AND WORDS ILLUSTRATIVE OF AINU RELIGIOUS BELIEFS	254
XIX. RELIGIOUS LEGENDS	262
XX. CAUSES OF AINU DECREASE	281
XXI. PREHISTORIC TIMES IN JAPAN	291
XXII. AINU HEROES AND LEGEND	313
XXIII. MISSIONARY WORK AMONG THE AINU	325
INDEX	333



LIST OF ILLUSTRATIONS



	PAGE
AN AINU	<i>Frontispiece</i>
AINU, OR ABORIGINES OF JAPAN	15
A HAIRY SPECIMEN	17
OUR AINU SERVANTS	21
ANOTHER HAIRY ONE	23
BACK VIEW OF AINU HEAD OF HAIR	25
AINU CHIEF'S COAT (BACK)	27
AINU MAN ABOUT TO DRINK	30
AINU WOMAN AND CHILD	36
AN AINU CRADLE	44
AINU WOMAN'S DRESS	46
AINU MAN'S COAT	47
AINU TREASURES	51
AN AINU VILLAGE	54
AN AINU HUT	56
A STOREHOUSE	60
HUT OF A NEWLY-MARRIED AINU	62
JAPANESE HUT WITH AINU ROOF	64
AN AINU FAMILY TAKING A MEAL	69
PLAN OF AN AINU HUT	73
AINU SPOONS	77
A COMMON MOUSTACHE LIFTER	78
A CEREMONIAL MOUSTACHE LIFTER	78
AINU PESTLE AND MORTAR	78
PARTS OF A LOOM	79
AINU WOMEN WEAVING	81
A TARA	88
TOBACCO PIPE-HOLDER AND BOX	84
INAO NETOBA, OR THE CHIEF INAO	88
CHI-EHOROKA-KEP, OR 'THE SHAVED BACKWARDS'	90
A NUSA, OR CLUSTER OF INAO	91
NUSA AND SKULLS AT EAST END OF A HUT	96
AN AINU FAMILY	100
AINU MEN SALUTING	102

	PAGE
AINU MEN SALUTING	103
AINU WOMAN SALUTING	105
SALUTING A CHILD	106
AINU BOAT AND BRIDGE	117
THE MUKKURI, OR JEW'S-HARP	129
UKARA	133
THE HOT-WATER ORDEAL	136
THE STAKE ORDEAL	137
IPAKKE-NI, OR DEER DECOY	144
AINU DECOYING DEER (<i>from a Japanese drawing</i>)	145
A SPRING-BOW SET	147
THE SPRING-BOW	147
AN OTTER-TRAP READY SET	149
AN OTTER-TRAP (IN SECTIONS)	149
RAT-TRAP (IN SECTION)	151
RAT-TRAP (SET)	151
A MAREK, OR SALMON-SPEAR	152
A SPEAR USED TO CATCH PIKE	154
A POISONED ARROW	170
A BEAR CAGE	172
THE CROWN WORN AT A BEAR FEAST	175
BLUNT ARROWS	176
ANCIENT WAR-CLUB, SHOWING PLACE FOR THE STONE	180
ANCIENT WAR-CLUB	180
A KAMSCHATKAN CANOE	184
A DOG-SLEIGH	185
A SLEDGE	186
A SNOW-SHOE	187
HANGING BY THE HAIR	189
TOMBSTONE OF AN AINU MAN	208
TOMBSTONE OF AN AINU WOMAN	211
A WIDOW'S BONNET	213
INTERIOR OF THE HUT IN WHICH THE CHILD DIED	214
INTERIOR OF THE HUT IN WHICH THE CHILD DIED	216
CHIEF PENRI	220
DESCENDANT OF AINU AND JAPANESE	289
FLINT KNIVES	296
STONE-MALLET SWORD	299
WAR-CLUB	299
PREHISTORIC POTTERY	301
INSCRIPTION AT OTARUNAI	303
STONE ADZES	306
PROBABLE SHAPE OF KOROPOK-GURU'S HUT	307
PLAN OF KURILE HUT	311
EXTERIOR OF KURILE HUT	311
AINU BOW AND QUIVER	315

THE AINU OF JAPAN

CHAPTER I

THE AINU

THE Ainu, of whom these pages treat, are the aborigines of Japan. Much has been said and written about the Japanese of late years, and almost every house of importance in England and America has something in the way of art of either old or young Japan in it. But the Ainu were in Japan ages before the present race of Japanese obtained their foothold in those islands, though very little indeed has so far been discovered about this peculiar race.

The oldest book of which the Japanese can boast was written A.D. 712, and in it the following sentence occurs: 'When our august ancestors descended from heaven in a boat, they found upon this island several barbarous races, the most fierce of whom were the Ainu.' This, translated into modern matter-of-fact

language, simply means that, when the present race of Japanese first came to Japan in their ships, they found the country already inhabited.

This ancient race has been gradually driven from the south of this 'Land of the Rising Sun' towards the north, till, at the present day, there are but sixteen or seventeen thousand of them left. This subject will be more fully discussed in Chapters XX., XXI., and those who take an interest in general ethnology are referred to those chapters.

The present home of the Ainu is Yezo and the Kurile Islands, belonging to the Japanese Empire, and Saghalien, which is now a part of Russia. Only the Yezo Ainu, the subjects of his Imperial Majesty the Emperor of Japan, are spoken of in this book. Yezo, now officially called Hokkaido, is an island of North Japan, extending from longitude $139^{\circ} 50'$ to longitude 146° east, and from latitude $41^{\circ} 30'$ to latitude $45^{\circ} 30'$ north, its area being 35,739 square miles.

The population consists of about 17,000 Ainu and 350,000 Japanese, who have immigrated to this island. The winters are very severe in Yezo, and there is often a heavy snowfall; while the summers are singularly hot, though short. The island, which is very mountainous, abounds in volcanoes; and earthquakes are frequent, though not often sharp. The country is well wooded with oak, limes, chestnuts, birch, magnolia, and pine, and water is very plentiful. The mineral wealth con-

sists chiefly of coal, sulphur and copper ore. The principal animals are bears, deer, wolves, otters, and hares; and the principal fish, upon which the Ainu



AINU, OR ABORIGINES OF JAPAN

in great measure subsist, are trout, salmon, herrings, codfish, swordfish, and, when obtainable, whale and walrus.

Objection may be taken to our spelling the name of these people Ainu, while others who have written of this race have called them Aino and Ainos. Aino is a Japanese nickname; and it is always applied by them to the Ainu when they speak of them. It is a term they anciently used to express their contempt for them, and has by degrees come into common use. The word *Aino* means 'mongrel' or 'half-breed,' and has reference to a degrading Japanese tradition, which describes the descent of the Ainu from a human being and a dog. Therefore, when any person uses the word *Aino*, he really means, whether knowingly or not, 'mongrel' or 'half brute beast, half human being.' Such a term should be studiously avoided. English writers, of course, are not to be in any way blamed for using the form Aino, since it unavoidably came to them at second-hand through the Japanese, and not directly from the people themselves.

But the name this race of people themselves use is Ainu, which means 'man' or 'men.' The sound is very similar, but the difference of meaning between the two words is emphatic and vital. It would be well, therefore, if henceforth all writers would discard the Japanese nickname, which is foreign, and use only that native word by which these people designate themselves.

By this tradition of their origin the lower class of Japanese have, in their ignorance, endeavoured to

account for the hairiness of the Ainu. That they are hairy is a matter of fact, which is noticed by all writers ; yet there are very many individual members of the race

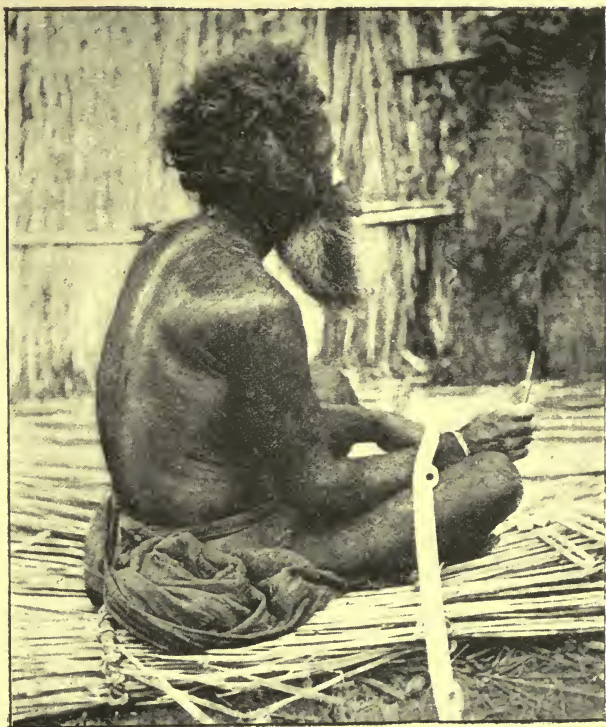

A HAIRY SPECIMEN

who are not a bit more hairy than ordinary Europeans. This hairiness has been greatly exaggerated. We should naturally expect that conspicuous specimens of

hairy men would be found among them ; but that is no reason for the conclusion that all are so thickly covered with hair as some would have us believe. The accompanying engraving is a good illustration of an extreme form of hairiness.

The body of the man depicted is completely covered, but not so thickly that the skin cannot be seen ; and there are not many so hairy as he appears to be. I know of but one other man who rivals him in this respect, though I could point to five or six nearly as well covered.

The Ainu people are not a handsome nation, though, as individuals, the race is strong, thick-set, squarely-built and full-chested. The chief thing that strikes one on meeting an Ainu for the first time is his fine beard, moppy hair, and sparkling eyes ; next, his dirty appearance, poor clothing, and, should he be near at hand, his odour. The Ainu certainly do not, upon first acquaintance, produce a very favourable impression ; in fact, to many people they quickly become repulsive, especially on account of their filth.

Perhaps this is the reason why so much that is not quite true and that is not very creditable has been written about them. A person who intends to visit the Ainu must be prepared to shut his eyes to a very great deal, and he must not turn up his nose at a little dirt. Foreigners, as a rule, have not much cared to mix with such a filthy and degraded-looking race, and have hence

not taken the trouble to seek and find out what lies beneath the rough and very rugged surface. Nothing is truer than 'all that glitters is not gold'; but it should also be remembered that some things which do not glitter are as good as gold, and that a diamond needs cutting and polishing before its beauty can be fully seen. When the Ainu are dressed in their best garments, and have been washed and trimmed, they are really a fine-looking people. The heart must not always be judged by the general outward appearance.

After more than eight years' experience amongst this people, and after having lived with them in their own huts and mixed with them both in their daily tasks and amusements—after having listened to their troubles, been by their side in sickness and in health, seen them at their religious exercises, and been present when the hand of death has been upon them—the present writer is prepared to affirm that a more kind, gentle, and sympathetic people would be very difficult to find. The Ainu only need sympathy and kind treatment to bring out their real character.

But they *do* look dirty, and they generally wear a depressed look. But the Ainu nature is as truly human as that of any other race. See him in a bear hunt, or meet him directly after he has killed a bear, and hear him describe the scene; or ask his help when you are in trouble, and you will have the opportunity of seeing both his bravery and his kindness. It is a great mistake

to say that the Ainu are as degraded as they look, or as irreclaimable as they appear. They can be the most faithful and honest servants, as we have often proved during our fourteen years' experience in Japan. The Ainu is very much what others make him. Treat him as a man, and he will show himself to be a man; but treat him as a child, and he will act as a child, and at the same time think how very foolish the one is who treated him so. Close acquaintance with them adds one more to the many proofs of the truth of those words of Scripture: 'God hath made of one every nation of men for to dwell on all the face of the earth, having determined their appointed seasons, and the bounds of their habitation.'

The average height of true Ainu men—that is, those who have no Japanese blood in their veins—is five feet four inches, and that of the women five feet one and a half or two inches. But the Ainu and Japanese half-breeds are smaller. The men average five feet two inches, and the women five feet. This is a curious fact, and one which I think has not before been noticed.

The men have very fine and handsome dark beards, shaggy eyebrows, sparkling dark brown or black deeply-set eyes, prominent cheek-bones, high foreheads, and bushy heads of hair. The skin is whiter than that of the Japanese, for they do not possess the bilious-looking complexion so prevalent in the latter race. The sun



OUR AINU SERVANTS



ANOTHER HAIRY ONE

has tanned the parts exposed to his rays, giving them a brunette complexion. The hair and beards turn grey

somewhat early, thus giving comparatively young men a venerable and patriarchal appearance.

The hair of both the men and women is cut behind in the shape of a quarter moon, the fore part sometimes being allowed to reach to the shoulders, whilst the nape of the neck and the fore part of the head are clean shaven. There are no barbers, however; so the women do the shaving—that is to say, each woman looks after the appearance of her husband. This operation must have been difficult in very ancient times, and was probably performed by the aid of sharp stones. The Ainu now use Japanese razors.

The illustration shows the general length of hair, and how it is cut behind. The women cut their hair after the same fashion.

On first coming into contact with those Ainu who reside near or upon the Japanese frontier, one cannot help noticing that before strangers they have an air of slavishness, slovenliness, and general depression, which renders them in appearance the reverse of interesting and pleasing to the eye. They are apt either to excite contempt and disgust, or to arouse one's pity. They very seldom wash their persons, and less often their clothes. Moreover, they all carry a somewhat large burden of minute but robust-looking, well-fed insects about their person and apparel.

This state of things is only what might be expected; for how have the Ainu been treated by the Japanese

during the slow march of the ages? They have been conquered and crushed under foot by them. Each official and person of the soldier class used, so the Ainu



BACK VIEW OF AINU HEAD OF HAIR

tell me, to make every Ainu he met go down upon his hands and knees and polish his head upon the bare ground, or thrust his nose into the very dust before him. If the downtrodden Ainu did not do this before these

high and lofty ones, his head was nipped off in the twinkling of an eye. Is it any wonder, then, that the Ainu still wear a slavish look? They never received any encouragement to look up, and if they did ever dare to exert themselves for their fatherland and their wives and children, it was only to receive a more crushing blow and deeper wound. But, thanks to the growth which the cause of humanity is making in all parts of the world, very much of this kind of oppression has for ever passed away. Would that an earnest, whole-hearted reparation could be made to them!

The Ainu people are most malodorous at times; but it should be borne in mind that the men and women sometimes walk ten or fifteen miles a day in a broiling sun with a heavy load of unsalted, sun-dried fish upon their backs. Such fish have by no means a pleasant smell, and, when once the odour gets well into their clothes, it most tenaciously remains there, and only requires a little perspiring dampness to bring it out in its strength. Not only so, but it is sometimes quite painful to sit in a hut with an Ainu who has lately been eating some kinds of dried fish, particularly the skate. It makes the breath peculiarly strong and noxious.

There appear to be only two occasions when the Ainu condescend to wash themselves, and then only their faces and hands are cleansed, and that but partially. These are bear feasts and funerals. Of course there are individuals who wash more often, or

even sometimes take a bath. But, on these occasions above mentioned, the Ainu, both men and women, cut their hair, shave their necks, wash their hands and

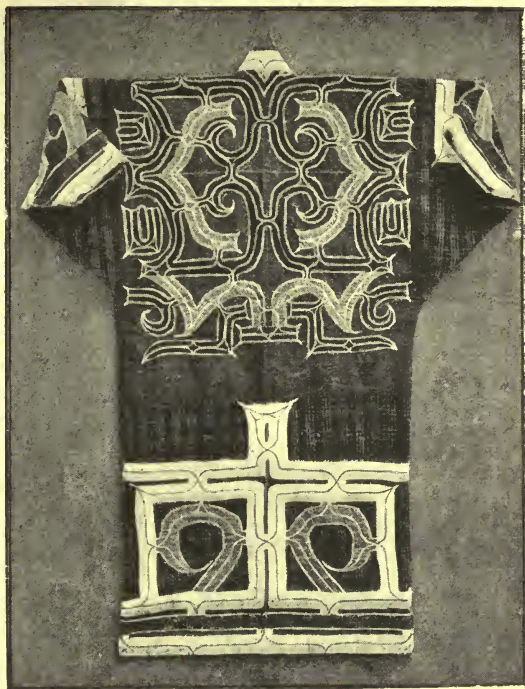

AINU CHIEF'S COAT (BACK)

faces, and put on their best or embroidered clothes and their ornaments. At such times the people are greatly improved in appearance, and are not at all a bad-looking race. Even their children are generally left

unwashed and uncared for, covered with incrustations of dirt.

Ainu men love inaction, as far as work in the gardens is concerned. But there is nothing an Ainu loves so much as hunting, excepting, perhaps, getting intoxicated. They have a wild nature, which breaks out every now and then. Servants have to be allowed to go off to the mountains for a day, to have a good run in the fresh air; or sometimes a horseback ride, or a day's fishing. No Ainu man will do any manner of work that can be done by his wife, who is too frequently his willing slave; for woman is a creature predestined to minister to man's wants, and to do everything that can be done in the shape of manual labour.

Thus, whilst the women are hard at work in their gardens, the men, if not fishing, or hunting, or drinking, or sleeping, or gossiping, or riding horses, may possibly be found helping their wives in the gardens, either with their hands or with their advice. However, they love horses; hence it is that so many of them are employed as horse-drivers by the Japanese. They are very good horsemen indeed. They ride off to the mountains, and will quickly find and drive a large drove of horses into any track they wish; down the paths they will gallop after them, and most skilfully head them and bring them home. These are the droves of wild horses Miss Bird speaks of in her book—every one of them, excepting the colts, of course, *broken in*!

Miss Bird has written, in her popular and widely-read book, 'Unbeaten Tracks in Japan,' to the effect that 'it is nonsense to write of the religious ideas of a people who have none, and of beliefs among a people who are merely adult children. The traveller who formulates an Aino creed must evolve it from his inner consciousness. I have taken infinite trouble to learn from themselves what their religious notions are, and Shinondi tells me that they have told him all they know, and the whole sum of them is a few vague fears and hopes, and a suspicion that there are things outside themselves more powerful than themselves, whose influences may be obtained, or whose evil influences may be averted, by libations of *sake*.'

Sake, it should be noted, is not an Aino word, but the name of an intoxicating spirit the Japanese make from fermented rice. I once tasted it, and then its flavour reminded me of very bad sherry. The Aino call it *Tonoto*—'official milk.' They probably named it thus in fun, and it would be just like the Aino if they did. In ancient times the Japanese used to trade with the Aino by barter. They never allowed the Aino to have money; but when they purchased skins, fish, deer's horns, and other commodities from them, the Japanese used to pay in household utensils, clothing, and *sake*, or rice-wine. If the Aino did any work for the Japanese officials, they were usually paid for their labour in *sake*. Hence, I think it quite possible that the name 'official

milk' was given to this drink because they were expected to thrive upon it, as though it were milk or food.

The evil effects this practice has had upon the Ainu may easily be imagined. It has made them a



AINU MAN ABOUT TO DRINK

nation of drunkards. In fact, strong drink has become such a power among them that by many it is supposed to be absolutely necessary for the acceptable worship of

the various deities. So that Miss Bird is right when she says that the Ainu think the 'powers outside themselves, more powerful than themselves,' will exert their good influences upon, or turn their evil influences away from them if they offer libations of *sake*. It will also be easily seen that the Ainu do not look upon drunkenness as wicked, or a thing to be detested. Fully ninety-five per cent. get drunk whenever they can obtain enough *sake*, and to be drunk is their ideal of supreme happiness.

Nevertheless, the power of the Gospel is beginning to be felt by those Ainu with whom we have been most in contact. The leaven is gradually working in their hearts for good. The way the people look upon drunkenness is steadily undergoing a change, and their views of what true happiness really is are becoming higher and purer. I have known Ainu women rush into their huts to hide their drunken husbands, when they have seen us about to look in upon them. Children, too, when they have been sent to the Japanese wine-vendors to purchase drink, look remarkably guilty when they meet us, and endeavour to hide their bottles behind them. They feel guilty and ashamed. They have learned that drunkenness is a vice, and this is the first step towards amendment of life. They are beginning to know, also, that the use of strong drink is not absolutely necessary to the acceptable performance of religious service.

There was a time, too, when I could have almost unreservedly endorsed what Miss Bird has stated in the passage just quoted concerning Ainu religious ideas. That, however, was before it had been my lot and privilege to dwell among these people. But after long residence in Ainu huts, and after continuous experience of their everyday life, dwelling with them and visiting them in times of sickness and of health, and after much personal intercourse with them, and a patient comparison of their early traditions with one another, and with their present words and actions, I entirely disagree with Miss Bird's views upon the religious notions of this peculiar and little understood people.

Everyone will agree that it would be 'nonsense to write of the religious ideas of a people who have none, and of beliefs among a people who are merely adult children'; but Miss Bird is clearly in the wrong when she implies that the Ainu are without religion, though they may be 'merely adult children.' As a matter of fact, these people are exceedingly religious, notwithstanding all that has been said to the contrary. And, however true it may be that a mere 'traveller who formulates an Aino creed must evolve it from his inner consciousness,' yet, as one who has spent more years with them than Miss Bird did weeks, I shall venture, in a later chapter, to give an Ainu creed. This creed will be evolved from their daily life and words, and from their highly-prized, carefully transmitted traditions.

It must not be thought that I intend to maintain that the Ainu have formulated the various articles of their faith, and hold them at hand ready for use, like people of a higher faith and more cultivated mind. Nor do I mean that an Ainu can, when asked, immediately repeat off-hand what he believes, as though he had learned it by rote. Creeds carefully drawn up according to theological order, logical sequence, and well-ordered thought do not belong to such a primitive, untrained, and uncontroversial race as the Ainu. Their faith is rugged, unpolished, and the various items that compose it are often disconnected and incoherent. It comes to light as the circumstances and events of daily life suggest or occasion it.

It is no matter for surprise, therefore, that Miss Bird's Ainu—Shinondi—could not give her any full account of his religious faith when invited to do so. Moreover, if there is anything an Ainu is likely to be reticent about when talking with a stranger who is ignorant of his language, it is his religious beliefs and observances.

CHAPTER II

AINU WOMEN

AINU women appear at first sight astonishingly ugly, dirty, and thoroughly spiritless. Pitiably miserable and unattractive do they look. They have dark, sooty-coloured tattoo marks upon the upper and lower lips, and sometimes a line of the same disfiguring ornamentation across the foreheads. Various patterns are engrained upon the backs of their grimy hands. Their feet are unshod; their hair, matted and unkempt, reaches down to the shoulders in front, and is cut in a kind of crescent shape behind. In addition to all this, their garments are slovenly, untidy, and their countenances sullen and dejected.

It is not, perhaps, surprising that some of those who come into contact with these people, and after a very slight acquaintance with them, should go away disgusted, and with the opinion that it would be no great loss to humanity if the Ainu were to become extinct. But such is not the writer's view.

It is true indeed that, intellectually speaking, a nobler race, the Japanese, is dispossessing the Ainu, and

that his disappearance or absorption is possibly being rendered necessary by the wonderful events which have taken place in Japan of late years; but, for all that, the Ainu is worthy not only of pity, but of practical sympathy and help.

It would, however, be a calumny to assert that all the hard-working Ainu women are ugly. Some of them, especially the younger ones, are quite good-looking. Their features are a little round, perhaps, and the cheek-bone somewhat high; but their complexion is of a pleasant, rosy kind. They are shy, and before a stranger, particularly if the stranger is of the male sex, they fix their eyes upon the ground, and place the hand over their lips, as a sign of reverence and respect. Before women, however, they are not so shy, but will look up and talk. It is then that their beauty may be seen. Their smile is pleasing and their eyes dark and sparkling; their voices are soft and musical, and their figures well formed. It is the tattooing that makes the elder women so unpleasant to the eye. Owing to this the women in middle life look inelegant, and in old age are positively ugly. The discontinuance of tattooing and the free use of soap and combs would soon work marked improvement in their looks—that is, according to Western ideas. They themselves, of course, believe that by tattooing their mouths, foreheads, and hands, they enhance their beauty.

We once took quite a young Ainu girl into our service,

that she might be the better able to learn house-work. When she came to the age of twelve years, there was



AINU WOMAN AND CHILD

not a vestige of tattoo upon her face, and my wife was particularly careful to request that she should not be

tattooed. After having lived with us for about two years, we left that village for a trip elsewhere, leaving the girl and her aunt in charge of our goods and chattels. We were away two months, and when we returned, behold, our little servant had had her face partially disfigured with tattoo. Upon asking her why she had done so, she replied: 'All the other girls are tattooed, and I felt lonely, not being as they.' The real cause was the force of habit upon her parents, particularly her mother. The old people always say, with reference to this, 'Our ancestors were thus tattooed, so therefore must we be.'

The tattoo of which the Ainu women are so fond is bluish-black in colour. Some of this colouring is put round the mouth, one stripe drawn across the forehead, various patterns placed upon the backs of the hands and upon the arms, and, in some cases, rings are stained into the base of the fingers. The process of tattooing is very primitive and simple. It is somewhat painful, and hence only a little is done at a time. It takes several years to properly decorate a person. The process is as follows. Some ash bark is first procured and put into a pan to soak; then a fire is made, and an iron pot or kettle hung over it. Next, a little birch bark is brought and burnt under the pot till the under part is well blackened. Birch bark is a wonderful thing for producing soot and blackness: hence its use for tattooing purposes. So soon as the bottom of the pot is thoroughly

black, a woman takes a knife, cuts a few dashes into the part to be tattooed, then takes some of the soot upon her finger and rubs it well in ; she then takes a piece of cloth, and, dipping it into the ash-bark liquor, well washes the tattooed parts. When children are operated upon, the centre of the upper lip receives the first touches, then the lower lip, and so on alternately until the marks reach almost from ear to ear. The forehead, hands, and arms appear to be done after marriage, though there seems to be no special rule about it.

Ainu women are treated as inferior beings by most of the men. Their whole life is a slavish drudgery. They are regarded almost as slaves. From morning till night, and from one year's end to the other, it is work, work, work ; and their work is manual labour of the heaviest and most tiring kind. This would not, perhaps, be quite so bad if men shared their labours ; but that is altogether out of the question. There is very little variety in their toil excepting that which is necessarily brought about by the seasons. They have next to no recreations or special amusements to brighten up their dull lives a little. Now and then a marriage occurs, and at very long intervals a bear feast comes to give them a little pleasure.

In the spring time the women, both old and young, crawl out of their sleeping places in the small hours of the morning, eat a hasty meal of cold vegetable stew, with perhaps a morsel of uncooked dried fish by way of

relish, shoulder their tools, and proceed to the patches of land they call their gardens, to dig up the soil and sow the seeds, returning to their huts at sunset only to take another meal like that of the morning, and again lie down to sleep. They often take but two meals a day—one in the early morning, and the other at night; but then they make up for the midday meal by eating in the evening perhaps twice or thrice as much as an ordinary person. Sometimes they eat a good meal, rest for about half an hour, then take another, and retire to bed in quite a happy frame of mind. It is on such occasions that one sometimes hears the expression—*Ibe aeramushinne*—‘I am in a state of knowing that I have eaten.’

Some women appear able to go without food for a very long time, and can carry heavy loads upon their backs all day without touching a particle of food. In the early spring the women and girls go to the mountains to get the fibre from elm-trees, with which they make a kind of cloth called *attush*.

During the summer months they have not quite so much to do in their gardens; they therefore work a good deal at weaving cloth, making and mending clothes, twisting string and coarse thread, and cutting wood. But as soon as the autumn comes round and the crops of barley and millet have to be reaped and harvested, the beans and peas gathered, and the potatoes dug up and stored, all are astir.

The Ainu mode of reaping is a long process, for it consists of walking through the gardens and pinching off the millet and barley heads with sharp shells. The straw is left standing; the Ainu have no use for that. Then, a little later on, just before the snow begins to fall, the women and children go away into the forests to pick up chestnuts, which are used as an article of food among them. About the same time they dig up the roots of the dog-tooth violet. These they wash, boil, and mash up into a pulp, then make into cakes and dry in the sun for winter food.

The Ainu gardens consist merely of small patches of land, generally upon the banks of rivers or in a valley. They cultivate one piece of land for two or three years running, then let that go to waste and take a fresh plot. This is quite necessary, for they use no manure. The Ainu understand nothing about agriculture; they have no idea as to how to cultivate the land. So long as a woman can procure sufficient food for her family to last through the winter, that is all she cares about. Whenever the gardens fail, the Ainu live by hunting in the mountains, by what they can catch in the sea, or by such things as grow naturally.

A few generations ago there was a very great famine in Yezo, so that thousands upon thousands of animals—deer, bears, foxes, wolves, and rats—died. The Ainu would not have minded the famine so much but for this. The death of the animals was far worse than the failure

of the crops; for the staple food was flesh. A great number of the Ainu died, starved to death. The people who lived towards the south of Yezo saved themselves by fleeing to Mororan, in Volcano Bay, where they were kept alive by eating shell-fish—the *Haliotis tuberculata*, or 'sea-ear.' These fish are very plentiful about Chiripet and Mororan. I believe the story of this ancient famine is quite true; for near the sea-shore, about two miles from Mororan, there are some very large lumps of sea-ear shells to be seen, covered with nearly a foot of black earth.

In the winter time, particularly during the latter part of November and the early part of December, the women assist the men to net or spear the large salmon which are found in the rivers about this time. After this the main stock of wood for winter firing has to be cut, split, dragged or carried home, and stored away. Then millet must be pounded, the beans and peas shelled, and a thousand and one other little things attended to. Thus is the woman the slave of the man.

It might be thought that, if an Ainu woman's lot is hard and laborious out of doors, she must surely lead an easier life at home, and there find rest and a little comfort. But even here she has a great deal to do, with little rest and next to no comfort. The cooking must be attended to. But this is not a very formidable task, as cooking has not yet attained to any very high perfection. In no sense are the Ainu epicures. The

women also must attend to the cleaning, smoking, and drying of fish; must keep the fire going and the water-butt full; must look after the children, and pay due attention to their husbands' wants, and see to the mending and making of clothes. There is, to be sure, very little scullery work to be done—not, indeed, because the utensils are in every case scarce, but because the Ainu do not see why an eating cup, shell, or platter need be washed at all excepting upon very rare occasions. 'After all,' they argue, 'it is only food that goes into our utensils; why need they, then, be washed? They will be used and dirtied again directly; therefore let them remain dirty.' Hence there is very little 'washing-up' in an Ainu hut. Nevertheless, there are a few exceptions to this, as well as to every other rule.

Nor do the Ainu women have any religious solace in all their cares. The men seem to think that they are not capable of learning anything about God, or are such inferior beings that the gods take no thought or care about them. Ainu widows are particularly unfortunate, and have a specially hard time, for their presence is barely tolerated. By no means may they be present where prayer is going on.

The existence of Ainu women being one of such trial, sorrow, and hard work, it is not to be wondered at that many of them have a downtrodden, hopeless look. They have no special joys in the present, and no bright hopes for the future. Their whole time and thought

are given to the necessary tasks of everyday life. A woman may do all she can, and yet receive neither thanks nor encouragement from her husband. No wonder that some of them, overcome by the troubles and worries of everyday existence, think life a burden and sorrow, and give way to despair. Some, thus tired of living, die by their own hand. They hang themselves, this being the favourite way of committing suicide.

Ainu women are very fond of their children. But the poor little mites, when about a month old, are often left quite alone in a hut, suspended from the roof in their cradles. Nevertheless, this is not from want of feeling, for the Ainu women do love their children; but to let a child lie in its cradle and cry is not only thought to be good for its lungs, but is a part of its education. 'Babies,' say they, 'are like talkative men and women; they must have their say.' So the best way to keep a child quiet is to let it cry as much as it will. It soon learns to grow tired of howling. Such, at any rate, is the Ainu feminine belief.

An Ainu cradle is made of wood, and is generally suspended from a beam in the hut in such a manner as to hang in a warm place by the fireside. It is about two feet and a half or three feet in length, and twenty inches or so wide.

For a married couple to have no children is supposed to be a great disgrace, and is by them traced to the belief that one or other of the parties has

committed some sin. This world is named *Uaremoshiri* —‘the multiplying world’—and people were placed in it to increase and multiply. If, therefore, no children are forthcoming, it is considered to be a special punishment from the gods. Having no offspring used to be considered an amply sufficient reason for divorcing a wife. The author knows an Ainu who has divorced no less than three wives because they bore him no children.

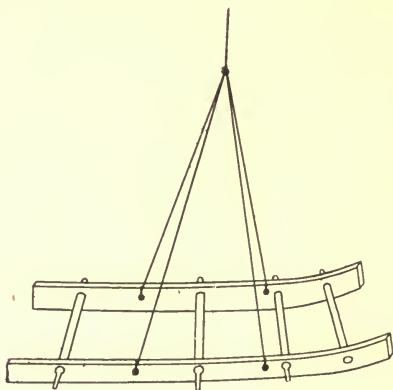

AN AINU CRADLE

A curious custom used to exist amongst this people. As soon as a child was born, the father had to consider himself very ill, and had, therefore, to stay at home wrapped up by the fire. But the wife, poor creature! had to stir about as much and as quickly as possible. The idea seems to have been that life was passing from the father into his child.

CHAPTER III

CLOTHING AND ORNAMENTS

THE chief article of dress worn by the Ainu is a long garment, which they call *attush*. This word really means simply 'elm fibre' or 'elm thread.' And, as these words indicate, the dresses are made from the inner bark of elm-trees. Such garments are very brittle when dry, but when wet they are exceedingly strong. The elm bark is peeled off the trees in the early spring, just when the sap commences to flow upward to the young shoots and newly-forming buds. When sufficient bark has been taken, it is carried home and put into water to soak and get soft; and when sufficiently soaked it is taken out of the water, and the layers of bark separated, and the fibres divided into threads and wound up into balls for use. Sewing thread is made in the same way, only that is chewed until it becomes round and solid. When all the threads have been prepared, the women sit down and proceed with their weaving. These garments are very rough indeed and are of a dirty brown colour. Those Ainu who can afford it prefer to wear Japanese clothing.

The women take pride in fancy needlework, and are very tasteful in their arrangement of both pattern and colour. This embroidery, or fancy needlework, is done



AINU WOMAN'S DRESS

with Japanese stuffs and coloured threads and cottons upon a groundwork of their own elm-bark cloth. One of these dresses, in the writer's possession, took up all the spare time of a woman during a whole year to make.

The work of different villages presents different patterns ; those of one are not necessarily the same as those of another. In fact, when an Ainu of one district goes

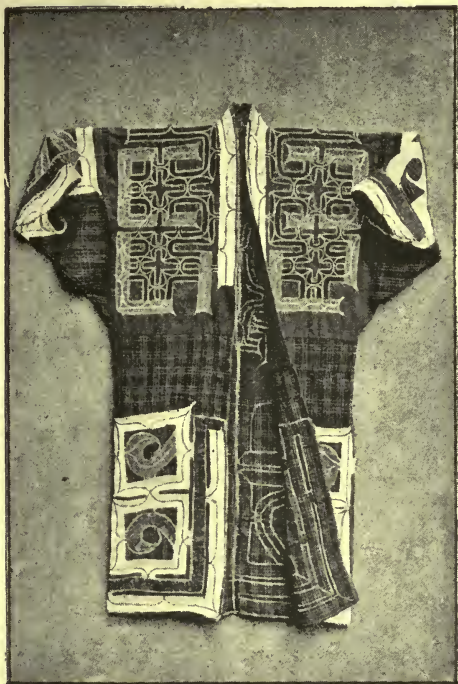

AINU MAN'S COAT

into another clothed in an embroidered dress, the people he meets can with almost certainty tell where he comes from by the patterns of his coat !

There are patterns suitable for men, and others for

women. No man would think of wearing a coat with patterns on it which are recognised as belonging to women; nor would a woman put on a coat that had patterns appropriated by the men. The women's garments are not so highly decorated as those of the men. The wives take a pride in dressing up their husbands, especially on the occasion of a bear feast; but they themselves prefer a good show of beads, earrings, finger rings, necklaces, and bracelets, set off with a tastefully tattooed mouth.

The men take great pride in their wives' needlework, and they are exceedingly particular about having the corners of their ornamental patterns properly turned. If a curve is not quite so well turned as a man thinks it should be, or a line not quite straight, he will storm away finely, and sometimes make his wife unpick her work and do it all over again.

For winter wear, the women sew dog, bear, deer, wolf, or fox skins upon the back of their *attush* or elm-fibre garments, and wear skin shoes. These shoes are made of deer and salmon skins. Formerly they used also to wear skin trousers; but as skins are now somewhat scarce, these articles of dress are dispensed with. The women, both in summer and winter, wear leggings made of grass or rushes, and both men and women sleep with their heads wrapped up in a cloth or head-dress.

The treasures and ornaments of well-to-do Ainu consist, not in such things as gold, silver, or precious

stones, but in Japanese lacquer-ware vessels and old swords. The former are called *shintoko*—that is, ‘things of beauty’—and the latter *tombe*—that is, ‘shining things.’ The *shintoko* used to be paid to the people, well filled with wine, in return for the skins of animals and fish, and were sometimes bestowed upon the chiefs as a mark of distinction. They are nearly all of Japanese manufacture; but some come from Corea. The *tombe* are ancient swords—old heirlooms, which, however, are now bladeless, for the Ainu were not allowed by the ancient Japanese to have any blades in their swords. These bladeless swords are usually stowed away in long boxes, and placed upon the beams of the huts. They also set a high value upon old bows and arrows and tobacco boxes.

Ainu women are very childlike in their fondness for toy-like ornaments, and some of the wary Japanese pedlars have taken advantage of this weakness and made large profits out of it. For instance, earrings made of white metal, but called silver, and worth about sixpence in Hakodate, are sold to the Ainu women for six shillings; and rings which sell at a shilling in Hakodate sold in Piratori for twelve shillings. If those who buy have not the money required for the purchase, the pedlars do not mind, though they haggle a great deal about it. Finally, at the earnest request of the buyer, they condescend to take skins or fish in payment. In this way two or three fox skins or a deer skin go for a pair of metal earrings!

Besides earrings, the women are extremely fond of glass beads. Some of these beads are of Japanese make, others have come from China. The Ainu believe that the ancients got them from the *Rushikai*—that is, Russians and Manchurians. Beads which cost a penny or two in Hakodate are sold to the Ainu for three shillings.

Finger rings—some made of brass and called gold, others made of white metal and called silver—are also eagerly acquired; and many a pedlar has made a good harvest out of such gimcrack trumpery. The necklaces of the Ainu women and children are generally home-made. These consist of a collar of leather or Japanese cloth, upon which melted white metal is fixed in shape something like a flower. They are sometimes made of lead. The women of Saghalien wear belts of the same shape, but ornamented with Chinese cash instead of lead. Ainu women are also very fond of fastening their clothes together by means of any shells which strike their fancy as being pretty; but if they can get hold of an old sword-guard, they place it in the fire to make it look like bronze, and their happiness is complete.

The Ainu, both men and women, wear earrings, although those the men wear are nothing more than pieces of red material. This fact reminds me of a circumstance of a somewhat peculiar nature which happened a few years ago. I had, one evening, been speaking to the Ainu about the brotherhood of man,

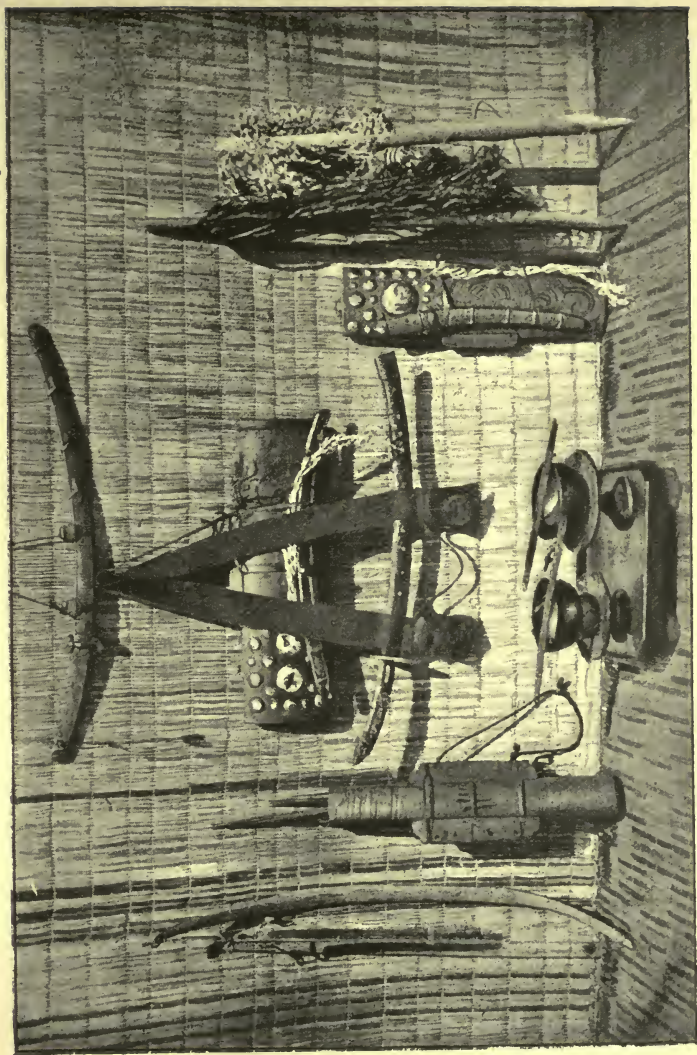

AINU TREASURES

whatever the country, race, colour, language, or civilisation might be. The address was well received, and appeared to have made some impression on the listeners, and I was, upon finishing my address, politely invited to have my ears bored, that my brotherhood with the Ainu race might thereby be sealed! Much of what good feeling may have been stirred up by my address was reduced, I fear, to a nullity because I refused to have my ears bored and a piece of red cloth stuck through! Of course, it would have made matters far worse had I attempted to explain to them that I desired to raise them up to the Christian level and Christian ideas in these things; for they might possibly have thought I was looking down upon them on account of this custom of ear-boring, and it always behoves us in such cases to be careful about causing any unnecessary offence.

CHAPTER IV

HUT-BUILDING AND HOUSE-WARMING

AINU huts are most uncomfortable places, for amongst this race household comfort is quite a secondary con-

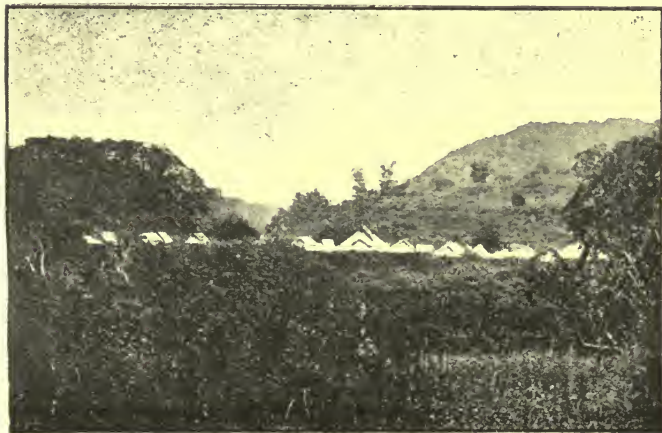

AN AINU VILLAGE

sideration. If they can secure bare existence and animal sustenance, they are content. Ainu villages, seen from a distance, appear quite picturesque, situated, as



AN AINU HUT

they generally are, along the banks of rivers. And the individual huts in some districts are neat and pretty-looking buildings, for some of the men and women take quite a pride in thatching their homes. But all the picturesqueness and the beauty disappear upon a closer inspection. After a few weeks or months—some people think a few days fully sufficient—spent in one of them, a Japanese hotel seems a very paradise for comfort.

In building their huts the Ainu commence at the roof. This consists of bare rafters tied to horizontal poles at the lower end, and a long ridge-pole at the upper, and across these again are laid smaller poles, to which the thatch is fixed. The inner layers of bark, especially of elm-trees, and pieces of creeping plants, are used as rope or strings for tying the separate poles together. As soon as the roof is finished, poles about five or six feet long are driven into the earth at a distance of four or five feet apart, and across these smaller pieces of wood are lashed, to which the thatch is tied, and thus the walls of a hut are formed. These poles have each a fork or branch in the top. When they are all set up in their proper places, the roof is lifted bodily up, and the bottom horizontal poles allowed to rest in the forks at the top of the uprights.

The thatching is then proceeded with. This takes several days to finish, for the huts are almost entirely thatched with reeds, from the ridge-pole of the roof to the bottom of the uprights, which are stuck into the

earth. Both men and women work at house-building, and the spring and autumn are the proper seasons for this occupation.

Every hut is furnished with two holes, made just beneath the eaves, which serve as windows—one in the east end, and the other on the south side. Screens made of rushes or reeds are placed on the outside of these, and in some cases wooden shutters also. These are all so fixed as to admit of being drawn up or let down from the inside at will, according as circumstances may require or the occupants desire; for the strings or cords to which the screens and shutters are attached pass upwards under the eaves, and over the horizontal roof-pole into the hut.

It is not considered polite to look into a hut through the south window, and it is a positive insult, both to gods and men, to look in at an east window; for a peculiar sacredness is attached to that part of the hut, and the people are very superstitious concerning it. Men often worship towards the east or sun-rising through the east window, and they are very careful not to desecrate it by expectorating or throwing anything out of it. The south window is often used for both of these purposes.

There are no chimneys in the huts, but a hole is purposely left in the west-end angle of the roof for the escape of the smoke. This, together with the two windows, is considered fully sufficient for all practical pur-

poses ; but the smoke is sometimes very trying to the eyes and throat.

At the west end of a hut is a door which leads directly into a porch or ante-chamber, which the Ainu call a *shem*. In the south wall of this is another door, which leads into the open air. This porch is used for various purposes, such as storing firewood, pounding millet, and shelling peas and beans. The dogs also are allowed to inhabit this part of a house.

A few of the larger huts are furnished with a doorway in the south wall of the main or dwelling part of the building. This doorway is situated near the east-end corner of the hut, and is fitted with a sliding door somewhat resembling a Japanese *amado*. The outer door of the porch is fitted with a hanging mat only, but the inner porch doorway has both a mat and sliding door. The wooden doors are closed only when the household is away from home or gone to bed.

Outside, and a short distance from the west end of the hut, is placed the family godown or storehouse. This erection consists of a little lodge placed upon piles. The reason why these buildings are placed upon piles is to keep the rats and mice from making raids upon the stores. Upon the top of each pile, and between it and the floor of the godown, the Ainu generally place a square piece of wood, which makes it next to impossible for a rat to enter by climbing up the pile. Peas, beans, millet, pumpkins, and other garden products are stored

in these places. At least one traveller, who made a casual visit to some Ainu villages, first guessed, and then had the audacity to state, that these buildings were Ainu *temples*! This is an example of what untrue statements people will make upon subjects of which they really know nothing.

At the east end of every hut, and near the sacred east window, about five or six yards from it, the Ainu has what might be called his temple; for to him it is

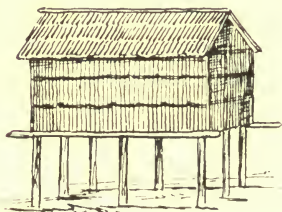

A STOREHOUSE

really his special place of worship. This consists of a few poles, upon which are placed the skulls of deer, bears, foxes, and other kinds of animals which have been killed in the hunt, and also of a large number of *inao* and *nusa*.

Of course many persons have, for the want of better information, thought these *inao* are placed there for worship; but such is not the case. They are offerings to the various gods—a sort of thankoffering or memento. Twice a year, at least, the owner of the hut, together with his immediate friends and relatives, reverently approach these skulls and shavings and offer worship. This takes place in the early spring and the autumn; also whenever there is a birth, a sickness, or death in the family. It is a touching sight to see the

old men with grave and reverent faces sitting before these sun-dried skulls, and praying to their gods. Libations of wine are often offered at this place, for it is supposed by some that the spirits of the slain animals reside there, or at least often visit their remains, and that they are pleased to accept the sacrifice of wine, and as a return for the devoutness and thoughtfulness of the offerers will render them successful in the hunt.

Each hut generally has a small plot of land to itself. This is done as a protection against fire, of which the Ainu are very much afraid. In fact, the Japanese affirm that the Ainu fear a fire and the fire goddess so much that if a house once takes fire they will not even attempt either to extinguish it or save any of their property. They will not be so foolish as to rob the fire goddess of that which she desires to have. This, however, the Ainu deny. The Japanese have made a mistake, and the fact is that when an Ainu hut once catches fire there is no time to save anything, for the thatch naturally burns very rapidly indeed.

I have seen two huts on fire, and they were both burnt down in less than fifteen minutes. In one case a few things were saved, but in the other the household only just managed to save themselves, and the clothes they had on. The Ainu are not so senseless as to attempt the impossible—that is, to put out the flames of a burning hut—but they do all they can to save their treasures, especially their heirlooms, and to prevent the

fire from spreading. The Ainu call or alarm of fire is a shrill, weird, unearthly noise, somewhat resembling the note of the screech-owl, and can be heard for a great distance. The women can best utter the scream; the men generally call out 'Wooi!'

Ainu huts vary very little in size. The chief's hut is generally a little larger than the rest in a village.



HUT OF A NEWLY-MARRIED AINU

Amongst the common people the hut differs slightly in size, according to the length of time the occupiers have been married. When a newly-married couple commence housekeeping, their first hut is very diminutive, their second is a little larger, the third larger still, and so on, till the husband can afford to build one of the proper dimensions. The first dwelling almost always

forms the porch to the second, and the second to the third, and so on: thus all is not labour in vain. However, a hut never consists of more than two sections, and these are the porch or ante-chamber and the main dwelling-place. Every time a new house is built, or an addition made to an old one, wine has to be procured, millet pounded and made into unleavened cakes or dumplings, and a feast given.

The Ainu are nearly as conservative a people as the Chinese. It is exceedingly difficult to get them to change any of their customs. In short, if one man amongst them desires to make some improvement or other, even in so slight a matter as adding a few planks or boards to his hut, he cannot do so unless all the other Ainu in his village are made joyful with strong drink, and so led to give their consent.

A man at Horobetsu, who, for an Ainu, was a rich man, determined to build a new house. He intended to improve on the Ainu mode of architecture, and build his house in the Japanese style. He had finished all but the roof when a deputation of his brethren waited upon him and informed him that, unless he put a roof thatched after the approved Ainu style upon the house, he would be boycotted. He was obliged to listen to this, for he was the proprietor of a large fishing station. That house has, it is needless to say, a proper Ainu roof upon it, as the illustration shows.

As soon as a new hut is built, and immediately after

the family has moved into it, the owner sends to his relatives and the chiefs and people of his village, who, by-the-by, all assist in the work of building, and invites them to the house-warming feast. Millet, made damp with water, is pounded into dough in wooden mortars, and kneaded into cakes, which are presently boiled. Of course all this is done by the women. *Sake* is procured from the Japanese wine-vendors, or, failing this, some liquor is made by fermenting millet. When all things

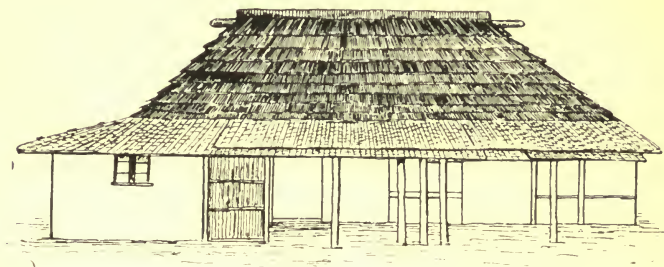

JAPANESE HUT WITH AINU ROOF

are ready, the chiefs, together with the men, sit down in a circle at the east or sacred end of the hut, having the tub of wine in the centre—the honoured chiefs and landlord first, and the common people after. Each in turn, according to age and dignity, has a cup of wine given him.

They then proceed to worship the various gods as follows. Each man dips the piece of wood used to keep the moustache out of what they may be drinking

into the wine, and offers three drops to the particular god or gods he may wish to worship. In this way a multitude of blessings are invoked from innumerable deities. For instance, one man addresses the goddess of fire; another the god of the sleeping places; another the god who presides over the treasures and hunting paraphernalia; another the god who is supposed to look after the pots, pans, kettles, water-tubs, and other household utensils; whilst another worships the gods who keep the windows and doors, and the east and west ends of the huts. After all the deities who are supposed to preside over the different places and goods within the hut have been duly honoured, the men go round the outside of the hut, and invoke the gods who guard the water-springs and out-houses, garden plots and paths.

After this, the men return to the hut, and continue their eating and drinking; and when they have satisfied their appetite they give a little wine—very little, for they do it grudgingly—to their wives and daughters, who, seated behind their husbands and fathers, have to take what they please to give. Each man likes to obtain all the wine possible, and delights in getting as drunk as he can. They often quarrel because they fancy some one person has had more than his share of drink. The hut is a pitiable sight after one of these feasts, the floor being covered with men dead drunk.

At this particular feast the Ainu make their *inao*, or

shavings of willow wood of different forms, some to hang inside, and others outside of the huts; some, again, to stick up by the fireside, next the sleeping places, in the treasure corner, at the east window, at the corner where the water-butts are kept, and at the doorways; and others at the springs in the gardens, and by the out-houses.

The house-warming feast is a most important affair in Ainu daily life. The favour of the gods, without any exception, must be solicited with proper words and in a befitting manner. None must be left out, lest they be angry and revenge themselves upon the inhabitants of the hut by bringing disease and death, misfortune and famine. Were the goddess of the water-spring, for example, forgotten, she might revenge herself by drying up the springs and ceasing to give water. If the gods who preside over the sleeping places were omitted, they might take away all sleep from the family. This very common act of life emphasises the fact that the Ainu have a creed, and it illustrates the way in which they believe in the ubiquity and daily providence of the gods.

In Christian lands it is customary for every true Christian to acknowledge God's providential goodness by 'saying grace.'

This is a right and godly act. But think for a moment what this act implies and involves. It implies a knowledge of a living, sentient Being higher than

man; it involves the idea of dependence upon that Being; and it is an act of worship indicating a proper sense of devotion. It further implies that the worshipper believes himself to possess some natural yet mysterious faculty or power by which he can approach that living Being whom he calls God, and to whom he returns thanks.

I was very much surprised, when I first visited the Ainu, to see many of them, especially the heads of families, acknowledge God's goodness, and give Him thanks before eating. I do not mean to say they always do this, but they are all taught to do so, and that in a set formula. And I have never yet met the Ainu who does not, before drinking wine, make his salutations, stroke his beard, worship and thank the gods for their benefits. One of their forms of 'grace' is: 'O God, our Nourisher, I thank Thee for this food: bless it to the service of my body.' Here, then, by this common everyday act, we get one article of Ainu religious faith—viz., that he believes in a power above himself, on whom he depends for his daily food, and whom he can approach in prayer and thanksgiving by a faculty within himself.

Ainu food, though not in every case that which Europeans prefer, does not, when properly cooked, come amiss at a pinch. For example, fresh salmon, codfish, venison, bear's flesh, beans, millet, potatoes, and peas, are all good in themselves when cooked properly. But

the Ainu do not know how to cook. They are remarkably fond of stew, strongly flavoured with badly-dried fish, and almost every article of food is cast into the stewpot, and is there completely spoiled.

However, their food is not always cooked in this manner, for fish is sometimes roasted before the fire, and potatoes are baked in the ashes upon the hearth. A hungry man can make a good and enjoyable meal off such things. They are very fond of salmon, salmon-trout, young sharks, swordfish, and whale; and, in the way of flesh, bear's fat and marrow-bones, the haunch of venison, and any part of a horse or bullock. Seaweed and various herbs, the roots of some kinds of lilies, and many water plants, as well as leeks and onions, are used as vegetables; while grouse, wild geese, and cranes serve for game.

When taking a meal, the mistress of the house, together with her husband and youngest children, sit on the side of the fireplace that is to the left-hand on looking into a hut from the west-end door. The rest of the family occupy the right-hand side, strangers the lower end, near the door, and honoured guests the east or sacred end of the hearth.

There is no dishing-up to be done. The mistress ladles the food out of the stewpot as it hangs over the fire, and passes it to the one for whom it is intended. One advantage of this is, a person gets his dinner really hot, and meat and pudding covers are not required.

Visitors are generally served first, then the husband, and lastly the remaining members of the family.

The Ainu have a very limited supply of eating utensils. Now, if the cups are not sufficient to go round the whole number taking food, two or more have to use the same cup. But this is not often the case, for each

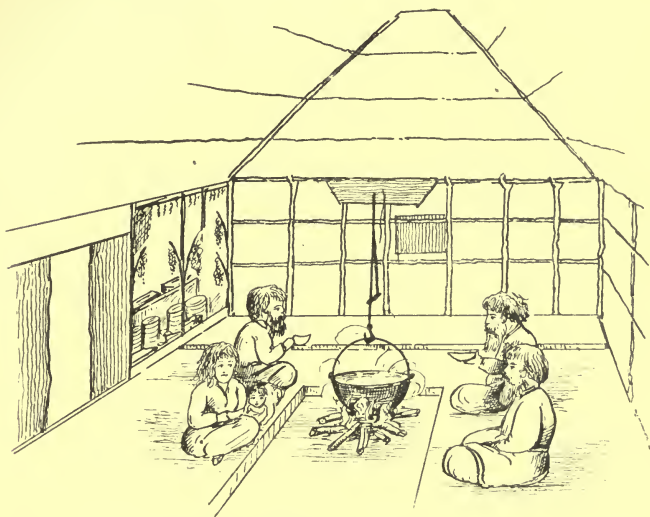

AN AINU FAMILY TAKING A MEAL

member of a family has generally his own cup or shell safely stowed away near his sleeping place, ever ready to be produced when required. When a person wishes for more food, it is the correct thing to ask the mistress to replenish his cup. If she is too much engaged, or at all inclined to be familiar, as she is, for instance,

among her own friends and relatives, she simply removes the pot-lid and points to the ladle, thereby indicating that the person may help himself.

The Ainu cannot be commended for their cleanliness in the treatment of food. They very seldom wash their pots and pans, and still less their eating cups. It is therefore worthy of remark that the index finger is called in Ainu *Itangi kem ashikipet*—that is, ‘the finger for licking the cup.’ It is so called because people generally cleanse their eating cups by first wiping the inside of them with their index finger and then licking it!

Various kinds of animal food the Ainu eat have been mentioned; but it must not be supposed that they are well off, or always in possession of a well-stocked larder. Nowadays many of the people do not know the taste of venison, as there are so few deer about. They were very numerous a few years ago, but have nearly all been killed off by the Japanese hunters, who came with their guns and proceeded to destroy them wholesale for the factories which the Government of Yezo established for the canning of venison. This exterminating process went on till now hardly any deer are left. The officials have at last seen the folly of this, and have lately prohibited both Japanese and Ainu alike from killing deer, and a fine is imposed if anyone is caught hunting them. Hence venison now must be struck off the list of articles of Ainu food. Bear’s flesh is also very scarce. Salmon

only comes at particular times each year, and the people know nothing about the art of preserving fish by salting, and do not even possess salt. They dry a few fish in the sun ; but fish so prepared is remarkably odoriferous, and of a very high flavour.

CHAPTER V

FURNITURE

THERE is not much furniture in an Ainu hut. The centre of the building is taken up with the hearth, which is a long open space surrounded with pieces of wood. In this space as many as three or four fires can be kept burning at one time if necessary. Above the fireplace is suspended from the roof an apparatus or frame containing pot-hooks and all kinds of cooking paraphernalia. This instrument is called *tuna*. Above this necessary piece of furniture, fish, bear's flesh, and venison are hung to dry; and as the *tuna* is a kind of framework with a few bars as a bottom, wheat, barley, or millet are placed in mats and put upon it, that they may be cured ready for threshing and pounding into flour.

That part of the hut extending from the head of the fireplace to the east window is, as already stated, held sacred, and is set apart for special strangers and visitors, particularly for honoured guests. The right-hand corner is the place where all the Ainu treasures are kept, also a great number of family *inao* and *nusa*; and upon the beams over these, heirlooms, old swords, bows and

arrows, spears, and fishing implements are stowed away. In long boxes next to these are preserved the special ornamental clothes and important things belonging to the master of the hut.

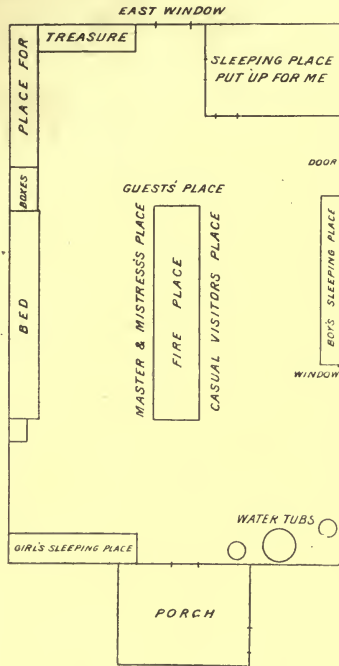

PLAN OF AN AINU HUT

Next to the sacred east corner comes the bedstead of the heads of the family. This consists merely of a raised platform or bench, having a screen of mats hung round it. After the bed comes the private corner of the mis-

dress, where she keeps a little box in which are stored her beads, rings, necklaces, and other little nicknacks. Next to this is the sleeping place for the daughters of the family ; then the doorway leading into the ante-chamber. On the other side of the doorway the water-butt, tubs, pots and pans are generally found. After this the sleeping shelves of the male members find a place. Then comes the south door, when a hut can boast of two doors. Friends sleep at the east end, near the window. The master and mistress and younger members of the family look upon the right-hand side of the hearth as their special place, and the rest of the family occupy the opposite side. Honoured guests take the head of the fireplace, and common visitors remain at the west end of the hearth near the doorway.

Sometimes the Ainu, especially when they expect visitors, place mats made of a hard kind of reed upon the floor ; and upon these they spread yet another softer mat, made of rushes and grass. These are used instead of stools and chairs to sit upon. Hence, to spread a mat for a person is equal to offering him a chair. I once got into a dreadful scrape, though quite unintentionally, through jokingly telling an Ainu that I would roll him in a mat. On this occasion I was packing up some of my things preparatory to paying a visit to another village. An old man, who was very eager to assist me, would insist on rolling up in mats for transportation the things I did *not* want to

go. I jokingly said, at last, that unless he ceased I would roll him up too. The old man flew into a passion at once, and I was quite at a loss to understand why he should be so angry. I have since learnt that to tell an Ainu one will roll him up in a mat is equivalent to informing him that you are ready to bury him! This is due to the fact that Ainu, when they die, are rolled up in mats and buried; they are not placed in coffins.

Ainu huts are so unsubstantially built that at times the wind whistles through them at such a rate that it is next to an impossibility to keep a lamp or candle burning. On one occasion I had mats hung up all round me in the attempt to keep my candle burning; but all my efforts were of no avail, and there was nothing for it but to retire early to bed. My bed was somewhat hard, for it consisted of bare boards. Nevertheless, after a few weeks' practice, even a board bed becomes quite a comfortable and healthy place for a tired body. The chief difficulty about a board bed is that, in winter, the boards seem to throw out no heat; hence I had to keep myself warm with the hard and dry untanned skins of animals and hot-water bottles—for Ainu huts are remarkably cold in winter. Moreover, the dried fish, some of which hangs rotting in the roof, emits anything but a savoury odour. The smoke, too, is a great nuisance, and causes the eyes to smart and run with water. As for fleas, beetles, and other

objectionable insects, the huts in some districts swarm with them during the summer months. Snakes occasionally visit the thatch of the roof in search of mice and sparrows' nests. Fleas are the most troublesome of the insects, and appear to have a special liking for white man's blood. On one occasion, when I arose in the morning, my body was completely covered with bites; but, strange to say, ever since that night they have been unable to make any impression whatever upon me. Intending travellers in Ainu-land should carry with them a large supply of Keating's insect powder.

The domestic implements used by the Ainu are not very numerous. Some of them are very simply made, but others are quite nicely carved. The cups, dishes, pots and pans are all of Japanese manufacture; but trays, spoons, and pounding mortars are home-made, as are also their weaving looms. Ainu children are not brought up on pap administered with silver spoons. Wooden spoons are quite sufficient for them. Sometimes pap made of millet is given to young children with a wooden spoon or with a piece of shell; sometimes with the fingers; and occasionally mothers give their offspring food from their own mouths. This is a favourite method of making very young children take medicine. By this means even babies are made to swallow noxious physic before they know what has taken place. It is certainly not a cleanly habit, but it is very effectual, and quickly done.

The spoons used for cooking purposes are of various shapes, and two of the most common patterns are shown in the illustrations. That marked 1 is used for stirring millet cakes when they are being cooked for a feast. That marked 2 is used for ladling out millet or rice or stew from the pot. There are spoons of other patterns and sizes, but they call for no special remark. The ornamentation is mere matter of taste, and is devised according to the carver's own fancy.

The engravings on the next page represent two moustache lifters. They are, of course, used only by the men. It is a curious instrument, and is only called into use when drinking. Its purpose is two-fold. The men invariably

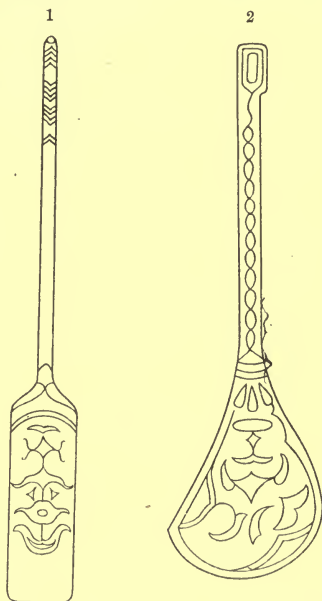

AINU SPOONS

use it when they are at worship; for with the end of it they offer drops of wine to the gods to whom they pray. Further, the moustache lifters are used to keep the moustache out of the cup whilst the men drink. It is considered to be very unseemly and impolite to allow

one's moustache to go into the wine as it is being drunk. It is disrespectful to the persons present, and is thought to be dishonouring to the deities.



A COMMON MOUSTACHE LIFTER



A CEREMONIAL MOUSTACHE LIFTER

At drinking ceremonies—that is to say, at a funeral or house-warming feast—the Ainu use what they call



AINU PESTLE AND MORTAR

a *kike-ush-bashui*, 'a moustache lifter having shavings attached to it.' They are made of willow. All of these instruments, however, do not have shavings attached to them; but the men who

pride themselves on their hunting abilities have bears carved upon them. They are very proud of these, and set great store by them.

The mortar and pestle are also in common use in

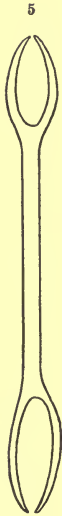
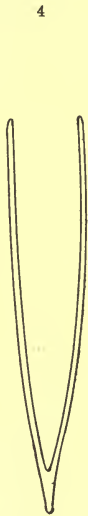
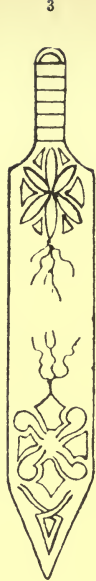
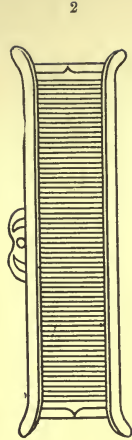
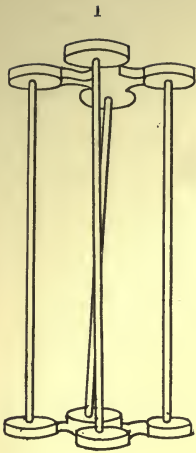

PARTS OF A LOOM

an Ainu hut. These instruments are home made, and each consists of a solid piece of wood. The mortar is used for threshing out wheat and millet, also for beating millet into flour and paste. This paste is used for making cakes for the special feasts. The pestle is held by the middle, so that it has really two ends.

Next to implements used in the preparation of food, the weaving loom is a most important article. It is a simple affair, consisting of six parts. The illustration shows what they are. No. 1 is called a *kamakap*; it very much resembles a ship's log-winder. It is used to keep the warp thread separated. No. 2 is called an *osa*. It is something like a comb, and is used to keep the warp straight. No. 3 is the shuttle, used for carrying the thread of the woof from one side of the cloth to the other, between the threads of the warp. It is called *ahunka-nit*. No. 4 is called a *peka-o-nit*, and is used for the purpose of changing the warp threads. No. 5 is called *attush-bera*. It is used to knock the woof close home. No. 6 is merely a small piece of wood used as a beginning or foundation for the cloth. It will be easily understood that this very primitive mode of weaving is most tedious, and therefore requires a great amount of patience. It takes a very long time to weave a yard of cloth with such a machine. However, the Ainu do not understand anything about the value of time.

Ainu candlesticks and lamps are not very elaborate affairs. They consist of a piece of stick split at one end.

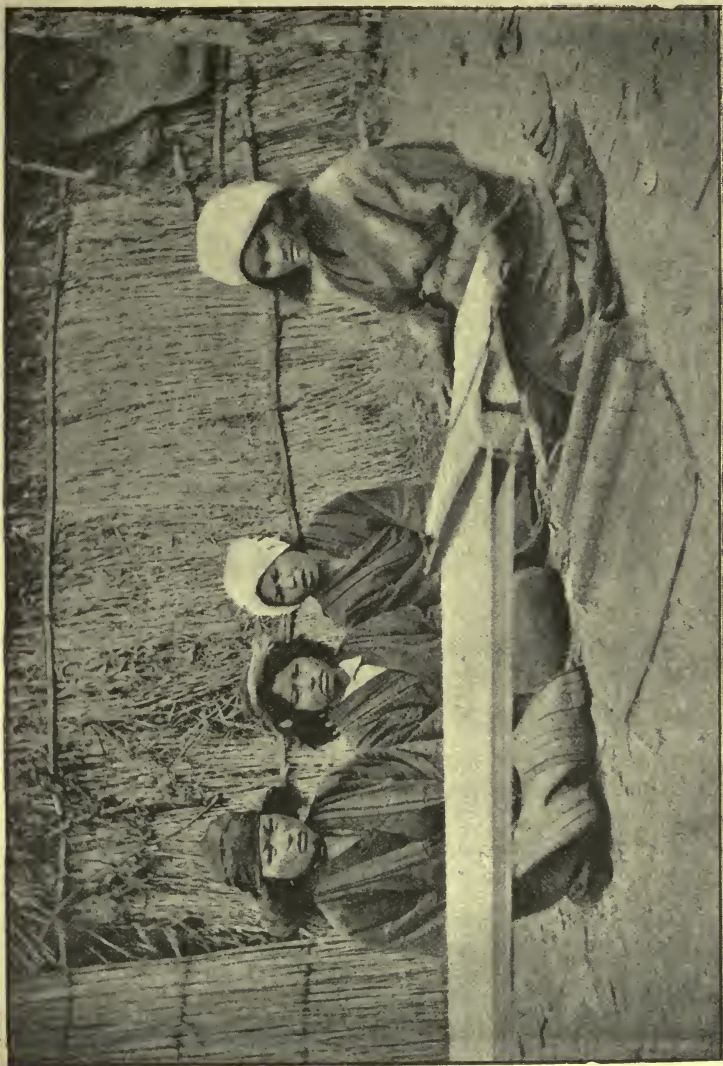

AINU WOMEN WEAVING



This stick is stuck into the hearth, and a piece of lighted birch bark is fixed in the split end. Birch bark burns very well indeed, but the light it gives is of a very glaring kind ; one cannot see to do much by it.

Fire used to be produced by rubbing very dry pieces of the roots of elm-trees together. Friction is said by the people to work quicker upon this kind of wood than upon any other. But as soon as the Ainu came into closer contact with the Japanese, they bought and used flints and steels. These were worked so that the sparks fell upon touchwood, which takes fire easily and quickly when dry. Now, however, matches of Japanese make are in daily use.

The Ainu like to carry their loads of fish, or wood, or whatever it may be, upon their backs.

They prefer to have their hands free, and use their heads to help carry their bundles. The person about to carry a bundle ties what is called a *tara* or *chi-ashke-tara* round the bundle, throws it on to the back, and places the headpiece of the *tara* over the forehead. There is not so much work for the head to do as one would expect, for the main part of the weight of the load is on the lower

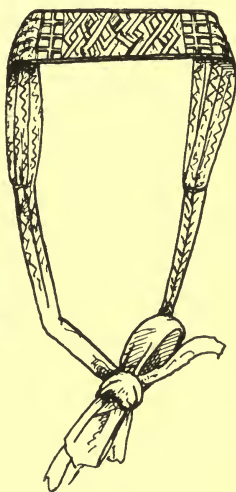

A TARA

part of the back. It is astonishing what heavy loads can be carried in this way. The preceding illustration represents a *tara*, showing particularly that part which goes over the forehead. It has cloth and cotton worked into it, which keeps it, in a measure, from hurting the carrier's head.

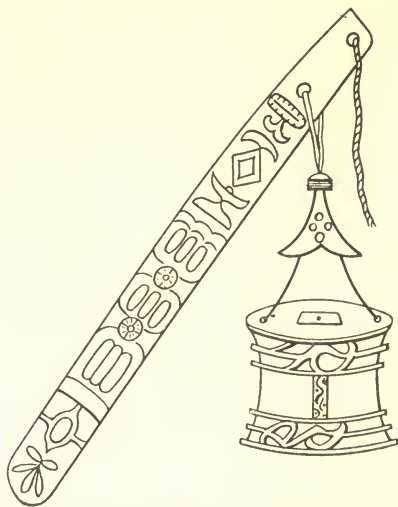

TOBACCO PIPE-HOLDER AND BOX

The Ainu do not use baskets much, though they have a few; but they have invented a kind of bag, which is a mat rolled up, and a piece of cloth sewn over each end. This article is very common. It is called *chitarabe*. This is also carried by means of the *tara*.

Smoking tobacco is not a real Ainu custom, any more than tobacco itself is indigenous to Yezo. Smoking was

probably learned from the Japanese. Certainly, many of the pipes used are of Japanese origin, though some appear to have come from Manchuria. The old women smoke as well as the men, though the younger do not.

The tobacco box and pipe-holder shown in the engraving are said to be very old. They are made of walnut wood. The box itself has some small pieces of deer bone inlaid, and the pipe-holder is prettily carved. It is very difficult to get hold of so good a set, for the Ainu prize them very highly, and sometimes have them buried with their owners, although they are smashed to pieces before being thrown into the grave. The little piece of wire which is attached to the top of the pipe-holder is used for cleaning out the bowl of the pipe, and the round hole at the bottom is to put the pipe through when finished with.

CHAPTER VI

INAO, OR RELIGIOUS SYMBOLS

MANY curious and most amusing, though perhaps very natural, mistakes have frequently been made by visitors to the Ainu. For example, a photographer once came to Ainu-land and took a photograph of a storehouse or granary. He developed his negative, printed off some pictures, wrote 'Ainu Temple' beneath them, and placed them in his shop window for sale. As a matter of fact, we have already noted that the Ainu have no temples, meeting-houses, or chapels, in which to meet for public worship, or shrines to hold their gods. Another visitor has told us that *inao* or willow-shavings are household gods; while a third has gravely remarked that some of these willow-shavings represent male, and others female, gods! These assertions are mere guesses, and nothing more; and even Miss Bird, correct as she generally is, was led astray on this point. Writing on this subject, she says: 'Household gods form an essential part of the furnishing of every house. In this one, at the left of the entrance, there are ten white wands, with shavings depending from the upper end, stuck in the wall;

another projecting from the window which faces the sunrise; and the great god, a white post, two feet high, with spirals of shavings depending from the top, is always planted in the floor, near the wall on the left side.'

Miss Bird is accurate as to these shavings being placed in different parts of the hut, but she is not correct in calling them gods. They are not gods, but sacred offerings to them; and they are made especially to show the faith and devotion of the offerer, and are offered as a token thereof. When placed about singly they are called *inao*, and when a number are put together they go by the name of *nusa*. *Nusa* is the name the Japanese give to certain pieces of silk they hang up in the Shinto temples before the gods.

Inao, then, briefly defined, are pieces of whittled willow wood, having the shavings left attached to the top; or, as Miss Bird says, they are 'white wands with shavings depending from the upper end.' The engraving represents one particular kind, which goes by the name of *inao netoba*—that is, 'the chief *inao*.' They are called 'chief' because they are of the highest importance, since they are specially made for the gods who are supposed to stand first in order. The Ainu way of explaining this fact is very peculiar, and well serves to illustrate their general ideas about the Godhead. These *inao netoba*, they say, are symbols or signs presented to the 'distant gods.' By distant gods they mean the

chief gods, or those who are remote from human beings, in contradistinction to the minor deities, or those near at hand. For, be it understood, the greater and higher and more honourable the god, the further off is his dwelling, and the more in number are the lesser and intermediary gods through whom he acts. We thus find the Ainu idea of the government of the world and

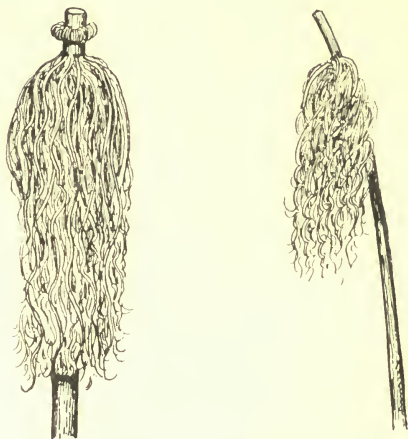

INAO NETOBA, OR THE CHIEF INAO

men to be fashioned after the model of human governments with their kings and officers.

This class of *inao*, sometimes also known as the *chisei koro inao*, or 'household *inao*,' is often made and placed, in the first instance, before the hearth, and the goddess of fire, who often goes by the name of 'angel' or 'messenger,' is called upon to notify the Creator, or

the goddess of the Sun, who is looked upon as the chief of the deities, that an offering has been made to them. The *inao* are always presented with prayers, and no prayer is supposed to be acceptable to the gods without this peculiar sign of devotion. This particular kind of *inao* is made by shaving the wood upwards. When done with they are placed in the sacred north-east corner of the hut; and when they have become very dry and brown with age they are further removed and placed outside the hut opposite the east window; and when they have become too shabby to remain there they are brought indoors, and respectfully burnt, with prayer, upon the hearth.

The kind of *inao* which appears to rank next in importance is the *chi-choroka-kep*—that is, ‘the shaved backwards.’ These, as their name implies, are made by being shaved downwards from the top instead of upwards from the bottom. Some of these wands have three sets of shavings left attached to them, while others have but two. I have never been able to learn the rule which governs the exact number of sets of shavings which should be left in given cases. The Ainu themselves do not appear to be quite certain on this point; they seem to fashion them after their uncertain ideas about what will be acceptable. But, though they may not be particular as to the number of clusters of shavings they leave on one stick, they are extremely careful about having six distinct shavings in each cluster upon either side of the

stem, for six is the sacred or perfect number of the people.

These *chi-choroka-kep* symbols are made as offerings to the *Ehange Kamui*, which signifies 'the gods near at hand.' By this term they mean those gods who are supposed to be between them and the higher gods, who

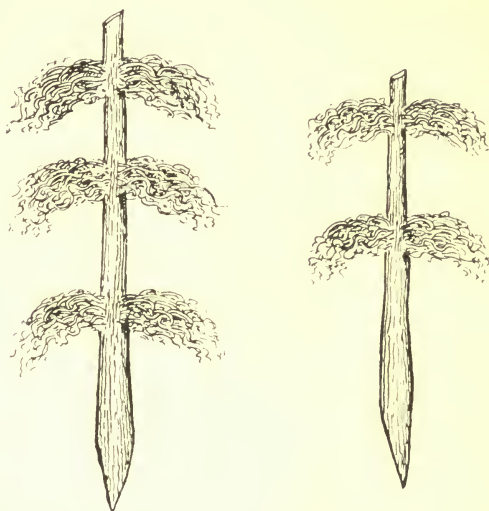

CHI-EHOROKA-KEP, OR 'THE SHAVED BACKWARDS'

are too honourable to act immediately and of themselves. Thus, for example, this kind of *inao* are often seen by the springs of water, upon the river banks, in the gardens, by the side of out-houses, near precipices, and sometimes, when a lesser deity is being invoked, by the fireside. It will thus be observed that this special kind

of offering is presented to the local deities, or those deities who are thought to be more in direct touch with men.

A third kind, *inao-kike*—that is, ‘*inao* shavings’—are simply shavings of willow, and appear to be used as much by way of ornament as for offerings to the gods. However, they never quite lose their religious value and



A NUSA, OR CLUSTER OF INAO

significance, as being associated with worship and made of the sacred willow-tree. Being but shavings, they are hung up in the windows and doorways of the huts, and are looked upon as charms, and considered safeguards from evil.

The *nusa*, to which reference has already been made, can hardly be called a kind of *inao*, since the word is applied especially to a cluster or great number of *inao*

placed together. Such clusters may be seen upon the sea-shore, at the fishing stations, and at the east end of the dwelling huts. The engraving represents one of these clusters as they appear upon the sea-shore.

These offerings are called *kema-ush inao*, or 'legged *inao*,' or '*inao* having legs,' and they are so called because they are tied to stakes stuck in the ground, which go by the name of *kema*, or 'legs.'

They are placed upon the sea-shore as offerings to one of the two sea gods, called *Rep un kamui*, or 'sea gods.' One of these, strange as it may appear, is thought to be good, and the other evil. They are brothers, and their names are *Shi acha*, the elder, and *Mo acha*, the younger. *Shi acha* means 'the rough' or 'wild uncle,' and he is supposed to be of a very evil and restless disposition, and to be continually pursuing and persecuting his younger brother, *Mo acha*. *Mo acha* means 'uncle of peace.' *Mo acha*, being of a benevolent character and a quiet, kindly disposition, does all he can to live in peace, and benefit the Ainu race. He comes and settles down by the sea-side, and brings still, quiet winds and good weather with him. Then it is that the Ainu fishermen launch their boats and go fishing. But *Shi acha*, the wild and malignant elder brother, ever ready and anxious to do all the harm he can, comes and chases his peaceable brother away, and brings bad weather, so that the Ainu are obliged to haul in their boats and lines and go home without any fish. *Shi acha*

is supposed to be the originator of all storms and shipwrecks, and hence the *nusa*, which are placed upon the sea-shore, are not presented to him, the 'wild uncle,' but to the peaceable and good god.

This dualism or struggle between two principles, a principle of good and a principle of evil, is said to be incessantly raging. The good and the evil are ever antagonistic the one to the other; they always have been and always will be. Thus, as there are two gods of the sea, one good and the other evil, so there are good and evil gods who are supposed to preside over the rivers. The river deities are called *Wakka-ush kamui*, 'watery gods.' They are feminine, and it is their province to watch over all springs, ponds, lakes, streams, waterfalls, and rivers. There is one particular goddess who has to watch the mouths of rivers and allow the fish, particularly the spring and autumn salmon, to go in and out. Her name is *Chiwash ekot mat*, which means 'the female possessor of the places where the fresh and salt waters mingle.' It is to this goddess that *nusa* are set up upon the banks near the mouths of rivers.

There are other gods who are supposed to have their home in the rivers; and they go by the general name of *Pet-ru-ush mat*, 'the females of the waterways.' They are supposed to have the oversight of all rivers and streams from their source to the sea. These deities, who are supposed to be good, are frequently worshipped. Thus, when the men go to fish in the rivers, they always

ask the gods to make them successful ; or, if they are descending rapids, they never forget to ask for guidance and protection, and they always remember to make offerings of *inao* and *nusa*.

But there is also the evil god of rivers, who goes by the name of *Sarak kamui*. *Sarak* is a word meaning accidental death, and *Sarak kamui* appears to be a god or demon who presides over accidents. Its evil deeds are not confined exclusively to the fresh waters, but are the cause of all land accidents. When an accidental death has taken place, either by drowning or otherwise, the Ainu, as soon as they find it out, proceed to perform a ceremony frequently called *Sarak kamui*. The ceremony is as follows. *Sake* is procured by the relatives of the victim, and messengers are sent to the different villages to invite the men and women to join in the proceedings. The men bring their swords or long knives, and the women their head-gear. On arriving at the appointed hut, the chiefs of the people assembled proceed to chant their dirges and worship the fire god. Then, after eating some cakes, made of pounded millet, and drinking a good proportion of *sake*, they all go out of doors in single file, the men leading. The men draw their swords or knives, and hold them, point upwards, in the right hand, close to the shoulder, and then altogether they take a step with the left foot, at the same time stretching forward to the full extent the right hand with the sword, and calling, as if with one voice, ' *Wooi!*' Then the

right foot is moved forward, the sword at the same time being drawn back, and the *wooi* repeated. This is continued till the place of accident is reached. The women follow the men, and with dishevelled hair, their head-gear hanging over the shoulders, they continue to weep and howl during the whole ceremony. Arrived at the place of accident, a continual howling is kept up for some time, and the men strike hither and thither with their swords, supposing that thus they are driving away the evil *Sarak kamui*. This finished, the people return to the house of the deceased in the same order as they came forth, and, sad to say, feast, drink *sake*, and get intoxicated. The ceremony of attending *Sarak kamui* is called *Niwen horibi*.

The larger clusters of *inao* which are to be seen outside the sacred east-end of every AINU hut may be called the AINU temple, for to him it is the most sacred place he knows upon earth. To this place he comes and worships the last thing before he sets out on a journey, and when he returns home again it will be nearly the first place he will visit. Here the mistress of the house generally throws her chaff after she has threshed her millet and corn; and here, too, the hunter places the skulls of deer and bears and wolves he may have killed in the hunt.

As these *inao* of various orders and descriptions are thus seen to be so extensively used and so closely connected with prayer and worship, it is no matter for surprise

that travellers have taken them to be gods; in fact, it would have been a great wonder had they not done so. But enough has been said to show that in no sense can these willow-wands be called gods. They are merely offerings to the various deities, though they hold a very important

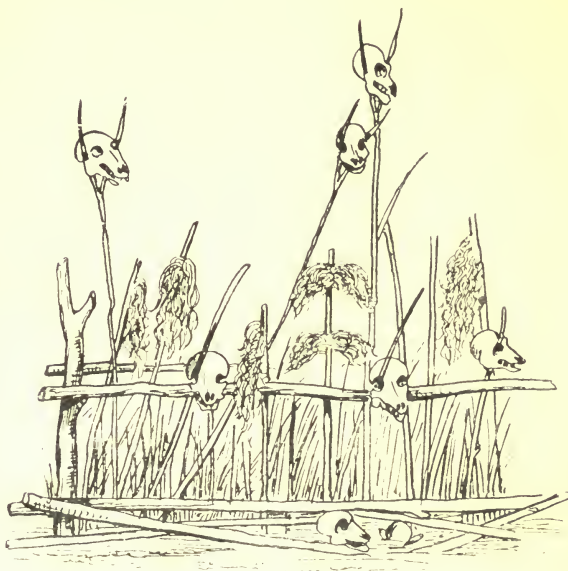

NUSA AND SKULLS AT EAST END OF A HUT

place in the Ainu religion. They are made and offered upon almost every occasion of prayer, and placed in the domain of particular titular deities, and near their supposed dwelling-places. Thus, when a person is taken ill, his friend or relative, the chief of the village,

gets a new piece of willow wood fresh from the forest, and sitting down before the fire, peels off the outer rind, and shaves the stick into an *inao*. When it is finished he places it in the corner of the hearth near the fire, and asks the fire goddess, who is supposed to be a great purifier from disease, to look kindly upon the sick one. He next addresses her by the name 'messenger,' and requests her to go to the Creator and ask Him to kindly accept the *inao* he has just made, to hear his prayers, and to allow her, 'the fire goddess,' to heal the sick one. The idea seems to be that the Creator is too great a personage to condescend to do the healing Himself.

In like manner, when the Ainu are out hunting, they will most devoutly, when they build their lodge to sleep in, stick up the second kind of *inao* before their fire. At the same time they will say, 'O goddess of fire, we present this *inao* unto thee! pray watch over us to-night, and ask the deities to grant us success when we awake.' At the spring where they get their water, they set up another, saying, 'O goddess of water, we come to drink at this, thy spring! please look upon our offering, and do us good, and watch over us.' On the morrow, before beginning the hunt, they make the first kind of *inao*, and offer it to the great God of all, and, using the fire goddess as mediator, ask Him to render them successful.

The Ainu never go to fish in the sea without a small

piece of willow wood and a knife. This is in case a storm should arise, and they therefore desire to call upon God to help them. In such a case, they hastily make a few *inao* shavings, and cast them into the sea, at the same time offering up a prayer that they may be saved.

Every Ainu is supposed to make his household *inao* at least once a year, usually during the winter, or, if possible, twice a year, in the spring and autumn. Of course he makes some on the occasion of any feast or death, or when he has been successful at hunting or fishing. The ordinary and extraordinary circumstances guide the Ainu in making these offerings.



AN AINU FAMILY

CHAPTER VII

ETIQUETTE

THERE is probably no race, however barbarous or savage, which has not some special and recognised forms of etiquette which must be observed in the social life of its individual members. These, when rightly and duly performed by a person, cause him to be regarded as an individual of good-breeding; if neglected, he is looked upon with disfavour, and his negligence is taken either as a personal insult or slight, or as a sign of ignorance and ill-breeding.

Now, the Ainu have various matters of national decorum, and about the observance of these they are very particular indeed. Personal behaviour is a subject in which the Ainu are always careful to instruct their youth. The salutation of the men, for example, is at once a common, and yet an important and curious, part of Ainu decorum. When living in an Ainu hut, as I have done for many months at a time, I have often seen two men saluting one another. The people also always saluted me after the orthodox Ainu style, as though I were one of themselves. Of course I endeavour,

according to the best of my ability, to do the proper thing in return, after the most correct manner.

The first step is to give a low cough and gently clear the throat before entering a hut. After this is done, and if no one comes out to invite the visitor in, he walks steadily up the centre of the hut by the right-hand side of the hearth, and sits down before the master, bare-headed and cross-legged, as though he were



AINU MEN SALUTING

a tailor. Then, when the throat has again been cleared, he stretches forward his hands as shown in the illustration. The person he is saluting goes through similar actions, looking both attentive and respectful. The two next proceed to gently rub their hands together, by drawing back first one hand and then the other in such a way as to allow the points of the fingers to rub the palms of each hand alternately. This is done for some

little time. While rubbing the hands, the parties, one at a time, ask after each other's health, and express a wish that every heavenly blessing may be bestowed, first upon each other, then upon their wives and families, next upon their relatives, and, lastly, upon their native place. Sometimes this form of salutation is kept up for a long time, at others for only a few moments, according to circumstances and the amount of business there may be on hand. However, when this

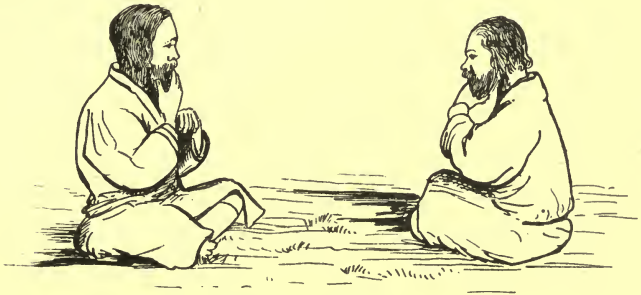

AINU MEN SALUTING

part of the performance has been satisfactorily gone through, they finish by each stroking his own beard, as shown in the engraving, each at the same time making a soft rumbling sound in his throat.

When this preliminary salutation is over, the visitor, after a short interval, again proceeds to rub the palms of his hands, and to tell his business. The listener also always rubs his hands in like manner as long as the speaker does. This is a very tedious affair, especially as

the palm rubbing goes on very often for twenty minutes or half an hour. As soon as the particular matter which has led to the interview is settled, the master of the house intimates by a few familiar remarks that all formality is at an end. They then stroke their own beards to each other and commence to talk in a natural and unrestrained manner.

This common salutation of the men is in a sense a religious exercise, because in the first part of the ceremony they ask God to bestow blessings upon each other and their families, and this, as will be seen, involves an act of prayer. When worshipping their unseen gods, they salute them in exactly the same way as they do their fellow-men.

The women's mode of salutation is very curious. They never, so far as I am aware, perform the ceremony to their own sex, but only to the men. On entering a hut the woman removes her head-dress and hangs it neatly over her left arm. She then brushes back the front locks of her hair and places the right hand over her mouth. All this is preliminary. When she sees that the man she desires to address has condescended to look at her, she draws the index finger of the right hand gradually up the middle of the left and up the arm to the shoulder; then from left to right across the upper lip and close under the nose, ending by stroking and smoothing the forelocks of her hair behind the ears. She then waits for an invitation to speak.

When the women have been away from their native villages for a long time, and again meet their sisters and other female relatives, they appear to take great delight



AINU WOMAN SALUTING

in seizing one another by the shoulders and weeping upon each other's necks. I have seen women in this position for half an hour or more at a time. In fact, in this position they will chant to each other their whole

personal history since they last met. Questions are put and answered in this weeping, sing-song fashion.

The men salute the boys and girls by seizing their heads and stroking their hair from the crown to the



SALUTING A CHILD

shoulders. The engraving shows how this is done. This possibly partakes more of the nature of a caress than of a salutation.

Whenever a person desires to visit a hut he should

never enter without being asked. But, as there are no wooden doors to knock at, what is to be done? Being unable to knock, a person has to make a noise with his throat; something like a long guttural sounding, hé-hé-hé-hé-hèm. If the person who desires to enter belongs to the village, he goes in without more ceremony; but if he is a stranger he must wait until someone who has heard the noise comes out and takes him in. Once inside he must go through the palm-rubbing, beard-stroking, and all the formalities of salutation. Men, after calling upon a person, always go out walking sideways.

Women also say hé-hé-hé-hé-hèm before entering a hut, and as soon as they get inside make an obeisance like that which has been already described. They leave a hut by walking backwards. It is impolite for a woman to turn her back upon a man.

There are many minor rules which have to be observed. Never enter a hut with a head-dress on. Never rush either in or out of a hut, but always go steadily and softly. Never look into a hut through the window, especially the end window. Never go eavesdropping. Never address a stranger unless he or she speaks first to you. These rules are binding upon all, men, women, and children alike.

The women are always expected to take their head-dress off when they meet a man, except widows, who never remove their head-dress, but always wear the

widow's hood. Women always step out of the way when they see a man coming, and make room for him to pass. They always salute a man when they meet one by covering their mouth with the hand and fixing their eyes upon the ground. They keep out of the way as much as possible, and consider they are quite an inferior order of beings. They ought to be obedient to their husbands, and never answer them back when they speak.

CHAPTER VIII

EDUCATION

AINU children used never to be troubled by schools or schoolmasters. The mountains, the rivers, and the sea were their school-house ; necessity was their instructor ; inclination and the weather were the only forces which made them work.

The first and chief duties that the children were taught were obedience to parents, a careful regard to their elder brother, and reverence for the old men of their village. They were to speak when spoken to, and at other times to be seen, but not heard. By no means were they allowed to interrupt their elders when engaged in conversation.

The men attended to the education of the boys, and the women looked after the girls of a family. The boys were taught to fish and hunt ; to make bows, arrows, and traps ; to set spring-bows in the trail of animals ; to decoy deer, and to judge of the weather by the skies. They were never taught to make poison for the destruction of animals until full-grown, and even then only a few were taught the secret.

Next they were taught the names and shapes of certain mountains and hills, the names and courses of the chief rivers and streams, so that they might not get lost when out on a hunting expedition. They also had to learn the secret and quickest routes to different places. And last, but not least, they were taught how to make *inao* and *nusa* offerings, and what forms of prayer to use upon different occasions; the various salutations and the proper course to pursue in the various ceremonies; also, the ancient traditions.

The women taught the girls to nurse children, and to prepare bark and weave it into cloth; to sew, embroider, and mend; to work in the gardens, to cook, to thatch huts, to cut wood, and a thousand and one other things. They were also instructed in the art of tattooing their arms and lips, and how to weep and howl for the dead. Lastly, they were particularly taught to honour and respect and wait upon the men; always to wait to be spoken to before addressing them; always to get out of their way when they came along a path; to cover the mouth with the hand when meeting them and to uncover the head in their presence; and they were instructed to never forget to enter a hut with the face towards the household, and to go out backwards.

Moral lessons were enforced by certain tales. Thus, for instance, diligence was encouraged and idleness discouraged by the following curious fable. Its title is:

THE MAN IN THE MOON

‘In ancient times there was a lad who would neither obey his father nor his mother, and who even disliked to fetch water; so, the gods being angry, put him in the side of the moon, as a warning to all people. This is the man in the moon. For this reason, let all the world understand that the words of parents, whether they be good or evil, must be obeyed.’

The Ainu give a curious explanation of this legend, which is as follows :

‘Though the lad was ordered to draw water, he was idle, and sat chopping at the fireplace with an edged tool. As he went out he struck the door-post, saying, “Ah, me! you, being a door-post, do not have to draw water.” Then, taking the ladle and the bucket, he went down to the river; and when he came to the river he saw a little fish coming up the stream, to which he said: “Ah, me! because you—you awfully bony creature—are a fish, you do not have to draw water.” Again, seeing a salmon-trout, he said: “Ah, me! you soft, flabby creature, you do not have to draw water.” Then, descending thence, he saw an autumn salmon, to which he said, “How do you do, how do you do, Mr. Salmon?” and straightway he was seized by the salmon, and, for the instruction of all people, placed in the moon. Thus did the angry gods to him who disliked to draw water.’

Greediness was discouraged by the following tale :

A TALE OF THE FOXES

(Characters—Pan'ambe and Pen'ambe)

‘Pan'ambe, having a great desire to become rich, stretched his tail across the sea to the town of Matsumai. When the Lord of Matsumai saw the tail, he said, “This is a pole sent from the gods. Hang all my clothes upon it to air.” So all the short-sleeved garments and good clothing were hung out. After a time, Pan'ambe drew back his tail, and all the soft silky garments and good clothing adhering to it came also; so that he gained a whole houseful of things and became very rich. Pen'ambe, hearing of his good fortune, called upon him and said, “My dear Pan'ambe, what have you done, that you have become so rich?” Pan'ambe replied, “Come and take some refreshment, and I will tell you.” When he had heard all, Pen'ambe withdrawing, said: “This is the very thing we ourselves had intended to do, and you—you abominable Pan'ambe, you disgusting Pan'ambe!—have forestalled us.” So saying, he went down to the sea-shore and stretched *his* tail across the sea to Matsumai. When the Lord of Matsumai saw it, he said, “Here is a pole sent by the gods. Hang out all my best clothes to air.” So the clothes were hung upon it. But Pen'ambe, being in a great hurry to become rich, began to withdraw his tail too quickly. The Lord of Matsumai, seeing the pole move, said: “Even thus it happened once before. There came a

pole from the gods, upon which we hung our clothes to air ; but a thief stole the pole away, and we all became poor. Now again a pole has come, and we have hung our clothes upon it, but look ! there appears to be a thief about ; be quick, and cut the gods' pole in two." So the officers drew their swords and cut the pole, thereby saving all the clothes. Pen'ambe was left with but half a tail ! so he drew it in, but had obtained nothing, and was in a very sorry plight. Now, if Pen'ambe had only listened to what Pan'ambe had said to him, he might have been a rich person and able to live ; but he did not like to be advised, so he became a very poor man.'

Reverence to old people was taught by the following legend :

'At the head of Japan there was a metal [i.e. very hard] pine-tree. Now, the ancients, both noble and ignoble, came together and broke and bent their swords [upon that tree]. Then there came a very old man and a very old woman upon the scene. The old man had a useless old axe in his girdle, and the old woman a useless old reaping-hook. So they caused the ancients to laugh at them.' [That is, the Ainu laughed at the bare idea of such an old couple coming to render assistance.]

'Even the ancients were unable to cut down that tree ; so they said : " Old man and old woman, what have you come hither to do ? " The old man replied,

“We have only come that we may see.” As the old man said this he drew his useless old axe, and, striking the metal pine-tree, cut a little way into it. And the old woman, drawing her useless old reaping-hook, struck the tree and cut it through. There was a mighty crash; the earth trembled with the fall. Then the old man and woman passed up upon the sound thereof, and a fire was seen upon their sword-scabbards. The ancients saw this and greatly wondered, and then they understood that it was Okikurumi and his wife.’

Therefore the Ainu say: ‘Let not the younger laugh at the elder, for even very old people can teach their juniors a great deal, even in so simple a matter as felling trees.’ Also they say: ‘Do not treat strangers slightly, for you never know whom you are entertaining.’ These strangers who appeared to the Ainu were no other than the great hero Yoshitsune (Okikurumi is his Ainu name) and his wife, and yet the people did not at first know them!

This curious legend probably enshrines the memory of some ancient battle with the Japanese. The ‘metal pine-tree,’ or ‘trees,’ were possibly Japanese warriors in their armour. If that be so, Yoshitsune was probably killed in helping the Ainu against his own countrymen. There are reasons for believing that he was buried at Piratori.

The education of the Ainu was done by word of mouth and actual work. They never had schools or

literature of any kind. They do not like, however, to admit that they never had any books or writing materials, for they seem ashamed of being such dunces. There is not even a native word for either *pen*, *ink*, or *paper*, and their word for book itself is of Japanese origin. Notwithstanding all this, many of them tell us that their ancestors did understand reading and writing, but that they have now lost the art. They have invented a tale by which the Japanese hero, Yoshitsune, is made to steal and carry off a certain book—the only book—the Ainu chief of Saru had in his possession. The name of this book is said to be *Tora no maki mono*; a purely Japanese name. It is, in fact, the name of a Japanese book on strategy.

The tale of the theft runs thus: 'When Yoshitsune came to Yezo he was kindly taken in by the Saru chief, who had his residence at Piratori. This chief had amongst his treasures a very ancient book called *Tora no maki mono*, but he would never allow Yoshitsune to see it. After a time the chief adopted Yoshitsune, and gave him his younger daughter in marriage. One day, after he had been in the family some time, Yoshitsune pretended that he had bad eyes, and could not go out to work as was his wont. So he stayed at home. On that day he reproached his wife greatly and refused to eat, and told her that neither did she love him, nor did she nor her father trust him, so that he might just as well go back to his native land. She asked him in what he

was mistrusted, and he replied that he had heard that his father-in-law had an ancient book somewhere in his possession, but that, although he had let him see all his other treasures, he had never produced it. Why was he so distrustful? Upon this his wife fetched the book and let him look at it. "Now," says he, "my eyes are quite well; and I shall go to work to-morrow." Yoshitsune noticed where his wife had put the book, so as soon as an opportunity presented itself he stole it and ran off with it.

'Now it happened that Yoshitsune's father-in-law was far away in the mountains, but he felt within himself that something wrong was going on at home. He therefore left his work to return. As he neared home he saw Yoshitsune fleeing down the river in his father-in-law's very best and swiftest boat.

'Now, the chief always carried two harpoons about with him, a black one and a white one, which he could cast, with unerring aim, to any distance. He therefore cast the white one at the stern of the boat and transfixed it, but Yoshitsune—the cunning man—had a file with him, and filed the line in two. Then the black harpoon was cast, with a similar result. Upon this Yoshitsune stood up in the boat and reviled his wife and her father, and fled, not only with the book, but also with the harpoons and the boat.'

This legend tries to account for what is undoubtedly the fact, that the Ainu have no literature.

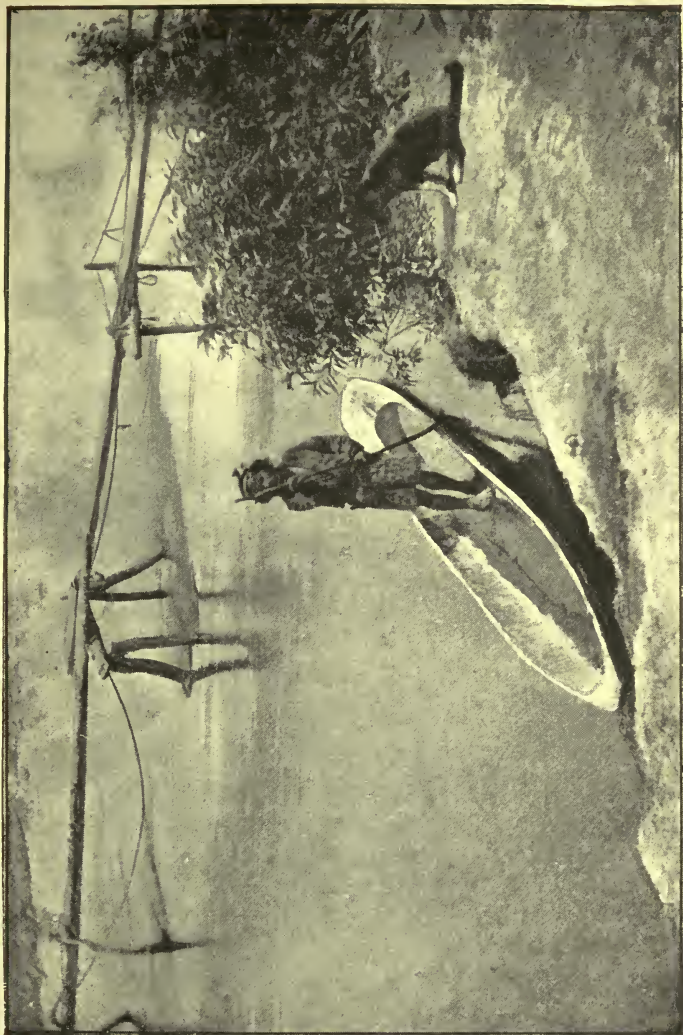

AINU BOAT AND BRIDGE



The following legend of Okikurumi (Yoshitsune), in love with an Ainu maiden, may be of interest to some. The object of it seems to be to teach young lovers never to despair, even if they cannot obtain the objects of their affections, and never to look too much after the softer sex.

‘The great Okikurumi fell deeply in love; he became very ill, exceedingly love-sick; he lost his appetite and bodily strength; he laid down in his hut in sullen despair, and would eat neither good food nor bad; he was, in short, ready to die of love. And, mark you, all this happened through taking just one glance at a beautiful woman. Dear, dear,’ says the legend, ‘how badly he felt!’ Therefore let the young beware.

But Okikurumi was cured of his dangerous malady. A little bird flew to the cause of this affliction, the object of his affections. Word was brought to her of his deep-seated love and critical condition. The pretty little bird wagged its tail and whispered in the lady’s ear that if Okikurumi died, the soul of Ainu-land would also depart. Therefore, the bird begged her to have mercy upon poor Okikurumi for the sake of Ainu-land. The intercession was successful. An unreal, unsubstantial woman was made in the likeness of the beauty with whom Okikurumi was smitten. She was brought to his hut, and forthwith proceeded to arrange the mats, furniture, and ornaments. Okikurumi took a sly glance at her through his arm-hole or sleeve; he was encour-

aged; he got up, rejoiced, ate food, was revived and felt strong again. This done, the lady took her departure; she was not. What then did Okikurumi do? Why, he saw that he had been deceived in the woman, and, as 'there was nothing to be done, nothing to be said,' he got well again, like a sensible man.

The following is the explanation of the legend.

The goddess (i.e. the beautiful maiden) felt lonely, and gazed upon the inside and surveyed the outside of the hut. She went out, and behold! the clouds were floating and waving about in beautiful terraces upon the horizon over Ainu-land. Yes, that is what she saw; so she returned into the hut backwards, and took down her needle-work.

[By this we are taught how it was Okikurumi first caught sight of this beautiful woman with whom he fell in love. She had been sitting in the hut, and now felt a little lonesome, restless, or tired. Her eyes had been wandering about from one object to another with weary solitude. She gets up, goes outside in an aimless kind of way, and scans the horizon, which she sees is very beautiful in its grandeur, the clouds being piled one upon another in terrace-like masses. She reviews and returns into her hut. But we are told that she returns backwards. This is a sign that she was paying great respect to something or some one outside. The Ainu say that she was paying respect to the brilliant beauties of Nature, which she saw depicted upon the heavens;

hence she came into her hut reverently walking backwards. Now, women never pray—never worship any deities at all; I therefore venture to think that she was paying her respects to Okikurumi, whom she saw outside.]

Again, she looked to the point of her needle, and fixed her gaze upon the eye-end thereof.

[That is to say, she paid great attention to her work.]

Then came a little bird, called 'water-wagtail,' and sat upon the window-shutter, and wagged its tail up and down, and waved it from right to left.

[The water-wagtail is much esteemed by the Ainu, for they consider it to be a bird of good omen. It is supposed to be the first bird that was created, and is thought to be a special favourite and companion of the gods. Hence it was that this bird was sent to convey the intelligence of Okikurumi's love-stricken heart and critical condition to this beautiful and industrious damsel.]

Then two chirps and three chirps came to her, and touched the inside surface of her ears, and what she heard was this :

'The mighty Okikurumi, who is the governor of all Ainu-land, went out of doors for a little while, and, seeing you, has fallen ill of love on your account.

'And though two bad fish and two good fish were placed before him for food, he refused to eat.'

[Two good and two bad fish is merely an expression

meaning that whatever food was placed before Yoshitsune he could not touch it, he was so love-sick.]

‘Now, if Okikurumi should die, the soul of Ainu-land will depart.’

Then the little bird called ‘water-wagtail,’ waving its tail, spake two words to her and said, ‘Have mercy upon us, that Okikurumi may live.’

Thus, then, by simply looking out upon the world, Okikurumi fell so sick of love that though two bad fish and two good fish were set before him he could not eat.

Dear, dear, how badly he felt !

Therefore the form of a woman resembling the goddess was made and sent down to Okikurumi.

The house was set in order ; that woman who was sent down put things to rights.

Then Okikurumi looked through his sleeve and saw the beautiful woman.

He got up, greatly rejoicing. He ate some food ; strength came back to his body, and—the woman was gone.

Okikurumi saw he had been deceived ; but there was nothing to be done and nothing to say, so he got well.

[Let everyone take warning from these last words. Okikurumi was deceived by the mere shadow of a woman.]

So much, then, for the hero, Kurohonguwan Nima-moto no Yoshitsune, and his servant, Benkei.

CHAPTER IX

THE ARTS AND PLEASURES OF LIFE

PASSING from Ainu education, the arts and pleasures of life demand some attention, and chief among these are music, dancing, and games. These things, of course, are not very highly developed amongst such a crude race as the Ainu.

Those who belong to Western nations are apt to suppose that all music must be formed of notes in scale, with their crescendos and diminuendos. This is the kind of music to which we have been accustomed from childhood. But the songs and chants of the Ainu do not run in fixed notes or tones, they are bound to no scale, so that their airs cannot be written down. In fact, the Ainu have music without tune. Some of the women and girls have really rich voices, and it is very pleasant to hear them hum their songs.

The men and women make up some very pretty tunes in which to recite their recent acts and experiences. Thus, I have sometimes sat and listened to our servants when they have returned from Hakodate to their homes. I have seen them sit for an hour at a

stretch and relate in chant or song that which has happened to them whilst away : where they have been, what they have seen, and what they have heard. Their friends, too, have in the same way made known to them what has taken place in their midst : what children have been born, who have died, who have married, how the fishing and hunting and gardening has gone on, and all such things. It is very interesting to listen to these chants, for they give many a peep into the inner workings of the mind, and show a good deal of the true nature of the Ainu, and their ways of looking at things.

Nor have the Ainu anything that we can call metre, or verses accurately measured in syllables. Rhyme, too, is quite unknown, and poetry exists only in the mind ; and this very often ceases to be poetry when translated into Japanese or English.

Here are two legends which show the manner in which the Ainu recite or chant their traditions.

AN AINU LEGEND OF A FAMINE

1. There was a woman who was ever sitting by the window and doing some kind of needle-work or other.

2. In the window of the house there was a large cup filled to the brim with wine, upon which floated a ceremonial moustache-lifter.

3. The ceremonial moustache-lifter was dancing about upon the top of the wine-cup.

4. In explaining the subject from the beginning, and setting it forth from the end, the tale runs thus :

5. Now look, do you think that the great God, do you think that the true God, was blind ?

6. In Ainu-land there was a great famine, and the Ainu were dying for want of food : yet with what little rice-malt and with what little millet they had they made (a cup of) wine.

7. Now, the great God had mercy, and, in order that our relatives might eat, produced both deer and fish.

8. And the great God had mercy upon us, therefore He looked upon us, and, in truth, saw that in Ainu-land there was a famine, and that the Ainu had nothing to eat.

9. Then was that cup of wine emptied into six lacquer-ware vessels.

10. In a very little while the scent of the wine filled the whole house.

11. Therefore were all the gods led in, and the gods of places were brought from everywhere ;

12. And they were all well pleased with that delicious wine.

13. Then the goddesses of the rivers and the goddesses of the mouths of rivers danced back and forth in the house.

14. Upon this all the gods laughed with smiles upon their faces ;

15. And whilst they looked at the goddesses they saw them pluck out two hairs from a deer ;

16. And, as it were, blow them over the tops of the mountains ; then appeared two herds of deer skipping upon the mountain tops, one of bucks and the other of does.

17. Then they plucked out two scales from a fish, and, as it were, blew them over the rivers ; and the beds of the rivers were so crowded with fish that they scraped upon the stones, and likewise the tops of the rivers were exceeding crowded.

18. So the things called fish filled all the rivers to the brim.

19. Then the Ainu went fishing and caused their boats to dance upon the rivers.

20. The young men now found fish and venison in rich abundance.

21. Hence it is that Ainu-land is so good. Hence it is that from ancient times till now there has been hunting. Hence it is that there are inheritors to this hunting.

The following curious lines were sung to me by an aged Ainu, to whom I had just been explaining the dangers and evil of drinking too much wine, and to whom I had been endeavouring to show how much better it is to worship God in spirit and in truth, than by offering Him wine and whittled pieces of willow wood. The old

man's object in singing this tradition to me was to enforce upon my mind the fact that, notwithstanding all I had said, the gods were, at the time of the famine indicated below, pleased with these offerings, and are still delighted when the devout worshipper indicates his sincerity by setting these things before them.

This song, tradition, legend, or whatever it may be called, is typical of the way in which the Ainu convey their thoughts on religion and other serious matters to one another.

1. There was something upon the seas bowing and raising its head.

2. And when they came to see what it was, they found it to be a monstrous sea-lion fast asleep, which they seized and brought ashore.

3. Now, when we look at the matter, we find that there was a famine in Ainu-land.

4. And we see that a large sea-lion was cast upon the shores of the mouth of the Saru river.

5. Thus the Ainu were able to eat, i.e. obtained food.

6. For this reason *inao* and wine were offered to the gods.

7. So the gods to whom these offerings were made *were* pleased, and *are* pleased.

The first and second of these verses are an introductory statement of the theme. The remote ancestors of the Ainu race are represented as having seen some

large and curious object floating about upon the tops of the waves of the sea, and rising and falling with them. The men, therefore, launch their boats and go and see what the object may be. They find it is a mighty sea-lion (*shietashbe*). They then seize the animal, and, by some means or other (how it is not stated), bring it ashore.

The third and fourth verses make known the fact that at this particular time there was a famine in Ainu-land, and that the Ainu of to-day, in looking back upon this sad calamity, see in the sleeping sea-lion the hand of the gods, working to preserve the race from starvation and certain destruction. This mighty sea monster is said to have been cast upon the shores of the mouth of the Saru river. Saru, it should be remembered, is regarded by the Ainu of the south of Yezo as the chief district in this island; and the *Shishiri-muka* is the largest river in Saru.

Verses six and seven are intended to show that libations of wine and the offering of *inao* have *always* been a well-pleasing sacrifice to the gods, and therefore *are* so now. They pleased the gods at *that* time, and that they please them *now* is seen from the fact that food is still extended to the Ainu race. Hence one great reason why such ancient religious customs should not be abolished. Hence, too, according to Ainu reasoning, this race of men have no cause to change one form of religion and its accompanying ceremonies and rites for another.

Thus we see that the Ainu, though without knowledge, are by no means without reason; nor are they so stupid and easily led as some people would suppose.

The Yezo Ainu possess but one musical instrument, a kind of Jew's-harp made of bamboo. It is not used by full-grown people; but the children are very fond of playing it. This instrument is about five inches long, and has a thin narrow tongue up the centre, which measures about four inches in length and the eighth of an inch in breadth. A piece of string is attached to the

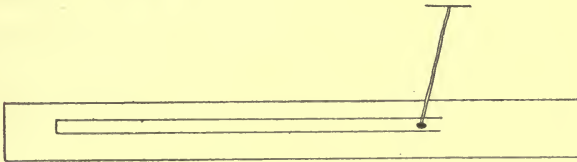

THE MUKKURI, OR JEW'S-HARP

butt end of the tongue. This instrument is played by holding it to the lips in the same way as children in England hold the Jew's-harp. Then the player breathes through the space in which the tongue is, and gives the string a sharp, sudden jerk. The tone produced is regulated by the breath of the player. The Ainu name of this instrument is *mukkuri*.

The Karafuto Ainu are said to have a kind of fiddle with two strings, and another with three, but I have never seen these.

If there is little to say about Ainu music and musical

instruments, there is also very little to tell about dancing. Ainu dancing is a senseless performance, quite devoid of elegance or grace. When the men dance it is called *tapkara*; and when the women dance they call it *rimsei*. The two principal *tapkara*, or men's dances, are *frot*. This they call *tonoto hau*, i.e. 'the voice of wine.' The *second* is called *chikup hau*, i.e. 'the voice of drinking.' These are dances accompanied by bacchanalian songs, and the men always require plenty of wine before they can produce 'the voice of wine!'

The women have four principal dances. These are called (1) *choma*; (2) *heranne*; (3) *ikken-ho-hum*; and (4) *heshkotoro*. The *choma* dance appears to be an attempt to imitate the movements of some kind of bird, possibly the heron. The dancers generally form a ring, and continually call out *choma* in unison. They also incessantly bend their backs forward, and as far back as possible when performing this dance. In the dance called *heranne* the performers form a ring and join hands, and, incessantly calling out *heranne*, continue to bow to one another, thus bringing their heads nearly together in the centre of the ring. *Ikken-ho-hum* consists in attempting to make oneself look as much like a see-saw as possible, by bending the back and head forward and back as far as one can, at the same time calling out *ikken-ho-hum*. *Heshkotoro* is indescribable, and appears to be a mixture of all the others, and the word *heshkotoro* is called out during the performance.

The Ainu do not much engage in games. The hard facts of daily life, such as looking out for food to eat and clothes to wear, take up their time. However, the people indulge in a game or two sometimes. Both men and boys think a great deal of a game called *karip-pashte*, i.e. 'causing the hoop to run.' This amusement appears to have been invented in order to teach the children to spear salmon in the rivers, and is played in this way:

Suppose twenty boys and men take part, these are divided into two parties of ten a side, separated from each other by about twenty steps or yards. Each individual is armed with a long stick or light pole, resembling a spear. A strong person, belonging to the side which leads off, takes a ring or hoop, about six inches in diameter, roughly made of a piece of vine, and throws it with all his might to the opposite party, making it run and bounce along the ground. Those to whom it is thrown then cast their sticks or spears at it as it passes them, and endeavour to transfix it to the earth. If successful they win, and one person from the other side comes over to theirs. Then the hoop is thrown back in the same way by a strong arm. And thus the game continues. When the individuals of one party are all brought over to the other, the game is finished, and the opposing sides cross over and begin again. It is really quite an exciting game, and gives very good exercise.

The men sometimes indulge in a very curious game they call *ukara*. It has the appearance of a painful experience rather than a game. It consists in beating one another with a war club, and is played thus :

Some soft material, such as a coat, is neatly wrapped round a stick and fastened with a piece of string. Then one man exposes his back, and, seizing a post or tree with his hands, leans forward. A second person takes the club and proceeds to beat him, apparently with all his might. When the subject has had enough, he calls out or runs off. Then a second comes forward and is operated upon, and a third, and fourth, and so on. He who has been able to stand the most whacks is the champion of the day !

Some of the Ainu despise a stick with cloth wrapped round it ; they prefer a bare war club. These are considered to be the real champions. It is wonderful what a number of strokes some of the men can bear ; sometimes, in fact, blood is drawn from the back ! But there is a suspicion that the art consists not so much in what a person can bear, as in the number of stripes a man can give. There is a knack in appearing to hit very hard, whilst in reality the subject is hardly touched at all. The operators, when asked about this point, only look very wise and grin, and kindly offer to practise on the back of the questioner.



UKARA

CHAPTER X

JUSTICE AND MARRIAGE

THE Ainu used to adopt a variety of methods by which to compel a person to confess a fault or crime. Curious and very effective methods they were. The following were the chief :

1. The barbarous hot-water ordeal. A very large cauldron, such as the Japanese use for boiling fish when they desire to extract the oil for lighting purposes, was procured. This was filled with cold water and placed over a blazing fire. As soon as the water was fairly warm the victim was put into it, as shown in the illustration. Here the person was compelled to remain till he or she, in the agonies of the moment, made a full confession. Such an ordeal was never resorted to, we are informed, unless the judge and people were pretty well assured of the person's guilt. This ordeal also constituted one mode of punishment.

2. Another hot-water ordeal consisted in making an accused person thrust his or her arm into a pan of boiling water. If afraid to undergo this test, the guilt of the subject was assumed ; or if, when the arm was

thrust into the water it was scalded, guilt was supposed to be proved. A person was only declared innocent if the arm came out uninjured.

3. The hot iron or stone ordeal. This consisted in merely placing a piece of hot iron or a heated stone in the palm of the hand, and keeping it there till confession was made. Of course, if the heated instrument did not burn the hand, a person's innocence was fully established.

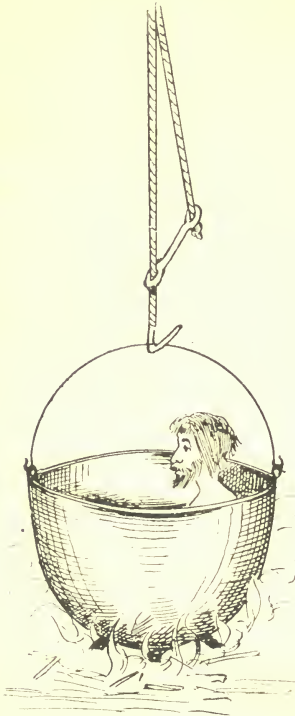

THE HOT-WATER ORDEAL

4. The drinking ordeal. This consisted in making a person sit down before a large tub of water and remain there till the whole was drunk. The mouth was not allowed to be taken away from the tub. This does not look so very formidable, but the Ainu

say it is most painful. If success followed the attempt to drink the water, innocence was proved; if not, a person was supposed to be guilty.

5. The cup ordeal. This consisted in causing a person to drink a cup of water. When this was done, he was made to throw the cup behind him, over his head. If the cup lighted the right way upwards, the innocence of the individual was supposed to be established; if otherwise, he was proved guilty.

6. Tobacco ordeal. A favourite way of trying women was to make them smoke several pipes of tobacco; and, having knocked the ashes out of the pipe into a cup of water, compel the woman to drink it. Those women who could smoke the tobacco and drink the ashes without feeling ill, were innocent; those who could not were, of course, guilty.

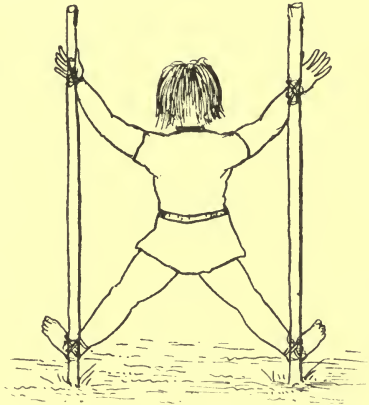

THE STAKE ORDEAL

7. The stake ordeal. This consisted in tying a person to two stakes driven into the earth. The arms were stretched out to their full extent and tied to the stakes. Next, the legs were treated in the same manner. Anyone tied up in this way had to remain there till confession was made.

Hanging by the hair of the head was sometimes

resorted to as an ordeal. Beating with a thorn bush was also a favourite method. But it should be remarked that all of these methods were, upon occasion, resorted to and inflicted as punishments for crime. Some of these ordeals were so painful that some Ainu have been known to commit suicide rather than have the test applied.

Among the Ostyaks of Siberia it was usual for oaths to be uttered, to call down future punishment either in this life or in that to come, and the ordeal an Ostyak went through when he swore was exceedingly curious. A bear's head was brought in, that he might bite at it, and whilst biting it he would call upon the bear to bite him in the world to come if he forswore himself, or was guilty of a charge laid against him. But the Ainu, who are great bear worshippers, seem to have no such custom.

In remote times the chief authority was vested in the head of a family. The husband could do as he pleased with his wives and children. He could, for instance, divorce all or any of his wives (the Ainu were polygamists), or disinherit his children. He could punish any members of his family as he thought proper. Now, however—i.e. since each village has established a little republic of its own—a member of a village can do very little as an individual. He has to consult with his companions.

How this came to be so can easily be explained. Suppose any single household to move away from all

friends and build a home in the wilds at some distance from any village. Such a thing has been done by the Ainu. A single family has often made a new settlement. Such a settlement necessarily commences under the rule of the father, who, as new huts are built near him for the accommodation of his sons as they get married, remains head of the growing clan. Then, as old age comes on, he retires, and his eldest son more and more acts in his stead, and at his death naturally succeeds him as head of the community. Then, in course of years, as the community increases in numbers, the whole village naturally desires to have something to say in any matter affecting any one of them, because each household is related to every other. A person could not, therefore, touch any member of his own family without giving offence to every other individual in the village. A kind of republican government, for this reason, became a necessity.

The Ainu consider marriage to be a social and family arrangement or contract which affects the parties immediately concerned more than anyone else. Hence, though the parents of a young woman or man desire them to marry into any particular family, or not to ally themselves with some other specified party, the young people may, after hearing the wishes of the parents and relatives expressed, marry whom they please. Both the young man and the bride, or either of them, have a final word in the matter. In short, the young people do their

own courting and wooing; and no one grumbles at this arrangement.

Let us suppose a young couple to have made up their minds to marry. If the young man made the first proposal, he asks his father and mother to call upon the parents of his chosen one and try to arrange for a marriage to take place. If, however, it was the young woman who did the wooing and courting, she gets her mother and father to call upon the parents of her choice. If all is well, the marriage takes place at once; if the parents will not agree, the young couple take the law into their own hands, build a hut and become husband and wife without any ceremony; and that relation stands good in Ainu society.

If the young woman or bride, or her parents, have been the main movers in the business, the bridegroom is removed from his own family to take up his abode close to the hut of his father-in-law. He is, in fact, adopted. But if the bridegroom did the wooing, or his parents were the prime movers, the bride is adopted into his family. Or, if a woman of one village chooses a man of another, he, if agreeable, goes to live with her; or, if a man chooses a woman who resides at a distance, she, if agreeable, goes to live with him. Persons who marry in their own villages are all called *uiriwak*, 'blood relations'; but those who remove from their homes to be married into some distant family are called *uiritak*, 'relation taken away,' or 'distant relations.'

The Ainu consider their daughters to be marriageable at about sixteen or seventeen years of age. The men marry when about nineteen or twenty. The youngest marriage I have yet seen amongst the Ainu took place when the bride's age, according to the Japanese register, was sixteen years.

The marriage ceremony consists of nothing but the usual feast of millet or rice cakes and wine, at which the bride officiates. There the bridegroom's father tells the father of the bride how happy he is with the arrangement; likewise the bride's father tells how proud he is. Then they each give the bridegroom some of their treasures as heir-looms, and the women give the bride a few trinkets, such as beads and earrings. Then *inao* are made, prayers are said to the different deities, and the ceremony is finished up with bacchanalian songs and dances. The wine is provided by the bridegroom, and the bride and her mother pound the millet and make the cakes. Of course, the very best embroidered garments are worn on this occasion.

The wife does not take her husband's name, but retains her old one. When not called by her own maiden name, she is merely called So-and-so's wife; that is to say, so long as her husband is living. Should her husband die, she is always known by the name of her childhood.

It seems to have been an ancient custom, though not general, to sometimes betroth children. But even in

this case the persons so betrothed were not absolutely bound to marry. Either of them could, when the time for marriage arrived, veto the decision of their elders. But the curious thing about this betrothal was that the boy and girl exchanged clothes, and, I believe, homes, until the season for their union came round. Then, if the parents of the lad were the prime movers in the betrothal, the young lady remained at his home, but if otherwise, the bridegroom went to live with the bride's parents, or at least in her village.

This will not be wondered at in the least when it is remembered that the Ainu have no surnames. Every person has but one name, and that is generally given between the ages of one and ten years, as any particular trait of character asserts itself, or some circumstance may suggest. Thus we sometimes hear such names as these: 'The selfish one,' 'The dirty one,' 'The good speaker,' 'The stutterer,' 'Bird mouthed,' 'Deer catcher,' and so on. Or, again, 'Bright,' 'Light,' 'Thunderer.' Or, when names are scarce, we sometimes find that such words as 'Pot,' 'Kettle,' 'Chop-sticks,' 'Ice,' &c., have been pitched upon. Thus Miss Pot remains a Pot, though she should marry a Kettle; and Miss Stutterer will always remain a Stutterer, though she becomes the wife of Mr. Good-speaker.

CHAPTER XI

DEER-HUNTING AND FISHING

STALKING deer was an occupation much beloved by the Ainu; even the women used frequently to take part in it when deer were plentiful. But since the introduction of guns both deer and bears have become remarkably scarce. Many of the people now hardly taste a piece of bear's flesh or venison from one year's end to the other. The animals have been immoderately and indiscriminately killed by Japanese hunters, and, unless something more is soon done to preserve what few deer now remain in Yezo, the animals must speedily become extinct.

Dogs were employed in hunting the deer. The Ainu used to take the dogs with them in packs, and these were so well trained that they would never attack and kill a deer, but stand by and keep it at bay till the hunters came up and shot it with their poisoned arrows. Many deer were also slain by the spring-bows.

The hunters generally carry an instrument with them on their expeditions with which to decoy deer. They are called *ipakke-ni*. These instruments consist of a single piece of wood made in a form which very much

resembles the 'horsing-irons' which are used in caulking ships. The illustration shows what it is like.

This instrument is three inches broad at the bottom or thin end, and measures two inches and a half from the top or thick end to the lower edge.

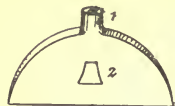

IPAKKE-NI, OR DEER
DECOY

From the thick round end to the mark in the centre, there is a hole which was made either with an awl, or by thrusting a red-hot nail into it. The hole starts at (1) and comes out at

(2). Over the surface of the instrument a very thin piece of fish skin has been stretched, being tied round the outside edges with fine strings made of twisted fish entrails. When a person desires to decoy a deer he wets the surface of the skin which is upon the face of the instrument and blows in at the top (1), whilst drawing his two thumbs over the skin. The noise thus produced resembles the cry of a doe, and is said to draw the bucks to the place whence the sound issues. The person decoying the animals of course keeps well out of sight and to the leeward, so as to be neither seen nor smelt. When the deer is within range it is shot with a poisoned arrow, and then followed up till it drops.

The accompanying illustration of an Ainu decoying deer was taken from a Japanese drawing in the Hakodate Museum.

The Ainu never made wolf-hunting an occupation, because wolves are so very shy and swift of foot. Nor



AINU DECOYING DEER. (*From a Japanese drawing*)



could they often succeed in catching them in their traps, or shooting them with their spring-bows; for these animals appear to understand these things nearly as well as the

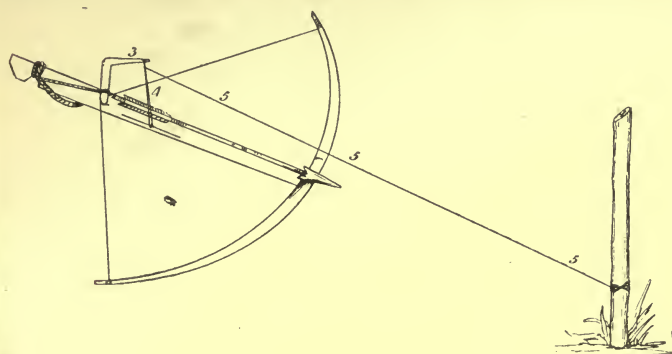

A SPRING-BOW SET

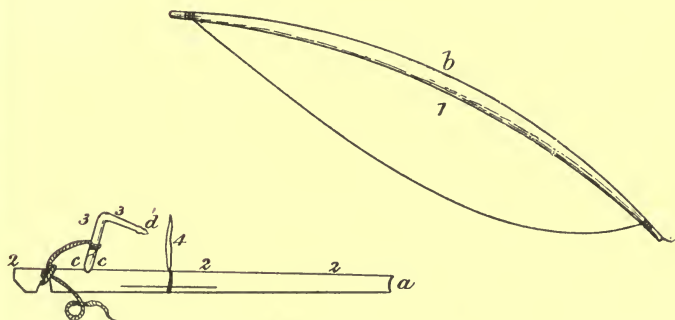

THE SPRING-BOW

people who set them. Yezo wolves, the Ainu affirm, never hunt in packs consisting of more than three or four animals. They are very fierce indeed when attacked

or wounded, or suffering from hunger ; but will never attack a human being unless under great provocation.

Ainu hunters have very few traps, but those which they use are of an odd-fashioned but interesting type. The spring-bow, used for killing bears and deer, stands first. This instrument consists of three parts : (1) the bow ; (2) is a piece of wood which has a slight groove (*a*) in the end, and which is placed in the centre (*b*) of the bow ; (3) is the trigger, the end of which (*c*) is so placed as to hold the bowstring whilst (*d*), which represents the top of the trigger, is held down by a piece of string (4). From this piece of string (4) another long piece of stout string or rope goes to a tree or pole situated upon the opposite side of the trail or run.

As soon as an animal, walking along the trail, touches the string (5), it pulls (4) off the trigger (3) and allows the bowstring to send the arrow into the side of the intruder, be it man or beast.

The next trap to be described is one that is used for catching river otters, foxes, racoons, hares, and—when they are about—wolves. This trap is usually set in the trails of these animals, so that when they step upon a small piece of string they let the spring of the trap loose, and so catch themselves by the leg.

Section (1) is the bow of the trap ; (2) is the main frame, consisting of a piece of wood split at the end, the two halves being kept apart by the bar at the bottom (3) ; (4) is a sliding piece of wood having a notch cut into it

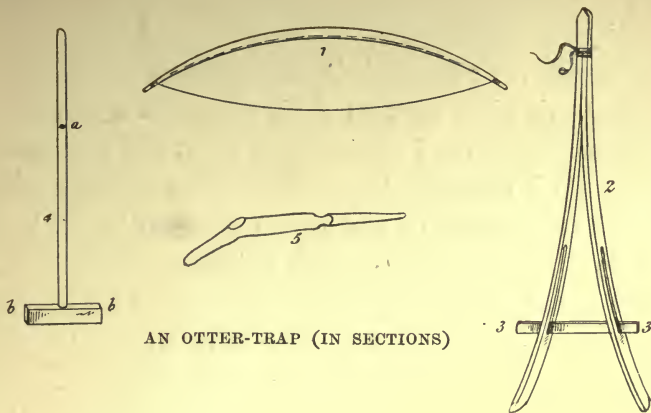

AN OTTER-TRAP (IN SECTIONS)

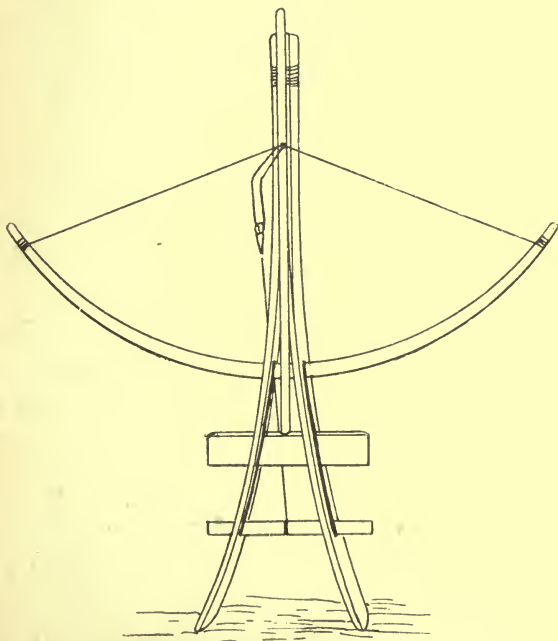

AN OTTER-TRAP READY SET

(a) in which to place and tie the bowstring. The lower end of this piece of wood (b) is placed on a slit, nine inches long, situated above the bar (3), and extending to it; (5) is the cock of the trap. A piece of string runs from the lower bar (3) and passes along under the bow to the trigger, so that when an animal treads upon the string it loosens it from the cock, and causes the bar (4) to come down against (3), where it securely holds the captive by the leg.

These traps are very powerful, and are pretty certain to break the leg of any animal that is so unfortunate as to get caught in one. They are generally secured to a tree near by, to prevent the animals running off with them.

The Ainu have various methods of killing rats. Bows are put up in their runs or trails in the same way as they are set for bears and deer, only on a smaller scale. The bears and other large kinds of animals touch the string connected with the trigger with their legs, whilst rats always gnaw it asunder. Another way of rat-catching is to suspend a heavy board over some meat which has been connected to some light mechanism for allowing the board to fall when pulled. This is a very sure way of killing a rat. Another rat-trap consists merely of an oblong box, with a bow so placed as to close the lid so soon as the animal shall pull the bait which is inside. This trap catches the rat by the middle, the head being inside the trap and the tail out.

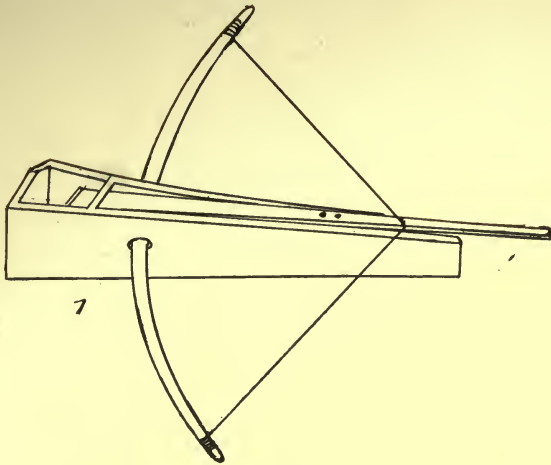

RAT-TRAP (SET)

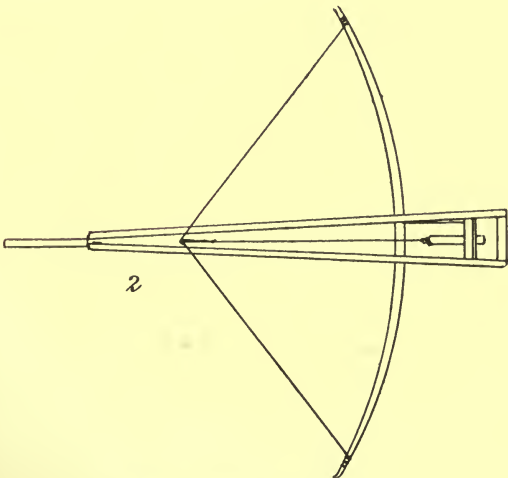

RAT-TRAP (IN SECTION)

Figure (1) shows the top of the trap already set up, and figure (2) shows the string inside the trap to which the bait is tied.

Salmon-fishing is a very favourite pursuit of the Ainu, and many of the people take great delight in it. Some of them are very clever at spearing salmon, for they commence to learn to use the fish-spear very early. I knew a lad only twelve years of age, who would sometimes start off to the river at daybreak, and return by eight o'clock with six or eight fine fish.

The spear used by the Ainu for taking salmon is called a *marek*. The pole to which this instrument is



A MAREK, OR SALMON-SPEAR

fixed is about eight feet long, and the *marek* is about eighteen inches in length. The hook (1) is of Japanese make, and is fixed so that, when a fish is struck, the point enters its flesh and it is drawn over, so as to keep the fish between it and the end of the pole (2); hence, the more the fish struggles the tighter the hook holds it, and the more securely it is held. The string (3) at the back is made of sea-lion's skin.

When using the *marek*, the people stand along the banks of the rivers, or perhaps up to their knees in the

water, and, when they see a salmon coming along, cast their spears at it. I have had several attempts at this work, but could never succeed in striking a fish, being unable to make out the exact allowance for the refractive power of water.

About the middle of November and the beginning of December the Ainu fish by torchlight. One person holds the lighted torch over the river's bank to attract the fish, whilst another strikes the unsuspecting creature with a *marek*.

Nets, too, are often used by moonlight with great success. Whether they thus fish by moonlight out of preference, or from fear of the Japanese, I cannot tell; but the Ainu are not allowed to net fish as they like, and there are always plenty of people on the watch for the breakers of the law.

The people used to make a kind of fish-trap they called *urai*, but they are no longer allowed to do so. These *urai* were generally placed across the rivers near to the various tributaries. They were made of stakes driven into the river bed, the spaces between the stakes being filled in with a kind of wicker-work. This served as a fence to keep the fish from passing. They were made in the shape of an arrow-head, and always pointed down-stream. At the end or point of the arrow-head a doorway was made, and a kind of square net, which was made to slip up and down at will, was fitted into it, whilst over the top was a platform upon which the

fisherman sat. The top bar of the net was allowed to rest in a notch left in the door-posts for its reception, whilst the bottom part, to which the handle was attached, rested upon the bed of the river. As soon as a fish was seen to enter the net, the person upon the platform drew the lower portion of the net up till it met the upper; and thus the fish was caught. Various other little

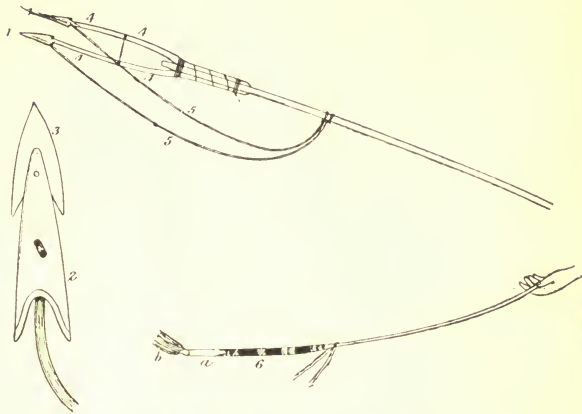

A SPEAR USED TO CATCH PIKE

wicker-work traps are still baited and placed along the streams for the smaller fry.

Trout and pike are caught with a spear called *chininiap*, or *apniap*. The handle of this spear is about eight or nine feet long, and when fitted up ready for use it is fully ten feet in length. As will be seen from the figure (1), this spear has two heads to it, which are fastened to the pole by means of string. These

heads (2) are barbed, and consist of two parts—an iron point (3) and a bone foundation (2). As soon as a fish is struck with this spear, the barbed heads come off the points of the pole (4), but the fish is secured by means of the strings (5) which are attached to the spear-heads and back part of the shaft or pole. Figure (6) represents a bait or decoy which is drawn along the bottom of the river. This bait is nothing but a piece of iron wrapped up in blue material bound on with white bark. At the end of this is a piece of white bone (*a*), two inches long, which is furnished with a tail (*b*) made of pieces of bark and a red piece of cloth. The fish are speared whilst following this bait or decoy.

Harpoons used in catching sharks, sea-lions, and swordfishes are like those shown at (2).

There is a fishing tradition concerning the great hero Yoshitsune which contains some matters of interest.

Okokurumi (i.e. *Yoshitsune*) and Samai (i.e. *Benkei*, Yoshitsune's henchman) came to harpoon the swordfish. And we waited for them at the fishing-place.

[The Ainu interpret this by saying that the ancients took their boats and went to the point where the fishing was to commence. Their motive was to see beforehand where the best fish might be caught, and to return more successful than their Japanese friends.]

When they came they effectually harpooned a large fish.

[Yoshitsune caught a fish; but the Ainu, though wishing to parade their skill, caught nothing.]

From this point the fish went from one end of the sea to the other, taking the boat with it. Now Samai collapsed for want of strength.

[Upon harpooning the fish, the boat, being fastened to the end of the harpoon line, was dragged out to sea, and Benkei was either drawn overboard with the line, or was killed in some other way.]

Upon this Okikurumi put forth all his strength and wrought with the grunt of a young man.

[i.e. He worked very hard.]

Then there arose upon the palms of his hands two blood-stained blisters. And with temper depicted upon his countenance he said :

‘ Oh, this bad swordfish ! As you are doing this, I will cut the harpoon line :

‘ And because upon the harpoon head there is metal, you shall greatly suffer from the noise of striking iron and grinding bones in your stomach ;

‘ Because the line is made of hemp, a plain of hemp shall grow out of thee ;

‘ Because the rope is made of *nipesh*, a *nipesh* forest shall grow from thy back ;

‘ And when you die you shall be cast into the mouth of the Shi-shiri-muka river, and crows and many kinds of dogs shall congregate upon thee and defile thee.’

[Thus Yoshitsune curses the poor fish.]

Now, though the swordfish said it understood, and thought it was Ainu that was spoken, yet it secretly laughed and went its way. But before it had gone far mighty pains seized it, and in its stomach was heard the sound of striking iron and of grinding bones. And plains of hemp and forests of *nipesh* and *shiuri* sprouting forth from its body, it was cast ashore in a dying state.

Then the dogs and crows congregated upon it and defiled it.

Upon this Okikurumi came down from the mountains and said :

‘ Oh, you bad swordfish ! it is by your own fault and for your own doings that you are thus punished.

‘ Your lower jaw shall be used in the out-house, and your upper one shall be sunk with a stone, and you must die a very hard and painful death.’

Do not treat this Ainu tale of the swordfish slightly.

[Thus did Yoshitsune’s curse take effect.]

CHAPTER XII

BEAR-HUNTING

THE Ainu consider bear-hunting the most manly, exciting, and useful way in which a person can possibly spend his time. It was certainly a very brave act to go and attack a bear with the very poor weapons the Ainu formerly used, and it must have been very exciting. Think, for instance, of attacking a she-bear, which had her cubs with her, with nothing but a long knife and a bow and a few arrows! It is quite true the arrows were poisoned, but the poison takes time before its effects are felt; and to wound a bear is no small matter at the best of times. Even a good shot, with a trustworthy rifle, a steady aim, and a cool head and heart, runs a great deal of risk in following a bear.

The Ainu feel that a bear-hunt is a great and serious undertaking, and before they set out they always have a meeting of the elders of their village, for the purpose of asking the favour of the gods. They ask the gods of the mountains to bring them upon the track of the game; they ask the goddess of the rivers to carry them safely over the ferries; they ask the goddesses of the

springs to nourish them when they drink ; and they beg the goddess of fire to comfort them, keep them from sickness, cook their food, dry their clothes, and warm their bodies. And, wherever they rest upon their journey, they never forget to worship and ask the favour of the local deities.

The Ainu say that the Yezo bears spend their winters in holes and caves, and that when they first come out in the spring their feet are very tender, so that they cannot move far away from their winter home. They do not, however, remain all this time in a torpid state, because they come out of their holes quite fat in the spring. Some say they store up fish and vegetables in their dens, and devour them in the winter ; others that they eat earth ; and others that, before they go into their dens in the autumn, they scratch open ants' nests and trample on the insects, thus causing thick layers of ants and their eggs, all mashed up together, to adhere to their four feet. They lick these during the winter months, and so keep themselves alive and fat.

In very early spring, when the snow is quite hard, so that a person can easily walk upon it, the Ainu take their dogs and go to see if they can find a bear's den. The dens are recognised by a slight discoloration of the surface of the snow, in the centre of which a small hole is to be seen. This is caused by the warm breath of the animal inside. If successful, prayers are said, the snow is cleared away, and long sticks poked into the

den to try and drive the bear out; the dogs, too, are set to worry the beast. Sometimes the bear comes out and is shot, but at others it refuses to stir.

If neither sticks nor worrying dogs can stir the beast, a fire is lighted over the mouth of the cave, and smoke is tried. This is said to be generally successful, but not always.

Some bear-hunters say that bruin absolutely refuses to kill anything in its own den. Therefore, if a bear will not come out when requested, in the ways above mentioned, a brave Ainu ties his head and face up, leaving only his eyes exposed, hands his bow and arrows to his friends, and, with his hunting-knife firmly fixed in his girdle, makes a call upon the bear in its home. The animal gets so angry and surprised at this that it unceremoniously seizes the intruder with its paws, and hastily thrusts him behind its back. The Ainu now draws his knife and pricks the beast behind, and this is said to make it take its departure. Of course, as soon as the animal gets outside, a few poisoned arrows are sent into its body.

This is the critical and dangerous moment; for the bear, now in pain and full of wrath, furiously attacks its enemies. If it comes to very close quarters with a man, and stands upon its haunches ready to strike him, this is considered to be a golden opportunity; for the man throws aside his bow and arrows, and, drawing his knife, rushes into the animal's embrace and thrusts the knife

home into its heart. This kills the beast in a moment. But the man who does this hardly ever gets off free ; he is pretty sure to get scratched, sometimes very severely, and some, we are told, have been nearly scalped and killed in this way.

It is not always that a man can be found brave or rash enough to run into a bear's embrace. Some of the hunters carry spears with them ; but they do not attack the animals with such things, because they say they are so quick as to be able nearly always to parry a thrust or blow with their fore-paws. A spear-man waits to be attacked by bruin. He keeps the point of his spear covered with a piece of cloth under his arm, and when the animal, standing upon its hind legs, makes a rush at him, he merely steps back a pace, and allows it to fall on of itself.

An Ainu, whose brother was the great bear-hunter of the district in which he lives, told the writer that some bears will not even touch a man when he enters their dens—especially if it is in the middle of winter. At this time men have gone into dens where, on account of the great darkness, they have had to feel with their hands to see where the bear lies, and, having found it, speared it and left it there to die. Others have gone into caves with torches and killed the beasts. This seems to prove that Yezo bears are in a more or less torpid state, at any rate, during part of the winter ; and yet it requires a good nerve to

enter a bear's den when the master or mistress is at home.

When a bear has been killed the Ainu sit down and admire it, and make their salaams to it. Then they skin it and cut it up, taking great care to do away with all the pieces that have been touched by the poison of the arrows. They are careful, too, not to allow the dogs to get the heart, for that is more affected by the poison than any other part. When the skinning is finished, the head is decorated with *inao*, and thanks are offered to the gods for rendering them successful.

The bear is divided as follows. The man who kills the animal takes the whole head, the breast, and the viscera as his special property. When the skin and gall are sold he also gets a little more money than the other hunters. The body of the animal is divided equally amongst them all. When the fortunate hunters return home to their village, a great feast is made, and the old men come in and make a great many religious symbols, and thank and praise the various deities for going with their brave young men and bringing them home safely. Then they commence to extol the bravery of the successful hunters, and ask for a full description of the hunt. This is the great time of the feast, for the hunters act the whole hunt over again in words before the assembled and admiring guests. But if a hunter should have been killed, the affair is turned into a feast of mourning.

The following is a story of a bear-hunt, originally

written in Kana, with a Japanese translation in parallel columns, and may be found in a Japanese work called *Ezo fuzoku i san*, Bk. ii., Vol. V., p. 10. The translation here given is by Prof. Chamberlain, and published in Pt. I., Vol. XV., *The Transactions of the Asiatic Society of Japan*.

‘Methinks it must have been some five years ago, in the middle of the eleventh month, on a day when the snow was falling fast, that with my neighbours, Usaragi of Mopet, Satonshige of Hashnaush, Yayokguru of Noyaush, Gomeki of Shimooi, Itarasara of Ush, and Pinakoro of Sakpet, altogether a company of six men, we came to the house of Megayuki, at Osarapet, and sat down to talk by the lighted fire. And when we had gone in there, and the talk was becoming lively, Sambas came in from next door, and likewise his younger brother, Esharon, came in to talk. And so we spent the rest of that day in Megayuki’s house.

‘Now, though the days are short, the nights are long. So we stayed quietly, having pleasant talk; and I fell asleep at last along with the rest, as the fire burnt low. But afterwards I woke from the cold, and, on looking round, saw that Megayuki’s little three-year-old child, Kiō, had crept to the edge of the hearth, and was sleeping there; and fearful that it might hurt itself if it fell in, I stretched out my hand and pushed the child under its father’s arm. But it woke at once, and began to cry, so that I knew not what to do.

‘The child’s crying wakened all the other men. So the fire was relit, and we fell to talking again, as the snow was piled up ever higher and higher, and all was desolate without. Then we consulted together, saying, “If the snow leaves off to-morrow, we will go bear-hunting.” And we waited for the day to dawn; and all were glad at the prospect of fine weather to-morrow, because the snowflakes were falling as big as hares. “Come along, we’ll boil the rice,” said our host; and with these words he took out of the rice-bag, which he had received in barter from the Japanese the year before, enough for nine men’s rations for a day. He brought forth also some dried salmon, which he had in store, and broiled some dried salmon-trout. Then we all ate a meal, and after it started off to the mountains behind Mopet and Osarapet.

‘While we were on the way, the snow left off falling and the wind blowing, so that we climbed the mountain with joy, and cleared away the snow in seven places beneath the rocks, where we set our spring-bows in order, trimmed our poisoned arrows, and baited the places with dried salmon-trout, saying to ourselves, “Now, all we have to do is to wait for the bear to come.” Then we huddled together.

‘But the cold, which we had not felt while climbing the mountain-side and working, became unbearable as we stood quiet. The breath from each man’s mouth froze, and hung like icicles from his moustache. Our

hands and feet were numb with cold. The snow on our heads had frozen into balls among our hair, and hurt our heads so that we could not stand it. So we all took counsel together, and climbed up a peak, where we collected dead wood, and kindled a fire, and warmed ourselves awhile. At last the sun rose, making our bodies feel more comfortable; and five of us—Yayokguru, Gomeki, Pinakoro, Esharon, and Itarasara—in order to disturb the bears, were told off to wait in a shelter under the rocks. So they separated from the others, and hid in a shelter under the rocks. As for the other four, Megayuki took the lead, telling the rest to follow him; and they divided up, and searched every hole and thicket. But the bears were hiding deep down, on account of the cold. So the men were of various opinions as to whether it were best to go in and drive them out, or to kindle a fire at the entrance and smoke them out. But I thought of a plan, which was to cut the branch of a tree and push it into the bears' den, and then to hide and wait quietly, to see what would happen.

'So, as we watched, there came two bears out of the den, with the branch in their mouths to throw it out. And, as we pelted them with branches of trees and with stones, they became furious, and made as if to come against us, growling fiercely twice or thrice, but merely shook themselves, and retired into their den again. We all burst out laughing, and, drawing nigh

again, pushed the branch in the den, and again retreated and watched. This time three bears came out with the branch in their mouths. So again we pelted them with stones and other things, and two of the bears ran back again into the cave. But one of them, more furious than ever, espied the place where we all were, and made for us with a tremendous growl

‘One and all, we fled in confusion. But what with the deep snow and our numb hands and feet, we did not care to run far. So some of us climbed trees, and some faced the bear with hatchets and with axes. Again it went back into its den. “Oh! oh!” cried we, “’tis a pity. If only we had driven it back at once, it would not have gone in.” So again we tried all sorts of means to anger the bears; whereupon the one that had come out first of all appeared again to attack us. But we, being prepared for it, came round on it in a body from behind, and tried to drive it to the spot where the poisoned arrows were fixed. But it would not go there, for all our driving; and at last, as we rushed hither and thither amidst the snow, and under the shadow of the rocks, it disappeared from our sight.

‘We were now at our wits’ end, and all our consultation, all our search, was in vain. There was nothing more to be done with *that* bear. So off we went to another den, distributing our men in the way most likely to drive out another bear. This lasted for some

time. The place being one famous for its bears, a large bear was next suddenly driven out, and was seen to be a she-bear. Gently did we draw nigh to her from afar, and pleasant was the driving of her towards the spot where our spring-bows lay stretched. The bear was perhaps hungry, but she was sly too, and it took long to get her to the spot where lay the bait of salmon-trout. At last she put her paw upon it. The bowstring twanged, and the arrow struck her in the loins. Instantly she started with affright, became furious, rushed round and round in the snow, biting stones and trees to pieces in her pain.

‘Meantime it was for us, who had climbed trees and hidden behind rocks, to let her rage as long as possible, and not to draw nigh and kill her until she should be nearly tired out. But Pinakoro, one of the five who had hidden behind the rocks, showed himself too soon. The wounded beast espied him, pursued him with frenzy, crunched him with a single crunch, and Pinakoro fell to the ground before the rest of us, with difficulty, could reach the place. Ah! ’twas indeed too cruel a sight. The bear, too, that had been so mighty, gradually lost her strength, and now falling down, now getting on her legs again and trying to escape. So, while three of the men stayed with Pinakoro, the other six surrounded and attacked the bear, which, great strong she-bear that she was, was soon struck and killed. Great was the joy of all of us as we gathered together; but the sad part of it

was poor Pinakoro's death. His breath was gone, and would not come back, for all that we lifted him up and pressed him in our arms. 'Twas piteous to see his wounds. He had been bitten in the arm, and the bone had been broken. There were two wounds in his back, one in the neck, one in the knee. Oh ! how cold it was ! And the sadness which filled our eyes with tears at witnessing his lamentable end left us no appetite for our midday meal. So our company all brought the bear home, three of them carrying Pinakoro's corpse ; and we all returned to Megayuki's house, where to bury the corpse was the first thing we did. How sorry, too, could we not but be for Karinki, his weeping widow !

'However, leaving that aside, we skinned the bear, took out its liver, cut the flesh up, and carried part of it to the Japanese office, getting food and rice beer in return. Then we invited all the Ainu of the neighbourhood, and treated them to the prize we had found in the snow. All through that day, and on into the night, all was feasting and merriment. But, in the midst of our revels, suddenly there rose up before us the recollection of dead Pinakoro—of how he had been in health till noon of this very day—of how, if things had not happened so, he would have been drinking with us at that very moment. Then, as there came over us the thought of his widow Karinki's woe, the rice beer and the bear's flesh lost their delicious savour. The absence of that one man from the feast made it taste nasty to all the

rest; and we fell a-talking together, and there was not one of us but wept. There is no joy in a feast without noise. Our talk turned to the subject of death—of how the father of such-and-such an one had been eaten at such-and-such a time—of how So-and-so's child had died at such another time. At last the day dawned, and first one left, then another, till at last none remained but we companions of to-day. Such is the way of the world. So the joyous feast succeeds sorrow, and even this is now an old story.'

The poison the Ainu formerly used upon their arrows (it is now forbidden by the Japanese Government) was made from the roots of aconite plants or 'monkshood.' The roots were dug up in the spring and peeled, and put in the sun to dry. When they were thoroughly dried, the Ainu ground them to powder between two stones. They then soaked some tobacco and capsicums in water. When this was well soaked they moistened the powdered aconite with the liquor, adding thereto a little foxes' gall. It was then again put to dry, and again wetted with the liquor; but this time some of the hunters added a poisonous kind of spider. Some of them used to bury the poison for a few days, but others did not do so. When an Ainu wished to know whether his poison was good or not, he applied a minute particle to his tongue. If good, it was said to quickly produce a peculiar sense of tingling and numbness; but care had to be exercised in tasting poison,

lest, by taking too much, a person should succumb from the effects. Too much was said to produce drunkenness and sleep, from which it was very difficult to arouse a person. No grease or fat of any kind was used to keep the poison moist, for it did not need it.

The arrows used to carry poison were made in three parts or sections. The arrow head (1) is made of bamboo. It is two inches long. Figure (a) represents the inside

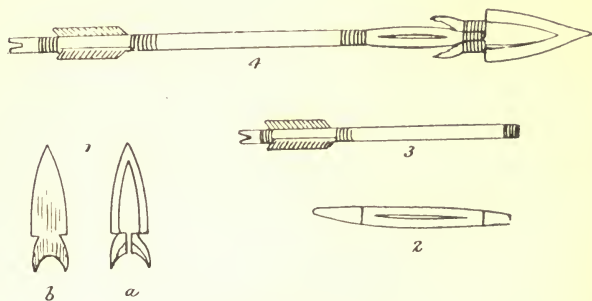

A POISONED ARROW

of the head scooped out so as to hold the poison. It is capable of holding a good lump of the aconitè. Figure (b) represents the back of the arrow head ; but no poison is put on this part of the arrow. (2) represents the piece of bone into which the arrow head is fixed, and (3) is the reed shaft of the arrow ; while (4) shows the arrow fitted up ready for use, but without the poison.

When a person applies the poison to his arrows, he first dips the head into some pine-tree gum ; then he

carefully sticks the poison on, and flattens it down with his thumb, and again dips it into the gum. The use of the gum is to cause the poison to remain firmly in the arrow head. These poisoned arrows were used, not only for bears, but also for deer and other kinds of animals.

The bows the Ainu used in hunting were very powerful, though they look poor, weak instruments. I have in my collection of Ainu instruments a bow that is just forty-seven inches long, and is made of yew, having a strip of cherry bark entwined round it.

The Ainu often used to set spring-bows in the trail of bears. Bears are said to always snatch an arrow out of themselves when they are hit, but the poisoned arrow heads being barbed remain under the skin, so that there is no escape or remedy. The Ainu aver that any animal which has been shot in this way is certain to be found within a very short distance of the spring-bow.

Another way of killing bears was to dig a deep pit in their trail, cover the top over with rotten wood and leaves, and hang a piece of fish or venison over it as a bait. Of course, when an animal fell into the pit, it was killed easily enough.

Ainu bear-hunters are very proud if they can secure a bear cub or two, to bring up at home, for the purpose of having a great feast. Men have been known to risk their lives in order to secure one, and when they do catch a cub, they bring it home with great glee, and, of course, get very drunk in honour of the occasion. Some-

times very young cubs may be seen living in the huts with the people, where they play with the children; and are cared for with great affection. In fact, some of the bear cubs are treated even better than the children themselves. But as soon as the cubs grow big and strong enough to cause a little pain when they hug a person, or when their claws are too powerful, they are

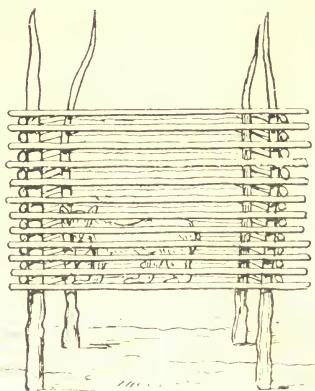

A BEAR CAGE

placed in a cage, strongly made of thick pieces of timber. Here they remain until they arrive at the age of two or three years, at which time they are killed for the feast.

There are persons who assert that these bear cubs are brought up by the women in the same way as children; but this is not true.

The opinion has received so much credence because many persons who have written about the Ainu race have, for some reason or other, either passed the subject over without a word of denial or explanation, thereby appearing to give assent thereto, or else they have stated it to be a fact. But no one—that I am aware of—has

ever seen an Ainu woman nursing a bear's cub. During five years' sojourn amongst, and almost daily intercourse with, them—living with them in their own huts—I have never once witnessed anything of the sort, nor can I find a single Ainu man or woman who has seen it done.

Bears' cubs are very seldom taken so young that they cannot lap water, and when a dish of millet and fish boiled into a soft pap is placed before the cub, it soon learns to feed itself. They never care to starve for more than a day or two. With those, therefore, that can lap (which is by far the greater proportion) no difficulty is experienced. The only inconvenience arises from the great noise they make in crying for their mother. This nuisance is soon cured, for the owner of the cub takes it to his bosom, and allows it to sleep with him for a few nights, thus dispelling its fears and loneliness.

When a cub is taken so young that it cannot even lap its food, it is fed from the hand and mouth, not from the human breast. Sometimes small portions of fish, or a little millet (often both mixed) are chewed by a person, and thrust little by little into the animal's mouth, and it is thus made to swallow. At other times millet is made into a kind of batter, or very thin paste, a mouthful of which is taken by a man or woman, and the cub allowed to suck it from the lips, which it will readily do. In fact, it is at first fed in much the same

way as boys in Europe feed young birds. The next step is to teach the animal to lap from the hand, which is also soon accomplished; then it learns to take its food from a wooden tray.

However, it is possible that a woman may occasionally have been found strong-minded enough to take a very young cub—that is, one whose eyes are not yet open—to her breast, once a day, for a day or two, and at the same time feed it from the hand and mouth in the manner above stated. Such women must be very scarce indeed, as also is the occasion for them. I have often seen the cubs of bears brought up by hand; but have never seen one nursed by a woman.

No doubt the Ainu are very low in the scale of humanity, and have some barbarous manners and customs; but their barbarity has been exaggerated, just as their stupidity has been taken too much for granted.

When a young bear is about to be sacrificed in a feast, the day before this cruel and barbarous feast takes place, the owner of the cub sends round to all the people of his village and invites them to come and take part in the sacrifice. He also invites guests from distant villages, and they are pretty certain to come, as there will be a chance of getting intoxicated. The men, particularly the old ones, will come with crowns upon their heads. These are made of the sacred willow shavings, and have an ornament representing a bear's head in

front. All of them, both young and old, put on their very best embroidered clothes, wash themselves, have their hair cut, whiskers trimmed, and foreheads and necks shaved for the occasion. The women and children too come, looking quite clean and well decorated. The women put on their earrings, bracelets, and beads; they touch up their tattoo marks, and don a new head-dress or bonnet.

As the guests arrive, they enter the hut, and sit round the fire, the men in front and the women behind. Millet cakes boiled are handed round, and wine is drunk. The women get what wine their husbands choose to give them, which, I have noticed, is sometimes very little indeed. But this is not the real feast; it is merely the beginning.



THE CROWN WORN AT A
BEAR FEAST

When the guests have all arrived, numbers of *inao* are made and stuck in the hearth; then the goddess of fire is requested to take them to the different gods, and let them know that the Ainu are about to sacrifice a bear. When this is done, the *inao* are carried to the *nusa* place outside the hut, and there stuck up, and two long poles are laid down at their base.

When these preparations are completed, another

Ainu goes to the bear, and, sitting down before it, tells it that it is about to be sent to its forefathers. He craves pardon for what they are about to do, hopes it won't be angry, and comforts it with the consolation that large numbers of *inao* and plenty of wine will be sent along with it.

Then another Ainu goes to the bear's cage, and catches the victim's head in a rope having a noose in it. The noose is made to pass round the neck and under the foreleg, so as not to choke the animal when it

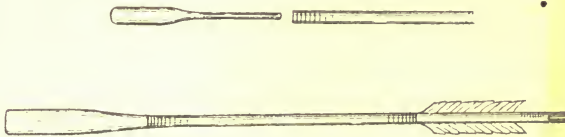

BLUNT ARROWS

struggles. Another noose is then made in another rope, and this is passed over the head in the same way, excepting that the end of the rope comes out on the opposite side of the bear; thus, when the bear comes out of the cage, it is led along by two men, one on each side of it.

Then the ancients of the people form a ring and sit down, whilst the younger people stand, and try to work the bear up into a passion. The two men lead the poor animal round and round the ring whilst the people shoot at it with blunt arrows. The shouting of the people is

quite deafening, and the rage of the bear furious. When the animal shows signs of exhaustion, a stake is driven into the ground in the centre of the ring, and it is tied to it. Now blunt arrows are shot at it with double vigour, and the poor animal tears and rages till thoroughly tired out.

Then comes the test of valour and bravery. All at once some brave young Ainu will rush forward and seize the poor brute by the ears and fur of the face, whilst another suddenly rushes out and seizes it by the hind-quarters. These men both pull at the animal with all their might. This causes the animal to open its mouth. Then another man rushes forward with a round piece of wood about two feet long ; this he thrusts into the bear's mouth. The poor beast, in its rage, bites hard at this, and holds it tight between its teeth. Next, two men come forward, one on each side of the bear, and seize its fore-legs and pull them out as far as they can. Then two others will, in a like manner, catch hold of the two hind-legs. When all this has been done quite satisfactorily, the two long poles which were laid by the *nusa* are brought forward. One is placed under its throat, and the other upon the nape of its neck. Now all the people rush forward, each eager to help squeeze the poor animal till it dies. And so the poor beast is choked to death. It is indeed a brutal scene.

As soon as the animal is dead, it is skinned and cut

up; but it has to be carried into the hut and laid before the east window for two or three days before it is eaten. During all these days some of the men are dead drunk. But enough of this revolting cruelty and debauchery.

CHAPTER XIII

AINU FATHERLAND AND GOVERNMENT

ACCORDING to some of the Ainu traditions, the ancients, wherever they originally came from, made Piratori their capital, upon their arrival in Yezo. Thence they gradually separated, some going one way and some another. Wherever they went they met the *Koropok guru*, or 'dwarfs,' whom they fought with their war-clubs and spears, and eventually exterminated.

An ancient Ainu war-club is in my collection of Ainu implements. It is made of yew, and is about two feet long. It is very strong, and weighs a little over one pound.

The handle measures three inches in circumference, and the club end seven inches and a half. The front part of the club has notches cut six inches down its face, whilst on the back of it a hole has been cut seven inches long, one wide, and three-quarters deep, in which to put a stone or some other heavy substance to render the instrument more weighty. It would prove no mean weapon in the hands of an expert.

All the Ainu do not claim Piratori as their capital.

The Northern Ainu point to Apashiri as their chief city; the Kusuru Ainu to Assuru, and the Ishkari Ainu to Ishkari; but the Southern Ainu, particularly those of Moruran, Usu, Aputa and Yurap, say that their ancestors came from Piratori and other places in



ANCIENT WAR-CLUB, SHOWING
PLACE FOR THE STONE

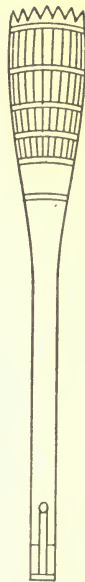

ANCIENT WAR-CLUB

Saru. Some say that their forefathers came down from the north, others that they were driven from the south by the Japanese; but all say that the ancients formerly inhabited Japan.

The Ainu do not stand alone in this diversity of

opinion as to their original fatherland, for some persons who are not of this race imagine that the Ainu are of southern origin. Others have brought the extreme hairiness of the Ainu into court to show that they must be of Aryan descent. Those Ainu who speak of the north as their former home point to the profusion of their hair as a proof of their northern origin; 'For why so much hair,' say they, 'and that over our whole bodies, unless we originally came from a cold country?' Certain it is that many of the Ainu customs resemble those of the inhabitants of parts of Siberia.

Nowhere in the south, for instance, do we find bear-worshippers; but we do in the north. Again, some of the oldest Ainu tell us that their ancestors came from a country which they designate *Nitai sak, chikap sak moshiri*—i.e. 'a land without forests or birds'—a land, say they, which is very cold indeed, and has much ice and snow in it. The names of the Kurile Islands, Saghalien, and Kamschatka are of Ainu origin. It is pretty clear also that the Ainu formerly had dealings with the Russians, whom they called *Rushikai*, and the Manchurians, whom they knew by the name *Manchu*.

Piratori certainly was once the chief place in Southern Yezo, and the head of that place or town was held in special dread and was particularly revered. His word was final upon any subject. He was always consulted before any great undertaking was entered upon, and he held the post of commander-in-chief during war. When

trading, the chief of Saru used to take his men and sail thence to Saghalien and Manchuria with skins and fish, and return with many necessaries of life, as well as ornaments, for his people.

In later times, trade with northern countries has been broken off, and barter has been carried on with the Japanese in Japan; and, still later, since the Japanese pushed their way into Yezo, Hakodate and Matsumaye, in this island, have been the chief centres of trade by barter.

The Ainu traded with the Manchurians when they were at war with the Japanese, and with the Japanese only since they were subjugated by them. Manchurian cash is the only relic of Manchuria to be found amongst the Ainu of the present day. Siberian dog-sleighs and canoes, made of seal and sea-lion skins, and which were used in trading with Manchuria, may still be seen in the Kurile Islands and Saghalien. Specimens of these are to be seen in the Hakodate museum.

It is hardly credible that the ancient Ainu could have travelled far for the purposes of war, though their sons would have us believe that they visited many distant lands with this intent, because their canoes could not stand even a moderately rough sea, and we have never seen or heard of any stronger sea-going craft. The river canoes or dug-outs could never have been used for warlike purposes. Ancient Ainu wars must then have been waged with very near countries.

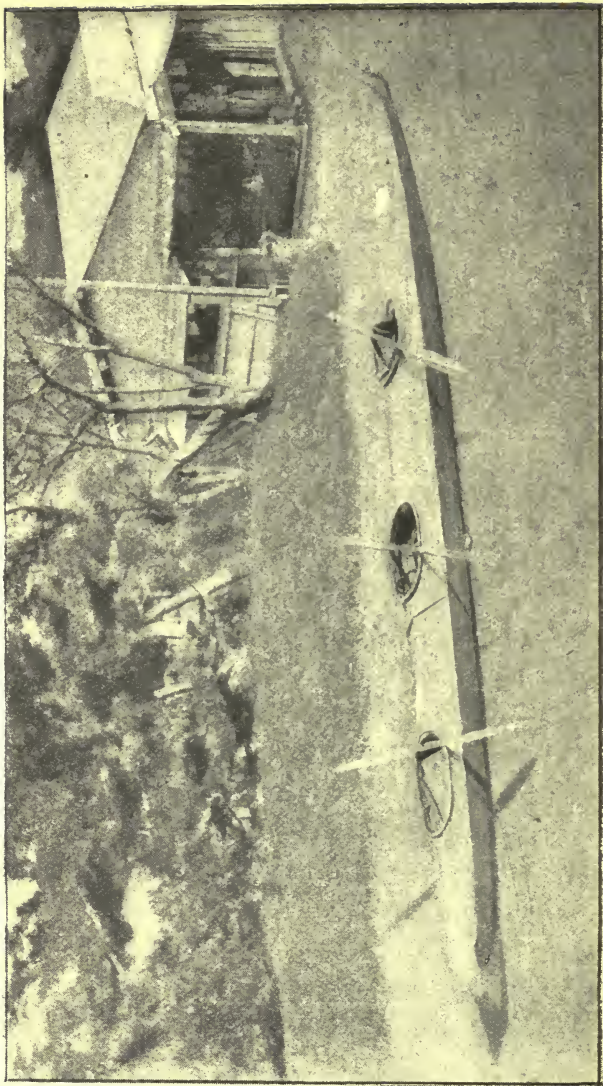

A KAMSCHATKAN CANOE

The illustration represents a canoe brought from Shekotan in the Kurile Islands, and which is now in the Hakodate museum. It is twenty-one feet long, and one foot ten inches wide at the top, and is paddled along by three persons. It is made of the skin of a sea-lion. Such canoes were used principally for fishing, and there is in the museum the model of a canoe with two fishermen in it, preparing to harpoon a walrus or sea-lion. We cannot believe that such light vessels could have been used for fighting. When the men are paddling these

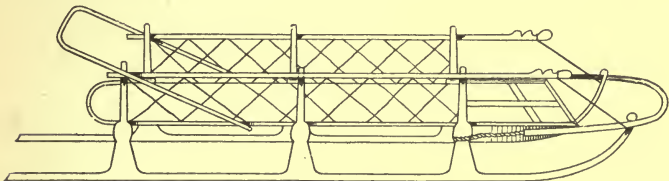

A DOG-SLEIGH

canoes along, they always tie a piece of skin, which is securely fixed to the hole they sit in, tightly round their waist. This is to keep the water from getting inside and swamping them.

Nor were such boats used for trade purposes, for they could not possibly carry any cargo. But in trading, especially with the people of the north, dog-sleighs were used. Two kinds of dog-sleighs which were formerly used in the Kurile Islands may possibly represent those used in ancient times by the AINU of Yezo. The first is four feet four inches long and thirteen

inches broad. It seems to have been designed for carrying food or articles of merchandise.

The other appears to have been intended for passenger transit. The runners are five feet six inches long, but the seat for the passenger is only two feet seven inches in length, and eight inches broad. One wonders how a person could possibly keep from falling over when travelling in such a small conveyance, but the passenger used to travel with his feet over the

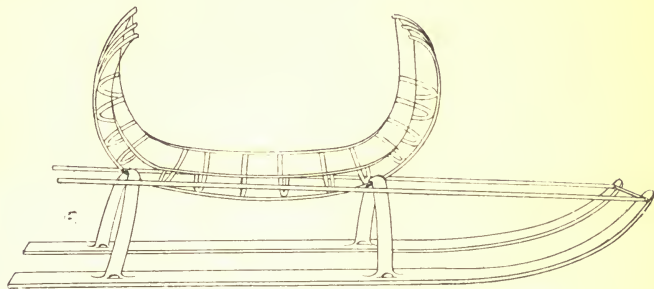

A SLEDGE

sides of the sleigh. He was shod with immense sandals or snow-shoes, so that he could not only prevent himself from being capsized, but could also assist the dogs in pulling when necessary. Of course these sleighs were drawn by reindeer further north.

These snow-shoes are somewhat clumsy-looking things, as the following picture will show. Each shoe consists of a single piece of wood neatly covered over with seal-skin. Their dimensions are five feet seven inches

in length, and seven inches and a half in breadth. They are fastened to the feet by means of a skin thong.

According to ancient traditions and certain customs, which are still more or less adhered to and practised by the people, the Ainu never had a monarchy, but always divided the government amongst the inhabitants of the separate villages, thus making each village a kind of independent republican state. The elders of each village assembled, we are informed, and chose a chief and two sub-chiefs to look after the affairs of the people. The principal chief or, in case of his absence, one of the sub-

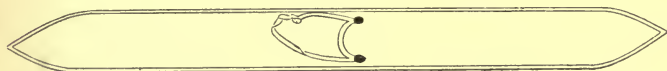

A SNOW-SHOE

chiefs, was always supposed to be present at a funeral to bury the dead, or at marriages to ratify the marriage covenant by his assent, and to cheer the young couple with his good wishes. The chiefs, together with the people, made the laws and sat in judgment upon the law-breakers. It was the duty of the principal chief to lead the people to hunt and to fight, and, in conjunction with the sub-chiefs, to see to the proper division of the land; to point out to each person a garden plot and fishing place; to visit the sick; to settle disputes; to pronounce sentence upon the guilty, and to see that such sentence was duly carried out. All trials took

place in public, and, unless the assembled elders of the people assented to the decision of the chief, his judgment was void. This mode of government is still sometimes practised in secret by the people, notwithstanding the fact that the Japanese have taken away all semblance of power from the Ainu as a race, deposed their hereditary chiefs, and set up creatures of their own in their places.

The Ainu had various methods and degrees of punishing offenders, which were regulated by the different misdemeanours committed, and the dispositions of the judges and people. However, they never favoured the death penalty, since they thought that no punishment at all. They thought that only the infliction of pain or disgrace was worthy of the name of punishment, and the more severe the pain, the greater the punishment. Beating with a stick or war-club was the most common method of punishing offenders, though this mode was often superadded to other kinds. Misdemeanours and their accompanying punishments were such as these :

For breaking into the storehouse or dwelling of another, a very sound beating was administered for the first offence ; for the second, sometimes the nose was cut off, sometimes the ears, and in some cases both the nose and ears were forfeited. Thus the culprit was marked and disgraced for life. Persons who had committed such a crime twice were driven bag and baggage out of the home and village to which they belonged. I have seen a man and a woman—they were husband and

wife—who had been treated in this way for breaking into a storehouse. They are most probably the very last that have been or will be hereafter thus treated in Ainu-land ; for Japanese law now reigns supreme, and that of the Ainu is, to all intents and purposes, for ever dead.

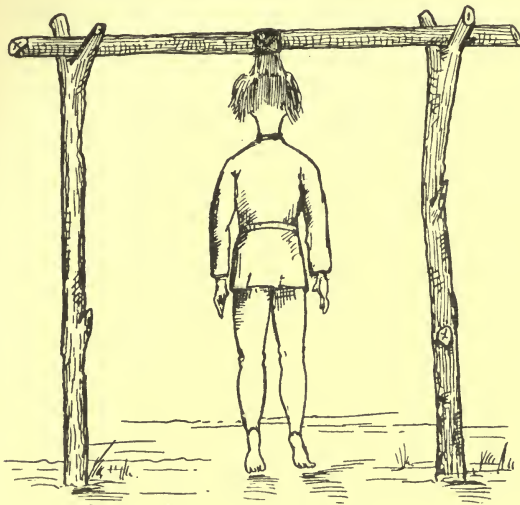

HANGING BY THE HAIR

For breaking the seventh commandment, it used to be the custom to tie the hands of the male offender behind his back, then hang him up to a beam by the hair of his head, leaving the toes, however, just touching the ground, something after the manner indicated by the illustration, and, as he hung, give him a severe beating. The female

offender was generally allowed to go free, though, of course, in disgrace. Sometimes, however, she also came in for a sound thrashing. If the culprits were single, they were generally made to marry immediately upon being found out.

For murder it was customary to cut the tendons of the feet in two, thus maiming a person for the remainder of his life. The tendons were severed close to the heels. This was a terrible punishment, for a person so treated could not possibly do any work or hunting; he was ever dependent on his relatives for the necessaries of life. I have seen one old man who had been so punished. He was unable to walk, and was obliged to move himself along upon his hands, in which he held two small blocks of wood.

Sometimes, however, the tendons of a murderer were spared; and in that case the guilty one was banished for ever to a place called *Nitai sak, chikap sap moshiri*—i.e. 'the land where neither trees nor birds exist,' and which is described as being a very cold and dreary place, where there is almost perpetual ice and snow. This is probably intended for Siberia.

When a person was charged with a crime, he was always supposed to plead guilty or not guilty. If he was proved guilty, and would not confess his crime, certain *ordeals* were applied. The Ainu, as we have seen, still resort to trial by ordeal, when they can do so secretly and without being found out by the Japanese.

CHAPTER XIV

FEAR OF ANGRY WOMEN AND TREATMENT OF THE SICK

THE way in which an Ainu woman can curse when she is angry is simply wonderful; and no trick is too mean, unclean, and unseemly for the expression of her wrath, and for vengeance upon the objects of her hate and fury. This cursing is not an invocation to the gods for harm or injury against a person, for Ainu women never pray for anything; nor is it what is commonly called swearing, or using profane language, for the Ainu are not addicted to this evil habit. They have, it is true, a word in their vocabulary which means 'to blaspheme'; but their cursing consists in uttering imprecations against a person, and in calling him bad names.

Thus, an angry woman will call an old man who has raised her ire, *shunuma-ush*—that is, a very aged, mangy deer—one about to die of old age, quite toothless and unable to run. A very young man she will call *tontoneppo*, which means, I believe, 'a little hairy thing,' and then 'wild boar,' next 'leather-like,' and lastly 'bald-pated.' A middle-aged man she will call *hokuyuk*

‘ a man-eating bear ’; but the worst term of contempt a woman can apply to anybody is *rai-guru*—‘ a corpse.’

Besides calling the men hard names, Ainu women have other means of venting their spite against them. They will, for instance, peep at them round corners, make grimaces at them behind their backs, put out their tongues to the utmost extent, and roll their eyes about, and otherwise act in a manner too indecent for description. Now, Ainu men are dreadfully afraid of angry women; not, indeed, so much that they fear their hard words and ugly looks, but they dread their actions. Two things they particularly dread: that the women will steal and hide their religious symbols, or offerings to the gods; and that the women will make them eat partially decayed human flesh, or some other filthy substance.

Angry Ainu women have been known to steal and hide away or burn their husbands’ *inao*. The men are particularly afraid of this kind of sacrilege, for they fear that the gods, not being able to find their accustomed offerings, will think they have been neglected, and thus be led to cease blessing and extending their favours to the offerers, and perhaps requite them by sending some calamity or trouble, especially in the shape of madness or paralysis.

Not only will the gods cease blessing any Ainu who neglects his *inao*, but his own tribe and people will cast him out. He then loses his fraternity, and is, in a

sense, boycotted. An Ainu who neglects his *inao* is looked upon by his household and friends as an atheist is in a Christian land. Perhaps the worst name that can be applied to an Ainu man, and that which most deeply wounds his feelings, is *inao sak guru*—‘a person without *inao*.’ Such an one receives no share of fish, and no bear’s flesh or venison after a successful hunt. He is not able to take part in the great national bear feast, and thus misses a good chance of getting drunk. He becomes an object of hatred and an outcast.

Hence, an Ainu greatly fears an angry and revengeful woman—especially if she be his wife—lest she should steal and make off with his *inao*, and so bring disgrace and ruin upon him. I know a man whose sister destroyed her husband’s *inao*. Of course she was divorced; but this appears to be what she desired. In consequence of her action, she was looked upon with the utmost detestation, and was much feared and suspected.

He also fears to make a woman too angry, lest she should go to a grave, exhume a corpse, cut off a piece of the flesh, and, after having put it in the pot and mixed it with the stew, cause him unwittingly to eat it. This filthy practice has, we are told by the Ainu, been resorted to by angry women, though, happily, not often.

It is curious that no punishment appears to have been devised for such misdemeanours. It might be thought that the women of so religious and superstitious

a race as the Ainu would not have nerve enough for such things. But the religion is all on the male side; the women have no share in it; and hence, when they are angry, fear neither gods nor men.

When ill, the Ainu, until within quite recent times, had to do without the aid of medicines, medical men, and special household comforts. They formerly depended almost entirely upon prayer to the gods, and upon Nature for recovery. Now they are attended by Japanese physicians, supplied by the Government. However, there are a few herbs and other remedies known as medicines by the people, which they prepare and administer in cases of sickness, and these remedies are still persisted in by many to the present day. If, for instance, a person takes a very heavy cold, they dig up the root of a plant called *upeu*, make a strong decoction of it, and drink a large dose. Failing this particular plant, they take a decoction made from the roots of the wild parsnip, which are also said to be good for stomach-ache. In cases of diarrhœa, soup made of the seeds of docks is considered very effectual. The dock seeds are gathered and dried, then beaten in a mortar. When they are well threshed, pounded, and cleansed so that nothing but the flour remains, the flour is taken and boiled till it becomes something like pea soup. A good dose of this is said to work wonders. For some complaints it is usual to administer a decoction made by steeping black alder bark in cold water.

For toothache a nail is heated to white heat and held on the affected tooth for a few seconds. This is said to kill the insects which are supposed to be the origin of the malady. For a slight cut the people chew burdock leaves and tie them on the wound; but for a severe wound they scrape deer's horn into powder and gently drop it into the cut, or, failing horn, the whiskers or bristles of whales are scraped fine and put upon the place. In cases where a person has been scratched or scalped by a bear, the wound is first washed with fresh water, then the scalp or skin is put into its proper place and sewn together with hair or a fine thread made of bark, after which powder made by scraping deer's horn or whale's bristles is put along the seams. If a person is accidentally poisoned by an arrow, the spot touched by the poison is immediately cut out, the place sucked, then washed, and horn powder put upon the wound. Where a leg or an arm is broken, the bones are merely set as well as possible and bound up in rough splints.

Of course there are diseases which cannot be touched by any of these remedies. When, therefore, a case becomes desperate, the elders meet together and pray to the goddess of fire and the Creator to remove the disease and heal the sick one. But this is not all; sickness is supposed to be the work of the devil or of some evil-disposed ghost. It is sometimes necessary, for this reason, to expel the evil spirit and drive it away before

a person can be expected to recover. But how shall this be done? Evil spirits and ghosts are thought to be very much afraid of the smell of a certain kind of wild convolvulus plant. The Ainu, therefore, dig up a few roots of this plant, chew them in the presence of the sick person, and then expectorate all over his or her body, and all round inside and outside of the hut. While some are expectorating, others are blowing over and upon the patient. When it is considered that this interesting though filthy ceremony has been satisfactorily performed in an orthodox manner, and the evil spirit is out of the body, the men strike hither and thither with knives and swords, expectorating the meanwhile, thereby driving the evil one out of the house and district.

It is often supposed that the people are possessed with devils. But this kind of possession is only thought to take place when the person afflicted has sold himself or herself to the evil one by some wicked act. I saw a crazy woman once who was tied up in a temporary lodge and there kept, being fed daily by the people of her village. Every now and then the Ainu went and expectorated the juice of convolvulus roots at her and around the lodge, and prayed for her. This woman got well in time, and so she has become a standing witness of the efficacy of this mode of treatment. So, too, if the people desire to keep some contagious disease away from their village, they will pray, chew the convolvulus root,

and march round the whole village, sword in hand, expectorating and howling wildly.

When a person desired to know the reason of his malady, he sent for a *tusu-guru*, 'a medicine man,' or 'prophet,' or 'wizard'; I hardly know which to call him. This wizard goes to the house of the anxious one, and, falling into a sort of trance and working himself up into a kind of frenzy, tells why the disease has come and what demon has sent it. He also makes some charms to be worn by the afflicted person. These charms were supposed to drive away the demon of sickness and bring back the god of health. He also makes medicines for the sick one to take.

There are still prophets among the Ainu who even now sometimes exercise their profession. Their chief duty is to find out the causes of illness, to charm away sickness, and to make known the ultimate result—i.e. to tell whether a person will die or get well again. When a person prophesies, he is supposed to sleep or otherwise lose consciousness. The spirit of prophecy or divination is then thought to enter into the heart of the prophet, so that the subject merely becomes a tool or mouth-piece of the gods. The prophet is not even supposed to know what he himself says, and often the listeners do not understand what his words portend. When in the act of prophesying he is in a fearful tremble; he generally breathes very hard, and beads of perspiration stand on his brow. Though his eyes should be open, they have,

for the time being, lost all power of sight. He sees nothing but with the mind. Everything he sees, whether relating to the past, present, or future, is spoken of in the present tense. This spirit of prophecy is fully believed in by the people, and the prophet is often resorted to.

But no person can prophesy just when he pleases ; he must wait till the spirit seizes him. Nor is a good drink of wine always required ; but contemplation and prayer are absolute necessities. The burden of prophecy sometimes comes out in jerks, but more often in a kind of sing-song monotone. When a prophet prophesies, absolute silence is observed by the people present. No voice is heard but that of the prophet. Old men with grey beards may be seen with tears in their eyes, silent and solemn, attentively listening to what is being said. The prophet beats himself with his hands, and, when he has finished, he opens his eyes with a stare and presents a very exhausted appearance.

One of the most solemn scenes of sickness I have witnessed among the Ainu took place in the hut next to that in which we were living. It was a case of sunstroke, I believe. The poor woman who was afflicted was quite unconscious, and it was expected every moment she would die. Word was quickly sent round to her friends, and a wizard, who happened to be her near relative, was fetched from a village about five miles off. I went into the hut to see the poor woman after dark in the evening.

She was lying upon a long stool near the fire-side. At her head stood the wizard, swaying to and fro in the fervour of his excitement and earnestness, prophesying and praying. I shall never forget his flashing eye and earnest look. Many women, friends of the sick one, were standing round her performing what they call *nitata*—that is, they were holding the patient with their hands, believing themselves to be able by this means to keep the spirit from leaving the body, at the same time blowing upon her with their mouths, and giving vent to their feelings by loud lamentations and much weeping. Some of the women held lights, while others turned out the pots, pans, and tubs, and swept the hut clean from end to end. This was to drive out the demon of sickness. There were also many men present, all of whom were engaged in prayer.

The Ainu think that sickness is a direct punishment from the Creator—the malignant and revengeful expression of ill-will of the evil one—that it is the visible result of an envious woman's ghost, or a punishment sent by their ancestors for some wicked act done by the person afflicted. Thus, paralysis goes by the name of *kamui irushka tashum*, 'the sickness of the angry god.' This disease is supposed to be sent especially by the Creator as a punishment for wickedness. Madness is a complaint demons delight to inflict upon people who, having done many wicked acts, have become their very children. 'Madness,' or 'possession by demons,' some-

times goes by the name of 'possession by snakes'; 'snake' thus being a convertible term with, and a synonym for, 'demon' or 'devil.'

The Ainu, particularly the women, are remarkably afraid of snakes. Many a time have I been sent for to act as snake executioner. On one occasion I was asked to go and kill a snake which had got into an old man's storehouse. I found it, and saw that it had a very large stomach, as though it had been gorging itself. As soon as it was killed I invited the master of the storehouse to come and look at it; and when he saw its great size he assured me that if I would but make a post-mortem examination of it I should find great treasure inside, which treasure, as the snake was killed on his premises, would belong to him. On examination we found that it had swallowed a large rat! The Ainu was dumfounded and angry at being thus rewarded or punished for his greed.

The Ainu believe that snakes are demons, and that if a person kills one the evil spirit will depart from the snake and enter into the heart of him who kills it; therefore it requires a brave Ainu to kill a snake. These reptiles are said to have a special spite against women, and will, if they only get the chance, bewitch them and drive them mad; hence the fear in which women hold them. It is also said that if snakes catch any man sleeping out of doors, they will enter his mouth and take up their abode within him.

The deities once determined to drive all snakes away from Ainu-land because they were so harmful to mankind. But the evil one—ever the enemy of gods and men—succeeded in frustrating their designs. The following legend, though short, will no doubt explain it all in a most satisfactory manner.

‘Once upon a time there was a famine among the snakes, so they made up their minds to migrate to another country. But the evil one, hearing of their determination, entered a frog and made it say to them: “Why should you leave this country? Stay here, for if you will only just swallow one of my legs you will be satisfied; therefore there is no necessity for you to go away.” Hence, having once tasted frogs, snakes have ever since had the desire of swallowing them whenever they met with them.’

According to some, wasps and stinging ants, and, according to others, mosquitoes and gadflies, are said to have originated from a huge serpent which the ancients killed. This serpent was of an extraordinary length, and very beautiful. It was in the habit of swallowing whole villages. One day this monster met an Ainu who was hunting in the forests, and asked him to do some very wicked deed; but the Ainu feared his gods and would not consent. Thereupon the serpent, instead of swallowing him, as he expected, told him that, as a punishment, he should not die for a thousand years. And so it happened that, when the Ainu became one hundred years old, he

shed his hair, whiskers, teeth and skin, and became young again. This happened every time he reached a hundred years. He was not able to die, poor man! However, this wicked serpent was at last cut to pieces; but, as it decayed, stinging ants issued forth from its remains.

CHAPTER XV

DEATH AND BURIAL

DEATH among the Ainu is an event full of dread, as their ideas of the future life are exceedingly vague and uncertain. They are so much afraid of it that they cannot bear to think of it, much less talk about it. They look upon it as the chief and most hateful enemy of mankind, and have no hope to buoy them up and to cast a brighter light upon the scenes beyond the grave.

Directly a person is dead, be it man, woman, or child, a messenger is sent to tell all relatives and friends, for burial generally takes place the day of death—or, at farthest, the next day—in the evening. A blazing fire is made immediately before death, or as soon after as possible, for which there appear to be two reasons. The first is, because coldness and death are looked upon as one and the same thing, and a good fire, it is thought, may possibly bring back the warmth and life of the body. The second reason for lighting a blazing fire is that the viands of the death-feast may be cooked. Directly after death the corpse is dressed in its best clothes, which are neatly laced up, and the body is laid

lengthwise upon a mat by the right-hand side of the fireplace. The assembled relatives and friends of the deceased sit round the remaining parts of the hearth, and they are often so numerous as to fill the whole hut. The crowd is great because prayers are to be said, a religious feast partaken of, and wine to be drunk. If a man has died, his quiver and bow, his well-filled tobacco-box and pipe, a flint and steel for striking fire, a knife, and sometimes an old sword, a moustache lifter or two, and a few eating and drinking utensils are laid by his side. If a woman, an iron saucepan (of Japanese make, for the Ainu do not work in iron) and her eating and drinking utensils, her little nicknacks and special treasures, such as beads, rings, and necklaces, are brought forth. In the case of a child its particular playthings are set beside it. In all cases many *inao* are made, and placed about the hut and body of the dead.

On one occasion I saw the corpse of a woman laid out, which, besides being well dressed and having all the particular utensils and ornamental paraphernalia about it (the beads and rings were, in this case, laid upon her bosom), was shod with pieces of white calico, which my wife had, a few days previously, given to the dead woman's husband to bind up a wounded foot. The people appear to be very pleased if they can get hold of a white garment in which to bury their dead, and several have asked us for one. Why this is I have failed to

learn ; but it may be that white is regarded as a symbol of purity, or it may be that the Ainu have taken the idea from the Japanese, who use white as mourning, just as we do black—the only difficulty with the last supposition being that the dead are clothed in mourning, and not the living. My own impression is that the former is correct, and that the Ainu desire their dead to enter the future world—or the world beyond the grave—in white, as an emblem of purity.

The corpse, as soon as it is properly clad and laid out, surrounded with the necessary eating utensils or hunting materials, has a cake made of millet, or a cup of boiled rice, and some *sake* placed by its side. The spirit is supposed to eat and drink the essences of these things, though the material parts remain the same, and these being properly arranged, the goddess of fire is worshipped. She is asked to take charge of the spirit and lead it safely to the Creator of the world and possessor of heaven. She is also specially charged with various messages, extolling the virtues of the dead and setting forth his praises.

Next, millet cakes and wine are handed round to men, women, and children alike, and each person then offers two or three drops of the wine to the spirit of the dead, then drinks a little, and pours what is left before the fire, as an offering to the fire goddess, all the time muttering some short prayer. Then part of the millet cake is eaten, and the remainder hidden in the ashes

upon the hearth, each person burying a little piece. After the burial of the corpse these remnants are collected together and carried out of the hut, and placed before the east window.

As soon as these ceremonies are finished, the corpse is carefully rolled in a mat, which the Ainu call a *toma*, neatly tied up, fastened to a pole, and carried to the grave between two men. The mourners follow the corpse in single file, the men leading—each, however, carrying some little article to be buried with the corpse. The grave having been dug, say from two and a half to three and a half feet deep, stakes are usually driven in all round the inside, and over these and upon the bottom mats are neatly placed. Then the corpse is laid in the grave; nicknacks, cups, a ring or two, a few beads, a saucepan, and some clothing are buried with the women; a bow and quiver, an eating and drinking cup, tobacco, a pipe, and knife are put in with the men; and playthings with the children—which are now more often brought away again than buried. In every case the things, which are not always the best the departed possessed during life, are broken before being placed in the grave. When the body and all the other things have been well covered up with the mats, pieces of wood are placed so as to form a roof over the whole; and then upon this roof the earth is piled, so that the interior of the grave is hollow.

A tub of water is usually carried to the grave, and



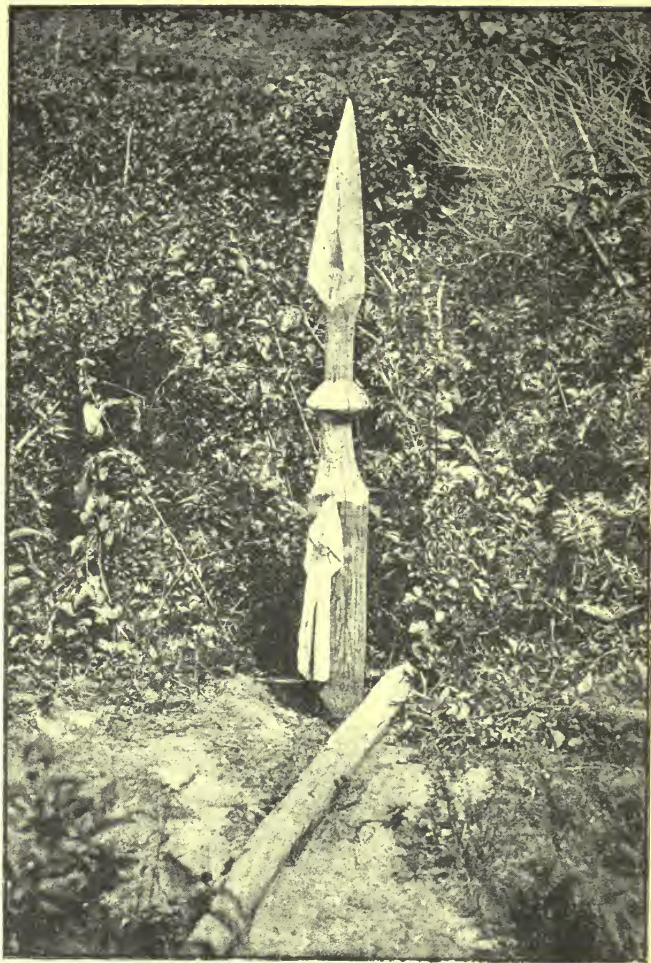

TOMBSTONE OF AN AINU MAN

when the body has been interred, those who have taken part in the ceremony wash their hands, and the water that is left is thrown upon the grave. The bottom is then knocked out of the tub and the remnants laid at the foot of the grave close to a post that is set up to mark the spot. The grave is usually covered with a large quantity of wood and bushes, which are said to keep off the foxes, wolves, and bears. When this has been done the mourners return to the hut of the deceased, where the men make *inao*, pray, eat, drink, and get helplessly intoxicated. This feast is called *wen iku*, *wen ibe*, 'the bad drinking and eating.' Not bad, indeed, because it is bad to have such a feast; but because the occasion of the feast is bad, being a death and burial feast. It is a fearful sight to witness these ceremonies, and heart-rending to see and hear the distress of the people.

The Ainu have a great desire to forget all about a person as soon as he is buried, yet they never bury without placing a pole, which for the sake of convenience may be called a tombstone, at the foot of each grave to mark the spot. This, however, is not so much to remember the deceased by, for no writing whatever is inscribed thereon, as to point out to a chance hunter that a burial has taken place there, and to prevent mistakes.

The tombstone marking a man's grave is made to represent a spear, though the Ainu tell me they intend

it for a boat oar, but it is certainly much more like a spear than an oar, as the engraving shows clearly. Whether there is any special meaning attached to this or not I cannot tell. The Ainu I have asked about it know of none, and say it is just an old custom handed down from very ancient times, and nothing more. Their ancestors made tombstones like these, and their successors do the same. The posts set up at the graves of men and boys are all of the same pattern. The piece of cloth which hangs from the centre of the pole is the head-dress of the deceased.

In the illustration here given a woman's tombstone is shown. The person over whom it is placed was the wife of the man and mother of the girl who appear in the engraving, and the cloth which hangs from the top of the pole was the woman's head-dress. If the reader looks closely at the bottom of the pole, he may see the little tub in which the water was brought for the men to wash their hands. The bottom has been knocked out and the tub slipped over the pole. The top of the pole has not been cut like a spear or oar; it has been merely rounded off and a hole burned through it. The poles that are set up at the graves of women and girls are all of this shape.

The Ainu have no cemeteries. Each person chooses a spot for the body of his relative, and they generally bury far away in the mountains. Formerly it was the chief's duty to seek out a burying-place and to attend to

the funeral. The people keep their graves as secret as possible, being, like the members of many other barbarous races, much afraid of the ghosts of the dead. They visit the graves only upon exceedingly rare occa-



TOMBSTONE OF AN AINU WOMAN

sions, or under very great pressure. Thus Ainu places of burial are very soon forgotten, and the graves quickly become quite indistinguishable from the forest around them.

Whenever the Ainu find it necessary to speak of death and burial, as of course it sometimes must be, they talk with a hushed voice, and use a figurative and round-about phraseology. Thus death is called 'sleeping,' 'overcome with deep sleep,' 'resting,' 'leaving the world behind,' 'going,' 'gone away,' 'is not.' Even a person's name is to be forgotten when death overtakes him. Perhaps this is the reason a woman never takes the name of her husband, or a child that of its parent. While her husband is living, a woman is called So-and-so's wife, but as soon as her husband dies she is always known by her maiden name. There are no posthumous names. I have heard only of one, and that is given to a Japanese hero, and is therefore not properly Ainu.

On the occasion of a funeral the men generally wash their faces and hands, have their beards trimmed, hair cut, and necks and foreheads shaved. Widows and widowers were formerly supposed to remain single five years, but now some of them remarry much more quickly.

When a man lost his wife it was the custom for him to have his hair cut short, and to remain indoors as much alone as possible till it grew decent again. If he had been fond of his wife, and felt her loss *very* much, he would sometimes show his intense sorrow by plucking out a great part of his hair and beard, and wearing a forlorn and dejected appearance.

A woman, upon the loss of her husband, had to have her head clean shaven. Not only was she supposed to remain indoors as much as possible, and keep herself entirely by herself till her hair grew long again, but as soon as it got any length she was obliged to have it shaved off again. This was to show her great loss and sorrow. This shaving of the head must have been a painful process before the Ainu got Japanese razors, and when they used sharp shells for the purpose. As soon as a woman has her head shaved she puts on a widow's bonnet, which she is obliged to wear during the whole period of her widowhood.

These are generally made of thick Japanese cloth, and have a hole left in the hinder part of the crown for ventilation.

A short letter, bearing upon this subject, which the author wrote in 1887 to the Church Missionary Society, may prove of interest here. 'The death of a little heathen child in this village a few days ago suggested to me the idea of forwarding to you the following facts. At 9 o'clock, A.M., on March 7 I was called into an Ainu hut to see a sick child who was supposed to be

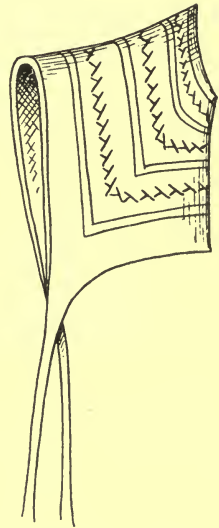

A WIDOW'S BONNET

dying. The child's age was four years, and I found it suffering from acute bronchitis, and in convulsions. As there was no doctor within thirteen miles of the village, I was asked to do what I could to check the disease. I immediately had the child placed in a hot bath, and gave it an emetic. The result was marvellous, so that the child



EXTERIOR OF THE HUT IN WHICH THE CHILD DIED

slept immediately afterwards for nearly an hour, and then was able to take some hot bread and milk. But, upon its awakening, the fond but foolish parents allowed the child to have its own way, and, being in a perspiration, actually took it almost naked too near an open window, a cold March wind blowing at the time.





INTERIOR OF THE HUT IN WHICH THE CHILD DIED

The result was a relapse, and the child died. I was with it at its death. This is but the second time I have been allowed to enter an Ainu hut when the hand of death has been upon any of its inmates.

‘When the child died there were some fifteen weeping women and twenty praying and howling men present. The uproar was very great, and the despair of the parents heart-rending to look upon. As I could do nothing more for the child I returned to our home to rest.

‘The next day the child was buried, and I took the opportunity of going to see the parents and mourners, that I might speak to them of the Christian’s hope. I found the hut full of people, but, alas! most of them, men and women too, were helplessly drunk, and lying scattered about all over the floor of the hut. Nevertheless, as there were some six or seven sober men and women among them, I spoke to them on the subject of a future day of resurrection and judgment, and of the gift of life eternal to the faithful redeemed. God grant that some of the seed sown may spring up and bear fruit to the glory of our blessed Saviour!

‘These few facts then I would leave to speak for themselves, but I earnestly desire to ask for the prayers and kind sympathy of all praying Christians.’

At the time of the death of this child all the women were weeping and howling most pitiably. One old man was calling upon the goddess of fire to help, and threatening never to worship her again if she did not

keep warmth in the child's body. Another person was looking out of the east window and accusing the goddess of fire to the Creator of not attending to her duty. A third was in a towering rage, and, facing the south-east corner of the hut, was telling the guardian gods that they were an entirely bad lot, and deserved never to be worshipped again. It was indeed a painful scene. I have since repeatedly seen similar praying and weeping, scolding and threatening, going on in other huts on like occasions.

CHAPTER XVI

GHOSTS AND THE FUTURE LIFE

ON one occasion, when taking a walk in the forest with an Ainu chief, I found that he strongly objected to go near a particular spot not far from one side of our path. Nothing I could say would induce him to go near the place, and he was also exceedingly anxious that I should not go either. After a great deal of questioning and coaxing, he at length confessed to me that the reason was fear; fear because a person had been buried there some time before. Upon making further inquiry I found out that the idea prompting him to avoid the grave was that he, in common with all others of his race, believed the spirit or soul of the dead to still live on. The spirit is supposed to haunt the grave in which the body has been laid, and also its immediate surroundings, and not only to have the *power* of bewitching the mind and doing bodily harm to any person whom it should discover near the resting-place of the body, but also, especially if the spirit be the ghost of a woman, the *will* to do so upon the very first occasion that opportunity is given. The chief who accompanied me

was Penri of Piratori, whose portrait appears in the engraving.

At another time, when I was visiting the grave of an old woman whom I had previously known, to see if I



CHIEF PENRI

could find any inscriptions on the pole that had been set up to mark the place of burial, the man who accompanied me would by no means come within twenty-five

or thirty yards of the spot, but stood that distance away, and directed me with his voice and hands. That man was afraid of his own mother's ghost.

Upon returning to the hut, the man, together with several women, brought a bowl of water to the door, and requested me to wash my face and hands. Whilst at my ablutions the women commenced to beat me and brush me down with *inao*. Upon inquiring into the ideas which moved the people to act in this manner, I discovered that the washing was to purify me from all uncleanness contracted at the grave through contact with the ghost of the deceased, and that the beating and brushing with *inao* was to drive away all evil influences and diseases she may have aimed at me. The water and *inao* were the antidote against, and the corrective of, the evil intentions the spirit is supposed to have directed towards me out of her wicked spite for trespassing on her domain.

Now, looking at these facts and peculiar actions and ideas, we ask, What is their purport? What is the underlying principle? We find one fundamental article of religious belief at its very foundation—viz. belief in the existence of the human spirit, with its capacities for knowing, seeing, willing, and acting intact, and even enhanced, after the death and burial of the body. The Ainu admit this without any doubts or questionings. Their actions speak even louder than their words, and their words explain their actions.

An Ainu fears nothing so much as the spirit, soul, or ghost, call it which you please, of a dead female ancestor. It is really wonderful what an amount of power for evil the ghost of a deceased old woman is supposed to possess. Not only so, but, strange though it may seem among such a people, even before death old women have a good deal of power over the opposite sex, and children are particularly afraid of them. Some of these ancient dames are veritable old witches if one offends them; and if they are against a person the men will be found to be so too.

When I first went to a certain Ainu village I found that all the people, quite contrary to all my previous experience, were set against me. I was very much puzzled at this; but afterwards found out that it arose through the influence of one old woman, the oldest in the village. She was a very conservative old dame, and could not tolerate the presence of either Japanese or foreigners in an Ainu village. However, I soon found out her weak point. She happened to be very fond of tobacco, and had a remarkably sweet tooth; so a handful of sugar and a small packet of tobacco quickly put things straight. That small consideration, now and again repeated, caused us to be close friends till the day of her death. She must have been more than eighty years old, for her son was a grey-headed old man.

The Ainu assert that in years long gone by the ancients used to burn down the hut in which the oldest

woman of a family had died. This curious custom was followed because it was feared that the spirit of the woman would return to the hut after death, and, out of envy, malice, and hatred, bewitch her offspring and sons- and daughters-in-law, together with their whole families, and bring upon them various noxious diseases and many sad calamities. Not only would she render them unprosperous, but she would cause them to be unsuccessful in the hunt, kill all the fresh- and salt-water fish, send the people great distress, and render them childless. She would curse the labour of their hands both in the house, the gardens, and the forest; she would blight all their crops, stop the fountains and springs of drinking water, make life a weary burden, and eventually slay all the people and their children. So vicious and ill-disposed are the departed spirits of old women supposed to be, and so much power for evil are they said to possess.

For this reason, therefore, the ancients used to burn down the hut in which an old woman had lived and died; the principal idea being that the soul, when it returned from the grave to exercise its diabolical spells, would be unable to find its former residence, and the objects of its hatred and fiendish intentions. The soul having been thus cheated of its prey, and its malignant designs frustrated, is supposed to wander about for a time in a towering rage searching for its former domicile; but, of course, to no purpose. Eventually the spirit

returns, defeated and dejected, to the grave whence it came, and woe betide the person bold or unlucky enough to venture near that spot!

One would have expected that, if the spirits of old women are so viciously disposed towards their progeny, and are vested with so much power for harm, the Ainu would endeavour to appease them by constantly offering libations of wine and *inao* to them; but the people do this very rarely indeed. They bury the bodies and try to forget that they ever had a grandmother or mother-in-law, and never go near their graves, nor even mention the name of the dead person.

This custom of burning down houses has long since been discontinued. It had happened a few times during the lifetime of some old men I knew, but the custom has died a natural death. No command was given by the chiefs to cease house-burning, but it was left off by common consent. It is true, indeed, that the spirits of the dead are theoretically feared as much as ever, but the Ainu of to-day do not see why house and home should for that reason be destroyed.

The Ainu do not, like the Japanese Buddhists, believe in metempsychosis, or the transmigration of souls, either into higher or lower orders of being. This is the belief of pantheists, and the Ainu are in no sense pantheists, but great polytheists. When, however, I make the statement that the Ainu do not believe in the transmigration of their souls into some other beings, I find I

must make a qualifying remark. The people do believe that the human spirit will have another home in a living body after death. That body will be exactly like the present, though perhaps not really the same. This, it will be seen, is a very different thing from what is generally understood by metempsychosis; for the soul is supposed never to have had any existence before it entered the human body, and will never inhabit any other than a human body. The Ainu do not believe that when they kill a mosquito or a flea or an earwig, they thereby slay or injure their grandmother, uncle or aunt; nor when an Ainu eats a fish or a fowl, or a piece of venison or bear's flesh, does he consider that very possibly he is thereby devouring his deceased father, or mother, or child! This creed does not suit the Ainu, and hence we find that none have been converted to Buddhism by the Japanese.

Not only do the Ainu believe that the souls of human beings will have a conscious and personal existence after death, but those of animals also. They seem to conceive of men and women as living in large communities in the other world in the same way and under the same conditions as they do in this, excepting that they can know no death. They believe that husband and wife, parent and child, will be rejoined to one another after death, and that there will also be marrying and giving in marriage, but there will be no more pain, or sorrow, or death. The living fully expect to have

bodies in form exactly like the present, to live in houses, to have their daily work to do, their hunting and fishing stations, their dogs and other animals. They will laugh and talk, eat and drink as now, and altogether they fully expect to have a very material existence.

But the curious thing about these people who live a life beyond the grave is, that they look upon persons who have not yet crossed the river of death as ghosts, and consider themselves to be the natural and substantial people. They think of us, in fact, just as we do of them. However, they are happier than we, and will live for ever. They can visit this earth in the shape of ghosts whenever they desire to do so; and some of us also, if we make up our minds, can make a call on them in the same capacity. When they come to us they are invisible to our eyes, and when we go to them they cannot see us. Their ghosts can see us when they pay us a visit, and can hear what we say, though they cannot address us; and our ghosts can likewise see and hear them when they go to the lower world, but cannot make themselves heard. Nevertheless, the dogs are able to discover when a ghost is about, and when they scent one they set up a tremendous howling.

The following story illustrating these notions of the Ainu with regard to the future world was told me by an Ainu.

‘Once upon a time there were two young men who were devoted friends. They had heard it said that the

entrance of a certain cavern in a rock led straight on to the place of departed spirits, and if anyone had courage to take the journey, he might go and see what that land was like. One of the young men determined to go and visit the place. On entering the cave, he could at first see nothing but thick darkness. But as he proceeded on his journey he discovered a speck of light straight in front of him. The farther he went, the stronger grew the light ahead, and the darker became the cave behind. At length he came to a most magnificent country, filled with the brightest light. Beautiful forests of trees, and mighty plains of reeds and grass, opened out before him, and rivers of sparkling water divided up the lowlands. Altogether, it was a splendid country. After a while he came to a village and saw many persons he had known in the upper world—that is to say, “during life.” He endeavoured to speak to them, but they all began to look this way and that with evident perplexity, wonder, and fear. The dogs, too, set up a grievous howling. Even his own father did not know him, and his mother fled away in fear, and the people all said he was a ghost. After this reception he gave up attempting to reveal himself, and set out on his return to the upper world. As he was journeying back he met a man, whom he thought to be his friend. However, it was somewhat dark in the passage, so that he could not be quite sure. The man had a weary, ill, haggard look about him, and was carrying a bag upon his shoulders. On addressing

him he rushed by in great fear, and sped swiftly towards the lower world. On reaching the cavern by which he entered, he immediately set out for his friend's house; but, alas! he found him dead. Without doubt it was his departing spirit he had met in the passage to the lower world.'

Another legend upon the same subject throws further light upon the Ainu idea of the next world. It tells us, that when the dogs on one occasion discovered in the world of the departed a ghost from the upper world, they set up a great howling. Upon this the inhabitants, including the father and mother of the ghost, made offerings of *inao*, and set the refuse of their food outside the east end of the hut for the ghost to eat. He was very angry at having such dregs offered to him, and endeavoured to knock it all away; but the filthy stuff only flew into his bosom, and he could not get rid of it, try how he might. It was only after he emerged into the upper world of living men that the refuse offered him could be got rid of.

So, say the Ainu, just as that man felt when the inhabitants of that country offered him such foul stuff, do the ghosts feel when they come to this earth of ours and are treated with the dregs of our food. We ought to treat ghosts with respect, lest they feel disgusted with us. Besides, how do we know whose ghost it is? It may be the spirit of our parent or child, for all we know. Therefore it behoves us to be careful. The

Ainu fancy that the ghosts which come from the nether world have the power of bewitching and otherwise harming those to whom they take a dislike, but especially the wicked.

The following is another Ainu legend about visiting Hades: 'Once upon a time there was a man who had two sons. Now it happened one day, when the younger son was away from home, the father died. Just before his death he called his eldest son to him, and told him that as he was about to take his departure from this world, and pursue his journey to Hades, he would leave his treasures, heirlooms, and general property to be divided equally between the younger brother and himself.

'A few days after his father's death the younger son returned home, and heard the sad news. He was very sorry; but, worse than all, the wicked elder son took all the heirlooms and other property to himself, and would not divide them equally, as his father had commanded. He said that all the things were left to himself only, as head and representative of the family. Upon this a great quarrel ensued, which waxed so hot that the brothers separated. The elder brother stayed at home and enjoyed himself; but the younger took his quiver and bow and set out to find the passage by which his father had gone to the lower world.

'Having found the entrance, he commenced the descent. He walked so quickly that he soon arrived at

a large village, full of people and fine houses. The dogs barked at him as he went along, and he heard the people saying to one another, "Oh! there is a ghost about; there must be a ghost about." They then began to present libations of wine to him. On and on marched the man, the dogs still barking, till he came to the house of his father. He entered the hut, and tried to speak to his parent, but could not make himself seen or heard. This greatly distressed him, and so he set to work to find a way by which he might learn what he desired to know. At last he thought of a plan. As a ghost, why should he not enter into some member of the village, and make him speak for him? He would try. So he entered the heart of a man near at hand, and, borrowing his mouth and tongue, asked his father how he had left his property in the upper world. The father made answer that he had divided it all equally between his two sons.

'Then the younger brother returned to the upper world and reported what he had done and seen and heard. Thereupon his brother begged his pardon and divided the goods with him; and ever since that time they lived happily side by side in the same village.'

In this legend, it will be seen, there is a distinct reference to the act of presenting libations of wine to the ghosts of deceased ancestors. It also states that a ghost is able to possess a person when it so desires. That is to say, ghosts are supposed to be able to enter

into the hearts of people when they please, and speak and act through them at will. As regards offering libations of wine to ghosts, that is a custom still prevailing at the present day, though only on a limited scale. I have sometimes seen the men, though very seldom indeed, and once or twice the women also, go out of their huts with a little wine and food, and place them at the sacred spot outside the east end of the hut, as offerings to the ghosts of their male ancestors. This might be called a modified form of ancestral worship, but it is on nothing like so large a scale as the ancestral worship of the Chinese and Japanese, with whom it is a fixed and regular custom.

Ainu ideas concerning the future life, and especially of their women, like those of many other half-barbarous races, are full of great and irreconcilable contradictions. It is extremely difficult to tell what they really do believe as regards the future, as some appear to hold one thing and some another. A few of the men seem to honour their women in the present life, and would give them a place and office in the great hereafter; but others again profess to despise them, and either positively assert that they can have no future life, or affect total ignorance of and indifference to the matter. Women are generally considered quite inferior to men, both spiritually and intellectually. By some, they are supposed to possess no souls, and this is sometimes stated as a reason why women are never allowed to pray.

They are also thought not to have sufficient mind to grasp the traditions of the ancients, and so are never taught them. And yet the actions of the men emphatically contradict their words, for, as we have seen, they all very greatly fear the ghosts of their departed grandmothers, and stand in constant dread of their anger even whilst living. They do all they can to appease and conciliate them before they die, and are particularly afraid of any person who is supposed to be possessed by an old woman's ghost.

Though most men state their belief in a future life for the women as well as for themselves, and all of them distinctly indicate by their actions that they really believe the spirit to survive even when the body has completely decayed, yet there appears to be but one definite article of faith on the part of those who would grant to woman a future life. This article of faith is thus set forth by the Ainu: 'Men and women are placed in this world simply that they may increase and multiply and replenish the earth; hence the world where men and women dwell is called *nare moshiri*, "the multiplying world." The gods did not create human beings to destroy them, but that they might increase and multiply here, and live in a future world hereafter. That future life in another world is for the women and children as well as for the Ainu, i.e. "men." A man will have the same wife and a woman the same husband hereafter as now; for in the world to

come all will be paired off. Though a man may marry twice or thrice during his sojourn upon earth, or have a great number of concubines, yet in the future world he can have but one wife, and she will be his first.'

Thus do some at least of the Ainu believe in a future life for all. What will become of a man's second or third wife is not stated, nor is the place of concubines known.

That some of the women believe in a future life of joy in company with their husbands and children is evident from the following incident. As I was once walking in the forest with an old Ainu, we happened to meet a woman from a neighbouring village. We stayed in the path, and had a long chat with her upon various common subjects. After she was gone the Ainu confided to me the fact that that particular woman was an excellently good one. As a proof of this he said she had lost her husband, and though often asked to marry again she would not, stating as her reason that she could not bestow her affections upon another, and that she was only waiting for the time to come when she should rejoin her lost loved one.

The fact that the Ainu women are never taught any prayers or even allowed to pray is very remarkable. It is sad to think they have not the consolations of a religion of any kind, or any sacred subjects upon which their heart and mind can feed, and from which they can draw some comfort, however little it may be. Even

upon those exceedingly rare occasions when their husbands send them to the east end of the hut to offer libations to the spirits of their ancestors, can it be said that they pray? They are specially told what words to use at those times, and what they repeat cannot be properly said to constitute a prayer. The words they use are merely these: 'O ye honourable ancestors, I am sent to present this wine and food to you.' Thus the Ainu women simply, as this formula shows, make a statement telling the spirit that they have brought it a little present.

Nor do the women worship the gods; and they can take no active part in the religious feasts, excepting to provide the food. The reason they never pray is not a belief that they have no souls to pray for, or no life in the future world. The very curious reason commonly given for this fact is very likely the true explanation, viz. that the men are afraid of the prayers of the women in general, and their wives in particular. An old man to whom I was once speaking on this subject said to me, quite seriously and in confidence, that 'The women as well as the men used to be allowed to worship the gods and take part in all religious exercises; but our wise and honoured ancestors forbade them to do so, because it was thought they might use their prayers against the men, and more particularly against their husbands. We therefore think with our ancestors that it is wiser to keep them from praying.'

This idea may appear at first sight stupid and irrational, but in reality it is consistent and in full accord with the principles of the Ainu religion. Moreover, it is a logical and intelligible reason. The Ainu believes in various gods who hear and answer prayer; he is aware that his wife is not treated so well and kindly as she ought to be; he knows that his own laziness must be compensated by the extra labours of his wife, and he recognises the fact that his inveterate drunkenness is the ruin of his family. Hence his fear of the prayers of women and wives. They are afraid of prayers for vengeance; or when a man prays for wine, and his wife that he may get none, the woman being morally better than the man, her prayers are very likely to prevail against his, and lead to his coming short of that which he loves so much.

In this connection we may glance at Ainu ideas of Heaven and Hell, meaning by Hell the future place and state of those who die in wickedness, in contradistinction to Hades, or the intermediate state. This subject is naturally very obscure, of a somewhat complicated nature. I have often talked to the people about it, and the definite beliefs I have come across respecting it are as follow:

1. The place to which good people go after death is called *Kamui kotan*, 'the place of god,' and *Kamui moshiri*, 'the kingdom of god,' or 'the world of god.' When persons go to this place, they live for ever in a

state of supreme happiness. Though far away from earth, they can see us, and they ever take a lively interest in all that is going on in this world. They also have power to send punishments upon those of their families who misbehave themselves, and peace to those who are good and kind. This power they frequently exercise.

Heaven is by many Ainu considered to be above us, though others think it is below. All are agreed that it is a place where the gods have their special home, and where all men who do that which is good and right will go when they leave the world. People in heaven do not lose their personal identity. The Ainu notion of heaven is therefore not the Japanese Buddhistic idea, which would absorb every person into the deity itself.

2. Hades, or the intermediate state, is called *Pokna-moshiri*, 'the underworld,' or 'the world below.' All spirits go first to this place when they leave the body. Hades, however, is not generally believed to be a purgatory, though some think it is; but upon going there the spirits, which are always spoken of as possessing a body exactly like the present one (though whether it is of a spiritual or material nature is not stated), are told where to go and what to do.

3. Gehenna, or hell, is called *Teinci-pokna-shiri*, and that means 'the wet underground world.' The wicked are punished in this place. What these punishments consist of the Ainu do not pretend to say. But the spirits which go to this world of misery will be wet,

uncomfortable, and very cold for ever. One idea is that they will be frozen up, yet never able to die; another is that they will burn for ever in the fires which exist in the centre of the earth; thus some will be for ever cold, and others for ever hot.

4. In the centre of Hades there are said to be three roads. The first leads from the earth upon which we live, and which the Ainu call *Kanna-moshiri*, 'the upper world,' to the centre of Hades. All spirits go by this road when they leave the body. The second and *third* roads start from the centre of Hades, one leading to heaven and the other to Gehenna. All along these roads there are watch-gods placed at different points, to direct the spirits on their journey, and to see that none go into the better world clandestinely or in a surreptitious manner.

As soon as a spirit from the 'upper world'—that is, our earth—passes down to the centre of Hades, a watch-god informs it that he has received a message from the Creator, sent through the goddess of fire, as to where it is to go. If it has done good during life it passes along the road to heaven, at the doors of which gods and men meet it and lead it inside. If the spirit belonged to a person who did evil during life, it is informed that, a message having been received concerning its evil deeds, it has now to proceed to Gehenna for punishment. Should the spirit deny having done any wrong, the goddess of fire is summoned, and she causes a great

picture representing the whole life of the spirit to be placed before it. Thus the spirit stands self-condemned, and there is no escape, for the fire goddess has a perfect picture of every word and act the spirit ever said or did while in a body upon earth.

The above are the only articles of faith concerning a future world that I have been able to collect. I have never heard any others being put forth by the Ainu; and these, I know, they teach some of their children.

CHAPTER XVII

AINU POLYTHEISM

THE Ainus are polytheistic, and believe in the existence of gods innumerable. This is only what might be expected from such unphilosophical, thoroughgoing children of Nature as the Ainu show themselves to be. Of the three natural religions—viz. Polytheism, Pantheism, and Theism—the first is the most natural, and is, most probably, the reason why polytheism is the religion almost always found among the barbarous, uncivilised, or semi-civilised races of the world. Even the Japanese, who have had an enlightened civilisation for ages, have never entirely emerged from the lower or polytheistic religious belief. This is, perhaps, a curious fact, seeing that this nation has a great love for speculation; but the speculation of the Japanese, it behoves us here to remark, is a very different thing from that steady, deeply philosophical contemplation which is sometimes seen among the devotees of Buddha in India, the home of pantheism and esoteric Buddhism. The Japanese, as a nation, have never universally accepted pure Buddhism, or actually lived that unpractical and well-nigh impossible

life of the devout believer in pantheism as taught in the Buddhistic religion.

Shintoism, the religion indigenous to Japan, does not, it is true, dogmatise about a future state. For the most part it teaches subjects to be loyal to their emperor, parents to be kind to their sons and daughters, children to be obedient, respectful, loving, and dutiful to their parents, all people to be mutually considerate and always polite to one another. Yet, inasmuch as Shintoism speaks of *Hachiman Sama*—i.e. ‘the eight myriads of deities;’ and inasmuch as until quite recently the people practised the worship of the *living* emperor as well as the spirits of those departed, and inasmuch as this religion is still believed in by some of the people, and so is not yet defunct, we must say that the Japanese have not entirely passed out of the polytheistic stage of ideas respecting the Godhead. The Ainu, however, are not Shintoists. They do not worship the spirit of any human being, unless, indeed, it be that of *Aioina kamui*, who the Ainu say was the ancestor of their race.

It appears to be a generally received opinion among those persons, whether Japanese or foreign, who have written or made any special inquiries respecting the subject, that the Ainu people are in the habit of worshipping the image or spirit of Kurōhanguwan Minamoto no Yoshitsune, who, it will be remembered, was driven to Yezo by his elder brother in the twelfth century of our era. And, indeed, when we call to mind that there is a

little shrine upon a cliff at the village of Piratori, containing an idol representing that great personage—that some Ainu residing at and immediately round Piratori itself actually tell inquirers that some of their number do at times, though not often, worship at the said shrine—and when we note the fact that most of the Ainu men recognise the name Yoshitsune—then we see that this generally received and constantly asserted opinion has, apparently, a good degree of foundation in fact. The writer of these lines formerly shared, in common with many others, the generally received views on this subject; but after long residence with the people themselves, after having spent many months in the village of Piratori—at the very doors of the shrine in question—he has been obliged to change his opinion, or at least very considerably to modify it in regard to this as well as many other subjects connected with the Ainu. The following facts tend to prove that the Ainu do not, in the commonly received meaning of the term, *worship* either the spirit or image of Kurōhanguwan Minamoto no Yoshitsune.

In the first place, it must be clearly understood that, when persons say the *Ainu* worship Yoshitsune, they mean not that people as a nation, but merely a few individuals resident in the Saru district. Again, it is not even asserted that all the Saru Ainu worship him, but only those of Piratori. Now, there are two Piratoris, viz. Piratori the upper, and Piratori the lower. These two villages

were once united, but now are situated from a quarter to half a mile apart. The shrine of Yoshitsune (and there is but one shrine in Yezo) is at the upper Piratori, and the inhabitants of the lower village will tell an inquirer that it is the people of the upper Piratori who worship the person in question. Now, the upper village contains only thirty-two huts, and we find that not even ten persons out of these families really worship Yoshitsune. It is clear, then, that the Ainu, considered as a race or nation, do not at the present day deify that hero.

Then, again, it should be noted that the present shrine is decidedly of Japanese make and pattern: in all respects it is like the general wayside shrines one may see anywhere in Japan. It was built about ten years ago by a Japanese carpenter resident at a place called Sarabuto (Ainu, *San-o-butu*). Previous to this there was also a Japanese-made shrine on the same spot, but a much smaller one. The idol in the shrine is both small and ugly; it is a representation not so much of a god as of a warrior, for it is dressed in armour and is furnished with a pair of fierce-looking, staring eyes, and has a horribly broad grin. It is just such an idol as one might expect in this case, seeing that Yoshitsune was a warrior. Besides this, the Ainus have treated the image to an *inao* or two. There is nothing more, and the shrine is too small for a person to enter.

Now, according to Ainu ideas and usages, it is necessary to turn to the east in worshipping God, the goddess of fire alone excepted. Hence the custom of building all huts with the principal end facing the east. But the shrine of Yoshitsune is placed in such a position that the worshippers would have to sit or stand with their backs to the east. The image of Yoshitsune is looked upon from the east; hence, speaking from analogy, it would appear that it is not the Ainu worshipping Yoshitsune, but either Yoshitsune worshipping the Ainu, or the Ainu insulting the Yoshitsune. Such a conclusion may appear far-fetched; but, in any case, the position of the shrine of Yoshitsune does not come up to the acknowledged requirements of the Ainu ideas of deity worship.

Again, the Ainu say that they would not worship an idol because it would be directly against the expressed command of Aioina Kamui, their reputed ancestor. The Ainu are, in many things, a very conservative people, and in the matter of religion particularly so. Note the following incident. In the days of the Tokugawa *régime*—so runs the tale—the Ainu were ordered by the Government, or rather by the authorities of Matsumai, to cut their hair in the Japanese fashion. The result was a great meeting of the Yezo chiefs, which ended in sending a deputation to beg that the order might be countermanded, or at least suffered to lapse. 'For,' say the Ainu, 'we could not go contrary to the

customs of our ancestors without bringing down upon us the wrath of the gods.' And though a few Ainu, particularly those at Mori, did cut their hair as ordered, the people as a whole were let off. If, then, a mere change in the fashion of cutting the hair was resisted, what would have been done to prevent the institution of idol-worship? Notwithstanding all this, there is still the fact to be accounted for that some Ainu state that Yoshitsune is worshipped by a few of their number, though very seldom. What is the explanation?

An Ainu himself shall answer the first question. 'You know,' says he, 'we have for a long time been subject to the Japanese *Tono Sama* and *Yakunin*, and it has been to our interest that we should try to please them as much as possible, so as not to bring down trouble upon ourselves. As we know that Yoshitsune did come among our ancestors, it was thought that nothing would please the officials more than for them to think that we really worship Yoshitsune, who was himself a Japanese. And so it came to pass that the shrine was asked for and obtained.'

This statement was made to the writer quite spontaneously and confidentially, along with many other matters. Taken by itself, it might not be worth much; but, viewed with other things of the sort, it speaks volumes. The spirit here unwittingly shown is happily fast dying out, for the Ainu begin to see there is now but one law for both peoples, and that there is justice ob-

tainable even by them. Nevertheless, the spirit above exemplified has been a real factor in the life and actions of the Ainu people.

The secret of the second question turns upon the meaning of the word 'worship.' The word used by the Ainu is *ongami*, and the meaning is 'to bow to,' 'to salute.' The Ainu are delightfully sharp in some things, and this is one of them. An Ainu told me one day, with a most benign grin, reaching almost from ear to ear, that he did *ongami* (salute) Yoshitsune's shrine or idol; but as for *otta inonno-itak*, 'praying to that person,' neither he nor any one that he knew did so; and, as regards *nomi*, the ceremony of offering *inao* or libations of wine to him, both he and many others were always ready to do so, providing some one else would find the *sake*!

Nor are the Ainu in any sense pantheists. The pantheist, believing as he does that God is *All*, and as such pervades everything and is everything—believing that all things both spiritual and material came from Him in the beginning, and will again return to Him in the end—endeavours to account for all the different phases of life and motion which he sees in things around him and feels to be in him, by looking upon them as mere pulsations of the life of the great *All*. He accounts for these phenomena by referring each of them to one grand common centre. But the Ainu, being a thorough-going polytheist, sees a separate deity in every single

phenomenon in Nature. He finds a special god in every diverse operation in the universe.

Hence, as we find the pantheist looks upon every kind and degree of life, be it that of a plant or an animal, a reptile, fish, or bird, a man, a god, or an angel, as part of the great universal *All*—a mere spark, so to speak, of the Divine fire of the incomprehensible All-life—so, in strict conformity with these principles, he hopes by-and-by to be absorbed into deity as entirely as a drop of water may become mixed up with and lost in the mighty ocean, if cast into it. Nay, the pantheist believes that, so far as he himself is concerned, he shall at length, after having passed into and out of innumerable bodies and lived through many long cycles of ages, merge into God. By so doing he thinks to attain unto an everlasting unconscious serenity and quiescent nothingness.

The Ainu religion has nothing of this. On the other hand, an Ainu looks upon each separate kind of life as in itself perfect—as a complete individual unit, though each living unit is confessedly dependent on a transcendental power—a power outside of and above itself. His own life is thought of as separate from the life of God. Nevertheless, the earthly continuance of that life is entirely dependent on the will of God. He hopes, therefore, when the body dies, to live a personal conscious life apart from God—a life of joy, happiness, and peace, in a world beyond the grave, and to maintain for ever his own

distinct and proper personal identity. He believes, in a sense, with David of old, that in 'God's presence (not in absorption into Him) is fulness of joy, and at His right hand are pleasures for evermore.'

Thus it will be seen that these people have never sunk so low in the scale of humanity as to dethrone God altogether; but they, like many other nations, have given way to such exaggerated lawlessness as to divide Him up indefinitely; and not only so, but to assign to Him both a good and an evil character, and thereby detract from His perfect greatness. Hence, instead of one absolute Lord of all, we hear of a great variety of rulers, with various dispositions. We find, for example, good and bad gods; gods both of the masculine and also of the feminine gender; gods to be loved, honoured, and worshipped; others to be hated, feared, and avoided. They have gods of war and gods of peace; one power to preside over storms, and another to bring peaceful, calm weather. There are deities of the sun, moon, and stars; separate gods to take care of the land and the sea, mountains, hills, and dales, lakes, ponds, springs, waterfalls, and rivers. There are gods of the clouds and rain, thunder, lightning, and fire. There are special gods, again, to preside over vegetable, animal, and rational life; gods of each village, town, country, tribe, race, and nation; gods of the heights and depths; gods who reign in heaven above, in earth below, and in Hades under the earth; gods, again, of health and sickness,

of weal and woe; gods, in fact, for almost every conceivable object.

Yet, strange as it may at first sight appear, the Ainu consider that there is One God towering above all, who is the Maker of all the others, and to whom all are responsible, for they are His servants and deputies. In short, the Ainu consider the government of this world to be carried on by the gods, who reside in the forces of Nature, in the same way as countries are governed by kings and their many officers in various departments.

It will now be readily understood that the Ainu do not worship all the objects they call 'god'; for that term is applied to beings who are conceived of as having the most diverse natures, some being good and others evil; some benevolent and ever ready to bless, and others malignant and seeking for an opportunity to curse with pain and misfortune. This naturally leads us on to a consideration of the Ainu word 'god,' and the special objects to which it is applied.

The Ainu term is *kamui*, which appears to come from the same root as the Japanese word for God, which is *kami*. In the most ancient times of which we have any knowledge, the form of the Japanese word was *ramu*, which is still nearer the Ainu word *ramui*. In fact, we are of opinion that the Japanese borrowed their word *kamu* from the Ainu *kamui*. This is not the place in which to discuss such a matter; but after much careful thought, and after duly weighing such evidence

as could be obtained, we have formed the opinion that, however unlikely it may at first sight appear, the Japanese owe their word for 'god' to an Ainu source.

Now, looking at the word itself, and taking into consideration its meaning, just as it stands, we find that it means 'he who,' or 'that which,' 'covers' or 'overshadows.' If, however, we trace it further back still, it means 'that which is,' or 'he who is highest,' or 'greatest,' or 'best,' or 'worst.' The first meaning, of course, is to be preferred, because it is the simplest, and does not require to be referred back to another term—for the simplest is generally found to be the best. Whichever of the two meanings are taken—for both or either may be taken—both alike are found to be akin to the word for 'heaven,' and that in its turn has 'top' or 'above' for its root. And so we catch a glimpse of what was in the Ainu mind when he first coined the name for god. He seems to have looked upon him as the great overshadowing Lord of all.

At the present day this word *kamui* is used very extensively. It has various shades of meaning, which vary if used before or after another word, and according to the object to which it is applied. The ancient Hebrews used to speak of the 'trees of God,' 'mountains of God,' and so on, when they intended to give the idea of 'greatness,' or 'height,' or 'beauty,' and such like qualities. So the Ainu speak at the present day. *Thus, for 'great trees,' we hear 'trees of

god'; for 'high mountains,' 'mountains of god'; for 'large rivers,' 'rivers of god'; for 'mighty winds,' 'winds of god'; or for a 'beautiful flower' we hear 'flower of god.' So, too, for a 'handsome face' the Ainu sometimes say 'face of god,' and a good and holy man they would naturally call a 'man of god.' In strict accordance with this we also find the people calling bears by the name 'god,' or 'animals of god.' But it must by no means be overlooked that the devil also, as well as such evil diseases as small-pox, have the same term *kamui* applied to them. In such cases as these it is evident that we cannot use the English term 'god': nay, it cannot be translated in those cases. It seems to be very like the Greek word *daimon*, for that also was applied to both good and evil objects.

By a careful analogy we find that, when the term *kamui* is applied to good objects, it expresses the quality of usefulness, beneficence, or of being exalted or divine. When applied to supposed evil gods, it indicates that which is most to be feared and dreaded. When applied to devils, reptiles, and evil diseases, it signifies what is most hateful, abominable, and repulsive. When applied as a prefix to animals, fish or fowl, it represents the greatest or fiercest, or the most useful for food or clothing. When applied to persons, it is sometimes expressive of goodness, but more often is a mere title of respect and reverence.

As, therefore, the Ainu apply their term for God to

such a variety of objects, both to the greatest and highest good, and also to the lowest and most malignant evil—to gods and devils, spirit and matter, reptile, animal, and man—it is not surprising that very much superstition is mixed up with their religion—that demonology is intermingled with their theology, and that evil is mixed with good. Hence, if we find that some of the Ainu ideas of and remarks concerning God and religion are full of contradictions, at one time high and sublime, at another gross and repulsive—if sometimes He is represented as a material substance, and at others as a spiritual Being, now as good, now as evil, and now as indifferent—we shall not be surprised.

If, then, an Ainu were to formulate his creed of religious beliefs and superstitions, it would be something like this. At any rate, almost every Ainu would assent to the following items as a concise summary of his belief :

‘ 1. I believe in one supreme God, the Creator of all worlds and places, who is the Possessor of heaven. Him we call *Kotan kara kamui, moshiri kara kamui, kando koro kamui*—“ God the Maker of places and worlds, and Possessor of heaven.”

‘ 2. I believe in the existence of a multitude of lesser deities, all subject to this one Creator, who are His servants, who receive their life and power from Him, and who govern the world under Him.

‘ 3. I believe there are many evil as well as good gods,

who are ever ready to inflict punishment for wicked deeds.

‘4. I believe in *Aiaina kamui* as our ancestor, a man become divine, and who has now the superintendence of the Ainu race; in a goddess of the sun; in a goddess of fire; in goddesses of the source, course, and mouths of rivers; in gods of mountains and forests; in the gods of animals; in the gods of the sea, and in gods of skies and all things contained therein.

‘5. I believe in demons, of whom the devil, called *Nitne kamui* is chief; and also that there are demons who preside over accidents; and I also believe that they are the embodiment of evil influences.

‘6. I believe that the souls both of human beings and animals are immortal; that separated husbands and wives will be rejoined hereafter; that all people will be judged, and the good rewarded, and the evil punished.

‘7. I believe that the souls of departed animals act as guardians to human beings.

‘8. I believe in ghosts; that the departed spirits of old women have a mighty power for harm, and that they appear as very demons in nature.

‘9. I believe that there are three heavens, called respectively “the high vaulty skies,” the “star-bearing skies,” and “the foggy heavens.” I also believe that there are six worlds below us.’

Such is a brief outline of the articles of Ainu faith

as they have so far come under my observation. Some of them are curious and interesting, and worth more than a passing thought; others are beliefs common to almost all peoples, and call for no special remark. But all, it will be seen, have their foundation in the heart of a distinctly religious people. Thus, then, though we find that the Ainu have no professional priests and no temples, yet we are again constrained to emphasise the fact that they are an exceedingly religious race. They see the hand of God in everything. The world, indeed, is His temple, Nature His book, every man His priest, and each chief His high-priest.

Further, although the Ainu give so much thought to religious matters, yet they have no special times for religious exercises. There are no family prayers, and they, of course, know nothing of Sunday, and have no special high-days. Their great religious exercises take place on the occasion of a bear feast, removing into a new house, and a death and burial.

CHAPTER XVIII

INCIDENTS AND WORDS ILLUSTRATIVE OF AINU
RELIGIOUS BELIEFS

ONE day, when coming down a river in a canoe with two Ainu, we chanced to pass some very bold cliffs which ran sharply down into the water. There were several openings in these rocks which led into deep and thickly-wooded dells. The tops of the rocks were well wooded, and at the base of them the water was dark, slow, and deep, and had a series of gentle eddies in it. Altogether the locality was exceedingly beautiful, quiet, and awe-inspiring. On nearing this place the Ainu ceased paddling the boat, took off their head-dresses, became quite silent, and only moved just enough to steer their little craft. On asking why they did this, I was immediately requested to remain silent for a short time, because some special gods were said to have their home in that place, and it behoved all men to keep silent when in the presence of any deity.

After passing the cliffs we entered into conversation respecting this home of the gods. The Ainu stated that two kinds of deities were supposed to reside in this

place. The first were dryads, or gods of the forests. These live in the dells, and keep watch over the cliffs and trees. They were both good and evil. To the good, reverent, and god-fearing person they show themselves good and benevolent; but to the wicked, irreverent, and ungodly they appear only in order to punish, and then are looked upon as evil. Woe betide the person who presumes to make a noise in their presence!

The other gods who dwell in this locality were the water-nymphs. They were of three sorts or degrees. The chief live in the centre of the eddy of water; the next preside over the water as it goes down the stream; and the third keep watch over the places where the water comes up again. These gods also must be treated with honour and respect, or they will revenge themselves by upsetting the boat and dragging the boatmen and passengers to the bottom of the eddy, and there drowning them.

The Ainu have a song or tradition which teaches all these things, and which they use to warn the women and children against presuming to go too far on a river in a boat. It is, however, too long to be quoted here.

The following incident is of the same class as the one just described:

An old Ainu was once working for me in my garden. It was the early spring, and the proper season for digging up the ground preparatory to sowing and planting the various seeds. Upon telling the old

fellow to improve the ground by digging in some manure, that we might reap a good and plentiful harvest, he replied to this effect: 'What! will you, a clergyman and preacher of religion, so dishonour and insult the gods? Will not the gods give due increase without your attempting to force their hand or endeavouring to drive Nature?' Considerably surprised, I looked at him to see if he were joking. But he was quite serious.

In the conversation which followed it came out that the Ainu believe strongly in the particular and special providence of the gods, and consider that they must be left alone to attend to their own special duties after their own fashion. Human beings must not attempt to interfere with their dispensations, and desire to get more than the gods intend to freely bestow. It is the place of the gods to look after men, and not of men to help the gods. Man must sow, but the gods alone can give the increase. After a long conversation with this old man, it was easy to understand why the Ainu never manure or attempt to improve their scraps of cultivated land. Instead of this they change their garden plots every second or third year, or even earlier, if the land shows signs of exhaustion. The readiest explanation that occurs to the stranger is idleness; but the people strenuously assert that this is not the case. However, they are now very sensibly modifying their beliefs and actions in this respect.

From these incidents it is evident that the belief in the special providence of the gods is an article of the Ainu creed. It is they who cause the seeds to germinate, the leaf to grow, the flower to blossom, and the fruit to ripen. It is man's duty to honour them, silently abide their time, and thankfully take what they have to bestow.

It is an underlying principle in all languages that the words used to describe consciousness, thoughts, feelings, and the general activities of the soul, as well as many religious expressions and ideas, were originally applied to material objects and physical phenomena. Thus, for example, spirit in its original signification was 'breath' or 'wind'; even in the Old and New Testaments the same word is in one place translated by 'spirit' and in another by 'wind.' Angel is 'messenger,' and by some the word god itself is said to have originally meant 'good.' This principle is true of the Ainu mode of speaking, for we find that they have taken many words especially applicable to material phenomena, and applied them to spiritual objects.

The Ainu word *tuntu*, which we will translate by 'brace' and then 'support,' is a noun, and is used to designate a piece of wood used in building huts, which forms the main support of the roof of the hut. The *tuntu* is to a hut what the corner-stone is to a house, or the key-stone to a vault or arch, or a pillar to a balcony. We might not, perhaps, expect to hear

this word applied to deity. Nevertheless, it is very often used by the Ainu when addressing God in prayer, and a thoughtful person will quickly see its appropriateness as a divine name. For, after due consideration of the word, and the different objects to which it is applied, we are led to conclude that when the Ainu pray to God as the *Tuntu* of the world they conceive of Him as being its living 'brace,' 'support,' 'pillar,' 'sustainer,' and 'upholder.' It reminds one of St. Paul's words, where he says, 'By Him all things consist.'

Further, the Ainu conceive this *Tuntu* as an intelligent power, and hence they delight to account for each step in every phenomenon of Nature which comes under their notice, by referring it back, though often through numerous and particular agencies, to that living power, the intelligent *Tuntu* or 'support' of the universe. This being is sometimes spoken of as the 'Creator' of all, and hence we are taught that the Ainu look upon Him as not only *in* the world, and holding it together, but also *outside* of it, and making it, and therefore transcending it. He is its summit, centre, and foundation, its originator and mighty 'support.'

The Ainu also use the word *shinda*, which means 'cradle.' I have sometimes heard the Ainu addressing God as the 'cradle' of men when at prayer. At other times he is called 'the god who rears us,' then 'she who feeds us,' and 'she who brings us up.' On

other occasions this god is addressed as 'grandmother god,' or 'old woman god,' and then as 'fire god.' After duly considering these facts, and the Ainu ideas concerning them, we find that the god whose province it is to 'rear,' 'nurse,' 'nourish,' and 'bring up' people, as well as comfort them in general, is believed to dwell in the fire, and to be of the feminine gender. This goddess is not only supposed to nourish mankind, but also to have great power over all kinds of sickness and disease. Hence it is that grace is said to her before meat, and a few drops of liquor given to her before drinking. Hence, too, the fire is particularly requested to have mercy upon and to heal the sick, and also to bless a newly-married couple, and make them happy.

Ainu babies, as we have seen, are left hanging in their cradles quite alone for hours, while their mothers have gone far away to work in the gardens, or to bring in firewood from the mountains. Of course the little ones cry lustily for their mothers sometimes, but they soon learn the virtue of quiet patience, and to know that, after all, they are not forsaken, but are in a safe and secure place. So, say they, human beings should exercise the like patience, knowing that whatever happens they are not forsaken by God, and are secure in His keeping.

How natural it seems that the thoughts and appellations of everyday life, and words in daily use,

should be taken and applied to the great 'cradle' of all, the 'nourisher' of every person, the great 'all-mother,' or, as we should say, the great 'all-father.' How natural, again, that these words should be taken and applied to the material fire which warms the body and cooks the food. Doubly natural does this appear when we consider that in the Ainu idea *heat* is looked upon as life, and *coldness* as death. In fact, the best way of saying 'good-bye' to a person is to use the expression, *Popke no okai yan*—that is, 'May you be kept warm.'

The idea underlying the name 'cradle' when applied to God appears to be this. Just as a child is nursed in the bosom of a cradle, and is made comfortable, and kept free from danger in it, so all men are brought up and nursed, as it were, in the bosom of God; for He is the Creator, support, sustainer of the universe, and the protector and nourisher of all mankind.

The word *turen* is very curious, and, like the name for God, can be applied to both good and evil objects. It signifies 'to be inspired by the gods,' as when a prophet prophesies; then to be possessed with a devil; then to be afflicted with disease as a punishment for evil deeds; next to receive special blessings from God; and lastly to have God's protection, as when engaged in some great or dangerous undertaking.

What particular meaning is intended in any given passage is to be explained by the context, and the

common sense of the listener. The particle *i* is sometimes prefixed to *turen*, making *ituren*. When this is done it makes the word stronger, or intensifies the meaning. It is used especially when God is thought of as the inspiring, guiding, guarding, protecting Angel of human beings. Every Ainu hut is supposed to have its special guardian god, who is thought to rest upon the roof when the master is at home, and give warning of approaching danger, and who accompanies the head of a family when he goes forth to his wars and on his hunting expeditions. They believe also that there is a special protecting angel for each individual.

Thus, then, we learn that the Ainu look upon God—first, as the Creator of the world and its Preserver; secondly, as the Providential Father and sustainer of mankind in general; and thirdly, as the guardian and special protecting Angel of each individual person. They also believe that every man has a faculty implanted in his nature by means of which he can know God, and commune with Him in prayer.

CHAPTER XIX

RELIGIOUS LEGENDS

It must not be supposed that the various articles of Ainu religious and superstitious faith are arranged in the mind of the people in the order in which they have been arranged at the close of the preceding chapter. Neither those items which have reference to the order and nature of the gods, nor those which have to do with the work and nature of the demons, are thought of by them in such order. Although the Creator of all things is naturally looked upon as the God of all gods, yet He is thought to have brought all things into existence in the beginning, and to have continually governed the whole universe ever since, not immediately by His own power, but by means of many living, personal intermediaries, who are all constituted chiefs in their own domain, who have all their special sphere and work, and who have angels to assist them in the execution of their duties.

These intermediaries are of various degrees of order, power, and authority; they are, in fact, what we might call laws of Nature invested with life, intelligence, and power. Some were appointed to create, others to

beautify, and some again to fructify the earth. One was ordered to rule the sun, another to attend to fire, a third to govern rivers, and so on. These rulers or living laws, however, exist not in their own right or by their own power, but by the will of a greater and more powerful personified Law behind them. He is the Almighty Power, the ever-living, vitalising, intelligent force of all Nature and being. All other divine beings, whatever their grade may be, are directly responsible to Him. They stand somewhat in the same relation to Him as a child does to its parents, or subjects to their rulers. Nevertheless, traditions inform us that the gods gather themselves together and consult with one another as to ways and means before they act, the Creator, of course, acting as president, just in the same way as the Ainu chiefs used to meet together for consultation before they acted. In short, the Ainu invest the gods with their own manners and customs and modes of thought and action.

By this we can easily understand how it is that, after the Creator, now this and now that god is spoken of as chief. Supposing, for instance, a person is sick, and the people have met together, as is their custom at such times, to pray that the sick one may be healed. The fire goddess, who is believed to be able to purify the body and heal disease, will be worshipped. Thus for a time she is uppermost in the mind, and the remembrance of the existence of *all* other gods, whether above or below

her, will be as it were in abeyance. Suppose, again, that a man is going out to sea to catch fish, what is more natural than that he should, particularly if he observes a storm coming on, call upon the god of fine weather to come to his aid? This is exactly what he does. Here then we see at one time one power, and at another time another god, standing at the head of affairs.

But we must be careful not to allow such instances to mislead us. Nothing is more easy than for an on-looker to get hold of an altogether heterodox opinion with regard to these things, and to imagine himself to be holding the orthodox faith. On carefully considering these matters, and after watching for years the actions of the Ainu under many peculiar circumstances, we find that, little as it might at first sight appear, the idea of mediation is very deeply rooted in the Ainu nature. If, for instance, they find that the particular god they are worshipping does not answer their prayer, they leave him and go to the Creator—the Fountain-head—Himself to see what He will do for them. Nay, they even sometimes go so far as to accuse the lesser deity to the greater of not doing his duty!

Upon asking these people why they do not go in the first instance directly to the Creator Himself, and not depend upon such intermediaries as the fire goddess, who, it seems, is not reliable at all times, they say, 'As God has appointed these intermediaries as channels through which we are to approach Him, we must, or

rather certainly ought, to do as He directs us, and not as we choose in this matter. If He has appointed means of approach to Himself, we ought to avail ourselves of those means, and not make others for ourselves.' They also say that neither the goddess of fire nor any other deity has power of will and choice to do just as they please. We are informed that the goddess of fire, besides her many other names, such as 'the Nourishing god,' 'the Cradle god,' and others, is also called 'the Divine Messenger,' or the 'Divine Angel'; and that she acts as a mediator between God and men. Thus we arrive at the true Ainu ideas of the particular offices of what we might very justifiably call their secondary gods. They were made *first* to do God's will in the universe, especially with respect to human beings; *secondly*, they are the servants of God's worshippers, and act as a medium through whom prayers go to Him, and the answers return to them.

We have seen that the Ainu look upon this God as the source of all life and being, the maker of men and so-called gods, the upholder of all things, and the dispenser of all authority to His servants. We have also seen that when this august Being intends to reach earth and men, He always acts through the lower orders of gods as His medium or means of communication, and so never does anything immediately Himself, that is to say, so far as our experience goes. Yet, although He is not supposed to work directly Himself, but always acts

through others, we find that He is not conceived of as idle, or merely sitting in the heavens like a machine, and selfishly happy in His own contemplation, and cruelly disregarding His creatures. Nay, He takes an interest in all that is going on in the world, and is always superintending the many officers of His government. However, these servants of His are sometimes remiss, and do not execute His orders properly. Hence, if there are some things in this world which *we* think are not quite as they ought to be, it is not because the Creator has been or is careless, but because His agents have not properly carried out His instructions, and also because the evil one is always endeavouring to frustrate His designs and supplant His counsels. For, be it remembered, the Ainu think that there are careless and unfaithful servants of God in heaven above, as there are evil and faithless servants of men in earth beneath. They believe there are fiends amongst the angelic beings, as there are among the terrestrial bodies of men. The following legends will illustrate these and many other points connected with this part of our subject.

One day, as I was walking towards the sea-shore with an Ainu, and talking about the west coast of Yezo, which is very rocky, and saying that it would have been much more useful had the shore been more flat, he rebuked me, and said that I ought not to murmur at these things, for I thereby reflected upon the good works of God. In

the course of conversation he volunteered the following legend as bearing upon the point at issue :

‘ It is said that the island of Yezo was made by two gods, a male and a female, who were the deputies of the Creator. The female god had the west coast allotted to her as her portion of work, and the male god had the south and eastern parts assigned to him. They vied with each other in their tasks. As the goddess was proceeding with her work, she happened to meet with the sister of Aioina Kamui, and, instead of attending to her duties, stopped in her work to have a chat with her, as is the general custom of women. Whilst they were talking, the male god worked away and nearly finished his portion of labour. Upon seeing this, the female god became very much frightened, and, in order not to be behind time, did her work hurriedly and in a slovenly manner. Hence it is that the west coast of Yezo is so rugged and dangerous. If, therefore, anyone is disposed to grumble at the very rough and dangerous condition of the west coast of Yezo, he should remember that it is not the Creator Himself who is at fault in this matter, but His deputy. The chattering propensity of the goddess was the original cause.’

This legend is sometimes quoted to women who are given to talking overmuch, and the moral drawn from it is this : ‘ Set a watch over your lips and attend to your duties, for see how rough the west coast of Yezo is, and that all owing to a chattering goddess.’

Ainu ideas are apt to become, as this legend shows, very anthropomorphic and materialistic, especially when they are thinking and speaking of Creation and its agents. The minor gods who made Yezo are spoken of as though they were human beings, one of the masculine and the other of the feminine gender. Nor must it be supposed that they could work without tools, any more than human beings can. Hence, when the world was formed, the principal tools used were mighty hammers and axes. Where the materials came from is not stated; they came, that was all. There is a large rock upon the sea-coast near Moruren called *Mukara-so*, 'Axe Rock.' This rock is said to be the axe with which one of the gods worked in making Yezo. It remains where he threw it down, for no man can move that mighty tool.

Some persons, again, take umbrage at the existence of rats, and others of cats. But let such people consider why these creatures were made. One night a rat attempted to procure, from the head of my landlord, a little human hair, with which to make its nest. The morning after the rat had aroused him from sleep by pulling his hair, we had a conversation on the subject of these vermin. I suppose I must have spoken too strongly against rats, for the old man again rebuked me, and bade me know that all things were made for a good purpose, and we should not, therefore, complain at anything. He went on to say: 'After the Creator had finished making the world, He came down from heaven

to see how all things looked. As He was viewing His works, the evil one appeared, and derided Him, saying : “ Doubtless you think you have done a very good action, and have made all things for the best. But look at this bramble bush and thistle, what can be the use of such things as these ? ” God was angry at these remarks, so He put His hands behind His back and secretly created a rat. As soon as the rat was made, it rushed into the evil one’s mouth, and bit out his tongue, thus leaving him tongueless. Hence, the evil one has no tongue to the present day, for it never grew again. He was so angry at being thus treated that, in order to retaliate, he caused rats to increase so mightily upon the earth that they soon became a nuisance and plague to men. For this reason the Ainu met together one day, and called upon God to remedy the evil ; for unless He did so, men would no longer be able to live in the world. God, who is ever willing to help human beings, heard the prayer, and in order to keep the rats under, created cats. Let us, therefore,’ said the old man, ‘ bear with rats a little, for they did a good thing in biting out the tongue of the evil one. Moreover, do not speak against anything God has created, for see how He punished the evil one for doing so.’

Among all the feathered tribe of Yezo there is no bird so saucy and bold as the crow. It has been known to fly into the huts and take the food from the very vessels out of which the people have been eating, and

to settle upon bundles of fish while the men and women have been in the act of carrying them upon their backs. On talking this matter over with an Ainu, he informed me that crows had reason to be saucy, and, as they once did a good thing for human beings, we must not grumble about them. His tale ran thus :

‘When God created the world, the evil one did all he could to frustrate His designs, especially with regard to human beings. Now, after all things were made, the evil one perceived that men could not possibly live without the light and warmth-giving sun. He, therefore, made up his mind to destroy that beautiful and useful work of creation, and thereby injure men. So he got up early one morning, long before the sun had risen, with the intention of swallowing it. But God knew of his designs, and made a crow circumvent them. When the sun was rising, the evil one came along and opened his mouth to swallow it; but the crow, who was lying in wait, flew down his throat, and so saved the sun. Hence the crows, remembering the benefits they once conferred upon the human race, have an idea that they may do just as they like with men, and live upon the food they provide for themselves and families. Thus we find that they have good cause for being bold and saucy, and it is not for men to say that crows are useless creatures.’

One would think that if human beings might grumble at anything at all it would be at those dreadful pests—

gnats, mosquitoes, and gadflies. As far as Yezo is concerned, these creatures are enough to try anyone's temper. But the Ainu bear even these torments patiently. Mosquitoes and all that family of flies are much better than hobgoblins; for hobgoblins take the blood, flesh, and bones, whilst mosquitoes suck only a little of the blood.

The following legend will give some idea of what the Ainu think on this subject. The story is sometimes told to children, and generally with good effect, to prevent them from straying away into the forests.

'Once upon a time, many many years ago, there was a great hobgoblin, who had his home far away in the midst of the mountains of Ainuland. In bodily shape he was like a man. His carcase was exceedingly large, and was closely covered with hair. In fact, his skin was like that of a bear, so hairy was he. However, he had only one eye, and that was situated in the middle of his forehead, and was as large as a common pot-lid. This creature was a very great nuisance to the Ainu, for he had such a tremendous appetite that he actually was in the habit of catching, killing, and eating everything and anybody coming in his way. For this reason the people were afraid to go far into the mountains to hunt, for though the one-eyed monster had been shot at several times, not an arrow had yet taken effect upon him. Now, it happened one day, that a brave hunter, who was an expert with the bow, unconsciously went

near the haunt of this cannibal. While he was in pursuit of game, he was astonished to see something brightly glaring at him through the undergrowth of the forest. Upon drawing near to see what it was, he discovered it to be the big-bodied, hairy, fierce-looking hobgoblin. When he saw what it was, the hunter became so frightened that he knew not what to do ; but he soon mustered sufficient courage to draw an arrow from his quiver, fit it in his bow, and stand on the defensive. As the creature drew nigh, the Ainu took a steady and deadly aim at his solitary eye, and, being a good shot, hit it fair in the centre. The hobgoblin immediately tumbled down dead, for the eye was the only vital part of his body. To make sure that so foul a creature and so deadly an enemy was quite killed, and would not again return to life to trouble the people, the brave hunter made a great bonfire over his body and burnt it quite up, bones and all. When this was done, he took the ashes in his hands and scattered them in the air, so as to make perfectly sure that the monster was thoroughly destroyed. But, lo ! the ashes became gnats, mosquitoes, and gadflies, as they were tossed upwards. However, we must not grumble at these things, for the lesser evil of flies is not so bad as the greater evil of having the one-eyed, man-eating monster amongst us.'

The foregoing legends have been brought forward here with the special purpose of showing Ainu ideas as

to how the world and all things therein contained was brought into existence. By them we see that the Ainu refer them all to the special creative act of God. We find that they are neither thought of as being eternal, nor as owing origin to chance, nor as having been evolved. They were brought into existence by the Creator when He pleased, and as occasion required. Some He made merely because He willed to make them. Others, again, He made as means to punish the evil one for his wickedness. Hence, we find it to be the fact that, amongst other things, the Ainus believe in the existence of one supreme God, the Creator of all, and in a multitude of lesser deities, all subject to Him.

The deity who is supposed to hold the most important office next the great Creator of all may be said to be the goddess of the sun, for she is conceived of as being the special ruler of the good things God has made and fixed in the universe. The Ainu are believers in a god of the moon. Some of them consider the moon to be the female principle, and the sun the male, and others *vice versâ*; but the majority speak of the sun as though it were of the feminine gender. However, neither the sun nor the moon is extensively worshipped by the Ainu, though some persons, few in number, may be met with who pay their respects to these useful works of creation.

The sun is really supposed to be rather the vehicle of a goddess, who is its ruler, than a goddess itself. It

is, therefore, not the sun that the Ainu worship, but the goddess who resides in the sun, and whose brightness shines through it. Yet it is exceedingly interesting and curious to learn that this goddess who lives in the sun and the god who lives in the moon are the very life or soul of these useful objects. Take the goddess from the sun, and immediately all becomes darkness and blackness by day ; and abolish the god of the moon, and there will not be a speck of light in the night. Hence it is that the Ainu, like so many uncivilised peoples, fear a total or partial eclipse of the sun or moon.

In 1887 an eclipse of the sun occurred, and I oblacked some glass, so as to enable an Ainu to see the eclipse when it took place. At the proper time we bade him look at the sun. Immediately the exclamation rang out : *Chup rai, chup rai*, 'The luminary is dying, the sun is dying.' Another person called out : *Chup chikai anu*, 'The sun is fainting away,' or 'The luminary is suddenly dying.' This is all that was said ; silence ensued, and only now and then an exclamation of surprise or fear was to be heard. But it was plainly evident that the people were in fear lest the eclipse should be total, in which case the sun might quite die away and not come to life again, and so all living beings would perish.

It might be expected that the Ainu would worship the sun at this particular time ; but such is not the case.

They are consistent, and treat the sun as they do a dying or fainting person. When a person is dying—on one occasion when I was present—one of the company will either fill his mouth with fresh water, and squirt it into the sufferer's face and bosom, or will bring water in a vessel of some kind, and sprinkle him with his hand, thereby attempting to revive him. In like manner, when there is an eclipse, particularly a total eclipse, of the sun, the people bring water and sprinkle it upward towards that luminary, thinking thereby to revive it, at the same time calling out, *Kamui-atemka, Kamui-atemka*, 'O god, we revive thee! O god, we revive thee!' If the water is sprinkled with branches of willow, it is supposed to have special efficacy and power in bringing the sun back to life.

The sun having been restored to his normal condition of brightness and glory, the cunning old *sake* drinkers have a fine pretext for getting intoxicated. Of course libations of wine must be held in honour of the sun's recovery from faintness and return to life, and the subject must be duly talked over, and ancient instances of a like occurrence recited. But a few cups of *sake* soon cause the talkers to speak what is not true or reliable, and they are not long before they begin to show signs of being in a somewhat maudlin state.

Sober Ainu traditions of eclipses are all of one stamp, and run thus :

'When my father was a child he heard his old

grandfather say that *his* grandfather saw a total eclipse of the sun. The earth became quite dark, and shadows could not be seen; the birds went to roost, and the dogs began to howl. The black, dead sun shot out tongues of fire and lightning from its sides, and the stars shone brightly. Then the sun began to return to life, and the faces of the people wore an aspect of death; and as the sun gradually came to life, then men began to live again.'

Eclipses are quite inexplicable to the Ainu; nor have I ever heard a single theory advanced with reference to their causes.

There is not much to be said about the stars, except that they are not worshipped; though the term used for god is sometimes, but not generally, applied to them. The term 'god' is merely used of them on account of their usefulness in the system of Nature, particularly out of regard to their usefulness in giving light. Comets are known by the name of 'broom star'; and the Milky Way is called 'the picture of the crooked river.' This 'crooked river' or Milky Way is also sometimes called 'the river of the gods;' and the various deities are supposed to spend much of their time upon this 'river' in catching fish. The appearance of a comet is regarded with fear and consternation; for it is thought to be the sure forerunner of some dreadful calamity, as, for instance, war, disease, famine, or death.

The deity who is generally looked upon as standing

next in order to the goddess of the sun is one already described at some length, namely, the goddess of fire. She is conceived of as being both useful and awful: useful, inasmuch as she warms the body, heals it when ill, and cooks its food; awful, inasmuch as she is a special witness to note the acts and words of men and women. It is she who will appear either for or against us at the Judgment Day. She will present the great Judge of all with a perfect picture of every word and action of each individual human being, and there can be no avoiding her. Thus every person will be rewarded or punished hereafter according to the representations of the goddess of fire. We can, therefore, easily understand the great importance the Ainu attach to fire-worship. But here again we must be careful not to think that it is the fire itself which is worshipped. Fire is not worshipped, but a goddess who is supposed to dwell in the fire, and whose vehicle the fire is thought to be. This is a subtle distinction, but it is nevertheless true.

It is curious that the ideas of the Ainu as to the shape of the world differ from those of the ancient Japanese and Chinese; for while these considered it to be flat, the Ainu look upon it as being round. According to them, the world is a vast round ocean, in the midst of which are very many islands, or worlds, or countries, each governed by its own special orders of gods. In fact, the Ainu have no word for the whole

world or universe. Islets in rivers and lakes, islands in the sea, and mighty continents are all called by the same name — *moshiri*, i.e. 'floating or swimming earth'; but whether an islet, or island, or country is intended is made known by adjectives. Thus *Rep-un-moshiri* is, 'land in the sea,' i.e. an island; *shamon* or *Samoro moshiri*, Japan, i.e. 'the island next to us.' Upon asking the people why they supposed the world, taken as whole, to be round, they replied 'that it was because the sun rises in the east, sets in the west, and comes up the next morning in the east again.'

Earthquakes are accounted for in the same way as the Japanese used to account for them. That is to say, the world, or the various islands composing the world, are supposed to be resting upon the back of a great fish, which the Ainu call *moshiri ikkewe chep*, i.e. 'the backbone fish of the world'; so that whenever this fish moves it naturally causes the islands founded upon it to shake.

The mention of this earthquake fish, which is supposed to be a large trout, brings to my mind a legend which an Ainu once recited to me, and with which I will close this chapter :

'At the source of the Saru River there is a large lake. In this lake there was a monster trout, which was so big that it used to flap its [pectoral] fins at one end and wave its tail at the other.

'Then the honourable ancestors met and went to kill

this fish, but found themselves unable to accomplish their end, though they attempted to do so for many days.

‘ Because, then, they very much desired to kill the fish, the gods, who had a special regard for Ainu-land, sent help from heaven.

‘ And, the gods descending, they seized the great trout with their hands [claws].

‘ Upon this it plunged mightily, and went to the bottom of the lake with great force.

‘ Then the gods put forth all their power, and, drawing the great trout to the surface of the water, brought it ashore.

‘ Upon this all the honourable ancestors drew their swords and chopped the fish till they quite killed it.

‘ It is said that this mighty trout was in the habit, not only of swallowing animals, such as deer and bears, that might come to the shores of the lake to drink, but would sometimes swallow up men, women, and children ; nay, not only so, but even whole boats full of people ! Yes, boats and all ! Hence it was that the ancients were so anxious to slay this monster.’

The Ainu appear to have a special dread of large lakes, because they say that every now and again one of these monster fish suddenly appears, and commences its destructive work of swallowing animals and human beings. Only a few hundred years ago, say they, one of these awful fish was found dead upon the shores of the

Skikot to (Chitose lake). This monster had swallowed a large deer, horns and all ; but the horns caused a severe attack of indigestion to come on, which the fish could not get over ; nay, the horns were so long that they protruded from its stomach and caused its death.

CHAPTER XX

CAUSES OF AINU DECREASE

THERE is a tradition among the Saghalien Ainu to the effect that the pit-dwelling dwarfs were their ancestors. If they are really descended from these 'dwarfs,' the race has certainly very much improved, for the Saghalien Ainu are fine, strong-looking people. Of course it may possibly be the fact that the Ainu as well as the *Koropok-guru* lived in holes. Such an idea does away with any necessity for believing that the Saghalien Ainu are the children of 'dwarfs.' They are most certainly akin to the Yezo Ainu. Their language is Ainu. The people are as hairy as the Ainu. Their manners and customs correspond; they call themselves by the name *Ainu*; and, like the Yezo Ainu, they worship bears.

The Ainu account for their origin in the name Ainu, by which they are known. The name, say they, of their most ancient forefathers was *Aioina Kamui*. *Aioina* is the proper name, but *Kamui* is merely a title of honour and respect. *Aioina's* descendants were first called *Aioina rak guru*, 'persons smelling of,' or 'having the

virtues of Aioina,' and this, according to Ainu idiom, is equal to saying 'descendants of Aioina.' This name being too long, the people, at an early date, changed it into *Ainu rak guru*; and in later times they dropped the *rak guru*, and called themselves *Ainu*. Many of them, particularly their old men, are well pleased even now to be called *Aioina rak guru*. That *Aioina* had a real existence seems highly probable, for his is the only human spirit worshipped by the Ainu.

If this derivation be true, the word *Ainu* loses its proper meaning, viz. that of 'man' or 'men.' It is more probable that *Aioina* was some religious teacher, and that *Aioina rak guru* really means 'persons obeying the instructions' or 'holding the traditions.' *Oina* is a word meaning first 'ancient,' then passing to the meaning 'to relate ancient traditions.' *Aioina* is the passive form of the verb, and means 'to be related or told.' *Aioina* signifies 'to hold the traditions which have been handed down.' *Aioina rak guru* (*rak* means 'to smell of' or 'to have,' and *guru* means 'person or persons') signifies 'persons obeying the instructions' or 'traditions,' and hence, *Aioina Kamui* was a 'great teacher of traditions.' This derivation is both reasonable and natural, and it does away with the necessity for destroying the meaning of the proper name *Ainu*, 'men.'

If this derivation, here set forth for the first time, is not thought to be satisfactory, we may say, although the

word *Ainu* does, in everyday language mean 'man' or 'men,' and nothing but 'man' or 'men,' just as *shiwentep* means 'woman' or 'women,' it may also once have had another meaning, viz. 'tradition hearers or obeyers,' or 'holders of traditions.'

There is a place in Volcano Bay upon Yezo, close to Tokkari, which is called Oinaushi, which means 'the place of traditions.' It received this name because those ancient Ainu who used to trade with the Japanese generally met at this place and put to sea together. They met there from all parts, and were in the habit of telling one another the traditions of their districts and the news of the day. Hence the name Oina-ushi, 'the place of traditions.'

There is another tradition accounting for the origin of the Ainu, told me several years ago by an old man. A person named Okikurumi was the true Ainu ancestor. He is said to have descended from heaven to a mountain in Piratori at a very early date. He had a wife who was called Turesh, and is always known by the name Okikurumi Turesh Machi. This lady bore a son, whom they called Wariunekuru, and it is from Wariunekuru that the Ainu are descended. But other persons say that Okikurumi was not the Ainu ancestor at all, but was sent by the chief god, the Creator, to teach the Ainu religion and law, and that his son Wariunekuru taught the common arts of daily life.

After more mature knowledge of the Ainu, I have

come to the conclusion that Okikurumi here stands for Yoshitsune, a Japanese hero, already referred to in Chapter VIII. p. 119. *Kurumi* is an ancient Ainu word for 'a male Japanese'; but it is not in use now, although the word *Kurumat*, 'a female Japanese,' is used daily. The terminations *mi* and *mat* mean 'male' and 'female' respectively.

Dr. A. Pfizmaier, of Vienna, who obtained his information of the Ainu from a Japanese work entitled *Moshiogusa*, calls this people Aino or Ainos, and then says that Aino means 'bow-men.' This is not correct; for, in the first place, Aino is not the name of this people; and, in the second place, even if it were their proper name, it could not possibly mean 'bow-men.'

In ancient times the Ainu must have been very much more numerous than they are now, for unless they were so, it is difficult to account for the names of very many places all over Japan, which are purely Ainu words. But the people have greatly decreased, and are now slowly, but surely, passing away. And the reason for this is not far to seek.

In the first place, it should be remembered that wars of extermination were carried on by the ancient Japanese against the Ainu. One need only mention in this connection two names which every Japanese schoolboy knows well, viz. Jimmu Ten no sama, and Saka no ue no Tamura Naru. In much later times the governors of Matsumai, in Yezo, did their share

of this work. These are historical facts, and require no comment.

The second cause for Ainu decrease is due to exposure. We have seen what Ainu huts and clothing are like. Then the fact must be borne in mind that the Ainu had no medicines or medical men; so that when a person became ill he simply wrapped his head in a cloth and laid down to die. Small-pox, it is said, has devastated whole villages.

Further, the intense longing for intoxicating drinks has done awful evil in the past, and is still eating the life out of the people. This taste and longing, as we have seen, was fostered and encouraged by their conquerors for ages, and has undermined the Ainu constitutions, sapped their strength, and taken nearly all that is manly from their souls.

Europeans also whilst travelling amongst the Ainu have encouraged this longing passion for strong drink by giving them liquor. Not only is this desire for strong drink fostered by those whose business it is to sell wine, but persons will give them a tub of rice wine merely to see a single dance!

The Ainu *will* drink if they can obtain the liquor. I once had an Ainu in Hakodate teaching me his language. I did all I could to keep that man from drinking. But the fiend was too strong upon him, and held him with far too firm a grip. He used to get out of the window at night after I had retired to rest and

obtain drink. Sometimes a friend would bring him drink after dark, and smuggle it through the window into the house. I smelt his breath one day, and went down to his room and searched for his bottle, and I found it snugly hidden under the floor! Drunkenness, therefore, must go in the catalogue of causes for the decrease of the Ainu; for we all know the effect of strong drink upon the human mind and frame, and upon the drunkard's children.

Petty wars and quarrels, which the Ainu used to get up amongst themselves, have also done their share in this work. Sometimes a whole district would make war upon its neighbour, and at other times a village would quarrel with another, and have a fight. Sometimes the people used to fight with their bows and arrows, and at others with stones and sticks. What ancient swords the Ainu now have amongst their treasures are all of Japanese make; though, strange to say, they used to wear them suspended from the shoulder, and not in the girdle, as the Japanese did. The spears, also, are of Japanese manufacture; we may therefore dispense with swords and spears as being not of native origin.

The wooden war-clubs which I have spoken of in Chapter IX. p. 132, seem to be entirely Ainu, for I have never seen any amongst the Japanese. The bows and arrows are likewise Ainu instruments. Most likely the ancients used flint heads for their arrows, and there is evidence to show that either the Ainu or the race that

lived in Yezo and Japan before them used flint and stone heads to their spears.

The Ainu also wore armour in their wars ; but it was of a very light kind, consisting entirely of leather. Some of them, however, wore Japanese armour, which they took from the dead in warfare. This is also one way in which they came by their swords and spears.

They also seem to have been in the habit of fighting with daggers. These were simply pointed knives about six inches long. The Ainu used to manufacture these from the broken Japanese swords and spears that they picked up after a battle. They never used poison in warfare, so they appear to have been a little humane even when fighting.

The quarrels and fights were generally caused by the men of one village or district hunting over the grounds recognised as belonging to the people of another ; for, in ancient times, the Ainu divided the land amongst themselves. One large district was set apart for a given village, and this district again divided into minor portions for the people, each family having its own special plot of garden land and hunting ground allotted to it. The river and seaside fishing stations were likewise so divided, and the Ainu were very jealous of their rights. Even to-day, notwithstanding that the Japanese Government does not recognise any land as belonging to the Ainu, when the Ainu of one district go hunting in another they always call upon the Ainu chief of that

place, and pay their respects to him, and ask for his good-will.

When the Ainu were at war with one another, it was a case of every able-bodied man and woman turning out to fight. There were no regular soldiers, but in fighting each person was supposed to take his or her part, and do their duty. The chief of a village, with his sub-chiefs, naturally took the lead on these occasions. The women were left to fight their own sex, whilst the men fought with the men. Thus the Ainu women were a sort of 'amazons.'

Not infrequently, too, the Ainu made night raids, which they called *topat-tumi*, one upon another. On such occasions nearly the whole of the male population were murdered during sleep, whilst the women and children were carried off as slaves to work in the gardens, and were called *usshui ne guru*. Some of the women, however, were kept as concubines. The women are said to have generally accompanied their husbands when they went on these night raids, and to have rendered very effective service.

The Ainu of the Tokapchi district in Yezo are spoken of as having been particularly addicted to this kind of warfare, and are even now held in abhorrence by the people of some villages. They are said not only to have murdered people, but also to have eaten some of them. They were, therefore, cannibals, and I have heard them spoken of as 'eaters of their own kind.'

These internecine wars not only helped to diminish their numbers, but also rendered their conquest by the ancient Japanese more easy.

Another cause of the Ainu decrease is intermarriage with the Japanese, which is ever going on, upon the Japanese frontier, if, indeed, frontier it can now be called. The Ainu women are, most of them, ever ready to become the wives or concubines of the more civilised Japanese. It is to their interest to do so. They are far better fed and clothed, and have less hard work to do. But the children of such marriages are not generally very strong. They are weaker and far less hairy, and generally die out in the third or fourth generation. The children of these mixed marriages become bald at an early age.

I know of no Ainu village containing a family which is not in some way connected by blood-relationship with every other family in that village. All *urirwak*—that is, 'blood relations living in the same village'—whilst



DESCENDANT OF AINU
AND JAPANESE

uiritak—that is, ‘blood relations living at a distance’—are, comparatively speaking, exceedingly few. Take Piratori, for instance. This village is the capital of the Saru Ainu. It has thirty-two families in it, but every person is related to all the others. It is the same with Usu and Horobetsu, and probably with every other village. This kind of intermarriage is not likely to increase the longevity or physical and mental strength of a people, or the diuturnity of a race or nation. On the contrary, it has a tendency to stunt the physical growth of the body, to weaken the mind, and to shorten life. Hence, if these family intermarriages have been going on for many generations, it is no matter for wonder that the Ainu are decreasing.

CHAPTER XXI

PREHISTORIC TIMES IN JAPAN

THE past history of the Ainu can now never be thoroughly known. Like that of many other tribes and peoples, their origin is lost in obscurity, and the time for obtaining exact, definite, and trustworthy information about their early history has for ever passed away. Just as old Japan commenced to die away at the time when Western light began to dawn upon and brighten the skies of Japan, the old-world life of the Ainu has either passed or is fast passing away before the rapid march of enlightened Japan civilisation.

The Ainu of to-day are but the remnant of a once much more numerous nation, the members of which formerly extended all over Japan, and were in Japan long before the present race of Japanese. Further, the Ainu were not the only natives of Japan resident in this country before the Japanese came here.

In establishing the first of these propositions we have recourse to many interesting names of places which are found all over the Japanese empire, from Satsuma in the south to Shikotan in the north; names which find no

place in the Japanese language, and which are Chinese only inasmuch as they are written with Chinese characters. Very many such names can be clearly shown to owe their origin to the Ainu tongue.

It will probably assist us in considering the mysteries of Ainu place-naming if we remember that some of the names were given merely to describe the nature of the place itself, others to mark some particular event in history, and others again to indicate that certain trees, herbs, or animals existed in particular localities. Thus we have *Memoro kotan*, 'the place of ponds'; *Kurumat nai*, 'the stream of the Japanese woman,' so called because a Japanese woman died upon the banks of that stream; *Ishkara kotan*, 'the place where birds' tails are made.' This place was so named because many eagles used to be killed at the mouth of the Iskari River, and their tails taken and sent to the governor of Matsumai, who bought them at a high price. Then there is *Otope*, 'the water containing a corpse'; a corpse ready dressed and otherwise prepared for burial. The water or pond so named had this designation given it because a dead body, already prepared for burial, was once found in it. All these names are taken from places in Yezo.

When we consider the names of places in Southern Japan—I mean those numerous places which are certainly not of Japanese origin, such, for instance, as Awa, Wakasa, Noto, and others—we should not forget that originally and in most cases such designations without doubt

applied to one village, or stream, or mountain, or tract of land. The Japanese have, in taking the already existing Ainu names, first mispronounced them, then covered them up with wholly inappropriate Chinese characters or hieroglyphics, and lastly, sometimes applied them to much larger localities than the Ainu intended them to cover. Hence, when we come across the name of a place whose meaning in Ainu can have no special application to the locality so designated, we may rest well assured it has, probably through ignorance of its true import, or possibly from political motives, been misapplied by the Japanese, or taken from one place and transferred to another. This process is still going on in Yezo at the present day.

One would naturally suppose that if any name in this country were of pure Japanese origin, that of the famous sacred mountain of Japan, Fuji-yama, would certainly be so. The Chinese characters with which the name is written mean 'mountain of wealth,'—a truly poetic and beautiful name. But poetry and sentiment must for a short time give way to dry fact. The Japanese will have to admit earlier or later that their much-esteemed mountain owes its name to the Ainu tongue, and that Fuji-yama does not really mean 'mountain of wealth,' except in so far as that term is written with Chinese hieroglyphics.

In support of a statement like this reasons ought, perhaps, to be given. However, I will not here give any

detailed account of the argument, but merely state that the word *Fuji* in Fuji-yama is merely a corruption of an old Ainu word 'fire,' the real pronunciation of which is *huchi*. The Ainu word *huchi*, or *fuchi*, means (1) 'an old woman'; (2) 'grandmother'; (3) 'the goddess of fire'; and (4) 'fire' itself. As the goddess of fire, *huchi*, or, as she is often called, *kamui huchi*, *hucha kamui*, or *iresu huchi*, is, as we have seen, always worshipped at a house-warming, a marriage, a feast, or a death; and she is specially invoked on the occasion of sickness. It should next be remembered that the beautiful Fuji-yama is an extinct volcano, and that there are very strong grounds for believing that the Ainu knew of the existence of this object of Nature and worshipped it long before the Japanese came so far north as the districts round about Fuji. What, then, is more likely than that the Japanese borrowed this designation from the Ainu, as they have done so many other names of places and objects? How exceedingly appropriate is the name *goddess of fire*, as originally and naturally applied to Fuji-yama by the Ainu, who are, as a matter of fact, fire-worshippers? 'Goddess of fire' is a much more reasonable name for this mountain than 'mountain of wealth,' which has nothing to be said in its favour, excepting that it is in the Japanese idea more poetical! Nor should it be forgotten that *Fuji*, as it is now written, is a Chinese name, though the Celestials have never yet, to our knowledge, possessed Japan; whilst *Fuji*, as above explained,

is a purely native Ainu word, full of the deepest Ainu thought and religion.

It may possibly be objected by some who do not understand the way in which the Japanese have borrowed place-names from the Ainu that the word *yama* is purely Japanese, and not Ainu. This is quite true, though it is in no way a difficulty, for many other instances might be produced, showing the Japanese word *yama*, or the Chinese *san*, suffixed to Ainu names. Thus we have *Usu-yama*, *Sawara-yama*, *Iwaki-san*, *Fuji-san*, and many other similar names. If in every one of these cases we were to take away the Japanese word *yama* or *san*, 'mountain,' and substitute the Ainu word *nuburi*, which also means 'mountain,' we should at once have living Ainu words pure and simple, words still in daily use.

Many other like topographical names might be produced if necessary from Hakodate to Maskishoya, as well as all over Saghalien and the Kurile Islands. But enough have been brought forward to show clearly strong grounds for the belief that the Ainu once inhabited the whole of the Japanese empire.

In passing on to the second point, which is that the Ainu were not the only aborigines who resided in Japan before the Japanese came, we have recourse to Japanese testimony and Ainu tradition. Consider for a few moments what the two Japanese ancient books, called *Kojiki*, or 'Records of Ancient Matters,' and *Nihongi*, or

'Chronicles of Japan,' have to say on this point. It should be remembered that the 'Records of Ancient Matters' are said to be traditions handed down by word of mouth; that the Emperor Temmu took particular pains to instruct Hujeda-no-Are, a woman of surprising



FLINT KNIVES

and prodigious memory, in the 'genuine traditions' and old language of former ages, and made her repeat them till she knew them by heart. These traditions were retained in the memory of this one woman for the space of twenty-five years; and when she was about the age of

fifty-three, i.e. in the year 712 A.D., these so-called 'genuine traditions' were committed to writing, and called *Kojiki*, or 'Records of Ancient Matters,' and recorded or written down at the dictation of Hujeda-no-Are. The book has therefore a direct reference to prehistoric times.

The *Nihongi*, 'Chronicles of Japan,' was completed in 720 A.D., or only eight years after the appearance of the 'Records.' After a perusal of the 'Records' and 'Chronicles,' we are fully justified in holding the opinion that when the ancient Japanese first came to 'the land of the rising sun' they found the country inhabited by a people with whom they fought, a race of barbarians whom they conquered and dispossessed. Indeed, there are some very good grounds for believing that the Japanese acted as a wedge by driving some of the real owners of the land, the aborigines, to the south, massacring others, and compelling others to seek refuge in the fastnesses of the mountains and the interior of the country, whilst others were forced towards the north. If we study the types of the Japanese people, it may be added that some few of the barbarians, more wise probably than the rest, acted as servants, slaves, concubines, or wives to their conquerors, and thus became amalgamated with them. An illustration of this process is seen in the amalgamation of the Ainu with the Japanese in Yezo, which is still in progress.

In the 'Records of Ancient Matters,' we read of a class or race of people called *Tsuchi-gumo*, or 'earth-

spiders'; a cognomen expressive of neither grace nor manliness. The people who bore this name are said to have possessed tails, and to have lived in caves with stone doors. The Emperor Jimmu, it appears, had many of these cave-dwellers cruelly and barbarously slaughtered in cold blood. Thus we read: ¹

'When his Augustness . . . made his progress, and reached the great cave of Osaka, earth-spiders with tails, namely, eighty bravoës, were in the cave awaiting him. So then the august son of the heavenly Deity commanded that a banquet be bestowed on the eighty bravoës. Thereupon he set eighty butlers, one for each of the eighty bravoës, and girded each of them with a sword, and instructed the butlers, saying: "When ye hear me sing, cut them down simultaneously." In the song by which he made clear to them to set about smiting the earth-spiders, he said:

Into the great cave of Osaka people have
Entered in abundance, and are there.
Though people have entered in abundance
And are there, the children of the augustly
Powerful warriors will smite and finish them
With their mallet-headed swords, their
Stone-mallet swords; the children of the
Augustly powerful warriors, with their
Mallet-headed swords, their stone-
Mallet swords, would now do well to
Smite.

¹ See *Kojiki*, by Prof. Chamberlain, in *Trans. Asiatic Soc. of Japan*, vol. x. supplement, p. 141, sec. xlvi.

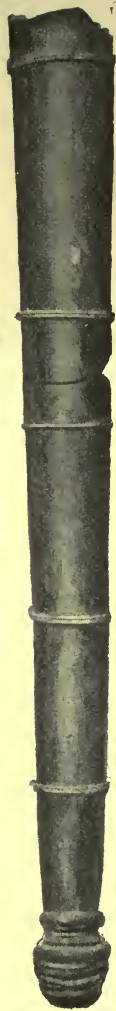

STONE-MALLET SWORD



WAR-CLUB

‘Having thus sung, the butlers drew their swords and simultaneously smote the bravoës to death.’

In this quotation we have a direct reference to ‘mallet-headed swords’ and ‘stone-mallet’ swords. It is therefore probable that the ancient Japanese in very early times used stone clubs or swords.

In the Hakodate museum there is a kind of stone mace or mallet-headed sword to be seen; but whether this article was intended for a sword, or was merely an ensign of authority, cannot be positively affirmed.

Nor was Jimmu the only emperor who fought against the ‘earth-spiders,’ as Sujin and Keikō are specially mentioned as having made successive wars of extermination upon them. But who were these ‘earth-spiders,’ or, as we prefer to call them, ‘cave-dwellers?’ Were they simply robber bands of barbarous Ainu? Or were they Koreans, or a people very closely allied to the Koreans? Professor Milne, in writing of the caves found in Japan, says:¹ ‘In many parts of Japan a large number of caves have been discovered. In the limestone districts and some of the old volcanic rocks these appear to be natural. I explored several of these caves in Shikoku, and also in other places. The only results which I have obtained were geological. Artificial caves near Kumagai, Odawara, and in other localities, which have been examined by Mr. Henry von Siebold, from the pottery they contained and other evidences

¹ See *Trans. Asiatic Soc. of Japan*, vol. viii. pt. 1. p. 76.

which they yielded, showed that they were of Korean origin.'

Thus, then, we have grounds for concluding that in ancient times there were Koreans residing in 'the land of the rising sun,' and that they lived in caves. In the island of Yezo, however, there appear to be no caves in which the ancient people dwelt, unless, indeed, a small one in Otarunai be an exception. The single cave which exists at that place gives one the idea of a tomb rather



PREHISTORIC POTTERY

than of a dwelling-place. In this cave there is an inscription which no one has as yet, I believe, succeeded in deciphering. There have been no similar inscriptions discovered anywhere else in the empire, and the Ainu inform me that they know of none, nor have they any idea where the characters engraved upon the back of the cave in Otarunai came from. They may have been created with the rock for all they know, or some child may have been exercising its skill in drawing.

With reference to these inscriptions, Professor Milne says: 'A rough sketch of the inscriptions which I saw at Otaru is given in the accompanying plate. They are wrought or cut upon the face of the cliffs on the north-western side of the bay. These cliffs are about one hundred feet in height, and are capped with small trees. The rock is a white, extremely soft, much decomposed tufa. It is now being quarried as a building stone, and during the process a portion of the inscription of which I have here given a rough copy has been broken away. If the quarrying continues in the direction it was taking when I visited the spot, it is not at all unlikely that the whole of these inscriptions will be very shortly destroyed. The characters look as if they had been scraped or cut with some incisive tool. I do not think it would be difficult to make similar markings with a stone axe. The lines forming the characters are usually about one inch broad and half an inch deep. They occupy a strip of rock about eight feet long, and they are situated about three or four feet from the ground. Above them the cliff considerably overhangs, and its form is very suggestive of its having been once more or less cave-like. So far as I could learn, the Japanese are quite unable to recognise any characters, and they regard them as being the work of the Ainos (*Ainu*). I may remark that several of the characters are like the runic *m*. It has been suggested that they have a

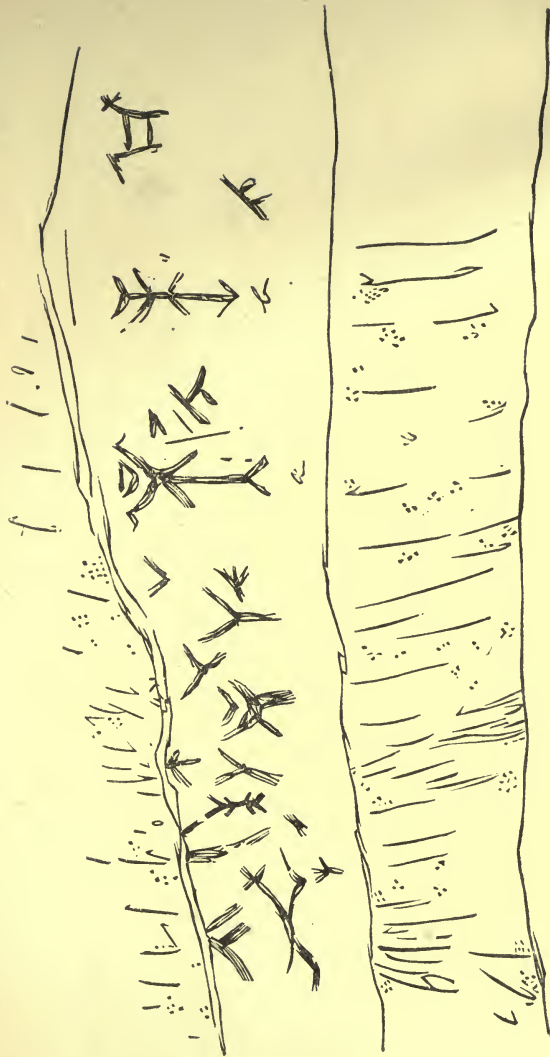

3 2-

INSCRIPTION AT OTARUNAI



resemblance to old Chinese. A second suggestion was that they were drawings to indicate the insignia of rank carried by priests. A third idea was that they were phallic. A fourth, that they were rough representations of men and animals, the runic *m* being a bird; a fifth, that they were the handicraft of some gentleman desirous of imposing upon the credulity of wandering archæologists.'

After due consideration of the evidences in existence of prehistoric times in Japan, we are, I believe, safe in concluding that, besides the aboriginal Korean inhabitants of Japan, there was at least one other race, if not two, also living here with them, possibly before them. Particularly is this true of the northern part of the empire. The *Nihongi* sets our minds at rest on this point. That book tells us that the most redoubtable of the barbarians were the Ainu, so that there must have been people other than the Ainu with whom to compare them. We read that the Ainu of those early times were savages, for they are said to have lived together promiscuously, dwelling in caves during winter and in huts in the summer; to have clothed themselves with fur; to have drunk blood; to have flown up the mountains like birds, and rushed through the grass like animals. They never remembered favours, but always revenged injuries. They carried arrows in their long hair and swords hidden in their clothing; they made raids upon the Japanese, and

carried off some into captivity. Thus, if the 'Chronicles' speak the truth, the aborigines were a savage race, and very difficult to subdue.

Whether the people referred to in the above passage were Ainu, or some other race akin to them, we

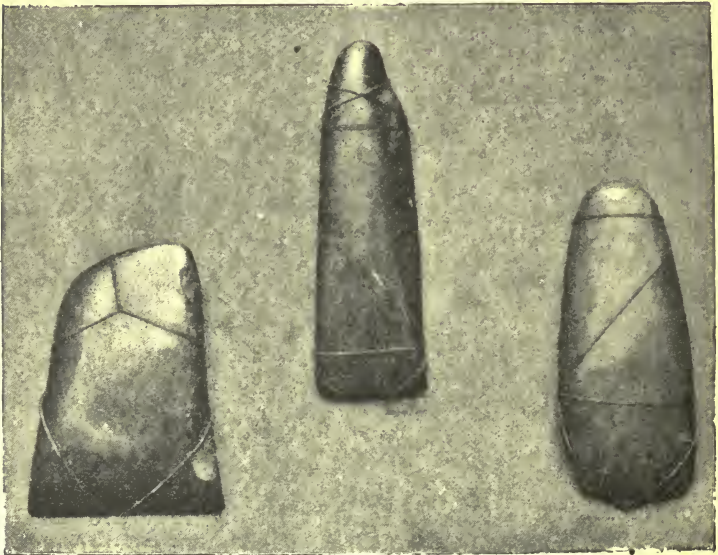

STONE ADZES

cannot now say. But that there was another race in Japan previous to, or contemporary with the Ainu—a race whom the Ainu found here, fought and drove out, just as the Japanese fought, conquered and drove out the Ainu—seems pretty clear from the pit-dwell-

ings and kitchen middens which are to be found here and there, and from the traditions of the Ainu. This race the Japanese have called *kobito*, i.e. 'dwarfs,' in contradistinction to the Ainu, whom they named *Ebisu* and *Yezo-jin*, but whom the Ainu designated *Koropok-guru*, i.e. 'pit-dwellers.'

Now, in speaking of Yezo particularly, it is a well-known fact that there are in many places upon this island a great number of round pits about three feet deep, by ten to twelve feet in diameter, though a few may be seen measuring as much as eighteen feet across. It

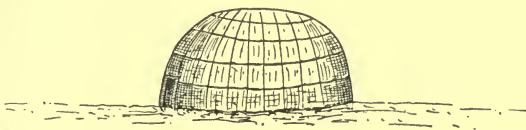

PROBABLE SHAPE OF KOROPOK-GURU'S HUT

appears that these pits were once the dwelling-places of human beings, for near them in rubbish heaps, upon the banks of some, and in others, many pieces of old pottery and numbers of stone axes, grinding stones, spear- and arrow-heads, as well as some fragments of bone, and portions of deer's horns, may be found by digging a few inches beneath the surface of the earth. From the general shape of these pits or holes we may assume that the huts were built over them something after the pattern of the snow houses of the Esquimaux. Ainu traditions

say that they were built somewhat conically, that they consisted of poles stuck into the earth upon the banks of the pits, and that these poles were made to bend over till they met in the centre, where the ends were tied together with bark string, or creeping plants. Over the poles were laid bark and grass, and upon this earth was placed, to keep out the wet and cold. Inside the hut the inhabitants had as many as five or six clear spaces left for fires, amongst which they slept. They are also said to have clothed themselves with the skins of animals.

If all this be true, we may conclude that Yezo was once much colder than it is at the present time. However, I do not think that these *Koropok-gurus* had so many fire-places in their huts, for in all those which I have dug out, or had dug out for me, but one place for fire was discovered, and that was near the centre. But, after all, it may be asked, is it not quite possible that these pit-dwellers may have been Ainu? It certainly is possible, though I do not think they were quite the same race as that existing to-day in Yezo. One Ainu did, it is true, once inform me that in ancient times their forefathers built huts over round holes dug in the earth, but that they changed this method of house-building upon coming into contact with the Japanese; and the Ainu of Saghalien profess to be the descendants of these pit-dwellers. However, Ainu huts of the present day do not resemble either the Japanese house or the

Esquimaux dwelling. Every other Ainu to whom I have spoken on the subject either emphatically denies that their ancestors lived in holes, or confesses absolute ignorance on the subject. In fact, though living in the very midst of these pits, some of them are quite ignorant of their existence; while others look upon them as natural phenomena; but none of them trouble their heads about the matter.

There seems to be good reason for believing that the pit-dwellers were shorter in stature than either the Japanese or Ainu; for whilst the Japanese tell us they were *kobito* (dwarfs), the Ainu say they were only about three or four feet in height, that they were of a red colour, and that their arms were very long in proportion to their bodies. Some have gone so far as to say that they were only about an inch in height. They were so small that if caught in a shower of rain or attacked by an enemy, they would stand beneath a burdock leaf for shelter, or flee thither to hide.

An Ainu once attempted to derive their name, *Koropok-guru*, from *koroko-ni* (burdock). This is on a par with calling the Ainu by the name Aino or Ainos, and saying that because Aino means 'mongrel,' or 'half-breed,' therefore the Ainu are half animal, half human; or that because Ainu sounds something like the Japanese word *inu* (dog), therefore the Ainu are dogs. *Koropok-guru*, however, is not derived from the word for 'burdock,' but has a distinct meaning of its own, and that is, 'people

residing below,' or 'pit-dwellers'; the full name is *choropok-un-guru*.

The Ainu say their forefathers destroyed this race of dwarfs in warfare. We are also informed by the Ainu that the *Koropok-gurus* used flint or stone knives, scrapers, and other implements, and that they were acquainted with the art of making pottery. This we may well believe, seeing that so many specimens of pottery have been disinterred. The Ainu say that they themselves never knew how to make pottery, and I have never yet seen anything of the kind manufactured by them. As for arrow-heads of stone, an Ainu once informed me that a few generations ago his race made and used them, but that they had since adopted the bamboo, because it is so much easier to work and is better adapted for carrying poison. Other Ainu deny this, and say they have never heard of the existence of such things as stone arrow-heads.

The question still remains, Who, after all, were these 'dwarfs' of the Japanese, and *Koropok-guru* of the Ainu? And who really used the stone implements? I am of opinion, but it is only an opinion, that these round holes, stone implements, and pottery are the remains of a race of people who existed in Japan and Yezo previous to, and by the side of the Ainu; though it is possible that the Ainu, in spite of all they say, might have used these implements, and have dwelt in such houses as the holes indicate. The Ainu may, as

their traditions say, have exterminated in warfare this race, as far as Yezo is concerned; but I am of opinion that these pit-dwellers were closely allied to the Ainu in descent, and that the remains of them may now be seen in Shikotan and other islands of the Kurile group.

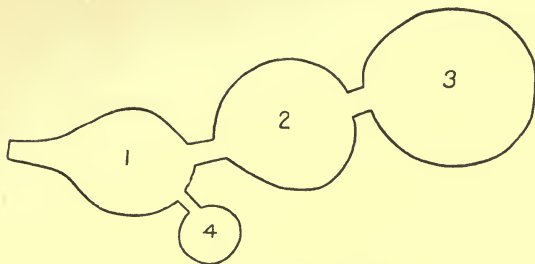

PLAN OF KURILE HUT

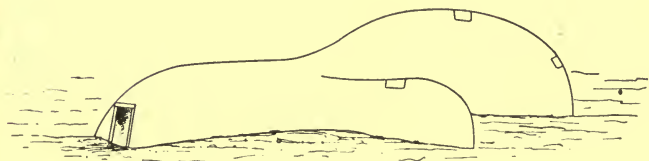

EXTERIOR OF KURILE HUT

The inhabitants of Shikotan are much shorter in stature than the Ainu of Yezo; they are not so good-looking, and are said to be a very improvident race. The Ainu look upon the Kurile islanders as the remnants of the *Koropok-gurus*; but this is mere opinion, and to be adopted or rejected at pleasure. That they are 'pit-

dwellers' is quite certain, for they live in pits at the present day.

These 'pit-dwellers' of Yezo were once very numerous on that island. At Kotoni, near Sapporo, there are many round holes, and not far from them, in a swamp, is a kind of fort. The fort is not a very imposing or formidable-looking affair. It is merely a small piece of dry land, with a wall of earth around it, and defended with a ditch full of water. In order to reach this fort, one has to wade through two or three feet of mud for about a hundred yards. I made one journey to it, but it was not worth the time and trouble. About Kushiro also there is a very large number of *Koropokgurus*' holes, showing that there must once have been a very large settlement about that place. Here also there is a kind of fort, castle, or watch-tower. It is about forty feet in height, and is in some places nearly perpendicular, and has a ditch around its higher section. Upon its summit there is a round hole like those over which the ancients are said to have built their huts.

CHAPTER XXII

AINU HEROES AND LEGEND

It is very curious that the Ainu have handed down to their posterity no names of heroes. They have, however, preserved to us the names of certain tribes, or rather, they point to districts in which certain of their brave warriors are said to have lived. Thus they speak of the inhabitants of a place named *Ureush-pet*, which is situated in the Ishkari mountains, as being a very warlike and brave people. This tribe, it appears, had their stronghold in the mountains, and have therefore been named *Kim-un-guru*, i.e. 'mountaineers.' These people are said to have been a particularly hardy and big-bodied race of men. Another party of fighting men are said to have lived at Tunni-pok, an unknown place; another tribe is said to have lived at Assuru, towards the source of the Kushiro river. Then we have another people who lived at Samatuye, also unidentified; and these are said to have been conquered by the *Poi-yaumbe*, which probably means 'the brave Ainu.'

We may quote in this connection a legend of a fight

between the 'brave Ainu' and the men of 'Samatuye.' It is a curious specimen of Ainu folk-lore. It is called

POI-YAUMBE, OR 'THE BRAVE AINU'

'We three, my younger sister, my elder brother and I, were always together. One night I was quite unable to sleep, but whether what I now relate was seen, a dream, or whether it really took place, I do not know.

'Now, I saw upon the tops of the mountains which lie towards the source of our river, a great herd of bucks feeding by themselves. At the head of this great herd there was a very large speckled buck; even its horns were speckled. At the head of a herd of female deer there was a speckled doe skipping about in front of its fellows. So I sat up in my bed, buckled my belt, winding it once round my body, and tied my hat-strings under my chin; I then fastened my leggings, made of grass, to my legs, slipped on my best boots, stuck my favourite sword in my girdle, took my quiver sling in my hand, seized my bow, which was made of yew and ornamented with cherry bark, by the middle, and sallied forth.

'The dust upon the road by the riverside was flying about; I was taken up by the wind, and really seemed to go along upon the clouds. Now, my elder brother and younger sister were coming along behind me. As we went along, in truth, we saw that the mountains

were covered with great herds of bucks and does ; the bucks had a speckled male at their head, even its horns were speckled, there was also a speckled female deer skipping about at the head of the does.

‘ On coming near them I took an arrow out of my quiver and shot into the very thickest of the herd, so

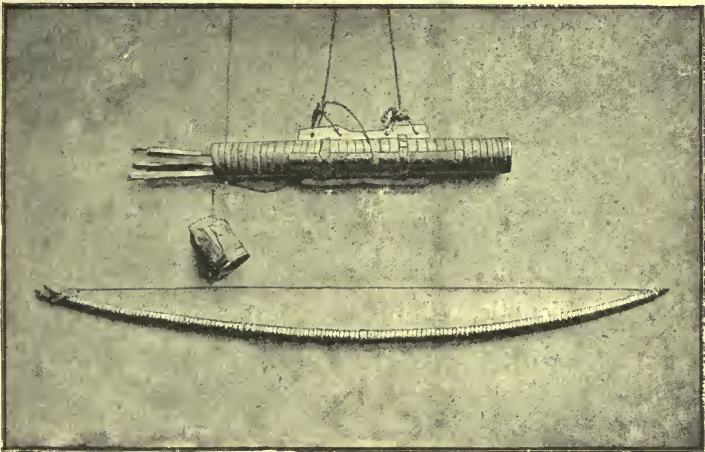

AINU BOW AND QUIVER

that the mountains became covered with the multitude of those which had tasted poison (i.e. which had been hit with poisoned arrows). And my elder brother shooting into the thickest of the herd of does, killed so many that the mountain was completely covered with their bodies ; within a very short time the whole herd both of bucks and does were slain.

‘How was it that that which but a short time since was a deer became a man? That I cannot tell.

[It should be noted here that the Ainu now, for the first time, discovers the deer to be human beings. They had hitherto appeared in the shape of animals, but they now assume their proper form, and were found to be enemies come to pick a quarrel and fight. The Ainu say that in ancient times their ancestors could assume the bodily shape of any animals they chose, and change again into their normal condition at will.]

‘With angry word he (i.e. the leader of the enemy) said to me, “Because you are a brave Ainu (Poi-yaumbe), and your fame has spread over many lands, you have come hither with the purpose of picking a quarrel with me. Thus, then, you see that you have slain my friends, and you doubtless think to defeat me, but however brave you may be, I think you will probably find that you are mistaken.”

[These words contain the challenge to fight. Here we see that the speckled buck, now turned into a man, accuses the Ainu of slaying his comrades. He seeks some grounds of quarrel, and attempts to shift the real cause of the war from his own shoulders to those of the Ainu, when, in truth, he himself had invaded the land.]

‘When he had spoken so much, this lordly person drew his sword with a flash and struck at me with powerful strokes; in return I also flashed out my sword,

but when I hit at him with mighty blows there was no corresponding crashing sound. It was extremely difficult to come upon him ; it was as though the wind caught the point of my sword. Though this was the case, though it was difficult to strike him, and though I did not realise that I was struck, yet much blood spurted forth from my body. That abominable, bad man was also bleeding profusely.

‘ Whilst things were going on in this way, my elder brother and younger sister met with the speckled doe (who had now become a woman), and both attacked it with drawn swords. With great fear they fought ; and when I looked, I saw that my elder brother was cut in twain ; as he fell, he put out his hands and raised himself from the earth. I then drew my sword and cut him twice or thrice, so that he became a living man again.

[The Ainu say that in ancient times, when fighting, their ancestors could raise the dead to life and heal their wounds by striking them with their swords. Truly this is a very curious idea, nevertheless the Ainu believe in it.]

‘ Then riding upon a sound like thunder he quickly ascended to the skies and again engaged in the fight.

[Thus the ancients could carry on their battles in the air.]

‘ I now heard a sound as of another person being slain somewhere ; it was my younger sister who was

killed. With a great sound she rode upon the setting sun (i.e. she died with a groan).

[This is a figurative mode of expressing death. Death is called 'a riding upon' or 'into the setting sun'; life is called 'a riding upon' or 'into' or 'a shining like the sun.']

'Upon this the bad foreign woman boasted that she had slain my younger sister and thrown her to the earth. Then the two, the woman and man, fell upon me with all their might and main, but I struck the bad woman twice or thrice so that she rode upon the sun (i.e. she died): she went to the sun a living soul. Then the bad, malignant man, being left alone, spake thus:

"Because you are a brave Ainu and the fame of your bravery has spread over many lands, and because you have done this, know ye that the place where I lie is called *Samatuye*.

[*Samatuye* really means 'to be cut in twain,' but it is said to be the name of a place or country. Its site is unknown.]

"The two, my younger brother and sister, are the defenders of my house, and they are exceedingly brave. Thus then, if I am slain by you, my younger brother will avenge my death and you will live no longer. You must be careful."

'Now, I made a cut at that bad, malignant man, but he returned the blow, and I swooned. Whether the swoon lasted for a long space or a short, I know not.

But when I opened my eyes I found my right hand stretched out above me and striking hither and thither with the sword, and with my left I was seizing the grass and tearing it up by the roots. So I came to myself, and I wondered where *Samatuye* could be, and why it was so called. I thought that name was given to the place to frighten me, and I considered that if I did not pay it a visit I should be laughed at when I returned home, and feel humiliated. Therefore I looked up and discovered the track by which this multitude of persons had come; I ascended to the path and passed very many towns and villages. And I travelled along this path for three days and three nights, in all six days, till I came down upon the sea-shore. Here I saw many towns and villages.

[The Ainu say that in ancient times their ancestors could travel through the air, and could carry on warfare far above the earth. Hence this hero travels through the air. He follows up the path till he comes to the sea-shore, upon whose side there are many cities or towns.]

‘Here was a very tall mountain whose top extended into the skies; upon its summit was a beautiful house, and above this circled a great cloud of fog.

[Here our hero again ascends to the path in the air.]

‘I descended by the side of the house, and stealthily walking along with noiseless steps, peeped in between the cracks of the door (this door was simply a mat made of

rushes and hung in the doorway), and listened. I saw something like a very little man sitting cross-legged at the head of the fire-place staring into the fire, and I saw something like a little woman sitting on the left-hand side of the fire-place.

‘Here again was a woman who in beauty equalled my younger sister [he falls in love with her]. Now, the little man spake thus :

“Oh, my younger sister, listen to me, for I have a word to say. The weather is clouding over, and I am filled with anticipation. You know, you have been a prophetess from a child. Just prophesy to me, for I desire to hear of the future.” Thus spake the little man.

[The little man seeks to know the cause of his anticipation of evil, so he asks his sister, who was a prophetess, to prophesy and explain the reason to him.]

‘Then the little woman gave two great yawns and said :

[To yawn means here, to fall into a trance or to go to sleep. Ainu wizards or prophets always lie down and close their eyes when they prophesy.]

“My elder brother, my little elder brother, listen to me, for I have a word to say. Wherefore is my brother thus in anticipation? I hear news from a distant land; there is news coming from above the mountains of Tomi-san-pet [Tomisanpet is the name of a river in Yezo]. The brave Ainu have been attacked by my

elder brother without cause, but a single man has annihilated my brother and his men. Whilst the battle proceeds a little *kesorap* [*kesorap* is the name of some kind of bird; it may be a peacock, or an eagle, or a bird of paradise, the Ainu do not know which. Here, however, the Ainu hero is intended] comes flying across the sky from the interior, and, though I earnestly desire to prophesy about it, somehow or other it passes out of my sight. When it crosses the sea [she now sees the Ainu on his way to their castle or village] it darts along upon the surface of the water like a little fish; coming straight to our town is the clashing of swords, the sword of an Ainu and the sword of his antagonist [she sees the battle carried on in the air]. Blood is spurting forth from two great wounds; the sword of our brother departs into the setting sun and is lost [i.e. her brother is slain]; the handle of the sword of the Ainu shines upon the sun [i.e. the Ainu conquers]. Although our house was in peace, it is now in danger [she sees the Ainu hero near the house]. In speaking thus much my eyes became darkened [i.e. she can prophesy no more]. Pay attention to what I say."

'As she said this I pretended that I had but now arrived, and knocking the dirt off my boots upon the hard soil just outside the house [i.e. making a noise upon the ground as if I had but just arrived], I lifted the door-screen over my shoulders and stepped inside. They both turned and looked at me with one accord;

with fear they gazed at me from under their eyebrows. Then I walked along the left-hand side of the fire-place with hasty strides.

‘ I swept the little man to the right-hand side of the fire-place with my foot [to touch a person with the foot is a gross insult amongst the Ainu], and sitting myself cross-legged at the head thereof, spake thus :

“ Look here, you little Samatuye man, I have a word to say, attend well to me. Why has your elder brother, the Samatuye man, attacked us without cause? Has he not done so [this question carries in it an affirmation. The same mode of speech is often used in this way. It is an affirmation under the guise of a question]? As you have stirred up this war without cause, you will be punished by the gods; you will be annihilated. Listen to what I say. Besides, although I am a wounded man, I will overthrow your town. Listen to what I say.”

‘ And when I had so said, I drew my sword and flashed it about. I struck at him with such blows that the wind whistled. We ascended to the ceiling fighting, and here I chased him from one end of the house to the other. Whilst this was going on, a very great multitude of men congregated upon the threshold. They were as thick as swarms of flies; so I cut them down like men mow grass.

‘ Whilst this was going on the little woman said: “ Oh my brothers, why did ye commit such a fault as to attack the brave Ainu without cause? Was it that ye

desired to slay those who had no wish to die that ye fell upon them? Henceforth I shall cast in my lot with the brave Ainu. Listen to my words."

'When the little woman had thus spoken, she drew a dagger from her bosom and cut down the men at the door like grass; we fought side by side.

[Here we see that the woman falls in love with the man, just as the man himself fell in love with her, as is stated above.]

'Fighting so, we drove them out of the house. And when we beheld them, there were but a few left, but behind them stood the little Samatuye man; yes, he was there. In a very short time those few persons were all killed. After this I went after the Samatuye man with hasty strides, and drew my sword above him. I struck at him with heavy blows. The Samatuye woman also stood by my side and hit at her brother with her dagger.

'In a very short time he received two or three cuts and was slain. After this the little woman wept very much and spake, saying:

"As for me, I am undone; I did not desire to draw my dagger against a man without friends.

"As the little hawks flock together where there is food, so have I an earnest desire to be with thee, O brave Ainu! Listen to what I say."

[Thus then this war ends in a marriage. The little woman seeks the hand of the brave Ainu. That they

were happy ever afterwards, and had a family of beautiful daughters and extraordinarily brave heroes of sons, is left to the hearer's imagination. That the woman should seek the hand of a man is quite a natural state of things amongst the Ainu, and constantly occurs in this land. It is with them one continual leap-year.]

CHAPTER XXIII

MISSION WORK AMONG THE AINU

MISSION work among the Ainu was commenced by the Rev. W. Dening, who at that time was connected with the Church Missionary Society. It was during a tour in 1876 that he first visited the Ainu in their villages. He lived for some weeks in an Ainu hut, winning the confidence of the people, learning their language, and endeavouring in a simple way to give them some notion of the Gospel. The Ainu and Japanese languages are wholly different, and the former may be regarded as a language altogether isolated at the present day. Other districts were visited during a second tour in 1878. But although much information was gained, and the way prepared for further efforts, not much was effected in a strictly missionary sense.

In 1880 the author accompanied Mr. Dening to Sapporo, and made his first visits to the Ainu settlements in that district, and began to study the Ainu language. During 1881 he paid two visits of two months each to Piratori, the old Ainu capital, and, whilst continuing his linguistic studies, made his first attempt to

preach the Gospel. After visiting England in 1882, he returned to the Ainu country, and remained there during six months in 1883. His Ainu friends had not forgotten him. They manifested great pleasure at his return, almost whole villages turning out to welcome him, and their chiefs expressing the hope that he would remain amongst them for a long time. He located himself with Chief Penri at Piratori, who lent him a corner of his hut. His study of the language was resumed, a vocabulary of about 6,000 words collected, an Ainu grammar compiled, and some translation work attempted.

In the way of preaching the Gospel, I held services at Piratori in Chief Penri's hut, and did a great deal of visiting and itinerating. The work was always very encouraging, for whole villages came together to listen, and sometimes very good questions were asked by the congregations. Several chiefs whom I was then unable to visit came to ask me to preach to their people.

As the Ainu of to-day is and lives, so Japanese art and traditions depict him in the dawn of history. His language, religion, dress, and manner of life are the same as of old. He has no alphabet, no writing, no numbers above a thousand. In character and morals they are stupid, good-natured, brave, honest, faithful, peaceable, and gentle.

The Ainu, though quiet and gentle, are much addicted to drunkenness. After careful inquiries in many villages, I estimate that ninety per cent. of the men are drunkards,

and that the women drink to excess whenever they have the opportunity. How God can be acceptably worshipped without wine is a puzzle to the poor Ainu, so intimately connected in his mind are wine and worship. The Christian injunction against intemperance offends him, and I see, even now, the beginnings of a hard struggle between strong drink and religion.

The Chief Penri sadly illustrates the power which this terrible vice has over the poor Ainu. He took a very great interest in the religion of Jesus, and did all he could to assist me. But drunkenness was his great stumbling-block. He tried twice to give up his drink, but each time he failed. On the first occasion he was sober for a whole month, and on the second for nearly three.

The Japanese Government seems to be desirous of protecting the Ainu, and improving their condition by education. But another great difficulty is with the Japanese traders, who are all wine-vendors. They buy the skins of animals from the Ainu, and they love to pay for them in wine rather than money. It is to the advantage of these wine-vendors to keep the poor Ainu in a state of ignorance, and that their taste for wine should be encouraged as much as possible. But they begin to see what effects Christian teaching would have upon the Ainu, therefore they bring all their forces to bear upon Christianity and the missionary. Christianity is said by them to be rotten, and therefore useless, and

not to be believed. As for that 'rascal of a hairy Chinaman' (meaning myself), he has come here to gain the confidence of the Ainu, learn their language, deceive them with a false religion, and in the end seize the country and the people.

Owing to the misrepresentations of these men, during part of 1884 I was unable to obtain a passport, and consequently could not visit the Ainu districts; but I invited the chief Penri to Hakodate, and there continued the study of the language. Later in the year I procured a passport, and, accompanied by my wife, spent some time in the Ainu villages. The greatest caution, however, was necessary, lest some difficulty should be raised to prevent us from remaining, and we were compelled to lodge at a Japanese inn.

In 1885 we stayed at Poropet Kotan, which is a particularly good centre for work, as it is nearly midway between the Saru and the Usu districts. In this village there are about 150 Ainu, all told.

As the Ainu are very unwilling to enter Japanese houses, we were seldom able to collect more than six Ainu together in the hotel at one time; but when preaching in an Ainu hut we were generally much crowded, the congregation never numbering less than thirty. The meetings were always largely attended when it was known that my address was to be illustrated by the magic lantern, which I found of the greatest use.

Before the close of this year the first Ainu convert

in connection with the mission was baptized. He was named Kanari Taro, and was son of the village chief. He was a good Japanese scholar, and held a school-master's certificate. He early showed a great interest in Christianity. He was baptized on Christmas Day, 1885; and two others—husband and wife—who were then inquirers, were baptized with their adopted Japanese daughters by Bishop Bickersteth, on August 29, 1886, when he was visiting the Ainu country. In 1886, the mother of our female Christian servant was brought to a saving knowledge of her Redeemer by her daughter and son-in-law. Her age was seventy-five. Nothing delighted her more than to hear the old, old, yet ever new, story of Jesus and the cross. Her last testimony was, 'Tane anakne apun no ku mokoro; tane, ratchitara ku shini eashkai ne' ('Now I can sleep quietly; now I can rest in peace'). Mrs. Batchelor started a singing-class for girls. These children also learned to read and write.

Several adults also learned to read. The Apostles' Creed, the Lord's Prayer, and the hymn 'Jesus loves me' were the first things ever printed in the Ainu language; these were done with a little press bought with money sent by the children of Jesus' Lane Sunday-school, Cambridge. Since then the translation of St. Matthew's Gospel has been proceeded with; and thus a new language is being reduced to writing, and the Word of God translated into it.

During the year 1887 a good school for the Ainu was started at Horobetsu, and Kanari Taro, the first Ainu Christian, was appointed schoolmaster. He had thirteen pupils. Also two more Ainu were baptized during this same year, making a total of six native Christians.

The next year there were no further baptisms, and the school had only two additional pupils, making fifteen in all—nine boys and six girls.

During the year 1889 a great deal of itinerating work was done. The full congregations and rapt attention of the hearers, the telling questions and intelligent remarks made by the people, were very encouraging features. The invitations to go to other villages were earnest and frequent. One Ainu only was gathered into the Church. He was a lame lad, aged nineteen, who was taken as pupil-teacher into the Ainu school.

During my furlough at home I have had the privilege of translating and seeing through the press the Gospels of St. Mark, St. Luke, and St. John in Ainu.

But the Ainu race is dying out. Year by year its members decrease, and, in spite of the laudable efforts of the Japanese Government to preserve it, its extinction seems inevitable. But, if the race perishes, a precious remnant, won to Christ, will abide for ever.

That the Ainu of Japan may prove a fresh and bright example of the readiness of primitive races to receive Him who has pictured Himself as the Shepherd,

leaving the ninety and nine in the wilderness, and going after that one which is lost until He find it, will surely be the prayer of every reader of these pages. May that blessed Spirit whose office it is to take of the things of Christ and reveal them unto men, work among the poor benighted Ainu, teaching them not to be drunk with wine, wherein is excess, but to bring forth the fruits of the same Spirit, to the glory of God the Father.



INDEX

ABL

ABLUTIONS, use of, 221
Adultery, penalty for, 189
Ainu, origin of, 13; etymology of name, 16; Japanese tradition of origin of, 16; hairiness of, 18; appearance of, 18; character of, 19; size of, 20; physiology of, 20; mode of dressing the hair, 24; dirtiness of, 24; how treated by Japanese, 24; they are malodorous, 26; wildness of, 28; women's work, 28; their love of horses, 28; their love of *sake*, 29; drunkenness of, 30; power of the Gospel on, 31; appearance of women, 34; tattooing, 35; position of women, 38; food of, 38; weaving of, 39; reaping, 40; cooking, 41; suicides among, 43; treatment of children, 43; divorce among, 44; curious custom at childbirth, 44; dress of, 45; mode of sleeping, 48; treasures of, 48; huts of, 54; temple of, 60; worship of, 60; libations of, 61; fear of fire, 61; conservatism of, 63; housewarming of, 64; mode of saying grace, 67; food of, 67; position of, at meals, 68; dirtiness of, 70; furniture of, 72; mode of feeding babies, 76; mode of carrying, 83; use of tobacco, 84; inao of, 86; temper of, 95; prayers of, 97; etiquette of, 101; modes of saluting, 101; education of, 109; legends of, 111-13, 115, 121, 124, 126; tales of, 112; music of, 123; dancing of, 130; games of, 131; ordeals of, 135; family life of, 138; marriage of, 139; names of, 142; mode of hunting deer, 143; traps of, 148; fishing of, 152; spears of, 152, 154; nets of, 153; fish-traps of, 153; harpoons of, 155; bear-hunting, 158; bear-feasts, 162, 174; their use of poison, 169; arrows, 170; bows of, 171; their bear cubs, 171; origin of, 179; trade of, 182; canoes of, 182; sleighs of, 185; snow-shoes of, 186; government of, 187; punishments of, 188; their fear of angry women, 191; medicines of, 194; treatment of the sick, 195; wizards of, 197; prophets, 197; their belief that sickness is a punish-

BIR

ment, 199; fear of snakes, 200; legend about them, 201; about insects, 201; death and burial customs of, 203; tombstones of, 210; mode of speaking of death, 212; belief in ghosts, 219; creed of, 219; dread of old women, 223; polytheism of, 224; beliefs of, 224; story as to the future world, 226; libations of, 230; ideas of heaven and hell, 235; worship of Yoshitsune, 240; their ideas of worship, 245; deities of, 247; belief in one great God, 248; creed of, 251; lesser gods, 254; ideas of Providence, 256; religious legends of, 262; the sun goddess, 273; conduct of during eclipse, 274; belief as to stars, 276; idea as to shape of the world, 277; dread of large lakes, 279; Saghalien Ainu, 281; decrease of, 284; extermination of, 284; effects of exposure, small-pox, drunkenness, 285; wars of, 286; armour of, 287; daggers of, 287; raids of, 288; cannibalism of, 288; intermarriage of, 289; place-naming of, 291; not the only aborigines, 295; heroes of, 313; mission work amongst, 325
Aioina Kamui, meaning of, 281
Armour, 287
Arrows, poisoned, 169
Attush, 45
Axe Rock, the, 268

BABIES, 259
Bags, 84
Barter, trade by, 182
Baskets, 84
Beads, 50
Bear-feasts, 162, 174
Bear-hunting, 158; story of, 162
Bear-pits, 171
Bears, tame, 171
Beating, game of, 132
Bedsteads, 73
Belts, 50
Betrothal, 142
Bird, Miss, mistake of, 29

BON

Bonnet, widow's, 213
 Book, extract from oldest Japanese, 13
 Bows, 171
 Building, mode of, 57
 Burial, mode of, 206
 Burning huts of old women, reason for, 223

CANDLESTICKS, 80

Cannibalism, 288
 Canoes, 182
 Cave-dwellers, 298
 Chants, 124
 Chestnuts used as food, 40
 Chiefs, government by, 187
 Child, death of a, 213
 Childbirth, curious custom at, 41
 Children, treatment of, 43
 Chronicles of Japan, the, 297
 Climate of Yezo, 14
 Cloth, Ainu, 33
 Convolvulus plant, use of, 196
 Cooking, 41, 67
 Cradle, 43 : word for, 258
 Creator, belief in the, 258
 Creed of Ainu, 219, 251
 Crops, 39
 Crow legend, a, 270
 Cup ordeal, 137
 Cursing, 191

DAGGERS, 287

Dancing, 130
 Dead, the treatment of, 203
 Decoy for deer, 143
 Decrease, causes of Ainu, 284
 Deer-hunting, mode of, 143
 Deities, 247
 Divorce, 44
 Dock seed, use of, 194
 Dog-sleighs, 185
 Dogs and spirits, 226
 Dogs, hunting, 143
 Doorways, 59
 Dress of Ainu, 45
 Drinking ordeal, 136
 Drunkenness of Ainu, 30
 Dryads, 255
 Dualism, 93
 Dwarfs, the, 281

EAR-BORING, anecdote concerning, 50

Earrings, 49
 Earthquake fish legend, 278
 'Earth-spiders,' 298
 East end of hut, sacredness of, 58
 Eclipse of the sun, legends of, 274, 275
 Education, 109
 Embroidery, 46

FABLE of the Man in the Moon, 111

Family life, 138
 Famine, a great, 40 ; legend of a, 124
 Firé, fear of, 61 ; mode of producing, 83
 Fire goddess, the, 259, 277

LAM

Fishing, 152
 Fish-trap, 153
 Fleas, 76
 Flint and steel, use of, 83
 Food, 67
 Foxes, tale of the, 112
 Fuji-yami, etymology of, 293
 Funeral customs, 203
 Furniture, 72
 Future world, story as to the, 226

GAMES, 131

Gardens, 40 : customs as to, 256
 Gehenna, 236
 Ghosts, belief in, 219
 Göl, etymology of word, 248
 Government, system of, 187
 Grace, mode of saying, 67
 Graves, dread of, 219

HADES, legend about, 229 ; belief in, 236

Hair-cutting, legend as to, 243
 Hairiness of Ainu, 18
 Hair, mode of dressing, 24
Haliotis tuberculata used as food, 41
 Hanging by the hair, 137
 Harpoons, 155
 Heaven, 235
 Hell, 236
 Heroes, 313
 Hokkaido, 14
 Horses, Ainu love of, 28
 Hot iron or stone ordeal, 136
 Hot-water ordeals, 135
 House-warning feast, 64
 Hunting, Ainu love of, 28
 Huts, mode of building, 57 ; thatching, 57 ; windows, 58 ; shutters, 58 ; sacredness of east end of, 58 ; ventilation of, 58 ; porch of, 59 ; doorways of, 59 ; size of, 62 : of newly married, 62 ; story of a rich man's, 63 ; draughtiness of, 75 ; insect pests in, 76 ; of pit-dwellers, 307

INAO, description of, 60, 87 ; value of, 192

Index finger, name for, 70
 Insect pests, 76
 Insects, legends as to origin of, 201, 271
 Inter-marriage, 289

JAPANESE tradition of origin of Ainu, 16 ; petlars, cheating of, 49 ; treatment of Ainu, 24

Jimmu, Emperor, slaughter by, 298

KAMUI, etymology of word, 248

Korean aborigines of Japan, 301
Koropok-gurus, the, 307 ; huts of, 307 ; etymology of words, 309 ; implements of, 310 ; pottery of, 310 ; who were they ? 310

Kotoni, fort at, 312

LAKES, dread of, 279
 Lamps, 80

LEG

Legends: the Man in the Moon, 111; as to reverence for the old, 113; of Yoshit-sune's theft, 115; of the water-wagtail, 121; of a famine, 124; as to the gods, 127; fishing tradition, 155; as to snakes, 201; as to the future world, 226; Hades, 229; on hair-cutting, 243; religious, 260; of the creation, 267; as to rats, 268; as to crows, 270; as to insects, 271; of eclipses, 275; as to earthquake fish, 278; as to Ainu origin, 283; as to massacre of earth-spiders, 278; of Poi-yaumbe, 314

Leggings, 48

Libations of wine, 61, 230

Looms, 80

MADNESS, 199

Mallet-headed swords, 300

Man in the Moon, the, 111

Marek, the, 152

Marriage customs, 139

Mats, use of, 74

Meals, position at, 68

Medical treatment, 194

Milne, Prof., on caves, 300; on Otaru in-scription, 302

Mo acha, the god, 92

Mortar and pestle, 78

Moustache lifters, 77

Mukkuri, the, 129

Murder, punishment for, 190

Music, 123

NAMES, 142

Necklaces, 50

Needlework, 46

Nets, 153

Nusa, 60

ONAUISHI, meaning of, 283

Okikurumi-Yoshit-sune, 119

Ordeals, 135

Origin of Ainu, 13, 16

Ornaments, fondness for, 49

Ostyak ordeal, 138

Otarunai, inscriptions at, 301

Otter-trap, 148

PANTHEISM, 245

Pap, 76

Paralysis, name for, 199

Pestle and mortar, 78

Pike-spear, 154

Pipes and tobacco, 85

Piratori, the capital, 179

'Pit-dwellers,' 307; huts of, 307

Place-naming, 291

Poison, 169

Poi-yaumbe, legend of, 314

Polytheism of Ainu, 224

Porch of hut, 59

Possession, belief in demoniacal, 196

Pottery, ancient, 310

Prayers, 97

TUN

Prophets, 197

Punishments, 188

RAIDS, 288

Rat legend, a, 268

Rat-trap, 150

Reaping, 40

'Records of Ancient Matters,' the, 295

Religious legend, 127

Rich man, story of a, 63

Rings, 49

River deities, 93

Robbery, punishment for, 188

Rushikai-Russians, 50

SAGHALIEN Ainu, 281

Sake, Ainu love of, 29

Salmon, use of, 41; fishing for, 152

Saluting, modes of, 101

Sarak kamui, the god, 94

'Sea-ear,' people saved by eating, 41

Seagods, offerings to, 92

Serpent, legend about a monster, 201

Shi acha, the god, 92

Shikotan, people of, 311

Shinondi, on Ainu creed, 29

Shintoism, 240

Shintoko, 49

Shoes, 48

Shrine of Yoshit-sune, 242

Shutters, 58

Sickness thought to be a punishment, 199

Sleeping, mode of, 48

Sleighs, 185

Smoking, 84

Snakes, fear of, 200; legend about, 201

Snow-shoes, 186

Spears for fishing, 152, 154

Spoons, 76

Spring-bow, 148

Stake ordeal, 137

Stars, belief in, 276

Stone implements, 310

Storehouses, 59

Sun-goddess, the, 273

Sunstroke, a case of, 198

Swords, Japanese, 49; mallet-headed, 300

TALE OF THE FOXES, 112

Tara, the, 83

Tattooing, 35

Temples, 60

Thatching, 57

Tobacco-boxes, 85

Tobacco ordeal, 137

Tombe, 49

Tombstones, 209

Toothache, treatment for, 195

Torchlight, fishing by, 153

Toro no maki mono, the meaning of, 115

Traps, 148

Treasures, Ainu, 48

Trousers, skin, 48

Trout-spear, 154

Tuna, 72

Tunes, 123

TUN

Tuntu, etymology of the word, 257
Turen, meaning of word, 260
Turesh, legend of, 283

UKARA, the, 132
Urai, 153
 Utensils, 42, 69

VENISON, scarcity of, 70
 Villages, destruction of, 54
 Violet, dog-tooth, used as food, 40

WAJ-CLUBS, 179
Warinnekuru, legend of, 283
 Wars, 286
 Water-nymphs, 255
 Water-wagtail, esteem for, 121
 Weaving, 39
 Widowers, 212
 Widows, 213
 Wife, position of, 141
 Windows, 58
 Wizards, 197
 Wolves, 144
 Woman, a good, 233

YOS

Women's work, 28
 Women, appearance of, 34; tattooing of, 35; position of, 38; food of, 38; garden work and weaving by, 39; at home, 41; ignorant of religion, 42; suicide among, 43; treatment of children, 43; needlework of, 44; fondness for ornaments, 49; mode of feeding babies, 76; etiquette of, 104; mode of salting, 104; mode of entering a hut, 107; education of, 110; dances of, 130; position of wife, 139; supposed to suckle bear cubs, 173; curses of angry, 191; spite of, 192; sacrilege by, 192; tombstones of, 210; widows, 213; opposition of, 222; dread of old, 223; condition of, 231; their religious status, 231
 World, shape of the, 277
 Worship at house-warming, 64
 Wounds, treatment of, 195

YEZO, description of, 14; the Ainu of, 14; legend as to creation of, 267
Yoshitsune, legends of, 115; fishing tradition of, 155; worship of, 240; shrine of, 242



Return to *

MRS. S. H. E. MOODIE
66 Hutchison Street
MONTREAL

200

10





