

UC-NRLF



QB 32 932



# Airplane Characteristics



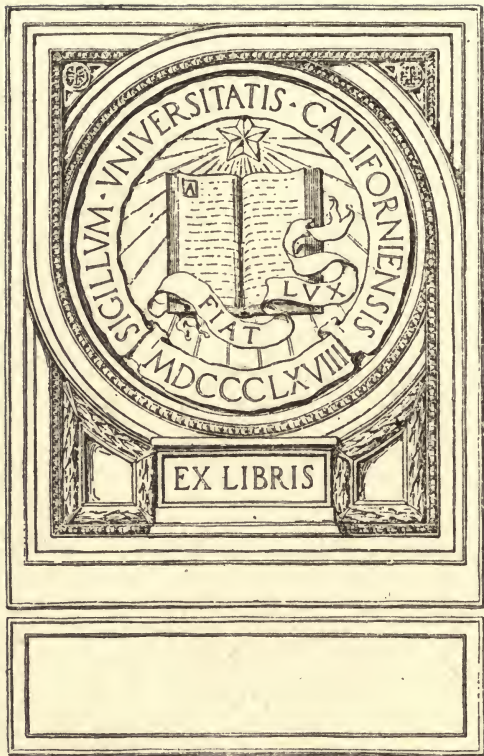





# AIRPLANE CHARACTERISTICS

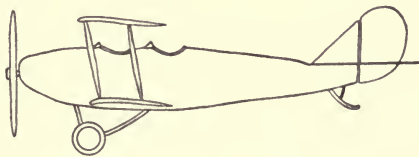

*By the same author*

---

**The Principles of the Transformer**

**Direct and Alternating Current Manual**

**Experiments with Alternating Currents** (being Part  
II of Volume II of A Laboratory Manual of  
Physics, edited by E. L. Nichols)

**Alternating Currents: an Analytical and Graphical  
Treatment for Students and Engineers** (jointly  
with A. C. Crehore)

Also, editions in French and German



1918  
1919  
1920  
1921  
1922  
1923  
1924  
1925  
1926  
1927  
1928  
1929  
1930  
1931  
1932  
1933  
1934  
1935  
1936  
1937  
1938  
1939  
1940  
1941  
1942  
1943  
1944  
1945  
1946  
1947  
1948  
1949  
1950  
1951  
1952  
1953  
1954  
1955  
1956  
1957  
1958  
1959  
1960  
1961  
1962  
1963  
1964  
1965  
1966  
1967  
1968  
1969  
1970  
1971  
1972  
1973  
1974  
1975  
1976  
1977  
1978  
1979  
1980  
1981  
1982  
1983  
1984  
1985  
1986  
1987  
1988  
1989  
1990  
1991  
1992  
1993  
1994  
1995  
1996  
1997  
1998  
1999  
2000  
2001  
2002  
2003  
2004  
2005  
2006  
2007  
2008  
2009  
2010  
2011  
2012  
2013  
2014  
2015  
2016  
2017  
2018  
2019  
2020  
2021  
2022  
2023  
2024  
2025



THOMAS-MORSE SCOUT



# AIRPLANE CHARACTERISTICS

A SYSTEMATIC INTRODUCTION FOR  
FLYER AND STUDENT AND FOR ALL  
WHO ARE INTERESTED IN AVIATION

BY  
FREDERICK BEDELL, PH. D.

*Professor in Physics, Cornell University*

Member Aeronautical Society of America, Vice-President American Institute of Electrical Engineers, Fellow and Past General Secretary American Association for the Advancement of Science, Member the American Physical Society and Managing Editor of The Physical Review.

FIRST EDITION

PRICE \$1.60 NET

*See Note in Regard to Publication on Following Page*

UNIVERSITY OF  
CALIFORNIA

TAYLOR AND COMPANY  
ITHACA, NEW YORK  
1918

B3

### NOTE IN REGARD TO PUBLICATION

In view of the importance *at the present moment* of any contribution to aviation, this first edition containing only part of the material contemplated is issued now. The remaining part, referred to in the Preface and Contents, is in preparation and this, it is expected, will be ready for publication in 1919.

TAYLOR AND COMPANY, Ithaca, N. Y., will send copies of this book, postpaid, upon receipt of \$1.75 per copy. Copies may also be obtained from The AERONAUTICAL LIBRARY, 299 Madison Ave., New York, and from leading dealers generally.

COPYRIGHT 1918  
BY  
FREDERICK BEDELL

TO THE  
AERONAUTICAL LIBRARY

TO  
FOUR NEPHEWS WHO ARE IN THE AIR SERVICE OF THE UNITED  
STATES AND HER ALLIES, AND TO THE MEMORY OF  
ONE NEPHEW WHO HAS DIED IN THAT  
SERVICE, THIS BOOK IS DEDI-  
CATED BY THE  
AUTHOR

382818



## PREFACE

Any contribution to aviation, however small, needs today no justification. The airplane is an accomplished fact and concerning it there is no longer any room for apology or speculation. So far has the art of flying progressed that the principles of flight can in the main be set forth as definite and without surmise, and a collection of the essential elements can now be made that will apply to all airplanes, irrespective of type or structure. Not that there is nothing further to be learned or discovered in aviation—for, far from it, there is ample opportunity for discovery and invention in this direction—but a codification of the well-known ground work can now be made that may be an aid to those who are advancing the art, as well as to those who are learning it.

The introductory discussion in this volume is a contribution to such a codification, which, it is hoped, will prove useful not only to the flyer and designer, for whom the book is primarily intended, but to students and engineers and to others who have only a general interest in aviation. Indeed, so important is the place now taken by the airplane that there are many who desire a knowledge of the principles of its operation.

It is the author's purpose to present the principles of airplane sustentation and stability and the characteristics of an airplane in flight in a way that is direct and simple and at the same time reasonably precise, laying particular stress on that which is vital. Except in minor ways, no claim is made for originality other than in presentation; in fact, the aim has been to include only those things that are essential and are accordingly well known to those versed in the subject. To those not thus well versed, the characteristics of an airplane

## PREFACE

are, however, not so well known as they should be; discussion of the subject is apt to be either superficial and inadequate or involved and complicated. The author has endeavored to give a treatment that is adequate but simple, and without the use of higher mathematics.

Logical sequence, rather than historical development has been kept in mind and no attempt has been made to ascribe particular features to their inventor or author. Military uses of the airplane, as well as its history, are left to others who may more appropriately discuss such phases of the subject. The author has confined his attention to the principles of airplane flight and has given no discussion of materials of construction—very important, of course, in airplane building—nor of the gas engine, on which there are many specialized treatises.

The author had occasion, as a member of a commission for planning the courses in our SCHOOLS OF MILITARY AERONAUTICS, to study carefully the needs of such courses. He has had occasion, also, to conduct several classes in aerodynamics and the principles of flight, made up not only of those with a direct practical interest in flight, as future pilots and designers, but likewise of others with an indirect interest—students in civil and mechanical engineering and physics—who have been interested in the airplane as in any of the mechanisms of our present day civilization. He has noted particularly those parts of the subject that have proved vital and of interest to all,—no matter from what angle the subject is approached.

It is planned that the book—with the added chapters now in preparation—shall be self-contained and complete in its own field, i. e., as an introduction; final practical instruction for flyer or designer must needs be obtained at the flying

## *PREFACE*

field or in the designing room. The author has had flying experience only as passenger and would make no attempt at specific flying instruction.

In view of the present emergency, it is thought best to issue the material contained in this first edition without delay, and to reserve for subsequent publication the material now in preparation (referred to in the Table of Contents) that is needed to complete the work. The author will be glad to have his attention called to any error or obscurity in this presentation and will particularly appreciate constructive suggestions from those practically engaged in airplane operation or development.

ITHACA, N. Y.,

July 30, 1918.





## CONTENTS

	PAGE
CHAPTER I. Sustentation - - - - -	1
CHAPTER II. Relations in Flight - - - - -	28
CHAPTER III. Resistance - - - - -	41
CHAPTER IV. Lateral Stability - - - - -	55
CHAPTER V. Directional Stability - - - - -	67
APPENDIX I. Glossary - - - - -	77
APPENDIX II. Thrust Characteristics - - - - -	91
APPENDIX III. Power Characteristics - - - - -	103
APPENDIX IV. Control and Other Diagrams - - - - -	115

### IN PREPARATION

The following chapters are in preparation: Thrust; Power; Climbing; Gliding; Altitude; Single and Multiple Planes; Stability in General; Longitudinal Stability.





## CHAPTER I

### SUSTENTATION

The *first essential* for flight is a sustaining force or **sustentation**. This is obtained in balloons and in airships by the buoyancy of a light gas which makes the craft as a whole lighter than air and capable of flotation. In an airplane, or in any aircraft heavier than air, this sustentation must be obtained by the reaction of the air upon planes or surfaces which are moving with relation to the air and which force or deflect the air downward. The airplane is the only craft of this kind that has been practically developed and it alone will be discussed in this volume. Other types of flying machines have, however, been contemplated, among which may be mentioned the **ornithopter**, with wings that flap like those of a bird and sustain the machine by forcing the air downward and at the same time backward; and the helicopter, equipped with propellers which revolve on a vertical shaft and lift the machine by forcing the air directly downward.

A *second essential* for flight is **stability**, discussed in later chapters.

The sustentation of an airplane is due to the fact that the air it encounters is deflected downward by the wings; although this downward deflection is but little, it is sufficient to sustain the machine, for new air is being continually encountered and deflected. An understanding of sustenta-

tion will best be gained by a consideration of the pressure exerted by the air upon flat and curved surfaces moving rapidly with relation to it.

### FLAT PLANE PERPENDICULAR TO AIR STREAM

We will first consider the pressure on a flat plane perpendicular to an air-stream.

#### Pressure varies as square of velocity.

If a thin plate or plane, say a book cover or the cover of a cigar box, is held out from a moving automobile — well away from the body and windshield — so that the air-

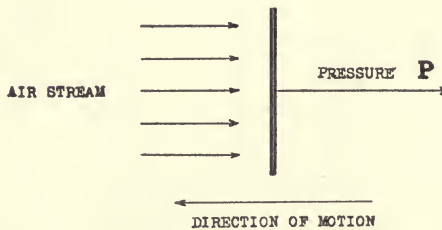

Fig. 1. Pressure on flat surface.

stream strikes the plane perpendicularly to its surface, as in Fig. 1, a pressure is felt that is small at low speeds but which increases very rapidly as the speed increases. In fact, if accurate measurements were made, it would be found that when the speed is doubled the pressure becomes four times as great, in other words that the pressure varies as the square of the speed.

Furthermore, this same relation would be found to be true if the plane were held still in a wind or in the air from a blower, and so it is seen that the pressure depends not upon the absolute velocity of the plane or of the air but upon their *relative* velocity, as the air-stream strikes the

plane. This is on account of the great mobility of the air particles, the effect being the same whether the air is stationary or moving. The law of the "square-of-the-velocity," although not a general law that holds for all substances and for all velocities, may be taken as practically true in air throughout the range of airplane velocities.

#### Pressure varies with plane area.

By using planes of different areas, it would be found, likewise, that the total pressure on the plane increases with the plane area and (practically) in direct proportion to the area; for example, an increase of ten per cent. in area is accompanied by an increase of ten per cent. in total pressure on the plane. This relation, however, must be considered as only approximate, particularly when the planes compared differ greatly in shape or area.

#### General law.

The total pressure  $P$ , upon a surface  $S$ , normal to an air-stream with velocity  $V$ , may accordingly be expressed by the following law:—

$$P = KSV^2.$$

Here  $K$  is a number or coefficient, the value of which depends upon the units used\*. When the area  $S$  is given in square feet, the velocity  $V$  in miles per hour and the total pressure  $P$  in pounds, a practical value for the coefficient  $K$ , that has been determined experimentally, is 0.003 for air at normal density; that is,

$$P = 0.003 SV^2.$$

The pressure per square foot of surface is thus seen to be

---

\*Thus, when  $P$  is expressed in ounces per square foot, the numerical value of  $P$ , and so of  $K$ , is 16 times as great as when  $P$  is expressed in pounds per square foot.

1.2 pounds at a velocity of 20 miles per hour, 4.8 pounds at a velocity of 40 MPH., 19.2 at 80 MPH., etc.

*Metric units.*— When  $V$  is velocity in meters per second,  $S$  the area in square meters and  $P$  the weight in kilograms, the value of  $K$  is 0.075. To get  $K$  in English units of pounds, square feet and miles per hour, multiply  $K$  for metric units by 0.0408.

### Variations in $K$ .

The value of  $K$  is not strictly a constant. It varies directly with the density of the air, decreasing, therefore, with altitude, as discussed later, and changing somewhat from day to day. It varies, also, with the size and shape of the surface. The values given above ( $K = 0.003$  in English

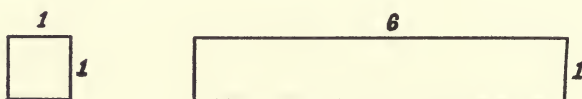

Fig. 2. Square with aspect ratio 1; and rectangle with aspect ratio 6.

units,  $K = 0.075$  in metric units) are for a square surface, 0.15 x 0.15 meters, in air of normal density. For squares of different sizes, experiments of Eiffel give values for  $K$  as follows:—

Length of side	.15m.	.375m.	.500m.	.707m.	1.00m.
Value of $K$	.066	.0716	.0746	.0772	.0789

For rectangles of equal area (0.225 m.<sup>2</sup>) and with different aspect ratios (the aspect ratio is the length divided by width, see Fig. 2) Eiffel gives:—

Aspect Ratio	1	3	6	10	20	30	50
Value of $K$	.066	.0705	.0725	.0755	.0885	.092	.097
$K_R \div K_S$	1.	1.07	1.10	1.145	1.34	1.40	1.47

The last line,  $K_R \div K_S$ , is the value of  $K$  for a rectangle

divided by the value of  $K$  for a square. The percentage increase in  $K$  with change of aspect ratio, shown in the last line, will hold approximately for rectangles of other areas, for the effect of aspect ratio is almost independent of size of surface.

Somewhat different values hold for circular discs and other shapes. Considerable experimental data must be gathered before the *precise* value of  $K$  can be determined for a surface of any size and shape. Meanwhile the value 0.003 (English system) or 0.075 (metric system) will prove practically useful,

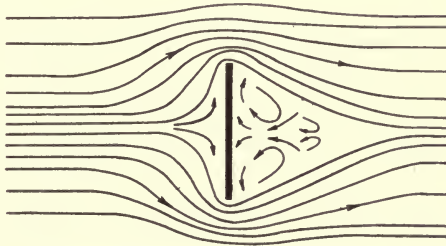

Fig. 3. Turbulent region and rarefaction back of plane.

it being borne in mind that this value is only an approximation and that a closer value should be sought whenever it may be deemed desirable.

### Eddies back of plane.

When a plane encounters an air-stream, there is a compression of the air on the front face of the plane. Immediately back of the plane there is a rarification, so that back of the plane air currents are set up that swing around toward its rear surface. These air currents may be felt, by one riding in an open trolley car or in an automobile behind a wind shield, as a wind on the back of the neck.

These air currents are, in a crude way, visualized in Fig. 3.

Back of the plane and near the edge is a turbulent region with complex eddy currents of air. These no doubt have a material effect upon the value of  $K$ , so that it is not surprising that  $K$  has different values for surfaces of different shapes and sizes, for in these the length of edge and the eddy-current effect is not proportional to the area.

### Methods of experimenting.

Experiments on the air resistance of different surfaces or bodies may be made in various ways. The necessary velocity of the body relative to the air may be obtained by dropping it from a suitable tower or other height (employed by Eiffel), by carrying it on a fast moving vehicle, by carrying it at the end of a long rotating arm (employed by Langley), by exposing it to a natural wind, and finally by carrying it through the air in airplane flight.

The most convenient and approved method now in use is to expose the body to an artificial wind in a *wind tunnel*, first used by Eiffel\* and now used in all aerodynamic laboratories. Air is forced through such a tunnel by means of a powerful fan; the body to be studied is held stationary, being attached to suitable devices for measuring the pressure and, in case of oblique surfaces, for "weighing" the vertical as well as the horizontal component of the pressure.

In such a tunnel can be tested not only surfaces or bodies of various kinds, including wing sections, but even complete airplanes in model size; and it is important to note that the performance of wings and airplanes in flight is found to agree remarkably well with wind-tunnel tests.

---

\*Eiffel's experiments are beautifully described in his book "The Resistance of the Air and Aviation," translated into English by J. C. Hunsaker.



## FLAT PLANE OBLIQUE TO AIR STREAM

Let us next consider the action of a flat plane at an oblique angle with the air-stream; such a consideration will show at once the source of the sustaining force in an airplane.

## Lift of an oblique plane.

If a plane be held so as to form an angle  $i$  (called the **angle of incidence** or the **angle of attack**) with the air-stream or

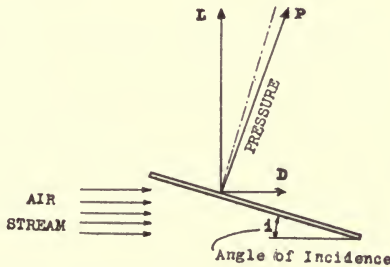

Fig. 4. Vertical and horizontal components of pressure on oblique plane.

“relative wind,” as in Fig. 4, it will be seen that the total pressure  $P$  of the air against the plane has two components:\*

A vertical component or **lift**, commonly designated by the letter  $L$ , tending to force the plane *upward* at right angles to the air-stream.

A horizontal component or dynamic resistance (called, in an airplane, **wing-resistance**,) commonly designated by the letter  $D$ , tending to force the plane *backward* in the direction of the air-stream.

These components may be observed by blowing upon a card held in the hand oblique to the air-stream, or by moving the

\*These two components are horizontal and vertical only in normal horizontal flight. More accurately defined, lift is the component of

hand—slightly inclined—rapidly through water; in the latter case the upward lift may be distinctly felt.

It is the lift that holds an airplane up in flight, *i. e.*, that gives sustentation; for an understanding of the airplane, therefore, a knowledge of what determines the lift is essential. Clearly for horizontal flight the lift must be just equal to the weight of the machine, otherwise the machine will either ascend or descend,—discussed later under *climbing* and *gliding*. The problem of horizontal flight is, therefore, the problem of securing a lift equal to the weight. As discussed later, this lift is better obtained from a “cambered” wing (*i. e.*, a wing that is slightly curved from front to back) than from a flat plane.

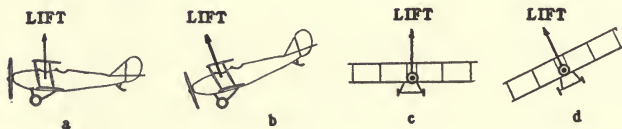

Fig. 4a. Lift is inclined when machine is inclined.

In order to get the lift, the plane or wing must move rapidly through the air. But in order to move the plane or wing through the air it is necessary to overcome the wing-resistance and this is done by the *thrust* from the propeller. To drive the propeller, so as to obtain this thrust, it is neces-

total pressure that is perpendicular to the air-stream and that lies in the plane of symmetry of the machine; this plane is vertical as long as the machine does not roll. Lift is accordingly vertical in normal flight, but becomes inclined when the machine is inclined, as shown in Fig. 4a. Wing-resistance is, in all cases, the component of total pressure that is in the direction of the air-stream.

It is recommended by the U. S. Advisory Committee on Aeronautics that the word “drift,” sometimes used as a designation for wing-resistance, be abandoned; see “drift” in Glossary, Appendix I. But the initial letter *D*, in such common use, may well be retained as a symbol for dynamic or wing resistance; likewise,  $K_D$ , formerly called the coefficient of drift, may be retained as the coefficient of dynamic or wing-resistance.

sary to have *power*. Obviously it is desirable to have the wing-resistance small, necessitating small thrust and small power, and to have the lift large so that the machine can sustain not only itself but some load in addition. But it is impossible to have the lift without the wing-resistance, and the wing-resistance has aptly been described as the price paid for the lift.

### Variation of lift and wing-resistance with incidence.

Highly important is it to know how the values of lift and wing-resistance vary as the angle of incidence is changed.

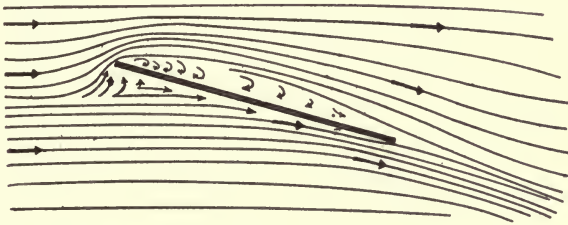

Fig. 5. Flow of air past oblique plane, showing turbulent region back of entering edge and the downward deflection of air after leaving the plane.

This information cannot well be derived theoretically on account of the complexity of the problem,—due in part to the eddy currents in the turbulent region back of the entering edge, as indicated in Fig. 5. The information, however, has been found experimentally.

The total pressure  $P$ , the lift  $L$  and the wing-resistance  $D$  all vary directly as the area  $S$ , of the plane or wing, and as the square of the velocity  $V$ ; that is,

$$\text{Total pressure} = P = K_P SV^2;$$

$$\text{Vertical component or lift} = L = K_L SV^2;$$

$$\text{Horizontal component or wing-resistance} = D = K_D SV^2.$$

We are particularly interested in the two components  $L$  and  $D$ ; also in the two coefficients,  $K_L$  called the **coefficient of lift** and  $K_D$  called the **coefficient of wing-resistance**. These coefficients have different values for each angle of incidence. Their values, furthermore, will depend upon the units used.

The values of these coefficients that will give lift and wing-resistance in pounds, for different angles of incidence, when  $S$

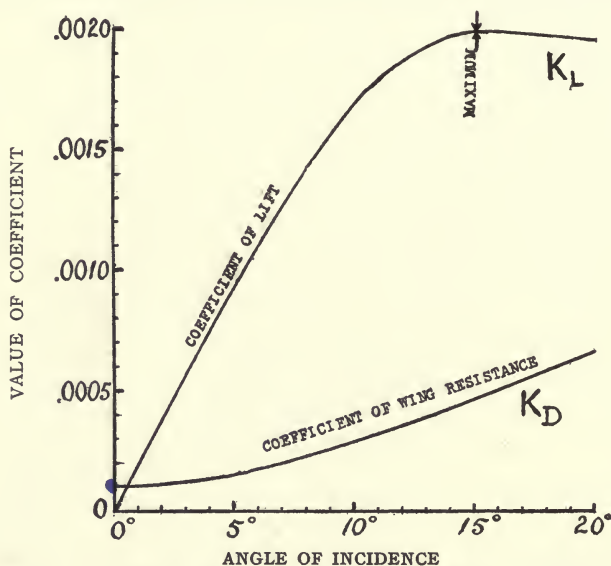

Fig. 6. Coefficient of lift  $K_L$  and coefficient of wing-resistance  $K_D$  for flat rectangle at different angles of incidence; aspect ratio, 6, *i. e.*, length  $\div$  width = 6, as in Fig. 2.

is in square feet and  $V$  is in miles per hour, are shown by the curves in Fig. 6. These are plotted from data by Eiffel\* for a flat rectangle with an aspect ratio 6.

For small values of incidence, it will be seen that the coefficient of lift increases nearly uniformly, in proportion to

\*"Resistance of the Air," p. 122; size of rectangle 90 x 15 cm.

the angle of incidence; if the angle is doubled, the coefficient of lift is approximately doubled. After reaching a maximum value (in this case about 0.002) the coefficient decreases somewhat irregularly\*, becoming zero at  $90^\circ$  incidence.

This maximum value is only two-thirds as great as the maximum value obtained by a cambered wing; see Fig. 11.

The coefficient of wing-resistance also increases more or less uniformly with incidence and reaches a value of about 0.003 at  $90^\circ$ ; but *in no case is  $K_D$  zero, even at zero incidence.*

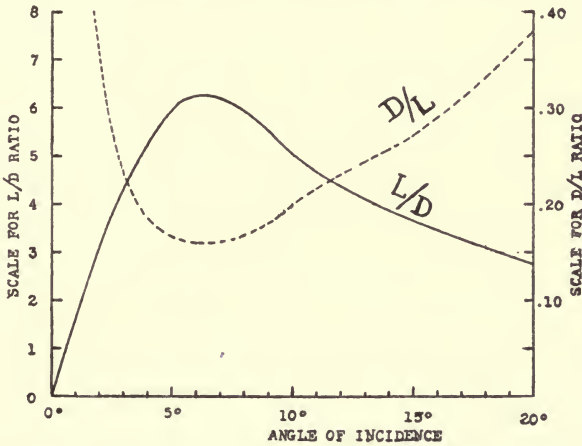

Fig. 7. Curves showing  $L/D$  ratio and  $D/L$  ratio for flat rectangle; aspect ratio, 6.

### Lifting efficiency or $L/D$ ratio.

The ratio of lift to wing-resistance, is frequently referred to as the **lift-over-drift ratio** or the  **$L/D$  ratio**, or as the **lifting efficiency** of a plane or wing, and this ratio is of much significance. As it is desirable to have  $L$  large and  $D$  small,

\*After  $20^\circ$ ,  $K_L$  increases slightly, having by Eiffel's data the same value at  $30^\circ$  as at  $15^\circ$ . The incidence at which the maximum occurs, and its value are different for different aspect ratios; but the curves are all of the type here shown.

it is obviously desirable to have the  $L/D$  ratio as large as possible. It is seen that the  $L/D$  ratio is equal to  $K_L \div K_D$ , values for which are obtained from the curves in Fig. 6.

The values of the  $L/D$  ratio for a flat rectangle with aspect ratio 6, thus obtained from Fig. 6 for different angles of incidence, are shown in Fig. 7. The maximum value for  $L/D$  is here seen to be a little over 6 at an incidence of  $6^\circ$ ,—a rather poor lifting efficiency compared with an  $L/D$  ratio 16 or more for a cambered plane.

In Fig. 7, the values are also shown for  $D/L$  (see dotted curve); but, as these values approach infinity when  $L$  approaches zero, they are not so convenient to use. It is more usual, therefore, to make use of the  $L/D$  ratio.

In the case of a theoretical plane with a perfectly smooth surface, the pressure  $P$  would be perpendicular to the surface, so that  $D/L$  would be the tangent and  $L/D$  the cotangent of the angle of incidence; and, at zero incidence, the resistance of the plane would be zero.

But in a practical case, the plate or wing that is used must possess an edge of definite thickness, and this with some skin friction (undoubtedly small) gives a certain resistance, even to a horizontal plate. The resultant pressure  $P$ , shown by the solid line in Fig. 4, is, therefore, not perpendicular to the surface but is a little back of the perpendicular,—which is shown by the dotted line. Its direction and magnitude can be determined by laying off the two components  $L$  and  $D$ , the resultant pressure being  $P = \sqrt{L^2 + D^2}$ .

### Center of pressure.

When the plane is perpendicular to the air-stream, *i. e.*, when the angle of incidence is  $90^\circ$ , the center of air pressure on the plane is at the center of the plane. When the plane is

oblique, the center of pressure is found to be in advance of the center of the plane, moving more and more forward toward the entering edge as the incidence decreases. The position of the center of pressure for different angles of incidence is shown by the curve in Fig. 8. The position is somewhat different for different aspect ratios, but in all cases with a flat plane the center of pressure moves forward from the center

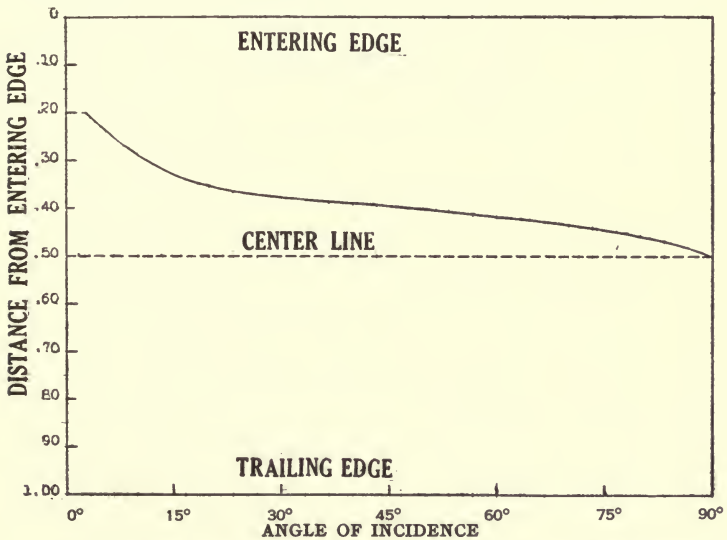

Fig. 8. Position of center of pressure on a flat plane, with aspect ratio 6, for different angles of incidence.

of the plane as the incidence decreases, thus becoming nearer to the front edge of the plane—which is called the entering edge or leading edge—and further from the rear or trailing edge.

### CAMBERED WING

#### Decreased turbulence when cambered wing is used.

A flat plane encountering an air-stream disrupts the air, the entering edge, and to a lesser extent the trailing edge,

tending to produce air eddies. The turbulence produced by such a plane has been shown in Fig. 5, which as already explained *indicates* the phenomenon but should not be understood to be an accurate representation of it. It would seem that this turbulence would increase the wing-resistance and that it might decrease the lift; or, put another way, it would seem that, if the turbulence could be eliminated or reduced by any means—for example by giving the wing more or less of a stream-line form,—an increase in lift and decrease in wing-resistance might be obtained. This indeed is the case, such a result being obtained by arching the wing from front to back. A wing thus arched is called a **cambered wing** and on account of its better performance is always used in airplane construction.

The flow of air past a cambered wing is shown in Fig. 9, which again is merely illustrative and is not exact in detail. The disturbance of the air by the wing is minimized by having the surfaces of the wing, throughout, more or less parallel to the stream-line flow; the wing then enters the air and leaves the deflected air without disturbance, and eddies are eliminated so far as they can be.

### Creation of lift.

It is to be borne in mind that it is the downward deflection of the air that creates the lift, it being the purpose of the designer to increase this lift and at the same time to decrease the wing-resistance. Lift is obtained to a certain extent by the positive pressure on the lower surface of the wing (indicated by  $p$  in Fig. 9) but to a much greater extent by the negative pressure on the upper surface, indicated by  $n$ ; indeed, as much as *three-fourths of the total lift may be due to this negative pressure*. It will be seen that, in a cambered wing as shown in Fig. 9, the upward trend of the upper



surface of the entering edge swings the air-stream upward over the wing before its final deflection downward; this decreases the pressure on the upper surface and so contributes materially to the lift.

The distribution of pressure on single and multiple planes is shown in a later chapter. See Appendix IV.

It is the curvature of the upper surface of a wing that is most important,—particularly its dip toward the entering edge, often referred to as the **dipping front edge**. The curvature of the lower surface is far less important; with a well

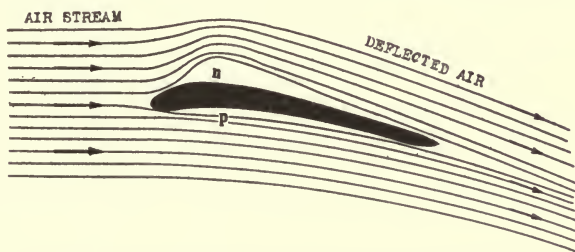

Fig. 9. Flow of air past a cambered wing; side view.

formed upper surface, a good wing can be constructed with a *perfectly flat lower surface*.

An upward turn in the lower surface toward the entering edge, corresponding to the dip in the upper surface and making what is known as “Phillips entry”, is not advantageous. The wing shown in Fig. 14, which is accurately drawn to scale, has a more effective entry than the wings sketched in Figs. 9 and 10.

### **Incidence, chord, span and area of a cambered wing.**

A **wing section**, or side view, of a cambered wing is shown in Fig. 10. The **chord** of a cambered wing is a straight line, as shown, tangent to its under surface at front and rear.

The **length of chord** is the length of the projection  $ab$  of the wing-section upon this chord. Similarly, the **area** of a cambered wing is its area projected on a tangent plane. The **span** or **spread** of a wing is the maximum distance from tip to tip. The **aspect ratio** is the ratio of span to chord. The **angle of incidence** of a cambered plane is the angle between its chord and the relative air, as shown in the same figure.

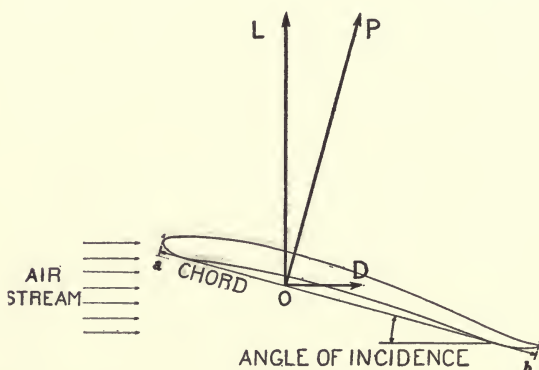

Fig. 10. Section of cambered wing, showing angle of incidence between the chord and the air-stream, and the components of pressure.

### Wing structure.

The whole wing structure is often referred to as an **aerofoil**. Wings are made in many ways; although no standard construction can be shown, the one shown in Fig. 10a is fairly typical. Each wing is commonly built up of two **spars**, as there shown, running from one end of the wing to the other. Spars may be of I-beam section, double I-beam, box construction, etc. Supported by these spars are the **ribs**, extending fore and aft, each rib having the exact shape of a wing-section. The top and bottom of each rib is commonly made of strips of spruce, held in place and strengthened by a thin web, which gives the rib an I-beam cross-section. The

web is partly cut away for lightness, as shown in the illustration.

The **camber** of either surface of a wing is the greatest distance between the chord and that surface, and is usually expressed as a fraction of the chord. The camber of the bottom surface indicated in Fig. 10a is about  $1/40$ . **Mean camber** is the mean between the **top camber** and the **bottom camber**.

### Components of pressure.

The pressure  $P$  is considered as having its point of application at the point  $O$  where it intersects the chord  $ab$ , as shown

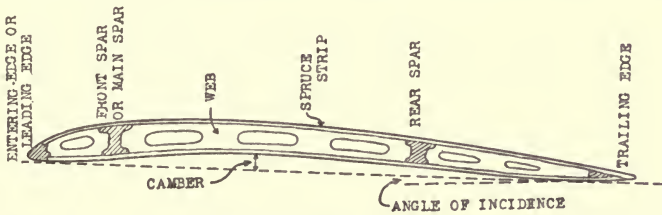

Fig. 10a. Wing structure.

in Fig. 10. This point is called the **center of wing pressure** and is located (unless the incidence is very small or negative, see Fig. 13) a little in advance of the middle point of the chord.

The pressure  $P$  is more or less perpendicular\* to the chord. The total pressure  $P$  is resolved into its two components, lift  $L$  and wing-resistance  $D$ , which also have their point of application at the center of pressure  $O$ . The direction of  $P$

\*For a certain angle of incidence (when cotangent  $i = L/D$ ),  $P$  coincides exactly with the perpendicular to the chord. For a smaller angle of incidence,  $P$  is *back* of the perpendicular, due to the relatively large value of  $D$  compared with  $L$ . For a larger angle of incidence,  $P$  is in *advance* of the perpendicular, due to the relatively larger value of  $L$ .

can be determined by laying off  $L$  and  $D$  where these are known;  $P = \sqrt{L^2 + D^2}$ . In ordinary flight,  $D$  is so small

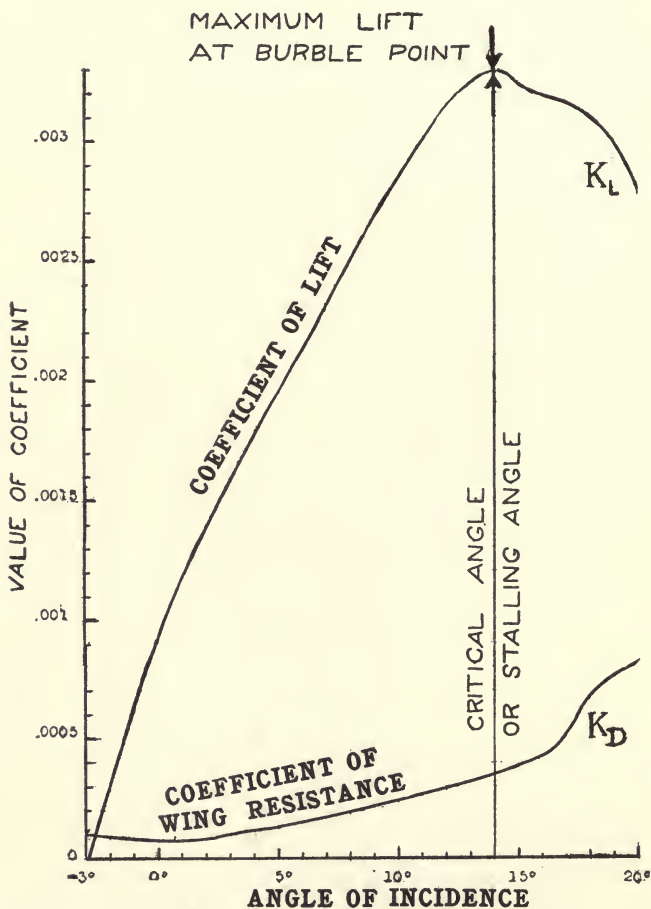

Fig. 11. Lift and wing-resistance for cambered wing, U. S. A. 5. Lift (in pounds) =  $K_L SV^2$ ; wing-resistance (in pounds) =  $K_D SV^2$ , where  $S$  is in sq. ft. and  $V$  is in miles per hour. For wing-section, see Fig. 14.

compared with  $L$ , as shown in Fig. 11, that  $P$  and  $L$  are practically equal, the difference being less than one per cent.

Variation of lift and wing-resistance with angle of incidence of a cambered plane.

Each different wing-section will have its own characteristic curves for lift and wing-resistance, but all such curves have

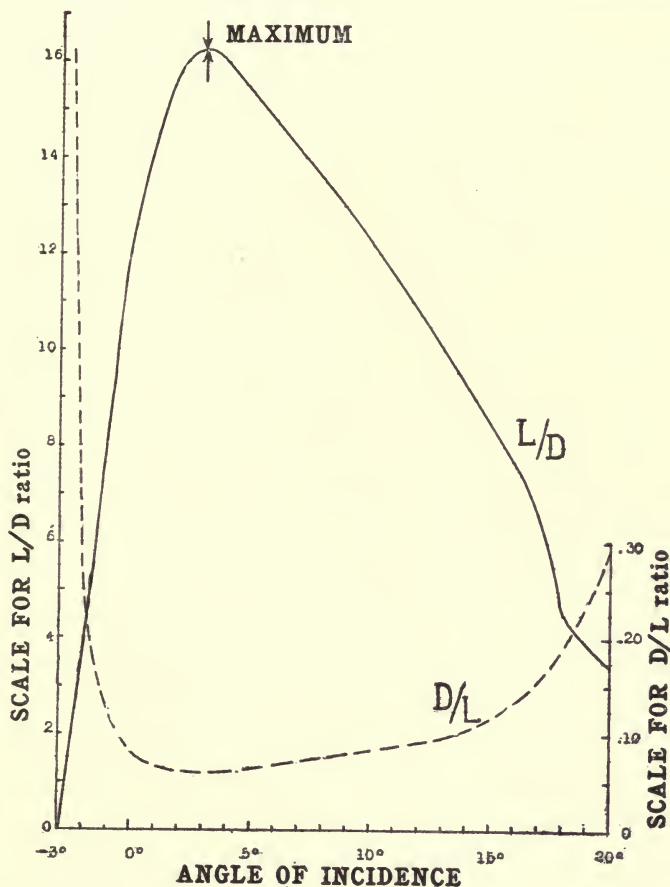

Fig. 12. Curves for  $L/D$  ratio and  $D/L$ , corresponding to Fig. 11.

the same general trend. Fig. 11 shows curves for the coefficient of lift  $K_L$ , and the coefficient of wing-resistance  $K_D$ , for a representative cambered wing, designated as

U. S. A. 5 and shown in Fig. 14. These curves are typical and will serve to illustrate certain general features that are characteristic of practically all cambered wings.

The corresponding values for the  $L/D$  ratio (obtained by dividing  $K_L$  by  $K_D$ ) are given in Fig. 12, the values for  $D/L$  being shown by the dotted curve in the same figure.

The numerical values\* from which these curves are plotted are given in Table I.; these values will be used in later calculations.

TABLE I. WING U. S. A. 5

$i$	$K_L$	$K_D$	$L/D$	$C.P. \dagger$
$-4^\circ$	— .000326	.0001500	— 1.58	....
$-2^\circ$	.000346	.0000948	3.64	.753
$-1^\circ$	.000636	.0000830	7.67	.566
$0^\circ$	.000910	.0000741	12.28	.498
$1^\circ$	.001145	.0000803	14.28	.444
$2^\circ$	.001355	.0000863	15.72	.415
$3^\circ$	.001565	.0000966	16.21	.377
$4^\circ$	.001740	.0001092	15.98	.348
$5^\circ$	.001950	.0001290	15.35	.337
$8^\circ$	.002470	.0001830	13.52	.315
$10^\circ$	.002870	.0002380	12.08	.303
$12^\circ$	.003130	.0002890	10.84	.300
$13^\circ$	.003240	.0003290	9.84	.298
$14^\circ$	.003285	.0003545	9.25	.288
$15^\circ$	.003235	.0003910	8.28	.292
$16^\circ$	.003205	.0004210	7.63	.298
$18^\circ$	.003150	.0006900	4.57	.330
$20^\circ$	.002790	.0008200	3.41	.368

$\dagger$ Distance of the center of wing pressure from the leading edge, expressed as a fractional part of the chord. Shown by curve in Fig. 13.

\*From tests made by Captains E. S. Gorrell and H. S. Martin, abstracted by A. Kelmin and T. H. Huff; published in *Aviation*, Vol. II., p. 256, 1917. These tests were made on a model, 18" x 3", made of brass; density of standard air: 0.07608 lbs. per cu. ft.; wind velocity, 30 MPH.

**Characteristic features of a cambered wing.**

An inspection of the curves in Figs. 11 and 12 shows the following:

*Lift with negative incidence.*—A cambered plane exerts a lift even at a small negative incidence. Zero lift is usually obtained when the incidence is between  $-2^\circ$  and  $-4^\circ$  (in Fig. 11 at  $-3^\circ$ ) but in extreme cases the incidence may be decreased to  $-6^\circ$  or  $-8^\circ$  before zero lift is reached. Although in most cases an airplane flies with a positive incidence, at high velocities it may fly with zero incidence or with a small negative incidence,—but not within two or three degrees of the point of zero lift.

In approaching the point of zero lift there is danger of going too far, so that the air is allowed to strike the top surface of the wing, causing the machine to take a nose dive.

*Lift is a maximum at about  $14^\circ$ .*—As the incidence is increased, the lift increases rather uniformly and reaches a maximum of more than 0.003 at an incidence of  $14^\circ$  or so, according to the particular wing. The angle of incidence at which  $K_L$  is a maximum is called **the critical angle**. Beyond this maximum, which is also known as the **burble point**, the lift decreases somewhat irregularly and again becomes zero at an incidence of about  $90^\circ$ .

Up to the burble point, *i. e.*, for an incidence of less than  $14^\circ$  or so, the air-flow past the wing is to a certain extent smooth and without eddies, as shown in Fig. 9. Beyond this point, *i. e.*, for an incidence of  $14^\circ$  to  $90^\circ$ , there is a confusion of eddies and a turbulence (such as was illustrated in Figs. 3 and 5), accompanied by a decrease in lift and an increase in wing-resistance. (“Burbles” means “confuse;” hence the term “burble point.”)

*Usual range of incidence is about 0° to 10°.*—It is seen that the lift increases more or less uniformly with incidence, from zero lift at  $-3^\circ$  to maximum lift at  $+14^\circ$ . (It is to be understood that other wing-sections would give slightly different values.) The range for practical flight must be within these limits, without either limit being reached.

The lower limit of zero lift cannot be reached, inasmuch as some lift is necessary for sustentation; it may be approached to a certain extent at high velocities, but too near an approach may lead to a nose dive as already mentioned.

The upper limit of maximum lift is possible but in ordinary flying it, too, is only approached, for as it is approached there is danger of a stall due to increase of wing-resistance, leading to a fall or tail slide. With the decreased velocity which accompanies increased incidence, the stability of the machine becomes less and may vanish entirely; as the power of control depends upon velocity, the recovery of equilibrium when once lost at low speed is difficult. *Too great an incidence is a frequent cause of accident.*

Exact limits\* can not well be set; but, roughly speaking, the range of incidence is between  $0^\circ$  and  $10^\circ$ , limits which are never greatly exceeded in ordinary flight.

(The angle of incidence may be increased beyond this limit—possibly up to the point of maximum lift †—as a machine

---

\*The question of *power* is taken up later. There is, for each machine, a certain angle of incidence—well within these limits—at which the power required is a minimum. If the incidence is either increased or decreased, there is a *very great increase* in the amount of power required.

†Although the main wing-surfaces may thus in some cases be at their maximum lift, the surfaces used for lateral control, called *ailerons* discussed later, should always be well below maximum lift. Otherwise they would become inoperative, for lateral control depends upon increasing the lift on one aileron and decreasing the lift on the other; if the ailerons were at maximum lift, any change would decrease the lift on both and would not give the desired control.



reaches the "ceiling," which is the highest possible altitude a particular machine can attain; also, when slowing down to minimum speed just prior to landing.)

A flat maximum in the lift curve is very desirable, being less dangerous than a sharp maximum in which the lift decreases rapidly after the critical angle is reached. A flat maximum is more readily obtained in a biplane or triplane—particularly if the planes are staggered—than in a monoplane for the maximum points for the separate planes may not coincide, so that when the separate lifts are added together to get the total lift the maximum point is broadened out.

*Wing-resistance is small through usual range of incidence; then increases rapidly.*—Wing-resistance, as already mentioned, is in no case zero. It is small throughout the useful range of incidence, gradually increasing throughout this range as the incidence increases. As the incidence is further increased, the wing-resistance increases a little more rapidly until the burble point or point of maximum lift is reached; after which the wing-resistance increases very rapidly,—finally reaching a value of 0.003 (more or less) at an incidence of  $90^\circ$ .

*L/D ratio has a maximum value of about 16 in middle range of incidence.*—If the wing-resistance were constant, the  $L/D$  ratio would be a maximum when the lift is a maximum. On account of the increase in wing-resistance with incidence, the  $L/D$  ratio reaches a well defined maximum before the maximum lift is reached. In Fig. 12, this maximum of 16.2 occurs at  $+3^\circ$ . This is a good value for  $L/D$ . A slightly greater value, 17 or 18, is obtained by some wings,—at a sacrifice perhaps of some other feature, such as stability or ease of construction.

*Comparison with flat plane.*—By comparing the curves in Figs. 11 and 12 for a cambered wing, with those of Figs. 6

and 7 for a flat plane, it is seen that the cambered plane gives more lift (the maximum value being about 50 per cent. more), gives less wing-resistance and a much greater  $L/D$  ratio,—nearly three times as great. For these reasons a cambered wing is always used.

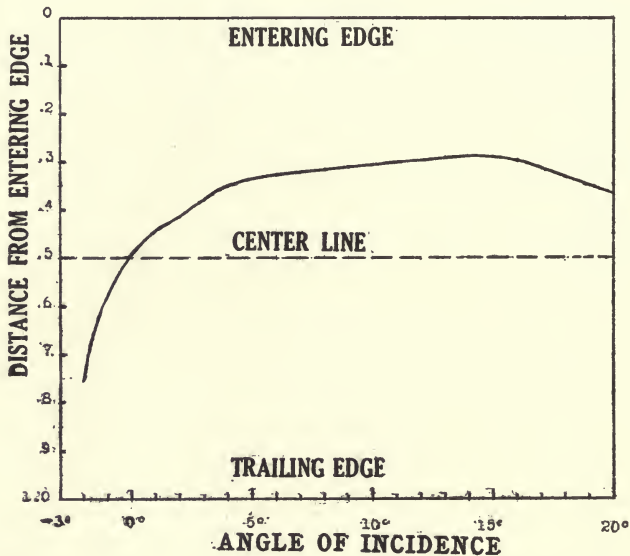

Fig. 13. Position of center of pressure on a cambered wing (U.S.A. 5.) with aspect ratio 6, for different angles of incidence.

### Shifting of center of wing pressure with incidence.

The position of the center of pressure for the cambered wing in question, U. S. A. 5, is shown in Fig. 13. *All cambered wings show a marked shifting of the center of pressure toward the rear of the plane, when the incidence is small and is decreasing,—a bad feature for stability as discussed in a later chapter.*

In this one respect a cambered wing is inferior to a flat plane, in which the center of pressure moves forward when the incidence is decreasing, as shown in Fig. 8.

The shifting of the center of pressure shown in Fig. 13 is much less than is found in the case of many wings, the section of wing here used being in this respect satisfactory.

### Wing-section.

There is no one type of wing that is best. The particular wing, to which all the curves here given refer, is shown in Fig. 14 and is fairly representative. But it will be understood that in different machines different wings may best be



Fig. 14. Section of wing, U.S.A. 5.

used, according to the particular features to be emphasized; high speed in one, large load-carrying capacity in another; stability in one, quickness in manouvering in another, and so forth.

The characteristics of any particular wing-section are shown by means of curves, such as those shown in Figs. 11, 12 and 13. The usefulness of these curves in determining the problems of flight will be brought out in the following chapters.

### Comments on wing sections.

A few comments on wing sections may here be made, although the reader may find it well to postpone their perusal until he has read some of the subsequent chapters describing various relations and characteristics of an airplane in flight.

Mechanical as well as aerodynamic considerations have to be kept in mind by the designer; there must be room for spars and ribs of adequate strength.

For climbing and for heavy lift, a wing with deep camber (particularly on the upper surface) and large value of  $K_L$  should be used. For this purpose a deeply cambered wing is flown at low speed, and at a large angle of incidence as shown in Fig. 15. Such a wing, however, is utterly unsuited for flying at high speed and small incidence, as shown in Fig. 16, on account of its great resistance at small angles of incidence.

For speed, the wing should be flatter with only a little camber, with less lift and with the least possible wing-resistance at small incidence and high velocity. It is necessary to sacrifice either speed or lift. A speed wing is sketched in Fig. 17.

Again, both speed and lift may be sacrificed for stability. As has been shown, the center of pressure on a cambered wing, convexed upward, shifts with change of incidence (when the angle of incidence is small) in the *wrong direction* for stability. If a cambered wing were concave downward—a very bad wing for lift—this shifting of the center of pressure would be in the *right direction* for stability. The two effects may be combined, in varying proportions, by giving a wing a **double curvature**, as shown in Fig. 18. In this case, when the machine starts to dive the air strikes the reversed curve near the rear of the wing and restores equilibrium; but this means less lift and more resistance.

The characteristics of an aerofoil, although in a general way shown by its section, are best shown by curves for its performance, as in Figs. 11, 12 and 13.

A high maximum to the  $K_L$  curve is of no advantage in a high speed machine nor in ordinary flight; it gives, however,

the ability to climb to high altitudes and gives a low landing speed, as brought out in the next chapter.

The  $L/D$  curve should show a good value, not necessarily a maximum, at about the incidence for which the machine is to be flown; thus, in a high speed machine, it is desirable to have a large value for  $L/D$  at a very small incidence. This is only another way of saying that wing-resistance  $D$  should be small.

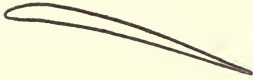

Fig. 15. Wing with high camber, suitable for big lift and slow speed, when blown at large angles of incidence as shown.

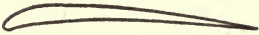

Fig. 16. Same wing at small incidence, entirely unsuitable for high speed on account of large wing-resistance due to its camber.

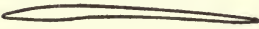

Fig. 17. Flat, stream-lined wing with little camber and small lift; suitable for high speed on account of its very small wing-resistance.

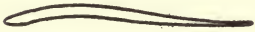

Fig. 18. Wing with reversed curvature toward trailing edge for increased stability. This is paid for by an increase in wing-resistance and a decrease in lift.

In a high speed machine, which is to be flown at small incidence and at small  $K_L$ , it is desirable to have a curve for  $K_L$  that is not too steep as it approached zero lift; thus, it is desirable to obtain a certain lift, when the plane, let us say, is  $3^\circ$  or  $4^\circ$  rather than  $1^\circ$  or  $2^\circ$  from the incidence of zero lift. There is then less danger of a nose dive, when the machine dips a little as it oscillates about its normal direction of flight.

## CHAPTER II

### RELATIONS IN FLIGHT

Some interesting relations in regard to flight can be drawn from the expressions derived in the preceding pages for the lift and wing-resistance of a cambered plane. In this chapter will be considered the significance of the lift equation, and certain relations between velocity and incidence that may be derived from it; wing-resistance will be considered in the following chapter.

**In horizontal flight, weight = lift =  $K_L SV^2$ .**

We have seen that the lift that supports an airplane is equal to the product of the area of wing  $S$ , the square of the

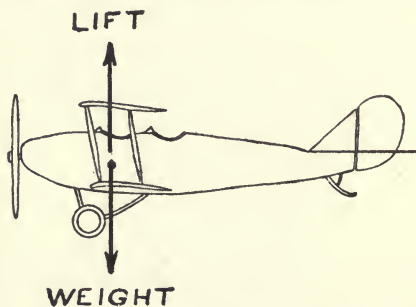

Fig. 19. Lift-weight in horizontal flight.

velocity  $V$ , and a coefficient of lift  $K_L$  that varies with the angle of incidence:

$$\text{Lift} = L = K_L SV^2.$$

For sustentation in horizontal flight, see Fig. 19, the lift must be just equal to the weight of the machine, including its load; we, accordingly, may write

$$\text{Weight} = W = K_L SV^2.$$

Weight acts downward through the **center of gravity** or **C. G.**; lift acts upward through the **center of lift** or **C. L.** These two centers are never far apart, although they rarely coincide exactly. When the center of gravity is in front of the center of lift, there is a moment or couple tending to make the machine nose down; when the center of gravity is back of the center of lift, there is a couple tending to make the machine nose up. In neither case does the couple have any affect upon the value of weight and lift (which are equal), although it does affect longitudinal stability.

**Velocity equals square root of loading divided by square root of  $K_L$ .**

The preceding equation, when transposed, gives the important formula for velocity,

$$V = \sqrt{\frac{W}{SK_L}} .$$

This formula, although simple, is quite complete and will bear careful study, for it leads to a number of interesting conclusions, the appreciation of which is essential to a proper understanding of flight.

The ratio  $W/S$  is the weight per unit area of wing and is called the **loading**. It is the loading, rather than weight or area, that effects the value of  $V$ . The formula shows that the velocity of an airplane depends solely upon the loading and upon  $K_L$ .

The only possible way for changing the speed of a machine, or for getting different speeds in different machines, is by changing the loading or by changing the value of  $K_L$ . In practice there are of course limits to both of these changes. For a machine in flight, in which the loading can not be

changed, the only way for changing the speed is by changing the value of  $K_L$ .

The loading  $W/S$  is commonly about 6 lbs. per sq. ft., being less in slow machines and being more (8 and even 10) in fast machines. The usual limits for  $K_L$  are about 0.0008 and 0.0032.

This gives us at once the speed variation, shown in Fig. 20, for any machine irrespective of wing-section or other features of design except loading. Each curve in Fig. 20 is for a

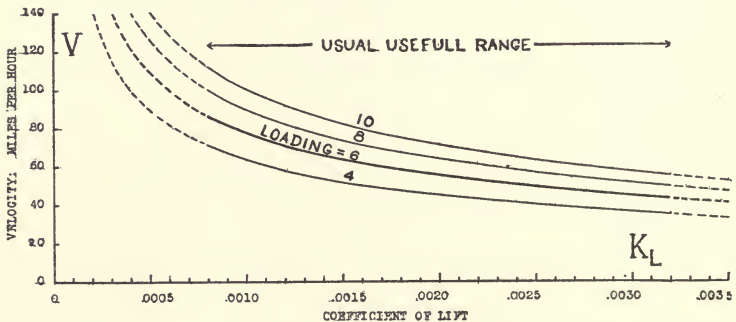

Fig. 20. Variation of velocity with coefficient of lift for any airplane, when loading is 4, 6 (heavy curve), 8 and 10.

different loading. The heavy curve shows the change of speed, with  $K_L$ , for a machine with loading  $W/S = 6$ , this being the plot of the equation  $V = \sqrt{6 \div K_L}$ . The light curves are for loadings 4, 8, and 10, an increase in loading raising the curve and thus indicating a greater velocity.

It is seen that velocity increases as  $K_L$  decreases; if  $K_L$  were zero,  $V$  would have to be infinite to create a lift equal to the weight, as is necessary for sustentation.

*Speed range.*—A machine that has a maximum speed of 100 miles per hour and a minimum speed of 45 miles per hour is said to have a speed range of 55 per cent. The range in speed depends upon the range in the value of  $K_L$ .



Thus it is seen that, if we take the limits of  $K_L$  as 0.0008 and 0.0032, the **speed range** for any machine is fifty per cent. The curves in Fig. 20 are drawn solid between these limits. Commonly the speed range is somewhat less than fifty per cent., but in some cases is a little more. (A minimum value of  $K_L$  a trifle less than 0.0008 may be attained in some instances; but a greater value, 0.0009 or more, is perhaps a more usual minimum.)

By way of illustration, with limits 0.0008 and 0.0032 for  $K_L$ , a machine with loading  $W/S = 10$  would have speed limits as follows, the speed range being 50 per cent.;

$$\text{Maximum speed} = \sqrt{10 \div 0.0008} = 112 \text{ MPH.}$$

$$\text{Minimum speed} = \sqrt{10 \div 0.0032} = 56 \text{ MPH.}$$

As a further illustration, with limits 0.00074 and 0.0034 for  $K_L$ , the speed range would be about 54 per cent.; thus,

$$\text{Maximum speed} = \sqrt{10 \div 0.00074} = 116 \text{ MPH.}$$

$$\text{Minimum speed} = \sqrt{10 \div 0.0034} = 54 \text{ MPH.}$$

The speed range is the difference between maximum and minimum speed, divided by the maximum speed; thus, in this case, speed range =  $(116 - 54) \div 116 = 0.54$  or 54 per cent.

A greater speed can be attained only by increasing the loading or by decreasing  $K_L$ . For example, if a speed of 200 MPH. is to be attained:  $W/S$  must equal 29.6, if  $K_L = 0.00074$ ;  $W/S$  must equal 20, if  $K_L = 0.0005$ ;  $W/S$  must equal 10, if  $K_L = 0.00025$ ; etc.

The advantage of a large speed range\*—not only a high

---

\*Some early machines had a very small speed range, let us say from a minimum of 35 to maximum of 50 miles per hour, giving a speed range of 15 miles per hour. A gust from behind of more than 15 miles per hour would reduce the relative air speed below the requisite 35 miles per hour necessary for sustentation; so that the machine had no support. This was one cause for the so-called *holes in the air*.

maximum speed for flying but also a low minimum speed for landing—is obvious. To get a sufficiently low landing speed is one of the problems of the designer.

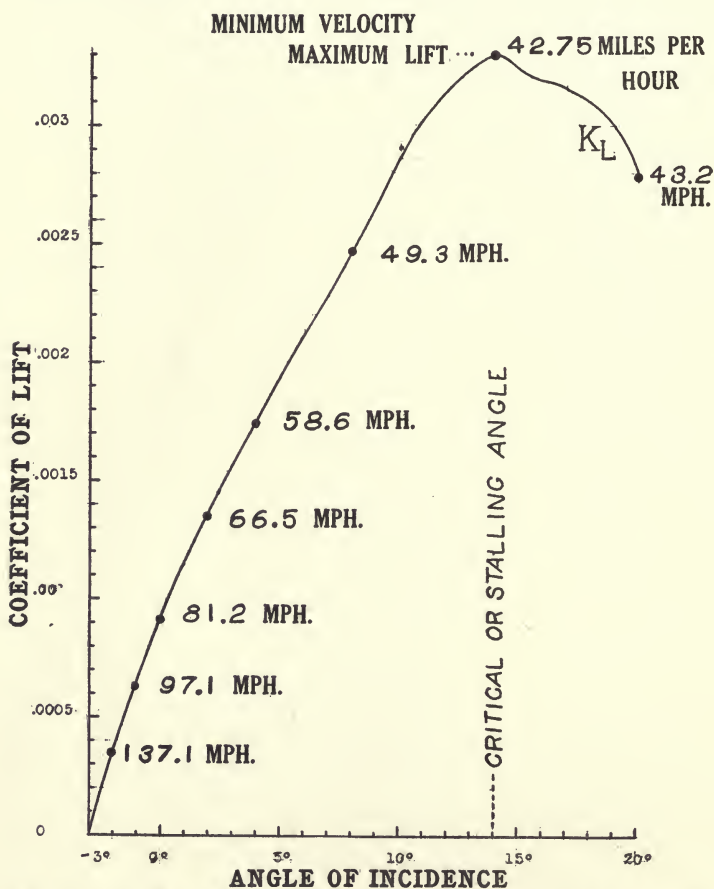

Fig. 21. Variation of coefficient of lift with incidence for a particular wing-section; aspect ratio 6. Velocities are marked for several points, assuming a loading of 6 lbs. per sq. ft.

A given machine has a definite velocity for each angle of incidence, and this is controlled by the elevator.

Since  $K_L$  has a different value for each angle of incidence, it is seen that the velocity of a machine varies with incidence

and, for a given loading, *velocity depends only\* upon incidence*. The angle of incidence is controlled by the pilot by means of the elevator.

The variation of  $K_L$  with incidence, for a particular wing-section, is shown in Fig. 21, reproduced from Fig. 11 of the preceding chapter. The numerical values from which the curve is plotted are given in Table I., page 20.

For any given loading, the values of  $V$  corresponding to any point on this curve is readily determined. For example, suppose  $W/S = 6$ . For an incidence of  $4^\circ$ , from the curve or table  $K_L = 0.00174$ ; hence,  $V = \sqrt{6 \div 0.00174} = 58.6$  miles per hour. The values of  $V$ , determined in this way, are marked for several points on the curve. It is seen that for each incidence, the velocity has one definite value.†

---

\*The density of the air is here assumed to be uniform; see a later chapter on change of density and  $K_L$  with altitude.

†*Modification in complete machine.*—The lift curve for a wing is modified in a complete machine by whatever lift there is (either positive or negative) on other parts of the machine—body, tail and other surfaces—and, in a biplane or triplane, by an interference between the planes that reduces the lift. This reduction is less when the gap between the planes is large and when they are given considerable stagger than when the gap is small and there is no stagger. Lift likewise increases with aspect ratio, the ratio of wing span to chord. For the curves here shown the aspect ratio is assumed to be 6, the usual standard value.

For simplicity a detailed consideration is not given here of these features, for they in no way affect the general character of the conclusions, although they do affect the precise numerical values. Proper corrections have to be applied when exact numerical values are to be obtained.

The net result of these corrections usually shifts each point on the lift curve a little to the right, say a degree or so, so that a lift  $K_L = 0.00174$  and velocity 58.6 MPH. shown by the curve at  $4^\circ$  would, for a complete machine, be at say  $5^\circ$ , and so on for other points, the shift being slightly different for different points. So far as lift and velocity are concerned, the effect of these corrections is merely to change the angle of incidence at which a particular value of lift and of velocity occur. Put in a different way, at small angles (perhaps through the working range) the lift curve is somewhat lowered and at large angles is

**Minimum velocity occurs at the point of maximum  $K_L$ , namely at the critical angle of incidence or burble point.**

It is seen that the minimum velocity occurs when the value of  $K_L$  is a maximum, namely at the critical angle of incidence or burble point. For any other incidence,  $K_L$  is less and  $V$  is correspondingly greater; in other words, when the angle of incidence is either greater or less than the critical angle, *a greater velocity is required in order to produce the lift equal to the weight, the condition necessary for horizontal flight.*

#### **Variation of velocity with incidence.**

The variation of velocity with incidence is well shown by the curves in Fig. 22, which correspond to Fig. 21 and refer, therefore, to a particular wing-section,—not to any wing-section as was the case in Fig. 20. Curves for the variation of velocity with incidence for other wing-sections would have much the same general form.

The heavy curve in Fig. 22 shows the velocity for a loading  $W/S = 6$ ; the light curves, for loadings of 4 and 8,—the greater loading always corresponding to the higher velocity.

It is seen that there is a definite minimum velocity which occurs at the critical angle of incidence—in this case  $14^\circ$ —when  $K_L$  is a maximum, as was also shown in Fig. 21. If a machine loses velocity below this minimum, it cannot sustain itself and is said to **stall**,—the critical angle of incidence being also called the **stalling angle**.

---

somewhat raised,—for at large angles the lift of the airplane body becomes effective.

The lift curve for a complete machine may be determined by applying proper corrections to the lift curve for the wing (which is of course the chief factor) when data for these corrections is available; but it is best determined by a wind-tunnel test with a complete model. Some of these corrections are to be considered later in the chapter on Single and Multiple Planes.

The velocity increases on each side of this minimum, with change of incidence, so as to furnish the necessary sustenta-

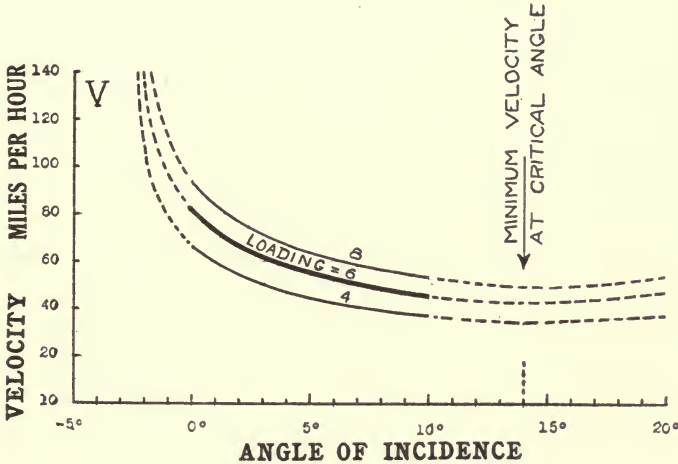

Fig. 22. Variation of velocity with angle of incidence for particular wing-section, when loading is 4, 6 (heavy curve) and 8. These curves correspond to the curve in Fig. 21.

tion, and would have to be infinite were  $K_L$  equal to zero, namely if the incidence were decreased (in this case) to  $-3^\circ$  or were increased to about  $90^\circ$ ; but, as already pointed out, there are limits to the working range of incidence and velocity.

### Usual working range.

Between the limits of  $0^\circ$  and  $10^\circ$  (corresponding to  $K_L = 0.00091$  and  $K_L = 0.00287$ ) the curves are drawn as solid lines; these limits would become  $-1\frac{1}{3}^\circ$  and  $12\frac{1}{2}^\circ$ , if the limits of  $K_L$  were taken as  $0.0008$  and  $0.0032$  as before. (It is understood that *precise* limits cannot be set.) This shows the usual working range: two or three degrees less incidence would cause a *dive*; two or three degrees more incidence

would cause a *stall*. An *inclinometer* is commonly used to indicate the degrees angle of incidence (usually by a bubble) and the advantage of its use is obvious. A *stall indicator* is less frequently used to display a danger signal when the *stalling angle* is approached.

### **Possibility of changeable wing-area or camber.**

For mechanical reasons, wings are made with fixed area and camber. A practical wing with either of these adjustable would do much to advance the art of flying, for it would make possible a great increase in speed range, both by increasing the maximum and decreasing the minimum speed. These improvements have long been considered, the adjustable camber now seeming the more promising of the two.

With adjustable wing-area, the pilot would use large area for low speed and would use small area for high speed.

With adjustable camber, the pilot would use for low speed such camber as gave maximum lift. For high speed he would flatten out the wing and so get less lift without a dangerous reduction in incidence. This flattening of the wing would also bring about a reduction of wing-resistance,—a highly important advantage at high speeds.

For the present, however, it is necessary to be content with wings of fixed area and camber.

### **Power has no direct effect upon velocity.**

It has been shown that the velocity of a machine is dependent only upon incidence (ignoring the possibility of a change in wing-area or camber and the effect of altitude), incidence being controlled by the position of the elevator. It may well be asked: What about power? What effect upon velocity has the amount of power supplied by the engine? The

answer is: The power supplied by the engine has no *direct* effect upon velocity, whatsoever; if the elevator is kept in one position without change, the same angle of incidence is maintained, and hence the same velocity, irrespective of the power supplied by the engine. The effect of power is shown in the following paragraphs.

Let us suppose, for example, a machine is flying with a certain angle of incidence—say,  $4^{\circ}$ —determined by the position of the elevator. The velocity of flight is then definite,—58.6 MPH., if we use the data in Fig. 21. At a definite velocity and incidence, the resistance of the airplane (structure as well as wings) is definite—in a certain instance 263 lbs.—to overcome which there must be an exactly equal thrust (263 lbs.) requiring the supply of a certain amount of power (in this instance 42 horse power). But this definite amount of power that is required may or may not be supplied by the engine, for this depends on the throttle. Let us see what happens when the engine does not supply this amount of power.

**Amount of power supplied by engine determines whether machine climbs, glides or flies horizontally; but, if incidence is not changed, does not affect velocity.**

If the engine supplies just the right amount of power required to overcome the total air resistance, the machine flies *horizontally*, as in Fig. 23. If it supplies more power, the machine takes an oblique path *upward*, as in Fig. 24, the “surplus power” being used *against gravity*. If the engine supplies less power than is necessary to overcome resistance, the machine takes an oblique path *downward*, as in Fig. 25, the necessary additional power being in this case *supplied by gravity*.

Thus, if the power required to overcome the total air resistance is 42 H.P., there are the three cases: when the engine delivers\* 42 H.P., flight is horizontal; when it delivers

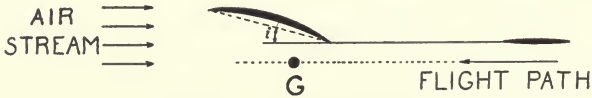

Fig. 23. Horizontal flight.

more power, 47 H.P. for example, the machine climbs, automatically taking a flight path inclined upward at such an angle that the surplus 5 H.P. is used in overcoming gravity; when the engine delivers 37 H.P., the machine takes an oblique path downward at such angle that 5 H.P. is derived from gravity. The angle of incidence—the angle between the chord and the relative air or flight path—being the same in the three cases, the velocity is the same irrespective of whether the flight path is horizontal or oblique.

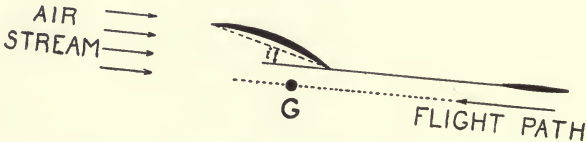

Fig. 24. Oblique flight, upward. The same incidence and speed as in Fig. 23.

It is seen that if the power is increased or decreased, by adjustment of the throttle, the inclination of the flight-path is changed, but (provided the elevator is not changed) the angle of incidence and velocity remain unchanged. Indeed, if the power is entirely cut off, the machine takes an oblique

\*The power available for producing thrust, delivered through the propeller, is here referred to. The question of propeller efficiency is not here taken into consideration.



flight-path downward at a definite **gliding angle**, while the velocity still remains unchanged. These relations will be more fully discussed in subsequent chapters on Climbing and Gliding.

**When horizontal flight is to be maintained, velocity is changed by a simultaneous adjustment of throttle and elevator.**

From the foregoing, it is seen that the one way to change velocity is to change the angle of incidence by means of the elevator; furthermore, if horizontal flight is to be maintained, the throttle must be adjusted at the same time so that the amount of power required for horizontal flight is supplied by the engine,—otherwise the flight path will be oblique. The pilot does not speed up and go faster merely by opening and closing the throttle, as in an automobile. As a matter of

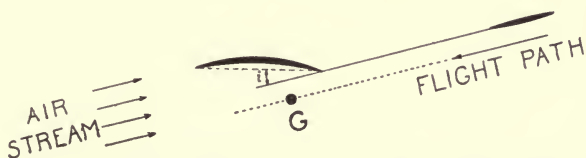

Fig. 25. Oblique flight, downward. The same incidence and speed as in Figs. 23 and 24.

fact an airplane is, in normal flight, practically a constant speed machine, flying usually at the one velocity corresponding to a certain best angle of incidence for which the machine is designed.

It takes more power to fly at low speed or at high speed than at an intermediate speed. The amount of power required to maintain horizontal flight, as shown in a later chapter, increases very rapidly when the velocity is either increased or decreased beyond a rather narrow range. Power

as well as stability is, accordingly, a factor—in many cases a determining factor—in deciding the range of velocity and the limiting values for the angle of incidence and for  $K_L$ .

To find out how much power is necessary for horizontal flight, we must first know the thrust and this is determined by the total resistance that is to be overcome. This will, accordingly, be next investigated.

## CHAPTER III

### RESISTANCE

**Resistance** is the force that impedes the progress of an airplane through the air, this force being in the same direction as the air-stream, and opposite to the direction of flight, as

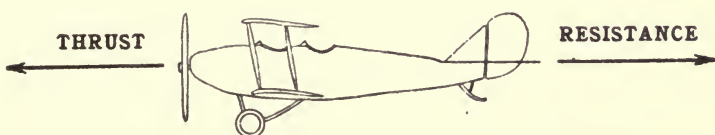

Fig. 26. Resistance is in direction of the air-stream and is overcome by thrust.

shown in Fig. 26. Resistance is overcome by **thrust** from the propeller, a force in the direction of flight, or nearly\* so.

In uniform flight a machine assumes such a velocity and attitude that resistance and thrust are exactly equal.

#### **Center of resistance.**

Thrust is a force forward through the propeller shaft, applied at the **center of thrust** or **C. T.** The total resistance of an airplane, the resistance of wings and structure all included, may be considered as a single force backward in the direction of the air-stream applied at the **center of resistance** or **C. R.**, which may coincide with the center of thrust as in Fig. 26, or may be a little above or below it. When the

---

\*When thrust is inclined with reference to the flight path, resistance is overcome by the component of thrust in the direction of the flight path. The small vertical component, when upward, supports part of the weight so that correspondingly less lift is required of the wing for sustentation; when downward, correspondingly more lift is required.

center of resistance is above the center of thrust, there is a tendency for the machine to nose up when power is on, and when the center of resistance is below the center of thrust there is a tendency for it to nose down. This affects longitudinal stability but in no way affects the value of resistance or thrust.

### **Wing-resistance and parasite resistance.**

Airplane resistance falls under two heads: **wing-resistance**, due to the wings; and **parasite resistance**, due to all other parts of the airplane structure. (Parasite resistance is sometimes called "structural resistance" or "head resistance.") The sum of the two is the **total resistance** or **drag**; thus,

Total Resist. = Wing Resistance + Parasite Resistance.  
In English units, resistance is expressed in pounds.

Although expressed by very similar fundamental formulas, each varying as the square of the velocity, wing-resistance and parasite resistance have quite different characteristics:—wing-resistance depends upon incidence, the variation of the coefficient of wing-resistance  $K_D$  with incidence having been shown in Fig. 11, page 18, of the first chapter; parasite resistance, on the other hand, is practically independent of incidence, except so far as incidence affects velocity.

Whereas parasite resistance always increases as velocity is increased, wing-resistance decreases as velocity is increased until a certain velocity is reached, after which it increases, as brought out in the following discussion.

On account of their different characteristics, wing-resistance and parasite resistance are considered separately.

## WING RESISTANCE

**Fundamental relation.**

Wing-resistance is equal to  $K_D SV^2$ , as shown in the first Chapter, and is fundamentally determined by this formula. A hasty inspection of the formula, however, might lead to the erroneous conclusion that wing-resistance always increases with velocity. This indeed would be true, if  $K_D$  were constant; but in fact, as mentioned above, the changes in the value of  $K_D$  with incidence actually cause wing-resistance to decrease through a certain range of velocities, and then to increase at high velocities. This is best shown by some practical calculations and the plotting of curves.

**Practical calculation.**

Wing-resistance can be calculated directly from the formula  $K_D SV^2$ . The calculation, however, can be made more readily from the  $L/D$  ratio for the particular wing in question. By definition

$$L/D \text{ ratio} = \text{Lift} \div \text{Wing-resistance.}$$

Since Lift = Weight, in horizontal flight, we may write

$$\text{Wing-resistance}^* = \text{Weight} \div L/D \text{ ratio.}$$

To get the wing resistance, it is merely necessary to divide the known weight by the  $L/D$  ratio, the value of this ratio being taken from a table or curve for the particular wing section.

---

\**Variation of wing-resistance with incidence.*—The formula given above may also be written:—

$$\text{Wing-resistance} = \text{Weight} \times D/L \text{ ratio.}$$

Wing-resistance is, therefore, proportional to  $D/L$ . A curve giving the values for wing-resistance for different angles of incidence would be similar to the  $D/L$  curve, Fig. 12, page 19, the only difference between the two curves being the scale.

*Example.*—For example, the weight of a loaded machine is 2000 lbs. The values for the  $L/D$  ratio for the wing used are given by the Table I., page 20, or by the corresponding curve, Fig. 12, page 19. Required to find the wing-resistance and velocity for an incidence of  $4^\circ$ . From the table,  $L/D = 16$  (approximately); hence

$$\text{Wing-resistance} = 2000 \div 16 = 125 \text{ lbs.}$$

It is seen that every 16 lbs. of weight adds one pound to the wing-resistance and will require one pound more thrust, and a corresponding increase in power, to overcome it.

To determine the velocity corresponding to the wing-resistance in the above example, it is necessary to know the loading, for velocity depends upon loading. Thus, if the loading is  $W/S = 6$  lbs. per sq. ft., using the formula of the preceding chapter, we have

$$\text{Velocity} = \sqrt{\frac{W}{SK_L}} = \sqrt{6 \div 0.00174} = 58.6 \text{ MPH.}$$

It is thus seen that when this particular wing-section is used in a machine weighing 2000 lbs., with loading 6 lbs. per sq. ft., the wing-resistance is 125 lbs. at a velocity of 58.6 MPH.

### Variation of wing-resistance with velocity.

The variation of wing-resistance with velocity is well shown by the curves in Figs. 27, 28, and 29, the points being calculated, in the manner just described, for different conditions of weight and loading.

It is seen that with increase of velocity (decrease of incidence) wing-resistance always decreases until a certain velocity is reached, after which it again increases. The minimum velocity for any wing-section is obtained at the critical angle of incidence; a greater angle of incidence is

beyond the range of practical flight. The critical angle for the particular wing-section here used is  $14^\circ$ , but the curves have been calculated beyond  $14^\circ$  in some instances and are shown by dotted lines.

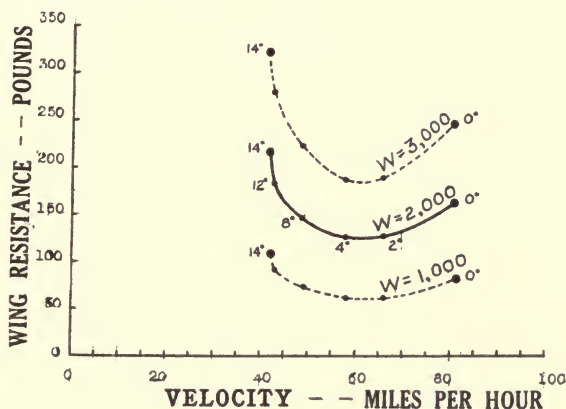

Fig. 27. Variation of wing-resistance with velocity. The three curves show effect of changing weight ( $W = 1000, 2000$  and  $3000$  lbs.) when loading is kept constant ( $W/S = 6$ ).

As incidence is decreased to  $0^\circ, -1^\circ, -2^\circ$ , etc., wing-resistance and velocity both rapidly increase and both would become infinite at the incidence that gives zero lift,—in this case at  $-3^\circ$ .

### Effect of changing weight or loading.

In calculating the curves here shown, it was necessary to know the weight and loading,—inasmuch as wing-resistance = weight  $\div L/D$ , and velocity =  $\sqrt{\text{loading} \div K_L}$ . Different curves for the variation of wing-resistance with velocity are accordingly obtained by changing either weight or loading, or both, and in no other way,—it being understood that we are dealing with a particular wing-section flying in

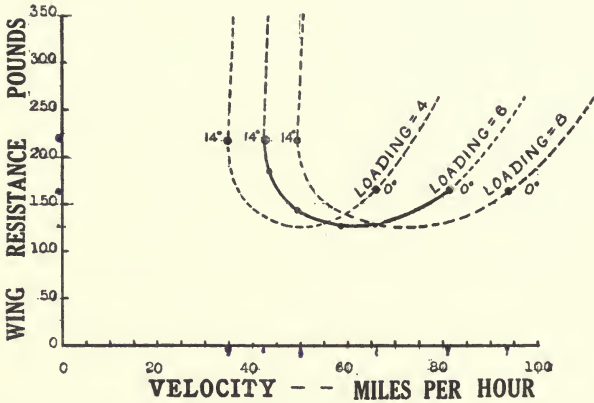

Fig. 28. Variation of wing-resistance with velocity. The three curves show effect of changing loading ( $W/S = 4, 6$  and  $8$ ) when weight is kept constant ( $W = 2000$  lbs.).

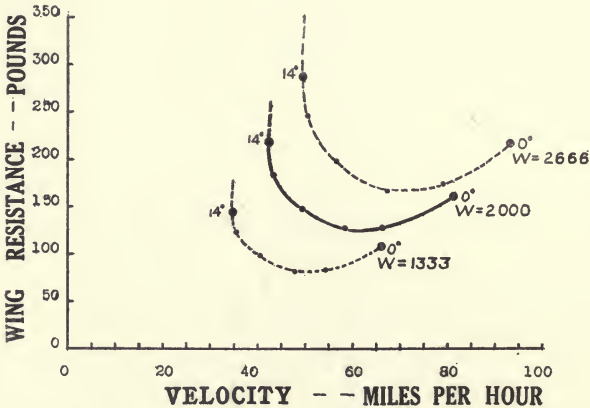

Fig. 29. Variation of wing-resistance with velocity. The three curves show effect of changing weight ( $W = 1333, 2000$  and  $2666$  lbs.) and loading ( $W/S = 4, 6$  and  $8$ ) in proportion, wing-area being constant.



air of constant density. It will be found that all the curves are similar in form and differ only in scale.

There are three cases:

- (1) when weight is changed and loading is kept constant;
- (2) when loading is changed and weight is kept constant;
- (3) when weight and loading are both changed.

**(1) Effect of changing weight when loading is kept constant.**

In this case machines with greater weight also have greater wing area, the loading remaining constant. Wing-resistance for different machines is then directly proportional to weight. This is shown by the curves in Fig. 27 for three machines of different weight. Any point on these curves, corresponding to a particular incidence and velocity, is merely moved up for a heavier, or down for a lighter, weight machine; the heavier the machine, the greater is the wing-resistance.

**(2) Effect of changing loading when weight is kept constant.**

In this case weight is constant and wing-area is changed so as to give different loadings. Changing the loading, for a certain weight, changes the velocity corresponding to a certain incidence, but does not change the amount of wing-resistance, for that incidence. Hence, as shown by the curves in Fig. 28, a change of loading shifts to right or to left the point corresponding to a particular angle of incidence, the velocity for that incidence being proportional to the square root of the loading.

The loading which gives the least wing-resistance is different at different velocities. Thus, for the case shown by the three curves in Fig. 28 with loading 4, 6 and 8, up to about 55 miles per hour the wing-resistance is least for a loading of 4; from 55 to 65 miles per hour, for a loading of 6; and above 65 miles per hour, for a loading of 8.

### (3) Effect of changing both weight and loading, wing-area being constant.

This is a combination of the two preceding cases. A point on any of the curves is moved up or down in proportion to weight, and to right or left in proportion to the square root of the loading.

The three curves in Fig. 29 show the effect of changing weight and loading in proportion, wing-area remaining constant; this might be brought about by taking up the same machine at different times with different loads. It is to be noted that, at the same angle of incidence, greater velocity is required to sustain the greater weight; or, at the same velocity, a greater angle of incidence is required.

### Variation of wing-section.

For a given wing-section there are the three possible ways just described for changing wing-resistance,—by changing the weight, the loading or both. If the wing-section is varied, the number of possible variations is infinite. A wing that has high camber in order to secure great lift, also has large resistance, particularly, at small angles of incidence; while, as already mentioned, a flatter wing with less camber and less lift is better adapted for high speed, having small resistance. But there are many intermediate forms and variations that make an interesting field for study.

## PARASITE RESISTANCE

### Meaning and importance of parasite resistance.

The wings of an airplane are its first essential, for they create the lift, but in creating lift they at the same time cause a wing-resistance. Wing-resistance, therefore, although not a cause of lift, is seen to be a necessary concomitant being

the price paid for the lift. In a preceding example, it was shown that, in a given case, every sixteen pounds of lift must be paid for by one pound of wing-resistance.

Unfortunately this is not all. In addition to wings an airplane must have other parts—body, landing gear, struts, wires, etc.,—all of which have a resistance; but unlike the wings, these parts do not contribute to the lift. The resistance of these parts is, therefore, with some appropriateness called **parasite resistance**.

One of the important problems in design is to make this parasite resistance as low as possible, for while small at low

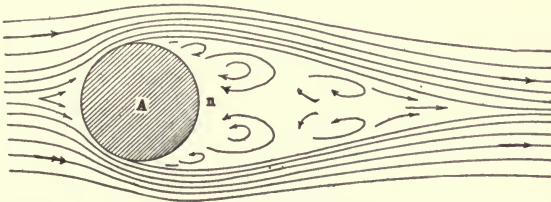

Fig. 30. Air-flow past a cylindrical strut; air eddies and low pressure back of strut cause high resistance.

velocities parasite resistance is very great at high velocities, being perhaps fifty per cent. more than wing-resistance at ordinary maximum flying velocities. In airplane flight, while about two-fifths of the power delivered through the propeller by the engine is used in pushing the wings through the air, **three-fifths of the power, approximately, is used up in parasite resistance.** It is seen that parasite resistance is the biggest obstacle to high-speed flight.

### Streamline flow.

Fig. 30 shows the flow of air past a cylindrical strut or wire. Behind the strut there is a turbulent space and a partial vacuum, or negative pressure  $n$ , that tends to suck the strut

along in the direction of the air-stream. A large part of the resistance of the strut to motion through the air is thus due to this region of low pressure behind it.

In Fig. 31, the space behind the cylindrical strut *A* is partly filled by a piece *B*, so as to reduce the region of tur-

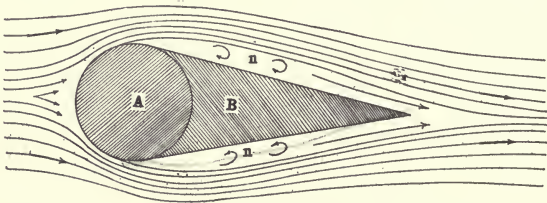

Fig. 31. Cylindrical strut *A*, backed up by a filler *B* of a form that reduces, but does not entirely eliminate, the air eddies and low pressure back of strut. Resistance is thus reduced.

bulence and low pressure. The resistance to motion through the air is thus greatly decreased. Struts are sometimes made in this manner, a piece *A* for strength being backed up by a piece *B*, of light material to save weight, and resistance may be reduced in this way.

Although the shape shown in Fig. 31 is an improvement on the cylindrical strut, it is by no means the best, for it does not

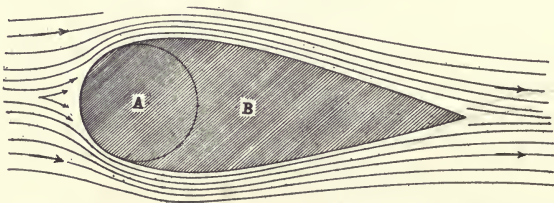

Fig. 32. Strut with air eddies and low pressure back of strut further reduced, by approaching a streamline form.

conform entirely to the streamline flow; there is still a turbulent region *n*, although this is much reduced. **The more**

nearly a body conforms to streamline flow the less is its resistance, the turbulence and suction back of the body being then reduced to a minimum. Fig. 32 shows a strut more nearly conforming to streamline flow.

Only a little is gained by tapering the front side of a cylinder or strut. Note the blunt breast and tapering tail of a bird, and the shape of a fast swimming fish that can dart through the water with scarcely a ripple.

For low resistance, wheels and body should be enclosed; these, as well as every strut and wire, should be streamlined so far as they can be. It should be remembered that a small cylindrical wire may offer much more resistance than a larger wire that is well streamlined.

#### Parasite resistance varies as the square of the velocity.

The law for parasite resistance is summed up in the statement, determined by experiment, that parasite resistance varies as the square of the velocity. This applies not only to the separate parts\* but also to an airplane as a whole. Thus, if a certain airplane has a parasite resistance of 64 pounds when flying at 40 miles per hour, it will have a resistance of 256 pounds at 80 miles per hour. In this case the parasite resistance is  $0.04V^2$ .

The curves in Fig. 33 show the values for parasite resistance at different velocities for three cases,  $R = 0.02V^2$ ,  $R = 0.04V^2$

---

\*There is an appreciable departure from the square law when the skin resistance of a body is large compared with the direct impact or dynamic resistance—the more so when the surface is rough and the fore-and-aft dimension of the body is large in proportion to the diameter—but practically it is simplest to neglect this and to assume the square law as strictly true. For only a small range in velocity, any error in this is inappreciable; for a large range, it may be necessary to take different values of the coefficient at different velocities.

and  $R = 0.06V^2$ , these illustrating the variation for a certain range of moderate size machines.

### Distribution of parasite resistance.

Parasite resistance is roughly distributed about as follows:—body, one-third; wires and struts, one-third; tail and

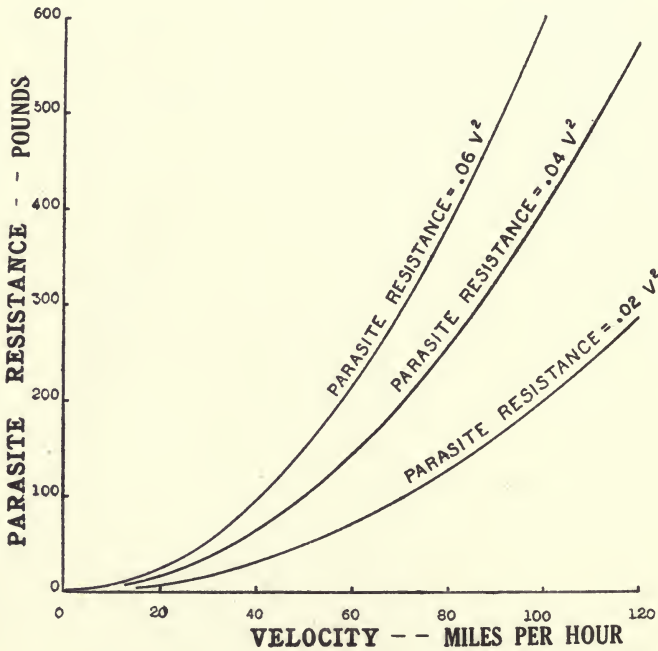

Fig. 33. Variation of parasite resistance with velocity; the three curves show  $R = 0.02V^2$ ,  $R = 0.04V^2$  and  $R = 0.06V^2$ .

landing gear, one-third (about one-sixth for tail and one-sixth for landing gear).

### Increase of parasite resistance due to propeller slip stream.

Back of the propeller the air is driven backward in what is called the *slip stream* or *propeller race*; in this slip stream

the velocity of the air relative to the airplane is increased, say, 20 or 25 per cent.  $V^2$  is thus increased about 50 per cent. The parasite resistance of the tail and all parts of the structure in the slip stream is accordingly increased, let us say, 50 per cent. when the propeller is running. Approximate calculations may be made on this basis. Another approximate method is to consider that the increase of the total parasite resistance due to the propeller slip stream is 10 per cent. To get accurate results, careful computation would be necessary.

### SOME CONCLUSIONS

Three lines for improvement are suggested by the foregoing discussions:—

- (1) Reduce parasite resistance.
- (2) Reduce weight.
- (3) Improve wing-section, so as to get a greater  $L/D$  ratio.

Wing-resistance, which is equal to weight  $\div L/D$ , is reduced by (2) and (3). Most important are (1) and (2), as the improvement that can be made in  $L/D$  ratio is probably rather small.

In design every effort should be made to reduce weight and to cut down parasite resistance.

The chief weight is in the engine and the reduction of weight is largely a problem for the engine designer. Reduction in parasite resistance is to be looked for in improved design of structure.

### Thrust and power characteristics.

The reader is referred to Appendix II and Appendix III for curves showing the variation of thrust and power required at different velocities.

For horizontal flight, thrust is equal to the total resistance, *i. e.*, is equal to the sum of wing-resistance and parasite resistance.

Horse power is equal to the product of thrust (in pounds) and velocity (in miles per hour) divided by 375.

NOTE. The following chapters are in preparation and logically should follow Chapter III. Thrust. Power. Climbing. Gliding. Altitude. Single and Multiple Planes. Stability in General. Longitudinal Stability.



## CHAPTER IV

### LATERAL STABILITY

Lateral stability of an airplane is stability about a fore-and-aft axis, called the "rolling" axis, which passes through the center of gravity and either coincides with the line of flight or is slightly displaced therefrom.

#### Rolling axis.

The rolling axis lies in the plane of symmetry of the machine and, as shown in Fig. 1, it may be either:

A *neutral axis*, when it coincides exactly with the line of flight;

A *raised axis*, when its forward end is raised above the line of flight (the common case); or,

A *lowered axis*, when its forward end is lowered below the line of flight, which is not a common case.



Fig. 1. Three positions of rolling axis.

The line of flight is always understood to be the path of the center of gravity.

Stability requires that a restoring moment be set up whenever the machine is displaced from its normal position. If the machine is rolled over to one side, with one wing raised and the other lowered, there must be a rolling moment tending to roll the machine back until the two wings are again on the same level. Although for steadiness in normal

flight a certain positive lateral stability is desirable, for quick manoeuvres a less positive or even an indifferent stability becomes advantageous. But in no case is it desirable to have a negative stability, which would tend to overturn the machine when once displaced from its normal position.

### **Neutral axis.**

A machine with a neutral axis has, from symmetry, a neutral or indifferent stability, inasmuch as the angle of incidence at which the air strikes the various surfaces (including keel and other surfaces as well as wings) and hence also the pressure, remain unchanged, irrespective of any displacement of the machine about its rolling axis. The displacement, therefore, causes neither a resorting nor an upsetting moment. Such a machine needs no further study. By "incidence" is always meant the angle between a surface and the stream of air it encounters; in case of a curved or cambered wing, the angle between the chord and the air-stream.

### **Inclined axis.**

The conditions for stability in a machine in which the rolling axis is inclined depend upon whether the axis is raised or lowered and upon the disposition of keel surfaces and upon the shape of the wings.

### **Keel surface as affecting lateral stability.**

An important element in lateral stability is the **keel surface** which includes all surfaces that can be seen in a "side view" of the machine, that is, when the machine is viewed in a direction perpendicular to the plane of symmetry. The keel surface of body, struts and other structure may in itself be sufficient, but it is frequently supplemented by a vertical stabilizer or keel so as to give a keel surface of desired

size and location,—*i. e.*, either a high keel above the rolling axis or (rarely) a low keel below the rolling axis, as may be required for stability.

Small keel surfaces are sometimes placed on top of the wings, when this position suits the design of the machine, or between the wings of a biplane. The keel or vertical stabilizer is, however, more commonly in the rear of the machine, with the rudder hinged to its back edge, as shown in Fig. 12 of the next chapter.

*Raised axis; high keel gives stability, low keel gives instability.*—Place a card on a stick or wire, so as to make a flag-shaped model as in Fig. 2, and view it from in front along the



Fig. 2. Stable.

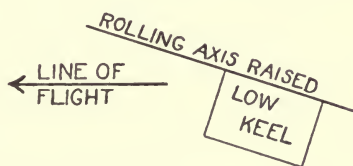

Fig. 3. Unstable.

line of flight; let the stick represent the rolling axis and the surface of the card represent the keel surface. When the model is thus viewed from the front (from the left in the illustration), it will be seen that with a raised axis a high keel surface is stable, for when displaced by rolling, one side of the keel plane is exposed to the wind (in the model, is exposed to view) and the pressure on this side is in a direction to restore the plane to its normal position. Likewise, as shown in Fig. 3, it will be seen that with a raised axis a low keel is unstable.

The restoring moment is seen to depend upon the position of the keel surface with respect to the rolling axis, and to be independent of its position with respect to the center of gravity,—that is, it may be above or below the center of

gravity, in front of or behind it, without affecting lateral stability. (The location of the keel surface with respect to the center of gravity has, however, a direct effect, on directional stability discussed later, and on stability in gusts.)

*Lowered axis; low keel gives stability, high keel gives instability.*—In a like manner, it may be seen that, with a lowered rolling axis as shown in Figs. 4 and 5, a low keel gives stability and a high keel gives instability.

As the center of pressure on the keel surface is never very far from the rolling axis, the restoring moment is correspond-



Fig. 4. Stable.

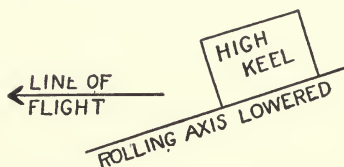

Fig. 5. Unstable.

ingly small. A longer lever arm and hence a larger moment would be obtained if the keel surface were located well out on the wings, and some machines have keel surfaces so placed. The same effect, however, is practically obtained by turning the wings up so as to form a dihedral angle, as discussed below.

### Wing shape, as affecting lateral stability.

Lateral stability is materially affected if the two wings, instead of lying in a straight line, when viewed from in front, are turned up so as to form a **dihedral angle** (or **V**) as in Figs. 6 and 7, or are made to retreat as in Fig. 8, or are given a raked end as shown in the same figure.

The dihedral angle (called "lateral" or "transverse" dihedral to distinguish it from the "longitudinal" dihedral

angle between the main plane and tail) may be caused or noticeably increased by flexure of the wings in flight. The dihedral angle often amounts to several degrees and is distinctly noticeable, but it may be so small (perhaps one degree or less) as to be scarcely noticeable to the eye.



Figs. 6 and 7. Dihedral angle for monoplane and biplane; front view.

### Model to show effect of wing shape.

The effect of wing shape upon lateral stability depends upon the position of the rolling axis and this is best seen by inspection of a model, readily made from a small rectangular board, as in Fig. 9.

Different types of wings, made of card board or tin, can

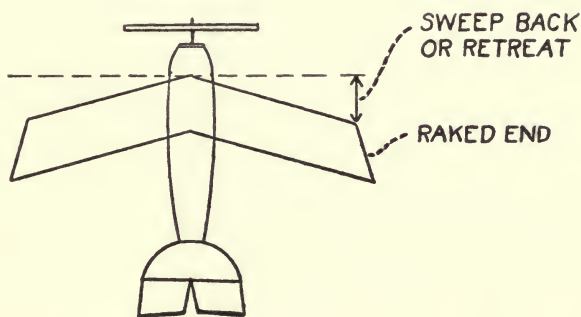

Fig. 8. Showing retreating or swept-back wings; showing also raked ends to wings. Top view.

be inserted in the slits 1, 2 or 3 to obtain different angles of incidence. The board can be rotated about the pegs *NN* for a neutral axis, about *RR* for a raised axis and about *LL* for a

lowered axis. (Other pegs may be used to give other angles to these axes.)

### Lateral Stability as affected by dihedral angle.

By such a model the following conclusions can be readily verified.

(1) *Dihedral angle (V) and raised axis, gives stability,* because, when the machine is displaced by rolling:

Raised wing has a smaller angle of incidence and hence less lift;

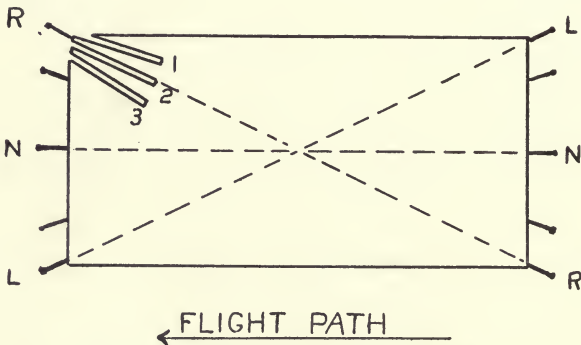

Fig. 9. Model. Wings of different forms are inserted in the slits 1, 2 and 3 and viewed from the front (from the left in the illustration) the line sight being in the direction of the air stream.

Lowered wing has a greater angle of incidence and hence more lift.

This makes a restoring moment and it can be shown that this moment is greater as the angle of incidence at which the machine is flying is greater.

Case (1) is the method actually employed for obtaining lateral stability.

(2) *Dihedral angle (V) and lowered axis, gives instability,* because, when machine is displaced by rolling:

Raised wing has a larger angle of incidence and hence more lift;

Lowered wing has smaller angle of incidence and hence less lift.

This makes an upsetting moment, which can be shown to be greater as the incidence\* is greater.

In a like manner, it may be seen that:

(3) *Inverted dihedral ( $\Lambda$ ) and raised axis, gives instability.*

(4) *Inverted dihedral ( $\Lambda$ ) and lowered axis, gives stability.*

With the inverted dihedral, the upsetting or restoring moment is less as incidence is greater. The inverted dihedral is practically never used, although machines have been so made and flown. It may be noted that a gull, when it lowers its head as it flies near the water in search of fish, also droops its wings so as to make an inverted dihedral; in this way stability is secured with what is now a lowered axis. As the head is raised again for normal flight and the rolling axis changes from a lowered axis to a neutral and then to a raised axis, the inverted dihedral ( $\Lambda$ ) may be seen to disappear and an upright dihedral ( $V$ ) to take its place.

A dihedral angle, or an inverted dihedral angle, makes a tendency for a machine to roll when struck by a side gust. Too large a dihedral angle is, accordingly, undesirable; but other means may be used for increasing lateral stability.

### **Straight wings.**

With straight wings, that is when there is no dihedral, the incidence on both wings is always the same. Irrespective of

---

\*This is true for small angles of incidence only, *i. e.*, for the range employed in flight in which the lift increases with incidence. Were the incidence increased beyond, say,  $14^\circ$  or  $15^\circ$ , the lift and the restoring moment would decrease.

whether the axis is raised or lowered, there is no difference in the incidence of the two wings when the machine rolls and hence no restoring or upsetting moment due to this cause.

A raised axis, however, has a small tendency toward stability, because when the machine rolls the lowered wing moves forward and its center of pressure (which is always ahead of the middle of a plane) now moves toward the wing-tip, thus increasing the lever arm of the lift on this wing; the raised wing on the other hand moves backward and its center of pressure moves towards the body of the machine, thus decreasing its lever arm. There is thus a restoring moment, obtained with straight wings and a raised axis; it is much less, however, than the restoring moment obtained by using a dihedral angle.

In a similar way, a lowered axis with straight wings tends toward instability.

### **Retreating wings and wings with raked ends.**

Retreating or swept back wings, with a raised rolling axis, give lateral stability, for (as may be seen by inserting such wings in the model, Fig. 9), when the machine rolls, the descending wing moves forward and enters the air more squarely so as to attack more air and get more lift, thus restoring the machine to its position of equilibrium.

In a like manner it can be shown by the model that, with a raised axis, lateral stability is increased if the ends of the wings are raked, *i. e.*, if the trailing edge is longer than the entering edge.

With a lowered axis, retreating wings and wings with raked ends would be unstable.

Retreating wings and wings with raked ends are thus seen to have the same effect as a dihedral angle upon lateral



stability, but with the advantage that in a side gust they create no tendency for a machine to roll. It will be shown later that all three devices—dihedral angle, retracting wings and raked ends—give directional stability. But they all have the disadvantage of reducing the so-called lifting efficiency, or  $L/D$  ratio, *i. e.*, there is a decrease in the amount of lift for a given wing-resistance.

### Effect of velocity on lateral stability.

All stability, depending upon the pressure of relative air upon surfaces, increases as the velocity increases.

### Control.

Lateral control might well be obtained by shifting the center of gravity, but this is not done. It has been obtained



Fig. 10. Aileron independent of main wings.

by warping (*i. e.*, distorting) the planes, but lateral control is now generally obtained by means of auxiliary planes or *ailerons* which may be independent of the main planes (*i. e.*, between the two planes of a biplane as in Fig. 10) or attached to the wings as wing flaps, as in Fig. 11. To roll the machine the pilot, simultaneously, turns the aileron on one wing down and the other aileron up, thus giving more lift to one wing so that it rises and less lift to the other so that it descends. This movement of the ailerons is commonly effected by pushing the control stick, or by turning the control wheel, to

left or to right, as illustrated in Appendix IV. The term "warping" is frequently used to include this control by ailerons.

### Banking may or may not produce turning.

A machine is said to be **banked** when it is keeled over on a turn, as a bicycle rider leans inward on a curve.

A machine is banked on a turn by elevating one wing and depressing the other, this being accomplished by manipulat-

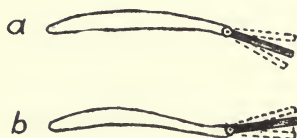

Fig. 11. Section of wing with wing-flap or aileron. In (a) the wing-tip and aileron normally have positive incidence; in (b) they are up-turned and have negative incidence.

ing the ailerons in the manner described; but this manipulation of the ailerons will itself tend to turn the machine to one side, if the wing-resistance is thereby increased on that side and decreased on the other side.

If the raised wing has its resistance increased when its aileron is turned down, and the lowered wing has its resistance decreased when its aileron is turned up (as will occur with many wing sections, as *a* in Fig. 11), the raised wing will be retarded and the machine will turn toward the higher (outer) wing. Such a turn is not desirable but, under these conditions, will occur unless prevented by the rudder.

A turn toward the lower (inner) wing is more desirable and this may be accomplished by having the wing tips (including ailerons) somewhat upturned so as to have a negative incidence in normal flight; see *b* in Fig. 11. The

resistance of the raised wing is then *decreased* when its aileron is swung down, and the resistance of the lowered wing is increased as its aileron is swung up, so that the lower wing is retarded and a turn is made toward the lower (inner) wing. Indeed some machines are made so as to depend entirely upon banking as a means for turning, *no rudder being provided*. (Conversely, as discussed in the next chapter, turning produces banking and in some machines the rudder has been the only means for banking, no ailerons or similar devices being provided.)

Although it is in many ways desirable to have a machine thus turn in automatically when it is banked, some prefer to have the control left entirely to the pilot, the machine having no tendency to turn either in or out. This condition may be approached by a nicety in design of section of wing and aileron. The negative wing-tip and aileron,—although advantageous for the reasons just described, mean a sacrifice for they give less lift and greater wing-resistance.

There is room for difference of opinion as to how great an extent banking and turning should be automatically dependent upon each other and to what extent their control should depend upon the pilot.

### **Propeller Torque.**

In a machine with one propeller, as the propeller rotates in one direction there is a tendency (when the power is on) for the whole machine to rotate in the opposite direction. This may be easily corrected for in the control by the pilot, or automatically by a difference in the lift of the two wings, as described below. When flying, any correction is made by the pilot unconsciously. When starting, however, the correction may be noticeable, for the amount of correction

changes as the engine accelerates; furthermore it is particularly important while near the ground to keep both wings even. When two propellers are used, rotating in opposite directions, the effects of propeller torque are neutralized.

#### **Automatic correction for propeller torque.**

The correction for the torque of the propeller when power is on is often made automatically by a lack of symmetry in the two wings so that one wing has more lift than the other. This is sometimes done by a **droop and rise** (a droop near the end of one wing and a rise near the end of the other) and sometimes by a **wash out** on one wing (a progressive decrease in incidence from body to wing-tip) and a **wash in** on the other wing (a progressive increase of incidence from body to wing-tip.)

Any such lack of symmetry, however, gives a tendency for the machine to rotate when power is off. In horizontal flight this may be corrected for by the controls, but in diving it may make a **spin** that can not be controlled; for this reason **lack of symmetry is very undesirable and should be avoided.**

## CHAPTER V

### DIRECTIONAL STABILITY

When an airplane swings off from its course, to left or right, it is said to **yaw**. Directional stability is the stability that keeps a machine on its course, that is it restores the machine to its course whenever it yaws. The **vertical** or **yawing axis** passes through the center of gravity of the machine, lies in the plane of symmetry and is more or less perpendicular to the flight path.

This stability is similar to that of a weathercock and depends upon having the center of the keel surface back of the yawing axis, thus insuring a restoring moment whenever the machine departs from its course. It is to be remembered that the keel surface is all the surface seen from the side, including structure as well as auxiliary keels or fins. In some machines enough directional stability is obtained by the keel surface of the body itself, but this is usually supplemented by the addition of a small keel or vertical stabilizer in the rear. If the keel center is too far aft, side gusts will cause the machine to yaw too much.

A machine should fly straight on its flight path; but it will fail to do so and will proceed crab-fashion if there is unequal resistance on the two sides. This might be caused by unequal incidence of the two wings, distorted surface or cambre, lack of symmetry in the tail, wrong alignment of body or fin or anything that might act as a rudder, for example the setting of struts or stream-line wires not in the line of flight,—points to be looked at in “tuning up” a machine.

#### **Dihedral angle and retreating wings.**

Although the keel surface is the chief element in directional

stability, the wings may contribute. Directional stability is in all cases aided by retracting wings and by wings with a transverse dihedral angle, on account of the greater resistance of the wing which advances when the machine swings off from its course; this is independent of the location of the rolling axis. The same is true of wings with raked ends (*i. e.* with trailing edge longer than entering edge). As pointed out in the preceding chapter (see Figs. 6, 7 and 8) these forms of wings likewise tend toward lateral stability, provided there is a raised rolling axis.

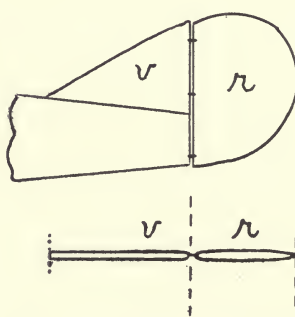

Fig. 12. Vertical stabilizer (*v*) and rudder (*r*).

On the other hand an inverted dihedral or advancing wing tips, forms of wings which are not used, would in all cases tend toward directional instability; with a lowered axis, these forms would, however, give lateral stability, as already explained.

### Turning.

Turning is the deflection of the flight path to left or right. Rotation of the machine about its vertical axis, although it usually accompanies turning, is not in itself sufficient. Although turning might be effected by other means,—as by shifting the center of gravity, extending a panel on one wing

to increase its resistance, etc.—it is usually effected by a rudder at the rear of the machine. This is often hinged on a vertical fin or stabilizer, already referred to in connection with lateral stability, which forms part of the keel surface; such a rudder is shown in Fig. 12. A **balanced rudder**, as in Fig. 13, reduces the force necessary for control and for this reason is commonly used on large machines. The rudder is usually operated by the pilot's feet, as illustrated in Appendix IV.

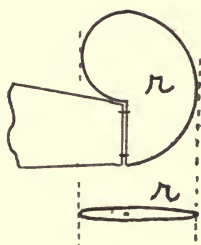

Fig. 13. Balanced rudder ( $r$ ).

### Turning by rudder.

A rudder alone without a keel would be ineffective, for the machine when rotated by the rudder would tend to skid along its original flight path, as does a toboggan on smooth ice. Turning control like all control depends also on a certain speed, as in watercraft which require "steerage way" in order to answer the helm.

The relation between keel and rudder in turning is shown in Fig. 14. When the rudder is turned to one side, the pressure on the rudder causes the whole machine to rotate about its vertical axis until the rudder moment ( $p$  times its lever arm) is balanced by the keel moment (the keel pressure  $P$  times its lever arm); the lever arm in each case is the distance measured from the center of gravity  $G$ , to the force  $p$  or  $P$ , measured on a line perpendicular to the force.

It is clear that, when the two moments are equal, the force  $P$ , with the shorter lever arm, is greater than  $p$ . The resultant of the forces  $P$  and  $p$  is a force  $R$ ,\* deflecting the machine from its original flight path.

This deflecting force:

Increases as  $P$  increases (increasing, for a given keel moment, as the keel surface is greater and its distance from  $G$  is less);

Increases as  $p$  decreases (increasing, for a given rudder moment, as the rudder surface is smaller and further back.)

A rudder is most effective, therefore, when it is placed far back, and the keel surface is placed near the center of gravity.

### Secondary effects.

There are important secondary effects on turning, the principal ones (see Fig. 14) being:

(a) *Turning causes banking*, for two reasons: (1) The outer wing having the higher velocity and greater lift tends to rise and the inner wing tends to descend on a turn; (2) The pressure on the keel surface on a turn tends to keel the machine over in the same direction as in (1), provided (as is usually the case) the keel center is above the rolling axis. (In some machines, as mentioned in the preceding chapter,

---

\*Strictly speaking,  $R$  is not the resultant of  $P$  and  $p$ , although for the present purpose it may be so called. More correctly,  $P$  and  $p$  may each be replaced by a couple and by a force acting at  $G$ , these two forces being shown in the figure by light dotted lines. The two couples thus formed are equal and opposite and so cancel each other. This leaves the two forces acting at  $G$  with the resultant  $R$ .

The two couples thus cancelled do not affect the motion of the airplane as a whole; they do, however, enter into strength computations.



the rudder has been the only means for banking, no ailerons or similar devices being provided.)

(b) *Turning causes increase of resistance and loss of speed due to the fact that the pressures  $P$  and  $p$  on keel and rudder each have a backward component.*

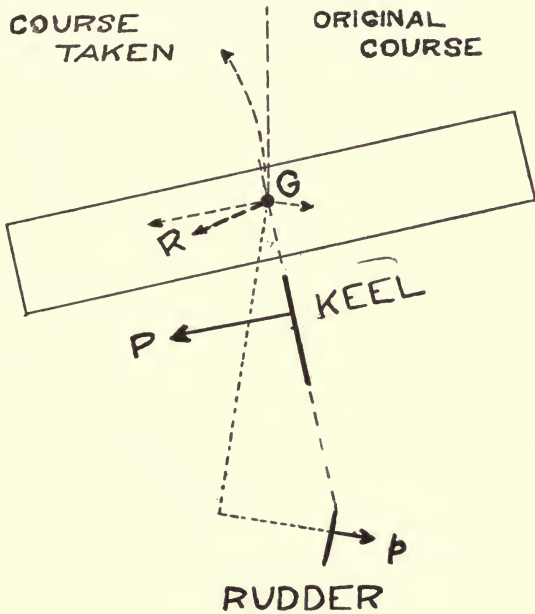

Fig. 14. Action of keel in turning.

(c) *Turning causes a decrease in lift and a tendency to descend, i. e., a tendency to stall, for two reasons: (1) On account of loss of speed described in b, the pressure on the wings, and hence the lift, is decreased; (2) On account of banking described in a, the vertical component of the lift is decreased, see Fig. 15; this component becoming zero when a machine is banked ninety degrees.*

(d) Machine may nose up on a turn and thus have a further tendency to stall, if the pressures  $P$  and  $p$  on keel and rudder are higher than  $G$ , on account of the backward component of these pressures. Stalling may end in a tail slide.

The tendency to stall on a turn may be overcome, if necessary, by maintaining speed either by putting on more power or by nosing down a little by means of the elevator. Loss of speed is to be avoided. Obviously, to attempt to climb on a turn is dangerous.

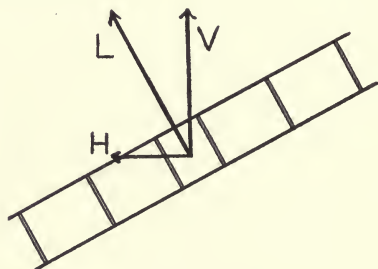

Fig. 15. Horizontal and vertical components lift when banking note that lift is not vertical.

### Side slipping and skidding.

If a machine is banked too much for a particular turn, it will slip *in* and *down*, on account of the horizontal component\* there is to the lift (see Fig. 15) and the decrease in the vertical component. This may result in a nose dive.

If a machine is not banked enough, it will skid *out* and (in some cases, due to the inertia of the machine) *up*, this being likely to happen on sharp turns and at high speeds. This may end in a stall, as the relative wind strikes the machine

---

\*It is to be kept in mind that lift, as the term is used, lies in the plane of symmetry of a machine and becomes inclined when a machine rolls.

less from the front and more from the side and so gives less support to the machine on account of its decreased forward velocity.

### **Banking on a turn.**

With the proper banking, the centripetal force towards the center of the turn due to the banking must just equal the centrifugal force away from the center. There being no skidding or side slipping, the pilot will feel no side wind on either cheek. He will feel a pressure holding him to his seat with no pressure to left or right. Strings tied to guy-wires, blow straight back and not at an angle. If rolling is indicated by an inclinometer like a level (arched upward), placed across the machine, the bubble remains central. In skidding or side slipping, the machine leaves the bubble behind; the pilot ought to keep in mind that **the control should follow the bubble**. It is a good plan to start banking just before beginning a turn.

The pilot instinctively gets the proper "feel" of a turn, as does the rider of a bicycle, without a study of moments and couples. The bicycle rider, however, usually learns by taking a few spills,—but this the air pilot can not afford to do.

### **Turning by banking.**

When the wings are inclined, whatever the cause, the lift on the wings has not only a vertical component but also a horizontal sideways component, as shown in Fig. 15, which tends to move the machine horizontally toward the side of the machine that is down. The flight path is thus deflected. This becomes more pronounced in machines with large keel surface. By placing large keel surfaces, both forward and aft, certain machines are turned entirely by banking and are provided with no rudder.

**Gyrosopic action.**

The propeller and revolving parts of the engine form a gyroscope, so that a sudden turn of the machine sideways will cause it to pitch or rear. Similarly any sudden pitching or rearing will cause the machine to turn to one side; for, when a sudden force is applied perpendicular to the axis of a gyroscope, the axis swings sideways at right angles to that force. The direction of this effect will depend upon the direction of rotation of the revolving parts, and so may be opposite in different machines. This effect will be but small when controls are not jerked suddenly; indeed they should not be operated suddenly on account of the severe stresses produced.

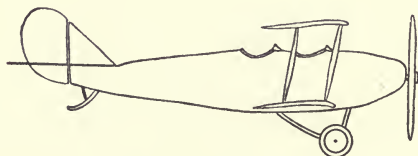

## APPENDICES

- APPENDIX I. Glossary.
- APPENDIX II. Thrust Characteristics.
- APPENDIX III. Power Characteristics.
- APPENDIX IV. Control and Other Diagrams.



## APPENDIX I

### GLOSSARY\*

**AEROFOIL:** A winglike structure, flat or curved, designed to obtain reaction upon its surface from the air through which it moves.

**AEROPLANE:** See Airplane.

**AILERON:** A movable auxiliary surface used to produce a rolling moment about the fore-and-aft axis.

**AIRCRAFT:** Any form of craft designed for the navigation of the air—airplanes, balloons, dirigibles, helicopters, kites, kite balloons, ornithopters, gliders, etc.

**AIRPLANE:** A form of aircraft heavier than air which has wing surfaces for support in the air, with stabilizing surfaces, rudders for steering, and power plant for propulsion through the air. This term is commonly used in a more restricted sense to refer to air-planes fitted with landing gear suited to operation from the land. If the landing gear is suited to operation from the water, the term "sea-plane" is used. (See definition.)

*Pusher.*—A type of airplane with the propeller in the rear of the engine.

*Tractor.*—A type of airplane with the propeller in front of the engine.

**AIR-SPEED METER:** An instrument designed to measure the speed of an aircraft with reference to the air.

**ALTIMETER:** An aneroid mounted on an aircraft to indicate continuously its height above the surface of the earth.

**ANEMOMETER:** Any instrument for measuring the velocity of the wind.

---

\*From Report No. 15, on "Nomenclature for Aeronautics," by the National Advisory Committee for Aeronautics.

## ANGLE:

*Of attack or of incidence of an aerofoil.*—The acute angle between the direction of the relative wind and the chord of an aerofoil; *i. e.*, the angle between the chord of an aerofoil and its motion relative to the air. (This definition may be extended to any body having an axis.)

*Critical.*—The angle of attack at which the lift-curve has its first maximum; sometimes referred to as the “burble point.” (If the “lift curve” has more than one maximum, this refers to the first one.)

*Gliding.*—The angle the flight path makes with the horizontal when flying in still air under the influence of gravity alone, *i. e.*, without power from the engine.

APPENDIX: The hose at the bottom of a balloon used for inflation. In the case of a spherical balloon it also serves for equalization of pressure.

ASPECT RATIO: The ratio of span to chord of an aerofoil.

AVIATOR: The operator or pilot of heavier-than-air craft. This term is applied regardless of the sex of the operator.

AXES OF AN AIRCRAFT: Three fixed lines of reference; usually centroidal and mutually rectangular.

The principal longitudinal axis in the plane of symmetry, usually parallel to the axis of the propeller, is called the fore and aft axis (or longitudinal axis); the axis perpendicular to this in the plane of symmetry is called the vertical axis; and the third axis, perpendicular to the other two, is called the transverse axis (or lateral axis). In mathematical discussions the first of these axes, drawn from front to rear, is called the X axis; the second, drawn upward, the Z axis; and the third, forming a “left-handed” system, the Y axis.

BALANCING FLAPS: See Aileron.

BALLONET: A small balloon within the interior of a balloon or dirigible for the purpose of controlling the ascent or descent, and for maintaining pressure on the outer envelope so as to prevent deformation. The ballonnet is kept inflated



with air at the required pressure, under the control of a blower and valves.

**BALLOON:** A form of aircraft comprising a gas bag and a basket. The support in the air results from the buoyancy of the air displaced by the gas bag, the form of which is maintained by the pressure of a contained gas lighter than air.

*Barrage.*—A small spherical captive balloon, raised as a protection against attacks by airplanes.

*Captive.*—A balloon restrained from free flight by means of a cable attaching it to the earth.

*Kite.*—An elongated form of captive balloon, fitted with tail appendages to keep it headed into the wind, and deriving increased lift due to its axis being inclined to the wind.

*Pilot.*—A small spherical balloon sent up to show the direction of the wind.

*Sounding.*—A small spherical balloon sent aloft, without passengers, but with registering meteorological instruments.

**BALLOON BED:** A mooring place on the ground for a captive balloon.

**BALLOON CLOTH:** The cloth, usually cotton, of which balloon fabrics are made.

**BALLOON FABRIC:** The finished material, usually rubberized, of which balloon envelopes are made.

**BANK:** To incline an airplane laterally—*i. e.*, to roll it about the fore and aft axis. Right bank is to incline the airplane with the right wing down. Also used as a noun to describe the position of an airplane when its lateral axis is inclined to the horizontal.

**BAROGRAPH:** An instrument used to record variations in barometric pressure. In aeronautics the charts on which the records are made indicate altitudes directly instead of barometric pressures.

- BASKET:** The car suspended beneath a balloon, for passengers, ballast, etc.
- BIPLANE:** A form of airplane in which the main supporting surface is divided into two parts, one above the other.
- BODY OF AN AIRPLANE:** The structure which contains the power plant, fuel, passengers, etc.
- BONNET:** The appliance, having the form of a parasol, which protects the valve of a spherical balloon against rain.
- BRIDLE:** The system of attachment of cable to a balloon, including lines to the suspension band.
- BULLSEYES:** Small rings of wood, metal, etc., forming part of balloon rigging, used for connection or adjustment of ropes.
- BURBLE POINT:** See Angle, critical.
- CABANE:** A pyramidal framework upon the wing of an airplane, to which stays, etc., are secured.
- CAMBER:** The convexity or rise of the curve of an aerofoil from its chord, usually expressed as the ratio of the maximum departure of the curve from the chord to the length of the chord. "Top camber" refers to the top surface of an aerofoil, and "bottom camber" to the bottom surface; "mean camber" is the mean of these two.
- CAPACITY:** See Load.  
The cubic contents of a balloon.
- CENTER:** *Of pressure of an aerofoil.*—The point in the plane of the chords of an aerofoil, prolonged if necessary, through which at any given attitude the line of action of the resultant air force passes. (This definition may be extended to any body.)
- CHORD:**  
*Of an aerofoil section.*—A right line tangent at the front and rear to the under curve of an aerofoil section.  
*Length.*—The length of the chord is the length of the projection of the aerofoil section on the chord.

CLINOMETER: See Inclinator.

CONCENTRATION RING: A hoop to which are attached the ropes suspending the basket.

CONTROLS: A general term applying to the means provided for operating the devices used to control speed, direction of flight, and attitude of an aircraft.

CONTROL COLUMN: The vertical lever by means of which certain of the principal controls are operated, usually those for pitching and rolling.

CROW'S FOOT: A system of diverging short ropes for distributing the pull of a single rope.

DECALAGE: The angle between the chords of the principal and the tail planes of a monoplane. The same term may be applied to the corresponding angle between the direction of the chord or chords of a biplane and the direction of a tail plane. (This angle is also sometimes known as the longitudinal V of the two planes.)

DIHEDRAL IN AN AIRPLANE: The angle included at the intersection of the imaginary surfaces containing the chords of the right and left wings (continued to the plane of symmetry if necessary). This angle is measured in a plane perpendicular to that intersection. The measure of the dihedral is taken as  $90^\circ$  minus one-half of this angle as defined.

The dihedral of the upper wing may and frequently does differ from that of the lower wing in a biplane.

DIRIGIBLE: A form of balloon, the outer envelope of which is of elongated form, provided with a propelling system, car, rudders, and stabilizing surfaces.

*Nonrigid.*—A dirigible whose form is maintained by the pressure of the contained gas assisted by the car-suspension system.

*Rigid.*—A dirigible whose form is maintained by a rigid structure contained within the envelope.

*Semirigid.*—A dirigible whose form is maintained by means of a rigid keel and by gas pressure.

DIVING RUDDER: See Elevator.

DOPE: A general term applied to the material used in treating the cloth surface of airplane members and balloons to increase strength, produce tautness, and act as a filler to maintain air-tightness; it usually has a cellulose base.

DRAG: The component parallel to the relative wind of the total force on an aircraft due to the air through which it moves.

That part of the drag due to the wings is called "wing resistance" (formerly called "drift"); that due to the rest of the airplane is called "parasite resistance" (formerly called "head resistance").

DRIFT: See Drag. Also used as synonymous with "leeway," *q. v.*

DRIFT METER: An instrument for the measurement of the angular deviation of an aircraft from a set course, due to cross winds.

DRIP CLOTH: A Curtain around the equator of a balloon, which prevents rain from dripping into the basket.

ELEVATOR: A hinged surface for controlling the longitudinal attitude of an aircraft; *i. e.*, its rotation about the transverse axis.

EMPANNAGE: See Tail.

ENTERING EDGE: The foremost edge of an aerofoil or propeller blade.

ENVELOPE: The portion of the balloon or dirigible which contains the gas.

EQUATOR: The largest horizontal circle of a spherical balloon.

FINS: Small fixed aerofoils attached to different parts of aircraft, in order to promote stability; for example, tail fins, skid fins, etc. Fins are often adjustable. They may be either horizontal or vertical.

FLIGHT PATH: The path of the center of gravity of an aircraft with reference to the earth.

FLOAT: That portion of the landing gear of an aircraft which provides buoyancy when it is resting on the surface of the water.

FUSELAGE: See Body.

GAP: The shortest distance between the planes of the chords of the upper and lower wings of a biplane.

GAS BAG: See Envelope.

GLIDE: To fly without engine power.

GLIDER: A form of aircraft similar to an airplane, but without any power plant.

When utilized in variable winds it makes use of the soaring principles of flight and is sometimes called a soaring machine.

GORE: One of the segments of fabric composing the envelope.

GROUND CLOTH: Canvas placed on the ground to protect a balloon.

GUIDE ROPE: The long trailing rope attached to a spherical balloon or dirigible, to serve as a brake and as a variable ballast.

GUY: A rope, chain, wire, or rod attached to an object to guide or steady it, such as guys to wing, tail, or landing gear.

HANGAR: A shed for housing balloons or airplanes.

HELICOPTER: A form of aircraft whose support in the air is derived from the vertical thrust of propellers.

HORN: A short arm fastened to a movable part of an airplane, serving as a lever-arm, *e. g.*, aileron-horn, rudder-horn, elevator-horn.

INCLINOMETER: An instrument for measuring the angle made by any axis of an aircraft with the horizontal, often called a clinometer.

INSPECTION WINDOW: A small transparent window in the envelope of a balloon or in the wing of an airplane to allow inspection of the interior.

**KITE:** A form of aircraft without other propelling means than the towline pull, whose support is derived from the force of the wind moving past its surface.

**LANDING GEAR:** The understructure of an aircraft designed to carry the load when resting on or running on the surface of the land or water.

**LEADING EDGE:** See Entering edge.

**LEEWAY:** The angular deviation from a set course over the earth, due to cross currents of wind, also called drift; hence, "drift meter."

**LIFT:** The component perpendicular to the relative wind, in a vertical plane, of the force on an aerofoil due to the air pressure caused by motion through the air.

**LIFT BRACING:** See Stay.

**LOAD:**

*Dead.*—The structure, power plant, and essential accessories of an aircraft.

*Full.*—The maximum weight which an aircraft can support in flight; the "gross weight."

*Useful.*—The excess of the full load over the dead-weight of the aircraft itself, *i. e.*, over the weight of its structure, power plant, and essential accessories. (These last must be specified.)

**LOADING:** See Wing, loading.

**LOBES:** Bags at the stern of an elongated balloon designed to give it directional stability.

**LONGERON:** See Longitudinal.

**LONGITUDINAL:** A fore-and-aft member of the framing of an air-plane body, or of the floats, usually continuous across a number of points of support.

**MONOPLANE:** A form of airplane whose main supporting surface is a single wing, extending equally on each side of the body.

**MOORING BAND:** The band of tape over the top of a balloon to which are attached the mooring ropes.

- NACELLE: See Body. Limited to pushers.
- NET: A rigging made of ropes and twine on spherical balloons, which supports the entire load carried.
- ORNITHOPTER: A form of aircraft deriving its support and propelling force from flapping wings.
- PANEL: The unit piece of fabric of which the envelope is made.
- PARACHUTE: An apparatus, made like an umbrella, used to retard the descent of a falling body.
- PATCH SYSTEM: A system of construction in which patches (or adhesive flaps) are used in place of the suspension band.
- PERMEABILITY. The measure of the loss of gas by diffusion through the intact balloon fabric.
- PITOT TUBE: A tube with an end open square to the fluid stream, used as a detector of an impact pressure. It is usually associated with a coaxial tube surrounding it, having perforations normal to the axis for indicating static pressure; or there is such a tube placed near it and parallel to it, with a closed conical end and having perforations in its side. The velocity of the fluid can be determined from the difference between the impact pressure and the static pressure, as read by a suitable gauge. This instrument is often used to determine the velocity of an aircraft through the air.
- PONTOONS: See Float.
- PUSHER: See Airplane.
- PYLON: A mast or pillar serving as a marker of a course.
- RACE OF A PROPELLER: See Slip stream.
- RELATIVE WIND: The motion of the air with reference to a moving body. Its direction and velocity, therefore, are found by adding two vectors, one being the velocity of the air with reference to the earth, the other being equal and opposite to the velocity of the body with reference to the earth.

**RIP CORD:** The rope running from the rip panel of a balloon to the basket, the pulling of which causes immediate deflation.

**RIP PANEL:** A strip in the upper part of a balloon which is torn off when immediate deflation is desired.

**RUDDER:** A hinged or pivoted surface, usually more or less flat or stream lined, used for the purpose of controlling the attitude of an aircraft about its "vertical" axis, *i. e.*, for controlling its lateral movement.

*Rudder bar.*—The foot bar by means of which the rudder is operated.

**SEAPLANE:** A particular form of airplane in which the landing gear is suited to operation from the water.

**SERPENT:** A short, heavy guide rope.

**SIDE SLIPPING:** Sliding downward and inward when making a turn; due to excessive banking. It is the opposite of skidding.

**SKIDDING:** Sliding sideways away from the center of the turn in flight. It is usually caused by insufficient banking in a turn, and is the opposite of side slipping.

**SKIDS:** Long wooden or metal runners designed to prevent nosing of a land machine when landing or to prevent dropping into holes or ditches in rough ground. Generally designed to function should the landing gear collapse or fail to act.

**SLIP STREAM OR PROPELLER RACE:** The stream of air driven aft by the propeller and with a velocity relative to the airplane greater than that of the surrounding body of still air.

**SOARING MACHINE:** See Glider.

**SPAN OR SPREAD:** The maximum distance laterally from tip to tip of an airplane wing, or the lateral dimension of an aerofoil.



**STABILITY:** A quality in virtue of which an airplane in flight tends to return to its previous attitude after a slight disturbance.

*Directional.*—Stability with reference to the vertical axis.

*Dynamical.*—The quality of an aircraft in flight which causes it to return to a condition of equilibrium after its attitude has been changed by meeting some disturbance, *e. g.*, a gust. This return to equilibrium is due to two factors; first, the inherent righting moments of the structure; second, the damping of the oscillations by the tail, etc.

*Inherent.*—Stability of an aircraft due to the disposition and arrangement of its fixed parts—*i. e.*, that property which causes it to return to its normal attitude of flight without the use of the controls.

*Lateral.*—Stability with reference to the longitudinal (or fore and aft) axis.

*Longitudinal.*—Stability with reference to the lateral axis.

*Statical.*—In wind tunnel experiments it is found that there is a definite angle of attack such that for a greater angle or a less one the righting moments are in such a sense as to tend to make the attitude return to this angle. This holds true for a certain range of angles on each side of this definite angle; and the machine is said to possess "statical stability" through this range.

**STABILIZER:** Any device designed to steady the motion of aircraft.

**STAGGER:** The amount of advance of the entering edge of the upper wing of a biplane over that of the lower, expressed as percentage of gap; it is considered positive when the upper surface is forward.

**STALLING:** A term describing the condition of an airplane which from any cause has lost the relative speed necessary for control.

- STATOSCOPE:** An instrument to detect the existence of a small rate of ascent or descent, principally used in ballooning.
- STAY:** A wire, rope, or the like used as a tie piece to hold parts together, or to contribute stiffness; for example, the stays of the wing and body trussing.
- STEP:** A break in the form of the bottom of a float.
- STREAM-LINE FLOW:** A term in hydromechanics to describe the condition of continuous flow of a fluid, as distinguished from eddying flow.
- STREAM-LINE SHAPE:** A shape intended to avoid eddying and to preserve stream-line flow.
- STRUT:** A compression member of a truss frame; for instance, the vertical members of the wing truss of a biplane.
- SUSPENSION BAND:** The band around a balloon to which are attached the basket and the main bridle suspensions.
- SUSPENSION BAR:** The bar used for the concentration of basket suspension ropes in captive balloons.
- SWEEP BACK:** The horizontal angle between the lateral axis of an airplane and the entering edge of the main planes.
- TAIL:** The rear portion of an aircraft, to which are usually attached rudders, elevators, stabilizers, and fins.
- TAIL CUPS:** The steadying device attached at the rear of certain types of elongated captive balloons.
- THIMBLE:** An elongated metal eye spliced in the end of a rope or cable.
- TRACTOR:** See Airplane.
- TRAILING EDGE:** The rearmost edge of an aerofoil or propeller blade.
- TRIPLANE:** A form of airplane whose main supporting surface is divided into three parts, superimposed.

- TRUSS: The framing by which the wing loads are transmitted to the body; comprises struts, stays, and spars.
- UNDERCARRIAGE: See Landing gear.
- WARP: To change the form of the wing by twisting it.
- WASH OUT: A permanent warp of an aerofoil such that the angle of attack decreases toward the wing tips.
- WEIGHT: Gross. See Load, full.
- WINGS: The main supporting surfaces of an airplane.
- WING FLAP: See Aileron.
- WING LOADING: The weight carried per unit area of supporting surface.
- WING MAST: The mast structure projecting above the wing, to which the top load wires are attached.
- WING RIB: A fore-and-aft member of the wing structure used to support the covering and to give the wing section its form.
- WING SPAR OR WING BEAM: A transverse member of the wing structure.
- YAW: To swing off the course about the vertical axis.  
*Angle of.*—The temporary angular deviation of the fore-and-aft axis from the course.



APPENDIX II  
THRUST CHARACTERISTICS



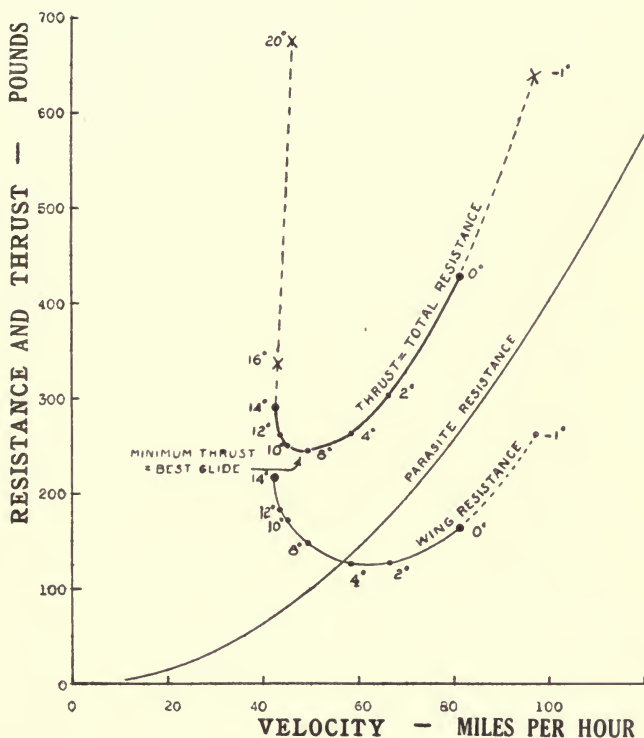

Fig. 34. Total resistance or thrust is the sum of wing-resistance and parasite resistance. The curves represent case when  $W = 2000$  lbs.;  $W/S = 6$ ; parasite resistance =  $0.04V^2$ .





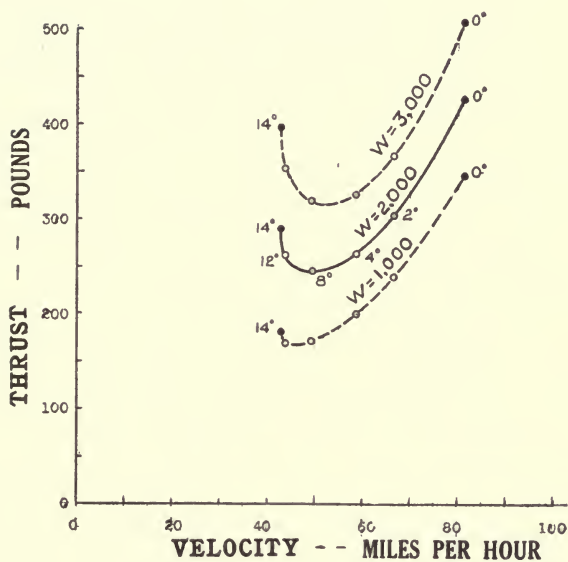

Fig. 35. Variation of thrust with velocity. The three curves show effect of changing weight ( $W = 1000, 2000$  and  $3000$  lbs.) when loading is kept constant ( $W/S = 6$ ); parasite resistance =  $0.04V^2$ .



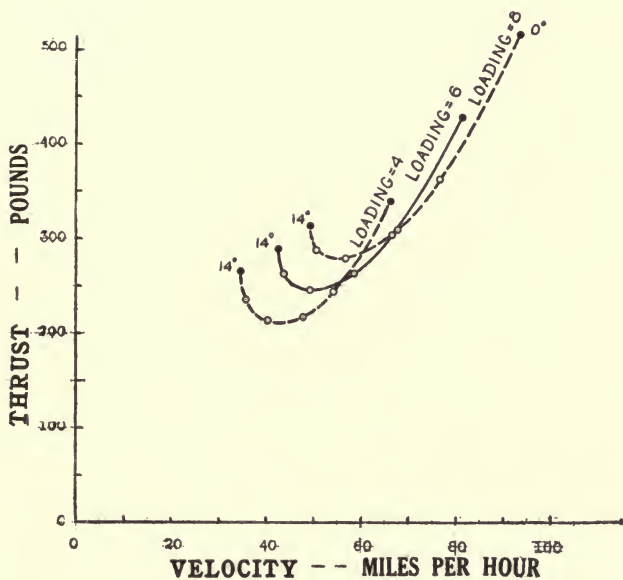

Fig. 36. Variation of thrust with velocity. The three curves show effect of changing loading ( $W/S = 4, 6$  and  $8$ ) when weight is kept constant ( $W = 2000$  lbs.); parasite resistance =  $0.04V^2$ .



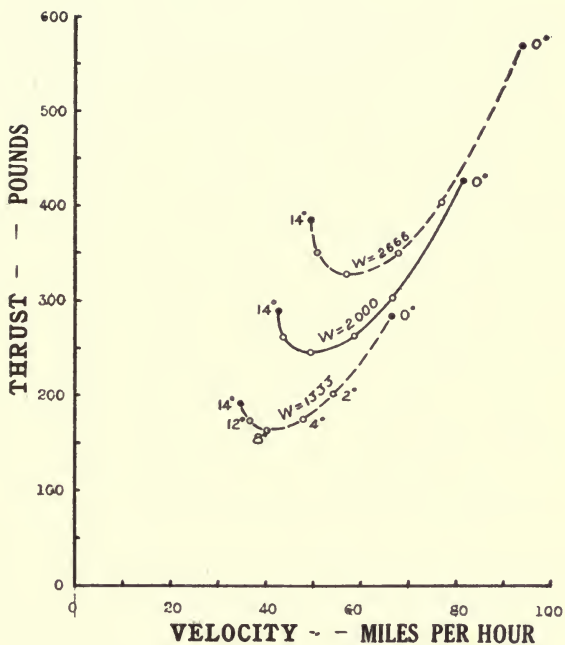

Fig. 37. Variation of thrust with velocity. The three curves show effect of changing weight ( $W = 1333$ ,  $2000$  and  $2666$  lbs.) and loading in proportion ( $W/S = 4, 6$  and  $8$ ), wing-area being constant; parasite resistance  $= 0.04 V^2$ .



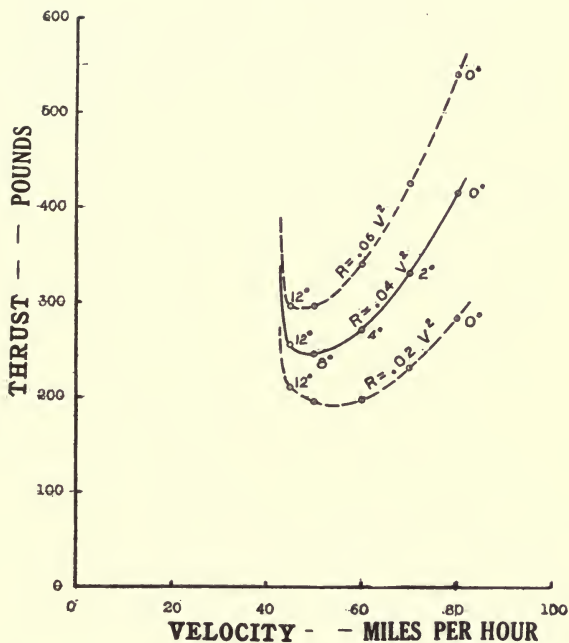

Fig. 38. Variation of thrust with velocity. The three curves show effect of changing parasite resistance ( $R = 0.02 V^2$ ,  $R = 0.04 V^2$  and  $R = 0.06 V^2$ ); weight and loading constant ( $W = 2000$  lbs.;  $W/S = 6$ ).





### APPENDIX III

#### POWER CHARACTERISTICS

Horse power required is equal to thrust, in pounds, multiplied by velocity, in miles per hour, divided by 375. The following **U**-shaped curves show the variation of required power with velocity. (The power available forms a **Ω**-shaped curve, as shown on outside cover.)



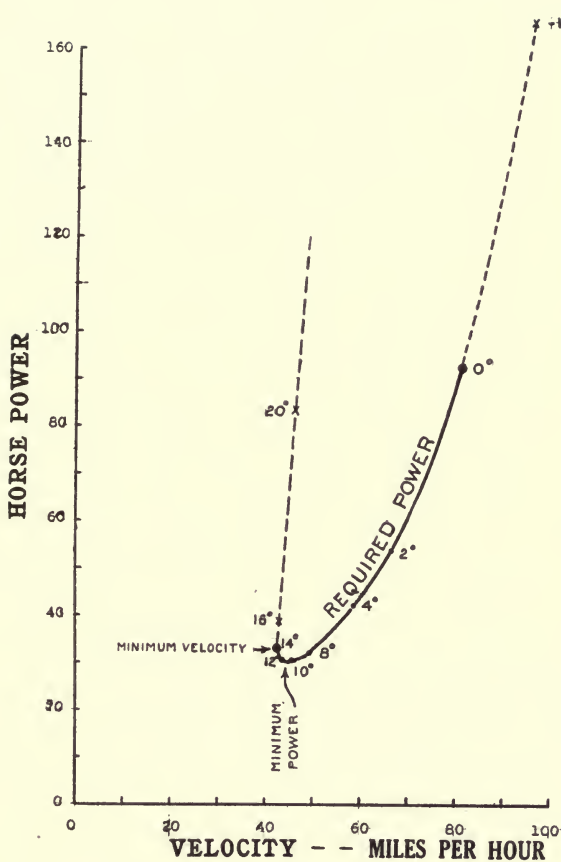

Fig. 39. Required power at different velocities, when  $W = 2000$  lbs.;  $W/S = 6$ ; parasite resistance =  $0.04 V^2$ .



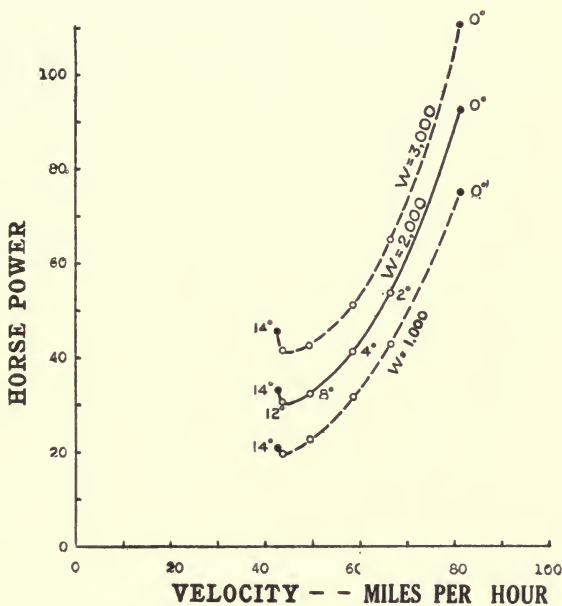

Fig. 40. Variation of required power with velocity. The three curves show effect of changing weight ( $W = 1000, 2000$  and  $3000$  lbs.) when loading is kept constant ( $W/S = 6$ ); parasite resistance =  $0.04 V^2$ .



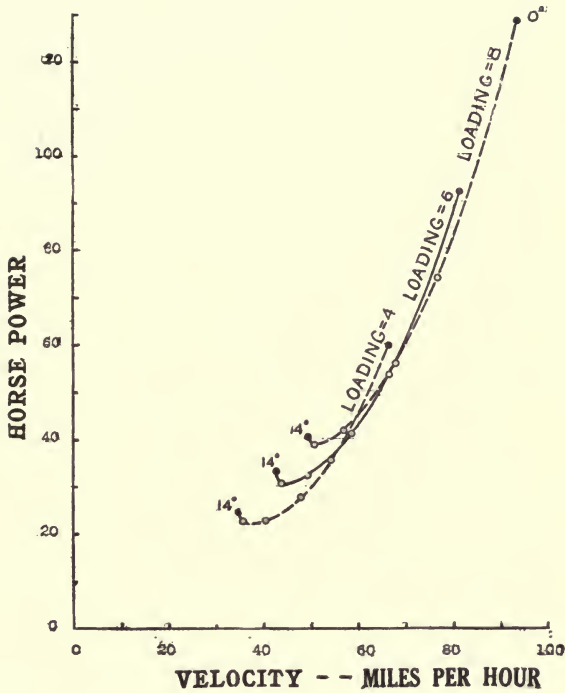

Fig. 41. Variation of required power with velocity. The three curves show effect of changing loading ( $W/S = 4, 6$  and  $8$ ) when weight is kept constant ( $W = 2000$  lbs.); parasite resistance  $= 0.04 V^2$ .





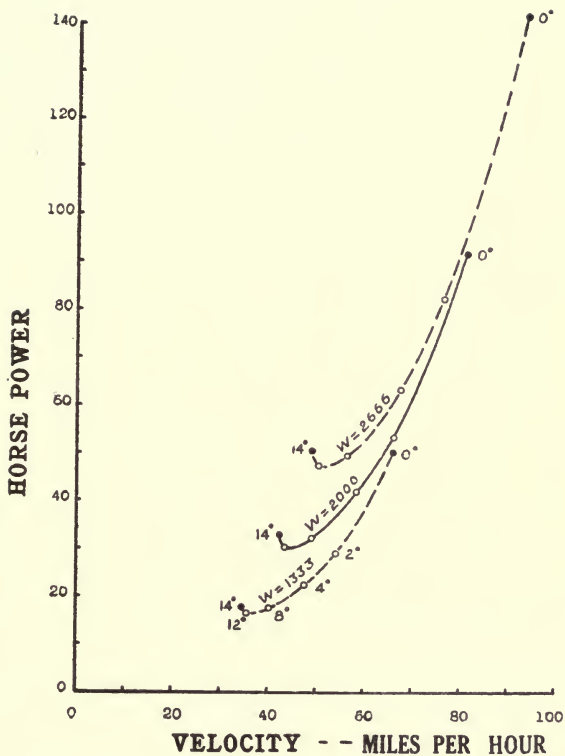

Fig. 42. Variation of required power with velocity. The three curves show effect of changing weight ( $W = 1333, 2000$  and  $2666$  lbs.) and loading in proportion ( $W/S = 4, 6$  and  $8$ ), wing-area being constant; parasite resistance =  $0.04V^2$ .



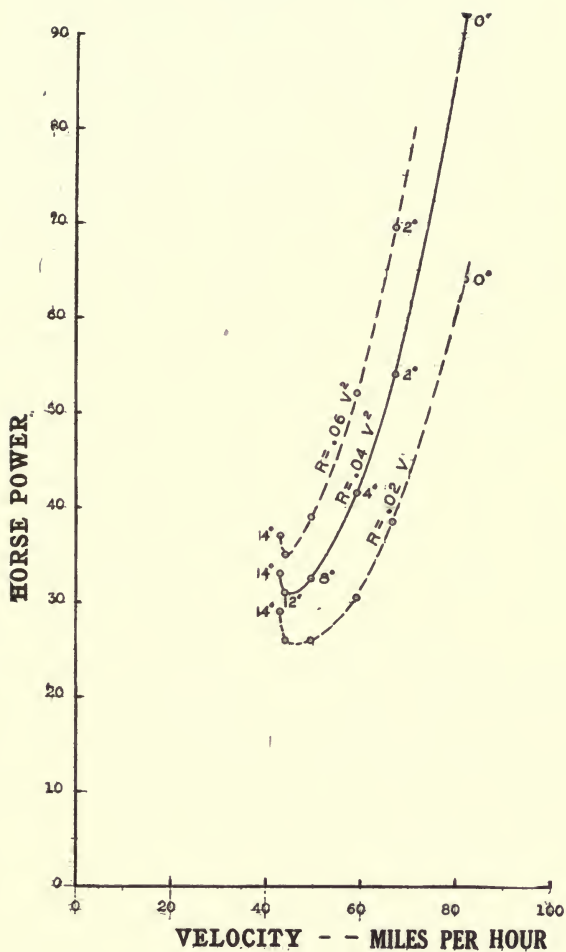

Fig. 43. Variation of required power with velocity. The three curves show effect of changing parasite resistance ( $R = 0.02 V^2$ ,  $R = 0.04 V^2$  and  $R = 0.06 V^2$ ); weight and loading constant ( $W = 2000$  lbs.;  $W/S = 6$ ).



APPENDIX IV.  
CONTROL AND OTHER DIAGRAMS.



Fig. 44. Distribution of pressure on a single wing. Negative pressure on the upper surface produces more lift than the positive pressure on the lower surface.

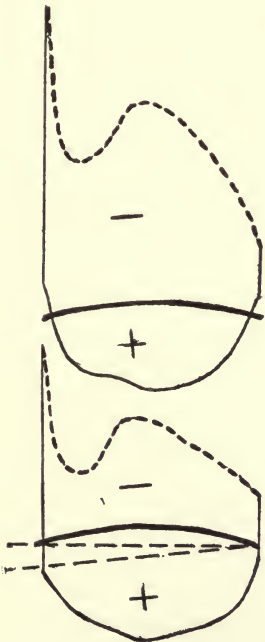
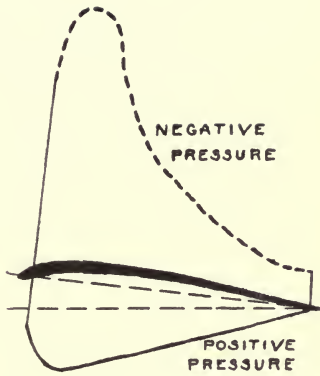

Fig. 45. Distribution of pressure on a biplane. Negative pressure on upper surface of lower wing is much reduced by interference with the upper wing.





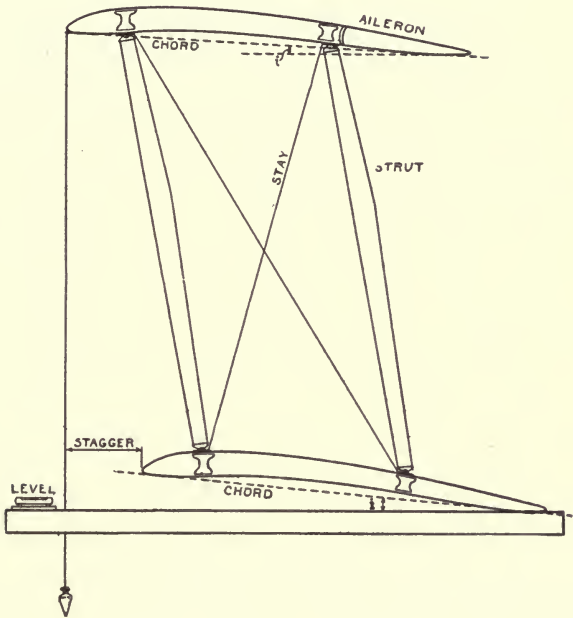

Fig. 46. Biplane Construction.



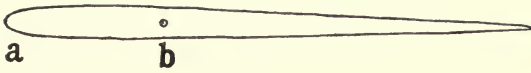

Fig. 47. Balanced Control.

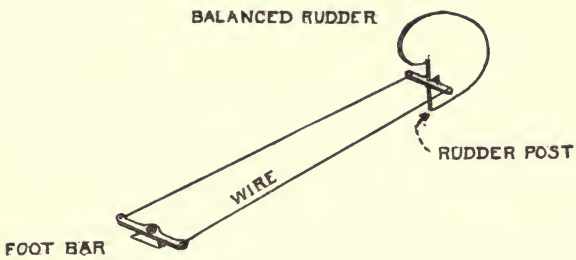

Fig. 48. Operation of rudder.



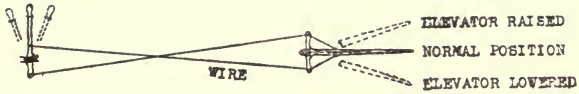

Fig. 49. Stick control for operating elevator. To nose down, push stick forward thus lowering elevator. To nose up, pull stick back thus raising elevator.

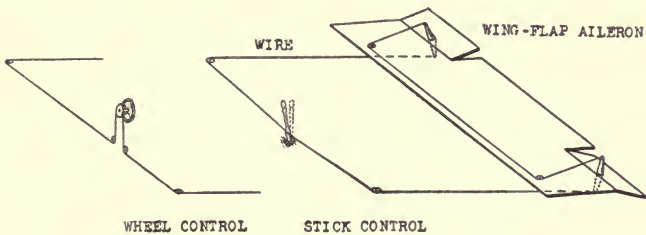

Fig. 50. Operation of ailerons for lateral control. Turning wheel or moving stick to one side causes wing to descend on that side.















THIS BOOK IS DUE ON THE LAST DATE  
STAMPED BELOW

AN INITIAL FINE OF 25 CENTS  
WILL BE ASSESSED FOR FAILURE TO RETURN  
THIS BOOK ON THE DATE DUE. THE PENALTY  
WILL INCREASE TO 50 CENTS ON THE FOURTH  
DAY AND TO \$1.00 ON THE SEVENTH DAY  
OVERDUE.

	19 Mar '57 BH
DEC 26 1935	REC'D LD
	MAR 7 1957
NOV 23 1936	23 Mar '57 HH
	REC'D LD
	MAY 14 1957
SEP 20 1939	'5 Dec '57 CS
JAN 25 1943	REC'D LD
OCT 28 1943	NOV 21 1957
DEC 10 1944	23 Jul 58 BF
6 Jan '54 F W	REC'D LD
	SEP 11 1958
DEC 13 1953 LU	
	LD 21-100m-7,'33

TL670

B3

382818

Book

UNIVERSITY OF CALIFORNIA LIBRARY

