



This is a digital copy of a book that was preserved for generations on library shelves before it was carefully scanned by Google as part of a project to make the world's books discoverable online.

It has survived long enough for the copyright to expire and the book to enter the public domain. A public domain book is one that was never subject to copyright or whose legal copyright term has expired. Whether a book is in the public domain may vary country to country. Public domain books are our gateways to the past, representing a wealth of history, culture and knowledge that's often difficult to discover.

Marks, notations and other marginalia present in the original volume will appear in this file - a reminder of this book's long journey from the publisher to a library and finally to you.

Usage guidelines

Google is proud to partner with libraries to digitize public domain materials and make them widely accessible. Public domain books belong to the public and we are merely their custodians. Nevertheless, this work is expensive, so in order to keep providing this resource, we have taken steps to prevent abuse by commercial parties, including placing technical restrictions on automated querying.

We also ask that you:

- + *Make non-commercial use of the files* We designed Google Book Search for use by individuals, and we request that you use these files for personal, non-commercial purposes.
- + *Refrain from automated querying* Do not send automated queries of any sort to Google's system: If you are conducting research on machine translation, optical character recognition or other areas where access to a large amount of text is helpful, please contact us. We encourage the use of public domain materials for these purposes and may be able to help.
- + *Maintain attribution* The Google "watermark" you see on each file is essential for informing people about this project and helping them find additional materials through Google Book Search. Please do not remove it.
- + *Keep it legal* Whatever your use, remember that you are responsible for ensuring that what you are doing is legal. Do not assume that just because we believe a book is in the public domain for users in the United States, that the work is also in the public domain for users in other countries. Whether a book is still in copyright varies from country to country, and we can't offer guidance on whether any specific use of any specific book is allowed. Please do not assume that a book's appearance in Google Book Search means it can be used in any manner anywhere in the world. Copyright infringement liability can be quite severe.

About Google Book Search

Google's mission is to organize the world's information and to make it universally accessible and useful. Google Book Search helps readers discover the world's books while helping authors and publishers reach new audiences. You can search through the full text of this book on the web at <http://books.google.com/>



NO LONGER PROPERTY OF COLUMBIAN UNIVERSITY

10 11/19/79





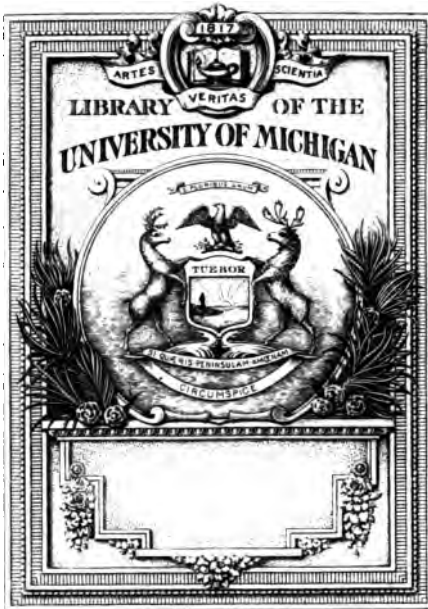

RECEIVED IN EXCHANGE
FROM
Columbia University

A MANUAL OF PHOTOENGRAVING

CONTAINING INSTRUCTIONS FOR PRODUCING
SINGLE PLATES IN RELIEF-
AND HALF-TONE

BY
F. W. WINKLER

WITH SUPPLEMENTARY NOTES ON THE THEORY AND
PRACTICE OF PHOTOENGRAVING WORK

EDITED BY E. J. JONES AND J. W. H. MORGAN.

Second Edition.

CHICAGO:
THE INLAND PUBLISHER COMPANY,
1902.



Fig. 1. *Myiophobus*
myiophobus (Linn.)

Fig. 2.

Fig. 3. *Myiophobus*
myiophobus (Linn.)

A MANUAL OF PHOTOENGRAVING

CONTAINING

PRACTICAL INSTRUCTIONS FOR PRODUCING
PHOTOENGRAVED PLATES IN RELIEF-
LINE AND HALF-TONE.

BY: H. JENKENS 1868

WITH SUPPLEMENTARY CHAPTERS ON THE THEORY AND
PRACTICE OF HALF-TONE COLOR WORK

BY

FREDERIC E. IVES AND STEPHEN H. HORGAN.

Second Edition.

CHICAGO:
THE INLAND PRINTER COMPANY.
1902.

~~Chem. R.R.~~
~~772~~

ALPHABET
COPYRIGHT, 1902,
BY
THE JOLAND PRINTER COMPANY,
CHICAGO, ILLINOIS.
V S A N I

~~D-772~~
~~JAN~~

Spet. 1904

INLAND PRESS,
CHICAGO.

W
3778

Exchange
Columbia Univ.
10-6-41

PREFACE.

THIS work is a revision of the "Manual" which appeared several years ago. While retaining the features of the first edition that hold good to-day, it presents a number of new formulæ and more complete descriptions of the processes involved.

My purpose has been to provide a practical guide that might be an aid to the beginner, and a useful book of reference for the more advanced worker. With this object in view I have, therefore, entered fully into the description of the details of the various operations, and have presented an outline of the chemical principles underlying the methods considered.

The importance of a study of the scientific laws upon which the practical work is based can not be too strongly emphasized. It is the possession of this knowledge that makes the difference between the intelligent investigator and the "rule-of-thumb" workman, and the student is urged to give ample attention to these fundamental principles.

The methods given in the following pages are those in use by regular engraving houses, and are the results

of the practical development of the art of process engraving. By carefully following the instructions, therefore, the beginner should be able to obtain creditable results.

In addition to the chapters devoted to the subject of the volume, those on the development of the gelatin dry plate and the printing of half-tones will be of interest.

H. JENKINS.

CHICAGO, September 1, 1902.

PUBLISHER'S NOTE.

The first edition of the "Manual of Photoengraving" being exhausted, the publishers arranged for the present work, which offers the latest and most approved methods of practice in this important art.

The chapters which have been added by Mr. Ives and Mr. Horgan present the three-color process in its scientific and practical aspects, and will be of great value to those who wish to enter upon investigations in this interesting field.

CONTENTS.

	PAGE
CHAPTER I. THE SCOPE OF PHOTOENGRAVING — THE APPARATUS REQUIRED	7
CHAPTER II. SHOP ARRANGEMENT	21
CHAPTER III. NEGATIVE MAKING — GENERAL PRINCIPLES..	26
CHAPTER IV. NEGATIVE MAKING — PREPARATION OF CHEMICALS	33
CHAPTER V. NEGATIVE MAKING — LINEWORK.....	39
CHAPTER VI. NEGATIVE MAKING — HALF-TONE WORK.....	48
CHAPTER VII. NEGATIVE MAKING — CAUSES OF DEFECTS IN COLLODION NEGATIVES — CARE OF THE SILVER BATH.	62
CHAPTER VIII. NEGATIVE MAKING — REVERSING NEGATIVES	66
CHAPTER IX. ETCHING — LINEWORK.....	70
CHAPTER X. ETCHING — HALF-TONE WORK	81
CHAPTER XI. FINISHING AND MOUNTING PLATES.....	90

	PAGE
CHAPTER XII. DRAWINGS — LITHOGRAPHURE	93
CHAPTER XIII. DEVELOPMENT OF GELATIN DRY PLATES....	100
CHAPTER XIV. PRINTING HALF-TONE PLATES	110
—————	
THE HALF-TONE AND TRICHROMATIC PROCESS THEORIES, BY FREDERIC E. IVES	119
THREE-COLOR PROCESS WORK, BY S. H. HORGAN.....	135
APPENDIX. TABLES OF WEIGHTS AND MEASURES.....	159

—————

Valuable Formulæ — Proving Color Plates — To Change
Reading of Thermometer Scales — Resist for Line
Etchings — Whirler for Coating Half-tone Plates —
Enamel for Zinc — Intensifying Negatives — Dry
Enamel Process — Printing Methods — Other Useful
Information.

MANUAL OF PHOTOENGRAVING.

CHAPTER I.

THE SCOPE OF PHOTOENGRAVING—THE APPARATUS REQUIRED.

BY the term photoengraving is meant the production of printing plates having images in relief upon the surface of metal, these images being obtained by a series of photographic operations.

There are two general classes of these engravings known respectively as line plates and half-tone plates—the former being reproductions of subjects formed only of lines, or masses of solid black and white, the latter those of subjects having intermediate tones.

In both classes, three general stages of work are involved as follows:

Negative making.

Etching.

Finishing and mounting.

Each of these includes a number of details which will be described under the proper heads.

THE APPARATUS REQUIRED.

The apparatus required for making photoengravings will vary in completeness with the amount of work to be turned out. For the experimenter or the estab-

lishment which devotes but a small department to the work, an equipment of high grade and large capacity would be out of the question. For shops, established with a view to commanding a large patronage, however, where rapidity of production and a uniformly excellent quality of work are important matters of consideration, it is essential that the apparatus be of the most approved pattern, and that each department be fully equipped.

The capacity of the apparatus must depend upon the conditions governing in the special case. In general, however, provision should be made for producing line negatives as large as 14 by 17 inches and half-tones not smaller than 10 by 12 or 11 by 14 inches and as much larger as the capital available will permit. The demand is usually for plates smaller than these dimensions, but the professional engraver should be prepared to fill exceptional as well as regular orders.

THE LENS.

The best lenses for photoengraving purposes are those known as anastigmats, of which the Goerz (Series IV), the Zeiss and the Cooke may be considered as approved types for this special use.

These lenses are rectilinear (that is, they reproduce straight lines without distortion), they are practically without curvature of field and cover a much larger plate area than the older types of the same focal lengths.

THE PRISM.

In making half-tone negatives, it is generally most desirable to secure reversal (see Chapter VIII) by



ZINC ETCHING—CRAYON EFFECT.
From sketch by Frank Holme.





ZINC ETCHINGS—FROM PEN DRAWINGS, GREATLY REDUCED.
Drawn by A. Cambensy.

UNIV
OF
MICH

using a glass prism silvered on one side and mounted so that it may be screwed to the hood of the lens.

THE CAMERA.

In selecting the camera it is advisable to obtain the form known as the enlarging, copying and reducing camera, as its construction presents several advantages over the ordinary copying camera.

For half-tone work it should be provided with an adjustable screen plateholder, which enables the kit to be dispensed with for holding the screen and sensitive plate. This holder is so constructed that the separation of screen and plate can be adjusted accurately and easily to any desired degree, and to allow different sizes of plates to be used with any screen.

It has displaced the kit in all leading shops, but for those who may desire to use the latter, details of its construction will be given below.

CAMERA STAND.

The camera should be provided with a stand, which may be in the form of a long table or bench to stand on the floor, or it may be swung from the ceiling, this condition being necessary if the building is subject to vibrations from the running of machinery or other causes. It consists essentially of an oblong frame upon which the camera will slide readily, the frame being suspended from a beam of the same length, ropes or strips of metal running from the ends of the beam and attached to each end of the frame in an inverted V shape. The beam being suspended from the ceiling, carries the frame upon which the camera is placed. At

one end of the frame is fastened the copy board, which should be in a position perpendicular to the bed, and arranged to slide to the right or left when desired. The length of bed should suit the capacity of the camera. For a 10 by 12 camera, ten feet; 11 by 14, twelve feet; and for a 14 by 17 camera fourteen feet

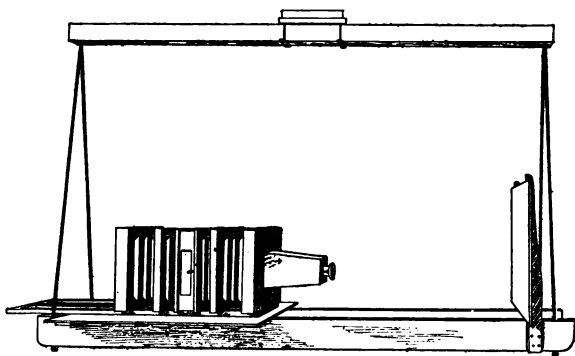

CAMERA AND SWING.

are good proportions. The camera stand can be easily constructed of ordinary planed scantling, or can be purchased from dealers in photoengravers' supplies.

SILVER BATH.

The silver bath is almost invariably kept in a glass vessel of special form, which, when holding the bath for use, should be kept in a "light-tight" box with a cover. It is important that a bath of ample capacity be provided, as it will require less attention than a small one and save the operator annoying delays. In all well equipped shops two or more baths are provided for

each operator, that one may be used while another is being rectified.

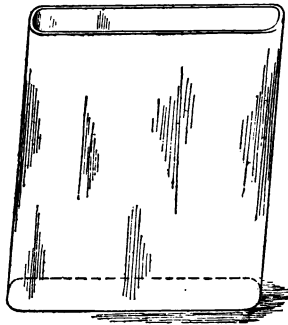

SILVER BATH.

EVAPORATING DISH.

For evaporating the alcohol from the bath, a porcelain evaporating dish is required. It should be large enough to hold the solution, with room to spare. As an accessory, it is well to have an iron dish to hold sand in which the porcelain dish can rest while heating.

TRAYS.

For line etching there should be one or more large trays or "tubs" arranged to rock at the will of the

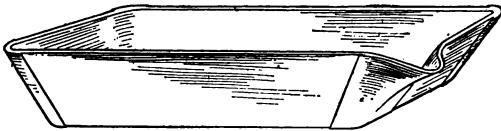

TRAY.

etcher. These "tubs" are made of wood, sealed water-tight and are usually protected by a coating of asphalt

varnish. For developing prints on zinc, any ordinary sheet metal tray will serve the purpose. For half-tone etching, porcelain or rubber trays may be used.

PRINTING-FRAMES.

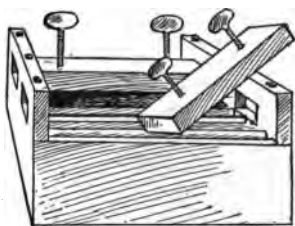

PRINTING-FRAME.

For printing on metal there are special frames so constructed that equal contact with the negatives can be obtained for all parts of the metal plates. For making silver prints as a basis for drawings, the ordinary photographer's printing-frame is used.

GLASSWARE.

For measuring solutions, several graduates of a capacity of from eight to sixteen ounces each should be purchased; also a large funnel for filtering the baths and several smaller ones for collodion, printing solutions, etc.

An important article is the "actino-hydrometer" for testing the strength of the silver baths.

Various sizes of plate glass should be provided for negative-making and for turning negatives upon. For the latter purpose the

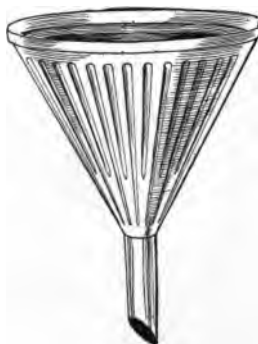

FUNNEL.

glass is usually obtained of about one-fourth inch in thickness, to stand the pressure in the printing-frame.

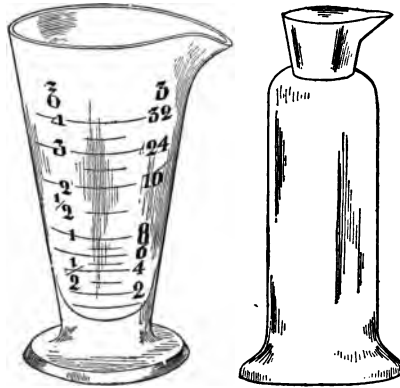

GRADUATE.

COLLODION VIAL.

Vials for holding collodion, large bottles for filtering the bath into, and smaller ones for other solutions are also necessities.

ROLLERS.

For inking line plates, composition rollers are used. These should be of the kind known as "hard" rollers, as they distribute the ink in a more even manner than soft rollers.

An excellent roller for this purpose can be made from white rubber, such as used for clothes wringers. For inking the plate after etching, a leather-covered roller is often used.

MISCELLANEOUS ARTICLES.

Besides the articles described above, there are other essentials, as follows: Gas stoves, for heating and drying plates; squeegees, for smoothing down negative films — these are simply strips of white rubber fastened to a strip of wood; scales, for weighing dry chemicals; negative racks; brushes for etching — bristle for line

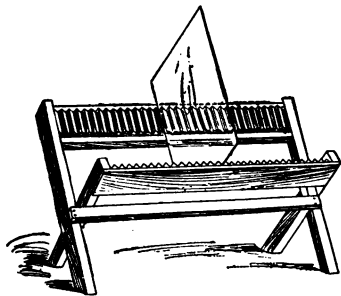

NEGATIVE RACK.

etching, and soft for half-tone; inking-slab for rolling ink upon — a smooth sheet of stone, zinc or glass will answer the purpose; pincers, for holding plates while burning in; “hooks,” for cutting zinc plates; small camel’s-hair brushes, for spotting and painting on plates; egg beater; hammers; nails; scraping tools, for cleaning spaces on zinc; engravers’ tools, for finishing plates after etching; files, for smoothing edges of metal; calipers, punches, etc.

MACHINERY FOR FINISHING.

For a well-equipped shop there are several machines which are essential. Small concerns are often operated

with only a small equipment of machinery, but for large establishments the outfit is usually very extensive.

The routing machine is used for deepening and cleaning out the spaces in zinc etchings, and sometimes for making a bevel around half-tones, etc. These machines can be obtained in various sizes according to the dimensions of plates to be routed.

A circular saw is also an essential piece of machinery, for sawing metal plates, blocks, etc.

The trimmer, as its name indicates, is used for trimming the edges of blocks after the plates are mounted.

The shoot-board is used for a similar purpose and, in small shops, is generally substituted for the trimmer.

The Daniels planer is used for making mounted blocks type-high. It is an expensive machine, and for small establishments the shaving machine operated by hand can be used instead.

A drill is often of use for various purposes, and is necessary in "anchoring" or mounting half-tone plates from the back.

The beveling machine is used for beveling the edges of plates.

The buffing machine is used for polishing metal. As a rule, it is not found in small shops, as the metal can be polished by hand.

For taking proofs, a printing-press is required, and for the engraving establishment that known as the "Washington" hand press is best.

The mounting slab is simply a smooth-surfaced block of iron upon which the cuts are placed when being mounted.

A detailed description of the above-mentioned machinery is not given here, on account of the various designs on the market, and as manufacturers are always ready to send specific descriptions to inquirers.

THE WHIRLER.

In coating plates for half-tones with the enamel solution it is necessary, in order to obtain an even coat-

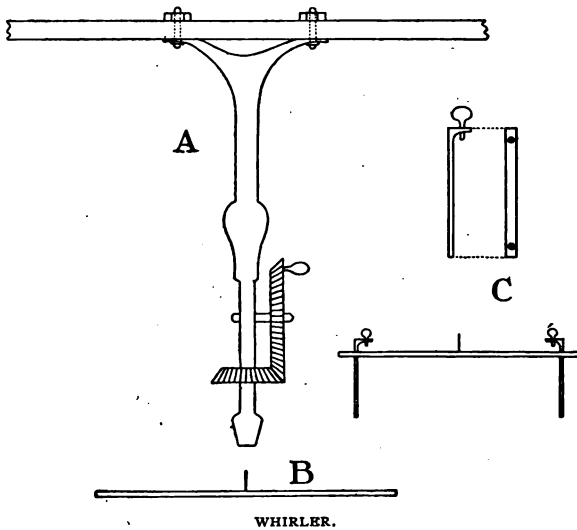

ing, that a rapid whirling motion be given while the solution is in the fluid condition on the plate.

A number of devices can be used for this purpose. A common form consists of a handwheel mounted in a horizontal position on a board and connected by means of a belt with a table similarly mounted at the other



ZINC ETCHING.

From Drawing by George Wharton Edwards.

end of the board, the table being provided with clamps to fasten the plate. Upon revolving the handwheel the table is caused to revolve also, thus spreading the solution evenly over the plate.

A good whirler can be constructed, however, as follows: To the bottom of a shelf, or at the end of a bracket placed at a convenient height, fasten a drill stock as shown in Fig. A. Then at a machine shop obtain a strip of iron about three-fourths of an inch or an inch in width, one-sixteenth of an inch in thickness, and twelve or fifteen inches long, and to its center fasten a round stem as shown in Fig. B. Also have two strips made about four or five inches long with apertures cut at each end, those at one end of a size and shape to admit the ends of strip B. Have one of the ends of each of the latter strips bent over, and a hole drilled to admit a thumb-screw, as shown in the cut, Fig C.

The long strip is fastened in the chuck of the drill by means of the stem, and the two short strips are slipped over the ends, as shown in Fig. C. A gas stove should be placed under the whirler to warm the plate and accelerate the drying of the coating.

The use of this whirler will be explained in Chapter X.

THE KIT.

Before the advent of the plateholder mentioned in a preceding paragraph, the kit was used by operators to hold the screen and sensitized plate during exposure.

It is simply a rectangular frame so constructed that when placed in the plateholder of the camera the negative plate will occupy the position of the ground

glass, the screen being held in front of it. Its construction can be understood by an examination of the illustration. A is a frame made of strips of cherry, walnut or other suitable wood, about one inch wide, one-eighth

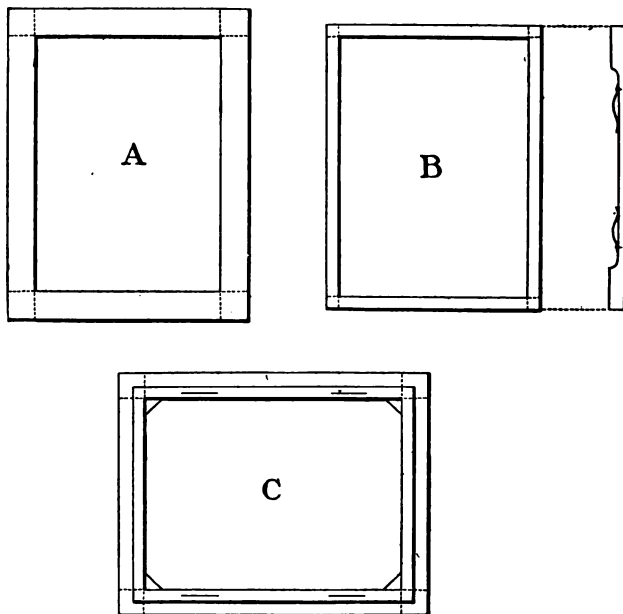

KIT.

inch thick and of lengths required by the size of the screen. The ends should be mortised and glued strongly together. On the opposite side of this frame is fastened a second frame of strips, one-half inch wide and one-fourth inch thick, placed so that the inner edges of this frame will be flush with the inner edges of the other. The ends of this second frame should

be fastened in a similar manner to those of the first. To the longest sides of this second frame should be fastened springs, which may consist simply of elastic curved strips of brass or steel, the springs being fastened at one end so that they can be moved to allow the loose end to press upon the screen when in position. These sides of the second frame should be thin in the center so that the springs will not interfere with the slide. Across the corners of the kit between the frames of which it is composed are placed four corner pieces to separate screen and plate. These are often of silver but may also be made of wood, and should be no thicker than to prevent contact of screen and plate, and should be set into the first frame to be flush with the side next the second frame. When a greater separation is desired small pieces of cardboard can be inserted between the corner pieces and the screen.

In the diagram, A represents the first frame; B, the second, with a view of one edge of the sides containing the springs; C, the complete kit.

The kit should be made of a size to readily admit the screen used, negative glass of the same size being used also. It should be thoroughly covered with shellac varnish, to prevent the silver solution destroying the wood.

The use of the kit is indicated by the description of its construction.

THE SCREEN PLATE.

The screen plate is, of course, absolutely necessary in half-tone negative making. The size obtained should be governed by the size of the half-tone plates which the establishment expects to make.

The description of the screen and its uses will be given in chapter VI.

CHEMICALS.

The chemicals required for making the collodion negatives and for the etching operations are as follows :

Alcohol (grain).	Castor oil.
Alcohol (wood).	Ammonium sulphide.
Ether (sulphuric).	Eosine.
Gun cotton.	Le Page's liquid glue.
Ammonium iodide.	Calcium chloride.
Ammonium bromide.	Mercuric chloride.
Cadmium bromide.	Ammonium chloride.
Cadmium iodide.	Acetic acid.
Potassium iodide.	Nitric acid (Com.)
Potassium bromide.	Nitric acid (C. P.)
Potassium cyanide (fused).	Chromic acid.
Ammonium bichromate.	Copper sulphate.
Strontium chloride.	Rubber cement.
Iron sulphate (ferrous).	Transfer etching ink.
Iron perchloride.	Lye.
Potassium permanganate.	Dragon's-blood.
Iodine.	Sodium bicarbonate.
Silver nitrate.	Absorbent cotton.
Turpentine.	Charcoal blocks.
Ammonia (strong).	

Ordinary charcoal will not answer for polishing the metal. The most suitable is that used by jewelers for soldering purposes, and is obtained in blocks of about 3 by 4 inches.

To insure success most of the chemicals mentioned above should be chemically pure. They should be kept in bottles corked or stoppered to prevent evaporation or deterioration. The bottles should be plainly labeled to prevent errors when the contents are wanted for use.

CHAPTER II.

SHOP ARRANGEMENT.

IT is a difficult matter to prescribe a set plan for the arrangement of a photoengraving establishment, as there is great variation in the size and relative positions of rooms which may be selected for occupation, and as large shops require more extensive accom-

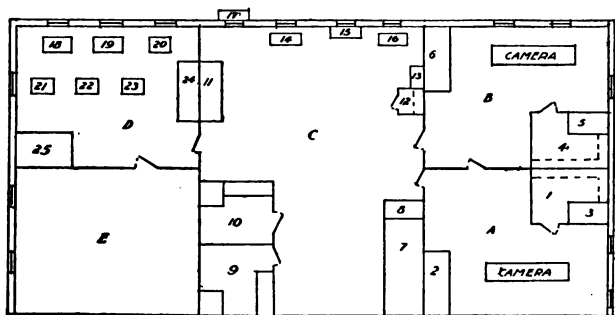

SHOP ARRANGEMENT.

modations and special features which need not enter into the equipment of smaller concerns.

There are general principles, however, which can be applied in fitting up any shop, and the accompanying diagram is given to represent an arrangement for a shop of moderate size.

THE OPERATING ROOMS.

A is the room for the half-tone, and B for the line operating. One room is often used for two or more cameras, but it is advisable, if possible, to provide separate apartments for the cameras, to avoid interference of one operator with another. 1 and 4 are the darkrooms. These may be constructed with walls of seasoned flooring joined to be light-tight. They should contain sinks 3 and 5, over each of which should be placed a tap for washing the negatives. At the right of the sink there should be a shelf for holding the bottles of developer and other solutions. Other shelves should also be provided for holding stock solutions and other accessories. Above the sink there should be a window containing a light of orange glass, arranged to slide upon readily at the will of the operator. If dry plates are to be developed, an arrangement should be provided to close up the yellow light and substitute the ruby light required for dry-plate work.

The silver baths should be placed in receptacles at the back of the darkroom, the bath holders being placed at such a level as to permit the convenient lowering of the plates into them. Above, or at one side of the silver baths, a shelf should be located upon which the plateholder can rest.

The darkroom should be large enough to give ample room, and should be free from cracks and openings through which light might pass. 2 and 6 are benches for holding negative racks and other articles.

The cameras should be placed near the darkroom, and swung at a height most convenient for the operators to manipulate.

The illumination of the copy is an important factor in producing negatives, and provision should be made for obtaining the best facilities. The light can be obtained either from a skylight, or by means of electric lamps. In many shops both methods are used, the light being obtained from the skylight during the bright hours of the day, and from the lamps at other times. The skylight should, of course, be large enough to furnish an ample volume of light. The lamps should be arc lamps, and one should be swung on each side of the camera stand, near the copy board, in such a manner as to be readily raised or lowered. They may, if desired, be arranged with movable stands, instead of being swung. Two lamps should be used, as a more uniform illumination can be obtained from two than from one, and reflections are then avoided. The lamps should be wired to burn independently of each other, and the current furnished should be uniform, to prevent, as far as possible, flickering and variation in the intensity of the light. Reflectors should be used to concentrate the light on the copy.

A shelf should be built outside of one of the windows to give facilities for sunning the silver baths. A gas stove should be placed on one of the benches, for evaporating the baths, heating negatives, etc.

ETCHING ROOM.

C is the etching room, which for convenience is located next to the operating rooms. 7 is a sink of ample capacity where the metal may be polished, glass washed, and negatives turned. 8 is a shelf for holding glass and other articles. 9 and 10 are rooms for sen-

sitizing metal, one being designed for line and one for half-tone work. They should be furnished with benches, shelving, and gas stoves. The illumination should be subdued, to prevent the action of light on the plates before printing, but not to the extent necessary in the darkrooms for negative-making. It is not necessary to provide sinks for these rooms, although they add greatly to convenience.

The construction, arrangement, and care of these rooms should be such as to prevent the accumulation of dust, which would cause spots in the coating of the plates. This remark will also apply to the darkrooms, 1 and 4.

In the room used for coating the line plates a bench and slab may be provided for rolling up the plates. 11 is a bench for general purposes, such as cutting zinc upon, holding negatives for printing, etc. 12 is the powder box to contain the dragon's-blood for the line etchings. In some shops an open box is used, but it is better to have a closet built around it to prevent the powder from being carried about the room. 13 is a bench for a gas stove for burning in the plates. 14 and 16 are etching tubs, placed near the windows, to obtain ample light. 15 is a sink or a bench to hold a tray of water to rinse the plates after etching. 17 is a shelf placed outside of the window for printing by daylight. An electric lamp should also be provided for use in printing.

THE FINISHING ROOM.

D is the finishing room in which numbers 18 to 23 represent the several machines. 24 and 25 are benches

THE FRENCH Garment Company
Manufacturers of
LADIES' FINE GARMENTS.

Kalamazoo Mich.

Courtesy C. P. Zacher & Co., Chicago.

ZINC ETCHING IN IMITATION OF LITHOGRAPH.





ZINC ETCHING—CRAYON EFFECT.
From Drawing by Frank Holme.



for mounting the plates upon, and for holding tools, material, etc.

The machinery should be operated from a line of shafting which should be provided with belt shifters, that any machine may be started or stopped as desired. If the building is equipped with a power plant the shafting may be operated by a belt running from some other line. If the place is not thus equipped the power may be obtained from a gas engine or an electric motor.

E represents the office.

In large establishments the half-tone etching is often done in a room separate from that used for line etching, but such an arrangement need not be considered necessary.

In selecting a location for a shop it is important to obtain one where there will be an ample supply of running water at all times, and where there is a number of windows, as it is desirable to have plenty of light.

In fitting up the shop, economy in expense should often be sacrificed to completeness and convenience, as future results may at times justify an outlay which at first might seem to be extravagant.

The above description is intended to give only general directions for the shop arrangement. Special situations will require various departures from this plan.

CHAPTER III.

NEGATIVE MAKING—GENERAL PRINCIPLES.

THE ACTION OF LIGHT ON SENSITIVE SALTS.

THAT light produces changes in most substances is a fact established by daily experience, the changes most readily observed naturally being those of color.

In considering the subject in hand we are concerned with the transformations that take place when light acts upon certain salts of silver, and further, with the chemical operations by which results of practical value are obtained.

We shall begin with the established proposition that when light is absorbed by any substance it does some kind of work which, it is readily conceived, must be necessary to produce the changes. This work is understood to be the tearing apart of the molecules* of the substance, the result being a change in its chemical composition.

White light is not elementary in nature, but is the

*A molecule may be defined as the smallest particle of matter that can exist without its chemical character being changed. Molecules are made up of atoms which are alike in elementary and different from each other in compound substances. When matter is so acted upon that its molecular structure is changed, a *reaction* is said to occur.

effect produced by a combination of colored rays readily detected by the common experiment of passing a beam of white light through a prism to obtain the solar spectrum, in which the only pure colors in nature can be observed — the term pure meaning unmixed. From the spectrum also we obtain the three primary colors — the least number that can be combined to give white light — and these are found in the red, green and blue-violet.

The silver salts as ordinarily prepared are acted upon most largely by the blue-violet rays, because the color of the salts is such as to absorb these rays to a much greater extent than the others. In practical photography, however, other colors usually have a greater or less effect on account of the fact that they are not "pure," but contain some of the blue element and also reflect more or less of the white light that falls upon them.

By using certain dyes upon the silver salts, however, a much greater range of color sensitiveness is secured, as the absorptive powers of the salts are thus extended. The practical application of this method will be found in a later chapter.

To illustrate the principles stated above, if silver chloride is exposed to light it becomes darkened, indicating that some change in its nature has taken place. Just what transformation has taken place has for many years been a matter of speculation and dispute, but the most eminent authorities assert that the probability is that a part of the chlorine has been separated from the molecule (which is composed of silver and chlorine — two atoms of each), there being left a molecule con-

sisting of two silver atoms and one chlorine atom, forming silver subchloride.

Similar action is supposed to occur when either bromide or iodide of silver is exposed, and it has been found that in any case the action is accelerated if there is in contact with the silver salt some substance that readily absorbs the element supposed to be liberated. In the case of the iodide, in fact, no change will take place unless such a substance is present.

The chemist expresses such transformations in symbols, as follows:

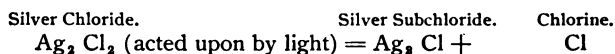

in which Ag represents an atom of silver and Cl one of chlorine, the number of atoms in the molecules being indicated by the small numbers attached.

It must not be understood that change in color always occurs with a change in the character of matter acted upon by light. Some colorless compounds split up into others which are also colorless, and others under certain conditions exist in such minute quantities that any color change is not perceptible. By acting upon the new compounds with certain chemicals, however, we may produce reactions bringing colored substances into existence. The making of negatives depends upon these principles.

In practice, the sensitive salt is mixed, or rather, it is formed, in some solution which can be spread in a film upon a plate. The plate is then exposed in the camera and afterward treated with chemicals which cause the image to appear. The two methods used in modern practice are the wet collodion process and the

emulsion, the latter being usually made with gelatin as a vehicle for the salts, although collodion was originally employed and for some purposes is used to-day.

THE WET COLLODION METHOD.

The collodion is made by dissolving gun cotton in a mixture of alcohol and ether, and certain salts containing bromine, iodine or chlorine, or combinations of these salts, are dissolved in it, the solution being then spread upon a glass plate and allowed to "set." The plate is then placed in a solution of silver nitrate, which reacts upon the salts and forms the corresponding silver salt and a nitrate of the metal. This may be expressed in the following symbols or equation:

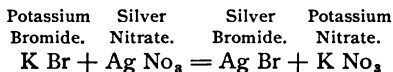

The silver bromide is sensitive to light. The potassium nitrate is a by-product of the reaction so far as our operations are concerned, and may be disregarded.

Some of the silver nitrate is left upon the surface of the plate and this acts as an absorbent of the chlorine which is freed during exposure. Exposure in the camera does not produce a visible image, but this is obtained by "development."

If a solution of ferrous sulphate is flowed over the surface it precipitates metallic silver from the free silver nitrate remaining, and this silver is deposited on the light-affected portions of the film, in proportions corresponding to or approximating the intensity with which the light has acted on the different parts. We thus obtain a visible image in silver, reproducing the

original object, except that the light and dark portions are reversed. In practice, the action of the nitrate is restrained by acetic acid in the solution. Otherwise the action would be too strong and fog the image.

It is supposed that the "invisible image"—that is, the portions affected by the light—possesses an attractive force which acts upon the particles of silver, varying in intensity as the light varies, and as the action of the developer continues more silver is precipitated and deposited upon the plate in similar proportions, so that the visible image increases in intensity.

The next operation is to remove the unaffected portions of the film, or as it is technically called, to "fix" the negative. This is done, after washing the plate, by applying a solution which forms soluble compounds with these portions, which are then washed out. In fixing wet collodion plates, cyanide of potassium is generally used, and the reaction is as follows with a bromized collodion:

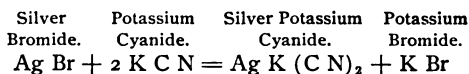

In photoengraving, the image after developing and fixing is never dense enough, and we therefore render it heavier and blacker. The most satisfactory means for doing this is by two operations, the first being to produce, with one solution, compounds in the film which, when acted upon by the second solution, will give the required intensity.

If we first apply a solution of copper (cupric) bromide, the reaction produces silver bromide and cuprous bromide, according to the following reaction:

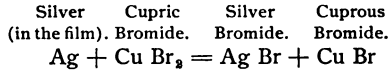

The film is now white and is blackened by the application of silver nitrate solution.

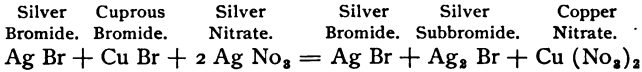

Intensification, therefore, renders the ground of the negative dense and black but leaves the clear spaces transparent.

When it is necessary to "clear" any of these spaces, solutions are applied which will dissolve the compounds adhering to them.

THE EMULSION METHOD.

In making emulsions, instead of first making an insensitive film and then treating it with silver nitrate, the nitrate is added directly to the solution, forming the sensitive compounds at once within the collodion or gelatin. The by-products are then removed by washing or precipitation, and the collodion is "ripened," that is, brought to a state of maximum sensitiveness.

In using collodion emulsion, it is generally coated before exposure with some substance that will act as a halogen absorbent, although with certain methods of preparation the silver salt may be sufficiently sensitive without it. This is always unnecessary with gelatin, however, as the gelatin itself is capable of absorbing the element set free.

In the development of emulsion plates, the chemical action involves different conditions than those which take place with the wet collodion. Instead of the silver

being deposited from a solution to form the visible image, it is freed from the molecules of the silver salt which were altered by the light, and a subsequent action takes place by which the unaltered particles of the sensitive compound in contact with the changed molecules also yield silver to add to the intensity of the image. The solution to be used for developing emulsions therefore must be capable of reducing silver from the transformed salts, while in the wet collodion method it is, as stated above, necessary to use one that can precipitate the silver from the solution of the nitrate. In developing an emulsion the image is built from below the surface, while in operations with the wet collodion it is built up from above.

The fixing and intensifying processes depend upon similar reactions in both methods.



ZINC ETCHING.
From Drawing by Frank Holme.

U.S. G. O.



ZINC ETCHING—ORDINARY NEWSPAPER CARTOON.

Drawn by R. C. Bowman.

CHAPTER IV.

NEGATIVE MAKING — PREPARATION OF
CHEMICALS.

COLLODIONS.

FOR line work or half-tone negatives in which contrast is desired.

Alcohol	8 ounces
Ether	10 ounces
Gun cotton	80 grains
Iodide of ammonium.....	30 grains
Iodide of cadmium.....	50 grains
Chloride of calcium.....	10 grains

For regular half-tone work :

Alcohol	8 ounces
Ether	10 ounces
Gun cotton	80 grains
Iodide of ammonium.....	48 grains
Iodide of cadmium.....	24 grains
Bromide of cadmium.....	16 grains

The amount of gun cotton may be increased if a thicker film is desired.

To prepare the collodion dissolve the gun cotton in the ether and six ounces of the alcohol. Then put the remaining two ounces of the alcohol in a clean mortar and add each salt separately, and grind with the pestle until dissolved. After all of the salts have been added

and dissolved, pour this solution into the solution of gun cotton and shake well. The collodion will usually be found to work well in a few hours after making, but should it fail to work clearly add a few flakes of iodine to turn toward a red color. Before using, the collodion should be filtered through a tuft of absorbent cotton placed in the neck of a clean, dry funnel which should be provided for this purpose alone. The collodion bottle should be kept tightly corked, as the ether rapidly evaporates, leaving the collodion thick.

THE SILVER BATH.

To prepare the silver bath, dissolve crystals of silver nitrate in water until the actino-hydrometer will, when floated in it, register 40. Distilled or clean rain water should be used if obtainable, but ordinary water as obtained from the faucets can generally be used. In any case the bath after mixing should be placed in the sun for a day or two until it becomes perfectly clear. After sunning, the bath should be carefully filtered, and, in order that it may give clear images, a few drops of pure nitric acid added until blue litmus paper will be turned red if placed in the solution. Too much acid, however, will cause weak images.

The bath is now placed in its holder, but must be "iodized" before good results can be obtained with it. If a collodionized plate is sensitized in it when first prepared, the plate when taken from the bath will look thin and be of a light bluish color, and will give a weak, thin image. This is due to the fact that in a fresh bath the silver salts when formed in the film are largely dissolved out by the silver solution. To prevent this

silver iodide must be formed in the bath. The best method is to place a collodionized plate in it as large as the holder will take and let it remain until the salts are dissolved out of its film into the bath. If necessary, this operation should be repeated, until the plates when taken from the bath will have a rich, creamy appearance, and give images of the desired strength. The methods for caring for the bath solution will be given in Chapter VII.

THE DEVELOPER.

The developer for these plates is a solution of ferrous sulphate, which may be dissolved in various proportions. The following will be found to give good general results:

Ferrous sulphate.....	4½ ounces
Acetic acid	3 to 3½ ounces
Water	48 ounces
Alcohol	2½ ounces or q. s.

The crystals of iron should be finely ground in a mortar and then thoroughly dissolved and the other constituents added.

The developer may also be made up by measuring its strength by the hydrometer, in which case it should register 20, and to each 20 ounces there may be added 1½ ounces acetic acid, and alcohol in sufficient quantity to make the solution flow readily. The action of the sulphate is to reduce the silver, as explained in the preceding chapter, the acid being used to retard its action and keep the image clear. Were the iron allowed to act alone it would cause a rapid reduction over the entire plate and veil the image. The alcohol is used to cause the developer to flow readily over the

plate, for after the bath has been used for a time it takes alcohol from the films, causing the developer to flow in streaks, but the addition of alcohol to the developer causes it to flow in an even sheet. If the baths are boiled at short intervals to prevent the alcohol from accumulating in them, it will not be necessary, however, to use alcohol in the developer.

FIXING SOLUTION.

Cyanide of potassium.

Water.

Make a solution strong enough to dissolve the un-reduced salts. If made too strong it will have a tendency to cut out detail in the negative.

Hyposulphite of soda may be used instead, but the cyanide is preferable.

INTENSIFYING SOLUTIONS.

There are several methods for intensifying negatives, but those most commonly used are with the copper and silver and the mercury intensifiers. The former is generally favored.

COPPER AND SILVER METHOD.

I. Make a saturated solution of copper sulphate, and also one of bromide of potassium.

Place some of the copper solution in a wide-mouthed bottle, and add some of the bromide solution. Exact proportions are not necessary. One part of the bromide solution to six or eight parts of the copper will be about right. In making the saturated solutions, it is

well to use warm water to more readily dissolve the salts.

2. Nitrate of silver. Water.

Make a solution about 25 grains of the silver to the ounce of water. It is not necessary in practice, however, to measure the quantities exactly. The operator will generally place a few crystals in the bottle and dissolve in some water, adding a few more crystals if the solution acts too slowly.

3. Nitric acid. Water.

Make a weak solution. About one part acid to eight or nine parts water.

4. Ammonium sulphide. Water.

One part of the sulphide to about five or six parts of water, to which a few drops of ammonia may be added. This solution should be renewed whenever it begins to cause yellowness in the negatives.

MERCURY METHOD.

Mercuric chloride. Water.

Make a saturated solution. Some ammonium chloride is usually added to cause greater saturation.

In connection with this solution, solutions 3 and 4 given above are used.

CLEARING SOLUTION.

1. Place some iodine crystals in a bottle with a few crystals of iodide of potassium and add enough water to make a deep red solution. The quantity of iodide should not be as great as the quantity of iodine used. Only a few crystals will be necessary.

2. Cyanide of potassium. Water.

Make a very weak solution.

This solution is most readily prepared by taking a small quantity of the fixing solution, and diluting it largely with water.

The iodine solution can be made weak and the cyanide strong or some of the cyanide can be added to the iodine until the red color is bleached and the resulting mixture diluted to the desired degree. In the latter case, of course, this single solution is applied to the negative instead of the two solutions being used separately.

CHAPTER V.

NEGATIVE MAKING — LINE WORK.

IN making negatives the operator must bear in mind that absolute cleanliness and care in manipulation must be observed in every detail of the work if success is to be attained. This remark will also apply to all other departments.

CLEANING THE GLASS.

The glass upon which the negative is to be made must be free from all dirt, grit or scum. To provide for this, two tubs, large trays, or jars should be provided, into one of which a strong solution of lye should be placed, and into the other a quantity of nitric acid diluted with water. The glass should first be soaked in the lye until any particles of matter adhering to it are destroyed or loosened. It should then be washed well to remove the lye and dirt, and placed to soak in the acid. When removed from the acid it should be washed again and placed in a negative rack to drain, or if desired for immediate use it may be dried by rubbing with a clean towel, and afterward with a piece of soft cotton cloth. Before collodionizing, it should be carefully dusted with a camel's-hair brush, to remove any specks which might enter the bath or cause spots in the film. A number of plates should be cleaned

at a time and kept in a negative rack for use. Some operators albumenize the glass by flowing over it, after washing, a solution of 1 ounce of albumen in 8 or 10 ounces of water, acidified with nitric acid. After drying in the rack the glass is put away with the albumenized sides all facing in one direction. Such glass does not require an edging of rubber before collodionizing.

FOCUSING.

In focusing, care should be exercised to obtain absolute sharpness of the image on the ground glass, as any blurring of the lines will render the negative practically useless. Fasten the copy to the board so that the image will occupy the center of the ground glass, put a large stop in the lens, and move the camera until the image, when perfectly sharp on the ground glass, is of the size desired. In general, the focusing should be done upon that part of the copy about midway between the center and the edge, particularly if the copy is one of large dimensions.

The lights should be placed so that the illumination of the copy will be as uniformly distributed as possible. In photographing large copies by the electric light, it is sometimes advantageous to move the lights during exposure, to obtain an even illumination over the whole. In photographing tracings or line drawings on thin paper, a sheet of white paper should be placed back of the copy. Copy which is crumpled, or which can not be made to lie flat on the copy board, may be placed in an ordinary printing-frame and photographed through the glass. The cover glass in such a case should be clear and well cleaned.



ZINC ETCHING—INTENSE BLACK-AND-WHITE EFFECT.
Drawn by J. C. Leyendecker.





Copyrighted.

ZINC ETCHING.

From Pencil and Pen Drawing by Farny.
By Courtesy The Ault & Wiborg Co., Cincinnati, Ohio.



A small magnifying glass is often of service in focusing to examine the lines of the image, especially if the ground glass is of coarse grain, or if the reduction is great, or the lines of the copy indistinct. With indistinct lines it often facilitates accurate focusing to place a piece of newspaper or other printed matter across the face of the copy, and focus on that, removing it afterward, of course. After the focus is obtained, fasten the camera in position by means of the set-screws at the back, take out the ground glass, remove the large stop and substitute a small one. Having the copy focused, the next operation is the

COLLODIONIZING AND SENSITIZING.

Having cleaned and dusted the plate, if it has not been albumenized, dip a small brush (or a small stick, around one end of which a tuft of cotton has been wrapped) into a solution of rubber in benzine (see Chapter VIII), and run a narrow strip of this around the edge of the plate. The solvent will evaporate, leaving the rubber around the edge, which will prevent the film slipping from the plate. Now hold the plate by one corner in a horizontal position in the left hand, and pour the collodion from the phial in a pool near the upper right-hand corner D, as shown in the diagram.

Use sufficient collodion to cover the plate and move the plate so that it will run first up to D, then to C, then to A, and finally to B, from which it is to be drained into the phial. It is recommended to have a second phial into which to drain the collodion, as this prevents chance specks of dust getting into the clean solution. While draining, the plate must be carefully

rocked to obtain an even coating. When the collodion has become set, invert the plate, place it on the dipper

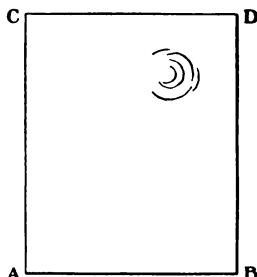

and lower steadily into the silver bath. Close the cover to the bath and let the plate remain for several minutes and it will then be ready for exposure.

EXPOSURE.

Close the darkroom door and have the plateholder resting on its shelf in an upright position and open to receive the plate. Then draw the dipper holding the plate from the bath. If properly collodionized and sensitized, the film will be free from any spots or streaks and will have a creamy appearance, with the silver solution on the surface in an even sheet. If the solution lies over the surface in greasy-looking streaks, return the plate to the bath at once, moving it around for a moment in the solution, and let remain for several minutes longer. When the plate is found ready to expose, let it drain for a minute or two, wipe the back with a rag or tuft of cotton, then place in the holder so that the film side will be toward the copy when placed in the camera, close the back of the holder and

place it in the position of the ground glass in the camera.

Having the cap on the lens and the lights properly placed, draw the slide from the holder, then remove the cap from the lens. The time of exposure must be a matter of experience, as it will vary with the intensity of illumination, the amount of reduction of the copy, etc. Short exposure gives broad lines, with lack of intensity in the negative, and the resulting print will be lacking in detail. Long exposure gives fine lines, detail and density, but tends to fill the fine lines. For blue or weak lines give as short an exposure as practicable, for such lines tend to affect the sensitive film, and if the exposure is lengthened, the lines in the image will fill. Light blue lines can not be reproduced on the ordinary plate. When the ground of the drawing is yellowish, give ample exposure, as such a color does not readily affect the film. Shorten the exposure time in proportion as the image is reduced in size. If the copy is brightly illuminated it will require less time than when the light is weak.

When the exposure has been considered sufficient, replace the cap on the lens, return the slide to the holder, and take the holder to the darkroom. The plate is now ready for development.

DEVELOPMENT.

This must of course be done by the non-actinic light in the darkroom. To develop the image, hold the plate horizontally in the left hand and flow the developer from a graduate or an ordinary tumbler over the film in an even wave; then holding the solution on the plate,

keep moving the plate gently to cause the developer to flow from side to side. The negative image will soon appear, and the time of its appearance will indicate whether the exposure was properly timed. If the right exposure was given, the image will appear in a few seconds, the white ground taking a dark appearance and the lines retaining the color of the film before the developer was applied. If, however, the image flashes up at once and some or all of the lines become darkened, it indicates overexposure and the lines will be filled, as the whole surface has been impressed and the silver will be deposited to a greater or less extent on those parts which should remain clear.

If, on the other hand, the image is slow in appearing, and the details are brought up with difficulty, the plate has been underexposed. If one portion of the image appears before another, it indicates uneven lighting of the copy, and when that portion which appears first is sufficiently developed, it should be washed under the tap while the developer is allowed to act upon the other portions of the plate. Otherwise the fine lines in one part might fill by the time the other parts were sufficiently developed. When the whole image has attained the proper intensity, which must be determined by experience, and the details are visible, the plate should be immediately washed under the tap to entirely remove the developer and unreduced silver solution. The remaining operations can be performed by daylight.

FIXING.

Now flow the fixing solution over the film until the unaffected portions are entirely dissolved, when the

lines should appear as clear glass. Then wash the plate well again, and examine it carefully to determine if the film has proper density, if the lines are fine enough, and if all are clear. Some experience will be required to detect these qualities. If any of the lines are filled they will have a hazy appearance, quite readily detected, but if not too badly filled they can be cleared by a subsequent operation explained below. If the plate is satisfactory thus far, it must be intensified to make the ground opaque, for in its present condition the light would pass through the ground so readily as to render the negative useless for obtaining a print upon the metal.

INTENSIFICATION.

Intensification may be done with either the copper and silver or the mercury intensifier. To intensify with the former, flow the copper solution over the fixed and washed negative until the film becomes white, then wash well and flow with the silver solution until it is blackened throughout, then wash well again. It will usually be necessary to repeat the process a second time, and sometimes even three or four times, if the exposure has been short, but twice will, as a rule, be sufficient if the exposure has been rightly timed. If any portion of the ground should still appear thin, after the other portions have become sufficiently dense, repeat the operation on that part alone, to increase its density.

If, after the entire ground has acquired the proper density, the lines all appear sharp and clear, additional blackness may be given to the film by flowing it with the ammonium sulphide solution No. 4. Before using

the solution No. 4, flow with the dilute nitric acid solution No. 3, and rinse. This will preserve clearness. Wash thoroughly after blackening with the sulphide solution. If the lines are at all veiled, the sulphide is liable to turn them yellow, and in such a case it should be omitted. Additional density in the intensification may be obtained by treating the film with a dilute solution of iodide of potassium, after the copper and before the silver is used. This turns the film a lemon-yellow color. This treatment will, however, sometimes cause a stain if the bath and other chemicals are not in a clean condition. The solution is made by dissolving a few crystals of iodide of potassium in water.

CLEARING.

If, after intensifying with the copper and silver solutions, any of the lines are filled, they must be cleared. To do this, flow over the filled portions the dark red solution of iodine and iodide of potassium, and rinse the plate. Then follow carefully with the *very* dilute solution of cyanide, applying it until the filled portions are cleared. If the cyanide solution is too strong it will dissolve the film also and ruin the negative. During the operation the water should be kept running from the tap and immediately applied if the action shows any tendency to proceed too far; and it is often to advantage to let the water run over the plate, while the cyanide is being applied, to cause the action to proceed slowly. This treatment of the film will cause it to become whitened. To blacken it, the ammonium sulphide solution must be used as directed above.

Instead of using the iodine solution strong and the cyanide solution weak, some operators prefer to dilute the former and use the latter strong, intensifying again after the clearing. Instead of using the solutions separately, they may be mixed by adding cyanide to the iodine solution until the color disappears, and diluting with water. The solution is then applied until the lines are cleared. If the lines are very much filled it will be impossible to clear them, and the negative will be worthless.

THE MERCURY METHOD.

Have the mercury solution in a tray and allow the fixed negative to remain in it until bleached. Then flow with the acid and sulphide solutions to blacken. For greater density, place in the mercury again until of a grayish color, and repeat with the sulphide solution, washing well after each operation. The sulphide solution tends to weaken the film, and in washing the negative after its use the water should not be allowed to run on it with much force. Having obtained a negative with clear lines and opaque ground, it may be dried spontaneously or over heat and is then ready for reversing, the operations for which are described in Chapter VIII.

CHAPTER VI.

NEGATIVE MAKING—HALF-TONE WORK.

THE SCREEN PLATE.

IN making half-tone negatives we encounter conditions which do not exist in the production of line negatives. In line work we have no gradations between black and white, but in half-tone operations we are required to reproduce intermediate tones.

To obtain a negative suitable to render these gradations upon the metal plate we cause an image to be formed, which consists of a great many little black dots and clear spaces, the sizes of these elements varying to accord with the variation in the tones of the original.

This result is obtained by having in front of the sensitive plate, during exposure, a glass plate ruled so as to have alternating parallel opaque lines and clear spaces. This "screen plate," or "half-tone screen," may have lines ruled in only one direction or in several, but ordinarily we use one which has rulings in two directions, the two sets of lines crossing at a right angle and forming clear spaces between the intersections. The light passing through the spaces produces the desired effect.

A "single-lined" screen, that is one having lines ruled in only one direction, was formerly used, but



ZINC ETCHING.
From Drawing by Fred Richardson.





ZINC ETCHING.

From Pen Drawing by Ralph Fletcher Seymour.



this necessitated turning the screen after half the exposure had been given, and for greater convenience, as well as to obtain more certain results, the cross-lined screen has been adopted.

These screens are usually made with equal widths of black lines and clear spaces, and for regular work these relations may be considered as giving the best results. The number of lines per inch should be selected with consideration for the class of printing to be done from the plates. For newspaper work a ruling of eighty-five lines is generally preferred, for regular use one hundred and thirty-three, and for fine printing and high-grade magazines one hundred and fifty to one hundred and seventy-five. Screens having as many as three hundred lines per inch are occasionally used for special work, but the plates require exceptional facilities and skill in printing.

THE HALF-TONE NEGATIVE.

A negative properly made by exposing the sensitive plate through the screen will have the largest dots in the portions corresponding to the white parts of the copy, and the next in size will be those representing the tone next in intensity to the whites. The dimensions of the dots will therefore decrease as the tints in the original grow darker until they almost or quite disappear in the solid blacks.

In order that a negative may give the most satisfactory results, certain relations must, in general, exist between the size of the clear spaces and the opaque dots. What may be termed a standard negative (that is, one properly made from a good original) will have

square opaque dots in the high lights, the corners of each of these dots being joined to a certain extent to the corners of the neighboring ones. The opaque dots in the next tone will either be more slightly joined or not quite uniting, and in the deeper shades we find the black dots surrounded by clear glass, those in the parts representing the solid blacks of the original being reduced to points, or perhaps absent.

A print made from such a negative will have separate black dots (corresponding to the clear spaces) in the high lights, and the dots will increase in size as the shadows deepen until they run into solid lines. The details in the shadows will be formed of open dots (corresponding to the separate opaque dots in the negative), these open dots decreasing in size as the shades increase in intensity until they are almost or quite absent in the blacks. There is, therefore, a simple gradation corresponding to the tones of the original, each shade being composed of elements of a certain size.

It is readily seen, therefore, that the character of the print will depend largely upon the relative sizes of the elements composing the negative and the extent to which the dots in the high lights are joined. If we have a negative in which these dots are but slightly united, it is evident that the high-light dots in the print will be large and will probably give an effect too dark. On the other hand, if the clear spaces in the negative are very small the corresponding dots in the print may not have sufficient strength to be sufficiently etched. It must also be considered that if the dots in the other portions of the negative do not bear the correct rela-

tions in size we will not have a correct reproduction of the original.

There are certain conditions to be fulfilled in the operations of making the negative if results most nearly approaching the ideal are to be attained. Principal among these are the adjustment of the distance between the screen and the sensitive plate and the size and shape of the aperture of the diaphragm. The formation of the dots in their relative proportions most largely depend upon the manner in which these relations are adjusted to each other. We will now consider these and other factors entering into the operations of half-tone negative making.

CHARACTER OF THE COPY.

It is evident that the nature of the object to be reproduced will determine to a greater or less extent the character of the results, and also that subjects of different characteristics will require variations in the methods of work to suit the different cases.

Some photographs and wash drawings have comparatively little gradation or detail and are too sharp in contrasts to have pleasing effects. Others are so deficient in contrast that they present a "flat" appearance. The former class, of course, requires treatment that will produce detail in the half-tone negative where it is deficient in the copy and the latter will require manipulation to obtain brilliancy in the resulting print. The surface upon which the drawing or photograph is made also has an effect in forming the results. The grain of rough surfaces usually causes an unpleasant effect in the half-tone, and smooth surfaces are therefore to be

preferred. The color of the original must also be considered in this connection. As a rule chocolate brown and black give the best effects, while bluish or lilac tones tend to give "flat" negatives.

ILLUMINATION OF THE COPY.

Uniform illumination is essential to insure success in making half-tone negatives. Flickering of the lights and variation in their intensity make it difficult to judge the exposure time accurately and to obtain the effects that the operator may desire. The lamps should be placed so that reflections on the copy may be avoided, and it will at times be found desirable to illuminate very large subjects by means of daylight rather than by the electric lamps.

SEPARATION OF SCREEN AND PLATE.

If, during exposure, the sensitive plate and the screen were in contact it is evident that the dots on the negative would be practically of the same size; that is, we would have little or no variation in the dimensions of the elements. The image would simply be cut up by a network reproducing the lines of the screen.

If, however, the screen and plate are separated to permit the light to spread or be diffracted between them, we find that the dots vary in size, and at a certain distance we obtain a negative image in which their relative proportions are at least approximate to those described in a preceding paragraph. The effect of such separation upon the relative size of the dots varies, of course, with the distance between the plates. The nearer they are together the less will be the variation,

the stronger will be the dots in the shadows, and the less the contrast in the negative. By varying the amount of separation we can, therefore, obtain detail or contrast as the case may require. When using coarse screens the distance must be greater than with fine screens to obtain similar results, as a less distance with the fine ruling gives the same ratio between the diameter of the screen openings and the distance of separation as a greater distance does with a coarser ruling. With the same stop, the necessary exposure time will be less as the separation is increased, and vice versa.

AREA OF THE DIAPHRAGM APERTURE.

Whether the half-tone negative shall have detail or contrast depends in a great degree upon the area of the aperture in the diaphragm used during exposure. If the exposure is made with a small aperture the resulting negative will be found to have the dots in the high lights separated from each other and those in the shadows strong and approaching in size to the dots in the high lights. The negative will therefore be made up of a network of clear lines and a print on metal made from it would be formed of lines corresponding. An etching made from such a print would have the high-light portions too dark, and as a whole it would be too "flat" and dark, that is, lacking in brilliancy. If, on the contrary, a very large aperture is used, the high lights in the negative will be formed of large dots uniting to make a network of dark lines with clear spaces between the intersections. The opaque dots will rapidly decrease in size as the shadows increase in

intensity, and some portions may be without dots to render the detail necessary to give the correct effect. A print made from such a negative would have its high lights made up of separate dots, the middle tints would be formed of dark lines varying in thickness, and the shadows would consist of solid masses. An etching made from such a print would give proofs with insufficient gradations, and if the dots in the high lights of the negative have been too much closed up, the corresponding dots in the print will not be large enough to allow a deep etch, rendering the plate liable to smudge in printing.

There is evidently a mean between the two extremes, it being possible to find a diaphragm having an aperture which, in conjunction with the right degree of separation between screen and plate, will give a negative the print from which will have the dots in the "whites" of sufficient size to allow a sufficiently deep etch and yet so separated that these high lights will appear of the requisite clearness, the dots and lines in other portions being of such dimensions that in the resulting print we will have a proper correspondence to the gradations in the original. Instead of using one diaphragm for the entire exposure, however, it will generally be found conducive to the best results to employ two — one having a small aperture, being used during part of the exposure, to obtain detail in the shadows, and another having a larger aperture for the balance of the time, to close up the dots in the high lights. When the original has the proper relations between detail and contrast, one size of aperture may give the desired effect, it being assumed that the screen

distance has been properly adjusted. In using two sizes of aperture during exposure the proportion of time to be allowed each must, of course, be determined by the character of the copy, and only experience can develop judgment in this regard.

SHAPE OF THE DIAPHRAGM APERTURE.

During exposure each transparent space in the screen acts in a manner similar to that of a lens and causes an image having the shape of the diaphragm aperture to be formed upon the sensitive plate. It is possible, therefore, to determine the form of the dots in the negative by using an aperture of a certain shape. We are also able in this way to secure dots that will most readily join in the high lights. It is evident, then, that a round aperture will cause round dots to be formed, and that a square one will give square dots, etc. If an aperture is used in the form of a narrow slit parallel to the lines of the screen, the negative will be formed of parallel lines, as the action of the light passing through such an opening will be to form a series of elongated dots which will join end to end. It is plain that square dots will more readily join than round ones, and are therefore to be preferred in operating to secure clear high-light effects. In using a square aperture, moreover, the action of the light at the corners may be intensified by extending the corners of the aperture, and this is, of course, particularly desirable when photographing "flat" subjects. To obtain still greater action on the high lights a stop may be used during part of the exposure, having four small openings, the center being closed. The light, passing through these openings, has

an action similar to that shown when the corners of the diaphragm are extended, but the closing of the center allows the action to take place only between the intersections of the cross lines and therefore the high lights are alone affected.

The diaphragms suggested by Max Levy and illustrated below represent the apertures described above, and the conditions presented by the character of the

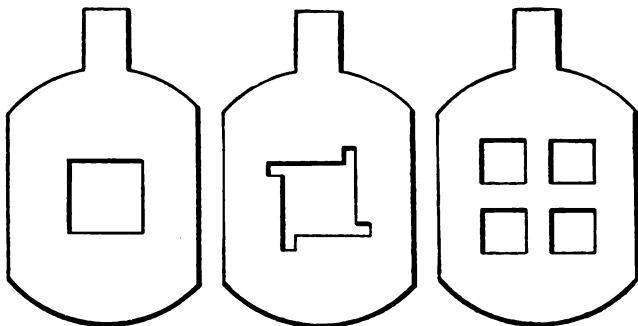

copy will determine whether one or two or three shall be used during exposure. For copy having normal relations as to contrast and detail, the square opening alone may give correct rendering, but if necessary to join the high-light dots properly, the aperture with extended corners may be used during part of the exposure, and if the original is "flat," the multiple aperture may finally be used.

As a rule, however, the stop with the multiple aperture is not used in practical work, as it is seldom that desirable results can not be obtained by the proper manipulation of two diaphragms. Mr. Horgan has



ZINC ETCHING OF PORTRAIT—MEDALLION EFFECT.

From Drawing by Jules M. Gaspard.





60-line.



85-line.



100-line.



110-line.



120-line.



133-line.



150-line.



175-line.



200-line.

CUTS SHOWING HALF-TONE SCREENS MOST GENERALLY IN USE.



devised those illustrated below and they are recommended as fulfilling practical requirements to the best advantage.

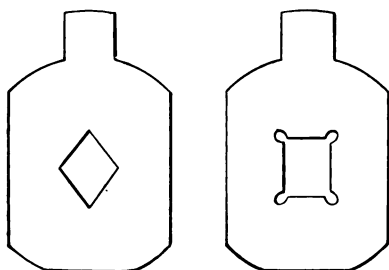

The diamond-shaped opening is used during part of the exposure to obtain dots for detail in the shadows, and the one with extended corners is used to close up the dots in the high lights.

From the foregoing it will be observed that the size and shape of the diaphragm openings and the relative time given with each when two different apertures are used must be determined by the nature of the copy and the effect to be produced.

EXPOSURE TIME.

The time of exposure will vary, of course, according to the conditions enumerated in the preceding paragraphs. Insufficient exposure, all other elements being properly adjusted, will result in the formation of dots that are not sufficiently joined in the high lights and not large enough in the shadows. If the time given has been too long the union in the high lights will probably be so excessive as to produce clear spaces too small to

allow the print to be etched to the required depth. It is well to remember that under the same conditions an aperture of a given diameter will require four times the exposure of one of similar form having twice this diameter. (Similar areas are to each other as the squares of their like dimensions, and therefore the larger opening will admit four times the light that would pass through the smaller one in the same time.)

MANIPULATIONS.

First see that the screen is clean. It should be rubbed with a soft, clean cotton cloth until any spots or streaks are removed from the surface or they will be reproduced on the negative. Breathing on the surface while rubbing will assist in cleaning it. When clean, insert the screen in the rack in the plateholder designed for it so that it will be in front of the sensitive plate when all is ready for exposure. The copy must be studied to determine the extent of separation to be allowed between screen and plate and also whether one diaphragm shall be used or two, and if the latter, what sizes of apertures shall be employed and the exposure to be allowed with each. These factors can usually be pretty accurately judged by the experienced operator, but in the appendix we give suggestions by Count Turati and Max Levy for use by those who may wish to make experimental determinations.

The operations preliminary to exposure are the same as described in the preceding chapter. The exposure is made in accordance with the conditions involved, the principles stated above being observed. If the copy is harsh in contrasts, with heavy black shadows, it is often

of great assistance in obtaining detail to hold a piece of white cardboard in front of it during a part of the exposure. This card should be kept moving to insure uniformity of light action on the plate. If, on the other hand, the copy is "flat," a reading glass may be used to concentrate the light from one of the lamps on the high-light portions, thus increasing action from these parts. This method may sometimes also be used to bring any parts up lighter that may be too dark in the copy to make good effects, although skill in manipulation is necessary to obtain satisfactory results. The plate is developed in the same way as a line negative by flowing the developer over it, flooding with water as soon as the image appears of the required intensity, and fixing and washing again. The negative is then examined to determine whether it has the qualities that will give the best rendering of the copy. As stated above, if the opaque dots are widely separated in the high lights and the shadows are filled with strong dots, the resulting print will be gray and "flat." If the dots in the high lights are very much closed the print may not have strong enough dots to etch deeply, and if sufficient detail is not present in the shadows the contrasts might be too harsh. In either case, the exposure should be repeated, varying the conditions to secure more or less brilliancy, or gradation, as required.

If the negative is satisfactory it must be intensified and the operations are carried out as with line negatives. It will be observed that intensification enlarges the dots, and allowance for this should be made in adjusting the conditions during exposure. Two applications of the intensifiers will generally be sufficient and sometimes

only one, although three may be necessary in certain cases.

The clearing solutions can often be used to advantage in "brightening" the entire image of a half-tone negative or in "cutting out" certain portions. In the former case the iodine and cyanide are used over the surface of the entire plate (after intensifying) in the same manner as described for line negatives, great care being taken to avoid any excess that would make the negative too "open." In local "cutting," the solutions can be applied to the portions only that are to be acted upon, although the iodine can usually be allowed to first act on the entire surface, then the cyanide on the parts to be cut out, one wash of the latter being finally given over the whole before applying the ammonium sulphide. The local application of the cyanide may be given by dropping it from a bottle upon the negative while water is allowed to flow over it to prevent too rapid action, but it is often best done by using a medicine dropper, and this is particularly advisable when the part to be cut out is quite small. Such clearing, of course, is not always necessary. Many negatives require only intensification to complete the work.

In making coarse-screen negatives for newspaper work, the best effects are generally obtained by working for contrast with the screen separation and diaphragms, and then, if necessary, "cutting out" the entire negative until the clear spaces in the high lights are large enough, using local reduction on the other parts afterward if required. This also applies, of course, when exceptionally brilliant negatives are required in any other class of work. If properly done, the high lights

in the print will be clear and the etching from it will have a character necessary for the best results upon soft paper. "Flat" negatives, that is, those having too great uniformity of size in the constituent dots, can nearly always be improved by this local treatment on the shadows.

In making half-tone negatives, a small magnifying glass, such as used by jewelers, is of great assistance in examining the dots. In deciding upon the quality of the results consideration must be given to obtaining effects which will appear best for the class of printing for which the plate is to be used.

After a satisfactory negative has been obtained it should be varnished or reversed, and is then ready for the printer.

CHAPTER VII.

NEGATIVE MAKING — CAUSES OF DEFECTS
IN COLLODION NEGATIVES — CARE
OF THE SILVER BATH.

THERE are various defects liable to occur in the making of collodion negatives, which may be due to faults in the chemicals, or lack of care in manipulation. The following are the most common :

Fog, by which is meant a filling up or deposit in those portions of the image which should remain clear. It may be caused by :

Actinic light entering camera, plateholder or dark-room, and striking the sensitive plate.

Insufficient acid in developer or in bath.

An unripened collodion.

Overexposure.

Overdevelopment.

Developer too strong or too warm.

Fumes of chemicals.

Transparent spots in the film may be caused by :

Dust in the collodion, in the bath, or on the plate.

Excess of iodides in the bath.

Undissolved salts in the collodion.

Streaks in the film may be due to :

Improper flowing of the collodion.

Scum on surface of bath.

Bubbles or specks of dust floating in collodion.

Removing plate from bath too soon.

Alcohol in the bath, in which case the streaks will be rather broad and wavy, and run in the direction of the dip.

Developer containing insufficient alcohol.

Developer striking film with too much force.

Developer too strong.

Collodion too thick, or overiodized.

Dirty plates.

Dirty plateholder, which will sometimes cause blotches like "oyster shells."

Thin images may be caused by:

A weak or insufficiently iodized bath.

Excess of acid in the bath.

Underexposure.

Poor lighting of copy.

Blurred images may be caused by:

Improper focusing.

Camera being jarred during exposure.

Uneven density of film may be caused by:

Uneven lighting of copy.

Uneven coating of collodion.

CARE OF THE SILVER BATH.

If uniformly good negatives are to be obtained, the silver baths must be kept in a proper condition. Every well-regulated establishment has several baths, so that when one needs rectifying another can be used without causing delay. The following rules will, if followed, keep the bath in proper order:

1. Be sure that all vessels in which the bath may be kept are perfectly clean and free from any traces of other solutions.

2. Keep it covered.

3. Isolate it from other chemicals.

4. Keep the hands clean while dipping plates or handling the bath.

5. Skim the top every morning with a strip of clean paper.

6. Filter often through absorbent cotton.

7. Keep the strength up. It does not waste silver to do so. Some clean saturated solution can be added to the bath occasionally when it is in use.

8. When the bath becomes charged with alcohol boil it down. By putting some water in the vessel in which it is boiled, and pouring the bath into it, some of the iodide will be precipitated, and aid in keeping the bath from becoming overiodized. Then place on the gas stove and let it steam until the odor of alcohol is entirely gone. It is generally best to let it boil down to a small volume. Then test with the hydrometer, and if necessary add clean water to make it register 50. Then filter well, and it is ready for use again. If it fails to work clearly, add a few drops of nitric acid C. P.

9. To remove organic impurities and matter in suspension, add some bicarbonate of soda to the bath and set it in the sun for a day or two. The silver nitrate will form dark-colored insoluble compounds with the impurities which will be precipitated.

Then filter the bath and if necessary add fresh, strong solution to bring it to required strength. The



HALF-TONE — 85-LINE SCREEN.







HALF-TONE.

**Border Obtained by Half-toning the Gray Card Mount, and Cutting
White Line.**

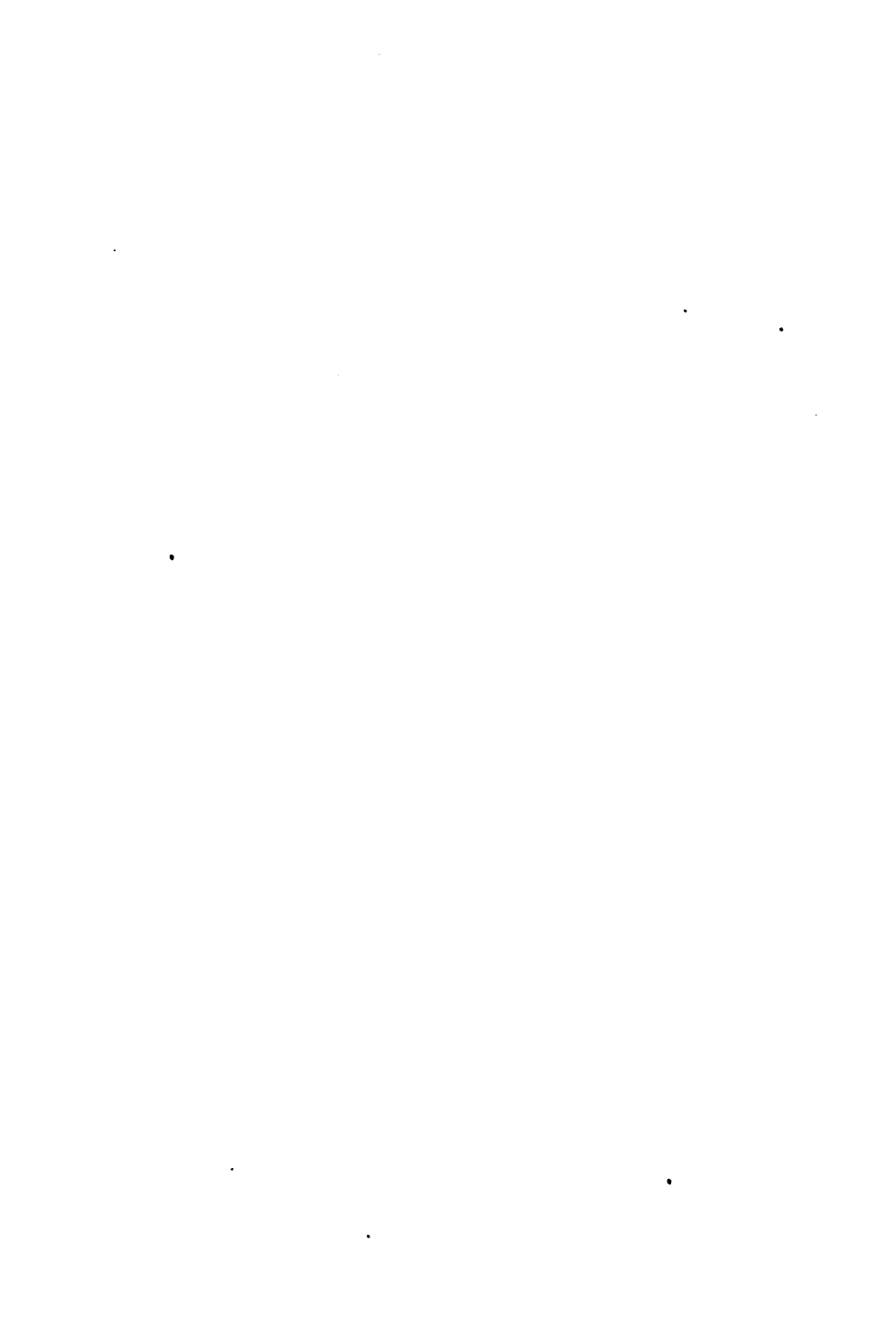

bath must also be acidified again by the addition of nitric acid C. P.

10. If the bath becomes overiodized, pour it into some clean water to precipitate the iodide, filter, and boil down to required strength. If the bath is evaporated at proper intervals, and the iodide removed as directed in paragraph 7, it will not become overiodized.

CHAPTER VIII.

REVERSING NEGATIVES.

IN order that the proof from the etching may appear unreversed as regards right and left, it is necessary to "turn" the negative film before obtaining the print from it. There are four methods by which this may be done, as follows:

1. The sensitive plate may be placed in the holder so that the glass side will be turned toward the copy, allowance being made in focusing for the thickness of the glass. The springs of the plateholder must be specially arranged to hold the plate when this method is used.

2. The image may be taken from the reflection of the copy in a mirror, or, what amounts to the same thing —

3. By having a glass prism with silvered hypotenuse arranged to fasten to the front of the lens, the rays of light being reflected from it through the lens and onto the sensitive plate. A modification of this arrangement has the prism as a fixed part of the lens.

4. By stripping the film from the glass support and placing it in a reversed position. The two methods last mentioned are those usually employed. The construction of the prism suggests its method of use.

For turning the collodion film it must be coated with the following solutions:

RUBBER SOLUTION.

Rubber cement.
Benzine, naphtha, or benzole.

Add sufficient of the solvent to the cement to make a thin solution.

PLAIN COLLODION.

Alcohol	6 ounces
Ether	6 ounces
Gun cotton	120 grains
Castor oil	1½ to 2 drams

When the film of the negative is dry and cold, flow the rubber solution over it, and place in the negative rack until dry. When the rubber is dry, flow the collodion over the film, and let it dry also.

Instead of being allowed to dry spontaneously, the collodion may be ignited and burned. This gives the same result as the slower method and is often done with line negatives in newspaper shops where it is necessary to turn work out in the shortest time possible.

After the collodion is dry, cut the film to the desired size around the image. If the cut is to be rectangular, the negative should be placed on a board or a table with a straight edge, and a T-square and triangle may be used in cutting the lines. If the board has two edges at right angles to each other, the T-square alone will answer the purpose. After the film is cut let the negative rest in a tray of water until the film is loosened, then lift one corner with a knife until it can be taken between the thumb and finger of one hand, raise from

the glass, take hold of the adjacent corner also, and strip the entire film from the glass and lay it in reverse upon a second sheet of clean glass wet with water. Then lay a sheet of wet paper upon the film and rub the squeegee over it in various directions to remove all of the water. After this is done, hold face down over the gas stove until the paper begins to dry, then remove it and heat the film, to thoroughly dry it, and place in a rack to cool. It is not necessary to use the paper if the film is tough and the squeegee free from grit.

If the film refuses to strip from the glass after soaking in the water, or if an albumen substratum has been used under the original collodion film, place the plate to soak in a solution of acetic acid. Curling of the film after transfer is sometimes caused by insufficient oil in the collodion. Should the film fail to adhere to the glass after stripping, flow a thin solution of gum-arabic under it, squeegee and dry as usual. Flowing the collodion or rubber over the plate while warm will cause bubbling. The collodion will sometimes bubble also on a cold plate. This may usually be remedied by flowing some ether over it after it has just set. It is customary in engraving establishments to turn several negatives upon one sheet of glass and print all together on the same sheet of metal. As a rule, however, it is best to print half-tones separately. Negatives made with the prism will require varnishing before being used to print from. A thin solution of gum arabic flowed over the plate while the film is wet will answer this purpose.

It is often required to combine a line and a half-

tone negative for printing upon one plate. This is readily done by stripping the respective films from the original negatives and mounting them together on one glass, in the positions desired.

CHAPTER IX.

ETCHING — LINE WORK.

THE etching processes described hereafter depend upon this principle —

If certain chromic salts are dissolved in solutions of organic matter and the solutions are then dried and exposed to light, the action of the light will be to render the matter insoluble.

In our practical applications, we coat a metal plate with the sensitized solution and, after drying, expose it under a negative. The light passes through the clear spaces and hardens the parts of the coating under them, but the other parts, being protected by the opaque portions of the negative, remain soluble.

By washing away these soluble parts, we have left an image corresponding to that on the negative, and, having by further operations rendered it resistant to the etching fluid, we etch away the exposed ground of the plate, leaving the image in relief.

PREPARATION OF THE METAL.

Zinc is almost invariably used for line etching on account of its comparative cheapness and its special adaptability for this class of work.

The metal may be polished by machine or by hand, the latter method being used in most establishments of

moderate size. To polish the metal by hand a board should be fitted in an inclined position in a sink so that water from the tap can run upon it when desired, a couple of nails being driven at the lower portion to hold the metal in position when lying upon the board.

If the metal is obtained polished from the dealers, it will be necessary to use the charcoal only to prepare the surface for coating. If it is unpolished, it should first be rubbed with pumice stone or Scotch hone until the roughness is removed, and then finished with the charcoal. If the pumice stone is used, its polishing surface should first be ground flat and smooth, otherwise it will scratch the metal. While being polished, the metal should be kept wet from the tap, being rubbed in one direction only with the pumice stone or a hone and in the transverse direction with the charcoal, the end of the charcoal being used. If any flaws are detected in the surface of the metal, they must be removed by punching from the back as follows — place a pair of calipers so that one point shall be directly over the flaw, the other, of course, being directly under it. Press the latter against the back of the plate so as to leave a scratch, the end of which will indicate the location of the flaw. Then turn the plate face down upon a smooth iron slab, place the end of a punch over the flaw as indicated and strike the other end of the punch with a hammer, which will bring the flaw up to the surface. Then polish again until the surface of the plate is free from scratches and pits. The condition of the finished surface will depend largely upon the charcoal. Some charcoal is gritty and leaves scratches which, if deep enough, would show in the

etching. Such grittiness can often be removed by soaking the charcoal in water or the jar of dilute acid.

LINE ETCHING.

SENSITIZING SOLUTION.

Albumen from fresh egg.....	1 ounce
Water	8 ounces
Bichromate of ammonium.....	15 to 20 grains

Dissolve the bichromate in the water, add to the albumen and beat up well with the egg-beater in a bowl or mortar. Filter until clean. Some etchers add a few drops of ammonia to the solution.

COATING THE PLATE.

Having polished the plate, file the roughness from the edges, wash it, let some water remain on the surface, and carry it to the room used for coating and drain the water off. Then pour some of the sensitizing solution to cover the plate and drain it off at one corner, repeating two or three times, draining at different corners to equalize the coating. Specks of dirt or bubbles should be removed.

Then hold the plate over the gas stove and warm until dry, keeping it slightly inclined to allow any surplus fluid to drain. A little practice will enable an even coating to be obtained. When the plate is dry, allow it to cool in the dark and it is then ready for printing.

PRINTING.

See that the heavy glass which is used for the bed plate in the printing-frame is clean, and also the back of the negative. Any grit between the two will some-



HALF-TONE.

From Drawing by J. Vaughn McFall.







HALF-TONE.
Solid Black Background.

UNIVERSITY
OF MICHIGAN

times cause them to crack when the pressure is brought to bear. Also see that there is no grit in the rabbet of the frame. Then place the negative, film side up, upon the bed plate, and carefully place the coated plate face down upon it. Place the back of the frame upon the metal (usually with a pad of felt or some folded papers between), lay the bars across and fasten at the ends, and turn the screws until sufficient pressure is obtained to make contact between the plate and negative. Then place the plate in the light to print. If in sunlight, support the frame so that the rays will strike directly upon the face. If the electric light is used, give half of the exposure while the frame rests upon one side, then turn it to rest upon the opposite side, and give it the balance of the exposure. If the negative is a large one, keep the light swinging, to equally illuminate the whole surface. Do not allow the printing-frame glass to become too hot, or it will crack. The exposure time will vary from one to three minutes in the sunlight and from three to ten minutes in the electric light. It will require but little experience to judge of it properly.

ROLLING UP AND DEVELOPING.

After the plate has been sufficiently printed, it must be rolled up with the special ink to obtain the image. Upon the slab provided for the purpose, place a little of the ink and with a knife spread it in a line across one end; then with the composition roller distribute it in an even coating over the slab. (Lifting the roller from the slab while rolling will aid in obtaining an even coating.) If any particles of hardened ink or other

matter cling to the roller, remove them with turpentine and a rag. When the roller has an even coating of the ink on it, roll it over the face of the zinc until it also is evenly coated. The ink on the zinc should not be too thick; the metal should appear faintly through it. If the ink should be too thick on the metal, clean the roller with turpentine, and when dry roll it over the zinc and it will remove a good deal of the ink. The ink coating should be heavy enough, of course, to absorb enough dragon's-blood to form sufficient resist to the acid, when burned in.

In cold weather the ink will sometimes refuse to distribute properly under the roller. In such a case wet it with a few drops of turpentine, or warm the slab, and this difficulty will be removed. The roller should be kept free from dirt, and in starting work for the day the slab and roller should be cleaned with turpentine and fresh ink used. A little experience will enable the worker to judge when the plate is properly rolled up. When the proper coating of ink is obtained upon the metal, place the plate in a tray of clean water (or hold it under the tap) and rub the surface carefully with a tuft of wet absorbent cotton. The parts of the coating which were not affected by the light will rub away, leaving the image in black lines. If the exposure has been properly timed, the lines will all remain unbroken upon a clean ground of metal. If the plate was under-exposed, many of the lines will rub away, and if over-exposed, the ink will cling to parts from which it should separate. In such a case a few drops of ammonia added to the water in the tray will often enable it to be removed. Rub the image with the cotton until all of

the lines are clean and sharp, being careful to see that the spaces are free from any adhering ink. Then dry the plate by draining and warming over the gas stove. By patting it before warming with a piece of damp chamois skin, rolled into a pad, the surplus water can be readily removed.

With a camel's-hair brush paint in with the transfer ink, wet with turpentine, any parts of the lines which



READY FOR ETCHING.

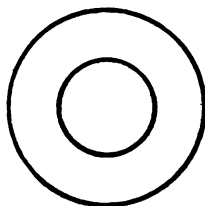

AFTER ROUTING.

may be broken, and also the largest open spaces as shown in the cut at the left. The one at the right shows the appearance after routing and finishing.

The painting in of these spaces supports the roller and prevents smudging in the subsequent rolling.

POWDERING AND ETCHING.

After the plate has been painted, it is ready for powdering. Have some dragon's-blood in the powder box and dump it upon the surface of the plate, and then brush off the surplus with a broad soft brush, finishing with a tuft of dry cotton until the metal spaces are

clean. The dragon's-blood will adhere to the ink. The plate should now be held over the gas stove and heated until the powder incorporates with the ink, as shown by its turning a rather glossy black. There are two grades of dragon's-blood, one a dark red color, the other lighter in color. The latter will burn in more readily than the other, and form a strong resist. After the plate is thus heated, paint the back with asphalt varnish, cool, and the image being now able to resist the acid, the plate is ready for the first "bite."

The acid used for this bite should not be very strong. The proportions are not arbitrary. The beginner, however, may take about two and one-half parts of the commercial nitric acid to thirty-two parts of water, for the first etch. Place this solution in the etching tub and immerse the plate in it. The action of the acid is to combine with the metal, forming zinc nitrate and hydrogen gas, the former being deposited on the plate and the latter passing off into the atmosphere. Then rock the "tub," and as the action of the acid proceeds, keep the plate clean by brushing with the bristle brush used for the purpose. This bite need not be deep. Three to five minutes will be sufficient, when the metal will be found so etched away as to leave a line in slight relief. Then remove the plate from the acid, rinse, dry off the surplus water with a towel or the damp chamois, and warm over the stove. Before continuing the etching the sides of the lines must be protected to prevent the acid attacking them and causing breaks. This is usually done by "powdering four ways," as follows: Take the plate to the powder box and dump some of the dragon's-blood on it; then,

beginning at one edge of the plate, pass the brush over it from that side to the side opposite, so that the powder will be brushed against the sides of the lines.

For instance, as shown in the diagram, if the brush is started at the side D, brush in direction indicated by the arrow A toward side B. Hold the brush upright,

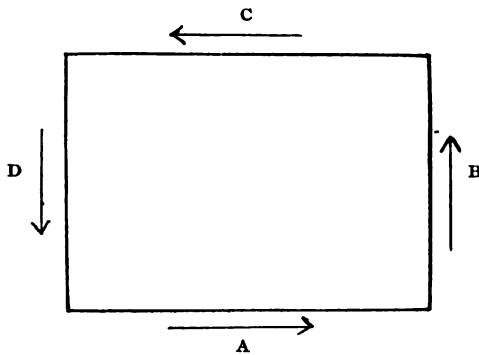

and move in even sweeps without lifting from one extreme edge to the other. When the spaces between the lines are clean, and the lines all "covered," heat the plate again to cause the powder to adhere to the lines, and, when cool, powder in a similar manner in the direction of arrow B, moving the brush from A to C, and heat again. Repeat the powdering in the remaining two directions, heating after each, and if properly done the powder will adhere so as to protect the lines on all sides.

When cool, the plate is ready for the second bite. The etching is done in the same manner as at first, the

time being increased somewhat, and when it has been carried far enough the plate is again rinsed, dried and powdered as before, and placed in the bath to etch again, the strength of bath and time being increased. When the action has again proceeded sufficiently, it is removed from the acid and prepared for the fourth bite. This may be done by simply powdering again as for the other bites, but it is customary with many etchers to roll the plate up again to form a thick coating of ink over the top of the lines before powdering for the fourth bite, so that the ink will run down the sides of the lines during the heating and form a heavier coating. This is best done with the leather-covered roller. After this "rolling up," the plate is powdered again and given the fourth bite. The four bites will, as a rule, be all that are necessary for ordinary work, and the plate can be cleaned, routed and mounted.

A "clean bite," however, may be given to remove the "shoulder" from the lines, although it need not be considered necessary in general work. During the operations of powdering and etching, the lines are not always etched straight down, but are formed in steps which, if prominent, will print up and make a broad line in the resulting proof. To remove this "shoulder" to a certain extent the ink and powder are first removed from the plate after heating and flowing with lye or alcohol, using a stiff scrubbing brush. A coating of ink is then rolled over the top of the lines and powdered and heated so that while the top will be protected, the sides will remain bare. The plate is then placed in a weak solution of acid and etched for a few moments, the effect being to etch away some of the shoulder and

give a sharper line. This must be done with great care. After cleaning, the plate is ready for the finisher.

While etching, the plate should be turned so that the action of the acid may be even on all sides. If the plate becomes heated during the etching, remove it and cool with water or put some ice in the bath. Heat has a tendency to soften the ink and cause the lines to break.

The strength of acid and time of etching for each bite can not be stated arbitrarily. They depend largely upon the character of the etching, some lines not being able to stand the action as long as others, and it requires some experience to judge when the biting has proceeded far enough, the object being to allow the acid to act as far as possible without undercutting or breaking the lines. As a rule, the experienced etcher does not measure the acid, and judges by the appearance of the lines when the operation must cease. The beginner, however, may commence by using the following proportions for the solution and times for biting:

First bite — $2\frac{1}{2}$ parts acid to 32 parts water. Etch two to three minutes.

Second bite — $2\frac{1}{2}$ parts acid to 32 parts water. Etch five to six minutes.

Third bite — $3\frac{1}{2}$ parts acid to 32 parts water. Etch eight to ten minutes.

Fourth bite — 5 to 8 parts acid to 32 parts water. Etch ten to twelve minutes.

The beginner should start with subjects having strong lines, and should carefully watch the action until he has acquired such experience that he can etch without timing the bites. For regular work four bites are

usually sufficient, but some plates may be given five and others will require only three, the latter being the case when the lines are close together. In many establishments the clean bite is omitted, care being taken to powder the plate clean, so that no excess of powder will cling to the lines and form a large shoulder. For a clean, deep job the plate may have the spaces routed before the last bite.

In powdering the plate, the brushing need not be confined to only the four directions. Some etchers apply it in various ways until the lines are sufficiently protected. No powder should be allowed to remain on the open spaces, and to prevent excessive shoulder no more than enough to protect the lines should be left adhering to them. However, where an extra strong bite is to be given, it is sometimes well to powder twice around the plate. After the second or third bite the small spaces will fill with the powder, but the lines being close together, great depth is not required as in the wider spaces. Should any of the powder adhere to the open spaces, causing roughness, a knife or scraper can be used to clean them. After the finishing etch has been given, the coating should be removed from the plate by scrubbing with lye, and the plate delivered to the router. Alcohol will also remove the coating, but is more expensive than lye.



HALF-TONE.
With Line Border Cut on Plate.



VIGNETTED HALF-TONE, HIGH-LIGHT EFFECT—
100-LINE SCREEN.

From Wash Drawing by W. L. Wells.

CHAPTER X.

ETCHING—HALF-TONE WORK.

HALF-TONE etching may be done upon either zinc or copper, but the latter is now almost universally employed on account of its superior printing and wearing qualities.

The metal is prepared in the same manner as described in Chapter IX, and although the same sensitizing solution may be used, it has been practically superseded by that known as the "enamel" process, so called because it forms a hard coating on the plate and remains after the etching has been completed.

SENSITIZING SOLUTIONS.

NO. 1.

Make three solutions, as follows :

- | | |
|---------------------------------|-------------|
| A. Albumen from fresh eggs..... | 5 ounces |
| Water | 2 ounces |
| B. Le Page's Liquid Glue..... | 4 ounces |
| Water | 4 ounces |
| C. Bichromate ammonia..... | 140 grains |
| Water | 2 ounces |
| Ammonia | A few drops |

Beat the eggs up well with the water, add solutions B and C, and mix thoroughly. Filter the resulting solution several times through a glass funnel, in the

neck of which a clean piece of fine sponge or wet absorbent cotton has been placed. Be sure that all specks of dirt are removed.

NO. 2.

Water	4 ounces
Le Page's Liquid Glue	2 ounces
Bichromate ammonia.....	60 grains
Ammonia	A few drops

Dissolve the bichromate and ammonia in the water ; add to the glue, mix well and filter.

COLORING SOLUTION.

Dissolve some eosine (red shade) in warm water ; let it cool and keep in a tray for use.

COATING THE PLATE.

For the purpose of illustration we will assume that the drill stock whirler described in Chapter I is to be used. The manipulations with any other kind will, of course, be similar.

Having the copper polished and a film of water upon the surface, take it to the darkroom, drain off the water and flow the plate with some of the enamel solution, draining the surplus off at one corner ; then flow once or twice again and drain, removing any specks or bubbles with a small brush or a stick. The solution being clean, put the plate in the whirler face down, having one corner in the opening in one of the clamps and the opposite corner in the opening of the other, the clamps being so placed that the plate will be centered. Then turn the hand wheel of the drill so that the plate will be given a rapid whirling motion which will spread

the solution evenly over the surface. The gas stove under the whirler should be burning so as to warm the plate and dry the coating. The plate need not be heated excessively. Enough to dry it will be sufficient. If it is not convenient to have a stove under the whirler, the plate may be whirled cold until the solution is partially dried, and then removed from the whirler and heated to dry.

EXPOSURE.

If the coating upon examination now appears clean upon the plate, let the plate remain in the dark until cold, and then expose under a half-tone negative as directed for exposing line plates. (In placing the plate on the negative be sure that it is not moved after the two are in contact or the negative will probably be injured.) It is always well to examine the negative before printing to see whether the clear spaces in the high lights are comparatively large or small and whether the dots in the middle tints and shadows are strong or weak. Some negatives will require less exposure than others, but a little experience will enable it to be pretty accurately determined. Sometimes it will be found that the high lights are a little too much closed to give a large enough dot by the time the shadows are completely printed, and in such a case a good print may often be obtained by shading the shadow parts with a card and exposing the denser portions of the negative longer, keeping the card moving slightly to let the tints grade into each other. The same method may be used if the high-light dots happen to be normal and the shadow dots weak. The object should be to obtain a print having separate dots in the high lights strong

enough to etch deeply and give clear results, and enough detail in the shadows to give the best reproduction of the original.

DEVELOPMENT.

After the exposure has been considered sufficient, remove the plate from the negative by carefully lifting it by one edge. Then dip it in the eosine solution for a moment and hold it under water running from the tap. The image will appear of a brilliant red color, and should be washed until the details are all clear. The eosine solution is simply to color the image to render it clearly visible during development. Some etchers omit it, but its use enables the development of the details to be more readily watched. If the plate has been properly exposed, the dots and lines of the image will correspond with the clear spaces in the negative, and if the negative is one of good quality the details will be open and the high lights will be clear with dots strong enough to allow sufficient depth in etching.

If the plate has been overexposed, the dots in the high lights will be too large and probably joined together and the shadows may be filled where there should be detail. If, on the other hand, the exposure has been insufficient, the print will be weak, with dots too small, and parts of the image may wash away. In either case, the coating should be removed and the plate resensitized and printed again.

Imperfect contact between the negative and plate will sometimes cause some of the parts to fill up, and when this defect is discovered a new print should be made, using a piece of metal that is flat enough to give

perfect contact. Slightly filled portions may occasionally be cleared during development by passing a tuft of wet absorbent cotton over them, although it is generally more satisfactory to make a new print.

The film may be given additional hardness if the plate, after development and before the alcohol is applied, is dipped in a dilute solution of chromic acid and rinsed. This is not an essential operation, but is often of advantage when enamel etchings are to be made upon zinc.

BURNING IN AND "SPOTTING."

When a properly exposed print has been obtained and developed it should be flowed several times, after being taken from the tap, with grain or wood alcohol to remove the water, and then dried spontaneously, or the alcohol may be ignited and burned off.

The print must then be burned in, which is done by holding the plate by means of a pair of pincers over a strong, steady heat until the coating becomes of a dark brown or black color. Keep the plate moving to secure uniform action of the heat. Then let it cool and rub with a dilute solution of chromic acid, which will clean the copper and enable any spots to be readily detected. The plate must now be "spotted," that is, any stipple which is missing must be replaced by some substance which resists the etching fluid. Either asphalt varnish or the transfer ink may be used for this purpose. A small camel's-hair brush should be obtained, and some of the asphalt being placed upon it, the brush is drawn to a point and touched to the spots from which

the stipple is missing, and any portions of the image which it is desired shall appear solid black are also painted in. If the ink is used, the plate is powdered with dragon's-blood, which is brushed off with cotton, and the plate then heated enough to burn in the powder adhering to the spots of ink. The back is then painted with asphalt varnish, the plate is cooled and is ready to etch.

If, during the burning, the coating turns a grayish color and will not change with continued heating, the enamel is too thin and would not hold in etching. In such a case remove it and coat the plate again.

ETCHING.

For the etching fluid, prepare a strong solution of perchloride of iron, place it in a tray, immerse the plate in it and brush the face of the plate with the etching brush. The plate can now be allowed to rest in the solution, being brushed occasionally to clean the face from the sediment which results from the chemical action. The tray may be rocked, if desired, but this is not necessary and is not generally to be recommended. Examine the plate at intervals, and when the dots in the high lights appear to have had as much etching as they will stand, brush the plate and wash immediately under the tap. If upon further examination the dots appear large enough to stand more, return the plate to the solution and continue the etching. In etching, avoid excessive brushing. Use the brush only occasionally to clean the plate, unless it is desired to etch out some part especially light. To obtain a better idea of the

actual depth of the etching than can be determined by the appearance of the stipple, scratch off with a knife some of the enamel on the margin of the plate. The scratch will etch down and the depth can be felt with the finger nail. When, finally, the action has proceeded far enough, rinse the plate, clean with solution of chromic acid, rinse again, clean the asphalt from the back with turpentine, dry and prove.

The result is what is technically termed a "flat etching." To bring the high lights up more clearly and to add brilliancy to the print it is usually necessary to "reëch" the plate.

RE-ETCHING AND VIGNETTING.

After the plate has been proved to determine what results it would give in its present condition, the printer's ink should be removed by washing thoroughly with benzole. The portions in the shadows and middle tints that are considered sufficiently etched may then be painted in with asphalt varnish and the plate returned to the etching solution for further treatment. After this second etching has proceeded sufficiently, the plate is proved again, other portions are painted in, and the plate is again etched, these operations being continued until the desired results are obtained. Care should be observed to paint in and etch in such a manner as to avoid the formation of lines where one tint should grade into the next. Reëtching is often done in the second and following stages and often altogether by omitting the painting and applying the etching solution locally to the parts to be reduced. The operator fills a

camel's-hair brush with the etching fluid, holding in his left hand a wad of wet absorbent cotton. He applies the brush to the parts that need lightening and as the action proceeds he removes the fluid from the plate with the cotton, examining the dots with a magnifying glass and repeating the operations until the dots are small enough.

Vignettes, which are wavy or irregular edges, may be etched around the image in the following manner: After the plate has been etched to a printing depth the center is painted in solid with the asphalt, the edge of the paint being allowed to make a line marking what is to be the inner edge of the vignette, the portions beyond this being left unprotected. A short etch is then given to the plate, which is then washed, dried and painted again, the asphalt being carried this time beyond the edge of the first painting. These operations can be carried on until several tints are etched around the border.

The next operation is to paint in to the edge of the vignettted image and etch away all the stipple outside, the paint being then removed from the face of the plate with turpentine and the border deepened with the router or hand tool. If the edges of the tints are too sharply defined, local applications may be made to blend them together.

When it is desired to have certain portions of an etching free from stipple so as to show pure white in the printing, the plate is painted in, leaving these portions unprotected, and it is etched until the stipple in these parts break away, further deepening, if necessary, being done with a tool.



HALF-TONE.

Made from Photograph and Finished in Outline, with Vignetted Base





HALF-TONE.

**Embossed Design on Card Mount Utilized as Ornamentation for the
Photograph.**

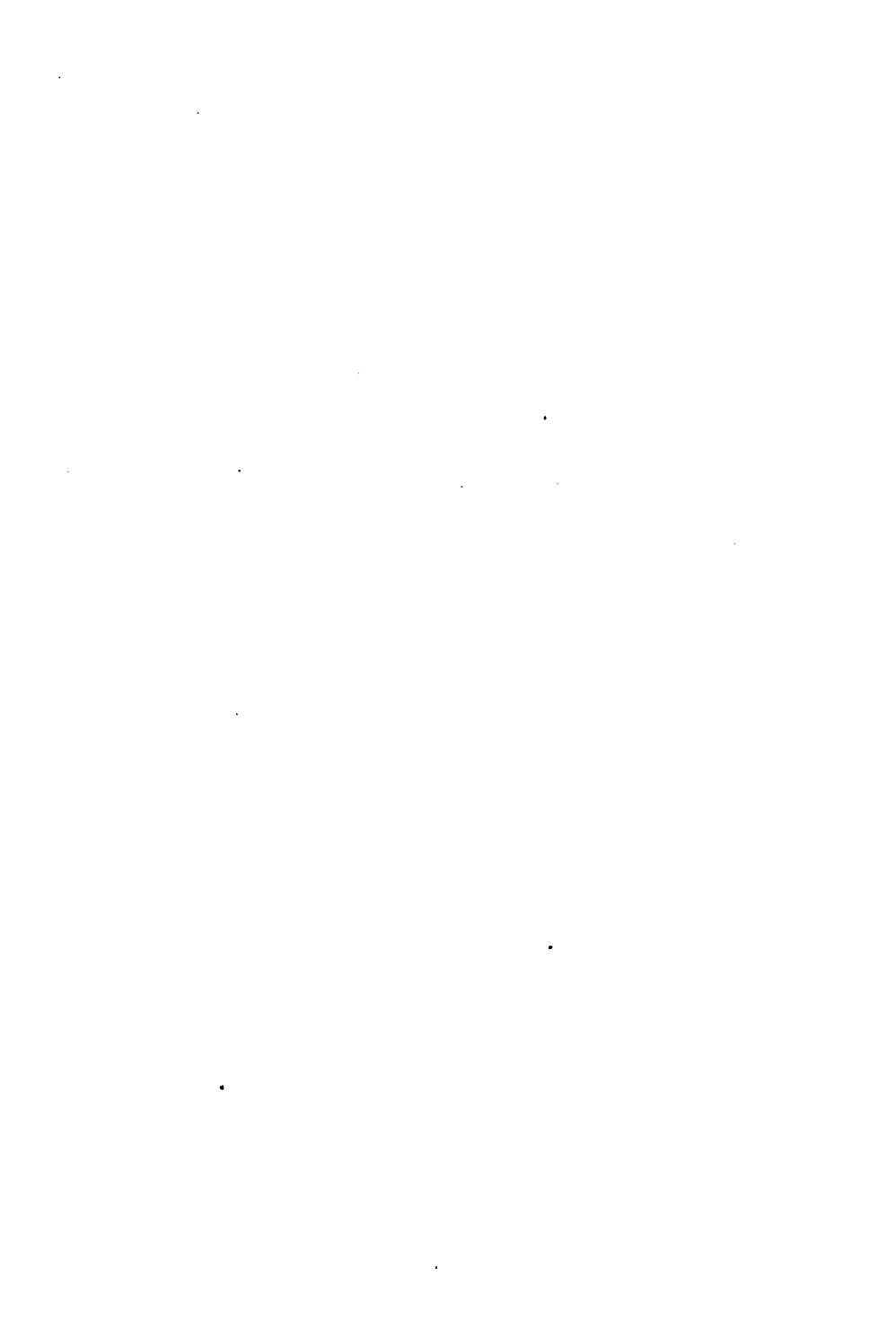

BURNISHING.

After the plate has been finally etched, it is sometimes desirable to have certain parts appear darker, and such portions are rubbed with a tool known as a burnisher, the depth of tone depending upon the extent to which this action is carried.

CHAPTER XI.

FINISHING AND MOUNTING PLATES.

AFTER the etching of the line plate is finished, it is tacked to a board and placed in the routing machine, and all the larger open spaces deepened with the routing tool. If several negatives have been printed on one sheet of zinc, each image is cut out, a thin border of zinc being left around it. The cut is then fastened to a block by tacks driven through the routed spaces and around the edge, and the block is planed type-high. Any burr remaining on the lines is then removed with a hand tool, and the plate is ready for proving.

In mounting a half-tone cut, a beveled edge may be formed around the cut with the routing or beveling machines, and the plate fastened to the block by tacks driven through this edge. Another method is to mount the plate from the back as follows: Saw the margin of metal from around the image, leaving enough for a black line (if the line is wanted), and bevel the edge with a file, removing the burr from both sides. Clean the back of the plate and scrape the surface bright in several places, leaving several deep scratches in the places thus brightened, then upon each place drop some hydrochloric acid, and lay a thin piece of solder upon it. Upon the solder set a small screw, and, holding it in

position with a piece of wire or any convenient tool, direct the flame of a blowpipe upon the solder until it melts and forms around the head of the screw. The solder should not be too large or it will form too large a mass when melted. Having thus soldered screws to the several points, which should be evenly distributed over the plate, set the plate with the screws down, upon the wood block, length of the plate with the grain of the wood, lay another block upon the face of the plate and strike it with the hammer, so that the screw will leave marks upon the face of the first block. Then, with a one-fourth inch drill, drill holes through the block at these points, after which insert a countersink drill in the chuck and with it drill from each side of the block into the holes made by the one-fourth drill, letting the countersink go below the surface of the block on each side. Sandpaper the face of the block and place the plate on it so that the screws will sink into the corresponding holes, allowing the plate to rest upon the surface of the block. Then, protecting the face of the plate with another block, clamp it tight and with a small ladle pour melted type metal into the holes on the opposite side, not allowing it to come to the surface of the block. When it is cool, the plate will be firmly fastened to the block.

Saw the block around the metal, leaving a small margin of wood, and then it is ready to trim. Place the block on the trimmer, having the gauge set so that the knives will just catch one edge, and pass the table back and forth, giving the gauge screw a slight turn each time until the wood is trimmed up to the metal.

If the plate is so placed that the wood will not trim parallel to the edge of the plate, place a piece of folded paper between the block and gauge to cause the part at which the wood is thickest to be moved farther toward the knives. Trim each edge, running the block through slowly when making the last cuts, and then make it type-high in the planer. If the type metal should be found to come to the surface of the block, it should be routed down. In mounting line and half-tone cuts together, if the plates are not of the same thickness, the thinner ones must be underlaid to bring their surfaces to the level of the thickest plate. Cherry wood is usually used for blocking plates, metal blocks being used for those from which stereotypes are to be made, such as line plates for newspaper work.

The first proofs from half-tone plates will often show black spots. In such a case the plate is given to the engraver, who tools them out. The half-tone may often be improved also by having certain parts burnished to make those parts in the proof appear darker. For fine magazine work it has become customary to use the tool very extensively upon half-tone plates, many of them being given the appearance of fine wood engravings. The tool is also often used to vignette the plates and to clear away the stipple in places where it is desired to have clear whites in the proof.

CHAPTER XII.

DRAWINGS — LITHOGRAVURE.

LINE DRAWINGS.

IN making line drawings for reproduction, the lines should be made with india ink and should be perfectly black. They should also be heavy enough to stand the necessary reduction and still be sufficiently strong to etch without breaking. The best results are obtained in the cut when the drawing is made larger than the reduction is to be, and it is customary to draw the original two or three times the size of the finished plate.

It is often necessary to translate a photograph or wash drawing into a line drawing or to make changes in a piece of linework. In such cases, it is a saving of time to draw over a silver print and then bleach out the photographic image, leaving the black lines upon a white ground.

The method is as follows: Obtain some plain salted paper and sensitize it by brushing the surface with a tuft of absorbent cotton wet with a solution of silver nitrate. Dry in the dark and expose under an ordinary negative made from the copy to be reproduced until the image shows a dark red or purple. Wash, then place in a dilute solution of acetic acid for several

minutes until the image is fixed. Wash again, then dry and make the drawing over it with Higgins' waterproof ink. When this is dry, flow over the print a saturated solution of mercuric chloride in alcohol. The red image will be removed, leaving the drawing, after which the paper should be rinsed and dried, being then ready for the photographer. Those who prefer to "salt" the paper also will find a formula in the appendix.

Instead of the "printing-out paper" described above, bromide paper may be used, the bleaching being done by means of the iodine and hyposulphite of soda solutions.

When it is desired to make tracings of a drawing or any portion of it, the back can be rubbed with a pigment (such as a blue pencil) and then laid back down on another sheet of paper or a card and the lines traced over to transfer them. The work is then finished by drawing the black ink over the lines thus obtained.

Guide lines, notations, etc., that are not to appear in the cut should be made in blue, as they need not be erased, the ordinary plate, as stated in a previous chapter, not being acted upon by this color.

In making symmetrical designs (that is, drawings of which one half is duplicated in form in the other), it is necessary to draw only one half. Two negatives can be made and joined to form the complete plate. To judge how the result will appear in the finished condition, place a piece of mirror glass along the edge of the drawing and the reflection combined with the lines of the drawing will show the results.

The card stock known as "scratch-board" is generally preferred for drawings, as it has a smooth sur-

face, takes ink readily and permits alterations to be made without materially changing the character of the surface.

DRAWINGS FOR HALF-TONE.

Drawings for half-tone reproduction are technically known as "wash drawings," from the method of producing them with the brush and india ink or other pigment in solution. The "air brush," with which air is used to blow a fine spray of the pigment upon the surface of the drawing is used to a great extent on certain classes of work, such as making vignettted backgrounds and softening tones.

Photographs can usually be much improved for reproduction by having certain portions painted over by the artist, the colors and strength of the pigments being determined by the results required. Combinations of photographs and "wash" work are also commonly used for various illustrative purposes. Photographic figures can be combined with backgrounds made with the brush, and fashion drawings are frequently made with faces taken from photographs and the bodies drawn in.

TINT-BLOCKS.

"Tint-blocks" are plates from which colors are printed, and each is usually only a part of the image, the entire reproduction being formed of a combination of printings from such plates. Usually a "key plate," which is a complete etching from the original drawing, is printed in black over the colors. These "tint blocks" are obtained by making as many separate prints, with transfer ink and dragon's-blood upon zinc, as there



A PHOTOLITHOGRAPHURE PLATE.



HALF-TONE.

From Wash Drawing by N. J. Quirk.



Courtesy Gatchel & Manning, Philadelphia, Pa.

HALF-TONE—OUTLINED AND HAND-TOOLED.

are to be color-plates. The artist scrapes out the portions of the image on each plate that are not to appear in the color to be printed from that block and paints in solids where required. The plates are then etched, routed and mounted. Tints can also be inserted with the Ben Day machine described below. This method of making color-blocks direct on the zinc insures more perfect register than can be obtained by making separate drawings for the different colors. The term "register" is used to define the relative position of the colors when the plates are printed. Perfect register means that each tint falls exactly in the place intended for it.

LITHOGRAVURE.

By the term lithogravure is meant the production of plates containing tints of lines or dots, or both, the effect being similar to that obtained by lithographic processes.

These tints are usually inserted upon drawings by means of the Ben Day machine.

The apparatus consists of a film of gelatin composition mounted in a frame, the form of the tints being so placed in relief upon it that when rolled up with ink they can be readily transferred to the copy by placing the film above it and pressing upon it with a burnisher or other convenient instrument. Similar results, however, may be obtained by the following method:

The necessary apparatus is simply several plates ruled to form tints of lines or dots, some examples of which are shown on the following page.

These rulings are made upon plates of stereo-metal mounted on blocks of wood to be type-high.

The outlines of the drawing are made and then a sheet of tissue-paper is stretched tightly over it and pasted at three of the edges, after which the outline of the tint first to be inserted is drawn on the tissue in pencil. After this is done, a card is slipped under the tissue and the tissue cut out with a sharp knife on the lines just drawn, the card being then removed, leaving the space on the drawing bare where the tint is to be

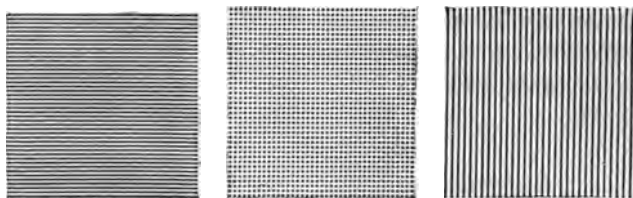

placed. The drawing is then placed on the bed of a hand press, the tint-block being rolled up with ink and placed face down upon it. The pressure being brought to bear, leaves the dots on the face of the drawing in the open space, the other parts of the drawing being protected by the tissue. This sheet of tissue being removed, another one is put on, the outlines for another tint drawn and cut out, the tint-block being rolled up and the impression being taken as before, leaving another tint on the drawing, and so on for the remaining tints.

To get the cross-line tints, two impressions are taken from a single-lined plate, the position of the plate for the second impression being at the angle desired to the first position. In making a shade line around letters, where it is desired to have a white space between

the letter and the shading, the tint may be allowed to run up to the letter when the impression is made, the white space being scraped out afterward. When letters which are to appear white are to be protected while the impression is being made, tissue cut out to fit the letters are pasted on them at two or three points, the tissue and paste being afterward removed. When the tints are all inserted in the drawings, the reproduction is made in the camera as usual. This process gives results similar to those obtained in lithographing, and very handsome effects can be obtained by running the tints in colors.

Hand-stippling is also often used to give characteristic effects upon drawings.

CHAPTER XIII.

DEVELOPMENT OF GELATIN DRY PLATES.

IN Chapter III it has been observed that the development of emulsion plates depends upon the action of a solution that will decompose the molecules of silver compound that have been acted upon by the light, the subsequent action being to attract from the neighboring particles of unaltered salt more silver to add to the intensity of the image thus formed. In practical work we not only apply the solution to reduce the silver from its compound, but we mix with it other solutions to modify its action.

There are a number of compounds suitable for developing emulsion plates, but as an example we will take pyrogallol (commonly known as pyrogallic acid). To the solution of pyro, as it is called for abbreviation, we add one of an alkali, as sal soda, one of sulphite of sodium, and often a small quantity of bromide of potassium. The sal soda softens the film on the plate, allowing the developer to readily penetrate it. The sulphite helps to keep the pyro from absorbing oxygen from the air and thus deteriorating, and also to a considerable extent governs the color of the negative, a matter of considerable importance. The bromide is used to restrain the action of the pyro sufficiently to prevent too

rapid action and consequent "flatness" or fog in case of overexposure or possible excess of the alkali. It thus tends to give clearness and contrast. With rightly timed exposures and a properly proportioned developer it is not a necessary constituent, although a few drops is usually added to the solution.

In using the developer, therefore, the following facts should be kept in view:

The alkali tends to give detail and if used in excess will produce a negative that is too much lacking in contrast or perhaps "fogged." If the negative has been underexposed a little excess of alkali helps to bring out necessary detail.

Excess of sulphite gives the negative a bluish-black color which tends to give "flat" prints. The quantity should be adjusted to produce a color which may be described as an olive-black.

Excess of bromide restrains the formation of detail and tends to give "hard" negatives.

Excess of pyro also has an action to give negatives with contrast and lack of detail.

It is evident that we may mix the developer in proportions to promote detail or contrast. There are, however, certain proportions of the constituents entering into the composition which may make what we may term a normal developer, that is, a developer which when applied to a properly exposed plate will bring out the gradations and intensity in proper order, producing a negative of the best technical quality.

The time of exposure, of course, is a matter of no less importance than the development of the negative, for while with skilful manipulation good results may be

obtained from the plate slightly under or over exposed, it is only with correct exposure that the best effects are produced.

The exposure time of the gelatin plate is much shorter than for the collodion, varying from a small fraction of a second to several seconds (or perhaps under special conditions to an extended time).

A correct exposure properly developed will yield a negative having gradations to render the details in the subject, but will preserve the contrasts sufficiently to avoid flatness in the resulting print.

Overexposure* tends to produce negatives full of detail, yielding prints without brilliancy.

Underexposure tends to produce negatives with strong contrasts, lacking in detail, the resulting print being "hard."

PYRO DEVELOPER.

Prepare stock solutions as follows :

- A. Sodium sulphite, 40 by actino-hydrometer.
- B. Sal soda, 20 by actino-hydrometer.
- C. Mix A and B in equal quantities.
- D. Bromide of potassium, 1 part to 9 or 10 parts water.

For convenience these solutions may be made up in quantities, but the sulphite solution should be kept as well as possible from the action of the atmosphere. Yellow, foggy negatives are often caused by using sulphite solution which has become changed by absorption of oxygen.

To prepare the solution for practical use, a certain

*The terms overexposure and underexposure should be considered as comparative. While under most conditions what we may define as normal exposure and development give the best results, there are some cases where it may be desirable to vary from it to produce a special effect.

amount of solution C is mixed with water, and for *each ounce* of the resulting solution two grains of dry pyro are added, and, if necessary, a few drops of D. (In practice it is more convenient to measure the pyro than to weigh it every time. A mustard spoon that will contain a certain quantity may be used as a measure, and enough spoonfuls added to make approximately the amount required.)

Just what proportion of C that is best to use depends upon the temperature of the atmosphere and the brand of plate. In warm weather $2\frac{1}{2}$ or 3 parts of C will usually be sufficient for a total of 16 ounces of the developer. In cold weather a greater amount of C may be taken. A few trials will determine the proper proportions to use in general, according to the way the negatives appear.

FIXING SOLUTION.

Plates may be fixed by immersion in a plain solution of hyposulphite of soda (about one part of the salt to four parts of water), but this plain bath soon deteriorates and the acid solution is best for fixing a number of plates and for continuous use. The following is a good formula :

FIXING BATH.

Water	64 ounces
Hyposulphite soda.....	12 ounces
Sulphite soda.....	1 ounce
Powdered alum.....	$1\frac{1}{2}$ ounces
Acetic acid.....	$1\frac{1}{2}$ ounces

Renew the solution when it becomes weak or shows any tendency to discolor the negatives.

DEVELOPMENT.

In the development of the plate, the points to be considered are: First, the time in which the image appears; second, the contrasts; third, the detail; fourth, the intensity. An intelligent judgment of these will enable the operator to determine whether the exposure has been of the proper duration, and to conduct the development accordingly.

Place the plates in a clean tray, which should be kept for this purpose alone, and flow the developer over them in an even wave, using enough to cover the plates. Then rock the tray to cause the developer to flow from side to side. If the exposure has been properly timed the high lights of the image will appear first, then the gradations in the middle tones, those corresponding to the lighter shades first, being followed by the darker shades, then the details in the shadows. When all the gradations have thus appeared in proper order, the development is continued until the proper intensity is reached, which is determined by the appearance of the plate when held up to the red light. Only experience will enable the intensity to be properly judged.

If the exposure time has been too short, the image will be late in appearing as compared to the normal, and the details in the half-tones and shadows will hang back, and if the development is carried on as for proper exposures the high lights will gain the desired intensity before the details will come out, thus producing a negative devoid of detail. In such a case simply place the plate in a tray containing developer diluted with water. The development will then take place slowly, the details having time to appear before the high lights assume any



HALF-TONE—VIGNETTED.
From Wash Drawing by George Spiel.





HALF-TONE FROM A HALF-TONE.
Original Cut Made from a Colored Japanese Print.

great intensity. When the details have properly appeared, the plate can be returned to the normal developer until the proper intensity is obtained. The underexposed negative may often better be placed for a time in a tray of water until the details appear, and then returned to the developer to bring out the intensity.

Some operators place undertimed plates in a developer to which an excess of alkali has been added, but such forcing of detail will seldom yield a good negative, and there is great liability to fog.

If there is any detail which can be brought out the method given above will do it. A badly undertimed plate will, of course, never produce a good negative.

If the plate has been overexposed, the image rapidly appears, the details coming up with the high lights, and the negative will be "flat." In such a case it should be placed at once in a tray containing normal developer to which there has been added more of the bromide solution. The restrainer will cause the reduction in the portions least affected by the light to be retarded, while the high lights will gain in intensity, thus producing contrasts.

When a number of plates are developed in succession the developer will deteriorate, and should be replaced by fresh as occasion may require.

During development, the plate should be examined from time to time by holding it between the eye and the red light, and when the proper intensity has been obtained it should be rinsed for a moment under the tap and placed in the fixing bath, in which it should remain for ten or fifteen minutes after the white color has left the film.

In developing orthochromatic plates they should be exposed as little as possible to the red light, particularly at the beginning of operations.

After fixing, the plates should be washed in running water for an hour or two to remove the hypo from the film.

When taken from the water the hand may be passed over the face of the negative to remove any sediment from the water, the plate being then placed in the rack to dry.

INTENSIFICATION.

If the negative is found to be too thin to give satisfactory prints, it should be intensified. This operation requires great care to avoid streaks and stains. It is best to have a glass tray to hold the solution, and this tray should be kept clean and for this purpose alone.

There are many formulæ for intensifying solutions, but the mercury method is very generally used.

NO I.

Mercuric chloride.....	1¼ ounce
Water	20 ounces

Have the negative thoroughly fixed and all hypo washed out of the film and bleach it in the above solution. Then wash well again in running water and blacken to the desired degree in a solution of

Sodium sulphite	1½ ounce
Water	15 ounces

Wash again in running water for half or three-quarters of an hour.

NO. 2.

Dissolve $2\frac{1}{2}$ ounces of iodide of potassium in 12 ounces of water and pour into it gradually a saturated solution of bichloride of mercury. A red precipitate of mercuric iodide will be formed. The mercury solution must be added until this precipitate can not be dissolved by shaking. Avoid adding any more mercury, however, than will make the solution very slightly turbid. Then add $2\frac{1}{2}$ ounces hyposulphite of soda, and when dissolved add water to make up to 40 ounces.

For use, take one part of the above solution to three parts of water and immerse the negative after fixing and washing until sufficient density is obtained. If the hypo has not been thoroughly washed from the film the intensifier will cause stains. If over-intensified, the density may be reduced by leaving the negative in the fixing bath for a short time.

With the mercury intensifiers it is best to use distilled or rain water if obtainable. Hard water is liable to cause markings in the negative.

URANIUM INTENSIFIER.

A. Nitrate uranium	30 grains
Water	8 ounces
B. Ferricyanide potass.....	30 grains
Water	8 ounces

For use mix 6 ounces of A with 6 ounces of B and add 2 ounces glacial acetic acid.

Have the plate thoroughly washed and flow the solution over it and keep the tray in motion until the required density is reached. Then wash for fifteen or

twenty minutes. Prolonged washing reduces the intensity and if the intensification has been carried too far, the remedy is obvious.

REDUCTION.

Negatives which are too dense may be reduced by a dilute solution of hyposulphite of soda to which a little of a solution of ferricyanide of potassium has been added.

The solutions may be made up in the proportion of $\frac{1}{2}$ ounce of salt to 8 ounces of water. Add a little of the potassium solution to the hypo solution and immerse the negative until sufficiently reduced. Finally wash well.

CAUSES OF DEFECTS IN GELATIN NEGATIVES.

Fog.—White light entering darkroom or camera, overexposure, excess of alkali in developer, hypo or other chemicals in developer, developer too warm.

Negative too thin.—If the shadows lack detail, underdevelopment; if the shadows have detail, weak developer, or exposure too great.

Intensity too great.—Overdevelopment, reagent in excess in developer, or warm developer.

Abnormal contrasts.—Underexposure or developer too strong.

Frilling.—Solutions too warm, insufficient alum in fixing bath or prolonged washing.

Flatness.—Overexposure or too much alkali in developer.

Spots.—Dust or bubbles in developer.

Stains.— Developer oxidized, impure chemicals or not enough sulphite in developer, deteriorated fixing solution or insufficient fixing.

Streaks.— Developer allowed to flow unevenly over plate when first applied, or fixing bath acid.

Crystals on negative.— Hypo not all removed from film.

CHAPTER XIV.

PRINTING HALF-TONE PLATES.

PHOTO-MECHANICAL engraved printing-plates have largely revolutionized pressroom theories, and owing to the shallowness of the engraving and to the greater necessity of dependence on the qualities of paper and ink, the judgment and skill of the pressman is more than ever before required to give life and brilliancy to cutwork. Unevenness in half-tone plates is a source of much annoyance to the pressman. All plates should be made perfectly level before etching and the greatest uniformity should be observed in the grinding and polishing.

The following instructions for preparing half-tone plates for printing obtains in one of the large establishments of America noted for the quality of the half-tone work produced. Obtain all the cuts on a certain piece of work from the composing-room before they are made up in the forms, and of each cut have proofs taken on three different weights of paper — 24 by 36, 60, 70 and 80 pounds — and then proceed to make cut underlays. Taking one of the proofs on the 70-pound stock, carefully trim it all around, leaving a margin of one-sixteenth of an inch of blank all around the print. Then cut out of the sheet all of the extreme high lights, being careful to cut a little of the surrounding shadows

with them, the purpose of this being to prevent too much impression on the point of division, which would have a tendency to bring up the shallows. Then take a proof on the 80-pound stock and remove from it the extreme blacks and solids — always cutting a little inside the line — and paste them on the 70-pound sheet already treated, using common flour paste or mucilage. Then take one of the proofs on 60-pound stock and cut out all of the intermediate shades such as should appear lighter or softer in the finished print. Take these several proofs and paste them together, and this would be called a four-ply cut overlay, excepting that all of the pieces comprising it are cut a trifle inside of the line. If the cut has more shade in it than can be properly treated with three sheets, take a 50-pound paper in place of the 60-pound and add one sheet to the underlay, treating it in the same way as the second sheet, with the exception that instead of cutting out the extreme solids remove all the semi-dark shades as well and paste them on. Having made the underlays in the manner described, proceed to unmount the cuts from their bases. In order to do this without injuring or scratching them, great care is required. The tools which will be found to be the most advantageous are a small hammer, a pair of pliers, and a small chisel — this last should be about a quarter of an inch in diameter at the shank and should have a long, tapering blade, and be about half an inch wide at the extremity of the blade. Some small wire brads, such as are commonly used for mounting the plates, a prick punch, a small nail set, an electrotyper's iron finishing plate, and a pair of plate calipers such as are used by electro-

typers, are the other requisites. Having removed the plate from the block, take the calipers and mark at least two distinct points on the back of the plate in order to be able to paste the underlay accurately in position. This done, lay the cut face up on the iron plate and with a small boxwood planer go over the entire surface, taking care to strike only a moderate blow. Take the block thereafter and examine it carefully to see that it is free from lumps and rough places and mount the cut on the opposite side to that from which it was taken and send it to the composing-room.

This method saves a great deal of time in the final make-ready of the form, as it is only necessary to even up the impression on the cut, and the underlay will throw the lights and shades where they should be without any further care on the part of the pressman, and for long runs will preserve the cut much better than if a plan of overlaying was followed. It holds up to the rollers the dark parts of the cut, properly supplying them with ink and protecting the lighter and more delicate shades from receiving unnecessary pressure.

The practice of many pressmen who obtain good results is to even up the cut by underlays, and then proceed to make such overlays as the character of the work will indicate to be the most suitable. To be successful in making any kind of an overlay, as little paste as possible should be used, only sufficient to compactly bind together the different portions of the overlay, and to register each piece of paper over the other with positive accuracy. For work of differing character the papers used in overlays vary. Impressions of the cuts are taken, for instance, on three grades of stock: One



HALF-TONE WITH RAGGED-EDGE EFFECT.
From Wash Drawing by F. D. Schook.





Courtesy Barnes-Crosby Co., Chicago.

HALF-TONE.

Hand-tooled Coat — Machined-ruled Background — Heavy Border.



sheet, say, of 10-pound folio, one of double that thickness of supercalendered, and one sheet of the stock upon which the cut is to be printed. Sometimes the last sheet mentioned is selected for the first treatment, which consists in cutting away from it any large, light backgrounds, and scraping down and slitting off many of the light and medium tones, so as to throw up the stronger ones and the solids. A sharp knife and some degree of skill is necessary to handle a sheet of paper in this way, but it is worth one's while to acquire it, for it saves time and much pasting on of parts of overlays, besides giving a firmer basis.

The sheet of supercalendered stock may now be taken, and from it should be cut all the light tints as well as some of the stronger ones. The sheet is also used as the foundation on which to paste the cut-out portions of the two other sheets.

The third sheet of thin folio should be used to make overlays for such portions of strong solids and shades as require them. These should be pasted accurately in place on the supercalendered sheet, and over them should be fastened the first sheet treated. From this arrangement it will be apparent that the first sheet, the folio and the supercalendered sheets press on the form in the order named, and in their relative degree of pressures.

VIGNETTED HALF-TONES AND PHANTOM EDGES.

To obtain the best results in printing half-tones the edges of which are designed to fade into the white or color of the stock without showing the line of demarka-

tion, it is necessary that the cut shall be lower than type-high. The cuts must be made absolutely true and level; any inequality permitting them to rock will be fatal to good work. If the cuts are too high or type-high, the most convenient means of lowering them is to sandpaper the backs until they are reduced slightly below type-high. The make-ready, overlay, etc., do not vary from that given in the preceding pages.

WHY PLATES FILL UP WITH PICKS.

This comes from several causes, usually unsuitable rollers or rollers not set light enough to properly roll the delicate plate surfaces and rollers not cast true in the stocks. Inks that are too stiff or too thin, or not sufficiently ground, or ground in inferior oil or varnish, will also cause this trouble. Washing the plates with either woolen or cotton rags forces into the sharp openings of the half-tone the flock from the rags, and this also causes "picks." Half-tone work should be washed with a good brush of medium fineness, and a clean cotton rag should be used to lightly sponge up the washing fluid — be it benzine, astral oil or turpentine. In no case should rags alone be used to clean these plates, nor should anything be carelessly, harshly or hurriedly rubbed over their surfaces.

Defective coating on enameled paper, or what is known as surfaced wood-cut paper, will produce picks and fill-ups on half-tone plates; and in such cases an ink with a very slight tack should be used to get fair working results; but the form should be washed off oftener than when better stock is running. After making ready, and between long stops, half-tone plates

should be thoroughly cleaned off, as by so doing clearer and more satisfactory work can be turned out.

COLORS FOR HALF-TONE PRINTING.*

In every child's storehouse are treasured many bits of color. This love of color, inborn, may always be made of strong appeal. The profusion of illustration constitutes one of the greatest influences in every grade of publication — commercial, scientific and literary. The form and detail being fixed by the subjects concerned, it remains only to print them in such quality and strength of color as shall be best. Since the greater portion of printing is confined to one color, this article is limited to printing in monotoes.

Fitness to the subjects themselves controls the choice of some colors. Figures, particularly nudes, require warm tones. It is not customary, however, to be restricted to such monotoes as approach flesh tints. Browns, deep reds and rich olives are all good. Marines are the most limited in range of color, greens and blues being generally used. Landscapes allow more license in color, all of the autumnal tints being possibilities.

Next to the subjects, the purposes and uses of the print must be regarded. For permanent value, simplicity of effect is of more importance than any striking contrasts which will, in time, prove a detraction. The plain catalogue page is made attractive by some monotone which is at once decorative and an approach

*From an article by Mr. Henry Lewis Johnson in *The Inland Printer* the above suggestive notes on colors for half-tone printing are taken by special permission.

to the true color of the subject. Commercial printing, such as catalogues and placards, admits of stronger colors than are used in bound volumes, purely illustrative. The practical value of a catalogue illustration often requires that all of the details be clearly shown, and dark colors are necessary for this. In art catalogues the reverse is found; everything is sacrificed to effect.

Black always shows the full strength and brilliancy of an engraving. Colors which approach black in density possess most brilliancy and detail. Browns, although good, are open to some prejudice, since for many years they have been used on every fine program, catalogue and specimen print. An order for a "fancy job" has been synonymous with brown ink. This color has one practical advantage. Where the same plates are used year after year in catalogues they become necessarily somewhat worn and battered. These defects are largely obscured by this neutral color.

Blues are not much used in half-tone printing. In their use all of the lights, which give contrast and brilliancy to a picture, are lost. It is naturally a color seldom used for landscapes. The slow drying qualities of the ink are an objection to its use on programs or any work which has to be bound soon after printing. Blue-black, of the darkest shades, is being largely used, giving marked brilliancy to the print.

Reds, in the richer carmine shades, are effective but somewhat costly. They are difficult colors to handle well, requiring very exact gradations to avoid being crude. Yellow has some important uses. Deep corn

yellow is preferable to the canary shade. Greens are good and are in favor at present. Particularly rich effects are obtained in deep shades of olive, yielding strength and warmth. Such prints closely approach photogravures in effect, having strength yet obscuring the half-tone lines. Instead of primary browns, blues and greens, each one is better for ordinary purposes as it approaches black.

For the printer there is a practical, and indeed, economical side to the use of colored inks. By using the engraver's proof in black in making ready, the print may be brought up to its proper condition. The element of "rush" usually enters in at this stage. Justice can not be done to the cuts in black in long, hurried runs, as it is difficult to maintain the color. A slight variation in the brilliancy of the print in an olive or brown does not constitute the defect which it would in black. In place of strained effects in descriptive lines and text the monotone is the desired decoration.

The use of monotonies is an interesting and a critical part of the work. For the simplest print the requirements of color are exacting, and, successfully handled, constitute a step in advance in the art of printing.

The
Half-tone and Trichromatic Process
Theories.

By FREDERIC E. IVES.



HALF-TONE — WITH WOOD-ENGRAVED EFFECT.
Made from Photogravure Print.







HALF-TONE.

From Wash Drawing by A. R. Windust.

U
P
P
P
P
P
P
P
P
P



HALF-TONE PROCESS THEORY.

THE idea of breaking a photograph up into lines by interposing a line-screen when printing it, as a means of converting it into a half-tone engraving, is very old in photographic history. To people who thought that such a breaking up of the photographic image was all that was required to make it like an engraving, the use of a screen was obvious. It naturally occurred to a great many, at different times, but in as many instances nothing of practical value resulted, for the simple reason that the problem is not to add lines to a photographic image, but to translate the body shading of a photograph into line shading, which is a very different proposition.

Therefore it was natural that the first true solution of the problem should not be by the application of a screen, but mechanically, by the regular application of an engraver's V-shaped tool, in a planing machine, to the irregular surface of a cast from a photo-gelatin or "Woodbury" relief plate. The depth of cut, varying with the height of the relief, resulted in the production of lines graduated in size like those of a wood engraving, but which, when inked, reproduced the shading of the photograph with a degree of precision which the most skilful hand engraving could not rival. The first commercially successful half-tone engraving process, which was introduced in 1881, was a practical modifica-

tion of this procedure, involving precisely the same fundamental conception. It consisted in pressing a fully inked surface of V-shaped elastic lines against a plaster cast of a photo-gelatin relief, thus producing by a single rectilinear movement a result similar to that obtained in the planing machine by many passages of the tool; and this photo-mechanical graduated line-print on plaster was used like a pen drawing as copy for a photoengraved printing-plate.

The more direct and now practically universal process by means of a cross-line sealed screen used in front of the sensitive plate in the camera, is merely a more or less perfect optical equivalent for the mechanical process, grew out of it, and is successful in proportion as it constitutes a successful application of the same fundamental principle.

In the mechanical process, the impact of the V-shaped elastic line, varying with the height of the relief, graduated the surface width of the lines.

In the optical process, when employing a single-line screen, with an air space between it and the sensitive plate, the wedge of rays reaching the plate through each clear line of the screen, is (or may be) so distributed laterally as to constitute an *optical V-line*, which corresponds to the mechanical V-line, and the impact of the dioptric image formed by the camera lens, varying according to its light and shade, corresponds to the photo-gelatin relief, and similarly varies the width of developable line by varying the depth of photographic penetration of the optical V.

All this involves a conception of the function of the process screen which should make it evident that rela-

tive width of clear spaces, distance of screen from sensitive plate, and form and diameter of lens aperture, are all working factors, and that their relations should be adjusted with the same care and precision as the mechanical relation of a V-tool to the surface of a photo-gelatin relief.

Even the mechanical process, however, was not quite so simple as the foregoing statement would make it appear, because it was necessary to provide means for producing cross-line effects, with white dots in the shadows, and black dots or points in the lights. It is not necessary to detail the means by which this was effected; suffice it to say that it is effected in the screen process by employing a black cross-line screen in place of a single-line screen, and that the character of this screen enables us to consider the matter from a new and simpler point of view, not losing sight of the fact that it does not negative anything that has been said about the essential relation of the optical to the mechanical process.

Each aperture of the cross-line screen may be regarded as a pinhole, forming upon the surface of the sensitive plate a pinhole image of the diaphragm aperture of the camera lens, the image round if the diaphragm aperture is round, but graduated in illumination from a bright point in the middle down to a dimly illuminated edge, so that it is equivalent to a V-cone stipple instead of a V-line, and the depth of its photographic impact, and consequent ultimate surface extension, is controlled by the relative intensity of that part of the dioptric image which illuminates it. Thus we secure a translation of body shades into dots which at their smallest (in

the negative) represent the deeper shades of the photograph, but growing larger in the lighter parts of the image, finally overlap and leave small transparent dots to represent the high lights, as is required for the production of the best printing-plates.

On a sufficiently large scale, i. e., with sufficiently coarse screens, all this works out as a simple problem in optics, the understanding of which will provide the operator with means to perfectly control the operation of the process, to produce every possible effect, by change of screen distance and size and shape of diaphragm aperture. With finer screens, diffraction introduces a disturbing element, which may be made either helpful or embarrassing, so far as regards the graduation and sharpness of line or dot, according as the adjustment of screen distance is favorable or otherwise; but always necessarily at the expense of microscopically sharp definition of outline, because every ray that is diffracted is bent away from its true defining path. If this were sufficient to very seriously affect the results, means would be found for entirely eliminating this factor; but commercial exigencies demand that we shall be content with the very simplest possible "good enough" process, and from that point of view nothing more can now be offered.

TRICHROMATIC PROCESS THEORY.

A TRUE theory is a logical scheme founded on inferences drawn from established principles. A false theory may be a logical scheme based upon false premises, or an illogical scheme based upon true premises. Even a false theory may lead to valuable results ; but it seldom leads to more than partial success, and oftener to failure and discouragement. A true theory will indicate correct practice and insure ultimate success.

The theory that red, yellow and blue are the primary colors of light will not serve as a basis for the most successful trichromatic process photography, because it is a false theory. If it were true, a mixture of yellow and blue spectrum rays would make a bright, pure green ; but they do not — the mixture appears almost white to the eye. A single proved fact that contradicts a theory proves that theory to be false.

The theory that spectrum red, green and blue-violet rays may be taken as the primary colors of light is not open to this objection, because every color can be reproduced to the eye by mixing these spectrum rays. Why this is so, we need not here inquire, because our object is merely to make a photographic color analysis in terms of the three most suitable colors, which are afterward to effect the synthesis in a triple color print.

Just here, those whose knowledge of the subject is

but superficial may say, " But we do *not* use red, green and blue-violet in our color print synthesis ; we use red, yellow and blue." As a matter of fact, if you get good results without much " faking " you use bright, transparent crimson (not true red*), bright, transparent peacock blue (not true blue), and light yellow (all of the spectrum except blue-violet) *inks*, which are the complementary or *shadow colors* of spectrum green, red and blue-violet ; and that is equivalent to working with green, red and blue-violet light colors. More about this later.

We have already stated that red, green and blue-violet spectrum rays can be so mixed as to reproduce all other colors. Would any other three colors of light serve this purpose? It has been asserted that "Any three colors farthest apart in the chromatic circle may be taken as the primaries." If we were to accept this theory and carry it to its logical conclusion, we would expect to succeed with spectrum yellow, spectrum green-blue, and a compound of spectrum blue-violet and red ; but if we try the experiment of mixing these colors of light to represent spectrum red, green, and blue, we shall find that, at best, there is a degradation of purity amounting to about fifty per cent. We must keep as close as possible to spectrum red, green, and blue-violet if we would avoid serious degradation of color.

Having settled upon our primary colors, we have to determine what relation these bear to the photographic process by which we get our analysis of all colors in three monochrome images. One might suppose that it

* Almost a magenta pink ; it is difficult to find a nomenclature that means the same to everybody. A physicist would call this color " purple."

would be sufficient to make one negative image by the exclusive action of spectrum red rays, another exclusively by spectrum green rays, and another exclusively by spectrum blue-violet rays. This would be the case if all the colors in nature were actually mixtures of red, green, and blue-violet spectrum rays; but they are not — they include also orange, yellow, yellow-green and blue-green spectrum rays, and all of these must be recorded in terms of the primaries in order to make an analysis which insures the preservation of all hue and luminosity values.

The key to the situation is Maxwell's celebrated color-curve diagram, which has been available for this purpose for more than forty years; but its bearing upon this problem was long overlooked.

Professor Clerk-Maxwell, the eminent English scientist, opposing Brewster's theory of red, yellow, and blue primary colors, devised an ingenious "color-box," with which he was able to prove, by measured mixtures of spectrum rays, that red, green, and blue-violet are the spectrum colors most competent to reproduce all others by mixture, and plotted curves upon a diagram of the spectrum, showing the proportions in which these "primaries" must be mixed to reproduce all other spectrum hues — and not only hues, but luminosity values. This diagram, first published in 1861, is reproduced on next page.

Reference to this diagram will show that all spectrum colors intermediate between the chosen primaries in the spectrum are covered by two curves, which, by their relative height at any given point, show the percentages of the two primaries which, by mixture, repro-

duce not only the spectrum hue at that point, but also the relative luminosity value.

As Maxwell pointed out at that time, it would be possible to obtain a colored representation of the spectrum with three photographic transparencies shaded in

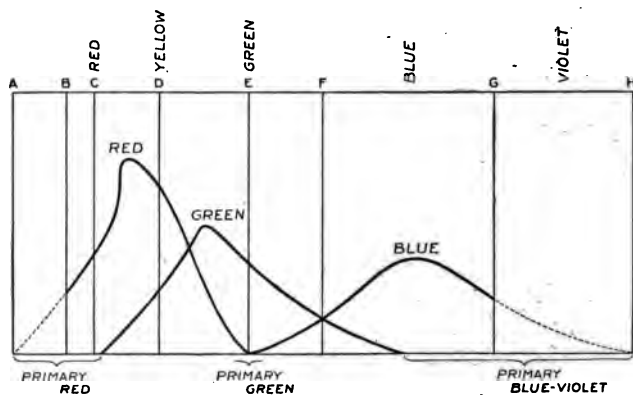

accordance with these three curves and projected upon a screen by means of three magic lanterns with red, green and blue lights. This he could not then do except by an artifice, because color-sensitive photographic plates were then unknown; but it can now be readily done with suitable combinations of orthochromatic plates and color screens.

Now, how does this apply to the reproduction of the colors of nature by trichromatic process? The answer is, that because all the infinite variety of colors are mixtures of spectrum rays, a method that will reproduce the hue and relative luminosity of all of these spectrum

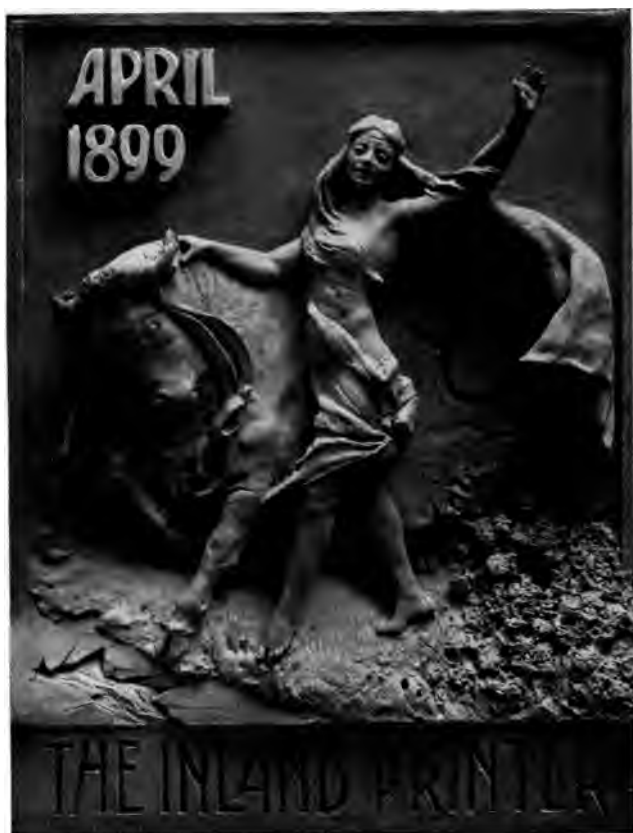

HALF-TONE.
From a Clay-modeled Design.



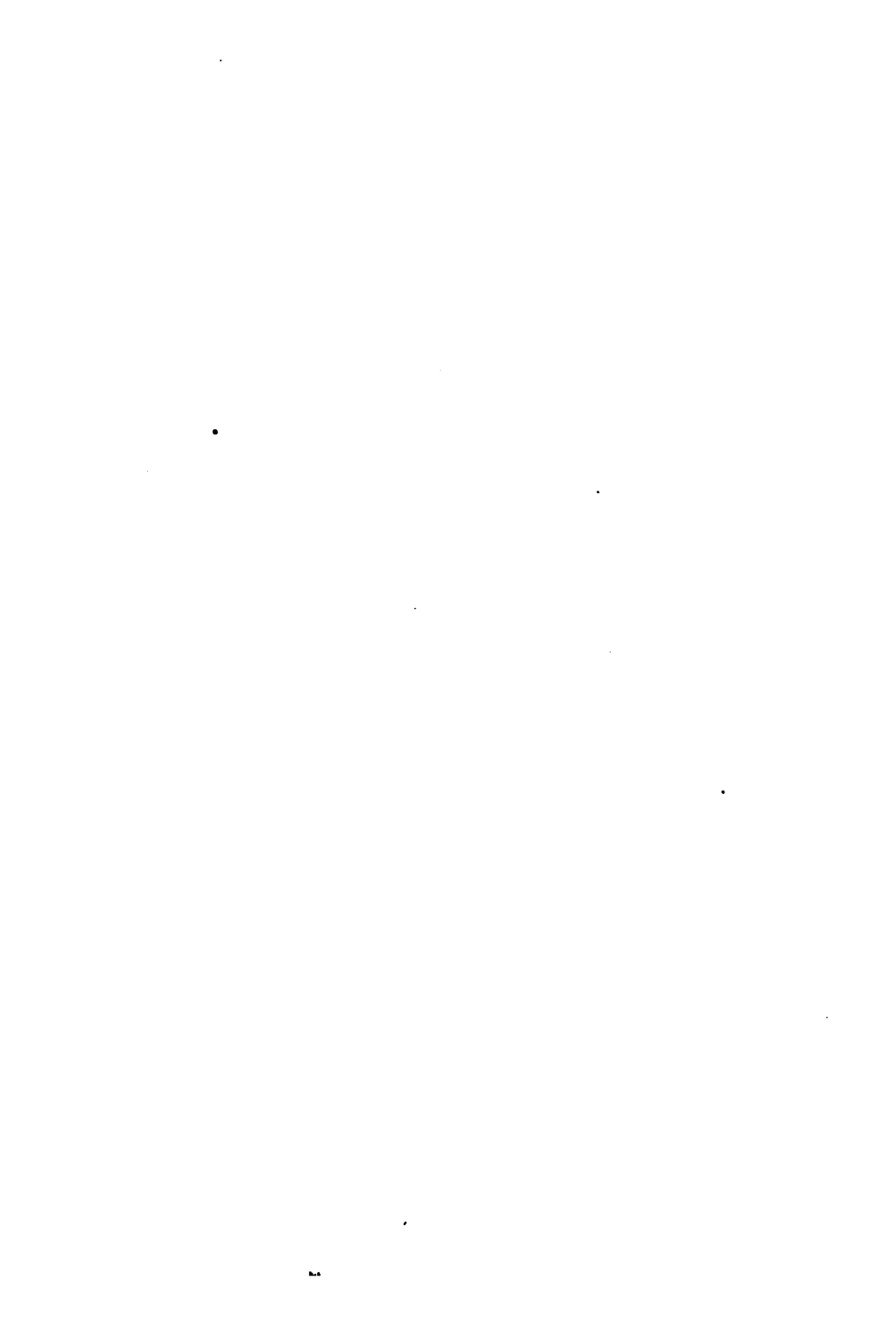



Courtesy Binner Eng. Co.

HALF-TONE.

From Combination Wash and Modeled Design.



rays separately must therefore necessarily reproduce them in every possible mixture.

This is not only a logical conclusion from a consideration of the facts, but works out in practice so perfectly that people who have seen such reproductions in the stereoscopic photochromoscope have frequently suspected a trick, and have even openly charged that the original objects which were shown for comparison were being directly reflected to the eye through the instrument.

So far, we have introduced no unnecessary complications either in the theory or the practice of trichromatic process reproduction. Such complications come when we extend the principle to synthesis by printing-inks instead of direct mixtures of light rays, and although equally clear to the mind when once really understood, have proved very puzzling to the majority of inquirers, even leading many to the conclusion that we have to deal with two quite distinct problems and methods.

It should be evident, however, from what has already been said, that, in the production of the negatives, no other procedure than the one described can be competent to yield a triple record which perfectly differentiates all hue and luminosity values; and if these subtle differences do not exist in the record, they can not appear in the result.

We should therefore seek to understand the relation of the printing colors in printmaking to the colored lights in triple lantern projection, and see if the two methods will not work out to the same result with the same negatives.

The key to the situation will be found to be a recognition of the fact that synthesis by triple lantern projection is a *plus* color synthesis, and synthesis by color prints is a *minus* color synthesis. In one case we commence with a darkened screen and build up to white by adding together three *light* colors, and in the other case we commence with a white surface and build up to blacks by adding three *shadow* colors.

The writer demonstrated this relation in lectures delivered some years ago, as follows: "Fixed pictures in color can be produced by a further extension and complication of the method, employing the same negatives to make three-color prints, which are mounted in contact between glasses, like a lantern slide, or superposed on paper. In this case, inasmuch as the superposition of color prints adds shade to shade, instead of light to light, the colors of the prints are complementary to the colors of light used in projection and in the photochromoscope. The print from the negative to represent red is peacock blue; the print from the negative to represent green is pink or crimson, and the print from the negative to represent blue-violet is a light yellow. Although I have already stated the reason for this, I may make it clearer by an experiment with the triple lantern. When there is no slide in the lantern, and the blending of the red, green and blue-violet disks makes white, we shall find that placing the positive of the red sensation in the red light produces a peacock-blue picture on the white ground. It is the function of the shades in this positive to take away red light from the white of the disk, making what looks like a peacock-blue photograph, and corresponds to the "blue" print

in three-color printmaking. In the same way, the positive of the green sensation throws pink or crimson shadows on the white disk, corresponding to the "red" print in three-color printmaking, and the positive of the blue-violet sensation throws yellow shadows on the white disk, corresponding to the yellow print in three-color printmaking. The mixture of the primary *light* colors in equal parts makes white, and the superposition of the primary *shadow* colors in equal parts makes black. Therefore, commencing with a darkened screen, we add light to light, red, green, and blue-violet; but, commencing with the white disk on the screen, or with white paper, we add shade to shade by our positives, peacock-blue, crimson and yellow."

It is thus proved that the correct printing colors are not "red, yellow, and blue," but a certain pink or crimson, a certain yellow, and a certain "peacock" blue. In fact, in order to reproduce all the colors in nature by a trichromatic printing process, it is as important to use these hues in printing-inks as it is to take red, green, and blue-violet spectrum colors as the basis of color analysis.

This also, besides being logical theory, works out successfully in practice, although the fact that the white of a color print is ordinarily a full spectrum white instead of a white made by mixing red, green and blue-violet spectrum rays, introduces a new factor, which must be taken into account, and its effect upon the result understood.

Given the condition that our whites are made up of all of the spectrum rays, it follows that our printing colors, taken together, should absorb all of the spectrum

rays, and that is equivalent to making our triple lantern projections with three groups of spectrum rays which, taken together, constitute the whole spectrum, instead of three isolated groups of the pure "primary" colors. It is quite easy to show what is the effect of doing this, by actual experiment with the triple lantern; but as this can not be done in the pages of a book, it may be stated that if the *hue* of the primaries is matched by the group mixtures, as it should be, the result is a slight loss of purity of color, but without any falsification of hue and luminosity values, and therefore without notable loss of "naturalness." Knowing that our synthesis was to be made with such group mixtures instead of "pure" colors, we could calculate an analysis that would yield somewhat less degradation of purity of color, but it would necessarily be at the expense of differentiation of hue, the relative importance of which is indicated in a recent statement by Sir William Abney that "it is much more important to obtain by means of the negatives a *correct hue*, and if the *proportions* of density are correct the admixture of white will not be observed detrimentally, so long as it is kept within reasonable limits . . . the appearance of color will appear to give a true representation."

It is possible to have three kinds of printing colors which fulfill the necessary conditions of collectively absorbing the entire spectrum, yet being correct in hue. They may either absorb evenly and exclusively the spectrum from A to D, from D to F, and from F to H, or the absorption bands may be a little wider but still abruptly defined, so that collectively the strongest absorption is on the D and F lines, or the absorptions,

strongest over the "primary" spectrum colors, may overlap in a falling ratio, so that they must be mixed or superposed to fully absorb every intermediate spectrum color. To the eye, these inks will appear almost identical, but they will not act exactly alike in forming the compound colors. The specific merits of each kind are capable of mathematical demonstration, but space not permitting of more definite treatment, the writer will merely express his preference for the second kind for half-tone trichromatic printing, and the third kind for color printmaking in gelatin transparencies.

From all that has gone before, it may be gathered that the half-tone trichromatic process is theoretically capable of correctly reproducing hues and relative luminosities, with some little dilution by white or black. This dilution, which would generally be negligible if it were not intensified by imperfections in the inks and printing, may be partly eliminated by employing a simpler analysis, which would be represented by color curves not overlapping to the same extent as in Maxwell's diagram, with some sacrifice of accuracy in the rendering of hue and luminosity values. The shorter and steeper the analysis curves, the greater the tendency to fail in the differentiation of hues, and so to produce crude color effects; but some compromise in this direction is justifiable in doing certain classes of commercial work, where accuracy of hue and gradation is less valued than vividness of color. In either case, in practice, the worst defects will usually be those due to errors in exposure and density ratios when the elements of the color record are made by separate operations, as is the usual practice. With the latter source of error elimi-

nated, the half-tone trichromatic process, carried out in accordance with the theory here set forth, can be made to yield, with very little reëtching (and often with none) results generally far more satisfactory to the critical eye than the most elaborately reëtched productions have averaged up to this time.

Three-Color Processwork.

A BRIEF OUTLINE OF THE KNOWLEDGE A PHOTOENGRAVER
MUST POSSESS TO UNDERTAKE THREE-COLOR
BLOCK MAKING.

By S. H. HORGAN.



LOUIS DUCOS DU HAVRON,

Who published, in 1859 and 1862, the first practical ideas on three-color photography. He published his first book on the subject in 1869, and is therefore the father of three-color processwork.



HALF-TONE.

Squared Base with no Line, and Vignetted Top.

INTRODUCTORY.

AN effort has been made in these pages to compress in the shortest possible space the information necessary for the photographer, engraver, or even the beginner at either of these occupations, to learn practical three-color negative making.

To maintain brevity all theories on the subject have been eliminated, as also the reasons for each operation. To avoid confusion to the reader, all mention of proper scientific terms, such as the solar spectrum, color sensations, density curves, etc., have been avoided.

Information regarding the operations of photographing, the making of the positives, half-tone negative making, sensitizing the metal plates, printing on them, developing, etching and proving is given by Mr. Jenkins, and is consequently omitted here. So also instructions to the printer about underlays and the selection and use of the three-color inks are not considered within the province of this book.

The manufacturers of lenses, sensitive plates, color filters, colored inks and other requisites in three-color processwork are making it easier each year to produce

three-color blocks, still the exact procedure in color photography has not as yet been definitely settled upon. Later developments, as they come to light, will be given among the "Process Notes" of *The Inland Printer*.

This is written by a process man for his brother process men, to whom he wishes all possible success in the most fascinating of photographic operations — Three-color Processwork.

S. H. HORGAN.

THREE-COLOR PROCESSWORK.

COLOR BLINDNESS.

THE person contemplating three-color photography should not trust his own judgment as to whether his color vision is normal, but have his eyes tested for color blindness. Some eyes lack entirely any appreciation of the sensation of red, others fail to distinguish green, while a few are blind to the violet sensation. There are degrees in the defectiveness of eyes to the color sensations, perfect color vision being rare. The nearer perfect color vision is the better will its possessor succeed at three-color photography.

THE THEORY OF THE THREE-COLOR PROCESS.

All three-color photography is based on the theory that there are but three primary colors, and that all the other colors or hues are mixtures of these three in varying proportions.

Tints in three-color block printing are obtained by allowing the white surface, on which the three colors are printed, to be exposed in varying degrees. Shades are the result of superimposing the three colored inks in dots on and between each other, until black is reached by printing the three colors solidly over each other.

For clearness sake the three colors used in the printing-inks will be called yellow, red and blue, according to Prang's standard colors.

Let it be remembered that in making a negative of a black-and-white subject, for ordinary photoengraving and printing in black ink, the black in the copy does not affect the sensitive plate; it is the transparent part of the negative. It is the same in three-color negative-making. The theory is that when making the negative

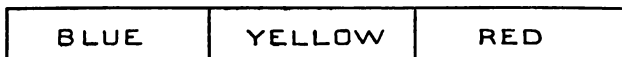

IF THIS WAS THE COPY IN COLORS FOR THREE-COLOR RECORD NEGATIVES.



THE YELLOW RECORD NEGATIVE SHOULD SHOW TRANSPARENCY AND OPACITY AS ABOVE;



THIS SHOULD BE THE TRANSPARENCY AND OPACITY OF THE RED RECORD NEGATIVE,



AND THE BLUE RECORD NEGATIVE SHOULD POSSESS TRANSPARENCY AND OPACITY LIKE THIS.

for the yellow printing-block the yellow in the copy should not affect the sensitive plate, but should be the transparent part of the negative. In making the negative for the red printing-block the red in the copy should not affect the sensitive plate and should be the transparent part of the negative. In making the negative for the blue printing-block the blue in the copy should not affect the sensitive plate, but should be represented by transparency in the negative. The nega-

tives in three-color work have no color in themselves, but record the amount of each of the three primary colors found in that which is photographed. Hence they should be properly termed color record negatives.

THEORETICAL SENSITIVE PLATES FOR THREE-COLOR WORK.

To make three-color negatives the yellow negative should be made on a plate that is sensitive to red and blue, and insensitive to yellow; the red negative should be made on a sensitive plate that is sensitive to yellow and blue, and insensitive to red; while the blue negative should be made on a plate that is sensitive to red and yellow, and insensitive to blue.

THE THEORY OF THE COLOR FILTERS OR SCREENS.

To aid in carrying out this theory, colored screens, or filters, are used, so that rays of light from the copy are screened or filtered before reaching the sensitive plate. In making the yellow negative a color filter should be used to shut out the yellow rays, and allow only the red and blue rays to pass through. For the red negative a color filter should shut out the red rays and permit the yellow and blue rays to pass; and for the blue negative a color filter should shut out the blue rays and permit the passage of the yellow and red rays of light from the copy. So much for the theory

PRACTICE VERSUS THEORY IN THREE-COLOR PHOTOGRAPHY.

In practice it will be found that neither color filters, sensitive plates or three-color inks are available

to carry on three-color block-making precisely as laid down theoretically in the previous paragraphs. Why this is so is too long a story to be told here. By numerous compromises and skilful manipulation, difficulties are overcome so that in practice three-color blocks can be produced which will be quite satisfactory.

THE LIGHT.

Daylight in or near large cities and in changeable weather is too variable to furnish the best illumination for three-color negative making. The color of the light from a clear sky, it will be understood, is bluer than from a clouded sky. So also is the light from the sun yellower as it sinks in the west. These variations in the color of the light alter the color of the copy, besides rendering it almost impossible to calculate correctly the time of exposure for the three negatives. Electric arc focusing lamps of a good make, with proper carbons and a steady supply of electric current, furnish the most reliable light for three-color photography.

Instead of using color filters between the copy and the sensitive plate, the copy itself can be illuminated with colored light. For instance, the illuminant may be a powerful electric light, between which and the copy color filters can be introduced. Just as great care, however, will be required to have these large light filters properly adjusted and maintained, as if they were the smaller ones.

THE LENS AND CAMERA.

The special feature of the lens should be its correction for chromatic aberration, so that all colored rays passing through the lens may come to a similar focus on the ground glass. Non-achromatic lenses focused the violet rays nearer the lens than the yellow rays. The violet rays were not visible, but were the ones which acted first on the sensitive plate. The yellow rays were visible and were consequently the ones focused. Hence, in using a non-achromatic lens it was necessary after focusing to move the ground glass forward to a point where the violet rays would be in focus. When the photographic dry plates came into use sensitive to the yellow rays, then lenses were constructed so as to bring the violet and yellow rays to the same focus, and such lenses were termed "achromatic." For three-color photography it is essential that the lens be corrected still further, so that the red rays are also brought to the same focus as the violet and yellow ones. With some "achromatic" lenses the image will have to be focused through each color filter used, or three times. The difficulty of keeping the images the same size and maintaining perfect register under such circumstances need not be pointed out. A lens properly corrected for chromatic aberration, at the same time quick working, is essential in three-color work.

If dry plates and wet plates are to be used it is better to have a separate camera and holders for the dry plates, or at least a special back to the camera adapted to take dry-plate holders and a ground glass frame.

TO TEST A LENS FOR ACHROMATISM.

A chart should be carefully drawn, consisting of outline squares, as shown in the diagram :

B	Y	R	B	Y	R	B	Y	R
Y	R	B	Y	R	B	Y	R	B
R	B	Y	R	B	Y	R	B	Y
B	Y	R	B	Y	R	B	Y	R
Y	R	B	Y	R	B	Y	R	B
R	B	Y	R	B	Y	R	B	Y
B	Y	R	B	Y	R	B	Y	R
Y	R	B	Y	R	B	Y	R	B
R	B	Y	R	B	Y	R	B	Y

CHART FOR TESTING A LENS FOR ACHROMATISM.

These squares are drawn in outline in the colors indicated by the letter in the center of each square. The lines should be made with a ruling pen, the lines in the different colors being precisely the same width, with the squares the same distance apart. The red ink can be used dilute, but should be free from any trace of blue. The chart should be one and one-half times larger than the largest plate it is intended to make with the lens, and should be focused on the blue squares.

A negative of this chart taken on a Cramer slow isochromatic, a Carbutt polychromatic, a Cadett spectrum, or a Lumière panchromatic plate, will give an



HALF-TONE.

Oval Shape, with Vignetted Effect at Base.





Courtesy John Royle & Sons.

HALF-TONE.

With Lined Border Effect Produced With Royle Lining Beveler.



idea of the achromatic property of the lens. If any squares are out of focus, or if the outer edges of the squares do not form a perfectly straight line, as in the drawing, then the lens is not suitable for three-color negative making.

THREE-COLOR FILTERS OR SCREENS.

The practical three-color worker should not attempt to make his own three-color filters. The makers of color-sensitive plates have studied out scientifically the color filters best adapted to their own make of plates. It will be a great saving of time and money on the part of the beginner, at least, if he adopt the color filters recommended by the maker of the sensitive plates he intends using.

Color filters are made in several forms. In all cases the glass used in them must be optically flat. The most scientific form of filter is the glass cell, filled with an aniline dye. These can be purchased with a pipette for filling and emptying them. In another form of color filter two optically flat glasses are coated with gelatin first, then stained with the proper dye, and when dry cemented together with Canada balsam. In another make of filter collodion is substituted for gelatin as a medium for holding the dye.

Three-color filters can be purchased from John Carbutt, of Philadelphia; Lumière, of France and the United States; Sanger Shepherd & Co., of England, and others.

The three-color filters should be used in grooved slides inside the camera, and immediately behind the back combination of the lens.

THE COLOR-SENSITIVE PLATES.

To make the color-record negatives, it is best theoretically to use color-sensitive plates sensitive to the whole spectrum. They should also be developed in the same kind of developer, its strength and temperature being maintained the same. Mr. Frederic E. Ives has invented — United States Patent No. 668,980, February 26, 1901 — an ingenious way of accomplishing this by securing with a single achromatic lens the three-color records on a single sensitive plate. If the color filters are properly balanced this single plate should contain the three-color record negatives of the same gradation of density.

John Carbutt's Polychromatic plates, used in combination with a set of three-color filters by the same maker, is one of the many brands of dry plates that can be used for the three-color record negatives.

Cadett's Spectrum plates, together with a set of color filters made by Sanger Shepherd, are used by some three-color workers.

The Messrs. Lumière recommend these screens and plates of their manufacture. With their blue filter use their Extra Rapid Blue Label plates; with the green filter, their Orthochromatic, Series A, and with their orange filter their Orthochromatic, Series B. The exposures through the orange and green filters are twelve times longer than the exposure through the blue filter.

Different plates of the same maker can be used. For instance, Cramer's "Banner" plates may be used for photographing through the blue filter; the Medium

Isochromatic for photographing through the green screen, and "Banner" plates, or Instantaneous Isochromatic, bathed in cyanine, for photographing through the red screen. The method of resensitizing dry plates with cyanine will be given later.

ISOCROMATIC COLLODION EMULSION.

Dr. E. Albert, of Munich, supplies a collodion emulsion called "Eos" which can be used in all kinds of processwork and is made isochromatic for three-color photography by the addition of sensitizing dyes which he also furnishes. This emulsion is flowed, in a dark-room, on the glass plate in the same manner as ordinary collodion, and is then ready for exposure in the camera. Under favorable conditions it will remain without drying for almost a half-hour. Emulsion dispenses with the silver bath. It is used without a sensitizer when photographing through the blue-violet screen; with a sensitizer marked "A" when photographing through the green screen, and a dye marked "R. P." for use with the red screen. The development is with hydroquinon, but the other operations of fixing, intensification, "cutting," drying and turning are the same as in making ordinary wet-plate negatives. Strong illumination is required for the copy, as the collodion emulsion is not as sensitive as gelatin dry plates.

HALATION IN THREE-COLOR RECORD NEGATIVES.

Halation, or reflections from the back surface of the glass on which the color record negative is made, must be guarded against, particularly in the negative

made through the red screen. The makers of color sensitive plates can furnish them possessing non-halation properties if so ordered, and as all color-sensitive plates should be. There are various non-halation backings in the market, and they should be used as directed.

RESENSITIZING DRY PLATES.

This is the procedure for rendering a good quality of dry plate sensitive to the red, for use with the red screen.

Make the following stock solution and keep it in a darkroom:

Gruber's or other C. P. cyanine..... 6 grains.
 Absolute alcohol10 ounces.

The sensitizing bath as wanted is made as follows:

Of the above stock solution..... 2 ounces.
 Alcohol (ninety-five per cent)..... 2 ounces.
 Distilled water20 ounces.

This sensitizing solution is filtered perfectly into a porcelain tray, and in an absolutely dark room dry plates are allowed to soak in this bath for about five minutes, when they are removed and stood up on chemically pure blotting paper for fifteen minutes to drain, after which these plates are bathed in the following bath:

Distilled water20 ounces.
 Alcohol (ninety-five per cent)..... 2 ounces.
 Aqua ammonia½ ounce.

After rinsing in this bath for a minute they are placed in an absolutely light-tight drying closet. The carbonic acid in this closet should be absorbed by a tray of quicklime.

The dyeing and washing operations are best carried out by using one of the makes of cages found in the market for holding a dozen or more dry plates and lowering them into an upright bath, which should contain the resensitizing solutions.

It is customary to perform these resensitizing operations in the evening or the last thing in the afternoon so that the plates may be dry by morning. It is better also to resensitize only sufficient plates for use the following day.

The important points to remember in resensitizing dry plates are: the cyanine must be pure, and absolute alcohol be used to dissolve it in; the same proportion of alcohol must be used in the washing bath as is used in the dyeing bath; that these cyanine plates will not keep long and that they must be developed in the dark at first, for a minute or so, and then in a safe light.

To determine if the darkroom light is safe for resensitized plates, in absolute darkness put a cyanine dyed plate into a plateholder, pull the slide of the plateholder half way out and expose the plate to the light used in the darkroom for from three to five minutes. Develop this plate first in the dark as before instructed and see if there is not a trace of exposure on the half which was uncovered to the darkroom light.

THE EXPOSURE.

The relative exposures can only be found by experiment, for they depend on the illumination, the lens, the diaphragms, the density of the color filters and the sensitiveness of the plates used.

It is recommended that the photographer making

three-color record negatives keep a day-book in which is registered for every exposure, the subject, the reduction or enlargement, lens, color filter, kind and size of diaphragm, time of day and length of exposure, together with any other data affecting the negative. Later, the kind of developer, its temperature, time of development and comments on the resulting negative should be added. This daily register will become one of the most valuable books of reference to the photographer; it will save much needless experimenting and waste of material.

Strips of paper containing three patches of color made from the three colors used in printing the three-color blocks, together with a patch of black, should be attached to each piece of copy so that these patches of color be included in every color-record negative made. These patches of color are of the utmost value in development. In fact, without them it is impossible to determine the correctness of exposure or development. These color patches serve afterward to distinguish the color-record negatives one from the other.

THE HALF-TONE DIAPHRAGM.

If from a single half-tone three impressions were made, one in yellow ink, the second in red ink and the third in blue ink; if, also, the register was so perfect that these impressions were exactly over each other, the result of the three superimposed printings would appear like a single impression in black ink. If these printings were repeated and the impressions be out of register, as they are most likely to be anyhow, then varying color effects will occur in the proofs.

To prevent, as far as necessary, the different inks from printing over each other, and to avoid these accidental color effects, it is best to engrave the half-tones in lines, so that in printing they can be used at angles of sixty degrees to each other.

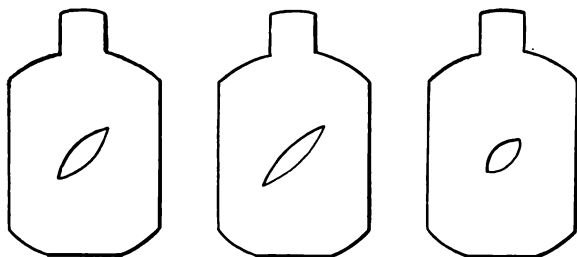

DIAPHRAGMS WITH ELLIPTICAL APERTURES.

To accomplish this with cross-line screens, diaphragms with elliptical apertures are used.

These diaphragms should be cut out of printer's pressboard or ferrotype plate, with the points of the slits at angles of forty-five degrees to the vertical sides of the diaphragm.

When used these diaphragms must be exactly in line with one of the lines of the cross-line screen. To insure this the plateholder containing the cross-line screen should be put in its place in the camera, a piece of ground glass substituted for the sensitive plate, and the lens turned until the images of the slots in the diaphragm make continuous lines on the ground glass. If the lens is fixed in this position this test as to parallelism of the elliptical stop and one of the lines of the screen need not be repeated.

To use these stops more than one-half the exposure may be given, then the lens capped, the diaphragm reversed and the remainder of the exposure made. Or a large elliptical stop may be used to close up the high-light dots in the negative, and a small elliptical stop, turned in the opposite direction to the large one, to furnish the small dots in the shadows of the negative.

Another plan is to use these elliptical diaphragms without reversing, the effect in the half-tone being the same as if a single-line screen were used.

TO PREVENT PATTERN IN PRINTING.

In Richmond's "Grammar of Lithography," pages 170-171, ninth edition, 1886, will be found instructions for laying down line tints, for color printing in three colors, in which it is stated: "The direction of this second series of lines is very important, and must make an angle of sixty degrees with those first transferred. The third transferring is then done, and the result should be that the lines coincide in direction with the three sides of an equilateral triangle. The reasons for putting the lines so exactly in this direction is that the production of any set pattern is thus avoided."

Ives used this disposition of lines in his three-color block printing of 1881. Without apparently knowing this, Albert, in Germany, patented the use of lines at sixty degrees in 1891. Du Hauron, unaware of its having been used before, received a patent on it in France in 1892, and Kurtz, thinking it an original discovery with himself, obtained a United States patent on it in 1893.

So the angle of sixty degrees, which lithographers



COMBINATION HALF-TONE AND LINE CUT ETCHED
TOGETHER ON ZINC.

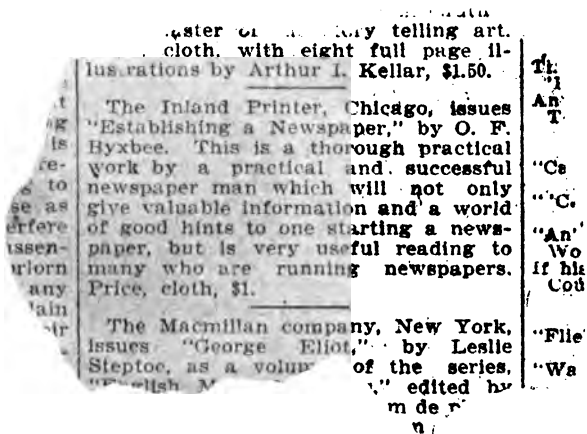

HALF-TONE OF NEWSPAPER CLIPPING.





Courtesy Juergens Bros. Co., Chicago.

HALF-TONE FROM WASH DRAWING.



found generations ago for laying down tints, is the proper one for the three-color block maker to-day.

To do this a single cross-line screen can be used if means are provided for rotating either the copy, the positives or the sensitive plate.

A disadvantage of rotating either the copy or the positives is that the size of the half-tones it is possible to make is so much smaller than the screen used.

The makers of screens furnish two cross-line screens for three-color half-tones that it is best to

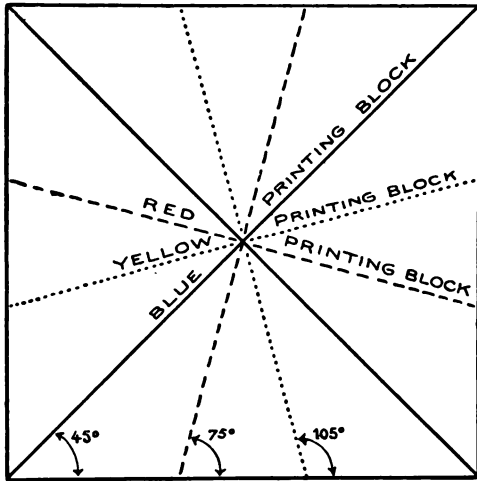

CHART SHOWING THE ANGLES AT WHICH THE HALF-TONE SCREENS IN THE THREE-COLOR PRINTING BLOCKS SHOULD CROSS EACH OTHER.

adopt. One is the ordinary cross-line screen ruled with lines at angles of forty-five to its sides. The other is a special screen made to match the first one both as to thickness of lines and the spaces between the lines.

The lines of the second screen are ruled at angles of seventy-five and one hundred and five degrees to its sides. This screen can be used one way for the yellow printing-block and reversed for the red printing-block negative. Owing to this reversal the two glasses of which the screen is composed should be of the same thickness.

THE PROCEDURE IN THREE-COLOR BLOCK MAKING.

The reader is presumed to be familiar with the half-tone process; it is only necessary to notice here the additional operations in the making of three-color blocks.

The previous chapters have told the necessity of an achromatic lens to bring the red, yellow and blue rays to precisely the same focus. It has been recommended to purchase the color filters, darkroom lights and color sensitive plates. It is also better to depend, for instructions in the development and handling of whichever brand of plate that is used, on the dry-plate maker. Just how to resensitize dry plates for special sensitiveness to the red has been carefully described. The danger of halation, the necessity of a reliable source of illumination for the copy, and the value of a register of the exposures and after treatment has been urged. How to make the diaphragms and the kind of half-tone screens to use has been pointed out. Having all these requisites we will now go over the operations in making three-color blocks.

We will assume that a water-color sketch is to be reproduced in color. Fasten the sketch securely to the copy board. Everything about the camera must be

fixed solidly so that there shall be no change in the relative position of either copy, lens or sensitive plates during the making of either negatives or positives. Remember always to have patches of the three-colored inks, to be afterward used in the printing, attached to

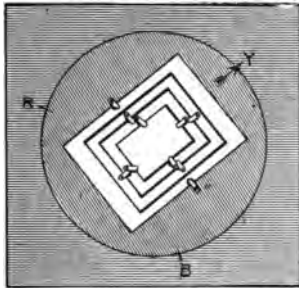

A ROTARY COPY BOARD OR KITS FOR HOLDING POSITIVES. WHEN USED FOR COPY A BOARD TAKES THE PLACE OF KITS.

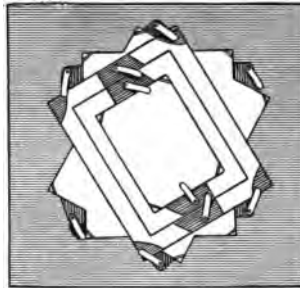

CHANGEABLE KITS FOR ALTERING THE ANGLE OF THE SENSITIVE PLATE.

the copy, so as to be photographed in each negative. Also have registry marks, one at each side of the copy.

The blue-violet color filter is polished clean and inserted in its slide behind the lens, and the copy focused to its proper size. Diaphragm the lens down until the image is sharp on the ground glass at every point. Cap the lens and insert the holder containing the blue sensitive dry plate, draw the slide one-third the distance, and expose the plate for what might be considered one-third the time required for the whole exposure. Cap the lens again, draw the slide out two-thirds of the way, and expose for the same length of time as at first, draw the slide out entirely, and expose once more for the same time. Do not fail to make a

record of all this in the daily register. Development of this test plate will determine the proper exposure for future plates. Repeat this time of exposure test with the green filter on the green-sensitive plate and on the red-sensitive plate with the red filter.

The exposure through the green screen is liable to be from three to twelve times longer than through the blue-violet screen, while the exposure through the red screen may be from twelve to twenty times longer than the exposure through the blue-violet screen.

The relations of the exposures vary with the illumination of the copy, its reduction or enlargement, the density of the color filters, the brands of plates used and their development, so that the operator must determine for himself through these time tests the proper exposures to be given.

DEVELOPMENT.

It is not necessary to go over the method of dry-plate development. Sufficient is it to caution against the danger of fogging the green and red sensitive plates by light in the darkroom. It is best to flow the developer on these plates in absolute darkness, and allow the development to proceed for at least a minute before turning up the light that is considered safe. A record should be kept of the time taken in development.

REDUCTION OR INTENSIFICATION.

After perfect fixing and a good washing, should the negatives not correspond in density, this can be remedied by intensifying the weak negative or reducing the strong one.

THE POSITIVES.

Positives are made from the three negatives, either on dry or wet plates, as the operator prefers. Equally good positives can be produced by either method. The positives represent in their shadows just how much ink of each color will be used in the printing. One with a well-trained eye for color can determine by comparing them with the original copy whether they possess the proper color balance — that is, whether, when printed over each other, the colors will be in the proportion they are in the copy. The proper color balance can be restored by careful reduction or intensification of the positives, either locally or over the whole plates.

THE HALF-TONE NEGATIVES.

The positives are placed in a rotatory holder in the copy board and turned to the proper angles before making the half-tone negatives, or, better still, fixed one after the other in exactly the same position in the positive holder, and the half-tone screen changed as explained in the chapter on how "To Prevent Pattern in Printing."

ETCHING THREE-COLOR BLOCKS.

There is no difference in etching plates for three-color and etching plates for black printing, only that it is better to etch all three plates together so that the color balance may be preserved. The registry marks having been preserved on the half-tone plates the plates are turned over to the printer to prove them. If, after proving, it is found that one color overbalances the

other by being too strong, the strong plate can be given a further etching, or either of the plates can be reetched locally where necessary.

PRINTING THREE-COLOR BLOCKS.

It is within the power of the printer, by skilful underlaying of the plate, to modify the result in any way he pleases, so that corrections can be made in many ways. There should not be any corrections for the printer to make after he receives the final proof from the maker of the plates. The inks should correspond with the color patches photographed with the copy. The best inks to use are the ones now used by almost all the three-color printers.

It was not intended to give in these few chapters instructions in presswork or the presses to use. Presswork is a business entirely distinct from three-color block making, and it is only the latter the writer has tried to the best of his ability, though briefly, to explain.

APPENDIX.

TABLES OF WEIGHTS AND MEASURES —
INFORMATION FROM VARIOUS
SOURCES.

MEASURES.

LINEAL.

Mile.	Rods.	Yards.	Feet.	Inches.
1 =	320 =	1760 =	5280 =	63360
	1 =	5½ =	16½ =	198
		1 =	3 =	36
			1 =	12

SURFACE.

Acre.	Roods.	Sq. Rods.	Sq. Yds.	Sq. Ft.
1 =	2560 =	102400 =	3097600 =	27878400
	1 =	160 =	4840 =	43560
		1 =	30¼ =	272¼
			1 =	9

VOLUME.

Gallon.	Quarts.	Pints.	Gills.	Cubic Inches.
1 =	4 =	8 =	32 =	231
	1 =	2 =	16 =	
		1 =	4 =	

FLUIDS.

Gallon.	Pints.	Ounces.	Drams.	Minims.	Cubic Centim's.
1 =	8 =	128 =	1024 =	61440 =	3785435
	1 =	16 =	128 =	7680 =	473179
		1 =	8 =	480 =	29574
			1 =	60 =	3697

WEIGHTS.

TROY.

Pound.	Ounces.	Pennyweight.	Grains.	Grams.
1	= 12	= 240	= 5760	= 373.24
	1	= 20	= 480	= 31.10
		1	= 24	= 1.56

APOTHECARIES'.

Pound.	Ounces.	Drams.	Scruples.	Grains.	Grams.
1	= 12	= 96	= 288	= 5760	= 373.24
	1	= 8	= 24	= 480	= 31.10
		1	= 3	= 60	= 3.89
			1	= 20	= 1.30
				1	= .06

AVOIRDUPOIS.

Pound.	Ounces.	Drams.	Grams.
1	= 16	= 256	= 453.60
	1	= 16	= 28.35
		1	= 1.77

1 gram = 15.43 grains = .03215 troy ounces = .03527 avoirdupois ounces.

1 grain = .0648 grams.

1 pound avoirdupois = $1\frac{3}{4}$ pounds troy = $1\frac{3}{4}$ pounds apothecaries'.

1 ounce avoirdupois = $1\frac{7}{8}$ ounces troy = $1\frac{7}{8}$ ounces apothecaries'.

1 pound troy = 1 pound apothecaries'.

1 ounce " = 1 ounce "

1 grain " = 1 grain "

1 pennyweight " = $\frac{1}{8}$ dram "

PROVING COLOR PLATES.

Mr. J. H. Siedenbug, of New York, says *The Inland Printer*, has devised the following method of proving color plates: In a worthless piece of zinc, say 10 by 12 in size, $\frac{1}{32}$ -inch holes are drilled in diagonal corners. Short pieces of a steel needle are driven into these holes and soldered there,



Courtesy Blomgren Bros. & Co., Chicago.

HALF-TONE FROM RETOUCHE PHOTOGRAPH.



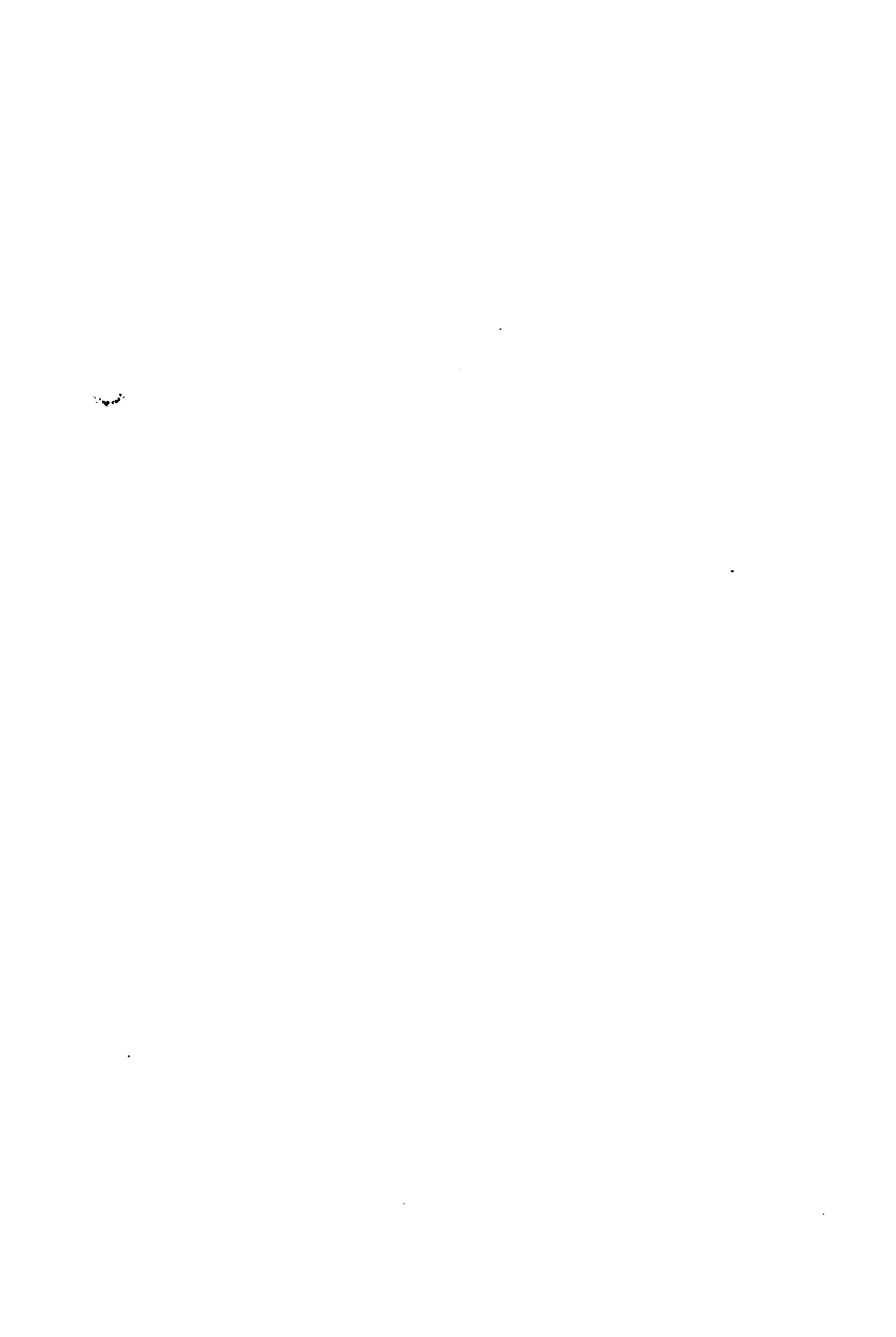

after which the upper ends of the needles are filed to sharp points. This he calls the "ground plate." After photographing and etching the color plates, one of them is taken and clamped securely to the center of the ground plate; $\frac{1}{32}$ -inch holes are drilled through the regular registry points, which were, of course, on the copy and photographed on each plate. These holes are bored through both the color plate and the ground plate. Now two blocking brads about $\frac{1}{32}$ inch thick are driven through the ground plate holes from the back and cut off to height of thickness of color plate. With nail set, punch the metal around the brads to hold them rigid. When $\frac{1}{32}$ -inch holes are bored in the center of the registry points in the other color plates they are all ready for proving. When the first color plate is proved the needle points in the ground plate puncture holes in the proof, which are used to register the paper in the subsequent printings, while the steel brads keep the plates in register.

TO CHANGE THE READING OF ONE THERMOMETER SCALE TO THAT OF ANOTHER.

Fahrenheit to Centigrade.— Subtract 32 from the Fahrenheit reading and multiply the result by $\frac{5}{9}$.

Fahrenheit to Réaumur.— Subtract 32 from Fahrenheit reading and multiply result by $\frac{4}{9}$.

Centigrade to Fahrenheit.— Multiply Centigrade reading by $\frac{9}{5}$ and add 32 to the result.

Centigrade to Réaumur.— Multiply the Centigrade reading by $\frac{4}{5}$.

Réaumur to Fahrenheit.— Multiply the Réaumur reading by $\frac{9}{4}$ and add 32.

Réaumur to Centigrade.— Multiply the Réaumur reading by $\frac{5}{4}$.

RESIST FOR LINE ETCHINGS.

Instead of using dragon's-blood to form a resist for the first bite in line etching, some etchers prefer rosin and graphite, in a very finely powdered form. After the plate is dried the rosin is applied and all surplus carefully dusted from the plate,

which is then heated just enough to cause that which adheres to the ink to be burned into it. Then the graphite is applied and treated in a similar manner. After the first etch, dragon's-blood is used, as described in the chapter on line etching.

A WHIRLER FOR COATING HALF-TONE PLATES.

A very convenient whirler, especially adapted for plates of not very large dimensions, may be made as follows:

Remove the handle from a plumber's force cup. Onto the stem of a small drill stock screw a nut, then slip a washer on, insert the stem through the hole in the cup, then slip on another washer, and finally screw another nut down to make the joint

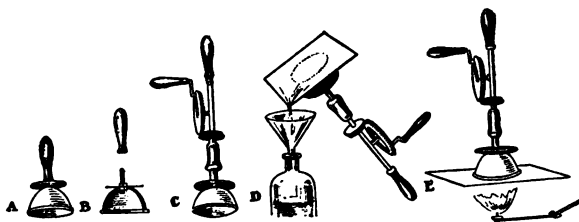

air tight. (If the drill stock has not a stem with a threaded end, but is provided with a chuck, fasten a threaded bolt of proper diameter into the chuck.) To use the whirler, wet the back of the plate, also the rim of the cup, and press it down upon the plate until it adheres. Then flow the face of the plate as usual, invert and whirl over the gas stove until the coating is dry. The illustration below will indicate the construction and use of this whirler.

ENAMEL FOR ZINC.

A contributor to *The Inland Printer* recommends the following:

Water	16 ounces
Glue	8 ounces
Bichromate ammonia.....	350 grains
Citrate of iron and ammonia.....	50 grains

After printing develop as usual and burn into a golden yellow or brown color. This formula is said to print very quickly.

INTENSIFYING NEGATIVES.

Instead of using ammonium sulphide to blacken the negative after intensifying with the copper and silver solutions, some operators use ferrous oxalate. The solution may be prepared as follows:

Make a saturated solution ferrous sulphate and a saturated solution potassium oxalate. Keep in separate bottles, but when ready to use mix one part of the first with three parts of the second, by pouring *the iron into the oxalate* solution. Wash the negative very thoroughly after blackening.

A DRY ENAMEL PROCESS.

The following formula appears in *The Inland Printer* for March, 1902:

Water	15 ounces
Albumen	7 ounces
White rock candy.....	½ ounce
Bichromate ammonia.....	½ ounce
Chromic acid.....	35 grains
Aqua ammonia.....	¼ ounce

Mix in order given and filter thoroughly. Coat and dry plate as usual. Before printing rub the negative with a little lard on a piece of cotton, to prevent sticking, and have negative and metal of same temperature. Expose two to three minutes in sunlight, or five to eight minutes by electric light. To develop rub over the image powdered washing soda that has been sifted through cheese-cloth. The powder will adhere to the unexposed parts. The development should be done in the darkroom, and the atmosphere should not be too dry. If necessary, moisten it by sprinkling the floor with water. When the image appears completely developed, burn into a deep cherry color, and while plate is hot plunge it into cold water and rub away the powder with wet cotton. If the powder

should stick to any portion of the image finely powdered salt applied to that part will remove the powder.

A German authority, Herr Tschorner, gives the following formulæ:

Sugar	250 grains
Gum arabic.....	30 grains
Ammonium bichromate.....	155 grains
Water	8 ounces, 2 drams
Chromic acid (35 per cent sol.).....	35 minims

Very even films on a zinc plate are given by this formula. After developing with magnesium carbonate, burning in is done at 380° Fahr., and a fine, hard enamel obtained, which resists even strong nitric acid etching. When using a mixture of gum arabic and grape sugar, development is still easier. The formula is:

Grape sugar.....	185 grains
Gum arabic.....	31 grains
Ammonium bichromate.....	154 grains
Water	7 ounces, 3 drams
Chromic acid (10 per cent sol.).....	35 minims

The film burns in at 380° Fahr., and gives a very hard enamel. Grape sugar and dextrin is another good formula, as follows:

Grape sugar.....	154 grains
Dextrin	31 grains
Ammonium bichromate.....	154 grains
Water	7 ounces, 3 drams
Chromic acid (10 per cent sol.)....	15 to 35 minims

The print develops well, burns in at 380° Fahr., and gives a hard enamel. Likewise excellent is a mixture of grape sugar and albumen, like this:

Grape sugar.....	185 grains
Dry egg albumen.....	31 grains
Ammonium bichromate.....	154 grains
Water	4 ounces, 2 drams

Either of the above enamels is poured as usual on a carefully cleaned zinc plate and dried over heat. The plate must be

fairly warm, or the negative is apt to stick to the sensitive film when printing. Exposure in bright sunlight runs to about three or four minutes under a line or half-tone negative; it is then dusted over (developed) with finely powdered magnesium carbonate by means of a brush or tuft of cotton. After burning in it is ready for etching in a five per cent nitric acid bath, to which some thick gum arabic, dextrin or glue has been added.

TO PREPARE PERCENTAGE SOLUTIONS.

For each fluid ounce of water take of the salt 4.557 grains to make a 1 per cent solution, twice the amount for a 2 per cent solution, etc.

When stated in parts per 1,000, etc., for each fluid ounce of water take of the salt 0.4557 to make 1 part in 1,000, twice the amount to make 1 part in 500, ten times the amount to make 1 part in 100, etc.

FINDING SCREEN DISTANCES BY FOCUSING.

Count Turati suggests the following method for determining the correct separation of the screen and sensitive plate:

With Canada balsam cement a thin piece of microscope glass to the center of the inside surface of the ground glass. Focus the image sharply, insert a stop with square aperture, in the lens, and gradually move the screen by means of the gear, closely examining the center of the ground glass with a magnifier. As the screen approaches dark dots will be noticed, gradually becoming more distinct and larger, and if the size of the aperture is correct they will join at the corners in the high lights and appear of the dimensions required in a good negative. They will not be very sharply defined, but if the correct distance is passed and the screen brought too near to the ground glass, the dots will disappear and be replaced by the image of the screen lines. If at all positions that the screen may be placed the dots are blurred, and if the lines are indistinct when the distance is at a minimum, it indicates that the aperture is too large, and a stop with smaller one should be

tried. A stop that is too small will require a screen distance too great.

Mr. Levy offers the following suggestion for determining the distance to correctly render the shadows:

Insert a round stop of a size from f-22 to f-32, and focus the screen until a small black cross appears sharp in the center of each dot. The distance is then correct, and the greater part of the exposure should be given with this stop, and the balance with a stop having a square aperture of proper size to close up the high lights.

PRINTING METHODS.

BLUE PRINTS — WHITE LINES ON BLUE GROUND.

1. Citrate of iron and ammonia..... 1 ounce
Water 4 ounces
2. Red prussiate of potassium..... 1 ounce
Water 4 ounces

Dissolve and mix the two solutions, coat the paper with sponge or absorbent cotton wet with solution, dry in dark and print under negative until details are visible. Then develop by washing under tap.

It is stated that blue-prints may be bleached by a very dilute solution of potassium carbonate and potassium hydrate, after which they should be flowed with dilute hydrochloric acid and washed. This being the case, they may be used similar to silver prints, as described in Chapter XIII.

BLUE LINES ON WHITE GROUND.

Gum arabic.....	385 grains
Sodium chlorid.....	46 grains
Tartaric acid.....	62 grains
Perchlorid iron.....	123 grains
Water	3½ grains

Coat paper and dry in dark. After exposure, develop in saturated solution of potassium ferrocyanide. Fix in 1 to 20 solution of hydrochloric acid. Wash.

BLACK LINES ON WHITE GROUND.

Oxalic acid.....	5 grains
Ferric chlorid.....	10 grains
Water	3 ounces

After printing, develop in 15 per cent solution of ferrocyanide of potassium; wash and fix in 10 per cent solution of hydrochloric acid. Wash.

ANOTHER PROCESS.

Water	300 cu. centim's
Gelatin	10 grams
Ferric chlorid, in thick solution..	20 cu. centim's
Tartaric acid.....	10 grams
Ferric sulphate.....	10 grams

When paper is dry, expose under negative and develop in

Gallic acid.....	20 grams
Alcohol	200 cu. centim's
Water	1 liter

and wash.

A SUBSTITUTE FOR GROUND GLASS.

There is scarcely any accident more aggravating to the photo-engraver than the breaking of the camera ground glass. As it is of frequent occurrence and it is difficult to obtain glass ground fine enough for the purpose, it behooves the photographer to be provided with the following varnish, which furnishes an excellent substitute for ground glass:

Sulphuric ether.....	4 ounces
Benzole	2 ounces
Alcohol	½ ounce
Gum sandarac or dammar.....	100 to 150 grains

If too much alcohol is used it will give a transparent instead of a ground glass effect. Flow this varnish on a sheet of plain glass, like collodion. It dries quickly and without heat, and

should give an excellent imitation of ground glass. In passing it might be said that if a little glycerin is rubbed into the grain of an ordinary ground glass it renders it much easier to focus on. It is best to rub it over but a portion of the ground glass, say a strip from the center to one edge.

PLAIN PHOTOGRAPHIC PAPER.

It is an easy matter to prepare one's own paper and it will keep for any length of time. All that is necessary is to use a good quality linen paper and soak it in a weak sizing of gelatin containing a chlorid salt, so that when applying nitrate of silver afterward to this paper a chlorid of silver will be formed. The following is an excellent formula: Take a smooth linen paper, if it is to be used for pen-and-ink work, or a rough paper like Whatman's drawing paper if for washwork, and immerse it in a warm solution of the following:

Water	1 ounce
Gelatin	12 grains
Chlorid of ammonium.....	8 grains

When the paper is soaked with this liquid hang it up to dry. It will keep indefinitely. To sensitize this paper use:

Water	1 ounce
Nitrate of silver.....	50 grains
Nitric acid.....	15 grains

VARNISHES.

VARNISH FOR COLLODION NEGATIVES.

Water	30 ounces
Borax	1½ ounces
White shellac.....	4 ounces
Glycerin	¼ ounce

Dissolve the borax in the water, then add the shellac and warm the water, keeping it so until the shellac is dissolved, then add the glycerin.

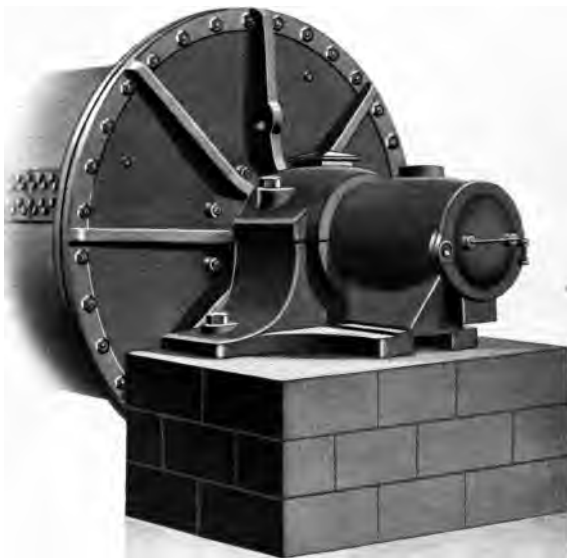

Courtesy Blomgren Bros. & Co., Chicago.

HALF-TONE FROM RETOUCED PHOTOGRAPH.





Courtesy Blomgren Bros. & Co., Chicago.

HALF-TONE FROM RETOUCHE PHOTOGRAPH.



DEAD BLACK VARNISH.

Gum lac.....	30 grams
Alcohol	200 cu. centim's

Dissolve.

Lampblack	60 grams
Alcohol	40 cu. centim's

Dissolve and add to the gum solution.

PERCHLORID OF IRON SOLUTION FROM LUMPS OF THE SALT.

Process Work gives the following directions for reducing perchlorid of iron in lumps to a solution for etching: Take seven pounds of perchlorid and boil in an enameled iron pan in five pints of water; when the perchlorid has completely dissolved the solution will be transparent. Take out a couple of ounces and stir into this portion strong liquid ammonia; the result will be a thick, pasty precipitate of ferric hydrate, which should be turned into a filter paper in a funnel and be washed free from ammonia by letting water filter through it. When the drippings from the filter no longer give a blue tinge to red litmus paper, the washing is complete. Take an ounce of perchlorid from the boiled solution and add a small quantity of the pasty hydrate to it. If all the hydrate is dissolved more will be required, and when it is seen that the hydrate is no longer taken up with the solution it will be evident that the latter contains no longer any free acid, and is in a suitable condition for etching. Having noted the quantity used in the test you will know how much is required by the bulk. It will not matter if a bit too much is put in, as it will filter out. It is best to filter the liquid. A solution prepared in this way will be transparent, and will not become muddy and green as that which contains free acid. It will also be ready for use at once, and will not be likely to deposit the green scum of oxide on the plate, which is so difficult to remove. The solution should be diluted to 35 degrees Beaume.

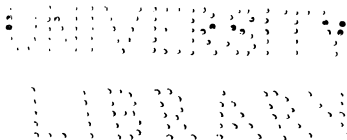

The Inland Printer Vest Pocket Manual of Printing ...



Indispensable to everyone interested in the printing trade. A compilation of the most valuable tables of reference arranged in the most convenient form, together with a practical and up-to-date treatise on punctuation and capitalization, with definitions of bookbinders' terms and a complete and accurate series of diagrams of imposition. Contains 86 pages.

LEATHER, - - - - - 50 cents.

Sent postpaid on receipt of price. Address

THE INLAND PRINTER CO., - - - Chicago or New York.

The Harmonizer *By JOHN F. EARHART, Author of "The Color Printer."*

A BOOK OF GREAT VALUE to any printer who prints on tinted or colored stock. 5 by 7½ inches; 248 pages, consisting of about eight pages each of about thirty different tints, colors and shades of paper, each page showing a different color effect. In addition to the two-color combinations shown, there are tables giving from ten to fifty others for each different tint of paper. At the bottom of each combination is given a list of colors, any one of which, if used with the two shown, will produce harmony.

Price, Cloth, \$3.50, prepaid.

Address all orders to

THE INLAND PRINTER COMPANY,
116 Nassau St., NEW YORK. 214 Monroe St., CHICAGO.

The Mechanism of the Linotype

By JOHN S. THOMPSON

The Latest and Best Work on this Subject

A complete and practical treatise on the installation, operation and care of the Linotype, for the novice as well as the experienced operator, with full information concerning the new two-letter machines, not to be found in any work heretofore published.

Fully illustrated. 128 pages. Cloth, \$1.50 prepaid.

Address all orders to

THE INLAND PRINTER COMPANY
212-214 Monroe St., Chicago 116 Nassau St., New York

STUBBS'S MANUAL

A PRACTICAL TREATISE ON

Linotype Keyboard Manipulation

BY WILLIAM HENRY STUBBS

Holder of Speed Record, 12,021 ems Corrected Matter an
Hour for 5 Hours, 33 Minutes

This little work is especially recommended to the beginner who is anxious to master the art of speedy and accurate keyboard manipulation. To the progressive, painstaking and careful learner this book will prove a boon. It contains 39 pages, the text matter being illustrated with 12 cuts showing proper position of hands in doing certain kinds of work. Bound in cloth, and neatly printed. Price, postpaid, \$1.00.

COST OF PRINTING

By F. W. BALTES.

THIS book presents a system of accounting which has been in successful operation for ten years, is suitable for large or small printing offices, and is a safeguard against omissions, errors and losses. Its use makes it absolutely certain that no work can pass through the office without being charged, and its actual cost in all details shown. Table of Contents; Forms of Job Tag, Job Book, Bindery Tag, Compositor's Daily Time Tag, Total Time on Job in Pressroom, Total Daily Time in Pressroom, Daily Register of Counters, Foreman's Daily Press Record, Form Tag, Time Book, Day Book, Journal and Cash Book, Job Ledger.—Tables: Weekly Summary of Labor, Monthly Register of Counting Machines, Monthly Summary of Press Records, Statement of Wages and Expenses, Cost of Time in Composing Room, Cost of Piecework, Cost of Work on Cylinder Presses, Cost of Work on Job Presses—Measuring Dupes—Paid Jobs—Legal Blanks—Monthly Statement of Loss or Gain—Inventory Books—Notes—Samples and Prices. 74 pages; 6¼ by 10 inches, on 100-lb. S. & S. C. book paper; cloth bound; \$1.50.



The above for sale by

THE INLAND PRINTER COMPANY,

116 Nassau St., NEW YORK.

214 Monroe Street, CHICAGO.

