

THE AMERICAN  
EDUCATOR

PRACTICAL HELP  
IN HOME AND SCHOOL

# AMERICAN



*Education commences at the mother's knee,  
and every word spoken within the hear-  
ing of little children tends towards the  
formation of character.*

*—Ballou*

# EDUCATOR

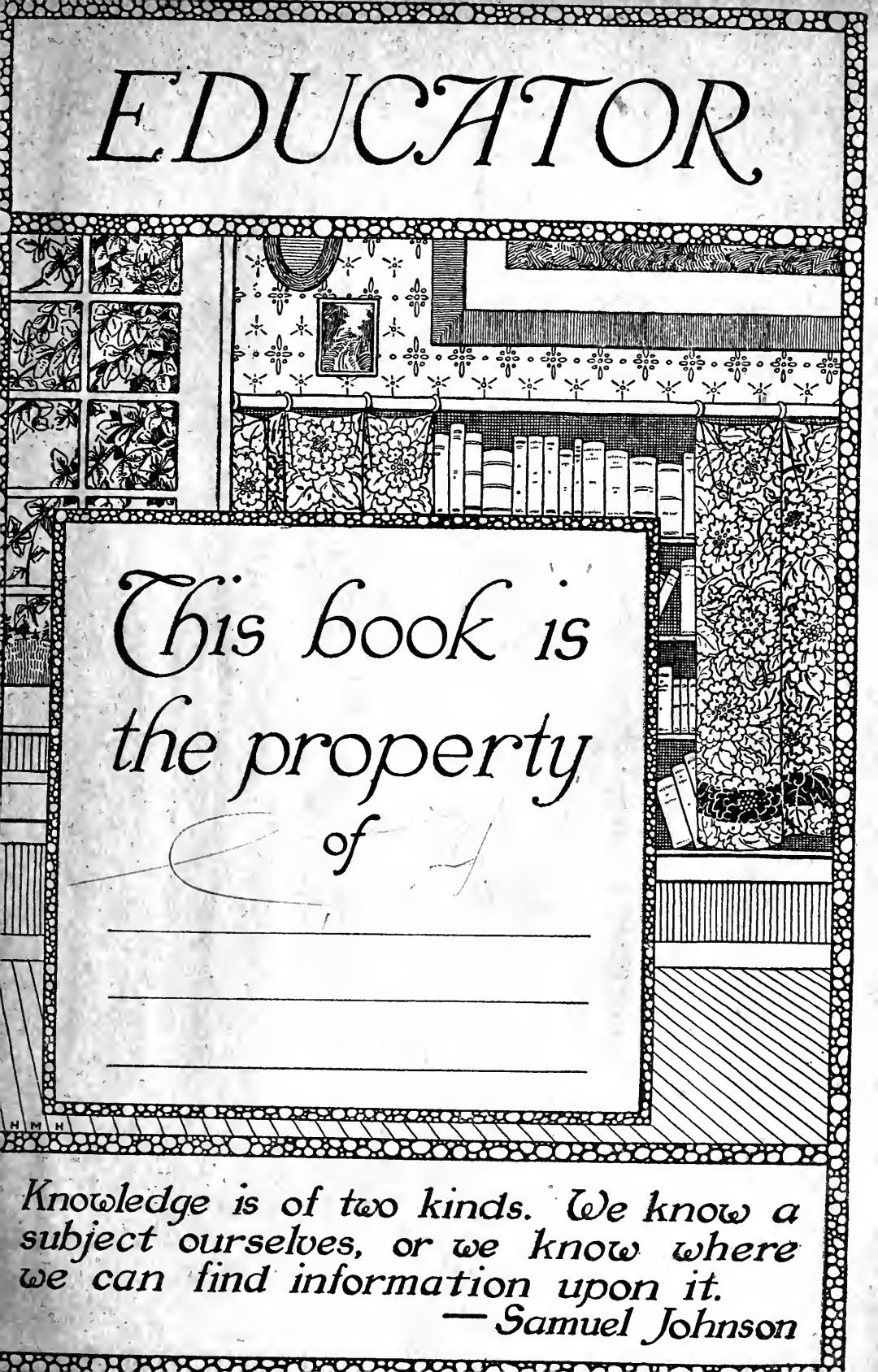

*This book is  
the property  
of*

---

---

---

*Knowledge is of two kinds. We know a  
subject ourselves, or we know where  
we can find information upon it.*

*— Samuel Johnson*

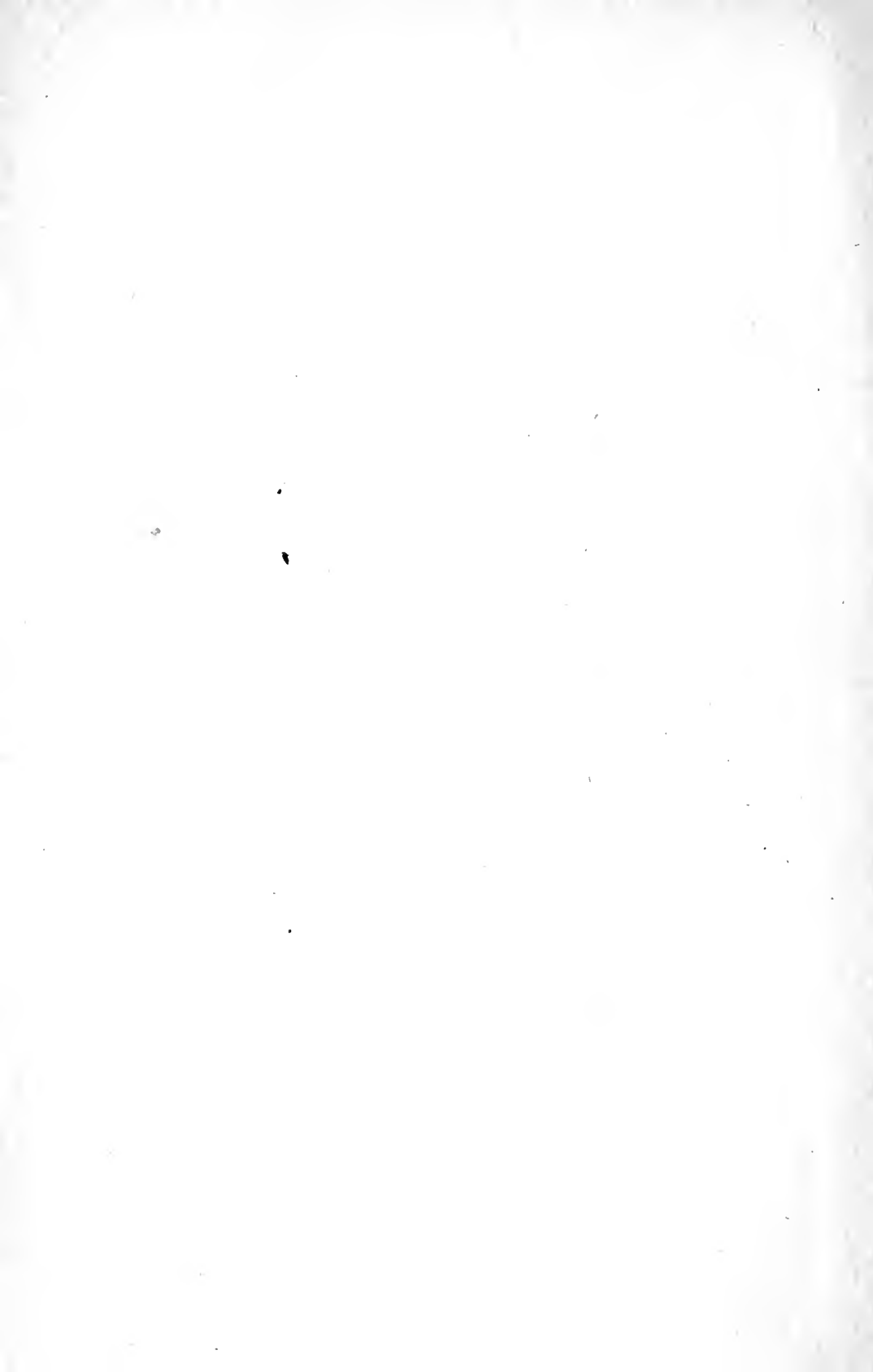

Digitized by the Internet Archive  
in 2010





# THE AMERICAN EDUCATOR,



COMPLETELY REMODELLED AND REWRITTEN FROM ORIGINAL  
TEXT OF THE NEW PRACTICAL REFERENCE LIBRARY, WITH  
NEW PLANS AND ADDITIONAL MATERIAL.



ELLSWORTH D. FOSTER, LL.B.,  
EDITOR IN CHIEF  
EDITOR, THE WORLD BOOK; AUTHOR, CYCLOPEDIA OF CIVIL  
GOVERNMENT



JAMES LAUGHLIN HUGHES  
EDITOR FOR CANADA  
AUTHOR, AND FORMER CHIEF INSPECTOR OF SCHOOLS, TORONTO



PEACE EDITION



IN EIGHT VOLUMES



RALPH DURHAM COMPANY  
PUBLISHERS CHICAGO



1920

Copyright, 1919  
HANSON-BELLOWS PUBLISHING COMPANY



## VOLUME FOUR

**GREYHOUND**, a long, lean dog, distinguished by long muzzle, very low forehead, short lips, thin and long legs, small muscles and contracted abdomen. There are sev-

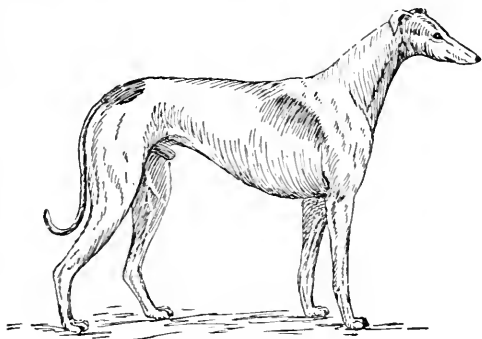

GREYHOUND

eral varieties, as the Irish, the Scottish, the Russian, the Italian and the Turkish. The common greyhound is universally known as the fleetest of dogs. The name appears to have no reference to the color, but is derived from the Icelandic *grey*, a dog. The chief breeds are the Newmarket, the Lancashire and the Scotch. See DOG.

**GRIEG**, *grieg*. EDVARD HAGERUP (1843-1907), one of the most famous of Scandinavian musicians, was born at Bergen, Norway. He studied at Leipzig and at Copenhagen, then made several trips as a concert pianist through Italy, Germany and England, his skill as a performer, his ambition turned him to composition, and to this he devoted the best years of his life. His themes are drawn from Norwegian folk-stories, and the music is full of the vigor and enthusiasm of Scandinavian life. Perhaps his best known composition is the *Peer Gynt Suite*.

**GRIMM**, JAKOB LUDWIG (1785-1863) and WILHELM KARL (1786-1859), the brothers Grimm, as they are generally called, two German scholars who are best known as the joint compilers and authors of a book of fairy tales. Both were born in Hanau, Germany, and were educated at the University of Marburg. Both were banished in 1837 for protesting against the abolition of the consti-

tution by the king of Hanover, but were later recalled and became professors in Berlin. The two brothers worked together until the death of Wilhelm, devoting their labors to an investigation of the earlier language, poetry and laws of Germany. Jakob wrote a *History of the German Language*, a *German Grammar*, *German Mythology* and *Origin of Language*. Together the brothers compiled a *German Dictionary*; and by collecting from old manuscripts and books and by word of mouth the popular legends and fairy tales of their country, they laid the foundation for a science of folk lore. Their nursery tales have made them known the world over.

**Grimm's Fairy Tales**. These stories, although they were put into a book only about a hundred years ago, are very, very old. In fact, they have been told by German mothers to their children for centuries. Of course, no one knows just when they originated, or where; they probably were altered in the telling as they were handed down from generation to generation. In the first half of the last century the two Grimm brothers decided to collect the interesting unwritten folk tales of their native land, so they went out over the country prevailing upon the old people to tell them the stories they had heard as children. *Rumpelstiltskin*, *Tom Thumb*, *Snow White*, *Hänsel and Gretel* and *The Goose Girl* were among the stories that were told to them. They wrote down all the stories just as they were told and arranged them later in a book and called them *Grimm's Fairy Tales*. The fairy tales which these two German scholars collected were translated into many languages and to-day they are read by the children of every land. Their charm is perennially fresh, and they will probably be eagerly read by boys and girls, and older people, also, who love good stories for hundreds of years to come.

**GRINDSTONE**, a circular stone used for sharpening edged tools and smoothing surfaces. Grindstones are made from blocks of sandstone, which are fashioned into the desired shape and size. The stone is mounted on an axis, which passes through the center and is supported at each end on a frame.

Small grindstones are frequently turned by hand or foot, but larger ones are operated by machinery. Those used in factories often weigh several tons. The best material for grindstones is found near Berea, Ohio. Artificial grindstones of small size are made from emery and carborundum. The latter ranks next to the diamond in hardness.

**GRIPPE**, *grip*, (French, *La Grippe*), the name commonly applied to an infectious disease that frequently appears in epidemics during cold, damp seasons. It is described under the heading INFLUENZA.

**GRIQUALAND**, *gré'kwah land*, EAST and WEST, two small provinces in South Africa, near Natal and the old Orange Free State, now parts of the British South African possessions. East Griqualand has an area of 7,594 square miles, and a population of 249,000 people, including 7,900 whites. West Griqualand has 15,197 square miles and a population of 108,500, of which 32,600 are whites. The capital of the former is Kokstad; of the latter, Kimberley, famed for its diamond mines. See KIMBERLEY.

**GRIS-NEZ**, *gré'né*, CAPE, a headland of France, the nearest point of the French shore to that of Britain, the distance being barely 21 miles.

**GRISTLE**, *gris'tl*. See CARTILAGE.

**GROMWELL**, a genus of plants of the borage family. There are about forty species, of which eight or ten are found in the United States. The *field gromwell*, common along roadsides, grows to a height of one foot or more. It has broad, pointed leaves, downy beneath, and the flower has a funnel-shaped corolla. Other names by which the plants are known are *wheat thief*, *red root* and *stone-seed*. The plants bloom in the summer, and their seeds, which are of stony hardness, are often mingled with the seed of grains. Some yield a dye which is similar to the alkanet.

**GROSBEEK**, *gró'sbeek*, a general name for a number of different birds whose beaks are large in proportion to the size of their bodies. In the United States the name is applied to a group of handsome finches that have strong, thick bills, which enable them to crack open even the stones of cherries. The *rose-breasted grosbeak*, which is one of the prettiest, has a sweet, simple little song. The male is largely black, with white lower parts and a beautiful rose-red breast. In the Southern states is found the *blue grosbeak*; to the north and west the *evening grosbeak*,

which sings at night; and in the pine and juniper woods of Canada, the *pine grosbeak*.

**GROTIUS**, *gró'shius*, or **DE GROTT**, HUGO (1583-1645), a distinguished Dutch scholar, the founder of the science of international law. In him were united a profound theologian, a brilliant jurist and an acute thinker. He became chief magistrate of Rotterdam, but was banished as an opposer of strict Calvinism. Later he was Sweden's ambassador to France. He wrote extensively and brilliantly, and his great work *On the Law of War and Peace* is still used as a textbook in international law.

**GROUNDHOG**. See WOODCHUCK.

**GROUND IVY**, a creeping weed of the mint family. The stems are hairy, and the leaves are rough, with scalloped edges. The small, purplish-blue flowers are funnel-shaped. The green part of the plant has a slightly pungent taste and odor.

**GROUND SQUIRREL**, the name of a genus of squirrels, somewhat resembling the marmot. They differ from the common

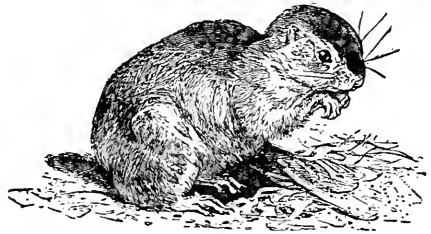

GROUND SQUIRREL

squirrel in that they possess cheek pouches and retreat into burrows. They are well known in America, but species are also found in Asia and Africa. See CHIPMUNK; GOPHER.

**GROUSE**, a group of wild birds, related to the domestic fowls. Grouse usually live on the ground, and they always nest there. During a part of the year they live in families and confine themselves to forests and partially barren regions, where they feed on berries, buds, leaves and insects, which they often uncover by scratching. When hunted, it is their habit to lie hidden until their enemy is almost on them and then fly off rapidly with a great whirring of wings.

The male birds become fierce in the breeding season and, after dancing, drumming and performing various antics before the hens, they fight viciously, the victor mating with the whole flock of hens; as soon as the

females begin to sit, the male leaves them alone to take the entire care of their offspring. The eggs number from eight to fourteen.



GROUSE

The young are very sprightly and leave the nest almost as soon as they are hatched, and on the least alarm they hide themselves skilfully.

In the United States there are a number of different species, chief of which is the *ruffed grouse*, *partridge*, or *pheasant*, as it is called according to locality. This bird is of a brownish color, with a light-spotted breast, and trim, plump form. On the neck of the male are two large patches of black feathers, which open out, fanlike, at times.

The ruffed grouse are considered among the finest American game birds. Most of the states limit to a few months the period during which they may be hunted. The *prairie chicken*, another grouse, once was exceedingly common throughout the Central States, but it has been almost exterminated. The sound the prairie chicken makes is a loud, hollow booming that is almost as peculiar as the drumming of the ruffed grouse. There are a number of different species of the grouse in Europe, where they are favorites with sportsmen.

**Related Articles.** Consult the following titles for additional information:

Partridge      Pheasant      Prairie Chicken

**GRUB**, any thick, wormlike larva (young) of an insect, such as a beetle. See INSECTS.

**GRUNTER.** See GURNARD.

**GUADALAJARA**, *gwah dah lah hah'rah*, MEXICO, capital of the state of Jalisco, situ-

ated in the fruitful valley of Atemajac, on the Rio de Santiago. It is the second city in the republic in size and in importance, has a fine cathedral, a university, a mint, several convents, an art academy, a library and a number of literary and scientific institutions. The Degollado is the largest theater but one in America. Paper, leather and Panama hats are manufactured, and the steel and glass industries are important. Population, 1910, 118,799.

**GUADALQUIVIR**, *gaw dal kwiv'ur*, an important river of Spain, which rises in the frontiers of Murcia, traverses Andalusia from northeast to southwest, passing the towns of Cordova and Seville, and thereafter flowing southwest, falls into the Atlantic. Its course is 250 miles, of which seventy are navigable.

**GUADALUPE HIDALGO**, *gwah da loo' pay he dal'go*, TREATY OF, the treaty between Mexico and the United States at the close of the Mexican War. It was signed February 2, 1848, at Guadalupe Hidalgo, and was ratified the following May. By it the Rio Grande was established as the eastern, and the Gila and Colorado rivers as the western boundary between the two countries. The United States agreed to pay Mexico \$15,000,000 and to assume the payment of all claims, not exceeding \$3,250,000, held by American citizens against Mexico.

**GUADELOUPE**, *gaw de loop'*, a French West Indian colony, in the Lesser Antilles, consists of two islands, with only a narrow intervening channel. The western and larger portion is Basse-Terre, or Guadeloupe proper, twenty-seven miles long and about fifteen miles broad. It is of volcanic formation, the culminating point being La Soufrière, 5,018 feet high. The eastern portion, called Grande-Terre, is nearly thirty miles long by ten to twelve miles broad. It is generally flat and of coral formation. The climate of Guadeloupe is hot and unhealthy, with a humid atmosphere, and hurricanes are frequent and destructive. The soil is fertile and is covered with fine forests. The chief articles of cultivation are sugar, coffee, cacao, bananas and manioc. The chief towns are Basse-Terre, the capital, (8,656 inhabitants), and Pointe-a-Pitre (population, 22,644). After belonging at various times to the English and the French, these islands were ceded to France in 1814. Population, 1912, 212,430.

**GUADIANA**, *gwah de ah'nah*, a river of Spain, which rises in New Castile, flows first northwest, then southwest, into Estremadura; on reaching Badajoz it begins to form part of the boundary between Spain and Portugal, and it finally reaches the Atlantic, below the town of Ayamonte. It has a length of about 520 miles, of which only thirty-five are navigable.

**GUAM**, *gwahm*, an island possession of the United States, in the Ladrone group, in the western Pacific Ocean, about 13° north latitude, and twenty degrees directly east of the Philippine Islands. Guam is thirty miles

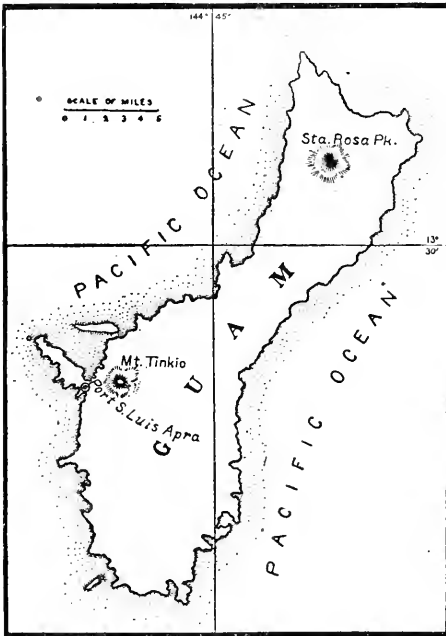

**GUAN**, *gwahn*, a bird related to the grouse and partridge, a native of Central and South America. The birds of one species, the *chachalaca*, range as far north as Texas. The guans are about thirty inches

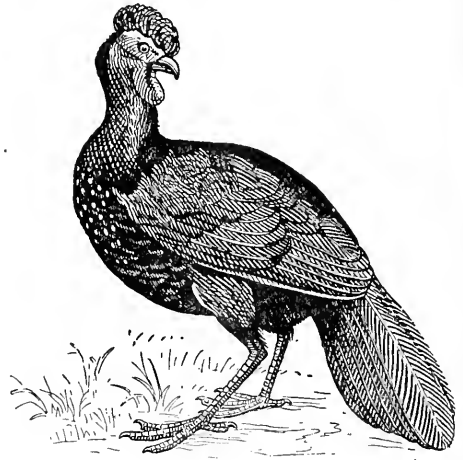

GUAN

long, and the plumage is black, glossed with green. Their heads are often crested and their tails long. Many of them have pendant wattles. They live in flocks, except during the breeding season, when they separate in pairs, and they feed upon fruits and seeds.

**GUANACO**, *gwah nah'koh*, one of a species belonging to the camel family, related to the llama and alpaca, and found in Chile and Patagonia. The animal attains a height of nearly four feet at the shoulders, and is extremely swift and surefooted. The hair is long, reddish and woolly, and the skin is much used for clothing and tents. The natives use the flesh for food, and they drink the milk of the domesticated animals. See ALPACA; LLAMA; CAMEL.

**GUANAJUATO**, *gwah nah whah'toh*, MEXICO, capital of the state of the same name, 165 miles northwest of Mexico City is situated in a narrow defile, hemmed in by mountains, at the height of 6,800 feet above the sea. It has steep, irregular streets. The most important buildings are the cathedral, a college, a gymnasium and a mint. The city is located in the vicinity of extensive silver mines. The leading manufactures are silverware, pottery, soap and chemicals. Population, 1914, 36,020.

**GUANO**, *gwah'no*, a fertilizer consisting of the decomposed excrement of sea birds

long and from four to nine miles wide. It is governed by an officer of the navy and is garrisoned by the marine corps. The natives, about 14,000 in number, are of Malay origin. They have great respect for authority, are docile, and their great ambition is to own land. They are rapidly becoming Americanized in their habits, dress, mode of living and ideals.

The chief products are live stock, copra, corn, rice, tobacco, sugar, sweet potatoes, and most tropical fruits. The island is visited frequently by disastrous typhoons, particularly during October and November. The capital is Agana (population 8,000). The island was ceded by Spain at the close of the Spanish-American War (1898).

that collect in large colonies. The largest deposits were formerly on the Chincha Islands off the coast of Peru, but these have been entirely exhausted, though smaller deposits are found on neighboring islands. In 1918 a valuable guano deposit was discovered on Pelican Island, Lake Miquelon, Alberta. This island has for many years been a bird reserve under the control of the Dominion government, and the government will take charge of the deposits. Because of its scarcity guano increased in cost from \$30 to \$150 per ton. See FERTILIZERS.

**GUARANTEE**, *gar an tee'*, in law, a written promise by which a person binds himself to answer for the failure of another. No person is liable on any special promise to answer for the debt, default or miscarriage of another person, unless a written agreement, or some memorandum in writing for such purpose, shall be signed by the promiser or some other party lawfully authorized by him. It is a general rule that the guarantor shall not be bound beyond the express words of the engagement.

**GUARD, NATIONAL.** See NATIONAL GUARD.

**GUARDIAN**, *gahr'de an*, in law, the custodian of a person incapable of directing himself; especially, the custodian of a person under twenty-one years of age. A guardian is not allowed to reap any benefit from his ward's estate, but must account for all profits. He can invest the money of his ward in real estate only by order of the court, and he can convert real estate into personal property only by a similar order. If he spends more than the interest and profits of the estate in the maintenance and education of the ward, without permission of court, he may be held liable for the principal thus consumed. He is entitled to the care and custody of the person of his ward. Guardianship lasts until the ward has attained legal age.

**GUATEMALA**, *gwah te mah'tah*, the largest and most important of the Central American republics, and the most northerly, has an area of 49,290 square miles and a population (1918) of 2,119,000. The climate is diversified, owing to the elevation of the central and southern regions. Its tropical location gives it naturally warm, moist weather, but the highlands are cooler, and more thickly settled than the lowlands. The lowlands are unsuited to white people, but the natives thrive fairly well in the humid atmosphere, despite ever-threatening fevers.

Over three-fifths of the people are Indians; the remainder are Spanish and mixed breeds, the latter predominating. The foreign population is small. There is no state religion, and there is freedom of worship, but nearly all the people are Roman Catholic. The capital city, Guatemala, was completely destroyed by earthquakes on January 3 and 4, 1917, but rebuilding was at once commenced (see GUATEMALA). Other cities are Quezaltenango (28,940 people), Coban (30,770), and Totonicapan (28,310).

The soil is fertile, and the principal products are corn, some wheat, rice, coffee, indigo, cotton, tobacco, sugar, cacao, and all tropical fruits. Most of the trade is with Great Britain and the United States.

The republic was established in 1847, after the country had been for nearly fifty years a member of the Confederation of Central America. The last modification of the constitution occurred in 1903. There is a National Assembly, consisting of one member for every 20,000 people, elected by universal male suffrage, and a Council of State, corresponding to the American Senate, consisting of thirteen members, partly chosen by the National Assembly and partly by the President of the republic. The President's term is six years. See CENTRAL AMERICA.

**GUATEMALA**, until 1917 the capital of the Central American republic of the same name, and destined again to be the capital. On January 3 and 4 of that year it was completely destroyed by disastrous earthquakes. The population was about 90,000. It was one of the handsomest cities of Central America, with an old viceregal palace, a costly cathedral, a bishop's palace and several fine public libraries. Rebuilding operations were in contemplation soon after the disaster, but reconstruction was regarded as a matter requiring several years.

**GUAVA**, *gwah'vah*, the popular name for certain small tropical trees with square branches, egg-shaped leaves and large white flowers. The fruits are fleshy berries, which are usually apple-shaped or pear-shaped. The pulp is of an agreeable flavor, and a delicious jelly is made from it. Florida and California have profitable yields of the fruit, the annual crop being valued at over \$11,500. The species cultivated in these states is the *lemon guava*, which grows about twenty feet high. An illustration of the guava appears on page 1590.

**GUAYAQUIL**, *gwah ya keel'*, ECUADOR, the most important seaport of the country, is situated on the west bank of the Guayas River, forty miles from its mouth. This



GUAVA

river empties into the Gulf of Guayaquil, an arm of the Pacific Ocean. The city has an annual export trade valued at more than \$15,000,000, and an import trade exceeding \$7,000,000. Its exports consist chiefly of cacao, coffee, quinine, hides, gold and silver, Panama hats and ivory nuts.

The city has an unhealthy location on a low plain, and is divided into old and new parts. In the latter are the homes of the better class and the important business establishments. Guayaquil is a two-days' journey from Quito, capital of Ecuador. Connection is made by way of Duran, opposite Guayaquil, the capital and Duran being joined by a railroad. Guayaquil enjoys electric car and telephone service, and has telegraph, cable and steamer communication with various parts of the world. Its industrial establishments include shipbuilding yards, sawmills, textile factories and sugar refineries. Population, 1915, estimated, 105,000.

**GUDGEON**, *guf'on*, a fresh-water fish, belonging to the carp family, common in rivers

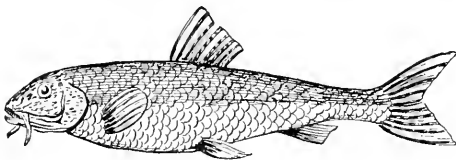

GUDGEON

of England. Neither jaw is furnished with teeth, but at the entrance of the throat there

are two triangular bones, which perform the office of grinders. These fish measure about six inches in length, and are marketed for the table.

**GUEBERS**, or **GUEBRES**, *ge'burz* or *ga'burz*. See **GIEBERS**.

**GUELDER**, *gel'dur*, **ROSE**, a name frequently given to the cultivated variety of the high-bush cranberry. On account of the shape and color of the flower clusters, it is sometimes called the snowball; the other name is derived from that of the Dutch province Guelderland, where, it is said, the plant grew originally. Cultivated varieties bear no fruit, but there is a wild guelder rose which produces pretty red berries.

**GUELPH**, *gwelf*, ONT., in Wellington County, on the Speed River and on the Grand Trunk and Canadian Pacific railroads. The river here has a fall of thirty feet, and furnishes power for organ and piano factories, flouring mills, iron foundries, woolen mills, sewing machine, furniture, boot-and-shoe and farm-implement factories. The surrounding country is agricultural and is also notable for stock raising. Here are the Ontario Agricultural College and the Macdonald Institute of Domestic Science. The town was settled in 1827, and became a city in 1877. Population, 1911, 15,175.

**GUELPHS AND Ghibellines**, *gwelfs*, *gib'el inz*, the names of two great Italian political factions in the thirteenth and fourteenth centuries. The names are corruptions of the German *Welf* and *Waiblingen*, party designations in Germany in the war between Welf VI of Bavaria and Conrad of Hohenstaufen, to whom belonged the estate of Waiblingen. About the year 1200 the terms Guelph and Ghibelline came to denote, respectively, the Italian patriotic party, which demanded an Italy freed from German interference, and the imperial party, which supported the domination of the German emperors in Italy. After the fall of the Hohenstaufens, the Ghibellines became the partisans of aristocracy and the Guelphs were the partisans of democracy and liberty; but the designations came in time to denote mere family feuds.

**GUERIN**, *ga raN'*, **JULES** (1866- ), an American artist born at Saint Louis, Mo. After studying in Paris he returned to America and developed a distinct style in colored magazine illustrations. His pictures, usually of architecture or landscape, are in flat

tones. The method is similar to that employed by present-day Japanese artists, though the effect produced is different. Mr. Guerin received awards at the international expositions at Chicago, Paris, Buffalo and Saint Louis, and had charge of the decorations of the Panama-Pacific Exposition in 1914. He is a member of the National Institute of Arts and Letters.

**GUERNSEY**, *gurn'zy*, the second largest and most western of the Channel Islands (which see), lying off the north coast of France, forty-six miles from Cherbourg and about sixty-eight miles southeast of Start Point in Devonshire. Guernsey is especially famous for its fine breed of cows. Horticulture and floriculture also receive much attention, and fruits, especially figs and grapes, are very abundant. The chief towns are Saint Peter Port, the capital, and Saint Sampson. The island has an area of twenty-five square miles. French is the prevailing language, though all of the Channel Islands have been under British rule since 1204. Population, about 43,000.

**GUERRIERE** *gair yair'*, THE. See CONSTITUTION, THE.

**GUIANA**. See BRITISH GUIANA; DUTCH GUIANA; FRENCH GUIANA.

**GUIDO RENI**, *gwe doh ra'ne* (1575-1642), a celebrated Italian painter, born at Bologna, the son of a musician. He studied music, but was allowed to follow his greater artistic bent. After his twentieth year he followed the ideals of the Eclectic, or Bolognese, school of painting, and became one of its chief masters. Artists of the Eclectic school advocated the bringing together of the best points of various systems. Guido Reni is particularly noted for the gentleness and sweetness of his characters. He was a good colorist and draughtsman, but lacked some of the originality that characterized other great artists. Among his most famous works are *Aurora*, *Magdalene*, *Michael Vanquishing Satan*, *Lot and His Daughters*, *Fortune and Rape of Helen*.

**GUILD**, *gild*, a society or association for carrying on commerce, a handicraft or some other undertaking. Such associations have been known from very early times in various countries, and they played a very important part in the Middle Ages. They often formed a bulwark against the oppression of the nobility and were thus conducive to the growth of municipal and civil liberty. In the

thirteenth century the German guilds of craftsmen obtained the right of defending by arms their own interests, and they became so powerful that persons unconnected with the trade were often glad to attach themselves to them. With the view of destroying the influence which they had acquired, emperors at different times abolished them by decree, but it was not until late in the nineteenth century that unrestricted freedom to practice any trade was established in Germany. In Great Britain trade guilds long possessed an importance which was mainly political. As the right of voting was involved in the membership of a guild, many persons acquired the rights of "freemen" by connecting themselves with some body of this kind. In England, these guilds had no legal right to prevent any man from practicing what trade he pleased. The guilds, or companies, of the city of London are still very important corporations, which give relief to poor and disabled members and also manage vast funds bequeathed for benevolent purposes. Many of the trades unions, especially in the United States, have now somewhat of the character of the ancient guilds.

**GUILDER**, *gil'dur*, or **GULDEN**, *gool'den*, the monetary unit of Holland, having a value of 40.2 cents. The coin is also called florin (which see).

**GUILFORD**, *gil'ford*, **COURT HOUSE**, **BATTLE OF**, a brief but hotly contested battle of the Revolutionary War, fought on March 15, 1781, between an American force under Greene and a smaller English force under Cornwallis, in which the former lost 400 and the latter 600 in dead, wounded and prisoners. Neither side gained a decisive advantage, but the engagement resulted in a strategic victory for Greene, who marched back to South Carolina and drove the southern division of the British forces back to Charleston. Cornwallis, on account of his heavy losses, retreated to Wilmington, abandoning the interior of the state, which he had been struggling to possess. When he saw that no gain could be made by the British he wrote to Washington, asking what would be his terms of surrender.

**GUILLEMOT**, *gil'e mot*, the name of several species of web-footed birds, belonging to the auk family. The birds inhabit the Arctic regions of both hemispheres and the colder parts of the temperate zone, migrating south in winter. They have straight, compressed

bills, covered with feathers as far as the nostrils; short, pointed wings, and short legs, far back under the body. They live principally on fish and build their nests on steep rocks near the sea. The bird lays but one egg, which is three inches long, pear-shaped and has a very hard shell. See **AUK**.

**GUILLOTINE**, *gil lo teen'*, an engine for beheading persons at one stroke, invented during the Middle Ages and adopted by the National Assembly of France during the

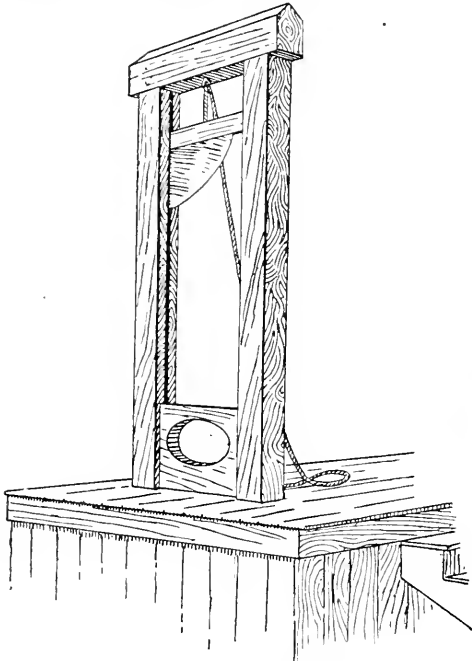

THE GUILLOTINE

French Revolution, on the proposal of Dr. Guillotin, after whom it is named. In this apparatus decapitation is effected by means of a steel blade, loaded with a mass of lead, and having a slanting edge. This blade slides between two upright posts, grooved on their inner sides. The victim's neck is confined in a circular opening between two planks, the upper one of which also slides up or down. A vivid description of the guillotine occurs in Dickens' *Tale of Two Cities*.

**GUINEA**, *gin'ee*, a geographical term applied to certain regions in West Africa bordering on the Atlantic Ocean. The name is usually restricted to Portuguese Guinea, a colony of about 14,000 square miles adjoining French Senegambia (see **PORTUGUESE GUINEA**). As formerly known, Guinea was

divided into two districts. That called North, or Upper, Guinea, included Sierra Leone, Liberia, the Grain, Ivory, Gold and Slave coasts, the states Ashantee, Dahomey, Benin; the division known as South, or Lower, Guinea, included Congo, Angola and Benguela.

**GUINEA**, an old English coin worth twenty-one shillings, or about \$5.04. Guineas were first coined in the reign of Charles II (1663), of gold brought from Guinea; they bore the figure of an elephant. In 1817 the coin was withdrawn from circulation, being superseded by the sovereign. It is, however, still customary to estimate professional fees in guineas, and the name is occasionally used in literature as a symbol for money.

**GUINEA FOWL**, a genus of pheasants, originally all natives of Africa. The common

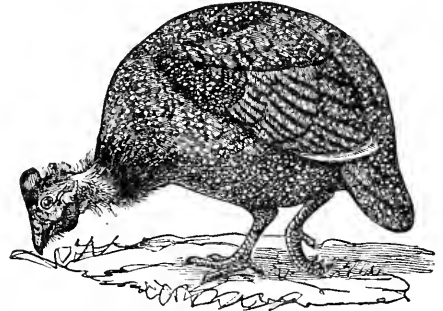

GUINEA FOWL

guinea hen, now well known as a domestic fowl, has slate-colored plumage, speckled with white. It is about the size of a common fowl, and is of a noisy and quarrelsome disposition.

**GUINEA PIG**, a tailless little animal, about six inches long, usually variously

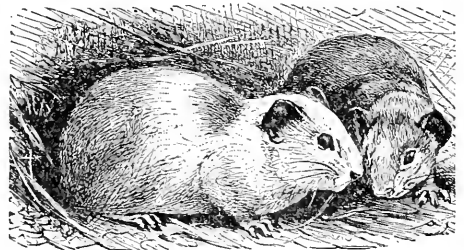

GUINEA PIGS

spotted with black, white and brown. It is in fact not a pig at all but a cavy, that is, an animal resembling in some respects rats and rabbits. Guinea pigs are timid little creatures that feed on vegetable food, and



they breed very rapidly. They are extensively used in bacteriological laboratories for the study of germ diseases; because they are clean and easily cared for they make attractive pets for children.

**GUISE**, *gweez*, a distinguished ducal family of France, a branch of the House of Lorraine. Several of its members took an important part in French history. The family acquired great political influence on the accession to the French throne of Francis II, who had been married to Mary Queen of Scots, the granddaughter of the first duke of Guise. Among the most famous of the family was FRANÇOIS OF LORRAINE, Duke of Guise (1519-1563), who early distinguished himself in war, especially at Metz, which he successfully defended against the attack of Charles V. Under Henry II and Francis II he was the real ruler of France. On the death of Francis II he was driven from France, but was recalled to take charge of the armies against the Huguenots (Protestants). While preparing to besiege Orleans, the central point of the Protestant party, he was assassinated. His son, Henry I of Lorraine, third Duke of Guise (1550-1588), became the leader of the Catholic party on the death of his father and took a prominent part in the wars against the Huguenots. He was a leader in the massacre of Saint Bartholomew, and for sake of revenge he personally conducted the assassins to the house of Coligny, the Huguenot leader. After defeating the allies of the Huguenots, he advanced to Paris. Henry III, afraid of his power, forbade him to enter. Guise disregarded the command and was received with great enthusiasm by the people. Henry, fearing Guise would make himself king, invited him to a conference and had him assassinated.

**GUITAR**, *ge tah'r'*, a stringed musical instrument, with a hollow body and a neck somewhat similar to that of a violin, used especially to accompany the voice. The modern, or Spanish, guitar has six strings, the three highest being made of gut, the three lowest, of silk, covered with fine wire. The tone is produced by vibration of the strings, from picking with the fingers and the pitch is regulated by pressing the wire against brass frets in the neck of the instrument, thus changing the length of the vibrating segment. The first, second and third fingers sound the three highest tones, the thumb the deepest,

and the little finger rests on the sounding board.

**GUIZOT**, *ge zo'*, FRANÇOIS PIERRE GUILLAUME (1787-1874), a French historian and statesman. In 1805 he commenced legal studies at Paris, but gradually drifted into the literary profession. In 1812 he became professor of history at the Sorbonne. On the fall of the Empire he obtained several public offices, such as councilor of state and director-general of the departmental and communal administration. He lost his offices and his position at the Sorbonne, on account of his openly expressed political principles, but in 1829 he was permitted to resume his lectures. After the July revolution of 1830, he was appointed minister of the interior, but resigned in 1831. After the death of Périer, Guizot helped to form a coalition ministry, and he rendered great service as Minister of Public Instruction. He became ambassador at the British court in 1840, and in the next year became the real head of the government of which Soult was the nominal chief. He retained the office of Minister of foreign Affairs until 1848, and during that period he opposed all measures of reform. After the fall of Louis Philippe, Guizot escaped and fled to England. Henceforth he practically retired from public life. Among his numerous works may be mentioned *The History of Civilization in France*, *General History of Civilization in Europe*, *History of the English Revolution*, *Washington* and *The History of France from the Earliest Times to the Year 1789*.

**GULDEN**, *gool'den*. See GUILDER.

**GULF STREAM**, one of the most celebrated of the oceanic currents, so called because it issues from the Gulf of Mexico. It owes its origin to the fact that the westward-moving waters of the tropical portion of the Atlantic, encountering the eastward projection of South America, become divided into two currents, one setting southward along the Brazilian coast, and the other northward past the mouths of the Amazon and Orinoco, into the Caribbean Sea. It enters the Gulf of Mexico and thence emerges through the channel of Florida as

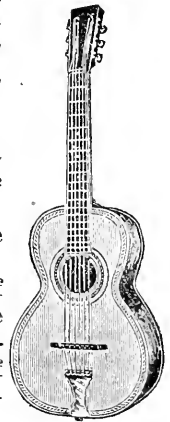

GUITAR

the Gulf Stream. Its course is next to the north and east, in a direction parallel to the coast of the United States, past Cape Hatteras, along the southern edge of the "great banks" of Nantucket and Newfoundland, after which it loses identity as a distinct current.

Stream on the temperature of Europe. If it possesses any *direct* influence, such must be extremely small, as the current is both too narrow and too shallow, and its slight amount of superior heat probably vanishes after it has passed Cape Hatteras. The relatively high temperature of western and north-

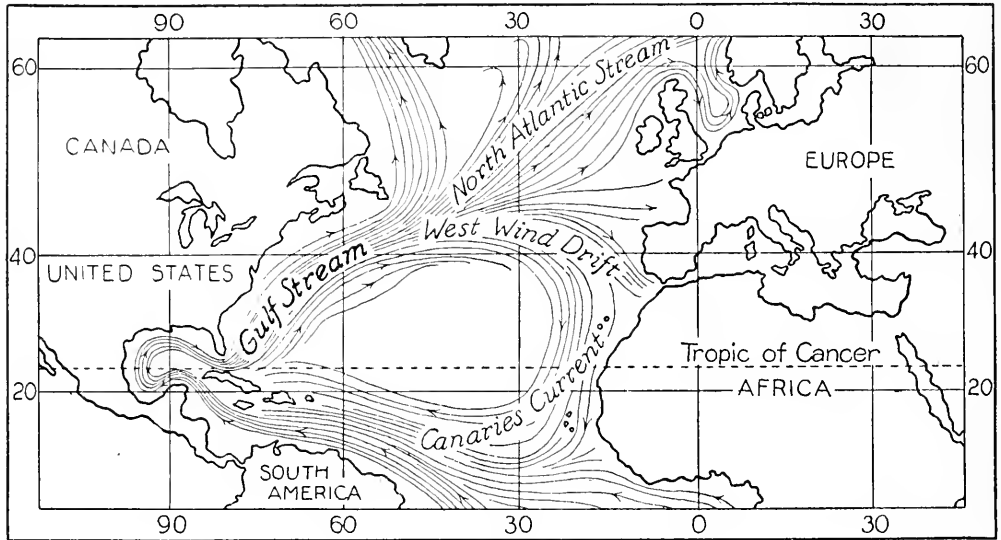

COURSE OF THE GULF STREAM

In the earlier part of its course, especially when rounding the extremity of Florida, the Gulf Stream forms a well-defined current, distinguished by its high temperature and its deep blue or indigo color. On account of the descent of the Polar, or Labrador, current along the coast in a direction opposite to that of the Gulf Stream, the water on its inland side is colder than that to the eastward of it. The difference of temperature between the Gulf Stream and this cold current sometimes amounts to 20° or 30°.

The velocity of the Gulf Stream varies with its course. Within the Florida channel it attains a mean velocity of sixty-five miles per day; this sinks to fifty-six miles off Charleston, becomes thirty-six miles to forty-six miles off Nantucket and twenty-eight miles to the south of the Newfoundland Banks; three hundred miles to the eastward of Newfoundland its movement is hardly perceptible.

At the bottom of the Florida channel the observed temperature is 34°, that of the surface from 80° to 84°. Geographers have greatly exaggerated the influence of the Gulf

western Europe must rather be referred to the general set of the tropical waters to the northeast, and to the warm winds blowing in the same direction. See OCEAN CURRENTS.

**GULICK, LUTHER HALSEY** (1865-1918), an American specialist in physical education, who founded, in coöperation with his wife, the organization known as the Camp-Fire Girls (which see). He was born in Honolulu, and was educated at Oberlin Academy, at the Sargent Normal School of Physical Training and at the medical department of New York University. From 1903 to 1908 he directed physical training in the New York City public schools, and between 1908 and 1913 had charge of the department of child hygiene of the Russell Sage Foundation. Since 1913 he has been president of the Camp-Fire Girls. He wrote extensively on his special subject.

**GULLIVER'S TRAVELS**, a satirical romance by Jonathan Swift, the greatest of English satirists. Lemuel Gulliver, the hero of the book, at first a surgeon and afterwards a sea-captain, is wrecked off the island of Lilliput, land of Pygmies; he voyages to

Brobdingnag, land of Giants; visits Laputa, a country of quacks and pretended scientists, and lastly journeys to a sort of Utopia where live the Houyhnhnms, which were horses endowed with superior intelligence. The work is an unrivalled satire on mankind. With certain parts omitted it is one of the most delightful books for children ever written.

**GULLS**, *gulz*, birds that live along the seacoast and on large bodies of waters of the interior, in almost all parts of the world. They are very graceful on the wing and are seen usually in large flocks, especially in the wake of steamers. They catch fish with great

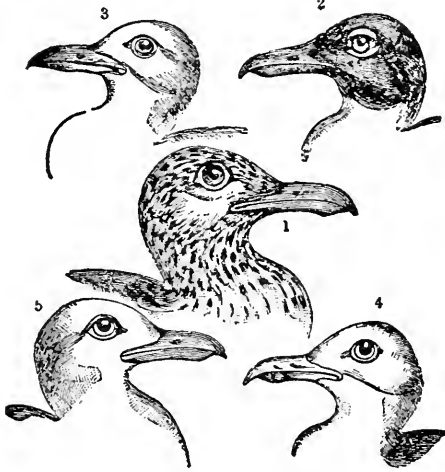

GULLS

1. Great black-backed; 2. black-headed; 3. kittiwake; 4. lesser black-backed; 5. herring gull.

skill, but are quite content to follow ships or to hang about harbors, gathering in the refuse from sewers, buildings and shipping. Unlike terns, they do not plunge beneath the water, but pick food from the surface.

There are a great many species, many of which resemble one another so closely that the ordinary observer cannot distinguish between them. Their prevailing colors are white or bluish-gray, but black, slate color and brown are mixed in various ways in some species. The *great black-backed gull*, the *herring gull*, the *laughing*, or *black-headed*, gull, *Bonaparte's gull* and the *kittiwake gull* are common American species. The *lesser black-backed gull* belongs to Europe.

**GUM**, a general name applied to a variety of substances obtained from the sap which exudes from certain trees, such as the peach

and plum. Gums form non-crystalline, rounded drops, or tears, the purest varieties being transparent or translucent, usually pale yellow, but sometimes of a dark color. When dissolved in water, gum forms a thick, smooth fluid, which is more or less sticky. Some gums, such as gum arabic, dissolve in water; others, like tragacanth, are only partially soluble; all are insoluble in alcohol and are thus distinguished from resins. They have no odor and only a very faint taste. The different kinds of gum receive their names from the countries from which they are imported—as gum arabic, used in the manufacture of medicines, candy and glue; gum Senegal; Barbary gum and East India gum; and from their individual features—as cherry-tree gum and tragacanth, used as a mixing agent in pharmacy. *Gum resins* require both water and alcohol to dissolve them.

**Related Articles.** Consult the following titles for additional information:  
Chewing Gum Gum Resins Resins

**GUM AR'ABIC**, a yellowish or reddish gum, gathered from several species of acacia trees that grow in Asia and Northern Africa. It is used in thickening ink and in making mucilage and pastes. See MUCILAGE.

**GUM'BO**, a soup having a base of chicken stock and thickened with gumbo, or okra pods. Gumbo, or okra, is a plant of the hibiscus family, and has a high percentage of mucilage. The unripe pods are excellent for thickening, and gumbo is one of the most popular soups in the Southern United States. The plant is native to the West Indies.

**GUMBOIL**, an abscess in the gum, generally the result of toothache or of the presence of decayed teeth or stumps. A sore of this kind should be treated by a reliable dentist. Decayed teeth and stumps are usually removed, and the abscess is lanced.

**GUM RESINS**, *rez'inz*, solidified juices obtained from plants. They contain a gum, which is soluble in water, and a resin, which dissolves in spirits; any gum resin, therefore, is generally nearly soluble in dilute alcohol. In addition there are usually present essential oil and a variety of impurities. The gum resins have frequently a strong and peculiar taste and smell. They are solid, opaque and brittle, and are used chiefly in medicine. The common gum resins are aloes, asafoetida, gamboge, ammoniac and myrrh. See GUM; RESINS.

**GUN.** See CANNON; RIFLE; HOWITZER.

**GUNBOAT**, a term applied to small war vessels, mounting usually a single gun and employed in coast defense. They are armed with one or more deck guns, which can be turned in any direction by means of a pivot. Except for patrolling where there is slight danger of meeting with heavy resistance, the gunboat is now obsolete.

**GUNCOTTON**, a highly explosive compound, made by soaking vegetable fiber in a mixture of nitric and sulphuric acids and allowing it to dry. Cotton is the fiber generally used, hence the name *guncotton*. Guncotton is used in the manufacture of celluloid, collodion and varnishes. Military guncotton is highly explosive and is used for charging torpedoes and in exploding mines. A form of guncotton known as *pyrocellulose* is used in making smokeless powder. See **TORPEDO**; **SUBMARINE MINE**.

**GUNPOWDER**, an explosive, consisting of a mixture of saltpeter, sulphur and charcoal. The origin of gunpowder is unknown. It was used by the Chinese before the beginning of the Christian Era, and it was known to the nations of Europe in the thirteenth century; but it did not come into general use in war until the sixteenth century.

The first essential in the manufacture of gunpowder is purity of materials. The saltpeter is purified by dissolving it in hot water and allowing it to crystallize. The sulphur is purified by distillation, and the charcoal is obtained by burning willow or alder in cast-iron retorts. Each of these substances is ground to powder; then all three are mixed in the proper proportions in revolving cylinders. The mixture is then moistened and ground between heavy stone rollers. The lime thus produced is sent to a hydraulic press, where it is subjected to different degrees of pressure, according to the grade of powder desired. A high pressure produces powder that burns quickly and has a high explosive power, while a low pressure gives a slow-burning powder. As the mass, called the *press cake*, leaves the press, it goes to the granulating machine, where toothed rollers break it into grains of various sizes, which are sorted by a series of screens. The powder is then polished by being placed for several hours in revolving wooden barrels. After this it is dried and is ready for use. The powder used in rifles is more highly explosive than that used for blasting and in cannon. Blasting powder contains 70 parts saltpeter,

18 parts sulphur and 12 parts charcoal. That used in cannon contains 75 parts saltpeter, 15 parts sulphur and 10 parts charcoal. Smokeless powder, dynamite and other explosives have largely replaced powder for many purposes. See **EXPLOSIVES**.

**GUNPOWDER PLOT**, a conspiracy formed in England in the reign of James I, by a group of Roman Catholics who were incensed at the government because of its severity toward them. They planned to put to death the king and members of Parliament, by wrecking the Houses of Parliament by an explosion of powder.

The plot originated with Robert Catesby, Guy Fawkes and others, and the time fixed for its execution was November 5, 1605, when Parliament was to be opened by the king in person. The plot was discovered by means of a letter sent by one of the conspirators to a relative of his, a Catholic peer in favor with the court, warning him not to be present at the approaching meeting of Parliament. Fawkes, with several others, was tried at Westminster and put to death.

**GURN'ARD**, a family of fishes of which there are about forty known species. The head is angular and covered with bony plates; the body is long and tapering. The three lower rays of the breast fins are detached and are used as feelers. The fish make their home in very deep waters; when brought to the surface they make a peculiar noise which has given them the name of *grunters*. In the United States and Canada they are also known as *sea robins*. One species, found on both sides of the Atlantic, is called the *flying gurnard*, because of its enormous, winglike fins. Many of the gurnards are beautifully colored.

**GUSTAVE V**, (1858- ), king of Sweden and son of Oscar II, came to the throne in December, 1907, on the death of his father. The new queen was Princess Victoria of Baden, a cousin of Emperor William II of Germany. During the years before his accession Gustave frequently acted as vice-regent, filling the position with



GUSTAVE V

such capability as to assure his success as king. By advocating a strong military policy he won the opposition of the Socialists and Liberals. During the World War he labored to keep the country strictly neutral, and in this he was successful.

**GUSTAVUS I**, commonly called **GUSTAVUS VASA** (1496-1560), king of Sweden. He was the son of a Swedish noble, served in the struggle for Swedish independence, was treacherously carried off with other Swedes by the king of Denmark and was kept a prisoner in Jutland for more than a year. At length, however, he escaped, reached, after many dangers, Dalecarlia, where he roused the peasants to resist Danish oppression, defeated the Danes, took Upsala and other towns and in 1523 was elected king. In 1529 he procured the abolition of the Roman Catholic religion in Sweden and established Protestantism. During his long reign Sweden made great progress in commerce and civilization.

**GUSTAVUS II ADOLPHUS** (1594-1632), king of Sweden, a grandson of Gustavus Vasa, came to the throne in 1611. He was trained to war, took his place in the state councils at the age of sixteen, and was in command of the army in his seventeenth year during the war with Denmark, by which Sweden recovered important possessions on the Baltic. He then turned his arms against the Russians and drove them from Ingria, Karelia and a part of Livonia, which were secured to him by the peace of Stolbova in 1617.



His first great war was that with Poland, which lasted nine years and was concluded favorably for Gustavus in 1629. His attention was then diverted from northern wars by the affairs of Germany. The oppression of the Protestants by Ferdinand II excited his sympathy, and the progress of Wallenstein alarmed him; perhaps, too, he was moved by ambition for foreign conquests. He embarked for Ger-

many in 1630, landed near the mouth of the Oder and in a short time had seized nearly all of Pomerania. After taking many fortified towns, defeating the imperial generals and conquering a great part of Germany, he was killed in the Battle of Lützen, in which, however, his army was victorious (see THIRTY YEARS' WAR). Though a severe disciplinarian, he was beloved by his soldiers, and the prestige of success derived from his victories lasted long after his death.

**GUSTAVUS III** (1746-1792), king of Sweden, succeeded to the throne in 1771. Finding the country weary of the misrule of the nobles, he gained the good will of the army, surrounded the States-General and forced it to accept a new constitution, which much restricted its privileges. In 1788 he took command of the army against Russia and Denmark, but accomplished nothing of importance. On the outbreak of the French Revolution he tried to form a coalition between Russia, Denmark, Sweden and Spain, but while he was making his preparations, a conspiracy of the nobles was formed against him and he was shot at a masked ball.

**GUSTAVUS IV ADOLPHUS** (1778-1837), king of Sweden, son of Gustavus III, whom he succeeded in 1792. On assuming power Gustavus showed that he had inherited his father's hatred of the principles of the French Revolution, which he carried to the extent of fanaticism. After the Peace of Tilsit he exposed himself to a war with Russia while he was at war with France, by refusing to join the Continental blockade and by opening his ports to England; and in 1808 he quarreled with England, his only ally. Finland was lost to Sweden, and in 1809 a revolution took place, in which Gustavus was dethroned, and his uncle, the duke of Sudermania, was proclaimed king as Charles XIII.

**GUTENBERG**, *goo'ten berK* JOHANNES, (1400-1468), the inventor of the process of printing with movable type. His original name was JOHANN HENNE GENSFLEISCH; Gutenberg was probably his mother's family name. Of the details of his life, apart from the invention which has immortalized him, but little is known. He was born in Mainz, of noble family, and was a prominent man in his native city until, in about 1420, he was, with others, obliged to leave, on account of political dissensions. He took refuge in Strassburg, spent twenty-four years there,

and then returned to Mainz, where he formed a partnership with Johann Faust, or Fust, a money lender, who advanced money to set up a printing press. Faust dissolved the partnership and, since Gutenberg could not repay the sum advanced, took possession of most of the printing outfit.

Faust and his son-in-law, Peter Schöffer, continued the business and claimed the credit of the invention, but the latter's son, Johann Schöffer, states in a preface of 1505 that the "admirable art of printing was invented in Mainz in 1450 by the ingenious Johann Gutenberg and was subsequently improved and handed down to posterity by the capital and labor of Johann Faust and Peter Schöffer."

The invention of the modern art of type printing has by some been ascribed to a Dutchman named Koster, but a thorough investigation has firmly established Gutenberg's claims. Gutenberg is known to have printed several religious books, but as his name did not appear on any of his printed works, it has been difficult to identify them, impossible, indeed, in many instances.

As has been true of many pioneers in invention and discovery, Gutenberg never was successful financially; in his last years he was the recipient of a modest pension from scholars who were profoundly grateful to him. Statues have been erected in his honor in many cities, among which is one by Thorwaldsen, erected in 1837 in Mainz. See PRINTING.

**GUTHRIE**, OKLA., the county seat of Logan County, and formerly capital of the state, thirty miles north of Oklahoma City, on Cottonwood Creek and on the Missouri, Kansas & Texas, the Santa Fe, the Chicago, Rock Island & Pacific, the Fort Smith & Western, the Oklahoma Eastern and the El Paso & Western railroads. The city was laid out and settled in 1889, on the day that the territory was opened for settlement, and was the capital from 1890 to 1911. It developed rapidly and now has an extensive trade. The factories include cottonseed oil, lumber and flour mills, foundries and machine shops, and cotton-spinning factories, and there is a creamery. The principal buildings are a city hall, a Carnegie Library and a Scottish Rite Temple. The city has the State Methodist University and Saint Joseph's Academy. The commission form of government was adopted in 1911. Popula-

tion, 1910, 11,654; in 1917, 12,098 (Federal estimate).

**GUTTA-PERCHA**, *gut'ta pur'cha*, a substance resembling india rubber in many of its properties, but stronger, more soluble and less elastic. It is the milky juice of certain trees found in Malacca, Borneo and other islands of the Indian Archipelago. When pure, gutta-percha is of a brownish-red color. Below the temperature of 50°, it is as hard



GUTTA-PERCHA

as wood and excessively tough. By an increase of heat it becomes more flexible, until, at a temperature of 115° F., it becomes pasty, and between this and 140° or 150° it may be molded into all varieties of forms with the greatest ease, retaining precisely the same form as it cools and hardens. It is insoluble in water, is soluble with difficulty in ether and other rubber solvents, but mixes very readily with oil of turpentine and naphtha. It is not attacked by solutions of alkalies nor by hydrofluoric acid, but it is acted on by sulphuric, nitric and hydrochloric acids. Gutta-percha has been applied to a variety of purposes, as a substitute for leather, especially in the soles of shoes and other articles; as an insulating coating for the copper wires of submarine telegraph cables; as an ingredient in mastics and cements; for the manufacture of flexible hose tubes and bottles, and for many other purposes.



**G**YMNASIUM, *jim na'ze um*, a building or room equipped for exercise and athletic uses. Gymnasiums are attached to almost all schools and colleges, and in many cities various clubs and societies support them. Many of the larger high schools have fine rooms, abundantly equipped with varied apparatus, where the pupils take regular and systematic exercise under trained instructors.

In the following paragraphs instructions are given for constructing a simple gymnasium, quite adequate for amateurs. Two or three boys with a few simple tools and the necessary lumber, bolts and rope can easily prepare it. If possible, the lumber should be purchased squared and cut to length.

**Horizontal Bar.** The most important piece of apparatus in the gymnasium is the horizontal bar. As many boys may not have place indoors for this apparatus, set it up outdoors.

by 3 in. by 3 ft. 9 in. long; and 1 piece, 2½ in. square by 5 ft. 7 in. long. This last piece should be well-seasoned, straight grained hickory, to make a bar. For the other pieces it is best to use cedar, as that wood rots very slowly, but ordinary yellow pine will do very well. If possible, the four 7 in. boards should be of hard wood. Besides the timber you need 2 bolts, ½ in. in diameter, and 7 in. long; 16 screws, 3 in. long; 4 heavy screw eyes with two ½ in. shanks; 50 ft. of heavy galvanized wire; 80 ft. of ¼ in. manila rope and 4 pulley blocks. Four cleats are also needed; these can be made at home.

Draw a line on the four 7 in. boards along the side of each from end to end, 1¼ in. from one edge. Beginning at one end of each board make 8 pencil dots on this line 5 in. apart. Bore holes through the board at these points with a 9/16 in. bit. Fasten two of these boards on each post with the 3 in. screws, as shown in the top view, forming a channel of the edges in which the holes were bored. Two of the filler pieces should now be fastened in each channel so as to make the space fit the squared end of the bar. The ends of the boards with the holes should be level with the top of the post, so that each pair of holes in the 7 in. boards coincide.

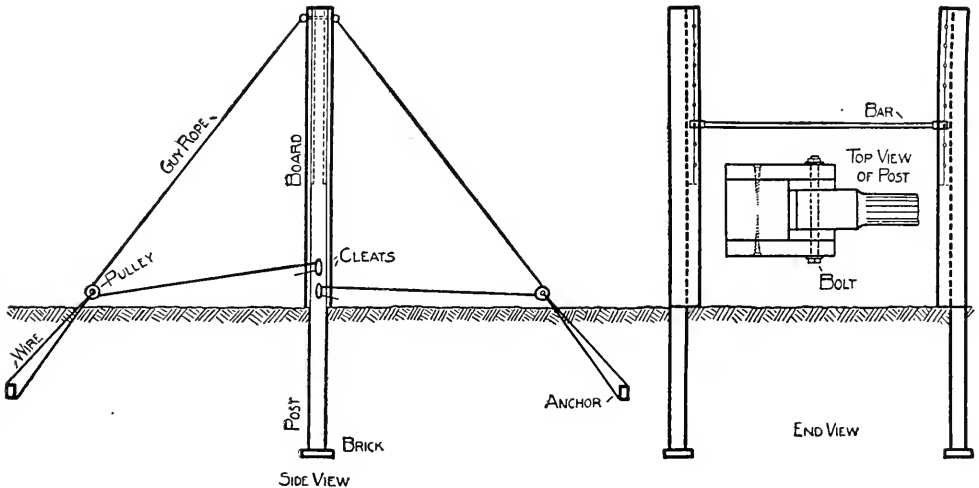

HORIZONTAL BAR

Once we have accomplished that much, we shall find it easy enough to bring it indoors if necessary, or set up a new one. The material we need is as follows: two pieces of wood, 4 in. square by 9½ ft. long; 4 pieces, 1 in. by 7 in. by 6½ ft. long; 4 pieces, ¾ in.

Dig two holes 6 ft. apart, each 3 ft. deep, and remove all loose dirt. Set the posts in these holes on bricks or small stones. A mixture of one part cement, two parts sand and three parts small stones will make a better foundation. Be careful that not too much water

is used in mixing. The channels formed by the boards must be set facing each other with the inner surface of the posts parallel, 5 ft. 8 in. apart. Fill in the holes and tamp the ground well. Each post must be well braced to keep it rigid while a person is swinging on the bar. Place four anchors in the ground at the corners of an imaginary rectangle enclosing the posts, so that the posts are 8 ft. from the short sides and  $1\frac{1}{2}$  ft. from the long sides. These anchors may be made of pieces of wood 2 ft. square, around whose center four strands of heavy galvanized wire are twisted, then buried to a depth of 2 ft. The wires should be carried above ground at an angle of about 45 degrees. The heavy screw eyes are turned into the posts at the top and lengths of rope tied to each. These ropes or guys pass through pulley blocks, which are fastened to the projecting ends of the anchor wires, and return to the posts where they are tied to cleats. Do not tighten the guy ropes without the bar in place, as to do so will strain the posts in the ground. For the same reason do not change the elevation of the bar before slacking up on the ropes.

For the bar you have secured a long hickory piece, which should be planed, scraped and sandpapered until it is perfectly smooth and round, except for 3 in. at one end. Through both square ends bore a hole to admit the  $\frac{1}{2}$  in. bolts which will hold the bar

use heavy screw eyes, which need not be set as far apart as the anchors were outdoors. To hold the posts in position you need L-shaped iron braces such as can be bought at any hardware store.

**Parallel Bars.** Exercises on parallel bars are among the best means for the development of the back and shoulders. One can make a set of these bars with very little trouble, if one has or buys the following material: 4 posts, preferably cedar; 4 in. square and 6 ft. long; 2 base pieces, 4 in. square and 5 ft. 6 in. long; 2 cross braces 2 in. by 4 in. by 2 ft. 2 in. long; 2 side braces 2 x 4 by 7 ft. 8 in. long; 4 knee braces 2 x 4 by 3 ft. 8 in. long; 2 bars; 2 bars of straight-grained hickory 2 x 3 by 10 ft. long; 4 wood screws 6 in. long; 4 bolts, 8 in. long; 8 bolts, 7 in. long; and one dozen large spikes.

First bevel the ends of the base pieces at an angle of 60 degrees. Chisel out two notches, 4 in. wide and 1 in. deep, beginning at a point 9 in. from either side of the center; these are to receive the lower ends of the posts. Bevel the two sides of one end of each post down to a width of the finished bar—a little less than 2 in. Cut notches in these ends to receive the oval bars. Bevel the ends of the knee braces, and fasten the lower ends to the beveled ends of the bases with spikes. The upper ends of the knee braces should be fastened to the uprights with 8 in. bolts put

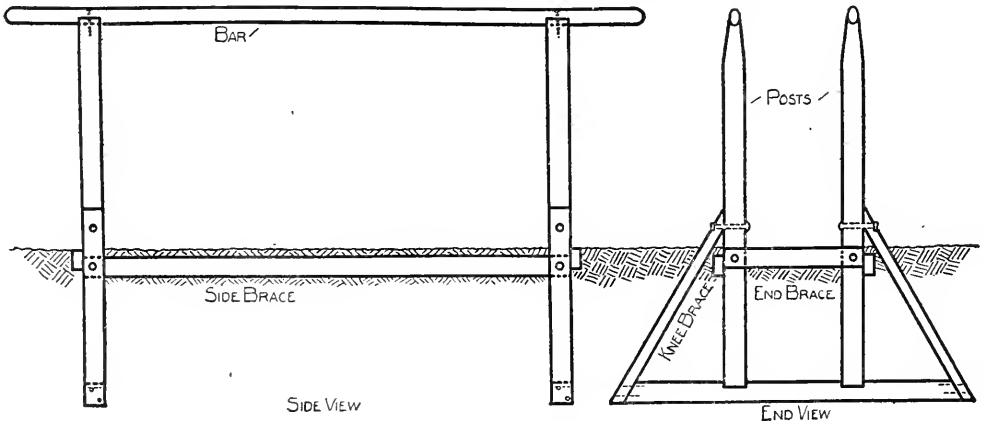

PARALLEL BARS

in place. The bar should be oiled and reversed occasionally to keep it from curving and drying.

To set up such a horizontal bar indoors is just as easy. The posts should be 3 ft. shorter. Instead of the anchors we should

through holes bored for the purpose. It will be best to countersink the heads of the bolts—that is, they should be below the surface.

With 7 in. bolts fasten the end braces with their top edges 2 ft. 6 in. from the bottom of the base. Drive nails slantingly into the ends



of the posts, merely to hold them to the base while the apparatus is being handled. Now we must dig two parallel trenches, 2½ ft. deep, about 5 ft. long, and 7 ft. apart, for the end braces and two more trenches just deep enough to hold the side braces. These side braces should be bolted to the posts just below the cross braces, so the bolts in both will not meet. The bars should be dressed down so that a cross section is oval as shown in the end view. Use the 6 in. screws to hold these to the notched uprights. Countersink the holes so that they can be filled with putty after the screws are in place. It would be wise to oil the bars with linseed oil to protect them from the weather.

It is not necessary to use dressed lumber from the mill for this apparatus, except for the bars. If mill-cut lumber is used, it should be undressed, and if round is used, it should be left with the bark on it, to protect it from the weather. If the timbers, except the bars, are painted, the wood will last for years, but even unpainted cedar is very durable.

**The Horse.** The horse may be used as an obstruction over which to leap, slide, or

the larger the better—and 5 ft. to 6 ft. long. The round part must be planed, scraped and sandpapered until it is perfectly smooth. Make two parallel saw cuts 2 in. apart, straight down in the round surface of the log until each cut is 9 in. long. 18 in. away make two more cuts of the same size. Chisel out the wood between each pair of cuts and insert the two hand holds, which should be made of two pieces of 2 x 4 x 9, cut rounding on one edge. Nail these hand-holds in place.

The body of the horse should be fastened to the posts so that its height may be adjusted. Two posts are needed, 4 in. square by 5 ft. long; 2 adjusting pieces 2 x 4 x 3 ft. 3 in. long; 1 cross brace 2 x 4 x 3 ft.; 2 bases, 4 in. square by 3 ft.; 4 knee braces, 2 x 4 x 3 ft.; 2 one-half inch bolts, 9 in. long, to fasten the knee braces at the top; ten ½ in. bolts, 7 in. long, 4 to fasten the knee braces at the bottom, 2 to fasten the cross brace, and 4 to fasten the adjusting pieces to the posts. Cut mortises, that is, cut out notches, on the bases so that the bottom ends of the posts are exactly in the middle; then cut a slanting notch 6 in. from each end for the knee braces.

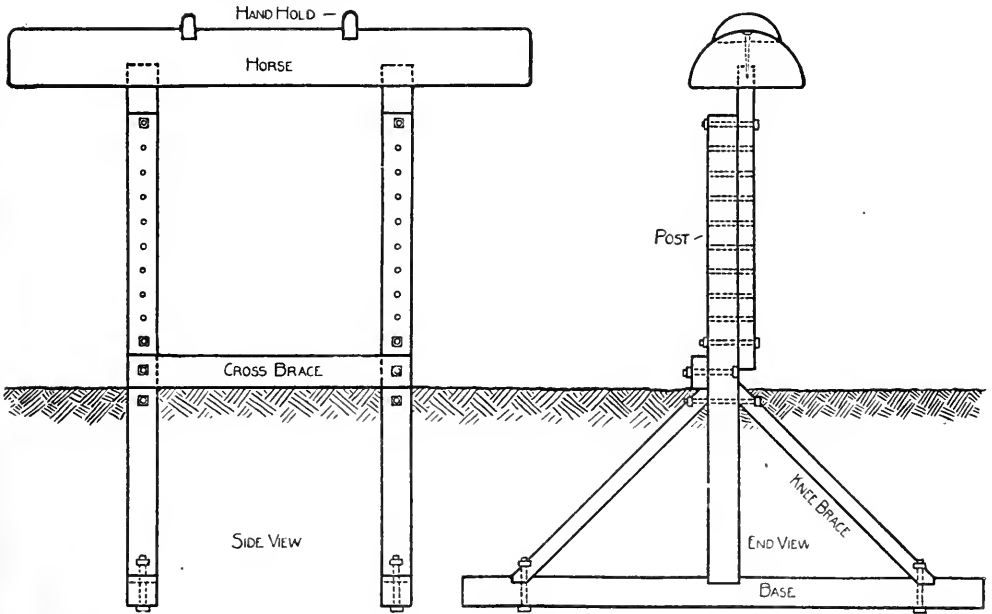

THE HORSE

swing, and also as an artificial back for a peculiar style of leap frog, and many other games which boys are constantly devising.

First, one must secure one-half of a tree trunk from a tree 9 in. to 15 in. in diameter—

Bevel the ends of the knee braces, put them in place and fasten with bolts, the upper ends with a 9 in. bolt, the lower with a 7 in. bolt. Beginning 1½ in. from the top, at intervals of 3 in., bore ½ in. holes through each

post parallel to the base. Nine or ten holes will be enough. The adjusting pieces should be bored in the same manner, then mortised into the flat side of the log 15 in. from each end and secured with screws put through the top and into the end of the adjusting pieces.

When the posts and knee braces have been securely fastened to the bases, these should be buried 2 ft. 4 in. in the ground, parallel to each other at the same distance apart as the adjusting pieces mortised in the horse top. Then bolt the cross brace with its lower edge resting on the ground.

After the ground has been tamped hard the horse is ready for use. The height of the horse is adjusted by changing the bolts in the different holes connecting the two adjusting pieces with the two posts. All sorts of jumps and leaps will be devised to keep the horse in constant use.

With some slight changes any of these pieces might be used indoors. The uprights would be shorter by so much as is now buried in the ground. The braces would have to be bolted at different angles. Probably the bases would have to be fastened to the floor to keep the uprights from upsetting. The apparatus bought for regular gymnasiums is made with heavy metal bases, but our apparatus will do fully as well if it is fastened to the floor. If we can weight it in some way, so much the better. Whatever we do we shall be sure to enjoy making the apparatus, and once it is made, how much prouder we shall be than if we had bought it readymade!

**Dumb-Bells.** No gymnasium, whether indoor or outdoor, can be complete without a pair of dumb-bells. Any boy can make as many as he wants. First get two large tin cans—such as a quart fruit can—and cut out the ends. Shape four round pieces of wood just large enough to fit tightly in the ends of the cans. Then cut a hole in the center of each just large enough for the bar, which may be any piece of hard wood from 12 in. to 18 in. long. To one part of cement and two parts of sand add water till the sand and cement have thoroughly mixed. Pack this mixture tightly into the cans and insert the wooden disks in the ends. Push the hardwood bar through the holes in the inside-disk so that it runs past the center of each can of cement and leaves a proper length of rod between. The two inner disks should first be strung on the bar and a few nails driven into the cement to give it a good grip.

After several days the cement will be dry. Then remove the tin and wooden disks. The cement may now be filed into any shape desired. If a dumb-bell of this kind is not heavy enough it may be weighted with stones or metal mixed in the cement and sand.

**GYMNASTICS**, *jim nas'tiks*, the technical term used to designate any system of exercises specially designed to promote the development of physical and, especially, muscular powers. An excellent gymnastic training is given by baseball, football, rowing and similar amusements, but the special value of formal gymnastic exercises is that they are capable of being scientifically arranged so as to secure not only a general development of muscular power, but also to give suitable training to the separate muscles. Furthermore, they are capable of being applied to each person so as to meet, allow for and, as far as possible, overcome defects in his physical organization. For these purposes an elementary course of gymnastics is of great value to all, especially to the person of sedentary habits.

Two general rules may be laid down, which form an efficient guide in self-imposed exercises. The first is the universal rule in mechanics, that the strength of any machine is the strength of its weakest part; the second is the fundamental law of muscular exercise, that it is exercise *within* the extreme power of a muscle which develops and improves, while *straining* a muscle weakens and injures it, and excessive exercise develops particular muscles at the expense of the general health. It is quite possible, indeed, to carry general physical exercises too far, and to develop muscular power at the expense of vital strength. Till the age of twelve the ordinary games and pastimes of childhood are generally quite sufficient exercise; after that some very light system of gymnastics may be adopted to aid the development of the system. After the age of thirty-five, unusual muscular efforts are apt to leave persistent strains, and moderate exercise becomes the safest means of developing and giving tone to the muscular system. See GYMNASIUM.

**GYMNOSPERMS**, *jim'no spermz*, one of the two great divisions of seed-bearing plants. The gymnosperms have naked, or exposed seeds; the name is derived from the Greek words for *naked* and *seed*. Plants with seeds protected by a seed-case are called angios-





7a



6a

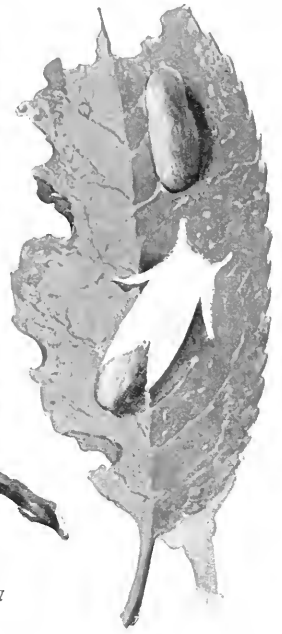

1a



3a



4a



5a



2a



7b



6b



5b



8b



2b



3b



4b



1b

### BROWN TAIL MOTH

### GYPSY MOTH

- 1A Egg Mass and Moth laying eggs
- 2A Winter nest
- 3A Full grown Caterpillar
- 4A Male Pupa

- 5A Female Pupa
- 6A Male Moth
- 7A Female Moth

- 1B Egg Mass
- 2B Full Grown Caterpillar
- 3B Female Pupa
- 4B Male Pupa

- 5B Male Moth
- 6B Male Moth at rest
- 7B Female Moth
- 8B Female Moth laying eggs

perms (which see). There are more than 400 species of the gymnosperms, and all are trees or shrubs. To this group belong the trees which yield rosin, tar and turpentine, and the hardy firs and pines which bear cones. Their flowers are small and inconspicuous, and each plant bears only one kind, pistillate or staminate.

**GYPSIES**, *jip'siz*, a group of strange people made up of numerous wandering tribes scattered throughout Europe, Asia, Northern Africa and America. It is not known with certainty where they first appeared, but a Hindu origin is probable. From Asia, where to-day there are countless thousands, they wandered, in the sixteenth century, to Europe, and now number there about 700,000. These people, who call themselves Romani, offer a baffling problem to the scientist, preserving as they do their racial existence through the centuries and in all lands.

Unlike the Jews, who have likewise retained their physical and racial characteristics throughout their history, the gypsies have no common bond of religion or tradition, no unifying influence of intercommunication among themselves which would tend to keep them distinct. Only instinct such as is found in the lower animals seems to lead them to follow in the path of their ancestors, speaking their own language, which is handed down from mouth to mouth, roaming from place to place, and marrying always within their own ranks. Untouched by the civilization about them or by the changes which modern inventions have made, they continue from generation to generation, the primitive, half-barbarous life of their predecessors.

Gypsies have the strong bodies and dark skin usually possessed by peoples who live in the open. Their hair and eyes are jet-black, their teeth very white. In youth they are not unattractive, but ugliness overtakes them early. Their nomadic habits interferes with settled occupations. The men are horse traders, and the women make baskets and tell "fortunes." They seem to have no definite religion. The marriage ceremony is of the simplest, and is not binding on the part of the husband if he tires of his wife. The children grow up in idleness and acquire habits of stealing and cheating. Gypsies are popularly supposed to be addicted to the vice of child-stealing.

**GYPSUM**, *jip'sum*, a hydrous calcium sulphate. It is found in a compact state as

*alabaster* (see ALABASTER), or crystallized as *selenite*, or in the form of a soft, chalky, stone, which in a very moderate heat changes to a very fine white powder, extensively used under the name of plaster of Paris. The last is the most common and is found in great masses near Paris, France; large beds are found also in Nova Scotia, Virginia, Michigan, New York, Iowa and Ohio. It may be geologically of any age, but it occurs abundantly in the more recent sedimentary formations and is even now forming, as a deposit from water holding it in solution; from the decomposition of iron pyrites, when the sulphuric acid combines with lime, or from the action of sulphurous vapors in volcanic regions on rocks containing lime. When gypsum occurs without water it is called *anhydrite*, but in its most ordinary state it contains water, together with the lime and sulphuric acid. Gypsum, pulverized by grinding or burning, has been used with good effect as a fertilizer, especially as a top dressing for meadows. See FERTILIZERS.

**GYPSY MOTH**, an insect which has long been exceedingly destructive to fruit and shade trees in Central Europe, and which in 1869 was introduced into America by a man who was experimenting to find a silkworm which would be free from disease. Some of his specimens accidentally escaped, and although he called the attention of the public to the fact, yet the matter was neglected until about twenty years later, when their ravages became so severe that the legislature of Massachusetts was compelled to take action to exterminate them.

The male moth is described as brownish-yellow, varying to greenish-brown in color, with a slender body and an expanse of wings ranging from one to one and one-half inches. The wings are darker than the body and have prominent black markings. The flight is characterized by a peculiar zigzag motion, which assists in identifying the insect. The body of the female is light buff and covered with hairs which are used by the moth to protect the eggs when they are deposited. The wings have an expanse of nearly two inches, and are nearly white, with small black markings. However, because of the large size of the body, the female is unable to fly.

The eggs are deposited in July and August in clusters about three-fourths of an inch wide and an inch and a half long, forming a yellowish hair-covered mass. The clusters

vary in size and contain from 75 to 1,000 eggs.

The eggs hatch about the first of May and the larvae or caterpillars feed upon the foliage of fruit and shade trees until mid-summer, when they enter the pupal state. The caterpillars are hairy, and when full grown have a sooty-colored body, containing on the back a double row of red spots. The head is yellow. Before they are half grown the caterpillars frequently suspend themselves from branches of trees and drop upon animals and carriages, by which they are taken to localities not previously infested. The sudden appearance of these caterpillars in such localities may often thus be accounted for.

The caterpillars prefer the leaves of the oak, the willow, the elm and the apple tree, but they will feed upon the foliage of all fruit and shade trees, and when other sources of food fail, will attack vines, shrubs and even garden and field crop in their vicinity. They even attack the white pine, and in some localities have caused the destruction of many of these trees.

The best method found for destroying the growing caterpillars consists in spraying the trees with a solution of arsenate of lead, using ten pounds of arsenate to one hundred gallons of water. The spraying is most effective when done in May and June. The egg clusters can be killed by soaking them thoroughly with a creosote mixture. This work can be done effectively between August and May. Banding the trees with strips of burlap or other coarse cloth, in such a manner that the bands fold over and form a shelter for the caterpillars, is a good means of destroying large numbers. The caterpillars crawl

under the folds during the night and the bands should be examined daily. At the end of the season the bands should be burned. Infested areas should be cleared of all brush, and hollow trees and untilled lands where egg clusters are supposed to exist should be burned over.

**GYROSCOPE**, *ji'ro skohp*, an instrument which exhibits the various phenomena of rotation. It consists of a heavy solid circular disc mounted upon an axis, both ends of which are supported in a circle at right angles with the disk. In the complete gyroscope this circle is upheld by two supports forty-five degrees from the axis supports. The joinings are equipped with bearings which allow free rotation of the disk at any angle. When set to revolving rapidly the disk is with difficulty moved out of its plane of rotation; the axis maintains its direction even though the position of the standard is constantly changed. If moved in a circle the axis remains at the same angle, just as the axis of the earth maintains its angle to the plain of its orbit.

The action of the gyroscope is based on the principle that if a mass is set rotating about a central axis it will continue to rotate in the same plane, the direction of the axis remaining unchanged, unless external force is applied. When first devised the gyroscope was regarded as a mere curiosity. It now has a number of practical uses. It is employed as a stabilizer on ships, aeroplanes and mono-rail cars. The heavier the disk and the higher its rate of speed, the greater the force required to disturb its poise. On ships the weight of the gyroscope is usually  $\frac{1}{10}$  of the ship's displacement.



**H**, the eighth letter of the English alphabet, is derived in form from the Phoenician character, which was but an *H* closed at top and bottom with a line. In sound, the Phoenician letter resembled the German *ch*, but in early Greek it corresponded nearly to our *h*. *H* in English is called the *aspirate*, as it is a mere breathing, with the vocal organs in the position demanded by the following vowel. It is very commonly joined to other consonants to represent sounds for which there are no special letters in the alphabet, as in *ch*, *sh*, *th*, or in other consonantal combinations, as in *enough*, *plough* or *philosophy*.

**HAAKON**, *haw'kon*, the name borne by six Norwegian kings in the Middle Ages. It was adopted by Prince Charles of Denmark, who came to the throne of Norway in 1905 as Haakon VII.

**Haakon VII** (1872- ), was the son of Frederick VIII of Denmark, and his wife is the sister of George V of England. King Haakon was trained in the royal navy and his love for and knowledge of the sea had much to do with making him popular with the sea-loving Norwegians.



HAAKON VII

In the World War his country suffered from German submarine warfare, but remained strictly neutral in circumstances often embarrassing. See *NORWAY*, subhead *History*.

**HAARLEM**, *hahr'lem*, THE NETHERLANDS, capital of the province of North Holland, located ten miles west of Amsterdam. It is well built and is one of the most attractive

cities in Holland. Among the chief structures are the cathedral of Saint Baro and the town hall. The industrial importance of Haarlem, as well as its population, is less than formerly. It still has various manufacturing establishments and a celebrated type foundry, the oldest and most famous printing office in Holland; and its flower trade, especially in hyacinths and other bulbs, is important. It is the birthplace of Laurence Coster, believed by the Dutch to be the inventor of movable types (see *PRINTING*), and of a number of painters, Ostade, the Wouwermans, Ruisdael and Van Loo. Population, 1911, 69,988.

**HABAKKUK**, *ha bak'uk*, or *hab'a kuk*, a book of the Old Testament, written about 600 B. C. by Habakkuk, the eighth of the minor prophets of Israel. The book is the fifth from the last in the Old Testament, and has but three chapters. In the first chapter the author expresses his fear that the innocent will suffer for the trespasses of the wicked. In the second Habakkuk is told that he must have faith, and the final chapter is an eloquent expression of the prophet's trust in the power and goodness of Jehovah.

**HABEAS CORPUS**, *ha'be as kaw'pus*, a term meaning (*that*) *you may have the body*. It is a legal writ, issued by a judge, compelling officers of the law who hold a man under arrest to appear before the court with the accused and show cause for detaining him. The object of the writ is to protect innocent people from unjust seizure and detention. If the inquiry before the court does not develop sufficient evidence to hold the accused the court may order his release on bonds; if an unailable offense is charged and the evidence presented appears to sustain it, the court may dismiss the writ and leave the accused to the due processes of law.

The executive authority of a state or na-

tion may suspend the operation of the writ of habeas corpus in times of public danger. In cases of grave rioting it is sometimes prudent to arrest trouble-makers and hold them temporarily. In time of war it may be necessary to arrest persons suspected of actions dangerous to the government and to hold them without trial. In such instances were the right to demand the operation of the writ not suspended, evil consequences might follow, for the government might be required, in opposing writs, to disclose information valuable to an enemy.

The Constitution of the United States declares (ART. I, SEC. 8):

The privilege of the writ of habeas corpus shall not be suspended, unless when in cases of rebellion or invasion the public safety may require it.

**HABIT.** The child learning to walk is conscious of every step he takes. Occasionally he falls down, and all his movements are unsteady and faltering. After a time the halting steps become firm, the gait becomes steady, and the young walker goes about with perfect assurance. The reason is that walking for him has become a habit. Habit may be defined as a fixed tendency to do something in a certain way. When the habit is firmly established the act is accomplished without conscious effort. A multitude of habitual acts are performed every day in the routine of life. The movements of dressing, combing the hair, sitting down to breakfast, walking to the train, dusting off the desk, and so on, are all acts of habit.

Why the body functions in this way is an interesting problem. The theory is that when a current of nerve force once traverses a nerve tract, it produces such a condition in that tract as to make it easier for the current to traverse it again, and that the more times the current traverses the tract, the easier its passage becomes, until the nerves become so habituated to the passage that the only volition necessary to the act is that which starts it.

As bodily habits are formed by repeated muscular movements, so are mental habits formed by repetition of the same mental act. This is what is meant by saying that any mental power, as memory, imagination or will, is developed by use. The person whose memory is well trained during childhood has a good memory through life; likewise, one whose will has received proper culture be-

fore he is twenty years of age, has developed a power of decision and action that will usually assure him success in his chosen work.

During childhood and youth the nervous system is in a plastic condition and can easily be trained in any direction; hence it is during this period that most of the habits of life are formed. It is therefore all-important that early habits be such as will contribute to the individual's highest good—physical, intellectual and moral. In order that this result may be secured, the child should be trained to do things in the right way, to speak correctly and to choose the right. After twenty, important habits are formed less frequently, and after thirty, new habits are acquired with great difficulty. In order that a habit may be formed, success should be secured at the outset. Failure leads to discouragement and often to the abandoning of the attempt. When the choice is made and the habit is once launched, every opportunity to practice it should be embraced until it becomes firmly established. All acts or thoughts which tend to interfere with the formation of the habit should be set aside.

Habit saves time and strength. Were each successive act as difficult as the first, the most common and necessary movements would consume all one's vitality and one could never make progress. By making our common acts habitual, the mind is left free to exercise its powers on higher things. Were it not for this, memory, reason and will would never be properly developed and that progress of thought which has produced our present civilization would have been impossible. Habit also gives us skill in execution. It is only as we become unconscious of the movement and fix our attention upon the result that we execute our work skilfully.

Habit is the great conservator of society. It keeps the various classes of people at their chosen vocations. The miner cannot easily become a mechanic, nor the merchant a physician, and whatever longing a man may have for another calling, after he has become thoroughly established in a given occupation he seldom changes. Habit is the result of will power and determines character (see WILL). "A well-trained nervous system is the greatest friend that the mind can have. An ill-trained nervous system is a relentless enemy to the highest mental powers."

For further suggestions as to the importance of habit in child training, see the articles Child Training and Kindergarten.



**HACK'BERRY**, also called *nettle tree*, *sugar berry* and *hoop ash*, the name of a number of trees of rapid growth which belong to the same family as the nettles. The best known species is a large tree sometimes 120 feet high, which grows in the Western United States and Western Canada. It has a rough bark and nearly horizontal branches, and it may be used in much the same way as the elm. There are two species, of which the smaller, more generally known as the sugar berry, grows in the southwestern part of the United States.

**HACK'ETT**, JAMES KETELTAS (1869–), an American actor, born at Wolf Island, Ontario. He was the son of James H. Hackett, a well-known American actor, and graduated at the College of the City of New York. He made his début in 1892 at the New York Lyceum, at the age of twenty-three, being at the time the youngest leading man in the history of the New York stage. His most notable successes have been in *The Prisoner of Zenda* and its sequel, *Rupert of Hentzau*, *The Pride of Jennico*, *Monsieur Beaucaire* and *Don Caesar's Return*. He also appeared in *The Crisis*, a dramatization of Winston Churchill's novel. In 1897 he married the actress Mary Mannering and subsequently appeared with her in various successful plays. She divorced him, and in 1911 he married again in London.

**HAD'DOCK**, an important food fish, of the cod family, though less valuable than the cod. It is smaller than the cod, which it much resembles, and it has a dark line along its side and a dark spot just behind the head. It commonly weighs from two to six pounds, though sometimes as much as ten pounds. It breeds in immense numbers in the northern seas in February and March. It is plentiful on the coasts of America, from New York to the Arctic regions. When dry-salted it is placed on the market as *finnan haddie*.

**HADES**, *ha'deez*, originally, the Greek name of the ruler of the lower world, afterwards known as Pluto. The name Hades was in later times applied to the region itself, which was supposed to be the abode of all departed souls, whether good or bad. The term is also used in the Greek scriptures to designate the home of the dead.

**HADJ**, or **HAJJ**, *haj*, the Mohammedan pilgrimage to the Kaaba at Mecca, which every Mohammedan is bound to perform once in his life, if his health and means

permit, after which he is entitled to prefix *Hadji* to his name. See KAABA.

**HADLEY**, ARTHUR TWINING (1856–), an American educator, born at New Haven, son of James Hadley. He was educated at Yale and at the University of Berlin. After completing his studies abroad, he became tutor at Yale and later professor of political science. In 1899 he was elected president of the university. Doctor Hadley attained more than a national reputation by his writings on financial and economic subjects, on both of which he is considered eminent authority. Because of his fame in this direction and also because of his ability as an executive he was elected a director of the New York, New Haven & Hartford Railroad in 1914, after financial scandals had nearly wrecked the company. He has been president of the American Economic Association and is the author of *Railroad Transportation, its History and Laws; Report on the Labor Question; Economics; An Account of the Relations between Private Property and Public Welfare, The Education of the American Citizen* and *Freedom and Responsibility*, besides a large number of articles which have appeared in the leading periodicals.

**HADRIAN**, (76–138) fourteenth Roman emperor. His father, cousin to the emperor Trajan, died when he was ten years old and left him under the charge of his illustrious kinsman. He married Sabina, Trajan's grand niece, accompanied the emperor on his expeditions, filled the highest offices and, on the death of Trajan, assumed the government as his adopted son (117). He made peace with the Parthians, renouncing all conquests east of the Euphrates, and bought off a war with the Roxolani by the payment of a sum of money. From the year 121 he spent most of his time visiting the various provinces of the Empire. He traveled into Asia and Africa and lived in Athens for three years. In 131 he promulgated a fixed code of laws, which formed an important epoch in the development of Roman law. In 132 the Jews revolted, and for four years they carried on a bloody war, the only notable one of his reign.

**HADRIAN'S TOMB**, an enormous round tower, erected by Hadrian in Rome about A. D. 130 and completed by his successor. In the Middle Ages it was used as a fortress and prison, and material changes have been made from time to time. Tradition says that

Beatrice Cenci, Cagliostro and Buenvenuto Cellini were confined in it. The structure is now called the Castello Saint Angelo.

**HAECKEL**, *hek'l*, ERNST (1834— ), a German naturalist, born at Potsdam. He studied medicine and science at Berlin, Wurzburg and Vienna. After traveling in Norway and Italy, he became professor of zoölogy at Jena in 1865. He became the most prominent exponent of the Darwinian theories in Germany. Among his works are *The History of Creation, Anthropology, History of the Evolution of Man, Collected Popular Discourses on the Development Theory and Origin and Development of Animal Tissues.*

**HAEMOGLOBIN**, *hem o glo'bin*, or *he mo-glo'bin*, the substance in the blood which gives it its red color. It is found only in the red corpuscles, and has the power of absorbing oxygen from the air in the lungs and giving it up to the body tissues. Haemoglobin contains iron. See BLOOD.

**HA'GAR**, an Egyptian servant of Abraham's wife Sarah. According to the narrative in Genesis, God had promised Abraham children, but when Sarah remained childless to an advanced old age, she ceased to hope for a child of her own; and, to bring about fulfilment of the promise, gave Hagar to Abraham as his secondary wife. To Hagar was born a son, Ishmael. Shortly afterwards Sarah also gave birth to a son, Isaac. Rivalry between the two families resulted in the expulsion of Hagar and Ishmael, who wandered in the wilderness of Beersheba, where an angel of the Lord saved them from perishing.

**HA'GERSTOWN**, Md., settled about 1740, is the county seat of Washington County, nearly ninety miles northwest of Baltimore, on the Baltimore & Ohio, the Norfolk & Western, the Western Maryland, the Philadelphia & Reading and the Cumberland Valley railroads. The city is an important commercial center for the western part of the state. Among more than 130 industries are machine shops, railroad shops, knitting mills and the manufacture of furniture, ice, pipe organs, agricultural implements and other articles. Population, 1910, 16,507; in 1917, 26,125 (Federal estimate).

**HAGFISH**, an eel-like fish, allied to the lampreys, that lives as a parasite upon other fishes. The mouth is large and adapted to sucking; there are no jaws; the eyes are rudimentary. A single fang upon the palate

enables the hagfish to rend its prey, which are small cod, halibut, flounder and such. The skeleton is composed entirely of cartilage. The body is covered with a leathery skin that secretes slime. An American species is common in rivers of New York and New England.

**HAGGAI**, *hag'ga eye*, the tenth, in order, of the minor prophets, and the first of those who prophesied after the captivity. The book of *Haggai* consists of four distinct prophetic addresses, two in the first and two in the second chapter, intended to arouse the disheartened Jews to the rebuilding of the Temple. They were delivered in 520 B. C. and are written in a concise style. The closing predictions foreshadows the establishment of Christ's kingdom upon the overthrow of the thrones of the nations.

**HAG'GARD**, HENRY RIDER (1856— ), an English novelist, born at Norfolk and educated at Ipswich Grammar School. He was admitted to the bar, but devoted himself almost exclusively to literary pursuits. He traveled extensively and developed a morbid taste for the wierd and strange. His most popular novels among nearly fifty that he has written are *King Solomon's Mines* and *She*. Others are *Jess*, *Allan Quatermain*, *Montezuma's Daughter*, *The Return of She*, *Lysbeth*, *Benita*, *Queen Sheba's Ring*, *The Mahatma and the Hare*, *The Holy Flower*, *The Ivory Child* and *The World's Desire*, the latter in collaboration with Andrew Lang. His works are of slight artistic value, but hold the attention by reason of their peculiar scenes and incidents.

**HAGUE**, THE, called for years the "peace city" of the world, the capital of the kingdom of the Netherlands, or Holland. It is situated three miles from the North Sea, in the province of South Holland, thirty miles southwest of Amsterdam. Commercially the city is not as important as its general reputation would indicate, for its manufactures are not extensive and it has no harbor; however, the railroad system of Holland was planned with The Hague as its center.

The city's claim to unusual fame lies in the fact that it is the home of one of the most popular sovereigns of Europe—Queen Wilhelmina—that here the government of the country is centered, that the world's Peace Palace is here, and that art lovers from everywhere visit The Hague galleries, where they may see nearly 500 of the world's great paint-

ings, largely by the Dutch masters. Moreover, there are more stately buildings in The Hague than in any other city of the little kingdom. The government and municipal buildings, picturesque churches, libraries, galleries and museums are on broad streets shaded by linden trees and intersected everywhere by the inevitable Dutch canals.

Dutch learning and culture is everywhere manifest. The most notable of the learned societies is The Hague Society for the Defense of the Christian Religion, founded in 1785. There is a Royal School of Music, an educational institute of the Free Masons, an artists' association known as Pulchri Studio, and the Netherland-India Institute. Over-shadowing all these in the estimation of the average man is the International Peace Palace, a gift to the nations by Andrew Carnegie (see PEACE CONFERENCE, INTERNATIONAL).

Some of the few manufactured articles indicate the aesthetic trend of the people; those of which they are proudest are manufactories of porcelains and gold and silver ware. Guns are made here, also, and there are machine shops and brass works and hat, furniture and carriage factories.

The city was originally the hunting center of the counts of Holland. In 1250 it became a princely residence and in the sixteenth century was the seat of the States-General. From this it became the capital of Holland. The Hague has held an important position among European capitals; many important treaties have been negotiated there, including the Triple Alliance of England, France and Holland, and in 1899 it was the seat of the International Peace Conference, which established there a permanent court of arbitration. Population, 1916, 334,061.

**HAGUE PEACE CONFERENCE.** See PEACE CONFERENCE, INTERNATIONAL.

**HAHN'EMANN, SAMUEL CHRISTIAN** (1755-1843), the founder of the homeopathic system of medicine, born at Meissen, Germany. He studied medicine at Leipzig, Vienna and Erlangen and took his degree at Erlangen in 1779. After practicing in various places, he published in 1810 his great work, which fully explained his new system of curing any disorder by employing a medicine which produces a similar disorder. Hahnemann was driven from Saxony when the government prohibited him from dispensing medicines, but he found an asylum ultimately in Paris, where his system was

authorized by the government and acquired great popularity. His works of *Materia Medica*, his essays on *Poisoning by Arsenic* and *Effects of Coffee* and his treatise on *Chronic Affections*. The principles advocated by Hahnemann are explained in detail under the heading HOMEOPATHY.

**HAIG, Hage, SIR DOUGLAS**, Field Marshal, (1861- ), one of the greatest military leaders of the World War, commander in chief of the British Expeditionary Forces in France and Belgium after 1915. He entered the army in 1885 as a member of the Seventh Hussars, served with distinction in Africa and India, and rose steadily in rank, attaining the position of general officer commanding at Aldershot in 1912. On the outbreak of the World War he was made commander of the first army corps which went with the British Expeditionary Force to France, received the grade of general, and in December, 1915, succeeded Sir John French (which see) as commander in chief. In 1917 he was raised to the rank of field marshal. The British armies won brilliant successes under his leadership, and he was considered one of the ablest commanders acting under Foch. See WORLD WAR.

**HAIL**, small masses of ice or frozen rain which fall from the clouds in showers or storms. Hailstones vary in their form, being either angular, pyramidal or star-shaped. Sometimes they are as hard as ice and sometimes as soft as snow. At the center there is generally an opaque spongy mass, resembling sleet in its composition, and round this a semitransparent frozen mass, consisting of a succession of layers of ice, is formed. Properly there are two kinds of hail, the small grains, which generally fall in winter and usually before snow, and the large masses, which fall chiefly in spring and summer. The small-grained hail is probably formed by the freezing of raindrops as they pass in falling through colder air than that from which they started. The large hail is probably due to the meeting of two currents of air, of very unequal temperature and electric tension. Hailstones are usually about one-fourth of an inch in diameter, but they are occasionally of much larger dimensions, being sometimes even three or four inches in diameter. In hot climates hailstones are very destructive to crops. In regions where summer hailstorms are prevalent, farmers usually purchase hail insurance.

**HAIL COLUMBIA**, a patriotic American song, written in 1798 by Judge Joseph Hopkinson. It was composed for the benefit of a young actor, who sang it to the tune of *The President's March*, an air composed ten years previously in honor of President Washington. The piece possesses little musical merit, but appeals to popular taste and is a favorite national air.

**HAINAN**, *hi nah'n'*, an island in the China Sea, separated from the mainland by Hainan Strait, a channel encumbered with shoals and coral reefs. The island has an area of 13,600 square miles and constitutes a part of the Chinese province of Kwang-tung. The interior, which is mountainous and covered with forests, is inhabited largely by a distinct race, still in a very primitive stage. The lowlands are fertile and produce rice, coconuts and sugar-cane. The neighboring fisheries are an important source of revenue. The capital is the treaty port of Kiung-chow, and the island has a population of more than 2,500,000.

**HAIR**, the covering of the skin of mammals. It has the same use as feathers in birds and as scales in fishes and reptiles, and it varies from the finest wool to the quills of the porcupine and the bristles of the hog. The human body is naturally covered with long hair only on a few parts, yet nearly all parts produce a fine, short, colorless, sometimes hardly perceptible hair. The only places entirely free from it are the palms of the hands and the soles of the feet.

Each hair consists of a shaft—the part outside the skin, which does not grow—and a root, imbedded in the skin, which expands at its lower end into a swelling, or bulb, composed of little cells. It grows by forming new cells, which press the old ones forward to become part of the shaft. Each hair is said to live from two to four years. If the root is destroyed there is

no means of reproducing the hair; but if the hair falls out, as is often the case after nervous fevers, it will grow again within a few weeks.

The color of the hair is due to pigment in the cells. Gray hair is caused by a deficiency of pigment. Baldness is caused by death of the papilla, or hair bulb, generally due to lessened circulation of the blood in the scalp. Connected with the bases of the hairs are small glands, called *sebaceous glands*, which secrete an oily substance that serves to keep the skin, as well as the hair, soft. Hair tonics and hair dyes should usually be avoided. By keeping the scalp clean and massaging it with the fingers, one can generally keep the hair in a healthful condition.

Hair, chiefly from the horse, the ox, the hog, the goat, especially the Angora or Mohair goat, the camel and the alpaca, is used for manufacturing purposes. That of the first three is used mostly for upholstery, the short hair being manufactured into curled hair for stuffing, and the long, straight hair being made into haircloth for seating. The long hair is also used for making fishing lines and brushes. White hair, because it can be easily colored, is used in the manufacture of fancy articles. The finer brushes, or hair pencils, of painters are made from the hair of the sable and the marten. The hair of the goat, the camel and the alpaca is chiefly used in combination with wool and other fibers for spinning and weaving into dress fabrics. Wigs, curls and beards are made from human hair. In every case and for any purpose hair taken from the living subject is best.

**HAIR DRESSING.** From the earliest times the care of the hair has been an important part of the toilet. The ancient Assyrians, Babylonians, Persians, and Egyptians curled the hair and beard with the utmost care and even wore wigs and false beards. The Hebrews gave much attention to the hair and considered a bald head a disgrace. The Greeks considered abundant hair one of the greatest marks of beauty, and Homer counts it among the gifts of Aphrodite. Examples of the various styles of hair dressing which obtained among the Greeks in very ancient times are seen in statues. Some of the arrangements were very elaborate, both for men and women. By the fifth century B. C., men began to cut their hair short, while the women developed even more elaborate styles.

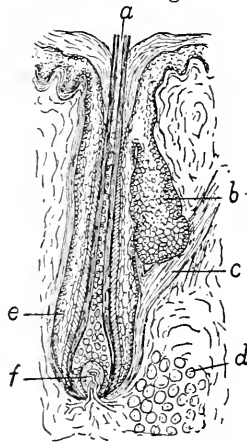

SECTION THROUGH THE ROOT OF A HAIR

a, Shaft of the hair; b, sebaceous gland; c, muscle that raises the hair; d, fatty tissue; e, root sheath; f, vessels that nourish the hair.

The custom of wearing false hair was brought from Asia to Greece and was for a time very popular.

Until about 300 B. C. the Romans wore long hair. Even at the time of Cicero the custom prevailed to a certain extent, although the warriors and artisans of the period wore short hair. In early times the Roman women wore their hair either flowing over the shoulders or gathered into a simple knot, but from the time of Augustus Caesar the fashions became more and more elaborate.

During the greater part of the Middle Ages the hair was worn very simply, but by the fourteenth century most elaborate coiffures began to appear. The men during the fifteenth and sixteenth centuries wore their hair rolled back from the forehead in a fashion similar to the later pompadour style for women, and their beards were tightly curled and gummed so as to stand out like a fan. For women, about this time it was fashionable to wear a broad cushion, or coronet, resting on a great mass of curled or crimped hair. Louis XIV of France had very long and abundant hair, and the desire of his courtiers to imitate him brought about the introduction of long curled wigs. The custom of wearing wigs was general for about a century after 1650. From about 1640 to 1670 women wore their hair curled and falling over the shoulders and covered with a veil of gauze. Toward the close of the seventeenth century, however, more elaborate fashions returned, and tall headdresses of lace and starched cambric were used. Under Louis XVI of France, hair dressing reached a point of elaboration which has been approached at no other period. The women built their hair into a sort of tower, which they stiffened with wire or haircloth and upon which they wore a little cap or hat. There is a record of one style in which this hat was replaced by a model of a ship of war.

By the beginning of the nineteenth century, elaborate hair dressing for men had entirely gone out of fashion, and in most countries men wore short hair. In the early part of the century women dressed the hair very simply, letting it fall at the sides in a series of ringlets and catching it at the back of the head with a ribbon. This was gradually superseded by an arrangement of the hair on top of the head. During this period the hair was often arranged over a large roll, in a style known as the *chignon*, or waterfall.

The general tendency during the last half century among civilized people has been toward simplicity in hair dressing.

**HAIR DYE**, a preparation for changing the natural color of the hair. The hair is darkened by solutions of salts of mercury, silver lead, bismuth, or sulphide of potassium. It is lightened by peroxide of hydrogen. A wash made by steeping henna leaves will give the hair a reddish tint. Hair-dyeing is at best unsatisfactory, and many dyes are poisonous. It is considered by most people the part not only of prudence but of good taste to shun them.

**HAIRLESS DOG**, the general name for those breeds of dogs whose bodies are almost entirely lacking in hair. Such dogs are found in various parts of the world. The Chinese have a small species of the greyhound-terrier type, which they esteem as a table delicacy. A hairless dog of ferocious temper is used in the eastern part of India in hunting. When the Spaniards invaded Mexico they found there a large dog devoid of hair, the puppies of which were eaten by the natives. In America, the few in favor as pets are quite small.

**HAIR WORM**, the common name for a number of slender worms. See TRICHINA.



**HAITI**, *ha'te*, excepting Cuba, is the largest island of the West Indies. Cuba, which is fifty miles northwest, is separated from it by the Windward Passage. Porto Rico is about seventy-five miles east, and Jamaica is 110 miles west by south. Haiti is 400 miles long and from 55 to 150 miles wide, and has an area of 28,250 square miles. It contains the republic of Haiti, once a colony of France, and the republic of Santo Domingo.

**The Republic of Haiti.** Haiti is the most westerly and the smaller of the two divisions of the island; its area is 10,204 square miles, and its population in 1912 was believed to be 2,500,000. Nearly all the people are negroes; of the 5,000 foreigners only about 500 are white. Port-au-Prince (population, about 100,000) is the capital; Cape Haiti has

30,000; Gonaives, 13,000. The official language is French, though most of the natives speak a dialect known as Creole French.

Haiti is an agricultural country, tropical in its climate, and its products are those of ever-warm countries. Sugar cane is extensively raised, and the country has several large sugar-making establishments. The cultivation of tobacco is a growing industry, and the allied business of cigar and cigarette making prospers. However, the most important product is coffee, and it is of excellent quality. Cocoa and cotton are exported in considerable quantities. Rum is made, but the whole output is consumed at home. Mineral resources of gold, silver, copper, iron, tin,

The President is elected for seven years, by the two chambers in joint session.

**History.** Haiti was discovered by Columbus in 1492, and the first permanent colony established by the Europeans in the western hemisphere was planted on the coast, the town of Santo Domingo being founded in 1496. For a long time the island belonged to Spain, but in 1600 the French began to settle here, and in 1697, by the Treaty of Ryswick, the western part was ceded to France. Most of the inhabitants were slaves, and in 1791 a fierce insurrection of the negroes broke out. They were led by Toussaint L'Ouverture, who established an independent republic and ultimately ruled as dictator over the

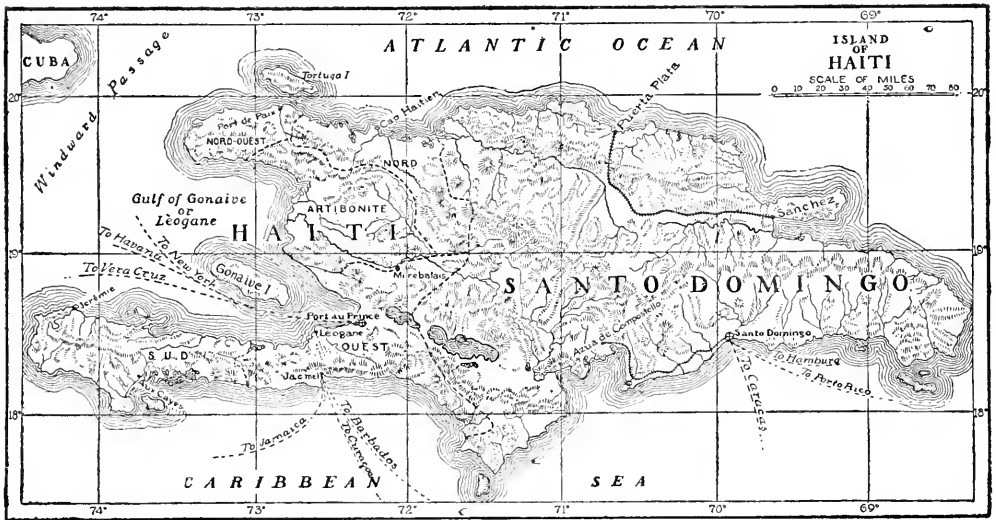

THE ISLAND AND THE TWO REPUBLICS

nickel gypsum and limestone are as yet in an undeveloped state.

**Communication.** There is regular steamship connection between the ports of Haiti and New York, but only an average of two vessels a week visit the country. In 1918 there were but fifty miles of railroad, from Port-au-Prince to Lake Assuei and to Léogane, but sixty-four miles were in process of construction between Cape Haiti and Port-au-Prince. There is a government telegraph system embracing 124 miles of line, and the country has thirty-one post offices.

**Government.** This negro republic is governed under a new constitution, adopted in June, 1917. The legislative power is vested in a Chamber of the Communes of thirty-six members and a Senate of fifteen members.

whole island. In 1802 Bonaparte waged war against him, and he was seized and taken to France. The next year the negroes rose and drove out the French. After the brief rule of Dessalines the Spaniards regained the eastern portion of the island. Most of its history has been marked by revolutions and insurrections, but order has been maintained since 1915, when the National Assembly ratified a treaty by which a virtual protectorate was established over Haiti by the United States. See PORT-AU-PRINCE; SANTO DOMINGO.

**HAJJ.** See HADJ.

**HAKE,** a marine fish related to the cod family. The North American silver hake abound off the northeastern "Banks," where they are caught with cod. They are usually eaten fresh, though some are smoked and

dried. The average weight is five pounds. The flesh is rather coarse and flaky. About 50,000,000 pounds of these fish, having a market value of \$1,115,000, are caught annually. A species of hake is found on the Pacific coast.

**HAKODATE**, *hak ko dah'te*, JAPAN, the most northerly of the old treaty ports of the empire, opened to trade in 1859. Its location is at the southern end of the island of Yezo. There are a town hall and a naval school, and here are located American and English missions. The people are engaged in fisheries, in sulphur mining and in the making of charcoal. After a very destructive fire in 1907 the town was rebuilt on a very substantial basis. Population, 1916, 102,400.

**HALCYON**, *hal'se on*, an old or poetical name of the kingfisher. It was a fanciful belief that the bird laid its eggs in nests that floated on the sea and had power to quiet the winds and waves during the period of incubation. From this superstition comes our term *haleyon days*.

**HALE**, EDWARD EVERETT (1823-1909), a Unitarian clergyman, philanthropist and author, son of Nathan Hale, a journalist, was born at Boston. His early education was received at the Boston Latin School. He was graduated from Harvard University in 1839 and settled as pastor of a Unitarian church at Worcester, Mass., in 1846. Ten years later he returned to Boston and took charge of the South Unitarian church and remained its active pastor forty-five years.

Mr. Hale has shown a keen interest in all reforms and progressive movements. He founded, and for a long time edited, the *Christian Examiner*, a Unitarian weekly, and *Old and New*, which in 1875 was merged with *Scribner's Monthly*. He became widely known as a brilliant lecturer and an able writer, and has been called "The American Defoe," because of the strong semblance of reality in his romances. This is



well illustrated in *The Man Without a Country*, a story which has done much to stimulate American patriotism. (This story is related elsewhere under its proper heading.) Of his later writings the most important are *Philip Nolan's Friends*, *The Story of Massachusetts*, *A New England Boyhood*, *Lowell and His Friends*, *Memoirs of a Hundred Years* and *Ten Times One is Ten*. The last led to the founding of such charitable clubs as King's Daughters, Lend-a-Hand and others. He also wrote and edited many important historical works. The last six years of his life he was chaplain of the United States Senate.

**HALE**, NATHAN (1755-1776), an American soldier a d hero, whose dying words are still quoted as an expression of the highest form of patriotism. Nathan Hale was born at Coventry, Conn. In 1773 he was graduated at Yale, and he taught school in East Haddam and New London, Conn., until the outbreak of the Revolutionary War. He enlisted as a volunteer, became a lieutenant in Colonel Webb's regiment and was assigned recruiting duty in New York. On Washington's call for a volunteer to enter the British lines and procure intelligence, he responded. Disguised as a Dutch schoolmaster, he visited all the enemy's camps in New York and Long Island, made drawings of the works and obtained all the information required. When about to return he was arrested as a spy, tried and condemned to be hanged. The execution took place in New York City. Just before the noose was placed about his neck he said, "I only regret that I have but one life to lose for my country." Statues have been erected to him in Hartford, Conn., and in City Hall Park, New York.

**HALEVY**, LUDOVIC (1834-1908), a French novelist and dramatist, was born at Paris. Much of his work was done in collaboration with Henri Meilbae. This includes librettos of Offenbach's light operas, notably *La Belle Helène* and *La Barbe Bleue*, which brought him fame, and the serious though sensational drama *Frou-Frou*, written in 1869, one of the greatest theatrical successes of the century. The two also wrote numerous farces. Their best work is *Tri-coche et Cacolet* and *La Boule*. Halévy wrote, without collaboration, the well-known novels *L'Abbé Constantin* and *Criquette*. Late in life he was made Chevalier of the Legion of Honor and (1900) Commander. He was also elected to the French Academy.

**HALFTONE**, a process of making, from photographs and engravings, plates which resemble electrotypes. The process of making halftones is somewhat complicated. Engravings, photographs and drawings can be reproduced by this method, but photographs give the best results.

The first step in the process consists in making a negative of the picture, in a camera containing a screen specially prepared for the process. This screen consists of two glass plates, ruled with parallel lines, which are very close together. The lines cross the plates diagonally and are so drawn that when the two plates are placed together they form diamond-shaped checks. These plates are cemented together with Canada balsam and placed in the camera near the plate upon which the negative is made. It is by means of these screens that the dots which give the shadow effect in the halftone are produced. (Observe one of the halftone illustrations in this volume under a magnifying glass.) The dots covering the portion of the picture which has the high lights are lighter and larger than those covering the portions in shadow, so that the lights and shadows in the picture are exactly reproduced in the negative.

After the negative has been developed, it is carefully removed from the plate and laid face downward upon the sensitized copper plate upon which the halftone is to be made. The copper plate is prepared by planing and polishing; it is then covered with a thin film of sensitized material, upon which the photograph is made. This material hardens under the action of light; and if the plate and the negative be exposed to an electric light for a few moments and the sensitized plate be "developed" in certain chemicals, a reproduction of the picture is left upon the copper. By washing, those portions of the sensitive film which were not acted upon by the light are dissolved away, leaving the others to protect the surface of the copper. The plate is then placed in an acid bath and etched (See ETCHING), after which it is cleaned and is then ready for printing.

The fineness of the halftone depends upon the number of lines on the screen. For halftones of the best grades from 150 to 200 lines to the inch are used. Poorer grades contain coarser screens, and in these the checks are plainly seen; coarse screens are necessary when a poor quality of paper is used in printing. See PHOTOGRAPHY.

**HALIBURTON, THOMAS CHANDLER** (1796-1865), a Canadian humorist and judge, was born at Windsor, Nova Scotia, and received his education at King's College, in his native town. He was called to the bar in 1820 and soon distinguished himself. At the age of thirty-two he was appointed chief justice of the Court of Common Pleas for Nova Scotia and in 1840 was promoted to the Supreme Court. After two years he resigned and removed to England, where he was for six years a Conservative member of Parliament. Despite his brilliant career as a jurist it is as a humorist and satirist, under the pen name of "Sam Slick," that he is best remembered.

The Sam Slick sketches, which first appeared in a local paper, pictured a Yankee clockmaker, whose shrewd sayings and knowledge of human nature won immediate recognition. These sketches were collected and published in 1837 under the title of *The Clockmaker, or Sayings and Doings of Samuel Slick of Slickville*. A second series of Slick stories appeared in 1838, and a third in 1840. He also wrote *The Old Judge*, *The Letter Bag of the Great Western* and *Traits of American Humor*.

**HALIBUT**, the largest of the flatfishes and an important article of food. Some specimens reach a very large size—six to eight feet in length—and weigh over 300 pounds. Those which weigh about seventy-five pounds are most desired for food, as the flesh is then tenderest. The halibut lies on its left side, with its right side, in which are both eyes, uppermost. It is white beneath and dark brown above. It abounds in all northern seas, and nearly 70,000,000 pounds are caught yearly, by the same methods as are employed in cod fishing.

Halibut prey upon smaller fish and crustaceans, and are themselves devoured by seals, whales and sharks.

**HALIFAX, ENGLAND**, a prosperous center of woolen and worsted manufacture, situated in West Riding, in York County, 194 miles northwest of London. The carpets made in Halifax are known everywhere for their superior quality, and the place also has iron, machine and chemical factories. Situated at the junction of two small rivers and in a rich coal district, and with excellent railroad facilities, Halifax is well located for industrial growth. There are extensive stone quarries in the neighborhood. The town



is well built and is progressive and modern in administration. Among its features of interest is an old inn where part of *Robinson Crusoe* was written. Population, 1914, estimated at 100,701.

**HALIFAX**, NOVA SCOTIA, the largest Canadian city on the Atlantic Ocean and one of the principal cities in British North America. It has one of the world's finest harbors, which is never closed by ice. The main part of the city rises on slopes at the western end of the harbor. It is the terminus of the Canadian Pacific and the Intercolonial railroads, and it also has a smaller road known as the Halifax & Southwestern.

Halifax is the nearest Atlantic Ocean port to Europe, and it has achieved considerable commercial advantage from such location. To accommodate for all time increasing ocean traffic the Canadian government has spent \$30,000,000 in improvement of the harbor and terminal facilities. The work was begun in 1914. The landing quay is half a mile long, and six piers are each an eighth of a mile in length. Steamers dock at one end of the terminal, and trains bound for the Pacific side of the continent start from the other end.

The greatest disaster in the world in the year 1917, outside of the World War, occurred in Halifax harbor on December 6, when a munitions vessel holding 2,800 tons of nitroglycerine and T.N.T. collided with a Belgian relief ship, resulting in fire and explosions which destroyed vast shipping, two and one-half square miles of the city and the suburbs of Dartmouth and Richmond. The loss of life was appalling; 1,226 were killed and over 8,000 were injured. The property loss exceeded \$50,000,000. Population, 1911, 46,619; in 1917, estimated, 53,500.

**HALL**, ASAPH (1829-1907), an American astronomer, born in Goshen, Conn., and educated in Central College, New York, and at the University of Michigan. In 1862 he became an assistant in the naval observatory at Washington, and in the following year was made professor of mathematics in the same institution; but in 1891 he left the government service with the rank of captain. Hall was sent with various scientific expeditions undertaken by the government, amongst which were those to Bering Strait in 1869, to Colorado in 1878 and to Vladivostok, Siberia, in 1874, to observe the transit of Venus. The greatest of his numerous discov-

eries was finding the two moons of Mars, and his most important work a study of the double stars. For six years he was professor of astronomy at Harvard.

**HALL**, GRANVILLE STANLEY (1845- ), an American educator and psychologist, edu-

cated at Williams College and in Germany. He held successively the positions of professor of psychology in Antioch College, lecturer on psychology at Harvard and Williams, professor of psychology in Johns Hopkins University and president



G. STANLEY HALL

of Clark University, Worcester, Mass. Doctor Hall is recognized throughout the country as an eminent authority upon education and has been one of the leaders in adapting methods of instruction to the new psychology. He is also an authority on, and one of the leaders in, the movement of child study in America. He is the author of *Methods of Teaching History*, *How to Teach Reading*, *Contents of Children's Minds* and *Adolescence*, an elaborate work touching on the relation of adolescence to education. Among his later books are *Educational Problems*, *Founders of Modern Psychology*, and *Jesus the Christ, in the Light of Psychology*.

**HALLAM**, HENRY (1777-1859), an English historian. He was educated at Eton and Oxford and studied for the law, but abandoned it for literary pursuits. His contributions to the *Edinburgh Review* brought him into notice, and his *View of the State of Europe During the Middle Ages*, which appeared in 1818, at once established his reputation. His next work, the *Constitutional History of England from the Accession of Henry VII to the Death of George II*, showed, like the first, the solid learning, patient research, accuracy and impartiality of statement which are characteristic of this author's work. In 1839 appeared his last great work, the *Introduction to the Literature of Europe in the Fifteenth, Sixteenth and Seventeenth Centuries*, a useful survey of literary history, though wanting in the fineness of judgment necessary for such

work. His youngest son, Arthur Henry, a youth of high promise, who died suddenly at the age of twenty-two, is the subject of Tennyson's *In Memoriam*.

**HALLE**, *hahl'e*, GERMANY, usually called HALLE ON THE SAALE to distinguish it from other places of the same name, is an important town in the Prussian province of Saxony, about twenty miles northwest of Leipzig, on the River Saale. Halle has an extensive trade and manufactures of chemicals, oil, malt, dyes, agricultural machines and salt. The latter is mined in large quantities on an island in the Saale. Among the most beautiful buildings is the town hall, erected in the fifteenth century. Population, 1910, 180,843.

The University of Halle, founded in 1694 as a Lutheran theological school, is one of the leading universities in Germany. In 1817 the University of Wittenberg was united with it. The school is very prosperous, maintains the usual departments of literature, theology, and science and gives special attention to instruction in agriculture. The number of students is usually about 2,300, and the library contains over 210,000 volumes.

**HALLECK**, FITZ-GREENE (1790-1867), an American poet, famed as the author of *Marco Bozzaris*. He became a clerk in a New York banking house and for years was in the employment of John Jacob Astor. In 1819, poems by him and a friend appeared in the *New York Evening Post*, under the signature of Croaker & Co, and attracted some attention. It was on the death of this friend that Halleck wrote his most beautiful poem, beginning "Green be the turf above thee." In 1820 he published *Fanny*, his longest poem, a satire on the follies and fashions of the day. Among his other notable poems are *To the Memory of Burns*, *Alwick Castle* and *Red Jacket*.

**HALLELUJAH, ALLELUIA**, or **HALLELUJA**, *hal le loo'yah*, meaning *praise ye the Lord*, is a Hebrew word often occurring in the Psalms. It is retained in translations, probably because its full, fine sound is an eminently appropriate expression of religious praise and rejoicing. The *Great Halleluja* is the name given by the Jews to *Psalms* 113-117, which are sung on the Feast of the Passover and the Feast of Tabernacles. The great "Hallelujah Chorus" in Handel's oratorio *Messiah* is one of the noblest and most inspiring pieces of music ever written.

**HALLEY**, EDMUND (1656-1742), an English astronomer and mathematician, born in London and educated at Saint Paul's School and at Queen's College, Oxford. He traveled extensively, observing important celestial phenomena, and made a catalogue of the stars of the southern hemisphere. Halley had charge of a voyage in the Pacific for the observation of the stars and was so successful that he was made a captain in the navy with half pay for life. He discovered "Halley's comet" in 1680; in 1703 he became a professor of geometry at Oxford, and ten years later secretary of the Royal Society which position he held until his death. A great many important discoveries are accredited to Halley and it was he who first predicted the return of a comet. Newton's calculations of a comet's orbit were based partly on Halley's observations.

**HALL OF FAME**, a building on the grounds of the New York University, erected as a memorial to famous Americans and completed in 1900. It consists of a colonnade 400 feet long, with provisions for 150 panels, two feet by six, each to bear the name of a famous American. Only persons who have been dead ten years or more and were born in territory of the United States were originally eligible. Fifty names were to be inscribed at the beginning, and five additional names were to be added every fifth year until the year 2000, when the 150 inscriptions will be completed. The nominations of the public were invited, and these, on being seconded by the senate of the University, were submitted to a board of 100 judges, eminent citizens chosen by the council. The rule requires that no one who receives less than fifty-one votes can be accepted. In 1900, of the 252 names submitted, twenty-nine received the required number of votes, the following were chosen:

|                     |                     |
|---------------------|---------------------|
| George Washington   | Nathaniel Hawthorne |
| Abraham Lincoln     | George Peabody      |
| Daniel Webster      | Peter Cooper        |
| Benjamin Franklin   | Robert E. Lee       |
| Ulysses S. Grant    | Eli Whitney         |
| John Marshall       | John J. Audubon     |
| Thomas Jefferson    | Horace Mann         |
| Ralph Waldo Emerson | Henry Ward Beecher  |
| Robert Fulton       | James Kent          |
| Henry W. Longfellow | Joseph Story        |
| Washington Irving   | John Adams          |
| Jonathan Edwards    | William E. Channing |
| Samuel F. B. Morse  | Gilbert Stuart      |
| David G. Farragut   | Asa Gray            |
| Henry Clay          |                     |

In 1905 the following were added:

|                    |                |
|--------------------|----------------|
| John Q. Adams      | Louis Agassiz  |
| James R. Lowell    | John P. Jones  |
| William T. Sherman | Mary Lyon      |
| James Madison      | Emma Willard   |
| John G. Whittier   | Maria Mitchell |
| Alexander Hamilton |                |

In 1910 these were added:

|                       |                    |
|-----------------------|--------------------|
| Harriet Beecher Stowe | William C. Bryant  |
| Oliver W. Holmes      | Frances E. Willard |
| Edgar A. Poe          | Andrew Jackson     |
| Roger Williams        | George Bancroft    |
| James F. Cooper       | John L. Motley     |
| Phillips Brooks       |                    |

In 1915 seven new names were added:

|                 |                   |
|-----------------|-------------------|
| Mark Hopkins    | Charlotte Cushman |
| Francis Parkman | Rufus Choate      |
| Elias Howe      | Daniel Boone      |
| Joseph Henry    |                   |

**HALLOWE'EN**, *hal o een'*, or **HALLOW-EVEN**, the evening of October 31. Though the occasion is usually given over to frolics, mischief and entertainments of an hilarious nature, the name means, literally, *Holy Eve*. In fact, October 31 is the eve of the Church festival of All Saints, which occurs on November 1. Long years ago pagan people celebrated All Saints' Day in honor of the good and evil spirits which were believed to inhabit the earth, and the frolicking of to-day is merely a survival of these superstitious customs. For the Christian festival of November 1, see ALL-SAINTS' DAY.

**Suggestions for Hallowe'en.** The observance of Hallowe'en in the school permits an attractive departure from the regular routine, and an enjoyable program can easily be prepared. The decorations for the occasion, such as colored paper figures of cats, witches, goblins, fairies, and the like, afford an opportunity for constructive work that is not without value. Below is a program that should prove suggestive to the teacher:

|   |                     |
|---|---------------------|
| Song, "The Bogie Man".....              | Alfred P. Graves.   |
| "Little Orphan Annie".....              | Riley.              |
| Selection from                          |                     |
| "The Goblin Market".....                | Christina Rossetti. |
| Song .....                              | Selected.           |
| "The Fairies" .....                     | William Allingham.  |
| Spelling Contest .....                  | All of the pupils.  |
| Costume Drill .....                     | Girls.              |
| "The Shoemaker and the Elves".....      | Grimm.              |
| "Tam O'Shanter" .....                   | Burns.              |
| Dramatization of "Rip Van Winkle."      |                     |
| Reading from Kingsley's "Water Babies." |                     |
| Song .....                              | Selected.           |

**HALLUCINATION**, *hal lu se na'shun*. a condition of mind in which a person thinks he sees or hears things that have no existence.

The mind acts without a sensation to produce the action. Hallucinations are to be distinguished from illusions, for in the latter there are real sensations, which are erroneously interpreted. The visions which people experience who are in a state of religious exaltation are hallucinations; an example of illusion is the mistaking of a white object in a lonely region at night for a ghost.

The senses are not equally subject to hallucinations. Hearing is most frequently affected, and then sight, smell, taste and touch, in order. Hallucinations of several senses may exist simultaneously in the same individual, and these may be complicated with certain illusions. The simplest form of hallucination of hearing is the ringing in the ears; but the striking of clocks, the sounds of musical instruments and of the human voice are often heard in imagination. Hallucinations are not confined to those whose mental faculties are disordered. Occasionally they appear in healthy persons, and the individual is fully conscious of the unreality of the objects that affect his senses. Sometimes after long periods of intense mental work, troublesome hallucinations may appear, but rest will drive them away.

**HA'LO**, the name given to colored circles of light sometimes seen around the sun or moon, and to other similar luminous appearances. These phenomena are classified as (1) *halos proper*, consisting of complicated arrangements of arcs and circles of light surrounding the sun or moon, accompanied by others tangent to or intersecting them; (2) *coronas*, simple rings, generally somewhat colored; (3) *aureolas*, bright rings surrounding shadows projected upon a cloud or fog-bank, or the colored rings observed by aeronauts on the upper surface of clouds. All these appearances are the result of certain modifications which light undergoes by reflection, refraction, dispersion, diffraction and interference, when it falls upon the crystals of ice or the raindrops that constitute clouds.

**HALOGENS**, *hal'o jenz*, a collective name given to a group of four chemical elements which have points of similarity. They are bromine, chlorine, fluorine and iodine, each of which is described in these volumes. The name means *sea salt producer*, and it applies to these elements because each in compound with other substances forms salt resembling common or sea salt.

**HALS**, *hahlz*, FRANS (1584-1666), a famous portrait and genre painter; of Dutch artists, he was second only to Rembrandt. Hals was born at Antwerp, but moved to Haarlem, where he studied under good masters and was held in high esteem throughout his jovial, care-free life. He was one of the greatest portrait painters of all time. Character and expression were his chief concern, and all details were made to emphasize the impression he wished to produce. He painted a great variety of types, but whatever his subject it was rendered with the utmost sympathy and faithfulness. Not only in the field of portraiture, but also in genre (portrayal of scenes of everyday life) he was preëminent. The spirit of his *Fool Playing the Lute*, of *The Jolly Trio*, of *Hille Boble*, representing an old woman turning from a tall open mug to grin broadly at a pet owl perched on her shoulder, is inimitable, and has given to Hals the title "father of Dutch genre painting." See **GENRE PAINTING**.

**HAM**, according to *Genesis* VI, 10, one of the three sons of Noah. He was the reputed ancestor of the North African races, and from this circumstance came the name *Hamites*, applied to those people in standard classifications of the human race.

**HAM**, the name usually given to the cured thigh of the ox, sheep or hog, particularly the last. The curing of hams forms an important part of the meat-packing industry. For ordinary trade they are first pickled in brine, then smoked in large chambers, built especially for the purpose. Each nation has its own method of curing hams, and the packing houses try to conform to these customs for their export trade. See **PORK**; **MEAT-PACKING**.

**HA'MAN**, a favorite of King Ahasuerus, of Persia, whose story is related in these volumes in the article **BIBLE**, subhead *Bible Stories*.

**HAM'BURG** (in German, *hahm'boork*), GERMANY, the greatest commercial port on the continent of Europe, situated about eighty miles from the North Sea. It lies on a low plain along the north branch of the Elbe, 178 miles by rail northwest of Berlin, the only city in Germany exceeding it in population. Before the World War Hamburg had a foreign trade surpassed only by that of London and New York. From the Elbe proceed canals which intersect the business part of

the city in all directions, while the River Alster, flowing across it, forms two large basins known as the Binnenalster and Aussenalster. The canals and Elbe are spanned by many fine bridges.

Around the Alster basins are grouped the modern sections of the city, and here are beautiful drives and many imposing buildings. Among the notable structures is the Saint Nicholas Church, whose beautiful spire towers 482 feet. The business section is at all times a scene of great activity, and the harbor is one of the finest in the world. From it small freighters proceed up the canals to the scores of warehouses along their banks. Hamburg is a famous coffee market, a ship-building center of first rank, and a center also of banking, exchange and marine insurance. In normal years it is an embarkation point for thousands of emigrants. Population, 1918, 1,014,664.

**Hamburg State**. This is a free state having an area of 160 square miles and including within its boundaries the city of Hamburg and numerous outlying towns and rural districts. The state lies between Hanover and Schleswig-Holstein. It has a republican form of government, and is governed by a senate and a house of burgesses. Among its towns is Cuxlaven, at the mouth of the Elbe, an important submarine base during the World War. The population of the state, exclusive of that of the city of Hamburg, is about 85,000.

**HAMIL'CAR BARCA**, *bahr'kah*, a great Carthaginian general, the father of Hannibal. While still a young man he was appointed to the command of the Carthaginian forces in Sicily, shortly before the close of the first Punic War, when the Romans were masters of almost the whole island. For several years he defied all the efforts of the Romans to dislodge him; but the defeat of the Carthaginian admiral, Hanno, compelled him to evacuate Sicily. He then entered on a series of campaigns in Spain, where he founded a new empire for Carthage. He had brought the whole southern and eastern part of the country under Carthaginian rule when he was slain in a battle against the Vettones, in 228 B. C. His plan to make Spain a base for attack against Rome was ably carried out by his son-in-law, Hasdrubal, and his son, Hannibal.

**HAMILTON**, ALEXANDER (1757-1804), a distinguished American statesman, one of the foremost among the builders of the American

republic, was born in the island of Nevis, West Indies. At the age of sixteen he became a student in Columbia College, New York, and early contributed some powerful letters to the discussion of pre-Revolutionary issues. On the outbreak of the war he received (1776) a commission as captain of artillery; Washington soon appointed him his aide-de-camp and employed him in the most delicate and difficult affairs.

In 1781 he left the service, studied law, became a delegate to Congress from the state of New York in 1782 and in 1787 was a conspicuous member of the convention called to revise the Articles of Confederation. He was a strong supporter of centralized government and on the Constitution as completed, and by the letters which he wrote, afterward published under the title of *The Federalist*, he exerted great influence in favor of its ratification.



ALEXANDER HAMILTON

On the organization of the government in 1789, with Washington at its head, Hamilton was appointed Secretary of the Treasury. In this office he displayed a remarkable grasp of problems, being responsible for the establishment of a national bank and a United States mint, for the organization of a capable Treasury Department, for the imposition of customs and excise duties and for the assumption by the nation of the Revolutionary debts of the states.

He resigned in 1795 and retired into private life. In 1798 he was appointed second in command of the provisional army, in the fear of a French war, and on the death of Washington, in 1799, he became commander in chief. In 1804 he became involved in a political dispute with Aaron Burr, then candidate for the governorship of New York, accepted a challenge for a duel and was mortally wounded. Hamilton was distinguished as soldier, author, debater, legislator, financier, lawyer and administrator.

**HAMILTON**, OHIO, the county seat of Butler County, twenty-five miles north of

Cincinnati, on the Miami River and the Miami & Erie Canal, (not now used) and on the Cincinnati, Hamilton & Dayton, the Pittsburg, Cincinnati, Chicago & Saint Louis, the Erie, the Pennsylvania and the Cincinnati, Indianapolis & Western railroads. The industries include paper, flour and woolen mills, foundries, machine shops, breweries, and manufactories of tools, agricultural implements, safes and other articles. In some of these products Hamilton leads the United States in output. The surrounding country is agricultural. Among the notable buildings are a courthouse, Mercy Hospital, a Y. M. C. A. building and a great high school. Here are located Miami University and Western College. A severe flood occurred in 1913; it was followed by the construction of engineering works to prevent future disasters of the kind. General Arthur Saint Clair built a fort here in 1791 and called it Fort Hamilton, in honor of Alexander Hamilton. A settlement grew up around this and was first incorporated in 1810. Population, 1910, 35,279; in 1917, 41,338 (Federal estimate).

**HAMILTON**, ONTARIO, founded in 1813, and now sixth city in Canada in size, is the capital of Wentworth County, on Burlington Bay and Lake Ontario, forty miles southwest of Toronto, on the Grand Trunk, the Canadian Pacific and the Toronto, Hamilton & Buffalo railroads. It has fifty branches of United States factories, besides numerous enterprises of its own, including cotton mills, flour mills, an iron foundry, stone foundries, wire works, screen works, canning factories and rolling mills. It is in the center of a rich fruit region. The city is governed by a board of control and sixteen aldermen. There are fourteen parks and squares for recreation purposes. There are normal and technical schools, a collegiate institute and nine separate schools. Nearly 6,000 men from the city volunteered for the World War. Population, 1911, 81,969.

**HAMLET**, a prince of Denmark who, according to tradition lived about 200 B. C. Shakespeare's famous tragedy follows closely, in its main outline, the semilegendary story of Hamlet, but varies in many of the details. According to the legend, Hamlet's father was killed by his own brother Fengo, after which the murderer ascended the throne. To save his own life, Hamlet pretended to be insane, and his mother helped him to avenge his father's death. In the play the murderer

marries the king's widow, and the whole plot is revealed to Hamlet by his father's ghost. To conceal his plans for vengeance Hamlet feigns madness. The character of Hamlet is one of the most fascinating subjects for study in all dramatic literature, and has been interpreted on the stage by the world's greatest actors.

**HAMLIN, HANNIBAL** (1809-1891), Vice-President of the United States in the first Lincoln administration, was born in Maine. He practiced law and served as a member of the Maine legislature from 1835 to 1840. In 1842 he was elected to Congress and served until 1846, commanding attention as an anti-slavery man. In 1848 he became United States Senator as a Democrat and was re-elected in 1851, but joined the Republican party when it was organized. He was elected governor of Maine in 1856. He returned to the Senate the following year, but was elected Vice-President in 1860, was again chosen United States Senator in 1869 and served until 1881, when he was appointed minister to Spain.

**HAMMER.** The common household or carpenter's hammer, is too common to warrant description. The present tool is a development of prehistoric hammers, which consisted of stone, jade or other hard substance fastened with thongs to a handle. The modifications of the hammer to-day include great implements capable of delivering powerful blows. See STEAM HAMMER; TRIP HAMMER.

**HAMMER, THROWING THE,** an athletic feat that calls for great strength and a high degree of muscular control. The thrower stands in the center of a circle having a radius of three and one-half feet, and from this point hurls a hammer, which he first swings about his head. The hammer consists of a metal ball, weighing not over sixteen pounds, attached to a handle made of wire ropes or chains, with wooden grips for the hands. The handle may not be longer than four feet. The highest record for hurling a sixteen-pound hammer thus far recorded is 180 feet 5 inches.

**HAMMERFEST, NORWAY,** not the most northerly settlement in the world, but the most northerly incorporated town. It is on the island of Kvalo, about 120 miles northeast of Tromsö. Considering the high latitude, the summers are mild, the average temperature during that season being 57°; the average winter temperature is slightly below

the freezing point. From November 18 to January 23 the sun is not seen, but there is continuous twilight; from May 13 to July 29 it is continuously visible. Fishing is the means of livelihood of the people, of whom there are about 2,300. They market large quantities of cod-liver oil.

**HAMMERHEAD, or HAMMERHEAD SHARK,** a shark with a head shaped like a double-headed hammer, with eyes at the end of the projections. There are a number of species inhabiting warm seas, and one species is found on the coast of the United States. All are savage and dangerous.

**HAMMOND, IND.,** a city in Lake County, twenty-two miles southeast of the business center of Chicago, on the Calumet River and on the Erie, the Baltimore & Ohio, the Michigan Central, the Wabash and several other railroads. It has growing importance as a commercial and manufacturing center. The city contains meat-packing plants, brick-yards, tanneries, foundries, flour mills, chemical works and manufactories of steel springs, starch, glue, nails and other articles. Population, 1910, 20,925; in 1917, 27,016 (Federal estimate).

**HAMMOND, JOHN HAYS** (1855- ), an American mining engineer, who has been connected with mining operations in two continents. He was born in San Francisco, and was educated at the Sheffield Scientific School of Yale and at the Royal School of Mines in Freiberg, Germany. In 1880 he was appointed special expert on the United States Geological Survey for the investigation of the gold fields of California, and in 1882 was made superintendent of silver mines at Sonora, Mexico.

After serving as consulting engineer to mining and railway companies in America, he became associated with various companies with holdings in South Africa, and while engaged in mining operations in that region became implicated in the Jameson Raid (see JAMESON, LEANDER STARR). He was charged with being in the conspiracy against the South African Republic, and was sentenced to death. This sentence was later commuted to fifteen-years' imprisonment, but Hammond was ultimately released upon his payment of a fine of \$125,000. On his return to the United States he became interested in several mining, hydroelectric and irrigation projects, and was a frequent lecturer at universities. In 1910 President Taft appointed him special representative at the coronation of George V.

**John Hays Hammond, Jr.** (1888– ), son of the above, is noted as the inventor of a type of torpedo for coast defense which is controlled by wireless energy from coast fortifications. He has applied for more than 220 patents in the United States and Europe for inventions concerned with radio telegraphy and telephony and torpedoes controlled by wireless energy.

**HAMPDEN, JOHN** (1594–1643), an English statesman, famous for his opposition to taxation by the king's decree. He entered Parliament at the beginning of Charles I's reign and served in the first three Parliaments (1625, 1626, 1628). Although he attracted some attention in 1627 by refusing to contribute to a forced loan, it was not until ten years later that his resistance to Charles's demand for ship money brought him generally before the public. Although Hampden's contention was the reasonable one—that an inland county should not be forced to pay ship money in time of peace—and although he himself argued his case ably, he was condemned. The popular opposition to the decision against Hampden greatly increased the hatred of Charles I and his arbitrary measures. Of the Short Parliament and the Long Parliament of 1640, Hampden was a member, and he was one of the five members whom the king in January, 1642, attempted to arrest. As commander of a regiment in the Parliamentary army, Hampden took part in a skirmish at Chalgrove Field in June, 1643, and was killed.



JOHN HAMPDEN

**HAMPDEN, WADE** (1818–1902), an American soldier and politician, was born at Columbia, S. C., and educated at the state university for the law, but he never practiced it. He served in both houses of the state legislature and on the outbreak of the Civil War organized and equipped a command of Confederate infantry, artillery and cavalry, known as Hampton's Legion, which rendered

valuable service to the Confederates throughout the war, especially at the first battle of Bull Run and in the Peninsula Campaign. As brigadier-general of cavalry, Hampton accompanied Lee in his second invasion. He was wounded at Gettysburg and in the following August was commissioned major-general. He opposed Sheridan in the Shenandoah Valley in 1864, and for his service in that campaign was made lieutenant-general and commander of all the Confederate cavalry. He was with Johnston in opposing Sherman's northward march from Savannah. After the war he did his utmost to heal the wounds of the South and to foster loyalty to the reunited nation. He was elected governor of South Carolina in 1876 and two years later entered the United States Senate, where he served until 1891. Two years later he was appointed United States commissioner of railroads and served until 1897.

#### **HAMPTON NORMAL AND AGRICULTURAL INSTITUTE**, an institution for the education of negroes and Indians, established at Hampton, Va., in 1868, under the auspices of the American Missionary Society and through the inspiration of General S. C. Armstrong, who was its first superintendent.

The school is located on a farm and contains nearly sixty buildings, including dormitories, recitation halls, shops, a trade school, a building for domestic science and agriculture, a church, a hospital, a gymnasium, a library, a sawmill and a planing mill. The institution maintains both collegiate and academic departments, and in addition to this it provides instruction in theory and practice in nearly all lines of industry. Courses in carpentry, blacksmithing, painting and other handiwork are open to the men, while the girls are instructed in all lines of work pertaining to the home. A large stock farm of 600 acres is owned by the school and is cared for by the students. The expenses of the institution are met by contributions, but students are required to pay their board, which most of them do by working. The student enrollment is over 1,800 in normal years, and the faculty has over 130 members. There are about 37,340 volumes in the library.

The influence of this institution on the education of the negro has been beyond measure, since many of its graduates have established similar schools in various parts of the country, the most noted of these being the Tuskegee Institute and Normal School.

established by Booker T. Washington. See TUSKEGEE NORMAL AND INDUSTRIAL INSTITUTE.

**HAMPTON ROADS.** See CHESAPEAKE BAY; MONITOR AND MERRIMAC.

**HAMPTON ROADS CONFERENCE,** a famous conference held on a vessel near Fort Monroe, February 3, 1865, between President Lincoln and Secretary of State Seward, on the part of the United States government, and Vice-President Alexander H. Stephens and others for the Confederate States of America. The conference was the result of the efforts of Francis P. Blair, who hoped, by securing the coöperation of the Federal and Confederate armies against the French in Mexico, to secure a reunion of the sections and the abolition of slavery. It accomplished nothing.

**HAM'STER,** a species of rodents, of the same family as the mouse. The animal is native to Central Asia and parts of Europe, is about ten inches long, has reddish gray hair and white spots on the sides and breast. It has a short hairy tail and cheek pouches, in which it carries grain and seeds.

**HANCOCK, JOHN (1737-1793),** a Revolutionary patriot and statesman, born in Braintree, Mass. He was a leading figure in the beginning of the Revolutionary struggle, working both with voice and pen, and the attempt to arrest Hancock and Samuel Adams on a charge of treason was one cause of the Battle of Lexington (see LEXINGTON, BATTLE OF). Hancock was a member of the Continental Congress from 1775 to 1780, and from 1785 to 1786, and served as president of the body from 1775 to 1777, in that capacity being first signer of the Declaration of Independence. Out of this incident rose the expression "to sign one's John Hancock," meaning to add one's signature. Hancock served as governor of Massachusetts twelve years. As a legislator he was not especially broad-minded or far-seeing, but was always persistent and courageous.



JOHN HANCOCK

**HANCOCK, MICH.,** in Houghton County, opposite Houghton, on Lake Portage and on the Duluth, South Shore & Atlantic and the Copper Range railroads. The village is in the Lake Superior copper region, near the famous Calumet and Hecla mines, and contains smelting works, foundries, machine shops and other industrial establishments. It is the seat of the only Finnish college in America. The place was settled in 1859, and was incorporated in 1863. Population, 1910, 8,981; in 1917, 12,578 (Federal estimate). Almost every nationality is represented.

**HANCOCK, WINFIELD SCOTT (1824-1886),** one of the leading Federal officers in the Civil War, was born in Pennsylvania and educated at West Point. He participated in the important battles of the Mexican War and was brevetted first lieutenant for bravery. In 1861 he was made brigadier-general and given command of a brigade in the Army of the Potomac. He fought at Williamsburg and at Antietam, at Fredericksburg led his men through such a fire as has rarely been encountered in warfare and at Gettysburg was dangerously wounded. In 1866 he was appointed major-general in the regular army, and in the following year was placed for a short time in charge of reconstruction in Louisiana and Texas. In 1880 he was the Democratic candidate for the Presidency of the United States, but was defeated by Garfield.

**HAND,** the termination of the human arm, corresponding to the paw or claw of the lower animals. The hand is so constructed that with it man can perform not only the ordinary tasks of everyday life, but those requiring the most delicate manipulation. This useful organ, says one authority, possesses the faculty of "opposing the thumb to the other fingers, so as to seize upon the most minute objects—a faculty which is carried to its highest degree of perfection in man." The skeleton of the hand has twenty-seven bones, including the eight *carpal* bones of the wrist. In the palm there are five *metacarpal* bones, and in the fingers and thumb there are fourteen *phalanges*. By means of strong tendons, distributed through the palm, thumb and fingers, and attached to the arm muscles, the fingers can be moved in many different ways, and the thumb has even greater flexibility.

**HAND'BALL,** a game adapted from one played in Ireland in ancient days. It is so



called because it is played with an elastic ball which is struck with the hand against a board or wall. Usually two or four persons make up the opposing teams, but it can be played by three persons. The court consists of a floor, marked off with side and front boundary lines, an upright board which serves as a back wall, and a surrounding field. Mid-

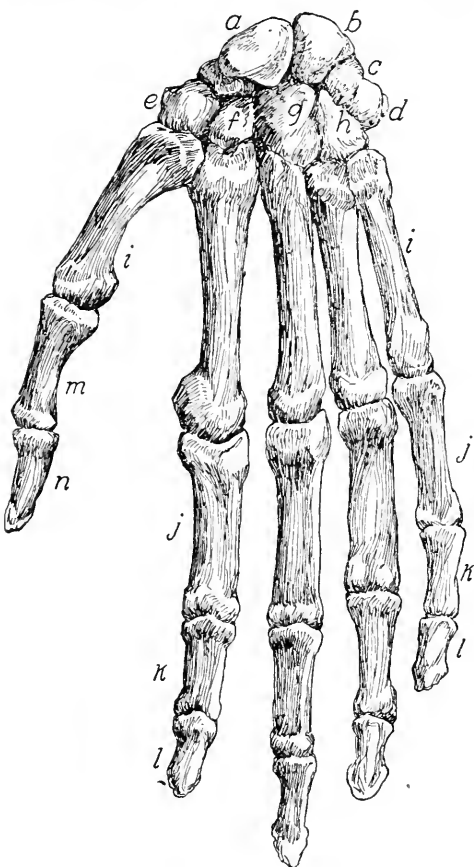

BONY STRUCTURE OF THE HAND

a, b, c, d, the four bones of superior row of carpus.

e, f, g, h, the four bones of inferior row.

i, i, i, the five metacarpal bones.

j, j, the first phalanges.

k, k, the second phalanges.

l, l, the third phalanges.

m, n, the two phalanges of the thumb.

way between the rear wall and the front line of the court is a service line drawn parallel to the back wall.

The player who starts the game—the server—stands inside the outer section of the court. He serves the ball by dropping it on the floor on the farther side of the service line. To be properly served the ball must

bound, strike against the upright board, rebound from the wall and touch the floor inside the section beyond the service line. If the rebounding ball touches the floor inside the service line it is a *short* ball; if it goes outside the front line of the court it is a *long* ball. In singles a server is out if he serves one long and one short, or two long or two short balls in succession, or if the ball falls outside the side lines of the court. In doubles in such cases the side is out.

A properly-served ball is returned by the opponent's striking it against the upright board. The ball may be struck after the first bounce or while it is in air. If the ball is successfully returned the server bounds it again from the board and the game continues. If the ball is not returned properly the server scores one and begins a new inning. Twenty-one points are considered a game. Full directions in regard to rules and scoring may be found in standard guide books for athletic sports.

**HANDEL**, GEORGE FREDERICK (1685-1759), a German composer whose oratorios have made his name imperishable. One of these, *The Messiah*, is one of the noblest compositions in all the literature of music. Handel was born at Halle, in Saxony, and at an early age was sent to Berlin to study. He made his *début* there as a performer at the age of twelve. For a time he was organist in the cathedral at Halle; afterwards he went to Hamburg, where he played second violin in the orchestra. In 1704 he published his first opera, *Almira*. He visited England twice, and ultimately, having received a pension from Queen Anne, settled there and became head of the newly-founded Royal Academy of Music. He produced in succession the oratorios *Israel in Egypt*, *L'Allegro and Il Penseroso*, *Saul* and *The Messiah*. The last mentioned, which is his chief work, was brought out in 1741, for the benefit of the Foundling Hospital in Dublin. It was not much appreciated at the first presentation, but increased in reputation each year, until to-day it is considered the greatest oratorio ever written. In 1752 Handel became blind, but continued to compose and to play in public. He was buried in Westminster Abbey.

**HANDICAP**, an extra burden placed upon those who, in competition, have by previous performance showed their ability to do things more successfully than their competitors. In athletic events records are kept of what is

accomplished by all the men; then some official, who is agreed upon, handicaps those men who need it, in such a way that apparently all are on a fair and even basis. In the races the best men start from the "scratch" and run the full distance, while others are allowed to start at different marks in front of the "scratch" line, according to the decisions of the handicappers. In horse racing the handicap is sometimes accomplished by requiring a heavier jockey to ride the horse or by weighting the saddle. In the various games different methods are used to bring about equality; a golfer is handicapped by being required to allow his opponent a specified number of strokes. No handicaps can be assigned in big field games like cricket and baseball.

**HAND ORGAN.** See HURDY-GURDY.

**HANGBIRD.** See BALTIMORE ORIOLE.

**HANG-CHOW**, *hahn'chow*, or **HANG-CHOO**, CHINA, a capital of the Province of Che-kiang, located southwest of Shanghai, near the southern end of the Grand Canal. It is one of the handsomest cities in China, with many magnificent temples, monuments and triumphal arches. Hang-chow has extensive manufactures of silks, furs, gold and silver ornaments, tapestries, lacquered ware and fans. The greater portion of the inhabitants live without the walls in the beautiful suburbs and in boats on the river. The city is a center of literary activity, and is noted for its wealth. It was opened to foreign trade in 1896. Population, 1910, estimated, 350,000 in the city proper; including suburbs, 600,000.

**HANGING**, the most common method of inflicting capital punishment. The method is sufficiently described by the sentence which is usually pronounced by the court, that the convict "be hanged by the neck until he is dead." The sentence also fixes the time and place for the execution. Hanging has been generally adopted for the reason that it is generally considered the most humane method of capital punishment, though in recent years it has been superseded in some states by electrocution (see ELECTROCUTION). The execution was formerly a public ceremony, but in later times the tendency has been to avoid publicity.

For details as to means employed in capital punishment in the various states, see that article.

**HANGING GARDENS OF BABYLON**, a structure of ancient Babylon, celebrated

as one of the "seven wonders of the world." It was a sort of pyramid which rose in terraces, was planted with trees, shrubs and flowers, and was intended to simulate a hill. It was built by Nebuchadnezzar for his queen, who on the Babylonian plain frequently grew homesick for the hilly scenery of her native land, Media. See SEVEN WONDERS OF THE WORLD.

**HANKOW**, *hahn'kou*, CHINA, a town and river port in the province of Hupeh, situated at the junction of the Han with the Yangtse-kiang. The native portion of the city is dirty and crowded, but the foreign settlement, occupied by British, French, Russian and German residents, stretches for three miles along the river and is beautifully laid out, substantially built and well kept. The port of Hankow was opened to foreign trade in 1862 and has become the chief distributing center for the central provinces. The chief articles of export are tea, rice, silk, tobacco, hides, cotton and wood oil. Hankow was captured by Chinese revolutionists in 1912 and made the provisional capital of the republic. Population, 1916, estimated, 1,321,280.

**HANNA**, MARCUS ALONZO (1837-1904), an American capitalist and politician, born at New Lisbon, Ohio. He removed with his father to Cleveland, where he acquired large business interests. Turning his attention to politics, he became Republican leader of his ward, city and state, and he was chairman of the Republican National Committee from 1896 to 1904, being special sponsor for William McKinley as a Presidential candidate in the convention of 1896. He was elected United States Senator in 1897 and was reelected in 1903. Hanna was identified with the National Civic Federation, was for a time its president and was always one of its most important and useful members.

**HAN'NIBAL** (247-183 B. C.), one of the greatest generals of antiquity, son of a Carthaginian general, Hamilcar Barca. As a child he was made to take an oath of lasting enmity towards the Romans, who had constantly sought to bring Northern Africa under subjection. At the age of twenty-two he went from Carthage to join the Carthaginian army in Spain, then commanded by his brother-in-law, Hasdrubal; three years afterwards, on the murder of Hasdrubal, he received the chief command, and prepared to march against Rome.

He set out with 90,000 foot soldiers, 12,000 horsemen and thirty-seven elephants. When he arrived, after incredible toil, at the southern foot of the Alps, his force numbered only about 26,000. However, he advanced and encountered a Roman army

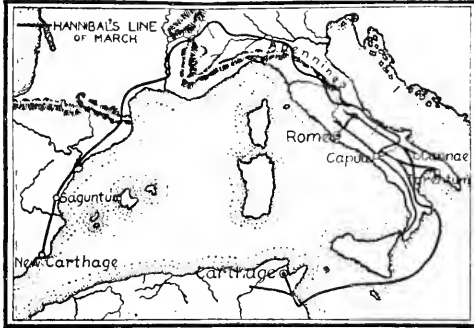

#### CAMPAIGN IN SPAIN AND ITALY

under Scipio on the banks of the Ticino, and defeated it (218 B. C.). The next year Hannibal defeated Flaminius and then marched into Apulia, spreading terror wherever he went. In 216 a battle was fought at Cannae, which resulted in total defeat for the Romans, of whom 50,000 were killed. The Romans then shut themselves up in their walled towns, against which Hannibal's army proved ineffective. After this Hannibal made no gains, and in 203 he was recalled to defend his country, which had been invaded by Scipio. He was defeated by the Romans at Zama (202 B. C.), and the Second Punic War, after having lasted eighteen years, came to a close, and Carthage was forced to accept the most humiliating conditions of peace.

Hannibal then devoted himself, as civil magistrate, to restoring Carthage. Seven years after the battle of Zama, and in the midst of his work for a reform of administration, the jealous Romans sent ambassadors to demand his surrender. He fled to the court of Antiochus of Syria and offered his services for the war then commencing against the Romans. They were accepted, but Hannibal's advice for the conduct of the war was not followed, and he himself, as commander of the Syrian fleet, failed in an expedition against the Rhodians. Hannibal, again obliged to flee, took refuge with the king of Bithynia, and he is said to have gained several victories against the king of Pergamus, an ally of the Romans. But

the Roman Senate once more sent to demand the surrender of their inveterate enemy, and Hannibal, unable this time to escape, took poison rather than fall into the hands of his foes.

**HANNIBAL, Mo.**, a city in Marion County, 100 miles northwest of Saint Louis, on the Mississippi River and on the Chicago, Burlington & Quincy, the Hannibal & Saint Joseph, the Missouri, Kansas & Texas, the Saint Louis & Hannibal and the Wabash railroads. It has a large trade in agricultural produce and contains flour mills, foundries, car works and manufactures of stoves, clothing, shoes, cement and other articles. The city has a number of good public buildings, among them being a fine city hall and a Y. M. C. A. building. The place was settled in 1819 and was incorporated twenty years later. It will always be remembered as the boyhood home of Mark Twain. Population, 1910, 18,341; in 1917, 22,399 (Federal estimate).

**HANOI**, *han'noi*, the capital and most important city of the province of Tongking, and the seat of the government of French Indo-China. It is located on the Songkoi, or Red River, on a very picturesque site, and is connected by rail with its port, Haiphong. Its wide streets, some of them lighted with electricity, and its well-built houses of brick, mud or timber make it a very attractive city. The most noteworthy building of the town is the cathedral. As a commercial center the city is important, although by far the greater part of the trade is in the hands of the Chinese. Silk, rice, embroidery and pearl work are largely exported, and there is also considerable trade in filigree work, leather articles and mats. Hanoi has belonged to France since 1882. Among its educational institutions is a school of medicine for natives. Population, 1915, estimated, 150,000.

**HANOVER**, formerly a kingdom in the northwest of Germany, now a province of Prussia. The area is 14,862 square miles. For administrative purposes it is divided into six districts, Hanover, Hildesheim, Lüneburg, Stade, Osnabrück and Aurich. The province is drained by the Elbe, Weser and Ems rivers. The Harz Mountains, in the southeast, are rich in minerals, the working of which is an important industry. The soil in the lowlands is very fertile and produces all kinds of grains, flax, hops, tobacco and potatoes. The manufactures consist of cot-

ton, woolen goods, leather and machinery, and shipbuilding is an important industry. The chief seat of learning is the University of Göttingen, founded in 1737. Hanover is the capital.

The early history of Hanover is that of Brunswick, of which it was a part. It was made an electorate in 1692. Its elector, George Louis, in 1714 became George I of England, and at this time Hanover began to grow in importance, until in 1814 it was made a kingdom by the Congress of Vienna. When Queen Victoria became queen of England, Hanover, by the Salic Law (which see), went to the nearest male heir, Ernest Augustus, Duke of Cumberland. In the war between Austria and Prussia in 1866, Hanover took the side of Austria, and the result was its annexation to Prussia by the Peace of Prague, to the utter regret of its people. Population, 1910, 2,942,436.

**HANOVER, GERMANY**, capital of the Prussian province of Hanover. It is a manufacturing town of great importance, has cotton factories, machine works, iron foundries, chemical works, tobacco and cigar factories and other industries. It is also a railroad center and within a few years has become the twelfth city in size in Germany. Like other German towns, it has an old city and a new city, the latter adorned by fine monuments, public buildings and residences and noted as the seat of educational institutions of importance. Hanover was founded before 1100 and joined the Hanseatic League in 1481. It became the residence of the dukes of Brunswick-Lüneburg and capital of the principality in 1636. Population, 1910, 302,375.

**HANSEATIC**, *han se at'ik*, **LEAGUE**, or **HANSA, THE**, a league formed in the thirteenth century by several cities of Northern Germany for the protection of their commerce. In the middle of the thirteenth century, the sea and land swarmed with pirates and robbers, who infested the thriving ports of the Baltic and the North Sea. A compact was made, therefore, between Hamburg and Lübeck, to keep open the road across Holstein, connecting the North Sea with the Baltic. In 1247 this league was joined by Brunswick, and out of this grew the Hansa, which at its most flourishing period included about eighty-five towns, maritime and inland. Among these the town of Lübeck was recognized as the chief, and here the deputies

of the other Hanse towns assembled to deliberate on the affairs of the confederacy.

During the fifteenth century the power of the league was at its height. It had armies and navies, gained victories in war over the kings of Norway and Denmark, and deposed a king of Sweden. It made thorough provision for the security of commerce on the Baltic and North Seas, constructed canals, introduced a uniform system of weights and measures and developed the principles of mercantile law. As its power and ambition increased it was felt to be an oppressive monopoly, established mainly in the interests of the great seaport towns. Moreover, in time it became less needful for commercial security, as princes learned the advantages of trade, formed naval forces of their own and encouraged navigation. After the discovery of America, European trade was readjusted and the Hansa declined rapidly.

**HANSEN, GERHARD** (1841- ), a Norwegian physician, noted for his discoveries concerning leprosy (which see). He traveled extensively and investigated the disease wherever he found it, and he finally discovered its cause to be a bacillus. Although he was unable to discover any treatment which was effective in curing leprosy, yet by establishing the nature of the contagion he has limited its spread.

**HAPSBURG**, *hahps'boorK*, or **HABS-BURG**, HOUSE OF, an imperial house of Austria-Hungary, members of which ruled until the end of the World War. The name, which is a contraction of *Habichtsburg*, meaning *hawk's castle*, is taken from the castle of Hapsburg, in the canton of Aargau. This castle, it is believed, was built in the eleventh century by Bishop Werner of Strassburg, and Werner II was the first to take the title of Count of Hapsburg. Rudolf and Albert, the great-grandsons of Werner II, were founders of the Hapsburg-Lauffenburg line and the present imperial line, respectively. Rudolf, the son of Albert, became Holy Roman emperor as Rudolf I in 1273, and his son succeeded him in 1298 as Albert I. In 1438 the family again came to the imperial throne, and from that time until 1806, when the title Holy Roman Emperor was abolished, all the rulers of the Holy Roman Empire except two were Hapsburgs. The male line of the Austrian Hapsburgs became extinct in 1740, on the death of Charles VI, but his daughter, Maria Theresa, as-

ended the throne and the dynasty continued through her descendants. Charles I, who ascended the throne of Austria-Hungary in 1916, abdicated in 1918, when the dual monarchy was dissolved. See **WORLD WAR**.

**HARA-KIRI**, *hah'rah ké're*, or **SEPPUKU**, *sep poo'ku*, a form of suicide allowed in old Japan among the nobles and Samurai. When unwilling to survive disgrace, or when condemned for crime, the unfortunate person availed himself of the privilege, preferring death to dishonor, in the former case, and in the latter, choosing to die by his own hand rather than by public execution. Hara-kiri consists in making two deep cuts in the abdomen in the form of a cross. It is rarely practiced to-day. The latest conspicuous instance occurred in 1912, when general Nogi and his wife both committed hara-kiri because they did not wish to outlive their beloved emperor Mutsuhito.

**HARDECANUTE'**, or **HARTHACNUT** (about 1019-1042), king of England and Denmark, the son of Canute. At the time of his father's death in 1035 he was in Denmark, where he was immediately recognized as king. His half-brother Harold, however, who happened to be in England at the time, laid claim to part of their father's dominions and succeeded in getting possession of Mercia, Northumbria and Wessex. He died in 1040, and Hardecanute peacefully succeeded him. He nominally reigned until his death, but the government was almost entirely in the hands of his mother and the powerful Earl Godwin.

**HARDNESS**. If two hard substances are rubbed together the one which will indent or scratch the other is the harder. Glass will scratch gold, therefore it is harder than gold. The degree of hardness of most metals is changed by heating and then cooling. If iron and steel are heated, and then cooled quickly they become harder; if cooled slowly, they become softer. The degrees of hardness of ten typical substances is given below, beginning with the softest:

- |              |             |
|--------------|-------------|
| 1. Talc      | 6. Feldspar |
| 2. Gypsum    | 7. Quartz   |
| 3. Calcite   | 8. Topaz    |
| 4. Fluorspar | 9. Sapphire |
| 5. Apatite   | 10. Diamond |

Numbers 1 and 2 can be scratched by the finger nail; numbers 3 to 6, inclusive, can be scratched by a knife, and number 6 will

scratch ordinary window glass. Number 10 can be ground or polished only by diamond powder. A mineral which ranks in hardness between any two successive numbers on the scale, as between 5 and 6, has its degree of hardness indicated by a fraction, as 5.5.

**HARDY**, *hahr'dy*, THOMAS (1840- ), an English novelist, whose stories are powerful and stirring, fascinating the reader in spite of the author's cruel realism and his fatalistic attitude, which regards men as helpless victims of uncontrollable circumstances. Hardy was born in Dorsetshire, England. He was educated as an ecclesiastical architect and for a time worked at that profession.



THOMAS HARDY

From 1868 he devoted himself to literature, and his first novel, *Desperate Remedies*, was published in 1871. This was succeeded by *Under the Greenwood Tree*, *A Pair of Blue Eyes*, *Far from the Madding Crowd*, *The Return of the Native*, *Two on a Tower*, *Tess of the D'Urbervilles* and *Jude the Obscure*.

**HARE**, the common name of an animal related to the rabbit. It may readily be recognized by its long ears, long hind limbs, by which it moves in long leaps, its short tail

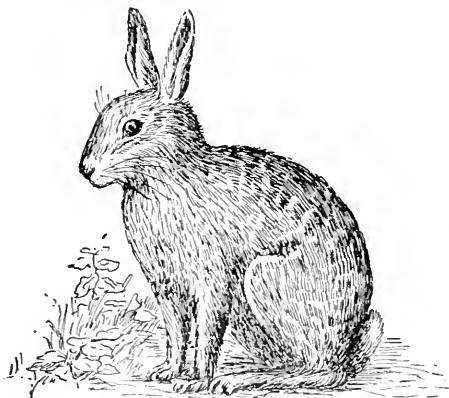

HARE

and its soft hair. The hare is distinguished from the rabbit by the fact that the former does not burrow, but builds nests in the

ground, where the young are born. The hare, too, is the larger, and is more fleet than the rabbit. The common hare is found throughout Europe and in some parts of Asia. It is tawny red or brown on the back and white on the belly and is about two feet long. The *mountain hare*, or *varying hare*, confined to Northern Europe and the mountainous regions of the South, is smaller than the common hare and becomes white in winter.

The *American hare*, not much larger than a rabbit, is found in most parts of North America. In North America there are also the *polar hare*, a variety of the varying hare, but of superior size and purer color, and the *prairie hare*, known as the *jack-rabbit*, from its size and length of limb. The Belgian hare is really a rabbit. Though hares have no courage and little cunning, they are protected from their enemies by sharp sight and hearing and extraordinary fleetness. A hare's voice is never heard except when the animal is seized or wounded. It then utters a sharp, loud cry, not very unlike that of a child. Its flesh is rather dry, but it is much prized because of its peculiar flavor. The young are not helpless at birth, like baby rabbits, but are able to care for themselves after a month or two.

**HAREBELL**, the Scotch blue-bell, a plant from four to six inches high, having slender stems each bearing one or more bell-shaped, blue flowers and scant foliage. Occasionally the flowers are white. The harebell is common on dry and rocky soil in many parts of Europe and America.



HAREBELL

**HA'REM**, a term used by Mohammedans to signify the women's apartments in a household, forbidden to every man except the husband and near relations. The word is also applied to the women themselves. The women of the harem may consist simply of a wife and her attendants, or there may be several wives and an indefinite number of

concubines, or female slaves. The greatest harem is that of the sultan of Turkey. The women of the imperial harem are all slaves, generally Circassians or Georgians, from Russia. In the harem the women are supreme. There they receive their friends, walk about in the gardens, indulge in dressing and feasting, employ themselves in needlework, and enjoy the dancing of the slaves.

The women of other Turks enjoy the society of their friends at the baths or in each other's houses and appear in public, accompanied by slaves and eunuchs, but the women of the sultan's harem have none of these privileges. It is of course only the richer Moslems who can maintain harems; a man of the poorer classes has generally but one wife. American and European ladies have entered Oriental harems during the past two centuries and studied the lives of the inmates. See ZENANA.

**HARGREAVES**, *hah'g'reevz*, JAMES (1720-1778), an English inventor. In 1760 he devised a machine for carding cotton, and some years afterward produced the spinning jenny, by which he was able to spin with several spindles at once. Believing that his employment of machinery would destroy labor, his neighbors broke into his dwelling and destroyed his machine. Manufacturers stole his designs, and he was unable to secure patents upon them, so that he never profited much by his inventions, though they, with the power loom, invented by Cartwright, revolutionized the cotton industry.

**HARLAN**, *hah'lan*, JOHN MARSHALL (1833-1911), an American jurist, born in Boyle County, Ky. He was graduated from Center College in 1850, studied law at Transylvania University, began practice in 1853 and became county judge in 1858. He took part in the Civil War as a Union soldier, and from 1863 to 1867 was attorney-general of Kentucky. In 1877 President Hayes appointed him Associate Justice of the Supreme Court, where he served with distinction for thirty-four years. He was one of the commissioners in the Bering Sea arbitration in 1893.

**HARLAND**, MARION. See TERHUNE, MARY VIRGINIA.

**HARLEQUIN**, *hah'le kw'in*, a general name for a comic rôle in pantomime. On the Italian stage Harlequin is a comic character, full of drolleries, tricks and knaveries,

and somewhat resembles the English clown. The Harlequin of British pantomimes is somewhat different. He is the lover of Columbine and possesses a wonderful working wand, with which he protects her against Clown and Pantaloon, who pursue and endeavor to capture her, until the pursuit is brought to a termination by a good fairy. Harlequin usually wears tights of bright colors and glittering spangles. In common usage the term has come to be almost interchangeable with clown.

**HARMONICA**, a musical instrument consisting of a series of glass cups, invented by Benjamin Franklin. The cups, shaped like half globes, were tuned by putting varying quantities of water into them. A simple mechanism kept them revolving during a performance and the tones were produced by touching the glass-rims with the finger-tips. The name is sometimes applied to the mouth-organ, or jewsharp.

**HARMONICS**, *har mon'iks*, the accessory sounds accompanying the predominant and apparently simple musical tone produced by a string, pipe or other sonorous body. No purely simple tone is producible. When a string is struck the whole string vibrates as a unit, giving rise to a strong tone called the *fundamental*. However, several other tones, much weaker than the fundamental, are simultaneously produced, owing to the varying lengths of the vibrations along the entire length of the string. These secondary tones are called *harmonics*.

The first harmonic of the fundamental note of any string is that produced by half the string and is the octave of the fundamental; the second harmonic is given by each third of the string and is the fifth, or dominant, of the fundamental note, and so on, the complete series of harmonics containing all the notes of the musical scale. But while harmonics enter into the composition of every musical sound, different vibrating bodies suppress some and emphasize others, thus producing different qualities of tone. See **MUSIC**; **SOUND**.

**HARMONY**, that part of the science of music which treats of cords, their structure and relation. It is the fundamental branch of musical composition, and its importance can readily be seen from the fact that any simple melody can be made to arouse widely different emotions when given different harmonic settings. Although a crude experi-

ment in harmony was made in the tenth century, not until the eighteenth century did the science revolutionize musical composition. By means of it the simplest melody can be transformed into a powerful and soul-stirring work of art.

The same term is used to denote the concord of two or more strains or sounds, differing in pitch or quality, as distinguished from melody, which consists of a pleasing series of single tones. See **MUSIC**; **CHORD**; **COUNTERPOINT**.

**HARMONY OF THE SPHERES**, a supposition of Pythagoras and his school, that the motions of the heavenly bodies produced a music which could not be heard by men. He supposed these motions to conform to certain fixed laws, which could be expressed in numbers corresponding to the numbers which give the harmony of sounds.

**HARMSWORTH**, ALFRED CHARLES WILLIAM. See **NORTHCLIFFE**, **LORD**.

**HARNESS**, a tackle or working gear of a horse, mule or other draft animal, except the ox. Harness is usually made of leather, but in some countries it is made of leather and cords combined. Harness used with driving carriages is often highly ornamented with brass, silver or gold plate. The parts of the harness are shown in the illustration. The blinds, however, are now frequently omitted.

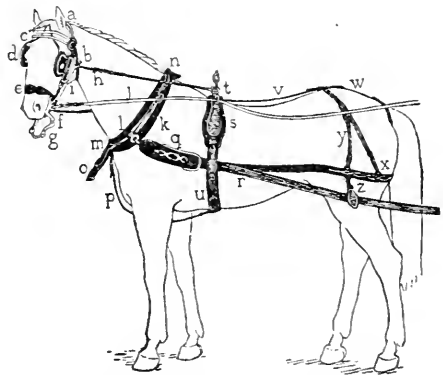

a. crown; b. checkpiece; c. front; d. blind; e. noseband; f. bit; g. curb; h. check; i. throatlatch; j. rein; k. collar; l. hame; m. hame-link; n. hame-strap; o. pole-strap; p. martingale; q. trace-tug; r. trace; s. saddle; t. terret; u. bellyband; v. turnback; w. crupper; x. breeching; y. hipstrap; z. trace-bearer.

**HAR'OLD**, or **HAR'ALD I** (about 850-933), a king of Norway. His father Halfdan was one of the numerous jarls, or petty kings, among whom Norway was divided.

On succeeding his father Harold overthrew and drove from the country all the other jarls and made himself sole ruler of Norway. Among the conquered jarls was Rolf, who emigrated to France, where he obtained a grant of land and established himself as first duke of Normandy. Harold also partially freed Norway from the pirates and brigands who had long disturbed the country.

**HAROLD**, or **HARALD III**, surnamed *Haardraade*, meaning *hard ruler* (1015-1066), king of Norway. He spent a number of years in Constantinople, as a member of the emperor's bodyguard, and had many adventures in Sicily and at Jerusalem. In 1046 he returned to Norway and was made by the king, his nephew, joint ruler. Two years later, on the death of the king, he became sole ruler. He took part with Tostig, brother of Harold II of England, in his attempt to wrest the crown of England from Harold II, and was killed in the Battle at Stamford Bridge.

**HAROLD I**, surnamed *Harefoot*, was a son of Canute, king of England, Denmark and Norway. On the death of Canute, in 1035, both Harold and his brother Hardecnute claimed the throne. Civil war was averted by dividing the kingdom. However, as Hardecnute remained in Denmark, the people, dissatisfied, crowned Harold sole king of England in 1037. Harold died in 1040.

**HAROLD II**, (1022?-1066), the last Anglo-Saxon king of England. On the death of his father, Earl Godwin, he became Earl of Wessex and head of the national party, which was trying to weaken Norman influence at the court of Edward the Confessor. On Edward's death in 1066 the nobles elected Harold king.

William of Normandy asserted that Harold had taken oath to support his claims to the throne; and to avenge himself on Harold and gain possession of the crown, he invaded England in October, 1066, and met Harold at Senlac, near Hastings (see **HASTINGS, BATTLE OF**; **WILLIAM I, THE CONQUEROR**). Harold was killed in the battle.

**HARP**, a stringed instrument which originated in very ancient times. The modern instrument is nearly triangular in form and stands upright upon one of its angles, which is supported by a base. Fifty-three strings are stretched parallel with the perpendicular column. The performer sits on the opposite side of this column and faces it, tilting the in-

strument toward him and striking or pulling the strings with thumbs and fingers.

**HARPER**, **WILLIAM RAINY** (1856-1906), an American educator, for fifteen years president of the University of Chicago. He organized the institution. He was born at New Concord, Ohio, and was educated at Muskingum College, and at Yale. Afterwards he became professor of Hebrew at the Baptist Union Theological Seminary in Chicago, and in 1879 was elected professor of Semitic languages in Yale University. Later he was principal of the Chautauqua College of Liberal Arts and director of the Chautauqua system.

In 1891 Professor Harper became president of the University of Chicago. Under his administration this institution was brought to a high degree of excellence and became widely known for its standards of scholarship. He had a world-wide

reputation as a student of Hebrew and other Oriental languages, and was the author of *The Elements of Hebrew*, *Elements of Hebrew Syntax* and a number of other similar works. He was also editor of the *American Journal of Theology* and the *American Journal of Semitic Languages and Literature*, both published at the University of Chicago.

**HARPER'S FERRY**, W. VA., a town in Jefferson County, on the Baltimore & Ohio railroad, fifty miles northwest of Washington, D. C. Harper's Ferry had an interesting history in the Civil War. It was the scene of the famous raid of John Brown, Oct. 16, 1859 (see **BROWN, JOHN**). At the outbreak of the war it was abandoned by a small Union garrison and was occupied by Confederates, first under Colonel ("Stonewall") Jackson and afterward under Gen. Joseph E. Johnston. It was evacuated June 15, 1862, and later occupied by a Union force, which in turn was captured by Jackson, Sep-



WILLIAM RAINY  
HARPER



tember 15, during Lee's first invasion of the North. Population, 1910, 766.

**HAR'PIES**, the ancient Greek goddesses of storms. Their parentage, ages, appearance, names and number are very differently given by the poets. In the Homeric poems they are merely storm winds. Hesiod represents them as two young virgins of great beauty, called Aëlo and Oeypete, but the later poets and artists vied with one another in depicting them under the most hideous forms, covered with filth and polluting everything in contact with them.

**HARPOON'**, a sort of spear used in killing whales and other large fish. The head has a sharp, wedge-shaped point, with barbs, and is usually of the same piece as the handle, which is about three feet in length. The harpoon is fastened to a long rope, that is coiled in the boat. When the boat approaches near the whale, the harpoon is thrust into his body. The rope can be paid out or taken up, as the safety of the boat requires. The bomb lance, which is a hollow harpoon containing a shell filled with gunpowder, is now used in catching whales. The lance is shot from a gun, and when it enters the body of the whale the bomb explodes and kills him instantly.

**HARPY**, a large and very powerful eagle of the tropics, that sometimes strays as far north as the Southern United States. It is larger than the golden eagle, being forty-two inches in length, but has a somewhat shorter expanse of wing. Its bill is crooked; its claws are extremely strong and sharp, and the muscles of its shoulders are exceedingly powerful. The harpy is dark gray, barred with black above and white below, except for a dark band across its breast. Its head bears a handsome crest. It will defend itself even against man, when wounded, but in spite of the numerous stories told of its marvelous fierceness and strength, it is doubtful if it ever attacks man of its-own accord.

**HAR'RADEN**, BEATRICE (1864- ), an English novelist, born at Hamsted, whose first novel, *Ships that Pass in the Night*, made her famous on its publication in 1893. She is a well-educated woman, having taken a degree at the University of London at the age of twenty-one. In 1894 and 1895 she traveled in the United States and lived for some time on a California ranch. Among later books are *In Varying Moods*, *The Fowler*, *Hilda Strafford*, *Out of the Wreck I*

*Rise*, *The Guiding Thread* (1916) and *Where Your Heart Is* (1918).

**HAR'RIER**, See MARSH HAWK.

**HARRIMAN**, EDWARD HENRY (1848-1909), an American capitalist and railway owner, born at Hempstead, Long Island, the son of an Episcopal clergyman. At fourteen years of age he left school and entered a broker's office in New York. At twenty-two he became a member of the Stock Exchange and continued in the brokerage business until, in 1887, he was elected vice-president of the Illinois Central Railroad. His greatest work was the reorganization and rebuilding of the Union Pacific Railroad and this was followed by the acquirement of the Southern Pacific and its western connections. Besides the roads mentioned, the Illinois Central, Chicago & Alton, Baltimore & Ohio, Pennsylvania and others became closely allied with the Harriman system. His country estate at Arden, N. Y., contains 26,000 acres, largely woodland. He built a great clubhouse on the East Side for poor boys.

**HARRIS**, JOEL CHANDLER (1848-1908), an American author, popularly known as "Uncle Remus," was born in Eatonton, Ga. He served an apprenticeship to the printer's trade, then studied law and finally settled down to journalism. In 1876 began his connection with the *Atlanta Constitution*, which lasted for twenty-five years; and for this paper he wrote the first of those negro dialect fables which were afterward published as *Uncle Remus: His Songs and Sayings* (1880). These sketches received such a warm welcome that *Nights with Uncle Remus* and *Uncle Re-*



JOEL CHANDLER  
HARRIS

*mus and His Friends* soon followed. The hero of these stories is "Brer Rabbit." Harris was one of the most popular Southern writers of fiction. His stories form a valuable contribution to American literature, by reason of their intimate, faithful pictures of Southern life and their accurate reproductions of negro dialect. His best works, besides those mentioned above, are *Daddy Jake*,

*the Runaway; Sister Jane; Stories of Georgia; Free Joe; Aaron in the Wildwoods; Tales of the Home Folks; Balaam and His Master, and A History of Georgia.*

**HARRIS, WILLIAM TORREY** (1835-1909), a distinguished American educator, the second and most notable United States Commissioner of Education, was born at Killingly, Conn., and educated at Yale University. He began teaching in Saint Louis, Mo., and became superintendent of the Saint Louis schools in 1867. The same year he founded *The Journal of Speculative Philosophy*, which he long continued to edit. This was the first journal of the kind in the English language.



While superintendent of the Saint Louis schools, Doctor Harris became widely known through his reports, which showed remarkable insight into educational problems, and these were sought by educators at home and abroad. He was elected president of the National Educational Association in 1875 and represented the United States at the International Congress of Educators, which met at Brussels in 1880. In 1889 he prepared the official *Statement of the System of Education of the United States*, for the Paris and Vienna expositions. In the same year he was appointed United States Commissioner of Education, which position he held until June, 1906, winning wide fame by his masterly and helpful administration of the office.

**HARRISBURG, PA.**, the capital of the state and the county seat of Dauphin County, 105 miles west by north of Philadelphia, on the Susquehanna River, and on the Philadelphia & Reading, the Pennsylvania and the Cumberland Valley railroads. The city is picturesquely situated along the river, which is here a mile wide and spanned by fine bridges. The most prominent building is the state capitol, costing more than \$4,000,000; the frontage is 520 feet 8 inches. There are a large public library, a state library, a conservatory of music, and various hospitals and

charitable organizations. Other prominent buildings are the governor's mansion, a state arsenal, a state hospital for the insane, a county prison, and a Y. M. C. A.

The city has excellent transportation facilities and conducts a large trade in lumber and other goods. The iron and coal mines close at hand have led to the development of a great variety of factories in the iron and steel industry. Shops of the Pennsylvania Railroad are here. Harrisburg has one of the largest boot and shoe factories in the United States, a large silk mill, a carriage factory, engine works and electrical plants.

In 1726 the English trader John Harris settled there. A ferry was established later, and the place was known as Harris's Ferry, until a town was laid out in 1785 and called Harrisburg. In 1812 it was made the capital of the state, and it was chartered as a city in 1860. Population, 1910, 64,186; in 1917, 76,710 (Federal estimate).

**HARRISON, BENJAMIN** (about 1740-1791), an American Revolutionary patriot and signer of the Declaration of Independence, was born at Berkeley, Va. He was one of the conservative patriots and opposed Patrick Henry's early resolutions against the Stamp Act, but later he represented Virginia in the Continental Congress and rendered important service as president of the Board of war. Returning to his state, he was speaker of the house of burgesses from 1777 to 1782, and for three years thereafter he was governor. He opposed the ratification of the Federal Constitution by Virginia.

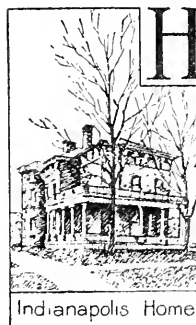

**HARRISON, BENJAMIN** (1833-1901), an American statesman, the twenty-third President of the United States. He was the grandson of William Henry Harrison, ninth President of the United States, and the great-grandson of Benjamin Harrison, a signer of the Declaration of Independence. Harrison is remembered as a President who was thoroughly honest and courageous in expressing his convictions, without being in any sense a great popular leader. He was born at North Bend, Ohio, August 20, 1833, and during his boyhood went to school in a log building and worked on the farm of his distinguished

## Administration of Benjamin Harrison, 1889-1893

- I. THE PRESIDENT
- (1) Ancestry
  - (2) Birth
  - (3) Education
  - (4) Military career
  - (5) Public life
  - (6) Character
  - (7) Death
- II. GOVERNMENTAL AFFAIRS
- (1) Domestic
    - (a) Sherman Silver Purchase Act
    - (b) McKinley Tariff Act
    - (c) Sherman Anti-Trust Law
    - (d) Renewal of the Chinese Exclusion Act
    - (e) Reduction of the surplus
      - (1) By increasing pension list
      - (2) Repayment of direct Civil War taxes to the states
      - (3) Appropriations for unnecessary internal improvements
      - (4) Rapid construction of battleships
    - (f) Dictatorship of the Speaker of the House of Representatives
    - (g) Admission of new states
  - (2) Foreign relations
    - (a) Bering Sea Decision
    - (b) Principle of Reciprocity
      - (1) Treaty with Spain
      - (2) Treaty with Brazil
    - (c) Act of Berlin, regarding Samoa
    - (d) Pan-American Congress
    - (e) International copyright law, 1891
    - (f) Panama scandal
      - (1) Revolution and anarchy on the Isthmus
      - (2) United States sent troops
    - (g) Proposed annexation of Hawaii
- III. LOCAL AND INTERNAL AFFAIRS
- (1) Adoption of the Australian ballot system
  - (2) Admission of Oklahoma to settlement
  - (3) Johnstown Flood
  - (4) University of Chicago and Leland Stanford Junior University founded
  - (5) Farmers' Alliance
    - (a) Originally a farmers' organization
    - (b) Later a political party
      - (1) Platform
        - (a) Abolition of National banks
        - (b) More paper money
        - (c) Against dealing in futures of agricultural and mechanical products
        - (d) Free and unlimited coinage of silver
        - (e) Government ownership of all means of transportation and communication
      - (2) Controlled some of the western states
      - (3) Merged in the Populist party, 1892
    - (6) Homestead Riots
    - (7) Election of 1892

### Questions

- Who was Benjamin Harrison's grandfather? Great-grandfather?
- Give a brief account of his early life.
- What law was superseded by the Sherman Silver Purchase Act?
- What did the new law require the Secretary of the Treasury to do?
- What was the character of the McKinley Tariff Act?
- What new states were admitted?
- What was the cause of the Bering Sea controversy? How was it settled?
- What were the objects of the Sherman Anti-Trust Law?

# HARRISON'S

1889

SOME OF THE MORE IMPORTANT EVENTS

-1890-

**T**HE FIRST EXECUTION BY ELECTRICITY.  
 THE 11<sup>th</sup> CENSUS POP. - 62,622,250-

THE PAN-AMERICAN CONGRESS.

IDAHO<sup>AND</sup> WYOMING ADMITTED AS STATES



THE TOWN FLOOD.  
 FOUR NEW WAR SHIPS BUILT

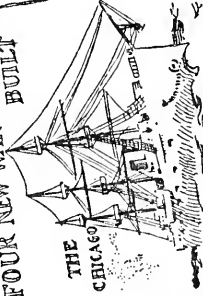

THE CHICAGO

# ADMINISTRATION

1893

OF PRESIDENT HARRISON'S ADMINISTRATION

-1892-

CHICAGO AND LEWISLAND STANFORD UNIVERSITIES FOUND.

THE HOMESTEAD LABOR TROUBLES

THE CHINESE EXCLUSION BILL RE-ENACTED.



THE EEHRING SEA TREATY.  
 OPENING OF DREXEL INSTITUTE IN PHILADELPHIA.

THE PANAMA SCANDAL.

THE UNITED STATES AID FAMINE STRICKEN RUSSIA.

THE FARMERS ALLIANCE MOVEMENT.

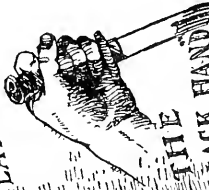

THE "BLACK HAND" IN NEW ORLEANS TROUBLE WITH THE "Mafia!"

grandfather. His early education was supplemented by lessons from a tutor and a course at an academy near Cincinnati, and in 1852 he was graduated from Miami University. After his graduation he studied law in Cincinnati, and two years later removed to Indianapolis, where he built up a large law practice.

When the Civil War broke out, Harrison entered the Union army as lieutenant, but was soon promoted to colonel and organized the Seventeenth Indiana Volunteers. He fought bravely in the Atlanta campaign and about Nashville, and at the close of the war had won the rank of brigadier-general. On his return to civilian life he became supreme-court reporter, but in 1868 resumed the practice of law. In 1876 he was nominated by the Republican party for governor of Indiana, but was defeated. Four years later he was elected United States Senator, serving one term, and in the Senate was a conspicuous advocate of civil service reform and of restriction of Chinese immigration.

Harrison was nominated for President in 1888 by the Republicans, and was elected, receiving 233 electoral votes to 168 for President Cleveland, the Democratic nominee. During the first session of Congress there were passed three

important measures favored by the Republicans—the Sherman Silver Purchase Act, the McKinley Tariff Act and the Sherman Anti-Trust Act. Another domestic event of great importance was the admission into the Union of six states—the two Dakotas, Montana, Washington, Idaho and Wyoming. In 1889 Oklahoma, then a part of Indian Territory, was opened to white settlement, and in a single day 50,000 new settlers pitched camps on its fertile acres.

In the realm of foreign affairs many events of interest took place. James G. Blaine, Harrison's Secretary of State, was the guiding spirit of the first Pan-American Congress,

held at Washington in 1889, and the United States entered into reciprocity treaties with Spain and Brazil. In 1892 a law restricting Chinese immigration was passed. Difficulties with Great Britain over the rights of American and British fishermen in the Bering Sea were settled peaceably by arbitration, and war with Italy over the lynching of eleven Italians in New Orleans was averted by the payment of an indemnity to the families of the victims. The tariff issue loomed large in the campaign of 1892, however, and on that issue the Republican and Democratic candidates staked their political fortunes. Harrison lost the election to his opponent, Grover Cleveland, and the Democrats also secured control of Congress.

Harrison was much in the public eye even after his retirement from office. He delivered a series of lectures at Leland Stanford Junior University, wrote for magazines, and was the counsel for Venezuela before the commission which settled the boundary dispute between that country and Great Britain. In 1899 he represented the United States at the Hague Peace Conference. He also resumed his law practice, and found time, meanwhile, to write *This Country of Ours*, a practical study of the way the United States government functions. This busy ex-President died at his home in Indianapolis on March 31, 1909, after an illness of a few days.

**Related Articles.** Consult the following titles for additional information:  
Chinese Exclusion Tariff      Pan-American Congress

**HARRISON, FRANCIS BURTON** (1873- ), governor-general of the Philippine Islands by appointment of President Wilson in 1913. He was born in New York City, became a lawyer in 1898, entered the Spanish-American war as a private in cavalry regiment and was promoted to the rank of captain. He represented a New York district in Congress from 1903 to 1913, when he resigned to accept the Philippines appointment.

As governor, Harrison felt it to be his duty to encourage the idea of political independence of the islands, in accordance with the announced views of the Democratic party, then in power in the government. In 1919, when on a visit to the United States, the question of Philippine independence came before Congress in an informal manner. While home in that year Harrison contracted his third marriage, two wives having died.



BENJAMIN HARRISON



Battle of the Thames

**HARRISON, WILLIAM HENRY** (1773-1841), an American soldier and statesman, ninth President of the United States, and the grandfather of the twenty-third President, Benjamin Harrison. One month after his inauguration, death brought his administration to a close, and his tenure of the Presidential office was thus the briefest in American history. He was also the first President to die a natural death before the close of his term. Harrison

was born on February 9, 1773, at Berkeley, Va., of a well-known and aristocratic colonial family. His father, Benjamin Harrison, was one of the signers of the Declaration of Independence.

The boy received a good education, and at the age of seventeen was graduated from Hampden Sidney College. After his father's death, in 1791, Harrison joined the army which Wayne was leading against the Northwestern Indians, and he showed great gallantry at the battle on the Miami (1794). He represented the Northwest Territory as a delegate in Congress in 1799-1800, and succeeded in securing the passage of an important law relating to the sale of the Federal land in small parcels. When Indiana Territory was formed (1800), including the

present states of Indiana, Illinois, Michigan and Wisconsin, besides parts of Minnesota and Ohio, he was appointed its governor, holding this position until 1812. He labored courageously to win the friendship of the Indians, but was compelled to

quell Tecumseh's outbreak and to beat off a fierce and treacherous attack under Tecumseh's brother. The Prophet, ending in an im-



WILLIAM HENRY HARRISON

### Administration of William Henry Harrison

- I. WILLIAM HENRY HARRISON
  - (1) Birth and parentage
  - (2) Education
  - (3) Begins a military career
- II. CAREER AS A SOLDIER AND ADMINISTRATOR
  - (1) Battle on the Miami
  - (2) Delegate for Northwest Territory
  - (3) Governor of Indiana Territory
  - (4) Battle of Tippecanoe
  - (5) War of 1812
  - (6) Represents Ohio in Congress and state senate
  - (7) Minister to Colombia
- III. PRESIDENTIAL CANDIDATE
  - (1) Campaign of 1836
  - (2) "Log cabin and hard cider" campaign of 1840
  - (3) Election and inauguration
  - (4) Death

### Questions on Harrison

Why can the Harrison family be called a notable one?

What was the meaning of the slogan "Tippecanoe and Tyler too"?

How long did Harrison's administration last?

What other accidental Presidents have held office?

What notable things did Harrison do before he was elected President?

How many times did he run for President?

How did he get his nickname of "Tippecanoe"?

portant battle at Tippecanoe (November 7, 1811). Harrison's bravery and good judgment in this incident won him his nickname of "Tippecanoe."

In the War of 1812 Harrison was appointed major-general of Kentucky militia, and later brigadier-general in the regular army, with chief command in the Northwest. He repulsed the British force under Proctor, and by the victory of Perry on Lake Erie he was enabled to pursue the invaders into Canada, where, on October 5, 1813, he totally

routed them in the Battle of the Thames. In 1816, having become a military hero, he was elected to Congress from Ohio, and in 1824 to the state senate. In 1828 he went as minister to Colombia, but was recalled the following year, and returned to his home in North Bend, Ohio. For twelve years he was clerk of a county court in Ohio.

Harrison was nominated for the Presidency in 1836 by Whig conventions in several states, and received seventy-three electoral votes against Van Buren's 170. He proved to be the most popular of the opposing candidates, and four years later, the Whig party having been reunited, he was nominated as a compromise candidate, with John Tyler as his running mate, and defeated Van Buren, obtaining 234 electoral votes to the latter's sixty. The contest is noteworthy as having witnessed the introduction of enormous mass meetings and processions and picturesque emblems and banners. "Tippecanoe and Tyler too" was the great rallying cry of the Whigs. The Democrats, to show Harrison's unfitness for the Presidency, had sneeringly referred to an old log cabin attached to his house at North Bend, and to his table supplied with cider.

This jeer proved to be a boomerang, however, for the Whigs accepted the challenge and used small log cabins in the campaign as symbols of their candidate's sympathy for the plain people. At the close of this "log cabin and hard cider" campaign Harrison was elected by 234 electoral votes. The President-elect was then sixty-seven years old, and the exciting campaign left him ill prepared to resist an attack of pneumonia, that followed soon after his inauguration. On April 4, 1841, he died, and was succeeded by the Vice-President, John Tyler.

**HARROW**, an implement used by farmers for pulverizing the soil on plowed ground. The common harrow is a wooden frame, square or triangular, into which iron teeth have been driven. As the harrow is dragged over the ground by horses, it breaks up the soil and prepares it for the seed. What little grain is yet sown by hand is covered by harrowing. The wheel harrow has revolving disks of steel, instead of teeth, and is used to pulverize the soil on newly broken ground.

**HART**, ALBERT BUSHNELL (1854- ), an American historian and teacher, born at Clarksville, Pa. He was graduated at Harvard in 1880 and soon after became an in-

structor in the institution, later being made professor of history. He early engaged in literary work and published numerous works on the history and government of America, of which the most important are *Introduction to the Study of Federal Government*, *Essays on American Government*, *The Formation of the Union* (Epochs of American History Series), *Guide to the Study of American History* (with Edward Channing) and a biography of Salmon P. Chase (in the American Statesmen Series). He was also the editor of the Epochs of American History Series, of the *American History Told by Contemporaries*, the *Source-Book of American History* and of the *American Nation*, a history of the United States by associated scholars. In 1914 he wrote *The War in Europe*, and in 1915 *The Monroe Doctrine, an Interpretation*.

**HARTE**, FRANCIS BRET (1839-1902), an American poet and short-story writer, whose vivid tales of life in western mining-camps are among the best American fiction. He was born in Albany, N. Y. His father died when he was young, and the boy and his mother went to California. There Harte tried various means of making a living—as miner, school-teacher and typesetter. While a typesetter for a San Francisco weekly he contributed sketches which won for him an editorship on the paper. He became at length editor of the *Weekly Californian*, and in this paper appeared his *Condensed*

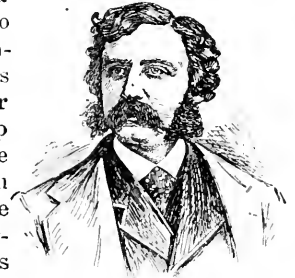

BRET HARTE

*Novels*, parodies on the styles of various authors. In 1868 Harte became editor of the *Overland Monthly*, in which were published the first of the stories that brought him fame—*The Luck of Roaring Camp*, *The Outcasts of Poker Flat* and *Tennessee's Partner*. These stories are told in a tense and vivid style, the characters revealing themselves in their own words and acts and without the aid of accompanying descriptions.

In 1871, after having served as professor of literature in the University of California, Harte went to New York to continue literary work. For several years he was in the consu-

lar service, stationed at Crefeld, Germany, and at Glasgow, Scotland. From 1885 until his death he lived in England, writing poems and stories of western life, the last of these being *Under the Redwoods*. Noteworthy among Harte's stories not already mentioned are *Two Men of Sandy Bar*, *The Twins of Table Mountain*, *The Three Partners* and *How Santa Claus Came to Simpson's Bar*. His most popular poem is *Plain Language from Truthful Jones*, better known perhaps as *The Heathen Chinee*.

**HARTEBEEST**, a species of antelope formerly found in large herds in South Africa, but now represented only by a few scattered specimens. The hartebeest is about four feet high and has a grayish-brown coat, varied by black markings on the face and a yellowish spot on the buttocks. The horns are heavily ringed, and they bend back sharply at the ends. In the days when it was eagerly hunted the hartebeest was considered the fleetest of all African antelopes, and it could even outrun the swiftest greyhounds.

**HARTFORD, CONN.**, the capital of the state, its third city in size and the county seat of Hartford County, 124 miles nearly west of Boston, on the Connecticut River and on several lines of the New York, New Haven & Hartford Railroad. The city has a beautiful state capitol, constructed of white marble in a modern Gothic style, one of the finest capitol buildings in the country. Among notable monuments are the soldiers' memorial arch over the Park River, and the Corning Fountain. The Hartford Theological Seminary, Saint Thomas's Seminary and Trinity College are located here, besides several other educational institutions. There are many large libraries and also a large number of charitable institutions. The city is one of the great insurance centers of the United States; its companies include the Connecticut Mutual Life, the Aetna Life, the Aetna Fire and the Travelers'. The city has Saint Joseph Cathedral, a state arsenal, a state library and the Morgan Memorial building, in addition to the great insurance buildings.

The position of the city, at the head of deep water navigation, has made it an important distributing center. Manufacturing was early developed, and the principal products are firearms, bicycles, automobiles, boilers, engines, machine guns, rubber tires, electric goods, church organs, silverware, carriages

and wagons, tobacco products, women's clothing, knit goods and great numbers of typewriters. The *Courant* was started in 1764 and is now the oldest newspaper in the United States.

About 1633 the Dutch built a fort here, which they called "House of Hope." In 1637 some Puritan colonists made a settlement and called it Hartford. The freemen of Hartford, Windsor and Wethersford assembled here on January 14, 1639, and adopted the "Fundamental Orders of Connecticut," said to be the first written constitution ever drawn up in America. Hartford was the capital in 1701, and then shared that honor with New Haven, but since 1873 it has been the sole capital. Population, 1910, 98,915; in 1917, 112,831 (Federal estimate).

**HARTFORD CONVENTION**, a political convention held at Hartford, Conn., from December 15, 1814, to January 5, 1815. It represented the Federalist party's opposition to the War of 1812 and to the manner in which the Anti-Federalists conducted the war. Its sessions were secret, and there were false rumors that it planned the secession of New England. Its real aim was to propose reforms in the government in the direction of greater independence for the states. It was one of the events which increased the unpopularity of the Federalist party and led to that party's downfall.

**HARTS'HORN**, in pharmacy, the horn of the common stag, from which substances deemed of high medicinal value were formerly prepared by distillation, such as spirits of hartshorn, oil of hartshorn and salt of hartshorn. The active ingredient of these was ammonia, which is now obtained from gas liquor and other sources. Hartshorn has been almost entirely superseded as a medicinal agent. See AMMONIA.

**HARUN-AL-RASHID**, *hah roon' al rah-sheed'* (?-809), a celebrated Saracen caliph. He figures conspicuously in *Arabian Nights Entertainments*, as also do his wife, Zobeide, his vizier, Giaffar, and his chief eunuch, Mesrour.

He was not a fanciful character of fiction, as many have supposed, but was one of the most important characters of the eighth century. Harun was an enlightened monarch whose reign was brilliant, though he was despotic. His true character has been somewhat obscured because he has been too much idealized in the literature of the ages.





**H**ARVARD UNIVERSITY, the outgrowth of the first college established in the American colonies, is to-day one of the largest universities in the United States. In scholarship and influence it likewise has a position among the very first American institutions of higher learning. On its graduate roster are found the names of many distinguished Americans, including Cotton Mather, John Adams and his son John Quincy, Theodore Park-

er, Emerson, Thoreau, Lowell, Holmes, George Bancroft, William H. Prescott, John L. Motley, Francis Parkman, Charles Sumner, Edward Everett, Wendell Phillips and Theodore Roosevelt.

Harvard had its beginning in an act of the general assembly of Massachusetts Bay Colony, which on October 28, 1636, voted £400 (\$2,000) for a school to be established at New Towne (later Cambridge). In 1638 the school was named Harvard College in honor of Rev. John Harvard, who died that year, bequeathing the institution half his property (probably about \$2,000) and his library of 300 volumes. The first class of nine members was graduated in 1642. The same year the college was placed under the management of a board of overseers and in 1650 it became a corporation under the name of the President and Fellows of Harvard College; the overseers and the corporation still remain the governing board of the college.

In 1824-1825 a reorganization was effected, and the college became a university, with organized departments and provisions for special students. In 1851 the charter was amended in such a way that all mention of Church control was eliminated, and since then the institution, once a center of Unitarianism, has been free from denominational influences. The accession of Charles William Eliot to the presidency of Harvard, in 1869, was the beginning of a period of expansion and prosperity, and when Dr. Eliot relinquished his post in 1909 the institution was second to none in America in scholarly ideals

and prestige. To him is due the credit for the establishment of the elective system, which is now general throughout Canada and the United States.

Harvard is organized into four general departments—arts and sciences, law, medicine and divinity. Included in the department of arts and sciences are the undergraduate college, the graduate school of arts and sciences, the graduate school of applied science and the graduate school of business administration. Affiliated with the university are Radcliffe College (for women) and Massachusetts Institute of Technology, both described elsewhere in these volumes. Summer courses in nearly all departments are maintained for both men and women.

In normal years Harvard has a student enrollment in all departments of about 6,000, and a faculty of nearly 900. Its libraries contain over 1,183,300 volumes. The institution lost many students through the entrance of America in the World War, but large classes of student soldiers were organized in the fall of 1918, in accordance with arrangements made by the government with all the leading colleges. Even before the outbreak of hostilities Harvard organized a Reserve Officer's Training Corps and established a course to prepare undergraduates for examination to be ensigns in the naval reserve.

**John Harvard** (1607-1638), whose name is perpetuated in the university, was an English clergyman, born in Southwark, London. He was educated at Emmanuel College, Cambridge, and came to America in 1637, settling at Charlestown, Mass. His generous gift to the school at New Towne has been described above. In 1828 a monument in his honor was erected in the Charlestown graveyard, and there is a statue of him on the Harvard campus.

**HARVEST MOON**, a name applied to the full moon as it appears about the twenty-first of September, when the sun is crossing the equator. At this time the moon rises at nearly the same time every night for several nights in succession, and is a most beautiful spectacle in the heavens, giving out a light that in northern latitudes is nearly as bright as that of day. The brightness of the moon at this time is due to the fact that it is then traveling in that part of its orbit at which it makes the least possible angle with the ecliptic. In the southern hemisphere the harvest moon appears in March.

**HARVEY, GEORGE** [BRINTON McCLELLAN] (1864— ), an American journalist, since 1899 president of the *North American Review* Publishing Company and editor of that publication. He was born in Peacham, Vt., and educated in an academy there and in the University of Vermont. For several years he was a reporter in Chicago and New York. In 1900 he became president of the publishing house of Harper & Brothers, but relinquished that post to give all his energies to the *North American Review*. During America's activity in the World War he edited *The War Weekly*, which later became *Harvey's Weekly*. He is forceful in all his writing, has been a severe critic of public men and measures, and is keen in analyzing a situation.

**HARVEY, WILLIAM** (1578-1657), an English physician, the discoverer of the true theory of the circulation of the blood. He entered Caius College, Cambridge, in 1593, and about 1599 he proceeded to Padua, then the most celebrated school of medicine in Europe. He took the degree of M. D. and returned to England in 1602. Settling in London, Dr. Harvey was admitted as a fellow of the College of Physicians, was elected physician of Saint Bartholomew's Hospital and in 1615 was chosen Lumleian lecturer. His views on the circulation of the blood were formally given to the world in his *On the Movement of the Heart and Blood in Animals*, published at Amsterdam in 1628. In 1623 he was appointed physician extraordinary to James I, and in 1632 he became the physician of Charles I. He was present at the Battle of Edgehill and afterward accompanied Charles to Oxford. Here he was elected master of Merton College, an office which he lost on the surrender of Oxford to the Parliament. Dr. Harvey returned to London in 1646 and spent the remainder of his life in retirement.

**HARZ, hahrts, MOUNTAINS**, a range of mountains about twenty miles wide, in Germany, extending a distance of sixty miles, through Prussia, Brunswick and Anhalt. The highest peak is the Brocken, 3,747 feet high, famous for the spectral shadows it throws on the morning and evening mists. Granite is the principal rock. Silver, copper, iron and manganese abound. The lower slopes are densely wooded with oaks, pines, and beeches, but the tops are bare. One of the principal occupations of the region has

been the raising and training of canaries. The scenery attracts many tourists.

**HAS'DRUBAL**, the name of several Carthaginian military leaders. Chief of these were the son-in-law and the son of Hamilcar Barca. Hasdrubal, the son-in-law of Hamilcar, succeeded the latter in command of the army in Spain in 228 B. C. He completed the subjugation of that country, which Hamilcar had begun, and founded New Carthage, now Cartagena, Spain. In 221 B. C. he was assassinated. Hasdrubal, the son of Hamilcar, on the departure of his brother Hannibal for Italy in 218 B. C., was left in command of the army in Spain, and carried on a long series of military operations against the Roman troops under the two Scipios. Hannibal requiring his assistance in Italy, Hasdrubal led an army from Spain into that country (207 B. C.), but before he could join forces with his brother he was defeated on the right bank of the Metaurus. It is said that the Roman commander had Hasdrubal's head thrown into Hannibal's camp, by way of announcing to the latter his brother's defeat and death.

**HASHISH, hash'eesh**, an intoxicating narcotic, made in Eastern countries from an Indian hemp, which is also called hashish. It produces a kind of intoxication, accompanied with ecstasies and hallucinations, ending in stupor and sleep. Hashish has been used to quiet pain in attacks of neuralgia and headache.

**HASTINGS, BATTLE OF**, the name given to the battle fought at Senlac, near Hastings, in 1066, between Harold II and William, duke of Normandy. Harold had promised to support William's claim to the throne, so the latter asserted, and when Harold allowed himself to be crowned king, William invaded England to assert his rights. The battle took place on August 14. The English were defeated, Harold himself was killed and England was brought under the rule of the Normans. This is regarded by historians as one of the fifteen decisive battles of the world.

**HASTINGS, NEBR.**, incorporated in 1874, is the county seat of Adams County, ninety-six miles west of Lincoln, on the Chicago, Burlington & Quincy, the Missouri Pacific, St. Joseph & Grand Island, the Chicago and North Western and the Union Pacific railways. It is in the center of a fertile wheat belt and stockraising region, and manufactures agricultural implements, flour, brick,

cement, and has a large foundry, marble works and canning factories. It is the seat of Hastings College, an Adventist Sanitarium and an insane asylum. Population, 1910, 9,338; in 1917, 11,292 (Federal estimate).

**HASTINGS, WARREN** (1732-1818), an English statesman, the first Governor-General of India. He was educated at Westminster School and in 1750 was sent to Bengal, as a writer in the service of the East India Company. Hastings won distinction in Clive's campaign in 1757, and 1761 he removed to Calcutta, having obtained a seat in the Bengal council, but he returned to England in 1764. Returning to India five years later, he became a member of the council at Madras, and three years later he was made president of the supreme council of Bengal. In 1774 Hastings was made Governor-General of India, and although his administration was most able, he was sometimes obliged to resort to questionable means for securing the large sums of money which the East India Company constantly demanded. After eleven years spent as Governor-General, he resigned his office and sailed for England, leaving his empire in a most prosperous state. Shortly after his arrival in England, he was impeached by Burke and was charged with acts of injustice and aggression, with maladministration and the receiving of bribes. This celebrated trial, in which Burke, Fox, Sheridan and Grey were arrayed against him, began in 1788 and terminated in 1795 with the acquittal of Hastings. The East India Company in 1796 gave him an annuity.

**HAT**, a covering for the head, which differs from a bonnet in that it covers only the upper part of the head, and from a cap in that it has a circular brim. Hats are usually made of straw, silk or felt and are worn for protection or ornament. While the hat was known to the Greeks and Romans, yet as an article of dress it is of comparatively recent origin. It was never generally worn until in the fourteenth century, when the manufacture of felt hats was begun in Germany and France. Hats were introduced into England in the seventeenth century, where they replaced caps and bonnets, and the soft felt hat was introduced into America about the middle of the nineteenth century by the Hungarian patriot, Kossuth.

Felt hats were originally made of beavers' fur, but this material has been superseded

by the hair of rabbits, hare and muskrats, which now are more plentiful and less expensive than beaver. The hair is soaked in chemicals, which reduces it to a pulpy mass that can be pressed into sheets of felt. The felt is then molded into hats of various sizes and shapes. The popular *Derby* hat is made of felt which is stiffened while the material is on the shaping block. The hat is then dyed and again pressed on a block, after which the surface is smoothed and finished and the sweat band, lining and other attachments are added.

Straw hats are made by plaiting straw. The finest work of this sort is done in Italy, China, Japan and some of the countries of South America. There are two methods, one of plaiting the straw into braids, which are then sewed together to form the hat, and the other of weaving the straw into a fabric, which is pressed into the shape of the hats. The higher-priced hats, such as the leghorns and Panamas, are made on the latter plan. A silk hat usually has a tall, cylinder-shaped crown and a narrow, curled brim. The crown is made of a stiff board, covered with a glossy silk plush.

Styles in hats are constantly changing, as can readily be seen by comparing the pictures of costumes of different periods from the time of the Puritans to the present day. The Puritans wore a steeple-crowned hat. This was succeeded by the cocked hat common in Europe and America during the eighteenth century. This was followed by the felt hat.

**HAT'TIESBURG**, Miss., founded in 1885, is the county seat of Forrest County, ninety miles southeast of Jackson and 110 miles northeast of New Orleans, on the New Orleans & North Eastern (Queen & Crescent), the Gulf & Ship Island, the Mississippi Central and the New Orleans, Mobile & Chicago railroads. A Federal building was erected in 1912 and a Y. M. C. A. building in 1915. The city has a state normal college, the South Mississippi Women's College, a business college, a library and two hospitals. The factories include cotton compresses, oil mills, foundries, a box factory, cabinet works and planing mills. The commission form of government was adopted in 1911. Population, 1910, 11,733; in 1917, 17,357 (Federal estimate).

**HAUPTMANN**, *howpt'mann*, GERHART (1862- ), a distinguished German dramatist, who in 1912 was awarded the Nobel prize for idealistic literature. Hauptmann is a

thoroughgoing individualist. "Live your own life," he preaches. Without offering any solution, he depicts with powerful insight the struggles going on in everyday existence. His earlier plays, among them *Before Sunrise* and *The Weavers*, are morbid in their emphasis upon the less pleasant sides of life, but the later plays are idealistic, sometimes mystic, in tone. Of these latter *The Sunken Bell* is best known. Other works are a volume of poems entitled *Springtime* and a book of *Travel Sketches*.

**HAUTBOY**, ho'boi. See OBOE.

**HAVANA**, ha van'a, or **HABANA**, hah bah'nah, CUBA, the capital and largest city of the island republic, and the chief commercial center of the West Indies. It lies on a spacious harbor on the northwest coast of the island, ninety miles south of the city of Key West, Fla. It has an area of about nine

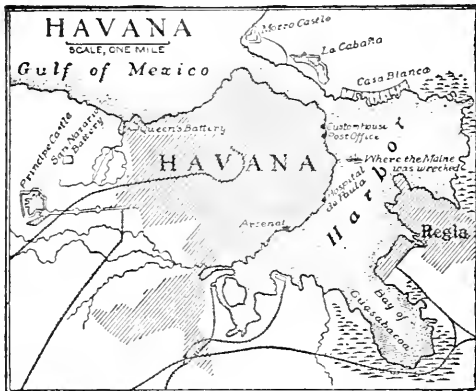

square miles, of which about half is the old portion of the city. This section is covered with buildings of quaint designs, ranged along narrow and irregular streets. However, many of the buildings, even of this quarter, are beautiful in their architecture, including the governor's palace and the cathedral, built in 1724.

The newer part of the city has numerous fine parks and boulevards, especially the Prado, running outside the city wall and terminating in Colon Park, the most beautiful in the city. The Alameda de Paula, which skirts the bay shore, is another attractive promenade. The private homes have all the charm of those of a typical Spanish city, with central courts beautified by gardens, and brightly colored roofs and walls. Havana has many educational institutions, including the University of Havana, the Jesuit Col-

lege de Belen and a normal school. Since the Spanish-American War, great advance has been made in sanitation, and the city is clean and well-kept.

Havana is the chief port of the island and handles a large part of its commerce. Its own exports consist chiefly of cigars, tobacco and sugar, while it imports food and cotton. In the city are the largest cigar and cigarette factories in the world. It is connected by steamship with the United States, Spain, England and France. The United States has the principal share of the trade, and Spain and England rank next. The town was founded in 1511, but was only fairly begun in 1519. Though suffering many times from depredations by Spain's enemies and by pirates, it soon became the leading Spanish station in America. The United States warship *Maine* was destroyed in the harbor, February 15, 1898. Population, 1918, estimated, 360,517.

**HAVELOCK**, HENRY, Sir (1795-1857), a British soldier. He went to India shortly after entering the army and served with distinction in the Afghan and Sikh wars. On the outbreak of the Sepoy Rebellion (which see), he was dispatched to Allahabad, in order to support Lawrence at Lucknow and Wheeler at Cawnpore. On arriving at Cawnpore he found that Nana Sahib had massacred the prisoners. Pursuing his march to Lucknow, he defeated the rebels in various struggles and, finally, with the aid of Outram, won the Battle of Alam Bagh. Having captured Lucknow, Havelock and Outram were shut up there until relieved by Sir Colin Campbell in November, 1857. Havelock died shortly after the relief. He was raised to the rank of major general and was made a baronet and a Knight Commander of the Bath before the word of his death reached England.

**HAVERHILL**, Mass., in Essex County, thirty-three miles north of Boston, on the Merrimac River and on the Boston & Maine Railroad, built to the city in 1837. It is an important industrial center, being one of the leading American towns in the production of boots and shoes. It has also extensive manufacturing of leather, shoes, machinery and supplies, hats, woolen, boxboard and wooden and paper boxes. The principal buildings include a city hall, a public library, a Masonic Temple, the Hale Hospital, an Elks' Home and Y. M. C. A. and Y. W. C. A. buildings.

Bradford Academy is located here. The first settlement was made in 1640, on the site of the old Indian town Pentucket. Population, 1910, 44,115; in 1917, 49,180 (Federal estimate).

**HAVRE**, *ah'vr'*, FRANCE (formerly Le Havre de Grace), an important seaport, second in importance in the country, is in the Department of Seine-Inferieure, on the north side of the estuary of the Seine, 140 miles northwest of Paris. Among the chief buildings are the Church of Notre Dame, dating from about 1550, and the Palais de Justice. The fortifications are extensive and make Havre a fortress of first rank. The manufactures include chemicals, machinery, cotton goods, earthen and stone ware, paper, glass, oil, refined sugar and ropes. The chief dependance of Havre is on its commerce, which is the greatest of all French ports, except Marseilles. It has a large trade with England and the United States, importing large quantities of cotton, coffee, grains, hides and silks. Havre was used as a port for American troops and supplies in the World War. Population, 1911, 136,159.



Diamond Head,  
near Honolulu

## HAWAII, *hah wī'e*, or HAWAIIAN, *hah wī'an*, ISLANDS,

a group of islands in the Pacific Ocean, constituting an organized territory of the United States. Described by Mark Twain as the "loveliest fleet of islands that lie anchored in any ocean," the Hawaiian lands are the joy of tourists from all over the world. Probably nowhere else on the globe does one find a more pleasant combination of scenery, climate and tropic bloom. Originally they were

known as the SANDWICH ISLANDS, a name bestowed by Captain Cook in honor of the English Earl of Sandwich. The present name is that of the largest island in the group. (The reader will find in these volumes various details not discussed in this article, under the heading TRAVELS IN DISTANT LANDS.)

The archipelago lies about 2,200 miles southwest of San Francisco and about 1,000 miles north of the equator. There are eight

inhabited islands and twelve that are uninhabited, and these extend for over 400 miles in almost a single line from southeast to northwest. Their total area is 6,449 square miles, divided among the inhabited islands as follows: Hawaii, 4,015; Maui, 728; Oahu, 598; Kauai, 547; Molokai, 261; Lanai, 139; Niihau, 971; Kahoolawe, 69. On Oahu is Honolulu, the capital and metropolis of the territory. Molokai is the home of a famous leper colony. In 1910 the population of the group was 191,909. In 1917, according to a Federal estimate, it was 250,627. Of the total estimated, 102,479 were Japanese; 23,990, Hawaiian; 19,100, Filipino; 15,850, part Hawaiian; 22,100, Chinese; and the remainder Porto Rican, Korean, European and American.

**Surface and Drainage.** The islands are of volcanic origin, with coral reefs partly lining most of them, but entirely encircling none. They are mountainous; but only Hawaii is actively volcanic. This island has two of the largest craters in the world, Mauna Kea and Mauna Loa, which are 13,805 and 13,675 feet high, respectively. On the eastern slope of Mauna Loa is the far-famed Kilauea (which see), the largest active volcano in the world (see, also subhead below, *Hawaii National Park*). The island is also traversed by other mountains, which give it a rugged and picturesque appearance; in places bold cliffs from 1,000 to 3,000 feet high front the sea. The Hawaiian coasts, especially those of Kauai, are indented with deep bays and inlets, but there are only two good harbors in the entire archipelago. Between the mountains and the coast extend fertile plains and valleys, where agriculture is extensively carried on. The rivers of Hawaii are mostly small mountain torrents.

**Climate.** The climate of the Hawaiian Islands is as nearly perfect in respect to human enjoyment as climate can be. It is never too warm, and is never cold, and there is sea bathing all the year. The average temperatures of the lowlands are 70° in January and 78° in July, and the mean temperature is about 10° lower than that of other countries in the same latitude. Thunderstorms, though severe, are rare, and hurricanes are unknown. The rainfall varies in different localities, averaging from 100 to 250 inches a year at Hilo, in Eastern Hawaii, the "wettest city in the world." In Honolulu it averages about thirty-two inches a year.

In many agricultural sections irrigation is necessary. Artificial wells and surface water are utilized for this purpose.

**Industries.** Agriculture is the principal industry. The soils vary in different parts of the islands. In the highlands they are poor and thin, but in the lowlands they are rich and very productive. Sugar is grown in the low plains; higher up are found coffee, fruits and vegetables and pasture grass. Sugar is the staple product and is grown very extensively. Over half of the popula-

areas on Hawaii Island. On the upland pastures herds of live stock flourish, and these supply the islanders with meat.

Sugar refining, rice polishing, the canning of pineapples and the cleaning of coffee are the chief manufacturing industries. Scarcity of labor is a permanent problem of the manufacturer, and one that prevents full development of the resources of the islands.

**Hawaii National Park.** Four tracts of land, having a combined area of about 118 square miles, were created a national park in

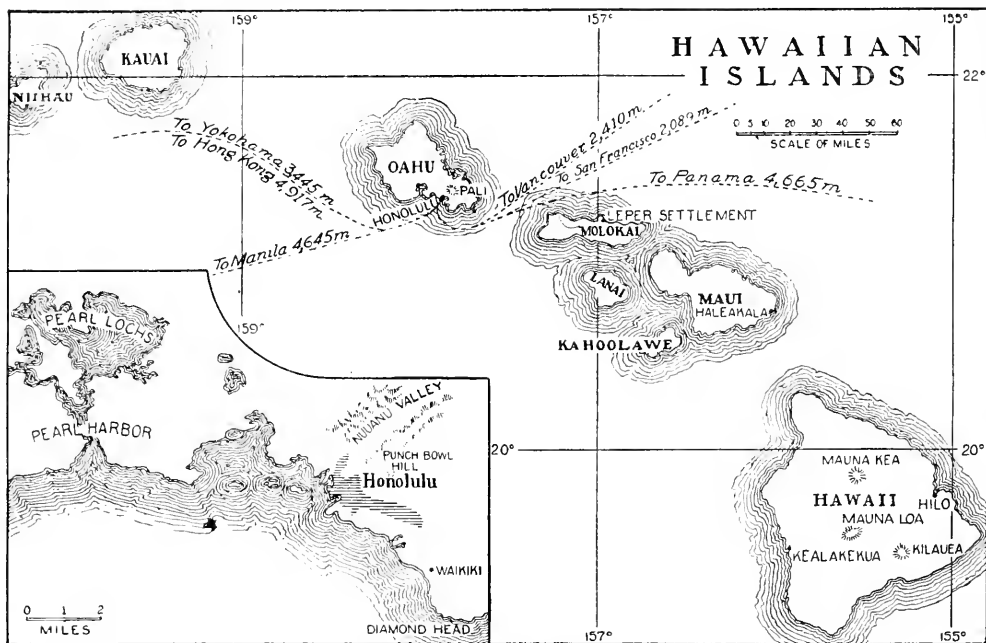

tion is engaged in its production, and in 1917, 581,318 tons were exported. Next in importance to sugar comes rice, which is grown in the lowest flats and is cultivated mostly by the Chinese. Coffee is not grown extensively yet, but the prospects for its cultivation are very favorable.

An industry of more recent and wonderful development is the raising of pineapples. In 1917 the value of the crop exported was \$8,933,056; nearly all the pineapples consumed in the United States are grown in Hawaii. Among other important industries are the raising of tobacco, cotton and Bermuda onions, and the exploitation of the rubber tree. Sisal hemp and grasses used in making Panama hats are other products of value, and a plant known as *olonu*, which yields a tough fiber, is grown in two limited

August, 1916. Their most remarkable scenic features are the world-famous volcanoes—Mauna Kea, the highest peak in the Pacific Islands; Mauna Loa, on whose eastern slope is the active crater Kilauea; and Haleakala, a mountain mass 10,000 feet high, having on its summit a crater eight miles in diameter. These are described in more detail in the article TRAVELS IN DISTANT LANDS, subhead *Hawaii*.

**Transportation and Communication.** The position of the islands is favorable for communication with most parts of the world. The territory is on the line of vessels trading between ports of Western North America on the one side and Eastern Asia on the other, and its position is responsible for its commercial development. Regular steamers come to Honolulu from San Francisco, Vancouver,

Yokohama, Hong-kong, the Philippines and different points in Australia. In the inhabited islands good roads have been constructed, and there are over 300 miles of steam railway. The city of Honolulu has first-class electric railway service. Communication between the islands is by steamboats, and they have cable and wireless connection with the outside world.

Pearl Harbor, near Honolulu, is the largest harbor in the archipelago. It has been made one of the safest and best harbors in the world, and is used by the United States as a naval base. The harbor of Honolulu is small, but it can accommodate large ocean vessels. These are the only first-class ports in Hawaii.

**Education and Religion.** There are schools in all sections of inhabited Hawaii, and elementary instruction is everywhere free. English is the standard language in the regular schools, but there are in addition about 137 Japanese schools attended by about 14,000 Japanese pupils. In these schools Japanese subjects are taught. There are over 33,000 pupils enrolled in the public schools, and about 7,000 in private institutions. The public schools numbered 168 and the private, fifty-one, in 1918. In the schools one finds studying together children of many races and colors. Higher institutions of learning include a normal and training school, reformatory industrial schools for boys and girls and a college of agriculture and the mechanic arts.

The majority of the native Hawaiians are Christians. At Honolulu there are churches representing various Protestant denominations, and this city is the residence of a Roman Catholic and an Anglican bishop.

**Government.** The island group is governed as an organized territory of the United States. There is a legislature of two houses—a senate of fifteen members elected for four years, and a house of representatives of thirty members elected for two years. The governor and secretary of the territory are appointed for four years by the President of the United States. The territory is represented in Congress by a delegate, elected biennially.

**History.** The islands are said to have been discovered by Gaetano in 1542 and rediscovered in 1778 by Captain Cook, who met his death at the hands of the natives in the following year. In early times each island had a king, but under Kamehameha I the islands were formed into one kingdom. Kame-

hameha died in 1819 and was succeeded by his son, Liholilo, who adopted on his accession the name of Kamehameha II, and whose reign was famous for the abolition of idolatry and the system of taboo throughout all the islands. Vancouver, who arrived with Cook in 1778 and returned in 1792 and again in 1794, made sincere attempts to enlighten the islanders, and he succeeded so far that he was requested by the king and his chiefs to send religious teachers to them from England. The first missionaries, however, who visited the islands came from America in 1820. The missionaries were well received, and the work of instruction was at once begun, as the king saw the necessity of introducing a new religion to take the place of the one which he had abolished. Kamehameha II and his queen visited England and both died in London in 1824.

Until the year 1840 the government of the islands was a simple despotism, but in that year Kamehameha III granted a constitution, which provided for a government consisting of a king, an assembly of nobles and a representative council. In 1843 the independence of the Hawaiian kingdom was formally guaranteed by the French and English governments. Kamehameha IV (1854–1863) was succeeded by his brother, Kamehameha V. With his death in 1873 the line of Kamehamehas became extinct, and the high chief Lunalilo was elected to the vacant throne. On his death in 1874 another high chief, Kalakaua, was elected king.

This ruler died in 1891 and was succeeded by his sister, Liliuokalani. She had shown during the previous reign her reactionary tendencies, and after her accession it became clear that she intended to rule without a constitution. A revolution therefore broke out, headed by the progressive party of the state, and the queen was deposed. A provisional government was then formed, and overtures were made for annexation to the United States.

As these were not favorably received, the Republic of Hawaii was proclaimed July 4, 1894, with a constitution modeled after that of the United States.

Repeated efforts were made to annex the islands, and in 1898 Sanford B. Dole, president of Hawaii, visited Washington in the interest of annexation. A joint resolution of Congress was passed and signed by President McKinley in July, 1898, in accordance with

which the President appointed a commission to visit the islands and draw up a plan of government. The United States took formal possession of the islands in August, 1898. The act of Congress approved in April, 1900, made provision for a territorial government, and under this act Dole, formerly president of the republic, took the oath of office as governor in June, 1900. Since that date the territory has enjoyed peace and prosperity. The people are enthusiastically loyal to the United States, and when America entered the World War four regiments and other units were organized to police the islands. The islands oversubscribed their quota of Liberty Bonds. In 1918, by executive order, the island of Oahu was created prohibition territory.

**Related Articles.** Consult the following titles for additional information:

|              |           |
|--------------|-----------|
| Cook, James  | Mauna Loa |
| Kilauea      | Molokai   |
| Liliuokalani | Pineapple |
| Mauna Kea    | Taboo     |

**HAWK**, a name given to many small birds of prey, though especially to those having shorter wings than the falcons and much resembling them in habits. In the United States it is the common name for all the quick-winged species, varying in size from the large chicken hawk to the little sparrow hawk. They vary in length from ten to about twenty inches, and live chiefly on insects and very small animals, such as snakes, field mice and ground squirrels. Hawks have an evil reputation around the farmyards; some species kill birds and some poultry, but authorities declare they are an asset, when accounts are balanced, for they destroy much insect and animal life which is destructive to crops.

**Related Articles.** Consult the following titles for additional information:

|          |         |
|----------|---------|
| Falcon   | Kite    |
| Hen Hawk | Sparrow |

**HAWKINS, ANTHONY HOPE** (1863– ), an English novelist, whose light and witty *Dolly Dialogues* attracted the fancy of a large circle of readers. After graduation from Balliol College, Oxford, he studied law and was admitted to the bar. His literary career began with a book entitled *A Man of Mark*, published under the name of "Anthony Hope." Later he wrote *Father Stafford*, *Mr. Witt's Widow*, *Sport Royal*, *Phroso*, *The Heart of Princess Osra* and *Double Harness*. His work is spirited and vigorous, highly romantic, and wholesome in tone. His most popular novels are *The*

*Prisoner of Zenda* and its sequel, *Rupert of Hentzau*.

**HAWKS' BILL**, a large, inedible turtle, found in warm seas. It has a peculiar-shaped tail which serves as a weapon of defense. From this turtle, which is also called *loggerhead* and *caret*, is taken the tortoise shell, an important article of commerce. It is common in the West Indies and the islands of the South Pacific seas. See **TORTOISE**.

**HAWK'WEED**, a large family of plants injurious to crops. The flowers, usually yellow, are clustered on the end of a stalk about twice the length of the leaves, which grow from the ground. The weed may be exterminated from fields with salt, and also by plowing under and planting the land to hoed crops.

**HAW'THORN**, a thorny shrub or small tree of the rose family, found wild in many parts of Europe, in North Africa and Western Asia, where it is native. The real hawthorn has been introduced in North America. It is in general use in many places as a hedge and is cultivated for the white and rose-colored blossoms, which make the country landscape very beautiful. The tree bears a small red fruit, called a *haw*, which affords a winter food for birds. The American thorn apple belongs to the same genus as the true hawthorn.

**HAWTHORNE, JULIAN** (1846– ), an American author, son of Nathaniel Hawthorne, born in Boston. He studied civil engineering in America and in Germany, but practiced that profession only a short time. He spent about ten years abroad, and while in Europe wrote *Bessant* and several other successful stories. Of the novels written after his return to America, *The Professor's Sister* and *John Parmlee's Curse* are noteworthy. His stories do not follow the common form of romance and have interesting touches of mystery about them. In 1913 Hawthorne was implicated in a mining promotion scheme that brought him under the investigation of the Federal authorities. Charged with misuse of the mails, he was tried and sentenced to serve a term in the Federal prison at Atlanta. The *Subterranean Brotherhood* is based upon his experiences there.

**HAWTHORNE, NATHANIEL** (1804–1864), the foremost of America writers of fiction, was born at Salem, Mass., July 4, 1804. His childhood, passed with his mother



at his father's home in Salem, was singularly free from the restraints of formal schooling. Spenser's *Faerie Queene*, Bunyan's *Pilgrim's Progress*, the works of Shakespeare and of Milton and the quiet natural scenes in which he loved to take solitary rambles were largely his teachers.

When he was fourteen, his mother went with him to an uncle's at Lake Sebago, Maine, and here his love of solitude was still further developed. He spent much time wandering about in the unbroken forests or skating on the lake. In 1821 he entered Bowdoin



NATHANIEL  
HAWTHORNE

College, where Longfellow and Franklin Pierce were his fellow students, and was graduated in 1825 without having distinguished himself as a scholar. The succeeding twelve years were passed in almost complete seclusion at Salem. He wrote much, but destroyed almost all that he wrote, because it did not satisfy him. Various articles were written for periodicals, but they attracted little interest, and although the reprinting in 1837 of some of these, notably *Twice-Told Tales*, won him praise, it did little toward helping him to maintain himself. Therefore in 1839 he accepted the position of weigher and gauger in the Boston customhouse, which position he held for two years.

After a year spent at Brook Farm in what was to him largely an uncongenial experiment, he married Miss Peabody of Salem and moved to Concord, to the house which he celebrated in his *Mosses from an Old Manse*. The four years spent in Concord were happy years, although the tales which he published in periodicals and the *Mosses from an Old Manse* afforded him but a scanty living. He was surveyor of the customhouse at Salem from 1846 until 1849, when a change of political parties removed him from office. Immediately on leaving the customhouse he published *The Scarlet Letter*, which made him famous on both sides of the Atlantic. Following this came *The House of the Seven*

*Gables* (1851) and the *Blithedale Romance*, the latter a thinly disguised account of his experiences at Brook Farm.

The election of his life-long friend, Franklin Pierce, to the presidency in 1853 brought Hawthorne an appointment to the consulship at Liverpool. After his term of office had expired, he spent a year and a half in Rome and Florence, and the record of his European sojourn was given in the *English Notebooks* and *French and Italian Notebooks*. The greatest result of this period, however, was *The Marble Faun*, published in 1860. On his return to America he brought out *Our Old Home*, which gives further impressions of England. The *Dolliver Romance*, begun in 1864, was never finished, for the failing health of the author compelled him to abandon his work and seek in travel to recover his strength. In the course of a tour made with ex-President Pierce he died suddenly at Plymouth, N. H.

Hawthorne's was a rare personality, uniting in an unusual degree strength of intellect and will with an almost feminine refinement and sensibility. He was an optimist at heart, although frequently adjudged a pessimist because he made the gloomier aspects of life so commonly his theme. Descended from pure New England stock, his genius was a genuine American product and gave to the traditions and tendencies of the Puritan life their most



"THE WAYSIDE," HAWTHORNE'S HOME  
AT CONCORD

fitting expression. His style is remarkable for its clearness, ease and beauty. A biography has been written by his son, Julian Hawthorne, entitled *Nathaniel Hawthorne and His Wife*.

**HAY**, in the ordinary use of the term, grass cured for fodder, but in its broadest sense, hay may mean grass or various grains which have been cured for this purpose. The

plants ordinarily cultivated for hay are timothy and various sorts of clover and alfalfa.

Cultivated grasses are usually cut before they are quite ripe and allowed to dry by lying on the ground as they are cut. However, in localities where dew is heavy or rain is liable to fall, the hay is raked together at the close of the day and bunched. If not sufficiently dry for stacking, it is spread out the next day and allowed to remain until it is dry enough to stack. In some parts of the United States, as in New England and New York, and also in Eastern Canada, where farms are small, hay is placed in barns, but in most regions it is stacked out of doors, and held in place by poles fastened over the stacks. The top of the stack is either conical or gable-shaped, with a steep slope, so water readily runs off, and only a small portion of the hay on the outside is affected by the weather.

**The Crop.** The great hay states of the American Union in order of importance, are New York, Iowa, Wisconsin, Kansas, Nebraska and Minnesota. They produce almost forty per cent of the entire average crop of 97,500,000 tons, grown on 72,280,000 acres.

In Canada the heaviest yield in the history of the Dominion was in 1916. Over 14,525,000 tons were in that year produced on 7,820,000 acres, or 1.86 tons to the acre. Ontario and Quebec together raised 11,342,000 tons, Ontario slightly exceeding Quebec.

**HAY, JOHN** (1838-1905), one of the most able of American diplomatists of the last generation, was born at Salem, Ind. He was graduated from Brown University in 1858, studied law and was admitted to the bar at Springfield, Ill., in 1861. The same year he left Illinois to become assistant secretary to President Lincoln, and subsequently he became his adjutant and aid-de-camp, positions which bore fruit in the *Life of Abraham Lincoln*, written by him in conjunction with Nicolay and considered the greatest biography of Lincoln. He took an active part in the Civil War, rising to the rank of colonel and assistant adjutant-general. From 1865 to 1870 he was secretary of several foreign legations. In 1870 he returned to the United States and entered newspaper work as one of the editors of the *New York Tribune*. In 1879 he was appointed assistant Secretary of State. He was appointed by President Mc-

Kinley ambassador to Great Britain in 1897, and in the following year became Secretary of State.

In 1901 he negotiated the Hay-Pauncefote Treaty, concerning the Panama Canal, and was prominent in the settlement of international affairs in China in the same year. He remained Secretary until his death, winning a high reputation as the exponent of a frank and fair diplomacy. He was also well known as an author, among his works being several volumes of poems, essays and criticisms, notably, *Pike County Ballads*, *Castilian Days* and *Sir Walter Scott: An Address*.

**HAYDN, h'i'd'n, JOSEF** (1732-1809), one of the greatest of composers, the "father of the symphony and quartet." The two forms reached perfection in his hands, where they became a pattern for all that were written afterward. Haydn was an indefatigable worker and produced in all about seven hundred works, including 125 symphonies, eighty-three quartets, thirty-eight trios, many light oratorios, fourteen operas, fifty sonatas, thirty-one concertos, and numerous songs. The beauty and simplicity of his character, his hopefulness and geniality are reflected in



JOSEF HAYDN

all his music and in the attitude of his pupils, to whom he was always "Papa Haydn."

From Rohrau, his birthplace, Haydn went as a boy to Vienna, his excellent voice having obtained for him appointment as choir-boy at Saint Stephen's Church. Later he became a teacher of music, and from 1761 to 1790 was musical director to Prince Esterhazy. After this he went to England, where he published *Twelve Grand Symphonies* and wrote his opera *Orpheus and Euridice*. His famous oratorios the *Seasons* and the *Creation* were written after his return to Austria in 1794. This last contains music of rare beauty and power and may be regarded as the foundation of modern descriptive music.

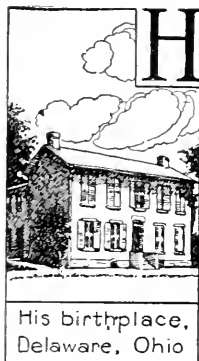

**H**AYES, RUTHERFORD BIRCHARD (1822-1893), American soldier and statesman, nineteenth President of the United States. He was a man without personal political ambitions, and throughout a public career in which he represented the state of Ohio in Congress and served the people of that state as governor, he always acted according to

principle. Hayes was elected President at a time when the country had been outraged by corruption and scandal in high places, and it was his hope to remedy the evils that were then debasing the national life. If he did not succeed in bringing about a complete reformation, he did at least prepare a sure foundation on which the Presidents who followed him could build.

**Early Career.** Hayes was born at Delaware, Ohio, October 4, 1822. He was a post-humous child, his father having died in the preceding July. His mother was able to give him a good education, and in 1838 he was graduated from Kenyon College with high honors. After completing a course in law at Harvard, Hayes began the practice of his profession, settling finally in Cincinnati, where he was very successful. From 1858 to 1861 he was city solicitor of Cincinnati, and in that capacity won general admiration for his ability and integrity. When the city received word of the bombardment of Fort Sumter, he was made chairman of the committee which drew up resolutions of loyalty, and when the literary club to which he belonged organized a military company, he became its captain.

Hayes remained in the army until the end of the war, and rose steadily through the various grades, being given the rank of brevet major-general in March, 1865. Grant in his *Personal Memoirs* spoke of his conspicuous gallantry on the field, and of his display of qualities higher even than personal daring. In 1864 the Republicans of the Second Ohio district elected him to Congress, and in December, after the termination of the war, he took his seat. At the close of his term he was elected governor of Ohio, was reelected for a second term, and in 1871, at the end of four years of service, asked to

be permitted to retire to private life. In spite of his reluctance, the Republicans again nominated him for governor in 1875, and he won in a campaign which had as one of its slogans, "honest money."

**Presidential Election Disputed.** Ohio Republicans by this time had come to realize that Governor Hayes was a Presidential possibility, and in the national convention of 1876 he won the nomination without great difficulty, defeating such well-known leaders as James G. Blaine and Roscoe Conkling. In the campaign his Democratic opponent was Samuel J. Tilden. The election was one of the most exciting in American history because of the closeness of the vote. Hayes received a popular vote of 4,033,950, and Tilden, a vote of 4,284,885. The electoral vote was apparently 185 to 184, in Hayes' favor, but charges of fraud were made by both parties, and the decision was finally left to an Electoral Commission. This commission declared Hayes legally elected, and he was duly inaugurated. Throughout the whole affair, when the most bitter feeling prevailed throughout the country, both candidates acted with restraint and dignity.

**His Administration.** The administration of Hayes was notable in that it marked the end of reconstruction in the South. Federal troops were withdrawn from all the Southern States, and the Southerners were permitted



R. B. HAYES

to settle their local affairs without interference. Another important event was the resumption of specie payments, on January 1, 1879. John Sherman, Hayes' Secretary of the Treasury, prepared for this emergency by accumulating an ample gold reserve, and all greenbacks presented for exchange were promptly redeemed. The money question was troublesome throughout the administration, as there was a strong feeling that the silver dollar should be restored as a standard coin. Congress, in support of this movement, passed the Bland-Allison Act, which required the Secretary of the Treasury to buy between

## Administration of Rutherford B. Hayes, 1877-1881

- I. THE PRESIDENT
- (1) Birth
  - (2) Education
  - (3) Profession
  - (4) Military career
  - (5) Public life after the Civil War
  - (6) Character
  - (7) Death
- II. END OF THE PERIOD OF RECONSTRUCTION
- (1) Disputed elections in Southern states
  - (2) Withdrawal of Federal troops
- III. CIVIL SERVICE REFORM
- (1) Civil Service Reform Association organized
  - (2) Removal of Federal office holders for using influence politically
- IV. FINANCIAL REFORM
- (1) Resumption of specie payments
  - (2) Bland-Allison Act, 1878
    - (a) Restored equality of gold and silver currency
    - (b) Required purchase of at least \$2,000,000 worth of silver monthly
    - (c) Vetoed by the President but passed over the veto
- V. A PERIOD OF AGITATION
- (1) Labor troubles
    - (a) Railway strike of 1877
    - (b) Miners' strikes
  - (2) The negro exodus
    - (a) Movement of free negroes
      - (1) Principally from Mississippi, Louisiana and Texas
      - (2) To the West and Northwest
    - (b) Causes
      - (1) Forced to pay high rents
      - (2) Unjust system of land tenure
      - (3) Exorbitant prices charged by southern merchants
      - (4) No political recognition
  - (3) Granger movement
    - (a) Organized by farmers
    - (b) To protect their interests
    - (c) Became important political influence
- VI. OTHER EVENTS OF IMPORTANCE
- (1) Telephone and electric light come into commercial use
  - (2) Death of William Cullen Bryant, 1878
  - (3) United States life-saving service established
  - (4) Grant's tour of the world
  - (5) Yellow fever epidemic in the South
  - (6) Canadian fisheries award
  - (7) Campaign and election of 1880
    - (a) Conventions
      - (1) Republican
        - (a) Nominated Garfield
        - (b) Platform
          - (1) Opposed Chinese immigration
          - (2) Defense of tariff system
          - (3) More pensions
      - (2) Democratic
        - (a) Nominated Hancock
        - (b) Platform
    - (3) National Greenback-Labor
      - (a) Nominated Weaver
      - (b) Platform
- Questions
- Give a brief account of Hayes' military career.
- What public offices did he hold after his retirement from the army?
- What act of his marks the end of the reconstruction period?
- Who was Secretary of the Treasury when specie payments were resumed?
- Give a short sketch of his public career.
- What did the Bland-Allison Act provide?
- What were the causes of the railway strike of 1877?

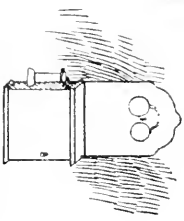

THE TELEPHONE GOES INTO GENERAL USE. 1877

1877

"He serves his party best who serves his Country best"

# HAYES' ADMINISTRATION

1881

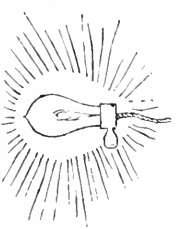

ELECTRIC LIGHTING ADOPTED 1877

SOME HIGHLIGHTS DURING "THE BUCKLE PRESIDENTS" ADMINISTRATION -

THE GREAT RAILROAD STRIKE 1877.

CIVIL SERVICE REFORM INTRODUCED.

TROUBLE WITH NEZ-PERCE INDIANS.

GREAT TEMPERANCE MOVEMENT - 1878.

DEATH OF W. C. CULLEN BRYANT.

LIFE SAVING SERVICE ESTABLISHED 1879.

THE NEGRO EXODUS.

TENTH CENSUS. POP. 50,155,783.

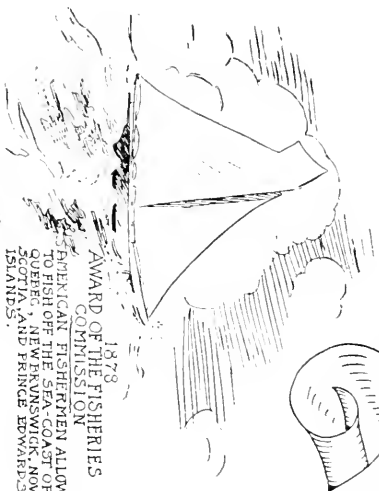

1878  
AWARD OF THE FISHERIES COMMISSION TO SPANISH FISHERMEN ALLOWED TO FISH OFF THE SEAS OFF NOVA SCOTIA AND PRINCE EDWARDS ISLANDS.



THE GREAT YELLOW FEVER EPIDEMIC WHICH SWEEPED THE SOUTH IN 1878-9



1879  
GRANT MAKES A TOUR OF THE WORLD



SILVER MADE A LEGAL TENDER - 1878

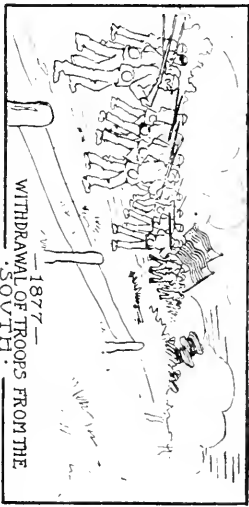

1877 - WITHDRAWAL OF TROOPS FROM THE SOUTH

\$2,000,000 and \$4,000,000 worth of silver a month and coin it into dollars. This bill was vetoed by Hayes, but it was passed over his veto.

In his efforts to remedy the evils of the "spoils system," the President worked earnestly to establish a civil service commission, but he was persistently thwarted by Congress, and reform of the civil service had to be worked out by his successors. Among other events of his administration were the settlement of the Atlantic fisheries dispute, the organization of the United States life-saving service and the completion of jetties along the lower Mississippi under the direction of James B. Eads.

**Later Years.** Hayes refused to be a candidate for reelection, and at the age of fifty-nine found himself free to devote his energies to philanthropy and reform. He served on the board of trustees which administered the John F. Slater and the Peabody Educational funds, and was active in various charitable, prison reform and educational projects. On January 17, 1893, he died in Fremont, Ohio.

**Related Articles.** Consult the following titles for additional information:

Electoral Commission Specie Payments,  
Reconstruction Resumption of  
Washington, Treaty of

**HAY FEVER**, or **HAY ASTHMA**, *as' mah*, an ailment that has all the symptoms of a severe cold, including profuse discharges from the nose, accompanied by sneezing, weeping eyes and a general feeling of lassitude and illness. Persons suffering from hay fever have annual attacks, occurring with great regularity at some time during the summer months. The majority of cases begin at some time in August and last till cold weather. The disease appears to attack persons in a weakened nervous condition and to be caused primarily by the pollen from plants or irritating dust from stables and other places. Medicines do not cure hay fever, but often a change of climate will give immediate relief. It very generally attacks persons who are subject also to asthma.

**HAYNE**, **ROBERT YOUNG** (1791-1839), an American politician, born in Colleton District, S. C. He was admitted to the bar in 1812 and soon attained prominence. He served in the War of 1812, at its close was elected to the legislature and in 1818 became attorney-general of his state. As a states' rights Democrat, he entered the United States Senate in 1823, where he vigorously upheld

the doctrine that slavery was not a subject for Federal legislation. He attained special fame for his brilliant debate with Daniel Webster upon the relation of the states to the Federal government, in January, 1830. In the nullification controversy of 1832 he upheld South Carolina and soon afterward resigned from the Senate, was elected governor of his state and issued a defiant proclamation guaranteeing the maintenance of the nullification ordinance (see **NULLIFICATION**). Later, however, he exhibited greater moderation and marked executive ability. From 1835 to 1837 he was mayor of Charleston, and thereafter until his death was president of the Louisville, Cincinnati and Charlestown Railway.

**HAY-PAUNCEFOTE**, *pauns'foot*, **TREATY**, a treaty between Great Britain and the United States, negotiated in 1901 by Secretary of State John Hay for the Americans and Lord Pauncefote, ambassador to the United States, for the British. It recognized the right of the United States to construct, own and control a canal across the isthmus connecting North and South America and thus superseded the Clayton-Bulwer Treaty of 1850. It also provided that the United States should have undivided control of the canal, and should not be obliged to keep it open to all nations in the event of war. In 1914 a provision which excluded American vessels from payment of tolls through the canal was stricken out, for it violated the spirit of the compact, which assured equal rights to all nations in times of peace.

**Related Articles.** Consult the following titles for additional information:

Clayton-Bulwer Treaty  
Mosquito Territory  
Nicaragua Canal  
Panama Canal

**HAYS**, **CHARLES MELVILLE** (1856-1912), a North American railway manager, born at Rock Island, Ill., and educated in the elementary and high schools of that city. At the age of seventeen he entered the passenger department of the Atlantic and Pacific Railroad Company at Saint Louis, Mo. From 1878 to 1884 he was private secretary to the general manager of the Missouri Pacific; from 1884 to 1886 was secretary to the general manager of the Wabash; and in 1886 became first assistant general manager and then general manager. In 1894 he was chosen general manager of the reorganized Wabash Railroad. He next accepted the position of general manager of the Grand

Trunk at Montreal. He remained here four years, during which he reorganized the Central Vermont Railway Company, a subsidiary of the Grand Trunk, and double-tracked the line of the Grand Trunk from Montreal to Chicago.

In January, 1901, Hays became president of the Southern Pacific, but in the autumn of that year was recalled to Montreal to become second vice-president and general manager of the Grand Trunk. It was largely due to his efforts that the Grand Trunk Pacific Railway Company, of which he was president, was organized. On January, 1910, he became president of the Grand Trunk Railway Company. While returning from a trip to England, where he had made arrangements with the directors for further expansion, he lost his life in the *Titanic* disaster on April 15, 1912. Hays was one of the great constructive railway men of the continent.

**HAYWOOD, WILLIAM D.**, an American labor agitator whose date and place of birth are unknown, but who from obscure origin rose to a commanding position in one of the organizations of labor, the Industrial Workers of the World (which see). Of this group he was secretary and its chief spokesman. The unsavory reputation of the I. W. W. reflected on Haywood, and he was associated with several enterprises connected with labor which brought him in conflict with the law. One serious incident was the charge of complicity in the murder of Governor Steunenberg of Idaho in 1905, but in trial the charge remained unproved. In 1918 he and ninety-two others of his organization were charged with violating the espionage act, passed after America's entrance into the World War. Haywood and five others were sentenced to twenty years' imprisonment; the remainder of the dependants, all found guilty, were given sentences from one year to fifteen years.

**HAZE**, a condition of the atmosphere which prevents one seeing objects through it distinctly. Haze varies in degrees of density and is caused in numerous ways, usually by quantities of fine dust. It may be raised by wind or by smoke arising from forest fires, or smoke arising from the burning of peat bogs, as in some portions of Europe. The color of the atmosphere and sky depends somewhat upon the formation of haze. That formed from smoke usually gives the atmosphere a dark, murky appearance, while that

formed from dust may cause the atmosphere and sky to appear light gray, yellow or some other color, according to the color of the dust. Haze preceding a rain storm is usually caused by the presence of minute particles of vapor. The color of such haze is usually light gray. See **DUST**, **ATMOSPHERIC**.

**HA'ZEL**, the tree that produces the nut called the filbert, or hazelnut. It is native to Europe, North Africa, Asia and North America. The nut is enclosed in a husklike bur, covered with fine barbs. The early frost opens these burs, and the nuts fall to the ground. Hazel trees never grow high. The leaves, which somewhat resemble those of the horse chestnut, turn a rich yellow in the fall. From the strong, flexible branches are made baskets, crates, whip-handles, hoops and such articles. A forked hazel branch in the hands of some persons has long been innocently thought capable of locating underground water and treasure.

**HA'ZEN, WILLIAM BABCOCK** (1830-1889), an American soldier, born in West Hartford, Vt., and educated at West Point. At the outbreak of the Civil War he was a captain in the regular army, but went to the front as colonel of a volunteer regiment. He won distinction at Shiloh, Corinth, Murfreesboro and Missionary Ridge, served through Sherman's Atlanta campaign, was prominent at the capture of Savannah and at the close of the war was brevetted major-general in the regular army. For fifteen years afterward he served on the frontier, except during his absence in Europe as a military attaché. In 1880 he attained the rank of brigadier-general, became chief of the signal service and accomplished a vast improvement in its equipment.

**HAZING**, *hays'ing*, at one time a common practice among college students. Hazers played practical jokes or inflicted punishment on newcomers or others whom it was desired to humiliate. Because hazing has been carried to such extremes as to cause serious injury and even death, it has been outlawed in all reputable institutions, and survives now chiefly in the form of harmless frolics.

**HAZLETON**, *ha'z'l ton*, PA., the county seat of Luzerne County, thirty miles south of Wilkesbarre, on the Lehigh Valley, and the Pennsylvania railroads. The city has a picturesque site, at an elevation of 1,700 feet,

in the anthracite coal region, and it has silk mills, knitting mills, foundries, machine shops and manufactories of carriages, lumber, coffins, caskets and other articles. During the World War it produced vast quantities of shrapnel. It contains a state hospital for miners, Saint Gabriel's Academy and four banks. The place was settled in 1820, and was chartered as a city in 1890. The commission form of government was adopted in 1914. Population, 1910, 25,452; in 1917, 28,981 (Federal estimate).

**HEAD.** See SKELETON.

**HEADACHE**, *hed'ake*, a sensation of discomfort in some part of the head other than the face, which may vary from a dull ache to the most severe pain. Headaches are but symptoms of bodily disorder, and are always a warning that some part of the system is not in normal condition. In most cases the nerves affected are registering a protest against the formation of poisons in the system. These poisons are often caused by foul air, indigestion, constipation or nervous fatigue. Headaches are also a symptom of eye strain, catarrh of the internal ear, malaria, typhoid fever, influenza, tonsillitis and other diseases. Violent pains in the head accompany tumor of the brain and other brain disorders. Headaches vary in location. A disordered liver usually produces a general headache; that from indigestion or constipation is felt across the forehead; that from eyestrain is felt behind the temples and in the eyeballs. Nervous prostration victims suffer from pain in the back of the neck.

Attention to daily habits will cure a large proportion of headaches. Fresh air, ventilation of the sleeping room, moderation in eating and abstinence from stimulants are foes to pains of this nature. Headache mixtures, except as prescribed by a reliable physician, should be avoided. Most of those advertised contain acetanilid, antipyrine and phenacetin, three dangerous substances. If headache persists in spite of attention to hygiene and diet, a doctor should be consulted.

**HEALTH** is that condition of the living body in which all the bodily functions are performed easily and painlessly. Perfect health is rarely seen, but the average person, by the application of a few simple rules, can keep his body in a very satisfactory condition. Practical suggestions along this line will be found under the heading **PHYSICAL CULTURE**.

**HEALTH, BOARDS OF**, organizations established by a government for the purpose of protecting the health of its citizens. Boards of health are municipal, state, provincial or national, according to the authority by which they are established and the region over which they have jurisdiction. The most important duties of city, or municipal, boards are to prevent the spread of contagious disease by enforcing vaccination and forming and enforcing strict quarantine regulations, to prevent the adulteration of medicines and food, to prevent the sale of injurious drugs, to see that the municipality is kept free from the accumulation of garbage and other material that is liable to cause disease; also, to prescribe and oversee the duties of coroners.

State boards of health have a more general line of duties than municipal boards, and their function in many cases is advisory. Nearly all states and provinces now have such boards, and their service is often of the highest value in preventing the spread of disease and in protecting citizens from the sale of injurious food products. During the influenza epidemic which swept over the United States in 1918, city and state boards worked in close coöperation.

In the United States there is no national board of health, the duties of such a body being assumed by inspectors of foods and drugs, and by the Marine Hospital Service, which is connected with the Department of the Interior. The duties of the Marine Hospital Service consist chiefly in enforcing United States quarantine laws, which are enacted to prevent the entrance into the country of persons afflicted with contagious or infectious diseases.

**HEARING.** See EAR.

**HEARN**, *hern*, LAFADIO (1850-1904), a writer whose observations on Japan have given him a permanent place in literature. He went to Japan at the age of forty-one as a newspaper correspondent, but soon resigned that post and became a teacher of English in the University of Tokyo. Later he married a Japanese woman and became a citizen of the empire. Thereafter he wrote exquisitely on things Japanese, interpreting Japan to Europe and America. A dozen books on the subject came from his pen.

**HEARST**, *herst*, PHEBE APPERSON (1842-1919), an American philanthropist, the widow of Senator George Hearst, to whom she was married in 1862. Mrs. Hearst es-



tablished kindergartens in California and maintained them until they became self-supporting; for ten years she supported a training school for kindergartners in Washington. She also established kindergartens in Lead, S. D., where she had mining interests. At Lead and Anaconda she built and maintained public libraries; at Washington, D. C., she established the National Cathedral School for Girls, at an approximate cost of \$250,000. She erected and equipped the mining building at the University of California as a memorial to her husband. She was the mother of William Randolph Hearst (which see).

**HEARST, WILLIAM RANDOLPH** (1863- ), America's most widely-known editor and publisher, was born in San Francisco, the son of George F. Hearst, a former Senator from California. He received his education at Harvard University and then entered journalism, becoming editor and proprietor of the San Francisco *Examiner* in 1886. He later bought the New York *Journal* and *The Advertiser* and established the *Chicago Examiner* (morning) and *American* (evening paper). Later he established or purchased the Los Angeles *Examiner*, the Atlanta *Georgian*, the Boston *American* (later abandoned), and a Jewish daily in New York City; a German daily in New York he abandoned. In addition to the above daily papers he owns *Good Housekeeping*, *Motor*, *Hearst's Magazine* and the *Cosmopolitan Magazine*. In 1918 he purchased the *Chicago Herald* and merged it with the *Examiner*. When the usual daily foreign news service was lost to his papers through abuse of privileges he established the International News Service. He is the world's leading exponent of "yellow journalism," the first to use great, flaring headlines, and the only editor who persistently advertises himself in his papers.

He was elected to Congress from New York and was made president of the National League of Democratic Clubs. He was a candidate for the Democratic nomination for President of the United States in 1904, and was defeated for the office of mayor of New York City on the municipal ownership ticket in 1905. He was the candidate of the Democratic party of New York for governor of the state in 1906, having first been nominated by an independent party created through his efforts. Before the United States entered the World War he was severely criticized for the

pro-German attitude of his newspapers, and for their anti-British leaning throughout that conflict.

**HEART**, *hart*, the most vital organ of the body. Its special function is to pump blood through the veins and arteries, and this task it performs day and night so long as there is life in the body. If the hand be placed between the fifth and sixth ribs a little to the left of the breastbone the beat or stroke of the heart can plainly be felt. This beating goes on continuously at the rate of seventy-two strokes a minute for the adult in normal health; in a single year the heart beats about 37,000,000 times. It has been estimated that one day's work of this busy organ is equivalent to the energy expended by the leg muscles of a man weighing 165 pounds who climbs a mountain 2,500 feet high. The only rest which the heart muscle gets is in the pause which occurs between beats. Rapid beating of the organ lessens the rest periods and causes the heart to become fatigued. Every six minutes it sends every drop of blood in the body through the kidneys.

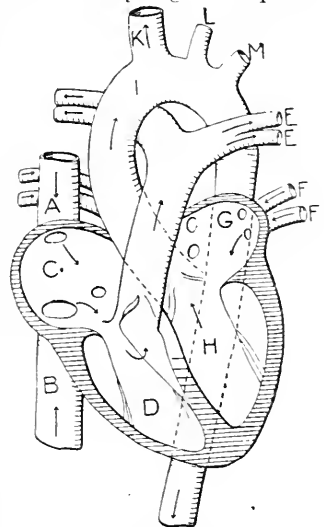

HEART AND BLOOD VESSELS

A, B, Superior and inferior venae cavae; C, right auricle; D, right ventricle; E, E, pulmonary artery and branches; F, F, pulmonary veins; G, left auricle; H, left ventricle; I, aorta; K, innominate artery; L, left carotid artery; M, left subclavian artery.

The heart in man is a cone-shaped organ, situated in the chest behind the breastbone and placed obliquely in an inverted position. The base points upward, inward and to the right, and the apex downward, outward and to the left. The heart is slightly to the left of the median line of the body. It is suspended in the chest by the large blood vessels attached to it, and is surrounded by a serous membrane known as the *pericardium*. A similar membrane of finer texture, known as

the *endocardium*, also lines the cavities. The heart of an adult is about five inches long, its greatest diameter is three and one-half inches, and the average weight is nine ounces for women and eleven for men. The walls are constructed of muscular fibers, and the muscular partition called the *septum* separates the organ into right and left sides.

The left side contains the *left auricle* and *left ventricle*, and the right side, the *right auricle* and *right ventricle*. The right side of the heart forces the blood through the lungs and is connected with the pulmonary circulation. Because of the functions of this part of the heart the muscular walls are much thinner and weaker than those of the left side, whose function it is to force the blood through the arteries in the systemic circulation. The auricles occupy the base of the heart and are formed by very thin walls. The right auricle receives the blood from the *superior* and the *inferior vena cavae*, and the left auricle receives it from the *pulmonary veins*. The ventricles occupy the apex and force the blood through the arteries.

Between the auricles and ventricles are valves, composed of a thin, strong white membrane, whose folds are so arranged that they allow the blood to flow from the auricle into the ventricle, but prevent its return when the muscles of the heart contract. The valve on the right side is known as the *tricuspid*, and that on the left side is called the *bicuspid*, or *mitral*, valve. The openings into the arteries are also guarded by valves, which in shape resemble a half-moon and are called *semi-lunar* valves. The course of the blood through the heart is illustrated in the diagram. Its circulation through the lungs and body is explained under the heading CIRCULATION.

To keep the heart strong and healthy one should not overwork or exercise too long or too violently. Tobacco and alcoholic liquors have a weakening effect and should be avoided.

**HEARTS**, a game of cards which may be played by two or more persons. If more than four play, two packs of cards are generally used. The object of each player in the game is to get rid of his heart cards. There are several varieties of this game, the directions for which may be found in any standard book of rules. In a common form of hearts the cards are dealt out until all players have the same number. The first player to the left

of the dealer plays any card he likes, and each of the others must follow suit, if he can; if he cannot do so he has an opportunity to play off a heart card. The person playing the highest card of the suit led takes the trick, and must lead off on the next round. When all cards have been disposed of the heart cards are counted, and the score of each person is marked down. When a specified score is reached by any player the game ends. The one with the lowest score is the winner. The queen of spades, called the "Lizzie," counts 13; an ace of hearts counts 14; a king, 13; a queen 12; a Jack, 11; and each of the other cards the equivalent of the spots marked on them. Occasionally, however, each ace and face-card counts 10. It is sometimes customary, before a round begins, for each player to pass to his left-hand neighbor any three cards he desires, thus relieving his hand of dangerous cards.

**HEAT**, *heet*, a degree of warmth manifested to the senses. It is a relative term, without definite standards; an object may be called hot by one person and warm by another. A hot body possesses a very considerable amount of heat; a warm body, a medium amount. Even a cold body, as ice, contains some heat. The *temperature* of a body indicates its degree of heat, and it is measured by the thermometer.

**What Heat is.** Heat is supposed to be produced by the motions of the molecules of bodies (see MOLECULE). However close together these molecules may appear, they are not supposed to touch one another, and they are supposed to have a constant motion, called *vibration*. It is also supposed that all space, even that between the molecules, is filled with an immaterial and invisible substance, called *ether*. This ether conveys to other bodies the heat produced by the vibration of the molecules (see ETHER). When this vibration increases, the temperature of the body rises, and when it decreases, the temperature falls.

**Where Heat Comes From.** The sun is the great source of heat. It warms the earth and all things on it. The stars also give off heat, but they are so far distant that we do not receive it. Mechanical action, such as rubbing bodies together, hammering them or compressing them into a smaller space, produces heat. Our hands are warmed by rubbing them together; a nail is made hot by hammering it; the barrel of an automobile

tire pump is warmed by the compression of the air while it is being forced into the hollow tire.

Chemical action, such as fire, produces heat. Fire is caused by the union of the oxygen of the air with the carbon in the fuel. The heat in the human body is produced by the action of the blood and digestive fluids upon the food, and also by the action of the oxygen of the air upon the carbon with which it comes in contact in the lungs.

**How Heat Travels.** Heat travels in three ways:

(1) **By conduction.** Heat travels by conduction, which means transmission by a conductor, when it passes from one part of a body to another part, without any noticeable movement in the body; such is the heating of the entire length of a stove poker when one end of it is placed in the fire. If a silver spoon be placed in hot tea, the heat passes from the tea to the hand through the spoon. Bodies through which heat passes readily by conduction, such as metals, are called good conductors; those through which it does not pass readily, such as wood, wool, fur and feathers, are called poor conductors. For this reason, iron tools are fitted with wooden handles; if used when hot, they do not burn the hand, and if used when cold, they do not conduct the heat away from the hand. Fur garments keep us warm, not because they produce heat, but because they prevent the heat of the body from passing off into the air.

(2) **By convection.** Heat travels by convection, that is, by transfer or transmission, when it is carried by the circulation of the body itself; a good example is the warming of buildings by hot air from a furnace, or by hot water carried through pipes. This mode of carrying heat is also used for a number of other practical purposes.

(3) **By radiation.** Heat comes to us by radiation from the sun; also, from a grate, a hot stove or the flame of a lamp. When it travels in this way, it always comes in straight lines and decreases in intensity as the distance from the source increases. That is, to be exact, the amount of heat varies inversely as the square of the distance from the source. If standing four feet from a fire you receive a certain amount of heat, you will receive only one-fourth that amount when eight feet away.

**What Heat Does.** The work performed by heat may thus be summarized:

(1) It makes bodies larger. When a body is heated, it increases in size. If an iron bar, which exactly fits a hole in an iron plate, is heated, it becomes too large to pass through the hole. This increase in size is called expansion, and it can be easily seen by observing the liquid in a thermometer; as the tem-

perature rises, the liquid expands and rises in the tube. The force which accompanies the change of size in bodies on account of heating and cooling is very great and is turned to a number of practical uses. Wagon tires are made just a little smaller than the rim of the wheel; they are then heated, when they become large enough to fit upon the wheel; as they cool, they contract and draw the parts of the wheel firmly together. Steel frames of buildings, the trusses of bridges and the plates of boilers are riveted with red-hot rivets; as the rivets cool, they draw the parts so firmly together that they make these structures very solid and strong.

(2) It changes solids to liquids. Ice is changed to water and metals become liquid when heated to a sufficient temperature. The temperature at which a substance changes from a solid to a liquid is called its melting point or fusing point. The melting point of most metals is very high.

(3) It changes liquids and solids to vapor. Some substances, such as camphor and zinc, when heated to a high temperature, take the form of vapor instead of liquid. When liquids are raised to the boiling point, they change to vapor, as boiling water changes to steam. The vapor occupies much more space than the liquid, and its expansive force is very great. In the case of steam, this force is used in the operation of the steam engine.

(4) It produces light. When certain substances are raised to a high temperature, they give off light, as a white-hot iron, a glowing coal, a flame, or an incandescent light. All such substances radiate both light and heat which come to us together.

**Related Articles.** Consult the following titles for additional information:

|            |               |
|------------|---------------|
| Combustion | Heating and   |
| Energy     | Ventilation   |
| Ether      | Melting Point |
| Expansion  | Sun           |
| Fire       | Temperature   |
| Freezing   | Thermometer   |

**HEATH**, *heeth*, or **HEATHER**, *heth'er*, the popular name for a large family of plants to which belong the cranberry, huckleberry, rhododendron, azalea and trailing arbutus. It is widely distributed over Europe and abounds in South Africa. From 400 to 500 species are known. Many of them bear flowers of brilliant color. Scotch heather has low, grayish, hairy stalks and broom-like branches, with needle-shaped leaves and sprays of countless, tiny, purple blossoms. In Scotland the poor use heather for thatching their houses, and in other European countries the plant is used in making brooms, brushes and mattresses. One species only of heather is found in the United States and Canada, and that grows sparingly in a few localities on the Atlantic coast, but a few varieties are cultivated by florists. The large

heather-covered tracts in England were called heaths, and this name has consequently been applied to any desolate, uncultivated tract covered with shrubs and coarse herbage.

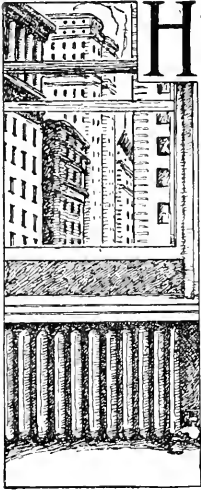

**H**EATING AND VENTILATION. In regions where artificial heating of houses at certain seasons is necessary for health and comfort, the problem of supplying such warmth is closely related to that of providing ventilation. It is a well-known fact that any closed room in which people remain for any length of time must be supplied with fresh air. It is also true that a certain degree of warmth is necessary for the human system. A ventilated room

without the proper degree of warmth is as much a menace to health as a heated room without ventilation. Hence the reason for treating heating and ventilation as related subjects.

**Heating Systems.** In America the temperature which is usually considered best in a room whose occupants are not engaged in any exercise varies from 68° to 70° Fahrenheit. In Europe people are accustomed to temperatures much lower than these, but they wear heavier clothing than do Americans. Overheated rooms are responsible for much sickness in cold weather, because of the inevitable sudden changes experienced in passing in and out of doors. On the other hand, too low a temperature is injurious, especially to those who are sitting quietly.

One of the earliest methods of heating rooms was by the open fireplace, and this still remains an excellent method, though the waste of heat is considerable. It was this waste, in fact, that led to the introduction of closed stoves, first made of earthenware and then of metal. These are now constructed in an infinite number of varieties and are commonly in use throughout America and in Europe. They do save fuel, but in so doing they have prevented the ventilation which fireplaces gave and are liable to overheat the rooms and render the air too dry.

Other methods of heating are now generally in use. Air-tight furnaces, sur-

rounded by jackets, connected by pipes with different parts of the building, from which return shafts bring foul air into the furnace proper, are common (see FURNACE). In such cases a conduit from the open air leads a supply of pure air inside the jacket of the furnace.

What is known as the pipeless furnace has been found an economical device for heating small houses. The furnace is placed in the



HEATHS

Three species in blossoms.

basement directly below the center of the house, and the warm air flows up through a central register and circulates through the various rooms. These must all be connected by archways or wide openings. There is a constant circulation of warm air upward and cold air downward, the latter flowing back to the heater through cool-air returns, to be reheated. At the bottom of the heater there is a device which washes the air, purifying and moistening it.

In other systems, steam and hot water are forced through pipes to all parts of buildings, and this forms an effective way of warming the rooms, though a separate system of ventilation must be used to make either steam or hot water satisfactory. From their superior neatness and cleanliness, steam and hot water seem to be gradually displacing the hot-air systems.

**Ventilation.** Ventilation is a means of renewing the atmosphere in rooms and of

maintaining its purity by driving out foul air and admitting fresh air without drafts. Carbonic acid gas, which is breathed from the lungs of all animals, is injurious if breathed again into the lungs. Moreover, the human breath pollutes the air with small quantities of ammonia and with organic matter, especially bacteria, and so tends to make the atmosphere not only unpleasant but dangerous for respiration. Authorities disagree in estimating the amount of pure air necessary for an adult, but it is generally admitted that not less than 1,800 cubic feet of fresh air per hour should be allowed for each healthy person. Invalids require from three to four times as much.

It is possible, of course, to secure change of air in a room very quickly by throwing open doors and windows, but the sudden change in temperature and the resulting drafts are dangerous to the occupants. Accordingly, in all living rooms some provision must be made for the removal of foul air and the introduction of fresh air. This is particularly important in sleeping rooms, where the windows should be opened from top and bottom. For protection against drafts, screens may be placed near the bed or window. Large buildings, such as halls and theaters, are generally ventilated by mechanical systems. One in common use is called the *plenum* system; the fresh air is forced in by means of blowers placed in air ducts.

Proper heating and ventilation is one of the most serious problems that confronts the teacher in small schools. Usually large stoves are placed in the room, and these make the temperature too high for the children sitting near them before the air in the remote portions of the room is warm. Such stoves should be surrounded by a jacket of tin or sheet iron, reaching from the floor to a point some distance above the heads of the children. A pipe laid from the outer air, under the floor and through an opening beneath the stove, will give a supply of pure air which, as it is heated by the stove, will be forced up into the room. Provision should be made to carry away the foul air from near the floor in some part of the room distant from the stove. If it is impossible to have the stoves fitted up as described, a screen may be used to protect those sitting near the stove from the heat, and a supply of pure air may be admitted by fastening a board six or eight inches wide at the bottom of the window casing, so that

it fits tightly into the space, and then raising the window about four inches. The air is then deflected upward and away from persons sitting in the room.

For a further discussion of this subject see Domestic Science subhead Ventilation.

**HEAVEN**, *hev'n*. In theology, this word denotes a region of the universe where God's presence is especially manifested, in contrast with the earth. Among Christians the opinion has been that heaven is the residence of the Most High, the holy angels and the spirits of just men made perfect, that this abode is eternal and its joys intensely spiritual. The word is also applied to the blue vault above us, which appears to rest on the earth at the horizon. In this sense the word in both the singular and the plural is used for sky.

**HEAVES**, *heevz*, or **BROKEN WIND**, a disease in horses often accompanied by an enlargement of the lungs and heart, which disables them for bearing fatigue. In this disease the expiration of the air from the lungs occupies double the time that the inspiration does and requires also two efforts. It is caused by rupture of the air cells, and there is no known remedy for a well-established case, though change of diet has been known to cure mild cases.

**HE'BE**, in Greek mythology, the goddess of youth and the cupbearer to the gods, a daughter of Jupiter and Juno and the wife of Hercules after he had been made a god. According to some accounts she gave up her celestial office when she became the wife of Hercules; according to others, she was dismissed because she stumbled while serving the gods. She was succeeded by Ganymede. See GANYMEDE.

**HEBERT**, *a bair'*, JACQUES RÉNE (1755-1794), a French journalist and politician, popularly known as Père Duchesne, from the revolutionary journal of that title which he founded at the outbreak of the Revolution. The radical opinions and violent language of this journal made Hébert popular with the people, and he was elected attorney-general of the commune and a member of the National Convention. As a member of the committee appointed to try Marie Antoinette, he increased her sufferings by the malicious and brutal charges which he brought against her. His violent methods were recognized by Robespierre as a menace to the cause of the Revolution, and he was accordingly put to death in March, 1794.

**HEBREW LANGUAGE AND LITERATURE**, the language which the Hebrews wrote and spoke, and the books they produced during their settlement in Palestine as an independent nation, and which has survived to the present day. The Hebrew alphabet is composed of twenty-two consonants; the vowels are expressed by marks placed above or below these letters, making possible verb conjugation and noun declension. There is no neuter gender, and the writing is from right to left.

Extant Hebrew literature is almost entirely comprised in the Old Testament, which represents a period of at least one thousand years, from 1200 B. C., when some of the poetical portions, such as the song of Deborah in the fifth chapter of *Judges*, were already in existence to 200 B. C., or later, when the book of *Daniel* and some of the *Psalms* were written. During this period the written language underwent surprisingly little change. In passing from the book of *Genesis* to the books of *Samuel* we do not recognize any very striking difference in the language. Even those who assert that the Pentateuch as a whole is of a comparatively late era admit the great antiquity of some of its contents, which do not differ in language from the rest. The writings which belong to the period following the Babylonian captivity differ from those which belong to the preceding age; the influence of the Aramaic or Chaldee language, acquired by the Jews in the land of their exile, greatly corrupted their tongue. Belonging to this age are the historical books of *Chronicles*, *Ezra*, *Nehemiah* and *Esther*. In the prophets who prophesied during and after the captivity, with the exception of *Daniel*, the Aramaic element is not so strong as might be expected, the style adhering to that of the older prophets. At what time Aramaic became the dominant element, it is impossible to determine, but by the time of the Maccabees it had become the spoken language. The fragments of the popular language in the New Testament are all Aramaic, and ever since that time the ancient Hebrew has been preserved and cultivated only as the language of the learned and of books, and not of common life.

After the return from the captivity, the Jewish literature was carefully cultivated. Under *Ezra* the Scriptures were collected and arranged into a canon. The Pentateuch

was publicly read, taught in schools and translated into Aramaic. The legal or religious traditions explanatory or complementary to the law of Moses were collected and established as the oral law. These labors resulted in the *Midrash*, a general exposition of the Old Testament, divided into the *Halacha* and the *Haggada*. To the epoch following the Maccabean belong some celebrated doctors of law—*Hillel*, *Shammai*, *Gamaliel*.

On being driven from their capital by the Romans, numerous schools were established by the Jews in which their language and literature were taught. Of these schools the most celebrated were those of *Babylon* and *Tiberias*. The *Mishna*, which contains the traditions of the Jews and interpretations of the Scriptures, is supposed to have been compiled in the latter part of the second or in the earlier part of the third century; and the rabbis of *Tiberias* and *Babylon* wrote numerous commentaries on it, which were at length collected into two separate works, the *Jerusalem Talmud*, completed about the end of the fourth century, and the *Babylonian Talmud*, about a century later, under the care of *Rabbi Ashe*. What was called the *Targums*—that is, Aramaic translations of portions of the Old Testament—belong partly to times earlier, partly to times later than this period.

When the Jews finally dispersed they adopted the languages of the various peoples among whom they happened to dwell; they continued, however, to write in classical Hebrew, as well as in the less pure form of the *Rabbinical* Hebrew; and Hebrew is the language of the synagogues to-day, except in the "reform" communities of *America* and *Germany*. Hebrew also serves as the medium of correspondence among Jews in different parts of the world. This language, however, is not the pure Hebrew of the Bible and synagogue. The most brilliant epoch of *Medieval Jewish literature* was during the time of the *Moors* in *Spain*. Of modern literature in the Hebrew language, there is little that is of general interest. See **JEWS**.

**HEBREWS.** See **JEWS**.

**HEBREWS, THE EPISTLE TO THE,** a book of the New Testament, concerning the authorship of which there is much doubt. Many claim it to be the work of *Apollos*, a Jew famed for his eloquence, but in the Scriptures it is attributed to *Saint Paul*.

The place and date of writing are not fixed. The letter is designed to help its readers, whoever they were, in avoiding the dangers which would lead them to forsake the faith in Christ. It shows oratorical power and sets forth Christ as the end and fulfilment of the law.

**HEBRIDES**, *heb're deez*, or **WESTERN ISLANDS**, a series of islands and islets off the western coast of Scotland. There are about four hundred islands in all, but only ninety are inhabited. The inhabitants are not Scotch, but a primitive people who speak Gaelic and live to themselves. They are divided among the counties of Ross, Inverness, Bute and Argyle. The islands are on the whole mountainous, and the climate is mild and humid. The soil is mostly poor, and agriculture, except in certain places, is very backward; oats, barley, potatoes and turnips are almost the only products. Cattle-raising and fishing are the chief industries. Population, about 100,000.

**HEBRON**. About nineteen miles southwest of Jerusalem is one of the oldest inhabited towns in the world. Abraham lived there, and when his wife, Sarah, died he purchased the nearby cave of Machpelah from the Hittites for her sepulcher. There David was crowned king of Israel. This town was called Hebron; to-day it is known as El-Khalil. It has at present a population of 20,000, most of them Mussulmans. From 1187 to 1918 it was under Mohammedan rule. Within the city is a great mosque, built over a cave, supposed to be the ancient sepulcher, in which not only Sarah, but Abraham, Isaac, Jacob and Rebecca were buried.

**HECATE**, *hek'a tee*, in Greek mythology, a goddess frequently represented as having three heads or three bodies and with serpents around her neck and shoulders. She had power to bestow or withhold wealth, victory, wisdom, good luck and prosperity. She was latterly confounded with other divinities, such as Ceres, Diana and Proserpina, and finally she became, especially, an infernal goddess, who was invoked by magicians and witches. Dogs, honey and eggs were offered to her at places where three roads met.

**HECLA**, or **HEKLA**, a volcano of Iceland, about twenty miles from the southwest coast. It is about 5,000 feet in height and has several craters. The mountain is composed chiefly of basalt and lava and is always covered with snow. One of the most tremen-

dous eruptions occurred in 1783, after which the volcano remained quiet till September, 1845, when it again became active and continued, with little intermission, till November, 1846, to discharge ashes, masses of pumice stone and a torrent of lava. The last outbreak was in March, 1878.

**HECTOGRAPH**, *hek'to graf*. See COPYING DEVICES.

**HECTOR**, in Greek mythology, the son of Priam and Hecuba, the bravest of the Trojans, whose exploits are celebrated in the *Iliad*. Having slain Patroclus, the friend of Achilles, he was in turn killed by Achilles, and his body was dragged at the chariot wheels of the conqueror about the walls of Troy. Priam afterward gained possession of it and gave it solemn burial. Hector is the most attractive warrior in the *Iliad*, and one of the finest episodes described therein is his parting from his wife, Andromache, before his last combat.

**HECUBA**, of Phrygia, in Greek legend, the second wife of Priam, king of Troy, to whom she bore Hector, Paris, Cassandra, Troilus and other children. After the fall of Troy she was given as a slave to Odysseus, and, according to one form of the legend, in despair she leaped into the Hellespont.

**HEDGEHOG**, *hej'hog*, a small animal found in Europe and the western part of Asia, whose most noticeable peculiarity is



HEDGEHOG

the presence of sharp quills on its back. These are extensions of the animal's stiff hair. Short fur covers the underside of its body. It is about nine inches long, and has a long nose and short ears. It feeds on fruits, twigs, birds, small reptiles and insects, using its long nose to root the latter out of the ground. By means of a special muscle the hedgehog can roll itself into a ball and straighten out its stiff quills, and in this

form can defy almost any enemy which attacks it. Four to eight young are born at a time, and the baby hedgehogs are soon covered with prickles. The American porcupine (which see) looks like the hedgehog, but differs from it in habits. Both animals belong to the order of rodents.

**HEDIN**, *heh deen'*, SVEN ANDERS (1865- ), a Swedish explorer, celebrated for his expeditions and researches in parts of Asia. His first explorations were in Eastern Turkestan, Northern Tibet, the Pamir, Mongolia and Siberia. *Through Asia*, published in 1899, contained the results of his observations. His chief contributions to geographical science have been data collected on a journey through Tibet from 1906 to 1908. From the material supplied it was possible to make the first detailed map of that part of the Asiatic continent. Among the numerous honors Hedin has received have been election to the Paris Academy of Sciences and enrollment in the Swedish nobility. Late in 1914 he was asked by Emperor William II, who was disturbed by world criticism, to visit Belgium for the purpose of studying the effects of the German invasion of that country. Hedin refused the mission, which was intended to be used as German propaganda.

**HEDJAZ**, a new kingdom in Western Arabia, lying in a long, narrow strip on the eastern shore of the Red Sea. See ARABIA, for description.

**HEGEL**, *ha'gul*, GEORG WILHELM FRIEDRICH (1770-1831), a German philosopher who has profoundly influenced modern theological and philosophical thought. He was born at Stuttgart and was educated at the University of Tübingen. Through Schelling's influence Hegel became a lecturer at the University of Jena. He afterwards was made director of the Nuremberg gymnasium, and later occupied successively the chairs of philosophy at Heidelberg and Berlin.

Hegel's attempt as a philosopher was to define the relation between the finite self and the universal self, or God. He found that the personal self is a conscious self only as it recognizes its relations to others, that is as it becomes a social self. The more we project ourselves into the lives of others the more fully do we realize our deepest self, that is, the one universal self, God. He held that happiness and virtue are known only in the conquest of their opposites, sorrow and vice.

Hegel was appointed school councilor by the Bavarian government, and was also made a member of the commission of education by the Prussian government. His chief contribution to education was the indirect influence of his philosophy, which changed educational thought and systems. He attributed great importance to the family and state as factors of education, and he placed great stress upon authority in the instruction of children. He believed that the reasoning powers should not be developed too early, but that they should receive attention as soon as the child had acquired a good fund of knowledge through the senses. He also believed in the value of the classics as a source of culture. His most important works are *Logic*, *The History of Philosophy*, *Aesthetics* and *Philosophy of Religion*.

**HEGIRA**, *he'je rah*, or *he j'ira*, the term commonly used to indicate Mohammed's flight from Mecca, July 16, 622 (see MOHAMMED). The Caliph Omar instituted, in 639 or 640, a new Moslem calendar, to begin with the first day of the first month in which the flight took place. The Mohammedan year, as a lunar year, is shorter than ours by about eleven days. A rough and ready method for finding the year in our calendar corresponding to a given year in the Mohammedan is to subtract from the latter  $\frac{1}{3\frac{1}{3}}$  of itself and add 622 to the remainder. As, 1324 of the Mohammedan calendar corresponds to 1906 ( $1324 - 40 + 622 = 1906$ ). To find the precise year and day, multiply the year of the Hegira by 970,224, strike off from the product six decimal figures and then add 621.5774; this will give the year of the Christian Era; the day of the year is obtained by multiplying the decimal figures by 365.

**HEIDELBERG**, *hi'del berK*, GERMANY, a city of Northern Baden, situated on the left bank of the Neckar River, in one of the loveliest districts of the country, about twelve miles southeast of Mannheim and fifty miles south of Frankfort. It stands on a narrow strip between the river and the castle rock, and it consists chiefly of one main street. The castle, begun in the end of the thirteenth century and exhibiting elaborate examples of early and late Renaissance architecture, is the most remarkable edifice in Heidelberg and one of the most famous structures in Europe. It is now an ivy-clad ruin, but it is carefully preserved from further decay; it stands high above the town in the midst of a beautiful



park. One of the greatest curiosities of the place is the Heidelberg Tun (liquor cask), kept in a cellar under the castle. It is thirty-six feet in length, and twenty-six feet in diameter, and is capable of holding 800 hogsheads. Heidelberg is also famous for its great university, the oldest in Germany (see below). The principal industry of the town is brewing. Population, 1910, 56,016.

**Heidelberg University**, founded in 1386, is one of the most famous universities in the world. It maintains faculties of theology, law, medicine and philosophy, and has about 100 professors and lecturers in normal times. At the outbreak of the World War its student enrollment was about 1,500. The institution is noted for the jovial spirit of its college life.

**HEILPRIN**, *hil'e prin*, ANGELO, (1853-1907), an American scientist and traveler, was born in Hungary. He came to the United States when three years of age, but returned to Europe to complete his education, studying in London, Geneva and Vienna, and making a specialty of natural history. On his return to the United States he was appointed professor of paleontology and geology at the Philadelphia Academy of Natural Sciences and occupied the position for sixteen years. During his connection with the Academy, Professor Heilprin made numerous journeys to Florida, Bermuda Islands and Mexico, and thoroughly investigated the geology of each of these regions. He led the Peary relief expedition in 1892, and in 1902 ascended to the crater of Mount Pelée while the volcano was in a state of eruption. Among his best-known works are *The Geographical and Geological Distribution of Animals*, *Principles of Geology*, *The Earth and Its Story* and *Alaska and the Klondike*. He was chief editor of a revised edition of Lippincott's *Geographical Gazetteer*.

**HEIMDALL**, *him'e dal*, in Scandinavian mythology, the son of Odin, who kept watch on the rainbow bridge over which the gods passed from Asgard, their home to the earth. His sight and hearing were more acute than those of mortals, and nothing could evade his vigilance.

**HEINE**, *hi'ne*, HEINRICH (1797-1856), generally accepted as the greatest name in German literature since Goethe. The delicacy and melody of Heine's lyrics, the railery, the graceful wit of his satires has not been approached by any of his compatriots.

Heine was born of Jewish parents at Düsseldorf. He studied law at Bonn, Berlin and Göttingen, took his degree and sordidly renounced his faith in order to obtain a license to practice. His revolutionary tendencies and his open admiration for Napoleon made him exceedingly unpopular in Germany, and by 1830 it had become practically impossible for him to live there. He removed, therefore, to Paris, where he was well received and where he lived until his death.

Most of Heine's writings were lyrical, but they include a large amount of journalistic, biographical and controversial material. Some of the exquisite lyrics in his *Book of Songs* were set to music by Schumann and Mendelssohn. The result of a vacation trip in the Harz Mountains was his *Harz Journey*. This was the first of a series of *Travel Pictures*, which were partly biographical, containing spirited and piquant discussions of religious and political subjects and satirical comments. During his last years, though disabled with paralysis, he continued to produce his wonderful melodious songs, satires and humorous bits.

**HEIR**, *air*, in law, one to whom the property of a deceased person passes. In America it denotes those to whom the *real* property descends, not by will, but only when the will is lacking (see WILL). In other countries, however, the term is used more broadly, to include all who have rights to property of a deceased person, either through will or by the natural laws of descent. See REAL PROPERTY; PERSONAL PROPERTY.

**HEIR APPARENT**, an heir to an estate or to a throne whose right to succession is undisputed if he survives the present holder. This is the title of the prospective heir to the Spanish and to the Italian thrones; in England the heir apparent is called the Prince of Wales; in Germany he was called the Crown Prince prior to November, 1918.

An *heir presumptive* is an heir in line of succession, but between him and the throne there are others who will first inherit unless death intervenes.

**HEK'LA**. See HECLA.

**HEL**, *hale*, in Norse mythology, the daughter of Loki, the goddess of the dead, who dwelt beneath one of the three roots of the ash Yggdrasil. Dark rivers surrounded her abode, and a dog watched without. She herself, in the guise of a woman of half black and half fair complexion, was supposed to

ride about on a three-footed horse. She was often to be propitiated by an offering of oats. Within her kingdom dwelt only those who died of disease or old age.

**HELEN**, in classical legend, the most beautiful woman of her age, the daughter of Jupiter and Leda and the sister of Castor and Pollux. By the advice of Ulysses, her numerous suitors had bound themselves by oath to respect her choice of a husband and to avenge any injury done to her or to her husband through her. When, therefore, after her marriage with Menelaus, she was carried off by treacherous Paris, her former suitors fulfilled their vow and set forth against Troy, the city of Paris. On the death of Paris, Helen was married to his brother, Deiphobus, but after the end of the struggle she was again received by Menelaus and they returned to Sparta, where they ruled in peace until the death of Menelaus. According to most legends Helen was afterwards murdered at Rhodes. For details of the war which followed Helen's abduction, see the article MYTHOLOGY.

**HEL'ENA**, ARK., founded in 1820, is the county seat of Phillips County, 110 miles east of Little Rock, on the Mississippi River and on the Saint Louis, Iron Mountain & Southern, the Yazoo & Mississippi Valley and the Missouri & North Arkansas railroads. There is steamboat service to various river towns. The city has an extensive trade, and contains lumber and cottonseed oil mills, foundries, railroad shops, box factories and stove mills. There is a public library and an excellent Federal building. Population, 1910, 8,772; in 1917, 11,122 (Federal estimate).

**HEL'ENA**, MONT., the capital of the state and the county seat of Lewis and Clarke County, seventy-two miles northeast of Butte, on the Great Northern and the Northern Pacific railroads. The city has a picturesque location and is surrounded on all sides by the Rocky Mountains. The Montana Wesleyan University, Mount Saint Charles College and Saint Vincent's Academy are located here, and the city has public, state and college libraries. Among the other important structures are the Federal building, the state capitol, the courthouse, two hospitals, a cathedral, a Y. M. C. A. building and a Masonic temple. There are extensive gold, silver and iron mines in the vicinity, and the city contains machine shop, mining machinery works, soap and candle factories,

smelters and flour and lumber mills. The place was settled as a mining camp in 1864 by four despondent prospectors who had named the gulch "Last Chance" and had vowed to give up their hunt for gold if they found nothing at this place. The first panful of gravel washed out \$20 in coarse gold, and during the next six years \$15,000,000 were taken out of this camp. Helena has been the capital of the state since 1869. The commission form of government was adopted in 1915. Population, 1910, 12,515; in 1917, 13,789 (Federal estimate).

**HELGOLAND**, *hel'go lahnt*, or **HELIGOLAND**, an island belonging to Germany, in the North Sea, about forty miles from the mouth of the Elbe. It is less than two miles long and one-half mile broad, and the highest point is 200 feet. Its rocks, of reddish sandstone, present a perpendicular face to the sea. Until 1914 there were 2,500 people on the island, but at the beginning of the World War they were removed and given homes on the German mainland. Thereupon Helgoland was made an impregnable fortress and a strong naval base. It was one of Germany's important defenses during the war. One condition of the treaty of peace imposed on defeated Germany was that Helgoland's fortifications should be dismantled.

Until 1890 Great Britain owned the island. In that year it was traded to Germany for Zanzibar, on the East African coast, an exchange the former possessor later had great cause to regret.

**HELIANTHUS**. See SUNFLOWER.

**HELICON**, a mountain range in Boeotia, Greece, celebrated among the ancients as the seat of the Muses. The highest summit is Mount Helicon (5,000 feet). On the eastern slope a temple adorned with statues stood in a grove sacred to the muses. On Helicon were two fabled fountains, Aganippe and Hippocrene. The poet Hesiod lived in a village at the foot of the mountain.

**HELIOGRAPH**, *he'le o graf*, or **HELIOSTAT**, a name given to various contrivances for reflecting the sun's light, either temporarily or continuously, to an observer at a distance. The simplest heliograph is a mirror hung up at a distant station so as to reflect a flash to the observer whose station may be many miles from it. This mirror is generally so adjusted that the flash occurs exactly at some prearranged hour, and by

being in readiness the observer can get an observation with precision in regard to time. Under good atmospheric conditions messages have been flashed more than 200 miles. By being fitted with an adjustment of clockwork, the mirror can be made to revolve with the sun and to reflect a beam of sunlight steadily in one direction. An instrument with this attachment is often called a *heliotrope*. The heliograph has been used for signaling in war, and it is employed by the United States coast and geological surveys in measuring long distances by triangulation.

**HELIOPOLIS**, *he te op'o lis*, (City of the Sun), the Greek name of an ancient city, called variously On, Rameses, or Beth-shemesh in the Hebrew Scriptures, and now called Matariah. It is situated a little north of Memphis and was one of the most ancient and extensive cities of Egypt under the Pharaohs. During the flourishing ages of the Egyptian monarchy, the priests taught within its temples, and both Endoxus and Plato visited its famous schools. Here Joseph and Mary are said to have rested with the infant Christ. Near the village stands the Pillar of On, supposed to be the oldest Egyptian obelisk, 67½ feet high and 6 feet broad at the base. The obelisks known as Cleopatra's needles, of which one is in New York, formerly stood here.

**HELIOS**, *he'li ohs*, in Greek mythology, the sun god, the offspring of Hyperion and Theia, and brother of Aurora. According to the legend his home was a magnificent palace beyond Colchis, from which he came in the morning to bring light, and to which he returned in the evening in a golden boat with wings. Temples in his honor were built at Corinth, Argos, Troezen, Elis and Rhodes. In art he was represented crowned with rays.

**HELIOTROPE**, a favorite garden and hothouse plant bearing small, salver-shaped flowers of delightful fragrance and bluish or pinkish-lilac color. The cultivated heliotrope is raised from cuttings, and is a plant that needs sunshine and warmth. From its flowers are made sachet powders and perfumes. Various wild species are natives of the warmer parts of the earth, but the familiar heliotrope of the gardens was found originally in Peru. There is a legend that the flower always faces the sun; hence the name, which is from two Greek words meaning *sun* and *turning*.

**HELIOTROPE**, or **BLOODSTONE**, a variety of quartz, partaking of the character of

jasper or chalcedony. It is of a deep green color and is marked with blood-red spots. It is hard and is used for burnishing. The finely marked stones are used for seals, signet rings and other ornaments. Heliotrope is found in Tartary, Persia, Siberia, in the island of Rum, Scotland, and elsewhere in smaller quantities. According to Pliny, an ancient historian, there was a belief that if the stone were put into a basin of water in the sun, (*helios*), the light rays reflected from the surface of the water would be changed to red, hence the name. The stone rubbed with the juice of the heliotrope plant was superstitiously thought to render its wear invisible.

**HELIUM**, a colorless gaseous element detected as early as 1868, but not regarded as having any practical value until 1918, when, after a long series of experiments, American chemists discovered a method of producing it in quantity. The important fact regarding helium is that it is noninflammable and can be used as a substitute for hydrogen in dirigible balloons. Had the Germans possessed the secret of its production during the World War their Zeppelins would have been vastly more destructive than they were, for the great balloons would have been uninjured by the shots that caused the hydrogen in their great gas bags to explode.

The new process of extraction is as follows: Natural gas is collected, compressed and cooled down in the same sort of apparatus as is used in liquefying air. As the process of cooling goes on the hydrocarbons liquefy first, then the nitrogen, and finally the helium, which is transformed at a temperature of 268° below zero (Centigrade). On an average, less than one per cent of the content of natural gas is helium, but the extensive deposits of the gas in Kansas, Oklahoma and Texas make possible a quantity production of this valuable element. In 1919 it was being produced in commercial quantities at a cost of ten cents per cubic foot, whereas formerly it was a laboratory product obtained at a cost of \$1,750 per cubic foot. This discovery will revolutionize the use of balloons as flying machines, for they can now be equipped with electrical apparatus, formerly barred because of the danger from sparks.

Helium is found in the air in the proportion of 1,000,000 volumes of air to four volumes of the element. It also occurs in

uraninite, fergusonite and other rare minerals, and in the gases from certain mineral springs. In 1903 a process of creating it from radium was discovered, which led to its production from the radio-active elements actinium and thorium. The atomic weight of helium (symbol He) is 3.99. It is almost twice as heavy as hydrogen, the lightest substance known, but liquid helium is lighter than any other known liquid.

**HELL.** In common usage the term *hell* signifies a place or condition of suffering of the wicked after death. Christian sects differ in their opinions as to the length and kind of punishment. Different ones declare that bodily torture is inflicted; that the fire in hell means only that the unrighteous are purified; that the suffering is eternal; that the suffering lasts only till the soul is purified. The Eastern and Western churches are at one as to the punishment of hell being partly "a pain of loss," that is, the consciousness of being debarred from the presence of God, and partly a "pain of sense," that is, real physical suffering. Originally the term signified *the covered, or invisible place*.

In the English Bible the word is used to translate the Hebrew *sheol* (*grave or pit*) and *Gehenna* (properly, the valley of Hinnom), as well as the Greek *Hades* (*the unseen*). In the Revised Version of the New Testament, however, *hell* is used only to translate *Gehenna*, *Hades* being left where it stands in the Greek.

**HELLAS AND HELLENES,** *hel'leenz*. See GREECE.

**HELLEBORE,** *hel'e bohr*, a genus of perennial, low-growing plants belonging to the buttercup family, with leatherly leaves and yellowish, greenish or white flowers. Black hellebore, named from its black rootstock, yields a violent poison, but it has some medicinal value when used in small quantities, as it is an emetic and purgative. The Greeks were familiar with a species which they thought would drive away sadness and make the mind clear and bright. White hellebore is a very different plant, belonging to the lily family.

**HELLESPONT.** See DARDANELLES, THE.

**HELL GATE,** the name given to a pass in East River, between Long Island and Manhattan Island and between Long Island and Ward's Island. The pass is a portion of the strait which connects New York Bay with Long Island Sound. The reefs of rock in the

main passage formerly made the pass very dangerous, on account of the currents and eddies caused by the rising and falling tides. By extensive undermining and blasting these obstructions were removed by the government in 1885. A huge railroad bridge spans the channel. This is the heaviest bridge in the world, and was erected at a cost of \$25,000,000. It was opened for traffic in January, 1917.

**HELMET,** an article of armor to protect the head. It is a development of the open headdress of early times. Homer represents his heroes wearing bronze helmets with lofty crests. Helmets were common also among the Romans, but they did not have protection for the face. In the Middle Ages they were made of steel and provided with bars and flaps for protection in battle. They were made in various styles, some having a *beaver*, or movable piece, and some a *visor*, which could be lowered to protect the eyes but allowed the wearer to see through small slits. During the World War the steel helmet became a very important part of military equipment, and was worn by the soldiers of all the belligerent nations. This "war hat," as it was called, proved a valuable protective device in the trenches against machine-gun bullets.

**HELMHOLTZ,** *helm'hohlts*, HERMANN VON (1821-1894), one of the greatest physicists of the nineteenth century. He was born at Potsdam and educated at Berlin. In 1848 he became professor of anatomy at the Academy of Fine Arts, Berlin, and in the next year he obtained the chair of physiology at Königsberg, from which he was successively transferred to the same post at Bonn and at Heidelberg. In 1871 he was appointed professor of physics at Berlin, and through his efforts Berlin became the greatest center in the world for the study of physics through experiment. His work was chiefly in those departments of physics which are in closest relation with physiology—acoustics and optics. Of his many publications the best known are *The Conservation of Force*, *Manual of Optics*, *Popular Lectures on Scientific Subjects* and *Sensations of Tone as a Physiological Basis for the History of Music*.

**HELOISE,** *a lo eez'*. See ABELARD.

**HELOTS,** *hel'ots*, or *he'lots*, slaves in ancient Sparta. They were the property of the state, which alone had the disposal of their life and freedom and which assigned them to

certain citizens, by whom they were employed in private labors. Agriculture and all mechanical arts at Sparta were in their hands, and they were also obliged to bear arms for the state in case of necessity. They behaved with great bravery in the Peloponnesian War, and were rewarded with liberty (431 B. C.), but 2,000 appear to have been subsequently massacred. They rose against their masters several times, but were finally completely subjugated. After the downfall of Sparta they were freed by the Theban leader Epaminondas.

**HEL'SINGFORS**, FINLAND, in Finnish, HELSINKI, capital of the country and a seaport on the north shore of the Gulf of Finland, 190 miles nearly west of Petrograd. Seven fortified islands protect the city. It has manufactures of linen, beer, sugar, carpets and tobacco and an important trade in timber, corn and fish. It is beautifully situated on a broad peninsula and has one of the best harbors in the Baltic Sea. Helsingfors has many fine buildings, broad, attractive streets and good educational institutions. During the World War, after the revolutionary government of Russia gave Finland its freedom, Helsingfors was occupied by the Germans, but was subsequently evacuated by them (see FINLAND). Population, 1914, 170,452, including suburbs.

**HELVETII**, *hel'vé'she i*, an ancient Celtic people who lived in the region now known as Switzerland. They were not much known to the Romans until the time of Julius Caesar, who, as governor of Gaul, prevented their intended emigration and after many bloody battles pressed them back within their frontiers. After their subjection by Caesar, several Roman colonies were established among them. On the death of Nero, the Helvetii, for refusing to acknowledge Vitellius as emperor, were mercilessly punished by Caecina, one of his generals, and thenceforth they almost disappeared as a people. Their successors to the land were the Alemanni.

**HEMANS**, *hem'anz*, FELICIA DOROTHEA (1793-1835), one of the most beloved English poets of her generation, was born in Liverpool. Her first volume, *Juvenile Poems*, published when she was fourteen, showed promise of the volume which was to follow—*The Forest Sanctuary*, containing *Hymns for Childhood*, *National Lyrics*, *Songs for Music* and *Scenes and Hymns of*

*Life*. Many of Mrs. Hemans' shorter poems, including *The Treasures of the Deep*, *The Better Land*, *The Voice of Spring* and *The Homes of England*, have become standard English lyrics.

**HEMATITE**, the ore from which most of the world's iron is obtained. The name, which means bloodlike, was given it because of its brownish red color. Hematite is found in almost all rock formation, even in loose earth. From the softer hematite the pigment red ochre is made. See IRON.

**HEMIPTERA**, *he'mip'ter ah*, a large class of insects, which includes those usually called bugs. They include the species most destructive to crops and most loathsome to humanity. Lice, bedbugs, chinch bugs and scale insects are all members of the class Hemiptera. The young do not resemble the parents very closely, but the life circle (see METAMORPHOSIS) is incomplete. The mouths of all these insects are adapted for sucking, and they live upon the blood of animals or the juices of plants. See INSECTS.

**HEMISPHERE**, *hem'is'feer*, half a sphere, especially one of the halves into which the earth may be supposed to be divided. It is common to speak of the Eastern Hemisphere and the Western Hemisphere, the former, also called the Old World, comprising Europe, Asia, Africa and Australia, with their adjoining waters and islands; the latter including North America and South America. The boundary between the two is quite arbitrary; a more natural division of the earth is into the Northern and the Southern hemispheres, the equator forming the dividing line. Some geographers also divide the earth into land and water hemispheres.

**HEMLOCK**, a poisonous biennial of the parsley family, which bears a shining, hollow stem, usually marked with purplish spots. The leaves are much divided and when bruised give a nauseous odor. The flowers are small white clusters in large umbels. Hemlock grows in Great Britain and throughout Europe and in temperate Asia; it has long been known because of its medicinal and poisonous properties. It is supposed that the poison given to Socrates was a decoction of this plant, though it may have been the water hemlock which was used in this case. The hemlock grows in ditches and other moist places, reaching a height of from two to six feet. It now grows in many places in North America.

**HEMLOCK**, or **HEMLOCK SPRUCE**, a large, graceful tree, not unlike some of the spruces in appearance. The leaves, which



HEMLOCK SPRUCE

are not more than half an inch long, are bright green above and silvery white below. They are not set so closely on the branches as are those of the spruces, and consequently, they give a more graceful appearance to the twigs and branches. The cones are small and open. The wood of the hemlock is not especially valuable, but the bark, dark-colored, hard, rough and less than two inches thick, is used in large quantities by tanneries, as it contains much tannin. In recent years the depletion of the pine forests has led to a greater use of hemlock lumber. The trees grow in forests throughout the Northern United States and Canada, in moist soil. Only four species are native to North America; two are near the Atlantic coast and two near the Pacific.

**HEMORRHAGE**, *hem'ora*je, a discharge of blood from the veins or arteries. Bleeding from the veins is called *venous hemorrhage*, and that from the arteries *arterial hemorrhage*. In case of a severe cut one may know

whether an artery or a vein is bleeding by the appearance of the blood. That from an artery comes in spurts; that from a vein has a steady flow and is dark colored. If the blood issues in jets, deep pressure should be made on the flesh between the wound and the heart, but if the vein is bleeding the pressure should be on the other side of the wound (see **TOURNIQUET**). Bleeding from the lungs is a symptom of tuberculosis, and should have the immediate attention of a physician.

**HEMP**, a plant belonging to the nettle family, extensively cultivated for the fibers found in its stalk, and for its seeds. The plant has a coarse, rough stem, which grows to a height of from four to twenty feet. The



HEMP

Showing seed, seed vessel and flower.

leaves are large and are composed of narrow, toothed leaflets, each from three to five inches long. The stamens are borne on one plant, in large clusters of flowers near the top. The pistils, which are inconspicuous, are borne on another plant. The fibers are long, soft and strong. They can be bleached as white as linen and woven into coarse fabrics, such as toweling and sheeting, carpets and rugs; but a large proportion of the fiber is employed in the manufacture of ropes and

cordage. Hemp seeds are used as bird food and are also the source of an oil used in cooking and in making varnishes.

Hemp is cultivated in much the same way as flax. The ground is carefully plowed and harrowed, and the seed is sown broadcast, from one to three bushels to the acre being used. The soil is lightly but evenly covered, to assure plants of a uniform size. In Kentucky the most important hemp state of the Union, seed is sown usually in April, and the first crop is cut about three months later. The fibers are freed from the woody part of the stalk by a process called *retting*. This consists in soaking the stalks in water or exposing them to the weather, the latter called *dew retting*. The dew method is commonly employed by American hemp growers. After the retting is completed the stalks are crushed and beaten until the fibers are freed from the stems, a process called *breaking*. The fibers are then tied into bales and placed on the market.

Hemp is native to the warm regions of Asia, but is extensively cultivated in Europe: Russia, Austria-Hungary and Italy are the chief European countries that produce it. The bulk of the crop grown in America, which amounts to about 7,500,000 pounds a year, comes from the Blue Grass region of Kentucky. Manila hemp, an important fiber plant of the Philippines, is a species of plantain (which see).

**HEMP, INDIAN.** See HASHISH.

**HENDERSON, KY.**, the county seat of Henderson County, on the Ohio River, ten miles below Evansville, Ind., and on the Louisville & Nashville, the Illinois Central, the Louisville, Henderson & Saint Louis and the Evansville & Terre Haute railroads. The city is a very important tobacco market. It also has a large trade in corn and wheat, and contains tobacco factories, fifteen large tobacco houses, planing mills, coal mines and manufacturing of cotton and woolen goods, hominy, furniture, wagons and other articles. The place has large wealth, a Federal building, a Carnegie Library and a well-equipped sanatorium. Other features of interest are the magnificent bridge across the river, the city fair grounds and Atkinson Park, the latter covering 130 acres. Henderson was one of the first settlements on the Ohio River, but was not incorporated until 1797. Population, 1910, 11,452; in 1917, 12,312 (Federal estimate).

**HEN'DRICKS, THOMAS ANDREW** (1819-1885), an American statesman and Vice-President of the United States, was born near Zanesville, Ohio. He was taken in infancy to Indiana, where he was graduated at South Hanover College, and was admitted to the bar. He served in the legislature, and was in Congress from 1851 to 1855. He was elected to the United States Senate in 1863, and was pronounced in his support of the Union. In 1868 he was a candidate for the Democratic nomination for President; in 1872, Greeley having died, many electoral votes were given to Hendricks. In the same year he was elected governor of Indiana. In 1876 he was the unsuccessful nominee of the Democratic party for the Vice-Presidency, was again a candidate in 1884, Cleveland being the candidate for President, and this time was elected. He died while holding the office.

**HEN HAWK, or CHICKEN HAWK**, a name given to a number of different species of hawks, who either attack poultry or are supposed to do so. In some instances, for example, in the common marsh hawk, the name is very unjustly applied. The *red-tailed hawk* captures small poultry and birds, but they form a small part of this bird's food. Gophers, mice, frogs and many injurious small animals which are eaten by this hawk render it probably on the whole beneficial. The *red-shouldered hawk* never attacks poultry, although often accused of doing so. It preys upon mice and other injurious animals and is really a good friend of the farmers. Some of the smaller hawks are called chicken hawks, and though they doubtless occasionally do some damage, yet they do not altogether deserve the enmity of poultry raisers. See HAWK.

**HEN'NA**, a shrub, native to Northern Africa, Arabia and the East Indies, from which dyes are made. The coloring-matter is in the leaves, which when dried, powdered and made into a paste with hot water and catechu produce a rich orange stain, much used by Eastern women on their nails and finger tips, also for dyeing skins, furs and leather. Mixed with indigo it produces a black dye, used by a few men to dye their beards and for blacking the manes and hoofs of horses. Aside from its utilitarian value the growing henna plant is prized for its fragrant blossoms.

**HEN'NEPIN, LOUIS** (about 1640-1706), a Belgian missionary and explorer in Amer-

ica. After preaching in France he set out, in 1675, with LaSalle to take the gospel to the American Indians. He preached first at Fort Frontenac, and then accompanied LaSalle on an exploring expedition. By way of lakes Erie, Huron and Michigan the party made its way to the Saint Joseph River, thence down the Kankakee to the Illinois River. They built Fort Crevecoeur near the site of Peoria, and Hennepin then started southward. He was captured by the Sioux, but escaped, and returned to France. When the Church again ordered him to America he fled to Holland. After the death of LaSalle he made extravagant claims of discovery and exploration, all of which have been proved false.

**HENRY, O.** See PORTER, WILLIAM SIDNEY.

**HENRY I** (1068-1135), king of England, the youngest son of William the Conqueror. He was hunting with William Rufus when that prince was killed, in 1100, and instantly riding to London, he caused himself to be proclaimed king in the absence of his elder brother Robert, duke of Normandy. He re-established by charter the laws of Edward the Confessor and married Matilda, daughter of Malcolm III of Scotland, thus conciliating the Scots. Robert landed with an army to oppose his brother's seizure of the throne, but was pacified with a pension and the promise of succession in event of his brother's death. Soon after, however, Henry invaded Normandy, took Robert prisoner and reduced the duchy. He was successful also in a struggle with France. Henry appointed as his heir his daughter Matilda, or Maud, whom he had married first to the emperor Henry V and then to Geoffrey Plantagenet of Anjou. See HENRY II.

**HENRY II** (1133-1189), king of England, the first of the Plantagenet line, the son of Geoffrey, count of Anjou, and Matilda, daughter of Henry I. He succeeded Stephen. The opening of his reign was marked by the reduction of the power of the nobles and the reorganization of the financial system. The most important events of his reign were the submission of the Church to the temporal authority of the Crown, through the Constitutions of Clarendon; the famous struggle with and murder of Thomas à Becket, resulting in the restoration of some ecclesiastical rights; the conquest of Ireland; the first subjugation of Scotland by England, and the division of England into judicial districts.

Henry ranked among the greatest of English kings, his chief services to his people being the revival of trial by jury, the construction of roads and the destruction of castles of lawless barons. Henry's sons greatly disturbed the latter part of his reign with insurrections; these were a continual menace to the country's welfare.

**HENRY III** (1207-1272), king of England, son of John, whom he succeeded in 1216. As Henry approached manhood he displayed a character wholly unfit for his station and a weakness which proved the opportunity of the great barons of the country. These, under Simon de Montfort, revolted and succeeded in forcing Henry, by the Provisions of Oxford, to resign the chief power to a committee of barons. In later years, Edward, son of the king, defeated the barons and freed his father from his early humiliating promises. Parliament, in its modern sense of two houses, was first called during this reign.

**HENRY IV** (1367-1413), king of England, first king of the House of Lancaster, the eldest son of John of Gaunt, fourth son of Edward III. He ascended the throne in 1399 on the abdication of Richard II. The first six years of his reign were filled with a series of insurrections, which were finally quelled, and the rest of the period was comparatively untroubled. The first persecutions of the Lollards occurred during his reign. See LANCASTER, HOUSE OF.

**HENRY V** (1387-1422), king of England. On succeeding his father, Henry IV, in 1413, he showed a wisdom in marked contrast to a somewhat recklessly-spent youth. The struggle in France between the factions of the dukes of Orleans and Burgundy afforded Henry a tempting opportunity for reviving the claims of his predecessors to the French crown. He accordingly landed near Harfleur in August, 1415, and though its capture cost him more than half his army, he decided to return to England by way of Calais. A large French army endeavored to intercept him at the plain of Agincourt, but was completely routed (October, 1415). He returned in triumph to England, but on the defeat of his brother, the Duke of Clarence, in Normandy, he again set out for France, drove back the army of the dauphin and entered Paris, forcing Charles VI to accept him as his successor to the French crown. A son was at this time born to him, and all his



great projects looking far into the future seemed about to be realized, when he died of fever. See HENRY VI.

**HENRY VI** (1421-1471), king of England, became king on the death of his father, Henry V, in 1422. As he was an infant, his uncle John, Duke of Bedford, was appointed regent of France; and his uncle Humphrey, Duke of Gloucester, was made protector of England. A few weeks after Henry's succession Charles VI of France died, and in accordance with the Treaty of Troyes, Henry was proclaimed king of France. The war which followed proved at first favorable to the English, but in the end, through the heroism of Joan of Arc (which see) the death of the Duke of Bedford and the defection of the Duke of Burgundy, it resulted in the loss to the English of all their possessions in France, except Calais.

In April, 1445, Henry married Margaret of Anjou, daughter of René of Provence, and the marriage was unpopular in England. Other causes increased this unpopularity, and various risings ensued, which led in 1455 to the opening of the Wars of the Roses (see ROSES, WARS OF THE). During the struggle Henry was several times taken prisoner by the Yorkists, and in 1471 he was found dead in the Tower, murdered, according to popular belief, by order of Edward IV. Henry was a gentle, pious, well-intentioned, hopelessly incompetent king.

**HENRY VII** (1456-1509), king of England, first sovereign of the House of Tudor (see TUDOR, HOUSE OF). He was proclaimed king in 1485, after the defeat and death of Richard III at Bosworth. His reign was troubled by repeated insurrections. In the main, however, the period was beneficial to England. Its freedom from wars permitted the development of the internal resources of the country, and Henry's policy of curbing the power of the feudal nobility was highly beneficial.

**HENRY VIII** (1491-1547), king of England, the second ruler of the Tudor line, and the sovereign in whose reign the Church of England was separated from the Church of Rome. He was the son of Henry VII, whom he succeeded in 1509.

After the election of Charles V as German emperor, both Charles and the French king, Francis I, sought the alliance of England. A friendly meeting took place between Henry and Francis at the "Field of the Cloth of

Gold" (1520), both the interest of Charles preponderated. Henry withdrew from the struggle between France and the emperor, however, when he found that he was being used as a tool. Meanwhile came the determination of the king to divorce his wife, Catharine of Aragon, who was older than he, had borne him no



HENRY VII

male heir and had, moreover, been in the first place the wife of his elder brother. The last of these points was the alleged ground for seeking divorce, though Henry was probably influenced largely by his attachment to Anne Boleyn, one of the queen's maids of honor. The Pope refused to grant a divorce, and Henry eagerly caught at the advice of Thomas Cranmer, afterward Archbishop of Canterbury, to refer the case to the universities, from which he soon got the decision that he desired.

In 1533 his marriage with Catharine was declared null, and a previous private marriage with Anne Boleyn was declared lawful.

As these decisions were not recognized by the Pope, two acts of Parliament were obtained, one in 1534 setting aside the authority of the chief



HENRY VIII

pontiff in England, the other in 1535, declaring Henry the supreme head of the Church. Henry suppressed the monasteries by act of Parliament, and thereby inflicted an incurable wound upon the Catholic religion in England. It was far from being his intention, however, to advance the cause of Protestantism, and he insisted on firm adherence to the doctrines of the Roman Catholic Church.

In 1536 Anne was beheaded for alleged unfaithfulness. Henry then married Jane Seymour, and the birth of Prince Edward, in 1537, fulfilled his wish for a male heir. The death of the queen was followed by Henry's marriage with Anne of Cleves, the negotiations for which were conducted by Cromwell. The king's dislike for his wife, which resulted in another divorce, was extended to the minister who had proposed the union, and Cromwell's disgrace and death soon followed. A marriage with Catharine Howard proved no happier, and she was executed on a charge of infidelity. In 1543 Henry married his sixth wife, Catharine Parr, a lady secretly inclined to the Reformation, who survived the king. In the meantime Scotland and France had renewed their alliance, and England became again involved in war. James V ravaged the borders, but was defeated at Solway Moss in 1542, and in 1544 Boulogne was captured, Henry having again allied himself with Charles V. Charles, however, soon withdrew, and Henry maintained the war alone until 1546. He died in 1547 and was succeeded by his son, Edward VI. See CATHARINE OF ARAGON; BOLEYN, ANNE.

**HENRY III** (1551-1589), king of France, third son of Henry II and Catharine de' Medici, came to the throne on the death of his brother, Charles IX, in 1574. The war against the Huguenots (which see), which had been begun in the previous reign, continued under Henry III, who was at length forced to grant to the Protestant party certain concessions. This led to the formation of a Catholic League, in response to whose demand Henry repealed the special privileges of the Huguenots, thus bringing on another war. The Huguenots, under Henry of Navarre, were successful, and to their camp Henry III fled, after he had made himself unpopular with the Catholic party by his murder of the duke of Guise and the cardinal of Lorraine, the Catholic leaders. In 1789 Henry III was murdered, and Henry of Navarre came to the throne as Henry IV.

**HENRY IV** (1553-1610), king of France, better known as HENRY OF NAVARRE, the son of Anthony of Bourbon, duke of Vendôme, and of Jeanne d'Albret, queen of Navarre. He was one of the greatest characters in French history. Educated by his mother in the Calvinistic faith, he joined, at her wish, the Protestant army of France and served

under Admiral Coligny. In 1572 he married Margaret of Valois, sister of Charles IX, and after the massacre of Saint Bartholomew's Day (see BARTHOLOMEW'S DAY) which took place during the marriage festivities, he was forced to adopt the Catholic creed. In 1576 he escaped from Paris, retraced, at Tours his enforced statement of Catholicism, put himself at the head of the Huguenots and took a leading part in all the subsequent religious wars.



HENRY IV

On becoming presumptive heir to the crown, through the death of the brother of Henry III, he was obliged to resort to arms to assert his claims. In 1587, he defeated the army of the League at Coutras, and after the death of Henry III in 1589, he gained the battles of Arques and Ivry. He was obliged, however, to raise the siege of Paris; and convinced that a peaceful occupation of the throne was impossible without a profession of Catholic faith, he became nominally a Catholic in 1593.

After his formal coronation in 1594 only three provinces held out against him—Burgundy, reduced by the victory of Fontaine-Française in 1595; Picardy, reduced by the capture of Amiens in 1596, and Brittany, which came into his hands in the spring of 1598. The war against Spain was concluded in 1598 by the Peace of Vervins, to the advantage of France. The same year was signalized by the granting of the Edict of Nantes, which secured to the Protestants religious liberty. Henry made use of the tranquillity which followed to restore the internal prosperity of his kingdom, and particularly the wasted finances, at the instance of his Prime Minister, Sully.

Henry divorced Margaret of Valois, and in 1600 he married Maria de' Medici, niece of the grand duke of Tuscany, mother of Louis XIII. She was crowned in 1610, but on the day following her coronation, Henry was stabbed by a fanatic, while examining the preparations for the queen's entry into Paris.

The great benefits which Henry IV bestowed upon France entitled him to the designation which he himself assumed—the Regenerator of France.

**HENRY III** (1017-1056), Holy Roman emperor, became king of Germany on the death of his father in 1039 and succeeded to the imperial dignity in 1046. He strengthened his power by forcing Hungary, Bohemia and Apulia to render him homage, and in 1046 he deposed the Pope and appointed a new one. From this time to the end of his reign his influence was strong in all Church matters. He was one of the most powerful of the early emperors.

**HENRY IV** (1050-1106), Holy Roman emperor, came to the throne on the death of his father, Henry III, in 1056. After some years of regency, Henry assumed the rule and found that much of the power in the kingdom had been usurped by the nobility and the Church. A formidable revolt of the Saxons was put down in 1073, and Henry was able to give his attention to a struggle with the Pope. The two came into conflict owing to a decree promulgated in 1075 forbidding civil rulers to appoint to any ecclesiastical office, a decree which Henry refused to obey. The result was that Henry called a council and deposed the Pope, and was in turn excommunicated. The Pope released Henry's subjects from their allegiance, and this forced Henry to the point of making peace with the Pope after most humiliating concessions. In 1080 the Pope again excommunicated Henry, who laid siege to Rome and appointed an anti-pope. A short time afterward he was driven out of Italy. In 1105 he was compelled by his nobles to abdicate.

**HENRY VI** (1165-1197), Holy Roman emperor, son of Frederick Barbarossa (see FREDERICK I.) He served as regent while his father was in the Holy Land, and in 1190 succeeded to the crown on his father's death. Through his wife he laid claim to the throne of Sicily, and this involved him during much of his reign in wars in Italy. When Richard I of England was captured, on his return from the Holy Land, it was to Henry that he was handed over for safe keeping. Among the early emperors of Germany Henry ranks as one of the strongest.

**HENRY, PATRICK** (1736-1799), an orator and patriot, one of the greatest Americans of the Revolutionary period, was born in

Virginia. He received a brief classical education, but at an early age entered business and married at eighteen. Having failed in storekeeping and in farming, he became a lawyer in 1760, and three years later, when employed to plead the cause of the people against an unpopular royal enactment, his great eloquence placed him at once in the front rank of American orators. His bold and unflinching opposition to the Stamp Act and the policy which it expressed, during which he uttered



PATRICK HENRY

the famous words, "Give me liberty or give me death," led to his election as delegate to the First Continental Congress. He delivered the first speech in that assembly, and it was worthy of so momentous a meeting. In 1776 he carried the vote of the Virginia convention for independence; in the same year he became governor of the new state, and was four times reelected. In 1791 he retired from public life and in 1795 declined the office of Secretary of State, offered him by Washington. Henry was rather eloquent than deep; no one who has come after him has been able to stir and sway the passions of an audience as easily as he; yet he was not a statesman of the most intellectual type.

**HENRY THE NAVIGATOR** (1394-1460), a Portuguese prince, celebrated as a patron of explorers. He founded a school of navigation at Sagoes, and from time to time sent its students on voyages along the western coast of Africa. These explorers mapped much of the shoreline of Africa and discovered the Madeira Islands. In 1433 one of Henry's navigators safely doubled Cape Bojador, and other adventurers, pushing still farther south, discovered Cape Blanco and Cape Verde. A profitable commerce with the natives of West Africa was soon developed, and Senegal and Gambia were partially explored. Henry's efforts not only laid the foundations of the commerce and colonial possessions of Portugal, but gave a new direction to commercial enterprises.

**HENSCHEL**, *hen'shel*, GEORG (1850- ), a composer and singer, the first conductor of the Boston Symphony Orchestra. From Breslau, his native city, where he made his first public appearance as a pianist at the age of twelve, he went to Leipzig and later to Berlin, where after several years of study he gained recognition as a baritone singer. In 1877 he went to London and there became a prominent teacher of voice. There he met, and afterwards married, an American soprano, Miss Lillian Bailey. Subsequently the two appeared together frequently in concerts both in America and in England, in both of which countries Henschel has exerted a strong influence on music.

**HENTY**, GEORGE ALFRED (1832-1902), a writer of juvenile fiction, a great favorite with boy readers. He received his education at Cambridge and engaged in newspaper correspondence for the London *Standard* during the Austro-Italian and the Franco-German wars. Among his best known works are *Under Drake's Flag*, *The Lion of the North*, *By Pike and Dyke*, *With Lee in Virginia* and *In Freedom's Cause*. These books are full of action, and are extremely interesting narratives with a historical background. The Henty stories have a wholesome tone and are far superior to books of the Horatio Alger type.

**HEPATICA**, *he pat'i ka*, a beautiful little flower that blossoms in earliest spring. The hairy stalks rise from the midst of the leathery, dark-colored, three-lobed leaves, that have lain on the ground during the winter. The flowers, which resemble the buttercups, vary in color from white to red and purple. The hepatica is sometimes known as the liverleaf or liverwort.

**HEPTARCHY**, *hep'tahr ki*, any group of seven governments. Specifically the term is applied to the seven kingdoms into which England was divided in Anglo-Saxon times. The kingdoms were founded at different times, and at no one time were they all independent monarchies. In 827 King Egbert of Wessex united all the kingdoms into one and assumed the title of king of England.

**HERA**. See JUNO.

**HER'ALDRY**. During the Crusades, when thousands of knights clad in armor fought for the possession of the Holy Land, it was the custom of the warrior to emblazon on his shield some device, called his coat of

arms, which made known his identity. As knights from all over Europe took part in the Crusades, they took this means of telling each other who they were. The symbols used varied widely, and included representations of birds, animals, plants, stars and many other things.

At first there was much confusion, as many knights from different countries chose the same device, which were emblazoned on the shield or embroidered on a coat worn over the armor, and there was no way of distinguishing between those whose emblems were alike. To overcome this difficulty, officers called *heralds* were appointed to systematize the selection of emblems, and in this way the science of heraldry originated.

Knights in armor with coats of arms on their shields no longer ride to battle, but the devices used in the medieval period have been carefully preserved, and many European households include the family coat of arms among their choicest possessions. In England an organization known as the Herald's College supervises the adoption of new coats of arms and the assumption of those borne by ancestors.

**HERBARIUM**, a collection of dried plants, arranged according to a recognized system of classification. The plants are usually mounted on sheets of white paper, and a good specimen shows the root, leaf, flower and fruit. The United States national herbarium, which is in the National Museum; the herbarium of the New York Botanical Garden, and the Gray Herbarium, in Harvard University, are the largest collections in the United States. The herbarium of the Jardin des Plantes, Paris, is noted for its large collection of type specimens.

**HERBART**, *her'bahrt*, JOHANN FRIEDRICH (1776-1841), an eminent German philosopher, the founder of modern pedagogy. His educational principles were based directly upon his philosophy, and his teachings have exerted an epoch-making influence upon education in Europe and America. Herbart strongly emphasized the fact that all subjects are related, and that knowledge of one strengthens knowledge of all the others. He was the originator of the doctrine of apperception; that is, the interpreting of new knowledge by that already in the mind. He believed that the end and aim of education is the development of the individual, whose claims he places above those of family or

state. He laid great stress upon the place of interest in education, believing that only as interest is stimulated and aroused by making subjects vital can the child be taught to the best advantage.

The seminary for teachers which Herbart founded at Königsberg attracted educators from all over Europe and from the United States. Although this institution was compelled to close in 1833 because of the hostility of the Prussian government, its doctrines continued to be taught by its students in various parts of the world, and it may be truly said that in the Königsberg Seminary the "New Education" had its birth.

The facts of Herbart's life are few. He was born at Oldenburg and studied at the University of Jena, where he was a pupil of the philosopher Fichte. He was an ardent follower of Fichte for a time, but later repudiated him. He taught in the University of Göttingen and at Königsberg. Among his works which have been translated into English are *General Pedagogy*, *Introduction to Philosophy*, *Application of Psychology to the Science of Education* and *A B C of Sense Perception*.

**HERBERT, VICTOR** (1859- ), a composer of light operas and musical comedies. He was born in Dublin, Ireland, and is a grandson of the novelist Samuel Lover. At the age of seven he began the study of music in Germany and eventually became an excellent performer upon the 'cello, securing an engagement as first 'cellist of the court orchestra at Stuttgart. In 1886 he accepted a similar position with the Metropolitan Orchestra of New York. He was chosen the successor of Gilmore as leader of the famous Twenty-second Regiment band and later accepted the conductorship of the Pittsburgh Orchestra. He is the author of numerous songs and pieces for the piano and orchestra, besides several well-known comic operas, of which the best are *The Ameer*, *The Idol's Eye*, *The Fortune Teller*, *The Singing Girl*, *Babette*, *Babes in Toyland* and *It Happened*



JOHANN HERBART

in *Nordland*; and in addition, the serious opera *Natoma*, which is one of the few attempts to produce grand opera with an American historic and scenic background.

**HERBICIDES**, *hur'bisides*, preparations for destroying weeds. Among the herbicides most commonly used, and apparently with greatest success, are solutions of carbolic acid, copper sulphate, arsenic, sal soda, kerosene and salt. The amount of the preparation to be used depends upon the conditions and habits of growth of the weeds. Recent bulletins of the Department of Agriculture at Washington give full information as to the best methods of eradicating weeds. See **WEEDS**.

**HERBIVOROUS ANIMALS**, an old classification in zoölogy referring to those animals which are not carnivorous (flesh-eating), but which graze. It is no longer recognized. See **ZOÖLOGY**.

**HERBS**, *urbz* or *hurbz*, plants that contain no woody tissue, and usually die down to the ground at the end of their growing season. Many of them are used in the preparation of foods and medicines, and most of the spices are obtained from herbs. Among the best known herbs are parsley, sage, thyme and caraway.

Nearly all the herbs valuable for the table for seasoning can be raised in the garden from seed; some of them, as mint and parsley, can be supplied to a family from a windowbox "garden," if the box is supplied with good soil and kept on the sunny side of the house.

**Related Articles.** Consult the following titles for additional information:

|           |            |             |
|-----------|------------|-------------|
| Anise     | Hop        | Rosemary    |
| Balm      | Horehound  | Sage        |
| Caraway   | Hyssop     | Sorrel      |
| Catnip    | Lavender   | Tansy       |
| Cicely    | Mint       | Thyme       |
| Coriander | Pennyroyal | Wintergreen |
| Fennel    | Parsley    | Wormwood    |

**HERCULANEUM**, an ancient city, about five miles southeast of Naples, at the base of Mount Vesuvius. It was completely buried, with Pompeii, Stabiae and other villages, by lava and ashes during an eruption of Vesuvius in the reign of the Roman emperor Titus, A. D. 79. The site had been long sought in vain, when, early in the eighteenth century, well-diggers found statues at the village of Portici. In 1738 the digging went deeper, and traces of the theater of Herculaneum were found. Explorations have disclosed wonderful examples of ancient art, far exceeding those found at Pompeii.

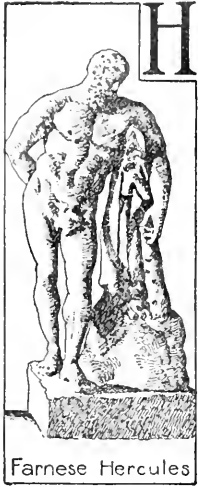

Farnese Hercules

**H**ERCULES, *hur'ku leez*, the most celebrated of the Greek heroes of mythology, famed for his great strength and daring. He was the son of Jupiter by Alcmena, a mortal princess, and was brought up at Thebes at the court of his stepfather. Juno, hating him because of Jupiter's love for his mother, troubled him throughout his career with all the disasters she could invent. When he was but an infant she sent two gigantic serpents to devour him, but the child, stretching

out his hands, grasped them by the neck and strangled them both. When he grew to manhood he married and settled down to a happy life. Juno, however, determined that he should know no peace and afflicted him with madness, so that he killed his wife and three children and wandered forth as an outcast. As a purification for his crime he was condemned to serve his cousin Eurystheus and to perform any tasks which might be laid upon him. The tasks which he accomplished were what are known as the Twelve Labors of Hercules. They were as follows:

(1) to kill a lion which ravaged Nemea; (2) to destroy the hydra (see Hydra); (3) to capture alive and unhurt a stag, famous for its incredible swiftness, its golden horns and brazen feet. (4) to capture alive a furious wild boar; (5) to clean the stables of Augeas (see Augeas); (6) to kill the savage birds which troubled the country near Lake Stymphalus and ate human flesh; (7) to bring alive to Eurystheus a prodigious wild bull which laid waste the island of Crete; (8) to obtain the mares of Diomedes (see Diomedes); (9) to procure for the daughter of Eurystheus the girdle which had been given by Mars to the queen of the Amazons; (10) to kill the monster Geryon and bring to Eurystheus his numerous flocks; (11) to obtain three golden apples from the garden of the Hesperides (see Hesperides); (12) most dangerous of all, to bring up from Hades Pluto's dog, Cerberus.

All of these tasks he performed, besides many others which he met with while on his enforced journeys.

After his release from Eurystheus he came into conflict with Apollo and was by him condemned to serve as a slave to Omphale, queen of Lydia. The occupations of Hercu-

les during this period were exceedingly effeminate. In female garb he worked at spinning, while his mistress clad herself in his



HERCULES AND THE NEMEAN LION

lion's skin and brandished his famous club. Released from the Lydian queen, he again set out in search of adventures; having married Deianira, he was now no longer alone in his wanderings. One day Hercules and Deianira came to a rapid stream. The centaur Nessus offered to carry Deianira across, but when he reached the opposite shore, instead of setting her down he galloped off with her. Hercules therefore shot him with one of his poisoned arrows and Nessus, with his dying breath, bade Deianira to dip in his blood a robe of Hercules, which should serve if ever his love wandered from her, to bring him back. When sometime later she became jealous of Iole, she innocently sent Hercules the robe. Its effect, however, was most agonizing, and all attempts of Hercules to tear it off were in vain. As the only way of stopping the pain, he had a huge funeral pile built, on which he laid himself. This was set on fire, but while the mortal part of the hero was consumed, Jupiter took the immortal part to Olympus, and there Hercules lived with the gods as the husband of Hebe.

**HERCULES, PILLARS OF**, the ancient name for the rocks projecting into the sea on either side of the Strait of Gibraltar at its narrowest point. See GIBRALTAR.

**HERCULES BEETLE**, a large beetle, about five inches in length, found in tropical America. Its great peculiarity consists in

the exceedingly long, curving horn which projects from the upper part of the head of the male, and the shorter one from the lower part of the head, which curves upward to meet it. The smaller female is hornless.

**HEREDITY**, the transmission from parent to offspring of physical and intellectual characteristics. The term is used in a very broad sense and applies to both plants and animals, though the greatest interest is attached, naturally, to heredity in human beings. Darwin, Spencer and Wallace have studied the subject thoroughly and embodied their discoveries in doctrines which, though at first received with skepticism, are now generally believed. It is known that heredity manifests itself in different ways. For instance, the qualities of the parents may blend in the children; they may alternate in the children; the qualities of one parent only may be transmitted to a child, or the inherited qualities may come from an ancestor—not the immediate parent. Both mental and physical characteristics are transmitted, but they do not necessarily manifest themselves in infancy; in fact, many hereditary traits come only with increasing age. To how great an extent an individual is governed by hereditary traits is still a question of discussion among scientists. See **EUGENICS**.

**HERETIC**, one who holds some theological doctrine that conflicts with the beliefs of the church to which he belongs, but who, at the same time, calls himself a Christian. Many of the early Christians preserved their Jewish or Greek philosophical notions and mingled them with the doctrines of Christianity. Among sects called heretics in later times by the Roman Catholic Church were the Waldensers, the Wycliffites, the Hussites, the Lutherans and all Protestant sects and churches. Before Christianity was made the religion of the Roman state, nothing but excommunication was inflicted upon the heretic; but severe laws were passed soon after the conversion of the emperors. The code of Justinian contains many ordinances against heretics, and the canon law made it a duty to denounce them under pain of excommunication. Persecution of heretics was common during the Middle Ages, and extended into the modern period, but is now generally replaced by religious toleration.

**HERMES**, *hur'meez*. See **MERCURY**.

**HERMIT CRAB**, a shrimp-shaped crab with no shell covering on its tail, which makes

its home in the cast-off shells of other animals. Sometimes it drags out the occupant of a suitable shell and after eating it takes possession of its habitation. The crab attaches itself firmly to the shell by means of a hooklike appendage and carries its stolen home about

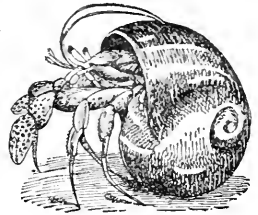

HERMIT CRAB

wherever it goes. It is impossible to draw it out without tearing its body. As the crab increases in size it seeks a larger shell.

**HERMITS** are those who in early ages withdrew from association with man and took up their abode in caverns or poorly made huts, in order to avoid the cares, temptations and business of the world. They often lived in complete solitude. The first hermit is said to have been Paul of the Thebaid, who fled to the desert after persecution by Decius and lived alone for ninety years, till his death, about 342. The hermits of the early church lived in a community, but each had a separate hermitage, and they met only at certain times for religious exercises.

**HERMON**, MOUNT, a mountain in Syria, said by tradition to be the one on which Christ was transfigured (see *Matthew XVII*). It has an altitude of 9,166 feet, and its summit, which is perpetually crowned with snow, is divided into three peaks. Mount Hermon forms the southern end of the Anti-Lebanon Range (see **LEBANON, MOUNTAINS OF**). To the ancient Hebrews it was a peculiarly sacred mountain, and about it are the ruins of many shrines and temples. Its modern names are *Jebel-el-Sheikh* and *Jebel-el-Thel*.

**HERNE**, JAMES A. (1840-1901), an American actor and author, born in Troy, N. Y. He made his stage debut at the age of nineteen, in his native city, in *Uncle Tom's Cabin*. His first original play was *Hearts of Oak*, which appeared in 1878. His greatest success was *Shore Acres*, as produced at the Boston Museum in 1892. It achieved instant popularity and brought its author fame.

**HERNIA**, *hur'ne ah*, or **RUPTURE**, a tumor, formed by the protrusion of parts of any organ by a natural or accidental opening from the cavity in which it is contained. The brain, the heart, the lungs and most of

the abdominal viscera may become totally or partially displaced and thus give rise to the formation of hernial tumors. The term is ordinarily applied to abdominal hernia, which may arise from violent strain, as in jumping or lifting. Various forms of abdominal hernia are recognized, and each has its peculiar method of treatment. The wearing of a truss or support to hold the organ in its natural position is a common and safe remedy for the less severe cases. In some instances the only cure is an operation.

**HERO**, a mythological priestess of Venus at Sestos, on the coast of Thrace, for love of whom Leander, a youth of Abydos, swam every night across the Hellespont, guided by a torch in her tower. He was at length drowned in the attempt, and his body was washed ashore. Hero, overcome with anguish, threw herself from the tower on the corpse of her lover and perished.

**HER'OD**, called *The Great*, (about 62-4 B. C.), king of the Jews, was a native of Ascalon, in Judea. Julius Caesar appointed him to the government of Galilee, and after the Battle of Actium, Augustus, to whom he paid court, confirmed him in his kingdom. He rebuilt the Temple at Jerusalem with great magnificence and erected a stately theater and amphitheater in that city. Herod's policy and influence gave a great temporary splendor to the Jewish nation, but he was also the first to shake the foundation of the Jewish government, by dissolving the national council and by appointing the high priests and removing them without regard to the laws of succession. The birth of Jesus Christ is said to have taken place in the last year of Herod's reign.

**HEROD AGRIP'PA I**, a king of Judea, grandson of Herod the Great. For his attachment to Caligula he was imprisoned by Tiberius, but on the accession of Caligula (A. D. 37) he received the government of part of Palestine and latterly all the dominions of Herod the Great. To please the Jews, with whom his rule was very popular, he caused Saint James to be put to death and imprisoned Saint Peter. He died in A. D. 44, under the circumstances related in *Acts* XII, 20-23.

**HEROD AGRIPPA II**, son of Herod Agrippa I and the last of the Herods. As he was, on his father's death, too young to govern, Judea was reduced to a Roman province. He subsequently received the

kingdom of Chaleis and the superintendency of the Temple at Jerusalem, where, with his sister Berenice, he heard the defense of Paul before Festus. Being driven from Jerusalem by the revolt of the Jews, he joined the Romans and during the siege of Jerusalem was very serviceable to Titus.

**HEROD AN'TIPAS**, son of Herod the Great, by his Samaritan wife, Malthace, was appointed tetrarch of Galilee on his father's death, about 4 B. C. This was the Herod who put to death Saint John the Baptist, at the request of his unlawful wife, Herodias. He was in Jerusalem at the time of the crucifixion, and Jesus was sent to him by Pilate. Herod went to Rome, where he was accused of being in league with the Parthians and was banished, in consequence, to Lyons, in Gaul, where he died in A. D. 39.

**HERODOTUS** (about 484-about 424 B. C.), a Greek historian, called by Cicero, the "father of history." He was born at Halicarnassus, in Asia Minor. Before writing his history, he traveled extensively, visiting the shores of the Hellespont and the Euxine, Scythia, Syria, Palestine, Babylon, Ecbatana, Egypt, as far as Elephantine, and other parts of northern Africa, everywhere investigating the manners, customs and religion of the people, the history of the country and the productions of the soil. On returning home he found that Lygdamis had usurped the supreme authority in Halicarnassus and had put to death the noblest citizens, among others, the uncle of Herodotus. Herodotus sought an asylum in the island of Samos. Having formed a conspiracy with several exiles he returned to Halicarnassus and drove out the usurper, but the nobles who had acted with him immediately formed an aristocracy more oppressive than the government of the banished tyrant, and Herodotus withdrew to Athens. Later he went to the colony of Thurii in Italy, where he seems to have spent most of the remainder of his life. Here he completed his great history of the contest of Greece with the East.

**HEROIN**, *her'oin*, a slightly bitter powder derived from opium, used in the treatment of tubercular and bronchial coughs. Because, like other opium derivatives, it has a habit-forming tendency, it should be used sparingly, and only as prescribed by a physician. A dose of not more than two and one-half grains has been known to cause exhaustion and impaired vision.



**HERON**, *hehr'on*, the common name for the group of graceful wading birds which live in swamps and along shallow rivers. They are very numerous, and different species are found almost all over the globe. They are easily distinguished by their long bills, cleft beneath the eyes; their slender, compressed bodies; their long, slender, naked legs; three toes in front, the two outer united by a membrane, and by their moderately long wings. Their tails are short, rounded and compressed. With their powerful necks and sharp, strong beaks, herons are able to strike fierce blows. Many of the species have long, ornamental crests and handsome plumes on the throat and body. Though not handsome in flight, because of their habit of stretching their long legs straight out behind them and curling their heads between their shoulders, they are graceful and attractive in their movements on land.

The *snowy heron*, living along the Gulf of Mexico, but sometimes straying farther



GRAY HERON

north, is a handsome bird with pure white plumage and black legs and bill. The *great blue heron* is common in the United States, where it is noticed as a very shy bird which nests even to the extreme north. This is the bird pictured so often on Japanese screens and fans.

**Related Articles.** Consult the following title for additional information:

|         |           |
|---------|-----------|
| Bittern | Nighthawk |
| Egret   | Stork     |

**HERRERA**, *er ra'rah*, FRANCESCO, the name of two famous Spanish painters, father

and son, both of whom were born at Seville. The father (1576-1656), is regarded as the founder of a new national school of painting. His *Last Judgment*, *Holy Family* and *Outpouring of the Holy Spirit* are masterpieces of design and coloring. He was a skilled fresco painter and worker in bronze.

His youngest son, called HERRERA THE YOUNGER (1622-1685), became celebrated for his pictures of still-life. He was painter and superintendent of the royal buildings for Philip IV of Spain. Examples of his work are in Seville and Madrid.

**HERRICK**, *hehr'ik*, ROBERT (1591-1674), an English poet, born in London and educated at Cambridge. He succeeded to the vicarage of Dean Prior in Devonshire, but because of his royalist principles was forced by the Long Parliament in 1647 to relinquish it. In 1662, after the Restoration, he was reinstated and remained until his death. For a considerable period following his death Herrick's poetry suffered neglect, but for more than a hundred years they have been read with pleasure and full appreciation of their fine poetic quality. Among his most popular poems are *Corinna's Maying*, *Cherry Ripe* and *Gather Ye Rosebuds While Ye May*, all of which possess in common with his other verse an exquisite sentiment and rare descriptive beauty.

**HERRICK**, ROBERT WELCH (1868- ), an American novelist born in Massachusetts. He was graduated from Harvard University, taught English in the Massachusetts Institute of Technology and later in the University of Chicago. The scenes of many of his novels, among which are *The Web of Life*, *The Real World*, *The Common Lot*, *Memoirs of an American Citizen* and *One Woman's Life*, are laid in Chicago. Among his other novels are *Together*, *A Life for a Life* and *The Healer*.

**HER'RING**, one of the most important families of sea fishes. The common herring is of wide distribution in the North Atlantic, extending as far south as 45° north latitude. The North Sea fisheries are famous for their herring catches. This fish measures from ten to twelve inches in length, is blue-green on the back, its under parts are of a brilliant silvery white, and it has small teeth in both jaws.

It was formerly supposed that herrings migrated in two great shoals every summer

from the polar seas to the coasts of Europe and America, returning in the winter, but the migration is probably only from a deeper part of the ocean to a shallower. The feeding ground of the herring is probably the mud deposits found in the deeper parts of



HERRING

the sea, and it seems to be a fact that during their visits to the shallower waters of the coast, for the purpose of spawning, they do not feed, or at least feed very little. In summer the herring leaves the deep water where it has passed the winter and spring months, and seeks the coast, where it may deposit its eggs to be exposed to the influence of oxygen, heat and sunlight, which are essential to their development. These schools are generally followed by multitudes of hakes and dogfishes, and gulls and other sea birds hover over the shoals. Were it not for the fact that untold millions of eggs are deposited, the species would long ago have been extinct, owing to the preying instincts of the larger fishes. The number of eggs produced by one female is known to be as great as 40,000.

The herring swim near the surface and are therefore easily taken by net. Without any apparent cause, they often desert parts of the coast where for a time they have been remarkably abundant, not returning in large numbers till after the lapse of a number of years.

The American species differs somewhat in its external appearance from the common European species. It varies in length from twelve to fifteen inches; the color above is deep blue, tinged with yellow, with silvery sides and lower parts. The mode of fishing for herring is by drift nets. Though not extensively used in the United States, the herring is considered the most important food fish in the world. The so-called herring of the Great Lakes belongs to the salmon family. The annual catch of herring has been as great as 1,500,000,000 pounds. The catch in the United States is about 125,000,000 pounds; in Canada, 235,000,000 pounds.

**HERSCHEL**, *hur'shel*, the family name of three distinguished astronomers, one of whom was a woman.

Sir William Herschel (1738-1822) was the first astronomer to convey to the human mind a conception of the immensity of the heavens. He discovered Uranus and located the two satellites of Saturn, and worked out the period of rotation of Saturn's ring. His researches place him among the foremost astronomers and natural philosophers. His sister, CAROLINE HERSCHEL (1750-1848), who was born in Germany, followed him to England, where she shared his labors, making several important independent discoveries.

Sir John Frederick William Herschel (1792-1871) son of Sir William Herschel, was distinguished as a chemist, as well as astronomer. He undertook as his chief work exploring the southern heavens, thus supplementing the work of his father, whose researches had been chiefly concerned with the northern heavens. At the Cape of Good Hope he spent four years making a complete telescopic survey of the southern constellations. For his contributions to astronomy he was honored by Oxford University and was knighted.

**HERVEY ISLANDS.** See COOK ISLANDS.

**HESPERIDES**, *hes per'e deez*, in Greek mythology, certain nymphs whose duty it was to guard the golden apples belonging to Hera. In their charge they were assisted by a sleepless dragon, Ladon. The garden where these apples grew was of rather uncertain locality, but Hesiod places it on an island far to the west. It was the eleventh labor of Hercules to kill the dragon and bring the golden apples of the Hesperides to Eurystheus. See HERCULES.

**HESPERUS.** See EVENING STAR.

**HESSE**, *hes*, a state and a former grand duchy of the German Empire, of which Ernst Ludwig (born 1868) was the reigning grand duke until his abdication in November, 1918. Hesse lies in the west-central part of Germany, and is in two parts, Upper Hesse and Rhenish Hesse. The area is 2,968 square miles; the population in 1910, 1,282,051, or 439 persons to the square mile. Darmstadt is the capital.

Upper Hesse is mountainous and contains the arable tract known as the Wetterau. Southern Hesse is partly mountainous, and the greater part of the land lies in the basin of the Rhine, the rest in that of the Weser. The soil is very fertile and produces rye, barley, oats, potatoes and fruit, and the minerals are coal, iron and salt. The vine forms a

most important object of culture, and fruit is very abundant. Darmstadt, Mainz, Gies-sen, Bingen and Worms are the principal towns.

The grand duchy of Hesse originated in the division of the landgraviate of Hesse in 1567, and soon afterward all the territories were included in the two landgraviates of Hesse-Darmstadt and Hesse-Cassel. In 1806 the landgraviate of Hesse-Darmstadt was erected into a grand duchy with an enlarged territory, by Napoleon. It was reduced to its present limits in 1866, in the war between Austria and Prussia, when it had to cede to Prussia some districts in the north, besides Hesse-Homburg, which had been recently reunited with it. Hesse was represented in the government of the Empire as it existed until 1919 by three members of the Bundes-rat and nine members of the Reichstag. See GERMANY.

**HESSIAN**, *hesh'an*, **FLY**, a two-winged fly whose young (larvae) are very destructive to wheat, barley and rye crops. It is called the Hessian fly from an unfounded belief that it was introduced into America in the baggage

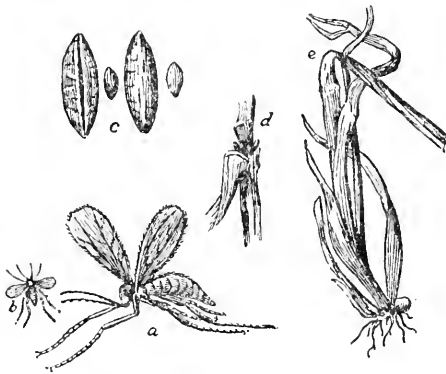

HESSIAN FLY

a, Fly, magnified; b, natural size; c, pupa cases ("flaxseeds") in different stages, natural size and magnified; d, barley stem, showing "flaxseeds" in position; e, stem bent down as a result of the work of the Hessian fly.

of the Hessians who were employed to fight against the Americans during the War of Independence. The female is about one-eighth of an inch in length, and has a wing expanse of about a quarter of an inch. The body is brown, with the upper parts of the head and thorax of a darker shade, approaching black. The wings are of a dusky gray, surrounded by fringes. The male is somewhat smaller than the female and has longer antennae. The eggs, which are laid in May

and in September of each year, hatch in from four to fourteen days. The maggots work themselves in between the leaf-sheath and the stem of the grain and, fixing themselves near the lowest joints, suck the juices of the stem. The Hessian flies are most injurious in wet weather. The best way to avoid their ravages to winter wheat is to plant the crop after the egg-laying period. To save spring wheat it is a good plan to plant a small strip early enough for the flies to lay eggs in it, and then to plow the grain under.

**HESSIANS**, *hesh'anz*, the German soldiers hired by Great Britain to fight against the American colonists in the Revolutionary War. As most of them were from two Hessian provinces, the term was applied to the entire body. These men were forced into the service by their princely rulers, who pocketed the salaries of the mercenaries, allowing each soldier but twenty-five cents a day for his own use. Many Hessians deserted and after the war became American citizens.

**HEWLETT**, MAURICE HENRY (1861- ), an English novelist, whose romantic novels picturing medieval life have given him a permanent place in English literature. He secured his education in London and was admitted to the bar in 1891, but the attractions of literature were stronger than those of the bench, and he devoted much attention to the writing of romance. His first popular success, *Forest Lovers*, was followed by *Richard Yea-and-Nay*, *New Canterbury Tales*, *Little Novels of Italy*, *Pan and the Young Shepherd*, *Fond Adventures* and *The Queen's Quair*, all on medieval themes. Mr. Hewlett's later novels deal chiefly with modern life, and are socialistic in tone. Among these are *Open Country*, *The Half-Way House* and *Rest Harrow*. His most recent books are *Brazenhead the Great*, *Love of Proserpine*, *Brendish*, *The Little Iliad*, *The Song of the Plow* and *Thorgils of Threadholt*.

**HEYSE**, *h'ize*, PAUL (1830-1914), a German novelist, poet and dramatist. Although his dramas were what first won him notice, his fame rests chiefly on his short stories, many of which are classics; of these *L'Ar-rabbiata* is considered one of the finest stories ever written. Heyse produced several deftly constructed but pessimistic novels, among them *The Children of the World* and *In Paradise*. *Merlin*, one of his later novels, is a pro-

test against the modern realistic movement. His poetic works include *Urica* and the epics *The Bride of Cypern* and *Thekla*. As a dramatist he was less successful, his plays usually lacking true dramatic qualities. He was awarded the Nobel Prize for literature in 1910.

**HEZEKIAH**, the twelfth and one of the best of the kings of Judah, who was the son of Ahaz, whom he succeeded. His reign covered the last quarter of the seventh century B. C. During this reign occurred the invasion of Judah by the Assyrians under Sennacherib (see *II Kings* XIX, 35). The destruction of the Assyrian army in a single night is one of the most interesting episodes of this period. It forms the theme of Byron's stirring poem, *The Destruction of Sennacherib*.

**HIAWATHA**, *hi a wah'tha*, a mythical character whom the North American Indians believed was sent among them to clear the rivers, forests and hunting grounds and to teach them the arts of peace. The myth was made the subject of a famous poem by Longfellow. Suggestions for the study of this poem, with extracts from it, will be found in the article LANGUAGE AND GRAMMAR.

**HIBBEN**, *hib'en*, JOHN GRIER (1861- ), an American educator, who succeeded Woodrow Wilson as president of Princeton University. He was born at Peoria, Ill., and was educated at Princeton and at the University of Berlin. After his ordination to the Presbyterian ministry, in 1887, he preached for four years in Chambersburg, Pa., and in 1891 accepted an instructorship in logic and psychology at Princeton, later attaining the rank of professor. In January, 1912, he was chosen president of the institution. Dr. Hibben has written extensively on philosophical subjects.

**HIB'BING**, MINN., in Saint Louis County, on the Great Northern and Duluth, Missabe & Northern railroads, eighty miles northwest of Duluth. It is an important iron and timber district and has great mining and lumbering interests. It is claimed that in the Hibbing district there are half a billion tons of ore. The town claims the largest open pit mine in the world. There is a \$300,000 high school and a village hall which cost \$125,000. Population, 1910, 8,832; in 1917, 17,550 (Federal estimate).

**HIBERNATION**, *hi ber na'shun*, the state of stupor in which many animals spend the cold months of winter or periods of

drought and scarcity of food. As the time approaches for this change, the animal takes on fat and becomes gradually more and more slow and inactive in its habits, until finally it passes into a deep sleep or stupor, from which it cannot, in some cases, be aroused until the period of cold or scarcity has passed. The depth and character of this stupor differ decidedly in different animals and in the same animals in different regions; they seem to be governed by the habits of the creatures during many generations. When an animal comes out of this state it has lost very much in flesh, and it is comparatively weak and inert, but after a short time it regains its natural vigor.

Not all animals hibernate; in fact, the hibernating animals are chiefly those that feed upon vegetable matter. Indeed, some of these store food upon which they live during the cold season or, like the squirrels, hibernate for brief periods, which alternate with other periods of hunting for food. The woodchuck is one of the most notable hibernators, and almost all of the burrowing animals are similar in habit. In some species of birds it is only the females that hibernate, though the males sleep for long periods of time. Some mammals hibernate in the Northern states, but not in the South. Frogs, snakes and some fishes hibernate, the land animals burying themselves in the ground below the frost line, and the fish going into the mud beneath the water.

**HIBERNIA**, *hi bur'ne ah*, the ancient name of Ireland, said to have been applied to it first by Julius Caesar. Aristotle speaks of the island as *Ierne*, and Ptolemy in his description of it uses the name *Juverna*.

**HIBERNIANS**, ANCIENT ORDER OF, a Catholic organization of Irishmen, said to have been founded as early as 1642, but more probably in 1651, when Cromwell outlawed the native population, placed a price on the head of priests and declared death to every person attending a Catholic service. The organizer was Rory O'Moore (died 1652); its object was to protect the people in this faith. When Catholics were emancipated in 1829 the Order became a benevolent and nationalist organization. It has extended to the United States, Canada, Mexico and Hawaii. The American branch has about 250,000 members.

**HIBISCUS**, *hi bis'kus*, a large genus of herbs, shrubs and trees. They are native to

tropical and subtropical regions. Some of them are cultivated for their ornamental value. Of these the *rose of Sharon*, a shrub which has large, variously-colored flowers, and the *Althea*, a small tree with purplish blossoms, are familiar. Belonging to the same family is *okra*, the pods of which are widely used as a vegetable and as a thickening (gumbo) for soup. The root of one variety of hibiscus, cultivated in Japan, produces a mucilage used in paper manufacture. In India hibiscus is cultivated for its fiber.

**HICCOUGH**, *hik'kup*, or **HIC'CUP**, a sudden convulsive spasm of the diaphragm, which stops the inspiration of air by closing the glottis, an opening from the pharynx into the larynx. The inrush of air against the glottis causes a sharp sound. These convulsions come at brief intervals and may continue for a few moments, for hours, or, rarely, even till they cause exhaustion and death. Acute attacks of hiccoughs may be caused by an overloaded stomach or by some derangement of the digestive processes. These acute attacks may often be stopped by a long, slow inspiration or by a drink of water taken slowly, and oftentimes the attack will stop if the person's attention is distracted from it. Stubborn cases will often yield to a dose of ammonia, camphor or musk, but the administration of an anesthetic is sometimes necessary. Hiccough is also an accompaniment of a number of diseases, such as peritonitis, appendicitis and pneumonia, in which it is regarded as a grave symptom.

**HICHENS**, *hick'ens*, ROBERT SMYTHE (1864- ), an English novelist, best known as the author of *The Garden of Allah*, a story which was first made into an elaborate play and then into a moving picture, and of *Bella Donna*, which was dramatized for Madame Nazimova. Hichens was educated at Clifton College, the Royal School of Music and the London School of Journalism. His novels, which include *Barbary Sheep*, *The Holy Land*, *A Dweller on the Threshold*, *Green Carnation*, *The Way of Ambition*, have considerable dramatic value. Hichens' taste for the theater has resulted in several successful arrangements, notably that of *Becky Sharp*, written for Mrs. Fiske, and *Business is Business*, translated from the French, and an original play called *The Real Woman*.

**HICK'ORY**, the name given to several species of timber trees, belonging to North America, but to some extent introduced into Europe. They are remarkable for stateliness and general beauty, and they grow to heights of seventy to eighty feet. The wood is heavy, strong and tenacious, and is used for making such things as carriage shafts, handles of golf clubs, whip handles and cogged wheels. The wood is liable to decay more quickly than some other woods, owing to exposure and the onslaught of worms. It makes a valuable fuel, for it develops great heat. The shag-bark species yields the hickory nut of commerce. This fruit, a hard-shelled nut, divided into four parts, has a delicate flavor.

**HIERARCHY**, *hi'er ahr ki*, a body of ecclesiastical rulers. The term comes from two Greek words, *hieros*, meaning *sacred*, and *arche*, meaning *government*. In the Middle Ages the papal hierarchy gathered great temporal strength, and the Pope became a spiritual monarch, ruling western Christendom with power but feebly limited by princes and councils. A reactionary movement began in the fourteenth century, and the general tendency of subsequent events has always been to make the civil and hierarchical power more and more independent of each other. The term *hierarchy*, as used to denote the governing and ministering body in the church, consisting of several ranks, can strictly be applied only to those churches which are ruled by bishops, such as the Roman Catholic and the Anglican churches.



**HIEROGLYPHICS**, *hi'ero glif'iks*, a term applied originally by the Greeks to the written inscriptions sculptured on Egyptian monuments. The word is from the Greek words for *sacred* and *carve*, and refers to the belief of the Greeks that the writing used was confined to sacred subjects and was legible only to the priests. The term as commonly used means any system of writing by means of pictures, but is particularly applied to the writings of

the Egyptians and the Mexicans.

Three different modes of writing were used by the ancient Egyptians, the hieroglyphic,

the hieratic and the demotic. Pure *hieroglyphic* writing is the earliest, and consists of figures of material objects from every sphere of nature and art, with certain mathematical and arbitrary symbols. Next was developed the *hieratic*, or priestly, writing, the form in which most Egyptian literature is written, and in which the symbols almost cease to be recognizable as figures of objects. Hieratic writings of the third millennium B. C. are extant. In the *demotic* writing, derived directly from the hieratic, the symbols are still more obscured. The demotic was first used about the seventh century B. C., and within two or three centuries it had become so common that it was used for practically everything except religious purposes.

Down to the end of the eighteenth century scholars failed to find a clue to the hieroglyphic writings. In 1799, however, a French captain of engineers discovered at Rosetta the celebrated stone which afforded European scholars a key to the language and writing of the ancient Egyptians. (see ROSETTA STONE). It contained a trilingual inscription, in hieroglyphics, demotic char-

Egyptian language, would be found adjacent to it. The discovery of an alphabet was the first task. The demotic part of the inscription was first examined by De Sacy and Akerbald, and the signification of a number of the symbols was ascertained. The hieroglyphic part was next carefully examined and compared with the demotic and Greek. At last, after much study, Champollion and Dr. Thomas Young, independently of each other, discovered the method of reading the characters and thus gave a clue to the decipherment of the ancient Egyptian writing.

Hieroglyphic characters are either *ideographic*, that is, using well-known objects as symbols of conceptions, or *phonetic*, that is, representing words by symbols standing for their sounds. The phonetic signs are again divided into alphabetical signs and syllabic signs. Many of the ideographic characters are simple enough; thus, the figures of a man, a woman, a calf, indicate simply those objects. Others, however, are less simple and convey their meaning figuratively or symbolically. Water was expressed by three zigzag lines, one above the other, to represent waves or ripples of running water; milk by a milk jar; oil by an oil jar; fishing by a pelican seizing a fish; seeing and sight by an eye, and so on. The accompanying illustration shows the phonetic spelling of a typical hieroglyphic writing.

The hieroglyphics of the Aztecs or Mexicans, used in Central America and Mexico previous to the discovery of America, were much less perfect than the Egyptian. The



EXTRACT FROM THE TALE OF THE TWO BROTHERS

Below the hieroglyphics are given the phonetic spelling and the translation. In this tale is the germ of the Cinderella story. (From the Orbiney Papyrus.)

acters and Greek, which proved to be a decree of the priests in honor of Ptolemy V, issued in 195 B. C. The last paragraph of the Greek inscription stated that two translations, one in the sacred and the other in the popular

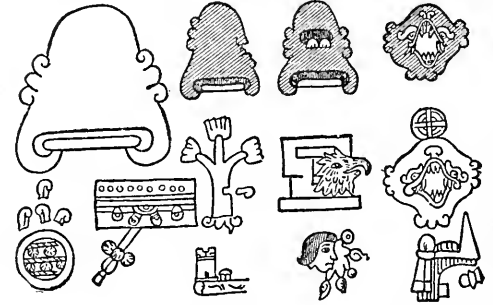

MEXICAN HIEROGLYPHICS

characters were for the most part ideographic, and the pictures used were highly conventionalized, though the system was for the most part rude. Most of the manuscripts containing these hieroglyphics have been destroyed, so that the Mexican writing is almost entirely unintelligible.

There have been found groups of hieroglyphics which combine the two kinds of characters—the ideographic and the phonetic. According to Ebers, in the perfected system of hieroglyphics the symbols for sound and syllables are to be regarded as the foundation of the writing, while symbols for ideas are mingled with them to render the meaning more intelligible, to furnish ornamentation or to keep up the mystic character of the hieroglyphics.

**HIGGINSON, THOMAS WENTWORTH** (1823–1911), an American essayist, conspicuous as an antislavery agitator before the Civil War and known in later years as a warm advocate of woman suffrage. He was born at Cambridge and educated at Harvard, where he studied for the ministry. In 1862 he served as captain of the fifty-first Massachusetts regiment, and in that same year he was made colonel of the first regiment of freed slaves mustered into the national service. After the war he devoted himself to literature and wrote *Outdoor Papers*, *Army Life in a Black Regiment*, *Oldport Days*, *Common Sense about Woman*, *Cheerful Yesterdays*, *History of the United States* and a memoir of Longfellow.

**HIGH POINT**, N. C., settled in 1840, is in Guilford County, on the Southern and the Carolina & Yadkin River railroads, thirty-four miles northeast of Salisbury. The surrounding country is devoted to agricultural and mining industries, among which poultry raising and truck farming are important. The leading industries of the city are the manufacture of furniture, safes, hosiery, cloth, tobacco and cotton. Government is by the commission form. Population, 1910, 9,525; in 1917, 13,439 (Federal estimate).

**HIGH PRIEST**, the head of the Jewish priesthood, who had oversight of the sanctuary and all that pertained to it. He presided over the Sanhedrin and offered sacrifices. His official garments consisted of a blue robe, over which was worn an embroidered vestment called an ephod. He wore also a jeweled breastplate and a coronet-shaped cap. On the Day of Atonement, when he alone was permitted to enter the Holy of Holies of the Temple, he put aside this rich costume and wore a pure white robe.

The office of high priest was first vested in Aaron and was handed down to his eldest son, Eleazer, and so on in lineal succession.

At first the office was for life, but Herod, and afterward the Romans, jealous of the power which so long a term gave the high priest, made and unmade the Jewish pontiffs at will.

**HIGH SCHOOL**, a public school, ranking in grade of instruction between the grammar school (see **COMMON SCHOOLS**) and the college. The first public high school in the United States was the English High School of Boston, which was established in 1821. Since that time the high school has become a general and potent factor in all systems of public education throughout the country. The courses of study usually include those subjects required for admission to universities and technical schools and such other branches as will fit for life those who do not desire to attend higher institutions of learning. Most high schools now maintain commercial courses, and many have departments of manual training and domestic science.

In large cities technical high schools are common. They have well equipped workshops, laboratories, kitchens, sewing rooms, etc., and they definitely prepare the pupils for various trades and occupations. High schools of commerce having a four-years course of study are also found in most large cities.

The support of the high school in the United States depends upon the system of education in the state where it is located. Most high schools are a part of the city system of schools and are supported in the same manner as other schools. In some states direct state aid is given to high schools which reach a required standing, and such schools are affiliated directly with the state university.

**Rural High Schools.** Towns and villages having a population of less than 1,500 people are unable to maintain complete high schools, from the standpoint of the Bureau of Education; most states, therefore, have some provision by which adjoining school districts, or one or more townships of the county may be organized with a school district for the organization and maintenance of a full high school course. Most rural communities are by these provisions able to have high schools of as high a standard as those found in the large cities. In Illinois and Indiana the township is the unit of organization, and in California adjoining

districts unite or form a high school district. The courses of study in these schools are similar to those in city high schools, with the exception that greater emphasis is likely to be placed on household arts and agriculture.

**Junior High School.** The Junior high school is the outgrowth of a recent movement in the reorganization of the American school system on what is known as the "six-and-six" plan, which divides the twelve-year public school period into two periods of six years each, the first including the first six grades and the second the seventh and eighth grades of the grammar school and the four years of the high school. The Junior high school includes the seventh and eighth grades and the first year high school under the old classification, and they are organized on the plan of the high school.

The following advantages are claimed for the junior high school:

1. It enables the pupils to begin high school subjects, for which they are prepared, earlier.

2. It brings pupils under a plan of organization and management better suited to their mental and physical condition than is possible under the old system.

3. By introducing pre-vocational subjects early, it admits of a much better adaptation of the course of study to the needs of the individual pupils.

4. It does away with the gap between the eighth grade and the high school.

5. It keeps pupils in school longer.

6. It brings the high school nearer the pupil, since several Junior high schools can be established in a town where only one senior high school would be possible.

7. It enables teachers to supervise the pupils' study more closely, and more readily to adapt methods of teaching to the mental condition of the pupil.

**The Smith-Hughes Act.** One of the greatest aids to secondary education which the United States government has given the country is found in the Smith-Hughes Act, which became a law February 23, 1917. The following are its chief provisions:

1. An annual appropriation for cooperating with the states in paying salaries of teachers, supervisors and directors of agriculture.

2. An annual appropriation for cooperating with states in paying the teachers of industrial subjects.

Each of these appropriations began in 1918 with the sum of \$500,000 and is to be increased \$250,000 annually until, in 1926 and each year thereafter, \$3,000,000 is appro-

riated. These appropriations are apportioned among the states according to the proportion of the rural population of each state to the rural population of the United States.

3. An annual appropriation for training teachers of agriculture and industrial education.

4. The creation of a Federal Board of Vocational Education, consisting of the Secretary of Agriculture, the Secretary of Labor, the Secretary of Commerce, the United States Commissioner of Education and three citizens of the United States, to be appointed by the President with the advice and consent of the Senate. One of these appointees represents the agricultural interests, one the labor interests and one the interests of manufactures and commerce.

**Requirements.** Any state desiring to derive benefits from this act must meet the following requirements:

1. The state must formally accept the offer by an act of its legislature, and appoint a state board with power to cooperate with the Federal Board of Vocational Education.

2. The state board must make definite plans showing the kinds of vocational education for which the appropriation is to be used; the kinds of schools and equipment, methods of instruction and qualifications of the teachers in these schools. This plan is submitted to the Federal Board of Vocational Education for approval.

3. The education to which this appropriation is applied must be below college grade.

**HIGH SEAS,** the open sea or ocean. The claims of various nations to exclusive rights and superiority over extensive tracts of the ocean-highway have been settled after much controversy by a general international agreement, namely, that the jurisdiction of maritime countries extends only for three miles from their own coasts; the remainder of the seas are accessible on equal terms to all nations. Inland seas and estuaries, of course, are excepted.

**HIGHWAY.** See ROADS AND STREETS.

**HILL,** an elevation of land rising above the surrounding country. The distinction between hill and mountain is one of altitude; any elevation over 2,000 feet high is technically a mountain.

Hills are frequently formed by erosion (see EROSION); for instance, the wearing away of plateaus by streams frequently cuts them into hills, whose crests are on a level with the surface of the plateau (see MESA). Hills are sometimes formed by volcanic action. These take the form of cones and are found in the craters of volcanoes, or they may



have been formed by the cooling of molten lava, in which case they are known as *coulees* (see VOLCANO). They may be formed by glaciers, which on melting deposit their load of stones and gravel (see MORAINE). The ranges of hills about the base of mountains are called foothills. See MOUNTAIN.

**HILL, AMBROSE POWELL** (1825–1865), an American soldier. He was graduated from the United States Military Academy in 1847, entered the first artillery and was made second-lieutenant. He served in the Mexican War and afterward on the frontier and in Florida. Later he was promoted to a captaincy. At the outbreak of the Civil War he entered the Confederate service, was appointed colonel of the thirteenth regiment of Virginia volunteers and was ordered to Harper's Ferry. He fought at the first Battle of Bull Run, at Antietam, Fredericksburg, Chancellorsville and Gettysburg, was made brigadier-general and later major-general.

**HILL, DAVID BENNETT** (1843–1910), an American politician and one of the ablest lawyers of his time, was born in Havana, N. Y. He was admitted to the bar in 1864, practiced law at Elmira and in 1870–1871 served in the state legislature. In 1882 he was elected mayor of Elmira; in November of the same year, was chosen lieutenant-governor of New York State, and in 1884, when Governor Cleveland resigned the position of governor, he succeeded to that office. In 1885 he was elected governor for the term expiring in 1888 and was reelected. He then became United States Senator for New York State, but failed of reelection because the legislature elected in 1896 was Republican. He was a Presidential candidate in 1892.

**HILL, DAVID JAYNE** (1850– ), an American author and educator, born at Plainfield, N. J., and educated at Bucknell University. He was professor of rhetoric in his *alma mater* for two years, and then became president of the institution. In 1888 he was called to the presidency of the University of Rochester, where he remained eight years. For five years he was assistant secretary of state at Washington. He was then in turn minister to Switzerland, minister to the Netherlands, and ambassador to Germany (1908–1911). He is the author of *A History of Diplomacy in the International Development of Europe, Americanism—What It Is* and *The Rebuilding of Europe* (1917).

**HILL, JAMES JEROME** (1838–1916), an American capitalist and railroad man, the "builder of a Northwestern empire," was born near Guelph, Ont., of Scotch-Irish descent. He early emigrated to Minnesota and settled in Saint Paul, then a village of 5,000 people, where he was employed in steamship offices until 1865. Later he engaged in independent fuel and transportation business, becoming interested in extending communication between the Mississippi River and the North and West. Gaining control of the Saint Paul & Pacific railroad company, he reorganized the system, became successively its general manager, vice-president and president and made it the nucleus of the Great Northern system, which he organized in 1890, having meantime completed rail communication between Lake Superior and Puget Sound and established a steamship line between America and the Orient. In 1902 he was the chief promoter of the Northern Securities Company, which aimed to establish a community of interest between several trans-

continental lines.

He became a great banker, and so keen were his perceptions that he was recognized as one of the ablest advisers and leaders in financial circles. Although always a Western man, he was made vice-president of the New York Chamber of Commerce. For several years before the World War he was the trusted friend and adviser of King Albert of Belgium in financial and economic matters.

**HILLIS, NEWELL DWIGHT** (1858– ), a Presbyterian clergyman, born at Magnolia, Iowa, and educated at Iowa College, Lake Forest University and McCormick Theological Seminary. He served as pastor at Peoria, Ill., and Evanston, Ill., and succeeded David Swing as pastor of Central Church, Chicago. In 1899 he accepted a call to Plymouth Church, Brooklyn. Among his principal books are *The Investment of Influence, How the Inner Light Failed, Great Books as Life Teachers, Prophets of*



JAMES J. HILL

*a New Era, Battle of Principles, Misfortunes of a World Without Pain, Studies of the Great War and The Story of Phaedrus.*

**HIMALAYA**, *him mah'la yah*, a chain of snowy mountains in Asia, the highest range on the globe, which separate the Indian peninsula from the plateau of Tibet. The great mass, which is nearly 1,500 miles in length, reaches from the great bend of the Indus on the west to the great bend of the Brahmaputra on the east, and the breadth is from 100 to 160 miles. The Himalayas are not a single mountain system, but form a series of rugged peaks. The average elevation of the range has been estimated at from 16,000 to 18,000 feet, but many of the peaks are known to exceed 24,000 feet. Among the highest points are Mount Everest, 29,002 feet, so far as known the highest point in the world; Nanga Parbat, 26,629 feet; Dhawalaghira, 26,826, and Kunchinjunga, 28,156. Among the numerous passes, which are the loftiest in the world, are the Ibi Gamin, 20,459 feet; the Mustagh Pass, 19,000 feet; the Mana Ghat; the Parang La, and the Chang La. The Himalayas abound in giant glaciers, the longest being the Zamu, which measures eighteen miles. There are no lakes in the region, and there are no volcanoes, but earthquakes are frequent. The chain is divided into a west, middle and east portion. The west is that drained by the five rivers of the Punjab, from the Indus to Sutlej; the middle portion, that drained by the Ganges, and the east, that drained by the Brahmaputra.

The vegetation is extremely varied, and on the steep southern slopes it is very luxuriant. Tropical plants, such as the plantain, fig and palm trees, are found up to a height of 3,000 feet, and beyond this, up to 7,000 feet, is a belt in which oaks, chestnuts and laurels are common. The succeeding belt, up to about 12,000 feet, has deodar, cedars and pines, and beyond this are the regions of gnarled trees and shrubs and the grass lands. The highest point at which trees are found is 14,000 feet, on the north side, but in the central range trees are not common above 11,000 or 12,000 feet. Grain is grown on the north side at 14,000 to 15,000 feet. The mountains are famous for their wonderful growths of rhododendron, and the flowering plants are found at an altitude of 19,500 feet. On the southern slope the tea plant is grown up to 5,000 feet. The

animal life is also abundant and varied and conforms in distribution to that of the plant life. Included among the animals are the tiger, leopard, rhinoceros and monkey. The region around Tibet is the home of the yak, and the mountains may also be considered as the home of the pheasants. The more important explorations of the Himalayas are those of Hooker, the Schlagintweit brothers, Waugh, Graham and Sir William Conway.

**HINCKS**, FRANCIS, Sir (1805-1885), a Canadian statesman, born at Cork, Ireland. In 1832 he engaged in business in Toronto, where he became a friend of Robert Baldwin. In 1835 he was chosen to examine the accounts of the Welland Canal, whose management was being attacked by William Lyon Mackenzie. His attention being thus turned to political life, he founded the *Examiner*, a paper supporting the Liberals, and in 1841 was elected to Parliament. In two of Baldwin's ministries he was in-spector general (Minister of Finance) and from 1851 to 1854, after Baldwin's retirement, he was Premier of Canada. In 1855 he



SIR FRANCIS HINCKS

was chosen governor of Barbados, and later of British Guiana. Returning to Canada in 1869 he became Minister of Finance in the Cabinet of Sir John Macdonald. He resigned in 1873 but continued to take an active part in public life until his death.

**HINDENBURG**, PAUL VON BENECKENDORFF UND VON (1837- ), one of the outstanding figures in the German army during the World War. Hindenburg's military career began in 1866, when he served in the Seven Weeks' War with Austria. He also fought in the Franco-German War, participating in the Battle of Sedan, and after the conclusion of hostilities he attended a military school. He reached the rank of lieutenant-general in 1903, but in 1911 was retired. Hindenburg was not in general favor when the Great War broke out, because he was believed to be riding a hobby. That is, he wearied people by insisting that the marshy region in East Prussia, in the vicin-

ity of the Masurian Lakes, was important from a military standpoint, and while lecturing in the War Academy he had located many imaginary battles there. This idea was ridiculed in military circles. Hindenburg, however, was able to prove the soundness of his theory, for on the outbreak of the war the emperor gave him the chief command of the campaign in East Prussia against Russia, and in the vicinity of those lakes he completely defeated two Russian armies.

The emperor later rewarded him by making him field marshal and chief of the general staff, and in the closing months of the war, with Ludendorff, he directed the German offensives on the Western Front. Later, when the allied forces broke the intricate system of German defenses, called the "Hindenburg line," and the Americans pressed forward to Sedan, he acknowledged defeat and insisted on the emperor's accepting the allied armistice terms. In a proclamation to the German forces he declared himself still head of the supreme army command, and announced his intention of leading the troops home in order and discipline. After peace was declared, he resigned, with the declaration that German militarism was dead. See WORLD WAR.

**HINDU-KUSH**, *hin'doo koosh*, or **INDIAN CAUCASUS**, a mountain system of Central Asia. It is generally considered as a continuation of the Himalayas. Its culminating point, Tirach Mir, in the range of Hindu-Koh, is far beyond the limit of perpetual snow and is supposed to measure 25,000 feet in height. The Oxus and several smaller streams have their source in these mountains.

**HINDUSTAN**, *hin'doo stahn'*, the name which was formerly given to the whole Indian Empire, but which properly applies only to the Punjab and the Ganges Valley. See INDIA.

**HIN'NOM**, VALLEY OF. See GEMENNA.

**HIPPOCAMPUS**, or **SEA HORSE**, a genus of sea animals belonging to the same family as the pipefish (which see). The name hippocampus, which comes from two Greek words means *horse* and *sea monster*, and was given this animal because of the similarity between its head and that of a horse. The animal resembles a fish only in that it lives in the water and breathes by means of gills. Its body, from six to ten inches long, is covered with bony plates, and

ends in a tightly coiled tail. It has a long snout, large eyes and a mane of spiny projections. It is a poor swimmer, moving about in an upright position, and usually is found anchored by its tail to growing seaweed. The male carries the eggs in a little pouch until they hatch.

**HIPPOCRATES**, *hip'poh'rateez* (460-357 B. C.), a famous ancient Greek physician, often called the "father of medical science," was born on the island of Cos, off the coast of Asia Minor. He was believed by the Greeks to have descended from the gods, and he became a priest-physician.

He advocated pure air, water and sunshine, and made hospitals of the temples, where his patients petitioned their gods at the same time that they received physical treatment. In some of his theories Hippocrates was 2,000 years ahead of his time. He died at an advanced age in Thessaly.

**HIP'PODROME**, the Greek name for the public place where the horse and chariot races were held. In Byzantine times the hippodrome at Constantinople was widely famous, and factions originating in the hippodrome caused perpetual confusion in all departments of the public service. The Circus Maximus at Rome was one of the largest of these structures that was ever built. It was 1,875 feet long, and according to Pliny, could accommodate 260,000 spectators. The name is sometimes applied to a modern circus, and specifically to great amusement places in London and New York.

**HIPPOPOTAMUS**, an unwieldy African animal, of which two living species are known. Next to the elephant it is the heaviest of all land animals. One species of large mammoth size, weighing as much as 8,000 pounds, with a length of twelve to fourteen feet, stands four to five feet in height. It is common throughout the greater part of the continent. The other is not only smaller, but has other important differences and is found only in the west coast rivers and those flowing into Lake Chad.

The large species has a thick, square head, a very large muzzle, small eyes and ears, a thick and heavy body, short legs, a short tail and no hair, except at the extremity of the



SEA HORSE

tail. The animal is killed by the natives, partly for food, but chiefly on account of the teeth, which are harder than ivory and less liable to turn yellow. Hunting it, however, is dangerous sport.

The hippopotamus is remarkable for its "blood sweat," a blood-red fluid exuded from

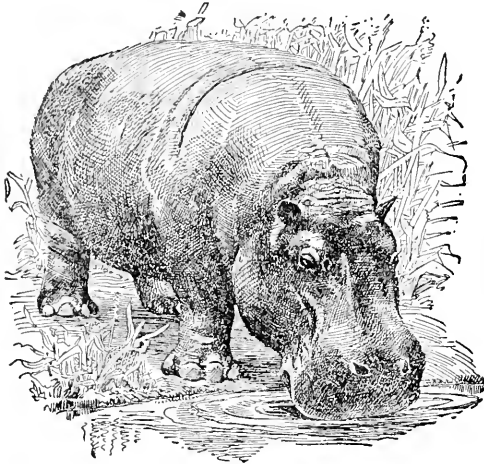

HIPPOPOTAMUS

and covering the skin, but it has no connection with the blood. The animal delights in water, living in lakes, rivers and estuaries and feeding on water plants or on the herbage growing near the water. Although very clumsy on land, it is an excellent swimmer and diver and can remain under water a considerable time. The hide is thick, spongy and rough, without hair.

**HIRAM**, a king of Tyre who lived at the time of David and Solomon. He contributed cedar from the forests of Lebanon and skilled workmen to help in the building of Solomon's temple (*I Kings V, 1-12*), and supplied the Israelitish king with a navy. Hiram constructed strong fortifications at Tyre, and waged a war against Cyprus, in which he was successful. See TYRE.

**HIROSHIMA**, *he ro she'mah*, JAPAN, situated near the southwestern extremity of the island of Hondo, on the coast and on the railway connecting Osaka with Shimonoseki. It is one of the important commercial ports of the empire and has a large trade in lacquer ware and bronzes. Population, 1916, 167,400.

**HIRSCH**, *heersh*, EMIL GUSTAV (1852- ), an American rabbi. He was born in Luxembourg and at the age of fourteen emigrated to the United States. After graduation at the

University of Pennsylvania he went to Germany for study at Berlin and Leipzig. At different times he was rabbi at Baltimore, Louisville and Chicago; in the last-named place he was highly influential in promoting Jewish social-settlement work. From 1888 to 1897 Rabbi Hirsch was president of the Chicago Rabbi Library Board. Since 1892 he has been professor of Hebrew in the University of Chicago.

**HISPANIA**, *his pa'ni a*, the ancient name given by the Romans to the peninsula of Spain and Portugal. The Greeks knew it as Iberia, and the earliest inhabitants were called Iberians. By some of the Roman poets it was called Hesperia, meaning the *western land*. See SPAIN; IBERIA.

**HISTOLOGY**, *his tol'o jy*, that branch of anatomy which treats of the microscopic structure of the different tissues of the body. The science originated as far back as the seventh century, but it made little progress until the invention of the compound microscope in the nineteenth century. Since that time, by the combination of the microscope and camera, many important discoveries have been made. It was through histology that the peculiar cell structure of the different tissues was discovered; also by the aid of the microscope the presence of nerves and blood vessels in these tissues was revealed. Many diseases are determined by studying the different tissues and glands under the microscope, because most of these diseases are due to disorganization of the cells.

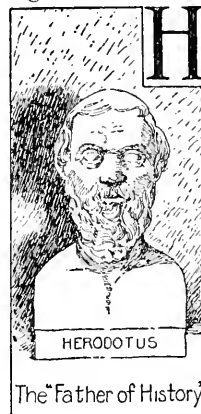

**HISTORY**, in the broadest sense of the word, refers to everything that has happened; not merely the history of people or of nations, but of the changes and phenomena of nature as well. It includes everything that changes. As modern science has shown that everything changes, therefore the whole universe and every part of it have a history. There is a history of geography, of

physics, of mathematics, just as there is a history of the nations of the world. And not only is there a history of geography, but geography is a part of the history of countries. Ancient Greece was divided into

many small states; some of them, like Athens, were cities smaller than many of our cities to-day. Why was Greece divided into so many states? Because mountains, rivers and the sea formed natural divisions which the people could not easily overcome. It is then clear that we must know something of the geological and geographical divisions of Greece before we can understand the political divisions.

So, too, if we consider the history of the United States, we shall see that the formation of the land held great significance. Why did the early settlements spread north and south along the Atlantic Coast? Why, when the settlements spread to the westward, did they travel in parallel lines, so that settlers from Pennsylvania crossed the mountains to Ohio, Indiana and Illinois, and settlers from Virginia and the Carolinas crossed to Kentucky and Tennessee? A moment's thought will show us how different the history of the country might have been if Virginians had mixed with Pennsylvanians in Ohio, and if New Englanders had mixed with Carolinians in Tennessee. It may seem strange to us that so many more elements are included in history than we had imagined. Many think of it as a list of kings and battles and a few important dates, but it is much more. History is a record of living forces and living people; history is being made every day just as history was made a hundred or a thousand years ago. Life was very much the same then as it is now. Probably there were other forces at work then; perhaps some of them were the same as those now in operation. To study these forces and their results, to show the development of nations as social, political and economic units, is the purpose of history in the common sense of the word.

The word *history* comes from a Greek word which was used centuries before Christ to denote the search for knowledge in the widest sense. History meant investigation and inquiry, not narration and description; it began as a branch of scientific research. It was not until many years later that the "historian" meant the man who told the story and not the seeker after knowledge. In the course of time a "history" became the story which the historian told.

**Present-Day Application.** There are three present-day uses of the word. In the first place, history means the individuals,

events, forces and institutions which together show the progress and growth of a nation, in other words, the facts of history; in the second place it means the branch of science which studies these facts; and finally, it means the branch of literature in which they are presented. The first meaning, the facts and materials of history, has already been explained; let us simply bear in mind that the "history of a people includes every item which has interest or importance in connection with that people's life and growth."

There remains the explanation of the two other meanings, which refer rather to the arrangement and presentation of the facts than to the facts themselves. Viewed as research, it is a science; viewed as a branch of literature, it is an art. In a general way, we find two schools of historians, one school giving prominence to the subject-matter, the other to the form. History as a science flourishes in a scientific age; history as an art rises and falls with the arts. As an art it calls upon the imagination and the powers of expression. Those periods which have been influenced by masters of style have been less interested in the methods of investigation than in the beauty of their rhetoric. Macaulay often seems to sacrifice strict accuracy of detail in order to make a rhetorical point. The historian as an artist looks upon his subject as a great picture whose details must be subdued in order to make a harmonious whole, even though the outlines are dimmed and the colors blurred. The scientific historian, on the other hand, generally feels that the facts must be presented as they are. History, the art, is dependent on the individual artist, but history as a science has developed along scientific lines.

The historian of to-day has at his disposal a great amount of machinery and material accumulated by the past, splendid collections of documents and manuscripts, now opened to research, giving him opportunities which were for many years denied to his predecessors. The scientific historian defends no theory or thesis, he seeks to lay bare the truth. To illustrate the relation of history to its sister arts and sciences, let us take two typical examples. The first years of the nineteenth century were, with a few exceptions, characterized by romanticism, with its exaggeration of the individual; Macaulay's History of England and Carlyle's works are typical of the age. Carlyle's "great man

## Outline of Ancient History; to A. D. 476

### I. RACES OF MAN

- (1) Divisions
  - (a) Caucasian or white
  - (b) Mongolian or yellow
  - (c) Malay or brown
  - (d) Negro or black
  - (e) American or red
- (2) Development of civilization
  - (a) Stone Age
  - (b) Bronze Age
  - (c) Iron Age

### II. CIVILIZATIONS OF THE EAST

- (1) Egypt
  - (a) Old Empire, first seventeen dynasties
    - (1) M e n e s, legendary founder
    - (2) Pyramid builders
      - (a) Cheops
      - (b) Shafra
      - (c) Menkara
  - (b) Hyksos or Shepherd kings
    - (a) Dark Ages of Egyptian history
    - (b) Exile of the Children of Israel
  - (c) New Empire
    - (a) A m o s i s establishes Theban dynasty
    - (b) Thothmes III
    - (c) Amunoph III
    - (d) Rameses I
    - (e) Rameses II
    - (f) Later rulers

- (2) China
  - (a) Legendary history
  - (b) Reign of Yao (about 2350 B. C.)
  - (c) Shun
  - (d) Yu
  - (e) Shang dynasty
  - (f) Chow dynasty
    - (1) Confucius
    - (2) People change from nomadic to agriculture state
  - (g) Tsin or Chin dynasty
    - (1) Great Wall of China built

- (h) Tang dynasty
- (3) Chaldea, Assyria and Babylonia
  - (a) Chaldean supremacy, 2300-1400 B. C.
    - (1) Nimrod, founder of the Empire
    - (2) Kudur-Nakhunta
    - (3) Kudur-Lagamer, also known as Chedor-laomer
  - (b) Assyrian supremacy, 1400-625 B. C.
    - (1) Tiglath-Pileser I
    - (2) Vul-lush III and his queen Semiramis
    - (3) Sargon
    - (4) Sennacherib
    - (5) Sarcus
  - (c) Babylonian supremacy
    - (1) Becomes independent under Nabonassar
    - (2) Nabopolassar
    - (3) Nebuchadnezzar, 604-561
      - (a) Captures and subdues Jerusalem
      - (b) Siege of Tyre
      - (c) Babylonia's Golden Age
    - (4) Fall of Babylonia
- (4) The Hebrew Nation
  - (a) Under the patriarchs
  - (b) In Egypt
    - (1) Joseph
    - (2) Moses
    - (3) Aaron
  - (c) The Exodus
  - (d) The Judges
  - (e) The Kingdom
    - (1) Saul
    - (2) David
    - (3) Solomon
  - (f) Kingdom of Israel
  - (g) Kingdom of Judah
- (5) The Phoenicians
  - (a) Sidon
  - (b) Tyre
- (6) Persia

- (a) Cyrus the Great
- (b) Darius I
- (c) Xerxes I
- (d) Artaxerxes I
- (e) Decline of the Persian Empire

### III. CIVILIZATIONS OF THE WEST

- (1) Greece
  - (a) Legendary Age
  - (b) Early history of Sparta
  - (c) Early history of Athens
  - (d) Graeco-Persian Wars
    - (1) First expedition of Xerxes
    - (2) Battle of Marathon
    - (3) Thermopylae
    - (4) Salamis
    - (5) Plataea and Mycaele
  - (e) Athenian supremacy
    - (1) Themistocles
    - (2) Aristides the Just
    - (3) Confederacy of Delos
    - (4) Ages of Pericles
  - (f) Spartan and Theban supremacy
    - (1) Peloponnesian Wars
    - (2) Sparta the leading state in Greece
      - (a) Xenophon and the Ten Thousand
      - (b) Oppression of the oligarchies
    - (3) Thebes
      - (a) Victory of Epaminondas at Leuctra
      - (b) Death of Epaminondas and decline of Thebes
  - (g) Macedonian supremacy
    - (1) Philip of Macedon
    - (2) Alexander
      - (a) Battle of Issus
      - (b) Siege of Tyre
      - (c) Conquest of Egypt
      - (d) Arbela
      - (e) In India
      - (f) Character of Alexander
  - (h) Division of the Empire
    - (1) Syria
    - (2) Thrace
    - (3) Macedonia

- (4) Egypt under the Ptolemies
- (2) Rome
  - (a) Legendary
    - (1) Romulus
    - (2) Numa
    - (3) Servius Tullius
    - (4) Tarquin the Proud
  - (b) The Republic
    - (1) Samnite Wars
    - (2) Struggle between Rome and Carthage
      - (a) First Punic War
      - (b) Second Punic War
  - (c) Third Punic War
    - (1) Roman treachery
    - (2) Fall of Carthage
    - (3) Civil wars and class strife
      - (a) The Gracchi
      - (b) The Social Wars
      - (c) Marius and Sulla
      - (d) The First Triumvirate
  - (1) Caesar
  - (2) Pompey
  - (3) Crassus
  - (e) Civil War between Caesar and Pompey
    - (1) Caesar in Gaul
    - (2) Caesar's triumph
      - (a) Crossing the Rubicon
      - (b) Battle of Pharsalia
    - (3) Death of Caesar
  - (f) Second Triumvirate
  - (g) The Empire
    - (1) Its glory
      - (a) Augustus
      - (b) Tiberius
      - (c) Nero
      - (d) Trajan
      - (e) Hadrian
      - (f) Marcus Aurelius
    - (2) Decline and fall
      - (a) Commodus
      - (b) Diocletian
      - (c) Constantine the Great
      - (d) Julian the Apostate
      - (e) Theodosius the Great

theory of history," his "hero-worship" is logically connected with the age of Scott, Byron and Keats; it was a philosophy of history which might furnish poets with inspiration. Later in the nineteenth century came a scientific age, the age of Darwin and Spencer, of Buckle and Guizot, of practical statesmen rather than poets. It is almost invariably true that histories deal with subjects which interested the age in which they were written. Modern historians began with politics and wars, but as the interest of the people was drawn toward the economic and social factors, these two were considered by historians. Histories of commerce, of industries, of cities are now as common as histories of wars and robber-barons. We know that no one of these is more than one of the many factors which make up the complex forces of civilization.

**Ancient History.** The period of ancient history is by far the largest of the three great divisions of recorded history. In addition to more or less authentic records there is a body of legend and tradition, some of it perhaps based on facts; most of it, unfortunately, is so mixed with myths and religious superstitions that its value as history is doubtful. Vergil's record of the wanderings of Aeneas and Homer's account of the Trojan war may be accepted as histories only because we have little other evidence in regard to these events; they may or may not present an accurate picture but they are founded on actual events and persons. These legends are of value because they tell us something of the people and events.

There are other great fields of historical study, which enable us to reconstruct ancient civilizations, though they tell us little or nothing of single incidents. These fields of study are anthropology, which is the history of man as a unit in the animal kingdom; ethnology, the history of man as racial units, and ethnography, the history of the distribution of the races and nations, thus formed, over the earth. The study of these topics properly accompanies a thorough knowledge of ancient history, because it gives a background and perspective which can be acquired in no other way. For the same reason the study of mythology, of painting and sculpture, of architecture, even of domestic life, has its proper place alongside the study of great men and important events. In our study of recorded history we should combine

these subjects so that history fulfills its true purpose of giving us a complete picture and an accurate understanding of past and present civilizations. Alexander's system of imperial government is as much a part of history as the Battle of Issus; the domestic life of the Romans is fully as important as the character of Caesar or Nero or Constantine the Great in explaining the course of Roman history. The following outline shows the outstanding events of ancient history. For a series of ancient history charts see the articles on Egypt, China, Greece, Rome, Mythology and Mohammedanism.

**Medieval and Modern History.** The more we study history the more fully we realize that all divisions into ancient, medieval and modern are purely arbitrary. It is convenient to be able to pick out a definite date and say "modern history begins here." As a matter of fact, we find that there is no real break in the continuity of events. We say the fall of Rome in A. D. 476 ends the period of ancient history, but Roman influence has continued even to our own time.

Some historians say that the discovery of the New World marks the beginning of modern history. The establishment of a new dynasty in one country may have an effect similar to a successful war in another country. The truth is that we must look beyond the mere date to a connected account of causes. The beginnings of the Reformation can be traced for a hundred years before Luther nailed the ninety-five theses to the doors of the church at Wittenberg. The beginnings of the French Revolution were apparent for many years before Louis XVI was executed. Especially in modern history it becomes almost impossible to pick out a date as the starting-point of a great movement or to isolate events in one country from those in another. Improved means of transportation and communication, the resulting intermingling of opinions and of peoples, and the inevitable effect on other nations make it impossible for us to say, "Let us study only England or Germany in the nineteenth century."

Not even among the ancient barbarians can we pick out a nation which had no relations with other nations. If we are to study the many wars between England and France as independent units we shall soon be in hopeless confusion. If we relate them to the general history of Europe, we shall find



## Medieval History, 476 to 1492

- I. THE DARK AGES, 476-1050
- (1) Germanic migrations
    - (a) Ostrogoths in Italy
    - (b) Visigoths in Spain and Gaul
    - (c) Burgundians in Gaul, 443-534
    - (d) Vandals, 439-533
    - (e) Franks, 486-752
    - (f) Lombards in Italy, 568-774
    - (g) Angles and Saxons in England, 449
  - (2) Fusion of Romans and Teutons
  - (3) Eastern Empire
  - (4) Mohammed and the Saracens
    - (a) Religion
    - (b) Conquests
    - (c) Driven out of Europe
  - (5) Empire of the West
    - (a) Pepin
    - (b) Charles Martel
    - (c) Charlemagne
    - (d) Division of the Empire
  - (6) The Northmen
    - (a) Causes of migrations
    - (b) Settlements and conquests
      - (1) Scotland and Ireland
      - (2) Iceland, Greenland, America
      - (3) Russia
      - (4) Constantinople
      - (5) England
      - (6) Gaul
  - (7) Rise of the Papacy
- II. THE AGE OF REVIVAL, 1050-1492
- (1) Characteristic institutions
    - (a) Feudalism
      - (1) Origin and causes
      - (2) Form of the system
      - (3) Chivalry
    - (b) Monasticism
      - (1) Origin
      - (2) Hermits and anchorites
      - (3) Monks and monasteries
  - (2) The Crusades, 1096-1272
    - (a) Causes
    - (b) The expeditions
    - (c) Effects
  - (3) Struggle between the Empire and the Papacy
    - (a) Gregory VII against Henry IV
    - (b) The Hohenstaufens
    - (c) Innocent III, 1198-1216
      - (1) His character
      - (2) Quarrel with John
      - (3) Lateran Council
    - (d) Great Schism, 1378-1414
      - (1) Rival popes
      - (2) Council of Constance
    - (e) Papacy loses its temporal power
  - (4) The development of nations
    - (a) England
      - (1) Under the Normans,
      - (2) Under the Plantagenets
    - (b) France
      - (1) House of Capet, 987-1328
        - (a) English possessions there
        - (b) Crusades and persecution of the Albigenses
        - (c) The States-general
      - (2) House of Valois, 1328-1498
    - (c) Germany
      - (1) The successors of Charlemagne
      - (2) Conrad of Franconia and the Saxons
      - (3) Lothair of Saxony, and the Hohenstaufens, 1125-1254
      - (4) The great Interregnum, 1254-1273
      - (5) Rise of the Hapsburgs
    - (d) Spain
      - (1) Union of Castile and Aragon
      - (2) Conquest of Granada, 1492
      - (3) Growth of royal power
      - (4) Inquisition and its lasting effects
      - (5) Discoveries in the New World
    - (e) Italy
    - (f) Russia

## Modern History, from 1492

- I. THE REFORMATION AND THE RELIGIOUS WARS, 1500-1648
- (1) Germany and Switzerland
    - (a) The humanists
    - (b) Luther and the Edict of Worms, 1521
    - (c) Council of Trent, 1545
    - (d) John Calvin
  - (2) Denmark, Norway and Sweden
  - (3) Rise and fall of Spain
  - (4) England under the Tudors, 1485-1603
    - (a) Henry VIII, 1509-1547
      - (1) Act of Supremacy, 1534
      - (2) Articles of Faith, 1539
    - (b) Edward VI, 1547-1553
    - (c) Mary, 1553-1558
    - (d) Elizabeth, 1558-1603
  - (5) France
    - (a) Beginnings of Reformation
    - (b) Civil Wars
  - (6) Thirty Years' War, 1618-1648
- II. ERA OF ABSOLUTISM AND DYNASTIC WARS, 1648-1789
- (1) England
    - (a) James I, 1603-1625
    - (b) Charles I, 1625-1649
    - (c) The Commonwealth and Protectorate, 1649-1660
    - (d) The Restoration
    - (e) William and Mary, 1688-1702
      - (1) Bill of Rights, 1689
      - (2) Act of Settlement, 1701
    - (f) Anne, 1702-1714
      - (1) War of the Spanish Succession
      - (2) Union with Scotland,
    - (g) Supremacy of England under the House of Hanover
      - (1) Development of cabinet government
      - (2) Foreign affairs
  - (2) France
    - (a) Ascendancy under Louis XIV
    - (b) The regency, 1715-1723
    - (c) The struggle with England for supremacy
      - (1) Loss of Colonies
  - (3) Russia
    - (a) Early history
    - (b) Peter the Great, 1682-1725
    - (c) Catharine II, 1762-1796
  - (4) Rise of Prussia
    - (a) The Great Elector, 1640-1688
    - (b) Frederick William I
    - (c) Frederick the Great, 1740-1786
- III. REVOLUTION AND RECONSTRUCTION
- (1) The French Revolution and the Era of Napoleon
    - (a) The National Assembly
    - (b) War against Austria
    - (c) The Reign of Terror
    - (d) The Directory
    - (e) The Consulate, 1799-1804
    - (f) The Empire, 1804-1815
  - (2) Great Britain
    - (a) The Reform Bill
    - (b) Repeal of the Corn Laws
    - (c) Free Trade
    - (d) A world-empire
  - (3) The revolutions in 1830
    - (a) July Revolution in Paris
    - (b) Belgium independent
    - (c) Insurrection in Poland
  - (4) The revolutions of 1848
    - (a) In France
    - (b) In Germany
    - (c) Italy
    - (d) Hungarians
  - (5) Unification of Italy
  - (6) Unification of Germany
  - (7) Russia
    - (a) Crimean War
    - (b) Revolt of Bosnia
    - (c) Congress of Berlin
  - (8) The United States
    - (a) Formation of the Union
    - (b) War of 1812
    - (c) The Civil War
- IV. THE WORLD AT WAR.
- (1) General European war, 1914.
  - (2) Involves Japan, British colonies, China, United States and many smaller American nations.
  - (3) Defeat of Germany and its allies
  - (4) Treaty of Versailles

that each falls into its proper place. If we consider only Napoleon during the Revolutionary and Napoleonic era we shall not be able to understand why it was that France, though a defeated nation, still held the balance of power after 1815. Of course we cannot at one sitting understand all European history since 1500, but we can grasp some of the main currents of events and subordinate the minor facts to their proper place.

**Material for Study.** Abundant material is provided in these volumes for the student who wishes to know the history of his own or any other country. The history of each nation is given in a subhead of the article upon that nation. These subdivisions contain numerous references to the histories of other nations, as well as to other articles upon important wars, battles, political events of sufficient importance to be known by distinctive names, such as Congress of Vienna, Barèbones Parliament, and others; treaties; famous documents; temporary systems of government, such as the commonwealth and the directory; great institutions, such as the feudal system and chivalry, and important special periods, such as the Dark Ages, the Middle Ages, etc. Frequent reference is also made to the biographies of famous individuals, and in a few cases general discussions of the periods in which they lived are given under their names; this is true of Napoleon and Cromwell.

The history of the United States from the discovery of America is contained in a long article which forms a subdivision of the article *United States*. This is subdivided by periods and contains frequent references to a great many other articles, such as those upon battles and wars, famous laws, treaties, congresses, documents and organizations. Among these titles are such as the following: *The Alabama; Gettysburg, Battle of; Antietam, Battle of; Anti-Federalists; Bacon's Rebellion; Bering Sea Controversy; Black Friday; Bon Homme Richard; Boston Massacre; Charter Oak; Chinese Exclusion Act; Cincinnati, Society of The; Clayton-Bulwer Treaty; Wilmot Proviso; Spanish-American War; World War, etc.*

Under the name of each President are given the principal events of his administration. The article upon each of the states contains a brief history of the state. In general references and cross-references have

been inserted whenever possible in order that related subjects may be studied in their proper connection.

If the pupil and teacher both realize that history is more than a set of dates and names to be memorized, that they are studying the deeds and thoughts of people who lived as we live, that they are considering forces many of which are at work to-day, then the study of history will be fascinating. It will open our eyes not only to the past but to the present and future, for it is by seeing how other people have lived that we ourselves learn to live. The article on **HISTORY, METHODS OF TEACHING**, will be found of great value in enabling the pupil to understand the true purposes of instruction in history; its general suggestions and specific methods of teaching in the primary, intermediate and grammar grades, and the lists of books suited to the work of these grades will be of special assistance to the teacher or parent.

*International Relations.* No nation can live in "splendid isolation" from the rest of the world; it is inevitably affected by events with which it has no immediate relation. For example, the infant republic of the United States, from 1807 to 1812 had no direct interest in the great Napoleonic struggle, but diplomacy was frequently strained during that period. No one can understand the Jefferson and Madison administrations without knowing Western Europe of that period. Therefore, to acquire a clear knowledge of a country's history it is necessary to know what is the trend of events elsewhere. The World War proves this.

**Related Material.** In addition these volumes contain biographies of the following men who have been writers of history.

|                      |                       |
|----------------------|-----------------------|
| Adams, Charles K.    | Lodge, Henry C.       |
| Bancroft, George     | Lossing, Benson J.    |
| Bancroft, Hubert H.  | Macaulay, Thomas B.   |
| Bede                 | McCarthy, Justin      |
| Bourinot, John, Sir  | McMaster, John B.     |
| Bryce, George        | Michelet, Jules       |
| Bryce, James         | Mommsen, Theodor      |
| Buckle, Henry T.     | Motley, John L.       |
| Caesar, Caius Julius | Nepos, Cornelius      |
| Eggleston, Edward    | Parkman, Francis      |
| Ferrero, Guglielmo   | Plutarch              |
| Fiske, John          | Prescott, William H.  |
| Froissart, Jean      | Ranke, Leopold von    |
| Froude, James A.     | Renan, Ernest         |
| Gardiner, Samuel R.  | Ridpath, John C.      |
| Geoffrey of Monmouth | Ross, Alexander       |
| Gibbon, Edward       | Sallust               |
| Green, John Richard  | Tacitus, Publius      |
| Guizot, F. P. G.     | Cornelius             |
| Hallam, Henry        | Taine, Hippolyte A.   |
| Hart, Albert B.      | Thiers, Louis Adolphe |
| Herodotus            | Thucydides            |
| Hume, David          | Thwaites, Reuben G.   |
| Josephus, Flavius    | Wilson, Woodrow       |
| Lecky, William E. H. | Xenophon              |
| Livy                 |                       |



## HISTORY, METHODS OF TEACHING. PURPOSES. The purposes of teaching history are:

1. To teach the facts of history so that the pupils will be well informed concerning the origin and growth of the country and the principles upon which the nation is established.

2. To stimulate patriotism. Patriotism may be considered as of two classes, military and civic. Of the former class there is no lack. The opportunity to join an army,

to engage in military parades and to go forth to war contains attractions that appeal strongly to young men, and whenever the country is imperiled by enemies, foreign or domestic, there are always thousands ready to rush to her defense.

Military patriotism needs little encouragement; it is not the sort that requires the greatest amount of attention on the part of the teacher. Civic patriotism is of a more quiet nature; yet it often requires the exercise of a moral heroism far greater than the physical courage required of the soldier. Civic patriotism includes all of those virtues that make the honest and upright citizen; the man who would not wrong another in business; who is careful and conscientious in the discharge of all of his political duties, and who is willing, if called upon, to accept public office and discharge his duties faithfully, because of his interest in the public welfare. Patriotism of this sort needs to be emphasized; nowhere can this be done to better advantage than in the history class.

3. To develop the minds of the pupils. History is a valuable study for the purpose of appealing to the imagination, exercising the memory and strengthening the reasoning powers. This last line of development, however, should be left largely to the work of the advanced grades; but the history stories suitable for the lower grades, both primary and intermediate, are remarkably well adapted to training the imagination and memory and to materially assisting the pupil in the development of language.

4. To train the judgment. History is far

from being a memory study. It presents a series of problems, each of which arises from certain causes and must be solved in accordance with certain conditions. In the discovery of these causes and conditions and the forming of conclusions by their comparison, there is afforded one of the best opportunities possible for training the reasoning powers. Since history is not an exact science, and since the causes and conditions are largely dependent upon human action, the problems to which they give rise are more various, more complex and more far-reaching than are the problems of mathematics and other exact sciences, and if history is properly taught in the grammar grades, it is one of the most valuable branches for training the reasoning powers.

5. To direct the reading of pupils. The breadth of the subject requires extensive reading on the part of the pupils, if they would acquire a comprehensive knowledge of history. This reading cannot all be done while they are pursuing the work as provided by the course of study or during their period in the public schools, but the proper use of supplementary reading and careful direction by the teacher will lead most pupils to acquire a love for the reading of historic works, and this love once acquired, it will lead to the continuance of historic study after the work of the school is finished.

6. To strengthen character. The study of the lives and characters of the great leaders of our own and other nations never fails to exert an ennobling influence upon the pupils and to give them an inspiration to attain high ideals and to live pure lives. This is the most important of all the results to be obtained from this study. In short, all that has been said under *Purposes* can be summed up in this: The purpose of teaching history is to make good citizens.

**Preparation of the Teacher.** In order that the above purposes may be attained, the teacher of history needs an adequate preparation for the work. This preparation should include:

1. A thorough knowledge of the subject, including its relation to other subjects, and especially to geography.

2. A knowledge of the methods of teaching. See *METHODS OF TEACHING*.

3. Ability to direct pupils in their study of history, especially in the use of supple-

mentary matter, such as reference books and books for collateral reading.

4. Ability to present the subject in a clear, vivid and interesting manner. This preparation can be obtained in professional schools, such as normal schools and colleges, in a measure in the public schools, provided the pupil is under a good teacher, and in a great measure by self study. The knowledge of history that the teacher should have as a foundation for her work must far exceed a knowledge of the facts that she expects to teach, for without this extensive knowledge she will be unable to make a wise selection of facts or to present them properly:

The work in history in the public schools naturally divides itself into three groups, that of the primary grades, that of the intermediate grades and that of the grammar grades.

**Primary Grades.** The teaching of history in the first and second grades should be wholly oral and should consist of history stories. These may be biographies, which include the boyhood of eminent men, such as Washington, Lincoln and Columbus, or the stories of certain phases of history that the children can easily understand. These will include stories of exploration, such as a brief account of John Smith, including the settlement of Jamestown and the story of Pocahontas; stories of invention, such as the invention of the cotton gin and the steamboat, and accounts of the manners and customs of the early colonists. These stories should be told by the teacher and after they have been repeated two or three times, reviews should be conducted, in which the pupils should tell back to the teacher the stories to which they have listened. As far as possible, the children should tell the story in a connected form. This gives training in language as well as in history. In the preparation of these stories the teacher should use care to keep them within the capacity of the pupils, to present them in such a way as to make them attractive and to enable the pupils to understand fully everything that is narrated. In order that this may be done, the teacher should prepare the story with a view to the facts that will be presented, to the language that is to be used and to the time required. Young children will listen to a vivid account for eight or ten minutes, but when the account is prolonged beyond this time many of them become inattentive; hence the story should be short and pointed.

In the third grade the stories told by the teacher should be supplemented by reading on the part of the pupils. If it is impossible to procure books for the pupils to read, the teacher should read from such suitable books as she can obtain. A good illustration of the class of books valuable for pupils of this grade is found in the following list: Edward Eggleston's *Stories of Great Americans for Little Americans* and *Stories of American Life and Adventure*; Mary Hall Husted's *Stories of Indian Children* and Annie Chase's *Children of the Wigwam*. Among biographies valuable for this grade are found Jesse R. Smith's *Life of Washington*; James Baldwin's *Benjamin Franklin*, also his *Stories of Great Americans*; Frances Perry's *Four American Inventors*, and Anna Holman Burton's *Four American Patriots*. These are fair samples of a large number of books now easily obtainable.

All through these grades the pupils should be taught sentiments of a patriotic nature, including patriotic songs and extracts from such poems as *The Landing of the Pilgrims* and the *Building of the Ship*. In the selection of subject-matter for this work the teacher should be guided almost entirely by the capacity of the pupils, since in grades having a large percentage of children of foreign extraction who are not familiar with English, memory gems can scarcely be attempted before the latter part of the second year.

**Intermediate Grades.** The work of the intermediate grades is a continuation of that in the first three grades. To the stories told by the teacher there should be added more or less systematic reading of history by the pupils. Such books as Edward Eggleston's *First Book in American History* and Mowry's *First Steps in the History of Our Country* are valuable for systematic reading in these grades. The pupils should also be encouraged to read biographies, provided they can be obtained. A good illustration of biographies suited to these grades is found in Elbridge S. Brooks's *Columbus, Franklin, Deatur and Grant*, and Louise Putnam's *Life of Abraham Lincoln*.

Thus far these suggestions have dealt only with American topics. In some schools it may be unwise to go beyond these, but whenever the capacity of the pupils and the work in the course of study will allow it, the children of the intermediate grades, especially of the fourth and fifth, should obtain

some knowledge of other people. If the pupils can obtain the books, they should read during this time the following and as many more as opportunity will permit: Jane Andrews's *Ten Boys on the Road from Long Ago to Now*, Guerber's *Story of the Greeks*, *Story of the Romans* and *Story of the Chosen People*. These are typical of a number of other works of similar nature, which can be used at this time to great advantage. The reading of this period should also include considerable biography, not only of Americans, but of the great men of other nations. Particularly suitable for these grades are Sarah Bolton's *Lives of Girls Who Became Famous* and *Lives of Poor Boys Who Became Famous*. Many other books of a like nature are easily obtainable, and in towns and cities school libraries are usually well supplied with material of this sort. If the pupils cannot obtain books, it is of great advantage in the history work for the teacher to possess them and read from them. The memory gems during this part of the work should be emphasized, and a large number of extracts from poems, orations and other utterances of public men should be memorized, care being taken to see that the pupils understand a selection before learning it.

**Grammar Grades. Text-books.** The systematic study of history usually begins in the seventh or eighth grade, where the text-book is introduced, and it is at this point that the teacher frequently meets her greatest difficulty. The book should be carefully studied by the teacher, its plan ascertained and the difficult points discovered. This should be done before any work is begun with the class. When the teacher is familiar with these difficulties, she should plan her work so as to remove them as far as possible from the pupils. This can be done first by teaching the pupils how to study history from a text-book. A good plan is to use the book in class for a few lessons, asking the pupils to read and discuss the paragraphs assigned, pointing out to them in this way what they are expected to retain from their study. They should learn the facts and the relation of these facts to one another, but they should not attempt to commit the text to memory. Care should also be taken in the assignment of lessons so that the important paragraphs may be properly emphasized and the unimportant ones passed over lightly. In case

the advance lesson contains any point that the pupils will have difficulty in understanding, the matter should be explained at the time of the assignment of the lesson. If other works are to be consulted, specific directions for their reading should be given. These directions should often include the page and the paragraph of the work to which the pupils are referred. The teacher should so plan the recitation as to make the history appear a live subject. In this way the interest of the pupils will at once be secured and retained.

*Cause and Effect.* History is a logical sequence of events, each depending upon certain causes and becoming a cause upon which events that follow are based; therefore, history should be studied from the standpoint of cause and effect. In proceeding according to this plan, special emphasis should be placed upon the relation of geography to history. The teacher should lead the pupils to see that all great movements of history have rested upon geographic conditions and have been determined by them.

A good illustration is the relation of the geography of North America to its settlement by the English and French colonists. Why did the French penetrate so much farther inland and range over so much larger territory than the English, during the same period? Why did the English settle in compact communities, while the French failed to establish many settlements? The answer to these questions is based very largely upon the geographical conditions. The Saint Lawrence formed a waterway leading far inland, by means of which the Great Lakes and the Mississippi Valley were reached with comparative ease, while the barrier of the Appalachian Mountains was an obstruction that the English colonists could not overcome for more than a century. Again, the purpose that led to colonization by each of these nationalities was an important cause in determining their method of life in the New World. The English came because they wished to establish a home wherein they would be free from all restrictions in carrying out the form of worship that they believed to be true. The French were actuated by the desire to acquire wealth through trading with the Indians, and they could not do this successfully if they remained in settled communities and devoted their time to tilling the soil. All events are susceptible

of similar treatment, and the connection between cause and effect should never be overlooked.

*Maps.* Maps should be constantly used in connection with the text-book in history, and it is an advantage to the class if they have been used in the lower grades in connection with some of the narratives. It is a good plan to have the pupils construct the map as the study proceeds. When outline maps are used, this can be done without consuming much time, and it is of great assistance in enabling the pupils to understand the geographic relations.

*Dates.* Only the important dates should be memorized, such as the discovery of America by Columbus, the settlement of Jamestown, the landing of the Pilgrims, Braddock's expedition and the capture of Quebec by the English. The tendency is to have the pupils memorize too many dates, and this is liable to lead to confusion.

*Outlines.* The skilful teacher will either construct for her class or direct them in the construction of an outline of the subject as the study proceeds. These outlines should not be elaborate, but they should show the relation of one event to another, should include the dates to be memorized and should be so constructed as to form the basis of review lessons.

*Government.* The underlying principles of government should be taught in connection with the history in the eighth grade, and these should be discussed and explained as they are reached in the regular course of study, as the difference between the royal and proprietary governments in the colonies previous to the Revolution. The difference in political principles which arose between the colonies and Great Britain and finally led to the Revolutionary War should be thoroughly discussed, and so much of these principles as is necessary to give the pupils a clear understanding of the points at issue should be learned.

*Wars.* In the study of wars the causes leading to the war and the results arising from it are far more important than the military campaigns. The tendency is to place too much stress upon the campaigns and battles, consuming so much time in this branch of study that but little time is left for the study of the more important features. In general, the military history of wars should be studied by campaigns. One cam-

## Outline of Methods of Teaching History

### I. PURPOSES

- (1) To present facts in such a manner that the principles of growth and government of nations will be established
- (2) To stimulate patriotism
- (3) To develop the minds of pupils to imagine and grasp a situation
- (4) To train the judgment and reasoning powers
- (5) To direct the reading of pupils along supplementary lines and create a permanent choice for historical reading
- (6) To strengthen and develop character

### II. PREPARATION OF THE TEACHER

- (1) A thorough knowledge of subject
- (2) A knowledge of methods of teaching
- (3) Ability to direct pupils in study
- (4) Ability to present subjects in an interesting manner

### III. PRIMARY GRADES—FIRST, SECOND AND THIRD

- (1) History stories
- (2) Biographies of great men
- (3) Stories of exploration
- (4) Patriotic songs; literature

### IV. INTERMEDIATE GRADES—FOURTH, FIFTH AND SIXTH

- (1) History stories
- (2) Biographies
- (3) Stories of travel
- (4) Memorizing patriotic songs and gems

### V. GRAMMAR GRADES—SEVENTH AND EIGHTH

- (1) Text-books
- (2) Causes and effects
- (3) Maps
- (4) Outlines
- (5) Dates
- (6) Government
- (7) Wars

paign can be thoroughly studied as a type and the others passed over lightly. A good type is Burgoyne's campaign in the Revolutionary War, the study of which should include the purpose for which it was organized, the army with which he started, the conditions of the country through which he passed, the causes that led to his defeat and the results following his capture. The campaign terminating in the Battle of Gettysburg in the Civil War is also excellent for systematic study. Minor battles should usually be ignored, unless they constitute the beginning of a chain of events that lead to important results.

*Supplementary Work.* No text-book contains a sufficiently full account of American history to make the subject interesting, and it should be supplemented by additional reading and research. To this end the teacher of history should be able to place before the pupils such reference works and other books related to the subject as will enable them to follow out the study along various lines. Many of these works partake of the nature of fiction, but they are no less valuable. The libraries are so well stocked with them that the problem before the teacher is one of selection. Every great text-book publishing firm offers a list of books of great value to the teacher and pupils. Catalogues of these are freely sent on request.

**HITTITES**, descendants of Heth, who occupied part of the country lying between the Dead Sea and the Mediterranean from before the time of Abraham until 717 B. C., when they were conquered by Sargon. At one time a Hittite empire extended over a large area in Asia Minor and Syria, and it was intermittently at war with Egypt and Assyria. After they were conquered by the Assyrians, the Hittites lost their national identity and existed only in scattered groups.

**HIVES**, *hvez*, an annoying disease which manifests itself in an eruption of white, swollen patches that turn red after the victim scratches them. These patches itch intolerably. The eruption appears and disappears with great suddenness; an attack is due to the presence in the blood of a substance poisonous to the victim. In most cases the poison is absorbed from the intestines, and the most effective remedy is to clean out the bowels and to diet. The poison most frequently present comes from an acid found in fish, milk, juicy meat and meats from carcasses containing much blood. Eat-

ing strawberries and other fruits will give some persons hives. If a person susceptible to this ailment knows what to avoid in eating he can usually ward off attacks. Local applications of witch hazel or solution of baking soda will often relieve itching.

**HOANG-HO**, or **HWANG-HO**, *hwahng'ho*, meaning *yellow river*, is the second river in China in size, the Yang-tse-kiang only being larger. Its sources are in mountains north of Tibet. It flows in a winding course in a generally easterly direction into the Gulf of Pe-chi-li. Its length is estimated at about 2,600 miles, and it drains an area of probably 400,000 square miles. The Hoang-Ho is navigable only a short distance from its mouth. It derives its name from the vast quantities of yellow earth held in a state of solution by its waters. This dirt, being deposited, raises its bed to such an extent that it frequently overflows, causing great loss of life and property.

**HOAR**, GEORGE FRISBIE (1826-1904), one of the foremost and most highly-respected American statesmen of his generation, was born in Concord, Mass. He was graduated at Harvard, began the practice of law in 1849, entered politics as a Free-Soiler, joined the Republican party at its organization, was elected to the legislature in 1852 and was a member of Congress from 1869 to 1877. He served on the Electoral Commission in 1877 and in the same year was elected to the United States Senate. He was four times reëlected, becoming conspicuous as a consistent opponent of anti-imperialism, for notable service on important committees and as an eloquent orator.

**HOBART**, GARRETT AUGUSTUS (1844-1899), a Vice-President of the United States, who died while holding that office. He was born at Long Branch, N. J., was graduated at Rutgers College and in 1869 became a lawyer, locating at Paterson, in his native state. Rising successively through the posts of city attorney, state assemblyman and state senator, he aspired to the United States Senate, but was defeated. He was four times a delegate to Republican national conventions, and in 1896 was nominated as the running-mate of William McKinley, who was named for President. His election followed, and he became a valued counselor of the President. Largely through his influence as Vice-President the proposal for independence of the Philippine Islands was defeated.



**HOBART**, TASMANIA, the capital and largest city, on the west shore of the Derwent River, twelve miles from the coast, with Mount Wellington as a fine background. The most noteworthy buildings are the government house, a town hall, two cathedrals, a public library, the parliament buildings, a royal theater and a museum and art gallery. As the harbor is excellent, the town is the center of a considerable trade. The temperature is never extreme and the region is very healthful; Hobart is therefore a favorite Australian summer resort. Population, 1911, with suburbs, 38,391.

**HOBBEWA**, *hob'e mah*, MEINDERT (1638-1709), one of the foremost landscape painters of the Dutch school. The place of his birth is unknown, but he spent most of his life at Amsterdam, where he probably studied under Ruysdael. During his lifetime his work was not appreciated, but since his death he has been ranked by critics second only to Ruysdael among Dutch landscape painters. HobbeWA differed from Ruysdael in choosing as subjects the gentler aspects of nature, such as woodland scenes and quiet pools. In technical skill he probably excelled Ruysdael. His colors are rich and transparent and depict with especial brilliancy the beautiful effects of sunlight. Among his famous paintings are *The Water Mill*, in the Glasgow Gallery; *The Avenue near Middelharnis* (Holland), in the National Gallery, London, and *The Ruins of Brederode Castle*, also in the National Gallery.

**HOBBS**, *hobz*, JOHN OLIVER. See CRAIGIE, PEARL RICHARDS.

**HOBOKEN**, N. J., in Hudson County, on the Hudson River, at the base of the Palisades, opposite New York, of which it is a suburb, and adjoining Jersey City, on the Delaware, Lackawanna & Western, the New Jersey Junction, and the West Shore railroads. The latter connects the city with several other roads. It is connected with New York City by ferries and the Hudson River tunnels. The city is the seat of Stevens Institute of Technology. There are also a public library, Saint Mary's Hospital and other prominent buildings. Hoboken is a great center for shipping, especially of coal, and is the terminus of many important transatlantic steamship lines. The principal docks were built by the Hamburg-American, the North German Lloyd, the Holland-American and the Scandinavian-American passenger

and freight lines. The German-owned property was confiscated by the United States government during the World War. Among important manufactures are machine shop products, marine engines, motors, fire engines, leather goods, silk, wall paper and caskets.

The town was first called Hobocan Hack-ing, and was a part of the patroonship granted to Marco Pauw in 1630. A house was built about ten years later, and a sparse settlement grew up. The present city really dates from 1804, when John Stevens, "the founder of Hoboken," bought the land and laid out the town. It was incorporated in 1849. Population, 1910, 70,324; in 1917, 78,324 (Federal estimate).

**HOBSON**, RICHMOND PEARSON (1870- ), an American naval officer, who won fame by a daring exploit in the Spanish-American War. He was born at Greensboro, Ala., and was graduated from the United States Naval Academy at Annapolis in 1889. At the opening of the Spanish-American War he was with Admiral Sampson's fleet. After the Spanish squadron was located in the harbor of Santiago Lieutenant Hobson conceived the plan of sinking a ship in the narrow entrance to the harbor and thus preventing the escape of the fleet. With seven companions he took the collier *Merrimac* into the entrance of the harbor on Friday morning, June 3, 1898, and sunk the boat in the channel, but did not accomplish the desired result. He was picked up by a Spanish boat and retained as prisoner of war until exchanged a few weeks later. After the war he was sent as a naval constructor to the Philippines. In 1903 he resigned from the navy. Five years later he was elected to the House of Representatives from Alabama, and was reelected in 1910 and 1912. Later he removed to Evanston, a suburb of Chicago, and devoted his time largely to the cause of prohibition.

**HOCK'EY**, or **SHINNEY**, a ball game in which each player is armed with a *hockey*, or *shinney stick*, with which he tries to drive a small ball through the team of his opponents to their goal line. It is a national sport of Canada.

In North America the development of the game is due chiefly to the Victoria Hockey Club and McGill University and to other clubs co-operating with them. About 1881 the first attempts were made to draw up a

recognized set of rules. Three years later the first general tournament was held, and in 1887, the "Amateur Hockey Association of Canada" was formed. Soon afterwards the efforts of several Canadian teams resulted in the spread of the game to the northern sections of the United States, where it has become fully as popular as in the Dominion. The "Canadian Amateur Athletic League" has jurisdiction over the numerous Canadian hockey clubs and the American Amateur Hockey League has a similar position in the United States. The emblem of supremacy among the Canadian leagues is the Stanley Cup, presented by Lord Stanley, once governor-general of Canada.

**Method of Play.** The game should be played on a rink at least 112 feet long by 56 feet wide. The goals should be 6 feet

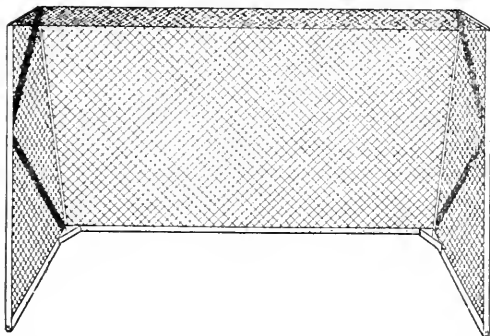

wide and 4 feet high and should be provided with nets like the lacrosse goal. The *puck* is a flat round piece of vulcanized rubber, one inch thick and three inches in diameter. The sticks are made of one piece of hard wood, and may be not more than three inches wide in any part. Each team consists of seven men. At the beginning of the match the puck is *faced* or *faced off*. Both sides try to secure the puck and to pass it to a

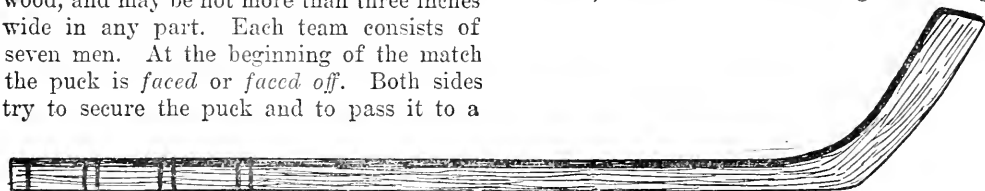

HOCKEY STICK

point from which a goal may be *shot*. The two centers then face off again and play continues as before. A game generally consists of two periods of twenty or thirty minutes each; in case of a tie an additional period is played.

Ice hockey requires good skaters, as speed and sureness are the essentials of a good hockey player. Because of the speed with which skaters can cover a rink, hockey is

one of the fastest of all games. At one moment the puck may be at one end, and then thirty seconds later a goal may be scored at the other end. Aside from the work of the offense, the goal-keeper has probably the most responsible position. A good goal will save his side from many a defeat even though his mates may be weaker in other parts of the game. Hockey offers considerable opportunity for individual effort, but the best results are obtained when the individual is subordinated to the team and consistent team-work is developed.

**HOE, RICHARD MARCH** (1812-1886), an American inventor, who gave a wonderful impetus to the business of newspaper publishing, was born in New York City. He was the inventor of the rotary printing press, having introduced in 1846 the Hoe Lightning Press. Later he and his brother invented the web-perfecting press, now in general use in the printing of newspapers. See **NEWSPAPER; PRINTING PRESS**.

**HOFMANN, hof'e'mahn, HEINRICH** (1824-1902), a German painter, born in Darmstadt. He studied at Düsseldorf, and in the Antwerp Academy. After traveling in Italy he settled in Dresden in 1862, and became professor in the Academy. Although his subjects cover a wide field, the great majority of his admirers know him only through his scenes in the life of Christ. The most popular of these pictures are *Christ Taken Prisoner*, *Christ in the Temple* and *Christ's Sermon on Lake Gennesaret*.

**HOFMANN, JOSEF** (1877- ), one of the world's greatest pianists, was born at Cracow, Poland. His father began teaching

him music when he was little more than an infant and then put him under Rubenstein. The boy began his public career at the age of six, and when nine years old made a concert tour of Europe. He was then taken to America, where fifty-two concerts were arranged for him in two and a half months. He showed signs of breaking under the strain, and the Society for the Prevention of Cruelty to Children was moved to pro-

test. Hofmann did not appear in public again until 1894; since then he has delighted both Europe and America with performances of his own compositions and scholarly interpretations of the great masters.

**HOG**, a common domestic animal, belonging to the same family as the boar. It is one of the most valuable of farm animals, and also one of the ugliest. The head is prolonged into a pointed or blunted snout, the skin is very thick, is mostly covered with stiff bristles, and the body is clumsily formed. Hogs are black, red, spotted and yellowish-white in color. The creatures are omnivorous in habits, that is, they devour almost any vegetable or animal substance. The hog is also prolific, having two litters in a year, an average litter consisting of nine young.

Its flesh, known as *pork*, forms a material part of the food of mankind, though Jews are strictly enjoined not to eat it, and Mohammedans agree in this prohibition. Pork takes salt better than almost any other meat, and hence it forms an important article in military and naval stores. The lard of the hog is used in a variety of preparations, and the bristles are used in large quantities in the manufacture of brushes, while the skin, when tanned, is used by saddlers and bookbinders.

The hog is erroneously looked on as a peculiarly stupid and gluttonous animal; it has also an undeserved reputation for filthy habits, but the too common filthiness of pigsties is more the fault of the owner than the tenant. It wallows in the mire, but this is a peculiarity of all animals having a thick skin, and they do it to cool themselves and provide a protection against insects. The wild boar, from which most of our domesticated varieties are derived, is found in most parts of Europe and Asia. In size the wild animal considerably exceeds the domesticated hog; the legs are longer and more muscular, and the back is therefore much higher.

**Related Articles.** Consult the following titles for additional information:

|      |              |
|------|--------------|
| Lard | Meat Packing |
| Meat | Pork         |

**HO'GARTH, WILLIAM** (1697-1764), a celebrated English pictorial satirist, whose paintings and engravings picturing the follies and vices of his time are masterpieces. He was born in London, and began his career as a silversmith. His ambition was to be a line engraver, but in 1724 he began the study of painting and succeeded better as painter

than as engraver. Some of his best work is in series, such as *Marriage à la Mode*, six pictures now in the National Gallery, London; other series are *The Harlot's Progress* and *Industry and Idleness*. His most important designs for engravings are *Masquerades* and *Operas* and illustrations for Butler's *Hudibras*. He painted a number of portraits, the most popular being that of himself with his dog. There are in England many private and public collections of his work.

**HOGS' HEAD**, an obsolete measure of capacity in the English system, containing 63 old wine gallons or 52½ imperial gallons. It varied in different times and places and for different substances. For beer it was 54 gallons, for rum, 40 to 50 gallons, for brandy, 45 to 60 gallons. In the United States, the measure is yet sometimes employed, and is equivalent to 63 American gallons or 52.485 imperial gallons.

**HOHENSTAUFEN**, *ho'en stow'fen*, the dynasty which ruled Germany from 1138 to 1254. The first of the House was Conrad III, who came to the throne on the death of Lothair of Saxony. The other kings of the line were Frederick I, Barbarossa; Henry VI; Otho IV; Frederick II, and Conrad IV, whose death in 1254 brought the rule of the House of Hohenstaufen to an end. The Hohenstaufens were, for the most part, strong kings, and the imperial title was with them something more than a name. The two Fredericks were among the most remarkable of medieval sovereigns.

**HOHENZOLLERN**, *ho'en tsohl urn*, the family name of the royal house of Prussia from the twelfth century to November 28, 1918. After 1871 the reigning member was also German emperor. The identity of the first Hohenzollern is not a matter of definite record, but the family name was derived from the Castle Zollern, or Hohenzollern, in medieval Swabia, or Suabia, which in turn took its name from the Suevi, as the Germanic people of the third century were called. The last of the Hohenzollerns, though he had six sons to assure the succession and perpetuity of the house, was William II, the "war lord of Europe" and the third German emperor. He was held responsible for the most atrocious war in history, forced by Germany upon the world in 1914.

Among the famous men of the line were Frederick William, the Great Elector; Frederick II, called Frederick the Great; William

I, under whom Bismarck fashioned the German Empire, and William II, his grandson. With notable exceptions the Hohenzollerns were strongly militaristic, and believed in the "divine right of kings." Frederick III, the father of William II, was one of the mildest and most democratic representatives of the family, but he ruled only three months.

William II, the last of the line, was idolized by his subjects during more than four years of the World War, but when defeat overtook the German army and privations had sapped the vigor of the nation he could not stay the tide of bitter resentment, and fled the country, finding sanctuary in Holland. The peace conference ordered Germany to deliver the former emperor for trial before an international tribunal (see William II).

**Related Articles.** Consult the following titles for additional information:

|                   |                   |
|-------------------|-------------------|
| Frederick II      | Germany (History) |
| Frederick III     | William I         |
| Frederick William | William II        |

**HOLBEIN**, *hohl'bine*, the name of two celebrated German painters, father and son, both born at Augsburg.

**Hans Holbein**, the Elder (1460-1524), who painted numerous Biblical scenes, worked at Basel, Ulm and Frankfurt. His style shows the influence of both the Flemish and Italian masters. Among the sacred legendary and historical subjects he depicted were *Virgin and Child*, *Enthroned with Angels*, *The Nativity*, *Coronation of the Virgin*, *The Last Supper*, *The Crucifixion* and *The Entombment*. He also depicted several scenes in the lives of the saints.

**Hans Holbein**, the Younger (1497-1543), was a son of the preceding. His youth was spent in Basel and his later life in England, to which country he went at the beginning of the Reformation, having procured through his friend Erasmus the patronage of the chancellor, Sir Thomas More. He was appointed court painter by Henry VIII. In the Windsor collection he left portraits of all the eminent Englishmen of the time. The most celebrated of his pictures is the *Madonna of the Burgomaster Meyer* at Darmstadt. Other works are *Passion Scenes*, *The Ambassadors* and various excellent portraits.

**HOLDEN**, EDWARD SINGLETON (1846- ), an American astronomer, born at Saint Louis, Mo., and educated at Washington University and the United States Military Academy. After eight years as professor of mathematics at the naval academy and four

years as director of the Washburn Observatory at Madison, Wis., Holden became president of the University of California in 1885 and later director of the Lick Observatory on Mount Hamilton in California. Here, surrounded by all the conveniences which modern science could furnish, he did his most important work. Among his writings are an *Index Catalogue of the Nebulae*, *A Life of Sir William Herschel*, an *Astronomy* (with Newcomb) and *Essays in Astronomy*.

**HOLIDAY**, any day set apart as a religious or secular festival, observed either nationally, by states or provinces, or locally. In a general sense it is a day during which a person is released from his every-day labors, with the expectation that to some degree, at least, he shall center his thought and actions upon the event which the occasion commemorates. In the United States the principal holidays are New Year's Day, Washington's Birthday, Decoration Day, the Fourth of July, Labor Day, Thanksgiving Day and Christmas, but nearly every state has its particular holidays. There is no national legal holiday in the United States, each state controlling this matter for itself.

In Canada the statutory holidays are Sunday, New Year's Day, Christmas, Empire Day (May 24), Dominion Day (July 1), and Labor Day (the first Monday in September).

**HOLLAND**, JOHN PHILLIP (1842-1914), an Irish-American inventor whose name is connected with the perfection of the submarine. He was born and raised in Ireland, where he became imbued with a deep hatred for England. During the American Civil War, while teaching in Cork, he read about the battle between the *Monitor* and the *Merrimac*, and determined to invent a device which could destroy the warship of the future, the iron-clad battleship. To him, this seemed the only way to overcome England's supremacy on the sea.

Then began a period of experiments. Holland succeeded in building a submarine for the Fenians, but it was never used. In 1898, over twenty years afterward, he completed a submarine for the United States government, fifty feet in length and equipped with one torpedo tube. All of the nations later modeled their submarines after the pattern of the Holland boat, and this holds true for those of the largest dimensions (see SUBMARINE). The inventor of this remarkable war machine died in poverty.

**HOLLAND, JOSIAH GILBERT** (1819-1881), an American author and editor. In 1844 he was graduated at the Berkshire Medical College, but he never practiced. At the age of thirty he connected himself with the Springfield *Republican*, and as he exhibited a remarkable aptitude for journalism, the paper soon became vastly popular. In 1870 he founded *Scribner's Monthly*, which, under another ownership, is now the Century Magazine. Among Holland's books, many of which became very popular, are the novels *Nicholas Minturn* and *Arthur Bonnicastle* and the poems *Bittersweet*, *Kathrina* and *Garnered Sheaves*.

**HOLLAND, KINGDOM OF.** See NETHERLANDS, THE.

**HOLLAND, MICH.**, in Ottawa County, twenty-five miles southwest of Grand Rapids, on the Pere Marquette Railroad, and at the head of Black Lake, which affords a good harbor. There are daily boats to Chicago during the season of navigation. It is in an agricultural region. The industries include flour and planing mills, tanneries, beet sugar factories, pickling plants and manufactories of wood-working machinery, launches, furniture, baskets and other articles. The place was settled by the Dutch in 1847, and the present inhabitants are largely of Dutch descent. It is the seat of Hope College and of the Western Theological Seminary, both under the Reformed Church. A number of summer resorts are situated near the city, on Black Lake. Population, 1910, 10,490; in 1917, 12,459 (Federal estimate).

**HOLLEY, MARIETTA** (1850- ), writer of humorous stories centering about "Samantha" and "Josiah Allen's Wife." Her books are over a dozen in number; the latest are *Samantha on the Woman Question* and *Josiah Allen on the Woman Question*.

**HOLLY**, a genus of plants embracing a number of evergreen trees or shrubs; it is forever associated with the celebration of Christmas, when holly branches and berries are a universal decoration. The common European holly is a handsome, conical evergreen tree, growing to the height of twenty or thirty feet. Its leaves are dark green, shining and leathery, abundantly armed with prickles on the lower branches, but free from them on the upper branches and on very old trees. The contrast between holly and its surroundings is thus set forth by Southey, in *The Holly-Tree*:

And as, when all the summer trees are seen  
So bright and green,  
The Holly leaves a sober hue display  
Less bright than they,  
But when the bare and wintry woods we see,  
What then so cheerful as the Holly-tree?

The flowers are white, appearing in May; the fruit is red, ripening in September and remaining on the tree all winter. A good many varieties are known, distinguished by the shape and color of the leaves, which are sometimes spotted or edged with yellow. Holly is excellently adapted for hedges and fences, as it bears clipping. The wood is hard and white and is employed for turnery work, knife handles and similar articles. Among the Romans it was customary to send boughs of holly to friends with new year's gifts, as emblematic of good wishes. The American holly is widely spread throughout the United States. It sometimes attains a height of eighty feet.

**HOLLYHOCK**, a biennial plant of the mallow family, native of China, but introduced into almost all countries. It is chosen as an ornament of gardens. There are many varieties, with single and double flowers, showing tints of yellow, red, purple and dark purple, approaching to black. Some of the double blossoms are among the most beautiful of flowers. Hollyhocks grow to the height of eight feet or more.

**HOLMES, ELIAS BURTON** (1870- ), an American traveler and lecturer, born in Chicago. Photography and travel interested him keenly when he was yet almost a boy, and at the age of twenty he lectured before the Chicago Camera Club on the subject *Through Europe With a Camera*. This was the beginning of a long period of travel, picture taking, and subsequent lectures in large cities of the United States. He has visited every quarter of the globe, and his pictures, which represent the highest development of photography, portray most vividly the manners and customs of various peoples and the physical features of the countries visited. He shows both still and moving pictures, and his travelogues are always educational and interesting. Six or eight months of the year are devoted to travel, and the rest of the season to lecturing. In 1919 Mr. Holmes gave a series based on conditions in the allied countries in Europe. His lectures have been published under the title *Burton Holmes Travelogues*.

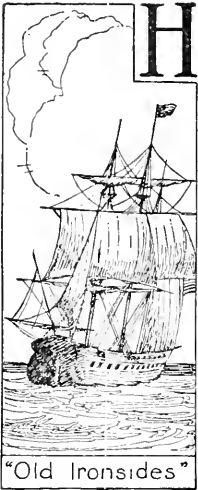

**H**OLMES, OLIVER WENDELL (1809-1894), an American essayist, poet and novelist, a contemporary of Longfellow, Lowell, Emerson and the others of that famous group of New England writers. He was one of the wittiest of them all, and his *Autocrat of the Breakfast Table* series is perhaps as original a creation as can be found in American literature. Holmes was born at Cambridge, Mass.

During his early years he spent much time in his father's library, and the great quantity of fragmentary reading which he did "in books rather than through them," as he himself said, had a marked effect on the writings of his later life. He was graduated from Harvard in 1829, in the class which he himself made famous in later years by his yearly poems at the reunions. After studying law for a time, he turned to medicine, at first with little seriousness. He became deeply interested, however, and the years during which he studied medicine in Paris were most industriously spent. His degree of M. D. was received in 1836, and he settled down to practice medicine in his loved city of Boston, where he remained for the rest of his life.

While still in college, Holmes had written numerous poems which, while they were not of the highest order of merit, included such popular and humorous poems as *The Spectre Pig* and *The Height of the Ridiculous*; he had also won a taste of fame by the publication in the year following his graduation from Harvard of *Old Ironsides*, which, by its remarkable popularity and the feeling it stirred up throughout the country, had the effect of compelling the Secretary of the

Navy to countermand the order for the destruction of the famous frigate *Constitution* (which see).

It was not until 1836 that Holmes published his first book of poems. He realized that the appearance of a volume of poetry in the same year that he started in to practice medicine would probably have a most unfavorable effect on his practice, as people might hesitate somewhat before applying to a poet for prescriptions. His heart was set, however, on a literary career, even more than on a medical, and he was willing to sacrifice something for it. In 1839 he was given a position as lecturer in Dartmouth College, and in 1847 gave up his practice entirely and became professor of anatomy at the Harvard Medical School, a position he filled until 1882. Meanwhile, in 1840, he had married Amelia Lee Jackson, with whom his life was most happy. Various medical papers, some of which were of great importance in the profession, came from Holmes's pen from time to time, and his poems written to celebrate every special occasion in Boston had made him locally famous as a wit.

It was not until the founding of the *Atlantic Monthly*, in 1857, however, that Holmes became widely famous. To this newly-founded magazine he contributed his papers known as the *Autocrat of the Breakfast Table*, which are up to the present day considered his masterpiece. It is simply talk in print, and this means a great deal when the talker is as brilliant and easy a conversationalist as was Doctor Holmes. This first series was followed by *The Professor of the Breakfast Table* and later by *The Poet at the Breakfast Table*. Three novels, *Elsie Venner*, *The Guardian Angel* and *A Mortal Antipathy*, are studies in hereditary tendencies, but the first has many elements of a good story. After a visit to Europe in 1836 appeared *Our Hundred Days in Europe*, and when Holmes was eighty, he wrote a final autocrat series under the title of *Over the Teacups*. This last possesses little of the spontaneous charm of his earlier writings, but is interesting as showing the change in his conversational methods and powers.

Among Holmes's best poems may be mentioned *The Chambered Nautilus*, *The Last Leaf* and the widely-known *Wonderful One-Hoss Shay*. Whether it is as poet or a prose writer that Holmes is considered, it is the same qualities, his sprightliness, his geniality, his absolute sanity and his power of combin-



OLIVER WENDELL  
HOLMES

ing wit and pathos, which stand out most prominently, and these are the same qualities which in his own generation made Doctor Holmes the most popular of men. For other details, see the article **READING**.

**HOLMES**, *holmz*, OLIVER WENDELL, JR. (1841- ), an American jurist, born at Boston, the son of Oliver Wendell Holmes, the poet. He was graduated at Harvard and from Harvard Law School, served for two years in the Civil War, taking part in the battles of Ball's Bluff, Antietam and Fredericksburg, and then engaged in law practice in Boston, where he became editor of the *American Law Review*. In 1882, he was appointed professor of law in Harvard Law School. In the same year he was nominated associate justice, and in 1899 chief justice, of the state supreme court. In 1902 President Roosevelt appointed him an Associate Justice of the Supreme Court of the United States. He is the author of several books on law, and he edited an edition of Kent's *Commentaries*.

**HOLY ALLIANCE**, a misnamed league formed at Paris in September, 1815, between Alexander I of Russia, Francis of Austria and Frederick William III of Prussia. It consisted of a declaration, that, in accordance with the gospel of Jesus Christ, the principles of justice, charity and peace should be the basis of their internal administration and of their international relations, and that the happiness and religious welfare of their subjects should be their great object. Its real aim, however, was to maintain the power and influence of the existing dynasties, and Metternich, the Austrian minister, gradually obtained the chief authority. It exerted no influence after 1848.

**HOLY CITY**, a term commonly applied to Rome, because it is the seat of the Roman Catholic Church and the residence of the Pope. However, it is properly applied to any city which is the center of a great religion. Thus, Mecca and Medina are holy cities to the Mohammedan; Benares, to the Hindu; Jerusalem, to the Christian masses; Moscow, to the member of the Greek Church.

**HOLY FAMILY**, the representations in art of the Virgin Mary and the Infant Jesus. In the sixth century artists of Byzantium (Constantinople) began representing the Christ-child seated in the lap of the Virgin, one hand raised in an attitude of blessing. The artists of the later Middle Ages intro-

duced other figures—Saint Anna, the mother of Mary, Saint Joseph, Saint John as an infant, and Saint Catherine. Some of the early pictures of the Holy Family were believed to possess miraculous healing powers. The Virgin and Child constituted the favorite subject of the supreme masters of the Renaissance. At various times the two have been pictured with earthly or with celestial attendants. See **MADONNA**.

**HOLY GHOST**, in Christian theology, the third person of the Trinity, the others being God the Father and Christ the Son. The term is used interchangeably with *Holy Spirit*. See **TRINITY**.

**HOLY GRAIL**. See **GRAIL**, **THE HOLY**.

**HOLY LAND**. See **PALESTINE**.

**HOLYOKE**, *hol'yoke*, MASS., in Hampden County, eight miles north of Springfield, on the Connecticut River and on the Boston & Maine and the New York, New Haven & Hartford railroads. The river here has a fall of sixty feet, and a granite dam 1,000 feet long has been constructed, so the city has extensive water power, probably the greatest horse-power capacity in New England. Holyoke is especially noted for its paper mills, particularly those which manufacture fine grades of paper, but there are also manufactories of cottons, woolens, thread, silk, alpaca, machinery, envelopes and school supplies. The city contains a public library, two public hospitals and a contagious disease hospital. Holyoke was settled chiefly by Irish people in the last part of the seventeenth century, and it was for a time called Ireland Parish. It was part of West Springfield from 1786 to 1850, and in 1873 it was chartered as a city. Population, 1910, 57,730; in 1917, 66,503 (Federal estimate).

**HOLY ROMAN EMPIRE**, the name given to the State created by Charlemagne, the assumption being that it was a development of the old Western Empire and that Charlemagne was the successor of the Roman emperors. The events connected with its history prompted Voltaire, centuries later, to say it was "neither holy, nor Roman, nor an empire." The title *Roman Empire* was first used in 962, when Otho the Great was crowned by the pope, and the word *Holy* was added by Frederick Barbarossa. In theory, all of the Christian countries of western Europe formed part of the Holy Roman Empire, but in reality only Italy and those

# THE HOLY ROMAN EMPIRE

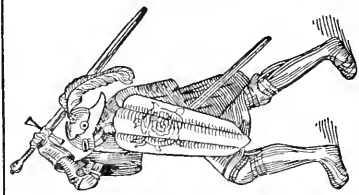

FIFTEENTH CENTURY KNIGHT IN FULL ARMOR

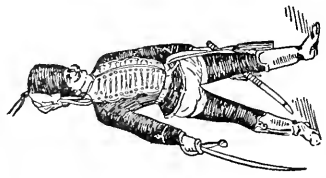

OFFICER'S UNIFORM, 1790.

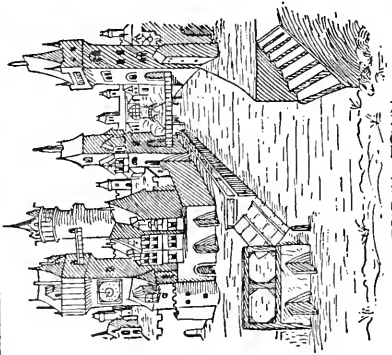

MEDIAeval TOWN (From a drawing of 1495)

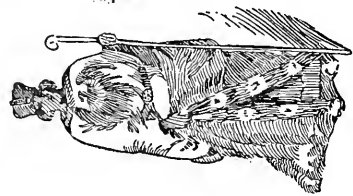

COSTUME OF GERMAN EMPEROR, 13th CENTURY



THE HOLY ROMAN EMPIRE, about 1520



WOMAN'S HEADRESS

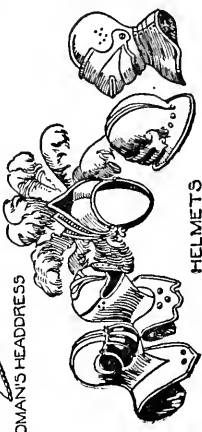

HELMETS

## Chronological Summary

|  |           |
|--|-----------|
| Otto the Great Crowned Emperor.....      | 962       |
| Division of Greek and Latin Churches.... | 1054      |
| House of Hohenstaufen.....               | 1138-1254 |
| Accession of Frederick Barbarossa.....   | 1152      |
| Great Interregnum.....                   | 1254-1273 |
| Hussite War.....                         | 1419-1433 |
| House of Hapsburg.....                   | 1438-1804 |
| Accession of Maria Theresa.....          | 1740      |
| Title Abandoned.....                     | 1804      |

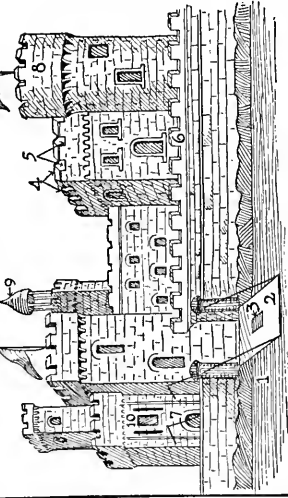

MEDIAeval CASTLE

- 1 Mural
- 2 Rampart
- 3 Porticulis
- 4 Ditch or Moat
- 5 Towers
- 6 Embasures
- 7 Escalcheon



countries which acknowledged the superiority of the king of Germany belonged to it. The Hohenstaufen emperors possessed something like imperial power, because they were strong monarchs individually, but after their time the term came gradually to be merely an honorary title. In 1804 Francis II took the title of *Emperor of Austria*, and two years later he gave up that of Holy Roman Emperor.

**HOLY SPIRIT PLANT**, an orchid of Central America, known, also, as the *Dove Plant*, from the resemblance of the united stamens and pistils of the flower to a dove hovering with expanded wings, somewhat like the conventional dove seen in artistic representations of the Holy Ghost. The round, sweet-scented flowers are a creamy white, dotted with lilac on the base of the lip, and are borne in a spike.

**HOLY WATER**, in the Roman Catholic Church, water which has been blessed by a priest for religious uses. It is sprinkled on the worshipers and the things used in the church and is employed at funerals and other special services.

**HOLY WEEK**, the week immediately preceding Easter, when Christian churches commemorate the last days of Christ on earth. In Roman Catholic and Anglican churches Holy Week is solemnized by prayer and fasting. The celebration begins with Palm Sunday, the Sunday before Easter, commemorating Christ's triumphal entry into Jerusalem. In the course of the week special services are held on Wednesday (Spy Wednesday), the day of Judas' betrayal; on Thursday, the day of the Last Supper; and on Good Friday, the day of the Savior's crucifixion.

**HOMAGE**, *hom'aje*, in feudal law, a formal acknowledgment and acceptance of the duties of a vassal, made by a feudal tenant to his lord. The tenant, being ungirt and uncovered, knelt and held up both hands between those of the lord and there professed himself to be his lord's vassal. He then received a kiss from the lord. See FEUDAL SYSTEM.

**HOMEOPATHY**, *home op'a thi*, the name of a system of medicine introduced by Samuel Hahnemann of Leipzig. It is a system founded upon the belief that drugs which will produce certain symptoms in a healthy person will cure a sick person who has developed the same symptoms. It exemplifies

the old belief long ago expressed in the Latin phrase, *similia similibus curantur* (like is cured by like). Strong and bitter medicines are not tolerated in homeopathic practice; simpler remedies, usually pleasant to the taste, are substituted, and homeopathy therefore makes a strong appeal to parents whose children are ill.

In the United States there are ten medical schools devoted to homeopathic instruction, and about 15,000 physicians who practice the system.

**HOMER**, the earliest named Greek poet, to whom ancient tradition assigned the authorship of the *Iliad* and the *Odyssey*. Of Homer's life and personality nothing is known, and it has been questioned whether such a person ever existed. Several ancient biographies of Homer are preserved, two of which, their titles state, were written by Herodotus and Plutarch, respectively. It is certain, however, that the statements of authorship are not true; the biographies are valuable only because they show what was the ancient popular tradition concerning the poet.

Many towns claimed the honor of being his birthplace, and the names of seven are preserved in an epigram beginning,

"Seven rival towns contend for Homer dead,  
Through which the living Homer begged his  
bread."

Of these towns, Smyrna seems to have had the strongest claim, Chios coming next. At the latter town was a clan of bards called Homeridae, who transmitted the epics from father to son and claimed Homer as their founder. In one of the *Homeric Hymns*—poems addressed to the gods and because of their similarity in style ascribed to Homer, but probably for the most part of later date—the author describes himself as the "blind bard of rocky Chios." The tradition of



HOMER

Homer's blindness was universally accepted. Ancient writers mention the name *Homer* as a pseudonym of the poet, and various interpretations of it are given, the most probable

being that it meant "one who puts together." This gives color to the theory that Homer was not an original poet, but merely a compiler of current lays.

The general belief of antiquity seems to have been that Homer was born in Smyrna, lived some time in Chios and was buried in Ios. His date has been variously placed between the beginning of the twelfth century and the beginning of the seventh century B. C. The dialect and a few local allusions indicate that the *Iliad* and the *Odyssey* originated on the Ionian coast of Asia Minor and the Aegean Islands. Lyeurgus is said to have brought them to Sparta, and there is record of the recitation of them by rhapsodists about 600 B. C. Solon regulated such recitation at Athens, and the Tyrant Pisistratus had the poems edited by a commission and arranged in what is practically their present form. Perhaps the lays or rhapsodies had previously been sung separately and were then for the first time united into two poems, the *Iliad* and the *Odyssey*.

**HOMER, LOUISE**, a famous American grand-opera contralto, was born in Pittsburgh, Pa., the daughter of a Presbyterian clergyman. She studied first in Boston and later in Europe, and in 1898 made her operatic début in Paris as Leonora in *Favorita*. Since then she has been popular in France, Belgium and England, as well as in her native America. Her repertory includes many leading operatic rôles. Mme. Homer is the wife of Sidney Homer, a song-writer, and is the mother of five children. She lives in New York City.

**HOME RULE**, in British politics, a measure advocated especially in regard to Ireland, the leading feature of which is the establishment of self-government for the island. It involves a native parliament in Ireland to conduct all local and internal legislation, leaving the general political government of the Empire, of which Ireland is a part, to the Imperial British Parliament.

The movement originated in the formation of the Home Government Association at Dublin, in 1870. The conversion of Gladstone and many members of the Liberal party to Home Rule principles, in 1886, added immense strength to the movement, then under the leadership of Charles Parnell, but failed to carry through its program. In 1893 Gladstone again attempted to secure Home Rule, but the bill was defeated in the House of

Lords. The bettering of economic conditions and the granting of local self-government under Balfour's Conservative administration, quieted the agitation for a time, but under the leadership of John Dillon, and later of John Redmond, the movement acquired new strength.

The general elections of 1910, which gave the Irish members the balance of power in the House of Commons, were interpreted by the Liberals as a complete vindication of the party's Home Rule program. Accordingly, in 1912 and again in 1913, Premier Asquith introduced a bill providing for Home Rule, but both times it was defeated in the House of Lords. By the terms of the Parliament Act of 1911, any bill which has passed unchanged three readings in three successive sessions of the House of Commons becomes a law without the assent of the House of Lords. The Home Rule Bill was introduced for the third time in the House of Commons on March 5, 1914, and was passed on May 25. The progress of the bill was marked by much bitterness in Parliament, by great enthusiasm in Dublin and vicinity and by the organization of Ulster volunteers and threats of armed resistance in all Protestant quarters in Ireland. In June, the Ministry introduced an amending bill, which provided that each county in Ulster might vote on the question whether or not it should be excluded from the operation of the law for a period of six years. Before this amendment could be passed, however, the great World War broke out, and Parliament passed a new bill postponing the beginning of Home Rule.

In 1917 Premier Lloyd George was obliged to face the issue, and he secured an understanding in England whereby Ireland should agree upon the form of local government it desired. A convention of all factions met at Trinity College, Dublin, on July 25, and after being in session several months it was dissolved without having reached any agreement. Meanwhile, the Sinn Fein party, which demanded complete independence for Ireland, was constantly growing stronger, and in the Parliamentary elections of 1918 the party won over seventy seats in Ireland, virtually wiping out the old Nationalist party. For further details see IRELAND, subhead *History*.

In American politics the home rule movement is an attempt to secure complete local self-government by cities, without interference by state legislation. A city and a rural

district have almost no problems in common, and legislation should not be applied indiscriminately to both.

**HOMESTEAD**, *home'sted*, a tract of government land open to occupation and ownership by a citizen who conforms to certain requirements. In the United States 160 acres may thus be acquired where irrigation is possible, and 320 acres, a half-section, in unirrigated areas.

The prospective "homesteader" must apply to the Federal land officer nearest the tract he wishes to secure. There he receives a *patent*, which entitles him to occupancy of the land. He must occupy the property five years, be in actual contact with it six months of each year, and cultivate a fixed percentage of it every year. At the end of the period final title to the land is given him. The fees in connection with the transaction are moderate—not exceeding \$50.

The homestead laws of the United States have opened over 85,000,000 acres to settlement and have dotted the former wilderness with homes. Although any person of good repute over twenty-one years of age may acquire a farm under the homestead act, preference is shown to soldiers and sailors; the period of their service is deducted from the five years of required occupation. Any person may pay a very nominal sum, about \$1.25 per acre, for his land, and thus be released from the rule requiring five years occupancy.

State lands have also been open to homesteaders, under conditions similar to those imposed in connection with the national domain. Homestead laws in the main are devoted to protection of the homesteader. A homestead cannot be taken for debt contracted prior to the issuing of the patent.

In Canada homesteaders must reside one-half of each year for three years upon homesteads and cultivate at least twenty acres of new ground each year. By what is called preëmption a settler can purchase adjoining government land to the extent of 160 acres, for which he must pay \$3 per acre, and he must cultivate fifty acres of it. A person eighteen years of age may become a Canadian homesteader.

**HOMICIDE**, *hom'y side*, the killing of one person by another, either through direct act, through instigation or through the omission of some act which would have prevented the killing. In this wide sense it includes manslaughter and murder (see MURDER), besides

so-called justifiable homicide. In this article the term is considered only in the last sense. This includes killing by accident, in self-defense, by a public officer in conformity to a judicial sentence, by an officer in performing a legal duty, or by a person to prevent the commission of a serious crime. If committed without any fault on the part of the slayer, homicide is not punishable at law.

**HONDURAS**, *hon doo'ras*, the third in size among the republics of Central America, lies between Guatemala and Nicaragua. The Caribbean Sea extends along almost all of its northern border; the Pacific Ocean bounds it partly on the south. The area of the country is 44,275 square miles. The population in 1910 was 553,446; in 1914 it was estimated at 562,000, or 12.7 persons to the square mile. The capital is Tegucigalpa, with 28,950 people in 1914. The chief Pacific port is Amapala; on the Atlantic coast Puerto Cortez and Omoa are the most important.

**The People.** Nearly all of the people are Indians or mixed Indian and Spanish groups. About one-sixth of the Indians of the interior possess but little civilization. There are a few Europeans and Americans, and these control all commerce, for the natives are indolent and unprogressive. The religion is strongly Roman Catholic, though there is freedom of worship. Education is free and compulsory, yet illiteracy prevails to a great degree in some sections. In the capital city is a university and a military school. The country supports five normal schools.

**The Country.** Honduras is mountainous, and in the interior there are large spaces where the usual tropical heat is modified. The coast regions are low, hot and unhealthy for white people. The wealth of Honduras is found largely in its immense banana crop and in the production of coconuts. The bananas are raised in the Caribbean coast regions, and about 8,500,000 bunches are shipped from the country each year. The coconut yield is about 8,000,000 nuts. Besides the above there is considerable rubber, coffee and tobacco. The main food crops, raised entirely for home use, are wheat in the highlands, beans, rice and sugar. There are 360 miles of railroad, and 4,300 miles of telegraph wire.

**Government and History.** The republic's laws are made by a Congress of Deputies of

forty-two members, elected for four years. Its meeting is on January 1 each year; sessions are limited to sixty days. The President is also elected for a four-year term; he has a Cabinet of five Ministers. The republic was founded in 1821. The present constitution was adopted in 1894.

Columbus discovered Honduras in 1502, and the first Spanish settlement was made in 1524. In 1539 the territory was joined to Guatemala, and there it remained until 1821, when the federation of Central American states was accomplished. After 1849 wars between the groups of states occurred, and it was not until 1874 that peace was established. However, several times since then there have been outbreaks of civil war.

In July, 1918, as an expression of sympathy for the allied nations in the World War, Honduras declared war on the German Empire. See CENTRAL AMERICA.

**HONE**, a stone used in sharpening edged tools. The coarse varieties of hones are made of sandstone and are commonly called *whetstones*. The finer varieties are usually made of a stone formed from placing pine logs in the sea and leaving them until they turn to stone. Another variety of hone stone is called *novaculite*, originating in a peculiar quality of clay rock. The finest hones of this variety are secured in Arkansas.

**HONEY**, *hun'i*, a sweet substance of delicious flavor and attractive appearance, made by bees from the nectar of flowers. These insects use honey as food for themselves and their young, and it is also an important food of mankind. Bee keeping, in fact, is a well-organized and profitable industry (see BEE). Honey varies in color from light golden to brown, according to the flower from which the nectar is collected. White clover nectar is the source of the best light varieties, while excellent dark honey comes from buckwheat. Honey is so rich in sugar that it should be eaten sparingly. The United States is the greatest honey-producing country, with an annual output of about 62,000,000 pounds.

**HONEY LOCUST, SWEET LOCUST**, or **BLACK LOCUST**, a beautiful forest tree belonging to the United States. It is much like the acacia in appearance. The leaves are divided into small leaflets, and the foliage has a light appearance. The flowers are greenish and are succeeded by long, often twisted pods, containing large, brown seeds,

enveloped in a sweet pulp. This tree is especially remarkable for its formidable thorns, on which account it has been recommended for hedges. It grows to a height of seventy feet.

**HONEYSUCKLE**, *hun'i suk'l*, a family of twining shrubs, of which there are several varieties. The most familiar bears flowers which are trumpet-shaped and are filled with nectar. Around the species bearing flowers which are red without and orange-yellow within flutter the humming birds in search of the sweets in the depths of the blossom. The flowers of another variety, the bush honeysuckle, are small and yellow, and these attract the bees. Most honeysuckles are evergreen, and when the flowers disappear small crimson blossoms take their place.

**HONG-KONG**, *hong'kong'*, the name usually applied to an island off the southeast coast of China and also to the city which nestles at the foot of its mountains on the shore of the China Sea. The island is Hong-kong, but the legal name of the town is Victoria. Hong-kong is at the mouth of the broad estuary that leads to the great city of Canton, ninety miles northwest. The island measures about four by ten miles in greatest width and length, and contains nearly thirty square miles. Within this area dwell 456,740 people (1911 census). Of these all but 12,000 are Chinese. These figures include the population of a small area on the mainland belonging to Hong-kong called the New Territories. In Victoria 216,022 out of a total population of 223,847 are Chinese.

There is little agriculture on the island. The Chinese engage in fishing, ivory carving, glass blowing and boat making and in the manufacture of soap, toothpowder, dyes and gold and silver ware. The white population manage sugar refineries, cement works, paper mills and the quarrying of granite, all with Chinese labor, and the English conduct all government and shipping affairs.

Hong-kong is the center of British commercial interests in its part of the world, and the island and city are very prosperous. Harbor frontage is more valuable than in Brooklyn or Jersey City. Steamships from all great ports in the world call here regularly, and to accommodate the vast shipping Victoria has the largest docks in the empire outside of London and Liverpool.

Hong-kong was occupied by the British in 1841, and in the next year it was ceded to England by China. In the same year it was

made a free port, and except that taxes were laid on liquors and opium it has so remained.

**HONOLULU**, HAWAII, the capital and largest city of the Hawaiian Islands, to-day a modern, Americanized town with all the public utilities found in cities in the United States. It is on the island of Oahu, 2,100 miles southwest of San Francisco, 4,800 miles east of Manila, 4,920 miles east of Hongkong and 3,400 southeast of Yokohama. The steaming time from New York to Honolulu was forty-five days before the opening of the Panama Canal; it is now twenty-one days. The population was 52,183 in 1910; in 1914 a Federal estimate gave it about 60,000. In 1910, 9,675 were Chinese; 12,093, Japanese; 7,910, Hawaiians; 6,175 Portuguese; 9,200, pure whites; 4,235 mixed whites and Hawaiians. It is truly a cosmopolitan city.

As the cultivation of pineapples, rice and sugar cane are the principal pursuits of Hawaiians, the industries of the city largely reflect these occupations. There are manufactures of rice-milling machinery, and there is also considerable shipbuilding. There are a number of hospitals and a good public library. Public schools are well organized, and Oahu College, founded in the days of Queen Liliuokalani, has about 750 students. A powerful wireless station is here, intended for communication as distant as the west coast of the United States, but in 1918 it established communication direct with Washington.

One hundred years ago Honolulu was but a village of the native kings. In 1820, under an English governor, it was fortified. Since that time its history has been a part of that of the Hawaiian islands (see HAWAII).

**HOOD, JOHN BELL** (1831-1879), a leading Confederate soldier of the Civil War, was born in Owingsville, Ky. He was educated at West Point and entered the army, but resigned in 1861 to enter the Confederate service. His gallantry in the Virginia campaigns won him a commission as major-general. He distinguished himself at Gettysburg and at Chickamauga, where he lost a leg. Afterwards he was made lieutenant-general and served with Johnston in the Atlanta campaign and succeeded him on July 17, 1864. He immediately abandoned Johnston's cautious tactics and took the aggressive, but was defeated on every occasion. In order to draw Sherman from his march to the sea, Hood led his forces northward into

Tennessee, where, in the battles of Franklin and Nashville, his army was overwhelmed.

**HOOD, MOUNT**, an extinct volcano, last active in 1875, in the Cascade range, in Oregon. It is about 12,000 feet high, but is easily ascended and affords a beautiful view of the surrounding country.

**HOOD, ROBIN.** See **ROBIN HOOD**.

**HOOD, THOMAS** (1799-1845), an English poet and humorist. In 1821 he became assistant editor of the *London Magazine*, and in this position made the acquaintance of Lamb, De Quincey and Hazlitt, who were on the same editorial staff. In 1826 appeared his *Whims and Oddities*, which was followed by *National Tales* and a volume of serious poetry. In 1829 he began his *Comic Annual*, and in the same year he contributed to another annual *Eugene Aram's Dream*, one of his best-known poems. In 1838 he started the monthly periodical called *Hood's Own*, and this was followed by *Hood's Magazine*. The famous *Bridge of Sighs* and *Song of the Shirt*, written shortly before his death, are among the finest poetical expressions of love and pity for poor and suffering humanity to be found in the English language.

**HOOKER, JOSEPH** (1814-1879), an American soldier, born at Hadley, Mass. He graduated at West Point in 1837, served on the Southern and Northern frontiers and in the Mexican war, rising to the rank of colonel. He resigned from the army in 1858, engaging in private business, but in May, 1861, was appointed brigadier-general of volunteers. In the following spring he was promoted as a result of excellent service in the Peninsula Campaign and



JOSEPH HOOKER

at South Mountain and Antietam to the rank of brigadier-general in the regular army. After commanding a division at the Battle of Fredericksburg, he was appointed to the command of the Army of the Potomac in January, 1863, and displayed remarkable ability in organization and discipline, but failed to show great military talent in command of large forces. On May 2 to 4, 1863,

he suffered a terrible defeat at Chancellorsville (see CHANCELLORSVILLE, BATTLE OF). He followed Lee upon his second invasion of the North, but just at the crucial point in the campaign was superseded at his own request by General Meade. He then joined Rosecrans before Chattanooga, and on November 24 distinguished himself as a leader at Chiechamauga in the famous "Battle above the Clouds." For this service he was brevetted major-general in the regular army, and with Sherman performed notable service in the Atlanta campaign.

**HOOKER, MOUNT**, one of the highest peaks in the Rocky Mountains in Canada, situated near the boundary line between British Columbia and Alberta. It was visited in 1826 by a party of botanists headed by David Douglass, and was named for two scientists in the party. The altitude is 10,505 feet.

**HOOKER, THOMAS** (1586-1647), an American colonist and clergyman, one of the founders and the chief promoter of the Connecticut colony. Driven by persecution to Holland, he preached there as he had in England, but in 1633 went to New England and settled in Cambridge. Three years later he moved with his congregation westward to the Connecticut Valley, where he established a settlement at Hartford. Hooker was one of the most influential men in the colonies, inspiring needed legislation and helping to organize the "United Colonies of New England."

**HOOKWORM**, a worm which lives as a parasite in the intestines of human beings, and is the cause of the so-called hookworm disease, or hookworm anemia. The parasite is threadlike in form, from one-fifth to one-half an inch in length; and bears in its mouth six incurving hooks, or teeth, with which it fastens itself to the lining of the intestines. When the number of these parasites is large, dyspepsia and profound anemia, with emaciation and even death, may result. A marked symptom of the disease in all its forms is a lack of ambition, a lessening of intellectual capacity, and a lowered power of resistance to other diseases.

The intensive study of the hookworm was begun in 1902. There was much amusement, at first, over the search for the "lazy worm," but the discovery of its habits and the methods of prevention and cure is considered one of the triumphs of modern science. The

larvae of the parasite enter the body either through the mouth, with infected food or drink, or more frequently through the skin, especially the skin of the feet. The disease is most common in the southern part of the United States, where in the country districts sanitary conditions are often far from ideal, and where warm weather allows many people to go barefoot. Experts declare that the hookworm is largely if not entirely responsible for the backwardness and lack of ambition among the "poor whites" of the South, and predict a remarkable improvement if the scourge can be done away with. The negroes have the disease, also, and some investigators believe that the worm was brought from Africa by the slaves, but the results are less serious with the black race than with the white. Preventive measures include better sanitary arrangements, greater personal cleanliness, and the wearing of shoes; the cure, very satisfactory in most cases, is a medicine which expels worms, such as thymol.

In 1909 a gift of \$1,000,000 from John D. Rockefeller made possible the establishment of the Hookworm Commission, which has made valuable discoveries and suggested methods of control. Care in the admission of immigrants has been recommended, as it is known that a large proportion of the natives of India, China, Egypt, Porto Rico and other warm countries are infected with the disease.

**HOOP'OE**, a bird common to parts of Europe, Asia and Africa, related to the kingfishers and hornbill. It is about twelve inches long and has a fine crest of pale, cinnamon-red feathers, tipped with black. The upper surface of the bird is, on the whole, ashy brown; its wings are black with white bars, and its throat and breast are pale fawn, shading to white, marked with black streaks and dashes on the abdomen. The hoopoe feeds on the ground, preying chiefly on insects, and is not particular about the cleanliness of its food. Large objects are rapped on the ground and usually tossed into the air before being swallowed. The birds fly well and run rapidly, and by the Mohammedans they are venerated as being the favorite birds of Allah.

**HOOSAC TUNNEL**, nearly five miles in length, the longest tunnel in America, in the Hoosac Mountains in Massachusetts. The cross section is twenty-four feet wide in the widest part and twenty-two feet eight inches high. There are double railway tracks

through it, used by the Boston & Maine Railroad. Work on this tunnel was first begun in 1856, but was soon abandoned. It was resumed in 1862 under control of the state, and the tunnel was completed in 1873, at a



HOOPOE

cost of about \$11,000,000. Work was carried on at the same time from each end from a shaft 1,028 feet deep, sunk near the middle. This shaft is now used for ventilating.

**HOOPER, HERBERT CLARK** (1874- ), a mining engineer who in a time of great need found his opportunity in a new and difficult field. He was born in West Branch, Iowa, and was educated at Leland Stanford, Jr. University. His life work was begun with the Arkansas Geological Survey, but soon he was employed by the Geological Survey of the United States. Later he was chief of various mining staffs; he went to China on a geological exploration and helped to defend Tientsin during the Boxer Rebellion (which see); he constructed a harbor at Ching Wang Tow, and then returned to America, where he followed his profession in important posts until the outbreak of the World War.

In 1914 Hoover went to London and became chairman of the American relief commission; in 1915 he was head of the Belgian relief commission, and so ably did he serve the stricken nation that he was called home in 1917 and placed in charge of the United States food administration bureau. In this post it became his duty to conserve the food of America so that there might be sufficient

for export to save from starvation the battling allied nations in Europe. In this he succeeded. His conservation orders to the American people were loyally obeyed; he was an executive who knew his business and who inspired confidence. In 1919 he was placed at the head of a commission to feed all of famished Europe.

**HOP**, a plant related to the hemp plant, cultivated for its seed catkins, which are used to give beer its bitter flavor. Hops are cultivated extensively both in Europe and the United States. They are propagated by cuttings, several pieces being planted together in hills. The vines are trained to climb poles inserted in the hills. At the proper season the poles are taken down, the catkins are gathered into huge baskets and carried to a building, where they are dried and pressed into solid bales. In this condition they may be kept for years, if they are not allowed to grow moist. Oregon, New York, California and Washington, in the order named, are the leading states producing hops. The annual crop averages 45,000,000 pounds.

**HOPE, ANTHONY.** See **HAWKINS, ANTHONY HOPE.**

**HOP**, *ho'pe*, or **MOKI**, *mo'ke*, a tribe of Indians inhabiting seven villages in North-eastern Arizona. They number about 2,000, and are the survivors of a once powerful tribe whose holdings at one time extended over a wide territory. The Hopi dwell in *pueblos*, villages built on the sides and tops of steep cliffs reached only by difficult trails (see **PUEBLO**). These Indians are small and active, and are industrious and good-tempered. They produce beautiful specimens of pottery, basketry and woven goods, and are successful farmers. Among their peculiar ceremonies is the snake dance, during which the performers dance about with live snakes in their mouths.

**HOPKINS, MARK** (1802-1887), an American educator, born at Stockbridge, Mass. He became professor of moral philosophy in Williams College, and later, president of that institution, which position he held for thirty-six years. During his administration the influence of the college was greatly extended, and it became widely known throughout the country as an institution of the first rank. Doctor Hopkins had a strong personality, which he impressed upon all students, and because of his influence in the development of character, as well as his power

as a teacher, he ranked as one of the greatest educators of his time. Some of his best-known works are *The Influence of the Gospel in Liberating the Mind, Moral Science, The Law of Love and Love as Law* and *The Spiritual Idea of Man*.

**HOPKINSVILLE, KY.**, the county seat of Christian County, seventy miles northwest of Nashville, Tenn., on the Louisville & Nashville, the Illinois Central and the Tennessee Central railroads. It is the seat of Bethel Female College and McLean College. The Western Kentucky Asylum for the Insane is located here, and there is a Carnegie Library. In 1915 a Federal building was constructed; in the same year the commission form of government was adopted. The city is principally engaged in the handling and manufacture of tobacco. The place was settled in 1797. Population, 1910, 9,419; in 1917, 10,979 (Federal estimate).

**HOPSCOTCH**, an outdoor game popular with children. It is played on a court marked out on the ground and divided into sections, as shown in the accompanying illustration. The first player, who stands a short distance from the end of the court, begins the game by tossing a stone or piece of earthenware

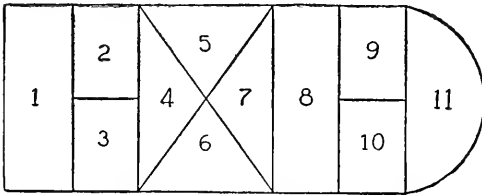

HOPSCOTCH COURT

into the first division (1 in illustration); he then hops into the division on one leg, picks up the stone and hops out again. He next throws the stone into the left one of the next two sections, hops into 1 and 2, picks up the stone and hops out through 1. The next throw is made into section 3, to the right of 2, and the next into 4, and so on. When the player goes into 4 he hops on one foot into 1, straddles the line dividing 2 and 3, and hops again on one foot into 4. To go into 7 he must straddle at 5 and 6.

The winner of the game is the one who succeeds first in throwing a stone into 11, hopping through the court into that division, picking up the stone and hopping out again without making a mistake. It is regarded as a mistake to step on a line, to lose one's balance, or to throw the stone outside the sec-

tion aimed for or on a line. A player may play continuously until an error is made. There is another form of this game, in which the players kick the stone out of the court instead of picking it up.

**HOQUIAM, ho'kwe am, WASH.**, in Chehalis County situated on Grays Harbor and on the Chicago, Milwaukee & Saint Paul, the Oregon-Washington and the Northern Pacific railroads, about ninety miles southwest of Tacoma. The city is in a valuable timber region and is an important commercial and manufacturing center. It has extensive lumber mills, a shipyard and other industries. It is an important shipping point for fish, furs and lumber. There is a Carnegie Library. Population, 1910, 8,171; in 1917, 12,230 (Federal estimate).

**HORACE, hor'ase** (65-8 B. C.), the common name of **QUINTUS HORATIUS FLACCUS**, the greatest of Latin lyric poets, was born at Venusia, in Southern Italy. When Horace was about twelve years of age his family removed to Rome. There he received an excellent education, and six years later went to Athens to complete his studies. After the assassination of Caesar, Brutus came to Athens, and Horace, along with other Roman youths, joined his army. He was appointed to a military tribuneship, was present at Philippi, and on the defeat of Brutus saved himself by flight. On the proclamation of an amnesty to the vanquished, Horace returned to Italy, but found his father dead, his paternal estate confiscated and himself reduced to poverty. He was, however, enabled to purchase a clerkship, which permitted him to live frugally and to cultivate his poetical talent.

His poems procured him the friendship of Vergil and Varius, and to them he was indebted for his first acquaintance with Maecenas, who was the friend and confidant of Augustus Caesar and who expended his wealth for the encouragement of literature and the arts. Maecenas received Horace among his intimate friends and, after some years presented him with a small estate in the Sabine hills, which was sufficient to maintain him in ease and comfort during the rest of his life. He had also a cottage at Tibur, and at Rome or at one of these country residences the latter part of his life was spent. Although he was ultimately introduced to Augustus, he never sought favors from him, and he is said to have declined an offer of



the management of the private correspondence of Augustus.

His works consist of four books of *Odes*; a book of *Epodes*, or short poems; two books of *Satires*, and two books of *Epistles*, one of which is often cited as a separate work, under the title of the *Art of Poetry*. The lyrics of Horace are largely based on Greek models, but the exquisite beauty of his language is all his own. It is, however, in his satires and epistles that he shows the greatest power and originality, wit, gravity and gaiety, tender sentiment and melancholy. His writings have been often translated, and into many languages. In English, Pope and Swift have given free imitations of various parts of his writings.

**HORATIUS**, *ho ra'shi us*, a legendary hero, immortalized in Macaulay's *Lays of Ancient Rome*. According to the story, an invading Etruscan army had almost reached Rome before the citizens realized their danger. To hold the invaders in check while his compatriots escaped Horatius, with two others, following an old custom, challenged the enemy leaders to engage in single combat before the clash of the two armies. The ruse was successful, and while the fray was in progress the Romans destroyed the bridge over the Tiber and then made their escape. Horatius, though wounded, swam across the river to safety.

**HOREHOUND**, a plant of the mint family, with whitish, downy leaves and stem. The flowers are small and nearly white, possessing an aromatic smell and bitter flavor. The leaves also are fragrant and in various forms are used as a popular remedy for coughs and colds. Horehound is a native of Great Britain and Continental Europe, and is naturalized in America, where there are half a dozen species.

**HORIZON**, *ho ri'zun*. To an observer whose view is unobstructed, the sky seems to meet the earth in a circular line. On the ocean there is a similar curve where sky and water apparently join. This line is called the *horizon*, a word from the Greek *horos*, which means *boundary*. The higher one ascends the farther away the horizon line appears to the eye. This variation is caused by the curvature of the earth's surface. In astronomy the name *rational horizon* is applied to the circle formed by a plane passing through the earth's center, perpendicular to the plumb line, and extended to meet the sky.

**HORN**, a brass wind instrument used in bands and orchestras. There are three main types of horn: the kind used by fox-hunters for signaling; the sort used by military bands, called a saxhorn; and the French horn, one of the most delicately toned of musical instruments. This last consists of a coiled metallic tube about ten feet in length, the two ends shaped to form mouthpiece and bell, respectively. It has been greatly improved by the addition of valves, which enrich the quality of tone and give variety to the pitch. Music for the horn is written in the key of C and an octave higher than it is played. However, by adjusting the length of the tube one can play it in almost any key.

**HORN**, a general term applied to all hard and pointed appendages of the head of animals, such as those in deer, cattle, sheep and goats. As a term denoting a particular kind of substance, nothing should be called horn which is not derived from the epidermis, or outer layer of the skin, whether on the trunk, hoofs or head. Horn is a tough, flexible, partially transparent substance, most liberally developed in the horns of animals of the ox family, but also found in connection with the "shell" of the tortoise, the nails, claws, and hoofs of animals and the beaks of birds.

In some species of animals the males only have horns, as, for instance, the stag. In cattle, both male and female have horns. Horns differ widely in the case of different animals. The horns of deer consist of bone, and they fall off at regular intervals; those of the giraffe are independent bones, with a covering of hairy skin; those of oxen, sheep and antelopes consist of a bony core covered by a horny sheath. The horns of the rhinoceros alone consist exclusively of horny matter. The horns of oxen, sheep, goats and antelopes are never shed, except in the case of the prong-horn antelope. See **MOLTING**.

The various kinds of horns are employed for many purposes. The principal ones used in the arts are those of the ox, buffalo, sheep and goat. Deer horns are almost exclusively employed for the handles of knives and of sticks and umbrellas. True horn can be softened by heat (usually in boiling water), and cut into sheets of various thickness. These sheets may be welded together, so as to form plates of large dimensions, and can be polished and dyed so as to imitate the much more expensive tortoise shell. The clippings of horn may be welded together in the same

manner and made into snuff-boxes, powder-horns, handles of umbrellas, knives, forks and other small articles. As horn has the valuable property of taking on and retaining a sharp impression from a die, many highly ornamental articles may be turned out. Combs for the hair are made from the flattened sheets; out of the solid parts of many horns beautiful carvings are made, particularly in Central Europe.

**HORN'BEAM**, a small, bushy tree common in Great Britain, where it is often used in hedges, as it survives cutting and in age becomes very stiff. The wood is white, tough and hard and is used by carpenters and wheelwrights in making various articles, but it does not withstand the action of water or the weather well and should not be used in exterior construction. The inner bark yields a yellow dye. The American hornbeam is a small tree sparingly diffused over the whole United States, where it is called *leverwood*, *ironwood* and *blue beach*.

**HORN'BILL**, a family of large, ungainly birds, species of which are found in Africa and East India. The bird's characteristic feature is an enormous bill, broad and curved; in some species it has a hornlike projection at the base of the bill nearly as large as the bill itself. The bill of the rhinoceros hornbill is about a foot long, but in spite of its great size it is very light. The bird is about five feet long, is stupid and clumsy, has a heavy, slow flight and feeds upon soft foods, insects and small reptiles. It nests in hollow trees, and when the eggs are all laid the female goes upon the nest and the male closes with mud all but a narrow opening. Through this opening he feeds the female, who sits in imprisonment upon the eggs until they are hatched.

**HORNBLLENDE**, *horn'blend*, called also **AMPHIBOLE**, is a widely distributed crystalline mineral, occurring in a number of different forms and in a great variety of colors. It is composed chiefly of magnesia, silica and alumina. Sometimes iron is present, and then the crystals are green. One variety is of a satiny whiteness, another is various shades of red. Common hornblende is either black or dark green. It is found not only in crystals, but also in granular formation, and sometimes occurs in flakes resembling mica, but, unlike mica, the flakes do not peel off. Hornblende is of the hardness of feldspar.

**HORNED TOAD**, a name given to a genus of lizards, of toadlike appearance, found in tropical America west of the Mississippi, where it lives in dry places and feeds upon

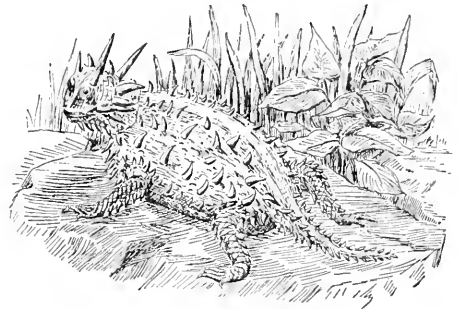

HORNED TOAD

flies and various insects. The scales covering the body bear sharp, horny spines; hence the name. It is also called horned lizard and California toad. There are nine different species. All are harmless.

**HORNELL**, N. Y., a city in Steuben County, ninety miles southeast of Buffalo, on the Canisteo River and on the Erie and the Pittsburgh, Shawmut & Northern railroads. It was settled in 1790 and was known as Upper Canisteo until 1890. The place has a public library, an academy, several city parks, and two hospitals. It is in a fertile agricultural and fruit region and has manufacturing of lumber products, railroad supplies, agricultural implements, furniture, silks and various other articles. Population, 1910, 13,617; in 1917, 11,918 (Federal estimate).

**HOR'NET**, an insect much larger and stronger than the ordinary wasp (which see), but like the latter in many of its habits. It is voracious, feeding on fruit and honey and on other insects. Hornets live in colonies

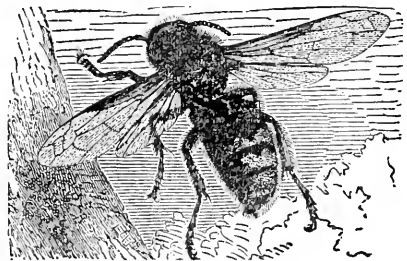

HORNET, ENLARGED

and make their nests of a kind of paper work, placing them in hollow trees, in the crevices of walls and upon the limbs of

trees. All species are able with their stings to inflict painful wounds, which are usually accompanied with considerable swelling.

**HOROSCOPE**, *hor'oskope*, in astrology, a word used to designate the distribution of stars in a part of the heavens at a given time and with reference to some person. The entire earthly career of a man was supposed at one time to be determined by the stars in the ascendant, or "rising" in the east, at the hour of his birth. The old astrologers attempted to "tell fortunes" by "casting a horoscope," that is, by making a diagram of the eastern heavens as they appeared at the time of the person's birth, and then interpreting, according to a body of lore on the subject, the signification for that person of the stellar arrangement at the hour he was born. Needless to say, the notion is no longer regarded seriously.

**HORSE**, a domestic animal more important to civilization than any other dumb creatures excepting cattle. Nobody knows when it was first domesticated; it was the servant of man, and used then principally in war, thousands of years ago. It was derived from breeds of wild horses, native of the East, and taken into Europe and thence to America by those who followed Columbus.

The horse belongs to the same family as the ass and the zebra. Its characteristics are a long mane and tail; a single, unparted hoof; a graceful, sleek body, covered with short hair, usually of a single color; and a slightly arched neck.

Modern horses can be classified under three groups. These are the small breeds, generally known as ponies; the heavy draft horses, and the more graceful thoroughbreds, used for carriage horses and racing. The ponies have descended from the wild horse of the mountainous regions of Northern India. The heavy draft horses have been developed by careful breeding with the larger types of central and northern Europe, and the thoroughbreds are from the Arabian and Turkish horses. In England and America horse racing has been an enticing sport for many years, and much attention has been given to the development of racing animals, until now horses that can trot a mile inside of two minutes are found on race courses. However, because of gambling which horse-breeders cannot separate from trials of speed, racing is prohibited almost everywhere.

The horse is one of the most intelligent of animals and is gifted with keen senses. He can distinguish objects at night, and his large ears, which can be turned in different directions, enable him to perceive sounds that a man cannot hear.

His sense of smell sometimes also warns him of the approach of danger, and it enables him to distinguish his master from other men.

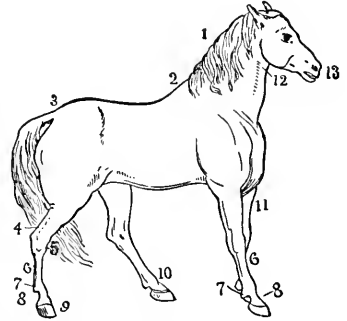

HORSE

1, Crest; 2, withers; 3, croup; 4, hamstring; 5, hock; 6, cannon; 7, fetlock; 8, pastern; 9, hoof; 10, coronet; 11, arm; 12, gullet; 13, muzzle.

The horse takes more kindly to man than other animals and becomes more devotedly his friend. The Arab loves his horse next to his family, and the animal returns his affection. Horses often show love for children and form friendships with dogs and other domestic animals. They can usually be ruled by kindness, and no animal deserves better treatment or returns it with more certain gratitude.

**HORSE-CHESTNUT**, *ches'nut*, a large family of handsome trees and shrubs, with snowy white, yellow or red flowers and fan-shaped leaves which grow on opposite sides of long stems. It was first known in Tibet. Some of the trees grow to be sixty or eighty feet high. The seeds are large, brown and highly polished, and the bitter meats have been used as horse feed, hence the name. The trees of the North America species are not as large as the true horse-chestnut, and their wood is of little value. The horse-chestnut is in no way related to the chestnut which produces the table nuts. See CHESTNUT.

**HORSEFLY**. See GADFLY.

**HORSE LATITUDES**, the sailor's name for the belts of tropical calm found near the tropic of Cancer and the tropic of Capricorn. These are not continuous belts of calm, but within these latitudes regions of calm appear, separated by spaces where there is a regular and constant breeze. They are but a few degrees wide and move slightly north and south with the movement of the sun. Within these regions the weather is clear,

and fresh, light, variable winds follow the occasional calms. The horse latitudes are not dangerous, as are the doldrums, but are a hindrance to sailing vessels. These calms are so named because before the days of steamships many horses were exported from the United States in vessels whose route lay through the regions of tropical calms in the North Atlantic. If becalmed for any length of time some of the horses were thrown overboard, since the ship could not carry a sufficient supply of fodder for the prolonged voyage. See DOLDRUMS.

**HORSEMANSHIP.** See RIDING.

**HORSE POWER,** the unit of force employed in measuring the power of steam engines and other motors. A horse power is a force which will raise a weight of 33,000 pounds one foot in one minute. An engine of one hundred horse power could lift the same weight one hundred feet in one minute. This estimate is theoretical. In a practical estimate one-tenth is deducted for friction.

The actual horse power developed in an automobile engine is found by what is known as the "S. A. E." formula, adopted by the Society of American Engineers. It takes into consideration only the area of the piston, and determines the horse power by multiplying the square of the diameter (the bore) of the cylinder by the number of cylinders and dividing the result by 2.5.

**HORSE RACING.** See RACE.

**HORSE-RADISH,** a plant belonging to the mustard family, whose whitish root possesses a pungent taste and odor and when grated is used with vinegar as a relish. It is also employed medicinally as a stimulant. Horse-radish is now cultivated in many parts of the world, but was first known in Southern Europe.

**HORSESHOE,** a shoe for horses, consisting commonly of a narrow plate of iron, bent into a form somewhat resembling the letter U, so as to accommodate itself to the shape of the horse's foot. Horseshoes are manufactured by machinery, except that projections, called corks, at the ends and in the center of the curve, are fashioned by the blacksmith when the shoe is fitted to the foot.

Horseshoes do not appear to have been known to the ancients. Xenophon, Vegetius and others mention various processes for hardening the hoofs so as to make them stronger, but say nothing of any protection like the horseshoe. Iron horseshoes are men-

tioned as being in use in Europe in the ninth century of our era. Their use is now universal.

**HORSESHOE CRAB,** a large crustacean which receives its name from the shape of its shell. It lives in deep waters and comes to the surface only during the spawning sea-

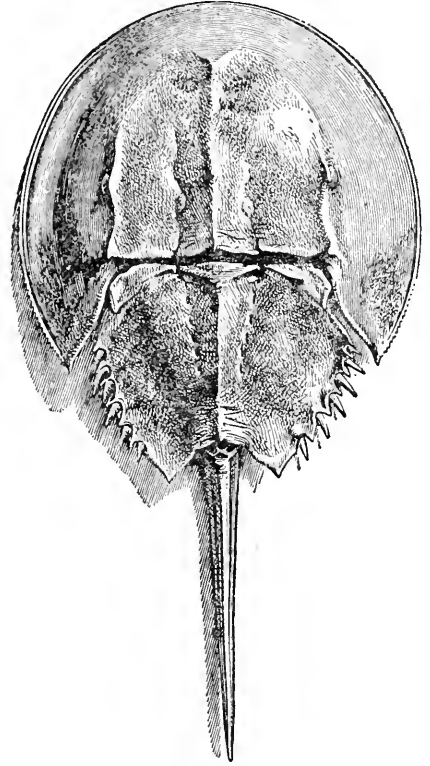

HORSESHOE CRAB

son, when great numbers appear. A species called the *king crab*, found on the northeastern coast of the United States, reaches a length of nearly two feet. The body of the horseshoe crab is composed of two parts, the horseshoe shell and a back region, which is prolonged into a long, spinelike tail. The animal burrows in the sand and mud and lives on shellfish and worms. In burrowing, the head is thrust downward and the tail is used as a brace to push the body forward.

**HORSETAIL RUSH,** or **EQUISETUM,** a peculiar plant, represented now by only one genus, though in the early history of the earth there were many kinds, some of which were enormous trees. The present plant is small and slender, with roughly ridged stem, and it may be recognized by the ease with which it is pulled apart at the joints, which

are surrounded by circles of minute leaves. The stem is green in all species, except that the fertile plants of some are colorless. In one or two species the stem is straight and unbranched, while in others it branches so that the plant resembles a little evergreen tree. These rushes are not flowering plants, but the fertile form produces spores not unlike those of the fern. These are held in cases that resemble miniature pine cones. Each spore is provided with two spiral bands which, while the spore is moist, are coiled tightly about its body, but when dried unroll to be again drawn up to the body when moisture is applied. It is an interesting thing to watch the action of these bands under a simple magnifying glass. The result of the opening and closing of the bands is to bring the spores tightly together in masses. The horsetail rush is commonly known as the *scouring rush*.

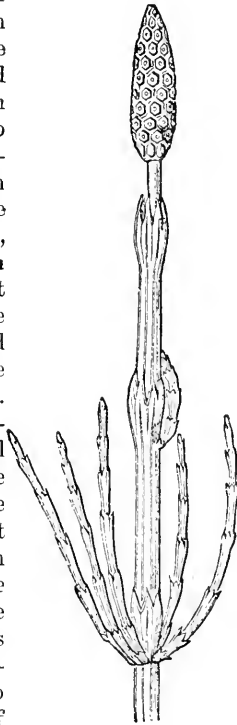

HORSETAIL RUSH

**HORTICULTURE**, *haw'ti kul ture*, the cultivation of vegetables, fruits and ornamental plants. It is divided into four classes—fruit growing in orchards; truck farming; floriculture, or the raising of flowers and ornamental plants; and landscape gardening.

A more detailed discussion of these branches will be found under the headings Gardening, Landscape Gardening, Floriculture, Grafting, Greenhouse. See also, under their respective headings, articles on various fruits, flowers and vegetables.

**HOSEA**, *ho zé'ah*, the first among the minor prophets of the Old Testament. Nothing is known of his life except that he was the son of Beeri and that he prophesied in the reigns of Uzziah, Jotham, Ahaz and Hezekiah, kings of Judah. The book of *Hosea*, which contains fourteen chapters, is divided into two parts, and is made up

chiefly of lamentations concerning the backsliding of the Israelites.

**HOS'MER**, HARRIET (1830-1908), an American sculptor, born at Watertown, Mass. She studied at Rome under John Gibson, and her art shows a leaning toward the classical. In addition to a fountain in Central Park, New York, and two fountains in private grounds in England, she has executed ideal heads, notably those of *Daphne*, *Medusa* and *Puck*. *The Sleeping Faun*, *The Waking Faun*, *Zenobia in Chains* and *Beatrice Cenci* are among her best pieces.

**HOS'PITAL**, in a broad sense, a building or group of buildings devoted to the care of various kinds of helpless and needy people. The name is used most commonly, however, in connection with institutions for the care of those who are sick and injured; that is, medical and surgical hospitals. It is with this group that this article deals.

There are two general types of hospitals, in respect to details of construction. There is the hospital consisting of one building of many stories (with possibly a few adjoining structures), on a comparatively small area, and the hospital consisting of numerous one-story buildings, covering many acres of ground. In the United States and Canada the *multiple-story* type is the more common, while in Europe the hospital of many buildings, called the *pavilion* type, is preferred.

The best modern hospitals are admirably equipped to carry on their work of saving human life. The patients are cared for in wards of several beds or in private rooms, according to the ability of the inmates to pay for service. Besides the sick rooms the hospital contains administrative offices, reception rooms, operating rooms, a pharmacy, diet kitchens, baths, lavatories, accommodations for nurses, laundries, etc. The finest possible equipment for heating, lighting and ventilation is used, and sanitary regulations represent the latest advance in that field.

**How Conducted.** The institution is governed by a board of managers, and is under the immediate supervision of a superintendent. He is assisted by various house officers, including a head nurse, a matron, or chief housekeeper, a steward, who has charge of food supplies, an engineer and a pharmacist. Graduates of medical schools, who reside permanently in the hospital for a specified period, direct the nurses. These doctors

are called *internes*. They often give their services free, but receive board and lodging, accepting experience in lieu of salary. The *internes* are under the direction of a house physician and of visiting physicians especially qualified for such service. Male attendants, called *orderlies*, assist in the menial work of the wards. In connection with the hospital is maintained a training school for nurses; the course includes theoretical and practical work, and extends over a period of two or three years.

**Military and Naval Hospitals**, or establishments for the reception and care of sick and wounded soldiers and seamen, have been in existence in all civilized countries for a long period. Military hospitals are either permanent or temporary establishments. Temporary hospitals are any available buildings in the immediate vicinity of the scene of operations, and they play an important part in keeping up the morale of armies. Hospital ships are fitted out to accompany all expeditions on sea. They serve either as stationary hospitals, or they sail home or to a near-by port with the sick on board. Such a ship is immune from attack, according to The Hague regulations, provided it carries no arms and makes no attempt to give aid except to sick and wounded. During the World War this humane rule was repeatedly violated by one of the belligerents.

**HOSTAGE**, *hahs'tayj*, a person given by one country, town or tribe to another as surety of the performance of contracts. It was once common in time of war for a town that had surrendered to give the victors the custody of several officers, or prominent civilians, as pledge that the conditions of surrender would be lived up to. Sometimes, also, the victors placed a hostage in the hands of the vanquished, to guarantee the fulfillment of their promises. When the conditions had been fulfilled, the hostages were returned. The old practice of taking hostages had been almost entirely abandoned when, at the outbreak of the World War, Germany exacted obedience from Belgian cities by threatening the lives of certain prominent Belgians it held captive. Scores of innocent Belgians thus suffered death.

**HOT-BED**, a small section of soil, usually enriched by fertilizer, and covered with a glass-topped frame to exclude cold air. It is generally employed to force the growth of plants in early spring, with the expecta-

tion of transplanting them in open ground after frosts have disappeared. The heat in a hotbed results from the rays of the sun through the glass and from fermentation. The usual fertilizer is manure, but other fertilizing agents may be employed.

Sometimes hotbeds are used during the entire growth of vegetables or flowers, to force them to early maturity, to take advantage of high prices for such products marketed out of season.

**HOTCH-KISS**, BENJAMIN BERKELY (1826-1885), an American inventor of guns employed in warfare, was born in Watertown, Conn. He designed a field gun on a new pattern, and in 1860 he submitted to the United States government a system of rifle projectiles, which was largely used during the Civil War. In 1867 he introduced his revolving cannon to the European governments, and after that he devised a magazine rifle. All his inventions have now been supplanted by other material of improved pattern, but they were at one time notable.

**HOTEL**, a house open for the accommodation of the public, with board and lodging. It is a comparatively modern development of the old inn, or road house, which is still common in Europe, where provision was made for occasional guests. Hotels are of two principal kinds—those managed upon the so-called *European* basis, according to which a set price is paid for a room and its accompanying accommodations, while the guest pays separately for the food which he orders; those on the *American* plan, according to which the guest pays a certain amount each day for both room and meals. Another kind of hotel has developed within recent years, though actually on the American plan; it is the so-called *family* hotel, which seeks permanent rather than transient guests.

Hotels must be conducted according to the laws affecting common carriers. No respectable-appearing guest may be denied service if he is able to pay for it, unless the place is already crowded to capacity. They are liable for the safety of goods left within their premises, unless the damage done is by act of God or the public enemy, and, on the other hand, they have a lien on the goods of guests to assure the payment of their bills. See CARRIER, COMMON.

In great cities hotel-building has reached remarkable proportions, and no less wonderful is the lavishness in equipment. There

are hotels having accommodations for more than 2,000 people, who are offered every luxury that the deepest thought of builders and managers can provide. The most recent development is the grouping of a number of hotels in various cities under a single ownership and management. Among the famous "chains" of hotels are the Ritz hotels, which may be found in the United States, Europe and South America. The Statler group confines locations to the United States; its hotels are located in Detroit, Cleveland, Buffalo, Saint Louis and New York.

**HOTEL DE VILLE**, *de veel*, the French name for *town hall*. Among the many fine buildings of this nature in France is the Hotel de Ville of Paris, a splendid example of Renaissance architecture. The interior contains many beautiful paintings and statues, and is noted also for its grand staircase and luxurious festival hall. Some of the town halls destroyed by the Germans in the northeastern part of France in the World War were among Europe's finest architectural designs.

**HOT SPRINGS, ARK.**, the county seat of Garland County, fifty miles southwest of Little Rock, on the Saint Louis, Iron Mountain & Southern, the Memphis, Dallas & Gulf and the Chicago, Rock Island & Pacific railroads. The city is in a beautiful location and has a mild climate. On account of the many flowing springs of hot water, it has become one of the greatest health resorts in the world. To accommodate as many as 150,000 of visitors annually there are a large number of hotels, some of them of palatial proportions. The water is prescribed for bathing and drinking and has strong curative properties. In 1832 the national government set off 2,529 acres of land, with the thermal springs in the center, as a government reservation, and it remains a government owned and controlled resort. Even the physicians who prescribe the baths are under government supervision. Considerable stone is quarried in the neighboring mountains, and it is a lumber and cotton market. Hot Springs was settled about 1804 and was chartered as a city in 1879. A fire on September 5, 1913, destroyed property to the value of \$6,000,000. Population, 1910, 14,434; in 1917, 17,690 (Federal estimate).

**HOTTENTOTS**, a peculiar African race, supposed by some authorities to be the aboriginal occupants of the south end of that

continent, south of the Orange River and west of the Kei. When young they are of remarkable symmetry; but their faces are ugly, and this ugliness increases with age. The complexion is a pale olive, the cheek bones project, the chin is narrow and pointed and the face consequently is triangular. The lips are thick, the nose is flat, the nostrils are wide, the hair is woolly and the beard is scanty. The ears are large, without lobules.

When the Dutch first settled at the Cape of Good Hope, in the middle of the seventeenth century, the Hottentots were a numerous nation, of pastoral and partially nomadic habits, and occupied a territory of 100,000 square miles. White settlers gradually drove them farther inland. When Germany colonized a large section of Africa thousands of the Hottentots came under their control. Through cruelty the number was reduced almost two-thirds; fewer than 10,000 remain in what was German territory, and there are probably no more than 20,000 on the entire continent.

**HOUDON**, *oo dawn'*, JEAN ANTOINE, the greatest French sculptor of his generation, was born at Versailles. When only thirteen years of age he began to attract attention, and at twenty won the Prize of Rome. After ten years' study in Rome he returned to Paris and became an instructor in the School of Fine Arts. In 1785 he visited America with Franklin and while here executed a statue of Washington, which is now in the state capitol at Richmond, Va. Among his other important statues is one of Voltaire and an ideal figure of Cicero. He executed more than 200 busts of eminent men and women, including Franklin, Washington, Napoleon, Lafayette, Rousseau and Molière, all of which show remarkable technical skill and insight.

**HOUND**, a name given generally to hunting dogs, but restricted by scientific writers to such as hunt by scent. Among the varieties are the bloodhound, staghound, foxhound, dachshund, harrier and beagle. Hounds are distinguished not only by their keenness of scent, but by gentleness and intelligence. Of the rough-haired and smooth-haired varieties, the former manifest the greater affection for man. See Dog.

**HOURGLASS**, *owr'glas*, an ancient instrument for measuring time, consisting usually of two hollow bulbs, placed one above the other, with a narrow neck of com-

munication, through which a certain quantity of dry sand, water or mercury is allowed to run from the upper to the lower bulb, the quantity being adjusted so as to occupy an hour in passing from one bulb to the other. When all the contents has run into the lower bulb, the glass is turned. The hourglass was used in churches in the sixteenth and seventeenth centuries to regulate the length of sermons. It is now only a curiosity. See CLOCK.

**HOUSEBOAT**, a floating house. In Europe and America such boats are used in the summer time for recreation purposes, but in some of the congested cities of China thousands of people live in river houseboats permanently. The houseboat for recreation is sometimes as luxuriously fitted up as the most pretentious summer cottage. Scores of these floating pleasure palaces may be seen in summer in the waters near New York City, on the Mississippi, along the Pacific coast, on the Great Lakes, and in Florida waters. Those of a humbler type are also in evidence, the property of fishermen or school boys. Houseboats are sometimes towed from place to place; sometimes they travel by means of sails, and some are fitted with engines and are propelled by their own power. A diverting story of the experiences of a young married couple in a houseboat is told by Frank Stockton in *Rudder Grange*.

**HOUSELEEK**, or **LIVE-FOREVER**, a group of plants widely distributed throughout Europe. They grow on rocky soil and are often found on the walls and roofs of cottages. Upright stems about six inches in height bear branches of purplish, star-shaped flowers. The petals equal in number the sepals, or divisions of the calyx. The leaves are arranged in the form of compact rosettes. If bruised or cut, they afford relief to burns, stings, or other inflammation.

**HOUSE OF COMMONS.** See GREAT BRITAIN, subhead *Government*.

**HOUSE OF LORDS.** See GREAT BRITAIN, subhead *Government*.

**HOUSE OF REPRESENTATIVES.** See REPRESENTATIVES, HOUSE OF.

**HOUSING PROBLEM**, a social problem that has developed from the overcrowding of the population in large industrial centers. In the poorer tenement districts of large cities, both in Europe and America, the people have been forced to live in crowded

quarters with deficient air, light and sanitation, and the result has been an increase in the death rate and a lowering of moral and health standards. Because conditions in New York were the most serious, the movement to improve housing conditions in America began in that city.

In 1867 the first law relating to tenements was passed, but not until 1901 was there enacted vital and effective legislation on the subject. Within recent years conditions in New York, though still far from ideal, have been greatly improved, and there has been a noticeable decline in the death rate. Since 1901 about a hundred cities in the United States and Canada have put into operation housing regulations. These laws have to do with the proportion of lot area which any building may cover; amount of light and air required for each room; plumbing requirements, and fire protection. New York City has a Tenement House Commission to enforce regulations, but boards of health and the police are entrusted with enforcements of rules in many cities.

**HOUSTON, SAM** (1793-1863), an American pioneer soldier and political leader, born near Lexington, Va. After his father's death, his family emigrated to Tennessee, and he later went to live among the Cherokee Indians, where he was adopted by Chief Olooteka as his own son. In 1811 he returned to his family and two years later enlisted in the regular army. He served under General Jackson, and in 1817 aided in the negotiations with the Cherokees. On his return to Nashville, he studied law and he once opened an office in Lebanon. He served in Congress from 1823 to 1827 and was then elected governor.



SAM HOUSTON

In 1832 he went to Texas and soon became the leader of the American colonists. He was a member of the convention in April, 1833, which attempted to form a state constitution. When the trouble with the Mexicans had led to an armed conflict, Houston was made the commander in chief of the Texan forces. With a small band of



undisciplined troops he conducted the military movements which led to the defeat of Santa Anna in the famous Battle of San Jacinto, April 21-22, 1836. This brought about the independence of Texas, and in September Houston was elected President of the republic. He served three terms and was the chief agent in bringing about the admission of Texas to the Union in 1845. He sat in the United States Senate for twelve years and in 1859 was elected governor of Texas. At the outbreak of the Civil War, he retired to Huntsville, where he died two years later.

**HOUSTON**, *hū'ston*, TEX., the county seat of Harris County, fifty miles northwest of Galveston, is situated on Buffalo Bayou, at the head of a new ship canal which makes Houston an ocean port, and on the Missouri, Kansas & Texas, the Texas & New Orleans, the Gulf, Colorado & Santa Fe, the Texas Central, the Southern Pacific and the International & Great Northern railroads. It is the seat of the William R. Rice Institute for the Advancement of Literature, Science and Art. There are a Carnegie Library, a cotton exchange, a city hall, a large auditorium, a Federal building and one of the finest and largest hotels in the South. Houston is one of the largest cotton markets in the world, and has, also, an important trade in lumber, fruit, sugar, rice and hardware. There are cotton compresses and rice mills, and the city is the center of one of the country's largest oil companies. The place was settled in 1836, and was named in honor of General Sam Houston. On the outskirts of the city during the World War was Camp Logan, for the training of soldiers. The city has the commission form of government, adopted in 1907. Population, 1910, 78,800; in 1917, 116,878 (Federal estimate).

**HOWE**, **ELIAS** (1819-1867), inventor of the sewing machine, was born at Spencer, Mass. He received a common school education and for several years was employed in a cotton-machinery manufacturing establishment at Lowell, Mass. While working in a machine shop in Boston he conceived the idea which resulted in the invention of the sewing machine. He perfected the machine in 1845 and patented it the next year. He was not successful in introducing it in America and so went to Europe, but there he received little encouragement. On his return from Europe he found manufacturers profiting by his invention. He prosecuted those who had in-

fringed upon his rights, and in 1854, after years of wearisome lawsuits, his claim to priority was legally established, and eventually he earned a large fortune from his invention.

Howe enlisted as a private in the Civil War, and on one occasion, when the pay of the regiment was delayed, he advanced the money to pay off the men. He was awarded many medals, and in the year of his death the Cross of the Legion of Honor was conferred on him at the Paris Exposition.

**HOWE**, **JOSEPH** (1804-1873), a Canadian statesman, the leader in Nova Scotia in securing responsible government. He learned the trade of printer and became a publisher and editor. He refused to unite with Mackenzie and Papineau in the Upper and Lower Canada Rebellion of 1837, though he vigorously attacked the existing evils in the government. In 1835 he was prosecuted for libel and defended himself. He won his case and became the idol of the province. He

was elected to the legislature and aided in securing the liberties which he demanded as an editor. Mr. Howe remained in public life until his death in 1873. During his career he was successively speaker, secretary of state and premier of Nova Scotia. After the confederation he became a member of the Dominion government, and at the time of his death was governor of Nova Scotia. On several occasions he represented his province in England. He was noted as an orator and was the author of *Speeches and Public Letters*, *Life and Times of Howe*, *Western and Eastern Rambles* and *Legislative Reviews*.



ELIAS HOWE



JOSEPH HOWE

**HOWE, JULIA WARD** (1819–1910), an American writer and philanthropist, a pioneer in the movement for woman suffrage, and the author of the most stirring song of Civil War days—

*Battle Hymn of the Republic*. She was born in New York City, and was given a thorough education. In 1842 she was married to Samuel Gridley Howe, for many years director of Perkins Institute



JULIA WARD HOWE

for the Blind, and with him spent some time in London, where she made the acquaintance of many of the most noted people of the day, including Dickens, Wordsworth, Landseer and Florence Nightingale. On returning to the United States the Howes settled in Boston, where they conducted an antislavery paper, the *Boston Commonwealth*. After the war Mrs. Howe took an active interest in many reform movements, including woman suffrage and prison reform. Her writings, besides the famous poem referred to above, include *Passion Flowers* (a volume of poems), *Sex and Education* and *Reminiscences*. See **BATTLE HYMN OF THE REPUBLIC**.

**HOWE, WILLIAM, SIR** (1729–1814), a British soldier, brother of Richard, Earl Howe. He served in America during the last French and Indian War, but returned to England and was elected to Parliament. At the opening of the American Revolution he condemned the British government's policy, but accepted a command in the British army in America, fought at Bunker Hill, was made lieutenant-general and succeeded Gage as commander in chief. After two successful campaigns, which, however, did not accomplish what he had expected, he resigned in 1788 and was succeeded by Clinton. His inactivity at Philadelphia in the preceding winter led to an investigation, but he was not censured.

**HOWELL, CLARK** (1863– ), the leading editor of the South after the retirement of Henry Watterson. Howell was born in South Carolina, and was educated at the University of Georgia, graduating in 1883. He made journalism his life work, and in 1897 became editor of the powerful Atlanta

*Constitution*, a post he yet holds. He has not been a professional politician, but has served in the Georgia legislature, as member of the house and as speaker (1890–1891), and in the senate, where he was presiding officer (1906). In 1906 he conducted a memorable campaign against Hoke Smith for the governorship of his state, but was defeated.

**HOWELLS, WILLIAM DEAN** (1837– ), an editor, a novelist, and a literary critic, the high quality of whose work has given him the title "dean of American letters." Howells was born at Martin's Ferry, Ohio, of Welsh-Quaker ancestry. He learned the printer's trade with his father and then went to Columbus, where, after working for some time as a compositor, he became assistant editor of the *Ohio State Journal*. In 1861 he was appointed United



W. D. HOWELLS

States consul to Venice, and as a result of his four years in Italy, he published *Venetian Life* and *Italian Journeys*. On returning to America he wrote for the *Nation* and the *Tribune*, and in 1871 he became editor of the *Atlantic Monthly*. After a residence of several years in England and Italy, he edited for a short time the *Cosmopolitan* and later became associated with the editorial department of *Harper's Magazine*. In this editorial work he constantly championed the realistic novel and opposed the romantic school. He has written many farces, among them *The Elevator*, *The Sleeping Car*, *The Mouse Trap* and *The Register*, many essays on literary topics and some poetry. His more important novels include *A Modern Instance*, *The Rise of Silas Lapham*, *A Foregone Conclusion*, *A Hazard of New Fortunes*, *The World of Chance*, *Story of a Play*, *Ragged Lady*, *The Kentons*, *Letters Home* and *Their Silver Wedding Journey*. Later works mostly of a general literary character, include *Seven English Cities*, *The Seen and Unseen at Stratford-on-Avon*, *Years of My Youth* and *The Leatherstocking*. Howells's characters and situations are such as may be encountered

at any time in real life, and his style is admirably clear and easy. His has been the chief influence in American fiction in the last quarter of a century.

**HOWITZER**, the name of the most destructive gun used in modern warfare. The howitzer is shorter than the usual naval and field guns, and is built for the purpose of dropping heavy missiles on the enemy at an angle not obtained by any other gun. The largest howitzer now known is the German weapon with a caliber, or bore, of 17 inches, firing a huge shell of more than a ton in weight. The howitzer is usually elevated to fire at an angle of 45 degrees. The shell goes up into the air and drops with tremendous force on the trench or fort at which it is aimed. The howitzer is one of the oldest forms of cannon, and was used in Europe before the end of the fifteenth century. Previous to the World War the howitzer was almost supplanted by smaller guns, but after the destruction of the forts at Liege and Namur, by the new Krupp howitzers, this terrible gun was recognized anew as a weapon of an invincible class. Sometimes howitzers are used as mortars (see **MORTAR**).

**HUBBARD**, **ELBERT** (1850-1915), an American writer, and maker of fine books, born at Bloomington, Ill. He founded the famous "Royercroft Shop" in East Aurora, N. Y., which is devoted to handcrafts, and established *The Philistine*, a magazine of philosophy and criticism, notable for its epigrammatic style, its independence of conventionalities and its frank tone, marred at times by vulgarity. Afterwards he published *The Fra*, another magazine of criticism and discussion. He also wrote many essays, including *A Message to Garcia* and a series of *Little Journeys* to the home of authors, musicians, artists and philosophers. Hubbard lost his life when the *Lusitania* was sunk by a German submarine.

**HUCKLEBERRY**, or **WHORTLEBERRY**, a well-known shrub of the heath family, whose fruit is a small bluish berry. Familiar species are the swamp huckleberry, which sometimes grows to a height of ten feet or more, and the lowbush huckleberry, whose stem is from one to three feet in height. The swamp huckleberry bears white, bell-shaped flowers, and its blue-black berries are sweet and juicy. The name is also applied to several species of blueberry, whose fruits make such delicious pies and preserves.

**HUDSON**, **HENRY** (?-1611), an English navigator and explorer. He sailed from London in the year 1607, with only ten men and a boy, to discover the northeast passage, and proceeded beyond the 80th degree of latitude. Two later voyages for the same purpose were embarked upon and also proved fruitless. In 1609, in the employ of the Dutch East India Company, he sailed for North America and discovered the Hudson River, which he ascended to about the site of Albany. In 1610 he sailed in an English ship named the *Discovery*, and, in an effort to find a northwest passage to Asia, discovered Hudson Strait and Hudson Bay, where he spent the winter. His crew, after suffering many hardships, mutinied and set him adrift in a boat, along with his son John and seven of the most loyal of the crew, none of whom was ever heard from again.

**HUDSON**, **N. Y.**, the county seat of Columbia County, twenty-eight miles south of Albany, on the Hudson River, at the head of navigation, and on the New York Central, the Boston & Albany and the Albany Southern railroads. The city is beautifully situated on the slope of Prospect Hill. Prominent buildings are the State Training School for Girls, a state armory, the State Volunteer Firemen's Home, a Federal building, a courthouse, a city hall, a library and the Hudson Orphanage Asylum. The various industries include machine shops, creameries, and manufactures of car wheels, steel springs, mattresses, Portland cement, stoves and other articles. The place was settled in 1783, under the name of Claverack Landing. Population, 1910, 11,417; in 1917, 12,898 (Federal estimate).

**HUDSON BAY** (not Hudson's Bay) a great inland sea in Eastern Canada, ten times larger than the state of Ohio and about the same size as the enlarged province of Ontario. Its area is about 400,000 square miles, including James Bay, at the south, and its average depth is about 425 feet. The outlet to the Atlantic Ocean is through Hudson Strait; to the Arctic Ocean, through Fox Channel and various lesser passages.

Hudson Bay is navigable for less than five months each year; the remainder of the year the harbors are icebound, although the bay never freezes. This body of water has heretofore been of little value to Canada except as the outlet of rivers which drain nearly 1,500,000 square miles of territory. In the future, however, it is to be a part of a new

waterway to Europe; plans to this end only await the completion of the Hudson Bay Railroad (see below).

**HUDSON BAY RAILROAD**, a rail route from the heart of Western Canada to Port Nelson, on the west shore of Hudson Bay. The Canadian Northern Railroad has built a line from Winnipeg to Le Pas (The Pass), Manitoba, and from that point the Dominion

possibly, than the Thames at London or the Mersey at Liverpool.

Its whole course is over 300 miles, and it is navigable to Troy, 150 miles from its mouth, and for the largest vessels to Albany, six miles farther south. In the greater part of its course it is from one-half to one and one-half miles wide. Tide-water extends to Albany, making the lower half of the river more

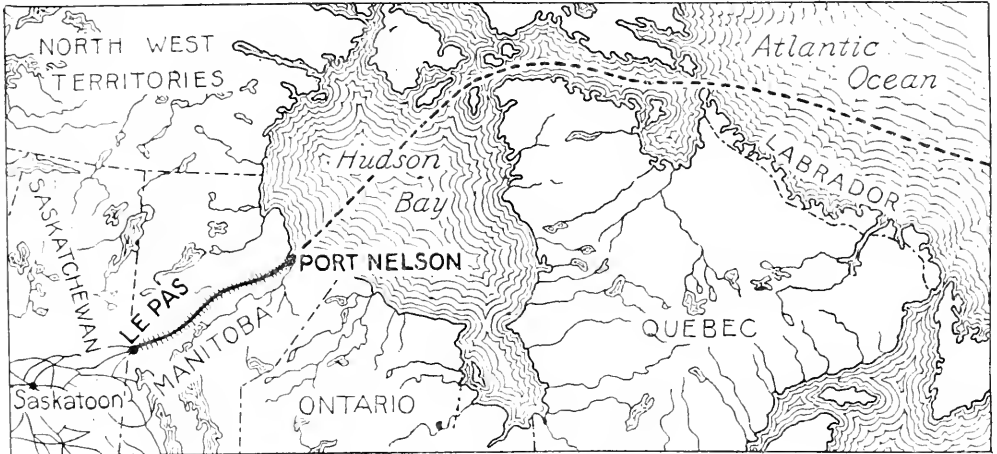

THE HUDSON BAY RAILROAD

government has built a road 424 miles in length to Port Nelson, along the Nelson River valley. The object of the complete line is to join the great agricultural midwest to a port which shall be open to direct steamship connection with Europe (see HUDSON BAY, above). It is estimated that even with a short navigation season shippers to Europe can effect a saving of \$3,000,000 a year on freight charges for wheat alone, and the line is expected to carry vast quantities of beef, as well.

At Port Nelson a landing dock extending 3,000 feet from the shore has been constructed for ocean vessels, and on it are numerous elevators and warehouses.

**HUDSON RIVER**, one of the most important short rivers in the world. In the lower miles of its course it floats a merchant marine of vast extent, which penetrates to the remote corners of the world. For the greater part of its course the river is wholly in New York state, but in its lower twenty-five miles New Jersey claims its western shore. Here it flows between Manhattan Island and New Jersey, and it is in this section that as a waterway it is crowded with commerce only a little less in volume.

properly an estuary. At Glens Falls the Hudson has a fall of fifty feet. Great commercial power is now developed here by means of a dam. Because of its beautiful scenery, especially along the lower half, where its banks are high and rocky, the river is often called the "Rhine of America." The Palisades, near its mouth, are considered one of the most beautiful natural formations on the continent. Many thriving towns are situated along the river's course. Above New York City and Hoboken the most important are, in order, Yonkers, Peekskill, Newburgh, Poughkeepsie, Kingston, Hudson, Albany, Troy, Cohoes and Glens Falls.

**Hudson River Tunnels.** See TUNNEL.

**HUDSON'S BAY COMPANY.** In 1670 King Charles II granted a charter to a number of "adventurers," headed by Prince Rupert, the sole right to trade with the Indians on the shores of Hudson Bay. The company had power to "establish laws and impose penalties, to erect forts, maintain ships of war, and to make peace and war with any prince or people not Christian." Thus the Hudson's Bay Company, as this organization was known, was practically a government in itself, though subject to England.

For many years the company grew slowly. Conflicts with the French were almost continuous, and the difficulties of transportation were considerable. The turning point in the history of the company was the conquest of New France by the English. When Canada became English the vast territory of the company could be reached from the south by land as well as from the sea. Trade increased enormously and profits advanced in proportion. But this monopoly was too profitable to be left to the Hudson's Bay Company. Competition, sometimes amounting to an actual warfare, sprang up, in which numerous lives were lost.

The principal rival was the famous Northwest Company, in which Lord Selkirk was one of the leaders. After Selkirk's death in 1820 the chief obstacle to combination was removed and a year later the Hudson's Bay Company absorbed its principal rival. After the union of the companies the management of the company's affairs was placed in the hands of an official known as the governor of Prince Rupert's Land. Sir George Simpson, a young Scotchman, was chosen for the position, and for forty years he guided the company's fortunes. Under his aggressive administration, Great Britain's control of the Pacific coast was made secure and British Columbia was occupied, Russia and the United States were thus prevented from shutting out Great Britain from the Pacific Ocean. The territory of the Hudson's Bay Company at that time included practically all of the Northwest, reaching the Arctic Ocean on the north and the Pacific on the west.

Under the control of the company the fur trade continued to increase. Trading stations and forts were built in every part of the country until the "fur trade," the "Northwest" and the "Hudson's Bay Company" became almost synonymous. In 1859 the trade monopoly of the company was abolished, and ten years later it surrendered its territorial rights to the Dominion for an indemnity of £300,000 (\$1,500,000) and 7,000,000 acres of land. The trading stations and forts, all of which the company retained, dot the entire Northwest. From these various stations the furs are sent to posts on Hudson's Bay and in Labrador, or to Montreal, St. John or other Atlantic ports for shipment to England, where they are generally sold at auction. Though competition

has increased in recent years the Hudson's Bay Company is still the greatest fur company in the world; it exports about one-half of all furs sent from the Dominion.

**HUERTA**, *hwair'tah*, VICTORIANO (1844-1916), a Mexican soldier and statesman, leader of the revolt that deposed President Madero. General Huerta was of pure Indian blood. Born of poor parents, he would probably have remained obscure but for a chance visit of some soldiers to his native village. The general in command needed a secretary, and employed Huerta, whose ability so impressed the general that he took the boy to Mexico City. For many years he served in the army, but for good reasons seems to have been distrusted by Diaz. Yet when Diaz fled from Mexico in 1911, it was Huerta, then minister of war, who saw to his safe conduct, and even ordered the firing of a farewell salute. When Madero became President, Huerta was for a time commander of the federal troops, but he soon headed a counter-revolution which resulted in the overthrow and death of Madero.

Huerta now became President, and maintained his authority for over a year, in spite of the opposition of the United States and of the revolutions of the Constitutionalists led by Carranza. On July 15, 1914, he resigned and fled to Europe, where he remained until the next spring. He then settled near New York City, but after a few months started west, ostensibly to visit the exposition at San Francisco, but really to start a new revolt. In July, 1915, he was imprisoned at El Paso, Tex., for violating the neutrality of the United States. He was already in poor health; six months later he was released, to die outside the prison walls.

**HUGHES**, CHARLES EVANS (1862- ), an American jurist and statesman, was born at Glens Falls, N. Y. He was educated at Colgate University, Brown University and Columbia Law School. In 1891 he was elected professor of law in Cornell University; later he was lecturer at the New York Law School. He first came prominently before the public in 1904 in his investigation, as counsel to the legislative committee of New York, of gas, electric light and power companies, and later of the great New York insurance companies. In 1906 and again in 1908 he was elected governor of New York. In 1910 he was appointed an Associate Justice of the United States Supreme Court.

In 1916 he received the Republican nomination for President, and resigned this post. He was defeated at the election and re-entered the practice of law in New York City. During American participation in the World War President Wilson appointed Hughes a special investigator to report on the conduct of the aeroplane committee.

**HUGHES**, *huze*, JAMES LAUGHLIN (1846- ), a Canadian educator, born in Durham County, Ontario. He lived on a farm till he was twenty years old; then, after teaching for a year, entered the Toronto Normal School. He taught at Frankford for six months after leaving the normal school and then was appointed assistant in the model training school in connection with the normal school. After three years he became principal, and in 1874, at the age of 28, was elected chief inspector of schools for the city of Toronto. Mr. Hughes was the leader in the movement for school cadet corps, the Toronto cadets being known throughout the Dominion. He resigned from his position of inspector of schools in 1912, but was later induced to withdraw his resignation. In 1913, after continuous service of almost forty years, he finally severed his official connection with the Toronto schools. Mr. Hughes is well known throughout the Dominion, has been president of the Ontario Education Association, and in his earlier days was prominent in amateur athletics. He is a lecturer and writer, among his publications being *Froebel's Educational Laws*, *Dickens as an Educator*, and *Mistakes in Teaching*.

**HUGHES**, SAM, SIR, (1852- ), a Canadian political leader who held the position of Minister of Militia and Defense in Sir Robert Borden's Cabinet at the outbreak of the World War. When word was received of the rupture between Germany and England, Sir Sam began at once to place the Dominion on a war footing. He organized four great training camps, and within six weeks had a trained and equipped division of 33,000 men ready to sail overseas. In 1916, because of criticism of his methods, he resigned, but up to that time he had trained almost 400,000 men.

Sir Sam was born in Durham County, Ontario. When a lad of fourteen he enlisted in the militia to oppose the Fenians (which see), and was an active member of the militia for thirty years. In 1869, he com-

pleted a course at the Toronto Normal School; later, having studied law, he taught for several years in the Toronto Collegiate Institute. Hughes was elected to the Dominion House of Commons in 1892, and since that date has represented Victoria County, Ont. He became Minister of Militia and Defense in 1911. The criticism which caused his resignation was said to be occasioned by his lack of tact and dictatorial methods.

**HUGHES**, *hews*, THOMAS (1823-1895), an English author who could portray with much sympathy and realism the incidents in the life of the typical English schoolboy of his time. His *Tom Brown's School Days* won him distinction; it is a clever revelation of boy nature. Authorship was only one of Hughes' activities. He enjoyed a long public career as an advanced Liberal in Parliament, was one of the founders of the Christian Socialists, and gave much of his time to the work of social uplift. In *Tom Brown at Oxford* he continues the career of his favorite hero, and in *The Scouring of the White Horse* and *Vacation Rambles* gives accounts of vacation trips. Other volumes are *The Manliness of Christ* and *Alfred the Great*.

**HUGLI**, *hoogly*, or **HOOGLY**, a river of Hindustan, in Bengal, formed by the junction of two streams about fifty-five miles above Calcutta. It constitutes the principal channel of the Ganges delta. It is fifteen miles wide at its mouth, but much enumbered by shoals. Ships drawing twenty-two feet ascend as far as Calcutta. Its total course is about 160 miles.

**HUGO**, VICTOR MARIE (1802-1885), the greatest French poet of his century, a distinguished dramatist, essayist and novelist. The world knows him best as the author of that great epic of the human soul, *Les Misérables*. This book, published simultaneously in ten languages in 1862, is the story of Jean Valjean, a man lifted out of sin and degradation through experience and purified by suffering.

Victor Hugo was born at Besaneon the son of a distinguished general. He was educated at Madrid and Paris, and as a boy was passionately devoted to the royalist cause and the Roman Catholic faith. In his later years he became an ardent champion of Democracy. In 1822 he published his first volume of verse, and in 1823 his first novel, *Hans of Iceland*, appeared, followed in 1825 by *Bug Jargal*. In 1826 a second volume of verse appeared.



JAMES LAUGHLIN HUGHES





and in these Hugo's anti-classical tendencies in style and treatment of subject became visible. The appearance of his drama, *Cromwell*, marked Hugo at once as the leader of the romantic school. *Hernani*, first presented in 1830, was a further attempt to overthrow the classic drama in France, and the result of its presentation was a great conflict between Romanticists and Classicists (See DRAMA). Other plays followed, *Marion Delorme*, *The King Amuses Himself*, *Lucrèce Borgia* and *Ruy Blas*.



VICTOR HUGO.

After 1843 Hugo forsook drama and turned his attention to other work. During the years in which he was chiefly occupied with dramatic composition, he had also published a novel, *Notre Dame de Paris*, and several volumes of poetry, among them, *Autumn Leaves* and *Twilight Songs*. The poetry of this period has a melody and grace perhaps superior to any that he afterward wrote, but it lacks that deep and original sense of life which is characteristic of his later poems.

In 1841 Hugo was elected a member of the French Academy, and in 1845 he was made a peer of France by Louis Philippe. The revolution of 1848 drew him into the thick of the political struggle. At first he favored Louis Napoleon, but afterward, whether from suspicion of Napoleon's designs or from other reasons, he became one of the chiefs of the democratic party. After Napoleon's seizure of power, in 1851, Hugo was one of those who kept up the struggle against him to the last. Then, while an exile in Brussels, he produced the bitterly satiric *Napoleon the Little* and *The Chastisements*, attacks on the Second Empire. Hugo went from Brussels to Jersey, but was expelled, along with the other French exiles, in 1855 by the English government. He settled in Guernsey, where he remained until 1870. It was during these years in the Channel Islands that he brought out *Les Misérables*. It was there he also published *The Toilers of the Sea*, and *The Man Who*

*Laughs*, besides the collection of poems known as *Contemplations*. After his return to France he was made a member of the National Assembly, but resigned and went to Brussels, where, on account of the communistic character of his writings, he was not allowed to remain. When he was past seventy he published his *Ninety-three*, one of the strongest of his novels, and several collections of poems.

**HUGUENOTS**, *hu'ge nots*, a name applied by the Roman Catholics to the Protestants of France during the religious struggles of the sixteenth and seventeenth centuries. The Huguenots were converts from Catholicism to Calvinism, and at first were heartily disliked by the court and by the great majority of the people. Under Henry II (1549-1559) the Protestant party grew strong, and under Francis II it became a political force, numbering among its supporters Henry of Navarre, his brother Louis, the Prince of Condé, Admiral Coligny and many others of high rank and ability. At the head of the Catholic party stood the Duke of Guise, and through the influence which he and his family exerted over the weak young king, a widespread persecution of the Huguenots commenced.

In 1560 Francis I died and during the minority of the next king, Charles IX, it was the policy of the queen mother, Catharine de' Medici, to encourage the Protestants in the free exercise of their religion, in order to curb the Guises. But in 1562 an attack on a Protestant meeting made by the followers of the Duke of Guise commenced a series of religious wars which desolated France almost to the end of the century. Catharine, beginning to fear that Protestantism might become a permanent power in the country, suddenly made an alliance with the Guises and between them they planned and carried out the massacre of Saint Bartholomew (Aug. 26, 1572). The Protestants fled to their fortified towns and carried on a war with varying success.

After the assassination of Henry III, the king of Navarre was obliged to embrace the Catholic religion (1593) in order to hold his kingdom together. Five years afterwards he issued the Edict of Nantes, which secured to the Huguenots their civil rights and made them eligible for all offices and dignities. This edict afforded them the means of forming a kind of republic within the kingdom,

which Richelieu, who regarded it as a serious obstacle to the growth of the royal power, resolved to crush. War was waged from 1624 to 1629. The Huguenots had to surrender all their strongholds, although they were still allowed freedom of conscience under the ministries of Richelieu and Mazarin. But when Louis XIV and Madame de Maintenon set the fashion of devoutness, a new persecution of the Protestants commenced. The Edict of Nantes was revoked in 1685, and more than 500,000 Protestants left the country. In the reign of Louis XV a new edict was issued, repressing Protestantism, but so many voices were raised in favor of toleration that it had to be revoked. The Revolution put the Protestants and Catholics on an equal footing.

**Related Articles.** Consult the following titles for additional information:  
 Bartholemew's Day, Coligny, Gaspard de  
 Saint Guise  
 Calvin, John Henry IV (France)  
 Catharine de' Medici Nantes, Edict of

**HULL**, or **KINGSTON-UPON-HULL**, ENGLAND, a river port and county borough, situated in the East Riding of York, at the influx of the Hull into the estuary of the Humber, on the North Sea coast. The city's situation is on an unpicturesque plain, though the new portion of the city itself is well arranged and presents an attractive appearance. Among the important buildings is Trinity Church, built in 1412; there is a grammar school which dates from 1486. Hull is the seat of several educational institutions, none of which is of more than local importance. The industries of the town are varied, comprising flax and cotton mills, ship building yards, rope and sail works, iron foundries, machine-making, seed-crushing, color-making, oil-boiling and many other and allied industries; but its importance arises chiefly from its shipping commerce. Hull being one of the important ports in importance in the kingdom; the docks are among the largest in the world. The city owns the markets, the tramways, as the street car lines are called, the lighting plant, the water supply, libraries, baths, a sanitarium, a crematorium, cemeteries and a sewage disposal plant. It is an ancient town, and was of some importance long before it received its charter from Edward I in 1298. Population, 1914, 287,472.

**HULL**, QUE., the capital of Wright County, on the Ottawa River, opposite Ot-

tawa, Ont. The surrounding country contains both agricultural and mineral resources, and is traversed by the Canadian Pacific Railroad and by electric lines. The principal manufacturing establishments are iron foundries, paper and pulp mills, pork-packing houses and lumber mills. The town was first settled in 1800 and became a city in 1870. It was almost destroyed by fire in 1900, but has since been rebuilt. Population in 1911, 18,217. The majority of the people are French-Canadians.

**HULL**, WILLIAM (1753-1825), an American soldier, born in Derby, Conn., educated at Yale and admitted to the bar in 1775. He served in the American army during the Revolution, taking part in the battles of Trenton, Princeton, Saratoga, Monmouth and Stony Point, and attaining the rank of lieutenant-colonel. He was elected to the state senate after the war, and in 1805 became governor of the Territory of Michigan. At the outbreak of the War of 1812 he was made brigadier-general and commander in the northwest. He immediately took the aggressive, but displayed mediocre military ability, and finally in August, 1812, he surrendered Detroit, after a brief resistance. He was court-martialed in March, 1814, and was sentenced to be shot, but President Madison remitted the penalty. It is now believed that blame lay as much with the misconduct of affairs at Washington as with Hull's management.

**HULL HOUSE**, one of the most notable social settlements in America, founded in Chicago by Miss Jane Addams and Miss Ellen Starr in 1889. Hull House is in the center of a poor district in which foreigners predominate. It aims to provide wholesome recreation for the people of the community, and to furnish instruction in various trade and handicrafts, in art and music, and in regular school subjects. This settlement was one of the first of its kind in America. See ADDAMS, JANE; SOCIAL SETTLEMENTS.

**HUMANE SOCIETIES.** See CRUELTY TO ANIMALS, SOCIETY FOR THE PREVENTION OF; CRUELTY TO CHILDREN, SOCIETY FOR THE PREVENTION OF.

**HUMBERT I** (1844-1900), king of Italy, eldest son of Victor Emmanuel II. In the war of 1866, in which Italy joined Prussia against Austria, he took the field in command of a division and distinguished himself for his valor. In 1868 he married Mar-

guerite of Savoy and ten years later succeeded his father on the throne. The most notable event of his reign was the formation, in 1891, of the Triple Alliance (Italy, Austria, Germany). On July 29, 1900, he was killed by an anarchist. The present king, Victor Emmanuel III, is his grandson.

**HUMBOLDT**, *hum'bohl't*, FRIEDRICH HEINRICH ALEXANDER, BARON VON (1769-1859), a German traveler and naturalist, the founder of the modern science of physical geography. Although born at Berlin, he was brought up at Potsdam, and he studied at the Universities of Frankfort-on-the-Oder, Berlin and Göttingen. His first work was *Observations on the Basalt of the Rhine*. In 1791 he studied mining and botany at the mining school in Freiberg, and subsequently became overseer of the mines in Franconia. He resolved to make a scientific



VON HUMBOLDT

journey in the tropical zones and arrived in Cumana, in South America, in 1799, and spent five years in exploring the region of the Orinoco and the upper part of the Rio Negro, the district between Quito and Lima, the City of Mexico and the surrounding country and the island of Cuba. In 1804 he returned to Bordeaux, bringing with him an immense mass of fresh data in geography, geology, meteorology, botany, zoology and every other branch of natural science. Humboldt selected Paris as his residence, as no other city offered so many aids to scientific study, and remained there, arranging his collections and manuscripts and preparing an account of his journeys in South America and their scientific results.

In 1827, Humboldt, who had been offered several high posts by the government of Prussia, and had accompanied the king on several journeys as part of his suite, was persuaded to give up his residence at Paris and settle at Berlin, where he combined the study of science with a certain amount of

diplomatic work. In 1829, under the patronage of Czar Nicholas, he made an expedition to Siberia and Central Asia, which resulted in some valuable discoveries, published in his *Central Asia*. In 1845 appeared the first volume of the *Cosmos*, his chief work, a vast and comprehensive survey of natural phenomena, in which is set forth the idea of the unity of all the forces of nature.

**HUME**, DAVID (1711-1776), an eminent English historian and philosopher. He was trained for the law, but was drawn away by his love of literature and philosophy. In France, during three years of quiet and studious life, he composed his *Treatise upon Human Nature*. The work, in his own words, "fell deadborn from the press." His next work, *Essays, Moral, Political and Literary*, met with a better reception. In 1746 and 1747 he accompanied General Sinclair in his expedition against France and in a military embassy to Vienna and Turin. He then published a recasting of his earliest work, under the title *Enquiry Concerning the Human Understanding*. In 1752 he published *Political Discourses*, which were well received, and *Inquiry Concerning the Principles of Morals*. The same year he obtained the appointment of librarian of the Advocates' Library, at Edinburgh, and began to write a *History of England* the first volume of which appeared in 1754. This was received with the highest praise and greatly increased his reputation.

As a philosopher, his contention was that there could be no mental experience apart from sense impressions and the ideas which are the direct reproduction by memory of these impressions.

**HUMIDITY**, the state of the atmosphere with respect to the amount of vapor it contains. The atmosphere is supplied with vapor by evaporation from the sea, rivers and lakes, the ground and plants. The amount of vapor that the air can contain depends upon its temperature, its capacity increasing as the temperature rises. When the air contains all the vapor that it can hold at a given temperature, it is said to be *saturated*. Next to oxygen and hydrogen, vapor is the most important constituent of the atmosphere. Dew, fog and rainfall depend upon its presence, and when existing in large quantities it is the principal cause of tornadoes and other violent storms. Vapor also equalizes the temperature. It

reflects back to earth the heat which is radiated into the air, serving as a blanket to prevent the escape of heat. Without this prevention there would be much greater contrast between the temperature of day and night and of summer and winter than at present.

Too little moisture in the air is injurious to the health, and some provision should be made to keep the air from becoming too dry in houses heated by steam or hot water. Pans of water placed on radiators are helpful in some cases. The amount of humidity in the atmosphere is measured by the hygrometer.

**Related Articles.** Consult the following titles for additional information:

|         |     |            |
|---------|-----|------------|
| Climate | Dew | Hygrometer |
| Cloud   | Fog | Rain       |

**HUMMING BIRD**, a beautiful little bird, of which there are more than 400 species, living exclusively in America, abounding especially in the tropics. Only eighteen of these are found in the United States. The name is given the birds because of the sound made by their rapidly moving wings in flight. Some humming birds are not larger than a bumblebee, and the largest do not exceed the sparrow in size. They have slender beaks, which are generally long and sometimes curved. The tongue is long, threadlike, forked at the point and capable of being protruded from the bill to a considerable distance.



Humming birds **HUMMING BIRD** never light to take food, but hovering before a flower, supporting themselves by the rapid vibrations of their wings, they search the blossom for insects, which form a great proportion of their food, and for the honey which the plants secrete. The little creatures are fearless, and will feed from the hand of a person who has gained their confidence. They build nests of wonderfully fine workmanship, which are lined within with soft wool and usually covered on the outside with lichens, which serve to conceal the nest. Two small eggs are laid, and they are always plain white. There are many species in the United States, but the only one found east of the Mississippi River is the

*ruby-throated humming bird*. The tropical species vary remarkably in outward appearance. Some are plainly colored, while others are ornamented in numberless ways by brilliant patches of color on the throat, long graceful feathers in the tail, crests, ruffs, bunches of feathers upon the legs and a brilliant metallic luster to the feathers.

**HUMPERDINCK**, *hoom'per dingk*, ENGELBERT (1854- ), a German composer, best known for his operas *Hansel and Gretel*, *The Snow Maiden* and *Children of the King*, founded on familiar fairy tales. These possess a delicacy and freshness peculiarly well adapted to the subjects. He was a special friend and protégé of Richard Wagner for the last few years of the great composer's life and gained renown as a vigorous supporter of the modern movement in music, which was given its first great impetus by Wagner. Among his larger and more important compositions is a *Symphony in C*. Although his works are not numerous, the quality of them all is high.

**HUMUS**, vegetable matter in a state of decomposition. Humus is rich in nitrogen, the material out of which the gluten in grains is produced, and it helps to conserve moisture in the soil and also improves its texture. Air space in the earth increases with the amount of humus. It may be added to the soil by the plowing under of green crops and by the application of barnyard manure.

**HUNDRED YEARS' WAR**, the name given to the struggle between France and England, which lasted with intermissions from 1337 to 1453. Edward III of England claimed the crown of France because his mother had been a sister of Charles IV of France, and this claim, together with minor differences, brought on the war. Although war was declared in 1337, the Battle of Crecy, fought in 1346, at which firearms were first used, was the first important engagement. Ten years later, at Poitiers, the French were again overwhelmingly defeated, but in spite of these advantages the English gradually lost ground, and Du Guesclín succeeded in driving them from the country, so that when Charles VI came to the throne of France, England had practically no hold there. When, however, in 1415, war broke out, France was so greatly disturbed by internal conflicts that she could make no head against her enemy, and Henry V was able in 1420 to compel Charles VI by the Treaty

of Troyes to recognize him as his heir. In 1429, inspired by Joan of Arc, France forced the English to evacuate all French territory except Calais. Thus they did not give up until a century later.



Peasant going to market

**H**UNGARY, formerly a kingdom in the central part of Europe, one of the two main divisions of the once great Austro-Hungarian monarchy. The sovereign power in the monarchy was vested in one ruler, who bore the titles king of Hungary and emperor of Austria. The Hungarian kingdom was made up of Hungary proper, Transylvania, the crownland of Croatia and Slavonia, and the Adriatic seaport, Fiume.

Altogether the kingdom covered an area of 125,641 square miles, comprising over half the territory of the dual monarchy. The empire of Austria, the other unit of Austria-Hungary, lay in the form of an arc about Hungary, bordering it on the west, north and northeast. The crownland of Croatia and Slavonia, occupying the southwestern corner of the Hungarian kingdom, and extending from the Drave and Danube rivers to the Adriatic Sea, was made a part of Jugo-Slavia at the close of the World War. Fiume is geographically a part of Croatia and Slavonia, but was awarded to Italy by the peace conference after the close of the World War.

The remaining portion of the original kingdom was an oval-shaped territory bordered on the northeast by Galicia, on the east by Bukowina and Rumania, on the west by Lower Austria and Styria, on the south by Serbia and Rumania, and on the north by Moravia, Austrian Silesia and Galicia. Transylvania (21,518 square miles) occupied the southeastern corner of the kingdom. Hungary was declared a republic in November, 1918. For subsequent events, see subhead *History*, below.

**Physical Features.** The chief physical features of Hungary are the Carpathian mountains and the wide-spreading plains enclosed by them. The Carpathians stretch in a broad curve from Pressburg, in the

northwest, to Orsova, in the southeast, forming a great wall along the Hungarian boundary for over 800 miles. In Transylvania, the ranges extending east and west are known as the Transylvanian Alps. The Great Hungarian Plain, which is one of the most fertile regions in Europe, lies in the central part of the country, between the Danube River and the highlands in the northeast. It slopes gradually from north to south and covers an area of nearly 40,000 square miles. The Danube, which enters Hungary near Pressburg, flows east, south and east again, forming the southern boundary and separating Hungary and Serbia. It receives nearly all the drainage of the country, and its chief tributaries are the Theiss, the Drave and the Save.

**The People.** In 1910 the old Hungarian kingdom had a population of 20,886,487; in 1914 it was about 22,000,000. Too many different racial elements were represented in the population for political harmony, as was true of Austria. At the outbreak of the World War the ruling class and chief land-owning element was the Magyar (Hungarian) group, representing less than half the population. Of Croats and Serbs, found chiefly in Croatia and Slavonia, there were about 2,940,000. In Slovakia, in the northern part of Hungary, there were about 2,000,000 Slovaks. Hungary also had about 3,000,000 Rumanians, over 2,000,000 Germans, 500,000 Ruthenians and a large number of gypsies, Armenians and Bulgarians. A large Jewish element was Magyar-speaking.

The largest city, Budapest, had a population of 880,371 in 1910. There are few large towns in Hungary, but hundreds of villages.

**History.** For the history of Hungary previous to 1914 see AUSTRIA-HUNGARY, subhead *History*. The Magyars and Germans loyally supported the Austro-Hungarian government from the beginning of the World War, but the oppressed nationalities, notably the Serbs, Croats, Slovaks and Rumanians, were as restive as were the discontented elements in Austria, and it was inevitable that the Hungarian kingdom should suffer the same sort of dismemberment as did Austria at the close of the war. The events leading up to the abdication of Charles I, emperor of Austria and king of Hungary, are related in the article AUSTRIA-HUNGARY. In the dissolution of the dual monarchy Hungary was

reduced to an interior state shut off from the sea. Croatia and Slavonia joined the Jugo-Slavic nation; Transylvania, which had a dominant Rumanian element, was tentatively awarded to Rumania by the peace conference before the final settlement, and Slovakia joined the Czecho-Slovak republic. Possession of Fiume was claimed both by Jugo-Slavia and Italy.

In November, 1918, the republic of Hungary was proclaimed at Budapest, with Count Michael Karolyi as President. The revolution which preceded this step was orderly and unopposed. Karolyi succeeded in welding together for common action his own party (the aristocratic), the Social Democrats, the middle classes and the radicals, but lack of food, scarcity of funds and the general demoralization of the times proved serious obstacles against the formation of a stable régime, and in March, 1919, a new revolution, led by Bela Kun, overthrew the Karolyi government. A communistic government was then set up in Budapest, and friendly advances were made to and received from the Lenine bolshevik government at Moscow. It was reported that among the causes of the revolution were dissatisfaction over the dismemberment of Hungary, and misunderstandings arising from the creation of a neutral zone between Hungary and Rumania.

In May, 1919, Bela Kun's prospects for a successful revolution were slight. He lost the favor of many adherents because he was "as dictatorial as Caesar," and because so few thousands of the population had really been converted to Bolshevik doctrines. In June, however, he had succeeded in establishing his authority on an apparently firm basis, and was threatening neighboring states.

**Related Articles.** Consult the following titles for additional information:

|                        |             |
|------------------------|-------------|
| Budapest               | Fiume       |
| Croatia and Slavonia   | Jugo-Slavia |
| Czecho-Slovak Republic | Rumania     |
|                        | World War   |

**HUNGER** is the desire for food. The physical cause which gives rise to the craving for food is not understood, but physicians agree that it is a natural sensation having positive value in regard to health. It may be called the body's call for nourishment. A healthy normal appetite is one of the best evidences of good health. Those who must have the appetite stimulated by tonics are not up to par, and those who

crave overseasoned foods and strong relishes have ruined the natural appetite by self indulgence. It is a good rule to eat slowly, so as to appease the appetite before the stomach becomes overloaded. The person who works up a keen appetite by exercise or hard manual labor should avoid overeating, as this is a menace to health.

**HUNS**, a nomadic and warlike people of the Mongolian race, part of whom entered Europe, probably in the fourth century after Christ. They continued to extend their dominion along the Danube till the time of Attila (A. D. 424), who uniting the whole Hunnish power, became the most powerful prince of his time. His defeat near Châlons was the commencement of the decline of the power of the Huns, and within a generation after his death, in 453, the great Hunnish Empire had completely disappeared, and the race had been absorbed among other barbarous peoples.

The name Hun has always been associated with acts of brutality and vandalism. During the World War it was applied to the Germans by practically all of the allied nations, including the United States. In this connection it was said that at the time of the Boxer outbreak in China, Emperor William II exhorted his troops to conduct themselves like their ancestors, the Huns. The Germans, however, resented the use of the term very bitterly.

**HUNT, HELEN FISKE.** See JACKSON, HELEN FISKE HUNT.

**HUNT, JAMES HENRY LEIGH** (1784-1859), an English poet and journalist, was born at Southgate and educated at Christ's Hospital, London. In 1808 he helped his brother to establish a paper called the *Examiner*, and he edited this for thirteen years. For lampooning the Prince Regent he was fined £500 (\$2,500) and imprisoned for two years. After his release he published *The Story of Rimini* and *Foliage*, a volume containing both original and translated poems. In *Lord Byron and Some of his Contemporaries* he gives his side of a quarrel with Byron over their magazine, *The Liberal*. Hunt's *Autobiography* is a complete and faithful record of his career. The titles of his books include *Men, Women and Books*; *A Jar of Honey from Mount Hybla*; *Imagination or Fancy*; *Wit and Humor*; *Palfrey*; *A Love Story of Old Times*; *Legend of Florence*, a play; and *Book of the Sonnet*.

**HUNT, WILLIAM HOLMAN** (1827-1910), an English painter, one of the founders of the Preraphaelite Brotherhood, and a consistent representative of that movement. He was born in London, trained in the Royal Academy School and began to exhibit in 1846. His first picture to attract attention was *Claudio and Isabella*, exhibited in 1853. This was followed by an allegorical representation of Christ as "the light of the world." Hunt made a trip to the East early in his career, the fruits of which are observable in the local coloring and realism of his succeeding pictures of Eastern life, among which are *The Scapegoat*, *The Finding of the Savior in the Temple*, *Shadow of Death* and *Triumph of the Innocents*. He was one of the foremost modern exponents of Christian art, and his work is marked by strong religious feeling.

**HUNT, WILLIAM MORRIS** (1824-1879), an American painter, born at Brattleboro, Vt., and educated at Harvard University. He studied in Europe, where he became a close friend and follower of Millet. He returned to the United States in 1855. In all his work he showed a remarkable technic and a fine feeling for color. Among his most important paintings are *The Flight of Night* and other mural decorations in the New York State capitol at Albany, several portraits of famous Americans and numerous figure subjects, many of which hang in the Boston Museum, notably *Marguerite*, *The Hurdy-Gurdy Boy* and *Girl with the Kitten*. In later life he devoted himself to landscape painting.

**HUNTING**, a sport which has been popular with mankind from the earliest times and which is still indulged in by all civilized people, though for years it has been decreased greatly by protective laws. In the United States, and Canada as well as in most countries of Europe, there are game laws which forbid shooting during the breeding season and which restrict the sport to a very limited period each year. Certain animals which are destructive, however, may be hunted at all times, and in many states a premium is placed on their death. See **GAME**.

Since the invention of firearms the killing of game by shooting is the most common way. The use of dogs to detect the presence of game and to rouse it is common, though in many localities the hunting of deer and

other animals with dogs is forbidden. Among the game birds those most sought for are the partridge, the grouse, the plover, the quail, the woodcock and various species of ducks though in different localities there are other birds almost equally favored. Among the mammals, squirrels, hares, rabbits and deer are most highly regarded. In most states little restriction is placed on hunting squirrels and rabbits, but the open season for deer is very short, sometimes not exceeding fifteen days in the course of a year.

"Hunting with the camera" has become very popular with people who believe that innocent animal life should not be sacrificed. Often more skill is required to approach near enough to take a "snap-shot" at an animal than to aim with a gun and take a deadly shot at it.

The refinements of modern life have taught us the charm that many wild animals possess and have led to the protection of song-birds and other harmless creatures to such an extent that in many cities and towns the squirrels are familiar, everyday visitors to homes, where they are fed and guarded by the children, instead of being hunted as they were formerly. The public schools have done much to educate children to see in the birds a beauty that is utterly destroyed when life is extinct, and accordingly a saner regard for them is growing among the people.

So long as there is a demand for game for the table, or for furs and plumage for wear and decoration, there will be hunting for the market, and professional hunters and trappers will continue to make their living, but it is not probable that hunting as a sport will increase in popularity.

**HUNTINGTON, IND.**, the county seat of Huntington County, twenty-five miles southwest of Fort Wayne, on the Little River and on the Wabash and the Chicago & Erie railroads. The city has water power, and the manufactures include shoes, agricultural implements, rubber goods, pianos, cedar chests, clamshell buckets and cement. There is also a trade in coal, lime and agricultural produce. A United Brethren college is near the city. A Federal building, one of the best courthouses in the state, a Carnegie Library and a city hall are among the important buildings. Population, 1910, 10,272; in 1917, 10,982 (Federal estimate).

**HUNTINGTON, W. VA.**, in 1917 the largest city in the state and the county seat

of Cabell County, is fifty-two miles west of Charleston, on the Ohio River and on the Baltimore & Ohio and the Chesapeake & Ohio railroads. The city is an important commercial center, with steamship connection on the river, and it has railroad shops, car-building shops, planing mills and manufactories of paints, glass, stoves and other articles. The West Virginia Asylum for Incurables and Marshall College, which is the state normal school, are located here. There are six hospitals, a Federal building and a Carnegie Library. The commission form of government was adopted in 1909. The place was settled in 1871, and named in honor of Collis P. Huntington. Population, 1910, 31,161; in 1917, 47,686 (Federal estimate).

**HUNYADY**, *hun'yah dy*, JÁNOS (about 1387-1456), a national hero of Hungary, renowned for his service in expelling the Mohammedans from Central Europe. In all the wars against the Turks, which were agitating his country, he took a prominent part. When at the Battle at Varna, in 1444, the Hungarian king, Ladislas, was killed, Hunyady was made regent during the minority of the new king, Ladislas Posthumus. Four years later he was defeated at Kossovo in Serbia and was held a prisoner for a time by the Serbians. His greatest victory was won in 1456 over Mohammed II, the conqueror of Constantinople, who was attempting the siege of Belgrade. Hunyady died a few days after this battle.

**HURDLING**, a foot race in which the contestants must leap over barriers called hurdles. In accomplishing this they endeavor to rise the least possible distance from the ground, and sometimes their feet graze the hurdles and even knock them down. Generally, however, the upsetting of a specified number of hurdles puts a man out of the race. There are two sets of contests—the *high hurdle* and the *low hurdle*. In the former the hurdles are three and one-half feet high; in the latter they are two and one-half feet. Ten hurdles are generally used in a race.

**HUR'DY-GUR'DY**, a medieval musical instrument. It consists of an oval, flat sounding board, across which strings are stretched, and a hollow chamber like that of a mandolin. With one hand the performer presses the finger keys, and with the other turns a crank attached to a wheel at one end, which acts as a bow. The name *hurdy-*

*gurdy* is also applied to the hand organ of the streets, which is built upon the same principle, the wheel being replaced by a cylinder supplied with pegs, which, as the cylinder is revolved, pick the strings or press valves in pipes, admitting air currents which produce the tones.

**HURON**, a powerful tribe of Indians that lived east of Lake Huron near Georgian Bay. When Champlain knew them in 1609, the Huron were allied to the Algonquian tribes and were at war with the Iroquoian, although the Huron naturally belonged to the latter group. Champlain, adopting the cause of the Huron, engaged in two expeditions against the Iroquois, in both of which he was successful. Naturally, the Huron became loyal allies of the French and accepted the teachings of the Jesuits, but the Iroquoian tribes, having learned the use of firearms, were too strong for their Huron enemies and ultimately drove the latter out of their country. Fleeing southward, they settled after many years on the site of the present city of Sandusky, O., where they became known as the Wyandotte Indians. About 300 of the tribe live in Oklahoma on a reservation, and there are a few hundred in Quebec and Ontario.

**HURON, LAKE**, one of the Great Lakes of North America, lying between the province of Ontario and the state of Michigan. The international boundary passes through the center of the lake, but including the great Georgian Bay (which see) Canada controls the greater part of the water surface. Drummond Island belongs to Mackinac County, Mich., the other islands are within the jurisdiction of Ontario.

Lake Huron receives the waters of Lake Superior through Sault Ste. Marie River and those of Lake Michigan through the Strait of Mackinac, which is eight miles wide. Its outlet is the Saint Clair River, into Lake Saint Clair. It is second in size among the Great Lakes, Superior alone being larger, but Lake Michigan is only slightly smaller. Its area is 23,800 square miles, a little less than that of West Virginia. The surface of Lake Huron is twenty-one feet below that of Lake Superior, and is 581 feet above sea level, the same as that of Lake Michigan. The length of the lake is about 250 miles, its greatest width 190 miles, and its depth from 200 to 700 feet. There are few good harbors, the best being Saginaw



Bay and Thunder Bay on the west shore. Its principal ports are Goderich and Kincardine, Owen Sound and Collingwood, Ont., and Bay City, Saginaw, Alpena and Cheboygan, Mich. See **GREAT LAKES** for comparative chart.

**HURRICANE**, the name given to a class of violent storms that form in the region of the West Indies. These occur only during the late summer and autumn, are most frequent in September and October, and are caused by the intense heat over portions of the sea where they originate. The wind blows in a circular course, whose direction is contrary to that of the hands of a clock. In the center of the storm no rain falls, and as the current is upward, no wind is perceived. This area is characterized by a heavy sea and frequently by a clear sky, for which reason it is termed the *eye* of the storm. The intensity of the storm is greatest near the place of its origin and diminishes as the diameter of the circle covered increases. This diameter is at first from 100 to 300 miles, but it may increase to a thousand miles or more. At the beginning the velocity of the wind is very great, being estimated in some instances as high as 200 to 300 miles an hour, and the rain falls in torrents.

These storms generally move toward the northwest until they reach the coast of the United States, when they turn toward the northeast and follow the coast from about the latitude of Cape Hatteras to Nova Scotia. As they advance their area increases and their violence diminishes, but they usually cause heavy rain or snow, and occasionally the wind is of such force as to cause considerable damage to shipping and to towns along the coast. The most extensive hurricanes extend inland as far as Indiana, but by the time a storm has reached this limit, its force has been expended.

**Related Articles.** Consult the following titles for additional information:

|         |         |
|---------|---------|
| Cyclone | Typhoon |
| Tornado | Wind    |

**HUSBAND AND WIFE**, the legal relation of a man and a woman who are married to each other (see **MARRIAGE**). The relations existing between husband and wife have within less than a century undergone a marked change. According to the old English common law, at marriage the person of the wife was merged with that of the husband and all of her personal and property rights were transferred to him. Many of the common law

principles, however, have been changed by the development of equity in England and of statute law in America, so that to-day the relations between husband and wife are in most respects those of practical equality.

Of the common law rules which still prevail, though in some ways modified by statute and equity, the following are of most importance:

(1) It is the husband's right to determine the place of residence and the wife's duty to live with the husband, her legal residence being identical with his.

(2) It is the husband's duty to provide support for the wife in accordance with his income and ability, and it is the wife's duty to render such domestic service as is reasonable and necessary.

(3) The common law rule that at marriage the husband becomes the absolute owner of the personal property and has the management and obtains the profits of all the real estate of the wife is still in force in some jurisdictions, but has now been generally changed so as to allow the wife to possess a separate estate, over which she has general direction. The husband's right may also be somewhat limited by a pre-marriage or post-marriage settlement.

(4) The husband is liable for debts contracted by the wife before marriage.

(5) The husband is liable for civil offenses committed by the wife during married life. If these offenses or crimes are committed in his presence, the presumption is that they were done under coercion, and the wife is not found guilty unless this presumption is overcome.

(6) The husband after marriage has the same power to make contracts as before, but the power of the wife in this direction is lost, except in cases involving her separate estate. She may, however, act as the agent of her husband in purchasing necessaries for the home.

(7) The wife cannot dispose by will of either real or personal property, except of her separate estate.

(8) At marriage the wife attains a so-called dower right in an undivided one-third of the husband's real property. The latter therefore cannot convey real property without the consent of his wife, who thereby forfeits her dower right in the same.

(9) Neither husband nor wife is a competent witness in cases in which the other is a party, except in certain cases instituted in order to secure protection of one against the other.

(10) Formerly, neither husband nor wife could sue the other, the only remedy against civil injuries being in separation or divorce; but now the courts of most countries allow the wife to sue in equity for certain rights recognized in equity, such as those established by settlement. See **Divorce**.

**HUSS, JOHN** (1373-1415), a Bohemian religious reformer and martyr, who was a link in the reform movement between Wy-

cliffe and Luther. He studied philosophy and theology in the University of Prague, and became professor in the university in 1398. Later he was made dean of the philosophic faculty and preacher for the Bohemians, having been ordained priest in 1401. At this time the writings of the English reformer Wycliffe were publicly read in Prague, and they so fascinated Huss that he made a translation into Bohemian. His translation was widely circulated among the people and attracted considerable attention.

Huss next openly criticized the censures pronounced by the Church on the writings of Wycliffe, and in his sermons he gave the latter unstinted praise, at the same time violently denouncing what he regarded as ecclesiastical abuses. Consequently, Pope Alexander issued a bull prohibiting preaching outside of collegiate, monastery and parish institutions. Huss defied the papal ban and was called to Rome by John XXIII to defend his principles. Refusing to comply with the summons of the pope, he was excommunicated in 1411. But setting aside all authority, he undertook, together with Jerome, a public denunciation of papal indulgences. For this action he was expelled from Prague.

In exile he wrote his *Tractatus de Ecclesia*, which denied all Church authority. Through the influence of the pope, King Wenceslaus and Emperor Sigismund prevailed on Huss, under promise of a safe conduct, to present himself before the Council of Constance, which opened on November 5, 1414. Huss was placed in the Dominican monastery near Lake Constance. He had three hearings before the Council, which condemned his doctrines as heresy and turned him over to the civil authorities. The laws of the empire at this time regarded heresy as a civil offense and provided death for refusal to retract it. Huss was accordingly condemned to be burned at the stake. The sentence was executed July 6, 1415. See HUSSITES.

**HUSSITES**, the followers of John Huss (see HUSS, JOHN). After the death of Huss, his adherents took up arms for the defense of their principles, and under the leadership of Ziska, captured Prague, fortified Mount Tabor and repeatedly defeated the troops sent against them by the emperor Sigismund. Ziska died in 1424 and was succeeded by Procopius, who also distinguished himself by many victories. The excesses of this party, however, who were called the Taborites, alien-

ated the other Hussites, who called themselves Calixtines. These latter finally united with the Catholics. The Taborites afterward declined as a political party, finally becoming merged in the Bohemian Brethren.

**HUTCHINSON, ANNE** (about 1590-1643), a religious enthusiast in colonial America, born in Lincolnshire, England. She married William Hutchinson and in 1634 migrated to Boston, Mass. She had peculiar theological views, held meetings, lectured and denounced the Massachusetts clergy. She was tried for heresy and banished from the colony, and with some of her friends she went to Rhode Island and started a settlement at Portsmouth. At the death of her husband she went to a new settlement in New York, where she and all but one of her daughters were massacred by the Indians.

**HUTCHINSON, KAN.**, the county seat of Reno County, forty miles northwest of Wichita, on the Arkansas River and the Chicago, Rock Island & Pacific railroads. It is near the center of the salt industry of the state; it also has an important trade in live stock and agricultural produce, and is a wholesale center. Other industries are meat packing and manufactories of machinery, automobiles, boilers, and the manufacture of soda ash and strawboards. The state industrial reformatory is located here, and the town is the home of the Kansas state fair. The place was settled in 1872, and two years later was incorporated. In 1909 it adopted the commission form of government. Population, 1910, 16,364; in 1917, 21,461 (Federal estimate).

**HUTCHINSON, THOMAS** (1711-1780), the last royal governor of Massachusetts. He was born in Boston and was graduated from Harvard College. Hutchinson early became prominent in political affairs, and finally became chief justice of the colony. While occupying this office he issued the famous Writs of Assistance, which authorized British officers to enter houses and search for smuggled goods. He opposed the Stamp Act on the grounds of expediency, but labored earnestly to enforce it. His house was sacked during this period and many valuable books were destroyed. He became governor in 1770, was extremely unpopular and when military law was proclaimed in 1774 went to England, where he lived until his death. Hutchinson's *History of Massachusetts Bay* in three volumes is one of the most valuable histories of colonial times.

**HUXLEY**, THOMAS HENRY, (1825-1895), a famous English naturalist. He was graduated from the University of London in 1845 and entered the royal navy as assistant surgeon the next year. He sailed with H. M. S. *Rattlesnake* on a surveying expedition to Australasia, during which he sent a number of valuable papers to the Royal Societies. When he returned from his cruise he found his papers had made him famous. In 1854 he became lecturer on natural history at the Royal School of Mines. About this time he made the acquaintance of the naturalist Hooker, and of



THOMAS HUXLEY

Tyndall, and these three eventually became the scientific criterion of London, directing and influencing public opinion.

By the time Huxley was twenty-five he had established a reputation as a comparative anatomist and palæontologist. When Darwin's *Origin of Species* was published Huxley was active in defending it and in elucidating it. At various times he held professorships, offices in learned bodies and memberships in government commissions. He retired from active life in 1885 on account of ill health, but continued to write his brilliant essays.

Among his works are *The Oceanic Hydrozoa*, *On the Theory of the Vertebrate Skull*, *Man's Place in Nature*, *On Our Knowledge of the Causes of the Phenomena of Organic Nature*, a series of lectures to working men, delivered in 1862, *Elements of Comparative Anatomy*, *Elementary Physiology*, *Introduction to the Classification of Animals*, *Critiques and Addresses*, *American Addresses*, *Physiography and Anatomy of Invertebrate Animals*.

**HYACINTH**, *hi'a sinth*, a beautiful garden plant which grows from bulbs and belongs to an important genus of the lily family. All varieties of garden hyacinths are the offspring of the *Hyacinthus orientalis*, a species native to Western Asia. Introduced

into Western Europe in the sixteenth century, it became the base of numerous varieties cultivated widely, both in Europe and North America. Holland was and still remains the most important European country producing hyacinths, as its soil is admirably adapted to the growing of bulbous plants. The cultivated hyacinths bear both double and single flowers. These appear in a dense cluster on an erect stalk in the center of the long, narrow leaves. The blossoms show blue, white or purple shades, and make a rich garden decoration in early spring.

An old Greek myth accounts for the origin of the flower as follows: Apollo, the Greek god, had as a friend a beautiful youth named Hyacinthus, who was killed one day in a game of quoits. As a token of his love for the youth and sorrow at his death, Apollo caused a beautiful purple flower to spring from the drops of

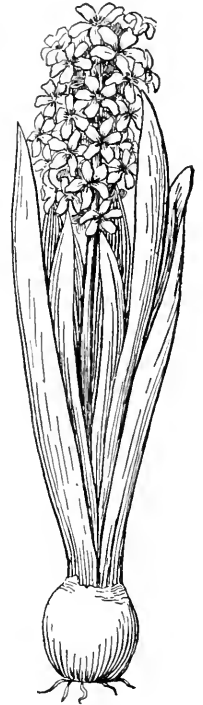

HYACINTH

blood that fell from the brow of Hyacinthus.

**HYBRID**, *hi'brid*, in the animal and vegetable kingdoms, the offspring of two distinct species. From a commercial standpoint the crossing of plants has been of more practical value than the cross breeding of animals, though that useful creature, the mule, is a hybrid, being half horse and half ass. Through the crossing of plants varieties are obtained which show greater size and vigor, increased power of endurance and better quality and flavor. Examples of what can be done by cross breeding are seen in the work of Luther Burbank. See BURBANK, LUTHER.

**HYDERABAD**, *hi dur a bahd'*, INDIA, the fourth largest city of the country and the capital of a native state of the same name, also called the NIZAM'S DOMINIONS. It is situated in Southeastern India, east of Bombay, on the River Musi, at an elevation of 1672 feet above the sea. Among the chief buildings are the extensive palace of the

nizam; the house of the British resident and adviser; the Char Minar, or Four Minarets, built about 1590 as a Mohammedan college, but now used for warehouses; the Jama Musjid, or cathedral mosque, which accommodates 10,000 people, and was designed after the one at Mecca. The city is an important railroad and commercial center and has manufactories of silks, trinkets and turbans. Population, 1916, 515,646.

**HYDRA**, in Greek mythology, a monster which lived in the neighborhood of Lake Lerna, in the Peloponnesus. Some accounts give it a hundred heads, others fifty and others nine, but all agree that as soon as one head was cut off, two others immediately grew in its place. Hercules undertook to destroy this monster, and he succeeded, with the assistance of Iolaus, who, as each head was cut off, applied a burning iron to the wound. The central head, which was immortal, Hercules buried under a stone. See **HERCULES**.

**HYDRA**, FRESH-WATER, or **FRESH-WATER POLYP**, a small animal, found in pond water. It can be seen easily with the naked eye, as it is about the thickness of fine sewing-cotton and has a length of from one-quarter to one-half of an inch. Hydras are found adhering by one end to twigs or weeds in the water. On the other end are

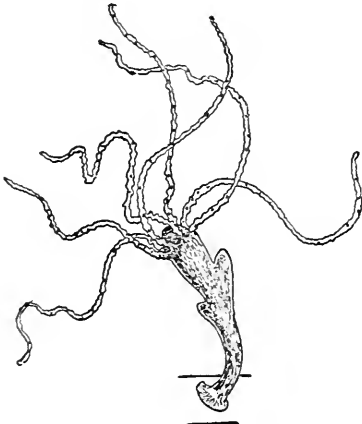

FRESH WATER HYDRA

a number of very delicate threads or filaments, called *tentacles*. If the hydra is watched under a microscope, it will be noticed that its form is continually changing. Sometimes it extends itself so much that its length is sixteen times its diameter and the tentacles appear like long, delicate filaments.

At another time it contracts itself into an almost globular mass, and the tentacles appear like little blunt knobs. Besides these two movements, the hydra is able to go slowly from place to place. It is a voracious creature. When a water flea or any other living thing that may serve as food touches one of the tentacles, it becomes suddenly paralyzed by the barbed stinging cells which are literally shot out of the tentacle into the body of the animal, causing it to adhere to the tentacle. This tentacle and the others gradually contract until the prey is brought near the mouth of the hydra, which expands widely and draws the prey down into the digestive cavity. Hydras reproduce by building. That is, tiny wartlike growths appear on the body of the parent animal, which, as they grow larger develop tentacles. When grown they break off and become independent hydras. See **COELENTERATA**.

**HYDRANGAEA**, *hi dran'je ah*, a genus of shrubs or herbs, belonging to the saxifrage family and containing about twenty-five species, natives of Asia and the Americas. The garden hydrangea is a native of China and was introduced into Great Britain by Banks in 1790. It is a favorite plant because of the beauty and size of its flowers, which are white, pink or blue in color.

**HYDRATES**, *hi'drayts*, a term used in chemistry to designate a class of compounds containing a metal in combination with one or more groups of oxygen and hydrogen in even proportions. The oxygen and hydrogen form a combination which acts like an atom in many chemical changes, and the union is known as an *hydroxyl* (symbol  $\text{OH}$ ). The term *hydroxide* is often used as a synonym of *hydrate*. The alkalis are typical hydrates, and are represented by caustic soda, or sodium hydroxide; caustic potash, or potassium hydroxide; and ammonia water, or ammonium hydroxide.

**HYDRAULIC ENGINE**, an engine operated by water under pressure. When the water is applied in such a way as to produce a direct rotary motion, the machine is usually termed a water wheel or water motor (see **WATER WHEELS**; **TURBINE WHEELS**). The term *engine* is more strictly applied to a water motor which operates on a plan similar to that of the steam engine, that is, being constructed with cylinders, pistons and valves (see **STEAM ENGINE**). The water is admitted and withdrawn alternately at oppo-

site ends of the cylinder and forces the piston from one end to the other. The piston rod is connected with a crank on the shaft, and its reciprocating motion is thus changed to a rotary motion when this is necessary. Hydraulic engines of this sort are occasionally used where a slow, steady motion and considerable power are required, as in operating hoisting cranes in foundries and working certain patterns of elevators, but the introduction of the electric motor has largely displaced them.

**HYDRAULIC** *hi draw'lik*, **PRESS**. See **HYDROSTATIC PRESS**.

**HYDRAULIC** *hi draw'lik* **RAM**, a machine for using the force of a stream of water to

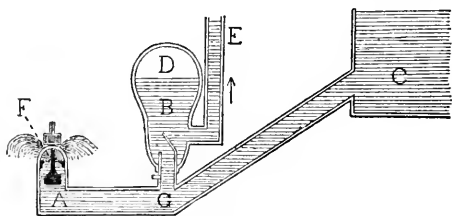

raise a portion of the stream to a level higher than that of the ram. In the figure, C represents the reservoir and G the pipe through which the water flows. At A the pipe is turned upward and flows by a cone-shaped valve, usually made of iron. At G there is a pipe connecting with an air chamber, D. The entrance to this chamber is through the valve B. The working of this machine is as follows: When the water begins to run through the pipe G, the valve is in its lowest position and allows the water to flow out through the orifice F. This flow continues until the force of the stream of water through the pipe is sufficient to raise the valve and close the orifice. When this is closed, the flow water in G suddenly stops and the force of the current is such as to drive a portion of the water through the valve B into the chamber. As soon as the flow in G stops, the valve at F again falls to its first position and the flow is again started. The water is forced into the delivery pipe E, and a constant flow is maintained by the elastic force of the air in D.

Hydraulic rams are used where the source of water is below the level of the place in which the water is required for use. Only a small portion of the water which flows through G passes through the valve at B; therefore these machines are not practicable,

except where the quantity of water at the source is much greater than that needed for use.

**HYDRAULICS**, *hi draw'liks*, the science which treats of the laws of flowing liquids. Two general principles are always considered in applying these laws. They are:

(1) The velocity of a jet of water is equal to that of a body falling from the surface of the water. If a jet flows from a dam ten feet below the surface of the water, it will have the same velocity as a stone which has fallen ten feet.

(2) A jet of water will rise to the level of its source. If a cistern is on a support twenty-five feet high and a pipe is attached leading to the ground and having an opening bent upward, the jet issuing from the pipe theoretically will rise as high as the surface of the water in the cistern. Because of friction and the resistance of the air, however, this result will not be quite obtained. The practical application of the laws of hydraulics has given rise to the science of hydraulic engineering. See Hydraulic Ram; Hydrostatics; Water Wheels.

**HYDROAEROPLANE**, *hi'dro aer'o playn*. See **FLYING MACHINE**.

**HYDROCARBONS**, a large and important group of chemical compounds, consisting of carbon and hydrogen. Hydrocarbons are the simplest of the carbon compounds and are commercially of importance. Many occur in nature; petroleum, paraffin and natural gas are entirely composed of them, while they form the principal ingredient of caoutchouc, gutta percha, turpentine and certain essential oils. Artificially they are produced by the dry distillation of many organic substances; for example, gaseous hydrocarbons produced from coal; also the solid hydrocarbons produced by fractional distillation from coal tar. In cookery the hydrocarbons include the fatty foods, as distinguished from the carbohydrates, or sugars and starches. See **FOOD**.

**HYDROCHLORIC**, *hi dro klohr'ik*, **ACID**, or **MURIATIC ACID**, a compound of equal quantities of hydrogen and chlorine. It is the strongest acid known. In nature it is found in the water of rivers which take their rise in volcanic areas, notably those which rise in the Andes; it is set free in volcanic eruptions; it constitutes part of the gastric juices of man and some of the lower animals. It may be artificially produced by heating together common salt and sulphuric acid (as is done in the manufacture of soda) or by mixing hydrogen and chlorine.

Hydrochloric acid is colorless, and has a pungent odor and an acid taste. It has many uses, both in the gaseous state and in liquid solution (the commercial product is in liquid form). It is used in preparing the chlorides of various metals, in dyeing, in tissue printing and in the manufacture of coal-tar colors. It is also used in the preparation of phosphates from bones. In medicine it is used as a tonic and an astringent. In concentrated form it is a powerful caustic.

**HYDROCYANIC**, *hi dro si an'ik*, **ACID**, See PRUSSIC ACID.

**HYDROFLUORIC**, *hi dro floo oh' ik*, **ACID**, an acid compound of hydrogen and fluorine. It may be produced either in liquid form or in the form of a colorless gas. In both forms it is very poisonous. Liquid hydrofluoric acid acts powerfully on glass and is used extensively in etching. It is obtained by distilling a mixture of fluorspar with sulphuric acid. In chemistry, it is used to decompose and dissolve silicates in mineral analysis.

**HYDROGEN**, *hi dro' jen*, the lightest of all known substances, is a colorless, odorless and tasteless gas. It is present in gases escaping from volcanos, petroleum wells and natural gas openings. It exists in large quantities in the sun, and in some of the stars. One can easily prepare hydrogen for experimental purposes, by placing scraps of zinc in a flask or wide-mouthed bottle and covering them with water containing a small quantity of sulphuric acid. In the chemical change that follows the hydrogen is set free and can be collected in jars inverted over water. It may also be prepared by passing an electric current through water, which separates the oxygen and hydrogen. See ELECTROLYSIS.

Hydrogen is only one-sixteenth as heavy as oxygen. It burns with a pale flame, but with intense heat. A hydrogen flame no larger than that of an ordinary match will melt glass or a small iron wire. When combined with air and ignited, hydrogen explodes with violence; therefore all lights should be kept from it. Combined with oxygen and ignited in a blowpipe it forms the oxyhydrogen flame, used where intense heat is required in soldering and smelting.

**Compounds.** Hydrogen forms many compounds. With oxygen it forms water, whose symbol is H<sup>2</sup>O. Water when decomposed yields one-ninth of its weight of hydrogen. The gas is found in nearly all animal and veg-

etable matter, and combined with carbon it forms a large class of substances known as *hydrocarbons*, of which illuminating gas, kerosene and naphtha are good examples. It is also an important ingredient of starch, sugar, wood, and many artificial products in common uses. With nitrogen it forms ammonia, and with sulphur the ill-smelling gas which is given off by many sulphur springs.

Because of its lightness hydrogen has been used to some extent for filling balloons, but its inflammability and the readiness with which it escapes through the smallest pores render it undesirable for this purpose, and helium (which see) is being substituted for it. It is used in converting liquid fats into solid fats and may be prepared in large quantities by passing steam over red-hot iron.

**HYDROGEN DIOXIDE**, or **OXYGENATED WATER**, or **PEROXIDE OF HYDROGEN**, a compound of hydrogen and oxygen which contains twice as much oxygen proportionately as water. It is found in small quantities in the juices of some plants and in rain water and snow. When the water which accompanies the artificial hydrogen dioxide has been evaporated, there is left an oily liquid which is colorless and odorless, but which has a bitter taste and will blister the skin if brought in contact with it. Hydrogen peroxide is a particularly valuable bleaching agent, and as a medicine it has proved an excellent antiseptic. Compounds advertised to bleach the hair are usually based on dilute solutions of this substance.

**HYDROGEN SULPHIDE**, *sul' fide*. See SULPHURETED HYDROGEN.

**HYDROGRAPHY**, *hi drog'ra fy*, that branch of geography which has for its object the description of the water on the surface of the globe, whether in seas, lakes or rivers. It may deal with the rivers, watersheds and lakes of a particular country; and it may also include the determination of winds, currents and other departments of marine surveying. Great Britain, France, the United States and other leading countries maintain hydrographic departments, under whose direction soundings, coast surveys and other maritime affairs are conducted.

**HYDROMETER**, an instrument for measuring the specific gravity of liquids. The hydrometer in common use consists of a small glass tube, enlarged at the lower end so as to form two bulbs, one above the other. A weight, usually consisting of mercury or

shot, is placed in the lower bulb to keep the instrument in an upright position. The upper part of the tube, which forms the stem, is marked with a graduated scale, zero being the point to which the hydrometer sinks when immersed in water. If immersed in a liquid heavier than water, it will not sink to the zero point, while, if immersed in a lighter liquid, it will sink beyond this point. Special hydrometers for testing the purity of milk are known as *lactometers*.

**HYDROPHOBIA**, *hi dro fo'be ah*, a disease resulting from the bite of a rabid animal, especially a mad dog. Inability to swallow is the first symptom of the disease, which, if unchecked, causes convulsions and death. A person bitten should have immediate treatment; delay is fatal. As a precaution the wound should immediately be sucked; this can be done with safety if the mouth contains no sore or infected spot. Then the victim should be taken promptly to a physician or other person competent to cauterize the wound, either with a hot iron or a powerful acid. If possible, the Pasteur treatment should be administered. This is a method of preventing the development of the disease by a system of inoculations with specially-prepared virus. Physicians will give information on this point.

**HYDROPHYTE**, *hy'dro fyte*, a plant whose natural habitat is very wet soil or water. See **AQUATIC PLANTS**.

**HYDROSTATIC**, *hi dro stat'ik*, **PRESS**, or **HYDRAULIC PRESS**, a machine which operates by the pressure of water and depends upon the principle that liquids transmit pressure equally in all directions. The working of the hydrostatic press is illustrated

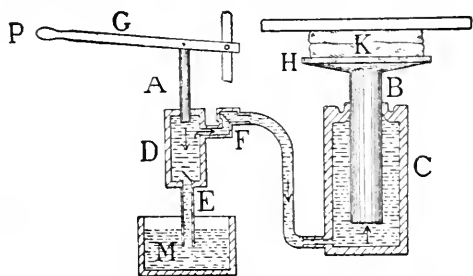

in the accompanying diagram. The machine consists of two pistons, A and B, fitted with water-tight collars to their respective cylinders, C and D. The piston and cylinder A and D, together with the valves E and F, constitute a force pump which is connected by a

pipe with the cistern M. The piston B is fitted with a platform H, which, when the press acts, is forced upward towards the plate. The object to be pressed, K, is placed upon the platform. The piston A is worked by the handle G, which is so attached as to constitute a lever. The power is applied at P. By working the piston A, water is pumped from M into the cylinder D and thence into the cylinder C, raising the piston B. If the cylinder A has an area of one square inch and the cylinder B has an area of a hundred square inches, every pound of pressure applied at A will produce one hundred pounds of pressure upon B. By the lever attachment of the handle G, a pressure of one pound at P will produce a pressure of five hundred pounds upon B.

The hydrostatic press is used in pressing cotton, raising heavy weights and for other purposes where great force is required. See **HYDROSTATICS**.

**HYDROSTATICS**, *hi dro stat'iks*, the science which treats of liquids at rest. Some authorities also include hydraulics under hydrostatics. The laws of hydrostatics are those governing the pressure of liquids, of which water is taken as the type. The most important of these laws are:

(1) Liquids carry pressure equally in all directions. Given, a bottle whose neck will just fit a cork having an area of one square inch. Fill the bottle with water and press down on the cork with a force of one pound; the pressure on the bottle will be equal to as many pounds as there are square inches in its surface. If it has an area of one hundred square inches, the pressure will be one hundred pounds.

(2) The pressure increases with the depth of the liquid. At the surface the pressure is nothing. At the bottom the pressure for any area is equal to the weight of a column of water of the same area extending to the surface. This principle must be taken into consideration in the construction of pipes which are to stand in a vertical position; also, in securing the flow of water for the purpose of turning water wheels, as turbines.

[When these two laws are combined, they explain some very curious facts concerning water. It is in accordance with these principles that the water in a small tube will sustain the pressure of that in a large tube, when both are connected with the same vessel. The water in the spout of the teakettle remains at the same height that it is in the kettle. It is also in accordance with these laws that we account for the great pressure exerted upon tanks, cisterns or boxes that are connected with standpipes which extend to a great height. If an ordinary cask be filled and at

upright iron pipe one inch in diameter and thirty feet long be connected with it and also filled with water, the pressure upon the cask is sufficient to burst it.]

(3) When a body is immersed in a liquid, the pressure upon it is equal to the weight of the liquid displaced. For instance, a cubic foot of water weighs 62½ pounds. If a box having a capacity of a cubic foot and weighing 2½ pounds be immersed in water, it can contain 60 pounds of sand before it will sink.

**HYDROSULPHURIC**, *hi dro sul fu'rik*, **ACID**. See SULPHURETED HYDROGEN.

**HYDROTHERAPY**, *hi dro ther'api*, a method of treating disease by the use of water. Few physicians now think that proper water treatment can be a cure for everything, yet most physicians use it in a great variety of cases. By applying pure hot or cold water it is possible to cleanse exposed tissues, to drive away excess of blood from one part of the body, or to call blood to the place where it is needed. Water affects all secretions of the body in a cleansing and stimulating way. Sprains, sore throat, tonsillitis and other diseases are relieved by compresses of cold or hot water, and fevers are reduced by bathing or by water packs. In America and Europe there are numerous institutions where hydropathic treatment can be administered in its most approved form, and these institutions are frequented by patients suffering from the diseases that yield most readily to water treatment. See BATHS AND BATHING.

**HYENA**, *hi e'nah*, a wolflike animal that prowls at night in search of food, at intervals giving vent to horrible shrieking howls. The forelegs are longer than the hind legs, and the animal necessarily moves with a

the *striped hyena* of Western Asia, the *spotted hyena*, yellowish in color with numerous dark spots, and the *brown hyena*, both African species. All are nocturnal (night-roaming) animals and are extremely voracious; they feed chiefly on carrion, and are thus of great value in the countries where they live. The aard-wolf of South Africa is included in this family.

**HYGEIA**, *hi je'yah*, the Greek goddess of health, daughter of Aesculapius, with whom she was often worshipped. She was represented as a blooming maid, with a bowl in her hand, from which she fed a snake, the symbol of healing power (see BRAZEN SERPENT). The modern word hygiene is traceable to her.

**HYGIENE**, *hi'ji en*, or *hi'jeen*, that branch of medical science which deals with the preservation of health. It differs from ordinary medical and surgical practice in that the latter has to do with the healing of those who are already sick. The science of hygiene has to do with keeping well those who are not sick. Each individual is morally bound to observe not only the laws of hygiene which public health boards impose, but others that concern himself personally. Standards of health are maintained by careful selection of foods, abstinence from alcoholic liquors, moderation in the use of tea and coffee, personal cleanliness, and observance of the laws of ventilation. By exercising care in regard to food, cleanliness and fresh air, by avoiding dissipation and overwork, and by keeping the mind free from worry, the average person can maintain a good state of health.

Domestic hygiene is also of great importance. Those who have charge of a home must look after the character, quality and quantity of food and its adaptation to the different members of the family, according to age, state of health and occupation; the clothing of beds and persons must be carefully and regularly cleaned and aired; and the minds of the young must be directed in the lines that will fit them for the duties of adult life.

In the field of public hygiene remarkable progress has been made since the beginning of the eighteenth century. Enforcement of regulations in regard to building construction, plumbing, house ventilation, street cleaning and water supply, and extermination of such pests as rats, flies and mosquitoes have accomplished much in preventing the spread of

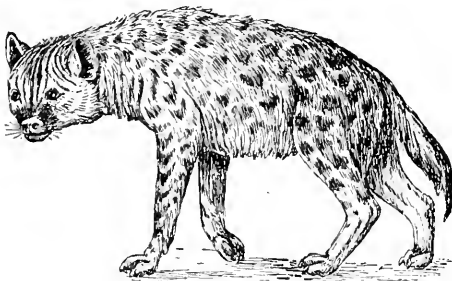

HYENA

swinging, shambling gait. The eyes are large and prominent; the ears, long and acute; the jaws, powerful. Not only is the animal ugly in appearance, but its odor is sickening. There are three species known—



disease. The public is being enlightened as to the cause of infections and as to methods of prevention, and the result is a higher standard of public health and a decrease in the number of deaths from disease.

**Related Articles.** Consult the following titles for additional information:

|                           |                          |
|---------------------------|--------------------------|
| Antitoxin                 | Health, Boards of        |
| Bacteria and Bacteriology | Heating, and Ventilation |
| Baths and Bathing         | Medicine                 |
| Breathing                 | Mosquito                 |
| Fly                       | Physical Culture         |
| Food                      | Quarantine               |
| Garbage                   | Sanitary Science         |
| Germ Theory of Disease    | Sewage and Sewerage      |

**HYGROMETER**, an instrument for measuring the amount of moisture in the atmosphere or in other words, the *humidity* of the atmosphere. The standard hygrometer consists of a glass tube with a bulb at each end, one of colored glass, or of glass painted black, and the other of plain glass. The colored bulb contains ether and a thermometer; the other is covered with a cap of muslin or with a wick, one end of which dips into a vessel of water. When the instrument is manufactured, the ether is placed in the larger bulb and raised to the boiling point so as to expel the air from the tube, which is then sealed, leaving a vacuum as the ether cools.

The principle upon which this instrument works is that of condensation of moisture in the atmosphere by the lowering of temperature. The water drawn up by the wick which covers one bulb evaporates and reduces the temperature, and this causes the continuous evaporation of ether in the other bulb and so reduces the temperature of this bulb that moisture from the atmosphere gathers upon the glass, as it does upon a pitcher of ice water. The thermometer in the ether bulb shows the temperature at which this condensation begins to form, while a thermometer on the stand shows the temperature of the atmosphere. By combining the readings of the two thermometers, and by means of tables which have been carefully worked out, the relative amount of moisture can be ascertained.

**HYKSOS**, *hik'soze*, the name given to a dynasty of kings which usurped the power in Egypt about 1700 B. C. See EGYPT, subhead *History*.

**HYMEN**, *hi'men*, originally a marriage song among the Greeks, but later the god of marriage. He was the son of Apollo and a Muse. In art he was represented as a beauti-

ful youth, crowned with flowers, shod with gold sandals and carrying a torch. His blessing was invoked at every marriage.

**HYMENOPTERA.** See INSECTS.

**HYMNS, NATIONAL.** Every nation has at least one song which expresses in a definite way the national sentiment of the people. Such a song is played or sung at patriotic meetings and on special occasions, and when its music is heard the people stand or bare their heads. In England special tribute is paid to *God Save the King*; in Canada, to *The Maple Leaf*; in France, to *The Marseillaise*; in the United States, to *The Star Spangled Banner*. National hymns are the outgrowth of folk music, but differ from the latter in that they express the sentiments of the whole people, instead of the feelings of the individual.

The following list gives the accepted national hymns of various nations:

Austria (before 1919), *Gott erhalte unsern Kaiser* (God preserve our Emperor). Music by Haydn; words by Haschka.

Brazil, Hymn of the Proclamation of the Republic. Words by Albuquerque; music by Miguez.

France, *La Marseillaise*, by de Lisle.

Germany, *Die Wacht am Rhein*, by Schneckenburger.

Great Britain, *God Save the King*, probably by Carey.

Greece, *Sons of Greece, Come, Arise*.

Holland, *William of Nassau*.

Italy, *Air—Royal March*, by Gabetti.

Japan (translated), *May the Empire Last*.

Mexico, *Mexicans at the Cry of War*, by Nuno.

Norway *Song for Norway*, by Björnson.

Spain, *Himm de Riego*. Music by Herta.

Sweden, *Out of the Swedish Heart*.

United States, *Star Spangled Banner*.

The following are popular hymns widely used upon patriotic occasions in the countries named:

United States, *Yankee Doodle*, *Dixie*, *America or My Country*, *Tis of Thee*, *Battle Hymn of the Republic* and *Columbia, the Gem of the Ocean*.

Germany, *Heil dir im Siegerkranz* (Prussia); *Deutschland über alles*.

Canada, *The Maple Leaf*.

**Related Articles.** Consult the following titles for additional information:

|                             |                      |
|-----------------------------|----------------------|
| America                     | Marseillaise Hymn    |
| Battle Hymn of the Republic | Star Spangled Banner |
| Dixie                       | Wacht am Rhein       |
| God Save the King           | Yankee Doodle        |

**HYMNS AND HYMN TUNES.** A hymn is a religious poem set to music. From the earliest times hymns were used in worship, and the Hebrew *Psalms* constitute a collec-

tion of hymns which has never been equaled. In the Christian Church there are records that hymns were used as early as the second century A. D., but the first which has come down to us dates from the beginning of the third century. A number of the world's most famous hymns are of Latin origin, such as *Come, Holy Spirit; Dies Irae* ("Day of Wrath"); and *Stabat Mater* ("The Mother Stood").

The Reformation inspired many noble songs, and gave a strong impetus to hymn writing. Luther was the greatest song writer of the period, and his *Ein' feste Burg ist unser Gott* ("A Mighty Fortress is Our God") is to-day a favorite Protestant hymn. Although many hymns were produced in England before the time of Isaac Watts (1674-1748), the name of the "father of English hymnody" is often given to Watts. His hymns are very numerous, and many of them are still exceedingly popular. The only possible rival to Watts in the number of his compositions was Charles Wesley (1707-1788), who wrote over six thousand hymns, almost four hundred of which are commonly used. Among the later hymn writers in England may be mentioned Cowper, John Henry Newman and Frances Ridley Havergal.

American writers who contributed to hymnology include Oliver Wendell Holmes, Phoebe Cary, P. P. Bliss, Julia Ward Howe, who wrote the *Battle Hymn of the Republic*; Samuel Francis Smith, author of *America*; Timothy Dwight; Ray Palmer, who wrote *My Faith Looks Up to Thee*, and Frances Jane Crosby, the author of a great number of gospel hymns, of which perhaps the most famous are *Safe in the Arms of Jesus*; *Pass Me Not, O Gentle Savior*, and *Jesus is Calling*. Several hymns which are among the most noteworthy in common use in the churches are *Lead, Kindly Light*, by John Henry Newman; *Nearer, My God, to Thee*, by Mrs. Sarah Flower Adams; *Just as I am, Without One Plea*, by Charlotte Elliot; *One Sweetly Solemn Thought*, by Phoebe Cary; and *I Love to Steal a While Away*, by Mrs. Phoebe H. Brown.

Previous to the Reformation, the music in use for hymns had been of the nature of chants, or had been heavy and somewhat somber. Luther, however, who had much to do with popularizing the words of hymns in common use, did much for the music, also,

by adapting certain popular airs and writing sacred words for them. In England the history of hymn tunes begins properly with the eighteenth century. With the music written for the hymns of Charles Wesley, hymn tunes reached, perhaps, their highest point. Modern hymn tunes, especially those used in Sunday Schools, have been criticized for their triviality.

**Interesting Facts About Hymns.** It has been estimated that there are at least 400,000 hymns in all languages. The greatest number of these are in German, the next greatest number in English.

The Mohammedans have no hymns.

The most ancient Christian hymn of any length which we possess to-day is the well-known *Te Deum*—"We praise Thee O God." It has come to us through the Latin from a very early Greek original.

Martin Luther's great hymn, *Ein feste Burg* was a great force in the spread of the Reformation. The tune to which this hymn is always sung was also composed by Luther.

Four hymns, *When I Survey the Wondrous Cross*, *Rock of Ages*, *Jesus, Lover of My Soul*, and *Coronation* are printed in more collections, translated into more tongues, and used in more congregations than any others. Some authorities, among whom is no less a critic than Matthew Arnold, consider *When I Survey the Wondrous Cross* the finest hymn in the English language; others place it second to *Rock of Ages*. This latter hymn has been translated into almost as many languages as the Bible itself, probably over three hundred. Gladstone translated it into Latin, Greek and Italian.

One of the best known hymns is *Blest Be the Tie That Binds*, by John Fawcett. Fawcett was an English Baptist pastor, who served for years a little congregation at Wainsgate, receiving from them a very small salary. Finally he decided to accept a call from an important church in London, but after his goods were packed he decided that he could not leave his people. It was on that occasion that he wrote this hymn.

*One Sweetly Solemn Thought*, by Phoebe Cary, was composed in a little chamber of a village cottage one Sunday morning, after church. It has been translated into nearly all languages of the civilized world.

Charles Wesley's most famous hymn, *Jesus, Lover of My Soul*, was written immediately after a narrow escape from death by ship-

wreck. Henry Ward Beecher said of it: "I would rather have written that hymn of Wesley's than to have the fame of all the kings that ever sat on earth."

Henry Francis Lyte wrote *Abide with Me* at the close of the service at which, "scarce able to crawl," he had taken part in his last communion with the congregation which he had served for twenty-five years, thus giving it a strongly-sentimental background.

**HYPATIA**, *hi pa'she ah*, (about 355-415), a famous Greek philosopher, of the Eclectic school, the daughter of Theon, a celebrated astronomer and mathematician of Alexandria. Her father taught her not only all the branches of polite learning, but also geometry, astronomy and, finally, philosophy. She acquired a great reputation in the last study and succeeded her father as lecturer at Alexandria, where she gathered a large number of students from all parts of the East. She was as virtuous and beautiful as she was learned. But the jealousy and intolerance of Cyril, the bishop of Alexandria, were aroused at the influence exercised by Hypatia; the lower and more ignorant clergy in particular were stirred against her, and at length a number of them, having excited a popular tumult, seized her as she was returning from the schools, dragged her through the streets of Alexandria, stripped her and finally murdered her with circumstances of the greatest barbarity. She is the heroine of Charles Kingsley's *Hypatia, or New Foes with an Old Face*.

**HYPE'RION**, in the earliest Greek legend, one of the twelve children of Uranus and Gaea who constituted the race of Titans. Uranus, afraid of his gigantic offspring, shut them up, but they escaped. Uranus became the sun-god, driving across the sky each day in a golden chariot. In later mythology Hyperion was identified with the sun-god Apollo. See APOLLO.

**HYPERMETRO'PIA**, a defect of the eye, caused by a shortening of the diameter extending from front to back, often referred to as flattening of the eyeball. Rays of light entering an eye thus affected are brought to a focus back of the retina, and the person is said to be *farsighted*. The defect usually increases with age. It is remedied by spectacles having convex lenses. The gradual shortening of this diameter as people grow older necessitates the use of such spectacles in nearly all cases. See EYE; SPECTACLES.

**HYPNOTISM**, *hip'no tiz'm*, a condition which may be artificially induced, in which the mind and body of one individual may be peculiarly influenced by another, apparently independently of the subject's will. Modern scientific investigation, while not fully explaining hypnotic phenomena, has shown that they are due to peculiar nervous conditions and that it is unnecessary to presuppose any supernatural force to account for them. Among the means employed to produce the hypnotic condition are touching and stroking with the hands, breathing on the person and fixing the eyes upon him. It may also, it is said, be produced by causing the patient to stare at an object, especially a bright one, placed in such a position as to strain the eye, the effect being completed by a few passes of the hand over the face without touching it.

In the condition thus induced, the patient seems to be in a kind of sleep and the limbs will remain in any position in which they may be placed. By stroking the surface of the body the muscles adjacent may be rendered rigid, as in a person suffering from catalepsy. Reason and memory are temporarily suspended, the will is paralyzed, and the subject is irresistibly impelled to act in accordance with suggestions, however absurd. He can be persuaded into any belief, such as that he is some one other than himself, or that he hears or sees, smells or tastes, something which is not present before him. As a curative agent, hypnotism has been successfully employed in certain forms of disease, especially in cases of nervous irritation and sleeplessness, disorders that have a nervous origin.

The first step toward scientific investigation of hypnotic phenomena was taken by James Braid, an English surgeon, in 1842, but general interest in the subject was originally awakened by the experiments of Dr. Mesmer (see MESMERISM). To Braid we owe the term *hypnotism*. Dr. Heidenhain of Breslau attributes the phenomena to what is known by physiologists as the inhibitory action of the nerves. Such action, he holds, has the result of suspending the action of that portion of the brain which is devoted to voluntary movements, thus putting the patient in a condition in which involuntary movements may be induced by impressions made upon the senses. Hypnosis comes, then, not through the power of some person without, but through the action of the subject's own

mind. One idea alone is held in mind, and as all the others have been discarded, the subject has nothing with which to compare it and it becomes the ruling power. Not everything concerning hypnotism is understood, but it is certain that no one can be at first forced unwillingly into the hypnotic state, and that only those having considerable mental power can pass into the condition.

**HYPOTHERMIC**, *hi po der'mik*, **INJECTION**, a method of introducing medicine beneath the skin and so directly into the blood. The instrument in use is a small glass syringe, fitted with a long, hollow, needle-shaped point of steel. Hypodermic injections are given when the condition of the stomach or other organs renders the use of drugs by the mouth objectionable, when rapidity of action is desired, and in the administration of anesthetics.

**HYPOTHESIS**, a supposition assumed for the sake of argument. In scientific and philosophical usage it denotes either a probable theory of phenomena not yet fully explained, or a strictly scientific theory which accounts for all the known facts of the case, and which only needs the verification of subsequent observations and deductions to become a certainty. Thus, the conjecture of Newton that the force of gravity, as shown on the earth, might extend to the moon, was an hypothesis; but when it was found to ac-

count for all the facts of gravitation it became a scientific theory.

**HYSSOP**, *his'sup*, a plant of the mint family, the common species being a perennial, shrubby plant, rising to the height of two feet. It is a native of Siberia and the mountainous parts of Austria, but it is common in the gardens of the United States. It flowers from June to September, having tiny blue blossoms which cluster on spikes. The leaves have an agreeable aromatic odor, and are slightly bitter. Hyssop was once valued for its reputed medicinal qualities. The hyssop of Scripture, the symbol of spiritual purification from sin, is believed by most authorities to be the caper.

**HYS'TE'RIA**, a nervous disease, more common among women than men, but affecting both sexes. It manifests itself in emotional outbreaks, such as violent sobbing, screaming and uncontrollable laughter. It is often spoken of slightly, and formerly it was thought to be entirely under the control of the patient, but it is now known to be frequently a disease of a very serious nature. Overwork, worry, shock or vicious habits may be the causes, and any form of great excitement may bring on an attack. The removal of the causes which produce the disease, nourishing food, exercise or massage and complete abstinence from worry and anxiety will usually effect a cure.



I, the ninth letter and third vowel of the English alphabet. In its form it has changed considerably from the Phoenician character from which it is derived, and which resembled



IBEX

a Z. The straightening out was gradual. The two principal sounds represented by it in English are the short sound, as in *pin*, and the long, as in *pine*, the latter being really a diphthong, composed of *ah* and *ee*. The other sounds of *i* are that heard in *first*; that heard in *machine*, which can scarcely be considered a modern English sound, though the most common *i* sound in foreign languages; and the consonant sound heard in many words when it precedes a vowel, as in *bullion*. *I* and *j* were formerly regarded as one character.

**IBERIA**, the name given by the ancient Greeks to the peninsula comprising Spain and Portugal. It is supposed to have been derived from the river Iberus or the present Ebro. The Iberians are probably the most ancient European nation. They form the basis of the population of Italy, Gaul, Spain and Portugal. The Basques are their descendants and still preserve the ancient Iberian language. The Romans knew Iberia as Hispania.

**IBERVILLE**, *e bair veel'*, PIERRE LE MOYNE, Sieur d' (1661-1706), a French-Canadian soldier and explorer, born in Montreal. He entered the French navy, but re-

turned to America and commanded several exploring expeditions northward and westward into Canada. He took part in King William's War. In 1699 he sailed from France to the Gulf of Mexico, entered the mouth of the Mississippi and established Biloxi, and later Mobile, being thus the founder of the French province of Louisiana.

**IBEX**, the name of two or three species of wild goats. The horns are flattened and long, in some species attaining a length of forty inches. A species once common in the mountains of Central Europe, but now very rare, is called *steenbock* by the Germans and *bouquetin* by the French. The *Himalayan ibex* is somewhat larger than the other species, and has huge horns. The animals live in groups,



SACRED IBIS

and have maintained their numbers in nearly all their native districts. Hunting the Himalayan ibex is a favorite sport, but is ex-

tremely dangerous because of the wildness and ruggedness of the country in which it roves. Notwithstanding the zeal with which the animal is hunted it maintains its numbers well, for it is very prolific. There is an *Arabian ibex*, which roams from Palestine to Upper Egypt.

**IBIS**, a wading bird, related to the storks, with a long, slender bill curved downward. Two or three species are found in the United States. The *white ibis*, with black tips to its wing feathers, is common in the South Atlantic and Gulf states. The *scarlet ibis*, found in the West Indies, and occasionally in the Southern States, has red plumage throughout, excepting the tips of the wing feathers, which are black. The *sacred ibis* of Egypt is a larger, heavier and less graceful bird. Because it migrated north with the rise in the Nile and was an enemy of lizards and small reptiles, it came to be held in great reverence by the Egyptians, who, after its death, preserved it as a mummy. The sacred ibis is now extremely rare.

**IBSEN**, HENRIK (1828-1906), a Norwegian dramatist and lyric poet, one of the foremost literary men of his age. His first play, *Catiline*, was published in 1850, and in the same year *The Warrior's Mound* was successfully produced in Christiania. He was successively director of the theater at Bergen and the Norske Theater at Christiania, which he managed from 1857 to 1862. In 1864 he left his native country, lived for several years in Rome and afterwards in Dresden, but went back to



IBSEN

Norway in 1878. His dramas are partly in prose, partly in verse, and they include historical plays and satirical comedies of modern life. Among his chief works are *Brand* and *Peer Gynt*, dramatic poems, *The League of Youth*, *A Doll's House*, *Ghosts*, *Rosmersholm*, *The Lady from the Sea*, *Hedda Gabler*, *Master Builder Solness*, *John Gabriel Borkman* and *When We Dead Awaken*. The vital character of Ibsen's themes, the fearless presentation of them and his wonderful mastery of dialogue give him a place among the greatest modern dramatists.



**ICE**, *ise*, water frozen into a solid mass. Water freezes when its temperature is reduced below a certain point. Under ordinary conditions pure water solidifies at a temperature of zero on the Centigrade scale, and at 32° above zero on the Fahrenheit (see THERMOMETER). The presence of certain substances in water, however, has the effect of lowering the freezing point; water containing salt in solution, for instance, freezes

at about 27° F. The application of strong pressure to the surface of water has a similar effect.

As water approaches the freezing point in temperature, it contracts, until at about 39° F. it reaches its greatest density. As the temperature lowers it begins to expand, and when it freezes it expands so as to increase its volume about one-ninth. This makes ice lighter than water, so that it floats. The force of the expansion is very great. This is why pipes, pitchers and other vessels in which water freezes are broken. The breaking of rocks from cliffs is often due to the freezing of water in crevices of rock. A cake of pure ice appears transparent, but when a thin slab of ice is held in water for a few moments to make the sides smooth and is then looked at towards a light, numerous brilliant six-pointed stars are seen. These are some of the six-sided crystals of which the ice is composed.

**Harvesting Ice.** The extensive use of ice for preserving perishable substances makes the harvesting, storing and shipping of it an important industry. Natural ice for use is obtained from the lakes and rivers of cold regions. The first step in harvesting ice consists in scraping off the snow and porous ice from the surface. After this, the field is marked off by a machine called the *marker*, which cuts parallel grooves in the ice about three feet apart; afterwards other grooves at right angles to the first and about the same distance apart are cut.

This marks off the field into cakes. The third step is cutting, which is done by means of a machine which follows the marker and is

of similar construction, except that it has longer knives. After this machine has completed its work, the first cake is cut out by a handsaw. When this has been removed, the others can be split off with a crowbar having a wedge-shaped end. The ice is then hauled from the water to the ice houses, where it is stored until needed.

Ice houses in some localities are from two to three hundred feet long and five stories high. They usually have three or four walls, between which spaces of dead air are enclosed, and are provided with drains and ventilators. The ice is packed in sawdust or spent tan bark. The most extensive ice harvesting is on the Hudson River, in Maine and on the lakes and streams of Wisconsin, Michigan and Minnesota.

**Manufacture of Ice.** In large cities and in localities removed from regions where ice forms in winter, it is often cheaper to manufacture ice than to import it. When the ice is intended for domestic purposes it is made from distilled water. The plant for the purpose must contain an engine, pumps, condensers, tanks, pipes and some other machinery. The freezing is done by the expansion of liquid ammonia into ammonia gas, which takes place in coils of pipe that are surrounded by brine. Since the brine freezes at a much lower temperature than fresh water, by immersing the tanks containing the water to be frozen in brine, the ice is readily formed. The water to be frozen is placed in tanks called *cans*. These are shaped like cakes of natural ice. When these tanks are placed in position the pump forces the ammonia gas into a small chamber under such pressure that it becomes a liquid. This liquid in turn is allowed to escape slowly into the pipes, where it immediately evaporates and absorbs heat from the brine, which is reduced to a temperature several degrees below the freezing point of water. The ammonia is used over and over, so that when the plant has been established the expense of manufacturing ice is comparatively little.

**ICEBERGS**, *ise'burgz*, gigantic masses of ice which have become detached from the glacial shores of the Arctic and Antarctic regions, and which float about in the ocean at the mercy of the winds and currents, until eventually melted by the sun in regions remote from their origin. They are, in truth, pieces of glaciers, broken from the parent

mass by the action of the sea and by their own immense weight.

Icebergs present the strangest and most picturesque forms, are sometimes miles in length and rise to heights of perhaps 250 or 300 feet above the sea. A better idea of their vast size is gained when it is known that the great mass which appears above the ocean's surface is only about one-eighth of the entire iceberg—that seven-eighths is below the surface. These great masses consist of clear, compact, solid ice, with a bluish-green tint. Their cavities contain fresh water, from the melting of the ice. They are frequently encountered in the North Atlantic Ocean, and have caused many wrecks, the most notable one in recent years being the loss of the great *Titanic*, on its first trip in 1912 (see *TITANIC*).

The ice that forms on the surface of the sea, called *field ice*, is porous, incompact and imperfectly transparent. The field ice forms in winter and breaks up in summer. A small field is called a *floe*; one much broken up forms a *pack*. Floes and packs are encountered by navigators.

**ICE BOATING.** See ICE YACHTING.



Icelandic Costume

**ICELAND**, an island between the North Atlantic and the Arctic oceans which in 1918 joined the ranks of the world's independent nations. Iceland was not well-named; it is as correct to call it Iceland as to call its nearest neighbor consisting of several hundred thousand square miles of ice. Greenland. The island is not a bleak, barren, frozen region though its most northern point crosses the Arctic Circle. It has a somewhat temperate climate for a considerable portion

of the year, and an atmosphere unrivaled in clearness.

The wonders of many widely-separated parts of the world are found within the confines of this little country. It has great glaciers, like those in Switzerland; the fiords and the midnight sun of Norway; volcanoes and grottoes such as are found in Italy; geysers like those in New Zealand and in Yellowstone Park; mineral springs as valuable

as those in Germany; and one of the largest waterfalls in the world.

Iceland contains 40,497 square miles, and is about as large as Ohio. It is 150 miles east by south of Greenland, from which it is separated by the Strait of Denmark, and about 500 miles northwest of Scotland. It is no farther north than Fairbanks, Alaska, or Dawson, in the Yukon. The climate is more harsh than it is cold; the temperature in the winter averages about 30°, while in the short summer it does not average more than 50° on the southern coasts. The comparatively-cold summers are caused by drifting ice masses from the polar regions.

The people do not engage largely in agriculture, although farming is on the increase and there are four agricultural schools. They raise sheep, cattle and horses, and exchange them in Europe, principally in Denmark, for the necessities of life. In 1917 the first vessel that ever sailed direct from Iceland to the United States carried home a cargo of flour. Only about two-fifths of the land is available for farming or stock-raising; the remainder is either glacier-covered or is too hilly and rough for cultivation. The hills rise 1,600 to 2,000 feet above the sea.

Icelanders are famous for a literature of note, dating to the sixteenth century. There are few schools, but every child is educated at home, and no one is unable to read. There are twelve printing presses and fourteen newspapers in the island; and about a hundred books are published every year.

In 1918 Iceland became practically free from Denmark, to which it had been attached as a colony almost since its discovery about the year 870. It was an entirely harmonious agreement between the two countries, by which they became united as free and equal federal states. The arrangement provides that the two shall remain independent until 1940, when at the will of the governments the federative constitution may be reframed or abrogated. During the period preceding 1940 the two countries will have the same king, and the name of each country is to appear in the title of the monarch.

**ICELAND MOSS**, a lichen of the Arctic regions, especially of Iceland and upper Norway. It is also found farther south, on the tops of high mountains. In Iceland and Lapland it is used as food, being dried, powdered and made into bread, or boiled with milk. It yields a thick glue, and much of it is

exported for use in the manufacture of paper-sizing and for dressing the warp in weaving.

**ICELAND SPAR**, a transparent mineral, which makes objects seen through it appear double. If a crystal of this spar is placed over a dot, two dots are visible. The phenomenon is due to double refraction of light. Iceland spar, which is a variety of calcite, crystallizes in the form of a rhombus. See **POLARIZATION OF LIGHT**.

**ICE PLANT**, a plant so named from the transparent cells which cover its whole surface and have the appearance of granules of ice. It is a native of South Africa and the Canary Islands, and is also found in Greece.

**ICE YACHTING**, *yacht'ing*, a sport limited in great degree to the United States and Canada, although it is occasionally enjoyed in Russia. It first made its appearance in North America late in the eighteenth century, and since that time has steadily increased in popularity, until ice yachts are now commonly seen on the lakes during the winter months.

The most common type of ice yacht consists of a triangular box mounted upon two crossbars, the lengthwise bar being from one-third to one-half longer than the crossbar. On both ends of the crossbar are fastened steel skates, and at the rear of the longer bar is a skate which is under the control of a lever and serves as a rudder. The boat has one large sail and often a smaller jib sail. In racing, a triangular course of about one mile on a side is laid out, and the contestants are compelled to sail five times around this triangle in each boat. Under favorable weather conditions and on good ice, remarkable time can be made, since in certain directions the boat can move considerably faster than the wind that propels it. From forty to seventy miles an hour is not an unusual speed. The principal points at which ice yachting tournaments are held are on the Hudson

River, at

Poughkeepsie and Newburgh; Lake Minnetonka, near Minneapolis, Minn., Lake Winnebago, near Osh-



ICELAND MOSS



kosh, Wis.; at Burlington, Vt., on Lake Champlain; on the Saint Lawrence River, and on Lake Ontario.

**ICHNEUMON**, *ik nu'mon*, a genus of flesh-eating animals belonging to the civet family. They have a long, slender body, a sharp and pointed muzzle and short legs. The best known species inhabits Egypt, where it is called *Pharaoh's rat*. It was held sacred by the ancient Egyptians on account of its hostility to crocodiles, whose eggs it digs out of the sand and sucks. It is expert in seizing serpents by the neck so as to avoid any injury to itself. The ichneumon is domesticated in Egypt, and is more useful than a cat in destroying rats and mice. The *mongoose*, or *Indian ichneumon*, is another species, not so large as the Egyptian, which it resembles in habits. It is kept in many families as a useful domestic animal. It is especially famous for its ability to kill the deadly cobra.

**ICHNEUMON FLIES**, a large family of insects, all of which agree in one particular, that they deposit their eggs either in or on the bodies, eggs or larvae of other insects. These apparently insignificant creatures confer inestimable benefits on man, as they destroy hosts of insects injurious to crops. They are delicate, long-legged insects, varying much in size. Their eggs are deposited by means of a pointed organ called the *ovipositor*.

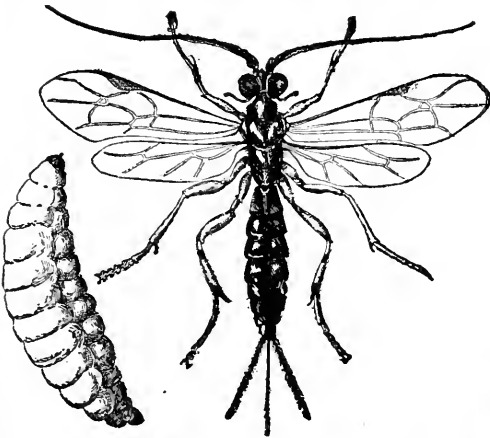

ICHNEUMON FLY AND LARVA  
Much enlarged.

**ICHTHYOSAURUS**, *ik thi o saw'rus*, an immense fossil marine reptile. It had four broad feet, or paddles, each enclosed in a single sheath, or integument, and a long and powerful tail. Its body was round and tapering, the head large, with long snout and short

neck. The vertebrae of the animal very closely resembled in shape those of a fish. Some of the largest of these creatures must have exceeded thirty feet in length. Their remains show that they existed in large numbers in some parts of Europe. In all, about thirty-five species are known, skeletons of which have been found in the formations of the East Indies, Australia, New Zealand, South America and Europe. (A picture of the ichthyosaurus as it was supposed to appear accompanies the article GEOLOGY.)

**ICONOCLASTS**, *i kon'o klasts*, a word applied to those who destroyed the images in the early Christian churches. It is derived from the Greek *eikon*, meaning *image*, and *klan*, signifying *to break*. In the first centuries of the Christian Era images of Christ and the saints were placed in the churches only as constant reminders of pious examples, but in the sixth century these figures began to be worshiped. In 726 Leo III issued an edict forbidding the worship of images and the burning of incense in their honor, and ordering them to be destroyed. There was consternation, and the Church was divided into two factions, those favoring images and the Iconoclasts.

The second council of Nicaea defined the use of images not as idol-worship but as religious symbolism, in which case the image was venerated for what it represented. In the Greek Orthodox and Roman Catholic churches images are still retained and revered as symbols. In Russia sacred pictures called *eikons* are placed in all churches, and up to 1917 were always taken with the armies into battle, but they are not worshiped.

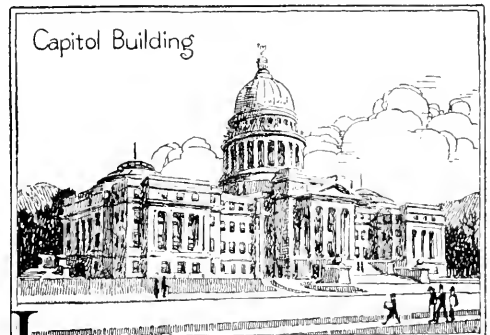

**IDAHO**, one of the states of the Rocky Mountains section, twelfth in size among the states of the American Union and in 1910 forty-fourth in population. The state is

called the *Gem of the Mountains*, for the word *Idaho* is derived from a Shoshone Indian term having that meaning. The northern boundary touches British Columbia; the state has Montana and Wyoming for eastern neighbors; Utah and Nevada are on the south, and Washington and Oregon bound it on the west. The area is 83,888 square miles; the population in 1910 was 325,594, or 3.9 persons to each square mile. According to a Federal estimate the population was 461,766 on July 1, 1918.

**Surface and Drainage.** Idaho is on a plateau which forms a portion of the Great Basin, and has an elevation varying from 2,000 to 5,000 feet. The state lies between the main axis of the Rocky Mountains on the east and the Cascades on the west. The Rocky Mountains with their extensions northward, the Bitter Root and Coeur d'Alene ranges, form a part of the northern and eastern boundaries. Spurs project westward from these in some places extending across the state. Among the most important of these spurs are the Salmon River Mountains in the east center, the Sawtooth Range in the west center and the Goose Creek and Bear River ranges in the south.

In the northern part are found spurs from the Rocky and Bitter Root ranges, the Cabinet Mountains, the Seven Devils and Clearwater Mountains and the northern slope of the Salmon River Divide. With the exception of a few peaks and ridges, none of these exceeds 5,000 feet in altitude. Among the spurs in the central part of the state, however, are occasional peaks which attain an altitude of 12,000 feet, and a large number which are crowned with perpetual snow. In the south there are some peaks which have an altitude of 6,000 feet, but most of them are lower.

A watershed crosses the state from east to west about halfway between the 44th and 45th parallels of latitude, and separates the basins of the Snake and Salmon rivers. With the exception of a great bend to the southward in the eastern part of Custer County, this divide extends practically east and west. Another watershed in the southeastern part of the state separates the waters of the Bear River Basin, which is drained into Great Salt Lake, from those of the Snake.

Throughout the state mountains and highlands are interspersed by deep, fertile valleys and level plains. Among the most noted plains are the Lost River Plains, Little and Big Camas Prairie and Bear River Valley in the south. The chief agricultural valleys in

the south are those of the Snake, the Weiser, the Payette, the Boise, the Little and Big Wood, the Portneuf, the Blackfoot, the Rock Creek, the Salmon, the Bruneau, the Goose Creek and the Long Valley. In the northern part are the Salmon, the Clearwater, the Palouse, the Coeur d'Alene, the Spokane and the Kootenai valleys, the Nez Perce and Camas prairies, the Palouse Country and the Saint Joseph and Doumaeq plains.

In the south-central part is a small basin containing a number of rivers, which, after flowing for distances varying from forty to eighty miles, disappear in the earth. This region is very appropriately named the Lost River Plains. Near the town of Hagerman, in Gooding County, there is a cluster of springs known as the Thousand Springs, which discharge a large volume of water into the Snake River. Some geologists advance the theory that in these springs the lost rivers find their outlet. In the northern part of the state are a number of depressions containing lakes. The most important of these are Lake Pend Oreille, Lake Coeur d'Alene and Priest Lake.

A part of the southeastern counties is drained by Bear River into Great Salt Lake. With this exception the entire state is drained into the Columbia River through the Snake, the Clark and their tributaries. The Snake pursues an irregular course across the southern part of the state, thence turns northward and forms about one-half of the boundary between Idaho and Oregon. The Salmon River waters the central part of the state, and flows in an irregular course northwest and thence north again, until it joins the Snake on the western boundary. The Clark drains Lake Pend Oreille and the northern part of the state. The Clearwater and a number of smaller streams are found between the Clark and the Salmon. Many of the rivers flow through deep canyons which are remarkable for the beauty and grandeur of their scenery. On the Snake River occur the great Shoshone Falls, which exceed those of Niagara in height and rival them in grandeur. Other falls in this river worthy of note are the American and the Twin. The Salmon Falls of the Salmon River should also be mentioned. All streams have their sources in the mountains and are fed from deep springs and melting snows. They supply an abundance of pure water suitable for domestic purposes and for irrigation.

**Climate.** The difference in altitude gives the state a diversity of climate, so far as temperature is concerned. In the valleys and on the plains the mean temperature is higher than on the uplands of the same regions. In the southern part during July and August the temperature may rise to 100°, but in the lowlands the winters are mild, and

mountain regions. For the latitude, the climate here is mild. Throughout the state the climate is temperate, free from extremes and remarkably healthful.

**Mineral Resources.** The mineral resources of Idaho are varied and extensive, and mining is one of the leading industries. In 1860 gold was discovered on Orfino Creek,



Administration Building,  
State University,  
Moscow

Syringa,  
State Flower

Arrowrock Dam,  
Highest in the World

the temperature seldom falls below the freezing point. Here but little snow falls. In the mountains the winters are more severe, and the snowfall is heavy, but the mountain valleys are sufficiently sheltered to allow stock to roam at large during the winter, and in many sections without feeding. In the southern part there is not sufficient rainfall for the production of crops without irrigation or for the practice of what is known as dry farming. In the northern part, however, there is an abundance of rainfall, caused by the contact of the western winds with the

in what is now the north central part of the state. It has been mined continually since, but in recent years the output has diminished. Silver has slightly increased in output; this statement is also true as regards lead and copper, although there are years when a decrease is noted. The production of all mined products was slightly in excess of \$54,000,000 during the year 1918. Zinc mining is becoming more and more profitable, and about 80,000,000 pounds a year are obtained.

**Irrigation.** In 1918 about 2,750,000 acres of Idaho land had been brought to

fruitfulness by irrigation. Only three states have larger irrigated areas. World famous is the Arrowrock Dam, the highest masonry dam in the world—349 feet. The length of its crest is 1,060 feet, and it has a reservoir capacity sufficient to cover with water 245,000 acres to the depth of one foot. The Salmon River project irrigates about 260,000 acres; this dam is 220 feet high. Two Twin Falls projects irrigate 400,000 acres. There are several lesser systems, each important in making Idaho a great irrigated section. See IRRIGATION.

**Agriculture.** Since 1900 the agricultural development has bordered upon the marvelous. In the northern part of the state there is sufficient rainfall for growing all crops adapted to the climatic conditions of that region. In the southern part two systems are followed: intensive farming upon irrigated land, and extensive farming, in which dry farming is practiced. The farmer receives ample returns for his labor from each system. Throughout the state, the soil, except on the mountains, is remarkably fertile, and nearly all crops can be successfully grown. The mild, equable climate and large number of sunny days make this an ideal region for raising fruit, and apples, pears, prunes, apricots, peaches and smaller fruits are grown in large quantities in the valleys and on the plains. Hay is the most profitable crop, worth \$34,000,000 a year; wheat is second; oats third; potatoes, fourth.

The raising of live stock, especially sheep, cattle and swine, is an important branch of agriculture, and dairying and poultry raising are also profitable. The state contains extensive pasture lands, and stock seldom requires shelter during the winter, conditions which give the stock grower a large profit on his investment.

**Manufactures.** As in other relatively new states, the manufactures are less important than mining and agriculture, but they have kept pace with the growth of the state. There are over 20,000,000 acres of white pine and other valuable timber trees, and the central counties are considered to have the largest virgin white pine forests in the world. Much of this timber is yet beyond reach; nevertheless, there are sufficient forest areas along streams and near railroads to make lumbering the leading manufacturing industry of the state. The manufacture of flour and other grist-mill products is also important.

### Items of Interest on Idaho

The elevation above sea level varies from 738 feet, at Lewiston, in Nez Perces county, to 12,078 feet, Hyndman Peak on the boundary between Custer and Blaine counties; the average elevation is 4,500 feet.

The most prominent features of the Columbia Plateau section are the dry Snake River plains with the three elevations, Big, Middle and East Butte, rising from their midst; the plains, which cover about 30,000 square miles, extend from the southeastern part of the state in a curved course to the northwest for nearly 350 miles.

The Snake River, which receives almost all the drainage of Idaho, rises in Yellowstone National Park only a few miles from the sources of the Missouri, whose waters reach the Gulf of Mexico, and of the Colorado, which flows into the Gulf of California; practically its whole course from Idaho Falls, in southeastern Idaho, to its mouth is through canyons from a few hundred to six thousand feet in depth.

In the mountains are many small glacial lakes, of which the largest are Coeur d' Alene, Priest, Pend Oreille and Bear lakes.

"Coeur d' Alene," signifying "heart of an awl," was the name of a tribe of Indians; it is said to have been first applied to one of the chiefs because of his stinginess.

The Snake River basin has a milder climate than the rest of the state.

Ninety per cent of the farms are cultivated by the owners.

The waters of the state, contrary to common law practice, belong to the state.

### Questions.

What is the area of Idaho?

What is the average elevation above sea level?

In a general way describe the surface and locate the principal mountain ranges.

What does "Coeur d' Alene" mean?

What is the area of the irrigated lands?

**Transportation.** The streams are so rapid that they cannot be navigated; besides, many of them contain falls at frequent intervals. The southern part of the state is crossed by the Oregon Short Line, the northern part by the Northern Pacific; the Milwaukee, Saint Paul and Puget Sound crosses into Washington. There are a few spurs extending from these trunk lines to various localities. The Spokane International Railway has 162 miles of line in Idaho.

**Government.** The legislative department consists of a senate and a house of representatives. Members of each are chosen at a general election for two years, and the legislature meets biennially. The executive department consists of a governor, a lieutenant-governor, a secretary of state, a state auditor, a state treasurer, an attorney-general and a superintendent of public instruction, each elected for two years. The judicial department consists of a state supreme court, district courts, probate courts and justice courts. The supreme court has three judges, who are elected by the people for a term of six years. The state is divided into six judicial districts for the administration of justice through the district courts, and each of these is presided over by a district judge. Boise is the capital.

**Education.** The public schools are under charge of a superintendent of public instruction, and the schools of each county are under the immediate charge of a county superintendent. Each of these officials is elected by popular vote. The support of the schools is derived from the income from a state fund; from the school fund, obtained from the sale of the sixteenth and thirty-sixth sections of land in each township, and from local taxation. The state university at Moscow is at the head of the school system. There are state normal schools at Lewiston and Albion. The Idaho Industrial Institute is at Weiser. There are also a number of colleges and secondary schools, supported by various religious denominations.

**Institutions.** The state penal institutions consist of a penitentiary, located at Boise, and an industrial and reform school, at Saint Anthony, which is designed for juvenile offenders of both sexes. The charitable institutions comprise hospitals for the insane at Blackfoot and Orofino; a school for the deaf and dumb at Gooding, and a state sanitarium at Nampa.

**History.** The first white men to visit Idaho were Lewis and Clark, who made explorations there in 1805-1806. Not until 1860, when gold was discovered, did actual settlers come. In 1862 a territory was organized which included Idaho and most of Wyoming and Montana. In 1870 agricultural development began, and from that time the section has steadily increased in wealth and population. For a few years the settlers suffered more or less annoyance from the Indians, but the latter were finally induced to part with most of their land and retire upon reservations. By 1875 Idaho was reduced almost to its present boundaries. It was admitted into the Union July 3, 1890, with its present territorial limits, and in 1896 it granted suffrage to women. Idaho has been troubled with lawless outbreaks connected with the labor situation in the mines. In 1917 a law was passed declaring criminal syndicalism or terrorism of labor to be a felony. A workman's compensation law is in effect.

**Related Articles.** Consult the following titles for additional information:

|                 |             |
|-----------------|-------------|
| Boise           | Lewiston    |
| Dry Farming     | Pocatello   |
| Lewis and Clark | Snake River |
| Expedition      |             |

**IDAHO, UNIVERSITY OF,** a state university, opened in Moscow in 1892. Tuition is free to all except non-residents of Idaho. The government is in the hands of a board of regents. The university maintains colleges of agriculture, law, commerce and engineering, and a college of letters and science, which includes departments of home economics, music and forestry. In normal years there is a student enrollment of about 860 and a faculty of about ninety. The library contains 39,000 volumes.

**IDEALISM,** *i dee'aliz'm*, in philosophy, a theory, that sensible or material objects do not exist outside of consciousness. Idealism makes the spiritual part of man the original and only true existence. See REALISM.

**IDES,** *idze*, in the Roman calendar, the fifteenth day of March, May, July and October and the thirteenth day of other months. Julius Caesar was assassinated on the Ides of March. In Shakespeare's play he is warned by a soothsayer to "beware the Ides of March."

**ID'IOM,** the name given to certain words or phrases which though in common usage in a language, do not admit of grammatical

analysis. The forms by which various nationalities express salutation are good examples of idiom. Americans say, "How do you do?" In France people greet each other with the equivalent of "How do you carry yourself?" The German equivalent is, "How goes it?" The term *idiom* is also applied to a dialect peculiar to a language.

**IDIOT**, a person who, from original defect, is almost destitute of intelligence, or in whom the intellect seems to be almost wholly wanting. The majority of idiots are of small stature and of weak constitution.

**IDOL**. The belief in the existence of a supreme being is very old, and speculation among primitive peoples in all lands has led to various conceptions of the form and nature of the deity. As men learned to carve in wood and stone they made images of the gods as they imagined them to be. In most cases an effort was made to represent the god as having human form; occasionally the supreme one was believed to possess likeness to some animal, and in many cases to partake of the form of both man and beast.

**IDOLATRY**. The carved images seemed very wonderful to these childlike people; and since they could not see the gods, the image or symbol came to be regarded as a personification of the Almighty and as such was worshiped. Superman powers were accredited to the images, and they were appealed to as guides in all the affairs of life. The Biblical prophets warned men against idol-worship, and Mohammed, in the Koran, forbade the making of any image in wood, stone or metal. Among some of the tribes of Africa a form of idolatry known as *fetish* is common (see **FETISH**). The superstition there often leads to the worship of objects of nature which are believed to possess influence over man. With the spread of Christianity and enlightenment idolatry is gradually disappearing.

**IDUN**, *e'doon*, in Scandinavian mythology, the wife of Bragi and the keeper of the apples of which the gods ate to preserve their youth and beauty.

**IDYL** or **IDYLL**, the name usually applied to a short and highly-finished descriptive poem, especially one which treats of pastoral subjects. This last characteristic, however, is not an essential of the idyl. All that is necessary to constitute a poem of this class is that it present to view a complete picture in small compass. Tennyson, however, used

the term to describe his elaborate poems treating of the King Arthur legend. They could properly have been called *Epics of the King*.

**IGNATIUS**, *ig na'she us*, **SAINT**, bishop of Antioch, one of the early Christian martyrs. Ignatius is supposed to have been born in Syria about the middle of the first century and to have been a disciple of the Apostle John. Seven Greek epistles bearing his name are included among the works of the apostolic fathers. These give evidence of intense religious enthusiasm. About A. D. 107, at the command of Emperor Trajan, Ignatius was thrown to lions in the arena at Rome (see **MARTYRS**).

**IGNATIUS OF LOYOLA**. See **LOYOLA**, **IGNATIUS OF**.

**IGNEOUS**, *ig'ne us*, **ROCKS**, in geology, those rocks which were formed by the action of heat. They include quartz, lava, basalt, granite and numerous others. Usually they are found to have been erupted from the heated interior of the earth and forced up to, or near, the surface. The word *igneous* means *fire*, or *burning*.

**IGNIS FATUUS**, *ig'nis fat'u us*, a term applied to a peculiar luminous appearance occasionally seen over marshy places at night. There are stories of its having been seen in churchyards, but these are generally regarded as superstitious tales. Will-o'-the-wisp and Jack-o'-lantern are other names given to this phenomenon. *Ignis fatuus* is the Latin for *foolish fire*. No satisfactory explanation for it has been given, but some believe that it is due to spontaneous combustion of gases.

**IGORROTE**, *e gor ro'tay*, a tribe or race inhabiting several islands of the Philippines. When American occupation of the islands occurred, the Igorrotes were savage head-hunters—that is, they sought battle with their enemies that they might carry human heads home as trophies. They are now civilized, and many of the young men are in the Philippine government service as members of the policing groups.

**IGUANA**, *ig wah'nah*, a genus of lizards, natives of South America, Central America, Mexico and the southwestern part of the United States. The animal has an average length of about four feet and is olive-green in color. Along the entire length of its back, to the tip of its tail, there is a crest of pointed scales. It is a timid, defenseless creature, and lives much in trees, usually near

streams. It climbs easily by reason of its sharp claws. If pursued, it at once attempts to reach water, in which it swims swiftly and can remain submerged for several minutes. It lives on fruit and fungi, and de-

king of Mycenae and brother of Menelaus, set sail to besiege Troy. Ten years they besieged the walled city without result, for the Trojans would not venture forth to combat, on account of their dread of the famous hero Achilles.

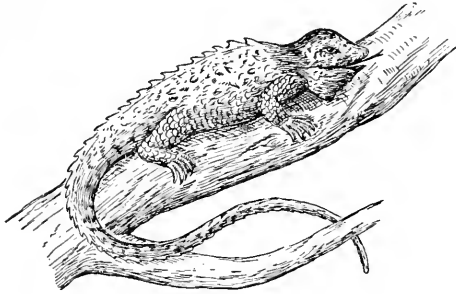

IGUANA

posits its eggs in tree-hollows. The flesh of the iguana is considered a table delicacy by South American Indians. One species, the *alligator lizard*, is found in the United States as far north as Tennessee. Certain species are valuable to farmers as destroyers of insects and harmful worms.

**IGUASSU**, *e gua soo'*, **FALLS**, a magnificent cataract eleven miles from the mouth of the Iguassú River, in Brazil. The falls are formed by a double drop, each of which is about 180 feet high. Few travelers have looked upon the cataract; because it is in the midst of a dense forest difficult to penetrate, but those who have journeyed to that point declare that the great waterfall is even more splendid than the falls of the Niagara.

**IK MARVEL**, *ike mah'r vel*. See MITCHELL, DONALD GRANT.

**IL'IAD**, the greatest epic of antiquity, attributed to the Greek poet Homer. There has been much controversy among scholars as to whether the *Iliad* originated with Homer or was merely folk-tale put into written form by him. It is even questioned by some investigators whether there ever lived such a person as Homer. The subject has occupied the world's greatest scholars and continues to be of absorbing interest.

The twenty-four books of the *Iliad* describe incidents of the Trojan War. To understand the description it is necessary to know the events which led up to the incidents related. Helen, the wife of Menelaus, king of Sparta, and the most beautiful woman of Greece, was stolen and carried off to Troy. To recover her and avenge the wrong, the Greeks, under command of Agamemnon,

Then a quarrel started because Agamemnon had taken from Achilles one of his slaves. Achilles left the conflict and withdrew to his tent by the seashore. This is the point at which the *Iliad* begins, and much of the poem is devoted to the wrath of Achilles, its causes, effects and the manner in which it was appeased. The Trojans, secure in the absence of Achilles, came forth to meet the Greeks, and fifteen of the twenty-four books tell the varying fortunes of the conflict. Finally, Patroclus, the friend and kinsman of Achilles, begs Achilles to lend him his armor, and with it he goes into battle. The Trojans believe they see Achilles and flee in terror, but at length Patroclus is afflicted with a stupor by the god Apollo and is slain by Hector. To avenge his friend, Achilles returns to the combat, with a new suit of armor given him by Vulcan. He slays Hector and drags his body behind his chariot. In the last book King Priam begs of Achilles his son's body, and during a truce Hector is buried with fitting rites. The struggle is participated in by the gods throughout the poem, Mars and Apollo aiding the Trojans, Juno, Minerva and the other deities sustaining the Greeks.

**Related Articles.** Consult the following titles for additional information:

|          |                      |
|----------|----------------------|
| Achilles | Menelaus             |
| Hector   | Mythology. The Story |
| Helen    | of the Trojan War    |
| Homer    | Troy                 |

**IL'ION.** See TROY.

**IL'IUM.** See TROY.

**ILLIMANI**, *cel ye mah'ne*, one of the loftiest volcanoes in the Bolivian Andes, whose highest peak, of which there are four, is nearly 21,000 feet in altitude. On the mountain there is a lake about 15,000 feet above sea level.

**IL'LINGTON**, MARGARET (1881- ), an American actress who excels in the portrayal of emotional rôles. She was born at Bloomington, Ill., and her name in private life, before marriage, was MAUDE LIGHT. When she came to choose a stage name she used the first syllable of the name of her state, and the last two syllables of the name of her city, becoming in public life, Miss Illington.

She married Daniel Frohman in 1903, and in 1909, after her divorce from him, became the wife of Edward J. Bowes, of Seattle, Wash.

Miss Illington first appeared on the professional stage in the company of James K. Hackett, in the *Pride of Jennico*. She subsequently became a leading woman to E. H. Sothern in *If I were King*, in 1907 was co-star with Kyrle Bellew in *The Thief*, and from that time rose steadily to the position of independent star. Her starring ventures include *The Lion and the Mouse*, *His House in Order*, *Kindling*, *Within the Law*, *The Lie*, *Our Little Wife* and *The Eyes of Youth*. In 1917-1918 she was co-star with John Drew in Pinero's *The Gay Lord Quex*. Miss Illington has also appeared in moving pictures. She possesses beauty and charm, and is an effective emotional actress.

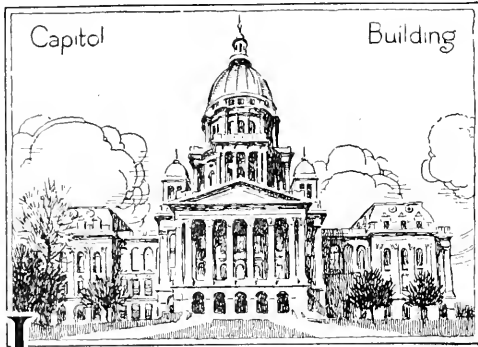

**I**LLINOIS, *ilinoi'*, or *ilinoiz'*, the twenty-third state of the American Union in size and the third in population, exceeded in number of people by New York and Pennsylvania only. The area of Illinois is 56,665 square miles; in 1910 there were in the state 5,638,591 people, an average of 100.6 people to the square mile. Of this number, about two-fifths lived in one great city, Chicago. A Federal estimate credited the state with 6,317,734 people on July 1, 1918.

Illinois is appropriately called THE PRAIRIE STATE, a name which emphasizes the character of its surface. It was entirely fitting that the soldiers of Illinois in the World War should call that division of the American army which was composed almost entirely of Illinois men the "Prairie Division." The Mississippi River forms the entire western boundary of the state; Wisconsin is on the north; Lake Michigan, Indiana and Kentucky are on the east; Kentucky, Missouri

and Iowa touch the west bank of the great river.

Though the southern part of the state is now less-thickly peopled than the central and northern portions, it was the southern section that was first settled. When Illinois became a state in 1818, its admission to the Union was granted because of the ambitious settlements in the south. There were few people north of Springfield; the foundations of Chicago were yet to be laid. The early settlers came into Illinois largely from Kentucky and Tennessee, among these was the family of Abraham Lincoln, and this migration gave the future Great Emancipator to Illinois. Not until after the completion of the Erie Canal in 1825 did the western trend of settlement appreciably affect the northern part of the state.

**Surface and Drainage.** The state lies within the Great Central Plain, and with the exception of Louisiana and Delaware is the most level state in the Union. It has an average elevation of 500 feet above the sea. The surface as a whole is a broad plain, sloping gradually to the south and southwest. In the northern part the surface is undulating, with occasional bluffs along the streams. In Jo Daviess County, in the extreme northwestern part, these rise to an altitude of more than 800 feet. In the northeastern corner is a small strip sloping towards Lake Michigan, which belongs to the Saint Lawrence basin. With this exception, the state lies wholly within the Mississippi basin. The central part is level, with the exception of bluffs along the streams. This region is characterized by a deep fertile soil and excellent farms. It is one of the most productive farming regions in the world.

The bluffs along the Mississippi, the Rock and the Illinois rivers form picturesque scenery in many localities. Black Hawk's Watch Tower, near Rock Island, and Starved Rock, on the Illinois near Utica, are of special interest because of their historical associations as well as for their beauty. In the southern counties, among the Ozarks, there are numerous picturesque valleys and charming ravines; a spur of the Ozark Mountains crosses the southern portion of the state from east to west and contains numerous hills having an altitude of from 1,200 to 1,400 feet above sea level. These hills, or mountains, as they are locally termed, rise abruptly in their northern slope, but descend to the level of the



Ohio River more gradually. In consequence of this feature the seven southern counties are more diversified in surface than any other portion of the state.

The important rivers are the Rock, crossing the northwestern portion; the Fox, draining into the Illinois, and the Desplaines and Kankakee, which unite to form the Illinois, the largest stream within the state. From its formation this river flows westerly and southwesterly until it enters the Mississippi, about twenty miles above the confluence of that stream and the Missouri. The Illinois flows in a deep channel, and it is bordered by fairly-high bluffs. It is navigable for small vessels as far as Utica. The principal streams in the central and southern parts of the state are the Sangamon, an important tributary of the Illinois; the Kaskaskia, which flows nearly across the state in a south-southwest direction and joins the Illinois, and the Big Muddy, joining the Mississippi. On the east are the Embarras, the Little Wabash and the Saline, flowing into the Wabash. The streams flowing into the Ohio are unimportant.

In the northeastern corner are Fox and Grass lakes and a few other smaller bodies of water. There are also numerous shallow lakes in the bottom lands along the Illinois, Mississippi and Ohio rivers, but they are small and of little importance. Peoria Lake is formed by the expansion of the Illinois River.

**Climate.** The extent of the state from north to south causes considerable difference in the climate of the extreme sections. That of the southern counties averages 11 degrees warmer than that of the northern counties. The entire state is subject to sudden and excessive changes in temperature, but extremes of heat and cold are of short duration. The climate is in most localities healthful. The average annual rainfall is thirty-eight inches. It is heavier in the south than in the north, but the better character of the soil in the north more than compensates for the deficiency.

**Mineral Resources.** The mineral resources of Illinois are of great value and place it among the most important of the mining states. The most valuable mineral is coal. A line drawn from Rock Island through the northern boundary of Grundy County practically separates the coal-bearing from the non-coal-bearing area. Nearly all the

state to the south of this line is underlaid with coal, and the area of the Illinois coal measures is about 42,000 square miles. There are coal mines in fifty counties. From three to five veins are found in all the measures, and these vary in thickness from a few inches to nine feet. The veins lie from 300 to 1,200 feet below the surface. The annual output is nearly 60,000,000 tons; thus Illinois is behind only Pennsylvania and West Virginia as a coal producing state.

There is quite an extensive deposit of petroleum in the southeastern part of the state. In 1906 the region was producing about 37,000 barrels of crude oil daily, and the annual output has increased to 19,000,000 barrels. Only Oklahoma, California and Texas exceed the Illinois production. Galena, a lead ore, is mined in the extreme northwestern section of the state. Tile and brick clay of excellent quality occur in many localities, and building stone is found in Will, Kane, Cook, Kankakee, Henderson, Hancock, Adams and Union counties.

**Agriculture.** Illinois is one of the foremost states in the extent and value of its agricultural products. The wide climatic range admits of a great variety of crops. Corn is the leading crop; the annual planting exceeds 10,000,000 acres, and the annual production is between 375,000,000 and 400,000,000 bushels, making this the leading state in the Union in the growing of this important crop. Large quantities of oats are raised, and this is the second crop in importance, with over 150,300,000 bushels a year. Hay and forage is next in value, then follow wheat, potatoes, barley and rye, though the last two are not as extensively grown as the other cereals. Nearly all sections are adapted to fruit, and in the northern and central portions apples, cherries and pears are raised, while south of the center peaches, plums, strawberries, apples, and small fruits are grown in large quantities. Illinois is the second state in production of broomcorn, first in gooseberries, first in the acreage of sunflowers for seed, and second in bushels of grass seed marketed.

The raising of corn and the ease with which hay can be procured, together with the presence of extensive tracts suitable for grazing, make Illinois an ideal state for the raising of live stock, and large numbers of cattle and hogs are fattened for the market each year. In addition to this, horses are raised through-

out the state, and an extensive dairy business is conducted in the northern half.

**Manufactures.** Notwithstanding its adaptability to agriculture, Illinois is the third state in the Union in the extent and importance of its manufactures, being exceeded only by New York and Pennsylvania. The reasons for this position of Illinois as a manufacturing state are the abundance of cheap fuel furnished by coal deposits and the unusual facilities for transportation afforded by Lake Michigan and over thirty railway lines centering in Chicago. About sixty-five per cent of the manufactures of the state are produced in and about Chicago. The most important of all these industries is slaughtering and meat packing (see MEAT PACKING).

Next in order are the manufacture of agricultural implements, iron and steel products, clothing, flour and grist mill products and printing and publishing. The great iron and steel mills are located principally at South Chicago and Joliet. The ore manufactured into iron at these mills is brought from the Minnesota and Michigan mines by boat as far as Chicago, and the Joliet mills obtain their portion thence by rail. Besides these cities the important manufacturing centers are Peoria, which before prohibition enactment had boasted the largest distilleries in the United States; Aurora; Elgin, noted especially for its manufacture of watches; Moline, containing extensive factories for the manufacture of automobiles and agricultural implements; Jacksonsville, Rockford, (noted for its furniture), Dixon, Bloomington and East Saint Louis.

**Transportation.** Illinois contains over 12,200 miles of railway, a larger mileage than any other state except Texas. Chicago is the terminus of trunk lines whose mileage exceeds 60,000. Among the important lines crossing the state are the Illinois Central; the Chicago & Alton; the Chicago, Milwaukee & Saint Paul; the Chicago & North Western; the Chicago, Burlington & Quincy; the Atchison, Topeka & Santa Fé; the Chicago, Rock Island & Pacific, and the Chicago & Eastern Illinois. A number of important trunk lines from the East also terminate in Chicago. There are more than 3,750 miles of interurban electric lines, one connecting Chicago with Aurora and Elgin, another extending from Evanston to Milwaukee, Wisconsin, and a system joining Peoria, Bloom-

ington, Springfield, East Saint Louis, Decatur, Champaign and Danville.

The Mississippi and Ohio are navigable along both borders of the state, and light-draft steamers can ascend the Illinois to Utica. The Illinois-Mississippi, or Hennepin, Canal connects the Illinois River at Hennepin with the Mississippi at Rock Island. Lines of steamers ply between Chicago and the ports on the Great Lakes and Saint Lawrence as far as Montreal. The Chicago Drainage Canal, connecting Lake Michigan with the Illinois River, will eventually be a link in a Lakes-to-Gulf waterway, a project which has long been agitated.

**Government.** The legislative department consists of a senate and a house of representatives. The state is divided into fifty-one senatorial districts, each of which is entitled to one senator and three representatives. The senators are chosen at popular elections for a term of four years, but the districts are so classified that the terms of one-half of the senators expire every two years. The 153 members of the house of representatives are chosen for two years, and the statute contains a peculiar provision by which the voter may cast three votes for one representative, one vote for each of three representatives or one and one-half votes for each of two representatives.

The executive department consists of a governor, a lieutenant-governor, a treasurer, a secretary of state, an auditor, an attorney-general and a superintendent of public instruction, each of whom is elected for four years, with the exception of the treasurer, whose term is two years and who is not eligible for immediate reelection. The governor is assisted by a cabinet of nine directors, each at the head of a department of the state government. The superintendent of public instruction is elected in the middle of the term for which the governor and other state officers are chosen. At the head of the judicial system is the state supreme court, comprising the judges of the seven judicial districts into which the state is divided, the judges being elected for nine years. The judges of these districts choose one of their number as chief justice. Below the supreme court are appellate courts, circuit courts and county courts; the larger counties have probate courts. At the bottom of the judicial system are the justice courts, which have jurisdiction over petty cases. The local govern-

PACKING HOUSE PRODUCTS



**ILLINOIS**  
 "By thy rivers gently flowing,  
 Illinois, Illinois,  
 O'er thy prairies verdant growing,  
 Illinois, Illinois,  
 Comes an echo on the breeze,  
 Rustling through the leafy trees,  
 And its mellow tones are these,  
 Illinois, Illinois."

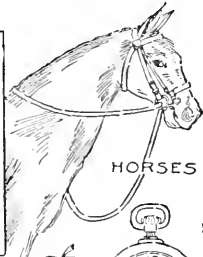

HORSES



ELECTRICAL GOODS



APPLES  
PEARS



WATCHES

MANUFACTURED ARTICLES

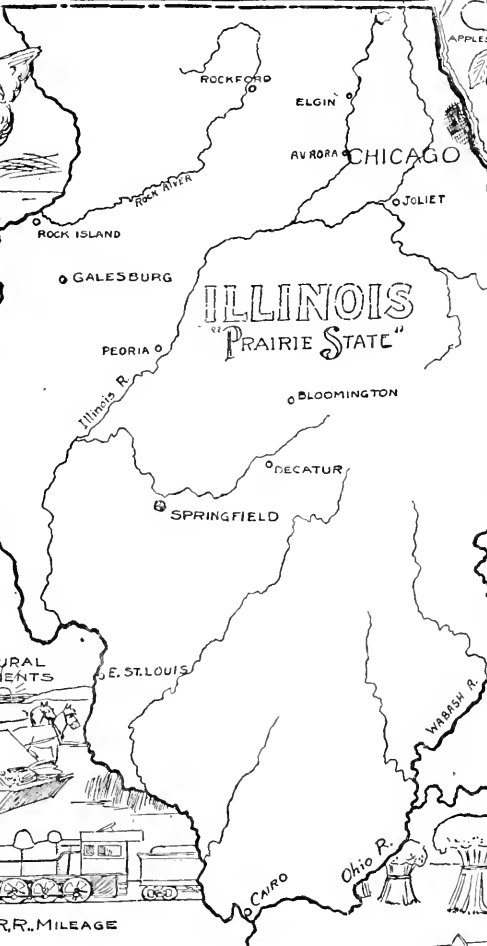
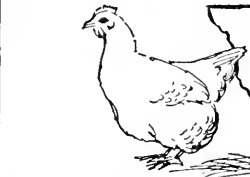

**ILLINOIS**  
 "PRAIRIE STATE"



COAL



CHERRIES



STRAW-BERRIES



CORN

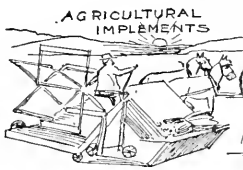

AGRICULTURAL IMPLEMENTS

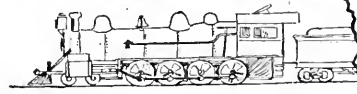

GREAT IN R.R. MILEAGE



BARLEY



WHEAT & OATS.

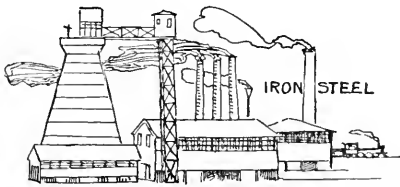

IRON STEEL

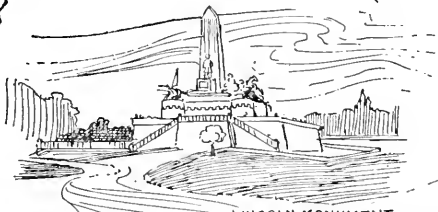

LINCOLN MONUMENT

ment is administered through county and township officers.

**Education.** The state maintains an excellent system of public schools on the district plan, with provision for township high schools in all communities choosing to have such institutions. The University of Illinois is at the head of the school system, though it is not officially affiliated with the high schools. The school fund is about \$18,000,000, and the support for schools is derived from interest on this, from fines and forfeitures, from an annual assessment of \$1,000,000 upon the taxable property of the state and by local taxation. The annual expenditure for education is over \$40,000,000, and the number of pupils enrolled is about 1,000,000. State normal schools are maintained at Normal, Carbondale, DeKalb, Charleston and Macomb; there is a city normal school in Chicago. The important universities, not connected with the public school system, are the University of Chicago, and Northwestern University at Evanston and Chicago. Besides these there are numerous smaller colleges and secondary schools, supported by various denominations and widely distributed over the state. Some of the most important of these are the Armour Institute at Chicago, Lake Forest University at Lake Forest, McKendree College at Lebanon, Illinois College at Jacksonville, Wesleyan University at Bloomington, Knox College at Galesburg, Augustana College at Rock Island, James Milliken University at Decatur and Monticello Seminary (for young ladies) at Godfrey.

**Institutions.** Schools for the deaf, dumb and blind are maintained at Jacksonville; the institute for feeble-minded is at Lincoln; the state penitentiaries are at Joliet and Chester; the state reformatory is at Pontiac, and the hospitals for the insane are at Jacksonville, Alton, Bartonville, Anna, Kankakee, Elgin and Watertown. There is a soldiers' and sailors' home at Quincy and a soldiers' orphans' home at Bloomington; there is also a United States soldiers' home at Danville.

**Cities.** There were in 1918 forty-three cities in the state each having more than 8,000 population. The first five, in order of size, are Chicago, East Saint Louis, Peoria, Springfield and Rockford.

**History.** Marquette and Joliet were the first white men to visit Illinois, crossing it by way of the Illinois River in 1673. In 1680

La Salle built Fort Crevecoeur (*the broken heart*) near Peoria, and in 1682 Fort Saint Louis was erected on Starved Rock. Settlements sprang up at various points, the first being at Kaskaskia, about 1700. In 1763 the territory came into possession of the English, at the conclusion of the French and Indian Wars. During the American Revolution, Col. George Rogers Clark captured the British posts on the Mississippi and at Vincennes, Ind. By the treaty of 1783 Illinois was ceded to the United States, and in 1787 it became a part of the Northwest Territory (which see).

It was organized as a separate territory in 1809, with the capital at Kaskaskia; a famous massacre occurred at Fort Dearborn in 1812, and Illinois was admitted into the Union December 3, 1818. In 1832 Indian troubles culminated in the Black Hawk War, which resulted in the final removal of the redmen from the state. The Illinois and Michigan Canal was projected in 1837, and was completed in 1848. Troubles arose with the Mormons, who had settled at Nauvoo in 1840, and in 1846 they removed to Utah. In 1850 Congress granted lands for the construction of the Illinois Central Railroad, which contributed much to the prosperity of the state. The state contributed six regiments of troops to the Mexican War, and nearly 250,000 men to the Union army during the Civil War. Great debates between Douglas and Lincoln, rival candidates for the Senate, occurred in 1858; in these Douglas lost his opportunity to become President of the United States. The chief events of the later period are the Chicago fire (1871), the anarchist riot (1886), the World's Columbian Exposition at Chicago (1893) and the riots consequent upon the railroad strike in 1894.

Illinois has had three constitutions; the first was adopted in 1818, the second in 1848 and the third in 1870; there have been repeated efforts within recent years to secure a convention to form a new constitution; these were finally successful in 1919. There have been likewise three capitals—Kaskaskia, Vandalia and Springfield. In 1913 Illinois granted to women the right to vote for all offices not created by the state constitution. This includes Presidential electors, all municipal offices except justices of the peace, and some state and county offices. The granting of full suffrage would necessitate a change in the constitution of the state.

## Items of Interest on Illinois

The area of Illinois is 56,665 square miles, and the state also has jurisdiction over 2,337 square miles of the water surface of Lake Michigan and the Mississippi River.

Illinois has more than 275 streams, grouped in two large river systems, one having the Mississippi and the other the Wabash or Ohio as outlet; the Mississippi receives about three-fourths of the drainage.

At Cairo the prevailing winds are from the south, and as far north as Springfield they are southerly except from January to April; but in the northern half of the state the prevailing winds are from the north, northeast or northwest.

The forest area, about 10,000 square miles, is almost wholly in the southern counties.

Twenty-five per cent of the wage earners are engaged in agriculture, twenty-six per cent in manufactures and mechanical trades and twenty-two per cent in transportation.

About nine-tenths of the total area of the state is inclosed in farms; the value of farm property, nearly four billion dollars, is greater than that of any other state.

In the total value of farm products Illinois is second only to Iowa, and in the value of crops alone it surpasses all other states.

Illinois ranks fourth in number of dairy cows and in the value of dairy products; in number of swine it is second to Iowa, and in number of horses it leads the Union.

The first pipe lines for petroleum were laid in April, 1906; before that date all shipments had been made in tank cars.

The capital invested in manufactures is over \$1,500,000,000 and the annual products are valued at nearly as much.

The state manufactures agricultural machinery to the value of \$60,000,000, more than one-third of the total output of the country.

It also leads in the building of railway cars, and stands second in railway construction and repairs.

There are over thirty direct and indirect products made from corn by glucose plants in the state; these plants consume one-fifth of the corn raised and produce from \$15,000,000 to \$20,000,000 worth of commodities.

The annual product of the clothing factories in the state is worth \$90,000,000.

For thirty years Illinois had a larger railway mileage than any other state, but the total is now second to that of Texas.

Through the Chicago Drainage Canal, the Illinois and Michigan Canal and the Illinois River, direct water traffic from Lake Michigan to the Mississippi has been made possible.

### Questions on Illinois

What is the area of Illinois? The population?

How does it rank among the states in population?

What is the average elevation above sea level?

In what way is the climate remarkable?

What per cent of the wage earners are engaged in agriculture? In manufacturing? In transportation?

What per cent of the farms are worked by owners?

What is the most important crop?

Name three other cereal crops.

How does the state rank in number of dairy cows? Of horses?

What is the value of the annual mineral product?

How many square miles does the coal area include? How does the value of the product compare with that of other states?

Name five other mineral products.

What is the leading manufacturing industry?

What part of the country's supply of dressed beef comes from Illinois?

How does the state rank as a producer of steel and iron?

What part of the agricultural machinery made in the United States comes from Illinois?

**Related Articles.** Consult the following titles for additional information:

## GEOGRAPHY

|                  |              |
|------------------|--------------|
| Alton            | Kankakee     |
| Aurora           | Kewanee      |
| Belleville       | La Salle     |
| Bloomington      | Lincoln      |
| Cairo            | Mattoon      |
| Canton           | Moline       |
| Centralia        | Monmouth     |
| Champaign        | Mount Vernon |
| Chicago          | Ottawa       |
| Danville         | Pekin        |
| Decatur          | Peoria       |
| De Kalb          | Quincy       |
| East Saint Louis | Rockford     |
| Elgin            | Rock Island  |
| Evanston         | Rock River   |
| Freeport         | Springfield  |
| Galesburg        | Streator     |
| Illinois River   | Urbana       |
| Jacksonville     | Waukegan     |
| Joliet           | Wabash River |

## HISTORY

|                        |                    |
|------------------------|--------------------|
| Black Hawk             | Illinois (Indians) |
| Chicago Drainage Canal | Joliet, Louis      |
| Clark, George Rogers   | Marquette, Jacques |
|                        | Mormons            |
|                        | Ordinance of 1787. |

**ILLINOIS**, a group of Indians belonging to the Algonquian family, who held at one time the territory now roughly included in Illinois, Missouri, Michigan and Iowa. La-Salle and his French followers won the friendship of the Illinois tribes, and in the French and Indian Wars they caused the English settlers much trouble. After the War of 1812 the United States had difficulty in subduing them. About 200 Illinois Indians are now living on a reservation in Oklahoma.

**ILLINOIS, UNIVERSITY OF**, a coeducational state university, occupying a campus of about 1,200 acres between Champaign and Urbana. It was founded in 1867 and was incorporated as the Illinois Industrial University. In 1885 the name was changed to the University of Illinois. It maintains departments in literature and arts, engineering, science, agriculture, law and commerce, music, education and library work. In Chicago are maintained colleges of medicine and dentistry and a school of pharmacy. A United States Agricultural Experiment Station is also connected with the university, and is located at Urbana. The library contains over 406,000 volumes, and in addition to this there are several department libraries at the disposal of the university for the purpose of reference. The annual income from all sources is \$3,600,000. The university has a student enrollment of over 6,800 and a faculty of over 850.

**ILLINOIS AND MICHIGAN CANAL**, a boat canal connecting Lake Michigan, at Chicago, with the Illinois River, at LaSalle, Ill. It is ninety six miles long, sixty feet wide at

the bottom and six feet deep, and it has seventeen locks, each one hundred ten feet long and ninety-eight feet wide. It was begun in 1836 and was completed in 1848. By means of this canal, boats can pass from Lake Michigan to the Gulf of Mexico. When first constructed the Illinois and Michigan Canal was an important waterway, but owing to the construction of railways, it is now little used. See CANAL.

**ILLINOIS RIVER**, a river in Illinois, formed by the union of the Kankakee and the Des Plaines, in the northeast part of the state. It flows southwest and falls into the Mississippi about 20 miles above the mouth of the Missouri. It is 500 miles long, the lower half of it being navigable. An expansion in the river forms Peoria Lake. Ottawa and Peoria are on its banks. The great Chicago Drainage Canal (see CHICAGO) connects the river with Chicago, and will in time form the connecting link for a deep waterway from Lake Michigan to the Gulf of Mexico.

**ILLITERACY**, *il lit'ur-a-si*, as generally understood, the state of being unable to read or write. Frequently, however, as in the United States census reports, the term is applied to those who can read but cannot write. The percentage of illiterates depends upon the educational facilities and regulations within a country, those countries having the smallest percentage which have the most stringent laws regarding compulsory education.

The following table shows the percentage of illiterates in European countries:

| COUNTRY          | PER CENT | AGE BASIS               | YEAR |
|------------------|----------|-------------------------|------|
| Austria.....     | 26.3     | Population over 10 yrs. | 1900 |
| Belgium.....     | 12.7     | Population over 10 yrs. | 1910 |
| Bulgaria.....    | 65.5     | Population over 10 yrs. | 1905 |
| Denmark.....     | 0.2      | Army Recruits           | 1907 |
| England.....     | 1.8      | Marriages               | 1910 |
| France.....      | 14.1     | Population over 10 yrs. | 1906 |
| Germany.....     | 0.02     | Army Recruits           | 1908 |
| Greece.....      | 57.2     | Population over 10 yrs. | 1907 |
| Hungary.....     | 63.3     | Population over 6 yrs.  | 1910 |
| Ireland.....     | 9.2      | Population over 9 yrs.  | 1911 |
| Italy.....       | 37.0     | Population over 10 yrs. | 1911 |
| Netherlands..... | 0.8      | Army Recruits           | 1912 |
| Portugal.....    | 68.9     | Population over 10 yrs. | 1911 |
| Rumania.....     | 61.2     | Population over 7 yrs.  | 1909 |
| Russia.....      | 70.0     | Population over 10 yrs. | 1897 |
| Spain.....       | 58.7     | Population over 10 yrs. | 1900 |
| Sweden.....      | 0.2      | Army Recruits           | 1911 |
| Switzerland..... | 0.3      | Army Recruits           | 1911 |
| United Kingdom.. | 1.0      | Army Recruits           | 1904 |

In Canada, of the population over six years of age, 8.48 per cent are unable to

read. The percentage of illiteracy is highest among the foreign-born, and lowest among the British-born.

**United States.** The illiteracy rate in the United States is affected by the backwardness of certain elements in the population, notably the negroes in the South and alien immigrants from unprogressive European countries. The rate for each state is shown in the following table, which is based on 1910 census reports:

| STATE         | PER CENT | STATE          | PER CENT |
|---------------|----------|----------------|----------|
| Alabama       | 22.9     | Nebraska       | 1.9      |
| Arizona       | 20.9     | Nevada         | 6.7      |
| Arkansas      | 12.6     | New Hampshire  | 4.6      |
| California    | 3.7      | New Jersey     | 5.6      |
| Colorado      | 3.7      | New Mexico     | 20.2     |
| Connecticut   | 6.0      | New York       | 5.5      |
| Delaware      | 8.1      | North Carolina | 18.5     |
| Florida       | 13.8     | North Dakota   | 3.1      |
| Georgia       | 20.7     | Ohio           | 3.2      |
| Idaho         | 2.2      | Oklahoma       | 5.6      |
| Illinois      | 3.7      | Oregon         | 1.9      |
| Indiana       | 3.1      | Pennsylvania   | 5.9      |
| Iowa          | 1.7      | Rhode Island   | 7.7      |
| Kansas        | 2.2      | South Carolina | 25.7     |
| Kentucky      | 12.1     | South Dakota   | 2.9      |
| Louisiana     | 29.0     | Tennessee      | 13.6     |
| Maine         | 4.1      | Texas          | 9.9      |
| Maryland      | 7.2      | Utah           | 2.5      |
| Massachusetts | 5.2      | Vermont        | 3.7      |
| Michigan      | 3.3      | Virginia       | 15.2     |
| Minnesota     | 3.0      | Washington     | 2.0      |
| Mississippi   | 22.4     | West Virginia  | 8.3      |
| Missouri      | 4.3      | Wisconsin      | 3.2      |
| Montana       | 4.8      | Wyoming        | 3.3      |

**ILOILO**, *e lo 'lo*, PHILIPPINE ISLANDS, the capital of a province of the same name, situated on the southeastern coast of the island of Panay. It is second only to Manila in importance as a commercial center, and has an excellent harbor. Its chief exports are sugar, tobacco, rice, coffee and dyewoods. The most important line of manufacture is the weaving of fabrics of various kinds. The chief buildings are a seminary, a church and the government building. Population, estimated, 48,000.

**IL TROVATORE**, or **THE GYPSY'S VENGEANCE**, an opera by Giuseppe Verdi, was first given a public performance in Rome in 1853. The time of the drama is the Middle Ages, the place, the Spanish province of Aragon. The plot, highly romantic, weaves together the destinies of two families, one a nobleman's, the other, an old gypsy's. The gypsy is superstitiously believed to be a witch, responsible for the illness of the nobleman's child, and is accordingly burned at the stake. The opera is con-

cerned with a series of events which result from the unjust deed and culminates tragically when the gypsy's daughter takes vengeance. Il Trovatore, because of its haunting melodies, is one of the most popular of all grand operas. The famous farewell to Leonora, sung by the hero, Manrico, on the eve of his execution, is perhaps as widely known as any other operatic song ever written.

**IMAGE WORSHIP**, the employment of painted or graven representations of persons or of the lower animals as objects of worship. If images are used solely as symbols of something higher in the thoughts of men, and not the symbol but the being which the symbol suggests, is worshipped, such practices do not constitute image worship. When the images themselves are the object of devotion there is true image worship. Civilizing influences have so decreased image worship that it remains a religion only among savage tribes.

**IMAGINATION**, *im aj i na'shun*, that form of mental activity by which mental pictures, differing from those actually experienced, are constructed. When the mind forms pictures of past experiences, memory is acting; when it reconstructs these pictures and creates images not previously existent, imagination is in force.

**Phases of the Imagination.** Psychologists have different methods of classifying the imaginative faculty. According to one school of thought there are three phases of the imagination, the modifying, the mechanical and the constructive. The *modifying phase* is common to all children and is used in reproducing images in modified form, as seen in the child's ideas of giants and fairies. Because this phase of the imagination is so active at this period of life, fairy tales are of especial interest to children. The modifying phase, in which objects are enlarged or made smaller, is later followed by the imitative phase, in which the child seeks to reproduce the various actions, tones of voice and other characteristics of those with whom he associates. During this period many of the habits of speech and action which last through life are formed.

**The Mechanical Phase.** In the exercise of this phase of the imagination, parts of objects are joined in such a way as to show no proper relation between them, as in the joining of the head and shoulders of a man to the body of a horse, or the bust of a woman to the

tail of a fish. The literature of mythology abounds in illustrations of this sort.

*The Constructive Phase.* This is the most important phase of the imagination, and its activity gives rise to a great variety of products which influence our lives. It consists in fitting together the elements which it contains, as in the construction of a machine, which must first be produced in the imagination of the inventor. All the parts are carefully molded and fitted, so that when put together they form a structure which works to a given end. One of the most common uses of this phase of the imagination is in the construction of images from the verbal descriptions of others, as the construction of images of countries and cities which one has never seen, either from listening to a verbal description or from reading. However, in order that correct images may be constructed in this way, it is necessary that the person have in mind the ideas embodied in the description.

Another important use of this phase of the imagination is in the invention and construction of tools, machines and the numerous articles in daily use. It is also employed by every artisan in connection with his work. Every stroke of the blacksmith's hammer, the carpenter's plane or the seamstress's needle is guided by the imagination. It is due to this power of the mind that such wonderful structures as the Brooklyn Bridge, the Eiffel Tower and the Panama Canal were produced. It is also this phase of the imagination which leads to the construction of the great works of art and literature. In these fields its products are more nearly perfect than in others, because it is not subject to so many limitations of material. The constructive imagination causes us to establish ideals, and because of this it is an important factor in the building of character. It also has much to do with one's happiness. One is usually cheerful or melancholy, according to the imaginary pictures of the future which he constructs. Worry consists in employing the imagination in picturing magnified evil results of a certain line of conduct or a definite act. In this case the image is much stronger than the reality.

**Cultivation of the Imagination.** Imagination is one of the most important powers of the mind, but in order that the greatest benefit may be derived from it, careful training is necessary. Those in charge of children

can greatly assist in the training of this power by observing the following principles, which should be studied with care and always kept in mind:

(1) The imagination is a practical power and is associated with every act of perception. Without its use a child cannot gain correct ideas of objects. When looking at a ball or a cube, one imagines the shape of the portion of the object which he cannot see.

(2) The imagination has abundant material from which to construct its images. It is impossible to put into the images ideas that are not already in the mind. One cannot imagine an iceberg or a gorilla if he has no idea of these objects.

(3) Fairy tales, myths and fables are particularly suited to young children, because they harmonize so perfectly with the phase of the imagination that is most active during that period of life.

(4) The imitative stage of imagination is strong during the first years of a child's school life and can often be used in such a way as to make the work of the school pleasant and profitable.

(5) The plays of children are actuated by the imagination, and when of the right sort they serve an important purpose in giving strength and culture to this power.

(6) Reading, language, geography and history afford excellent opportunity for giving culture to the constructive phase of the imagination, but in order that the desired results may be obtained, both teachers and parents should see that the subject-matter is thoroughly understood; otherwise, correct images will not be formed.

(7) Within the limits of their capacity, children should be encouraged to exercise the constructive phase of their imagination in invention and creation. They should be led to give as much life as possible to their recitations and exercises in school and to their work and play at home.

(8) A full development of all the senses is essential to the formation of correct images. This should never be overlooked. See Perception; Sensation.

(9) The imagination exerts a strong influence upon the physical condition of young children; consequently, only such subjects should be presented in primary grades as will lead to a happy frame of mind and to the enjoyment of healthful exercise.

(10) The imagination is the power by which ideals are formed. The nature of these ideals will depend upon environment and instruction. Through appeals to the imagination, more than to any other power, children can be led to form right character.

(11) Ideals are progressive, and one gradually leads to another. The wise mother and teacher will see that the ideals presented to children under their charge are constantly and gradually progressing towards higher and nobler types.

For further suggestions, see the article Child Training.





**IMMIGRATION AND EMIGRATION.** These two terms signify the removal of people from one country to another for the purpose of residence. From the standpoint of the country which receives them, such travelers are *immigrants*, or *in-comers*; from the viewpoint of the country they leave, they are *emigrants*, or *outgoers*.

The causes of such removal are as varied as human motives and temptations; but among the important ones are over-population, industrial and economic depression, religious or political oppression, the spirit of adventure and the desire for fame and fortune. In barbarous times a tribe, having exhausted the tract on which it had established itself, naturally migrated to more tempting territory. In Greece, the limited territories of the states rendered the occasional deportation of part of the inhabitants to new colonies a necessity; while at Rome, where the land was held by a few proprietors, and the trades and professions were mainly exercised by slaves, the larger part of the free population eventually

mans, who colonized Pennsylvania; the Dutch, who made settlements in New York; the Swedes, who took possession of Delaware; and the French, who established themselves in Louisiana. Not until 1815 was the tide of immigration rapid enough to cause particular comment, but after that there was a gradual increase, with certain fluctuations, until the high-water mark was reached in 1913. In 1820 the first accurate statistics of immigration were compiled, and in 1864 the first laws on the subject were passed.

No other country on the globe has had its population increased by alien immigrants in the same proportion as the United States. Between 1820 and 1914, the year of the outbreak of the World War, about 32,000,000 aliens entered the ports of the country, exclusive of temporary arrivals. In 1913 the permanent comers numbered 1,197,892, and in 1914, 1,218,480. In 1915 there was a drop to 326,700, because of war conditions, and by 1918 the immigration tide had further decreased. In January of that year there were 6,346 arrivals, as compared with 46,441 for the same month in 1913. In regard to nationalities represented, the following table shows that the greater number of recent immigrants are from Italy, Poland, Russia and the former Austria-Hungary, countries where opportunities for individual development have not been especially favorable:

| IMMIGRANT FROM                                  | PER CENT OF TOTAL IMMIGRATION |           |           |           |           |           |           |           |
|---|-------------------------------|-----------|-----------|-----------|-----------|-----------|-----------|-----------|
|   | 1821-1830                     | 1851-1870 | 1871-1880 | 1881-1890 | 1891-1900 | 1901-1905 | 1906-1910 | 1911-1914 |
| United Kingdom .....                            | 76.5                          | 54.5      | 43.5      | 29.9      | 19.4      | 10.0      | 9.3       | 8.4       |
| Germany .....                                   | 6.8                           | 38.2      | 34.3      | 30.7      | 14.1      | 4.6       | 3.2       | 3.1       |
| Sweden, Denmark and Norway.....                 | 0.2                           | 1.0       | 11.2      | 16.0      | 9.9       | 7.6       | 4.1       | 3.2       |
| Italy, Poland, Russia and Austria-Hungary ..... | 0.3                           | 0.4       | 8.1       | 19.4      | 49.3      | 66.8      | 62.5      | 63.6      |
| All others .....                                | 16.0                          | 5.9       | 2.9       | 4.0       | 7.3       | 10.9      | 20.9      | 21.7      |

had to occupy conquered territory in Italy and elsewhere. In modern times, however, people migrate not as nations or tribes, but as individuals, though thousands of the same race may decide to emigrate in the same year.

**Immigration to the United States.** The first immigrants who made a permanent settlement in what is now the United States were the English colonizers of Jamestown (1607). In 1620 the Pilgrim Fathers reached the "stern and rockbound coast" of New England. They were followed by the Quakers and Ger-

*Immigration Problems.* The great influx of aliens into the United States occasioned many serious problems. While America has freely welcomed the people of other lands, it has realized the danger attending the unrestricted immigration of the weak, the vicious and the ignorant alien. Laws have been passed which forbid entrance into the country of certain classes of "undesirables," including criminals, those afflicted with contagious disease, the feeble-minded and moral degenerates. In 1917 Congress passed over President Wilson's veto a bill which re-

stricted immigration to those able to read at least one language. This so-called literacy test is considered unfair by many authorities.

Another problem that presents itself is the Americanization of the alien. The intelligent immigrants from progressive countries like the United Kingdom, Denmark, Germany, Norway and Sweden are readily assimilated and almost without exception become loyal, law-abiding American citizens. There are other nationalities, however, which need special attention and instruction, and it is among immigrants of this class that various organizations are working with earnest effort. Among the agencies helping in this field are church missionary societies, night schools, civic welfare clubs, social settlements and visiting nurses' associations. The danger of permitting the existence of unassimilated foreign groups was clearly brought out after America's entrance into the World War, and the movement to Americanize all resident aliens and foreign-born inhabitants received a new impetus (see NATURALIZATION).

At the close of the war labor in the United States was confronted by the prospect of a great increase in unemployment, due to abandonment of many lines of war work, the return to civil life of thousands of soldiers, and the general confusion resulting from the transition from a war to a peace footing. At once a vigorous campaign was started for prohibiting immigration for a specified period, until American labor could adjust itself to new conditions. Organized labor was at the back of this movement, which promised to be one of the problems of the Sixty-sixth Congress.

**Immigration in Other Countries.** Canada's immigration history is similar to that of the United States, with the exception that fully half of the Dominion's foreign-born population is made up of immigrants from the British Isles. The largest number of immigrants came between 1911 and 1914, when the mean annual average was 363,000. Canada has restricting laws similar to those of the United States. Argentina and Australia are other important countries whose population has increased largely through immigration.

**IMMORTALITY**, exemption from death; the state of everlasting life. The belief in the immortality of the soul is very ancient. It is a fundamental part of nearly all reli-

gions, though infinite are the varieties of individual and racial conceptions concerning it. In general, it means the endless continuation of personality, consciousness and will. In the minds of most men belief in God and the belief in immortality are intimately associated, and have been from the earliest times. Among rude peoples the life after death is thought to differ little from life before death—an existence wherein the hunter renews the chase and his bodily sensations do not change. The Greeks and Romans believed life continued after death, but only as a shadow of the physical existence. Among some sects a belief is held in the doctrine of transmigration, the passing of the soul after death into another body or successively into several bodies, either human or animal.

**IMMORTELLE**, *im mortel'*, from a French word meaning *immortal*, is applied to a small, strawlike flower which does not wither or lose its color. The flowers last indefinitely, but eventually become so dry they fall to pieces. This flower is sometimes called *everlasting flower*.

**IMMUNITY**, a term derived from the Latin *immunis*, meaning *freedom from obligation*. In law and politics immunity signifies exemption from certain duties and exactions, such as military service, taxation, jury service, etc. The term is also used in connection with the susceptibility of human beings and animals to certain diseases. A person who has had measles, for instance, is supposed to be immune from other attacks of that disease. In this case the immunity is characterized as *acquired*. Arabs are said to be *naturally* immune from typhoid fever. Horses are immune from tuberculosis. The practice of inoculating persons to prevent their taking typhoid fever and other infections is for the purpose of bringing about acquired immunity.

**IMPEACHMENT**, the act of a legislative body by which an accusation is made against a public official for conduct unworthy of his office. Impeachment is no greater evidence of guilt than is an ordinary arrest on suspicion of complicity in crime; it is only an accusation. The accused has the right to a speedy trial to determine his innocence or guilt.

United States officers accused of improper acts in their official capacity are impeached by the United States House of Representa-

tives, by a majority vote the members declare the accusations, presented in legal form, are so serious as to demand investigation. After an official is impeached the Senate of the United States sits as a jury to try the case. Unless the President is the defendant, the Vice-President, in his capacity of President of the Senate, is the presiding officer. If the President of the United States is tried, as once occurred, the Chief Justice of the Supreme Court presides. The Vice-President is in such event disqualified because of his personal interest in the outcome of the trial, for in case the President should be found guilty and deprived of his office the Vice-President would succeed him.

The penalty imposed following a verdict of guilt concurred in by two-thirds of the Senate can extend no further than removal from office and disqualification to hold any other office of honor, profit or trust in the United States government. If the accusation against an official is of a criminal character, state or Federal officers may cause the arrest of the accused after his dismissal from office, and he may be regularly tried in state courts and punished by fine or imprisonment, or both.

The procedure in all the states follows the forms prescribed above. The state house of representatives votes impeachment and the senate tries the case, the lieutenant-governor usually presiding. In England the House of Commons impeaches, and the House of Lords sits in judgment.

There have been ten impeachments voted by the United States House of Representatives, as follows:

(1) **William Blount**, senator from Tennessee, was impeached on July 7, 1797, for conspiring to wage war with Spain in favor of Great Britain, and for attempting to stir up the Cherokee Indians against Spain and the United States. His trial lasted from December 17, 1798, to January 14, 1799, and resulted in his acquittal.

(2) **John Pickering** of New Hampshire, judge of the United States District Court, was impeached in 1803 for drunkenness and profanity on the bench, and for unlawful decisions. He was found guilty on all counts and removed from office.

(3) **Samuel Chase**, associate judge of the Supreme Court of the United States, was impeached in 1804 for injudicious actions and decisions in several political trials. He was acquitted in March, 1805.

(4) **James Peck**, of Missouri, judge of the United States District Court, was impeached

in 1830 for arbitrary conduct while trying a case. In January, 1831, he was acquitted.

(5) **West H. Humphreys**, of Tennessee, judge of the District Court of the United States, was impeached in 1862 for giving support to the secession movement and unlawfully acting as judge of the Confederate District Court. He was found guilty and removed from office.

(6) **Andrew Johnson**, President of the United States, was impeached in 1868 for violating the Tenure of Office Act, for corrupt use of the veto power, interference at elections and other high crimes and misdemeanors. His case came to trial on March 30 and ended on May 26. Thirty-five senators voted him guilty, nineteen declared for his acquittal. The vote lacked one of a sufficient number to convict, and he was therefore acquitted.

(7) **William W. Belknap**, Secretary of War of the United States, was impeached in 1876 for accepting bribes. He was acquitted.

(8) **Charles Swayne**, of Florida, judge of the District Court of the United States, was impeached in 1905 for misconduct in office. He was acquitted.

(9) **Robert W. Archbald**, associate judge of the United States Commerce Court, was impeached in 1912 for entering into corrupt alliances with coal-mine owners and railroad officials while in office. In January, 1913, he was found guilty and removed from office.

(10) **Alston G. Dayton** of West Virginia, judge of the United States District Court, was impeached in 1914. Proceedings were dropped without trial, March 15, 1915.

**IMPERATOR**, *im pe ra'tor*, a Latin word meaning *commander*, or *leader*, from which is derived the modern word *emperor*. Among the Romans in the time of the republic the title was bestowed upon certain magistrates and victorious military commanders, and did not imply imperial power. In the time of Caesar Augustus *imperator* signified supreme authority. The king of England affixes to all official documents the signature *George R. I. (Rex Imperator)*.

**IMPERIALISM**, a term applied in modern politics to the policy of a government which establishes wide spheres of influence far from its own shores. The leading exponent of this policy in recent years has been Great Britain. In the United States the acquisition of the Philippines and Porto Rico aroused the protest of many men, on the grounds that it was a step toward imperialism and was contrary to American precedent. This issue became an important one in the Presidential campaign of 1900, in which the so-called "anti-imperialists" played a conspicuous part, but the issue did not survive. It was the imperialistic tendency

of Germany, whose leaders sought world-wide extension of Teutonic influence, that occasioned the World War in 1914.

**IMPRESSIONIST**, *im presh'un ist*, **SCHOOL OF PAINTING**, the name given to a style of painting which originated with Edouard Manet in France about 1860. The impressionist painter seeks to render a first-hand "impression" of what he sees. He works with great rapidity, doing all his drawing with the brush and subordinating form to light and color. The leading impressionists of to-day are Claude Monet, Degas, Renoir, Sisley and Raffaelli, but they are little known to the masses of the people.

**IMPRESSMENT OF SEAMEN**, a term applied to the compulsory induction of men into naval service. This policy has not been put into practice by any of the powers since the War of 1812 (which see). The insistence of England on the right to board and search American vessels for seamen who owed allegiance to the British was one of the causes of that war.

**IMPRISONMENT, FALSE.** See FALSE IMPRISONMENT.

**IMPRISONMENT FOR DEBT.** To-day it seems absurd to put a man in jail because he cannot pay his debts, for he is thus de-

no person is now imprisoned for such a cause, unless in connection with the debt there is discovered fraud or false pretenses. England abolished general imprisonment for ordinary debts in 1869, France in 1867, Belgium in 1871, Ireland in 1872, and Switzerland in 1874. In the United States no sentence of this kind has been passed since 1849, though it was common in the republic's early years.

**INCA**, *in'ka*, the name of the ruling class of the Peruvian Indians at the time of the Spanish conquest. The government of the Incas was the most stable and the best on the continent, though in some respects the people were not so enlightened as the Aztecs and Mayas. The Peruvians were agricultural people, who irrigated their lands and built great granaries and fine roads to all parts of the empire. Gold was owned by them in abundance and was used in the decoration of their palaces and temples. The capital of the empire was at Cuzco, until just before the arrival of Pizarro, when Atahualpa, heir to the throne, moved it to Quito, to protect himself from a rebellion started by his brother (see ATAHUALPA). It was in 1523 that the Spaniards conquered the country, but it was forty years later be-



RUINS OF AN ANCIENT INCA CAPITAL

Believed to have been built before the time of Christ. Discovered in 1911.

prived of an opportunity to work and meet his obligations. However, for many years people were regularly sent to debtor's prisons. While yet legal in many countries,

fore the Indians were fully subdued. Some of their descendants, now civilized and respected, are living in Peru. See PIZARRO, FRANCISCO.

**INCLINED PLANE**, a mechanical device used to facilitate the hoisting of heavy weights. With the aid of it a workman may perform feats otherwise beyond his strength. For example, if a 200-pound barrel is to be lifted upon a dray three feet high the labor is lightened by the use of a plank, which may be twelve feet long, placed with one end on the ground and the other on the back of the wagon. The plank is what in physics is called an *inclined plane*. The mathematical law of the inclined plane is thus stated; the power multiplied by the length of the plane is equal to the weight of the article lifted multiplied by the height. In the example noted, with very little mathematics it can be seen that a very considerable load is taken from the weight; the man has only fifty pounds to hoist. See **MECHANICAL POWERS**.

**INCOME TAX**, a tax levied directly upon incomes of every description, whether derived from land, capital or industry. The income tax has long formed a prominent feature of the revenue system of England. The rate is progressive, that is, it increases with the size of the income. An income tax was imposed in the United States as a war measure in 1862, and was repealed in 1871. A subsequent statute in 1895 was declared unconstitutional by the Supreme Court. In 1913, instead of excessive protective tariff duties, the tariff bill of that year provided for a tax on the net incomes of individuals, as authorized by the Sixteenth Amendment, which had been approved by the states a few months earlier.

The entrance of the American republic into the World War made it imperative to raise vastly more revenue, and a more drastic law affecting incomes was passed. Under its provisions all unmarried persons whose incomes were over \$1,000 were taxed, and all married persons or heads of families whose incomes were over \$2,000. The rate was 2% on what is called the *normal* tax until the income exceeded \$4,000; above \$4,000 the normal tax was 4%. Upon greater incomes, in addition to the normal tax, another tax called a *surtax* was levied. This surtax ranged from 1% on incomes between \$5,000 and \$7,500 (1% on \$2,500), 2% on sums between \$7,500 and \$10,000 (2% on \$2,500) to 62% surtax on incomes between \$1,500,000 and \$2,000,000 (62% on \$500,000). On incomes exceeding \$2,000,-

000 the rate was 63%. The surtaxes just quoted were in addition to the normal taxes.

In 1918 the stern necessity for a vastly greater Federal income to meet the mounting costs of war led to the passage of still another law which was to be applied to all incomes for that year and for subsequent years, until repealed by new legislation. It was the most exacting law of the kind ever passed by an American Congress. The exemption of \$1,000 for unmarried men and women, and of \$2,000 for married men, remained, as in the preceding law, but on incomes exceeding these amounts for each class the increase was heavy. Below \$4,000 the normal tax was 6%; above \$4,000, 12%. Surtaxes began at \$5,000. The new law imposed a war tax averaging \$60 on every man, woman and child in the United States, for the intent of the law was that it should produce a revenue of \$6,000,000,000 a year. Not all of this was to be derived from incomes, however; a part was to come from taxes, especially upon luxuries. For the second year of its operation, the tax on incomes was to be decreased one-third.

The table below gives the rate of income taxation in the law of 1918, effective in 1919. In another column the war taxes on incomes in Great Britain are given. Comparisons show that the Englishman's tax burden is heavier, except on very large incomes:

| INCOME      | UNITED STATES       |            | UNITED KINGDOM  |                 |
|-------------|---------------------|------------|-----------------|-----------------|
|             | 1918 RATE<br>Amount | (Per Cent) | Rate (Per Cent) | Unearned Earned |
| \$2,500..   | \$30                | 1.20       | 11.25           | 8.44            |
| 3,000..     | 60                  | 2.00       | 14.84           | 11.87           |
| 3,500..     | 90                  | 2.57       | 16.24           | 12.96           |
| 4,000..     | 120                 | 3.00       | 18.16           | 14.53           |
| 4,500..     | 150                 | 3.33       | 18.75           | 15.00           |
| 5,000..     | 180                 | 3.60       | 18.75           | 15.00           |
| 5,500..     | 220                 | 4.00       | 22.50           | 18.75           |
| 6,000..     | 260                 | 4.33       | 22.50           | 18.75           |
| 6,500..     | 330                 | 5.08       | 22.50           | 18.75           |
| 7,000..     | 400                 | 5.71       | 22.50           | 18.75           |
| 7,000..     | 470                 | 6.27       | 22.50           | 18.75           |
| 8,000..     | 545                 | 6.81       | 26.25           | 22.50           |
| 8,500..     | 620                 | 7.29       | 26.25           | 22.50           |
| 9,000..     | 695                 | 7.72       | 26.25           | 22.50           |
| 9,500..     | 770                 | 8.11       | 26.25           | 22.50           |
| 10,000..    | 845                 | 8.45       | 26.25           | 22.50           |
| 12,500..    | 1,320               | 10.56      | 30.00           | 26.25           |
| 15,000..    | 1,795               | 11.97      | 32.08           | 32.08           |
| 20,000..    | 2,895               | 14.48      | 34.06           | 34.06           |
| 25,000..    | 4,245               | 16.98      | 35.75           | 35.75           |
| 30,000..    | 5,595               | 18.65      | 37.29           | 37.29           |
| 35,000..    | 7,195               | 20.56      | 38.75           | 38.75           |
| 40,000..    | 8,795               | 21.99      | 39.84           | 39.84           |
| 45,000..    | 10,645              | 23.66      | 40.97           | 40.97           |
| 50,000..    | 12,495              | 24.99      | 41.88           | 41.88           |
| 55,000..    | 14,695              | 26.72      | 42.84           | 42.84           |
| 60,000..    | 16,895              | 28.16      | 43.65           | 43.65           |
| 70,000..    | 21,895              | 31.26      | 44.91           | 44.91           |
| 80,000..    | 27,295              | 34.12      | 45.86           | 45.86           |
| 100,000..   | 39,095              | 39.10      | 47.19           | 47.19           |
| 150,000..   | 70,095              | 46.73      | 48.96           | 48.96           |
| 200,000..   | 101,095             | 50.55      | 49.84           | 49.84           |
| 300,000..   | 165,095             | 55.03      | 50.73           | 50.73           |
| 500,000..   | 297,095             | 59.42      | 51.44           | 51.44           |
| 1,000,000.. | 647,095             | 64.71      | 51.97           | 51.97           |
| 5,000,000.. | 3,527,095           | 70.54      | 52.39           | 52.39           |

**INCUBATOR**, an apparatus for hatching eggs artificially. It is a cabinet on legs, containing as its essential parts drawers for the eggs and, at one end, a lamp connected by flues which convey warm air to the hatching chamber. It also has a device for ventilating and another for supplying the air with necessary moisture. Hens' eggs hatch in three weeks; the eggs of geese and ducks in four weeks. As soon as a chick hatches it naturally walks toward the light, which comes through a glass door at the front of the incubator. When it reaches the edge of the tray it tumbles into the compartment below, where proper provision is made for it.

The incubator should be placed in a room free from drafts and jars, and the temperature must be kept uniform. The trays should have a temperature of 102° the first two days and should be kept at 103° from then until the eggs are hatched. The eggs should be turned once each day until two days before time for them to hatch.

Hospitals use a specially built incubator for housing weak or prematurely-born babies, who would die if exposed to the air of an ordinary room.

**INDEMNITY**, in international law, remuneration exacted of one nation by another, to compensate for damage, insult or other wrong. In case of war it has been a time-honored custom for the conqueror to exact indemnity from the vanquished. Germany forced France to pay an indemnity of \$1,000,000,000 at the close of the Franco-German War. The United States is a notable exception to this rule, however. At the close of the Spanish-American War the victorious nation paid Spain the sum of \$20,000,000 for the colonies won from it, and the United States government voluntarily remitted to China half of its share in the indemnity arising from the Boxer Rebellion.

At the close of the World War in 1919 the allied nations found it to be a physical impossibility for Germany to pay in full for damage inflicted through more than four years of conflict; the bill was more than two hundred billion dollars. An indemnity of close to fifty billion dollars was decided upon, to be paid in installments. The first installment was to be \$5,000,000,000, to be paid by 1921. Later amounts were to be determined by commissions. See **WORLD WAR**.

**INDEPENDENCE, KAN.**, the county seat of Montgomery County, eighty-five miles southwest of Fort Scott, on the Verdigris River and on the Atchison, Topeka & Santa Fé and the Missouri Pacific railroads. Natural gas and oil wells are numerous near the city. There are cotton, flour, paper, sugar and planing mills, and the manufactures include crackers, glass, vitrified brick, Portland cement, asphalt and other articles. The city has a considerable trade with the surrounding agricultural region and contains a public library, a court house, two hospitals, an Elks' Home and a park system. Population, 1910, 10,480; in 1917, 15,111 (Federal estimate).

**INDEPENDENCE, Mo.**, the county seat of Jackson County, nine miles east of Kansas City, on the Chicago & Alton, the Missouri Pacific and Kansas City Southern railroads. It is two and one-half miles from the Missouri River. The city is a popular residence suburb of Kansas City. It contains several manufactories and is the seat of the Saint Mary's Academy. The place was settled in 1827 and was chartered as a city in 1889. A new Federal building graced the city in 1911, and there is a hospital, a sanitarium and a public library. The city is a center for stock breeding, and fruit growing interests support a canning factory. Population, 1910, 9,859; in 1917, 11,964 (Federal estimate).

**INDEPENDENCE DAY**, the national holiday most dear to the hearts of the American people. It commemorates the adoption of the Declaration of Independence, July 4, 1776. On the fourth of each July this great event is celebrated throughout the Union with patriotic exercises of a varied nature. Formerly it was a day of noisy demonstrations, in which firecrackers and other explosives had a prominent part. The loss of life and property damage resulting from these celebrations led to a campaign for a "sane Fourth," and noise is no longer regarded an essential feature of the patriotic demonstrations. Congress has never enacted a law making Independence Day a holiday, but most of the states have passed such a law, and in every state it is celebrated as a legal holiday. It is an interesting fact that July 4, 1918, was officially celebrated in England, as in that year the two great Anglo-Saxon nations were united in the great war for democracy.



THE SIGNING OF THE DECLARATION OF INDEPENDENCE



**INDEPENDENCE HALL, PHILADELPHIA**

Congress met in the room on the first floor, at the right, during the Revolutionary War.



**INDEPENDENCE HALL**, a brick building in Chestnut Street, Philadelphia, erected between 1729 and 1734 as a meeting hall. Later it was turned into an office building, but during the Revolutionary War it was the meeting place of the Continental Congress. The Declaration of Independence was signed there, July 4, 1776. The building is now used as a museum of historical relics.

**INDETERMINATE SENTENCE**, the sentence of a criminal to an indefinite period of imprisonment. It is the conviction of many prison reform advocates that criminals should not be sent to prison for a definite number of years, but that they should be imprisoned only so long as is necessary to bring about a moral reformation. They would leave the duration of the term to competent authorities. A modified form of the indeterminate sentence is in force in various parts of the United States and Canada. This consists in sentencing a criminal to a term which shall be not longer than a specified number of years (usually four-teen), and not shorter than one year.

**INDEX EXPURGATORIUS**, a catalogue of books which the Roman Catholic Church prohibits its members from reading. The works of Calvin and Luther are absolutely forbidden. Books relating to magic and any book that would tend to weaken the faith of a Catholic are placed in the index. The first volume of an Index Expurgatorius was issued at Rome in 1607. The list was revised by Pope Leo XIII in 1895, and about 3,000 books were taken from it. The work of censoring is done by the *Congregation of the Index*, composed of theologians and cardinals.

The prohibitions upon reading books listed in the index are either total and absolute, without hope that the ban will ever be lifted, or are provisional and partial. In the absolutely prohibited list are all books written by the founders of other religions—denominated heresies—no matter on what subjects. That is why Calvin and Luther are not tolerated. The second group includes books the Church considers immoral; all publications on necromancy, or black art, magic, etc.; and books of whatever nature which contain statements prejudicial to the Roman Catholic religion, the prohibition to be in force until the offending passages are removed. All new books which it is suspected may be harmful are promptly passed upon.



A ruling prince

**INDIA**, a great country in the southern part of Asia, wonderful in resources and fascinating in its atmosphere of mysticism and romance. India, which has been called the "brightest star in England's diadem," constitutes an empire of the greater British Empire, and economically is one of the most valuable of the British possessions. In size it is surpassed by Canada and Australia, but it has forty times as many inhabitants as the former and eighty times as many as the latter.

This magnificent Oriental empire is not a single nation, but a land of many nations. "It contains," writes one historian, "a bewildering variety of races, languages, alphabets; of religious sects and castes; of differing stages in civilization, from the lowest upward; of contrasting landscapes and regions; mountainous to a degree dwarfing the Alps, or flat and riverine like a larger Egypt, or forest-clad or jungle-covered, or ranging over high table-land or desert, or ocean-bathed." It is the cradle of one of the most ancient civilizations, of two of the world's great religions—Brahmanism and Buddhism—and of that ancient tongue, Sanskrit, upon which modern language study is based.

**Location, Size, Population.** The map of Asia shows on the southern coastline three irregular peninsulas—Arabia and French Indo-China jutting out from the two edges of the continent, and India about halfway between. India, however, comprises not merely the middle peninsula, but a considerable area belonging to the body of the continent. On the north its boundary adjoins that of Afghanistan and China; Baluchistan and Afghanistan form the western boundary of the continental portion, while the peninsula portion is bordered on the west by the Arabian Sea. The tip of the peninsula is washed by the Indian Ocean, and the eastern shore by the Bay of Bengal. Across the Bay of Bengal to the east lies Burma, politically, but not geographically, a part of India. Between India and China

on the north are two small independent states, Nepal and Blutan.

The name British India is applied to that part of the Indian Empire which is administered by the British sovereign through the Governor-General of India in Council. In addition there are native states under the suzerainty of the British government. The table below shows the area of British India by provinces, the total area of the native states, and their population:

| PROVINCES                                  | SQ. MILES | POP.        |
|--|-----------|-------------|
| Ajmer-Merwara .....                        | 2,711     | 501,395     |
| Andamans and Nicobars.....                 | 3,143     | 26,459      |
| Assam .....                                | 53,015    | 6,713,635   |
| Baluchistan .....                          | 54,228    | 414,412     |
| Bengal .....                               | 78,699    | 45,483,077  |
| Bihar and Orissa.....                      | 83,181    | 34,490,084  |
| Bombay .....                               | 123,059   | 19,672,642  |
| Burma .....                                | 230,839   | 12,115,217  |
| Central Provinces and<br>Berar .....       | 99,823    | 13,916,308  |
| Coorg .....                                | 1,582     | 174,976     |
| Madras .....                               | 142,330   | 41,405,404  |
| North-West Frontier<br>Province .....      | 13,418    | 2,196,933   |
| Punjab .....                               | 99,779    | 19,974,956  |
| United Provinces of Agra<br>and Oudh ..... | 107,267   | 47,182,044  |
| British India .....                        | 1,093,074 | 244,267,542 |
| Native states .....                        | 709,583   | 70,888,854  |
| Total .....                                | 1,802,657 | 315,156,396 |

**The People.** One frequently hears the name Hindu used as an equivalent for native of India. As a matter of fact, in addition to a few scattering nationalities, there are four distinct racial groups in the empire. The Hindus are by far the most numerous. They are Aryans, of pure and mixed blood, and they inhabit particularly the region known as Hindustan, in the north-central part of the country. Then there are the Mohammedans, made up of the descendants of the Arabian invaders of India, and later converts; the Dravidians, a group of non-Aryan peoples living in peninsular India; and the wild hill tribes of interior India. These latter are thought to be the descendants of the first peoples who inhabited the country.

According to the most recent census, there are in India 264 spoken languages, though this figure includes certain related dialects belonging to the same language stock. It is probable that there are about 150 distinct languages current. Over 80,000,000 people use the Hindi dialect, and between 40,000,000 and 50,000,000, the Bengali. This latter

is of special interest as the form used by Rabindranath Tagore, the winner of the Nobel prize for literature in 1913. These dialects belong to the Indo-Germanic family of languages, but a variety of tongues of a different stock are found in the southern part of the peninsula. Chief among these is the Dravidian. The European residents in India use their own languages, but these have not as yet been learned by any considerable number of the native inhabitants.

There is much poverty and misery among the masses of this great country. The people have too long been under the sway of superstition and too closely bound down by the caste system to make much progress economically or educationally. Among the social customs which have tended to degrade them are infant marriages, the killing of unwelcome girl babies, cruelties practiced on widows and the sacrifice of human beings to the gods. While the British government does not as a rule interfere with native religious customs, such barbarous practices have been suppressed, and progress has been made in lessening the hardships of the lowest classes. As the division of the people into castes is a firm principle of Brahmanism, only by the institution of Christianity can the people be brought to throw off the cruel system that keeps the poor in a state of perpetual misery. Missionaries are permitted to work freely among the natives, and they are slowly bettering conditions.

**Religion and Education.** Brahmanism, the most important religion, is the faith of about 217,000,000 of the inhabitants. As has been suggested, its prevalence in India has been a serious obstacle to the enlightenment of the masses. Mohammedans are next in point of number, for there are about 66,000,000 followers of the Prophet. Of the other faiths, Buddhism, with 10,000,000 adherents, and animism (spirit-worship), with an equal number, are most important. There are also 3,000,000 sikhs, who worship one invisible god and form the majority of the inhabitants of the Punjab. Of the more than 3,000,000 Christians, about one-half are found in Madras Presidency.

Such a thing as popular education in India is as yet a dream of the future. An influential London paper stated in 1918 that only ten per cent of the inhabitants of India are literate, and that "the educated minority fit for political life in our sense do not num-

ber one in a hundred.' The caste system has prevented the greater number of the children of the lower classes from attending the elementary and secondary schools established by the British. The missionary schools, however, which receive government aid, are doing good work among the children of families that have accepted Christianity. There are various colleges and special schools, but the so-called universities, in Calcutta, Bombay, Madras, Allahabad and the Punjab, are merely examining bodies.

**Cities.** India is a country of rural population, and notwithstanding its huge population, the number of great cities is comparatively small. Of these the most important are Delhi, the capital; Madras and Bombay, the great commercial ports; Calcutta, Benares, Hyderabad, Lucknow, Rangoon and Lahore.

**Surface and Drainage.** The surface of India (not including Burma) is divided into three regions. These are the mountainous region of the Himalayas in the north; the great plain of the Ganges and the Indus, adjoining this region, and the table-land of Deccan, which forms the larger part of the peninsula, with its surrounding lowlands on the coast.

The mountainous region contains the loftiest peaks and passes of the Himalayas and descends by long, steep slopes to the Ganges valley. The valley of the Ganges and Brahmaputra is generally broad, low and quite level, the lower part of it being inundated during a portion of the year. The southern slope rises gradually to meet the plateau of Deccan. Between the valley of the Ganges and that of the Indus there is a height of land, which consists of a low swell, extending in an irregular line from the Gulf of Cutch northeastward to the mountains.

The table-land of Deccan occupies the space between two coast ranges of mountains, known, respectively, as the Eastern Ghats and the Western Ghats, and is bounded on the north by the Vindhya Mountains. Its altitude varies from 1,400 to 3,000 feet, and on its surface are found numerous conical peaks, that rise from 1,000 to 2,000 feet above the table-land. This table-land is divided by the Nerbudda and Kistna rivers into north and south sections. The general slope of the region is toward the east, and most of the surface is fertile soil.

The great rivers of India are the Indus, with its tributaries, the Sutlej and the Chenab, in the northwest; the Ganges, with its tributaries, the Jumna and the Brahmaputra; and the Godavari, the Kistna and the Nerbudda in the central and southern part of the peninsula. Of these, only the Indus empties into the Arabian Sea. The Ganges is the most important commercially.

**Climate.** The climate of India has a wide range, owing to the extent of latitude and the various elevations of the different portions of the country. In the south and central portions and along the coast the temperature is high throughout the year, but in the elevated regions in the interior, as the highest portions of the Deccan, and especially among the mountains in the north, the climate is salubrious, so these regions afford relief to Europeans and others, who dwell in the lowlands during the cooler season and retire to the mountains for the hot period. The rainfall is extremely varied. To the north, along the Bay of Bengal, in the province of Assam, it is from 500 to 600 inches a year, and in extraordinary seasons it has been known to exceed this amount. This region receives the heaviest rainfall in the world. In the extreme northwestern portion of the country the rainfall is light and there is a region, extending northward from the Gulf of Cutch for nearly 500 miles, in which rain scarcely ever falls. The annual precipitation at Calcutta is about sixty-six inches, at Bombay, seventy-five inches and at Madras, fifty-two inches. The arid regions, which famine has often blighted, are in the upper regions of Bengal provinces, in the north-central portion of the country.

**Mineral Resources.** Explorations show that there are extensive deposits of coal, and considerable copper, iron and lead in India proper. Small quantities of silver and gold ore have been found in some sections, and there are some precious stones. The diamond, which was formerly obtained in India in considerable quantities, is now seldom found. Coal is the only mineral extensively mined, and it is produced chiefly for the purpose of supplying the railways. Other mining interests have not been developed.

**Agriculture.** The country has a great variety of vegetation. The slopes of the Himalayas below the tree line are covered

with timber, valuable for many purposes. The lowlands, especially around the mouths of the great rivers, contain extensive swamps filled with rank vegetation and harboring many fierce wild animals. Trees of various species are scattered throughout the country, though, except on the mountain sides, there are no extensive forests. The most useful trees are blackwood, sandal, teak, various kinds of cedar and some species of palm and oak. Bamboo is also a valuable product.

Agriculture is the leading occupation of the country and engages the attention of a large part of the inhabitants. The people who till the land live in villages, which may consist of a few houses or of several thousand inhabitants. The land is near the village, and each occupant tills a comparatively small area. The native inhabitants are opposed to the introduction of agricultural machinery and of implements such as are used in Europe and the United States; consequently, the methods employed are primitive and the results are far less than they might be with better methods of tillage. Nevertheless, the soil is fertile, and where supplied with sufficient moisture it yields good crops. In some sections of the interior irrigation is regularly practiced, and in others it is used when the rainfall is less than the average. The government has, with the expenditure of large sums, constructed reservoirs in these localities, for the purpose of reserving the surplus of water to be used as needed. The most important crops are rice, wheat and other cereals, cotton, sugar, indigo, opium, jute, tobacco and tea. The northwest provinces raise the largest quantity of wheat, and cotton is grown most extensively in the central portion of the peninsula, while sugar cane is most extensively cultivated in Bengal and the United Provinces. Indigo is an important product in the lowlands of Bengal, tea is cultivated in Assam and Lower Bengal, and opium is restricted to the region around Benares and is a government monopoly. Oil seeds also constitute an important crop in several localities.

**Manufactures.** Ever since India has been known to civilization, the native inhabitants have been famed for their skill in the manufacture of textile fabrics remarkable for their fineness and delicacy. Many of these are made wholly by hand labor

and with the simplest of implements. Among them are the products of the province of Kashmir. Rugs and carpets peculiar to this country are also produced in large numbers. Within recent years, however, modern machinery and factories have been introduced for the manufacture of cotton goods, and this has resulted in the production of large quantities of a coarse, cheap fabric, which has an extensive sale and forms an important article of export. Other products peculiar to India are furniture and articles of beautifully carved woodwork. There is also some metal work in gold and silver of similar nature. Because of the skill used in their manufacture and their beauty of appearance, all articles of this sort command a high price in European markets. Manufactures of jute and hemp are also important, and the extension of commerce with Western countries has increased the output of woollens, paper, flour and lumber, while in some localities there are breweries and in others indigo and sugar factories.

**Transportation.** The large rivers, the Ganges, the Brahmaputra and the Indus, admit of navigation for a good portion of their length, but smaller streams, particularly in the mountainous regions, are too rapid for successful navigation, even by small boats. Since the occupation of the country by the British government, railways have been constructed between all of the important cities and into the districts which are liable to be affected by famine. The government was actuated in this work largely by a desire to relieve the famine-stricken districts, by providing means of transporting supplies whenever they were needed. Numerous cross-lines have also been constructed, so that now India is well supplied with railways, there being about 35,900 miles in operation in 1918. Much of this is under control of the government, but some systems are leased to private corporations. Canals connecting some rivers have also been constructed, so that, with the exception of the mountainous regions in the interior, all sections have reasonably good transportation facilities.

**Commerce.** The commerce of India is among the most important of all Asiatic countries. The principal exports are cotton, rice, jute, opium, tea, coffee, indigo, raw wool, wheat, oils, silks, chemicals, drugs, textiles and other articles peculiar to the

manufactures of the country. The imports consist of foodstuffs, machinery and manufactured articles of great variety, especially those that can be obtained from Western markets more conveniently and cheaply than they can be produced in the country. A great part of the trade is with Great Britain. Germany, France, the United States and Egypt are also important countries in the foreign commerce; Japan is the most important of the Asiatic nations in this respect.

**Government.** In government, India is a Crown colony. The officer at the head of the government is the Secretary of State for India, who is a member of the British Cabinet and is assisted by a council. The executive officer of the government is the governor-general, usually styled the viceroy, who is appointed by the Crown for a term of six years, and has his residence in Delhi. He is assisted by a council, which by the addition of members may be enlarged into a legislative body. In the addition of members for legislative purposes, a portion of the council must consist of natives of the country. The presidencies of Madras and Bombay are governed by governors appointed by the Crown, but the other political divisions are administered by lieutenant-governors or high commissioners, who are appointed by the governor-general. With the exception of important questions pertaining to foreign affairs, the governor-general is free to use his judgment in the administration of the Empire.

Local government varies according to conditions. India contains many native states which are ruled by their native rulers subject to the sanction of the governor-general, and some of them are required to maintain a military force which can be called into the service of the empire any time it is desired. Local government is almost entirely in the hands of the natives, who choose the officers for stated periods. The object of the home government is to place the responsibility for the maintenance of local authority in the hands of the inhabitants, as far as possible.

*The Home Rule Project.* In 1918 the Secretary of State for India made public a plan for the introduction of home rule in the Indian Empire. The projected scheme embodied the following points: There would be created provincial legislatures, chosen by direct election; a viceregal legislature for all

India, comprising a Legislative Assembly and a Council of State; an Indian Privy Council appointed by the Crown, and a Council of Princes. The legislative assembly would consist of 100 members, two-thirds to be elected; twenty-one of the fifty members of the Council of State would also be elected. At stated intervals there would be a systematic survey of the situation, and necessary changes would then be made.

**History.** The early history of India is obscurely written in the myths of Sanskrit literature. The first fact of any certainty is that about the year 2000 B. C., or even earlier, an Aryan people of comparatively high civilization descended from the mountain regions of the northwest into the plains of India and subdued the original inhabitants there. The expedition of Alexander the Great to the Indus gives a momentary glimpse of that part of India, but between his invasion and the Mohammedan conquest there is little authentic history. In the third century B. C. Buddhism was established throughout India, but it afterwards gave way almost entirely to Brahmanism. In A. D. 1001 the sultan Mahmud of Ghazni invaded India, and the Mohammedan power was gradually established throughout the country. Late in the fourteenth century Timur, or Tamerlane, led a great Mongol invasion and proclaimed himself emperor of India. He shortly retired, however, to Central Asia, and it was not until 1526 that the Mogul Empire in India was really founded under Sultan Baber, a descendant of Tamerlane. The Mogul Empire began to decline after the death of Aurungzebe in 1707, and about thirty years later Nadir Shah of Persia invaded India and sacked Delhi. Throughout the empire, which had been firmly held together under the great Moguls, the viceroys under the weaker emperors began to declare themselves independent.

The breaking up of this strong empire offered a good opening to European nations, and the Venetians, Portuguese and Dutch, who had been visiting India from the fifteenth century, began to make their influence strongly felt. The English East India Company had formed commercial settlements in India as early as 1613, and from the first there was a rivalry between them and the French settlements, which had also been established early in the seventeenth century. The first real conflict with the French did

not take place, however, until 1746, when the English lost Madras, which was, however, restored to them by the Treaty of Aix-la-Chapelle.

From the time of Clive the English held the dominant influence in India, and 1757, the year in which Clive defeated the Moguls at Plassy, is the date of the foundation of the British Empire in India. The strong government set up by Clive was preserved under Warren Hastings, who, by the appointment of English officers to collect the revenues and preside in the courts, laid the foundations of the present system of British administration in India. In 1774 Hastings was made first governor-general of India. In 1778 the intrigues of the Bombay government led to the first war with the Mahrattas, and in this the British arms were saved from disgrace only by the achievements of the Bengal army which Hastings sent to the aid of the Bombay presidency.

In 1838 the first Afghan War was undertaken, the object of which was to set up a native province as a northern guard to British India. The war terminated in disaster for the British, but later in the same year a second campaign was undertaken, which proved more successful. In 1857, shortly after the appointment of Canning to the governor-generalship, the Sepoy Mutiny occurred. Several outbreaks among the Sepoys took place during March, 1857, but the most formidable revolt was at Meerut, on May 10, when the Sepoys massacred the Europeans. They then fled to Delhi, where they were immediately joined by the native garrison, and another massacre took place. The revolt spread rapidly in the northwestern provinces, from Oudh down to Lower Bengal. In the Punjab the prompt measures of the government officials in disarming the Sepoys prevented an outbreak, and the Sikh population continued steadily loyal. Wherever the mutiny broke out, it was attended with savage excesses.

At Cawnpore the revolting Sepoys were headed by Nana Sahib, the heir of the last peshwa of the Mahrattas. The Europeans, after a heroic attempt to defend themselves capitulated on the sworn promise of Nana Sahib that he would allow them to retire unmolested; but as they were embarking, they were set upon and indiscriminately massacred. The women and children were carried back to Cawnpore and kept until

July 15, when they were all put to death on the approach of Havelock's army. Havelock took Cawnpore by storm on the following day. At Lucknow Sir Henry Lawrence was besieged in the residency and, despite Lawrence's death, the place was held until Havelock relieved it in September. He himself was in turn besieged and was with difficulty relieved by Sir Colin Campbell. By May, 1858, order had been partially restored, and the mutiny was at an end.

In 1858, as a result of this mutiny, the sovereignty of India and the powers of government hitherto vested in the East India Company were transferred to the British Crown. The Empire was consolidated by the viceroys who followed, and in 1877 the queen of England was proclaimed empress of India. In the following year occurred an Afghan war with Shere Ali, but peace was finally established, and Abdurrahman Khan was placed on the Afghan throne by British arms. In 1897 another serious outbreak on the Afghan frontier occurred, but the British at length were completely victorious. A severe famine in 1899 affected millions of people throughout the country, and there were some attempted revolts, but on the whole the country proved loyal.

The determination of England to treat Tibet as an independent power, which was to remain neutral territory between the dominions of Russia and Great Britain, led to constant friction with Russia. The government of India in 1903 invited Tibet to send representatives to a conference for the settlement of various misunderstandings, and when the request was refused an expedition under Colonel Younghusband was dispatched into the country. After a difficult march and some severe fighting, the force reached and took Lhasa. The grand lama fled, a new ruler was appointed who was more favorable to British interests, and a treaty was made which secured important commercial concessions to the English. Russia objected on the ground that England was establishing a virtual protectorate over Tibet, but the English government steadily maintained that its object was to secure the commercial rights of India and not to annex Tibet.

Of late years relations between the people of India and the British have been on the whole very cordial, and there was a striking demonstration of loyalty to Great

Britain during the World War. India furnished thousands of fighting men for the allied armies, as well as artisans and other laborers, and contributed vast quantities of bridge material, provisions and other supplies for the campaign in Mesopotamia. Over half of the river vessels used in that campaign were supplied by India. In 1917 an Indian war loan of £32,000,000 (\$160,000,000) was subscribed. There was a noticeable increase in national consciousness in the empire as the war progressed, and it was recognition of this spirit, as well as the strengthening of democratic principles resulting from the war, that inspired the plan to confer home rule on India.

The plague of bolshevism (see **BOLSHEVIKI**) which spread from Russia after the World War affected some of the northwestern provinces, particularly in April, 1919, but prompt measures soon brought a return to normal conditions. This trouble did not reach the central, eastern or southern provinces; the native princes were strongly loyal to the established order.

**Related Articles.** Consult the following titles for additional information:

## GEOGRAPHY

|                |              |           |
|----------------|--------------|-----------|
| Agra           | Cawnpore     | Lahore    |
| Allahabad      | Deccan       | Lucknow   |
| Arabian Sea    | Delhi        | Madras    |
| Bangalore      | Ganges       | Mandalay  |
| Baroda         | Golconda     | Mysore    |
| Benares        | Himalaya     | Nepal     |
| Bengal         | Hyderabad    | Nerbudda  |
| Bengal, Bay of | Indian Ocean | Punjab    |
| Bombay         | Indus        | Rajputana |
| Brahmaputra    | Irrawadi     | Rangoon   |
| Burma          | Jaipur       | Serinagar |
| Calcutta       | Laccadives   | Sutlej    |

## HISTORY

|                        |                 |
|------------------------|-----------------|
| Black Hole of Calcutta | Sepoy Rebellion |
| Clive, Robert          | Suttee          |
| East India Company     | Tibet           |
| Hastings, Warren       | Timur           |

## RELIGION

|            |               |
|------------|---------------|
| Brahmanism | Caste         |
| Buddhism   | Mohammedanism |

## UNCLASSIFIED

|         |           |
|---------|-----------|
| Aryan   | Fakirs    |
| Bengali | Sikhs     |
| Durbar  | Taj Mahal |

**INDIA INK**, an absolutely black pigment. The usual basis used in its manufacture is a finely-divided carbon, mixed with a glue or gum which holds it in suspension when liquified with water. The ancient Chinese made a black ink from soot obtained from oil of sesame, and another kind has been produced from the black secretion of the cuttlefish. India ink is used chiefly in making pen-and-ink line drawings of the sort used in book illustration.

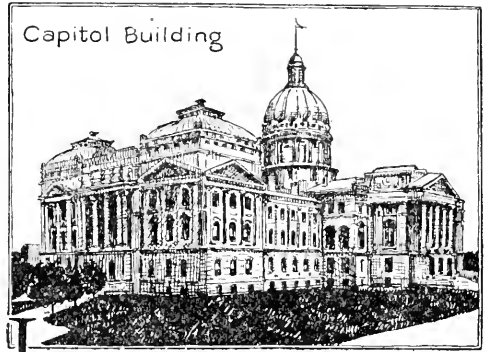

**INDIANA**, the thirty-seventh state in size in the American Union and the ninth in population. It was the second of the five states which were formed from the Northwest Territory, the first being Ohio, which lies east of it. Kentucky is south, Illinois is west, and Michigan and Lake Erie are north. The area of Indiana is 36,354 square miles, and the population, in 1910, was 2,700,876, an average of 74.9 to the square mile. A Federal estimate credited the state with 2,854,167 people, on July 1, 1918.

For some one outstanding thing most states are best known in sister commonwealths. Possibly Indiana's greatest fame lies in the long list of men who have made voluminous, and in some cases, notable, contributions to American literature. Surely among America's most loved poets is James Whitcomb Riley. Second only to him in point of worth most critics would place General Lew Wallace. Below them is a numerous group of writers whose work has attracted wide attention; in the list may be included Edward Eggleston, Meredith Nicholson, Booth Tarkington, George Barr McCutcheon, George Ade and Maurice Thompson. John T. McCutcheon became one of America's greatest cartoonists.

**Education.** The state has an excellent school system, based upon the township plan. The township is the smallest unit for public school administration, and the schools of that unit are placed in the hands of a trustee who is elected by the voters of the township. A unique feature of the school system is a monthly meeting of all the teachers in each township during the school year. This partakes of the nature of a teachers' institute. The public school fund expended yearly exceeds \$16,500,000. The University of Indiana at Bloomington is at the head of the school system. Purdue University, with the state

agricultural and technical school, at Lafayette, and the state normal school at Terre Haute are also parts of the public school system. Other important educational institutions are De Pauw University at Greencastle, Indianapolis University, the University of Notre Dame, Wabash College, Vincennes University, Rose Polytechnic Institute, the university at Valparaiso, Wabash College at Crawfordsville, Earlham College at Richmond, Concordia College at Fort Wayne, Butler College at Indianapolis, Taylor University at Upland, and Vincennes University, all co-educational except Wabash. One of the state's greatest schools is the University of Notre Dame, at Notre Dame, for men; another Catholic institution of note is Saint Mary's of the Woods at Terre Haute, for women. There are a number of private normal schools.

**Surface and Drainage.** Indiana is in the prairie region, and its surface is similar to that of Illinois. The highest land is in the northeastern part of the state, where elevations of 1,000 and 1,200 feet are found. The elevation of the northwestern part is from 500 to 700 feet. Bordering on Lake Michigan is a chain of sand hills or dunes which have been formed by wind. These hills are of great interest to geologists and are frequently visited by geological parties; the section may become a state park, to insure their preservation. There are a number of low marshes near the lake, some of which have been drained and transformed into farms for growing vegetables. Along a line extending from the northeastern corner of the state to Logansport is a range of low sand hills, containing a number of depressions in which shallow lakes are found. Several of these lakes have become favorite summer resorts.

South of this region and extending to a line running across the state just south of Indianapolis to the Wabash River is a broad, level plain, with scarcely any variation in altitude, but this region blends into a rolling prairie north of the Wabash. The southern part of the state has a decidedly broken and uneven surface. This region includes the counties bordering on the Ohio and those adjoining them on the north. The region contains no high hills or mountains, but in some sections there are extensive limestone formations, which have been washed by underground streams. In some places the streams have disappeared, leaving sink holes and caverns.

Some of these caverns contain formations of rare beauty. The most noted is Wyandotte Cave, which yearly attracts many visitors. This remarkable formation, about twenty-three miles long, is second in size to Mammoth Cave.

A small portion of the northeastern part of the state is drained by the Maumee into Lake Erie; the Kankakee, in the northwest, drains a large area into the Illinois River and thence to the Mississippi. The southeastern counties are drained by the Whitewater, which enters the Ohio just across the eastern boundary. The remainder of the state is drained by the Wabash and its tributaries. The Wabash traverses the state from the northeast to the southwest and is joined by the White, its principal tributary, which, with its west fork and other tributaries, drains a large part of the south central region. The streams flowing into the Ohio from the southern counties are short and of little importance.

**Climate.** The extent of latitude covered by Indiana causes a difference of about nine degrees between the mean temperature of the northern and the southern tiers of counties. The summers are usually warm, and during July and August many hot days are experienced. Owing to the sweep of the north winds the winters, especially in the northern part, are often severe, having from seventy-five to ninety days of freezing weather and sometimes as much as forty inches of snow. In the southern half the winters are short and mild, and snowfall here seldom exceeds fifteen inches. The rainfall varies from thirty to fifty inches and is heavier in the south than in the north, the average for the state being about forty-three inches; but the periods of precipitation are unevenly distributed. July and August are liable to be dry months.

**Mineral Resources.** The coal measures of Indiana are located in the southwestern part of the state, and have an area of 6,500 square miles. Many of the mines yield an excellent quality of bituminous coal; the output is steadily increasing, and now exceeds \$19,000,000 in value yearly. The petroleum industry is also important, but since the opening of the Illinois fields oil production has declined. The state ranks first in the production of lime and second in the production of Portland cement. The output of building stone is also of great value, Bedford limestone having acquired a wide reputation. Brick and tile clays are widely distributed



over the state and give rise to important industries. The total mineral output exceeds \$42,000,000 in value annually.

**Agriculture.** Agriculture is the leading industry of Indiana, and ninety-five per cent of the tillable land is under cultivation. Hardwood forests are scattered over the state, though, except in the southern counties, they now cover only small areas. With scarcely an exceptional spot, the soil is fertile. The chief crops, in the order of importance, are corn, wheat, hay and oats. Over 255,000,000 bushels of corn are raised, wheat, 34,000,000 bushels; oats, 77,000,000 bushels. The counties near Chicago are well suited to truck farming, and large sections in this region are devoted to it. Stock raising also receives attention throughout the state. There are extensive areas of valuable pasturage, and large numbers of horses, cattle, sheep and swine are raised. However, the raising of sheep is now confined almost entirely to the northwestern counties. Fruit is quite generally grown throughout the state, and in the southern half potatoes, plums, pears and small fruits are raised in quite large quantities.

**Manufactures.** Hammond, East Chicago, Indiana Harbor and Gary are important manufacturing centers near Chicago; they form practically a continuous manufacturing district around the southern end of Lake Michigan. The first has extensive meat packing houses and the others are noted for the manufacture of iron and steel and their products. Gary has the largest steel works west of Pittsburgh. There are numerous factories for the manufacture of agricultural implements, automobiles and other wares. At South Bend is the largest wagon factory in the world. A considerable quantity of coke is manufactured, and the manufacture of cotton, woolen and knit goods forms an important and growing industry. The manufacture of glass, which was formerly one of the leading industries, has declined, owing to the failure of the supply of natural gas, and some factories have removed to other localities.

**Transportation.** Indiana is traversed in all directions by a large number of trunk lines of railway, which have their western centers in Chicago and Saint Louis and their eastern centers in New York, Philadelphia, Baltimore and other large cities. With the exception of the two southern tiers of counties, all portions of the state are well supplied with

### Items of Interest on Indiana

In the southern and south-central part are many mineral springs, which have become famous health and pleasure resorts, especially French Lick and West Baden.

Among song birds are the cardinals, scarlet tanagers, meadow larks, catbirds, wood thrushes, robins, bluebirds, red-headed woodpecker, and several species of warblers.

The soil of the greater part of the state consists of loose loam, exceedingly fertile, especially in the Wabash Valley; the least fertile part is the sandy region just south of Lake Michigan.

Indiana ranks eighth among the states in the value of agricultural products.

Indiana ranks second as a manufacturer of carriages and wagons, glass, and distilled liquors, fourth in furniture, sixth in agricultural implements, and seventh in packing-house products.

The mineral resources seem to be declining; the output of petroleum, natural gas, and coal was formerly greater than it is now, but the state still ranks seventh in natural gas and sixth in coal.

The state ranks third as a producer of Portland cement and also furnishes annual supplies of building stone and fine clays, sandstone and limestone, valued at \$10,000,000.

The center of population of the United States, by the census of 1910, is in Bloomington.

### Questions on Indiana

What is the character of the surface?

In what direction is the general flow of drainage?

How many varieties of flowering plants are found in the state?

What is the leading industry?

What causes are responsible for the growth of Indiana's manufacturing industries?

What are the most important manufactured products?

How does the state rank in the manufacture of carriages and wagons?

# INDIANA THE HOOSIER STATE



COAL MINE

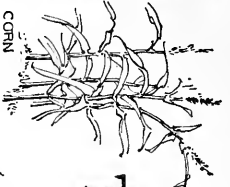

CORN



PEARS



APPLES

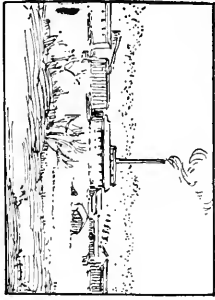

TILE FACTORY



CATTLE

WHEAT



SOUTH BEND

GARY

HAMMOND

FORT WAYNE

LOGANSPORT

LAFAYETTE

INDIANAPOLIS

RICHMOND

BLOOMINGTON

TERRE HAUTE

NEW ALBANY

EVANSVILLE

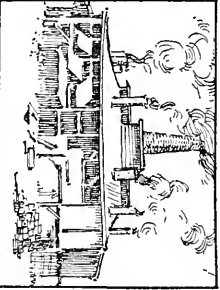

GLASS FACTORY

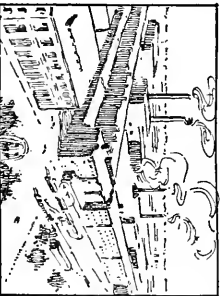

WAGON FACTORY



BEDFORD STONE



HOGS



PEACHES



CHERRIES



OATS

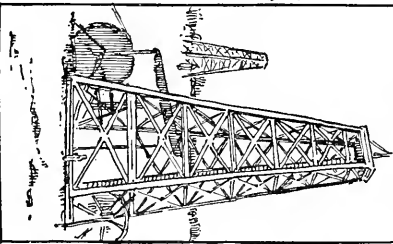

PETROLEUM

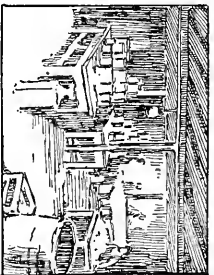

PASSENGER HOUSE

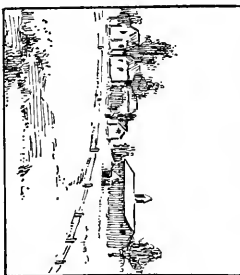

FARM SCENE

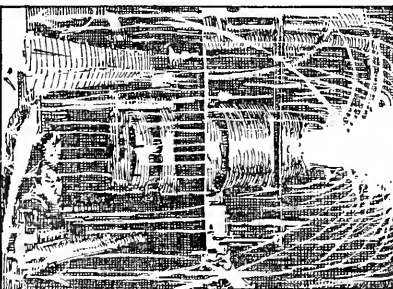

BESSEMER CONVERTER

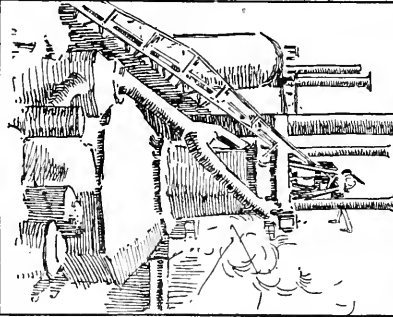

BLAST FURNACE

railway facilities, but owing to the unevenness of the land in the region named only a few lines have been constructed there. The entire mileage of the state exceeds 7,500 miles, and in addition to this there are 2,350 miles of electric lines. Indiana has joined all important cities with a network of interurban lines, and Indianapolis has the largest interurban station in the world. The Ohio is the only navigable river which is of value to the state as a means of transportation.

**Government.** The legislative department consists of a senate of fifty members, elected for four years, and a house of representatives of not more than 100 members, elected for two years. The legislature meets every other year. The executive department consists of the governor and the lieutenant-governor, each elected for four years, a secretary of state, a treasurer, an auditor, an attorney-general and a superintendent of public instruction, elected for two years. The judicial department consists of the supreme court, an appellate court and circuit courts. In addition to these there are superior courts in the large cities. In local government the township has greater recognition than in most states in the central part of the country.

**Institutions.** The hospitals for the insane are located at Logansport, Richmond, North Madison, Indianapolis and Evansville; the state soldiers' home is at Lafayette; the soldiers' and sailors' orphans' home is at Knightstown; schools for the deaf, dumb and blind are at Indianapolis; the state reformatory is at Jeffersonville; the penitentiary is at Michigan City; the women's prison is at Indianapolis; a village for epileptics is at New Castle; a tuberculosis hospital is at Rockville, and there is a state farm at Putnamville.

**Cities.** Indiana has thirty-five cities each of which in 1918 had more than 8,000 inhabitants. The capital and largest city is Indianapolis; the next five cities in order of size are Fort Wayne, Evansville, South Bend, Terre Haute and Gary.

**History.** The first permanent white settlement in Indiana was made at Vincennes (1734) by emigrants from Canada. But as early as 1680 La Salle had made explorations in the Ohio and Wabash valleys, and early in the eighteenth century trading and military posts, missions and settlements had been made at several points. The territory constituted a part of New France until 1763,

when it was ceded to England. By the treaty of 1783 it became a part of the United States, having been conquered during the Revolution by a band of frontiersmen under George Rogers Clark. Indiana became a territory in 1800; at that time it included Michigan, Illinois and Wisconsin. In 1809 it was reduced to its present size. In 1811 the Indians, who had been giving constant trouble, were defeated by General Harrison at the Battle of Tippecanoe. Indiana became a state December 11, 1816, with a constitution forbidding slavery. After a period of financial weakness and political confusion, the state steadily prospered; and it has taken advanced steps toward the solution of political and industrial problems, such as the establishment of an industrial arbitration tribunal and an anti-trust law. It has been doubtful in politics for many years, and has been the scene of memorable political battles. It has given to the United States one President, General Benjamin Harrison, and four Vice-Presidents—Schuyler Colfax, Thomas A. Hendricks, Charles W. Fairbanks and Thomas R. Marshall. In 1908 a local option law was passed to regulate the liquor business, and ten years later statewide prohibition was adopted, in advance of national action.

**World War.** Indiana furnished more than five times its quota of voluntary enlistments for the war against Germany; double its quota of marines; oversubscribed by many millions of dollars each Liberty Loan. The first American shot in the great war was fired by an Indiana soldier from South Bend; the first soldier to perish was Private Gresham of Evansville; and the first soldier taken prisoner was Hoyt Decker of Vincennes.

**Related Articles.** Consult the following titles for additional information:

| CITIES         |                |             |
|----------------|----------------|-------------|
| Anderson       | Goshen         | Mishawaka   |
| Bedford        | Hammond        | Muncie      |
| Bloomington    | Huntington     | New Albany  |
| Brazil         | Indianapolis   | New Castle  |
| Columbus       | Jeffersonville | Peru        |
| Crawfordsville | Kokomo         | Richmond    |
| Elkhart        | Lafayette      | Shelbyville |
| Elwood         | Laporte        | South Bend  |
| Evansville     | Logansport     | Terre Haute |
| Fort Wayne     | Marion         | Vincennes   |
| Frankfort      | Michigan City  | Wabash      |
| Gary           |                |             |

#### GENERAL

|                      |                       |
|----------------------|-----------------------|
| Clark, George Rogers | Tippecanoe, Battle of |
| Dune                 | Wabash River          |
| Harrison, William    | White River           |
| Henry                | Wyandotte Cave        |

**INDIANAPOLIS, IND.**, the county seat of Marion County, the capital and largest city

of the state, 110 miles northwest of Cincinnati and 175 miles southeast of Chicago, on the Pittsburgh, Cincinnati, Chicago & Saint Louis, the Lake Erie & Western, the Pennsylvania, the Monon, the Illinois Central, the Lake Erie & Western and the Cincinnati, Hamilton & Dayton railroads. In addition to its adequate railroad facilities Indianapolis is the greatest interurban railroad center in the world. Electric lines to the number of twelve radiate in all directions, reaching or connecting with almost every county seat within a hundred miles.

The city is noted for its wide, well-paved and beautiful streets. The chief business streets are Washington, Market, Maryland and Georgia. Meridian, Pennsylvania and Delaware, three of the finest residence streets in the city, and Illinois, Massachusetts, Indiana, Virginia and Kentucky avenues radiate from Monument Place, a circular plaza in the center of the city. There are nine public parks, with nearly 1,700 acres in area; Riverside, Garfield and Brookside are the most important.

The most notable structure in Indianapolis is the Soldiers' and Sailors' Monument, standing in Monument Place. It was designed by Bruno Schmitz and cost over \$500,000. The statehouse, costing \$2,000,000 and occupying two large blocks, is the most noteworthy building. Others are the county building, costing \$1,750,000; the new Federal building, containing government offices; the police building, the Propylaeum (a woman's building), the public library, Tomlinson Hall, the Commercial Club, the Columbia Club, the Majestic, Law and Stevenson office buildings, and Claypool Hotel. Fort Benjamin Harrison is north of the city, and was named for the President of 1841. His grandson, Benjamin Harrison, President from 1889 to 1893, was an honored resident of Indianapolis. The city has about 140 churches.

Indianapolis is well supplied with educational facilities in addition to the public schools. The medical department of the state university is here; the city also has Butler College, Indiana Law School, Indiana Dental College, Indiana Central University, and a large art school.

Among the important industries of the city are slaughtering and meat packing, iron works of various kinds, flour, grist and lumber mills and manufactories of carriages, wagons, furniture and malt liquors. There

are also extensive printing and publishing establishments. More than 125 industrial establishments are located on a belt line of railroad sixteen miles in length.

Indianapolis was settled in 1819, received its name two years later and became the capital of Indiana in 1825. The growth of the town dates from the opening of the first railroad in the state, in 1847. Since the introduction of natural gas, in 1889, the manufactures have increased rapidly and the city has grown. The gas supply, however, failed after several years. Population, 1910, 233,650; in 1917, 283,622 (Federal estimate).

**INDIAN ARCHITECTURE**, the architecture developed by the peoples of India. Several styles are represented, including the Buddhist, the Jaina, the Dravidian, or style of Southern India, the Chalukyan and the Modern Hindu, or Indian Saracenic. All these styles possess certain common traits, among which are minute and profuse ornament, executed in laborious carving; the use of many horizontal lines and bands, giving a stratified appearance; a repetition of the same motif, and a neglect of structural requirements. Among the principal forms of Buddhist architecture, which prevailed between the third and seventh centuries A. D., are the following: First, the *topes*, *stupas*, or towers, built to mark some sacred spot, and the *dogobas*, constructions of a similar nature, containing relics of Buddha or Buddhist saints; and second, the rock-cut *chaitya halls*, or *churches*, and the *viharas*, or monasteries. In rock-cut buildings architectural skill is confined to the façade and the interior, which are generally cut out with most beautiful and perfect detail.

The Jaina style, most highly developed in the eleventh century, is an outgrowth or corruption of the pure Buddhist. The temples in this style consist of a small sanctuary, surmounted by a lofty and nearly solid tower, the whole standing in a court surrounded by small cells, each surmounted by a smaller dome. The Dravidian style, that of the peoples of Southern India, arose not earlier than the tenth century. The characteristic feature here is the *gopura*, a lofty, truncated pyramid, covered with countless bands of sculpture and carved ornament.

The Indian Saracenic style is a general name for a number of somewhat varying styles, the result of the mixture of Saracenic principles of architecture, brought by the

Mohammedan conquerors of India, and the distinctive architectural features of the different localities where they settled. Under the Mogul emperors in the sixteenth century were erected some most magnificent buildings, such as the tomb of Humayun Shah at Old Delhi, that of Akbar at Secundra, the palaces of Shah Jehan at Agra and Delhi, and the Taj Mahal, built by the same monarch at Agra. See TAJ MAHAL.

**INDIANA UNIVERSITY**, a coeducational state institution at Bloomington, chartered as a university in 1838. It includes a college of liberal arts and schools of education, law and medicine and a graduate department. It also maintains a summer school and a biological station on Winona Lake. In normal years the faculty numbers over 200 and the enrollment is about 2,800. The library contains 108,000 volumes.

**INDIAN HEMP.** See HASHISH.

**INDIAN MALLOW, VELVET LEAF, or STAMP WEED**, a weed of the mallow family. It grows to a height of four feet and has heart-shaped, velvety leaves and small, orange-colored flowers. The fiber is almost as strong as hemp-fiber, and many species are utilized in textile manufacture. Mallow is of perennial and persistent growth, and as a weed is injurious to other crops, especially corn.

**INDIAN OCEAN**, one of the great salt-water divisions of the earth, extending from Africa eastward to Australia and the East Indies and from Asia southward to the Antarctic Ocean. It is the third ocean in size, only the Pacific and Atlantic being larger. Its area is 17,084,000 square miles. The northern shores are broken up by the projection of the peninsulas Arabia, India and Indo-China. Among the numerous islands in the Indian Ocean, Madagascar, Mauritius and Ceylon are the most important. The chief rivers flowing into it are the Salwin, the Irrawadi, the Brahmaputra, the Ganges, the Indus, the Chat-el-Arab, in Asia, and the Zambezi, in Africa. The winds over this ocean are gentle, though hurricanes are very frequent. The greatest depth is found in the northeastern part, where soundings have been made of 20,340 feet. The average depth is about 10,970 feet.

Through the northern part of this ocean runs the equator, and still in the northern and smaller section runs the tropic of capricorn. Below this latter line the great ocean is little touched by commerce.



A Blackfoot girl

**INDIANS, AMERICAN**, the red-skinned race which held undisputed possession of the wilds of the Americas before the European invasion of those continents. Once masters of the fairest regions on the globe, the Indians are fast dying out as a pure-blooded race, and in time will be reckoned among the lost peoples of history. When found by the Europeans they represented many degrees of civilization, for they ranged from wild savages to peoples whose achievements made even their conquerors marvel. Of the latter class were the Aztecs of Mexico and the Incas of Peru. Among all primitive peoples, the American Indians as a whole are least associated with that which is degrading and vicious, and that much of romance and charm is connected with their history is shown in the fascinating stories of the conquest of Mexico and Peru, and the *Leather-Stocking Tales* of Cooper.

The name *Indian* is a misnomer, having been bestowed by Columbus and his followers because of the mistaken idea that the newly-discovered lands were a part of India. This name, however, clung to the red man, and he is to-day called *Indian* everywhere, with the qualifying word *American* added for clearness. When the Europeans first entered the present United States and Canada, or Anglo-Saxon North America, the Indians numbered, it is supposed, about 1,000,000. There are at present about 400,000, including those in Alaska. In Mexico, there are nearly 6,000,000 pure-blood Indians, and a still greater number of mixed Indian blood. The millions of South American Indians, of whom a census has never been taken, are in large part admixtures of the primitive race and European stocks. In the United States there are about 175,000 full-blood Indians, but the time is not far distant when there will be none of pure stock, because of the tendency of whites and Indians to intermarry. Counting admixtures, the Indian population of the United States on June 30, 1917, was 335,998.

The origin of these interesting peoples is a subject that has awakened considerable re-

search. So marked is their divergence from Old World types that authorities believe they have inhabited the American continents a very long time. It is thought probable that they entered North America from Asia by way of Alaska, and later spread over the whole of the New World. In appearance they are most like the Mongolian race. Whether they represent a mixture of Asiatic and European races, or are an original stock, scientists have not been able to determine.

Though the various tribes differ from each other in many particulars, they show certain marked characteristics: the long, straight black hair, reddish-brown skin, scanty beard, heavy brows, receding forehead, prominent nose, high cheek bones, full lips and broad face. As to their traits of character, much can be said in praise of their faithfulness to family ties, reverence for religious ideals, virtuous habits and patient endurance of hardship and pain. The stories of their savage cruelty and treachery were sometimes colored by the viewpoint of the white settlers who replaced them. Certainly the conquerors of the Mexican Aztecs were in every way as savage and unscrupulous as any Indians ever were, and in our own day civilized peoples have been guilty of extreme cruelty under stress of the excitement of war.

**Indians of Anglo-Saxon America.** *Villages.* When Columbus discovered America the Indians lived in villages, each tribe by itself, in dwellings peculiar to the tribe. Among the Pueblo Indians in the southwestern part of the United States the houses were then, as now, built of mud or stone and crowded together one above another upon the plain, or were built in almost inaccessible caves in the sides of high cliffs. In the Lake region, circular huts of bark, split in broad slabs, were built, while to the east and south, the wigwams were of the same material, but rectangular in shape. The plains Indians, who traveled about much more than the tribes of the east, built temporary *tepees*, or wigwams, of poles, over which they stretched skins of buffalo and other large animals. Generally one house was larger than any of the others, and in this the chiefs met for council; and around it was an open space where the Indians met for worship or amusement.

*Dress.* The everyday dress of the Indians consisted of little clothing—no more than was necessary for comfort, some tribes going

almost entirely naked. From the skins of animals, fibrous plants and the bark of trees the Indians constructed the few garments which were necessary, except in the southwest, where the Pueblos made serviceable woolen garments. In times of ceremony most of the tribes dressed elaborately, with showy garments bedecked with shells, teeth, feathers and other bright objects. Enormous head-dresses of feathers and brilliant necklaces, metal ornaments, earrings and bracelets were also a part of this full-dress costume. Not uncommonly the Indians tattooed themselves, and always before going to war or engaging in any other great undertaking they painted their faces and bodies with bright colors in fanciful designs, which showed the tribe to which the Indians belonged and their purpose in painting themselves.

*Food.* Most of the tribes cultivated corn, beans and squashes, and some of them, like the Pueblos, lived almost entirely by agriculture. Whenever possible, the Indians ate freely of fruits and of other edible parts of many plants. The northern Indians gathered and stored wild rice and cranberries and made syrup from the maple trees. East of the Alleghany Mountains tobacco was a general product, and along the seacoast and the Great Lakes fish formed a staple article of food. West of the Mississippi the Indians were great hunters, but it is manifestly unfair to say that Indians in general lived wholly by the chase. Except in times of scarcity, they were well fed and lived healthily and at ease.

*Language.* Tribes that lived near one another were able to communicate by means of signs or with a jargon of mixed words from all languages, and while many of these languages seem to have come from the same stock, yet more than fifty distinct and unrelated languages have been noted.

*Domestic Animals.* To our mind, the plains Indian is so associated with his horse that it is surprising to remember that until the Spaniards brought the animals to the United States there were no horses there. Domestic animals, in fact, were very rare, the dog being the only one that was common and almost universal. To many tribes he was a beast of burden, a companion-hunter and a protector.

*Industries.* Flint, obsidian and pipestone were used by the Indians in making most of their implements, such as knives, spears, fish-



AMERICAN INDIANS

1. Mandan.  
2. Blackfoot.  
3. Dakota.

4. Y. Indian.  
5. Sioux.  
6 and 7. Pueblo.

8 and 9. Mexican.  
10. South American.  
11. Apache.

12. Bella Coola.  
13. Eskimo.





hooks, sewing needles, axes, pots, bowls, mortars and pipes. Many of these were cut out with considerable skill and were handsomely decorated. Some tribes made an article of pottery from clay, and though they did not understand how to glaze it, yet some of their work was capable of taking a high polish. From rushes and grass and the fibers of various plants, such as hemp and cotton and their like, they wove coarse fabrics, and some tribes constructed household utensils with marvelous skill; for instance, baskets of graceful shape, beautified by antique designs, were woven so closely as to be waterproof. They understood the art of preserving skins and making fine leather from them. This and all other industries were practically in the hands of the women, for the men considered it a disgrace to labor.

*Games and Amusements.* Boys and girls played happily very much as their white brothers and sisters do, imitating in their childish way the labors and amusements of their elders. The girls had dolls, often dressed skilfully in the costumes of grown men and women; while the boys played with bows and arrows, walked on stilts, wrestled among themselves or went on mimic hunting and fishing expeditions. The adults, too, were fond of amusements, most frequently of an athletic type. They played ball, ran races, wrestled, danced, feasted and told stories, and many times neighboring tribes joined in exciting contests. They sang on all occasions, but their music was coarse and rude, being in fact, little more than monotonous chants. They had rude drums, whistles, rattles and flutes, all of which were more noisy than musical. Betting and gambling were very common among the men, who frequently lost all their possessions when luck was against them.

*War.* The highest ambition of a youth was to be a great warrior, for the tribe celebrated the deeds of its leaders and kept a record of their valiant doings. In most instances the Indians were courageous to a degree, wore no armor and fought savagely with bows and arrows or knives, hatchets and spears of stone. The Indians usually scalped the dead, and the victors put their captives to death, sometimes with cruel torture. Occasionally, however, these captives were adopted by the victors and became loyal members of the tribe that had subdued them. The victorious fray was always celebrated with feasting

and dancing, and sometimes the flesh of conquered braves was eaten by the victors in the belief that the virtues of the dead would be transmitted to the living.

*Burial.* Though the customs varied in different localities, yet great respect was paid to the dead, and efforts were made to preserve the bodies and protect them from indignity. Usually the favorite possessions of the deceased were buried with him, sometimes in the earth, but occasionally on platforms among the trees.

*Government and Religion.* It is difficult to give any account of the government and religion which will apply to all the tribes, but in general each tribe was composed of a number of related families or clans. The oldest man in each clan was its leader and ruler, and in turn the oldest head of a clan was the chief of the tribe. Marriages among members of immediate families were forbidden, but there were rarely any marriages outside the members of a tribe, except in those cases where tribes were gathered in a confederacy. Children usually belonged to the mother and were cared for by her relatives, so that a man kept ward over his sister's children rather than his own. Laws were very strict, and punishments were severe. Land was not owned by individuals, but personal property was so held. The limited rights of woman were respected, especially in the household, but the man was supreme. Some tribes held slaves, but the practice was far from common.

For the Indian there was no supreme god; each tribe had its own spirit, that was its special patron. Every living thing was inhabited and controlled by a spirit. The sun, moon and stars were the great spirits; the wind was the breath of the gods, and rain and snow were poured upon the earth by the kindly spirits. The animal or plant which was to any particular tribe most important might become the chief spirit for that tribe, as, for instance, on the plains the buffalo held this rank. The priest and the medicine man were one and the same person, in his latter capacity curing by charms and ceremonies because of his priestly characteristics. While a few simple remedies were used, yet each Indian carried his private charm, which was supposed to protect him from injury and assist in his cure when ill.

*Tribal Families.* The Indian tribes of North America may be gathered into a num-

ber of families which show some relationship in language and various habits and customs. The principal families are the Algonquian, Athapasean, Caddoan, Iroquoian, Muskho-gean, Shoshonean and Siouan.

**Mexican and Central American Indians.** At the time the Spanish invaded Mexico and Central America, they found there many tribes having a civilization almost the equal of their own. These Indians built permanent houses of squared and polished stone, had a written language and many books, knew something of arithmetic and a little of astronomy. They made finely woven cloths, brilliant feather work and beautiful ornaments of gold and silver. Of iron they knew nothing. Their religion, bloodthirsty and cruel, was characterized by human sacrifices, and their priests exerted a power little less than that of the king himself. In contrast to these, the Indians of Lower California were the most degraded savages known.

**South American Indians.** Along the western coast of South America, from a few degrees north of the equator to 25° south of it, were several tribes with a civilization equal to that of the Aztec in Mexico. They built great palaces, the ruins of which still exist, and ornamented them with fine work in gold, silver and bronze. The conquering Spaniards were amazed at the skill of the Indians and carried away with delight vast quantities of their ornaments. The tribes of the tropical regions bordering the Amazon and Orinoco were wild and savage. They knew nothing of work, for the climate made clothing and shelter almost unnecessary, and the streams and forests produced food for the taking. Most of them were fierce cannibals, who did not preserve the scalps of their enemies, though in some cases the entire head was kept. The pampas Indians to the south were more like the plains Indians of the United States. They were not civilized, but had large herds of domestic animals and lived principally upon meat. See accompanying color plate.

**Present Condition in the United States and Canada.** In both of these countries the Indians are gradually adopting the customs of the white man. In the United States the problem of dealing with the nation's "wards" has been very serious. As settlement proceeded westward the Indians were steadily dispossessed of their lands, the government having adopted the policy of making treaties

with the tribes whose holdings were acquired. Resentment on the part of the Indians because of fancied or real injustice has occasioned numerous wars, but there have been no outbreaks since 1886, when the Apaches surrendered. Since 1849 the conduct of Indian affairs has been managed by a bureau in the Department of the Interior. It has been the policy of the government of late years to encourage the Indians to give up their tribal relations and to become citizens of the United States; in 1917 the Commissioner of Indian Affairs made the following statement:

"The time has come for discontinuing guardianship of all competent Indians. Every Indian, as soon as he has been determined to be as competent to transact his own business as the average white man, shall be given full control of his property and have all his lands and moneys turned over to him, after which he will no longer be a ward of the government. This means the ultimate absorption of the Indian race into the body politic of the nation, and the beginning of the end of the Indian problem."

A practical working out of the government policy is shown in the history of the Five Civilized Tribes.

Indian affairs throughout Canada are administered by the Dominion government, under authority granted by the British North America Act. At the head of the Department of Indian Affairs is an official known as superintendent-general. All property held for the Indians can be sold or leased only with their permission, and if such transfers of property take place the money received is carefully invested for them. In certain provinces Indians who meet specified qualifications are permitted to vote. Government inspectors visit the different Indian agencies at intervals to see that the interests of the Indians are properly safeguarded.

**Indian Education.** In both the United States and Canada the Indians are given opportunity to attend schools under government supervision. In 1917 the United States government was supporting 107 boarding schools and 210 day schools for them. The Indians, both boys and girls, are taught not only the common school subjects, but various vocational branches. In addition to the government schools there are about seventy-five mission schools, conducted by various churches and religious societies. The Carlisle Industrial and Training School was abandoned in 1918. In Canada government aid is extended

# THE AMERICAN INDIAN

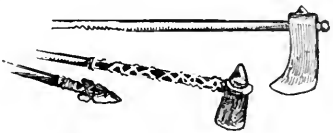

EARLY WEAPONS



WIGWAM  
INDIAN DWELLING PLACE

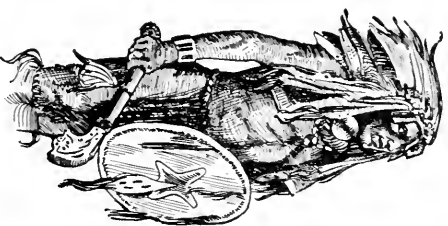

TYPE OF INDIAN WARRIOR

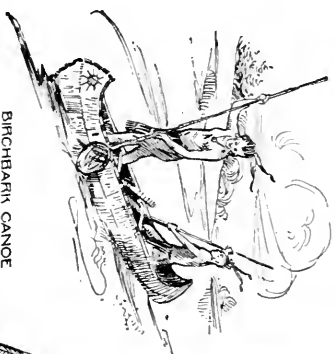

BIRCHBARK CANOE

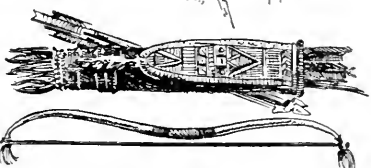

LATER WEAPONS



SNOWSHOE

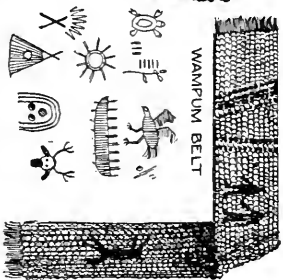

WAMPUM BELT

PICTURE WRITING

## SUBJECTS FOR STUDY

|                   |                     |                  |
|-------------------|---------------------|------------------|
| ORIGIN            | HABITS              | ENDURANCE        |
| NUMBER            | INVENTIONS          | HIEROGLYPHS      |
| ETHNOLOGY         | MONEY               | GOVERNMENT       |
| CIVILIZATION      | DOMESTIC LIFE       | TRIBAL RELATIONS |
| PROGRESS          | CULTIVATION OF SOIL | FAMILY RELATIONS |
| EDUCATION         | OCCUPATION          | CLANS            |
| CHARACTERISTICS   | MODE OF TRAVEL      | DWELLINGS        |
| APPEARANCE        | LANGUAGE            | WEAPONS          |
| AGE               | RECORDS             | DIVISIONS        |
| SIZE              | ARCHAEOLOGY         | SAVAGE           |
| PERPETUAL WARFARE | RELIGION            | BARBAROUS        |
| DISPOSITION       | HAIF CIVILIZED      |                  |



THE CALUMET  
THE PIPE OF PEACE

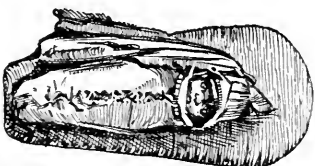

A FAPOOSE

to denominational schools, and most of the institutions are controlled by religious bodies. There are about 7,000 Indians in school in the Dominion.

**Indian Reservations** are territories set aside for the Indians. In Canada they are known as *reserves*. Residents in such areas are under special government protection, and whites are not permitted to settle on their lands. Schools are maintained in the reservations, and the Indians are taught the customs of civilization, though they retain their tribal relations. In the United States the reservations are gradually disappearing as the Indians are being incorporated into the body politic as citizens. When a reservation is closed, each member of the tribe within it is given a tract of land, and what is left is divided up and sold to white settlers, the proceeds being given to the Indians.

**Related Articles.** Consult the following titles for additional information:

INDIAN TRIBES

|                       |              |            |
|-----------------------|--------------|------------|
| Algonquian            | Huron        | Onondaga   |
| Apache                | Illinois     | Osage      |
| Arapaho               | Inca         | Ottawa     |
| Assiniboin            | Iowa         | Pawnee     |
| Athapascan            | Iroquoian    | Pequot     |
| Aztec                 | Kaw          | Pima       |
| Blackfoot             | Kickapoo     | Potawatomi |
| Catawba               | Kiowa        | Pueblo     |
| Cayuga                | Klamath      | Quapaw     |
| Cherokee              | Kootenay     | Sac        |
| Cheyenne              | Makaw        | Seminole   |
| Chickasaw             | Mandan       | Shawnee    |
| Chinook               | Maya         | Shoshonean |
| Choctaw               | Modoc        | Shoshoni   |
| Comanche              | Mohave       | Sioux      |
| Cree                  | Mohawk       | Sioux      |
| Creeks                | Mohegan      | Tuscarora  |
| Crow                  | Mohican      | Ute        |
| Delaware              | Munsee       | Wampanoag  |
| Five Civilized Tribes | Muskogean    | Winnebago  |
|                       | Narragansett | Yakima     |
| Five Nations          | Navaho       | Yaqul      |
| Flathead              | Nez Percé    | Yuma       |
| Fox                   | Ojibwa       | Zuni       |
| Hopi                  | Oneida       |            |

MISCELLANEOUS

|                  |                    |
|------------------|--------------------|
| Atahualpa        | Pizzaro, Francisco |
| Black Hawk       | Pocahontas         |
| Erant, Joseph    | Pontiac            |
| Calumet          | Powhatan           |
| Cortez, Hernando | Sitting Bull       |
| Gerónimo         | Sun Dance          |
| Hiawatha         | Tecumseh           |
| King Philip      | Tomahawk           |
| Massasoit        | Totem              |
| Montezuma        | Wampum             |
| Osceola          | Wigwam             |

**INDIAN SUMMER**, the name applied to a short season of fair, warm weather which occurs in the late fall in temperate latitudes. It lasts from one to three weeks, and may occur three or four times in a season. On the North American continent it comes in October or November. The air is usually very dry at such times, and forest fires and prairie fires are frequent. In Europe a corresponding season has been variously called "Saint

Martin's summer," "old woman's summer," and "all-hallow summer." The term *Indian summer*, however, has come to be generally used.

**INDIAN TERRITORY**, a former territory of the United States, set aside between 1820 and 1830 by the government as a permanent home for the American Indians, who were being steadily driven from the rapidly-developing East. The principal occupants of the territory were the Cherokees, Creeks, Chickasaws, Choctaws and Seminoles. Here they established their governments, maintained their own institutions, and prospered under the fostering care of the United States. By 1889 there was no longer reason for continuing a separate organization for them, for they had become civilized and well-to-do, and many had become citizens of the United States. In the latter year Indian Territory was merged into the new state of Oklahoma (which see).

**INDIA RUBBER.** See RUBBER AND RUBBER MANUFACTURE.

**INDICTMENT**, *in dite'ment*. See JURY AND TRIAL BY JURY; PROCEDURE.

**INDIGESTION.** See DYSPEPSIA.

**INDIGO**, a genus of plants and the blue coloring matter obtained from some of the



INDIGO PLANT

species. The plant is a tall herb of the pea family. That yielding the indigo of com-

merce is native to India. It is about five feet high. The coloring matter is obtained from the leaves and stems, which are cut in mid-summer, boiled and allowed to ferment under water. The liquid is then drawn off and beaten, in order that it may mix with oxygen, after which it is allowed to stand for some time. When the indigo settles to the bottom, the water is then drawn off and the indigo is cut and pressed into cubes, in which form it appears on the market. Commercial indigo contains from fifty to sixty per cent of pure indigo blue, the remainder consisting of substances called indigo gluten, indigo yellow and indigo red. Indigo dyes are made by dissolving the coloring matter in liquids containing more or less ammonia or some other alkali. They are used in coloring silk, cotton and woolen goods and in calico printing. See CALICO PRINTING; DYEING.

**INDIGO BIRD**, or **INDIGO BUNTING**, a North American bird of the finch family, which ranges from Canada to the Gulf. In winter it is often seen in Southern Mexico, in Cuba and as far south as Panama. The male is a bright indigo, with a greenish back; the female has brown plumage, and her back is slightly streaked. The birds are easily tamed, and are beautiful songsters.

**INDIUM**, a metal which leaves a mark on paper like that of lead. It is silver-white in color, and soft. The metal is related to cadmium and zinc, and its spectrum exhibits two characteristic lines, one violet and the other blue. Indium was discovered in 1863 by Reich and Richter in the zinc-blends found near Freiburg, Germany.

**INDO-CHINA**, a name sometimes given to the southeastern peninsula of Asia, comprising Burma, Siam, Cambodia, French Cochin-China, Tongking, Anam, Laos, Malacca and the Shan country.

**INDOOR BASEBALL**, a popular gymnasium game, differing little in character and purpose from the outdoor game, except as it is of necessity modified to suit the small area on which it is played. A floor forty by fifty feet is almost a necessity, but the exact shape and size does not matter. The ball, which weighs eight and one-half ounces, is about seventeen inches in circumference, and the bat is smaller than the one used in the outdoor game. There is a national indoor baseball association in the United States, which regulates the game and formulates the rules under which it is played. See BASEBALL.

**INDUCTION**, *in duk'shun*, in logic, the process of reasoning from a part to the whole, from the particular, to the general, from the individual to the universal. It is the counter-process to deduction (which see). In inductive reasoning we proceed from the known to the unknown and obtain a conclusion much broader than the premises. Many important laws of natural science have been formulated from the observation of individual cases. For example, Galileo discovered the law, by dropping balls of various weights from the leaning Tower of Pisa, that all falling bodies travel through space with the same rate of speed. Sir Isaac Newton worked out the law of gravitation by pondering over the fact that unsupported bodies fall to the earth. According to a well-known story, his line of thought was started by his observing an apple fall from a tree. In logical induction, therefore, the mind works from particular cases to a general theory.

**INDUCTION, ELECTRIC**, the process by which an electrical conductor or a magnetizable body becomes electrified or magnetized in the presence of an electrically-charged body. If a body charged with either positive or negative electricity is brought near an uncharged insulated conductor it magnetizes the side farthest from itself with its own kind of electricity, and the side nearest with an unlike electrical charge. The Leyden jar owes its high electrical potential to the mutual induction between its inner and outer coatings of tinfoil, the one positively charged, the other negatively. See ELECTRICITY, subhead *How Electricity Travels*; LEYDEN JAR.

**INDUCTION COIL**, an instrument for increasing the strength of an electric current. The principal parts of the coil are the *core*, *A*, made of a bundle of soft iron wire; a short *primary*, or *inner*, coil, *B*, of coarse

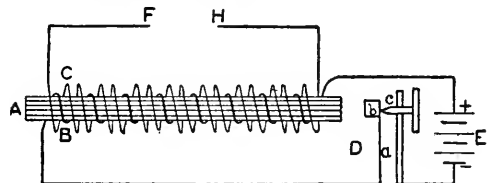

wire; a long *secondary*, or *outer*, coil, *C*, of fine wire; an *interrupter*, *D* and the *battery*, *E*. The coils are copper wire, carefully insulated with coats of varnish or some other non-conducting substance.

The interrupter consists of a spring, *a*, to the upper end of which is soldered a small piece of soft iron, *b*, against which a screw, *c*, presses. The screw is tipped with a fine platinum point. When not in action, the end of the spring rests against the platinum point. As soon as the current passes through the primary coil, the core, *A*, becomes magnetized and attracts the piece of soft iron, but as soon as this touches the core, the magnetism ceases and the spring recoils to the platinum point. Thus the circuit is alternately opened and closed with great rapidity. The current in the primary induces a current of a higher potential in the secondary coil. Electro-motive force is thus induced in the secondary coil at each make and break of the circuit. When the opposite ends of the coil, *F* and *H*, are brought near each other, a spark passes between them. Induction coils are used chiefly in producing X-rays and in wireless telegraphy. See ELECTRO-MAGNETISM.

**INDUCTIVE METHOD**, in pedagogies, that method of instruction which proceeds from the individual to the general notion, or from separate ideas, gained through observation, to definitions, rules and classifications. It is also called the observational method and the method by discovery. Children obtain their first knowledge by observation and experience; hence they learn inductively, and from the comparison of ideas thus gained they form certain conclusions or class ideas, such as that a body without support will fall, fire is hot, two and two are four. In a similar manner, by the inductive method the child learns the principles of number and is led to formulate the rules for addition, subtraction, multiplication and division. In nature study he proceeds through the examination of plants and insects and other objects to discover certain facts common to all the objects of each class, as, that plants have leaves and insects have heads and legs.

In the study of geography by the inductive method, the pupil would begin with the study of objects immediately about him, such as the forms of land and water and the plant and animal life around the schoolhouse and in the neighborhood. From this he would proceed to the study of the township and the county. During the progress of the study he would be led to classify and name those objects that are alike, such as hills, valleys, creeks and meadows. Having learned these

classifications, later he would be able to apply them in the classification of similar ideas which he might obtain through reading descriptions of places which he has never seen.

The inductive method is the method best suited to instruction in primary grades. It conforms to the child's method of learning when he enters school, trains his powers of observation, keeps him interested in his work and, above all, leads him to acquire his ideas at first hand. With few exceptions it is also the best method to use in beginning the study of any subject. It is the method pursued in all scientific investigations, and it is that this method may be followed that the higher institutions of learning, such as high schools, colleges and universities, are equipped with expensive laboratories.

But the inductive method has its limitations and cannot be used exclusively. It requires too much time to be followed all through life; hence, when pupils arrive at the age where they can reason, they should depend upon the experience of others for a part of their knowledge. For instance, in the study of grammar, more knowledge can be acquired in a given time by beginning with definitions and rules and learning their application through the study of suitable illustrations in selections of literature, than by first discovering these definitions and rules by observation and experiment. Some studies, such as higher mathematics and history, are essentially deductive in their nature and cannot be successfully studied by the inductive method. Again, conclusions reached through the inductive method may be erroneous because they are based upon insufficient observation. See DEDUCTIVE METHOD; METHODS OF TEACHING.

**INDULGENCE**, *indul'gens*, a term in the Roman Catholic Church, meaning "a remission of punishment still due for sin after sacramental absolution, this remission being valid in the court of conscience and before God; and being made by an application of the treasure of the Church on the part of a lawful superior." "Indulgence can not be obtained for unforgiven sin. Before anyone can obtain for himself the benefit of an indulgence the guilt must have been washed away and the eternal punishment, if his sin is mortal, must have been forgiven." In order to gain an indulgence the person must be a Roman Catholic and must do the work prescribed. In the Middle Ages almsgiving, pil-

grimaces and engaging in holy wars were means of obtaining indulgences. Indulgences are plenary and partial. A plenary indulgence is the total remission, and a partial indulgence a partial remission of the temporal punishment due for sin.

**INDUS**, one of the three greatest rivers of India. It rises in Tibet, north of the Himalaya Mountains at an elevation of 18,000 feet, and flows into the Arabian Sea. With its branches, the Shayok, the Kabul, the Punjab, the Sutlej and the Chenab, it drains an area of 372,700 square miles. Its delta extends 125 miles along the coast. The river is navigable from its mouth to its confluence with the Kabul River, but it is of chief economic value in irrigating the country through which it flows.

**INDUSTRIAL EDUCATION.** See TECHNICAL AND INDUSTRIAL EDUCATION.

**INDUSTRIAL SCHOOL**, a name which has been frequently applied to a class of schools intended for reformatory or philanthropic purposes, in which trades and industrial work of all kinds are taught. In such schools the industrial work is taught merely as a means of discipline, while the primary purpose is to develop character and concentration. Many states have established such institutions. These, however, are generally known by other names, as reform schools or reformatories. See TECHNICAL AND INDUSTRIAL EDUCATION; MANUAL TRAINING; REFORM SCHOOLS.

**INDUSTRIAL WORKERS OF THE WORLD**, popularly known as the I. W. W., is the name of a labor organization of revolutionary tendencies. Its growth was at first largely confined to the western part of the United States, and its greatest strength still remains in that section, but its membership has included many malcontents as far east as the Atlantic seaboard. It has about 40,000 members.

The organization was effected in Chicago in 1904, and that city has remained its headquarters. That it has nothing in common with the better class of labor unions is unmistakably shown in its platform of principles, the preamble of which recites:

"The working class and the employers have nothing in common. Between these two classes a struggle must go on until the workers of the world organize as a class and take possession of the earth and the machinery of production. Instead of the conservative motto, 'A fair day's wages for a fair day's

work, we must inscribe on our banners the revolutionary watchword, 'Abolition of the wage system.'"

The organization does not believe that agreements with employers are binding. Every earnest I. W. W. member hopes to see the employer class destroyed and himself and his fellows in possession of all industry (see BOLSHEVIKI); he feels it his duty to inflict all possible financial injury upon employers; he believes in sabotage (which see) and practices it whenever he believes it will advance his cause; he will join a strike at a moment when his employer is responsible for quick completion of production contracts.

The strength of the organization has centered about the lumber, textile and mining industries, though its influence has been felt more widely. In 1917 the I. W. W. violently opposed the nation's participation in the World War—not from motives of patriotism, but because "all war is capitalistic" and "enslaving to labor." Its energies that year were given to active antagonism of industries engaged in government work and printed propaganda intended to cripple the nation.

As a result of such disloyalty 103 members of the organization, including all leaders, were arrested and tried in Chicago, and ninety-three of them were sentenced to the Federal penitentiary at Fort Leavenworth for periods ranging from one year to twenty years. The chief official who was given the latter sentence was William B. Haywood, secretary and most prominent member of the organization.

Popular opinion has given to the I. W. W. the name I Won't Work, a humorous interpretation of the initials.

**INERTIA**, *in ur'she a*. If a person tries to stop a moving object, such as a rolling ball, or to move an object which is at rest, he must use a certain amount of muscular force, and he finds himself dealing with a property of matter which is called inertia. Scientifically stated, inertia is "that property of matter by which a body when at rest tends to remain at rest, and when in motion to continue that motion, in the same straight line or direction, unless acted upon by some external force." The amount of force required to stop a moving object depends upon the rate it is moving and the weight of the body. In other words, theoretically it requires as much force to stop it as was required to set it in motion. An inert body is one which cannot

move or cannot cease moving in a straight line unless some force acts upon it.

**INFANT.** See **MINOR.**

**INFANTILE PARALYSIS**, an infectious disease which attacks children more frequently than adults, and is feared because it tends to cause paralysis of the muscles. This disease, first recognized in 1840, caused a high death rate among American children in 1916, and its peculiarities and methods of combating it were then thoroughly investigated. The germ which causes attacks of infantile paralysis travels by routes not well understood. In fact, the source of no one case has ever been satisfactorily traced. Physicians can only urge the usual preventive methods in case of epidemics, including isolation of patients, cleanliness, careful attention to dieting, elimination of flies, etc.

A child coming down with the disease has fever (not generally above 103°), headache and irregular bowel movements. Sore throat and symptoms of a cold may accompany the early indications of an attack. As the disease develops pains are felt in the legs and feet, the neck becomes stiff and the spine sensitive. Within twelve hours there may be paralysis of the limbs, and in severe cases convulsions and delirium may be present.

No positive cure has as yet been discovered, but injection into the spinal column of a specially-prepared blood serum has been found helpful. The utmost care is needed to prevent permanent deformity of limbs affected by paralysis. Massage, electrical treatment and the use of braces or splints are among the remedies used. Such treatment should be under the direction of a reliable physician and be continued for months if necessary.

**INFANT MORTALITY.** Vital statistics compiled in all civilized countries show that the death rate among babies is far too high. Fully one-fifth of all persons who die in a specified period are children who have not reached their first birthday. In the United States the highest mortality of infants occurs among the poor foreign-born, where ignorance, poor ventilation and lack of sanitation claim many victims. The United States Children's Bureau of the Department of Labor, which is conducting a zealous campaign to reduce the baby death-rate, states that there are three groups of diseases which are responsible for the majority of deaths among infants. These groups are as follows:

(1) Digestive diseases, which cause most of the deaths of babies in summer, especially of those fed from the bottle. The causes include improper feeding, impure milk, heat, overcrowding, bad sanitary conditions, flies and carelessness.

(2) Diseases of the lungs, caused by germs that thrive on filth and bad air.

(3) Diseases due to conditions affecting the child before or at birth, caused by sickness of the parents, overwork of the mother, and improper care before or at birth.

A survey of these facts shows that individual education and concerted action on the part of the community are necessary to remedy conditions. The community must be aroused to the need of proper standards of living and the elimination of poor housing conditions. Mothers must be taught how to care for their babies, and how to take care of themselves. Some of the agencies which are working for these results are infant welfare societies, health boards, social settlements and visiting nurses associations. Those who are directly interested in the welfare of children will find helpful suggestions in the article **CHILDREN'S DISEASES.**

**INFANTRY**, the principal branch of modern armies, strongly supported in its operations by artillery and aircraft. Infantry maneuvers rapidly and fights on foot. Most of the great armies of the world have been of infantry, and we read in history of the solid phalanx, eight or ten files deep, that moved with almost irresistible force against the foe. Under modern conditions of warfare troops massed in solid formation are subjected to terrible slaughter because of the deadly force of rapid-fire machine guns and heavy artillery. Accordingly, an open or extended order of advance is now necessary with infantry, and this openness requires more perfect discipline and more individual intelligence than when the infantryman was closely supported by his comrades.

During the World War it was the habit of German officers to send their infantry against the allied armies in solid formation, hoping to crush opposition by sheer weight of numbers. Such tactics were used in the early drives of the spring offensive of 1918, when Germany was staking all on a final blow. The severe losses resulting caused an abandonment of this policy (see **WORLD WAR**). For the organization of the United States infantry in the war, see **ARMY.**

**INFECTION**, a diseased condition produced by the growth of bacteria in the body.



Every infectious disease, as scarlet fever, smallpox, diphtheria, typhoid or cholera, is propagated by some organism. These are freed from the diseased body by expectoration, coughing, breathing and various other means and are thus liable to be transmitted to others. This may be done either directly or through the contamination of drinking water or milk. See GERM THEORY OF DISEASE, and articles on various diseases.

“IN FLANDERS FIELDS.” See McCRAE, JOHN.

**INFLUENZA**, or **GRIPPE**, *grip*, an infectious disease having the symptoms of a severe cold, notably headache, chills, fever, discharges from the nose and an aching throughout the body. Ordinary attacks yield to such measures as the administration of laxatives, hot mustard foot baths (to bring on perspiration), and the administration of hot drinks and medicines containing quinine. Absolute rest in bed, warmth and quiet are necessary for speedy recovery.

**Spanish Influenza**, a virulent form of influenza which swept over various parts of the world in 1917-1918. It was so called because its ravages were in the beginning of the epidemic most serious in Spain. It caused an abnormally-high death rate both in Europe and America, and was equally a menace to World War soldiers and to civilians. Besides manifesting the ordinary symptoms of influenza, this form of the disease frequently developed serious complications, such as pneumonia, bronchitis, heart trouble and mastoid abscess.

Nearly every community in the United States adopted quarantine regulations for varying periods. People were urged to avoid crowds, to smother coughs and sneezing in handkerchiefs, to keep their homes well ventilated and to take good care of the general health. Sources of infection were secretions from the nose and throat, which were carried about in the air by dust and were transmitted both directly and indirectly. A few months after the epidemic subsided a peculiar disease developed in which the patient experienced prolonged sleeping spells, sometimes dying without regaining consciousness. Physicians were unable to determine its relation to influenza.

**INFUSORIA** *in fu so' ri a*, a class of microscopic one-celled animals, which are to be found in almost any exposed body of stagnant water. The animal has one or more hair-

like appendages near the mouth opening, which enables it to seize food. Most infusoria live free, detached lives; some, however, attach themselves to the stalks of aquatic plants or to stones. The largest are visible without a microscope.

**INGELOW**, *in'je lo*, JEAN (1820-1897), an English poet and novelist, of whose private life little is known. In 1863 she published her second volume of poems, which gained immediate and wide popularity; and some of the poems included in this volume, notably *The High Tide on the Coast of Lincolnshire* and *Divided*, have retained much of their early popularity. Later poems are *Songs of Seven* and *Poems of the Old Days and the New*. The author's novels, notably *Off the Skelligs*, *Sarah de Berenger* and *Don John*, possess much charm.

**INGERSOLL**, ONT., in Oxford County, on the Grand Trunk and Canadian Pacific railways, ten miles southwest of Woodstock. Its principal industries use wool and agricultural products as raw materials; furniture, pianos, woolens, fertilizers, oatmeal, condensed milk and flour are among the manufactures. There are nearly forty factories. Population, 1916, 5,500.

**INGERSOLL**, ROBERT GREEN (1833-1899), an American lawyer, lecturer and writer, and world-famous as an opponent of Christian orthodoxy, born in Yates County, N. Y. He began the practice of law in 1857 in Peoria, Ill., and in 1862 was made colonel of a regiment of Illinois cavalry. He was appointed attorney-general for Illinois in 1866, having transferred his allegiance from the Democratic to the Republican party. At the national convention in 1876 he leaped into prominence by an eloquent speech in favor of the candidacy of James G. Blaine. In his lectures and in his writings he attacked such common religious views as belief in a personal Deity, an actual hell and heaven, the inspiration of the Bible, the divinity of Christ, immortality and everlasting punishment. His eloquence and personal magnetism gave him an influence in favor of agnosticism second only to that of Thomas Paine, from whom he drew most of his arguments. He was the author of several essays upon literary criticism.

**INHERITANCE TAX**, a tax levied on property acquired as a legacy. Since the period of the Roman Empire this method of raising revenue has been widely employed.

In the United States there were only five states in 1918, having no provision for levying a tax on inheritances; these were Alabama, Florida, Mississippi, New Mexico and South Carolina.

These state laws differ widely in detail, but most of them differentiate between the succession of property to lineal descendants and the succession to distant relatives or those not related. The rate is usually progressive; that is, large inheritances are taxed at a higher rate than small inheritances, and there is usually an exemption varying from \$500 to \$5,000. In California a person inheriting over \$500,000 from some one to whom he is remotely related or unrelated, must pay 30 per cent of the income. During the Civil War Congress passed an inheritance tax, but it was repealed after the restoration of peace. In 1916 this form of taxation was revived as a war necessity. In 1917 the rates were fixed to range from 2 per cent on estates below \$50,000 to 25 per cent on estates of \$10,000,000 or more.

In Canada the central government imposes inheritance taxes, though the provinces are permitted to levy them. Courts have held that deathbed gifts, made obviously to avoid the inheritance tax, are liable the same as any other part of the estate.

**INITIATIVE**, *in isk'i a tiv*, a device in government originating in Switzerland by which the people may take the first step in law-making, and may thus acquire laws which ordinarily might be denied them by a reluctant legislature. The initiative aims not to abolish the usual law-making bodies, but to supplement the work which they do. In 1918 more than twenty states possessed some form of initiative legislation.

Such laws differ in detail, but in general they provide that a small percentage of the voters of a state, generally from 3% (in Ohio) to 25% (in Arizona), may petition for special legislation, the exact form of the law desired being a part of the petition. According to the usual method, the measure must then be brought, without amendment, before the legislature. In some states, if the legislature gives an adverse vote the measure is dead; in others it is then brought before the people, and if carried by them becomes a law without legislative interference; the governor has no veto power in such cases. According to another method, which has not as yet become very firmly established, after

the initial petition has been filed the proposition is submitted directly to the people.

The initiative has become popular in city governments, where it is somewhat simpler in its operation than in state affairs; several states permit initiative privileges in cities while denying them to the rest of the state. Oregon was the first state to embody initiative provisions of the most advanced kind in its constitution (1902), see **RECALL**; **REFERENDUM**.

**INJUNCTION**, in American law, a writ issued under the seal of a court of equity to restrain a person known as the defendant from doing, or to order him to do, something contrary to his wishes. Thus an injunction may be issued to prevent a man from turning a stream of water from its course, to restrain a street-railway company from laying tracks on a street without gaining permission of the property owners, to restrain a person from transferring property, or to compel a man to stop the construction of a fence which he is building on land claimed by another. An injunction is temporary in its immediate effects; its provisions must be respected until a general hearing can be conducted. When the merits of the case are presented, if the court concludes that the petitioner's grievance is justified in law the injunction will be made *permanent*, and its provisions must be obeyed. If the petition seeks to impose unlawful measures against a defendant the court will reject it by dissolving the injunction. Disobedience of an injunction constitutes contempt of court (see **CONTEMPT**).

**INK**, a colored fluid used in writing and printing. The black writing ink of commerce is the most common kind. It is made from nut galls, copperas, gum senegal and water. Twelve pounds of nut galls, five pounds of copperas and five pounds of gum make twelve gallons of ink. In much of the ink placed on the market, logwood takes the place of nut galls, since it is somewhat cheaper. The iron in the copperas acts upon the tannin in the solution of nut galls and on exposure to the air turns this black. This is the reason why ink turns dark as it dries. The so-called writing fluids contain little or no coloring matter except such as is formed by the union of the copperas with the tannin, but inks usually contain other coloring matter, so that they can be more readily seen when applied to paper.

Colored inks are prepared by dissolving various dyes in water to which a solution of gum arabic or some other gum is added. Red ink is made from Brazil wood or carmine or aniline dye. Blue ink is colored by Prussian blue. Green ink is usually made from the aniline dye. Copying inks contain a small quantity of glycerine or sugar to prevent their rapid drying and to enable them to stick to the copying paper.

Printing ink is made by mixing the best quality of lampblack with boiled linseed oil, to which a small quantity of soap and rosin has been added. This ink is thicker than paint and is thoroughly mixed and ground, making a preparation that will flow readily over the ink rollers and spread evenly upon the type. See PRINTING.

**INLAND REVENUE.** See INTERNAL REVENUE.

**INNESS, in'is, GEORGE** (1825-1894), one of the greatest landscape painters America has produced. He was a pioneer, in a way, branching out into new and original expression in the portrayal of nature. His earlier pictures show influence of the Barbizon School, but those of his maturer years lean toward the impressionistic ideal. All show a fine poetic feeling for light and color. In his later work form is subordinated to atmospheric effect. The objects in his scenes have no individual value apart from the whole, but all melt together to form a harmonious ensemble.

Inness was born at Newburgh, N. Y. He had little instruction of value until he went to Paris in 1854. On returning to America he opened a studio at Brooklyn, N. Y. Later he moved to Medfield, Mass., where he painted *Medfield Meadows*. In 1862 he went to live at Eagleswood, N. J., and the last years of his life were spent in or near New York City. Inness was honored both at home and abroad. He was a member of the National Academy and of the Society of American Artists. His *American Sunset* was chosen as a representative work of American art for the Paris Exposition of 1867. A fine collection of his paintings is owned by the Art Institute of Chicago; a smaller collection is in the Metropolitan Museum, New York; his two landscapes *Georgia Pines* and *Niagara* are in the National Gallery, Washington. See BARBIZON PAINTERS; IMPRESSIONIST SCHOOL OF PAINTERS.

**INNOCENT**, the name of thirteen popes, the third of which was most prominent in history.

**Innocent I**, was Pope from 402-417. During the pontificate the Holy See developed relations with other Churches, both Eastern and Western. He maintained the right of the Roman bishop to hear appeals from other churches, and his letters contain numerous assertions of unlimited jurisdiction. After Rome was plundered by Alaric, Innocent undertook to repair the damage done to the churches. He espoused the cause of Saint Chrysostom, who had been unjustly deprived of the See of Constance. He governed the Church well for more than fifteen years, and after his death was canonized.

**Innocent II**, was Pope from 1130 to 1143. He was opposed by a faction of the cardinals who set up Anacletus II as antipope. In 1133 he was installed in the Lateran at Rome by Emperor Lothair, but did not gain undisputed possession before the death of Anacletus in 1138. In 1139 he held the second Lateran Council and confirmed the condemnations pronounced by several previous councils on Abélard and the followers of Brescia.

**Innocent III**, after a distinguished career as a student at Rome, Paris and Bologna, was made cardinal, and eight years later, at the age of thirty-eight, he became Pope. He was the greatest Pope of the name, and held office from 1198 to 1216. The chief aim of his ecclesiastical policy was to vindicate the Papal claim of the supremacy of the Church over the State. He began with the restoration of the Papal authority in Rome, but soon extended his influence to all parts of Europe. He forced Philip Augustus of France to take back his repudiated queen; instituted the fourth Crusade, which resulted in the capture of Constantinople from the Greeks and the establishment of the Latin Empire; compelled John of England to acknowledge the feudal sovereignty of the Pope and pay an annual tribute; instituted the crusade against the Albigenses in 1208 and presided at the celebrated Lateran Council in 1215. He was, moreover, an energetic worker for public and private morality and lent his influence to the advancement of every good cause. He died in the midst of labors to promote peace among the Italian cities.

**Innocent XI**, who was Pope from 1676 to 1689, was an energetic and judicious reformer. Throughout his pontificate he was involved with Louis XIV in conflicts, of which the most serious arose when the Pope attempted to put an end to the king's practice of keeping sees vacant and appropriating their revenues. The French clergy expressed their views of the matter in their Four Propositions of the Gallican Clergy.

**Innocent XII**, after filling a number of important diplomatic posts, was made a cardinal by Innocent XI and was elected to the Papacy after a session of the conclave lasting nearly six months. During his Papacy (1691-1700), he brought about a reconciliation with

France after the French clergy had retracted the Four Propositions.

**INNOCENTS, FEAST OF HOLY**, variously styled by the Roman Catholic Church *Innocents' Day* and *Childermas*, a festival observed in commemoration of the massacre of the male children of Bethlehem by order of Herod (*Matthew II, 16*). The celebration in some churches is on the twenty-eighth day of December, in others on the twenty-ninth.

**INOCULATION**, *in ok u la'shun*, in medical practice, a minor operation for the prevention and cure of certain infectious diseases. A specially-prepared substance is injected into the tissues or fluids of the body. This substance has the power of destroying the poisonous germs then present in the system or which may later be present, and it consists usually of a weakened culture of germs causing the disease. Vaccination to prevent smallpox and injection of antitoxin to prevent diphtheria are examples of preventive inoculation. Injection of a substance to cure a disease already developed is called *curative* inoculation. An example is the use of Flexner's serum for the cure of cerebrospinal meningitis. Through the instrumentality of inoculation typhoid fever and smallpox were almost eliminated in the armies of the fighting nations during the World War. In 1918 physicians were at work on the preparation of a serum to prevent influenza and pneumonia, two diseases that caused many deaths among the soldiers.

**INQUEST**, *in'kwest*, a legal inquiry into the cause of death of any person when the cause has not been attested by a physician as natural. The investigation is in charge of the coroner (which see), who impanels a coroner's jury of six men. Under his direction the jury seeks for facts by calling witnesses, who testify under oath. Their verdict may declare that a crime has been committed, and it may order that suspected persons be held for trial; or, it may not be possible to reach conclusions which warrant criminal action. Suspected persons may testify in their own behalf at an inquest.

**INQUISITION**, *in kwi zish'un*, THE, an ecclesiastical court in the Roman Catholic Church, officially known as the Holy Office, for the discovery and suppression of heresy. In the early ages of Christianity, civil as well as ecclesiastical government rigidly opposed all heresy. A person suspected, or discovered to be guilty, of heresy was liable

to be arrested and detained in prison to await trial by the judges. The proceedings were usually conducted secretly. The suspect had the right to make known his enemies, whose evidence would be excluded, but a confession of guilt was sometimes extorted by torture, though such a confession, in order to be accepted, had to be repeated afterwards without torture. As a punishment, those convicted had to make pilgrimages, wear some badge, as the yellow cross, as a mark of disgrace, or be sentenced to imprisonment and, in extreme cases, to death (see HERETIC). The death penalty could, however, be inflicted only by the State and was resorted to in comparatively few cases. Thus, between 1308 and 1322 out of 636 persons convicted of heresy only 40 were condemned to death.

From the time of Constantine the doctrines of the Church were regarded as the basis of social order and the bulwark of thrones. Those who opposed them were therefore regarded as the enemies of both. A ruler was required to enforce the laws of the Church as part of his duty as a Christian. If he refused to do so, he might be excommunicated or even deposed. After the formation of the Nicene Creed, Constantine made strenuous efforts to suppress all dissent from the principles laid down therein. He punished the Donatists with fines and confiscation and caused the books of the Arians to be burned. His successors for several centuries cooperated with the bishops in discovering and punishing heresy. The measures resorted to were usually mild and yet quite effective. In the East, from 385, heresy was legally punishable by death, but this sentence was seldom delivered. In the twelfth and thirteenth centuries, the spread of certain heretical sects—as the Albigenses and Waldenses—roused the Church to a realization of the necessity of increased vigilance. Finally, a permanent court, confined chiefly to the Dominican order, was instituted, its duty being to deal with this branch of the work of the Church.

In Spain the Inquisition developed into an organization whose work is generally condemned by Protestants and Catholics alike. There are, however, those who are inclined to defend it and who hold that the facts have been grossly misrepresented in history. One concession must in all justice be made—that many of the cases tried by the Spanish In-

quisition were not really heresies, but, rather, crimes such as would now be brought into the ordinary civil courts, and the punishments inflicted were probably in many cases just. An ordinary tribunal similar to those of other countries had existed in Spain from an early period. The rulers Ferdinand and Isabella, because of a Jewish plot to overthrow the government, obtained permission from the Pope to reorganize the Inquisition, reserving, however, the right of appointing the inquisitors and of controlling the entire action of the tribunal. In 1480 the Cortes sanctioned the institution, and the best authorities agree that from this time on the Spanish Inquisition became a State tribunal. Its work began in 1481 and was actively conducted until the latter part of the seventeenth century. A conservative estimate places the number of executions at 4,000. The popes endeavored to mitigate the rigor of the Spanish court's proceedings, but were unable to accomplish much with the royal tribunal. Finally, in 1808, the Inquisition was suppressed, but under the Restoration it was revived. On the establishment of the Constitution, in 1820, it was again suppressed, but was not finally abolished until 1834.

In Rome and the Papal States the Church never ceased from the time of its establishment to exert a watchful control over heresy, punishing it with imprisonment and civil disabilities, but rarely, if ever, with death. Berger says there is no instance of death for heresy at Rome, and Archbishop Spalding says that it would be difficult to prove such an instance. The Congregation of the Holy Office still exists, but its chief concern now is with the suppression of heretical literature.

**INSANE' ASYLUM, or HOSPITAL FOR THE INSANE**, an institution established for the treatment of persons who are mentally unsound. Many of these are public institutions, under the care of the state or county in which they are located, and are supported by taxation; others are established by charitable persons and are given large endowments; a third class consists of private institutions, in which patients are kept at fees proportionate to the accommodations they receive.

Whether public or private, such institutions are now under strict control of the government and are frequently visited by of-

ficials, who see that the patients are kindly and properly treated. Formerly, the insane were considered as little better than wild beasts, and many hospitals were places of unmitigated cruelty, but now everything possible is done to make a patient's life pleasant; force is not used except when necessary, and the nurses and attendants are trained in their work. The result of such conditions has been manifest, not only in the increased comfort of the confined patients, but in the large numbers of cures that have been effected, even of cases that were once considered hopeless.

**INSANITY**, a general term applied to every form of mental disorder, whether consisting of a total lack or loss of understanding, as in idiocy, or in the diseased state of one or several of the faculties. Medical writers have adopted different systems of classification, but perhaps the most convenient is that which includes all mental diseases under the four heads of mania, melancholy, dementia and idiocy.

*Idiocy* is a condition of feeble-mindedness. The victim is below normal in intelligence, and is incapable of intellectual development.

*Dementia* is marked by a confusion of thoughts, loss of memory, childishness, diminution or loss of will power and general weak-mindedness.

*Mania* is characterized by the disorder of one or several of the faculties or by blind impulses to acts of fury.

*Melancholy*, or *melancholia*, consists in a depression of spirits; the mind is so occupied by dark forebodings that by degrees it becomes unable to judge rightly of existing facts, and the faculties become disturbed in their functions. Sometimes melancholy ceases of itself or is cured by medical aid, and in other instances it progresses to death. Not infrequently the patient is led to suicide.

The causes of insanity are numerous; the most common, as shown by the records of state hospitals for the insane, are loss of friends, business troubles, overwork, religious excitement, alcoholism and a great variety of physical causes arising from disease or vicious habits. There can be no sudden cure of insanity by the use of drugs, and the treatment of cases must vary according to the causes which produced the malady. It is estimated that more than half of the cases of mania and melancholia recover, though certain other forms are never curable. In civi-

lized countries provision is made for the cure of insane patients in well-appointed hospitals, where skilled attendants may give each sufferer the best attention. See INSANE ASYLUM.



**I**NSECTICIDES, *in sekt' i sidez*, AND FUNGICIDES, *fun'jy sidez*, preparations for destroying insects and fungi injurious to plants. The preparations for destroying insects are known as *insecticides*, and those for destroying fungi as *fungicides*. Sometimes the same preparation is suitable for both purposes.

**Insecticides.** Insecticides need to deal with two classes of insects, those that live upon the outside of the plant, such as caterpillars, and those that live by sucking the sap of a plant, such as plant lice; preparations which are suitable for the first class of insects have no effect upon the second. Insects which feed upon the leaves or other plant tissues may be destroyed by some preparations containing arsenic. The most valuable of these are the following three mixtures, according to the best authorities:

**Arsenic Solution.** This is prepared by adding to four ounces of Paris green two pounds of slaked lime and forty gallons of water. This makes a good solution for spraying.

**Kedzie Mixture.** This is prepared as follows: Boil two pounds of white arsenic with eight pounds of sal-soda (carbonate of soda) in about two gallons of water, until the arsenic is dissolved. Put this solution into a jug and keep it corked. It is a stock solution, to be used as needed. For spraying, slake two pounds of fresh lime. Add this and one pint of stock solution to forty gallons of water and mix thoroughly. The stock solution is intensely poisonous and should be labeled poison and kept in a secure place.

**Kerosene Emulsion.** This is the best mixture for the sucking insects. To prepare it, dissolve two pounds of hard soap in a gallon of boiling soft water, add two gallons of kerosene and mix thoroughly. For a strong solution add to this twenty-seven gallons of water. For a weak solution add forty-five gallons of water.

**Fungicides.** Fungi can be divided into two classes, those that grow on the outside of a plant and those that grow on the inside and appear on the surface only when full-grown. The fungicide must be adapted to the nature

of the growth. The following are the most useful preparations in destroying fungi:

**Sulphur.** This is a common fungicide of the hothouse. It is used by sprinkling it on a surface sufficiently warm to vaporize it. This deposits the fine sulphur powder or flowers of sulphur on the plants, and when the work is successfully done the results are satisfactory. Care should be taken not to ignite the sulphur, since gases from its burning will destroy the plants as well as the fungi.

**Bordeaux Mixture.** This is prepared as follows: Dissolve four pounds of copper sulphate (blue vitriol) in four gallons of water, by suspending the sulphate in a bag in the water. Slake four pounds of fresh lime in five gallons of water. Pour these solutions into thirty gallons of water and mix thoroughly. For delicate plants, such as peach trees and those having young foliage, an extra pound of lime and twenty-five gallons more of water should be added.

**Copper Carbonate Solution.** This is prepared by dissolving an ounce of copper carbonate in one pint of ammonia and adding ten gallons of water to the solution. This solution will not discolor foliage and is nearly as effective as the Bordeaux mixture.

Insecticides and fungicides should be applied with the greatest care. The work is most successful when the application is in the form of a spray. The apparatus required is a force pump and a hose having a nozzle constructed especially for the purpose. The spray should be so fine that it will touch all parts of the plant and moisten them, but will not throw a sufficient quantity of liquid to cause it to run down. In spraying tall trees, as apple trees, ladders are necessary. Plants should be sprayed when the condition indicates that the insect or fungus is making its appearance. These conditions must be determined by the orchardist; but he should observe one very important principle, which is, never spray while the blossoms are on the trees.

**INSECTIVORA**, *in sec tiv'o rah*, from two Latin words, *insectum*, meaning *insect*, and *vorare*, meaning *to devour*, is the name applied to a class of mammals that feed chiefly on insects. Most of these animals are small. They hunt their prey at night and are provided with teeth well adapted for breaking the shell covering insects. They are of value to farmers in preventing an overwhelming increase of insect pests.

**Related Articles.** Consult the following titles for additional information:

|          |       |
|----------|-------|
| Hedgehog | Mole  |
| Insects  | Shrew |

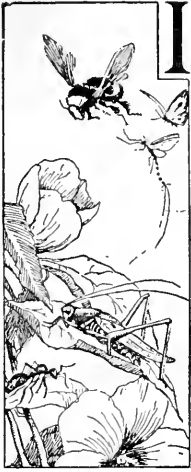

**I**NSECTS. Is an insect useful? Is it beautiful? Is it dangerous? No one could answer questions like these simply by saying "yes" or "no," because the class to which the name insects is applied includes thousands of different species and uncounted millions of individuals, of many degrees of usefulness, beauty and harmfulness. There is no other class in the animal kingdom, on land or in the sea, which claims so many members

as the class *Insecta*, as scientists designate it. The various species include groups that prey on fruit trees and other valuable crops, causing serious losses to the farmer, but in considering these we must remember also the beneficial butterflies and bees, which feed on the nectar of flowers and by carrying pollen from one plant to another help in the work of fertilization, and so make flowers and fruit possible. Again, many useful products are contributed by insects, including honey, silk, wax and a valuable dyestuff called cochineal. While some insects, like the mosquito and fly, are carriers of disease, others help to check disease by feeding on dead and decaying matter. Thus we see that the favorable and unfavorable things to be said about these small creatures about balance one another.

**What Is an Insect?** While an insect is generally thought of as any tiny creature that crawls about or has wings, scientists tell us that there are certain particulars that are common to insects alone, and that not all crawling creatures possess them. The spider, for example, is not an insect, though it may resemble one. Insects never have more than three pairs of legs, while the spider has four. Another characteristic peculiar to insects is the division of the body into three parts—head, thorax and abdomen—each part consisting of several rings, or segments. All insects, except a few undeveloped forms, have wings, and they are divided into seven different classes according to number and kinds of wings. These classes are named and described in the accompanying chart.

**Other Characteristics.** There are usually about eighteen segments, or rings, to each

insect, though it is not often possible to see all of them. The head is usually composed of four segments, closely joined together; the thorax, of three segments, and the abdomen, of the remaining ones. The legs are all borne upon the thorax. Each leg consists of from six to nine joints. Normally, two pairs of wings are present, but one or the other may be wanting. The wings are expansions of the sides of the second and third sections of the thorax and are attached by slender tubes. In the beetles the anterior pair of wings are hardened into protective cases, which cover the membranous posterior wings. The head carries a pair of feelers, a pair of eyes, usually compound, and the appendages of the mouth. The latter are in two typical forms, one intended for chewing, as is shown in the beetle, and the other for sucking, as is shown in the butterfly. The abdominal segments move easily one upon another, and at the extremity they are often armed with defensive organs.

The insect breathes through pores along the sides of its body, and has a well-developed digestive tract, consisting of gullet, crop, gizzard, stomach and intestine. The colorless or greenish blood runs through the body, but not in a regular system of blood vessels. The sensitive nervous system is composed of a series of knots or ganglia, placed along the lower side of the body and connected by a set of double nerve cords.

Insects are produced from eggs. When these hatch, the little animals usually show no resemblance to the insect that laid the eggs. In this, their first state, they are called caterpillars or worms, or, more accurately still, *larvae*. Of course they are not worms in the sense in which the zoölogist uses that word. They live for some time as larvae, eating heartily and shedding their tough skins whenever they become too confining. When the larva is full-grown, it goes into a quiet, resting state, unlike either caterpillar or perfect insect. In this form it is called a *pupa*, which in some species is enclosed in a silk cocoon. After resting a time in this condition, the insect emerges from the pupa as an *imago*, that is, the fully perfected form in which eggs are laid for another cycle of life. These three changes constitute what is known as a complete metamorphosis. Not all insects pass through these three stages. The grasshopper, for instance, can be recognized as a grasshopper as soon as it comes out of

## GENERAL FACTS AND CLASSIFICATION

### I. General Facts.

1. The most numerous class of animals and called insects because of the three divisions of the body—head, thorax, and abdomen—divided distinctly from each other.
  2. Never more than three pairs of legs in a perfect insect.
  3. The wings are expansions of sections of the thorax.
  4. The antennae—a pair of feelers on the head. The eyes, usually compound.
  5. Breathes through pores along the sides of the body.
  6. Produced from eggs. The three stages of metamorphosis:
    - a. The larva. Remains in this state for a time eating heartily.
    - b. The pupa. The state of rest, coming to a perfect insect. In some species it is enclosed in a silk cocoon.
    - c. The imago.
- Emerging from the pupa, the fully perfected form.
- All insects do not pass through these three forms.
7. Some possess unusual beauty, and some, remarkable intelligence.

### II. Classes.

1. The Neuroptera.
2. The Orthoptera.
3. The Hemiptera.
4. The Coleoptera.
5. The Diptera.
6. The Lepidoptera.
7. The Hymenoptera.

## PARTICULARS.

1. The Neuroptera.
  - a. So called because of the network appearance of the ribs of their wings.
  - b. Head distinct from thorax; the antennae generally slender.
  - c. Have no stings.
2. The Orthoptera.
  - a. Examples: Springtails, May flies, dragon flies, ant-lions, scorpion flies, caddis flies.
  - b. The young bear a strong resemblance to their parents.
  - c. Have four wings lying straight along the body.
3. The Hemiptera.
  - a. Examples: Crickets, cockroaches, grasshoppers, katydids.
  - b. Usually called bugs, destructive and loathsome.
  - c. The metamorphosis incomplete; the young do not resemble parents.
4. The Coleoptera. The beetle.
  - a. The mouth adapted for sucking, live on blood and juices of plants.
  - b. The largest order, 150,000 species.
  - c. Pass through a regular metamorphosis, their pupa state lasting sometimes for several years.
5. The Diptera.
  - a. Different in size, shape and characteristics. Various methods of defense.
  - b. Two-winged insects. Two families—the fly and the mosquito.
  - c. The eggs of mosquitoes laid in stagnant fresh water, 200 to 400 to a mass.
  - d. Only the female proboscis fitted to pierce the skins of animals.
  - e. The life-history of the mosquito during the summer from 11 to 14 days.
6. The Lepidoptera.
  - a. Transmission of disease by mosquitoes.
  - b. The moths and butterflies.
  - c. Their larvae injurious to vegetation.
7. The Hymenoptera.
  - a. Wings covered with minute hairs or scales, and their mouths adapted to sucking.
  - b. The gauze-winged insects.
  - c. Mouth formed for biting and sucking.
  - d. The abdomen of the female usually formed with a sting or saw, as in the case of the bee and certain species of ants.



the egg. Insects have been divided into three sections, according as they undergo no metamorphosis, an incomplete one or a complete one.

**Suggestions for Study.** The chief ends to be sought in lessons on insects should be the gaining of knowledge of their life history, and along with this an understanding of practical means for preventing the ravages of those destructive to crops. In this work the following suggestions will be helpful:

1. Only a little work of this sort should be attempted by children below the fifth grade, and this should be of the most general character.

2. In beginning the study, select insects large enough to enable the pupils readily to see the principal parts. The grasshopper, butterfly or moth are good specimens for the first lessons.

3. Place a number of the insects to be studied in a cage where the children can observe them for a few days before beginning the lessons.

The cage can readily be made by taking a box and cutting away a part or all of one side and covering the opening with a wire screen, being sure that the meshes are fine enough to prevent the escape of the insects. A few perches should be placed in the box, and the one having it in charge should see that the insects are kept supplied with fresh leaves from the plants upon which they feed. A daily sprinkling of these leaves will provide all the water necessary.

4. Prepare an insect net. To do this, procure four or five feet of No. 12 wire from a hardware store. Bend it around a flower pot or some other cylindrical object so as to form a loop about a foot in diameter, crossing the wire six or eight inches from the end and giving it two firm twists. Clamp this loop into a vise and twist the ends closely together. Take a broom handle or any other stick of similar size and fasten the twisted end of the wire to this handle. Procure about a yard of tarlatan or cheesecloth, and make a conical bag having a mouth the size of the loop. The bag should be at least two and one-half times as deep as the frame is wide, so that it will lap over easily when the insect is caught. With a little care and skill one soon becomes expert in capturing insects with this little apparatus, and it furnishes the children with a great deal of sport and outdoor exercise.

5. Provide yourself with a magnifying glass. A small microscope costing less than a dollar will answer for all ordinary purposes. The glass should be kept where it can be used by the pupils when they need it.

6. Accustom yourself to handling insects without aversion. The teacher who cringes at the appearance of a June bug or screams at the sight of a caterpillar will never succeed in giving lessons on insects, because instinctively the pupils will acquire the teacher's attitude.

7. Begin the lessons with some insect which the children are accustomed to handle, as the grasshopper or butterfly. Proceed from the study of this insect to that of another nearly as familiar and in this way lead the children by easy steps to the study of any insect that you desire to take up.

**Parts of an Insect.** The accompanying diagram shows the parts of an insect. It should be used in the same manner as the diagram showing the parts of the bird.

1. If possible, procure a number of large flies, so that every pupil in the class can have a specimen. Collect the flies without injuring them before distributing them to the class. If large flies cannot be obtained, the common house fly will answer the purpose.

2. With the specimens in hand, ask the

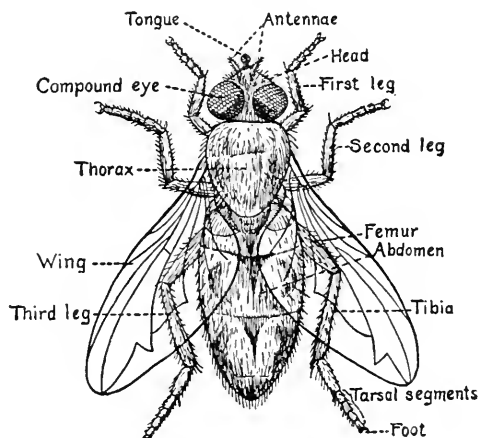

PARTS OF A FLY

children to observe the three parts into which the body of every insect is divided: head, thorax and abdomen.

3. Next call attention to the other prominent parts: legs, wings, eyes, etc.

How many legs does the fly have?

To what parts of the body are they attached?

Do all insects have the same number of legs?

The answer to this question should be left for the children to discern by examining a number of insects.

Are all the legs the same length?

Can you see any reason for the difference in length?

How many parts has each leg?

Compare these with the parts of your legs.

What sort of a foot does the fly have?

Why can the fly walk upon the ceiling and upon the vertical surface of glass?

How many wings does the fly have?

To what part of the body are they attached?

Do all the wings have the same structure?

Do all insects have wings?

Do all winged insects have the same number of wings?

How do the wings of the butterfly compare with the wings of the fly in size and structure?

Use the magnifying glass in finding answer to these questions.

Study the head in the same manner. Lead the children to observe the structure of the eyes and the tongue. Place a drop of molasses or milk where a live fly can get at it, and see how it eats.

**Danger from Flies.** The practical purpose of the study of the fly is to impress upon the class the fact that this insect is a constant source of danger to health.

1. Ask the class to study the habits of the fly.

Where are flies found in the largest numbers?

On what do they feed?

After the fly crawls over the garbage and other filth what is the condition of its feet?

When one of these insects flies from the garbage to the dinner table, what does it carry?

When this fly crawls over the food what does it leave upon it?

These and similar questions will awaken new trains of thought in the minds of many children who have always considered flies harmless.

2. Attention should be called to the rapidity with which, under favorable conditions, flies multiply.

Where does the fly lay its eggs?

When the eggs hatch, what do they form?

Upon what do the maggots feed?

How long before they become flies?

How many broods will be produced in the summer? See the article Fly.

In connection with these lessons, means of preventing the multiplying of flies and of excluding them from houses should be discussed.

**Life History of Insects.** Pupils in the older classes should learn how to study the life history of insects. These studies will require a series of lessons extending through the season and frequently through the year. The study may begin with the egg or with the mature insect, but it must continue until the cycle is completed. To illustrate: if the study begins with the mature insect, it must continue until the mature insect of the next brood is produced.

The only way to prevent the damage caused by noxious insects is first, by knowing their life history, and second by knowing how to destroy the existing broods and how to prevent the multiplying of these insects in the future. The Colorado beetle or potato bug, the codling moth and chinch bug and the gypsy and brown-tail moths and the canker-worm are good examples of insects that

should be studied in this way. See articles on these and various other insects in regular alphabetical arrangement in these volumes.

**Related Articles.** Consult the following titles for additional information:

|               |                  |               |
|---------------|------------------|---------------|
| Ant           | Codling Moth     | Larva         |
| Antennae      | Cricket          | Leaf Insects  |
| Ant-lion      | Death's-head     | Locust        |
| Aphides       | Moth             | Louse         |
| Army Worm     | Dragon Fly       | Mantis        |
| Bedbug        | Firefly          | May Fly       |
| Bee           | Flea             | Mealy Bug     |
| Beetle        | Fly              | Metamorphosis |
| Blowfly       | Gnat             | Mole Cricket  |
| Bombardier    | Grasshopper      | Mosquito      |
| Beetle        | Gypsy Moth       | Moth          |
| Boll Weevil   | Hemiptera        | Neuroptera    |
| Botfly        | Hercules         | Orthoptera    |
| Brown-tail    | Beetle           | Potato Bug    |
| Moth          | Hessian Fly      | Scale Insect  |
| Bug           | Hornet           | Scarab        |
| Butterfly     | Ichneumon        | Scorpion Fly  |
| Cankerworm    | Flies            | Silkworm      |
| Carpet Beetle | Insecticides and | Stag Beetle   |
| Caterpillar   | Fungicides       | Termites      |
| Chinch Bug    | Jigger           | Tsetse Fly    |
| Chrysalis     | June Bug         | Tussock Moth  |
| Cicada        | Katydid          | Walking Stick |
| Click Beetle  | Lace-winged      | Wasp          |
| Cockchafer    | Flies            | Weevil        |
| Cockroach     | Ladybird         |               |

**INSIGNIA**, distinguishing marks of authority, office or honor, such as the crown and scepter of a king, the shield and helmet of a knight, the banner of a warrior and the tiara and ring of a pope. Typical and characteristic signs by which the members of any trade, profession or society, or of any civil, military or religious order are distinguished, are also known as its insignia. Of especial importance are the military insignia, which are badges or devices to distinguish the various corps, arms, ranks and grades of military and naval service.

**Early Military Insignia.** Strictly speaking, the use of the military insignia dates back to ancient times, when troops were distinguished by the devices on their banners and shields; but in the modern accepted sense of the term the military insignia include only the characteristic devices on the uniforms. Such devices, so far as is known, were first used in the Second Crusade, when, to avoid confusion, the French wore a red cross and the English a white cross on the sleeve.

**Modern European Military Insignia.** Time has wrought notable changes in everything pertaining to the equipment of soldiers. While alterations in uniforms has been most important, distinguishing marks of rank have also changed to less conspicuous designs. Formerly large, fringed epaulets were worn conspicuously on the shoulders of officers, rendering them in their bright-colored clothing excellent marks for the enemy. All nations now dress their soldiers in what might

be termed protective coloration. Marks of rank are worn on small and narrow cloth shoulder-straps of the same material as the uniform. The only exception to this rule are certain badges, mottoes or other devices employed by famous regiments to commemorate valorous incidents in their history. For example, until 1914 the sphinx of Egypt was worn by members of thirty English regiments whose predecessors served in the Egyptian campaign against the French. It is permissible, also, for a soldier to wear whatever medals of honor he may earn by exceptional bravery on the field of battle.

**United States Insignia.** During the Revolutionary War American soldiers in their uniforms and insignia copied European customs, and these were retained in the War of 1812 and the Mexican War. Many modifications had been effected by 1861, and during the Civil War the most conspicuous insignia had disappeared.

Extremely modest insignia were employed by the time the United States entered the World War in 1917. Of special interest are the distinguishing marks of the various arms of the service. The accompanying illustration shows the designs for the leading branches of the army.

**The Story of Insignia.** Many people desire to know the significance of the various insignia by which United States officers are designated. From the *Non-Commissioned Officers' Manual* the following extract is taken:

The second lieutenant stands on the level ground, looking up to his superiors at varying altitudes above him. He begins to climb toward the top, his first step being the lower bar of the fence, which position is typified by the one silver bar of the first lieutenant.

Upon reaching the top of the fence, the officer wears two bars, which represent the bottom and the top bars of the fence, from which point of vantage he can now survey the field. At this stage he is a captain.





From the fence the officer must climb to the branches of the oak, the tree of might and strength. It is a long climb and symbolizes the marked difference that exists between the company and the field officer. The gold leaf on the major's shoulder strap symbolizes this position.

The next step is to the tallest tree of the forest—the straight, towering silver poplar, with no branches for many feet from the ground. Although this point of vantage is somewhat higher than the oak, it is not materially so, and the duties and responsibilities of the position are about the same. The officer is now among the silver leaves of



# UNITED STATES ARMY INSIGNIA

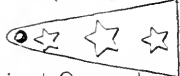

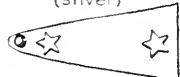
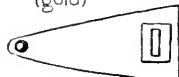
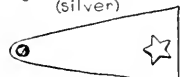
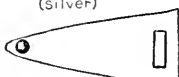
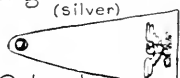
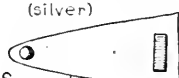



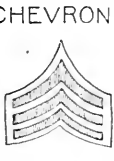







### OFFICERS' SHOULDER STRAPS

|  |  |
|--|--|
| <br>General<br>(silver)           | <br>Lieut.-Colonel<br>(silver)   |
| <br>Lieut.-General<br>(silver)    | <br>Major<br>(gold)              |
| <br>Major-General<br>(silver)     | <br>Captain<br>(silver)          |
| <br>Brigadier-General<br>(silver) | <br>First Lieutenant<br>(silver) |
| <br>Colonel<br>(silver)           | <br>Second Lieutenant<br>(gold)  |

### CHEVRONS

|  |  |  |
|--|--|--|
| <br>First Sergeant | <br>Sergeant | <br>Corporal        |
|  |  | <br>Lance Corporal |

### COLLAR DEVICES

|  |  |   |
|--|--|---|
| <br>Infantry        | <br>Cavalry       | <br>Field Artillery |
| <br>Coast Artillery | <br>Engineers     | <br>Medical Dental  |
| <br>Signal Corps    | <br>Aviation      | <br>Ordnance        |
| <br>Veterinary      | <br>General Staff | <br>Chaplain        |

the poplar, which fact is typified by the silver leaf of a lieutenant-colonel. The silver eagle symbolizes the bird that

soars above the top of the towering poplar. This is worn by a colonel.

The next step is the greatest of all: To the stars, up in the firmament, far, far above the eagle's flight, which position is typified by the star on the general officer's shoulder strap.

Officers may wear the regulation cap or the service hat. The branch of the army in which a soldier serves is indicated by his hat cord.

In the United States Navy the following insignia are worn:

1. **Insignia of all naval officers and cadets.** Attached to the front of the cap is a device consisting of a silver shield divided by thirteen upright stripes and with its chief, or upper part, strewn with stars, surmounted by a silver spread eagle, the whole placed upon two crossed anchors in gold.

2. **Insignia of rank.** Rank is indicated by the strips of lace or braid on the sleeve and by the devices on the collar, shoulder marks, shoulder straps and epaulets. The sleeve of an admiral has two strips of two-inch gold lace, with one strip of one-inch gold lace between; a rear admiral, one strip of two-inch gold lace, with one strip of half-inch gold lace above it; a captain, four strips of half-inch gold lace; a commander, three strips of half-inch gold lace; a lieutenant commander, two strips of half-inch gold lace, with one strip of quarter-inch gold lace between; a lieutenant, two strips of half-inch gold lace; a lieutenant (junior grade), one strip of half-inch gold lace with one strip of quarter-inch gold lace above; an ensign, one strip of half-inch gold lace; staff officers, the same as for line officers with whom they rank, except that bands of colored cloth are placed between the strips of lace; naval cadet, one strip of quarter-inch gold lace; chaplain, lustrous black braid of the same size and disposition as for line officers of the same rank. The device on the collar, shoulder marks and epaulets is the same for each rank as that on the shoulder straps. See Uniform.

**INSOLVENCY**, in law, the legal status of any person who is unable to pay his debts. In the United States the term is used commonly in distinction to bankruptcy, an insolvent person being unable to pay all of his debts and a bankrupt person being unable to pay any considerable part of them. Insolvency and bankruptcy are both regulated by Federal laws, of which the latest was the Federal statute of 1898. See **BANKRUPT**.

**INSOMNIA**, or **SLEEPLESSNESS**, a condition caused by excitement, exhaustion, intoxication, grief or any other emotional disorder. As persistent insomnia has led to nervous prostration and even suicide, it is treated as a serious ailment by physicians.

Removal of the cause is the first step in combating insomnia; warm baths, fresh air and massage are also helpful. The practice of taking drugs to induce sleep is one that cannot be too strongly condemned.

**IN'STINCT**, the innate power which compels an animal to perform certain acts without having a knowledge of the purpose of the act or without a conscious connection between the act and its purpose. In the lowest animals, such as mollusks and worms, instinct is nothing more than reflex action. In the higher animals, as birds and most mammals, it verges so closely upon intelligence that it is difficult to find a dividing line between them. Instincts are closely related to the preservation of the individual as the instinct of taking food, common to all young animals, and the instinct of fleeing from danger, or of reproduction, as in nest-building and the sitting of the bird to hatch the eggs. It is also closely allied with the feelings. Undoubtedly, laughter, weeping, anger and some other emotions are instinctive.

Instinct differs from intelligence in that it does not gain by experience. The robin builds its first nest as well as its fifth, and the young eagle seizes its prey as skilfully as the old one. Among the higher animals there are some apparent exceptions to this rule. An old fox is liable to be more cunning than a young one, and the dog and horse undoubtedly gain in intelligence as they gain in years. Some instincts are destroyed by removing for several generations the necessity for them. Canary birds that have been reared in a cage from one generation to another lose the nesting instinct. Man is guided by intelligence rather than instinct, but he is subject to some instinctive movements. These are usually due to heredity and can be suppressed or modified by training. See **KINDERGARTEN**, subhead *Instinct*.

**IN'STITUTE OF FRANCE**, a name given to several learned societies united into one body under the patronage of the French government. At present these societies are the following:

(1) The French Academy, organized by Cardinal Richelieu in 1635, devoted to literature. Its members are often called the Forty Immortals. They have in their hands the distribution of many valuable prizes for literary excellence.

(2) The Academy of Inscriptions, founded in 1663, devoted to the study of ancient inscriptions.

(3) The Academy of Sciences, founded in 1666, for the promotion of mathematics, physics, chemistry, astronomy and other sciences.

(4) The Academy of Fine Arts, founded in 1648, devoted to music, painting, sculpture and architecture.

(5) The Academy of Moral and Political Science, founded in 1795, suppressed in 1803, but restored in 1832, given to the discussion of psychology, history, finance, law and political economy.

Each has a fostering care over some art or science, the interests of which it promotes in numerous ways, notably by offering prizes for progress or excellence of production in its field. A small salary is allowed each member. Each Academy has its own officers and its own funds, while the collections and libraries are enjoyed in common. The general fund is in charge of a committee of eleven, comprised of two from each society, and the Minister of Education, who acts as chairman.

**INSTRUMENTAL MUSIC**, music produced by instruments, as distinguished from *vocal music* (see SINGING). The art of arranging the parts of a composition for orchestra is known as *instrumentation*. It is of rather recent origin, even Bach and Handel having but elementary ideas upon the subject. The importance of a thorough knowledge of instrumentation is manifest, for a chord which, sounded by some instruments, would produce exquisite harmony, sounded by others would be discordant. The greatest masters of instrumentation have been Haydn, Mendelssohn, Mozart, Beethoven, Weber, Wagner, Brahms and Tschaiakowski. The art is also called *orchestration*. See ORCHESTRA.

**INSULATOR**. Cone-shaped pieces of glass are chosen for use on telegraph poles to give support and stability to the wires which are strung from pole to pole. The current of electricity in the wires will not pass to the glass at the point of contact with it because glass offers too great resistance for the current to overcome. If some such substance were not used, the electric current would travel to the earth and would be lost.

The spark plug in an automobile motor is largely of porcelain. An examination will show that the part of the plug which transmits the electric current from the source of power to the chamber where the current ex-

plodes the gasoline vapor is enclosed in porcelain. Porcelain resists the flow of the current, and keeps it in the track designed for it.

Both glass and porcelain are *insulators*, or substances through which electricity will not pass. Other insulating materials are rubber, gutta percha, resin, shellac, sulphur, paraffin and dry silk.



**INSURANCE**, in *shoor'ans*, in law, as defined in the statutes, is "a contract by which one party, for an agreed consideration (which is proportional to the risk involved), undertakes to compensate the other for loss on a specified thing, from specified causes. The party agreeing to make the compensation is usually called the insurer, or underwriter; the other, the insured, or assured; the agreed consideration, the premium; the written contract, a policy; the events insured against, risks or perils, and the subject, right or interest to be protected, the insurable interest."

**Kinds of Insurance.** If the risk is fire, the system of insurance is known as *fire insurance*; if the risk is connected with navigation by sea, the insurance is known as *marine insurance*; if it is accident of any kind, explosion, breakage, destruction or the loss of future earnings, it is *accident insurance*; if the event is death, the insurance is called *life insurance*.

Insurance companies are of two kinds, *proprietary* or *stock* companies, which have a certain capital stock and which establish such rates or premiums as not only will cover expected losses, but will provide a reasonable profit or interest upon the capital invested; and *mutual* companies, in which the policy-holders are also the stockholders, and the rates or premiums are fixed at just that amount which will pay for the losses to be incurred and for the management of the company, the profits, if any, being returned to the policy-holders in dividends. Familiar examples of this kind of insurance companies are the so-called "friendly societies" or "fraternal societies," such as the Odd Fellows or the Modern Woodmen of America.

Some of the largest insurance companies in the world, however, besides the fraternal societies are also organized on this basis.

**Fire Insurance.** In fire insurance the contract by which insurance is undertaken establishes certain rights and duties upon each party. The underwriter promises specifically or by implication to indemnify the insured to a certain specified extent, and thereby guarantees that the insurance company will endure as long as the contract of insurance runs; that the risks which it undertakes shall be selected with careful regard to quality, quantity and exposure; that the premiums charged shall be adequate to afford a profit which shall make the insurance secure, and that its funds shall be guarded against wasteful or dishonest expenditure or investment.

The insured in signing his applications, answers a series of questions, and if at the time of loss it can be shown that he has misrepresented or untruthfully answered any of these questions he is entitled to no indemnity. It is customary for insurance companies to classify the risks against which they insure in certain orders, known as ordinary, hazardous and extra-hazardous, the rates charged being apportioned accordingly. It is especially important that the insured state truly the class under which his property should fall. Repairs and alterations on the premises insured, if they do not affect the character of the risk, do not invalidate the policy, but the insurance companies should usually be notified of such changes. Courts generally are inclined to construe insurance policies liberally on behalf of the insured, and unless fraud can be shown, damage resulting from fire, even though due in part, and in some cases in whole, to the negligence of the insured or his servants, must be indemnified by the insurance company. It is customary for insurers to stipulate that they may rebuild or repair the premises if they choose, instead of paying for the loss.

It has become the rule that heat alone does not create liability on the part of the insurers unless there be actual fire; so a loss by lightning is not held to be a loss by fire unless the property be destroyed by flames occasioned by the lightning. On the other hand, loss occasioned by direct efforts to put out a fire, as by water, or a loss sustained by removing insured goods from

the peril of fire or of tearing down or blowing up a structure to stop the progress of a conflagration, would fall on the insurers, provided the steps taken were reasonable and necessary. Marine insurance is largely governed by the same principles as fire insurance, with such modifications as the nature of the property and of the risks necessitates. The same is true in regard to accident insurance.

**Life Insurance.** Life insurance originated in the desire of a man to provide for a helpless or dependent family after his death. It has now, however, entered the field of investment, and policies are written whose main object is the safe-keeping and increase of funds. Three classes of policies are most common in the United States, those known as *life*, or *straight life*, policies, *term-payment* policies, *endowment* policies and *tontine* policies. Each of these classes has been varied in innumerable ways, in order to meet the demands of different classes of persons. For instance, in taking out a life policy the person may agree to pay a certain amount annually as long as he lives, the company agreeing to pay a certain amount at his death to his heirs or to some specified beneficiary. He may make annual payments for a term of years, as ten, fifteen or twenty, and then pay no more, the company promising that at his death a certain amount shall be paid to his heirs or beneficiaries. Or he may pay a certain amount once for all, with the understanding that at his death a certain amount will be paid to his heirs or beneficiaries. In the endowment policy the insurance company agrees to pay at the end of a certain term if the insured is alive, or before that, in case of his death, a certain amount. In both classes of policies the premiums are determined on the same basis, that is, the insured pays enough each year to the company, so that at the end of the given time the accumulation of his premiums and of a low rate of interest upon them will equal a certain amount, which the insurance company then agrees to pay to his beneficiaries. Life insurance upon either of these plans is therefore exactly opposite to the principle governing the payment of annuities (see ANNUITY).

The premium to be paid either upon life policies or upon an endowment policy is regulated in accordance with a mortality or insurance table, compiled from the experience of many companies in accordance with the

law of probabilities and the law of averages (see MORTALITY, LAW OF). In accordance with this table the company can determine approximately what proportion of persons insured at a given age will die each year until the whole number have died; that is, they can determine the average number of years that persons at a given age will live. Therefore, if the company agrees to pay a certain amount at a certain person's death, it will fix the premium which that person shall pay annually until his death at such an amount that if he died at the time that the average person of his age will die, he will have paid to the company enough, with the accrued interest, to equal the sum which his beneficiary will receive. The tontine policy differs from both of these, and may be of either of two kinds. According to one system, if the insured allows his policy to lapse, he forfeits whatever he has paid in, the profits on his investment accruing to the others of the same class. By the later, or *semi-tontine*, plan, certain extraordinary profits, not taken into consideration at the time of the writing of the policy, are allowed to accumulate throughout the term of the policy, ten, fifteen or twenty years, and at that time are divided among the persons of the same class whose policies are still in force.

**Soldiers' and Sailors' Insurance.** This is a form of government insurance, designed to compensate soldiers and sailors, and their families, for injuries and death incurred in government service. It was inaugurated in the United States after the country entered the World War. The act providing for such compensation was passed in October, 1917. The machinery for carrying out the plan was already in operation, as a Bureau of War Risk Insurance had been in existence since September, 1914, having begun by insuring vessels and cargoes in foreign trade. The act of 1917 provided for insurance in multiples of \$500 for sums between \$1,000 and \$10,000. Premiums were payable monthly, and ranged from sixty-five cents per \$1,000 at age twenty-one to \$1.20 at age fifty-one. On November 18, 1918, shortly after the armistice was signed, Secretary McAdoo announced that more than 4,000,000 officers and men had taken out policies, and that the grand total was more than \$36,000,000,000. Holders of policies were permitted to retain them for five years after leaving the service, and the law provided that not later than five

years after the termination of the war as declared by Presidential proclamation, the insurance could be converted into ordinary life, endowment or other form of insurance.

**History of Insurance.** Insurance is many centuries old; it was recognized in English statutes as early as 1600. Its oldest form is marine insurance; its latest, fidelity insurance, that is, insuring an employer against the defalcation of his employees, or burglary insurance, against robbery, and employer's liability insurance (see EMPLOYERS' LIABILITY). In recent years, the vast growth in the power and influence of insurance companies, through the concentration of funds in their hands, has led to searching investigations of their methods, and this, in turn, to more rigid governmental control over their activities.

**INTAGLIO**, *in tal'yo*, a term in engraving applied to a hollowed representation of a subject. It is the opposite of bas-relief, which is a figure raised above the background. In carving an intaglio the design is cut away; in carving a relief the background is cut away. A wax impression of an intaglio produces a bas-relief. Cameos are frequently made in intaglio. See PRECIOUS STONES.

**INTENSIVE FARMING**, a term denoting that policy in agriculture by which every acre on a farm is made to produce to its utmost in quantity and quality. In other words, the man who farms intensively gets everything possible out of all the land he possesses. In some countries if intensive farming were not practiced the population would always be hungry. The Chinaman terraces his small two-acre hillside and plants foodstuffs on every available square foot. In Europe small farms are the rule, and no ground capable of producing is left uncultivated.

Not only does intensive farming mean the utilization of ground, but it includes keeping it in a high state of fertility by liberal use of all available fertilizing agents. No waste that will serve as fertilizer is destroyed, but is returned to the soil that production may be stimulated. European acres that have been cultivated for a thousand years are thus kept more fertile than much of the newer North American lands. Belgium raises nearly twice as many bushels of grain on every acre as is raised in Canada or the United States in the same area.

Land in Europe, where there are from 200 to 650 people to each square mile, cannot be treated as carelessly as in Canada and the United States, where vast domains yet await the plow and the harrow.

**INTEREST**, a sum paid for the use of money. The sum to be paid as interest should always be stipulated at the time the

ent states, but it is six per cent in thirty-one states. The highest rate is eight per cent, legal in eight states. If agreed to in the contract, a higher rate may be exacted in all but thirteen states. Any rate in excess of the legal rate is known as *usury*. The rates established by law in the various states appear in the following table:

| STATE             | LEGAL RATE | BY CONTRACT | STATE          | LEGAL RATE | BY CONTRACT |
|-------------------|------------|-------------|----------------|------------|-------------|
| Alabama           | 8          | 8           | Montana        | 8          | Any         |
| Alaska            | 8          | 12          | Nebraska       | 7          | 10          |
| Arkansas          | 6          | 10          | Nevada         | 7          | Any         |
| Arizona           | 6          | 12          | New Hampshire  | 6          | 6           |
| California        | 7          | Any         | New Jersey     | 6          | 6           |
| Colorado          | 8          | Any         | New Mexico     | 6          | 12          |
| Connecticut       | 6          | 6           | New York       | 6          | 6           |
| Delaware          | 6          | 6           | North Carolina | 7          | 6           |
| Dist. of Columbia | 6          | 10          | North Dakota   | 7          | 12          |
| Florida           | 8          | 10          | Ohio           | 6          | 8           |
| Georgia           | 7          | 8           | Oklahoma       | 6          | 10          |
| Idaho             | 7          | 12          | Oregon         | 6          | 10          |
| Illinois          | 5          | 7           | Pennsylvania   | 6          | 6           |
| Indiana           | 6          | 8           | Rhode Island   | 6          | Any         |
| Iowa              | 6          | 8           | South Carolina | 7          | 8           |
| Kansas            | 6          | 10          | South Dakota   | 7          | 12          |
| Kentucky          | 6          | 8           | Tennessee      | 6          | 6           |
| Louisiana         | 5          | 8           | Texas          | 6          | 10          |
| Maine             | 6          | Any         | Utah           | 8          | 12          |
| Maryland          | 6          | 6           | Vermont        | 6          | 6           |
| Massachusetts     | 6          | Any         | Virginia       | 6          | 6           |
| Michigan          | 5          | 7           | Washington     | 6          | 12          |
| Minnesota         | 7          | 10          | West Virginia  | 6          | 6           |
| Mississippi       | 6          | 8           | Wisconsin      | 6          | 10          |
| Missouri          | 6          | 8           | Wyoming        | 8          | 12          |

In Canada the rate is five per cent, unless a higher rate is stipulated in the contract.

money is borrowed, as must also the date on which the sum borrowed is to be returned to the lender. Unless the interest rate is named, the legal rate only can be collected. The document attesting the contract between lender and borrower is usually a *note* (which see).

The money loaned is called the *principal*; the ratio of the interest for one year to the principal is the *rate*, or *rate per cent*; the sum of any principal and its interest together is the *amount*. Interest is either simple or compound. *Simple interest* is that which is allowed upon the principal only, for the whole time of the loan. *Compound interest* is that which arises from increasing the principal at fixed periods by the interest then due, and from that time forward till the end of the next period, obtaining interest upon this amount. In other words, in compound interest, interest due is added to the principal, and on both principal and interest further interest is paid.

**How Much Interest May Be Charged.**

The *legal rate* of interest is that rate per cent which the law declares shall be the maximum interest charged, in default of other understanding. This varies in differ-

**Interest Methods.** The method of computing interest that is most widely used is called 6% method. Arithmetics usually explain only in brief from the philosophy of this method.

**Six Per Cent Method.** It may be well here to outline the philosophy of the 6% method.

In all interest computations 360 days are assumed to be one year. If the interest on \$1.00 for one year is \$.06, it is clear that for one month the interest on \$1.00 would be one-twelfth of \$.06, or one-half cent, or \$.005. If for one month or 30 days the interest on \$1.00 at 6% is \$.005, then it is clear that the interest for 6 days is \$.001. If the interest is \$.001 for 6 days, for 1 day it would be \$.0001. Now, let us put the above analysis in tabular form for quick reference:

|   |       |
|---|-------|
| Interest on \$1.00 for 1 year   | .06   |
| Interest on \$1.00 for 1 month  | .005  |
| Interest on \$1.00 for 6 days   | .001  |
| Interest on \$1.00 for 1 day  | .0001 |
| Let us apply the above to the following problem: What is the interest for 2 years, 6 months, 24 days, on \$500.00, at 6% per annum? |       |
| Interest on \$1.00 for 2 years is   | .12   |
| Interest on \$1.00 for 6 months is  | .03   |
| Interest on \$1.00 for 24 days is   | .004  |

Interest on \$1.00 at 6% for 2 years, 6 months, 24 days, is . . . . . \$1.54

If the interest on \$1.00 at 6% for 2 years, 6 months, 24 days, is \$1.54, the interest on \$500.00 will be 500 times \$1.54, or \$770.00.



In the above problem, if the interest were 8% instead of 6%, we would find the interest first for the full time at 6%. As 8% is  $\frac{2}{3}$  more than 6%, we would add  $\frac{2}{3}$  to the interest on \$1.00 at 6%, and find that the interest on \$1.00 for 2 years, 6 months, 24 days, at 8%, is \$.205 $\frac{2}{3}$ , after which we would multiply this interest on \$1.00 by the principal.

Should the interest be 7%, we would first find the interest on \$1.00 for the given time at 6%, divide this by 6, which would give us the interest on \$1.00 for the given time at 1%; then multiply by 7, which result would be the interest on \$1.00 for the given time at 7%.

**The Thousand Day Method.** But few people know of the existence of a brief method of computing interest, known as the thousand

Solution. 2 years, 2 months, 20 days equals 800 days. Pointing off three places, we have the interest on \$1.00 for the given time at 36%. Multiplying the interest on \$1.00 by the number of dollars, the product is \$198.864, which is the interest on the whole amount for 800 days at 36%. We require the interest at 9%, which is one-fourth as much as 36%. Therefore, dividing \$198.864 by 4, we find the interest on \$248.58 for 2 years, 2 months, 20 days, at 9%, to be \$49.716.

**INTEREST**, in psychology, the feeling of satisfaction or dissatisfaction which one has towards a subject, or that bent of mind which causes one to contemplate certain subjects

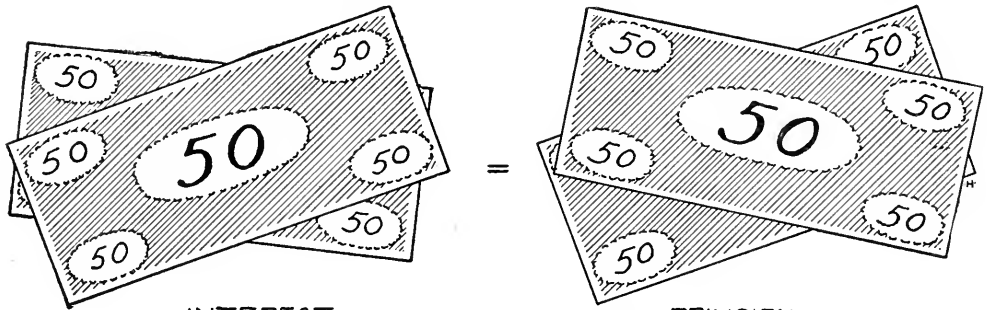

INTEREST = PRINCIPAL  
IN 1000 DAYS AT 36%

ILLUSTRATING THE THOUSAND DAY METHOD

day method. This is one of the few methods not complicated, and it has the virtue of clearness. Next to the 6% method it is recommended as the best, for no other system of computing interest excels the thousand day method in simplicity and perfect adaptation to nearly every problem. The theory of this method may be stated as follows:

The simple interest of any sum of money will exactly equal the principal in 1000 days at 36%.

Before proceeding to learn a rule by which to solve a problem under this method, find the interest on \$100.00 for 1000 days at 36%, by the six per cent method. You will find this interest to be \$100.00. You can now without doubt write your own rule for the thousand day method. It is as follows:

Multiply the principal by the number of days, point off three decimal places in the product, and the result is the interest on the principal for the given time at 36%.

If your problem requires the interest at 6%, divide the result by 6.

If 3% is required, divide by 12;

If 4% is required, divide by 9;

If 9% is required, divide by 4;

If 12% is required, divide by 3;

If 1% is required, divide by 36;

If 10%, multiply the interest at 1% by 10.

Below is a solution of a problem by the thousand day method. Find the simple interest at 9% upon \$248.58 for 2 years, 2 months, 20 days.

with pleasure and to have an aversion for others. Interest is a phase of feeling and differs from desire in that in interest the mind is satisfied with contemplating the subject, while desire is not satisfied until possession is obtained. Interest may be pleasurable or painful, according to the nature of the subject by which it is aroused. Contemplation of the same subject may be painful to one and pleasurable to another. In contemplating a surgical operation which a friend must undergo, one may be sorrowful because of the pain and risk that the patient must suffer, while the surgeon, contemplating the same operation, derives pleasure from considering the skill which makes the operation and its consequent benefits possible.

Interest is the foundation of knowledge, since without it prolonged attention is impossible. The child voluntarily directs his attention only to those things which he feels can supply his wants, and it is from these that he gains his early store of knowledge. He is interested in whatever supplies his bodily needs, appeals to his love of the beautiful and satisfies his affections. Interest is most easily aroused in those objects of which

we have some knowledge. Mere novelty, as a strange sound or an unusual color, will attract the child for a moment; but it does not serve to hold his attention, because he is unable to place it satisfactorily in his store of ideas, while a color that he has before seen, and a tone with which he is familiar, appeal to him because of their association with the ideas already in the mind. This principle should be borne in mind in selecting subjects upon which to give instruction to children in primary grades. The theory that children will be interested in any subject if it is properly presented is fallacious, because there are many subjects which are of such nature that they cannot appeal to the immature mind of the child.

Interest is closely related to volition, and children's activities are largely directed by their interests. All children take interest in something. "The most careless and inattentive boy in school is not without interest, not even without attention. The trouble is he is interested in wrong things." Parents and teachers can do much in directing the child's interest by seeing that he is surrounded by proper associations. See, in the order named, ATTENTION; PERCEPTION; APPERCEPTION; WILL.

**INTERIOR, DEPARTMENT OF THE**, one of the executive departments of the United States government, whose head, the Secretary of the Interior, is appointed by the President and is a member of his Cabinet (which see).

The scope of the department is summarized in the detailed duties pertaining to the office of the Secretary. He is charged with the supervision of public business relating to patents for inventions, pensions and bounty lands, the public lands and surveys, the Indians, the Bureau of Mines, National Parks, the Capitol Building and Grounds, distribution of appropriations for agricultural and mechanical colleges and certain hospitals and eleemosynary institutions in the District of Columbia. The Bureau of Education is a branch of the department. By authority of the President the Secretary of the Interior has general supervision over the work of constructing the government railroad in Alaska. He also exercises certain other powers and duties in relation to the territories of Alaska and Hawaii.

The salary of the Secretary of the Interior is \$12,000 per annum.

**INTERJECTION**, *in ter jek'shun*, a part of speech used to express sudden or intense feeling, such as joy, surprise and disapproval. Grammatically, the interjection is independent of the rest of the sentence, and dropping it does not make the sentence unintelligible. At the same time, its elimination might change the entire tone of the sentence, and take away its force and vividness. For example, "Hurrah! the parade is moving," has quite a different effect from "The parade is moving." Such words as *oh*, *alas*, *bravo* and *pshaw* are always interjections, but nearly every word may be so used. An expression used for emphasis at the beginning of a sentence, as in the following, serves as an interjection: "To arms! the foe is upon us." "Away! the time has come for us to depart."

**INTERLAKEN**, *in'tur lah ken*, a Swiss summer resort, twenty-six miles southeast of Berne, beautifully situated near the left bank of the Aar, between the lakes Thun and Brienz. The name is applied to a plain containing three villages, Aarmühle, Matten and Unterseen. An old monastery building dating from the twelfth century houses a hospital, government offices and an auditorium used for religious services. The delightful climate and beautiful scenery of Interlaken draws to it annually in normal times from 20,000 to 50,000 tourists. Population, 1910, 3,700.

**INTERMEZZO**, *in tur met'so*, a short musical piece, generally of a light, sparkling character, played in slow tempo between the parts of a more important work, such as an opera or a composition in the sonata form. Originally intermezzos were short musical divertissements performed between the acts of a tragedy. The most popular intermezzo of the present day is probably that in *Cavalleria Rusticana*.

**INTERNAL-COMBUSTION ENGINE**, See GAS ENGINE.

**INTERNAL REVENUE**. Expenses of national governments are defrayed by duties levied upon imports from other countries and by taxation. In the United States the Federal government may lay direct taxes upon all the people, but it has never done so except in three periods of stress—in 1798, 1812 and 1861. Import duties have always been of vast extent, but taxes have also been levied upon articles made within the country. Taxes so assessed are called *internal*

revenue taxes. Alcoholic liquors and tobacco have always been taxed, and the revenue from these has been very large. At various times taxes have also been placed upon many other articles, as oleomargarine, matches, playing cards, bank checks and all legal papers, and other commodities people are sure to use and which therefore are certain to be productive of revenue. The extent to which internal revenue taxes are laid depends upon national necessities.

In Canada and England such taxes are called *inland* revenue. See **INCOME TAX**.

**INTERNATIONAL DATE LINE.** When it is Monday where you live, is it Monday on all parts of the earth's surface until the day

directly overhead and it would still be noon with you, on Sunday. In another hour you would have traveled  $30^\circ$ , yet it would still be Sunday noon. In another hour you would have gone  $45^\circ$  from home and it would still be Sunday noon, for you are keeping with the sun. Continuing at this rate around the world you would find upon returning to the place from which you started that it is still noon on Sunday, so far as your reckoning is concerned. But would it be still Sunday noon to the people you had left behind and to whom you have gone back? No. There would be a difference of 24 hours in time. People will tell you that it is then Monday noon. Somewhere in your travel with the sun the

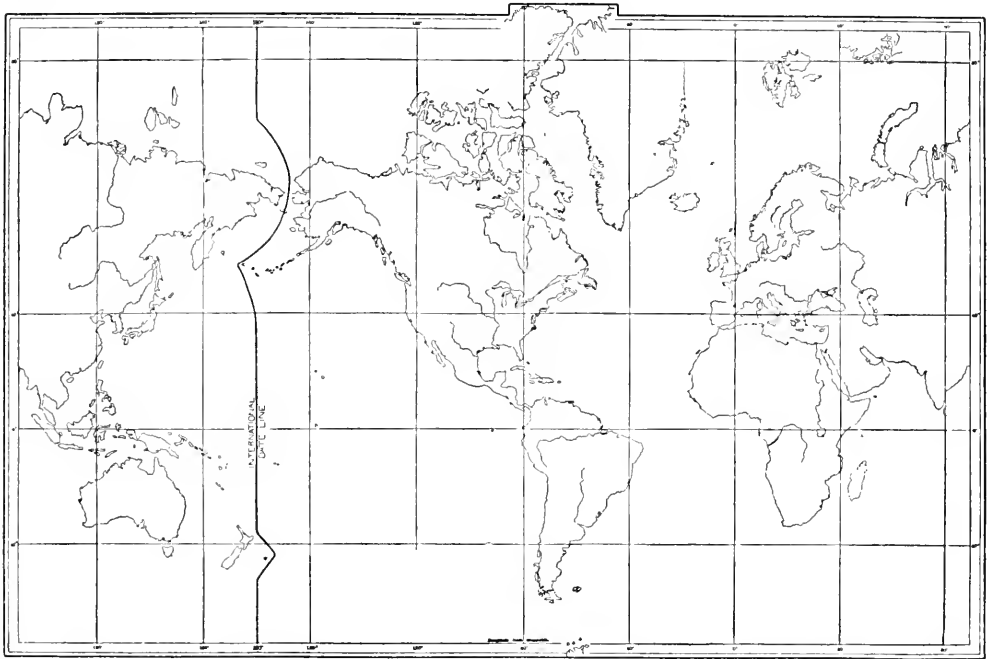

INTERNATIONAL DATE LINE, SHOWING CHANGES IN DIRECTION

changes to Tuesday at your home? You will readily see that such is not the case, for all people cannot reckon the beginning of their day from your meridian. We may understand, therefore, that there is a certain line drawn in imagination on the earth's surface where the date changes.

Suppose we imagine that on Sunday noon you are able to leave your home and travel westward with the sun and with the same rapidity, keeping the sun directly over your head all the time. In one hour you would have traveled  $15^\circ$ , but the sun would still be

time instantly changed from Sunday to Monday. Had you asked of native peoples in the progress of your journey the day of the week, you would have been told, even as far west as the Sandwich Islands, that it was Sunday; but a little beyond that point, as you neared the coast of Asia, you would have been told that it was Monday. Through all of Asia and entirely through Europe people would have declared that the hour was Monday noon, although during the entire trip it was continually the same day and the same hour of the day to you—Sunday. If you had wished to

be in accord with the people among whom you were traveling, you would have had to change your day from Sunday to Monday, somewhere along the route.

It is customary for mariners to change their day at a point exactly halfway around the world from Greenwich, on the given meridian. This is 180° east or west of Greenwich. However, to run a straight line arbitrarily north and south 180° east or west from Greenwich would prove a great inconvenience in some portions of the world, so the line is run crooked in places to accommodate all of the islands of one group on one side of the line rather than to divide them. For instance, the Aleutian Islands, off the coast of Alaska, are partly east and partly west of the 180th meridian. If the international date line were drawn exactly north and south from pole to pole, it might run midway of one of these islands and one little fur-clad native might be living in Thursday while with his neighbor over the hill the day might be Friday. Therefore, the date line deviates from its direction due north and south and moves southwest until those islands are passed, when again it turns straight south to the equator, then it moves east about 45°, thence south about 30°, thence with a slight variation to the southwest. This international date line is imaginary, and authorities do not absolutely agree as to its location. It is evident that no necessity compels an arbitrarily fixed line, but all are in accord as to its general position and direction.

**INTERNATIONALISM**, *in ter nash'un al iz'm*, a term having more than one application, but associated in whatever way used with the idea of the universal brotherhood of man. The most radical internationalists believe that national sentiments and aspirations should be abolished, and a World State be set up with none but the laboring classes in full control. Instead of establishing a League of Nations, they would destroy all capitalistic governments, and free the world from all existing national boundary lines, tariffs, rulers, cabinets and other symbols of modern organized states. This is the ideal of Lenine, the man who overthrew the Kerensky government in Russia in 1917.

The internationalism of the advocates of the League of Nations is of another sort. They believe in the peaceful development of organized democracy and the development of the nations as separate entities, but they

hope to see a closer coöperation of different peoples, the abolition of wars, and the destruction of the spirit of aggression. There is an international organization of Socialists, which is the outgrowth of the International Workingmen's Association, established in 1864. During the World War Socialists in all the belligerent nations made efforts to hold an international conference at Stockholm, but the allied governments refused to issue passports to the delegates. However, early in 1919 such a conference was held at Berne, Switzerland. See SOCIALISM; BOLSHEVIKI; NATIONS, LEAGUE OF.

**INTERNATIONAL LAW**, the unwritten law or agreements between nations; those rules or maxims which independent countries observe, or ought to observe, in their conduct toward one another. International law is divisible into two parts, that which regulates the rights, intercourse and obligations of nations, as such, with one another; and that which regulates the rights and obligations more immediately belonging to their respective subjects or citizens. Thus, the rights and duties of ambassadors belong to that head which respects the nation in its sovereign capacity; and the rights of the subjects of one nation to property situated within the territory of another nation, belong to the latter head. Some of the maxims regarding the rights and duties of nations during a state of peace are the following:

(1) Every nation is bound to abstain from all interference with the domains of other nations.

(2) All nations have equal and common rights on the high seas, and they are not bound to admit any superiority there. The sea which washes the coast of a nation is, to the extent of three miles from shore, now deemed to be a part of the territory of the nation, over which it may exercise an exclusive jurisdiction. And, in respect to persons subjected to its laws, every nation now claims a right to exercise jurisdiction on the high seas, for the purpose of enforcing both international law and its own municipal regulations.

(3) No nation has a right to pursue any criminal or fugitive from justice in a foreign country; its claim, if any, is a mere right to demand him from the nation in which he has taken refuge.

(4) Every nation has a right to regulate its own intercourse and commerce with other nations.

(5) Foreigners are bound to obey the laws of a country as long as they reside within it and under its protection; and the property held by foreigners within a country ought to

be protected in the same manner as that of natives.

(6) Every nation has a right to send and to receive ambassadors and other public ministers; the persons of such ministers are held sacred and inviolable, and their property, servants and retinue enjoy a like privilege.

**Changes Caused by War.** War introduces an entirely new order of rules. The right of declaring war results from the right of a nation to preserve its own existence, its own liberties and its own essential interests. In a state of nature men have a right to employ force in self-defense, and when they enter into society this right is transferred to the government. What are just causes for entering into a war is a question which has been much discussed by publicists. Defensive wars are necessarily justifiable, from the fact that they involve the existence or safety of the nation and its interests. But offensive wars are of a very different character, and can be justified only in cases of aggravated wrongs or vital injuries. The first effect of a declaration of war is to put the subjects of one nation into a state of hostility to those of the other nation. The property belonging to one is deemed hostile by the other. If it be personal property it may be captured as a prize; if lands, they may be seized and confiscated at the pleasure of the government; if it be merely in debts of stock it may, in the extreme exercise of the laws of war, be equally liable to confiscation. As soon as a battle is over, the conquerors are bound under international law to treat the wounded with kindness and the prisoners with a decent humanity; a nation violating this rule debases itself. And there are some things which seem positively prohibited, from their cruelty and brutal barbarity; such are the torturing of prisoners, the poisoning of wells, the use of inhuman instruments of war. In the World War (1914-1919) one of the belligerents was notorious for proved instances of violation of such humane provisions.

In time of war there is occasionally intercourse between the belligerents, which should be held sacred. Such intercourse includes the interchange of prisoners, the temporary suspension of hostilities, the passage of flags of truce, the engaging in treaties of capitulation. When any conquest of territory is made, the inhabitants pass under the dominion of the conqueror and are subject to such laws as he chooses to impose upon them, which, however, must be humane.

There are also certain rights which war confers on the belligerents in respect to neutrals. Thus, they have a right to blockade the ports or besiege the cities of their enemies and to interdict all trade by neutrals with them. But no blockade is to be recognized unless "the besieging force can apply its power to every point in the blockaded state." Belligerents have a right also to insist that neutrals shall conduct themselves with good faith. A neutral nation is bound to observe entire impartiality between the belligerents, but it has a right to insist upon carrying on its ordinary commerce with each of the belligerents in the same manner as in times of peace.

**Related Articles.** Consult the following titles for additional information:

|                    |                     |
|--------------------|---------------------|
| Blockade           | Red Cross Societies |
| Nations, League of | War                 |
| Neutrality         | World War           |

**INTERNATIONAL PEACE CONFERENCE.** See PEACE CONFERENCE, INTERNATIONAL.

**INTERSTATE COMMERCE ACT,** a popular name for a law passed by the United States Congress in 1887 to regulate commerce between the states. It grew out of the rapid development of railways and the abuses which arose from sharp competition among them. Under the law all common carriers, either by rail or water, are prohibited from granting unreasonable preferences to individuals or localities; from agreeing to pool the traffic (See TRUSTS) and to divide the profits; from concealing any rates, or from changing them without due notice. A commission of five members was created to hear complaints, make investigations of violations of the law and require reports from carriers. The law accomplished much good in regulating abuses and standardizing many policies; in order to broaden its work and increase its effectiveness the membership of the Commission was increased to nine members, and the personnel of its force was strengthened. Amendments to the original law have brought railroads more intimately within the control of the Commission; particularly, the Commission is empowered to set aside unjust freight rates and to declare what are reasonable rates in all cases brought to its attention. The salary of each commissioner is \$10,000 per year. During the period of government control of railroads, a condition forced by the World War, the work of the Commission was practically nullified.

**INTESTACY**, *in tes'ta sy*, in law, the condition of a person who dies without having left any will, or who leaves one not legally valid. In such case the property is disposed of according to a rule fixed by law. In the case of a person dying partially intestate, that is, without disposing of *all* his property, the property not included in the settlement goes to the next of kin or to the heir-at-law, according as it is real or personal.

**Related Articles.** Consult the following titles for additional information:

|                   |               |
|-------------------|---------------|
| Estate            | Real Property |
| Personal Property | Will          |

**INTES'TINE**, a muscular tube which receives food from the stomach and serves as an organ of digestion and elimination. It is composed of the *small* and the *large* intestines, the former varying in width from two inches to an inch and a third, and the latter from two and one-half inches to one and one-half. The small intestine is about twenty feet long. It is doubled into a mass that occupies the central part of the abdominal cavity; at one end it joins the stomach, and at the other, the large intestine. Physiologists apply the term *duodenum* to the first ten or twelve inches of this intestine, and the names *jejunum* and *ileum* to the remainder (see illustration accompanying the article ABDOMEN). The special function of the small intestine is to continue the digestion of food received from the stomach (see DIGESTION).

The large intestine, which is about five feet long, extends nearly around the small intestine. It is made up of the *caecum*, the *colon* and the *rectum*. The small intestine joins the large on the right side of the abdominal cavity, at the point where the colon begins. Through the muscular movements of this portion of the large intestine waste matter is pushed into the rectum, from which it is expelled from the body. When its movements are sluggish the condition known as constipation results, and harmful bacteria accumulate in the body (see CONSTIPATION). The vermiform appendix, inflammation of which causes appendicitis (which see), is a small tube extending from the caecum. Other diseases having their seat in the intestine are typhoid fever, hookworm, dyspepsia and cholera. Each of these is treated under its proper heading.

**INTOXICATION**, a term for drunkenness. See ALCOHOLISM.

**INVALIDES**, *aN va leed'*, HOTEL DES, an establishment in Paris where poor and infirm veterans of the French army are cared for at the expense of the state. The building, erected by Louis XIV, between 1670 and 1673, can accommodate 6,000 men. In vaults under the splendid dome lie the bodies of Napoleon I, Turenne and several other great French commanders.

**INVENTION**, *in ven'shun*, a device or contrivance containing some idea not before developed by man. The nations which produce the highest type of inventive genius take the leading rôle in world development. Governments recognize the stupendous importance of encouraging men to apply their special talents in perfecting new devices. In the Constitution of the United States (Art. I, Sec. 8) Congress is empowered—

To promote the progress of science and useful arts, by securing for limited times, to authors and inventors, the exclusive right to their respective writings and discoveries.

The means taken to assure inventors the permanent benefits from their labors to which they are justly entitled are described in the article PATENT.

History, in the broadest sense of the word, has been defined to include "everything that has happened." A nation's progress is measured by many factors—by its territorial expansion, by governmental development, by social and industrial growth. At first glance a table of great inventions and discoveries may seem to have no place in history; yet it is true that all inventions have exercised some influence, whether direct or indirect, on the progress of nations. Few realize that growth of slavery as an institution was due largely to the impetus given cotton growing by the invention of the cotton gin. Not many of us are conscious every day of our lives that the great internal development of the United States would have been impossible without the railroad, steamboat and the telegraph. Many people still living can appreciate the difference that the telephone and the telegraph have made in the development of the United States. If telegraph and cable systems had been in use in 1815 the Battle of New Orleans would never have been fought, for the treaty of peace had already been signed.

Among the most vital inventions of the world are the following:

| DISCOVERY OR INVENCIÓN             | DATE    | DISCOVERER OR INVENTOR    | REMARKS   |
|------------------------------------|---------|---------------------------|---|
| Books Printed from Movable Type... | 1450    | Johannes Gutenberg...     | An invention which did more to end the Dark Ages and to further the spread of knowledge than any other before or since.   |
| Telescope.....                     | 1609    | Galileo.....              | Galileo is given credit for this invention, because he made the first practical instrument. This invention opened a new field in astronomy.   |
| Submarine Boat....                 | 1775    | David Bushnell.....       | As developed by later inventors, this invention has resulted in the construction of a new type of war vessel; its practical uses have already been demonstrated.  |
| Power Loom.....                    | 1784    | Cartwright.....           | Has revolutionized the cloth-making industry.   |
| Cotton Gin.....                    | 1792    | Eli Whitney.....          | The cotton gin reduced the labor of separating the fiber from the seed; made the American cotton industry possible, and through it enabled this country to supply a large part of the cotton used in the world. |
| Steamboat.....                     | 1807    | Robert Fulton.....        | Revolutionized transportation on the water; made definite time schedules possible for boats, and has reduced the time for crossing the Atlantic from several weeks to less than one week.                       |
| Locomotive.....                    | 1825    | Stephenson.....           | The first American-built locomotive was made in New York; without the development of railway building the enormous expansion of the United States would have been impossible.                                   |
| Reaping Machine ..                 | 1834    | C. H. McCormick....       | This machine is doubtless the most useful of agricultural inventions. It reduced the labor of harvesting to such an extent as to make possible the great farms in the grain-growing regions of the world.       |
| Vulcanizing Rubber                 | 1837    | Charles Goodyear....      | The discovery that the addition of sulphur renders rubber elastic, waterproof, and unchangeable in texture has been responsible for the application of rubber to hundreds of new uses.                          |
| Friction Matches...                | 1837    | John Walker.....          | The introduction of this invention has been of untold benefit to every civilized nation.  |
| Telegraph.....                     | 1837    | S. F. B. Morse.....       |   |
| Screw Propeller....                | 1839    | John Ericsson.....        | Made possible almost instant communication between distant points. Its influence upon commerce is beyond measure.   |
| Submarine Cable....                | 1842    | S. F. B. Morse.....       | This device perfected the steamboat and changed the plan of ocean steamers, resulting ultimately in the modern ocean liner.   |
| Sewing Machine....                 | 1845    | Elias Howe.....           | This is but another application of the telegraph. Its use practically brings all parts of the world together, making it possible to communicate within a few minutes with points thousands of miles away.       |
| Cylinder Printing Press.....       | 1847    | Robert Hoe.....           | This machine was to the manufacture of clothing what the reaper was to the harvesting of grain. It made the factory system of manufacturing clothing possible.  |
| Gatling Gun.....                   | 1861    | Richard Gatling.....      | This form of press has made possible the rapid printing of newspapers and magazines in large quantities at low cost.  |
| Typewriter.....                    | 1868    | Chas. L. Sholes.....      | The adoption of the rapid-fire machine-gun has revolutionized modern warfare.   |
| Gas Engine.....                    | 1876    | Otto.....                 | The typewriter is an important invention for business purposes. Its use has practically changed the methods of correspondence and greatly systematized the office methods.                                      |
| Telephone.....                     | 1876    | Alex. G. Bell.....        | A forerunner of the superb motors of modern automobiles.  |
| Phonograph.....                    | 1876-88 | Edison.....               | The telephone has made it possible to converse at long distances. In a great measure it has taken the place of the telegraph, and in cities and towns has become indispensable to the transaction of business.  |
| Incandescent Electric Light.....   | 1879    | Edison.....               | Originally merely a toy and a diversion, the phonograph is now of great commercial importance; various forms are in use as dictating machines and other appliances in daily business use.                       |
| Steam Turbine.....                 | 1884    | Parsons and De Laval..... | The perfection of this invention and its commercial development have made possible easy regulation of the quantity of light.  |
| Kinetoscope.....                   | 1893    | Edison.....               | The application of the steam turbine to steamships in 1897 revolutionized marine transportation.  |
| Wireless Telegraph ..              | 1897    | Marconi.....              | The invention of this apparatus was an important step in the development of moving pictures.  |
| Flying Machine....                 | 1903    | Wright Brothers.....      | Marconi was the first to demonstrate the practical uses of wireless telegraphy. His system is now in use in all parts of the world, and has become especially valuable for communication with vessels at sea.   |
| Wireless Telephone..               | 1915    | Bell Co. engineers....    | The swiftest vehicle known; the most wonderful step in the evolution of transportation.   |

**INVERTEBRATES**, *in ver te braytz*, or **INVERTEBRATA**, *in ver te bra'tah*, animals which have no backbone or spine. While there is no well defined boundary-line between vertebrates (animals with backbone) and the invertebrates, the latter may roughly be classified as embracing the lowest divisions of animal life, the protoza, sponges, sea anemones, corals, jelly-fish, worms, insects, shellfish and such. See ZOOLOGY.

**INVOLUTION**, raising a quantity to an assigned power; the opposite of evolution. See ARITHMETIC.

**IO**, in Greek mythology, the daughter of Inachus, beloved by Zeus, who, to protect her from the jealousy of Hera changed her into a beautiful white heifer. She was given into the care of the hundred-eyed Argus, from whom she was rescued by Hermes. Then Hera sent a gadfly to torment her.

and Io, pursued, wandered to Egypt, where she was changed back to her original form.

**IODINE**, *yo din*, or *yo dine*, a bluish-black solid element used in medicine, in photography and in the manufacture of dyes. It was discovered by a French manufacturer in kelp, the ashes of seaweed, in 1812, and for a long time seaweeds continued to be the most important source of this element. At present, however, the greater part of the commercial supply is obtained in Chile as a by-product in the purification of sodium nitrate, or Chile salt-peter (see NITRATE). Other sources are ocean water, the water of mineral springs, sea plants and sea animals.

At the ordinary temperature of the atmosphere iodine is a solid crystalline body. Its vapor is of an exceedingly rich violet color, a character to which it owes its name, which comes from the Greek word for *like a violet*. It has an extremely acrid taste, and its odor resembles that of chlorine. It is an irritant poison, but in small doses it has been of great service in certain forms of glandular disease. In the form of compounds, such as iodide of potassium, it has been found of great benefit in goiter, scrofula, rheumatism and other diseases, as well as in cases of lead poisoning. Iodine is not usually given internally, but as a disinfectant and destroyer of parasites it is freely used externally.

**IODIFORM**, *i o' dōh form*, a chemical compound of iodine, carbon and hydrogen. It is a yellowish, crystalline substance, which dissolves in ether or alcohol. In medicine it is used as an antiseptic and disinfectant and is a cure for certain ulcers and sores. It gradually decomposes under the action of light. Iodoform has a very disagreeable odor, which is sometimes neutralized by adding to it musk or camphor oil. There are several methods of manufacturing it. It may be produced by subjecting to electrolysis a solution of potassium iodide and alcohol in water with a current of carbonic acid gas passing through the solution.

**IO'LA, KAN.**, the county seat of Allen County, 110 miles southwest of Kansas City, on the Neosho River and on the Missouri Pacific, the Atchison, Topeka & Santa Fé and the Missouri, Kansas & Texas railroads. The industries include cement works, foundries and machine shops and large zinc smelters and rolling mills. The city is in

the heart of the natural gas region of the state. There is a Federal building, a court house, a Carnegie Library and three hospitals. The place was settled in 1857, was chartered as a city in 1898 and has been growing rapidly since the discovery of natural gas. Population, 1910, 9,032; in 1917, 11,396 (Federal estimate).

**IO'NIA**, that part of the seaboard of Asia Minor which was inhabited by Ionian Greeks, a beautiful and fertile country opposite the islands of Samos and Chios, which were included in it. According to tradition, the Greek colonists came over from Attica about the middle of the eleventh century B. C. and founded twelve towns, which, though mutually independent, formed a confederacy for common purposes. Commerce, navigation and agriculture rendered them wealthy and flourishing, but the country lost its independence and successively was tributary to Croesus, Cyrus, Alexander and the Roman emperors. It was later totally devastated by the Saracens, so that few vestiges of its ancient civilization remain.

**IO'NIAN ISLANDS**, a number of Greek islands in the Ionian Sea, extending along the western and southern shores of Greece. The surface is mountainous, but there are fertile plains in some of the islands. The staple exports are oil, currants, valonia, wine, soap and salt, and the few manufacturers are chiefly textiles and ornaments. These islands belonged to Venice from the Middle Ages to the nineteenth century; in 1814 they were organized into a republic and placed under the protection of Great Britain. By consent of the European powers they were annexed to Greece in 1864. Population, 270,000.

**IONIANS**, *i o' ni anz*. See GREECE; IONIA.

**IONIC**, *ion' ik*, **ORDER**. See COLUMN.

**I. O. U.**, an expression standing for "I owe you," and applied to a statement of a debt, the form commonly accepted of which is as follows:

Chicago, January 1, 1920.  
John Doe, I. O. U. \$50.

Richard Roe.

Though it is not the equivalent of a promissory note (which see), in that it contains no statement of a promise to pay, it has been made legally a promissory note in certain states of the Union. In those states failure to pay a debt recorded in this form makes the signer liable to lawsuit, as in case of ordinary notes.





# IOWA

## The Hawkeye State

**HISTORY**  
 VISITED BY MARQUETTE AND JOLIET IN 1673  
 FIRST SETTLEMENT IN 1785  
 ORGANIZED AS A TERRITORY IN 1838  
 ADMITTED TO THE UNION IN 1846

**GEOGRAPHY**  
 AREA 56,015 SQUARE MILES  
 EQUAL TO 7 OF MASSACHUSETT'S  
 AVERAGE LENGTH FROM EAST TO WEST, 300 MILES  
 LENGTH FROM NORTH TO SOUTH 200 MILES

**INDUSTRIES**  
 DAIRYING  
 RAISING LIVE STOCK  
 AGRICULTURE

**EDUCATION**  
 PUBLIC SCHOOL SYSTEM SECOND TO NONE  
 HIGHER INSTITUTIONS  
 UNIVERSITY OF IOWA  
 TEACHERS' COLLEGE  
 STATE COLLEGE OF AGRICULTURE  
 AND MECHANIC ARTS

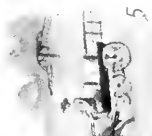
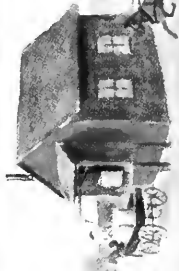

1, Swine.  
 2, Horse.

3, Coal.  
 4, Cornfield.

5, Creamery.  
 6, Harvesting Oats.

7, Milch Cows.  
 8, Limestone.

9, Haymow.  
 10, Young Short-horns.

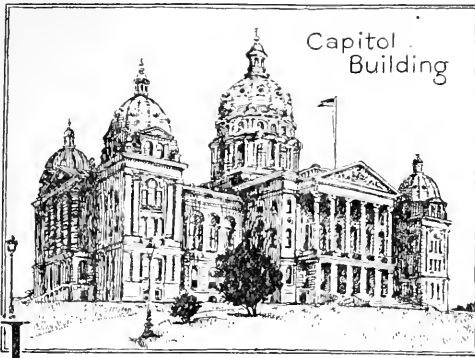

**IOWA**, one of the foremost states in the American Union, although there are twenty-three that are larger and fourteen that have greater populations. It lies between the Mississippi and the Missouri rivers, with Minnesota on the north and Missouri on the south. The state is rich in agricultural resources, and it has important though comparatively small coal fields. The well-to-do condition of the people is evidenced by the fact that one out of every eight people in Iowa owns an automobile—a greater proportion than in any other state.

The popular name of Iowa is the **HAWKEYE STATE**, but why the name was applied is not known. It was admitted to the Union as the twenty-ninth state on December 28, 1846. The area is 56,147 square miles, and the population, in 1910, was 2,224,711, an average of forty to the square mile. This is one of the few states in which the population is increasing very slowly, indeed, a slight decrease has occurred in some years.

**Surface and Drainage.** The surface of nearly the entire state is what is generally known as rolling prairie, consisting of long, low swells, separated by broad, shallow valleys. About three-fourths of the state slopes gently to the southeast. The average elevation is about 1,100 feet, the highest point being in the northwest corner, with an altitude of 1,700 feet; the lowest point is in the southwest corner, which has an altitude of about 500 feet. The rivers have broad valleys which are bordered by lines of bluffs. In the northern part there are occasional hills which rise above the general surface.

The Des Moines is the largest river, it flows across the central part of the state in a southeasterly direction. About two-thirds of the state is drained into the Mississippi, and aside from the Des Moines the streams of im-

portance in this drainage area, in order of importance are the Iowa, Cedar, Skunk, Wapesepeon and Turkey. The portion of the state drained into the Missouri is watered by the Big Sioux, the Little Sioux, the Nodaway and the East and West Nishnabotna. The northwestern counties are a continuation of the lake region of Minnesota and contain a number of lakes noted for the beauty of their scenery and their clear water. The most important of these are Spirit Lake, East and West Okoboji, Clear Lake and Storm Lake. There are smaller lakes in several counties.

**Climate.** Iowa has a cool temperate climate, with a wide range of temperature between the extremes of summer and winter. In July and August the temperature may reach 100°, while in midwinter it occasionally falls as low as 40° below zero. In the northern part of the state the snowfall is often heavy. The atmosphere is rather humid, and the climate is generally healthful. The average annual rainfall is 31.5 inches.

**Mineral Resources.** The middle and southern sections are underlaid with coal, and the area extends northwesterly to near the central counties, though the mining area is confined to the valley of the Des Moines River, in an area of about 19,000 square miles. Most of Iowa's coal is consumed within the state. There are valuable deposits of lead ore in the vicinity of Dubuque, these being extensions of the deposits found on the opposite side of the Mississippi, in Illinois and Wisconsin. Clay suitable for brick and tile is very generally distributed over the state, and clay suitable for pottery is also abundant. In value the clay products rank next to coal. In Webster County, in the center of the state, there is a large deposit of gypsum, valuable for making stucco (see **GYPSUM**; **PLASTER OF PARIS**). Limestone and building stone are also distributed over the state. However, with the exception of the mining of coal and lead ore, the mining industries are comparatively unimportant. The total value of minerals sold each year is about \$26,000,000.

**Agriculture.** Over ninety-seven per cent of the surface of Iowa is included in farms, and of this area over eighty-six per cent is improved. Nearly the entire state is covered with a deep, rich soil, free from stones and easily tilled. There are practically no forest areas, the timber being confined to narrow belts along the streams. These conditions,

combined with its thriving population, have made Iowa one of the leading agricultural states in the Union. Corn is the chief crop, and nearly one-fourth of the tillable area is planted to this cereal each year. The annual crop is about 300,000,000 bushels, placing Iowa second only to Illinois among the corn-growing states. The state is also second in the production of hay, being exceeded only by New York, by a very small margin. It is also second in the production of oats, Illinois being first. It is sixth in the yield of barley. Apples, grapes, cherries and other fruits are produced in large quantities.

The state contains an abundance of grass land for pasturage and the growing of hay. This, with the large crops of corn and other cereals and an abundance of pure water, especially adapts Iowa to stock raising, and this branch of agricultural industry is very important, Iowa being exceeded in its number of cattle only by Texas, 7.2 per cent of the nation's cattle being in Iowa. Large numbers of draft and driving horses are also raised, as are swine and sheep. Many farmers purchase animals from the grazing regions to the west and fatten them through the winter, so the state exports a very large number of beef cattle. The dairy industry is also important and is of such magnitude as to place Iowa in the front rank as a dairy state. Creameries and cheese factories are numerous, and large quantities of butter and cheese are made in the homes. Iowa is exceeded only by New York and Wisconsin in the number of milch cows.

**Manufactures.** The manufacturing industries are limited, because of the great advantages in agriculture. The most important manufactures are those pertaining to meat packing, butter, cheese and condensed milk, farm implements and machinery, pottery, glucose and food products, such as syrup and canned goods. The manufacture of pearl buttons, made from the shell of a fresh-water mussel which is found in abundance along the streams, is also an important industry. The value of the goods manufactured annually is about \$265,000,000.

**Transportation and Commerce.** The Mississippi affords transportation for the eastern part of the state, and the Missouri is also navigable, but the construction of many lines of railway and the obstructions to navigation, such as snags and shallow water, make these streams of less importance as means of

transportation than they formerly were. Trunk lines of railway extend across the state from east to west in the northern, central and southern parts of the state, and these are connected by numerous cross lines. As most of these lines have constructed spurs wherever the traffic would warrant, every county in the state has one or more railway lines passing through it, and nearly every town is within a few miles of a railway station. Thus transportation facilities are adequate and convenient for all industries. The railway mileage exceeds 10,000 miles.

The commerce of the state is large; it consists in the export of grains, live stock, meat, butter, poultry products and some manufactures, and the import of manufactured goods and foodstuffs that cannot be profitably produced within the state.

**Government.** The legislative department consists of a senate, restricted to fifty members elected for four years, and a house of representatives of 108 members, elected for two years. The senators are divided into two classes, the term of one-half of their number expiring every two years. The executive department consists of a governor, a lieutenant-governor, a secretary of state, an attorney-general, a treasurer, an auditor and a superintendent of public instruction. The term of all state officers is two years, excepting the school head, whose term is four years. The judicial department consists of a supreme court, composed of six judges, elected for six years; twenty district courts, each district having from two to four judges, elected for four years; various superior courts; justice courts, and police courts. There is also a board of control which has charge of the state reformatory and charitable institutions.

**Education.** Iowa maintains an excellent system of public schools, and its percentage of illiteracy is very low, in 1910 being only 1.7 per cent. The schools are supported almost wholly by local taxation. The public lands given by Congress to the state for the support of the schools were sold in pioneer days at a very low figure, largely from \$1.25 to \$5.00 per acre, and consequently the state fund is small. The highest officer is the superintendent of public instruction; the schools of each county are under the supervision of a county superintendent. The state institutions of higher learning include the state university at Iowa City, the state

college of agriculture and mechanic arts at Ames and the state teachers' college at Cedar Falls. The three institutions are managed by a state board of education, recently established by the legislature to displace three separate boards. These institutions are among the best in the United States. The agricultural experiment station is located at the state college. There are numerous colleges and secondary schools of high grade maintained by the various religious denominations. Important among these are the Upper Iowa University at Fayette, Iowa College at Grinnell, Cornell College at Mount Vernon, Iowa Wesleyan University at Mount Pleasant, Central University of Iowa at Pella, Penn College at Oskaloosa, Luther College at Decorah, Tabor College at Tabor, Des Moines College and Drake University, both at Des Moines, Simpson College at Indianola, Morningside College at Sioux City, and Ellsworth College at Iowa Falls.

**Institutions.** There is a soldiers' orphans' home at Davenport and a soldiers' home at Marshalltown. The state maintains a college for the blind at Vinton and an inebriate hospital at Knoxville, whose character will soon be changed by order of the legislature; also a school for the deaf at Council Bluffs and home for feeble-minded children at Glenwood. The hospitals for the insane are at Mount Pleasant, Independence, Cherokee and Clarinda. A hospital for epileptics was opened in 1917 at Woodward. The state penitentiaries are at Fort Madison and Anamosa; there is an industrial school for boys at Eldora and one for girls at Mitchellville. These are all under the board of control of state institutions, excepting the schools for the blind and the deaf, which are managed by the state board of education.

**Cities.** There are in Iowa nineteen cities each having more than 8,000 inhabitants. The capital and largest city is Des Moines; the next five, in order of size, are Sioux City, Davenport, Dubuque, Cedar Rapids and Waterloo.

**History.** Iowa was originally inhabited by Indians of the Iowa, Illinois, Sac and Fox tribes. In 1673 Marquette and Joliet entered the territory, but no attempt at permanent settlement was made until 1788, when a French Indian, Julien Dubuque, built a fort on the site of the city now bearing his name. This was later abandoned. Mean-

### Item of Interest on Iowa

It is almost equally distant from the Atlantic and the Pacific Oceans and is about midway between the North Pole and the equator.

Vladivostok, Salt Lake City, Chicago, New York, and Constantinople are all in the same latitude as parts of Iowa.

The highest point in Iowa is Primghar, 1,800 feet above sea level.

In Iowa the winds from the west and northwest are generally cool and dry, while those from the east and south are warm and bring rain.

Practically one-half of the population is engaged in farming.

Iowa stands eleventh among the states in value of fruits raised.

In the value of its horses and hogs, as well as in the total value of all domestic animals, Iowa leads all other states. Iowa produces twice as many hogs as any other state.

The annual production of butter is about 130,000,000 pounds, or 65,000 tons: nearly two-thirds of this is shipped to other states.

One of the finest gypsum deposits in the United States is near Fort Dodge.

Iowa has exceptionally developed transportation facilities: no point in the state is distant more than thirteen miles from a railroad, and but three states in the Union have a greater railroad mileage.

### Questions on Iowa

How does Iowa compare with Wisconsin, New York and Rhode Island in area? In population?

How does Iowa rank in the value of crops produced? In the value of corn, oats, hay, fruits?

What is the most important mineral deposit?

Name the leading manufacturing industries.

What can you say about Iowa's transportation facilities?

Name the important colleges or universities.

For whom was Dubuque named?

time, in 1803, the United States gained possession of the territory by the Louisiana Purchase, and thereafter Iowa formed a part, in turn, of the territories of Louisiana, Missouri, Michigan and Wisconsin, until 1838, when it was organized as Iowa Territory. A few years before, settlements had been established at Fort Madison, Dubuque and Iowa City. After considerable agitation the state was admitted to the Union in 1846. Thereafter its growth was rapid until the outbreak of the Civil War. During the last decade advanced legislation has been passed concerning the problems of labor and railway control. There have been two constitutions, the second supplanting that of 1848 in 1857. From 1884 to 1894 Iowa was a prohibition state; in January, 1916, prohibition again became effective, in advance of national action. Presidential suffrage was granted to women in 1919.

**Related Articles.** Consult the following titles for additional information:

## GEOGRAPHY

|                  |                   |
|------------------|-------------------|
| Boone            | Iowa City         |
| Burlington.      | Keokuk            |
| Cedar Rapids     | Marshalltown      |
| Clinton          | Mason City        |
| Council Bluffs   | Mississippi River |
| Davenport        | Muscatine         |
| Des Moines       | Oskaloosa         |
| Des Moines River | Ottumwa           |
| Dubuque          | Sioux City        |
| Fort Dodge       | Waterloo          |

## HISTORY

|                |                    |
|----------------|--------------------|
| Amana Society  | Louisiana Purchase |
| Fox (Indians)  | Sac                |
| Iowa (Indians) | Sioux              |

**IOWA, UNIVERSITY OF**, a coeducational institution, founded at Iowa City in 1847, and formally opened in 1855. From 1858 to 1860 only a normal department was maintained, but a reorganization on a broader basis was effected in 1860. At present the university has a graduate college, a college of liberal arts, two schools for nurses, a school of commerce and one of music, and colleges of law, medicine, homeopathic medicine, dentistry, pharmacy, applied science and education. At Lake Okoboji is maintained the Lakeside Laboratory. The college of liberal arts maintains a summer session for teachers and a summer school for library training. It also maintains a lecture and university extension department. The university now has about thirty-five buildings, situated on a campus of about fifty acres on the banks of the Iowa River. The buildings are grouped artistically about the "Old Capitol," the corner stone of which was laid

on July 4, 1840. In normal years the university has a student enrollment of about 3,400 and a faculty of 300. There are 123,600 volumes in the library.

**IOWA**, a tribe of Indians, the remnants of which are now living in Kansas and Oklahoma on reservations, but which early in the eighteenth century inhabited Minnesota and that region to the south which is now the state of Iowa. They number fewer than 300.

**IOWA CITY, IOWA**, the county seat of Johnson County, fifty-four miles west of Davenport, on the Iowa River and on the Chicago, Rock Island & Pacific railroad and two interurban lines. It was the capital of the state until 1854, and the original capitol building and grounds are now used by the state university. Here are also the Iowa City Academy, the state historical society's library, a Carnegie Library, a homeopathic hospital, the university hospital and Mery Hospital. Other important structures are a court house, a city hall, a Masonic Temple and an opera house. The various manufactures include gloves, jewelry, perfumes, extracts, flour and woolen goods. The place was founded in 1839 and became a city in 1853. Population, 1910, 10,091; in 1917, 11,626 (Federal estimate).

**IOWA RIVER**, a river in Iowa, rising in Hancock County. It flows in a southeasterly direction and enters the Mississippi thirty-five miles north of Burlington. It is 300 miles long, and is navigable to some degree for small boats to Iowa City, eighty miles from its mouth.

**IOWA STATE COLLEGE OF AGRICULTURE AND MECHANIC ARTS**, a coeducational institution established at Ames in 1858, which has developed into one of the best technical and industrial colleges in the United States. Besides the agricultural department, which has admirable facilities for teaching practical farming, the institution maintains departments of mechanical, civil, electrical and mining engineering, veterinary medicine, home economics, industrial and economic science, and a department of manufacturing industries. In normal years the faculty numbers more than 460 and the student body over 7,400. There is a library of 62,200 volumes. The college has property valued at \$4,000,000, including a farm of 1,200 acres.

**IPECAC**, *ip'e kak*, a medicinal substance of a nauseous odor and a repulsive, bitterish

taste. It is the dried root of several kinds of plants growing in South America, which bear the name

*ipecacuanha*. The active principle of ipecac is called *emetine*. The medicinal preparation is a white odorless powder, which in small doses causes violent vomiting. It has been found useful in treating bronchitis, croup and other diseases where an expectorant is needed, and in treating disorders in which it is desired to



IPECACUANHA

stimulate the activity of the skin, as in small and repeated doses ipecac stimulates the secreting organs of the skin.

**IPHIGENIA**, *if i je n'ah*, in Greek legend, the daughter of Agamemnon and Clytemnestra. Agamemnon, by killing a hind sacred to Diana, had so enraged that goddess that she detained at Aulis the fleet which was prepared to sail against Troy, and when the oracles were consulted as to means of gaining favor with the goddess, they replied that Agamemnon must sacrifice his daughter. Iphigenia was accordingly sent for on the pretext that she was to be married to Achilles, but when she arrived at Aulis she was delivered to the priests to be sacrificed. As she was about to be killed, she was caught up by Diana in a cloud and carried to Tauris, while a hart was left in her place. At Tauris she became priestess of Diana, and here her brother Orestes found her.

**IQUIQUE**, *e ke'kay*, CHILE, capital of the department of Tarapaca, is situated on the Pacific coast, in the northern part of the country, in the vicinity of valuable saltpeter and silver mines. The town has railroad connection with the mines, and is the port for the export of their output. Borax, iodine and copper ores are also exported. Population, 1916, 45,502.

**IRADE**, *e rah'da*, an imperial decree by the sultan of Turkey, corresponding to British Orders in Council (which see).

**IRAN**, *e rah'n'*, the name given by the ancient Persians to their native land. It is still used by the modern Persians, though it is also employed in a wider sense to designate the whole of the country from the Indus to the Tigris.

**IRA'NIANS**, a name applied to Persians, ancient and modern, Bactrians and Kurds. It is derived from *Iran*, the native name of Persia. Conquest and the natural intermingling of tribes has made it impossible to define closely the limits of the Iranian stock as it exists to-day. The ancient Medes and Persians were a highly civilized people, but some of the Iranian hill tribes were never far from savagery. The ancient religion of the Iranians was that of Zoroaster, but in modern times most of them profess Mohammedanism.

**Iranian Languages**, a group of allied languages belonging to the Indo-European stock, closely resembling the Indian group and called by some philologists Persian, from the best-known member of the group. The two oldest known Iranian languages are the Old Persian of the cuneiform inscriptions and the Old Bactrian, or Zend, the latter the language in which the Zend-avesta, or sacred writings of the Parsees, is written. The Middle Iranian languages are the Pehlevi, and, later, the Parsee, which are preserved in the commentaries to the Zend-avesta. The latter approaches closely the modern Persian. The most important of the New Iranian languages is modern Persian, in which has been produced a rich and celebrated literature.

**IRAWADI**, *ir a wah'di*, or **IRRAWADDY**, the largest river of Burma, traversing the country from north to south and flowing into the Bay of Bengal. Its upper course is through mountain ranges and through rocky defiles; farther down it passes through undulating agricultural lands interspersed by forests of teak. It discharges through a broad delta in the midst of flat rice fields, and is navigable for small steamers as far as Bhamo, 1,168 miles from its mouth. Embankments protect the country from inundation for a hundred miles from the sea. A railroad runs parallel with the river and crosses it at Mandalay.



**I**RELAND, the beloved ERIN of Irishmen throughout the World, is the smaller of the two islands which comprise the United Kingdom of Great Britain and Ireland. It has another poetic name—EMERALD ISLE—bestowed with reference to its velvety-green vegetation. Erin was the name used in early days, when the Irish war cry, “Erin go bragh” (Erin forever), called the tribes to battle. A certain picturesque phase of Ireland has been presented to everyone through the songs, plays and stories that are full of references to the shamrock, Erin’s national flower; the harp, whose silencing betokens the decline of national glory; the River Shannon, the beautiful lakes of Killarney, and the legend of Saint Patrick.

There is another phase of this small island of a more serious aspect, one that has brought its name into political discussions in many quarters of the globe. Though for centuries politically attached to England, Ireland has always been seething with discontent, and no matter where its sons and daughters emigrate, they carry with them the passionate longing of the people at home for severance of the present political ties. Not all of Ireland desires independence, or even Home Rule, for North Ireland is a stronghold of those who are intensely loyal to the British Empire, but the protest raised by their opponents has literally been heard round the world.

**Location and Size.** Ireland is separated from the island of Great Britain, to the east of it, by the Irish Sea, and is surrounded on all other sides by the Atlantic Ocean. With an area of 32,586 square miles, it is a little smaller than the state of Maine and sixteenth in size among the islands of the World. Measured diagonally, the greatest length, from Mizen Head in the southwest to Fair Head in the northeast, is 302 miles; its breadth through the center, between Dublin and Galway bays, is 110 miles.

**Surface and Drainage.** The coast, forming a line of nearly 3,000 miles, is, in general, bold and rugged and has numerous in-

dentations, some of which run far into the land and form excellent natural harbors. There are a number of islands, chiefly on the west coast, the largest being Achill. The mountains, generally speaking, rise in isolated masses at a short distance from the coast, the interior having the form of a vast plain, in which are extensive tracts of bog. The Macgillicuddy’s Reeks, in the southwest, are the highest land, the culminating summit being Carranta Hill, 3,414 feet. The mountains of Wicklow, in the southeast, reach a height of over 3,000 feet.

Rivers are not only numerous, but are very equally distributed over the surface. The Shannon, in the west, the largest river of Ireland, if not of the United Kingdom, is navigable to its source in Lough Allen, forming a waterway of 240 miles. The other rivers of most importance are the Bandon, the Lee, the Blackwater, the Suir and the Barrow, which enter the sea on the south, the last two by the union of their waters forming the broad estuary of Waterford harbor.

The lakes, or loughs, of Ireland are numerous, and in Lake Neagh the island possesses the largest lake in the British Isles. It is situated in the northeastern part of the country, and has an area of 158 square miles. The Lakes of Killarney, famed in song and story, are in a picturesque region in the southwest.

**Climate.** The climate is on the whole more moist, milder and more equable than that of the greater part of Britain. It is highly favorable to vegetation and allows many delicate plants to winter in the open air; some species of plants grow in Ireland but nowhere else in the British Isles, as, for instance, the strawberry tree or arbutus, found in the southwest. See GREAT BRITAIN, subhead *Climate*.

**The People.** The greater number of the inhabitants are descendants of the ancient Celts, who occupied the island at the time of the Roman conquest of Great Britain. The people are known as Irish, and their language, a branch of the Celtic tongue, is used quite generally by the country people; English, however, is the prevailing language in towns, is the official language and is spoken to some extent and quite generally understood by all. The Irish people are noted for their kindness, industry and wit. Thousands of them have emigrated to other coun-



tries, particularly to the United States, where they have become naturalized.

In 1911 the population of the island was 4,381,398. In June, 1915, it was estimated at 4,337,000. Over two-thirds of the people live in the country or otherwise under rural conditions, but a gradual movement in the other direction is taking place. There are eight cities having a greater population than 25,000. Two of these are suburbs of Dublin, the capital. The other six are Dublin (estimated population with suburbs, 406,000 in 1914); Belfast (399,000), Cork, Londonderry, Limerick and Waterford.

**Language and Literature.** The Irish language belongs to the Gaelic branch of the Celtic group of languages, and it is closely akin to the Gaelic of Scotland and the Manx, and more remotely allied to the British dialects—Welsh, Cornish and Breton. Irish literature is rather varied and extensive, including history, legendary and actual, in prose and verse; annals, genealogies and pedigrees, mythological and imaginative tales, lyric poetry, satire, lives of saints and treatises on law, science and grammar. Some of these may be as old as the fifth century of our era. One of the earliest historic pieces is a metrical life of Saint Patrick. The glosses written to Latin works by Irish ecclesiastics, in the monasteries on the Continent, founded during the seventh and eighth centuries, are among the oldest specimens of the language. Many bardic remains belong to the period of the English conquest, but after that date Irish poetry appears to have sunk. Many bards, however, who were still maintained by the native chiefs, helped by their songs to keep up a national feeling hostile to the English domination. The chief interest, in fact, in mediæval Irish literature attaches to the ballad cycles.

Although Irish prose almost ceased to be produced after the seventeenth century, the Irish language has been used in poetry up to the present time. The last years of the nineteenth century saw the beginnings of a movement in literature which corresponds roughly to the Home Rule or nationalist idea in government. A drama and poetry in which the Irish nation may express itself, are the aim of this new school, led by William Butler Yeats, Lady Gregory and John M. Synge. Most of the works of this newer generation of writers are in English, but a few are in Gaelic.

**Agriculture.** Aside from the waste lands on the mountains and the marshes of the lowland plain, the soil of Ireland is very fertile, and farming is the most important industry. Nearly 15,000,000 acres are under cultivation, over 91,000 acres being devoted to flax, a plant whose fiber is indispensable for the manufacture of linen. Potatoes constitute the chief food crop; in fact, the name *Irish* is applied to that vegetable because of its general cultivation and use in the island. The greatest number of acres is devoted to oats, and there are profitable yields of barley, turnips and other garden vegetables. There are broad tracts of meadow grass, and in some sections hay is cut. Cattle and sheep are of chief importance among livestock, but large numbers of horses of excellent breed are also produced.

*The Land Question.* One cannot discuss Irish agriculture without referring to the Irish land situation. Years ago the English took over for themselves large sections of the best land, and Ireland suffered the horrors of absentee landlord rule. Oppressive rents and other forms of injustice reduced the people to misery, but since the latter part of the nineteenth century there has been great improvement in conditions. In accordance with the provisions of a series of Land Acts the British Government has been buying back the land and reselling it to the tenants on the basis of annual installments. A Department of Agriculture for Ireland has been established, which provides traveling lecturers who give instruction in farming, fruit raising, bee-keeping, butter making, etc. There are also maintained a number of agricultural schools and experiment stations, and schools of rural domestic economy.

**Manufactures.** Ulster, in North Ireland, is the chief manufacturing section of the country. The most important manufactured product is linen, which is everywhere famed for its superior quality. The city of Belfast, where the linen industry is chiefly centered, has an annual output valued at about \$75,000,000. Considerable attention is also given to woolen textiles, especially tweeds. Belfast is also the center of a thriving ship-building industry. Other branches of manufacture include brewing and distilling, and such home occupations as lace making and the embroidering of muslin. Lack of suitable fuel prevents any great development of Irish manufactures.

**Mineral Resources.** In some places particularly in the southwest, the coal measures occupy considerable areas, but the quality of the coal is generally very inferior, and it is worked only to a very small extent, the yearly output being only about 100,000 tons. The peasants burn peat (which see), found in inexhaustible quantities in the mireland. Among minerals other than coal, Ireland yields small quantities of marble and other stones. There are valuable deposits of iron ore, but these are not being developed.

**Fisheries.** The government is forced to stimulate interest in fishing, as the industry has suffered a serious decline within recent years. In 1913 the total catch, including shellfish, had a value of about \$1,404,725. Along the rivers and coasts salmon are caught; the haddock fisheries are found east of the Leinster coast, mackerel are pursued on the west coast, and hake on the south coast. Fishermen are aided by government loans, and harbors and piers have been built for them.

**Transportation and Commerce.** Railways connect all of the leading towns. The Shannon is navigable for ocean steamers as far as Limerick, and nearly all streams are navigable in their lower courses for smaller boats. Many of the rivers have been canalized, and all of the principal streams are connected by canals, so that Ireland has an excellent system of inland waterways, which, combined with the railways and good roads, afford ample transportation facilities.

Over 3,400 miles of railroads are in operation, representing a number of small systems having connection with each other. As a war measure, on January 1, 1917, the Irish railways passed under the control of the government, to be administered by an Irish Railway Executive Committee, as in England. On March 1 the canals operated by private companies were also placed under government control.

Ireland has a prosperous foreign trade, and Belfast, Dublin, Waterford, Cork and Queenstown are busy ports. Queenstown is the chief Irish port of call for steamers from America. Live stock, linens, liquor and meat and dairy products are exported to England in large quantities, and the island imports from other countries large amounts of farm products.

**Education and Religion.** Since 1831 elementary education has been under the con-

trol of the Commissioners of National Education in Ireland. Nearly 700,000 pupils are enrolled in the schools. Children of Protestant parents receive instruction from Protestant teachers, and those of Roman Catholic parents from teachers of that faith. The board of commissioners has full control of the schools and selects the textbooks. Illiteracy is on the decline, and has been reduced to nine per cent. The state does not maintain high schools, but aid is granted to such schools established by religious bodies as are worthy of support. Throughout Ireland technical instruction is organized under councils of local units, and is controlled by the Department of Agriculture and Technical Instruction.

The higher educational institutions are Dublin University and the three Queen's Colleges of Belfast, Cork and Galway. The Queen's Colleges were formerly connected with an examining and degree-conferring body (Queen's University); but for this a similar body, the National University of Ireland, was substituted in 1882.

About three-fourths of the people are Roman Catholics, but there is no state Church establishment. In Ulster the Protestants outnumber the Catholics, the Episcopalians, Presbyterian and Methodist bodies being strongest.

**Government.** Ireland has the right to elect 103 representatives to the House of Commons in London, and twenty-eight peers (elected for life) to the House of Lords, under the Act of Union passed in 1800. At present the chief executive is a Lord-Lieutenant, or Viceroy, who represents the Crown and is advised by a Privy Council. The chief Secretary for Ireland, who is generally a member of the British Cabinet and has the actual management of affairs, is the next highest official.

Ireland as a whole is divided into four provinces, Leinster, Munster, Connaught and Ulster, and for local government purposes these provinces are divided into thirty-two counties. In each county the executive authority is vested in a council elected by popular vote, but the larger cities themselves are county boroughs under the administration of similarly-elected councils. In Western Ireland, where overcrowding and poverty have done much to make the people miserable, a Congested Districts Board, created in 1891, operates to improve conditions.

**History.** Little is known of the earliest history of Ireland. From the native legends we know that the island was for many centuries inhabited by various Celtic tribes; but the authentic record begins with the fourth century A. D., when the Scoti, the strongest tribe, subdued the other tribes inhabiting the island and descended upon Britain, then a Roman province. From Britain they extended their expeditions into Gaul. In these early centuries, Ireland seems to have been divided into numerous provinces, each of which, although it had its own king, was dependent on one monarch, to whom the central province was given. Each clan also had a chief, who was chosen from its most important family.

The religion of Ireland in the early centuries of the Christian Era was a nature worship, and the priests, or Druids, and poets, or bards, occupied a position almost equaling that of the king in honor. Christianity found its way into Ireland at an early date, and by the middle of the fourth century it had made considerable progress. It is said that more than in any other heathen country, conversion to Christianity in Ireland was bloodlessly effected. By 432 the young British priest, afterward known as Saint Patrick, began his great mission in Ireland. Other missionaries continued the work in the sixth century, and many churches and monasteries were founded. Religion and learning flourished in the monasteries, which soon began to send out zealous missionaries to establish churches in Britain and on the continent.

In the eighth century the Norsemen began to make incursions upon the Irish Coast, and by the ninth century they had pushed far into the interior and founded a kingdom. Brian Boroinhe defeated them in 1014 and united the greater part of the island under his rule. After the death of Brian, the island relapsed into its former state of division and anarchy. Henry II of England was authorized by the Pope in 1155 to take possession of Ireland on condition of paying an annual tribute, but not until twelve years later was he able to turn his attention to the island. Dermot MacMurragh, king of Leinster, who had been driven from his kingdom, fled to England and, seeking refuge at the court of Henry II, obtained permission to enlist the services of English subjects for the recovery of his realm. Returning with a force

of English, led by Richard Clare, called "Strongbow," Dermot was for a time successful, and regained his seat on the throne. Upon his death Strongbow, who had married Dermot's daughter, came to the throne, and his English subjects were permitted to establish themselves on lands in the eastern part of the island. When Henry II visited Ireland in 1172 he received the homage of the great princes and was recognized as lord of Ireland.

Many Norman barons and their followers now settled in the country, but the English power was far from being established over the whole of it, and the gradual adoption by these new settlers of the customs and languages of the natives decreased British power. By the time of the Wars of the Roses the only part over which England had real authority was a few towns on the coast and a small district about Dublin and Drogheda, known as the Pale. The Irish lived according to their old customs, under their own chiefs, and in manners and mode of life were still totally uncivilized. Under Henry VII a law was enacted making Irish Parliament dependent upon the English king, and the power of the English thus became somewhat stronger.

Soon after Henry VIII had declared himself the head of the Anglican Church, he began his crusade against the Catholics in Ireland. He caused the monasteries to be destroyed and their wealth to be confiscated, and ordered the prosecution of all persons who refused to recognize him as the head of the Church. To offset these attacks on the religion of the Irish, Henry allowed the Irish chiefs a share in the confiscated property of the monasteries and left them under their own laws. In 1541, by an act of the Irish Parliament, Henry was given the title of *King of Ireland*, instead of *Lord*. Edward VI continued the policy of his father of combating the Catholic religion in Ireland, but this change was bitterly opposed, and Mary was able to undo all that had been done by her two predecessors in establishing the Protestant religion.

Elizabeth in her turn imposed Protestant clergy upon the people, and her reign was marked by a series of rising which terminated in the reduction of the whole island. Great stretches were taken from the Irish chiefs and distributed among English noblemen, who were to settle their new estates with Eng-

lish farmers. The injustice of this system and the fact that Catholics were excluded from all public appointments led in 1641 to another attempt to shake off the English yoke. Great atrocities were committed on both sides. In 1641 Cromwell was appointed lieutenant of the island and energetically but cruelly reduced the country in nine months. James II, himself a Catholic, advanced Catholics in Ireland to important positions, and when, after the revolution which placed William and Mary on the throne, James landed in Ireland and sought Irish aid for his restoration, he was enthusiastically received. In 1690, however, William III landed in the island and in the Battle of the Boyne completely defeated the forces of James. Limerick, the last place which held out for James, capitulated in 1691, and a treaty was concluded by which the Catholics in Ireland were to be allowed the exercise of their religion. This treaty was not well kept by the English. By a decree of Parliament passed a short time later, hundreds of thousands of acres of Irish land were confiscated and divided among Protestants. Cruel penal laws were passed against those who adhered to the Catholic religion; Catholic ecclesiastical dignitaries were banished, and all Catholics were declared incapable of holding public office, acquiring land-property or marrying a Protestant.

Not all of these laws were always rigorously carried out, yet they excited great bitterness of feeling and led to frequent risings. In 1778 the laws were made much more lenient, the Catholics were given a right to acquire landed property, erect schools and exercise their religion under fewer restrictions. In 1798, while England was engaged in the war with the revolutionists in France, the Irish again revolted, but the rebellion was speedily crushed. The British government now resolved to unite the English and Irish Parliaments, and an act providing for the legislative union of the two countries passed the Irish and the British Parliaments in 1800. This act went into effect on January 1, 1801.

The Irish patriots bitterly opposed this extinction of the legislative independence of Ireland, and from that day until the present there has been more or less agitation for its repeal and the establishment of the old Irish parliament. In 1841, under Daniel O'Connell, Ireland was brought to the verge of insurrection, but the movement was suppressed.

For many years other troubles had racked Ireland, occasioned by the oppressive land laws which had been enacted from time to time. The suffering caused by these laws came to a climax in 1845 and 1846, when a great potato famine occurred. Thousands died of starvation and hundreds of thousands emigrated to America. Subsequently certain reforms in the land laws were carried out, and agricultural and manufacturing interests revived, but the struggle for liberty continued and took form in an agitation for home rule. (For the details of this long struggle, see HOME RULE.)

A permanent act for the repression of crime in Ireland was passed in 1887. In 1898 an important act was passed, establishing Irish county councils, rural district schools and boards of guardians, and encouraged by this the people began to proclaim more boldly their discontent with the existing land laws and their desire for home rule. In 1903 the Land Purchase Bill was passed, providing that tenants or sub-tenants may purchase the land from great landlords and hold it as their own. The disposal of the land question removed one of the vexing preliminaries to Home Rule. In 1914 the Government of Ireland Bill, as the Home Rule measure was officially called, became a law, but its application was postponed on account of the outbreak of the World War and the opposition of the people of Ulster.

*The World War.* The attitude of the Irish people in this great crisis was anxiously watched by friends of the allies. Germany, it is known, counted on England's remaining neutral because of its Irish problem, but when England actually declared war thousands of Irishmen from all parts of the island enlisted for active service. The Ulster men who had been drilling and making preparations to resist Home Rule now offered to fight for England, and for a time it seemed that the political quarrel was forgotten. The Nationalist Irish party in Parliament, led by John Redmond, unanimously voted to support the war, though they were dissatisfied with England's postponement of Home Rule.

The political truce did not, however, bring harmony. A strong and growing faction in Ireland, the Sinn Fein Society, took advantage of England's difficulties, and in April, 1916, led a rebellion in Dublin for the purpose of securing complete independence. It was proved that they had been in commun-

ication with persons in Germany, and after the rebellion was crushed several of their chiefs, including Sir Roger Casement, were executed. The Sinn Fein agitation continued, however, and the situation was further complicated by the announcement, in the spring of 1918, that the British government would put conscription into force in Ireland. This threat met with such violent opposition, from Sinn Feiners and Home Rulers, alike, that the government decided finally to abandon the plan. The approach of the end of the war and the military aid extended by the United States were factors in this decision. In December, 1918, a general Parliamentary election was held throughout the United Kingdom, and the Sinn Feiners gained an overwhelming victory. They captured over seventy seats in Ireland, virtually wiped out the Irish Nationalist party, and announced their intention of setting up an independent assembly in Dublin.

*After the War.* Such an assembly was held in January, 1919. The Sinn Fein members elected to the British Parliament constituted themselves an Irish Parliament, and proclaimed the establishment of the republic of Ireland. Subsequently they elected Edward de Valera President of their republic, although at the time he was held a prisoner in England. Early in February he escaped, and in March rejoined his countrymen. Beyond keeping a large number of armed troops in Ireland to preserve order, the British government did not interfere with the Sinn Fein activities. In the United States Irish-Americans by the thousands exerted themselves to aid their kinsmen, and a delegation of three was sent to Paris to present the Irish claims to the peace conference. They were not officially received.

**Related Articles.** Consult the following titles for additional information:

## GEOGRAPHY

|                  |            |
|------------------|------------|
| Belfast          | Killarney  |
| Cork             | Limerick   |
| Dublin           | Queenstown |
| Giant's Causeway | Shannon    |
| Irish Sea        |            |

## HISTORY

|                   |                |
|-------------------|----------------|
| Emmet, Robert     | Patrick, Saint |
| Home Rule         | Redmond, John  |
| O'Connell, Daniel | Sinn Fein      |
| Parnell, Charles  | World War      |
| Stewart           |                |

**IRELAND, JOHN** (1838-1918), an American Catholic prelate, born in County Kilkenney, Ireland. When still a boy he migrated with his parents to Saint Paul, Minnesota. Afterwards he was sent to France to be edu-

cated for the priesthood, and was ordained in 1861. In 1875 he became coadjutor bishop of Saint Paul, and on the resignation of Bishop Grace, in 1888, was made archbishop of Saint Paul. He was active in establishing the Catholic University in Washington and in colonizing the Northwest, and was an ardent temperance advocate.



JOHN IRELAND

**IRIDIUM**, a metallic element found in various ores, chiefly in the Ural Mountains and on the western coast of the United States. Iridium takes its name from the variety of colors it exhibits while dissolving in hydrochloric acid. It is not malleable and is the most infusible of metals. It forms a number of alloys, one of which, *iridosmine*, occurs native. The alloy with gold is malleable and much resembles gold in appearance; that with copper is pale red and ductile.

**IRIS**, in Greek mythology, the fleet, golden-winged messenger of the Olympian gods, represented with wings and with a herald's staff in her hand. The rainbow was originally regarded as the path over which she passed to earth, and thus



BLUE FLAG

Iris herself came in time to be regarded as the personification of the rainbow.

**IRIS**, a family of plants related to the lilies found in marshes and wet meadows in the

north temperate zones of both hemispheres. The foliage is sword-shaped and erect, the flowers showy and with an almost rainbow range of color, hence the name. The chief American species are known as *blue flag* and *purple flag*. One species, known as the *fleur-de-luce* or *fleur-de-lis*, became the national flower of France in the thirteenth century, and later was adopted on the national emblem. It is also the emblem of the Italian city of Florence. Orris root comes from a European species. The iris has within recent years been extensively used in landscape gardening, where it is remarkably effective in connection with small ponds.

**IRIS** (in physiology). See **EYE**.

**IRISH MOSS**, a name given to several species of seaweed which grow off the rocky coasts of most parts of Europe and in some North American waters. The weeds are used

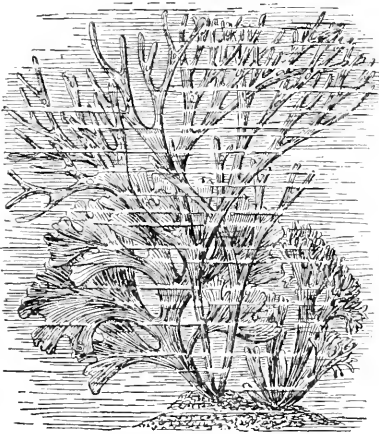

IRISH MOSS

medicinally and as food. The principal commercial species is from two to twelve inches long, is flexible, reddish brown in color and has numerous forked branches. Preparing it for market consists in washing, bleaching in the sun and drying. Nutritious soups and jellies are made from it. *Carrageen* is one of its local names.

**IRISH SEA**, that part of the sea between Great Britain and Ireland, north of Saint George's Channel and south of the North Channel. It is 130 miles long and about sixty miles wide. It contains Anglesey Island and the Isle of Man.

**IRITIS**, an inflammation of the iris of the eye. It is accompanied by a remarkable change in the color of the iris and causes

great pain in the eye, forehead and side of the head, a pain which frequently grows more severe at night. Iritis may be caused by wounds in the iris, from too prolonged use of the eye or from constitutional diseases; such as rheumatism or tuberculosis. A disorder of this nature should have the attention of a reliable physician.

**IRKUTSK**, *ir kootsk'*, SIBERIA, an important commercial center and the largest city in Siberia, capital of the province of the same name. It is situated forty miles from the southern end of Lake Baikal, near the Mongolian boundary, on the River Angara and on the Trans-Siberian Railroad. At the outbreak of the World War Irkutsk was a beautiful modern city carrying on an active trade in silk, porcelain, furs and other articles. In June, 1918, it was reported captured by the Czecho-Slovak forces operating against the Bolsheviki. Population, 1913, 129,700.

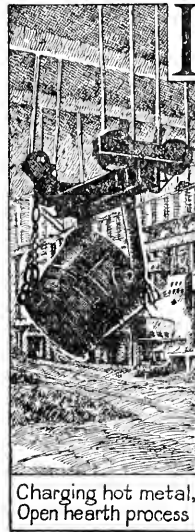

Charging hot metal,  
Open hearth process

**IRON**, the most useful and one of the most plentiful of all metals, more needed by man than any other commercial element in the universe. Were we to be deprived of all gold and silver their loss would prove embarrassing for but a short time; substitutes for them could be provided. But if the world were to be deprived at once of all its mines of iron all material progress would be stopped, and civilization soon would have to content itself with the crude devices of past ages. As soon as existing things

made of iron were worn out there could be no more railroad trains or steamboats, no telegraphs or telephones (not even wireless). There would be no great newspapers, for they could not be printed; the cloth for our clothing would again be homespun; there would be no modern plows, binders or threshing machines. We would be deprived of automobiles; there would be no more tall buildings—and only simple ones of any kind for there would be no nails to bind their parts together—no stoves such as we know now, no battleships of steel and no great

guns—no more murderous modern wars. Every child can name a hundred common things that could not be made without iron.

Iron in a pure state is a silver-gray metal, and it has a brilliant luster. It is seven and three-fourths times as heavy as water, is highly ductile and malleable, and can be tempered to varying degrees of hardness.

**The Iron Age.** Before iron was discovered and man learned how to use it, civilization was in the slowly-developing periods of prehistoric ages known as the Stone Age and the Bronze Age. There are no dates for the beginning of the Iron Age; it began at different times in different parts of the world and progressed slowly because of lack of ready communication. Indeed, the Iron Age has not yet dawned among a few isolated peoples. The greater part of the world is now in the period of greatest development of this wonderful Age.

**The Nature of Iron.** Considered from the standpoint of the chemist, iron is one of the eighty-three elements which compose the material universe. There are thousands of other materials, but all of them are compounds or mixtures of two or more of these elements. Iron in its state of purity has been found as yet only in one small area in Greenland, and there only in a few masses of several tons, imbedded in rocks.

The iron we dig from the earth is not chemically pure; it contains other materials, such as oxygen, sulphur, carbon, lime, arsenic and phosphorus. We find it mixed in the mines, too, in many places, with nickel, copper, aluminum, manganese and other metals. Before it can be made commercially useful the foreign substances must be removed from it, and to this fact are due the great smelting works and iron and steel mills of the world. Steel is included in the above statement, for steel is iron which has undergone certain hardening and refining processes.

**Iron Ores.** The common iron ore that great ships carry from the vicinity of the mines to manufacturing centers is rusty-red in color; it has the appearance of finely-grained material that has been burned. This is really the case, for in the earth where it has reposed for uncounted thousands of years it has been subject to the influence of oxygen.

The most common ore is known as *hematite*; it is also called *specular iron ore*, *red hematite* and *fossil ore*. Hematite is 70 per cent pure iron. Another kind is *magnetite*,

or *magnetic oxide*, containing 72.4 per cent of iron. Others are *brown ore*, or *brown hematite*, with 60 per cent iron; and *siderite*, also called *spathic ore*, *carbonate ore* and *kidney ore*, with 49 per cent iron. *Pyrite* is often used as iron ore after undergoing purifying processes.

The above figures explain why ores taken from the ground are not fit at once for commercial use. If such ore were to be melted and cast into solid form the impurities it contains would condemn it. Notwithstanding the care exercised in manufacturing grades of iron and steel for various uses, sometimes errors result, and months or years later we read of a railroad steel rail breaking or a steel bridge crumbling at a vital point, with resulting disaster. This may happen if even a little too much oxygen is left in the steel in the process of manufacture.

**Where Iron is Obtained.** The United States contains more iron ore than any other country in the world. About 93 per cent of that country's ore is hematite, and the greater part of that is mined in the Lake Superior region of Minnesota and Michigan, in six



#### IRON

Representing average production of ore in normal years.

important locations, known as the Marquette, the Menominee, the Gogebic, the Vermillion and Mesabi, and the Cuyana. Hematite is found also in the states of the Appalachian Mountains, roughly from Northeastern Pennsylvania to Alabama. The greatest mining development in the eastern region is in a large district of which Birmingham, Ala., is the center. The brown ores are most plentiful in the Southern Appalachians, from Western Virginia southward. The other ores are obtained from scattering localities in the same regions. Colorado, New Mexico and Wyoming have a few mines, and together produce about 600,000 tons yearly.

Before the World War about 60,000,000 tons of ore were shipped annually from the mines of the United States to manufacturing centers. The greatly-increased demand for steel during that unprecedented conflict so stimulated production that the output was nearly doubled. Before the war Germany's best production, from its own mines and

## Outline on Iron and Steel

- I. PROPERTIES
- (1) Ductility
  - (2) Malleability
  - (3) Hardness (tempering)
  - (4) Magnetism
- II. IMPURITIES
- (1) Carbon
  - (2) Silicon
  - (3) Sulphur
  - (4) Phosphorus
- III. COMPOUNDS
- (1) Oxides
  - (2) Sulphides
  - (3) Chloride
  - (4) Hydrates
- IV. ORES
- (1) Kinds
    - (a) Red hematite
    - (b) Brown hematite
    - (c) Magnetite
    - (d) Spathic
  - (2) Distribution
    - (a) United States
    - (b) Foreign Countries
- V. MINING ORE
- (1) Methods
    - (a) Blasting. Ore in form of ledge
    - (b) Steam shovel. When ore is soft
  - (2) Shipping
    - (a) Methods
    - (b) Ports
  - (3) Smelting—Object
    - (a) Crusher
    - (b) Blast furnace
    - (c) Manner of tapping, cooling, etc.
- VI. PIG IRON
- (1) Characteristics
    - (a) Rough
    - (b) Coarse
    - (c) Brittle
  - (2) Uses
- VII. WROUGHT IRON
- (1) Characteristics
    - (a) Soft
    - (b) Flexible
    - (c) Ductile
    - (d) Malleable
  - (2) Uses
- VIII. STEEL
- (1) Characteristics
    - (a) Tough
    - (b) Hard
    - (c) Tenacious
    - (d) Gray in color
  - (2) Uses
    - (a) Framework of large buildings
    - (b) Bridges
    - (c) Steel rails and ties
    - (d) Watches—Mainsprings, etc.
- IX. USES OF IRON IN MEDICINE
- (1) Blood purifier
  - (2) Stimulates digestion
- Questions on Iron and Steel**
- Why does iron rust easily? What is rust? What kind of iron in your kitchen range?
- Is there any other known metal that could be used for the same purposes as iron?
- Which could you do without the better, gold or iron? Which constitutes the greatest factor in the world's progress? Who was Bessemer?
- Why is coke used for blast furnaces? Distinguish between pig iron, cast iron, wrought iron and steel. Name articles made from each.
- How did they handle iron in the Iron Age? What are some of the new uses of steel?
- How much heavier is iron than water? For what purpose is pure iron used? How does the United States stand in the production of iron ore? What is the method of mining iron ore? How are the impurities separated from the iron? How is a blast furnace operated? In what is the molten iron cooled? What Southern city is a great center of the iron industry? Which is the most common of the ores of iron? Is iron ever in a pure state when it comes from the mine?



those of Luxembourg, which it controlled, was 29,500,000 tons. France was next, with 16,500,000 tons, but during the first month of the war Germany captured the iron-producing territories of the republic. Great Britain was fourth in production, with over 15,500,000 tons. No other country mined as much as 9,000,000 tons. Figures on the mining industry of Europe since 1914 have not been available, but with the French mines Germany easily remained second in this indispensable military resource. See VER-SAILLES, TREATY OF.

**How Ore is Shipped.** Very little iron ore is carried for country-wide distribution on trains during the greater part of its journey. Lake Superior ore is taken largely to Duluth, Minn., and Superior, Wis., and there loaded on great steel barges, each of which can carry 10,000 tons. The loading and unloading devices are marvels of ingenuity, making it possible to transfer an entire boat load in a few hours. These boats take it to South Chicago, Ill., to Gary, Ind., and to Conneaut and Ashtabula, O. At the two cities on Lake Michigan are some of the greatest iron and steel plants in the world. South Chicago and Gary ship a part of their ore by train to other mills at Joliet, Ill., and Milwaukee. The Lake Erie ports receive the ore and ship most of it by train to the great Pittsburgh district. Appalachian ore is transported by the railroads to various eastern mills.

**Related Articles.** The processes of iron manufacture are so closely related to the story of steel that they are combined with the latter under the title Steel. Consult, also, for additional information:

|           |              |           |
|-----------|--------------|-----------|
| Ductility | Iron Age     | Pyrite    |
| Hematite  | Malleability | Tempering |

**IRON AGE**, a stage of civilization and culture in the history of peoples when they began to use iron for tools and weapons. It is the last of the three prehistoric ages of progress, following the Stone Age and the Bronze Age. In Europe the knowledge of iron began at the south and extended northward. Greece was changing from the use of bronze to that of iron in the time of Homer, while Scandinavia did not enter its Iron Age until about the beginning of the Christian Era. The implements and weapons of the early Iron Age were not cast, but were hammered into shape, and accordingly they took a great variety of forms. During the early centuries of this age written characters were introduced, and the foundation

of historic records was laid. See **STONE AGE**; **BRONZE AGE**.

**IRON CROSS**, a Prussian military decoration, instituted by Frederick William III in 1813. It was revived by Emperor William I in 1870, on the occasion of the Franco-German War, and it then became the war decoration of any German soldier in that war. In 1914 William II again revived the decoration for soldiers of the Empire in the World War. It was awarded to soldiers who had distinguished themselves in war. The cross is Maltese in form, about two inches in length and width, is made of iron, edged with silver, and is worn suspended from the neck or pinned to the coat. Officers of high rank received a cross double the ordinary size.



THE IRON CROSS

In the latter war the Iron Cross lost much of its value to German soldiers because it was so freely bestowed. Several thousand were distributed for each grant of the Victoria Cross of Great Britain, the Croix de Guerre of France or the Distinguished Service Cross of America.

**IRON CROWN**, the name of the old crown of the Lombards. It was made of gold and set with precious stones. On the inside of the crown is an iron circlet, said to have been made from a nail used at Christ's crucifixion, and given by Pope Gregory I to the Lombard Princess Theodelinda. The crown was used at the coronation of the Lombard kings and of the German emperors as rulers of Italy. It is preserved in the Church of Saint John the Baptist at Monza, Italy.

**IRON GATE**, a narrow pass in the lower course of the Danube at a point where the Transylvanian Alps nearly close in upon the river. It is just above Cladova, near the point where Rumania, Serbia and Hungary meet. Within very recent times excavations have been made in the river bed and a passage has been opened for vessels.

**IRON MASK**, THE MAN WITH THE, a mysterious prisoner confined in several French prisons in the reign of Louis XIV. All that is known of him is that he was above middle height, of a fine and noble figure and delicate brownish skin; that he had a pleasant voice, was well educated and fond of

reading and guitar playing, and that he died in the Bastille in 1703. The mask he wore seems to have been of black velvet, not iron. According to one conjecture he was a twin brother of Louis, imprisoned to prevent political complications; according to another, he was one Marechiel, a soldier of fortune of Lorraine, at one time head of a plot to assassinate the king.

**IRON MOUNTAIN**, a hill in Saint François County, Missouri, eighty miles south of Saint Louis, and 1,097 feet elevation above the sea. This mountain consists mainly of porphyry, traversed by an iron bed which contains one of the purest and richest ores in the United States.

**IRON MOUNTAIN**, MICH., the county seat of Dickinson County, forty-seven miles southwest of Marquette, on the Menominee River, and on the Chicago & North Western, the Chicago, Milwaukee & Saint Paul and the Wisconsin & Michigan railroads. The city is in the vicinity of large iron mines and has manufactures of mining implements and lumber products. The place was settled in 1879 and incorporated in 1888. There is a city park of forty acres, and the town has a Carnegie Library and two hospitals. Population, 1910, 9,216; in 1917, practically unchanged.

**IRONSIDES**, OLD. See CONSTITUTION, THE.

**IRONTON**, *I'urnton*, OHIO, the county seat of Lawrence County, 140 miles southeast of Cincinnati, on the Ohio River and on the Cincinnati, Hamilton & Dayton, the Norfolk & Western and the Detroit, Toledo & Ironton railroads. The Chesapeake & Ohio also makes connection from the other side of the river by a car ferry. The city is in a region rich in iron ore, coal and pottery clay, and it has extensive manufactories of iron, cement, lumber, machinery, furniture and other articles. The important buildings are Memorial Hall, Masonic Temple, Odd Fellows' Hall, Briggs Public Library and a good court house. The place was settled in 1832 and was incorporated in 1849. Population, 1910, 13,147; in 1917, 14,079 (Federal estimate).

**IRONWOOD**, a popular name given to any tree with heavy timber. One of these trees, the American hop hornbeam, a small tree with a trunk only six inches in diameter, is so heavy it sinks in water. Several trees

of Africa and Asia have the same quality—ebony, for example.

**IRONWOOD**, MICH., a city in Gogebie County, 150 miles west of Marquette, on the Montreal River and on the Chicago & North Western and the Minneapolis, Saint Paul & Sault Ste. Marie railroads. It is in the Gogebie iron region, and mining and lumbering are the principal industries. Ironwood has a fine city hall, a high school and a Carnegie Library. The town was settled in 1884, and was incorporated in 1887. Population, 1910, 12,821; in 1917, 15,095 (Federal estimate).

**IRONY**, *ĩroni*, the name applied to that style of expression used by writers and orators when they say the opposite of what they mean. Irony is a favorite device of satirists, and when skilfully used it is one of the most effective weapons of pen and tongue. Irony may be either bitter or kindly. The writings of Swift are full of harsh irony, while in the novels of Thackeray one finds irony of a kindlier tone.

**IROQUOIAN**, *ir o kwoi'an*, **INDIANS**. The tribes belonging to this group held the land lying along the Saint Lawrence River from the coast to Lake Huron and south through the greater portion of New York and Pennsylvania. They tilled the soil, raising many vegetables, much tobacco and maize. Their houses were substantially built of split timber, and their respect for law and family ties gave them a strong organization. The name Iroquoian was originally applied by Champlain to the five tribes which had formed a league for mutual protection—the Mohawks, Oneidas, Onondagas, Cayuagas and Senecas.

The Huron, though of Iroquoian stock, never belonged to the confederacy, were continually at war with the Five Nations, and were finally driven out of Southern Ontario, their ancient home. Champlain took the part of the Huron, and in doing so he aroused the enmity of the Five Nations against the French—an enmity which was largely responsible for driving the French from their northern possessions. During the American Revolution the Iroquois sided with the English until they were thoroughly defeated by General Sullivan. There are now in the United States and Canada about 17,000 Iroquoian Indians, of whom the Cherokee is the largest tribe.

**Related Articles.** Consult the following titles for additional information:  
 Cherokee Huron  
 Five Nations Mohawk

**IRRAWADDY,** *ir a wahl'dy.* See IRAWADI.

**IRRIGATION,** *ir i ga' shun,* that development of engineering which carries water from never-failing sources and distributes it over vast areas of "thirsty" land and makes arid places fit for homes of men. Plant life exists only when supplied with water in fairly plentiful quantities. Where not more than twenty inches of rain falls in a year arid regions exist; when ten

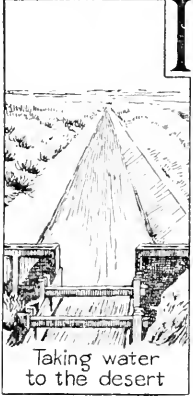

inches or less falls, the region is practically desert, and moisture must be applied artificially if the land is to be of value. Under well-planned irrigation systems the farmer does not have to scan the heavens for indications of needed rain; he can open gates on his irrigation ditches at regular intervals and maintain exactly the degree of moisture on his soil that his various crops may need.

**More Particular Details.** Irrigation is necessary under the following conditions:

1. When the annual rainfall is less than twenty inches.
2. When the annual rainfall, though sufficient for agricultural purposes, is unevenly distributed through the year, the greater portion occurring in months when crops cannot be grown.
3. In the growing of such crops as rice, which require the land to be flooded.

These conditions often render irrigation necessary in regions generally known as humid, and they account for the irrigated districts in Texas, Louisiana and other southern states where rice is grown.

**How Water is Obtained.** Nearly all rivers in the Western United States are irregular in flow. At times they may be torrential; at other periods, dry, or nearly so. Great dams have been built to hold the water of plentiful periods, and it is thereafter available for distribution at all times through great networks of ditches. Gates at needed places control the flow of water. Another source of supply where reservoirs are not necessary are rivers that rush down

the valleys from the mountains, where they are fed by perpetual snow.

It will be seen from the foregoing that irrigation requires three kinds of work:

1. Conserving the amount of rainfall around the sources of rivers which are used to water the arid regions. This is the work of the state and national governments and is one of the principal reasons for creating forest reserves. See Forests and Forestry.
2. The saving of water from melting snow and that which causes the overflow of streams during the rainy season. This requires the construction of numerous reservoirs and often involves expense too great for profitable investment of private capital.
3. Distribution of water to the irrigated districts. This is accomplished through systems of canals. One main channel conducts the water through the irrigated district, and from this small canals branch off at frequent intervals. From these, small canals, ditches and small channels distribute the water to all parts of the field.

The plan for obtaining the water from its source depends upon the source of supply and the topography of the country. Whenever possible, streams are tapped by the canals, as this is the least expensive method.

In many localities dams are constructed for the purpose of making reservoirs in which to store the surplus water for use during the dry season, or to divert the water of a stream from its original channel into the canals. In other localities the water has to be pumped to the height of several thousand feet in order to reach the irrigated surface. In some sections the water is obtained from artesian wells. When possible, the wells are so located as to do away with the necessity of canals and large ditches.

Irrigation is available for comparatively small farms only, and is suited to intensive farming, such as fruit growing. In some instances cereals can be raised with profit by irrigation, and in some localities it is resorted to for forage crops.

**Irrigated Regions.** There are fifteen American states and Canadian provinces north of them that are called arid or semi-arid, in whole or in part. These states are Arizona, New Mexico, California, Oregon, Washington, Nevada, Utah, Idaho, Montana, Colorado, Kansas, Nebraska, North Dakota, South Dakota and Oklahoma. In Canada the arid regions are particularly in Alberta and Saskatchewan.

The vast area named in the United States is greater than that of all the countries of

Europe and of Japan, exclusive of Russia. Some of this is true desert, where crop production is wholly dependent upon artificial application of water. For many years irrigation of parts of this area was debated, but the immensity of the undertaking was one to be considered only by the government, as the cost was beyond the means of private individuals.

**Government Aid.** Since 1894 most irrigation projects have been carried on under one of two laws, the Carey Act, passed in 1894, and the Reclamation Law of 1902.

the Interior, under whose authority construction may be authorized and contracts let.

3. The return to the fund of the actual cost of each project by the sale of water rights, the payments to be made in installments running over a period of twenty years.

4. The holding of public lands for actual settlers, under the Homestead Act, in small units sufficient to support a family.

5. The sale of water rights to private landowners, restricting this to not more than 160 acres to each owner, thus making land monopoly impossible.

6. The final turning over to the people of the irrigation works, except the reservoirs, to be operated and managed by them under a

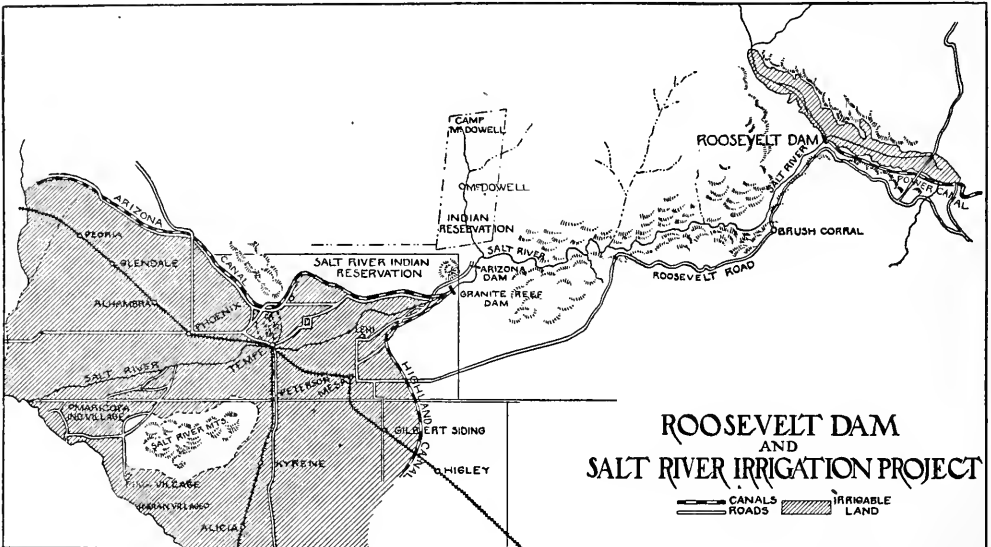

**The Carey Act.** This act grants to each of the states in the arid region, 1,000,000 acres of desert land, on condition of its reclamation. The national government has no further control over this land after it is granted to the state. Most of the projects undertaken upon the lands thus appropriated have been under private enterprise, the parties entering into contract with the state to reclaim a certain area.

**The Reclamation Act.** This act was passed by Congress in 1902. It contains the following important provisions:

1. The creation of a reclamation fund which shall consist of the proceeds of the sales of public lands in the fifteen arid or semi-arid states and territories, this fund to be held in the treasury of the United States.

2. The establishment of a reclamation service in the United States Geological Survey, to investigate and report on the irrigation projects for the approval of the Secretary of

system of home rule. By this provision the users of the water within ten years of the completion of the works will have repaid to the government the amount such works cost, without interest, and the money so returned can be used again and again in the construction of other works.

**Extent of Irrigation Projects.** Colorado had more acres under irrigation than any other state in 1918. It has over 2,795,000 acres which are irrigated; California, 2,665,000 acres; Montana, 1,680,000 acres; Idaho, 1,435,000 acres; Nevada, 702,000 acres; Oregon, 687,000 acres; Washington, 335,000 acres. In no other state are there as many as 300,000 acres under irrigation.

**The Roosevelt Dam.** One of the greatest irrigation projects of all times is called the Salt River Project. It has become more popularly known as the Roosevelt Dam and Irrigation Project, named for the former President of the United States, and dedicated

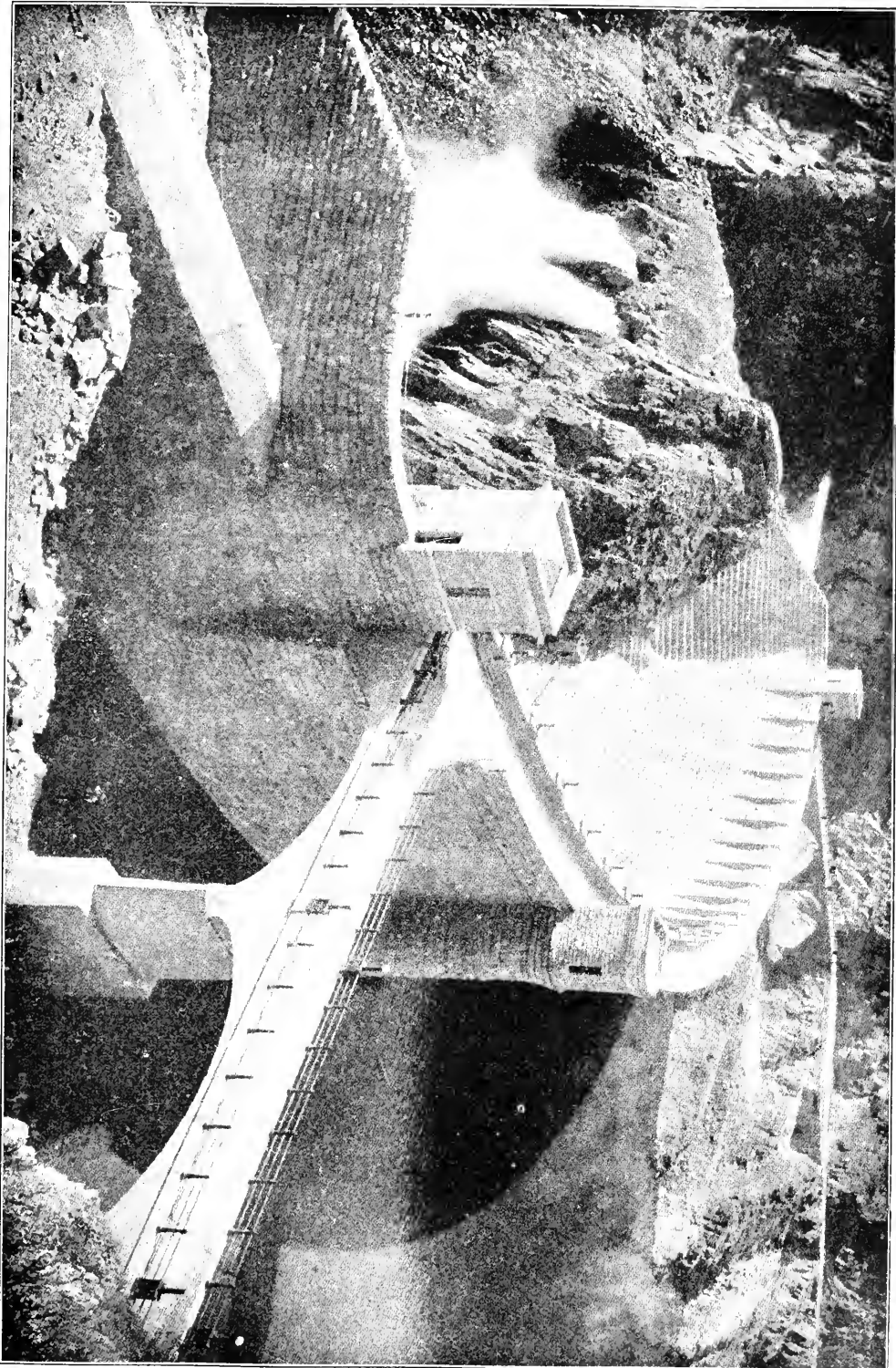

ROOSEVELT DAM, IN SALT RIVER VALLEY, ARIZONA



by him in March, 1911. The accompanying sketch will give the reader a comprehensive idea of the project as a whole, the location of the dam, the land affected and the cities which cannot fail to benefit from the operation of this gigantic enterprise. Behind the dam is stored 1,300,000 acre-feet of water, or water enough to cover that number of acres to the depth of one foot. This means a supply of three years for Salt River Valley. Below the dam about fifty miles is a diversion dam, by means of which the water is turned into various canals. The body of water stored by the dam is the largest artificial lake in the world. If spread out a foot deep, it would more than cover the state of Delaware.

**The Arrowrock Dam.** This is a storage dam, completed in October, 1915, across the Boise River, Idaho. It has the distinction of being the highest masonry dam in the world,

of the Truckee River into the channel of the Carson. The work was completed in 1905. The total cost of the project was nearly \$9,000,000, and it reclaimed about 200,000 acres of desert land.

In the Gunnison project in Colorado the construction of a tunnel six miles long under a mountain over 2,000 feet high was necessary. This tunnel, which is the largest single irrigation project ever undertaken by the United States government, carries water from the Gunnison River to Uncompaghre Valley. The Shoshone project in Wyoming is another of the larger enterprises of the government.

**Irrigation in Canada.** Most widely known is the project undertaken by the Canadian Pacific Railroad. There are other notable projects in Alberta, Saskatchewan and British Columbia.

*The Canadian Pacific Project.* This tract

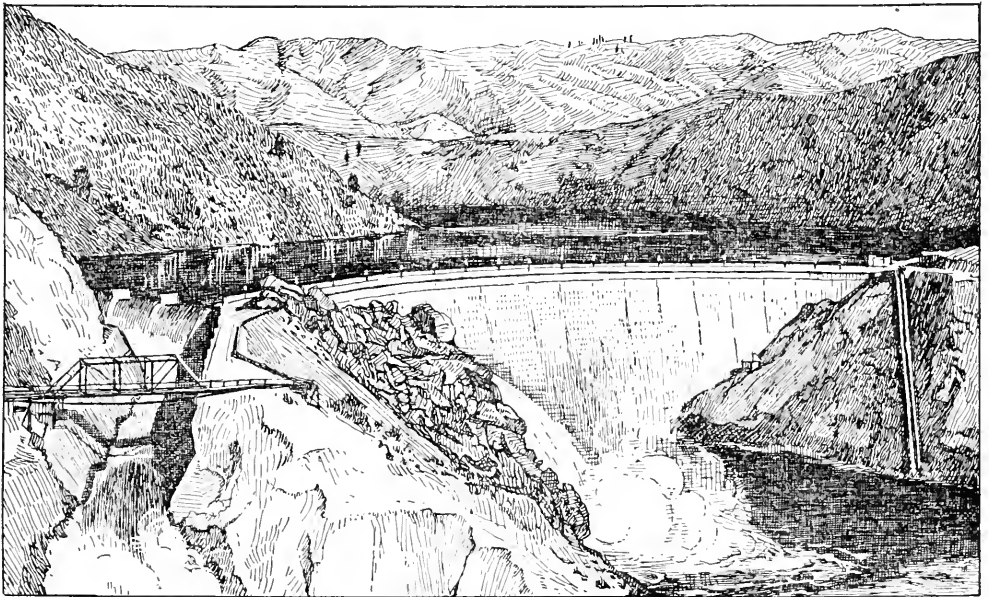

ARROWROCK DAM, IN IDAHO

Completed on October 4, 1915, it ranks all other dams in the world in its height—350 feet above bedrock. It is of rubble concrete, arch gravity type, and contains 585,130 cubic yards of material. It was built by government forces, and not by contract.

extending 350 feet above bedrock. The dam is constructed of rubble concrete and contains 585,130 cubic yards of material. The cost was about \$5,000,000, and it will serve to irrigate 240,000 acres.

**Other Projects.** Among other notable projects in the United States is the Truckee-Carson enterprise, in Nevada. The main canal, thirty-one miles long, diverts the water

consists of about 3,000,000 acres along the main line of the railway, between Calgary and Medicine Hat. It has been divided into three sections, known as the western, central and eastern. The Bow River furnishes water for all three sections; for the western and central sections it is taken near Calgary; and for the eastern section near Bassano, at the Horse Shoe Bend, where a great dam has

been built. The western section has been covered by a complete system of canals and reservoirs and the remaining areas are being rapidly supplied with excellent works.

*Alberta Railway and Irrigation Company.*

tually under irrigation, but when fully developed, the system will provide for the irrigation of about 150,000 acres more. Alfalfa and sugar beets have been profitable, especially near Lethbridge and Raymond.

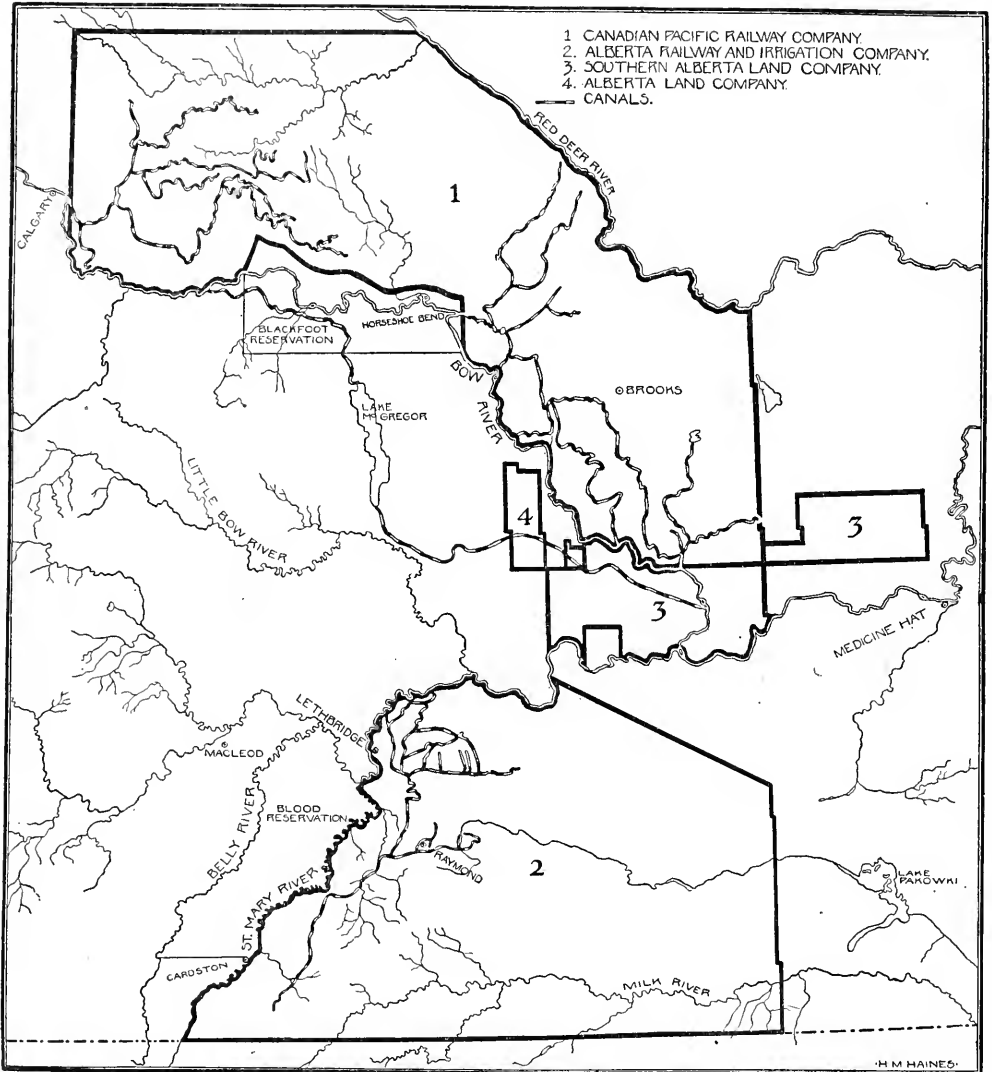

IRRIGATION IN ALBERTA

The lands of this company, which have recently been acquired by the Canadian Pacific, lie between the line of the company's railroad and the St. Mary, Belly and Milk Rivers. Its system of canals and ditches is about 250 miles long and the main canal has a maximum flow capacity of 800 cubic feet per second. At present only about 75,000 acres are ac-

*The Southern Alberta Land Company.* This company also uses water from the Bow River. Its main canal begins about thirty-five miles southeast of Calgary and runs in a southeasterly direction for fifty miles, where it empties into a large reservoir known as Lake McGregor. This reservoir covers 18,000 acres and holds about 360,000 acre-feet of water.



At the north end of the reservoir is an earth dam 3,600 feet long, 173 feet wide at the base, 53 feet wide at the high water mark and 48 feet high; the dam has an eight inch reinforced concrete face on the reservoir side. The dam at the southern end is 2,100 feet long and 46 feet high. From the southern end of the reservoir a canal runs in an easterly direction to the tract irrigated. The company owns over 400,000 acres, probably half of which can be easily irrigated.

*The Aylwin Project.* This was formerly a private enterprise including about 70,000 acres of irrigable land just west of the eastern section of the Canadian Pacific project, but it is now a part of the Southern Alberta Land Company's project.

**In British Columbia.** In recent years irrigation in British Columbia has taken enormous strides. In the southeastern part of the province are great areas which produce a good quality and large quantity of fruit when properly irrigated. It is here—in the Okanagan, Thompson and Columbia valleys—that irrigation is being extensively carried on. The district embraced in the valleys of the Okanagan and Thompson rivers, with their tributaries, contains 500,000 acres. It is claimed that ten acres of good irrigated fruit land here are equal in producing value to 160 acres of wheatland. A respectable beginning has been made in reclaiming this area, about 100,000 acres being covered by various systems now in operation or in course of construction. The provincial government has done much by revising the water laws, reserving the watersheds, protecting the forests from destruction by fire, providing survey for water measurements, etc.

The Central-Okanagan and Belgo-Canadian Companies at Kelowna, the White Valley Company farther north, Fruitlands at Kamloops and the British Columbia Horticultural Estates at Wallachin are examples of companies who are putting in permanent modern systems of steel and concrete. One of the chief factors in extending the areas of irrigated land is the utilization of natural storage basins; for instance, the water stored in Lake Aberdeen, the reservoir at the head of the White Valley, cost 60 cents per acre-foot, while at Penticton the reservoir cost \$17 per acre-foot. In this district the average cost of reclaiming lands by irrigation has been from \$30 to \$80 per acre, according to the character of the works. The average

annual cost to the user varies from \$5 to \$8, while the average difference in value due to irrigation is about \$100 an acre.

**The Great Assuan Dam.** The most famous irrigation dam in the world is the Assuan Dam, across the Nile River at Assuan and Assuit. It is one and one-fourth miles long, 144 feet high and contains 180 sluices. It is the largest structure of the kind ever built. The reservoir formed has a depth of sixty-six feet, and is large enough to store all the flood water of the Nile from one period of high water to the next (see NILE). Over 6,000,000 acres of land are thus opened to cultivation.

**IRVING, u'ving, HENRY, Sir** (1838–1905), an English actor, born in Somersetshire. His name was JOHN HENRY BRODRIBB, but the name Irving, which he assumed for the stage, was legalized by royal license. For a time Irving was a clerk in London, but in 1856 he adopted the theatrical profession. For some years he met with no success, but at length in various light comedy parts he attracted some attention, and in 1870 he gained a real triumph in *The Two Roses*. With his presentation of Matthias in *The Bells* and the title rôles of



HENRY IRVING

*Eugene Aram, Hamlet, Macbeth, Richelieu* and *Othello* his fame steadily rose. In 1878 he leased the Lyceum Theater for himself, and with Ellen Terry as his leading actress he soon won recognition as the greatest of living English actors. In his repeated visits to the United States, both alone and with Miss Terry, he met with the most enthusiastic receptions. Besides the characters named, Irving appeared as Shylock, Mephistopheles, Robespierre, Benedick in *Much Ado About Nothing*, and in the title rôle of Tennyson's *Becket*. It was but a few hours after a presentation of this last play that Irving died. As an actor of great intellectual power, Irving ranks with the foremost of English actors. In emotional strength and fire he was somewhat deficient, however, and this prevented his attaining supreme rank.

**IRVING, WASHINGTON** (1783-1859), a famous American author, born in New York City. He was educated for the legal profession, but his tastes were in the direction of literature, and as early as 1802 his *Letters of Jonathan Oldstyle* appeared in the *New York Morning Chronicle*. Shortly afterward, being threatened with lung trouble, he sailed for Europe, visited most Continental countries and did not return to America until March, 1806. In the same year he was called to the New York bar. His pen was now very busy, and his sketches of Dutch character, in his *Knickerbocker's History of New York*, which made its appearance in December, 1809, proved him possessed of quaint and genial humor to a high degree.



WASHINGTON  
IRVING

About this time he joined his two brothers in a mercantile venture, and the failure of this business, while he was in London in 1818, threw upon him the burden of his own support and the support of his brothers, as well. He settled in London, where his previous literary work secured him warm reception, and devoted himself entirely to literature, which up to this time he had scarcely regarded as a means of livelihood. His first publication, *Geoffrey Crayon's Sketch Book*, which contained the now classic *Rip Van Winkle* and *Legend of Sleepy Hollow*, became immediately popular. For seventeen years, until 1832, Irving resided in Europe, principally in England, France and Spain. This was a period of great literary activity and brought forth some of his most famous works, such as *Bracebridge Hall*, the *Tales of a Traveler*, the *Life of Columbus* and *The Alhambra*. In the course of this sojourn he was secretary to the American embassy in London.

In 1832 Irving returned to the United States and was proudly welcomed as the first man who had secured in Europe recognition of American literature. He bought a country-seat on the Hudson, near the Sleepy Hollow he had made famous, and named it "Sunnyside." Here, excepting four years spent in Spain as ambassador, he passed the remainder of his life. The chief

works of the period before his departure for Spain are *A Tour of the Prairies* and *Captain Bonneville*. He had planned a history of Mexico; had collected much material and had written one chapter; but he learned that Prescott was planning the same work and he magnanimously abandoned his intentions. After his return to "Sunnyside," Irving produced his *Life of Goldsmith*, a sympathetic biography which he was peculiarly fitted to write, by reason of the resemblance of his kindly genius to Goldsmith's own; and he also wrote the affectionate and impartial *Life of Washington*, his last finished work.

Irving took no part in public life, but his character won him a place in the affections of the whole nation. His generous nature, his optimism, his loyalty to truth and right are evident in his works and make it easy for us to understand the esteem in which he was held by his contemporaries.

**ISAAC, *ʔzak***, one of the Hebrew patriarchs, the son of Abraham, by Sarah. He is remarkable as the offspring of very old age, Sarah being ninety and Abraham a hundred years old at the time of his birth; for his miraculous escape from death as a burnt offering, and for the fraud perpetrated upon him, at his wife Rebecca's instigation, by his son Jacob. He died at Hebron when 180 years old and was buried in the cave of Machpelah, the resting place of Sarah, Abraham and Rebecca. The story of Isaac is told in detail in these volumes in the article BIBLE, subhead *Bible Stories*.

**ISABELLA OF CASTILE** (1451-1504), queen of Castile, daughter of John II of Castile and Leon, and wife of Ferdinand of Aragon. She was a woman of great courage and sagacity and contributed no small share to the many remarkable events of the reign of Ferdinand V, including the introduction of the Inquisition, the discovery of America by Columbus and the final expulsion of the Moors after the conquest of Granada. See FERDINAND V.

**ISAIAH, *i za'ya***, the first of the great Hebrew prophets. His name means salvation of *Jehovah*. He began his predictions in the last year of Uzziah's reign. Of his father, Amoz, we know nothing, and of the circumstances of his own life, but little. He had great influence over the kings and people of Judah, and he is supposed to have died at a good old age in Jerusalem at the begin-

ning of Manasseh's reign. The first portion of the writings that pass under his name consists chiefly of declarations of sins and threatenings of judgments, while the last twenty-seven chapters, together with some previous ones, hold out promises of a glorious future for Israel, and predict the birth of Christ.

**ISHMAEL**, *ish'ma el*, the son of Abraham, by Hagar (*Gen. XXI, 8-21*). He married an Egyptian wife and had twelve sons and one daughter, who became the wife of Esau. His descendants are called Ishmaelites.

**ISH'PEMING**, *MICH.*, in Marquette County, fifteen miles west of Marquette, on the Chicago & North Western, the Duluth, South Shore & Atlantic and the Lake Superior & Ishpeming railroads. It is in the vast Lake Superior iron region and has important smelting works, foundries and machine shops and lumber industries. Marble is also found in the vicinity. There are two hospitals and a Carnegie Library. Several summer resorts are in the vicinity. The place was settled about 1857, and was chartered as a city in 1873. Population, 1910, 12,448; in 1917, practically unchanged.

**ISINGLASS**, *i'zin glas*, a tough substance resembling glass in appearance and applicability, made from the swimming bladders of certain fishes—the sturgeon, cod, hake and others. Isinglass is from eighty-five to ninety per cent gelatin. It is reduced to a jelly in a solution of sulphuric acid. In this form it is used extensively as a base for glue and cement. Boiled in milk the jelly is a nutritious food; mixed with other substances and spread on silk it forms courtplaster. The small mica windows seen in stoves are incorrectly called isinglass (see *MICA*).

**ISIS**, the principal goddess of the Egyptians, the sister and wife of Osiris. As Osiris represented the sun, so Isis was identified with the moon. The ancient Egyptians believed that Isis taught their ancestors agriculture, and accordingly made her an offering of the first cereals gathered. Isis was variously represented in Egyptian art as a woman, with horns of a cow (an animal sacred to her); as crowned with a disk (a heavenly body); as bearing upon her head a lotus flower or a throne and in her hand the sistrum, a musical instrument. She is often shown accompanied by her infant son Horus. She was worshiped first at Memphis and later throughout all Egypt. From Egypt worship of Isis was introduced into Rome by

Sulla in 86 B. C. The abuses it occasioned there caused it frequently to be prohibited, but it was repeatedly revived. The immorality attending it was vigorously lashed in the satires of Juvenal.

**ISLAM**, *is'lam*, the name by which Mohammedans designate their religion. It is an Arabic word meaning *submission*; by application, submission to the will of God. The term Islam has come to be used generically to designate the whole body of Mohammedan peoples.

**ISLAND**, *i'land*, in physical geography a term denoting a body of land surrounded by water, smaller in size than the great masses of land known as continents. Islands are divided into two main classes: *continental* islands, lying in proximity to continents, and *pelagic*, or *oceanic*, islands, such as the Hawaiian Islands. A continental island is usually of the same geological structure as the neighboring continent, and contains like vegetation and animal life. Oceanic islands are mostly of volcanic or coral formation. A cluster of islands, such as the West Indies, the Canaries or the Hebrides, is called an *archipelago*.

**Largest Islands.** The six largest islands of the world, with the approximate areas in square miles, are named below:

|                     |                      |
|---------------------|----------------------|
| Greenland, 827,300  | Baffin Land, 236,000 |
| New Guinea, 330,000 | Madagascar, 228,000  |
| Borneo, 284,000     | Sumatra, 180,000     |

**ISLANDS (or ISLES) OF THE BLESSED**, according to Greek mythology, were a group of islands lying somewhere far in the West, peopled by those on whom the gods had conferred immortality. In other words, they were a sort of Greek heaven. There summer was perennial, and all good things were in abundance.

**ISLE OF MAN**, a British island 227 square miles in area, in the center of the Irish Sea, between the coasts of England and Ireland—twenty-seven miles south of Scotland. It was called Man from *Maunin*, meaning *middle*, referring to its location. The highest point is 2,034 feet above sea level, in a range of hills extending across the island. Mineral riches include a great deal of lead and some iron, zinc and copper. The people are of Celtic origin, known as Manx (which see).

There is a separate government for the island, and local officers under an English governor execute the laws. Population, 1911, 52,016.

**ISLE OF PINES**, in Spanish, *ISLA DE PINOS*, is a beautiful island thirty-five miles south of the western section of Cuba, to which it belongs. It is forty miles long and thirty-four miles in greatest width, and has an area of 840 square miles. The population is about 4,000; most of the people are in the two towns of Nueva Gerona, the capital, and Santa Fé which has considerable fame as a winter resort. Forest woods of value are pine, cedar and mahogany; the chief products of the soil are pineapples, and potatoes.

**ISLE OF WIGHT**, an island in the English Channel, near Southampton, separated from the English coast by the Solent and the Spithead. It is nearly twenty-four miles long, is thirteen miles in greatest width, and the area is 147 square miles. Notable chalk cliffs are at the western end. There is beautiful scenery and a mild climate, which attracts many summer visitors. Population, about 90,000.

meeting places having equal barometric pressure (see **BAROMETER**). Since winds blow toward areas of low pressure, weather forecasters, by referring to maps showing areas of high, low and normal pressure, can make accurate weather predictions. Weather bureaux issue daily charts showing isobaric lines. See **WEATHER BUREAU**; **STORMS**; **WIND**.

**ISOCRATES**, *i sok'ra teez*, (436-338 B. C.), an Athenian philosopher and orator, one of the most famous of the Sophists. He contended that man cannot expect to gain truth itself, but must be content with appearances. The orations and essays of Isocrates are among the most famous of Greek prose writings and were the models on which Cicero formed his style.

**ISOTHERMAL**, *i so thur'mal*, **LINES**, or **ISOTHERMS**, lines drawn upon maps connecting places having the same average temperature. Maps showing isotherms are constructed on the basis of daily, monthly and

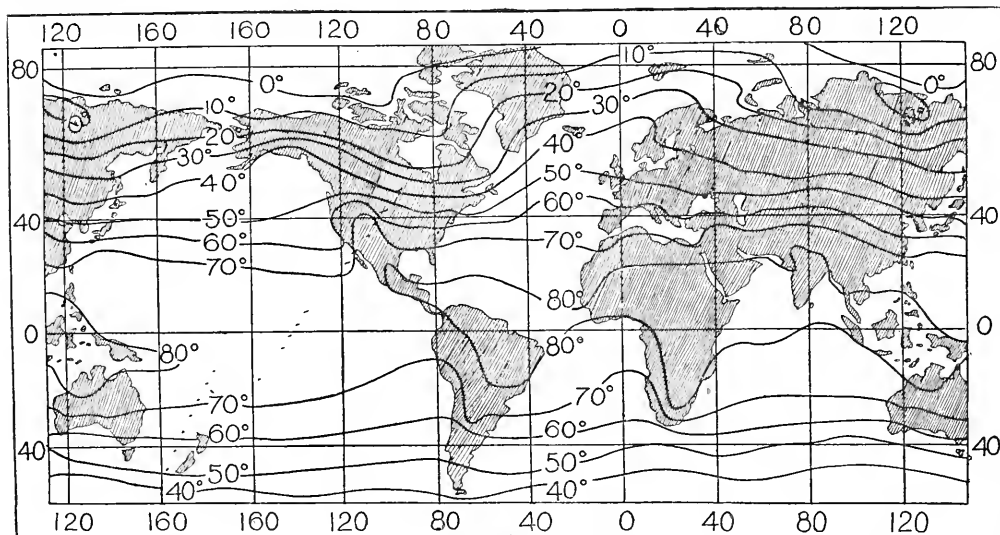

ISOTHERMAL LINES

**ISLE ROYALE**, the largest of a small group of islands in the northwestern part of Lake Superior, forming a part of Houghton County, Michigan. It is forty-five miles long and nine miles wide, and contains 229 square miles. By steamer the island is eight hours from Duluth and three hours from Port Arthur, Ontario, and it is becoming a popular summer resort. The international boundary is eight miles from the north shore.

**ISOBARS**, *i'so bahrz*, or **ISOBARIC LINES**, lines drawn on weather charts, con-

yearly averages (see **WEATHER BUREAU**). They are of value in forecasting weather conditions. Isotherms do not follow parallels of latitude, because places in the same latitude often have wide variations of temperature. They are explained in the accompanying map. See **CLIMATE**.

**ISPAHAN**, *ees pa hahn'*, or **ISFAHAN**, *ees fa hahn'*, a very ancient city of Persia, for centuries its capital, situated on the Zendeh Rud about 210 miles south of Teheran, the present capital. It was once one

of the most important and magnificent cities in the East, but little is now left of its former splendor, most of the city being in ruins. Among the chief structures, some of which rank with the finest in the East, are the palace of Shah Abbas, known as Chehel Situn, the Mesjid-i-Shah, or royal mosque, and a magnificent palace known as Hasht Behesht. The river is crossed by five bridges, one of which is remarkable for its size and architectural beauty. The manufactures are still extensive, including trinkets, firearms, sword blades, glass, earthenware, artistic brass-work, woollens, cottons, velvet and satin. Much opium is produced in the neighborhood, also tobacco and madder. Ispahan is the center of the inland commerce of Persia. Population, about 80,000.

**ISRAELITES.** See **JEWS.**

**ISRAELS**, *ees ra ayls'*, JOSEF (1824-1911), a Dutch genre painter, who depicted with tender pathos the moving dramas in the lives of the Dutch peasants and fisher-folk, was born in Holland, of Jewish parents. He studied at Amsterdam, and at Paris under Delaroche. The first important pictures he produced were *The Cradle* and *The Shipwrecked Mariner*, both of which brought him renown. Other works are *Expectation*, *The Frugal Meal*, *Alone in the World*, *David Before Saul* and *The Toilers of the Sea*. Israels' etchings, like his paintings, are notable for simplicity and faithfulness of treatment. See **GENRE PAINTING.**

**ISTHMIAN**, *is'mi an*, **GAMES**, public games of ancient Greece, celebrated on the Isthmus of Corinth. They took place every other year, in April and May. The contests were open to all Greeks, except the Eleans, and were similar to those held at Olympia. They included boxing, wrestling, foot, horse and chariot racing and throwing the discus. The prizes were a wreath of parsley and a palm branch, in the early period, and at a later date, wreaths of laurel. The origin of the games is lost in antiquity, but it is generally believed they were held first in honor of Poseidon (Neptune).

**ISTHMUS**, *is'mus*, any neck of land connecting two continents or uniting a peninsula to a mainland. Conspicuous examples are the Isthmus of Panama, between North and South America, and the Isthmus of Corinth, connecting the Morea with the mainland of Greece. Its geographical name usually clings to an isthmus after it has been

cut by a canal, though it is in reality an isthmus no longer.

**ITALIAN LANGUAGE.** The Italian language is descended from the Latin through the intermediate stage of the so-called "rustic Latin." This is the name given to the corrupt dialects of the uneducated, which arose after the fall of Rome and the consequent disuse of the language as a standard of literature. The dialects had existed before, but they became predominant only under favoring circumstances. In the twelfth and thirteenth centuries, the poets, especially those of Tuscany, employed Italian, the natural result being that their dialect took precedence over the others. Dante (1265-1321) did much to arrange and consolidate the various elements, and thus, long before most other European languages had reached their full development, Italian received substantially the form it has to-day. In the fourteenth century the language was further perfected by Petrarch and Boccaccio, and in the late fifteenth and early sixteenth centuries prose form became fixed and elaborated in the works of Leonardo da Vinci and Machiavelli.

Italy has now a uniform written language, but the spoken dialects differ widely, sometimes as much as utterly different tongues. The standard aimed at by educated Italians is a combination of the pure Tuscan dialect with the pronunciation of Rome. The broad vowels and the vast preponderance of vowel-endings give to Italian a particularly musical character. This makes it well adapted for singing. The poetic structure of the language, in choice of words and pronunciation, differs more widely from the prose than that of any other European language. The vocabulary is rich in poetic words and in such as were received from classical sources, but in the expression of material things in modern life it is singularly poor.

Reference to the article **LANGUAGES OF THE WORLD** shows Italian to be one of the major languages; only eight, according to careful estimates, are more widely employed. This is the more remarkable when it is recalled that the mother country is small—slightly smaller than the state of Nevada—and its overseas possessions are not numerous; yet its people are prolific, the country is densely populated, and Italy's sons are found in every civilized country on the globe.

**ITALIAN SOMALILAND.** See **SOMALILAND.**



**I**TALY, the central peninsula of the three that project into the Mediterranean Sea from the southern coast of Europe. Politically, this peninsula and a number of neighboring islands, including Sardinia and Sicily, constitute the kingdom of Italy. About the name, Italy, the "Italia" of the poets, there cluster many glorious associations. In ancient days the world's greatest empire had its birth in the Italian peninsula,

when Rome, "from her throne of beauty, ruled the world." Later, in the medieval period, when the Roman Empire had passed into history, the same narrow peninsula became the cradle of the Renaissance movement, which in the full flower of its growth produced that marvelous thing we call Italian art. The tourist who loves beauty, whether it be the beauty of blue skies and bright sunshine, or of noble churches and palaces, or of painting and sculpture, turns with enthusiasm to the land of Italy. It also has its religious associations, for the city of Rome is the residence of the spiritual head of the Roman Catholic Church.

**Location, Size, Population.** Such figures and descriptive phrases as are used here apply to Italy as it was constituted at the outbreak of the World War. One of the objects which Italy had in entering the war was to redeem the Italian-speaking provinces of Austria-Hungary, the beloved *Italia Irredenta* of its patriots; another was to secure the Dalmatian coast, on the northeastern Adriatic. The new Italy which came out of the war was enlarged. In 1914, however, it consisted of the boot-shaped peninsula and several near-by islands. Except along the northern boundary of the mainland, Italy is surrounded on all sides by the Mediterranean Sea and its branches, the Adriatic bordering it on the east, the Tyrrhenian bathing a portion of the western coast, and the Ionian washing the "toe of the boot." In the north the eastern land boundary is formed by Austria, and now includes the triangular *Italia Irredenta*, redeemed from Austria; the western boundary adjoins that of France, and on the north are Switzerland and Austria. On

the east of the Adriatic Sea, Italy will in 1923 come into possession of the city of Fiume (see VERSAILLES, TREATY OF).

The dividing line between Italy and Switzerland is considerably to the south of the central part of the great range of the Alps which cuts off Italy from the rest of the continent. With the island of Sicily, from which it is separated only by the narrow Strait of Messina, Italy reaches almost across the Mediterranean Sea and is thus commercially in a very favorable location.

Including its islands, the Italian kingdom in 1914 had an area of 110,688 square miles, almost the same area as that of the state of Nevada. Without the islands, the area is about 91,000 square miles, a little less than that of Illinois and Indiana combined. In 1911 the population was 34,671,337; in 1915, 36,120,118.

**Surface and Drainage.** There is in Italy only one large plain, the valley of the Po, in the northern part of the country. This plain is about 37,000 square miles in area and is almost surrounded by a great curve of the Alps. The mountains of the country may be separated into three divisions: the Alps in the northern part; the Apennines, which are about 800 miles in length and extend through the central part of the peninsula, dividing it into two slopes, a western and an eastern, and the chain which runs parallel to the Apennines in Sardinia and Corsica. Mount Vesuvius, on the Bay of Naples, is the only active volcano on the continent of Europe, while Mount Etna, in the Sicilian continuation of the Apennines, is its loftiest volcano.

The coast line of the peninsula of Italy is about 2,000 miles long, and that of the islands is about 1,945. While the country is well watered, there is but one large river, the Po, which is navigable as far as Turin. Of the other rivers, among which may be mentioned the Tagliamento, the Brenta, the Adige, the Arno and the Tiber, many are but torrents, the beds of which are dry in the summer. Some of the largest mountain lakes of Europe are located in Italy. The Alpine lakes of Maggiore, Lugano and Garda lie only partly in Italy, but Como and Isea are entirely Italian. The Apennines also contain numerous lakes, many of which seem to have been formed in the craters of extinct volcanoes. Among these Apennine lakes are Trasimeno, Bolsena, Albano and Averno.

**Climate.** Italy extends through eight degrees of latitude, the southern part being in about the same latitude as North Carolina, and the northern in about the same latitude as Maine. There is therefore considerable variation in regard to climate. The southern part of the peninsula, with its arid, burning climate and its sirocco winds, resembles Africa rather than Europe, while the northern parts have a climate which is practically that of Central Europe. Local conditions, such as the nearness to the sea and the protection afforded on the northern boundary by the Alps, have considerably modified the climate as a whole. In general the most noteworthy features are the absence of extremes of heat and cold and the clearness of the air. This latter peculiarity accounts for the remarkable blueness of the Italian skies. For the most part Italy is healthful, although there are exceptions in the pestilential marshes, the most notable of which are the Maremma in Tuscany, the Campagna of Rome and the Pontine marshes. The rainfall is abundant during the winter, but irrigation is necessary in most parts of the country.

**Mineral Resources.** The mineral resources of Italy are few. Coal is almost entirely lacking, and this prevents the thorough working of such mineral beds as are found. Iron ore is found in some localities. Zinc is mined in Lombardy and Sardinia, and limited quantities of gold, silver and antimony are produced. Sulphur is by far the most important mineral found in the country, and almost all of the world's supply of this mineral is obtained from Italy. The famous Carrara marble, which is largely exported, is found in the Apennines. See CARRARA MARBLE.

**Agriculture.** Agriculture is distinctly the most important industry of Italy, and the range of latitude and altitude permits the production of all the crops of the temperate regions and many tropical products as well. The length of the warm season in many parts of the country makes possible the raising of two or even three crops during the year. The great plain of Lombardy is the most important agricultural district. Wheat, grown in the more southerly sections, is the principal cereal raised, but there is not enough to supply the domestic need, and large annual importations are necessary. Corn is raised on the northern plain, and rice, oats, barley and rye are also produced, though in limited quantities.

The fruits of Italy are more important than the cereals, and olives, in the production of which Italy leads the world, are the most important agricultural product. Immense quantities of oranges and lemons are grown; almonds are produced in Southern Italy and in Sicily, and in the production of wines Italy ranks next to France. The climate in the northern part is peculiarly adapted to the growth of the mulberry tree, the leaves of which are food for silkworms, Italy being one of the leading countries of the world in the production of silk. Little has been done in stock raising, but in the northern part of the country horses and horned cattle are bred to a limited extent.

From the richness of the soil and the favorable climate it might be expected that Italian farmers would constitute a well-to-do class of people. They are, on the contrary, very poor, for the most part, and receive but a small proportional return for their labors. This is accounted for chiefly by the fact that much of the land is owned by wealthy landlords, who rent it out on terms most disadvantageous to the tenants.

**Manufactures.** The manufactures include silk, which is made chiefly in the north in Lombardy and Piedmont, woolens, straw goods, coral ornaments, mosaics, jewelry, ivory carvings and marble and alabaster products. The Italians have a special aptitude for art work, and the most of the exports of the country consist of such articles. Macaroni, which is produced in large quantities, is largely consumed at home. In the northern districts, dairy products are important, and certain varieties of cheese, especially Gorgonzola and Parmesan, are famous. During the World War engineering skill of a high order was displayed by Italian workmen in the construction of aeroplanes, especially in the making of aeroplane motors. Italian airships were among the finest used by the allied armies. Italy also contributed vast stores of munitions.

**Transportation and Commerce.** In 1916 there were 11,722 miles of railway in operation in Italy, over 8,600 miles being state owned. The railways are organized into two trunk lines, one on either side of the Apennines, known respectively as the Mediterranean and the Adriatic groups. The extensive coast line of Italy and the fact that all Mediterranean ports and most ports of the East are easily reached, have given Italy a

large carrying trade, but the merchant marine declined greatly during the World War, because of submarine attacks and lack of raw materials to replace losses. The imports have of late years somewhat exceeded the exports. In the foreign trade with Italy, before the World War Germany ranked first, the United States next, then Great Britain, France and Austria-Hungary. The exports from Italy to the United States consist largely of art goods, Carrara marble, olive oil and straw goods, while the United States sends to Italy cotton, agricultural implements, machinery and hardware.

**Inhabitants and Language.** The population of Italy is more homogeneous than that of almost any other large country. There are, of course, in Italy numerous representatives of all the other European countries, but their proportion to the native Italians is remarkably small. For the language of Italy, see ITALIAN LANGUAGE.

**Education.** By a law passed in 1877 compulsory education was provided for all children between six and nine years of age. The law is not strictly enforced in many of the provinces, and the proportion of illiterates is still very high in certain portions in the south. The system of higher schools is remarkably efficient, considering the low educational status of the population in general. There are twenty-one universities, of which the state maintains seventeen. The University of Bologna is the oldest of the state universities, and that of Naples, with a normal enrollment of over 5,000 students, is the largest. There are also more than twenty-five art institutions, besides six government and a number of private musical conservatories. The famous Montessori Method is the achievement of an Italian educator (see MONTESSORI METHOD).

**Literature and Art.** See LITERATURE, sub-heads *Latin Literature* and *Italian Literature*; PAINTING; SCULPTURE, subhead *Italy*; ARCHITECTURE, subhead *Renaissance Architecture*.

**Government and Religion.** The government of Italy is a constitutional hereditary monarchy. The royal family is that of Savoy. The king is theoretically very powerful, but the real governing functions are in the hands of a Cabinet of eleven members, who are at the head, respectively, of the departments of Interior; Foreign Affairs; Treasury; Finance; Justice and Religion; War; Marine;

Commerce; Industry and Agriculture; Public Instruction; Posts and Telegraphs, and Public Works. The Minister of the Interior is the Premier.

The legislative power is vested in a parliament, which consists of a Senate and a Chamber of Deputies. The Senate is composed of the princes of the blood and an indefinite number of notables appointed by the king for life. Usually the Senate has about 320 members. There are 508 members in the Chamber of Deputies, and they are elected for a term of five years. The suffrage is limited to male citizens; those between twenty-one and thirty are allowed to vote, if they can read and write, and all above thirty have suffrage rights regardless of their literacy.

The Roman Catholic religion is the religion of almost all of the inhabitants of Italy. It has an importance here which it has not in other countries, because Rome, the capital of Italy, is the center of the Church. According to the last statistics, the Jews and Protestants number respectively about 35,600 and 65,600.

**Colonies.** Italy's dependencies in Africa are Tripoli, Eritrea and Italian Somaliland. Tripoli is the largest and most important colony. The colonies have an area of about 591,200 square miles, and a population, which is partly nomadic, of about 1,400,000.

**Cities.** The chief cities of Italy are Rome, the capital, Naples, Milan, Turin and Palermo. Others of special interest include Venice, Florence, Leghorn and Genoa.

**History.** The ancient history of Italy belongs properly under that of Rome. Before the period of Roman supremacy, the country was peopled by various Italic tribes, among which were the Etruscans, or Tuscans, the Umbrians, the Sabines and the Latins. The last-named became supreme and gave their name to the ancient race and language. With the fall of Rome in A. D. 476, begins the history of Italy proper. The invading barbarians proclaimed their leader Odoacer king of Italy, but in 493 they were overthrown by Theodoric the Great, king of the Ostrogoths, who united the whole peninsula under Gothic rule and proved himself a wise and benevolent king. Italy had not seen such prosperity since the earlier glory of the Roman state.

In 552 the Ostrogoths were vanquished by the army of the Eastern Emperor Justinian, under the famous general Belisarius, and



Italy became an exarchate of the government at Constantinople. After the recall of Narses, the first governor, the Lombards, a Germanic tribe, invaded Italy, introduced Germanic feudal institutions and greatly modified the political and social life of the country. About the middle of the eighth century, the Lombards threatened Rome, but were defeated by Pippin, king of the Franks, whose aid had been asked by the Pope. Certain territory was given to the Pope by Pippin, and this gift was confirmed by Charlemagne, who conquered the Lombards and annexed their country to the Frankish kingdom in 774. This gift to the Pope was the beginning of the temporal power of the Church.

In 800 Charlemagne was crowned Roman emperor by the Pope, and the assumption of this title led to the claims of the German emperors in Italy during the following centuries. By the Treaty of Verdun (843), Italy fell to Lothair, and for over a century anarchy reigned throughout Italy, but in 951 Otho the Great reduced the Lombard king to vassalage, and in 961 Otho himself assumed the crown of the Lombards. In the following year he was crowned emperor, thus founding the Holy Roman Empire. The rule of the Germans was never acceptable to the Italians, and from the beginning of the eleventh century frequent revolts occurred against the German emperors, who with difficulty maintained their authority. The Lombard kingdom was gradually resolved into city states, such as Milan, Genoa, Pisa, Florence and Venice. During the eleventh and twelfth centuries arose the famous factions of the Guelphs and the Ghibellines, and the Emperor Frederick I was compelled to relinquish all rights in the cities of the Lombard League (1183). In the latter half of the thirteenth century the German dynasty was completely overthrown, and the kingdom of the Two Sicilies was secured by Charles of Anjou. Italy was at this time prosperous, but this prosperity was marred by the continued feuds and rivalry of the Guelph and Ghibelline factions.

The Guelphs continued victorious and defeated the attempt of Henry VII to restore German supremacy in Italy (1312). This party, however, was torn by disputes and gradually succumbed to petty tyrants. From the middle of the fourteenth century to the end of the fifteenth, the history of Italy as a whole ceases, and we have only the annals of

several powerful states and the famous families who ruled them, among them being Venice, Florence, Genoa, Milan, Naples and Rome, as well as the larger divisions of Sicily and the Papal States. The smaller states dwindled into insignificance.

During the early sixteenth century, Italy was the scene of the struggles between France and the German emperors, of the Austrian House of Hapsburg. These struggles began in 1494 with the attempt of Charles VIII of France to conquer Naples. The Battle of Pavia (1525) decided the struggle finally for the German emperors, who thereafter appointed rulers over the several states. Italy enjoyed comparative peace for one hundred fifty years, during which some progress was made toward national consolidation. Charles V in 1535 secured Milan and Naples for Spain, but in the early eighteenth century Austria acquired both, together with Sardinia, which was later exchanged for Sicily. The condition of Italy, nationally, was one of apathy and decay down to the French Revolution.

In 1793 Italy attempted to join the coalition against France and as a result was reduced to the condition of a dependency. By the Treaty of Campo-Formio in 1797 Napoleon surrendered Venice to Austria and transformed the remainder of Italy into republics. In 1806 Naples was made a kingdom for Joseph Bonaparte, who was succeeded two years later by Murat. From 1809 until 1814 Napoleon's supremacy in Italy was undisturbed.

The Congress of Vienna in 1815 left Italy almost entirely in the hands of Austria and the Papacy, and the wishes of the Italian people for unity and independence were hopelessly crushed by this restoration of the Austrian and the Papal power. Conspiracies and secret societies directed against the foreign rule sprang up almost immediately. The liberal concessions made by Charles Albert after his accession in 1831 to the throne of Sardinia laid the foundation for the ultimate union of Italy under his house. Mazzini made vigorous pleas for national unity, calling upon Charles Albert to act as liberator for his country. The revolution in France in 1848 increased the discontent in Italy, and insurrections were common throughout the country. Naples, Sardinia and Rome were forced to grant constitutional rights, and in Milan the people rose

against Austrian rule and compelled the foreign troops to retreat. Charles Albert now entered Lombardy at the head of his army. The Pope at first supported the movement, and his subsequent change of position weakened the national cause of the fighting force. Charles Albert was defeated at Novara early in 1849, and reaction was triumphant throughout Southern and Central Italy. Only in Sardinia were the liberal reforms continued under the new king, Victor Emmanuel.

Toward the close of 1858 it became evident that Sardinia and France were preparing to ally themselves against Austria, and early in the following year Victor Emmanuel proclaimed his intention to aid in freeing Italy from the Austrian yoke. War began in April, 1859, and the Austrians, after a few smaller engagements, were routed in the great Battle of Magenta, June 4, and compelled to relinquish Milan and Northwestern Lombardy. They were again defeated at Solferino, after which the French emperor, fearing the interference of Prussia, suddenly concluded the Peace of Villafranca. This proposed a confederation of the Italian states under the Pope, but it was rejected by all Italy. In 1860 the duchies of Tuscany, Parma and Modena, whose sovereigns had been driven out, declared for annexation with Sardinia, and Victor Emmanuel was proclaimed king of Italy, March 17, amid great rejoicing. Savoy and Nice were ceded to France to indemnify the country for its share in the war. In May began the conquest of the Two Sicilies by Garibaldi, and in November, Victor Emmanuel formally annexed the provinces which had composed this kingdom. In the Seven Weeks' War between Austria and Prussia, Italy was the ally of Prussia, and after the defeat of Austria, Venetia was added to the kingdom of Italy by treaty. In the following year the Italian volunteers under Garibaldi attacked Rome, but Napoleon III refused to permit the annexation of Rome to the kingdom of Italy.

When, in 1870, France was forced to withdraw its troops from Rome, for use in the war against Prussia, the government troops entered the city, and in July, 1871, Rome became the capital of United Italy. In 1878 Humbert, son of Victor Emmanuel, succeeded to the throne, and he was succeeded in 1900 by his son, Victor Emmanuel III. In 1911 Italy attacked Turkey for alleged injustice to

Italian interests in North Africa; early in 1912 Tripoli became an Italian possession.

*In the World War.* The next great event in Italian history was Italy's intervention in the World War. Notwithstanding the country's ancient hostility toward Austria, in 1882 Italy had joined with Austria and Germany in the Triple Alliance. However, when the great war broke out, in 1914, Italy refused to join its allies because it regarded the Central Powers as aggressors; by the terms of the alliance Italy had promised help only in the event of a defensive war. The explicit statement of Italy's neutrality, early in 1914, relieved France from the necessity of guarding its Italian frontier. This act on the part of Italy helped bring about the victory on the Marne, which saved France and won the war for the entente (as later events proved).

The continuance of the war served to revive the national aspirations of the Italians, and the *Italia Irredenta* (Italy unredeemed) movement swept the peninsula like a flame. With the avowed purpose of reclaiming the Trentino and other Italian-speaking districts of Austria, Italy declared war on Austria in May, 1915, and began an offensive immediately. In August, 1916, war was declared on Germany. The Italian armies won a series of brilliant victories that carried them well into Austrian territory, but in the fall of 1917 a counterattack by the combined Austrian and German forces drove them far back into Italy. A year later the Italians brilliantly redeemed this defeat by overwhelming the Austrians and compelling them to ask for an armistice on the field of battle. Other details of this struggle will be found in the article **WORLD WAR**.

At the peace conference Italian claims for territory conflicted with those presented by the new state of Jugo-Slavia. Italy asked for the region known as Dalmatia, on the eastern shore of the Adriatic, and the city of Fiume, a Croatian seaport forty miles south-east of Trieste, on the ground of an understanding arrived at with England and France in 1915. The Jugo-Slavs insisted that possession of Fiume was necessary to them to give the new state access to the Mediterranean Sea. President Wilson upheld the latter view, and in April, 1919, issued a statement showing why he believed the Jugo-Slavs were justified in their claim. The Italian peace delegates thereupon withdrew from the conference, but returned within a week, on the

# ITALY SINCE 1815



VICTOR EMMANUEL III  
PRESENT KING

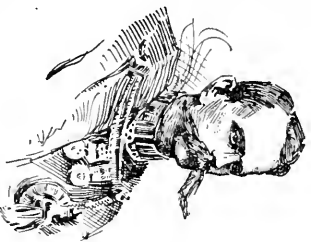

KING HUMBERT I  
FATHER OF VICTOR EMMANUEL III

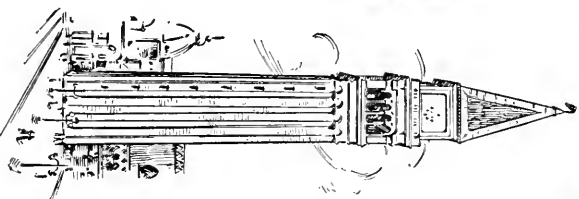

CAMPANILE E  
OF ST MARK'S

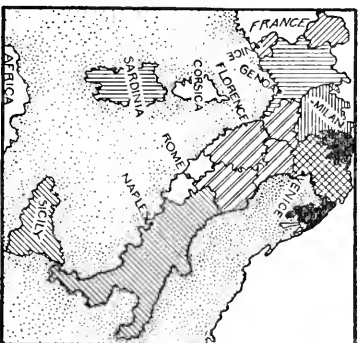

GROWTH OF ITALY

- ▨ Added August, 1859
- ▨ Added May, 1860
- ▨ Ceded to France
- ▨ Added May-Nov., 1860
- ▨ Original Sardinian Kingdom
- ▨ Added 1866
- ▨ Added 1919

## Chronological Summary

- Treaty of Paris . . . . . 1815
- Revolution of 1848 . . . . . 1859
- Battle of Magenta . . . . . 1861
- Victor Emmanuel Declared King . . . 1861
- Garibaldi Invades Sicily . . . . . 1862
- Florence Made Capital of Italy . . . 1864
- Unity of Italy Complete . . . . . 1870
- Rome Made Capital . . . . . 1871
- Accession of Humbert . . . . . 1878
- Foundation of Triple Alliance . . . 1882
- Accession of Victor Emmanuel III . 1900
- Italy Enters World War . . . . . 1915

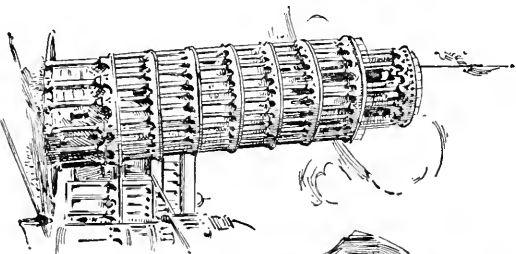

LEANING TOWER  
OF PISA



HELENA  
PRESENT QUEEN



GARIBALDI  
THE LIBERATOR

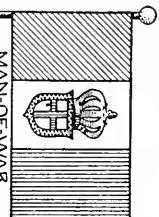

MAN-OF-WAR

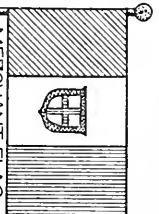

MERCHANT FLAG

promise of satisfying compromises. Among these was the promise of eventual cession of Fiume.

**Related Articles.** Consult the following titles for additional information:

GEOGRAPHY

|              |             |          |
|--------------|-------------|----------|
| Adriatic Sea | Herculaneum | Pompeii  |
| Alps         | Leghorn     | Rome     |
| Apennines    | Lombardy    | Rubicon  |
| Avernus      | Matterhorn  | Sardinia |
| Bari         | Messina     | Sicily   |
| Bologna      | Milan       | Sirocco  |
| Cagliari     | Mont Blanc  | Tiber    |
| Catania      | Naples      | Triest   |
| Como         | Padua       | Turin    |
| Como (lake)  | Palermo     | Tuscany  |
| Etna         | Piedmont    | Venice   |
| Florence     | Piso        | Vesuvius |
| Genoa        | Po          |          |

HISTORY

|                         |                      |
|-------------------------|----------------------|
| Etruria                 | Mazzini, Giuseppe    |
| Garibaldi, Giuseppe     | Sardinia, Kingdom of |
| Guelphs and Ghibellines | Sicilies, Kingdom of |
| Jugo-Slavia             | the Two              |
| Latium                  | Triple Alliance      |
|                         | Victor Emmanuel II   |

**ITAS'CA, LAKE**, a small lake in Minnesota, long regarded as the source of the Mississippi River. It is about eight miles in circumference, is situated between Beltrami and Cass counties and is surrounded by beautiful pine-covered hills. The Mississippi where it issues from the lake is a stream about ten feet wide and one foot deep. See MISSISSIPPI RIVER.

**ITCH**, *ich*, an annoying sensation that is too familiar to need description. It is sometimes a symptom of a definite disease, but may be merely a nervous irritation. A modern theory is that itching is caused by pressure upon the nerves lying between the blood vessels and the horny layer of the skin. Increase in the amount of blood in the skin blood vessels or a thickening of the horny layer may cause the sensation, but usually it is the result of the two acting together. To treat a case of itching one should know the source of the trouble. A serious case should have the care of a physician.

A small insect called the *itch mite* is the cause of a contagious skin disease known specifically as itch. Small, watery sacs appear on the skin and bring on the sensation of itching, and if scratched these sacs cause inflammation of the skin. The insects may be killed with lard and sulphur, while naphthol, oil of cade and carbolic acid are used to allay itching and inflammation.

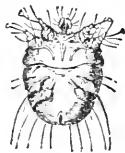

**ITCH MITE**  
Much magnified.

**ITH'ACA** (now **THIAKI**), one of the Ionian Islands of Greece, between the main-

land and Cephalonia. It is oblong in shape, very narrow near the middle, and comprises an area of thirty-eight square miles. The country is mountainous, the coasts indented. The inhabitants are agriculturists and mariners. On the slopes are grown grapes, currants, olives and other southern fruits. Ithaca was celebrated as the home of Ulysses, the hero of Homer's *Odyssey*. Recent excavations have brought to light several sites mentioned by Homer. Vathi is the present capital. Population, 11,000. See ODYSSEY; ULYSSES.

**ITHACA, N. Y.**, the county seat of Tompkins County, sixty miles southwest of Syracuse, at the head of Cayuga Lake, on the Lackawanna, the Lehigh Valley and the Central New York Southern railroads, and on a branch of the New York State Barge Canal. The city has an especially beautiful location on the shores of the lake and near numerous gorges and waterfalls. Cornell University, located here, has one of the most beautiful sites in the world, lying 400 feet above the lake and overlooking the city and the water (see CORNELL UNIVERSITY). The Cornell Library, a Federal building, the Ithaca Conservatory of Music and Renwick Park are other features of interest.

Ithaca is in a productive farming region. The manufactures include machinery, agricultural implements, firearms, glass, calendar clocks, gasoline engines, chains and other articles. The first settlement was made in 1789, and it was variously called The Flats, Sodom and The City, until Simon DeWitt gave the place its present name in 1806. Population, 1910, 14,802; in 1917, 16,017 (Federal estimate).

**ITO, ee'to**, HIROBUMI, Prince (1840-1909), one of the greatest constructive statesmen of modern times, a leading spirit in the reforms in Japanese civilization and methods of government. He visited the United States in 1871 to study our system of coinage, and on his return he established the Japanese mint. He was minister of public works in 1873, and he was prime



PRINCE ITO

minister for four terms, the last ending in 1901. He wrote Japan's present constitution, and his *Commentaries* on Japan's fundamental law are pronounced worthy to rank with the American *Federalist Papers*. Ito was a leader in the war with China also in the war with Russia. In 1908 he was appointed Japanese Resident General of Korea, and was virtually ruler of the country. He was assassinated by a native of Korea at Harbin October 25, 1909. See JAPAN, subhead *History*.

**ITURBIDE**, *ee toor bee'dah*, AGUSTIN DE (1783-1824), for a brief period emperor of Mexico. He was born in Spain, the son of a nobleman. In 1798 he entered the Spanish army in Mexico and fought against the insurrectionists in 1810. After the proclamation of the constitution in 1820, as commander of the Spanish army in the south he intrigued with the revolutionary leaders for the acceptance of the so-called "Plan of Iguala," which contemplated independence of Mexico under a prince of the royal family. Pending negotiations with the royal family, he was placed at the head of a Ministry and became commander in chief of the army. The national Congress was held, and Iturbide, being accepted by the party in favor of the monarchy, was proclaimed emperor, as Agustin I, in July, 1822. His harsh repressive measures led to a rebellion under Santa Anna, and Iturbide was banished. In the following year he returned to Mexico, where a republic had meantime been established, was immediately arrested, and was executed at Patola. See MEXICO, subhead *History*.

**IVAN IV**, *e vahn'*, called THE TERRIBLE (1530-1584), was a czar of Russia, the grandson of Ivan III. His father died when he was three years old, and under his mother's regency the country became turbulent. At thirteen he assumed the mastery of his dominions, overthrew the revolutionary leaders, and in 1547 assumed the title of czar. His cruelty in dealing with the insurgent princes gained for him his familiar epithet. Ivan did much to improve conditions in Russia, particularly by bringing that country into touch with the civilization of Western Europe.

**IVORY**, the bonelike substance of which the tusks of the elephant and the teeth, or tusks, of the hippopotamus, walrus and narwhal are composed. Ivory is characterized by a beautiful creamy-white color, hard-

ness and elasticity. It is fine-grained and susceptible of a high polish. The best ivory is taken from the elephants of Africa. The tusks of these males weigh from fifty to 150 pounds each; the tusks of the Asiatic elephant are not so large. Vast quantities of ivory are found among the fossil remains of mammoths and mastodons in Siberia. This, though in a fair state of preservation, is not so valuable as ivory taken from animals that have not long been dead. Celuloid and vegetable ivory (see IVORY PALM) are extensively employed as substitutes for ivory.

Ivory is used in the manufacture of a large number of articles, and has therefore a high commercial value. No other material known has been found so suitable for making billiard balls. Piano keys, cutlery handles, toilet articles and objects of ornament are made of it. It is the ideal medium for carving, and the finest carving of small art objects has been done in ivory. It has been used for small sculptures, called *figurines*, but its rarity makes its use prohibitive for larger pieces. Where ivory articles are manufactured no particle of the material is wasted. The shavings and sawdust are saved and burned to ashes, which are used in making an artists' pigment.

**IVORY, VEGETABLE**. See IVORY PALM.

**IVORY COAST**, a French colony in West Africa, lying between Liberia on the west and the British Gold Coast Colony on the east and between the Senegal on the north and the Gulf of Guinea on the south. It has an area of about 130,000 square miles and a population of about 1,530,000 of which the Europeans number about 1,200. The seat of government is now Bingerville, formerly called Adjamé. The principal centers of population and commerce are Grand Bassam and Assinie. The climate is extremely hot and unhealthy, particularly along the seventy miles of seacoast. Maize, plantains, bananas, pineapples and other fruits, besides coffee, are cultivated with success, and there are considerable exports of mahogany, rubber and coconuts. There is a deposit of gold near Grand Bassam. A railway runs 197 miles from the coast inland between Abijeau and Bouake. There is also telephone and telegraph communication between the principal cities. The French gained possession of the colony about 1843, but for forty years paid little attention to it. Within recent years they have undertaken a policy of de-

velopment, which the World War halted temporarily.

**IVORY PALM**, a low palm, native of the warm parts of South America. It has a creeping trunk from the end of which springs a large handsome cluster of fronds and bunches of fruit, weighing, when ripe about twenty-five pounds. Each fruit contains within its husk from six to nine seeds as large as hen's eggs, the kernels of which are close-grained and very hard, resembling ivory in texture and color. These nuts are



IVORY PALM

(a) Female tagua palm; (b) tagua bur.

exported under the name of *vegetable ivory*, and they are extensively used in the manufacture of buttons, knobs for doors, umbrella handles and numerous other small articles.

**IVY**, a climbing plant with five-lobed, glossy leaves, perennially green. The flowers

are greenish and inconspicuous and are succeeded by deep green or almost black berries.

The common English ivy is very plentiful in Great Britain, growing in hedges and woods and climbing on stone walls and trunks of trees. Several varieties are grown in American gardens, among them Boston ivy, Virginia creeper and ground ivy. The ivy attains a great age, and its main stems become several inches thick. The wood is soft and porous. The plant has been celebrated from remote antiquity, and in some ancient countries, notably Egypt and Greece, it was held sacred.



IVY

**IXION**, in Greek legend a king of Thessaly, who for his wickedness was punished in the lower world by being tied by serpent bands to a perpetually-revolving fiery wheel.

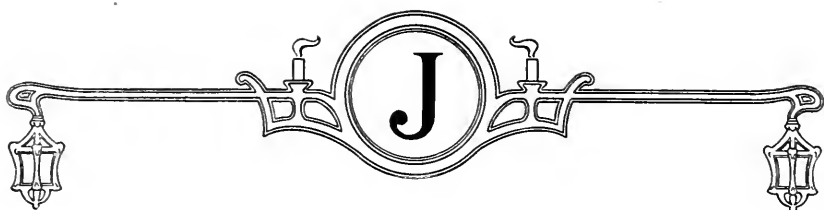

**J**, the tenth letter in the English alphabet. As a character it was formerly used interchangeably with *i* as either vowel or consonant, and the separation of these two letters in English is of comparatively recent date. Gradually *i* came to represent the vowel sound and *j* the consonant sound. In form also *j* is a modification of *i*. In English *j* has but one sound, a combination of *d* with *zh*, identical with the soft sound of *g*.

**JABIRU**, a large tropical American stork, about four feet from bill to tail-tip and seven feet across its wings. The head and neck are bare; the rest of the body is covered with white plumage. The jabiru is the only true stork found in North America.

**JACANA**, *jak'a na*, a class of birds related to the plovers. The birds have extraordinarily long toes and claws which enable them to walk easily on floating leaves of aquatic plants in search of food—small water animals and insects and green sprouts of water plants. Another remarkable feature of the Jacana is its spurs, which protrude at the bend of the wings and constitute useful weapons in the birds' frequent fights with one another. The common South American species is ten inches long. The back and wings are brown, the rest of the body is black. The *surgeon bird*, an Indian species, has a white



JACANA

head, a body covered with brown and purple plumage and four very long, dark brown curved tail feathers.

**JACKAL**, *jak'al*, a group of animals belonging to the same family as dogs, wolves and foxes. They are found in Southeastern Europe and in Asia and Africa. Jackals somewhat resemble foxes, having a pointed muzzle, bushy tail and erect ears. They are smaller than wolves, usually being not

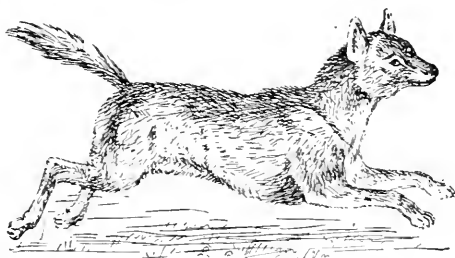

JACKAL

over fifteen inches high from shoulder to ground. The fur is grayish-yellow, somewhat grizzled, and the tip of the tail is dark. Jackals hunt for food at night, traveling in packs, and their cries are dismal howls. They eat almost any kind of animal and vegetable food, including carrion, but the belief that they help lions to capture prey and then feed on what is left, has been proved untrue. A species found in Eastern and Southern Africa, known as the *tenlie*, is valued because of its handsome fur, a mixture of reddish-yellow and black. The jackal is not a courageous animal, and it can easily be domesticated.

**JACK'DAW**, a small European crow, with comparatively-short bill and whitish eyes. It nests in towers, spires and other elevated places, often in the midst of large towns. Jackdaws are very sociable, intelligent birds, and, being easily tamed, they make enter-

taining pets. Like other crows, they are prone to mischief and accustomed to steal

bloom from April to June, and are followed by red berries. Later in the season all parts, excepting the stem and the bunch of scarlet berries, wither. The plant belongs to the arum family.

**JACK-O'-LANTERN.** See IGNIS FATUUS.

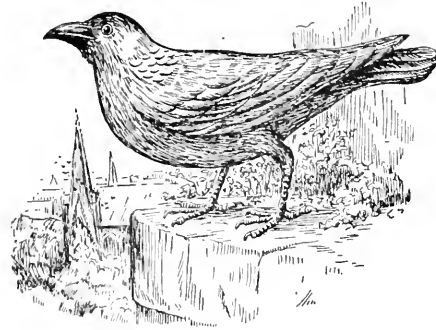

JACKDAW

small objects that come to their notice.

**JACK-IN-THE-PULPIT, or INDIAN TURNIP,** a common plant of North America that blossoms in early spring in low grounds or along streams. The flowers come from the flattish, turnip-shaped root, the



**JACKSON, ANDREW** (1767-1845), an American soldier and statesman, seventh President of the United States. If not one of the greatest of the Presidents, he was one of the most forceful men who ever held the office of chief executive, and in his own day his personality made a striking impression, equal to that produced by such men as

Webster or Calhoun. Jackson has often been compared to Theodore Roosevelt, because of the influence each wielded with the masses. In one respect, however, they were exact opposites. Jackson was born of poor parents in a log cabin, and his schooling was of the most meager character; Roosevelt came of an old, aristocratic family, and had all the advantages afforded by wide education and extensive travel.

**Ancestry and Boyhood.** The father of Andrew Jackson was one of the pioneer settlers of the Carolinas. He came from Ireland in 1765, and settled on a claim not far from the boundary between North and South Carolina. The limits of the two colonies were then not definitely known, and there is some doubt as to the exact location of the Jackson cabin. The future President, however, claimed that he was born near Waxhaw Creek, in Lancaster County, S. C. The date of this event was March 15, 1767.

The elder Jackson died a few days before Andrew was born, leaving a widow and two older sons. Mrs. Jackson seems to have had no control over her younger child, who fought all the boys in the community, loved nothing better than a cockfight or a horse race. In his fourteenth year he enlisted in a colonial regiment to help finish the Revolutionary War. His two brothers were killed in this struggle, and the mother died of a fever contracted while she was nursing American prisoners.

**Early Public Career.** After the war Andrew was left to his own devices. He not

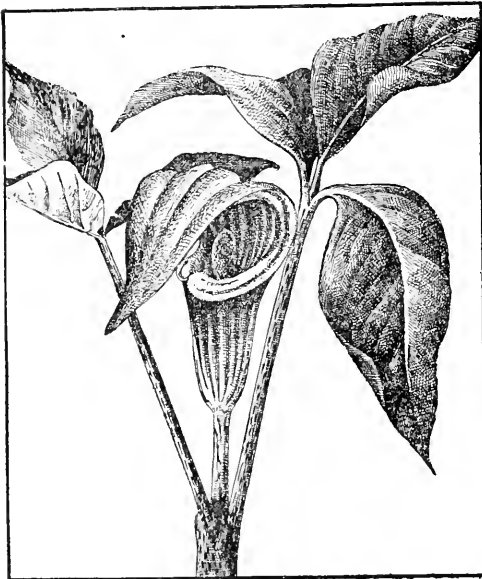

JACK-IN-THE-PULPIT

juice of which is very biting. The flowers are very small and are grouped closely together at the base of the long, slender stalk, or *spadix*, and around the whole is wrapped a curving, leaflike *spathe* having a peculiar flap that looks like the sounding board of a pulpit; hence the name of the plant. The leaf is greenish on the outside and striped with purple or green within. The flowers



only supported himself but was able to complete a course in law, and before he was of age he had been admitted to the bar. At the age of twenty-one he became public prosecutor in the district now forming the state of Tennessee, and in this capacity he made a reputation for firmness and honesty that won him not only strong friends but made bitter enemies. During this period he was married to Mrs. Rachel Robards, the daughter of a Tennessee settler.

In 1796 Jackson was elected to the House of Representatives. By this time he had become a recognized Jeffersonian; that is to say, a pioneer member of the present Democratic party, and in Congress he was outspoken in his opposition to President Washington. In 1797 he was elected United States Senator, but resigned the office after a few months, and from 1798 to 1804 served as judge of the Tennessee supreme court. Between 1804 and the outbreak of the War of 1812 he engaged



ANDREW JACKSON

in the peaceful pursuits of business and managing his plantation, but varied the routine by indulging in occasional quarrels of a violent character. In one of these he killed a man in a duel.

**As a Soldier.** When in 1812 war was declared against England, Jackson offered his services as the leader of about 2,000 Tennessee militiamen, for since 1802 he had been major-general of the state militia. He went to the front, and began organizing his men at Natchez, but in March, 1813, he was dismissed without pay for himself or his men. Enraged at this treatment, he paid transportation expenses for the troops out of his own pocket, but later the government reimbursed him. A few months after this episode Jackson took command of a company of Tennessee volunteers in a fight against the Creek Indians, defeating them at Horse-shoe Bend, in Alabama. As a reward for this service, in 1814 he received a commission as major-general in the regular army, and was given a command in the South. In

January, 1815, he established his military reputation by the repulse of an elaborate British attack upon New Orleans. It is noteworthy that this battle, the greatest American victory won on land in the War of 1812, was fought two weeks after the treaty of peace was signed.

In the following April Jackson was appointed commander in chief of the United States army in the South. His career for the next few years was stormy. In 1818, while engaged in a campaign against the Seminole Indians in Spanish Florida, he executed two British subjects whom he accused of inciting the Indians, and then seized the city of Pensacola. This episode caused much excitement in England and nearly brought upon Jackson a vote of censure from Congress, but the cession of Florida to the United States, in 1819, brought the dispute to an end. Jackson was appointed governor of the new territory in 1821, and two years later he was elected to the United States Senate from Tennessee. In 1824 he was nominated for President by the state legislature.

**Election to the Presidency.** The contest for the Presidency was exceedingly bitter, and four candidates received electoral votes—Jackson, John Quincy Adams, William H. Crawford and Henry Clay, in the order named. No one had a majority, however, and the House of Representatives, through Clay's influence, elected Adams. Jackson was bitterly incensed at this, and he and his followers unjustly charged Clay and Adams with having made a dishonest bargain. As a result of the controversy Adams withdrew from the Democratic party and formed the National Republican party (see **POLITICAL PARTIES IN THE UNITED STATES**) Jackson resigned from the Senate in 1825, and after three years of persistent opposition to Adams, was himself elected President of the United States.

**Administrations.** The election of Jackson to the Presidency marks an important epoch in American political history, as he was the first real representative of the so-called "common people." During his administration the spirit of democracy was given a tremendous impulse throughout the country, though it was his fate to introduce into American Federal politics that corrupt thing called the "spoils system." The first important event during his term was his re-

THE FIVE  
IMPORTANT  
EVENTS

1829

1837

# JACKSON

OLD HICKORY

**SPOILS SYSTEM**

TO THE VICTORS  
BELONG THE  
SPOILS

ROTATION IN OFFICE  
KITCHEN CABINET  
POCKET VEToes

**ANTI-SLAVERY  
MOVEMENT**

NEW ENGLAND  
ANTI SLAVERY  
SOCIETY ORGANIZED

**"THE LIBERATOR"**

GARRISON

**U.S. BANK**

CHARTER VEToesD  
SPECULATION  
SPECIE CIRCULAR

**STATE BANKS**

"Pet Banks"  
THOS. BENTON

**NULLIFICATION**

RESISTANCE TO  
NATIONAL LAW

**FORCE ACT**

**GAG RULE**

**LITERARY**

AGE OF AMERICAN LITERATURE  
AND GREAT WRITERS

BRYANT - WHITTIER  
HAWTHORNE - IRVING  
LONGFELLOW - COOPER  
EMERSON - HOLMES  
- POE -

N.Y. SUN FOUNDED  
N.Y. HERALD FOUNDED

THE FIRST  
HARVESTER

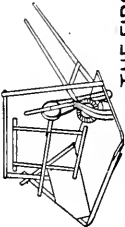

CHICAGO IN 1832

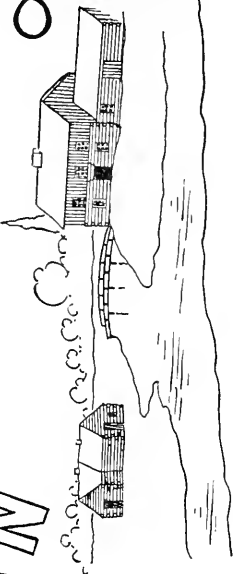

**OTHER EVENTS**

INDEPENDENCE OF MEXICO  
MORMONISM ESTABLISHED  
DEATHS: MONROE AND MADISON

TREATY WITH BRAZIL  
TEXAS DECLARES INDEPENDENCE  
GREAT FIRE IN NEW YORK  
CHOLERA VISITS U.S.  
ARK. & MICH. ADMITTED



SEMINOLE  
AND  
BLACK-  
HAWK  
WARS

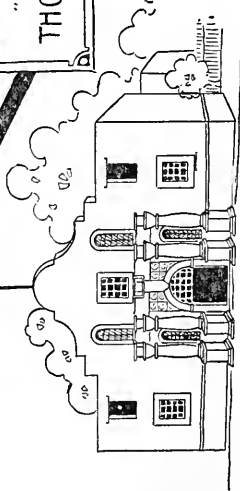

ALAMO

## Administration of Andrew Jackson, 1829-1837

### I. THE PRESIDENT

- (1) Parentage
- (2) Birth
- (3) Youth
- (4) Study and practice of law
- (5) Military career
- (6) Career in public office before he became President
- (7) A representative of the West
- (8) Personal character
- (9) Death

### II. GOVERNMENTAL AFFAIRS

- (1) Domestic
  - (a) The "Spoils System"
    - (1) Its introduction
    - (2) Effects
  - (b) Indian affairs
    - (1) Policy
    - (2) Indian disturbances
  - (c) Financial affairs
    - (1) Bank of the United States
      - (a) Opposed by Jackson
      - (b) Removal of deposits
      - (c) Censure by the Senate
      - (d) End of the bank
    - (2) Wild-cat banking
  - (d) The Tariff and Nullification
    - (1) The principle of Nullification
      - (a) Webster - Hayne debate
      - (b) Calhoun's views
    - (2) In practice
      - (a) South Carolina's Ordinance
    - (3) Jackson's Proclamation to South Carolina
    - (4) Compromise Tariff of 1833
    - (5) Force Act
      - (a) Gave President power to enforce the law
      - (b) Led South Carolina to repeal Nullification

### (e) Election of 1832

- (1) Parties
- (2) Issues
- (3) Result and significance

### (f) Admission of new states

### (2) Foreign

- (a) Treaty with France
- (b) Treaty with England
- (c) Treaty with Brazil
- (d) Relations with Texas
  - (1) Texan War of Independence
  - (2) Republic of Texas

### III. INTERNAL AFFAIRS

- (1) Anti-Slavery movement
  - (a) The Liberator founded, 1831
  - (b) New England Anti-Slavery Society
  - (c) American Anti-Slavery Society
  - (d) Petitions to Congress
- (2) Growth of Mormonism
- (3) Development of American literature
- (4) Deaths of Monroe and Madison
- (5) Invention of the harvester, 1834

### IV. ELECTION OF 1836

- (1) Parties
- (2) Candidates
- (3) Issues

### Questions on Jackson

Give a short sketch of Jackson's career before he became President.

Describe his personal character.

What is the "spoils system"?

What was its famous motto?

Who was the Black Hawk?

What was Jackson's attitude toward the Bank of the United States?

What was the principle of nullification?

Who was its greatest exponent?

When did the Webster-Hayne debate take place? What was the subject?

Give a short account of the Texan War of Independence.

What religious movement was coming into prominence?

What was "the Hermitage"?

removal of public officers upon the ground of their political affiliations, in accordance with the doctrine enunciated by his friend Marcy, that "to the victors belong the spoils of the vanquished." His motives deserve less censure than his methods, however, for he sincerely believed that he was working for the good of the country by appointing Democrats to take the place of "aristocrats."

During Jackson's first term Congress passed a high-tariff law that was bitterly resented in the South, where it was feared that the laying of duties on foreign importations would cause reprisals against American cotton in foreign ports. In South Carolina the law was declared unconstitutional and "null and void" by the legislature, and the state threatened to secede if attempts were made to enforce it. Jackson met this threat by sending two warships to Charleston harbor and issuing a proclamation of warning. Though not in favor of protection, he was determined to maintain the authority of the Federal government. The passage of a compromise bill allayed the controversy.

Another mooted question was that of the United States bank. In 1832 the President vetoed a bill for rechartering it, because he was convinced that it was controlled by the "money ring." When, in the same year, he was reelected by a decisive majority, he construed this victory as a popular vindication of his attitude, and promptly set about destroying the institution. All government deposits were withdrawn, which practically put an end to its career, but such arbitrary proceedings did not pass unchallenged. The Senate voted formal resolutions of censure against the President, and they remained on the records until 1837.

Jackson precipitated another crisis by issuing, in July, 1836, a famous "Specie Circular," which forbade government agents to accept paper money in payment for public lands. This order, coupled with an inflation of credit due to loans made to the states out of surplus national funds, brought on the great financial panic of 1837. Unhappily for Jackson's successor, Van Buren, the storm did not break until Jackson was out of office. Other notable events were the removal of the Cherokee Indians from Georgia, the admission of Arkansas and Michigan as states, the rise of the Abolitionists (see GARRISON, WILLIAM LLOYD) and the founding of the Mormon Church.

Upon retiring from office, Jackson returned to his home near Nashville, which he called the "Hermitage." There he passed the remainder of his life, dying in 1845.

**Related Subjects.** Consult the following titles for additional information:

|                   |               |
|-------------------|---------------|
| Banks and Banking | Nullification |
| Civil Service     | Tariff        |
| Democratic Party  | War of 1812   |

**JACKSON, HELEN [FISKE] HUNT** (1831-1885), an American novelist and poet, born at Amherst, Mass. She was educated in Ipswich and New York and at twenty-one married Major Edward B. Hunt. Her first poems, written at Newport, R. I., after her husband's death in 1863, and signed "H.H.," were encouragingly received. She remarried in 1875 and afterwards lived in the West, where she wrote *A Century of Dishonor*, a plea for better treatment of the Indians, and *Ramona*, a romance on the same theme. To this period also belong poems, humorous sketches of travel, two novels and several stories for children. Some of her lyrics rank with the best America has produced.

**JACKSON, MICH.**, the county seat of Jackson County, seventy-six miles west of Detroit, on the Grand River and on the Michigan Central, the Lake Shore & Michigan Southern, the Grand Trunk and the Cincinnati Northern railroads. The city is in an agricultural region and is an important railroad center. It has a considerable trade in agricultural produce and implements, and there are large railroad shops and extensive manufactures of carriages, wagons, automobiles, machinery, stoves, sewer pipe, flour, corsets and paper. A state prison is located here, and there are two hospitals, a Carnegie Library and a Masonic Temple. The place was settled in 1829, but it did not grow rapidly until after the construction of the Michigan Central Railroad in 1841. Population, 1910, 31,433; in 1917, 35,996 (Federal estimate).

**JACKSON, MISS.**, the capital and largest city of the state, is the county seat of Hinds County, forty miles east of Vicksburg, near the geographical center of the state, on the Pearl River and on the Illinois Central, the Alabama & Vicksburg, the Yazoo & Mississippi Valley, the Gulf & Ship Island and the New Orleans Great Northern railroads. The city has handsome public buildings, of which the most important are the state capitol, an imposing structure, the governor's mansion, the Federal building, the state library and





THOMAS J. (STONEWALL) JACKSON

the state institutions for the blind, deaf, dumb and insane. Millsaps College (Methodist Episcopal), Bellhaven College for women and Campbell College (colored) are located here. Good railroad connections and river navigation for small vessels furnish excellent transportation facilities. A large amount of cotton is raised in this section, and the important industries are the cottonseed oil mills, wood-working establishments and manufactories of fertilizers, agricultural implements and other articles. The place was settled in 1830 and was incorporated in 1840. The commission form of government was adopted in 1912. Population, 1910, 21,262; in 1917, 31,104 (Federal estimate).

**JACKSON, TENN.**, the county seat of Madison County, eighty-five miles northeast of Memphis, on the south fork of the Forked Deer River and on the Illinois Central, the Mobile & Ohio, the Birmingham & Northwestern and the Nashville, Chattanooga & Saint Louis railroads. It is an important trading center for a rich farming district, and contains cotton-seed mills and manufactories of engines, furniture, clothing, carriages and other articles. The West Tennessee branch of the State Agricultural Experiment Station, Union University, Lane College and the Memphis Conference Female Institute are located here. There are two hospitals, a Carnegie Library, a fine Y. M. C. A. building and an Elks' Home. Jackson was settled in 1816 and was incorporated in 1854. The commission form of government was adopted in 1915. Population, 1910, 15,779; in 1917, 17,946 (Federal estimate).



The house where he died

**JACKSON, THOMAS JONATHAN** (1824–1863), more commonly known as “STONEWALL” JACKSON, one of the outstanding personalities of the American Civil War. Though he never had the opportunity to show his ability as leader of large forces, he was the most able of all the officers

who served under Lee. Jackson was born on January 21, 1824, at Clarksburg, Va. (now W. Va.), of Scotch-Irish parentage. He early showed marked qualities of leadership, and was elected sheriff at the age of eighteen. At about the same time he entered West Point, where he was graduated in 1846

with honors, in a class which included McClellan, Pickett and A. P. Hill. He entered the army immediately, served in the Mexican War and was brevetted captain and major for gallantry in action.

Having resigned from the army in 1851, Jackson became professor of military tactics in Lexington Military Institute. Here he remained until April, 1861, never attaining distinction as an instructor but exerting a powerful influence for good. He was an ardent Presbyterian and gave much of his time and money even while in active service to the betterment of the negroes who belonged to his class in Sabbath School. It is interesting to know that after the war, when a bronze monument was to be raised to his memory in Lexington, the first contribution came from the colored Baptist Church. Jackson personally did not favor secession, but when volunteers were called for to coerce the states he said, “I have longed to preserve the Union and would have been willing to sacrifice much to that end. But now that the North has chosen to inaugurate war against us, I am in favor of meeting her by drawing the sword and throwing away the scabbard.”

He was commissioned colonel in the Virginia forces and later placed in command of the Virginia brigade which afterwards became so famous under him. At the Battle of Bull Run, when Jackson was seen fighting valiantly against what seemed to be overwhelming odds, General Bee called out, “There stands Jackson like a stone wall.” The phrase was taken up and from that time on Jackson was known as *Stonewall* and his troops as the *Stonewall brigade*. He was promoted to be major-general in September of the same year, and in a campaign in the Shenandoah Valley against General Banks he won brilliant victories at McDowell and Winchester and completely baffled the Federal commanders.

In June, 1862, Jackson joined Lee in the defense of Richmond against McClellan and took a prominent part at the battles of Mechanicsville and Malvern Hill, and, after McClellan's withdrawal, at Cedar Mountain and the second Battle of Bull Run, against General Pope. His force was conspicuous in Lee's first invasion of the North, and at Antietam and Fredericksburg he was a source of great strength to the Confederate army. In May, 1863, at Chancellorsville, he fell upon Hooker's right flank under Howard

and almost destroyed a full corps. At nine o'clock in the same night he was accidentally shot by his own men, while reconnoitering, and died May 10. His loss was a severe blow to the Confederate cause, for he had been a tower of strength in every campaign.

**JACKSONVILLE, FLA.**, the largest city in the state and the county seat of Duval County, 165 miles east of Tallahassee, on the west bank of the Saint Johns River, on the Southern, the Atlantic Coast Line, the Seaboard Air Line, the Florida East Coast and the Georgia Southern & Florida railroads. The ocean beaches near here are among the finest on the Atlantic coast, and the city has long been a popular winter resort. There are many fine churches, also several institutions, among them being De Soto Sanitarium, Saint Luke's Hospital, Saint Catherine's Hospital, a county hospital and a private sanitarium. Other prominent structures are a Federal building, an armory, a board of trade, a Masonic Temple, a Carnegie Library and several club houses and hotels.

The city is an important trading port and ships large quantities of lumber, shingles, cross-ties, naval stores, turpentine and garden produce. The principal manufacturing establishments are lumber mills, ice plants, foundries, brick and tile works, shipyards and various factories. The city is a headquarters for naval stores. The place was settled in 1822 and was named in honor of Andrew Jackson, who was first territorial governor of Florida. It was incorporated in 1833. In 1901 a fire destroyed a great number of buildings, causing a loss of about \$12,000,000, from which the city has completely recovered. Population, 1910, 57,699; in 1915, 79,065 (Federal estimate).

**JACKSONVILLE, ILL.**, the county seat of Morgan County, thirty-four miles west of Springfield, on the Chicago, Burlington & Quincy, the Wabash, the Chicago & Alton and the Chicago, Peoria & Saint Louis railroads. Illinois College, which was founded here in 1829, is the oldest institution of higher education in the state. Several years ago it absorbed Jacksonville Female Academy and also includes the Whipple Academy and a conservatory of music. The city is the seat of the Illinois Woman's College and of state institutions for the insane, the blind and the deaf and dumb; also it has a Carnegie Library, two hospitals, a park and county fair grounds. Other prominent buildings are the

city hall, the courthouse and the high school. The industries include railroad shops and wool, flour and paper mills and bridge works, and there are also considerable exports of live stock. The place was settled as the county seat in 1825 and was incorporated as a city in 1867. The commission form of government was adopted in 1911. Population, 1910, 15,326; in 1917, 15,506 (Federal estimate).

**JACK'STONES**, a game played with five small pebbles, marbles or iron pieces made specially for the purpose. The player lays four of these on the ground. With one hand he tosses the fifth (jack) in the air and before catching it picks up one of the four. Still holding the first one picked up he tosses the jack a second time and picks up another, and so on until all are in hand, the object being not to drop any.

**JACK'STRAW**s, a game played with from fifty to a hundred small wooden sticks of uniform size but shaped to represent implements and tools, such as hoes, rakes and bars. The players throw the sticks on a table in a heap and each in turn tries with a tiny hook to see how many sticks, lifting one at a time, he can take from the pile without causing any of the others in the pile to move. The player removing the greatest number of straws is the winner.

**JACOB**, the son of Isaac, the grandson of Abraham, and the last of the Jewish patriarchs. His story is told in these volumes in the article BIBLE, subhead *Bible Stories*.

**JACOBINS**, *jak'obinz*, the most famous of the political clubs of the French Revolution. When the States-General assembled at Versailles in 1789, a club was formed by a number of deputies from Brittany, called the *Club Bréton*. On the removal of the court and national assembly to Paris it acquired importance and rapidly increased. It adopted the name of *Société des Amis de la Constitution*, but as it met in a hall of the former Jacobin convent in Paris, it was called the Jacobin Club. It gradually became the controlling power of the Revolution, and its influence spread over France, hundreds of branch societies being established. The Jacobins were foremost in the insurrectionary movements of June 20 and August 10, 1793, and they originated the formidable Commune of Paris. For a while they ruled supreme, and the Convention itself was but their tool. Robespierre was their most influential member, and through him they ruled during the



Reign of Terror. After his downfall in 1794 they were overthrown. The term *Jacobin* is now often used to designate any one holding extreme views in politics.

**JACOBITES**, *jak'o bites*, a Christian sect, the members of which are distributed through Syria, Mesopotamia and Babylonia. The name is derived from that of **JACOBUS BARBADAECUS**, a Syrian monk who during the reign of Justinian united the scattered adherents to his creed into a single party. The Jacobites number now about 80,000. They are governed by the patriarch of Antioch, who has under him three bishops and eight metropolitans, or superior bishops. The metropolitan of Jerusalem ranks higher than the others, and with the patriarch he lives at a monastery near Mardin. The doctrine of the single nature of Christ is common to them and to the Copts and Armenians. The form of their ceremony differs little from that of the orthodox Greek Church.

**JACQUARD**, *zha'kar*, **JOSEPH MARIE** (1752-1834), a French inventor whose fame rests on a machine for figured weaving, known as the Jacquard loom. It was first exhibited in 1801. Jacquard endeavored to introduce it into general use in Lyons, but was mobbed, and almost lost his life. Ultimately, however, his invention was bought by the French government, and he was able to spend the latter part of his life in comfort. See **WEAVING**.

**JADE**, a tough, compact stone, commonly of a yellow-green color, susceptible of a high polish. It was much employed by primitive peoples for weapons and implements, and among the Chinese it has been widely used for small ornaments; they carve it exquisitely. An inferior kind of jade, called *nephrite*, has been superstitiously believed to possess healing power. *Jadeite* is a very fine quality of jade. True jade contains calcium, magnesium and silica. See **JEWELRY**.

**JAFFA**, *yah'fah*, or **YAPA**, **PALESTINE**, a city of commercial importance, situated on the Mediterranean Sea, thirty-one miles northwest of Jerusalem, with which it is connected by railway. The site of the city slopes toward the sea. The place contains a number of buildings of considerable note because of their architecture. Among them are mosques and churches, several hospitals and hotels. The commerce is of considerable importance, the exports consisting of fruits, wool, wine, sesame and a few manufactures.

Being the nearest port to Jerusalem, its tourist trade is large. Joppa, as it was known in Bible times, was at one time the seaport of Jerusalem, and it is probable that through this port came most of the wealth that Solomon received from his seafaring expeditions. The place was captured by the British during the World War, and in 1918 it became the headquarters of the committee having in charge the establishment of a Jewish state in Palestine. It was confidently expected that this would be accomplished within a few years.

**JAGUAR**, *ja gwahr'* a member of the cat family, found in South and Central America. It is not quite as large as a tiger and is of a yellowish or fawn color, marked with large dark spots and rings, the latter with a dark spot in the center of each. Some species are

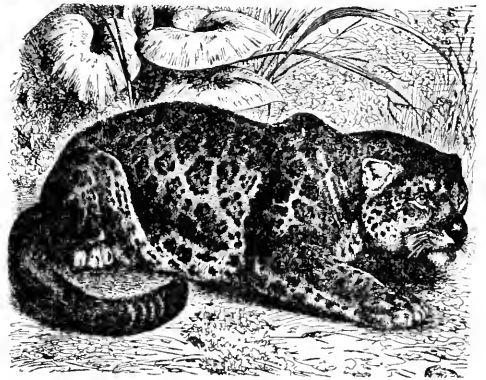

THE JAGUAR

nearly black. The jaguar rarely attacks man unless hard pressed by hunger or driven to bay. The favorite haunts are the forest swamps of the Amazon. The skin is valuable, and the animal is hunted by the South Americans in various ways.

**JAHN**, *yahn*, **FRIEDRICH LUDWIG** (1778-1852), a German who laid the foundation for physical training in his country. He was born at Lanz and educated at the universities of Halle and Greifswald. His theory that the German nation could be strengthened by giving systematic physical training to the younger generation gained the emperor's approval and support. The open-air gymnasiums established through his influence became a permanent institution far-reaching in its effects. Jahn was active in the war of 1813. In 1848 he was made a member of the national assembly and was one of the leaders in securing German unity.

**JAIPUR**, or **JEYPORE**, *ji poor'*, INDIA, the capital of the native state of Jaipur, is an important industrial city, situated 148 miles southwest of Delhi. The streets are laid out regularly, and are lighted by electricity, and the waterworks are municipally owned. Pink stucco, in imitation of sandstone, is largely used for building purposes, and Jaipur has the aspect of a modern city as well as many of the picturesque features common to Oriental towns. There are bazaars, banks, colleges and hospitals, and manufactories of textiles, pottery, jewelry and brass work. Population, about 137,000.



JALAP

**JAL'AP**, a perennial twining plant of the convolvulus order, with heart-shaped leaves and handsome, deep-pink flowers. It grows



**JAMAICA**, *ja ma'kah*, called by Columbus **SANTA GLORIA**, is a beautiful island of the West Indies, about ninety miles south of Cuba and nearly the same distance west of Haiti. It is Great Britain's most important possession in the Antilles, and has the status of a Crown colony. The island is 140 miles long and a little less than half as wide; it contains 4,207 square miles, is about one-half as large as Massachusetts, and in 1916 had

894,735 inhabitants. Of these, only two per cent were white; seventy-seven per cent were pure negroes, descendants of slaves transported from Africa; the self-styled colored element, about twenty per cent, is composed of offsprings of whites and blacks, and the remainder are Englishmen and Americans.

The coast line is low and attractive, with green verdure and snow-white roads stretching back to the elevation of the Blue Mountains in the interior, whose peaks are reared 7,000 feet above the blue of the sea.

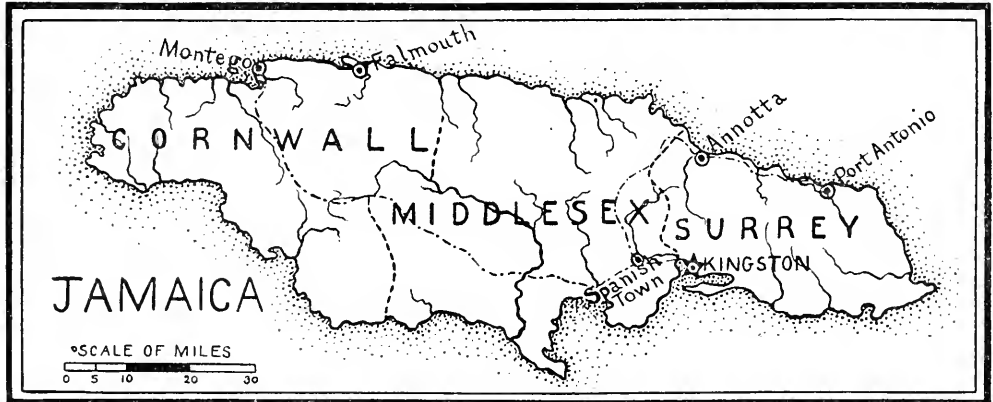

native on the eastern side of the Mexican Andes, at elevations of from 5,000 to 8,000 feet. It has irregular, dark-brown roots, ranging in size from half an inch to three inches in diameter, which yield a resinous substance containing convolvulin. From this a purgative medicine is made. The roots are the part used medicinally. They are brown and wrinkled when placed on the market, but white and juicy when fresh.

Government under the British is conducted to the complete satisfaction of the native population. The governor is appointed by the Crown for a term of six years. Turks Islands and Caicos Islands are joined with Jamaica in the same jurisdiction. The capital and chief city is Kingston, with nearly 60,000 people and fine harbor.

Jamaica was discovered by Columbus in 1494, and in 1509 the Spaniards settled there.

The native population rapidly decreased during the Spanish régime, and by the middle of the seventeenth century it was almost extinct. In 1655 the island was captured by a British expedition, and in 1670, by the Treaty of Madrid, Great Britain gained possession of the island. In the eighteenth century many negroes were brought to the island for sugar-plantation labor. These negroes rose in revolts and were a great draw-back to the prosperity of the settlements. They were not completely subdued until 1796. In 1831 another negro insurrection occurred, and two years later an emancipation act was passed, providing for the total extinction of slavery after 1838.

The island has been frequently visited by earthquakes and cyclones. The most recent earthquakes were in 1907 and 1918; the former caused 600 deaths and the loss of much property, but the latter was not serious. In 1912 a cyclone severely damaged property on the western half of the island.

**JAMES I**, of England, who was also **JAMES VI** of Scotland (1566–1625), was the only son of Mary Stuart by her second husband, Lord Darnley. In 1567, on his mother's abdication, he was crowned at Stirling. He had much trouble with his nobles, a party of whom made him captive at Ruthven Castle in 1552; but a counter party soon set him at liberty. In 1589 he married Princess Anne of Denmark. In 1603 he succeeded to the crown of England, on the death of Elizabeth, and was received with great enthusiasm. One of the early events of his reign was known as the Gunpowder Plot (which see).



JAMES I

An unsuccessful attempt was made to unite Scotland and England, and by a decree all Scotchmen born after the accession of James to the English throne were declared English subjects. In 1613, Elizabeth, the daughter of James, was married to the elector palatine, and at the outbreak of the Thirty Years' War it was expected that James

would send aid to his son-in-law, who had been made king of Bohemia. This James seemed unwilling to do, and the little assistance which popular feeling at length compelled him to render was too late to do any good. He wished to marry his son Charles to a Spanish princess, but this project failed, and war was declared against Spain. The king, however, died soon after. In his reign the authorized translation of the Bible was executed and is called King James' version.

**JAMES II** (1633–1701), king of England, second son of Charles I and of Henrietta Maria of France. In spite of attempts which had been made to exclude him from the throne, because he had adopted the Catholic religion, he succeeded his brother Charles II as king in 1685 and at once set himself to attain absolute power. A rebellion headed by the Duke of Monmouth was easily put down, but the result confirmed the king in his arbitrary measures. He even accepted a pension from Louis XIV, that he might more readily effect his purposes, especially that of restoring the Roman Catholic religion. The result of this course of action was the revolution of 1688, and the arrival of William, prince of Orange. Soon James found himself completely deserted; he quitted the country and repaired to France, where he was received with great kindness and hospitality by Louis XIV. Assisted by Louis, he attempted in 1689 the recovery of Ireland; but the Battle of the Boyne, fought in 1690, compelled him to return to France. All succeeding projects for his restoration proved equally ineffectual.

**JAMES, EDMUND JANES** (1855– ), an American political economist and university president, was born at Jacksonville, Ill. He was educated at Northwestern University, at Harvard and in Germany. In 1883 he became professor of public finance and administration in the University of Pennsylvania. While occupying this position he was chosen by the American Bankers' Association to make a study of European business methods, and his report is considered a standard authority. In 1896 he became director of the extension division of the University of Chicago. Six years later he was chosen president of Northwestern University, and in 1904 he became president of the University of Illinois, filling both positions with high distinction. In 1918 President James announced his resignation as head of the University of

Illinois, and his decision to engage in war work, but his resignation was not accepted. He is the author of *The Canal and the Railway*, *The Federal Constitution of Germany*, *Education of Business Men in Europe*, *The Growth of Great Cities in Area and Population* and numerous other works of an economic or sociological nature.

**JAMES, HENRY** (1843-1916), an American novelist and essayist, an unrivalled interpreter of character. The son of an eminent theological writer, he had exceptional educational advantages. Much of his boyhood was spent in Europe, where he studied under tutors in England, France and Switzerland. At seventeen he returned to America and began the study of law, but soon abandoned it for literature. The last years of his life were spent in England, where he became a naturalized citizen.

As a novelist, James holds an exceptional place in American letters. He was, in his field, as great a psychologist as his brother, Professor William James. There are few dramatic situations in his novels, the action taking place chiefly in the minds and hearts of his characters, most of whom live in an artificial environment and belong to a class with whom suppression of impulse and emotion is the finest of arts, yet who are nevertheless susceptible of the most poignant spiritual tragedies. The earlier novels, which make appeal to the general reader, are *Roderick Hudson*, *The American*, *Daisy Miller* and *The Portrait of a Lady*. Mr. James's more searching exposition of character is seen in *The Bostonians* and *The Princess Casamassina*, while in *The Sacred Fount* his style becomes even more subtle. He was an extremely prolific writer and produced nearly forty other volumes, all of which are distinguished, like his essays, by a fine perception and delicacy of style. His novels are popular with only a small proportion of the people.

**JAMES, SAINT**, called *the Greater*, the son of Zebedee and the brother of John the evangelist. Christ gave the brothers the name of Boanerges, or *sons of thunder*. According to the Gospels, they witnessed the transfiguration, the restoration to life of Jairus's daughter, the agony in the garden of Gethsemane and the ascension. Saint James was the first of the apostles who suffered martyrdom, being slain by Herod Agrippa about A. D. 42. There is a tradition that he went

to Spain, of which country he is the tutelary saint.

**JAMES, SAINT**, called *the Less*, the brother or cousin of Christ, who appeared to James in particular after the resurrection. He is called in Scripture *the Just*, and is probably the apostle described as the son of Alphaeus. He was first bishop of Jerusalem, and in the first apostolic council he spoke against those wishing to make the law of Moses binding upon Christians. The progress of Christianity under him alarmed the Jews, and he was put to death by Ananias, the high priest, about A. D. 62. He is the traditional author of the epistle which bears his name, a book written in pure Greek.

**JAMES, WILLIAM** (1842-1910), an American psychologist, son of a distinguished theologian and brother of the novelist Henry James. He was born in New York and educated at Harvard and in German universities. In 1872 he became professor of anatomy at Harvard, then of philosophy and finally of psychology. Professor James gained a wide reputation by his writings and lectures and was one of the chief American exponents of the new psychology, or psychology viewed from a physiological standpoint. His *Psychology* is a standard text-book in colleges and universities, and his *Talks to Teachers on Psychology* and *The Will to Believe* are among the most readable works of the sort in the English language. Professor James's books are all written in a lucid style which hold the attention of the layman.

**JAMES BAY**, the southern extension of Hudson Bay, 300 miles long and 160 miles wide. It was named from Captain James, who explored it while trying to find the northwest passage. It has numerous rocks and islands, and its navigation is dangerous. The chief affluents are the Albany and Moose rivers. The country surrounding the bay is little settled. The principal settlements are Fort Albany and Moose Factory.

**JAMESON, LEANDER STARR** (1853- ), a Scotch physician and administrator. He received his medical education at London University, and in 1878 he went to South Africa, where he acquired a lucrative medical practice. In 1888 he became associated with Cecil Rhodes and in 1891 was made administrator of Rhodesia. In 1895 he was the leader of the famous "Jameson's Raid," a result of the Uitlander agitation in Johannesburg. His advance was checked, and his

band surrendered. He was taken to England, tried, convicted of misdemeanor and sentenced to ten months' imprisonment. In 1900 he became a member of the Cape Legislative Assembly for Kimberley, and from 1904 to 1908 was premier of Cape Colony. He was made a baronet in 1911. See SOUTH AFRICAN WAR.

**JAMES RIVER**, a river in Virginia, formed by the union of the Jackson and Cowpasture rivers, which rise in the Alleghany Mountains. It flows east-southeast, passing the towns of Lynchburg and Richmond, and communicates by means of a broad estuary, through Hampton Roads and the mouth of Chesapeake Bay, with the Atlantic. Its length is 450 miles, and it is navigable from the ocean to Richmond. The principal tributaries are the Appomattox and the Chickahominy. The first English settlement in America was formed at Jamestown thirty-two miles from the mouth of this river, in 1607.

**JAMESTOWN**, the first permanent English settlement in America, founded by an expedition sent out under the auspices of the London Company and under the immediate command of Christopher Newport and John Smith. The site chosen was about fifty miles from the mouth of the James River, on a low peninsula, and the landing took place May 13, 1607. In 1619 the town was the meeting place of the Virginia house of burgesses, the first representative assembly in America. For later history of this colony, see VIRGINIA, subhead *History*.

**JAMESTOWN**, N. Y., in Chautauqua County, sixty-nine miles south of Buffalo, at the outlet of Lake Chautauqua and on the Erie and the Jamestown, Chautauqua & Lake Erie railroads. It is in a rich agricultural region and has become a popular summer resort. The town is 1,300 feet above sea level—800 feet higher than Lake Erie, twenty miles distant. The extensive manufactures include furniture, metallic goods, voting machines and other articles, while in the production of worsted goods it is one of the leading cities in the state. Jamestown has a Y. M. C. A., a Y. W. C. A., a municipal hospital and the Prendergast Free Library. The place was settled in 1810 and was incorporated as a city in 1896. Population, 1910, 31,297; in 1917, 37,431 (Federal estimate).

**JANESVILLE**, *jajnz'vill*, Wis., the county seat of Rock County, seventy miles south-

west of Milwaukee and twenty miles from the Illinois state line, on the Rock River and on the Chicago & North Western and the Chicago, Milwaukee & Saint Paul railroads. The city is in an agricultural region noted for its fine tobacco, and it has a large trade in farm and dairy produce. The manufactures include cotton and woolen goods, agricultural implements, fountain pens, furniture and other articles. It is the seat of the state school for the blind. The commission form of government was adopted in 1912. The place was settled in 1837 and was incorporated in 1853. Population, 1910, 13,894; in 1917, 14,411 (Federal estimate).

**JANUARY**, *jan'u a ri*, the first month of the year in the present-day calendar, named for the Roman god Janus, the deity who was invoked at the beginning of all religious ceremonies (see JANUS). In the original Roman calendar the year began in March. Numa Pompilius is said to have added January, giving it thirty days, but when Julius Cæsar reformed the calendar he made January the first month of the year and gave it an extra day. It comes soon after the winter solstice, and in most sections of the northern hemisphere is a dreary, cold month. December has many days that remind one of autumn, and February brings thoughts of March and the return of the birds. January, however, is dead winter, with no tokens of fall or spring. Its birthstone is the garnet; its special flower is, appropriately, the snow-drop.

**Special Days for Observance.** The first day of January, *New Year's Day*, is celebrated in almost every Christian land. Home festivities, calling, family reunions, dancing and theater parties are characteristic New Year's activities. New Year's Eve is quite generally celebrated by gatherings in which the old year is watched out and the New Year ushered in. At midnight the bells ring and there is a happy exchange of greetings.

*Twelfth Day* (which see), the twelfth day after Christmas, is the time of the celebration of the festival of the Epiphany.

**Anniversaries for Celebration.** The following birthdays of notable people fall in January:

Paul Revere, January 1, 1735.  
James Wolfe, January 2, 1727.  
Cicero, January 3, 106 B. C.  
Joan of Arc, January 6, 1412.  
Israel Putnam, January 7, 1718.  
James Longstreet, January 8, 1821.

Ethan Allen, January 10, 1737.  
 Alexander Hamilton, January 11, 1757.  
 Edmund Burke, January 12, 1729.  
 Robert W. Service, January 16, 1876.  
 Benjamin Franklin, January 17, 1706.  
 Daniel Webster, January 18, 1782.  
 James Watt, January 19, 1736.  
 Robert E. Lee, January 19, 1807.  
 Edgar Allan Poe, January 19, 1809.  
 John C. Fremont, January 21, 1813.  
 Stonewall Jackson, January 21, 1824.  
 Robert Burns, January 25, 1759.  
 Mozart, January 27, 1756.  
 William McKinley, January 29, 1843.  
 Ben Jonson, January 31, 1574.

The following important events occurred in January:

United Kingdom of Great Britain and Ireland formed, January 1, 1801.  
 Greece declared its independence, January 1, 1822.  
 Lincoln issued the Emancipation Proclamation, January 1, 1863.  
 Commonwealth of Australia proclaimed, January 1, 1901.  
 Utah admitted to the Union, January 4, 1896.  
 First United States Presidential election, January 7, 1789.  
 President Wilson addressed Congress and stated fourteen points for which the United States was fighting, January 8, 1918.  
 England adopted penny postage, January 10, 1840.  
 Norway united with Sweden, January 14, 1814.  
 Queen Elizabeth crowned, January 15, 1539.  
 British Museum opened, January 15, 1759.  
 Discovery of gold in California, January 19, 1848.  
 First session of English Parliament, January 20, 1265.  
 Abdication of emperor of China, January 20, 1912.  
 Edward VII became king of England, January 22, 1901.  
 Naval battle in the North Sea, January 24, 1915.  
 Beginning of Webster-Hayne debate, January 25, 1830.  
 Michigan admitted to the Union, January 26, 1837.  
 Canadian Great Western Railway opened, January 27, 1854.  
 Paris surrendered to the Germans, January 28, 1871.  
 Kansas admitted to the Union, January 29, 1861.  
 Count von Bernstorff announced the inauguration of unrestricted submarine warfare, January 31, 1917.

**JANUS**, an ancient Roman divinity, whose name was invoked at the beginning of any important undertaking. After him the first month of the year was named. He was held in uncommon reverence by the Romans, and as the guardian of doors and gates he was usually represented with two faces, one look-

ing forward, the other backward. In time of war the gates of the chief temple of Janus at Rome were always left open, and in time of peace they were closed. The ninth day of January was celebrated in his honor for several centuries.



**JAPAN**, *ja pan'*, an island empire lying east of the continent of Asia, the only Asiatic country which has successfully adopted the organizing methods of Western nations. Until the second half of the nineteenth century Japan was as remotely separated from Western modes of thought as was China. To-day it is the supreme power in the East, and a world

power second only to the United States and Great Britain, with a modern army and navy and a great merchant marine. The rise of Japan is undoubtedly one of the outstanding wonders of recent history, and one destined to have no small influence on the trend of events.

**Make-up of the Empire.** Japan proper consists of four large and numerous small islands, but these are only the nucleus of an empire covering 260,738 square miles, an area somewhat greater than the combined areas of Oregon and California. An aggregation of about 4,000 islands, the empire stretches in a narrow chain for 2,000 miles along the eastern coast of the continent of Asia, with its northern tip almost reaching the latitude of Kamchatka, and the southern extremity extending south of the Tropic of Cancer. Besides this chain of islands, the empire includes the Asiatic peninsula of Chosen (formerly Korea) and the southern half of the island of Sakhalin, off the south-

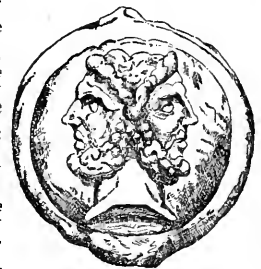

HEAD OF JANUS  
 From a Roman coin.

eastern coast of Siberia. In 1916 the Japanese Empire was estimated to have a population of 77,240,000.

The four principal islands of Japan proper are as follows: Honshiu, or Hondo

(86,953 square miles); Kiushiu (13,870); Yezo (30,340); and Shikoku (6,907). The Kurile Islands, the group farthest north, obtained from Russia in 1875; Formosa, the most southerly island, acquired from China in 1895; the Loo-choo group, between Japan proper and Formosa, acquired from China in 1874; Chosen and Sakhalin, treated in these volumes in separate articles. This article will be confined chiefly to Japan proper, the population of which was estimated at 55,965,292 on January 1, 1917.

**The Japanese People.** With the exception of the wilds of Yezo, peopled by 12,000 Ainos, Japan proper is inhabited by a single race, speaking various dialects of the same tongue. Like the Chinese and Koreans, the Japanese are Mongolians. It is believed by some authorities that they represent the intermarriage of victorious Tartar settlers, who entered Japan from the Korean peninsula, with Malays in the south and people of the Aino race in the main island. Japanese annals contain tales of constant war with savages, and in comparatively recent times the Aino race occupied the northern extremity of Hondo. There are two distinct types of Japanese face, that which is found in art designs being the aristocratic and rarer type. It is distinguished by an oval head and face, rounded frontal bones, a high forehead, a nose curved and well shaped but not prominent, narrow and slightly oblique eyes, with an overlapping of the eyelid. In the man the face is almost hairless, with the exception of a narrow and short mustache. The complexion is pallid or slightly olive, and the expression is demure. The commoner type, almost universal in the northern districts, is full-eyed, flat-nosed and good-humored in expression.

The stature of the race is small, and the trunk is proportionately long as compared with the legs, which are short. Intellectually, the Japanese are quick and alert. They are invariably of a pleasant temperament and readily adapt themselves to new conditions. This characteristic has been of the greatest importance to the nation in enabling it to introduce and profit by Western civilization, and it accounts very largely for the rapid development which the Japanese have made. The basic traits of their character, however, are unchanged. (For a more intimate picture of these people consult the article **TRAVELERS IN DISTANT LANDS**, subhead *Japan*.)

The Japanese language, like the people is the result of the combination of a number of languages, including the Tartar, Mongolian, Manchurian and Tungusic tongues. It differs from the Chinese in being polysyllabic. The alphabet contains forty-seven characters; the verb usually follows the noun, and the language is inflected. It is written in two forms, known as the *Kata-kana*, or half-letter signs, and the *Fira-kana*, or full-letter signs. The former is much the simpler and is sometimes known as man writing. The Japanese language is somewhat difficult to learn, because its mastery necessitates the learning of a large number of different forms, known as idiographs. Students of the language believe that should it be written in the English alphabet, its mastery would be very much easier.

**Surface and Drainage.** The four main islands form approximately a crescent and are separated from each other only by narrow straits. Their surface is mountainous, and the trend of the main range of mountains is in the same direction as the greatest extent of the islands. Hondo, about 700 miles in length, is characterized by a continuous mountain range, extending from the southwest to the northeast. In this, as well as in the other islands, this range is crossed at intervals by short ranges, extending north and south, and where these ranges meet the mountains are the most numerous and reach their highest altitudes. The islands are of volcanic origin, and among the mountains are many extinct volcanoes, as well as some that are still active. Fujiyama, sixty miles southwest of Tokyo, with an altitude of 12,390 feet, is the highest peak in these islands; it is famous for the symmetry of its cone and the distance from which it can be seen at sea. In Formosa, Mount Morrison rises to the height of 13,595 feet. The mountain ranges and many peaks are separated by deep valleys with steep slopes, through many of which flow rapid streams. The level land is along the lower courses of the streams and near the coast. This and most of the mountains are covered with forests and tall grass, except where the land is suitable for tillage.

In general, the rivers are short and rapid and are navigable for only a short distance. The longest stream is the Ishikari, in Yezo, which has a length of 275 miles. The Shinano Gawa in Hondo is the second stream in importance, with a length of 215 miles. The others seldom exceed 100 miles, and some are

much shorter. While not useful for commercial purposes, most of these streams are of value as furnishing means for irrigation. In the mountain sections many picturesque lakes are found. The most important is Lake Biwa, in the south-central part of Hondo.

**Climate.** On account of its great extent north and south, the climate of Japan varies from sub-tropical, in the vicinity of Formosa, to sub-arctic, in Sakhalin and the Kurile Islands. The central part of the empire has an equable and moderate temperate climate, due very largely to the influence of the warm current in the Pacific Ocean. In the northern islands the winters are severe and the snowfall is heavy. In Hondo, Shikoku and Kiushiu, more or less snow falls throughout the winter, but in the southern half of Hondo it remains only a short time. The rainfall depends largely upon the winds; hence the necessity for irrigation during certain seasons of the year, when otherwise the annual precipitation would be enough for agriculture. The climate is healthful, although the summers are hot.

**Mineral Resources.** Coal is found in paying quantities in Yezo and Kiushiu and in smaller quantities in various places. The total yearly output is over 20,000,000 tons. Copper, silver, lead, pig iron, iron pyrites and petroleum are produced in paying quantities, and gold, salt, sulphur and antimony are other products of commercial value.

**Fisheries.** The streams as well as the coast waters abound in fish, and the taking and curing of these gives employment to a large number of people. Many varieties of fish are caught, the most important including mackerel, sturgeon, haddock, halibut and salmon, in the north, and perch, pike and trout, in the streams. Fish culture is given careful attention by the government, and numerous hatcheries are maintained. The yearly production of fish and fish products is valued at more than \$150,000,000.

**Agriculture.** Only seventeen per cent of the country is suitable for tillage, and farming is on the intensive plan. Naturally much of the soil is unfertile, but by means of fertilization known to the Japanese, careful irrigation and thorough tillage this is made to produce abundant crops. Rice, the Japanese "staff of life," is the most important food crop, and is grown wherever the land can be sufficiently irrigated. Following this cereal are barley, rye, wheat, corn, buckwheat and

millet. Potatoes, soy beans and all sorts of vegetables are also grown. Tea is raised in the central part of the empire, and fruits common to the temperate regions are grown to some extent, though they do not seem to thrive as well as upon the continent of Asia. The mandarin orange and persimmon are exceptions to this rule. Cherry and plum trees are cultivated for their blossoms. Considerable sugar cane is raised in the southern portion.

The growing of live stock has not in the past received very much attention because of lack of grazing areas, but within recent years the government has introduced cattle for food, and meat, butter, cheese and milk are now a part of the diet of the well to do. Among the poor, fish is the chief animal food. Silk is produced in those regions adapted to the growing of the mulberry tree.

**Manufactures.** The manufacturing industries of Japan may be classed as original and introduced. The original are those which have existed from ancient times. The chief of these industries are pottery making, weaving, embroidery, lacquer work, paper industry, metallic industry, leather work, wood and bamboo work, carving, camphor producing, vegetable wax making, salt making, sugar making, sake brewing, soy brewing, oil producing and tobacco manufactures. It is probable that these industries were introduced from China and Korea, but the original trace has been obliterated. The scope of the work is generally small and is done with rude and simple instruments, especially in the fine arts. The artisans use their residences for workshops and employ only a small number of apprentices. The process of manufacturing is very tedious, but the taste and magnificence of purely Japanese arts are admired throughout the world.

The principal introduced industries, that is, those brought from America and Europe, include spinning, glass work, brick making, preparation of drugs and chemicals, cement making, ship-building and machinery, match, paper and soap manufacture. These industries are generally carried on in a large factory employing many workmen and utilizing water and steam power, thus forming a decided contrast to the native industries. The latest returns show the number of factories and workshops belonging to companies and individual persons to be many thousands, with millions of capital. The textile-produc-



ing factories, especially those devoted to cotton and silk manufactures, are of first importance. Other important works are for the manufacture of tobacco, porcelain, earthenware, matches and bricks. There are numerous government workshops under control of various departments, such as the imperial mint, the printing bureau, the Tokyo arsenal, the Osaka arsenal, and the woolen-cloth factory; in connection with the war department there are operated several dock yards, naval arsenals and gunpowder factories, all of which are engaged in the manufacture of goods required by the government.

Both men and women are employed in the factories, where the hours are long, and health conditions are very unsatisfactory. The wage scale is low, but the working people live quite frugally. An attempt at industrial reform was made in 1916 with the passage of a factory act regulating hours of labor. This, however, is only a much-needed beginning. Strikes in Japan are illegal, and the organization of laborers is forbidden, under severe penalties.

**Transportation.** The first line of railway in Japan was constructed from Tokyo to Yokohama in 1872, and from that time to the present both the government and private corporations have been engaged in extending railway lines, so that now all of the principal cities on the large islands have railway connection with each other. The empire contains 7,500 miles of railways, over 5,700 miles of which belong to the government. The extensive coast line and numerous good harbors give Japan unusual facilities for communication by sea, and it maintains a large merchant marine, consisting of over 3,700 steamships and about 20,000 sailing vessels. Japanese lines of steamers ply regularly between the leading ports of the empire and the Pacific ports of the United States, and between Japan and India and Europe. In addition to these, the lines of other commercial nations make regular trips to the leading Japanese ports. Through the American and British Pacific cables there is also telegraph communication with the entire civilized world; telephone and telegraph lines are in common use throughout the empire, and an excellent postal system is maintained. The most common vehicle for the transportation of passengers is the jinrikisha, but street cars have been introduced into Tokyo and other large cities.

**Commerce.** The commerce is extensive and is increasing. The construction of railways has widely extended the trade within the islands, since it enables the manufactures to be distributed. The foreign trade amounts to about \$700,000,000 annually. Of this amount over half is in imports. The leading countries with which this trade is carried on are Great Britain, India, the United States and China. Among the exports are raw silk, cotton yarn, floss silk, manufactures, copper, rice and tea. The leading imports includes raw cotton and seed, sugar, iron and steel and other manufactures, including arms and machinery, fiber and pulp for paper.

**Government and Religion.** The present government is a constitutional monarchy based upon the constitution adopted in 1889, and in its form and functions it closely resembles the government of Germany, after which it was patterned.

The emperor remains the source of all laws, in so far that without the imperial approval no parliamentary measures can become law, but the making of laws is the function of the Diet, and no law can be put in force without its assent. The emperor determines the organization of every branch of the administration, appoints and dismisses all civil and military officers and has the supreme command of the army and navy. The rights of the people are safely guarded.

The Japanese parliament consists of a House of Peers and a House of Representatives, together called the Imperial Diet, which hold an ordinary annual session of three months—which, however, may be extended by imperial orders—and extraordinary sessions in urgent cases. For the upper house there are four classes of members: (1) members of the imperial family, holding office for life; (2) counts, viscounts and barons, not less than twenty-five years of age, elected by their fellows for seven years; (3) members nominated for life by the sovereign for meritorious service or for erudition, and above the age of thirty; (4) commoners elected in the prefectures and urban districts, one for each district, by the fifteen largest taxpayers. The lower house consists of 379 members, elected by popular vote.

The suffrage is limited to males not less than twenty-five years old, who must have resided in the district at least a year before registration and must be paying direct national taxes to the amount of not less than

fifteen dollars per annum, as well as an income tax. Candidates for election must be at least thirty years old. The duration of each parliament is four years, unless previously dissolved. Members of the government may sit and speak in either House, but can only vote in that of which they are members. For the purpose of local administration the country, with the exception of Yezo and Formosa, is divided into forty-six districts, each having a governor and a local assembly elected by the people. These districts are again subdivided into villages, towns, municipalities and counties, each having its chief magistrate, council and assembly.

The religions of Japan are Shintoism, Buddhism and Christianity. Entire religious freedom is granted, and Christianity is making rapid progress. By far the largest proportion of the inhabitants are devotees of Shintoism or Buddhism. The former is a religion based upon the worship of the goddess from whom the emperor is supposed to have descended. It is a mild form of spirit and ancestral worship and is the original religion of the country. Buddhism was introduced from China and engrafted upon Shintoism. Later this was modified by the introduction of Confucianism. While the government has not forbidden the extension of Buddhism, in 1868 it ordered the destruction of all Buddhist symbols and images in temples which had formerly been consecrated to Shintu.

**Education.** Education is general and compulsory. Women are educated with nearly as great care as men. There is a complete system of kindergarten, elementary, middle and high schools, and four imperial universities, at Tokyo, Kyoto, Tohoku and Kyushu. All receive government support. There are numerous special, technical and professional schools, and mission schools are also doing excellent work. The elementary school course extends over eight years (six to fourteen), four years being devoted to an ordinary and four to a higher course. The printing press is very active and daily newspapers abound.

**Literature and Art.** The oldest literature dates from the fifth and sixth centuries and is devoted almost entirely to the promulgation of religious doctrines. This continued until about the ninth century, when the introduction of Buddhism caused the development of another literature, based almost entirely upon the Chinese and containing many Chinese

words. This was considered for centuries the classic literature of Japan and was learned and taught, but in the seventeenth and eighteenth centuries there was a revival of Shintoism in its pure form. The followers of this school attempted to establish a literature in pure Japanese, but they were not very successful. Later, as the nation came in contact with Western civilization and imbibed Western ideas, Japanese literature took on a new form, with many modern tendencies. This literature was at first repudiated by the educated class, but it has continued to gain in extent and influence, and at the present time Japanese literature embraces a wide range of subjects, including history, science, geography, religion, philosophy, drama, romances and poems. There are also numerous reference works compiled in the language, such as dictionaries and encyclopedias. The Japanese are especially fond of drama, and this class of literature has received considerable attention, most of their dramas being founded on national events. Critics of Japanese fiction assert that it contains many creditable works.

Japanese art has a wide range, as shown in their lacquer and pottery ware, carving in ivory and wood, the extensive ornamentation of their temples and other buildings, all of which are constructed of wood. Painting is universal. In its principles, style and technique Japanese painting resembles quite closely that of China, but in the selection of subjects it is original. Many art critics consider that it takes very high rank because of the excellence of its decorative applications, but it falls far below the standard of painting in modern Europe in completeness. In applications, Japanese art does not vary in important respects from that of European nations. Wall paintings are represented by pictures drawn upon sliding panels, which occupy the place of doors and walls in European and American dwellings. Often portions of the solid wall are ornamented in a similar manner. Painted screens also constitute an important feature of the decorative furniture of rooms. Another mode of decorating is that on fans. Books and rolls made up of drawings, with or without manuscripts, and loose sketches are made in unlimited numbers. Designs for engravers, for workers in embroidery and lacquer, for pottery and for sculptors are first made by painters. Much of the painting is executed

on silk and paper especially prepared for the purpose. The colors were formerly prepared from native or Chinese material, but since the establishment of intercourse with European traders, most of them have been imported. Pictures executed in embroidery, and cloisonne enamels are Japanese products greatly admired in Western countries.

**Cities.** The important cities are Tokyo, the capital; Yokohama, Nagasaki, Kobe, Hiroshima and Hakodadi.

**History.** The reputed founder of the present dynasty in Japan was Jimmu Tenno, who ascended the throne in 660 B. C., but all Japanese history before A. D. 500 is to be classed as legendary. In A. D. 552 Buddhism was introduced from Chosen (then Korea) and became, forty years later, the established religion. In the sixth century, direct relations were entered upon with China, and Chinese culture was rapidly assimilated. During the five centuries which ensued, the people made immense strides in civilization. A complete system of officialdom was organized under the rule of the Fujiwara family, whose members filled all the chief posts under the government.

The loss of power of this family and the growing weakness of the government favored the rise of the hitherto subordinate military class, which in the person of Yoritomo, who was created *shogun*, or general, in 1192, seized the reins of power. The usurpation of supreme authority by this officer led to the erroneous belief in Europe that down to 1868 there were two emperors in Japan, a *mikado*, or spiritual emperor, who did not govern, and a *shogun*, who really governed, though he paid formal homage to the mikado.

From the thirteenth to the beginning of the seventeenth century Japan was torn by civil strife. The military fiefs organized by Yoritomo raised up a feudal baronage, who succeeded in making themselves virtually independent of imperial power. At one time (1336-1392) two dynasties held sway, one in the North and one in the South. The shogunate itself lost its importance, but the military genius of Hidéyoshi prepared the way for its revival by Iyéyasu, the illustrious general and statesman, who gave a lasting peace to Japan. Iyéyasu in 1600 fixed his seat of government at Yedo, and, backed principally by the northern clans, was able to consolidate his power and to found a per-

manent succession, his dependents ruling at Yedo until 1868. From a collection of small, scattered villages this place soon grew to one of the most populous cities in the world.

The Portuguese, who first landed in Japan shortly before the middle of the sixteenth century, carried on a lucrative trade, but the ruling powers took alarm, ordered away all foreigners and forbade the introduction of the Christian religion (1624). The Portuguese continued to visit Japan until 1638, when they and their religion were finally expelled. From this time the Japanese government maintained the most rigid policy of isolation. No foreign vessels might touch at Japanese ports under any pretense, and Japanese sailors wrecked on any foreign shore were with difficulty permitted to return home. In 1853 Commodore Perry entered a Japanese harbor with a squadron of United States war vessels. He extorted a treaty of commerce from the shogun in 1854, and other countries followed the example of the United States until sixteen in all had obtained the same privileges.

The discontent which had for long been felt with the shogun gradually became general, and in 1867 he was compelled to resign. Yedo was recognized as the capital of the remodeled government, but its name was changed to Tokyo. Educators from the United States were invited to found a new educational system in Japan; British seamen reorganized the navy; French officers remodeled the army. Western laws were introduced, a new nobility was created on a Western basis and in 1889 a constitution was proclaimed. During the last quarter of a century the Japanese court has emerged from the seclusion in which it had maintained itself through the centuries.

In 1894, through trouble in Korea, Japan became involved in a war with China. The Japanese had a decided advantage in equipment and numbers, and the war had not been long in progress before it became clear that defeat for China was certain. The Chinese navy was almost completely destroyed, and in February, 1895, China was compelled to ask for peace. Japan took an active part in the rescue of the foreign legations in Peking during the Boxer uprising, and greatly added to its prestige by defeating Russia in the war of 1904-1905. In 1910 Korea was formally annexed as a Japanese Province, and its name was changed to Chosen.

On August 23, 1914, Japan declared war against Germany, because that country ignored the Japanese demand that Kiao-chau be surrendered at once. Japan's declaration, it was officially stated, was made at the request of Great Britain. Japan did not send an army to Europe, but it rendered the allies valuable service by transporting troops and helping to keep Pacific waters clear of submarines. In the spring of 1919 a serious uprising occurred in Chosen, which the government found difficulty in suppressing. At the peace conference Japan laid claim to certain Pacific islands which had formerly belonged to Germany. A request for a statement in favor of racial equality, to be a part of the league of nations covenant, was denied. This action created considerable ill feeling in Japan, but was regarded necessary by certain allied nations, notably Australia, where Japanese immigrants are particularly unwelcome.

One of the decisions of the peace conference, in which Japan won a notable diplomatic victory, was that Shantung, on the China coast, which Germany had possessed, should pass to the ownership of Japan. The Japanese were also charged with the mandate of governing, under the league of nations, all the former German islands in the Pacific Ocean lying north of the equator.

**Related Articles.** Consult the following titles for additional information:

|           |          |          |
|-----------|----------|----------|
|           | CITIES   |          |
| Hiroshima | Nagasaki | Tokyo    |
| Kobe      | Nagoya   | Yokohama |
| Kyoto     | Osaka    |          |

|                      |                |  |
|----------------------|----------------|--|
|                      | HISTORY        |  |
| Boxer Rebellion      | Mutsuhito      |  |
| China (history)      | Russo-Japanese |  |
| Chinese-Japanese War | Shogun         |  |
| Chosen               | World War      |  |
| Mikado               | Yoshihito      |  |

|           |                |           |
|-----------|----------------|-----------|
|           | MISCELLANEOUS  |           |
| Aino      | Japanning      | Kuro Siwo |
| Formosa   | Jinrikisha     | Loo-choo  |
| Fujiyama  | Jujutsu        | Sakhalin  |
| Hara-kiri | Kurile Islands | Samurai   |

**JAPAN CURRENT.** See KURO SIWO.

**JAPANNING**, the art of applying varnish to wood, metal, leather and other materials in imitation of the lacquered work of Japan and China. The article to be japanned is made thoroughly dry and brushed over with two or three coats of seed-lac varnish, to form the priming. The next coat of varnish is mixed with the color desired; or, if a design is to be used, it is at this stage painted on the primed surface. The whole is then covered with additional coats of varnish, which are dried and pol-

ished as applied. Iron articles when japanned are baked in an oven to give the desired finish.

**JAPHETH**, *ja'feth*, a son of Noah (*Gen.* IX, 18), born when Noah was about 500 years old. His descendants, according to *Genesis* X, 5, peopled the isles of the Gentiles, and thus Japheth is often considered the ancestor of most European nations.

**JAPURA**, *shah poo'rah*, or **YAPURA** (sometimes called **CAQUETA** in its upper course), a large river of South America, a branch of the Amazon. It rises in the Andes of Colombia, and flows in a general east-southeast direction and forms for some distance the (disputed) boundary between Ecuador and Colombia. It passes through forests of Ecuador and Brazil for many miles and enters the Amazon opposite the town of Teffe. Its length is about 1,800 miles, and it is navigable to Cupaty Falls, a distance of 620 miles. Above the falls it is navigable for 200 miles.

**JASMINE**, *jas'min*, or **JESSAMINE**, the name of a genus of plants native to warm parts of Asia. The common jasmine has become naturalized in sub-tropical latitudes throughout the world. In cool climates it is cultivated as a garden shrub. It grows

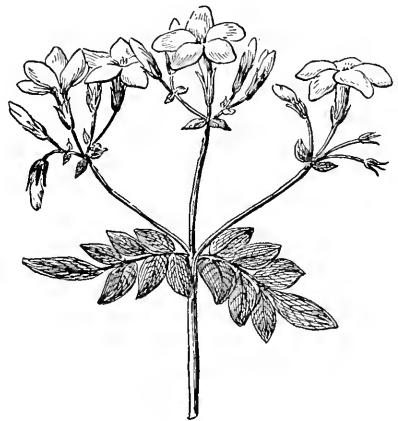

JASMINE

from six to ten feet high, has fragrant white blossoms and resembles the evergreens. The flowers are used in making oil of jasmine, a delicate perfume. *Cape jasmine* is the name commonly applied to the gardenia, not a true jasmine, but a subtropical plant belonging to the madder family. The flowers are large, white and fragrant, and the leaves are very beautiful. This species is a hot-

house plant in England and the United States, except in the South, where it grows in the open. The *Carolina jasmine* is a beautiful climbing vine which is common in South Carolina and some of the other Southern states. The flowers are a deep, bright yellow, with a fragrance similar to that of the true jasmine. Still another species is the *Spanish jasmine*, having very fragrant flowers which yield an essential oil.

**JASON**, in Greek legend, king of Iolcos in Thessaly, the leader of the Argonautic expedition. On his return from this quest he brought with him, as his wife, Medea, and she helped him to renew the youth of his father and to put to death his uncle Pelias, who had usurped the throne. After the death of Pelias, however, Jason was unable to keep possession of his throne and fled to Corinth, where some time later he deserted Medea and married Glauce, daughter of the king of that country. See ARGONAUTS; MEDEA.

**JASPER**, an impure, opaque, colored quartz, less hard than flint or even than common quartz, but giving a spark when struck with steel. It is opaque, sometimes feebly translucent at the edges, and presents almost every variety of color. It is found in metaphoric rocks and often occurs in very large masses. Jasper admits of a high polish and is used for table tops, seals and other ornaments. There are several varieties, red, brown, blackish, bluish and Egyptian. Agate jasper is a stone in which jasper and chalcadony occur in alternating layers (see AGATE). *Porcelain jasper* is only baked clay. The massive varieties of jasper constitute excellent building stone.

**JASPER, WILLIAM** (about 1750-1779), an American soldier, who was famous in Revolutionary history, was born in South Carolina. He distinguished himself at the siege of Fort Moultrie by leaping over the parapet and rescuing the colors which had been shot away. The commission as lieutenant which was offered him as a reward for this act, he refused to accept on account of his lack of education. In many later engagements he showed great bravery, and it was while trying to fasten the colors to a parapet during the attack on Savannah that he was killed.

**JASSY**, *yahs'se*, RUMANIA, a town in Moldavia, the northern division of the Rumanian kingdom. It is situated on the Bachlui River, not far from the Russian

boundary. Jassy is a place of interesting historic associations. Here, in 1821, Alexander Ypsilanti began the movement to bring about Grecian independence, and previous to 1861, when Moldavia and Wallachia were united to form Rumania, it was the capital of Moldavia. In 1916, when Rumania was overrun by the Austro-German forces, the government was removed from Bucharest to Jassy, and the town continued to be national headquarters until late in 1918. Jassy is not a manufacturing center of importance, but in normal years it carries on an active trade in agricultural products, salt and petroleum. There are numerous educational institutions, including a university which had 900 students at the outbreak of the World War. Population, 1914, 76,120.

**JAUNDICE**, *jahn'dis*, or *jawn'dis*, or **ICTERUS**, *ik'ter us*, a disorder which manifests itself in a yellowish color of the skin and the whites of the eyes. The victim of jaundice also suffers from weakness, failing appetite, constipation and stimulation of the kidneys. Nausea and vomiting are occasional symptoms. Jaundice is not itself a disease, but an indication of a disease of the liver, which prevents that organ from separating the coloring matter of the bile from the blood. The yellow color first appears in the whites of the eyes and then in the whiter parts of the skin. Careful attention to the diet and correction of constipation conditions are the usual measures used to cure an attack of jaundice. The patient should be under the doctor's care.

**JAVA**, *jah'vah*, the most important island of the Dutch East Indies. It is the most fertile island of its size in the world, is noted also for its beautiful scenery, and is a conspicuous example of competent colonial administration. It lies northwest of Australia and south of Borneo; Sumatra is northwest of it. For governmental purposes the island of Madura and other smaller islands are joined to Java, under the name "Java and Madura." Java is 666 miles in greatest length and from fifty to 121 miles in width, and its area is 48,503 square miles—almost exactly that of Louisiana. Java and Madura combined have 50,557 square miles.

**Products.** The country is very mountainous, and contains forty-five volcanic peaks from 2,000 to 12,000 feet high. There are great plains, valleys and forests, all highly productive. Nearly all the natives are en-

gaged in agriculture; rice is the principal crop, and it is therefore the main food reliance of the people. Great quantities of coffee of the quality known throughout the world as "Java" are produced, also sugar, tea, pepper and indigo. On higher lands, yet in the warm zone, bananas, oranges, lemons and coconuts are a source of revenue. The forests are rich in teak, (which see).

**The People.** The native inhabitants are of the Malay race, but are in numerous distinct groups, of which the Javanese, the Sundanese, the Baduwis and the Tenggerese are prominent. Java and Madura together had 36,035,435 people in 1912. Of these, 105,000 were Europeans, about one-half of them Dutch; after them, in order of numbers, were Germans, Belgians, English, French and Swiss. There were 563,000 Chinese and 29,000 Arabs. The Europeans live under the laws of the mother country, the Netherlands, but the laws applied to the natives are framed in consideration of their customs and institutions. The chief executive is a Governor-General, appointed from The Hague.

The capital of Java and Madura is Batavia, which in 1915 had a population of 138,551. Other cities of importance are Soerabaya (156,752) and Soerakarta (118,378). There is freedom of worship throughout the island.

**History.** The history of Java is unknown up to the eleventh century, when it became the site of powerful Hindu realms. The Hindus founded a dynasty and converted the natives to Brahmanism. This was overthrown by the invasion of the Mohammedans in 1478. In the early sixteenth century the Portuguese made their way to the island and were succeeded by the Dutch in 1595, who wrested from them the supremacy. At this time the two chief states were Mataram and Bantam. After the Dutch conquest was completed Mataram was divided into the sultanates of Soerakarta and Jokyokarta, which exist at present. Bantam disappeared a century ago. From 1811 to 1815 Batavia was in the hands of the English. Since then the Dutch have held the supremacy.

**JAY**, a bird related to the crow, but of smaller size. It has a trim shape and beautiful plumage, blue usually predominating. Some species have long tails and high crests. The jays have harsh voices and do not sing, but some of them are skilful in imitating the calls of other birds. They are noted for their

fighting disposition and for the bad habit of destroying the nests, eggs and even the young of weaker birds.

Some of the jays are brilliantly colored. The beautiful American *blue jay* is bright



BLUE JAY

blue marked with black and white. The *Canada jay*, or *whisky Jack*, or *lumber Jack*, is a bird of rather somber coloring, but with the bold, noisy and active habits of the other jays. The common European jay is cinnamon-colored, varied with white, black and blue. Its head is provided with a conspicuous black-marked crest.

**JAY**, JOHN (1745-1829), an American jurist and statesman, remembered especially for his work in behalf of the Federal Constitution and for his connection with the treaty that bears his name (see **JAY TREATY**). Jay was graduated from King's College (now Columbia University) in 1764 and in 1766 was admitted to the bar. In 1774 he was chosen a delegate to the first American Congress at Philadelphia, and was also a member of the second Congress. Appointed minister plenipotentiary to Spain in 1778, he became one of the commissioners to negotiate a peace with Great Britain after the Revolution.



JOHN JAY

Returning afterwards to the United States, Jay served as Secretary of Foreign Affairs until the government was organized under the Constitution, and later was made Chief Justice of the Supreme Court. In 1794 he was sent as envoy extraordinary to Great Britain, where he signed the famous treaty referred to above. In 1795 he resigned his position as Chief Justice to become governor of New York, and after serving two terms retired to private life. See FEDERALIST, THE.

**JAY TREATY**, the name given to a treaty between Great Britain and the United States, negotiated and signed for the United States by John Jay, in 1794. It provided for the evacuation of the forts in the Northwest by the British, for a commission to determine the northeast boundary between Canada and the United States and for compensation to the United States for illegal captures of American merchantmen after the Revolutionary War. The United States also agreed to pay debts due British merchants at the beginning of the Revolution.

The treaty was exceedingly unpopular in America, since it contained no reference to the impressment of seamen or to the kidnaping of negroes by the British army, and because it placed restrictions on United States trade with the West Indies. Charges of bribery and corruption were leveled at Jay and even at President Washington; the ratification of the treaty was made a party issue, but was finally accomplished after a hard struggle. While the treaty was not favorable to the young nation, the country was in no condition to engage in a new war. Historians agree that Washington and Jay did all possible to secure what they could and at the same time avert hostilities.

**JEFFERSON, JOSEPH** (1829-1905), an American actor, born in Philadelphia. His great-grandfather was a member of Garrick's company at Drury Lane, while his father and grandfather were well-known American actors. Jefferson was on the stage from his very infancy, appearing as a child in *Pizarro* when only three years of age, and dancing as a miniature "Jim Crow" when only four. For many years he went through the hard training of a strolling actor and then played in New York, where in 1857 he made a hit as Doctor Pangloss, in the *Heir-at-Law*, and in 1858 created the part of Asa Trenchard in *Our American Cousin*, the elder Sothorn playing Lord Dundreary. Some time later

he assumed for the first time the rôle of Caleb Plummer in *The Cricket on the Hearth*.

In 1865 he visited London and at the Adelphi Theater played for the first time his world-famous part of Rip Van Winkle in the play arranged by Boucicault from Irving's story. The character was a perfect work of art—beautiful in conception, subtle and delicate in



JOSEPH JEFFERSON

execution. After a long run with Rip Van Winkle, Jefferson returned to his earlier parts, and in 1868 he made for himself another famous rôle, as Bob Acres in *The Rivals*. From 1880 until his death Jefferson did not attempt new rôles, but played Rip, Caleb Plummer and Bob Acres, retaining all his early popularity. He had considerable talent as a painter, and many of his pictures, produced for recreation and amusement, have been given high praise by critics. Aside from his remarkable ability as an actor, Jefferson was of high character and charming personality.

**J**EFFERSON, THOMAS (1743-1826), an American statesman and diplomat, author of the Declaration of Independence and third President of the United States. Among the fathers of the American republic, two stand out as eloquent representatives of opposing schools of thought. They were Thomas Jefferson

and Alexander Hamilton. The political theories of the former are summarized in those deathless phrases embodied in the Declaration that he fathered: "All men are created equal; governments derive their just powers from the consent of the governed." It is recorded of Hamilton, on the other hand, that he characterized the people as "a great beast," and that he believed that only the well-born and the able should participate in the government.



The American Constitution and forms of government represent a blending of the theories of these two men, equally patriotic and equally devoted to their country's welfare. That a strong central government was established, endowed with sufficient powers to maintain itself, we owe to Hamilton, but the spirit of democracy, the vital spark that makes any government endure, is the gift of Thomas Jefferson. History shows nothing more plainly than that an autocratic government is the most unstable of all forms in a time of overwhelming crisis. It was the mission of Jefferson to proclaim that the basis of a successful government is justice to all and recognition of the right of the people to govern themselves.

**Ancestry and Education.** Thomas Jefferson was born at Shadwell, Albemarle County, Va., on April 2, 1743. His father, Peter Jefferson, was owner of a large estate and a man of some distinction in the community. He was, however, thoroughly democratic in his views and manner of living, qualities he seems to have imparted to his eldest son, Thomas. The mother of the future President was one of the Virginia Randolphs. The boy was educated in the common schools and under private instructors, later studied at William and Mary College, and after his graduation studied law, being admitted to the bar in 1767.

**Early Public Career.** Jefferson was elected to the lower house of the Virginia legislature in 1769 and took a prominent part in the advocacy of radical measures of resistance to Great Britain. In March, 1773, Jefferson, with Patrick Henry and other kindred spirits, formed a committee of correspondence, an action which led to a second dissolution of the legislature. He took a prominent part in the agitation in favor of the Continental Congress, and a tract which he had drawn up as instructions to Virginia's delegates was later published as *A Summary View of the Rights of British America*, which had a wide circulation and exerted a powerful influence. Jefferson's radical stand for colonial rights made him a marked figure in the colonies, and in 1775 he was appointed a delegate to the Continental Congress, becoming, on June 10, 1776, chairman of that famous committee which was authorized to draft a declaration of independence. The memorable document, which was largely the work of Jefferson, was debated in Congress from July 1 to July 3,

and was finally adopted on July 4, which day became the birthday of a new nation.

**Statesman and Diplomat.** Jefferson retired from Congress in the fall of the same year to devote himself to political work in his own state. There he had an important influence in incorporating democratic ideals in the new constitution and laws. He served in the legislature and as governor, and at the close of the Revolutionary War he was chosen one of America's commissioners of peace, but did not sail, the work having been practically accomplished before he was ready to leave America. Jefferson reëntered Congress in 1783 and for a year performed important service. In the following summer he was sent to Europe with Franklin and Adams to make commercial treaties, and in 1785 he became sole American representative in France.



THOMAS JEFFERSON

For five years he remained abroad and, though not negotiating many important treaties, he did much to raise the prestige of the American government and to popularize the American cause.

In 1789 he returned to America and reluctantly accepted the office of Secretary of State in Washington's first administration. Here he first came into conflict with his great rival, Alexander Hamilton. Their opposition became particularly acute during the trouble between France and England in 1793, when Jefferson's followers desired not only recognition for Genet but wished the United States to take actively the side of France. He retired from office in the same year, and at the close of Washington's second term he became the candidate of the Anti-Federalists for President. As he was defeated by Adams, Jefferson became Vice-President. In this position he also came into conflict with his superior officers, and at the passage of the Alien and Sedition Laws he wrote a series of resolutions for the Kentucky legislature, protesting against the laws as unconstitutional.

**Administrations.** The campaign of 1800 was extremely bitter, and Jefferson and Burr, the two candidates of the Democratic-Republicans, received the same number of votes,



# 1801 JEFFERSON'S ADMINISTRATION 1809

## TRIPOLITAN WAR

- TIME: 1801-5
- 1801-TRIPOLI DECLARED WAR
- 1803-NAVAL FORCE IN MED. SEA
- PHILADELPHIA FOUNDERED CREW HELD AS SLAVES
- 1804-DECATUR'S EXPEDITION FREELE BOYBARREDTRIPOLI
- 1805-TROUBLE CEASED
- BASHAW GLAD TO MAKE TREATY

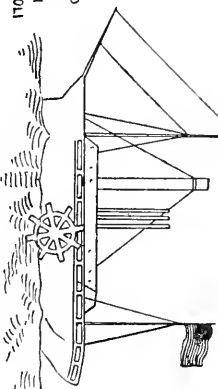

FULTON'S CLERMONT 1807

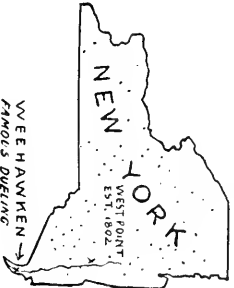

VEE HAWKEN → PHOENIX DUELING GROUND



ORDERS IN COUNCIL

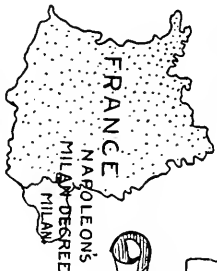

FRANCE  
NAPOLEON'S MILAN DECREE MILAN

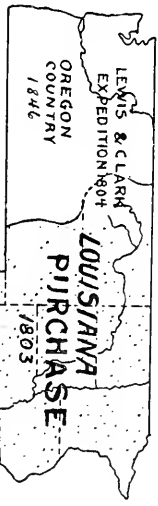

LOUISIANA PURCHASE 1803

FROM: NAPOLEON BY WHOM: LIVINGSTON & MONROE

- CAUSE: 1- TO SETTLE THE TERRITORY OF NAPOLEON
- 2- TO PREVENT ENGLAND FROM GAINING A RIVAL OF ENGLAND
- 3- TO MAKE THE UNITED STATES

### OBJECT-

- 1- TO OPEN THE MISSISSIPPI TO THE WESTERN COMMERCE
- 2- TO EXTEND U.S. TERRITORY
- TERMS: ABOUT 15,000,000 DOLLARS
- RESIDENTS: 1- TERRITORY OF US MORE THAN DOUBLED
- 2- STRENGTHENED SLAVE TERRITORY AND GAVE RISE TO THE MISSOURI COMPROMISE



OHIO ADMITTED 1802

## FOREIGN AFFAIRS

- 1806 ENGLAND ORDERS IN COUNCIL
- NAPOLEON-MILAN DECREE
- EMBARCO ACT
- CHESAPEAKE FIRED ON
- 1809-NON-INTERCOURSE LAW PASSED

## DOMESTIC AFFAIRS

- 1801- FIRST WRITTEN MESSAGE TO CONGRESS
- ARMY & NAVY REDUCED
- EXCISE TAKEN FROM WHISKEY
- 1808- IMPORTATION OF SLAVES PROHIBITED

## Administrations of Thomas Jefferson, 1801-1809

### I. THE PRESIDENT

- (1) Birth
- (2) Ancestry
- (3) Education
- (4) Early career
- (5) Career after formation of the Union
- (6) Character
- (7) Death

### II. GOVERNMENTAL AFFAIRS

- (1) Domestic
  - (a) First written President's message to Congress
  - (b) Ohio admitted to the Union
  - (c) United States Military Academy established
  - (d) Louisiana Purchase
  - (e) Twelfth Amendment adopted, 1804
    - (1) To avoid contested elections
    - (2) Separate ballots for President and Vice-President
  - (f) Lewis and Clark Expedition
  - (g) Slave trade prohibited
- (2) Foreign
  - (a) Trouble with England
    - (1) Causes
      - (a) England's claim to the allegiance of naturalized Americans
      - (b) Claim the right to search neutral vessels
      - (c) Impressment of seamen
    - (2) Results
      - (a) Embargo Act
      - (b) Non-Intercourse Act
      - (c) British Orders in Council
      - (d) Napoleon's decrees
  - (b) War with Tripoli

### III. INTERNAL AFFAIRS

- (1) Invention of steamboat
- (2) Duel between Hamilton and

Burr

(3) Cumberland Road begun

(4) Burr's Conspiracy

### IV. ELECTION OF 1808

- (1) Issues
- (2) Parties
- (3) Candidates
- (4) Election of Madison

### Questions on Jefferson

When was Jefferson born?

What services did he render before the adoption of the Constitution?

What was his interpretation of the Constitution?

Who was the great advocate of the opposite interpretation?

By what name was the party of Jefferson known?

When was the first written President's message sent to Congress?

What state was admitted to the Union during Jefferson's administration? When?

When was the Military Academy at West Point established?

From whom was Louisiana purchased?

What was the price?

Why was it purchased?

What was the purpose of the Twelfth Amendment?

When did Lewis and Clark make their famous expedition?

What was the Embargo Act? What were its effects?

What were the purposes of the Non-Intercourse Act?

Was the Non-Intercourse Act effective?

Who was the author of the Berlin and Milan decrees? What great system were they to enforce? Explain briefly what this system was.

What were the causes of the war with Tripoli?

Who was Stephen Decatur? What part did he take in the war with Tripoli?

Give a short account of the career of Commodore Preble.

What was the name of the first steamboat? Who was its inventor? When and where did it make its final trip?

Jefferson finally being chosen President by the House of Representatives. As a result of the bitterness which developed in this election the Constitution was amended in 1804, and the practice of having a nominee for Vice-President was adopted.

Immediately after his inauguration, in 1801, Jefferson proceeded to carry out his democratic theories. He reduced the navy, had appropriations for the army and diplomatic service cut down, and endeavored in other ways to secure simplicity and economy. During this administration, however, the young nation showed its mettle by compelling the Tripolitan government to abandon its piracy on American vessels in the Mediterranean Sea. It is an interesting fact that the most splendid achievement of Jefferson's career as President—the Louisiana Purchase—was a departure from his expressed theories on strict construction of the Constitution. When he saw, however, that the people overwhelmingly approved of the purchase, he had the good judgment to accede to popular feeling in the matter.

In 1804 Jefferson was reelected by a large majority. Unfortunately for the progress of the nation, France and England were at War throughout Jefferson's second term, and in their efforts to destroy one another's commerce they greatly encroached on the rights of the neutrals. An added irritation was England's policy of searching American vessels for contraband and for British seamen. In retaliation Congress passed the Embargo Act, forbidding French or English vessels to enter American ports, but this measure harmed the United States more than the belligerents, and it was superseded by the Non-Intercourse Act in 1809. Other events of this administration include the establishment of the military Academy at West Point, the beginning of work on the Cumberland Road, the abolition of the right to import slaves from Africa, the Lewis and Clark Expedition and the conspiracy of Aaron Burr.

**At Monticello.** In 1809 Jefferson retired to his home in Albemarle County, which he named Monticello. Though he never again undertook a public office, the "sage of Monticello," as he was called, was visited by people from all parts of the country and from Europe, and his advice was eagerly sought by two Presidents who followed him, Madison and Monroe. Towards the close of his life he founded the University of Virginia, and the

place which this institution had in his heart is indicated by his request that the words "Father of the University of Virginia" be included in his epitaph. On July 4, 1826, just half a century after the adoption of the Declaration of Independence and the same day on which John Adams died, he passed away.

As some one has said, he was a friend of the common people, "who not only served them, as many have done, but who honored and respected them, as few have done." In impressing this democratic ideal upon the American government and society, Thomas Jefferson performed his most notable service.

**Related Articles.** Consult the following titles for additional information:

|                             |                                   |
|-----------------------------|-----------------------------------|
| Alien and Sedition Laws     | Hamilton, Alexander               |
| Declaration of Independence | Kentucky and Virginia Resolutions |
| Embargo                     | Lewis and Clark Expedition        |
| Genet, Edmund Charles       | Louisiana Purchase                |

**JEFFERSON CITY, Mo.,** the capital of the state and the county seat of Cole County, 125 miles west of Saint Louis, on the Missouri River, and on the Missouri Pacific, the Chicago & Alton and the Missouri, Kansas & Texas railroads. The city is 600 feet above sea level, near the geographical center of the state. It is the seat of Lincoln Institute, a normal school for negroes, and has a Carnegie Library, state and supreme court libraries, open to the public, and a hospital. Among the other prominent buildings are the state capitol, the penitentiary, the armory, the governor's mansion, the supreme court building and the United States Federal building. The city is an important trade center for a rich agricultural and mining region. There are railroad shops of the Missouri Pacific and extensive manufactories of agricultural implements, shoes, clothing, flour, foundry products, brick and other articles. The place was settled in 1826 and was incorporated in 1839. Population, 1910, 11,850; in 1917, 13,712 (Federal estimate).

**JEFFERSONVILLE, IND.,** the county seat of Clark County, on the Ohio River, opposite Louisville, Ky., with which city it has connection by two great bridges. It is on the Baltimore & Ohio, the Cleveland, Cincinnati, Chicago & Saint Louis, the Pittsburgh, Cincinnati, Chicago & Saint Louis and the Louisville & Nashville railroads. There are extensive manufactories of river boats, railroad cars and various smaller articles. The state reformatory for men and

a United States quartermaster's supply depot are here. Population, 1910, 10,412; in 1917, practically unchanged.

**JEHOSHAPHAT**, *je hosh'a fat*, son of Asa and fourth king of Judah, who reigned about 896-871 B. C. He was noteworthy for his strenuous endeavors to abolish the use of idols. See *II Chronicles*, XVII-XX.

**JEHO'VAH**, the name used by pious Hebrews of Old Testament times to designate God. The Hebrews cherished the most profound awe for this name, which led them to avoid pronouncing it and to substitute the word *Adonai*, signifying *the lord*. This custom still prevails among the Jews. In some portions of the Pentateuch Jehovah is the name regularly applied to God, in others Elohim, which has led to a theory of two authors respectively for these portions.

**JE'HU**, a Bible character represented first as a general of Ahab and Jehoram, and later as king of Israel. The illness of Jehoram gave him opportunity to seize the throne and put the king to death (842 B. C.). Jehu then proceeded to kill Ahaziah, king of Judah, and his forty-two kinsmen, Ahab's seventy children and his wife, Jezebel. After the extermination of the royal houses of Judah and Israel, Jehu reigned twenty-two years. Jehu is represented (*II Kings*, IX-X) as an instrument of God in bringing about just punishment, at Elijah's instigation, for the murder of Naboth (*I Kings*, XXI) and in suppressing Baal worship.

**JELlicOE**, *jel'i ko*, JOHN RUSHWORTH, Sir, (1859- ), a British naval officer who was in command of the Grand Fleet of Great Britain from 1914 to 1916. He entered the navy at the age of thirteen, rose rapidly in position and honor, after serving in China from 1898 to 1901 was chief of staff to Vice-Admiral Seymour during the Boxer Rebellion. Jellicoe was made rear-admiral in 1907, was appointed commander of the Grand Fleet in 1914, and in 1915 received the rank of admiral. In 1916 he commanded the fleet in the Battle of Jutland, but later in the year was succeeded as commander by Sir David Beatty (which see). Admiral Jellicoe then became First Lord of the Admiralty, and held this position until 1917, when he relinquished it to Sir Eric Geddes. In 1919 he published a volume entitled *The Grand Fleet, 1914-1916*, in which he showed that the British navy was in a perilous condition until the middle of the year 1915.

**JELLY**, the name applied to animal or vegetable substances which liquefy when heated, but become a tremulous, partly-solid mass when cold. Fruit jellies, which are a nutritious and widely used class of foods, are made by pressing out the juice of fruits and boiling the liquid with a certain proportion of sugar. Animal jelly is prepared from the soft parts of animals, and even from bones when sufficiently crushed. It is a colorless, elastic, transparent substance, which dissolves quickly in hot water and is tasteless and odorless. See GELATIN.

**JELLY-FISH**, the popular name of several different animals found in the sea and so called because of the transparent, jelly-like substance constituting most of the body. They are often called *sea blubbers* or *sea nettles*, from their shape or their long stringing tentacles, with which they seize their prey. In the water they move rapidly and present a singularly-beautiful appearance. One of the most common forms is a bell-like body which swims gracefully through the water by alternately expanding and contracting. The animals are sometimes cast up on sea beaches, but out of the water they lose their beauty and have the appearance of formless masses of jelly.

**JENA, BATTLE OF**, a battle fought at Jena, October 14, 1806, between the Prussians under Prince Hohenlohe and the French under Napoleon. The French, who considerably outnumbered the Prussians, were completely victorious. The town Jena is situated in Saxony, ten miles southeast of Weimar. It is the seat of a celebrated university and of the famous Zeiss optical works. Population, 1910, 38,487.

**JENGHIS KAHN**, *jen'giz kahn*. See GENGHIS KAHN.

**JENNER**, EDWARD (1749-1823), an English physician, celebrated for having discovered in vaccination a preventive of smallpox. He studied at London and settled in Gloucestershire as a medical practitioner. About 1776 the belief common among the peasants that casual cowpox acquired in milking cows was a preventive of smallpox caused him to direct his inquiries to the subject and, at the expense of his medical practice, he began to devote much time to investigation. In 1796 gave his first public demonstration. After years of sacrifice he was financially rehabilitated by the British government and received from the world at large

the honor and recompense due a great man who contributed immeasurably to the world's progress. See VACCINATION.

**JEPHTHAH**, *jef'thah*, one of the Hebrew judges, whose story is told in the eleventh and twelfth chapters of the book of *Judges*. Jephthah led the Gileadites to battle against the Ammonites, and defeated them. He had rashly made a vow that if he were victorious he would sacrifice to God as a burnt-offering whatever should first come to meet him from his house. Being met on his return by his daughter, his only child, he sacrificed her to the Lord, in accordance with his vow.

**JERBO'A**, a genus of small rodents having extremely long hind legs, which give them extraordinary power in leaping; their movement seems more like flying than running.

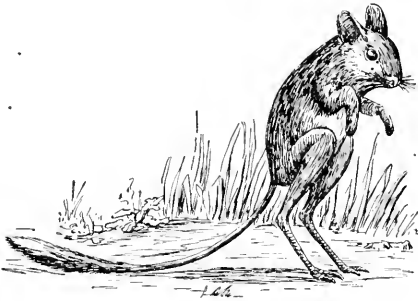

EGYPTIAN JERBOA

The fore legs are armed with short, powerful claws, with which the animal excavates its burrows and extracts the roots on which it chiefly lives. Jerboas live in communities; they are abroad principally at night, and they hibernate during the colder seasons, though they do not store food for the winter. They are found chiefly in Asia and Northern Africa; the typical species is the Egyptian form. The jerboa is closely allied to the American jumping mouse, or deer mouse. See JUMPING MOUSE.

**JEREMIAH**, the second of the great prophets of the Old Testament. He flourished during the darkest period of the kingdom of Judah, under Josiah, Jehoahaz, Jehoiakim, Jecemiah, or Jehoiachin, and Zedekiah. He was called to the prophetic office about 629 B. C., in the reign of Josiah, and he lived to see the capture of Jerusalem by Nebuchadnezzar in 586 B. C. Nebuchadnezzar offered him a home at Babylon, but he preferred to stay among the wretched remnant of the people left in Judah. He is said to have been

stoned to death in Egypt by some of his countrymen who were irritated by his rebukes. Jeremiah wrote the books *Jeremiah* and *Lamentations*, and probably some of the *Psalms*.

**JEREMIAH**, LAMENTATIONS OF. See LAMENTATIONS.

**JERICHO**, *jer'i ko*, PALESTINE, a town of ancient Judea, on a plain about eighteen miles northeast of Jerusalem. It was noted, especially in Solomon's time, for its balsam gardens and its thickets of palm trees and roses. Jericho was the key to the possession of all Palestine, and was therefore invested by the Israelites who had passed the Jordan under Joshua to conquer this country. The account of the invasion and capture is told in the book of *Joshua* II, V-VII (see, also, BIBLE, subhead *Bible Stories*). Joshua pronounced a curse upon him who should rebuild the city, but it was rebuilt in the days of Ahab. It grew to considerable importance and is often spoken of in later history. Herod favored it and resided there, and Christ performed many miracles at Jericho. Vespasian destroyed the city, but it was again rebuilt. Its site is now occupied by the small village of Er-Riha.

**JERICHO ROSE**, or **RESURRECTION PLANT**, a small plant belonging to the mustard family, which came originally from Arabia. After the plant has finished blooming the leaves drop off and the branches dry



JERICHO ROSE

up and curve inward. In this state the plants are often broken off by the wind and blown about. If they happen to fall into

water the branches open out again, turn green, and the seeds fall out of the pods. The plants sometimes live for years. They are sold in many markets and are much enjoyed by children.

**JEROBOAM**, the name of two kings of Israel. **JEROBOAM I**, the son of Nebat, of Solomon's death, 931 B. C., was made king of the ten tribes who separated from Judah and Benjamin. He died in the twenty-second year of his reign (*II Kings XI, XII, XIII*). **JEROBOAM II**, the most prosperous of the kings of Israel, ascended the throne in 790 B. C. He repelled the Syrians, took their cities of Damascus and Hamath and reconquered Ammon and Moab. Licentiousness and idolatry were prevalent during his reign. Amos and Hosea prophesied during this time.

**JEROME**, **JEROME KŁAPKA** (1859- ), an English humorist, born at Walsole, Staffordshire. He was educated at Marylebone School and was successively clerk, tutor, actor and journalist. He gained a reputation as a humorist in 1889 with *Idle Thoughts of an Idle Fellow* and *Three Men in a Boat*. His plays include *Barbara*, *Sunset*, *Wood Barrow Farm* and *The Passing of the Third Floor Back*. His more recent books are *The Angel and the Author*, *They and I* and *Malvina of Brittany*.

**JERSEY CITY**, N. J., the county seat of Hudson County, the second largest city of New Jersey, and the twentieth in size in the United States in 1917. It is situated in the northeastern part of the state, and is the terminus of twelve railroads which approach New York from the south and west. From the heights back from the water front there is a fine view of the Hudson River, the great harbor and the New York City skyline. The city is connected with New York City by ferries and tunnels, and several lines of trans-Atlantic steamships dock at this point. Among the prominent buildings are the city hall, the Fourth Regiment Armory, Saint Francis and Christ hospitals, the People's Palace, a historical museum, the railroad terminal building, a great courthouse which cost over \$3,000,000 in 1910, a Federal building erected in 1913 at a cost of about \$1,000,000, and a public library. The educational institutions include Hasbrouck Institute and Saint Peter's College. Jersey City Heights, practically the southern ridge of the Palisades, contains many beautiful residences

and fine streets. A boulevard 100 feet wide and eighteen miles long traverses Hudson County from north to south and commands an extensive and impressive view.

The shipping and railroad facilities of Jersey City are excellent. There are inter-urban connections with all the large cities of the state, besides local lines throughout the tributary region, and among the industries are locomotive and railroad supply works, steel, foundry and machine shops, grain elevators, sugar refineries and manufactures of crucibles, glass, zinc, chemicals, jewelry, fireworks, lead pencils, chains, rubber goods and copper ware. Foreign and domestic commerce in iron, coal, produce and general merchandise is very extensive. There are large stockyards in the vicinity. The site of Jersey City was formerly called Paulus Hook, but in 1820 it was chartered as the City of Jersey and in 1838 as Jersey City. It is one of the largest cities in the United States that is governed on the commission plan. Population, 1910, 267,779; in 1917, 312,557 (Federal estimate).



The Damascus Gate

**JERUSALEM**, a city like unto no other, whose capture by the British, late in 1917, was the signal for Christian rejoicing the world over. Jerusalem, the "Mother City" of devout Jews, sacred to Christians as the scene of the labors and death of our Lord, and beloved of Mohammedans, is one of the most ancient and interesting cities in the world, and by far the most interesting place in

Palestine, a country in Asia Minor. It stands on an elevated site about 2,500 feet above the sea, within the fork of two ravines, the valley of Jehoshaphat on the east, and the valley of Hinnom on the south and west. The Tyropoean, a third valley, traverses it from south to north. The city stands on four hills, once separated by deep valleys, which are now partially filled up by the debris of successive ruins. Zion, the most celebrated of these summits, on the southwest, rises to a height of 300 feet above the valley of Hinnom. Mount Moriah is on the east, and on the northeast is Mount Bezetha, a little higher than Moriah. Mount Akra is

on the northwest, and the Mount of Olives, to which Christ often repaired for prayer, is to the east of the city.

**Jerusalem As It Is To-Day.** Modern Jerusalem is surrounded by a high wall, pierced by eight gates, through which roads lead into the surrounding country. Jaffa, Bethlehem, Hebron and Jericho and the Dead Sea are all connected with the city by good roads, and a railroad is in operation between Jerusalem and Jaffa. The city wall as it stands at present was built by Solyman the Magnificent in the sixteenth century, and occupies practically the same place as the walls which were standing during the time of the Crusades. The most important gates are the Jaffa gate, at the west; the Damascus gate at the northwest, and another gate which has been opened to the north of the Jaffa gate. Outside the walls to the northwest is a suburb, the new part of the city. Here are numerous Christian churches, schools, hospitals, monasteries and modern private dwellings.

The town within the walls covers an area of 210 acres, thirty-five of which are occupied by the Temple enclosure, which is called Haram-esh-Sheif. The remaining space is divided into different quarters, the two Christian quarters, including an Armenian portion, taking up the western part, the Mohammedans having the northeast and the Jews the southeast. The walls are irregular, and the city is also laid out in the most irregular way, with narrow, tortuous streets. The chief features of interest in Jerusalem are still its historical places. The Temple, or Dome of the Roek, sometimes wrongly called the Mosque of Omar, stands upon the summit of Mount Moriah. This building has eight sides, each sixty-eight feet long, and four doorways, and the whole is covered with porcelain tiles of various colors. The dome is ninety-eight feet high and seventy-five feet in diameter, and is made of wood. The present shrine was built in 688 by Abd-el-Melek. The Church of the Holy Sepulcher is one of the most interesting buildings and is believed by many to cover the tomb of Christ. The first church on the site was built by Constantine in A. D. 326, and since that time many others have been built. The present building was completed in 1810. The Tower of David, the mosque known as the Tomb of David, and the Via Dolorosa, or "Ways of Sorrows," are other features.

Jerusalem is a busy mercantile place; it has modern hotels, various educational and religious institutions and numerous stores, all of which are in strong contrast to the Jerusalem of the past. The principal industries now are the production of ornaments, carved in mother-of-pearl, and the making of various articles from olive wood. These articles find ready sale among the 15,000 to 20,000 tourists and pilgrims who annually visit the city.

The climate is not unhealthful, but for many centuries the unsanitary condition of the city, its filthy streets and crowded population, resulted in a heavy death rate. After the British occupation in 1917 there were notable changes. Mosquito-breeding places were rendered harmless, and the old-fashioned cisterns, infested with germs, ceased to be used as sources of water supply. British engineers constructed a pipe line into Jerusalem from a group of springs in neighboring hills, and now the people are supplied with pure drinking water in abundance. Work was also begun on a Hebrew University, and General Allenby, of the British army, witnessed the laying of the twelve foundation stones—one for each tribe of Israel.

**History.** The written history of the ancient city begins with inscriptions on clay tables, dating from the fifteenth century B. C. At that time Palestine was under Egyptian rule. About 1200 B. C., when the Hebrew conquest of Palestine began, Jerusalem and the surrounding country were in the hands of the Canaanites. A small clan called Jebusites controlled the city itself, and the lower part was taken from them by Joshua. The upper part continued in their possession till the time of David, who captured the citadel and took up his residence in the stronghold of Zion. He made the city the capital of his kingdom and called it "City of David."

It reached the height of its glory under Solomon, who erected the Temple on Mount Moriah. In 586 B. C. Nebuchadnezzar took and destroyed Jerusalem after a long siege and carried off as captives to Babylon those of the inhabitants whom the sword had spared. On their return from captivity the Temple was rebuilt, in 515 B. C., but the walls were not rebuilt until the time of Ezra and Nehemiah, 255 B. C.

In 332 B. C., the city passed into the hands of Alexander the Great. It regained a con-

siderable degree of prosperity by 168 B. C., but in that year it was sacked and its walls leveled by Antiochus of Syria. Under the Maccabees, Jerusalem, in common with Judea, once more became independent, in 165 B. C. It next became tributary to Rome, and was a part of the Roman Empire

British possession at the close of the World War, the future of Jerusalem was one of the problems of the Peace Conference. Population, about 85,000.

**Related Articles.** Consult the following titles for additional information:

|              |                  |
|--------------|------------------|
| Crusades     | Maccabees        |
| David        | Palestine        |
| Jesus Christ | World War        |
| Jews         | Zionist Movement |

**JESSAMINE**, *jes'a min*. See JASMINE.

**JESTER**, or **COURT FOOL**, in former times a witty buffoon or professional fool at a king's court or in a nobleman's household, employed to make jests for the entertainment of the master and his friends. The professional jester usually wore a dress of motley colors and a gaily-colored cap, or cowl, furnished with bells and asses' ears, or crowned with a cock's comb. Several of the court jesters made names for themselves in history.

**JESUITS**, *jez'u its*, or **SOCIETY OF JESUS**, the most celebrated of all the Roman Catholic religious Orders, was founded in the sixteenth century by Ignatius Loyola (see LOYOLA, IGNATIUS OF), and was established by a Papal bull in 1540. The first general of the Order was Loyola. The members, in addition to the usual vows of poverty, chastity and implicit obedience to their superiors, were bound by a fourth vow, to go whithersoever the Pope should send them, as missionaries for the conversion of infidels and heretics, or as other servants of the Church. Popes Paul III and Julius III, seeing what support they might have in the Jesuits against the Reformation, granted to them privileges such as no body of men, in Church or State, had ever before obtained. Their general was invested with unlimited power over the members, the dispersion of whom throughout society was made the basis of the Order. The constitution of the body was drawn up in great part by Loyola himself, but the second general, Laynez, had much to do with directing its early movements.

The Order, through its zealous activity and its success against the growing power of Protestantism, soon gained the approval of the Pope. The Jesuits carefully avoided all appearance of spiritual pride, often wore the ordinary garb of the country and generally dealt with all matters in a spirit and with a policy adapted to circumstances. In Europe they became the teachers of the higher classes and carried out on a large scale

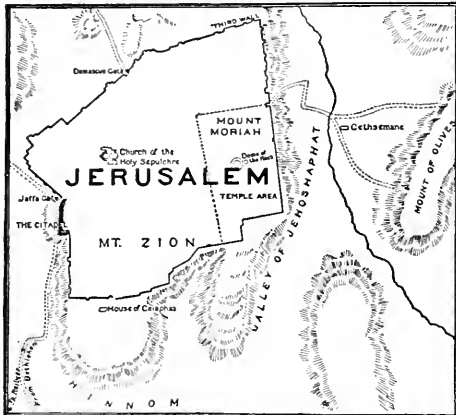

throughout Christ's ministry. In A. D. 66 Jerusalem was taken by a party of Jews, who had revolted against Rome. Titus, the son of the Emperor Vespasian, regained it in the year A. D. 70, after a siege which was one of the most terrible in history. The Temple, built by Herod, was burned, and the city was utterly destroyed. In 131 Hadrian ordered the city to be rebuilt, but it continued depressed till the beginning of the fourth century.

Rome having become more Christian, Jerusalem then shared in the benefit and assumed the appearance of a distinguished Christian city under Constantine the Great. Constantine built the first Church of the Holy Sepulcher over the supposed site of Christ's burial, but this church was burned by the Persians in 613. This period of prosperity, prolonged by a succession of Christian emperors, was suddenly terminated in 636 by the conquest of the Mohammedans under the Arabian caliph, Omar. In 1099 the Crusaders took Jerusalem by storm and made it the capital of a Christian monarchy, which with difficulty maintained its existence till 1187, when it was finally overthrown by Saladin and the city again came into the power of the Mohammedans. In 1517 Jerusalem fell into the hands of the Ottoman Turks, and remained a part of the Turkish Empire for four centuries. With all of Palestine in



improvements in the system of instruction. The young nobility were sent almost exclusively to them, even from Protestant countries, to be educated.

At an early date the Jesuits began to send missionaries to heathen nations. The greatest of these was Saint Francis Xavier (which see), a close friend of Loyola. He is often called the "Apostle of the Indies," because his first work was done in India. He was not only the means of converting thousands to Christianity, but had a supreme faculty for organizing his converts into communities under the constant care of competent native teachers.

The story of the work of the Jesuit missionaries in America is thrilling. Garnier, Daniel and others were shot, and De Brébeuf and Lallement were burned at the stake. Marquette discovered the Mississippi and explored it as far as the mouth of the Arkansas. Other Jesuits from Mexico reached the Pacific coast and established the missions of California. The records, or *Relations*, of the French missions have been published in seventy-two volumes replete with valuable historical matter. Members of the English and Spanish Orders also came to America at an early date, and many of their records have also been preserved.

Wherever the Jesuits went they were considered as the special upholders of the Papacy and the most faithful defenders of the Roman Catholic Church. This close adherence to the Pope often made their position insecure, even in Catholic countries. Finally, in 1764, the united efforts of their enemies in France brought about their suppression by royal edict throughout the French dominions. This example was followed within a few years by the other Bourbon courts—Spain, Naples, Parma and Modena. In 1773 Pope Clement XIV issued the brief *Dominus ac Redemptor Noster*, by which, without entering in any way into the justice of the charges made against the Jesuits, but acting solely on the motive of "the peace of the Church," he suppressed the society in all the states of Christendom. In all the Catholic countries, except Spain and Portugal, the Jesuits were, however, allowed to remain, and as individuals continue their ministerial or literary work. In 1814 the Order was reestablished in all Christendom.

Since then the Society of Jesus has flourished in all parts of the world. It is the

most zealous of all missionary bodies of the Roman Catholic Church and has over 3,000 priests in heathen lands. It is foremost, too, in the work of education. The preparation for this work, a comprehensive and thorough course consisting of seven years of study, embracing the humanities, philosophy and science, must be completed by each candidate for orders.

**JESUS CHRIST**, the founder of Christianity, was born in Bethlehem, Judea, according to the generally accepted chronology in the year of Rome 750, that is, 4 B. C. This apparent discrepancy in date is due to an error that was made when the Christian calendar originated with Dionysius, A. D. 556. He fixed upon the year of Rome 754 as that in which Christ was born. Later information proved beyond a doubt that this date should have been 750, which gives the birth of Christ four years before the beginning of the Christian Era according to the calendar of Dionysius. The mother of Jesus was Mary, who was probably a descendant of David, and her husband, Joseph, was also a descendant of the same family. The birth of the holy child occurred in a manger at a public inn in Bethlehem, where Joseph had gone to be registered in accordance with the Jewish law relating to taxation.

The miraculous conditions connected with His birth prove to the satisfaction of most followers of Christianity that Jesus was of divine origin. His parents remained at Bethlehem for some time. The infant Savior was circumcised on the eighth day, and at the end of the fortieth day He was presented in the Temple, and His mother, according to the Jewish law, made the customary offers for her purification. Soon after this He was visited by wise men, or Magi, from the East, who claimed to have been guided to the spot where He was by the miraculous appearance of a star. Inquiries of these men as to where the child who was to be king of the Jews was born, led Herod (at that time Roman ruler of Judea) to cause all the male children in Bethlehem under three years of age to be put to death. Joseph, however, was warned by an angel, and he fled with Mary and Jesus into Egypt, where he remained for a few months, until after Herod's death, when the holy family returned and took up their residence at Nazareth. Here Jesus lived and grew to maturity, and because of this He is frequently called the Nazarene.

Of the boyhood and youth of Jesus almost nothing is known. The only authentic account given is that of His appearance in the Temple when twelve years of age (*Luke II, 46-50*). The public ministry of Jesus was preceded by the preaching of John the Baptist, who proclaimed the coming of the kingdom of God and called men to repentance. Following His baptism by John, Jesus retired into the wilderness of Judea, where He was subjected to various temptations. After the temptation He was pointed out by John as the Son of God, and some of John's disciples from that time became His followers. His first public appearance was at the marriage in Cana of Galilee, where He wrought the miracle of turning water into wine. He then visited Capernaum, appeared in Jerusalem at the time of the Passover and revealed His majesty and power by cleansing the Temple of those who were changing money and selling animals for sacrifice. His works and teachings immediately aroused the opposition of the leaders of the Jews and, finding that this work in Judea was to be rejected, He departed into Galilee. During the remainder of the first year of His ministry He preached at Nazareth, where the people attempted to cast Him over a precipice because of His teachings; then at Capernaum, where He called the apostles Andrew, Peter, James and John. After the calling of His disciples He began His first circuit through Galilee. During this occurred the Sermon on the Mount and the Sermon in the Boat, which was followed by the miraculous draught of fishes. Near the close of this year He called Levi, or Saint Matthew, who became one of His most devoted followers.

The second year's ministry began with the attendance upon the Passover at Jerusalem and the healing of the lame man at the Pool of Bethesda. Following this were several other miracles, followed by discussions with the Pharisees and other leaders of the Jews, in which Jesus set forth the doctrine of the new dispensation and showed clearly the difference between the underlying principles of the Jewish law and the ceremonies largely practiced at that time. This increased the already growing opposition and was followed by the sending out of the twelve apostles to promulgate the doctrine of Christianity. After the visit to Jerusalem, Jesus began His second general circuit through Galilee. This circuit was characterized by the per-

forming of a number of miracles and the relating of some of the most important parables in the New Testament, among them those of the sower, of the tares, of the mustard seed, of the leaven and of the treasure. This was followed by the third general circuit, during which occurred the death of John the Baptist, the feeding of the five thousand and the walking on the water.

The third and last year of Jesus' ministry was by far the most important and included many discourses, miracles and parables. The great events of this year were the Transfiguration, His appearance at the Feast of Tabernacles, the raising of Lazarus, which so aroused the envy of the Jews that they resolved upon putting Him to death, and the events of the last week before the Crucifixion, generally known as Passion Week. As this week drew near, Jesus prepared to eat the last Passover with His disciples. On the first day of the week, which is still celebrated as Palm Sunday, He made his triumphal entrance into Jerusalem. During the next two days He spent his time in Jerusalem, cleansing the Temple and delivering discourses in which He used a number of parables to teach the truths which He wished to establish, after which He retired to Bethany. On Wednesday He gave a warning of the betrayal, and on the following day He ate the last Passover with His disciples. After the Passover meal, having been betrayed by Judas, He was arrested in the Garden of Gethsemane, brought before the high priest Caiaphas, condemned by the Jewish sanhedrin and early on Friday morning sent before Pilate, the Roman governor of Jerusalem, in order that the sentence of death might be legally confirmed. By Pilate He was released to the Jews, by whom He was crucified on that day.

After His death the body was taken from the cross and buried by Joseph of Arimathea and Nicodemus. The tomb in which the body of Jesus was laid was one belonging to Joseph, and was in a garden near the place of crucifixion. On the morning of the first day of the week, or the third day after His death, Mary Magdalen and other women with spices hurried to the tomb in order to complete the work of embalming the body, but they found the stone rolled away from the door of the tomb and the place where Jesus had lain occupied by an angel, who gave them the message that Jesus had risen. See RESURRECTION; SABBATH.

After His resurrection Jesus remained on earth for forty days, during which time He appeared eleven times to His disciples and followers. At the last gathering on the Mount of Olives He ascended into heaven and was received by a cloud out of their sight.

Of the many works treating of the life and teachings of Jesus Christ, the following are authentic and are the most satisfactory to the general reader: For young readers, *The Children's Life of Jesus*; for adult readers, Cunningham Geikie's *Life and Words of Christ*; Edersheim's *Life and Times of Jesus the Messiah*; S. H. Andrews' *Life of Our Lord upon the Earth*.

**JET**, a variety of bituminous coal, which is very hard, takes a high polish, and is used for ornaments. It was called *Gagates* by the Romans, because it was first obtained near the mouth of the river Gagas in Syria.

**JETSAM**. See FLOTSAM, JETSAM AND LIGAN.

**JETTY**, an artificial embankment, extending into the sea or other large body of water, or used as a breakwater, or extending along the course of a river and parallel to its banks, for the purpose of deepening the channel. In the United States the term is usually applied to a construction of the latter character. Jetties are made of piles, mattresses of wood and stone and of stone alone. The most noted illustration of this use of jetties is at the mouth of the Mississippi River. This river empties into the Gulf of Mexico by several channels and deposits annually a large quantity of silt, which made the channel so shallow as to prevent ocean-going vessels of large size from ascending the river.

In 1874 Captain James B. Eads (which see) recommended the construction of jetties on the Southwest Pass as a means of deepening the channel, and the following year he was authorized to construct the jetties. The east jetty has a length of 11,800 feet, and the west, a length of 7,800 feet. The jetties are constructed of mattresses, made by binding together willows with planks and dowels. The willows were cut fifteen feet long, and each mattress consisted of four layers, each crossing the one beneath it. The mattresses were 100 feet long; for the bottom course they were fifty feet wide, but were narrower for each succeeding course until those of the upper course had a width of twenty feet. The mattresses were sunk by piling stones upon them. As they filled with silt they continued

to settle in the bed of the river until they were immovable. Within two years from the time of their completion a thirty-foot channel was secured, and it has been maintained ever since. See MISSISSIPPI RIVER.

In the Columbia River there are jetties over four miles long—the longest in the world.

**JEWELRY**, a collective name applied to personal ornament made of handsome colored stones and metals, usually of precious metals and precious stones. The love of jewelry is very old. Most of the large museums contain examples—some of it of great antiquity, made 5,000 years ago—taken from the royal tombs of Egypt, from among the remains of the ancient Assyrians, Mycenaeans, Greeks, Etruscans and Romans. The kinds of articles differ but little from those worn to-day—bracelets, rings, earrings, necklaces, pendants, and the like. Some of the pieces, notably those of the best Greek period (450 B. C.) and the Etruscan have never been surpassed for exquisite design and delicacy of workmanship. The designs cover a wide range, human and animal forms, floral and geometric patterns occurring, the embellishments showing result of a high degree of skill in engraving, enameling, inlaying, chiseling and filigreeing.

In the Middle Ages the art of jewelry-making declined, but in the fourteenth century it was revived, and has persisted through various stages to the present. Some of the Renaissance workmanship showed a high degree of excellence, combining lightness and delicacy with durability and strength; but much of it, that for example which produced the gaudy ornamentation of Louis XIV's day and some subsequent epochs, had little to recommend it.

Most of the jewelry of recent times is made by machinery. In machine-made jewelry there is much repetition of design and a conspicuous lack of originality. Moreover, the industry has branched out into the manufacture of all sorts of cheap imitations which are poured upon the market to catch the fancy of an indiscriminating public. The flood of machine-made jewelry in Paris, London, Vienna and New York, the principal centers of manufacture, brought about a reaction which started in France late in the nineteenth century. At the head of this movement was René Lalique, an artist in Paris, who began making jewelry characterized by extreme simplicity of design, in

which stones and metals were used without regard to their intrinsic value, but with respect to their adaptability to the pattern. Baser metals were as frequently employed by him as precious stones and gold. In America the return to simplicity in jewelry is identified with the arts-and-crafts movement.

**Related Articles.** Consult the following titles for additional information:

|             |              |                 |
|-------------|--------------|-----------------|
| Agate       | Diamond      | Opal            |
| Amethyst    | Emerald      | Pearl           |
| Aquamarine  | Garnet       | Platinum        |
| Beads       | Gold         | Precious Stones |
| Birthstones | Heliotrope   | Ring            |
| Brooch      | Jade         | Ruby            |
| Cameo       | Jasper       | Sapphire        |
| Caruncle    | Lapis Lazuli | Topaz           |
| Coral       | Onyx         | Turquoise       |

**JEWFISH**, the name given to two species of large fishes well known in American waters. The one, known also as the *guasa*, or *black grouper*, sometimes reaches the weight of seven hundred pounds. It has a large, flat head and huge mouth and is olive-green in color. This fish is common around Mexico, Florida and the West Indies. The other inhabits the California coast, often weighs five hundred pounds, is from five to seven feet long and has flesh of excellent quality for the table.

**JEWS**, the name commonly applied to the descendants of the people who settled in Palestine in early Bible times, and established there the Israelitish kingdom. In the Old Testament they were called both Hebrews and Israelites. In the period after the loss of national independence the term *Jew* became prevalent, and is the correct name under present conditions, as it denotes a religious body having a common racial descent. It is derived from *Judah*, the name of the tribe which was dominant in the kingdom set up in the southern part of Palestine after the death of Solomon. The Jewish religion, or *Judaism*, was preserved through the establishment of this kingdom, and Jerusalem was the center of the national religion for centuries after the Jews lost their independence.

The early history of the Jews is obtained from the Old Testament, which, in the *Pentateuch*, *Joshua*, *Judges*, *I* and *II Samuel* and *I* and *II Kings*, gives a history from the creation of the world to the destruction of Jerusalem by Nebuchadnezzar, in 586 B. C. The works of Josephus and the records of Egypt contribute also to the history. (For stories of the early Hebrews, see BIBLE, sub-head *Bible Stories*.)

In 930 B. C. these people were divided, and they were known thereafter as the tribes of Israel, occupying the northern part of Palestine, and the tribes of Judah, occupying the southern part. Sargon, king of Assyria, took the northern tribes captive in 722 B. C., and eventually they were lost to history. The kingdom of Judah paid tribute to the Assyrian government, but was not overthrown till 586, when Nebuchadnezzar besieged Jerusalem and took the inhabitants to Babylon; then independence of the Hebrew nation came to an end. Cyrus, after overthrowing the Babylonian kingdom, gave the Hebrews permission to return to Jerusalem and rebuild their Temple. The "Priestly Code" brought from Babylon by Ezra was adopted then, and the real Jewish history began.

After the time of Alexander the Great the Jews had to pay tribute to the Egyptians and to the Selucid rulers in Syria. Many went to Egypt, and under the advantages they enjoyed there they became well versed in science, art and statesmanship. The Greek translation of the Bible, the *Septuagint*, was produced at this time. Antiochus Epiphanes, about 170 B. C., forbade, in Jerusalem, Jewish sacrifices, circumcision and the observance of the Sabbath. Altars to idols were built in the small towns, and the people were compelled to observe Greek rites. Judas Maccabeus and his brothers Jonathan and Simon succeeded in gaining a victory over the Syrians in 169 B. C. This family continued in power till the capture of Jerusalem by Pompey, 63 B. C., but the last male representative, Antigonus, was put to death by Herod in 37 B. C. The Herodian line succeeded.

In A. D. 6 both Judea and Syria came under Roman procurators. Claudius gave authority over Judea to Herod, who gained for the Jews Roman citizenship and other privileges. After Herod's death, the Roman governors came into conflict with the Jews, and this led to the destruction of Jerusalem by Titus in A. D. 70 and the banishment of the people. The final overthrow of this people was brought about by the capture of Bethar, the Jewish stronghold, 135. Many Jews in the year 70 went to Arabia, where they gained considerable power. Mohammed regarded them favorably till he found they would not accept his religion, when he began persecuting them. Many went to Syria and Meso-



EZEKIEL

**TWELVE TRIBES OF ISRAEL**



- Reuben
- Simeon
- Levi
- Judah
- Zebulun
- Issachar
- Dan
- Asher
- Naphtali
- Gad
- Joseph
- Benjamin



DANIEL

# THE HEBREW NATION

From 2000 B.C. to the Destruction of Jerusalem A.D. 70.

ARK OF THE COVENANT

TOMB OF RACHEL

TABERNACLE

REVERSE

REVERSE

SILVER SHEKEL

INSCRIPTION IN EARLY HEBREW LETTERS.

HEBREW PRIEST OFFERING INCENSE.

**TWELVE PROMINENT HEBREWS**

- Abraham
- Isaac
- Jacob
- Moses
- Aaron
- Elijah
- Elisha
- Samuel
- Joshua
- Rachel
- Rebekah
- Esther



HOSEA



AMOS

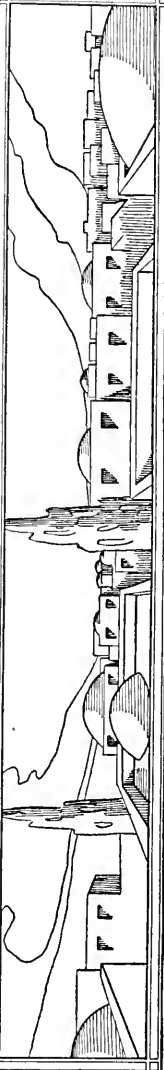

potamia. In Spain the Jews were famous for their learning and were allowed free worship in their religion and were nearly on terms of equality with the Moors.

In the fourteenth century, however, they were compelled to be baptized and to accept the Christian religion. Those who objected were persecuted or even murdered. Under Ferdinand and Isabella, all who refused to become Christians were commanded to leave Spain, taking neither silver nor gold with them. Many hundred thousand left, to find almost every country hostile to them. Those who went to Portugal were compelled to leave in 1496 by order of King Emmanuel. Since 1837, the Jews have been allowed to return to Spain, but very few have taken advantage of the permission. In the eighth and ninth centuries, the Jews of France were well treated, but during the Crusades they were persecuted and many were massacred in a most horrible manner.

The first real settlement of Jews in England was made under William the Conqueror, who favored them. But when their wealth increased they became very unpopular, and in 1253 their condition became so unbearable that they asked leave to go from England. They were persuaded to remain, but in 1290, under Edward I, they were driven out. Many went to Germany and France, where they received the same treatment that had met them elsewhere. For 300 years, no Jews were allowed in England. In 1655 Cromwell favored their admission, but they did not go till the time of Charles II. Since then, they have by degrees gained access to public offices, and in 1885 they were admitted to Parliament. In France, since 1790, Jews have had full rights of citizens, and in 1806, under Emperor Napoleon, they were allowed religious liberty.

In Russia, under the old régime the Jews suffered terrible persecution, and more than 800,000 left the country and settled in America and parts of Europe. After the revolution of 1917 religious freedom was proclaimed, and it is an interesting fact that the leaders of the Bolsheviki, who overthrew the Kerensky régime, were Jews. In 1914, according to the Jewish Year-Book for that year, the Jews were distributed as follows:

|                     |           |
|---------------------|-----------|
| Africa .....        | 413,259   |
| North America ..... | 2,500,054 |
| Asia .....          | 356,617   |
| Australia .....     | 19,415    |
| Europe .....        | 9,988,197 |

The conquest of Palestine by the British in 1917 foreshadowed the setting up of a Jewish state in that country free from Turkish rule. For many years prominent Jews in various parts of the world have been planning for a revival of the Jewish nation as an independent body (see ZIONIST MOVEMENT), and a committee met at Jaffa late in 1918 to discuss a course of action.

**Related Articles.** Consult the following titles for additional information:  
 Bible Nebuchadnezzar  
 Cyrus Palestine  
 Hebrew Language Semites  
 Jerusalem Temple  
 Judea World War

**JEW'S HARP**, a toy musical instrument. It is made of metal, and the sound is produced by holding it between the teeth and inhaling and exhaling air, at the same time striking with the finger the elastic tongue stretched across the middle of the instrument. It was known as early as 1619.

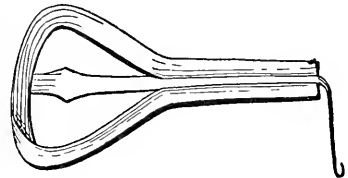

JEW'S HARP

**JEYPORE**, *ji por'*. See JAIPUR.

**JEZEBEL**, *jez'ebel*, the wife of Ahab, king of Israel. She was a daughter of Ethbaal, king of Tyre, and after her marriage introduced into Israel the Baal-worship of her native country, Canaan. She was therefore hated by the followers of Yahweh (Jehovah) and was a bitter enemy of Elijah. She is represented (*I Kings*, XXVIII) as cruel and treacherous and responsible for the murder of Naboth. Fourteen years after the death of her husband she was murdered by Jehu, when, instigated by Elijah, he seized the royal power of Judah and Israel (842 B. C.). See AHAB; JEHU.

**JIGGER**, **CHIGGER**, or **CHIGOE**, a very curious insect closely resembling the common flea but of minute size. In the United States the name is given to a minute scarlet insect, found in the grass and weeds of the Southern states. It attaches itself to the skin of man and burrows

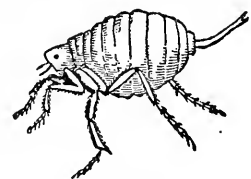

JIGGER

beneath it. Here its eggs are deposited, and troublesome itching sores result unless the

insects are killed. Salt water will relieve the itching. If the bites result in festering sores the wounds should be cut or burned out by a physician. In the Southwestern states the harvest mite is called jigger.

**JIMSON WEED.** See STRAMONIUM.

**JINRIKISHA**, *jin rik'e shah*, a vehicle which has become associated in the public mind throughout the world with the transportation facilities of Japan. However, it is also used to a very considerable extent in China and in some parts of India.

The jinrikisha is a light, two-wheeled carriage, provided with a hood and drawn by a man. Near the outer end of the shafts is a crosspiece, which is used by the runner in pulling the carriage. By attaching cords to the crossbar, one or more outrunners can assist when more than ordinary speed is required or when the load is especially heavy. The puller is known as the *hiki*. He can go at a rapid pace and for long distances, frequently covering from thirty to forty miles in a day; he and his carriage may be engaged for service for about sixty cents a day. The invention of the "riksha," as it is frequently called, is attributed to an American Baptist missionary.

**JIUJUTSU.** See JIJUTSU.

**JOACHIM**, *yo'a Keem*, JOSEPH (1831-1907), a famous Hungarian violinist. When twelve years of age he appeared in concert at Leipzig, attracting the attention of the musical world, but continued to study for several years. After 1849 he received several important appointments at European courts, and in 1869 he became head of the Royal School of Music at Berlin. His playing was characterized by remarkable sincerity and emotion and by rare purity of tone.

**JOAN** *jo an'*, **OF ARC**, THE MAID OF ORLEANS (1412-1431), the national heroine of the French people, and to all peoples a noble and inspiring figure. JEANNE D'ARC, as she is properly called, was born in the village of Domremy, France, of peasant parents. While she was still a girl she was deeply affected by the woes of her country, much of which was in the possession of the English. In 1427 Orleans was being besieged by the English, and its fall would have ruined the cause of France. At this time Joan, who had been noted for her solitary meditations and pious enthusiasm, began, as she declared, to see visions and hear angelic

voices, which finally called upon her to take up arms for Charles, to raise the siege of Orleans and to conduct Charles to Rheims to be crowned. At first she was regarded as insane, but eventually she found her way to the king and his councilors, and having per-



JOAN OF ARC

From a statue by Chapu, in the Luxembourg, Paris.

suaded them of her sincerity, received permission to hasten to the deliverance of Orleans. In male dress, fully armed, she bore the sword and the sacred banner, as the signal of victory, at the head of the army.

The first enterprise was successful. In April, 1429, she entered Orleans with supplies, and through the inspiration of her courage the French forced the English from their entrenchments and compelled them to abandon the siege. Other successes followed; Charles entered Rheims in triumph, and at his anointing and coronation Joan stood at his side. She was wounded in the attack on Paris, where Bedford repulsed the French troops, but continued to take part in the war till May, 1430, when she was taken prisoner by the Burgundians and sold to the English. She was taken to Rouen, and after a long trial, accompanied with many shameful circumstances, she was con-

demned to death as a sorceress by the ecclesiastical tribunal. On submitting to the Church, however, and declaring her revelations to be the work of Satan, her punishment was commuted to perpetual imprisonment. But pretexts were soon found to treat her as a relapsed criminal, and as such she was burned at Rouen, May 30, 1431. She died with unshaken courage. In 1456 she was cleared by the Church of all charges against her, and in 1909 Pope Pius X beatified her, giving her the name "Blessed." In March, 1919, the Maid was formally canonized at the Vatican, Pope Benedict taking part in the official ceremonies. She thus became a saint in the Roman Catholic Church.

The story of Joan of Arc has been immortalized in countless poems and plays, and her pictures and statues are found in many lands. In 1915 an equestrian statue of the Maid of Orleans was erected in New York City, on Riverside Drive. It is the work of Anna Vaughn Hyatt. The pedestal was made partly from eighteen tons of stone which were brought from the dungeon at Rouen.

**JOB**, *jobe*, the hero of an ancient Hebrew poem, which forms one of the books of the Old Testament. Job, an upright man with a family of seven sons and three daughters, with large herds and numerous servants, is suddenly, with the permission of Jehovah and by the agency of Satan, deprived of his possessions and his children and smitten with a sore disease, yet he submits patiently to the divine will. Three friends come to console him, and a large part of the poem is occupied with their speeches and his replies. They attribute his misfortunes to wickedness and hypocrisy. Near the close, God himself is introduced answering Job out of a whirlwind. In the sequel Job is delivered from his calamities, lives 140 years, becomes richer than before and begets seven sons and three daughters. The design of the book seems to be to enlarge men's views of the providence of God. The basis of the story was probably traditional, and it is not known at what time the book of *Job* was written.

**JOFFRE**, *zhó'fr'*, JOSEPH JACQUES CESAIRE (1852- ), a French military leader, hero of the first Battle of the Marne, which saved the allied cause early in the World War. Joffre was born at Rivesaltes, in the Eastern Pyrenees, of humble parentage. He

served in the artillery during the Franco-German War, when only a lad, and after the restoration of peace entered the engineering corps. In 1874 he became a captain. Joffre took part in campaigns in Tongking, Dahomey, Madagascar and Timbuktu, and in 1911 was appointed Chief of the General Staff. Though occupying so responsible a position, he was not widely known at the outbreak of the World War, for he was a man of great reserve. His generalship at the Battle of the Marne, however, where the German invasion was thrust back, made him a national hero and a figure of world-wide prominence. In December, 1915, he was appointed commander in chief of the French armies; a year later he relinquished this post and was made marshal of France, the highest honor his country could bestow.

In May, 1917, Joffre and several other distinguished men visited the United States on an official mission to confer on matters pertaining to the war. The commission visited several large cities, going west as far as Chicago and Saint Louis, and everywhere Joffre was received with boundless enthusiasm. In December, 1918, he was made a member of the French Academy, thereby attaining one of the highest civil honors possible to a Frenchman.

**JOHANNESBURG**, *yo hahn' nes burg*, SOUTH AFRICA, in the Transvaal, thirty-five miles south by west of Pretoria and connected by railway with Cape Town, Port Elizabeth, Durban and Delagoa Bay. The city is at an altitude of 5,735 feet, in the midst of the great South African gold district. It is a modern town in every respect, with broad, well-planned streets, electric lights, telegraph and telephone lines and street cars. The chief public buildings are the courthouse, the public library, the stock exchange, and a number of theaters. The city also has the Transvaal University College. Population, 1911, 237,104, of whom 119,253 were whites. It was a Boer city until the South African War, and was captured by the British in May, 1900.

**JOHN**, called *the Baptist*, the forerunner of Christ, was born six months before Jesus (their mothers were cousins), of a Levitical family in Judea. He lived a life given up to solitary meditations till A. D. 26, when he began to preach in the deserts of Judea, announcing that the kingdom of heaven was at hand and proclaiming himself the har-





JOSEPH JACQUES CESAIRE JOFFRE  
Field Marshal of France



binger of the Messiah. John baptized many converts and testified to the higher mission of Jesus at the time of Christ's baptism in the Jordan. To gratify a vindictive woman, Herod Antipas, tetrarch of Galilee, caused him to be beheaded in prison.

**JOHN**, the name of twenty-three Popes, among whom the following were most prominent:

**John I** (Saint John), who was Pope from 523 to 526, was sent to Constantinople by Theodoric to induce Emperor Justin to adopt milder measures toward the Arians, and on his returning without success Theodoric threw him into prison, where he died.

**John XII** was Pope from 955 to 964. His name was originally Octavian, but on becoming Pope he adopted the name John, being the first Pope to change his name on mounting the Papal throne. He crowned Otto the Great of Germany in 962.

**John XIX**, Pope from 1024 to 1033, crowned Conrad II in the presence of Canute, the Danish king of England.

**John XXII** was Pope from 1316 to 1334. He possessed extraordinary abilities, was a patron of learning, wrote some medical treatises and was a zealous worker for the propagation of his faith in distant lands. He lived a simple, student's life himself, but collected vast sums of money for the Church.

**John XXIII**, Pope or rather anti-pope, from 1410 to 1415, was a Neapolitan. While cardinal, he was prominent in the Council of Pisa. As Pope he called the Council of Constance, by which he was deposed. After four years' imprisonment he was released and made dean of the Sacred College.

**JOHN** (about 1167-1216), king of England, the youngest son of Henry II, from whom was forced Britain's great charter of liberty. As he was left in youth without any particular provision, he was given the name of Lackland; but his brother, Richard I, on his accession conferred large possessions on John. John obtained the crown on the death of Richard in 1199, although the French provinces of Anjou, Touraine and Maine declared for his nephew, Arthur of Brittany, who was lineally the rightful heir. A war ensued, in which John recovered the revolted provinces.

In 1205 began a great quarrel with the Pope regarding the election to the see of Canterbury, to which the Pope had nominated Stephen Langton. The result was that Innocent III laid the whole kingdom under an interdict and in 1211 issued a bull deposing John. Philip of France was commissioned to execute the decree and was already preparing an expedition when John

made abject submission, even agreeing to hold his kingdom as a vassal of the Pope (1213). John's arbitrary proceedings led to a rising of his nobles, and he was compelled to sign the Magna Charta, or Great Charter, June 15, 1215 (see *MAGNA CHARTA*). But John did not mean to keep the agreement, and obtaining a bull from the Pope annulling the charter, he raised an army of mercenaries and commenced war. The barons, in despair, offered the crown of England to the dauphin Louis, who accordingly landed in England in 1216 and was received as lawful sovereign. The issue was still doubtful when John was taken ill and died.

**JOHN III**, SOBIESKI (1624-1696), a king of Poland, son of a Polish captain. He served in the French army, returned to Poland to assist in repelling the Russians in 1648 and distinguished himself in several campaigns, winning, in 1667, the rank of commander in chief of the Polish army. On the death of the Polish king, in 1673, John was chosen his successor. His most celebrated achievement was the defeat of a great Turkish army before Vienna in 1683, in a conflict regarded as one of the decisive battles of the world.

**JOHN, KNIGHTS OF SAINT, OR KNIGHTS HOSPITALERS OF SAINT JOHN**, afterward called *Knights of Rhodes* and finally *Knights of Malta*, were a celebrated military and religious Order which originated in a monastery founded at Jerusalem in 1048 by some merchants from Amalfi. The monastery was dedicated to Saint John the Baptist, and the monks, who were called Brothers of Saint John, or Hospitalers, cared for the poor and sick and assisted pilgrims. A branch of the Order was established in America in 1889.

**JOHN, SAINT**, one of the apostles, often distinguished as *Saint John the Evangelist*, the reputed author of the fourth Gospel, three epistles and *Revelation*. He was the son of Zebedee and Salome and the brother of James. Previous to his call by Jesus he was a fisherman on the Sea of Galilee. His Gospel was written later than any of the others—according to some critics, to refute particular heresies—and contains fuller details of our Lord's conversation and discourses than the other Gospels and is also more doctrinal in character. Of the three epistles, the first has much resemblance to the Gospel; but the other two were considered

doubtful even by the early fathers. After the death of Jesus, John continued at Jerusalem, and later he was at Samaria (*Acts VIII, 14-25*). Tradition handed down by the fathers declares that he died at Ephesus, and if he wrote *Revelation* he must have been banished to Patmos. The time of his death is unknown.

**JOHN BULL**, the name used to signify the personification of the English people. It was first used in Arbuthnot's *The History of John Bull*, designed to ridicule the Duke of Marlborough. "John Bull," like "Uncle Sam," may be known by his picture. He is represented as a stout fellow with a "tile" hat, swallow-tail coat and a waistcoat adorned with the British flag. His feet are thrust into heavy British boots, and he carries a cane. (See illustration, in article GREAT BRITAIN.)

**JOHN OF GAUNT, DUKE OF LANCASTER** (1346-1399), fourth son of Edward III of England. He was created Duke of Lancaster in 1362, served in the French wars and became governor of Guienne. On the death of his father-in-law, the king of Castile, he assumed in right of his wife the title of king of Castile and invaded the kingdom to assert his claims. These he subsequently relinquished in favor of Henry of Castile, Pedro's successor, who became John's son-in-law. John's eldest son became king of England as Henry IV.

**JOHNS HOPKINS UNIVERSITY**, an educational institution located at Baltimore, Md. It was named for Johns Hopkins, a wealthy merchant of that city, who left a fortune of \$7,000,000 to be used in the establishment of a university and a hospital. The university was incorporated in 1867 and formally opened in 1876. The hospital was opened in 1889, and the medical school in 1893. Although the university and hospital have separate funds and controlling boards, they are closely affiliated.

Johns Hopkins has a national reputation for the high rank of its graduate department, and its facilities for research in philosophy and medicine are not surpassed elsewhere in America. Both the graduate and undergraduate departments offer courses in philosophy and psychology, mathematics, the natural sciences, historical and economic science, education, and ancient and modern languages and literatures. The university awards a large number of scholarships and fellow-

ships to American students wishing to do research work in literature, science and medicine. A beautiful campus in the suburbs of Baltimore was presented to the institution in 1902, and new buildings have been constructed. There is a library of 200,000 volumes. In normal years the total student enrollment is over 2,100; the faculty numbers about 340.

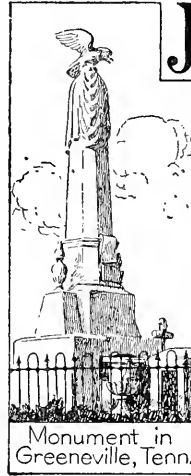

**JOHNSON, ANDREW** (1808-1875), the seventeenth President of the United States. Elected Vice-President in 1864 on the ticket with Lincoln, he succeeded to the Presidency when the Great Emancipator was assassinated, and to him fell the responsibility of directing the reconstruction of the seceded states. It was a burden that would have taxed the ability of even the great Lincoln, especially as Congress was opposed to the moderate attitude announced by the martyred President before his death. Johnson had neither the tact nor the self-control of Lincoln, and he was led to make many rash and ill-advised statements, coming finally to an open breach with Congress. His impeachment by the House of Representatives is the only example in American history of such action against a President. The whole episode is regarded as unedifying by historians of to-day, but it can be said of President Johnson that he upheld the independence of the Presidential office, and as a result the nicely adjusted balance between the executive and legislative branches of the government was not destroyed.

**Early Life.** Johnson was born at Raleigh, N. C., on December 28, 1808. Of his origin, Woodrow Wilson says in his *History of the American People*:

"He came of plebeian stock; had risen, not by address, but by blunt force of character, from among the humbler whites who owned no slaves, boasted no privilege, had no initiative voice in affairs."

The boy's father died in 1812, leaving the family in poverty, and Andrew was put to work as a tailor's apprentice at the tender age of ten. Eight years later he opened a shop for himself in Greenville, Tenn., where,

1865

1869

# JOHNSON'S ADMINISTRATION

1862-1867  
 France declares war  
 Maximilian ruler  
 United States protest  
 Thomas, Seward's  
 Maximilian shot.  
 End of French dream

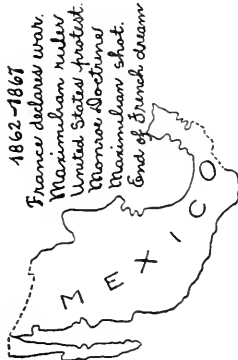

Human  
 Liberty

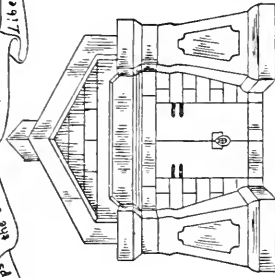

LINCOLN'S TOMB



GRAND REVIEW  
 June 9, 1865  
 Held at Washington

Grandest military display ever  
 held in America.

200,000 men took part

Lasted two days

RECONSTRUCTION  
 President  
 1. Repeal Act of Secession  
 2. Repeal Act of Extradition  
 3. Repeal XIII Amendment  
 Congress  
 1. Repeal Act of Secession  
 2. Repeal XIII Amendment  
 3. Repeal Act of Extradition

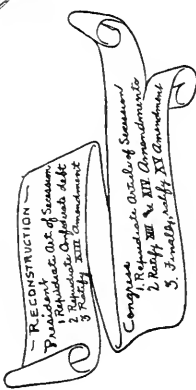

Amendments  
 XIII  
 Anti Slavery  
 XIV  
 Equal Rights



NEBRASKA  
 ADMITTED 1867

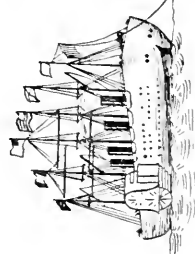
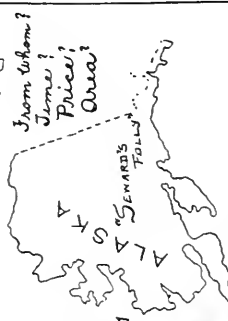

GREAT EASTERN  
 Cost \$300,000  
 Length 680 ft  
 Breadth 118 ft  
 Height 70 ft  
 Launched 1868  
 Sold 1885 for \$126,000  
 8 Engines  
 11,000 Horse power

Fans  
 Freedman's Bureau  
 Civil Rights  
 Tenure of Office  
 Amnesty  
 Pardon

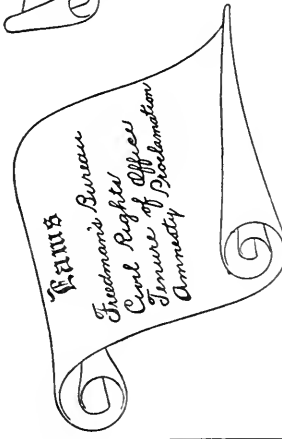

ATLANTIC CABLE

Success due to energy of  
 Cyrus W. Field  
 1857 First attempt: Cable parted  
 1865 Great Eastern successfully  
 accomplished the work.

Reach

shortly after, he was married to a girl two or three years his junior. The youthful couple were ambitious, and Mrs. Johnson, herself a woman of considerable education, gave her husband lessons in writing and arithmetic. He had taught himself to read while serving his apprenticeship. Such was the schooling of a future President.

**A Political Leader.** His first rise to power was his election as alderman in Greeneville, on a workmen's ticket. Though barely twenty, he had organized the party himself, and his constituents not only returned him twice to the office of alderman, but made him mayor of the town. In 1835 and in 1839 he was sent to the Tennessee house of representatives as a Democrat, and in 1840 was elected state senator. Three years later he entered the national House of Representatives, representing his district until 1853, when gerrymander gave the district a Whig majority. Instead of entering a contest he knew to be hopeless, he announced his candidacy for the position of governor of Tennessee, and was elected. In 1857, after a notable career as state executive, he entered the United States Senate.

Johnson's election to the Senate came at a time when the slavery controversy was approaching a climax. Hardly any other Southern statesman took just the stand he did, for though he believed that slavery should be protected where it had taken root, he was uncompromising in his determination to preserve the Union. When secession actually took place he refused to follow his state, and in March, 1861, declared publicly in the Senate that the secessionists were traitors. The indignation aroused in the South by this statement knew no bounds.

Nevertheless, in the same year he returned to Tennessee, and the following year accepted from Lincoln appointment as military governor of the state. The courage and loyalty he displayed in this trying position gave him a national reputation, and in 1864 he was placed on the ticket with Lincoln. It was felt that the "War Democrats" deserved recognition because of their loyalty, and Johnson was one of their most conspicuous representatives. The compromise ticket was elected, and on April 15, 1865, the Democratic Vice-President was called upon to fill the place of the great man who had safely led the nation through four years of storm and stress.

**His Administration.** The new President was at first as radical as Congress in favoring a severe policy toward the South, but he soon came under the influence of Secretary Seward and adopted a conciliatory attitude. It is probable, too, that the great responsibility thrust upon him tempered his harsh view. As the first step in reconstruction he proclaimed general amnesty and ordered the establishment of provisional congresses in several states.

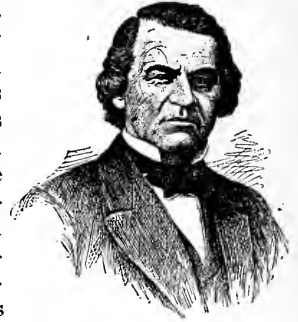

ANDREW JOHNSON

Then came the opposition of Congress. The contest continued with the greatest bitterness, President Johnson vetoing all the important reconstruction measures and Congress immediately passing them over his veto with insulting resolutions. The crisis in the struggle came when Johnson requested the resignation of Edward M. Stanton, Secretary of War. The Senate refused to ratify this removal, and the President refused to recede from his position. The result was an impeachment trial, the principal charges being violation of law in the removal of the Secretary, and insulting statements in the President's public speeches against Congress. After a long trial, presided over by Chief Justice Chase, the President was acquitted, the prosecution lacking one vote of the two-thirds necessary for conviction. There were other notable events of this administration. In 1865 the Atlantic cable was laid; in 1867 Alaska was purchased from Russia for \$7,200,000, and the same year Nebraska was admitted to the Union.

Though the Democrats had favored Johnson's policy, he had forfeited claims to leadership by deserting the party at the opening of the war, and he was not renominated. His last official act was to pardon all who had been concerned in secession. After his retirement from the Presidency he sought election to Congress and finally, in 1875, entered the Senate. On July 31 of that year he died from a stroke of paralysis, and was buried at Greeneville, Tenn., where a fine monument has been erected in his honor.

## Administration of Andrew Johnson, 1865-1869

- I. THE PRESIDENT
- (1) Birth
  - (2) Early career
  - (3) Education
  - (4) Political principles
  - (5) Character
  - (6) Policy as President
  - (7) Death
- II. FOREIGN AFFAIRS
- (1) Relations with France
  - (2) Laying of the Atlantic Cable
  - (3) Purchase of Alaska
- III. THE ERA OF RECONSTRUCTION
- (1) Johnson's views on reconstruction
    - (a) First harsh
    - (b) Then suddenly lenient
    - (c) Proclamation of amnesty
  - (2) Attitude of Congress
    - (a) Freedmen's Bureau
      - (1) Purposes
      - (2) Results
    - (b) Civil Rights Bill
      - (1) Guaranteed negroes a vote
      - (2) Required every candidate for office to swear that he had not taken part in secession
      - (3) Supported by Fourteenth Amendment
  - (3) Quarrel between Congress and President
    - (a) On general policy
    - (b) On specific questions
      - (1) Of law
      - (2) Organization of provisional state governments
    - (3) Tenure of Office Act
      - (a) Forbade President to remove any civil officer without consent of Senate
      - (b) Removal of Stanton from office
    - (4) Impeachment of the President
      - (4) Congressional policy of reconstruction
        - (a) Five military districts
        - (b) Civil governments provisional and subject to military authority
        - (c) All persons, regardless of race or color, not disqualified by participation in a rebellion, to be voters
        - (d) Readmission of states with approval of Congress
      - (5) Results of reconstruction
        - (a) Admission of the Southern states
        - (b) Practical bankruptcy of the states
        - (c) Rule of "carpet-baggers"
        - (d) Ku Klux Klan
      - (6) Election of 1868

### Questions

When and where was Andrew Johnson born?

Sketch briefly his career before the outbreak of the Civil War.

Why did he become prominent when Tennessee seceded?

What office did he hold during the war?

Who was Maximilian?

What was the attitude of the United States toward him?

When did the attempts to lay a permanent Atlantic Cable become successful?

Through whose efforts was the enterprise brought to success?

From whom was Alaska purchased?

What was the price paid?

Explain the Civil Rights Bill. Which amendment to the Constitution was passed in order to ensure its enforcement?

What was the Tenure of Office Act?

Why was the President impeached? Was he convicted?

Explain "impeachment."

What provision did Congress finally make for the government of the Southern states?

What is meant by "carpet-baggers"?

What was the Ku Klux Klan?

**Related Articles.** Consult the following titles for additional information:

|                |                      |
|----------------|----------------------|
| Impeachment    | Tenure of Office Act |
| Reconstruction | Stanton, Edwin M.    |

**JOHNSON, HIRAM WARREN** (1866– ), an American statesman widely known for his fearlessness in upholding political ideals. He was born in Sacramento, was educated at the University of California, and at the age of twenty-one was admitted to the bar. In 1906–1907 Johnson won a notable victory as assistant prosecuting attorney of state in helping convict a group of San Francisco “grafters,” and from that time he was a notable figure in California politics. Elected governor as a Republican in 1910, he carried out his plan of “kicking out of state politics the Southern Pacific Railroad,” and during his term of office he put into effect the progressive policies for which he stood. In 1912 Johnson accepted the nomination for Vice-President on the Progressive party ticket with Theodore Roosevelt, and two years later he was reelected governor. In 1916 he was sent to the United States Senate as a Republican, though the state went Democratic on the Presidential issue. Senator Johnson attracted wide attention in the closing weeks of the Sixty-fifth Congress by his severe criticism of the administration’s Russian policy.

**JOHNSON, RICHARD MENTOR** (1780–1850), an American statesman, Vice-President of the United States, was born in Kentucky. He was educated at Transylvania University, was admitted to the bar, became a member of the state legislature and in 1806 was elected to Congress, serving with slight interruption until 1819. He fought in the war with Great Britain in 1812–1813 and, it is said, fired the shot which killed Tecumseh, at the Battle of the Thames. He was a member of the United States Senate from 1819 to 1829 and of the House of Representatives again until 1837, when he was elected Vice-President on the ticket with Van Buren. He was a strong supporter of Jackson. Johnson was again nominee for Vice-President in 1840, but was defeated and was an unsuccessful aspirant for the Presidential nomination in 1844.

**JOHNSON, SAMUEL** (1709–1784), an eminent English author, son of a bookseller, was born at Lichfield. The most important part of his education was the wide reading in which he indulged in his father’s shop. In 1728 he entered Pembroke College, Oxford,

but was obliged by poverty to retire after three years, without taking a degree.

In 1735 he married a widow to whom he was sincerely attached. With the money she provided he started a school, which was not successful, and in 1737 he moved to London, where he entered on his long course of literary toil. His reputation rose very slowly. His poverty was at times almost unendurable, and it is not strange that, always melancholy, he grew more and more pessimistic and expressed his pessimism in such poems as *London* and the *Vanity of Human Wishes*. When *Irene*, a tragedy which Johnson had written before coming to London, was brought out, he received some relief from his poverty.

From 1750 to 1752, and again in 1758, Johnson conducted periodicals modeled on the plan of *The Spectator*, but these, *The Rambler* and *The Idler*, with their essays in Johnson’s formal, heavy style, were never popular. Meanwhile, Johnson’s attention was chiefly engaged with his *Dictionary of the English Language*, a work which appeared in 1755. This dictionary, though it raised his fame, added little to his worldly means; and when in 1759 his mother died, Johnson, to provide money for the funeral, wrote in one week the philosophical novel, *Rasselas*. In this poverty he lived until 1762, when he obtained from the government a pension of £300 a year. He was thenceforth in easy circumstances and could enjoy without restraint the society of Burke, Reynolds, Gibbon, Garrick, Goldsmith and others in the famous club which became so formidable a power in the world of letters. Although Johnson was uncouth in his manners and slovenly in his dress, he was looked up to by these men, and in fact he easily dominated the club. The work of his last years includes *Journey to the Western Isles*, describing a trip to the Hebrides, and *Lives of the Poets*. Johnson was buried in Westminster Abbey.

Boswell’s *Life of Johnson* gives us a better idea of the man than we can gain from his own works, because, eminent as he was in his day as a writer, he was still more influential as a conversationalist, and many of his conversations Boswell has reported.

**JOHNSON CITY, TENN.**, a city in Washington County, 106 miles nearly east of Knoxville, on the Southern, the East Tennessee & Western North Carolina (narrow



gauge) and the Carolina, Clinchfield & Ohio railroads. The city lies near the foothills of the mountains, and it attracts many visitors. The East Tennessee state normal school is here, and there is also a branch of a United States Soldiers' Home. The city has about forty manufacturing plants; a Federal building was constructed in 1910, and there is a public library. Population, 1910, 8,502; in 1917, 11,885 (Federal estimate).

**JOHNSTON, ALBERT SIDNEY** (1803-1862), an American soldier, born at Washington, Ky. He graduated at West Point, entered the army and fought in the Black Hawk War, but resigned in 1834 and went to Texas. He fought with the Texans in their war for independence, became commander of the Texan army and in 1838 was Secretary of War of the new republic. In 1840 he resigned and became a planter. At



ALBERT SIDNEY  
JOHNSTON

the outbreak of the Mexican War, he again entered the service of Texas, and at its close he became an officer in the United States army. In 1857 he won distinction in command of an expedition against the Mormons, exhibiting remarkable discretion and courage, both on the march and in his negotiations with the Mormon leaders. He was brevetted a brigadier-general, but at the opening of the Civil War resigned his commission and entered the Confederate army, being placed in command of the forces in the west. During the winter of 1861 he exhibited marked ability in the defense of Kentucky and Tennessee. He was killed at Shiloh, in April, 1862, while leading a brilliant charge at the crucial point of the battle. He won the esteem of military critics on both sides for his management of large forces and his courage in battle.

**JOHNSTON, JOSEPH EGGLESTON** (1807-1891), an American general, born in Prince Edward County, Va. He graduated at West Point in 1829 in the same class with Robert E. Lee, took part in the Black Hawk War and in the Seminole War, but resigned in 1837, to become a civil engineer. In the following year he entered the engineering

service of the army and in 1846 became captain. He served with distinction in the Mexican War, was severely wounded at the Battle of Cerro Gordo, and was brevetted colonel for his conduct there and lieutenant-colonel for his gallantry at Chapultepec. In June, 1860, he became quartermaster-general of the army, with the rank of brigadier-general, but in the following spring he resigned and became brigadier-general in the Confederate army and, later, general.

He took part in the first Battle of Bull Run and for a time had full command of the Confederate forces in Virginia. At Fair Oaks he was wounded and was succeeded by Robert E. Lee. Later he became commander of the military Department of Tennessee, but was defeated by Grant at Jackson, while attempting to relieve Vicksburg. After the battles of Chattanooga, he became commander of all the Confederate forces in the southwest and conducted a brilliant retreat before General Sherman from Chattanooga to the vicinity of Atlanta, winning a great victory at Kenesaw Mountain. Notwithstanding, he was superseded by General Hood; later at the insistent request of General Lee, he was assigned to the command of forces to resist Sherman's advance northward from Savannah. He was several times defeated, and surrendered April 26, 1865. After the war he engaged in business in the South, was elected to Congress from Virginia in 1876 and was appointed United States commissioner of railroads in 1885. Military critics agree in considering General Johnston one of the greatest commanders in the Civil War.

**JOHNSTON, MARY** (1870- ), an American novelist, the author of many romantic tales with historic backgrounds. She was born at Buchanan, Va., and was privately educated. Miss Johnston first came to public notice by her novel, *Prisoners of Hope*, a story of colonial days in Virginia. A second romance with much the same setting, *To Have and to Hold*, appeared in 1899 and met with great success. A third, *Audrey*, with the same theme, also was well received. The last two were dramatized and created a favorable impression. Her later novels include *The Long Roll*, a Civil War story, *Hagar*, *The Witch*, *The Fortunes of Garin*, *The Wanderers* and *Foes*. The last, published in 1918, is a story of the Stuart uprising in Scotland.

**JOHNSTOWN, N. Y.**, the county seat of Fullerton County, forty-five miles northwest of Albany, on the Cayadutta River and on the Fonda, Johnstown & Gloversville Railway. The industries of the city are almost exclusively devoted to the production of gloves and mittens. In Johnstown and the neighboring city of Gloversville there are 150 factories, which supply more than half of all the gloves that are used in the United States. The place was settled in 1760 and was named after Sir William Johnson, whose mansion, erected in 1761, is still standing. There is a Federal building and a Carnegie Library. The courthouse and jail are also of historical interest, for both were built in 1772. Population, 1910, 10,447; in 1917, 10,678 (Federal estimate).

**JOHNSTOWN, PA.**, in Cambria County, seventy-six miles east of Pittsburgh, on the Conemaugh River, and on the Pennsylvania, the Baltimore & Ohio and the Johnstown & Stony Creek railroads. It is situated in an irregular and narrow valley at an elevation of about 1,200 feet. The city became especially well known by the flood of 1889. Heavy rains had so swollen the streams that the dam across the south fork of the river, twelve miles east of the city, gave way and released the water in Conemaugh Lake. Johnstown and the neighboring villages in the valley were very soon submerged in a roaring torrent of water, and about \$10,000,000 worth of property was destroyed, with a loss of at least 2,235 lives. Aid was generously contributed, and the place was at once rebuilt.

There are deposits of bituminous coal in the vicinity, and the city has extensive iron and steel works, coke ovens, tanneries, brick-yards, manufactures of fire-clay products and other works. There are about 110 industrial plants in the city. Important features are the public parks, Conemaugh Valley Memorial Hospital, Cambria Free Library, a Federal building and the city hall. There is a 10-story hotel. Johnstown was settled about 1790, but it was not incorporated until 1889. Population, 1910, 55,482; in 1917, 70,473 (Federal estimate).

**JOINTS**, in anatomy, the joining of the bones to give the various parts of the body freedom of movement. They may be classified as movable and immovable. The movable joints are of four kinds, and are classified as follows:

(1) Ball and socket joints, found at the shoulders and the hips, admit great freedom of motion. In the ball and socket joint the rounded head of a long bone fits into a cavity made by other bones and is held in place by a loose sac, called a capsular ligament, and by surrounding muscles. In the hip the articulation is still further strengthened by a ligament attached to the head of the thigh bone and to the cavity. At the shoulder, the socket is not as deep as at the hip, hence there is much greater freedom of motion.

(2) Hinge joints, which admit of motion in two directions, that is, can be bent and straightened, are found in the knee, the fingers, the toes and, in a modified form, between the lower jaw and the cranium. In this joint the bones articulate by ridges that fit into grooves.

(3) Pivot joints, in which one bone rotates on another, as the first cervical vertebra on the second. The power to turn the hand over without moving the shoulder is due to a modified pivot joint at the elbow where the radius rotates on the humerus and over the ulna.

(4) Gliding joints, which admit of but little movement, are found in the wrist and ankle. There are also slight movements between the vertebrae.

Immovable joints are found between the bones of the cranium and face. Those of the skull are designed to protect the brain, for they possess enough flexibility to move in case of accident and may prevent fracture. In movable joints the ends of the bones are covered with a smooth cartilage, which is kept moist by a secretion, called synovia, from a very thin membrane which surrounds the joints. This secretion serves the same purpose that oil does in a machine. Any dislocation in a joint should receive immediate attention, as swelling so soon follows as to make it difficult to replace the bones or, as physicians say, to reduce the dislocation. If medical aid is not at hand the joint should be kept in hot bandages. The same action should be taken in case of a *sprain*, an injury that if neglected may give permanent trouble. See **LIGAMENT**; **TENDON**.

**JOINTS**, in geology, the cracks or fissures

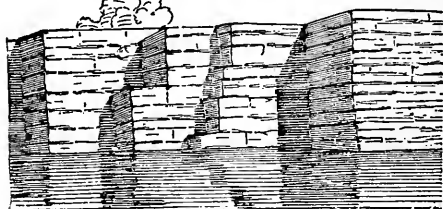

**JOINTS**

which divide rocks into more or less regular blocks. They occur usually in systems, the

joints occurring in parallel planes, those which run parallel to the strike being called strike joints, those parallel to the dip, dip joints, and others, diagonal joints. Joints are caused by earthquakes and the contraction of rocks upon cooling or drying. See DIP.

**JOINT STOCK COMPANY**, the term used in British and Canadian business circles for what corresponds closely to the corporation in America. See CORPORATION.

**JOKAI**, *yo'kah e*, MAURUS (1825-1904), a celebrated Hungarian novelist, editor and publicist. His literary activity began in 1846 with *Working Days* and continued fifty years, during which time he produced more than a hundred volumes, in which he pictured the political and social life of the Hungary of his day. Jokai was a leader of the Nationalist party in 1848, and fell with it. Subsequently he was many times elected to the lower house of the Hungarian Parliament and in 1897 was called to the House of Magnates. He wrote a history of Hungary, and many of his novels are a romantic treatment of phases of the same subject. *The New Landlord* is considered his masterpiece.

**JOLIET**, ILL., the county seat of Will County, forty miles southwest of Chicago, on the Desplaines River, on the Illinois & Michigan Canal and on the Chicago & Alton, the Chicago, Rock Island & Pacific, the Atchison, Topeka & Santa Fé, the Elgin, Joliet & Eastern, the Chicago, Milwaukee & Eastern and a local belt line railroad. A state penitentiary is located here, and the city has a public library, two hospitals, the Saint Francis and the Saint Mary academies, a great township high school, a Masonic Temple and a clubhouse for working men, built by the Illinois Steel Company. The industrial establishments are large steel, wire and tin plate works, stove factories, machine shops, implement works and other factories. The steel and wire mills alone employ 8,000 men. A number of large limestone quarries are found in the vicinity. Joliet was settled about 1831 and was incorporated as a city in 1852. Population, 1910, 34,670; in 1917, 38,549 (Federal estimate).

**JOLIET**, *zho lyay'*, LOUIS (1645-1700), a Canadian explorer, born in Quebec and educated for the priesthood. He was fond of adventure and made several expeditions to the head of the Great Lakes. In 1672, with a Jesuit priest, Jacques Marquette, he was

given command of an enterprise, the object of which was to trace the course of the Mississippi River. By his explorations it became certain that the Mississippi flowed into the Gulf of Mexico.

**JOLY DE LOTBINIERE**, HENRI GUSTAVE, Sir (1829-1908), a Canadian statesman, born at Epernay, France. His father, Gaspard Joly, was the owner of famous vineyards at Epernay. The son was educated at Paris but came to Canada as a young man and began to practice law in the city of Quebec. In 1861 he was elected to the Canadian Assembly as Liberal member for the County of Lotbiniere, and from 1867 to 1874 he represented the county in the House of Commons. He was opposed to Confederation, and took an active part in the opposition to the Ministry formed by Sir John Macdonald. In 1878 he was premier of Quebec; then for four years was leader of the opposition. He retired from public life in 1885, but ten years later, in response to party appeals, took an active part in the campaign and was again elected to the House of Commons. On the formation of the Laurier Ministry he accepted the portfolio of Inland Revenue. From 1900 to 1906 he was Lieutenant-Governor of British Columbia. He rendered special service in the promotion of Canadian agriculture and forestry.

**JO'NAH**, one of the minor prophets, son of Amittai, and according to *II Kings* XIV, 25, a contemporary of Jeroboam II, was born at Gath-Hepher, in Galilee. The book which bears his name is historical, rather than prophetic, and the story of Jonah remaining three days and three nights in the belly of the fish has been regarded by some as an allegory, a parable or a myth. Mention of it is made, however, by Christ, in *Matthew* XII, 40. Jonah's grave is shown at Mosul, the ancient Nineveh, and also at Gath.

**JON'ATHAN**, in Bible history, was the son of Saul, first king of the Israelites. Jonathan was the devoted friend of David, and their love for each other is often cited as an example of perfect friendship. For the story of David and Jonathan, see the article BIBLE, subhead *Bible Stories*.

**JONES**, JOHN PAUL (1747-1792), a famous commander in the American naval service during the Revolution, was born in Kirkcubrightshire, Scotland. In 1773 he emigrated to Virginia, and added "Jones"

to his real name, JOHN PAUL, for what reason is not known. On the outbreak of the Revolutionary War he offered his services to the United States. He was successively in command of the *Alfred*, *Province*, *Ranger* and *Bon Homme Richard*. It was as commander of this last vessel that he won, in 1779, a famous victory over the English sloop-of-war

*Serapis*, after a fierce engagement off Flamborough Head. On his return to America he did not receive from Congress the consideration he had expected and, in resentment, entered the Russian service with the rank of rear-admiral. This act took some of the luster from his name, and in 1915 excluded him from the American Hall of Fame. (See HALL OF FAME). Owing to the jealousy of Russian commanders, Admiral Jones soon retired from the service and went to Paris, where he died. In 1905 a search was instituted for his remains, which were at length discovered, brought to the United States and buried with military formality at Annapolis, Md.

**JON'QUIL**, a bulbous plant, a species of narcissus, allied to the daffodil. It has long, rushlike leaves. The flowers, very fragrant, open at the tip of straight, crisp, leafless stems. They are used in the manufacture of toilet waters and extracts.

**JON'SON**, BEN or BENJAMIN (1573?-1637), a celebrated English dramatist, the contemporary and friend of Shakespeare. He was born at Westminster and was placed in the Westminster or Grammar School at an early age, but was withdrawn, it is said, by his stepfather, a master bricklayer, who wanted his assistance in the business. He soon tired of this occupation, entered the army as a private soldier and showed much personal courage during a campaign in Holland. Returning to England, he began his

career as an actor, and in 1598 his drama, *Every Man in His Humor*, was produced, Shakespeare playing a part in it. A duel, in which he killed his antagonist, led to Jonson's imprisonment, and after his release he was deprived of his possessions and branded on the thumb.

In 1599 he brought out his comedy, *Every Man Out of His Humor*, which was followed by *Cynthia's Revels*; *The Poetaster*; *Sejanus*, a tragedy; *Volpone*; *Epicocoene*, or *the Silent Woman*, his best work, and *Catiline*, a tragedy. In 1619, on the death of the poet laureate, Jonson was appointed his successor, and the salary was raised to the sum of \$500 by Charles I. Much of his time was spent at the Apollo, Mermaid and other taverns, feasting, drinking and engaging in those brilliant contests of wit in which in earlier days Shakespeare also had taken part. His latter days were spent, not perhaps in



JOHN PAUL JONES



JONQUILS



BEN JONSON

much prosperity, but certainly in fame and honor, as the acknowledged chief of English literature. He died of an attack of palsy, leaving behind him an unfinished pastoral poem of great beauty, *The Sad Shepherd*. Jonson was buried in Westminster Abbey, where a monument was erected to his memory with the inscription, "O rare Ben Jonson." Jonson's best dramas are excellent in

plot and development, have strongly conceived characters and excellent traits of humor, but he is sometimes forced and unnatural and deals perhaps too much with passing manners and eccentricities. He had genuine lyrical power, which is seen in his short poems and the songs interspersed in his masques. His *Drink to me only with Thine Eyes* is still a popular favorite.

**JOPLIN**, Mo., in Jasper County, sixty-eight miles west of Springfield, on the Missouri Pacific, the Saint Louis & San Francisco, the Kansas City Southern, and the Missouri, Kansas & Texas railroads. It is in the center of the zinc and lead fields of Southwestern Missouri, which are the most important in the United States. There are extensive smelting works, white lead and paint factories and large foundries, machine shops and flouring mills. A valuable trade from a large agricultural district centers here. The especially notable structures are a Federal building, a Carnegie library, an opera house, and a Y. M. C. A. Joplin was settled in 1870 and was incorporated three years later. Population, 1910, 32,073; in 1917, 33,400 (Federal estimate).

**JOPPA**. See **JAFFA**.

**JORDAN**, the most important river of Palestine, and of unusual historical interest, because of the events connected with the life of Christ. It rises in the northern part of the country and is formed by the union of several small streams, which have their sources in the mountains. The river flows southward through Lake Huleh, or the biblical Merom, and the Lake of Tiberias, or Sea of Galilee, entering the northern end of the Dead Sea. The distance between its source and its mouth in a straight line is about sixty-five miles, but owing to its winding course the length is 200 miles.

The Jordan is a very rapid stream and descends during its course from an altitude of about 700 feet above sea level to that of 1,300 feet below sea level. Between Lake Huleh and the Sea of Galilee it falls sixty-nine feet to the mile, and below the Sea of Galilee its average fall is nine feet to the mile. Where it enters Lake Huleh it is about 100 feet wide; between the Sea of Galilee and its mouth it varies in width from ninety to 250 feet, and at its mouth it is 540 feet wide. Its usual depth below the Sea of Galilee is from two to three feet, but occasional depressions in the river bed

cause pools of greater depth. Except during the period of flood, the river is navigable in many places. It is also crossed by a bridge at a point a little below Lake Huleh and another below Lake Tiberias.

The Jordan flows through a remarkable valley, which consists of a smaller valley within a large one. The great valley, called the Ghor, varies in width from one to sixteen miles and is bounded by precipitous ridges, which in places attain a height of from 3,000 to 4,000 feet. The small valley, called the Zor, which is the real valley through which the river flows, is narrower, varying from one-half mile to two miles in width, and in many places is bounded by steep sides. During the rainy season the valley of the Jordan is covered with grass; and trees, such as the tamarisk, the acacia, the oleander and other trees, flourish. See **PALESTINE**.

**JORDAN**, DAVID STARR (1851- ), an American educator. He was born in Gainesville, N. Y., and attended Cornell University, where he became instructor in botany in 1870. Two years later he was professor of botany and biology in Lombard University, Galesburg, Ill., and at this time he began the study of fishes under the instruction of Agassiz. From 1875 to 1879 he was a professor in biology at Butler University, Indianapolis, Ind., and later, in 1885, after



DAVID STARR  
JORDAN

having served as professor of zoölogy at the University of Indiana, he was made president of that institution. For many years Jordan was connected with the United States Fish Commission and made many valuable researches and investigations. From 1891 to 1913 he was president of Leland Stanford Junior University. Upon his retirement the position of chancellor was created for him, in order that he might maintain some connection with the university and yet give further study to the problems of international peace and arbitration, of which he is a leading advocate. After 1912 he wrote voluminously against war. In addition to many reports and papers prepared for the Fish Commission, he has written various

books, including a *Manual of Vertebrate Animals of the Northern United States*, *Science Sketches*, *Fishes of Northern and Middle America*, *Care and Culture of Men*, *Imperial Democracy*, *A Guide to the Study of Fishes*, *War's Aftermath*, *War and the Breed and Ways to Lasting Peace*.

**JOSEPH**, *jo'sef*, one of the two sons of the patriarch Jacob by his favorite wife, Rachel. His story is told in these volumes in the article **STORY TELLING**.

**JOSEPH**, the husband of Mary, the mother of Jesus, was a descendant of the House of David, though resident at Nazareth, where he followed the trade of a carpenter. Early tradition represents him as an old man at the time of his marriage, and he seems to have died before the commencement of the public ministry of Jesus. His day in the Roman Catholic calendar is March 19.

**JOSEPHINE**, *zho za feen'*, MARIE ROSE (1763-1814), empress of the French, wife of Napoleon Bonaparte. She was married to the Vicomte de Beauharnais, by whom she had two children, Eugène and Hortense. In 1794 her husband, who had been commander of the army of the Rhine, was executed by order of the Convention. After the fall of Robespierre she paid a visit to Napoleon to thank him for restoring the sword of her husband, and she so pleased him that he soon after married her (1796). Josephine's friendly manners won the hearts of everybody and helped to secure her husband's position. When Napoleon ascended the throne in 1804 she was crowned along with him. But the fact that the union was childless stood in the way of Napoleon's ambition to become the founder of a dynasty, and in 1809 Josephine was divorced. She retained the title of Empress, and was allowed a large annual grant.

**JOSEPHUS**, *jo se'fus*, FLAVIUS (37-?), an illustrious Jewish historian, born at Jerusalem of royal lineage and well educated. At the outbreak of a war between Romans and Jews he was made defender of the province of Galilee. He was captured by Vespasian and kept in imprisonment three years. Subsequently he lived in Rome and devoted himself to literary studies, assuming the name Flavius. He lived to the end of the century, but the exact time of his death is not known. Notwithstanding their inaccuracies, his writings have a high value as history, supplying narratives of events

nowhere else recorded. These include *Jewish Antiquities*, a history of the Jews from the earliest times to the reign of Nero; an *Autobiography*, covering the period of his military activity, and *History of the Jewish War*.

**JOSH BILLINGS**. See SHAW, HENRY WHEELER.

**JOSH'UA**, the successor of Moses in the command of the Israelites, the son of Nun, of the tribe of Ephraim. He was nominated by Moses to succeed him in the command of the army of Israel, led the Israelites over the Jordan and in the course of seven years conquered the greater part of Palestine and divided the country among the tribes. He died at Timnath-Serah, in Mount Ephraim, at the age of 110. His history is contained in the book which bears his name and of which he is usually regarded as the author.

**JOSIAH**, king of Judah, succeeded his father Amon at the age of eight years (639 B. C.). He took an active part in the reform of public worship and commenced the restoration of the temple, during the progress of which the high priest Hilkiiah discovered the book of the law, thought by some to be substantially the same as the book of *Deuteronomy*. In Josiah's thirty-first year, prompted probably by friendship for the king of Assyria, he marched out against Pharaoh Necho, who was on his way to attack that kingdom. The two armies met at Megiddo, where Josiah was slain.

**JOURNALISM**. See NEWSPAPER.

**JOURNALISM, SCHOOLS OF**. Schools or college departments which give courses designed to train men for newspaper work are becoming a prominent factor of modern education. In the United States twenty-eight state universities offer courses in journalism, and there are besides about sixty state schools and endowed colleges and universities having similar departments.

The school of journalism of the University of Missouri gives to its graduates the degree of bachelor of journalism, and the department has the same standing as the other professional schools. Columbia University has a college of journalism of wide reputation. It was founded in 1903 by Joseph Pulitzer, former owner of the *New York World*, and has an endowment of \$2,000,000. The course of study includes the ethics and law of journalism, besides a serviceable course in general ethics and practical

law, rhetoric and composition, with especial regard to the requirements of newspaper work; and advanced courses in literature, United States history, contemporary European history, economics, sociology and political science.

**JUAN DE FU'CA**, a strait between Vancouver Island and Washington, an arm of the Pacific Ocean, connecting the sea with the Strait of Georgia on the north and with Puget Sound on the South. It is about a hundred miles long and from fifteen to thirty miles in width. The cities of Port Townsend, Wash., and Victoria, B. C., are at its eastern end.

**JUAN FERNANDEZ**, *hwahn fer nahn'* *dath*, a group of small islands in the South Pacific Ocean, about 400 miles off the coast of Chile, to which the islands belongs. They are of volcanic origin and reach in some parts a height of 6,000 feet. Parts are fertile,

producing various kinds of timber, peaches, figs, grapes and cherries. The islands are occupied by some hundreds of settlers, whose chief occupation is cattle rais-

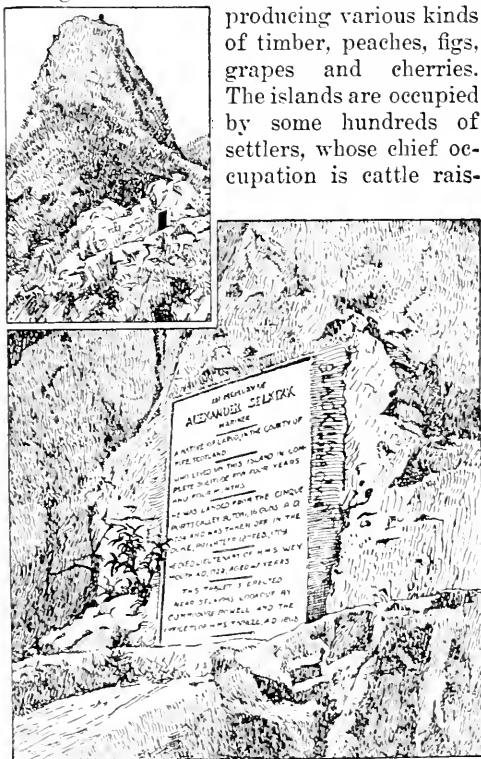

**INSCRIBED TABLET ON THE ISLAND**

It commemorates the four-years' residence of Selkirk, and is located on a high rock overlooking the sea. The small, black area in the upper picture indicates its position.

ing. In 1918 a wireless telegraph service was established with Chile.

De Foe is said to have founded his *Robinson Crusoe* on the history of the solitary residence here for over four years (1704-1709) of a Scotch sailor, Alexander Selkirk. The islands were discovered in 1574 by Juan Fernandez. See ROBINSON CRUSOE.

**JUAREZ**, *hwah' res*, BENITO PABLO (1806-1872), a president of the Mexican republic. He was born of pure Indian parentage, received a good education, was admitted to the bar and after holding various important public offices, was elected president in 1861. As the Mexican government at his accession was bankrupt, he declared the suspension of payments on the foreign debt for two years, a step which occasioned the interference of Britain, Spain and France. Troops were landed in Mexico in 1862, but Britain and Spain soon retired, leaving Napoleon III to carry out his plans alone. Maximilian of Austria came, on Napoleon's invitation, to assume the throne, but Juarez, in spite of defeats and losses, continued to head a resistance, and when Napoleon under pressure from the American government withdrew his troops in 1866, the republicans carried all before them. Maximilian was captured and shot, and Juarez was reelected to the presidency (1867), which he held till he died. See MAXIMILIAN; MEXICO, subhead *History*.

**JUAREZ, MEXICO.** See CIUDAD JUAREZ.

**JU'BILEE, YEAR OF**, an institution among the ancient Hebrews by which for twelve months every fiftieth year society was shaken out of its accustomed channels; all slaves and captives were released; estates (with few exceptions) sold in the interim following the preceding jubilee reverted to the original owners or to their descendants; the land was not cultivated, but left fallow. The object was to prevent the growth of an oligarchy and to equalize the fortunes of families and tribes. It has been doubted whether the law of jubilee was ever actually observed until the return from Babylonian exile, when, for a time at least, it came into operation.

**JUD'AH**, the fourth son of the patriarch Jacob by his wife Leah, the forefather of one of the twelve tribes.

**JU'DAS**, surnamed ISCARIOT, was one of the Twelve Apostles of Jesus. Having betrayed his Master into the hands of the Jewish priests for thirty pieces of silver, he committed suicide out of remorse for his crime. It is supposed that the name *Iscariot* means *man of Keriioth*. Keriioth was a small

town in Judea, while Galilee was the home of the other disciples.

**JUDAS**, or **JUDE**, brother of James, one of the twelve apostles. Matthew and Mark call him Thaddeus, surnamed Lebbaeus. Nothing is known of his life. By many he is considered the author of the *Epistle of Jude*.

**JUDAS TREE** a name given to a number of trees of the same genus and belonging to the same family as the locust. The name originated in the tradition that Judas hanged himself on one of these trees, which grow wild throughout the Orient, in southern Europe and in tropical America. One species, called the *red bud*, is common in the warmer parts of the United States. This has pointed leaves and produces numerous clusters of bright red flowers in early spring, before the leaves appear on the branches.

**JUDE**, one of the books of the New Testament. Its acceptance by the early Church was delayed until, like the writings of the evangelists, its divine inspiration was undoubted. In it the apostle denounces the heresies of the Simonians, the Nicolaites and the Gnostics and appeals to the members of the Christian Church to adhere faithfully to its teachings. It was probably the work of Judas, a brother of Jesus.

**JUDE'A**, a term applied, after the return of the Jews from exile, to that part of Palestine bounded on the east by the Jordan and the Dead Sea, on the north by Samaria, on the west by the Mediterranean and on the south by Arabia Petraea. Jesus was born in Bethlehem, a small town of Judea. See **PALESTINE**.

**JUDGE**, *jud*, a person duly invested with authority to preside over a court and to determine questions between parties according to law. The term is quite a general one, being applicable to any one appointed to sit in a court of law and try cases; but certain judges are designated by particular titles, as *justice*, in the Supreme Court of the United States, and *lord justice*, in Great Britain. The judge at common law decides points of law and enables the jury rightly to decide questions of fact, while in equity he decides both classes of questions. A judge cannot be prosecuted for the consequences of his decisions, except in the case where he may have acted without jurisdiction, nor can he officiate in a case where he has a personal interest, unless it be merely his common interest as a citizen. See **LAW**; **COURTS**; **PROCEDURE**.

**JUDGES**, **BOOK OF**, one of the books of the Old Testament, so called because the greater part of the narrative is occupied with the history of the judges who were raised up to deliver their countrymen from the oppression on their neighbors.

**JUDGMENT**, in law, the judicial determination and decision of a court in an action. It is either *interlocutory* or *final*. In the former case it is given only on some particular point or proceeding; upon the final judgment execution may follow, unless it be appealed against, suspended or recalled. See **PROCEDURE**.

**JUDGMENT**, in logic, a mental act by which we examine and compare two or more ideas or concepts and ascertain their relations. In the process of thinking, the judgment and the concept interact and are interdependent. For example, we form a concept or abstract idea of hardness, apart from an object with which it is associated; we form a concept of wood. By putting the two ideas together we form the judgment: *wood is hard*. In building up concepts we necessarily form many judgments, and in turn use the concepts to arrive at higher judgments. Both concepts and judgments are constantly undergoing change as a man's experience broadens; both are involved in the growth of his ideas and opinions upon every subject which occupies his thought. See **CONCEPT**; **REASON**.

**JUDICIAL DEPARTMENT OF CANADA**. Every power, executive, legislative, or judicial, exercised by the Dominion or provincial governments, is subject to the constitution. As with all statutes or laws, the meaning of this constitution must be interpreted by judges who are authorized to do so. The judiciary is thus the third great department of the government. The judges of the provincial courts, from the highest to the lowest, can and do decide on constitutional questions that arise under the laws governing their respective provinces. The judges of the provinces are appointed and paid by the Dominion government, but the organization and maintenance of their courts are in the power of the provincial governments. It is worthy of notice that the British North America Act made no specific provisions for a federal court. It provided for the appointment of the judges of the provincial courts by the governor-general, but in regard to federal courts it merely said that—



"The Parliament of Canada may, notwithstanding anything in this Act, from time to time provide for the constitution, maintenance and organization of a general court of appeal for Canada, and for the establishment of any additional courts for the better administration of the laws of Canada."

The problem of creating a Supreme Court for Canada was an important one for the first premier, Sir John Macdonald, but it was not until 1876, in the Premiership of Alexander Mackenzie, that the court was finally established. Since that time two other Federal courts, the *exchequer court* of the Dominion and the *admiralty court*, have been established. The admiralty court is, properly speaking, a division of the exchequer court which has jurisdiction over all matters pertaining to navigation and shipping.

**Related Articles.** Consult the following titles for additional information:

|                 |                     |
|-----------------|---------------------|
| Admiralty Court | Canada (Government) |
| Exchequer Court | Supreme Court       |
| of Canada       | of Canada           |

**JUDICIARY**, *ju dish'e a ry*. See COURTS.  
**JUDSON**, HARRY PRATT (1849- ), an American educator, the successor of William R. Harper as president of the University of Chicago. He was born in Jamestown, N. Y., and was educated at Williams College. Between 1870 and 1885 he was principal of a high school in Troy, N. Y., and in 1883 received a master's degree from Williams College. From 1885 to 1892 Professor Judson occupied the chair of history and pedagogics in the University of Minnesota, in the latter year becoming professor of political science at the University of Chicago, then in its infancy. When President Harper died, in 1906, Professor Judson, who had previously been appointed dean of the faculties, became acting president of the university, and received formal appointment to the office in 1907.

He is an authority on international law, and the author of various works on history and political science. In 1918 Professor Judson spent seven months in Persia as head of the American commission for Persian relief. He also acted as unofficial representative of President Wilson in the work of studying industrial and political conditions in the East.

**JUG'GERNAUT**, or **JAGANNATHA** (lord of the world), the name given to the Hindu god Krishna and to a very celebrated idol of this deity in a temple specially dedicated to Jagannâtha at Puri, on the Bay

of Bengal. The idol is a rudely cut wooden image, with a red body, black face and gilt arms; the mouth is open and blood-red; the eyes are formed of precious stones. It is covered with magnificent vestments and is seated upon a throne between two others—his brother Bala-Rama and his sister Subhadra, colored respectively white and black. Great numbers of pilgrims, sometimes a hundred thousand, at the time of the festivals of Jagannâtha, come from all quarters of India to pay their devotions at this shrine. On these occasions the idol is mounted on a huge car resting on sixteen wheels and is drawn by the pilgrims to his summer home. The task requires several days, on account of the great weight of the car and the sandy condition of the roads, and the pilgrims, becoming exhausted, usually secure professional car haulers to complete the task. There is no truth in the popular belief that the devotees prostrate themselves before the car to be crushed.

**JUGO-SLAVIA**, *joo'go slah'vi a*, the name commonly applied to a new Balkan state representing a union of certain oppressed peoples liberated by the outcome of the World War. *Jug* is a Slavic word meaning *the south*, and the name *Jugo-Slavia* is simply the equivalent of *state of the southern Slavs*. This new nation is a union of three groups—Serbs, Croats and Slovenes. The Serbs, who are the most numerous, occupy the modern kingdom of Serbia, Montenegro, most of Bosnia, Herzegovina and Dalmatia, and the districts north of the Danube—Batka and the Banat. The Croats, second in point of numbers, occupy Croatia and Slavonia, and the western parts of Bosnia, Herzegovina and Dalmatia. The Slovenes occupy Carniola, Southern Carinthia, Southern Styria and part of Istria. Before the World War the Croats and Slovenes were subjects of the emperor-king of Austria-Hungary. Serbia and Montenegro were independent, though weak, kingdoms. Together the Jugo-Slavs number more than 12,000,000, and the territory tentatively included within the boundaries of their state covers about 100,000 square miles. All use practically the same language, as Slovene is merely a dialect of Serbo-Croat.

The Pan-Slav movement, of which Jugo-Slavia is the tangible outcome, has been agitated for many years. It assumed definite form in 1906 with the formation of the

Serbo-Croat party, and the annexation of Bosnia and Herzegovina by Austria-Hungary, in 1908, was for the purpose of checking the movement. When the World War broke out several prominent Jugo-Slavs formed a committee in London to look after the interests of the oppressed Austrian nationalities, and in April, 1918, a great congress was held at Rome to effect an organization. A national council was formed in Agram, capital of Croatia and Slavonia, and on November 26, 1918, this council appointed Prince Alexander of Serbia regent of the state. Difficulties with Italy arose over the question of Dalmatia and the seaport of Fiume, which is geographically a part of Croatia. Italy's claim to Fiume was rejected by President Wilson, who precipitated a crisis in the conference by issuing a public statement in behalf of the Jugo-Slavs. At this juncture the Italian delegates withdrew from the conference. See WORLD WAR; AUSTRIA-HUNGARY.

**Related Articles.** For descriptions of various countries and provinces included in Jugo-Slavia consult the following titles:

|                      |            |
|----------------------|------------|
| Bosnia               | Montenegro |
| Croatia and Slavonia | Serbia     |
| Dalmatia             |            |

**JUGULAR VEIN**, one of the large trunks by which the greater part of the blood that has circulated in the head, face and neck is returned to the heart. There are two jugular veins on each side, an external, or superficial one, lying just underneath the skin, and an internal, or deeper, one, near the carotid artery. The cutting of an internal jugular vein is usually followed by death, as it stops part of the flow of blood to the brain.

**JUGURTHA** (?-104 B. C.), a king of Numidia. He was brought up at the Numidian court and in due time shared the kingdom with two cousins. One of these he murdered; the other, driven from the country, appealed to Rome. Roman armies were sent against Jugurtha, but he bribed the generals, and for years exercised his power unchecked. Finally, in 106 B. C., he was defeated by Metellus and fled the country. Marius further prosecuted the war, and in 104 B. C. took Jugurtha a prisoner to Rome, where he was thrown into an underground dungeon to die of hunger. This episode was known as the Jugurthine War.

**JUJUBE**, *joo'jooob*, the popular name of a genus of spiny shrubs or small trees. There are numerous species, several of which bear a blood-red or saffron-colored fruit about the

size and shape of an olive. A species native to Persia and parts of Africa produces a fruit from which the natives make a cake resembling gingerbread. The jujube paste, which is used as a confection, is no longer made from the jujube fruit, but is prepared with gum arabic and sugar. Tradition says that the crown of thorns which was placed on the head of Christ was made from the spines of jujube.

**JUJUTSU**, or **JUIJITSU**, *joo jit'soo*, a Japanese method of defense or offense without weapons. It has been popular in Japan for centuries, but until recently was taught only to privileged classes, who took oath not to reveal the system. Now it is the basis of all physical culture that is taught in Japan; it is a part of the work in the schools, and soldiers, sailors and policemen are required to be expert in it.

Recently it has become popular in Europe and America, for it is recognized as one of the best possible methods of physical training. It consists not in a display of physical strength, but in the practice of certain twists, blows or clutches which will incapacitate an opponent, and it thus demands a knowledge of anatomy. The word itself means *muscle science*.

In his *Out of the East*, Lafcadio Hearn, one of the world's authorities on Japan, presents this information:

In jujutsu there is a sort of counter for every twist, wrench, pull, push, or bend; only the jujutsu expert does not oppose such movements. No; he yields to them. But he does much more than that. He aids them with a wicked sleight that causes the assailant to put out his own shoulder, to fracture his own arm, or, in a desperate case, even to break his own neck or back.

**JULEP**, in medicine, a solution of sugar in aromatic water, not so concentrated as syrup. In the United States the name is given to a drink, composed of brandy or whisky, sugar, pounded ice and a seasoning of mint. It is also called mint julep.

**JULIAN**, in full, **CLAUDIUS JULIANUS**, called **JULIAN THE APOSTATE**, (331-363), was a Roman emperor. He was brought up in the Christian religion, studied philosophy and letters and resided in Athens, where he was induced to accept paganism. Having received command of an army against the Alemanni, he defeated them at Strassburg and drove them beyond the Rhine. He also displayed great talent as an administrator in

Gaul. The emperor became jealous of Julian and recalled his best troops, under pretense that he wanted to employ them against the Persians. This order caused a rebellion among the soldiers, who proclaimed Julian emperor in 360, in spite of his own resistance. Constantius prepared to proceed against him, but soon after died, and Julian was generally recognized as emperor. He sought to restore the heathen worship in all its splendor, and on that account he opposed Christianity as much as was in his power, without, however, persecuting the Christians themselves. In 363 he headed an expedition against the Persians and took several cities, but was mortally wounded in battle.

**JULIAN CALENDAR.** See CALENDAR.

**JULIUS**, the name of three Popes, the most distinguished of whom were the following:

**Julius I**, Pope from 337 to 352, was noted for the assistance he gave to the bishops in their opposition to the son of Constantine. He is considered a saint, and is honored as such in the Roman Catholic Church, his date being April 12.

**Julius II**, Pope from 1503 to 1513, gave his attention chiefly to the political and military movements to restore Papal sovereignty and end foreign rule in Italy. In pursuance of his policy he entered, in 1508, into the League of Cambrai with Louis XII, Emperor Maximilian and Ferdinand of Aragon. When the purposes of this league had been attained, he withdrew and joined the Holy League. The Holy League secured to the Papal government a controlling influence in France, Northern Italy, Bologna, Reggio and some smaller Italian states.

**Julius III**, Pope from 1550 to 1555. He was one of the three legates appointed to preside over the Council of Trent, which he reopened as Pope in 1551.

**JULY**, the seventh month in the modern calendar, having thirty-one days. In the Roman year it bore the name of *Quintilis*, as originally it was the fifth month. Its change of name to *Julius* was in honor of Julius Caesar, who was born on the 12th of the month.

July is the midsummer month in northern climes, when many garden flowers are in full bloom, and the birds begin to gather in flocks preparatory to their migration southward. It is generally a month of fair skies and many days of sunshine, and the lovely freshness of June is likely to be replaced by hints of the fall of the year. Leaves begin to droop and the grass to lose its velvety greenness. In American history July is honored as the

month in which the United States had its birth as an independent nation. The water lily is the special flower of July, and its birthstone is the ruby.

**Special Days for Observance.** *Dominion Day*, or *Empire Day* (which see), is celebrated in Canada on July 1, in commemoration of the Act of Confederation. July 4, the anniversary of the adoption of the Declaration of Independence, is the greatest patriotic holiday of Americans. In France, on July 14 is celebrated the fall of the Bastille (see BASTILLE).

**Anniversaries for Celebration.** The following birthdays of notable people fall in July:

Nathaniel Hawthorne, July 4, 1804.  
Giuseppe Garibaldi, July 4, 1807.  
Stephen C. Foster, July 4, 1826.  
David G. Farragut, July 5, 1801.  
John Huss, July 6, 1369.  
John Paul Jones, July 6, 1747.  
John D. Rockefeller, July 8, 1839.  
Elias Howe, July 9, 1819.  
John Calvin, July 10, 1509.  
John Quincy Adams, July 11, 1767.  
Julius Caesar, July 12, 100 B. C.  
Henry D. Thoreau, July 12, 1819.  
Rembrandt, July 15, 1606.  
Sir Joshua Reynolds, July 16, 1723.  
Mary Baker Eddy, July 16, 1821.  
Isaac Watts, July 17, 1674.  
John Jacob Astor, July 17, 1763.  
William Makepeace Thackeray, July 18, 1811.  
Alexander Dumas, the Elder, July 24, 1802.  
Simon Bolivar, July 25, 1783.  
Arthur James Balfour, July 25, 1848.  
Thomas Campbell, July 27, 1777.  
John Ericsson, July 31, 1803.

The following important events occurred in July:

Debate on the Declaration of Independence, begun July 1, 1776.  
Battle of Gettysburg begun, July 1, 1863.  
Canadian Confederation Act went into effect, July 1, 1867.  
President Garfield shot, July 2, 1881.  
Idaho admitted to the Union, July 3, 1890.  
Declaration of Independence adopted, July 4, 1776.  
Vicksburg surrendered, July 4, 1863.  
Salvation Army founded, July 5, 1865.  
Martyrdom of John Huss, July 6, 1415.  
Annexation of Hawaii, July 7, 1898.  
Duel between Hamilton and Burr, July 11, 1804.  
Wyoming admitted to the Union, July 11, 1890.  
Adoption of the Ordinance of 1787, July 13, 1787.  
District of Columbia established, July 16, 1790.  
Charles VII of France crowned at Rheims through the help of Joan of Arc, July 17, 1429.

Last allied offensive of the World War on the Western Front begun, July 18, 1918.

First Battle of Bull Run, July 21, 1861.

Discovery of the island of Trinidad by Columbus, July 31, 1498.

**JULY, COLUMN OF**, a bronze column in Paris on the old site of the Bastille, in commemoration of the citizens who fought for the liberty of France, July 27, 28 and 29, 1830. The column bears the names of the 615 who fell in the revolution, and in the vaults below are the bodies of these victims and also those of the Revolution of 1848. See **BASTILLE**.

**JULY REVOLUTION**, the name given to the revolution in France in 1830 which placed Louis Philippe on the throne and drove out the restored House of Bourbon. The reactionary policy of Louis XVIII and Charles X had made the Bourbon dynasty exceedingly unpopular, and when, in July, 1830, edicts interfering with the liberty of the press and with the franchise privileges were issued, matters came to a climax at once. The July Revolution extended scarcely beyond Prais, but its influence reached all Europe.

**JUMPING BEAN**, a name given to the seeds of a number of different plants of the spurge family, because the seeds when laid upon a level surface will move about by jerks and jumps. The motion is caused by a larva or small grub which lives in the seed until ready for its transformation into a moth. The plants and insects are found in Central and South America and to some extent in the Southwestern United States. In the latter section *bronco beans* is a local name for the seeds.

**JUMPING MOUSE**, an interesting wild mouse, found in the Eastern United States. Its name is derived from the fact that it has long and strong hind legs, like the jerboa (which see), and its movement is by long leaps. It hibernates during the cold months.

**JUNCO**, *jung'ko*, the popular name of several species of small snow birds, common in winter in parts of the United States and Canada. They are akin to the sparrows and have dark slaty or ash-colored plumage, more or less white on the under side. They spend the summers in Canada and in regions just south of the border, and in winter range as far south as the Gulf of Mexico. They nest on or near the ground, and the nests are hidden by brush. The eggs, from four to five in number, are bluish-white speckled with brown.

**JUNE**, the sixth month in the year. It consisted originally of twenty-six days, to which it is said Romulus added four, and from which Numa took away one. Julius Caesar again lengthened it to thirty days, and it has ever since remained unaltered.

The origin of the name is a matter of dispute, but the most probable theory is that it was derived from *juniores*, meaning *younger men*. The month of June was dedicated to the younger men of Rome, and May to the older ones, the *maiores*. The "rare days" of June are praised by the poets, and it is everywhere known as the month of roses, of brides and of graduations. The pearl or the moonstone is the special gem of this month. Its flower is the honeysuckle.

**Anniversaries for Celebration**. The following birthdays of notable people fall in June:

Ben Jonson, June 1, 1573.  
King George V of England, June 3, 1865.  
Socrates, June 5, 469, B. C.  
Nathan Hale, June 6, 1758.  
Charles Reade, June 8, 1814.  
John Howard Payne, June 9, 1792.  
Charles Kingsley, June 12, 1819.  
Harriet Beecher Stowe, June 14, 1812.  
Edward Grieg, June 15, 1843.  
John Wesley, June 17, 1703.  
Josephine, wife of Napoleon, June 23, 1763.  
Jean Jacques Rousseau, June 28, 1712.  
Peter Paul Rubens, June 29, 1577.

The following important events occurred in June:

Kentucky admitted to the Union, June 1, 1792.  
Tennessee admitted to the Union, June 1, 1796.  
First steamship entered Boston Harbor from England, June 3, 1840.  
Lincoln nominated for President, June 8, 1864.  
Public schools opened in the Philippine Islands, June 11, 1906.  
First Canadian Parliament opened in Ottawa, June 13, 1841.  
Form of the national flag of the United States adopted by Congress, June 14, 1777.  
Arkansas admitted to the Union, June 15, 1836.  
Battle of Bunker Hill, June 17, 1775.  
Corner Stone of Bunker Hill Monument laid, June 17, 1825.  
Battle of Waterloo, June 18, 1815.  
Meeting of the first Virginia assembly, June 19, 1619.  
West Virginia admitted to the Union, June 19, 1863.  
Statue of Liberty received from France, June 19, 1885.  
Michigan admitted to the Union, June 20, 1837.

Accession of Queen Victoria, June 20, 1837.  
 Purchase of Alaska, June 20, 1867.  
 Abdication of Napoleon, June 22, 1815.  
 Coronation of George V of England, June 22, 1911.  
 Discovery of North American Continent by the Cabots, June 24, 1497.  
 First Telegraphic Message passed between New York and Boston, June 27, 1847.  
 Coronation of Queen Victoria, June 28, 1837.  
 Signing of Magna Charta, June 29 (?), 1215.

**JUNEAU**, *joo no'*, since 1906 the capital of Alaska, is situated on Gastineau Channel, 110 miles south of Skagway and 100 miles nearly north of Sitka, the former capital. It is in the center of a great mining district and is the largest town in Alaska. It has banks, an electric light plant, newspapers, telegraph and telephone service, and is connected directly with Seattle, San Francisco and other Pacific towns by steamer. Other lines also give it communication with Sitka, Nome and Skagway. It is an important point for miners' supplies, for more than \$70,000,000 in gold have been mined in the vicinity, largely from the famous Treadwell mines. Population, 1910, 1,644; in 1914, about 4,000.

**JUNE BERRY**, a family of plants, embracing about twenty-five species of trees and shrubs. The leaves are simple, and the white flowers grow in abundant clusters. The fruit is a soft, juicy berry, purplish in color and about the size of a pea. It is good to eat. Service berry, shad bush and May cherry are other names by which the plants are known.

**JUNE BUG**, or **MAY BEETLE**, a small brown beetle common in the United States. In May and June the insects swarm at night, frequently entering dwellings, attracted by the light. They are very destructive to young leaves and fruit, upon which they feed. The larvae, which are fat, white grubs, live beneath the surface of the soil and are very harmful to roots, cutting them off from the rest of the plant. They can be destroyed by pouring into the ground a dilute kerosene and soap emulsion. See **BEETLE**.

**JUNGFRAU**, *yoong'frou*, a mountain of the Swiss Alps, twelve miles southeast of Interlaken. The slenderness of its form and the virgin whiteness of the snow with which it is crowned have given it its name, which means *maiden*. It is one of the most magnificent peaks in Europe, rising in stately majesty to a height of 13,670 feet. It was first ascended in 1811 by two Swiss brothers, but since has been climbed by many tourists. Most visitors make the ascent over a re-

cently-built electric railway, the last six miles of it through a tunnel ending at an underground station, from which elevators rise to the top.

**JUNGLE FOWL**, one of a genus of birds of which four species are known, living in the East Indies and Northern India. The most common species is much like our domestic fowls, and it is believed that the barnyard poultry have descended from these birds.

**JUNIOR HIGH SCHOOL**. See **HIGH SCHOOL**, subhead *Junior High School*.

**JUNIPER**, a genus of evergreen shrubs and trees of the cone-bearing family, growing in cold and temperate regions of the northern hemisphere. In some species the leaves are long and needlelike; in others, the foliage has the appearance of short, thick branches and is formed of small, overlapping scales. The cones are fleshy and berrylike, and each contains from one to twelve seeds, which require two years to mature. These yield an essential oil, used in medicine, and a flavoring for certain liquors. One species of juniper is the common red cedar of North America, a wood used in cabinet-making and in the manufacture of pencils and cigar boxes.

**JUNIUS LETTERS**, **THE**, certain letters on public affairs which first appeared in the *Public Advertiser*, a London paper published by Henry S. Woodfall, from which they were copied into most of the other journals of the time. The earliest bears the date January 21, 1769; the last, January 21, 1772. After they were completed they were collected and published by Woodfall, with a dedication to the English nation and a preface by the author. Although so long a time has elapsed since the publication of these papers, their authorship seems as far from being settled as ever. It was evident from the first that the author was fully acquainted with British politics, with the proceedings of both houses of Parliament and with the characters of all the leading statesmen. To this wide information he united a boldness, vehemence and rancor which, combined with his epigrammatic and unsparing invective, rendered him an object of terror to those whom he attacked. Among those suggested as the author were Burke, Viscount Sackville and Sir Philip Francis.

**JU'NO**, in classical mythology, the wife of Jupiter, the chief Roman deity, and consequently queen of the gods. The Greeks

called her *Hera*. Juno is represented by poets as an exacting and a jealous wife, spending much of her time in devising punishments for Jupiter's mortal wives and their children. Artists pictured her as a beautiful woman of matronly aspect, carrying a staff. Juno was the special protectress of women and of all that concerned marriage and the birth of children. Many temples were erected in her honor, and women appealed to her for aid in every great emergency. She was attended by nymphs and hours, particularly by Iris. The goose, the cuckoo and the peacock were sacred to her. Frequently she is represented as drawn through the air by sacred peacocks, hitched to her chariot.



JUNO

**JUPITER**, the fifth planet from the sun, the largest planet of the solar system and, excepting the sun, the largest solar body. It is more than three times as large as all the other planets put together, and yet it is not more than  $\frac{1}{1000}$  part as large as the sun. Its mean diameter is about 88,000 miles, and the mean distance from the sun 483,000,000 miles. Jupiter rotates on its axis in nine hours and fifty-five minutes, and is accompanied by nine moons. Until 1892 but four were known. The fifth satellite was discovered by Prof. E. E. Barnard, then of the Lick Observatory. A sixth was discovered at the same institution by C. D. Perrine in 1904, and a seventh by the same astronomer in 1905. The eighth was noted in 1908 and the ninth in 1914.

As the inclination of Jupiter's axis is very small, changes in season must be almost unknown. Jupiter is recognized by the naked eye as, next to Venus, the brightest of the planets, and during January, 1908, February, 1909, and so on for several years, a month later each year, was the brilliant evening star, easily located by means of a chart of the heavens.

Jupiter and its satellites, making a miniature solar system, have always been studied

with great interest by astronomers. The surface of the giant planet shows belts of dark and light shade, which are usually, but not always, parallel to each other and undergo quick changes, seeming to merge one into another. These are thought to be masses of clouds, swept about by air currents in an atmosphere much heavier than ours. The moons appear from the earth to move in nearly straight lines from one side of the planet to the other, so that the planes of their orbits are nearly the same as those of Jupiter. They are eclipsed in the shadow of the planet, and their own shadows may be seen passing over the planet's surface. It was by observation of the eclipses of the satellites of Jupiter that Römer discovered that light does not travel instantaneously and computed its velocity. Through a telescope, Jupiter appears like a sphere more flattened at the poles and more bulging at the equator than our earth. It is probable that Jupiter is not a solid body, like Venus and Mars, but is still in a heated and probably partially gaseous state, resembling the sun except that the light given off is slight. See PLANET; SUN.

It would require over 1,300 bodies like the earth to equal Jupiter's bulk, but only 316 earths to equal it in weight.

**JUPITER**, or **JOVE**, the greatest of the Roman gods, called Zeus by the Greeks. He was the son of Saturn and Rhea, and in the division of the world by lot, which took place after the overthrow of Saturn, Jupiter received, as his share of the universe, the heavens and the earth, while Neptune received the sea, and Pluto, the lower world.



JUPITER

His first wife Zeus Otricoli, Vatican, Rome. was Metis, the goddess of wisdom, whom to prevent a prophecy that his first child should be wiser than himself, he swallowed. Shortly after, however, Minerva sprang full armed from his head.

Juno was the chief wife of Jupiter, but he was by no means always faithful to her and was constantly pursued by her jealousy. Besides the goddesses Themis, Ceres, Mnemosyne and Latona, he had many mortal wives, among them Alemene and Antiope, Danae, Europa, Leda and Io. Among his children were the Fates, the Graces, the Muses, Apollo and Diana, Mars and Hebe and many of the famous Greek heroes. Jupiter was represented in art as a man of middle age and dignified appearance, usually seated on a throne and bearing in his hands his spear and thunderbolts. He was usually accompanied by an eagle, his sacred bird. See MYTHOLOGY, and the gods and goddesses mentioned above.

**JURA MOUNTAINS**, *zhū'rah*, a range on the Swiss-French frontier, extending nearly 200 miles in a general southwest-northeast direction, describing a curve. At its northern end it lies wholly within Switzerland. The mountains are in parallel ridges and are from thirty to sixty miles in breadth, and are composed of sandstone and limestone. Numerous glacial boulders are scattered over the slopes. The summits are covered with snow most of the year; the slopes are clothed with pine forests. The mineral products are gypsum, salt and lithographic stone. The highest peaks are Reculet, Dôle, Mont Tendre and Snowerest, the last 5,553 feet high. Two French rivers, the Aine and the Doubs, have their source on the western slopes. The Jurassic Period takes its name from this mountain range.

**JURAS'IC PERIOD**, a period of geologic time following the Triassic and preceding the Cretaceous periods. It is named from the Jura Mountains in Switzerland, where the rock formations are especially exposed. Jurassic rocks are prominent in Europe, but in North America they are comparatively unimportant. In California and Oregon they constitute some of the gold-bearing rocks, but are so closely related to those of the Triassic that it is impossible in many instances to tell to which system the formations belong. During the period of their formation most of the earth was covered with shallow seas, inhabited by a variety of fishes. It was the age of reptiles, dinosaurs and pterodactyls. The archaeopteryx, the gigantic ancestors of birds, also belong to this period. See GEOL-OGY; MESOZOIC ERA.

**JURY AND TRIAL BY JURY.** The history of trial by jury is not traceable to its origin. It probably began among northern European races, the first known form being found among the Anglo-Saxons, where an accused person could summon twelve neighbors to swear to his innocence.

**The Grand Jury.** To-day in criminal trials two juries act, the *grand jury* and the *petit jury*. The former may consist of any number more than eleven and less than twenty-four men (usually twenty-three), whose names are drawn by lot from a list of eligible men and who are summoned by the sheriff of the county. Their names are returned in a written report, which is called a *panel*. After the oath has been administered they proceed to consider in private the charge, or *indictment*, which is brought against the accused. If the majority agrees that the accusation has a basis of truth they return a *true bill*. If they find that the accusation is unfounded they *ignore* the bill, and the accused is dismissed.

**The Petit Jury.** Petit juries consist of twelve persons, and are required in the trial of all criminal offenses and of all issues of fact in civil cases, except when by consent of the parties the decision is entrusted to the presiding judge.

The petit jurors are chosen in the same manner as the grand jurors, but the attorney for either the defendant or the plaintiff in any suit has the right to challenge the right of any one to sit upon the jury for reasons either of prejudice or ignorance, or for other good cause. When once accepted, no juror is at liberty to leave his post without the court's permission. When a prisoner is charged with murder the jurymen are usually allowed to retire only in custody of the sheriff or his deputies, who are sworn to keep them together and not to speak to them with reference to the case.

When the evidence has been given, the presiding judge instructs the jury in the points of law which apply to it, leaving the jury to deal with the facts, and their decision is final. In considering the evidence they withdraw to a private room, and until reaching an agreement, or until it becomes evident that they cannot reach an agreement, no communication is permitted with other persons, even food and other necessaries being supplied by officers of the court. If the twelve jurors fail to agree they are discharged by the judge,

and the case can be tried anew before a new jury. An *appeal* can be taken from any verdict to a higher court upon showing some legal error in the conduct of the case, or upon the presentation of new important evidence.

The so-called *coroner's jury* is summoned to inquire into cases of sudden or violent death.

**Related Articles.** Consult the following titles for additional information:

|                   |                  |
|-------------------|------------------|
| Coroner<br>Courts | Law<br>Procedure |
|-------------------|------------------|

**JUSTICE**, DEPARTMENT OF, one of the executive departments of the government of the United States. Though the office of Attorney-General was organized in 1789, this official did not become a member of the President's Cabinet until 1870. He is fourth in line of succession to the Presidency. The Department has charge of all legal business of the government, the Attorney-General being the chief law officer. It is his duty to advise the president and the secretaries of the departments in all legal matters, to represent the government in court, to direct the district marshals and attorneys of the government, to supervise the penal and reformatory institutions, to administer the national bankruptcy law and, when required, to revise and codify the Federal laws. The salary of the Attorney-General is \$12,000 per year. See UNITED STATES, subhead *Government*; CABINET.

**JUSTICE OF THE PEACE**, a judicial magistrate of a township, intrusted with the conservation of the peace. In the United States the office is held either by appointment or election, and the incumbent has judicial power in certain petty civil and criminal cases. He can examine offenders, in some states, and hold them to upper courts for trial. In some states he has a right to celebrate marriages. In Great Britain the justice is practically appointed by the lord chancellor and has certain executive as well as judicial functions.

**JUSTINIAN I**, in full, FLAVIUS ANICIUS JUSTINIANUS (483-565), Byzantine emperor from 527 to 565, was born of an obscure family. On the death of his uncle, Emperor Justin, with whom he had for a time shared the imperial power, he was proclaimed emperor. The early part of his reign was disturbed by party riots and a great part of Constantinople (Byzantium) was burned. He took much interest in its rebuilding, restored the Church of Saint Sophia and was active in building in many other places. Aided by

his generals Belisarius and Narses, he was able—after victories over the Persians, the Ostrogoths in Italy and conquests in Africa—to restore to the Roman Empire a part of its former possessions.

Turning his attention to the laws, Justinian commissioned ten learned civilians to draw up a new code, and the result was the *Corpus Juris Civilis*, (body of civil laws). To obtain money for his projects he oppressed the people with taxes and permitted his servants to commit the most flagrant crimes. His reign of thirty-eight years was a great period in the history of the Empire, but his surname, "the Great," was a misnomer.

**JUTE**, a fiber obtained from a plant belonging to the same family as the basswood. The jute plant is a native of the warmer parts of India, where it is cultivated, especially in Bengal, on an extensive scale. It is an annual, growing to a height of twelve or fourteen feet. The fiber forms the inner



JUTE PLANT

bark of the plant and possesses in a marked degree the tenacity common to the bark of plants of this order. The fiber is fine and has a shining surface; it is injured by exposure to water and hence is not suitable for



cordage except when mixed with hemp, as it frequently is in the United States and Great Britain, where also it is sometimes mixed with silk in the manufacture of cheap satins. It is chiefly used in the manufacture of coarse bagging, rope, twine, yarn and the foundation of inferior carpets and mats.

In Bengal, the center of the industry, jute has been manufactured on hand looms for centuries. To-day there are numerous jute factories in India that are filled with modern machinery. The United States, in addition to what it produces, uses in a year more than eleven million dollars' worth of imported jute. It is only since about 1830 that the manufacture of jute has risen to importance in Europe. The headquarters of this branch of industry are at Dundee, Scotland. The rice, cotton, sugar, coffee, pepper and other articles of East Indian commerce are almost wholly carried in gunny bags made from jute.

**JUTES**, a German tribe that assisted the Angles and Saxons in their conquest of England, in the fifth century. See **ANGLO-SAXONS**.

**JUTLAND** (Danish, *Jylland*), the peninsula and most important portion of Denmark, surrounded on three sides by the sea—the Skagerrak, the Cattegat and the North Sea—and on the south by Schleswig; it has an area of 9,755 square miles. The surface is generally low and is diversified by a ridge of hills through the center of the peninsula. The west coast is sandy, and the east coast has many fjords. The inhabitants are considered to be the most genuine specimens of the old Danish stock and have preserved both the language and the manners and customs of early times in their greatest purity. The earlier inhabitants, the Jutes, took part in the expedition of the Saxons to England (see **DENMARK**). Population, 1911, 1,198,457.

**JUVENAL**, DECIMIUS JUNIUS JUVENALIS, a Latin satirical poet, born probably about the middle of the first century A. D. He is said to have been the adopted child of a wealthy freedman; to have been by profession a pleader; to have been the friend of Martial and to have died in Egypt as an exile in charge of a cohort of infantry. Nothing of this is authentic; we know certainly only that he resided in Aquinum about the end of the first century after Christ. His extant works

are sixteen satires, composed in hexameters, giving in powerful language, inspired by a bitter and heartfelt indignation, a somber picture of the corrupt Roman society of that era. His satires have been translated by Gifford and some of them by Dryden, while Johnson's imitations of two of them, entitled respectively *London* and the *Vanity of Human Wishes*, are well known.

**JUVENILE COURT.** It has long been a recognized fact that it is harmful to children to be brought, some of them for a first and very mild offense, into contact with the careless, often depraved crowd that fills the ordinary police court. The result of this conviction has been the establishing of special courts where juvenile offenders against the law may be tried. Massachusetts was the first state to provide for separate hearing of children's cases, but the first regular juvenile court was opened in Chicago in July, 1899. Two years later there was founded in Denver the most famous juvenile court in the world—that presided over by Benjamin B. Lindsay, whose fame became worldwide.

The idea on which these courts are based is that the child is not a criminal—that most children would rather be good than bad, if opportunity be given. Instead, then, of punishing the delinquent children brought before them, these courts attempt to educate them and plant in them ideas of right living. In many instances the every-day surroundings and the home influences are carefully studied, and action is taken to improve these, if possible. Some states give to the juvenile courts power to punish adult persons who through neglect or active wrong leading contribute to the delinquency of the child. Children are never to be put, before trial or afterward, with older criminals, and in most cases a probation scheme is tried, the child being allowed to go free but required to report at intervals to the court until his period of probation is over. Judge Lindsey has applied the honor system with great success. When boys have been sentenced to the Industrial School at Golden, he has permitted them to go unattended; and out of several hundreds so trusted, less than a dozen have failed him. The age limit of those tried in juvenile courts varies in different states, but is never over twenty.

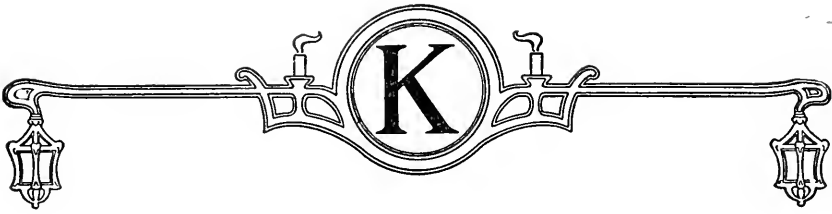

**K**, the eleventh letter of the English alphabet, derived in its form from the Phoenician character, which resembled a reversed *k*. In Anglo-Saxon this letter was little used, *c* being regularly substituted for it. Gradually, however, it came to replace *c* in positions where the latter would be ambiguous in sound. It has but the one sound, and it is silent before *n*, as in *knot*. In words of one syllable *k* is often used after *c* as a final letter, to secure the proper pronunciation of derived forms, as in *crack*, *cracked*.

**KAABA**, or **CAABA**, *kah'ba*, a cube-shaped stone building in the court of the mosque at Mecca, held sacred by Mohammedans. It is about forty feet long, thirty-three feet wide and fifty feet high. In one corner of it, built into the wall, is the famous Black Stone, held in extreme veneration by Mohammedans. Legend says the stone (probably of meteoric origin) was once white, but has been blackened by the millions of kisses imprinted upon it by devout pilgrims. The Mohammedan, in whatever part of the world he may be, turns his face toward the shrine in prayer.

**KABUL**, or **CABUL**, *ka bool'*, the capital of Afghanistan, on the Kabul River, at an elevation of 6,400 feet above the sea. It has no remarkable buildings except the citadel and the palace. All the city's foreign trade is with India, through the celebrated Kyber Pass. Three times within a hundred years the city has been held by the British, to enforce treaty rights. Population, 150,000.

**KADIAK**, *kadyak'* or **KODIAK**, *kohd yak'*, the largest island of Alaska, 36,000 square miles in area, situated off Cook Inlet, on the southern shore. It is notable for salmon fisheries and for the Kadiak bear, the largest bear in the world. The natives live mostly in the three villages of Karluk, Kadiak and Akhiok; these together have

about 1,000 people. There is some agriculture and cattle raising, for the climate is temperate.

**KAFFIR CORN**, or **KAFIR CORN**, *kah'fer*, or *kafir*, a cereal grain belonging to the sorghum group, used chiefly as a food for live stock. It contains a high percentage of starch, but is lacking in saccharine. Kafir corn is raised in large quantities in the western part of the United States, especially in the dry-farming sections. It is so called because the seed was first brought from Kaffraria, in Africa.

**KAFFIRS**, or **KAFIRS**, several tribes of negroes, belonging to the Bantu family inhabiting Southeastern Africa. They possess most of the characteristics common to the negro—brown skins, thick, coarse woolly hair, thick lips and flat noses, but the shape of the head resembles that of the European, and they are mentally superior to other natives of the race: their religious conceptions are on a higher plane and their practical thinking is superior. They are cattle-breeders and agriculturists, raising millet, maize, yams, melons and vegetables. Except when fighting, they are vegetarians. They are governed by a hereditary chieftain with absolute power. The women are drudges, and the men are warriors, fighting with knobkerriers, clubs and assegais (lances for hurling) behind ox-hide shields.

**KAISER**, *ké'zer*, the Teutonic equivalent for *emperor*, was the title popularly applied to the reigning monarchs of the German Empire and Austria-Hungary until November, 1918. The last of the German House of Hohenzollern was William II; the last of the Austrian Hapsburgs was Charles (Karl) I. Their disappearance from power occurred when the central empires capitulated to the entente nations at the close of the World War.

The name *kaiser* is from *Caesar*, and became current in medieval times when the Teutonic emperors attached Caesar to their names as a mark of imperialism.

**KAISER-BLUME**, the German name for the cornflower, and the national flower of Germany. See CORNFLOWER.

**KAISER WILHELM CANAL**. See KIEL CANAL.

**KALAHARI**, *kah lah hak're*, **DESERT**, an arid plain in the southern part of Africa, extending from the Orange River to Lake Ngami and occupying most of Bechuanaland and part of what was formerly German Southwest Africa. Although this region has no water except shallow salt lakes, it is covered in part by grass, bushes and shrubby trees, and is roamed by herds of antelopes and other wild animals. The natives, who are Bushmen and Bakalahari, raise water-melons and vegetables.

**KAL'AMAZOO**, MICH., the county seat of Kalamazoo County, fifty miles south of Grand Rapids, on the Kalamazoo River and on the Lake Shore & Michigan Southern, the Michigan Central, the Grand Trunk, the Chicago, Kalamazoo & Saginaw, and the Kalamazoo, Lake Shore & Chicago railroads. The city is in an agricultural district where celery is a celebrated product. Kalamazoo College and the Western State Normal School are located here. Important structures are the Michigan Asylum for the Insane, a city hall, a post office, a public library, five hospitals and sanitariums and a Y. M. C. A. The manufactures include paper, wagons, buggies, windmills, engines, machinery, undertakers' supplies and various articles for women's wear. In 1918 Kalamazoo adopted what is claimed to be the most progressive form of city government in America, embodying both the commission form and the city manager. The place was settled by the Titus brothers in 1829 and was chartered as a city in 1884. Population, 1910, 39,437; in 1917, 50,408 (Federal estimate).

**KALB**, JOHANN DE. See DEKALB, JOHANN.

**KALEIDOSCOPE**, *kæli'doh skope*, an optical instrument invented by Sir David Brewster. It consists of a tube, inside of which are three long, narrow mirrors, hinged together lengthwise. In one end is an eye-glass, in the other two glass discs, between which are placed small pieces of colored glass. These bits looked at from the opposite end of

the tube appear more numerous than they are, and, owing to the reflection, they form symmetrical patterns. A slight shaking of the instrument alters the design. The kaleidoscope is not only a fascinating toy for children, but an aid to designers of fabric patterns and of wall papers.

**KAL'ENDS**, or **CAL'ENDS**, in the Roman calendar the first day of the month. The name refers to the custom of the college of priests of assembling the people on the first day of the month. At that time announcements of festivals were made. The Latin word for *assemble* is *calare*. A Roman writer who wished to mention the date January 31 would call it *the day before the Kalends of February*. See CALENDAR.

**KALEVALA**, *kah le vah'tah*, a Finnish epic poem of ancient origin. For centuries it was handed down from mouth to mouth, but in 1835 Elias Lönnrot, a philologist, gathered the parts together, by wandering from house to house, and reduced the poem to written form, calling it *Kalevala*. It has been translated into many languages. The style of Longfellow's *Hiawatha* is an imitation of the Finnish epic.

**KALISPELL**, *kal'is pel*, MONT., the county seat of Flathead County, on the Great Northern Railroad, thirty-seven miles from Glacier National Park, to which the city has built a fine road. Lumbering, mining and farming are the chief occupations in the vicinity. The town has a Carnegie Library, a hospital and a government weather bureau station. Population, 1910, 5,549.

**KAL'MIA**, a genus of North American shrubs, which bear cup-shaped rose or purple flowers in clusters. The kalmias belong to the heath family and are known commonly in the United States as laurel. The *mountain laurel*, or *calico bush*, has been carried from its home in the Alleghany Mountains to Europe, where it is a favorite garden shrub. The flowers of the kalmia have a peculiar arrangement for fertilizing themselves. When the flower opens, the stamens are bent back away from the pistil and are held in little pockets in the corolla. Whenever an insect touches them they fly loose, scattering the pollen from little holes in the tops of the anthers. Some of the pollen falls upon the insect and is by him carried to the stigmas of other flowers, and in this way cross fertilization is secured. For interesting details see CROSS FERTILIZATION.

Under favorable conditions the trunk of the mountain laurel attains a diameter of three inches, and as the wood is hard like box, it is used by turners for small objects, such as handles to tools. All laurel is more or less poisonous if eaten. Sheep are sometimes poisoned by eating a species of *kalmia* variously called *sheep laurel*, *lamb kill* and *staggerbush*.

**KAL'MUCKS**, or **CALMUCKS**, a wandering, warlike Mongol race, originally natives of the territory of Central Asia, but now inhabiting not only parts of the Chinese Empire, but also districts of Siberia and European Russia. They are intrepid soldiers and splendid horsemen, and troops of them are attached to almost every Cossack regiment. Many of the Russian Kalmucks have been converted to Christianity. Physically they are small of stature, broad-shouldered, with small, round heads and narrow, oblique eyes.

**KALSOMINE**. See **CALCIMINE**.

**KAMERUN**, *kah mah roon'*, until early in 1916 a possession of Germany, is a territory in West Africa with an area of 305,000 square miles and a population, mostly of Bantu negro stock, of about 2,650,000. In 1916, 1,863 were Germans, and there were only twenty-six other white people.

In November, 1915, the British captured Buea, the capital; the Germans moved the capital to Yaunde, only to lose it two months later. The conquest of the territory was completed February 18, 1916, and Kamerun became one of the political divisions to be disposed of at the peace conference at the conclusion of the World War. Germany had held control since 1884.

The southeastern tip of Kamerun lies across the equator. French Equatorial Africa is south and east; Nigeria and the Gulf of Guinea are west. The exports are palm oil, cola nuts, bananas, cacao and ivory. The Kamerun Mountains extend northward through the country, and in places reach an elevation of 13,760 feet.

**KAM'LOOPS**, **BRITISH COLUMBIA**, in the Yale District, is situated at the junction of the North and South Thompson rivers, 250 miles from Vancouver. It is on the Canadian Pacific Railway, of which it is a divisional point, and it is also a divisional point on the Canadian Northern. The surrounding region is devoted to stock raising, mixed farming, fruit growing, lumbering and min-

ing. In the town the leading industries are saw mills, sash and door factories, machine shops, a brick yard, a brewery and a cigar factory. The town owns its light and water systems. It has a convent, a hospital, an old man's home, and is the seat of Dominion government land, Indian agent and customs offices. The site is 1,150 feet above sea level, and the town is noted for its dry and healthful climate, which makes it a delightful summer resort. Population, 1916, 5,500.

**KAMTCHATKA**, *kam chat'ka*, a large peninsula on the northeastern coast of Siberia, between the Bering Sea on the east and the Sea of Okhotsk on the west. It is about 700 miles long, and from seventy to 250 miles wide, and has an area of 104,000 square miles. The chief wealth of the country lies in its fur-producing animals, which include the sable, the Arctic fox, the beaver and the bear. The Kamtheadales, once the predominant race of the peninsula, are a branch of the Mongol family, a low type, physically and morally; but they are rapidly vanishing before the Russian settlers. Population, estimated, 7,500.

**KANAKAS**, *ka nah'kas*, a name given by white sailors and traders to the natives of the Hawaiian Islands. The term is now used colloquially to designate Polynesians generally, but is rarely used in the Pacific islands.

**KANAWHA**, *ka naw'wah*, a river of West Virginia, the headstream of which rises between the Blue Ridge and Iron Mountains in North Carolina. It flows in a northeasterly direction, as the New River, through the western part of Virginia, and then, flowing to the northwest, traverses several ridges of the Alleghanies. In Fayette County, W. Va., the river is joined by the Gauley. From this point the main stream, under the name Kanawha, follows a course of 100 miles to the Ohio River, at Point Pleasant. The total length of the headstream and main river is 400 miles. The Kanawha is an important commercial waterway of West Virginia.

**KANDAHAR'**, or **CANDAHAR'**, **AFGHANISTAN**, a town of considerable commercial importance in the southern part of the country, on the direct route to India, 210 miles southwest of Kabul. It lies 3,484 feet above the sea, and has a large transit trade in silk and felt, chiefly carried on with British India. The town is said to have been founded by

Alexander the Great. Population, estimated, 31,500.

**KANE**, ELISHA KENT (1820-1857), an American surgeon, traveler and Arctic explorer. In 1850 he joined the Grinnell Arctic Expedition, as medical and scientific member, in the unsuccessful search for Sir John Franklin. His observations led him to the belief that there was a large open sea near the pole, and on his return he organized a second Arctic expedition. He left New York in the *Advance* in May, 1853. At 78° 43' north latitude he was frozen in for twenty-one months. Finally, he was obliged to abandon the vessel. A perilous journey of 1,300 miles in boats and sledges brought him back to Greenland, and he reached New York, in November, 1855. Much broken in health, he sailed for Cuba to recuperate, but died there. (See NORTH POLAR EXPLORATION.)

**KANGAROO'**, one of the most strangely-formed animals in the world, found in a wild state only in Australia and nearby islands. The most noticeable feature about

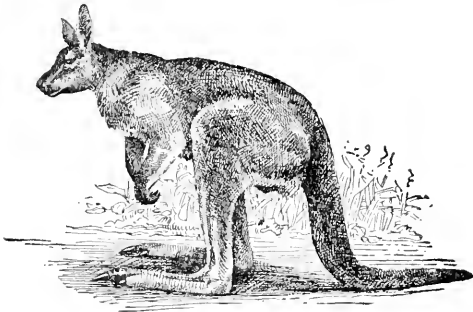

KANGAROO

the kangaroo is the disproportion between the upper and lower parts of the body. The head is small and deerlike in shape, with large ears; the fore legs are small, and the hind legs are relatively large and powerful. The tail is long and thick at the base and helps to support the animal when it sits erect, and to assist it in its long leaps. When moving at an ordinary rate, the kangaroo jumps about its own length, but when frightened it can leap from three to four times that far. Kangaroos are among the most ludicrous of all animals, and are objects of great interest in a "zoo."

The young are born very immature, being in most instances less than an inch long, and are protected and nourished for about eight

months in a pouch on the mother's abdomen. Kangaroos live entirely upon vegetable growths, and where still plentiful, they are a serious pest to farmers. They are very timid, but are alert in time of danger. The kangaroos include many species, varying in size from that of a hare to that of a large sheep, and remains of still larger extinct species have been found in Australia. The larger and more common kinds belong to a genus including the *giant kangaroo*, the *gray kangaroo* and the *brush kangaroo*. The kangaroos can kill a dog with a blow of the hind foot. The animals are hunted for their hides, which make excellent leather, and also for their flesh. Smaller species include the *tree kangaroos* and the *wallabies*.

**KANKAKEE'**, ILL., the county seat of Kankakee County, on the Kankakee River and on the Illinois Central, the Cleveland, Cincinnati, Chicago & Saint Louis and the Chicago, Indiana & Southern railroads. The most important manufacturers are plows, pianos, iron beds, mattresses, cigars, hosiery and wagons. There are also extensive limestone quarries and brick and tile yards in the vicinity. It is the seat of the Eastern Illinois Hospital for the Insane, which is the home of 3,000 insane persons. Other fine buildings are the Arcade, the county jail, the opera house, the public library, a conservatory of music and the Y. M. C. A. building. Saint Viateur's College, a prominent Roman Catholic divinity school, is located at Bourbonnais Grove, a suburb three miles distant. There are two important pleasure resorts on the river, Electric and Riverview parks. Kankakee was settled in 1853 and was incorporated the next year. Population, 1910, 13,986; in 1917, 14,270 (Federal estimate).

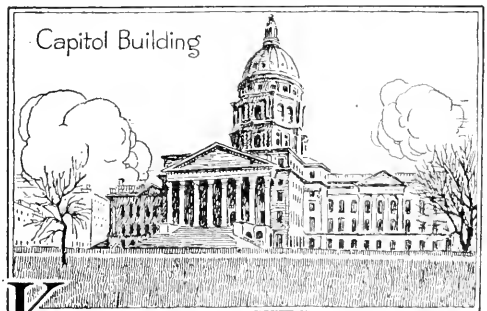

**KANSAS**, the thirty-fourth state to be admitted to the American Union, lies exactly in the geographical center of the United

States. Only twelve states are larger, and but twenty-one contain more people. Kansas is among the most progressive states; it has no state debt, and after 1881 did not license saloons. It was first peopled by pioneers who reached the territory in "prairie schooners"—wagons with canvas covers—and was contested ground on the slavery question, for its admission as a state occurred on January 29, 1861, just as the clouds of the great Civil War were gathering.

The area of Kansas is 82,158 square miles, which is more than twice that of Ohio; its population in 1910 was 1,690,949, an average of 20.7 people to the square mile, as compared with 30.9 to the square mile for the entire United States. A Federal estimate gave the state a population of 1,874,195 in 1918. With the exception of the northeast corner, where the boundary is formed by the Missouri River, the state is a rectangle. Its length from east to west is 402 miles; its width from north to south is 207 miles. It is popularly known as the **SUNFLOWER STATE**, from its choice of state flower.

**Surface and Drainage.** The state occupies a portion of the great plain lying between the Rocky Mountains and the Mississippi River. As a whole it is an undulating prairie, rising on an average of about seven feet per mile from the eastern to the western boundary. The average altitude of the eastern boundary is about 800 feet, and that of the western boundary is about 3,500 feet. The highest point is in Sherman County, on the extreme western boundary, and is over 4,400 feet in altitude. In general, the surface is characterized by low swells, separated by shallow valleys. Here and there are hills rising above this plain to the height of 400 or 500 feet and giving some variety to the scenery. The banks of streams in the eastern portion are frequently characterized by bluffs on one side or the other, varying in altitude from 100 to 200 feet; but the streams in the western section flow through shallow valleys and have low banks.

The Missouri drains the northeastern portion. The Kansas and its tributaries flowing eastward drain all of the northern half; the Arkansas, flowing eastward through a little more than half of the state and then bending southward; the Neosho and Verdigris, flowing east of south, and the Osage, flowing east, drain the remainder. Among the important tributaries of the Kansas River are the

Republican, the Smoky Hill and the Solomon. The Verdigris flows into the Arkansas. The Missouri is navigable, but in general the streams are shallow and have but little fall, though a few have sufficient fall to afford some water power.

**Climate.** Kansas has a temperate climate; it is mild, without tropic heat or arctic cold, and everywhere is healthful. The atmosphere is clear and dry, and throughout the year there is a predominance of sunny days. The winters are short and mild, and but little snow falls. The mean annual temperature in the northern part of the state is about 50° and in the south about 55°. However, cold storms sometimes occur, accompanied with temperatures running from 0° to -25°. The average rainfall for the entire state is about twenty-seven inches, but it is much heavier in the eastern third than elsewhere. Here it exceeds from forty to forty-four inches. In the central third of the state it is about twenty-five inches, and in the western third it is from ten to fifteen inches.

**Mineral Resources.** The southern counties contain extensive deposits of bituminous coal, which are worked in many places and yield a sufficient quantity of coal for local purposes (over 7,000,000 tons a year). There are also in this vicinity deposits of lead ore and of zinc, the latter being extensively mined. To the northwest of the zinc and lead deposits is an extensive field of natural gas, and a little to the north and west of this are great deposits of petroleum, yielding over 43,000,000 barrels per year. The gas and oil territory has been greatly extended in recent years. Gypsum, limestone, chalk and large deposits of salt, clay and other minerals are scattered through the state, and in many localities appear in unlimited workable quantities. In output of salt Kansas ranks fourth among the states.

**Agriculture.** Agriculture is the chief industry of the state. The soil is fertile, and the climate is well suited to the growing of all products that can be raised in a temperate climate. The only drawback to agriculture is the lack of rain in the western third of the state; however, the annual rainfall of this district is noticeably increasing. In the eastern third the chief crops are corn, oats, rye, potatoes, sorghum, broom corn, hay, hemp, flax and fruit. Only six states exceed Kansas in corn production. It is fourth in hay.

The central portion of the state is devoted to raising winter wheat, and in the production of this variety of wheat, Kansas leads the other states of the Union. As a wheat-producing state Kansas is first, producing 11½% of the nation's wheat crop. In this region are also found many thriving fruit orchards. Alfalfa is quite generally raised throughout the state, its total area being about 1,000,000 acres. The western third of the state is generally devoted to the raising of live stock, for which it is abundantly suited, since the mild winters allow stock to remain without shelter. The upper Arkansas Valley, in the western section, has considerable sugar-beet culture, principally in Finney and Kearny counties. Large numbers of cattle, horses and sheep are marketed every year, and the wool clip is large.

**Manufactures.** Compared with agriculture, manufacturing is of minor importance. The leading industries, in the order of their value, are slaughtering and meat-packing, with their chief center in Kansas City, Kansas; the manufacture of soap, butter, cheese and condensed milk; building and repairing cars and other rolling stock for railroads; the manufacture of flour and other grist-mill products, beet sugar, foundry and machine shop products.

**Transportation.** The eastern and central portions are well supplied with railway lines, and a number of trunk lines extend through the state from east to west, but in the western third there are few cross lines connecting these, so some portions of this part of the state (two counties, Stanton and Grant) are without railway communication. In 1918 there were 9,380 miles of railroad.

**Government.** The legislature is composed of a senate, restricted to forty members, and a house of representatives, restricted to 125 members. The senators are elected for four years, and the representatives for two years. The legislature meets biennially, and the members cannot draw pay for a session exceeding fifty days.

The executive department consists of a governor, a lieutenant-governor, a secretary of state, an auditor, a treasurer, a superintendent of public instruction, an attorney-general, a bureau of labor and industry, a superintendent of insurance and the state printer, each elected for two years. There are also several administrative boards, whose officers are appointed by the governor, such

as a state board of agriculture, a public utilities commission, a state board of administration, a board of control of charitable institutions, a free employment bureau, a state board of health, a state tax commission, a bureau of mining industries, a state horticultural society, a board of medical registration and examination, a bureau of labor and industry, a welfare board and a civil service commission.

The judiciary department is vested in a supreme court consisting of seven judges, elected for six years, and numerous district judges, elected for four years, who preside over the courts in their respective districts. Each county has a probate judge, who is also judge of the juvenile court, and large cities have city courts. Townships, villages and cities have justice courts for the hearing of petty cases.

**Education.** The widely-scattered rural population in the western part of the state is adopting the consolidated country school idea. The school fund is derived from the sale of school lands, two sections in each township, and is supplemented by local taxation. The public schools are under the supervision of the superintendent of public instruction, and those in each county are under a county superintendent. Cities of the first and second class are each under a city superintendent employed by the board of education of the city. The state university at Lawrence is at the head of the public school system. There is a state normal school at Emporia, with a branch school at Hays, and another for industrial branches at Pittsburg. Graduates of schools of collegiate rank, accredited by the state board of education, are granted three-years' state certificates. The state agricultural college and experiment station are at Manhattan, with an extensive branch of the station at Hays. Besides these there are numerous colleges and secondary schools maintained by religious denominations. Among those worthy of mention are Baker University at Baldwin (Methodist Episcopal), Fairmount College at Wichita, Friends' University at Wichita, Southwest Kansas College at Winfield (Methodist Episcopal), Ottawa University at Ottawa (Baptist), College of Emporia at Emporia, Kansas City University, Bethany College, McPherson College at McPherson, Kansas Wesleyan University at Salina and Midland College at Atchison.

**Institutions.** The school for the deaf and dumb is at Olathe and that for the blind is at Kansas City. There is a state orphans' home at Atchison and a national soldiers' home at Leavenworth. The state soldiers' home is at Dodge City. The state penitentiary is at Lansing; the industrial reformatory for young men is at Hutchinson. A great Federal prison is near Leavenworth. The state also maintains an industrial school for girls at Beloit and an industrial reform school for boys at Topeka. There are hospitals for the insane at Topeka, Osawatimie and Larned, a tuberculosis sanitarium at Norton and a farm colony for women delinquents at Lansing.

**Cities.** There were sixteen cities in Kansas in 1918 each with over 8,000 population. Kansas City was the largest of these; the next five, in order of size, were Wichita, Topeka, Hutchinson, Leavenworth and Pittsburg. Each prominent city is described in these volumes.

**History.** Kansas was first visited by Spaniards under Coronado about 1541, but it was not again explored until the eighteenth century, when Frenchmen passed through it. It came into possession of the United States in 1803 as part of the Louisiana Purchase. Lewis and Clarke passed up the Missouri River, on the northeastern border of the state, and Pike passed through the territory in 1805. Fort Leavenworth was established by the government in 1827. It was a part of the territory of Missouri in 1821, but from that time until 1854 it was an unorganized territory. In that year occurred the great contest over organization, precipitated by the Kansas-Nebraska Bill. Several attempts to form constitutions and elect legislatures were made, and a lively contest ensued between immigrants from the South and from the North to gain control of the state. A pro-slavery party gained the first success in 1855, but in October of the same year a convention of free-state men met at Topeka and adopted a constitution prohibiting slavery. An election was held under this instrument in January, 1856, and a free-state governor was chosen, the pro-slavery party taking no part in the election.

In 1856 occurred the famous raid of John Brown at Pottawatomie Creek. With the aid of Federal troops the free-state legislature was prevented from meeting, but a constitution adopted by the pro-slavery party

### Items of Interest on Kansas.

The lowest point in the state is in the southeastern part, in Montgomery County, only 725 feet above sea level; the west central portion has noticeable irregularities of surface, and the northwestern part is distinctly hilly.

An unusually great variety of birds is found in the state, nearly 350 being known to breed there or pass through in their migrations.

The fruit product of Kansas is not as yet large when compared with that of other states, but apples, pears, peaches, plums, grapes, cherries and many smaller fruits grow well in almost all sections.

The manufactured products are yearly increasing in value; the most important industry is slaughtering and meat packing, in which Kansas ranks second only to Illinois.

The flour and grist-mill industry ranks second in importance, with an annual product valued at \$70,000,000; one-fourth of the wheat crop is handled by the mills of the state.

### Questions on Kansas

What is the shape of Kansas?

What is its area? How does it rank in size among the other states?

How many acres has the United States government reserved for forestation?

What per cent of the area is included in farms?

What are the three leading crops? How does the state rank as a producer of each?

What fruits are raised?

What is the annual value of all crops?

How does Kansas rank as a producer of natural gas? Of salt?

What are the two most important manufacturing industries?

Name five of the largest cities and tell why they are important.

How does Kansas rank among the states in corn production?

What state raises more wheat than Kansas?



# KANSAS

## THE SUNFLOWER STATE



SUNFLOWER



REAPER

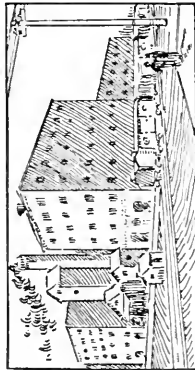

FLOURING MILL

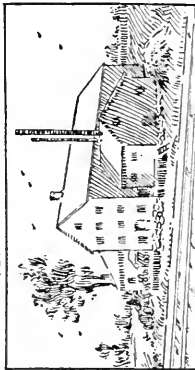

CREAMERY

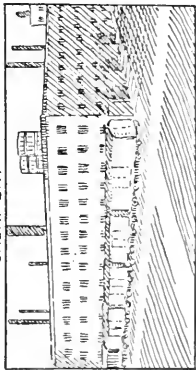

PACKING PLANT



COAL MINE

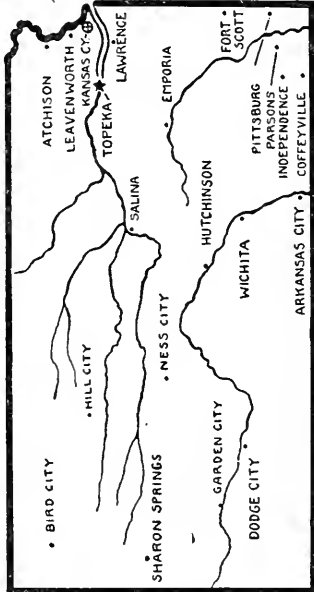

• BIRD CITY  
 • HILL CITY  
 • NESS CITY  
 • GARDEN CITY  
 • DODGE CITY  
 • WICHITA  
 • ARKANSAS CITY  
 • COFFEYVILLE  
 • HUTCHINSON  
 • LAWRENCE  
 • EMPORIA  
 • PITTSBURG  
 • PARSONS  
 • INDEPENDENCE  
 • FORT SCOTT  
 • ATCHISON  
 • LEAVENWORTH  
 • KANSAS CITY  
 • TOPEKA  
 • SALINA



WHEAT

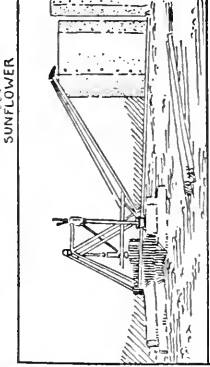

PETROLEUM

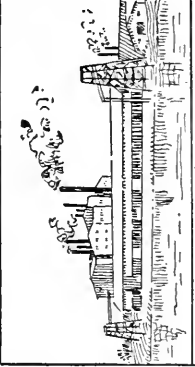

SALT PLANT

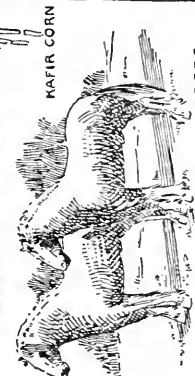

HORSES



SHEEP

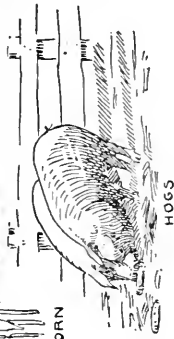

HOGS



CATTLE



GRAPES

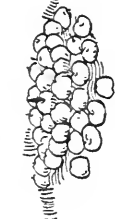

APPLES

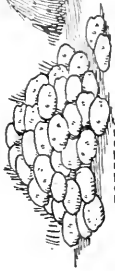

POTATOES



HAY



KAFIR CORN

at Lecompton, in November, 1857, was voted down. The immigration from free states thereafter became so preponderant that a constitution, adopted in 1859, prohibiting slavery, was finally ratified, and the state was admitted to the Union in 1861.

After the Civil War the state received a great impetus from the development of railroads. The principle of prohibition was incorporated in the constitution after a long struggle, and the state has also taken advanced ground in opposition to railway and other trusts. It was the first state to enact so-called "blue-sky" laws (which see) for the control of stock-selling by corporations owned outside of the state. In 1917 it was made possible by an act of the legislature for cities to adopt the city manager plan of operation. A double plan of election boards was also adopted, whereby one board receives the ballots and another counts them. In 1912 full suffrage was granted to women. Kansas has provided a juvenile court in every county, a welfare board to protect wage-earning women, a mothers' pension law and other modern measures. The board of state administration is a state commission plan. All the educational, penal, charitable and reform institutions are placed under a board of three; the governor, *ex officio*, is the fourth member. A business manager is chosen for the institutions.

**Related Articles.** Consult the following titles for additional information:

## GEOGRAPHY

|             |                |                |
|-------------|----------------|----------------|
| Atchison    | Independence   | Parsons        |
| Chanute     | Iola           | Pittsburg      |
| Coffeyville | Kansas (river) | Missouri River |
| Emporia     | Kansas City    | Salina         |
| Fort Scott  | Lawrence       | Topeka         |
| Hutchinson  | Leavenworth    | Wichita        |

## HISTORY

|                      |                     |
|----------------------|---------------------|
| Brown, John          | Lecompton           |
| Coronado, F.         | Constitution        |
| Kansas-Nebraska Bill | Louisiana Purchase  |
|                      | Missouri Compromise |

**KANSAS, UNIVERSITY OF,** a state institution established by act of the legislature at Lawrence in 1864. It was opened in 1866, has enjoyed steady growth and prosperity, and had a student enrollment of 3,200 in 1918. At that time the faculty numbered 241, and the library contained 110,000 volumes. The university consists of a graduate school, a college of liberal arts, schools of fine arts, law, pharmacy, medicine and education, a summer session, a division of university extension and a division of state work. It also cooperates with the public utilities commission and the state board of health.

**KANSAS CITY, KAN.,** the largest city of the state and the county seat of Wyandotte County, situated on both sides of the Kansas River at its confluence with the Missouri. It is adjacent to and connected with Kansas City, Mo., and is on the Missouri Pacific, the Union Pacific, the Atchison, Topeka & Santa Fé, the Chicago Great Western and the Chicago, Rock Island & Pacific railroads. Kansas City is the site of the state school for the blind and of the Kansas City University. It has a fine library building, costing \$75,000. The live stock interests are very important, and this city, together with the larger Kansas City, forms the second largest live-stock center in the United States. The industries include grain elevators, with capacity for nearly 9,000,000 bushels of grain, flour mills, scales, railroad car and machine shops, manufactures of soap, foundry products and a great number of other articles. The city, known as Wyandotte, was chartered in 1886, at the time adding to its territory a number of suburbs. Its recent growth has been very rapid. Population, 1910, 82,331; in 1917, 102,096 (Federal estimate).

**KANSAS CITY, Mo.,** a flourishing industrial city of the Middle West, forming with Kansas City, Kan., the second largest live-stock center in the United States. It is the second city in the state in size, Saint Louis being larger, and is situated on the western border, in Jackson County, at the junction of the Kansas and Missouri rivers. Kansas City, Kan., adjoins it on the west, the two being separated by the state line. Kansas City is 280 miles northwest of Saint Louis and 483 miles southwest of Chicago. It is an important railroad center, and is served by several trunk lines, including the Atchison, Topeka & Santa Fé, the Chicago, Burlington & Quincy, the Chicago & Alton, the Chicago, Milwaukee & Saint Paul, the Chicago, Rock Island & Pacific, the Missouri Pacific and the Saint Louis & San Francisco. The city is twenty-first in size among the cities of the Union; in 1910 the population was 248,381; in 1917 it was 305,816 (Federal estimate).

**Parks and Boulevards.** The site of the city is one of unusual beauty, for it is built on picturesque hills that rise high above the river level. Along the river are found the wholesale and factory districts; above this section are the office buildings and retail stores, and on higher elevations are the residential districts. The bluffs have been greatly

beautified by landscape treatment and the construction of splendid parks and boulevards, the system having an area of more than 2,600 acres. About sixty miles of boulevard connect the various parks, the largest of which, Swope Park, has an area of 1,380 acres. Among the beautiful avenues for which Kansas City is widely known are Cliff Drive, Kersey Coates Drive and the Paseo.

**Buildings and Institutions.** The most imposing structure of this city of many splendid edifices is the Union Station, one of the largest in America and costing \$6,000,000 to build. Among other noteworthy structures are the Board of Trade, Convention Hall (seating 18,000), the Live Stock Exchange, the Federal building and the City Hospital. The city also has numerous churches, schools and banks of great architectural beauty. There are more than 130 public schools and a large number of professional schools, academies and colleges. There are also all the charitable and reformatory institutions usually supported by a progressive city.

**Commerce and Industry.** The two municipalities named Kansas City form one great livestock and meat-packing center, and in these enterprises they are surpassed only by Chicago. Kansas City, Mo., is the largest winter-wheat market in the country, and the third largest primary grain market. Its grain elevators have a total capacity in excess of 18,000,000 bushels, and it is the distributing center of the rich farming districts to the west and southwest. The city is also a busy market for the sale of hay, mules and lumber, coal, cement and flour.

**History.** Kansas City, which developed from a pioneer fur-trading station, was marked out as a town in 1838. In 1850 it was incorporated as the Town of Kansas; in 1857 it was changed to City of Kansas, the present name being adopted in 1889. The first postoffice was established in 1845, and the first newspaper six years later. In 1865 the first passenger train over the present Missouri Pacific entered Kansas City, and in 1863 work was begun in the city on the first line west of the Missouri River (the present Union Pacific). The year 1869 marked the completion of the first bridge across the Missouri. Since that date three others have been constructed.

**KANSAS-NEBRASKA BILL**, a bill passed by the Congress of the United States

in 1854 separating and organizing the territories of Kansas and Nebraska. It was introduced by Stephen A. Douglas. It was chiefly important as embodying the "squatter sovereignty" idea of Douglas, that is, as expressed by the bill, that "all questions pertaining to slavery in the territories and the new states to be formed therefrom, are to be left to the decision of the people residing therein, by their appropriate representatives." This provision would have overridden the Missouri Compromise, which prohibited slavery north of the latitude of 36° 30'.

The original bill was superseded by another prepared by Douglas, which distinctly repealed the slavery clause of the Missouri Compromise. The bill passed the Senate against the opposition of Sumner, Chase, Everett, Seward and others, and it passed the House after a long and bitter struggle. It revived the bitter slavery contest which had been allayed by the Compromise of 1850, for it practically opened to slavery an area of 500,000 square miles, including the present states of Kansas, Nebraska, Montana, North Dakota, South Dakota, Wyoming and part of Colorado. Thus it had the effect of hastening the Civil War.

**KANSAS RIVER**, a river of Kansas, formed by the junction of the Republican and the Smoky Hill (the latter rising in the Rocky Mountains). It traverses the state in an easterly direction and falls into the Missouri at Kansas City. It is 250 miles long and is not important for navigation. Topeka, Lawrence and Junction City are among the cities on its banks.

**KANT**, *kahnt*, IMMANUEL (1724-1804), a celebrated German philosopher, born at Königsberg, Prussia. He was educated at the University of Königsberg, where he supported himself as a private tutor and later served as a lecturer until 1770, when he became professor of logic and metaphysics, a position which he held until old age. Kant's personal appearance and manner of living gave no suggestion of the strength of his influence. He was small of stature, being scarcely more than five feet tall, and lived a most methodical, unpretentious life. Although he was deeply interested in travels and in descriptions of the characteristics and customs of foreign nations, it is said that he was never outside the borders of the province in which he was born.

Kant attempted to reconcile the conflicting philosophical systems which had dominated the seventeenth and eighteenth centuries. In doing this, he constructed a new system. His chief work, *The Critique of Pure Reason*, contains a complete exposition of his philosophy, and through it and other writings he exerted a more potent influence upon thought than any other man of his time. His other important works are *The Critique of Practical Reason* and *The Critique of the Power of Judgment*.

**KAOLIN**, *ka'olin*, a white clay consisting of decomposed feldspar and containing silica, alumina and small quantities of lime and soda potash. The name is that of a hill in China where it was first found. The Chinese use kaolin in making the porcelain and pottery for which they are famous.

Similar clays, differing slightly in color and in the percentage of constituents, are found at Schneeberg in Saxony, furnishing the material of Dresden china; at Limoges, in France, employed for Limoges ware, and at Saint Austell, in Cornwall, the source of supply for the British potteries. In the United States kaolin is found in Nebraska, North Carolina, Delaware, Georgia, Pennsylvania, Connecticut and Vermont, but the best quality is obtained from Cornwall, England. In its natural state kaolin somewhat resembles mortar; by sorting and repeated filtration it is freed from all coarse ingredients, then dried in pans and sheds and sent into the market cut into blocks. When burned it becomes pure white. See POTTERY; CLAY.

**KARAKORUM**, *kah rah ko'rum*, **MOUNTAINS**, a mountain range in Central Asia, forming a sort of rampart between Kashmir and Eastern Turkestan. Mount Godwin-Austen, 28,278 feet in height, is, after Mount Everest, the highest mountain in the world. The range has a high average elevation, and rises from one of the loftiest tablelands in the world.

**KARLSBAD**, a German health and fashion resort. See CARLSBAD.

**KARLSRUHE**. See CARLSRUHE.

**KARNAK**, *kahr'nak*. See THEBES.

**KASHGAR**, *kahsh gahr'*, **TURKESTAN**, a city on a river of the same name and at the junction of roads to Peking, India and Russia. It is very old, dating from 76 B. C. It has a mixed population, estimated to be from 60,000 to 70,000 and is under Chinese rule. Except for the Chinese quarter, it is

built of mud huts. The chief industry is the manufacture of textiles.

**KASHMIR**, or **CASHMERE**, *kash meer'*, **INDIA**, an extensive principality in the north-western part of Hindustan, subject to a ruler belonging to the Sikh race. It is politically subordinate to the British Indian Empire. The area is estimated at 84,432 square miles. Kashmir proper, which forms a small portion of the whole, is a valley surrounded by mountains, the Himalaya and Hindu Kush, and traversed by the river Jhelum. There are ten chief passes through the mountains into this valley, varying in height from about 9,000 to 12,000 feet. The elevated situation of the valley and the mountains of snow which surround it render the climate rather cold; but the region is well watered by streams and is very fertile.

Forests on the slopes, fields of corn, rice crops along the sides of the rivers, rich orchards and an abundant growth of flowers are features of the district. The common European fruits are grown, and attention is now being paid to the culture of the vine. The chief crops are wheat, barley, rice and Indian corn, and two harvests are reaped in the year. The chief article of manufacture is the celebrated Cashmere shawl, made from the inner wool of the wild goat. The capital of the whole principality is Jamoo. Srinagar, or Kashmir, is the maharajah's summer residence and is the largest town. This city was founded in the sixth century, coming under British protection in 1846. Population of the principality 1916, 3,246,467.

**KATAHDIN**, *ka tah'din*, **MOUNT**, in the northern part of Maine, is the most prominent peak in the state, having an altitude of 5,200 feet. It is formed principally of granite, large areas of which are exposed on its abrupt slopes. The summit is bare, except for lichens, and commands a magnificent view of the surrounding wilderness.

**KATRINE**, *kat'rin*, **LOCH**, a lake in Perthshire, Scotland, famous for its picturesque scenery. It is serpentine in form and lies in a lovely little valley from which rise lofty hills—Ben Venue, Ben A'an and others. It is the scene of Scott's *Lady of the Lake*, and the subject of some of Wordsworth's most exquisite verse. The lake is eight miles long, about one mile wide, and has an average depth of 142 feet. It is 364 feet above the sea. Numerous small streams flow into it and the little river Gyle; it drains into Loch

Vennacher. Loch Lomond is five miles distant. Loch Katrine is the chief water supply of Glasgow.

**KATTEGAT.** See CATTEGAT.

**KATYDID**, the name applied to a species of locusts whose "singing" sounds like the syllables *ka ti did*. These notes are not made

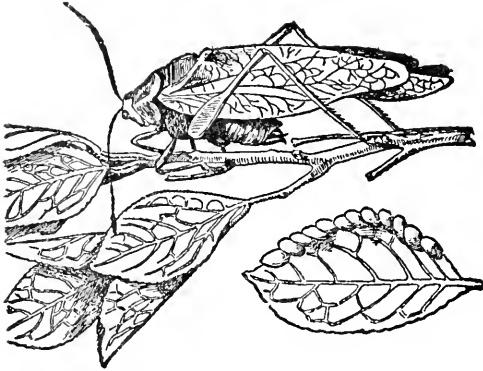

KATYDID AND EGGS ON A LEAF

by the throat, but are formed as the male rubs the bases of its front wings together. The katydid is about an inch long and is of a pale green color. See LOCUST; GRASSHOPPER.

**KAULBACH**, *kowl'bahk*, WILHELM VON (1805-1874), one of the greatest of modern German painters. He studied at the art academy in Düsseldorf under Cornelius, and in 1847 became director of the Munich Academy. He painted a large number of frescoes in public buildings and private palaces and executed many portraits of royalty. His most ambitious pictures, with the exception of the realistic canvas *The Madhouse*, are a series in the Berlin Museum depicting typical scenes from the great historic periods. They include *Tower of Babel*, *Age of Homer*, *Destruction of Jerusalem*, *Battle of the Huns and Romans*, *The Crusades* and *The Reformation*.

**KAUNITZ**, *kow'nits*, WENZEL ANTON DOMINIK, (1711-1794), an Austrian statesman and prince, the great minister of Maria Theresa. His most famous service to Austria was the alliance which he concluded with France, the hereditary enemy of Austria, against Frederick the Great. His influence in the government declined under Joseph II and Leopold II, and in 1792 he retired.

**KAW**, or **KANSA**, a tribe of Siouan Indians who formerly lived in Kansas and Missouri, near the mouth of the Kansas River. Driven from their holdings by the Dakota

Indians, they wandered about until they reached the present Oklahoma. About 200 Kaws are now living on a reservation in that state with the Osage (which see).

**KAZAN**, *ka zah'n'*, RUSSIA, formerly an important Russian educational center, and capital of the government of the same name, is on the Kazanka River, about four miles above its junction with the Volga, 430 miles east of Moscow. There are several mosques, a cathedral and imposing monuments. Before the revolution of 1917 the university was a great seat of Oriental learning, with nearly 1,000 students. The city had large wool-combing, weaving and dyeing establishments, tanneries and soap works and the timber, flour and hemp fairs were among the largest in the country. Population, 1913, 195,300.

**KEARNY**, *kahr'ni*, PHILIP (1815-1862), an American soldier, who served both his native country and France. He was born in New York City, was graduated at Columbia College in 1833 and then studied law. Having entered the army in 1837, two years later he went to France to study the tactics of the French cavalry. While abroad, he served in the French army in the Algerian War, and in 1840 he was made aid to General Macomb, general in chief of the United States army, and was on the staff of General Scott, his successor, from 1841 to 1845. Kearny took an active part in the Mexican War, fought in an Indian campaign in 1857, resigned, entered the French army and served with distinction in the Italian war, receiving the cross of the Legion of Honor. Returning to America in 1861, he reenlisted in the Union army, and was killed at Chancellorsville in September, 1862.

**KEARSARGE**, *keer'sahrj*, THE. See ALABAMA, THE.

**KEATS**, *keets*, JOHN (1795-1821), an English poet of the Romantic period, whose writings are distinguished for their lyric beauty. Keats was born at Moorfields, London. From 1803 to 1810 he was at a school at Enfield, and at the close of this period he was apprenticed to a surgeon. Although he was a fairly good surgeon, he found the work very much against his inclinations, which were all toward the beautiful and fanciful, and he gave up the profession that he might devote himself to study, preparatory to a literary career. His first volume of poems came out in 1817; *Endymion* appeared in 1818; his last volume of poetry, contain-

ing *Lamia*, *Isabella*, *The Eve of Saint Agnes*, *Hyperion* and other poems, appeared in 1820. By this time he had become so ill of consumption that he was advised to seek a warmer climate; but it was too late, and though he reached Rome he survived only a short time. Shelley honored his memory by his elegy *Adonais*.

Keats first volume of poems attracted little attention; the second, while it met with some favorable notice, was most severely criticised in *Blackwood's Magazine* and *The Quarterly Review*, and to the effects of this harsh treatment on a sensitive nature, Shelley in *Adonais* attributed Keats's early death. Modern critics do not, however, accept Shelley's conclusion. It is on his third volume that the fame of Keats rests, and the delicate, often faultless, beauty of these poems gives him rank with the foremost of British poets. According to his conception, philosophy, politics and ethics had no place in poetry, which should concern itself merely with beauty. And the beauty to the worship of which Keats gave himself was not spiritual beauty, but the highest type of sense-impressions. In description of form and color, he has never been surpassed.

**KEELEY CURE**, a method of treating confirmed drunkards, so called because it was originated by Dr. Leslie Keeley (see below). The first sanitarium offering the cure was opened at Dwight, Ill., in 1880, and the reputation it won led to the establishment of numerous others in various parts of the Union. Eventually Dr. Keeley sold his rights to the cure, which was based on a secret compound containing bichloride of gold. The Keeley method is being rapidly replaced by others involving less restraint.

**Leslie Keeley** (1836-1900) was born in Saint Lawrence County, N. Y. He was educated at Rush Medical College, Chicago, and during the Civil War was an army surgeon.

**KEENE**, **LAURA** (about 1820-1873), the stage name of **MARY MOSS**, an actress, a native of England and eventually a resident of the United States. She first achieved



JOHN KEATS

success in London, in 1851, as Pauline in *The Lady of Lyons*. In 1855 she opened a theater in New York City, and three years later produced *Our American Cousin*, having among the supporting actors Joseph Jefferson and the elder Sothorn. It was at a presentation of this play that President Lincoln was assassinated in Ford's Theater at Washington, in 1865.

**KEENE**, **N. H.**, the county seat of Cheshire County, forty-three miles west of Manchester, on the Ashuelot River, and on four lines of the Boston & Maine Railroad. The city contains railroad repair shops, sash and blind factories, furniture and other woodenware plants, a shoe factory and a woolen mill, and it manufactures manifold books and loose-leaf ledgers. It is located on a plain surrounded by high hills, and has about 220 acres in parks. The city has a state normal school, a library and a hospital. The place was settled in 1734, and was known as Upper Ashuelot until its incorporation under the present name, in 1753. The city was chartered in 1874. Population, 1910, 10,068; in 1917, 10,725 (Federal estimate).

**KEEWATIN**, *kee wah'tin*, formerly a district of Canada, later a part of the Northwest Territories, stretching from Manitoba to the Arctic Ocean and from Saskatchewan to Hudson Bay. The district was 1,300 miles long and had an area of 756,000 square miles. In 1912 178,100 square miles of the district were added to the province of Manitoba, the remainder being divided between Ontario and North West Territories.

**KELLER**, **HELEN ADAMS** (1880- ), an American writer and lecturer whose life story shows the wonderful progress made in modern times in teaching those who are blind and deaf. An attack of scarlet fever destroyed the senses of sight and hearing when she was but nineteen months old. When she was seven years old Miss Anne Sullivan (Mrs. John A. Macy) was secured as her teacher, and the child's progress was extraordinary. She learned to read, write and talk with her fingers and finally to speak. In 1900 she was graduated from Radcliffe College, and since that time has written magazine articles and books, and has appeared on the lecture platform. In 1918 she acted in a moving picture. Miss Keller's works include *Story of My Life*, *The World I Live In* and *Out of the Dark*.

**KELLOGG**, **CLARA LOUISE** (1842- ), an American soprano, born at Sumterville,

S. C. She was educated in New York, but made her *début* in London and appeared with great success in many tours of Europe and America. The story of her life is told in *Memories of An American Prima Donna*.

**KELP**, a crude alkaline substance obtained by burning seaweeds which themselves are known as kelp. They are found on the coasts of Brittany, Scotland and Ireland. Kelp consists of potassium chloride, salt, sodium carbonate and other chemicals. It is of commercial value as a source of iodine (which see), and formerly was used extensively in soap making. Kelp plants, partly dried, are valued for fertilizing purposes.

**KELVIN**, WILLIAM THOMSON, BARON (1824-1907), one of the greatest mathematicians and physicists of modern times, born at Belfast. He was educated first at Glasgow University and then at Peterhouse, Cambridge, and at the age of twenty-two he was appointed professor of natural philosophy in the University of Glasgow, a post which he held for fifty years. The same year he became editor of the Cambridge and Dublin *Mathematical Journal*, to which he contributed valuable papers on the mathematical theory of electricity. He was also a distinguished contributor to the *Philosophic Magazine*. Among the most important of his contributions to electrical science is the construction of several delicate instruments for the measurement and study of electricity. It is, however, in connection with submarine telegraphy that Baron Kelvin's name is most generally known, his services being rewarded, on the completion of the Atlantic cable in 1866, with knighthood and other honors, (see CABLE, ATLANTIC). He also made important additions to our knowledge of magnetism and heat, and invented an improved form of mariner's compass, now in extensive use. He was president of the British Association for the Advancement of Science, and at one time was president of the Royal Society of London.

**KENDALL**, AMOS (1789-1869), an American politician, born at Dunstable, Mass. He was graduated at Dartmouth in 1811, and several years afterward he was a tutor in the family of Henry Clay, in Kentucky. There he was admitted to the bar and became a warm supporter of Andrew Jackson. After Jackson's election to the Presidency, Kendall became one of the leading figures in the famous "Kitchen Cabinet" (see KITCHEN

CABINET), and as such did much to shape the policies of the administration. He became Postmaster-General in 1835 and retained the office through most of Van Buren's term. Later he edited several newspapers, and finally made investments in telegraph patents with Samuel F. B. Morse, thus acquiring a large fortune. In the last years of his life he devoted himself to philanthropy. He was a warm supporter of Lincoln during the war, but still wished to be known as a Jacksonian Democrat.

**KENESAW MOUNTAIN**, BATTLE OF, an important battle of the Civil War, fought near Marietta, Ga., June 27, 1864. General Sherman with a force of about 95,000 Federals had begun his march from Chattanooga to Atlanta and had compelled the Confederates, 60,000 strong, under Gen. Joseph E. Johnston, to retreat before him. The latter, however, had taken up a strong position on Kenesaw Mountain, and there successfully met the determined assault led by Logan and McCook, the latter being killed. The loss of the Confederates was 700, and that of the Federals, 3,000. Soon after the battle, Sherman succeeded in turning Johnston's position and later moved still farther southward.

**KENILWORTH**, ENGLAND, a town in Warwickshire, four miles north of Warwick. Nearby is Kenilworth Castle, founded in the reign of Henry I, and conferred by Queen Elizabeth upon the Earl of Leicester, whose gorgeous entertainment of the queen there, in 1575, is described in Scott's novel *Kenilworth*. The castle is now an ivy-covered ruin. Population, about 4,800.

**KENNAN**, GEORGE (1845- ), an American traveler and writer, born at Norwalk, Ohio. He was educated in the common schools, studied telegraphy and became an operator on the lines of the Russo-American Telegraph Company in Kamchatka and Siberia. Kennan returned to the United States, but in 1870 continued his explorations in Russia. In 1885 and 1886 he investigated the convict and exile system of Siberia, making a journey of 15,000 miles. Later he embodied his experiences and conclusions in many magazine articles, books and lectures. He was expelled from Russia in 1901, while making further investigations. Kennan served as special war correspondent for New York papers during the Spanish-American and Russo-Japanese wars. His publications include *Siberia and the Exile System*, *Cam-*

*painging in Cuba, The Tragedy of Pelee, A Russian Comedy of Errors* (1915), *Misrepresentation in Railroad Affairs* (1916) and *The Salton Sea* (1917).

**KENNEBEC**, *ken'e bek* a river of Maine which rises in Moosehead Lake and after a course of 150 miles, mostly in a southerly direction, empties into the Atlantic Ocean twelve miles below Bath. Its chief tributary is the Androscoggin. The Kennebec has falls at various points in its course and furnishes valuable water power. It is navigable for large ships as far as Bath.

**KENORA, ONT.**, on Lake of the Woods, and the Canadian Pacific, Grand Trunk Pacific and Canadian Northern railways. It is the industrial center of the Lake of the Woods district, and has large flour and lumber mills, two boat-building factories and two grain elevators. The town owns its telephone, light and water systems. Good hunting and fishing in the neighborhood have made it a popular summer resort. Population, 1916, 6,159.

**KENOSHIA, WIS.**, settled in 1835, is the county seat of Kenosha County, thirty-four miles south of Milwaukee, on Lake Michigan and on the Chicago & North Western railroad and electric lines connecting with Milwaukee and Chicago. The city has a fine harbor, with an increasing trade, and the manufactures include automobiles, underwear, hosiery, leather, typewriters, lamps, carriages, furniture and various machine-shop products. Particularly in the making of automobiles has the city become well known. It contains the Kemper Hall School and Simmons Memorial Library. The place was first incorporated in 1841. Population, 1910, 21,371; in 1917, 32,833 (Federal estimate).

**KENT, JAMES** (1763-1847), an eminent American jurist, author of a famous work entitled *Commentaries On American Law*. He was born at Fredericksburg, N. Y. Kent was educated at Yale College, and was admitted to the bar in 1785. He became professor of law at Columbia College and rose to be chancellor of New York (1814-1823). His *Commentaries*, published between 1826 and 1830, at once became a standard work which has had a great influence upon American legal practice and legislative principles. No man can qualify for examination for a legal diploma until he has read this standard book of fundamental law.

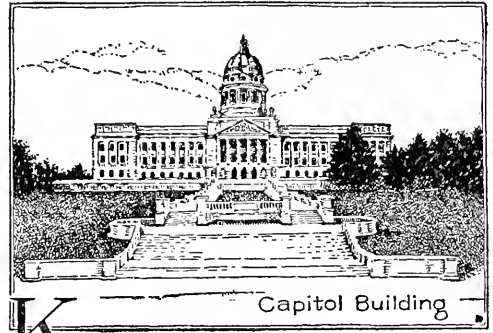

**K**ENTUCKY, a south-central state of the American Union, the fourteenth in population and the thirty-sixth in area. Its popular name, **BLUE GRASS STATE**, refers to the beautiful grass-covered plain in the north-central part, on which have been reared many of the thoroughbred horses for which Kentucky is famous. Its history dates back to colonial days, for the first settlements west of the Alleghenies were made in Kentucky just before the outbreak of the Revolution; when it entered the Union as a state, June 1, 1792, it was represented on the flag by the fifteenth star. Only Vermont, outside the thirteen original states, preceded it in point of time.

Kentucky lies south of Illinois, Indiana and Ohio, from which it is separated by the Ohio River. Big Sandy River and Tug Fork separate it from West Virginia on the northeast; the Mississippi is the west boundary, forming the dividing line between Kentucky and Missouri. On the southeast the state touches Virginia, and its entire southern boundary line adjoins the northern frontier of Tennessee. The greatest length from east to west is about 500 miles, and from north to south, about 175 miles. The area is 40,598 square miles, of which 417 square miles are water. Kentucky is between Ohio and Indiana in size, having an area over 4,200 square miles in excess of that of Indiana. In 1910 the population was 2,289,905; on July 1, 1918, according to a Federal estimate, it was 2,408,547.

**Surface and Drainage.** The surface as a whole is mainly a plateau having an average of about 800 feet above sea level. This plateau, however, is divided into a number of distinctly marked physical regions. The Cumberland Mountains run along most of the southeastern boundary. West of these and nearly parallel to them is the shorter range



of Pine Mountains. The highest peaks in these ranges attain an altitude of 4,000 feet, and others are from 2,000 to 3,000 feet. Between these ranges lies the Cumberland Valley, having a length of seventy-five miles and a breadth of about fifteen miles. The floor of this valley is from 1,200 to 1,500 feet above sea level. The combination of mountain and valley in this region forms some of the most beautiful scenery in the entire Appalachian Mountain system. The entire eastern part, north and west of the Pine Mountains, is diversified by hill and valley, giving a pleasing effect to the entire region. This portion of the state is quite heavily timbered with a number of varieties of hard wood.

Descending across the state from the northeast to the southwest and bordering upon the region already described is a region diversified by numerous conical sandstone hills, which rise from 1,200 to 1,300 feet above sea level. The peculiar appearance of this region has caused it to be named the *Knobs*. The Knobs extend along the southern boundary near the central portion of the state for a number of miles, and another branch extends northerly and northwesterly to the Ohio River. Lying between the branches of the Knobs and extending from the most northerly point in the state somewhat more than halfway to the southern boundary, is the celebrated Blue Grass region, so called because in summer the seed pods give the landscape a bluish hue. To the west of this is an area of slightly diversified country, underlaid with thick formations of limestone, in which are found Mammoth Cave and numerous other caverns of less note. To the west and north of a portion of the limestone region is found a hilly section, closely resembling in its appearance and structure the southern portions of Indiana and Illinois, and the southwestern part of the state also bears a very close resemblance to those regions.

The general slope is toward the north and northwest, and all of the rivers flow into the Ohio or the Mississippi. Some of these streams have worn deep channels through the hills and low mountains which they have crossed. A number of them are important because of their size. Passing from west to east, these rivers, in the order of their occurrence, are the Tennessee, the Cumberland, the Green, the Kentucky and the Licking.

The Tennessee and the Cumberland are navigable across the state, and the Green, the Kentucky and the Licking are navigable through the lower parts of their courses; previous to the construction of railway lines they formed important outlets to the Ohio River. There are no lakes of importance.

**Climate.** The climate of Kentucky is warm-temperate, equable and healthful. The mean annual temperature is about 55° F. In summer the thermometer may reach 100°, and the average temperature for July is 78°. The winters are warm, having an average of 35°, and the snowfall is light. The average rainfall is about forty inches in the northern part, and fifty-three in the southeast.

**Mineral Resources.** The eastern and southeastern portions are underlaid with coal measures, which have an area of about 9,000 square miles and yield an excellent quality of bituminous coal. Another coal region having an area of about 4,000 square miles is located in the northwestern part and is a continuation of the coal fields of Illinois and Indiana. Though of smaller area than the eastern region, this produces a larger quantity of coal, due mainly to its greater transportation facilities. For many years past Kentucky has been producing about 20,000,000 tons of coal a year, but the output has increased to about 25,500,000 tons. Kentucky is the fifth coal state of the Union, and the value of the output is usually about three-fourths that of all minerals combined. Another product of increasing importance is petroleum, the output of which has more than doubled in recent years. A million and a quarter barrels a year are obtained. The state is one of the few localities producing fluor spar (which see), and it possesses valuable quarries of sandstone and other building stones. Clay suitable for pottery, brick and tile occur in abundance and is worked extensively. Other minerals include iron, lead, zinc, barytes, natural cement, asphalt and natural gas.

**Agriculture.** Nearly nine-tenths of Kentucky is farm land, and at least two-thirds of the area under cultivation is improved. By far the most important agricultural product is tobacco, in which the state leads all others of the Union. The annual crop, averaging 350,000,000 pounds a year, is more than that of North Carolina and Virginia combined, and is about one-third the total crop of the entire country. Nearly 500,000 acres

are devoted to this product. Next in importance is corn, the crop at the present time exceeding 120,000,000 bushels; for many years it has not fallen below 90,000,000 bushels. Kentucky also produces good crops of wheat and oats, and its potato yield is sometimes over 6,000,000 bushels. Hay, sweet potatoes, yams, watermelons and orchard fruits are produced in large quantities, and sorghum cane is also of importance. Hemp, a plant whose fiber is used in making ropes, is a valuable product in the southern section, and in this crop Kentucky is the leading state of the Union, producing about nine-tenths of the total yield.

Kentucky has many natural advantages for the production of livestock—excellent pasturage, a mild climate and abundant crops of hay and corn. The splendid horses bred in the Blue Grass region have already been mentioned. Besides horses, the state produces large numbers of cows, mules, swine and sheep.

**Manufactures.** The making of tobacco products is one of the leading manufacturing industries, and it was one of the first to be established. Louisville is a world center for the marketing of leaf tobacco, and the value of the yearly output for the state as a whole is in the neighborhood of \$20,000,000. The products of the tobacco factories include chewing and smoking tobacco, cigars, cigarettes and snuff. Formerly Kentucky was a leading state in the distillation of whisky, but war-time prohibition and the Constitutional amendment ended that industry. An industry of rapidly-increasing importance is the manufacture of lumber and timber products, and these products have about the same value as those of the flour and grist mills, between \$20,000,000 and \$25,000,000 a year. Meat packing, tanning and the manufacture of iron and steel are also important.

**Transportation.** In most parts of the state the carriage roads are fairly good. Kentucky contains over 4,000 miles of railway, but it is too far south to receive direct benefit from the great east and west trunk lines. There are a number of lines running from north to south; these are connected by cross lines, and some of them contain spurs extending into the most fertile regions. A number of counties in the eastern and south-central regions are without railway communication, and as a whole the railway lines are inadequate to the needs of the state.

The Ohio and its largest tributaries, the Tennessee, the Cumberland, the Green and the Licking, furnish important waterways. The Dixie Highway crosses the state between Louisville and the southern boundary, in a nearly north and south direction.

**Government.** The legislature consists of a senate of thirty-eight members, elected for four years, and a house of representatives of 100 members, elected for two years. The legislature meets biennially, and the session is limited to sixty legislative days. The executive department consists of a governor, a lieutenant-governor, a treasurer, an auditor of public accounts, a commissioner of agriculture, labor and statistics, a secretary of state, an attorney-general and a superintendent of public instruction, each elected for four years; they are ineligible for reelection at the succeeding term. The judicial department culminates in a supreme court, known as the court of appeals, comprising seven judges, each selected from a district for a term of eight years. The lower courts are the circuit courts, county courts and justice courts. The circuit courts consist of courts in each district into which the state is divided, and they are presided over by a judge who is elected in the district for a term of six years. The local affairs are administered by county and magisterial district officers.

**Education.** Separate schools are provided for white and colored pupils. The larger towns and cities have excellent systems of graded schools, and the county is the unit for rural school organization, management and support. There are two state normal schools, the eastern at Richmond and the western at Bowling Green. They are maintained for the training of white teachers. As one of the older states, Kentucky was unable to profit by public lands which have been so beneficial in aiding the school systems of newer states. The state university at Lexington, which includes the agricultural and mechanical college, is at the head of the public school system. There is also a state normal school at Frankfort, for colored teachers. These institutions are supplemented by numerous colleges and secondary schools maintained by various denominations. Among the most important of these are Transylvania University at Lexington, the University of Louisville, Wesleyan University at Winchester, Ogden College at Bowling Green, Berea College at Berea and Central University at Danville.

# KENTUCKY

## THE BLUEGRASS STATE



Trumpet Vine,  
State Flower



State Seal



A Kentucky  
Thoroughbred

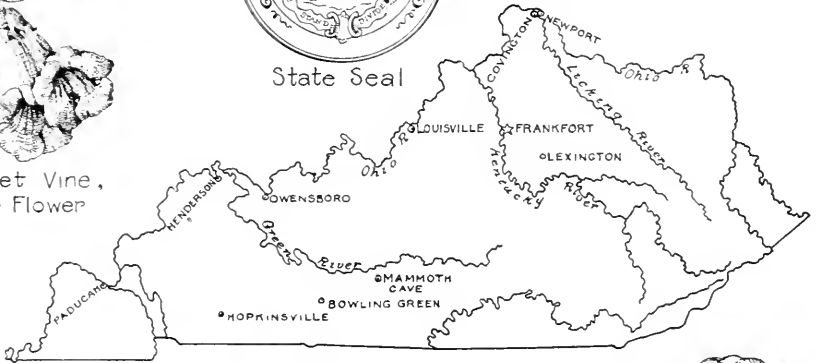

Sixth State in  
Production  
of Corn

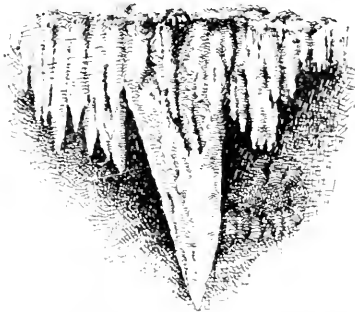

Stalactites in Mammoth Cave



First State in Production  
of Tobacco



Federal Hill, where  
"My Old Kentucky Home"  
was written

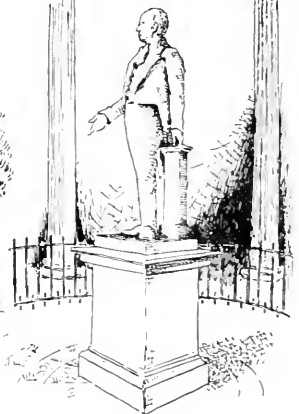

Henry Clay Monument, Louisville

## Items of Interest on Kentucky

Kentucky has jurisdiction over the entire breadth of the Ohio River, which forms its northern boundary.

The highest point in the state is Big Black Mountain, with an altitude of 4,100 feet, in Harlan county, on the Virginia state line.

The Blue Grass Region is like a beautiful park, without ragged cliffs, precipitous slopes, or flat marshy bottoms, but marked by rounded hills and dales; the blue grass spreads a thick, soft mat over the country.

The drainage of the cave region is mostly underground. The cave region covers an area of 8,000 square miles.

The principal rivers wholly within the state are the Licking, Kentucky, Green, and Tradewater.

Of the larger game there remain a few bears, deer, and lynx, but panthers, wolves, foxes, beavers and many other beasts were formerly common.

Extensive timber areas still remain, the tulip tree, oak, maple, beech, chestnut, elm, cypress, ash, hickory and walnut being the important species.

The best soils are the deposits of the rivers and those of the Blue Grass region, which are decayed limestone, rich in phosphorus.

The two most important tobacco-growing areas are the "Black Patch," in the southwest, adjacent to the Tennessee "Black Patch," which grows a black heavy leaf sold almost entirely for export, and the Blue Grass region, whose product, the red and white Burley, is a light leaf, a good absorbent, used largely for chewing tobacco.

Pearls are found in the state, especially in the Cumberland River, and it is supposed that there are diamonds in Elliott county.

Kentucky now has over 4,000 miles of railway; the first train drawn by a steam locomotive ran from Lexington to Franklin, a distance of twenty-seven miles, in 1835.

Kentucky has had four constitutions,

those of 1792, 1799, 1850, and 1891. By the present constitution corporations are forbidden to contribute money for campaign purposes, on penalty of forfeiting their charters, or, if not chartered in the state, their right to carry on business in the state.

The constitution provides for local option on the liquor question; in 1916, out of 119 counties ninety-one had voted for prohibition.

Child labor is carefully regulated by acts of the state legislature which prohibit the employment of children under fourteen during the term of school, of children between fourteen and sixteen unless they have employment certificates showing the child's ability to write and read English, etc.; children under sixteen are further not allowed to work more than ten hours a day or sixty hours a week or between 7 P. M. and 7 A. M.

In 1917 there was a school population of 740,576, with an enrollment of 555,568.

### Questions on Kentucky

What is the area of Kentucky?

What are the main physical divisions?

Name the principal rivers lying wholly within the state.

Where is Mammoth Cave?

What and where is the Blue Grass region? Why is it famous?

What is the average temperature?

What is the most valuable crop? The next valuable?

How does Kentucky rank in the production of hemp? Of cannel coal?

How many miles of railway are there in the state?

When was the present state constitution adopted?

What are its provisions on the subject of campaign contributions? On the liquor question?

Why is Louisville important? For what commodity is it a great world market?

Why are Frankfort, Lexington, Paducah and Owensboro noteworthy?

Since 1912 a strict compulsory education law has been in effect, and a new office was created the same year, that of rural supervisor of schools. These innovations are having the effect of reducing the illiteracy which resulted from the scattering of the population in the country districts. Another effective agency in reducing illiteracy is the "moonlight" school, in session at night and conducted by voluntary teachers. In 1911 the schools of Rowan County were opened at night to those who wished to attend, and by 1914 the illiteracy of the county was almost wiped out. The movement spread to other parts of Kentucky and to many other states.

**Institutions.** The state school for the blind is at Louisville, the school for the deaf is at Danville and the institution for feeble-minded children a Frankfort. The insane asylums are at Lexington, Hopkinsville and Anchorage, and the penitentiaries are at Frankfort and Eddyville.

**Cities.** Kentucky has eleven cities with populations over 9,000. The first five, in order of size, are Louisville, Covington, Lexington, Newport and Paducah. Frankfort is the capital.

**History.** Kentucky was probably first visited by Dr. Thomas Walker in 1750, but it was not settled until 1774, when James Harrod planted a colony at Harrodsburg. Meanwhile, Daniel Boone had led exploring expeditions into the region, and in 1775 he established Boonesborough. Virginia claimed the territory until 1790, when the Virginia legislature passed an act allowing separation, and this was accepted by a convention of the citizens of Kentucky. For many years, however, a strong sentiment in favor of the creation of an independent state had been growing, and had been fostered by a land company known as the Transylvania Company, headed by Richard Henderson. The state was admitted to the Union June 1, 1792, and Isaac Shelby was elected first governor.

Kentucky took a prominent part in the War of 1812; its great leader, Henry Clay, was a conspicuous member of the war party. It also was honorably represented in the Mexican War. In the Civil War it first attempted to maintain neutrality, though slaves were held in the state and its inclinations were naturally with the South. The Union armies, however, soon were in possession, and the state was saved to the Union. It was the scene of important battles, including those of

Mill Spring, Richmond and Perryville. Forty thousand Kentuckians fought for the Confederacy during the war, and about 90,000 for the Union. Civil government was reestablished a few months after the close of hostilities, and the state entered upon a period of prosperity. Within recent years many progressive laws have been enacted, including measures regarding workmen's compensation, pure food, forest conservation and minimum hours of labor for women and children.

**Related Articles.** Consult the following titles for additional information:

## GEOGRAPHY

|                  |              |
|------------------|--------------|
| Ashland          | Henderson    |
| Bowling Green    | Hopkinsville |
| Covington        | Lexington    |
| Cumberland       | Louisville   |
| Mountains        | Mammoth Cave |
| Cumberland River | Newport      |
| Dixie Highway    | Owensboro    |
| Frankfort        | Paducah      |

## HISTORY

|               |           |
|---------------|-----------|
| Boone, Daniel | Civil War |
|---------------|-----------|

**KENTUCKY AND VIRGINIA RESOLUTIONS**, a series of resolutions adopted by the Kentucky and Virginia legislatures in 1798 and 1799. Those adopted by Kentucky were nine in number, were probably written by Jefferson and contained radical denunciation of the Alien and Sedition Laws, besides a protest and warning against the assumption by the Federal government of powers belonging to the states. In 1799 the legislature passed a resolution declaring the right of a state to nullify any Federal law which it deemed unconstitutional.

The resolutions passed by the Virginia legislature in December, 1798, were eight in number, and were probably written by James Madison and were much milder in their expression. However, they contained the same principles. The two sets of resolutions were sent to the executives of all the states, and replies were received from many. All were unfavorable to the principles expressed in the resolutions.

**KENTUCKY**, STATE UNIVERSITY OF, an institution of higher learning, located at Lexington. It was founded in 1865 as a part of a school now known as Transylvania University, and remained a part of that organization until 1880, when the present name was adopted. The campus of over fifty acres was donated by the city of Lexington. The university is organized into colleges of arts and sciences, agriculture (including home economics), civil engineering, mechanical

and electrical engineering, mines and metallurgy, law and the graduate school. A farm of 250 acres, with valuable equipment, is maintained in connection with the agricultural college, and there is also an experiment station with a liberal income. In normal years there is a faculty of over ninety; the student enrollment is more than 1,300. The library contains over 33,000 volumes.

**KE'OKUK, IOWA**, called the **GATE CITY** and the **POWER CITY**, is one of the county seats of Lee County (Fort Madison being the other), 160 miles southeast of Des Moines, on the Mississippi River at the mouth of the Des Moines River, and on the Chicago, Burlington & Quincy, the Chicago, Rock Island & Pacific, the Wabash, the Toledo, Peoria & Western railroads and several interurban lines.

The Keokuk Dam, the basis of the greatest hydro-electric power plant in the world, was formally dedicated in August, 1913. The dam is a mile long, from Keokuk to Hamilton, Illinois. The power plant, built at a cost of \$27,000,000, develops over 300,000 horsepower, besides allowing enough water to convert the Des Moines rapids, formerly an obstacle to navigation, into the placid Cooper Lake. The steamboat lock adjoining the dam is greater than any of those at Panama, having a higher lift and allowing two boats to pass abreast. The electric power generated by the dam provides current for cities miles distant. The city contains lumber mills, lead and zinc refinery, a cereal and glucose plant, and stove and shoe factories, and there are manufactures of automobile tires and store fixtures. There are Y. M. C. A. and Y. W. C. A. buildings, a Masonic Temple, a Federal building and an Elks' Club. The Indian chief Keokuk, after whom the place was named, is buried in Rand Park. Keokuk was incorporated in 1848; it adopted the commission form of government in 1910. Population, 1910, 14,008; in 1917, practically unchanged.

**KEPLER, JOHANN** (1571-1630), one of the world's greatest astronomers, a native of Württemberg, Germany. From the chair of astronomy and mathematics at Gratz he went to Prague as assistant to Tycho Brahe in the royal observatory, and succeeded Tycho in 1601. The latter part of his life was passed as a professor of mathematics. Kepler's chief title to fame is his discovery of the three laws of planetary motion.

**Kepler's Laws**, in astronomy, three laws discovered by Johann Kepler, on which were founded Newton's discoveries, as well as the whole modern theory of the planets. They are:

(1) Every planet describes an ellipse, the sun occupying its focus.

(2) The radius vector of each planet (line joining the center of the sun with the center of the planet) sweeps over equal areas in equal times.

(3) The squares of the periodic times (the periods of complete revolution round the sun) of two planets are proportional to the cubes of their mean distances from the sun.

These laws enabled Newton to determine the laws of the attraction of gravitation.

**KEROSENE**, *ker'o seen*, an illuminating oil now made by distilling crude petroleum. It was originally made from coal, and even yet is sometimes called coal oil. The manufacture of kerosene in America dates from about 1856. For many years it was extensively used for lighting, cooking and heating purposes, of late years it has been largely replaced in cities by gas and electricity, and after the introduction of the gasoline engine it lost its importance as a by-product of petroleum manufacture. Chemists and engineers hope to make kerosene a satisfactory fuel for internal-combustion engines, to relieve possible gasoline shortage and provide a cheaper fuel. Kerosene is usually colorless, and has a strong disagreeable odor. See **PETROLEUM**.

**KESTREL**, or **WINDHOVER**, a species of falcon widely distributed over Europe and Northern Africa and found in some parts of Asia. The kestrel is closely related to the American sparrow-hawk, which it resembles in size, color and habits. The color is red above, buff and fawn beneath, marked throughout with black. On the head and rump the feathers are bluish-gray. The female is usually a rusty brown. The kestrel is a strong flyer and is able to hover over one spot for a long time. When holding itself in this position it keeps its head to the wind, and because of this it is sometimes called the *windhover*. It feeds on mice and insects and can be trained to capture small birds. It occupies nests that have been deserted by crows and other birds, or lays its eggs among rocks, ruins of buildings or in tree hollows.

**KETCH'UP**, or **CAT'SUP**, said to be derived from the Malay word *kechap*, is the

name of a pungent sauce introduced from the East and employed as a seasoning for gravies, meat and fish. It was formerly prepared from mushrooms only, but tomatoes, cucumbers and numerous other products are now used for the purpose. The best ketchup is made from mushrooms and walnuts.

**KEWANEE**, *ke wah'nee*, ILL., in Henry County, fifty miles northwest of Peoria, on the Chicago, Burlington & Quincy railroad, which was built to the city in 1855. The city is the seat of extensive iron works and has manufactories of agricultural implements and steam-heating apparatus. The commission form of government was adopted in 1910. There is a Carnegie Library; other important buildings are a Federal building, an armory, a Masonic Temple, a large hotel and a public hospital. Population, 1910, 9,307; in 1917, 13,607 (Federal estimate).

**KEY**, in music, a term used to designate all the tones of any given scale, considered collectively. As distinguished from scale, which means a melodic succession of single tones, the key is the harmony of tones produced simultaneously by the entire scale or by any group of tones in it. For every scale there is a key—twelve major and twelve minor, named according to the tone with which each begins. The key of *C* has no sharps or flats, and is called the *normal*, or *natural*, key.

The word *key* is also used to denote the parts of certain musical instruments manipulated by the fingers. On the piano the keys are the exterior white and black parts of levers which when pressed cause the hammers to strike the strings; on the organ they are similar levers which open valves for the passage of wind to the pipes. The keys of wind instruments are metal contrivances which cover the air holes.

**KEY**, *kee*, FRANCIS SCOTT (1780–1843), an American lawyer who won lasting fame by writing the song that is to-day the national anthem of the United States—the *Star-Spangled Banner*. (How he was moved to write this favorite among patriotic songs is told in these volumes in the article STAR-SPANGLED BANNER.) Key was born in Frederick County, Md., and was educated in Annapolis at Saint John's College. He practiced law at Frederick City and at Washington, becoming district attorney for the District of Columbia. A collection of his poems was published in 1857.

**KEY WEST**, FLA., the county seat of Monroe County, on Key West Island, which is the most westerly of the Florida Keys, at the southern extremity of Florida, about ninety miles nearly north of Havana, Cuba. In 1912 a railroad to the mainland was opened for traffic. This is the strangest railroad in the United States. It is built across the string of narrow islands between the mainland and Key West, and on concrete viaducts between the islands. The harbor is defended somewhat by Fort Taylor, at the entrance, and there are two lighthouses. It is on a number of steamship lines and has a considerable trade in fish, fruit, vegetables, turtles, salt, tobacco and other goods. The



THE RAILROAD THAT GOES TO SEA  
Florida East Coast Railway extension to  
Key West.

manufacture of cigars, mostly by Cubans, is the principal industry, and it employs 6,000 people; sponge fishing is also of considerable importance. The city has a naval station, with docks, machine shops, a marine hospital and barracks. The principal educational institutions are the Methodist Missionary College and the Holy Name Academy. Other interesting features are a courthouse, a Federal building, a city hall, a convent, a public library and a hospital. An old Spanish fort here is the southernmost building on American soil. Key West was settled in 1822 and was chartered as a city ten years later. Population, 1910, 19,945; in 1917, 22,011 (Federal estimate).

**KHAIBAR**, *kī'bur*, PASS. See KHYBER PASS.

**KHAKI**, *kal'ke*, a Hindu word meaning *dusty*, applied to a twilled, closely-woven, dust-colored cotton fabric, used principally

for military uniforms. Khaki was first used by Great Britain for its native Indian troops in 1848. The word has had an elastic application, having been used to designate strong twilled-cotton goods of whatever color and also dust-colored military serge. Since 1900 a certain olive-drab dye has had so wide a use for uniforms that the two have become inseparably associated, with the result that the color or the uniform material with which it is dyed are both called khaki. As material for uniforms khaki has never been excelled, its color blending with the landscape.

**KHAM SIN**, *kahm seen'*, the name of a warm wind, or sirocco, which blows over Northern Africa in the early spring. The word means *fifty*, and this name is given the wind because it is usually of fifty days' duration. The khamsin is a high, hot wind and often fills the air with dust. It originates in the Sahara Desert.

**KHAN**, *kahn*, a title given by Eastern nations to princes, commanders and governors. It is now generally reserved for governors of cities and provinces. The title is sometimes used independently, and sometimes with the surname.

**KHARKOV**, *kahr'kawf*, a Russian city in the district known as the Ukraine (which see). It is situated 420 miles southwest of Moscow. Before the revolution of 1917 it was the capital of the government of Kharkov, and a thriving commercial center, maintaining four fairs a year. In the city are tobacco factories, soap factories and a sugar refinery. The many educational institutions included a university, a technical school and a medical school. Population, 1913, 258,360.

**KHARTUM**, or **KHARTOUM**, *kahr toom'*, EGYPT, the capital of Anglo-Egyptian Sudan, situated on the left bank of the Blue Nile, near its junction with the White Nile, and on the Cape-to-Cairo Railway. There are several mosques, Christian churches, government buildings and barracks here. Khartum is the emporium of a large trade, ivory, gums, ostrich feathers and senna being exchanged for European goods. The town maintains eight primary schools, and an industrial workshop, and is the seat of Gordon Memorial College, which gives academic, normal and technical courses. It was made the seat of the governor-general of the Egyptian Sudan in 1850, and since that time it has grown in commercial importance. In 1885 it was taken by the Mahdi, who mas-

sacred the whole British garrison, including their gallant commander, General Gordon. In 1898 it was again captured by Lord Kitchener, who overthrew the Mahdi. Population, 1917, 16,325.

**KHAYYAM**, OMAR. See OMAR KHAYYAM.

**KHEDIVE**, *keh deev'*, the title borne for many years by the ruler of Egypt. It is a Persian word, meaning *prince*, or *lord*, and was adopted in 1867.

**KHIVA**, *ke'vah*, a state in the central part of Asia, which became a vassal of Russia in 1872. It is bounded on the north by the Aral Sea, on the east by the Oxus River, and on the south and west by the Russian province of Transcaucasia. Khiva has an area of 24,000 square miles and an estimated population of 646,000. Nearly two-thirds of the people are nomad Turkomans. The religion is Mohammedan. Cotton and silk are the chief commercial products. The capital, Khiva, lies on an alluvial flat at the junction of two canals, fifty miles west of the left bank of the Amu. Population, about 5,000.

**KHYBER**, *ki'bur*, **PASS**, a narrow mountain defile leading from Afghanistan into India. It is thirty miles long, and though of considerable width in some places, it is in others not more than twenty feet wide. On each side of it rise cliffs of shale and limestone from 600 to 1,000 feet, and beyond them tower lofty mountains. The pass is fortified and has been of great military importance for probably 2,000 years. It is under the control of the government of India.

**KIAO-CHAU**, *kyou' chow'*, CHINA, a town, district and harbor situated on the east coast of Shantung province. The area, exclusive of the bay, is about 200 square miles, and the population is about 192,000. The town is a walled Chinese municipality, which at one time was a thriving port of Kiao-chau Bay. Through the filling in of the harbor it has become an interior town. The district was seized from China in 1897 by Germany, as a measure of reprisal for the killing of two German missionaries. A long-term lease was secured, and Tsing-tau, a small village on the eastern shore of the bay, was purchased. The Germans transformed the village into a strong naval base and erected a line of forts for its protection. On August 15, 1914, Japan, as an ally of Great Britain, called upon Germany to surrender the entire leased territory by September 15. No reply having been received, Japan began a siege



of Tsing-tau, which was captured on November 7. After that date the district was administered by Japan, and its final disposal was one of the problems of the peace conference which met in Paris early in 1919.

**KICKAPOO**, *kik'a poo*, an Algonquian Indian tribe which lived in the Ohio Valley prior to 1819. Fewer than 1,000 Kickapoo are now living. There are about 300 in Oklahoma, and the remainder are in Mexico. The American Kickapoo are slowly dying out. After 1819 the tribe moved westward, and in 1852 hundreds went to Texas; from that state they journeyed into Mexico, and the number there is said to be on the increase.

**KIDD, WILLIAM** (about 1650–1701), a celebrated pirate, known as **CAPTAIN KIDD**. He was probably born in Scotland. He became a trader in the American colonies, and in 1696 was appointed captain of the *Adventure*, a galley of thirty guns, and was given a king's commission to suppress piracy in the waters near Madagascar. He sailed for the East Indies and, instead of capturing pirates, turned pirate himself and robbed a number of trading vessels. On his return to New York he was arrested on charges of piracy and for the murder of one of his gunners. He was taken to England and tried, being allowed no counsel, and was condemned and hanged. Many fruitless searches have been made for the treasure which, according to rumor, Kidd and his crew buried on Long Island or near the Hudson River.

**KID'NAPPING**, the act of depriving a person of his liberty without his consent, or the consent of his legal guardians. The act may be committed against children or adults, and is punishable by fine or imprisonment. The exact penalties for kidnapping, and statements defining the meaning of the term, are found in the statutes of all civilized countries.

**KIDNEYS, THE**, in the human body a pair of organs which separate waste matter from the blood. They are situated one on each side of the spinal column and extend downward from the eleventh rib. The right kidney is a little lower than the left, owing to the position of the liver. The kidneys are about four inches long, two and one-half inches broad and one and one-half inches thick, and each weighs about four and one-half ounces. They are shaped somewhat like a bean, are reddish in color, are composed of

a dense substance that is easily crumbled, and are abundantly supplied with blood by the renal artery, a branch of the aorta. A corresponding renal vein carries the returning blood to the ascending vena cava. The kidneys take urea and other waste from the blood that circulates in the capillaries around them.

Urea is the most important substance found in urine, which is carried by the ureters to the bladder, where it is held until expelled from the body (see **URINE**). Infections of the kidneys are responsible for serious diseases, including Bright's disease (which see); irregularities in the functioning of these organs should have the attention of a reliable physician.

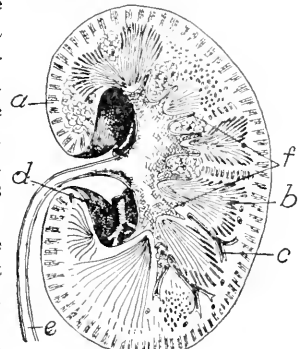

TRANSVERSE

SECTION

(a) cortex; (b) medulla; (c) small branch of the renal artery; (d) renal artery; (e) ureter; (f) pelvis.

**KIEL**, *keel*, GERMANY, a great naval center and the chief city of the Prussian province of Schleswig-Holstein, located fifty-three miles northeast of Hamburg, on an inlet of the Baltic Sea. Kiel is the eastern terminus of the Kaiser Wilhelm Canal, or Kiel Canal, (which see), and until the end of the World War it was the headquarters of the German Grand Fleet. The chief industrial establishments of this prosperous city include shipbuilding yards, iron foundries, oil mills, tanneries and tobacco works. In normal years Kiel carries on an active trade with Denmark and Sweden in flour, coal, fish and dairy products. Population, 1918, 370,358.

**KIEL CANAL**, to the end of the World War in 1918 also known as **KAISER WILHELM CANAL**, is a great German artificial waterway connecting the Baltic and the North Seas. As completed in 1895 it was 61.3 miles long, 190 feet wide at the surface and 29.5 feet deep. The original cost was \$39,000,000. The rapid growth of shipping and the increased size of vessels made a larger canal necessary. In 1908, accordingly, work was begun, and the enlarged canal was formally opened by Emperor William II on June 24, 1914.

The new Kiel Canal is 140 feet wide at the bottom and 330 feet wide at the water surface. The depth is thirty-six feet and there are eleven points at which the largest vessels may pass each other. The new locks at the

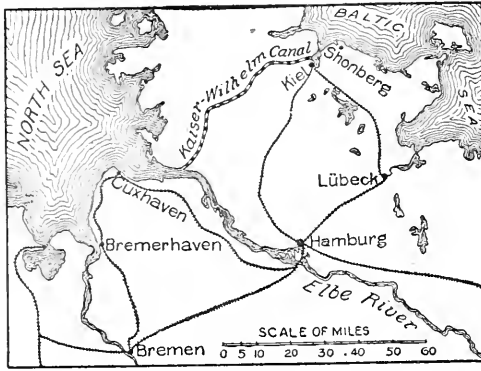

KIEL CANAL OR KAISER WILHELM CANAL ends are 1,140 feet long and forty-six feet deep, large enough to accommodate the largest dreadnought or ocean liner. The Kiel Canal was built primarily for its usefulness in case of war. It connects the North Sea with the Baltic, thus eliminating the need of a voyage around Denmark and enabling the German fleet to be quickly shifted from one sea to the other without exposure to attack.

During the World War (which see), the canal was the safe refuge of the German main fleet; the warships of the empire could not freely operate on the seas because of the effective blockade by the fleets of Great Britain, France and the United States.

The canal is also used by merchant ships; in times of peace its annual tonnage is about ten times that of the Suez Canal. The peace treaty closing the World War demanded that the canal be opened to all nations without restrictions.

**KIEV**, *ke'yef*, RUSSIA, a city in the district known as the Ukraine, of which it became the capital when the Ukrainians set up an independent government in 1918. Kiev is so old that it is sometimes called the "mother of Russian cities." It is situated on the Dnieper, 670 miles south of Petrograd. The city is divided into three parts—old Kiev; the commercial quarter, Podol, and the portion which contains the old fortifications, known as Petchersk. In the early years after the introduction of Christianity into Russia, the city was the center of the new religion,

and it contains many notable old ecclesiastical buildings. Before the revolution it had manufactories of tobacco, paper, chemicals and hardware, but its chief industries were the refining of beet sugar and milling and distilling. It has a good harbor, and normally its trade is extensive. In 1919 it was in possession of Russian bolshevist forces, but loyal troops recaptured it and at the same time dealt a heavy blow to bolshevist forces in the south. Population, 1913, 610,190.

**KILAUEA**, *ke lah oo d'ah*, a famous crater on the eastern slope of the volcano of Mauna Loa in Hawaii. It forms a great cavity on the mountain side nine miles in circumference and in places is from 500 to 800 feet deep. Parts of the crater floor are frequently covered with vast pools of boiling lava, which sometimes threaten to overflow upon the surrounding mountain sides. Kilauea has had five great eruptions, the last in 1868.

**KILLIMANJARO**, *kil e man jah'ro*, the highest mountain in Africa. It is situated at the eastern end of the great equatorial plateau, about halfway between the southern shore of Lake Victoria Nyanza and the Indian Ocean. It has two peaks, Kibo, 19,710 feet, and Mawenzi, 17,570 feet in height. Both of the peaks have extinct snow-capped craters, that of Kibo being 6,000 feet in circumference and 600 feet deep. On the gentle incline of the southern slope are numerous small streams and glaciers.

**KILLARNEY**, *kil ah'r'ni*, LAKES OF, three connected lakes in Ireland, in County Kerry, celebrated for their beauty and for the picturesque scenery of the region in which they lie. Verdant islands stud the lakes, and on their shores rise richly-wooded mountains. Ross Island is especially interesting to tourists as the site of an old castle once used as a stronghold by the O'Donoghues; on Innisfallen are the ruins of a famous abbey dating from the sixth century.

Killarney is also the name of a small market town situated a mile and a half from the lower lake of the group, and forty-six miles northwest of Cork. Its inhabitants earn a good living by making fancy articles and souvenirs to sell to the tourists who annually flock to the district. Population, 1911, 5,796, exclusive of summer residents.

**KILL'DEER**, a variety of plover common in America, named from its plaintive cry. See PLOVER.

**KILN**, *kil*, a structure of brick or stone used to harden, dry or burn various substances. In brick drying (see BRICKS AND BRICKLAYING) kilns from ten to twelve feet high and thirty feet in diameter are used. In pottery making various styles of kiln are used, according to the kind of ware manufactured. All kinds of kilns are constructed on the same principle; namely, the generation of ample and regular heat with the greatest possible economy of fuel.

**KILOGRAM**, a weight in the metric system, equal to 1,000 grams, or 2.2046 pounds. The word is sometimes shortened to *kilo*. See METRIC SYSTEM; WEIGHTS AND MEASURES.

**KILOGRAM-METER**, *kilo gram me ter*, a unit of measurement in the metric system, expressing the mechanical work expended in raising a body whose weight is one kilogram (2.2 lb.) through the vertical height of one meter (3.2809 feet). It is equal to 7.233 foot pounds. See FOOT POUND; METRIC SYSTEM.

**KILOMETER**, a unit of linear measurement in the metric system, equal to 1,000 meters, or 3280.8 feet. This is about five-eighths of a statute mile. Americans and Canadians were unaccustomed to the word and its meaning until the World War, during which struggle all advances and retreats of armies were referred to in terms of kilometers. See METRIC SYSTEM; WEIGHTS AND MEASURES.

**KIL'OWATT**, the unit in general use for measuring electrical energy, even in countries where the metric system is employed. A kilowatt is 1,000 watts; 746 watts are equivalent to one horse power, hence the kilowatt is equivalent to one and one-fourth horse power, or a power that would raise a weight of 41,250 pounds one foot in one minute.

**KIMBERLEY**, *kim'bur ly*, SOUTH AFRICA, a town in the province of Cape of Good Hope, capital of Griqualand West, and the

center of the rich diamond fields of South Africa. It is 647 miles northeast of Cape Town, with which it has rail connection. A railroad also joins Kimberley and Port Elizabeth. The place has fine public buildings, a free library, botanical gardens, a theater and a museum. It is lighted by electricity and is supplied with water by an up-to-date system. Kimberley was founded in 1871. It is a seat of the diamond industry and is a prosperous trading center. During the South African War (which see) it withstood a long siege. Population, 1911, 29,500; white population, 13,598.

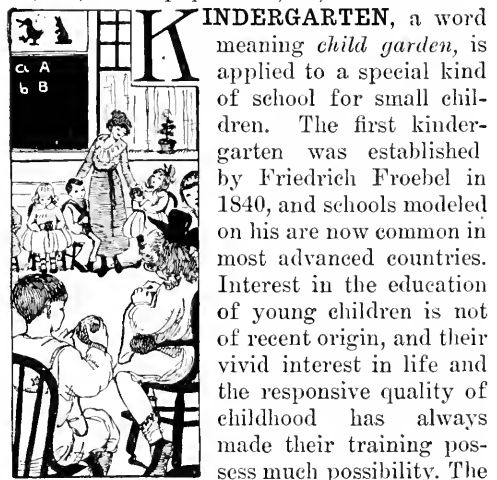

Greeks planned for definite care of children under seven. The Romans invented methods of instruction which should tempt these beginners into paths of learning, and after the establishment of Church schools the children became proficient in many studies early in life.

Indeed, we learn of wonderful prodigies of learning during the years of the Renaissance, when three- and four-year-old children became experts in Greek and Latin and discoursed piously on many serious subjects. This, indeed, was the difficulty. The children were regarded as immature men and women and they were forced into mental processes entirely unfitted for them.

In the seventeenth century Comenius, Bishop of Moravia, instituted a reform in supplying a reading book with pictures for little children and organizing what he called the "School of the Mother's Lap." He was followed by Rousseau, Pestalozzi and many others, who all contributed to a clearer insight into the natures of young children, and to a

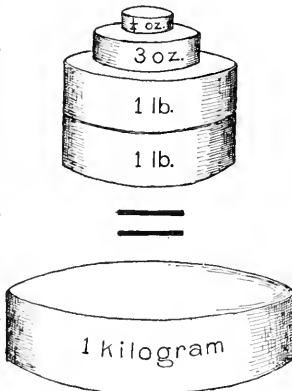

A COMPARISON

sympathetic planning for their needs. But it remained for Friedrich Froebel to touch the heart of the mother in the establishment of the kindergarten, or education for young children according to principles of natural growth.

For the Montessori Method, see that article.

**Biographical.** Friedrich Froebel was born in 1782, in the little village of Oberweissbach, in Thuringia, in Germany. His parents were in fair circumstances, his father being the village pastor, but his mother died soon after he was born and he was left to the care of servants and of his brothers.

His father married again when he was four years old, and his stepmother neglected the little Froebel. An uncle, however, adopted him, and while with him the boy received good education, affection and wise care. He needed these things very much, for he was a sensitive, affectionate, earnest boy, with a lanky, awkward body and a strong vigorous mind, with much constructive and imaginative power. Profiting by these years of good care he grew through boyhood, was then apprenticed to a forester for two years, and afterwards studied at the University of Jena. He fitted himself for work in an architect's office and was going to Frankfort to take a position of this nature, but lost his articles on the journey. Looking for other work, he was offered an opportunity to teach in the Frankfort Model School, under a fine leader, Dr. Grüner. Here he found his true vocation, and for the rest of his life devoted himself to education. He worked with Pestalozzi for two years, founded a boy's school which was most successful, lectured, taught, read, and constantly endeavored to arouse people to the necessity of a reform in education. Then he originated a school for young children, and was working out a future development of this for the schools when he died.

He lived to be seventy-one years old, was married twice, both times to interesting, thoughtful and devoted women. His life was marked by many hardships and a constant struggle with opposing circumstances; but it was distinguished throughout by a single-hearted devotion to the cause of humanity and an earnest purpose faithfully followed.

**Character of Froebel's Work.** His works are remarkable in their insistence on requirements for hygienic conditions, that are wholly in harmony with modern knowledge,

though written seventy-five years ago. He wrote and edited much during his long life, but his best-known works are "The Education of Man" and the "Mother-Play Book."

Froebel's educational work was first carried out with children beyond six years of age, but he gradually realized that he must begin at the beginning, and was just organizing the work for the first years, to be followed by related work for other children, when his life was closed. Therefore few people realized that the kindergarten was only the application of his principles to the beginning of education, and was to be a part of an educational procedure co-extensive with growth.

**One of the First Principles.** Development is one of the most important of these principles; it might be phrased as "Continuous Evolutionary Growth."

Froebel saw this as a basic principle of the world, and of man's life, bodily and mental. He applied it to method in education in every way he could. He believed that the child's activities and powers, physical, mental, spiritual, have, as plants have, a necessary and natural growth; that the tendency and rate of this growth depend on the kind of nurture supplied, as it does with plants; some being quicker, some slower, some stronger or weaker in certain qualities, so that right education means neither arbitrary control in forced directions, nor wild spontaneous growth. It means such cultivation, following what we observe of the child's needs and nature, as only patient and thoughtful people can give. He believed that such a method would give us a finer type of human beings, and would result in developing the best possibilities of which each child is capable.

**Starting Point in Education.** Another principle, that of Creative Activity, or Self-Activity, is a natural accompaniment of the first.

Froebel regarded the smallest active power in the child as important, as the starting point of education. Not only this, but as the spark of divine inheritance, the proof of our being God's children. "God," he says, "creates and works progressively in uninterrupted continuity." Again, "Think not, mother, that the almost infinitesimal powers of your child may be neglected. Out of least things, God created the greatest, therefore cherish and encourage your child's feeble

efforts to use his power." He persistently urges that education means the drawing forth



FRIEDRICH FROEBEL

and training of the child's spontaneous energy and activity in all right and possible directions.

**Preventive of Wrong Activity.** Froebel says, "There is but one sure preventive of wrong activity, that is right activity; an activity as persistent as it is fit and lawful, and that is not of the head alone, but of the head, the heart, and the body." As Col. Parker once said, "The whole child goes to school," but under old-fashioned methods it was almost a crime for a child to be active in school, and teachers would no doubt have preferred, had it been possible, to have heads there alone.

It is the natural consequence of Froebel's principles, that manual training, gymnastics, art and music—in a word, everything that trains and develops the physical nature and the emotion as well as the intellect—should form part of education.

**Value of Play.** Play as a valuable agency in early education was a natural conclusion from this belief in self-activity, since it was the child's earliest form of expression.

Froebel believed play to be one of the highest, most wholesome forms of human activity; partly because it is the form of activity in which little children and ordinary

people are best able to be spontaneous and creative. He thought the plays of children, if watched and studied, gave valuable hints for training them. He says, "I believe that whatever affords a child a pure (or wholesome) and persistent pleasure, is founded on a real need." In other words, that the native instincts and impulses give true information as to the powers and needs of children, though the need may often be to control and train the impulse, not to let it run wild.

It is a great mistake to suppose that Froebel thought everything which is spontaneous should be let alone. He says, "All true education should be double-sided, prescribing and following, active and passive—positive, yet giving scope." He believed that in guiding play it is possible to give a valuable social training in sympathy and cooperation, leadership and comradeship, as well as in originality.

**Unity Contributes to Growth.** Another principle of Froebel is generally spoken of as Organic Unity; by it is meant that as all the parts of a plant have their share in the activity which contributes to the whole growth, so should all humanity contribute, each to the benefit of all.

Froebel felt deeply the relation between all created things; he felt that men were dependent on nature, God and each other, and should be full of gratitude and helpfulness. The child should learn gladly and actively to do his share as what Froebel calls a "Member-Whole" in the world. He is to give care to animals and plants, sympathy and help to his family, neighbors and fellow-citizens, with loving obedience and gratitude to God.

In planning the kindergarten, the latest of his educational efforts, he strove to invent and suggest means for planting the germ of this idea in the minds of young children—mainly through action, for "Learn by doing" is his guiding rule. But Froebel's most urgent point is, that the child's life and education should be an organic unity, or natural whole.

As a plant or tree has root, stem, leaves, blossoms and fruit, each needing the rest for its perfect growth, so every part of life should help every other; and parents, teachers, ministers, playmates, neighbors, should have a necessary and helpful part in all children's development; as the plant grows from the moment the seed life stirs, so each day of a child's life belongs to the whole.

Froebel is most anxious that education and training for life should begin in the home; that parents should co-operate with the school, heartily, intelligently. He urges, "Come, let us live with our children," meaning, let us share their play and have them share our more serious pursuits, let us enter into the spirit of childhood, and so learn how to teach children.

**Plan of the Kindergarten.** In his kindergarten, or child-garden, he plans for something of the order and grouping of the community-action of the school; and with this, some of the training in language and manners, the play and exercise of the senses, the moral training, the free movement and the happiness of a good home.

The games are simply physical exercises, the preliminary to gymnastics; the hand work is the beginning of manual training; the songs, stories, verses and conversations are the beginning of literature, nature study, civics, and moral teaching; the touch, ear, eye and mind are made more alert and ready for the work in reading and writing; the experiments with simple objects in contrasts of number, measurement and color are a basis for science and arithmetic; while the child's love for his home and his parents, and his duties to them as well as to teachers and playmates, are emphasized.

**First Training in the Home.** Training, that is, seeing the right thing is done over and over again until it become a habit, is especially the office of the home; for the younger we are, the more plastic we are in forming habits. Every day that a garment lies folded makes the crease deeper; so every time we act a certain way, the habit gets more set, and every day a child is not forming good habits he is forming bad ones, for the wrong way becomes more set, if the right does not. (See *James' Talks on Psychology*, Chap. VIII.)

So a child should carry with him from home to kindergarten habits of obedience, cleanliness and politeness and the habit of attending when he is spoken to. Above all, he should have the habit of happiness and good humor. For this is habit, too, and can be made natural to a child, especially by example at home; for young children learn more by imitation than any other way. If in addition the child has become interested in observing what he sees, has heard some pleasant childish rhymes and stories, and has

been given toys such as he can arrange, take apart and put together by himself, not mechanical ones, he will enter easily into kindergarten activities. One warning must be given; neither home nor kindergarten must push or overstimulate growth. It must never be hurried.

**References.** In the references given there is no attempt at a complete list of Froebel's statements on any point or principle of education; a few only of the most definite statements on each subject are mentioned, with a few similar or related views from other educators and psychologists.

See *Education of Man*, pp. 8, 17, 27, 29, 194, 328, 329, and *A Study of Child-Nature*, by Elizabeth Harrison, chapter on "The Training of the Intellect." Froebel's *Mottoes and Commentaries on Mother-Play*, pp. 106, 199, 201, 307.

See *Education of Man*, pp. 30, 34, 39, 71, 75, 99, 107.

Froebel's *Mottoes and Commentaries on Mother-Play*, pp. 27, 153, 213, 297.

Read *Education of Man*, pp. 29, 255, 60, 107, 114; *Mottoes and Commentaries of Froebel's Mother-Play*, pp. 26, 29, 250, 255, 297.

*James' Talks to Teachers*, Chapters VI, VII, X, XI, pp. 123, 146, 147, 235, 241. *Education and the Larger Life*, C. Hanford Henderson. *Essay on Child's Play*, R. L. Stevenson.

*Love and Law in Child-Training*, Emile Poulson.

Froebel and Self-Activity, Chapter III; Bowen.

*Psychology of Childhood*, Tracy.

### The Relation of Child Training to Natural Impulses and to Habits

**Habit.** We are all, as Professor James says, bundles of habits; Americans prefer chairs to sit upon because it is their habit to do so; that is, they have done it every day of their lives since infancy and have done it thousands of times; their muscles and nervous system are set in the habit, which makes it a discomfort to sit on the floor, as the Japanese do. With the latter it is just the reverse; and in early childhood it is possible to make either habitual.

Going to bull-fights and seeing wounds and blood without distress has become habitual to many Spaniards; traveling on skates for long distances without fatigue has become habitual to Dutch peasant women; carrying baskets on the head, to West Indian women. Neglected children in the street get the habit of swearing; well-cared-for children get the habit of being shocked at bad language.

**Instinct.** Instincts are things which we do without being taught—laughing, crying, grasping things, using our senses and limbs. Every natural impulse and instinct has a stronger tendency to repeat itself each time it is used, if not checked by unpleasant consequences; “repetitions form habits, habits form character and character forms destiny.” But the crucial point is that instincts can be trained; the grasping can be trained into right ways of handling knife and fork, the hearing into listening with attention to certain sounds and neglecting others, and so on through the whole range of instincts.

A mother taught her little girl to look away from the advertising posters of theaters, etc., fearing she might see harmful things, and the habit persisted all through life. A baby whose mother put his hand down from his mouth every time he tried to put buttons, etc., in it, had learned at nine months’ old never to put anything in his mouth except food.

“Mother,” says Froebel, “you can now by a slight effort do for your child what later all your powers will be insufficient to accomplish. How eagerly (young children) begin to share in what father and mother do. Be thoughtful, be cautious, O parents! You may destroy, at least for a long time, instincts of activity in children, if you repel their help. Their minor power is aroused, but they do not know what to do with it; it becomes a burden to them and they are fretful and indolent.”

We have seen children of good ability constantly made to be quiet and inactive, because their parents disliked noise and the trouble of guiding and attending to them. They became in time dreary and lazy, so they could hardly concentrate on any effort; they were unskilful and awkward about household matters, lazy at school, uncouth in manners and afraid of social functions, because they had been restricted from, instead of trained in, the habits needed for these.

**The Child’s Natural Impulse.** A child’s natural impulse is toward activity of some kind; it depends largely on its surroundings, parents and playmates, which direct its activity in action, speech or thought shall take, and into what habits it will crystallize. A scolding mother, who allows her children to imitate her tone and words to brothers and sisters, trains them in the habit of scolding; a mother who caresses and

speaks gently, and reminds her children to do so, forms gentle habits in them. A mother who insists that her children shall wash their hands and faces before meals trains them to the habit.

“We must make automatic, as early as possible, as many useful actions as we can, and as carefully guard children against growing into disadvantageous ways; we are bundles of habits, imitators and copiers of ourselves.” (James.)

**Tendency Towards Activity.** Froebel is constantly urging in his “Mothers’ Book,” or *Mother-Play*, that children naturally tend toward activity, therefore we must show them wholesome actions and let them practice them; that they tend to imitate, so we must watch ourselves and teach them to imitate good things. They wonder, are curious; so we must give them interesting and worthwhile things to notice; they like to handle, take apart, and put together; therefore give them materials with which to work.

I will quote again on this subject from James, the great psychologist:

“Constructiveness is another great instinctive tendency. The more different kinds of things a child gets to know by treating and handling them, the more confident grows his sense of kinship with the world; the wise education from the kindergarten up takes the tide at the flood, and devotes the early years to training in construction and object teaching.”

**When to Develop Instincts.** It is now known that certain instincts appear at certain times of life and if not used and trained then, may fade and become useless, or almost so. The child’s tendency to handle and construct is one of these. One of Froebel’s merits is that he seizes the right time to train the child’s senses and instincts. It is found in training the blind that the finger tips seem to lose some of their sensitiveness after a person is six or seven years old, and that those taught later are not so quick to learn. Manual work, the sense for color, etc., are things to be begun early.

### Description of the Kindergarten

**Attractive and Pleasant.** A kindergarten is so pleasant a place that at first one can hardly believe it is for anything but a playroom. The walls are generally of a soft tan, green or grey, with plenty of pictures; there are flowers in jars and plants in pots; there

is a piano and a sand-table; and the furniture is just right in size for the small persons who use it. There is generally a globe of goldfish, and sometimes another with tadpoles, snails, or curious sea creatures in it; there may be a glass box, or a terrarium, where caterpillars and butterflies or toads and beetles live; indeed, any pet which can properly be kept indoors may be found in a kindergarten, and wherever it is possible, there is something of a garden outside.

When the children come in, one sees that the small people have responsibility as well as pleasure; from four to six years old, they hang up their hats and wraps neatly, the hooks being well within reach; then, while some find playthings, and use them, others help in arranging the little chairs in a ring, or they dust the room, feed the fishes, and water the plants, unless some other time is appointed for this. Perhaps there are forty children in the room before nine o'clock, and they are free—no one is directing them; but they employ themselves happily and peacefully.

At nine, a chord struck on the piano is sufficient to bring all to their places in the ring. Songs of greeting are sung, the day of the week and month is told and marked on a calendar; bits of home news are given by one or another; then a conversation or a story is begun on some topic suggested by a picture, or by some experience which is important for the children, the teacher guiding the talk, yet allowing the children to express their ideas and ask questions. A few more songs are sung and then each child carries his chair to its right place at one of the tables.

**Plan of Exercises.** A short period of running, skipping, or other exercise follows, for the day is carefully planned to alternate quiet with active times; and then there is an orderly march to the tables. Here are balls, large and small and of different colors; at another table there will be blocks, simpler or more varied in combination, larger or smaller, according to the age of the children and the time they have been in kindergarten; or there may be sticks, seeds, shells, rings, etc., for making outline pictures. All must be taken out and put away in orderly fashion; but the work may vary in many ways; the material is adapted for experiments which bring to the children's notice contrasts in color, in shape, size, roughness and smooth-

ness, in sound and weight; but the play of the children and what they suggest is either the starting point, or they are allowed to play freely with it, after the teacher has guided the first half of the period. An important point is that each should notice what the others do, and so gain new ideas. Sometimes several children build or design together. Next comes half an hour of active games, where consideration for others and courtesy are emphasized, as well as fun. After this there may be a rest, or a little luncheon, where the children are taught to give thanks and to be polite.

Half an hour of handwork succeeds, and then all come together to show what they have done and to say good-bye. On certain days, walks may be taken to the parks to notice birds, etc., or to see a market, a blacksmith shop, an engine-house; the conversation afterward helps the little ones to understand how other people work for their comfort and protection, though only the simplest of such experiences are used. Sometimes when pictures of the cow and the farmer are the topic, the children make a little butter in a toy churn or glass jar, so as to get a little way toward understanding some steps of the wonderful process in which nature's forces, man's labor and Providence work together to provide food and convert it into our growth and strength. They learn to follow the course of the seasons; to notice the provision birds and animals, as well as human beings, make for their young and against the weather; and to trace all gifts and all power back to the love of their Heavenly Father. Of course, some of this can be done at home; but neither so systematically, nor, as a rule, with so much training in habits of attention, as when with other children. There are many interruptions at home, and too great attention is paid by the adults to the one or two children.

In kindergarten each must behave well, and attend, because it is the law for the whole group; the attitude is, "We are all partners, we can all make pretty things for the room, we must all do our share in taking care of things; we must take turns in talking, in choosing games or stories; no one must be too noisy, or too pushing, because it prevents others hearing or seeing, or having a good time." The discipline is on this basis; if anyone should spoil another's work, the children will tell you, he must put it right again or give his own piece of work to the other child;





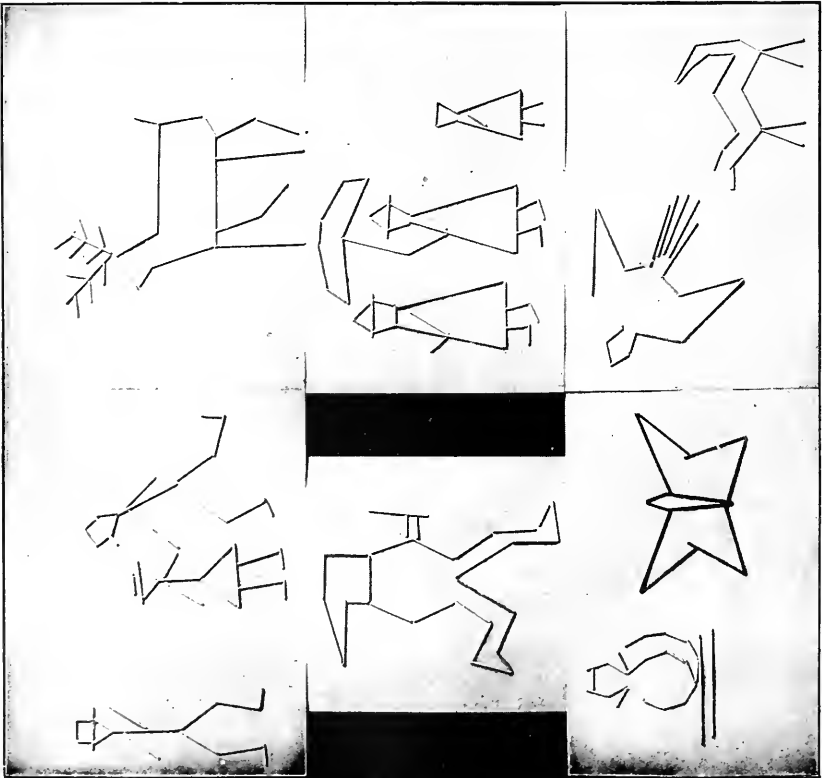
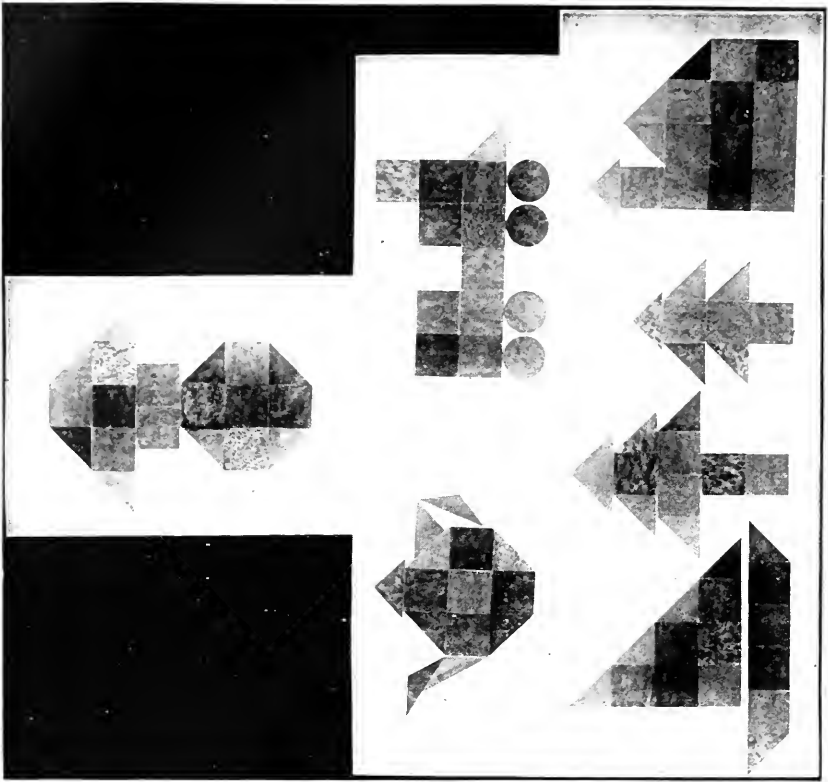

TYPICAL ILLUSTRATION OF PICTURE MAKING, WITH COLORED STICKS AND CARD TABLETS.  
 These may be selected, repeated and varied to form groups and designs. (See text.)

if anyone is unkind and makes his neighbors uncomfortable, he must sit by himself until he can be pleasant again. "There is one law of right for all, which both you and I must obey," is Froebel's principle.

**Kindergarten Supplies.** Froebel's boxes of blocks and other playthings and occupations for children are numbered in series, and the lists and descriptions of them may be found in the catalogues of the Milton Bradley Company or other kindergarten supply houses.

It is not advisable to buy them indiscriminately for home use, as they cannot be very

cisco, Springfield, Mass., and Toronto, Canada.

3-A, Third Gift } Blocks  
4-A, Fourth Gift }

2-B, Second gift, blocks of three shapes in bulk, is desirable, but expensive. The price is \$5.00. The Hennessy blocks are a useful set for the home.

Parquetry papers, for arranging and pasting in design.

2002—Assorted package to be used with paste.

3003—Gummed pieces, to be used with water.



1

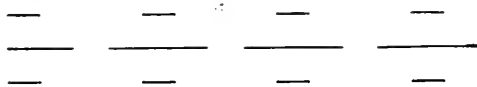

2



3

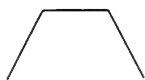

4

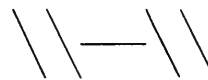

5

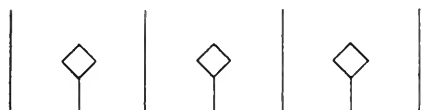

6

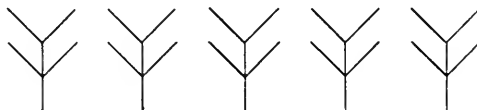

7

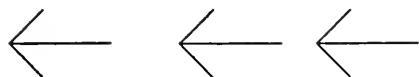

8

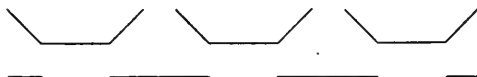

9

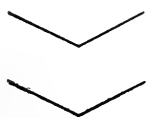

10

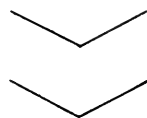

11

PICTURE-MAKING MATERIAL

1—Rain; 2—Water; 3—Tents; 4—Mountains; 5—Necklace; 6—Postboxes and Telegraph Poles; 7—Trees; 8—Fishes; 9—Boats; 10—Birds; 11—House and Garden.

much used without a regular course of instruction. A list of those which are most useful in the home follows. The catalogue numbers are those used by the Milton Bradley Company, Springfield, Mass.

Bradley's Kindergarten Supply-Houses are found in Boston, New York, Philadelphia, Atlanta, Chicago, Kansas City, San Fran-  
123

Stodder design cards for sewing with silkaine; assorted.

Mrs. Kraus' booklet on *Sewing Without a Needle*. E. Steiger Co., New York.

Shoe-lace sewing cards for very young children. The laces are colored and sold with the cards.

Paper for folding forms;

204, 210, 211X, 213E, 217X.

Blunt-pointed scissors.

Hailmann wooden beads for stringing on boot laces, Nos. 464 and 470. These are in six different colors, and there is a gross in a box. They give great pleasure to children.

Peg tile 474X, and pegs 472X. The peg tile is a board with rows of holes in it, into which colored pegs are stuck in patterns.

Boxes of wood and sentence-building tablets, number tablets, etc., are an amusement to children who have learned their letters. But they can also be made at home. These last are not Froebel's materials.

### The Kindergarten Gifts

**Power and Control.** Froebel always claims that education should lead man to freedom. By freedom it is evident that he means the large and varied control of power, which is attained by acting under various conditions of limitation, until one has mastered each condition; for instance, as a gymnast gains power by training all parts of his body. How limitation helps a child may be seen in questioning. If you ask, "What did you see when you were out to-day?" there is no real thought demanded; something may come up which has no value. But ask, "What kind of animals did you see?"

"How many things on wheels did you see?"

"What were the people (or the birds) that you saw, doing?"

"Did the trees look just the same as they did last week?" (In spring or fall.) In this way you contrive that his thought shall become definite, by limiting to a certain degree what he shall think about.

The kindergarten gifts are an example of this kind; and they cannot be successfully used by a mother or by a teacher who has not been trained in their use, because only one who has learned their various limitations, intelligently and experimented under them, can help children to achieve the interesting results which are possible.

Of course, children will play with them, at any time, because they are first of all play-things, but the plays will be hap-hazard.

**The Gifts.** The first gift, soft woolen balls of six colors, is intended to bring out the contrasts of color and of movement; the children learn to roll, toss, bounce, and swing them (the balls having strings) rhythmically; and the colors are emphasized by opposite or alternate children having different colors. By

and-by, plays where the balls may represent fruit, flowers, etc., being sold, or where various colors are called for to be rolled in turn, test the children's certainty of color, as well as their certainty of aim and control. The little songs which describe the action may be found in kindergarten music-books, and will enable mothers to use some of the play.

After these, the ball games should be continued with rubber, celluloid and other balls, of different sizes and weights, for each gives a new test of skill and control. A good game for children who can aim well is tossing balls in turn, into an open box or basket; or rolling them to hit some object in the middle of the floor.

Froebel always plans that after each gift has been well mastered, the same plays shall be tried with other things, rather like them, but such as can be found among common objects about the house, and ordinary toys. In other words, the things he organized are meant to be a key to all sorts of possible use and mastery of other things in the world.

The soft balls are succeeded by hard balls, blocks of different sizes and shapes, and flat materials, suitable for making pictures and designing patterns; and after two successive kinds have been mastered separately, the two are used together, so as to give a larger quantity of material and new opportunities. At any time, two or more children may use their materials together, if they wish, either to make the objects larger, or to complete something, as a house and barn, table and chairs, church and steeple, etc., or to carry out a pattern, which may extend round the table.

Each gift has its own contrast, and is best suited to certain things; the children's discovery of these and their success in making new inventions is the test of the freedom they have gained by trying to achieve things in spite of the limitation.

The "picture-making" material can be used at home; not only the regular sticks, but pine twigs, stripped of needles, and leaf stalks may be arranged in very pretty pictures and designs. Leaves, also shells, grains of corn, beans of different colors, pebbles; seeds of pumpkins, water-melons, citron-melons; glass and china colored buttons are very pretty, used in this way. The page of material suggested for drawing designs will do for sticks or twigs also.

The outlines given are for suggestions, not for copies. Children's expression of this sort

is much like the early picture-writing of savages, and is not meant to be perfect representation. By repetition with colored chalks along a strip of paper, or with strips of colored paper, pasted on patterns on white, this leads to the beginnings of design. Originality should be encouraged.

Stories may be illustrated in this way, but little children will not care to do connected things at first. Drawing of this kind may be followed by drawing "borders" with the colored chalks, on paper towels and paper napkins; drawing pictures for the doll's house, to be framed in folded paper; decorating paper plates and cups to be used for tea-parties; and making original pictures to illustrate the seasons and months of the year, fairly tales, dreams, etc.

### Kindergarten Games

**The Necessity for Play.** Gross says that young creatures do not play because they are young, but they are young because they must play, in order to be well fitted for the energy and effort required in later life; so, mothers, above all things, plan that your children may have place, time and companions for play—for it is a dismal thing to play all by one's self. I once talked with a woman who said: "There were seven of us at home, but we were never allowed to play in the house lest we should make disorder, and we had no place for it out-of-doors. We are now a set of wretched, nervous, morbid people, and we have no love for our home, nor wish to go to it. My mother cannot understand it. My youngest sister," she added, "told me that when she came from school on dark winter afternoons, she used to run around and around the block as hard as she could so as to be able to sit still when she got in."

**Find a Place for Play.** But how are we to find a play place if we live in cities and in small modern houses or flats? If it is not possible to give up a room to the children, have one room where there is as little unnecessary furniture as possible, and where what there is can be moved into corners and put out of the way, for at least part of the day. Have a straw rug to spread on the floor and a large cupboard where the playthings are kept. If there is a gallery or balcony which can be glassed in or screened in with canvas, for fine weather, or any place out of doors, where a playhouse can be put, it is better than

having the children indoors; but if not, and if there is no yard, supplement the indoor rooms by walks and afternoons spent in the nearest park.

Because of the larger space for play and for company, children in kindergarten get experiences in games which are hardly possible at home.

**Recommended Games.** Froebel's games are of many kinds: Ball games, "sense-training" games, partner games, where the children skip or dance by twos, "courtesy" games, where bowing, or some other expression of pleasure in meeting is the point. Running, hopping, chasing, all kinds of childish activity—marching as soldiers, playing at "blacksmith" or some other of the many imitations of workmen which children love; and animal games, not only playing "horse," but any animal or bird in which the children are interested. All these are included. The triple value is, first, that the child's attitude towards his playmates must be just and fair, "taking turns" in leadership or in following; second, that a large and varied series of physical activities exercise his body and limbs, with the happy feeling of play rather than drill, and last, that the spirit, especially of the "representative" games, is one of loving, kindly recognition, of the helpful attitude of persons and things towards him, and a better understanding of them. However, most of these games require a large group of children; only the "finger games," ball games, and "sense" games can be well played at home or with very few children.

Finger-games have been played by mothers, with little ones, almost since history began.

"Here are Mother's knives and forks;

"Here is Mother's table;

"Here is Mother's looking-glass, and

"Here's the baby's cradle."

This teaches a child to separate his fingers and close his whole hand in different ways: thus getting control of it; while the little "story" of home life gives meaning to it.

"Pat-a-cake, baker's man," and "Pittypatty polt, Shoe the wild colt," call the child's attention to activities of people about him.

The best series of finger-plays, with directions for playing, is by Miss Emilie Poulson.

**Sense Games.** These are easily played at home, and from one to any number of children can play them. They are used to exercise and make alert the five senses, and

are extremely important for backward children.

*For Touch:* The child shuts his eyes or is blindfolded, and something is put in his hands that he may guess the name by handling. If the guess is right, the playmates clap. The value of this game can be increased by giving things which contrast with each other in some point, successively or on different days; or several objects connected with some one occupation, or with some experience, such as a visit to the park.

*For Hearing:* As before, the child is blindfolded and listens to sounds, guessing them; the voice of someone behind him, the sound of metal, wood rapped, paper rustled, stamping on the floor, water being poured, a bell tinkled, etc.; the window may be opened and the child asked to tell a sound that he hears. Voices may be disguised by letting the children speak very high or low, sing, or imitate the cat, dog, etc.

*Tasting:* The tastes should be contrasted and given in connection with different occupations and interests. Froebel intended warnings against hurtful food and unripe or over-ripe fruit to be connected with this game.

*Smelling:* The scents of flowers, fruit, herbs, etc., are to be distinguished; with very young children, only two or three very familiar flowers should be used at first; when the mother takes her turn, she will be surprised to find how hard it is to recognize scents or tastes with eyes shut.

*Seeing:* The best form of this game is to choose some familiar object, such as a toy, then let the guesser turn his back or leave the room, while it is put in some unusual place, which his "sharp eyes" are to find, when he returns; or some familiar thing may be hidden, and he must tell what is gone. This is too hard for very young children, until they have been used to see others play the game. Songs accompany the games.

### Story-Telling

**A Powerful Factor.** Froebel makes stories a necessary part of education; and who that recalls his own childhood does not remember the delight of hearing stories?

It is a powerful means of influencing children, for the story seizes on the child's imagination, and the vividness with which he pictures it aids his memory in retaining it. Moreover, the happy recollection of the

"Story-hours," by the natural process of association, lends an additional charm to the time, the place and the person to whom the memory is due. It is a means to strengthen the bond with home and with family affections and influences.

Story-books in plenty there are now, but the story read can seldom hold the attention of a young child as well as that where the eye and tone make a direct appeal to him.

If short stories are told at first, the child will be sure to ask for them over and over, and even if the story-teller has not a good memory, the practice and repetition will quickly improve it.

**Nursery Rhymes.** Children of three and four years old like nursery rhymes best, such as "Mother Goose", and the relation of simple incidents which have happened to themselves. The visit to grandmother's; the walk in the park; going to the zoo and seeing the animals; the birthday, etc. If courage is lacking to originate the composition of these, the "Arabelle and Araminta" stories, and the Reggie and Roggie stories, by Gertrude Smith, are excellent models, until confidence is gained. The recall of small details, which means so much to the small person, in whose life the experience was a great event, must be practised.

After the first story has been told, and the story-teller has seen the bright eyes dance with pleasure and has heard the eager little voices say, "Tell it again," she or he will be glad to try it often.

**With Dramatic Effect.** The stories should be short, definite and bright; as far as possible they should be told dramatically; in *The Three Bears*, for instance, it is important to give the big, gruff voice of the Big Bear, and the tiny voice of the Little Bear, even with exaggeration of tone.

It is, of course, not desirable to emphasize ideas which are unwholesome for a child; but the occasional tragic death of the bad character in the old classic tales, or even a seeming tragedy for the good hero, who is sure to come out right in the end, is not to be eliminated. Virtue rewarded and vice rebuked, in strong contrast, are characteristic of primitive tales and primitive states of mind. It is the general result, not the particular feeling, which a child holds in mind.

**Kinds of Stories.** Children are generally ready for fairy tales when about five years old. Imagination is active and needs food;





"SOMEBODY HAS BEEN SLEEPING IN MY BED—AND THERE SHE IS!"



wonder is alive, and has a needful part to play in rousing thought and fancy. A child needs the contrast of the new and the familiar, the strange and the natural.

Animal stories are always loved and Bible stories never fail in their charm, if begun early and followed out continuously. Froebel warns us not to explain or urge the moral of a story, but rather to tell it so earnestly and often that it makes a deep impression, and the child will gradually realize the moral ideal.

It adds much pleasure when the incidents or characters can be reproduced by drawing or paper cutting, and they may also be dramatized by the children, at times; it is best to wait for this till they show inclination to do it. Stories should give good standard and ideals in language as well as in thought, and should not be too much simplified.

#### The Three Bears

Once upon a time there was a little girl named Goldilocks, who lived with her mother

were good bears, and never thought that anybody would touch what belonged to them.

Now, when Goldilocks saw the door open, she thought she would go in and rest for a while. So she went in, and on the table she saw the three bowls of porridge; a big bowl for the big father bear, a middle-sized bowl for the middle-sized mother bear, and a little tiny bowl for the little tiny boy bear. Goldilocks was very hungry, so she tasted the father bear's porridge, but it was too hot, and she burned her mouth. Then she tasted the mother bear's porridge, but that was too cold, and then she tasted the little boy bear's porridge, and that was so good that she ate it all up, and left none for the poor little bear.

Then she went into the parlor, and there she saw three chairs; a big chair for the big father bear, a middle-sized chair for the middle-sized mother bear, and a little tiny chair for the little tiny boy bear. First she sat down in the father bear's chair, but that was too high; so she got out of that and sat down in the mother bear's chair, but that was too low. Then she sat down in the little boy bear's chair, and that was just right. But she jumped up and down in it, so that at last she knocked the bottom out of it,

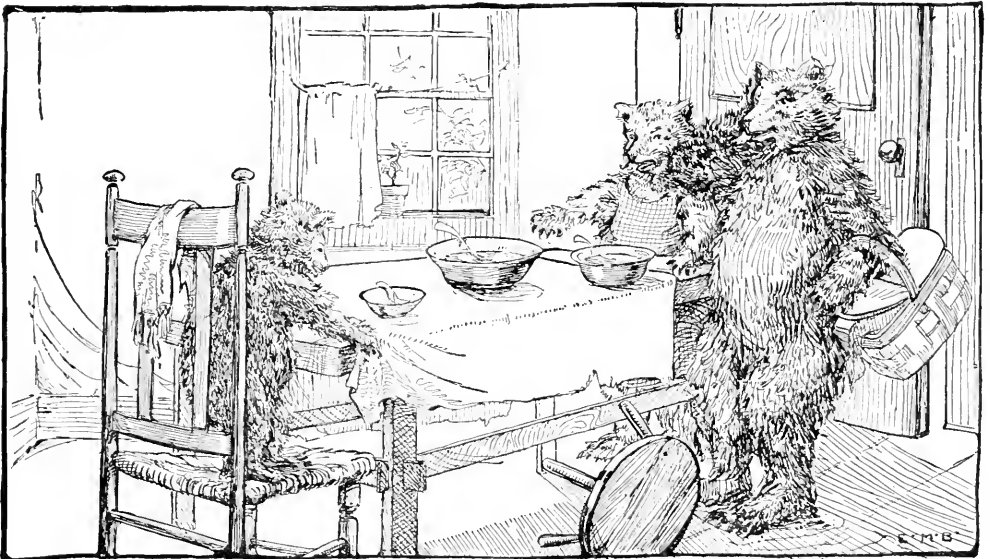

"SOMEBODY HAS BEEN EATING MY PORRIDGE," SAID THE LITTLE TINY BOY BEAR.

near a great wood. One morning Goldilocks ran out into the wood without asking leave from her mother, and she ran on and on and on, till she became very tired. At last she saw a little house. Now in this house three bears lived, a father bear, a mother bear, and a little boy bear. That morning the mother bear had made porridge for their breakfast, but it was too hot, and while it was cooling they went out for a walk in the wood. They left the door of their house open, for they

and the poor little boy bear's chair was broken.

Then she went up stairs, and there she saw three beds; a big bed for the big father bear, a middle-sized bed for the middle-sized mother bear, and a little bed for the little boy bear. Goldilocks was very tired by this time, so she thought she would lie down and take a nap. First she climbed into the big father bear's bed, but that was too hard; then she got into the middle-sized mother

bear's bed, but that was too soft; at last she got into the little boy bear's bed, and that was so comfortable that she very soon fell fast asleep.

Now the bears came home and they went into the kitchen to eat their porridge.

"Somebody has been eating my porridge," said the big father bear in his big, rough, gruff voice.

"Somebody has been eating my porridge," said the middle-sized mother bear in her middle-sized voice.

"Somebody has been eating my porridge," said the little tiny boy bear in his little tiny voice, "and has eaten it all up." And the poor little bear began to cry.

So they went into the parlor next, and there they saw the three chairs which were pushed out of their places.

"Somebody has been sitting in my chair," said the big father bear in his big rough, gruff voice.

"Somebody has been sitting in my chair,"

at her, and remembered how naughty she had been, she was very much frightened; she jumped out of bed and ran down the stairs as fast as ever she could, and she ran straight home to her mother. And after that she never went out into the woods without asking her mother first, and she never went into anybody's house, or used anybody's things, without asking leave.

### The Three Tiny Pigs

Once upon a time there were three tiny pigs, and they went out to seek their fortune. The first little pig met a man with a bundle of fir-branches, and he said:

"Please, man, give me some firs to build a house with, because I have none to live in."

So the man gave him some firs, and he built a nice house. But presently the wolf came along, and he knocked at the door, and said:

"Tiny pig, tiny pig, let me come in." But the pig said:

"No, no, by the hair on my chinny-chin-

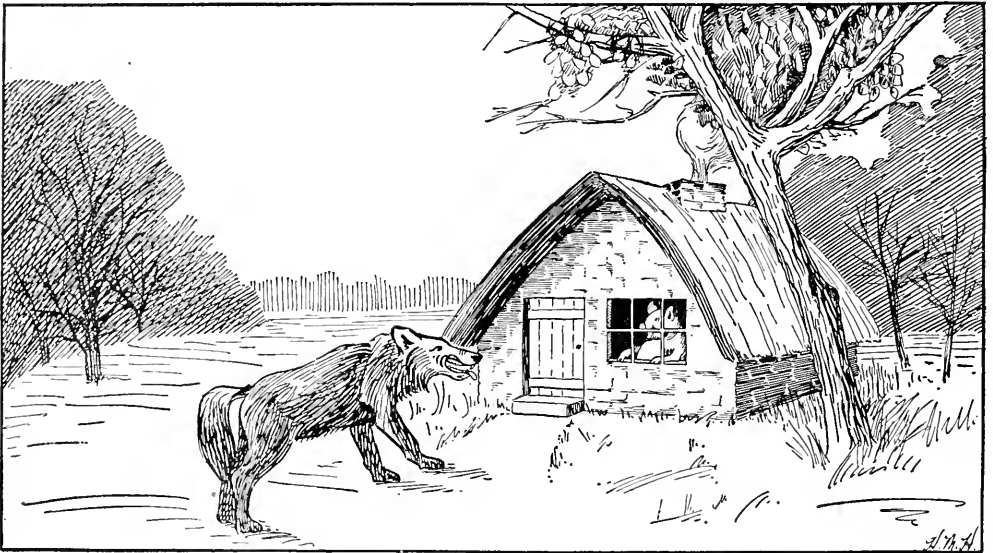

"TINY PIG, TINY PIG, LET ME COME IN"

said the middle-sized mother bear in her middle-sized voice.

"Somebody has been sitting in my chair, and it's all broken," said the poor little tiny boy bear in his little tiny voice.

Then the bears went upstairs.

"Somebody has been lying in my bed," said the big father bear in his big rough, gruff voice.

"Somebody has been lying in my bed," said the middle-sized mother bear in her middle-sized voice.

"Somebody has been lying in my bed," said the little tiny boy bear in his little tiny voice, "and here she is."

Now, when Goldilocks heard the voices of the three bears, she woke up. And when she saw them all by the side of her bed looking

chin." Then said the wolf: "I'll huff and I'll puff and I'll blow your house in." So he huffed and he puffed and he blew the house in, and he ate up the tiny pig.

The next little pig met a man with a bundle of sticks, and he said: "Please, man, give me some sticks to build a house, for I have none to live in." So the man gave him some sticks and he built a house. Presently the wolf came along, and he knocked at the door and he said: "Tiny pig, tiny pig, let me come in." But the pig said: "No, no, by the hair on my chinny-chin-chin." Then the wolf said: "I'll huff and I'll puff and I'll blow your house in." So he huffed and he puffed and he blew the house in, and he ate up the tiny pig.

The third little pig met a man with a load of bricks, and he said: "Please, man, give me

some bricks to build a house, for I have none to live in." So the man gave him some bricks, and the pig built a nice, strong house, with a door and a window and a chimney. Presently the wolf came along, and he said: "Tiny pig, tiny pig, let me come in."

But the pig said: "No, no, by the hair on my chinny-chin-chin." Then the wolf said: "I'll huff and I'll puff and I'll blow your house in." So he huffed and he puffed, and he huffed and he puffed, and he huffed and he puffed, but he couldn't blow the house in, for it was too strong. Then he said: "Tiny pig, I know where there is such a nice field of turnips, and if you like, I'll take you there to get some."

"Where is it?" said the pig.

"Down at Mr. Brown's farm," said the wolf. "I'll come for you tomorrow morning."

"What o'clock?" said the pig.

"At five o'clock," said the wolf.

So the pig got up at four o'clock, and went down to the garden and gathered the pears. But they were so nice that he began to eat some while he was up in the tree, and presently he saw the wolf coming. He was very much frightened, but he called out to the wolf: "I'll throw you down some pears," and he threw them a very long way off. Then, while the wolf was running to get the pears, the pig scrambled down from the tree and ran home as fast as he could.

Then the wolf came back to the pig's house, and said: "Tiny pig, there is a fair at Merrytown tomorrow, and if you like I'll come and go with you."

"At what o'clock?" said the pig.

"At four o'clock," said the wolf.

So the pig got up early, at three o'clock, and went to the fair at Merrytown. There he

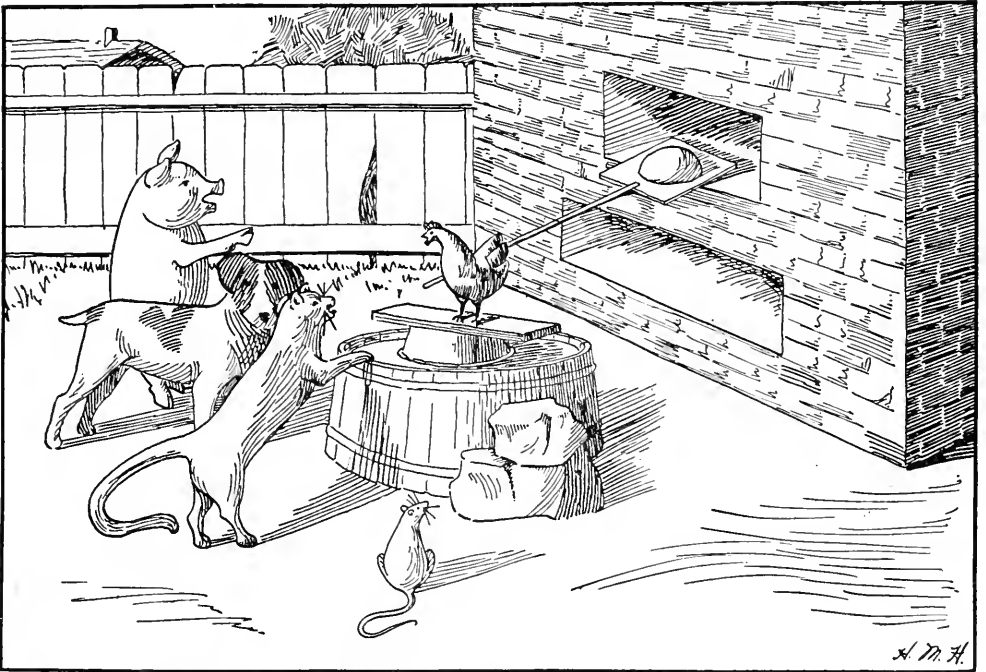

"WHO'LL EAT THE BREAD?" SAID THE LITTLE RED HEN

"At six o'clock," said the wolf.

So the pig got up very early, at five o'clock, and went to Mr. Brown's farm; he got a nice bag of turnips and carried them home. Then the wolf came along and said: "Tiny pig, are you ready?"

"O," said the pig, "I went long ago and brought the turnips home." Then the wolf said: "Tiny pig, I know where there is such a nice pear-tree."

"Where is it?" said the pig.

"In Mr. Sweet's garden," said the wolf, "and if you like, I'll come and take you there tomorrow morning."

"At what o'clock?" said the pig.

bought a nice new churn, and he set out for home very soon, for fear of the wolf coming. Just as he got to the top of a long hill he saw the wolf at the bottom, so he got into the churn and it rolled over and over and over, down to the bottom of the hill. The wolf was so frightened when he saw it coming that he turned around and ran to the woods as fast as he could, and after that he never bothered the pig any more.

**The Little Red Hen and the Grain of Wheat**

Once upon a time there was a little red hen, who was scratching and scratching in the ground to get her living. And one day she

found a grain of wheat, so she thought she would plant it and have more wheat.

"Who'll help me to plant it?" said the little red hen.

"Not I," said the cat.

"Not I," said the rat.

"Not I," said the dog.

"Not I," said the pig.

"Then I'll plant it myself," said the little red hen. So she planted it. Then she planted more. And by and by the wheat grew up. And then it was time to cut the wheat.

"Who'll help me to cut the wheat?" said the little red hen.

"Not I," said the cat.

"Not I," said the rat.

"Not I," said the dog.

"Not I," said the pig.

"Then I'll have to cut it myself," said the little red hen. So she cut it down, and then it was ready to be threshed.

"Who will help me to thresh the wheat?" said the little red hen.

"Not I," said the cat.

"Not I," said the rat.

"Not I," said the dog.

"Not I," said the pig.

"Then I'll thresh it myself," said the little red hen. So she threshed the wheat. And then it had to be taken to the mill to be ground.

"Who'll help carry it to the mill?" said the little red hen.

"Not I," said the cat.

"Not I," said the rat.

"Not I," said the dog.

"Not I," said the pig.

"Then I'll carry it myself," said the little red hen. So the wheat was ground into flour at the mill. And the little red hen carried it home. And then it was to be baked into bread.

"Who'll help make the bread?" said the little red hen.

"Not I," said the cat.

"Not I," said the rat.

"Not I," said the dog.

"Not I," said the pig.

"Then I'll bake it myself," said the little red hen. And by and by a nice round, brown, crusty loaf came out of the oven.

"Who'll eat the bread?" said the little red hen.

"I will," said the cat.

"I will," said the rat.

"I will," said the dog.

"I will," said the pig.

"I will eat it myself," said the little red hen. So she carried the loaf down to the corner of the barnyard, where all the other little red hens were, and they all had a fine dinner. But the cat and the rat and the dog and the pig had none of it.

### The Two Green and Glittering Gold-Chafers

A gold-chaffer is a very bright beetle with a shiny back.

Once there were two green and glittering gold-chafers. They were very young, and they lived in a beautiful garden, full of sunshine and flowers. One day, as they played in

the sunshine, the first green and glittering gold-chaffer said to the second one:

"Let's play tag."

"Yes," said the second green and glittering gold-chaffer, "you run and I'll tag you."

"No," said the first one; "you run and I'll tag you."

But they could not agree which should run first, and so they couldn't play tag.

"Let's play hide and seek," said the second green and glittering gold-chaffer.

"Yes," said the first one; "I'll hide and you find me."

"No," said the second one; "I'll hide and you find me."

And they couldn't agree which should hide and which should find, and so they couldn't play hide and seek.

Then they saw two beautiful dragon-flies dancing over the pond in the garden. One was a green dragon-fly and one was a blue dragon-fly.

"Let's dance with the dragon-flies," said the first green and glittering gold-chaffer.

"Yes," said the second one; "I'll dance with the green dragon-fly and you dance with the blue one."

"No," said the first green and glittering gold-chaffer; "I'll dance with the green dragon-fly and you dance with the blue one."

And they couldn't agree which should dance with which dragon-fly, and so they couldn't dance.

And they were not having a good time, though the sun was shining and the flowers looked beautiful and everything else was having a good time.

Then a very old green and glittering gold-chaffer came by, and he listened to what they were saying. He walked on, but he turned his head over his shoulder and looked back at them, and he said: "Silly, silly, silly. Don't you two young ones know that the only way to have fun is to take turns?" And they had never thought of that.

So the first green and glittering gold-chaffer ran and the other one tagged him, and then the second green and glittering gold-chaffer ran and the first one tagged him. And they had a lovely time. Then they played hide and seek. The second green and glittering gold-chaffer hid and the first one found him, and then the first one hid and the second green and glittering gold-chaffer found him. And they had a lovely time playing hide and seek. And then they danced. The first green and glittering gold-chaffer danced with the green dragon-fly and the second one danced with the blue dragon-fly, and then the second green and glittering gold-chaffer danced with the green dragon-fly and the first one danced with the blue dragon-fly. And they had a lovely time dancing in the sunshine among the flowers. And always after that they remembered that the way to have a good time was to take turns.

### The Pancake.

Once there was a mother who was frying pancakes, and seven hungry children were waiting for the pancakes to be done.

"O, mother, please give me some pancake," said the first child. "O, dear mother, please give me some pancake," said the second child. "O, dear, nice mother, please give me some pancake," said the third child. "O, dear, nice, sweet mother, please give me some pancake," said the fourth child. "O, dear, nice, sweet, good mother, please give me some pancake," said the fifth child. "O, dear, nice, sweet, good, pretty mother, please give me some pancake," said the sixth child. "O, dear, dar-

Then the pancake met a duck. "Where are you going, pancake," said the duck. "Stop and let me go with you." But the pancake said: "I've run away from a father and a mother and seven hungry children and a hen and a turkey, and I'll run away from you-oo-oo."

Then the pancake met a goose. "Where are you going, pancake?" said the goose. "Stop and let me go with you." But the pancake said: "I've run away from a father and a mother and seven hungry children and a



#### SO THE FATHER AND THE MOTHER AND THE SEVEN HUNGRY CHILDREN RAN AFTER IT

ling, nice, sweet, good, pretty mother, please give me some pancake," said the seventh child.

"Yes, indeed, I will," said the mother, for they were such good children, and were asking so nicely.

Then the mother turned the pancake over, but just as she turned it, it got onto the edge of the pan, and in a minute it rolled down on the floor, and out of the open door, and down the road. So the father and the mother and the seven hungry children ran after it.

Then the pancake met a hen. "What are you running away for, pancake?" said the hen. "Stop and let me go with you." But the pancake said: "I've run away from a father and a mother and seven hungry children, and I'll run away from you-oo-oo."

Then the pancake met a turkey. "Where are you going, pancake?" said the turkey. "Stop and let me go with you." But the pancake said: "I've run away from a father and a mother and seven hungry children and a hen and I'll run away from you-oo-oo."

hen and a turkey and a duck, and I'll run away from you-oo-oo."

Then the pancake met a pig, and the pig said: "Where are you going, pancake? You'd better stop and let me go with you, for you are coming to a stream of water, and you can't get over it alone." "How shall I get over?" said the pancake. "You may ride on my nose," said the pig. So the pancake got onto the pig's nose, to ride over the stream. And the pig made one bite and swallowed the pancake up. So the father and the mother and the children had to go back and wait for some more pancakes to be fried.

#### The Crane Express

Once upon a time there were six little fat fluffy friendly sparrows, sitting on the shore of the Mediterranean Sea. "Fat and fluffy friends," said the first little sparrow. "I have heard that the cold weather is coming. What shall we do?"

Said the second little sparrow: "Let us go to Africa."

"Why should we do that?" said the third little sparrow.

"Because," said the fourth little sparrow, "I have heard that the sun is always shining there, and that when you open your mouth the worms go walking into it."

"But it is across the sea, I have heard," said the fifth little sparrow. "And our wings are very short."

"We must get somebody to take us," said the sixth little sparrow.

Just then they saw a big sheep walking by.

"Dear sheep, will you carry us to Africa?" said the little sparrows. "O, no," said the sheep, "I must stay here with my little lambs, and I can't swim."

So then they went down to the waterside, and there they saw a big fish.

"Dear fish, you can swim," said the sparrows. "Will you carry us to Africa?" "I will carry you to the bottom of the sea," said the fish, and he turned and made a big dive down in the sea.

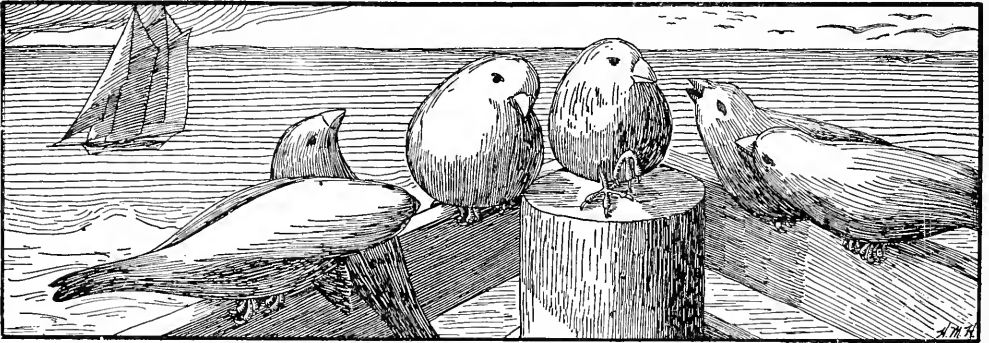

SIX LITTLE FAT FLUFFY FRIENDLY SPARROWS

"Dear me," said the little sparrows. "It is a good thing we did not go with him." Then the sheep said: "You must get the cranes to carry you."

"What are the cranes?" said the little sparrows.

"Don't you know?" said the sheep. "The cranes are very big birds, with long necks and still longer legs, and every year they fly over the sea to Africa."

So the little sparrows watched until they saw some of these big cranes come along. "Will you carry us to Africa, dear cranes?" they said.

"My back is full," said the first crane, and indeed his back was covered with little birds. "But the fourth behind me has room," he said. So when the fourth crane came along, up went every one of the little sparrows, hop, skip flutter, scramble, and away they went to Africa.

Now, the cranes do really carry little birds with them to Africa, but as to the worms walking into their mouths when they open them, if I were you I would wait until I saw that before I believed it.

### The Musician and the Dancer

Down by the farmer's threshing floor some large black ants once settled and built their nest, because they wanted to be near good food, such as wheat, corn and barley.

They worked hard, and they prospered, and grew to be so many that by and by they had to have a king to govern them. The king was very wise and brave, and he wore a gold crown and a scepter. The crown was made of a tiny piece of gold wire, that the ants had found in the work-basket of a village maiden, on one of their excursions. The scepter was a tiny gold key which had dropped from the farmer's watch chain, but as soon as it was in the king's hand it became a scepter. The king was now so old that he had to drive all the time in a carriage. He had his own carriage made of a nut-shell and drawn by two well-trained beetles. All his people loved him very much, but he was so old that he was now quite white, and he was very weary and feeble, so that he took no pleasure in anything.

One day there was a great tumult, for the ant soldiers had been out fighting, and they brought in some prisoners. The king came down to see them and the soldiers saluted him as they brought forward their prisoners.

The first was a spider.

"What is your name," said the king, "and where were you born?"

"My name is Spider," she replied humbly, "and I was born in the dark cellar."

"What can you do?" said the king. (For the ants are always busy themselves, and they like to know what other people can do.)

"I know how to weave cloth, your Majesty," said the spider. "There is no one in the world who can weave better than I."

"Good," said the king. "You may show what you can do, and weave some hangings for my house. If you do well, you may be set free afterward."

Now the second prisoner was brought in.

"What is your name, and where were you born?" said the king.

"My name is Bee, your Majesty," she said, "and I was born in a hive, which is a large house for bees to live in."

"Do you know how to work at anything?" said the king.

"Certainly, your Majesty," she replied. "I can make a most delicious kind of food, which is called honey."

"Very good," replied the king. "You may make some sweet-meats for a grand festival that I am going to give to my people, and if you do it well, you may go free afterwards."

Then the king rapped on the floor with his scepter, and the soldiers took the bee and the spider away.

"Bring in the others quickly," said the king, "for I have business to attend to this morning."

These two prisoners were named cricket and grasshopper. One had been born in the field and the other under a bush.

"And what do you know how to do?" said the king.

"I know how to sing, your Majesty," said the cricket, "and the grasshopper knows how to dance."

"Tut, tut, tut," said the king angrily, so loud that he frightened the soldiers and courtiers. "Those things are of no use. I shall have your heads cut off, the pair of you."

"Please, your Majesty," said the cricket, "we really are of some use. We amuse all the other creatures, when the sun is hot and they are tired. I make music in the fields in the summer, and the grasshopper dances so merrily that everybody enjoys seeing her. Allow us to show you what we can do."

The king was not hard-hearted, so he said: "I grant your request. If you can amuse me, I am sure you can amuse other people, for I am so tired that I can never laugh."

Then the cricket sang with all the skill she possessed, and the grasshopper danced and hopped as hard as he could. The king had never heard so sweet a voice or seen so graceful a dancer, and he laughed until he almost fell off his throne.

"Yes," he said, "I will set you free, and only ask that when you have time you will come and amuse us a little after our work is done. I will grant each of you whatever favor you like to ask."

"I ask that the poor spider may be released," said the cricket.

"And I that the bee may be set free," said the grasshopper.

"You have good hearts," said the king. "What you ask shall be granted."

So they went back to the fields with great happiness.

#### How Baby Ray Got Up in the Morning

The sun was up and the breeze was blowing, and the five chicks and four geese and three rabbits and two kitties and one little dog were just as noisy and lively as they knew how to be.

They were all watching for Baby Ray to appear at the window, but he was still fast asleep in his little white bed, while mamma was making ready the things he would need when he should wake up.

First, she went along the orchard path as far as the old wooden pump, and said: "Good Pump, will you give me some nice clear water for the baby's bath?"

And the pump was willing.  
The good old pump by the orchard path  
Gave nice, clear water for the baby's bath.

Then she went a little farther on the path, and stopped at the wood-pile, and said: "Good Chips, the pump has given me nice clear water for dear little Ray; will you come and warm the water and cook his food?"

And the chips were willing.  
The good old pump by the orchard path  
Gave nice, clear water for the baby's bath.  
And the clean, white chips from the pile of wood  
Were glad to warm it and cook his food.

So mamma went on till she came to the barn, and then said: "Good cow, the pump has given me nice, clear water, and the wood-pile has given me clean, white chips, for dear little Ray; will you give me warm, rich milk?"

And the cow was willing.  
Then she said to the top-knot hen that was scratching in the straw; "Good Biddy, the pump has given me nice, clear water, and the wood-pile has given me clean, white chips, and the cow has given me warm, rich milk for dear little Ray; will you give me a new-laid egg?"

And the hen was willing.  
The good old pump by the orchard path  
Gave nice, clear water for the baby's bath  
The clean, white chips from the pile of wood  
Were glad to warm it and cook his food.  
The cow gave milk in the milk-pail bright  
And the top-knot Biddy an egg new and white.

Then mamma went on till she came to the orchard, and said to a red June apple tree. "Good Tree, the pump has given me nice, clear water, and the wood-pile has given me clean, white chips, and the cow has given me warm, rich milk, and the hen has given me a new-laid egg for dear little Ray; will you give me a pretty red apple?"

And the tree was willing.  
So Mamma took the apple and the egg and the milk and the chips and the water to the house, and there was Baby Ray in his night-gown looking out of the window, watching for her.

And she kissed him and bathed and dressed him, and while she brushed and curled his soft brown hair, she told him the Wake Up story that I am telling you:

The good old pump by the orchard path  
Gave nice, clear water for the baby's bath.  
The clean, white chips from the pile of wood  
Were glad to warm it and cook his food.  
The cow gave milk in the milk-pail bright,  
And the top-knot Biddy an egg new and white;

And the tree gave an apple so round and so red

For dear little Ray who was just out of bed.  
—From Eudora Bumstead's Wake Up and Go Sleep Stories.

**Importance of Stories.** The importance of stories and talks with children at bedtime can hardly be over-emphasized. It is the time when childish fears, troubles and wrong-doings can be drawn out, in confidence, and when help can best be given. The opportunity for winning confidence, and leaving the child with happy and affectionate feelings, as he goes to sleep, is most valuable. With nervous and sensitive children, to be left with something wholesome and interesting to think of prevents wakefulness and other bad habits.

The list of children's stories and other books, published by the Frederick A. Stokes Company, New York, is one of the best.

LIST OF STORY BOOKS SUGGESTED  
FOR VERY YOUNG CHILDREN

Mother Goose Rhymes.  
Nursery Finger-Plays.  
Through the Farm-Yard Gate. } Emilie  
Father and Baby Plays. } Poulson  
Arabella and Araminta. } Gertrude Smith.  
Reggie and Roggie. } Small, Maynard &  
Co., Boston.  
The Three Ting Pigs.  
The Three Bears.  
Little Black Sambo.  
Peter Rabbit. } Beatrix Potter.  
Benjamin Bunny. }

FOR CHILDREN FROM FIVE TO EIGHT YEARS OLD  
Squirrel Nutkin (and other books by) Beatrix  
Potter.  
The Child's Garden of Verses. R. L. Steven-  
son.  
Mother Stories. Maud Lindsay.  
Stories of East and West Red Children. Mara  
L. Pratt.  
For the Children's Hour. Bailey.  
The Story-Teller's Book. Throop and O'Grady.  
The Story-Hour. Wiggin & Smith.  
In Story-Land. E. Harrison.  
Songs for the Little Ones. Walker & Jenks.  
Nature Songs for Children. Knowlton.  
Small Songs for Small Singers. Neidlinger.  
First Book of Birds. O. T. Miller. Houghton,  
Mifflin Company.

FOR CHILDREN FROM EIGHT TO TWELVE YEARS OLD  
Grimm's Fairy Tales.  
Andersen's Fairy Tales.  
Legends Every Child Should } Mable.  
Know. } Houghton,  
Myths Every Child Should } Mifflin & Co.  
Know. }  
The Heroes. Kingsley.  
Stories of Colonial Children. Mara L. Pratt.  
Heidi. Johanna Spyri. Everyman's Library,  
Wanamaker, New York.  
The "Little Cousin" Books (Life of children in  
foreign countries).  
The Children's Book. H. E. Scudder.  
Just So Stories. Kipling. Scribner's, New  
York.  
Alice's Adventures in Wonderland. Carroll.

Plutarch's Lives. (Pocket Classic.)  
The Song of Life. M. Morley.  
Second Book of Birds. Miller. Houghton,  
Mifflin Co.  
Stories of Plants and Animals. }  
Stories of Earth and Sky. } Wright,  
Stories of Birds and Beasts. } MacMillan  
(Heart of Nature Series.) } Co.  
Child's Book of Verses. E. V. Lucas.  
The Posy Ring. Wiggin & Smith.  
The Fairy Ring. Doubleday, Page & Co.

All books whose publishers are not named  
may be obtained from the Milton Bradley Co.,  
New York, or Springfield, Mass.

The stories suggested are not a complete  
list. A much larger one can be had for 10  
cents, by addressing the chairman of the Lit-  
erature Committee of the International Kin-  
dergarten Union, Chicago Teachers' College,  
Chicago, Illinois.

### List of Home Occupations for Children

Paper tearing, cutting and pasting, paper  
and cardboard folding or modeling; string-  
ing objects into chains; sewing, fancy work,  
dressing dolls, using tools, glue, passepartout,  
clay work, sand, plasticine, dough; scrap  
books; collecting of post-cards, stamps, coins,  
minerals, curiosities; blue prints; puzzles,  
bought and home-made; nature work out of  
doors.

**Materials Needed or Desirable.** All those  
named in the list of kindergarten materials,  
and also the following:

Clay or plasticine, with a book on clay  
work. *Clay-Modeling in the Schoolroom*, by  
E. S. Hildreth, is simple and practical,  
though not artistic.

A book on paper cutting. The catalogue  
of the Dennison Paper Co., New York City,  
gives many suggestions for using paper.

Books of "Finger-Plays" or simple songs.  
(A list will be found at the end of this sec-  
tion.)

The beads for stringing and the peg tiles,  
pegs and plasticine may be kept for "rainy  
day" playthings, to be used when the children  
cannot go out, and reserved for this only.

If home material, at very small expense, is  
desired, a job-carpenter will prepare one  
hundred oblong and one hundred cubical  
blocks for a small price. A good size for the  
oblongs is 2x4x1 inch and 2-inch diameter  
for the cubes. Boxes of blocks can be bought  
in stores, but generally contain too few.  
Plasticine, silkaline for sewing, and worsted  
needles may be bought at department stores.  
If beads are bought there, the largest size  
should be asked for.

Colored paper for folding and cutting can  
sometimes be bought cheaply at a printing



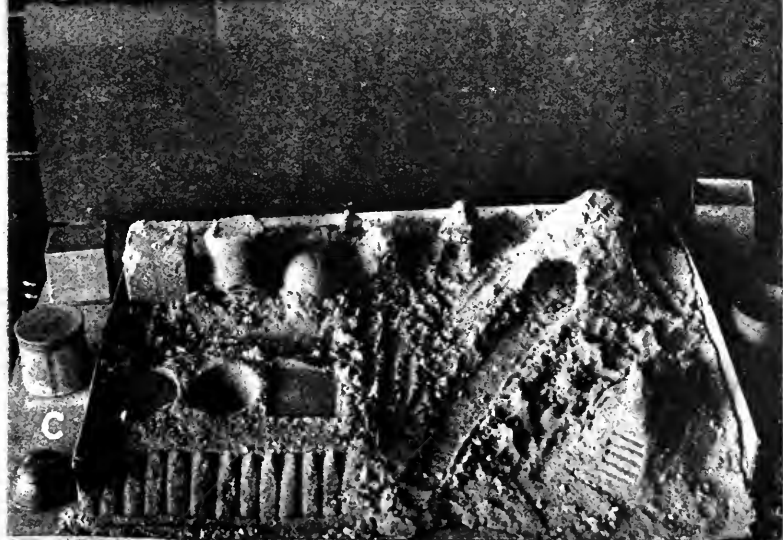
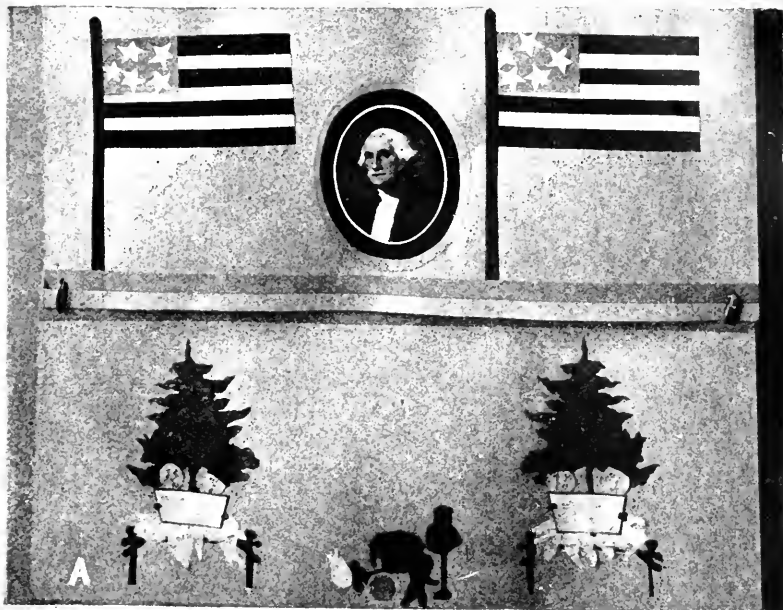

Objects prepared by Chicago Kindergarten College.

### KINDERGARTEN OCCUPATIONS

A Poster Work B Clay Modeling C Sand Modeling



office, which will cut a quantity into square pieces of any desired size; 5x5 or 6x6 inches is a good size. Prepared clay can sometimes be obtained at a pottery. Sand for a sand-box or for trays can be had from a builder, and if covered, can be used out of doors. A box of it may be kept in a covered porch or gallery.

Spools, cylinders on which ribbons are wound and cards which have had buttons on them, are all useful for making toy furniture; and the paper strips sometimes rolled with the ribbons may be cut in lengths, and some of them colored, for plaiting or making paper chains. Small pill and medicine boxes, match boxes and bits of wood, help to make furniture. Large sheets of ordinary wrapping paper may be cut in suitable sizes for drawing paper; and the children may save colored wrapping paper, to cut in strips or squares for themselves. Small brass tacks, and brass fasteners, such as are used for papers and note-books, are very useful.

The first necessity is a place for children to keep their materials; preferably a play-room or attic, with cupboards; if not that, a large cupboard where each child has a share of space with shelves and boxes which are his own; if that is impossible, at least a book-case or wall cupboard where each may have a shelf for boxes, or at worst, a bureau drawer for his treasures. A child can have no joy in materials if he cannot preserve his results; for a time, anyway. A little girl, asked what she most wished for in the world, said: "A place to keep my things." What is trash to an adult is often dear to a child; but once a place is taken, tidiness may be the price paid for it, and this is a fine training; the child has rights, but he should not make life intolerable for the rest of the house. Shoe boxes and others of various sizes should be saved and the children's names put on them; no one to interfere with the contents. When they overflow bounds, the owner may choose what he will keep and what must be got rid of.

**Develops Self-Expression.** The keynotes of the kindergarten handwork are two: expression, or "self-expression" as it is generally called, and development, or step-by-step progress, from easy to difficult, from simple to advanced, from familiar to new work. That is, the child has many sides of his nature which need other expression than words, and many ideas, especially the germs

of artistic ones, which he could not put into words. He can, through his power of "creating," express them by materials. He has a chance to express, to clinch the perceptions of color, contrast, etc., which are awakened by the experiments with the gifts; and he expresses, besides, all his childish delight in nature and life, by trying to make the objects he sees about him. Froebel tried to provide a large range of materials, which covered many degrees of resistance, flexibility, or plasticity, so that a fairly complete set of life experiences might be expressed: string, clay, sand, chalk, seeds, worsted, paper, cardboard, peas with sticks, wooden slats, etc. A teacher uses these in a more systematic way than they can be used at home. The aim of home work is to use a variety of materials, so that the children can soon learn to employ themselves independently, and be happy in it; and to work, in some degree, from easier to more difficult things. For this reason, all the objects illustrated here for home use will be grouped so as to have three or four of each in connection.

1. **Stringing.** This is the simplest occupation; beads, which should be large enough to be threaded on a cord without a needle, or on a worsted-needle; buttons of all kinds; spools of all sorts (if many can be collected, some may be colored with Diamond Dye); clay beads made by the child (about  $\frac{1}{2}$  to 1 inch diameter) and pierced while soft; these also may be colored; nature materials, as seeds, acorns, sweet gum, seed-vessels, poppy-heads, are good for stringing.

**Sand.** The first sand-play for very young children is merely filling and emptying a pail; or a mug may be filled with a spoon, if the child plays with a small sand-box or sand-table in the house.

2. Making heaps; piling up mug-fulls, or making "sand-pies" with the hands.

3. Making rows of holes, with a smooth stick; the child will enjoy fitting his fingers into these, or sticking twigs into them, to play "garden."

4. Lines or "roads" drawn with a stick in the sand; children will enjoy making toy animals or little dolls walk along these and jump "ditches," etc.

5. Combining the heaps and lines, as a "house," with a "garden" round it, or a fort with a ditch, etc.

6. Impressions made in the sand with toys, the outline of the hand, etc.

7. Picture-tracing in the sand.

8. Molding the sand in definite shapes by using tin patty-pans, boxes, etc., to pack the moist sand in and turn it out; the children will call them cakes, pies, etc. These give them the idea that they can shape forms better, and they will try.

9. Castles, towers, or anything the children want to imitate or illustrate.

10. Illustration of stories, etc. Little Red Riding Hood going through the wood can be

In sand and in clay, the suggestions are only intended to help out the children's ideas and to be interspersed with them, and should cover quite a long period of time, being repeated with slight differences.

**Clay.** If this is not bought ready for working, it will take a little practice in mixing, to get it of the right stiffness. It must then be kept moist, in an earthen crock, with a wet cloth over it.

"Plasticine," a sort of prepared modeling

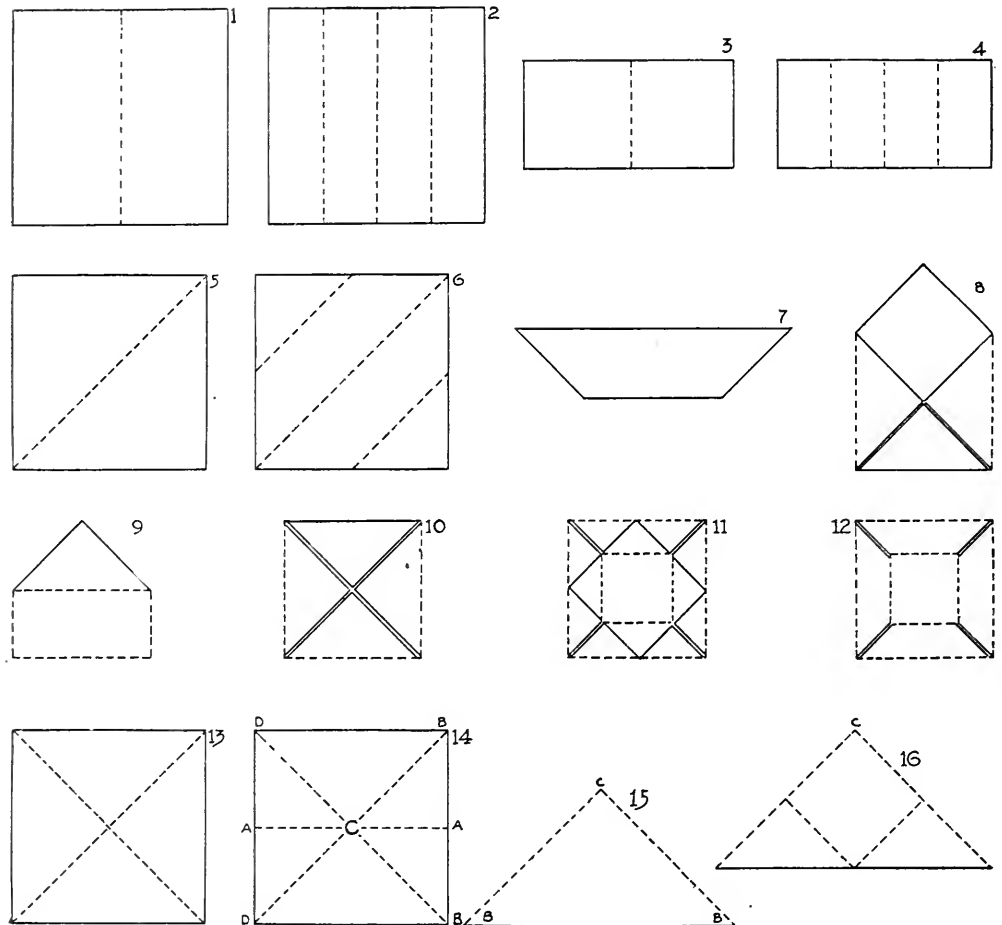

FIRST SIMPLE PAPER FOLDING

1—Fold opposite edges together. 2—Fold edges to center line. 3—Fold No. 1, then fold across again. 4—Fold No. 3, then fold ends to center line. 7—No. 6, doubled. 8—Three corners to center. 9—No. 8, folded. 10—Envelope. 11—Frame; corners of No. 10, folded back. 12—Frame; corners turned inside. (13, 14, 15, 16, steps in making soldier caps.) 13—Fold on diagonal; open, and fold opposite diagonal. 14—Open and fold across A-A, as shown. 15—Join (in 14) C-B to C-B, C-D to C-D, so A-A is folded in between. 16—Turn (in 15) corners B-B under, so they will meet at C.

represented by sticking in twigs; the grandmother's and mother's houses at each end, and a small doll for the little girl, etc.

wax, may be bought at toy-stores or department stores. It is more expensive than clay, but is more convenient.

Any modeling material should be handled quickly and worked over as little as possible, since the heat of the hands dries it. When giving it to the children, it may be divided, by drawing a string across it.

The only tool needed for home use is a small sharp stick or long pin, to make decorative lines or markings with, or to indicate the veins on leaves, the edge of the lid on a dish, or the eye or mouth of an animal.

Each child should have a square of kitchen oil-cloth, on which to put his material.

The children can, of course, play with it by themselves, and express their ideas, in a measure; but they will soon come to the end of their powers, from lack of technical skill and method.

It is better for an adult to work with them part of the time, giving definite suggestions or helping them out with their ideas; and then to leave them to invent other things.

It is better to work in solid masses, as much as possible; e. g. when a basket, cup, jug, etc., is made, to make it solid, not hollow;

of a cup, the spout, handle and knob of a teapot, must be quickly put on, before the clay dries.

Extreme correctness or form must not be aimed at.

Much less handling is needed when simple mass forms are made, several alike, with only the detail varied. For instance, the same ball form will make cups, teapot, sugar-bowl and creamer for a tea-set; the cups need only to be flattened on the bottom, and pressed in slightly at the top; the same treatment forms the jug with one side pinched out for the spout; a tiny rolled piece makes the handle. The sugar-bowl and teapot have a line slightly pressed in, on the top, to show the edge of the lid, and a wee knob is put in the middle of it. In clay, as in other things, to try what can be made under a certain limitation really gives freedom. Another interesting group of objects is a set of loaves of bread, twists, rolls, buns, etc.; the children will invent doughnuts and cookies.

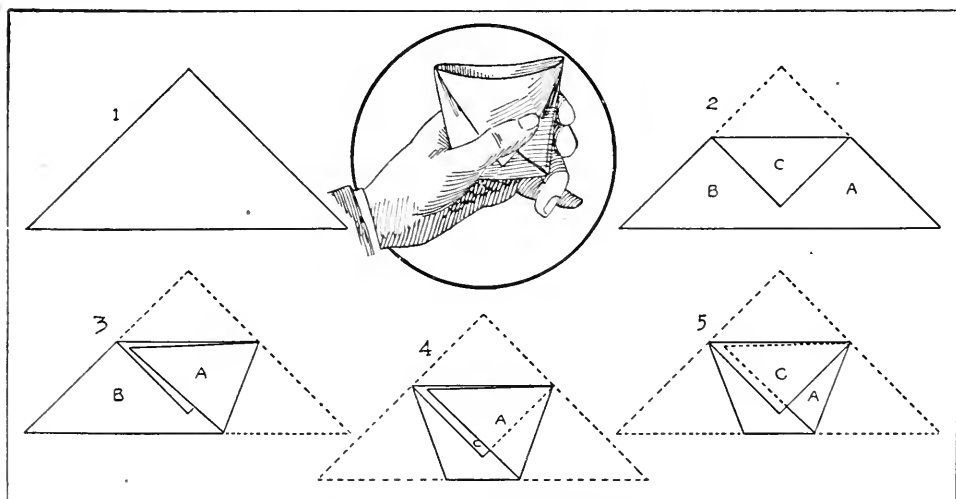

HOW TO FOLD A DRINKING CUP

the children can play that it is full of something if they wish. Plates, saucers and dishes should be made thick, as they keep shape better.

It is best to begin with round things, as a little gentle pressure and rolling in the palm will round a small mass into shape quickly. Marbles, round beads, which may be pierced or strung, while soft; apples, cherries, tomatoes, etc., are good to begin with; details added, such as the stalks of fruit, the handle

The roll form, such as a "jelly-roll" cake, may be adapted in various ways. Set on end with a handle added, it makes a mug, and a lip pressed out turns it into a straight jug. Rolls of butter, sausages, potatoes, ears of corn,—the grains marked with a tooth-pick—are other suggestions that will please the children. A rolling-pin, pail with lid, etc., may be invented.

Many other fruits and vegetables can now be made; potatoes, bananas, pears (made by

elongating and narrowing a ball-form), a bunch of grapes, carrots, radishes; eggs, bowls and dishes of several shapes, flower jars and vases of simple forms may be tried, for the doll-house. Animals are more difficult, but good directions for these, with illustrations, may be found in Mrs. Hildreth's little book. *Clay Modeling in the School-room* (Milton Bradley Co.).

The children may also trace pictures, outlines of flowers, leaves, etc., on tiles or flat

probably occur to them, according to the position it is in; for instance, a square or oblong piece of paper, doubled once, will be called a sofa when placed sideways; a door or screen when standing upright; a cradle when placed with the angle down, and rocked between the hands; a barn, reversed from this, with the angle up. Little children will much enjoy making this several times in red, blue and brown paper, playing "furniture shop," with sofas and screens to sell.

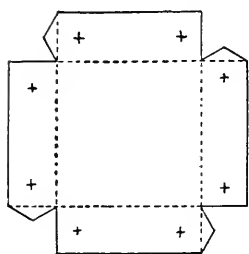

1

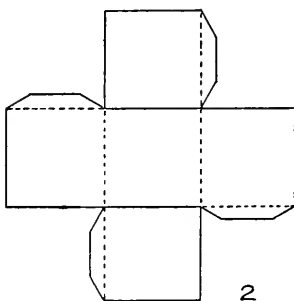

2

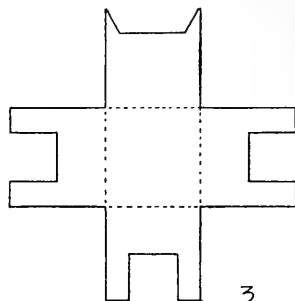

3

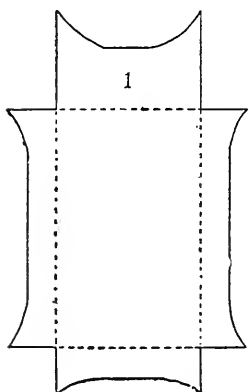

4

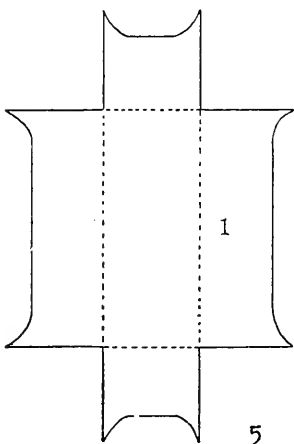

5

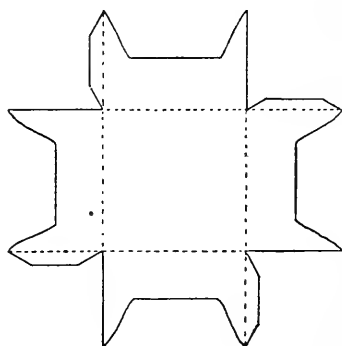

6

#### CARDBOARD FURNITURE FOR DOLL HOUSE

1—Box, or pin tray. 2—Box. 3—Chair; top section is to be bent up; the other pieces, bent down. 4—Bed; bend ends up, sides down. 5—Sofa; bend (1) up, others down. 6—Table.

tablets of clay; but the raised work which really belongs to these is for a more advanced stage of work.

**Simple Paper Folding.** In working with very young children, remember that practice is to be given by letting them make each thing several times, perhaps many times over. They will cheerfully do this, if a different color of paper is supplied, and if they are allowed to play with what they have made; several different names for each thing will

They should on no account be hurried from one thing to another, and in making the various forms illustrated in this article, remember that there is continuous progress from easier to harder forms, so that the easier should be made first, even though the others seem more attractive. If the children make mistakes at first, do not let them be discouraged, as the form made can generally be used for something else, and even a mistake may lead to a new invention.

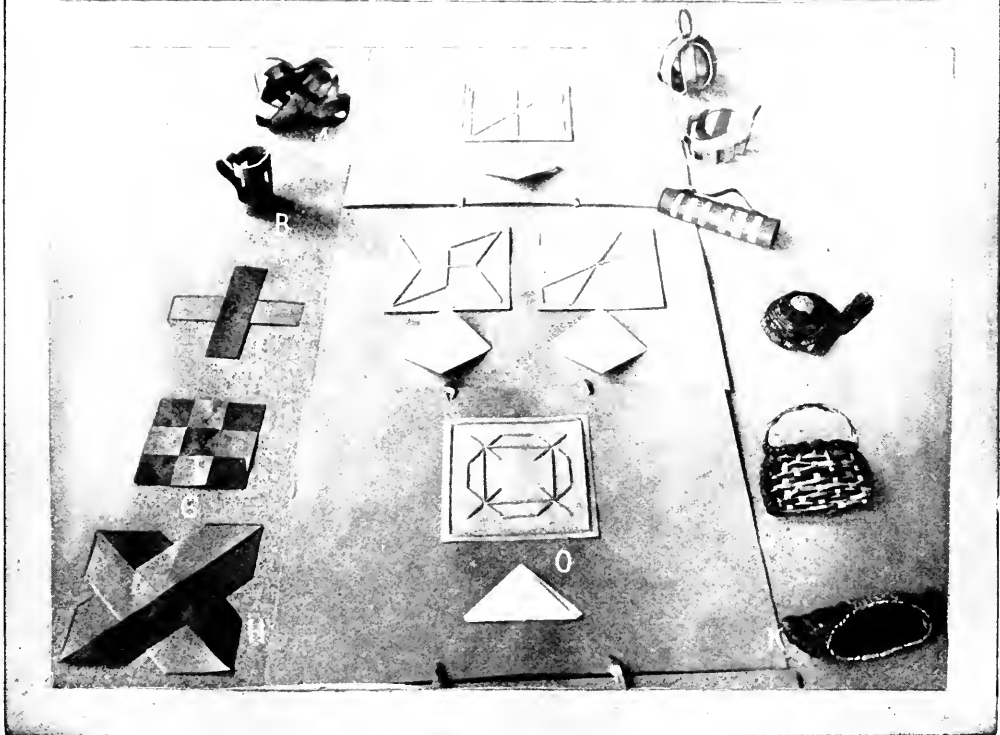
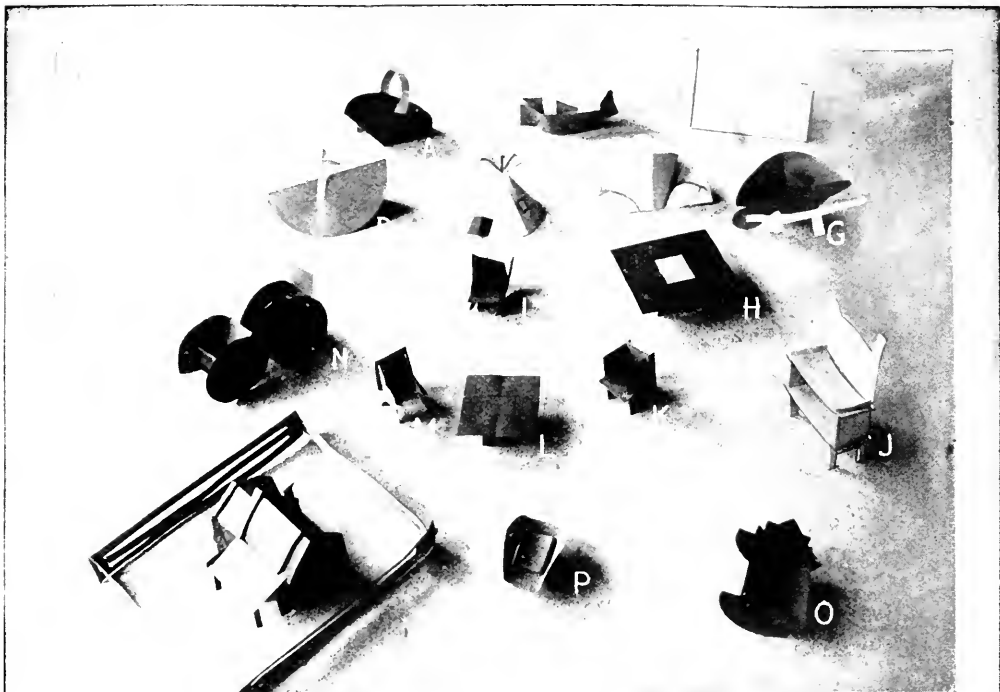

Objects prepared by Chicago Kindergarten College.

KINDERGARTEN OCCUPATIONS

1. Paper Folding—A, B, C, D, E, F, G. Construction Work—H, I, J, K, L, M, N, O, P, Q.
2. Strip Weaving, A, B, C, D, E. Free Weaving, F, G, H. Raffia Weaving, I, J, K. Sewing, L, M, N, O.





Success depends only on having the edges straight, and folding or creasing neatly and firmly.

The first forms are for practice in folding, folds or creases being always dotted lines, while black lines are edges and cuts.

No. 1, page 1966, to be used for a door, book, screen, seat, barn, or roof.

No. 2, after being folded in the middle, is to be opened and the sides folded to touch the center line. This the children will use for a cupboard with doors, when set on end. Laid flat, with the sides opened, it will serve for a "bed" or "cradle," and reversed, for a long table.

No. 3 is the same as No. 1, when folded, and is to be folded across again, making a small seat. Sets of these should be made for a furniture shop.

No. 4 has the ends of No. 3 folded to the middle line, making a small cupboard, bed, or table. A folding bed can be made by making two of No. 4, and inserting the open ends of each into the other, to close it up.

No. 5 the children will call a shawl, or push it for a "choo-choo"; No. 7 is No. 6 doubled at the center line, for a boat. The children will like to make a whole fleet of these in

paper across the corners. These boxes will give more pleasure if made in sets of several sizes, fitting in like Japanese boxes; and they may also be made in twos, one serving as cover. By taking an oblong, instead of a square sheet of paper, and trying the same folds, different shapes of similar objects may be made. By cutting an inch in, on the slanting line at the corner, lapping this part over at the ends and pasting it, a water-trough and other forms may be made. The drinking cup illustrated, or any of the boxes, may become a "basket" by having a handle put on.

**Directions for Cardboard Boxes and Furniture.** The boxes are best to do first, because the other things are made on the same plan and when the children have learned to cut and modify the box form, they can change it in other ways, at pleasure. The dotted lines are creases.

For No. 1, cut a piece of thin card, of stiff paper, 5 inches square. Crease it 1 inch in from each edge. Then cut the corners by

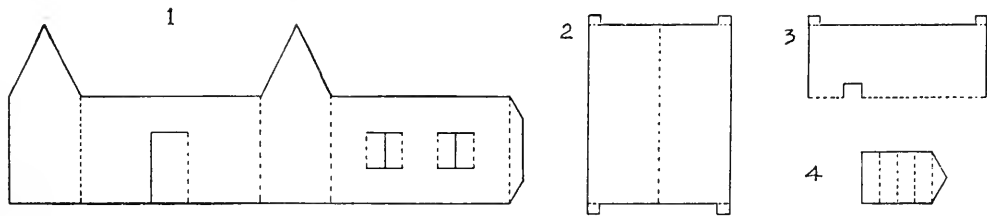

CARDBOARD HOUSE

1—The dotted lines show where the paper is to be folded and bent; the solid lines show cut edges; the doors and window-shutters are to stand open. 2—Roof. 3—Roof, showing cut to insert chimney. 4—Square chimney. For this house, cut a piece of cardboard 14½ inches long, 3 inches deep at sides, and 5 inches at the gables. Paste overlapping pieces. The roof is 5x2 inches inside of pasting pieces. Side walls are 5 inches; ends, 2 inches.

different colors and sizes, giving names to them, and "sailing" them along the table. Nos. 8 and 9 may be used for wall-pockets; No. 10 for letters or valentines to play "post-man" with; Nos. 11 and 12 may have small pictures inserted in the frames.

Nos. 13-16 are the stages in making a soldier-cap. The cap may be made in large size in newspaper or wrapping-paper for the children to play "soldiers" with.

This outline of simple forms gives material enough for two or three weeks' work, as the children should not go on to new folds until they can easily do the earlier ones, and should repeat each, in other sizes and colors, and play with them.

By folding the paper into 16 squares and cutting out an inch at the corners, another box may be made, by turning up the sides an inch in depth and pasting a small bit of

aid of the creases, 1 inch in, except for the tabs, which are to be pasted over on the inside of the next piece. If it is hard for the children to paste neatly at first, the tabs may be omitted, and the sides joined, by piercing holes where the little crosses are marked and tying with colored cord or baby ribbon. Made in colored cardboard, these are nice little pin-trays, and may be decorated with stars or fancy stamps for Christmas gifts. See drawings on page 1968.

No. 2. This square box is made from a piece of cardboard 6 inches square, the sides being 2 inches deep, and the bottom the same. A lid can be made by cutting a similar box from a 3-inch piece and making the sides only half an inch deep.

No. 3. The chair is made like box No. 2, except that it is not pasted together. The back is bent up, and the three sides down. The cutting of open spaces in the sides is optional.

No. 4. The bed is made of a piece 8 inches long by 5 wide. The crease for the head is

made 2 inches from the end, and this is bent up. The sides and other end are only 1 inch deep; as with the chair, the sides and ends may be cut straight instead of being curved in.

No. 5. The sofa is cut from a piece of cardboard 9 inches long by 6 wide, the seat being 5 inches long by 2 wide. The creases are made 2 inches from the edge on every side.

No. 6. The table is made like the first box, but from a piece 7 inches square, so that each side is 2 inches deep and the table top  $3 \times 3$

articles are made in school. The children should be encouraged to notice the proportions of each article—whether the length is once-and-a-half, or twice, the width, etc.; they should also be allowed to invent new articles.

**Directions for Making Lantern, Cage, Etc.**

In all work of this kind, the children become more independent if the work leads gradually from the old to the new. It is best to begin by letting the children fringe paper towels for the doll-house, cutting the ends in parallel lines as evenly as they can. Next, they may fold a strip of paper doubled lengthwise, and cut it the same way; this will do for a ham-bone frill, when opened out and doubled the reverse way.

For the lantern, take a piece of colored paper, 4 or 5 inches square; fold it double, according to the crease in No. 1. Then make straight cuts as in No. 2, one-fourth of an inch apart and an inch and a half deep. If the children cannot at first keep the cuts reg-

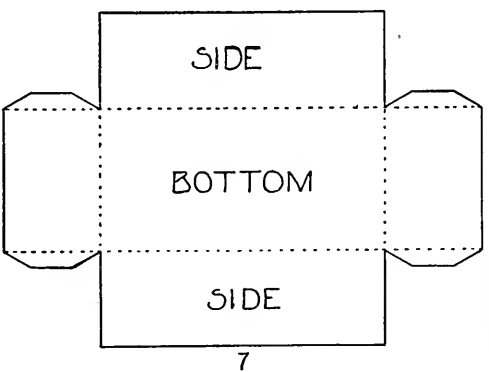
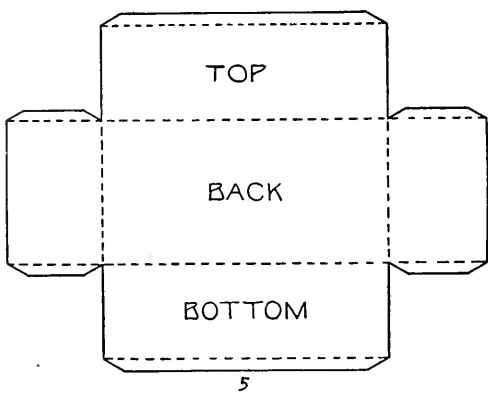
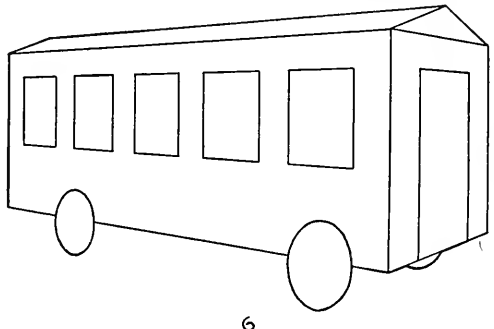
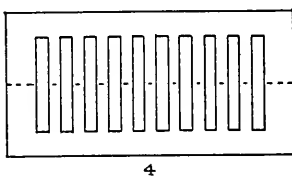
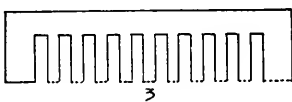
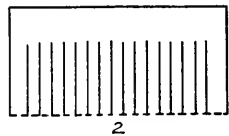
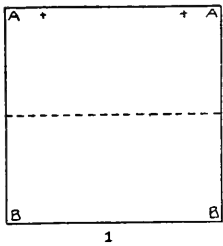

**PAPER CUTTING**

1—Lantern. 3—Front of cage, folded. 4—Body of cage (best if made of cardboard). 5—Front of cage, finished. 6—Street car; windows as in cage; roof may be added, as in cardboard house. 7—Wagon; add a long strip for tongue, and mount on wheels, like street car.

inches; the flaps for pasting are optional. The children will soon learn that they can make the height and depth of each article what they please and this work becomes an excellent exercise in mensuration, when the ar-

ular, the lines may be penciled. Then open it and paste it together, A overlapping at A, and B at B, so as to make a cylindrical lantern, which will stand out a little at the middle crease. A strip of paper for a han-

ple is pasted to the top, where marked with crosses. In colored paper these make a pretty decoration for a Christmas tree, or may be hung in the doll-house. The next step is an animal-cage for a menagerie. The front of the cage is made like the lantern; the strip of paper being 6 inches long and 3 wide, and

6, except where the ends, which are 2x3, project, making the center strip 10 inches long. After the creases are made along the dotted lines, the laps are to be pasted over on to the barred front piece. The ends need not be pasted but only tucked in. They serve as doors. The "cage" may be turned into a



1



2

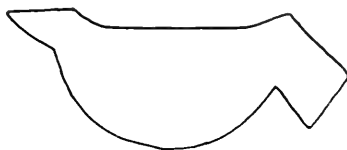

3

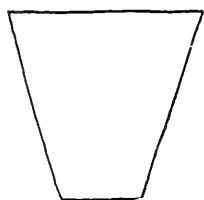

4

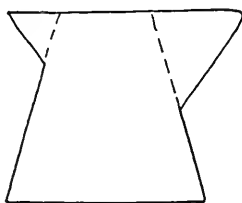

5

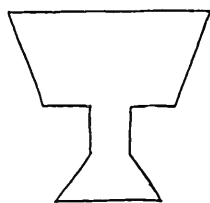

6

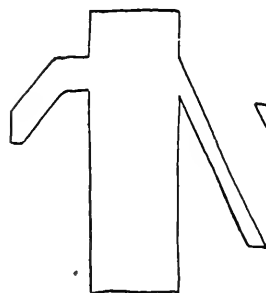

7

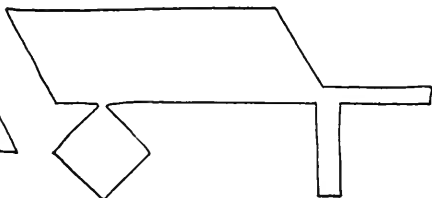

8

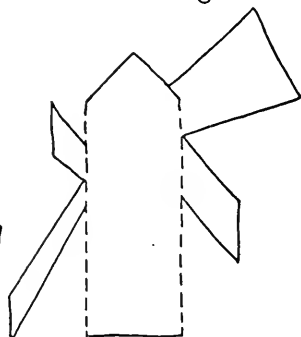

9

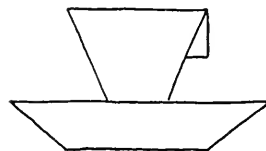

10

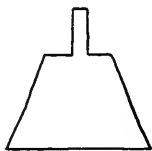

11

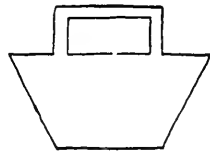

12

PAPER CUTTING

1—Apple. 2—Sugar Bowl. 3—Cream Jug. 4—Tumbler. 5—Coffee Pot. 6—Berry Bowl. 7—Pump. 8—Wheelbarrow. 9—Windmill. 10—Cup and Saucer. 11—Bell. 12—Basket.

the cuts one inch deep after it is folded lengthwise. Next, every alternate strip is to be cut out so as to leave the remaining strips for bars, as in No. 5.

The rest of the cage is in box-form, the main part of it being 7 inches and a half by

street car, or railroad car, by fixing gunwads or circles of stiff card, such as milk-bottle stoppers, for wheels on the ends of two small sticks. Meat skewers, cut the right length, will serve. The car is then set on the sticks and may be held in place by strips of paper

slipped under the sticks and pasted to the bottom of the car. A sloping roof can be added like that used for the house already mentioned.

**Free Paper-Cutting.** The children may begin by cutting paper in bits to stuff cretonne cushions for the play-room; this may be followed by cutting paper in short strips and tying it on sticks for toy brooms; square pieces for napkins and round pieces for plates for a "tea-party" will be the simplest things to do next, and all sorts of picture-cutting may follow. Practice in

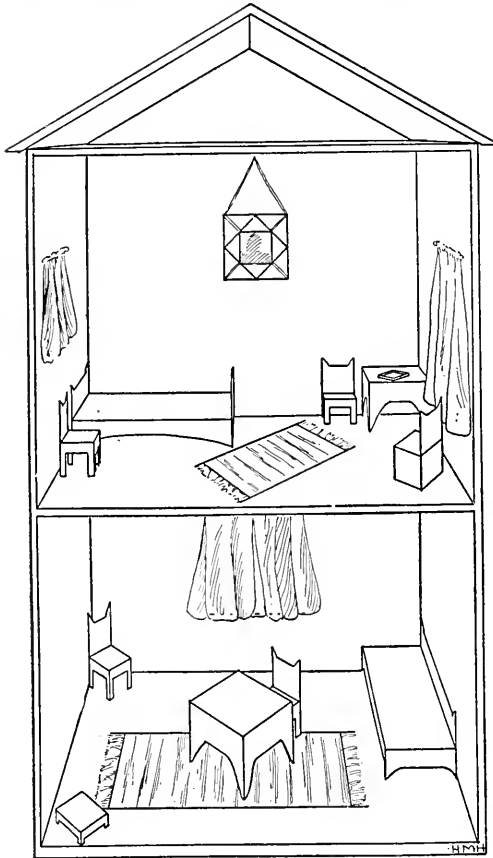

DOLL HOUSE

using the scissors to keep to an outline may be gained by taking a round piece and cutting round and round till the center is reached; this "snail-shell" will give pleasure, and the same thing be done with a square piece. Dolls and animals can be more easily cut after the children have cut these out of advertisements, old toy-books, etc.; that is, if the same kind of picture is cut a number of times, the children will gain some "mus-

cular impression" of the outline. This plan is part of the Montessori method; but there is no reason why the children should not also originate freely. A page of examples is given here to show how the same sort of outline, with different details, may be modified to make several different pictures.

Paper dolls are not given here, because they can be better made by cutting out figures from fashion-magazines and pasting a piece of stiff cardboard at the back, with a free strip for a support; or they can be bought for a penny at any stationer's. Children seven or eight years old can make their own by imitating these. A home-made doll house is a never-ending delight to children. A soap-box makes a good one. It should have a piece of board fixed in the middle, so as to give either two rooms side by side, or an upstairs and downstairs, if the box is on end. A roof may easily be added by forming a gable of two slanting pieces. On this, shingles cut out of brown paper may be tacked. The children can paint the sides of the house and design wall paper for the inside with paints or colored chalks. See illustration of a doll house on this page.

The toy furniture in boxes may be used, but it is far better to let the children make their own, either of paper and cardboard or of spools, bits of scrap-wood, etc. Paper fringed and "cut fancy ways" will serve for curtains, table cloths, etc. Rugs can be sewed, braided or woven for the floors. Boys may prefer to furnish one room as a shop, and in any case the fittings may be changed from time to time. Of course, work like this should be done on Saturdays, or in the evening, and it will furnish a powerful incentive to the children to get up early and get lessons done in good time.

**Suggestions for Sand Table.** A farm-yard, a ranch, a circus or menagerie, or a home-made Noah's Ark will give pleasure and occupation to children for a long time.

It can be arranged in the sand table or sand pan; or on a small table with a strip of wood or cardboard tacked round it, to keep the things from falling off. See illustration of sand table, later in this article.

The animals may be made from clay and colored; or may be cut out of magazines, such as *Outing*, *Country Life*, etc., pasted on thin cards and cut out again; a tiny support of cardboard must be pasted to the back so that they will stand up. The hunters, cowboys,

farmers, etc., are to be made in the same way. A description of the way to make cages for the animals will be found on another page.

Dough is almost as useful and delightful for children to work with as clay, and keeps them happily employed under mother's eye, when she is making pies, bread, or cookies. Cottage loaves and twists, in miniature size, are a joy for children to make; a "snow-man," "cookie-boy," etc., with currants for eyes, and dots of sugar or chocolate for buttons; animals of various shapes; rows of cats and kittens, made by tracing out a large oval for the body, with a small one for ears, for the head, and a long tail; stars and moons, flowers, etc., cut out in cookie-dough, and ornamented in fanciful ways. These make a never-forgotten joy for childhood, when looking back on it.

**Keeping Christmas.** The German cakes, illustrating fairy tales, made for Christmas, are full of happy suggestions; and simple home-made things, both for Christmas-tree decorations and for gifts, are part of Froebel's plan for the ideal home Christmas or birthday. The essence of his thought is, that the tiniest, most trifling expression of the child's affection, through his own activity, is far beyond any purchased gift in value, and is important in strengthening his emotion, keeping it alive. "Even the child's love," he says, "will fade and die if it be not turned into active forms of expression." So, in the kindergarten, the children make the decorations for the tree, and make the gifts for their parents, inviting them to come and receive them. The pleasure of preparation, and the joy in their own doing of it, is far greater than when they receive anything themselves.

The decorations may be "snow-balls" made of folded circles or squares of tissue paper strung as for shaving-balls; chains made of gold, silver and colored paper cut in strips and pasted into rings; lanterns, paper stars and snowflakes, colored paper baskets, etc. The gifts may be pieces of "picture-sewing," weaving, etc., with small calendars, or sand-paper for scratching matches, pasted on them; cardboard pin-trays or blotters decorated with parquetry paper circles, rings, stars, etc., or with little pictures or designs in colored crayon; court-plaster cases, also made of cardboard tied or pasted, napkin rings, made of a decorated strip of cardboard,

tied with ribbon; or little picture frames of card, wound with colored raffia. Things of no value in themselves, they are beautiful to the child, because they are his own work, and should never be treated lightly.

Such Christmas keeping, with songs and stories to complete it, will be more enjoyed than if much money were spent. Froebel urges, too, that instead of loading the child with gifts, he should be shown the shops, but given a limited choice. The pleasure in seeing the things is not lessened by feeling that only a very few can be his possession; something is left for the future, and he does not wear out his powers of enjoyment, or get blasé. This principle of enrichment by making the *most* of things under limitation, is a most important aid in moral training and runs all through Froebel's thought. Not the quantity of power or possession, but the way we use what we have, is what makes life rich.

**Scrap Books.** There is no end to the number of ways in which scrap books may be used. First of all, the older children may make picture books for the babies, or to give away to poor children, by fastening together leaves of glazed calico into a book and pasting pictures into them. These are practical because they will not tear. Flour paste with a little powdered alum in it is best, if you are not near enough to town to buy paste in tubes or jars. After the muslin scrap books come bought ones, which should not be used until the children can paste neatly. Old account books and scribblers with every second leaf cut out can be filled with pictures, and old copy books may also be used.

A great deal more interest will be found in these if the pictures are classified. i. e., animal scrap books, bird books, flower books, may be made by children old enough to have special tastes; when they can read well enough clippings on the subject from magazines or newspapers may be added.

Now that the periodicals of the day furnish so many illustrations, a boy fond of engines and machinery can put these in a special book, and the same way with ships, Indians, soldiers, etc. A girl interested in cooking can make a receipt book when she is old enough.

The pictures should be kept in envelopes of manila paper or wrapping paper, labeled; and they may be collected from the advertisement pages of magazines, as well as the regular pages. A variety of books, which is

interesting to children from seven to ten, is a doll-house book. The pages may be furnished as the rooms of a house with cut-out pictures, showing all the "comforts of home" and a family of paper people may live in the book, passing from room to room by doors cut through. In collecting flower pictures, or leaf pictures for a book of trees, blue prints will be an interesting addition. All that is needed is a frame for printing photographs and a package of blue print paper. The child can soon learn to arrange leaves or blossoms so as to make a clear image on the paper, fasten them in the frame, and leave them in the sun long enough to take the impression. No one who has not tried it can believe how much interest may be found in a neighborhood seemingly almost barren, when one begins to observe trees, birds, etc., closely.

**For a Sick Child.** The paper-work given here is excellent for a sick child, because it can be burnt and renewed easily. A small board may be fitted like a bath-tub seat, with hooks at the end to support it on a crib. A kindergarten toy called the gonigraph, made of slats jointed together, is easily handled by a sick child and may be twisted into many different "pictures." Paper scrap books may be made for a sick child by the other children, to be burnt after the child's recovery. A child may often be tempted to eat by having some little fancy decorations on its food tray, or bread in tiny loaves, or a paper napkin folded in a box form for its fruit, etc. A prism hung in the window, which makes dancing beams of light, is one of the kindergarten experiences which will please a little invalid. At places where builders' supplies are kept, the round pieces of colored glass which are used for ornaments in glass doors may be bought at so much per hundred. A child will delight in arranging these in patterns, on a tray or board.

**Out-Door Amusements.** Children are always interested in gathering and collecting blossoms, leaves, seeds, nuts, etc. In many places it is forbidden to pick flowers, but fallen leaves and seed-vessels may always be taken; chains, often very pretty, may be made of seeds and seed-vessels strung with a worsted needle and coarse thread; stoles or garlands may be made of leaves by pinning them together with leaf stalks; all sorts of funny objects may be made by sticking burrs together; perhaps the funniest is a "teddy-

bear." Dollies may be made of corn husks, the end serving as head, part of the husk separated on each side for arms and the rest of it tied in with a sash forms the skirt.

Dolls may be made of marguerites; the white petals form a bonnet, being cut away at the bottom; a little face is traced on the yellow center, and a bunch of grass tied around the stem for a skirt.

Many kinds of blossoms may be made into chains; poppy heads make tea-pots, with twigs stuck in for spout and handle. Milkweed pods may be turned to parrots and other funny forms. However, the most interesting out-door occupation is making houses. A very small space of ground will allow of building mound-shaped houses and forts, with sand or clay, to which gardens, fields, etc., may be added; tent or wigwam houses may be made of branches (small branches are best, a foot long is quite enough); log houses may be made of crossed twigs, with leaves laid over sticks for the roof; small stones, bits of brick, shells, even bits of moss may be used to make ground plans of houses with one or more rooms, which the children find quite as satisfactory as more realistic ones. If space allows to lay out a toy village, colonial or Indian, a camp or even a farm or ranch, every addition will be a new pleasure, and a useful connection with history or literature may be made. Toy animals may be used if they can be made of clay, wood or paper. A stream, however small, will give endless joy in sailing boats and making miniature mills or dams; snow buildings are of equal interest in winter; and when a winter picnic can be held in a spot sheltered enough to light a fire and eat a meal, it is quite as enjoyable to healthy children as a summer one.

Gardening is, of course, a most wholesome occupation for children, and one constantly urged by Froebel. Even a window box garden gives pleasure; but there are now so many garden magazines that advice on practical work is always to be had. Many state universities furnish information and even seeds free to boys and girls. Doubleday, Page & Company and many other publishers have a large assortment of books and magazines on nature work, and gardening. It is a good plan to write for specimen copies of magazines.

Of course, clothes must not be a burden to children in out-door occupations. Simple

rompers, overalls or pinafores, which can be soiled with impunity and allow freedom of action, are a necessity.

**Walks with Children.** Following is a list of things to be observed:

1. Flowers, leaves, berries or seed-vessels, trees, bushes, birds, insects, animals, bees, butterflies, ants, caterpillars, spiders, lizards, frogs, toads, snakes, cats, dogs, goats, chickens, horses, mules, fish, snails, turtles, beetles, dragonflies.

Fruits, vegetables.

Snow, ice, frost, water, soil, dew; fountains and water-power.

Conveyances, buildings, trades, windows, doors.

Wheels, fences, gates, statues; other children, workmen, etc.

The State Agricultural bureaus are very willing to supply information, and sometimes publications, on nature-study. Also, the United States Department of Agriculture can provide many valuable helps.

### Home Discipline and Government

**Busy Children Not "Naughty."** Two things in Froebel's writings are little understood, first, his urgency that when children are considered "naughty" they are often misunderstood, and that the fault is with the adult; secondly, that freedom is the goal and object of education.

Froebel's ideas are expressed at so great length, and with so many digressions, that people often lose his main points.

He insists that when fully employed, with natural occupations and companionship, children are seldom wilful or cross, but that they must be active; if activity is stifled, they will be cross, unhappy and lazy; if it is not guided, it will be perverted to wrong forms, and they will be troublesome. But this is because the adults have not patience and knowledge enough to keep them employed.

It is common experience with kindergarten and other teachers that children who are said to be "very naughty" at home are contented, happy and helpful in school. A little child in a kindergarten who never wanted to go home, said, pathetically: "You see, I'm always good here, it's so easy; but I don't know why it is, I always seem to be naughty at home." The child had no companions at home, and no suitable employment.

"Plenty to do" is the usual solution of the trouble; but there is also another source of it. Froebel constantly reminds us that children are nothing if not imitative, "therefore

be careful, parents, what you say and do in their sight." If we are selfish, cross, and untidy, it is unreasonable to expect children to be otherwise, merely because we *talk* of virtues which we do not practice. "Actions speak louder than words." On the other hand, if love, cheerfulness and regular habits of order in meals, occupations, going to bed and rising are the rule of the home, the child unconsciously imitates and forms habits on these lines.

**Freedom under Limitation.** As to the freedom Froebel urges, it is, as in all other things, freedom under limitation, and only to be attained progressively, as we become able to use it. The children may have materials, but must keep them tidy and put them away. They may have pets, but must feed and take care of them. They may have romps with father when he comes home, but must be made clean and tidy before he comes. "Every normal child gladly fulfils duties, when he is rightly taught, but these must be clear, genuine and above all, *inexorable*." So says Froebel in his *Mother-Play* book. That is, it is an injustice to the child if in teaching him habits and duties you do not keep him steadily and continually at them. "There must be no vacations" in forming habits. One point which solves many difficulties is to give a choice. "You may have this pleasure or privilege, may stay with us, if you are good-humored, but you must go away by yourself if you are not. Which will you do?" The decision means much in training.

Let us try always to remember that a little child is like a traveler who has arrived in a strange country; many of the words, ideas, customs and laws are unknown or puzzling to him, and if he offends against them it is quite often from ignorance and lack of habit in those directions. Let us form the practice of looking back to our own childhood, especially our childish blunders, fears and troubles, that so we may learn the things which cause these in children, and remember we were as human as they are.

**Train to Meet Difficulties.** Froebel would not have children, sheltered from difficulties, but trained to meet them. "Yonder," he says, "is a child gliding in a sledge over the snow. His eye is not sure; his hand not strong; he falls. What says his pain? Train your eye, exercise your strength, so that you may avoid a fall. Yonder is a boy skating. Heedlessly his eye wanders; he falls, but happily

only grazes his hand. Collect your mind, fix your eye, rule your feet and legs that you may not fall. . . . As he grows older you, mother, will find many opportunities to show him that without watchful care, slips and falls may easily be serious. Through play, in which he is watched over by your love, and protected by your care, your baby increases *both his strength and his consciousness of strength.*

The consciousness of strength can come only by being helped over and over again to meet difficulties both physical and spiritual.

"On a windy, almost stormy, day, the children go out with their mother . . . . Hark, how the weather vane creaks. . . . How the clothes flap and rustle on the line! This delights the children. . . . A little girl is watching the waving handkerchief in her hand. . . . Out runs a little boy with his paper windmill. A third child is flying a kite." "Where does the wind come from, mother, that moves so many things?" "You would not understand if I were to explain to you now, but you can see many things great and small that it can do. Your hand moves, but you cannot see the power that moves it. . . . Hereafter, though you will never see it, you will understand better whence it comes."

Mothers keep children in the house, often from fear of colds and other dangers to health; often from fear of their learning bad habits and manners from other children; sometimes, I fear, because it is inconvenient to go out with them and they are too small to be alone.

**Perils of Growing Up Alone.** In reality, to a child the danger of growing up solitary is worse for mind and body than any of the perils mentioned. Such children generally become dreamy, and live in a inner world of their own; they often invent imaginary companions to satisfy the craving for real ones; and they frequently form dangerous physical habits, from lack of activity and the indolence of will which is apt to go with indolence of body. Froebel warns us against this.

The imaginary companions never make inconvenient demands; the child may be as selfish, as masterful, as ill-tempered as he pleases, and the playmates of his inner world make no protest. Or these qualities may lie hidden in him and never come to the surface till he meets the real world. Many a failure in business or family life might

be saved if mothers only saw in time the temper or tendency in their children which does not show except when drawn out by the actions of others; and many a natural power and capacity fades away because never aroused or assisted by imitation, competition or the good spirits and interest in life which come with companionship.

**Comparisons Drawn from Play.** More than one kindergarten teacher has said that in jumping, running, skipping, playing games of skill, etc., the poorest in power and slowest of the children are those who come from the wealthier homes, where they are waited upon, instead of having to help others and act for themselves; or they are only children, who have no stimulus from others at home. You do not know your own child's powers; invite other children to walk and play with him; watch them in games and in exercises or anything that requires effort, and see what are the impulses that need repressing, or the talents needing to be drawn out; whether timidity or hastiness is what prevents successful results.

One child will show timidity in jumping, or in playing with animals, which can be overcome by showing him that his playmate is not afraid. Another will be slow to perceive, and will learn much from what others notice. A third will be discouraged if he fails at first in throwing or catching and will want to give up. If he had no companions, he would never make an effort and would lose both vigor and will power; but the insistence of the others leads him to do more than he would alone. When children begin to help at home, which they love to do when very little, this is a great opportunity for training. Some mothers let them try things beyond their powers and scold or punish them when they drop or break things. A little one who carries breakables or dishes and glasses which may spill over needs to be warned: "Hold tight, open the door, before you carry the dish out; watch what you are carrying to see that it does not spill; walk slowly." These counsels need to be repeated, not once, but many times. "Many a loss comes from anxious care mated with weakness. Draw these pictures from life for your child, as need and occasions call for them." So says Froebel. Of course, this needs love and patience, but what are mothers for but to show love and patience? A mother lamented that her delicate child did



not gain strength and wished she would run more. She was asked whether the child did not run after her ball. "Oh, no," she said, "we always pick it up for her." Another child would not have done this; her adult playmates gave her no chance of exercise.

A strange lack of sympathy and understanding was shown by a mother whose little girl constantly talked to, and of, an imaginary child she called "Dora." The mother said, "I will not have this go on; I cannot stand having her talk as if there were someone here when there is not. I'll stop it." One day she threw down some heavy article with a crash in the room next to where her child was and ran in, saying to her, "Dora is dead; that box fell on her and killed her." This was a real cruelty to the child, whose innocent fancy made her happy, and was no safeguard against the invention of another playmate. The real remedy would have been to invite other children constantly until the dream playmate was "crowded out," or at least, counteracted as to any morbid influence, by the commonplaces of ordinary child-life.

**Harmless Animals as Companions.** Animals are satisfactory companions because they, too, are generally active, and are nearer the child's level in motives and habits than most grown people, and they are, as a rule, most satisfactory out-of-doors, which is an incentive to the child to go out for fresh air and exercise. However, children in kindergartens keep, and delight in, a range of pets, including birds, fish, turtles, cats and kittens, chickens, white rats, white mice, guinea-pigs, snails, ants, caterpillars and butterflies, toads, frogs, wild bees and pigeons, with occasional visits from dogs. The last can only be properly kept, however, where there is plenty of ground for them to run in.

It is not easy at first to train a child to take good care of pets; but it is wrong to let him leave the responsibility to others. Froebel begs the mother to give her child both the pleasure and the training of caring for, "nurturing," the life of plants and dependent creatures. Nothing, says he, is so valuable and important an influence on the child's character as to be capable of this unselfish, patient nurture, and any mother who truly wishes her child to be his best self will not regret the care and patience needed to train him.

### List of Recommended Books

#### BOOKS FOR PARENTS

- Beckonings of Little Hands. Du Bois. Lippincott.  
 Children's Rights. K. D. Wiggin. Milton Bradley Co.  
 That Boy. Forbush. D. C. Heath & Co.  
 The Making of Character. MacCrum.  
 Misunderstood Children. E. Harrison. Sigma Publishing Co., Chicago.  
 Study of Child Nature. E. Harrison. Sigma Publishing Co.  
 Story of My Life. Helen Keller. Doubleday, Page & Co.  
 Mind and Work } Gulick.  
 The Efficient Life } Doubleday, Page & Co.  
 Froebel's Education of Man, and Mother-Play Book. Appleton, New York.  
 The Study of Children. Warner. Macmillan.  
 The Care and Training of Children. S. G. Kerr, M. D. Funk & Wagnalls, New York.  
 Mentally Defective Children. Shuttleworth & Potts. Blakiston Pub. Co., Philadelphia.

Many other valuable articles and publications may be found, or names obtained in:

- Kindergarten Review, Springfield, Mass.  
 Child-Welfare Magazine, Philadelphia, Pa.

#### ON NATURE AND OUT-DOORS

- How to Know the Wild Flowers. Dana.  
 Familiar Trees. F. S. Matthews. Appleton.  
 The Cabin. Stewart E. White. Macmillan.  
 Bird Stories. Burroughs. John Lane Co.  
 When Mother Lets Us Keep Pets. Johnson, Moffat, Yard & Co.  
 How to Grow Vegetables. French. Macmillan.  
 Insect Life. Comstock. Appleton.  
 Citizen Bird. Wright. Macmillan.  
 Our Feathered Friends. Grinnell. D. C. Heath.  
 Garden Magazine. Doubleday, Page & Co.

#### FOR PRIMARY TEACHERS

- Handwork for Kindergartens and Primary Schools. J. S. Hoxie.  
 Story-Telling with Scissors. M. H. Beckwith.  
 Holiday Songs. E. Pulsson.  
 Suggestions for Handwork in School and Home. Hoxie.  
 Arnold's Rhythms for Home and School.  
 Educational Gymnastic Play. Johnson & Colby.  
 Froebel's Educational Laws. Hughes.

All the above can be obtained from the Milton Bradley Co., Springfield, Mass.

### The Primary Department

**Suggestions from the Kindergarten.** Primary teachers will find suggestions from the kindergarten material valuable for seat work, especially if they have some very young or backward children. However, the regular material is too expensive for large classes, that is, if it is only to be used for seat work, though it is extremely helpful to have several boxes of the "gifts" and beads, if real

connecting class work, as Froebel called it, can be done.

For ordinary work, paper, cardboard, paste, colored chalks and scissors are needed. If possible, clay from a pottery, and paints made from Diamond Dyes should be used for modeling and coloring exercises about once a week.

**For Seat Work.** For school seat-work the same advertisement and picture pages of old magazines as for the home are useful; the children should cut out pictures of animals, farm work and farm implements, plants, trees, mountains and lakes, etc., anything that will connect with geography and nature study, for scrap-books or wall charts, which last are far better when made than when bought. Old school readers and large calendars, such as are distributed by business

e. g., three, red; two, white, etc., and designs be made with the pieces cut.

A box of Milton Bradley's "gummed paper dots" is useful for the children to paste on cards to make sets of dominoes; this is a good number exercise.

Boxes of toothpicks and shoe pegs may be colored with Diamond Dyes, and used both for number work and for toy furniture. The doll house planned for the home is an equally valuable school training in manual work. Every object in it may be used as an exercise in mensuration, especially the wall-paper and rugs.

**Scrap-Books.** A scrap-book may be made on any school subject: nature study, history, civics, geography—a scrap-book of famous persons, either foreign or home celebrities, one on current events of importance, on in-

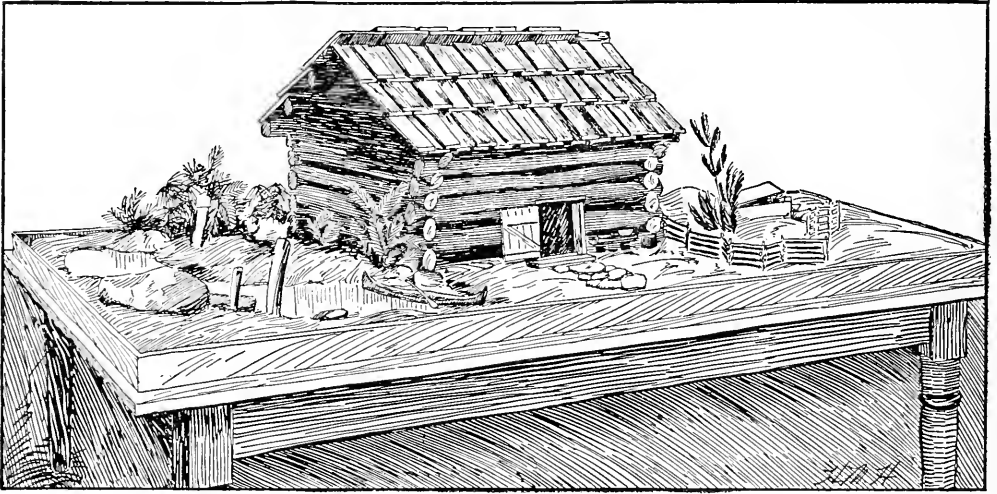

POSSIBILITIES OF THE SAND TABLE

houses, are very valuable in school. The younger children may cut out the words from the readers and the separate letters and numbers from the calendars; they then mount them on small cards, using the words and numbers to make original sentences and examples.

**Number Work.** For number work, they can also cut the colored squares of paper into halves, fourths and other fractions. Some can be cut into inch squares or thereabouts, which are to be pasted on strips of paper to show number groupings; e. g., a class may show all the possible ways of picturing five, six, ten, etc. Number groupings may also be illustrated with paper chains;

vention and discovery, or on religious studies. There is really no limit to the possibilities in this way.

Pictures may be neatly mounted on cards and sliced into puzzles, or the stiff picture covers of old toy books may be used in the same way; while geometrical puzzles may be made of cardboard squares cut through in various directions. Sets of dominoes and geography card games may be made also.

**Sand Table.** A sand table for either school or home may be made, by having a wooden strip three or four inches deep nailed round a kitchen table, or any small table; it should be lined with kitchen oilcloth. The lining is needful because the sand must at times be

moistened. The table must have the legs shortened so as to be of proper height for working. In school there is no limit to the use of the sand table. A house and yard, a village of cardboard houses and stores; a farm, with fields and orchards, may be worked out as a neighborhood study, the children collecting the material.

**Indian and Colonial Life.** Indian life with paper wigwams, a piece of glass or tinfoil for a lake, paper boats and toy or clay people and animals makes a fascinating exercise which will last for weeks.

Colonial life should follow this, and the clearing of the forest, planting of fields and making roads will make pioneer life vivid. Other geographical and historical exercises will easily follow, and the children will eagerly collect bits of wood, stone and bricks, twigs, bark, etc., to fill in the scene. Clay is very helpful here, as most things, not otherwise at hand, can be easily represented with it; Eskimo huts, for instance; colored chalks and paints are useful in this, and also for designing the wall papers, rugs, etc., for the doll house or "Home," as it may be better to call it, for a school exercise.

**Nature Study.** Nature study on plants, flowers, fruits and birds of the locality should whenever possible be followed by an exercise in representing these in color on the sheets cut from wrapping paper; and large sheets with lists of the birds, plants, trees, etc., which are known should be hung on the wall, and added to from time to time.

Similar sheets with new words and sentences written large in colored chalk may be hung up for review work, and colored chalk is most useful for outlining the difficult elements in misspelled words.

**Suggested Material.** A cutting board and knife for papers and cardboard is most useful for either school or home, as home-made programs and menu cards, passepartout mountings, etc., can be prepared by its aid; the cost is from \$2.00 to \$5.00, according to size, at Milton Bradley's or supply houses.

**Games for Primary Teachers to Use.** All the sense games suggested for the home may be used and should be carried further; e. g., with coverings of animals, shell, fur, wool, fish-scale, leather, for touch; with sounds of animals, birds, musical notes and instruments, for hearing; with tastes and smells of natural products, etc. These may be connected with geography and nature study.

A good game to exercise observation is to choose some object of interest, while one child is sent out, and have her guess it from the answers to her questions. These may be made exercises in language.

A good game for language exercise, especially with foreign children, is "Little Travelers." The children leave the room in groups of three or four at a time, telling when they return that, "We have come from 'snowy (or shivering) land,' where the snow was falling." "We have come from 'summer' or 'fanning' land, where people all were 'fanning.'" The action must be used with the word.

An imitation game is a pleasant change of position. The children rise from their seats, and standing in the aisles, imitate the action of a child who is chosen to stand in front of the room as leader. A song which may be sung as accompaniment to some simple air is:

"O, a merry band are we,  
Standing here so quietly;  
What one can do, we all can do!

Let {Susie } show us something new."  
      {Willie }

Another form of this is "Follow My Leader." The leader may either stand still and dramatize actions for imitation, or may walk, run, hop, march or creep around the room, the others imitating. Animal movements imitated, ponies, ducks, kangaroos, etc., are good gymnastic exercises.

Another good game is "I Went to Paris." The teacher asks "What did you do there?" or "What did you buy there?" and the child replies, dramatizing some action which all must imitate.

This may be played in rows, the first row saying, "I went to Paris, London, etc." The second row asks the question, and receives an answer, accompanied by some action with the right hand. The third row begins with the statement; the fourth row questions the third, and an action with the left hand follows, the children who began the game still continuing the action; the fifth row may add some action with the head or foot.

The old "Quaker" game—  
"I put my right hand in,  
I put my right hand out;  
I give my right hand a shake, shake, shake,  
And I turn myself about,"  
is a good one for the first grade.

## Outline on Kindergarten

- |   |   |
|---|---|
| <p>I. HISTORY</p> <p>(1) Origin</p> <p>(2) Froebel's ideal school</p> <p>(3) Recent Development</p> <p style="padding-left: 20px;">(a) In the United States</p> <p style="padding-left: 20px;">(b) In other countries</p> <p>II. PURPOSE</p> <p>(1) Wise direction of the child's activity</p> <p style="padding-left: 20px;">(a) In self-expression</p> <p style="padding-left: 20px;">(b) In relations to others</p> <p>III. METHODS</p> <p>(1) Songs and stories</p> <p style="padding-left: 20px;">(a) <i>Mother-Play Songs</i> (Froebel)</p> <p style="padding-left: 20px;">(b) Class singing</p> <p style="padding-left: 20px;">(c) The mother's or teacher's story</p> <p style="padding-left: 40px;">(1) Its purpose</p> <p style="padding-left: 60px;">(a) To call into play the imagination and feelings</p> <p style="padding-left: 60px;">(b) To develop the sense of right and wrong</p> <p style="padding-left: 40px;">(2) Its character</p> <p style="padding-left: 60px;">(a) Usually of the fanciful type, suggestive of simple truths</p> <p style="padding-left: 40px;">(3) How it should be told</p> <p style="padding-left: 20px;">(d) Conversations</p> <p>(2) Games</p> <p style="padding-left: 20px;">(a) Marching, guessing, and contest games</p> <p style="padding-left: 40px;">(1) Use</p> <p style="padding-left: 60px;">(a) Entertainment</p> <p style="padding-left: 60px;">(b) Development of imagination of reason, and social instinct</p> <p style="padding-left: 40px;">(2) Suggested games</p> <p style="padding-left: 20px;">(b) Gift-plays and games</p> <p style="padding-left: 40px;">(1) Purpose</p> <p style="padding-left: 60px;">(a) Self-expression</p> <p style="padding-left: 60px;">(b) Exercise of imagination and power of observation</p> <p style="padding-left: 20px;">(2) Character</p> <p style="padding-left: 40px;">(a) Representation of</p> | <p>persons or objects of nature with their characteristic actions and feelings</p> <p>(3) Gifts</p> <p style="padding-left: 20px;">(a) Classification</p> <p style="padding-left: 40px;">(1) The five groups</p> <p style="padding-left: 60px;">(a) Solids, (b) surfaces, (c) lines, (d) points, (e) construction material</p> <p style="padding-left: 40px;">(2) The eleven gifts</p> <p style="padding-left: 60px;">(a) Six colored balls, (b) ball, cylinder, and cube, (c) eight one-inch cubes, (d) eight brick-shaped blocks, (e) twenty-seven one-inch cubes, (f) twenty-seven brick-shaped blocks, (g) wooden tablets, (h) sticks or splints, (i) wire rings, half-rings, and quarter-rings, (j) pebbles, seeds, etc., (k) construction materials (wax pellets, cork cubes, etc.)</p> <p style="padding-left: 40px;">(b) Use as playthings</p> <p style="padding-left: 60px;">(1) Amusement</p> <p style="padding-left: 60px;">(2) Indirect instruction</p> <p style="padding-left: 80px;">(a) Ideas of form, measurement, and motion awakened</p> <p style="padding-left: 80px;">(b) Constructive power called into action</p> <p style="padding-left: 40px;">(4) Occupations</p> <p style="padding-left: 60px;">(3) Drawing and painting</p> <p style="padding-left: 40px;">(b) Purpose</p> |
|---|---|

Another form of this is played by the rows of children.

1st Row: "Queen Anne's dead."

2nd Row: "How did she die?"

3rd Row: "With one hand going this way."

The fourth row again says, "Queen Anne's dead," and this is continued till hands, feet and head are all "going" as in the "Quaker Dance."

A simple gymnastic play is "See-saw." The children stand together in threes; the middle child stretches out his arms; the two on either side, facing each other, clasp their hands over the "board" he thus makes, then rise and fall by bending and straightening the knees alternately.

Another simple game is the "Swing." Stevenson's verse may be sung:

"How do you like to go up in a swing,  
Up in the air so blue?

Oh, I do think it the pleasantest thing  
Ever a child can do."

Singing is not necessary, but rhythmic counting is desirable, or

"Swing-swing, the days grow long."  
may be sung.

The children stand in threes around the room; two face with hands clasped; the third rests his hands upon theirs and pushes them back and forward, as if pushing a swing; after three, or six, swinging movements, each child pushes the "swing" high enough to run under it and goes on to the next one.

Another dramatic game is—

"What can you do?"

A child stands in front of the others, and the teacher asks:

"What can you do?"

He answers: "I can pull ropes, like a sailor," and stretches his arms up, with the action of pulling, the others imitating.

Other suggestions may be:

"I can drum, like a drummer."

"I can saw, like a carpenter."

"I can sew, like a dressmaker."

"I can skip with a rope."

"I can shoot, like an Indian."

"I can ride a bicycle."

Bean-bags made by the children give opportunity for many games. They may be tossed between the children of opposite rows, as in a "potato-race;" tossed by successive children of each row into a chalk circle or paste-board box placed in front of each row; the rows may face the back or

the front of the room, in whichever place there is most space.

The bags may also be passed up and down the rows; whichever row gets all to the end first wins.

A similar game may be played with clothes-pins.

The dramatization of stories is a good exercise, but there should be an effort made to provide action for more than one or two children.

**KINEMATICS**, that branch of mechanics which treats of motion without reference to mass or to the forces causing the motion. See **DYNAMICS**; **FALLING BODIES**; **STATICS**.

**KINETOSCOPE**. See **MOVING PICTURES**.

**KING**, a sovereign who rules over a country by right of succession. In the earliest times the king was absolute ruler and the source of all authority. He was considered the representative of God on earth, and his person was held sacred. But this conception of a king has gradually changed with the growth of the spirit of liberty, until most rulers are now restricted by constitutions; many are subject to removal by a body representing the citizens of a state. No king now holds supreme authority; he is only coördinate with the national legislature and the national courts. The office as it exists to-day has been described as that of hereditary president, but usually it carries less power than is placed in the hands of a president.

**KINGBIRD**, a useful and interesting little flycatcher, common in the United States and

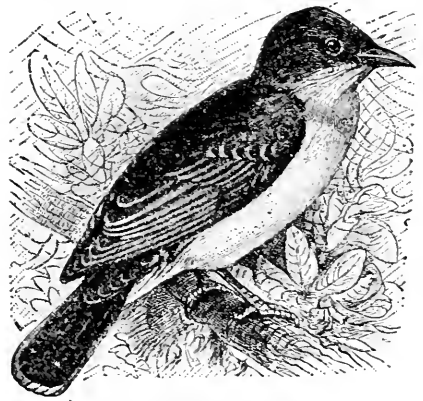

KINGBIRD

parts of Canada from May to September. The winters it spends in Central and South America. It is about nine inches long, is

drab-colored above and white underneath. On the top of its head is a bright red patch of feathers, ordinarily inconspicuous, but when the bird is angry and in fighting mood, as it frequently is in defending its nest, the little red patch rises like a crest, giving the bird a pugnacious aspect.

The kingbird is not musical, but has a pleasing cry of rather robust tone. It has very keen sight, and even when sitting on its nest it keeps a sharp lookout for insects, which it darts out at and catches on the wing. The kingbird is charged with eating bees and is consequently not favored by the bee raiser, though on the whole few birds are of greater assistance to the agriculturist. The eggs are buff brown, covered with fine, irregular lengthwise markings.

**KING CRAB.** See HORSESHOE CRAB.

**KINGFISHERS**, a family of birds having long, stoutly-formed, four-sided bills, which are broad

at the base and terminate in a fine, sharp point; short legs, strong feet and somewhat elongated toes. The common kingfisher of Great Britain has a greenish head, back and neck, spotted

with blue, and is a bright blue on back and rump. Its throat is white, and the under surface of the body is pale brown. In the United States the *belted kingfisher* is a bluish bird with white under parts, crossed over the breast with a bar of blue. In the female and young this blue band is bordered with chestnut. This bird nests at the end of a long tunnel, which the bird makes in the bank of a stream.

The kingfisher spends most of its time perched on the bough of a tree overhanging the bank of a river. From this place it watches for fish, and as soon as it sees one,

it dives into the water, secures the fish with its feet and carries it to land, where it swallows it entire. This bird has been the subject of many superstitions. People formerly believed that it laid its eggs in a nest and floated it out upon the sea, stilling the waves with its wings. It was then called the halcyon bird, and from its name beautiful days came to be known as *halcyon days*.

**KING GEORGE'S WAR.** See FRENCH AND INDIAN WARS.

**KINGLET**, a delicate little bird of the thrush family, olive-green above and yellowish below. Two species are common in the United States, the *golden-crowned kinglet*, which has a stripe of beautiful gold or orange through the middle of its head, and the *ruby-crowned kinglet*, which has a fiery red crest, hidden by grayish feathers except in moments of anger or excitement. Both are common in the Northern states during the period of migration. The ruby-crowned kinglet is one of the sweetest of the spring songsters.

**KING PHILIP** (?-1676) or **METACOMET**, son of Massasoit, chief of the Wampanoags. Though Massasoit was a steadfast friend of the whites, his son had become suspicious of them and planned an outbreak which for a long time caused terrible loss of life and property. Finally Philip was defeated. After he had taken refuge in a swamp near Mount Hope, he was slain by another Indian.

**KINGS**, BOOKS OF, two books in the English and one book in the Hebrew canon of the Old Testament. The history, as related in the books of *Kings*, begins with the close of David's reign and carries the events onward to the capture of Jerusalem and the destruction of the Temple. See CHRONICLES.

**KING'S COUNSEL**, in Great Britain and its dependencies a title of honor bestowed on barristers of distinction. Those who are so honored are privileged to sit within the bar and wear a silk robe. In the United States there is no dignity corresponding to king's counsel.

**KINGSLEY**, CHARLES (1819-1875), an English clergyman and author. At Magdalen College, Cambridge, he took his degree with high honors. He became curate of Eversley, and later was rector there. His opinions on the social and economic questions of the time are treated in his earliest novels, *Alton Locke*, *Tailor and Poet* and *Yeast*, *A Problem*. In



BELTED KINGFISHER

1853 *Hypatia* was published, and in 1855 *Westward Ho*, both historical novels, the former dealing with the early Christian Church, the latter with the South American adventures of the Elizabethan Era. Among his other well-known works are *Two Years Ago*, *Hereward*, *The Hermits* and *The Water Babies*. He was appointed professor of modern history at Cambridge in 1859 and afterwards was successively canon of Chester and canon of Westminster. Though not a profound thinker, Kingsley was a very versatile writer, interested in social questions and in natural science.

**KING'S MOUNTAIN, BATTLE OF**, a battle of the Revolutionary War, fought October 7, 1780, between a detachment of Cornwallis's army and a force of backwoodsmen, under a number of partisan leaders, including James Williams, Isaac Shelby and John Sevier. The British were posted at the summit of a hill about a hundred feet in height, but the Americans stormed the position from all sides, killing 119 men, wounding 123 and capturing 664. Twenty-eight Americans were killed, including Colonel Williams, and sixty were wounded. The victory contributed largely to Green's defeat of Cornwallis.

**KINGSTON, JAMAICA**, the capital of the island, situated on the southeast coast. The harbor is long and wide and forms an excellent anchorage for vessels. On January 14, 1907, the city was visited by an earthquake, which, with the fire that followed, caused a loss of 2,000 lives and much property. Population, 1916, 57,379.

**KINGSTON, N. Y.**, the county seat of Ulster County, fifty-five miles south of Albany, on the Hudson River and on the New York, Ontario & Western, the Walkill Valley and West Shore railroads. The city is the center of a large trade in stone, brick, lime, lumber and cement. The city has several libraries, Kingston Point Park and a railroad bridge 150 feet above tidewater. The Senate House is historically interesting as the early seat of the state legislature, when the city was for a time the capital of the state. There are a Federal building, a Carnegie Library and three hospitals. The first settlement was made in 1652 by the Dutch and was called Esopus, from the neighboring Indians. It was a dependency of Fort Orange until organized as Wiltwyck in 1661. Three years later the English took control and changed the name to Kingston. The villages of Ron-

dout and Wilbur were added in 1872, and the place was incorporated as a city. Population, 1910, 25,908; in 1917, 26,910 (Federal estimate).

**KINGS'TON, ONT.**, the capital of Frontenac County, on Navy Bay, at the northeast corner of Lake Ontario, 172 miles southwest of Montreal, on the Grand Trunk, the Kingston & Pembroke and the Bay of Quinte railroads. Queen's University and College, a collegiate institution belonging to the Presbyterians, a mechanics' institute, the Anglican and Roman Catholic cathedrals and a hospital are located here. About a mile west of the city is the Provincial penitentiary. Next to Quebec and Halifax, Kingston has the strongest fortifications in Canada. The harbor is accessible to ships of large size. There are manufactures of machinery, steam engines, cotton, leather and pianos. Shipbuilding is carried on extensively. There are mineral springs in the neighborhood, and the city is a popular summer resort. Kingston was founded in 1783, on the ground formerly occupied by Fort Frontenac, and was incorporated in 1838. Population, 1916, about 20,000.

**KINGSTON-UPON-HULL.** See HULL.

**KING WILLIAM'S WAR.** See FRENCH AND INDIAN WARS.

**KIOTO**, *kyo'toh*. See KYOTO.

**KIOWA**, *ki'owa*, a tribe of North American Indians, originally holding land in the old Indian Territory, Colorado and New Mexico. They were opposed to the westward movement of white settlers, and caused the government much trouble before they were overcome, in 1875. After that date they remained peacefully upon a reservation in Oklahoma. By a treaty made in 1901 the surviving Kiowas became in law American citizens. They number about 1,000.

**KIPLING** [JOSEPH] RUDYARD (1865- ), a distinguished English poet and writer of fiction, winner of the Nobel Prize for literature in 1907. He was born at Bombay, India, but was sent to England to be educated, and in 1878 entered the United Service College at Westward Ho, Devonshire. Many of the incidents of his life here were afterwards described in *Stalky & Co*. On his return to India he became sub-editor on the *Civil and Military Gazette* at Lahore, which position he held until 1887, when he became assistant editor of the *Allahabad Pioneer*. In 1892, having in the mean-

time suddenly become famous, he visited the United States, where he married Miss Caroline Balestier. He remained in America four years. In 1899 he again visited America and also traveled in South Africa, afterwards settling in England.

Kipling is undeniably the most forceful and original genius among English fiction writers of his generation. He possesses a penetrating insight and a rare facility in seizing the significant and in communicating to his readers, by subtle shades of phrasing, the exact impression he wishes to convey. As a prose writer Kipling is at his best in writing of life in India, the long romance *Kim* marking the summit of his achievement in this field. Other stories of India are *Soldiers Three*, *Plain Tales from the Hills*, *The Seven Seas*, and *The Phantom Rickshaw*. *The Just-So Stories* and the two *Jungle Books*, highly imaginative stories for children, reveal another facet of this many-sided genius. Kipling's versatility may be best seen by a comparison of the almost brutal realism of *Soldiers Three* and the stories in the collection known as *Many Inventions*, with the supersensual, mystic atmosphere of *The Brushwood Boy*, or *They*.

The originality and fine lyric quality of Kipling's verse has given it a wide vogue. In some of his poems, notably *The Recessional* and *The White Man's Burden*, he so accurately expressed the spirit of British imperialism that he has been called "the Laureate of the Empire." Among those of his titles not already mentioned are *Departmental Ditties*, *The Five Nations*, *Traffics and Discoveries*, *Puck of Pook's Hill*, *Actions and Reactions*, *Rewards and Fairies*, *The Light that Failed*, *Captains Courageous*, *Wee Willie Winkie and Other Stories*, and *The Harbor Watch* (a play).

**KIRGHIZ**, *kir geez'*, a wandering Mongol-Tartar race, numbering in its various branches about 3,000,000 and ranging over Northern Asia from European Russia to China. They are short and square built, have long black hair, scant beards (or none),

high cheek bones, broad flat noses and black, oblique eyes. They are divided into hordes or Nomadic armies and are governed by tribal rulers who have almost unlimited authority. The chief branches are the Kara-Kirghiz and the Kazaks. See **COSSACKS**; **NOMAD LIFE**.

**KISHINEV**, *ke she nyawf'*, RUSSIA, a city of the Ukraine (which see), in the fertile farming province of Bessarabia, of which it is the capital. It is situated eighty-six miles northwest of Odessa, on the River Byk. Before the revolution Kishinev was a prosperous industrial center, producing tobacco, grain, wool and other commodities. It is the residence of a bishop, and has many schools, churches and theaters. Kishinev was the scene of terrible Jewish massacres in 1903 and 1905. Population, 1913, 128,700.

**KITCHEN CABINET**, a name applied to a group of men who during Andrew Jackson's administrations exercised a great influence upon the policy of the government, though they held no important offices. The chief members of this circle were Major William B. Lewis, Amos Kendall, Isaac Hill and Francis P. Blair, Sr.

**KITCHENER**, HORATIO HERBERT, Earl Kitchener of Khartum, of the Vaal and of Aspall (1850-1916), one of the greatest British military leaders of his day. He was born at Crotter House, Bally Longford, in County Kerry, Ireland, and educated at the Royal Military Academy in Woolwich. In 1871 he entered the army as a lieutenant of engineers. Later he

was rapidly promoted to commands with the British force in Egypt, being conspicuous in the expedition which vainly tried to keep open communication with General Gordon at Khartum. In 1896



EARL KITCHENER

active campaign for the recovery of the lost provinces of Upper Egypt, and the capture of Khartum in September, 1898, marked the successful close of a brilliant series of engagements. During the Boer War he was chief of staff to Lord Roberts, and when Roberts returned to England Kitchener became commander in chief. After the war he was commander in chief in India for seven



RUDYARD KIPLING



years and in the Mediterranean for a few months. From 1912 to 1914 he was consul-general in Egypt, and on August 5, 1914, one day after Great Britain had declared war on Germany, he became Secretary of State for War, thus assuming supreme command of the army.

Kitchener's great task was to raise a fighting army. Within three months he had a force of 1,250,000 men under arms, and "Kitchener's army" played an important part in stemming the tide of the German invasion. He predicted a war of three years, and fully recognized the magnitude of England's task. It is said that he had a bed carried into the War Office, that he might remain there night and day, and before his death he had raised and trained for service an army of nearly 5,000,000. In June, 1916, while he and his staff were proceeding to Russia on the cruiser *Hampshire*, the vessel was sunk by a German mine off the West Orkney Islands. There were no survivors.

**KITCHENER, ONT.**, before 1916 called BERLIN, is in Waterloo County, about sixty miles nearly west of Toronto, on the Grand River and the Grand Trunk Railroad. The town manufactures furniture, boots and shoes, trunks, leather goods and gasoline engines, and it owns and operates its street cars and public utilities. Saint Jerome's College, founded in 1865, is here. Population, 1916, 19,000.

**KITCH'EN MID'DENS**, refuse heaps marking the sites of primitive human habitations. Large numbers of such heaps have been discovered in various parts of the world. Those on the seashore are composed chiefly of the shells of edible mollusks. The deposits, first studied in Denmark, have been found to contain fragments of rude stone and bone implements, such as knives, scrapers, axes, hammers, horns and bone needles, and also pottery and the bones of wild animals.

All are relics of the very earliest stages in man's life on the earth. Some of the savage peoples living to-day have not advanced beyond the stage of the early races who left these relics perhaps 10,000 years ago; so that heaps in some parts of the world are still in process of formation. Some of the ancient beds of refuse are enormous and must have taken a thousand years or more to accumulate. There are numerous though very widely scattered deposits in Canada and in the United States.

**KITE**, a bird of prey belonging to the family of falcons, having a somewhat long, forked tail, long wings, short legs and weak

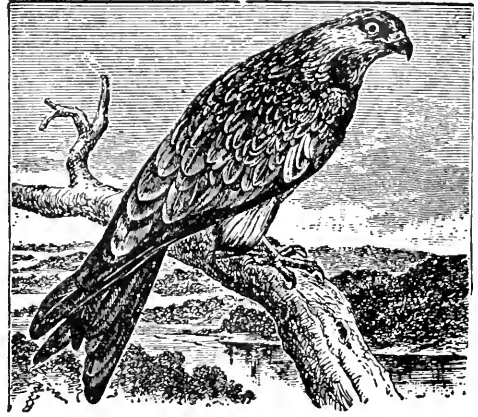

KITE

bill and talons. It sails and wheels gracefully in flight, often sighting its prey—reptiles, mice, moles, fowls—from high in the air. The birds are useful scavengers. The American swallowtail kite is a beautiful bird with glossy black back, wings and tail, and white head and under parts.



**K**ITES are not only interesting playthings, but they are used in meteorological observations, in carrying messages, in photographing landscapes and, to a considerable extent, in advertising. It has become no uncommon thing to see over a large outdoor assembly a number of kites bearing advertising banners on their strings.

Kites have been known since earliest times and in certain countries are still the chief amusement of the people. In Japan kites strong enough to lift a man were made 600 years ago, in order to spy out the force of an enemy in times of war. Not only the youths of Japan but the adults, also, enter into kite-flying with great zest, and some of the kites themselves are beautiful and elaborate productions, decorated with the highest art. In China the kite-flyer often has a number of kites in the air at once, all attached to a

common string, and the greatest skill and patience are necessary to keep them separate or disentangle them when they have been blown together by a strong wind. Fish, butterflies, dragons and birds are imitated in kites by the skilful Chinese, and many of these peculiar forms have found their way into stores of the United States.

**How to Make a Kite.** Probably every boy has made the common kite, of two crossed sticks, a bit of string, paper, and old rags. If this shape of kite is made with three sticks as shown in the illustration on this page, the kite will fly better and last longer.

Most boys do not remain satisfied with this common kite; they want something different. One of the easiest to make is a box kite. The sticks should be made of straight-grained wood, either spruce, basswood, or white pine. Box kites may be different sizes; the dimensions given below will be found useful for a

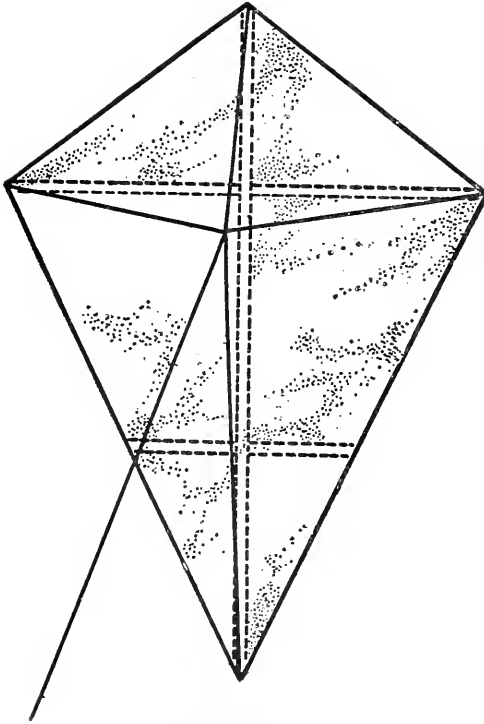

COMMON KITE

kite of a good size. The kite when finished should be 42 in. long by  $18\frac{1}{2}$  in. wide. In cutting the cloth and sticks it may be well to allow for errors. The long sticks should be  $\frac{3}{8}$  in. square by 42 in. long and the four diagonal braces should be  $\frac{1}{4}$  in. by  $\frac{1}{2}$  in. by 26

in. Two cloth bands should be made 12 in. wide and 74 in. long. These bands should be fastened to the four long sticks with 1 ounce tacks. Care should be taken to see that the sticks are equally distant, for the sides of the kite must be of the same size. It will strengthen the bands if the edges are hemmed and the ends turned over for half an inch. Nainsook or cambric makes the best cloths, but any light weight stuff will do.

The diagonal braces should be cut a little too long, so that they will be slightly bent when put in position, thus holding the cloth out taut. The ends should be notched to fit the long sticks and then wound with coarse thread or fine wire to prevent the braces from slipping. If made as described the kite may be taken apart and rolled up.

The bridle or guiding ropes should be fastened as illustrated. H is a square knot which may be easily loosened and shifted to a different position on the bridle. A bow-line knot may be tied at J to prevent slipping. For flying in a light wind loosen the square knot and shift nearer to G, thus shortening G and lengthening F; in a strong wind lengthen G and shorten F. If the wind is exceptionally strong it is better not to use the bridle but to fasten the string at K.

Another kite interesting to make is not as common as the box kite; this is the Chinese kite. From a sheet of thin tough tissue paper about 20 in. square the Chinese boy gets a perfectly square kite that is light and strong. First he shapes two pieces of bamboo, one for the backbone and one for the bow. The backbone is flat,  $\frac{1}{4}$  in. by 3-32 in. and 18 in. long; this is pasted diagonally to the paper. Over the ends of the stick should be pasted triangular bits of paper to prevent tearing. The Chinese generally use boiled rice, but any quick-drying paste will do. The bow should now be bent and its ends fastened to the other corners of the paper. In cutting the paper it is best to leave little projections at the corner to fold over for this purpose, but separate strips may be used. The difficult task of fastening the band or bridle comes next. This must be done by experimenting, till the kite balances perfectly. The string is fastened by a slip-knot to the band and moved back and forth until the kite flies properly; then the knot must be tightened.

With a little practice boys will have no trouble in flying these kites. Chinese boys often have battles with them. One of them

will be flying a pretty kite, perhaps from a low flat-topped roof in some big city. Several hundred feet away on another roof appears another boy, who begins maneuvering to drive his kite across the wind over to the first kite. First he pays out a large amount of string till his kite wobbles to one side, with its nose pointing toward the first kite; then he tightens his line and commences a quick steady pull. If properly done his kite will cross over and above the other. The string is now played out until the second kite is hanging over the first one's line. It will take some skilful work now before the first boy's kite can spear the other one or perhaps cut the kite string. As it is not considered fair to haul down the other boy's kite the battle may be long and exciting.

There is almost no end to the variety of sizes and shapes of kites. An easy one to make is called the butterfly kite. To make this get two thin kite sticks of equal length. Bend each into an arc and tie one end of a strong string to one end of each stick and the other end of the string to a point about 3 in. from the other end of the stick. This leaves one end of each stick free: now tie strings

top part of the wing frames near the intersection of the sticks, so that the wires will cross. These are the "antennae" or "feelers." Over this frame paste any colored paper you choose. First lay the paper on the frame,

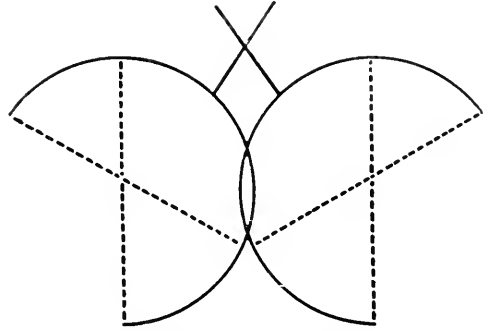

FRAMEWORK OF THE BUTTERFLY KITE then cut out the paper to the right shape, but leave about one-half inch margin for pasting. Cut slits about 2 in. apart around the curves and at all angles to keep the paper from wrinkling when it is pasted. When the kite is dry decorate it with paint or strips of colored paper. Add the usual tail.

Another interesting kite is the boy kite. To construct the kite use two straight sticks, say 3½ ft. long, to serve as legs and body:

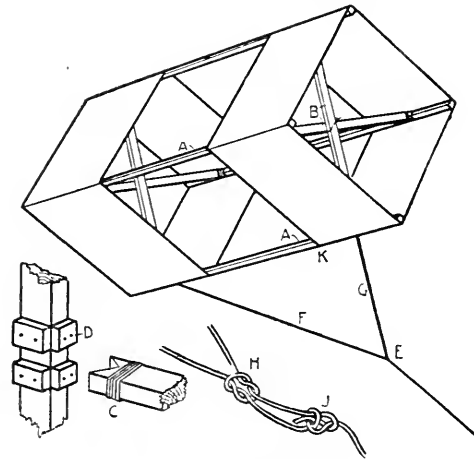

BOX KITE

A, frame, with B, crosspiece; C D, details of joints; F G, bridle; E, string jointed to bridle; H J, knots.

to each of these free ends and tie the other end to a point 3 in. from the opposite arc. Be careful that the two sticks are now in exactly the same shape. Then use thread to fasten the two frames together so that they overlap as shown in the sketch. To make the butterfly's head secure two heavy broom straws or stout wires and attach them to the

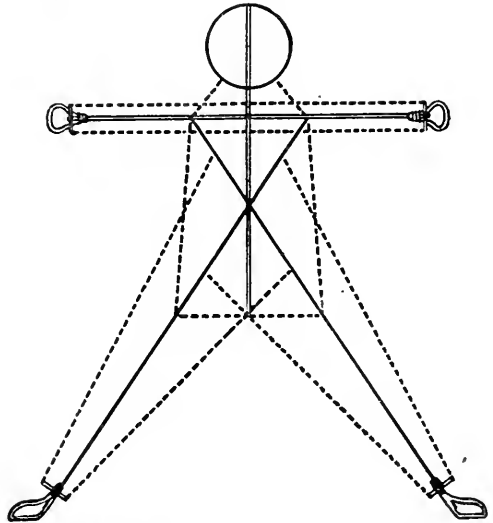

FRAMEWORK OF THE BOY KITE

another straight stick about 2 ft. 4 in. long forms the spine; a stick about 3 ft. 3 in. for the arms. If a light tough stick is at hand this can be bent in a circle about 7 in. in diameter for the head; bind the ends firmly with

twine. Fasten it to the spine, then tack on the arm stick three inches below the circle so that the arm stick is divided in the middle. The leg sticks should be fastened to the arm stick about 6 in. on either side of the spinal column and crossed so that the other ends are 3 ft. apart. Small hoops and cross stick of the same material as the head frame should be fastened to both ends of the arm stick and the lower ends of the leg sticks for hands and feet. See that both hands are of equal size; likewise the feet. No boy will want his kite to be a cripple any more than he would want one leg or one arm shorter than the other. The dotted lines in the diagram show how the strings should now be fastened.

To cover the kite select your paper, cut it to the shape of the frame, but allow one-half inch all around to paste over, and make slits 2 in. apart around the head to prevent wrinkles.

**KIT'TIWAKE**, a medium-sized, snow-white gull, with pearly blue upper parts, found in great abundance in the cold regions of the northern hemisphere. It takes its name from its peculiar cry. The birds breed among the inaccessible crags of rocky coasts.

**KLAMATH**, *klah'mat*, a group of Indians, comprising several tribes, who lived originally in Oregon and California, along the Klamath River. The surviving Klamath reside on a reservation along Klamath Lake in Southern Oregon, and are successful stockmen. They number between 600 and 700.

**KLEPTOMANIA**, *klep toh ma'ni a*, a form of mental disorder which causes the victim to engage in petty thieving. Kleptomaniacs are sometimes normal in every other particular, but their impulse to steal is overpowering. Usually they take objects that are attractive and highly colored, and there is no attempt to use or sell them. At times the stealing is done with no effort at concealment. In law a kleptomaniac is held accountable for his thefts unless it can be proved that he cannot distinguish between right and wrong.

**KLONDIKE**, a region in the western part of Yukon Territory, Canada, bordering on Alaska. Whenever the name is heard the thoughts of men turn to the magical word *gold*. It was here that gold mines of great richness were discovered in 1896 by an Illinois man named Cormack; the next year a

veritable procession of fortune seekers headed towards the section. In the one year of 1897 over \$2,000,000 was taken from the mines, and the amount during the next five years exceeded \$30,000,000. Since then the yearly diggings have decreased somewhat in value.

Dawson City (which see) was founded at the time, and it has remained the center of the mining industry in the Klondike region. The town is 2,200 miles from the mouth of the Yukon River.

**KNEIPP**, *knipe*, SEBASTIAN (1821-1897), a German priest who is best known for the "water cure" which he advocated. Sunshine and settled routine of exercise in the open air are important in his system. His patients walk with bare feet in the snow in winter and on wet grass in summer. Establishments of the Kneipp treatment are to be found in many cities, including several in the United States.

**KNIFE**, *nife*, a tool used for cutting, consisting of a blade and a handle. These are usually made separately and joined. There are nearly as many kinds of knives as there are uses for them. Savages made knives of stone by hewing the edge very thin and giving the blade a rough point. Bone, ivory and horn are used for paper knives, but table knives are made of steel or of bronze and plated with silver. Steel is used for the blades of knives that require a sharp edge. The pocket knife is a Yankee invention and was first made in Connecticut. A pen knife is a small pocket knife with a thin, narrow blade; it was so named because knives of this style were in general use for making quill pens before steel pens became common (see PEN). In sharpening a knife both sides of the blade should be ground alike, and in using it, generally the edge should be turned so as to whittle from the holder. The best results are obtained by drawing the blade slowly toward the point as it is pushed forward through the wood.

**KNIGHT**. See CHIVALRY.

**KNIGHTHOOD**, ORDERS OF, the name given to organized bodies of knights. The orders of knighthood are of two classes—associations or fraternities possessing property and rights of their own as independent bodies; and merely honorary associations, established by sovereigns within their respective dominions. To the former class belonged the three celebrated religious orders founded

during the Crusades—Templars, Hospitalers and Teutonic Knights (see **TEMPLARS**, **KNIGHTS**; **TEUTONIC KNIGHTS**; **JOHN**, **KNIGHTS OF SAINT**).

The other class embraces most of the existing European orders, such as the Order of the Golden Fleece, the Order of the Holy Ghost, the Order of Saint Michael. The chief British orders are the orders of the Garter, the Thistle, Saint Patrick, the Bath, Saint Michael and Saint George, the Star of India and of the Indian Empire. The various orders have each their appropriate insignia, which generally include a badge or jewel, a collar, a ribbon of a certain color and a star.

**KNIGHTS HOSPITALERS OF SAINT JOHN.** See **JOHN**, **KNIGHTS OF SAINT**.

**KNIGHTS OF COLUMBUS**, a fraternal organization, founded in 1882 at New Haven, Conn., with membership limited to men professing the Roman Catholic faith. Except that it has intimate relations with a great Church it is similar in character to other benevolent organizations. It furnishes benefits to needy members and promotes the social and intellectual virtues. The chief authority is a supreme council. There are nearly 390,000 members in the United States, Canada, Cuba, Porto Rico, the Philippines and Alaska. During the World War the Knights organized a large force for relief work among the soldiers of America in the war zone in France.

**KNIGHTS OF LABOR**, a labor organization founded at Philadelphia in 1869. Its operations were secret, but its professed object was the amelioration and protection of the laboring classes. Of late years the membership has largely decreased through internal dissensions and ill-advised strikes, and it has been largely superseded by the American Federation of Labor. See **LABOR ORGANIZATIONS**.

**KNIGHTS OF PYTHIAS**, *pyth'ias*, a benevolent and fraternal organization founded in 1864 in Washington, D. C., the members of which are pledged to help each other at all times. The name refers to the story of Damon and Pythias, whose friendship endured "even unto death" (see **DAMON AND PYTHIAS**). Since it was organized the society has expended more than \$50,000,000 in benefits. There is a supreme lodge, which has control over not only the order of knights, but over the so-called uniform, or military, rank, and over the endowment, or insur-

ance, branch, as well. Three degrees,—page, esquire and knight—are given. The society has a membership of about 730,000, confined to the United States and Canada. Over 70,000 belong to the insurance branch, and about 18,000 to the military.

**KNIGHTS OF THE BATH.** See **ORDER OF THE BATH**.

**KNITTING MACHINE.** The first knitting machine was the stocking frame, invented by William Lee of England, in 1589. An improved form of this machine was intro-

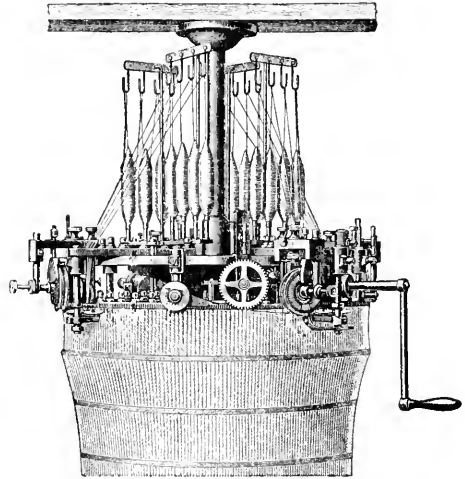

EARLY KNITTING MACHINE

duced into the United States early in the eighteenth century, and power was first applied to the knitting machine at Albany, N. Y., in 1831.

The most common form of knitting machine now in use is the circular, or rotary, machine, which knits a circular web. The needles are arranged in rows around a horizontal circular frame. Each needle has a hook at the end, by means of which it draws down the thread and makes a loop as it is depressed. When the needles are again elevated the loop is slipped off over this hook and forms a part of the web as the next hook is joined to it. The needles are upright and have an upward and downward motion, produced by means of cams on the side. The web extends downward within the circle and has a weight attached to its lower end to hold it in position. The machines are automatic and so perfectly adjusted that a boy can tend four of them. They are used extensively in the manufacture of hosiery and underwear and for ordinary purposes goods knit by

machines are serviceable. After the entrance of America into the World War thousands of hand-knit socks and sweaters were sent to the soldiers, as it was generally agreed that the hand-knit garments were more durable for army purposes than those made by machines.

**KNOT**, *not*, a nautical term indicating distance-marks on a ship's log-line. Formerly the log-line was knotted at intervals to form sections  $\frac{1}{120}$  of a geographical mile in length. The line was wound upon a reel and one end of it was attached to a small flat board which was drawn through the water as a kite is sailed in the air. The pressure of water against the board caused the line to unwind slowly or rapidly, according to the ship's speed; and the number of knots run off the reel in a given time indicated the rate at which the vessel was moving. The latest devices are of more complicated mechanism. A rotator, or propeller, drawn through the water in the wake of a ship tends to twist the rope, transmitting the motion to a register. Loosely speaking, a knot is a nautical mile, or 6,080.27 feet.

**KNOT GRASS**, a plant of the buckwheat family, one of the most widely-distributed plants in the world. Its many-branched, trailing stems with knotty joints form a thick mat, even on hard or trampled ground. Tiny flowers, two or three in number, grow from the axils of the leaves. Several species of knotgrass yield a valuable blue dye.

**KNOTS** include the various methods of tying, fastening and joining ropes or cords. The subject of knots is one that has to be mastered by the sailor, who makes dozens of different kinds, but almost all occupations using ropes or cordage have special kinds of knots adapted to their different requirements. While the great majority of these are purely technical, there are a few so generally useful that they may be briefly described. The figures represent the various knots before they are drawn taut, the better to show the method of tying. Generally, the requirements of a useful knot may be stated to be that it should neither slip nor jam; that is, it should hold without danger of slipping while the strain is on it, and when slackened it should be easily untied again.

The simplest knot is the common one tied on the end of a thread or cord to prevent its slipping. By passing a loop, instead of the end of a cord, the common *slip* knot (1)

is formed; and a useful fixed loop is obtained by tying a simple knot, or the *figure-eight* knot (2), on the loop of a cord. One of the simplest and most useful *running* knots for a small cord is made by means of two simple knots (3). The most secure method of fastening a line to a bucket is the *standing bowline* (4); and a *running bowline*

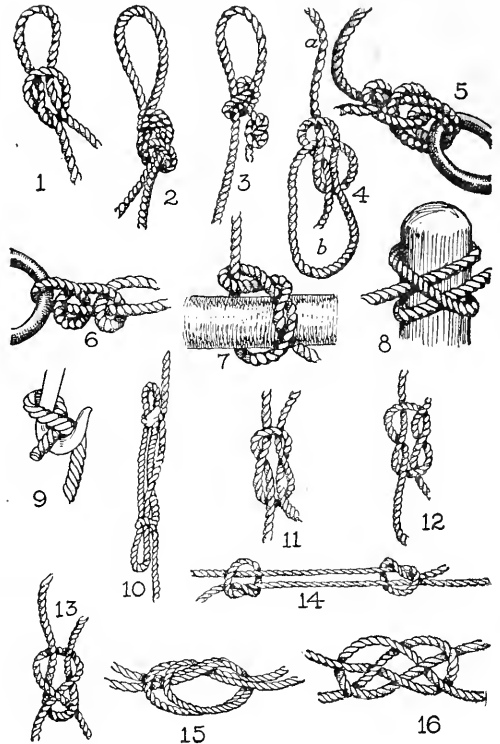

is formed by passing the end *a* through the loop *b*, thus making a running loop. Another good knot to make fast a bucket is the *anchor bend* (5).

Out of the score or so of methods of fastening a boat's painter the one which will be found most useful is the well-known *two half-hitches* (6). The *timber hitch* (7) is useful for attaching a line to a spar or a stone, and the *clove hitch* (8) is invaluable for many purposes. It is very simple and cannot slip. A simple method of fastening a rope to a hook is the *blackwall hitch* (9), where the strain on the main rope jams the end so tightly against the hook that it cannot slip. There are many methods for shortening a rope temporarily, one of them being the *sheep shank*, the simplest form of which is shown in 10.

Of the methods for uniting the ends of two cords, the simplest and one of the most secure is the common reef knot (11), which must be carefully distinguished from the granny (12), which will jam if it does not slip; the reef knot will do neither. For very small cords or thread the best knot is the weavers' (13). The fisherman's knot is a very useful one for anglers and is formed by a simple knot in each cord being slipped over the other (14); when drawn taut it is very secure, and it is easily separated by pulling the short ends. A useful method of uniting large ropes is shown in 15; tie a simple knot on the end of one rope, and interlace the end of the other and draw taut. This tie may also be made with the figure-eight knot. For very large ropes the car-rick bend (16) is the simplest and most secure. The bowline bend is formed by looping two bowline knots into each other. See SPLICING.

**KNOW-NOTHINGS**, the popular name for the American party, which was formed in the United States shortly before 1855. The party gained considerable success in that year, lost its ground hopelessly in 1856, and soon after disappeared from American politics as a separate organization. Its distinctive principle was that the government of America must be in the hands of Americans; naturalization was to follow only after twenty-one years' probation, and allegiance to any foreign potentate or power was to be a bar to selection for political office. The term *Know-Nothings* was applied to its members because they refused to tell anything that transpired at their meetings. See POLITICAL PARTIES IN THE UNITED STATES.

**KNOX**, *noks*, HENRY (1750-1806), an American revolutionary soldier, born in Boston. At an early age he entered on a military career, and took part in the battles of Bunker Hill, Brandywine, Germantown, Monmouth, Trenton and Yorktown; was for a time a member of Washington's staff, and was appointed by Washington to receive the surrender of the British forces in New York state. In 1785 he was appointed Secretary of War, and he held the office for ten years. His bravery, skill and constant loyalty to Washington made him one of the commander in chief's most trusted friends.

**KNOX**, JOHN (1505-1572), the chief promoter of the Reformation in Scotland, was born in Gifford, in East Lothian. He was

educated in Glasgow and at Saint Andrews, became an ardent advocate of the reform faith in about 1542, and four or five years later preached to the beleaguered Protestants in the castle of Saint Andrews. When this castle was taken by the French, Knox was sent to France with the other prisoners and put to the galleys, from which he was released in 1549. Two years later he was appointed chaplain to Edward VI and preached before him at Westminster. On the accession of Mary in 1554, Knox left England and sought refuge at Geneva. Here he was soon involved in a controversy and, after a few months, returned to England, but again went back to Geneva the following year at the request of the congregation which he had left there.

In May, 1559, Knox returned to Scotland and joined the lords of the congregation. He preached at Perth with such fire and effect that his hearers made a general attack upon the churches of the city, overturned the altars, destroyed the pictures, broke the images and almost leveled the monasteries to the ground. He was appointed minister of Edinburgh, and from that time until his death he took a leading part in the proceedings of the Protestants and had the principal share of the work in drawing up the confession of faith which was accepted in 1560 by Parliament. The next year he was involved in a sharp controversy with Mary Stuart, because of her attempt to reestablish the Roman Catholic form of worship in Scotland. In 1569 he retired for a time to Saint Andrews, and three years later his health gave way. Among his works are the *First Blast of the Trumpet against the Monstrous Regiment of Women* and the *History of the Reformation of Religion within the Realm of Scotland*.

**KNOX**, PHILANDER CHASE (1853- ), an American lawyer and statesman, born in Brownsville, Pa. He was graduated from Mount Union College, Alliance, Ohio, in 1872, was admitted to the bar three years later, and with the exception of one year, in which he was assistant United States district attorney, was engaged in active practice in his native city until 1901, when he was appointed Attorney-General by President McKinley. This position he retained until June, 1904, when he resigned to accept an appointment to the United States Senate, as successor of M. S. Quay. From 1909 to 1913 he was

Secretary of State in President Taft's cabinet. In 1916 Knox was elected United States Senator for the term 1917-1923.

**KNOXVILLE, TENN.**, the county seat of Knox County, on the Louisville & Nashville, the Southern and the Knoxville, Sevierville & Eastern railroads. It is beautifully situated on the Tennessee River, in the heart of the valley of East Tennessee. The University of Tennessee, Knoxville College (for colored students), the State Agricultural College, the State School for the Deaf and Dumb and the Eastern Hospital for the Insane are located here. Knoxville is an important jobbing and wholesale center for dry goods, hardware, groceries and coal, and has a large trade in marble, furniture and leather goods. It exports considerable quantities of agricultural products and contains manufactures of cotton and woolen goods, flour, wagons, plows, cars, furniture, trunks and other articles. Chilhowee Park contains ten acres, and the city has a fine Federal building and three hospitals. The place was settled in 1792. It was the capital of the "Territory South of Ohio" from 1792 to 1796, and of the state from 1796 to 1811. West Knoxville and North Knoxville were annexed in 1898, and commission government was adopted in 1911. Population, 1910, 36,346; in 1917, 59,112 (Federal estimate).

**KOALA, *ko ah'lah***, an Australian animal, in appearance somewhat resembling a small bear, hence, sometimes called the *native bear*. It differs from all other quadrupeds in that its toes are divided into groups of two and three. This arrangement enables the animal easily to grasp and hang from the branches of trees. The koala is about two feet long and is covered with a short, gray, wooly fur. It roams at night and feeds on leaves, chiefly of the eucalyptus. Like the kangaroo, the female koala carries her young in a pouch.

**KOBE, *ko'ba***, JAPAN, a seaport on the southern coast of Hondo Island, adjoining the town of Hiogo so closely as to form one city with it. Since 1892 both have been under the same municipal government. Kobe lies on the western shore of the Bay of Osaka and is twenty-two miles from the city of Osaka. It has docks, railway shops and a shipyard, and its harbor is safe and deep. There is direct steamship communication with China, Australia and various European and American ports. Among its manufactures, the chief is paper. Kobe is one of the ports

opened by treaty to foreign commerce, and it is considered the most attractive of them. Its trade is more extensive than that of any of the other treaty ports. Population, 1916, 498,317.

**KOCH, *koK*, ROBERT (1843-1910)**, a noted German physician and bacteriologist, born at Clausthal, Hanover, and educated at Göttingen. He practiced medicine for a number

of years with great success, and in 1885 was appointed professor in the University of Berlin. Doctor Koch's fame rests upon his investigation of bacteria as a source of disease. In 1882 he discovered the germ which produces tuberculosis. The next year he was sent by his government to



ROBERT KOCH

Egypt to investigate cholera, and there discovered the bacillus which causes that disease. He has published a large number of bacteriological works and his services have been of inestimable value to the world. See GERM THEORY OF DISEASE; CHOLERA; TUBERCULOSIS.

**KOH-I-NOOR, *ko e noor'***, the name of the most celebrated of historic diamonds. According to legend, it was in possession of a ruler in India more than five thousand years ago. It first came into history in the fourteenth century, when it was brought to Delhi. At the sacking of this city in 1739 it was carried to Afghanistan, but was returned to India later, and on the conquest of the Punjab it came into possession of the British East India Company, by whom it was presented to the royal family of Great Britain. It has been reduced by successive cuttings, from 793 to 106 carats, and it is now valued at \$600,000.

**KOHL-RABI, *kohl rah'bi***, a variety of cabbage, cultivated for the stem, which swells into a peculiar bulblike growth just above the ground. This part is cooked in about the same way as the turnip, and it tastes much like the rutabaga, or Swedish turnip. Kohlrabi is more popular in Europe than in America.

**KO'KOMO, IND.**, the county seat of Howard County, on the Wildcat River and on the



Lake Erie & Western, the Pittsburgh, Cincinnati, Chicago & Saint Louis and the Toledo Saint Louis & Western railroads. The city is in an agricultural region, but is principally engaged in manufacturing. Glass, pottery, paper, stoves, skates, rubber goods and automobiles are the principal products. It has a Carnegie Library, a Federal building, a park of sixty acres, a hospital, a Y. M. C. A. and a city hall. Kokomo was settled in 1844 and was chartered as a city in 1855. Population, 1910, 17,010; in 1917, 21,929.

**KONGO.** See CONGO.

**KONGO FREE STATE.** See FRENCH EQUATORIAL AFRICA; CONGO.

**KONIGSBERG,** *ko'niKs berK*, GERMANY, a fortified town of Prussia, capital of the province of East Prussia, situated about five miles from the mouth of the Pregel. There are a number of buildings of historical interest, among them the Schlosskirche, in which Frederick I and William I were crowned. The university, founded in 1544, is attended in normal years by 1,700 students and has a library of 225,000 volumes, a zoölogical museum and other valuable collections. The manufactures of Königsberg are various, including machinery, pianos, tobacco and cigars. The chief trade is in grain, flax and hemp, timber, tea, petroleum, amber and leather products. The town is connected with Pillau, on the Bay of Danzig, by the Königsberg Ship Canal. Population 1910, 245,994.

**KOO'DOO,** or **KUDU,** the native name of a striped antelope of South Africa. The male has fine horns, nearly four feet long and beautifully twisted in a wide spiral. The koodoo is of a grayish-brown color, with a narrow white stripe along the back and eight or ten similar stripes down each side. It is about four feet in height and eight in length.



KOODOO

**KOOTENAY, KOOTENAI,** or **KUTENAI,** a small family of Indian tribes who lived on the borderland between Montana and British Columbia, and are now living comfortably on their reservations in the same locality. They have always been honest and good friends of the whites, and are devoted

Roman Catholics. About 600 are found on the Flathead Reservation in Montana, and about 550 in British Columbia.

**KOOTENAY RIVER,** a river of British Columbia, which rises in the Rocky Mountains and flows southward into the United States, passing through Montana and Idaho. It then reënters British Columbia, where it flows through Kootenay Lake and thence into the Columbia River. It is about 450 miles long, but only a small part of it is navigable, because of rapids.

**KORAN,** *ko'ran,* or *ko rahn'*, or **ALCORAN,** meaning *that which is to be read*, is the book containing the religious and moral creed and civil code of the Mohammedans, by which all their transactions are regulated.

According to the Mohammedan belief, the Koran was written in the beginning in golden rays on a gigantic tablet in the highest heavens, and portions were communicated by the angel Gabriel to Mohammed at intervals in the course of twenty-three years. These parts were dictated by Mohammed to a scribe and kept for the use of his followers. After Mohammed's death, they were collected into a volume at the command of Mohammed's father-in-law and successor, Abu Bekr. This form of the Koran, however, was considered to contain erroneous readings, and in order to remove these, Caliph Othman, in the thirtieth year of the Hejira (A. D. 652), caused a new copy to be made from the original fragments and then ordered all the old copies to be destroyed. The leading doctrine of the Koran is, "There is but one God, and Mohammed is his prophet." Adam, Noah, Abraham, Moses, and Christ are also regarded as prophets, occupying a place in the seventh, or highest, heaven, in the immediate presence of God. The belief in good and bad angels, the resurrection and the final judgment are fully set forth. God's mercy, rather than a man's merits secures entrance into heaven. Idolatry and the deification of created beings are prohibited.

The Koran prescribes prayer five times a day, with the face turned toward Mecca; also fasting, alms, and pilgrimage to Mecca. Purification must precede prayer, and where water is not obtainable, dry dust or sand may be used. To give alms was always a characteristic trait of the Arabians, but Mohammed made it obligatory. The language of the Koran is considered the purest Arabic. See MOHAMMEDANISM.

**KORDOFAN**, *kor do fahn'*, a country of Africa, in the Egyptian Sudan, between Darfur and the White Nile. From 1821 to 1883 it formed one of the Sudanese provinces of Egypt, but at the latter date it was freed from Egyptian rule through the Mahdi's insurrection, and was virtually independent until 1889, when it came under the control of the British Sudanese government. The surface is generally flat, and the soil, barren during the dry season, is covered with vegetation during the rainy season. The climate in the wet season, lasting from June to October, is extremely unhealthful; in the dry season, though healthful, it is intolerably hot. The principal articles of trade are acacia gum, used in making glue, and ostrich feathers. Cultivation is almost wholly confined to millet and sesame. The inhabitants consist of negroes, Berbers and Arabs. The chief town is El Obeid.

**KOREA.** See CHOSEN.

**KOSCIUSKO**, *kahs ki us'ko*, (Polish pronunciation, *kos choosh'ko*), THADDEUS (1746-1817), a Polish patriot who aided the American colonies in their struggle for independence. He was a man of noble family, and after receiving a military education at Warsaw and in France, he became a captain in the Polish army. A love affair led him to leave Poland and go to America in 1776, bearing letters of recommendation from Benjamin Franklin. Washington appointed him engineer with the rank of colonel and, later, general of brigade. Kosciusko did not return to Europe till three years after the conclusion of the Peace of 1783.

For some years after his return he lived in retirement, but after serving in his own country under Poniatowski, he was appointed, in 1794, generalissimo of the insurgent forces, and he defeated the Russians at Raclawice, near Cracow. At the battle of Maciejowice, however, his army was defeated, and he himself was wounded and taken prisoner. He remained in captivity for two years, but was liberated on the accession of Paul I of Russia, in 1796. After visiting England and America, he spent the remainder of his life chiefly in France. In 1817 he issued a letter of emancipation to his serfs.

**KOSSUTH**, *kosh'oot*, LOUIS (1802-1894), a great Hungarian patriot. He studied law, and in 1832 entered the upper house of the Diet as substitute for an absent member,

where he acquired immediate influence. In 1841 he became editor of the *Pesth Journal*, an exceedingly liberal paper. He was leader of the Hungarian revolution of 1848 and 1849, and was made governor of the short-lived Hungarian republic; however, to promote unity he resigned in favor of Görgey, another revolutionary leader. Soon afterwards the intervention of Russia on the side of Austria brought the revolution to an end. Kossuth fled to Turkey, where he was interned, but was released on the intervention of Great Britain and the United States. In 1851 he visited England and America and was everywhere received with demonstrations of sympathy. When the settlement was effected between Austria and Hungary in 1867 he might have returned to Hungary, but he remained an exile until his death, which occurred in Turin.

**KOUMIS**, or **KUMISS**, *ko'o'mis*, a fermented beverage, made in Russia of milk and yeast, but in the United States and England of cows' milk, and on the Asiatic steppes, where it has been long used as a beverage, of mares' or goats' milk. Koumis is a very nutritious and an easily digested beverage, and is recommended by physicians in cases where the stomach will not retain food.

**KOVNO**, POLAND, in the government of the same name, of which it is the capital. It is 506 miles southwest of Petrograd, on the left bank of the Niemen. Before the revolution Kovno was a manufacturing center of some importance. The place has many interesting old buildings, and dates from the eleventh century. Population, 1913, 92,810.

**KRACOW.** See CRACOW.

**KREFELD**, or **CREFELD**, *kra'felt*, GERMANY, an unfortified town in Rhenish Prussia, in the government district of Düsseldorf, thirty miles northwest of Cologne. It is the principal locality in Prussia for the manufacture of silks, velvets and mixed silk goods. There are also manufactories of woolen, linen and cotton cloth, wax cloth, hosiery, soap, candles, paper, leather, chemical products and tobacco. During the Reformation the place was a refuge for many of the reformed faith. Population, 1914, 131,392.

**KREMLIN**, the name used to designate the citadel of a Russian city. The most famous kremlin is that of Moscow, situated on the north bank of the river Moskva. It occupies a high triangular piece of land

covering 100 acres, and is surrounded by a wall a mile and a half long. The wall has eighteen towers and five gates. The chief buildings comprising the Kremlin are the Cathedral of the Assumption, in which all the monarchs of Russia since Ivan IV were crowned; the Cathedral of Saint Michael, a former royal burial place; the Cathedral of the Ascension; the Tower of Ivan the Terrible, crowned with a gilt dome and containing thirty-four great bells. Two famous curiosities of the Kremlin are the Czar Bell, with a rim circumference of sixty feet and a weight of 200 tons, cast in 1735, and the enormous Czar Cannon, cast in 1586. Most of the Kremlin palaces are modern. Both the cathedrals and the palaces contain relics of fabulous wealth.

**KRONSTADT**, or **CRONSTADT**, RUSSIA, the most important naval station during the empire, situated twenty miles west of Petrograd, at the eastern end of the Gulf of Finland. It has three harbors, which will accommodate a thousand vessels. These harbors are closed by ice during five months of the year. Kronstadt was founded by Peter the Great in 1710. Here were established a naval school, government navy yards and cannon foundry, building yards and saw-mills. Population, 1911, 68,273.

**KROPOTKIN**, or **KRAPOTKIN**, PETER ALEXEYEVITCH, Prince (1842- ), a Russian geographer and anarchist, born at Moscow. Though intended by his father for court life, he entered the army as a member of a Cossack regiment in 1862 and while stationed in Siberia made numerous valuable geographical explorations. The policy of the Russian government toward prisoners in Siberia embittered Kropotkin, and it was not long before he had openly espoused the anarchist cause. His convictions upon social and political matters were confirmed by a visit to Finland. Soon afterward he devoted himself to spreading anarchist doctrines in Russia, was imprisoned, escaped to England and finally reached Switzerland, where he continued his propaganda.

In 1879 he founded *Le Révolte*, the official organ of the anarchists at Geneva. Expelled from Switzerland, he continued his work in France, where he suffered three years' imprisonment. He lives in England. Among his principal works are *The Memoirs of a Revolutionist*, *Law and Authority* and *In Russian and French Prisons*.

**KRUGER**, *kroo'gur*, STEPHANUS JOHANNES PAULUS (1825-1904), the great Dutch President of the former South African Republic. As a boy he migrated to the Transvaal with his parents and other Cape Colony Boers who were dissatisfied with the British colonial policy. There he grew up, on the borderland between civilization and savagery, in constant conflict with the natives. He became prominent in administrative affairs, and in 1872 was made a member of the executive council of the Transvaal. Five years later, in spite of Kruger's vigorous opposition, the Transvaal was formally annexed to British territory, but he steadfastly refused to be reconciled.

In 1883 he was elected President and he was successively reelected in 1888, 1893 and 1898. Kruger used all his influence against the growth of Great Britain's power in South Africa, and in 1884 succeeded in obtaining a considerable reduction in its powers. He was also successful in defeating the Jameson raid in 1896. He believed that war with Great Britain was inevitable, and had his country equipped with arms and ammunition long before the struggle began. When the British approached Pretoria in 1900, Kruger moved his capital eastward and in September crossed into the Portuguese possessions, whence he sailed for Europe in October. He made several attempts to secure the assistance of the European powers in putting an end to the war, but without avail, and he finally took up his residence at The Hague, where he died.

**Related Articles.** Consult the following titles for additional information:  
 Jameson Leander Starr Transvaal  
 South African War Union of South Africa

**KRUPP**, FRIEDRICH ALFRED (1854-1902), grandson of the man who founded the greatest munitions works in Europe. Upon the death of his father, who had inherited the great Krupp establishment in Essen, he undertook the direction of the works and vastly increased the capacity of the business. He invented a new bessemer steel, out of which he made rifles and cannons and a seamless tire for car wheels, and discovered a new method of hardening armor plate. At his death he was the richest man in the empire. He was well known for his generous dealings with his employes, having built for them comfortable modern dwellings, each with its garden, and provided a pension fund of over \$4,000,000 for their benefit.

His daughter Bertha, who succeeded to the business, displayed a talent for practical business management. In 1906 she married Dr. Gustav von Bohlen, who became manager of the works, assuming the name Krupp von Bohlen und Halbach. Late in 1918, when revolutionists gained control of the government in Berlin, following Germany's defeat in the World War, he was reported a fugitive.

**KRYOLITE.** See CRYOLITE.

**KRYPTON**, *krip'ton*, a gaseous element resembling argon and helium, which exists in the air. As only minute quantities have been obtained, very little is known of its properties; however, it has been liquefied and even solidified. It is estimated that the atmosphere contains only one part in a million. Krypton boils at  $-152^{\circ}$  C. When an electric spark is passed through it, it emits a yellowish-green light.

**KUBELIK**, *koo'beleek*, JAN (1880- ), a Bohemian violinist. He received his early education under his father and entered Prague Conservatory when twelve years old. In 1898 he made his first public appearance and two years later made his debut in Berlin and in London. Thereafter he made several tours of both Europe and America, where he created a furor by his remarkable technique, which surpasses his interpretative abilities.

**KUBLAI KHAN**, *koob ly kahn'*, more properly, KHUBILAI KHAN (1214-1294), a Mongol emperor of China. In 1259 he succeeded his brother as grand khan (ruler) of the Mongols, and in 1260 conquered the whole of Northern China, driving out the Tartar and putting an end to the Kin dynasty. Marco Polo, who lived at the court of this ruler, described the splendor of his palaces and of his court; the elaborateness of his entertainments and hunting expeditions; his revenues; his extraordinary paper currency, and his extensive system of posts. Kublai Khan is the title of a beautiful poetical fragment by Coleridge.

**KUDU**, *koo'doo*. See KOODOO.

**KU'FIC.** See CUFIC.

**KU-KLUX KLAN**, a secret society which existed in some of the Southern states of America, immediately after the Civil War. Its primary object was to intimidate the negroes, who, it was said, at the close of the war were demoralized and in need of restraint. It had thousands of members, who operated under disguise and usually at night. Conflicts were frequent between the members

of the Klan and those of the Loyal League, a secret political organization of the negroes, formed under the direction of politicians. In the beginning many of the best citizens of the South belonged to the society, but these withdrew as the Ku-Klux degenerated into a lawless and criminal band. The government succeeded in breaking up the organization in 1872.

**KUMISS**, *koo'mis*. See KOMISS.

**KUMQUAT**, *kum'kwot*, a very small variety of orange tree, growing not above six feet high, whose fruit, of the size of a large gooseberry, is delicious and refreshing. It is a native of China and Japan, but has been introduced into Australia and the United States. Florida produces almost the entire American output, which averages 1,100 boxes a year; a few are grown in Alabama.

**KURDISTAN**, *koor dis tahn'*, an extensive region with indefinite boundaries, lying south of Armenia, in the western part of Asia. Armenia and Kurdistan together have an area of 186,500 square miles, and a population of about 2,500,000. Previous to the World War Kurdistan formed a part of Turkish and Persian dominions, and during the war the northern part of the country was the scene of bitter fighting between the Turks and the Russians. Before the collapse of Russia the forces of that country had penetrated to the Lake Van region, in the vicinity of Bitlis. The disposal of this great region was one of the matters settled by the peace conference.

The Kurds, to whom the territory owes its name, are not confined within its limits, but are found in considerable numbers eastward in Khorasan and over the hilly region of Mesopotamia, as far west as Aleppo and the Taurus. They are a stout, dark race, well formed, with dark hair, small eyes, wide mouth and a fierce look. On their own mountains they live as shepherds, cultivators of the soil, and bandits. Their language is a dialect of Persian, now much mixed with Arabic and Syriac; their religion is Mohammedanism. The Kurds owe but slight allegiance to any country, living in tribes under their own chiefs, who commonly exact duties on the merchandise which passes over their territory.

**KURILE, koo'ril, ISLANDS**, a group of volcanic islands belonging to Japan, stretching between the peninsula of Kamchatka, on the eastern coast of Siberia, and the Japanese island of Yezo. There are thirty-one is-

lands in the group; their area is 6,153 square miles, and their population is estimated at 6,000. The islands were discovered by a Dutch navigator, and were later held by Russia (from 1766 to 1875). In the latter year they were ceded to Japan in exchange for the southern half of the island of Sakhalin. In 1899 a Japanese trading company began to develop the Kuriles; the chief products are timber, fur and fish.

**KURO SIWO**, *koo'ro se'vo*, or **JAPAN' CUR'RENT**, the name of a warm current in the North Pacific Ocean corresponding in position and general direction to the Gulf Stream in the North Atlantic. It flows past Formosa, Japan, the Kuriles, the Aleutian Islands and thence bends southward to California. It is much inferior to the Gulf Stream in volume and is of a lower temperature. See OCEAN CURRENTS.

**KUSKOKWIM**, *kus'ko kwim*, **RIVER**, a river whose source is in the glaciers of the McKinley Mountains, and next to the Yukon the largest stream in Alaska. It is 700 miles long, and drains an area nearly equal to that of Alabama. The Kuskokwim follows a southwesterly course and empties into the Bering Sea. Steamboats ascend the stream for a distance of 500 miles, and several na-

tive settlements have been established in its valley, as well as numerous mining camps and trading posts.

**KUTENAI**, *koo'ten i*. See KOOTENAY.

**KY'ANITE**, a mineral of the garnet family, found both massive and in regular crystals. Its prevailing color is blue, of varying shades. The best specimens take a high polish and are used for table tops, ink stands, paper weights and other ornaments. Kyanite is found in the United States in Massachusetts, Connecticut, Delaware and Virginia, and in Europe in Switzerland, Tyrol and Bohemia.

**KYOTO**, or **KIOTO**, *kyo'toh*, JAPAN, a city on the island of Hondo, in an extensive plain 230 miles southwest of Tokyo, with which it is connected by railway. It was formerly the special residence of the mikado and the seat of his court, and the chief buildings are the old imperial palace and the residence of the shogun. It is the center of religion, of learning and of artistic manufactures, such as carved ivory ornaments, lacquered ware, bronze ornaments, brocaded and embroidered silks, porcelain and cloisonné ware. Kyoto has many good schools and an imperial university. Population, 1916, 539,153.



L, the twelfth letter of the English alphabet, derived in form from the Phoenician, through the Greek and Latin. *L* has only one sound in English, but is silent in a few words, as *half*, *talk*. Its nearest allied letter is *r*, and there is no letter, accordingly, with which *l* is more frequently interchanged, instances of the change of *l* into *r* and of *r* into *l* being very common in various languages. In fact, in the history of the Indo-European alphabet, *l* is considered to be a later modification of *r*.

**LABIATAE**, *la be a'tee*, the botanical name of the mint family, a very important and extensive group of plants, so named because most of the flowers present prominent upper and lower lips. The name is derived from the Latin *labium*, meaning *lip*.

The labiatae have a four-lobed ovary, which changes into four seedlike fruits. There are about 3,000 species, mostly herbs or small shrubs, with opposite or whorled leaves and usually square stems. They are found throughout the world in temperate latitudes. Many, such as lavender and thyme, are valued for their fragrance; others, such as mint and peppermint, for their stimulating qualities, and still others, such as savory, basil and marjoram, as aromatics. Many of them possess bitter tonic qualities, and not a few bear beautiful flowers, that make them favorite garden plants.

**LABOR, DEPARTMENT OF**, one of the executive divisions of the United States government, whose head, the Secretary of Labor, is a member of the President's Cabinet. The Department came into existence March 4, 1913, on the day that Woodrow Wilson became President of the United States. The object of the Department of Labor is—

“. . . to develop the welfare of wage earners of the United States, to improve their working conditions, and to advance their opportunities for profitable employment.”

In the organization of the Department it was given authority over the Bureau of Immigration, the Bureau of Naturalization, the Division of Information, the Immigration Service, the Children's Bureau and the Bureau of Labor Statistics, all of which had been formerly a part of the Department of Commerce and Labor.

The Secretary of Labor is empowered to act as mediator in labor disputes or to appoint commissioners of conciliation in such cases. See **CABINET**.

**LABOR, DIVISION OF**. In days which can be recalled by the oldest people now living one man made all of a shoe or boot, all of the ironwork or woodwork of a plow, or an entire suit of clothing. The stress of competition has changed this condition, and today one man makes only one part of a shoe or boot, and he does that part by the use of a machine; one man makes only one small part of a plow, and in clothing factories one man's work is limited day by day to work on only one portion of a suit of clothes. Each workman in the olden time was an all-round master workman; to-day in a highly specialized factory he knows nothing about any part of the manufacture of an article excepting that portion he has been taught to make. This new plan in manufacturing is called division of labor.

There are two reasons for this evolution in methods. The introduction of modern machinery limits the activity of one man to one simple operation, wherein he becomes expert in a briefer time than would be possible if he had to learn a series of other operations, also. This results, too, in time-saving and in reduced cost of production without decreasing the workman's earning capacity. On the other hand, such working conditions discourage individual initiative; doing the same thing day after day tends to make of

a person a human machine and to destroy his ambition. Division of labor, however, cannot be abandoned, for the increasing use of intricate machinery in production compels specializing to a greater degree year by year.

**LABOR DAY**, a day set apart in the United States, Alaska and Canada in honor of organized labor. All places of business are closed, and the celebration of the holiday is marked by parades, public meetings in the interest of labor, and similar demonstrations. In most places the first Monday of September is observed, but in New Orleans the day is celebrated on the fourth Saturday of November, and in North Carolina on the first Thursday of September. Labor Day is legalized by Congressional action only in the District of Columbia. The legislatures of most of the states have taken action to make it a legal holiday, and in the others it is observed by proclamation. The custom of observing such a day had its origin in a labor celebration held by the Knights of Labor in 1882. In Europe May 1 is observed in like fashion.

**LABOR LEGISLATION** includes all laws which affect the relations of employers and employes. During centuries when small factories were the rule and the employer and a dozen workmen labored together and were bound by ties of more or less intimacy, legislation defining their respective rights was unnecessary. To-day a corporation may have thousands of employes; the managers know but a few score of them, and there is total lack of close relation and feelings of comradeship.

Abuses eventually crept into the operations of large enterprises, such as too long hours of labor, disregard of sanitary conditions in factories, child labor, and lack of reasonable safeguards against accidents, with consequent disasters resulting in injury or death.

With the disappearance of the paternalistic attitude workmen began to combine for their common good (see **LABOR ORGANIZATIONS**) and to bring pressure upon legislatures for remedial laws. Governments were called upon to protect the workmen. As early as 1802 the first laws relating to factory legislation were passed, in England and Germany. To-day such laws are on the statute books of nearly all states and provinces. Particularly insistent has been the demand within recent years for laws limiting the working day to eight hours, or even fewer.

Much had already been accomplished in this direction when in 1916 the United States Congress passed the Adamson railroad law which provided an eight-hour day for over 400,000 trainmen.

This law largely influenced action in other labor fields. In the United States and Canada all government work is on the eight-hour basis; eight hours has been a legal day's work in Australia and New Zealand for many years. Europe is most backward, but there are indications there of conformity to a world-wide demand.

More recent are efforts to restrict child labor and to make employers liable for accidents to workmen due to negligence or refusal to equip their factories with reasonable safeguards. The accounts of these phases are given in the articles **CHILD LABOR**; **EMPLOYERS' LIABILITY**.

**LABOR ORGANIZATIONS**, societies of laboring men organized to obtain mutual benefit and protection. These organizations are of two classes, those organized within separate trades, for the purpose of obtaining benefits for the workmen within those trades alone, and those admitting workmen of all trades and classes, for the purpose of improving the condition of laboring men as a whole. The methods of these two classes of organizations differ in accordance with these purposes. The former rely chiefly upon such direct influences as strikes or collective bargains, while the latter depend upon more indirect means, such as agitation and political action. The former, or *trades unions*, were organized first, appearing in England about the middle of the eighteenth century, and were the result of natural evolution from the ancient guilds (see **GUILD**). They did not attain great influence in the United States until about 1830. During the period from 1830 to 1850, the tendency was toward the formation of general organizations rather than trades unions, but after 1850, which marks the appearance of the Typographical Union, laborers in almost every line of trade organized separate local unions.

About 1865 a reaction set in, marked by the organization, in 1869, of the Knights of Labor, a general society admitting members of all classes of labor, and including, when at its height, probably 200,000 workmen. Its influence in politics was at times notable, but this very activity also brought it into disrepute, and since about 1885 it has gradually

lost influence, being superseded more recently by the American Federation of Labor. This organization, founded about 1887, consists of the federation of trades Unions, and it rapidly gained strength, until in 1917 it included nearly 35,000 local unions, with a membership of more than 3,000,000. Its policy was, at first, to keep out of politics, but to maintain a continuous agitation through the general and special press and to obtain its demands by means of strikes and conferences. Later, however, it entered politics, devoting itself to securing the nomination and election of candidates favorable to the laboring classes. It sometimes worked through the old parties and sometimes through independent candidates.

There has been a great deal of distrust of labor unions, particularly in the United States, owing to the class of men who in earlier days controlled them. These men were often unworthy of the confidence of their fellow members or of the public, and their motives were frequently mercenary. Labor men gradually have discovered that their interest lies in placing men in power in their councils whose careers entitle them to public respect and who are intelligent leaders. Under such men the public has come to have a better understanding of the position of labor unions with respect to the vital questions that are pressing for solution, and their influence has increased remarkably. Particularly important among such men in the present generation have been Samuel Gompers and John Mitchell.

**Related Articles.** Consult the following titles for additional information:

|                                 |                    |
|---------------------------------|--------------------|
| Debs, Eugene V.                 | Labor, Division of |
| Factory and Factory Legislation | Labor Legislation  |
| Gompers, Samuel                 | Mitchell, John     |
| Knights of Labor                | Open Shop          |
| Labor Day                       | Sabotage           |
| Labor, Department of            | Strike             |
|                                 | Syndicalism        |
|                                 | Wages              |

**LABRADOR**, *lab'ra dawr*, a narrow strip of Eastern Canada which lies along the Atlantic coast, from Hudson Strait south-eastward to Newfoundland, to which it is attached politically. The presence of the cold Labrador, or North Polar, current along its shores makes the territory icebound almost all the year. It is in consequence but sparsely settled. The area is 120,000 square miles—almost twice as great as that of all the six New England states, but it had only 4,073 inhabitants in 1916, or one person to about thirty square miles.

The natives are chiefly Algonquian Indians in the South and Eskimo in the north. Only in the few settlements are white people found. The most important person in Labrador is Dr. Wilfred T. Grenfell (which see).

There is no agriculture in Labrador, for the summers are too short to permit any crops to mature. Animal life supplies meat; other foodstuffs are shipped to the country. In the north are found mosses and lichens only; farther south there are such trees as the pine, birch, poplar and willow. The only domesticated animals are dogs and reindeer, and they are the beasts of burden and the only means of transportation except canoes.

**LABRADOR CURRENT**, a cold current which is so named because it flows southward from the frozen north along the coasts of Labrador. It starts in the Arctic Ocean and is a distinct current until it merges with the Gulf Stream in the vicinity of Newfoundland. This current affects the climate of Labrador very noticeably, the harbors being ice-bound half the year. Those of the British Isles, which are washed by the Gulf Stream and are across the ocean in the same latitude, are never blocked by ice. The heavy fogs off the coasts of Labrador and Newfoundland are the result of the cooling effect of this current on the air.

**LABRADORITE**, *lab ra dawr'ite*, a variety of feldspar, which consists of aluminum, calcium and sodium silicate. It occurs in cleavable or granular masses, and is an essential constituent of the early eruptive rock, such as basalt, dolorite and diabase. It abounds on the coast of Labrador, where cleavable varieties occur in enormous masses of changeable colors, ranging from dull gray to gorgeous blues, greens, copper red, purple or yellow. Large quantities of the mineral are also found in the Adirondacks. Labradorite is used as an ornamental stone, especially in inlaid work.

**LAB'RADOR TEA**, a popular name for a small evergreen shrub, a species of *ledum*. It grows in the swamps and bogs of Greenland and in the extreme northern part of North America. The leaves are tough and have dense brown furry substance on the under side. They are used by the natives of Labrador as a substitute for tea.

**LABUR'NUM**, a small tree of the pea family, which grows native in most mountainous parts of Southern Europe. On account of its glossy foliage and its large hang-



ing clusters of yellow flowers it is much cultivated in gardens and parks throughout Europe. It grows rapidly and sometimes attains a height of forty feet. The wood, of a dark brown or dark green color, is hard, fine-grained and very heavy, and is used for cabinet work. The leaves, seeds and bark are poisonous.

**LABYRINTH**, *lab'irinth*, a structure having numerous intricate winding passages, difficult for a person to find his way through. Out of the legendary labyrinth of Crete, Theseus found his way, guided by a thread. The Egyptian labyrinth was a building situated in Central Egypt, above Lake Moeris, in the district now called the Fayum. The building, half above and half below the ground, contained 3,000 rooms, in all probability intended for tombs.

In gardening, a labyrinth, or *maze*, is an intricate system of pathways through dense, impenetrable shrubbery, in which those who enter may walk for hours in an effort to find the center or an exit. The name is also given to an intricately designed series of paths set apart by wooden partitions in which people may lose themselves. Such structures are common in pleasure resorts.

**LAC**, *lak*, a general name designating the various products of the lac insect. These insects, of which there are about 5,000 females to each male, live upon the twigs of certain trees. They attach themselves to the bark, pierce it with holes and draw out the resinous juices, upon which they feed. They secrete a resinous substance through the pores, become glued to the twig, and after a time die, their bodies forming tiny mounds over the myriads of minute eggs. When the eggs hatch the young dig their way out and swarm over the branch, giving it the appearance of being covered with red dust. Immediately they begin secreting the lac, repeating the life-history of the parent.

In time the bark may become covered to a depth of half an inch with gum. The lac encrusting the twigs is gathered and dissolved in hot water. It is then strained through canvas and poured out in shallow receptacles to thicken. The thin, hardened layers are known as *shellac*. Lac forms the basis of varnishes and cements, and is the principal ingredient of sealing wax. The water in which the crude lac is washed is evaporated and from the residue lac dye, resembling cochineal, is produced.

**LAC**, or **LAK** (from Sanskrit *laksha*), an Oriental term signifying 100,000. In the East Indies it is especially used to denote denominations of money. Thus, a lac of rupees means 100,000 rupees.

**LACCADIVE**, *lak'ka dive*, **ISLANDS**, a group of coral reefs and islands in the Indian Ocean, about 200 miles west of Malabar, belonging to British India. The islands are small, none of them exceeding a mile in breadth; the total area is about eighty square miles. They are low and flat, and are covered with cocoanut groves. Only eight are inhabited. The natives, called Moplahs, of mixed Hindu and Arab descent, are Mohammedans. They live on coconuts, coarse grains, pulse, plantain, vegetables and fish. The men are bold seamen and expert boat builders. Quantities of cocoanut fiber are exported. Population, approximately 14,500.

**LACE**, *lase*, a delicate kind of network, formed of silk, flax or cotton thread, used for decorative purposes. Hand-made laces are divided into two classes, *needle-point* and *bobbin*, or *pillow*. The former is made with a single thread and a needle; the later is made with several threads attached by pins to a cushion or pillow, each thread being wound on a small bobbin. Specimens of the early Venetian point lace may still be seen in collections. The *point d'Alencon* is the most expensive and complicated of modern needle laces. Among the cushion laces are the Honiton, made in England; Mechlin, made in Germany; Valenciennes and Chantilly, made in France, and Duchess lace, made in Belgium at Bruges; there are, besides, the celebrated Brussels, Venetian and Florentine laces. Guipure lace consists of a network ground, on which patterns are wrought in various stitches with silk. It was originally made in silk, gold or silver thread on little strips of parchment or vellum.

Machine-made lace is now produced in great quantities, and finds a ready market because of its moderate price. Some of the high-grade laces made by machinery are so nearly like the hand-made that the two can scarcely be told apart.

**LACE-WINGED FLIES**, a large family of insects, so called because of their gauzelike, net-veined wings. The commonest is a green or yellowish-green insect with a disagreeable odor. The larvae (young) are short grubs, with tuberculated, hair-tufted bodies, and they feed largely upon plant lice.

**LACHESIS**, *lak'e sis*. See FATES.

**LACHINE**, *la keen'*, QUEBEC, the location of Lachine rapids, on the Saint Lawrence, which are avoided by means of a canal from Montreal harbor to a point above them. The shooting of the rapids is a favorite trip for tourists. Population, 1911, 10,778.

**LACHRYMAL**, *lak're mal*, GLANDS, the glands by which tears are secreted. There is one for each eye, and it is situated in a depression in the upper and outer part of the orbit. The fluid secreted is distributed over the inner surface of the upper eyelid by a number of minute ducts, and is just enough at ordinary times to keep moist the mucous membrane and conjunctiva, or membrane that lines the lid and covers the ball of the eye. After being spread over the eye by the upper lid, this fluid passes through two small openings near the inner angle of the eye into the lachrymal sac. This is the upper opening of the nasal duct, a small tube about a half inch in length that conducts the fluid to the back nasal passage. The secretion of an unusual amount of fluid, such as is caused by irritation of the eye or excessive grief or joy, overflows the lower lid in the form of tears. See EYE.

**LACKAWANNA**, *lak a wahn'nah*, a river in Pennsylvania which rises in the north-eastern part of the state and flows into the Susquehanna, between Pittston and Wilkesbarre. It is about fifty miles in length, and is important chiefly because of the valuable anthracite coal beds in its valley. Scranton is the chief city on its banks.

**LACONIA**, *la ko'ni a*, the ancient name of a district of Greece, of which Sparta was the capital. It occupied the southeastern division of the Peloponnesus and comprised about 1,048,000 acres. The country is wild and rugged, broken by two mountain ranges, the Pentadactylon, in the west, and the Malevon, in the east. Between these lines the valley of the Eurotas, the largest river of the district, which flows southward into the Gulf of Laconia. The island of Cerrigo (Cythera) lies to the southeast. The coasts are rocky and dangerous, and there are few harbors. Laconia was the realm of Homer's hero, King Menelaus. The district is now divided into two departments of modern Greece, Lacædaemon and Laconia, the respective capitals being Sparta and Gythium.

**LACONIA**, N. H., the county seat of Belknap County, 103 miles north of Boston, on

the Winnepesaukee River, between Lakes Winnisquam and Winnepesaukee, and on two lines of the Boston & Maine Railroad. It is a prosperous manufacturing city, producing freight and passenger cars, hosiery, lumber and foundry products, paper boxes and knitting machinery. The beautiful lake region, with its cool climate and good fishing, has made the place a popular resort. The chief buildings are a public library, an opera house, a hospital, the state home for feeble-minded children and a state fish hatchery. The place was settled about 1780; it was incorporated in 1852 and the city was chartered in 1893. Population, 1910, 10,183; in 1917, 11,745 (Federal estimate).

**LACQUER**, *lak'ur*, the name applied to colored, sometimes opaque, varnishes used as a finish on metal or wooden objects. Properly it is used to designate surfaces treated with a varnish of which resin lac is the basis. It is much used as a finish in the East. In Japan, however, from which comes the most exquisite so-called lacquer, the varnish is made from the sap of the varnish-tree. Even ordinary Japanese lacquer ware is prepared by a very tedious process, requiring about thirty distinct operations and about twenty days, fifteen or more coats of varnish being put on. The finer lacquer, consisting of even more coats, is polished with calcined deer horn, finely powdered, and oil. This remarkable lacquer constitutes a very hard surface, one which stands a high degree of heat. The Japanese use lacquered vessels for hot soups and hot alcoholic drinks. The best lacquer is very expensive, but there are many cheap imitations.

**LACROSSE**, *la kross'*, a national game in Canada, which undoubtedly originated among the North American Indians. The name was applied to the sport by the early French explorers, who noted the resemblance of the hooked stick to a bishop's cross. The *crosse* is a light stick, five or six feet long, crooked at the end to allow a net of cat-gut or deer skin to be stretched across. The ball used by the Indians was made of hide, stuffed with hair, bark or the knot of a tree, but all the balls are now made of India rubber, 2½ inches in diameter. Many interesting anecdotes of this game are related by the early settlers and explorers. As many as 1,000 Indians sometimes played on a side. The players were put through a long course of training and the game was preceded by elaborate

ceremonial dances. History records that on one occasion a band of Indians led by Pontiac invited the garrison of Fort Michilimackinac (now Mackinac) to witness a game of "baggataway," as they called it, and pro-

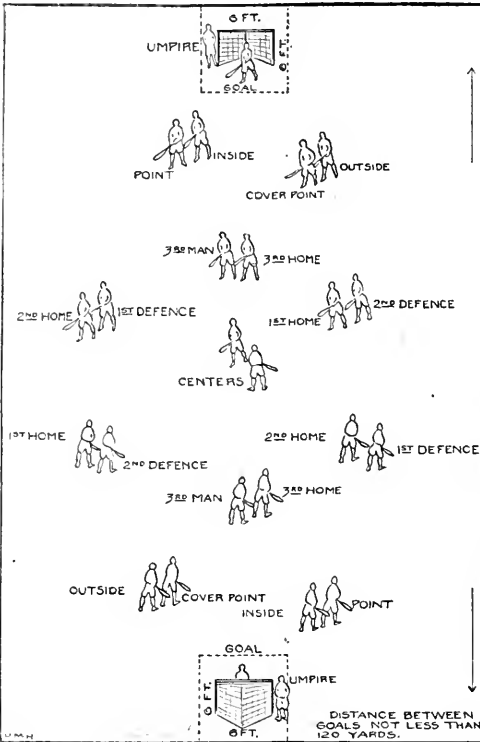

THE GAME OF LACROSSE

ceeded to massacre all the whites. In time the game was adopted by the white settlers, but it is only since 1867 that it may be called the national game. In that year a set of practical rules were adopted, clubs were organized and a great impetus given to the game in every part of Canada.

**How It Is Played.** The object of the game is to drive the ball as many times as possible through the opponent's goal, at the same time defending one's own goal from a similar attack. There are twelve men on each side.

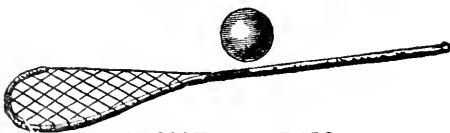

CROSSE AND BALL

Each player, except the goal-keeper (generally known simply as "goal"), is opposed by

another player whose duty it is to outmaneuver his opponent. The two centers begin the game by "facing off;" that is, after the ball is placed in the center of the field, the two players place the backs of their crosses on either side of the ball and at the word "play" each tries to draw the ball toward him. The ball is scooped up from the ground and carried horizontally on the crosse, while the player runs towards his opponent's goal. The other team tries to stop his progress by securing possession of the ball. If the center now sees a good opportunity he tosses the ball to one of his team-mates, who then runs with it or tosses it on. When one side has scored a goal the centers again face off and the game goes on. In the necessity for quickness of eye and limb, not to mention brain, in the general effect on the players and in the fascination for both players and spectators, are found the reasons for the great popularity of lacrosse.

**LA CROSSE, Wis.**, the county seat of La Crosse County, 200 miles northwest of Milwaukee, on the Mississippi River and on the Chicago, Burlington & Quincy, the Chicago & North Western, the La Crosse & Southeastern and the Green Bay & Western railroads. The city is an important farming and dairying center for a large section. The principal manufactures are agricultural implements, rubber shoes, crackers, gas engines, plows, tractors, candy, knit goods and flour. The city has the Washburn Public Library, four hospitals, a Federal building and a state normal school. The place was settled in 1841 and was incorporated in 1856. Population, 1910, 30,417; in 1917, 31,833 (Federal estimate).

**LACTEALS**, *lak'te alz*, tiny vessels of the small intestine, which convey chyle to the blood during digestion. The lacteals have their origin in small projections, called *villi*, which are found in the mucous membrane of the small intestine. Each villus has its own lacteal vessel or network of vessels. The lacteals discharge their contents in to the *receptaculum chyli*, from which the contents pass to the thoracic duct. The lacteals absorb the fatty particles of the chyle, which, after they have entered these vessels, change their character. In the intestines, these particles exist in the form of minute drops, while in the lacteals they are found to be as fine as dust and to have changed from the kind of fat that was eaten—tallow, butter or lard

—to the fat of the animal in whose lacteals they are found. See THORACIC DUCT.

**LACTIC**, *lak'tik*, **ACID**, the name applied to several acids composed of carbon, hydrogen and oxygen. Ordinary lactic acid is found in sour milk and in animal blood and muscle. It is produced by the action of a bacillus on sugar-cane juice. It is sour, odorless and of a syrupy consistency.

**LADING**, BILL OF. See BILL OF LADING.

**LADOGA**, *lah'doh'gah*, the largest lake in Europe, in the northwestern part of Russia, 7,000 square miles in extent. About seventy rivers, the Volkhov being the largest, enter it, pouring into it the waters of several lakes at higher levels. It is drained by the Neva, and is forty miles from Petrograd. Navigation, which is difficult, owing to fogs and gales, is possible only half the year. The water is pure and cold and abounds in fish.

**LADRONE' ISLANDS**, or **MARIAN'A ISLANDS**, a group of sixteen islands in the Pacific Ocean, about 1,500 miles east of the Philippines. Eight of the islands are inhabited, chiefly by Tagologs. Guam is the southernmost and largest; next in importance are Saipan, Tinian and Rota. The islands are mostly of volcanic origin and are very rugged and picturesque. They are densely-wooded and perennially green. The soil is fertile, and rice, coffee, tobacco, maize and indigo are cultivated. Coconut and breadfruit trees are native. There are few insects and reptiles and no native mammals except bats and rats. The islands were discovered by Magellan in 1521. Guam which has a population of 9,000, was ceded to the United States by Spain in 1898. The rest of the group, having a population of about 2,000, sold by Spain to Germany in 1899, were taken by the allies in the World War, and were definitely lost to Germany. Their fate was left to the decision of the peace conference at Paris.

**LADYBIRD**, a pretty little beetle, ornamented with bright red, yellow or black spots. The bug is almost hemispherical in form, the under side being flat. It feeds on scale insects and plant lice and thereby renders a great service to fruit growers. Some ladybirds eat the leaves of vegetables.

**LADYSMITH**, SOUTH AFRICA, in the northern part of Natal, capital and third largest town of Ladysmith district. It is situated on the Klip River, 322 miles southeast of Pretoria, at the junction of two railroads.

The place was founded in 1851 and named for the wife of Sir Henry Smith, at that time governor of Cape Colony. During the Boer War it was the scene of a memorable siege lasting for 118 days. In February, 1900, the British forces, commanded by Sir George White, were relieved by General Buller. Population, 1911, 5,340.

**LADY'S SLIPPER**, or **MOCCASIN**, *mok'a sin*, **FLOWER**, one of a genus of beautiful orchids, widely distributed throughout temperate regions of the northern hemisphere. About ten species are found in America, including the "showy lady's slipper" and the "pink lady's slipper."



LADY'S SLIPPER

A species often seen in florists' windows is light yellow, marked with brown. The plants easily cultivated. See ORCHIDS.

**LA FARGE**, *la fahrz*, JOHN (1835-1910), an American figure and landscape painter, born in New York City. His father, a retired French army officer, gave him a liberal education, and in 1856 the son went to Paris to study art. On returning to America he married Miss Margaret Perry, great-granddaughter of Benjamin Franklin, in 1876 was elected president of the Society of Mural Painters, and about the same time turned his attention to stained glass, a field in which he gained distinction. His windows, which are remarkable for beauty of design and purity of color, are a decorative feature of numerous churches and fine private houses. They may be seen in Trinity Church, Buffalo; Memorial Hall of Harvard University; Judson Memorial Church, New York City; the Crane Memorial Library, Quincy, Mass., and the second Presbyterian Church, Chicago. Since the artist's death the increased value of his stained glass is attested by the fact that it is sought by museums.



LADYBIRD

La Farge was a versatile genius, depicting a wide variety of subjects and exhibiting a diversified style. Of his paintings those exceptionally worthy of mention are *The Arrival of the Magi*, in the Church of the Incar-

nation, a large altar piece in the Church of the Ascension, both in New York City, and the mural decorations in the Minnesota State Capitol, Saint Paul. La Farge wrote two volumes of art criticism. *Considerations on Painting and Great Masters*.

**LAFAYETTE**, *lah fa yet'*, IND., the county seat of Tippecanoe County, sixty-four miles northwest of Indianapolis, on the Wabash River and on the Cleveland, Cincinnati, Chicago & Saint Louis, the Wabash, the Lake Erie & Western and the Chicago, Indianapolis & Louisville railroads. The city has a beautiful location on the bluffs and terraces of the river, and is surrounded by an agricultural region. The manufactures include wagons, bicycles, automobile trucks, meters and transformers, cardboard, wire works, agricultural implements and other articles. The city is the seat of Purdue University (which see), a public library, Wabash Valley Sanitarium, a soldiers' home for veterans and their wives, Saint Elizabeth's Hospital and Saint Joseph's orphan asylum. The city was built near the site of a French fort, Post Oniatanon, which was constructed about 1720. Lafayette was settled in 1820 and was incorporated in 1854. Population, 1910, 20,081; in 1917, 21,481. (Federal estimate).



**LAFAYETTE**, MARIE JEAN PAUL YVES ROCH GILBERT DU MOTIER, Marquis de (1757-1834), a French general and statesman, whose memory is revered by Americans because of the aid he rendered the colonies at the time of the Revolution. He began his career at the court of Louis XV, at the period

when hostilities were commencing between Britain and the colonies. In 1777 he left France for America, having fitted out a vessel for himself, and was received most cordially by Washington and his army. He was made a member of Washington's staff, with the rank of major-general, was wounded at Brandywine and commanded the vanguard of the American army at the capture of Cornwallis.

Lafayette returned to France on the close of the campaign, was called to the Assembly of the Notables, and in 1789 was elected a member of the States-General, which he was

partly instrumental in converting into the National Assembly. In the Assembly he proposed a declaration of rights and the decree providing for the responsibility of the officers of the Crown. Two days after the attack on the Bastille, he was appointed commander in chief of the National Guards of Paris. It was through his means that the king and queen were saved from the mob that had taken possession of the palace at Versailles. His popularity, however, was not great with any party in the state; he was too moderate for the radicals and too liberal for the court party.

After the adoption of the constitution of 1790, Lafayette resigned all command and retired to his estate of La Grange. In 1792 he was appointed one of the three major-generals in command of the French armies and directed some small operations on the frontier of Flanders, at the same time striving unsuccessfully to overthrow the Jacobins at Paris. Commissioners were sent out by the Jacobins to arrest him, and he determined to leave the country and take refuge in some neutral ground. He was captured by an Austrian patrol and confined at Olmütz till



LAFAYETTE

1797, when Napoleon procured his release; and on his return to France he took little part in public affairs, on account of his opposition to the Consulate and the Empire. In 1818 he was chosen a member of the Chamber of Deputies and was a constant advocate of liberal measures.

Lafayette visited the United States in 1824 and was received with great enthusiasm. Congress voted him \$200,000 and a township of land. During the revolution of July, 1830, he was appointed general of the National Guards of Paris, and it was chiefly through him that Louis Philippe obtained the crown. A monument to Lafayette was erected in New York in 1876. His son, George Washington Lafayette, was prominent in French politics during the early nineteenth century.

Lafayette's services to America were fittingly honored during the World War, when the American nation gave generous aid to France, and helped save the country from

defeat. Even before the United States entered the war many young American aviators enlisted in the famous Lafayette Escadrille, a flying corps, offering their lives for France.

**LAFAYETTE NATIONAL PARK**, until 1918 Mount Desert Island. See **PARKS, NATIONAL**, for description.

**LA FOLLETTE**, *la fol'let*, ROBERT MARION (1855- ), an American political leader who won a national reputation as an advocate of progressive legislation, both in behalf of his native state of Wisconsin and for the nation at large. He was born at Primrose, and during his boyhood and youth worked hard to secure an education. In 1879 he was graduated from

the University of Wisconsin, in 1880 was admitted to the bar, and after a notable career as district attorney of Dane County, entered the national House of Representatives (1885). In 1890 he was defeated for reëlection, and



LA FOLLETTE

for the next ten years engaged in law practice in Madison, meanwhile coming into public notice as an opponent of machine politics. In 1900, after a stirring campaign, he was elected governor of Wisconsin on the Republican ticket, by the reform element.

La Follette made a notable record as governor, for during his four years of office Wisconsin adopted direct primaries, equalization of taxation, control of railroad fares and other progressive measures. In 1905, after a second reëlection, he resigned to enter the United States Senate, to which he was reëlected in 1910 and 1916. In Congress he was one of the leaders of the insurgent Republicans, and in 1912 and 1916 was an unsuccessful candidate for the Presidential nomination.

La Follette became too radical to support either the Republican or the Democratic nominee in the campaign of 1916, though he seemed to lean toward President Wilson. In 1917, however, he broke with the administration on the war issue, and put forth every effort to avert a break with Germany. This attitude made him very unpopular wherever the war spirit was strong, and an anti-war speech which he delivered in Saint Paul led

to a movement to expel him from the Senate. This punishment, however, was not visited upon him, as the committee appointed to take action finally cleared him of charges of disloyalty.

**LAFONTAINE**, *lah fon tané'*, JEAN DE (1621-1695), a French poet, noted chiefly for his fables. His early verses won him influential friends, who induced him to go to Paris and provided for him while there. He enjoyed the friendship of Molière, Boileau, Racine, and all the first wits of Paris, by whom he was much beloved for the candor and simplicity of his character. But he was no favorite with Louis XIV, who even hesitated some time before confirming his nomination to the French Academy.

Lafontaine's first volume of *Tales* appeared in 1664, a second in 1671. The *Fables*, of which innumerable editions have appeared since the first volume in 1668, make a universal appeal by reason of their homely truths, unobtruded moral lessons, lively and natural descriptions and shrewd analysis of character.

**LAFONTAINE**, LOUIS HYPOLITE, Sir (1807-1864), a Canadian statesman, born in Chambly, Quebec, and educated at Montreal. After his call to the bar quickly became a leader, and in 1830 was returned to the legislative assembly for Lower Canada. At first a follower of Papineau, he soon became a rival and eventually succeeded to Papineau's position as leader of the French party. Elected to the joint assembly after the Act of Union, he was recognized as the leader of the French-Canadians and in 1842 joined with Robert Baldwin in forming a Ministry. During the struggle for responsible government Lafontaine was one of the leaders of reform and after the election of



SIR LOUIS HYPOLITE LAFONTAINE

1848 again formed a Lafontaine-Baldwin Ministry, the first Ministry really acknowledged to be responsible to a majority of the people. Naturally an aristocrat and conservative, Lafontaine felt himself out of accord with the younger and more radical reformers, and in 1851 retired from active political life, when he and Robert Baldwin resigned office. He was made chief justice

for Lower Canada in 1853 and on August 28, 1854, he was created a baronet. He continued to hold the office of chief justice until his death.

**LAGERLOF**, *lah'ger luf*, SELMA (1858- ), a Swedish novelist, one of the greatest woman writers of all time. She was born on her father's estate in Wermland, Sweden, and was educated in Stockholm at the Royal Women's Superior Training College. After her graduation she taught school for ten years. Her first novel, *The Story of Gösta Berling*, appeared in 1891, while she was still teaching. It at once placed her in the front rank of Scandinavian authors. The popularity of this book was even exceeded by that of *The Miracles of Antichrist*, a brilliant portrayal of country life, published in 1897. *The Adventures of Nils*, based on the fairy tales of the Swedish people, was written at the request of the Association of Common School Teachers, and is used as a supplementary reader in Swedish schools. Among her other books are *From a Swedish Homestead*; *Jerusalem*; *Legends of Christ*; *Invisible Links*; and *The Girl from the Marsh Croft*. In 1909 she received the Nobel prize in literature.

**LAGOON**, a shallow sheet of water near the sea, usually separated from it by narrow areas of sand; or, an expanse of deep water separated from the sea by an atoll, or coral reef. Famous lagoons of the first type are those near the head of the Adriatic Sea, on the edge of which Venice (often called "the City of Lagoons") is situated. Many large cities situated near great bodies of water have parks containing artificial lagoons. See **ATOLL**.

**LA GUAYRA**, *lah gwí'rah*, VENEZUELA, a seaport on the northern coast, situated five miles from Caracas, the capital, of which it is the port. A railroad joins the two cities. La Guayra is built on a narrow plain shut in by mountains and the sea, and the climate is hot and unhealthful. Within recent years modern improvements have made the place more sanitary, and it has become a leading commercial city. Steamers ply between this port and Europe and America, cacao, coffee and hides constituting the chief exports. The harbor is protected by a fort and a breakwater. Population, about 12,000.

**LAHORE**, *lah hohr'*, INDIA, the capital and largest city of the Punjab, a province in British India (see **PUNJAB**). It is also the

administrative headquarters of Lahore division and district, and is a railroad center of considerable importance. The native city is not impressive, as the streets are unpaved and narrow, and the houses are irregularly built. It possesses, however, a magnificent mosque and an old palace of the early Mogul kings. This section is surrounded by a brick wall fifteen feet high; the European quarter has grown up on the outside. Lahore contains the chief educational institutions of the Punjab, including a university. The principal manufactures include coarse textiles, vegetable oils and carpets. Population, 1916, 240,715.

**LAISSER FAIRE**, *lay say fair'*, a French expression which means *non-interference*. In economics the term is applied to the theory that a public authority should interfere in the concerns of a community as little as possible; that wealth tends to be produced more peaceably and economically where a government leaves individuals free to produce and distribute on mutually arranged terms. This rule in practice has various exceptions, as in matters of education, child labor and public health and morality. Advocates of the theory generally agree that the state should perform those functions that cannot be adequately performed by an individual or association of individuals.

**LAKE**, a large body of water wholly surrounded by land, having no direct or immediate communication with the ocean or with any seas, or having such only by means of rivers. Lakes are divided into four classes:

(1) Those having no outlet and receiving no running water, usually very small.

(2) Those having an outlet, but which have no running waters on the surface and are consequently fed by springs.

(3) Those which receive and discharge their water by streams, by far the largest class.

(4) Those which receive streams but have no visible outlet, being generally salt, such as Great Salt Lake, the Caspian Sea, the Dead Sea and the Aral Sea.

Large lakes have a moderating effect on the climate of regions about them. They make the winters less severe and the summers cooler. It is due to the moderating effect of the Great Lakes that there is a fruit belt along the east shore of Lake Michigan and a tobacco belt in New York along lakes Erie and Ontario.

**LAKE AGASSIZ**, *ag'a se*, an extinct lake that existed during the latter part of the

Glacial Period (which see), in the valley of the Red River of the North. The bed of this great body of water, which had an area exceeding that of the Great Lakes combined, is one of the most fertile wheat regions in the world. Its existence is proved by traces of deltas and shore lines. Geologists believe that the vast lake discharged at its southern end into the Minnesota River, through a channel fifty miles in length.

**LAKE CHARLES, LA.**, the parish-seat of Calcasieu Parish, 216 miles west of New Orleans, on the Southern Pacific, the Kansas City Southern, the Saint Louis, Iron Mountain & Southern and the Lake Charles & Northern railroads. The city has a beautiful location on the Calcasieu River and an interoceanic canal and on the shore of Lake Charles. There are great rice fields and forests of long-leaved pine, and extensive rice, cotton and lumber mills, a ship-building plant and other industries. It is the seat of a convent, and there is an orphanage and a Federal building. The place was settled in 1849 and was incorporated in 1860. Population, 1910, 11,449; in 1917, 14,930. (Federal estimate).

**LAKE DWELLINGS**, primitive dwellings built on piles or other foundations in lakes or creeks near shore. The name is usually applied to such prehistoric dwellings as those of the Swiss lakes, the first relics of which were discovered in 1853. Two plans of construction were employed by the builders. In one, numerous piles were driven into the water bed, and on these the house was built; in the other a foundation was made of stones, brush and mud, held together by supporting piles. The latter type, called the *crannog*, was common in Scotland and Ireland. Boats or narrow pile bridges provided means of communication with the shore. Discoveries have been made which show that some of the villages built on piles in the water were constructed during the Stone Age, that others were built after the Iron Age began, and that a period of possibly 4,000 years must have elapsed between the building of the first and the last of those now known. Among the remains various grains and fruit seeds and pieces of pottery have been found; bones indicate the lake dwellers' ownership of herds of cattle and of goats.

There are to-day peoples living the same sort of existence in parts of South America, Central Africa, the Malay Peninsula and in

some of the islands of the Asiatic Archipelago.

**LAKE OF THE WOODS**, a lake which constitutes part of the boundary between Minnesota and the extreme western end of Ontario. It has an area of 1,500 square miles and receives the drainage of an area 36,000 square miles in extent. Although the lake is only about seventy miles long, its irregularity gives it a shore line of 300 miles. It lies in a region of dense forests and is thickly studded with wooded islands. The lake discharges into Lake Winnipeg through Winnipeg River.

**LAKE SCHOOL**, or **LAKE POETS**, a name given by the *Edinburgh Review* to Wordsworth, Coleridge and Southey, because they lived in the Westmoreland and Cumberland lake district. They were representative poets of the new Romantic Period, of the early nineteenth century, and though they differed in many respects, they agreed in their disapproval of the formal and unimaginative verse of the preceding century.

**LAMAISM**, *lah'mah iz'm*, a corrupt form of Buddhism which has prevailed in Thibet and Mongolia since the middle of the eighth century. Lamaism embraces the doctrine of Church and State unity. The highest dignitaries are two Lama popes, one called *Dalai-Lama* (Grand Lama) the other *Tashi-Lama*. The former, the more powerful, lives at Potala, near the sacred city Lhasa. He is recognized the supreme head of the Church, the superior of all in temporal power, not only in Mongolia and Thibet, but also in parts of Western China, Siberia, Mongolia and Manchuria. The chief sacraments of the religion are baptism and confirmation; the fundamental doctrine is reincarnation or transmigration of souls. See **BUDDHISM**.

**LAMAR**, *la mah'r*, **LUCIUS QUINTUS CINNATUS** (1825-1893), an American lawyer, politician and jurist, born in Putnam County, Georgia. He was graduated from Emory College, then studied law, was admitted to the bar in 1847, and was successively professor of mathematics in the University of Mississippi, member of the Georgia legislature and member of Congress from Mississippi. In 1861 he resigned and joined the Confederate army as lieutenant-colonel, but later spent two years in Europe as unofficial representative of the Confederacy. He was professor of law in the University of Mississippi from 1867 to 1872, was again a mem-



ber of Congress from 1872 to 1877, and a member of the Senate from 1877 to 1885. He was Secretary of the Interior in President Cleveland's Cabinet, and was later appointed Associate Justice of the Supreme Court of the United States. During his political career his single purpose was to effect complete reconciliation between North and South, and he did much to accomplish this end.



L. Q. C. LAMAR

**LAMARCK**, *la mahrk'*, JEAN BAPTISTE PIERRE ANTOINE DE MONET (1744-1829), a French naturalist. He was educated for the Church but entered the army and served in the Seven Years' War. Disabled by an accident, he went to Paris and devoted himself to the study of medicine and physical science. His chief works are *Philosophie Zoologique*, a work in which he introduced great reform in the classification of animals and set forth a theory foreshadowing what is now known as the doctrine of evolution; *Histoire Naturelle des Animaux Vertébrés* (Natural History of Vertebrate Animals), and *Encyclopedia of Botany*.

**LAMB**, CHARLES (1775-1834), an English writer whose fame rests chiefly on his charming and fanciful essays. He was educated at Christ's Hospital, where he formed his lifelong friendship with Coleridge. After leaving school, the greater part of his life was devoted to the safe-keeping and care of his sister Mary, who in a fit of acute mania had stabbed her mother fatally. Charles refused to allow her to be confined permanently in an asylum, and except during attacks of her mania, she was in his home. To care for her he was obliged to renounce the idea of marriage with a girl he loved, and his life was one long sacrifice.



CHARLES LAMB

Lamb's first appearance as an author was in 1798, when he published a number of poems, in conjunction with his friends, Coleridge and Lloyd. These attracted little attention, nor was he more successful with his two attempts at the drama, *John Woodrill*, written in imitation of the early English dramatists, and a farce entitled *Mr. H.* His *Tale of Rosamund Gray*, although it was well received, did not bring him fame; but with the publication of his *Tales from Shakespeare*, written in conjunction with his sister Mary, he came at once into popular favor. *The Adventures of Ulysses* followed, and in *Specimens of English Dramatic Poets Contemporary with Shakespeare*, he brought to public notice the almost unknown lesser dramatists of the sixteenth century. He owes his chief literary distinction, however, to his delightful *Essays of Elia*, contributed chiefly to the *London Magazine*. Here, in a style ever happy and original, he has carried the short humorous essay to a point of excellence perhaps never before attained.

**LAMENTATIONS**, a book in the Old Testament in the Authorized Version of the Scriptures, occupying a place between the books of *Jeremiah* and *Ezekiel*. *Lamentations* is a poem in five chapters, which, with the exception of the fifth, are arranged in verses corresponding to the letters in the Hebrew alphabet. In chapters one, two and four the verses are arranged alphabetically. In chapter three the first three verses begin with the first letter of the alphabet, the second three with the second, and so on. This chapter has sixty-six verses, while the first, second and fourth have twenty-two verses each, the number of verses corresponding in this case to the number of letters in the alphabet. The fifth chapter is not alphabetically arranged and is supposed by some critics to have been written by another author, though the entire book is generally ascribed to the prophet Jeremiah. *Lamentations* treats of the destruction of Jerusalem and the suffering of its defenders.

**LAMMERGEIER**, *lam' mur gi ur*, the largest bird of prey in Europe, sometimes called the *bearded vulture*, and intermediate between the eagles and the vultures. It is found in the Swiss and German Alps, as well as in the higher mountains of Asia and Africa, is about four feet in length and has a wing expansion of from nine to ten feet. It preys on small quadrupeds, on chamois,

lambs and hares, and also eats dead and decaying meat.

**LAMP**, a device for producing an artificial light. Originally the lamp consisted of a vessel for holding an inflammable fluid in which a wick was suspended, but now the term is applied to any arrangement for illuminating purposes, whether it uses gas, electricity or an illuminating fluid. The first lamps had shells or the skulls of animals for cups, and reeds or rushes for wicks. The fluid usually consisted of the fats of animals, but later oils from plants came into use and were more acceptable, because they remained liquid at a lower temperature. Cloth or a roll of tow was finally substituted for rushes as wicks. Lamps of this sort gave a dim light, made a great deal of smoke and were not very satisfactory.

In the latter part of the eighteenth century a Swiss chemist named Argand invented a burner which used a flat wick in a round tube, so arranged that the air could pass through the tube and reach the center of the flame. This improvement is the greatest ever made in the oil lamp. With the introduction of kerosene came further changes. The wick was made broad and flat, and the flame was enclosed in a glass chimney, resting upon a perforated bottom. This arrangement caused a good circulation of air about the flame. To-day, in localities where gas and electricity are available, the kerosene lamp is little used.

**LAMP'BLACK**, a fine soot, formed by the condensation of the smoke from imperfect combustion of burning oil, pitch or resinous substances, as in a chimney. It is used in the manufacture of pigments, blacking and printing inks. See **CARBON**.

**LAMP'PREY**, the popular name of several species of eel-like, scaleless fishes, which inhabit both fresh and salt water. The breathing organs are seven gill-openings on each side near the head. The mouth is in the form of a sucker, lined with strong teeth and cutting plates. The *marine*, or *sea*, *lamprey* sometimes reaches a length of three feet and a weight of five pounds. It is of a dusky brown, with yellowish patches, is common round the British coasts and is also found in the Mediterranean. It ascends rivers in the spring for the purpose of spawning and was formerly much valued as an article of food. The *river lamprey*, or *lamp-fern*, is a smaller species that abounds in the fresh-water lakes and rivers of northern

countries. It is often seen clinging to stones with its mouth. It is black on its upper parts and of a silvery hue on its under surface.

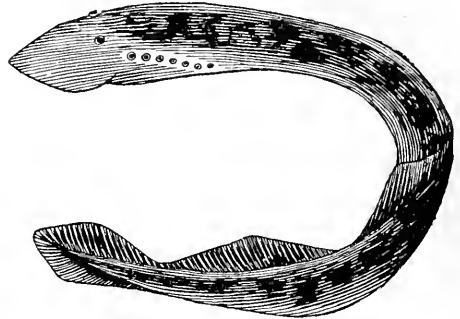

LAMPREY

Lampreys attach themselves to other fishes, such as the shark, sturgeon or salmon, and suck their blood; they also eat soft animal matter of any kind. See **HAGFISH**.

**LANCASTER, HOUSE OF**, the name used in English history to designate the line of kings immediately descended from John of Gaunt, fourth son of Edward III. Henry IV, who received the crown on the enforced abdication of Richard II (1399), was the first king of this House and established a strong government, which was continued under his successor, Henry V. Henry VI was a weak king, and during his rule arose the Wars of the Roses. This period of English history is vividly pictured by Shakespeare in his *Henry VI*.

**Related Articles.** Consult the following titles for additional information:  
 England (History) Henry VI  
 Henry IV Roses, Wars of the  
 Henry V York, House of

**LANCASTER, OHIO**, the county seat of Fairfield County, thirty miles southeast of Columbus, on the Hocking River and the Hocking Canal and on the Pennsylvania and the Hocking Valley railroads. The city is in the natural gas belt and is surrounded by a rich agricultural region. The shipping facilities are good, and the city is the seat of railroad shops and manufactories of agricultural implements, foundry products, carbons, tires, lenses and glass. The state industrial school for boys is located here, and there is a Federal building, a library, a hospital and an armory. The place was settled in 1800. Population, 1910, 13,093; in 1917, 16,086 (Federal estimate).

**LANCASTER, PA.**, the county seat of Lancaster County, sixty-eight miles west of

Philadelphia, on the Conestoga River and on the Philadelphia & Reading and the Pennsylvania railroads. The city is the seat of large tobacco factories and extensive manufactories of cotton, silk, cigars, cork, umbrellas, watches, carriages, corks, iron and steel goods and other articles. Franklin and Marshall College, Shippen School for girls and theological seminary are located here, and one of the state normal schools is at Millersville, near the city. The public institutions include the Lancaster General and Saint Joseph's hospitals, the Children's and Stevens' homes, a Federal building and several libraries. Other features of interest are several parks and a soldiers' monument. The place was settled about 1718 and was called Hickory Town until 1729. From 1799 to 1812 it was the capital of the state. It was chartered as a city in 1818. Population, 1910, 47,227; in 1917, 51,437 (Federal estimate).

**LANCE**, *lans*, a weapon consisting of a long shaft with a sharp point. It was common among the Greeks and Romans. The Macedonian phalanx was armed with it, and it was the chief weapon of the Roman infantry. The lance was the chief weapon in the Middle Ages and was especially the weapon of knighthood. The introduction of firearms gradually led to the disuse of the lance in the west of Europe, though it continued in the east. Napoleon organized several regiments of Polish lancers for service in his army, and now most of the armies of Europe have regiments of Uhlans, or lancers.

**LANCELOT**, *lan'se lot*, **OF THE LAKE**, the name of one of the knights celebrated in the traditions and fables relating to King Arthur and the Round Table. According to tradition, Lancelot was of royal birth, was educated by the Lady of the Lake and was taken by her to Arthur's court, where he became one of the chief knights. His love for Guinevere, the beautiful wife of Arthur and his disregard of Morgana, a fairy and the sister of Arthur, placed the knight in the most dangerous and marvelous situations, from which, however, he always extricated himself by his valor and the help of the Lady of the Lake. Elaine, the maid of Astolat, loved Lancelot and died of her love. Lancelot is one of the chief figures in Tennyson's *Idylls of the King*.

**LANCET**, *lan'set*, **FISH**, so called from its sharp spines, one on each side of the tail.

It is from two to four feet long, is scaleless, and has a long snout. The mouth is supplied with long fangs and sharp teeth; it has no air-bladder. These fish live in profound depths and are never seen unless cast ashore dead or brought up in drag nets. The Pacific species is known as the *handsaw fish*, from the sawlike ventral fin. Still another species is called the *wolf fish*.

**LANCEWOOD**, *lan's wood*, the popular name of the wood of several tropical trees which possesses in a high degree the qualities of toughness and elasticity and is on this account extremely well adapted for the shafts of light carriages, fishing rods and all those uses where light, strong, but elastic timber is required. It attains a diameter of nine inches.

**LAND AND SEA BREEZES**, the name of daily winds, which blow alternately on and off shore. During the day the land becomes heated to a higher temperature than the sea, and a little before noon a breeze begins to blow landward. This increases in strength until about the middle of the afternoon, when it gradually subsides. During the night the land radiates heat rapidly and becomes cooler than the sea, so that after midnight in most localities a breeze sets in, blowing off shore and continuing until about sunrise. Land and sea breezes are regular occurrences in the tropical regions that are free from local storms, and they are gentle winds. In the temperate latitudes they are not as regular, since they are liable to be disturbed by local conditions. Similar breezes occur along the shores of the Great Lakes and other large bodies of fresh water, though they are not as distinctly marked as the true land and sea breezes.

**LAND CRAB**, a crab which takes its name from the fact that when full-grown it lives upon the land. All live in warm countries. The land crabs resemble the common crabs very closely. They breathe by gills, though some inhabit dry places and burrow in the earth. They make periodical migrations to nearby bodies of water, supposedly for the purpose of depositing their eggs. Among the most common are the *black crabs*, or *mountain crabs*, of the West Indies, which live in the woods and hills often two or three miles from shore, regularly visiting the sea in April and May. Nearly all land crabs are active during the night and, except in rainy weather, remain concealed during the day.

Some are good to eat; the eggs also are considered a delicacy. Land crabs usually feed upon plants, and in some localities they are a nuisance to agriculturists. See CRAB.

**LANDIS, KENESAW MOUNTAIN** (1866- ), a United States District judge of the Illinois Federal District, appointed in 1905 by President Roosevelt. He has achieved a nationwide reputation for fearlessness and independence, and has maintained the highest traditions of the Federal bench. In 1907 he fined the Standard Oil Company \$29,200,000 for rebating, and in 1918 sent nearly 100 leaders of the Industrial Workers of the World (the I. W. W.) to a Federal prison for conspiracy to obstruct the war work of the government and on other grave related charges, for terms ranging from one to twenty years.

Landis was born in Millville, Ohio, and was graduated from the Union College of Law, Chicago. In that city he has since resided, except for a brief period when he served Secretary of State Walter Q. Gresham as private secretary.

**LANDLORD AND TENANT.** See TENANT; LEASE.

**LANDOR, WALTER SAVAGE** (1775-1864), an English poet and prose writer. He was educated at Rugby and Oxford, from both of which he was expelled for unruliness. In 1795 he issued a small volume of poems, and in 1798 he published a long poem, *Gebir*, which he afterwards translated into Latin. His fame rests chiefly on his *Imaginary Conversations* between celebrated persons of ancient and modern times, which is a model of a pure, vigorous, finished English style.

**LANDS, PUBLIC,** a part of the national domain which is owned exclusively by the government and is subject to its sale or disposal. It consists wholly of land secured from other nations by treaty, from the states by cession and from Indian tribes by treaty, cession and conquest.

**How They Originated.** At the organization of the national government there were no public lands, except those under the jurisdiction of the several states or claimed by them. This, however, included a large territory northwest of the Ohio River, known as the Northwest Territory. Before the adoption of the Articles of Confederation (which see) the several states ceded to the national government all their claims to this territory, and at that time the first public

domain was created. Soon afterward North Carolina, Georgia, South Carolina and Virginia ceded their claims to other lands south of the Ohio River and west of the Alleghanies. In 1803 the United States gained by the Louisiana Purchase (including Oregon) more than 1,000,000 square miles. In 1819, by the acquisition of Florida, it secured some 60,000 square miles. By the annexation of Texas in 1845, the public domain received an addition of 262,000 square miles. At the close of the Mexican War in 1848 the present territory of New Mexico and California was added, with a total area of 523,800 square miles. In 1853, by the Gadsden Purchase, 36,200 square miles was added, and in 1867, with the purchase of Alaska, another increase of 577,000 square miles was secured. The part of this vast territory which has been reserved by the general government at the time of the organization of states and territories is known popularly as the *public lands*.

**How Disposed Of.** Six methods of disposing of these lands have been followed, of which the most important in the early years of the government was that of gift and special grant. These were of several kinds: those made to individuals by reason of special service; those made to the states for the purpose of encouraging education or building public roads or railroads; those made to the railroads and other corporations as an inducement to develop the resources of the country. The government also disposed of its lands by sale, at first in large quantities for a nominal sum, and later in smaller quantities for reasonable compensation. It has also sold them at public auction, the minimum price accepted being \$1.25 per acre. It has granted them by preëmption (which see). According to this scheme persons who desire to secure lands for farming or some other direct use, may settle upon the land, live there for six months and at the end of that time, by paying \$1.25 per acre, receive the clear title to the property. This law has been repealed. The Homestead Laws provide a somewhat different course of procedure. They require a residence of five years upon the land, when the title will pass to the occupant upon the payment of a nominal fee, rarely more than \$30. The maximum amount granted to any one settler or head of a family is 160 acres. By the so-called Timber Culture Act of 1878, which has recently been repealed, any person who

proved that he had planted a certain number of acres of land with timber would receive a patent for not more than 160 acres.

**Survey of Land.** The management of the public lands rests with a bureau of the department of the interior, known as the General Land Office, presided over by a Commissioner appointed by the President. He has charge of the survey and disposal of the land and carries on the work through land offices scattered throughout the states.

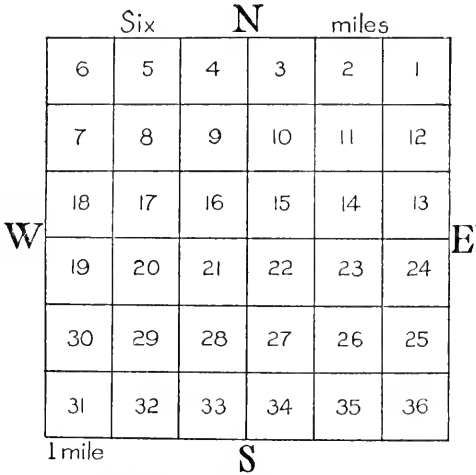

TOWNSHIP IN SECTIONS

It may be assumed that the section at the right represents Section 22 of the township. The land in the small white square above the square in black is thus described: "The n. e. 1/4 of the s. e. of the s. w. 1/4 of Section 22." Describe the square in black. How many acres does it contain?

The survey of the public lands is made according to the so-called rectangular system, which was first adopted in surveying the lands in the Northwest Territory, about 1790. It provides for the division of lands into ranges, townships, sections and quarter-sections. The ranges extend in a north and south direction and are numbered east and west from a principal meridian. These

ranges are six miles wide and are divided into townships six miles square, which are numbered north and south from a fixed parallel. The townships are subdivided into sections, each one mile square and numbered according to a uniform system. Each section is divided into quarter-sections, which are designated by their direction from the center, as northwest, southwest, northeast and southeast. It is therefore possible to designate any plot of land as small as five

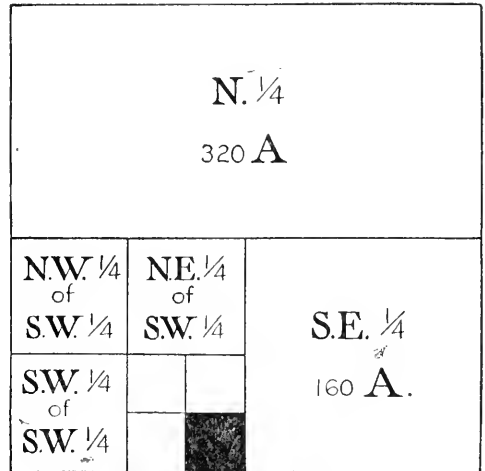

DIVISION OF A SECTION

acres with perfect accuracy (see drawing).

**Extent of the Public Domain.** In twenty-five states of the American Union there were in 1918 over 225,000,000 acres of land subject to entry under the laws and rules of the General Land Office. The average, surveyed and ready for occupancy, as well as the unsurveyed area, is given in the following table. Much of it must be irrigated.

| STATE       | AREA IN ACRES. |            |            | STATE        | AREA IN ACRES. |            |             |
|-------------|----------------|------------|------------|--------------|----------------|------------|-------------|
|             | Surveyed       | Unsurveyed | Total      |              | Surveyed       | Unsurveyed | Total       |
| Alabama     | 33,120         |            | 33,120     | Nebraska     | 130,016        |            | 130,016     |
| Arizona     | 6,402,270      | 15,906,830 | 22,309,100 | Nevada       | 30,923,338     | 24,323,493 | 55,246,831  |
| Arkansas    | 316,560        | 40         | 316,600    | New Mexico   | 14,625,669     | 6,437,496  | 21,063,165  |
| California  | 15,103,078     | 4,402,139  | 19,505,217 | North Dakota | 141,514        |            | 141,514     |
| Colorado    | 8,479,934      | 1,936,383  | 10,416,317 | Oklahoma     | 42,133         |            | 42,133      |
| Florida     | 119,464        |            | 119,464    | Oregon       | 12,776,589     | 1,074,166  | 13,850,755  |
| Idaho       | 7,970,227      | 6,345,881  | 14,316,108 | South Dakota | 956,992        | 53,781     | 1,010,773   |
| Kansas      | 9,363          |            | 9,363      | Utah         | 13,846,826     | 17,693,845 | 31,540,671  |
| Louisiana   | 38,839         |            | 38,839     | Washington   | 1,002,884      | 280,435    | 1,283,319   |
| Michigan    | 80,319         |            | 80,319     | Wisconsin    | 6,329          |            | 6,329       |
| Minnesota   | 587,576        |            | 587,576    | Wyoming      | 24,754,837     | 2,004,663  | 26,759,500  |
| Mississippi | 32,038         |            | 32,038     |              |                |            |             |
| Missouri    | 274            |            | 274        |              |                |            |             |
| Montana     | 5,875,675      | 5,942,739  | 11,818,414 | Grand total  | 144,255,864    | 86,401,891 | 230,657,755 |

The unappropriated lands in Alaska are not included herein. The total area of Alaska is 378,165,760 acres, of which 23,884,000 acres are reserved. Approximately 850,000 acres have been surveyed under the rectangular system.

**Land Offices.** The United States Land Offices in the various states are located in the following states.

- Alabama: Montgomery.
- Alaska: Fairbanks, Juneau, Nome.
- Arizona: Phoenix.
- Arkansas: Camden, Harrison, Little Rock.
- California: El Centro, Eureka, Independence, Los Angeles, Sacramento, San Francisco, Susanville, Visalia.
- Colorado: Del Norte, Denver, Durango, Glenwood Springs, Hugo, Lamar, Leadville, Montrose, Pueblo, Sterling.
- Florida: Gainesville.
- Idaho: Blackfoot, Boise, Coeur d'Alene, Hailey, Lewiston.
- Kansas: Dodge City, Topeka.
- Louisiana: Baton Rouge.
- Michigan: Marquette.
- Minnesota: Cass Lake, Crookston, Duluth.
- Mississippi: Jackson.
- Missouri: Springfield.
- Montana: Billings, Bozeman, Glasgow, Great Falls, Havre, Helena, Kalispell, Lewiston, Miles City, Missoula.
- Nebraska: Alliance, Broken Bow, Lincoln, N. Platte, O'Neil, Valentine.
- Nevada: Carson City, Elko.
- New Mexico: Clayton, Ft. Sumner, Las Cruces, Roswell, Santa Fe, Tucumcari.
- North Dakota: Bismarck, Dickinson, Minot, Williston.
- Oklahoma: Guthrie.
- Oregon: Burns, La Grande, Lakeview, Portland, Roseburg, The Dalles, Vale.
- South Dakota: Bellefourche, Gregory, Lemmon, Pierre, Rapid City, Timber Lake.
- Utah: Salt Lake City.
- Washington: N. Yakima, Seattle, Spokane, Vancouver, Walla Walla, Waterville.
- Wisconsin: Wausau.
- Wyoming: Buffalo, Cheyenne, Douglas, Evanston, Lander, Sundance.

**Homes for Soldiers.** When the World War ended and 2,000,000 soldiers of the United States were to be returned from France the suggestion was made in many quarters that unusual facilities be afforded them for securing homes on the public lands. If the plan were successfully carried out it would remove the dread of unemployment for many thousands of young men and would establish them for life.

**Public Lands in Canada.** The public lands of Canada consist of granted and ungranted lands. The ungranted lands are in the older provinces and are the property of the provinces in which they lie. They are disposed of by the officials appointed by the respective legislatures of these provinces for this purpose. The ungranted lands in the Northwest Territories belong to the Dominion and are administered by the Dominion government

under direction of the department of the interior.

**Survey.** The Dominion lands are laid out in quadrilateral townships, each containing thirty-six sections of as nearly one square mile, or 640 acres, as the convergence of the meridians permits. The sections are numbered consecutively, beginning in the southeast corner of the township and following the order shown in the diagram:

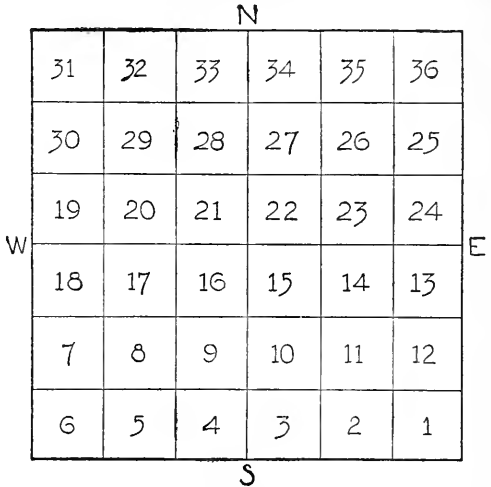

Each section is divided into quarter sections of 160 acres, and these quarter sections may be sub-divided into quarters. The numbering of the sub-divisions follows the same order as the numbering of the sections in the township, as shown by the diagram:

The townships are numbered in regular order northward from the international boundary lines on the 49th parallel of latitude, and lie in ranges numbered in Manitoba east and west from a prime meridian, which is named the principal meridian, and extends northerly from the 49th parallel. Throughout the northwest provinces the ranges are numbered westerly from other initial meridians, which are named 2nd, 3rd, 4th, and so on, according to their order, westward from the prime meridian.

**Disposal of Dominion Lands.** The Dominion lands of the northwest are divided in two classes, viz., even-numbered and odd-numbered sections. The sections numbered 8 and 26 were allotted to the Hudson's Bay Company; numbers 11 and 29 are reserved for school purposes and are known as school

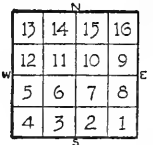



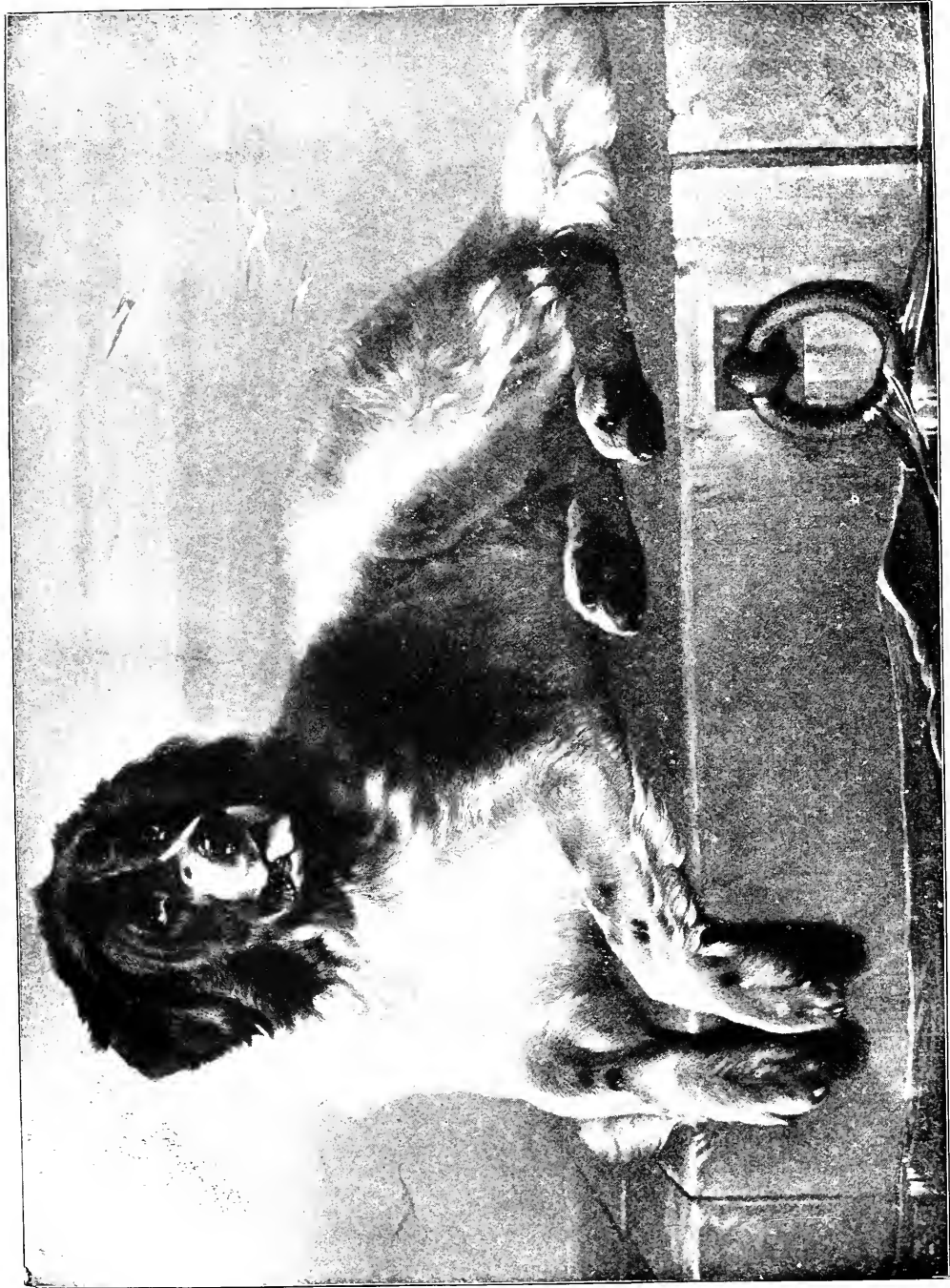

A DISTINGUISHED MEMBER OF THE HUMANE SOCIETY — *Landseer*  
London, England



sections. All other sections are held for sale and as land grants in aid of the construction of colonization railways. The latter provision has greatly aided the great transcontinental railroads.

**Homesteads.** Any person, male or female, who is the sole head of a family, or any male who has attained the age of eighteen years, who is a British subject, or any alien who declares his intention of becoming a British subject, is entitled, on making application before the local agent of the district in which the land he desires is located, and on paying an office fee of ten dollars, to obtain homestead entry for any quantity of land not exceeding 160 acres. In former years 320 acres could be acquired.

Anyone granted an entry for homestead is required to conform to the provisions of the Dominion Land Acts, under one of the following acts:

(1) At least six months' residence upon and cultivation of the land in each year during the term of three years.

(2) If the father (or mother, if father is deceased) of any person who is eligible to make a homestead entry under the provisions of this act, resides upon a farm in the vicinity of the land entered for such person as a homestead, the requirements of this act as to residence prior to obtaining patent may be satisfied by such person residing with father or mother.

(3) If a settler has obtained a patent for his homestead, or a certificate for the issue of such patent countersigned in the manner prescribed by the act, the requirements of this act as to residence prior to obtaining patent may be satisfied by residence upon the first homestead, if the second homestead is in the vicinity of the first homestead.

(4) If the settler has his permanent residence upon farming land owned by him in the vicinity of his homestead, the requirements of this act as to residence may be satisfied by residence upon said land.

(5) Should a number of homestead settlers, embracing at least twenty families, with a view to greater convenience in schools and churches, desire to locate in a village or hamlet near their homesteads, the minister of the interior may dispense with the condition of residence, but the condition of cultivation must be carried out.

The privilege of homestead entry applies to agricultural land only.

**LANDSCAPE GARDENING**, the art of laying out grounds, arranging trees, shrubbery and flowers, so as to bring into harmonious combination all the varied characteristics of a park or lawn. It disposes flowering plants, shrubs and trees over varying levels, in such a manner as to produce

the most pleasing effects; it shuts out undesirable views by means of judicious planting, and it introduces rock work, water and other artistic embellishments, where the local peculiarities of the ground permit. Landscape gardening has become a distinct art, and landscape gardeners of great skill are employed to lay out city parks and other public grounds. Frederick Law Olmsted may be considered the father of landscape gardening in America; several notable men have followed him. See HORTICULTURE.

**LANDSEER**, EDWIN, Sir (1802-1873), a celebrated English painter of animals, was born in London. He began to draw animals when a mere child, and at the age of twelve was able to paint and etch with much skill. In 1825 he went to Scotland to visit Sir Walter Scott, whom he painted with his dogs; after this he rapidly rose to fame. His pictures of animals are painted with sympathy, sentiment and feeling.

In 1831 Landseer became a member of the Royal Academy and later was knighted. Among his best known works are *Dignity and Impudence*, *Alexander and Diogenes*, *A Distinguished Member of the Humane Society*, *Connoisseurs*, *The Return from Deer Stalking*, *High Life and Low Life*, *Highland Drover Departing from the South*, *The Return from Hawking*, *The Shepherd's Chief Mourner*, *There's Life in the Old Dog Yet*, *The Stag at Bay* and *Dialogue at Waterloo*. The fine engravings of his paintings executed by his brother Thomas have made Landseer's paintings well known to the public.

**LAND'S END**, a headland in Cornwall, the westernmost point of England. There is a lighthouse on the dangerous rocks, the Longships, about a miles to the west.

**LANFRANC** (about 1005-1089), the first Archbishop of Canterbury after the Norman Conquest. Lanfranc was born at Pavia, Italy. He founded a law school in France and in 1046 was chosen prior of the Benedictine monastery of Bec. William of Normandy made him prior of Saint Stephen at Caen, as a reward for procuring the Pope's consent to William's marriage to his cousin, and in 1070 he made him Archbishop of Canterbury. Among Lanfranc's writings are *Commentaries on the Epistles of Saint Paul*, *A Treatise against Berenger* and *Sermons*.

**LANG**, ANDREW (1844-1912), a British scholar who wrote on many different subjects, and is remembered affectionately for

his sympathetic translations of fairy tales. He was educated at Edinburgh Academy, Saint Andrew's University and Balliol College, Oxford, where he took a distinguished position. A most versatile writer, he has published several volumes of ballads and other light verse; *Custom and Myth*, a valuable contribution to the science of comparative mythology; translations of Homer (with collaborators), of Theocritus and of Bion; *Letters to Dead Authors* and *Letters on Literature*, and volumes of fairy tales.

**LANGLAND, WILLIAM** (about 1332-1400?), an English poet, after Chaucer considered the greatest English poet of his century. His fame rests on his allegorical and satirical poem, *The Vision of Piers Plowman*, in which are vigorously pictured contemporary abuses in Church and State.

**LANGLEY, SAMUEL PIERPONT** (1834-1906), an American scientist, entitled to fame as one of the inventors of the flying machine, was born at Roxbury, Mass. He was educated in Boston, and he also studied in Europe. He was successively assistant in Harvard Observatory, professor of mathematics in the Naval Academy at Annapolis, director of the Allegheny Observatory; in 1887 became secretary of the Smithsonian Institution. Professor Langley made special observations which have added substantially to our knowledge of the sun's heat. He also extended the invisible portion of the solar spectrum and invented the bolometer, a very delicate instrument for measuring radiant heat. For several years he gave his attention to aerial navigation and was granted an appropriation of \$5,000 by Congress for experiments. His work in this field is related in the article **FLYING MACHINE**.

**LANGTRY, MRS. LILLIE** (1852- ), an English actress, born at Le Breton, on the island of Jersey. She was the daughter of a clergyman. After her marriage to Edward Langtry in 1874, she became conspicuous in English society, being known as the "Jersey Lily," on account of her beauty. In 1881 she made her debut in London in *She Stoops to Conquer*, and in the following year she appeared in America with great success. After the death of her husband she again married, and in 1903 she returned to America, where she appeared in *The Crossways*, a play written by herself in collaboration with J. Hartley Manners. In 1912 she appeared in vaudeville in cities.



**L**ANGUAGE AND GRAMMAR. The real purpose of language teaching is not to teach pupils to talk; it is to teach them to express their thoughts. The really fundamental thing, then, if successful work in language is to be done either in the home or in the school, is to interest the child in something, it matters comparatively little what, so that he will of his own accord

be willing to make statements or ask questions. When he wants to use words, it is easy enough to teach him what words to use, if he is anxious to talk about a subject he is willing to be taught the best, most effective way to talk about it. From the first grade to the eighth, whether the work be the simple "language work" of the primary children, or the more advanced "grammar and composition," little is ever gained by forcing pupils to talk or write on subjects which are beyond their comprehension or outside their interest.

One of the greatest advances that has been made in recent years in the teaching of such subjects as language lies in this very fact; it is not so very long ago that pupils in grammar schools were assigned for their compositions such topics as "Perseverance," "Success"—abstract topics which could not, in their very nature, call up in the child any spontaneous, vigorous, individual thoughts. To a person who was trained on such composition topics, the subjects that are assigned to pupils now—such subjects as "My Happiest Christmas," "When Father Took Me Fishing"—seem almost too good to be true, just by reason of their relation to the child's life. Nor has this change sprung simply from a desire to cater to the child's likes; it has come from a real perception of the fact that only by allowing a child to talk and write of what is capable of interesting him can the school give to him that greatest of gifts in its power—the ability to use his own language easily and forcefully.

For the benefit of teachers and mothers a graded outline of work is given here, showing the development of the subject throughout the years of grammar school. These lessons should be studied in connection with the article **STORY TELLING**. References to that

discussion will be given in the course of the treatment on language.

### First Year

**Introduction.** When a child starts to school he has command of a certain number of words—many more, probably, than the most of us imagine. Some of these he uses freely; some he is fairly well acquainted with, but uses seldom. Of course there is a very great difference observable in children from different types of homes; the child of intelligent, English-speaking parents will naturally have a much wider vocabulary than the child of foreign or uneducated parents. But to whichever class a child belongs, it is the object of the language work to enlarge and enrich the child's vocabulary and to make surer and more exact his use of those words he does know. Nor are these all the purposes of the language course in the early grades. Imagination should be strengthened, appreciation awakened for what he reads and hears, and a taste cultivated for what is good in literature.

In a sense, every lesson in any subject throughout the day should be a language lesson; for slovenly work in other classes may undo much that is done in the language class. An ungrammatical statement should not be allowed to pass in the number-work class nor a particularly bunglesome expression in the reading class. But of course such things can be dealt with in the language class in a detailed way which is impossible in other classes.

At least the first half of the first year's work will of necessity be oral; not until the sixth month, perhaps, will the children be ready for written statements, which will then be of the very simplest. In connection with these simple written sentences the pupils may be taught the use of the capital letter at the beginning of the sentence and of the period and the question mark at the end. Farther than this formal language work cannot well go in this grade.

**Conversation Exercises.** The subjects which will suggest themselves to any teacher for the all-important oral exercises of the first grade are practically innumerable. The one great point to be remembered, of course, is that the topic must interest the children; and in connection with this the fact that the same thing does not interest all children. Suppose, for example, that the subject for

conversation is the home—an excellent topic which might well furnish material for half a dozen or more discussions. The girls will naturally be more interested in the interior of the home; the way mother bakes cake or sets the table, or makes the bed or puts the baby to bed will lead them on to talk, once the first embarrassment is over, freely and willingly. The boys, on the other hand, will care more to discuss such subjects as a barn, or father's work, or why they do not like to take care of the lawn. At certain seasons of the year special facts of interest naturally come up in relation to the home which give variety. For instance, at Thanksgiving time both boys and girls will enjoy discussing the preparations which are being made at home, and the guests who are coming. Just before Christmas so many subjects of interest will come up that the pupils will be over-eager to discuss them; they will want to tell about the decorating that goes on at home, about the making and hiding of presents, about their suspicions as to where their own gifts are hidden, about the presents they are making for father and mother. And just such spontaneous subjects for conversation are the teacher's greatest opportunity. Of course the discussion must be kept within bounds; new words must be suggested to the children, wrong ones corrected, false grammatical forms made right. But if the teacher shows that she is interested in what the child is telling, and not just in the manner of the telling, she may slip in her corrections without making the child self-conscious.

Discussion of home affairs may easily be connected with nature study. In the fall the pupils may tell of the preparation for winter at home, of the laying in of food and fuel and warm clothing; and from that they may be led to the subject of the preparation animals make for winter. In the spring, talk of awakening life in the garden and the fields will be natural; wild flowers and tame flowers, the birds that may be seen in the home garden, the butterflies and insects that flit about the flowers are all topics about which the children will talk themselves and gladly hear the teacher talk.

Description by the pupils of places where they have been and of things they have seen stimulates imagination and trains powers of observation, and may also prove highly entertaining. Try, as far as possible, to teach the pupils to have some system in giving descrip-

tions. Let them tell when they saw the object, where they saw it, how it looked and how it made them feel. By forming this habit, a pupil may tell a connected and comprehensive story without needless repetition and unnecessary words.

A conversational exercise in the form of a game may be effectively introduced, the teacher, as in all the conversational work, noting and correcting all faulty construction. One pupil may think of some object, and the pupils and teacher, by asking questions, may try to guess the object in question. All questions and answers should be in complete sentences. For instance, a pupil should ask, "Is it in this room?" or "Do I see it every day?" and the answer should be "No, it is not in this room," or "Yes, you see it every day."

The interweaving of stories and games is a helpful as well as an attractive feature of this work, and the following practical suggestions should prove of assistance to the teacher in this important branch of her work:

Read or tell the class simple but interesting stories, told in words of the pupils' vocabulary, and after they have become familiar with the story allow one to commence it, another taking it up where the first one stops, and continuing until several pupils have taken part in the exercise. Stories which may be effectively used in this way are to be found in the article *STORY TELLING*.

Another attractive form of language work is to let certain pupils take the parts of the different characters in the story and in original sentences tell their part. Such portions of the story as the child may not remember can be supplied by the teacher. In conducting these lessons any incorrect forms or sentences should be immediately corrected, but in such a way that the pupil will not feel self-conscious. *The Little Red Hen* and *The Three Bears* may be treated in this way.

**Memory Work.** The memorizing of simple poems comes under the head of language work, and can easily be made one of the most attractive parts of that work. Almost all children love the swing and rhythm of the nursery rhymes, and it is well to begin with the learning of a number of them, if the children have not already had them in kindergarten. The following selections should give teachers and mothers all of the Mother Goose rhymes they need:

Daffy-Down-Dilly has come up to town  
In a yellow petticoat and a green gown.

Humpty Dumpty sat on a wall;  
Humpty Dumpty had a great fall;  
And all the King's horses and all the King's  
men  
Can't put Humpty Dumpty together again.

Rock-a-bye, baby, in the tree top;  
When the wind blows, the cradle will rock;  
When the bough breaks, the cradle will fall;  
Down will come baby, cradle and all.

Little Boy Blue, come, blow your horn;  
The sheep's in the meadow, the cow's in the  
corn.

"Where's the little boy that looks after the  
sheep?"

"He's under the haystack, fast asleep."

Ding, dong, bell,  
Pussy's in the well!  
Who put her in?  
Little Tommy Linn.  
Who pulled her out?  
Big John Stout.

There was an old woman who lived in a shoe;  
She had so many children she didn't know  
what to do;  
She gave them some broth without any bread;  
She whipped them all soundly and put them to  
bed.

Little Miss Muffet  
Sat on a tuffet,  
Eating her curds and whey;  
Along came a spider,  
And sat down beside her,  
And frightened Miss Muffet away.

"Pussy-cat, pussy-cat, where have you been?"  
"I've been up to London to look at the queen."  
"Pussy-cat, pussy-cat, what did you there?"  
"I frightened a little mouse under the chair."

Little Bo-Peep has lost her sheep,  
And can't tell where to find them;  
Leave them alone, and they'll come home,  
Wagging their tails behind them.

The north wind doth blow,  
And we shall have snow,  
And what will poor Robin do then?  
Poor thing!  
He'll sit in a barn,  
And to keep himself warm  
Will hide his head under his wing,  
Poor thing!

Three little kittens  
Lost their mittens;  
And they began to cry,  
"Oh! mother dear,  
We really fear  
That we have lost our mittens."

"Lost your mittens!  
You naughty kittens!  
Then you shall have no pie."

"Mee-ow, mee-ow, mee-ow."  
"No; you shall have no pie."  
"Mee-ow, mee-ow, mee-ow,  
Mee-ow."

There was a man of our town,  
 And he was wondrous wise:  
 He jumped into a bramble bush,  
 And scratched out both his eyes.  
 And when he found his eyes were out,  
 With all his might and main  
 He jumped into another bush,  
 And scratched them in again.

There was an old woman, and what do you think?  
 She lived upon nothing but victuals and drink;  
 Victuals and drink were the chief of her diet,  
 Yet this grumbling old woman could never  
 keep quiet.

When I was a bachelor I lived by myself,  
 And all the bread and cheese I got, I put upon  
 a shelf;  
 The rats and the mice did lead me such a life,  
 That I went to London to get myself a wife.

The streets were so broad and the lanes were  
 so narrow,  
 I could not get my wife home without a wheel-  
 barrow;  
 The wheelbarrow broke, my wife got a fall;  
 Down tumbled wheelbarrow, little wife, and  
 all.

Simple Simon met a pieman,  
 Going to the fair;  
 Says Simple Simon to the pieman,  
 "Let me taste your ware."  
 Says the pieman to Simple Simon,  
 "Show me first your penny."  
 Says Simple Simon to the pieman,  
 "Indeed, I have not any."  
 Simple Simon went a-fishing  
 For to catch a whale;  
 All the water he had got  
 Was in his mother's pail!

Old King Cole  
 Was a merry old soul,  
 And a merry old soul was he;  
 He called for his pipe,  
 And he called for his bowl,  
 And he called for his fiddlers three.  
 Every fiddler he had a fiddle,  
 And a very fine fiddle had he;  
 Twee, tweedle dee, tweedle dee,  
 Went the fiddlers three.  
 O! there's none so rare as can compare  
 With King Cole and his fiddlers three.

There was a crooked man, and he went a  
 crooked mile;  
 He found a crooked sixpence against a  
 crooked stile;  
 He bought a crooked cat, which caught a  
 crooked mouse,  
 And they all lived together in a little crooked  
 house.

I had a pony, his name was Dapple Gray;  
 I lent him to a lady to ride a mile away.  
 She whipped him, she lashed him,  
 She rode him through the mire;  
 I would not lend my pony now,  
 For all the lady's hire.

Twinkle, twinkle, little star;  
 How I wonder what you are!  
 Up above the world so high,  
 Like a diamond in the sky.

When the glorious sun is set,  
 When the grass with dew is wet,  
 Then you show your little light,  
 Twinkle, twinkle, all the night.

In the dark-blue sky you keep,  
 And often through my curtains peep;  
 For you never shut your eye  
 Till the sun is in the sky.

As your bright and tiny spark  
 Lights the traveler in the dark,  
 Though I know not what you are,  
 Twinkle, twinkle, little star!

After the children have learned one of these rhymes, various uses may be made of it. The simpler ones, the children may be allowed to illustrate on the board; the others they may give in prose, in their own language. This is a valuable exercise, but it should not be carried too far. For instance, in the case of a poem which has real beauty, like some of those which follow, no attempt should be made to translate into prose. The children should memorize them and should not be asked to spoil them by changing them from the beautiful form in which they were written. Of course the list of poems that follows is merely for the teacher to choose from; no first-year class could be expected to learn all of them, or even to take up all of them for study and discussion in class. Other poems may be read aloud by the teacher.

#### October's Bright Blue Weather

HELEN HUNT JACKSON

O suns and skies and clouds of June,  
 And flowers of June together,  
 Ye cannot rival for one hour  
 October's bright blue weather,

When loud the bumble-bee makes haste,  
 Belated, thriftless vagrant,  
 And goldenrod is dying fast,  
 And lanes with grapes are fragrant:

When gentians roll their fringes tight,  
 To save them for the morning,  
 And chestnuts fall from satin burrs  
 Without a sound of warning:

When on the ground red apples lie  
 In piles like jewels shining,  
 And redder still on old stone walls  
 Are leaves of woodbine twining:

When all the lovely wayside things  
 Their white-winged seeds are sowing,  
 And in the field still green and fair,  
 Late aftermaths are growing:

When springs run low and on the brooks,  
 In idle golden freighting,  
 Bright leaves sink noiseless in the hush  
 Of woods, for winter waiting;

O suns and skies and flowers of June,  
 Count all your boasts together,  
 Love loveth best of all the year  
 October's bright blue weather.

### A Visit from St. Nicholas

CLEMENT C. MOORE

'Twas the night before Christmas, when all  
 through the house  
 Not a creature was stirring, not even a mouse.  
 The stockings were hung by the chimney with  
 care,  
 In hopes that St. Nicholas soon would be there.  
 The children were nestled all snug in their  
 beds.  
 While visions of sugar plums danced in their  
 heads;  
 And Mamma in her kerchief, and I in my cap,  
 Had just settled our brains for a long winter's  
 nap—  
 When out on the lawn there arose such a  
 clatter  
 I sprang from my bed to see what was the  
 matter.  
 Away to the window I flew like a flash,  
 Tore open the shutter, and threw up the sash.  
 The moon on the breast of the new-fallen  
 snow  
 Gave a lustre of mid-day to objects below;  
 When what to my wondering eyes should ap-  
 pear  
 But a miniature sleigh and eight tiny reindeer,  
 With a little old driver, so lively and quick,  
 I knew in a moment it must be St. Nick!  
 More rapid than eagles his coursers they  
 came,  
 And he whistled and shouted and called them  
 by name:  
 "Now, Dasher! now, Dancer! now, Prancer and  
 Vixen!  
 On, Comet! on, Cupid, on Donner and Blitzen!  
 To the top of the porch, to the top of the wall,  
 Now, dash away, dash away, dash away all!"  
 As dry leaves that before the wild hurricane  
 fly,  
 When they met with an obstacle, mount to  
 the sky,  
 So, up to the housetop the coursers they flew,  
 With a sleigh full of toys and St. Nicholas too.  
 And then, in a twinkling, I heard on the roof  
 The prancing and pawing of each little hoof.  
 As I drew in my head, and was turning  
 around.  
 Down the chimney St. Nicholas came with a  
 bound:  
 He was dressed all in fur from his head to his  
 foot,  
 And his clothes were all tarnished with ashes  
 and soot:  
 A bundle of toys he had flung on his back,  
 And he looked like a peddler just opening his  
 pack.  
 His eyes, how they twinkled! his dimples, how  
 merry!

His cheeks were like roses, his nose like a  
 cherry;  
 His droll little mouth was drawn up like a  
 bow,  
 And the beard on his chin was as white as the  
 snow.  
 The stump of a pipe he held tight in his teeth,  
 And the smoke, it encircled his head like a  
 wreath.  
 He had a broad face and a little round belly  
 That shook, when he laughed, like a bowl full  
 of jelly.  
 He was chubby and plump—a right jolly old  
 elf,  
 And I laughed when I saw him, in spite of  
 myself;  
 A wink of his eye, and a twist of his head,  
 Soon gave me to know I had nothing to dread.  
 He spoke not a word, but went straight to his  
 work,  
 And filled all the stockings; then turned with  
 a jerk,  
 And laying his finger aside of his nose,  
 And giving a nod up the chimney he rose.  
 He sprang to his sleigh, to his team gave a  
 whistle,  
 And away they all flew like the down of a  
 thistle.  
 But I heard him exclaim, ere they drove out of  
 sight,  
 "Happy Christmas to all, and to all a good-  
 night."

### The Wind

ROBERT LOUIS STEVENSON

I saw you toss the kites on high  
 And blow the birds about the sky;  
 And all around I heard you pass,  
 Like ladies' skirts across the grass—  
 O wind, a-blowing all day long,  
 O wind, that sings so loud a song!

I saw the different things you did,  
 But always you yourself you hid,  
 I felt you push, I heard you call,  
 I could not see yourself at all—  
 O wind, a-blowing all day long,  
 O wind, that sings so loud a song!

O you that are so strong and cold,  
 O blower, are you young or old?  
 Are you a beast of field and tree,  
 Or just a stronger child than me?  
 O wind, a-blowing all day long,  
 O wind, that sings so loud a song.

### The Tree

BJORNSTJERNE BJORNSON

The Tree's early leaf-buds were bursting their  
 brown:  
 "Shall I take them away?" said the Frost,  
 sweeping down.  
 "No, leave them alone  
 Till the blossoms have grown,"  
 Prayed the Tree, while he trembled from  
 rootlet to crown.  
 The Tree bore his blossoms, and all the birds  
 sung:

"Shall I take them away?" said the Wind, as he swung.

"No, leave them alone  
Till the berries have grown."

Said the Tree, while his leaflets all quivering hung.

The Tree bore his fruit in the midsummer glow:

Said the girl, "May I gather thy berries now?"

"Yes, all thou canst see:  
Take them: all are for thee,"

Said the Tree, while he bent down his laden boughs low.

### . Rain

ROBERT LOUIS STEVENSON

The rain is raining all around,  
It falls on field and tree,  
It rains on the umbrellas here,  
And on the ships at sea.

### The Swing

ROBERT LOUIS STEVENSON

How do you like to go up in a swing,  
Up in the air so blue?

Oh, I do think it the pleasantest thing  
Ever a child can do!

Up in the air and over the wall,  
Till I can see so wide.

Rivers and trees and cattle and all  
Over the countryside—

Till I look down on the garden green,  
Down on the roof so brown—

Up in the air I go flying again,  
Up in the air and down!

### What Does Little Birdie Say?

ALFRED TENNYSON

What does little birdie say,  
In her nest at peep of day?  
"Let me fly," says little birdie,  
"Mother, let me fly away."  
Birdie, rest a little longer,  
Till the little wings are stronger.  
So she rests a little longer,  
Then she flies away.

What does little baby say,  
In her bed at peep of day?  
Baby says, like little birdie,  
"Let me rise and fly away."  
Baby, sleep a little longer,  
Till the little limbs are stronger.  
If she sleeps a little longer  
Baby, too, shall fly away.

### Seven Times One

JEAN INGELOV

There's no dew left on the daisies and clover,  
There's no rain left in heaven:  
I've said my "seven times" over and over,  
Seven times one are seven.

I am old, so old I can write a letter;  
My birthday lessons are done;  
The lambs play always, they know no better;  
They are only one times one.

O moon! in the night I have seen you sailing  
And shining so round and low;  
You were bright! ah, bright! but your light is  
failing—

You are nothing now but a bow.

You moon, have you done something wrong in  
heaven

That God has hidden your face?

I hope if you have you will soon be forgiven,  
And shine again in your place.

O velvet bee, you're a dusty fellow,

You've powdered your legs with gold!

O brave marsh marybus, rich and yellow,  
Give me your money to hold!

O columbine, open your folded wrapper,

Where two twin turtle-doves dwell!

O cuckoo-pint, toll me the purple clapper  
That hangs in your clear green bell!

And show me your nest with the young ones  
in it;

I will not steal them away;

I am old! you may trust me, linnnet, linnnet—

I am seven times one to-day.

**Study of a Poem.** As with the nursery rhymes, the children may find much interest in illustrating the poems. Let each child choose a line from some poem, as, for example, *October's Bright Blue Weather*, and draw on the board his idea of the picture the line gives. This little poem is full of pictures.

Of course it is absolutely necessary when children are learning or studying a poem that they shall understand it thoroughly. This does not mean that they must grasp the thought entire; a poem which will appeal very strongly to children may have shades of meaning which they cannot possibly grasp. But they should know the meaning of every word and such facts as will serve to make the poem clear. Let us take, once more, the poem referred to in the last paragraph—*October's Bright Blue Weather*. Before the children even attempt to learn it the teacher should be sure that they can answer the following questions:

Who wrote this poem? (Information for use in reply to this question may be found by the teacher in these volumes.)

What does "rival" mean?

Which does the author like better, October or June?

What does "belated" mean? "thrifless"? "vagrant"?

Why is the bumble-bee called a "thrifless vagrant"?

What are gentians? What does the author mean by speaking of their "fringes"? Why does she speak of the fringes as "rolled tight"?

Why are chestnut-burrs called "satin"?

What is woodbine?

What are the "lovely wayside things," and what are "white-winged" seeds?

What are "aftermaths"?

What is meant by "In idle golden freighting"?

The children should be encouraged to ask questions about the poem, for often children get and keep misconceptions about some point in a poem which the teacher could never suspect.

**Nonsense Verses.** There are few children to whom nonsense rhymes do not appeal. The following from Edward Lear is almost certain to be a great favorite:

#### The Owl and the Pussy-Cat

The Owl and the Pussy-Cat went to sea

In a beautiful pea-green boat;

They took some honey, and plenty of money

Wrapped up in a five-pound note.

The Owl looked up to the stars above,

And sang to a small guitar,

"Oh, lovely Pussy! Oh, Pussy, my love!

What a beautiful Pussy you are!"

Pussy said to the Owl, "You elegant fowl!

How charmingly sweet you sing!

Oh, let us be married—too long we have tarried—

But what shall we do for a ring?"

They sailed away for a year and a day

To the land where the Bong-tree grows,

And there in a wood a piggy-wig stood

With a ring in the end of his nose.

"Dear Pig, are you willing to sell for one shilling

Your ring?" Said the piggy, "I will."

So they took it away, and were married next day

By the turkey who lives on the hill.

They dined upon mince and slices of quince,

Which they ate with a runcible spoon,

And hand in hand on the edge of the sand

They danced by the light of the moon.

**Nature Studies.** The teacher may find interesting material for nature stories in the article NATURE STUDY in these volumes. The articles on the *Dog*, the *Squirrel*, *Ants*, *Trees*, *Flowers*, *Birds*, have facts which may be used as the bases of the nature stories which are so fascinating to children. Many points, too, in the articles BOTANY and ZOÖLOGY may be so used.

**Fables.** It is perfectly natural for children to personify animals and inanimate objects, and to endow them with all sorts of human qualities. A four-year-old child had two Teddy-bears, one a small dilapidated animal, the other a beautiful big new one. The new one was neglected and the old one

was carried everywhere, and when the child's mother asked the reason for his preference, he replied without hesitation, "The big Teddy never says 'Thank you,' no matter where I take him; but the little Teddy always says 'Thank you, Charles,' just as *nice*." The two playthings had to their own characters as distinct as two human beings could have. And with this faculty so strongly developed it is natural that children should thoroughly enjoy fables. After the following fables have been read the children may be asked to reproduce them in their own language or they may be allowed to illustrate them or to act them out. Frequently children show a surprising amount of dramatic instinct in acting out these simple little stories.

#### The Fox and the Crow

A Fox once saw a Crow fly off with a piece of cheese in its beak and settle on a branch of a tree.

"That's for me, as I am a Fox," said Master Renard, and he walked up to the foot of the tree.

"Good-day, Mistress Crow," he cried. "How well you are looking to-day; how glossy your feathers; how bright your eye. I feel sure your voice must surpass that of other birds, just as your figure does; let me hear you sing, that I may call you queen of birds."

The Crow lifted up her head and began to caw her best, but the moment she opened her mouth the piece of cheese fell to the ground, only to be snapped up by Master Fox.

"That will do," said he. "That was all I wanted. For your cheese I will give you a piece of advice: Do not trust flatterers."

#### The Hare and the Tortoise

"O you slow one, you clumsy one, your ugly shape and plodding motions make me roar with laughter," said the Hare to the Tortoise one day as they met in the road.

"Perhaps I am ugly and do move slowly," replied the Tortoise, "but I can beat you in a race to the next river."

This made the Hare laugh more loudly than ever, and a Fox coming along stopped to see what caused the uproar. The Hare explained the joke and finally asked the Fox to hold the stakes and judge the race.

Off started the rivals, and almost in the twinkling of an eye the Hare was out of sight. Only a little cloud of dust remained to show where he had gone. The day was hot and sultry, and soon he was choking with dust.

"Pshaw!" said he; "I can rest here an hour—can even take a nap—and beat that lazy Tortoise to the brook. Suppose he does pass me, I can overtake him quickly enough."

Meanwhile the Tortoise plodded slowly along, kicking up no dust, feeling no heat. When he came up to the Hare the latter was sleeping soundly, and the Tortoise passed on



slowly but surely, moving steadily, never resting a minute.

It was late afternoon when the Hare awoke and looked up and down the road. "I declare," he said; "that slow-poke has not come along yet. I'll take a few nibbles at this clover and then run back and meet him."

The clover was sweet and juicy, and it was some time before the Hare again remembered his race. When he did, he turned to the road and examined the dust. Think how surprised he was to see the trail of the Tortoise leading by him toward the brook. There was no more nibbling of lanches, no more sleeping or resting, for off down the road he ran, covering the ground in long leaps that brought him quickly to the brook, where, sitting lazily at the edge of the water, was the Tortoise, calmly waiting.

"Here, take your money," said the Fox to the Tortoise; adding as he turned to the Hare, "Steady going wins the race."

### The Lion and the Mouse

Do you know the story of the Lion and the Mouse? It runs like this:

One day a huge Lion lay sleeping soundly in the shade of a great tree. His strong legs were stretched out limply on the ground, and his shaggy head and powerful jaws looked very beautiful in repose, for the wicked teeth were covered and the fierce eyes closed. Two little Mice, seeing him there, began to play about him, and finally one of them, much braver than the other, ran over the Lion's head, through his tawny mane and beneath his great fore paw.

The Lion's rest was nearly over, and the little feet of the Mouse tickled the huge beast into wakefulness. Opening one eye, he spied the Mouse under his paw, and closed his big toes over his trembling prisoner.

"What are you doing here, you miserable little Mouse?" said the Lion in a terrible roar. "Why do you disturb my noonday nap in the shade? I'll break every bone in your ugly little body."

Down came the big toes, out sprang the awful claws, just as they do on the cat's foot when she dreams of hunting. The Mouse thought surely his last hour had come, and he cried as loud as he could in his weak, trembling voice:

"O Mr. Lion, spare me! spare me! I didn't mean to disturb you, truly I didn't. You see, I was just playing, and your mane was so soft and beautiful, I couldn't keep out of it, and under your paw was just the place to hide, so here I came. I didn't mean any harm—I didn't think you'd care, Mr. Lion. Don't kill me this time. I'll never, never do it again."

"Well, see that you don't," growled the Lion. "Killing you would be small business for me, anyhow."

It was not many days after this that the Lion, while hunting near by, was caught in a net which some hunters had spread for him. He struggled fiercely and roared in anger, but the more he rolled about and the harder he kicked and pawed, the more closely the net clung to him, till at last, weary with fighting,

he lay bound and helpless, an easy prey for the hunters when they should return.

The Mouse which the Lion had spared lived in a little round nest of grass not far from where the Lion was caught. He heard the noise of the struggle and sat at home with a beating heart, afraid to venture out of doors while such a furious combat was going on. When the Lion grew quiet, however, the Mouse stole out, and soon saw what was the matter.

"O Mr. Lion," he said, "you are the very Mr. Lion that let me go that other day, aren't you? And now the hunters will kill you if you can't get away, won't they? I'll help you."

"What can you do, you little mite?" growled the Lion. "Better run away yourself, or when the hunters come for me they'll step on you."

"O, I can help. I can gnaw the ropes in two. I'd like to do it," said the mouse. "Just you keep still till I tell you to move."

So the Mouse began to gnaw on the big ropes. It was a hard task, and his lips grew sore and his sharp teeth ached, but he kept on bravely till one after another the ropes gave way and the King of the Woods was almost free."

"Wait just a few minutes more," said the Mouse, as he paused to rest his little jaws. "Don't jump up till I get out of the way. I'll tell you when."

In a little while the last rope was cut in two, and the Mouse, scrambling down from the Lion's big head, called out:

"Now jump up, Mr. Lion; you're free. Aren't you glad you didn't kill me the other day?"

The big fellow stood up on his feet, shook himself a few times, stretched his aching limbs, washed his face and walked away. But just as he was going he looked back over his shoulder and sang out, "Little friends are great friends."

### The Mice and the Cat

A gentleman once owned a Cat that was a very fine mouser. She hunted so much that after a time she had caught and killed nearly all the Mice in the gentleman's house. The remaining Mice were very much frightened and called a council to see what could be done. They met secretly in their hall behind the coal-bin and locked the doors carefully before they began to talk. Many plans were proposed and discussed, but the Mice could agree on nothing.

Finally a dapper young Mouse arose and said:

"Mr. President, I wish to propose a plan. It is so novel and so excellent that I am certain every one of you will approve it. A little silver bell must be hung about the Cat's neck. Then every step she takes will make the bell tinkle, and we shall have warning in time to run to our holes before she comes too close! Isn't that a perfect plan? We can then live in safety and happiness in spite of this wonderful Cat."

The young Mouse took his seat, smiling with an air of complacent pride, and from the

other Mice came the sound of lively applause.

"Mr. President and Fellow Mice," interrupted an old gray-whiskered Mouse who rose from the back of the hall and looked his companions over with a merry twinkle in his eye, "the plan proposed by the last speaker is indeed an admirable one, but I fear there is one slight drawback to it. The honorable gentleman has not told us who is to hang the bell around the Cat's neck."

**Pictures.** Children of the first grade are not too young to begin to take an interest in pictures. Murillo's *Melon Eaters*, (see PAINTING), is a picture which will appeal to children; use this and others, and have the children tell stories about what they see in the pictures. Such exercises strengthen the mental faculties.

### Second Year

**Introduction.** The work of the second grade is much like that of the first, of which it really forms but a continuation. There is, however, a little more emphasis placed on written work than was possible in the first grade. But it must not be forgotten that the chief thing is still the oral work, and the teacher should always be certain that the pupils can tell things before they are allowed to write them.

**Written Work.** As an illustration of the way in which written work may be presented in this class, let us take a simple subject—the orange, for example. Let each child, after the topic has been discussed in class, hand in a paper on which are written five or six sentences describing the appearance of the orange. These sentences may be somewhat as follows:

The orange is pretty.  
The orange is round.  
The orange is yellow.  
The skin of the orange is rough.  
The skin of the orange is shiny.

The arrangement, form and spelling of the words are criticized, and the papers are handed back for rewriting. After further discussion of the orange, its taste, its uses, the places it grows, other papers similar to the first may be written, dealing with these other points. After all the groups have been corrected, they may be combined, but no attempt should be made in this grade to have the children produce anything like formal compositions.

**Formal Language Work.** Then, too, a little more attention is given in this grade to the formal side of language work, though per-

haps the work is even yet too elementary to deserve that name. Let the pupils, after reading a paragraph in their readers, pick out words with "a" before them, and words with "an" before them. Explain to them the difference and write on the board exercises like the following, asking the children to fill in the blanks:

I have ..... apple.  
John has ..... dog.  
Have you ..... aunt?  
I have ..... book and ..... ink well.  
Mary got ..... doll and Frank got ..... engine.

The use of capital letters to begin sentences and of the simplest marks of punctuation, begun in the first grade, should be continued in this, so that the pupils feel perfectly acquainted with the rules.

The use of the singular and plural forms of verbs and of nouns may be introduced in this grade. The children will readily grasp the difference between singular and plural in the regular forms, and irregular forms should not be introduced until later.

**Nature Study.** The language work can again be combined profitably with the nature-study work, and flowers which are brought to school by the pupils can well be used as a basis. Of course the early lessons should deal with the simpler flowers—the violet, the wild rose, the tulip, the daisy. Point out the various parts of the flower and describe their uses, in so far as the pupils may be expected to understand them. When the children have become familiar with the flowers, see how many sentences they can write descriptive of each one.

**Conversation Exercises.** As in the first grade, the emphasis is still on the oral expression of ideas, but the topics should of course be varied. Interesting lessons, for example, may be drawn from the lives of different races of people. The teacher, of course, will have to give most of this material to the children, they being called on to reproduce parts of it for her. THE NEW PRACTICAL REFERENCE LIBRARY contains many articles of which the teacher may make excellent use in preparing such material. One lesson could be given on the *Cave Dwellers*, while the articles on *Cliff Dwellers*, *Eskimo* and *Indians* should form the basis for several lessons each. After the pupils have become familiar with several of these topics, call on some child to say or to write on the board sentences descriptive of

some one of them, the other children to guess of what he is thinking. If, for instance, the child chosen says, "I live in a hut. I eat fat food. I wear fur clothes. I ride on a sled," the other children should have no difficulty in guessing "Eskimo."

**Acting Stories.** In this grade, as in the first, much good work may be done on the basis of stories told by the teacher. A story is read or told and the children are asked to reproduce it as nearly as possible. When they have gone over it often enough so that they are fairly familiar with it, but not so often that it has lost its charm for them, they should be allowed to dramatize it. The teacher should offer them as little help as possible in this dramatization; the children themselves should arrange the dialogue and work out the scenes. The result may not be as attractive as it would be if the teacher managed the affair, but it will be far more helpful to the children. There are a number of stories in the article **STORY TELLING** which will lend themselves very well to this treatment. *The Ugly Duckling*, for instance, has about all the good points that any story could have. It is absorbingly interesting to children; it has a good moral which is not too plainly pointed out; it has plenty of dialogue, and offers opportunity for the making up of more; it has a large number of characters, all of whom have distinct, interesting personalities; it divides itself readily into scenes.

The first scene might be the farmyard, with the mother duck, the family of little ducks, the old Spanish duck, the turkey-cock, and other fowls. In the second scene, that in the marsh, will appear the ugly duckling, the wild ducks, the two wild geese, the hunters and the dog. The old woman's cottage will give the third scene, a very interesting one, in which appear the duckling, the old woman, the hen and the cat. Some of the children will have a chance to show any real dramatic instinct which they may possess in this scene. In the fourth scene, the last one, will appear the swan-duckling, the other swans, and the children. The teacher should have talked the story over with the children before it is acted out so that she feels certain they appreciate the outstanding features of each character.

*The Wolf and the Seven Kids* will also be a good story for the children to play. *Rhoccus*, while a good story to tell, is not quite so well adapted to dramatization, as it

has few characters and only a little action.

*Hiawatha*. Much of the work of this year may well deal with *Hiawatha*; there is no poem or story which the children enjoy more if it is presented rightly. The reproduction of the story by the children, the dramatization of certain scenes, the memorizing of specially fine passages should all form part of the work. The poem should not, of course, simply be taken up from beginning to end in its order; some parts are obviously more simple than others, and should be taken first. The story of Hiawatha's childhood, given in Chapter III, verse 64 to the end, is the best portion with which to begin. As in all lessons on *Hiawatha*, the teacher should first tell the story simply but fully in prose; then she should read the passage as understandingly and as musically as possible. After they have got the swing of the lines, the children will be glad to learn parts of the passage. By dividing the work up, each child learning a part, the whole passage may be memorized and given, each child speaking in his turn.

For the dramatic part of the work on this passage, a dialogue may be arranged between Hiawatha and Nokomis about all the wonderful things the child sees about him. The dialogue will be about as follows:

Hiawatha sits and sings:

"Wah-wah-taysee, little fire-fly,  
Little, flitting, white-fire insect,  
Little, dancing, white-fire creature,  
Light me with your little candle  
Ere upon my bed I lay me,  
Ere in sleep I close my eyelids!"

Hiawatha (glancing over his shoulder at the moon): What is that, Nokomis—what are all those flecks and shadows on the brightness?

Nokomis:

"Once a warrior, very angry,  
Seized his grandmother, and threw her  
Up into the sky at midnight;  
Right against the moon he threw her;  
'Tis her body that you see there."

Hiawatha (pointing to the rainbow in the east): What is that, Nokomis? What are all those colors stretched across the heavens?

Nokomis:

"'Tis the heaven of flowers you see there.  
All the wild flowers of the forest,  
All the lilies of the prairie,  
When on earth they fade and perish,  
Blossom in that heaven above us."

Hiawatha (listening in fright to the owls): What, O what is that, Nokomis?

Nokomis:

"That is but the owl and owlet,  
Talking in their native language,  
Talking, scolding at each other."

The owl loves the owlet and takes good care of it; when I sang you to sleep when you were a fretful baby in your linden cradle, did I not sing?

"Ewa-yea! my little owlet!  
Who is this, that lights the wigwam?  
With his great eyes lights the wigwam?  
Ewa-yea! my little owlet!"

The lines which deal with little Hiawatha's hunting may also be acted out, one child being Hiawatha and the others the various wild animals.

The poem of *Hiawatha* is too long to be given here. Probably there are few school-rooms where a copy of it is not to be found; in case, however, the school library does not contain the poem, it may be secured in very cheap but satisfactory form from any dealer in school books.

**Memory Poems.** The children in this grade may of course be expected to do more work in memorizing than those of the first grade. In every school there will be found children who are eager to "learn by heart" and who do it very easily; others seem to have to be driven to it. But there is nothing that so helps the memory as learning things that are worth while and may be reviewed occasionally, and no child should be permitted to shirk all work of memorizing poems. Those who wish to, of course, may be allowed to learn more than the required number. The following selections will be found well adapted to second-year children:

#### Where Go The Boats?

ROBERT LOUIS STEVENSON

Dark brown is the river,  
Golden is the sand.  
It flows along forever,  
With trees on either hand.

Green leaves a-floating,  
Castles of the foam,  
Boats of mine a-boating—  
Where will all come home?

On goes the river  
And out past the mill,  
Away down the valley,  
Away down the hill.

Away down the river,  
A hundred miles or more.  
Other little children  
Shall bring my boats ashore.

#### Autumn Fires

ROBERT LOUIS STEVENSON

In the other gardens  
And all up the vale,  
From the autumn bonfires  
See the smoke trail!

Pleasant summer over  
And all the summer flowers,  
The red fire blazes,  
And the grey smoke towers.

Sing a song of seasons!  
Something bright in all!  
Flowers in the summer,  
Fires in the fall!

#### While Shepherds Watched

While shepherds watched their flocks by  
night,  
All seated on the ground,  
The angel of the Lord came down  
And glory shone around.

"Fear not!" said he, for mighty dread  
Had seized their troubled mind;  
"Glad tidings of great joy I bring  
To you and all mankind:

"To you in David's town this day  
Is born of David's line  
A Savior who is Christ the Lord,  
And this shall be the sign:

"The heavenly babe ye there shall find  
To human view displayed  
All meanly wrapped in swathing-bands  
And in a manger laid."

Thus spake the seraph; and forthwith  
Appeared a shining throng  
Of angels praising Christ the Lord,  
Who thus addressed their song:

"All glory be to God on high,  
And to the earth be peace;  
Goodwill henceforth from heaven to men  
Begin and never cease."

#### The Day Is Done

HENRY W. LONGFELLOW

The day is done, and the darkness  
Falls from the wings of Night,  
As a feather is wafted downward  
From an eagle in his flight.

I see the lights of the village  
Gleam through the rain and the mist,  
And a feeling of sadness comes o'er me  
That my soul cannot resist:

A feeling of sadness and longing,  
That is not akin to pain,  
And resembles sorrow only  
As the mist resembles rain.

Come, read to me some poem,  
Some simple and heartfelt lay,  
That shall soothe this restless feeling,  
And banish the thoughts of day.

Not from the grand old masters,  
Not from the bards sublime,  
Whose distant footsteps echo  
Through the corridors of Time.

For, like strains of martial music,  
Their mighty thoughts suggest

Life's endless toil and endeavor;  
And tonight I long for rest.

Read from some humbler poet,  
Whose songs gushed from his heart,  
As showers from the clouds of summer,  
Or tears from the eyelids start;

Who, through long days of labor,  
And nights devoid of ease,  
Still heard in his soul the music  
Of wonderful melodies.

Such songs have power to quiet  
The restless pulse of care,  
And come like the benediction  
That follows after prayer.

Then read from the treasured volume  
The poem of thy choice,  
And lend to the rhyme of the poet  
The beauty of thy voice.

And the night shall be filled with music,  
And the cares that infest the day  
Shall fold their tents, like the Arabs,  
And as silently steal away.

### Windy Nights

ROBERT LOUIS STEVENSON

Whenever the moon and stars are set,  
Whenever the wind is high,  
All night long, through the dark and wet,  
A man goes riding by.

Late at night when the fires are out,  
Why does he gallop and gallop about?

Whenever the trees are crying aloud  
And ships are tossed at sea,  
By on the highway, low and loud,  
By at the gallop goes he.  
By at the gallop he goes, and then  
By he come back at a gallop again.

### The Brown Thrush

LUCY LARCOM

There's a merry brown thrush sitting up in a  
tree;

"He's singing to me! He's singing to me!"  
And what does he say, little girl, little boy?

"Oh, the world's running over with joy!

Don't you hear? Don't you see?  
Hush! look! In my tree  
I'm as happy as happy can be!"

And the brown thrush keeps singing. "A nest  
do you see,

And five eggs hid by me in the juniper tree?  
Don't meddle! don't touch! little girl, little  
boy,

Or the world will lose some of its joy!  
Now I'm glad! now I'm free!  
And I always shall be,  
If you never bring sorrow to me."

So the merry brown thrush sings away in the  
tree.

To you and to me, to you and to me;  
And he sings all the day, little girl, little boy,  
"Oh, the world's running over with joy!  
But long it won't be,  
Don't you know? Don't you see?  
Unless we're as good as can be."

### Robert of Lincoln

WILLIAM CULLEN BRYANT

Merrily swinging on brier and weed,  
Near to the nest of his little dame,  
Over the mountain-side or mead,

Robert of Lincoln is telling his name:  
Bob-o'-link, bob-o'-link,  
Spink, spank, spink;  
Snug and safe in this nest of ours,  
Hidden among the summer flowers.  
Chee, chee, chee.

Robert of Lincoln is gayly drest,  
Wearing a bright black wedding-coat;  
White are his shoulders and white his crest,  
Hear him call in his merry note:  
Bob-o'-link, bob-o'-link,  
Spink, spank, spink;  
Look, what a nice new coat is mine,  
Sure there was never a bird so fine.  
Chee, chee, chee.

Robert of Lincoln's Quaker wife,  
Pretty and quiet, with plain brown wings  
Passing at home a patient life,  
Broods in the grass while her husband  
sings:

Bob-o'-link, bob-o'-link,  
Spink, spank, spink;  
Brood, kind creature; you need not fear  
Thieves and robbers while I am here.  
Chee, chee, chee.

Modest and shy as a nun is she;  
One weak chirp is her only note.  
Braggart and prince of braggarts is he,  
Pouring boasts from his little throat:  
Bob-o'-link, bob-o'-link,  
Spink, spank, spink;  
Never was I afraid of man;  
Catch me, cowardly knaves, if you can!  
Chee, chee, chee.

Six white eggs on a bed of hay,  
Flecked with purple, a pretty sight!  
There as the mother sits all day,  
Robert is singing with all his might:  
Bob-o'-link, bob-o'-link,  
Spink, spank, spink;  
Nice good wife, that never goes out,  
Keeping house while I frolic about.  
Chee, chee, chee.

Soon as the little ones chip the shell  
Six little mouths are open for food;  
Robert of Lincoln bestirs him well,  
Gathering seed for the hungry brood.  
Bob-o'-link, bob-o'-link,  
Spink, spank, spink;  
This new life is likely to be  
Hard for a gay young fellow like me.  
Chee, chee, chee.

Robert of Lincoln at length is made  
Sober with work, and silent with care;  
Off is his holiday garment laid,  
Half forgotten that merry air:  
Bob-o'-link, bob-o'-link,  
Spink, spank, spink;  
Nobody knows but my mate and I  
Where our nest and our nestlings lie.  
Chee, chee, chee.

Summer wanes; the children are grown;  
 Fun and frolic no more he knows;  
 Robert of Lincoln's a m drum crone;  
 Off he flies, and we sing as he goes:  
 Bob-o'-link, bob-o'-link,  
 Spink, spank, spink;  
 When you can pipe that merry old strain,  
 Robert of Lincoln, come back again.  
 Chee, chee, chee.

#### Old Gaelic Lullaby

Hush! the waves are rolling in,  
 White with foam, white with foam;  
 Father toils amid the din;  
 But baby sleeps at home.

Hush! the winds roar hoarse and deep—  
 On they come, on they come!  
 Brother seeks the wandering sheep;  
 But baby sleeps at home.

Hush! the rain sweeps o'er the knowes,  
 Where they roam, where they roam;  
 Sister goes to seek the cows;  
 But baby sleeps at home.

A good nonsense poem for the children of  
 this grade is from *Through the Looking Glass*,  
 by Lewis Carroll.

#### The Walrus and the Carpenter

The sun was shining on the sea,  
 Shining with all his might:  
 He did his very best to make  
 The billows smooth and bright—  
 And this was odd, because it was  
 The middle of the night.

The moon was shining sulkily,  
 Because she thought the sun  
 Had got no business to be there  
 After the day was done—  
 "It's very rude of him," she said,  
 "To come and spoil the fun!"

The sea was wet as wet could be,  
 The sands were dry as dry.  
 You could not see a cloud, because  
 No cloud was in the sky:  
 No birds were flying overhead—  
 There were no birds to fly.

The Walrus and the Carpenter  
 Were walking close at hand;  
 They wept like anything to see  
 Such quantities of sand:  
 "If this were only cleared away,"  
 They said, "it would be grand!"

"If seven maids with seven mops  
 Swept it for half a year,  
 Do you suppose," the Walrus said,  
 "That they could get it clear?"  
 "I doubt it," said the Carpenter,  
 And shed a bitter tear.

"O Oysters, come and walk with us!"  
 The Walrus did beseech.  
 "A pleasant walk, a pleasant talk,  
 Along the briny beach;

We cannot do with more than four,  
 To give a hand to each."

The eldest Oyster looked at him,  
 But never a word he said:  
 The eldest Oyster winked his eye,  
 And shook his heavy head—  
 Meaning to say he did not choose  
 To leave the oyster bed.

But four young Oysters hurried up,  
 All eager for the treat:  
 Their coats were brushed, their faces washed,  
 Their shoes were clean and neat—  
 And this was odd, because, you know,  
 They hadn't any feet.

Four other Oysters followed them,  
 And yet another four;  
 And thick and fast they came at last,  
 And more, and more, and more—  
 All hopping through the frothy waves,  
 And scrambling to the shore.

The Walrus and the Carpenter  
 Walked on a mile or so,  
 And then they rested on a rock,  
 Conveniently low:  
 And all the little Oysters stood  
 And waited in a row.

"The time has come," the Walrus said,  
 "To talk of many things:  
 Of shoes—and ships—and sealing wax—  
 Of cabbages—and kings—  
 And why the sea is boiling hot—  
 And whether pigs have wings."

"But wait a bit," the Oysters cried,  
 "Before we have our chat;  
 For some of us are out of breath,  
 And all of us are fat!"  
 "No hurry!" said the Carpenter.  
 They thanked him much for that.

"A loaf of bread," the Walrus said,  
 "Is what we chiefly need:  
 Pepper and vinegar besides  
 Are very good indeed—  
 Now if you're ready, Oysters dear,  
 We can begin to feed."

"But not on us!" the Oysters cried,  
 Turning a little blue.  
 "After such kindness, that would be  
 A dismal thing to do!"  
 "The night is fine," the Walrus said,  
 "Do you admit the view?"

"It was so kind of you to come!  
 And you are very nice!"  
 The Carpenter said nothing but  
 "Cut us another slice:  
 I wish you were not quite so deaf—  
 I've had to ask you twice!"

"It seems a shame," the Walrus said,  
 "To play them such a trick,  
 After we've brought them out so far,  
 And made them trot so quick!"  
 The Carpenter said nothing but  
 "The butter's spread too thick!"

"I weep for you," the Walrus said:  
"I deeply sympathize."

With sobs and tears he sorted out  
Those of the largest size,  
Holding his pocket-handkerchief  
Before his streaming eyes.

"Oh, Oysters," said the Carpenter,  
"You've had a pleasant run!  
Shall we be trotting home again?"  
But answer came there none—  
And this was scarcely odd, because  
They'd eaten every one.

Almost all of the poems which are given here and in the first-year work are by very well-known poets. Children will have more interest in a poem if they are taught just a little, the very simplest facts about its author, and a teacher can readily provide herself with such facts by reference to the other volumes of this set.

**Type Study of a Poem.** As a type of the way a poem may be studied in this year, let us take Bryant's *Robert of Lincoln*. Of course all that is given here cannot be given to the children in one lesson, or in two; the teacher is the best judge of the way in which the material should be divided. When there is a possibility that the children may be able to answer, questions should be asked, even, in some instances, questions which suggest the answers. Much of the information, however, the teacher will have to give the pupils.

After reading the poem aloud, the teacher may ask the children, "Don't you think you would like to know something about a man who could write such a bright, lively poem about a little bird?" and she may give them, in as interesting a manner as possible, some such brief biography as follows:

The man who wrote this poem was born in a little log house, over a hundred years ago. Children in those days did not always have things made as pleasant for them as children do now; their fathers and mothers loved them just as much, but they did not show it in the same way. They were more strict and stern, and seldom thought of playing with the children or planning games for them. And they were very ready to punish, taking down the bundle of birch sticks that hung behind the stove. Little William Cullen Bryant must often have been punished in this way, though he was by no means a bad boy. He was rather a quiet child, but I think we should have liked him, for he tells, as if he really enjoyed it, about the exciting times they used to have building snow forts and fighting over them. His accounts of their battles, with their heaps of snowballs and their attacks and retreats, sound very much like the stories boys of these days might tell their fathers

and mothers when they go home after a winter day's play.

But Bryant did other things besides playing. He studied hard, and before he got to the age when most boys stop playing he had written some poems that grown people were very glad to read. When he grew up he wrote many, many poems, most of which you will have to wait until you are older to enjoy. This little poem, however, you can understand now; and if you hear the grown people talking of William Cullen Bryant you may feel that you know him, too.

The name of the bird that Bryant is talking about is the bobolink, but the poet pretends that "bobolink" is just the bird's nickname for itself, and that its real name is Robert of Lincoln.

Did you ever see a bobolink? What color is he? If you do not know, listen while I read the second stanza again.

Did you ever see a Quaker in the plain drab clothes that the Quakers wear? What does the poet mean by speaking of the bobolink's "Quaker wife"? Are the mother-birds usually as brightly dressed as the father-birds?

Do you think the bobolink is good to his mate? Does he fly away to have a good time, or does he stay by the nest? Is the nest built in a tree or on the ground? How do you know?

How many eggs are in the nest? What color are they? Who are the "thieves and robbers" from whom Robert of Lincoln promises to protect his mate? Do you think perhaps they may be thoughtless boys and girls? Do you think he could really protect her? Is this why the poet calls him "prince of braggarts"?

When the little birds come is Robert of Lincoln a good father? Why does Bryant say that his "holiday garment" is laid off and his song "half forgotten"? (The bird loses its brilliant plumage after the nesting season is over, and like most birds, rarely sings in the autumn.)

The bobolink flies to the southland, as do so many of our summer birds, before the coming of winter, and the poet begs him to come back when he can sing his cheerful song again.

Let us see whether there are words in this poem which we do not understand or which we should not be likely to use. I think we shall find very few. What does "dame" mean in the first stanza? What does "mead" mean? "crest"? "brood"? "braggart"? "flecked"? "bestirs"? "wanes"? "humdrum crone"?

Sometimes poets use many words in their poems which are not often used in ordinary every-day talk; but our poet has used very few such, and that is one reason why this is a good poem for children.

If you ever hear a bobolink, listen to him carefully and see whether he really says:

"Bob-o'-link, bob-o'-link,  
Spink, spank, spink."

**Fables.** A child never really gets too old to enjoy a fable; as soon as he has outgrown

liking it for one reason he begins to like it for another. But a second-grade child is still at the point when he likes it in the most childish way—just as an imaginative story. The teacher should take care not to point out the moral too specifically; if the tale is well told, the child will catch the moral, never fear.

#### The Goose that Laid the Golden Eggs

Once upon a time there lived a man who had a handsome Goose that every day laid a large golden egg. The man thought the Goose must have much gold inside of her, and so one day he wrung her neck, and found that she was just like any other Goose. Thinking to find wealth, he lost the little he had.

#### The Shepherd Boy and the Wolves

In the summer time the shepherds used to drive their sheep out into the mountains some distance away from their homes, where the grass was green and tender and the sheep fattened rapidly.

But there was always some danger in this, for the wolves hid in the mountains and often came down and carried off the little lambs, and even killed the old sheep themselves. So the shepherds never thought it was safe to leave the flocks alone, and some young lad was always chosen to watch them during the day, while the shepherds worked on the little fields they cultivated near at hand. It wasn't a hard task for the boy unless the wolves came in sight, and then he was so near that by calling loudly he could bring the shepherds to his aid. One lad they sent out to do this work was a mischievous little chap, who thought it would be great sport to bring the shepherds about him even if no wolf was in sight. Accordingly, he ran up the side of a high rock, shouting at the top of his voice "Wolf! Wolf!" and swinging his arms wildly about.

The shepherds saw and heard him and came running to the spot, where they found nothing but the lively boy, laughing merrily. They reproved him for his mischief and went back to their work.

In a few days they had forgotten all about his pranks, and when they saw him again upon the rock, swinging his arms and calling "Wolf! Wolf!" they ran a second time, with their hoes and spades in their hands to beat off the attack. Once more they found that the sheep were perfectly safe, and that no wolves were in sight, and the boy laughed noisily at their surprise. This time they were very angry and scolded the boy roundly for his deception.

More days passed, and nothing happened; but then as the boy was lying idly in the warm sun, he saw the sheep huddle together in alarm and finally scamper off over the hill with wolves in close pursuit.

Frightened almost out of his wits at the very real danger, the boy climbed again upon the rock shrieking "Wolf! Wolf!" at the top

of his voice, waving his hands, stamping, and swinging his hat as though his very life depended on it.

The shepherds looked up and saw the boy, but returned to their work. They had been twice fooled and were not going to risk the chance again. No matter how loudly the boy called or how much he wept, they continued with their work, paying no further attention to what the lad said, even when he ran to them and assured them that he was telling the truth.

When the sheep did not return that night, the shepherds went out to find them, but though they hunted long and earnestly they could discover nothing but torn and bleeding bodies, for every sheep had been killed.

Naturally they laid all the blame on the shoulders of the boy.

#### The Wolf and the Lamb

As a Wolf was lapping at the head of a running brook, he spied a stray Lamb paddling at some distance down the stream. Having made up his mind to seize her, he thought himself how he might justify his violence.

"Villain," said he, running up to her, "how dare you muddle the water that I am drinking?"

"Indeed," said the Lamb humbly, "I do not see how I can disturb the water, since it runs from you to me, not from me to you."

"Be that as it may," replied the Wolf, "it was but a year ago that you called me names."

"Oh, Sir!" said the Lamb, trembling, "a year ago I was not born."

"Well," replied the Wolf, "if it was not you, it was your father, and that is all the same; but it is no use trying to argue with me." And he fell upon the Lamb and tore her to pieces.

**Picture Study.** Every schoolroom should have pictures, good pictures, even if cheap, for its walls, or at least in an unframed state for use in classes. Types of the pictures which may be studied with a class of this age are to be found in article PAINTING, in these books. Such pictures may be treated so that the children will feel no interest in them and will actually dislike them, or they may be treated so that the children will love them all their lives and find in them beautiful lessons.

#### Third Year

**Introduction.** There is a little more of a change between the third year and the second year than there was between the second and the first. Much of the second-year work is continued, but increased emphasis is placed on certain points that were passed over lightly in the earlier years. The children have reached the point when they can really read for their own pleasure, and



where they see that writing is something more than an exercise in the full-arm movement. Composition work thus becomes very much more important and will be dealt with more fully in the outline for this year's work.

**Correction of Errors.** Of course even in the lower grades the teacher corrects errors in the speech or the written work of the pupils; but the emphasis must be so strong on the securing of spontaneous expression of thought by the children that the work of correcting errors can be at the best but incidental. Each correction made stands by itself—little attempt can be made at enforcing rules of speech. But in the third grade conditions are a little different. The children, if their work and the teacher's work has been well done in the lower grades, have learned to express themselves with some degree of freedom, and there is less danger of frightening a shy child into not-to-be-broken silence by the correction of a verbal error. This does not mean that rules can be taught to children at this time; that generalizations may be made to which they must make their speech conform. But it does mean that right forms can be held up before them so persistently that they will themselves make the generalizations.

Every teacher has perhaps wondered whether if children never heard mistakes in grammar their own speech would be free from them. This is a question which will probably never be settled; but it is certain that the kind of speech they hear at home and at school and on the street has everything to do with what a child's language is to be. Thus some children speak comparatively correctly, while others seem scarcely able to utter a sentence without making some mistake. Moreover, common mistakes differ in different parts of the country and in different parts of the city, so that the teacher has always to adapt her work of this nature to her own pupils.

There are a few general rules which may be laid down in regard to this work. First, it should be systematic. Attention should not shift rapidly from one mistake to another but should center on one point until it is certain that the children have that point clearly in mind. One or more common errors should be covered each month.

Second, pupils should first of all be made to see that they do commit the error before they are asked to spend time in correcting it.

Third, technical rules should not be brought into the discussion; third-year pupils are too young to feel strongly the force of a grammatical rule. Moreover, they will easily establish the rule for themselves if they are thoroughly drilled in specific instances.

Fourth, attention should not often be called to the wrong form. It is not wise with children of the third grade to write on the board such a sentence as "I done it," and ask what is wrong with it. The mere seeing of the wrong form has a tendency to impress it on their minds.

Perhaps the simplest way to deal with the matter is for the teacher to write on the board sentences, leaving blanks for the doubtful forms. These blanks the pupils may be asked to fill in. The sentences should be numerous enough for the children to perceive from them that the right form does not vary. Later, the children may be asked to write independently sentences containing the correct forms.

A good example with which to begin drill in the correction of errors is the distinction between *teach* and *learn*. Most pupils may be trusted to confound them. Let the first sentences be as simple as possible:

1. I ---- my lesson.
2. My sister ---- school.
3. John ---- to skate
4. His older brother ---- him.
5. I ---- my lesson and ---- it to my little sister.
6. If my teacher did not ---- me, I could not ---- so well.
7. I must ---- to read before I can ---- anybody else.

These are merely samples; many more sentences will be needed in a typical drill. Nor is it enough that the children's eyes be led to see the difference between the correct and the incorrect forms; their ears must recognize it too. That is, the sentences should all be read aloud, both by the teacher and by the pupils.

The use of *their* and *there*, and of *to*, *too* and *two* furnishes material for some good work. Such sentences as the following may be used:

1. The book is ---- on the table.
2. Who put it ---- ?
3. John and Frank lost ---- hats.
4. ---- mothers may scold them.
5. All the children may put ---- books ---- on the table.
6. ---- is a flower in my vase.
7. Do you know where ---- house is?

8. No, I have never been ----.
9. I have ---- apples.
10. I will give them ---- you.
11. It is ---- hot in this room.
12. This candy is ---- sweet.
13. ---- boys have gone ---- the store.
14. What have they gone ---- get?
15. They have gone ---- get ---- loaves of bread.
16. Will ---- verses be ---- much for you ---- learn?
17. No, it will not be ---- much.

*Saw* and *seen* and *did* and *done* trouble many children. A child is almost as likely to say "I *seen* it" as "I *saw* it," so that opportunity for introducing the drill will not be difficult to find. Of course, the correction should not be made so that it will embarrass unnecessarily any child. *Sit* and *set* are also stumbling-blocks—and sometimes for others than children. It may be necessary in this instance for the teacher to write on the board a number of correct sentences so that the children may perceive the distinction:

1. I SET my doll in the chair.
2. She SITS there quietly.
3. The farmer SETS the hen on the eggs.
4. The hen SITS on the eggs.
5. The dress SITS well.

*Lay* and *lie* cannot very well be taken up at this time, since the fact that *lay* is the past tense of *lie* complicates matters.

The personal pronouns offer opportunity for very helpful drill; the correct form and the proper position may both be emphasized. Of course the difficulty as to the proper form comes largely when the pronoun is used with a noun, so that the *case* force is not felt. If simple sentences in which the pronoun stands alone are given first, there will be less danger of error.

First person:

1. ---- am going skating.
2. Tom and ---- went skating.
3. She gave ---- an apple.
4. She gave Mary and ---- an apple.
5. Father wrote a letter to ----.
6. Father wrote letters to Tom and ----.
7. Jane and ---- were sent home.
8. He sent Jane and ---- home.

Third person (masculine or feminine):

1. ---- and I are friends.
2. I gave the apple to ----.
3. They asked ---- and me.
4. John's teacher likes ----.
5. Our teacher likes ---- and me.

If children are taught when they are young that *awful* has a distinct meaning of its own, and has none of the sense of *very*, the use of it for *very* will not be so much a matter of course to them when they grow up. Make

them feel the bigness of the word, and the fact that at times it is the only word which will express an idea, and show them how it is wasted by being made to do duty for *very*.

The above will show the kind of work that may be done in the third grade toward the correction of common errors. Every teacher will encounter in her own schoolroom others that may serve as the basis for similar exercises.

**Composition Work.** Besides such exercises as those outlined above, and the conversational exercises similar to those in the two lower grades which should be continued in this, composition work of a more or less formal character is now taken up. This work should be based on the subjects discussed in the oral lessons, for children in the third grade should not be asked to write on any subject until the teacher is sure that they have a thorough understanding of it. And this knowledge should extend not only to the content, but in a measure to the form as well. That is, the statements of which the composition is composed should not be set down hit or miss, with no obvious connection with what precedes or follows. Related sentences should be together. To accomplish this, an outline should be drawn up before the pupils begin to write. Of course the teacher may make the outline and put it on the board, allowing the children to fill it out, but this is not a particularly helpful method. A far more valuable exercise is to have the pupils give suggestions as to points that should be treated, which the teacher may then arrange in proper order.

Suppose, for instance, that the subject chosen for a composition is "My Last Birthday." When the children are asked to talk on the subject, such statements as the following will probably be forthcoming:

"It was in the summer." "I got a doll." "I had a party." "I got a bicycle." "We had a picnic." "I had on a new pink dress." "There were candles on my cake." "Ten children came to my party." "I was eight years old." "We had pink and white candies and frosted cookies." "The children brought me presents." "There were red roses on the table." "I was nine years old." "I went to my grandmother's house."

After this jumble of statements has been set down the teacher may put them in order before the pupils' eyes. First will come the "when" statements, then the "where" statements, then the "what" statements, until the

outline appears in the form of a series of questions, somewhat as follows:

When was your birthday? Where did you spend it? Who was with you? What presents did you get? What did you do? What did you have to eat?

If the children write on some such outline, they will simply have the feeling that they are answering in a natural way natural questions. The unpleasantness that always attaches to a formal "composition" will be absent.

Every teacher will find constantly in her work excellent topics for compositions, but a few suggestions as to subjects suited to children of this grade may not come amiss:

1. Tell what month of the year you like best, and why.
2. Tell about some game you can play, in winter but not in summer.
3. How to trim a Christmas tree.
4. Making presents for father and mother.
5. Why you like the snow.
6. Helping mother.
7. A letter to a good friend.
8. The tree and the flower you like best.
9. Why you are glad you learned to read.
10. The happiest day of your vacation.

Often children can express themselves more easily in a letter than in any other form of composition. They can all imagine themselves wanting some day to write a letter, and having something to say, whereas it is a little hard for them to imagine themselves ever voluntarily writing a "composition."

There are a number of things which are closely related to the composition work and which may be taken up in preparation for it or in connection with it. First, stress must be laid again on the beginning of sentences, and on the simplest punctuation points, the period and the question mark. Then the subject of margins may be taken up, and in connection with that, paragraph indenting and the nature of a paragraph. Before a letter is written, the chief points of form in letter-writing should be made clear—the dating, the address of the writer, the salutation, the body, the ending and the signature. A good method to pursue in taking up the subject of letter-writing is to have the pupils copy from the board a letter written in proper form. This letter should be such as to interest them by its contents. The following will serve as an example:

417 Metcalfe Street,  
Ottawa, Ontario,

My dear Frances:                   September 14, 1912.

It was very good of you to ask me to come

to see you during my vacation. I was afraid my mother would not let me go, but she said "yes" without my having to coax her. My sister Blanche is at home, so that my mother and father will not be lonesome.

I have never been on a farm, and I suppose I'll see many, many things I know nothing about. You will have to promise that your brothers will not laugh at me if I make mistakes or ask foolish questions.

A week will not be so very long to wait, will it? And I am glad, because you know I want to see you and your family and your home.

Your happy friend,  
GRACE WALKER.

The use of the hyphen to divide words at the end of a line; the simplest use of the comma, that is, to divide the terms in a series; and the use of capital letters to begin names of persons and places will of necessity have to be taken up in connection with composition work. The use of quotation marks may be called to the attention of the children by having them copy brief conversations from their readers.

**Poems.** The work on poems begun in the first and second grades is continued in this, but the study here is a little more detailed. The study should never, however, be carried so far that the beauty of the poem is spoiled for the pupils, for after all, poems should be regarded first of all as literature, and only secondarily as a basis for language work. It is impossible to give here enough poems for use throughout the entire third year, but those given here will serve as examples. In addition Wordsworth's *The Kitten and the Falling Leaves*, Helen Hunt Jackson's *Down to Sleep*, Celia Thaxter's *Spring*, and parts of *Hiawatha* may be used.

#### The Children's Hour

HENRY W. LONGFELLOW

Between the dark and the daylight,

When the night is beginning to lower,

Comes a pause in the day's occupations

That is known as the Children's Hour.

I hear in the chamber above me

The patter of little feet,

The sound of a door that is opened,

And voices soft and sweet.

From my study I see in the lamplight,

Descending the broad hall stair,

Grave Alice, and laughing Allegra,

And Edith with golden hair.

A whisper, and then a silence:

Yet I know by their merry eyes

They are plotting and planning together

To take me by surprise.

A sudden rush from the stairway,  
 A sudden raid from the hall!  
 By three doors left unguarded  
 They enter my castle wall!

They climb up into my turret,  
 O'er the arms and back of my chair  
 If I try to escape, they surround me;  
 They seem to be everywhere.

They almost devour me with kisses,  
 Their arms about me entwine  
 Till I think of the Bishop of Bingen  
 In his Mouse-Tower on the Rhine!

Do you think, O blue-eyed banditti,  
 Because you have scaled the wall,  
 Such an old mustache as I am  
 Is not a match for you all?

I have you fast in my fortress,  
 And will not let you depart,  
 But put you down into the dungeon  
 In the round-tower of my heart.

And there will I keep you forever,  
 Yes, forever and a day,  
 Till the walls shall crumble to ruin,  
 And moulder in dust away!

### The Corn Song

JOHN GREENLEAF WHITTIER

Heap high the farmer's wintry hoard!  
 Heap high the golden corn!  
 No richer gift has Autumn poured  
 From out her lavish horn!

Let other lands, exulting, glean  
 The apple from the pine,  
 The orange from its glossy green,  
 The cluster from the vine.

We better love the hardy gift  
 Our rugged vales bestow,  
 To cheer us when the storm shall drift  
 Our harvest-fields with snow.

Through vales of grass and meads of flowers,  
 Our ploughs their furrows made,  
 While on the hills the sun and showers  
 Of changeful April played.

We dropped the seed o'er hill and plain,  
 Beneath the sun of May,  
 And frightened from our sprouting grain  
 The robber crows away.

All through the long, bright days of June  
 Its leaves grew green and fair,  
 And waved in hot midsummer's noon  
 Its soft and yellow hair.

And now, with autumn's moonlit eves,  
 Its harvest-time has come,  
 We pluck away the frosted leaves,  
 And bear the treasure home.

There, richer than the fabled gift  
 Apollo showered of old,  
 Fair hands the broken grain shall sift,  
 And knead its meal of gold.

Let vapid idlers loll in silk  
 Around their costly board;  
 Give us the bowl of samp and milk,  
 By homespun beauty poured!

Where'er the wide old kitchen hearth  
 Sends up its smoky curls,  
 Who will not thank the kindly earth,  
 And bless our farmer girls!

Then shame on all the proud and vain,  
 Whose folly laughs to scorn  
 The blessing of our hardy grain,  
 Our wealth of golden corn!

Let earth withhold her goodly root,  
 Let mildew blight the rye,  
 Give to the worm the orchard's fruit,  
 The wheat-field to the fly:

But let the good old crop adorn  
 The hills our fathers trod;  
 Still let us, for his golden corn,  
 Send up our thanks to God!

### A Boy's Song

JAMES HOGG

Where the pools are bright and deep,  
 Where the great trout lies asleep,  
 Up the river, and o'er the lea,  
 That's the way for Billy and me.

Where the blackbird sings the latest,  
 Where the hawthorn blooms the sweetest,  
 Where the nestlings chirp and flee,  
 That's the way for Billy and me.

Where the mowers mow the cleanest,  
 Where the hay lies thick and greenest,  
 There to trace the homeward bee,  
 That's the way for Billy and me.

Where the hazel bank is steepest,  
 Where the shadow falls the deepest,  
 Where the clustering nuts fall free,  
 That's the way for Billy and me.

### Winter

ALFRED TENNYSON

The frost is here  
 And fuel is dear,  
 And woods are sear,  
 And fires burn clear,  
 And frost is here  
 And has bitten the heel of the going year.

Bite, frost, bite!  
 You roll away from the light  
 The blue wood-louse, and the plump dor-  
 mouse,  
 And the bees are still'd, and the flies are kill'd,  
 And you bite far into the heart of the house,  
 But not into mine.

Bite, frost, bite!  
 The woods are all the searer,  
 The fuel is all the dearer,  
 The fires are all the clearer,  
 My spring is all the nearer.  
 You have bitten into the heart of the earth,  
 But not into mine.

During the month of October take up with the language class Whittier's *Corn Song*. By way of biographical introduction, tell them that Whittier gave very good pictures of his childhood days in some of his own poems; and then read to them *The Barefoot Boy* and parts of *Snow-Bound*. They will get the idea from these that Whittier was a poet of the country rather than of the town, and will realize that in this poem he is talking of something which he really knows about. A series of questions and statements like the following will bring out the points of the poem and help the children to appreciate it before they begin to learn it:

First let us see whether there are any words which we may look up. What does "hoard" mean? "lavish"? Is "lavish" a word which you would use? What does "exulting" mean? "glean"? "hardy"? "rugged"? "meads"? "pluck"? "knead"? "vapid"? "loll"? What is "samp"? Did you ever taste it?

Did you ever hear of a cornucopia, or horn of plenty? The poet imagines Autumn as a beautiful, generous woman, pouring gifts out of such a horn on to the earth. What are some of the gifts that Autumn pours out of her horn of plenty? Lead the children to mention such things as grapes, apples, pumpkins, beautiful bright days, gorgeously colored leaves, nuts. What does the poet think is the best of all these gifts? Does he mention any of the other things that we have talked of?

Is there anything in the second stanza which you do not understand? Did you ever hear of gathering apples from a pine? That sounds strange to us until we see that it is only the poet's way of talking of pineapples. He says "other lands," because he lived up in New England where such things as pineapples and oranges, which love the hot weather, never grow.

Think of some way in which corn can cheer us "when the storm shall drift our harvest-fields with snow." Did you ever sit before a glowing fire on a winter night and pop popcorn?

Does the poet seem to know when corn is planted and how it is cared for? How do you suppose he found out these things? What do you think he meant by frightening the "robber crows away"? Some of the children will have seen scarecrows, others will not. Let some of those who have seen

them describe them for the benefit of the rest.

Tell briefly of Apollo (an account of the god is found in its alphabetical order in these volumes) and his gift of gold. Ask the pupils whether they have ever seen anything made from corn which is almost as bright and yellow as gold.

Corn, or maize as it is more correctly called, was not known to civilized people until after America was discovered. The Indians had cultivated it for centuries, and it was known as Indian corn. This fact, as well as the fact that even now four-fifths of the corn used in the world is raised in the United States, makes it really a very important national grain, and that is why the poet Whittier can sing of it with so much enthusiasm.

**Stories.** Children in this grade are able to read easy stories to themselves, and will frequently read stories and books which are so difficult that they can really do little but get an idea here and there. And while it is a good plan to allow them to read, the teacher should still read to them occasionally, as she should, indeed, to the children in the higher grades. Animal stories will still be found prime favorites, and of these few are more attractive than Kipling's *Jungle Book*.

**Picture Study.** Guido Reni's *Aurora* (see article PAINTING) will show the kind of work with pictures that may be done in this grade.

#### Fourth Year

**Correction of Errors.** The drill on this is continued from the third grade, a brief review of the work done in that year forming the introduction to the work. Suggestive sentences on the various possible errors which it is wise to guard against in this grade are here given; in no case, however, are there enough sentences here.

Distinction between GUESS and THINK:

1. I ---- my mother will let me go.
2. I can ---- the riddle.
3. You must ---- until you know the answer; do not try to ----.
4. It will do me no good to ---- the answer to that problem.
5. Will you go to the party? I ---- so.

The children will hear the colloquial use of *guess* for *think* so frequently from persons whose opinion they trust, that it is well to explain to them that it is not absolutely wrong, like "I done it" or "I seen it."

Correct use of COME and CAME:

1. I ---- to school every day.
2. I ---- to school yesterday.
3. I have ---- every day this week.
4. I should have ---- if I had known.
5. Who ---- in just now?
6. Where did he ---- from?
7. Have the children all ----?
8. Spring ---- early this year.
9. I wish it would ---- early every year.
10. He ---- to ask us to ---- to his party.

The children by this time are ready for rules of some sort on such subjects as this. These should be, however, of the simplest form, and not technical. That is, do not say "Came is the past tense of *come*, and *come* is the perfect tense." To fourth-year children *come* and *came* are two different words. But if they are told that *come* is used after *have* and *had*, it has the effect of a rule without making use of technicalities.

The proper use of LIKE:

1. He looks LIKE you.
2. He looks ---- a sachem.
3. He acted ---- a man.
4. He acted ---- a man should.

The fact may be impressed upon the children, if the examples given are numerous enough, that *like* is never used before a statement; that *as* and *as if* are the correct terms.

The correct use of IN and INTO will not be difficult to impress upon the children.

1. We are IN a room; we go INTO a room.
2. Mary's mother was ---- the kitchen, when Mary ran ---- the room.
3. You will find it ---- the yard.
4. He ran ---- and out. (Show that when no word follows to show the place toward which motion is directed, IN may be used. Of course the distinction between adverb and preposition cannot be made here.)

The correct use of the word GOT may be taken up somewhat as follows, the teacher asking the questions:

"If I say 'I HAVE five dollars' or 'I have GOT five dollars,' is there any difference in my meaning?"

"Which form do you like better?"

"Is it better always to use as many words as possible to express our thought, or as few words?"

Then write on the board a list of sentences, such as the following, directing the children to read them without putting in *got* unless they feel that it is really needed.

1. The United States has ---- a number of large cities.
2. This little boy has ---- no brothers or sisters.
3. He has ---- his money by hard work.
4. Everybody has ---- some work to do.
5. Have you ---- all your work done?

6. I might have ---- that for you while I was in town.

7. I wish I had ---- better marks this week.

After this exercise is finished, have the children, pick out the sentences in which *got* is really necessary, and find some other word which might take its place. For instance, in the third sentence the word *earned* might be used. Show them that such definite, specific words are better than the general word *got*, which is called on to mean so many things.

The use of two negatives is common with children, just as it was common with the language in its early stages. If the fact that "I haven't done *nothing*" means "I have done *something*" can be impressed upon them, they will be interested enough to try to correct this error in their speech. Let them write two sets of sentences, showing the two ways in which a negative thought may be expressed, as—

I haven't any candy; OR I have no candy.  
I do ---- want ---- books. I want ---- books.  
I am ---- doing anything. I am doing ----  
I have ---- seen ---- one. I have seen ---- one.

**Compositions.** Letter-writing is an excellent form of composition work for children in this grade. Let each pupil write a letter to some other child in the class, folding it correctly and addressing the envelope. Then one pupil may act as postman, collecting the letters and distributing them as directed. Each pupil in turn reads the letter he has received, omitting the name, and criticisms on the construction and language forms are made by the teacher and by the class. At the close of the recitation all letters are handed to the teacher. If no names are read, criticisms can be made freely without causing any child embarrassment.

Topics should still be discussed in class and outlines drawn up before formal compositions are called for. Correctness of form, as to margins, headings, paragraphing, and so forth, should be insisted upon, but the teacher should be careful not to criticize too severely the thought expressed, or the manner in which it is expressed, provided that it is grammatical. The main point is to lead the child to express himself freely, and if he is hurt in the least by a criticism he is likely to draw back and keep his thoughts to himself.

Suitable subjects for compositions in this grade will be found in connection with the daily work, but a number of suggestions may

not come amiss. Such topics as "A Nutting Trip," "Berrying," "An Afternoon in a Hayfield," "Thanksgiving at Our House," "What I Like Best to Do in Winter," "What I Like Best to Do in Summer," "How We Play My Favorite Game," "How Hiawatha Built His Canoe," cannot fail to interest the children. It will not always be possible to have all the children write on the same subject; some of them may never have gone nutting, some may never have seen a hayfield. But the assigning of different topics will merely add interest.

**Related Topics.** Further work on paragraphing should be done in this grade. If the subject of "Nutting" is chosen for a composition, have a simple outline worked out by the children and put on the board. The outline will take some such form as the following:

1. Who went. When we went. Where we went. Why we went.
2. The trip to the woods.
3. What we did while there.
4. The trip home.

The pupils should then be instructed that each numbered topic in the outline must have a paragraph. This, it should be made clear, is not just for form's sake, but because every paragraph should have one central thought which it is built around, and each central thought should have a paragraph.

The use of the apostrophe to show possession and to show that a letter has been dropped out should be taken up in this year, together with further work on capitalization.

The work on synonyms can be made very interesting to children in this grade. It is well to take as a starting-point some poem, for instance, Bryant's "Planting of the Apple-Tree:"

#### The Planting of the Apple-Tree

Come, let us plant the apple-tree.  
 Cleave the tough greensward with the spade;  
 Wide let its hollow bed be made;  
 There gently lay the roots, and there  
 Sift the dark mould with kindly care,  
 And press it over them tenderly.  
 As, round the sleeping infant's feet  
 We softly fold the cradle-sheet,  
 So plant we the apple-tree.

What plant we in this apple-tree?  
 Buds, which the breath of summer days  
 Shall lengthen into leafy sprays;  
 Boughs where the thrush, with crimson  
 breast,  
 Shall haunt and sing and hide her nest;  
 We plant upon the summer lea  
 A shadow for the noontide hour,

A shelter from the summer shower,  
 When we plant the apple-tree.

What plant we in this apple-tree?  
 Sweets for a hundred flowery springs  
 To load the May-wind's restless wings,  
 When, from the orchard-row he pours  
 Its fragrance through our open doors;  
 A world of blossom for the bee,  
 Flowers for the sick girl's silent room,  
 For the glad infant's sprig of bloom,  
 We plant with the apple-tree.

As a start, the children may be asked to pick out words which the author used which they never use. They will probably make some such list as "cleave," "greensward," "mould," "infant," "sprays," "haunt," "lea," and perhaps others. First make sure that the pupils understand these words; then let them make a list of words which they would have used instead. It is perhaps a little beyond children of this grade to understand why the poet's words are better than their own, except in cases like "lea," when it is a rhyme word that is in question.

The teacher may then make a list of simpler words from the poem—words which are used by the children every day—and ask them to make a list of words which mean the same. Of course in many instances the children's words will not mean exactly the same, but unless the difference is essential, it should not be pointed out. The word *synonym* need not be used if the teacher prefers; but it will be found that a name will not frighten the children if its meaning has been thoroughly explained to them.

Word-study of a different kind takes up the use of descriptive adjectives, not, however, under that name. The pupils may be directed to find words in the poem chosen for study which describe something. After such lists have been made, the children should use each one to describe something else. Some famous character from history or from literature may then be chosen, and each pupil may make a list of words describing that character.

**Poems.** One poem suitable for work in this grade has just been given; two others, *The Village Blacksmith* and *Paul Revere's Ride*, will be found in the article **READING**. Studies of these two poems are there given which should prove very helpful to the teacher. In this grade a number of poems which have been used and learned in the earlier grades may be taken up for further study, for the children are now able to ap-

preciate many points which were beyond them before. In addition, Whittier's *The Pumpkin* and selections from his *Snow-Bound*, Celia Thaxter's *The Sandpiper*, Tennyson's *Owl* and Browning's *Pied Piper of Hamelin* may be used. When a poem contains a story, the pupils may be asked to write out the story for their composition work.

Many a child who is not given exercises in composition work from poems in the fourth or fifth grade finds he is seriously handicapped in higher grades when required to paraphrase prose and poetry in connection with lessons in grammar and composition. For a child to tell in his own words the story a poem contains is to make a simple paraphrase; such an exercise develops the reasoning faculties, tends to thoughtfulness and brings to the surface those bits of human interest contained in the poem which leads one to enjoy better not only that particular poem but makes all poetry more interesting.

**Stories.** The teacher will find that Kingsley's *Water-Babies* will afford her material for the most of her reading to her pupils throughout this year. There are some parts which the children will not understand and which need not be read to them; but there are editions of the work which give only the story part, omitting the political parallels and allusions.

Work of a slightly different kind may be done with stories in this year. A story should be read by the teacher, and when the pupils are familiar with it a test of their understanding may be made by reviewing it by means of an outline like the following:

#### I. PRINCIPAL CHARACTERS

- (a) Appearance
- (b) Life
- (c) Home
- (d) Traits of character
- (e) Place in story

#### II. OTHER CHARACTERS

Part in story

#### III. INCIDENTS

- (a) Principal happenings
- (b) Where they take place
- (c) Minor happenings

*The Ugly Duckling*, given in the article STORY-TELLING, is an excellent story for use in this way. There are many characters in the story and some of them have very well-marked personalities, so that they may be studied quite like human beings. A little

character sketch of some one of the more important minor characters would make a good composition.

Such a story as *The Ugly Duckling* should be invested with all the realism possible. The children should see that there are types of people who in their relations with their fellow-men are quite likely to act in the same way as did the animals in the story. When such a view is taken the moral the story teaches is driven home with all the greater effect. Probably there is not another story of its length which can be used with better results, from every point of view the teacher and mother can summon to their aid.

**Essays.** The essays which appear here-with show the sort of composition work which may be expected from pupils in this grade; the two which are presented were photographed from the work of students.

Essay writing usually fails to interest boys; the girls' attitude is more receptive, as a rule. The teacher who can invest work in essays with a new feature, a new element, in which the competitive idea is prominent, and which appeals to the inventive and artistic mind, is assured of a good measure of success. Illustrated essays may be a novelty; pictures, though rude, surely add strength to the language work, and train the hand and eye in expression, just as writing the subject-matter trains the mind in the fine art of composition.

### Fifth Year

**Approach to Grammar.** There is still in the fifth year no formal grammar work, but a closer approach to it is made in the language work. The points in language forms to be covered this year are many; not all of them can be covered here, but many will come up in connection with the ones discussed here. A review of *sit* and *set* will lead naturally to *lie* and *lay*.

1. I LAY the book on the table.
2. The book LIES on the table.
3. The book LAY there for a week.
4. He LAID the book on the table.
5. Where does that city ---- ?
6. Who will ---- this away for me?
7. I am going to ---- down.
8. She ---- down for half an hour.
9. The ship ---- at anchor.
10. You may ---- the pencil on the desk.
11. The sheep were ---- in the field.
12. He ---- still a long time.

A good method for combining work on right word forms with the study of synonyms





By HARRY SCOTT.

**B**rick is a sort of artificial stone made by molding a mixture of clay and sand and drying it in the sun or baking or burning in a kiln. The ordinary brick used in building and paving is eight inches long, four inches wide, and two inches thick.

The art of brick making dates from very early times. Sun dried bricks have been found in Egypt, Assyria, Babylonia and many other ancient countries. Many of these bricks contain inscriptions which are of great historic value, since they constitute the only known record of the people and events of the time in which they were made.

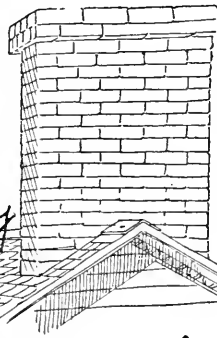

Bricks are extensively used in the foundations and walls of buildings. They are also used for sewers, cisterns, and numerous other purposes.

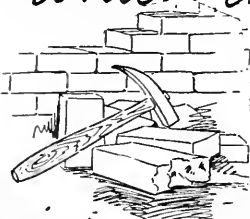

# STONE

~BY CHARLIE SMITH~



**S**tones are of extensive use for a great variety of purposes, such as building, paving, grinding and ornamental purposes.

Granite, slate, limestone, marble and sandstones are the building stones in most common use in the United States. There are numerous other stones however suitable for finishing

interiors such as serpentine and onyx.

Granite is the strongest and slate the most durable of building stones. Soft sandstones absorb a great deal of water and are not durable for exteriors. Stones containing iron or other substance which the water dissolves frequently becomes discolored. Stone generally withstands the weather best when used near the locality where it is quarried.

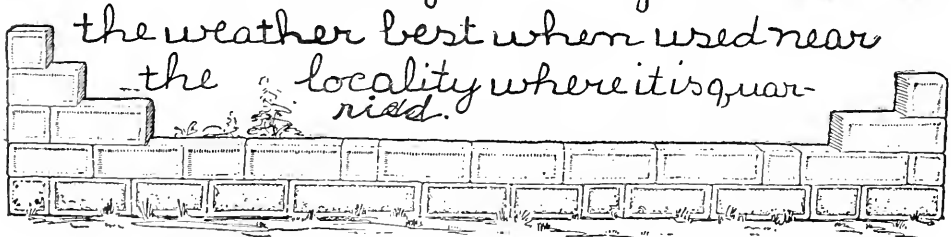
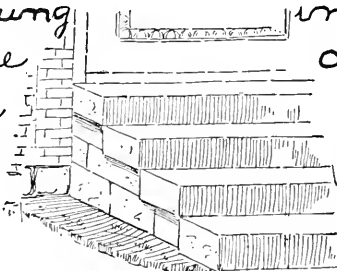

is to give sentences such as the following and ask the class to replace the capitalized words with forms of *lay* or *lie*.

1. She RECLINES on a couch.
2. He PLACED it on the floor.
3. Let it REST there.
4. She PUT the baby down.

*Raise* and *rise* may well be considered at the same time, since their relation is the same. It may be explained to the pupils, without the use of technical terms, that *raise*, *set*, *lay* are always followed by the name of what is *raised* or *set* or *laid*, while the other forms are not.

1. The stream ---- in the woods.
2. The stream has ---- several inches.
3. It has ---- the water level.
4. I ---- the window.
5. We have ---- a large sum of money.
6. The sun ---- an hour ago.
7. It has ---- over the mountain top.
8. He ---- his kite.
9. It ---- gaily into the air.
10. If you had ---- before the sun ---- your mother could have ---- no objections to your plan.

Such words as *nice* and *awful* are common words which are misused almost constantly. Review the use of *awful* given on preceding pages, and take up the word *nice*. Every child thinks he knows what the word *nice* means; he uses it frequently. "I have a nice apple. She is a nice girl. We live in a nice house." Make such a list of statements with the word *nice*, and have the pupils replace the word in each instance by another which gives the meaning more exactly. Then explain that *nice* really means *exact*, and have sentences made giving the word its correct meaning. As:

1. It will take NICE work to fit those corners together.
2. What you say will mean more if you are NICE in your choice of words.

Children may be easily interested in slang phrases and provincialisms which are current in their neighborhood, and may be set to work to find expressions which will better give the same meaning. Care is necessary in this work not to take the life out of the children's language and not to give them the idea that written language is something utterly different from spoken language.

Drill on the use of *them* and *those*, together with cautions against such expressions as "that there," "this here," may come in this year.

1. Give me ---- books.
2. I have given ---- to you.
3. All of ---- books belong to ---- children.
4. Who gave ---- ---- books?

Added drill may well be given on the proper forms of the pronouns; in fact, this is work which can with profit be taken up in almost any grade, for many of the most common faults of English come from a misunderstanding of the uses of the pronouns.

1. WHO is that?
2. It is I (or HE, SHE, WE or THEY).
3. WHOM did they see?
4. They saw ME (or HIM, HER, US, or THEM).
5. WHOM did she speak to?
6. She spoke to HIM and ME.
7. WHOM did the teacher scold?
8. She scolded HER and HIM.
9. Will you give it to ME?
10. I will give it to you and HIM.
11. Let you and ME take a walk.
12. Do you want US girls?

There is not so much danger when pupils have reached this stage of their being misled by seeing incorrect forms if it is firmly impressed upon them that the forms are wrong. There is, too, a certain eagerness about correcting errors which adds new interest to the work. Let the pupils tell what is wrong with the following sentences:

1. Whom did you say was here this evening?
2. What did you and her talk about?
3. Whom did you think he was?
4. I can certainly do that better than her.
5. Such a person as him has no right here.
6. He can play better than me.
7. It might have been him.
8. I suppose it was them.
9. Who did you take him for?

The question of the singular and plural of nouns and verbs, with reference to the agreement of subject and predicate, may seem rather elementary to take up in this grade. A pupil of the fifth grade is not very likely to say "We goes," or "They thinks," but the possibilities for mistakes are still practically endless. The danger is particularly strong in sentences where prepositional phrases appear between the subject and the predicate. Let the pupils correct the wrong forms in the following sentences, and in others like them:

1. Either you or I are right.
2. When does your brother and your sister go?
3. The crowing of the roosters tell that it is morning.
4. The use of alcoholic drinks are dangerous.

In connection with the use of the contractions *isn't*, *hasn't*, *doesn't*, and so forth, which may be taken up in this grade, it should be impressed on the pupils that *don't* means *do not*, and should be used only where *do not* is correct. *He don't*, *it don't*, *she don't* are therefore incorrect, for we may not say *he do not*, and so forth. Have the blanks in the following sentences filled with contractions of *not* and some form of the verb *do*:

1. It ---- seems right to do it.
2. A pupil ---- work as hard as a teacher.
3. I ---- care to go.
4. We ---- like some of our studies.
5. Mary ---- come very regularly.
6. You ---- need to pretend to like it.
7. That tree ---- bear many apples.
8. ---- he like his school?

The use of *kind* and *sort* with *these* and *those* is a most persistent error which it will require much drill to overcome. Let the pupils observe the correct forms in the first four sentences that follow, correct the wrong forms in the second four, and fill in the blanks in the last sentences.

1. I like THIS kind of apples.
2. There are many of THAT kind of trees.
3. THAT sort of berries is very expensive.
4. THIS sort of collars is very popular.
5. These kind of people cause much trouble.
6. Those kind of flowers are most beautiful.
7. Do you like these sort of books?
8. Will those sort of games ever be popular?

(Observe that in some of these sentences two corrections are necessary.)

9. I do not care for ---- kind of hats.
10. ---- sort of pencils ---- too hard.
11. ---- kind of electric lights ---- brighter than ---- kind.
12. Do you prefer ---- kind of shoes, or ----?

The distinction between *can* and *may* is easily grasped, but easily forgotten when it comes to a question of every-day use. *Can* expresses power or possibility; *may*, permission or probability. *Could* and *might* differ in the same way. *May* and *might* are seldom if ever incorrectly used for *can* and *could*, but the opposite error is heard almost constantly.

1. ---- I have another piece of pie?
2. She said I ---- play with Mary.
3. No, I ---- not go for a walk today; mother will not let me.
4. You ---- have a drink if you want one.
5. You ---- not leave the room until I tell you to.

These, with review of exercises from former grades and exercises suggested by

errors made by the pupils, will furnish sufficient material for language drill for this grade.

**Poems.** The poems which are suitable for study in this year are numerous and should appeal to the pupils for at least two reasons—for the stories they tell and for the pictures they present. Some of the poems have both pictures and story; some have only one. A list of poems which may well be used in this grade is as follows:

- Barbara Frietchie—Whittier.  
 In Time's Swing—Lucy Larcom.  
 The Wreck of the Hesperus—Longfellow.  
 The Fountain—Lowell.  
 Song of the Brook—Tennyson.  
 Lochinvar—Scott.  
 Sheridan's Ride—Thomas Buchanan Read.  
 Landing of the Pilgrims—Felicia Hemans.  
 Christmas Bells—Longfellow.  
 Lord Ullin's Daughter—Thomas Campbell.  
 The Arrow and the Song—Longfellow.  
 Death of Lincoln—Bryant.  
 Bell of Atri—Longfellow.

The most of these poems will be found in any school library; a few, however, such as the ballad of Campbell's, *Lord Ullin's Daughter*, and Lucy Larcom's *In Time's Swing*, will not be so easy to find, and we give them here. One is a typical story poem, the other a typical picture poem. Longfellow's *Wreck of the Hesperus* is given for comparison with *Lord Ullin's Daughter*.

#### Lord Ullin's Daughter

A chieftain, to the Highlands bound,  
 Cries, "Boatman, do not tarry!  
 And I'll give thee a silver pound,  
 To row us o'er the ferry."

"Now who be ye, would cross Lochgyle,  
 This dark and stormy water?"  
 "O, I'm the chief of Ulva's isle,  
 And this Lord Ullin's daughter.

"And fast before her father's men  
 Three days we've fled together,  
 For should he find us in the glen,  
 My blood would stain the heather.

"His horsemen hard behind us ride;  
 Should they our steps discover,  
 Then who will cheer my bonny bride  
 When they have slain her lover?"

Out spake the hardy Highland wight,  
 "Till go, my chief—I'm ready;  
 It is not for your silver bright,  
 But for your winsome lady:

"And by my word! the bonny bird  
 In danger shall not tarry;  
 So though the waves are raging white,  
 I'll row you o'er the ferry."

By this the storm grew loud apace,  
The water-wraith was shrieking:  
And in the scowl of heaven each face  
Grew dark as they were speaking.

But still as wilder blew the wind,  
And as the night grew drearer,  
Adown the glen rode armèd men.  
Their trampling sounded nearer.

"O haste thee, haste!" the lady cries,  
"Though tempests round us gather;  
I'll meet the raging of the skies,  
But not an angry father."

The boat had left a stormy land,  
A stormy sea before her,—  
When, oh! too strong for human hand,  
The tempest gather'd o'er her.

And still they row'd amidst the roar  
Of waters fast prevailing:  
Lord Ullin reach'd that fatal shore,  
His wrath was changed to wailing.

For sore dismay'd, through storm and shade,  
His child he did discover:—  
One lovely hand she stretch'd for aid,  
And one was round her lover.

"Come back! come back!" he cried in grief,  
"Across this stormy water:  
And I'll forgive your Highland chief,  
My daughter!—oh my daughter!"

'Twas vain: the loud waves lashed the shore,  
Return or aid preventing;  
The waters wild went o'er his child,  
And he was left lamenting.

This poem is written in the style of the old ballads, but it has very few of the strange old forms or the roughness of meter which mark the ballads. Longfellow's *Wreck of the Hesperus* shows more of the ballad characteristics.

#### Wreck of The Hesperus

It was the schooner Hesperus,  
That sailed the wintry sea;  
And the skipper had taken his little  
daughter  
To bear him company.

Blue were her eyes as the fairy-flax,  
Her cheeks like the dawn of day,  
And her bosom white as the hawthorn buds  
That ope in the month of May.

The skipper he stood beside the helm,  
His pipe was in his mouth,  
And he watched how the veering flaw did  
blow  
The smoke now West, now South.

Then up and spake an old Sailor,  
Had sailed the Spanish Main,  
"I pray thee, put into yonder port,  
For fear a hurricane.

"Last night the moon had a golden ring,  
And tonight no moon we see!"

The skipper he blew a whiff from his pipe,  
And a scornful laugh laughed he.

Colder and colder blew the wind,  
A gale from the Northeast;  
The snow fell hissing in the brine,  
And the billows frothed like yeast.

Down came the storm, and smote amain,  
The vessel in its strength;  
She shuddered and paused, like a frightened  
steed  
Then leaped her cable's length.

"Come hither! come hither! my little  
daughter.  
And do not tremble so;  
For I can weather the roughest gale,  
That ever wind did blow."

He wrapped her warm in his seaman's coat  
Against the stinging blast;  
He cut a rope from a broken spar,  
And bound her to the mast.

"O father! I hear the church-bells ring.  
O say, what may it be?"  
" 'Tis a fog-bell on a rock-bound coast!"—  
And he steered for the open sea.

"O father! I hear the sound of guns.  
O say, what may it be?"  
"Some ship in distress, that cannot live  
In such an angry sea!"

"O father! I see a gleaming light.  
O say, what may it be?"  
But the father answered never a word,  
A frozen corpse was he.

Lashed to the helm, all stiff and stark,  
With his face turned to the skies,  
The lantern gleamed through the gleaming  
snow  
On his fixed and glassy eyes:

Then the maiden clasped her hands and  
prayed  
That savèd she might be;  
And she thought of Christ, who stilled the  
wave,  
On the lake of Galilee.

And fast through the midnight dark and  
drear,  
Through the whistling sleet and snow,  
Like a sheeted ghost, the vessel swept  
Towards the reef of Norman's Woe.

And ever the fitful gusts between  
A sound came from the land;  
It was the sound of the trampling surf,  
On the rocks and the hard sea-sand.

The breakers were right beneath her bows,  
She drifted a dreary wreck,  
And a whooping billow swept the crew  
Like icicles from her deck.

She struck where the white and fleecy  
waves  
Looked soft as carded wool,

But the cruel rocks, they gored her side  
Like the horns of an angry bull.

Her rattling shrouds, all sheathed in ice,  
With the masts went by the board;  
Like a vessel of glass, she stove and sank,  
Ho! ho! the breakers roared!

At daybreak, on the bleak sea-beach,  
A fisherman stood aghast,  
To see the form of a maiden fair,  
Lashed close to a drifting mast.

The salt sea was frozen on her breast,  
The salt tears in her eyes:  
And he saw her hair, like the brown sea-  
weed,  
On the billows fall and rise.

Such was the wreck of the *Hesperus*,  
In the midnight and the snow!  
Christ save us all from a death like this,  
On the reef of Norman's Woe!

Have the children read the poem through first to get a general idea of the story and of the swing. Then ask them to point out any strange words or any seeming breaks in the swing. In the very first stanza there is a word which has to be pronounced incorrectly to make it sound right; *daughter* must be accented on the second syllable. In the fourth stanza *sailor* must be treated in the same way, while in the same stanza are found two expressions which are not usual—"up and spake" and "had sailed," with *who* omitted. The children will be able to pick out other instances. Explain to them that Longfellow did not write in this way because he knew no better, and read to them some particularly musical passage from the same poet. Then, in explanation of the irregularities, tell a little about the old ballads: how they grew up among people who knew nothing of poetry, and how they were intended to be set to music. Describe the way they were kept alive, by word of mouth for centuries, and tell of the changes that took place in them. Make your pupils feel, if you can, that what would be defects in more formal poems are really the chief charm of the old ballads.

*The Wreck of the Hesperus* is primarily a story poem, but are there pictures in it? The second stanza gives a picture of the little daughter; the sixth stanza has the brief picture of the billows that "frothed like yeast;" the thirteenth stanza gives the painful picture of the dead skipper lashed to the helm, with the lantern-light gleaming on him. Let the children find other pictures.

#### In Time's Swing

Father Time, your footsteps go  
Lightly as the falling snow.  
In your swing I'm sitting, see:  
Push me softly; one, two, three,  
Twelve times only. Like a sheet  
Spread the snow beneath my feet.  
Singing merrily, let me swing  
Out of winter into spring.

Swing me out, and swing me in!  
Trees are bare, but birds begin  
Twittering to the peeping leaves,  
On the bough beneath the eaves  
Wait,—one lilac bud I saw.  
Icy hillsides feel the thaw;  
April chased off March today;  
Now I catch a glimpse of May.

Oh, the smell of sprouting grass!  
In a blur the violets pass.  
Whispering from the wildwood come  
Mayflower's breath and insect's hum.  
Roses carpeting the ground;  
Thrushes, orioles, warbling sound:  
Swing me low, and swing me high,  
To the warm clouds of July.

Slower now, for at my side  
White pond lilies open wide.  
Underneath the pine's tall spire  
Cardinal blossoms burn like fire.  
They are gone; the golden-rod  
Flashes from the dark green sod.  
Crickets in the grass I hear;  
Asters light the fading year.

Slower still! October weaves  
Rainbows of the forest leaves.  
Gentians fringed, like eyes of blue,  
Glimmer out of sleety dew.  
Meadow-green I sadly miss:  
Winds through withered sedges hiss.  
Oh, 'tis snowing, swing me fast,  
While December shivers past!

Frosty-bearded Father Time,  
Stop your footfall on the rime!  
Hard you push, your hand is rough;  
You have swung me long enough.  
"Nay, no stopping," say you? Well,  
Some of your best stories tell,  
While you swing me—gently do!—  
From the Old Year to the New.

This is, first and last, a picture poem. Point out to the children, if they do not get it from their own first reading, that the swinging is only a symbol of the passing year, and then let them direct their attention to the pictures. Have them find first the winter pictures, then the spring pictures, then the summer pictures, then the autumn pictures. Point out to them the fact that each picture is made with a very few words.

There are many birds and flowers mentioned in the poem, some of which are familiar to teachers and mothers, but not so

much is known about others. Great good will result from studying about them, under their regular alphabetical titles.

The children will enjoy making illustrations for this poem. The whole course of the year cannot be accurately covered, but enough pictures can be made to ornament beautifully practically all of the calendars of the months.

"Underneath the pine's tall spire  
Cardinal blossoms burn like fire."

"..... the golden-rod  
Flashes from the dark green sod."

"Asters light the fading year."

"..... October weaves  
Rainbows of the forest leaves.  
Gentians fringed, like eyes of blue,  
Glimmer out of sleety dew."

These are some of the pictures which will give ideas for illustrations to the pupils.

**Composition Work.** A part of the composition work of this year may be connected with the work on the poems. Once or twice during the year it will be well to have the pupils give for their compositions the story of some narrative poem which they have studied in this grade or an earlier one. *The Pied Piper of Hamelin* and *The Bell of Atri* are good poems for use in this way. Or, after the study of a narrative poem, it may be well to have the children write a story—either an original story or one from history. Their own original stories, of course, need not be of the same heroic proportions as the tales in the narrative poems.

After some time has been spent on the study of a descriptive poem, let the children write descriptions of some scene with which they are familiar. Impress upon them that they cannot describe a scene or an object clearly until they really know what it looks like, until they have a picture of it with its lights and shadows, its important points and its minor points, distinct in their own minds. *A Garden I Have Seen*, *My Favorite Corner of the Park*, *Our Front Yard* are subjects which it should be possible for the children to handle well.

There is one subject for composition work which rarely fails to interest children. Let each pupil choose an animal or an article which he wishes to be—a rabbit, a fish, a coin, a bottle—and write the experience of that animal or article in the form of an autobiography. These may be fanciful, but

not too much so; the experiences should be those which are possible to the article in question. Andersen's *Constant Tin Soldier*, *The Darning-Needle* and *The Pea Blossom* should be interesting to the children in this connection.

Composition topics which fit the season are useful in varying the monotony. Thus in October some such subject may be assigned as *How My Garden Has Changed*. In December the topic may be *A Christmas Picture*, which affords numerous possibilities—the Christmas tree, the family taking down the stockings, the Christmas dinner table, the group about the fire in the twilight. In February the subject may well be George Washington. His life may be divided into several parts—his youth, his early manhood, his career as a soldier, his presidency, his later life. Each of these parts may be assigned to several pupils, and when all the work is in, a number of lives of Washington may be made by putting the different chapters together.

**Related Topics.** This year should ground the children still further in the use of capitals, punctuation marks, simple abbreviations, such as those for the different months, and paragraphing. Conversations should be copied from readers or made use of in original compositions until the use of quotation marks is well understood, and practice in letter-writing should not be neglected.

#### Sixth Year

**Correction of Errors.** The work of the sixth grade is very closely related to that of the fifth. The drill on the correction of common errors begun in the earlier grades should be continued in this, until the teacher is sure that the pupils understand thoroughly the end to be accomplished. Additional errors on which exercises may be based are given here.

The distinction between *most* and *almost* is one which is frequently overlooked. *Most* means the *greatest quantity*, the *greatest number*; *almost* means *nearly*, and should be used only in places where *nearly* might be used. Place the following sentences on the board and let the children correct those which are wrong:

1. I can go most any time you are ready.
2. Most of us have been here.
3. Most all of us have been there.
4. It is most always impossible to find a seat in this train.

5. I shall be most too tired to go.
6. Most everybody likes flowers.

The proper use of *between* and *among* requires thought. Have the blanks in the following sentences filled correctly with one or the other of these two words:

1. She and I divided it ---- us.
2. He had only two apples, but he divided them ---- the three of us.
3. John and Mary and I appealed to father, but he said we must settle it ---- us.
4. There are four beautiful little lakes, and a village nestles ---- them.
5. Father and mother divide the responsibility ---- them.

The statement that *good* is an adjective and *well* is often an adverb cannot be made to pupils of this grade who have not yet been introduced to formal grammar, but the difference in their use may be made clear by numerous illustrations.

1. You are a GOOD boy; you have done your lessons WELL.
2. The bread looks GOOD (meaning, the bread looks as if it were good).
3. The bread is baked WELL.
4. He is never WELL but her health is very GOOD.
5. She is a ---- worker and does everything ----.
6. Can you do this ---- ?
7. My work is not done as ---- as yours.
8. Is your health fairly ---- ?
9. If you do this ---- you shall have a ---- rest.

*Without* and *except* should not be used in the place of *unless*, to introduce a dependent statement. The first four sentences which are given here are incorrect:

1. I shall not go WITHOUT you do.
2. She will not do it EXCEPT she feels like it.
3. EXCEPT the teacher tells you to, you must not do it.
4. They never do anything WITHOUT they are forced to.
5. ---- the sun comes out, it will be ruined.
6. I shall not go with you ---- you wear a hat.
7. There is no use in promising ---- you intend to do it.

*Had* or *had not* should never be used with *ought*.

1. She OUGHT to go, NOT, She had ought to go.
2. I had not ought to do it, NOT, I had not ought to do it.
3. Ought we to speak of it? NOT, Had we ought to speak of it?
4. She thought we ought not to buy the house, NOT, She thought we had not ought to buy the house.

The word *real* is often incorrectly used in place of *very*. Do not say:

1. I am REAL sick.
2. She is a REAL strong girl.
3. We had a REAL good time at your house.
4. If you are REAL sure you do not mind, I will take it.
5. I think I shall like the new teacher REAL well.

In each of these cases the word *very* is the proper word to use.

**Word Study.** The study of synonyms, begun in earlier grades, may well be continued in this. Such groups of words as *aged, ancient, old, antique; abandon, desert, forsake; admit, confess, acknowledge; at last, at length*, may be discriminated and used in sentences. Very fine distinctions between words should not be drawn with children in this grade.

Very helpful exercises may consist in making lists of adjectives describing certain objects. For example, ten words may be called for which describe a tree, ten which describe a horse, ten which describe a person. These, of course, are not called adjectives in this grade; they are simply descriptive words. The comparison of adjectives, always without using the technical terms, may also be taken up here. After the pupils have given several words describing a tree, as, for instance, *tall, beautiful, sturdy*, call on them to express those qualities in three different degrees and point out the difference between *tall, taller, tallest*, and *beautiful, more beautiful, most beautiful*.

**Poems.** Any of the poems listed in the fifth-grade work which have not been studied may be used in this year. In addition, the following will be found adapted to pupils of this age:

**How They Brought the Good News from Ghent to Aix**—Browning.

The Bugle Song—Tennyson.

An Incident of the French Camp—Browning.

The Fringed Gentian—Bryant.

The Daffodils—Wordsworth.

Old Ironsides—Holmes.

The Leak in the Dyke—Phoebe Cary.

These poems should be studied just as those for the fifth year were studied, though of course with each grade a little truer appreciation may be expected from the children. The teacher may first in each instance give a brief sketch of the life of the poet; this may, in all the cases given for this year, be found in these volumes. Then,



if the poem is a story-poem, it will be of interest to the pupils to learn whether or not the incidents on which the poem is based are true or imaginary. For instance, the two poems of Browning named for study in this year may be contrasted. Let the children read *How They Brought the Good News from Ghent to Aix*, and *An Incident of the French Camp*, and see whether they feel that one is any more *real* than the other. Perhaps the fact that Napoleon is named in the latter poem may make that one seem a little more actual, but for the most part one rings as true as the other. In the case of *An Incident of the French Camp*, however, the historical background, at least, is true; the French did take Ratisbon just in the way Browning describes. As to whether or not the story of the boy, as he tells it, is true, we do not know; but the character of Napoleon, from the glimpse we have of him here, is very true to life. When it comes to the other poem, we find that Browning invented the circumstances entirely; there is no record that there was ever any good news sent from Ghent to Aix. But so real does Browning make the story seem that we almost hold our breath as the galloping ride goes on.

The story of Browning's *Pippa Passes*, if told simply and well, will make a strong appeal to children of this grade, and they will enjoy learning the beautiful little song which Pippa sings as she starts on her day's pleasuring:

"The year's at the spring,  
And day's at the morn;  
Morning's at seven;  
The hillside's dew-pearled;  
The lark's on the wing;  
The snail's on the thorn;  
God's in his heaven—  
All's right with the world."

**Composition Work.** This, again, differs in kind very little from the work of the fifth grade. The subjects may be much the same, but of course a little better results may be expected. A list of topics suitable for composition work in this grade is given here:

1. Business letters:
  - (1) To a magazine, inclosing money order for one year's subscription.
  - (2) To a large department store, ordering six or eight articles, and giving directions about delivery.
2. Why I Like My Favorite Book.
3. The Boyhood of Lincoln.
4. The Story of "The Bell of Atri."

5. A Brave Deed I Saw.
6. The Story of a Dollar Bill.
7. The Adventures of a Pin.
8. A January Thaw.
9. A February Blizzard.
10. The Toboggan Slide.
11. How I Ran Away.
12. Having a Tooth Pulled.
13. My Grandma's Kitchen.
14. Our Church.
15. What I See from My Window.
16. The Most Beautiful Place I Know.
17. My First Teacher.

Compositions on such subjects as *Sugar, Coffee, Cotton, Lumber, Apples, Iron, Fisheries, Wheat, Corn* will connect the language work with other studies. The teacher may find it advisable to draw up an outline for such compositions first, that the work may be orderly in form. Material on these subjects may be found in THE NEW PRACTICAL REFERENCE LIBRARY, in regular alphabetical order, and also with special treatment in this volume, under the heading *Industries*.

### Seventh Year

**The Simple Sentence.** In the seventh grade formal grammar is taken up. Of course this should be connected as much as possible with the language work of the previous years, but the line between the two is distinct. The greater part of the seventh-year work concerns itself with the sentence, and that subject should be the first thing taken up. Put before the pupils the two groups of words *Flying birds* and *Birds fly* and have them discuss the difference. Lead them to the statement that the former simply *assumes* something about birds, while the latter *asserts* the same fact. Then give them the definition of a declarative sentence—that it is a group of words which asserts something about something else.

Given this definition, it is apparent that there must be two parts to every sentence, no matter how simple; there must be the part that asserts and the part about which something is asserted. Thus in the sample sentence given, the word *fly* asserts something about *birds*. The asserting part of a sentence is called the *predicate*, the part about which something is asserted, the *subject*.

Though the difference between groups of words which assert and groups of words which merely assume is very simple to the teacher, it is by no means always so clear to the pupils. They should have much drill on groups of words such as the following,

distinguishing the sentences from those expressions which only assume:

1. The fishes swim.
2. Swimming plants.
3. The roaring storm.
4. The train runs.
5. The tree falling.
6. Children play.
7. Books are read.
8. The drifts of snow.
9. The green grass.
10. The grass grows.

It will thus be made plain to the pupils that in order to have a sentence, two things are absolutely essential—a subject and a predicate; but it may then be pointed out that comparatively few sentences have this very simple form. Even in the little sentences in the list above, the word *the* is used before the subject more often than not. This modifier of the subject does not, however, make the sentence any less simple; it merely makes the subject less simple. By a combination of the last two groups of words in the list above, *The green grass* and *The grass grows*, it may be shown that the same sentence may both assume and assert something of the subject. *The green grass grows* assumes the greenness and asserts the growth.

**Complements.** After sufficient drill has been given on the very simplest form of sentences, the point may be made that some predicates do not in themselves contain enough to assert about a subject all that is meant. Thus for instance, if we want to assert about flowers the quality assumed in the expression *beautiful flowers*, it is not enough to say *Flowers are*; we must add to the predicate the word *beautiful*. Give many examples of this use of a word after *is*, *are*, *was*, *were*, etc., to complete the meaning, using adjectives in some and nouns in others. The distinction between these two parts of speech need not be pointed out to the pupils at this stage.

1. Birds are graceful.
2. Swallows are birds.
3. Man is an animal.
4. Men are intelligent.
5. You are good.
6. You are a boy.

The word which is thus used after some form of *to be* is known as the *attribute complement*.

But there are other predicates besides forms of *to be* which need something to complete their asserting power. If we say *The*

*man wants*, we feel that something is lacking. *What* does the man want? The word which answers that question is the *object*, or *object complement*, of the word *wants*. The object is that which receives the action expressed by the verb. Have the pupils point out objects or object complements in such sentences as these:

1. I ate an apple.
2. He threw the ball.
3. John sang a song.
4. The bird caught a worm.
5. The teacher scolded the pupil.
6. He was reading the book.
7. You like flowers.
8. I broke the glass.

When the pupils have reached this point in their study of the sentence, they may make some such table as the following:

| Complete Subject | Predicate | Attribute Complement | Object |
|------------------|-----------|----------------------|--------|
| John             | is        | good                 |        |
| He               | has       |                      | a dog  |
| The girl         | likes     |                      | apples |

Let them analyze as above and place in their proper compartments the parts of the following sentences, giving, as they do so, their reasons. In analyzing the first sentence, for instance, the pupil will say: "*Cats* is the subject, because something is asserted of them; *catch* is the predicate, because it makes the assertion; *mice* is the object, because it is that which receives the action."

1. Cats catch mice.
2. The boy is tall.
3. The clock was old.
4. A boy was making kites.
5. The kite had a tail.
6. It flew.
7. Gold is heavy.
8. My home was beautiful.
9. The dog was running.
10. The pupil knows the lesson.
11. Cats scratch.
12. Horses eat corn.

Such sentences as the fourth and the ninth will call to the attention of the pupils the fact that a predicate is not always only one word, but the subject of conjugation need not be taken up just at this point.

**The Noun.** The first part of speech which is given definite treatment is of course the noun. The statement that "a word used to name an object is a noun" is so simple that the children will find no difficulty in understanding this first part of speech; but after

the word *noun* is learned it should be used—"name" and "name word" and such expressions should be dropped. Give plenty of practice in the recognition of nouns, by having the pupils point out all that occur in the following examples:

1. "The breaking waves dashed high  
On a stern and rockbound coast;  
The woods against a stormy sky  
Their giant branches tossed."
2. "Their home was a little hut on the edge  
of a little village—a Flemish village a league  
from Antwerp, set amidst flat breadths of  
pasture and corn-lands, with long lines of  
poplars and of alders bending in the breeze  
on the edge of the great canal which ran  
through it."
3. "I was rich in flowers and trees,  
Humming-birds and honey-bees;  
For my sport the squirrel played,  
Plied the snouted mole his spade;  
For my taste the blackberry cone  
Purpled over hedge and stone;  
Laughed the brook for my delight  
Through the day and through the  
night."
4. "Up from the meadows, rich with corn,  
Clear in the cool September morn,  
The clustered spires of Frederick stand,  
Green-walled by the hills of Maryland."

*Antwerp*, in the second selection, and *Frederick* and *Maryland*, in the last, will give opportunity for pointing out the distinction between common and proper nouns.

**The Pronoun.** The pronoun, the "word used instead of a noun," follows very easily after the work on the noun. *I, you, he, she, it, we, they, who, me, him, her, us, them, and whom* may be taken up now, but the possessive forms cannot be understood until after the subject of adjectives has been studied. The nouns common and proper, and the pronouns, may be picked out from the following paragraph, the pronouns being classified from their forms as subject, attribute complement and object.

"In a remote village among some wild hills in the province of Lorraine, there lived a countryman whose name was Jacques d'Arc. He had a daughter, Joan of Arc, who was at this time in her twentieth year. She had been a solitary girl from her childhood; she had often tended sheep and cattle for whole days where no human figure was seen or human voice heard; and she had often knelt, for hours together, in the gloomy, empty, little village chapel, looking up at the altar, and at the dim lamp burning before it, until she fancied that she saw shadowy figures standing there, and even that she heard them speak to

her. The people in that part of France were very ignorant and very superstitious, and they had many ghostly tales to tell about what they had dreamed, and what they saw among the lonely hills when the clouds and mists were resting on them. So they easily believed that Joan saw strange sights, and they whispered among themselves that angels and spirits talked to her."

**The Verb.** The study of the verb comes next, and while this is more complicated than the work on the noun, there is no reason why it should not be presented as to be perfectly simple. The definition usually given of a verb is that it is "a word which asserts." There is a difficulty in this, however; the word *assert* has been used of the predicate of a sentence, and there is a danger that the pupils will become confused when such verb forms as *giving, given* are introduced, since these forms obviously never of themselves assert anything. The old definition that "a verb is a word that tells what some object is or does" is as simple a starting point as any. The distinction between transitive and intransitive verbs may be easily connected with the study of the object complement, and if that work has been thorough there is no reason why the classification of verbs as transitive and intransitive should give any trouble. For drill, the verbs in the following sentences may be classified in this way:

1. Mary is a good child, but she has a quick temper.
  2. The cat has sharp claws.
  3. The dog runs swiftly.
  4. The river carries ships to sea.
  5. I see four pine trees from my window.
  6. The girl sang well.
  7. She sang a beautiful song.
- (These last two sentences may be used to show how the same verb may be both transitive and intransitive.)
8. I stood on the bridge.
  9. You own a horse, do you not?
  10. The sun shines.
  11. The rain freshens the flowers
  12. The flowers grow.
  13. I like dogs and horses; you like cats.
  14. I walked slowly.

**Inflection.** The word *inflection* is not too difficult to introduce to seventh-grade pupils, but it should be introduced after the fact of inflection, not before. Call attention first to the fact that verbs do something in sentences besides asserting. When we say "I eat an apple," "I ate an apple," the verb tells us that there is a difference in time in the two actions; when we say "I go to school,"

"I *may go* to school," the verb tells us that in one case the speaker is certain, in the other doubtful. Different forms of the verb are necessary if it is to tell us all of these things when used in a sentence. Write on the board *give, gives, gave, giving, given* and ask the pupils how many words you have written; then explain that these five are really only five different forms of the one word *give*. The use of copulas, *is, has, may, etc.*, may be introduced here, by showing that even the five forms of the verb *give* cannot always tell us all that a verb needs to tell.

Point out, too, that some forms of the verb can assert, while others have not that power; "I *give,*" "you *gave,*" "he *gives*" assert, while *giving* and *given* do not, however they may be used. Such forms of the verbs as do not assert are called *verbals*. Give a brief drill on verbals, letting the pupils pick them out from the following list:

have, has, having, had.  
go, goes, going, went, gone.  
break, breaks, breaking, broke, broken.  
buy, buys, buying, bought.  
bring, brings, bringing, brought.  
paint, paints, painting, painted.

The study of verbals leads up to the *verb phrase*—the combination of one or more verbals with a verb. By combining the forms picked out as verbals above with copulas, the verbals may be used in making assertions. Perhaps the simplest definition that can be given of a verb phrase is that it is "a group of words used like a verb of one word." Verb phrases may be pointed out in the following sentences:

1. The sun has risen.
2. The moon rose.
3. The children were playing.
4. He has learned his lessons.
5. They did their work.
6. We earned the money.
7. The boys will run races at the picnic.
8. I shall go tomorrow.
9. She lost her book.
10. The cat is watching for a mouse.
11. The girls were having a good time.
12. We had much trouble before we found it.

Have each of the above sentences rewritten, directing the pupils to employ different forms of the same verbs, so that where simple verbs are now used there may be a verb phrase, and where there are now verb phrases, verbs of one word may be used. The first sentence would thus be written:

The sun **ROSE**, or  
The sun **RISES**.

It is not necessary that the time expressed be the same.

**The Adjective.** The adjective, with its uses as direct modifier and as attribute, and the adverb, modifying verb, adjective or adverb, should next be introduced, and from the study of these two parts of speech the transition be made to adjectives and adverb phrases and clauses. This brings in the study of prepositions, conjunctions and relative pronouns. In connection with the complex sentences, or those containing dependent clauses, may be introduced the compound sentence, with its two or more coordinate parts. A list of sentences is given here, which may be used for drill in work with all of these topics.

(a) Pick out the adjectives in the following sentences and tell whether they are direct modifiers or attributes:

1. The long day is over.
2. The blue flowers have faded.
3. Over the brown fields the pale autumn sun shone.
4. The water is cold.
5. The days in summer are long and sunny.
6. On the chill days of November we long for the bright, fresh days of spring.
7. The red leaves of the vine are beautiful against the dark, shaggy trunk of the old tree.
8. Far above us, graceful birds circled in the blue sky.
9. Do you think these red flowers will be pretty in this green vase?
10. The soft, fleecy snow has covered up the ugly, bare ground.
11. She is well, but her sister is ill.
12. I have been very happy all day.

(b) Pick out the adverbs in the following sentences and tell whether they express place, direction, manner, degree, time when, or duration of time. Also point out the word which each adverb modifies:

1. She plays well.
2. She plays very well.
3. I am extremely sorry that you cannot go.
4. The frightened animal fled still more rapidly.
5. The Indian vanished swiftly in the forest.
6. Put it there.
7. The crayfish scuttled backward.
8. He seems to do everything easily.
9. If you do not do it now, you will never do it.
10. They worked long and hard.
11. The army moved forward as one man.
12. He searched eagerly for the house where he had lived so happily.
13. A very tall man rose and said emphatically, "We are wasting the swiftly passing time in utterly useless debate."

(c) Pick out the prepositions in the following sentences, and tell what each prepositional phrase modifies:

1. Pansies grow in the garden, but their violet cousins grow in the open fields.
2. Through the window came a snowball, which broke against the wall.
3. It was thrown by a small boy who was hiding behind a bush in the garden.
4. Above the tree tops floated a gorgeous kite.
5. Scores of people were rushing toward the spot, asking wildly about the accident.
6. The dog ran around the house and under the barn.
7. It is on the table, just inside the door.
8. Between you and me, I do not believe it.
9. Such talk is out of place among friends.
10. A cottage in the woods is all I desire.
11. This letter from my mother has news for all of us.
12. Beyond the park paling is the unbroken forest.

(d) Tell whether the following sentences are complex or compound, and pick out the clauses. In the case of complex sentences, tell whether the dependent clauses are adjective or adverb clauses, and whether they are introduced by conjunctions or by relative pronouns:

15. I prefer to read but I will play tennis if you wish.
16. If you hear from him before I do, send me word.
17. The flowers which I bought yesterday are still fresh, and I think I shall wear them when I go out this evening.
18. She is the girl whom we all love.
19. "The world goes up and the world goes down."
20. He was pardoned, though he was guilty.
21. He was pardoned but he was guilty.
22. I cannot go until my work is done.
23. "Knowledge comes, but wisdom lingers."
24. "You never miss the water till the well runs dry."
25. "Blessed is the man that walketh not in the counsel of the ungodly."
26. Bring me the book which you will find on the table.

No attempt has been made here to instruct the teacher as to just how each of these subjects should be introduced; the intention has been rather to furnish a fund of illustrative material for the needed drill.

For the work on sentence analysis, any or all of the above sentences may be used. A table similar to that used for the simple sentences at the beginning of the year's work may be made, and the various parts of the sentences may be classified under it:

| Subject Modifiers         |   |        | Subject               | Predicate            | Predicate Modifiers |                                      |        | Object | Attribute |
|---------------------------|---|--------|-----------------------|----------------------|---------------------|--------------------------------------|--------|--------|-----------|
| Word                      | Phrase                                  | Clause |                       |                      | Word                | Phrase                               | Clause |        |           |
| A gorgeous<br>This<br>The | from my mother<br>who sent the presents |        | kite<br>letter<br>man | floated<br>has<br>is |                     | above the tree tops<br>for all of us |        | news   | rich      |

1. She came while I was there.
2. They went, though they should have remained at home.
3. John and Mary walked rapidly to the top of the hill, but they were afraid to go farther.
4. The man who sent the presents is rich.
5. Birds sing and flowers bloom.
6. The home which I like best of all is too expensive.
7. She ran toward the box that contained the gold.
8. Since I have been here, I have seen two bears.
9. Because his father would not let him go, he ran away.
10. You had better stay at home, for you could never stand the journey.
11. The wind is not blowing, nor does it rain as it did an hour ago.
12. This is the man who wrote the letter.
13. We found the house which we were seeking.
14. The boy whom the teacher scolded yesterday did better today.

**Composition Work.** The grammar work should not be emphasized to the exclusion of composition work in this grade. In fact, the composition work may be made a real help in the grammar, for illustrations of the principles being introduced may constantly be found in the compositions, and the pupils may be more easily interested in a form if they know they make use of it themselves. The topics for composition work in this class should be varied from month to month. Here follows a list of suggested composition topics:

1. Why I Should Not Like to Live in ---- (some country being studied in geography).
2. The Woods in Autumn.
3. Our Autumn Out-of-door Games.
4. A Newsboy's Christmas, or, A Selfish Girl's Christmas.
5. The Story of Barbara Frietchie (as it

might be told to a child of ten).

6. Why I Should Like to Have Lived in the Time of Lincoln (or Washington).

7. A Windy March Day, or,  
The First Real Spring Day.

8. What I Have Learned in Grammar This Year.

**Poems.** Much of the work on poems will come with the reading, but there should be occasional exercises in the grammar class. This does not mean that just the grammatical features are to be taken up, for while it may be very beneficial to point out ways in which the poetical expression differs from the prose, a poem may well be spoiled by too long dwelling on such points. But the re-telling of stories, the reproduction of descriptions contained in poems, and the putting into words of the impression produced by a part or the whole will make helpful exercises. The following poems are suitable for use in this grade:

The Building of the Ship—Longfellow.

A Robin Hood Ballad.

The Courtin'—Lowell.

The Song of the Brook—Tennyson.

The Diverting History of John Gilpin—Cowper.

The Children's Hour—Longfellow.

Rhocucus—Lowell.

The Hot Season—Holmes.

The Old Clock on the Stairs—Longfellow.

As it may not always be possible to find a *Robin Hood* ballad, we give here the one dealing with *Robin Hood and the Stranger*.

#### Robin Hood and the Stranger

Come listen awhile, you gentlemen all,  
With a hey down, down, a down, down,  
That are this bower within,  
For a story of gallant bold Robin Hood,  
I purpose now to begin.

"What time of day?" quoth Robin Hood then;  
Quoth Little John, "'Tis in the prime."  
"Why then we will to the green-wood gang,  
For we have no vittles to dine."

As Robin Hood walkt the forest along,  
It was in the mid of the day,  
There he was met of a deft young man  
As ever walkt on the way.

His doublet was of silk, he said,  
His stockings like scarlet shone,  
As he walkt on along the way,  
To Robin Hood then unknown.

A herd of deer was in the bend,  
All feeding before his face;  
"Now the best of you Ile have to my dinner,  
And that in a little space."

Now the stranger he made no mickle adoe,  
But he bends a right good bow,

And the best buck in the herd he slew,  
Forty good yards him froe.

"Well shot, well shot," quod Robin Hood then,  
"That shot it was shot in time;  
And if thou wilt accept of the place,  
Thou shalt be a bold yeoman of mine."

"Go play the chiven," the stranger said;  
"Make haste and quickly go,  
Or with my fist, be sure of this,  
Ile give thee buffets sto'."

"Thou had'st not best buffet me," quod Robin Hood,  
"For though I seem forlorn,  
Yet I can have those that will take my part,  
If I but blow my horn."

"Thou wast not best wind thy horn," the stranger said,  
"Beest thou never so much in haste,  
For I can draw out a good broad sword,  
And quickly cut the blast."

Then Robin Hood bent a very good bow  
To shoot, and that he would fain;  
The stranger he bent a very good bow,  
To shoot at bold Robin again.

"O hold thy hand, hold thy hand," quod Robin Hood,  
"To shoot it would be in vain;  
For if we should shoot the one at the other,  
The one of us may be slain."

"But let's take our swords and our broad bucklèrs,  
And gang under yonder tree."  
"As I hope to be sav'd," the stranger said,  
"One foot I will not flee."

Then Robin lent the stranger a blow  
'Most scar'd him out of his wit:  
"Thou never felt blow," the stranger he said,  
"Thou shalt be better quit."

The stranger he drew out a good broad sword,  
And hit Robin on the crown,  
That from every haire of bold Robin's head,  
The blood ran trickling down.

"God a mercy, good fellow!" quod Robin Hood then,  
"And for this that thou hast done,  
Tell me, good fellow, what thou art,  
Tell me where thou doest wone."

The stranger then answered bold Robin Hood,  
"Ile tell thee where I did dwell;  
In Maxwel town I was bred and born,  
My name is young Gamwel."

"For killing of my own father's steward,  
I am forc'd to this English wood,  
And for to seek an uncle of mine;  
Some call him Robin Hood."

"But art thou a cousin of Robin Hood then?  
The sooner we should have done."

"As I hope to be sav'd," the stranger then said,

"I am his own sister's son."

But lord! what kissing and courting was there,

When these two cousins did greet!  
And they went all that summer's day,  
And Little John did (not) meet.

But when they met with Little John,  
He unto them did say,

"O master, pray where have you been,  
You have tarried so long away?"

"I met with a stranger," quod Robin Hood,  
"Full sore he has beaten me."

"Then Ile have a bout with him," quod Little John,

"And try if he can beat me."

"Oh no, oh no," quod Robin Hood then,  
"Little John, it may not be so;

For he is my own dear sister's son,  
And cousins I have no mo'.

"But he shall be a bold yeoman of mine,  
My chief man next to thee;

And I Robin Hood, and thou Little John,  
And Scallock he shall be."

There are a number of expressions in this old poem which will not be clear to a modern reader. Explain to the pupils the nature of the old ballads, as given in the fifth-year work, and tell them the meanings of the following words:

"Gang" is a Scotch word meaning go; "deft" means carefully dressed, neat; "Ile" is an old spelling for I'll; "Mickle adoe" means much ado; "froe" is from—the strange order of this line is due to the ballad form. No one can be just sure what "chiven" means, but it is probably an old word for coward; "buffets sto'" means store of buffets; "quod" is an old form for quoth. "Cousin" formerly meant almost any relative; here it means nephew. "Mo'" is a shortened form of more, as "sto'" is of store, above.

### Eighth Year

**Introduction.** The eighth-grade work in grammar is a continuation of the seventh-grade work in an unusually real and close sense. There is little that is now introduced in the eighth year, but all of the subjects studied in the seventh year are expanded and systematized.

**Nouns.** The definition of this part of speech, together with many facts about it, was learned in the seventh grade. There yet remains, however, much systematic information about the noun which the pupils have not yet had given to them. The division into common and proper nouns has been touched upon, but it may be emphasized here, together

with the further division of common nouns into classes. Lists of *collective* nouns, names which denote a group, and of *abstract* nouns, words which name qualities, conditions or actions, may be made. Have collective and abstract nouns pointed out in the following sentences:

1. A crowd gathered rapidly.
2. Truth crushed to earth will rise again.
3. Praise the Lord for his goodness.
4. I find much pleasure in talking with him.
5. The row of houses looked bright and fresh in the sunlight.
6. My memory is not good.
7. Honesty is the best policy.
8. She had much trouble with her children.
9. Death comes to all.
10. The whole tribe was in arms.
11. A great herd of cattle was frightened by the storm.
12. His weight has increased.
13. One needs a good imagination to call up during the winter a picture of a summer day, with groups of children playing on the lawn, flocks of birds hovering over the trees, and the wonderful summer "feel" in the air.

Let the pupils make a list of all the ways they have studied in which nouns may be used; as subject, as object, as attribute, as part of a prepositional phrase. Add to these the uses as possessive modifier, as indirect object, independently in address, and in apposition. In the following sentences, the capitalized words illustrate the various uses in the order given above:

1. The BIRD flies.
2. He threw a STONE.
3. John is a good BOY.
4. I found the book on the TABLE.
5. The BOY'S hat blew off.
6. The teacher sent his MOTHER a note.
7. JOHN, come here this instant!
8. Mr. Smith, an upright, intelligent MAN, was elected.

After the pupils thoroughly understand the use of each noun in the above sentences, they may tell the way in which each one in the following sentences is used:

1. Child, did you not hear me call you?
2. He is a strong man, in mind as well as in body.
3. Did you see the mountains while you were away?
4. Rover, the most faithful dog I ever knew, is dead.
5. Mother, may I go out to swim?
6. He bought books, books, nothing but books.
7. The prisoner is guilty; there is no doubt about that fact.
8. The violet is a dainty flower.
9. The violet is one of the daintiest of flowers.

- 10. Father, John says that in the woods he saw a squirrel, a tiny fellow, steal a bigger squirrel's horde of nuts.
- 11. Give John that apple.
- 12. They never offer a visitor a chair.

The regular formal inflection of nouns follows this. Explain first the reason for inflection of nouns—to indicate differences in number and in case—and tell the pupils that inflection in English is very much simpler than in any of the ancient languages or many of the modern. The matter of number will give them little trouble, for they have been used to considering singular and plural forms of nouns ever since they began language study. But in dealing with the question of *case*, be sure that all understand that while there are only two case *forms* of a noun (as *boy, boy's*) there are three *cases*, one form doing duty for nominative and objective. Let them now turn back to the sentences in seventh-year work and classify each noun according to number and case. A little table may be worked out, dividing up the various uses of nouns which they have been studying according to the cases which they demand:

noun in as many as possible of the constructions in which nouns are used. Take, for example, the third personal pronoun, *he his, him*. It may be used:

- (a) As subject: HE crossed the river.
- (b) As object: John saw HIM yesterday.
- (c) As attribute: Yes, it was HE who did it.
- (d) As object of preposition: In HIM I find my ideal.
- (e) As possessive modifier; He snatched HIS hat.
- (f) As indirect objective: The teacher gave HIM the prize.
- (g) In apposition: The stranger, HE in the fur coat, is from Alaska.

This work with the personal pronouns is comparatively easy; that on the relative will be a little more difficult. The following will serve as examples of what may be done:

- (a) As subject: The man WHO bought our house is here.
- (b) As object: There is one boy WHOM we all like.
- (c) As object of preposition: There is the woman to WHOM I gave the message.
- (d) As possessive modifier: The boy WHOSE hat was knocked off was very angry.

| NOMINATIVE CASE   | POSSESSIVE (OR GENITIVE) CASE   | OBJECTIVE (OR ACCUSATIVE) CASE   |
|---|---|--|
| subject<br>attribute<br>independently in address<br>in apposition with another<br>noun in nominative. | possessive modifier<br>in apposition with another<br>noun in possessive | object<br>part of prepositional phrase<br>indirect object<br>in apposition with another<br>noun in objective |

Of course rules for the formation of plurals and possessives, together with a discussion of gender in English, form a part of this work on inflection.

**Pronouns.** The classes of pronouns, personal, relative, interrogative, adjective, will require considerable drill, though if each step is connected as closely as possible with the work which has previously been done on the noun, the subject will be much simplified. When the subject of inflection is reached, call the attention of the pupils to the fact that certain of the pronouns have fuller inflections than have the nouns, possessing, indeed, a distinct form for each case of each number.

|             |          |           |
|-------------|----------|-----------|
|             | SINGULAR | PLURAL    |
| Nominative: | I        | we        |
| Possessive: | my, mine | our, ours |
| Objective:  | me       | us        |

Although all of the pupils may have had drill on the correct forms of pronouns, there is no danger that they will be given too much practice. Let the blanks in the following sentences be filled in with the proper forms of the pronouns:

1. The man -- --you met is my father.
2. I shall give this to the person to ---- it belongs.
3. If you and ---- (3rd person) will go, I shall go too.
4. She asked her and ---- (1st person) to come to the house after school.
5. ---- do you suppose I met today?
6. ---- do you think he meant?
7. They demanded to know ---- I was waiting for.
8. Frank, John and ---- (1st person) will do it for you.
9. Was that John in the first seat? No, it was not ----.
10. I do not think that it could have been ---- (3rd person).
11. He declared that it was not ---- (3rd person) who broke the window.

An interesting exercise will consist in letting the pupils try to use each kind of pro-



12. The teacher scolded Mary and ---- (1st person) for being late.

13. Jane is crying because some bad boys hit Mary and ---- (3rd person) with snowballs.

14. ---- that honor me, I will honor.

**Adjectives.** The work on adjectives includes a review of their various uses, as studied in the seventh grade, and a drill on the comparison of adjectives.

**Verbs.** The subject of verbs will need much time, for conjugation is not a simple subject, and nothing but continued drill will make the pupils familiar with it. The fact that each number, each person, each mode and sometimes each tense does not have a distinct form makes the memorizing of conjugations easier, but makes parsing more difficult, because there are not always "tags" to help the pupil recognize each form. Another source of error which must be cleared away is the idea that the name of the tense always tells the time of the action. Thus in the sentence "He leaves town next week," the verb form is present, but the time is plainly future; in the sentence "Even though he saw me, he would not speak to me," the subjunctive *saw* is past in form, but present or future in meaning.

The difference between weak, or regular, verbs, which form their past tense and past participle by adding *d* or *ed*, and strong, or irregular, verbs, which make those forms by changing the vowel of the root, should be emphasized.

Regular: play, played, playing, played.

Irregular: write, wrote, writing, written.

There are certain verbs which resemble each other in form whose past tenses are likely to give trouble. There should be, therefore, special drill on such verbs as

|       |        |        |
|-------|--------|--------|
| sit   | sat    | sat    |
| set   | set    | set    |
| lie   | lay    | lain   |
| lay   | laid   | laid   |
| rise  | rose   | risen  |
| raise | raised | raised |

It is impossible to give here complete directions for the method of presenting all phases of this subject of the verb; any good textbook, however will, with the aid of the teacher, make the subject clear.

**Parsing.** The parsing of sentences is a very important part of this year's work. It forms in fact, in itself a complete review of all that has been learned about sentences and about the parts of speech. Too much emphasis cannot be placed on this subject. The

exact form of words in which the parsing is done may vary, but each teacher should have a method which should be rather rigidly adhered to. In parsing a noun, the following facts regarding it should be given:

1. The class to which it belongs.
2. Its number and gender.
3. Its case.
4. The reason for its case—that is, its construction in the sentence.

In parsing a verb or verb phrase the following facts should be given:

1. Class—whether transitive or intransitive, regular or irregular.
2. Principal parts.
3. The voice, mode, tense.
4. The person and number, and the subject with which it agrees.

A personal or relative pronoun is parsed as a noun is parsed, except that there is no distinction between common and proper, while the person and the antecedent if there is one, must be mentioned.

In parsing an adjective give:

1. The class to which it belongs.
2. The degree.
3. Its use.

In parsing an adverb, tell:

1. The kind of adverb, whether of time, place, manner, etc.
2. The verb, adjective or adverb which it modifies.

To parse a preposition, state its object and the relation which the phrase bears to some other word in the sentence; to parse a conjunction, tell whether it is coördinate or subordinate, what elements of the sentence it connects, and what its special significance is.

The complete parsing of a sentence should proceed about as follows:

"His house, which was very old, burned quickly."

"His" is a third personal pronoun, singular number, masculine gender and possessive case. It is a possessive modifier of "house."

"House" is a common noun. It is in the singular number, neuter gender and nominative case. It is the subject of the sentence.

"Which" is a relative pronoun, singular number, neuter gender and nominative case. It is the subject of the clause "which was very old." Its antecedent is "house."

"Was" is an irregular copulative verb. The principal parts are IS, WAS, BEING, BEEN. It is in the indicative mode and the past tense. It is third person, singular number, agreeing with "which," the subject of the clause.

"Very" is an adverb of degree, modifying the adjective "old."

"Old" is a descriptive adjective. It is in the positive degree, and is used attributively, after "was."

"Burned" is a regular, intransitive verb. The principal parts are BURN, BURNED, BURNING, BURNED. It is in the active voice, indicative mode and past tense. It is in the third person and singular number, agreeing with "house," the subject of the sentence.

"Quickly" is an adverb of manner, modifying the verb "burned."

**Composition Work.** The same general directions apply to composition work in this grade as were given for the seventh grade.

**Poems.** Any or all of the following poems will be good material for study in this grade:

- The Gift of Tritemius—Whittier.
- Herve Riel—Browning.
- To a Mountain Daisy—Burns.
- The Chambered Nautilus—Holmes.
- The Burial of Sir John Moore—Charles Wolfe.
- O Captain! My Captain!—Whitman.
- The Last Leaf—Holmes.
- Abou Ben Adhem—Leigh Hunt.

**LANGUAGES OF THE WORLD.** It is estimated that there are at least 5,000 dif-

| LANGUAGE       | PLACES WHERE SPOKEN  | NUMBER USING THEM                           |
|----------------|--|---|
| Basque         | Southern part of France; Northern Spain  | 440,000                                     |
| Bulgarian      | Bulgaria   | 5,650,000                                   |
| Czech          | There are 6,500,000 Czecks in Bohemia, Moravia and Silesia, 125,000 in Germany, 65,000 in Russia, and 500,000 in the United States. Besides these there are 2,500,000 Slovaks living in Northeastern Hungary, who speak practically the same language as the Czechs. In 1918 these peoples set up a Czecho-Slovak republic with Prague, Bohemia, as the capital. |   |
| Chinese        | China  | 400,000,000<br>(This includes all dialects) |
| Danish         | Denmark and Northern Schleswig. Danish is also spoken by the educated classes in Norway.   | 3,500,000                                   |
| Dutch          | Netherlands. A dialectic form is spoken by the Boers of South Africa   | 6,500,000                                   |
| Egyptian       | Egypt  | 10,500,000                                  |
| English        | The British Isles, Canada, Australia, New Zealand and officially in all the British colonies; the United States.   | 180,000,000<br>(or more)                    |
| Flemish        | Northern Belgium   | 3,500,000                                   |
| French         | France and its dependencies; French Canada; part of Switzerland. Walloon, a French dialect, is spoken in Southern Belgium.   | 52,000,000<br>(or more)                     |
| German         | Germany, Luxemburg, Northern Switzerland, German Austria. There are also German-speaking people in Russia, the United States, Brazil and elsewhere.  | 80,000,000                                  |
| Greek          | Greece, Asia Minor, Cyprus, Crete.   | 9,000,000                                   |
| Hindustani     | Northern India   | 100,000,000                                 |
| Italian        | Italy and its islands; parts of Switzerland, France and the former Austria-Hungarian Monarchy.   | 37,000,000                                  |
| Japanese       | Japan  | 53,000,000                                  |
| Norwegian      | Norway   | 2,400,000                                   |
| Persian        | Persia   | 9,500,000                                   |
| Polish         | The regions in Central Europe which formerly comprised the Kingdom of Poland. Also spoken in the United States.  | 16,000,000                                  |
| Portuguese     | Portugal, Brazil, dependencies of Portugal.  | 26,200,000                                  |
| Rumanian       | Rumania; parts of former Austria-Hungary, Russia, Serbia, Greece   | 12,000,000                                  |
| Russian        | Regions comprising old Russian Empire; by Ruthenians of Galicia, Bukowina and Hungary.   | 114,000,000                                 |
| Serbo-Croatian | Serbia, Montenegro, Croatia, Slavonia, Bosnia and Herzegovina, Southern Hungary  | 8,000,000                                   |
| Spanish        | Spain, Mexico, Central America, many countries of South America, Philippines, West Indies.   | 50,000,000                                  |
| Swedish        | Sweden   | 5,500,000                                   |

The following list of topics is meant to be suggestive merely; the teacher can relate the subjects with the work in other classes:

1. An original story on "The Last Day of Johnny's Vacation."
2. A letter from Norway, telling of the midnight sun.
3. Indian Summer.
4. An Original Fable.
5. A Visit to a Haunted House.
6. What I Shall Have in My Garden.
7. My Kitten, or, My Dog.
8. A letter to some author whose stories or poems you have read.
9. A Moonlight Evening.

ferent languages and dialects spoken throughout the world, ranging from the undeveloped systems of the most primitive races to the elaborate languages of the great civilized peoples, with their formal grammar and voluminous literatures. The most important languages, however those that are used by peoples or nations which have to-day a vital part in the making of history, number fewer than twenty-five, if we disregard dialects belonging to the same tongues. In respect to the number of persons using a particular tongue, with its various dialects, Chinese has

first place, for it is spoken by about 400,000,000. English is used by at least 160,000,000, ranking next to Chinese among all languages. English is preëminently the commercial language of the world, and is likely to develop considerably in this respect because of the part played by the great English-speaking nations in the World War.

The preceding table gives the world's chief languages, the number using them, and the places where they are spoken:

**LANIER**, *laner'*, SIDNEY (1842-1881), an American poet and musician born at Macon, Ga. After graduating from Oglethorpe College, he taught one year and then entered the Confederate army. He served through the war, suffering so much from exposure and imprisonment that he was an invalid the rest of his life. After the war he supported himself for a time by teaching, serving as clerk in a shop and practicing law with his father in Macon. He devoted all his spare time to literature and music, and after 1873, his entire time. For several years he played the flute as a member of symphony orchestras. In 1876 he was asked to write a cantata for the Centennial Exposition; in 1879 he became a lecturer in English at Johns Hopkins University, where he delivered the lectures afterwards published as *The Science of English Verse* and *The English Novel*. Lanier's poems, the best of which are *Corn*, *The Marshes of Glynn* and *Song of the Chattahoochee*, are remarkable for exquisite melody. He was one of the foremost poets of his generation and his fame is growing steadily.

**LANSLOWNE**, HENRY CHARLES KEITH PETTY-FITZMAURICE, Marquis of (1845- ), a British statesman, educated at Eton and Balliol College, Oxford. When a young man he entered upon a political career as a Liberal. Between 1868 and 1883 he held successively the offices of Lord of the Treasury, Under-secretary of War and Under-secretary for India. In 1883 he was appointed Governor-General of Canada, to succeed the Marquis of Lorne, and from 1888 to 1893 was Viceroy of India. In 1895 he became Secretary of War, and in 1900 Secretary of State for Foreign Affairs.

After 1905 Lord Lansdowne became leader of the Unionist opposition in the House of Lords. He led the opposition during the discussion of the Lloyd-George budget in 1909, and his attitude in that debate showed

that his sympathies were with the Conservatives rather than with the Liberals. In May, 1915, he entered the coalition Ministry headed by Premier Asquith, and on the accession of Lloyd George to the Premiership he retired to private life. Lord Lansdowne aroused spirited discussions in allied countries by issuing a declaration in November, 1917, in which he urged the allies to restate their war aims and prepare the way for peace negotiations. See WORLD WAR. (For portrait, see article GOVERNOR-GENERAL.)

**LANSING**, MICH., the capital of the state and the county seat of Ingham County, ninety miles northwest of Detroit, at the junction of the Grand and Cedar rivers, on the Grand Trunk, the Michigan Central, the Pere Marquette and the Lake Shore & Michigan Southern railroads. The city was settled in 1837, and was laid out as the capital ten years later, when the place was still a comparative wilderness; the town then had but one family.

The state capitol is a fine structure, located in a twelve-acre park near the center of the city. The state school for the blind and the state industrial school for boys are located here and the state agricultural college, with its farm of 680 acres, is near the city. Other important structures are a city hall, a public library, a hospital and a Federal building. The Grand River has a fall of eighteen feet and furnishes good water power; there are over 200 manufacturing enterprises. The manufactures include flour, stoves, automobiles, tractors, gas engines, furniture, cut glass, agricultural implements, artificial stone, machinery, condensed milk, beet sugar and knit goods. Population, 1910, 31,229; in 1917, 44,499 (Federal estimate).

**LANTERN FISH**, a name applied to certain deep-sea fishes, some of which are of remarkably grotesque appearance. They are called lantern fish because they possess phosphorescent organs which give the light necessary for them to see in the dark ocean abysses in which they live.

**LANTERN FLY**, so called on account of its long proboscis, which is said to be phosphorescent and luminous. It belongs to a large family, numbering among its members some of the biggest insects known. Many of them resemble butterflies and moths; some are brilliantly colored. All are vegetarians, and some are destructive to certain crops. In China the wax secreted by these insects is used in making candles.

**LAOCOON**, *la ok'o on*. See SCULPTURE, subhead *Laocoon*.

**LA PAZ**, *lah pahz'* BOLIVIA, the metropolis and capital of the republic and capital of the department of Bolivia, is magnificently situated on a great plateau at an altitude of more than 12,000 feet above the sea. The city lies thirty miles southeast of Lake Titicaca, and is surrounded by lofty mountains, being dominated by the towering Illimani. It occupies a deep U-shaped canyon, whose steep sides completely hide the place from the observer until he is at the very edge of the abyss. Travelers express in glowing terms their delight in the panorama which spreads itself before them as they approach La Paz. Three railroads lead to the canyon, and two of them have been extended down the steep sides.

Near the heart of the city is the imposing national Capitol, occupying one side of the Plaza Murillo, the most important public square. Near by are the President's and the legislative palaces and a magnificent cathedral. The latter, which was completed in 1919 is one of the largest churches in South America, covering an area of more than 43,000 square feet. La Paz is also the seat of a National Museum, housing collections of priceless value, and its municipal theater, a beautiful structure completed in 1909, has a seating capacity of 1,500.

The private homes are nearly all built of stone, and many of them are embellished with courts, balconies and carved portals. There are many wide and beautiful streets, such as the Alameda promenade as well as steep and winding ones; the more important thoroughfares are lighted by electricity. An electric street-car line traverses the chief business and residential streets. The city has many educational institutions, including the National University, the School of Applied Arts, the National School of Commerce, a military college, the school of war for officers (1917), the American Institute and a normal college for training teachers of the Indians. The city's industries are not important, but La Paz carries on a thriving trade in mineral and farming products. The town was founded in 1548 by Mendoza, the Spanish explorer. Population, about 82,000.

**LA'PIS LAZ'ULI**, or **LAZ'URITE**, a mineral composed of aluminum and sodium sulphide and several less important substances. It occurs massive and in crystals and is a

beautiful ultramarine blue. The best specimens come from China, Siberia, Persia and Chile. Lapis lazuli was much used by the ancients as a setting for jewelry and for fine inlay work and ornaments. It is similarly used to-day, though less extensively.

**LAPLACE**, *lah plas'*, PIERRE SIMON, MARQUIS DE (1749-1827), the greatest of French astronomers. His parents were very poor and unable to give him an education, but through the assistance of influential friends he was enabled to go to school, and at the age of twenty he became professor of mathematics in the military school, through the influence of D'Alembert, who was his patron. He is especially known by his important work in regard to improvements of the lunar theory, the question of tides and the stability of the solar system. He was the originator of the theory known as the nebular hypothesis (which see), for years generally accepted as a solution of the problem of the stability of the universe, but now generally discredited. His most noted works are *Celestial Mechanics* and *Exposition of the System of the Worlds*.

**LAP'LAND**, a territory in the extreme north of Europe, containing about 150,000 square miles, but having no definite boundaries, for it is not a political division. The name is derived from the Lapps, its native people. Over half the territory is within the limits of Russia, as that country existed under the czar and the remainder is divided nearly equally between Sweden and Norway. The population does not exceed 30,000.

The Lapps are a small muscular large headed race, with high cheek bones, wide mouth, flat nose and scanty beard. Many of them are nomadic, owing their subsistence to their herds of reindeer; others support themselves by fishing. They are generally ignorant, simple-hearted and hospitable. The Norwegian Laplanders belong to the Lutheran, and the Russian Laplanders belong to the Greek Church. The climate for nine months is excessively cold; spring and autumn are short, and the summer of two months is extremely hot. Vegetation is scanty, except in the form of birch, pine, fir, and the mosses which supply food for the herds of reindeer.

**LA PLATA**, *la plah'tah*, ARGENTINA, a modern and progressive city, founded in 1882 as the capital of the province of Buenos Aires. It is situated five miles from its

port, on the estuary of the Rio de la Plata and thirty-two miles southeast of the city of Buenos Aires, with which it has rail connection. La Plata is laid out on the same plan as the capital city of the United States, and has beautiful squares and parks, handsome public buildings, one of the best museums in South America and a fine observatory. At the head of the excellent public school system is a national university, with an enrollment of over 2,100. The city is connected by a canal with its port, Ensenada. It carries on actively the manufacture of cotton and woolen goods. Population, estimated, 119,000.

**LA PLATA, RIO DE.** See RIO DE LA PLATA.

**LA PORTE, la port',** IND., the county seat of La Porte County, twelve miles from Lake Michigan and sixty miles southeast of Chicago, on the Lake Erie & Western, the Lake Shore & Michigan Southern and Pere Marquette railroads. The city is in a farming region, and its manufactures include woolen goods, threshing machines, tractors, pianos, slicing machines and other articles. There are beautiful lakes in the vicinity, and the place has become an attractive and popular summer resort. There is a fine court house, library and a hospital. It was settled in 1830 and chartered as a city in 1852. Population, 1910, 10,525; in 1917, 13,572 (Federal estimate).

**LAPWING,** a beautiful bird of the plover family, found in Europe and Asia. It is about the size of a pigeon, has a glossy green back, jet-black throat and white under parts; the head is surmounted by a handsome crest. The bird is often called *peewit*, a name suggested by its plaintive cry. The eggs are a rare table delicacy.

**LARAMIE, lar'a me,** Wyo., the county seat of Albany County, fifty-six miles northeast of Cheyenne, on the Big Laramie River and on the Union Pacific and the Colorado, Wyoming & Eastern railroads. It is located on an elevation of over 7,000 feet, in the neighborhood of rich deposits of coal, iron, lead and other minerals. The city has extensive railroad shops, cement mills, rolling mills, soda works, flour mills and glass works. Laramie is the seat of the state university, the state agricultural college, a United States Agricultural Experiment Station and the state fish hatchery, and is the see of the Protestant Episcopal bishopric of Wyoming. There are five hospitals and

a Carnegie Library. The railroad company started the first sale of lots in what should comprise the future city in April, 1868. Population, 1910, 8,237; in 1917, 8,259 (Federal estimate).

**LARCENY, lah'r'se ny,** the fraudulent appropriation of the property of another person without that person's consent. To constitute this crime the removal of the goods to any distance is not necessary, but the article must completely pass, for however short a time, into possession of the criminal. The common law restricted the classes of things the appropriation of which is larceny, to personal property, but this distinction has been abolished by later statutes. Larceny was formerly divided into two kinds, *grand* and *petty*, according to the value of the thing stolen, but the distinction is now abolished in many states. Petty larceny is charged when the value of the stolen goods does not exceed \$15, or thereabouts, the amount varying in different states. The penalty varies, but in ordinary cases a person convicted of larceny is generally liable to imprisonment with hard labor for not more than two years; on second conviction not more than ten, nor less than four. See ROBBERY; BURGLARY.

**LARCH,** the common name of a genus of trees belonging to the cone-bearing family,

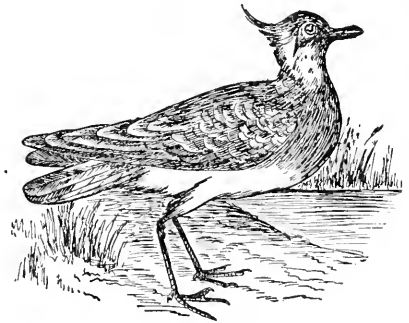

LAPWING

but not themselves fragrant. In New England and Canada the native species is known as *hackmatack*, and in the Western and Southern states the same tree is known as *tamarack*. This American larch often grows to a height of seventy feet in swampy places, where the soil is deep. It has a slender trunk and horizontal branches which are covered with fine, needlelike leaves that fall in autumn. The small cones turn to a beautiful deep red before they ripen. The wood, which is compact and durable, heavy and difficult

to burn, is valued for fence posts, railroad ties, telegraph poles, and in shipbuilding.

**LARD**, the fat of the hog. Lard is obtained by extraction from the fatty portions of the carcass, in kettles heated by steam. It is clarified by heating to a high temperature, straining and then cooling by refrigeration. Just before it solidifies, the lard is run into pails, barrels or other vessels for marketing. The best quality, called *leaf lard*, is found in the fat which surrounds the kidneys, and this is employed in pharmacy for the preparation of ointments. When subjected to pressure the oleine is liberated, forming lard oil, which is much used as a lubricant for machinery. Lard is used in cooking, in the manufacture of soap and for other purposes.

**LAREDO**, *la ray'do*, TEX., the county seat of Webb County, 140 miles southwest of San Antonio, on the Rio Grande, opposite Neuvo Laredo, and on the International & Great Northern, the National of Mexico and the Rio Grande & Eagle Pass railroads. The city is in a fertile agricultural and stock-raising district, and is an important shipping point between the United States and Mexico. There are coal mines in the vicinity, and the city contains ear and machine shops, brick and tile works, cracker and pickle factories, a tannery, foundries and other factories. Laredo has a fine courthouse and jail, an old Spanish cathedral, the Mexican National and Mercy hospitals and Ursuline Convent, and it is the seat of Laredo Seminary and Ursuline Academy. The place was settled by the Spaniards in 1767, and was first incorporated in 1848. Population, 1910, 14,855; in 1917, 15,894 (Federal estimate).

**LARES**, *lay'reez*, **AND PENATES**, *pe nay'teez*, the lesser Roman gods who presided over the home and over families. The Penates were gods from the beginning, while the Lares were erstwhile human beings who came back after death to watch over their friends or descendants. As far as the two classes of deities had separate provinces, it was believed that the Penates protected the interior of the home and watched over its happiness, while the Lares guarded it from danger from without. Small images of these deities were kept in the home and worshiped. When a family moved, it took with it its Lares and Penates and provided a place for them before the welfare of the family was looked after.

**LARK**, a song bird related to the finches, having a strong, short bill, nostrils covered with feathers, forked tongue and the power to raise the feathers on the back part of its head into the form of a crest. Larks are found generally distributed over the old world, but the only species in America is the *horned lark*. The larks live upon the ground, feeding on worms and larvae, and bring forth two broods in a year. The best known is the *English skylark*, which is celebrated for the prolonged beauty of its song, which it utters as it rises high in the air in spiral flight. It usually sings early in the morning and only during the nesting season. No bird has been more celebrated by poets than this and Shelley's *Ode to the Skylark* is one of the most beautiful poems in the English language. A few of these birds have been introduced into the United States, and some are now living wild on Long Island and elsewhere in the East.

The so-called *titlark* and *meadow lark* are not true larks. The meadow lark (which see) is an oriole. For the titlark, see PIPIT.

**LARK'SPUR**, the common name of a genus of plants belonging to the buttercup family. Some medicinal properties are possessed by several species, but the plants are cultivated principally for their handsome, irregular flowers, which grow in large open clusters or in spikes. One hundred or more species are found wild in the United States, but the most beautiful are natives of Asia. Gardeners have produced handsome double flowers with a great variety of coloring.

**LARVA**, *lahr'va*, in natural history, the name applied to the first stage in the life history of insects, and to the early form of any animal, in which there is little resemblance to the parent. In the latter sense the tadpole is the larva of the frog. In insects this is the grub or caterpillar stage. When the insect first appears, it is usually in the form of a maggot, or small worm, as it is popularly, though wrongly, called. The larval stage is usually the active stage of insect life, during which the animal accomplishes most of its growing. From time to time the larva sheds its skin to permit of greater growth. See METAMORPHOSIS; INSECTS; CATERPILLAR.

**LARYNGITIS**, *lar in j'i'tis*, inflammation of the larynx, the organ that produces the voice. It may be acute or chronic, the latter form being a common affection of

public speakers and singers who overtax the voice. The chief symptoms of acute laryngitis are chills and fever, rapid pulse, sore throat, hoarseness, difficulty in swallowing and a painful cough. The membrane of the glottis, or opening between the pharynx and larynx, becomes inflamed, and this makes the breathing difficult and noisy. An attack usually lasts four or five days, and the symptoms are most acute at night. This form of the disease is caused by exposure to cold, breathing dust or irritating gases, or drinking irritating liquids. Measures of relief include cold pack on the throat, inhalations of warm steam and the use of such drugs as the attendant physician may prescribe. Persistent hoarseness is the characteristic symptom of a chronic laryngitis. Tubercular laryngitis which often accompanies consumption of the lungs, is usually fatal.

**LARYNX**, *lar'inks*, the organ of voice, situated between the hyoid bone and the upper part of the trachea, communicating with the pharynx above and the trachea below. It is composed of nine cartilages. The *cricoid* cartilage has the shape of a signet ring, with the broad part toward the back of the throat, and is attached by fibrous tissue to the upper part of the trachea. The two *arytenoid* cartilages are placed on top of the wide part of the cricoid, with which they articulate in a movable joint. The vocal membranes are attached to them. The two halves of the largest cartilage, the *thyroid*, meet in an angle in front, but its sides do not form a complete ring. The projection of this cartilage is known as *Adam's apple*. The *epiglottis* is attached to the top of the thyroid in such a manner that it may close the opening from the pharynx to the larynx during the act of swallowing.

The vocal cords are two membranes which extend from the arytenoid cartilages across the larynx to the thyroid. They may be compared to the head of a drum, the membrane of which has been slit across the middle. The length and tension of these membranes are controlled by the movements of the arytenoid cartilages. In quiet breathing the slit, called the glottis, is wide open, being narrow in front and wider behind. A set of muscles pulls the arytenoid cartilages backward, thus stretching the vocal cords; another set pulls the same cartilages toward the thyroid cartilage, making the vocal cords slack; a third

set pulls the arytenoids toward each other, making the glottis narrower behind, while a fourth set has an opposite effect. The space above the vocal cords is triangular in shape, and its mucous lining, just above them, makes on each side a fold known as the false vocal cords. See VOICE; LARYNGITIS.

**LA SALLE**, *la sal'*, ILL., a city in La Salle County, 100 miles southwest of Chicago, on the Illinois & Michigan Canal and on the Chicago, Burlington & Quincy, the Chicago, Rock Island & Pacific and the Illinois Central railroads. It lies on high bluffs along the Illinois River, near productive bituminous coal fields. Other important industries are zinc smelting and the manufacture of cement, brick, sulphuric acid, implements, clocks and glass. The city has a Carnegie Library, a Federal building, a township high school and a hospital. The town is near Starved Rock and Dear Park, the most beautiful spots in the state. The place was settled in 1830 and was named in honor of La Salle, the explorer. Population, 1910, 11,537; in 1917, 12,332 (Federal estimate).

**LA SALLE**, RENÉ-ROBERT CAVELIER, Sieur de (1643-1687), a French explorer in America. He went to Canada early in 1666, and from there conducted many expeditions. In 1669 he descended the Ohio to the site of Louisville and later explored part of the region of the Great Lakes. He descended to the mouth of the Mississippi and took formal possession of the river valley in the name of France, naming the country Louisiana, in honor of Louis XIV. He built Fort Crèvecoeur, on the Illinois River, the first white settlement in Illinois. In 1684 he started on an expedition to the Gulf of Mexico. The party was overtaken by unforeseen hardships, and La-Salle was shot by a mutinous member of his company.



LA SALLE

**LASSA**, *lah'sah*. See LHASÁ.

**LASSALLE**, *la sal'*, FERDINAND (1825-1864), a celebrated German socialist, educated at the University of Berlin. He first became prominent as a leader during the democratic troubles of 1848, and was imprisoned for a year. In 1861 he published

his *System of Acquired Rights*. His organizing of the working classes led to an accusation of sedition, and he was imprisoned for four months. In May, 1863, he founded a labor union, whose object was to secure political representation for labor. Lassalle may be regarded as the founder of the German Social Democratic Party.

**LAS VEGAS**, *las va'gas*, N. M., chartered as a city in 1896, is the county seat of San Miguel County, forty-eight miles east of Santa Fé, on a branch of the Pecos River and on the Atchison, Topeka & Santa Fé Railroad. The city is composed of two parts, the old Mexican settlement and the modern city, known as East Las Vegas until it was incorporated as the city of Las Vegas. The city is located between the Rocky Mountains and the plains. It has a large trade in wool and contains wool scouring works, flour mills, wagon shops, foundries, and other factories. The city contains the New Mexico Normal University, the state insane asylum, a Carnegie Library and a sanitorium. The famous Las Vegas hot springs are six miles from the city. There are about forty of these springs, and on account of their curative properties they have become a favorite resort for invalids. It is to these springs that the fame of Las Vegas is largely due. Population, 1916, 6,935.

**LATERAN**, a Roman Catholic Church at Rome, built originally by Constantine the Great and dedicated to Saint John of Lateran. The site on which the buildings stand originally belonged to Plautius Lateranus, who was put to death by Nero. The Lateran is the principal church of Rome. In connection with it is a palace, now used as a museum of statues and antiquities, and several other buildings. Every newly-elected Pope takes solemn possession of the church, and from its balcony he bestows his blessing on the people. The palace and the church belong absolutely to the Popes, having been given them by the Italian government in 1871. Pope Leo XIII and many of his predecessors are buried in the Lateran.

**LATHE**, *layth*, a machine for turning and polishing flat, round, cylindrical and oval objects of wood, ivory or metal. The object worked receives a rotary motion. The important parts of the lathe are the frame, the balance wheel, the two heads, to which the object to be turned is fastened, and the rest for the chisel. One head slides in the groove

the frame and can be firmly fastened at any point by a screw. This admits of turning articles of different lengths. A belt passes from the balance pulley over another in the head and imparts the motion. A series of

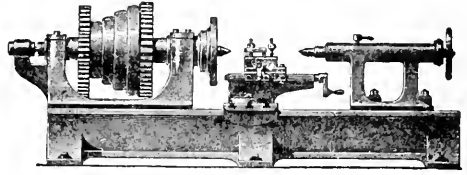

LATHE

pulleys of different sizes on the balance wheel and head enable different rates of speed to be maintained. A lathe for turning wood has a much higher speed than one for turning metal. The tools used are chisels made especially for the purpose. Small lathes are often run by foot power, but large ones use steam or electric power. Steam power is being rapidly supplanted.

**LATHROP**, JULIA CLIFFORD (1858- ), an American social settlement authority, the first chief of the Children's Bureau in the Department of Labor. She was born at Rockford, Ill., studied at Rockford College, and later at Vassar College, where she took her degree in 1880. Her chief interest was in the care of the insane, and she visited European institutions and made a study of the methods in use there; but other departments of philanthropic work also claimed her attention, and she helped to establish the Chicago juvenile court and the Chicago School of Civics and Philanthropy. Much of her time after 1899 was spent as a worker at Hull House in Chicago. In 1912 President Taft appointed her to be the head of the newly-formed Children's Bureau, and she was continued in this position indefinitely. See CHILDREN'S BUREAU.

**LATIMER**, HUGH (1490-1555), an English prelate, reformer and martyr. He was educated at Cambridge, was made chaplain to Henry VIII in 1530 and during the ascendancy of Anne Boleyn in 1535 he was appointed bishop of Worcester. In 1539 he resigned his bishopric, not being able to accept the Six Articles, and lived in privacy for six years. On coming to London, he was put in prison, but on the accession of Edward VI was released and became popular at court. When Mary ascended the throne, Latimer was condemned as a heretic and burned at the stake.



**LATIN LANGUAGE.** Latin is a branch of the Indo-European, or Aryan, family of languages. It was spoken by the people of Central Italy perhaps as early as 1500 B. C. In the period of the Roman Republic and the Empire it received its literary form, and it is to the language of that time the designation *classical* is given. During the last two centuries of the Empire, Latin became much corrupted through contact with other languages, and this process was still more marked after the fall of Rome. By the eighth century it had ceased to be a generally spoken tongue, and in the several countries where Roman civilization had been established, it had developed into the several tongues which have survived in the modern Romance languages. The chief representatives, besides Italian, are French, Spanish, Portuguese and Rumanian. In Great Britain the effect upon the language of the first contact with Latin was not considerable, owing to the early extinction of Roman supremacy there and the overpowering inroads of Germanic tongues. Of the largest proportion (about three-sevenths) of words of Latin origin in the English language, the most came in through the Norman Conquest (see ENGLISH LANGUAGE).

It is an interesting fact that the Romance tongues are descended, not from classical Latin, but from what is known as folk-Latin, the corrupted idiom of later popular speech. During the Dark Ages, Latin continued, in a corrupted form, to be the language of the Church, law and learning, and in some countries it remained so until within two centuries. In still later times it was employed, restored to its classical form, in learned writings and as a means of international communication. It was the clergy who preserved the Latin language and literature in the Dark Ages, and to the convents were carried the remnants of the libraries.

In structure and vocabulary Latin is more closely related to Greek than to any other Indo-European language, an interesting evidence of the probably close relationship of the two races. The Latin language is remarkable for its accuracy of expression and its perfect mechanical structure. It was, indeed, well fitted for its important service in the law. As Latin has never ceased to be spoken as a learned language, its pronunciation has followed in general the principles governing the language of each country in

which it is used. In America a method known as the *Roman* is, however, now almost universal in the universities, colleges and high schools of the country. This is an attempt to attain to the real pronunciation of Latin in the time of Cicero. The vowels are pronounced almost as in Italian, but the consonants as in English, with the exception that *c* and *g* are always hard; *r* is trilled; *s* is voiceless; *z* is like *dz*; *ph*, *th* and *ch* are really aspirated consonants. In England the *English method* is still used in the schools, the Latin words being pronounced as if they were English.

**LATIN PHRASES.** See page 1373.

**LATITUDE**, in geography, is distance north or south of the equator. A place is in *north latitude* or *south latitude* according as it is north or south of the equator. The highest or greatest latitude is 90°, that is, at the poles; the lowest or smallest, 0°, at the equator, between which and the poles any number of parallel circles called *parallels of latitude* may be supposed to be drawn. One method of finding the latitude of a place is by measuring the altitude of the polar star, the latitude of the observer being equal to the altitude in degrees of the star above the horizon. When the latitude and longitude of a place are given, its position on a map is easily found. Certain parallels of latitude are more noteworthy than others (see below).

**Related Articles.** Consult the following titles for additional information:

|                  |           |
|------------------|-----------|
| Antarctic Circle | Longitude |
| Arctic Circle    | Tropics   |
| Equator          | Zone      |

**LATIUM**, *la'she um*, the ancient name of a district of Italy, lying midway on the western coast between the Appennines and the Mediterranean, extending between Etruria and Campania and inhabited by Latins, Volsci, Aequi and other peoples.

**LATTERDAY SAINTS**, officially The Reorganized Church of Christ of Latter Day Saints, a religious body which claims to be the true successor of the Mormon Church established by Joseph Smith. The headquarters are at Lamoni, Iowa, and the present head of the church is Frederick Smith, grandson of Joseph Smith. The reorganized church has no connection with the Mormons. The denomination has about 70,000 members and 800 churches. See MORMONS.

**LAUD**, WILLIAM (1573-1645), archbishop of Canterbury in the reign of Charles I, born

at Reading in Berkshire. He was educated at Saint John's College, and took priest's orders in 1601. He became unpopular with the university authorities because of his strong opposition to Puritanism. He was made archbishop of Canterbury in 1633, and was twice offered the cardinal's hat. As archbishop he instituted rigorous proceedings against all who would not conform to the Church of England. By means of spies he hunted out the Puritans, and sought to extinguish all forms of dissent through fines, imprisonment and exile. When the Long Parliament met (1640), the archbishop was impeached for high treason. The House of Commons passed a bill of attainder (1644) and declared him guilty of high treason. He was beheaded on Tower Hill.

**LAUDANUM**, or **TINCTURE OF OPIUM**, a brownish-red fluid, prepared from opium and having the qualities of that drug, but in a milder degree. It is a frequent ingredient of "soothing syrups" for infants and is sometimes given to relieve colic and pains. Its use, however, is liable to be very injurious, and it causes not a few deaths among infants. See OPIUM.

**LAUDER, HARRY, Sir** (1870- ), a popular composer and singer of Scotch songs, born at Portobello, Scotland. Before he began his professional career he worked in a flax-spinning mill and as a coal miner. During these years of manual toil he managed to learn something of music and became a successful amateur singer of ballads. His regular stage career began with tours in the British Isles, and in the music halls in London he speedily won an enviable reputation. Subsequently he repeated his success in America, where, season after season, from 1907, he drew immense and enthusiastic audiences. He led a company of bagpipers on a recruiting tour through England in 1915, and after America entered the war they toured the United States to raise war-relief funds. Lauder's son died in Flanders while fighting for the cause. The words and music of the ballads sung by this popular comedian are of his own composing, and he renders them in a manner that is often imitated but never duplicated. Besides songs, he has written *Harry Lauder at Home and on Tour* and a Scottish comedy. Lauder is his stage name; his real name is MacLennan. In 1919 he was knighted by King George "for empire service rendered during the war."

**LAUGHING**, *lahf'ing*, **GAS**, nitrous oxide or nitrogen monoxide or protoxide of nitrogen; so called because, when inhaled, it usually produces exhilaration. It is administered by dentists to deaden pain and produce unconsciousness during the extraction of teeth, as its effects are usually less severe than those of ether or chloroform. A recent substitute in dental operations is a mixture of nitrous oxide and oxygen. See NITROGEN.

**LAUGHLIN**, *laf'in*, **JAMES LAURENCE** (1850- ), an American economist and educator, born at Deerfield, Ohio. He was graduated from Harvard in 1873, taught in the public schools of Boston and later was instructor and assistant professor of political economy at Harvard. In 1890 he became professor of political economy at Cornell and two years afterward accepted a similar position at the University of Chicago. As a member of the monetary commission, he took an active part in its discussions and wrote a report of the greatest value. He was a delegate to the Pan-American Scientific Congress in Santiago, Chile, in 1909, and from 1911 to 1913 was a foremost member in the National Citizens' League for the Promotion of Sound Banking. Among his published writings are *The History of Bimetallism in the United States*, *Elements of Political Economy* and *Facts About Money*.

**LAUREATE**, *law're ate*. See POET LAUREATE.

**LAUREL**, a plant native to Northern Africa and Southern Europe. It is cultivated in gardens, not only on account of its elegant appearance, but also for the aromatic fragrance of its evergreen leaves. The fruit, which is of a purple color, and the leaves, have long been used in medicine. From the fruit of the sweet bay, a species of laurel, several valuable oils are extracted; the cherry laurel yields a volatile, poisonous oil when its leaves are distilled in water. The name *laurel* is also given in America to species of rhododendron and other plants having thick leaves of a dark, glossy green. In ancient times heroes and



LAUREL

scholars were crowned with wreaths of bay leaves, and thus the terms *laurels*, *bays* and *laureate* came to be significant of honor.

**LAUREL**, *law'rel*, Miss., founded in 1894, is the county seat of Jones County, ninety miles southeast of Jackson, in the heart of the yellow pine district, on the New Orleans & Northeastern, the Gulf and Ship Island and the New Orleans, Mobile and Chicago railroads. Pine lumbering is the chief industrial item which has contributed to the rapid growth of the town. There are also cotton mills, a mattress factory, a pattern and model works, a fertilizer factory, a foundry and a wagon works. A Federal building was completed in 1914, and there are two hospitals, a city hall and a Y. M. C. A. The state agricultural fair is held near the city. Population, 1910, 8,465; in 1917, 12,313 (Federal estimate).

**LAURENTIAN**, *law ren'shan*, **MOUNTAINS**, a range of low mountains in Canada, extending for over 3,000 miles from Labrador to the Arctic Ocean, forming the watershed between Hudson Bay, the Saint Lawrence River and the Great Lakes, and dividing Hudson Bay from the sources of the Mackenzie River. The average elevation is about 1,500 feet, but some peaks attain a height of over 3,000 feet.

**LAURIER**, *lo'ri a*, WILFRID, Sir (1841-1919), a distinguished Canadian statesman and orator, Premier of the Dominion from 1896 to 1911. He was the first French-Canadian to head the national Cabinet, and his administration of fifteen years was a period of progress for Canada.

Laurier was born at Saint Lin, Que., and educated at L'Assomption College and McGill University, where he took the course in law. At graduation he delivered the valedictory address, which, like so many of his later speeches, closed with an appeal for sympathy between the French and English peoples as the secret of Canada's future. After a number of years of law practice and journalism he was elected to the Quebec assembly in 1871, and three years later to the House of Commons, where he quickly rose to prominence. In 1877 he became Minister of Inland Revenue in the Liberal government of Alexander Mackenzie. After the defeat of the Mackenzie government in 1878 because of its low tariff platform, Laurier became one of Edward Blake's chief lieutenants in the opposition, and on Blake's retirement in 1887

he became the recognized leader of the Liberal party.

From the first he won great popularity and showed unusual capacity for leadership. In 1896 his party carried the country and Laurier was called to form a Ministry. The following year he received the honor of knighthood. During his long term in power, 1896-1911, he saw Canadian prosperity advance by leaps and bounds. The chief features of his administration



LAURIER

were the enactment of special tariffs for goods imported from Great Britain, the sending of Canadian troops to South Africa during the Boer War, the contract with the Grand Trunk Railway for the construction of a new transcontinental railroad, the appointment of a Federal commission with power to regulate freight and express charges and telephone rates, the reduction of the postal rate from three to two cents for domestic postage and from five to two cents for Great Britain, the United States and Mexico, and the formation of the provinces of Alberta and Saskatchewan. In 1910 he arranged a reciprocity treaty with the United States, but when the question was submitted to the voters the Liberals were defeated and the treaty failed of ratification. The Laurier Ministry resigned on October 6, 1911, and was succeeded by a Conservative Ministry under Sir Robert Borden (which see).

Sir Laurier then became leader of the Opposition, but during the World War he urged his followers to support the war program of the government. This attitude he maintained until 1917, when the Borden coalition Cabinet declared for conscription. An appeal to the country followed the passage of the Parliamentary conscription act, and in the ensuing election Sir Laurier led the Liberals, who were opposed to conscription. Though Quebec was almost solidly anti-conscription, the country as a whole returned Sir Robert to power by a decisive majority. Sir Laurier was a polished and eloquent orator, and a man of vision and high ideals.

**LAURIUM**, *law'ri um*; MICH., in Houghton County, seventeen miles northeast of

Houghton, on the Mineral Range and the Copper Range railroads. The town is in one of the richest copper regions in the world; near here is the famous Calumet and Hecla mine. Laurium and Red Jacket comprise the township of Calumet. Population, 1910, 8,537; in 1917, 10,649 (Federal estimate).

**LAUT**, AGNES CHRISTINA (1872- ), a Canadian author, born at Stanley, Ontario, educated at Manitoba University. She became an editorial writer on the *Manitoba Free Press* in 1895 and later was correspondent for United States, Canadian and English publications. Miss Laut is well known as the author of a number of books on Canadian history and biography; among these are *Lords of the North*; *Heralds of Empire*; *Pathfinders of the West*; *Vikings of the Pacific*; *Canada, Empire of the North*; *Freebooters of the Wilderness*, and *Through the Unknown Southwest, the Wonderland of the United States*.

**LAVA**, *lah'va*, the general name for all rocky matter which flows or has flowed in a molten state from volcanoes and which, when cooled forms varieties of tufa, trachyte and basalt, according to the proportions of feldspar, hornblende and augite which enter into its composition. The texture of rocks formed from lava depends upon the rapidity with which the mass has cooled. When cooled rapidly the lava forms a compact rock. If cooled slowly, the rock is porous and often brittle and easily crumbled. Lava beds occur in two forms; those which have been deposited by the overflow of volcanoes, and are found on the sides and at the base of volcanic mountains, and those which have been forced up between other layers of rock and have cooled in this position. Such beds often outcrop at the summits of mountains or at high altitudes upon their sides. See **VOLCANO**.

**LAVAL**, *la vah'l*, **UNIVERSITY**, a Canadian educational institution, established at Quebec in 1852, under the auspices of the Roman Catholic Church. It maintains departments of theology, law, medicine and arts. The faculty numbers over seventy, and there are about 475 students. The library contains 140,000 volumes, and the museum has one of the most complete collections of Indian relics in America. At Montreal there is an affiliated university, established in 1876. It is independent in administration,

and has full control of its educational affairs, but degrees are awarded by the Quebec institution.

**François Xavier de Laval Montmorency** (1623-1708), for whom the university was named, was a French churchman, born at Laval, France. He became a priest at twenty-three and a few years later became archdeacon of Evreux. In 1659 he was sent to Canada, as a special envoy of the Pope, and in 1668 established the Seminary of Quebec, besides actively engaging in the upbuilding of French and Roman Catholic influence in the region.

**LAVENDER**, a fragrant shrub, three or four feet high, which is native to Southern Europe. From the flowers of the lavender is extracted an oil used in making perfume. The oil is pale yellow, and has an aromatic odor and a "hot" taste; it is used as a medicine. Lavender water is a solution of oil of lavender, flavored with attar of roses, bergamot, musk, cloves or other preparation. Florida water, a favorite American perfume, is largely prepared from lavender.

**LAW**, as a feature of government, may be defined as follows:

(1) It is a rule of conduct, prescribing what must be done or shall not be done, made effective by competent authority, as a city council, a legislature, Congress or Parliament.

(2) It includes the entire compilation of such enactments.

(3) It includes the science which investigates and reaches decisions on all phases of human conduct bearing upon the personal and business relations of men.

Law in the first meaning given above originated in custom, in the precedents of the action or forbearance from action of individuals, kinsmen, tribes and finally, of the community as a whole, or society. Eventually, the necessity of establishing tribunals for settling controversies became apparent, and the decisions of these tribunals gave to precedent a much greater force and eventually practically established laws by declaring what previous custom had been. Gradually these tribunals or courts evolved a new set of rules, not founded entirely upon precedent, but upon common sense and conscience (see **EQUITY**). It was not a long step from law making by judges to the establishment of a special law-making body, or legislature. Thus, the three great branches of law were developed, *common law*, or the law of custom; *equity*, or the law of right, and *statutory law*.

Law in its modern sense is said to be of two kinds, *substantive*, which deals with principles of right to be followed, and *remedial*, which deals with procedure in case of violations, that is, with the arrest and trial of offenders. Substantive law is in turn divided into *public law*, which deals with the state and its relations, and *private law*, which concerns private persons and property.

Another division of public law is sometimes made. It is said to consist of *international law*, or the law recognized between nations, *constitutional law*, which regulates the organization and the relations of the parts of a single state and *administrative law*, which regulates the procedure of the various organs of government. Remedial law has to do not only with civil and criminal procedure, but with the classification of crimes and penalties.

This article treats only of the fundamental principles and the general organization of the subject of law. The many variations in the treatment and framing of laws by different nations and races cannot be profitably discussed except in many volumes.

**Related Articles.** Consult the following titles for additional information:

|                           |                               |
|---------------------------|-------------------------------|
| Admiralty                 | Expectation                   |
| Admiralty Court of Canada | Ex Post Facto                 |
| Adoption                  | Extradition                   |
| Affidavit                 | False Imprisonment            |
| Age                       | False Pretenses               |
| Agent                     | Finger Print Identification   |
| Alias                     | Flotsam, Jetsam and Ligan     |
| Anti-Trust Laws           | Franchise                     |
| Appeal                    | Garnishment                   |
| Arrest                    | Garrote                       |
| Assignment                | Guarantee                     |
| Attachment                | Guardian                      |
| Attainder                 | Guillotine                    |
| Bail                      | Habeas Corpus                 |
| Bankrupt                  | Hanging                       |
| Barrister                 | Heir                          |
| Benefit of Clergy         | High Seas                     |
| Bertillon System          | Homestead Laws                |
| Bill of Attainder         | Husband and Wife              |
| Bill of Rights            | Impeachment                   |
| "Blue Sky" Laws           | Imprisonment for Debt         |
| Bona Fide                 | Indeterminate Sentence        |
| By-law                    | Injunction                    |
| Capital Punishment        | International Law             |
| Chancery                  | Intestacy                     |
| Chattel                   | Judge                         |
| Civil Law                 | Judgment                      |
| Code Napoleon             | Judicial Department of Canada |
| Commercial Law            | Jury and Trial by Jury        |
| Common Carrier            | Juvenile Court                |
| Common Law                | Labor Legislation             |
| Contempt                  | Lease                         |
| Contract                  | Libel                         |
| Convict Labor             | License                       |
| Copyright                 | Lien                          |
| Court                     | Lynch Law                     |
| Court of Claims           | Malice                        |
| Crime                     | Martial Law                   |
| Criminology               | Morals Court                  |
| Deed                      | Mortgage                      |
| Demurrer                  | Navigation Acts               |
| Easement                  | Negligence                    |
| Eminent Domain            | Neutrality                    |
| Enemy                     | Notary Public                 |
| Equity                    |                               |
| Estate                    |                               |
| Exchequer Court of Canada |                               |
| Executor                  |                               |

|                   |                         |
|-------------------|-------------------------|
| Nuisance          | Search, Right of        |
| Oath              | Slander                 |
| Parent and Child  | Statute                 |
| Parliamentary Law | Subpoena                |
| Patent            | Sumptuary Laws          |
| Peer              | Supreme Court           |
| Perjury           | Supreme Court of Canada |
| Personal Liberty  | Title                   |
| Personal Property | Torrens System          |
| Petition          | Tort                    |
| Pillory           | Torture                 |
| Power of Attorney | Treadmill               |
| Preemption        | Treason                 |
| Primogeniture     | Trespass                |
| Prison            | Trustee                 |
| Probate           | Usury                   |
| Procedure         | Wager                   |
| Public Defenders  | Warrant                 |
| Pure Food Laws    | Wheel                   |
| Quorum            | Will                    |
| Rack              | Witness                 |
| Reform Schools    | Writ                    |
| Retainer          |                         |
| Riparian Rights   |                         |

#### JURISTS AND LAWYERS

|                             |                                   |
|-----------------------------|-----------------------------------|
| Alverstone, Lord            | Ingersoll, Robert G.              |
| Blackstone, Sir William     | Jay, John                         |
| Brandeis, Louis             | Kent, James                       |
| Brewer, David               | Lamar, Lucius Quintus Cincinnatus |
| Chase, Salmon P.            | Lindsey, Benjamin                 |
| Choate, Joseph Hodges       | Earr                              |
| Davis, David                | Marshall, John                    |
| Fuller, Melville Weston     | Reading, Baron                    |
| Gray, George                | Taney, Roger                      |
| Harlan, John Marshall       | Brooke                            |
| Holmes, Oliver Wendell, Jr. | Waite, Morrison Remick            |
| Hughes, Charles Evans       | White, Edward D.                  |

**LAW, ANDREW BONAR** (1858– ), a British statesman, born in the Canadian province of New Brunswick and educated in Scotland. Before he became prominent in politics he was a successful iron manufacturer, attaining a partnership in one of the largest iron establishments in Glasgow. In 1900 he was elected to the House of Commons as a Unionist; two years later he was appointed Parliamentary Secretary of the Board of Trade, and in 1911 became leader of the Opposition in the House. Law held the position of Secretary of State for the Colonies in the Asquith coalition Cabinet of 1915, and in 1916, when Lloyd George formed a new Cabinet, he accepted the post of Chancellor of the Exchequer and became one of the five members of the War Council. In 1917 he resigned from the War Council, but continued the position of Chancellor of the Exchequer until the dissolution of Parliament in 1918. Law was re-elected to Parliament in December of that year, and when the new Cabinet was organized in January, 1919, he was appointed Lord Privy Seal and leader of the House of Commons. He was also appointed to serve on the British peace commission in Paris.

**LAW, JOHN** (1671–1729), a celebrated financier and speculator, son of a goldsmith of Edinburgh. In 1691 he went to England,

but was compelled to leave the country after a four years' residence, on account of a duel. Having made a fortune by gambling, he went to Paris and there set up a bank. His exceptional financial ability secured for him the confidence of the people, and in 1717 he floated the celebrated Mississippi Scheme and became powerful. But the large amount of paper currency issued caused the stock to depreciate, and in 1720 the Mississippi Scheme, with the bank, collapsed, and Law fled from France. See MISSISSIPPI SCHEME.



**LAWN TENNIS**, a modified form of an old English game, played with rackets and light rubber balls about 2½ inches in diameter and thinly covered with felt. The ground, or *court*, on which tennis is played should be 78 feet long by 27 feet wide when two play, or 36 feet wide when four play. It should be laid on a level surface of turf or firm ground. The court is marked with white lines

indicating the boundaries, and the space is divided in the middle by a net 3 feet in height, stretched across from one side to the other. The accompanying diagram shows a court properly laid out. When two play, the narrow court only is used; when four play, the entire court. The racket is 8 inches wide and 15 inches long, and weighs from 12 to 15 ounces.

The object of the game is to knock the ball with the racket into the opponent's court, as explained later in this article, so that he

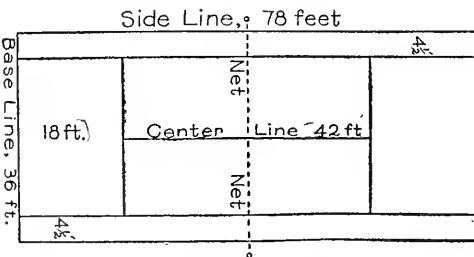

LAWN TENNIS COURT

cannot return it. Whenever this is accomplished, a score is made. The first point won by either side counts 15. The second point

won by either side makes its score 30, and the third, 40. The fourth point wins the game, unless each side has won three points, which would make the score of both teams 40. When the sides are tied at 40, the score is said to be *deuce*, and one side must win two points in succession in order to win the game. That is, the game continues until one side scores two points in excess of the other, and thereby wins. A *set* is played when either side has won six games, the side first winning this number of games winning the set. One modification of this statement is necessary. If in any set both sides have won five games, this becomes a *deuce set*, and neither side is the winner until it has won two games in excess of the other.

At the beginning of the game one player takes the ball and *serves* it; that is, he tosses it into the air and knocks it with the racket over the net and into the small square on the opposite side, near the net and diagonally opposite the server. It must be returned by the other player on the first bound after it strikes the ground. The server then returns the ball, either before it strikes the ground or on the first bound. The player who first misses the ball or knocks it outside of the outside lines or fails to knock it over the net, loses the point. There are numerous rules which govern the niceties of plays, and these may be learned from a manual of the game.



TENNIS RACKET

Lawn tennis is an excellent game, requiring great activity and skill and giving vigorous exercise. It is played by both sexes.

**LAWRENCE, JAMES** (1781-1813), an American naval officer, born at Burlington, N. J. In 1798 he entered the United States navy as midshipman. He served under Commodore Bainbridge in the War of 1812, and as commander of the *Peacock* captured the *Hornet*. This victory gained for him the command of the *Chesapeake*. But a few days



JAMES LAWRENCE

after taking command of this ship he engaged in battle with the British ship *Shannon*. His ship was captured and he was mortally wounded. His dying words, "Don't give up the ship!" became the motto of the American navy.

**LAWRENCE, KAN.**, the county seat of Douglas County, forty miles west of Kansas City, on the Kansas River and on the Atchison, Topeka & Santa Fé and the Union Pacific railroads. It is the seat of the state university (see KANSAS, UNIVERSITY OF) and of the Haskell Institute, a national industrial school for Indians, which occupies a site of 600 acres. The manufactures include flour and paper mills, pianos, creameries, foundries, machine shops and woodworking establishments. The commission form of government was adopted in 1914. There are two hospitals and a Carnegie Library. Lawrence was founded by the Emigrant Aid Society in 1854, after the passage of the Kansas-Nebraska Bill, and was for a time the headquarters of the antislavery party in the territory. Population, 1910, 12,374; in 1917, 13,477 (Federal estimate).

**LAWRENCE, MASS.**, one of the county seats of Essex County, twenty-six miles northwest of Boston, on both sides of the Merrimac River and on six lines of the Boston & Maine Railroad. The Common, which is the largest public park, contains a monument in honor of the soldiers of the Civil War. Glen Forest, on the banks of the Merrimac, is a popular park resort. There are various educational and numerous charitable institutions, besides a large public library. Prominent buildings include the city and county courthouse, a state armory and Odd Fellows' Building.

The first settlement was probably made here about the middle of the seventeenth century, but the modern city dates from the construction of the great dam across the Merrimac. The river falls twenty-six feet in half a mile and furnishes abundant water power. The city has long been known for its extensive manufactures of cotton and woolen goods, including shirtings, calicoes, flannels, broadcloths and other goods. There are various other establishments, including paper mills, foundries and carriage, engine, sewing machine and other factories. The town was incorporated in 1847 and was chartered as a city in 1853. Population, 1910, 85,892; in 1917, 100,560 (Federal estimate).

**LAW SCHOOLS**, educational institutions for preparing students for the legal profession. The first law school established in America was at Litchfield, Connecticut, in 1784. This was an entirely independent institution and continued for about fifty years, when it suspended.

The beginning of law schools as departments of the different colleges was in the form of courses of lectures on law, delivered in such institutions as the College of Philadelphia, Columbia and Harvard. Later, law departments were organized in these institutions, and these finally became law schools. In addition to schools of this nature, there are in the large cities of the country many independent law schools having courses similar to those connected with the universities. The standards for admission vary somewhat in different states. The best schools require a college course as preliminary to their work, and the law course occupies from three to four years. Other schools admit students without this preparation and do much more elementary work. Graduates are examined by state boards before being licensed to practice law.

**LAWSUIT.** See PROCEDURE.

**LAW'TON, HENRY WARE** (1843-1899), an American soldier, born at Manhattan, Ohio. He entered the Union army in 1861 and served during the Civil War, attaining the brevet rank of colonel. In 1866 he was commissioned second lieutenant in the regular army, and later he was made inspector-general, with the rank of major. At the beginning of the war with Spain he was promoted to the rank of brigadier-general of volunteers and commanded the division that captured El Caney, July 1, 1898; as major-general he had command of the Department of Santiago. In 1898 he was assigned to the Philippines, where he rendered valuable service in putting down rebellion. He was killed in battle at San Mateo, in December, 1899.

**LAZ'ARUS**, a Bible name meaning *God hath helped*. It is used as (1) the name of the beggar in the parable of the rich man and Lazarus (*Luke XVI, 19-31*); (2) as the name of the brother of Martha and Mary, whom Jesus raised from the dead (*John XI, 1-44*).

**LAZ'URITE.** See LAPIS LAZULI.

**LEAD**, *led*, a soft metal of bluish-gray color, which, when cut, has a bright metallic luster, but soon tarnishes on exposure to

the air. It is about eleven and one-third times heavier than water and is easily indented or bent, but is not elastic. It is somewhat ductile and quite malleable, but it is not strong. Lead melts at a temperature of about three times that of boiling water, but it contracts on solidifying, and for this reason is not suitable for castings.

Lead is used for lining tanks and tea chests, in the manufacture of lead pipe and in making numerous alloys and compounds, such as solder, Britannia metal, powder, shot and type metal, which is a compound of lead and antimony. A number of compounds of lead are also in general use. Of these, the oxides,

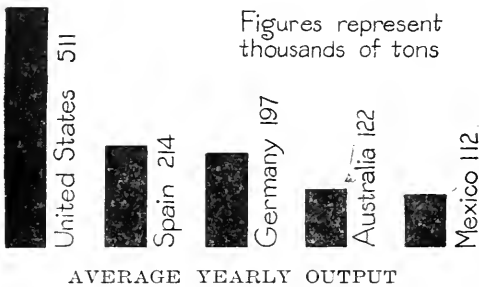

*litharge* and *red lead*, are used in paints and the manufacture of glass, and the carbonate of lead, or *white lead*, forms the basis of many paints. *Lead acetate*, or *sugar of lead*, is used in coloring and sometimes for medicine. See LEAD POISONING.

Lead ore is quite generally distributed, but it is found in paying quantities in only a few localities. The most important ores are the *sulphide*, or *galena*, sometimes known as *lead glance* (see GALENA), and the *carbonate*, which often contains considerable silver and copper. Such ore is worked for various metals which can be obtained from it; considerable silver is obtained in the reduction of lead ore, and considerable lead in the reduction of silver ore.

The United States leads all countries in the production of lead: Spain is second, Germany has been third, Australia fourth, and Mexico, fifth, in output. In the United States the production is greatest in Missouri, Idaho, Utah and Colorado, in the order named.

**LEAD, SOUNDING**, a weight attached to a cord, used in casting into the water that the mariner may ascertain its depth, and thus avoid shoals and possible destruction to his ship. See SOUNDING.

**LEAD, lead**, S. D., in Lawrence County, thirty miles from the western boundary of the state, on the Chicago, Burlington & Quincy and the Chicago & North Western railroads. It is the chief city in the gold-mining center of the Black Hills, and there is some tungsten. The chief mine is called the Homestake, one of the richest gold producers in the world. There are manufactories of mining tools and camp supplies. The city has a business college, the Hearst Library and the Lead Coliseum. The commission form of government was adopted in 1912. Population, 1910, 8,392; in 1917, 9,984 (Federal estimate).

**LEAD GLANCE**, another name for galena (which see).

**LEAD POISONING** is caused by the presence of lead in the system. Lead is often contained in water or other beverages which have been in lead pipes or vessels, and it is not infrequently found in confectionery which has been colored and in wine that has been sweetened by lead preparations. Sufficient lead may be taken from any one of these sources to cause more or less serious illness, but the most frequent and virulent cases occur among painters and persons engaged in white lead factories. The effects of poisoning may manifest themselves in severe colic, in a species of rheumatism, in paralysis or, rarely, in brain diseases that terminate at length in delirium, convulsions and death.

**LEADVILLE**, *led'vil*, COLO., the county seat of Lake County, eighty miles southwest of Denver, on the Colorado Midland, the Denver & Rio Grande and the Colorado & Southern railroads. The city is picturesquely located at an elevation of 10,200 feet. Rich placers were discovered here in 1860 in California Gulch, but in a few years they were almost exhausted and the camp was practically abandoned, when, in 1877, rich silver and lead deposits were discovered. It then became widely known as a silver camp. After the decline in silver late in the nineteenth century, attention was again turned to gold mining, and for years the district has been a heavy producer of gold, also of zinc, copper, bismuth and manganese. The city contains large sampling, refining and reduction works and smelting furnaces. There is a Federal building, a Carnegie Library, an Elks' Opera House and a United States fish hatchery. Population, 1910, 7,508.

**LEAF**. See LEAVES.



**LEAF INSECTS**, popularly known by the name of *walking leaves*. Some of them have wing-covers so closely resembling the leaves of plants that they are easily mistaken for them. The eggs, too, have a curious resemblance to the seeds of plants, and certain wingless species look like slender twigs. Leaf insects are for the most part natives of the East Indies, Australia and South America. The males have long antennae and wings and can fly; the females have no organs of flight. These insects spend their lives among foliage.



LEAF INSECT

**LEAGUE**, *leeg*, a measure of length dating from the ancient period. At present it is a nautical measurement, equivalent to three nautical miles (the mile of 6,080 feet) and 3.456 statute miles (the mile of 5,280 feet). The French metric league is reckoned as equal to four kilometers, or 4,374 yards, or over 2.5 miles.

**LEAGUE OF NATIONS.** See **NATIONS, LEAGUE OF.**

**LEAGUE TO ENFORCE PEACE**, an organization formed at a conference at Independence Hall, Philadelphia, in 1915. It did not seek to influence the World War, then in progress, but it advocated a league of nations after the war, to establish and maintain a condition of law and order among all countries. The means to be employed were summarized in these proposals:

**Article One.** All justiciable questions arising between the signatory powers, not settled by negotiation, shall, subject to the limitations of treaties, be submitted to a judicial tribunal for hearing and judgment, both upon the merits and upon any issue as to its jurisdiction of the question.

**Article Two.** All other questions arising between the signatories and not settled by negotiation, shall be submitted to a council of conciliation for hearing, consideration and recommendation.

**Article Three.** The signatory powers shall jointly use forthwith both their economic and military forces against any one of their number that goes to war, or commits acts of hostility, against another of the signatories

before any question arising shall be submitted as provided in the foregoing.

**Article Four.** Conferences between the signatory powers shall be held from time to time to formulate and codify rules of international law, which, unless some signatory shall signify its dissent within a stated period, shall thereafter govern in the decisions of the judicial tribunal mentioned in article one.

William H. Taft, former President of the United States, became head of the League, which established headquarters in New York City. At the close of the World War Mr. Taft became one of the strongest advocates of the League of Nations. See **NATIONS, LEAGUE OF.**

**LEAN'DER.** See **HERO.**

**LEAP YEAR**, a year which has 366 days. It is probably so named because it "leaps" over a day more than a common year. Thus, in common years, if the first day of March is on Monday in the present year, it will the next year fall on Tuesday; but in leap year it will leap to Wednesday, for every leap year has a day added to the month of February. Every year which is exactly divisible by four is a leap year unless the number representing the year terminates in two ciphers, in which case it must be divisible by 400 to be a leap year. See **CALENDAR.**

**LEASE**, a contract for the temporary possession of land or buildings, or both. It may be for life, for a fixed period, or during the pleasure of the parties to it. Legally, a lease is an act or instrument whereby any estate or right in land less than a fee is created (fee being practically the equivalent of ownership). The party who leases is called the *lessor*, he to whom the lease is made is the *lessee*, and the compensation or consideration is the rent.

Every properly drawn lease includes the following principal clauses:

First, the date, which fixes the time for the commencement of the lease; if no date is mentioned, delivery of the lease constitutes the commencement.

Second, the names of the parties, the Christian names being written in full.

Third, the consideration. It need not be what is formally called rent, but it may be a sum of money in a lump sum, or grain, animals or personal service, or merely the affection of one party for the other.

Fourth, the operative clause or clauses, telling what the parties agree to do.

Fifth, the description of the premises. This description need not specify all the particulars; for example the general description of a farm includes all the buildings and lands

belonging to the farm. Almost any kind of property, real or personal, may be the subject of a lease—not only lands and buildings, but fisheries, rights of way and annuities.

Sixth, the limitations on the rights or liabilities of both parties, as to repairs, taxes, insurance, etc.

A short form of lease is given below:

THIS AGREEMENT, Made this seventh day of March, A. D. One Thousand Nine Hundred Fourteen (A. D. 1914) Between Charles Alfred Marshall, party of the first part, and Horace Brooks Stearns, party of the second part.

WITNESSETH, That the said party of the first part does hereby lease to the said party of the second part, the following described property, situated in the City of Chicago, County of Cook and State of Illinois, viz: (here describe property) for the term of one year beginning the first day of May A. D. 1914, and ending the thirtieth day of April A. D. 1915.

And the party of the second part agrees to pay as rent for said premises, the sum of twelve hundred dollars, payable monthly in payments of one hundred dollars each on the first day of each month.

And the party of the second part covenants with the party of the first part, that, at the expiration of the term of this lease he will yield up the premises to the party of the first part without further notice, in as good condition as when the same were entered upon by the party of the second part, loss by fire or inevitable accident, and ordinary wear excepted, and will pay all assessments that shall be levied upon said premises during said term for water tax.

AND IT IS FURTHER EXPRESSLY AGREED between the parties, that if default shall be made in the payment of the rent above reserved, or any part thereof or in any of the covenants or agreements herein contained, to be kept by the party of the second part, his heirs, executors, administrators or assigns, it shall be lawful for the party of the first part, or his legal representatives to enter into and upon said premises, or any part thereof, either with or without process of law, to re-enter and repossess the same, and to distrain for any rent that may be due thereon, at the election of said party of the first part; and in order to enforce a forfeiture for nonpayment of rent, it shall not be necessary to make a demand on the same day the rent shall become due, but a demand and refusal or failure to pay at any time on the same day, or at any time on any subsequent day, shall be sufficient; and after such default shall be made, the party of the second part shall be deemed guilty of a forcible detainer of said premises under the statute.

IN WITNESS WHEREOF, the parties have hereunto set their hands and seals, the day and year first above written.

CHARLES ALFRED MARSHALL (Seal)  
HORACE BROOKS STEVENS (Seal)

**LEATHER**, *leth'ur*, the dressed skins of animals, prepared by a process known as tanning. Most leather is made from the skins of cattle and horses, but the skins of mules, pigs, goats and sheep are also used. The leather made from the skins of large animals, such as the horse and the ox, takes the name *hide*, combined with the name of the animal, as *cowhide* and *horsehide*; that from the skins of small animals is named by combining the word *skin* with the name of the animal, as *sheepskin* and *calfskin*.

**Tanning**. When received by the tanner, hides are hard, rough and stiff. Those coming from a distance are usually cured by salting or drying, sometimes by both processes, so they will not quickly rot. Before they can be tanned the cured hides need to be brought back as far as possible to the condition of fresh hides. This is done by soaking and softening them in water, to which, sometimes, salt or carbolic acid is added. Softening is generally hastened by the use of machines, which subject the skin to a kneading process. The hair is then removed by the use of lime, the customary method being to spread the hides in a tank containing milk of lime and to expose them frequently to the air. After the hair has been loosened by this process, it is scraped from the hides, either by hand or by machines.

After being thoroughly cleansed to remove all traces of lime or other matter, the skins are placed in the tanning vats, which contain a solution made by soaking ground oak or hemlock bark in boiling water. The skins are first placed in a weak solution of the liquor, and as the process continues they are changed from this to one a little stronger, and so on until the process is completed in the liquor of greatest strength. The gradation is necessary to secure a thorough tanning of the hide and to prevent the formation of hard and brittle leather. The tanning of large hides from horses and cattle requires from four to twelve months by this process. Skins from smaller animals can be tanned much more quickly. In some works a chemical process which is much more rapid is now employed, especially for the manufacture of the leather used for the uppers of shoes and other purposes where great strain is not required. Sheepskins and goatskins are prepared by a process called *tawing*. In this process bran and alum take the place of the tan bark and produce a very soft, pliable leather, which is extensively used in making gloves and mittens and the uppers for women's shoes.

**Kinds of Leather**. Sole leather for shoes and boots is made from the thick parts of horsehide and cowhide, found along the back. Boot and shoe upper parts are made from the thin portions of these skins or from the skins of smaller animals, such as calf, sheep and goat. From goatskins various grades of *kid* and the so-called *Morocco*, extensively used in bookbinding, and making pocket-

books and other fine leather articles. An imitation Morocco is also made from sheepskin. *Cordovan* is made from horsehide and is waterproof. *Patent leather* is made by treating the tanned skin with coatings of lamp-black and oil, each of which is allowed to dry, and by rubbing down with pumice stone. The finishing coat contains varnish, after the application of which the leather is baked.

**Artificial Leather**, the name for certain materials which resemble leather in general appearance and are used for practically the same purposes. The demand for leather has exceeded the supply for a number of years, and it has been necessary to produce some article which could take its place. The first substitute was made in America in 1849, and was called leather cloth. The method of manufacture was as follows: The cloth was covered with oily pigments, was then dried in a heated oven, and after passing between rollers was covered with pumice dust, to make it smooth, after which it was coated several times with enamel paint. Another kind is now made of leather parings and shavings, which, on being reduced to a pulp, are molded into sheets or other required forms. Still another kind, called *vegetable leather*, consists of rubber dissolved in naphtha and spread over linen cloth.

A modern substitute is called *pantasote*, which is, however, a trade name and conceals the identity of the constituent elements which enter its manufacture. So nearly like leather in appearance is pantasote that only those who habitually handle leather can distinguish the genuine article from the real in a manufactured article. Pantasote is used in upholstery and for automobile and carriage seats and tops.

**Fabricord**, the most recent substitute for leather, consists of a base of cotton cloth which is coated with tough, flexible material and finished by steel plates and rollers to give it the flexibility and appearance of leather. The best grades are waterproof, and are used for upholstering automobiles and carriages, also for tops and curtains. Lighter grades are used for drapery and wall furnishings and in bookbinding.

**LEATHERBACK**, or **LEATHERBACK TURTLE**, a marine turtle found in all tropical seas, but most frequently in the western part of the Atlantic Ocean. It sometimes comes as far north as Long Island, in the United States, and as far north as France,

in Europe. This is the largest turtle known, and specimens measuring six feet in length and weighing upwards of a thousand pounds

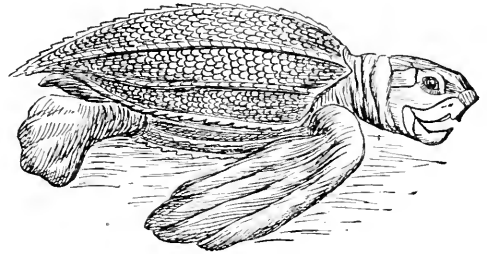

LEATHERBACK

have been found. The brown shell is soft and leathery. The flesh is not suitable for food.

**LEAVENWORTH**, *lev'en worth*, KAN., the county seat of Leavenworth County, eighteen miles northwest of Kansas City, on the Missouri River and on the Atchison, Topeka & Santa Fé, the Chicago, Burlington & Quincy, the Chicago, Rock Island & Pacific, the Chicago Great Western, the Union Pacific and other railroads. The city is near valuable coal mines, and is an important commercial center. The manufactures include brick, stoves, furniture, machinery, flour and wagons, and there is a packing house. Among the chief buildings are the Cathedral of the Immaculate Conception, a city orphanage, two hospitals, a Federal building, a courthouse and Whittier Library. The United States has a large penitentiary for civilian convicts here, and near the city is the state prison and a national soldiers' home. On the north is Fort Leavenworth military reservation, at which a military school for post-graduate courses for subaltern officers is maintained. There are several hospitals and asylums. A conspicuous object in the town is a large bronze statue of Ulysses S. Grant. The commission form of government was adopted in 1909. Leavenworth was settled by Southern sympathizers in 1854, and was chartered the next year. Population, 1910, 19,363; in 1917, 13,477 (Federal estimate).

**LEAVES**, *leevs*, the foliage of trees, contribute so much to the beauty of the plant kingdom that the average observer fails to consider the service they render in helping sustain the life of plants. First of all, leaves manufacture starch and sugar upon which plants feed. In the leaf covering, or epi-

dermis, there are numerous small openings. Through these, carbon dioxide is taken into the inner cells of the leaf, which contain a wonderful substance called *chlorophyll*. It is this substance that gives leaves their green color. Water is carried into the leaves from

breathing is much less than the amount of the same gas given off in starch making; and the amount of carbon dioxide given off in breathing is small compared with the quantity absorbed in starch making. It thus happens that plants and animals help to

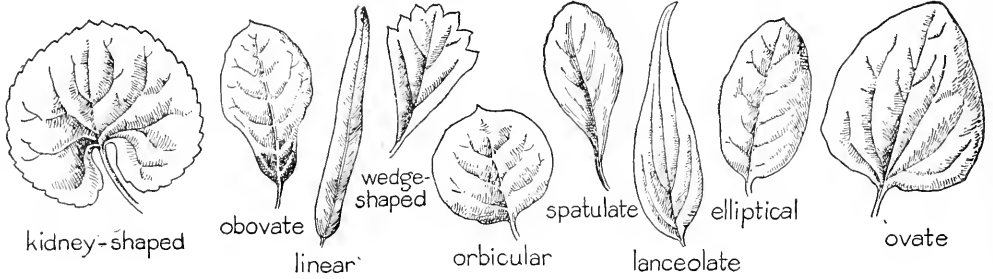

VARIATIONS IN GENERAL OUTLINE

the soil by way of roots and stem, and the water and carbon dioxide are the raw materials out of which sugar and starch are made. The energy necessary for this process is absorbed from the sun by the green coloring matter.

The leaves also serve as the lungs of the plant. That is, oxygen is absorbed from the air through the openings in the epidermis, and carbon dioxide is given off, just as human lungs absorb oxygen and give off carbon dioxide. During the process there goes on a decomposition of certain substances, as a result of which there is a release

maintain the proper balance of these gases in the air, for animals must have oxygen and plants carbon dioxide to keep alive. Carbon dioxide is poisonous to animals, but is essential to plant life.



Alternate arrangement

Opposite arrangement

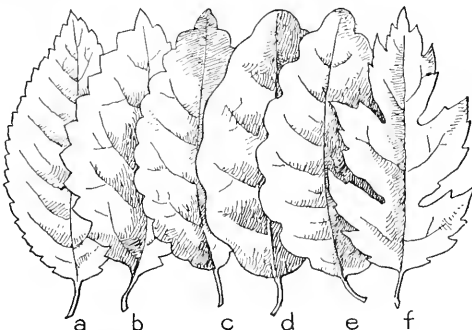

- a - serrate, or saw-toothed
- b - dentate, or toothed
- c - crenate, or scalloped
- d - repand, undulate, or wavy
- e - sinuate
- f - incised, cut, or jagged

MARGINAL FORMS OF LEAVES

GROWTH FROM THE BRANCHES

Another function of leaves is that of giving off water into the air, a process called *transpiration*. This moisture is the surplus water of the crude sap which comes up from the soil into the plant tissues.

Leaves are arranged on the branches in a certain definite, regular order, always the same in the same species. Usually as they grow they arrange themselves in this definite order, so as to expose the largest possible surface to light and moisture. A typical leaf consists of an expanded blade and a stem, with, in some species, two small bracts at the base. The blade may be a simple and rounded expansion of the stem, with

of energy. This energy is used by the plant to do its work. It is an interesting fact that the amount of oxygen absorbed by plants in

a perfectly smooth outline, or it may be notched or cut and divided, or be found in any one of the hundreds of intermediate shapes, even to the delicately dissected featherlike leaf of the acacia.

Leaves of trees change their color in the autumn in preparation for the winter, and the gorgeous reds and yellows are not the work of Jack Frost, as some suppose. When cool weather heralds the approach of winter the leaves no longer carry on their work of making plant food, for during the winter months the plant is to be nourished by stored-up food in its cells. Accordingly, the chloro-

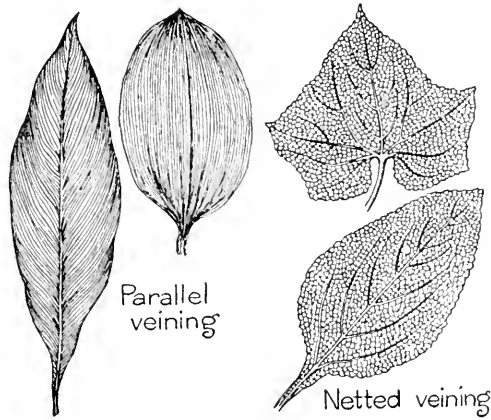

VENATION OR VEINING

phyll is broken up into the substances of which it is composed, and the food that remains is transmitted to the tree to be used during the winter months. The chemical changes that take place in the breaking up of the chlorophyll bodies cause the leaf to change its color. At the point where the stem of the leaf is attached to the tree a layer of cork cells forms, and in course of time the leaf is severed at this point and falls. Dead leaves are an aid in fertilizing soil, as the rains wash out and dissolve the mineral substances contained in them. See PLANT; TREE.

**LEBANON, MOUNTAINS OF**, two nearly parallel ranges in the north of Palestine, extending parallel with the coast of the Mediterranean. The range on the west is called Lebanon, and that on the east, Anti-Lebanon. The former is by far the loftier range of the two and presents an almost continuous ridge, the loftiest summit of which is over 10,000 feet above the sea. Though under the snow limit, snow and ice remain throughout the

year in the higher ravines. The ranges were formerly famous for their cedars; there were but a few hundred of the trees left in 1914. These were the "cedars of Lebanon" used by Solomon in the building of the Temple. The Germans in their campaign in Palestine in the World War destroyed most of these. In the southern part of the chain the Upper Jordan has its source. See PALESTINE.

**LEBANON, PA.**, the county seat of Lebanon County, twenty-five miles east of Harrisburg, served chiefly by the Philadelphia & Reading Railroad. The city is in the Lebanon Valley, between the Blue and the South Mountains. There are also deposits of iron (the famous Cornwall mine being within five miles of the city), brownstone, limestone and brick clay in the vicinity. The industries are mainly mining, quarrying, brick-making and manufacturing of silk, machinery, nuts and bolts, chains and other articles, all employing at least 10,000 people. The city has a Federal building, a Y. M. C. A., a city hall and an armory. The place was settled by Germans about 1700. It was incorporated in 1820, and was chartered as a city in 1885. Population, 1910, 19,240; in 1917, 20,947 (Federal estimate).

**LECKY, lek'i**, WILLIAM EDWARD HARTPOLE (1838-1903), an English historian, born in Ireland and educated at Trinity College, Dublin. His *Leaders of Public Opinion in Ireland* was published anonymously, but with the publication, four years later, of the *History of the Rise and Influence of the Spirit of Rationalism in Europe*, he gained a wide reputation. He became the representative of the University of Dublin in Parliament, where he attained distinction as a speaker and later was called to the Privy Council, but resigned in 1902. His best works besides those mentioned are *History of European Morals from Augustus to Charlemagne*, *History of England in the Eighteenth Century* and *Democracy and Liberty*.

**LECOMPTON CONSTITUTION**, a constitution adopted by a convention held at Lecompton, Kan., in 1857. It contained provisions declaring the legality of slavery in Kansas, prohibiting emancipation and forbidding the amendment of the instrument for seven years. The only portion submitted to the vote of the people was the question of the extension of slavery in the state, the rights of the present slave owners being declared inalienable. In the election the con-

stitution was adopted, the free-state men declining to vote and the slavery vote being swelled by Missouri voters. In an election over the same instrument held under the auspices of the free-state legislature, the constitution was rejected in January, 1858. After a long contest in Congress it was voted that it should be again submitted to the people and the acceptance of the constitution was a prerequisite for admission. It was again rejected, however, and an anti-slavery constitution was adopted in 1859. See KANSAS, subhead *History*.

**LE CONTE**, *le kont'*, JOSEPH (1823-1901), an American geologist who did much to popularize the science of geology throughout America. He was born in Liberty County, Ga., and educated at Franklin College and the College of Physicians and Surgeons in New York City. At Harvard University he studied under Agassiz, whom he accompanied on a scientific expedition to Florida. Later he was made, successively, professor of natural science in Oglethorpe University, professor of natural history in Franklin College, professor of chemistry and geology in the University of South Carolina and professor of geology in the University of California, which position he held until his death. Le Conte wrote many valuable works, among which are *Religion and Science*, *Elements of Geology* and *Compend of Geology*.

**LEE**, CHARLES (1731-1782), an American Revolutionary general. He was the son of a British officer, took part in Braddock's campaign in 1755 and served during the last French and Indian war. He then returned to England, but removed to America in 1773, and on the outbreak of the war he was appointed major-general, by Congress. He took part in the siege of Boston, commenced the fortifications around New York and was given credit for the victory at Charleston, S. C., in 1776, though William Moultrie deserved the honor. Lee was captured in the autumn of that year, but was exchanged in time to take a command in the Battle of Monmouth. In that battle he disobeyed orders and nearly caused the defeat of the Americans. For this he was suspended from his command for a year. Later it was learned that he had been a traitor while in the hands of the British, for he had disclosed plans of Washington. Not long afterwards he fought a duel and was wounded. An impudent letter to Congress regarding this event led to his

discharge from the army and he died soon afterwards.

**LEE**, HENRY, called LIGHT-HORSE HARRY (1756-1818), an American soldier and statesman of the Revolutionary period, was born at Leesylvania, Va., and educated at Princeton College. In 1776 he was appointed captain of a company of cavalry in Colonel Bland's Virginia regiment, and in the following year he joined Washington's army just before the Battle of Brandywine. He served through the war as scout, and he had command of the brilliant expedition against the British at Paulus Hook. In the memorable retreat of Greene before Lord Cornwallis, Lee's legion acquired fame as the rear guard of the American army, the post of greatest danger, and at the battles of Guilford Court House and Eutaw Springs, Lee especially distinguished himself. On the conclusion of the war he was sent to Congress as a delegate from Virginia, and in 1792 he was chosen governor of that state.

After the death of Washington Lee was chosen to deliver the funeral address before Congress and was the author of the oft-repeated phrase, used on that occasion, "First in war, first in peace, first in the hearts of his countrymen." He retired from public life in 1801, but again became a major-general when trouble with Canada threatened, but died from injuries received in quelling a mob in Baltimore.

**LEE**, RICHARD HENRY (1732-1794), a distinguished American of the Revolutionary period, was born at Stratford, Virginia. He was chosen a delegate to the House of Burgesses, and in opposition to unjust British claims he played an important part. On being sent as delegate to the first Colonial Congress at Philadelphia (1774), he was at once recognized as a leader. He drew up many addresses to the king and the English people, which were admitted, even by his political opponents, to be unsurpassed by any of the state papers of the time. On June 7, 1776, he introduced the motion finally breaking political connection with Britain. In consequence of poor health, he was unable to serve in the field, but his activity at home was unceasing and extremely valuable. In 1784 he was unanimously elected president of the Congress. He opposed the ratification of the Federal Constitution, but later entered the Senate as an Anti-Federalist.



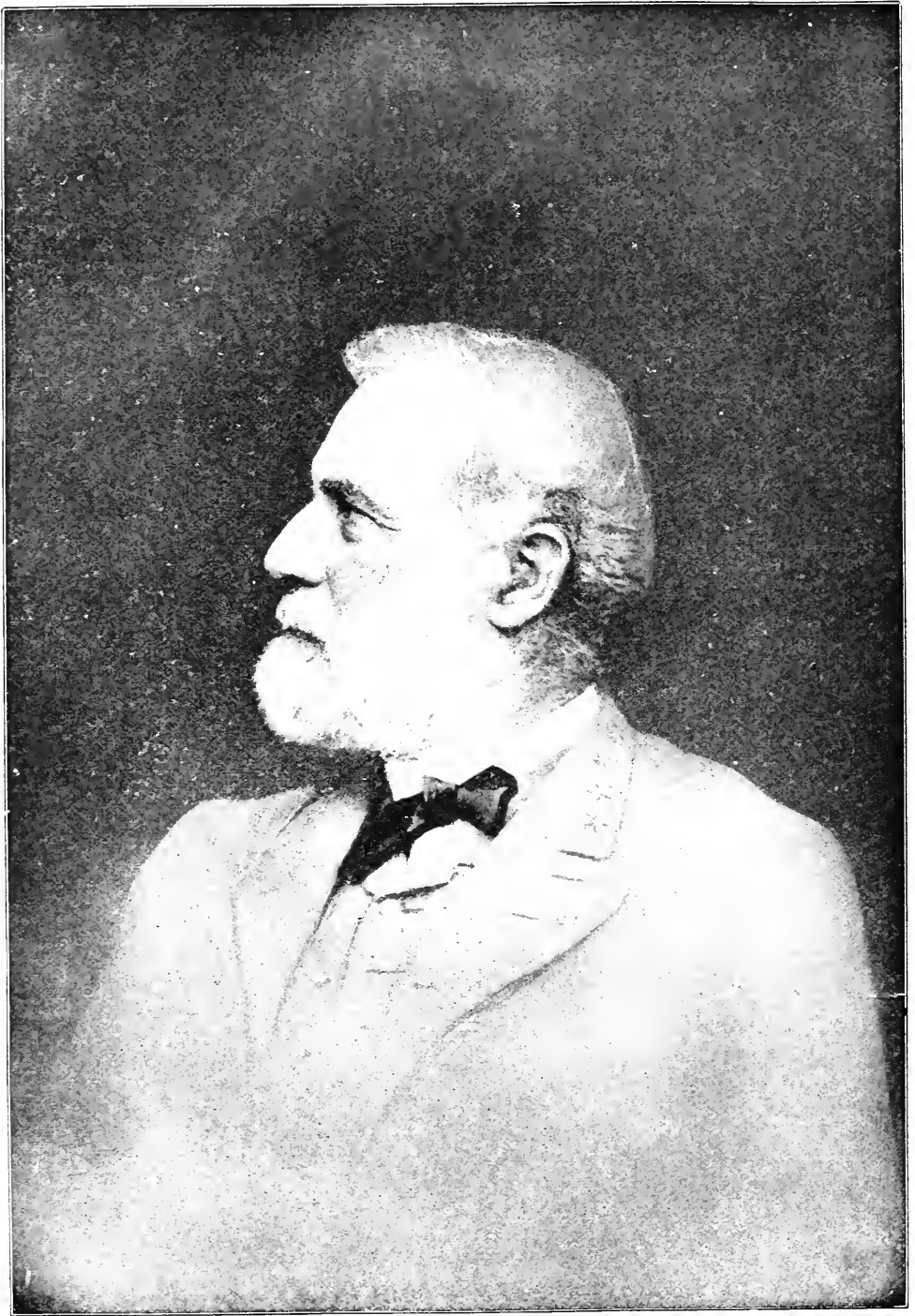

ROBERT E LEE





**L**EE, ROBERT EDWARD (1807-1870), an American general, commander in chief of the Confederate army and one of the most skilful tacticians who took part in the Civil War. Lee's personal bravery, his irreproachable life and his splendid idealism have made him a commanding figure in American history, and to-day his memory is revered by the North as well as the South. He was the son of the Revolutionary cavalry leader, "Light-Horse Harry" Lee, and was born in Westmoreland County, Va., on January 19, 1807. In 1829 he left the Military Academy at West Point with the rank of second-lieutenant of engineers. After serving for a time as chief engineer of the army in Washington, and superintending the construction of defenses in New York Harbor, he was appointed in 1847 engineer in chief of the army of the Mexican campaign. His brilliant services at Cerro Gordo, Contreras, Churubusco and Chapultepec gained for him the rank of colonel. From 1852 to 1855 he was superintendent of military studies at West Point, and in 1855 he was made lieutenant-colonel of cavalry.

In 1861 Lee became colonel of his regiment, but on the secession of Virginia from the Union he threw up his commission and, despite the fact that he was strongly opposed to disunion, accepted the command of the Virginian army and subsequently was selected by President Davis as commander in chief. In June, 1862, he defeated the Federal army under McClellan in a series of battles around Richmond, and, aided by "Stonewall" Jackson, he defeated Pope in a number of engagements commencing August 20 and ending with the victory of Manassas Junction on the thirtieth. Lee then crossed the Potomac into Maryland to threaten Washington itself, but a series of checks obliged him to withdraw behind the Rappahannock. The plan of the Federals now was to advance on Richmond, but this was prevented by Lee, who on December 13, defeated Burnside at Fredericksburg, and on May 2 and 3, 1863, gained the victory of Chancellorsville over Hooker.

After this series of victories Lee resolved

on an invasion of Pennsylvania, but was beaten by Meade at Gettysburg, July 1, 2 and 3, and forced to retreat into Virginia. The campaign of 1864 was begun by the advance of General Grant on May 4. A succession of stubbornly contested battles followed, from the "Wilderness," by way of Spottsylvania and Cold Harbor, to Petersburg. On April 2, 1865, Grant broke through Lee's defenses, and Lee's attempt to unite with Johnston was prevented. The Union forces with their great superiority of men gradually hemmed in the Confederate army, which on April 9 surrendered to Grant at Appomattox Court House. General Lee retired into private life, but in October following the end of the war he was elected president of Washington College, Lexington, Va., now Washington and Lee University. There he remained until his death.

**LEECH**, the common name of certain worms which are provided with sucking disks, one at each end of the body. The body consists of rings or segments, very numerous and closely set. Leeches chiefly inhabit fresh-

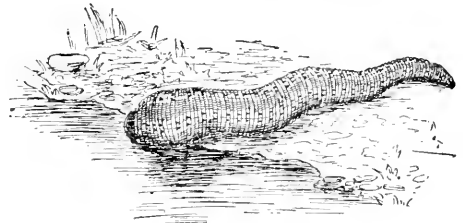

LEECH

water ponds, though some live among moist grasses and some are marine. They breathe through the general surface of the body or through little pouches. In Ceylon there are land leeches, which live in damp foliage and are often a serious pest to travelers. In those species generally employed for medicinal purposes, the mouth is situated in the middle of the anterior sucker and is provided with three small white teeth capable of making a peculiar Y-shaped wound, which is difficult to close and permits a large flow of blood. A single leech may draw as much as one ounce of blood. After the leeches are satiated and have detached themselves, they will disgorge the blood they have drawn if placed in a weak solution of salt. Many years ago blood-letting was a common medical practice, and leeches were used in large numbers as a cure for all sorts of diseases.

**LEEDS**, *leeds*, ENGLAND; the fifth city in size in the country, is situated on the River Aire, with sea connection by the Humber, and is twenty miles southwest of York. Leeds has been for generations the chief site of the woolen manufacture of Yorkshire. The city is situated in a rich coal and iron district, and the iron industry is almost as important as the cloth industry. Among the chief buildings and institutions are Saint Peter's Church, Saint John's Church, the townhall, the royal exchange, a grand theater, Mechanics' Institute, Central Public Free Library and University of Leeds. Near by is the Kirkstall Abbey, a magnificent ruin. Besides cloth and iron manufactures, there are manufactures of boots and shoes, locomotives, agricultural machines, glass, tobacco, oil, worsted, silk and pottery. Nearly a hundred collieries are worked in the district, and some of the largest tanneries in the kingdom are located here. Population, 1914, 457,507.

**LEEK**, an odd little plant which is native in the southern mountain ranges of Europe, but now found almost everywhere. The superstitious peasants of the continent used to plant leeks on the roofs of their cottages as a protection against lightning. The common leek is a biennial (which see), related to the onion, for both are members of the lily family (see color plate, in article LILY). It may grow to a height of three feet, but instead of possessing a bulb, like the onion, the lower part of the stalk is slightly thickened. The flavor is milder than that of the onion.

**LEEWARD ISLANDS**, a British colony including a number of the West Indies, divided into five administrative districts, namely, Antigua, Saint Christopher, Dominica, Montserrat and Anguilla. The area of the group is 715 square miles. The capital is Saint John, in Antigua. Population, 1916, 129,452.

**LE GALLIENNE**, *le gal'ly en*, RICHARD (1866- ), an English journalist, poet and critic, born in Liverpool, and educated at Liverpool College. He became literary critic for the *Star* in 1891 and was also associated with other papers. He first came into prominence in a religious controversy, which resulted in the publication of the *Religion of a Literary Man*, and he later attained notoriety by his attack on Rudyard Kipling's method and ability. In 1898 he

came to the United States on a lecture tour and later settled in New York. His works include several volumes of poems, and numerous essays and sketches on literature, travel and other topics. A daughter, Eva Le Gallienne, became an actress of note.

**LEGAL TENDER.** See TENDER.

**LEG'ATE**, a title borne by certain officials who represent the Pope outside of Rome. There are three classes of legates. The highest bear the title *legate a latere*, a dignity conferred now only on cardinals. The second class, called *nuncios*, or *legati missi*, have the same rank as ambassadors or ministers at the capitals of foreign countries. Then there are the *legati nati*, or "legates by virtue of their office." Certain archbishops bear this title. The United States does not recognize such officials; they are accredited only to Catholic countries.

**LEGEND**, *lej'end*, or *lej'end*, originally the title of a book containing the lessons that were to be read daily in the service of the early Church. The term was afterward applied to collections of biographies of saints and martyrs, or of remarkable stories relating to them. The modern legend is a tale which may or may not be susceptible of a basis of fact, but which the author does not allege to be so founded. Such a tale, and one of the best in any language, is Irving's *Legend of Sleepy Hollow*.

**LEGERDEMAIN**, *lej er de mané*, the art of performing deceptive tricks by skill of hand, sometimes aided by mechanical devices. Conjuring and magic are other names applied to the same art. The purpose of the performer is usually to portray something as operating contrary to the laws of nature, as the appearance or disappearance of an object without apparent cause, drawing yards of paper ribbon from some victim's nose, or silver dollars from his ears, etc. The success of the operation depends upon two things, the operator's skill of hand, and his ability to divert the attention of his audience. The changes are caused by substituting one object for another of identical appearance, as in the trick of placing a handkerchief in a box and taking out a guinea pig. The operator has two boxes exactly alike; the guinea pig is in one, and the other, as he shows his audience, is empty. He places the handkerchief in the empty box, then diverts the attention of his audience and instantly changes the boxes.

. The trick is often done by changing from one hand to the other, and sometimes it may be accomplished through the operation of mechanical devices operated by an assistant.

Legerdemain, or sleight of hand, is still practiced by specialists who use their skill in giving public entertainments. It has no connection with the old ideas of witches or evil spirits, and in the sense in which it has been described is nothing more than a harmless form of amusement.

**LEG'HORN**, ITALY, a seaport on the Mediterranean, sixty-two miles west of Florence. It is the capital of the province of Leghorn, and is a modern and well-built city. Ranking next to Genoa and Naples among Italian ports, Leghorn is also known as a shipbuilding center and for the manufacture of the famous "Leghorn hats," made from wheat straw. Among its other exports are coral jewelry, wine, silk, olive oil and marble. It has many buildings of great architectural beauty, including a cathedral built in the seventeenth century, and a Jewish synagogue richly decorated with marbles. The public squares are adorned with imposing statues. Leghorn is also a favorite tourist resort because of its sulphur springs and sea bathing. Population, 1915, estimated, 108,585 (including suburbs).

**LEGION**, *le'jun*, in ancient Roman armies, a body of infantry, at different periods consisting of different numbers of men, from 3,000 to above 6,000, often with a complement of cavalry. Each legion was divided into ten cohorts, each cohort into three maniples, each maniple into two centuries. Every legion had sixty *centurions* and the same number of *optiones*, or lieutenants, and standard bearers. The standard of the legion was an eagle.

**LEGION OF HONOR**, a French order for the recognition of military and civil merit, instituted by Napoleon in 1802 and inaugurated in 1804. The order has been remodeled several times, the last time just after the downfall of the Second Empire. There are now five ranks or classes: ordinary chevaliers, or knights; officers, commanders, grand officers, grand crosses. The profuse granting of the decoration of the order latterly brought the institution into discredit and the number of chevaliers is now restricted to 25,000, the officers to 4,000, the commanders to 1,000, the grand officers to 200 and the grand crosses to seventy. The emblem is a

five-pointed star of white enamel which bears a figure emblematic of the Republic, with the inscription "*Republique Francaise*," and on the reverse, two flags, with the inscription, "*Honneur et Patrie*" (Honor and Country).  
**LEGISLATIVE ASSEMBLY**, in Canada.

In all the provinces except Quebec and Nova Scotia the legislature is composed of one house, the legislative assembly. In Nova Scotia and Quebec, there is also an upper house, known as the legislative council, whose members are appointed by the lieutenant-governor. They may retain their positions for life, unless they become bankrupt, are convicted of crime, or otherwise disqualified by law. The council of Quebec consists of twenty-four members and that of Nova Scotia of seventeen members; one of the members is chosen speaker by the lieutenant-governor. In Prince Edward Island the assembly is a combination of the former legislative council and of the assembly; since 1893, when the union took place, each district elects one member with a real estate qualification (\$3,250) and one member on the general franchise.

The legislative assemblies are elected by manhood suffrage, except in Nova Scotia and Quebec, where a small property qualification is necessary. The method of election corresponds to that for Parliament: the lieutenant-governor, by the advice of his council, issues a proclamation dissolving the old legislature and appointing the day for the return of the writs; he also calls the new legislature together. The members receive a sessional allowance of \$200 in Prince Edward Island, \$500 in New Brunswick, \$700 in Nova Scotia, \$1,000 in Manitoba and Alberta, \$1,200 and extra mileage in British Columbia, \$1,400 in Ontario, and \$1,500 in Saskatchewan. The legislatures have a duration of four years (five in Quebec and Nova Scotia) unless dissolved by the lieutenant-governor, and they must meet each year.

**LEGISLATURE**, *lej'is la ture*, that department of government which has the power to make, amend and repeal laws, subject, in some cases, to an organic law, or constitution, from which it receives its powers.

Legislatures of modern states, though varying widely in size and power, are agreed in essential principles. The legislature of a country, state or province usually consists of two houses, or chambers. In most states

one of these is composed of representatives of the people, chosen directly by the votes of citizens having certain qualifications, such as a certain age and, in some instances, conformity to educational and property requirements. This house generally possesses the sole power to initiate financial legislation and sometimes other legislation affecting the general interests of the people. The other house is representative of classes, as in England (the House of Lords), or of territorial divisions, as in the United States (the Senate).

There is a general agreement as to the rights and privileges of members of a legislative body during their terms of office, such as freedom from arrest, except for treason or other high crimes, and freedom of debate, subject only to the rules of the body. The tenure of legislators varies greatly. In some states, as in most European countries, members of the upper house serve for life or for long periods, or at the pleasure of the government of the division which they represent. The tenure of the members of the lower house of the legislature varies from one to seven years, though usually it is a short period. Members of the legislature are sometimes compensated, as in the United States, but frequently are not, as in Great Britain.

Among the states of the Union different names are given to the legislative body in the state government, though it is most frequently known merely as the *legislature*. In small units of government, as in the county, the legislative body is merged with the executive body in a board of supervisors, but in cities it is usually a separate body, known, generally, as the *common council* or *board of aldermen*.

For descriptions of various legislative bodies, see Congress of the United States; Parliament; Representatives, House of; Senate.

**LEGUMINOUS**, *le gu'min us*, **PLANTS**, or **PULSE FAMILY**, one of the largest and most important families of plants, including about 7,000 species, which are dispersed throughout the world. They are trees, shrubs or herbs, differing greatly in habit. The largest division is characterized by a flower, called *papilionaceous*, because of its resemblance to a butterfly; a good example is the sweet pea. The fruit is usually a pod, or legume, and from this the family takes its botanical name. The leaves are usually compound and sometimes are doubly so.

Wood, timber, medicine, dyes, foods and a great variety of substances used in domestic life are produced by this great family, and many species are highly ornamental in foliage or in flower. A great many of the plants of this order are described in their proper places; as, for instance, INDIGO; PEANUT; PEA; BEAN; CASSIA; ACACIA; CLOVER. For an illustration of typical plants belonging to this family see BOTANY, page 526.

**LEHIGH**, *le'hi*, **RIVER**, a river of Pennsylvania which rises near Wilkesbarre, flows southeast, then northeast and joins the Delaware at Easton. It has a course of about 120 miles, through a region of iron and coal, and is navigable for about eighty miles.

**LEIBNITZ**, *lip'e'nitz*, GOTTFRIED WILHELM, Baron von (1646-1716), a German scholar and philosopher, born at Leipzig. He studied law, mathematics and philosophy at the university of his native town, where he published a philosophical essay when only seventeen years of age. After holding political appointments under the elector of Mainz he went to Paris, where he applied himself particularly to mathematics. He also went to England, where he was elected a member of the Royal Society and made the acquaintance of Newton. About this time he made his discovery of the differential calculus (see CALCULUS). The Duke of Brunswick-Lüneburg then gave him the office of councilor, with a pension, and after a further stay in Paris he returned to Hanover and entered upon the superintendence of the library. Having assisted the elector of Brandenburg (afterward Frederic I of Prussia) to establish the Royal Academy of Sciences at Berlin, he was made president for life. His writings included mathematics, science, philosophy and religious topics.

**LEICESTER**, *les'tur*, ENGLAND, the county town of Leicestershire, on the Soar River, 100 miles nearly north of London. It is a place of considerable antiquity and was known to the Romans under the name of Ratae. Its walls and strong castle were demolished in the reign of Henry II. It suffered severely during the wars of Lancaster and York and also during the Civil War of 1642. Its manufactures consist of boots and shoes, hosiery, laces, thread and iron ware. The city owns all its public utilities, including abattoirs, baths, technical schools and sewage farms, in addition to light, water and traction lines. Population, 1916, 235,369.

**LEICESTER**, ROBERT DUDLEY, Earl of (about 1532-1588), an English courtier, a favorite of Queen Elizabeth. In 1550 he was married to Amy Robsart, daughter of a Devonshire gentleman, and is said to have been accessory to her murder in 1560. Elizabeth created him Earl of Leicester and privy councilor and lavishly bestowed titles and estates on him, her fondness for him causing his marriage with her to be regarded for a time as certain. So great was the opposition that Elizabeth was obliged to renounce any intention she may have had of marrying him; but his marriage with the Countess of Essex in 1578 deeply offended her. *Kenilworth*, by Sir Walter Scott, gives the story of Amy Robsart.

**LEIDY**, *l'idy*, JOSEPH (1823-1891), an American naturalist who made valuable contributions to the natural sciences. He was born in Philadelphia and received his education at the University of Pennsylvania. In 1846 he was made chairman of the board of curators of the Academy of Natural Sciences and also filled a position as demonstrator of anatomy in the University of Pennsylvania. Later he was made professor of anatomy in the medical school of the same university, and in 1853 he became professor of biology in the faculty of philosophy. He was elected president of the Academy of Natural Science at Philadelphia in 1881, and four years later became president of the Wagner Free Institute of Science. Leidy's works include *A Flora and Fauna Within Living Animals*, *Cretaceous Reptiles of the United States*, *The Extinct Mammalia Fauna of Dakota and Nebraska* and *Treatise of Human Anatomy*.

**LEIF**, *l'ife*, **ERICSON**. See ERIC THE RED.

**LEIGHTON**, *la'ton*, FREDERICK, Lord (1830-1896), an English painter, born at Scarborough. When twenty-five years of age he sent to the Academy his picture of *Cimabue's Madonna Carried in Triumph through Florence*, which called forth general admiration. For the next four years Leighton lived in Paris, then took up his residence in London. In 1869 he was elected a Royal Academician, and in 1878 he became president of the Academy, was knighted and was named an officer of the Legion of Honor. In addition to his painting, he gained a high place as a sculptor by his *Athlete Strangling a Python* and his *Stuggard*. The special merit of his work lies in the perfection of his

drawing and design, as well as in refinement in execution. Among his many works may be mentioned his *Hercules Wrestling with Death*, *The Bath of Psyche*, *The Music Lesson*, *Lachrymae*, *Cymon and Iphigenia*, *Captive Andromache* and *Ball Players*. The large frescoes at South Kensington Museum, representing the *Industrial Arts Applied to War* and the *Arts of Peace*, are also by him.

**LEIPZIG**, *lip'e'tsiK*, or **LEIPSIC**, *lip'e'siK*, GERMANY, the largest city of Saxony and the third in size in the country, is situated on the Elster, Pleisse and Parthe rivers, sixty miles nearly west of Dresden. The market place in the old town has a picturesque appearance, having about it the old townhall (Rathaus) and other buildings in the Renaissance style.

The Augustusplatz is one of the finest squares in Germany and contains the university, the museum, the theater and the post office. The Pleissenburg, or castle, now used in part as a barrack, withstood the attacks of Tilly and is memorable as the scene of the famous disputation between Luther and Doctor Eck. The suburbs contain the Church of Saint John, the Church of Saint Peter and the Roman Catholic church, the Rosenthal (Valley of Roses), with pleasant wooded walks, and numerous places of recreation. The university, founded in 1409, is the third in importance in Germany and before the World War had almost 4,000 students and a library of about 500,000 volumes. Schools are numerous and good, and there is a famous conservatory of music. Besides being the center of the book and publishing trade of Germany and world famous for its color printing, the city possesses many great factories, and has important general commerce.

Leipzig early received the Reformation. In 1631 Gustavus Adolphus defeated Tilly near it, at Breitenfeld. It suffered much from the Seven Years' War. In October, 1813, the great "Battle of the Nations" was fought around and in Leipzig (see LEIPZIG, BATTLES OF). Population, 1910, 589,850; in 1915, after annexations of suburbs, 626,627.

**LEIPZIG, BATTLES OF**. Two important battles were fought near Leipzig during the Thirty Years' War, and one during the war against Napoleon. The first was in September, 1631, and resulted in the defeat of the imperial army, under Tilly, by the Protestants, under Gustavus Adolphus. This was the first great victory which the Protestants

had won. The second battle took place in November, 1642, and was also between the Swedes and the imperialists. The imperialists were again defeated. See THIRTY YEARS' WAR.

In October, 1813, a great battle was fought at Leipzig between Napoleon and the Austrians, Prussians, Russians and Swedes. This battle, known as the "Battle of the Nations," resulted in a complete defeat for Napoleon.

**LELAND STANFORD JUNIOR UNIVERSITY**, a coeducational institution of higher learning, located at Palo Alto, Cal., thirty-three miles south of San Francisco. It is thoroughly democratic in spirit, and permits a high degree of freedom in the selection of subjects. This university was founded by Leland Stanford and his wife in memory of their only child, Leland Stanford, Jr., who died in 1884. The university was opened to students in 1890. To the original endowment of about 90,000 acres of land Mr. Stanford added \$2,500,000 by his will, and after his death his wife deeded to the institution most of the remainder of the estate, after which the total endowment was over \$25,000,000.

The university maintains departments of Greek, Latin, Germanic languages, Romance languages, English, psychology, philosophy, education, economics and social science, history, drawing, mathematics, civil, mechanical and electrical engineering, mining, physics, chemistry, botany, physiology and hygiene, zoology, geology, and professional schools of law and medicine. At Monterey Bay is maintained the summer session of the marine biological laboratory.

The usual class divisions are not recognized, and students graduate whenever they have completed the work required for the degree for which they are studying, regardless of the amount of time spent at the university. The buildings are patterned after the old California missions and are arranged around two quadrangles. The material used is gray stone, with red tile for roofing. This combination, together with the arrangement of the buildings, makes Leland Stanford one of the most attractive universities in the country. The beautiful memorial chapel was destroyed and a number of the other buildings were badly damaged by the earthquake which occurred April 18, 1906, but the buildings were replaced at once. The enrollment

in the fall of 1917 was 1,500; the faculty numbered 225. There are about 288,000 volumes in the library.

**LEMBERG**, *lem'berK*, GALICIA, at the outbreak of the World War the fourth city in population among the cities of Austria-Hungary. It was the capital of the crownland of Galicia, and the seat of the third largest university in Austria. Lemberg is situated 365 miles northeast of Vienna, on the Pelteu River. Before the war it was industrially and commercially the chief city of Austrian Poland, with prosperous manufactories of farm machinery, boilers, musical instruments, malt liquors, flour and other products, and it had a thriving trade in flax, hemp, wool and linen.

During the war and afterwards Lemberg suffered greatly. It was captured by the Russians in 1914, and retaken in 1915 by the Austro-German forces, both armies causing great material damage through bombardment. Even after the armistice was signed, in November, 1918, warfare against the city continued, for it was bombarded again and again by the Ukrainians, who sought to capture it. The city water system and the lighting and electric car plants were made useless, and the people suffered correspondingly. Population, 1914, estimated, 212,000. See WORLD WAR; GALICIA.

**LEMMING**, a burrowing animal much like the rat. There are several species, found in Norway, Lapland, Siberia and the northern parts of America. The best-known species is the *common*, or *European*, *lemming*, whose body color is brownish, variegated with black, while the sides of the head and belly are white or of a grayish tint. The legs and tail are gray. The lemming feeds on plants and is exceedingly destructive to vegetables and crops. Vast hordes, at intervals ranging from five to twenty-five years, migrate toward the Atlantic and the Gulf of Bothnia, destroying vegetation in their path. Bears, wolves and foxes make them their prey while they are migrating, and many also die from hunger and exposure. It is a curious fact that when they reach the sea they jump in by thousands and die by drowning. One species, called the *banded lemming*, is found in the Hudson Bay region of North America. Like some other fur-bearing animals inhabiting cold countries, it turns white in winter.

**LE MOINE**, *le mwahn'*, JAMES MACPHERSON, Sir (1825-1912), a Canadian author and

naturalist. He was born in Quebec and received his education at Le Petit S  minaire de Quebec. In 1850 he was admitted to the bar. His first public position was collector of inland revenue at Quebec, and later he became inspector. Much of his time was spent in the study of natural history, especially the study of birds, and he made many careful researches and investigations. He was the author of *The Ornithology of Canada*, *Legendary Lore of the Lower Saint Lawrence*, *Maple Leaves* and *Quebec, Past and Present*.

**LEMON**, a widely-used citrus fruit, closely resembling the orange in structure. It grows on a tree found originally in India, and now cultivated extensively in Southern Europe, California, Florida and Mexico as well as in other tropical lands. The yearly output of California and Florida is about 2,770,000 boxes, California producing the greater part of this yield. The lemon tree reaches a height of from ten to twenty feet, and bears pale-green, oval leaves and small flowers of a purplish color on the outside.

Trees begin to bear fruit the third or fourth year, but do not produce fully until the sixth or seventh year. The oblong, yellow fruits ripen in winter, but since the lemon is in greatest demand during the summer, the ripened fruit is preserved under cold storage. The fruit does not ripen well on the tree; hence it is picked green and allowed to mature slowly in a darkened room. The sour juice of the lemon is extensively used as a flavoring and in making cooling beverages. It is also of value in calico printing and in the manufacture of citric acid. Lemon extract, common in cookery, is made by expressing oil from the peel.

**LEMUR**, the name applied to a family of animals between the monkeys and the apes. There are about fifty species, all of which live in Africa or Madagascar and neighboring islands. The fur is soft and delicate and usually of a light color, and the tail is long. Lemurs vary from the size of a cat to that of a mouse. The *ring-tailed lemur*, a species which lives on cliffs and along the sea, is gray in color, with black and white rings about its tail. The *ruffed lemur* is about the largest of the lemurs; the *mouse lemur* is about the size of a rat. The *avahis* is about a foot long, with a tail three inches longer; it lives a solitary life and appears only at night. The *indris* is of a black color, with white upon the rump and limbs. The natives

of Madagascar call this lemur the *dog of the forest*, because its howls resemble those of a dog.

Lemurs are harmless little creatures and are easily tamed, but the peculiar appearance



LEMUR

of the face, their large eyes and their habit of feeding at night made them objects of superstition and awe, and gave them the name lemur, which means ghost.

**LENA**, a river of Siberia. It rises west of Lake Baikal, flows northeasterly, then northwesterly and enters the Arctic Ocean through several mouths. It forms a delta 250 miles wide. Its total length is 2,700 miles. Its chief tributaries are the Aldan, the Olekma, the Vitim and the Vilyui. Eight hundred miles from the ocean the Lena attains a width of five or six miles, and it is generally navigable during the open season. It is free from ice between Yakutsk and Kirensk from the middle of May to the middle of November, and during this season it is navigable for steamers between these points. The Lena is one of the largest rivers of Asia and the largest within the boundaries of Siberia. It drains an area of about a million square miles.

**LENGTH OF LIFE.** See LONGEVITY.

**LENINE**, NIKOLAI (1870- ), a Russian revolutionist and agitator, one of the most prominent leaders of the Bolsheviki movement which overthrew the Kerensky provisional government in Russia, in November, 1917. He was born of a noble family, at Simbirsk, on the Volga. Lenine is an assumed name; his real name is VLADIMIR ILITCH ULYANOFF. Lenine came into public notice soon after 1890, when he became leader of the radical Socialist party. Though elected to the Duma after the revolution of 1905, he was subsequently expelled, and when the World War broke out he was living in Cracow, Galicia. He was permitted by the Austrian government to go to Switzerland, where he remained until the Russian revolution. Under an agreement between the German government and provisional Russian government, he was unfortunately allowed to return to Russia, and he reached Petrograd in May, 1917. Lenine began at once to agitate immediate peace, and in July he attempted to overthrow the government. The effort was unsuccessful, and he was obliged to go into hiding for a time, but eventually his theories gained such ground that a new régime supplanted the moderate Socialist government in November, 1917. Leon Trotzky was his able assistant.

On November 9 the All-Russian Congress of Workmen's and Soldiers' Delegates named a provisional Cabinet, at the head of which Lenine was placed, with the title of Premier. In February, 1918, Russia formally withdrew from the war. In spite of economic disaster to Russia and the opposition of many powerful forces the Bolshevik Premier held his place as leader, and in the spring of 1919 he saw his theories spreading through Central Europe. The principles advocated by Lenine are stated in full in his book *The Soviets at Work*. See BOLSHEVIKI; RUSSIA; WORLD WAR.

**LENNI-LENAPE**, *len'ne le nah'pay*. See DELAWARE (Indians).

**LEN'OX**, JAMES (1800-1880), an American philanthropist, born in New York City. He was educated at Columbia College and was admitted to the bar. Having inherited from his father several millions of dollars, for half a century he devoted himself to the forming of a library and gallery of paintings. This he conveyed to New York City in 1870, having erected a beautiful structure to receive it. He was a liberal donor to many

churches and societies. In 1895 his library was consolidated with the Astor Library and the Tilden Trust to form the present public library of New York City.

**LENS**, *lenz*, a transparent body having at least one curved surface. Glass lenses are used in spectacles, field glasses and all other kinds of optical instruments, and it is therefore important to know the various forms.

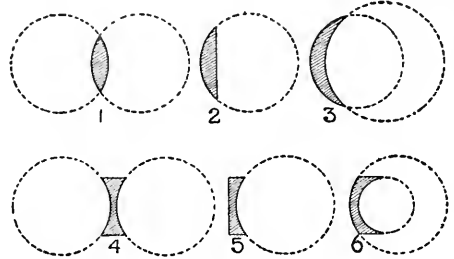

FIG. 1

Lenses have either one plane and one spherical surface, or two spherical surfaces. If the surface curves outward, the lens is *convex*; if inward, it is *concave*. There are six kinds, as shown in Fig. 1.

1. Double-convex lens; both surface convex.
2. Plano-convex lens; one surface convex and one plane.
3. Concavo-convex lens; one surface convex and one concave.
4. Double concave lens; both surfaces concave.
5. Plano-concave lens; one surface plane and one concave.
6. Convexo-concave lens; one surface concave and one convex.

Lenses refract rays of light which pass through them. If the lens is convex, the refraction tends to bring the rays to a point, called the *focus*, as shown in Fig. 2. The parallel rays, 1, 2, 3, 4 and 5, passing through the double-convex lens  $LM$ , come to a point at  $F$ , which is the focus. When the rays of the sun are collected in this way by a double-convex lens, they afford sufficient heat to set such substances as tinder, paper and dry pine wood afire. For this reason, such a lens is sometimes called a *burning glass*.

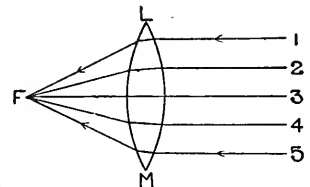

FIG 2

Convex lenses form two kinds of images. When the object is at a long distance from the lens, the image formed is smaller than the



object, and inverted, as shown in Fig. 3.  $AB$  represents the object. The parallel rays from  $A$  and  $B$  strike the lens respectively at  $a$  and  $b$ .  $Aa$  is refracted to  $A'$  and  $Bb$  to  $B'$ . The rays  $AA'$  and  $BB'$  strike the lens vertically and pass through its center; consequently they are not refracted. A screen

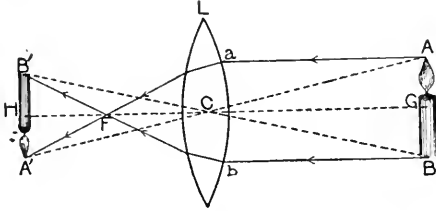

FIG. 3

placed at the point where these rays meet the refracted parallel rays will receive the image. If the screen is moved either backward or forward from this point, some of the rays are lost and the image becomes indistinct.

When the object is between the focus and the lens, the image is erect and magnified. In Fig. 4,  $AB$  is the object and  $A'B'$ , the image. The parallel rays from  $A$  and  $B$  are refracted and meet at  $F$ , while the rays  $A'A$  and  $B'B$  pass through the center of the lens and are not refracted. The image appears where these rays meet the refracted parallel rays. In this case both the object and the image are on the same side of the lens, while in the former the image is on the other side of the lens from the object. Fig. 4 illustrates the use of the convex lens as a simple magnifying glass. The images formed by concave lenses are erect and smaller than the object.

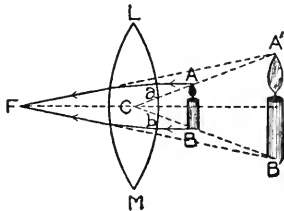

FIG. 4

**Related Articles.** Consult the following titles for additional information:  
 Camera                      Opera Glass  
 Eye                              Telescope  
 Microscope

**LENS**, *lahn*, FRANCE, an industrial town in the center of one of the most valuable coal fields of France, captured by the Germans early in the World War and not recovered for the French until November, 1918. The town is situated seventeen miles south-southwest of Lille (which see). Before the war Lens

was known as a "workingman's paradise," as its houses were surrounded by beautiful gardens. The principal industrial establishments were iron and steel foundries, engineering works and factories for the making of wire rope, soap and beet sugar. The town and surrounding region were almost continuously the scene of bitter struggles until the close of the war. Every house in the place was razed, the gardens were ruined, and the valuable coal mines of the region were flooded. Population, 1911, 31,746.

**LENT**, the forty days' fast in spring, beginning with Ash Wednesday and ending with Easter Sunday, celebrated by Christian churches. In the Latin Church Lent formerly lasted thirty-six days, but in the fifth century four days were added, in imitation of the forty days' fast of the Saviour, and this usage became general in the Western Church. Its close is celebrated in the Roman Catholic countries with great rejoicings. The English Church has retained Lent and many other fasts, but gives no directions respecting abstinence from food, as does the Roman Catholic Church. The forty days of Lent do not include Sundays. Palm Sunday is the last Sunday in Lent.

**LENTIL**, the seed of a plant that resembles the pea vine. Lentils are flattish, rounded and, when cooked, reddish in color. They are more easily digested than peas, are very nutritious and are an important article of diet in Egypt, Syria and other Mediterranean countries. Lentils are also seen in the markets of the United States, but these are imported. According to tradition the pottage for which Esau sold his birthright was a dish of lentils. See BIBLE, subhead *Bible Stories*.

**LE'O** (the lion), a bright and interesting constellation, containing ninety-five stars, noteworthy because of its remarkable nebulae. Leo is the fifth sign of the zodiac, between Cancer and Virgo, and is entered by the sun about July 22. In ancient astrology the symbol ( $\Omega$ ) was the breastbone or the tail of a lion.

**LEO**, the name of thirteen Popes, of whom the following were the most important:

**LEO I**, Saint, Pope from 440 to 461, was a very able ruler and strengthened the power of the Papacy. When Attila took Rome in 452, Leo visited the conqueror in person and induced him to spare the city, and three years later, when Genseric attacked the city, by his interposition he saved many of the most beautiful buildings of the city.

**Leo III**, who became Pope in 795, was the Pope who crowned Charlemagne emperor of the West.

**Leo IX**, Pope from 1048 to 1054, was a learned man and devoted much attention to the correction of abuses within the Church. He firmly upheld the power and rights of the Church and thus prepared the way for the later struggle over prerogatives between the Popes and the emperors.

**Leo X**, Giovanni de Medici, was the son of Lorenzo the Magnificent and became Pope in 1513. His court was splendid and, like the other members of his family, he was a munificent patron of learning and art. The University of Rome was reorganized by him. It was during his reign that the Reformation broke out in Germany. At first Leo refused to take the new movement seriously, but in 1520 he went so far as to proclaim a bill of excommunication against Luther.

**Leo XIII**, (1810-1903) was born at Capriente, Italy. He became titular archbishop in 1843, was apostolic delegate, successively, of Benevento, Spoleto and Perugia, and was bishop of Perugia in 1846. He was raised to the rank of cardinal in 1853 and appointed chamberlain of the Sacred College in 1877; the Conclave of Cardinals elected him successor to Pius IX in 1878. The new Pope at once made known his election to the powers, and his first official act, March, 1878, was to restore the Roman Catholic hierarchy of Scotland, thus inaugurating a policy somewhat different from that of his predecessor. In 1879 he issued an encyclical aimed at Socialists, Communists and Nihilists. The Czar ordered this to be read in all the Roman Catholic churches of Russia. The policy of Leo XIII was to harmonize the diversified opinions and interests of the Church and to strengthen all lines of work which it is authorized to undertake. He was very friendly to the United States; he established the Catholic University at Washington, and expressed great interest in the Columbian Exposition. Leo was noted for his learning, holiness and statesmanlike qualities.



LEO XIII

**LEOMINSTER**, *lem'in stur*, MASS., in Worcester County, five miles southeast of Fitchburg, on the Nashua River and on the New York, New Haven & Hartford and the Boston & Maine railroads. The principal manufactures are pianos, baby carriages, celluloid articles, toys, furniture, paper, cement and brick. There is a Carnegie Library and a hospital. The place was settled in 1725, and remained a part of Lan-

caster until 1740. Population, 1910, 17,580; in 1917, 21,365 (Federal estimate).

**LEON**, *la own'*, NICARAGUA, founded in 1523, is the largest city of the country, situated on a fertile plain thirteen miles from the Pacific coast. It is regularly built, and the public buildings, which are considered among the finest in Central America, include a massive cathedral, an old episcopal palace, a new episcopal palace and a university. A railway connects it with the coast at Corinto. Population, 1916, 62,569.

**LEONARDO DA VINCI**, *la o nah'r'doh dah veen'che*. See VINCI, LEONARDO DA.

**LEONIDAS**, a king of Sparta, who ascended the throne in 491 B. C. When Xerxes invaded Greece, the Greek congress assigned to Leonidas the command of the force destined to defend the pass of Thermopylae. His force, according to Herodotus, amounted to over 6,000 men, of whom 300 were Spartans. After the Persians had made several vain attempts to force the pass, a Greek named Ephialtes betrayed to them a mountain path, by which Leonidas was assailed from the rear, and he and his followers fell fighting (480 B. C.).

**LEOPARD**, *lep'urd*, one of the largest animals of the cat family, next in size to the lion and the tiger, but more treacherous than even the latter. It is found in Africa, Persia, India, some parts of China and some of the East India islands. The color varies

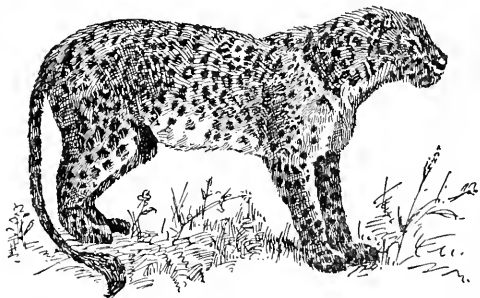

THE LEOPARD

from a pale fawn to a deep buff, which fades into white on the under side of the body and the inner parts of the limbs. The coat is thickly marked with black or deep brown spots. It is a beautiful and graceful animal, and its home is usually in forests. It feeds on antelopes, monkeys, sheep, goats and other small animals, but seldom attacks man. While it is easily subdued when in captivity, great risk and danger attend hunting it. One

variety is nearly black and is more fierce than the common leopard. The *chetah*, or *hunting leopard*, is found in Northern India.

**LEOPOLD II**, LOUIS PHILIPPE MARIE VICTOR (1835-1909), king of the Belgians, eldest son of Leopold I, ascended the throne in 1865. The organization of the African International Association was his work, and he assisted Stanley with money in his exploration of the Congo. When the Congo Free State was established in 1885, Leopold was made its sovereign. He exploited the African natives in such a cruel manner in his rubber operations that an international protest was launched against his practices. He was profligate in many of his relations, and died without leaving an heir to the throne. Albert I, a worthy nephew, who became the Belgian hero in the World War, succeeded him. See ALBERT I.

**LEPIDOPTERA.** See INSECTS.

**LEPIDUS**, MARCUS AEMILIUS (?-13 B. C.), a Roman triumvir. He was praetor in 49 B. C., consul with Julius Caesar three years later and in 44 was appointed by Caesar to the government of Nearer Spain. He was in Rome at the time of Caesar's death and joined Mark Antony. In 43 he united with Antony and Octavianus to form the second triumvirate, obtaining Spain in the division of the Empire. After the Battle of Philippi (42) a revision of the allotment took place, in which Lepidus received Africa. In 36 he was summoned to assist Augustus against Sextus Pompey. He then tried to seize Sicily, but was overcome by Augustus, who forced him to retire to private life.

**LEPROSY**, a skin disease which from earliest times has inspired more fear than almost any other affliction of mankind. Yet in highly-civilized countries leprosy is very rare, and its death rate is far below that of tuberculosis, cancer or pneumonia. The hideous deformities caused by leprosy, and the fact that the victim of the disease drags out a miserable existence covering years, are responsible for the horror which the name incites.

Leprosy is caused by a bacillus which was first identified by a Norwegian named Gerhard Hansen. According to many authorities there are three main forms, namely, *macular*, *anesthetic* and *tubercular*. Some cases show all three forms. In macular leprosy dark red or black stains appear on the skin. In anesthetic cases the patient experiences the loss

of feeling in the sections of tissue that are diseased. In the tubercular form the affected tissue becomes a mass of small, grain-like elevations. In well-developed cases there are ulcerations in various parts of the body, causing affected areas to drop off. Sometimes even the bones are destroyed. Leprosy is spread by personal contact, and it requires from two to seven years for a case to develop.

Of the various remedies that have been used, the most effective is chaulmoogra oil. Because of the nauseating effects of this drug, it is given most satisfactorily as a hypodermic injection. In the leper colony at Culion, Philippine Islands, the oil is mixed with camphorated olive oil and resorein. This colony takes care of all the lepers of the islands, and up to 1917 it had admitted 10,425 patients. In time it is hoped that the islands will be free of the disease, as patients are not permitted to return home until they are cured. The other leper colonies maintained in the United States or its dependencies are as follows: San Francisco Leper Home; Louisiana State Leper Home; Massachusetts Leper Station; Hawaiian Leper Colony, on the island of Molokai; Porto Rico Leper Colony, Cabras Island.

In February, 1917, President Wilson signed an act appropriating \$250,000 for the establishment of a national home for lepers, to be administered by the Public Health Service. The entrance of America into the World War prevented immediate action on this important law.

**LESAGE**, *le sahzh'*, ALAIN RENÉ (1668-1747), a French novelist and dramatic writer. His early attempts were in imitation of the Spanish drama, but he enjoyed his first success with *Crispin, his Master's Rival*. *The Devil on Two Sticks*, imitated from a Spanish romance, appeared the same year. In 1715 he published the first two volumes of *Gil Blas*, one of the best romances in the French language, the third volume appearing in 1724, the fourth in 1735. This story is notable as preparing the way for the French novel of realism. Lesage is also renowned for a comedy, *Turcaret*, a drama of life in Paris.

**LES MISERABLES**, *leh me za rah'bl'*, a celebrated novel by Victor Hugo, first published in 1862. The title, which means *The Miserable People*, suggests the character of this fascinating story, which has been justly called a "prose epic" of the human soul.

The central character, Jean Valjean, becomes a criminal because of unjust treatment, but experiences a transformation of character through the influence of the good Bishop Bienvenu. Thereafter his own life is one of self-sacrifice and devotion to ideals. Throughout the story, with its complex plot, matchless descriptions and vivid pictures of all classes of life, there is the background of the unhappy lot of the poor and downtrodden. *Les Miserables* has been dramatized for the regular stage, but was much more successful when presented through the medium of moving pictures.

**LESSEPS FERDINAND, VICOMTE DE** (1805-1894) a French diplomatist and engineer, the builder of the Suez Canal. After holding several consular and diplomatic posts he retired from the government service, and in 1854 went to Egypt and proposed to the viceroy the cutting of a canal across the Isthmus of Suez. This great work was successfully completed in 1869, under his supervision, and brought him high honors of various kinds. He subsequently proposed several other grand schemes; but the only one really taken in hand was the Panama Canal, which, under French management, proved an unfortunate venture. See PANAMA CANAL.



DE LESSEPS

**LESSER ANTILLES**, *ant il leez*. See ANTILLES.

**LETHBRIDGE, ALBERTA**, on the Belly River and the Canadian Pacific and Great Northern railways, 109 miles from Medicine Hat. It is an important railway center, is the shipping point for a rich coal-mining and farming region, and has natural gas. The crop shipments are large, averaging 5,500,000 bushels a year, mostly wheat, oats and flax. Six large coal mines are within sight of the city. The head office of the Alberta Railway and Irrigation Company, which is operating a great irrigation system in Southern Alberta, is located here (see IRRIGATION). The chief industries of the city include iron and brick works, flour and woolen mills. The city is the headquarters of a division of the Royal

Northwest Mounted Police, and has a land office, a district court, a Y. M. C. A., a Dominion experimental farm and stock yards. Population, 1916, 9,437.

**LETHE**, one of the streams of the lower regions, celebrated in ancient mythology. Its water had the power of making those who drank of it forget the whole of their former existence. Souls before passing into Elysium drank to forget their earthly sorrows; souls returning to the upper world drank to forget the pleasures of Elysium. The word is from the Greek for *forgetfulness*.

**LETTER OF CREDIT**, an order given by bankers or others at one place, to enable a person to receive money from their agents at another place. It differs from the common *check* or *draft*, in containing a statement, not of the exact amount to be paid, but of an amount which the payment shall not exceed. It may contain coupons, each of which calls for a certain amount. If it names several banks which shall honor drafts, it is known as a *circular letter of credit*, and in this form it is much used by travelers.

**LETTER WRITING**, a form of composition that is practiced by all civilized people beyond the period of childhood. The demands of friendship, of social intercourse and of business make letter writing one of those tasks that fall practically to everyone, and a knowledge of how to perform this duty acceptably is very important. Like all forms of written composition, letters should be expressed in correct English, and the details of punctuation, spelling and paragraphing should have careful attention.

**The Form of a Letter.** There are certain rules of form which all persons who follow convention will observe in writing a letter. That is, the conventional letter will consist of the following parts: the heading, the introduction, the body of the letter, the close and the superscription. The heading, which is placed at the top of the first sheet, on the right-hand side, consists of the address of the writer and the date of writing. It may occupy two or three lines, but if three lines are used the first should consist of the street and number, the second of the town and state, and the third of the date.

The introduction includes the address of the person or firm that is to receive the letter, and a salutation, such as *Dear Madam*, *My Dear Mr. Jones*, *Dear Alice*. The body of the letter, which is by far the most important



of the Mediterranean and the adjacent countries of Asia Minor.

**LEVÉE**, in engineering, an artificial embankment constructed on the banks of a river for the purpose of keeping the waters in the natural channel during floods. According to this definition the dikes of Holland and the embankments along a number of European rivers, such as the Danube, Po and Vistula, are levees. In the United States, however, the term is applied particularly to the artificial embankments along the Mississippi River, which aggregate more than 1,500 miles in length and are constructed along the river at various places from Cairo to the Gulf of Mexico.

The first levees were built after very disastrous floods in 1882. Between that date and 1903 nearly \$20,000,000 had been expended in their construction by the Federal government, and about \$45,000,000 by state governments. More than 20,000,000 acres of fertile land are now protected from the river floods. See MISSISSIPPI RIVER.

**LEVEL**, an instrument used to find, or draw, a straight line parallel to the plane of the horizon. By this means is determined the true level or the difference of ascent or descent between several places. There is a great variety of instruments for this purpose, differently constructed and of different materials, according to the particular purposes to which they are applied, as carpenter's level, mason's level, gunner's level, balance level, water level, mercurial level, spirit level and surveying level. All such instruments, however, may be reduced to three classes:

(1) Those in which the vertical line is determined by a suspended plumb line, or balance weight, and the horizontal indicated by a line perpendicular to it. Such are the carpenter's and mason's levels.

(2) Those which determine a horizontal line by the surface of a fluid at rest, as water and mercurial levels.

(3) Those which point out the direction of a horizontal line by a bubble of air floating in a fluid contained in a glass tube. When the air bubble rests directly under the middle point of the tube, the instrument is level. Such are spirit levels, which are by far the most convenient and accurate. All levels depend on the same principle, namely, the action of gravity.

**LEVER**, *le'ver*, or *lev'er*, one of the simplest of devices for accomplishing work. It may consist merely of a solid bar, such as a crowbar, resting upon a rock or block of

wood, as a fulcrum. In performing work a third object, a weight, is introduced. Thus in manipulating a lever three elements are present, namely, *power*, *weight* and *fulcrum*. The parts of the lever on each side of the fulcrum are called the *arms*. The power arm is the part between the fulcrum and the point where the power is applied; the weight arm is that part between the fulcrum and the weight.

**Three Classes of Levers.** The principle of the lever has a wide variation in mechanics. There are three classes of levers, distinguished by the different applications of the fulcrum, power and weight.

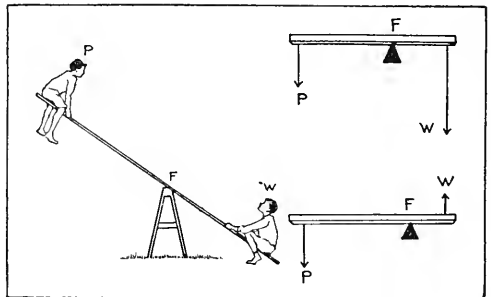

LEVER OF THE FIRST CLASS

The lever of the first class has the fulcrum between the power and the weight, as shown in the first figure.  $F$  represents the fulcrum,  $P$  the power and  $W$  the weight. A common crowbar, a pump handle, a pair of scissors and a boys' seesaw are good illustrations of levers of the first class.

The lever of the second class has the weight between the power and the fulcrum, as shown in the second illustration. A nutcracker and

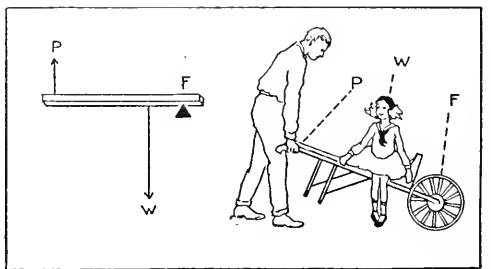

LEVER OF THE SECOND CLASS

a wheelbarrow are good illustrations of this class of levers.

The lever of the third class has the power between the weight and the fulcrum, as

shown in the third figure. Good illustrations of the third class lever are the treadle of the

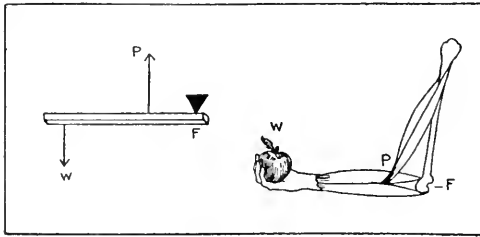

LEVER OF THE THIRD CLASS

sewing machine and the forearm. See MECHANICAL POWERS.

A lever is said to be in *equilibrium* when the power and the weight balance each other. The law of equilibrium is that the power multiplied by the length of the power arm is equal to the weight multiplied by the length of the weight arm. In a lever of the first class which is three feet long and has a fulcrum one foot from one end, a power of one pound would balance a weight of two pounds. In levers of the third class the positions of the power and weight are reversed. By levers of the first and second classes we gain power and lose speed; by those of the third class we lose power and gain speed.

Compound levers consist of a number of levers so arranged that the power arm of one acts upon the weight arm of the other. Their effect is to increase the power of the lever. They are illustrated by the hay scale, in which the weight of the hand may balance a load of hay. See WEIGHING SCALE.

**LEVER**, CHARLES JAMES (1806-1872), an Irish novelist, born in Dublin and educated at Trinity College. In March, 1834, he contributed his first paper to the newly started *Dublin University Magazine*, and the first chapter of *Harry Lorrequer* appeared in that magazine in 1837. Among his later novels are *Charles O'Malley*, *Tom Burke of Ours*, *Jack Hinton*, *Arthur O'Leary* and *Roland Cashel*. The lively humor which is considered characteristic of Lever is more in evidence in his early than in his later writings. For the last thirty years of his life he was in the diplomatic service, holding appointment as consul at Spezia and Trieste.

**LEVIATHAN**, the name applied in *Job* XLI and elsewhere in the Scriptures to an aquatic animal variously held to be the crocodile, the whale or some species of serpent.

The word is Hebrew for *long-jointed monster*.

The name *Leviathan* was given the German steamship *Vaterland* after it was taken over by the United States in 1917. It was at the time the largest ship afloat.

**LEVIS**, *le veé'*, or **POINT LEVI**, QUEBEC, capital of Levis County, on the Saint Lawrence River, opposite Quebec. It is on the Intercolonial, the Quebec Central and the Grand Trunk railways and is connected with Quebec by ferry and by a cantilever bridge. The city has a college, a hospital and convents. There are machine shops, an iron foundry, boot and shoe, cigar, soap, woolen and other factories and lumber mills. The first settlement was made in 1647, and it became a city in 1861. Population, 1916, 8,657.

**LEVITES**, the name generally employed to designate not the whole Jewish tribe that traced its descent from Levi, but a division within the tribe itself, in contradistinction to the priests, who are otherwise called the "sons of Aaron." They were the ministers of worship, especially singled out for the service of the Temple, and with the priests formed the priestly tribe. A permanent arrangement was made for their maintenance. In place of territorial possessions they were to receive tithes of the produce of the land, and in their turn to offer a tithe to the priests. After the settlement in Canaan, forty-eight cities, six of which were cities of refuge, were assigned to the tribe of Levi, thirteen of the total number being set apart for the priests. To the Levites was to belong the office of preserving, transcribing and interpreting the law, and they were to read it every seventh year at the Feast of Tabernacles. Their position was much changed by the revolt of the ten tribes, and in later history they merely performed minor tasks about the Temple.

**LEVITICUS**, the third book of the Old Testament, containing the laws relating to the priesthood and to sacrifices. In the Greek translation it was called "the Levitical book," *Levitical* meaning *priestly*. It contains besides the laws considerable historical matter, and is a continuation of *Exodus*.

**LEWIS**, MERIWETHER (1774-1809), an American explorer, who gave his countrymen their earliest knowledge of the far West, was born near Charlottesville, Va. He fought in the United States army during the Whisky Rebellion in 1794 and later became an ensign and captain in the army. In 1801, Presi-

dent Jefferson appointed him his private secretary, and two years later he was chosen to lead an expedition for the purpose of exploring the territory recently acquired from France (see LEWIS AND CLARK EXPEDITION). As a reward for his service in this expedition, Congress voted him 1,500 acres of land, and he was appointed governor of Louisiana Territory in 1807. He displayed energy and ability in administration and during his incumbency prepared a valuable account of his journey.



MERIWETHER  
LEWIS

**LEWIS AND CLARK EXPEDITION**, a famous tour of exploration under the leadership of Meriwether Lewis and William Clark, whose purpose was to explore the territory between the Mississippi River and the Pacific Ocean. It was undertaken the year after the purchase of Louisiana Territory, and was inspired by President Jefferson.

The party left Saint Louis, Mo., May 14, 1804, ascended the Missouri River, wintered among the Mandan Indians in North Dakota, again set out in April, 1805, crossed the Rocky Mountains in September and came in sight of the Pacific Ocean, November 7. They started on their return in the following March and arrived at Saint Louis, September 23, after a journey of 8,500 miles. The trip resulted in the collection of a great mass of exceedingly valuable information concerning the geography, climate, natural products and animal life of the region explored. See CLARK, WILLIAM; LOUISIANA PURCHASE.

**LEWIS AND CLARK EXPOSITION**, an industrial exposition held at Portland, Ore., in the summer of 1905, to commemorate the one-hundredth anniversary of the journey of Meriwether Lewis and William Clark from the Mississippi River to the Pacific coast. The exposition buildings, of which there were eleven main structures, were artistically grouped on a beautiful sloping greensward, facing two attractive bodies of water, which made possible the development of landscape and architectural scenes of rare beauty. The exhibition covered about 406 acres. Its total cost to its promoters was about \$7,500,000; to the states that had special exhibits,

\$1,000,000, and to the Federal government, \$500,000.

**LEWISTON**, IDAHO, the county seat of Nez Perces County, about 145 miles south-east of Spokane, Wash., on the Clearwater and Snake rivers, and on the Northern Pacific and the Oregon-Washington Railroad and Navigation Lines. The city is in a rich farming, fruit-growing, stock-raising and mining district, has a considerable trade and is growing very rapidly. The most important industrial establishments are flour and lumber mills. The city is the seat of the state normal school and a parochial school, and it has a Carnegie Library, a Federal building and a hospital. The city is governed on the commission plan. Population, 1910, 6,043.

**LEWISTON**, MAINE, in Androscoggin County, thirty-five miles north of Portland, on the Androscoggin River, and on the Grand Trunk and the Maine Central railroads. It has many factories, of which the most important are cotton and woolen mills; power is furnished by falls in the river. There are also extensive bleaching and dye works and manufactures of boots and shoes, lumber, machinery and various products. Bates College is located here, and the city has a public park, a city hall, a Federal building, a Carnegie Library, two hospitals, two convents and a soldiers' monument. The place was settled in 1770, was incorporated as a town in 1795, and chartered as a city in 1863. Population, 1910, 26,247; in 1917, 28,061 (Federal estimate).

**LEXINGTON**, KY., the county seat of Fayette County, about 100 miles south of Cincinnati, on the Chesapeake & Ohio, the Louisville & Nashville and the Cincinnati, New Orleans & Texas Pacific railroads. The city is in the famous "blue grass region" and is the chief market for the products of that section. The greatest industrial enterprises center around the tobacco crop; Lexington is the world's largest market for loose-leaf tobacco. Near the town are some of the finest stock farms of the country. In former years one great product of Lexington was Bourbon whisky. Lexington has a Carnegie Library, and is an important educational center, being the seat of Kentucky University, Sayre Female Institute, Hamilton Female College, Saint Catherine's Academy and Transylvania University. The Kentucky reform school is here; the charit-



able institutions are the state asylum for the insane, Saint Joseph's Hospital, an industrial home for negroes and the Good Samaritan Hospital. Henry Clay had his home in Lexington for many years.

The first settlement was made in 1775; in 1782 the town was incorporated, and when Kentucky became a state it was made the capital. The commission form of government was adopted in 1913. Population, 1910, 35,099; in 1917, 41,997 (Federal estimate).

**LEXINGTON, BATTLE OF**, the first battle of the Revolutionary War, fought at Lexington, Middlesex County, Mass., April 19, 1775. A British force of 800 soldiers had been dispatched by General Gage to seize the stores which had been collected at Concord by the colonists and to capture Samuel Adams and John Hancock, who were said to be in hiding at Lexington. News of the expedition was carried through the country by Paul Revere, who rode from Charlestown to Lexington. When the soldiers reached the latter point, they were confronted on the Common by about seventy militiamen. The British commander, Pitcairn, demanded that the company disperse, and some one, minuteman or grenadier, fired a shot. A brief skirmish ensued, in which eight militiamen were killed and ten wounded. At Concord the British found the stores removed and encountered another force of about 400 militiamen, who forced them to make a rapid retreat towards Boston. On the route they were constantly harassed by bands of farmers who fired upon the British columns from behind rocks and trees. The loss to the British was 273 men.

Lexington is a village eleven miles northwest of Boston. The famous ride of Paul Revere to the town is the theme of a stirring poem by Longfellow. It may be found in these volumes in the article **READING**.

**LEYDEN, or LEIDEN**, *l'iden*, **NETHERLANDS**, an important educational center, situated twenty-two miles southwest of Amsterdam. The most important educational institution is the university, formerly one of the most famed in Europe. In normal years it is attended by about 900 students, nearly one-half studying law. Leyden has cloth and other manufactures, although it is no longer so famous for its textiles, as it was during the fifteenth century. The historical event for which Leyden is most famous is the siege by the Spaniards in 1573-1574 and the

relief by the Prince of Orange, who had the dikes opened and the country flooded. The Pilgrims started from Leyden to found the colony at Plymouth, Mass. The city was the birthplace of Rembrandt, Jan Steen and Gerard Dou, eminent painters. Population, 1916, 60,266.

**LEYDEN JAR**, an early form of electric accumulator, introduced to the scientific world by Muschenbroek of Leyden in 1746; hence its name. It consists of a glass jar, coated inside and outside, usually with tin foil, to within a third of the top. The mouth is closed by a wooden cover. A metallic rod, with a knob at the top, is fixed into the cover and is made to communicate with the inside coating; when the jar is to be charged the knob of this rod is applied to the prime conductor of an electric machine and the two coatings are brought into opposite electrical states, the inside being positive and the outside negative. The jar is discharged by establishing a communication between the outside coating and the knob. When a number of jars are placed in a box lined with tin foil connected with the earth, their knobs being joined together, they form a *battery*. A quantity of electricity equal to the sum of the charges which would be received by each jar can be collected in such a battery. See **ELECTRICITY**.

**LHASA, or LASSA**, *lah'sah*, **TIBET**, capital of the country and the sacred city of its people. It is situated on the Kyi-ch'u, a tributary of the Brahmaputra. All the public edifices worthy of notice are connected with the Buddhist religion, as Lhasa is a great center of Buddhism and is visited by thousands of pilgrims from China, Turkestan and Nepal. Lhasa is the principal emporium of Tibet, silk stuffs, tea and other articles being here exchanged for Tibetan, Indian and European goods. Late in the eighteenth century a law was established that no foreigner should enter the city, but it was entered by British forces under Colonel Younghusband in 1905. Population, about 15,000.

**LIBAU, le'bou**, **COURLAND**, a port on the Baltic Sea, before the Russian revolution of 1917 a fortress of the second class. It lies at the end of a sandy peninsula separating Lake Libau from the sea, and is divided into two parts by a channel. Before the World War the city was a prosperous commercial and manufacturing center, exporting large quantities of petroleum, grain, flax, timber,

dairy products and other commodities. It had large factories, grain elevators, etc., and numerous educational institutions. During the war it was set on fire several times by shells from German warships. Population, 1913, 90,400. See COURLAND; WORLD WAR.

**LIBEL**, in law, the act of publishing malicious statements with the intent to expose persons to public hatred, contempt or ridicule. The difference between libel and slander is that in the former case the defamation must be in writing, printing or in some other visible manner, while in the latter the offense is committed verbally (see SLANDER). Publication is held to have taken place if the libel is seen by but one person other than the person libeled. In criminal law it is a misdemeanor to publish, or threaten to publish, a libel; or as a means of extortion, to offer to abstain from or to prevent others from publishing a libel. In the United States the punishment for this offense is imprisonment, fixed by statute in the different states.

Recent legislation and decisions in this branch of law have a tendency to limit liability for action to purely false, scandalous and malicious libels. Truth, if published with good motives and for justifiable ends, is now admitted as a good defense; and even an innocent motive alone is so considered, though the statements may prove untrue.

**LIB'ERAL**, in a broad sense a person who advocates the principles of freedom, reform and progress. Within recent years the term has been applied specifically to the political parties in Great Britain and Canada which work for reforms, and are opposed by the Conservatives (called Unionists in England), who are slow to advocate changes. Sir Wilfrid Laurier (which see) was the greatest modern Canadian Liberal. In Great Britain the Liberal party was in power under the leadership of Herbert Asquith from 1908 to 1916 and during that period many notable reforms were effected. Lloyd George, regarded as a radical Liberal, became Prime Minister in December, 1916, and a new alignment of parties took place under the strain of the World War. The Unionists and Lloyd George Liberals formed a Coalition, and in the Parliamentary election of December, 1918, the old Liberal party almost disappeared, carrying but thirty-seven seats in the House of Commons. The Coalition Liberals, on the other hand, carried 127. See ASQUITH, HERBERT; GEORGE, DAVID LLOYD.

**LIBERAL REPUBLICAN PARTY**, the name given to a coalition of political factions during the presidential campaign of 1872. It was organized by Missouri Republicans under Carl Schurz as a protest against the Reconstruction policy of Congress following the Civil War and in favor of tariff reform and civil service reform. The national convention was held in January, 1872, at which Horace Greeley was nominated for President and B. Gratz Brown for Vice-President, the issues being the same as in Missouri, with the omission of the tariff question. The Democratic convention accepted the Liberal Republican candidates; but a small Democratic element made independent nominations. After a campaign remarkable for its bitterness and for the widespread interest it aroused, the party was so badly defeated that it disappeared. See POLITICAL PARTIES.

**LIBE'RIA**, the world's only negro republic, and one of two independent countries on the entire continent of Africa, the other being Abyssinia. It is situated on the west coast, with the Atlantic Ocean extending for 350 miles on its southern side. The Ivory Coast is east, Sierre Leone is west, and French Guinea is north. It lies between 5° and 9° north of the equator. The area is about that of Ohio—40,000 square miles; the number of people is not known, but the population is supposed to be between 1,500,000 and 2,100,000, all of the African race. Only about 50,000 are civilized; these control the government, but they exercise no authority over the half savage tribes of the interior.

The first settlement was made where Monrovia (named for President James Monroe), the capital, now stands. The establishment of the country was due to international efforts to make a permanent provision for freed American slaves, by which they might develop a free negro state. The initial effort succeeded so well that in 1847 the Free and Independent Republic of Liberia was constituted. The basic law is modeled after the Constitution of the United States, from which there are only trifling departures.

The agricultural development of the republic has scarcely begun, and the valuable forests are practically untouched. The products of the soil are cocoa, cotton, rice and coffee. There is also rubber, and its export is slowly increasing. Gold has been found in small quantities, and there is some tin, copper, corundum and lead.

In 1917 Liberia made known its sympathies in the World War by declaring war upon the German Empire.

**LIBERTY, STATUE OF**, a huge bronze statue on Bedloe's Island, in New York Harbor. It was presented to the United States by the people of France in commemoration of the one hundredth anniversary of American independence, and was placed on the island in 1885 and dedicated in the following year. The Statue of Liberty is the largest statue in the world and represents a female figure with a torch. From the base to the top of the torch the statue is 151.41 feet high. A stairway in the inside of the statue leads to the head, and there is a branch stairway within the extended arm. It was designed by Frederic Bartholdi. The complete name, given it by its donors, is "Liberty Enlightening the World."

**LIBERTY BELL**, the bell which hung originally in Independence Hall, Philadelphia, and first pealed forth the news of the signing of the Declaration of Independence. It was cast in England in 1752, and bears the inscription: *Proclaim liberty throughout all the land unto all the inhabitants thereof* (Lev. XXV, 10). The bell was cracked at its first ringing, was recast in 1753 and was again cracked while tolling on the funeral day of John Marshall, July 8, 1835. It is on exhibition at Independence Hall, Philadelphia, but has been shown at several recent expositions.

**LIBERTY BONDS**, the patriotic name applied to United States government bonds issued after the nation entered the World War (which see). Never before had the country needed such vast sums of money for immediate use, and but a small part could wisely be raised by taxation. The people had never been taught to buy bonds of any character as

an investment, and the first issue, it was believed, was absorbed as a patriotic duty; by many people it was not viewed as a personal benefit. However, the second and subsequent loans, larger and larger in the aggregate, were taken by millions of people who for the first time in their lives were developing the money-saving habit.

The first issue was put out at 3½% interest; the second, at 4%; the third and fourth, at 4½%; the fifth (Victory Loan) at 4¾%. Purchasers of early issues were permitted to convert their holdings into bonds bearing 4½%. The various issues and the amounts subscribed are given below:

| DATE OF ISSUE   | AMOUNT ASKED    | SUBSCRIBED      |
|-----------------|-----------------|-----------------|
| June 15, 1917   | \$2,000,000,000 | \$3,035,226,850 |
| October 1, 1917 | 3,000,000,000   | 4,617,532,300   |
| March 15, 1918  | 3,000,000,000   | 4,158,599,100   |
| Sept. 15, 1918  | 6,000,000,000   | 6,954,875,200   |
| April 21, 1919  | 4,500,000,000   | 6,100,000,000   |

**LIBERTY CAP**, a symbol used on various American coins, copied from a form of headress worn by freed slaves in ancient Rome. A design consisting of a cap between two daggers was stamped on coins by order of Brutus and Cassius, the assassins of Caesar. At the time of the Dutch revolt against Spain the Netherlands adopted the liberty cap as a symbol of freedom, and it appeared at the time of the French revolution as the *bonnet rouge*, or red cap, of the revolutionists. The liberty cap is sometimes seen in national coats of arms.

**LIBERTY OF THE PRESS**, the liberty of every citizen to print whatever he chooses, under the limitation of being liable for abuse of that liberty. The right of printing rests on the same abstract grounds as the right of speech, yet it is only since men's views of the just limits of government have become clearer that the liberty of the press has been recognized as a right. The Constitution of the United States and those of many of the states declare for liberty of the press. There is complete liberty in Canada; in France and England the press is also free, but in Germany, Austria and Russia, there were still many restrictions before and during the World War. The German and Austrian press, in particular, became bold and independent when the central powers were defeated in the war.

**LIBERTY PARTY**, a political party organized in the Northern states of the Union about 1839, its purpose being to oppose slavery by political action. Its formation in

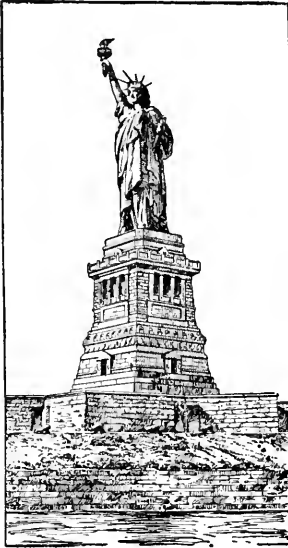

STATUE OF LIBERTY

reality voiced a protest against the non-resistant and non-participant attitude of Garrison and his radical followers. James G. Birney was the first candidate of the party for President. The ticket polled only about 7,000 votes, more than one-third of which were cast in New York state. In 1844, another convention again nominated Birney for President. In this election the Liberty party polled 62,000 votes. Moreover, by drawing many votes from the Whig party in New York, it defeated Clay and elected James K. Polk. Its last candidate was John P. Hale, who, however, withdrew after Van Buren's nomination by the Free-Soil party, in 1848. See POLITICAL PARTIES IN THE UNITED STATES.



**L**IBRARY, a term which is used with several meanings, all of which have some connection with books. The word is derived from the Latin *liber*, which means *book*. The ancient Romans had another word, *libraria*, which they applied to a place where books were sold. At the present time *library* may mean a building containing collections of books, it may signify a room in a private house

containing books, or it may refer to the books themselves. The greater number of people are interested in public libraries, now found in most towns and cities throughout the civilized world. The influence for good which they have wielded in disseminating information and raising the standards of general culture can hardly be estimated.

In large cities the public library is an institution of many departments. There is, first of all, the circulation department, the books of which are borrowed by holders of cards for a specified length of time. In connection with this department there is sometimes maintained an open-shelf division, where books may be examined by the reader, and a selection be made from those on the shelves. The public does not, of course, have direct access to the major portion of the books, as this would not be practicable in a large city. Catalogues are available to all card holders, and lists of books desired are handed to attendants who make selections

from the stacks in the rear of the circulating department.

The reference room, which contains comfortable tables and chairs, is another important department, and one very popular with those who desire a quiet place in which to study. Readers in this department are privileged to use any number of books or magazines while they remain in the room. The borrowed volumes are returned to the main desk when the reader is through with them. Another department, called the reading room, is used by those who wish to consult current magazines and newspapers. In large libraries there are also other special departments, such as the civics room, music department, children's room, etc.

The main building of the largest free circulating library in the world—the public library of New York City—contains besides its book collections valuable collections of sculpture, painting and pottery. This institution maintains also more than forty branch libraries. The branch libraries are likewise a feature of the public library system of Chicago, Boston, Philadelphia and other large cities. In Canada, cities like Toronto and Montreal maintain public libraries similar in plan and equipment to those of the great American cities, and in the Dominion as a whole there are several hundred of these institutions.

Besides the libraries supported and controlled by the city governments, there are in America a number of endowed reference libraries giving the public service free. The John Crerar Library of Chicago, for example, is a splendid science library, and the Newberry Library, in the same city, contains valuable collections in literature and history. Though books may not be taken out of these libraries, they are at the disposal of any who wish to refer to them. Other institutions of this class include the Boston Athenaeum and Pratt Institute Free Library, of Brooklyn.

There is still another class of public libraries—those supported by subscriptions from their members. The Mercantile Library of New York City belongs to this group. Book exchanges, which rent books for a small fee, are also becoming common. The great collections of colleges, universities, historical societies, etc., are generally available to persons having the proper credentials, and thus they become in a sense public libraries. See CARNEGIE LIBRARY.

**LIBRARY OF CONGRESS**, a library at Washington, D. C., established by the United States government in 1800. It was destroyed in 1814 at the burning of the Capitol by the British, but received a new start with the purchase of the library of Thomas Jefferson. It was again partially destroyed in 1851, but since that time it has constantly increased in extent and value until in 1918 it contained 2,614,533 printed books and pamphlets, besides more than 1,000,000 pieces of music, maps, charts, photographs, engravings and manuscripts. It is the largest library on the western hemisphere and one of the finest in the world. It is especially rich in history and political science and in collections of American newspapers. The library is replenished through regular appropriations by Congress, through gifts and exchanges and through the addition of copies of all books copyrighted in the United States.

In 1897 the library was removed from the Capitol to a special building begun in 1889 and completed at a cost of \$6,500,000. It stands just east of the Capitol building. Its ground plan is oblong, covering three and three-fourths acres of ground, and it has a floor space of more than eight acres. The building is of Concord granite on a framework of steel, and the interior walls are encased and decorated wholly with stucco and marble. The vast copper dome terminates 195 feet from the ground in a gilded torch of learning. The decorations represent the finest work of American artists, more than forty of whom were engaged upon the work at different times. The building is considered to be the finest of its kind in the world.

**LICENSE**, *l'ensens*, in law, is permission to do some act, otherwise unlawful; also the name is given to the document conferring such authority. All civilized countries require that persons should not carry on certain trades or professions or do certain acts without previous grant of license, and such licenses are imposed for the sake of regulating traffic and raising revenue. The most common licenses are issued to empower persons to sell such articles as liquors, to peddle, to assemble in public meetings, or to keep certain animals, such as dogs. In regard to the sale of liquor, the license question was long of great importance in the United States, as the source of a heated controversy between the *Prohibitionists*, who would forbid the liquor traffic; the advocates of *low license*, who

would collect a license as a source of revenue, but not for regulation, and the advocates of *high license*, who would collect the license primarily for regulation of the business and secondarily for revenue. As the sentiment of the country gradually made entire states and then the nation prohibition territory the licensing of saloons became a dead issue.

**LICHENS**, *l'kenz*, a very extensive order of flowerless plants which have neither stem nor leaves, but consist mainly of a leaflike thallus, which derives its nourishment from the air. According to theory generally accepted, lichens represent a combination of fungus spores and algae.

Probably 4,000 species of lichens have already been described, and doubtless more will be found. They are gray, yellow or brown in color, and they sometimes present a beautiful and varied appearance.

They are found in greatest variety in high mountain regions and in Polar

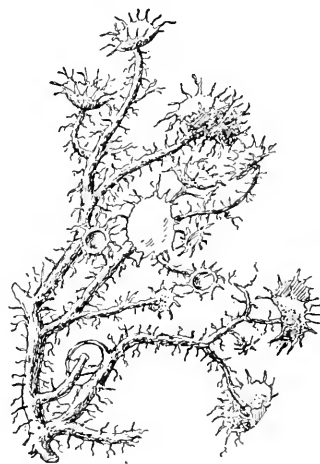

A LICHEN

lands, where they are the principal form of vegetation. Some species are widely distributed, being found in almost all parts of the northern hemisphere. Some are valuable articles of food, as the Iceland moss, which grows abundantly in the northern regions, and the so-called reindeer moss, which is the chief article of food for reindeer and other animals during the cold winters. Several dyes and litmus, so extensively used in chemistry, are lichen products. The chief service which the lichens perform in nature is to pave the way for plants of higher orders. They are able to derive their subsistence from the air. Growing as they do upon exposed rocks and in barren soil, they dissolve the rock and soften the soil, and in time, when their decaying bodies mix with the soil, they enrich it so that more highly developed plants can grow there.

**LICK OBSERVATORY**, *ob zurv'a to ry*, an astronomical observatory in California, situated on Mount Hamilton, 4,285 feet above sea level, and about twenty-five miles east of San José. The telescope is the second-largest refracting telescope in the world. The objective has an aperture of thirty-six inches, being exceeded only by the 40-inch telescope of Yerkes Observatory at Lake Geneva, near Chicago. The point of suspension of the telescope tube is thirty-six feet from the floor, and the diameter of the dome is thirty-six feet. In 1892 Edward E. Barnard discovered at this observatory the fifth moon of Jupiter.

**James Lick** (1796-1876), for whom the observatory was named, was born in Fredericksburg, Pa. He engaged in the manufacture of pianos and in 1847 settled in California, where he accumulated a large fortune by real estate investments. In 1874 he placed \$3,000,000 in the hands of trustees, for use in the promotion of educational enterprises. Of this, \$540,000 was given for a school of mechanical arts and \$700,000 was granted to the University of California for the erection of the observatory described above.

**LICORICE**, or **LIQUORICE**, *lik'o ris*, a name for several herbs of leguminous (pod-bearing) plants.

Though the purplish flowers are large and attractive, the plant is known best for its juice, prepared from the small, yellowish roots and most familiar in the form of a black, gummy substance, sold in sticks or lozenges. A great deal of the licorice sold in the markets was formerly much adulterated with cheaper materials, and this is true yet of that which



LICORICE PLANT

comes from Spain. The pure food laws of America forbid adulteration.

**LICTORS**, in Rome, public servants, usually freedmen, who attended upon the chief magistrates—dictators, consuls, praetors and propraetors—to clear the way for them and to cause due respect to be paid to them. They carried axes tied up in bundles

of rods, called *fascēs*, as ensigns of office. The number of lictors depended upon the rank of the magistrate, a dictator having twenty-four, a consul twelve, a praetor two and a propraetor six.

**LIEBIG**, *le'biK*, **JUSTUS**, Baron von (1803-1873), one of the most eminent of modern chemists, born at Darmstadt, Germany. Through the favor of Humboldt, he was appointed, in 1825, professor of chemistry at the University of Giessen, a chair he held for twenty-five years. Later he held similar positions at Heidelberg and Munich. He is regarded as the founder of organic chemistry, owing to the many discoveries he made in this department. He did much to improve the methods of analysis; his *Chemistry of Food* has brought about a more rational mode of cooking and use of food, while agriculture owes much to his application of chemistry to soils and manures.

**LIEBKNECHT**, *leep'neKt*, **KARL** (1871-1919), a German Socialist of radical views. He was born in Leipzig, and was educated in that city and in Berlin for the law. In 1908 he became a member of the Prussian House of Deputies, and four years later won a seat in the Reichstag, the lower house of Parliament under the former German Empire. Liebknecht soon became a prominent figure because of his fearless opposition to Germany's military policy, and in December, 1914, he was the only deputy in the Reichstag who refused to vote for the war credits. He would refuse to support any war except one against capitalism, he declared, and to this course he consistently adhered.

In 1916 a large number of his fellow Socialists censured him for what they declared to be unpatriotic conduct, and as a result of radical utterances made on May 1, which is Labor Day in Europe, the German government sentenced him to a long term of imprisonment. He was not released until shortly before the armistice was signed, in November, 1918. His release was the occasion of violent demonstrations in Berlin, and in the revolution which followed he figured as a leader of the Spartacus group, the most extreme Socialist faction in Germany, who followed the practices of the Bolsheviks of Russia. In January, 1919, he was shot and killed by soldiers who were taking him to prison, from whom he tried to escape.

**LIECHTENSTEIN**, *leeK'ten stine*, an independent state of Europe, bounded on the

north and east by the Austrian crownland of Vorarlberg and on the south and west by the Swiss cantons of Graubunden and Saint-Gall. The western boundary is the Rhine. The surface, except in the western part, is covered with mountains, branches of the Rhaetian Alps. The chief industries are agriculture, stock raising, weaving and the production of wines and various wooden articles.

Liechtenstein has an area of sixty-five square miles. Its inhabitants are of German origin and adherents of Roman Catholicism. Population, 1912, 10,716.

**LIEGE**, *le ayzh'*, BELGIUM, at the outbreak of the World War, the most important manufacturing city in the kingdom. It was the chief Belgian center for the making of firearms and railroad equipment, and contained also important woolen mills, tanneries, zinc foundries, watch factories and leather establishments. Liège is the capital of the province of Liège, and is situated fifty-four miles southeast of Brussels, on both sides of the Meuse River. It lay directly in the path of the German advance, and was the first city to resist the invasion of August, 1914. After a stubborn resistance against bombardment from siege guns, it was captured on August 7, and until late in 1918, it was in German hands.

Liège was founded in the sixth century and by the end of the tenth century was so powerful that it was recognized as an independent principality. In 1830 it became a part of Belgium. Population, 1912, 170,630.

**LIEN**, *leen*, in law, in its most usual acceptance, "the right which one person, in certain cases, possesses of detaining property placed in his possession belonging to another, until some demand of the one possessing the property is satisfied." In the United States liens are of two kinds:

(1) **Specific Liens**, where the person in possession of goods may detain them until a claim, which accrues to him from those identical goods, is satisfied; such are the lien on baggage, possessed by hotelkeepers or common carriers; on goods sold but remaining in possession; of workmen on the product of their labor.

(2) **General Liens**, where the person in possession may detain the goods, not only for his claim accruing from them, but also for the general balance of his account.

**LIEUTENANT**, *lu ten'ant*, a junior military officer in all armies. There are two grades. A second-lieutenant is the lowest commissioned officer, in rank above the ser-

geant, who is a non-commissioned company officer. A first-lieutenant ranks above a second-lieutenant, and below a captain. During the World War an American second-lieutenant received \$142.66 per month; a first lieutenant, \$166.67. Each was obliged to furnish his own uniform and pay for his meals. The duties of a lieutenant are to assist his captain and supervise routine detail in his company. There are usually one first- and two second-lieutenants in each company. See RANK IN ARMY AND NAVY.

**LIEUTENANT-GENERAL**, in peace times, in the United States, usually the officer of highest rank in the military establishment. In authority he is above the major-general. Only when war impends is the higher office of general filled. Scott, Grant, Sherman, Sheridan, Schofield, Miles, Young, Bates, Chaffee, McArthur, Liggett and Bullard have been honored with the rank of lieutenant-general. The two last named were eminent commanders in France under Pershing. The salary is \$9,000 per year. Additional allowances are usually given for service on foreign soil. See GENERAL; RANK IN ARMY AND NAVY.

**LIEUTENANT-GOVERNOR**. The chief executive of a province of the Dominion of Canada, appointed by the Governor-General in council. He ordinarily holds office for five years, but he may be dismissed by the Governor-General for "cause assigned," which in accordance with the constitution, must be communicated to Parliament. He is, therefore, an officer of the Dominion, as well as of the province. His position in the province corresponds almost exactly to that of the Governor-General in the Dominion. He appoints his executive council, and is guided by their advice so long as they retain the majority and confidence of the assembly. He can summon, prorogue, and dissolve the assembly, make appointments to office, and perform all executive acts, with the advice of the council, which are necessary for the government of the province. The salary is \$10,000 per year in Ontario and Quebec; \$7,000 in Prince Edward Island; \$9,000 in the other provinces. See GOVERNOR-GENERAL.

In the United States there are lieutenant-governors in nearly all of the states. The office is relatively unimportant, except that the incumbent succeeds to the governorship in case of a vacancy in that office. He is, however, the presiding officer in the state

senate, and in that post yields considerable political influence.

**LIFE, LENGTH OF.** See LONGEVITY; MORTALITY, LAW OF.

**LIFE/BOAT**, a special boat for saving persons from shipwreck. The first lifeboat was patented in Great Britain in 1785, but a very successful improved form was introduced in 1789 and remained almost the only one in use till 1851. Since that time many improvements have been made, so that now strong and serviceable boats, so constructed that it is almost impossible to upset them, capable of carrying heavy loads and fully prepared for all the emergencies of a shipwreck, are in use at the life-saving stations on the coasts of the great nations. Modern lifeboats are so constructed as to discharge water that breaks into them, and are propelled by motors. See LIFESAVING SERVICE.

**LIFE INSURANCE**, *in shoor'ans*. See INSURANCE.

**LIFE PRESERVER**, or **LIFE BUOY**, *boi*, a device intended to support persons who have fallen into the water, until assistance can reach them. The common life buoy consists of a ring of canvas, stuffed with cork. The ring is usually about thirty inches in diameter, and has one or more loops on the outer rim, to which a life line can be attached. When in use the buoy is placed around the wearer under the arms, and is usually put on over the head. Another common style of life buoy consists of a sort of jacket, made of connected plates of cork covered with canvas. This is buckled around the body under the arms and serves the same purpose as the ring buoy.

**LIFE-SAVING SERVICE**, an organization in each of the principal maritime nations for the preservation of life along the sea-coasts, particularly at dangerous places along the paths of ocean commerce. In January, 1915, the life-saving service and the revenue-cutter service of the United States were united under the name of Coast Guard. Under that title the organization is discussed in these volumes.

**In England.** Here the government does not exercise direct control over the life-saving establishment; it is in the control of the Royal National Lifeboat Institution, founded in 1824. It is maintained, without profit, at a cost of over three-quarters of a million dollars a year, by voluntary contributions. Patrons of the service include the

highest personages in the realm. There are 275 stations under its management.

**In Canada.** The government supports the Canadian service, which was established in 1880. In organization the United States service was largely followed (see COAST GUARD). There are nearly fifty stations.

**In Other Countries.** France has a volunteer service, organized in 1865, with the English service as a pattern. In Germany the organization is also voluntary, and has existed since 1865. There are about 100 stations on the Baltic and North seas. The Belgian stations were organized by the government in 1838, and are supported entirely by the state. In Italy there is one general volunteer society, with numerous local organizations. In Denmark the government organized the service in 1852, and has since controlled it. Japan's organization is private, but has had government support since it came into existence in 1889.

#### LIFE-SAVING GUN AND ROCKET.

At nearly every life-saving station is a mortar, loaded with gunpowder and with a projectile with a line attached to it. The missile in one form is armed with curved barbs, something like the flukes of an anchor, which are intended to grapple the rigging or the bulwarks of a ship. The mortars may be discharged with accuracy at a range of from 700 to 1,000 yards. The object of the discharge is to carry a life line to a vessel in distress. A so-called *rocket* is also sometimes used. It is fired in the ordinary way, but in its head is a line that uncoils as the rocket speeds toward its mark.

**LIG'AMENT**, in anatomy, a strong, inelastic white body which surrounds the joints and connects bones, or which strengthens the attachments of various organs or keeps them together. Every joint is surrounded by a capsular ligament; the tendons at the wrist and ankle are bound down by what are called the annular ligaments. In dislocation of joints the capsular ligament is often broken.

**LIG'GETT**, HUNTER (1857- ), an American military leader, commander of the first corps of the army which won the Battle of Saint Mihiel, in September, 1918. He was born at Reading, Pa. After graduating at the West Point Military Academy, in 1879, he was appointed second-lieutenant of infantry. Thereafter he rose steadily in the service, had an active part in the Philippine campaigns, was an instructor in the



war college and served as a member of the general staff. In March, 1917, he became a major-general in the regular army, and after America's entrance into the World War he was appointed lieutenant-general for the duration of the war. His first corps had an honorable part in the victory of Saint Mihiel, and early in October, 1918, on the reorganization of the American forces, he was given the immediate command of the First Army; a newly constituted Second Army was placed under command of General Bullard. In May, 1919, he assumed command of United States troops in the occupied zone centering in Coblenz, Germany.



**L**IGHT, *lite*. Everyday experience tells us that we see objects by the aid of something that comes from them to the eye, and that this agent is thrown off by the sun and other bright objects. We call this agent *light*. Like sound (which see), light is produced by vibrations or waves, but there are several important differences. In the first place, it is not a vibration of air, but of a finer medium, known as ether, which penetrates between

the small particles of ordinary matter. Just what ether is, nobody knows; scientists assume that it exists. Another difference is that sound may travel around corners and curves—that sound waves need not flow in a straight line—but light waves flow only in straight lines.

**Where Light Comes From.** So far as we know, light is given off only by very hot bodies. The sun is the great source of light, as well as of heat. The stars also are sources of light, a small portion of which comes to us. Other sources are chemical and mechanical action. The lights used to light our houses and streets are from one or the other of these sources. Candles, lamps and gas jets give off light by burning. The burning is caused by the union of the oxygen of the air with the carbon in the tallow, oil or gas. This is a form of chemical action. Electric lights are produced by friction, which is a form of mechanical action (see ELECTRIC LIGHT). Bodies that give off light are called

*luminous*. Luminous bodies give off light equally in all directions.

**Some Interesting Facts.** Light travels through substances of uniform density in straight lines, called *rays*. For this reason we cannot see through a bent tube or around the corner of a house. Light travels at the rate of 186,000 miles per second. It requires eight minutes and nineteen seconds for light to pass from the sun to the earth, but many of the stars are so far away that it requires a number of years for the light to reach us from some of them. Sound travels only 1,090 feet a second when temperature is at the freezing point. This fact explains why we usually see a lightning flash several seconds before we hear the thunder clap. For all distances on the earth, however, light is practically instantaneous.

A substance which allows light to pass through it freely, like glass and water, is *transparent*.

A substance that will not allow light to pass through it, as iron, tin and black cloth, is *opaque*.

A substance which allows some light to pass through it, but not enough to enable us to see objects beyond it, as ground glass, white paper and white cloth, is *translucent*.

The brightness of light varies directly as the brightness of the luminous body and decreases as the square of the distance from the luminous body increases. A lamp having a flame four times as bright as a candle will give four times as much light; an object two feet from a lamp will receive four times as much light as it will when four feet distant.

**Reflection of Light.** When rays of light strike an object, some of them enter it, or are *absorbed*, and others are thrown back, or *reflected*. It is by the reflected rays that we see objects. A rough surface scatters the reflected rays more than a surface that is highly polished, like a mirror, and the objects that are poor reflectors can be seen more easily than those that are good reflectors. That is because the reflected rays are so scattered that the object can be seen from any point. The reflection of the object which we see in the mirror is an *image*. Rays of light are reflected at an angle equal to that with which they strike the reflecting surface. For this reason, images of objects mirrored in bodies of water are inverted. This can be illustrated by laying a mirror on a table and

setting an object beside it. In Fig. 1, the ray from the top of the candle *A* strikes the

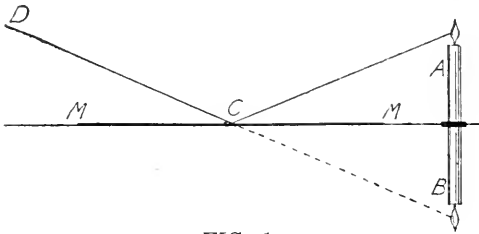

FIG. 1.

mirror *MM* at *C* and is reflected to the eye at *D*; the flame is seen in the direction of the reflected ray and appears near *B*. This is true of all the rays; so the image of the candle is inverted.

Have you ever stopped to think why the image in a camera is upside down? The lens of the camera is much smaller than the object to be reflected. But rays of light travel

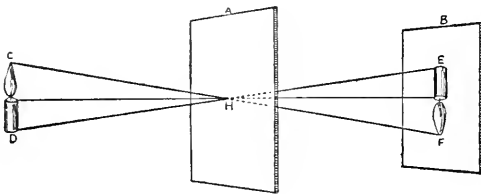

FIG. 2.

in straight lines. Therefore, a ray of light from *C* must travel through the lens or hole *H* in the direction *CF*; and a ray from *D* must pass through *H* in the direction *DE*. If we hold a screen at *B* the image is caught in the position *EF*, upside down. For the same reason you always put the slides in a magic lantern upside down. Can you explain that to your own satisfaction?

Light may be reflected a number of times. We see objects by the moonlight which they reflect, and we know that the moon's light is reflected from the sun. When we see an image in a mirror, the light from the object is reflected to the mirror and from that to the eye.

**Refraction of Light.** When a ray of light passes from one substance to another of a different density, it is bent out of its course, or *refracted*. If we stand a stick in a pail of water, it appears to be bent or broken at the surface of the water; the handle of a spoon in a cup of clear tea presents a similar appearance. The object is seen in the direction

of the refracted ray. In Fig. 3, the stick *AB* appears bent at *C*, on account of the refraction caused by the water. The eye sees the

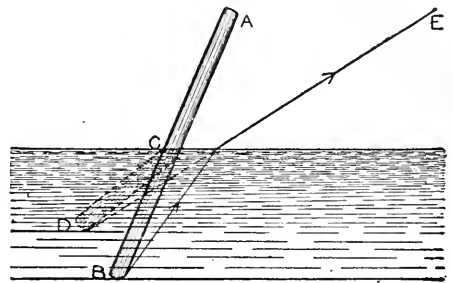

FIG. 3.

end *B* in the direction of the refracted ray, and it appears at *D* instead of where it really is. This is the reason why the bottom of a vessel filled with water appears some inches above the support upon which the vessel rests.

When a ray of light passes through a triangular prism, it produces the effect shown in Fig. 4. The ray from *A* is refracted at

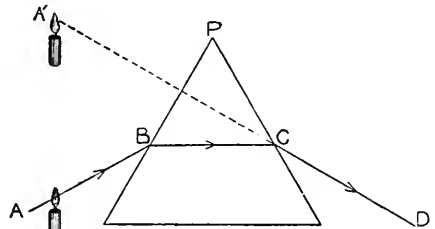

FIG. 4.

*B* toward *C*. On leaving the prism at *C*, it is bent towards *D* and the candle is seen at *A'*.

The law of refraction is: When light passes from a rare to a dense substance, it is bent in the direction of a line that is perpendicular to the surface of the refracting body; when light passes from a dense to a rare substance, it is bent away from a line perpendicular to the surface of the refracting body.

Rays of light passing through a window pane are refracted twice, but in such a manner as to make them appear straight, as shown in Fig. 5. The ray *AB* passing through the pane *MN* is refracted at *C* and *D*, but it has the same general direction as the line *EF*.

**Shadows.** You can perform a few simple experiments to illustrate some of the prin-

principles for the study of shadows. Hold a ball or round bit of cardboard between a

- |        |                 |
|--------|-----------------|
| Color  | Polarization of |
| Ether  | Light           |
| Lens   | Prism           |
| Mirror | Rainbow         |

For the application of the principles of light, see:

- |               |              |
|---------------|--------------|
| Camera        | Spectroscope |
| Magic Lantern | Telescope    |
| Microscope    |              |

For a new theory of light, see Electro-Magnetic Theory of Light.

**LIGHTHALL**, WILLIAM DOVER (1857- ), a Canadian poet and novelist, born in Hamilton, Ontario, and educated at the Montreal high school and McGill University. He began the practice of law in 1881, but in connection with his profession he has been a student of Canadian history and was one of the founders of the Society of Canadian Literature. He originated the series of historical tablets placed in the streets of Montreal and was a leader in the movement which secured the erection of the Maisonneuve monument. He has been a prolific writer of poems as well as books on psychology and ethics, and is the author of *Thoughts, Moods and Ideals*, a volume of poems, *Songs of the Great Dominion, Canadian Poems and Lays, Canada, a Modern Nation, The Masters of Life and The Governance*.

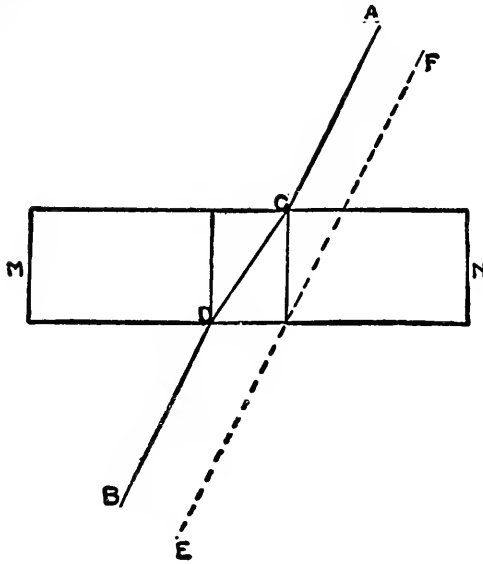

FIG 5

light and a white screen, as in Fig. 6. The space behind the object from which the light is excluded is called the *shadow*. You will find that the center of the shadow is darker than the edges; the diagram shows why. The

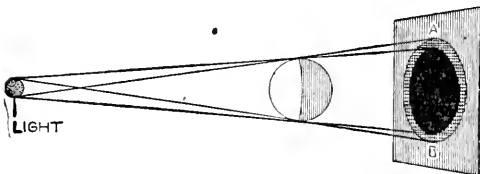

FIG 6

flame is so large that some light streams to A and B. The darker part of the shadow is called the *umbra*, the lighter part the *penumbra*. Now try experiments with a smaller flame, also vary the distances between the light and the ball, and between the ball and screen. What conclusions do you derive:

**The Spectrum.** When sunlight is passed through a triangular prism, the rays are separated by refraction and form the colors seen in the rainbow. The band of color so formed is called the solar, or prismatic, *spectrum*. From this experiment we learn that white light is composed of seven colors.

**Related Articles.** The explanation of the action of light is further illustrated in the articles:



**LIGHTHOUSE**, a tower or other elevated structure bearing a light at the top and erected at the entrance of a harbor or on some rock or headland to serve as a guide or warning of danger to navigators at night. The Pharos of Alexandria, erected about 300 B. C., is, as far as known, the first structure erected expressly for a lighthouse. This tower was so high that it was reckoned among the seven ancient wonders of the world. The lighthouse of Cordouan, at the mouth of the Garonne in France, founded in 1584 and rebuilt in 1727, can be considered as the forerunner of modern lighthouses. Its tower is 197 feet high, and it is a model of strength and neatness. The first lighthouse in the United States was erected in 1716, on the north side of the entrance to Boston Harbor.

**Construction.** The plan of a lighthouse and the material of which it is constructed depend upon its location and the distance to which

Construction. The plan of a lighthouse and the material of which it is constructed depend upon its location and the distance to which

it is necessary to throw the light. Wherever possible lighthouses are placed on high promontories or other sites on the mainland where they will be free from the action of waves, but many of them have to be located on very dangerous places and are subject to great strain from the waves and, in some instances, from floating ice. Lighthouses built in such positions are constructed of the strongest masonry. The tower is in the form of a truncated cone, gradually sloping as it ascends. The construction of the foundation is usually the most difficult and expensive part of the work, since it often happens that this must be laid under water, under such conditions that the work can be done only during periods of low water and when the sea is quiet. After the foundation is completed, the tower rises with comparatively little difficulty. The stones are doweled and cemented together so as to make the walls particularly firm. For the strongest towers the walls at the base are usually five or more feet in thickness and gradually narrow until at the top they are about eighteen inches in thickness. The interior of the tower is usually lined with brick, and between the walls there is left a narrow space for dead air.

A lighthouse is usually divided into the following sections: A cistern, for storing fresh water; a storehouse for supplies; a shop; the living rooms, for the keeper and his family, and the lantern, which surmounts the tower. All of these compartments or floors, are connected with one another by stairways.

*The Lantern.* This is the most important part of the structure, and only to hold it is the tower erected. The lantern consists of a light metallic frame, holding in position a series of lenses and rings, which form the sides. In the larger lights this lantern is about twelve feet in diameter and ten feet high. The number of sides or faces depends upon the style of light desired. The simplest of these lanterns have but four faces, but they may have as many as eight or ten. The center of each face contains a large plano-convex lens (see LENS), and this is surrounded by a series of prisms, each of which is the portion of a ring and has its sides and edges so cut and curved as to reflect all rays of light which strike it from the lamp so that they will be parallel to one another. The lantern is mounted on a vertical shaft and is supported either in a tank of mer-

cury or upon conical rollers which move over a hard, smooth metallic track. When in use the lantern is caused to revolve by clock-work, which is kept in motion by a weight. Lanterns of this style and of the best construction will throw light so that it can be seen for more than twenty miles. The light can be seen only when a face of the lantern is directly opposite the observer, hence a revolving light is a flash light, and in one revolution the lantern gives as many flashes as it has sides. By covering any side with red glass a red light is produced.

The lamp is a comparatively small structure. In small lanterns it resembles very closely the largest sized kerosene lamps having circular wicks, but in the larger lights the lamp contains two or more circular wicks arranged one within the other and each in its special tube. These lamps burn the best grade of kerosene. Occasionally, as in the case of the light at the entrance to New York harbor, the light is electric.

One of the greatest lighthouse lenses is in Hawaii. It is twelve feet high and directs a 940,000 candle-power beam which can be seen thirty miles.

**Lightships.** There are many places dangerous to navigation where a lighthouse cannot be erected, and lightships are used to warn mariners of their approach to such points. The ship carries two or more reasonably high masts, from the top of which lights are suspended. It is moored near the point of danger and securely anchored.

**Management.** The lighthouses in the United States are under the control of the United States Lighthouse Board. This is an organization authorized by Congress in 1852 and consists of the secretary of the treasury, who is ex-officio, its president, two naval officers, two engineers and two civilians of noted scientific ability. All are appointed by the president. By them the country is divided into districts, each of which is under the management of a naval superintendent. Lighthouse tenders, which are vessels in the employ of the board, make periodical visits to all lighthouses. These ships carry inspectors who inspect the lighthouse and report upon its condition, and they also carry the needed supplies for the light and the keeper's family. See BUOY.

**LIGHTNING**, *lit'e'ning*, a bright flash of light between two clouds or between a cloud and the earth. That lightning and elec-

tricity are identical was proved by Franklin when he made an experiment with a kite in a thunderstorm. There are two kinds of electricity, called *positive* and *negative*. An electrical discharge, taking the form of a shower of sparks, occurs when two clouds or a cloud and the earth, oppositely charged, come close together. A flash of lightning is in reality a succession of sparks only a fraction of a second apart. There are three main forms of lightning, *chain*, or *zigzag*; *heat*, or *sheet*; and *ball* lightning.

Zigzag lightning is a line of brilliant light near to the earth; very often the line breaks into a number of forks, or branches. Sheet lightning is a bright illumination in the sky, which takes the form of a great sheet of flame. It is really the reflection of zigzag lightning which itself is invisible to the eye of the observer. Ball lightning is not very well understood by scientists. It manifests itself in balls of fire which fall out of the clouds and explode as soon as they hit the earth.

Thunder is caused by the sudden expansion and compression of the heated air along the path of the discharge. A partial vacuum is created along this path, and when the air rushes back again into the space a crash or prolonged roll is heard, according to the position of the observer. A person hears a sudden crash when the two surfaces between which the discharge takes place are equidistant from him. If he is in such a position that the ear receives the sound from different parts of the path at different times he hears a rolling sound.

Clouds sometimes reflect the thunder and hills echo it, and these conditions produce a rumbling roar. Light travels faster than sound, and that is why thunder follows lightning. The rate at which light travels is 186,000 miles per second, while the rate for sound is about 1,100 feet per second. That for light is practically instantaneous. If you count the number of seconds between the flash and the clap of thunder you can estimate the distance of the flash. If the interval is six seconds, for instance, you know that it required one-tenth of a minute for the sound waves to traverse the space. The rate being 1,100 feet for one second, for six seconds it is 6,600 feet, or 1.25 miles. When the flash is very near the interval may be so brief as to be imperceptible to the ear. In that case flash and sound seem to be simultaneous. If

you hear the thunder crash you may know that the danger from the lightning is past in so far as you are concerned. See LIGHT; LIGHTNING ROD.

**LIGHTNING ROD**, an instrument by means of which either the electricity of the clouds, the cause of lightning, is conducted without explosion into the earth, or the lightning itself is received and conducted into the earth or water without injuring buildings, ships or other structures upon which the rod is placed (see LIGHTNING). It was invented by Benjamin Franklin in 1752, and the idea since then has been adapted in various ways. The lightning rod usually consists of a stout iron rod, with one or more points at the top, the lower end being metallically connected with thick strips of copper or iron, which are carried into the ground to a considerable depth and laid, if possible, in water or wet earth. The rod is insulated from the building by passing through glass insulators, which are attached to the supports.

**How to Make a Lightning Arrester.** To prevent lightning from damaging any apparatus we can make a "lightning arrester."

The sketch shows how to cut and mount three pieces of brass  $1\frac{1}{16}$  in. thick. The upper binding posts on A and B should be connected to the live wires; the lower binding posts to

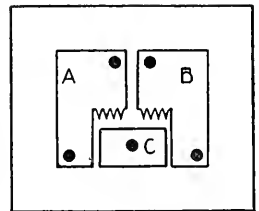

LIGHTNING ARRESTER

the instrument, and the post on C to a ground wire. Any charge of lightning will jump from A and B to C and will run into the ground without harming the instrument.

**LIGHTSHIP.** See subhead, in article LIGHTHOUSE.

**LIG'NITE**, a soft, brownish-black coal, midway between peat (which see) and bituminous, or soft, coal. Any coal may be called lignite in which the texture of the original wood may be traced. See COAL.

**LI HUNG CHANG**, *le hoong chahng*, Earl (1822-1901), a Chinese statesman, one of the foremost diplomats of his age. As governor of the Kiang provinces, he put down, in conjunction with General Gordon, the Taiping rebellion. He was viceroy of the province of Chi-li and Senior Grand Secretary of State from 1870 to 1894. Earl Li

was commander of the Chinese forces during the war with Japan and negotiated the treaty of peace. In 1896 he represented his government at the coronation of the czar and visited the United States. After he had returned to China he became the real head of the foreign office. In 1899 he was decorated with the Double Dragon, an unusual honor, and in 1900



LI HUNG CHANG

he was appointed with Prince Ching to negotiate a treaty with the foreign powers operating in China. Li Hung Chang managed the affairs of his country with consummate skill. He was a friend of Western culture, and to him is due much of China's progress during the latter part of the nineteenth century.

**LILAC**, a shrub belonging to the olive family, cultivated commonly in gardens for its large clusters of fragrant flowers. Many varieties are known, both single- and double-flowered, and white, blue or purple in color. The common lilac, which was introduced into Europe from Northern Persia, grows freely in almost any good soil and spreads rapidly by means of suckers.

**LILIUOKALANI**, *le le oo o ka lah'ne*, LYDIA KAMEKEHA (1838-1917), the last independent ruler of the Hawaiian Islands. She succeeded her brother, King Kalakaua, in 1891, but immediately aroused the greatest antagonism among her subjects by a policy of reaction against the liberal laws which had prevailed. A body of white citizens of the islands finally deposed her, in January, 1893, and organized a republic, with Sanford B. Dole, an American, at its head. The new government attained the islands' annexation to the United States, and the queen was compelled to retire to her private estates in Honolulu. She became fully resigned to the new order, and in her last years was an earnest champion of the United States rule. See HAWAIIAN ISLANDS, subhead *History*.

**LILLE**, or **LISLE**, *leel*, FRANCE, a fortified city, capital of the department of Nord, situated on the Deule River, seven miles from the frontier of Belgium and 155 miles by rail north by east of Paris. For months

during the World War Lille was the scene of furious fighting, and many of its buildings were destroyed by German artillery. It was also forced to pay a war tribute while in the possession of Germany. Among the chief public buildings are the Renaissance town-hall; the Porte de Paris, which was built in the seventeenth century to commemorate the union of French Flanders with France; the Palais des Beaux Arts, and a number of prominent churches. The city is the seat of a Protestant university and of a Catholic university; and of an Institute of Technology and a Pasteur Institute. The municipal library contains 100,000 volumes, and the city has a number of museums of natural history and archaeology.

At the outbreak of the war Lille was one of the leading cities of France in the manufacture of textiles, and its mills produced large quantities of linen and cotton goods. Population, 1911, 217,807.

**LILY**, the common name of a large family of plants and also of the characteristic genus of that order. The leaves and stem are produced from a scaly bulb and bear at the summit flowers which are in many species large and elegantly formed. The typical lily has a colored perianth of six parts, either tubular with spreading divisions, bell-shaped or with re-curving parts. Many of the lilies are common in cultivation and are among the favorite plants of the gardeners, though some which are commonly known by the name of lily belong to very different families, as, for instance, the calla and the water lily.

White lilies are universally regarded as emblems of purity and innocence, and among these are the Easter, or Bermuda, lily, the Mediterranean lily, the beautiful Chinese and Japanese varieties, with their rosy or golden markings, and the small, bell-shaped lilies of the valley, of charming appearance and fragrance. The hyacinth, another small-flowered lily, is one of the earliest spring plants. The strangely named dog-tooth violet is a nodding flower borne singly on a short stem. Other familiar members of the family are the trillium, tulip and tiger lily. (See accompanying color plate.)

**LILY OF THE VALLEY**, a beautiful little plant of the lily family. It bears a dozen or more small, white, bell-shaped flowers on a slender stalk, which rises from between two large, dark-green leaves. Its beauty and the pleasing fragrance of the flowers make it one



W. L. J. B. M.

Painted expressly for New Practical Reference Library by the Art Institute, Chicago

SOME MEMBERS OF THE LILY FAMILY

- 1—Easter Lily. 2—Onion. 3—Lily of the Valley. 4—Hyacinth. 5—Dog-tooth Violet.  
6—Asparagus. 7—Trillium. 8—Tulip. 9—Tiger Lily.





of the most popular of cultivated plants. Under favorable conditions it spreads rapidly in rich gardens and requires very little attention. Florists force the plant to bloom at all seasons of the year, but outdoors it appears early in the spring.

**LIMA, OHIO**, the county seat of Allen County, seventy-two miles south of Toledo, on the Ottawa River and on the Cincinnati, Hamilton & Dayton, the Erie, the Lake Erie & Western, the Detroit, Toledo & Ironton and the Pennsylvania railroads. The city is in the great petroleum and gas belt of the state, and ships large quantities of oil. It contains extensive railroad shops, locomotive and car works, machine shops and refineries. The Ohio state asylum for the eriminal insane is located here. Population, 1910, 30,508; in 1917, 37,145 (Federal estimate).

**LIMA, le'mah, PERU**, the capital of the country, is situated 12° south of the equator, 500 feet above sea level, on the Rimac River, seven miles from Callao, its port on the Pacific Ocean. The city seldom receives rain, but it is troubled with dense fogs from the ocean. Among the chief buildings the most notable is the cathedral, begun in 1535. The houses are for the most part built of adobe, with plaster stuccoes. The manufactures are unimportant, but there is a considerable import and export trade through the port of Callao. Lima was founded in 1535 by Pizarro and was called Ciudad de los Reyes (City of the Kings). In January, 1881, the city capitulated to the Chileans, who occupied it for two years, and destroyed some of its treasured landmarks. Population, 1913, 143,500.

**LIME**, a small globe-shaped lemon, the fruit of a shrub about eight feet high. It is a native of India and China, but was introduced into Europe long before the orange and is now extensively cultivated in the south of Europe, the West Indies, Mexico and some parts of South America. The fruit is



LILY OF THE VALLEY

agreeably acid, and its juice is employed in the production of citric acid and in the preparation of cooling beverages.

**LIME**, the oxide of calcium, produced by heating limestone, or calcium nitrate. Pure lime is perfectly white, has the properties of a strong lye, dissolves slightly in water and is not affected by heat. The ordinary quicklime of commerce is made by heating some varieties of limestone in kilns. The heating drives off the carbon dioxide and leaves the lime. The limestone is usually put in at the top of the kiln, and the lime is taken out at the bottom. This lime is not pure, but answers for most purposes for which lime is used. The best quality is obtained from marble. *Hydraulic lime* is obtained by burning limestone that contains silica and clay. When burned, these substances form with the lime a compound which hardens under water.

Lime is used for making mortar, cements, glass and numerous other commodities. It is also used in tanning, to remove the hair from skins; for a fertilizer, in the manufacture of soap and as a flux in smelting ores. Slaked lime is made by pouring water upon quicklime. Unless used immediately, slaked lime absorbs carbon dioxide from the air and becomes worthless. The limewater used in medicine is prepared by dissolving a small quantity of pure lime in water.

**In Agriculture.** Lime is now being used in great quantities to improve the quality of soil. There are very few acres that will not be benefited by an application of lime once or twice a year. In some parts of the Southern states, where there are few sections showing lime near the surface, the soil is very acid, and in this section five times as much lime is used as formerly.

**LIME LIGHT, or OXYHYDROGEN LIGHT**, a brilliant light, produced when a jet of mixed hydrogen and oxygen gas is ignited and directed on a solid piece of lime. It is commonly used in magic lantern exhibitions; and the two gases are kept in separate air-tight bags or iron cylinders, into which the gas is forced under very high pressure. From these receptacles, tubes conduct the gases to meet in a common jet. Electric light has largely superseded lime light.

**LIMERICK**, a nonsense verse having a special rhyme scheme and a sing-song meter. Anyone with a sense of rhythm and a gift for making rhymes can compose limericks. The following are typical:

For beauty I am not a star,  
There are others more handsome by far.  
My face I don't mind it,  
Because I'm behind it;  
It's the people in front that I jar.

There was a particular bride  
Who objected to eggs being fried.  
Not because of the grease,  
But the shocking decease  
Of the poor little chickens inside.

As shown by these examples, the first two and the fifth, and the third and fourth lines of the limerick rhyme. The name is believed to have its origin in the chorus of an old song of that meter in which there is a reference to the city of Limerick.

**LIMERICK, IRELAND**, an Irish seaport, capital of Limerick County. It is built on both sides of the Shannon and is 106 miles southwest of Dublin. The three parts into which the city is divided are known as Englishtown, Irishtown and Newtown Pery. The industries include the curing of bacon, flax spinning and weaving and lace making. There are also distilleries, breweries, tanneries, corn mills; a large military clothing establishment and shipbuilding slips. Limerick is the leading port on the west coast of Ireland for the shipment of produce. Population, 1916, 41,472.

**LIME'STONE**, one of the most useful of common rocks, composed of either calcium or magnesium with oxygen and carbon. The ordinary limestone is of a grayish color and is somewhat coarse-grained, but there are many varieties, varying in color from white, as in the pure marble, to black. The pure



AVERAGE YEARLY PRODUCTION OF LIMESTONE

Figures represent millions of dollars.

limestone forms in crystals, which from their form are often called dog-tooth spar. Iceland spar is another pure variety. When changed by heat in the earth, limestone becomes marble (see MARBLE). Limestone

forms about three-fourths of the sedimentary rocks. It is not so hard as granite, but is strong and constitutes an excellent building stone for foundations and walls where a nice finish is not required. It is also used as a flux in smelting iron ore, in the manufacture of glass and for making quicklime. (See LIME; BUILDING STONE.)

**LIMOGES, le mohzh'**, FRANCE, capital of the department of Haute-Vienne, is situated in the central part of the country, 215 miles southwest of Paris, on the Vienne River. The principal industry is the manufacture of artistic porcelain, known as Limoges ware. About 6,000 men are employed in making this porcelain in normal years. There are also wool and cotton spinning mills, cloth factories, foundries, paper mills and extensive shoe and clog making establishments. Limoges is the seat of a bishop. Population, 1914, 94,275.

**LIMON, le mohn'**, COSTA RICA, the leading seaport of the country, on the Caribbean coast, and the eastern terminus of a short railroad which runs across the republic from coast to coast. Half a dozen lines of steamers to American and European ports make Limon a regular port of call. Nearly all the coffee grown in Costa Rica is shipped from here; there is also a good export trade in rubber and dyewoods. Population, about 6,700.

**LIMONITE**, a very important ore of iron, the varieties of which are bog iron ore and brown hematite. It is of a brownish color, occurs in rounded masses and is found in various parts of England and abundantly on the Continent and in America. Its location in the United States is described in the article Iron. See HEMATITE.

**LIMPET**, a mollusk which adheres to rocks, partly by the suction of its broad, disklike foot and partly by a sticky secretion. The common limpet is often found sheltered in a shallow bed, excavated by itself out of the rock. From this pit the limpet, when covered by the tide, makes short journeys in search of its food, which consists of seaweeds. These it eats by means of a long, ribbonlike tongue, covered with rows of hard teeth. The limpet is used as bait by fishermen and is eaten by the poorer classes of Scotland and Ireland. Some of the tropical limpets grow to be about a foot wide; such shells are often used in the homes of the people as basins, and many of them are of great beauty.





ABRAHAM LINCOLN

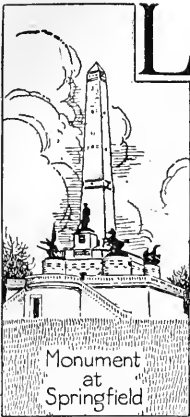

**L**INCOLN, *ling'kun*, ABRAHAM (1809-1865), the sixteenth President of the United States, and one of the best loved of American statesmen. Today his countrymen honor him as the man who saved the American republic from disunion, and gave the black man his freedom. More than this, he stands as the supreme type of the democratic statesman, and the ideals which he expressed by

voice and in his daily life are treasured as the greatest spiritual possessions of the American nation. By birth and by training Lincoln was in a literal sense a man of the common people. Born in a log cabin and with his entire schooling covering not more than a year, he could make no claim to aristocratic blood, to scholarship or to social prestige. He was what he was by virtue of inborn greatness.

**Ancestry and Boyhood.** The ancestry of the Lincoln family may be traced to an English weaver named Samuel Lincoln, who emigrated to America in 1637 and settled in Hingham, Mass. His descendants moved southward until they reached Kentucky, where Thomas, the father of Abraham, learned the trade of carpenter. In 1806 he married a girl named Nancy Hanks, and in the course of a year or two they removed to Hardin (now La Rue) County, Kentucky. On February 12, 1809, a son was born to the couple, whom they named Abraham,

less, and containing only the barest necessities of life. Thomas Lincoln was of a roving disposition, and after one removal in Kentucky, he took his family to a new farm in Spencer County, Indiana, where for a year they lived in a shed open to the weather on one side. Seven-year-old Abraham helped his shiftless father build a more suitable home, but even this was without doors, windows or floor when they moved into it, and it remained half finished for months. In 1818 the mother died. In that lonely region there was no one to preach the funeral sermon, and the husband himself made the simple coffin and dug the grave.

A year later, while on a visit to Kentucky, Mr. Lincoln married an old friend, Mrs. Sarah Bush Johnson. She was a widow with three children, a woman of considerable force of character, and her entrance into the family was the beginning of better things for Abraham and his sister. She made the cabin decent by comfortable furnishings, and forced her procrastinating husband to finish it without any more delay. Her stepson was encouraged to study at home, for the only schooling available in that neighborhood, which was still roamed by bears and other wild animals, was the instruction given occasionally by half-educated masters who could only read, write and "cipher to the rule of three." Abraham zealously practiced writing and ciphering at home, using in lieu of pencil and paper, a bit of chalk and the cabin walls, or a piece of wood which he whittled clean when he had covered it with marks.

Such books as he could beg or borrow he read and reread, and his library included the Bible, *Aesop's Fables*, *Pilgrim's Progress* and *Weems' Life of Washington*. How much his reading influenced him is indicated by that clear and illuminating style that characterized all of his state utterances. As time passed he gained a local reputation as a humorist, for he could tell a funny story expertly, and he had, besides, a fund of original humor that made him very human and likable. Before he became of age he had reached his great height of six feet four inches, and his awkward appearance itself was certain to arouse the mirth of his hearers.

**Early Career.** When Lincoln was twenty-one his father moved to Macon County, Ill., settling on a claim on the Sangamon River. The young man helped his father build a

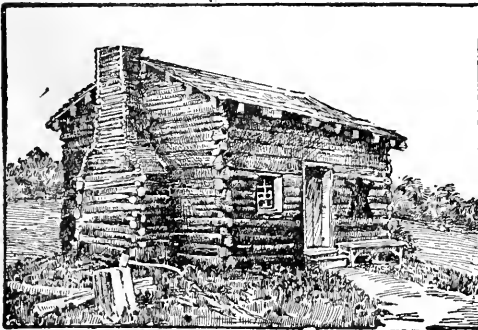

LINCOLN'S BIRTHPLACE

after the father of Thomas. They were then living in a hut made of rough logs, floor-

house and break fifteen acres of land, and he also split rails for fences. A year later, in 1831, he was hired by John Hanks, a relative, to help take a boatload of goods down the Mississippi to New Orleans. This was Lincoln's first extended journey from home, and it was of some importance in that it gave him his first view of slavery. After his return, in 1832, he enlisted in the Black Hawk War, serving from April to June, made an unsuccessful attempt to enter the state legislature as a Whig, and for a period kept a dry-goods and grocery store at the settlement of New Salem. This venture burdened him with debts which hung over him for the next fifteen years, and it was quickly abandoned. In May, 1833, he was appointed postmaster at New Salem, an office with light duties and lighter pay. During his three years' tenure of this position he studied law and politics to good purpose, and served also as deputy surveyor.

Lincoln was elected to the lower house of the state legislature in 1834 and retained his seat until 1842. In the campaign of 1836 he went on record as an advocate of woman suffrage, a movement which then was decidedly not popular. He was also forming his views on slavery, to which he was always opposed on principle. He then believed, however, that Congress could not under the Constitution interfere with slavery where it existed. Meantime he had steadily continued his law studies, and in 1837 was admitted to the bar. In 1839 he set up an office with John T. Stuart as his partner, in Springfield, the newly established capital of Illinois. Two years later Lincoln formed another partnership with ex-Judge Stephen T. Logan, but this was dissolved in 1843, when the partners became rival candidates for election to Congress. Lincoln, though defeated this time, won a Congressional seat in 1846, and served one term.

He gained no particular distinction in Congress, but he consistently voted and talked against slavery. Meanwhile, in 1842, he had married Mary Todd, daughter of the Hon. Robert S. Todd, of Lexington, Ky. At the close of his term Lincoln resumed his law practice in Springfield, becoming one of the best known lawyers of the state. An excellent account of his method as a cross-examiner will be found in Edward Eggleston's *The Graysons*, in which an episode based on fact is narrated.

**A National Figure.** For several years Lincoln was absorbed in his practice, but the great slavery controversy, ever growing more intense, could not fail to awaken his interest in political issues. In 1854 he publicly announced his opposition to Senator Stephen A. Douglas, father of the Kansas-Nebraska Bill and of the doctrine of squatter sovereignty, and his speeches on the subject were so logical and forcible that the Whigs in the state legislature chose him as their candidate for Senator. Lincoln was not elected, but his friends, by combining with the anti-slavery Democrats, elected Lyman Trumbull, who was opposed to Douglas. In the organization of the new Republican party Lincoln stood out as the leading figure from Illinois, and in the national convention of 1856 his name was mentioned for Vice-President.

Two years later came the famous Lincoln-Douglas debates, by which, though defeated in his candidacy for the Senate, Lincoln attracted the attention of the whole country. In them he displayed not only admirable sincerity and insight, but exceptional political shrewdness, and it was not long before his name was prominently mentioned as a candidate for President. His famous Cooper Union speech in 1860 at New York made him the most conspicuous figure in Republican politics, and at the convention at Chicago, after a spirited contest with Seward, Chase, Cameron and Bates, he was nominated upon a vigorous anti-slavery platform. The campaign which followed was one of the most momentous in the history of the United States. The Democratic party, having been disorganized and divided, presented two candidates, Douglas and Breckenridge, while the Constitutional Union party, which took a neutral stand, nominated John Bell. Lincoln secured 180 electoral votes out of a total of 303, and his popular vote was 1,866,452. He lacked almost a million votes of a majority.

His election was the signal for secession by South Carolina, which had long contemplated the possibility of such a step if the demands of the slavery faction were not heeded. The action was taken in December, and South Carolina was followed by the Gulf States and within a few months by four others. Lincoln was inaugurated March 4, 1861, and in a memorable address he urged the people of all sections to unite in upholding the Union. He called to his Cabinet all



NEVADA  
TO THE UNION-1864  
ADMITTED

# LINCOLN'S ADMINISTRATION



VASSAR COLLEGE  
FOUNDED 1861



THE  
SIOUX WAR  
1862-63

**EVENTS.**  
GROUND PURCHASED FOR RAIL CITIES-1864  
ADDITIONAL TAKES TO PROVIDE FOR WAR-1864  
HOMESTEAD LAW - 1861-  
BUREAU OF AGRICULTURE FOUNDED-1862  
PACRR & TEL. AUTHORIZED -1862-  
THE ANTI-POLYGAMY ACT -1862-



## THE CIVIL WAR

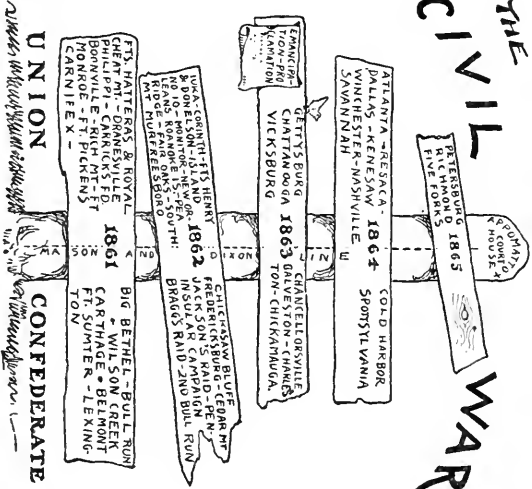

WEST VIRGINIA  
TO THE UNION-1863-  
ADMITTED

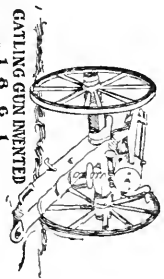

GATLING GUN INVENTED  
1861



FREE MAIL DELIVERY  
IN LARGE CITIES  
ESTABLISHED-1863

**EVENTS.**  
FIRST ISSUE OF GREENBACKS-1862  
CONSCRIPTION ACT - 1863  
NATIONAL BANK FOUNDED-1863  
EMANCIPATION PROCLAMATION-1865  
POSTAL MONEY ORDER SYSTEM EST-1864  
THE PHILADELPHIA FAIR -1864-

## Administration of Abraham Lincoln, 1861-1865

- I. THE PRESIDENT
- (1) Birth
  - (2) Parentage
  - (3) Youth
  - (4) As a lawyer
  - (5) Public career
  - (6) Character
  - (7) Death
- II. GOVERNMENTAL AFFAIRS
- (1) Domestic
    - (a) First call for militia
    - (b) Blockade ordered
    - (c) Suspension of "habeas corpus"
    - (d) Financial measures
    - (e) Emancipation Proclamation
    - (f) Thirteenth Amendment
    - (g) Nevada and West Virginia admitted
  - (2) Foreign
    - (a) *Trent* affair
    - (b) *Alabama* affair
- III. THE CIVIL WAR
- (1) Outbreak and campaign of 1861-62
    - (a) Fall of Fort Sumter
    - (b) Campaigns in the east
      - (1) Bull Run
      - (2) Army of the Potomac
      - (3) The Monitor and the Merrimac
    - (c) Campaigns in the west
      - (1) Fort Henry and Fort Donelson
      - (2) Pittsburg Landing and Shiloh
      - (3) Capture of New Orleans
      - (4) Missouri saved to the Union
  - (2) Campaigns of 1862-63
    - (a) In the East
      - (1) The Peninsula Campaign
      - (2) Jackson in the Shenandoah
      - (3) Lee's invasion of Maryland
      - (4) Fredericksburg
    - (b) In the West
      - (1) Buell-Bragg in Kentucky
        - (a) Battle of Perryville
        - (b) Stone River
      - (3) Campaigns of 1863-64
        - (a) In the East
          - (1) Chancellorsville
          - (2) Gettysburg
        - (b) In the West
          - (1) The Mississippi Campaign
          - (2) The campaign in Tennessee
      - (4) The last year of the war
        - (a) The Richmond campaign
          - (1) Battle of the Wilderness
          - (2) Sheridan's Campaign
          - (3) Fall of Richmond
          - (4) Surrender of Lee at Appomattox
        - (b) The Atlanta campaign and the March to the Sea
          - (1) Kenesaw Mountain
          - (2) Battle of Atlanta
          - (3) Franklin and Nashville
          - (4) Capture of Savannah and Charleston
          - (5) Surrender of Johnston
      - (c) Death of Lincoln

### Questions

When and where was Abraham Lincoln born?

Give a brief account of his youth and the character of his education.

What public offices had he held before he was elected President?

What is meant by the privilege of the writ of habeas corpus?

Do you see any reasons why Lincoln should have desired its suspension during the war?

What was the Emancipation Proclamation?

How was it justified?

When was the Thirteenth Amendment adopted? What are its provisions?

What bombardment began the Civil War?





ABRAHAM LINCOLN—STATUE AT ENTRANCE TO LINCOLN PARK, CHICAGO



his principal rivals in the Chicago convention, and by every means in his power he sought to avert a civil war, which seemed inevitable. His efforts were in vain, however, and on April 14 the war began with the bombardment of Fort Sumter.

**As President.** Throughout the war Lincoln displayed that firmness, generosity and foresight which he had disclosed in his previous career. He was tender-hearted, patient and absolutely lacking in malice, but unyielding when it came to a question of principle. Therefore he resolutely refused to come to terms with the South until the idea of secession should be abandoned. Though he hated slavery as an inhuman and undemocratic institution, he stated publicly in August, 1862, "My paramount object is to save the Union, it is not either to save or to destroy slavery." When he became convinced that the nation could never endure half slave and half free, he decided on one of the most important steps of his career, the issuance of the Emancipation Proclamation. This decision had the effect of uniting and strengthening the anti-slavery people of the North, and it gave the government increased prestige abroad.

Though the North had been fighting the first two years of the war without signal success, there were encouraging signs of a turn in the tide in the summer of 1863, when Meade checked Lee at Gettysburg, and Grant captured Vicksburg. In November, 1863, Lincoln spoke at the dedication of the battlefield of Gettysburg, giving a short, simple address that has since become a classic of American literature. (For the full text, see GETTYSBURG ADDRESS.) These stirring events were followed by the appointment of Grant as commander in chief of the Union armies, and the Presidential and Congressional elections of 1864.

In the light of the universal esteem in which Lincoln is held to-day it seems difficult to realize that he had bitter opponents in the North. His enforcement of the unpopular draft act, his suspension of the writ of *habeas corpus*, and certain arbitrary measures which were taken to check Southern sympathizers, aroused much hostile criticism, and he was denounced as a tyrant. A strong faction also clamored for peace on the ground that the war was a failure, and on this platform the Democrats nominated McClellan in 1864. The result showed that

the people as a whole trusted Lincoln and knew that he was exercising what seemed to be autocratic power because he had the consent of the people. He was returned to office by an electoral vote of 212, against twenty-one for McClellan. The popular vote was 2,330,552 against 1,835,955. In his second inaugural address Lincoln again rose to heights of simple eloquence and to an idealism rarely equaled in American oratory, and in closing he uttered words that could come only from the mind and heart of a truly great man: \*

"With malice toward none, with charity for all, with firmness in the right as God gives us to see the right, let us strive on to finish the work we are in; to bind up the nation's wounds, to care for him who shall have borne the battle, and for his widow, and for his orphan—to do all which may achieve and cherish a just and lasting peace among ourselves, and with all nations."

**His Death.** The war by this time was inevitably drawing to a close, and on April 9, 1865, Lee surrendered to Grant at Appomattox Court House. Five days later the nation was plunged into deepest grief. Lincoln was assassinated by John Wilkes Booth, while attending a performance at Ford's Theatre in Washington, on the evening of Good Friday, April 14. He died the following morning. Southern leaders mourned his loss as that of a sincere and magnanimous opponent, and European statesmen united in conceding to him all the highest qualities of manhood and statesmanship, while the grief of the people of the North, who had considered him their truest friend—indeed, their savior—was almost too great for expression. The years since his death have served to raise, rather than to lower, the general estimate of his service to the Union and of the high moral qualities which his character exemplified.

An illustration of the famous statue of Lincoln by Saint Gaudens accompanies the article Sculpture.

**Related Articles.** Consult the following titles for additional information:

|                           |                      |
|---------------------------|----------------------|
| Black Hawk                | Kansas-Nebraska      |
| Booth, John Wilkes        | Bill                 |
| Civil War in America      | Political Parties in |
| Conscription              | the United States    |
| Douglas, Stephen A.       | Squatter Sovereignty |
| Emancipation Proclamation |                      |

**LINCOLN**, *link'on*, ENGLAND, capital of Lincolnshire, an interesting city dating from the Roman period, situated 130 miles northwest of London. The city is very imposing in appearance, being situated on a hill which

is crowned by the cathedral. Among the interesting buildings are the remains of the Norman castle, the palace and stables of John of Gaunt and the townhall. The cathedral, which is one of the finest in England, has three towers, two of which are 180 feet in height and the third 300 feet high. In the central tower hangs the famous bell called Tom of Lincoln. There are several iron foundries, manufactories of steam engines an agricultural machines, and large steam flour mills, and the city is the center of an important trade in live stock, corn and wool. It is also noted for the horse races which are held here. Under the Romans and also under the Saxons and Danes, it was a place of importance, being specially famous in the time of the Norman conquest as a place with an extensive shipping trade. Population, 1916, 63,742.

**LINCOLN, ILL.**, the county seat of Logan County, thirty miles northeast of Springfield, on the Chicago & Alton and the Illinois Central railroads. The city is in a farming region, near extensive deposits of coal. The chief manufactures are of flour, mattresses, caskets, clay products, automobile horns, shoes, excelsior and cellulose, and the city has extensive green houses. Lincoln University (Presbyterian), affiliated with Milliken University at Decatur, is located here, and the city has a Carnegie Library, several hospitals and children's homes, including the state institution for imbecile children. The place was settled in 1835 and was incorporated in 1854. Population, 1910, 10,892; in 1917, 11,991 (Federal estimate).

**LINCOLN, NEB.**, the capital of the state, the second city in size, and the county seat of Lancaster County, fifty-five miles southwest of Omaha, on the Chicago, Burlington & Quincy, the Chicago, Rock Island & Pacific, the Missouri Pacific, the Chicago & North Western and the Union Pacific railroads. The most prominent buildings are the capitol, the Federal building, the courthouse, Saint Elizabeth's Hospital, the Home for the Friendless and a Carnegie Library. The city is an important distributing point; the water is of good quality, being of the artesian type. Flour, furniture, leather goods, brooms, farm implements, paints, gas engines, corsets, creamery products and clothing are the chief manufactures. Lincoln is an important educational center: here is located the University of Nebraska, Nebraska Wesleyan

University, Cotner University and Union College. The site was chosen for the city in 1859, and was called Lancaster until made the capital and named in honor of Abraham Lincoln in 1867. Population, 1910, 43,973; in 1917, 46,957 (Federal estimate).

**LINCOLN, ROBERT TODD** (1834- ), the eldest son of Abraham Lincoln, was born in Springfield, Ill., when his father was a struggling lawyer. Robert studied law at Harvard College, then joined the Union army in the Civil War and became a captain. In 1867 he was admitted to the bar, and he practiced law in Chicago until 1881, when he became Secretary of War in Garfield's Cabinet, and was continued in the office by President Arthur. From 1889 to 1893 he was minister to England. Thereafter his career was in the line of business, for he became legal adviser of the Pullman Car Company, then its president and later chairman of its board of directors.

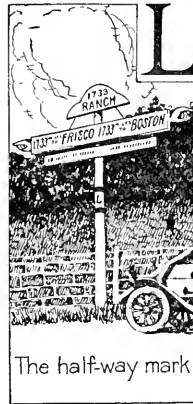

**LINCOLN HIGHWAY**, a public road stretching from the Atlantic Ocean across the continent—from Newark, N. J., to San Francisco. The project was first discussed in 1912, and the response from the entire country was encouraging. The plan adopted (in 1913), provided that a Highway Association should decide upon the route, and that voluntary work to provide a good road

should be done in each state through which the highway runs. The route was announced during the same year. To identify the road, markers were placed at short intervals along the entire route, and with enthusiasm the states set about the task of improvement. Several years will be required to make a continuous hard, smooth road, but eventually a streak of macadam and asphalt on which travel will be a pleasure will link the two oceans.

The route is 3,331 miles in length. From Newark and Jersey City the direction is southeast to Philadelphia; then the road runs westward through Ohio, Indiana and Illinois, passing twenty-five miles south of Chicago, to Council Bluffs, Iowa, and Omaha, Neb. From Omaha the course is almost directly

west through Nebraska to Cheyenne, Wyo., with a branch southward to Denver, Colo. It leaves Wyoming at Evanston, runs southwest to Salt Lake City, thence across Nevada deserts to Reno, with a branch south to Carson City, thence through Sacramento to San Francisco.

Transcontinental travel by motor cars will greatly increase when the entire route is improved. Americans will learn more of the extent and greatness of their own country, and, not least of the results to come from the maintenance of the highway, there will be before the public an example of good roads which will create a demand for many other highway im-



MARKER

Unter den Linden, is so named because it is bordered by stately linden trees. The wood of the linden is soft and close-grained.

**LINDSAY**, *lin'zy*, ONT., the county town of Victoria County, on the Grand Trunk Railway, seventy miles northeast of Toronto. Its trade in lumber and grain is extensive, and it is an important railway center. There is a collegiate institute and a convent. Population, 1911, 6,964.

**LINDSEY**, BENJAMIN BARR (1869- ), an American judge, best known for his wonderful influence upon boy offenders against the law. He was born in Jackson, Tenn., educated for the law, and since 1901 has been judge of the County Court and Juvenile Court at Denver, Col. He introduced many new features into juvenile court work, specifically the one of putting boys on their honor. He wrote *The Beast and the Jungle* and *Problems of the Children*. Judge Lindsey is identified with the general democratic

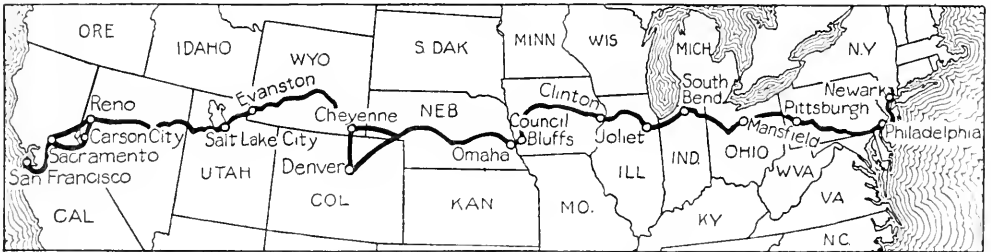

ROUTE OF THE LINCOLN HIGHWAY

provements. Already this effect is seen in the new Dixie Highway (which see), the second most ambitious road-building project in the United States.

**LIND**, JENNY, 1820-1887), a famous Swedish soprano, called the "Swedish nightingale." In private life Miss Lind was known as MADAME OTTO GOLDSCHMIDT. She was born in Stockholm and received her musical training under Garcia at Paris. She made her first appearance in London at Covent Garden in 1847 before an enthusiastic audience, and in 1850 went to the United States, where she married Herr Goldschmidt in 1852. During a two-years' sojourn in America under the management of P. T. Barnum she was received everywhere with highest admiration, and her concerts were overwhelmingly successful. Miss Lind was paid \$1,000 a night, a miraculous sum in those days.

**LIN'DEN**, a handsome tree, most common in Europe. Berlin's most famous street,

movement of the times, and his most bitter opponents have been those who believe in special privilege. See JUVENILE COURT.

**LINE**, a geometric magnitude having but one dimension, length. It is also sometimes regarded as a boundary between two surfaces or as the path of a moving point. A *straight* line does not change its direction between any two of its points. A *curved* line or *curve*, changes its direction between every two points. A *broken* line is a continuous succession of straight lines in different directions. A *mixed* line is one composed of straight and curved lines.

**LINEN**, a cloth made of the fiber of flax, celebrated for its durability, luster and strength. Among the linen fabrics are lawn, cambrie, dimity, damask, dress linens, sheeting, toweling, crash, duck and canvas. Beautiful laces and coarse twine and rope, the choicest linen tablecloths and the strong fabric that composes the sails of ships all

come from the same valuable fiber (see FLAX). During the World War huge quantities of linen were used as wings for aeroplanes.

Linen was known to the ancients, for the cloths in which the Egyptian mummies are wrapped give evidence of its early and extensive manufacture in Egypt. The Greeks learned how to make it from the Egyptians, and the Romans from the Greeks. In the Middle Ages linen was made extensively in all parts of Europe and especially in Italy, Spain, Flanders and France. The Flemish weavers introduced it into England. The soil of France is especially adapted to the growth of flax, and the French are celebrated for the superiority of their lawns and cambrics. Belgium, Holland and Ireland are close rivals and have very fine products. The United States did not begin to manufacture linen until the eighteenth century, and the industry has been confined chiefly to the making of toweling, thread and twine. In comparison to cotton, the American linen industry is of minor importance. See WEAVING.

**LING**, PEHR HENRIK (1776-1839), a Swedish poet and teacher of gymnastics. He was a great traveler through Germany and France, and after teaching fencing at Karlberg he settled in Stockholm and established there a school of gymnastics. While here he developed a system of exercise which is still used in some countries and is known as the *Swedish movement cure*. As a patriotic poet he enjoyed a high reputation, especially from his dramatic works.

**LINIMENT**, in medicine, an application to be rubbed into the skin for stimulating the tissues and relieving pain. Typical preparations of this nature include a mixture of soap, camphor and spirits of rosemary, used for sprains and bruises; carron oil, a preparation of linseed oil and limewater, applied to burns; and camphor liniment, a standard sprain remedy.

**LINNAEA**, *lin e' ah*, a delicate little evergreen, of the honeysuckle family, with creeping stems. It is found in woods and in mountainous places in northern countries, including North America as far south as Maryland. Two beautiful, drooping, fragrant, bell-shaped pink flowers are borne on each flower stalk. It was named for the naturalist Linne.

**LINNE**, *leen nay'*, KARL VON (1707-1778), commonly called *Linnaeus*, a great botanist

was born at Rashult, Sweden. He showed an early interest in plant life, but because of poverty was unable at first to go to school; later, through the assistance of a friend, he entered the University of Lund, where his botanical tastes were encouraged. In 1728 he removed to Upsala, where he undertook the supervision of the botanic garden. Aided by the Academy of Sciences at Upsala, Linné made a journey through Lapland, the result of which was shown in his *Flora Lapponica*. After he went to the University of Harderwyk, in Holland, and took the degree of M. D. While visiting Leyden he published the first sketch of *Systems of Nature and Fundamental Botany*. One of his most important works is *Species of Plants*. After traveling in England and Paris, he settled in Stockholm as a physician. He became professor of medicine at Upsala in 1741, and then of botany and natural history. The great merit of Linné as a botanist was that he arranged plants on a simple system of sexual relationship and prepared the way for the more natural and satisfactory classification which has superseded the Linnaean system. Linné is considered the originator of modern systematic botany and zoölogy.

**LIN'NET**, a small singing bird of the finch family, popular as a cage bird in Europe. It is one of the commonest of British birds and

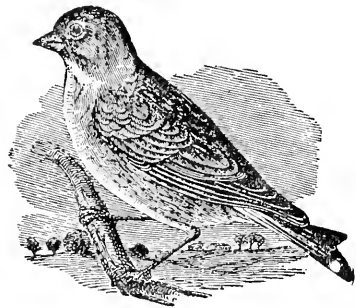

LINNET

breeds in firs and low bushes. The name linnet is given to a number of different species, one of which, the *redpoll*, is found both in Europe and the United States.

**LINO'LEUM**, a preparation of linseed oil with chloride of sulphur, by which it is rendered solid and useful in many ways. When rolled into sheets it is used as a substitute for india rubber or gutta-percha; dissolved, it is used as a varnish for waterproof textile fabrics, table-covers, felt carpets and

the like; as a paint it is useful both for iron and wood and for ships' bottoms; as a cement it possesses some of the qualities of glue; vulcanized or rendered hard by heat, it may be carved and polished, like wood, for moldings and knife handles; and mixed with ground cork and pressed upon canvas, it forms floor cloth.

**LIN'OTYPE**, a typesetting machine, with a keyboard on the typewriter principle, though larger, in general use throughout the world. It casts its own type in solid lines as they are set, and its case carries matrices instead of types. The matrices are brass molds used in casting the type. As the operator fingers the keyboard, the matrices called for are set in order. When a line has been set, the machine moves it automatically to the casting apparatus, where the words are properly spaced, and the matrices are filled with melted type metal, casting the type into a solid line. This is then automatically set in the stick in its proper place, and the matrices are returned by a lever arm to the case, where by means of an automatic arrangement they are distributed to their proper channels. Each matrix has a number of nicks on the back, and these are used in distributing. They allow the matrix to fall into its proper channel and prevent it from falling into any other. The operator pays no attention to the casting, the placing of the type in the stick or the distribution of the matrices, the machine performing all of these operations automatically.

The linotype is the invention of Mr. Ottmar Mergenthaler, of Baltimore, who spent over twenty years in completing it, but died in poverty, as he permitted others to exploit his invention. By its use one operator can do the work of about eight men working by hand. By using different cases of matrices, more than one style of type can be set by the same machine. The disadvantage of this machine is that when an error is made, it can be corrected only by recasting the entire line.

**LINSEED**, the seed of the flax plant. Though this plant yields a fiber from which valuable linen fabrics are made, in the United States the greater part of the crop is cultivated for the seed (see **FLAX**). The two products of linseed are linseed oil and linseed meal.

**Linseed Oil** is obtained by extraction with such solvents as naphtha, and by pressure

accompanied by heat. The former process is the more satisfactory. The oil is used in paints and varnishes, and in the manufacture of oilcloth and linoleum.

It is placed on the market in two forms, *boiled*, or *drying*, oil, and *raw* oil. The boiled oil contains a small quantity of oxide of lead, which causes it to dry quickly. It is the kind used in the manufacture of paints and varnishes. When pure, linseed oil is colorless, but the commercial grade is usually of dark amber hue. Its taste and odor are disagreeable.

**Linseed Meal** is the product left after oil is separated from the seed. It appears first in the form of hard cakes, which are ground into meal. Linseed meal is used chiefly as a food for cattle and horses. It contains considerable protein, and should be given only in small amounts because of its richness.

**LION**, a wild animal belonging to the cat family, celebrated for its strength and ferocity. The large head, flashing eye and heavy mane, characteristic of the male, give it a regal appearance that is reflected in the name *king of beasts*. The voice of the creature is a mighty roar, and is probably the loudest call among animals. By nature the lion is less ferocious than the tiger, and is disinclined to attack man, but when angered or driven by hunger, it becomes fierce and terrible; when roused is a most dangerous adversary.



THE MALE LION

The lion is one of the largest members of the cat family, sometimes reaching a height of three feet and a weight of 500 pounds.

It is distinguished by its tawny or yellow color, tufted tail and, in the male, full flowing mane. When the male is three years old its mane begins to grow; at six or seven years the lion is full-grown, and at about twenty-two it is feeble and decrepit.

Lions make their lairs in hidden caves, dense thickets, brushwood and other secluded places. They hunt their prey at night, attacking antelopes, zebras and other wild animals, if these are available; in regions where wild game is scarce they seize camels, cattle, ponies, goats, etc. The young are born in the spring, and the whelps, usually three in number, begin life with their eyes open. They are given tender care by both parents until able to take care of themselves.

Lions are found at large only in Africa and parts of Central and Western Asia, but long years ago they were common in Europe and in many parts of Asia. To-day there are none in Asia Minor, Egypt or Arabia, and there are few left in India. They thrive in captivity, and are always a source of interest in "zoos" and menageries. Trick lions are commonly seen, as these animals can be trained to go through some very interesting performances. The trainer can at no time with safety be off his guard, for the lion never loses his savage nature, and if his temper is aroused he is liable to tear his captor to pieces.

**LION OF LUCERNE**, *lu surn'*, the name given to a famous piece of carving in Lucerne, Switzerland, which commemorates the heroism of the Swiss Guards who were killed while defending the palace of the Tuileries, in Paris, on August 10, 1792. The carving, chiseled in solid rock out of the side of a grotto, is the work of the Danish sculptor Thorwaldsen. It represents a dying lion, and is twenty-eight feet in length.

**LIPARI ISLANDS**, a group of islands comprising less than fifty square miles, in the Mediterranean, north of Sicily, a part of a province of Sicily. They are of volcanic origin, and two of the islands, Stramboli and Vulcano, have active volcanoes. There are hot springs and pumice stone quarries here. Population, 1917, about 20,500.

**LIPPI**, FILIPPO (1406-1469), a Florentine painter. He was a pupil of Masaccio, and his works are noted for their warm, transparent color and expression of human sympathy. He is considered the first representative of the Florentine school of painters, and his greatest

works now existing are the frescoes in the Cathedral of Prado, which were executed between 1452 and 1464. These frescoes represent scenes from the lives of John the Baptist and Saint Stephen. Lippi's son, Filippo, usually known as Filippino, inherited his father's talent and continued his work with marked distinction. For further details concerning Lippi, see the article PAINTING.

**LIP READING**, the art of interpreting what is said by watching the movements of a speaker's lips. This method of reading speech is now taught in the majority of schools for the deaf, and is rapidly replacing the older sign language (see DEAF AND DUMB). Those who wish to take it up privately should secure, if possible, an expert teacher, but if this is not practicable much can be accomplished by means of an instruction book and the use of a mirror for practice.

The upper teeth constitute the point at which the vision should be directed. In the beginning the teacher repeats many times phrases or short stories, and the pupil watches the lip movements until he can interpret them. More complicated exercises follow, and the various motions corresponding to different sounds are learned. As practice work the pupil watches his own lip movements in a mirror. Lip reading has proved a wonderful benefit to many who are totally deaf, and there are those who have become so skilled in the art that their deafness is almost unnoticeable. Physicians generally advise the partially deaf to take it up if there is evidence that their infirmity is gradually becoming worse. Information on this subject may be obtained from the Volta Bureau, Washington, D. C.

**LIPTON**, THOMAS, Sir (1850- ), the world's greatest tea-plantation owner and a British yachtsman of international reputation. He was born in Scotland, worked as laborer and clerk in the United States when a boy, then returned to his home and opened a small grocery store. He prospered and within a few years owned many stores, then became interested in tea, coffee and rubber plantations in India and Ceylon. Lipton has always been an enthusiastic sailor, and has made several unsuccessful attempts to win the yachting trophy, the *America* cup, with his boats *Shamrock I*, *Shamrock II* and *Shamrock III*. In 1919 he announced that further attempts would be made.



**LIQUID**, that form of matter which, if placed in any gas with which it does not mix, as air, forms a spherical drop; or, if placed in a hollow solid vessel, takes the shape of the vessel, maintaining a constant volume.

**LIQUID AIR.** By lowering the temperature of air to 220° below zero F., or 140° below zero C., then subjecting the air to a pressure of 585 pounds to the square inch, it can be changed to a liquid. For a number of years physicists attempted to liquefy air, without success, because they could not reduce the temperature sufficiently, but when this difficulty was overcome, it was found that air could be liquefied more easily than some other gases. When exposed in a glass vessel, liquid air absorbs heat rapidly from certain objects and boils violently until it has evaporated. The nitrogen part of air evaporates more rapidly than the oxygen. Notwithstanding its exceedingly low temperature, liquid air can be frozen. It instantly freezes all substances immersed in it. Meat is frozen so hard as to become brittle, and even iron is affected by the low temperature. Liquid air is so much colder than ice that when placed in a tin vessel and set upon a cake of ice it boils rapidly. For a time it was supposed that great commercial advantages would be derived from liquid air, but these hopes proved to be without foundation. Now it is regarded only as a curiosity for physical laboratories.

**LIQUID**, *lik'wid*, **FIRE**, a modern successor to a war device of the ancient Greeks. Liquid fire in its present-day sense was invented and used by the Germans in the World War (1914-1918), and it proved a terrible weapon. It was composed of a mixture of gasoline and pitch (or other coal-tar product) and was projected toward the enemy, with a favoring wind, from a flammenwerfer (flamethrower). This device possessed two barrels; from the lower the mixture was forced through a nozzle, and it was ignited automatically from the other barrel. The flaming stream, which was unbearably hot, could be used with deadly effect when the enemy was at close range. Thick gray smoke and a nauseating smell added to the agony endured in a liquid fire attack.

**LIQUIDAMBAR**, a genus of handsome trees, with lobed, shining leaves and catkins, or globular heads of flowers. The fragrant liquid resin, called oil of liquidambar and copal balsam, is obtained from the sweet

gum, or liquidambar, of Mexico and the United States.

**LIQUORS**, *lik'kurz*. See DISTILLED LIQUORS.

**LIRA**, *le'rah*, a silver coin of Italy, the monetary standard of the country, as is the franc in France or the dollar in the United States or Canada. It is of the same American value as the franc, namely 19.3 cents.

**LISBON**, *liz'bon*, PORTUGAL, the capital and chief seaport of the country, beautifully situated on the right bank of the Tagus River, about seven miles from the Atlantic Ocean. The old town is built in the form of an amphitheater, on a series of hills, and presents a most picturesque appearance, although it has narrow, ill-paved streets. The new part has broad, well-kept streets and open squares. There are in Lisbon several royal palaces, an old Moorish citadel and numerous notable churches and convents. The exports consist chiefly of wine, oil, cork, fish and fruit, and the principal imports are cotton, cotton tissues, sugar, grain, coal, tobacco and coffee. The principal manufactures include cotton textiles and gold and silver wares.

Lisbon is a place of remote antiquity, its earliest name being Olišipo. In 1755 it was visited by an earthquake, which destroyed the greater part of the city and caused the death of about 40,000 of its inhabitants. It was taken by the French in 1807, but resisted an attack by Massena in 1809. Population, 1911, 435,359.

**LISGAR**, LORD, SIR JOHN YOUNG (1807-1876), an English diplomat and statesman, born in Bombay, India, and educated at Eton and Oxford University. He prepared for the practice of law, but while still a student was elected to the House of Commons, where he continued to represent his constituency for nearly twenty years. In 1852 he was appointed Chief Secretary for Ireland, and three years later, Lord High Commissioner for the Ionian Islands. In 1860 he became governor of New South Wales, and in 1868 succeeded Lord Monck as Governor-General of Canada, holding the position until 1872. During his administration in Canada, Manitoba and British Columbia entered the confederation, the Treaty of Washington was signed, and plans for the construction of the Canadian Pacific railway were perfected. In 1870 Sir John was created Baron Lisgar. When he left Canada

he retired to his estates in Ireland, where he died. (For portrait, see article GOVERNOR-GENERAL.)

**LISTER, JOSEPH, Sir** (1827-1912), an English surgeon, born at Upton, Essex. From 1860 to 1869 he was professor of surgery in Glasgow University; from 1869 to 1877 he was professor of clinical surgery in the University of Edinburgh, and in the latter year he was appointed to the corresponding chair in King's College, London. His name is especially connected with the successful application of the antiseptic treatment in surgery, which inaugurated a new era in this branch of medical science. He published various papers on surgical pathology. Listerine, a soothing, healing lotion, was named for him. See SURGERY.

**LISZT, list**, **FRANZ** (1811-1886), an eminent pianist and composer born in Hungary. He made his first public appearance in his ninth year, studied in Vienna and Paris, and produced an opera at the age of fourteen. In 1861 he went to Rome, where he joined the priesthood, and in 1870 he became director of the Conservatory of Music at Pest. His chief works are the *Faust* and *Dante* symphonies and the oratorios, *Saint Elizabeth* and *Christus*; but his fame largely rests upon his ability as a pianist, for he has been unhesitatingly accorded first place among the world's artists in that field.

**LIT'ANY**, a solemn supplication to God that he will turn aside his anger. Of the three litanies in the Roman Catholic Church, the "litany of the Saints" is the only one having a place in the service books of the Church. The other two are the "Litany of the Name of Jesus" and the "Litany of Loreto." The most common form in the early Church was "Kyrie eleison" (Lord have mercy), given by the priest, to which the congregation responded "Christe eleison." The use of the litany in Latin churches is required only on Rogation Days, or the Monday, Tuesday and Wednesday before Ascension Day, and on Saint Mark's Day, April 25. It is common, however, on special occasions, as ordinations and consecrations, and is ordered in time of famine, pestilence, war or like calamities.

**LITER**, *le'tur*, the standard measure of capacity in the metric system of weights and measures. The liter is a cubic decimeter, that is, it contains about 61.028 English cubic inches. It is equivalent to about one English

quart, or, more exactly, to .23 of a gallon. See METRIC SYSTEM.



**LITERATURE.** We use the word *literature* very commonly, and yet if we were called on to give a definition of it, many of us might find the question embarrassing. The simplest way out of the difficulty would be to say that literature means everything that has been set down in writing and preserved. That is, English literature would include everything that has been produced in the English language from the Scripture commentaries of the earliest ecclesiastics to the last feeble volume of verse which has just come from the press. However, such a definition is too wide really to be accepted, and the term "literature" has come to mean a much more restricted thing. When a professor of mathematics turns over eagerly the leaves of a new technical work on differential calculus, he is not reading literature; when a boy, hidden behind the barn, devours cheap tales of the lives of bandits, he is not reading literature. As distinguished from what is merely technical, from what is harmful, or from what is of a merely passing interest, literature is the body of writings which by reason of beauty of form or beauty or interest of content make a continued appeal to the higher emotions or the intellect of men. Even when we have narrowed the definition this much it is very wide, embracing as it does poems, dramas, essays, biographies, histories, novels, orations and countless writings which cannot be classified under any of those heads. Wherever we find it, that which brightens, uplifts, encourages, is literature.

**English Literature.** The beginnings of English literature may be said to lie in the songs of the Saxon gleemen, who encouraged their warriors in battle and enlivened their victorious feasts with praise of the heroes; the most important relic of this old literature is the epic *Beowulf*. There was an early literature of the Celts, light and poetic, filled with delicate sentiment and humor that the Saxon tongue did not show. Very little of it remains, but it exerted a strong influ-



1. F. Hopkinson Smith.  
 2. Helen Hunt Jackson.  
 3. Joel Chandler Harris.

CONTEMPORANEOUS WRITERS

4. Selma Lagerlof.  
 5. Count Lyoff Tolstoi  
 6. Mary E. Wilkins Freeman

7. William Allen White  
 8. Julia Ward Howe  
 9. Ralph Connor.



ence on Anglo-Saxon literature. The first poem that really originated in England is Caedmon's *Paraphrase*, a metrical version of parts of the Bible, which was composed about A. D. 670. Because of his numerous translations of Latin into English, the name of "Father of English Prose" has been given to King Alfred, though his prose was by no means the first. The growth of the literature was slow, and it was not until the end of the fourteenth century that the *Vision of Piers Plowman*, the first great poem, was written. At about the same time John Wycliffe was translating the Bible into English. Geoffrey Chaucer, the "Father of English Poetry," was born about 1340, and his *Canterbury Tales*, a collection of stories ostensibly told by pilgrims who met at the Tabard Inn and journeyed to Canterbury, are still filled with beauty and charm for the reader who has skill and patience to study them sufficiently to understand the language used by the old poet.

With Chaucer may be said to have closed the age of preparation in literature, for thereafter the development was steady and rapid. After the introduction of printing in the fifteenth century, books multiplied with great rapidity; but, nevertheless, it was not until the time of Queen Elizabeth, in the latter half of the sixteenth century, that English literature took the position of first importance in the world. Then, awakened as the nation was by the wonderful discoveries and explorations in America, by scientific discoveries and by the great victories of the navy, England produced a group of writers of a high order. Thoughtful essays, filled with the new science and sparkling wit of the day; poetry, glowing with the love of nature and splendid with beautiful phrases, and marvelous dramas, never since equaled, were poured out in those fifty resplendent years. The period is said to close with the accession of James I in 1603, though Shakespeare, the greatest genius of the period, lived until 1616.

During the Puritan Age, which closed in 1660, England changed its literary style completely and sacrificed the love of the beautiful to the search for truth. Milton, the one great literary man of his age, shows in his poetry the changes that were taking place, for he began his long literary career under the first Charles and did not complete his greatest poem till, old and blind, he lived

alone after the Revolution had done its work. With the restoration of Charles II, the literature of England quickly responded to French influences and rapidly developed into the striking brilliancy and beauty of the age of Queen Anne (1702-1714), which produced Defoe, Swift, Addison and Pope. It was during this time that *The Spectator*, chiefly the work of Joseph Addison, made its appearance. Then followed a remarkable development of the novel, represented by the works of Goldsmith, Richardson and Fielding; a new spirit in poetry also became apparent.

The early part of the nineteenth century, the period of Romanticism, saw a marvelous development of the new order of poetry, and the production of imaginative verse of a high order. The great poets of the period were Burns, Coleridge, Wordsworth, Shelley, Keats, Byron and Southey. Lamb and Scott were eminent prose writers. Then came the Victorian Era, which produced Carlyle, Macaulay, the Brownings, Tennyson, Dickens, Thackeray, George Eliot and other famous writers.

A brilliant group of novelists, poets, dramatists and essayists followed the great Victorians, and made notable the first quarter of the twentieth century. Among these gifted writers may be mentioned Arnold, Bennett, H. G. Wells, Mrs. Humphry Ward, A. Conan Doyle, Joseph Conrad, William De Morgan, Rudyard Kipling, G. K. Chesterton, Bernard Shaw, James Barrie, Henry A. Jones, John Galsworthy, Rupert Brooke, Alfred Noyes, John Masefield and William B. Yeats.

**American Literature.** In early colonial days there was little that could be called really American in the writings of the literary men of this country, but, beginning with the excellent prose of Franklin's *Autobiography*, a new life appeared, though it was not until the early part of the nineteenth century that poetry, essays and fiction of a characteristic American type became common. Irving, Bryant, Cooper and Poe were the greatest writers of the early period. Before, during and after the Civil War lived a remarkable group of poets, essayists and novelists, the greatest America has ever known. Most of them resided in and around Boston and were deeply moved by new ideas in religion and by the slavery agitation that was then at its height. Representative of

this group are Emerson, Holmes, Lowell, Longfellow and Whittier. Since the Civil War numerous writers, in both prose and poetry have kept the level high, and there have appeared many of enduring fame, such as Howells, Mark Twain, Riley, Field, Bret Harte, O. Henry and Churchill. (See outline at close of article.)

**Greek Literature.** The literature of the Greeks has served as a model and inspiration to writers of every age and race. Its poetry is musical and finished, its essays are refined, thoughtful and polished, and its oratory is noble and eloquent. Its great epic, Homer's *Iliad*, is still studied in every school where the language is taught and still has its influence on the writers of to-day. It is a storehouse of allusions which are in constant use, and without a knowledge of it reading becomes difficult.

Greek lyric poetry was connected with, in fact was, almost a part of Greek music. The Greeks employed a great variety of meter and developed many forms of poetry that are still imitated. To their historians, notably Herodotus, Thucydides and Xenophon, we are indebted for much of our knowledge of the earlier peoples. In philosophy, Greece had no rivals, and in one way and another its famous trio, Socrates, Plato and Aristotle, foreshadowed the greater part of what has been perfected in our times.

Greek orations were among the greatest ever delivered, and if we consider their effect upon the people they must be called the greatest. In their modern form they have served as models for many an orator, who looks to Demosthenes as his guide. But the greatest triumph of Grecian literature, if we except the *Iliad*, lay in the drama. Both tragedy and comedy had their origin in Greece in the worship of the god Bacchus, and for beauty, strength and passion, the productions of the old Athenians still rank among the greatest in the world. The greatest writer of comedy was Aristophanes; of tragedy, Sophocles, Euripides and Aeschylus.

**Latin Literature.** Scarcely behind the Greeks were the Romans, though the latter were in a sense imitators and really originated few things. Both their prose and poetry, however, have influenced the literature of modern Europe more forcibly than that of Greece and have entered more deeply into the education of mankind than those of any other nation. There was a period of crude begin-

nings, in which the language was taking form. During this time little was produced that has remained alive. Following this came a period of improvement, which lasted to about 84 B. C., during which time there were many great literary names in Rome, chief of which was Cato. From 84 B. C. to A. D. 14 is usually known as the Golden Age, in which lived Vergil, Caesar, Cicero and Livy. From the death of Augustus to the time of Hadrian is often called the Silver Age, the age of Juvenal, Tacitus and Pliny. From then till the fourth century there was a falling off in literary power, and after the fourth century there was a distinct decline that finally resulted in the extinction of Latin as a living language.

**Italian Literature.** For Italy the fourteenth century was the most brilliant period, although it was the first in which the modern Italian tongue was used. Latin still remained the scholarly language, but a trio of great writers used the language of the people, and the beautiful poems and perfect prose produced by these men made Italy for a time the most prominent literary nation in Europe. The three were Dante, Petrarch and Boccaccio. Ariosto and Tasso flourished in the sixteenth century. By the latter part of the sixteenth century other nations had taken the lead, and thereafter the influence of Italy became of less importance. Within recent years such notable writers as the historian Ferrero and the poet D'Annunzio have gained wide fame. It should be remembered that Italy gave the sonnet to poetry, and that the imagery, metrical forms and materials for plots in both drama and story used by such writers as Chaucer, Spenser and Shakespeare came directly from the Italians or were the fruitful result of their art.

**French Literature.** It was not until the sixteenth century that France was moved by the awakening spirit that had caught the souls of the English, but then little tales and polished essays were produced in great number, as the characteristic feature of the age. Montaigne ranks as the originator of the modern essay. The Golden Age of the French appeared at the end of the seventeenth century, the epoch of Louis XIV. Then French art really dominated Europe, though the full effect of its influence was not felt until some time later. Dramatists, essayists, wits and poets all are represented among French men of genius, among whom may be mentioned

Corneille, Racine, Molière, Lafontaine and Fenelon. The eighteenth century produced many brilliant men, and established France firmly in the high position it occupies today. Among the writers of that time are Montesquieu, Voltaire and Rousseau. Of later writers there have been many in every field of literature, including Hugo, Dumas, Guizot, Bergson and Rostand.

**German Literature.** The literature of Germany did not attain world-wide importance until modern times, though its poems and tales date back beyond Charlemagne. After the country recovered from the effects of the Thirty Years' War, which closed in 1648, a new spirit of national consciousness came into being, and was reflected in the poetry of Klopstock and Wieland and in the drama of Lessing. Then followed that famous group of authors who have given German writings a commanding place in the world's literature—Goethe, Schiller, Kant, Fichte, Schelling, Uhland, the Brothers Grimm, Heine and others. Of more recent date are the dramatists Hauptmann and Sudermann.

**Related Articles.** Below are given various topics treated in these volumes, which should be read in connection with the article on literature:

## GENERAL

|                |              |               |
|----------------|--------------|---------------|
| Allegory       | Didactic     | Melodrama     |
| Alliteration   | Poetry       | Mastersingers |
| Anagram        | Drama        | Meter         |
| Anthology      | Edda         | Minnesingers  |
| Augustan Age   | Elegy        | Minstrel      |
| Autograph      | Epic         | Novel         |
| Ballad         | Epigram      | Ode           |
| Bard           | Essay        | Oration       |
| Belles-Lettres | Fable        | Poet Laureate |
| Bible          | Farce        | Poetry        |
| Bibliography   | Fiction      | Reading       |
| Biography      | Figures of   | Romance       |
| Blank Verse    | Speech       | Romanticism   |
| Book           | Folklore     | Sagas         |
| Burlesque      | Idyl         | Satire        |
| Charade        | Irony        | Skalds        |
| Comedy         | Legend       | Sonnet        |
| Concordance    | Lyric Poetry | Tragedy       |
| Debate         | Manuscripts  | Troubadour    |
| Dictionary     | Masque       | Trouvère      |

## LITERARY REFERENCES

|                     |                     |
|---------------------|---------------------|
| Aeneid              | Evangeline          |
| Aesop               | Galahad, Sir        |
| Aladdin             | Godiva, Lady        |
| Alice's Adventures  | Grimms' Fairy Tales |
| in Wonderland       | Hamlet              |
| Ancient Mariner     | Hawatha             |
| Arabian Nights      | Iliad               |
| Autocrat of the     | Junius Letters      |
| Breakfast Table     | Lake School         |
| Becky Sharp         | Les Miserables      |
| Ben Hur             | Lochinvar           |
| Beowulf             | Macbeth             |
| Biglow Papers       | Merchant of Venice  |
| Bluebeard           | Midsummer Night's   |
| Camille             | Dream               |
| Canterbury Tales    | Mother Goose        |
| Charge of the Light | Nibelungenlied      |
| Brigade             | Odyssey             |
| Cid, The            | Paradise Lost       |
| Cinderella          | Poor Richard's      |
| Courtship of Miles  | Almanac             |
| Standish            | Rip Van Winkle      |
| Don Juan            | Robinson Crusoe     |
| Don Quixote         | Vedas               |

## BIOGRAPHY

These volumes contain biographies of the most important writers mentioned in the general article. See also special lists accompanying the articles Drama, Essay, History, Novel, Poetry.

**How to Read Literature.** It is not necessary to emphasize here the important part which good literature plays in the building of character and of intellect. But it is not enough that one should read; one should read systematically, with a purpose. This does not mean that all the works of the eighteenth century should be read before those of the nineteenth are touched, or that essays should be read one year and dramas the next. But there is an immense gain in connecting reading in some way with what has gone before. To follow, for instance, the growth of the English novel through the two centuries and a half of its existence will give one a more real knowledge of that most popular of all forms of literature than years of scattered novel-reading can do.

**Outlines.** The outlines on English and American literature which follow are intended not only to give a general comprehensive view of the literature of those two countries, but to make possible some such systematic plans of reading. In connection with the articles on the various outlines and on the various forms of literature given in these volumes, these outlines may be used in many ways to suggest schemes of reading:

## English Literature

## I. Early Literature

## 1. Before Chaucer

## a. Poetry

Beowulf

Caedmon's Paraphrase

Vision of Piers Plowman

## b. Prose

The Venerable Bede

King Alfred

John Wyclif

## 2. Geoffrey Chaucer

Legend of Good Women

The Canterbury Tales

## II. Elizabethan Age

## 1. Poets and Their Principal Works

## a. Non-Dramatic

Edmund Spenser. 1552-1599

Shepherd's Calendar

Faery Queen

## b. Dramatic

William Shakespeare. 1564-1616

The Merchant of Venice

Hamlet

Macbeth

Ben Jonson, 1573-1637

Every Man in His Humor

## Selections for Memorizing

We sow a thought and reap an act; we sow an act and reap a habit; we sow a habit and reap a character; we sow a character and reap destiny. —*Thackeray.*

The only reason we don't see good things everywhere is because we haven't good eyes.  
—“A Fool of Nature,” *Julian Hawthorne.*

Ah, faithful to Little Boy Blue they stand,  
Each in the same old place,  
Awaiting the touch of a little hand,  
The smile of a little face.  
And they wonder, as waiting these long years through,  
In the dust of that little chair,  
What has become of our Little Boy Blue  
Since he kissed them and put them there.

—“Little Boy Blue,” *Eugene Field.*

Then here's to our boyhood, its old and its gray!  
The stars of its winter, the dews of its May!  
And when we have done with our life lasting toys,  
Dear Father, take care of Thy children—The Boys.

—“The Boys,” *Oliver Wendell Holmes.*

“With malice toward none, with charity for all; with firmness in the right, as God gives us to see the right, let us finish the work we are in—to bind up the nation's wounds; to care for him who shall have borne the battle and for his widow and his orphans; to do all which may achieve and cherish a just and lasting peace among ourselves and with all nations.

—From Second Inaugural Address: *Abraham Lincoln.*

In battle or business, whatever the game,  
In war or in love, it's ever the same;  
In the struggle for power, or scramble for pelf,  
Let this be your motto, “Rely on yourself.”

—*Saxe.*

Our greatest glory consists not in never falling, but in rising every time we fall.

—*Emerson.*

My son, observe the postage stamp! Its usefulness depends upon its ability to stick to one thing until it gets there.

—*Josh Billings.*

But chief of all,  
Oh loss of sight, of thee I must complain!  
Blind among enemies, O worse than chains,  
Dungeon, or beggary, or decrepit age!  
Light, the prime work of God, to me's extinct,  
And all her various objects of delight  
Annulled, which might in part my grief have eased;  
Inferior to the vilest now become  
Of man or worm the vilest here excel me.  
They creep, yet see; I, dark in light, exposed  
To daily fraud, contempt, abuse and wrong,  
Within doors or without, still as a fool  
In power of others, never in my own  
Scarce half I seem to live, dead more than half.

—*Milton.*



## Questions on Literature

Which of Charles Reade's novels was directed against the English prison system?

What desire of Walter Scott eclipsed even his literary ambition?

When did Tennyson become poet laureate and what was the first great poem written after the event?

What career did Thackeray first plan for himself and why did he give it up?

To what subject is the literary talent of Israel Zangwill devoted?

What work of Hans Christian Andersen was written by him in English?

What was the period of Goethe's and Schiller's intimate association?

How does Aristophanes rank in Grecian literature?

How did Herodotus prepare himself for his great work? What well-known appellation has been given him?

In which of his writings is Horace at his best?

What was Livy's great purpose in his works?

What peculiar circumstance directed Virgil toward a literary career?

Whose translation of the *Æneid* has become most popular?

For what reason has the history of Dante's life become half mythical?

Has Dumas a rightful claim to the 1,200 volumes which bear his name?

What is the characteristic of Jules Verne's writings which makes them appeal to readers of all ages?

For what is Emile Zola noted?

What is literature? How old is it?

How old is Sanskrit Literature? Chinese?

What is poetry? Prose? What is a Lyric? An Epic? A Sonnet? An Ode?

Name the divisions into which prose is subdivided.

What is the difference between an essay and an oration?

When did Chaucer live? What is he popularly called because of his relation to English poetry?

When, where, and by whom was print-

ing invented? When was the first book printed?

Where and when was Shakespeare born? When did he die? Where is he buried?

How does Shakespeare rank as a dramatist?

Name five of his most noted productions.

Name five contemporary writers of Shakespeare.

Who wrote "Paradise Lost"?

For what was Spenser noted?

When did Burns live? Name some of his noted poems.

Is Walter Scott more famous for his poems than for his novels? What caused Scott to give up poetry for prose? What are his most famous novels? Name three.

When did Tennyson live? What is the character of his poems?

What famous American orator lived during the Revolutionary War?

For what was Franklin chiefly noted in the field of literature?

Who wrote *The Star Spangled Banner*? *Home, Sweet Home*? *America*?

For what is James Whitcomb Riley best known?

Name three prose writers and three poets of the United States living to-day.

Why is the study of literature so important? Give three reasons for your answer.

Why was Whittier called the Quaker poet?

For what production is Oliver Wendell Holmes best remembered? Lowell? Hawthorne? Cooper?

What is known as the Golden Age of French literature?

Why is King Alfred known as the Father of English Prose?

To the influence of what nation is to be traced much of the correctness and elegance of the literature produced during the age of Queen Anne?

What is the theme with which the *Iliad* deals? How does this epic rank in ancient poetry?

Christopher Marlowe. 1564-1593  
Tamburlaine

2. Prose Writers and Their Principal Works

a. Historical

Sir Walter Raleigh. 1552-1618  
History of the World

b. Theological

Richard Hooker. 1553-1600  
The Ecclesiastical Polity

c. Philosophical

Francis Bacon  
Novum Organum (New Instrument)  
Essays

III. The Age of Milton

1. Poets and Their Principal Works

a. John Milton. 1608-1674

Paradise Lost

L'Allegro

Il Penseroso

b. Abraham Cowley. 1618-1667

Daveids

2. Prose Writers and Their Principal Works

a. Izaak Walton. 1593-1683

The Compleat Angler

b. Jeremy Taylor. 1613-1667

Holy Living and Holy Dying

c. Dr. Richard Baxter. 1615-1691

The Saints' Everlasting Rest

Call to the Unconverted

d. John Milton

Areopagitica

Tenure of Kings and Magistrates

IV. The Age of Restoration

1. Poets and Their Principal Works

a. John Dryden. 1631-1700

Alexander's Feast

Religio Laici

Hind and Panther

2. Prose Writers and Their Principal Works

a. John Bunyan. 1628-1688

Pilgrim's Progress

Life and Death of Mr. Badman

b. John Locke. 1632-1704

Essay Concerning Human Understanding

c. Sir Isaac Newton. 1642-1727

The Principia

Optics

V. Augustan Age

1. Poets and Their Principal Works

a. Alexander Pope. 1688-1744

Essay on Man

Iliad

Dunciad

b. Edward Young. 1681-1765

Night Thoughts

Revenge

2. Prose Writers and Their Principal Works

a. Joseph Addison. 1672-1719

Sir Roger de Coverley Papers

Essays

b. Richard Steele. 1672-1729

Essays

c. Jonathan Swift. 1667-1745

Gulliver's Travels

Journal to Stella

d. Daniel Defoe. 1661-1731

Robinson Crusoe

Journal of the Plague Year

VI. The Age of Johnson

1. Poets and Their Principal Works

a. Thomas Gray. 1716-1771

Elegy Written in a Country Churchyard

The Bard

b. Oliver Goldsmith. 1728-1774

The Vicar of Wakefield

The Traveler

She Stoops to Conquer

The Deserted Village

c. William Cowper. 1731-1800

The Task

The Diverting History of John Gilpin

d. Robert Burns. 1759-1796

Cotter's Saturday Night

Tam O'Shanter

2. Prose Writers and Their Principal Works

a. Samuel Richardson. 1689-1761

Pamela

b. Henry Fielding. 1707-1754

Tom Jones

c. Samuel Johnson. 1709-1784

Rasselas

d. David Hume. 1711-1776

History of England

Essays

e. Edward Gibbon. 1737-1794

Decline and Fall of the Roman Empire

f. Edmund Burke. 1729-1797

On Conciliation with America

VII. Age of Scott

1. Poets and Their Principal Works

a. Walter Scott, 1771-1832

The Lady of the Lake

Marmion

Lay of the Last Minstrel

b. George Gordon Byron. 1788-1824

Childe Harold's Pilgrimage

Don Juan

The Giaour

c. John Keats. 1795-1821

Endymion

Eve of St. Agnes

Hyperion

Lamia

d. The Lake School

William Wordsworth. 1770-1850

Ode on Immortality

Lines on Tintern Abbey

The Excursion

We Are Seven

Samuel Taylor Coleridge. 1772-1834

The Ancient Mariner

Kubla Khan

Christabel

Robert Southey. 1774-1743

Joan of Arc

Roderick, The Last of the Goths

The Curse of Kehama

Percy Bysshe Shelley. 1792-1822

Queen Mab  
Ode to the West Wind  
Ode to a Skylark

2. Prose Writers and Their Principal Works

a. Novelist

Walter Scott. 1771-1832  
Ivanhoe  
Kenilworth  
Quentin Durward  
Guy Mannering

b. Essayist

Charles Lamb. 1775-1834  
Essays of Elia  
Tales from Shakespeare

VIII. Victorian Age

1. Poets and Their Principal Works

a. Alfred Tennyson. 1809-1892

The Princess  
In Memoriam  
Idylls of the King

b. Elizabeth Barrett Browning. 1806-1861

Sonnets from the Portuguese  
Aurora Leigh  
Prometheus Bound

c. Robert Browning. 1812-1889

My Last Duchess  
Andrea del Sarto  
The Ring and the Book  
Rabbi Ben Ezra

d. Thomas Babington Macaulay. 1800-1859

Lays of Ancient Rome  
The Battle of Ivry

e. Dante Gabriel Rossetti. 1828-1882

The House of Life  
The Blessed Damozel

f. Matthew Arnold. 1822-1888.

Sohrab and Rustum  
Dover Beach

g. Algernon Swinburne. 1837-1909

Tristram of Lyonesse  
Atalanta in Calydon

2. Prose Writers and Their Principal Works

a. Historical

Thomas Babington Macaulay  
History of England  
Henry Hallam. 1777-1859  
Constitutional History of England  
James Anthony Froude. 1818-1894  
History of England  
Thomas Carlyle: A History

b. Essayists

Thomas DeQuincey. 1785-1859  
Confessions of An Opium Eater  
Joan of Arc  
The English Mail Coach  
Thomas Carlyle. 1795-1881  
Sartor Resartus  
French Revolution  
John Ruskin. 1819-1900  
Seven Lamps of Architecture  
Stones of Venice  
Sesame and Lillies

c. Theological

John H. Newman. 1801-1890

Apologia pro Vita sua  
Lead Kindly Light

C. H. Spurgeon. 1834-1892

The Saint and His Saviour  
Speeches at Home and Abroad

d. Scientific

Sir William Hamilton. 1788-1856  
Discussions on Philosophy and Literature

Sir Charles Lyell. 1797-1875  
Elements of Geology  
Antiquity of Man

Charles Darwin. 1809-1882  
Origin of Species  
Descent of Man

Thomas Huxley. 1825-1895  
Man's Place in Nature

Elements of Comparative Anatomy

Herbert Spencer. 1820-1903  
First Principles

e. Novelists

Charles Dickens. 1812-1870  
Pickwick Papers

David Copperfield  
Nicholas Nickleby

William Makepeace Thackeray.  
1811-1863

Henry Esmond  
The Newcomes

Vanity Fair

George Eliot. 1819-1880

Silas Marner  
Adam Bede

Felix Holt

Charles Kingsley. 1819-1875

Hypatia

Robert Louis Stevenson. 1850-1894

Dr. Jekyll and Mr. Hyde  
Treasure Island

IX. Modern Period

1. Poets and Their Principal Works

Robert Bridges. 1844-  
Eros and Psyche

William Butler Yeats. 1865-  
The Wind Among the Reeds

John Masefield. 1875-  
The Tragedy of Nan  
The Widow in the Bye-Street

Alfred Noyes. 1880-  
The Loom of Years  
The Enchanted Island

2. Prose Writers and Their Principal Works

George Bernard Shaw. 1856-  
Man and Superman  
Androcles and the Lion

Arthur Conan Doyle. 1859-  
The Adventures of Sherlock

Holmes

The White Company

James M. Barrie. 1860-  
The Little Minister

Peter Pan

Rudyard Kipling. 1865-  
The Jungle Book

Kim

Herbert G. Wells. 1866-

Tono-Bungay  
 Mr. Britling Sees It Through  
 Arnold Bennett. 1867-  
 The Old Wives' Tale  
 Clayhanger  
 John Galsworthy. 1867-  
 Justice  
 The Pigeon

#### American Literature

### I. Colonial Period

1. Poets and Their Principal Works
  - a. Anne Dudley Bradstreet. 1612-1672  
The Tenth Muse
2. Prose Writers and Their Principal Works
  - a. Thomas Hooker. 1586-1647  
Fundamental Orders—First Written Constitution
  - b. Cotton Mather. 1667-1728  
Witchcraft  
Wonders of the Invisible World  
Magnalia
  - c. Jonathan Edwards. 1703-1758  
Freedom of the Will
  - d. Benjamin Franklin. 1706-1790  
Poor Richard's Almanac  
Essays  
Autobiography

### II. Revolutionary Period

1. Poets and Their Principal Works
  - a. Philip Freneau. 1752-1832  
The British Prison Ship  
Political Poems  
John Trumbull. 1750-1831  
McFingal
  - c. Francis Scott Key. 1780-1842  
Star Spangled Banner
2. Prose Writers and Their Works
  - a. Alexander Hamilton. 1757-1804  
The Federalist
  - b. Thomas Jefferson. 1743-1826  
Rights of British America  
Declaration of Independence
  - c. James Madison. 1751-1836  
The Federalist
  - e. Charles B. Brown. 1771-1810  
Wieland

### III. National Period

1. Poets and Their Principal Works
  - a. William Cullen Bryant. 1794-1878  
Thanatopsis  
My Country's Call  
The Ages  
Flood of Years  
Translation of the Iliad and Odyssey
  - b. Henry Wadsworth Longfellow. 1807-1882  
Evangeline  
Hiawatha  
The Spanish Student  
The Courtship of Miles Standish
  - c. John Greenleaf Whittier. 1807-1892  
The Barefoot Boy  
Snowbound  
Among the Hills
  - d. Edgar Allen Poe. 1809-1849  
Annabel Lee

- The Raven
- e. James Russell Lowell. 1819-1891  
The Commemoration Ode  
The Vision of Sir Launfal  
The Cathedral
- f. Oliver Wendell Holmes. 1809-1849  
Old Ironsides  
The Poet at the Breakfast Table  
The Chambered Nautilus  
The Last Leaf  
Wonderful One-Hoss Shay
- g. James Whitcomb Riley. 1853-  
The Old Swimmin' Hole  
Afterwhiles  
Rhymes of Childhood
- h. Eugene Field. 1850-1895  
Little Boy Blue  
Jes' 'Fore Christmas  
Seein' Things
2. Prose Writers and Their Principal Works

#### Essayists

- a. Ralph Waldo Emerson. 1803-1882  
Representative Men  
The Conduct of Life
- b. Henry David Thoreau. 1817-1862  
Walden  
The Maine Woods
- c. William E. Channing. 1780-1842  
Sermons and Reviews

#### Critics

- a. James Russell Lowell. 1819-1891
- b. Edmund Clarence Stedman. 1833-1908

#### Historians

- a. George Bancroft. 1800-1891  
The United States of North America  
History of the Revolution in North America
- b. Richard Hildreth. 1807-1891  
The White Slave  
History of the United States
- c. William H. Prescott. 1796-1859  
Conquest of Mexico  
Conquest of Peru
- d. John L. Motley. 1814-1877  
The Rise of the Dutch Republic  
The United Netherlands
- e. Francis Parkman. 1823-1893  
California and the Oregon Trail  
The Jesuits in North America  
Montcalm and Wolfe
- f. John Fiske. 1842-1901.  
Outlines of Cosmic Philosophy  
The American Revolution
- g. Theodore Roosevelt. 1858-1919  
American Political Ideals

#### Novelists

- a. Nathaniel Hawthorne. 1804-1869  
The Scarlet Letter  
The Marble Faun  
The House of the Seven Gables
- b. James Fenimore Cooper. 1789-1851  
The Spy  
The Pilot  
The Last of the Mohicans
- c. Harriet Beecher Stowe. 1811-1896  
Uncle Tom's Cabin

- d. William Dean Howells. 1837-  
The Rise of Silas Lapham  
A Modern Instance  
Venetian Life  
A Foregone Conclusion
- e. Henry James. 1843-1916  
Daisy Miller  
A Passionate Pilgrim
- f. George W. Cable. 1844-  
Old Creole Days  
The Louisiana Lovers
- g. James Lane Allen. 1849-  
The Kentucky Cardinal  
The Choir Invisible
- h. Frances H. Burnett. 1849-  
Little Lord Fauntleroy  
The Shuttle  
T. Tembarom
- i. Gertrude Atherton. 1857-  
The Conqueror  
The Avalanche  
The White Morning
- j. Margaretta Deland. 1857-  
The Awakening of Helena Richie  
The Rising Tide  
The Iron Woman
- k. Edith Wharton. 1862-  
The House of Mirth  
The Reef
- l. George Barr McCutcheon. 1866-  
Brewster's Millions  
Beverly of Graustark  
The Prince of Graustark
- m. William S. Porter (O. Henry) 1867-  
1910  
Cabbages and Kings
- n. Booth Tarkington. 1869-  
The Gentleman from Indiana  
Seventeen  
Penrod  
The Magnificent Ambersons
- o. Winston Churchill. 1871-  
The Crisis  
The Crossing  
Coniston  
The Inside of the Cup
- p. Harold Bell Wright. 1872-  
The Winning of Barbara Worth  
The Calling of Dan Matthews  
When a Man's a Man
- q. Mary Roberts Rinehart. 1876-  
The Street of Seven Stars  
The Amazing Interlude  
The Sub-Deb  
Tish

**Humorists**

- a. Joel Chandler Harris. 1848-1908
- b. Samuel L. Clemens. 1835-1910  
Tom Sawyer  
Pudd'nhead Wilson  
Innocents Abroad

**Miscellaneous Writers.**

- a. Washington Irving. 1783-1859
- b. Bayard Taylor. 1825-1876
- c. J. G. Holland. 1819-1881
- d. George Ticknor. 1791-1871
- e. Charles Dudley Warner. 1829-1900
- f. Silas Weir Mitchell. 1829-1914
- g. Thomas Bailey Aldrich. 1836-1907.



David Copperfield  
and Emily

**L**ITERATURE, BOYS AND GIRLS IN. The portrayal of child life is an interesting and delightful feature of a considerable portion of the world's literature. In the following paragraphs some of the well-known child characters in fiction are presented, and their stories are given in condensed form. It is hoped that the perusal of these narratives will inspire those who have not already done so to seek an acquaintance with the authors represented.

**Eppie, the Heroine in "Silas Marner."**

The story of little Eppie, one of the most delightful in all the writings of George Eliot, is a beautiful exposition of the theme, "A little child shall lead them." The scene of the story is the old-fashioned English village of Raveloe, which the author describes as "nestling in a snug, well-wooded hollow, quite an hour's journey on horseback from any turnpike." The time is in the nineteenth century.

On the outskirts of the village, not far from a deserted stone-pit, stood a stone cottage inhabited by a hermit weaver named Silas Marner. He was a mystery to all the villagers, and his solitary habits and a rumor that he was subject to fits caused them to regard him with something like fear. Year after year he lived his uneventful life, industriously plying his loom and hoarding his savings like a miser. The superstitious villagers could not know that his precious pieces of gold, which he kept in two thick bags beneath his brick floor, took the place of faith in God, friendship and love. For, before he came to Raveloe, Silas Marner had been betrayed by his best friend, falsely accused of stealing church money, and abandoned by the girl he had hoped to marry. So with faith and hope dead, he had come to let the love of gold take the place of all human interests and affections.

Fifteen years after his appearance in the village Silas was violently torn from his solitary habits by what seemed to him a terrible disaster—the loss of his gold. One evening, while he was out on an errand, a thief entered the cottage and took up the money bags from beneath the floor. One can hardly imagine the agony which came over Silas when he discovered his loss. In his despair he rushed to the village tavern and startled the company there with a request for the constable and justice. It was not long before all the village knew that the miser weaver had been robbed, and his misery was so real and so intense that

it awakened the sympathy of those who had hitherto regarded him with fear or repulsion. People even came to see him in a vain effort to comfort him. But it was the touch of a little child that opened the door to his heart.

On New Year's Eve, when the "great folk" of Raveloe were feasting at the home of Squire Cass, a wretched woman with a sleeping baby in her arms was making her way along a snow-covered path leading to the village. She was the unacknowledged wife of the squire's eldest son Godfrey, and was on her way to the mansion to shame her husband before his guests. In her weariness she had recourse to the only comfort in life that she knew—opium. The dose, in addition to the cold and her fatigue, benumbed her, and just as she came near Silas' cottage she sank down upon the snow and fell into the sleep that has no waking. Aroused from slumber, the little child slipped from her mother's arms and crawled out on the snow. A dancing light had caught her eye, and she toddled after it—on to the open door of Silas Marner's cottage, where there was a bright fire of logs and sticks. Soothed by the warmth and light, the little girl laid her golden head on an old sack before the fire, and was soon fast asleep.

Silas, all this time, was standing in the open doorway, gazing out on the trackless snow. In his ceaseless craving for his beloved money he often went to the doorway and looked longingly about him, as if to see if there might be news of his lost treasure. On this evening, just as he was about to re-enter, he was seized with an attack of catalepsy, and when the child crossed the threshold he was holding open the door and staring out with wide but sightless eyes. When his sensibility returned he closed the door and turned toward the hearth, for he felt cold and faint. As he stooped to push the logs together he saw on the floor before the hearth what seemed to his blurred vision a pile of gold. With a beating heart he stretched out a hand to grasp his treasure, but his fingers touched soft curls instead of gold, and when he knelt down and saw that it was the golden hair of a little child, he thought for a moment that his little sister, who had died years before, had come back to him.

The days that followed held new and strange experiences for the miser. No one came to claim the child, and the mother was buried in a pauper's grave. What stirred the villagers to amazement was the news that Silas Marner was determined to keep the "tramp's child." In answer to questions he would say, "It's a lone thing—and I'm a lone thing. My money's gone, I don't know where—and this is come from I don't know where." The difficulties that are likely to beset a lone bachelor with a two-year-old child on his hands were not lacking in Silas's case, but he had the practical help of his neighbor, Dolly Winthrop, who brought over some of her little Aaron's outgrown garments and mothered the little waif in the good old-fashioned way. "Anybody 'ud think the angils in heaven couldn't be prettier," said Dolly, after

she had washed and dressed the child, and smoothed her golden curls.



SILAS FINDS EPPIE

So the tramp's child became an inmate of the stone cottage, and as the days passed by chords of love, sympathy and kindness, long dormant in the miser's heart, were slowly stirred to life. Silas had the baby christened Hepzibah, after his mother and sister, but he called her Eppie, for thus the long name had been softened in the days gone by. And as the child grew, "his mind was growing into memory; as her life unfolded, his soul, long stupefied in a cold, narrow prison, was unfolding too, and trembling gradually into full consciousness." The care and training of the lively little girl, however, presented many a problem, as Silas often discovered. His friendly counsellor, Dolly Winthrop, advised "smacking" her or putting her in the coal hole when she misbehaved. Silas could not bear to "smack" her, but one day he did try the coal hole form of discipline. He had tied Eppie to his loom to keep her out of mischief, and while he was busy "setting up" a new piece of work, she snatched his scissors and cut the strip of linen that bound her. Finding herself free, she ran out into the sunshine and was out of sight before he missed her. The anguish that Silas suffered before he found her, playing on the edge of a small pond, stirred him to unusual resolution. How he punished her we will let the author tell.

"Naughty, naughty Eppie," he suddenly began, holding her on his knee, and pointing to her muddy feet and clothes—"naughty to cut with the scissors and run away. Eppie must go into the coal hole." He half expected

that this would be shock enough, and that Eppie would begin to cry. But instead of that, she began to shake herself on his knee, as if the proposition opened a pleasing novelty. Seeing that he must proceed to extremities, he put her into the coal hole, and held the door closed, with a trembling sense that he was using a strong measure. For a moment there was silence, but then came a little cry, 'Opy, opy,' and Silas let her out again, saying 'Now Eppie 'ull never be naughty again, else she must go in the coal hole—a black naughty place.'

"The weaving must stand still a long while this morning, for now Eppie must be washed, and have clean clothes on, but it was to be hoped that this punishment would have a lasting effect and save time in future—though, perhaps, it would have been better if Eppie had cried more.

"In half an hour she was clean again, and Silas, having turned his back to see what he could do with the linen band, threw it down again, with the reflection that Eppie would be good without fastening for the rest of the morning. He turned round again, and was going to place her in her little chair near the loom, when she peeped out at him with black face and hands again, and said, 'Eppie in de toal hole.'

In commenting on the futility of this method of discipline the author goes on to say that the stone hut was made a soft nest for Eppie, lined with downy patience; and also in the world that lay beyond the stone hut she knew nothing of frowns and denials. For the little curly-haired Eppie, the weaver's child, became an object of interest throughout the neighborhood. Silas usually carried her with him when he delivered his yarn and linen, and he was always heartily welcomed in these days. At home, in the atmosphere of love and sympathy, she grew to be the sole comfort of his life.

The story of Eppie would not be complete without a look into her future. It seems perfectly natural that Dolly's little Aaron, who grew up with her, should learn to love her, and that the story should end with a wedding. One episode in Eppie's life, however, was never known to the villagers, though we may share the secret. Shortly before her marriage the stone cottage was visited by Mr. and Mrs. Godfrey Cass. Mr. Cass confessed to the wondering girl that he was her father, and that to atone for his neglect he wished to adopt her. I am sure you will be glad to know that Eppie decided that Silas had more claim to her daughterly love than the repentant gentleman. In answer to Godfrey's request, she said, "I can't feel as I've got any father but one. I wasn't brought up to be a lady, and I can't turn my mind to it. I'm promised to marry a working man, as 'll live with father, and help me to take care of him."

And let us take leave of Silas and Eppie with the words the bride utters as she returns from the simple church wedding: "O, father, what a pretty home ours is! I think nobody could be happier than we are."

**Tom and Maggie Tulliver.** A considerable portion of George Eliot's *Mill on the Floss* is devoted to the childhood of Tom and Maggie Tulliver, and to many readers this is the most charming section of the book. Maggie, as first presented, is a dark-haired, restless child of nine, whose naughty ways are a perpetual source of worry to her dull but amiable mother. Maggie is decidedly her father's favorite, though he sometimes wishes her "cuteness" could have been bestowed upon thirteen-year-old Tom, as the following dialogue indicates:

Mr. Tulliver: What I'm a bit afraid on is, as Tom hasn't got the right sort o' brains for a smart fellow, I doubt he's a bit slowish. He takes after your family, Bessy.

Mrs. Tulliver: Yes, that he does; he's wonderful for liking a deal o' salt in his broth. That was my brother's way and my father's before him.

Mr. Tulliver: It seems a bit of a pity, though, as the lad should take after the mother's side instead of the wench. The little un takes after my side, now: she's twice as 'cute as Tom. Too 'cute for a woman, I'm afraid. It's no mischief much while she's a little un, but an over-'cute woman's no better nor a long-tailed sheep—she'll fetch none the bigger price for that.

This dialogue occurs in a discussion about sending Tom to a school where he can get his brains "smartened up" and be trained "to make a nest for himself." For Mr. Tulliver considered that his son had exhausted the resources of the neighboring academy, and ought to go where they would make a "scholar" of him. The day that Tom was brought home from the academy was a red-letter day for Maggie, for she loved her brother with all her heart. To be sure, she was bitterly disappointed at not being allowed to ride in the gig with her father to fetch Tom, and therefore refused to have her hair combed, but her childish sorrow was forgotten later in the day, when her rosy-cheeked brother arrived, especially when he showed her the new fish-line he had bought for her out of his own savings.

A few days later the house was enlivened by the arrival of Mrs. Tulliver's three sisters—Aunt Glegg, Aunt Pullet and Aunt Deane. This influx of relatives was the result of Mrs. Tulliver's determination that the subject of Tom's schooling should be talked over by the family. When Mr. Tulliver first broached the subject she had said, "Well, Mr. Tulliver, you know best; I've no objections. But hadn't I better kill a couple o' fowl and have th' aunts and uncles to dinner next week, so as you may hear what Sister Glegg and Sister Pullet have got to say about it?" From which it may be seen that Mrs. Tulliver set great store by the opinion of her family. Tom and Maggie considered the aunts an unmitigated nuisance, but Tom found compensation in the extra goodies that his mother always baked when company came, especially "apricot roll-up," and Maggie was solaced by the presence of her pretty little cousin, Lucy Deane.

Maggie was not a favorite with any of her aunts. They considered her thick, shaggy locks and brown skin an unpardonable blot on the family reputation for beauty, and her boisterous ways a reflection on Sister Bessy's methods of discipline. So when the child first entered the room where her aunts were collected they began to "pick on" her. Because she rushed at once to greet the much-loved Lucy, Aunt Glegg called out loudly, "Heyday! Do little gells come into a room without taking notice o' their uncles and aunts? That wasn't the way when I was a little gell." Maggie's rough hair next brought a comment from Aunt Pullet: "I think the gell has too much hair. I'd have it thinned and cut shorter, Sister, if I was you; it isn't good for her health. It's that as makes her skin so brown, I shouldn't wonder. Don't you think so, Sister Deane?" Maggie had suffered too much from her teasing locks to bear amiably any critical remarks about them. Her mother was always worrying her by trying to curl her hair, and as it never stayed in curl more than a few minutes the front locks were always getting in her eyes. Accordingly, she came to a quick decision about the fate of that unlucky head of hair.

As soon as an opportunity came she whispered to Tom to follow her upstairs, and led

Tom cut the back locks, and he found as much joy in obeying her as when he had secretly cut the pony's mane. But the result was a disappointment to poor Maggie, for Tom cried out in great glee, "Oh, my buttons, what a queer thing you look! Look at yourself in the glass—you look like the idiot we throw out nutshells to at school." Such unkind remarks brought an outburst of angry tears, and Tom hurried down to dinner leaving his sister weeping before the mirror. However, after a few minutes he returned with reports of "custard, and nuts and things," and so she decided to go down and face the family.

Her appearance startled the family and the guests alike. Mrs. Tulliver screamed, but Mr. Tulliver laughed outright and said, "Did you ever know such a little hussy as it is?" Aunt Glegg gave it as her opinion that "gells" who cut their own hair should be whipped and fed on bread and water, while Uncle Clegg jokingly added that jail was the place for such girls. Aunt Pullet thought she looked "more like a gypsy nor ever," Mrs. Tulliver prophesied she would break her mother's heart some day, and even Tom whispered, "Oh, my! Maggie, I told you you'd catch it." Poor Maggie knew of only one unfailing source of comfort, and running to her father, she buried her face on his shoulder and burst into wild sobbing. "Come, come, my wench," he said kindly, "never mind; you was in the right to cut it off if it plagued you. Give over crying; father'll take your part." Many years afterward, when people said that Mr. Tulliver had done ill by his children, Maggie remembered the times that "father took her part."

The hair-cutting episode is typical of Maggie's tempestuous childhood. Yet we love her better than we do Tom, for she is tender-hearted, generous and impulsive, where he is cold, hard and narrow. He develops a stable, well-controlled character, which comes out strongly when his father's financial ruin and death put heavy burdens on his young shoulders, but our sympathy is always with his sister. One of the most pathetic notes in the story is the final estrangement of brother and sister, after many heartaches and misunderstandings. For in a bitter crisis in Maggie's life her brother judged her harshly and told her that he would never see her again. The days that followed were full of despair for Maggie, and she did not see her brother again until their last meeting on earth. One night a disastrous flood broke over the town. Maggie managed to get a boat out on the flooded fields, and she rowed it to the old home where her childhood had been passed. A call brought her brother to an upstairs window, which was then on a level with the water, and he stepped into the boat with her. Face to face they floated out on the river, and in that hour of peril all was made right between them. But as they came into the current of the stream a huge mass of wreckage bore down upon them. Then said Tom, in a deep, hoarse voice, as he clasped his sister to him, "It is coming, Maggie."



TOM AS MAGGIE'S BARBER

him into her mother's room. Then she took out a large pair of scissors from a drawer. "What are they for, Maggie?" asked her brother, his curiosity awakened. Maggie replied by seizing the front locks and cutting them straight across the middle of her forehead. When she had snipped off all the hair that she could reach conveniently she made



"The boat reappeared—but brother and sister had gone down in an embrace never to be parted: living through again in one supreme moment the days when they had clasped their little hands in love, and roamed the daisied fields together."

**David Copperfield.** This popular story by Charles Dickens is in part a narrative of the author's own life. The opening chapter presents a picture of a charming old house in the English village of Blunderstone, where David, the hero of the tale, was born. On a windy March day, not many hours before he made his entrance into the world, his mother, six months a widow, was sitting sadly before the parlor fire. As she was drying her tears she saw through the window a tall, rigid lady coming up the garden path. This unexpected visitor proved to be Miss Betsy Trotwood, the eccentric aunt of Mrs. Copperfield's late husband. The conversation that followed gives us a clue to this remarkable lady's character, and it is important to know about her, for she plays a large part in the later chapters of the story.

She was a practical, unsentimental sort of a person, and she became very indignant when the poor young widow, between her sobs, told her that Mr. Copperfield had named their home the "Rookery" because there were some deserted rooks' nests in the tall elm trees that grew in the garden. Later, when Mrs. Copperfield's servant brought in the tea and Miss Trotwood discovered that her name was Peggotty, that strong-minded person demanded, "Do you mean to say that any human being has gone into a Christian church, and got herself named Peggotty?" She was only appeased when it was explained that Peggotty was her last name, and it was used because both mistress and maid bore the first name of Clara. In the course of her remarks Miss Trotwood informed the young widow that she expected the coming little stranger to be a girl, and that she was to be named Betsy Trotwood Copperfield. When, a few hours later, young David arrived, his great aunt considered herself unduly affronted, and departed in great indignation. And that was the last they heard of Miss Trotwood for many a year. Later she enters the story again and becomes a lovable character.

David lived very happily with his mother and his good nurse Peggotty until he was about eight years old. Then his mother married a black-whiskered gentleman by the name of Murdstone, and all their happy times came to an end. Between the stern stepfather and his sour-tempered sister, Miss Jane, David had anything but a cheerful time, and he was finally sent off to a boarding school near London. Mr. Barkis, the carrier who took him as far as Yarmouth, was very inquisitive about Peggotty as they rode along together, and when David told him what delicious pies and cakes she baked, the carrier asked him to send the following message in his first letter—"Barkis is willin'." But it was quite a long time before David knew what Barkis meant.

In due time young Copperfield arrived at a school called Salem House, conducted by a Mr. Creakle. The chief educational qualifications of this gentleman were a strong right arm and an inclination to use it in caning the boys. David, being a chubby lad, had good reason to get well acquainted with the cane, for Mr. Creakle took great delight in cutting at the chubby boys as he passed up and down the aisles. Among David's schoolmates there were two for whom he acquired a special liking—handsome James Steerforth, the cock of the school, who was never punished, and Tommy Traddles, who was clad in a tight suit that made his arms and legs look like sausages, and was caned every day. Both of these boys David saw again in after years, and both entered deeply into his life.

The days passed quickly by and brought the first half-year to a close. Then David returned home for a month's vacation. Fortunately for him he arrived at a time when Mr. Murdstone and his sister were away visiting, and the lad and his mother and Peggotty had one of their old cozy times before the parlor fire before the others returned. David had found a baby brother in his mother's arms, and he loved him for her sake. As they dined together at the fireside he told Peggotty about Mr. Barkis and his strange interest in her. She interrupted the story by throwing her apron over her face and laughing as if she could never stop.

"What are you doing, you stupid creature?" said Mrs. Copperfield.

"Oh, drat the man!" cried Peggotty. "He wants me to marry him."

"It would be a good match for you, wouldn't it?" asked her mistress.

"Oh! I don't know," said Peggotty, "Don't ask me. I wouldn't have him if he was made of gold. Nor I wouldn't have anybody."

"Then, why don't you tell him so, you ridiculous thing?" said David's mother.

"Tell him so," retorted Peggotty, "he has never said a word to me about it. He knows better. If he was to make so bold as say a word to me, I would slap his face."

These and similar protestations from Peggotty seemed to prove a relief to Mrs. Copperfield, who appeared to David to look careworn and delicate. But they had a very happy time together until ten o'clock, when Mr. and Miss Murdstone returned. David hurried to bed when he heard the sound of wheels, and so did not meet his lately-acquired relatives until the next morning. The gracious and charming Miss Murdstone greeted him with the tea-caddy scoop and the remark, "Ah, dear me! How long are the holidays?" When she was told they lasted a month from that day, she said, "Then here's one day off." Both she and her brother contrived to make David about as miserable as a small boy can be, and he was not sorry when it was time to return to school. To be sure, he was going back to beatings, but he was also returning to Steerforth and the other boys. His last view of his loved mother is well worth recording here, in his own words:

"I kissed her, and my baby brother, and was very sorry then, but not sorry to go away, for the gulf between us was there, and the parting was there, every day. And it is not so much the embrace she gave me, that lives in my mind, though it was as fervent as could be, as what followed the embrace.

"I was in the carrier's cart when I heard her calling to me. I looked out, and she stood at the garden gate alone, holding her baby up in her arms for me to see. It was cold still weather; and not a hair of her head, nor a fold of her dress, was stirred, as she looked intently at me, holding her child.

"So I lost her. So I saw her afterwards, in my sleep at school—a silent presence near my bed—looking at me with the same intent face—holding up her baby in her arms."

The next event of importance occurs two months later. On the morning of his birthday David received the news that his mother had died and he was to go home. The chief solace of the desolate little orphan during the sad days that followed was kind old Peggotty, and when the amiable Miss Murdstone gave her notice to leave, she obtained permission to take the boy away with her for a visit to Yarmouth. For Peggotty had a fisherman brother living there, in the jolliest kind of a house David had ever seen. He had visited there once before, and knew the joys of living in a house that had once been a boat. He knew also he would find there pretty, blue-eyed little Emily, an orphan niece of Mr. Peggotty. David admired Mr. Peggotty immensely; and thought him the finest man who ever sailed the seas. He considered him a model of generosity, as well, for he supported, besides little "Em'ly," a husky nephew by the name of Ham, and a lone, lorn widow who complained from morning till night. But, even when Mrs. Gummidge was the most disagreeable, Mr. Peggotty always excused her by saying she was thinking of the "old un."

In the company of these simple, kindly people, David forgot some of his troubles, though he did wish little Em'ly wouldn't tease him so much. In fact, he decided that he was desperately in love with the mischievous little maid. A romance of another sort was taking place at the same time, for every evening Mr. Barkis came to woo Peggotty, and brought her oranges, onions, pickled pork and other delicacies. As for Peggotty, she used to laugh by the hour after he had departed, but she was not blind to the virtues of the good carrier. One day, shortly before David returned to Blunderstone, Mr. Barkis drove up in a chaise cart, and took Peggotty, David and Emily out for a holiday ride. The first place they stopped at was a church, where the two elders seemed to have some business to transact. After they had come out of the church and were riding along again, Mr. Barkis announced with a roar of laughter that Peggotty's name was now Clara Peggotty Barkis. So the holiday ride was a wedding trip, and I doubt if there ever was a wedding journey enjoyed more than that one.

After David returned to the Rookery he had

a sorry time of it, for the Murdstones regarded him as a hateful burden. Finally his stepfather sent him to London to work in a wine warehouse in which he had an interest. Never in his life had David suffered as he did then. He worked all day long washing empty bottles and pasting labels on full ones, for about seven shillings (\$1.75) a week. He had no congenial companions, no opportunities to study, no home comforts. In fact, the only people who took any interest in him were the Micawbers, at whose house he lodged. Mr. Micawber was always in debt and always looking for something to "turn up," but Mrs. Micawber, with perfect confidence in her husband's abilities, declared she would never desert him. This worthy couple and their four children lived chiefly on hope and gentility. After several months, during which David grew shabbier and more discouraged every day, Mr. Micawber was sent to prison for debt. This event proved to be a crisis in that hopeful gentleman's career, for Mrs. Micawber's family helped him out of his difficulties and assisted the unfortunate family to remove to another town. This left David practically friendless, and he decided to run away, lest he should become a vagabond.

During those months of degrading toil he had formed a desperate resolution—that he would throw himself on the mercy of his aunt, Miss Trotwood. He knew she lived near Dover, and was comfortably well off. Though he had heard many times the story of her abrupt departure on the night of his birth, he remembered his mother's fancy that Miss Betsy had, in a moment of tenderness, gently touched the widow's pretty hair. This softening note in the story gave him the necessary courage to start on his journey. At the outset a rascally cart-driver robbed him of his box of clothing and a half-guinea piece (about \$2.50) that Peggotty had sent him. Thus he had to pawn what clothes he could spare to get money to buy food, and when, after many days, he arrived at Dover, he was in the last stages of dilapidation and weariness.

Miss Trotwood lived just out of Dover, in a pretty little cottage by the sea. She was at work in her garden when the forlorn little fellow approached her. Without a scrap of courage, but with a great deal of desperation, he went to her side and touched her. "If you please, ma'am," he said, timidly. She started and looked up. "If you please, Aunt, I am your nephew." "Oh, Lord!" she said, and sat down flat in the garden path. Then David told his pitiful story, ending it with a passion of crying that had been pent up within him all week.

There is no space here to tell in detail how she took the little waif into the house and washed and fed him. But you will be glad to know that David at last found a comfortable home and someone to love him, for austere Miss Betsy proved to be one of the kindest and most generous of guardians. Before she formally adopted the little runaway she wrote to Mr. Murdstone and informed him of David's

arrival. He and his sister condescended to pay Miss Trotwood a visit, as a result of which they were relieved of all responsibility over David, and were treated to a piece of Miss Betsy's mind. The reader who doesn't enjoy that episode as the author relates it isn't quite human.



DAVID MEETS HIS AUNT

We will take leave of our little hero in Miss Trotwood's cottage by the sea. How she sent him to a splendid school, and what use he made of his advantages in later years, together with a multitude of interesting details about the Peggotty's, little Em'ly, Steerforth, Traddles and many others, are all told in the fascinating way that makes Charles Dickens loved by hosts of readers.

**Rebecca of Sunnybrook Farm.** Kate Douglas Wiggin Riggs is the author of this charming story of a little American girl. The book is published by Houghton, Mifflin and Company. Rebecca was the second child in a family of seven children, whose widowed mother found it difficult to make ends meet. They lived on a Maine farm which Rebecca described as "away off from everywhere," whose one redeeming feature was a chattering little brook full of sparkles all day long when the sunshine played on it. A farm possessing such a pretty little brook ought to be called Sunnybrook, according to Rebecca, but the neighbors called it simply Randall's Farm. Mrs. Aurelia Randall, Rebecca's mother, was one of the three Sawyer girls of Riverboro. She had contracted a luckless marriage with a good-looking dancing master, whose chief asset was the high-sounding name of Lorenzo de Medici. Lorenzo proceed-

ed to spend Aurelia's little fortune as fast as possible, by making an investment for each son and daughter that blessed their union. His last investment, the purchase of Sunnybrook Farm, was made just before his seventh child was born. On the day she came into the world he departed from it. "a duty somewhat too long deferred," as the author puts it.

Aurelia's two spinster sisters, who lived in the family brick house in Riverboro, tried to do their duty by the happy-go-lucky family, and the elder, Miss Miranda, finally offered to educate one of the children. She asked to have the oldest girl, Hannah, sent to her, but Aurelia could not spare her, and sent Rebecca instead. At this time Rebecca was a lively child of about ten. What her aunt thought of her may be judged from her remarks when she had read Aurelia's letter informing her of Rebecca's coming. In that letter the hopeful mother expressed the belief that the schooling her aunt would give the child would be the making of Rebecca. "I don't know as I cal'lated to be the makin' of any child," said Miranda, grimly; "I s'posed, of course, Aurelia would send us the one we asked for, but it's just like her to palm off that wild young one on somebody else." But Aunt Jane took a more hopeful view of the case.

The "wild young one" arrived in Mr. Jeremiah Cobb's stagecoach in due time. She was dressed in a stiffly-starched buff calico gown "buttoned down before," and she carried a bunch of faded flowers and a pink parasol. The flowers she presented to her Aunt Miranda, who received them with the gracious remark that the garden was full of flowers and there was no call to bring any. As Miss Miranda showed Rebecca to her room upstairs she said, "Ain't you got your dress on hind side foremost?" Rebecca surveyed the row of pearl buttons running up and down her chest and said cheerfully, "Hind side foremost? Oh, I see! No, that's all right. If you have seven children you can't keep buttonin' and unbuttonin' 'em all the time—they have to do themselves. We're always buttoned up in front at our house. Mira's only three, but she's buttoned up in front, too."

The Monday after Rebecca's arrival in Riverboro she started to school in Riverboro Centre, a mile away. Mrs. Rigg's clever pen has given a vivid picture of an old-fashioned New England village school, where nobody studied the same book with anybody else, and everybody had his own particular fund of learning. Rebecca was in the same reading class with two older boys preparing for Wareham Academy. She recited arithmetic, her weak point, with a small, lisping Simpson child, "Thuthan." Emma Jane Perkins, her special confidante and playmate, was her partner in geography, and she recited history with Alice Robinson's class. It should be added that Rebecca could easily have left the history class far in the rear, except that such progress would necessitate her reciting with Seesaw Simpson. This youth had earned his remarkable name through his fondness for changing his mind, for his playmates rightly

considered his baptismal name of Samuel inappropriate for one who never could come to a decision. Opposites are often mutually attracted, but in the case of Seesaw and Rebecca the attraction was entirely one-sided. She despised the pale, round-shouldered, stammering Seesaw, and he was fascinated by the energetic, dark-eyed little maid who certainly knew her own mind on all occasions.

Amid such surroundings Rebecca began her ascent of the ladder of learning. She knew that she must learn all she could so that some day she might help to pay off a hateful mortgage that rested on Sunnybrook Farm. It was this knowledge that helped her to endure the restrictions and commands of her grim Aunt Miranda, for she usually fell far short of that austere lady's standards. "She continually forgot and started up the front stairs because it was the shortest route to her bedroom; she left the dipper on the kitchen shelf instead of hanging it up over the pail; she sat in the chair the cat liked best; she was willing to go on errands, but often forgot what she was sent for; she left screen doors ajar, so that flies came in; her tongue was ever in motion, she sang or whistled when she was picking up chips; she was always messing with flowers, putting them in vases, pinning them on her dress, and sticking them in her hat; finally, she was an everlasting reminder of her foolish, worthless father." But had Miss Miranda only known it, it was the fact that Rebecca was not all Sawyer that saved her from being commonplace. The stars that presided over her destiny decreed that she should inherit her father's graces but none of his weak points.

The effect of Rebecca's personality on Miss Dearborn, her teacher, and on her playmates is well brought out in the chapter describing a special day program. Special programs were held on Friday afternoons, and they were usually periods of anguish for teacher, pupils and parent alike. The imaginative Rebecca brought about radical changes, and the program for this particular Friday seemed so promising that some of the more important adults of the village were invited to attend. Rebecca and Emma Jane Perkins had learned an interesting dialogue, lisping Susan Simpson had been taught a poem in which she took the part of a lisping child, and there were other good features. In the morning Rebecca and Living Perkins were commissioned to decorate the blackboard, and when Rebecca drew a beautiful American flag that looked exactly as if it were fluttering in the breeze the teacher asked the pupils to give her a good hand-clapping. Then they all stood up and sang "Three Cheers for the Red, White and Blue," and all pointed to the flag when they came to the chorus.

Our little heroine went home to lunch that day in a very exalted mood, for never before in her short life had she been so praised and applauded. She found the brick house deserted, and on the dining room table a note from Aunt Jane saying that the sisters had gone to a neighboring village. Flying up

to her bedroom, she saw on the bed a pretty pink gingham dress that kind Aunt Jane had finished that morning. There was no opportunity to ask leave, and she decided to wear the dress without permission, for this was a grand occasion, "almost like a Sunday School concert." Then she put on the new dress and her best shoes, and unbraided her pretty dark hair, letting it fall in waves and tying it back with a ribbon. She completed her toilet by getting out her pink parasol, the most precious thing she possessed. As she had to take the part of a city girl in the dialogue with Emma Jane, she decided that the parasol would be entirely appropriate. It was a transformed Rebecca who started back to school that afternoon—a girl with glowing cheeks and sparkling eyes. "Rebecca Randall," exclaimed Emma Jane when she saw her, "You're handsome as a picture!" As for the entertainment, it was a success from start to finish. The mothers for once did not have to blush for shame at their children's failures, for nobody forgot his "piece," and nobody broke down. Rebecca's magnetism and enthusiasm dominated everything, and though she did not put herself forward, she seemed to lead them all.

The reception the happy child received on reaching home that afternoon is typical of a good many episodes in Rebecca's career in



MISS MIRANDA ABOUT TO FREE HER MIND

the brick house. "Step right in here, Rebecca," were the words that greeted her as she came face to face with Miss Miranda. Then followed a scene that was the anticlimax of that eventful day. Her sins were

enumerated one by one—that she had worn her good dress without permission, used the front stairs to go to her room, left the screen out of her window, never cleared away her lunch dishes, and left the side door unlocked from half past twelve to three o'clock. In fact, the scolding that she received was so severe that she crept to her room convinced that life was an utterly joyless thing. As she lived through the scenes of the day she decided she could bear her aunt no longer, and after putting on her oldest clothes she climbed out of her window and slid down to the ground by way of a lightning rod, porch and woodbine trellis. Though it was raining hard she made her way to the home of Uncle Jerry Cobb, who had never ceased to love her since the day he drove her to Riverboro. If you want to know how he talked her out of her foolish plan to go back home, and how he smuggled her into the brick house that night without Miss Miranda's knowledge, you must read Mrs. Riggs' book. As to the effects of Miranda's discipline, hear the dialogue that took place the next day:

"I never see a child improve in her work as Rebecca has today," remarked Miranda Sawyer to Jane on Saturday evening. "That settin' down I gave her was probably just what she needed, and I dare say it'll last for a month."

"I'm glad you're pleased," returned Jane. "A clinging worm is what you want, not a bright, smiling child. Rebecca looks to me as if she'd been through the Seven Years' War. When she came downstairs this morning it seemed to me she'd grown old in the night. If you follow my advice, which you seldom do, you'll let me take her and Emma Jane down besides the river tomorrow afternoon and bring Emma Jane home to a good Sunday supper. Then if you'll let her go to Milltown with the Cobbs on Wednesday, that'll hearten her up a little and coax back her appetite. Wednesday's a holiday on account of Miss Dearborn's going home to her sister's wedding, and the Cobbs and Perkinses want to go down to the Agricultural Fair." After all, there is an Aunt Jane in this world for every Miranda.

Three years passed and Rebecca was ready to enter Wareham Academy. In those three years she learned many lessons about self-control, thoughtfulness and similar qualities supposed to be lacking in a Randall. Several milestones marked her course, such as the day when she and Emma Jane sold soap in order to get a premium for the luckless Simpson family. The premium, a banquet lamp with a gorgeous shade, was acquired after Rebecca had interviewed a delightful and generous gentleman named Adam Ladd, who ordered three hundred cakes on the spot. Mr. Ladd, by the way, became Rebecca's loyal friend, and the reader suspects that he married her after she grew up. Another milestone was the visit of the Syrian missionaries to the brick house. It may sound improbable, but through Rebecca's "interference" Miss Miranda entertained two missionaries and

their two children overnight, and had refreshments in the evening for a few church members who called.

Wareham Academy opened up a new world to Rebecca. She was accompanied there by the faithful Emma Jane, who would have gone to China to school to be near Rebecca. The girls roomed together at the academy during the winter months, and traveled on the cars between Wareham and Riverboro when the weather was mild. In subjects like Latin translation, history and English literature Rebecca did so brilliantly that she became a marked character in the school, and in the spring of her second year she was elected assistant editor of the "Wareham School Pilot."

Mr. Ladd sometimes came to Wareham to see his protege, and she also enjoyed the special friendship of the gifted literature teacher, Miss Maxwell. As for Rebecca, she adored Miss Maxwell with a fervor that cannot be described. These joys of school life were offset, about the middle of her course, by financial troubles at the brick house and at Sunnybrook Farm. Rebecca had to wear turned and made-over clothes day in and day out, and the fifty dollars she won as a prize in a composition contest had to be used to pay the interest on the hateful mortgage. Rebecca wrote a poem about this mortgage one day:

"Will you pay a little faster?" said the mortgage to the farm;

"I confess I'm very tired of this place."

"The weariness is mutual," Rebecca Randall cried;

"I would I'd never gazed upon your face."

By dint of hard work Rebecca completed her course in three years, and was elected president of the graduating class. Her commencement dress was a marvel of ingenuity, for, seeing nothing else to do, she and Emma Jane raided the Perkins attic and brought out of it yards of white cheesecloth. Though she was not graduating, Emma Jane had to sing with the school, and since she was to wear a white dress, she determined to have it a duplicate of Rebecca's. The dresses were made lovingly by means of pin-tucking, hem-stitching, tatting and similar forms of needlework, and the president of the class, on commencement day, was truly a joy to the eye. As she read the class poem, "Makers of Tomorrow," her personality made the school-girl effort seem like the verse of a Milton. And when she came forward to get her diploma, Jeremiah Cobb nearly wore out the pew in which he was sitting, in his efforts to express his satisfaction over the occasion.

Rebecca had expected to go to Brunswick with Miss Maxwell the day after graduation, but the serious illness of her Aunt Miranda called her back to the brick house. Then came a hard, weary summer, which she bore patiently because of her gratitude for what the cross old aunt had done for her. After a few weeks Miranda grew stronger, and Rebecca began to get ready for her postponed visit. On the day she expected to leave,

word came that her mother had hurt herself badly, and the Brunswick journey had to be abandoned. Rebecca was sorely needed at Sunnybrook Farm, for Hannah had been married for some time. During two months of washing, ironing, cooking and taking care of the children our heroine learned the beauty of self-denial and unselfishness, and she learned, too, that though life is often hard, it is a good thing to be alive. But this time of trial, like other troubles, came to an end.

One day Rebecca received word that Aunt Miranda was dead. Within an hour after the message came she was on her way to Riverboro, and when she arrived at the brick house she heard from poor Aunt Jane that Miranda had willed her the house and furniture and the land about as far as one could see. Later, as she sat in the quiet doorway, a sense of gratitude and peace came over her.

"This was home; her roof, her garden, her green acres, her dear trees; it was shelter for the little family at Sunnybrook; her mother would have once more the companionship of her sister and the friends of her girlhood; the children would have teachers and playmates.

"And she? Her own future was closed-folded still; folded and hidden in beautiful mists; but she leaned her head against the sun-warmed door, and closing her eyes, whispered, just as if she had been a child saying her prayers: 'God bless Aunt Miranda; God bless the brick house that was; God bless the brick house that is to be!'"

**The Birds' Christmas Carol.** This is another of Kate Wiggins Riggs' delightful child stories. It is about a little girl who came on Christmas morning into the home of the Bird family. Her happy mother, as she listened to the boy choir of the church next door singing, "Carol, brothers, carol," decided that Carol was just the name for a child born on Christmas Day, and so Carol Bird became the new baby's name. As she was the first girl in a family of four children, Carol was considered the dearest little sister in all the world, and her birthdays were occasions for wonderful celebrations. But she was not strong, and in the years following her fifth birthday she became a helpless invalid. The room in which she was born was made as beautiful as could be, and was so filled with windows it looked like a conservatory. Here she was shut in day after day, but when she was strong enough she used to love to look out through the back windows on the alley below, for it contained the house of the nine Ruggles children. Never was there a more obliging family of children. When Carol was feeling well they played circus and other noisy games, but when she had a headache they substituted deaf and dumb asylum and were as quiet as mice.

A few days before her tenth birthday Carol's beloved Uncle Jack arrived from London to spend Christmas with her. As she talked over her plans for the day she told him she wanted to give that Christmas to the Ruggleses, and have them eat a real Christmas dinner in her own room. Uncle Jack was to

sit at the head of the table and Mamma Bird was to be there to help, but Papa Bird and the boys were to eat down stairs, so as not to embarrass the nine Ruggleses. Of course every one agreed to Carol's plan, and her invitation caused wild excitement in the little house in the alley. Mrs. Ruggles had her brood up and at the breakfast table by seven o'clock Christmas morning, for she had to see about their costumes and give them some necessary lessons in manners before half past five. Sarah Maud was the oldest, and Baby Larry the youngest; in between were Peter, Susan, Kitty, Peoria, Cornelius, Clem and Eily. They all looked exactly alike, except that some of them had more freckles than the others.

After breakfast there ensued such a scrubbing and dressing up as the little house had never before witnessed. Kitty's red hair was curled in thirty-four ringlets, Susan and Eily wore theirs in two braids, Sarah Maud rejoiced in one pig-tail, and Peoria's hair stuck out on all sides. As for the boys, Larry had a suit made out of a red plaid shawl, and Peter's purple necktie was adorned with a wonderful green glass breastpin.

For an hour before it was time to go the Ruggleses were given a severe course in manners. As the nine children took their seats in a semicircle about her, Mrs. Ruggles endeavored faithfully to show them how to behave at their first dinner party. After they were coached in the formalities of entering a room properly, and Sarah Maud had learned by heart a polite speech to explain their lack of hats, the anxious mother turned to one of the boys:

"Now, Cornelius, what are you goin' ter say ter make yerself good com'ny?"

"Do? Me? Dunno!" said Cornelius, turning pale.

"Well, ye ain't goin' to set there like a hump on a log 'thout sayin' a word ter pay for yer vittles, air ye? Ask Mis' Bird how she's feelin' this evenin', or if Mr. Bird's havin' a busy season, or how this kind o' weather agrees with him, or something' like that. .... If they have napkins, Sarah Maud down to Peory may put 'em in their laps, 'n' the rest of ye can tuck 'em in yer necks. Don't eat with yer fingers—don't grab no vittles off one 'nother's plates; don't reach out for nothin', but wait till yer asked, 'n' if you never git asked don't git up and grab it. .... Don't spill nothin' on the tablecloth, or like's not Mis' Bird'll send yer away from the table—'n' I hope she will if yer do! Now we'll try a few things ter see how they'll go! Mr. Clement, do you eat cramb'ry sarse?"

"Bet yer life!" cried Clem.

"Clement McGill Ruggles, do you mean to tell me that you'd say that to a dinner party? I'll give ye one more chance. Mr. Clement, will you take some of the cramb'ry?"

"Yes, marm, thank ye kindly, if you happen ter have any handy."

"Very good, indeed. But they won't give yer two tries to-night, yer jest remember that!"

After a few more suggestions, as to table etiquette, Mrs. Ruggles said, "Now, is there anything more ye'd like to practice?"

"If yer tell me one more thing, I can't set up an' eat," said Peter gloomily; "I'm so cram full o' manners now I'm ready to bust, 'thout no dinner at all."

"Me too," chimed in Cornelius.

"Well, I'm sorry for yer both," rejoined Mrs. Ruggles sarcastically; "if the 'mount o' manners yer've got on hand now troubles ye you're dreadful easy hurt! Now, Sarah Maud, after dinner, about once in so often, you must get up 'n' say, 'I guess we'd better be goin';' n' if they say, 'Oh, no, set a while longer,' yer can set; but if they don't say nothin' you've got ter get up 'n' go. Now hev yer got that int' yer head?" Then came the last injunctions and the parting message—"Whatever you do, all of yer, never forget for one second that yer mother was a McGill."

The Christmas dinner was a joyful success for all concerned. Uncle Jack knew how to make everyone feel at home, and there were no bad breaks in manners. As for the "festal board," it can best be described in the words of Susan: "I declare to goodness, there's so much to look at I can't scarcely eat nothin'!" After every little Ruggles had eaten all that a mere mortal can possibly consume, the door of an adjoining room was opened on the spectacle of a wonderful, glittering Christmas tree. There were useful presents, such as hoods, comforters and dresses, and real presents, like dolls and books and toys, and the Ruggleses thought that this was surely a taste of heaven.

That night, after the house was quiet, a boy soprano in the church next door sang in a sweet and tender voice:

I am far frae my hame,  
I am weary aften whiles  
For the langed-for-hame-bringin'  
An' my Faether's welcome smiles;  
An' I'll ne'er be fu' content,  
Until my e'en do see  
The gowden gates o' heaven  
In my ain countree.

Even while he sang the loving heart of the little girl next door quietly ceased to beat; the "wee birdie in the great house had flown to its home nest in that far countree."

**LITERATURE OF CANADA.** The literature of Canada may be divided into the period of exploration and discovery; period of settlement; pre-Confederation period; period since Confederation.

The period of discovery and exploration begins with the earliest accounts of those who attempted to plant on the North American continent a new civilization. The very beginnings of this literature lie far back in the old French annals. The chief of these works reach down to the very bedrock of Canadian history. The chronicles of Cartier's voyages; Champlain's narratives; the

histories of Marc L'Escarbot and G. Sogard; the writings of Father Hennepin; the annals of Father le Clerq, and the history by Pierre de Charlevoix are the most important. These furnish the basis of the early literature and are the most important source of history. It is as true of Canada as of any other country, that the development of the institutional life of the country colors the literature of any particular period.

Of the later authors who have written of the early period of Canadian history, mention should be made of the following: Douglas's *Old France in the New World* offers a good survey of Canada in the seventeenth century. The romantic story of Quebec is admirably told in Arthur G. Doughty's *Cradle of New France*. Charles William Colby's *Canadian Types of the Old Régime* treats interesting aspects of French colonization. Colonel William Wood's *Fight for Canada* is a popular and thoroughly accurate account of the conflict between England and France. Sir Alexander Mackenzie's *Voyages*, published in 1802, La France's *Exploration of the Country Adjoining Hudson Bay* (1744), Hearne's *Journeys* (1795), Henry's *Narrative* (1809), and Ross' *Red River Settlement* (1856), discuss in most interesting manner the lives and labors of the period of settlement.

The ax of the settler and the pen of the pioneer alike mark the progress of the settlement of this country. One of the earliest native productions was the *History of Canada* by François Xavier. It holds a very important place in the literature of the country. Biband's *History of Canada Under the French Régime* is a work of much value. With the War of 1812 came a list of writers, many of whom are deserving of notice. Auchinleck wrote the *History of the War of 1812* (1855), and Bouchette gave us *British Dominions in North America* (1831). These writings, numerous and varied, belong directly to the period between that of the settlement and the Confederation.

The fur trade has been so extensive and so vitally connected with the development of the country that we may reasonably expect it to wield an important influence on Canadian literature. This influence has persisted to the present day, especially in fiction and poetry. Especially noteworthy are the novels of Sir Gilbert Parker and the poems of William Henry Drummond. Agnes C. Laut's

*Conquest of the Great Northwest* and Dr. George Bryce's *Remarkable History of the Hudson's Bay Company* are valuable books of reference which are also of interest to the general reader.

After the Confederation the great Northwest came into prominence and there grew up a mass of descriptive and historical literature. The *North-west Passage by Land* by Lord Milton and Mr. Cheodle, *Great Lone Land* by Butler, *Highways from Ocean to Ocean* by Cumberland, *Columbia and Canada* by Rae, *Red River Rebellion* by Huyshe, *The Canadian Dominion* by Marshall, *A Sketch of the North-west of America* by Archbishop Taché, *From Ocean to Ocean* by Rev. George Munro Grant, are a few of the many which are beautifully descriptive of the country.

The Confederation period is rife with a new spirit, and the gradual growth of the literature of this period is worthy of careful study. A Canadian national spirit first asserts itself, and perhaps for the first time a truly national literature crystallizes. Heroic achievement, appreciation of sacrifice, scenery and just pride in home and native land, inspire the author and poet. Not alone do we see the kind of literature which expresses itself in history and adventure and travel, but the literature as expressed in the educational, scientific and political journals of the day deserves attention. The various historical societies are producing a literature distinctly Canadian, yet of such importance that we may say it is sure of universal acknowledgment.

Biography has been devoted mainly to political subjects, especially the statesmen of the period immediately preceding and following Confederation. Among the best of these are Joseph Pope's *Memoirs of Sir John Macdonald*, Sir John Bourinot's *Lord Elgin*, D. C. Scott's *John Graves Simcoe*, Charles Lindsey's *William Lyon Mackenzie* and A. D. de Celles' *Papineau and Cartier*.

In fiction Canada was for a long time far behind the rest of the English-speaking world. There were authoritative historians and famous poets long before any novelists were known outside her borders. Towards the close of the nineteenth century Canadian novelists rapidly came to the front and many of them now rank among the best of English writers. Sir Gilbert Parker easily stands first among contemporary Canadian novel-

ists. Among others who have a secure place are the following: Joanna E. Wood, Sara Jeannette Duncan (Mrs. Everard Cotes), Grant Allen, Robert Barr, P. J. O. Chauveau, James de Mille, Margaret Marshall Saunders, William Kirby, Charles G. D. Roberts and Ralph Connor (Rev. Charles Gordon).

In poetry Canada deserves a high place. Louis Honoré Fréchette, who received the laureated approval of the French Academy, and who has been termed the chief of the French-Canadian authors, is, perhaps, the greatest writer produced in this country. Charles Heavysege was the author of *Saul*, probably the most remarkable poem ever written by a Canadian. William Kirby, author of *The Golden Dog*, a fascinating romance of early Quebec, also wrote excellent verse. Charles Sangster, Alexander McLachlan, John Reade and Isabella Valancey Crawford hold high rank among the earlier poets of English-speaking Canada.

Other poets of note are J. J. Proctor, Isidore G. Aseher, Helen M. Johnson, William Murdoch, Evan McCall, Alexander McLaughlin, Jean Blewett, S. Frances Harrison, William D. Lighthall, Duncan Campbell Scott, Charles G. D. Roberts, Harriet Annie Wilkins, Charles Mair, Bliss Carman, Archibald Lampman, William Henry Drummond and Robert W. Service.

No account of Canadian literature would be complete without reference to two remarkable men, Thomas Chandler Haliburton and Goldwin Smith. Each in his field won a place second to none: Haliburton as a humorist, Smith as publicist. Haliburton's stories, under the pen name of Sam Slick, won for him the place of Canada's greatest humorist. Had he known how to construct a plot he would certainly rank as a great novelist. But he knew human nature in all its phases, and the characters he created live and talk naturally. To read his books merely for their humor is to lose much of their value. Goldwin Smith, on the other hand, as teacher, author and lecturer gained world-wide fame for his influence for progress and sanity, especially in political affairs. Though his views were not always those of the majority, his high standards of thought and action won for him a unique position in the affections of Canadians.

Canadian literature has won a distinct place as one of the productions of the English-speaking race. For a more extended



view of the subject read Lareau's *History of the Literature of Canada*, Dewart's *Selections from Canadian Literature* and G. Mercer Adams' *Outline History of Canadian Literature*.

**Related Articles.** The following list contains the names of important Canadian writers whose biographies occur in these volumes:

|                       |                       |
|-----------------------|-----------------------|
| Allen, Grant          | Laut, Agnes C.        |
| Bengough, John W.     | Lighthall, William D. |
| Bourinot, John G.,    | McCrae, John          |
| Sir                   | Parker, Gilbert, Sir  |
| Bryce, George         | Roberts, Charles      |
| Carman, Bliss         | G. D.                 |
| Cotes, Sara           | Ross, Alexander       |
| Jeannette             | Saunders, Margaret    |
| De Milie, James       | M.                    |
| Drummond, William H.  | Service, Robert W.    |
| Duncan, Norman        | Seton, Ernest T.      |
| Gordon, Charles W.    | Smith, Goldwin        |
| Haliburton, Thomas C. | Traill, Catherine P.  |

**LITHIUM**, a metallic element of silver-white luster, that quickly tarnishes in the air. Although lithium may be cut with a knife, it is scarcely as soft as potassium of soda. It fuses at 180° C. and takes fire at a slightly higher temperature. Lithium, which is the lightest of all known metals, floats upon rock oil. It is distributed very widely, but always in small quantities. It forms salts similar to those of potassium and sodium, and these are used extensively in medicine. Effervescing lithium water is sometimes used in place of soda or potash water. The citrate of lithia, whose properties are similar to those of the carbonate, is also used by physicians. On account of the splendid red color they impart to flame, some of the lithium compounds are used in the manufacture of fireworks.

**LITHOGRAPHY**, *lithog'ra fy*, the art of artistic printing from specially prepared stones. The stone used is a fine-grained limestone of light gray color and is generally known as *lithograph stone*. That of the best quality is obtained in Bavaria, where most of the world's supply is secured.

Lithography is based on the principle that grease and water will not mix, and the preparation of the stone consists in so treating the surface that the portion containing the drawing will retain ink, while the remaining portion will not. The stones are cut into slabs 4 inches thick and varying in size from 6 by 8 inches to 44 by 62 inches. The surface of the stone is ground to a grain resembling that of fine drawing paper or polished with pumice stone, according to the style of print to be made. If the picture is to be drawn with a crayon, the ground surface is used, but if it is to be worked on with a pen, the polished surface is required.

After the stone is prepared, the picture is drawn upon it with a lithograph crayon, just as it appears in the copy, except that it is reversed, like the face of a type. The drawing is then washed with a solution of gum arabic and nitrate of soda, to keep the grease from spreading and to render the other portions of the surface more porous and more capable of absorbing water. After the coating of acid and gum is dried, the stone is washed with water, then with turpentine, which removes all traces of the drawing except the grease from the crayon. The turpentine is then removed by washing with water, and the stone is ready for use. When the picture is engraved on the stone, the work is done in a manner similar to that of engraving steel or copper. See ENGRAVING.

In printing, the stone is first wet with a sponge. The water does not stick to the greased portion constituting the picture, so that part of the surface remains dry while the other is wet. When ink is applied the process is reversed. The ink sticks to the greased surface in such a way as exactly to reproduce the drawing when the paper is pressed upon it, while it leaves the wet surface clean. The printing is done in a cylinder press especially prepared for this work, and transfer plates, made by transferring the picture from the stone to a metal plate, are usually employed. By this means a number of pictures can be impressed upon the same plate, so that by using a large sheet of paper several pictures are produced at each revolution of the press.

**Color Lithography.** This is the process of producing lithograph pictures in the natural colors of the object and differs from ordinary lithography only in the elaboration of the process. First, a good plate or stone is made, which contains the complete outline of the picture. This plate contains registering marks on each of its margins, and all of the other plates must be made to register accurately with it. Each color requires a special plate, and the final effect is produced by printing in the right order the different colors required. This order is usually yellow, red, brown or gray, blue and then the tints of any other colors necessary.

Lithography reproduces art work of a high order of excellence and is often employed to reproduce in a comparatively inexpensive way paintings and other works of the old masters. It is also used in the production

of colored pictures when results finer than those which halftones can produce are required.

**LITHOTOMY**, *li thah'to mi*, in surgery, the operation for the removal of stones from the gall bladder. When properly performed, the operation seldom requires more than three minutes, and in favorable cases the wound heals in the course of a month.

**LITHUANIA**, a region in Central Europe, south of the so-called Baltic provinces, which formed a grand duchy in the eleventh century, became united to Poland in the fourteenth, and on the dismemberment of the latter in 1795 was divided between Russia and Prussia. The greater part of Lithuania was annexed to Russia, and in 1849 an edict was issued forbidding the official use of the old name, "Northwestern Country" being substituted. A determined effort was made to destroy the Lithuanian language, both spoken and written, but it persisted in spite of the attempts at Russianizing the people.

At the outbreak of the World War, in 1914, Russian Lithuania embraced the governments of Suwalki, Grodno, Vilna, Kovno, Minsk, Vitebsk, and part of Courland, the combined area of which was 102,632 square miles. In January, 1918, after the overthrow of the czar, an independent Lithuanian state was proclaimed, but subsequently, by the Treaty of Brest-Litovsk, 80,000 square miles of the territory were erected into a German principality. Germany was forced to renounce this treaty in November, 1918, and on the last day of that month a Lithuanian republic was announced at Riga. The boundaries could not then be definitely decided because of chaotic conditions in the Baltic regions of the former empire.

The Lithuanians, in common with the nationalities along the Baltic, were forced to fight Bolshevik regiments sent against them by Lenine and Trotzky, and throughout the spring of 1919 conditions were very unsettled. Whether Lithuania would become a part of the new Polish state, unite with Livonia or be a separate nation was undecided. Vilna, capital of Lithuania in the fourteenth century, was captured by Polish troops in April, in their campaign against the Bolsheviks. It was announced that the Polish military operations in Lithuania were for the purpose of protecting the people.

The Lithuanians are physically well developed, and have light hair, blue eyes and

white skin. They are a branch of the Aryan family and claim to be the most ancient race in Europe. Between 1905 and 1915 about 172,000 Lithuanians emigrated to America.

**LIT'MUS**, a peculiar coloring matter, procured from lichens. Paper tinged blue by litmus is reddened by the feeblest acids and hence is used as a test for the presence of acids. Litmus paper which has been reddened by an acid will be turned blue again by an alkali. Hence the paper is indispensable in chemical laboratories, especially in all analyses.

**LITTLE FALLS**, N. Y., a city in Herkimer County, twenty miles southeast of Utica, on the Mohawk River and the Erie Canal and on the New York Central, the West Shore and other railroads. It is in a grazing region, and exports considerable dairy products. The river here flows through a rocky defile over many little falls and affords good water power for extensive manufactures. These include great quantities of knit goods, paper, carriages, leather, machinery, foundry and creamery products and other articles. The city has a public library and a city hospital. The place was settled about 1770. The settlement was destroyed by Indians and Tories in 1782, but was rebuilt by a colony of Germans eight years later. It became a city in 1895. Population, 1910, 12,273; in 1917, 13,653 (Federal estimate).

**LITTLE ROCK**, ARK., the capital of the state and its largest city and the county seat of Pulaski County, situated in the geographical center of the state, about 130 miles southwest of Memphis, Tenn., on the Arkansas River and on the Chicago, Rock Island & Pacific, the Saint Louis Southwestern and two lines of the Saint Louis, Iron Mountain & Southern railroads. The city is built on a rocky bluff about fifty feet above the river. The new capitol is the most prominent building, and there are, besides this, Federal buildings, a state arsenal and penitentiary, a county courthouse and state supreme court and Carnegie libraries and Saint Andrews' Cathedral. The city contains the Marquand, supreme court, state and collegiate libraries. Among the educational institutions are the Philander Smith College (Methodist), Arkansas Baptist College, Shorter College (colored), the Arkansas Military and other academies and state schools for the blind and deaf. The charitable institutions in-

clude a Confederate soldiers' home, a state asylum for the insane, the Saint Vincent's Infirmary, the Old Ladies' Home, a county hospital and a children's home. There are over 400 acres in public parks.

Cotton is the principal agricultural product, and fruit growing, truck farming and coal mining are also carried on. There are various industrial establishments, including cottonseed oil mills, foundries and railroad shops, granite quarries, flour mills, brick and tile works and other manufactories. The place was settled in 1814 and was known as Little Rock, in contrast to Big Rock, one mile above the city, which is now the site of Fort Logan H. Roots. It was made the seat of the territorial government in 1820, was incorporated as a town five years later and was chartered in 1835. Population, 1910, 45,941; in 1917, 58,716 (Federal estimate).

**LITURGY**, *lit'ur jy*, the form of worship in the celebration of the Lord's Supper, which is in general the same in all Churches. The first part of the service consists of Scripture reading, sermon and prayers; the second, of prayers and the offering of the consecrated bread and wine. The Book of Common Prayer contains the form of communion service used in the churches of the Anglican communion. The liturgies of the Eastern churches have been named the *Syrian rite*, still used by the Maronite Church, the *Persian rite*, now used by the Nestorians; the *Byzantine rite*, used in many parts of the world and by the Greek and Russian churches; the *Egyptian rite*, a version of which is used by the Copts. The Western liturgies are the Roman mass, called the Latin liturgy, and that of Protestant churches, known as the vernacular, which grew out of the Reformation.

**LIU-CHIU, LU-CHU, LIU-KIU**, *lyoo kyoo*. See LOO-CHOO.

**LIVE-FOREVER**. See HOUSELEEK.

**LIVER**, the gland which secretes bile. In man, the liver is situated just below the diaphragm, on the right side, extending across the middle line of the body toward the left. (For picture, see illustration accompanying the article ABDOMEN.)

From its position it is liable to compression and injury. In its general form the liver is flat, broad and thick toward the right side, becoming narrow and thin toward the left. Its upper surface is convex or arched and fits into the concave surface of the dia-

phragm, while its lower surface is irregularly divided into lobes, five in number, separated by clefts, or fissures. In texture it is soft and easily crumbled. Its color is a dark reddish-brown.

An important function of the liver is the separation of waste matter from the blood, and the changing of sugar into a starch called *glycogen*. The liver also makes bile. The liver is supplied with blood by the hepatic artery. The portal vein carries to it the venous blood from the intestines, spleen and stomach, and after this blood circulates through the cells of the liver it is carried by the hepatic veins to the inferior vena cava. The bile secreted in the liver is carried by the hepatic duct to the gall bladder, a little pear-shaped sac on the under side of the liver, where it is stored when digestion is not going on; during digestion it is poured directly into the duodenum.

**Related Subjects.** Consult the following titles for additional information:

Bile                      Circulation              Digestion

**LIVERMORE, MARY ASHTON RICE** (1821-1905), an American reformer, born in Boston. She early was active in the anti-slavery and temperance reform movements and during the Civil War gained special fame by her unselfish relief service for the Union soldiers. After the war she lectured upon moral and social problems, and was a powerful advocate of temperance and woman suffrage. She was at one time editor of a woman's journal in Boston and was the author of numerous books.

**LIVERPOOL, ENGLAND**, the second city and the second seaport of the United Kingdom, in size next to London. It is situated on the River Mersey, three miles from its mouth, thirty miles southeast of Manchester and 201 miles northwest of London.

The city is built on a bend in the river, which gives it a semicircular water front between six and seven miles in extent. From this level the land rises gradually to an altitude of 250 feet. The main streets lead from the water front to different parts of the city. The newer and better part of the town is on the highland back from the river. Here are located some of the finest public buildings in the world. Chief among these is Saint George's Hall, constructed from the profits arising from the docks, and used for various purposes. It contains a large audience room, which has one of the largest

organs in the world; it also has other apartments used for public gatherings and educational purposes. Around this building or near by are located the free library, the Walker Fine Art Gallery and the Picton Lecture Hall, with a large reference library, the Lime Street railroad station and the great theaters. The town hall is a fine building, begun in 1754. The city maintains a large number of hospitals and other charitable institutions, designed to meet all the wants of its inhabitants. Nearly all of the public utilities, such as waterworks, lights, tramways or street cars, are owned and operated by the municipality.

Liverpool has a more extensive foreign commerce than any other port in the United Kingdom, and the docks, which extend along the river for nearly seven miles and contain over twenty-four miles of wharfage, are the chief objects of interest. Near the center of the line of docks is an immense floating dock, supported on pontoon boats. This is 2,060 feet long and is connected with the mainland by eight bridges. Here most of the passenger steamers land. The docks have been constructed at great expense and include basins which are enclosed by gates, so that vessels loading or unloading are not affected by the change of tide. Nearly all of the cotton, grain, dressed meat and other produce shipped from Australia, Canada and the United States to England enter through the port of Liverpool; likewise most of the exports from the United Kingdom to these countries leave from this port. Population, 1914, 763,926.

**Related Articles.** Consult the following titles for additional information:  
Board of Trade      Dock      Mersey River

**LIVERWORTS**, *liv'ur wurts*, a group of plants forming one of the two suborders of the *bryophytes*, the other including the mosses. Liverworts grow in various places, though they are commonly found in moist regions. The name refers to the shape of the plants, which are flat, lobed and leaf-like, somewhat resembling the liver of the human body. Liverworts are attached to objects by small rootlets. See BRYOPHYTES.

**LIVINGSTONE**, *liv'ing stun*, DAVID (1813-1873), a missionary and African traveler, born at Blantyre, in Scotland. Under the auspices of the London Missionary Society he went in 1840 as medical missionary to South Africa, where he joined

Robert Moffat. His first station was in the Bechuana territory, and here he was associated for nine years with Moffat, whose daughter he married. Having learned from the natives that there was a large lake north of the K a l a h a r i Desert, he explored the region and discovered Lake Ngami. Three years later, in 1852, he undertook another expedition, exploring the upper lakes of the Zambezi River and arriving at Loanda, on the Atlantic coast, in 1854. Returning to Livinganti, he struck east-



ward from there in 1855, tracing the Zambezi to the Indian Ocean and thus crossing the entire continent. The record of this journey is found in his *Missionary Travels and Researches in South Africa*, published in London in 1857.

In 1858 he was placed in command of an expedition for the exploration of Eastern and Central Africa, and during this expedition he discovered lakes Shirwa and Nyassa. Seven years later he started out to set at rest the question of the sources of the Nile, and from this time until his death he was engaged in laborious explorations in the lake region of South Africa, especially to the westward of Nyassa and Tanganyika, where he discovered lakes Moero and Bangweolo. For about three years no communication from him reached the outer world, and doubts regarding his safety were set at rest only when it was known that Henry M. Stanley, the correspondent of the *New York Herald*, had seen and assisted him at Ujiji, on Lake Tanganyika. They parted in March, 1872, Livingstone going to explore the southern end of Lake Tanganyika and Stanley proceeding to Zanzibar. Another year's hardships completely exhausted Livingstone, and he died in May, 1873, near Lake Bangweolo. His body was taken to England and was buried in Westminster Abbey. He was the author of *Missionary Travels and Researches in South Africa* and *The Zambesi and Its Tributaries*. Consult Stanley's *How I Found Livingstone* and Hughes's *David Livingstone*.

