

D  
570  
.309  
T6

UC-NRLF  
  
\$C 14 987

AMERICAN ENGINEERS  
BEHIND THE  
BATTLE LINES IN FRANCE  
—  
TOMLIN

YE 03346

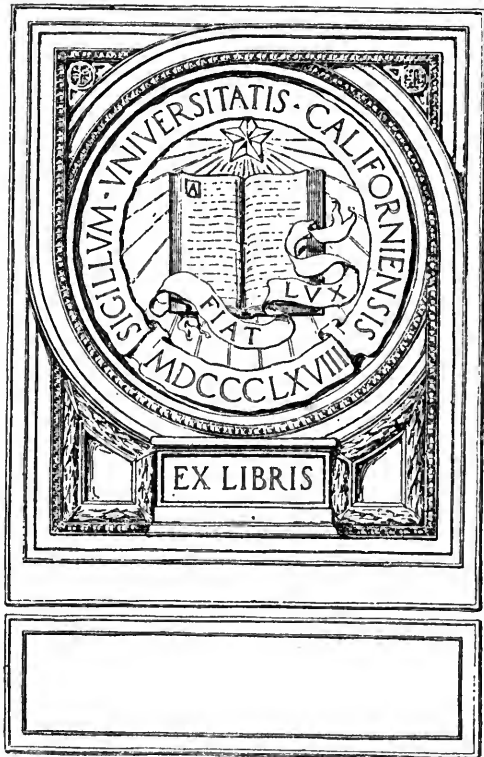

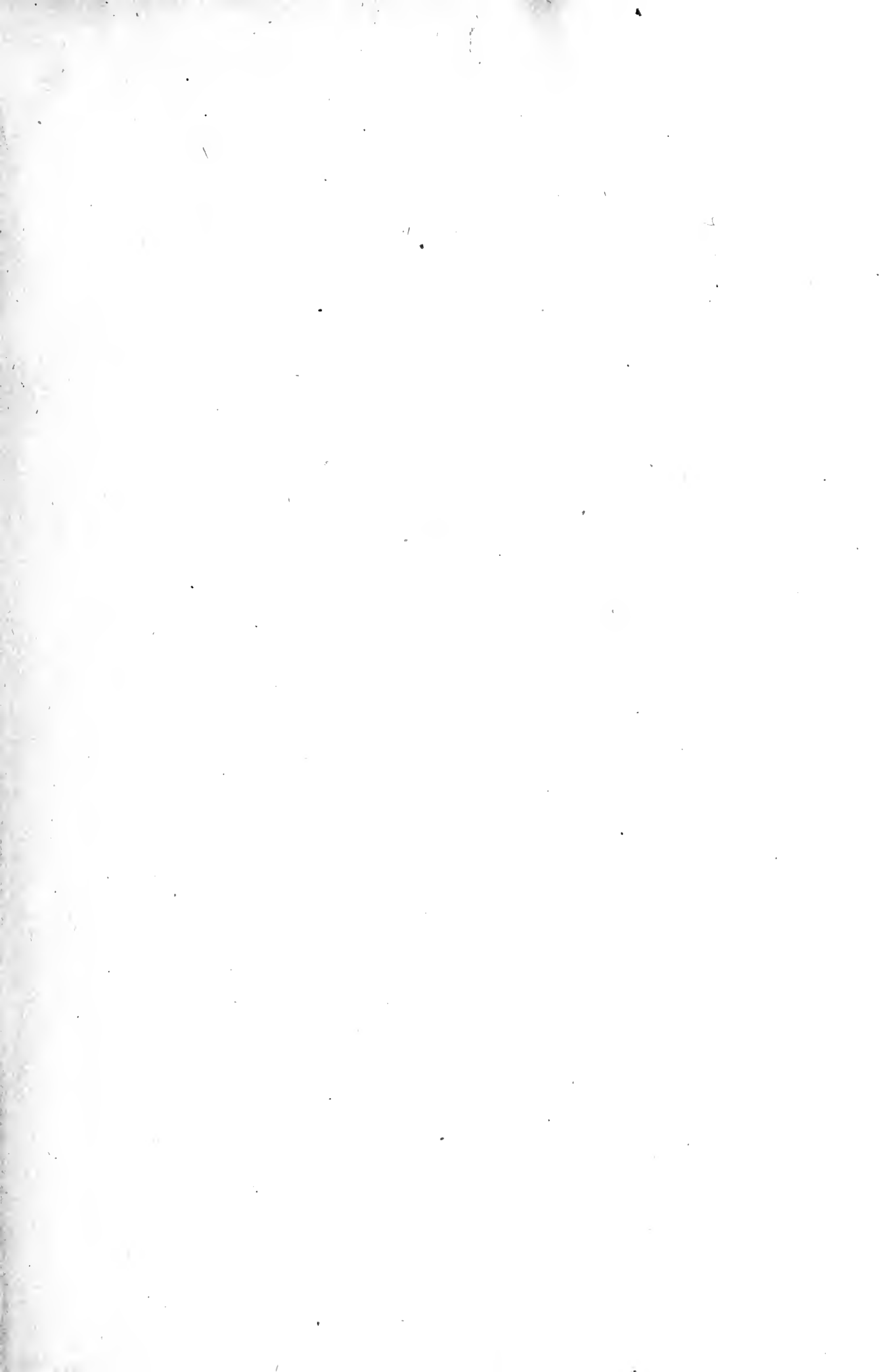

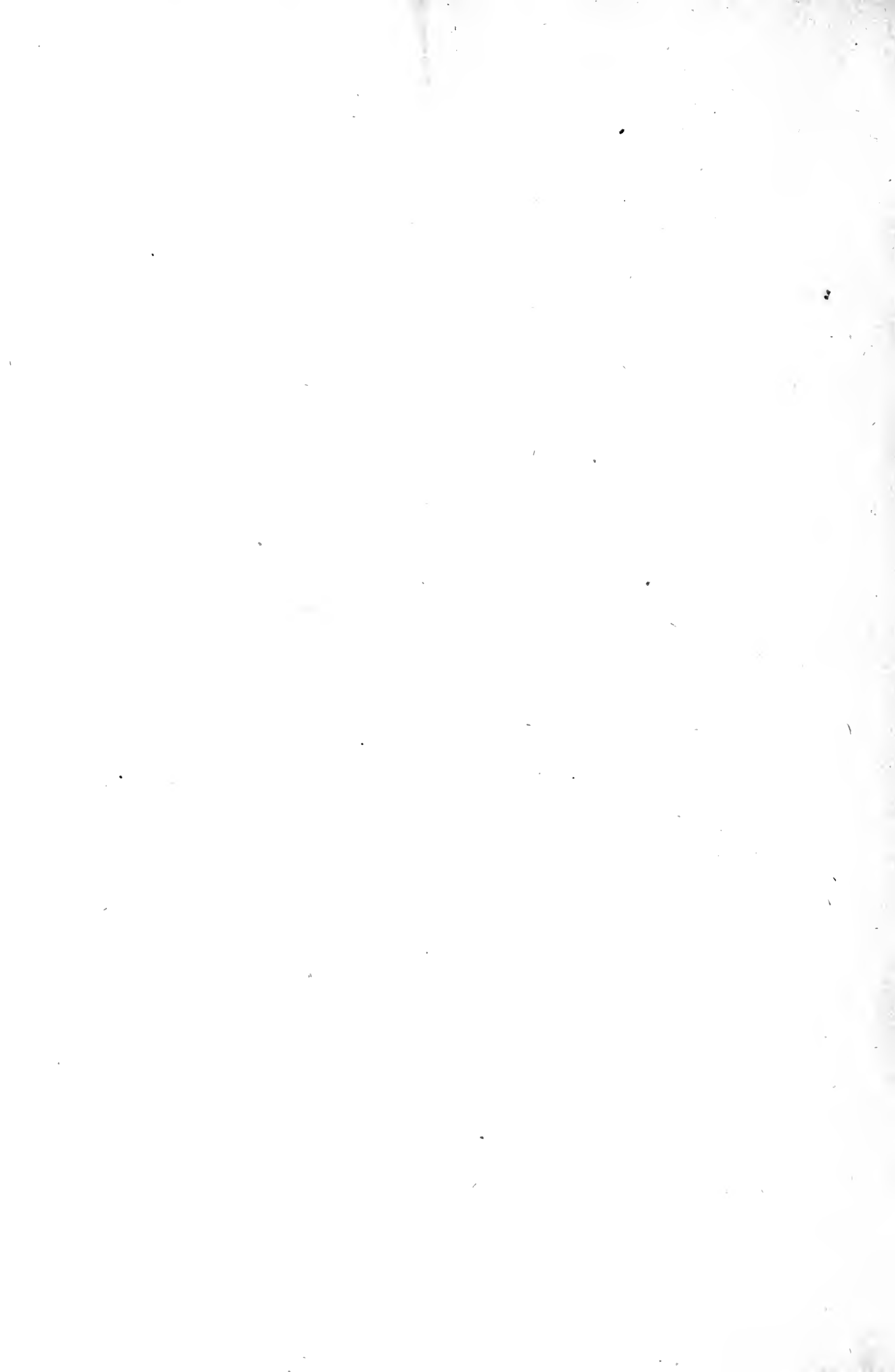

American Engineers  
Behind the Battle Lines in France

Digitized by the Internet Archive  
in 2008 with funding from  
Microsoft Corporation

# American Engineers Behind the Battle Lines in France

By

ROBERT K. TOMLIN, Jr.

War Correspondent for the McGraw-Hill Publications

*FIRST EDITION*

PUBLISHED BY  
ENGINEERING NEWS-RECORD  
—  
McGRAW-HILL BOOK COMPANY, Inc.  
SOLE SELLING AGENTS  
239 WEST 39<sup>TH</sup> STREET, NEW YORK  
1918

D570  
.309

COPYRIGHT, 1918, BY THE  
MCGRAW-HILL BOOK COMPANY, Inc.

1918  
MCGRAW-HILL



## PREFACE

---

LAST December when Mr. Tomlin, formerly managing editor of *Engineering News-Record*, went to France as war correspondent of the McGraw-Hill engineering publications, he went as a pioneer. No other technical publication in this country was similarly represented at the front, and though he went armed with letters of introduction and the authority of our War Department to get and print whatever the British and French censors deemed proper, there was no certainty that the busy officers directing the great engineering programs would have time to tell him their stories, or that the censors would permit him to publish them. Mr. Tomlin writes in glowing terms, however, of the full cooperation he has had from officers and censors. Everywhere he has been shown over the work and been given as much information as could be consistently done—and everywhere there has been appreciation of the journalistic need for prompt attention.

The first articles, of course, were largely general. The work was just being organized. The first, second and fourth articles are confined to the organization of road building, railway yard and terminal development, and light railway construction, and an outline of some of the problems to be solved, and the third, also in the general preliminary class, relates to the inspection of French quarries by American engineers. In the fifth we first see the engineers actually on construction, in the varied activities of the railway regiment. In the remaining articles, with the exception of that on "Water-supply at the Front in France," which again tells only of the organization and the general problems—we also get details. Besides the views of road building and the light railways at close range, supplementing the first and fourth articles, we have an article on the industrial problems at a shrapnel plant, one on map-making in air and on the ground, one on the construction of an advance depot and two on the work of the army engineer school—which is far in advance of anything of the kind in this country before this year.

The articles are here gathered together in book form because of the great interest they have aroused, and the assistance they have rendered army officers engaged in this country in training men for the front.

ENGINEERING NEWS-RECORD.



## CONTENTS

---

	PAGE
PREFACE . . . . .	v
AMERICAN ROAD-BUILDING WORK IN FRENCH WAR ZONE ORGANIZED . . . . .	1
AMERICAN RAILWAY YARD AND TERMINAL DEVELOPMENT IN FRANCE PRESENTS MANY NEW PROBLEMS . . . . .	4
FRENCH QUARRIES INSPECTED BY U. S. ENGINEERS . . . . .	6
LARGE MILEAGE OF LIGHT RAILWAYS WILL SERVE AMERICAN TROOPS AT THE FRONT . . . . .	9
RAILWAY REGIMENT HANDLES JOBS OF ALL KINDS IN FRANCE . . . . .	13
HUMAN PROBLEM THOUGHT OF PARAMOUNT IMPORTANCE IN PARIS SHRAPNEL PLANT . . . . .	17
WATER-SUPPLY AT THE FRONT IN FRANCE . . . . .	21
ROAD BUILDERS AT WORK CLOSE TO FRONT OF AMERICAN SECTOR IN FRANCE . . . . .	28
ARMY TOPOGRAPHICAL DIVISION CO-ORDINATES WORK OF MAP MAKERS IN AIR AND ON GROUND . . . . .	32
ALONG THE BRITISH FRONT BY LIGHT RAILWAY . . . . .	37
THE LIGHT RAILWAY ALONG THE BRITISH FRONT AT CLOSE RANGE . . . . .	41
ENGINEERS CONVERT FRENCH BEET-SUGAR FIELDS INTO ADVANCE DEPOT . . . . .	49
ARMY ENGINEER SCHOOL IN FRANCE STANDARDIZES WORK IN THE FIELD . . . . .	55
ARMY ENGINEER SCHOOL IN FRANCE STANDARDIZES WORK IN THE FIELD—(Continued) . . . . .	61
AMERICAN-BUILT DOCKS IN FRANCE COMPLETED BY PACIFIC COAST ENGINEERS . . . . .	65
ROADS IN BASE SECTION OF AMERICAN FORCES REQUIRE WIDENING AND RESURFACING . . . . .	74
AMERICAN ARMY'S WATER-WORKS PROJECTS IN FRANCE . . . . .	79
AMERICAN MOTOR TRUCKS CARRY WATER PURIFICATION PLANT . . . . .	83
AMERICAN INTERMEDIATE DEPOT IN FRANCE. PROBLEM IN GETTING LABOR AND SUPPLIES . . . . .	86



# American Road-Building Work in French War Zone Organized

Inspection of British and French Systems by United States Highway Engineer Officers Aids in Development of Methods—Waterbound Macadam the Main Reliance

By ROBERT K. TOMLIN, JR.

Formerly Managing Editor, and now War Correspondent in France, of "Engineering News-Record"

**A**MERICAN road construction and maintenance work in that part of France assigned to United States troops has been definitely organized, and I was given an opportunity at the office of the Director General of Transportation, American Expeditionary Force, of learning some of the general features of how the immense task of maintaining our highway lines of communication will be handled. As yet no large-scale field operations have been undertaken by our road-building forces, but the nucleus of American engineer officers, who were sent to France some time ago, and who will become the administrative heads in charge of the several subdivisions of the great project, have been spending their time in inspections of the British and French lines of communication, in conferences with the officers in charge of these operations for our Allies, and in formulating plans for our own work. As a result of this coöperation our road engineers have been able to utilize to great advantage the experiences of the French and British and to blend these with the best American practice in mapping out the work to which they have been assigned.

## THE MANAGER OF ROADS

All road-building and maintenance work in the American territory has been placed under the general control of the Director General of Transportation, who has delegated the responsibility for all highway operations to a Manager of Roads, with an organization of his own. The Manager of Roads is well known professionally, a member of both the American Society of Civil Engineers and the British Institution of Civil Engineers, and recently gave up his consulting practice to become one of the administrative heads of a commission directing municipal subway construction operations involving the expenditure of many millions of dollars. It is not permitted to mention by name the men who are handling the road work. The Manager of Roads will concern himself principally with the executive end of the highway work, while the actual field operations will be in the hands of special road building and quarry regiments, such as those in behalf of which *Engineering News-Record* conducted its recent recruiting campaigns. The relations between the staff of the Road Manager and the technical troops in the field will be somewhat similar to those which ordinarily exist between a State Highway Department and a contractor. The Office of Road Manager, however, will not only designate where work will be done, but will also relieve the field officers of the routine involved in getting shipments of construction plant, materials and supplies to specific places and

at specific times. The Road Manager's office will be, in effect, a sort of clearing-house, a place where the efforts of the various construction regiments will be coördinated and rendered of maximum value. It will serve also as a sort of priority board in the distribution of such materials as the output of crushed stone from quarries.

## WORK DEPARTMENTALIZED

Under the Road Manager will be various department heads. The organization chart, which I was permitted to examine, shows such titles as Deputy Manager of Roads, Road Engineer, Assistant Road Engineer, Superintendent of Supplies, Superintendent of Equipment (who will be a mechanical engineer), Superintendent of Quarries, Engineer of Bridges, and, a very significant title, Superintendent of Business Affairs. There will also be a General Superintendent of Construction and division engineers assigned to prescribed areas occupied by American troops. The organization scheme was developed only after a careful study of the British and French systems.

In making a tour of the office of the Road Manager I saw many familiar faces. There were engineers from State Highway Departments, who know construction methods in detail, men who have seen service in United States Office of Public Roads at Washington, men who have formerly been consulting engineers and city engineers back in the "States"; men who had served on the faculties of our engineering colleges; bridge designers, computers, and so on, right down the line to draftsmen, clerks and stenographers. All, of course, were in uniform, with the castle insignia on collar band denoting the Corps of Engineers. It is no inexperienced corps of road builders who form this staff of the Manager of Roads. Each is a specialist in his line, with years of practical training back of him, and when I left the building I carried away the impression that our highway work is in the hands of men eminently qualified for the work to be done—men who have given up positions of great responsibility back home to place at the disposal of the Government their specialized knowledge of engineering administration and of the various branches of road construction and maintenance.

So much for the general scheme of organization—and it must be stated in general terms only, for these are not times when it is desirable to be specific. The road building and quarry regiments from the States will reach the scene of action completely equipped with the construction plant necessary to the efficient conduct of their operations in the field. Much of the French work.

I learn, has been done by hand. For example, a French officer told me yesterday that the bulk of the stone he used for road maintenance work was quarried and crushed by hand. With mechanical crushers the American forces will be able to effect a great increase in output of crushed stone from quarries. And on this subject of crushers an interesting point developed. It appears that the prevalent rock for road building in France is a very soft limestone, so soft, in fact, that it is apt to clog a crusher of the gyratory type. For this material, therefore, a jaw-crusher rather than a gyratory crusher would seem to be best adapted.

#### BRITISH AND FRENCH METHODS

I have said before that the American road engineers have been making frequent trips back of the British and French lines. They told me some of the results of their observations. The waterbound macadam road is in almost universal use, although, I believe, the British have a small mileage of tarred surface. From what I can learn the caption "Macadam Roads Best for War Traffic," which appeared over the editorial in *Engineering News-Record* of Sept. 13, 1917, and to which exception was taken in a number of letters to the editor, needs no revision. A tour of the front, I have heard, alters many preconceived opinions as to types of road construction adapted to conditions of actual warfare. In any event I have not been able to verify any reports as to the extensive use of any of the so-called "permanent" types of road surface by the Allied forces. It is possible, I understand, that some form of surface other than straight waterbound macadam may be used far back from the front-line trenches, but macadam seems to be the main reliance in any territory where operations are at all active.

American highway engineers seem to be greatly pleased with the properties of the French limestone as a material for *speedy* road construction. It is very soft, and compacts quite readily under a road roller, and is the chief reliance as a road-building material, although it requires constant maintenance. A limited amount of trap-rock is available and a French engineer, now returned from active service, told me on his section of road work he employed slag successfully. The roads where the slag was used, however, were near industrial centers where supplies of this material could be secured without the necessity of a long haul. One objection to the waterbound macadam road, I find, is the dust which rises from it under traffic during dry periods in summer. Some use of oil as a binder and dust palliative may be tried, but I hear that it is next to impossible to secure any quantity of bituminous material for road work in France today. In certain of the towns near the front there are large signs along the roadside cautioning the drivers of motor trucks, or camions as they call them here, to drive slowly. Fast driving, with its attendant dust clouds, is apt to draw artillery fire on the roads.

#### MAINTENANCE THE CHIEF PROBLEM

The chief problems of the American road-builders over here will relate to maintenance, as the mileage of

existing French roads is very great; one estimate placed it at 1 mile of road to every  $1\frac{1}{2}$  sq.mi. of ground surface. New construction will take the form of widening roads already built. While the French national roads have ample widths, some of the secondary routes having widths of 18 ft. must be widened to about 34 ft. These roads generally have extensive berms so that the widening operation merely entails the placing of road metal on both sides for the extra width desired without disturbing the existing drainage ditches or interrupting traffic. Where new roads must be built observers state that the French lay the bottom course of one-man stone by hand, while it is common in British military practice merely to dump the stone for the bottom course directly upon the subgrade without any very refined attempt in the placing of the stone. On this base course, 10 or 12 in. in thickness, is spread a layer of  $2\frac{1}{2}$ -in. stone and on top screenings are placed and rolled. The English have used tarring to a limited extent, generally in the vicinity of hospitals.

Military roads of course are subjected to unusually severe loadings and the "tank," with its cleated caterpillar traction bands—a load of perhaps 30 tons on a 4-ft. wheel base—is a disturbing factor to the officer in charge of road-maintenance. Artillery loads of 18 tons on one axle, I am told, are not unusual. As for the tank, I understand that it kept off the roads wherever possible; if it must take to the right of way a road-maintenance crew follows in its wake. The tank also has given the bridge builders something to worry about.

#### PLANK ROADS NEAR FRONT

Where highways must be advanced close to the front lines the construction type takes the form of plank road. In this territory the ground may be merely a succession of shell craters, so irregular in surface contour as to preclude any of the ordinary types of construction without elaborate grading operations. In this work plank of a standard length and cross-sectional area, 5 x 9 in. by 9 ft. is employed. Three of these planks are laid parallel to the longitudinal axis of the road, like bridge stringers, and the surface timbers are laid transversely on the stringers, to which they are spiked. At each side longitudinal guard timbers are spiked and the surface is built with a pitch of 3 in. toward one side to shed water. This plank construction generally is only wide enough for one-way traffic.

American officers are enthusiastic over the excellent system of traffic regulation on military roads used by the English. At specified points military "traffic cops" are stationed and are provided with red, green and white signals—flags by day and small lamps by night. A red signal brings traffic to a stop, green slows it down, while white means "all clear." When large stores of munitions and supplies are in transit the traffic is said to compare in density to that on Fifth Avenue, New York, while the actual tonnage, of course, is much greater.

It may happen that a brigade of artillery, stationed in fields alongside the road, is suddenly called into action. The road police stop all motor-truck traffic instantly, get the right-of-way clear so that the artillery

may reach its position without delay. Another feature of the road work is the prevalence of the large sign-boards indicating the way to different towns.

At night, of course, it is dangerous for vehicles to show lights, and to aid the driver in keeping on the right-of-way wooden pickets, whitewashed, are driven along the outer edges of the roads at about 10-ft. intervals. I was talking last night to an American ambulance driver who had seen service in the Verdun sector, and he told me that it was a favorite stunt of the Boche airmen to fly over the road at night when supplies were being brought up and rake the center line with machine guns in an effort to "get" the drivers of the camions.

On the question of plant for road building, the American engineer officers with whom I spoke pointed out the danger of a steam-roller near the front. Puffs of smoke or exhaust steam disclose the position of work to the enemy. Gasoline-driven machines are preferred on account of what I suppose a naval man would call their

"low visibility," although the steam outfits are useful further back. The exhaust steam and smoke from a road roller makes a fine target for shells or bombs, and much of the road work must be done in the danger zone. In regard to gasoline machines, the single-cylinder type is not regarded with favor, preference being given to the two-cylinder machine as more dependable. If the engine stalls it is generally a long way back home.

Narrow-gage track is a big factor in the transportation problem and I hope in later reports to give some of the details as to laying and handling of these units. Standard-gage railroad track, narrow-gage industrial track, and waterbound macadam highway for motor-truck traffic form the great triumvirate of transportation used in France today. It is significant in the scheme of organization behind the fighting front that the control of all of these aids to the movement of supplies, munitions and men, is centralized in one department, that of Director General of Transportation.

# American Railway Yard and Terminal Development in France Presents Many New Problems

Engineers Preparing for Big Construction Program at French Seaports—At Docking Basins Readjustment of Track System for American Rolling Stock Is Necessary—Training School for Traffic Officers Proposed

BY ROBERT K. TOMLIN, JR.

"Engineering News-Record's" War Correspondent in France

**T**RACKAGE in railway yards alone equivalent in aggregate length to a standard-gage line from New York to Chicago is merely one detail of the colossal program of construction which the occupation of French territory by the ultimate quota of the American Expeditionary Force has demanded. And let it be understood at the outset that this does not include main-line construction and repair or narrow-gage, light railway track; it is merely the new trackage required in the immediate vicinity of the huge seaport freight terminals, classification depots and warehouses which United States forces are building or planning to build in France in order that supplies and munitions in staggering quantities may be received and routed expeditiously from ships to points at the front. This information I obtained in interviews with two of the high ranking officers on the staff of the director general of transportation—one the general manager, and the other the engineer of design and construction. Both held high executive positions in a large railroad organization before the war.

## TRANSPORTATION THE IMMEDIATE NEED

Without doubt transportation is the immediate big business of the war for us. Practically everything which our fighting forces will need in the conduct of field operations must come from across the Atlantic, for the available supply of local equipment for American troops is almost negligible. The problem resolves itself, therefore, into one of providing facilities for receiving huge volumes of freight at the waterfront, and either delivering it to the interior or storing it for future use. As one engineer officer expressed it, this phase of our task is not war in the popular conception of the word, but a gigantic business enterprise, which, to insure success, must be conducted on the best American business principles.

Along with the railway yard construction work will go the building of innumerable storehouses and classification depots, the provision of mechanical equipment for the handling of freight, and the enlargement of port facilities such as wharves and docks.

It was impressed upon me very forcibly that the great need now is for cars, which must all come from the States, for crews to load and unload them, and for a skilled force to operate the trains between French seaports and our supply bases behind the fighting front.

The task of our engineer officers and men in providing terminal and transportation facilities over here is complicated by many difficulties which railway operators or constructors in the United States do not experience. First of all, there are differences between French and American railway practice which must be

adjusted before effective work can be done. It should be realized, however, that existing French main-line track is in good condition, available for the use of our rolling stock, and that tales of new four-track lines across France, to be built by American forces, are absolutely without foundation. The big problem is the terminal problem.

## DIFFERENCES IN PRACTICE

In the matter of main-line track gage the French roads are very nearly the same as our own, and slight adjustments in the wheel coning of our rolling stock will render it serviceable on French track. The French operating system, however, is left-handed, and certain track-construction details show variations from American practice. French rails, for example, are supported on chairs with a wedge knocked in to tighten them, while our rails rest either direct on the ties or on metal tieplates. French rail joints are placed opposite each other instead of being staggered. In the matter of curves the French work upon a scale of meters of radius, while American railway men deal in degrees of curvature.

As the first stage in the mapping out of the American railroad work our engineers have collected and are studying and redrawing to a new scale existing French plans. Here again new conditions must be faced. European methods of showing things on blueprints differ from our own, and all of the lettering, of course, is in French. Interpreters, to be sure, are available, but for the most part they are laymen, while the accurate interpretation of the data on the French plans calls in many cases for the services of technical specialists who understand both English and French engineering terms. Dimensions and quantities are in the metric system, and in the hands of men who have been dealing principally with feet, inches and cubic yards in their own work at home the French units are not so easily handled at first.

## MUCH PRELIMINARY WORK

It therefore can be seen that before any large scale construction operations are possible a tremendous amount of preliminary work must be done in order to establish what might be called a uniform datum plane, from which effective coördinated effort must start. It is this preliminary work, this business of taking stock of existing facilities and fitting them into the plans for the future, that has been the chief task of our American railway and terminal engineers.

Just what the new work will involve can be stated only in rather vague terms. In addition to the railway yards and terminal structures there will be regulating yards whose function will be to preserve a proper



balance of traffic between the storage yards and main-line tracks leading to the front—a sort of compensating reservoir, to maintain a smooth, steady flow of traffic. Innumerable sidings will have to be built to hospitals, sawmills (where our forestry regiments will work cutting French timber), bakeries and various other structures. New engine terminals are included in the project, and connections must be made to our ordnance and munitions stores. The latter must be located at least half a mile distant from main-line track and buildings, and the type of construction, I am told, will be scattered units, in order to minimize the effects of explosions or bombing from enemy airplanes.

#### DOCK AND TERMINAL STRUCTURES

To get back to the railway terminal and dock structures, the freight classification sheds are to be long buildings 50 ft. in width with 8-ft. platforms and depressed track on the outgoing side. I asked the chief engineer what material would be used for these buildings. His reply was, "Anything we can get."

Ships will also dock in rectangular basins which, as built by the French, require entrance locks, as the variation in tide is considerable. Parallel to the sides and ends of these basins three lines of track will be laid where feasible and as much freight as possible will into cars. The remainder will be delivered to the classification sheds just back of the tracks which extend around the sides of the docking basins.

Some readjustment of the basin trackage system where existing docks are to be used will be required to adapt it to the use of American rolling stock. As now built, the tracks make right-angled turns at the corners of the basin and by means of turntables the French cars, on four wheels, negotiate changes of direction. Our freight cars, of course, will be carried by two four-wheeled trucks and will be too long for the turntables. This condition of affairs means the ultimate ripping out of the turntable system and a rearrangement of trackage to provide curves which our cars can negotiate, instead of right-angle turns.

For the terminal structures of various sorts tentative plans were prepared, and it is an index of the sort of things our engineers are confronted with to find out that many of these will have to be substantially revised on account of the low stresses which must prevail when certain French timber is used. For example, certain wood roof-truss designs based on the use of timber commonly employed for this purpose in the States are practically useless, for the lengths and

the strengths of French timber are much inferior to those of American-grown material. I hear that it is impossible to get French timber piles more than 45 ft. in length.

#### LARGE LABOR FORCE NEEDED

All of this railway and terminal construction program calls for a large labor force. Local labor, in so far as it can be obtained, will be used, but the bulk of the work must be done by men brought over from the States. In addition to the construction men there must be large quotas of stevedores. All will be under military regulation. On some of the English military projects great forces of Chinese labor have been employed. At the present writing the railway terminal and dock work is being done by United States troops of all kinds—marines, line troops and engineer units. When the labor battalions arrive from the States these men will be assigned to other duties. Among the wielders of pick and shovel in one of the temporary construction units is the son of a very wealthy man. "To think," he said, "that I had to get letters of recommendation from two men high up in official life at Washington to secure this job."

As for the operating end of the system which the American Expeditionary Force will control, its organization, according to what the general manager told me, will follow almost exactly that of the best large American railways, with general manager, general superintendent, master mechanic and so on down the line. There is one post to be created here, however, which has no counterpart in American railway practice. This is the R. T. O.—railway traffic officer. He was defined for me as a "100% man." Here are the constituent parts of this remarkable individual: "25% military, 25% French, 25% diplomat, 25% railway man." In addition, I was told, he must be able to work about 22 hours out of every 4. "It will be hard to find men of this type," the general manager continues: "In fact we are making plans now to establish a training school for them. There will be a number of these R.T.O.'s stationed at various points on the system, and to my mind the best raw material to work on will be a type represented by the highest class of station agent. The job of the R.T.O. will be to keep traffic moving and straighten out all difficulties which may crop up in his territory. Upon them will rest responsibility for teamwork with the French railway operators at important points of junction with the American system." The R.T.O. on military railways is a development of British methods of organization.

# French Quarries Inspected by U. S. Engineers

In 900-Mile Automobile Trip Two Officers Find Hand Labor the Prevailing Method of Operation—Average Daily Output 1 to 1½ Metric Tons Per Man

BY ROBERT K. TOMLIN, JR.

"Engineering News-Record's" War Correspondent in France

WITH up-to-date mechanical equipment installed in those French quarries which will be worked ultimately by American forces to supply crushed rock for military road building and track ballast, it is hoped that substantial increases in the present output per man per day may be made. Under the present methods of operation by the French the average daily output per man is from 1 to 1½ metric tons. In order to get first-hand information regarding French quarry resources in the territory which our troops will occupy, the manager of roads, American Expeditionary Force, delegated two of his officers to make an inspection trip. The engineers, one formerly in the quarry business on the Pacific coast, the other a former representative of a large machinery manufacturing company, have just completed their mission, which involved a 900-mile automobile journey, and have told me in a general way the results of their observations.

Almost the first thing an engineer learns in France is that mechanical equipment of any kind, except in the plants now working on munitions and other war material, is about as difficult to get as white bread, or telephone service which has even the semblance

of efficiency. And so, while one can make all sorts of estimates of quarry output with mechanical plant, the first real big job is to land the machinery and the men to operate it safely on this side of the Atlantic. Then the output will very largely take care of itself. With regard to the French quarries, however, I am told that with a few exceptions hand labor has been the chief reliance ever since the war began. No local quarries are being worked by American forces at this writing, and until some definite arrangement is made with the French for the taking over of quarries in certain territory by our men, very little can be said on the subject.

The labor used in the French quarries which were visited by the two engineers of the road department of our army is to a large extent African, although some French workers are used. Sometimes an Ingersoll-Rand compressor and jackhammer drills were in evidence, but for the most part the drilling is done by hand. I was told that the rate of drilling was from 1 to 1½ meters per man daily. The rock is a soft limestone, with layers of clay intervening. The quarries as a rule are worked in low faces, and drill holes are commonly

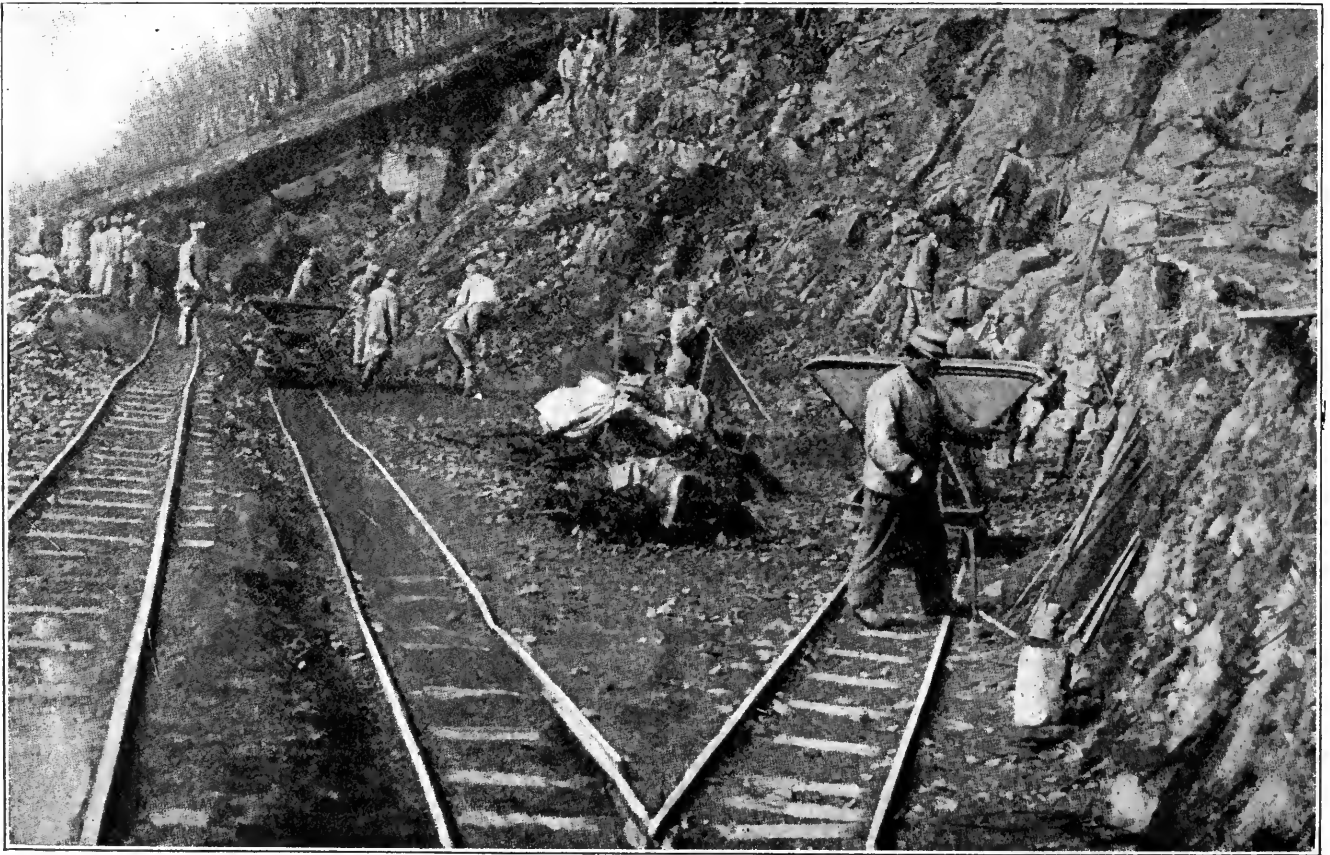

French Official Photo

IN THE FRENCH METHOD OF QUARRY OPERATION HAND LABOR HAS BEEN USED TO A LARGE EXTENT



*French Official Pictures*

DELIVERY QUARRY OUTPUT TO CRUSHERS—NOTE GABLED SHAPE OF MOTOR-TRUCK BOTTOM IN FOREGROUND—DUMPING BODIES ON TRUCKS VERY UNUSUAL

about 8 ft. deep. After being broken out by explosives, the rock is fed into small jaw crushers, or else reduced in size by hand tools. The rock is screened in inclined grizzlies with  $\frac{1}{2}$ -in. spacing, and for breaking the large chunks one of the prevailing implements is a small hammer on the end of what is described as a "bamboo cane." Such mechanical crushers as were observed were run with any kind of power available—sometimes steam, sometimes gasoline, sometimes electricity.

Most of the loading into cars is hand work, and a radical difference between these wartime quarries and the kind an American engineer is accustomed to is the absence of storage bins. This lack of bins was noted throughout their trip by the two American engineer officers. All rock storage of the smaller quarries is either in stockpiles on the ground or in the cars themselves. Two reasons are advanced for this practice. In the first place, lumber in France is pretty much

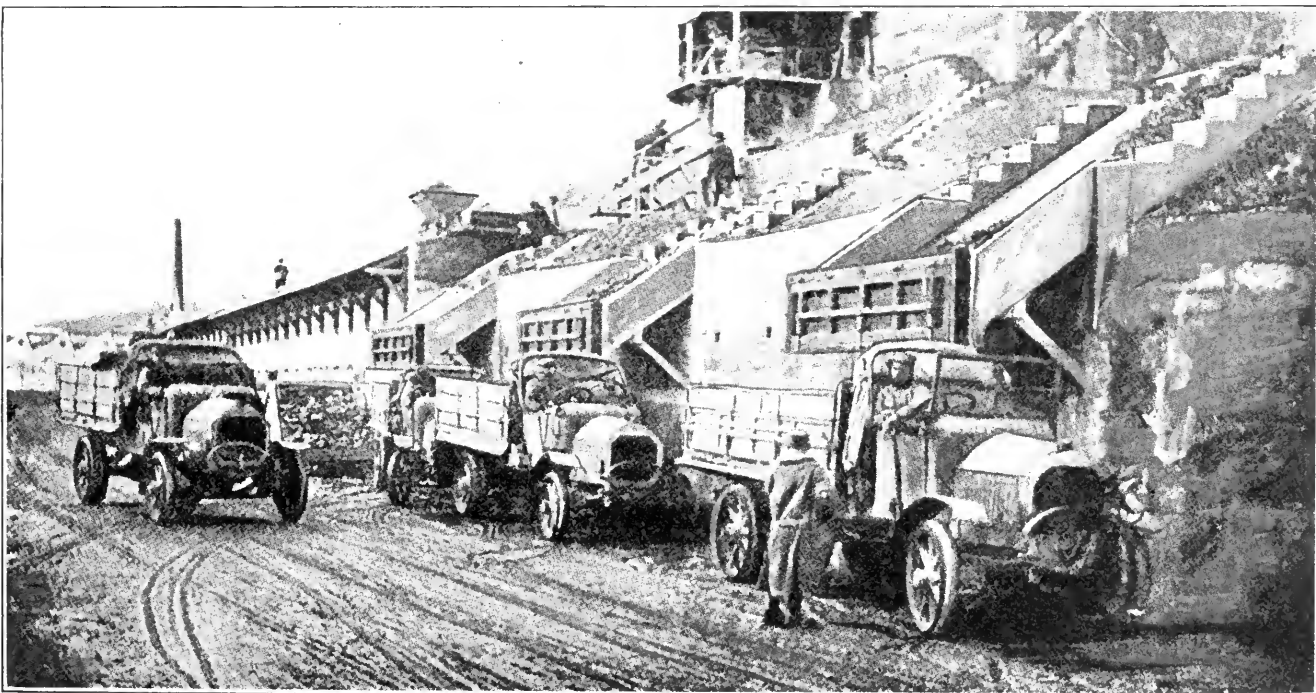

*French Official Pictures*

AT THIS QUARRY MECHANICAL PLANT IS MORE IN EVIDENCE—NOTE LOADING OF TRUCKS FROM CHUTES

of a luxury these days, and in the second, a group of storage bins might tempt an enemy airman to a test of his marksmanship with high-explosive bombs. As a means of increasing output in any quarries which American forces may operate, it is the intention to dispense with hand loading of cars to as great an extent as possible. Much of the crushed rock, I learn, is transported by means of the French system of canals in boatloads of 250 metric tons each.

There is one French quarry of large size where trap-rock is procured and where crushers and mechanical devices of various kinds are more in evidence than at the smaller limestone quarries. This big quarry is in the form of a large "glory hole" which is worked in six benches each 25 ft. high. The stone, however, is lowered in cars on gravity planes to the tunnel level instead of being drawn through chutes. The output

of this quarry is 600 tons a day with a force of about 400 men. Steam-driven air compressors, tripod drills, jackhammers and mechanical chain haulage through a long tunnel are features of these works. The storage, however, is principally on the ground or in the small wooden quarry cars, of which there are about 1500. This is the biggest of the French quarries, and trap rock is shipped from it by rail to points as far distant as 150 miles.

From my conversation with the engineers who inspected the French quarries, I infer that our chief task in procuring crushed rock for road construction and maintenance will be to revise the operating system now in force with a view to securing greater output with fewer men. This will mean the installation of up-to-date machinery, the provision of elevated storage capacity, and the speeding up of car loading.

# Large Mileage of Light Railways Will Serve American Troops at the Front

Department Organized for Big Construction Program—Relation of Light Railways and Highways Explained—Narrow-Gage Lines Have Been Big Factors in Relieving Congestion of Motor Trucks on Roads

BY ROBERT K. TOMLIN, JR.

"Engineering News-Record's" War Correspondent in France

**F**OLLOWING the experience of the French and British armies, the American Expeditionary Force is preparing to construct in France a large mileage of "light railways"—60-centimeter gage—as a part of the necessary transportation system serving the troops at the front. These railways are the connecting links, to a great extent, between the railroads or termini of the standard-gage lines and the trenches and batteries. The service which the light railways render is also closely coordinated with that of the military highways.

An indication of the importance which is attached to the light railway work is gained from the fact that the director general of transportation has created a special department to have charge of the construction, maintenance and repair of these lines of communication and of the equipment used in their operation. At the head of this organization is one of the high ranking engineer officers of the American Army. Associated with him in the administrative headquarters of the department are men, all engineer officers, of the following caliber: One, in civil life, is president of an American railway; another is a vice president and general manager; a third bears the title of chief engineer of a system in the western part of the States; a fourth is assistant general superintendent of lines in the East; a fifth is master mechanic, a man with a wealth of practical experience, to whom will be entrusted the upkeep and repair of equipment in the engine terminals and machine shops which form an important part of the light railway project.

As the result of a conference with these officers, I have been given the following information regarding

one of the most important phases of our military transportation problems:

Early in the war it was found that to undertake the supply of the front lines with motor trucks required such a great number of them that the highways were continually congested. It was found, too, that this excessive motor traffic soon wore the roads down to such an extent that the greater part of the motor trucks were required to haul road material to repair the damage caused by their own traffic. The light railways were developed to overcome these difficulties, and they have been so successful that it is possible now to keep the highways in repair and to devote them entirely to the use of fast-moving automobiles, motorcycles and motor trucks. In short, heavy and bulky traffic is moved on the railways; light and fast traffic on the highways.

The function of the light railways is to carry forward as near to the front as possible ammunition, forage, road material, rations, lumber, fuel and miscellaneous engineer supplies. They are also used in transporting troops, and wounded men are brought back from the front on these lines in better condition than by road ambulances. In addition, artillery trains, having guns mounted on specially constructed cars, are moved on these railways; as the position of these guns can thus be quickly changed they are not so likely to be accurately located by the enemy.

The location of light railway lines requires considerable skill. They must be located so that they are concealed from the enemy as far as possible. They should not be under direct observation, and, if located so that

they do not show up in aéro-photographs too prominently, the chances of their being hit by shell fire is minimized. With advantage taken of woods and rough features of the ground, lines can oftentimes be built so as to be invisible to the aéroplane. Lines must be located to follow the contour of the ground as nearby as possible, thus minimizing damage to the country and permitting the greatest rapidity in construction.

On an average, 1000 men can grade, lay and ballast a mile of track in a day. Grades are usually restricted to not more than 3 to 4%, but in some instances this is

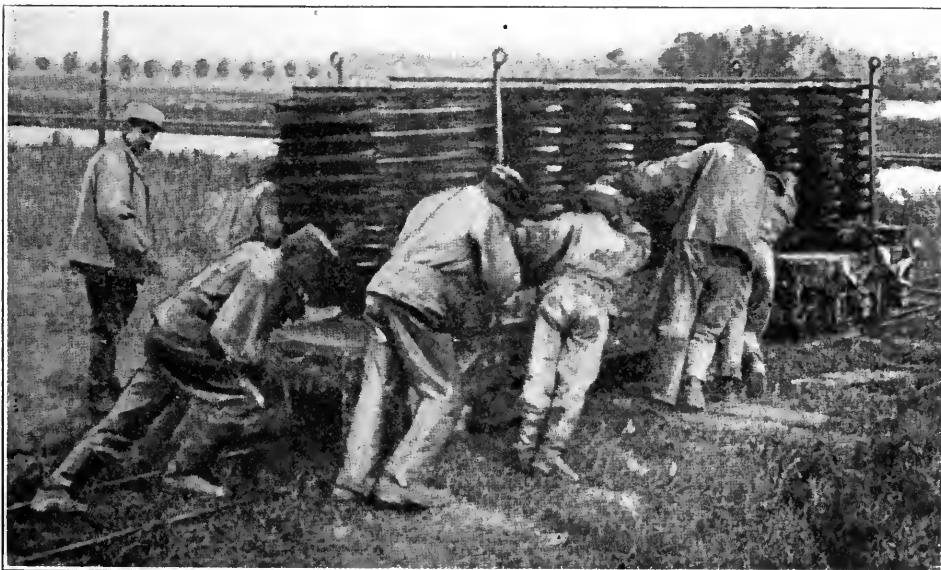

French Official Photo

GERMAN PRISONERS MOVING LOAD OF LIGHT RAILWAY TRACK SECTIONS IN THE REGION OF THE MARNE

exceeded, and sharp curvature, 30-meter radius, is often used. The roadbed is usually 9 ft. wide on top; cuts are 14 ft. wide on the base, with side ditches, leaving a 9-ft. crown.

The track is 60-centimeter gage (22 $\frac{5}{8}$  in.); the rails are generally 20 lb. to the yard, but American track will be constructed with rails weighing 25 lb. per yard, bolted to steel ties. The ties are 43 in. long, 5 $\frac{1}{2}$  in. wide and  $\frac{1}{16}$  in. thick. Wood ties 4 x 6 in. by 4 ft. 6 in., however, are used under certain conditions. The rails are received in 5-meter lengths (15.4), and the track is assembled and bolted, eight ties to a section, before being sent to the front. These sections of tracks are connected on the grade. It has been found that the track must be well ballasted, and for this purpose gravel, broken stone, broken brick, slag and cinders are used.

These lines radiate in various directions toward the front from the broad-gage railheads, so that a considerable mileage is embraced in one group or system. Oftentimes the ends of these spurs will be linked up by a connecting line which, in a general way, parallels the front-line trenches. Thus a system sometimes shows up as a series of loops; in other cases a system assumes a tree formation, with main trunk and branches.

The American equipment consists of steam locomotives of the 2-6-2 type, weighing about 17 tons, built by the Baldwin Locomotive Works, and having a tractive effort of 6200 lb. The cars are of the gondola type, about 17 ft. long and 5 ft. wide, with a capacity of 10 tons. A certain number of box, flat and tank and ambulance cars are also used. The steam locomotives operate to within a certain distance of the front—up to a point where smoke and steam would betray their presence to the enemy, after which the cars are taken still farther forward by gasoline locomotives, and final distribution of supplies to some of the most advanced points is made by motor trucks, by animal traction, occasionally by cableway or rope tramway, by pack mules and by hand. The lines are also laid into quarries where road material is obtained, and into forests where lumber and fuel are loaded directly for the front.

The hard usage to which the equipment is necessarily subjected, and the damage or destruction of equipment by shell fire, make necessary, of course, a large force of skilled mechanics, shop equipment and an abundant reserve of materials.

A great amount of crushed stone is hauled by these railways and set out on spurs alongside the highways, whence it is distributed by

the road motor trucks. To appreciate fully to what extent these railways have relieved the highways, it is only necessary to remember that the average motor truck carries 3 tons, and the average light railway train of 6 cars carries 60 tons, thus doing the work of 20 trucks. From one railhead on the British front, a single line of light railway recently handled 2100 tons in a day, or 700 motor truck loads.

With a low maximum speed, an average train run of only a few miles, and such a network of tracks that only the initiated can distinguish between main lines and branches, it goes without saying that no very elaborate methods of train dispatching and signalling are required. However, it rarely pays to install double track, and the intensive use of single track lines, together with the frequent interruptions to traffic in forward areas due to enemy shell fire, make the personal equation in dispatching of great importance. Rules are necessarily few and simple. Both British and French methods of operation reflect to some extent their broadgage practice, and similarly employees of American military railroads find their work simplified by rules which follow certain rudimentary principles of American Railway Association practice. A simple form of telephone train dispatching, combined with a modified block system, has been found most practicable. While every effort is made to operate without waste, the primary object of the light railways is to meet the needs of the armies in the field, and no questions of economy are permitted to interfere with regularity and reliability of service.

The orders placed in the United States for locomotives, both steam and gas, cars and track material, some of which have already been received in France, indicate

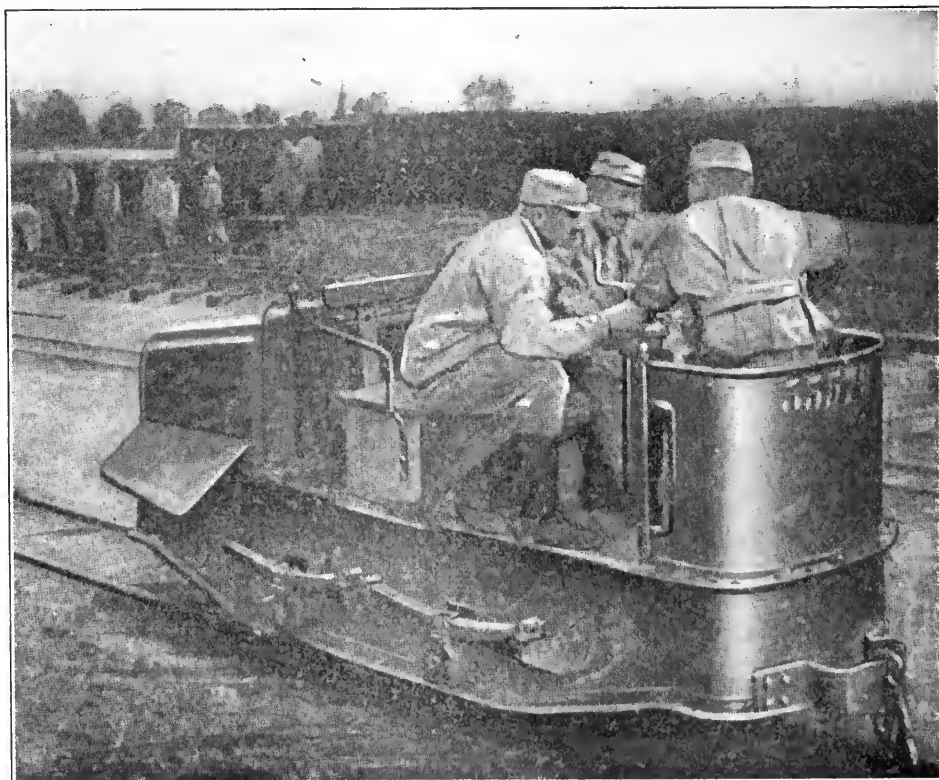

*French Official Photo*

ONE OF THE GASOLINE LOCOMOTIVES USED ON LIGHT RAILWAYS NEAR FRONT—NOTE SECTIONS OF TRACK PILED IN BACKGROUND

that the U. S. Army will be provided with as many thoroughly equipped miles of light railway as it can use.

The sections of light railway track are transported to the work in various ways—sometimes on standard-gage cars, sometimes on motor trucks, sometimes along existing light railway track, or by a combination of any or all of these transportation facilities. At the main yards cranes, where available, will be used for loading the sections of track for transport, but in the actual construction of these narrow-gage lines no plant is required. In fact, this need for nothing but manual labor is one of the features which make the light railways so

use of both steel and wood ties for supporting the light railways. Steel ties will be the prevailing type, but the wood ties will be employed where a large bearing area is needed, as, for example, where the ground is soft or where the curvature is sharp. Sometimes, of course, stone ballast may be scarce, and here again the wood tie, with a bearing area greater than that of the steel tie, will serve a useful purpose.

As for the ballast, the intention is to secure most of it from quarries operated by the Department of Roads (highways), but a limited supply is obtainable from the shattered remains of brick and stone buildings in the devastated areas. Whole brick, however, are exceedingly

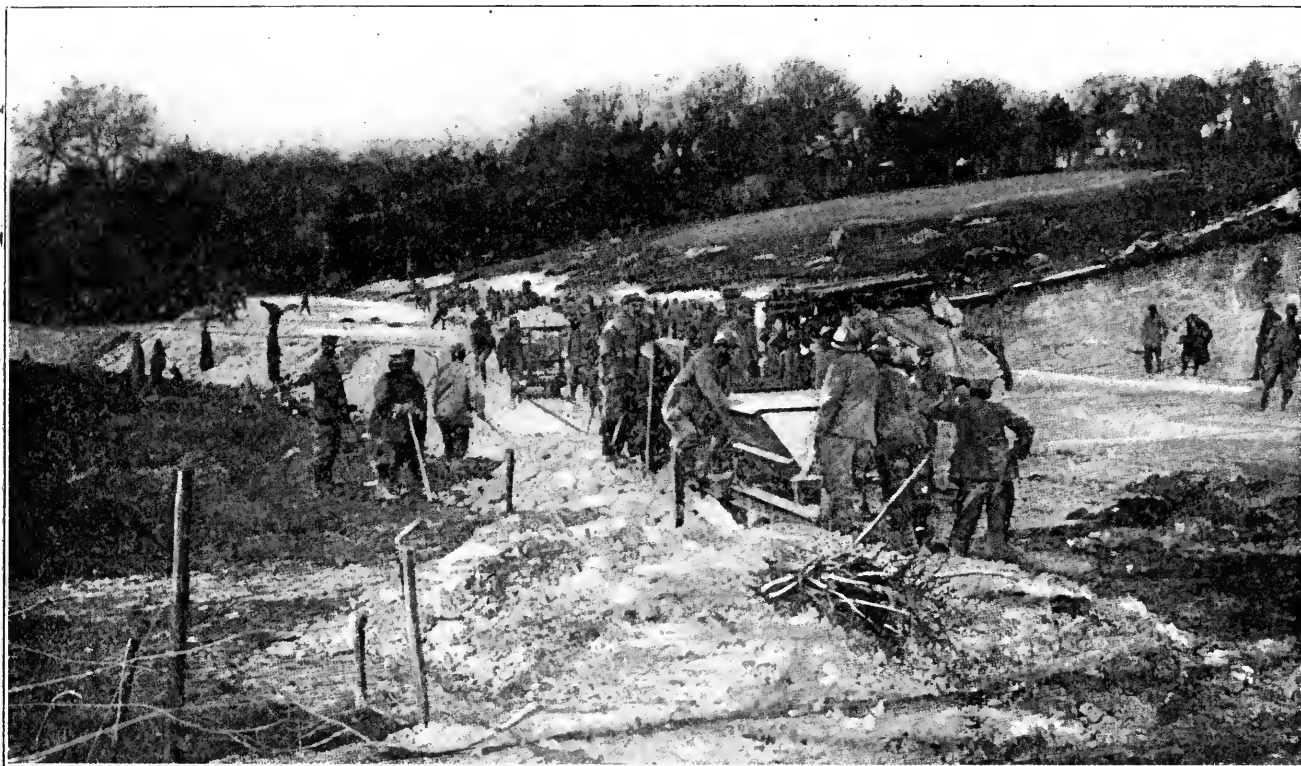

French Official Photo

THE LIGHT RAILWAY IS USED EXTENSIVELY TO DELIVER ROCK FOR ROAD CONSTRUCTION

admirably adapted for work in the field of enemy observation and fire. In one sector where artillery operations were active, I am told, a single line of light railway was broken and repaired 95 times in one day.

In some areas which have been heavily shelled it is necessary to advance lines of light railway over "rights-of-way" which are literally pockmarked by craters ranging in size from slight depressions to deep, wide gullies. Here the needs of the moment determine the methods of procedure. If a large labor force is available the pits are filled in and roughly graded. When the work can be done more quickly by carrying the lines across the craters on timber grillages this form of construction is employed—provided timber is available. It is situations such as these that bring out the resourcefulness of the engineer. His job is to advance the lines or to repair a broken section, and any method which accomplishes this end, and accomplishes it with *speed*, is acceptable.

In a preceding paragraph reference was made to the

valuable in France at present, and use of this material is permitted on the basis of culling out the whole brick from the débris and carrying away only the bats for railway ballast purposes. The Department of Light Railways will work in close coöperation with the manager of roads in this matter of the production and transportation of crushed stone.

The location of the light railway lines involves also some topographical surveying work, and parties are now collecting the data from which contour maps are being prepared. Officers have been out over the territory where it is probable that our network of light railways will be built and have done a great deal of rough reconnaissance work as a preliminary to actual construction.

The man who visits the headquarters of the Department of Light Railways and talks to the engineer officers who are directing its activities, as I have done, is impressed at once by their enthusiasm for the work in hand. Their experience on standard-gage lines back in

the States, an invaluable asset over here, is being diverted into new channels of usefulness, and there is in the planning and execution of the light-railway project for war service enough of novelty to take it out of the class of routine and make it a new and intensely interesting job. And yet the satisfaction which these engineers are getting in the performance of the duties to which they have been assigned is not that, if I interpret signs correctly, of the man who merely solves

some technical problem. There is more to it. These little railway lines—almost toy railroads in appearance—will form a great steel web over the American sectors, and on the integrity of its double bands of steel will depend, in large measure, the effectiveness of the fight we are to wage and the speedy transport of our wounded to the rear. Here is work, therefore, that calls for the best there is in the engineer, and that best is being given freely.



# Railway Regiment Handles Jobs of All Kinds in France

Organized Primarily For Track Construction, Operation and Maintenance, the "Steenth" Engineers Have, as a Side Line, Built Dams, Hospitals, and Even Installed Plumbing Fixtures and Baking Ovens

By ROBERT K. TOMLIN, JR.

Paris Representative of Engineering News-Record

TO KNOW that the "Steenth" Engineers are with the American Expeditionary Forces, and that they are engaged on railway construction somewhere in France, is of course a starting point for the correspondent of a technical journal who wants to send back to his paper a story on the work that these troops are doing, but it is like one of those town constable "clues" of the "ten-twenty-thirty" melodrama—a mighty elusive thing when you attempt to crystallize it into something specific. It's a "clue"—and that is about all you can say of it. For our people over here are not advertising their whereabouts or the details of the work they are doing. On the contrary, pretty definite instructions have gone out to our forces to do no promiscuous talking; so any civilian, even with the best of credentials, is apt to chase around in circles if he approaches an officer through irregular channels with such words as "where," "what," "who," "why," or any other members of the great family of interrogatives. And all this, of course, is as it should be, for enemy agents may be anywhere and any sort of information may be useful to them.

Still I had my "clue"—the "Steenth" Engineers were in France and were doing railway work—and by piecing together bits of information from here and there, I finally reached a decision as to where I thought they might be, and made plans to pay a visit to their head-

quarters. Now to begin with, this matter of making a railroad trip in France is not so simple as it sounds. It is by no means a case of merely choosing your destination, buying a ticket and getting aboard. You can't travel anywhere these days without a permit, and you must have mighty good reasons before any such permit is forthcoming. After being over here a while you get the impression that a very large percentage of French police and railway officialdom has been delegated to the job of asking the question "why?" But the reasons for my trip apparently were sufficient and I managed to secure my "laissez passer."

The selection of a train is the easiest part of the whole procedure—there is generally only one train a day to anywhere. The purchase of a railroad ticket, however, is possible only after submitting your pass to the gendarme, one of whom guards the approach to each ticket office. When this formality is completed you pass by armed guards at the gateway to the train—wondering if they too will hold you up again at the last minute—and finally you get aboard.

And so it was that I started on my quest of the "Steenth" Engineers. It was an all-day trip across flat country, and the chief item of interest en route was our passage under a veritable flock of airplanes in the vicinity of an aviation school. As our train went puffing along, planes were above us and on both sides, racing along beside our car, and cutting across the tracks ahead and behind like a school of porpoises playing alongside a ship. We reached our destination, a little town on the French coast, at dusk, and after again going through the formalities of showing passes and telling why I thought I should be so far away from Paris, I was allowed to leave the dingy railroad station and put in for the night at a ramshackle hotel, where every board on the uncarpeted floor creaked with the weight of passersby, where the electric light was just a dull, depressing glow away up in the corner of the high ceiling, and where the wind moaned down the bleak, bare corridors and through chinks in the door in fitful gusts. But in the morning things looked more cheerful. The sun, which has been a missing quantity in Paris for almost a month, broke out like an omen of good luck, and after a hurried "petit déjeuner" of chocolate and brown war bread I set forth in search of my engineer regiment. I first made inquiry of the American military police, who are stationed along all the principal streets of the little seacoast town, and ended by going for more detailed information to the local office of the American Provost Marshal. Here, after some delay in looking up records, I was informed



CONCRETE HAND-MIXED FOR NEW TRACK LAYOUT AT DOCKING BASIN

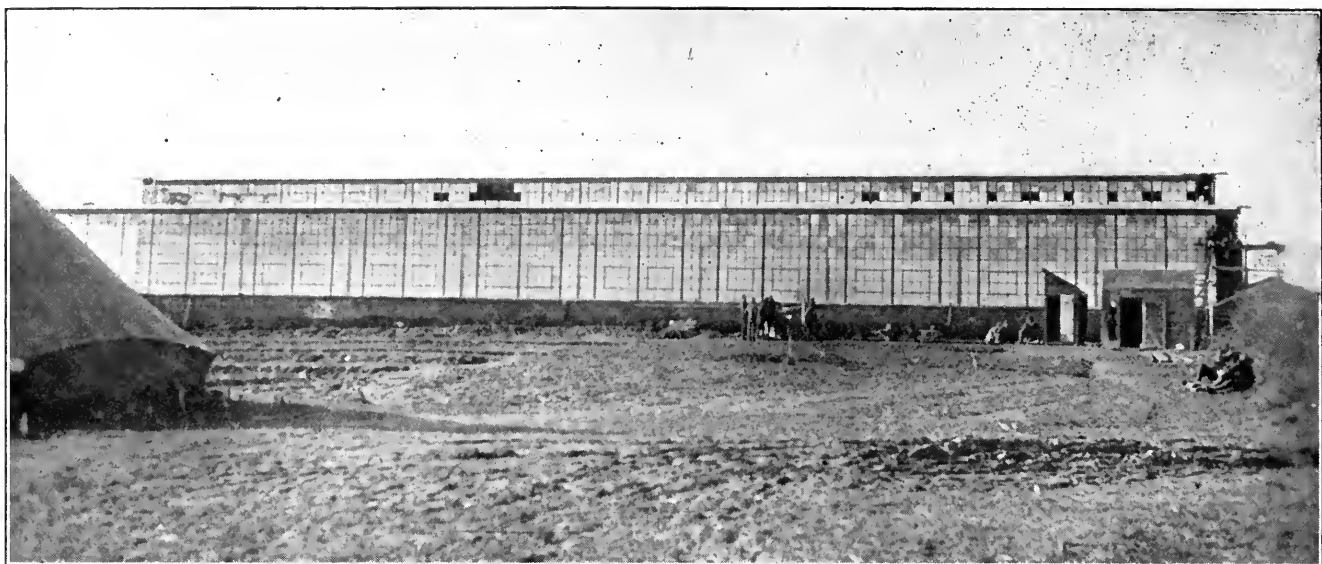

NEW AUTOMATIC ASSEMBLING PLANT IS STEEL FRAME STRUCTURE WITH GLASS SIDES AND MONITOR

that my goal was "Camp No. 1, about two and a half miles out of town."

My "clue" apparently was developing nicely. The "Steenth" Engineers were actually within striking distance, and in buoyant spirits I left the Provost Marshal's office in search of some conveyance which would take me to camp. In these war times transportation throughout France is badly crippled. The automobile is practically extinct, even in Paris, and the only thing available there is the taxi or fiacre. In the little seaport where I had landed the previous night I had a very clear premonition that taxis were an unknown luxury, but I went scouting about the streets until I finally located a "seagoing" hack, a brokendown affair with a cripple of a horse sagging between its shafts. It seemed like a forlorn hope, but these are not times for fastidious tastes, so I hailed the driver and managed to convey the idea that I wanted to be taken to Camp No. 1. The driver "got me" finally, and after belaboring his poor nag, which was in a sort of semi-comatose state, we got under way. It was rough going and slow. The road we took evidently had been used for heavy motor truck haulage and was pretty well broken up and rutted. However, my skipper appeared to know the channels and at last a sign with "Camp No. 1" painted on it in big black letters loomed up off our starboard bow. After making a turn to the right we were hauled up sharp by a sentry. I had my papers out of my breast pocket in a jiffy—it is surprising how practice makes this business of flashing credentials almost automatic; with me now it comes as easy as the hip-pocket motion of the Western "gunman" who is always getting the "drop" on some one.

"What do you want here?" said the man in uniform, after scanning the documents which I handed him.

"I have come to see Colonel S——, of the 'Steenth' Engineers," I replied. He looked puzzled for a moment. "The 'Steenth' Engineers," he repeated; "why, they ain't here any more!"

In my early days in France this information, delivered at the end of many weary hours of travel, might have had the effect of a knockout blow, but one thing

I have learned since I have been over here is that "no" sometimes means "no," and then again it may mean something else. Things are shifting rapidly. Units come and go. A man or a regiment may be here one week and hundreds of miles distant the next, so there is every reason for a poor sentry to become muddled in his knowledge of the location of troops even in his own camp. At any rate, I did not intend to give up my "clue" without a fight.

"You must be mistaken," I said to the man who barred my road, although the conviction I tried to throw into the words had very little solid foundation to rest upon. "I know that the 'Steenth' Engineers are here and I have an important message to deliver to the Colonel."

"Wait a minute," said the sentry, and he marched off to confer with a non-commissioned officer of the guard. While this parley was in progress a captain

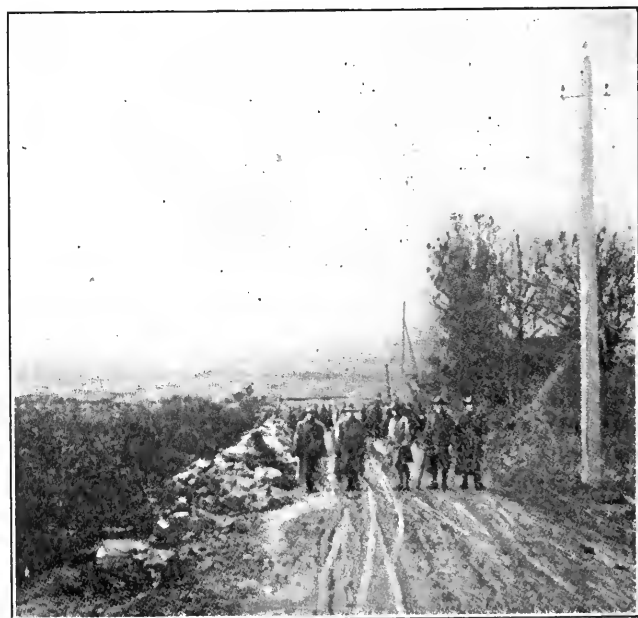

RIPRAP AT ROADSIDE WAITING FOR TRANSPORT TO EARTH DAM

walked by and to my delight I saw the castle insignia of the engineers on his collar band.

"Captain," I shouted, "can you tell me how to reach Colonel S— of the 'Steenth' Engineers?"

"Certainly," replied the officer, "his headquarters are right over there. I'm going there myself; come along." Never did more heartening words pass the lips of any man than those which I had just heard. With a wave to my sentry, who came to the present arms as I passed him with my Heaven-sent convoy, and a signal to my cabby to let go anchor—an unnecessary detail, as

has included pretty nearly everything from the actual laying of railroad track of the installation of a baking oven and shower-baths in one of the base hospitals.

The immediate big task of the "Steenth" Engineers, however, is the development of ocean and railway terminal facilities at the French seaport near its main camp. This problem was outlined briefly in a former article (see *Engineering News-Record*, p. 348, Feb. 21, 1918). The job consists essentially in rearranging the track system which serves the docking basins and in providing an immense new freight classification and

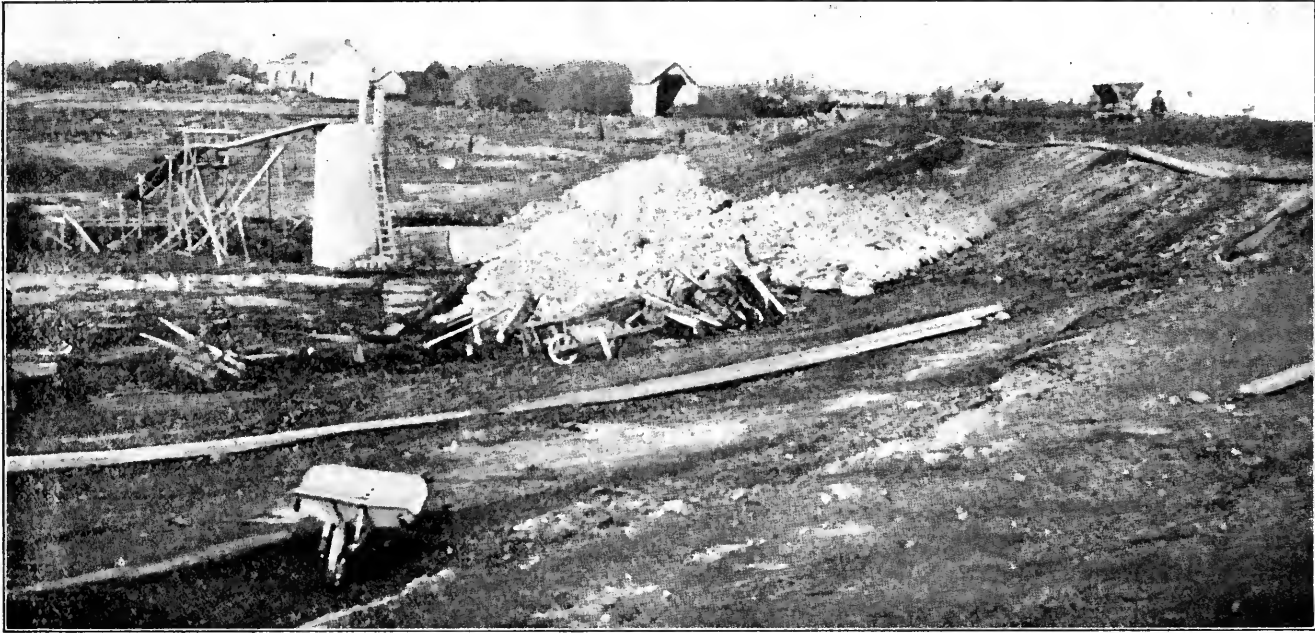

THIRTY-THOUSAND YARD EARTH DAM AT FRENCH SEAPORT BUILT WITH PICK AND SHOVEL

both he and his horse had passed away by this time—I climbed up a steep bank from the roadside, and there, about a hundred yards away was a long low wooden shack with a sign bearing the magic words "Headquarters, 'Steenth' Engineers." I had reached port at last!

Headquarters was a busy place. Typewriters were clicking away noisily. Uniformed men were bent over drafting boards. Others were engaged, apparently, in computing work. A group of surveying instruments was stacked in one corner of the room, and a first sergeant, coatless, with sleeves rolled up elbow high, was busy with a batch of reports which he was filling out on a sort of combination desk and military trunk. To him I presented my card and was soon escorted to the Colonel's private room. The Colonel had left town, I was informed, but Major A—, in command of the unit during his absence, gave me a hearty greeting.

Now the "Steenth" Engineers is one of the so-called "Railway Regiments" which were recruited with volunteers early in the war, and were among the first American troops to arrive in France. This particular unit is made up very largely, although not exclusively, of men from the South. About 1200 strong when it left the states, it has grown in numbers, principally by the addition of labor battalions, until its quota is now several thousand men. Its operations cover a territory about 210 miles long and 150 miles wide, and its work

storage yard on the flat lands which flank the waterfront. There are projected also four new steamship piers, each 1000 ft. long, with the necessary unloading equipment and trackage to hook them up to the freight classification yard and storehouses. These new piers, which will have a 30 ft. depth of water, will have a docking capacity sufficient for 16 ships at one time.

Work on the big railway yard is now in progress. The job is essentially one of track laying and very light grading as the ground is practically flat. Steam shovels are at work in a borrow pit delivering sand for track ballast, as this material, it has been found, will answer the purpose well enough; crushed rock is a very difficult commodity to secure. At the time of my visit one Marion steam shovel was in operation and two large Bucyrus and one Marion machine were being set up. Other equipment included half a dozen locomotive cranes of from 5 to 10 tons capacity. The installation of the trackage in the railway yards is calling for a sand fill of about a foot or so over the entire area. But the tracks are, of course, only part of the project. There will be 4,000,000 sq.ft. of covered freight storage structures and about 9,000,000 sq.ft. of uncovered storage area. Steel for some of these buildings is on the ground and I saw a few of the bents in course of erection. All connections are bolted, as there are no facilities here for riveting.

At the existing docks American labor units and

gangs of German prisoners were rearranging the trackage system and replacing the French turntables, which are too short for American rolling stock, with curved track and switches. A small amount of concrete was being placed between the rails, but all of this was hard work, the mixing being done in small batches on wooden platforms which were moved about from place to place as occasion demanded. Lack of construction plant is, of course, responsible for so large a use of hand labor methods. The engineers, however, are on the lookout for mechanical equipment, and have scouts in various parts of Europe whose job is to corral anything that can be shipped quickly to the work. One of the officers of the "Steenth" Engineers who has had wide experience in the purchase of supplies got news of a big steam shovel in Spain which had been used on some hydro-electric construction work in that country. Agents were dispatched to round up this excavator and through their quick action it was purchased, delivered, and set to work digging sand for track ballast. In like manner quite a sizable consignment of railroad ties from Portugal was secured. Anything of this sort that can be done to reduce the demands on transatlantic shipping is considered good business.

While the railway yards and docks are engaging a portion of the strength of the "Steenth" Engineers there are scores of other jobs which the organization has been called upon to do. "Although we are, in name, a railway regiment," Major A— explained, "we have tackled about every sort of job which you can imagine since we landed in France. Let me give you an idea of the variety of our program. At two near-by towns we are building hospitals, sewerage systems and dams for water-supply, and are assisting in the double tracking of one of the French main line routes through another town. At another place we will soon begin construction on a division engine terminal, an overhead railroad crossing, and a yard for car erection. Additions to hospitals in the form of one-story timber structures have taken up a large part of our time. At one large base hospital we are putting in a new water-supply system which involves the construction of a curved concrete dam about 40 ft. high. For supplying water to the town near our camp we have almost finished an earth dam containing about 30,000 cu.yd. of material. The laying of 15 miles of 16-in. pipe, the reconstruction of a water-filtration plant and the provision of Imhoff tanks for sewage disposal are other details of our work."

"How about the German royalties on the Imhoff tank patents, Major?" I interrupted.

"Let them come over and collect them," was the Major's reply.

I spent the afternoon in an automobile trip, inspecting features of the regiment's varied work. The earth dam was well along toward completion, but it, like



HAND DRILLING IN CUTOFF TRENCH FOR CONCRETE DAM

most of the other jobs, had been a hand labor proposition. Shovels, wheelbarrows, and a line of narrow-gage industrial track and cars constituted the main items of plant equipment. At the concrete dam the work was in its initial stages and the main operation at the time of my visit was rock excavation for the cutoff wall. This job has been let by the Army to a Mexican contractor. Rock drilling was as usual being done with hand tools, although on this job I saw two concrete mixers, the first machines of their kind which have come under my observation since I have been in France. Another job we passed by was a steel frame structure which was being built for the assembly and repair of motor trucks and automobiles.

This, then, is a sketch of the work which a "railway regiment" has done and is planning to do. But the important thing about it all is this fact: No matter how diversified have been the demands upon them, the "Steenth" Engineers have been able to produce from their organization men qualified to handle every one of the scores of different jobs assigned to them.

# Human Problem Thought of Paramount Importance in Paris Shrapnel Plant

Health of 6000 Women Employees in Total of 9000 Studiously Safeguarded, and Provisions Made for Care of Their Infants—Excellent Meals Served at or Below Cost in Large Dining Hall

By ROBERT K. TOMLIN, JR.  
War Correspondent of Engineering News-Record

IF YOU had been in Paris three years ago and had decided, in a whimsical mood, to leave the beaten track of the tourist sightseer and visit the most commonplace and uninteresting spot in the whole city, you could not have selected a better objective than the strip of land which flanks the River Seine in the western outskirts of the town, known as the Quai de Javel. A few rickety buildings of the typical "shanty" type, a machine shop or two, and here and there patches of ground devoted to truck gardening—these would have been the sights to reward you for your trip. But all this was three years ago. That spot has since undergone an almost magical transformation. Acres of long, low buildings have sprouted upon it, railroad cars and motor trucks are busy delivering to and taking away from it huge volumes of material, men and women by the thousands come and go daily, and the steady hum of machinery continues day and night. And all of this activity is the result of a man with a purpose. In the early days of the war André Citroen decided to manufacture artillery munitions. He chose the Quai de Javel as the site for his plant. Ground for the foundations of his shops was broken in March, 1915, and four months later—in July—buildings were erected, machinery installed and finished shells were actually being shipped to the front for use by the famous French "soixante-quinzes," "75s."

But this was only the beginning of things. Citroen is not the kind of man who is content to do things on a small scale. Starting with a daily output of 10,000 shells, the plant capacity was soon increased to 20,000: in 1916 the output was again doubled, and today the enlarged works are delivering the stupendous quantity of more than 50,000 shells every day. Along with this achievement other things have happened. War's draft upon the manhood of France has made the manufacture of munitions largely woman's work, thereby introducing into the industrial problem entirely new elements. Obviously, old precedents had to be discarded and new conceptions of machine shop administration formed. To this task Citroen applied himself with characteristic energy, individuality and thoroughness, and created a new order of things in French industrial life, the workings of which I was permitted to observe during a recent tour of the plant. The outstanding impression which I carried away was this: In organizing the work of producing 50,000 shells day after day at the Citroen plant, the human problem—the problem of the worker as a woman or man—has received fully as much attention by the executive heads of the company as has the problem of machines and materials.

My visit to the great munition-producing center was arranged through the French "Maison de la Presse," and of course credentials of one sort or another had to be viséd before the necessary permits to enter the works could be obtained. It was Thursday, "visitor's day," and in our party of inspection was George Randolph Chester, creator of "Get-Rich-Quick Wallingford," his wife, a French lady who is a specialist in social welfare work, a Spanish journalist and one or two others besides myself.

We began our tour through the executive offices, first visiting the library in which 100,000 volumes are available for the use of the company's employees. Then we passed through the chemical, metallurgical and testing laboratories, all equipped with the most up-to-date apparatus. Noon found us at luncheon in the *cantine*, or huge dining hall, which seats 2700 employees at one time. After we



DINING HALL WHERE 2700 EMPLOYEES CAN BE SEATED AT ONCE  
Note the ever-present electric truck on the right

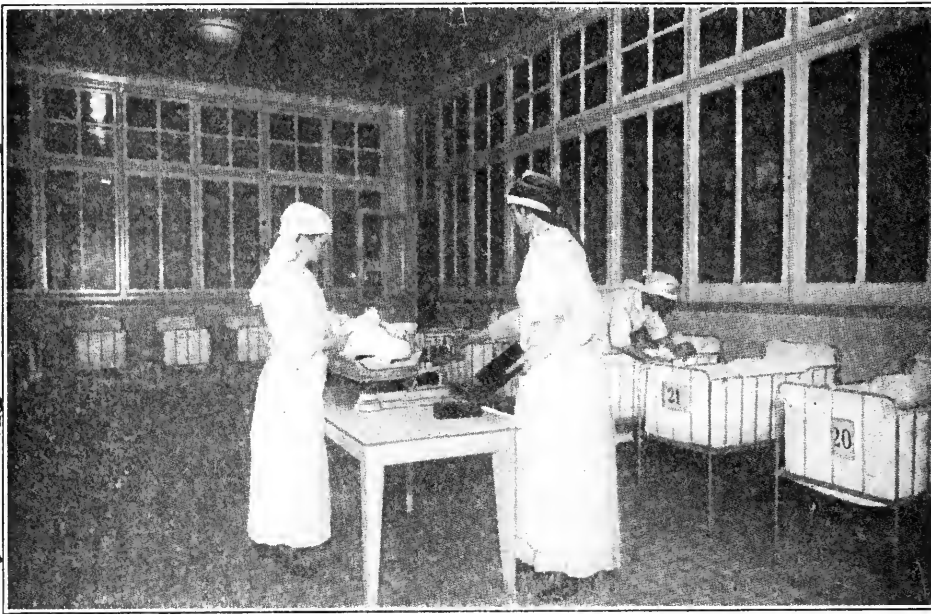

QUARTERS FOR THE CARE OF INFANTS OF WORKING MOTHERS

locker number and the number of the timeclock on which he checks in and out. By the system which has been developed a man can be set to work in a few minutes. After six months at the same kind of work an employee, on request, is assigned to different duties.

Two systems of wages are in force—payment by piecework and by time. On time work all employees performing the same kind of duties generally receive the same wages, but in some cases bonuses are paid, depending on the diligence and capacity of the worker. Wherever possible, however, payment is made on the piecework basis. To save time in paying off the workers the following

had finished our meal we made the tour of the various shops, and ended by inspecting the welfare institutions which form an important part of the administrative scheme of the works. Our guide during the day was the company's dentist, a French Army officer, who had formerly been a student at the University of Pennsylvania. Readers of *Engineering News-Record* will not be interested in the details of the process of shell manufacture, but should be in what we may call the human side of the institution—and it is an institution.

At the time of my visit the employees numbered about 9000, and of this number 6000 were women. The work is conducted in two shifts of about 10 hours each. The day shift of 6000 employees comes on at 7 a.m.; stops at noon for *depeuner* (lunch); resumes work at 1:30 p.m., and continues until 6:30 p.m. The hours for the night shift (3000 employees), are from 7:30 p.m. to midnight, and from 12:45 a.m. to 6 a.m. About one-third of the employees live in the immediate vicinity of the works and arrive and depart on foot. For the others there are adequate transportation facilities, as the Qual de Javel station of the "Metro" (the Paris subway) is only a few minutes walk from the shops, and street-car lines are also within easy reach.

After an applicant for employment has been examined by a superintendent he is assigned to a shop and receives a time card, a service card, a card indicating the name and location of his particular shop, the name of his foreman,

scheme has been developed. Only even sums of money are given out, irrespective of the actual amount which has been earned. The balance is credited and issued on the next payday. Payment is made fortnightly from about 100 windows, and from each window sums of only one amount are issued. For example, there will be a window at which sums of 70 francs—and only 70 francs—are paid; another for 80 francs; another for 90 francs; another for 100 francs, and so on upward. In order to receive their wages employees must present vouchers. To aid in still further simplifying the procedure, payment cards of various colors are used, and the corresponding colors are painted on the pay windows. A bureau for adjusting complaints is open continuously.

General or special announcements to the force are made either in the form of printed sheets or (at night)

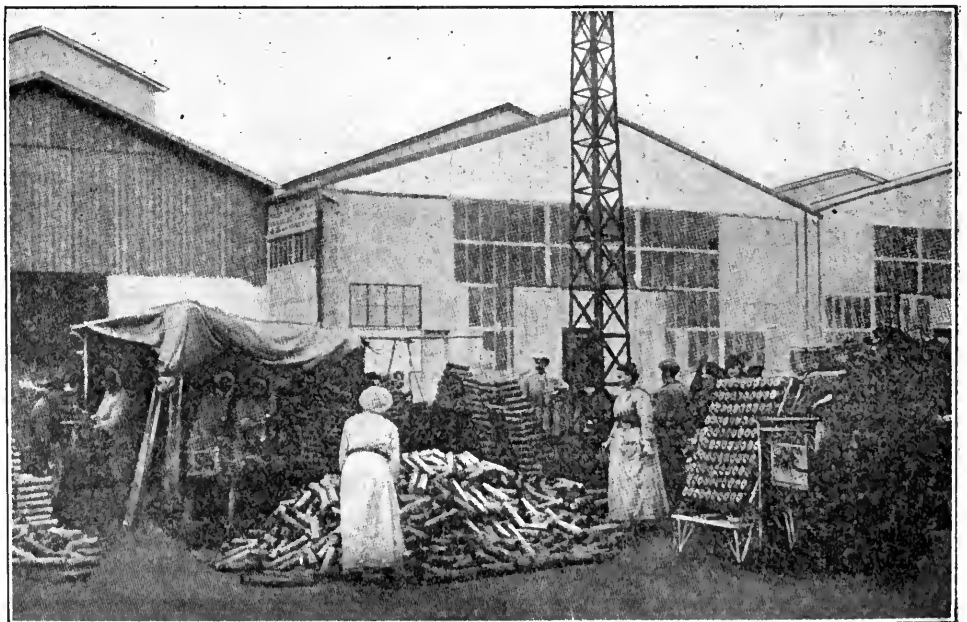

TRUCK REMOVING SHELL FORGINGS FROM AN INSPECTION POINT

of illuminated signs over the shop exits. A service for investigating absences from work, by means of visits to the homes of employees, also has been organized.

Very elaborate measures have been taken to safeguard the health of employees. They assume two forms; prevention and cure. On the side of prevention frequent lectures on sanitation and the care of the human body are given, there being special conferences at which female ailments are discussed. Care of the teeth is considered so important that the plant employs regularly a staff of dentists, and has provided them with offices equipped with every modern dental appliance. At the dental rooms 100 patients can be treated every day. Printed bulletins on the care of the teeth are issued regularly. Of course there is also an infirmary with doctors, both male and female, in constant attendance.

One of the most spectacular things which Monsieur Citroen has developed is his *cantine*. I had the pleasure of eating luncheon in this mammoth hall, receiving the same fare as the workers. And a mighty good meal it was—*hors d'oeuvres*, bread, roast lamb, beans, red wine, baked apples and coffee. This meal, without the wine, costs the employees 1.50 francs (26¢ at the present rate of exchange on French money), but I was informed that the company loses about 1 franc per head at this rate. The food is cooked in a large, well equipped kitchen and is delivered by means of electric trucks to warming ovens at the ends of the transverse aisles in the hall. It must be remembered that the job of feeding 2700 people in one hall involves the transport of food rather long distances, and unless mechanical means were employed the service would be slow and the dishes cold.

Men and women eat together at the same tables, and the meal is much more prolonged than would be the case with American mechanics. An hour and three-quarters is allowed for luncheon. With the French this meal is a leisurely occasion, and this characteristic was well exemplified at the *cantine*. There is no bolting of food. It is eaten slowly, between sips of wine, which is supplied at a small extra charge. Another point is that service by uniformed waitresses is provided and that dishes of meat and vegetables are passed to each individual so that taste as to the size of the helping can be satisfied.

Adjoining the *cantine* is a clubroom, where the employees, men and women, can spend what remains of the luncheon "hour." I saw the men here playing billiards and chess and the women in groups talking, knitting or playing games. This luncheon "hour" forms a decided break in the day's work, and offers means of complete relaxation. Whether or not it is his usual custom I do not know, but on the day I visited the plant M. Citroen

himself ate at the table adjoining ours in the *cantine*.

In works where so many women are employed the matter of childbirth presents a rather important problem, which resolves itself into two main subdivisions—the woman about to become a mother, and the newly born infant. With the probable increase of woman labor in United States machine shops this question is one which American executives cannot dismiss lightly. Here is the way the situation is dealt with at the Citroen plant. The prospective mother receives 30 francs a month in addition to her regular wages, and must visit the company's doctor twice a month. When her condition becomes such as to prevent her from performing her regular duties in the shops she is sent to a hospital, where all of her expenses are defrayed by the company. After giving birth to the child the woman is sent to rest quarters, where she remains six weeks before returning to work.

For the newly born infants the company has a special

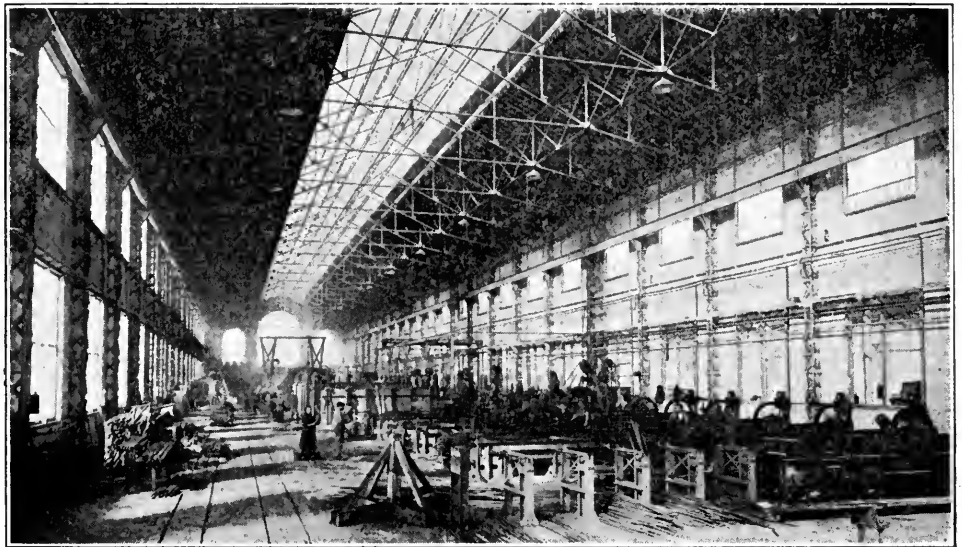

TUBE-DRAWING SHOP FOR SALVAGING REJECTED SHELL BODIES

building, called the *pouponnière*. Here the children remain day and night, if the parents so desire, under the care of competent nurses. The mother calls for her baby on Saturday, takes it home over Sunday and returns it to the *pouponnière* when she comes back to work Monday morning. During the regular hours of shopwork each mother is allowed two periods for visiting and nursing her child, while additional visits are made before and after hours and after luncheon.

I was taken through the *pouponnière*. It is light and warm, finished inside with white and blue tile, and is kept scrupulously clean. Every one of the 30 cribs in the ward through which I passed was occupied by a healthy looking infant. M. Citroen, however, is going one step farther than the *pouponnière*. He is now building a *garderie*—a building to which the children from the *pouponnière* will be transferred when they have begun to develop. As an indication of the detail into which this man goes when he undertakes anything, he has purchased a large consignment of puppy dogs for the children in the *garderie* to play with. This institution will be large enough to house at one time 150 sons and daughters of the plant's employees.

Various educational and amusement facilities are furnished to the men and women who are turning out shells at this plant for the French Army's 75-mm. field pieces. Every Saturday night in the huge *cantine*, or dining hall, a moving-picture program is given. Seats are provided for 3500 workers and members of their families. There has been organized among the employees a band of 60 instruments, which gives concerts on these evenings. On Christmas and other holidays special programs of entertainment are arranged.

In fact, the features other than those directly connected with the manufacture of shells are almost endless. A coöperative store, where goods and food are bought in bulk and sold practically at cost; classes in

English, physics, mechanics and metallurgy; a legal-aid department; a social club, a company newspaper, and a library are a few of the special activities.

As we finished our tour of the works and were about to depart, I turned to our guide. "What will become of this institution," I said, "with its thousands of employees and thousands of machines, after the war, when France will not need 50,000 shrapnel a day? I suppose there will be a wholesale lay-off of workers." He smiled. "On the day peace is declared," he replied, "M. Citroen will have completed plans for taking on 10,000 new men from the returning armies. From shrapnel we intend to transform our plant output into automobiles and agricultural implements."



# Water-supply at the Front in France

Engineering Work for American Forces Centralized in Specialists—Horses Important Factor in Quantity Estimates—"Water Points" Must Be Provided—British and French Water-Supply Practice Reviewed

BY ROBERT K. TOMLIN, JR.  
War Correspondent of Engineering News-Record

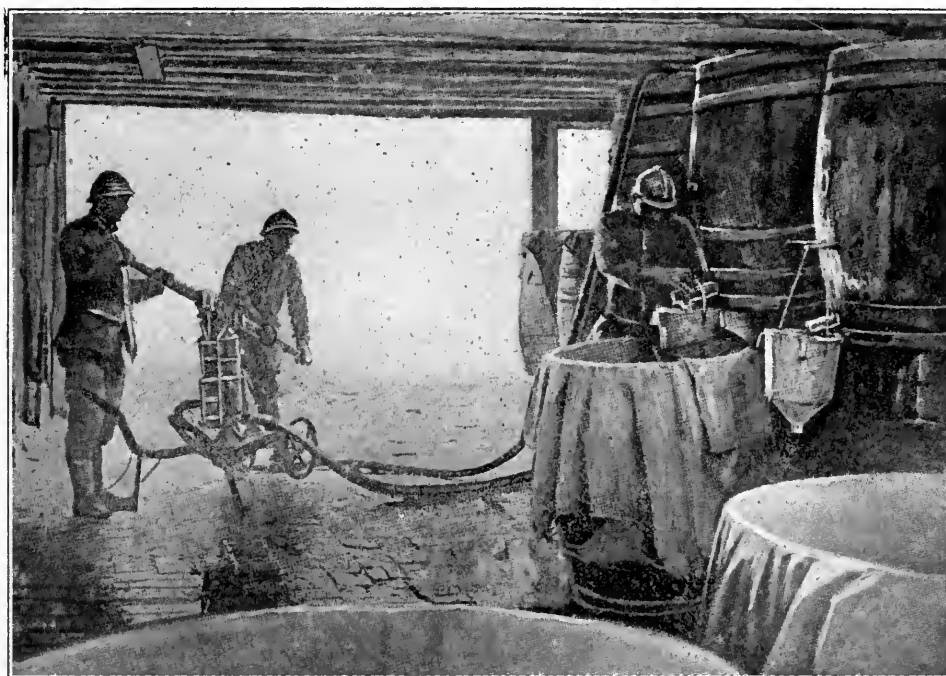

French Official Photo  
A WATER PURIFICATION "PLANT" OPERATED BY THE FRENCH IN THE MARNE SECTOR

DURING a recent interview at our general headquarters in France, the chief engineer of the American Expeditionary Forces in telling me about the activities of our technical troops, made this remark: "In addition to what you can now see in the field, our engineers have done a tremendous amount of work the results of which, as yet, do not all appear on the surface." At the time I did not appreciate the full significance of this statement. A little later that day, however, after I had been given an opportunity to inquire into the subject of water-supply for American forces in the field, its real meaning became clear. This problem, involving two great subdivisions, water-supply for the advance areas and for the sections of the rear, is one of countless ramifications; one that has demanded a prodigious amount of detailed preliminary investigation, for into its solution enter not only most of the factors with which the water-supply engineer in civil life has to deal, but also scores of others arising out of the special conditions of modern warfare.

These investigations of our army engineers in France have led along some strange bypaths, routes unexplored in the course of ordinary municipal water-supply practice at home. How much water does a horse or a mule drink daily? What is the minimum requirement per capita for troops during an advance? What is the best means of sterilizing water on the field? How shall pipe lines, pumping stations and tanks be protected from shell fire? Shall each army, corps or division be responsible for its own water-

supply, or shall this matter be controlled for all of our forces directly from headquarters? To what extent can water be delivered by pipe lines, and how much pipe can be procured in France? Where should pipe-line delivery stop and transport by motor truck, light railway or animals begin? How much water does a soldier need for a shower bath, and how often should he be permitted this luxury? These are samples of the questions our water-supply engineers at the front have been busy answering. And from the answers it has been possible to evolve two very important things—a policy governing the supply of water to the American Expeditionary Forces and an organization to direct the work in all of its branches.

In the development of this organization we have been fortunate, for we have been able to profit by the experiences of the British and French armies, which have been placed so freely at the disposal of our engineers. We have been able, for instance, to avoid the mistake of making *mobile* units directly responsible for their own water-supply. We have, at the very beginning, done what our Allies did only after paying the price for their experience, and reorganizing their systems of water-supply: We have organized water-supply on a *geographical* rather than upon a shifting military unit basis. By this I mean that the service of water-supply has been established as an organization attached to headquarters, and, through the chief engineer, A. E. F., exercises central and direct control over all field operations by means of districts. *The geographical constancy of the men*

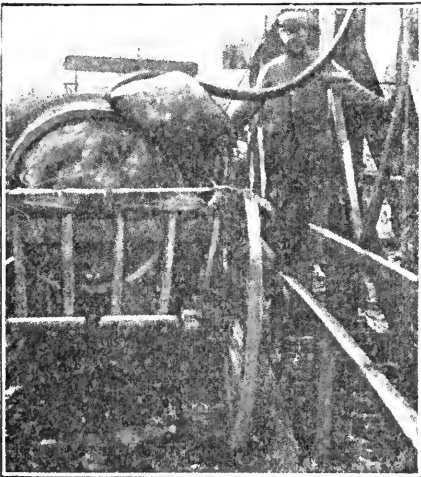
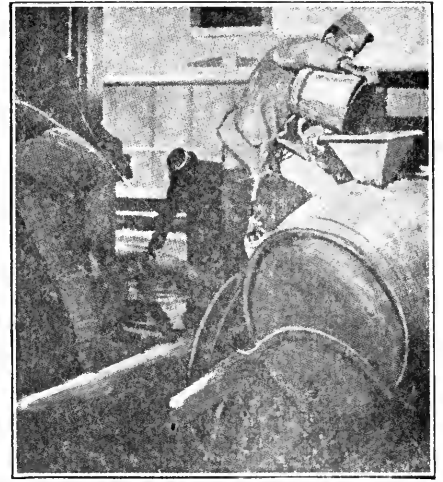
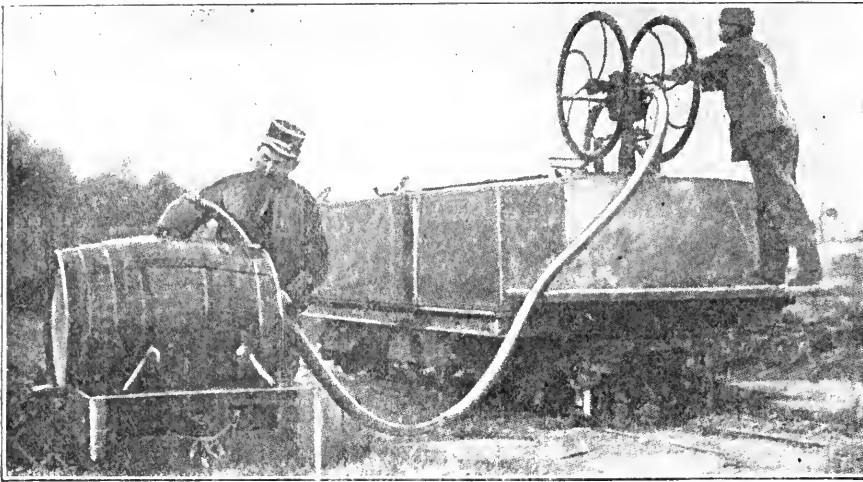

French Official Photo

VARIOUS FORMS OF CARTS ARE USED FOR WATER DELIVERY IN ADVANCE AREAS

engaged in water-supply field work, therefore, is assured, irrespective of the shifting from one sector to another of divisions or other units. The big advantage of this plan is that the water-supply force in each district remains continually in charge of work with which it is familiar, instead, as was the case in the first year of the war, of being moved from one locality to another, facing a new set of conditions, with regard to the supply of water, at each shift. The accompanying diagram of organization indicates the tentative lines along which we are working, and is of course subject to modification as experience shows such alteration to be desirable.

The principal uses of water in the forward areas—and it is with the forward-area work only that this article will deal—are these: Drinking (men and animals); laundry; culinary; locomotives and steam boilers; washing wagons and harness; shower baths and fire protection. Behind a rapid advance of troops the following methods of supplying water are employed: (1) Hand portage in bottles and cans. (2) Horse-drawn carts. (3) Tank trains and cars. (4) Construction of new water delivery points. (5) Laying new pipe lines. (6) Equipment of advance pumping stations. Each case determines the method or combination of methods that will serve best. Past experience has shown, however, that most advances are more or less intermittent, with lapses of time between move-

ments, which allow the water-supply forces to install first-aid pumping stations, pipe lines, and water points for the use of large numbers of horses, hauling artillery and supplies. This work must be done under shell fire. Pipe lines are broken and must be kept in repair. Mechanical equipment is pretty much of a minus quantity. Casualties deplete the working force. But come what may, the water-supply engineers must stick to the job and keep the delivery of water close up behind the troops moving ahead.

Having reached the decision that geographical constancy should be the basic element of the Army water-supply work, the chief engineer, A. E. F., authorized the creation of a new department, the Service of Water-supply and Sewerage, and placed at its head a colonel of engineers who, after graduation from West Point and service some years in the corps of engineers, became associated with Allen Hazen, consulting engineer, New York, for whom he took charge of many important water-supply projects, among them being the large filtration plant at Toronto. The chief of the water-supply service, A. E. F., is responsible for all water-supply and sewerage work undertaken by the forces in France, including design, construction, supply of materials, laboratory control of quality of water, and investigation of water resources. Collaborating closely with him in this work, and directly in charge of the office which handles much of the water-supply work

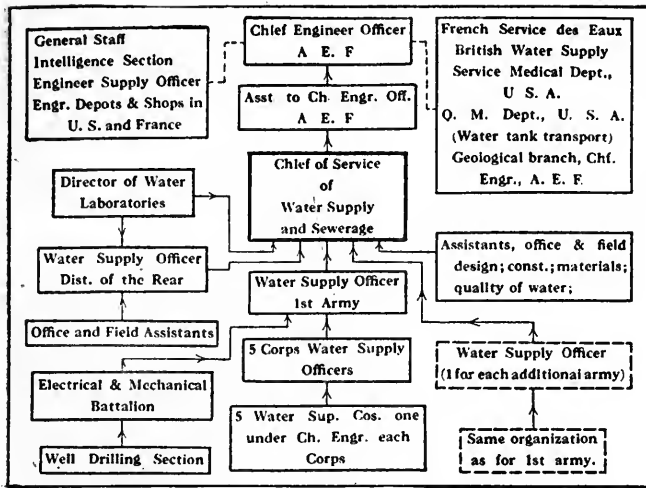

TENTATIVE ORGANIZATION SCHEME FOR WATER-SUPPLY OF AMERICAN FORCES AT THE FRONT

connected with American interests in France outside the zone of the armies, is another engineer officer whose qualifications result from long experience on New York's Catskill Aqueduct and other important projects.

The field work, as now contemplated, will be controlled by districts, each district including the area occupied by one army. The district, in turn, will be subdivided into sections for each army corps. There will be, therefore, water-supply officers representing the chief water-supply officer, A. E. F., in each army, and in each corps area. If a corps should move to a new position in the field, and another corps take its place, the original water-supply officer of the corps would remain. For every army there will be, also, an electrical and mechanical battalion and a well-drilling section, reporting through the chief engineer of the army to the water-supply engineer of the army. Through each chief engineer of a corps the water-supply officer of the corps will have control of a water-supply company, made up of picked men. Then, too, there will be a director of laboratories, with a staff of assistants for office and field work, reporting to the chief water-supply officer, A. E. F. Through the chief engineer, A. E. F., contact will be had with the British Water-Supply Service, the French *Service des Eaux*, the medical and quartermaster departments, U. S. A., the engineer supply officer and the various engineer depots and shops



French Official Photo

A HASTILY MADE "WATER POINT" FOR HORSES—TROUGH MERELY A WATERPROOF CANVAS SHEET HUNG OVER A WOODEN FRAME

both in France and the United States. There is, in addition to the organization outlined above, a force which is in charge of water-supply in the district of the rear. This does not come within the scope of this article. It reports through the water-supply officer, district of the rear, to the chief of the water service, American Expeditionary Forces.

In organizing our water-supply work along the lines indicated we have followed in a general way the scheme which has been found to give the best results in both the French and the British armies. In the early days the French delegated the work of water-supply to each division, to be performed as fatigue duty by troops taken at random from tactical units. Generally these troops had little or no knowledge of the work, their technical control was inadequate and a general state of confusion and inefficiency was the result. In 1915, with the creation of the *Service des Eaux*, a big change for the better was wrought, for in each army a chief of water service was appointed and about 1000 engineer

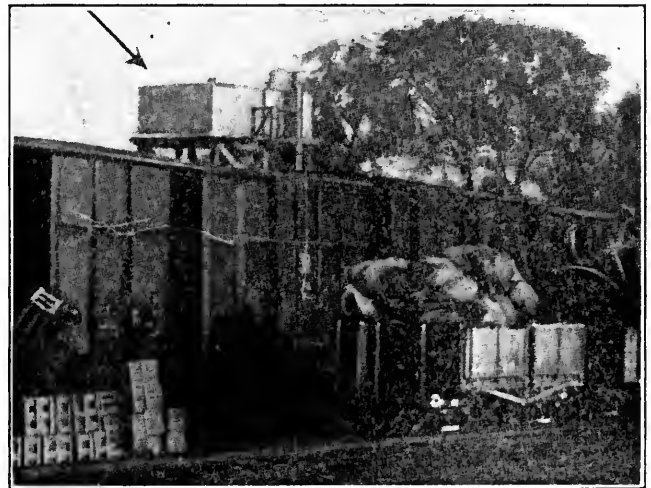

British Official Photo

ELEVATED TANK (IN BACKGROUND, CENTER) FOR SUPPLYING WATER TO RAILWAY LOCOMOTIVES

troops were given him for the performance of water-supply work. A similar change occurred in the British armies, where, until 1915, field companies were assigned to water-supply. The creation of a separate service, composed of men trained in this branch of engineering, became imperative and the Service of Water-Supply for the British armies was the outcome.

The chief of the water-supply service for the American forces and his assistants have made a thorough study of methods employed behind the British and French fronts. To a large extent water for our allies is obtained from wells. The British territory is underlaid with chalk, and it is necessary to sink driven wells from 150 to 250 ft. to reach the level of saturation. With two shifts the drilling progress on a 6-in. hole varies from 20 to 60 ft. a day, and the yield per well may range from 50 to 150 gal. per minute. In the Somme valley, British troops used river water, which was passed through purification plants mounted on barges. About four-fifths of the French army water-supply in the region of Verdun was obtained from wells. Wells dug by hand, in addition to drilled wells, are also employed to some extent—one of these was put down to

a depth of 65 ft. If time permits, these dug wells are lined for the upper 10 or 12 ft., and a curb 2 ft. high is built around the top to prevent debris or waste water falling back into the well. For dug wells a round section about 4 ft. in diameter is common.

The engineer in civil life who is accustomed to design a water-supply system on the basis of a consumption of 150 to 200 gal. per capita per day must reconstruct his ideas when he reaches the front and compares these figures with military allowances for advance areas. For an advancing army the consumption oftentimes must be as low as  $\frac{1}{2}$  gal. per soldier daily. Three days after the beginning of a movement, during which time the water-supply forces have been able to extend their lines forward, the allowance per man daily is increased to 1 gal. For the guidance of engineers of our army water-supply forces, the following table of allowances and rationing, based on the experience of the British and French, has been prepared:

WATER-SUPPLY ALLOWANCE AT THE FRONT

Kind of Service	Gallons per Man or Animal per Day
Advancing army (men)	0.5
Animals (drinking)	7.5
Army after 3 days (men)	1.0
Field hospital	5.5
Rear regions	10.0
Base hospitals	25.0
General use at stables	10.0

As to allowance of 1 gal. per man daily, British records show that a 6000-gal. overhead canvas tank,

filled once a day, supplied an army camp of 6000 men without serious complaint. Of course, in this case, as in all others where water is at a premium, a very strict surveillance is kept over consumption, and policing at water points prevents waste. In the instance cited no cart was allowed to fill from the overhead tank without a ticket of permission from the area commandant.

For advance areas the present war has developed the "water-point," which assumes various forms. It may be a well, the end of a pipe line, a trough, an elevated tank of metal or wood, or merely a reservoir of canvas. It establishes, however, a line of demarkation between the work of the special water-supply forces and the troops in the field—between producer and consumer. The water-supply service establishes these water points at frequent intervals, and divisional or other units must assume responsibility for getting the water from them to their men and animals by light railway, wagon transport, motor truck, hand carrying, or such other means as the local situation may demand.

During an advance the sequence of operations relating to water-supply begins with horse-drawn transport by individual military units from existing water-delivery points. Then, as the distance from these water bases to the new front increases, water-tank trains operate up to a point where pack-mule or other service begins. These water-tank trains are operated by the

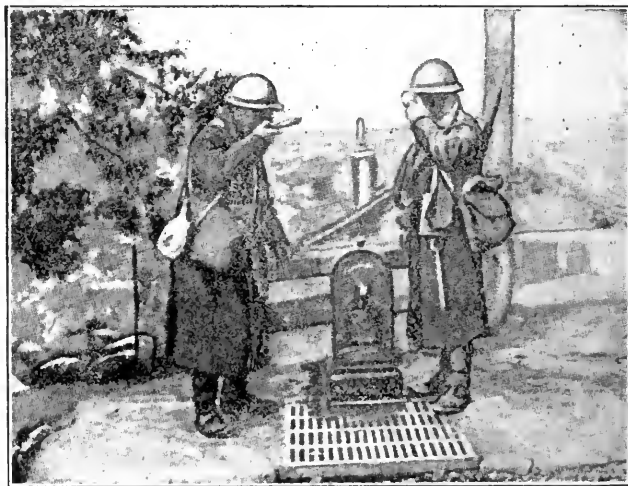
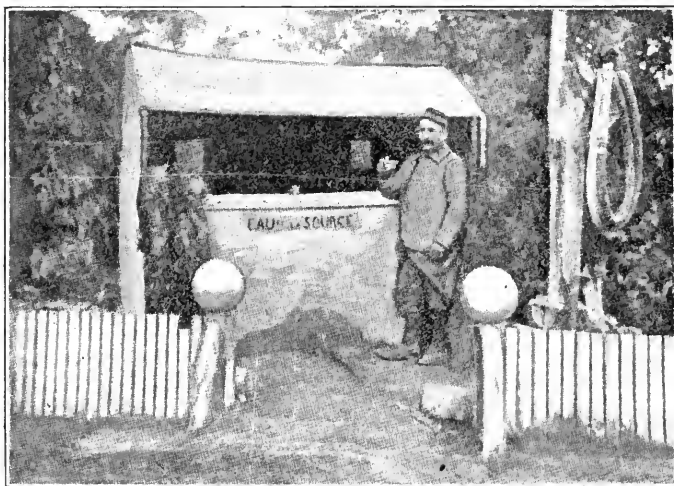

French Official Photo

A FEW OF THE PLACES ALONG THE FRENCH FRONT WHERE POILUS MAY QUENCH THEIR THIRST

quartermaster department, and tide over the period during which engineers of the water-supply service are establishing new water points in advance of the old ones. It is absolutely essential for the success of the movement of troops forward that the distance between water points and the rear of advancing units shall not be so great as to make transport of water difficult. As a general rule, I am told, this distance should not exceed four or five miles. The extreme range of water-tank transportation is set at 10 miles, to which not more than three miles should be added for delivery by small carts or pack mules. Obviously, any such distance as 13 miles between a water-delivery point and the point of actual consumption can be maintained only for a very short time. If the roads are congested this distance must be halved to insure service that is all effective.

During forward movements frequent use is made of "first aid" tanks. These are established as far forward as possible, and offer a means of supply until a more permanent water point can be established. These "first aid" tanks are nothing more than large pieces of sail-cloth, waterproofed with tar and pitch, or linseed oil and pine resin, laid directly on the ground and banked up around the sides with sand bags. It is desirable to cover them with some form of camouflage screen as the reflection of the water in the sunlight discloses their position to aviators.

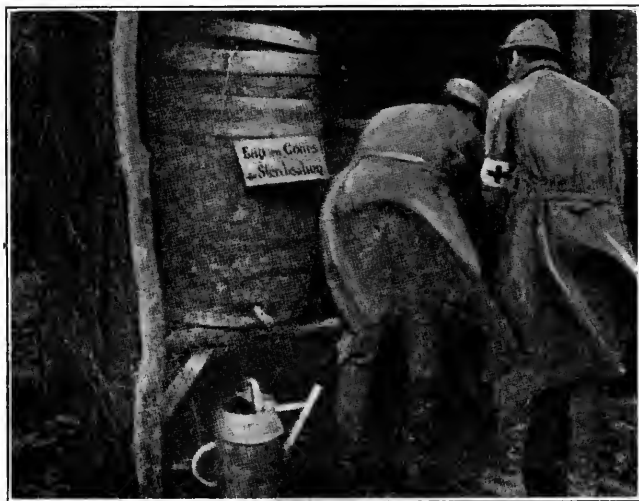

*French Official Photo*

WATER IN BARREL AT LEFT IS BEING STERILIZED (PROBABLY BY HYPOCHLORITE OF LIME)

Traveling along the roads back of the front one sees numbers of these water points. A typical one (British) consists of one 9000-gal. canvas tank; one 2300-gal. canvas tank; one 200-gal. galvanized-iron tank; six 600-gal. canvas horse-troughs; one water-bottle filler.

Here are a few other types: (A) Air-lift pumping station; 2800-gal. tank reservoirs; main pipe line; elevated storage tank, feeding (1) elevated trough for filling carts, trucks and flat cars (2) tank for filling canteens (3) watering trough for animals, with cordu-



*French Official Photo*

SOLDIERS IN THE TRENCHES MUST HAVE MEANS OF FILLING THEIR WATER BOTTLES

roy "standing" and heavy guard rails around it (B) Pumping station delivering water from stream; elevated storage tank; pipe line to distribution troughs and elevated tanks for filling trucks (C) Well-pump in tent delivering direct to trough (this layout included a fire-hose under a culvert crossing as part of the main pipe line (D) Depressed concrete reservoir filled with water delivered by means of light railway tank cars; pipe line to elevated troughs for filling water carts; also concrete troughs for animals.

Water points should be located near highways, but not directly alongside main routes, as they would tie up traffic. Where horses must be watered it is very important to build "standing" around the troughs—this may be plank or any other paving material which offers solid support. Without "standing" the horses' hoofs cut up the ground until it develops into a veritable bog. Among the consideration which must enter into the location of a water point are ease of access; permanency; demands upon the supply; liability to congestion; safety from shell fire; concealment from enemy observation, and drainage.

The last consideration, drainage, is of great importance, and where possible a water point should be located on a side-hill. In this case water slopping over during the filling of tank wagons or spilled along horse troughs is quickly carried off, preventing the formation of mud. It is difficult to have a true appreciation of the mud over here unless one has actually tried to navigate through it. Officers of our water-supply service have told me that several of the large water points established by our allies had to be abandoned because of poor drainage facilities. The stamping of thousands of hoofs daily around a water point puts the ground to a severe test, and it must be well drained and paved if it is to be of any use.

In the design of water delivery points at the front, engineers must give a great deal of attention to the horse and mule. This applies not only to the actual

design of troughs, etc., but also to computations and estimates of the quantity of water it is necessary to provide. A few references to conditions earlier in the war will serve as illustrations. Back of Verdun in 1915 the French had a concentration of 175,000 horses. For 100,000 animals in the second army (French) alone it was necessary to supply daily 2,800,000 liters of water, equivalent to about 7½ gal. a head. Another census at a French veterinary hospital, with 1200 horses, showed a per capita consumption of 8½ gal. daily, this figure including water used by attendants, waste, washing horses and cleaning troughs. In the valley of the Somme the British, during one week, supplied 50,000 horses with an amount of water equivalent to 5½ gal. per head per day. Ordinary British practice, however, has adopted a daily supply of 8 gal. per horse daily.

So important is the matter of horse watering in modern warfare that it is one of the controlling factors in water-supply estimates. In a recent report the water-supply officer of the American Expeditionary Forces devoted many pages to this subject—and the report, let it be said, was on the general work of advance-area water-supply, not specifically on water-supply for animals. The tables of organization for the United States Army show, approximately, about 1 horse per 5 men, but in an advance the animals will be concentrated at the front so that the ratio may change to 1 horse per 3 men, as is said to have been the case in the French forces back of Verdun. Thus, recalling the fact that an animal needs from 7 to 10 times as much water as a man, it is clear that the water-supply engineer must often provide more water for animals than for the men actually engaged in fighting.

The watering troughs are simple affairs, consisting generally of wooden frames supporting canvas containers. They extend often to great lengths, however. The British have one run of trough 720 ft. long, composed of eight 90-ft. sections, fed from three 1500-gal. canvas tanks elevated 15 ft. above ground. Separate lines of 4-in. pipe deliver water to groups of four trough sections. At this point a city fire engine pumped 10,000 gal. of water an hour into the tanks, which, however, were bypassed, and delivery was made directly into the troughs when horses arrived in large numbers. The chief of our water-supply service, during his investigations among the British and French armies, found that a trough gives from 100 to 150 waterings per yard of trough daily, but that with good service and constant watering throughout the day this number can be doubled. The French have found that when horses succeed one another without interruption along a 20-m. trough, at least 8 cu. m. of water per hour must be supplied. About 6000 waterings a day is an ordinary performance for a 20-m. trough. As a rough guide, the British estimate 200 horses per hour at a 30-ft. trough. A 90-ft. trough, it has been found, can accommodate 40 horses on each side at one time without undue crowding.

In addition to the figures covering the drinking water allowances for men, previously given, the following on shower bath requirements are worth noting: A 6-in. shower head must be fed with at least 3 gal. per minute (the pressure of course being very low). Four such shower heads, supplied with from 800 to 1000 gal. per

hour, are estimated to be sufficient for baths for 2000 men in 24 hours.

The experience of the British and French has indicated the desirability of having as few different sizes of pipe as possible. Wrought-iron pipe, 18-ft. lengths with screw couplings, in three sizes, 1, 2 and 4 in. in diameter, is much used and has demonstrated its usefulness. During a hurried advance pipe must be laid on the ground surface, but in this position, of course, it is exposed to rupture by shell fire, and should be covered at the earliest opportunity. Pipe should never be laid on the surface of continuous *straight* lines, as expansion due to the sun's heat is apt to cause breaks. Wavy lines are always recommended.

The British practice is to have an advance pipe-laying gang proceed with all rapidity, leaving gaps in the line for sharp bends, specials, or where extra work would consume valuable time. This first gang is followed by a "make-good" party, whose job is to connect up sections of the line left unfinished by the forward gang—for example, at highway or railroad crossings. Behind the "make-good" party comes a third gang which tests the line and places the back fill. Screw-joint pipe laid on the ground surface has been pulled over into trenches without much damage—but it is better to lay the pipe originally in the trench if con-

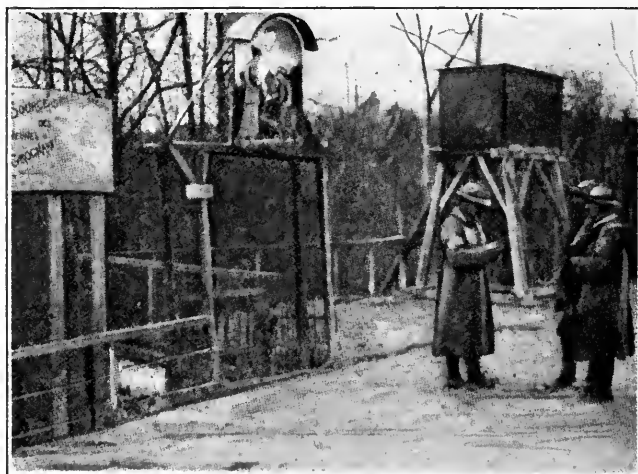

French Official Photo

ELEVATED WATER TANK SUPPLIED BY NEARBY SPRING, ALONG ROADSIDE IN THE SOMME VALLEY

ditions permit of the digging of the trench first. Pipe-line trenches are about 2 ft. wide and 2½ ft. deep, as a rule. While it is possible with straight wrought-iron pipe to make bends, cold, in the field, the better practice is to provide lengths of bends in advance.

According to the recommendations of one of our army water-supply officers, a pipe-laying gang should include one noncommissioned officer and six men—four to handle the material and pipe tongs and two to fit and grease or lead the joints. In good weather it is possible for one of these gangs to lay 40 lengths of 18-ft. pipe (4 in. in diameter) in eight hours. These figures are for laying on the ground surface or in prepared trenches under favorable circumstances. Cases arise which require this progress to be liberally discounted.

To prevent breakage by shell fire, a 2-ft. earth cover over a pipe line is regarded as sufficient, except in case of a direct hit. In the case of an uncovered pipe

line a high-explosive shell bursting on hard ground 30 ft. away will rupture the joints. Pending the digging of a trench, however, pipe on the surface can be protected in a measure by laying sand bags over exposed joints. When shrapnel bullets puncture a line repairs can often be made, where the pressure is low, with plumber's tape. For large holes split sleeves are useful. When whole pipe lengths are sprayed with shrapnel the section must be taken out and replaced. On the repair work it has been found advantageous to have a fairly plentiful supply of one-half and one-quarter lengths of pipe with long screw threads and sockets.

The work of the water-supply service of the American Expeditionary Forces indicates also supervision over the

quality of the water furnished to our troops. The British and French have used hypochlorite of lime for this purpose; but our engineers have developed plans for the extensive use of liquid chlorine apparatus of the Wallace & Tierman type. Some of these outfits, I am informed, will be mounted on motor trucks.

What has been said in the foregoing notes refers exclusively to advance area water-supply. This is only part of the story. Back of the front at our supply bases and along our lines of communication many water-supply projects, some of them involving filtration plants, are included in the program of work for our Army water-supply service. In a later article I hope to give an outline of water-supply in the district of the rear.

# Road Builders at Work Close to Front of American Sector in France

Maintenance, Reconstruction and Quarrying Proceed Despite Interruptions by German Shelling—Our Engineers Have Installed a Mechanically Operated Quarry, First of Its Kind on Any Front in France

BY ROBERT K. TOMLIN, JR.

War Correspondent of Engineering News-Record

IN TWO previous articles dealing with the work of the road service of the American Expeditionary Forces here in France my reports of progress were necessarily confined to matters of organization, inspection and planning. These were the early days back in January, when the principal activities of the chief of the road service and his department heads took the form of investigation and report. The results of our efforts were then on paper, not on the ground, for the rank and file of our special road-building and quarry regiments were still at Camp Meade in Maryland, and practically no construction plant or tools had been received. Since those days a big change has been wrought. The vanguard of our special road construction and quarry forces landed in France some time ago. Road service headquarters was immediately shifted from Paris to a point nearer the front. A limited amount of equipment was received, some of it from the states, some from local sources. Men who had been chafing at desk jobs were transferred to open country. District offices were established; construction gangs were detailed to selected areas; and the real work of road reconstruction and maintenance in the zone of American operations in France began.

The machinery of the organization up to this time had been in the assembly stage. Now, however, the throttle has been opened and the wheels are turning. We are not yet going at full speed, but we are moving along nicely, and each week sees the lever jacked forward a notch or two. American road builders are now

at work on military highways and in quarries within the range of German artillery fire as well as in other areas between the front and our seaport bases.

I have just come back from the advance section of our road service, where work, subject to interruption at any time by high explosive shelling or drenching by mustard gas, is being carried on under the direction of a captain of engineers who was formerly a division engineer in the New York State Highway Department. Upon his shoulders has fallen the responsibility of getting the job in the forward area started. His status, like that of several other engineer officers assigned to different areas of France, is that of a division highway engineer reporting directly to the chief of the road service, who is located at present at the general headquarters of the American Expeditionary Force.

Just a little more than a month ago—on Feb. 15, to be exact—road work up near the front was begun by American forces. Since then things have moved swiftly. About 1500 men are now engaged in road reconstruction, maintenance, and quarrying in this advance zone. They are operating in seven groups, each group being assigned to a territory with definite limits. Five quarries are being worked by our men. Mechanical equipment has begun to arrive. Several crusher installations have been set up, among them one with overhead bins and mechanical elevating equipment, said to be the first of its kind to be erected behind any front in France since the war started, almost four years ago. Four days after the machinery and wood for the bins arrived at the quarry site our men had this outfit producing crushed rock. Nor have we stopped at the innovation of the portable crusher plant with its elevating conveyors and storage bins. We are causing a good deal of comment among French engineers, I am told, by the use of bottom-dump wagons and elevating end-dump motor trucks. Such equipment as we are using for quarrying and transporting rock is a decided novelty over here, where the practice of depending on hand labor rather than mechanical plant is far more general than is the case in the United States.

As I stated in a former report, our road builders do not have to concern themselves to any great extent with the construction of new roads. There are already plenty of highways leading to the front, and our job now is maintenance, reconstruction and widening of existing waterbound macadam roads. Where our road and quarry regiments are operating near the front the amount of work to attend to is about one mile of road per square mile of land. Certain "national" highways leading toward our battery positions and trenches are already of ample width and possess good foundations and drainage. Ordinary maintenance work is all they

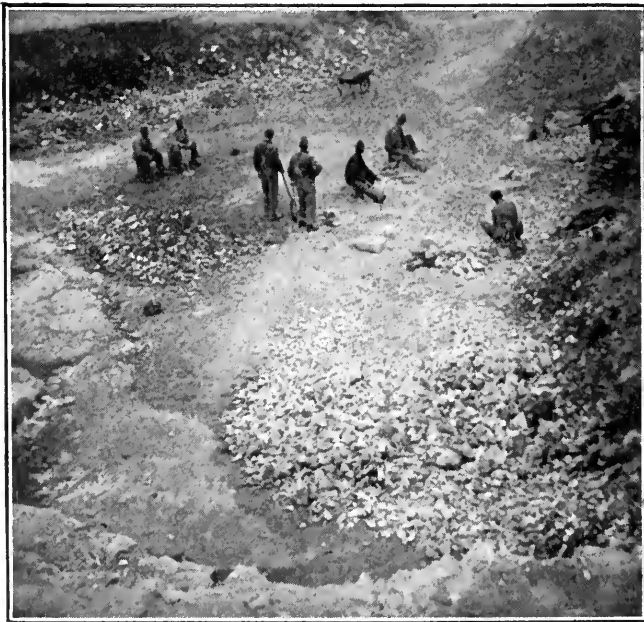

HAND QUARRYING PENDING ARRIVAL OF CRUSHER



require. Some of the offshoot roads, however, are only from 9 to 12 ft. wide and these must be increased to from 18 to 25 ft. in order to carry artillery and motor truck traffic. These offshoot roads are in most cases too thin to stand the heavy traffic of war and our men are reconstructing them, as shown in the sketch.

The reconstruction work involves the preparation of a subgrade, which is not rolled, and the laying of a foundation course of large stone or "blockage" to a thickness of 20 cm. This blockage is set by hand and chinked in with smaller stones. Then on top of it is spread a 10 cm. layer of crushed stone 1 to 4 in. in size,

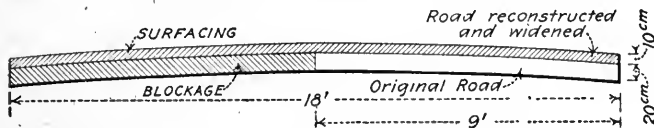

AMERICANS USE OLD ROAD AS HALF BASE FOR NEW

this layer being extended across the surface of the existing road, which serves as a base for about half of the widened route. When a roller is available the top course is rolled down; otherwise the compacting must be done by the traffic itself.

There is nothing very elaborate about the work. It is macadam road reconstruction reduced to its simplest form, for under the conditions that obtain in the advance section our engineers have found that this is the only type of road it is practicable to build and maintain. The captain of engineers in charge of our advance section work states the case thus: "The war-time type of road for France is the waterbound macadam road. It is the road for which local material is available and for which the methods of maintenance and reconstruction are simple. The fact that the local stone has

a high cementing value is another argument in its favor." The stone referred to is a soft limestone, almost white.

Our policy in road building is to use local material as far as possible, thus cutting down on the length of haul for crushed stone. This is very important, for with quarries located far from the job the motor trucks hauling crushed rock for maintenance and reconstruction destroy the very roads for which they are bringing up repair materials. Then, too, it is now, in the early spring, that the roads are subjected to their severest test, for at this time military activity generally increases after the winter's lull and the roads must be cleared, so far as possible, of all traffic which does not carry ammunition, supplies and the other essentials of combat and sustenance. Giving weight to all of these factors, our road service is opening up, or taking over from the French, many quarries, on the theory that many quarries mean short hauls for crushed rock, and consequently fewer trucks operating on the highways.

Up to within a short time ago most of our quarrying was a hand-labor job. Some of it still is, but our aim is to install mechanical equipment at all quarry sites just as soon as such equipment is to be had. *The accompanying photograph shows the first mechanically equipped quarry which American engineers have installed near the front.* It is of the semiportable type, with jaw crusher, overhead bins and elevating conveyors. This is the plant which was set up in four days. As previously noted, this layout is a decided departure from previous practice of the allied armies behind the front. The rock here is the prevailing soft limestone which, after being blasted—generally at night—is loaded into wheelbarrows and delivered by inclined runways to the jaw crushers.

The elevated bins, it will be noted, have two openings below. The larger of these is for motor trucks, while the other is for light railway (60 cm. gage) cars. American quarry practice over here is making a marked cut in the man-power required for operation by the provision of gravity loading of crushed rock into motor trucks, light railway cars and bottom-dump wagons.

Another of the views shows a gyratory crusher which had been set up only a couple of days before I took this picture. At the time overhead storage bins had not been erected at this site, which had previously been worked by the French.

In another photograph a detachment of our quarry regiment is shown breaking rock by hand, pending the arrival of a crusher. The captain in charge of this work had established his camp only a few days before my visit to this quarry, and, eager to increase his output of crushed stone, he was preparing to build a crusher of his own from odds and ends of metal which he had ferreted out in a junk shop in a near-by town. "As soon as I can get the authorization to spend a few hundred dollars for this stuff," he said, "I will have a crusher set up and running in a few days." This spirit is typical. Our men have had to proceed with their work in the face of difficulties of all sorts, shortage of men, shortage of plant, delays in railroad shipments, etc. Yet they are not sitting down and waiting for something to turn up. When mechanical plant does arrive it is set up in a jiffy; if it is delayed, some sort

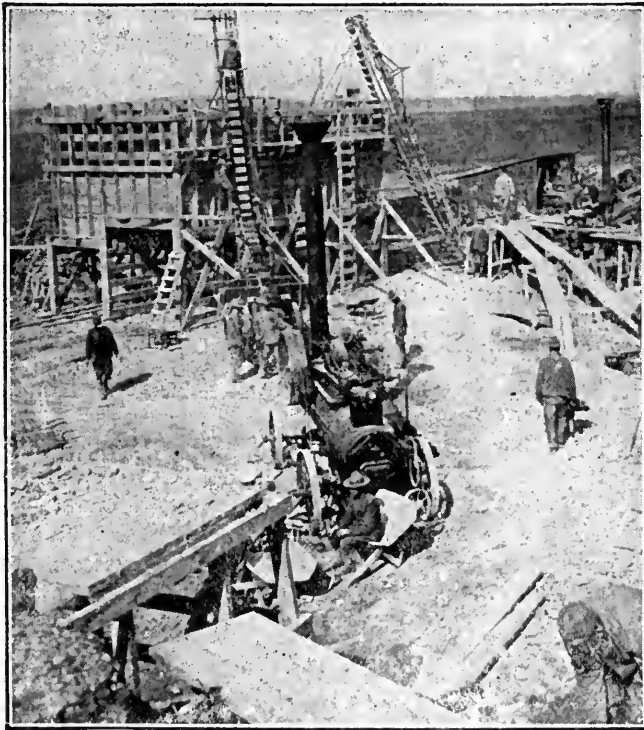

AMERICAN ENGINEERS HAD THIS QUARRY IN OPERATION FOUR DAYS AFTER EQUIPMENT ARRIVED

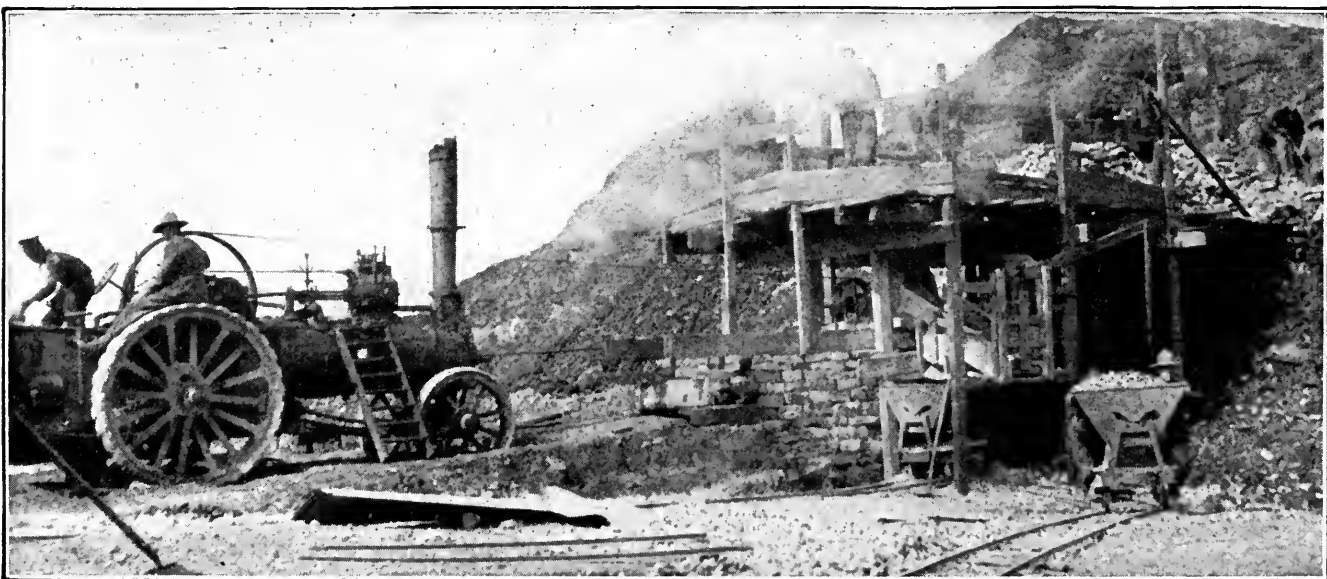
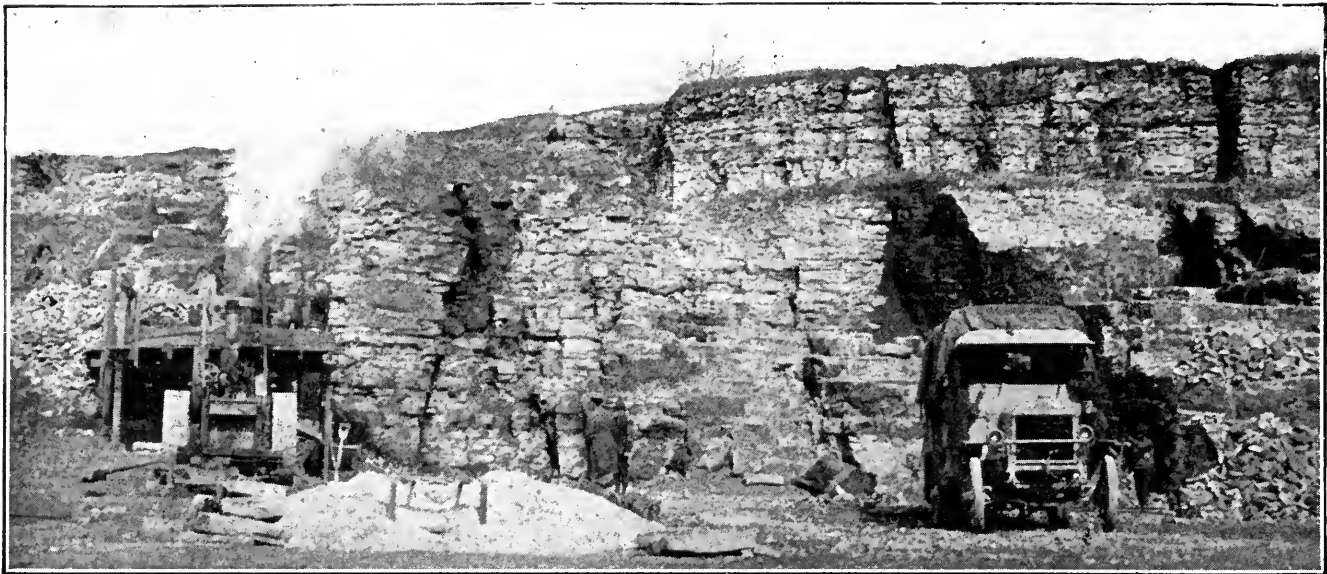

THIS QUARRY, TAKEN OVER FROM FRENCH, IS SHOWN PARTLY EQUIPPED WITH GYRATORY CRUSHER, THE OVERHEAD STORAGE BINS NOT HAVING BEEN BEGUN

of makeshift is resorted to, or else the rock is barred out and broken by hand. From four of our quarries where mechanical plant of some type is in service we are turning out about 500 cu.m. of rock daily, and the work is as yet hardly organized.

Most of the transportation of crushed rock from quarry to road is done, at this writing, by motor truck or horse-drawn dump wagon. A number of Mack motor trucks are in service for the longer hauls and Watson bottom-dump wagons for lesser distances. Both schemes of dumping—the automatic elevating body in the case of the motor truck, and the bottom opening leaves in the case of the wagon—are decided novelties among French road builders and their first performances were in the nature of spectacles watched with the keenest interest. Much of the road stone is delivered by the French in small, two-wheel carts hauled by a pair of horses in tandem.

The men of our road-building and quarry regiments have been divided into gangs and are quartered close to the particular jobs to which they have been assigned.

At some places camps have been established and the men live in wooden barracks. Others, newly arrived, are occupying canvas tents for the present. Still others are billeted in French towns. The road service is providing everything possible in the way of good food and clothing to make life comfortable for the men. Many of the rank and file are experienced construction men, road builders or engineers with degrees from our leading technical schools, who expected to be assigned, on their arrival in France, to jobs of a supervisory capacity; for example, as bosses of gangs on road reconstruction or maintenance. Up to the present time it has not been possible for all of these expectations to be realized and men with qualifications which would ordinarily place them in positions carrying varying degrees of authority are at present swinging pick and shovel or breaking rock. When we have at our disposal a larger supply of labor battalions and have captured more prisoners it is probable that there will be a change in the status of many of our road builders who are now doing ordinary day-labor jobs. Neverthe-

less, the men are buckling down to their tasks and showing an excellent spirit.

Judging by what I had to eat at one of the quarry camps there is nothing to complain of on the score of "grub." To some of us here in France who have either to pass up coffee or sweeten it with saccharine, eat brown war bread without butter and smoke French cigarettes, the lot of the military road builder, even if his job is for the time being of the routine, manual labor sort, seems to have its compensations, for he gets white bread to eat, real sugar in his coffee and American "smokes," which, in themselves, should discount many of the things which may be not quite to the liking of the man who is spreading crushed stone instead of supervising the work of German prisoners.

It is still a little early to attempt to tell the real story of our road-building work. That will come later,

when all of our quarries are located, equipped and running full blast, and when our work of reconstruction and maintenance has been extended and put to the test of carrying the traffic of war for a longer time than it has done up to the present. Yet I am able to report real progress in the advance section of our road service, and I cannot do it better than by quoting from a note written to the commanding officer, lines of communication, advance section, by the general commanding the first division of the American Expeditionary Forces, behind which our road builders have been at work. Here is what the note says:

"I was very hard pressed in the sector on account of terrible roads, daily growing worse under hard usage. It was necessary to act quickly and directly with G.H.Q. Your men are doing good work. They are really saving the situation."

# Army Topographical Division Co-ordinates Work of Map Makers in Air and on Ground

Existing French Maps Used as Basis for New Work—Aerial Photographs, Taken by Our Own Machines, Bring Valuable Data from Enemy Territory—Relief Maps a Specialized Work in Which U. S. Details Are Trained

BY ROBERT K. TOMLIN, JR.

War Correspondent of Engineering News-Record

USING French army maps and civil records from various local sources as a basis, the topographical division of the intelligence section, American Expeditionary Forces, which has been passing through the organization and training stages for some months past, has been developed to a point where it is now furnishing to our staff and field officers in France maps on which the more recent information represents the work

engineer organization and training them in the various details of the service, that has occupied much of the time of the topographical division. But now the results of this preliminary work have begun to bear fruit, and week by week the scope of operations is being extended. Where formerly we were entirely dependent on the French Armies for maps of both sides of No Man's Land, we are, at this writing, drawing more and more

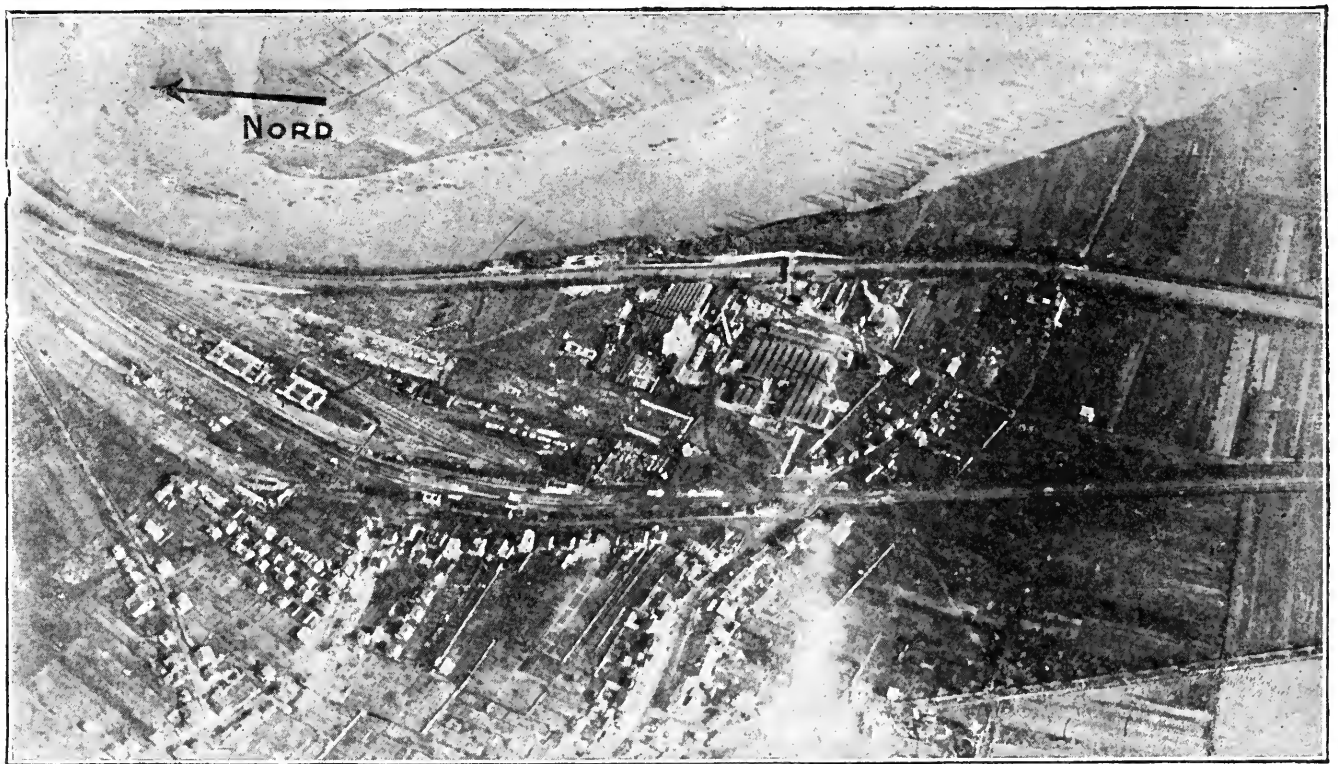

WHEN THE LENS IS NOT HORIZONTAL, CURIOUS EFFECTS FROM DISTORTION APPEAR

Height, 1700 meters—The river is the Moselle

of American engineers; cooperating with them is our air service, which is responsible for the taking of all aerial photographs for map-making purposes. This statement I am in a position to make as the result of an interview at American Army headquarters with Col. A——, Corps of Engineers, U.S.A., commanding our topographical division. Its significance can be appreciated only when it is realized that the present war has revolutionized methods of map making, that a new art has been created, and that men, even though topographical specialists in civil life, must be put through an extended course of training before they can become useful in the new work at the front, which involves the taking and, of equal importance, the interpretation of aerial photographs. It has been this task, this rounding up of the technically qualified men, molding them into an

upon our own resources for this information, and will continue to do so in larger measure as time goes on.

The topographical division must be able to furnish at quick notice maps of enemy ground and also that occupied by our own troops, the latter including not only the advance areas but also the territory in the rear, such as sites of supply bases, hospitals, aviation training stations, artillery and machine gun ranges, storage yards and camp areas. Obviously, it would be difficult, if not impossible, for a single detached organization to do the field and air work necessary for the production of all of these maps, especially on an extended front. The plan is, therefore, to have each Army map the territory along its own front, while the topographical division of the intelligence section, a headquarters unit, acts as the general clearing house for map informa-

tion, and outlines the broad questions of policy by which the special map-making forces in each Army are guided. Its work involves, of course, very close coöperation with the air service.

Fortunately, the American Expeditionary Forces have not had to start from the very beginning in the matter of maps. Those portions of the front which we are taking over have been completely mapped, as the result of more than three years' occupation by the Armies of our Allies, although the changing conditions on both sides of the line, involving the location of new field gun positions, roads, railways, and similar data of military importance, call for a large amount of work by our men. And it is pertinent to emphasize that our map-making forces must concern themselves with the sections of the rear as well as those of the front, and that while the aviator and observer with their photographic apparatus are now bringing back information from areas occupied by the German armies, engineer detachments, with transit, level, sketching-board and the rest of the equipment needed, are performing equally valuable service back of our lines and in other zones, at supply and ordnance bases, for example, where sizable cities must be created, at railroad yards, at artillery training grounds, and aviation fields.

Our topographical division's first work was a study of existing French maps. There is, to begin with, a set of maps with 20-m. contours, and drawn to a scale of 1 to 200,000. These maps, prepared by the *Service Géographique*, correspond in a general way to those issued by the United States Geological Survey. They are useful for certain military purposes, but obviously the scale is too small for detail work. For Army staff work the French use the *cartes d'état major*, maps on a scale of 1 to 80,000. There is a series of these maps covering the whole of France, and they give information of military value, such as the location of bridges, roads, railroads and canals. Topographical features, however, are shown by hachures instead of contour lines, the elevations of strategic points being indicated by lettering. There are also maps on a somewhat larger scale, 1 to 50,000, but these are merely enlargements of the *cartes d'état major*. In the vicinity of all fortified places special large-scale maps had been prepared by the French before the war. These maps contained a considerable amount of detail, such as the location of trenches, mines, etc.

Next in the list comes the *plan directeur*, on a scale of 1 to 20,000, equivalent, approximately, to 3 in. to the mile, which is, practically, the standard for use in every day field operations at the front. Existing supplies of these maps, however, did not cover the training areas and our topographical division has been filling in the gaps by plotting the results of old French surveys which has never before been completed in the form of battle maps. For this work American engineers are using old civil records, such as those involving titles to land, and department tax maps, which correspond, in a general way, to those which would be on file in the office of a county surveyor in the United States. In connection with the work of making the new *plans directeurs* the American topographical division is also producing for special purposes a number of maps on still larger scales, 1 to 10,000 or about 6 in. to the mile,

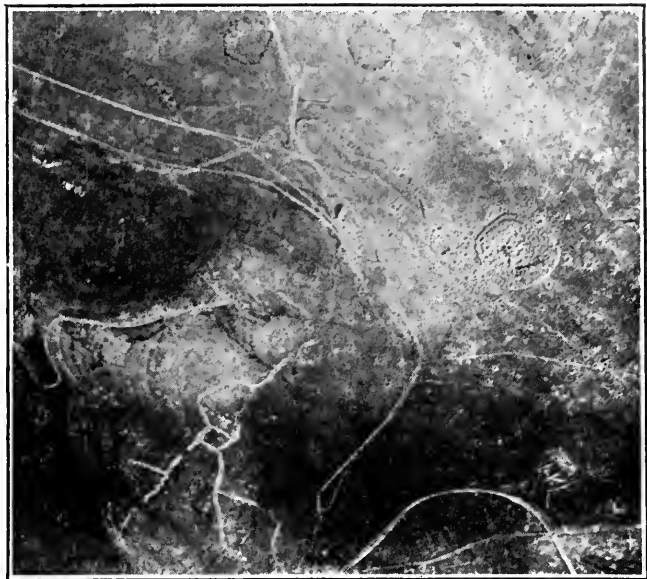

A MUCH-BATTERED HILL—DOUAUMONT—2400 METERS

and even 1 to 5000, the latter, for infantry use, showing machine gun emplacements and practically every other detail along the front.

One of the first field operations which the topographical division of the American Expeditionary Forces carried out in France was the establishment of triangulation stations and the making of a network of traverses covering the zone of our army operations in the rear areas. To this task the division assigned picked men of its organization who had specialized in just this kind of work, many of them having held important posts in the United States Geological Survey and the United States Coast and Geodetic Survey. This triangulation work has been completed and is serving not only as a means of coördinating the individual large scale maps which are being produced, but also is of extreme value in the establishment of reference points for the guidance of our artillery fire.

Early in the war, when the fighting in France ceased to be in the open and developed into trench warfare, the conditions became, practically, those of a siege, and large-scale maps were in demand in numbers greater than had ever before been considered necessary. This state of affairs was responsible for the widespread production of the 1 to 20,000-scale map, this scale being now practically a standard on the French, British and American fronts. These 1 to 20,000-scale maps are known under different names, *plans directeurs* in the French armies, "trench maps" in the British, and "battle maps" in the American, but they are of practically the same type for all the armies. The contour interval is 5 m. Each map covers an area 20 x 16 km., and is divided into squares 1 km. on a side. These main grid lines are numbered for general reference, and a secondary system of coördinate numbers is applied to the 1-km. squares for the closer location work required by the artillery. It is not strictly accurate, by the way, to say that the grid lines form true squares, for they are actually projections, by the Lambert system, of imaginary north and south, and east and west lines on the ground. Due to the earth's curvature, the projection of the lines produces a slightly distorted "square."



TRENCH SYSTEM SHOWS PLAINLY AT 1900 METERS

The origin of the coordinate system applying to all of the *plans directeurs* is fixed at a point so that all horizontal map distances are measured toward the east, and all vertical distances toward the north. The same scheme applies to the indication of positions within the 1-km. squares where the southwest corner of the square is always the origin of coordinates. Thus, in reference to a gun emplacement by coordinates there are not both plus and minus numbers; all are plus. These *plans directeurs* show the position of the enemy trenches, but not our own, except on secret editions for our staff. They also indicate German battery locations, roads, etc.

In connection with the use by artillery of the *plans directeurs*, the topographical division furnishes the means for locating the position of each fieldpiece by means of reference points on the ground. These reference points are tied in to the permanent triangulation points. If any movement of batteries forward or backward occurs, the topographical division must see to it that new points of reference are quickly available. By their aid the battery commander can readily determine the coordinates for the position of each of his guns,

and having been given similar data for his objectives behind the German lines, the setting of the proper ranges becomes a simple matter.

By far the most valuable source of information for making maps of forward areas is the aerial photograph. It is, however, a subject on which few details can be given. The work divides itself into three phases, the taking of the picture, its interpretation after development and reconstruction of the data in map form. Our topographical division has developed a force of specially trained men for the last two steps of this work, which calls for the highest type of technical skill, long experience and thorough familiarity with almost everything connected with modern warfare. To the uninitiated some of these pictures would be absolutely meaningless. After the exposures are made at great heights, when machines are forced upward by anti-aircraft fire; conditions of light may be poor; the machine not be flying horizontally when the exposure is made, causing distortion in distances. In fact, scores of variable factors enter into the work, and the interpreter of photographs taken in the air must be a man of seasoned judgment, able to evaluate each streak or spot and discover its true meaning. His work is made doubly difficult by attempts to camouflage the positions of enemy guns. The photograph reader, therefore, must be a student of camouflage in all of its many variations. After a picture is made, no attempt is made to enlarge or reduce it to some uniform scale. It is put under lenses of high power, as well as stereoscopes, which bring the details out in relief, and the man who reads its message must be able to make the proper allowances for the height at which the exposure was made. The usual height for taking a picture from an airplane for map-making purposes, I was told, is 2500 meters.

In addition to its standard maps, the topographical division is called upon for many special maps, which must be prepared and issued quickly to staffs. Speed and accuracy are both essential. If an attack is being planned, for example, orders from headquarters must be illustrated by diagram maps. The topographical division, therefore, must be well supplied with all the map data which could be demanded, and must be ready to send it out at almost a moment's notice.

As to the accuracy of maps of enemy areas based largely on information from aerial photographs, the English and French, after the advance in the valley of the Somme was made, had an opportunity of checking their maps. I am told that the degree of accuracy discovered was, on the whole, very satisfactory, although the results of field surveys disclosed some points which needed revision. During a recent trip to the front I saw an enemy map which was found on the charred body of a German aviator who had been shot down behind the allied lines. Half of it had been burned away, but on what remained was plotted accurately in red ink the location of a light railway spur of one of our Allies which had been constructed only three days before the map was taken from the dead body of its owner.

Having begun with the use of French maps, the American Expeditionary Forces have adopted the metric system for all of our topographical work. To change to

miles, instead of kilometers, at this date, would, it is believed, result in considerable confusion, especially as there are many situations demanding the interchange of maps between our own armies and those of our allies. Nevertheless, on our maps, in addition to the standard metric scale, is surprinted in red a scale in miles, and also a conversion table for metric and English linear measurements. French terminology also will be retained on new maps, although a glossary of terms is issued to facilitate their interpretation.

A tour of the "plant" of the topographical division at headquarters disclosed the work of map making in many of its phases. Leaving the offices of the chief of this service we went first to the filing room, in which is classified and stored a large stock of maps ready for immediate issue. An entire room was devoted to map storage, and piles of prints were arranged in rows on wooden shelves extending from floor to ceiling. Then we inspected the photo-lithography equipment, the printing presses, the gelatine process (used only when a limited number of copies is needed), the blueprinting machines, the drafting-room, the photographic copying apparatus and the various other features which the production of maps for use in war demands. By the gelatine process, which is patented, an impression is secured directly from a blueprint and transferred by inking the gelatine film and applying blank sheets over which a roller is passed. The gelatine process is employed extensively for color work, and especially for



THE AIR CAMERA IS FLEXIBLY MOUNTED

making over-prints—that is, adding new information to an existing map.

One of the interesting sights in the topographical division was a collection of relief maps. They are used

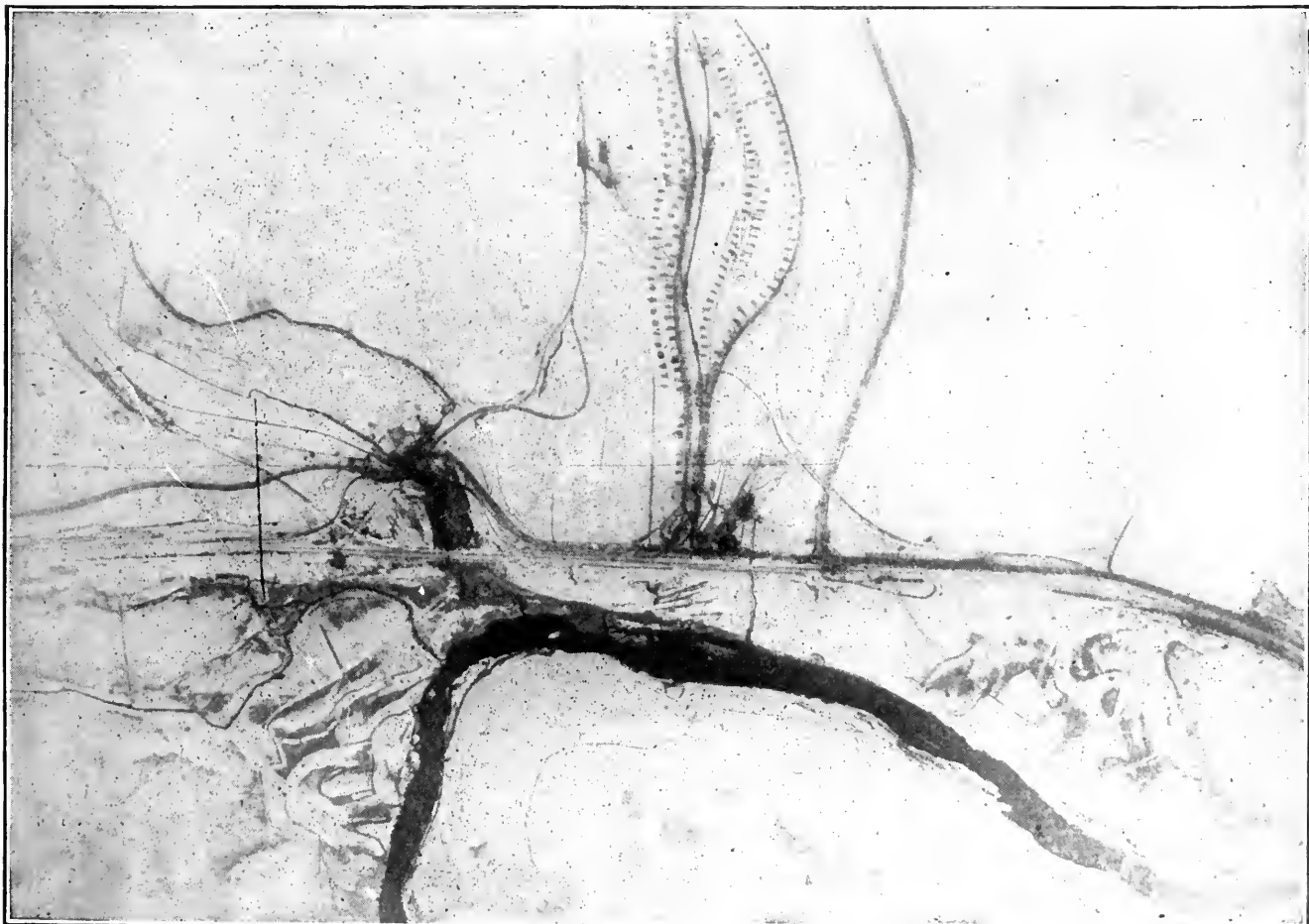

HOW A RIVER, A RAILWAY JUNCTION, BILLETS AND FORTIFICATIONS APPEAR FROM 3200 METERS UP

to quite an extent in staff work, and a detachment of our forces has been sent to a shop in Paris to learn how to make these maps. One method is to mold them directly while the other involves the cutting up of copies of a map, mounted on cardboard, along every contour and the arrangement of these sections, one above the other, forming a series of steps. The angles of the steps are then filled with putty and a casting in plaster of paris is taken, giving a reverse relief map. A second casting, from the reverse, gives a true relief map, and over it a contour map is stretched and pasted down. The process is said to require a good deal of skill, as the application of the contour map to the casting in-

volves the stretching of the map fabric (it looked like paper) over the mounds representing hills.

While the work of our topographical division is proceeding its personnel is gradually being enlarged, and many new men are now being instructed in the details of the several branches of this service. Every day sees changes on both sides of the front which must be recorded on maps. Thus the work of the division is a never-ending one, and its members must continually be on the alert in order to be ready night or day to supply our forces with maps that are both accurate and up-to-date.

---



# Along the British Front by Light Railway

Experiences and Impressions of a Week's Study of the Narrow-Gage System at Close Range—How It Has Revolutionized Salvage

BY ROBERT K. TOMLIN, JR.

War Correspondent of Engineering News-Record

*It was in February, before the big drives on the Somme and in Flanders, that Mr. Tomlin spent a week studying the light railways along the British front. His story reached the British authorities for censoring just before the March drive. Nothing was heard of it for weeks, but the Boches did not capture it, and it has lately returned from the hands of the British cen-*

**L**ESS than a year ago the British Armies in France were carrying weekly, about 12,000 tons of munitions and supplies over a system of "light railways" (60-cm. gage and 20-lb.-per-yard rails) involving a total trackage of less than 100 miles. Motor-truck, or lorry, transport over highways was, at that time, the main reliance for deliveries from standard-gage railheads to the front. Today the weekly tonnage on light railways has soared well into six figures, the track mileage into four figures, and during a period of about 10½ months the highways have been relieved of millions of lorry-miles of traffic.

For obvious military reasons I cannot make this statement more specific, but it will serve to indicate the really tremendous traffic development which has taken place along the British front. Light railways have already revolutionized transportation practice, and the end is not yet in sight. Far from resting on its present enormous mileage of 60-cm. tracks, British staff officers are calling for more mileage, more engines, more tractors, more cars. A year's actual test has demonstrated in the most convincing manner the supreme importance of the light railway in the conduct of modern warfare, for every 3-ton load hauled relieves the highways of one lorry. Even now, the British tonnage figures on light railways for successive weeks are showing regular jumps of 10,000 to 15,000—there had not been a break in the curve during the 17 weeks preceding my visit to the British front in February. In this article reference to tonnage is based on the long ton of 2240 lb., not our own short ton of 2000 lb. To the engineer these statistics, general as they are, will indicate the place which the light railway now occupies in the scheme of transportation in the war zone of France, and how the highways have been relieved of the heavy overload of traffic which demanded high tribute in materials and men for maintenance.

I have just returned from a week's tour along the front, where, thanks to the splendid hospitality of our British allies and the detachments of our own American railway troops which are operating in northern France, exceptional facilities were given me for observing the actual working of the light-railway systems from Flanders southward through the valley of the Somme. But before I get into the engineering details of my story, let me give a hasty outline of my trip.

I was met at a certain railroad station by a British staff officer, and proceeded by automobile to British

*sors. So interesting is Mr. Tomlin's narrative of his experiences and impressions in getting the story that this, with an account of what the light railways have made possible in the way of salvaging of material, is made the basis of the present article. A second article, setting forth how the railways are built, maintained and operated, will be published next week.—Editor.*

general headquarters, where I was introduced to the Director General of Transportation of the British Expeditionary Force. I spent the afternoon with a brigadier general, the D.G.T., who very kindly permitted me to inspect his organization charts and graphic records of the trackage and tonnage of the light railway system for all of the British Armies in France—charts on which the curves were ever mounting at steeper angles.

After tea, I met a brigadier general, the Director of Light Railways, who is responsible for the construction, maintenance and operation of the system along the entire British front; a captain of the Royal Engineers, a veteran of the Gallipoli campaign and the great drive in the valley of the Somme, who had been assigned to act as my guide during the trip; and the several department heads in charge of construction, operation, maintenance and repair. Then we proceeded to the field headquarters of a major general, Director of Light Railways for the American Expeditionary Forces, where we spent the night.

Getting away to an early start next morning in a British staff car, we reached an Army light-railway headquarters in Belgium and from there traveled by light railway through the Ypres sector, the superintendent of operation in this zone having ordered a special train run out toward the front lines for my benefit. We had about half completed our ride when an enemy airplane came soaring over the lines, evidently intending to attack an observation balloon which we had just passed. British aircraft appeared. Machine guns cut loose. Its petrol tank riddled by bullets, the Boche plane suddenly emitted a great cloud of black smoke. The framework caught fire. The flaming machine reeled about in a spiral for fully a minute, exhibiting remarkable stability, and then plunged downward, leaving a wake of fire.

Night found us at ———, where the buildings are in every conceivable stage of demolition from heavy shelling. The room we occupied in one of them was ventilated by two great gashes which shells had torn in the ceiling.

Next day we crossed into the territory of another Army, where the Assistant Director of Light Railways explained the workings of the operating control and train-dispatching systems. Our next stop was at the headquarters of the commander of one of the first American railway regiments to reach France Outfitted



British Official Photographs

THE BRITISH ARMIES, DURING THE PAST TWELVE MONTHS, HAVE LAID A TREMENDOUS MILEAGE

with "tin hats" and gas masks, we ran by light railway, under the guidance of two captains, to within a little more than a mile of the front-line trenches, looping back again to camp; thence by automobile to British A.D.L.R. headquarters, where we were the guests of a major at dinner. Into a shell-ruined town for the night and away again in the morning for another Army area where a Canadian lieutenant colonel, formerly with the Union Pacific, showed me the workings of his light-railway system, which has the largest mileage of any in the British armies. Then with a major through a salvage yard, where all sorts of materials recovered from the territory from which the German armies were forced to retire are collected and made available for use by British troops. And so on, under the guidance of another major to two other detachments of American railway troops. The last leg of our field trip took us by automobile to ———, where we spent the night. In the morning I caught the train for Paris, leaving my conducting officer, for whom I had quickly developed a great liking, and who, for four days, had so cheerfully submitted to my steady bombardment of questions.

During this tour I made several trips toward various parts of the front on light-railway trains which British and American officers ran especially for my benefit. I estimate that I rode 50 miles or more by light railway and at least 500 miles by automobile, and I walked over a few miles of track. Most of our journey was through territory formerly occupied by German forces, and I had the pleasure of crossing and recrossing many sections of the old "Hindenburg line." It was a wonderful trip.

My first ride was behind a 20-hp. petrol-tractor. Starting from a point near the standard-gage railhead of one of the British armies, we bowled along over a fine straight section of track, but as we got nearer to No Man's Land curves became more frequent. The ground on either side was pitted with shell craters of all sizes, and through half-closed eyes the barred fields, with their mounds and depressions, looked like a choppy, mud-colored sea. And yet it is through areas of this sort that light railways must be built and kept to fairly level grades. In the early days, I was told, it was not uncommon for a steam locomotive to get its boiler water from a shell crater. Now elevated water tanks are provided at various points.

We stopped our train to watch the progress of the air battle to which I have referred, and when we resumed our trip I began to notice the very thorough system of guide signs and warnings which the British have installed along their light railways. In addition to direction signs there were others such as "Unload Here for Siege Battery." One of the first signs to greet me as we got up toward the front was this:

**If You Think Your Respirator Is Faulty Go to the Gas Hut and Have It Tested**

Mine was new, so we dispensed with this formality. A little farther along, another white signboard with black lettering bore this legend:

**Steel Helmets To Be Worn and Gas Respirators Carried at "Alert" Position Beyond This Point**

There were other white signs along the route, little crosses of two painted sticks, here planted singly, there in groups of a dozen or more, signs which needed no legend to tell of the brave sacrifice which had been made in order that British light railways might run where German trenches used to be.

It was at a grade crossing in the shelled area, where an old highway and the light-railway line intersected, that a certain grim-humorist sign painter had outdone himself. It was in territory that might be upheaved at any moment by a high-explosive shell, where gas attacks were an every-day possibility, and airplane bombs a constant menace. Here, where tiny tractors passed occasionally, the arch wag had inscribed this legend:

**DANGER—RAILWAY CROSSING**

Much of the country over which I passed on this and subsequent trips had formerly been in German hands. "We're running light railways now," said a British officer to me, "where only a few months ago we were crawling forward on our bellies." I saw a number of enemy "pill boxes" along the light-railway line, concrete structures with walls 4 ft. thick. Some of these were built of molded blocks, while others, apparently, had been cast in place, heavily reinforced with steel. Here and there a branch would lead off to



OF LIGHT-RAILWAY TRACK ALONG THE FRONT, IN BOTH THE FORWARD AND THE REAR AREAS

a gun emplacement, and the variety of camouflage at these points was almost unlimited. A most remarkable sight was the crater of an old British mine. The hole was, I should judge, nearly 300 ft. in diameter, and from 50 to 75 ft. deep.

It was on the section operated by an American detachment that I got closest to the enemy line. It happened to be a cloudy day and we passed around a loop which is about 3000 yd. from the first-line trenches. Part of the way a hill sheltered us, but running beyond it we were, for 15 minutes or so, under direct observation by German artillery.

"See that line of trees over there?" one of the officers asked. "The Boches are on the ridge just behind them." It had never occurred to me until then how slowly our train was running!

That our troops are not working in what might be termed a health resort is evident from a few excerpts from the weekly reports of an American officer which I was allowed to read. Here is one entry:

"On ———, while tractor was hauling cars of rations and water, gas shell struck ration car and derailed it. Another gas shell struck tractor as it was backing away, derailling it also. One British and three Americans gassed, but are recovering."

Farther on I read:

"Track blown out. While repairs being made track near by broken in three places by shell fire. Two men knocked down."

One of the surprising developments which have followed in the wake of the light-railway work is the salvage of material on old battlefields. Without light railways it was difficult, if not impossible, to collect and transport to the rear the equipment used in former activities. In one army area where I studied the salvage system—which, by the way, is of fairly recent origin—about 250,000 tons of usable material had already been recovered and shipped back for reissue to the British forces. All of this stuff was from ground which the Germans had been forced to relinquish. The principal products which the salvage forces had collected, as shown in one of the photographs, were timber from old German dugouts, rail, corrugated iron, barbed wire, chicken wire and expanded-metal trench revetment, ties, duck-boards, old rifles, shell cases, clothing, tools of various kinds, stakes, hose, bolts and

nuts—in fact, the thousand and one odds and ends which constitute the *débris* of battle.

A major in charge of a salvage dump which I inspected told me of the results of this work in his own area. "We are now getting thousands of timber sets from old dugouts and tunnels," he said. "In the past 10 days, for instance, we have recovered about 1600 tons of wire, and before the Cambrai 'show' we were responsible for 33,000 tons of recovered material which was sent forward for reuse by British troops." Timber is so exceedingly valuable at the front that special crews of tunnelers are organized and trained to recover it from old dugouts.

At the dump where we happened to be, I was told that the weekly turnover of material averaged 1200 tons. On one day 3500 shovels were sent back to be reissued. Shell cases to the number of 12,000, each worth from seven to ten shillings, represented another single week's haul. Three hundred rifles is considered a normal week's return. Old rifles receive an oil bath and a cleaning before being shipped back. Old tin cans are a profitable source of solder. They are heated in a homemade furnace, itself made of salvaged material, and supply enough solder to keep a few large workshops in babbitt metal. The walls of the melting furnace are made of old petrol cans filled with sand.

The salvage organization is left very much to its own resources in the matter of its equipment. "Go out and find it," seems to be the motto. It recovers rail for its own trackage, and often must build its own cars out of the old trucks and timber brought in from the field. While most of the material from the field is delivered to the salvage dump by the light railways, some comes in by lorries. The dump itself is arranged for lorry delivery on one side, and light-railway delivery on the other. Material is all classified at the dump. Here one sees a pile of duck-boards, there a mound of wire, then some piles of shell cases, railroad ties, rails, etc. Through the middle of the dump a standard-gage railroad line runs for delivery to bases in the rear, where the material is put in serviceable condition for further use.

In the old days nobody paid much attention to the possibilities of salvage, and for a good reason; there was no way to recover material quickly and—the important point—with a low expenditure of man power.

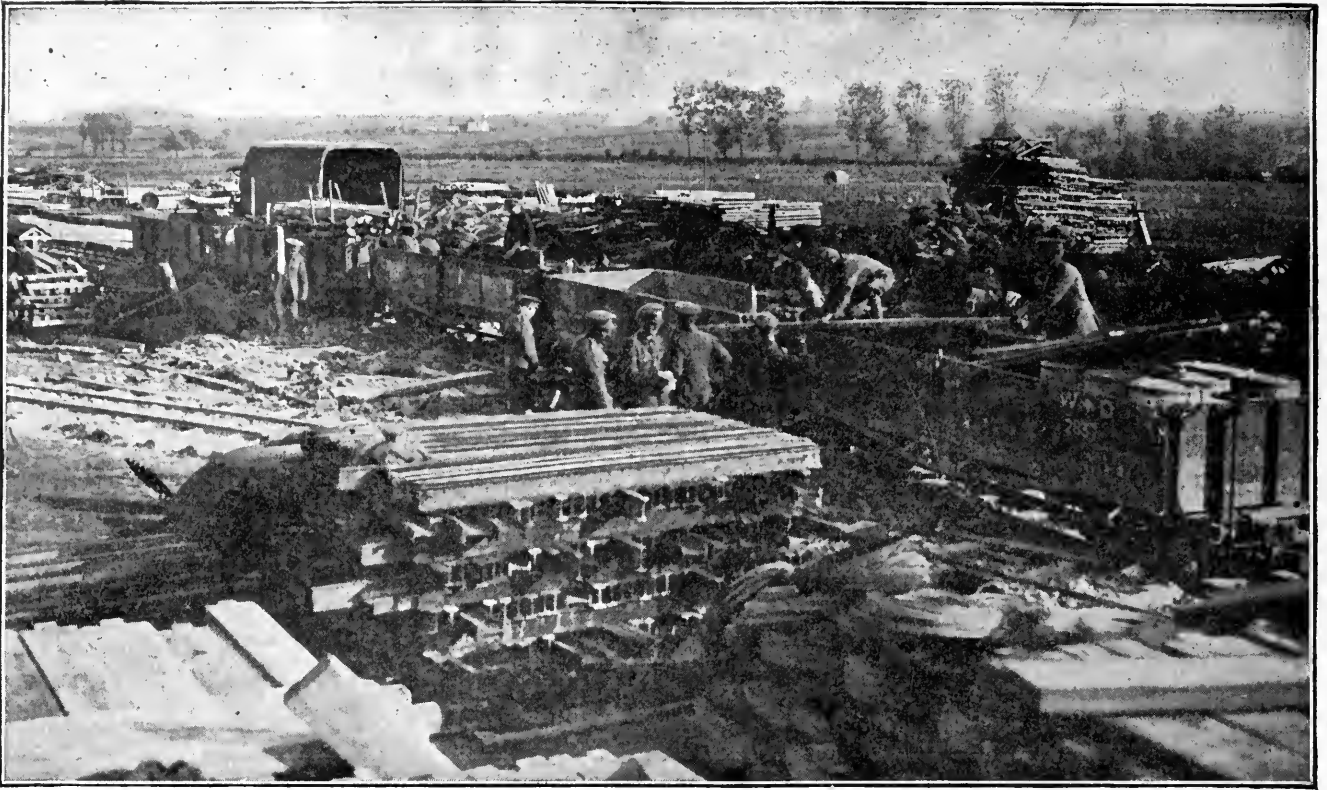

British Official Photograph

THIS IS THE KIND OF MATERIAL THE SALVAGE FORCES RECOVER BY MEANS OF THE LIGHT RAILWAYS

This condition light railways have changed. Into crater-marked regions where highway building would be a long and tedious operation, light railways can be extended without much trouble. With transportation

facilities available the whole economic situation with regard to salvage on a large scale appeared in a new light, and the work now returns an excellent income on the comparatively small investment in labor.



British Official Photograph

## The Light Railway Along the British Front at Close Range

Where and How the Lines Are Built, How They Are Maintained and Operated, and What They Accomplish—Highways Relieved of Their Overload

BY ROBERT K. TOMLIN, JR.

War Correspondent of Engineering News-Record

*Last week Mr. Tomlin related how he obtained the story of the light railways along the front. He also set forth how these railways have revolutionized the salvage of material. This week he tells how the railways are built, maintained and operated.—Editor.*

THE primary function of the light railway, as explained in a former article (*Engineering News-Record* of Mar. 14, 1918, p. 508) is to deliver ammunition, troops, rations and supplies from standard-gage railheads to points near the front, and by so doing relieve the highways of the enormous burden of traffic which they used to carry. The accompanying sketch plan (Fig. 1), which is purely theoretical and does not convey information as to any actual location on the ground, will show the general relation to one another of the parts of a light railway system for the battlefield, and the area in the rear.

In the extreme forward section, it will be noted, ropeways or push trolleys may be provided, although many situations demand the packing of ammunition and supplies on the backs of animals or men. Where possible, spurs are run out to artillery batteries, to which ammunition is delivered, one carload at a time. Further to the rear will be noted the various "dumps" for ammunition and stores. The designation "R. E." on the sketch means "Royal Engineers," and when used in connection with supplies refers to such material as timber, sand bags, wire mesh trench revetment, barbed wire, corrugated-iron covering for dugouts and huts, duckboards, etc. At the extreme left the letters "C. C. S." signify "Casualty Clearing Station," to which the wounded are brought back, on light railway cars.

The layout at the railhead (Fig. 3) provides for the transshipment of material from the standard-gage railroad to the light railway, for the assembly of cars into trains, and for the storage of ammunition, ordnance and supplies. Fig. 2 shows a light railway delivering a load of rations to wagon trains.

The diagram shows also the loop system and cross connections which are characteristic of British light-railway practice. The idea is to have the loaded cars move forward on only one side of the loop, and the empties return on the other. Even where turnouts are built, the British endeavor to prevent even short-haul train movements in opposite directions on the same side of a loop, and during my trip over the lines a non-commissioned officer in charge of a gang building dugouts was called to account for running a light push car forward on the track over which our train was making the inbound journey.

Although I saw some short sections of double track, the general practice here is to construct single track only, thus offering a smaller target for shell fire and cutting down the time needed for repair work if the track should be hit.

The mileage of light railway track per mile of battlefield varies within wide limits. In a quiet sector it may be as little as five miles, while in territory where there is much activity there may be a mileage of 10, 12 or even more per mile of front. A single-track light railway weighs about 72 tons a mile for rail, connections and ties, while, as a rough average, 800 tons of ballast per mile is necessary, unless the ground is unusually bad. I was told that the grading, laying and ballasting of one mile of finished track requires, normally, about 2400 man-days of labor. On some speedier work 1760 man-days of labor per mile of track were recorded, while during the Cambrai "show"—every big engagement is called a "show" over here—a Canadian lieutenant colonel and his men laid six miles of track in 60 hours.

Repair work for all British armies at the time of my visit was involving the replacement each week of from 1500 to 2000 ft. of track broken by shell fire. This is an almost insignificant percentage of the total. In one army, however, 95 breaks in one day, due to shelling, were recorded, but this army has a greater track mileage than any other.

At the head of the organization which is assigned to light railways is the Director of Light Railways (D. L. R.) who reports to the Director General of Transportation (D. G. T.). A mere listing of the various rungs in the organization ladder, however, would fail to convey an adequate idea of its real character. It is only when you circulate through the headquarters offices, go out on the line among the men, and see the splendid work they are doing, that you obtain a true appreciation of the light-railway forces. Both British and American officers are all railway specialists, hailing from every corner of the world—men who have built and operated railroads in Great Britain, the United States, Brazil, Canada, the Argentine, India, Mexico and elsewhere. The American force on one section of the line, for example, had been recruited, whole companies at a time, from such American roads as the Boston & Albany, Maine Central, New York, New Haven & Hartford, and Boston & Maine. The commissioned officers in these various companies, as a rule, came from the same railroads as the enlisted men.

Having spent most of my time among officers and observed the splendid *esprit de corps* which prevails over the whole front, I was interested in getting the enlisted man's point of view, and during a stop at a siding I went up forward for a chat with the engine driver and the brakeman of our train. One, I found, had served on the B. & A., and the other on the New York, New Haven & Hartford.

"Quite a difference between this job and the one back home on the B. & A.," I said to the driver. "What gives you the most trouble in running one of these tractors?"

He didn't hesitate a minute. "She's off the iron a little more than I like."

Here was a man, who, by night or by day, nosed his trainloads of ammunition or supplies up into the dan-

ger zone where high-explosive shells, gas attacks and bombs from airplanes were all part of the day's work, and his chief concern was not of these things, but of engine derailments, of being "off the iron," of delays which would slow up deliveries. In answering my question, he had, unconsciously, given me something for which I had been blindly groping—a crystallization in words of the spirit which animates the light-railway organization.

In the location of light railways no hard and fast rules other than those given in the article in this journal, previously referred to, can be laid down. The basic principle is that the line must follow the contour of the ground as closely as possible, although sometimes a trestle is built (Fig. 4). Heavy cuts or fills must be avoided. It follows, therefore, that a light railway line, particularly near the front, contains a good many curves; the sharpest are of 30-m. radius. An effort is made to keep the ruling grade below 2½%, but in some places 4% grades are required by local conditions.

As to proximity to the front, practice varies considerably also. In very quiet sectors, however, the lines may run as far forward as the reserve trenches. In others, single track known as "trench tramways" are used. Location depends upon the ground and the conditions with regard to observation by the enemy.

Fig. 5 gives a good idea of how a light railway line is constructed. Rail connections are made by fishplates and bolts, four bolts per joint. A radical change in practice has gone into effect recently involving the substitution of wood for steel ties. I traveled over a great many miles of line in the Flanders area, and close contact with the all-prevailing mud of that region indicated quickly the reason for providing as large a bearing area as possible for the track. The wood ties are about 4½ ft. long, 7 in. wide and 4½ in. thick. When steel ties were used the track sections, built up complete with ties, were delivered and laid in lengths of 5 m. The change to wooden ties, however, makes it necessary to spike down the rails in the field. I passed over long sections of old construction where wooden ties had been inserted under the rails between pairs of the steel ties.

Much of the ground in the north-

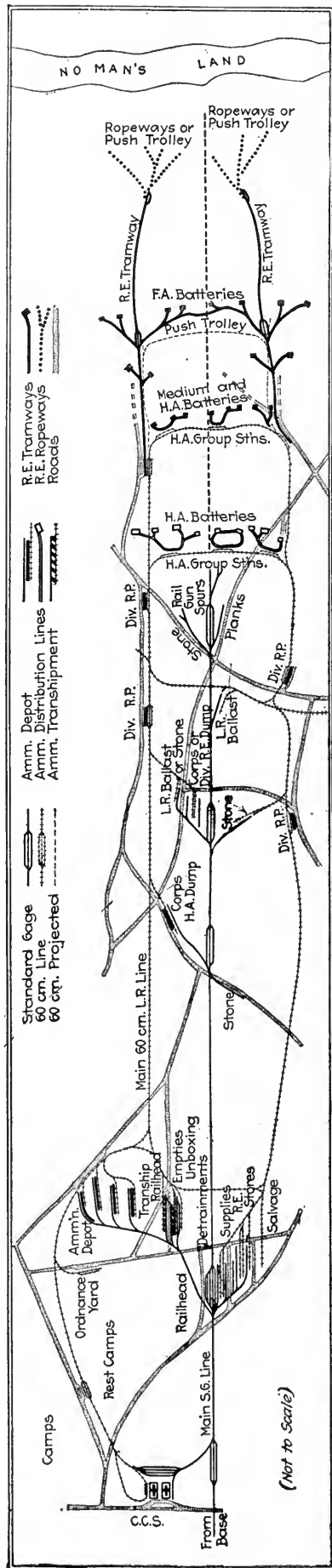

FIG. 1. SKETCH PLAN INDICATES RELATION OF VARIOUS PARTS OF A LIGHT-RAILWAY SYSTEM



*British Official Photograph*

FIG. 2. THE PRIMARY FUNCTION OF LIGHT RAILWAYS IS TO DELIVER RATIONS, AMMUNITION AND SUPPLIES TO POINTS FROM WHICH THEY CAN BE QUICKLY DELIVERED TO THE TROOPS

ern areas occupied by the British armies is a regular morass, so that the drainage of the light-railway road-bed is an extremely important part of the construction. Ditches on one or both sides of the line are universal. In looking over the weekly reports in an American captain's quarters, I found a record of a 17-ton locomotive which had toppled over on its side when standing still, due to settlement of the saturated ground on which the track was laid.

The construction and maintenance problems are further complicated by the scarcity of good ballast. The most easily obtainable material is the chalk which is characteristic of this region, and large quantities of it are employed for track ballast if nothing better can be had (Fig. 6). The chalk, fairly satisfactory in dry weather, "turns to cream when it rains"—to use the phrase of one of the officers who was discussing its properties with me. Another objection to chalk ballast is that it shows up prominently in aerial photographs and offers a good target for artillery fire or bombing.

Back of one of the American railway camps is a pit from which sand is being taken for track ballast, and it is proving very satisfactory. In this area the old chalk ballast is either being removed and replaced by sand, or else covered with sand. Another material for ballast is what is called "mine earth," but this is to be had only in places near the coal-mining regions. It is a waste product, looks like slate, and serves fairly well as ballast.

Traveling over certain sections in northern France and Belgium, I looked down between the rails and read there the tragedy of cities that are no more, for brick and stone—all that remains of the buildings in what used to be towns near the front—are used to a limited extent near destroyed villages for ballasting light-railway tracks. A Government permit is required for the removal of this debris.

In spite of all the difficulties of construction and scarcity of materials, the track, in all of the regions where I traveled, is in very good condition. Derail-

ments occur, of course, but with the comparatively light rolling stock used it is not much of a job to get an engine or tractor back on the rails. Rounding a curve at Ypres, where the track makes sharp turns to dodge the ruins of buildings, our petrol tractor—a 20-hp. machine—was derailed. With a few wood blocks and steel bars, carried by every train, we got it quickly on the rails. Another time, when our tractor became unruly and jumped the track, it was lifted bodily and replaced by a working crew which happened to be near—just a case of "Off agin, on agin, gone agin—Finnegan."

Maintenance is consolidated with construction in the extreme forward areas, while farther to the rear separate gangs are assigned to these two duties. The chief task is the relining and reballasting of track—for some of the very muddy areas are great "ballast eaters"—and the repair of breaks due to shelling. The maintenance crew must also keep the drainage ditches and culverts clear. During periods of frost and thaw a great deal of resurfacing is called for, and at such times the chalk ballast is particularly troublesome. Repair of track broken by shell fire falls to the lot of the maintenance or construction gang, according to whether the damage is at the front or rear. I was told at headquarters that for all the British armies the maintenance work requires about 14 men per mile of track. Breakage due to shelling at the time of my visit varied between 1500 and 2000 ft. of track a week for the entire front.

The hauling of light-railway trains is done by several types of engine. In the rear area three makes of coal-burning steam locomotives predominate. Near the front, where smoke and steam would draw enemy artillery fire, petrol-electric and plain petrol tractors do the work. Two of the types of steam locomotive weigh about 14 tons each and the third 17 tons. The 40 to 45-hp. petrol-electric, or "P. E.," as it is called, weighs six tons. The light petrol tractor, 20-hp., weighs somewhat less than two tons. There is, in addition, a tractor weighing about one ton, which consists of a small auto

engine on a special truck; it is used for inspection trips or for hauling single carloads near the front. The table printed elsewhere in this article gives the load test on different grades for the several types of machine.

The steam locomotives, on account of their visibility, as before noted, and also the desirability of running them on track which is fairly well aligned, are reserved

I asked one engine driver about the relative operating difficulties with the light and heavy rolling stock.' He replied, in substance, that the "P. E.'s" and steam engines, if derailed, dug down into the roadbed, and, on account of their weight, came to a quick stop. The lighter machines, while easier to handle in case of accidents, generally ran farther off the rails.



*British Official Photographs*

FIGS. 3 AND 4. THE LAYOUT AT THE STANDARD-GAGE RAILHEAD PROVIDES FOR TRANSSHIPMENT TO THE

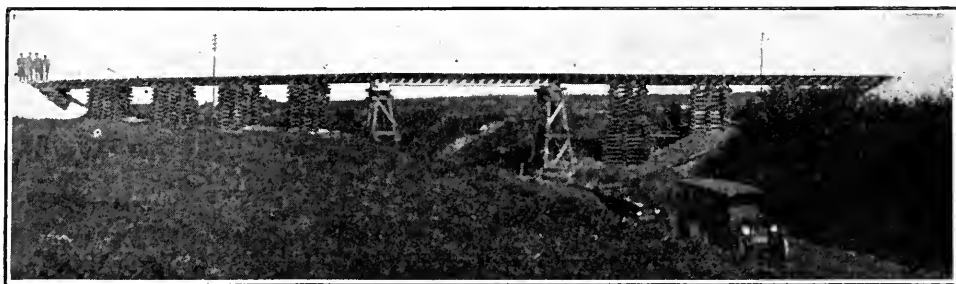

LIGHT RAILWAY CARS—OCCASIONALLY IT IS NECESSARY TO BUILD A TRESTLE

principally for the rear-area haulage, while the petrol-electrics, and particularly the lighter petrol tractors, are for use close to the front lines. The petrol-electrics are equipped with internal combustion engines and generators, the motors being mounted directly on the axles. As indicated in the table, they are for heavier work than the plain petrol machines.

On the petrol-tractor trains the crew consists of two men, driver and brakeman. With steam haulage, a third man, the fireman, is required. The maximum speed allowed is about eight miles per hour, with a limit of three miles per hour at grade crossings.

A great many types of cars are used in light-railway operation, depending on the kind of material to be

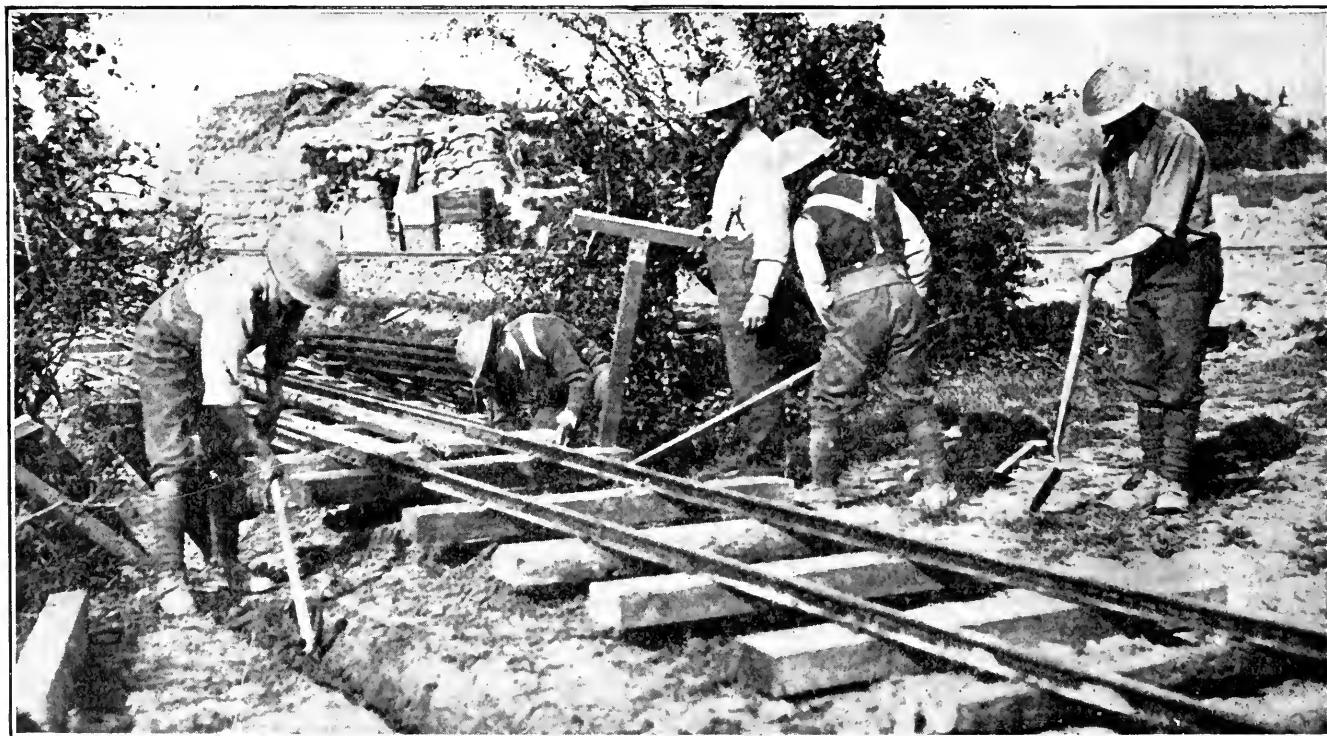

*British Official Photograph*

FIG. 5. IN CONSTRUCTING LIGHT RAILWAYS IT IS ALMOST UNIVERSAL PRACTICE NOW TO USE WOODEN TIES, INSTEAD OF THE STEEL TIES FORMERLY MADE UP AS PART OF EACH TRACK SECTION



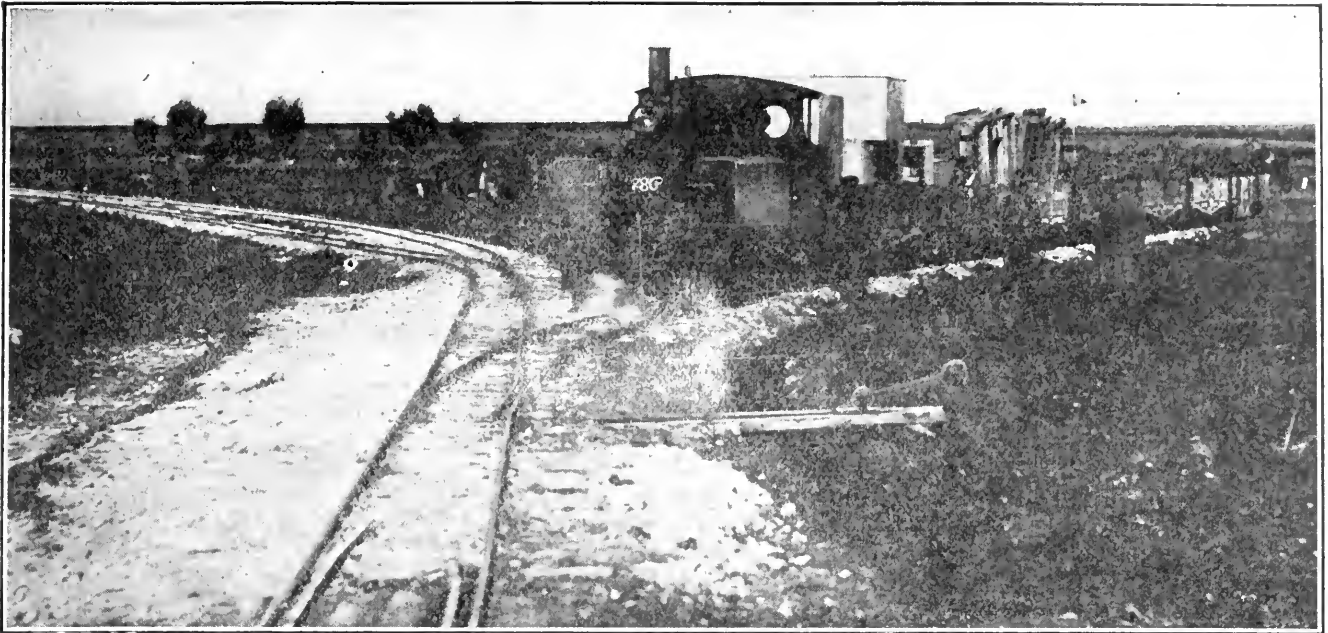

*British Official Photograph*

FIG. 6. A SECTION OF TRACK BALLASTED WITH THE CHALK FOUND IN THE VICINITY

Note also the switches, the drainage ditch at the right, which is a very important feature in muddy ground, the type of steam locomotive with water tanks on either side of boiler, the cars and the character of material carried in them

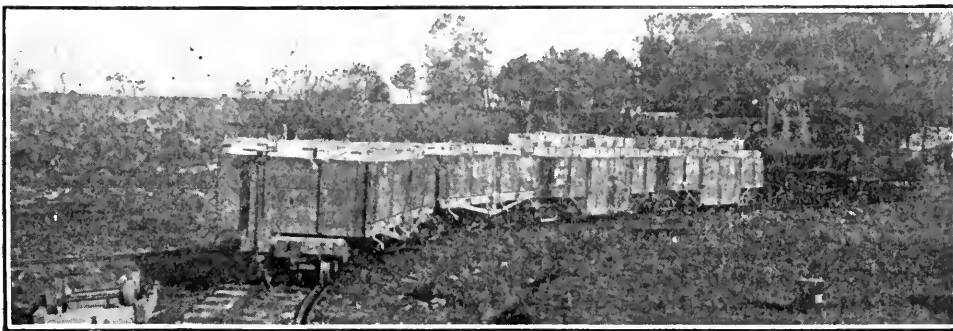

*British Official Photographs*

FIGS. 7 AND 8. GONDOLA CARS OF THE FLAT-BOTTOM AND WELL-BOTTOM TYPES ARE USED IN LARGE NUM-

BERS—THE WOUNDED ARE TRANSPORTED IN SPECIAL CARS BY LIGHT RAILWAY

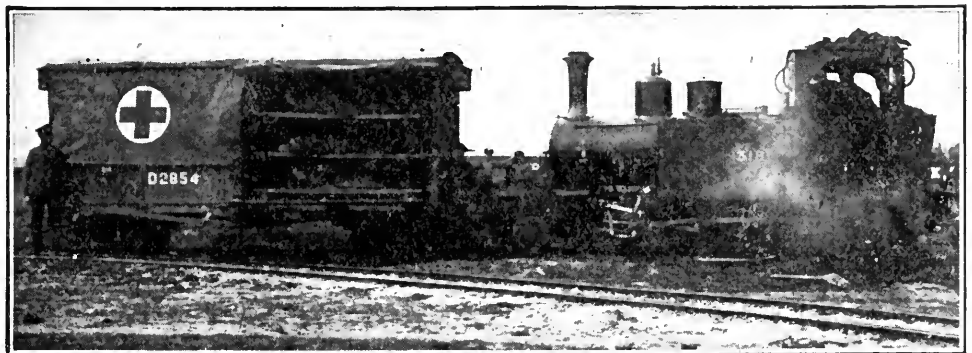

hauled. The bulk of the freight handled comes under the following classifications: Ammunition, timber, coal and coke, rations, ballast, R. E. stores, salvage, stone for highway maintenance, with troops going to or returning from the front. In one army which I visited about

LOAD TEST, IN LONG TONS, FOR LIGHT RAILWAY ENGINES AND TRACTORS ON BRITISH FRONT IN FRANCE

Equivalent Grade, Per Cent.	Steam Locomotives	Petrol-Electric, 40-Hp.	Petrol Tractor, 20-Hp.
0.5	164	82	33
0.5-1.0	105	53	21
1.0-1.5	78	39	16
1.5-2.0	62	31	12
2.0-2.5	50	25	10
2.5-3.0	44	22	9

a dozen different kinds of car were in service. The prevailing car (Fig. 7) is a gondola about 20 ft. long and 5 ft. wide, made in both the flat and the well types. These cars can carry about 10 tons of ammunition, but with lighter and more bulky material, such as R. E. stores, the load per car may be only five or six tons. With troops the load per car will average about three tons. For perishable rations covered box cars are available. Then, too, there are small four-wheeled wagons, 8 ft. in length, for loads of  $3\frac{1}{2}$  tons each. For the hauling of heavy ordnance special trucks have been developed.

Hospital cars (Fig. 8), fitted up with banks of berths for carrying the wounded, are included in the rolling

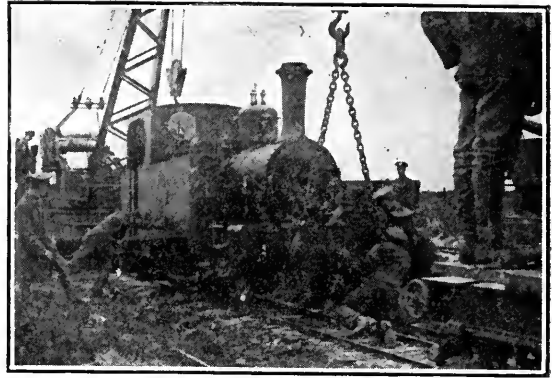
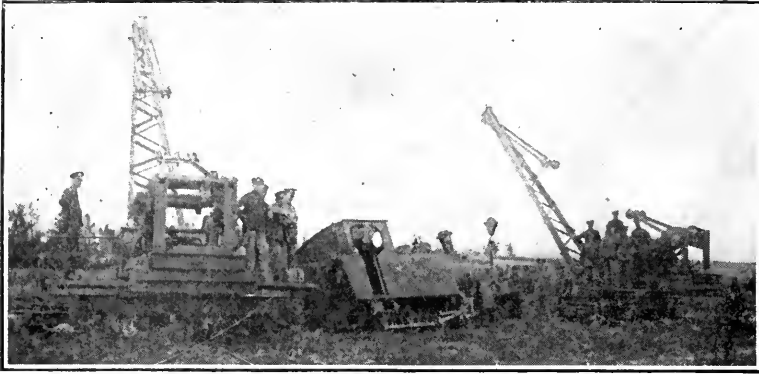

*British Official Photographs*

FIGS. 9 AND 10. WHEN THE HEAVIER STEAM LOCOMOTIVES ARE DERAILED, WRECKING CARS LIFT THEM BACK  
The lighter petrol tractors can often be handled by blocking, steel bars or rerailing irons

stock. I was told by the Assistant Director of Light Railways in one army zone that under normal operating conditions he considered 75 tons per 10-ton car per week a fair working average.

In addition to the car types enumerated, there are wrecking cars and cranes (Figs. 9 and 10), for lifting derailed engines and tractors, and special groups of four or more cars, each 20 ft. long and 5 ft. 4 in. wide, constituting machine shops on wheels (Fig. 11). The equipment in the latter includes drills, grinders, hacksaws, lathes and planers. These tools are operated by power from one of the standard petrol-electric tractors, which, if the occasion should demand, can haul the machine shop forward or backward. The shop on wheels remains in one location, however, unless it is decided to change the light-railway base. The sides of these machine-shop cars are hinged at the bottom and open outward, forming a platform extension on each side.

Where the repair work is too heavy or complicated to be handled readily in the field, the rolling stock is shipped to a large central repair plant, thoroughly equipped with machine tools, spare parts and appliances of every sort for rehabilitating engines or cars suffering from "shell shock" or other ailments incident to light-railway operation. We had intended to make a detour in our route for a visit to this central plant, but our schedule was so full that time did not permit an inspection of this very important feature of light-railway work.

The information concerning light railways which I had picked up in scraps of conversation here and there before my visit to the front had led me to believe that these systems were operated to some extent on the go-as-you-please plan. An inspection of the field control posts and central train-despatching offices in every army on the British front quickly dispelled this impression. Traffic is closely regulated, and the system in force allows the A. D. L. R. or his assistants to know at every hour of the day where each engine, tractor or car is, whether it is loaded or empty, what kind of freight is being hauled, and scores of similar details. In fact, one of our American railway operating detachments has gone to the length of preparing a timetable for its section. The operating scheme in all of its main features is standardized along the whole front. From the nature of things operation in the forward zone is largely at night.

In every army zone there are a central control station near A. D. L. R. headquarters and district control posts at various points on the line, in direct telephonic communication with the main station. The time of departure of a train from the yards is telephoned to the district posts, with the approximate time of arrival at the latter, and no train is allowed to pass a district post unless the attendant has been so authorized.

On one wall of every central control post is a long board with slotted wooden strips corresponding to every section of main track and siding in the system. Code numbers are given to each "station" on the line, and

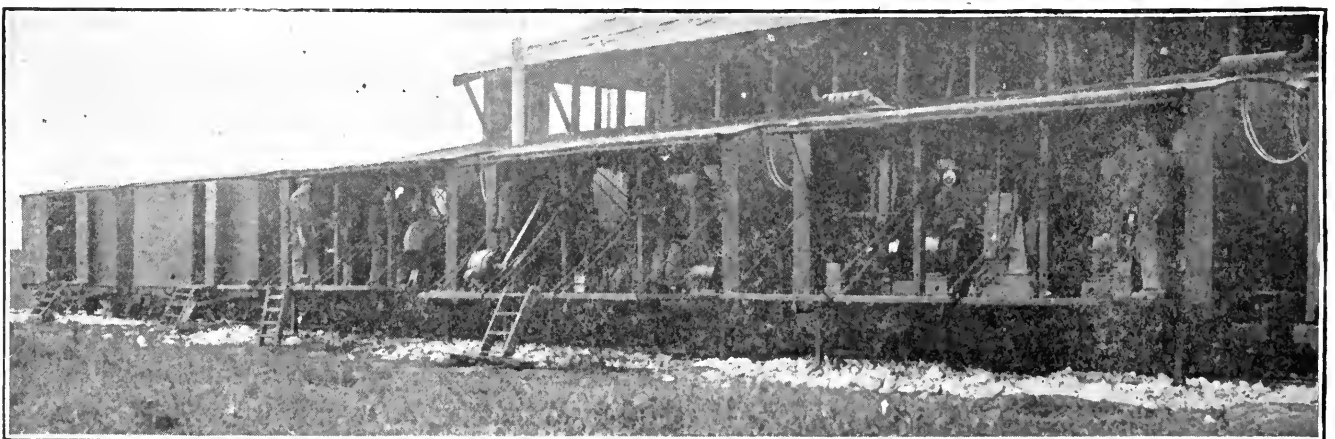

*British Official Photograph*

FIG. 11. ORDINARY FIELD REPAIRS TO ROLLING STOCK ARE MADE IN A MACHINE SHOP ON WHEELS  
For heavy repair work and general overhauling equipment is sent to a central repair plant

L.R./C. 100. Loco Tractor No. \_\_\_\_\_ Class: \_\_\_\_\_  
 Depot: \_\_\_\_\_ Date: \_\_\_\_\_ 19\_\_\_\_  
 Driver: \_\_\_\_\_ On Duty: \_\_\_\_\_  
 Fireman: \_\_\_\_\_ On Duty: \_\_\_\_\_  
 Guard: \_\_\_\_\_ On Duty: \_\_\_\_\_

PRINTED IN FRANCE BY A.F. & S.S. Form No. 700. 40000. 10/11.

Train No.	STATION	Arr.	Dep.	ATTACHED.		DETACHED.	
				No.	Contents.	No.	Contents.
57	C-1		800	5032	Ammo		
				154	"		
				897	"		
	C-3	8.30	8.35			5032	Ammo
	C-5	8.50	8.55			154	Ammo
	C-9	9.15	10.15	2.35	Water		
	C-103	10.25				897	Ammo
						235	Water

FIG. 12

L.R./C. 101. Wagon No. 61 Class K. Date 2-10 Train No. 120  
 C.G. Line FROM \_\_\_\_\_ TO \_\_\_\_\_  
 Time Loaded \_\_\_\_\_ Departed \_\_\_\_\_  
C 201 \_\_\_\_\_ 6.43  
 \* TO \_\_\_\_\_ Returned \_\_\_\_\_  
C 202 \_\_\_\_\_ 7.53  
 Printed in France by A.F. & S.S. Form No. 800. 100000. 10/11.  
 Contents: \_\_\_\_\_ C.C. Weight: \_\_\_\_\_

FIG. 13

L.R.P. 4. 14. LIGHT RAILWAYS.  
 TO \_\_\_\_\_ DATE \_\_\_\_\_  
 LOADED AT \_\_\_\_\_  
 MATERIAL \_\_\_\_\_  
 CONSIGNOR \_\_\_\_\_  
 CONSIGNEE \_\_\_\_\_

Tons	Owts.

PRINTED IN FRANCE BY ARMY PRINTING AND STATIONERY SERVICES. Press B. 604. 20000. 10/11.

FIG. 14

these are lettered on the board Clips, with hooks which fit into grooves representing the track, are hung up for each train and moved forward or backward in accordance with reports on movements. A glance at the chart with its clips—red for “loaded” and green for “empty”—shows the position of every train in operation.

When a train is made up a form (Fig. 12) is filled out, showing the number of the engine or tractor, the names of the crew, the destination, etc. For each car a “chit” (Fig. 13) and waybill (Fig. 14) are prepared. Then all the forms for one train are attached to the clip on the main board and are moved back and forth with it. This gives a complete and immediate record. In light railway operation time is recorded according to a 24-hour system, starting at midnight. Thus a train does not leave at “9 p.m.,” but at “21 hr.”

At each “station” on the main board is a small tin box with two divisions labelled “loaded” and “empty.” When a car is dropped from a train at any “station” or siding this fact is reported by telephone to the central control station. The “chit” for the car is then removed from its clip and deposited in the “loaded” compartment of the proper tin box and transferred to the “empty” compartment at the right time. Thus, information as to the location of the empties, for subsequent collection, is always at hand. When an engine has finished its run the chits are removed from the tin boxes on the control board and given to clerks who keep complete statistical records of the tonnage hauled.

In addition to this main train-despatching board there are separate boards at the central control stations designed to show the status, by districts, of each tractor and of each car—the number loaded and empty and the number working or idle. For each tractor or car there is a perforated metal disk, numbered, and, in the case of the cars, painted in two colors, red signifying loaded, and green empty. The locomotive and tractor disks are hung on hooks under three classifications: “Working,” “spare”

FIGS. 12, 13 AND 14. THESE FORMS TRACE EACH TRAIN AND EACH OF ITS CARS

DISPK.	600 a. 200 PM			BRANCH		DATE <u>Feb 21st 1918</u>	
<u>Jones</u>	<u>600 a.</u>	<u>200 PM</u>					
<u>Brown</u>	<u>200 P.</u>	<u>1000 PM</u>					
<u>Smith</u>	<u>10 PM</u>	<u>1000</u>					
			WESTWARD				EASTWARD
Conductor	<i>White</i> <i>Black</i> <i>Conds</i> <i>Yellow</i> <i>R. Box</i> <i>Johnson</i> <i>Johnson</i> <i>Johnson</i> <i>Johnson</i>						
Engine	<i>772</i> <i>315</i> <i>Engine 571705</i>						
Engineman	<i>Johnson</i> <i>Johnson</i> <i>Johnson</i> <i>Johnson</i>						
Train			<u>30</u>	<u>24</u>	Train	<u>17</u>	<u>19</u>
Loads				<u>2</u>	Loads	<u>10</u>	<u>8</u>
Empty			<u>12</u>	<u>7</u>	Empty		
C-9	<u>13.2</u>	<u>7.15</u>			C-1	<u>10.15</u>	<u>11.45</u>
C-8	<u>13.47</u>	<u>9.00</u>			C-3	<u>9.40</u>	<u>11.25</u>
C-6	<u>13.55</u>	<u>9.15</u>			C-5	<u>9.20</u>	<u>10.50</u>
C-5	<u>14.20</u>	<u>9.45</u>			C-6	<u>8.53</u>	<u>10.40</u>
C-3	<u>14.25</u>	<u>10.10</u>			C-8	<u>8.45</u>	<u>10.15</u>
C-1	<u>14.50</u>	<u>10.35</u>			C-9	<u>8.30</u>	<u>9.15</u>
	<u>PM</u>	<u>AM</u>				<u>AM</u>	<u>AM</u>
C-1205					C-1211		
C-1211					C-1205		
Tr No	Tm Ca	Eng No	Tm Ca	Tr No	Tm Ca	Eng No	Tm Ca

FIG. 15. THIS FORM OF TRAIN SHEET IS KEPT BY THE AMERICAN RAILWAY DETACHMENTS

and "under repairs," assigned properly to their districts. A similar scheme of metal checks and hooks is employed for the cars, the classifications being "on hand," "loaded," "empty," "in transit" and "demurrage." The American railway detachments employ the system in vogue in the British central and district control posts, and in addition keep a train sheet (Fig. 15). While the latter is not officially recognized, it is the method which members of the operating force had employed on their own railroads in the States, and is kept up to date as a piece of extra work.

A very necessary part of the control system is the telephone lines, and to each A. D. L. R. headquarters are assigned a signal officer and men whose job is to keep the wires, switchboards and instruments in working order.

The number of cars per train varies widely. In the rear area one steam locomotive may haul on fairly level track nine 10-ton cars of ammunition or 12 cars of R. E. stores. These loads must be reduced in wet weather. As for the performance of light railways in carrying troops, one British officer told me that in his army zone alone as many as 160,000 had been carried in one day.

As an indication of the relative amounts of the various materials which the light railways haul, the following figures, representing a month's traffic on a certain section of line operated by American troops, is of interest, although I do not know whether these figures could be considered typical, for they are now several months old: Ammunition, 4522 tons; rations, 6284 tons; personnel, 3281 tons; light-railway ballast, 7277 tons; salvage, 4144 tons; miscellaneous, 6992; total, 32,500 tons.

I am, of course, not at liberty to state the tonnage carried by the British light railway system, the figures for which I saw, among other records, at the headquarters of the Director General of Transportation, but in lieu of something specific this observation is pertinent: During the course of my trip over a good many hundreds of miles of highway, the routes were unobstructed and I noted scores of empty motor trucks, parked and idle along the roadsides and in adjoining fields, both by day and by night. They told a silent, though none the less convincing, story of the work the light railways have done in the relief of traffic congestion behind the British front.

# Engineers Convert French Beet-Sugar Fields Into Advance Depot

Build Railway Receiving and Classification Yards, Nineteen Warehouses and Balloon Shed—Regulating Officer Controls Train Movement To and From the Battlefield

BY ROBERT K. TOMLIN, JR.

War Correspondent, Engineering News-Record

All Photographs by Engineering News-Record War Correspondent.

**N**INETEEN warehouses, each 50 x 500 ft., railway receiving and classification yards with 50 miles of track laid and 50 miles more yet to be placed, two steel ordnance structures which sprawl over about seven acres of land, a big balloon shed 180 x 100 ft. in plan, scores of smaller wooden buildings serving as barracks for troops—this is an advance depot and regulating station for the American Expeditionary Forces as I saw it during a recent tour of the places in France where our engineer regiments have been at work. American construction genius has taken a string of beet-sugar fields and in only a few months' time, has converted them into one of the most important railway and freight-handling centers in France.

An advance depot contains, in effect, the pulse of the great arterial system of army traffic whose heart is at our army's docking basins and railway yards on the coast of France, for through it passes the daily flow of food, ammunition supplies and men on their way to the front. Much of our engineering work over here has, until recently, been on paper or in the early stages of construction, but now we have begun to strike our stride, and things are moving rapidly. This advance depot is already a going concern. "It is a job 125% completed," said Colonel B——, the commanding officer of the engineer troops which did the bulk of the construction work, when I called at his headquarters recently. He went on to explain how the original plans have been expanded to one-quarter more than the size contemplated when the job was begun, and how new projects for a big bakery, a power plant and acres of additional covered storage space promised to dwarf the volume of work as first laid out. Look at a map of France and see that the front north of Toul, which the first official announcement stated was being occupied by American troops, is something like 400 miles, in a straight line, from the coast. By the railroad routes over which supplies must be carried the distance is somewhat greater. In these traffic chains which connect our seaport terminals and front-line trenches there are three master links—the so-called base, intermediate and advance depots. At the base

depot, I was informed, there must always be on hand, as a minimum, army supplies of all kinds for a long period. The intermediate depot is a supply station for a shorter period, while at the advance depot supplies for a still shorter period must be held in reserve. The names of the depots indicate their relative positions in the scheme of transport and storage. If, for example, something should go wrong at a base or intermediate depot, or on the railway lines running to the advance section, the advance depot could continue making deliveries of all essentials to combat troops for a considerable period. Likewise an accident at the advance depot—a big fire, or damage by an air raid, for instance—would not stop the flow of material to the front, as the intermediate depot reserve would immediately be drawn upon.

The scheme is almost exactly the same as is followed in the design of large water-works systems. For example, in the Catskill Aqueduct system for New York City's water-supply, we have the big Ashokan reservoir, or base depot, at the end of the line farthest from the ultimate consumer. Then, the Kensico reservoir, or intermediate depot, near the city, and finally the Hillview reservoir, corresponding to the advance depot or regulating station, close to the city limits. It is with the advance depot that this article will deal.

In place of a plan showing the relations of the railway yards and warehouses to each other, which, of course, cannot be published under present conditions,



A. THE NINETEEN WAREHOUSES ARE EACH 500 x 250 FEET IN PLAN AND ARE ARRANGED IN SIX PARALLEL ROWS

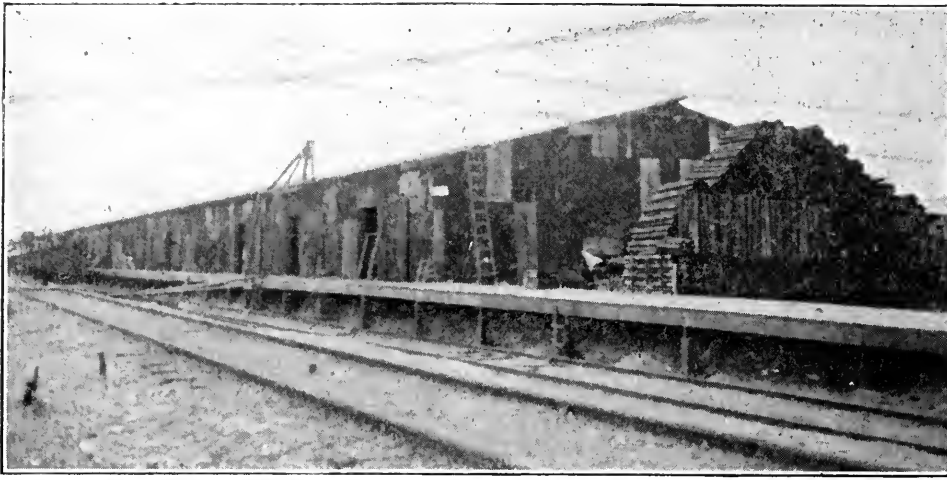

B. AFTER THE WOODEN FRAMEWORK WAS SET UP THE BUILDINGS WERE SHEATHED AND ROOFED WITH CORRUGATED IRON

I must give only a rather vague outline of the layout. The storehouses are arranged in six parallel rows, running north and south, one of these rows, half a mile long, comprising five of the 50 x 500-ft. standard structures. There are two aisles for open storage between the lines of buildings and a third larger open storage space to the east of the last line of warehouses. Along the sides of the warehouses run platforms flanked by lines of depressed track on both the incoming and outgoing sides, as shown in the photographs. The warehouse structures are of extremely simple design, having wood frames sheathed with corrugated iron sheets. The floors are of earth. The several rows of buildings are connected at intervals by wooden drawbridges to permit the handling of freight across the railway tracks. There are in all 14 lines of railway track, such as that shown in Photographs A and B, serving the warehouses and uncovered storage strips.

South of the warehouse group are the main-line tracks of a French railway from which connections have been made to the new receiving and classification yards (Photograph C), which American engineer troops have built to the west of the warehouses. Some distance to the north of the yards are the buildings of the engineer's camp and the headquarters of the commanding officer of the advance depot, while the two ordnance buildings and balloon shed (Photograph D), previously noted, are at the southeast end of the warehouse site.

When the engineer regiment arrived at the site of this advance depot last October it began work on the receiving and classification yards and the diversion of about 1½ miles of existing double-track French railroad, which, to accommodate the new yard layout planned, had to be moved laterally about 400 ft. This job required the removal of about 30,000 cu.yd. of rock by hand-drilling and blasting, as practically no mechanical equipment was then available. In fact, in the early days the en-



C. THE RAILWAY RECEIVING AND CLASSIFICATION YARDS ARE THE WORK OF AMERICAN ENGINEERS

gineers made most of their own tools. About 200,000 cu. yd. of earth were removed by hand-labor methods before horse-drawn scrapers arrived. On the railway yard work the American engineers were assisted by a French engineer company. For the 160 kilometers of track in the yards, of which about 70 km. have been laid, 120 km. of rails were received from the United States and 40 km. have been borrowed from the French. For the first unit of the depot it was necessary to provide 700,000 sq.ft. of covered storage

and 3,250,000 sq.ft. of uncovered storage. One of the men of the American engineer regiment had formerly been connected with a large building construction company in the United States, and his experience was used to good advantage in organizing and directing the work. It was not until the job was in full swing, however, that the engineer troops began to think about barrack buildings for themselves. Up to Jan. 20 they lived in canvas tents. After that date, however, wooden barrack structures were set up, a water-supply system and two electric lighting plants were installed. In addition, a number of miscellaneous jobs were handled—the placing of plumbing fixtures in nearby hospitals, the building of a medical laboratory, and an extra job involving camouflage warehouses and painting shed.

In connection with the latter job this incident is related: The officer who wanted the work done—it consisted of two 50 x 250 ft. warehouses and a 50 x 250 ft. painting shed—went to Colonel B——, of the engineers, to explain his needs. The colonel agreed to help him. In concluding his interview the camouflage officer said, "Colonel, we would like to keep posted regarding the headway your men are making. If convenient, I should like to receive monthly progress reports." Colonel B——, whose men had become adept at just this kind of work as the result of their experience on the depot warehouse sheds, smiled inwardly in acceding to this request. He set his men to work on Monday morning and the build-

ings were completed on Thursday of the *same week*. The camouflage officer is still waiting for his "monthly" progress reports.

On the long warehouses for the depot, 500 x 50 ft., the normal time for completing one building was four days. Much of the timber employed on this construction was the product of American forestry companies which are now operating in France. There was nothing elaborate about the job. It was just a case of putting in the base blocks, erecting the timber frames, sheathing the sides and putting on the roof. Later, sheets of corrugated iron were used to cover both the roof and the sides.

After my talk with Colonel B—— of the engineers I met the commanding officer of the advance depot, who has supervision of all activities at this site; the regulating officer, whose exacting duty is the control of all train movements, and the chief supply officer in charge of the load-quartermaster department ing, unloading and storage of supplies. "Our job," the regulating officer explained, "boils down to this: It is to keep the fellows up at the front who are doing the fighting from worrying about regular deliveries of food, forage, ma-

terial and ammunition. No matter what happens, we've got to get the supplies there and get them there on time."

No one can go through the advance depot and watch the machinery of transportation and storage at work without realizing that the depot commandant, the regulating officer, and the supply officer have a man's size job on their hands. For each combat organization there is a rail-head in the advance zone where supplies from the advance depot are delivered. From the rail-head the army field unit, whatever it may be, is responsible for getting the material to filling points, and thence to the troops, and for this purpose a division, for example, operates its own supply trains, which may be in the form of motor trucks, horse-drawn wagons, light railways, etc. At the rail-heads small reserve stocks of supplies and food are maintained to tide over the non-arrival of a train from the advance depot.

But the regulating officer's duties do not stop with the transportation of supplies and ammunition. He must provide facilities for large-scale troop movements and the delivery of the wounded from the front to base hospitals. The regulating officer, therefore, must keep in close touch with all army activities, not only at the front, but at the ports. For example, he must know the date of arrival of all troopships and supply transports, the character and quantity of their cargoes, the amount of material on hand at the base and intermediate depots, the number of combat troops and their location at the front or in the advance zone, the number of empty beds at each base hospital, the intended movement of forces from one sector to another, and scores of similar data of the most confidential nature. He is one of the

few men in France who know the total resources in men and material of the American Expeditionary Forces.

From the very nature of the war-time transport problem, the mechanism of the advance depot must combine properties of great strength and elasticity with the capacity for sudden and tremendous expansion. Even when conditions at the front are quiet the receipt and transmission of supplies and personnel on regular schedule make exacting demands on the organization responsible for this service. Nevertheless, the wires at any time may bring in word of some big activity at the front.

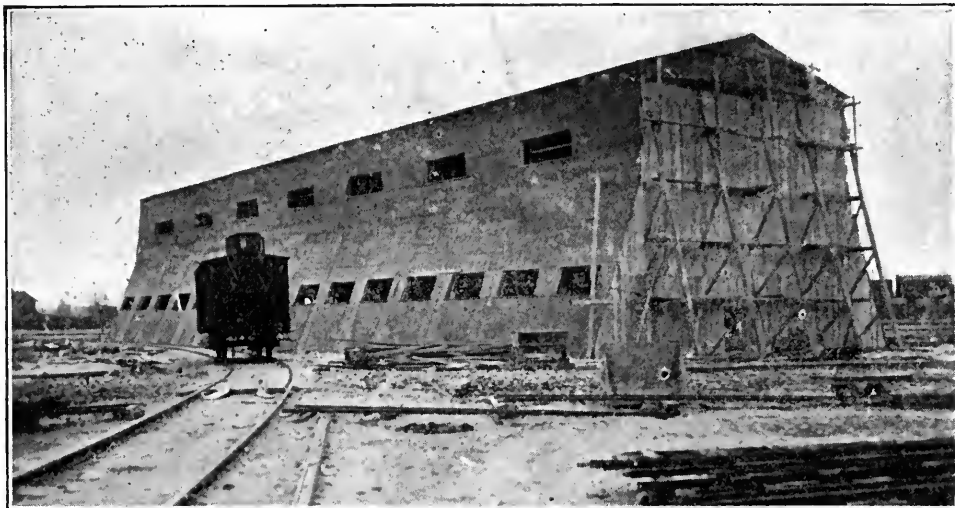

D. THE ENGINEER REGIMENT, ORGANIZED PRIMARILY FOR RAILWAY MAINTENANCE, BUILDS A BALLOON SHED

Troops must be shifted from one point to another, the supply of ammunition speeded up, supplies diverted from their regular channels, the wounded carried back. These are the times when the advance depot must work at a tremendous overload and it must stand up under the strain—a strain not applied gradually but with the force of impact. In such circumstances, the clamor for railway transportation comes in to the advance depot from all sides, and the depot commandant, the regulating officer, the supply officer and the rest of the staff must keep clear heads and assume the functions of a priority board in the allotment of engines and cars and supplies.

In the ordinary course of events, however, the supplies go forward in what are known as automatic shipments. For example, a certain number of men served by a certain rail-head mean so many pounds of meat, bread, vegetables, etc., every day, and a routine schedule of shipments can be foreseen and established until there occurs a large-scale movement of troops. By keeping a close check on the stock on hand at the advance depot, the amounts available at the intermediate and base depots, and the daily requirements of the troops in the advance zone, it is possible for the regulating officer to exercise a judicious control over the movement of trains and material. Even now, with American man-power here in France far below what it will be ultimately, the advance depot is handling every month something like 20,000 cars (this number including cars arriving, departing, rebilled, loaded or unloaded)—and this volume of business, I may state, is based on data obtained before the German drive developed its present proportions.

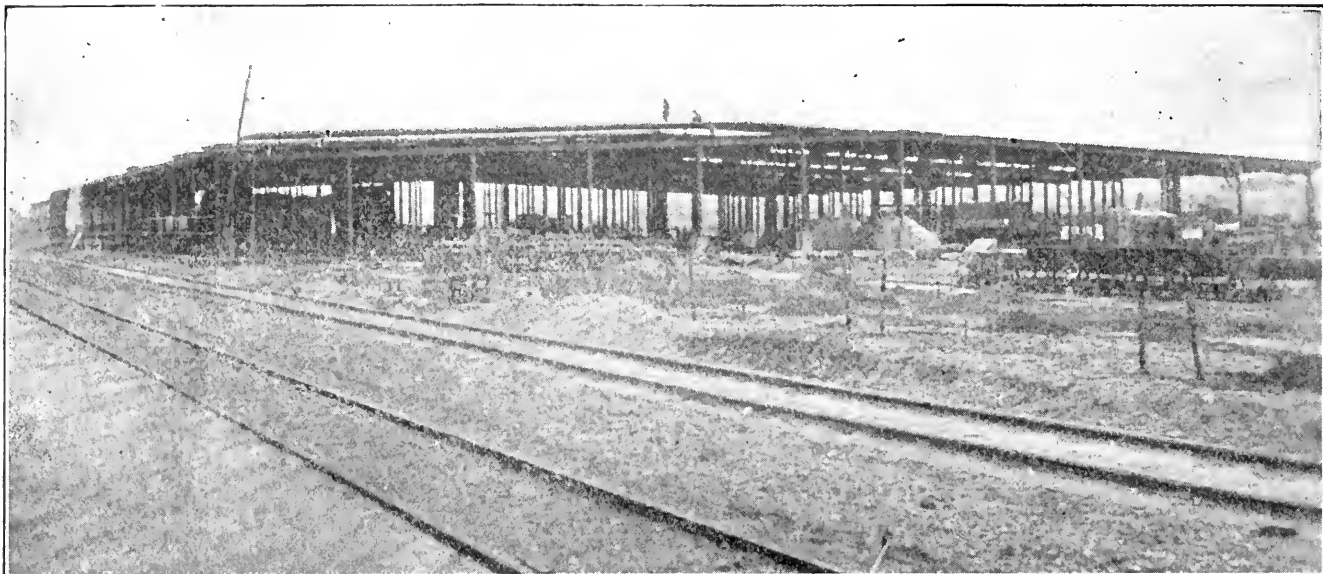

E. HOW ONE OF THE STEEL-FRAME ORDNANCE BUILDINGS, THE MACHINE SHOP, LOOKED ON APRIL 5

Everything from the rear en route for the front must pass through the advance depot. Of course, in the case of supplies, not every car is unloaded. Sometimes it suffices merely to rebill a car and send it forward. But with the depot authorities rests the decision as to whether a shipment shall be allowed to go onward or shall be held for storage. In the conduct of this work the regulating officer receives and transmits several hundred telegrams daily, to say nothing of telephone messages in equal numbers.

In the case of troop movements the regulating officer

receives by wire a statement as to the number of men, animals and tonnage of material, their present location and their ultimate destination. It is then up to him to get them there. At the time of my visit to the advance depot the regulating officer told me that food and clothing constituted the bulk of the tonnage which he was moving for the American forces. Ammunition, of course, varies from week to week according to the extent of the activity in the battle area. At every railroad head the regulating officer has representatives, and every train that leaves the depot for the front carries a representative whose duty is to see that the train arrives at its proper destination.

The actual loading and unloading of cars and the storage of supplies is under the direction of representatives of the quartermaster department, engineer corps, signal corps, medical corps, etc., each department having a certain number of warehouses assigned to it. The quartermaster stores form the largest bulk of freight handled by the depot. They include everything in the way of food, fuel, forage, and wearing apparel, and a good many miscellaneous side lines. The captain in charge of the quartermaster stores, who conducted me through his string of warehouses, receives daily from the regulating officer figures indicating the numerical strength of the forces in the advance zone. Adhering to certain prescribed limits for the Army ration, the warehouse officer loads cars with the proper quantity of supplies for the men, and forage for the animals.

To simplify this task, each warehouse is marked off in certain lengths for different kinds of supplies. Starting at one end, for example, there will be a section for flour, next a section for baked beans, and succeeding sections for tobacco, jam, etc. Other warehouses, are similarly apportioned, there being sections for overcoats, shoes, socks, underclothing, etc.

In the storage scheme the total supply of one kind of material is not put under one roof, but is distributed among several warehouses. Thus, in case of fire, or bombing by airplane, damage to one warehouse unit would have no appreciable effect on the continuity of dispatching supplies from the others.

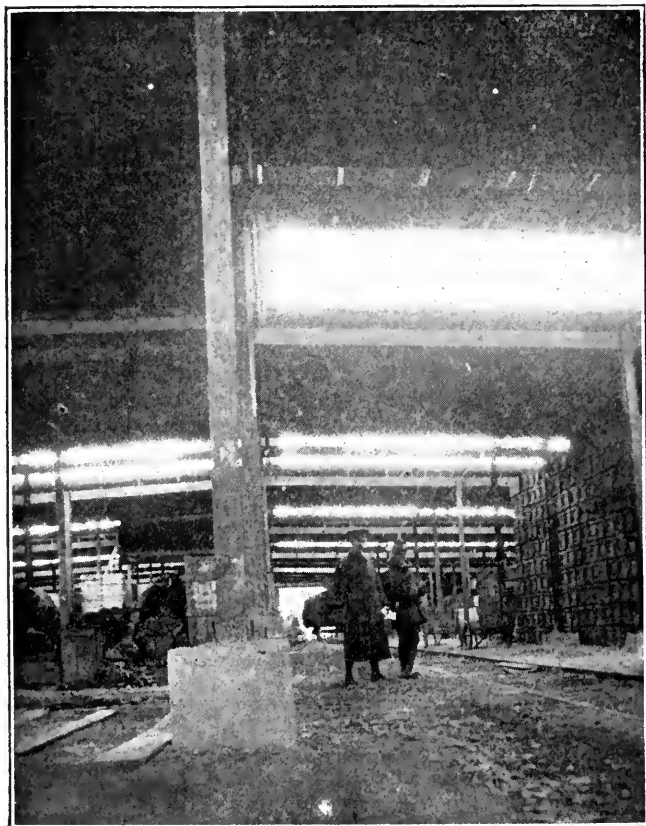

F. WIRE GLASS REPLACES CHEESECLOTH IN THE ORDNANCE BUILDING MONITORS



In the loading and unloading of cars, sections of ball-bearing roller tracks are largely used. Boxes and crates are thrown on the roller track, shoved along the warehouse platforms, and removed at the proper places for car loading or storage. A box car containing 570 cases of baked beans was unloaded, delivered into the warehouse and stacked by three men in 1 hour 35 minutes. Both for incoming and outgoing material a checker is stationed in each car and on each warehouse stack.

Since that time there have been a number of important changes affecting this work. In the first place, no such extensive layout of buildings at a single site, as was originally planned, has been carried out. Instead, a few units are being built at one place, a few more at another, splitting the job up. Then, too, in the actual construction, there has been a change from the original policy. The firm of Stone & Webster, which designed the ordnance base structures, was to have handled the

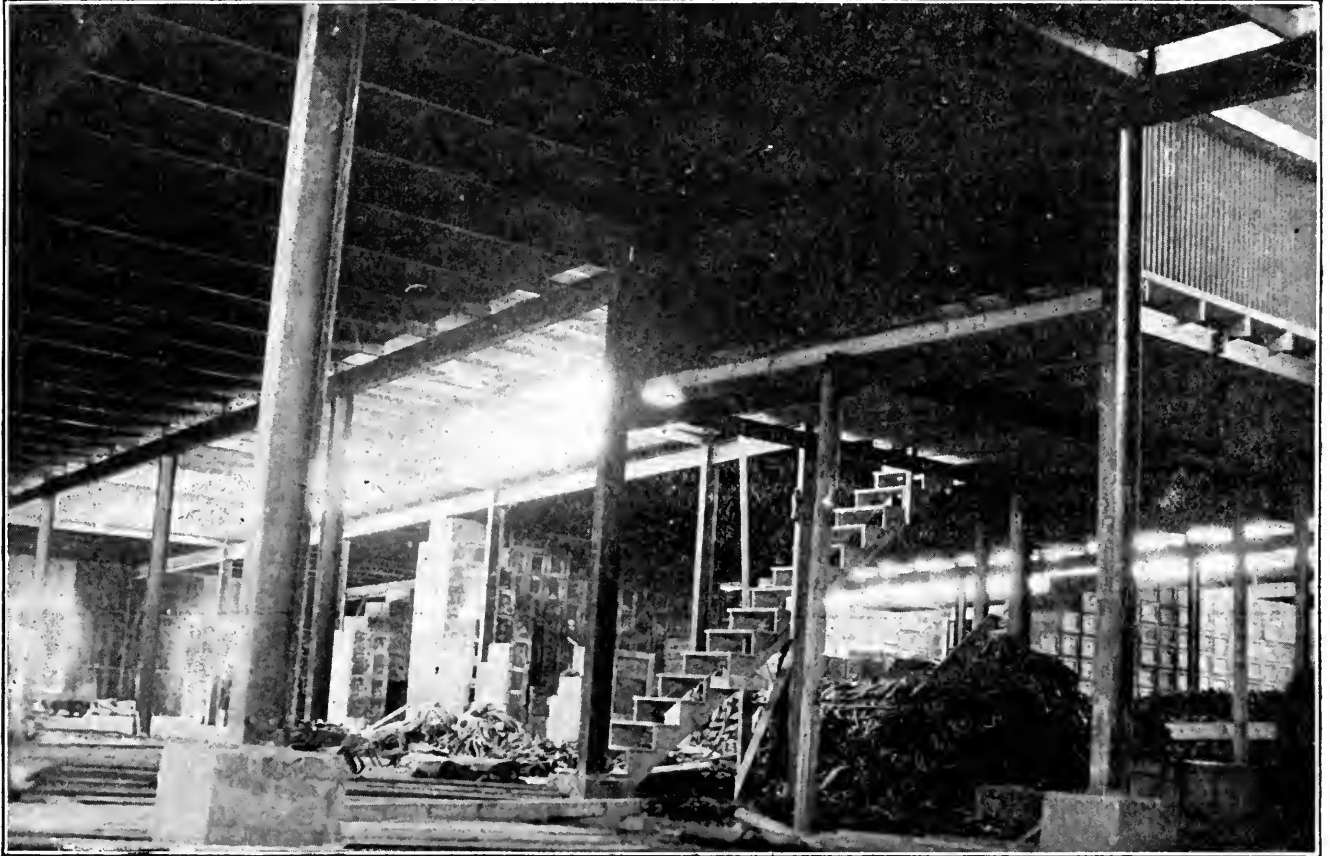

G. INTERIOR OF FINISHED ORDNANCE STORAGE BUILDING—COLUMNS SUPPORTED ON CONCRETE FOOTINGS OF DIFFERENT HEIGHTS TO GIVE SLOPE TO ROOF, SINCE ALL COLUMNS ARE OF SAME LENGTH

Records are kept to show output, input and the amount of supplies that is on hand in the advance depot.

After making the tour of the sustenance and clothing warehouses, I examined the medical stores and, finally, the engineer supplies. The latter were all grouped by sections, and among the things I noted were stacks of chicken wire, shovels, wheelbarrows, mining timber, trench flooring, water pipe, demountable barracks buildings, wire rope, hemp rope, carpenters' tools, saws, a few electric generators, water tanks, etc.

In contrast to the wood frame warehouses, with corrugated iron siding, which are such a prominent feature of the advance depot, are the two large steel-frame structures for the Ordnance Department. One, 500 x 240 ft. in plan, which is practically finished, is serving as a storehouse for ordnance material, while the other, 240 x 260 ft., which may later be expanded to the size of the first, is still in course of construction, as shown in Photograph E. It will be used as a machine shop and repair plant. Both of these buildings are part of the big ordnance building project which was described in *Engineering News-Record* of Jan. 3, page 23.

construction work also. A number of their men were sent to France early this year, and when a final decision had been reached regarding the sites of the buildings, the job was started by them. However, the Army has now concluded to complete the ordnance building project with its own personnel, and at the time of my visit relations with the Stone & Webster organization had been practically terminated.

The storage building, or larger of the two units, was started with Stone & Webster foremen and a detail of 65 men from the ranks of the ordnance service, while the machine shop structure, now under construction, is being built by a detail of infantry—about 100 men—under the direction of an ordnance captain. The engineer company which built the warehouses and yards at the advance depot assisted in the ordnance work by making a 4-ft. earth fill covered by a 3-in. layer of gravel to form the floor of the storage building.

The buildings are of simple design—light steel members with corrugated iron siding. Bolted connections are used throughout, and all columns are of one length, the roof slope being secured by carrying the concrete footings

for the columns to different elevations (Photograph G). Bays are spaced 20 ft. apart along the longitudinal axis of the building. On the erection work the practice originally was to handle the steel members singly. Later, however, a steel column and rafter were bolted up on the ground and raised by a gin-pole in a single operation. The purlins, however, were all raised by hand. The progress on the 500 x 240 ft. storage building was as follows: Footings completed Dec. 6, 1917; first steel column erected Dec. 29; all columns, rafters and girders placed Jan. 10.

For the roof the original plans contemplated a thin concrete cover over corrugated iron. This scheme had to be abandoned because of lack of concrete materials; two layers of felt and a layer of roofing paper were substituted. Until very recently the roof monitors were "glazed" with strips of cheesecloth. Now, however, a shipment of wire-glass has been received and has been substituted for the cheesecloth windows as shown in Photograph F.

The machine shop building, unlike the one for storage, is to have a concrete floor. When I inspected the work going on one mixer was delivering the concrete into ordinary wheelbarrows which were moved along plank runways to points of deposit on the floor. The progress of the machine shop structure is shown in Photograph E, which I took Apr. 5.

The construction was done under the usual conditions which affected most of our early engineering work in France—difficulties of transport, scarcity of mechanical plant and shortage of labor. Added to these was the fact the job had to proceed in spite of alternate periods of extremely cold weather and rain. For one week the mercury remained at zero (Fahr.) and made it hard for the men who had to handle the steel columns, rafters

and girders. Holes worn in their gloves allowed the skin of their hands to come in contact with the cold steel, where it stuck fast and was torn off in patches. Then, in the rainy periods, the fields would become vast seas of mud, and in walking through this tenacious material it was difficult for a man to keep a pair of rubber boots on. The "office," where the administrative end of the job was handled, was opened up in midwinter, and consisted of a canvas tent lighted by a candle. Due to the nonarrival of clips for attaching the corrugated siding to the steel framework, a detail of men was assigned the job of rounding up a supply of wire for this purpose. As a result, much of the corrugated iron siding is now held in place by scraps of wire taken from old crates and boxes and other odd sources. A single small auto was the sole means of delivering food from a town a couple of miles distant. Then, too, few of the men from the ranks of the Army had had any previous experience in construction work of this sort, but owing to the fact that the designers of the buildings had made the work as nearly fool-proof as possible, foreseeing the contingency of erection by unskilled labor—no serious trouble was experienced on the erection work. The officer in charge of the job, appreciating the trying conditions under which his men were working, took special pains to have them supplied with plenty of warm clothing and good food, and this policy was a big factor in maintaining the morale of the force. By the time this appears in print the job will probably have been finished. What these words mean can be appreciated only by those who know of the game fight that has been carried on in midwinter by the ordnance captain and his men, not in the front line trenches, but in the mud and snow of those beet-sugar fields which are now the advance depot.

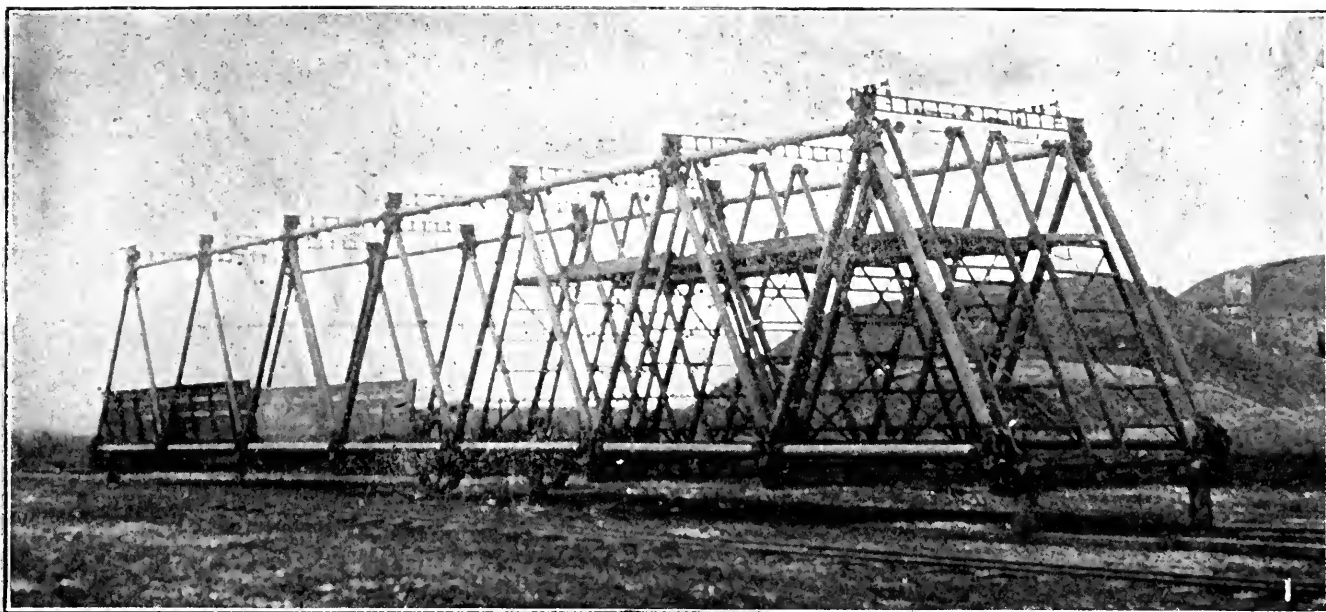

FIG. 1. HEAVY TYPE OF PORTABLE STEEL BRIDGE—RESEMBLES LIGHTER STRUCTURE SHOWN IN FIGS. 5 TO 11

## Army Engineer School in France Standardizes Work in the Field

**Gives Courses of Training to Men Recommended for Commissions—Operations Conducted Mostly in the Open—Classes Trained in Mining, Pioneering, Bridging, Topography, Camouflage, Sound Ranging and Interpretation of Aërial Photographs—Model Battle Sector Laid Out and Completely Equipped**

BY ROBERT K. TOMLIN, JR.

War Correspondent of Engineering News-Record  
All Photos by Engineering News-Record

**T**O SUBSTITUTE standardization for improvisation in the conduct of military engineering operations, in both field and office, and to give the man in the ranks an opportunity of becoming a commissioned officer, are the two main objects of the Army engineer school of the American Expeditionary Forces in France, which was formally inaugurated Apr. 1 with a class of 110 enlisted men from various technical units. This school is, in effect, a super-Plattsburg, where facilities for instructing our men in the latest phases of military engineering practice are being mobilized.

The need for such training is great, for many of the standards of practice laid down in former engineering field manuals have either become entirely obsolete or need substantial revision to bring them up to date; and, in addition, there is a host of new phases of the work of the engineer under the conditions of modern warfare. For example, the latest methods in the erection of barbed wire entanglements, the location and construction of trenches, the excavation of dugouts by rock tunneling, the interpretation of aërial photographs, the registering of enemy batteries by sound and flash ranging, the detection of enemy sapping operations by microphone, the rapid assembly and launching of new types of bridges, measures for gas offense and defense, the location and protection of machine-gun emplacements, the camouflaging of gun positions—these and scores of other subjects go to make up the curriculum of our newly established overseas engineer school.

Where training camps in the United States gave candidates for engineer commissions a grounding in the duties of the engineer service, the work at the school here on French soil begins where the others terminate, corresponding to a postgraduate course for commissioned officers and an intensive period of instruction for noncommissioned officers aspiring to higher rank. Just as the air-pilot candidate who has become proficient in straight flying must master the "circus stunts" which are an essential part of modern aërial combat, so must the Army engineer's education be topped off with a course in the less sensational, but equally specialized, phases of the new military engineering which the war has developed.

### HOW COURSES ARE CONDUCTED

It was my good fortune to be present at the opening of the American Army Engineer School over here and spend the day in an inspection trip with its commandant, a colonel of engineers well known readers of this journal by reason of his series of articles on the engineer in war which appeared in *Engineering Record* about two years ago. I say "an inspection trip," for the school's work is not all done within the four walls of the classroom which we generally associate with the word "school." This engineer school conducts the greater part of its operations in the open, by means of practical demonstrations, and to cover its field of activities Colonel B—— and I started out in the morning and

traveled over many miles of French highway by automobile before we got back to his headquarters late that afternoon. Of course, it must not be supposed that classroom work and lectures are omitted from the curriculum. The indoor work is an important part of the course, for, in addition to lectures by our own officers, candidates have the opportunity of attending conferences conducted by specially selected men from the forces of our allies, so that the experiences of those who have been playing the war game for a longer period than we have are made available for our use.

#### TRAINING COVERS MANY SPECIALTIES

The school of "military engineering" is departmentalized under three main subdivisions, as follows: (1) mining; (2) pioneering and (3) bridging. Closely allied with the so-called military engineering courses are six others covering the fields of camouflage, flash and sound ranging, topography, mapmaking and the interpretation of aerial photographs; orientation (artillery) and, finally, gas attack and defense. From the nature of things and the constantly increasing number of American troops in France, it is not possible to give every officer a course at the engineer school. Nevertheless, selected men are sent to the school for a period of training and are then available as instructors either in the corps schools or in their own organizations, to pass along to their fellow officers the knowledge they have acquired. This applies to the men with commissions now.

In the case of the man in the ranks who is found de-

serving of promotion the mode of procedure is thus: A regimental commander of engineer troops is authorized to recommend for promotion a certain small percentage of his enlisted strength. On reports from his battalion and company commanders he chooses certain men, generally corporals or sergeants, whose work has been of a high order and who, it is thought, have the qualifications of commissioned officers. These specially recommended men are then temporarily detached from their own organizations and sent to the engineer school for a course of instruction. Their work is carefully watched, they receive examinations of one kind and another, and, if the tests are passed successfully, they receive their promotions. The future policy, I was informed, will be to draw largely upon the ranks for all new commissioned officers in the engineer service.

It is not necessary for every engineer officer or candidate for a commission to take all of the courses previously noted. The idea is to produce a supply of specialists for each branch of the service. Certain courses, however, are obligatory, no matter what particular duty is to be performed later in actual field service. Among these is the course in gas defense. Nowadays, with the tremendous increase in the use of gas shells, rather than the gas-cloud form of attack, regions very far back from the front lines are never safe, and it is considered absolutely necessary that our engineer officers and men be thoroughly versed in the measures of gas defense. All officers on their way to the front, therefore, must either pass directly through the gas school, or else re-

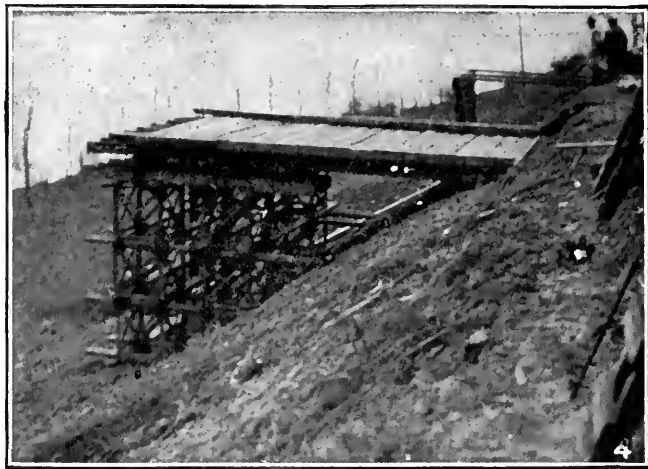
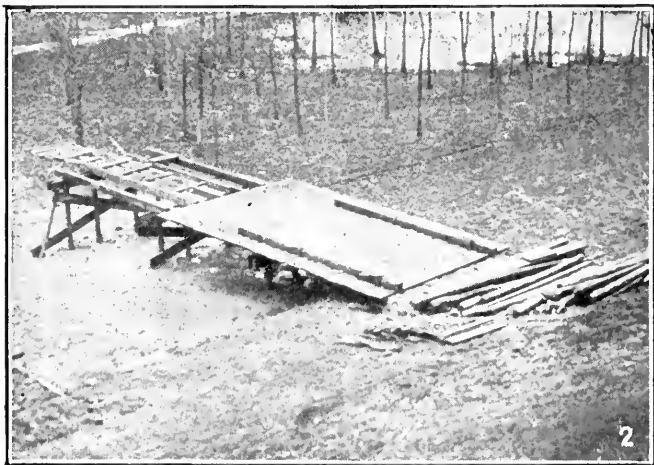

FIGS. 2 TO 4. AT ONE OF THE FIELDS OF THE ARMY ENGINEER SCHOOL MANY DIFFERENT TYPES OF PARTIALLY COMPLETED WOODEN BRIDGES ARE AVAILABLE FOR STUDY BY STUDENTS. IN FIG. 4 NOTE PARTICULARLY THE FORM OF ABUTMENT, WHICH CONSISTS OF CUBES OF STRUCTURAL STEEL BUILT UP LIKE BLOCKS

ceive instruction at the hands of graduates of the school. During the time of my visit an experimental field was being prepared for gas work, both defensive and offensive, to take the place of a wooden gas hut located in the courtyard of the engineer school, which had been used principally to test the adjustment of gas masks. One of the chief functions of the gas school is to qualify men to act later in the capacity of instructors for their own units. For instance, a group of prospective division gas officers will arrive at the school, the commandant having been previously directed to "give them a week of gas." With the new facilities for instruction at the experimental gas field, both this work and offensive training can be readily handled. The week's course enables the men to go back to their organizations well equipped to take charge of all defensive gas instruction. The offensive course is longer and more elaborate and is not of universal application.

#### MODEL BATTLE SECTOR

In order to make the instruction as practical as possible a certain area of selected ground has been marked off as a battle sector for a division, and is being developed exactly as it would be if it were part of the front. In this sector one sees trenches in various stages of completion; dugouts just begun, with entrances finished, and finally with all underground passages excavated; machine gun emplacements; trench mortar batteries properly located; barbed wire entanglements of several different types; various exhibitions of camouflage work, and so on through the entire category of defensive and offensive measures. All of these works represent the efforts of students at the school. However, one man is not kept at trench digging day after day. He puts in a certain number of hours, let us say, on excavation, then he passes along to the point where revetment work is needed, and works there awhile. His next task may have to do with trench drainage, and after that with barbed wire entanglements, and finally with the more complex structures, such as observation posts, machine gun emplacements, and the like. And so it is with the dugouts. Successive groups of men each do a little work on each type of structure in each stage of the work—enough to familiarize themselves with the actual construction methods—and then pass on to something else.

"The principal idea of the school," Colonel B— explained, "is to capitalize for war purposes American genius for quantity production. We have before us as an example our achievements in the quantity production of automobiles. Such results are possible only by standardizing parts and operations. We are trying to carry this principle into the work of the Army engineer school. We are trying to develop standard methods of building trenches, dugouts, bridges, machine gun emplacements and all of the other works needed at the front. Of course I appreciate fully that many cases will arise where our standards must be scrapped and where we will have to improvise, and improvise quickly. Nevertheless, the standards we are developing will be good at least seven times out of ten. A man must use his own judgment in departing from the routine way of doing things. In the development of our field engineering methods, however, we are combining our own ideas

with the best experience of our allies, and are evolving a standard practice which will, I think, be a big factor in saving time at the front—and time is the all-important element these days.

"Take the matter of dugouts and underground passages, for example. We have a set of standard casings or mining timbers which we are teaching the men at the school to use. When they get out into actual service they won't have to spend time devising a scheme of timbering for a tunnel. All that is done beforehand, and their job will be almost automatic, using the methods and material with which they have become familiar here at the engineer school. The same thing applies to bridge work and to what we call "pioneer" work; that is, trenches, obstacles, etc. We think we are now in a position to say what is the best way of doing all these things, and it is this 'best way' that we are making standard and driving home to the men by means of our recitations, demonstrations and actual work in the field by students."

#### BRIDGE BUILT IN EIGHT MINUTES

On the inspection trip of the field work of the engineer school our first stop was at a point where instruction in bridging was in progress. In addition to pontoon bridges, a number of other types of structure, both wood and steel, were in various stages of completion. There were the heavy steel portable bridge made of steel tubing, Fig. 1, and wooden bridges and trestles as shown in Figs. 2, 3 and 4. In Fig. 4 the abutment should be particularly noted. It is made up of individual cubes of structural steel shapes piled one on top of the other like a child's building blocks. This form of abutment is of British origin, as is also the demountable bridge shown in Fig. 1. The bridges in Figs. 1 to 4, inclusive, serve as models which are first studied and then built by the students at the school.

Following the same design as the bridge in Fig. 1 is another, much lighter, which is especially adapted to conditions where very speedy work is required—in crossing a river or canal under shell fire, for example. This is the light Inglis portable bridge (British), which is made up of sections of drawn or welded steel tubing, with special pin-connected joints. The bays are 8 ft. long. The parts of this bridge were placed along the ground parallel to the moat of an old French fort when we arrived. "If you want to see how we handle this work," said Colonel B—, "I'll have them set up this bridge and launch it for you." I certainly did want to see such an exhibition; so the colonel summoned the lieutenant in charge of a detail of 34 men and gave orders for the erection of the bridge. I had my camera with me and the resulting photographs, Figs. 5, 6, 7, 8, 9, 10 and 11, will indicate more clearly than words what happened.

Just a few words of explanation, however, are necessary. The method is to erect the bridge on the ground parallel to the watercourse, swing it around through an angle of 90° and run it forward as a cantilever over the moat. It will be noted that the structure is mounted on a two-wheel truck, or "dolly," which makes the launching operation very simple, and that the rear end where the men are assembled, as shown in Fig. 10, is counterweighted. When the far end of the bridge rests

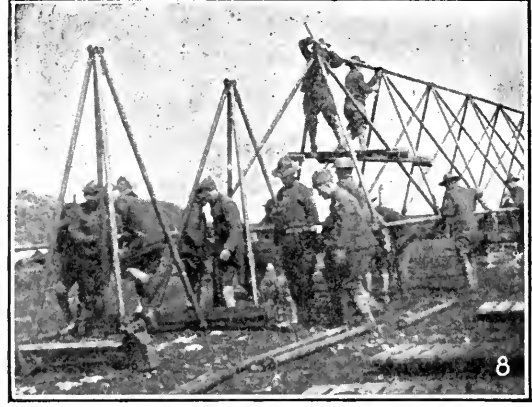
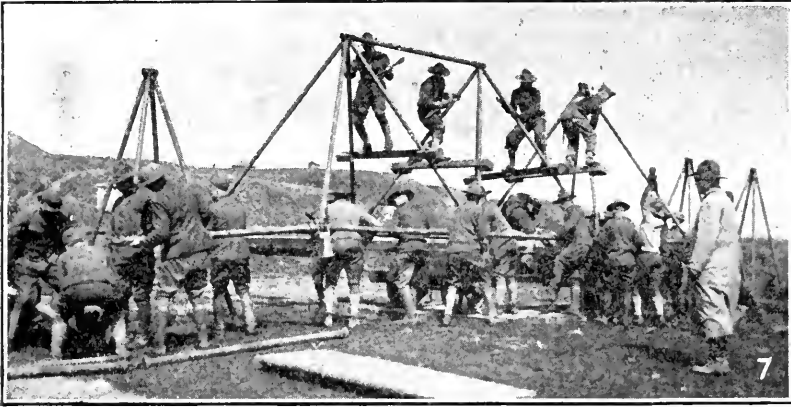
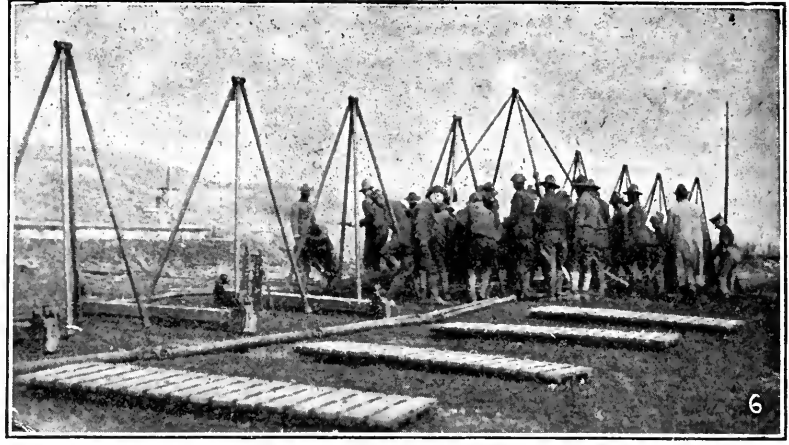
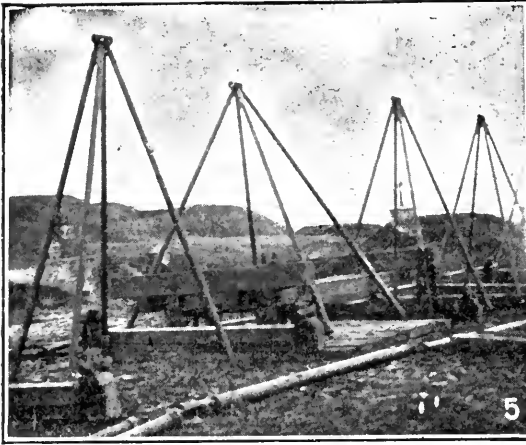

### Building a Bridge in 11½ Minutes

FIG. 5. BEFORE ERECTION AND LAUNCHING. PARTS OF THE LIGHT PORTABLE BRIDGE ARE LAID OUT ON THE GROUND PARALLEL TO LINE OF STREAM TO BE CROSSED

FIG. 6. AT ORDERS FROM COMMANDING OFFICERS MEN OF BRIDGE BUILDING COMPANY START THE WORK OF ERECTION

FIG. 7. THE FIRST BENT ERECTED AT ABOUT MIDDLE OF STRUCTURE, DIRECTLY OVER TWO-WHEEL TRUCK USED LATER FOR LAUNCHING

FIG. 8. BY THIS TIME A CONSIDERABLE LENGTH OF BRIDGE HAS BEEN SET UP—NOTE BOTTOM-CHORD MEMBERS LYING ON GROUND AND POSITION OF JOINTS AT BASE OF FOUR-LEGGED SECTIONS

FIG. 9. FINISHING ERECTION OF LAST BENT—NOTE POSITION OF MEN, EACH HAVING SPECIFIC PLACE TO OCCUPY AT SPECIFIC TIME

FIG. 10. ERECTION HAS BEEN COMPLETED AND BRIDGE IS BEING SWUNG ROUND AND RUN FORWARD ON TWO-WHEEL TRUCK LOCATED JUST TO LEFT OF OFFICER IN LIGHT RAINCOAT

FIG. 11. BRIDGE LAUNCHED ACROSS MOAT OF OLD FRENCH FORTRESS AND IN PLACE ON ITS ABUTMENTS

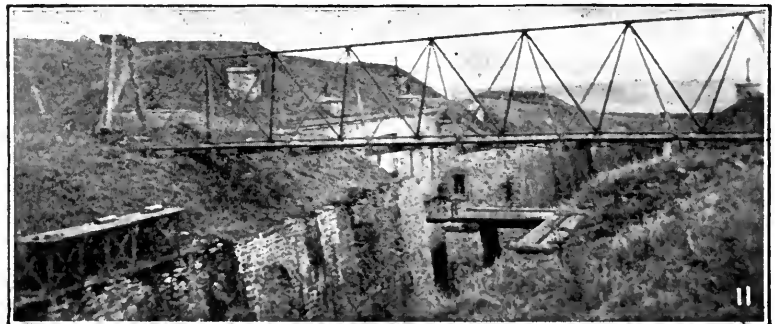
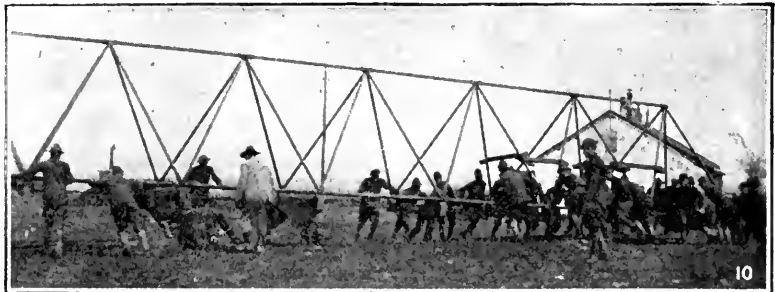
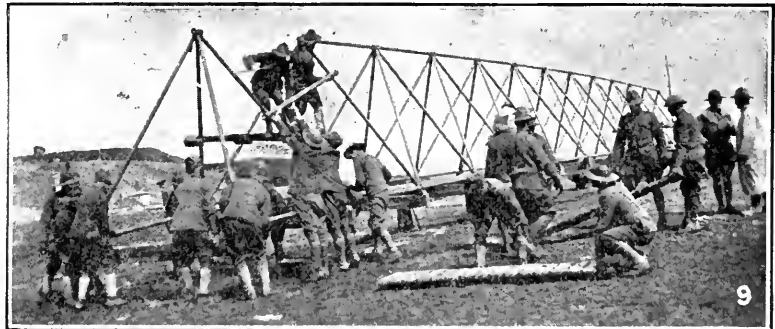

on its abutment across the stream the dolly is removed, the extra bays at the counterweighted end are knocked down, and the near end is seated on its abutment. With these bridges it is, of course, the practice, for the launching operation, to construct a greater length of bridge than is ultimately placed in service. In the present case 104 ft. of bridge was erected to give an ultimate useful span of 56 ft. It is practicable, however, to place the bridge in position by means of a derrick on the far side without cantilevering. This latter method is slower than the cantilever method, but allows the launching of a longer span.

Here is how the work progressed on the bridge I saw erected and launched: Thirteen bays, each 8 ft., or a total of 104 ft. of bridge, were erected in 5 min. 10 sec. The launching required 1 min. 20 sec. The removal of the "dolly" took 50 sec. In 4 min. 10 sec. more the counterweights had been removed, the extra launching bays had been knocked down, and the bridge was ready for service. In other words, exactly 11 min. 30 sec. was consumed in the entire operation.

*I have just received a note from Colonel B— saying that on May 4 his men cut the time of this whole operation to 7 min. 50 sec.* The erection of the bridge proper required only 4 min. 12 sec., nearly a minute better than the time made the day I saw the bridge-building demonstration.

#### 64 POUNDS PER FOOT OF SPAN

This type of light portable bridge weighs 63.75 lb. per foot of span, and can be used for spans as great as 96 ft. when launched by the cantilever method, and for spans up to 120 ft. when launched by derrick and tackle. The flooring consists of portable wooden sections such as those shown in the foreground of Figs. 6 and 10. The bridge is intended primarily for the use of troops on foot, although horses are occasionally carried by it. In the latter case, I was told, the practice is to use canvas sheets stretched on siderails to cover up the openings in the floor and sides; otherwise the horses become frightened and it is difficult to get them across the structure.

The principal feature of this portable bridge is that it can be assembled and launched without tools of any sort, except several small spanner wrenches. The joints are an important part of the design and are well shown in Figs 6, 7, 8 and 9. Note also in Figs. 6 and 8 the bottom-chord members lying on the ground. Their ends are held fast, as are the ends of all the chord and web members of the bridge, when in position, by pins which extend through the holes shown. There is a steel tongue welded into each end of each tube, and provided with a screw and nut. To make the connection, the nut is run back on the screw, and the tongue inserted into the joint-box. The pin is passed through the hole in the tongue and through the pear-shaped slots in the sides of the joint-box. The nut is then screwed up, causing the tongue to draw out of the box until further movement is resisted by the pin. To prevent these pins from being lost they are attached to the joint blocks by short lengths of chain.

The heaviest single member of the bridge proper (except the transom) weighs but 56 lb. To attain speed in the assembling and launching of this bridge it is es-

sential that each member of the crew have a specific job to perform, and that the sequence of operations, by reason of repeated performances, shall become practically automatic. The heavy bridge in Fig. 1, which will carry the heaviest of military loads, has a joint scheme similar to that described above for the light bridge.

#### DUGOUT CONSTRUCTION AND MINE WARFARE

From the bridge work we proceeded to the model "front," where the school's members were busy on dugout construction, barbed wire entanglements, trench digging and other activities. The school's battle sector is underlaid with rock, so that the dugout work was a regular hard-rock tunneling job. The entrances to two of these underground works are shown in Figs. 12 and 13. They assume the form of inclines extending to such depth that they have about 25 ft. of head cover over the roof where a horizontal passage begins. The incline was timbered solid with standard mining sets. Excavation required rock drilling with jackhammers fed by hose from a compressor driven by a gasoline engine. This plant was mounted on a steel frame so that it could be placed on a motor truck and moved from place to place. Blasting was done with light charges of explosives.

In addition to the construction of dugouts and shelters the course of instruction given by the mining section includes the principles of mine warfare and the subject of demolitions. In mine warfare it is necessary to gain information regarding the location and progress of the enemy's underground work, and in that way be in a position to forestall his plans of attack, or by noting a defect in his defensive system take advantage, for offensive action, of his weak points. To ascertain the enemy's underground positions it is necessary to employ very sensitive listening apparatus which greatly intensifies the sounds made in the rock during the progress of the work. By noting at different points the directions from which these sounds appear to come, it is possible by means of triangulation to locate the enemy's workings quite accurately.

The mining section is equipped with a listening circle and galleries where detailed instruction is given in the art of listening. The students are then given a practical course in actual listening and plotting of results, after which their papers are corrected and graded.

In connection with the listening work a course of mine rescue is given by the mining section, in which the students are required to wear oxygen helmets and are taught the methods employed in rescuing men who have become casualties in underground warfare. In addition to these subjects practical instruction is given in the employment of different kinds of explosives in the execution of military demolition.

#### WIRE-ENTANGLEMENT WORK

In front of the dugouts were the barbed wire barriers. One of the most effective types consisted of circular hoops of stiff plain wire connected by strands of barbed wire, forming an obstruction that looked like an elongated squirrel cage, except that diagonal strands crisscrossing from one hoop to another blocked up the cylindrical longitudinal opening. This form of obstruction is made up in 20-ft. lengths behind the lines, and before it is placed in position, it is packed close like a

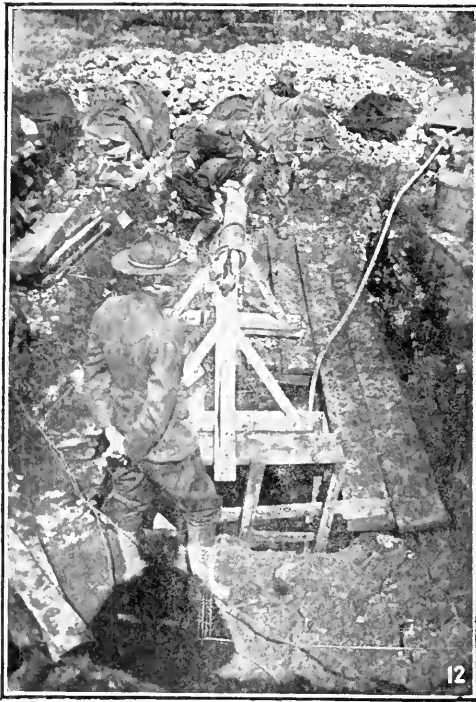

FIGS. 12 AND 13. THESE ARE THE ENTRANCES TO TWO MODEL DUGOUTS WHICH STUDENTS AT THE ARMY ENGINEER SCHOOL ARE EXCAVATING IN ROCK



coil of wire rope. It is then carried forward and opened out like the bellows of an accordion.

Iron stakes, of the screw type, are used to hold the framing hoops upright. These screw stakes, or pickets, possess an advantage over stakes that must be driven with a mallet, in that they can be set noiselessly. This is a very important feature when working in No Man's Land.

Other types of wire obstacles are constructed in advantageous locations by the students. There are regular drills for the erection of these various forms of entanglement, a certain crew being assigned to a definite length of obstacle. Each man of the crew has certain definite tasks, which he goes at in turn, so that the placing of a stretch of wire is like a silent game.

Further along we find a real front-line fire trench—this standard trench as well as the barbed wire entanglements being the work of the pioneer section. It is laid out to conform to the requirements of the ground. In this trench are all types of standard revetment, supporting the sides, there being several fire bays in each type. A real observation post has been put in, so cunningly concealed that it is impossible to detect it from the enemy's side. The drainage of trenches is always a problem—and here it is well worked out, so that the students can get real practice for use later when they are in charge of sectors at the front.

The tracing of trenches is worked out in this sector by the students, both in the daytime and at night. To be ready to do this work quickly and noiselessly when under the observation of the enemy takes much practice, and it is of the utmost importance that an officer should know just how to go about it. The method of placing a working party on the job is also practiced, after the trace of the new trenches has been laid down.

Under "pioneering" come also the construction and maintenance of roads, always one of the most vital problems with which military engineers have to deal, and there are at present at the school roads in every

stage of construction, from the preliminary excavation to the completed product.

A light railway connects the front line with the rear of this "battle sector." When one sees the immense amount of rock and gravel that has been hauled over its rails, one realizes how important is the construction of such means of transportation at the front, and here again the student gets that practical instruction which is the only adequate training to prepare men for actual service in the field.

The conferences of the pioneer section not only prepare the students for outdoor work in field fortification, construction of roads and communications and light railways, but also take up in detail the study of French maps, billeting, construction of various types of huts, and layout of water-supply systems.

To see a class of fifty students earnestly studying a map to discover the best position for a strong point is to convince oneself that they mean business. This map study is of the greatest value, because an officer must be able to orient himself quickly on the ground and—with the aid of his map—know exactly how to lay out and hold his position.

Billeting was a new proposition to our Army when it came to France, and it really requires considerable study. Conferences of the pioneer section study this subject in detail, as well as methods of constructing huts when billets are not available.



# Army Engineer School in France Standardizes Work in the Field

Gives Courses of Training to Men Recommended for Commissions—Operations Conducted Mostly in the Open—Classes Trained in Mining, Pioneering, Bridging, Topography, Camouflage, Sound Ranging and Interpretation of Aërial Photographs—Model Battle Sector Laid Out and Completely Equipped

BY ROBERT K. TOMLIN, J. J.

War Correspondent of Engineering News-Record

THE British say that "an army advances astride a 4-in. pipe." To familiarize our students with water-supply, they are taught the organization of our water-supply service, and the requirements of men and animals in gallons of water daily, and they are warned of the probable difficulties they will encounter. To make these difficulties appear more real, they are worked into interesting water-supply problems, approximating as closely as possible those which occur daily in trench warfare, and which graduates of the Engineer School will be undoubtedly called upon to solve. Working out such examples in a classroom has proved excellent training for the efficient execution of water-supply schemes at the front. The accompanying British official photographs show the kind of water-supply work done at the front.

The inclusive heading of "Pioneering" takes in practically every subject in military engineering except those specifically relating to mines or bridges, and everywhere at the Army Engineer School one sees encouraging evidence that no point has been overlooked.

## SOUND RANGING

Students at the school are receiving instruction in certain highly specialized phases of mapping and plotting in connection with artillery work. Among these is sound ranging—the registering of an enemy battery by means of apparatus operating on the general principle of a seismograph. It is disclosing no secret to outline the general principles of this work as practiced by the American Army, inasmuch as the scheme has already received publicity in the French press. In fact, one of the papers gives to French sound-ranging apparatus the credit for locating the long-range guns which have been bombarding Paris since the German drive began, although it is asserted in other quarters that *la grosse Bertha* was spotted by means of aërial photographs.

Briefly, the sound ranging work involves the installation of recording apparatus at three points, some distance apart, the location of each being definitely known in advance. The detonation of an enemy gun will be heard at point A at a certain time, at point B, let us say, a second later, and at point C, two seconds later. Knowing the velocity at which sound travels, it is easy to determine that the gun is a certain distance,  $x$ , nearer A than B. By taking A and B as origins, plotting pairs of circles, one radius always being longer by  $x$  than the other, and connecting the intersections, we get a curve on any point of which the enemy gun may be located. This curve is obviously a hyperbola, for the difference between the distances of any point on it from the two fixed points, or foci, A and B, is always the same.

Repeating this performance for points A and C we plot a new series of circles, the radii differing in this case by a distance of  $y$  corresponding to the time elapsed between the recording of the sound of the shot at A and at C. Again connecting the intersections of these pairs of circles, we get a second hyperbola which forms another locus of points for the gun position. Obviously, the intersection of these two hyperbolas gives the true position of the battery which is doing the firing.

Of course the actual registering of a battery position does not involve all of the clumsy details cited above to explain the principle of the method. Graphical charts have been developed for accelerating the interpretation of the data, and the recording apparatus operates with sensitized paper, which passes into a chemical development solution and is ready for use in a very short time.

The first thought that comes to mind is that with many guns firing along the front the work of interpreting the sound records would be exceedingly confusing. To some extent this is the case, but with a proper location of the recording posts and practice in reading the records, surprisingly accurate results are obtained. It must be remembered that a gun will probably fire a number of shots from one position and that every time the same *series* of time intervals will be recorded at the three observation posts. Thus, by comparing several records which are apparently complicated by other sounds than that from the gun it is desired to register, it is possible to identify the recurring *series of three marks* on the sensitized paper, eliminate others and spot the position of the battery.

Another aid to confirming the position of an enemy field piece is the method of flash ranging; that is, taking the direction of the flash of a gun at night from two or more posts of observation, the intersection of the azimuths, of course, disclosing the gun positions.

## AËRIAL PICTURES AID TOPOGRAPHICAL WORK

In a previous article, in *Engineering News-Record* of May 23, p. 984, I touched on the subject of the interpretation of aërial photographs for mapmaking and artillery purposes. At the Army Engineer School I had an opportunity of seeing a class being instructed in this fascinating branch of work; the officer in charge is a former topographic engineer of the United States Geological Survey.

The aërial picture must be accompanied by data giving the approximate height of the camera when the exposure was made, the date and time of day, direction of north, etc. It is examined under lenses and stereoscopes, the latter bringing out objects in relief. The study of shadows is a vital part of the work, for where

camouflage covers up an object from a point of observation overhead the shadow it casts is often the telltale mark by which important bits of information are disclosed. It is clear, therefore, that in the interpretation of shadows it is desirable to know the time of day at which the picture was taken.

Tracks or trails of any sort also are carefully studied, for they always mean activity of some kind—possibly the delivery of ammunition to a dump which is otherwise

protected from observation by camouflage. A favorite enemy trick is to place “dummy” batteries in the field to fool the mapmakers. Absence of a track or trail leading to these places shows them up as “fakes.” Sometimes, too, “faked” tracks and blast marks are fixed up with the white chalk so abundant in the war zone of France. The canny interpreter of photographs, however, is not misled by these subterfuges.

All of these data are reduced to map form by means

THE BRITISH SAY: “AN ARMY ADVANCES ASTRIDE A FOUR-INCH PIPE LINE.” AT THE ARMY ENGINEER SCHOOL OUR MEN ARE TRAINED IN WATER-SUPPLY WORK, THE SCOPE OF WHICH IS INDICATED BY THESE BRITISH PICTURES

FIG. 14. BRINGING UP WATER PIPES TO SUPPLY THE FRONT LINE

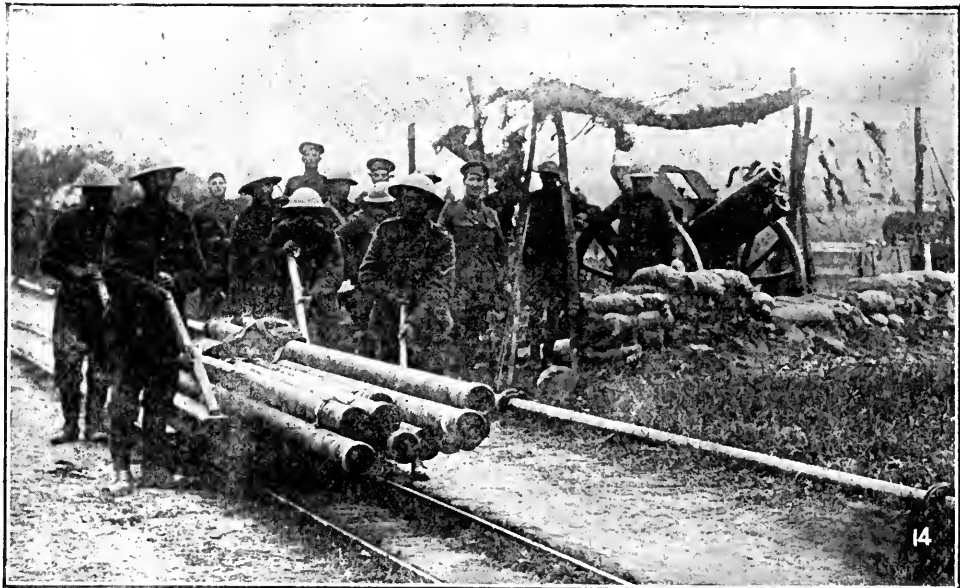
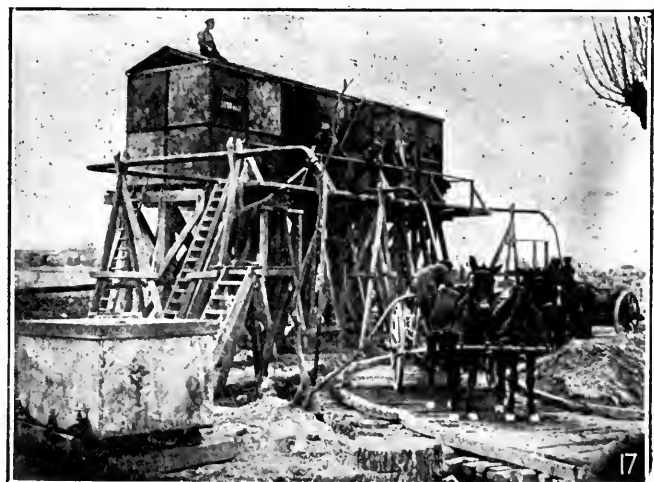
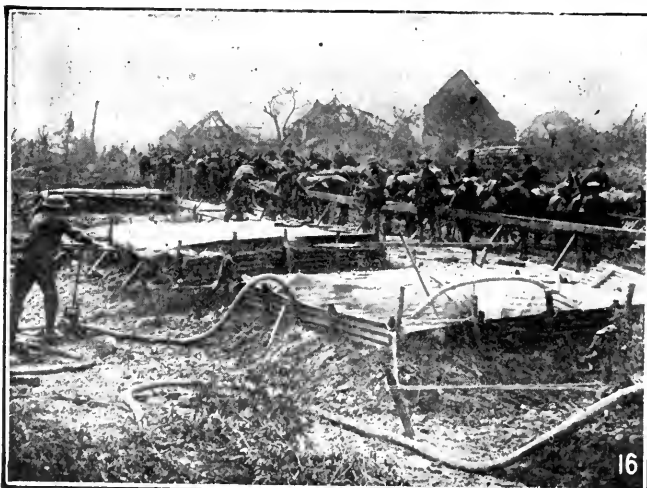

FIG. 15. PUTTING UP A WATER TROUGH FOR THE CAVALRY

FIG. 16. TEMPORARY WATER TANKS

FIG. 17. A BIG WATER DEPOT

*British Official Photographs.*



of straight-line intersections, by the use of the *camera lucida* and the *appareils roussilhes*. The first named method is most generally used, and the several steps are as follows:

On the photograph, select four points easily identi-

fied on the map, which are so situated that the lines joining them intersect on or close to the particular detail it is desired to fix. On the map, draw lines joining the corresponding points. The intersection of these lines will give the true position of the particular detail

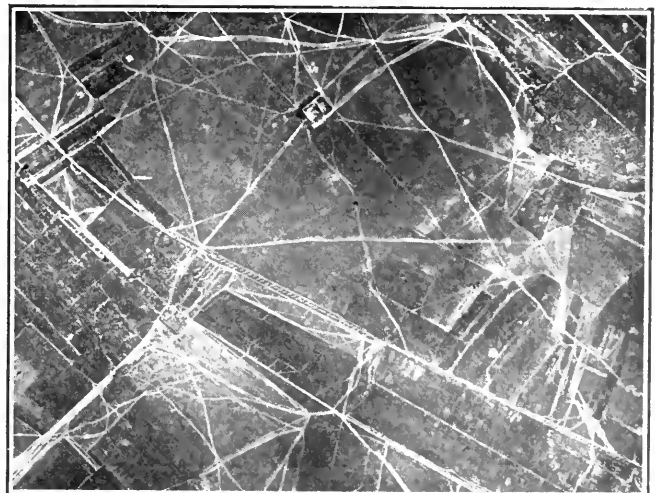
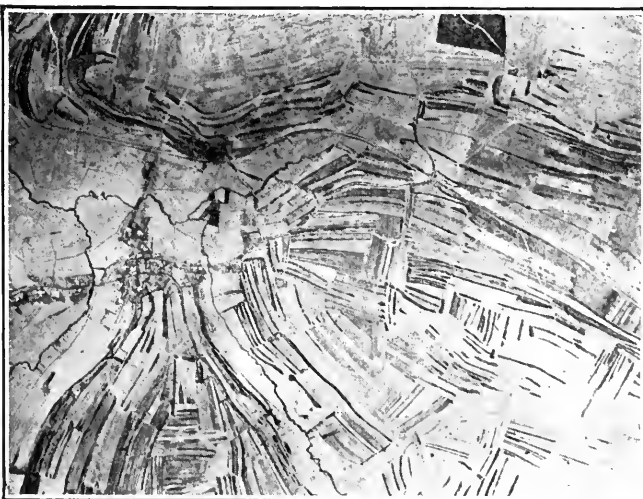
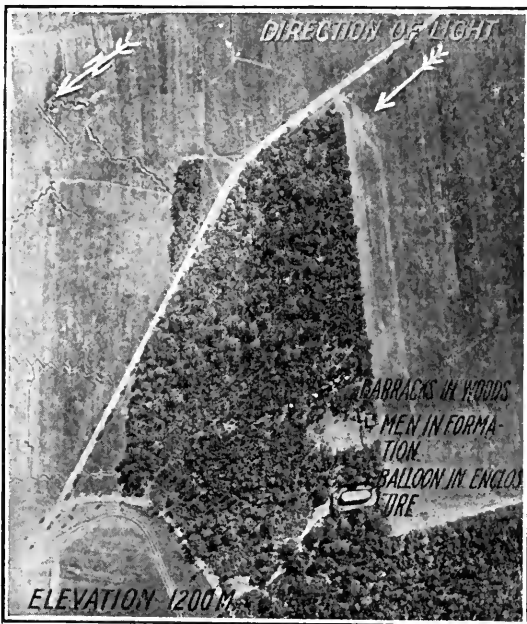
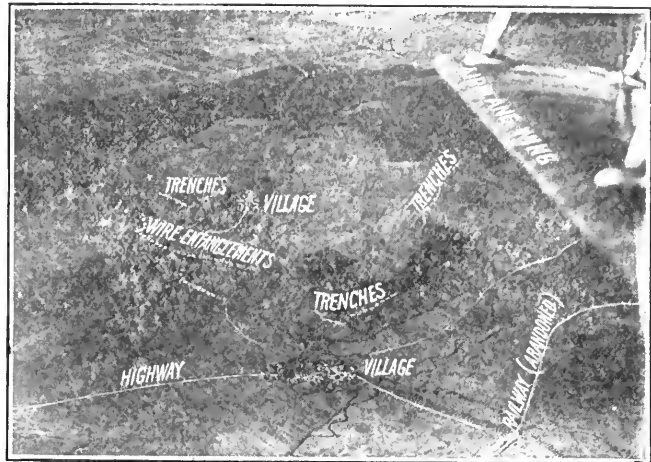
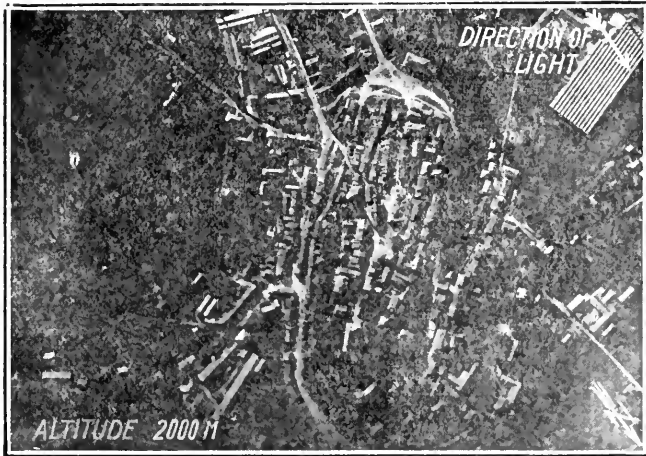

THE INTERPRETER OF AERIAL PHOTOS MAKES SUCH AS THESE (ON WHICH THE LETTERING HAS BEEN SUPERIMPOSED) TELL AN IMPORTANT STORY

in question. The remainder of the detail can be quickly drawn in with the aid of proportional compasses. This method simplifies the matter of adjusting errors.

The *camera lucida* is nothing more than a prism mounted by means of extension rods upon a light wooden framework comprising a base and a sliding easel. The photograph is pinned on the easel, and the map on the drawing board, the plane of the photograph being perpendicular to the plane of the map. Looking vertically through the prism, a faint image of the photograph is projected down on the map, and with a pencil small sections at a time are traced.

The *appareils roussilhes* method is carried out by means of an *optique cinématographique*. A photographic plate is used and the image thrown on the map in the same way screens pictures are shown. By various adjustments of the instrument the proportion of the image projected on the map is reduced or enlarged until it fits the map scale, and then the lines are traced. The accompanying aerial photographs show the kind of material that must be made to reveal its story.

The topographic section of the school, of which the interpretation of photographs is a part, also gives instruction in map reading, surveying and landscape sketching, and includes an artillery orienting course.

The camouflage section has a wider scope than any other in the Engineer School, inasmuch as camouflage

must be applied to every branch of the service. It includes heavy artillery; field artillery; trench mortars, light and heavy; gas projectors; dugout and mine entrances with spoil banks; observation and listening posts of many types; tanks; snipers' posts, and the numerous not-to-be-described "fakes" and front line work.

Many people have the idea that camouflage work is mostly done by artists, painting in studios far removed from the front. About one per cent of it is produced in studios. The rest is military engineering erected under fire, and the camoufleur must have a working knowledge of all *materiel* of war.

On account of the broad scope of camouflage, the students in this section of the school range from major generals to privates. Special attention is given to camouflage discipline. Another interesting study is the camouflage of shadows, which are successfully concealed.

It is obvious that this subject can not be written about in detail. *The familiar illustrations often published in magazines and newspapers are the obvious and theatrical ones, seldom used. The real camouflage would not make an interesting picture, because no one would see it in a photograph.*

The Army Engineer School, to the technical man, is one of the most interesting places in France today. It is, in effect, a museum where one sees the practical application of the new military engineering.

# American-Built Docks in France Completed by Pacific Coast Engineers

Second Battalion Had 4100-Foot Timber Structure Ready April 15—  
First Battalion at Work on Huge Storage Depot

BY ROBERT K. TOMLIN, JR.

War Correspondent of Engineering News-Record

*Photographs D, G, H and N from Committee on Public Information—  
All Others by Engineering News-Record*



**A**T AMERICAN-BUILT docks in France transatlantic freight from American-built ships has been unloaded, classified and routed to the front via American-built railway yards since the middle of April. With brand-new berths for 10 vessels, in addition to an existing string of docks near by, previously constructed by the French, the great marine terminal at Base Section No. — of the American Expeditionary Forces, a timber structure supported by wooden piles, extends for almost a mile over a site which was nothing but mud flats half a year ago. Long, low classification sheds flank the shore side of the docks; further inland a receiving yard and a departure yard for the handling of empty and loaded freight cars are well along toward completion; specially designed timber rigs, for the handling of ships' cargoes, and heavy steel gantry cranes are being erected; railway cars and motor trucks, in a steady stream, flow along the quay, picking up their burdens of freight for transport either directly to the advance section, or for storage at the base or intermediate depots.

## BUSY SCENES AT THE DOCKS

This is the scene at the docks: A solid background of spars, rigging and weirdly camouflaged hulls motionless at their moorings, and a foreground of action kaleidoscopic in its variety. Booms are swinging crates from ships' holds, engines are spotting cars along the quay, negro stevedores are trucking loads into the classification sheds. Motor trucks are darting to and fro over the broad timber flooring, and labor gangs are grading and laying railroad track back of the classification sheds. Here is a group of Spaniards, in brown corduroys and canvas slippers, unloading crushed stone from cars; there, German prisoners in the faded remnants of field-gray uniforms, piling lumber under the direction of a blue-coated French guard with a long bayoneted rifle

slung over his shoulder. Back along the road which parallels the waterfront pass truck-loads of Chinese powder-factory employees, or negro stevedores going to or from work. Things are moving down at the American docks in France.

But what of the men who set the stage for this spectacle—the engineers who took the plans of the docks and transformed lines on blueprints into realities of timber, concrete and steel? Their job on the main dock structure practically completed, these constructors have stepped back from the center of the stage to make way for the operating forces, but they have left behind them a convincing record of achievement since they landed in France last September.

## MEN FROM PACIFIC COAST DID WORK

The construction of the new docks and yards at Base Section No. — is largely the work of the second battalion of an engineer regiment consisting of men from the Pacific coast. It is a "hand-picked" organization of volunteers, for the regimental quota of about 1700 was culled from 6000 applications. Its commanding officer is the chief engineer of Base Section No. —, and, in addition to the dock and railway-yard construction, he is responsible for a score of other big projects—an immense general storage depot and railway yard, which is in charge of the first battalion of his regiment; hospital construction, railroad extension, ordnance warehouses, engine terminals, car-erecting plants, repair shops, a refrigerating plant, etc., all of this work being scattered over an area of a great many hundred square miles. The construction program in Base Section No. — is staggering. For example, entirely separate from the dock work—a huge job in itself—is the general storage depot six miles distant, which will consist ultimately of 144 warehouses, each 500 x 64 ft. in plan, and a railway yard with 170 miles of track.

To anyone familiar with the army transport problem in France, the fact that the American docks at Base Section No. — have been built and in operation for some time past is big news. It means *more tonnage* and, consequently, a general speeding up of construction work throughout the areas of France occupied by the American forces, for the big obstacle in the way of more rapid progress in the past has been delay in the deliveries of construction plant, construction materials and construction men. Everywhere I have gone I have heard this same story—not a complaint, but a frank statement of conditions as they have been. Lacking peace-time facilities for the handling of large-scale jobs, our engineers have succeeded in making progress without them. When machinery does not arrive the only recourse is hand labor. When the erection of a warehouse calls for a bill of timber of certain sizes and lengths, and nothing of the sort is to be had, something else must be made to do. It is no new experience for our men to build up 4-in. timber members from 1-in. stuff.

And that is the important point about the engineering work for the army in France. It must get along with the tools and materials at hand. It would be misleading and unfair to the men who have accomplished such wonders with the facilities available to picture the construction program over here as a sort of triumphal march over smooth roads. It has been nothing of the sort. It has been pretty hard sledding all the time, but never so hard as to make our men let up in their efforts to put the job through. And, in the case of the docks, they have put the job through splendidly, these engineers from the Pacific slope, for there is a great deal of the pioneer in their make-up, the sort of stuff inbred by life in the great open country of the West, which enables a man to face new and difficult conditions with a calm confidence in his ability to win out ultimately. And so, when they needed a sawmill for framing timber, for example, and could not get one ready-made, they ferreted out a steam boiler here, an engine

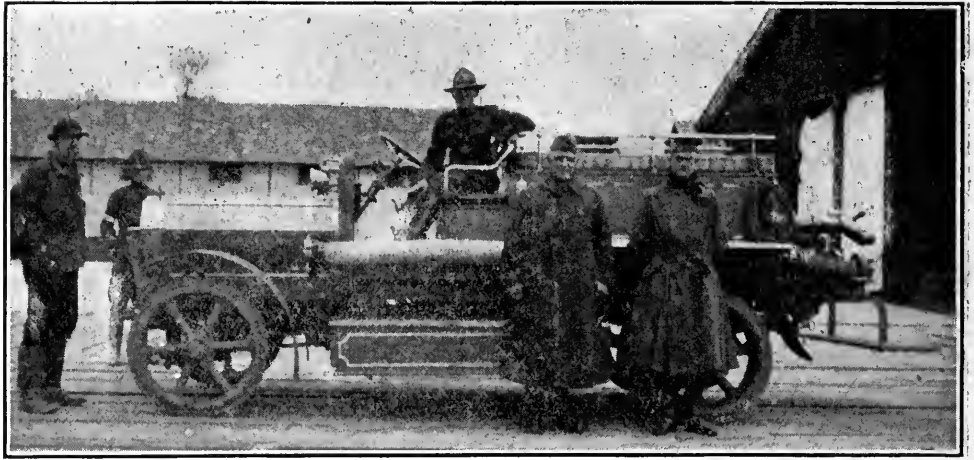

A. WOODEN DOCKS ARE PROTECTED BY MOTOR-DRIVEN FIRE-FIGHTING APPARATUS—IN FOREGROUND, MAJOR COMMANDING ENGINEER BATTALION AND CAPTAIN WHO HAD IMMEDIATE CHARGE OF DOCK CONSTRUCTION

there, other accessories where they could find them, and in a little while the outfit was assembled and cutting timber. "See that two-story classification shed down at the end of the docks?" asked Major R—, commanding the second battalion during my visit to the job. "The floor joists are the only sticks in it which are in accordance with the blueprint plans!" *But the building was up and ready for service.*

On the docks and railway yards the force comprised about 2500 men, including the engineer troops, labor battalions and a crew from the Phoenix Construction Company.

At Base Section No. — large shipments of transatlantic freight are being handled—just how large I am, of course, not in a position to say—but it should be realized that not all of our cargoes from the United States are being received at this one port. However, in the scheme of transport and supply to the front, this terminal is playing a large part. In a former article on the advance depot (see *Engineering News-Record* of July 4, p. 27) I outlined the general scheme of zoning and distribution back of the front. There are, as the main parts of the transportation and supply system, the advance depot, the point of distribution nearest the front; the intermediate depot, somewhere between the advance depot and the seacoast; and finally, the base depots, which are, of course, bigger than any of the others. Freight from ships, in the case of Base Section No. —, is passed either directly into railroad cars or into the

classification sheds along the inner wall of the quay, and thence goes by rail either directly toward the front or into the huge base storage depot, from which it is later removed on requisition. The new docks at Base Section No. —

parallel the waterfront and are 4100 ft. long, with berths for handling 10 ships simultaneously, as previously noted. Timber flooring, 86 ft. wide, carrying four parallel lines of standard-gage railway track and one line of 44-ft gantry-crane track, is supported by timber pile bents spaced 10 ft. on centers. As to the choice of the type of structure, it was essential to design something which could be built quickly and

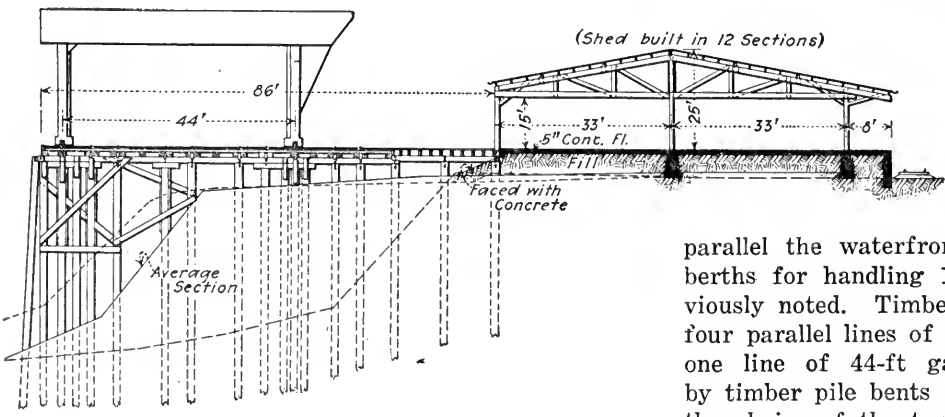
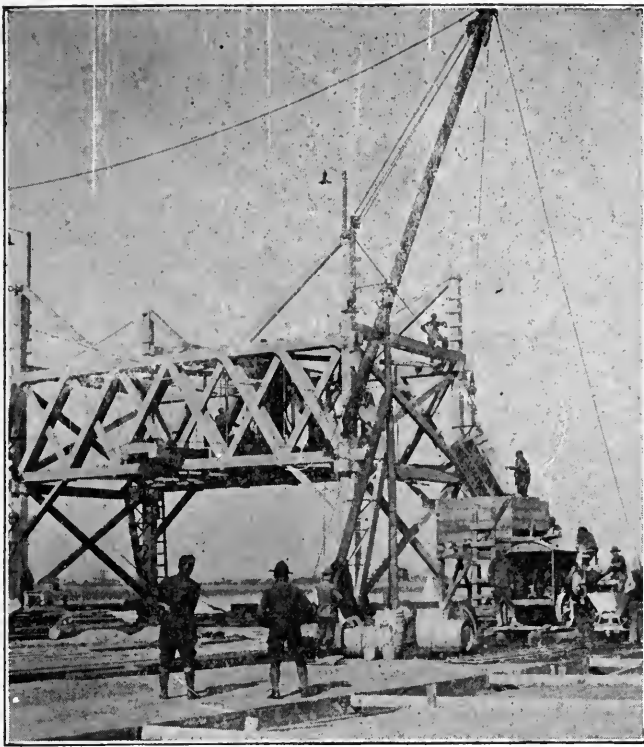

FIG. 1. CROSS-SECTION OF DOCK STRUCTURE AND CLASSIFICATION SHED



B. SPECIALLY DESIGNED CARGO-HANDLING DEVICE BEING USED TEMPORARILY FOR DELIVERING MATERIAL TO PORTABLE MIXER

with materials at hand or immediately in prospect. A wood-pile dock seemed best adapted to these conditions.

Too much emphasis cannot be placed upon this phase of the engineering work for the American armies in France. Our men cannot pick up a telephone or a telegraph blank and send in a rush call for the delivery of concrete mixers, locomotive cranes, cement, sand and crushed stone, sawmills, timber piles of predetermined lengths and sizes, dimension lumber, derricks and all of the other plant luxuries of peace-time construction.

I say they cannot call for these things, referring to conditions under which the dock work was started late last year. Of course, the situation is improving every day, and our supplies of plant and equipment are now much more satisfactory than formerly. But the engineer at home must constantly keep in mind the fact that all of our work over here was begun with mighty few of the mechanical, material and transportation aids to which the engineer in civil life is accustomed. This condition of affairs, however, developed no Micawbers in the ranks of our engineer units; no one waited for "something to turn up." Instead, every one buckled down to the job, with the result that something was made to "turn up"—and that something is the string of classification sheds and the long line of completed quay at which loaded ships from the other side of the Atlantic are now discharging.

The timber structure for the docks was chosen at the beginning as being the only one possible under the conditions imposed on the designers—speed of construction and use of available materials. There is a considerable range of tide at the site (I am not allowed to state this quantity in feet) and the foundation material is a combination of silt and ooze, into which 9200 piles ranging in length from 45 to 70 ft. were driven for the dock structure proper. Piles put down at other places near by swell the total to about 13,000. A number of test piles were driven to refusal before the job was begun, and it was found that they could be depended upon to carry safely loads of 20 tons. The piles are of untreated timber, as no creosoted material was available for quick delivery.

The accompanying cross-section drawing, Fig. 1, renders unnecessary any detailed description of the dock structure. It should be noted, however, that a batter pile, not shown on the main cross-section, is driven under the inner gantry crane rail. While the plans call for three 12-in. steel I-beams under each gantry crane rail, this type of construction was employed only at the

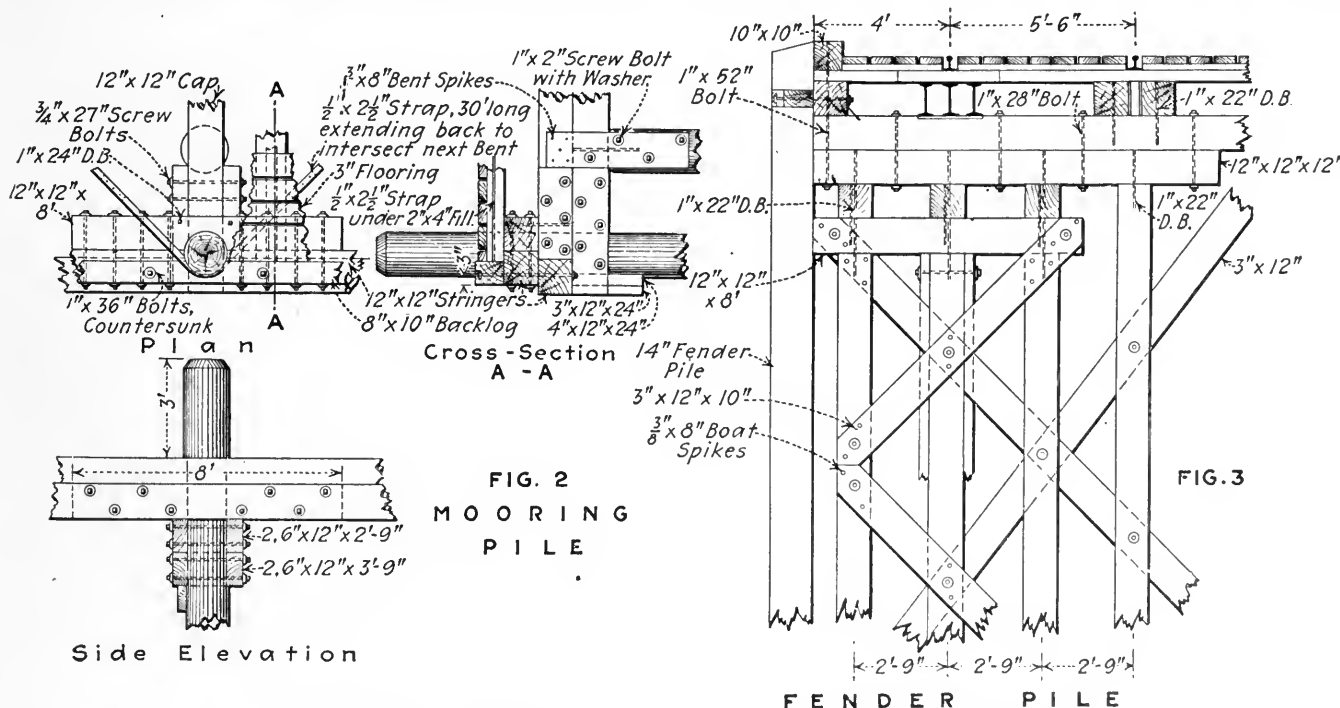

FIGS. 2 AND 3. DETAILS OF THE MOORING PILE AND THE FENDER PILE

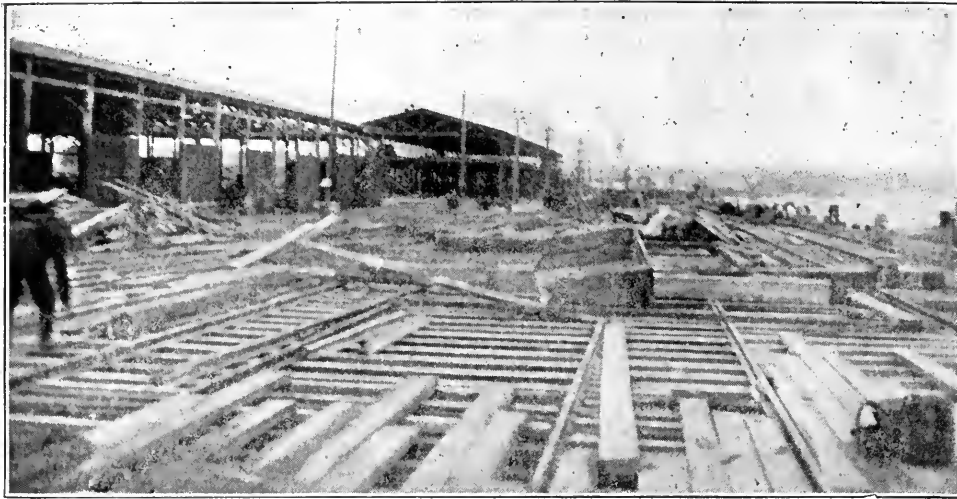

C. AT ONE END OF DOCKS SOME WORK REMAINS TO BE DONE

south end of the docks, where heavy steel gantries will be used. For the northerly section 12 x 12-in. timber stringers support the gantry rails, on which a special and lighter unloading device, shown in Photograph B, will operate. The piles are capped with 12 x 12-in. timbers, the stringers are also 12 x 12 in., and the decking is 3 x 8-in. stuff carried by 4 x 10-in. crossties. Practically all connections are made with 1-in. driftbolts.

For the standard-gage track on the dock flooring 80-lb. rails are used, but the gantry-crane rails are 100 lb. per yard, and are fastened to the ties by hookbolts. The pile bents are cross braced both transversely and longitudinally with 3 x 12-in. timber. Figs. 2 and 3 show the mooring-pile and fender-pile details.

An important feature of the design is the transverse fire walls underneath the decking, at about 300-ft. intervals. They are of solid timber planking to prevent the sweep of flames underneath the flooring along a considerable length of dock. From the photographs it will be observed that the decking planks are brought up flush with the tops of the rails, forming a surface on which motor trucks as well as railway cars may operate. Motor-driven fire-fighting apparatus, shown in Photograph A, is part of the dock equipment.

To furnish at a proper level a foundation for the concrete flooring of the classification sheds and open storage areas, it was necessary to make a fill of about 55,000 cu.yd. First, a concrete retaining wall, averaging about 8 ft. in height, was built back of the classification sheds for the entire 4100-ft. length of the docks. At the in-shore side of the dock structure a dike of puddled clay was formed and faced on the waterfront slope with a 4-in. slab of concrete to prevent washing out by wave action during periods of high water. Between these two walls—the concrete-paved dike on the waterfront side and the concrete retaining wall on the shore side—the fill was made by hydraulic sluicing. The material is sand-dredged at a point 40 miles from the dock site and delivered by French barges. From the barges moored along the timber quay wall the sand was pumped out by a hydraulic dredge. This fill was compacted by steam rollers before concrete was laid upon it.

The floors of the classification sheds and the open storage spaces between successive pairs of buildings

are all concreted, this job involving the covering of an area 4100 ft. long and 76 ft. wide with concrete 5 in. thick. The concrete was placed in transverse strips 12 ft. wide and is not reinforced. In all, three mixers were employed. One rig, shown in Photograph E, consisted of a 1½-yd. mixer, driven by a gasoline engine, the whole outfit being mounted upon a flat car which could be moved along the dock as work progressed. Distribution from this mobile plant to the floor area was by narrow-gage railway and V-shaped industrial cars. In addition there were

used two smaller concrete mixing plants, as shown in Photograph F. The capacity of these mixers was ½ yd.; they were driven by gas engines, both mixer and engine being mounted on a low four-wheeled truck. Aggregate and cement were brought in by railway cars operating on the inner one of the four dock tracks. The aggregate was dredged gravel and sand obtained at a point some distance from the docks and delivered by barges; the cement was shipped from England. With 160 men engaged on the work of concreting the classification-shed floors and open storage spaces, about 7500 sq.ft. of concrete 5 in. thick were laid each day with the three mixers available.

The following summary shows the volume in cubic yards of concrete required by the docks, yards and accessory structures, such as a new warehouse, 100 x 3000 ft. in plan, and a cold-storage plant.

Classification-shed floors.....	4,400
Retaining wall.....	3,800
Apron wall.....	4,400
New warehouse.....	7,200
Departure yards.....	2,200
Cold-storage plant.....	4,000
Total.....	23,600

Paralleling the docks, the classification sheds are located in a straight line with gaps between each pair for open storage. There are, in all, eight of these sheds; two of them are 312 x 74 ft. in plan, while the other six are 205 x 74 ft. They are timber-frame structures sheathed with corrugated iron, Photograph C showing one of the sheds partly completed. All are one-story in height except the building at the southerly end of

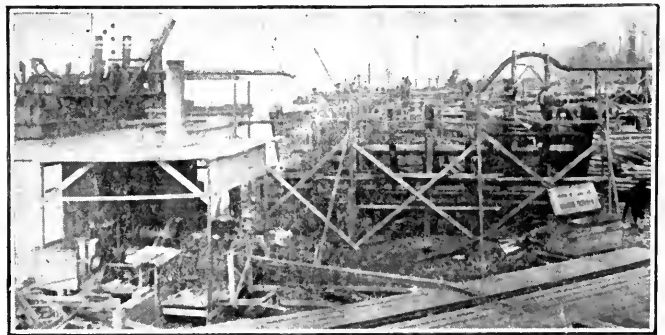

D. DREDGE PUMPING SAND FROM SCOW TO MAKE RAILROAD FILL—NOTE END OF ELEVATED PIPE LINE AT RIGHT, THROUGH WHICH SAND IS PUMPED



the string (Photograph C), which has a second story which will be used as the administrative offices of the dock-operating force. The cross-section, Fig. 1, illustrates the prevailing type of structure. As a general rule a gang of 50 men worked on one shed. The frame was set usually in one day and the entire structure completed in one week.

All of the timber for these sheds came in the rough from the States. It was framed by a homemade sawmill operated by a boiler obtained from Spain. The engineers were successful in receiving from the States a circular saw, but had to construct for themselves wooden pulleys and mount these on a piece of shafting obtained locally. On this makeshift sawmill most of the framing of timber for the classification sheds was done. The work was started by the making of templets for each member of the building, and with these as patterns the lumber was run through the mill in bunches of half a dozen pieces at a time. The members for the wooden roof trusses were bored by compressed-air tools

and connected by bolts. On the erection of the timber framework double-block gin poles were employed.

Behind the string of classification sheds are three lines of depressed railroad track, 3 ft. 4 in. below the elevation of the floors. Then comes a platform 10 ft. wide, set at the same elevation as the classification shed floors, followed by a storage warehouse 100 ft. wide with an 8-ft. platform on the inshore side. Flanking this latter platform are two more lines of depressed track at the same elevation as those previously mentioned. Another accessory is a 25-ft. teamway for the use of trucks, followed by two other team tracks, making, in all, six additional miles of trackage in connection with the dock facilities.

While work on the docks was in progress other detachments of the engineer regiments, assisted by labor battalions, were grading and laying track in the receiving and departure yards. The plan of the whole project is roughly in the form of a quadrilateral whose sides are formed by the line of docks, the receiving yard, the de-

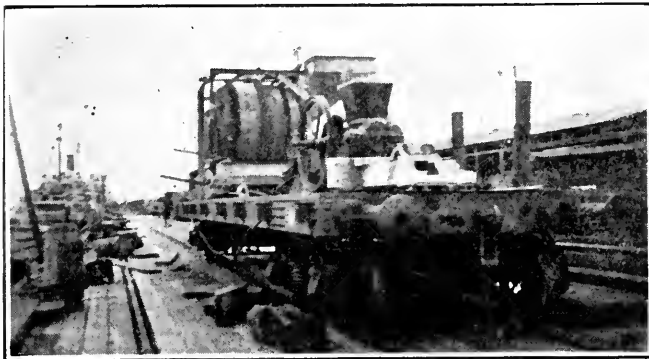

E AND F. MOVABLE MIXER PLANTS USED IN

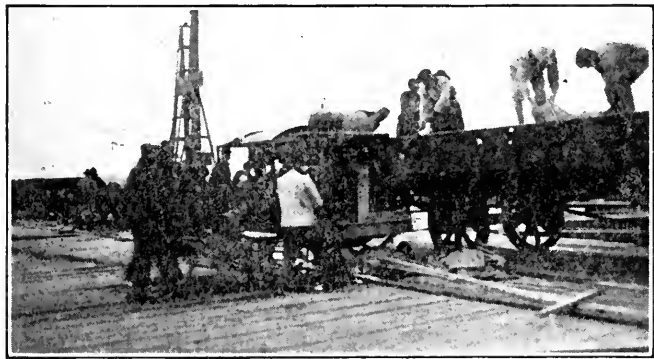

CONCRETING FLOORS OF CLASSIFICATION SHEDS



G. CAPPING PILES AND LAYING THE TIMBER DECKING AT THE AMERICAN DOCKS  
H. LOOKING ALONG DOCK SITE—PILEDRIVER ON LEFT, TIMBER CLASSIFICATION SHED IN CENTER  
J. THE ENGINEERS HAD TO BUILD THEIR OWN PILEDRIVERS AND DERRICKS

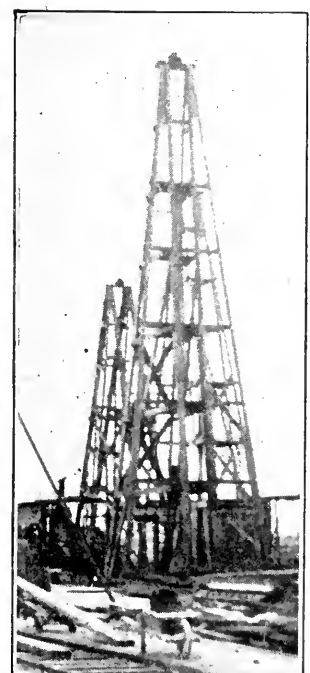

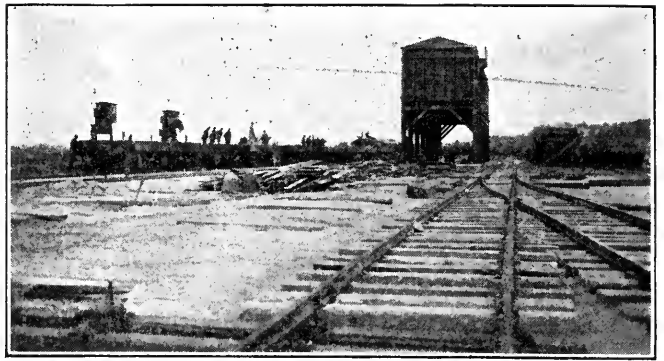
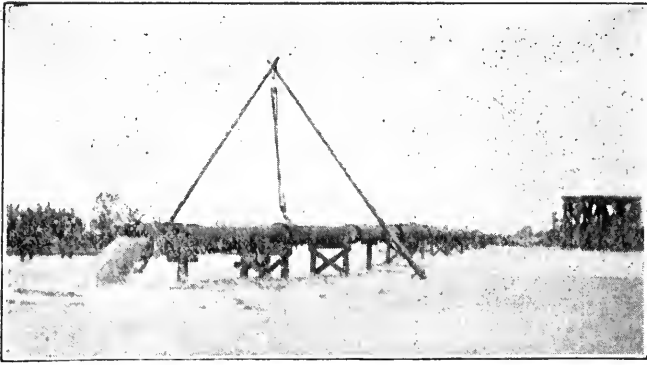

K. AT THE DEPARTURE YARD THE FILL IS BEING MADE BY HYDRAULIC SLUICING

L. PLACING FILL AND LAYING TRACK IN DEPARTURE YARD—ENGINEERS BUILT ELEVATOR COAL BINS IN CENTER

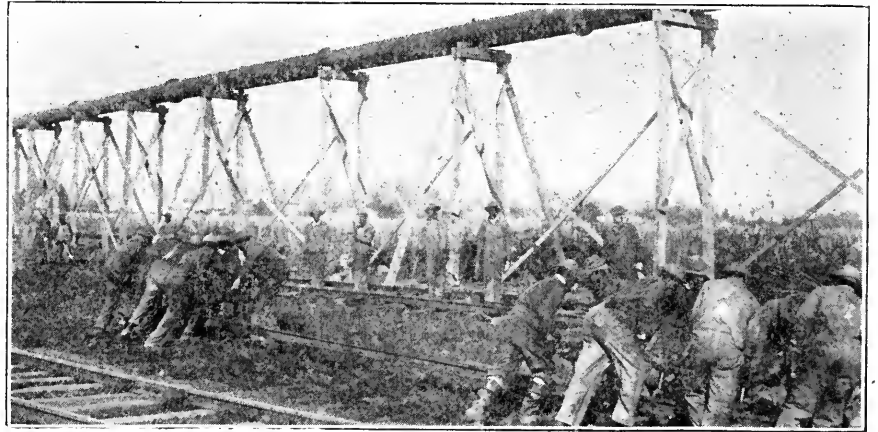

M. LABOR BATTALIONS AID IN TRACKLAYING—IN BACKGROUND TRESTLE - SUPPORTED PIPE USED IN MAKING HYDRAULIC FILL

N. OPEN STORAGE FOR SUPPLIES IS PROVIDED AT MAIN DEPOT

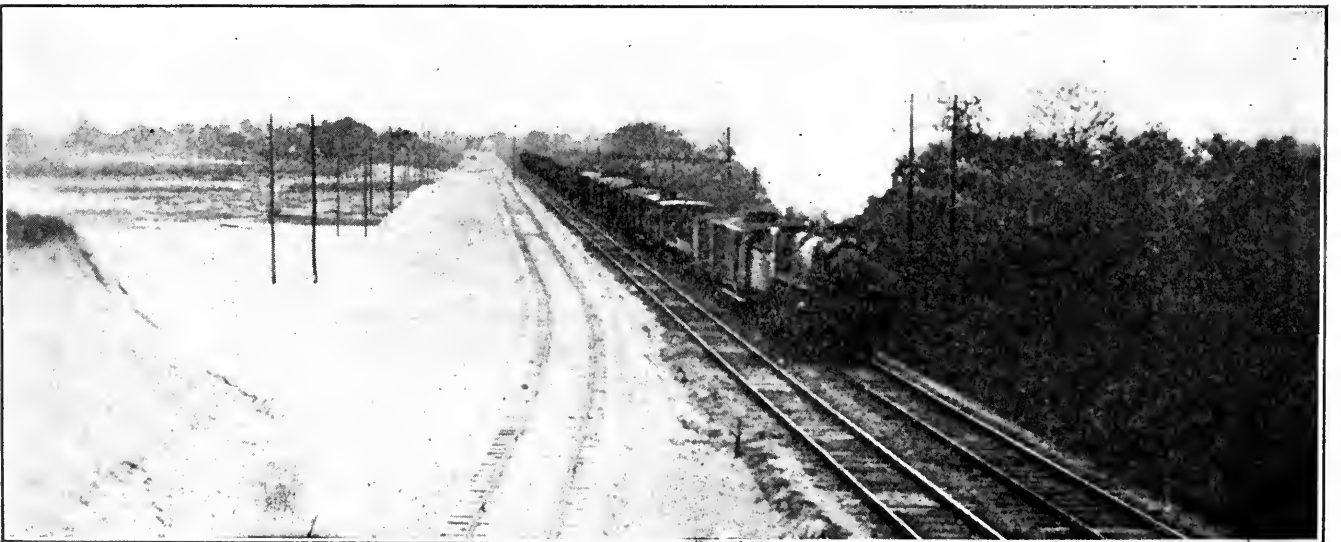

O. NEW RAILROAD, 6½ MILES LONG, LEADING FROM DEPARTURE YARD AT DOCKS TO BASE STORAGE DEPOT—NOTE GRADING FOR ADDITIONAL TRACKS

parture yard and the existing tracks of a French railway to which connections have been made for incoming and outgoing traffic.

### BUILD PILEDRIVERS

On Oct. 1, exactly one month after the engineer regiment arrived in France, the first shipments of piles and lumber from the United States came. At that time the men were without the cant hooks and peaveys with which they had been accustomed to handle lumber, and tools from home were arriving in mere dribbles. A batch of French axes and shovels was purchased locally. One of the first jobs was to build piledrivers, derricks, sawmills and planers out of such material as could be found. For the railway yard excavation two 60-ton steam shovels were obtained from Spain. Purchases of French track and piping also were made, while Spain was drawn upon for railroad ties.

In all there were built two floating piledrivers, five skid and two roller piledrivers, and eight skid derricks for handling lumber. While working with the two floating drivers and four of the skid drivers the progress amounted to about 150 piles per day. The first pile was driven Nov. 12 and on Feb. 10 the driving of the 9200 piles for the docks proper was completed. Not all of the nine piledrivers, however, were working until about Christmas.

The piles themselves were of longleaf yellow pine which had been tapped for turpentine. They were driven with 3000-lb. drop hammers by the floating and skid rigs. The timber is not treated in any way, as there was neither the time nor the facilities for any such procedure. Taking into account the alternate wetting and drying of the dock substructure, due to tide variations, the life of the piling is estimated at from 12 to 15 years. Including piling, capping, stringers and flooring, the docks at Base Section No. — represent about 5,000,000 ft. b.m. of lumber.

Where the gantry-crane rails are carried by 12 x 12-in. wooden stringers rather than I-beams, which did not arrive in time to be used throughout the entire length of the docks, a special unloading device is to be used. It is of timber construction, as shown in Photograph B, and weighs considerably less than the 70-ton steel gantry cranes which will operate at the south end of the docks. This unloading device, called the "Boschke," after the name of the captain of engineers who designed it, is about 20 x 44 ft. in plan and consists of a timber-truss frame carrying a pair of 45-ft. ship's booms, tackle and hoisting engine. The rig is mounted on wheels which run on the regular gantry tracks, these being spaced 44 ft. apart. The hoisting equipment, electrically driven, is housed between the two overhead trusses, as shown in the picture. With this rig a line from the water-side boom is run down into the ship's hold and made fast to the load. The load is then hauled up by the hoisting engine and when clear of the ship's deck is swung shoreward, the weight being transferred by means of suitable tackle to the second or inshore boom, which deposits it on the platform of a classification shed.

A speed test of this apparatus, which, its designer explained to me, is merely an adaptation of the practice of generations of seamen in handling freight by ships' booms, resulted in a round-trip time of only 40 sec.; that is, 40 sec. for picking up a load from a vessel, delivering it to the classification-shed platform and returning empty to the point of starting. The device is capable of handling weights of five tons, although in the ordinary course of events the individual loads will average only two tons or less.

### RAILWAY RECEIVING AND DEPARTURE YARDS

The railway receiving yard immediately back of the docks will, when finished, have a track mileage of 6.25. From it connection is made to the main-line tracks of a French railroad. At the receiving yard empty freight cars will be delivered and sent forward along the trackage system on the dock structure as needed. The four lines of tracks on the docks are equipped with double-slip switches, and the layout is such that any one of the ten berths can be pulled without interfering with operations at the others. The construction work at the receiving yard involved nothing unusual in the way of grading and tracklaying, as the ground is fairly level.

The departure yard, where cars loaded at the docks are made up into trains, contains about 18 miles of track. The feature of the grading work here is the employment of the hydraulic sluicing method for making the fill. Sand dredged at a point 40 miles from the docks is brought up in barges and from them pumped by a French dredge boat to the departure yard through a 30-in. steel pipe line about one mile long, carried on timber trestles. Photograph K shows this work in progress. The dredge boat delivers at the rate of 2,250,000 gal. of water per hour, and the flow contains about 10% of sand. The fill required in all the yards amounts to about 450,000 cubic yards.

A number of accessory structures are being built at the departure yard. There are, for example, a group of overhead coal-storage bins (Photograph L) and an engine pit and repair shops of concrete construction, with timber-pile foundation. When I went through the yard, work was just about to start on a huge refrigerating plant. This structure is being built and equipped for a capacity of 7500 tons of meat.

At both the receiving and departure yards much of the grading and tracklaying is being done by American negro labor battalions under the supervision of engineer troops. Two 60-ton American-built steam shovels, hailing from Spain, were cutting down banks preliminary to the grading of the roadbed for track.

Because of the increase of traffic between the departure yard and the general storage depot for Base Section No. —, 6½ miles distant, it was considered necessary to parallel the existing double-track line of a

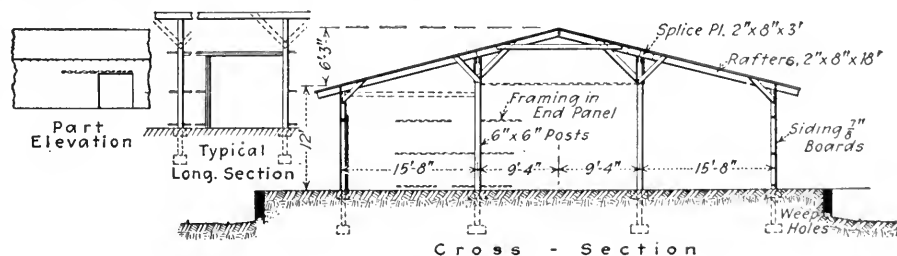
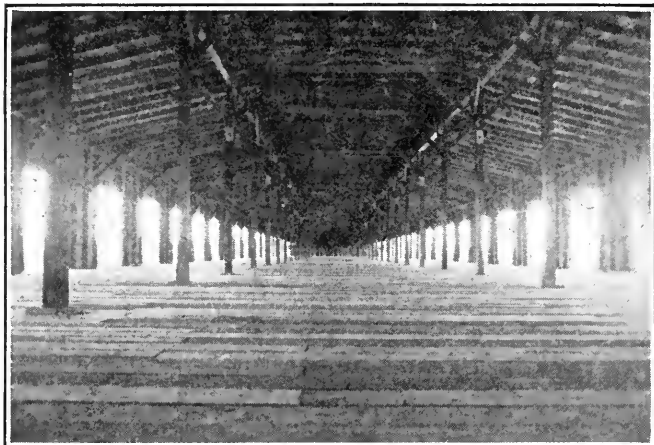
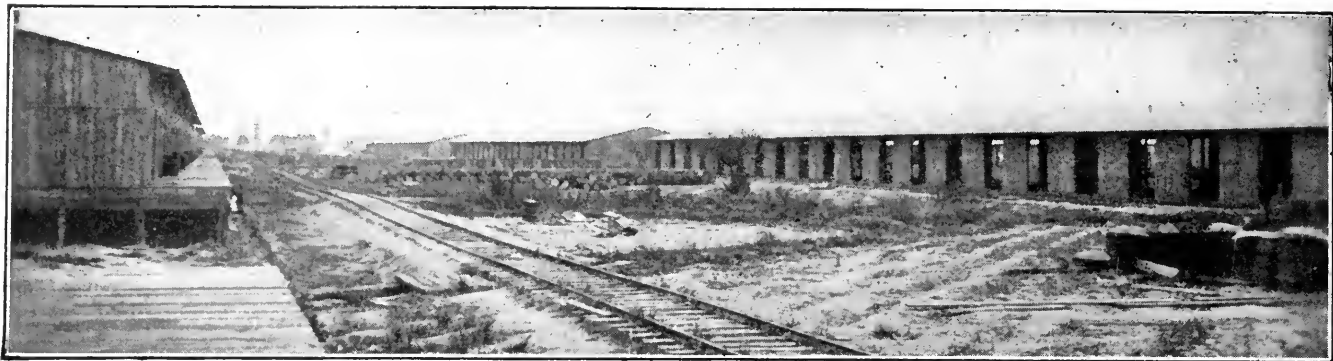

FIG. 4. CROSS-SECTION OF WOODEN WAREHOUSE AT BASE STORAGE PLANT



P AND Q. AT THE BASE STORAGE DEPOT THERE WILL BE, ULTIMATELY, 144 WOODEN BUILDINGS OF THIS TYPE.



R. INTERIOR OF A SHED AT THE FRENCH DOCKS NEARBY

French railway with a third track, which is shown in Photograph O. To provide for future contingencies the new route has been graded for two additional tracks, as shown at the left of the picture, thus constituting, with the existing French tracks, a four-track railroad.

#### BASE STORAGE DEPOT AND YARDS

The base storage depot, which is connected with the departure yards at the docks by the 6½-mile railway line referred to in the preceding paragraph, is an immense project, designed to hold three month's supplies for 2,000,000 men. In its essential features it will consist of 144 wooden warehouses, each 64 x 500 ft.—30 of them were completed at the time of my visit—two railway classification yards, two receiving yards, one departure yard and three storage yards, involving a total trackage of 117 miles—of which 30 miles have been laid at this writing—and 815 switches, of which seven are of the double-slip type. This construction is in the hands of the first battalion of the engineer regiment whose second battalion handled the docks and classification sheds, the engineers being assisted by labor battalions of almost every nationality and by big gangs of German prisoners. The available labor force here numbered about 6000 on the day I called at the headquarters of the engineer captain in charge of the job.

#### TRAINED GANGS IN "WAVES." BUILD WAREHOUSES

The sight of row after row of these long wooden warehouses brings to mind the picture of the big-scale cantonment construction in the United States which was begun a year ago. This job at the base depot in France is one of quantity production and is being handled by

gangs, each trained in a single specialty. The work has been carefully analyzed and segregated into certain major operations, as is the common practice in the manufacture of munitions, where a shell casing, for example, will pass down a line of machine tools, each operator performing a single operation upon it. Thus, in the case of the 500 x 64-ft. warehouses we have "waves" of construction crews passing in succession over each building. The first gang digs post holes and passes on to the next building. It is followed by a gang which sets the foundation posts. Then come, in order, gangs which saw off the posts at the correct elevations, erect the timber frames, sheathe the sides and finally apply the roofing material. On the warehouse construction about 700 men are at work.

Figure 4 shows the type of structure used for the base warehouses. It will be noted that it involves no roof trusses—merely posts, rafters and knee bracing. The drawing shows the building at the ground level with depressed track on either side, but as a matter of fact many of the buildings I saw were supported on posts to bring the floor and platform level flush with the floor of the freight cars operating on track: not depressed but laid at about the general level of the ground.

#### DESIGN SUBJECT TO CHANGE

Of course, it must be understood that the publication of a sketch of this sort does not presuppose a rigid adherence to the theoretical design, particularly as regards the sizes and lengths of the members. The constructors use what they can get. Rafters, for example, are often built up of 1-in. plank. Railroad ties cheat destiny by becoming foundation posts for warehouses. Packing cases, weary with travel, find a permanent resting place as sheathing or bracing. As Captain S— remarked, "We must be ready to change our designs with each new building erected, depending on the kind of material available for our use." Interior and exte-

rior views of one of the 500-ft. warehouses are shown in Photographs P and Q.

While the dock and railway yard work has been essentially a construction problem, it has made other and exacting demands upon the engineer officers in charge. Upon the fund of experience available in such a regimen as the one which is in charge of operations at Base Section No. —, it is possible to draw for the solution of almost any technical problem. But in the case of the dock and railway-yard project, not all of the difficulties the major in charge of the first battalion had to face were technical. What textbook or field manual gives the construction man the slightest hint of approved practice in mollifying an irate French housewife who has been informed that her house must be torn down to make way for American railway tracks? Over here the little one-story stone dwelling, with its red tile roof, which has been passed down from one generation to another for centuries, is something almost sacred. Surely *les Américains* will not be so stony hearted as to destroy it! The fact that they will pay the French

handsomely for the privilege is a matter of secondary, though not of minor, importance. And so the scene in the engineer's office proceeds through the several stages of indignation, entreaty and tears. But our major has had his orders to let nothing interfere with the progress of the job, so he must remain obdurate—and sometimes this is one of the hardest decisions he must make.

Just as I was leaving the docks on my journey back to Paris the Major of the second battalion of the engineer regiment who had tramped over the whole job with me pointed to one of the ships lying along the new timber quay. "She's one of our new vessels," he said, "turned out at a yard in Seattle. Quite a coincidence—she's carrying a cargo of lumber from Seattle, and here she is unloading at a dock in France built by Seattle boys." As he looked out over the line of docks his men had built and spoke of the ship newly arrived from across the Atlantic, there was just a touch of wistfulness in the Major's voice. I discovered later that he, too, came from Seattle.

---

# Roads in Base Section of American Forces Require Widening and Resurfacing

Heavy Traffic by Motor Trucks and Artillery on Practice Marches Necessitates Continuous Maintenance—Many Narrow Roads Were Never Designed for the Traffic They Are Now Carrying

BY ROBERT K. TOMLIN, JR.

War Correspondent of Engineering News-Record  
Photographs by Engineering News-Record

AS A result of the occupation of large areas in France by troops of the American Expeditionary Forces, existing roads are being subjected to more intensive traffic than they have ever before carried. It goes without saying that upon the highways in the advance section a heavy burden is imposed, and in a former article I dealt with the work of our Road Service in this forward zone (see *Engineering News-Record* of May, 16, p. 953). Somehow or other, it seems to be taken for granted that the problem of road reconstruction and maintenance is confined to the territory immediately behind No Man's Land. I know that before I arrived over here I had a rather vague idea that most of the engineering activity of the armies was confined to that mysterious region known as "the front." This is by no means the case. In so far as the duties of the highway engineer are concerned, the road problem begins at the French seacoast and extends from there to the trenches.

Let us remember that the trenches which American divisions are now occupying and the west coast of France are separated by several hundred miles. Let us remember, also, that practically all of our supplies must be delivered from America at French ports and transported across this stretch of land, several hundred miles long, before they can reach the combatant troops. We have, therefore, a main base of supplies some 3000 miles across the Atlantic, certain places in France where ships carrying these supplies dock, and then this distance of several hundred miles between the marine terminals and the points of ultimate consumption. This condition of affairs is one which has a very decided bearing on the upkeep of the roads.

Of course, most of our material is shipped across France by railroad to the advance section. Yet, strung along in a wide band between the seacoast and central France is village after village crammed full of American troops. There are our cantonments, artillery training camps, forestry camps, aviation grounds, storage depots, railway yards, ordnance dumps, repair shops—all of these groups marking the way between our base sections and forward lines. The creation of these new centers of population along our lines of communication,

together with the practice of billeting American troops in scores of old French villages, means, of course, a substantial increase in motor-truck traffic on roads which were never designed for such hard usage as they are now receiving. Between towns where two-wheeled oxcarts proceeding at a snail's pace used to supply the bulk of the traffic, one sees now lines of motor trucks hauling supplies, or big powerful French camions pulling 6-in. field artillery pieces in long convoys.

In the immediate vicinity of the newly built American docks in the base section traffic has become specially heavy. Motor trucks are arriving and departing constantly on short-haul trips. Then, too, the presence of American troops in this region means a great deal of fast moving traffic in the form of army cars carrying officers from one point to another. The roads subjected to this ever-increasing heavy traffic are for the most part either dirt or plain macadam, and labor, material and plant for maintenance or reconstruction are extremely scarce.

I have recently returned from a tour of inspection of the roads in a base section which includes the new docks which our engineer troops have built, huge storage depots and railway yards, a big artillery training camp and scores of other important army centers. The superintendent of roads for this section is a major of engineers who was formerly chief engineer of the Bureau of Highways of the Borough of Manhattan, New York City. According to his analysis of the situation the road work in this base section includes the construction of 20 km. of new roads, the complete maintenance of 120 km., and the partial maintenance of 180 km., resulting in a total of 320 km., or, roughly, 200 miles of road. This mileage includes all of the standard types of French road: (1) *Route nationale*; (2) *route départementale*; (3) *chemin de grande communication*; (4) *chemin d'intérêt local* and (5) *vicinal ordinaire*. These roads, all of the water-bound macadam or

plain gravel types, vary in width from 6 or 7 m. in the case of the *routes nationales* to as little as 3 m. for the *vicinaux ordinaires*, which correspond, roughly, to an American dirt road through farming country. At the present time the French Government, through the *Ponts*



THE SUPERINTENDENT OF ROADS  
WAS FORMERLY CHIEF ENGINEER,  
BUREAU OF HIGHWAYS, BOR-  
OUGH OF MANHATTAN,  
NEW YORK CITY



FIGS. 1 AND 2. TWO VIEWS ALONG FARM ROAD THREE METERS WIDE NOW BEING USED BY OUR FIELD ARTILLERY TROOPS FOR PRACTICE MARCHES — NOTE MARKS LEFT BY CATERPILLAR TREADS OF BIG GUN CARRIAGES AND NOTE ALSO HOW TRAFFIC HAS BEEN FORCED OUT ON SHOULDERS AND INTO DITCHES

FIG. 3. PASSAGE OF AN ARTILLERY TRAIN THROUGH A SMALL FRENCH VILLAGE HAS BROKEN CULVERT

*et Chaussées* and Departmental forces, is endeavoring to do the bulk of the maintenance on the national roads and departmental roads; but as American Army activities over here in France expand, much of this work will have to be taken over by the United States.

The problem of the American road force in the base section resolves itself mainly into the upkeep of existing roads, and the building of new roads in the camps, and can be classified under the three main heads of (1) ordinary maintenance, consisting mainly of the filling in of holes; (2) repairs, involving complete jobs of resurfacing, and (3) widening. Many of our centers of military activity in the base section are off the lines of main traffic, with the result that ordinary farm roads are the only existing routes available for motor-truck traffic and practice marches and maneuvers by field artillery with their heavy guns, limbers and camions. In the case of the *vicinal ordinaire*, or farm road, the width of only 3 m. is insufficient for the passage of two trucks, and sometimes, in fact, difficult even for the passage of a single line of the wide artillery carriages. Fig. 1 shows how a practice march of field artillery over these narrow dirt highways chews up the shoulders of the road, even when running on caterpillar treads,

whose marks are clearly shown. In Fig. 2, note from the wheel tracks how traffic has been forced off the road into the ditches. Then, too, these artillery loads, amounting to 7 tons per axle, must be hauled over culverts never designed for such weights, with results such as those shown in Fig. 3. This broken culvert was a cement pipe about 1 $\frac{3}{4}$  in. in thickness and a foot or so in diameter. For such traffic the demand is for wider roads, or for turnouts at frequent intervals. Then, too, the intersections of these farm roads are not designed for vehicles with the long wheel bases that now use them, so that our road force must build out the edges to provide easier curves at crossroads.

In the case of the wider trunk roads the foundation course of *bloccage* ranges from 6 to 10 in. and the top course is about 6 in. On the town and village roads which are now receiving so much American traffic, however, the top course is very thin, often only about 3 in., and often there is no special foundation course. The problem of maintenance of these routes is complicated by the difficulty of getting crushed stone delivered on the job. It is necessary to resort as far as possible to local material. Fig. 4 shows a gravel and sand pit opened up by the American Army Road Service.



FIG. 4. SAND AND GRAVEL PIT BEING WORKED BY SPANISH LABOR, DIRECTED BY A DETAIL OF ONE OF OUR ROAD-BUILDING REGIMENTS

It is being worked by Spanish labor under the direction of a detail of our roadbuilding regiment. Owing to the scarcity of materials it is not always possible to resurface roads with as thick a course as would be desirable.

For handling the work of complete and partial maintenance on the 320 km. of roads in the base section, the force at the time of my visit consisted of the superintendent of roads, two other engineer officers, 225 men of a roadbuilding regiment, and a labor force of 350 Spaniards. The equipment included one passenger automobile, one light truck, 18 dump wagons, three road rollers, 36 animals and 20 motor trucks, including a number borrowed from the French, a certain proportion of which, however, were always in the repair shops.

The superintendent of roads of the base section recently prepared a statement of the personnel and equipment which, in his opinion, the needs of the work in his district for the next six months demanded. It was essentially as follows: One superintendent of roads, 12 engineer officers, 1500 men. As for plant desired, the following were the chief items: 12 steam rollers, 50 5-ton back-dumping motor trucks, eight light trucks, 85 wagons, 188 animals, 15 sprinkler wagons and a large quantity of small tools such as wheelbarrows, forks and shovels. During the next six months estimates have placed the amount of crushed stone needed at 50,000 tons, or about 5000 carloads. For purposes of inspection there were requested eight passenger automobiles, and nine motorcycle side cars. The present situation in France with respect to the available supply of men and materials is one which has resulted in the giving of priority to requisitions from the zone of the advance section, so far as road matters are concerned.

The labor problem is being partly solved by the employment of Spaniards, who receive 11 francs per day of 8½ hours. These men must house and feed themselves—not a difficult matter, in view of the proximity to the work of a large city and innumerable villages. The army, however, must transport these men, generally in motor trucks, to and from their jobs, or at least to and from points where transport by electric railway is possible. The Spaniards, I am told, are proving to be fairly good workmen. They are not under military control and can be hired and fired as desired. Their wages of 11 francs daily is big money for them, and most of them seem eager to hold down their jobs by doing a real day's work.

This is not the case, however, with some of the Chinese

labor which has been imported into France and is under French control. I had an opportunity of seeing a great many hundreds of newly arrived Orientals on French jobs in and near a large camp. They were sprawled along the roadsides, asleep, or squatting in groups, talking. Several times I saw these fellows start out with wheelbarrows containing one-third of a real load. They would take a dozen steps, and then, when the French boss of the gang had his back turned, would flop down on their knees, lay their heads in the bodies of their wheelbarrows, and go to sleep. The only sign of real activity among these Chinamen was along a roadside where a gang, presumably on work of spreading crushed stone, was clustered around a cage containing two canary birds—which I suppose were the mascots of this crew. They had brought the birds out on the job with them, hung the cage on the limb of a tree, and were sitting around like an audience at an open-air theatre, watching their pets jump from one perch to another of the wire cage. I understand that there is some clause in the agreement under which these Chinese "work" which prevents their being disciplined.

After seeing them in action I could appreciate the humor of the scene enacted the next day in the office of the American major of Engineers who has charge of our road work in the base section. The door opened and a French officer entered. After greeting the major, he said, "At last I can help you with labor for your road work. I have 500 Chinamen I will let you have."

The superintendent of roads shook his head in a decisive, unmistakable negative.

"*Mon Dieu!*" exclaimed the Frenchman. "Why do you not want them?"

"*Mon Dieu!*" countered the American. "Why do you want to get rid of them?"

One of the solutions of the labor problem for road work in the base sections may be the use of French refugees from areas in the zone of the armies. A bureau has been established in Paris, and the plan is to organize labor battalions which will be paid, housed and policed by American interests.

"There is this difference between the road problem of the French and American armies," said the superintendent of roads of the base section. "For the forward areas the French have their special engineer troops, while in the zones of the rear the work is attended to by civil organizations, such as *Ponts et Chaussées*, and departmental and *vicinal* services. The equivalent of our own *Ponts et Chaussées* is 3000 miles



FIG. 5. FRENCH ROAD OF "GRANDE COMMUNICATION" TYPE—USE BY ARTILLERY IS PRODUCING RUTS AND HOLES WHICH WILL SOON NEED ATTENTION



away, in the form of the Federal Office of Public Roads and the various state, county and town highway bureaus. The result is that the American Expeditionary Forces must perform work, in the territory they take over, with their own roadbuilding forces, while this job for the French is done by an existing and thoroughly well-organized department of civilians, leaving the army engineers free for work immediately behind the front.



FIG. 6. 7 AND 8. WIDENING A NARROW ROAD LEADING INTO AN IMPORTANT AMERICAN ARMY CAMP — MOTOR TRUCKS DELIVER CRUSHED STONE TO THE JOB, AND THE STONE IS SPREAD ON EITHER SIDE OF THE ORIGINAL ROAD



To get results equivalent to those of the French we must look forward to a considerable expansion in the American roadbuilding personnel in the regions back from the advance section."

One rather difficult job which the road service is handling is the maintenance of a road leading to our new docks. This route is, in places, flanked by houses which extend flush with the edges of the road, so that at some points there is no opportunity for widening. The traffic of motor trucks to and from the docks is very heavy, and all that can be done is to throw crushed stone into the holes which develop in the road surface. In one place, to secure better drainage, it was necessary to tunnel under a barn, for these buildings form regular walls along both sides of the road, there being no room even for sidewalks. This road is particularly difficult to maintain, because in addition to the almost endless stream of traffic it carries it is frequently inundated during high tide, being fairly near the water. Under conditions of lighter traffic the superintendent of roads in the base section told me he would like to try some form of road construction other than macadam—possibly a concrete road—but inasmuch as this is practically the only route leading to our new docks,

the traffic over it continues in a steady stream all day, and sometimes far into the night, and there is no opportunity for putting the road out of service for reconstruction, even during a comparatively short period. About the only thing that it is possible to do with this road under present conditions is to fill up the ruts with broken stone as they develop.

On another rather heavily traveled road the maintenance force in the base section accomplished the feat of making a 3-ft. fill under traffic. This fill consisted of sand and gravel, and was spread in thin layers between the movement of vehicles.

Particularly in the vicinity of large American army camp centers for the repair of machinery and equipment, it has been necessary to do a considerable amount of road widening. Figs. 6, 7 and 8 give an idea of the problem and how it is being handled. This road was originally only about 3 m. wide and of macadam construction with rather thin surfacing—too thin, in fact, to stand up under the motor-truck traffic which it will soon have to bear. The widening process consists of adding about one meter of paved surface to each shoulder, and putting on a top surfacing of about 4 in. Crushed stone for this job has been delivered by motor

trucks as shown in the pictures. This process of widening generally is not complicated by the necessity of providing new drainage ditches, inasmuch as French practice generally places these ditches some distance from the shoulders of the road, leaving space for additional paved widths when this becomes necessary.

In another route which had to be resurfaced, the following scheme of construction has proved effica-

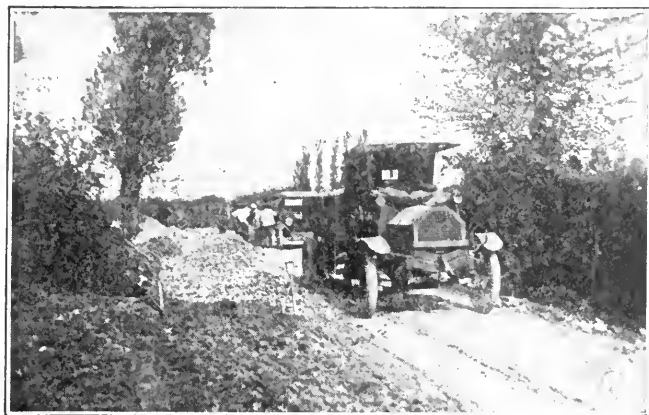

cious: The road is first scarified, and upon it a layer of hard blue stone 4 in. thick is spread. For binder material there is added a thin layer of soft limestone. The surface in this condition is then watered and rolled with a 17-ton roller until it becomes sloppy. Then a layer of sand is sprinkled over the top and the material rolled again. When it dries out this form of construction makes a hard, smooth road.

One of the difficulties of the road work in this base section is the matter of securing an adequate supply of crushed stone. Plans are under way for the opening up of several quarries by our forces. The rights for these must be secured from the French property owners, and it is not always an easy task to reach an agreement on prices, particularly as the negotiations must be conducted in French, either directly or through interpreters.

Of course, the local quarry owners are losing no opportunities of getting as high prices as possible for their rock, and our superintendent of roads is equally vigilant in his efforts to secure a fair price from the standpoint of the American Army. I happened to be present during one of these quarry-buying negotiations, and I noted particularly that the major of engineers who is looking after our interests in this section has learnt enough French to judge of values when stated in francs, and to say "*trop cher*" when an exorbitant figure is quoted to him.

In addition to the road work proper, there is the matter of bridges. Our work did not include the building of any new bridges, for in this region there are numbers of structures of all types, some of them built more than 100 years ago. In walking over one of the

oldest bridges (suspension type, 250-ft. span), in the wake of a two-wheel ox-cart, the floor could be seen to rise and fall in a regular wave, and there was a noticeable creaking and swaying of the bridge. The road superintendent is responsible for keeping our troops off such structures as he considers to be unsafe. Among his many other duties he must examine these old bridges and reach a decision as to whether or not they are suitable for use.

On the subject of types of roads over here the superintendent of roads in the base section has authorized me to quote him as follows:

"The French national and departmental roads are masterpieces of thoroughly first-class construction. The alignment, gradients, curves, drainage and roadbed are perfection, and the water-bound macadam surfaces have been developed to the last degree in both use of materials and execution of the work. Water-bound macadam, however, has proved in France, as in the United States, to be unfit for heavy motor-truck traffic, and many millions of dollars would have been saved and much greater efficiency in the motor transport service would have resulted had these loads received a hard-paved surface before the war. This is the lesson to be derived from an intensive study of the roads of France."

# American Army's Water-Works Projects in France Number About Four Hundred

Great Range in Size and Character of Systems of Supply—Several Mechanical Filters Under Way—  
Laboratory Division Controls Quality of Water

BY ROBERT K. TOMLIN, JR.

War Correspondent of Engineering News-Record

**T**HREE HUNDRED AND SEVENTY-FIVE separate water-works projects—ranging in scope from the utilization of a shallow farm well to the building of a curved concrete dam, pipe line and mechanical filtration plant—represented the volume of work on hand in France early in June by the water-supply division of the American Expeditionary Forces. These activities are entirely distinct from those described in the article "Water-Supply at the Front" in *Engineering News-Record* of May 9, p. 892. The figures given above indicate the extent of the program which is being carried out by our water-supply engineers, and should disillusionize those to whom "the front" and "France" have

taken as a matter of course. In France, however, conditions are vastly different. Water-supply systems with house connections are decidedly the exception in all but large cities. Small towns often are supplied from wells or from springs by means of pipe lines and public taps at various points in the village streets or squares.

With the coming of the American Army into France, it became necessary at the very outset to prepare an extensive program of water-supply for hundreds of localities. For example, there are the cantonments, training areas, railroad yards and terminals, aviation fields, supply depots, ordnance plants, repair shops and hospitals—to say nothing of the big developments required

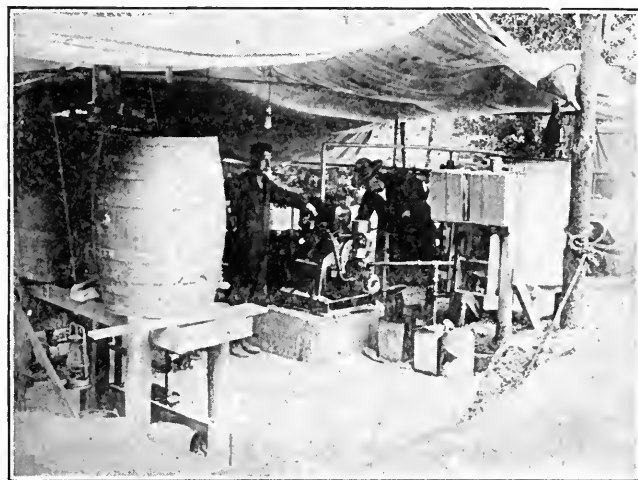
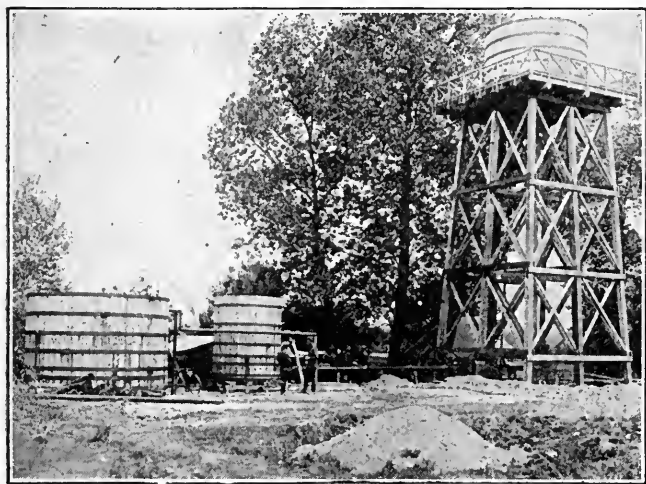

© Committee on Public Information

FIRST AMERICAN WATER-FILTRATION PLANT FOR USE OF THE AMERICAN EXPEDITIONARY FORCES IN FRANCE.  
1. GENERAL VIEW OF TANKS. 2. PUMPING MACHINERY

become synonymous terms. As I pointed out in a former article, there is, between the coast and the so-called zone of the armies, an area containing hundreds of important centers of one sort or another, all essential parts of the military machine, where the services of the engineer are in demand. It is natural, however, that there should be a tendency for interest to focus upon the great drama which is being played in the immediate vicinity of No Man's Land and to pass by the less sensational, but highly important, activities which are being conducted in the areas of the services of supply.

Troops in large numbers are stationed in or near French villages or at sites which have been developed from farm land into large centers of population since our entry into the war. All demand water-supplies. Where existing systems are available, they are used or enlarged, but over here there is no such general provision of water-supply systems in small towns as in the United States. By the American at home the finding of running water, even in houses of small towns, is

at base ports where, according to the official figures made public in July, American troops were landing on French soil at the rate of a quarter of a million per month. It is clear, therefore, that the problem of water-supply in the areas back from the front is one of segregated projects in great number rather than of a single large project.

An engineer organization reporting to the Director of Construction and Forestry, a brigadier-general, at the headquarters of the services of supply, has been formed to handle the water-supply work. At its head is a captain of engineers who was formerly principal assistant engineer in charge of the design of the \$200,000,000 Catskill aqueduct for New York City. Assisting him are other engineers, experienced in the various special lines of water-works construction, filtration, sterilization, pumping machinery, etc. An important part of the work is the control of the quality of the water-supply. Laboratories for the chemical and bacterial analysis of water have been established at a number of points and are under the control of a director of labora-

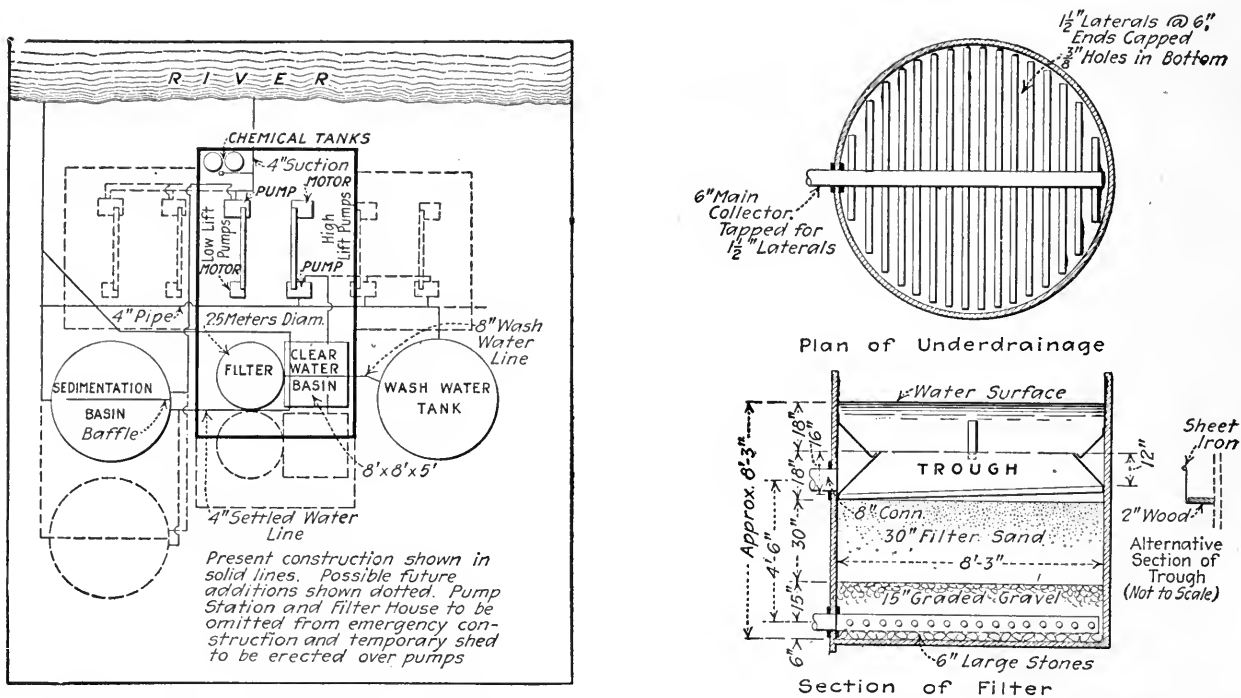

FIGS. 1 AND 2. DETAILS OF FIRST MECHANICAL FILTRATION PLANT BUILT BY AMERICAN ENGINEERS IN FRANCE

series who was formerly director of the Illinois State Water Survey.

All projects designed to obtain supplies from navigable streams or to pump water into existing French pipe lines required, originally, the approval of the French Ministry of War and also that of the local French officials. In the early stages of the work progress was delayed by the necessity of attending to a great many formalities, but recently the procedure has been simplified, and in the matter of requisitions of land, permits, etc., we are now dealing directly with French local officials, such as representatives of *Ponts et Chaussées*, prefects and mayors. This change in practice followed a request by the French Ministry of War for the submission of complete reports and plans on all water-supply projects contemplated for the use of the American Expeditionary Forces. With the limited force of men available and the huge number of projects in hand, the granting of such a request would have meant practically the shutting down of regular work for a good many weeks to prepare reports and wait for them to pass through official channels and receive the necessary approval. An understanding has been reached lately, however, whereby cumbersome procedure of this sort may be by-passed and our dealings conducted directly with the local authorities in the town or village where we are planning to operate.

As to the types of water-supply installations on which our engineers are engaged, there are, first of all, the large hospitals. At most of the 10,000-bed hospitals the water requirements are estimated to be 460,000 gal. per day. On these projects there are generally two alternatives, pumping from a river or obtaining a supply from wells. The use of liquid chlorine for water sterilization is included in many of the American Army projects.

Near the docks at one of our base sections an artesian well 700 ft. deep has been driven and is yielding about

500,000 gal. per day of excellent water, requiring no purification or sterilization.

Railroad water points must be established at frequent intervals. Negotiations are under way with the French railroads for increasing or supplementing their supplies along lines to be used by the American Army. The actual needs at these points are determined by the director general of transportation and the work is then turned over to the director of construction and forestry for whom it is handled through the water-supply division.

One of the more elaborate installations has involved the construction of a curved concrete dam 50 ft. high and a new mechanical filtration plant. At another point an old French slow sand filter plant is being remodelled as a rapid filter.

At a port where American troops arrive in large numbers it has been necessary to supplement the existing water-supply by pumping from a river 800,000 gal. daily. The pumping station has been installed and 600 ft. of 10-in. pipe and 2200 ft. of 8-in. pipe laid. Sterilization here is by means of liquid chlorine. The French requirements as to the quality of water which we introduce into their mains are very high—no *b. coli* in one liter. With the liquid chlorine sterilization methods in use, we have been successful in meeting these requirements by applying a heavy dose of liquid chlorine and, later, dechlorinating with a thiosulphate solution.

The first filtration plant built in France by American engineers is situated at an aviation production center, and its general features are shown by Figs. 1 and 2. It supplies about 100,000 gal. of water per day (and may ultimately be enlarged to a capacity of 500,000 gal. daily), and it consists of an 8-ft. wooden tank containing about 30 in. of sand and from 12 to 15 in. of graded gravel. The main collector is a 6-in. pipe tapped for 1/2-in. laterals. It was, of course, impossible to secure strainers, so holes were drilled at 6-in. intervals

in the under side of the lateral collectors. The annular wash-water trough is made of old biscuit tins. For cleaning the filter sand a straight water wash is em-

Knowles, consulting engineer, Pittsburgh. Speaking of the design of this first filter plant and other water-works projects, he summed up the situation about in

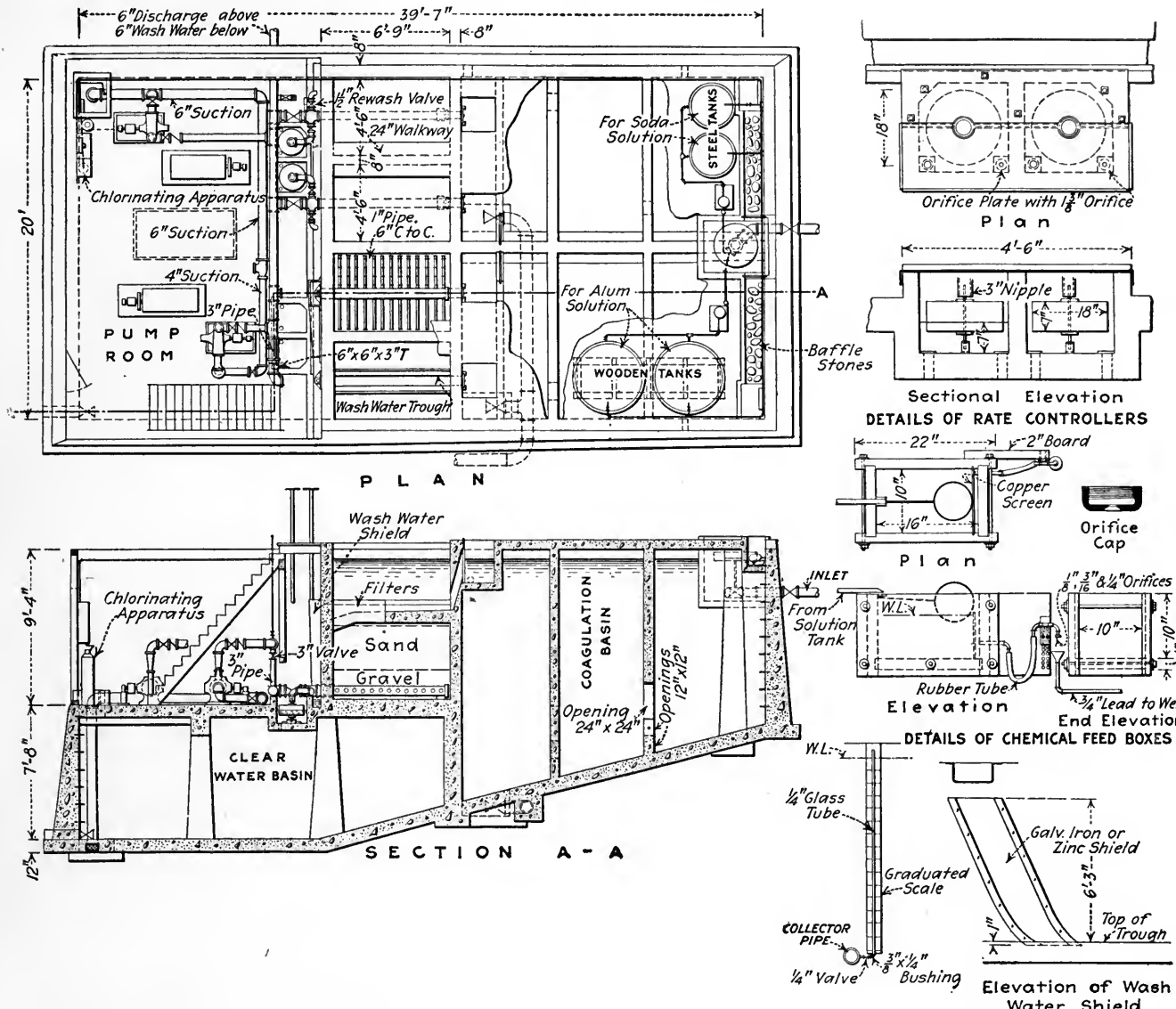

FIG. 3. ONE OF THE LARGER CONCRETE WATER-FILTRATION PROJECTS ON WHICH THE AMERICAN ARMY ENGINEERS ARE AT WORK IN FRANCE

ployed, the velocity of the upward flow being about 2 ft. per minute.

In this plant the raw water is pumped from a river, and first passes through a circular sedimentation tank with a vertical baffle. The coagulant is an alum solution applied at the suction lift at the rate of 2 grains per gallon. The clear-water basin is concrete-lined, and wash-water is taken care of in a wooden tank whose bottom is elevated about 30 ft. above that of the filter floor. The filter effluent is treated with liquid chlorine.

One of the novel features of this plant is the pumping layout. Both the low-lift and the high-lift centrifugal pumps are driven by the same motor by means of belting and pulleys from a single shaft. The high-lift pump works against a head, including friction in the distribution system, of 160 feet.

The engineer officer who had immediate charge of this project was formerly on the staff of Morris

these words: "We must work with the materials at hand—not with what we might like to order in normal times, but with what we can get quickly. The procedure in design resolves itself into these steps: Get a copy of the stock list of materials at the storage yards in France, see that machinery, pipe and fittings are available and prepare a design which will fit them together."

A more elaborate filtration project is one serving a large hospital site, which is supplied from a 120,000, 000-gal. reservoir formed by a curved concrete dam about 50 ft. high. From the dam a 6-in. pipe line delivers by gravity to a float chamber at the end of the coagulating basin. The water for this plant has low alkalinity and it is necessary to apply both soda ash and alum. The tank inlet is a concrete trough. The unusual feature is that this trough is filled with large stones which serve as baffles and cause a thorough mixture of the chemical solutions with the raw water before

entry into the coagulating basin. The latter is fitted with two baffle walls, as shown in the drawing, and the floor inclines toward a pump and blow off.

While the design (Fig. 3) provides for four mechanical filter units, with a combined capacity of about 330,000 gal. daily, only two of these units are being equipped at present. Each filter tank measures  $4\frac{1}{2}$  x  $46\frac{3}{4}$  ft. and contains 30 in. of sand and 18 in. of gravel. The collector system is, in type, the same as that used at the aviation production center plant previously noted. The header is a 6-in. pipe into which 1-in. laterals, perforated with holes on the under side, are tapped. The filtered water is sterilized with liquid chlorine applied on the suction lift line of the pumps delivering to the distribution system.

The filter effluent passes through rate controllers of the type shown in one of the details of the drawings. These maintain a fixed head on pairs of  $2\frac{1}{2}$ -in. orifices, the latter discharging into the clear-water basin.

The chemical feed control is another detail that should be noted. It is of a very simple type—a constant-head tank discharging through a flexible tube, the elevation of whose orifice end may be varied by the series of steel pin supports shown.

Another water-supply and purification project at an important base point has involved the creation of 1,500,000,000-gal. storage capacity in reservoirs 15 miles from an existing French slow sand filtration plant. This water is delivered about 10 miles of the distance by canals, and the remaining 5 miles by a 24-in. cast-iron pipe line laid on the ground surface. The old filter plant is being remodeled into a rapid mechanical filter. Before the pipe line was completed, it was necessary—so heavily was the existing plant capacity taxed—to bring water in tank boats to a point where it could be pumped into the reservoir supplying the old filter plant. The remodeled filters will have an output of 3,000,000 gal. daily.

#### OTHER WATER-SUPPLY PROJECTS

Other places at which water-supply projects are completed, under construction or contemplated are the engine terminals and yards, the depots and repair shops,

the remount stations where large numbers of horses are stabled, the aviation and the motor-truck assembly and repair centers. From these places demands for a supply of water come, and it is the duty of the water-supply division to investigate the needs and design the works. Construction is generally carried out under the direction of the commanding officer at the place where the works are to be installed. In a general way, the water-supply division performs a triple rôle—state department of health, consulting engineer and purchasing agent.

Not the smallest of its tasks is the obtaining and distributing of water-works supplies. From scores of places come calls for pipe, fittings, pumps, motors. Before the work of allocating these materials was controlled, it sometimes happened that one locality would attempt to "corner" the available supply of cast-iron pipe by direct requisition on the storage depots, leaving other water-works projects at a standstill for lack of supplies. Someone would hear that "they have just received some pumps down at ——" and the result was a rush to get there first and bring them back home. This method of scrambling for water-works supplies has been eliminated by compelling all requisitions to pass through the headquarters office of the water-supply division. One engineer spends all his time examining these requisitions and assigning the available stock where it is most urgently needed. Of course, there is generally not enough to go round. Then, too, requisitions often call for an excessive amount of material, the canny man at the other end of the line having evidently decided to put by something for the future. The result is that the engineer who allocates the material, snipping off items here, canceling whole requisitions there, is probably the most cussed-out individual in France today.

It is necessary for the water-supply division to look far ahead as to its needs. At the present writing its forecasts are completed up to April, 1919, and a regular schedule of priority for transatlantic shipment of material has been prepared. The method of requisitions for material to be placed in stock on wharves in America, with monthly tonnage priority cables, appears to be the only practical way to handle the matter, according to the chief of the division.

# Army Motor Trucks Carry Water Purification Plant

Provided with Mechanical Filter, Chlorinating Apparatus and Testing Laboratory, They Insure Safe Water for Troops

BY ROBERT K. TOMLIN, JR.  
War Correspondent of Engineering News-Record

FOR emergency filtration, sterilization and analysis of water supplied to American troops at the front in France, specially designed mobile plants, mounted on standard motor trucks, have been placed in service. The first outfits of this sort were sent to a division in an American sector early in June. They are the forerunners of others which, it is planned, will be used pretty

tively large scale, to the special needs of Army service, the features of the new outfits being mobility and such compactness in arrangement that a complete water purification plant and analytical laboratory are carried on the chassis of a 3-ton truck.

There are at the present time three different types of these motor-truck plants. The first is known as the

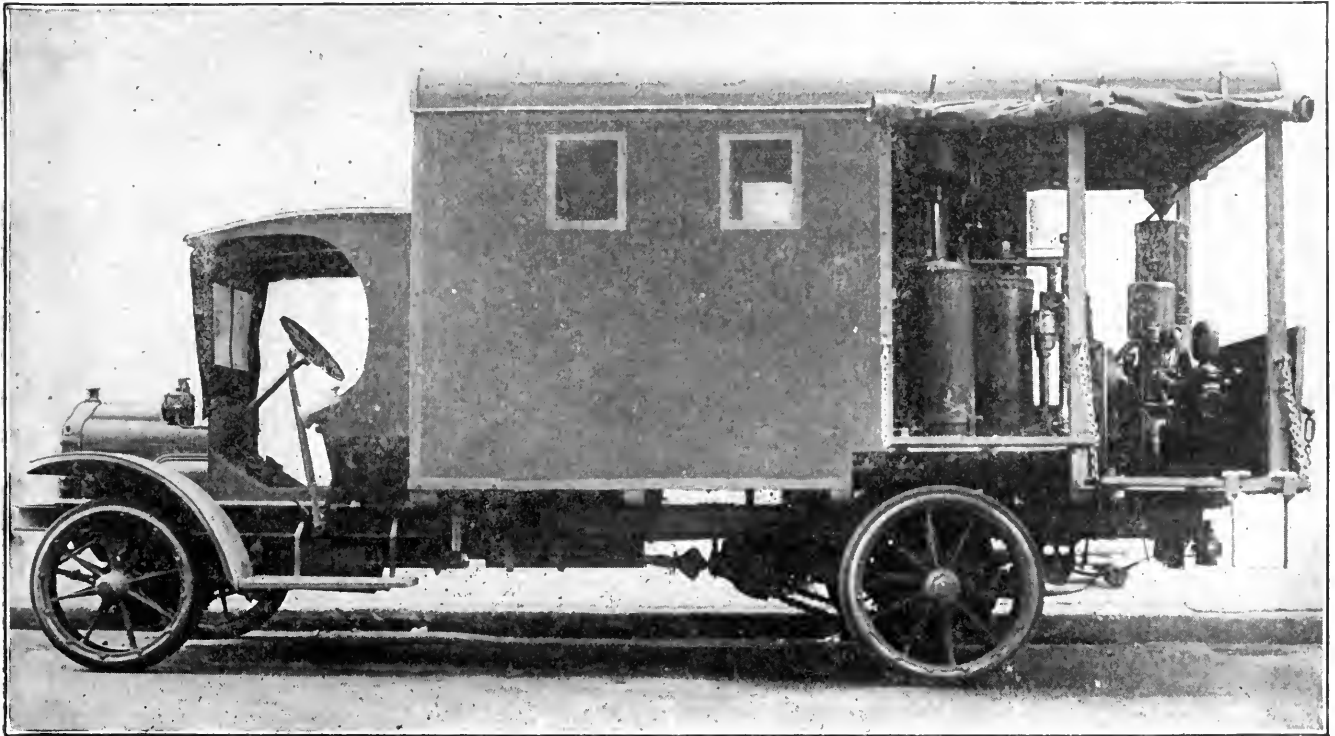

ALL THE STERI-LAB EQUIPMENT IS COMPACTLY ARRANGED AND CARRIED ON A THREE-TON TRUCK

generally by the American Expeditionary Forces for producing temporary supplies of potable water pending the creation of the more or less permanent "water points" which present military engineering practice has developed for the advance zones. While they embody no principles of water treatment which have not been employed for years past in the United States, the portable plants are nevertheless unique in so far as sanitary engineering practice of the allied armies is concerned. They represent an ingenious adaptation of standard American methods of water purification, on a compara-

"Steri-Lab" and comprises a pump, a pressure filter, a chlorinating apparatus and a laboratory. The second, the "Chloro-Pumping" outfit, is like the first, except that it carries no pressure filter, and has a pump of greater capacity than the "Steri-Lab." The third is essentially a laboratory on wheels for the chemical and bacterial analysis of water. These mobile plants were designed and equipped by the Wallace & Tiernan Co., Inc., of New York, working in collaboration with officers of the Corps of Engineers.

The details of the "Steri-Lab" truck are shown in the

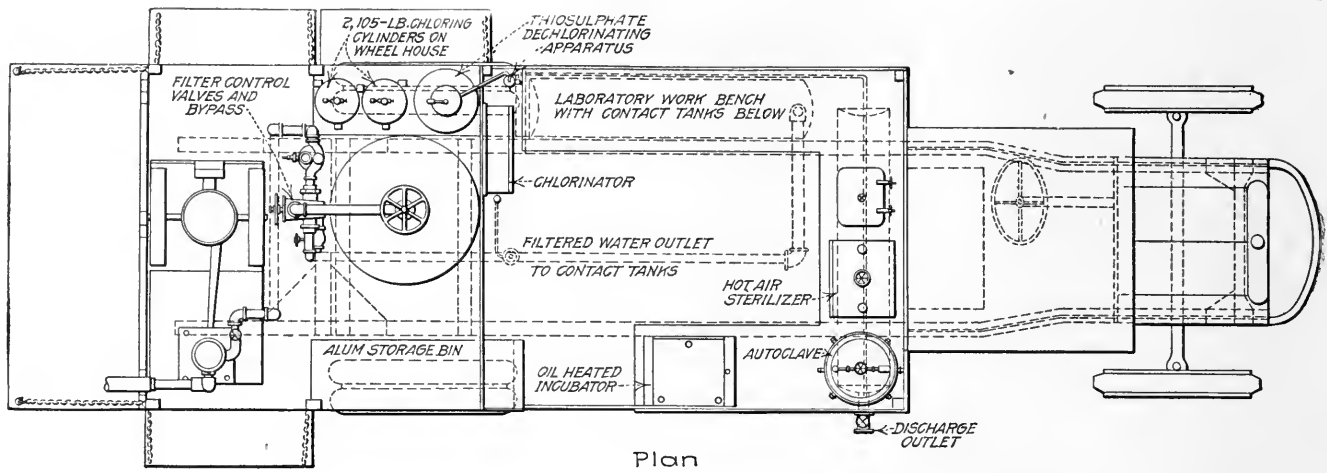

Plan

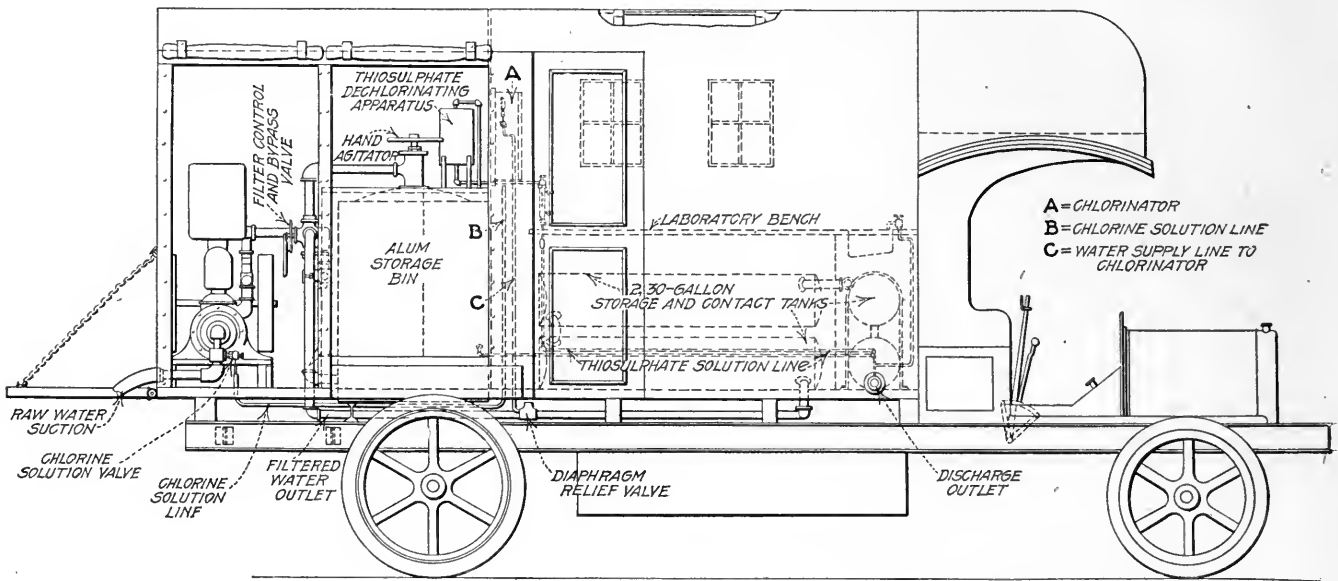
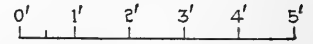

Elevation

SIDE ELEVATION AND PLAN SHOW DETAIL OF MOBILE WATER PURIFICATION PLANT

accompanying drawing and photographs. At the rear end is a gasoline-driven pump of the double-acting piston type with a rated capacity of 20 gal. per minute which may be operated against a pressure of 100 lb. per square inch. It is equipped with 50 ft. of 2-in. hose, foot-valve and strainer. The pump delivers direct to a Roberts mechanical filter of the pressure type, a 30-in. diameter vertical tank mounted over the rear axle. This filter has a hand agitator and is fitted with an alum pot. An alum storage bin is mounted over the right rear wheel of the truck.

Chlorine gas is applied at the pump suction, and the dose generally is much heavier than that employed in ordinary municipal water-works practice. It may vary from 4.5 to as much as 10 parts per million. A contact period of from 10 to 15 minutes is afforded by cylindrical tanks mounted under the work bench of the laboratory compartment of the outfit. With such an intensive application of chlorine, which is adopted to insure absolute safety in the quality of the treated water, it will frequently be necessary to dechlorinate with a thiosulphate solution applied through an adjustable sight feed. The chlorine is carried in 105-lb. cylinders. To

a large extent our water-supply sterilization will be carried on with chlorine obtained from the gas service of the American Expeditionary Forces.

The filtered and sterilized water passes either to a discharge valve, where it can be fed to tank carts or stationary storage, or it may be left in the contact tanks for storage there. These four tanks have a capacity of 30 gal. each, and are tested for a pressure of 100 lb. per square inch.

The forward part of the truck body is occupied by the testing laboratory. This room is completely inclosed, and provided with a door from the rear and wire-glass windows on the side. It is completely equipped as a water-testing laboratory, with working bench, wash sink, water under pressure through faucets, hot air sterilizer for sterilizing glassware, autoclave, bottle and instrument rack, and a full line of laboratory utensils. The laboratory will be used to test waters before and after treatment and for such tests as are required on other occasions.

This type of machine will be able to sterilize 1200 gal. of water per hour when operating through its full system. A bypass is provided around the filter, so that if



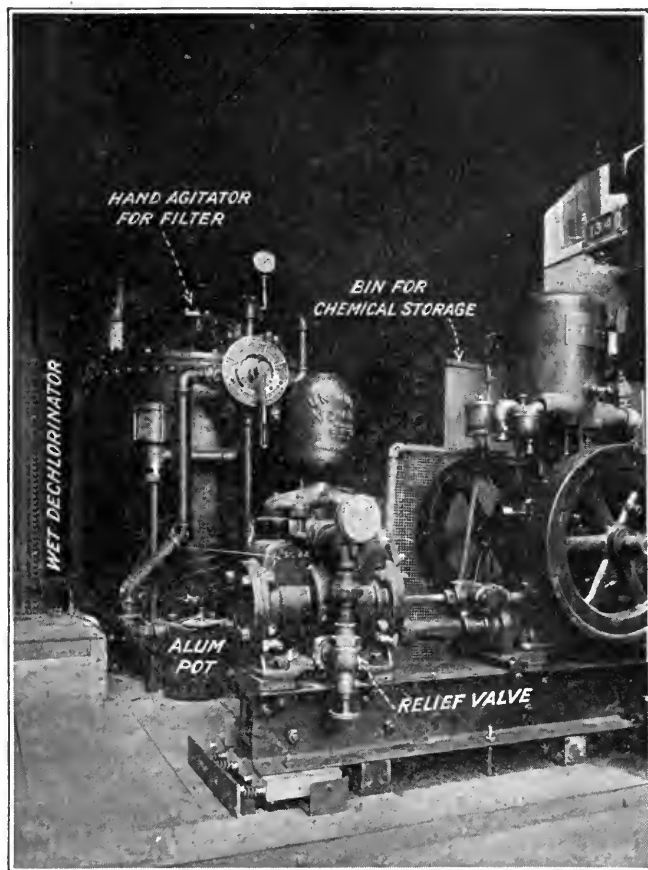

CORNER OF WATER ANALYSIS LABORATORY—PUMPING PLANT, PRESSURE FILTER AND DECHLORINATOR

a water supply is encountered which does not require filtration to remove turbidity and color, but simply chlorination to make the water bacteriologically safe, the capacity may be increased.

The second type of mobile plant, or "Chloro-Pumping" outfit, is carried on a 1½-ton instead of a 3-ton truck. Here there is no pressure filter. The pump has a capacity (40 gal. per minute) double that of the "Steri-Lab" machine. This outfit is designed for emergency work during an advance or a retreat where filtration may be

dispensed with. The chlorinating and thiosulphate apparatus is of the same kind as that previously described.

The "laboratory," or third, type of truck is also carried on a 1½-ton chassis. It is fitted with the usual equipment for making chemical and bacteriological examinations of water. All racks and cases are felt-lined to prevent glass breakage. Water for laboratory use is contained in a tank fitted with a hand air pump to supply pressure. On this truck will be carried a bicycle for the use of the laboratory assistant in collecting samples.

# Army Intermediate Depot in France Problem in Getting Labor and Supplies

Project Covers Site Six Miles Long—Three Types of Warehouse Are Being Built—Chinese Labor Used on Railway Grading—Installation Completed for Storing 5000 Tons of Beef at Zero Temperature

BY ROBERT K. TOMLIN, JR.  
War Correspondent of Engineering News-Record

*Photographs not otherwise indicated are from Committee on Public Information.*

TO PROVIDE storage and railroad yard facilities at a point midway between the front line trenches and the United States Army seacoast bases in France where supplies and equipment are unloaded, engineer troops, assisted by labor units of several nationalities and German prisoners, have partially completed the construction of what will be, eventually, the largest of the so-called "depots" for the American Expeditionary

Forces. This is the intermediate depot, where reserve stores for the engineer, quartermaster, medical, signal, ordnance and the various other special services of the Army are delivered, held until needed, and then shipped to points of use.

Even over here in France it is hard to visualize the vast extent of the construction program which our engineers have laid out, and of which the intermediate depot, though a big project, is only a part. One journeys from place to place between the seacoast and the front, and all along the line the work of the engineer is in evidence. I have covered by railway, motor car and "hiking" a good many thousand miles since I landed in France, and even to-day there are many sites where construction is in full swing which I have not visited. There are others, too, I will venture to say, of whose very existence I am ignorant—and this in spite of fairly steady contact for six months with engineer officers grading in rank from second lieutenant to major general. The thing is appallingly big to "cover" in any comprehensive way. We can pick out jobs here and there for description, in an attempt to give our engineers in America some idea of the main types of construction which our technical troops in France are doing, but under present conditions it would take a sizable staff of men to record in adequate fashion the

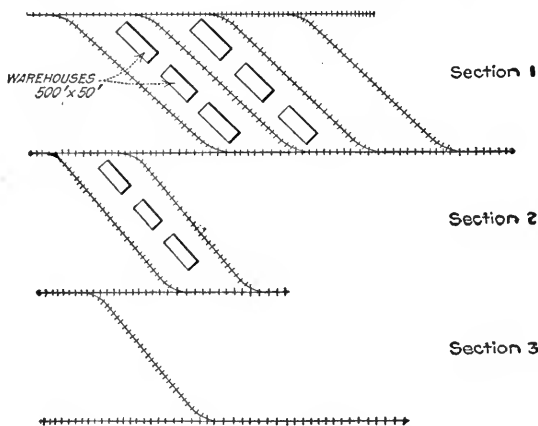

FIG. 1. SKETCH SHOWS TYPICAL LAYOUT OF WAREHOUSE SECTION OF ARMY INTERMEDIATE DEPOT

In previous articles, on the advance depot and the docks, storage and railroad yards at one of our base sections, I have outlined the general purpose and relation to one another of the several "depots" for our overseas supplies. It is, therefore, unnecessary to go into details as to the function of the intermediate depot. Suffice it to say that it is, in effect, a vast storage and regulating reservoir of materials of all sorts upon which the draft from day to day varies, depending upon the needs at the front and at other places in France where American army activities are under way.

The intermediate depot must be equipped to meet hurry calls for almost anything in the form of food or supplies. On the heels of a requisition for canned beans in car-load lots may come a demand for a shipment of cast-iron pipe, specials, and valves for a water-supply project. To meet such demands involves the provision of millions of square feet of covered and open storage and the creation of railway yard facilities for delivering and taking away the almost endless variety of products called for by the war program upon which we are engaged. Aside from its tremendous size the intermediate depot is unique in that it contains the larg-



FIG. 2. WOOD-FRAME WAREHOUSE HAS HOLLOW TILE WALLS

est refrigerating plant in France—a plant with a capacity of storing at a temperature of 0° F. 5000 tons of fresh beef.

engineering work which is being done for the American Expeditionary Forces. Take for example the single project of the intermediate depot. In plan it is a diamond-shaped layout 6½ miles long and 1¼ miles wide. The plans provide for more than 200 warehouse buildings, each about 500 ft. long and 50 ft. wide. These dimensions are only approximate, for there are buildings of several different types, but, on the average, they are of about the size indicated. Coupled with the building construction is the matter of laying about 225 miles of railway track to serve the warehouses.

With the exception of the refrigerating plant, however, the depot problem presents nothing difficult in the matter of engineering design. The wooden buildings

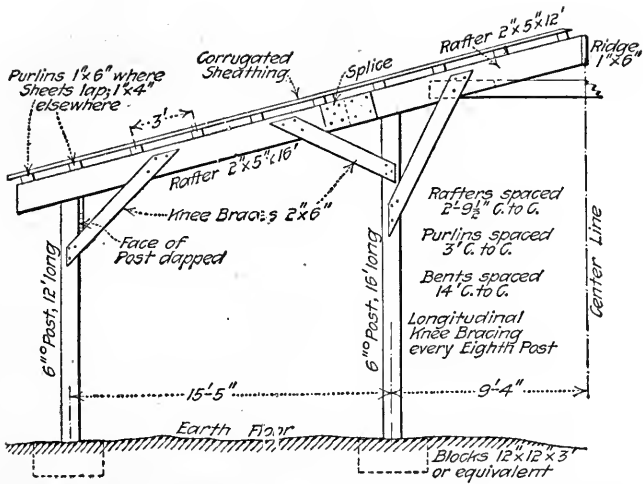

FIG. 3. TYPICAL CROSS-SECTION OF WAREHOUSE SHED

are of extremely simple types, and the railroad yard grading and track laying has been principally a job of obtaining materials and handling labor, rather than one of elaborate technical detail. This does not mean that the work has proceeded in any haphazard way, but

As to the layout of the warehouses and the tracks the plan shows the work divided into five sections, four of these being parallel bands running in an east and west direction, and the fifth extending diagonally along the western ends of the others. In addition, there is a special yard for the storage of engineer material. Between pairs of parallel east and west track the warehouses, generally in groups of three, are placed end to end as shown in the accompanying sketch (Fig. 1). At the time of my visit early in June there had been laid about 60 miles of track, and 80 warehouse buildings were finished. During the early stages of the job about 15 miles of rail had to be obtained from the French, but at the present writing 80-lb. steel rail from the states is being employed exclusively. The same situation existed in the case of wooden ties but now, with the work of our forestry service speeding up the production of lumber from local sources, the tie shortage is being relieved.

The grading of the railway yards has been done both with small hand tools, pick, shovel and wheelbarrow, and with the aid of heavier plant such as locomotive cranes and clamshell buckets, and road graders



FIG. 4. ENDS OF WOOD-FRAME WAREHOUSES ARE SHEATHED WITH CORRUGATED IRON BUT SIDES HAVE ONLY CANVAS COVERS

rather that it has been studied with a view to eliminating anything savoring of "fancy" engineering or construction. The main large-scale map of the yard layout, for example, is one on which all unnecessary draftsmanship has been omitted. It is a straight "working" drawing. Tacked down upon the rough plank table in the shack which serves as the headquarters of the commanding officer of the engineer troops and his principal assistants, the paper has been worn through in spots by the elbows of the men who have to consult it regularly and mark up progress. No one has had time to make a new drawing. The holes in the old one are patched up with adhesive tape as they develop, and the work goes on.

hauled by caterpillar tractors. The labor represents many nationalities. In addition to our own service battalions there are large gangs of Chinese on the job. While the site of the yards is fairly flat, large areas were originally covered with brush and small trees, necessitating a considerable amount of grubbing. On this work of clearing and grubbing, as well as that of digging drainage ditches and grading the earth floors of the warehouses, the Chinese were used. Labor of higher grade, both negro and white, was reserved for the more difficult jobs of track laying and ballasting. However, a few of the Chinamen were employed on tasks demanding some degree of mechanical skill; for example, in assembling a few road graders and concrete

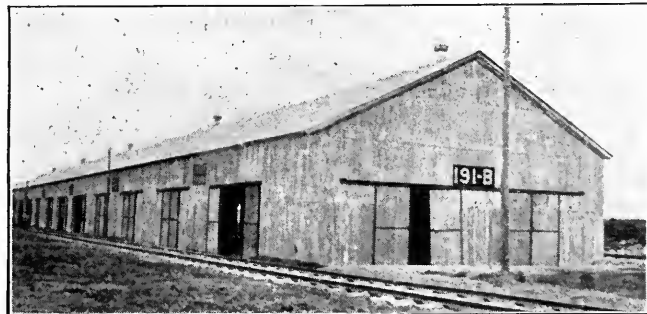
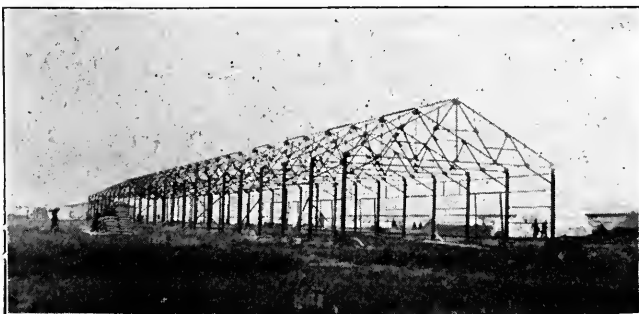

FIG. 5. STEEL FRAME WAREHOUSES ARE SIMPLE IN APPEARANCE

mixers. The major of engineers who made this experiment told me that the Orientals became intensely interested in putting together the parts of American machinery, and often they worked hours overtime tinkering with the equipment which had been entrusted to them.

The track layout of the yard involves the provision of two humps and two separate groups of receiving, classification and departure yards, one for east-bound

ing operations and stripped of their bark. The ends of each warehouse are sheathed with corrugated iron sheets, as shown in Fig. 4. The sides are not sheathed. As a means of protection for the material placed beneath this form of shelter large sheets of canvas are hung from a point beneath the eaves and extend down to the ground level, as shown in the picture. On this job, as on all others which have been undertaken by our engineer troops in France, scarcity of materials was one

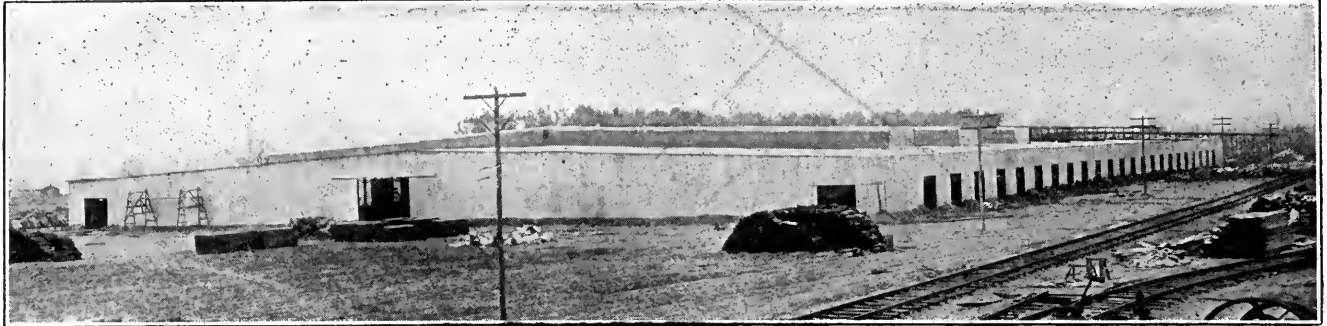

FIG. 6. ONE OF THE VERY LARGE STEEL FRAME WAREHOUSES SHEATHED WITH CORRUGATED IRON

and the other for west-bound traffic. The hump starts with a 4-per cent grade which is eased off in 100-ft. stretches to 1 per cent. Among the accessory structures for the railway yard are engine sheds, coaling stations, inspection and repair pits.

For the warehouses there are three different types of structure: (1) wood frame with open sides and corrugated iron roofing; (2) steel frame entirely sheathed with corrugated iron; (3) wood frame with walls of hollow clay tile or cement blocks. The steel

of the conditions which we had to face. As one of the majors of an engineer regiment at the intermediate depot expressed it to me, "Our principal difficulty has been to put the job through using only about one-half the original bill of material."

In the sketch showing a typical cross-section of a warehouse shed (Fig. 3), it will be noted that the sizes of the various members are given. This means that such sizes are used when they are available, which is not always the case. In this type of warehouse no roof

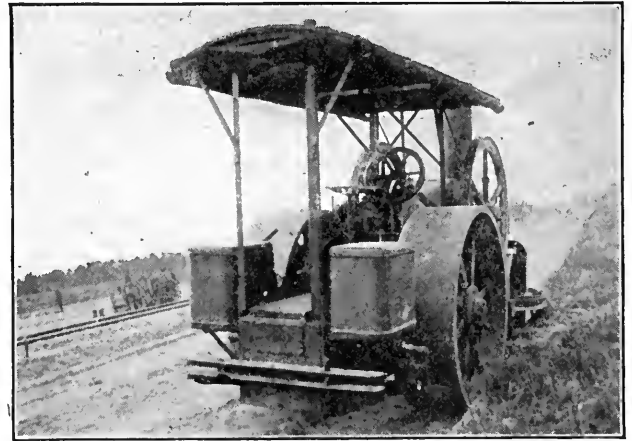

Photographs by Engineering News-Record  
 FIG. 7. GRADING DONE BY AMERICAN ROAD GRADER HAULED BY CATERPILLAR, SHOWN ON LEFT, AND ROAD ROLLED BY AMERICAN MACHINE, IN VIEW AT RIGHT

and the clay-tile warehouses are used to store supplies which would be damaged by wetting, such as flour and sugar in sacks. The open wood-frame houses, on the other hand, are suitable for the storage of canned or boxed goods. The steel-frame structures serve as fire-stops, being interposed here and there between the wooden structures.

The wood-frame warehouse is merely a shed formed by timber bents and corrugated roofing, as shown in Fig. 3. Most of the posts are young pine trees, 6 in. or less in diameter, obtained on the site during the clear-

truss is employed. The rafters, 2 x 5 in. in section, are kneebraced to the vertical posts. It is practically impossible to obtain in France to-day long timber, and in the case of the warehouse rafters a splice is introduced as shown. The purlins are spaced on 3 ft. centers and are usually of very light material. The corrugated roofing is nailed to them.

Many of the storage warehouses at the other depots of the American Expeditionary Forces in France are raised above the ground level on posts, or are provided with depressed railroad track along both the incoming

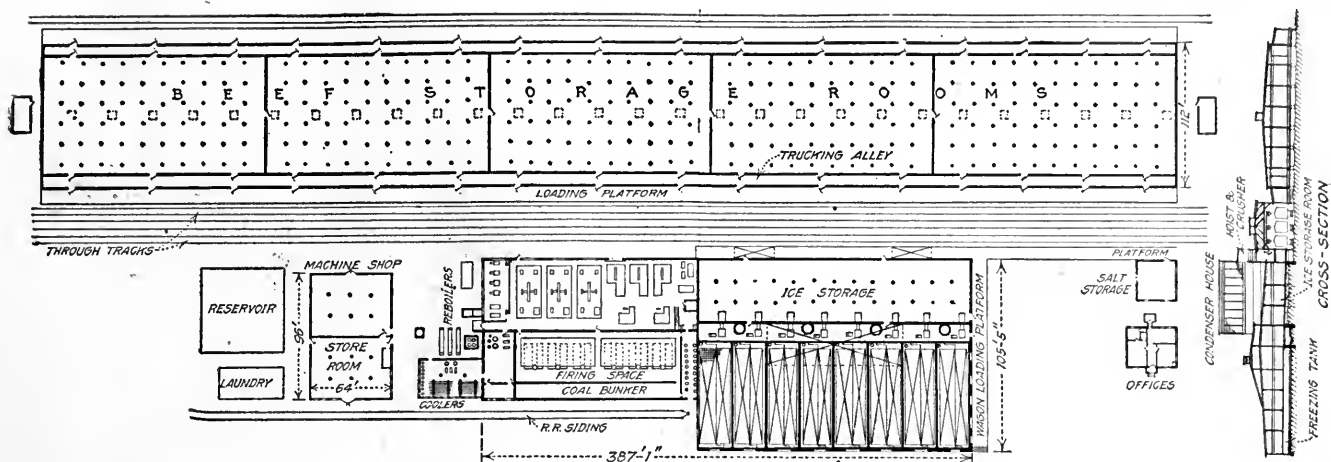

FIG. 8. LAYOUT OF THE HUGE REFRIGERATING PLANT BUILT BY AMERICAN SOLDIERS IN HEART OF FRANCE

and outgoing platforms, thus making the warehouse floor level the same as that of the freight car. In the case of the present wood-frame warehouses at the intermediate depot this practice has not been followed; as a general rule, there is no flooring other than the earth at the original ground level. In some cases, logs are placed on the earth floor in parallel rows to raise cases of goods a few inches above the ground.

More substantial types of warehouse are shown in Figs. 5 and 6. Those of the hollow-tile type were built for us by French contractors. In the steel-frame type of warehouse all connections are bolted rather than riveted, and the structure is sheathed on roof, ends and sides with corrugated iron.

The first lumber for the warehouse construction came from the United States, but since these early shipments a certain quantity has been secured from Swiss and French sources and from American forestry regiments. As a general rule, about five warehouses of the wood-frame type are under construction at one time, and to each building a gang of 60 or 70 men is assigned. Portable saw-rigs have been used for the framing work and have proved decidedly useful. Very little concrete is used on this job, the principal demand for it being at the refrigerating plant, in the footings for the columns of the steel-frame warehouses and for the inspection and engine pits for the railroad yard.

At the time of my visit to the intermediate depot, warehouses of the three different types, wood-frame, steel-frame and wood-frame with hollow-tile walls, had been built and were in service. About 25 locomotives were being used on the railway yard operation and construction, and shipments in large volume were being received, stored or routed for the front. One of the depot's biggest days occurred on June 13, when 520 cars were loaded and hauled out.

A very large labor force has been required on the depot construction work. I was told that the force, at times, has exceeded 10,000 men. Of course, this number does not remain constant. The situation over here is one that is characterized by shifting, sometimes sudden, of units from one place to another. For example, the work at the intermediate depot was begun by one of the regiments of railway engineers which were among the first to arrive in France a year ago. A few of them,

principally officers serving in administrative capacities or as superintendents of big labor gangs, are still on the job. The rank and file, however have left for other parts. While a great deal of the grading work for the railroad yards has been done by hand labor, mechanical plant is to be seen at work here and there. For example, in one section the roadbed for the track is

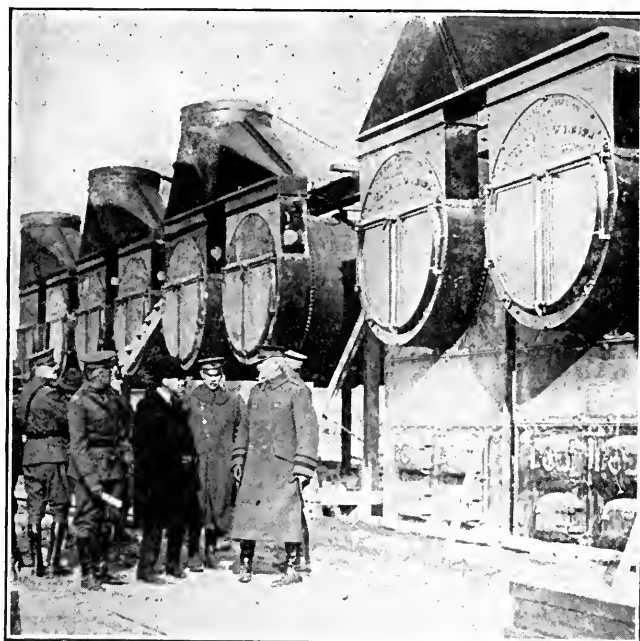

FIG. 9. SECRETARY BAKER AND GENERAL PERSHING IN FRONT OF BOILERS OF REFRIGERATING PLANT

being formed with a road grader hauled by a caterpillar tractor (Fig. 7). The method is to make two cuts, one on either side of the center line, thus forming ditches, and at the same time throwing the material into subgrade where it is levelled off by hand prior to the placing of the ties. A certain amount of road building is required at the intermediate depot. One of the views in Fig. 7 shows a gasoline roller which was put to work as soon as it had been received from the United States.

One of the features of the intermediate depot is the big refrigerating and ice-making plant which has been in operation since May 2. It serves as a cold-storage house for meat and other perishable products required



FIG. 10. REFRIGERATING PLANT UNDER CONSTRUCTION LAST WINTER

by the Army, and was designed originally to have a capacity of 5000 tons of frozen meat at a temperature of 12° F., in addition to the production of 500 tons of ice daily. The first plans have been altered to some extent as regards the temperature in the cold-storage rooms. In order to obviate the necessity of icing the railway cars in which the meat is transported from the refrigerating plant to the front, a lower temperature than that originally contemplated is being maintained in the cold-storage rooms. During my visit to the plant the thermometer indicated 1° below zero. By maintaining this zero temperature—which is the present operating practice—meat can be delivered to points of consumption without the use of iced cars.

The refrigerating plant consists of a group of 12 principal buildings, some of which are of the following sizes: beef storage, 112 x 896 ft.; ice-making, 100 x 218 ft.; ice storage, 68 x 218 ft.; engine room, 60 x 170 ft.; boiler room, 53 x 170 ft.; pump room, 25 x 38 ft.; machine shop and store room, 64 x 96 ft.; laundry, 24 x 50 ft. In addition there are a few miscellaneous buildings and a concrete reservoir 65 x 65 ft. in plan. For its operation the refrigerating plant requires 4,000,000 gal. of water daily, which is obtained from a river  $\frac{2}{3}$  of a mile distant, by means of a 16-in. pipe line and a pumping station. A general layout is shown in Fig. 8.

The engine, boiler and pump-room equipment includes eight 225-hp. boilers (Fig. 9), four refrigerating machines with a total capacity of 1100 tons refrigeration, equivalent to the cooling effect obtained from the melting of 1100 tons of ice daily. There are two 150 kva. electric generators and three turbine-driven centrifugal pumps, each with a capacity of 1800 gal. per minute, or a total capacity of 5400 gal. per minute.

Refrigeration is by direct expansion of ammonia circulating in coils hung from the ceiling of the refrigerator building, which is divided into five rooms, each with a capacity of about 1000 tons of meat. Means are also provided for storing vegetables and other products at a somewhat higher temperature than the zero degrees maintained in the meat-storage rooms. As an indica-

tion of the immense size of this plant, it may be noted that for the refrigerating coils alone 30 miles of 2-in. pipe were required.

While the original plans for the manufacture of ice, as distinguished from the provision of refrigeration in the meat-storage rooms, have been modified for a smaller output, the plant is nevertheless equipped to produce ice. In the ice-making building, there are six freezing tanks, each with a capacity of 62½ tons of ice daily. The freezing tanks contain a solution of brine cooled by 26 miles of 1½-in. iron pipe.

Into the construction of the refrigerating plant 4,000,000 ft. b.m. of lumber, equivalent to about 6000 tons, have entered. Insulation for the cold-storage rooms, roofing paper, insulating paper, and brick for boiler settings, represented a tonnage of 2600, while 2000 tons is the weight of the mechanical equipment for the plant. Then, too, there are items of 400 tons of salt and 200 tons of ammonia, including the weight of the drums in which it is shipped. Summing up, the refrigerating plant represents a tonnage of 11,200. This figure is important when it is recalled that practically everything which entered into the construction of the plant had to be shipped from the United States. In addition, concrete for footings, walls, engine foundations, etc., was required, most of the cement for this purpose having been obtained from Europe. Exclusive of the cost of transportation from the United States—itsself an item of no mean size under present conditions—the refrigerating plant represents an outlay of more than \$2,000,000.

Obviously, such work as that required for the installation of a large plant of this kind could have been handled only by specialists. This fact was appreciated last year, and while the designs were being prepared at Washington there was organized a so-called ice plant company of engineers of about 350 men, most of whom were recruited from the personnel of the large packing companies of the Middle West. Actual work on the refrigerating plant was started in France in December, 1917, but the promise by those in charge of the installation that operation could be begun in five months was regarded with skepticism in some quarters. Never-

theless, in spite of all the difficulties which surround construction work in France these days, this promise was fulfilled ahead of schedule, and the placing of the works in operation on May 2 of this year is a splendid tribute to the men of the ice plant company.

In explaining to me the plans for the refrigerating plant, which were prepared under the direction of the cantonment division of the Quartermaster Department—now known as the construction division—a major of the Quartermaster Corps who is an expert on refrigeration mentioned a few of the outstanding features of the design. Great pains have been taken to insure flexibility in the layout of the piping. A break would be serious, especially over here where ammonia losses cannot be so easily replaced as in the United States. Horizontal return-tube boilers were selected on the grounds of ease of installation and ease of shipment. On the liquid ammonia lines ample provision is made for expansion and—a very important point—these lines are sectionalized by the introduction of valves at frequent points; in case of a break a section of piping may be at once cut out of the system and ammonia losses thereby greatly reduced.

Provision is made for the use of exhaust steam for distilled-water ice which may be needed for special purposes, as, for example, in hospitals. In the manufacture of ice which, in the case of the plant at the intermediate depot, is accomplished by suspending cans of water in a brine solution, the impurities in the water are forced toward the center of the block as the freezing operation progresses from the outside inward. To offset this trouble pipe lines are introduced which, when the block is partially frozen, suck out the impure water at the core, and replace it with clean water. A clear block of ice is the result.

By maintaining a zero temperature in the freezing rooms, and allowing meat to remain there four days before shipment, it will be possible to dispense with special refrigerating cars and to forward the frozen meat in plain box-cars. This feature of the plant operation is an exceedingly important one in view of the present car shortage in France and the undesirability of introducing special cars for special purposes.

Provision is also made in the operation of the plant for salvaging oil. Judged by many other engineering structures which have been built by our engineers in France, the plant occupies an almost unique position. I was told that it had been built exactly in accordance with the drawings.

A view of the refrigerating building (Fig. 11) from the roof of the ammonia condenser shows that the feature of our plant, so far as the layout of this building is concerned, is the use of a long, low, single-story structure, rather than a more compact building of several stories as is common elsewhere. The advantage of the layout adopted is that long trains can be quickly loaded and unloaded. The main refrigerating building, measuring 896 x 112 ft., will accommodate 25 freight cars on each side.

The successful completion of the refrigerating plant is due in no small measure to the precautions taken in America in the crating, marking and shipping of the multitude of mechanical parts required. At Washington the delivery of the material ready for shipment

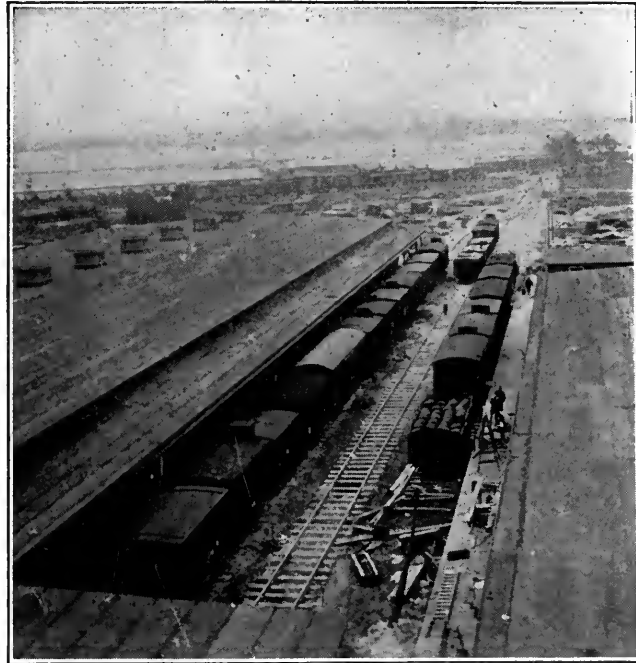

*Photograph by Engineering News-Record*

FIG. 11. HOW CARS ARE HANDLED AT THE BEEF STORAGE BUILDING

abroad was controlled by charts, and shipments were well coordinated, and as a result the machinery arrived in France when and as needed—a most remarkable performance when one considers the unprecedented volume of transatlantic freight now being carried and the difficulties involved in avoiding mistakes and delays.





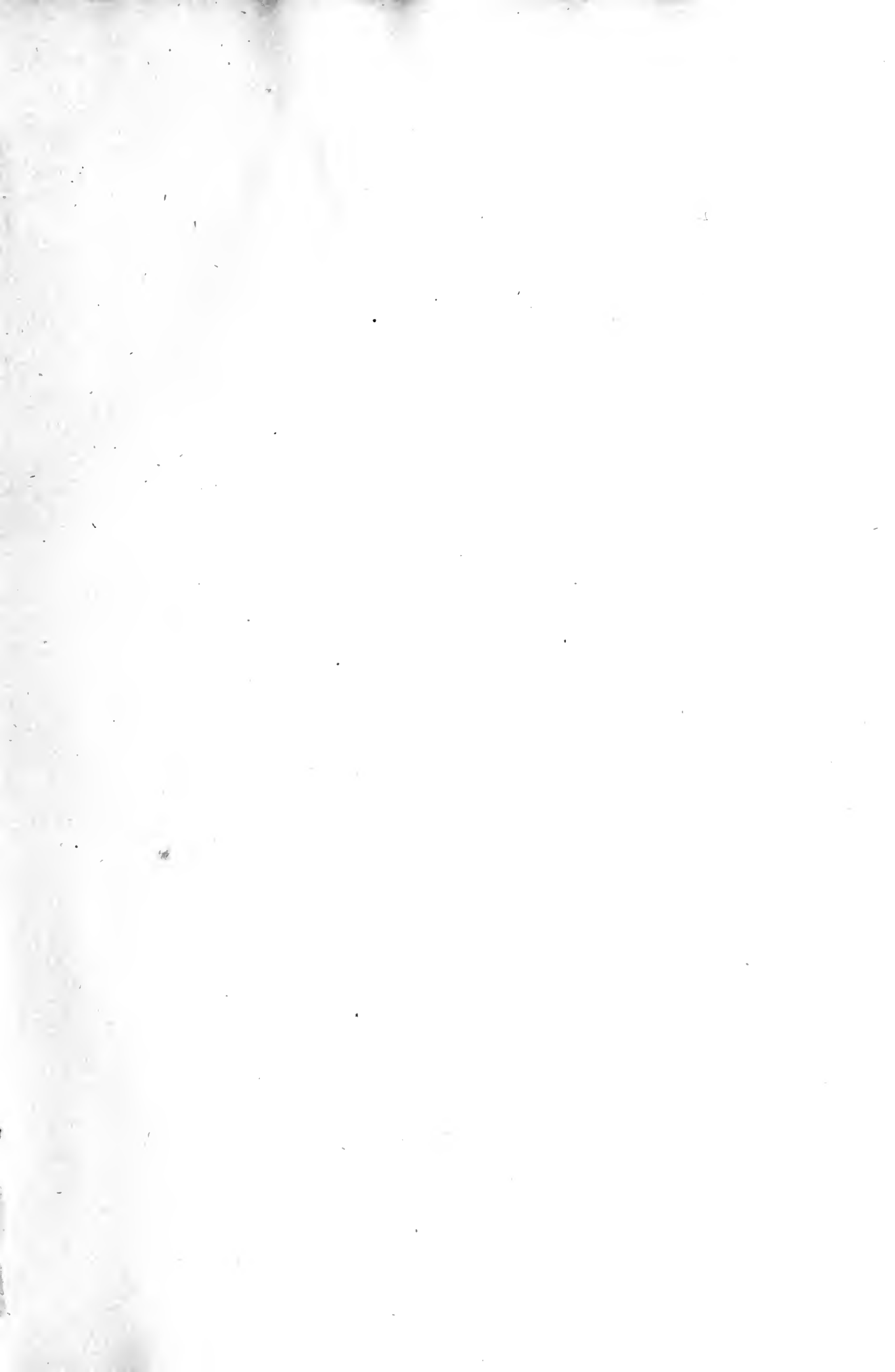

THIS BOOK IS DUE ON THE LAST DATE  
STAMPED BELOW

**AN INITIAL FINE OF 25 CENTS**  
WILL BE ASSESSED FOR FAILURE TO RETURN  
THIS BOOK ON THE DATE DUE. THE PENALTY  
WILL INCREASE TO 50 CENTS ON THE FOURTH  
DAY AND TO \$1.00 ON THE SEVENTH DAY

RETURN TO the circulation desk of any  
University of California Library  
or to the

NORTHERN REGIONAL LIBRARY FACILITY  
Bldg. 400, Richmond Field Station  
University of California  
Richmond, CA 94804-4698

ALL BOOKS MAY BE RECALLED AFTER 7 DAYS

- 2-month loans may be renewed by calling (510) 642-6753
- 1-year loans may be recharged by bringing books to NRLF
- Renewals and recharges may be made 4 days prior to due date.

DUE AS STAMPED BELOW

9/18/01

~~NOV 18 2000~~

(402s)

YE 03346

**386941**

D570  
.309  
T.6

*Tomlin*

UNIVERSITY OF CALIFORNIA LIBRARY

