

AMERICAN
STATIONARY
ENGINEERING

CRANE

LIBRARY
OF THE
UNIVERSITY OF CALIFORNIA.

Class





AMERICAN STATIONARY ENGINEERING

A
Practical work which begins at the Boiler room and
takes in the whole Power Plant. Gives facts,
rules and general information gathered from
thirty years' practical experience as
running, erecting and designing
engineer

BY
W. E. CRANE
"



Contains complete examination for a license

SECOND EDITION

NEW YORK:
THE NORMAN W. HENLEY PUBLISHING COMPANY
132 NASSAU STREET
1910



TJ275
C8

GENERAL

Copyrighted 1906 by
THE DERRY-COLLARD COMPANY

Copyrighted 1910 by
THE NORMAN W. HENLEY PUBLISHING COMPANY

Preface.

The writer bought a million-gallon pumping engine and the low pressure side did not work smoothly. The builders sent three experts to remedy the trouble at as many different times, but made no improvement. These men were sent without giving me notice, so that I was never there to meet them.

I wrote the builders to please not send any more experts, but if they had a plain, practical man that had a fair knowledge of steam pumps I would be pleased to meet him at the station.

This is what this book is intended to be; a plain talk on every-day work about engines, boilers and their accessories. It is not intended to be scientific or mathematical. I have tried to put all formulas in a simple form so that any one understanding plain arithmetic can readily understand any of them.

The writer commenced when books were very scarce and he has seen the need of just such a book as this. Some of the matter I have been unable to find in any book at the present time.

Some of the subjects have been covered completely in other books devoted exclusively to the particular branch like the indicator, slide valves, etc., and these subjects have not been treated at length here.

Sometimes when questions are asked it sets a man thinking deeper than by just reading the text, and a large number of questions has been introduced on subjects mentioned in the book. Direct answers have not been given in all cases, but the reader can refer to index and learn what has been done under similar conditions and study and determine what he would do under like conditions.

A number of books are published purporting to give questions and answers before an examining board when applying for a license.

No man can know the questions that will be asked nor the answers that will be required.

The examiners wish to learn how experienced a man is and the information he has of his own knowledge.

A young man can get much information from the experience of practical men, but this must be supplemented by study, experience and research of his own if he is to impress others with his ability.

It will usually be found that thoroughly well-posted men are willing to give some of their time to imparting information to those whom they think will appreciate and profit by it.

It is generally the rule that it is only those possessing but a small fund of knowledge that become so important with their small lore that are churlish in the matter.

It is the man that is willing to help others that gets along in life, and it is this man that will become posted in his business.

July, 1906.

W. E. CRANE.



The Boiler Room.



In a boiler room, neatness should be observed in everything. The floor should be kept clean,—and for this purpose a hose should be conveniently located,—the side walls and top of boilers should be cleaned once per week.

All surfaces in contact with the fire should be swept as frequently as time will allow, but the tube surface should be cleaned at least twice per week.

With some classes of boilers, and with fairly clean, soft water washing out once in six months may keep them in good condition, but the water should be changed every two or three weeks. With some types of water tube boilers, where the water enters at the front of the drum, it is frequently only necessary to let the water run out and then turn on the feed water full and the water will wash out all deposit in the drum and mud-drum. With most water tube and with tubular boilers, however, it is necessary to take a hose, and there should be considerable pressure. Where there is scale and considerable mud, the boiler should be gone over thoroughly as frequently as the opportunity offers.

Filtration - Piping—Testing Water.

With very muddy waters a filtration plant will pay, as mud and clay are more to be feared than lime.

With tubular boilers properly set and the water fed at the proper place, the larger part of deposit will be found at the rear end, as that is the part with the slowest circulation.

In water tube boilers the larger part will be found in the rear circulating tubes, rear manifolds and rear end of tubes.

The important things for a man to look after when taking charge of a set of boilers for the first time is to see that his water gauges are all clear by blowing them all out. Look his piping all over and see if there are any water pockets that would be liable to collect water and let it over in a body; note the position and design of all the stop valves and the manner of getting to them in case of emergency; look the water piping over and the source of supply for the pumps; the type of pumps, and try them to see that they work properly and that there are no broken valves; note the heater, or the absence of any, and test the water to see if it is hard.

This can be fairly well decided by putting some in a pail and washing the hands with soap. If the water is soft there will be nothing but soap suds on top; if hard, there will be a scum formed on top. A chemical analysis will be required to determine the kind of impurity and quantity. Silica means sand and the like, while this mixed with alumina and iron means clay and a dirty boiler.

The safety valves should be looked to. If lever valves, they should be raised to see if they respond readily and if they leak after use.

If "pop" valves, bearing down on the lever will

Safety Valves—Gage Glasses.

cause them to blow, if not set for too high a pressure. At the first opportunity the steam should be raised to the pressure at which it is desired to blow and see that they blow freely from the pressure. Note the blow-off pipe and valves and try the valves. The grates and furnace can be attended to the first time the fire is out. Note condition of brick work, connection of flues, etc., and see if there are any large cracks for air to enter.

When firing up in morning be sure to try the water gauges the first thing, and see that everything about them is free, and that there is no stoppage at top of column, provided the water goes down in the glass and raises partially.

On modern glass gauges there are levers put across the stop cocks and chain attached to both top and bottom so that they can be closed from the floor. These are fastened to the stem with a set-screw. Should this set-screw become loose when the top is closed it will not open and the gauge will show nearly full of water until the water is entirely out of the water column. Any time that the glass gauge shows different from the gauge cocks, either this has hapened or the connections are closed. There was one case on a new boiler where the cocks and glass showed different, the glass showing nearly full, while the cocks showed steam, and it was found that the top glass gauge fitting had no hole through it and no valve seat.

Firing.

When using anthracite coal Professor Thurston's rule is correct—that the fire should be five times as thick as the average piece of coal. This applies to all sizes.

With a fire on a flat grate much thicker than the above there will be a tendency for the coal to melt and

Thickness of Fire—Clinkers.

form an excessive amount of clinker, and if much thinner, too much air will pass through.

Care should be used never to poke or molest a hard coal fire, except when cleaning, and then the fire should not be reduced too thin, even if all the clinkers are not removed, as when disturbed, and too thin, the fire will go out.

It is important that the fire should be kept of uniform thickness, and that this be done with the shovel, and never with hoe or poker.

After cleaning a fire and the first layer of coal is ignited, it is sometimes beneficial to run a thin slice bar along just on top of the grates, and return in the same manner, being careful not to disturb the body of the fire. This loosens up any clinker that may be forming, and keeps the air space open. This slice bar is shown in Fig. 1. The cross-piece can be 12 to 15 inches long and $1\frac{1}{2}$ to 2 inches wide. It should not be more than $\frac{3}{8}$ inch thick.

Clinkers that form on the brick are most easily removed after cleaning fires at night, when they are cooling off. They cool on the outside first and contract, which, in a measure, helps to pull them from the wall, and, being in a partially plastic condition at the wall at that time, they are separated with little injury to the wall. The hard case that is formed on the outside of the clinker makes them sufficiently rigid for a poker or breaking-up bar to get a good hold on them. The woman's method is to put oyster shells in the fire next the brick.

Should a slice bar be run under the fire just top of grates every time the fire is replenished, the fire will be kept fairly clean, so that but little cleaning is necessary

Tools for Cleaning Fires.

at night. This will make hot and warped grates, unless the ash pit is kept cool. This can be done with water in the ash pit or a small amount of steam. A small amount of steam will materially reduce the size and hardness of the clinker.

A hoe, shown below, is a favorite for cleaning fire. This hoe is round on top, and by turning this side down and shoving the coal off the ash, it will do it much neater, get the coal off quicker and with less ash in the coal than when using the straight side.

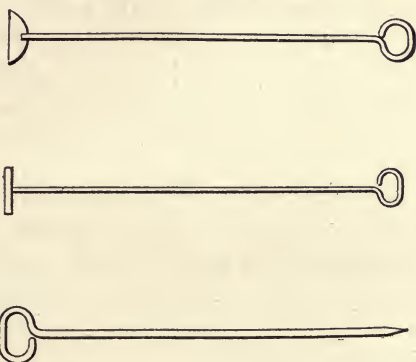

Fig. 1. Hoe (at top)—Slice Bar—Breaking up Bar.

The better plan is to have a bar made something like a boat oar, with the blade 15 inches long and 4 inches wide. Push all the coal from one side of the furnace to the other side, pull out the ashes, then push all the coal on to the clean grates, and when the ashes are removed the fire can be leveled off and have a perfectly clean fire.

The best plan is to have dumping grates with front and rear sections, push the fire back, dump the front part, pull the fire forward and dump the rear. This leaves a clean fire and is very quickly done.

Soft Coal and Smoke.

A "Lazy bar" made from a piece of $\frac{3}{4}$ -inch iron or of gas pipe and arranged to lie across the front of the door so as to support the weight of the hoe, makes the work much easier, both in cleaning the fire and hauling the ashes out of the ash-pit.

When it comes to burning the soft coal the problem is altogether different. These coals cake together and the air can only get through where there are breaks; there the fire burns rapidly and soon makes a large hole that allows too much air to pass through, which has a cooling effect. These coals contain a large amount of hydrocarbon gases that distill at a low temperature, and unless the firing is done so that they distill slowly, a large amount will pass up the chimney without imparting the heat to the boiler that would result from its proper combustion.

Improper firing, when the fires are run hot, results in the emission of a large amount of smoke. It requires but a small amount of carbon to color a large amount of gas; so that the smoke alone is not a great waste, but it indicates that there is a great amount of gas, unconsumed, going away with it.

During the Civil War, coal, like everything else, got very high. At one time and place coal was \$16 per ton delivered. At that time the buckwheat sizes were unknown, nut being the smallest size, and all smaller being thrown away.

One man procured a patent for a steam blower to burn yard screenings, which included everything below nut, fine dust and all.

The blower was made by making a circle of hoop iron, inside of which was a center with $\frac{3}{8}$ -inch pipes radiating therefrom. In these pipes 1-16-inch holes were

An Old Time Blower.

drilled. The steam part is shown in Fig. 2. The center supported a little fan blower, the blades being of the same number as the steam pipes and the steam jets blowing against these blades made a steam turbine and a fan all in one. It revolved with a high velocity, and screenings were burned very satisfactorily. Great stress was laid by the inventor on the high velocity of the fan.

Such a fan could not be durable, while the pipes would last for years, and when the fan went to pieces it was found that the blower consisting of steam jets did the business just the same.

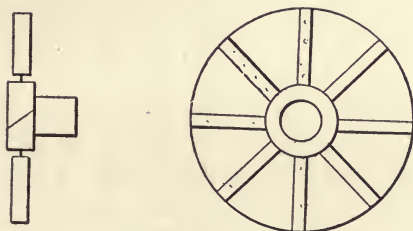

Fig. 2. An Old Steam Fan Blower.

Since that time there have been innumerable inventions of steam blowers for burning small anthracite, and, of course, all of them improvements like the "improvements" on George H. Corliss' engine.

They sell for all kinds of prices, depending a good deal on the talking ability of the maker.

A home-made affair is shown in Fig. 3. The pipes are $\frac{1}{2}$ inch, are set 3 inches apart and have 1-16-inch holes, 3 inches apart. The opening in the wall of the ash pit should be 3 inches wider than the blower on each side.

Home-made Blower.

As anthracite deadens rapidly when stirred, the cleaning should be done quickly, leveled off, the fresh coal put on and draft given as quickly as possible.

It is not possible to keep a fire with small sizes clean with a slice bar, as, if a fire is run so as to burn 12 to 15 pounds of coal per square foot of grate per hour, the clinkers will be too large to go through a grate opening of suitable size for such coal.

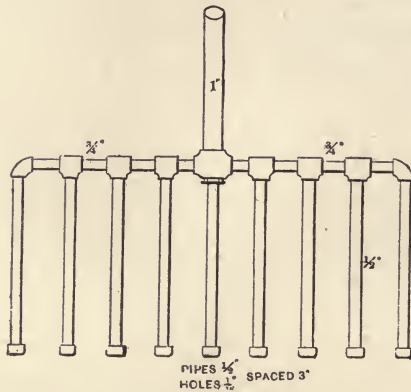

Fig. 3. A Home-made Blower.

Where only a flat grate is provided, one method is to push the coal back against the bridge wall, haul out the ashes in front, pull the coal down in front and pull the ash and clinker from the rear over the coal. This leaves some ash and clinker in the coal.

Various methods have been tried to prevent this waste, and many, also, to prevent smoke. It has been assumed by many that if the smoke was prevented the economy was sure. Among the early methods was that of admitting large quantities of air over the fire. This

Smoke Prevention—Pulverized Coal.

plan, carried so far as to completely prevent all smoke, will result in loss; although if properly applied, and the smoke reduced to a dull brown, there may be a good saving in fuel.

One plan described by C. W. Williams was the down draft system, which consists in taking in the air through the furnace doors and down through the fire, where the gases pass over a bed of incandescent fuel, chiefly from the fire that has fallen through the grates.

This style of firing cokes the green coal top of the fire and requires some slicing to let the air through, and also requires water grates as the fire must pass between the grates. A furnace of this type should be entirely outside of the boiler. Where the grate is under the boiler, the cold air rushing in at the furnace door cools the boiler at that point and sets up a strain.

A later form on somewhat the same principles is to feed the coal under the fire with a screw.

Another idea that has been tried, but not with much enthusiasm for boiler work, is to reduce the coal to fine powder and blow it into the furnace. On account of the power required to pulverize the coal it has not met with much success. To pulverize 1,000 pounds of coal per hour and blow it into the furnace would require about 15 horse-power.

In the cement industry powdered fuel is used almost exclusively. The kilns rotate so that a grate is inadmissible and the heat required is over 3,000 degrees. Pulverized fuel blown in is the ideal plan. Where the air is so thoroughly mixed with this finely pulverized fuel no more than the theoretical amount of air is required and the combustion can be carried on without a particle of smoke.

About Firing.

Anthracite coal cannot be used for this purpose, gas coal being the best of all the soft coals.

One of the best methods when firing by hand is the coking plan. The favorite plan is to have a plate at the front of the furnace, put the necessary quantity of fresh coal on to this plate; the gases will distill slowly and, in passing over the fire, will be consumed. When the coal has parted with the volatile gases it can be spread over the grates with a hoe and will produce very little smoke.

Where the fires are run thin with hand firing and the coal is spread thin all over the furnace, the gases are distilled too rapidly for the furnace, cooled by the addition to the fresh fuel to completely consume.

Keeping the fire somewhat thicker and "patching" the fire—that is, throwing the coal so as to fill up the holes—will result in the loss of a large amount of gas unconsumed.

Prevention of smoke has received a large amount of attention of late years because of the growing use of soft coal. One plan is to put in small steam jets over the fire; the valves to same opened when the door is opened by a suitable connection. Then, by another device, these valves are slowly closed automatically, the object being to be sure that the steam is turned on, and kept only when there is fresh coal put on and during the period of smoky fire.

The better method of firing the soft coal is to put the coal on heavy on one side of the furnace. Just before the other side needs replenishing use a breaking-up bar, as shown in Fig. 1. This bar is run along the top of the grates and the coke raised easily, so as to break it up as finely as possible, but not in such a man-

A Good Plan of Firing.

ner as to throw out great pieces and leave large holes. The bar should be of steel, 1 to 1½ inches diameter, according to the length of the furnace. It should be about 3 feet longer than the grate. It requires a little practice and patience to learn to do this easily, but if handled right, it is easily done and the fire kept even.

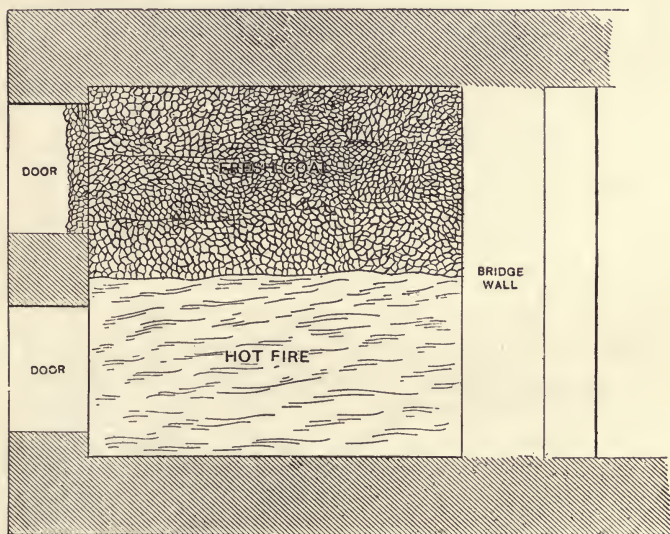

Fig. 4. Firing Soft Coal—Top View.

After the coke on one side has been broken, then cover the other side in the same manner.

For a furnace 7 feet square the coal would be put on one side, as shown in Fig. 4, nine shovelfuls with No. 6 scoop.

Firing in this manner, the smoke will be reduced to a minimum, but where there are city laws regarding

Mechanical Stokers.

smoke, recourse would be necessary to the steam jets on top of the fire. The smoke will come only from the part that is broken up, and not from the fresh coal.

Another important thing is: With coal spread even and light over a thin fire, the evaporation of water was 9.81 pounds for each pound of coal from 212 degrees of feed water to steam at atmospheric pressure.

With the coking fire, as indicated, the evaporation was 10.63 pounds.

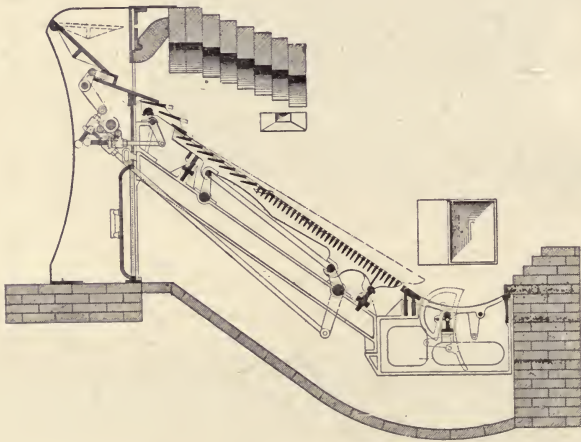

Fig. 5. Sectional View of Stoker.

An afternoon was spent in a boiler house having stokers like Fig. 5. Some of the boilers were being run above their rating, while two were running light, but not a particle of smoke came from the chimney. In furnaces where the fire was hot the fire was a white, incandescent flame.

Chemicals for Coal.

With this stoker there is an opening under the coal hopper, where a slice bar can be put down under the fire to break it up if necessary, sometimes an important item.

Occasionally a man will come along with a chemical, which he will dissolve in water and sprinkle over coal, and will show you the coal takes fire almost as readily as wood, and will give off more flame with hard coal than when the coal is used without it. He usually succeeds in selling large amounts for a snug sum.

A friend who thought of taking an agency for such a mixture wanted the writer to make a test. The test showed that more fuel was required with it than with the untreated coal.

A short time after this the company had a cargo of coal to use that had been sunk in salt water and raised again. It burned in the same manner as the chemically treated coal. Salt may not be the chemical used, but salt will do the same work.

This can be tried in the kitchen stove. When new coal is put on sprinkle on a little salt and note how quickly the coal becomes ignited and the nice flame.

Boiler Feeding.

In feeding boilers, care should be exercised to keep the water level uniform, for two reasons—first, so that the water shall come from the heater as hot as possible, and, second, if the water level is continually changing the weight in the boiler is changing with it, which subjects the boiler to different bending strains.

Should the water be found low after an absence for a time, and the pump has been running and supplying the

Feeding the Boiler.

usual amount of water, the water cannot be very low unless there is some leak of water from the boiler, or from some person opening a steam valve and drawing of large quantities of steam. If the latter, the condition of the fire will indicate it, if there be an automatic damper. If the damper be regulated by hand, the steam will be low. By covering the fire, either with fresh coal or ashes, all danger of further overheating will cease. The steam, however, will run down rapidly and load will be thrown off the engine, as speed cannot be maintained, so that it is not important that the engine should continue to run.

We have the following conditions: After the fire is covered the circulation in the boiler ceases and the water level is slightly lowered. There is a slight circulation, but in the same form as an ordinary kettle, if the engine continues to run; but the water level will lower gradually as it cools down.

Letting the pump continue to operate will, under the new conditions, slowly raise the water line if its speed be maintained. Should the pump slow down with the decreasing pressure the water will not rise until load is thrown off the engine; after that it will rise.

Opening the safety valve or any other valve will raise the water at first, but it will be very much lowered after the steam pressure is reduced.

Suppose there be 100 pounds steam pressure and the boiler contains 6,000 pounds of water, the temperature of water will be 341° , or a little over 341 heat units. If no water goes into the boiler, but steam is all blown down to atmospheric pressure, and 212° temperature of the water.

Six thousand pounds of water, with 341 heat units per pound, will be 2,046,000 heat units in the water.

Heat Units—Duplex Pumps.

Six thousand pounds of water, with 212 heat units per pound, will be 1,272,000 heat units in the water.

The difference between the two is 774,000 heat units, which has been given up in evaporating water that has gone off in form of steam, 966 H. U. being the amount per pound required to evaporate the water. $774,000 \div 966 = 800$ pounds, which is the amount of water that has been evaporated from 6,000 pounds of water at 100 pounds pressure in reducing the pressure to the atmosphere, or 13 per cent.

This is one of the points that examining boards make a strong point on, but they are not of the same idea. One board will want the engine and pump stopped and let all valves remain as they are. Another will want the engine and pump left running, while still another will want the engine and pump stopped and safety valve opened.

It should be remembered that the above refers to a single boiler. When there is a battery of boilers it is evident that the stop valve on the offending boiler must be closed, and then the only complication is as to the policy of opening the safety valve or not.

With a shell boiler there should be a fusible plug in the rear head. This plug should be filled with pure tin that melts at 440° . If this plug has not melted, it is evident that the water has not fallen low enough, or that the fire was not hot enough to do any harm.

Pumps for Boiler Feeding.

A duplex pump will produce less strain and shaking of pipes than a single pump.

It seems strange at this late day that there can be

Pumps that Pound.

found books and men that will claim that a power pump is a cheaper method of feeding a boiler than a steam pump, regardless of conditions. Where non-condensing engines are used it is true; but not with compound engines.

One place may be taken as a sample.

This place has a number of engines and boiler plants and the manager somewhere having read that power pumps are more economical has put in power pumps and taken the feed, either from hot wells with water at 110 degrees, and in some instances right from cold streams, and put the same through economizers.

A power pump is not flexible and runs at its maximum and the surplus must be pumped against the 150 to 170 pounds pressure and go to waste. The suction can be throttled, but will make a pounding pump.

It is only with non-condensing engines that power pumps are the cheaper to use as with a condensing plant the heater will usually condense all the exhaust from the pumps, etc., and all the heat from the steam is carried back to the boilers, while if the pumps are driven from the main engine or from motor, the latent heat of steam producing the power goes out with the condensing water.

In the place mentioned they were running small engines driving dynamos, the engines using not less than 5 pounds of coal per horse-power, then driving the power pump by motor and half the water pumped up to 150 pounds pressure going to waste, and then pumping cold water to the economizer, which delivered it to the boilers at less than 180 degrees.

In two cases the pumps were driven by belts from the main engine, the steam from the condenser pumps

Scale Removing Solvents.

going out to heat up the river.

Had they used steam pumps and put the exhaust from the boiler feed and condenser through a heater, then through the economizer, they could have delivered the water to boilers at 300 degrees. With the water going to the economizer cold, or nearly so, the tubes sweat and the soot cakes on to the tubes, breaking the scrapers and rendering the economizer but of little value.

Scale in Boilers.

Where water contains lime, some agent should be employed to neutralize it, which can be done with a carbonate of lime. Kerosene will sometimes do this very nicely, and is a handy dissolvent, because it can feed constantly in the same manner as cylinder oil. Sal-soda is a good neutralizer, but when carbonate and sulphate both are present there is need of a strong astringent. This is found in tannic acid. Tannin can be procured in "japonica" that comes from Japan, or from "cutch," which is acacia catechu, and comes from the East Indies. Gambier is another form, and comes from Africa.

To make this preparation ready for use, take 50 pounds of sal-soda and 30 pounds of japonica, or cutch; put in any old barrel that will hold about 50 ballons; fill half full of water and boil until dissolved, then fill in water.

If a water tube boiler is badly scaled, put in a gallon of the mixture for each 100 horse-power for three or four days, at which time most of the scale should be removed, when the quantity can be reduced until the right amount is ascertained.

With a shell boiler more care is necessary, as it throws down the scale very fast, so that the preparation

Electrical Boiler Cleaner.

should not be put in until two or three days before cleaning, otherwise enough scale might accumulate over the fire sheets to burn them.

These preparations when made up and sold under fancy names, are sold for about 60 cents per gallon, which makes kerosene a cheap substitute.

The sal-soda should be procured for less than 2 cents per pound, and the crude catch or japonica for not to exceed 6 cents, so that it will cost less than 10 cents per gallon.

There are a number of makers of scale resolvents that will analyze the water and mix chemicals accurately to do the required work.

Boiler Cleaning.

In about 1865 there was an electric arrangement invented to charge the metal with an electric current, as shown in Fig. 6.

This consisted of a number of copper points radiating from a common center and from ten to twelve inches in diameter. This was placed inside and near the top of the boiler about four feet from the front end, the points nearly touching the shell. From the center a wire was led to an insulated plug about the same distance from rear of boiler and thence out to a battery. The boiler by this means was kept charged with an electric current and was free from scale. Sometimes little particles would be found as thick as paper, but these were rare.

This instrument was attached to a boiler for \$80, and because people thought the price exorbitant very few were applied. All the neighbors paid as much per year for scale solvents.

Potatoes as a Boiler Cleaner.

The feed and blow-off in this boiler was through a 1½-inch pipe in the front head, a connection common in those days; there was no hand hole in the rear head, and from all that could be seen the boiler was perfectly clean. After a time a hand hole was cut in the rear head and about two bushels of dirt was found banked up against it. A bottom blow-off remedied all this.

Some years afterward the engineer had occasion to want something that would keep the scale from forming in boilers and wrote to his former employers for the

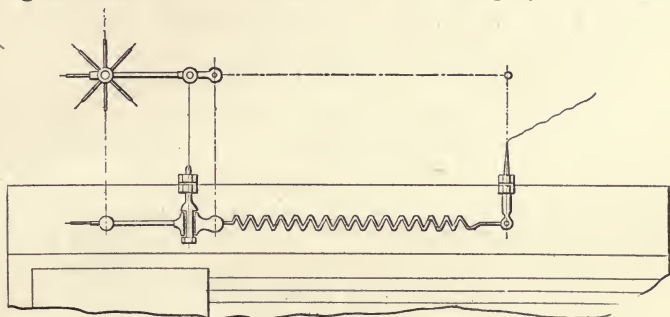

Fig. 6. Electric Boiler Cleaner. 1865.

name of the maker, asking also if it continued to do good work. He received a reply that the battery got out of order and it had been disconnected, and that a half bushel of potatoes put in the boiler each week would do for compounds.

For the neutralizing of the scale-forming elements in the water there have been numberless compounds prepared, but most good ones have been expensive. Kerosene oil has been used as much as any one thing, fed in the same way as cylinder oil in a steam cylinder, and in many cases has given excellent results.

Utilizing Waste Heat.

Probably the most extensively used and at the same time the cheapest is the carbonate of soda. This acts on carbonate of lime, rendering it soluble in water and in a state where it will not bake. The carbonic acid taken up by the alkaline carbonate is liberated again by heat and the soda is in its original state and ready to act again as before, which accounts for the necessity of using such a small quantity. A receptacle should be made for it and after dissolving it should be fed continuously. From one to two pounds per 100 horse-power boiler per day will do the work in fair shape. Soda ash will require more; caustic soda less.

When it comes to feeding water with clay and lime, and in some cases saline matter, there are but two ways; a surface condenser or an efficient filter. Where surface condensers are used, vertical engines are desirable, and sometimes necessary, as will be mentioned later under the subject of cylinder oils.

Special Boiler Setting.

Figure 7 represents a tubular boiler set to utilize waste heat from a steel furnace. The cut shows the original setting. There was a 9-inch space under the boiler and the waste gases could go through the tubes and under the shell. They preferred to go under the shell, and made but little steam.

The boilers were then let down on to the brick and the space under the boiler entirely closed, thus causing all the gases to go through the tubes. This raised the steaming capacity over 30 per cent., but still there was not sufficient steam made from the waste heat for the work required. A battery of boilers were put in to be fired by hand, gases going under the boiler and through

Cooling Boilers for Cleaning.

the tubes in the usual manner, and then over the top to chimney. As there was a good draft and egg coal was burned, these boilers would make a great deal more steam than those with the waste heat, and there were those in authority who thought that was the only way to set a boiler, and that if the first boilers were set that way, the boilers requiring coal could be shut down. So these boilers were raised to their original positions; arranged so the gases would go under, then through the

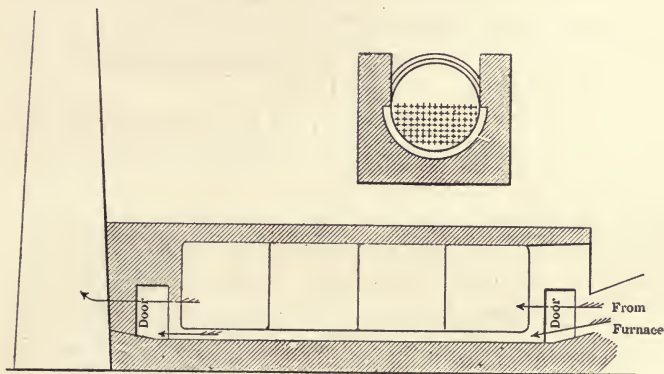

Fig. 7. Boilers Set to Utilize Waste Heat.

tubes, then over the top, and they did not do as well as in the first design and were finally taken out and abandoned.

These boilers were among one engineer's first experience, and it was here he got an insight into cooling off boilers for cleaning. He was assistant here and worked under orders.

It will be noticed that there is a door at each end of the boiler. Saturday nights both of these doors were opened, as well as all the doors on the furnace. It was

Leaky Tubes from Over Heating.

his duty Sunday forenoon to draw the water out of the boilers and refill them with fresh water. After a few months the tubes on the end of the boiler towards the fire commenced to leak. A peck of horse manure was put in each boiler every week, which for a time kept the leak down, but finally a boilermaker had to be called, who reported that the fire ends of the boilers had been burned. As the boilers had had the best of care, and water had never been low, and as a good quality of water had been used and frequently changed, this was a surprise and could hardly be believed. The fact remained, however, that that end of the boilers had been overheated sufficiently to cause the tubes to leak.

He studied over the problem, and to his mind the cause was plain. It has been mentioned that the two doors shown were both opened. This, in effect, was nearly the same as leaving them both closed, as the door at base of chimney was as large as the area of chimney, and would supply all the air the chimney could take, so that none entered the other door, and the result was hot brickwork and a hot boiler when the water was changed. He remembered this, and in his practice when he was in charge of boilers, always left ash and fire doors opened, as well as the damper, and no other doors that could interfere with the draft through the boiler, and never had a leaky tube sheet or shell from any strains set up in changing water. The boiler was always cool enough so that the deposit would not bake on, the brickwork was cool so that the boiler was not overheated, and plenty of water could be used for washing without cooling portions of the boiler suddenly.

As an illustration of the opposite policy which obtains in many places, he was sent to a place to attempt to



Cooling off Boilers.

reduce their coal bills. He saw that the fires were banked in such a manner that steam was blowing through the safety valves continually during the times the boilers were idle, with the result that the valves were leaking badly.

He recommended new safety valves, a condenser and two or three other minor changes, and put them in. The boilers were 5x16 tubulars in a small electric station.

In the afternoon he told the regular engineer that he wished to put on the safety valves the next day, and when he shut down at midnight to have his fire out and leave dampers and firedoors opened, so that steam would be down.

In the morning he found firedoors and dampers closed and front flue door open, and steam up to nearly running pressure. Opening the flue door had stopped any possible entrance of air. It was three hours before any work could be done, and as some of the pipings had to be changed, it made a lively day's work.

When the regular engineer came around after dinner he was asked why he had not carried out instructions about having the boiler cool. He replied he was told he must not allow any cold air to strike the tubes in rear end of boiler, as it would surely cause them to leak; that the inspector had instructed him, and he had been very careful not to let any cold air under the boilers. Being asked for his procedure when changing water; he left everything closed, pumped in cold water and let it out until he got it cooled down so the steam was gone, then let out the water and pumped the boiler up. Asked if he realized the strains set up when letting out the water from the boiler surrounded by hot brickwork and filling the same, his reply was always the same—he could

Leaks in a Cool Boiler.

not let cold air under the boiler, as it would cause the tubes to leak; he had been told so by the inspector, and he did not want his tubes to leak.

By this time the boiler was cooled down, as well as the brick. A cool boiler will show leaks when it will not when heated, and the seam in head commenced to leak over the firedoor. It was pointed out to him that the leak was caused by the boiler being enclosed in hot fire brick while the water was let out; that the boiler in contact with the brick got excessively hot, and that the cold water put in had strained this joint so that it leaked; that his tubes and seams in the shell would go the same way in a short time; that if he opened his doors and damper he would not get cold air on his tubes for a long time, as the air passing through the hot furnace would be hot when it got to the rear end, and that everything had to cool down together. Any explanation had no effect. When the engineer got everything together it was Saturday evening, and that evening being the heaviest load, he started up with one boiler, much to the regular engineer's concern, as it had been hard work for two boilers to carry the Saturday evening load. The one boiler carried the load easily.

The engineer heard no more from this job for two years, when he was again sent there to put in a new boiler.

The regular engineer's care to allow no cold air to reach the rear end of the boiler had resulted in leaks in all the seams, patches over the fire, leaky tubes in the rear end, which had been rerolled until used up so that one boiler had to be taken out and one 5½x16 put in its place. The engineer learned that shortly after leaving the first time the two boilers were deemed necessary and

Another Waste Gas Boiler.

finally blowers had to be put in. On account of the manner of cleaning, here were two boilers less than four years old with every tube and seam strained apart and finally condemned, and still they had not let go and killed anyone. He has found a number of instances where the practice is to leave furnace doors and dampers closed and the attempt made to clean boilers in that condition, and the result was always the same, although the complete destruction is sometimes longer delayed. To clean a boiler thoroughly the boiler must be cool, and the desposit must be soft. To prevent strains on the boilers the change of temperature must be gradual, but when cold water is put on hot plates, or tubes, leaks will occur soon.

Incidents.

Figure 8 is a type of boiler that was put in a flue taking waste gases from crucible casting furnaces. There were three rows of bottle shaped projections, 6 inches in diameter and 2 feet long. The necks were 3 inches in diameter and were screwed into a bottom shell. There were partitions through the center, and one-half of the neck with this partition extended into the boiler about 3 inches higher than the other half, which was level. This was to insure circulation. This type worked very nicely and was easily cleaned.

The arrangement shown in Fig. 7, being in a steel mill, provision against frost was not first class. There was a man whose duty it was to fire up the furnaces and get them hot enough Monday mornings to commence work on time, and also to watch the boilers. One morning he made haste to wake the engineer up about 4 o'clock with the cheerful news that there was 160 pounds of steam on the boiler intended to carry but 90, and that

Imagination and Leaky Joints.

the steam was coming out of every joint. He hurried to the scene and found all the joints all right, as well as the safety valves, but there was 160 pounds indicated by the gauge. An investigation revealed the fact that the gauge pipe was frozen, and the expansion had extended to the spring. Imagination had seen all the joints leaking.

In another place he was aroused by the watchman

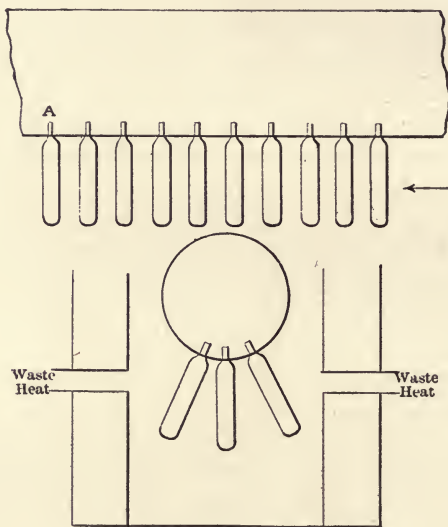

Fig. 8. A Boiler to Use Waste Heat.

with a request to come right down to the boiler room, as one of the boilers showed 165 pounds. He explained to the excited man that it was all right, that the boilers were connected and the gauge showing 80 pounds was correct, while that showing 165 had a leak in the spring, allowing enough steam to enter to expand the spring by heat. No explanation would satisfy, and he was obliged

Points About Gage Glasses.

to go down and make sure that it was all right. Gauges that are in very hot or very cool places may sometimes show a little out because of the extreme temperatures.

Sometimes a gauge under high pressure will vibrate excessively, even when the cock is closed all that is possible, and still have the gauge indicate. In such cases put a quarter-inch globe valve about four feet from the gauge, and that and the cock will check the vibrations, as so much will be taken up by the enclosed water between the two that energy on the gauge is gone. To keep glass gauges, gauge cocks and all places where there are slight leaks, and where salts from the water leave a deposit, put on ordinary machine oil, or wipe them over occasionally with a greasy waste.

At one place the engineer was awakened by his fireman and told that something was the matter with one of the boilers. This was one of the early types of water-tube boilers, the end of every tube and header being a ground ball joint, with the idea that expansion could take place without strains and without leaks. There were two or three leaky joints, but looking into the furnace revealed the fact that all of the tubes that could be seen were at a bright red heat.

The fireman had changed the water Sunday and left the water at a proper level. The blow-off valve was a 2-inch globe. A piece of clinker had in some way got into the hollow on the bottom, and the guide stem had reached it, so that the valve had leaked sufficiently to let nearly all the water out. The fireman, knowing he had left the water all right, had not examined it in the morning before firing up.

Sometimes a man will try his gauges and take it for granted that the small amount of water issuing there-

Taking Water From Stream.

from comes from the boiler instead of lying in the gage. In one case a fireman reported to his engineer that a boiler being heated by waste heat was not taking any water. This boiler, which was an upright water tubular, had a pipe extending from top to bottom, in which was the gauge column with a valve at the bottom of the pipe. This boiler was in a secluded place, where workmen used to get to do their heavy loafing, and some of them had closed the valve at the bottom of the water column and the gauges showed water all right. The boiler was burned up.

The boiler, with the clinker in the blow-off, had the leaky joints reground and was in use for some time afterwards. It was arranged with tile placed in the tubes so that the gases passed to rear end, then along a portion of the tubes to the front end and under the drums to the chimney.

It was finally abandoned, because "it could not be cleaned." It was impossible to get the ashes out of the tubes on top of the tile partition, and when it was finally taken, thirty cartloads were taken from those places.

Strainers.

Wherever water is taken from a stream for use for power purposes, such as pumps, condensers, etc., there should be a good system of strainers. Where possible or practicable to use them, a pair of strainers, like Fig. 9, is easily controlled. The frame should be made from $3 \times 1\frac{1}{2}$ inch finished material, and brass rods put through, as shown. These help to stiffen the frame, but their principal use is to keep the screen in shape, as the pressure of the water against a partially clogged strainer

Plan of Strainers.

would soon ruin it were it not supported. Over this should be fastened the copper wire netting.

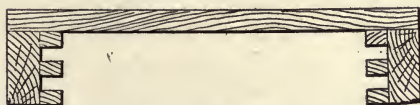
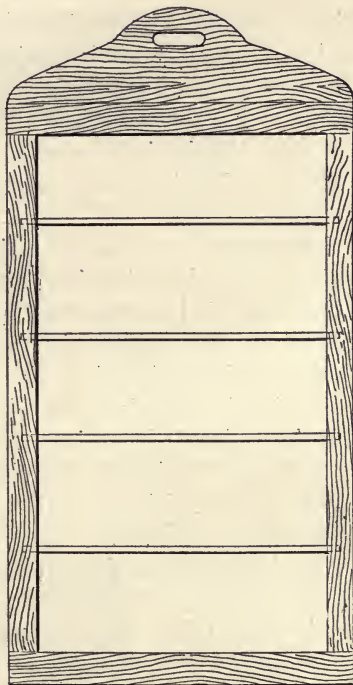

Fig. 9. Strainer Frame and Rack.

A cheaper strainer is made by punching a sheet of copper. These holes may be punched with machinery.

Double Strainers.

The strainer should extend over the framework $1\frac{1}{4}$ - $1\frac{1}{2}$ inches, and be securely fastened. Then there should be a cleat put over that and the nails driven through the frame and clinched. At the top should be a top board with a hole sufficiently large to admit getting hold of it with the two hands for drawing it out.

There should be two of these, as shown by the section below. Fig 9. This should be anchored in such a manner that it will keep its shape and be made tight at the sides and bottom.

The strainers should be used one at a time. When the strainer in use becomes foul the clean one should be put in and the foul one taken out and cleaned. To do this easily it should be thoroughly dried, as the slime from most waters, together with the other accumulations, makes a paste that is difficult to remove when wet. To do good work there should be at least ten times the area through the holes of the pipe or conduit it supplies. Small strainers stop up too quickly.

If deemed necessary, a solid gate can be made of the same dimensions as the frame of the strainer and used as a gate to shut off the water when occasion requires.

Where water is to be taken from a running stream and it is necessary to build a little dam, the proper method is that shown in cross-section in Fig. 10 and plan in Fig. 11. If possible, arrange to have the strainer put in in the bend of the stream. If this cannot be done, build the dam the highest at the side of the stream opposite from the strainer, so as to throw the larger part of the water over the strainer. Excavate a place in front of the dam and build a heavy bottom of concrete, the top of it being about two diameters of the pipe lower than the bed of the stream below the dam. Concrete the side of

Dam and Strainer.

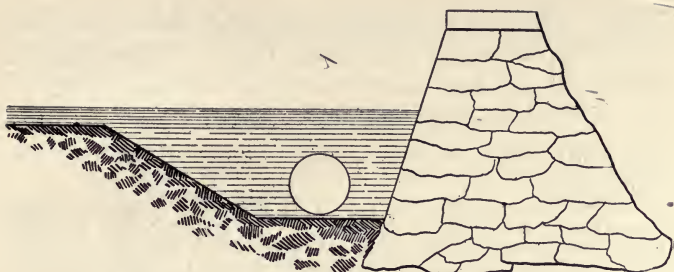

Fig. 10. Dam for taking Water from Running Stream.

the stream for a space from the dam to 20 feet below the strainer to prevent washing of the bank. The strainer should be put across the flow of water, as shown. This should be made from sheet copper with punched

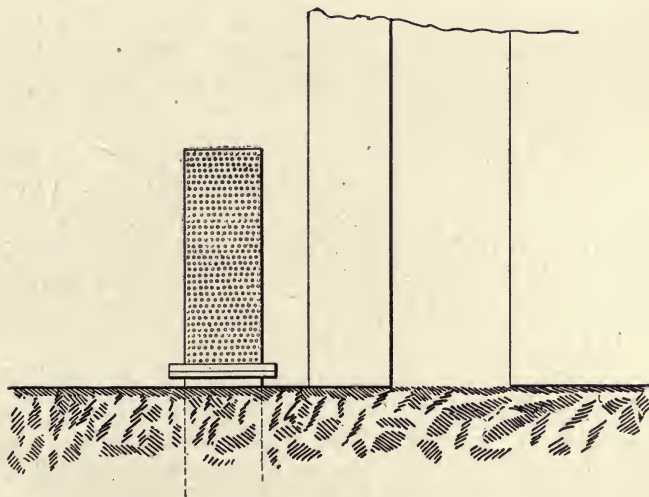

Fig. 11. Plan or Top View of Dam and Strainer.

Water From Dirty Streams.

holes. The water flowing over the dam passes the strainer so strongly and rapidly that it washes away all debris of every kind and the strainer is always clean.

A strainer put in as shown above has been in use ten years, and has never been foul nor required any attention.

When a strainer is put in where the water is sluggish, the drain through the strainer will attract all floating material, and when drawn to the strainer there is nothing to carry it away, and soon there is trouble. When a strainer is put into an eddy, unless the movement of the water is very rapid, the same clogging process goes on.

There are places where the only available water supply will be from a small stream carrying a large amount of debris of various kinds and the stream will be sluggish and the only way will be to excavate a place to put in a suction pipe and strainer. Here everything will move towards the strainer and it soon becomes foul and requires attention.

If it is impracticable to make strainers after the plan in Fig. 9, there are double strainers and foot valves made to meet this emergency. This arrangement consists of a foot valve and strainer. Over the strainer is put a sliding strainer, which can be lifted and cleaned. When it slides back to place it scrapes off such material as has accumulated on the inside strainer.

There are conditions when none of the methods named could be of use, such as taking water from an iron penstock, or through a pipe from a canal on the side used for the tow-path. In such cases there should be used two boxes with a strainer in each. These strainers are put in the pipe line at some convenient place of

Material for Boilers.

access. It is necessary to place a valve each side of each strainer box, so that the strainer can be removed and cleaned.

Strength of Boilers.

There are many experiences to be found in the boiler-room. We will take for example a tubular boiler, as this is the simplest form, and many points about a tubular boiler apply to all.

The first thing is the material from which it is made. Of late years steel is the general material. Where the plates are in contact with the fire, firebox steel should be used, and flange steel can be used for the heads. The firebox steel should not contain enough to exceed .04 of 1 per cent, of either phosphorus or sulphur.

Phosphorus makes the steel cold short, and sulphur hot short. Carbon adds tensile strength, but the higher the tensile strength the lower will be the ductility. In some cases it has been the practice among the workmen, when they found a sheet was not coming up to the tensile strength, to spray water over it when hot. This will be detected in the ductility later, if the physical test is made by a disinterested party, and for this reason it sometimes pays to have a firm that makes a specialty of tests make an inspection of the material, both physically and chemically.

A plate having a tensile strength of 65,000 pounds per square inch will make a strong shell, and is not sufficiently high to interfere materially with its ductility.

It is not possible, however, to get all plates just alike in tensile strength, so that plates should be not less than 58,000 nor more than 65,000 pounds tensile strength. They should stand the test of being bent cold around a rod equalling their own thickness, without cracking, and

Rules for Strength of Boilers.

should stand the same test after heating and plunging into cold water.

After this test there should be no laminations, blisters nor other mechanical defects. Each plate should be plainly stamped with the maker's name, and with its thickness, quality and tensile strength in a place that can be plainly seen after the boiler is erected.

Boilers should have the longitudinal seams made with butt joints, with double covering strips and triple riveted. After steel came into use it was discovered that the lapped double riveted joint was unsafe. This joint had a way of causing the plate to crack just under the lap on the inside of the boiler, where it was impossible to discover it before it showed itself by leaking or letting go.

A well-designed single-riveted seam has 54 per cent. of the strength of the solid plate, a double-riveted seam 70 per cent., and a butt strap 87 per cent. Sometimes specifications for drums in a water tube boiler call for the roundabout seams to be double riveted. The party sending out the specifications insisted that, for the pressure they wanted to carry, it was absolutely necessary. The drums were 3 feet in diameter, and the metal 9-16 of an inch thick.

Take the well-known rule for the longitudinal strength of a cylinder:

$$\frac{\text{Thickness} \times \text{tensile strength}}{\text{radius in inches.}}$$

$$\text{we have } \frac{9}{16} \times 60000 \\ \frac{\quad}{18} = 1875$$

Boiler Calculations.

and with butt strap joint of 87 per cent. 1631 pounds bursting pressure.

We now take the roundabout joint:

$$\frac{\text{tensile strength} \times \text{thickness} \times \text{circumference}}{\text{area of head}} = \text{bursting pressure}$$

or

$$\frac{9}{16} \times 60000 \times 113$$

$$1018 = 3746 \text{ lbs.}$$

and taking 54 per cent. for a single-riveted seam, we have a bursting pressure of 2,022 pounds, or 400 pounds greater capacity than the longitudinal seam. If we take 70 per cent. for the double-riveted roundabout seam, we will have 2,622 pounds or 1,000 lbs. greater. There will never be a longitudinal joint made that will need a double-riveted roundabout joint.

Allowing a factor of safety of 5 for the longitudinal joint, we have a safe load of 344 pounds, and allowing a factor of safety of 6 for the roundabout seam we have 347 pounds as the safe load.

Tubular boilers require stays above the tubes. First find the area to be braced. Two inches above the tubes and 3 inches around the shell need not be taken into account.

The distance between stays should be square root of

$$\frac{6,900}{\text{working pressure} \times \text{diameter of bolts}}$$

Instead of 6,900 use of 5,530 for salt water and 5,000 for copper bolts.

Tubes should be of wrought iron. Steel tubes

Too Many Tubes.

require annealing, are too stiff, and will leak sooner than iron. Tubes give a cheap heating surface, and in order to get a boiler of large capacity it is the practice of some builders to put in all the tubes possible, so as to make the horse-power large. For this purpose they put in tubes away above the center of the boiler, reducing the area of the surface of the water for disengaging the steam, and a pulsating boiler is the result. The tubes are simply an economizer and are not as important as some other things.

When the temperature in the furnace is 2,200 degrees the shell will absorb the heat, so that when it enters the flues it is down to 1,000 degrees, and not over one-half of that can be absorbed by the tubes with modern high pressure.

Should an excessive number be put in, the hot gases will only go through a portion of them. Tubes which are too small break up the gases so much that the draft is restricted, and they become easily choked with soot.

Boiler Settings and Fittings.

Water issuing easily from the open end of a vertical pipe will assume the form shown in Fig. 12.

When entering a pipe, water or gas will assume the same form, shown in Fig. 13, so that the volume would be represented by the small cross-section, rather than by the area of the tube.

In putting in large pipes in water powers the pipe can be enlarged at the intake for what is termed the "entry head," and the pipe filled. This cannot be done with the ends of tubes in boilers. Could it be, the velocity through the tubes would be greater and the deposit of soot less.

Feed Pipes—Circulation.

Tubes should be put in so as to obstruct the circulation of water within the boiler as little as possible. A free and full circulation of water counts for capacity and economy and is more important than a few extra tubes.

Care should be taken that the tubes are of full thickness of metal, also that the material for the shell is the specified thickness at the thinnest part.

The feed pipe should discharge at the coolest part



Fig. 12.



Fig. 13.

Shapes of Water or Gas Entering or Leaving Tubes.

of the boiler, which will be that portion the farthest from the fire.

One reason for this is that the circulation is the least disturbed. The boiler will deliver up the most heat from the fire when water is flowing fast over it, so a rapid circulation means more rapid taking up of heat and easier steaming.

Where water is admitted directly over the fire in a

Boiler Settings.

sheet boiler, it means leaks at the joint at head of boiler and at the first joint near the bridge wall. The correct plan is to put the feed at front head, top of tubes and to one side of boiler. Carry it to the rear of boiler, then across to opposite side and down between shell and tubes.

The blow-off pipe should extend down to the floor

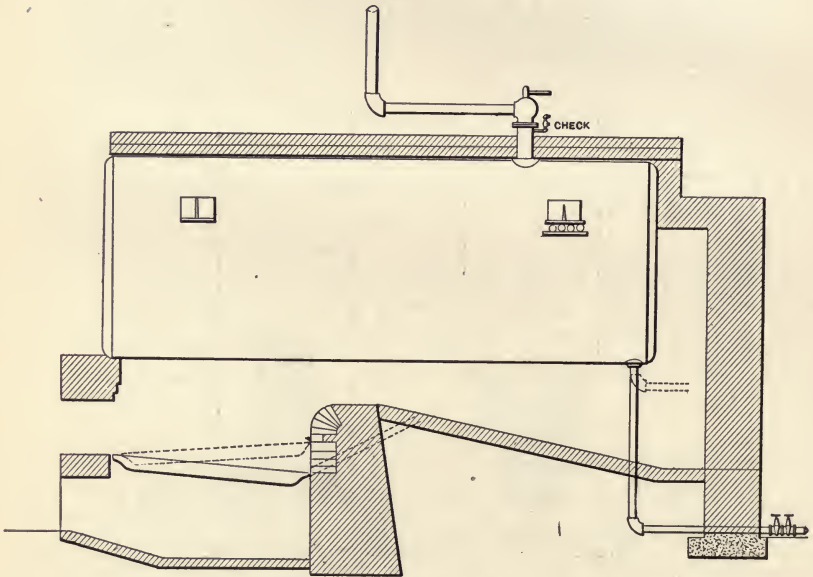

Fig. 14. Best Location of Blow-off pipe and valves.

level, as shown in Fig. 14. It should be extra heavy iron pipe and a casing of larger pipe put around it. Should the water get to boiling, it can circulate in this vertical pipe, which it would not do with the horizontal pipe shown by dotted lines.

The blow-off valve for high pressures has given a

About Safety Valves.

great deal of trouble. Put on two valves, both extra heavy solid disk gate valves with outside screw.

When using, the valve nearest the boiler is opened first and then the other. When closing, the outside is closed first. This brings all the wear on the outside valve, as the inside is always balanced and moves freely. If preferred, an asbestos packed cock can be used for the outside valve.

Lever safety valves have about gone out of date. They or single-seat spring valves should never be used alone, but there should always be a double seat or "pop" safety valve. The latter, with a rise in pressure of 3 or 4 pounds, will open wide, and no further rise is possible; while with the two first the pressure may rise 20 to 40 pounds before the valve will relieve it. For years to come, in some cases, lever valves will be used.

"Pops" are set before leaving the factory. They can be changed by tightening or loosening the spring,—one side of the hex nut for five pounds, but if this is changed very much the ring at the bottom of the valve wants changing to preserve the sensitiveness of opening and closing. All boilers should have two safety valves.

The rules for area of safety valves are: For "pop" valve allow 1 square inch area of valve for each 3 square feet of grate. For lever valves allow 1 square inch for each 2 square feet of grate; or, multiply the weight of water evaporation per hour by .005; the result is area of valve disc in square inches.

The water gage fittings should all be of a heavy pattern, and the glass gage $\frac{3}{4}$ inch. The water glass gage should have automatic valves in the event of the glass breaking, or else levers on the valve stems, with chains so that the gage can be shut off. In case the

Side Walls.

glass breaks and none of these are at hand, always shut off the water, or bottom, valve first. By doing this and using care one need not get burned. If steam is shut off first, look out.

When building a bridge wall, put the fire-brick face as shown in Fig. 14.

When the brick on the face are laid up square, the tools used in cleaning the fire will gradually knock off the

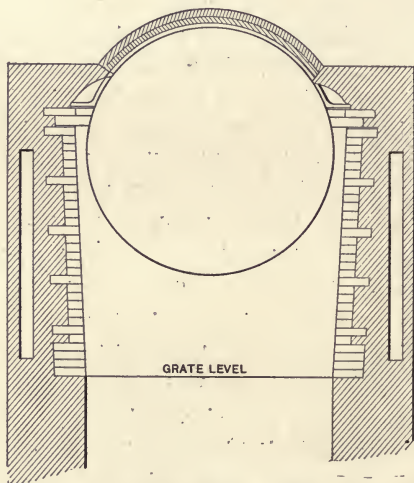

Fig. 15. How Side Walls Should Be Built.

top course, and after a time the whole bridge wall disintegrates. Putting in bricks as shown locks the top brick effectually and makes a durable wall.

When building the side walls the same course should be taken in putting in the fire-brick at the furnace as shown at the bottom of the bridge wall. This makes

Fire Brick Arch.

repairs quickly and cheaply done. This is shown in Fig. 14. These are headers above the clinker line, then a stretcher for binding, then all headers, but the top bricks are wedged so as to have the top ones embedded.

This form of construction accomplishes two things: The bricks at the bottom burn out, and they can be taken out up to the stretcher, which will fall out, leaving the remainder of the wall intact. The bottom brick and stretcher can be replaced without the necessity of taking down the whole face.

Where air space is left, it should be 3 or 4 inches next to the outer course of brick.

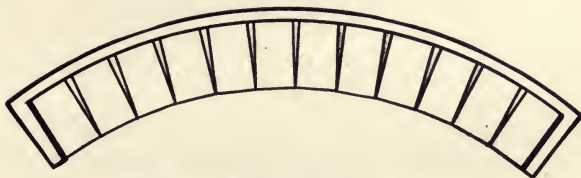

Fig. 16. Making a Fire Brick Arch.

The walls should be sloped away from the boiler as shown, leaving a space not less than 3 inches from the shell until the wall closes in to the boiler.

Fig. 16 is a design for making an arch with fire brick.

It consists of an iron form, as shown by the heavy line which can be either of wrought iron bent into proper shape for any length or radius of arch desired, or it may be of cast iron.

The brick are built into it tight and the structure is set into place.

It can be used over doors or at rear of boilers.

As the metal is protected by the brick, the arch will last until the brick are burned out, if no mortar is put between them; that is, if the brick are laid solid.

Furnace Plates.

For a plate over the furnace the style shown in Fig. 17 is the best, if cast iron is used. This was designed by the Hartford Steam Boiler Inspection & Insurance Company.

With this form the iron next the fire can expand until the spaces are entirely closed, and the plate will still keep its shape. The casting can be made in the form of a box, so as to take in the sides and top of the door; but it should all be serrated, as shown, on the side towards the fire.

Shell boilers are usually supported by two lugs on each side. The rear lug should rest on rollers. It would

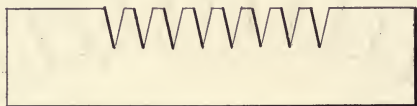

Fig. 17. Best Cast Iron Plate for Over Furnace

be a better plan to put up columns and channel bars and hang the boilers from these, after the manner in which tube boilers are supported, so as to have them entirely free from the brickwork. This would make the boilers more expensive, and as one reason for putting in this type of boiler is the low first cost, this form of support is rarely attempted.

Fig 14 shows a pipe leading from the safety valve for a distance and then turned up. This is unsafe unless there be a firm support under the ell. Wherever there is an open end just beyond an ell, the ell should be well supported. Pipes like this will break open the valve case when blowing off. One man had one ear partially torn off

Floor Plates.

at one time with a $\frac{3}{4}$ -inch drain pipe put up in a similar manner.

There should also be a drain at the ell. The better plan is not to put any pipe from the safety valve, but let it blow directly into the boiler-room. If this is done, one can always see just what the valve is doing.

At one place where the pipe from the safety valve led out of doors in a horizontal direction, the valve leaked,

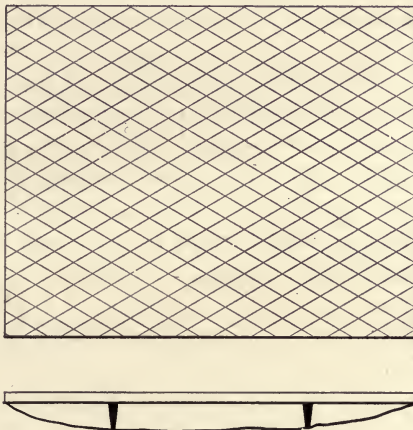

Fig. 18. Floor Plates.

and one cold Saturday night the pipe filled with ice. The fires were banked, but during Sunday night the boiler got to making steam, and while the safety valve did its duty the steam could not get away, and an explosion was the result.

For a floor for boiler-house put in Portland cement concrete. Where no teaming is to be done on it, 4 inches will be sufficiently thick. Where teams bring in the coal it should be 6 inches. There should be a drain at the

Draining of Floors.

corner of each boiler, leading down into an underground drain.

The floor should slope in all directions to this drain. When this is done all water flows away quickly and the floor can be washed at any time. There should be a 1-inch water pipe of cold water brought to the boiler-house, if the pumps are in another place, and plenty of $\frac{3}{4}$ -inch hose on hand for wetting ashes and washing the floor.

In front of the boilers the floor should be of iron, as this will not wear out with the shovel and will stand hot ashes.

Front of boiler put down a floor of iron plates like Fig. 18. These plates are $\frac{3}{4}$ inch thick, diamond tread on top and ribbed on the bottom. They are 24x30 inches, and can be laid in two rows, so as to make the iron floor 4 or 5 feet wide, as desired. They are laid in soft cement, and should be hammered down to place, when they will stand all sorts of hard usage.

Boiler Explosions.



Boilers explode in all cases from lack of strength to sustain the pressure.

In some cases a sound boiler explodes from more pressure than it was designed to hold.

Boilers become weakened from many causes.

Pitting is one cause.

In some cases the water is of such nature that scale is formed, and underneath the scale there will be pitting that can be discovered only by the removal of the scale. It may be caused by insufficient circulation.

In a tubular boiler the circulation rises over the fire, passes along the top of the rear; then descends and flows along the bottom, when the boiler is properly set and worked.

Should such a boiler be run for any considerable portion of the time at one-quarter its duty, the circulation would stop before it reached the rear and descend, leaving the rear of the boiler without circulation, and the stagnant warm water at the rear would cause pitting.

Sometimes acids in the water will cause it.

One of the worse things is ammonia from sewage in the water.

The writer had a case of this kind, and succeeded in stopping the pitting until a better water supply was secured, by painting the sheets with red lead and boiled linseed oil.

External corrosion will be caused by water or dampness getting on the outside of the shell. One of the

Destructive Explosions.

surest things to cause this is water dropping from a leaky valve stem or flange joint.

Internal grooving occurs along the inside of the joint and can be caused by the bending strain set up by constantly changing temperatures, caused by shutting off and turning on the feed frequently, or firing unevenly, at times having a very hot fire, then leaving it to burn out until it is full of holes.

When these strains are set up and resisted by the stiff seam it opens the surface of the metal at that point and makes it easy for impure water to attack that point.

Unequal expansion will weaken iron so that it will let go easily. This is caused by sudden changes in temperature by incidents named in the preceding paragraph, by the practice of many in cooling off a hot boiler by filling it full of cold water several times while the brickwork is hot; by regulating the steam pressure by opening and closing the furnace doors; by feeding the boiler over the hottest part, thus bringing great strains on the boiler at that point and checking the circulation throughout the entire boiler.

Boiler explosions are destructive, because of the expansive force of steam. A boiler well filled with water will be the most destructive, because, as the rupture occurs and the steam expands and the pressure is reduced, the heat in the water liberates a large amount of steam instantly. This can be observed when blowing water out at the blow-off or at the water gauge. It will be noticed how largely the stream of water expands and that a large portion of it appears to be steam.

At 150 pounds pressure a cubic foot of steam will weigh .885 of a pound and the temperature will be 366, the heat units 1224.

Facts About Steam.

A cubic foot of water at the same temperature will weigh $55\frac{1}{4}$ pounds, and the heat units contained will be $366 \times 55\frac{1}{4} = 20220$, a large portion of which is ready to become steam at a sudden lowering of the temperature.

Sensible heat is that portion that can be measured by a thermometer.

From 32° to boiling the thermometer will register the heat added to water, and this heat is termed sensible.

After the water reaches the boiling point the temperature is not raised, but the heat is absorbed in evaporating the water. This cannot be measured by a thermometer and is called latent heat, or the heat of vaporization. The amount of this heat is determined by the heat that can be imparted to other bodies when the steam is condensed and changed to water at 212° .

The total heat is the sum of the sensible and latent heat.

The temperature of the steam and water will depend upon the pressure.

At the pressure of the atmosphere the sensible heat will be 212° , the latent 996° and total 1178° . The weight of a cubic foot will be .038.

At 100 pounds pressure the sensible heat will be 338° , the latent 875 and the total 1223. As the pressure rises, the total rises slowly, the sensible rapidly, while the latent decreases.

The properties of steam are its sensible, latent and total heat, volume and pressure. These are all given in steam tables. Most steam tables are given from 32° and 15 pounds pressure, and when so given to the steam pressure must be added 15 pounds, or rather at 50 pounds, look forward to 65 pounds, and also add 32°

Too Light Pipe.

to the total heat. Thus, if the total heat in steam table is given as 1190, by adding 32° to it gives 1222.

Water is heaviest at 39.1° . As the temperature is raised above this, the water expands and grows lighter.

Because of this property, when it becomes steam its expansion is so great it moves the manufacture and commerce of the world.

All matter other than water continues to contract as it grows colder. Unlike everything else, water contracts and grows dense as the temperature decreases until it gets to 39.1° , when it begins to expand, so that when it gets to 32° and ice forms the ice is lighter than the warmer water and floats on top. Were it not for this, when ice formed it would be at the bottom, turning the streams into glaciers, destroying all life therein, shutting off all water supply and making the northern and southern portions of the world a desert.

Piping.

In the matter of piping, an important item is the pipe itself. It should be of iron, as steel pipe ruins dies and the threads are inferior. The pipe should be of full standard thickness. The outside must be of standard diameter to insure good threads, and if the pipe is thin, the thread will go through on one side. If the outside of the pipe is not full size, the thread will not be full and a tight joint impossible.

At one place a company decided that it was large enough to have a purchasing agent, and this agent bought some pipe at a greater discount than the company had been getting. The engineer showed the pipe to the secretary, pointing out to him that it was deficient both in weight and thickness, but the secretary, after a talk with

About the Weld.

the dealer, decided that the pipe was stamped with the name of a maker who had a national reputation and that it was all right. The company paid for it in repairs later.

Soon after this the engineer was at the works where the pipe was made, and he asked them how they came to put their name on thin pipe. The reply was that very few bought full-weight pipe and very little was made; that it came about in this way: A contractor would bid low on a job and would buy his pipe by weight; a dealer would try to give a bigger discount than another dealer, and he would order his pipe by weight; a concern would get a new purchasing agent, who would try to make a better showing, and he would buy of the dealer giving the best discounts; so that everything was working together to reduce the weight, and of course the thickness, of pipe.

Another important thing is the weld. Pipe up to and including $1\frac{1}{4}$ -inch is butt welded, and $1\frac{1}{2}$ -inch and above is lap welded. The weld should be such that it will not give out when it is necessary to cut long threads, neither should it crush under pipe tongs. There are brands of pipe that will stand neither of these tests.

Another important thing is the threading of pipe and fittings. When threading fittings, it is absolutely necessary, in turning out good work, that the taps be standard thread and taper; that there be a stop, so that the tap will go a certain distance and no farther, so that all shall be tapped to a uniform depth. When the pipe is threaded, equal care should be taken.

Many accidents have occurred because the taper was not right, or the thread was not long enough, and the pipe has pulled out. Cases are not rare where a 4-inch pipe has been put in with less than five threads. In some cases

Pipe Threads.

the taper is too great or the die has been run over it two or three times, reducing the end of the thread, and though the pipe may be screwed in the full length of thread, it actually holds only by the imperfect threads at the bottom, and all others are soon corroded.

The short and imperfect thread on pipes is usually
Standard Pipe and Pipe Threads.

STANDARD
 PIPE
 AND
 PIPE
 THREADS.

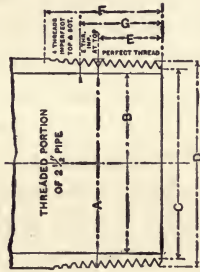

- A = outside diameter of perfect thread.
 B = inside diameter of pipe.
 C = root diameter of thread at end of pipe.
 D = outside diameter of thread at end of pipe.
 E = length of perfect thread.
 I = total length of thread.
 G = length of perfect thread plus two threads.

BRIGGS' FORMULA.

$$E = \text{perfect thread} = (4.8 + 0.8 A) P.$$

$$P = \text{pitch of thread} = \frac{1}{N}$$

N = number of threads.

F = length of taper at top.

Taper $\frac{3}{4}$ " to one foot.

$$\text{Height of thread} = 8 \frac{1}{N}$$

G = length of taper at bottom.

Standard Pipe Tables.

made when piping is cut where the work is put up and the men have hand machines. The dies are usually dull, and the men stop as soon as they have a thread long enough to screw up and make a tight joint.

The thread and taper for pipes that have been generally adopted are known as the "Briggs standard."

Size.	Thread.	A	B	C	D	E	F	G
$\frac{1}{8}$	27	.405	.270	.334	.393	.19	.41	.264
$\frac{1}{4}$	18	.540	.364	.433	.522	.29	.62	.402
$\frac{3}{8}$	18	.675	.494	.567	.656	.30	.63	.408
$\frac{1}{2}$	14	.840	.623	.702	.816	.39	.82	.534
$\frac{3}{4}$	14	1.050	.824	.911	1.025	.40	.83	.546
1	11 $\frac{1}{2}$	1.315	1.048	1.144	1.283	.51	1.03	.683
1 $\frac{1}{2}$	11 $\frac{1}{2}$	1.660	1.380	1.488	1.627	.54	1.06	.707
1 $\frac{3}{4}$	11 $\frac{1}{2}$	1.900	1.611	1.727	1.866	.55	1.07	.724
2	11 $\frac{1}{2}$	2.375	2.067	2.200	2.339	.58	1.10	.757
2 $\frac{1}{2}$	8	2.875	2.468	2.618	2.818	.89	1.64	1.138
3	8	3.500	3.067	3.243	3.443	.95	1.70	1.200
3 $\frac{1}{2}$	8	4.000	3.548	3.738	3.938	1.00	1.75	1.250
4	8	4.500	4.026	4.233	4.443	1.05	1.80	1.300
4 $\frac{1}{2}$	8	5.000	4.508	4.733	4.933	1.10	1.85	1.350
5	8	5.663	5.045	5.289	5.489	1.16	1.91	1.406
6	8	6.625	6.065	6.347	6.547	1.26	2.01	1.513
7	8	7.625	7.023	7.340	7.540	1.36	2.11	1.612
8	8	8.625	7.981	8.332	8.532	1.46	2.21	1.712
9	8	9.625	8.937	9.324	9.524	1.56	2.31	1.812
10	8	10.750	10.019	10.445	10.645	1.675	2.425	1.925
11	8	12.000	11.224	11.694	11.894	1.80	2.55	2.050
12	8	13.000	12.180	12.685	12.885	1.90	2.65	2.150

The threads have an angle of 60 degrees, but are rounded off slightly at top and bottom, so that the depth of the thread is only four-fifths as great as it would be if the threads were sharp. The outside surface of the pipe is tapered to a certain distance from the end, the standard taper being such that the surface inclines towards the axis of the pipe by 1 in 32. This makes the total taper, as measured by the variations in outside diameter, equal to 1 in 16, or $\frac{3}{4}$ inch to the foot. The total length of the tapered part is given in the table.

High Pressure Piping.

For some reason it has become the custom to list pipe above 12 inches inside diameter as O. D., or outside diameter. At the present writing there is a movement on foot to list 10-inch pipe and above as O. D.

Fig. 19 shows a section of 5-inch pipe reproduced from *The Locomotive*. The taper is slightly exaggerated for greater clearness. Two threads, it will be seen, are perfect at the bottom but flat on top, and four are imperfect at both top and bottom.

Standard weight pipe will withstand any steam pressure that will ever be put upon it if the weld is good and the threads perfect.

For hydraulic work up to 1,000 to 1,200 pounds pressure, use ordinary pipe and fittings up to $\frac{3}{4}$ inch.

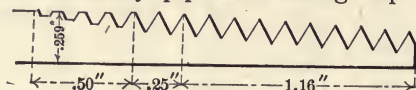

Fig. 19. Section of Threaded Pipe.

Above that, extra heavy is safer. For those high pressures, cast-iron fittings are unsafe and brass should be used.

For high pressures, it is better to use flanges rather than couplings, or sockets, as the end of the pipe in a flange can be expanded or peened in. This should be the case in all work 5 inches and over. The standard flanges for heavy work are safe for pressures up to 130 pounds, but for larger work the flanges should be steel castings, or, what is still better, drop-forged steel. Ordinary cast iron is too weak and even iron in which there is sufficient charcoal iron or steel to bring the tensile strength up to 26,000 to 28,000 pounds is liable to crack.

For cold water at high pressures the tongue and

Flanged Joints.

groove joint, where the tongue fits the groove accurately, with a thin rubber gasket at the bottom makes the best joint. If the tongue does not fit the groove this joint is but little better than an ordinary faced joint.

For steam, the use of rubber for packing is inadmissible. For large work and high pressures, the making up of large pipe mains requires close and accurate mechanical work. It is a machinist's job throughout. The flanges require to be fitted as closely as engine work, and after the pipe is put in the flanges and expanded, the ends

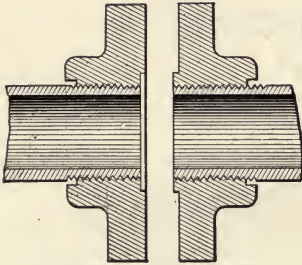

Fig. 20. Rabbetted Joint.

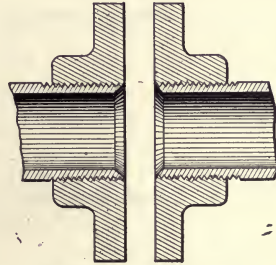

Fig. 21. Peened Joint.

still must be faced off. A rabbetted joint is shown in Fig. 20, in which a corrugated copper gasket painted with black lead is used. This copper gasket packs the flange joint and also the end of the thread on the pipe. If accurately done, this makes a tight and durable joint, but is very expensive.

Another joint is shown in Fig. 21, but this joint is not trimmed after peening. The end of the pipe is peened in the form of a round corner down on to the thread. Where a pipe does not pulsate it will make a good joint, but should there be pulsations so as to strain the thread and

Joints Without Threads.

get it loose, it will eventually leak, and it is a bad joint to tighten once it leaks at the thread.

Riveted joints on piping are apt to leak. Some jobs of this kind are put up where the joints are all tight, so it is claimed. The engineer never saw one of these jobs.

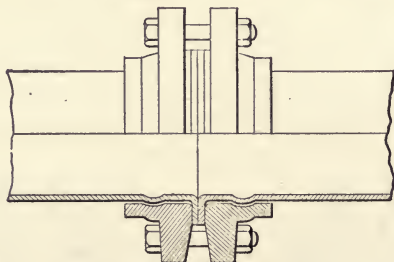

Fig. 22.
Van Stone
Pipe Joint.

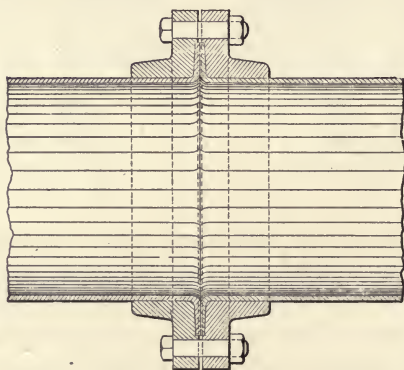

Fig. 23.
Mitchell
Pipe Joint.

All that he had seen, that had rivetted joints, leaked more or less. Of course they can be caulked, but his observations led him to think that caulkng a leaky joint that was pulsating was not a thing to look forward to with pleasure.

Fig. 22 is the Van Stone joint, made by the Walworth

Expansion and Leaks.

Company. This has no thread and cannot leak between pipe and flange. Fig. 5 is a joint made by W. K. Mitchell & Co. This cannot leak along the pipe. Both of these joints need to be faced, and the flanges can be turned on the pipe. In ordinary flange joints the gasket should never be extended outside the bolts.

All drillings should be made in multiples of 4, and then flanges can be turned. When a job is being put up, all bolt circles and all drilling should be alike for the same size of pipe.

Taking Care of Expansion.

I find a paper which states that for taking care of expansion in steam pipes, expansion joints and corrugated copper have gone out of date and that the proper way is to arrange to have a screwed joint acting something like a swivel joint in a gas bracket; except that in this case the pipe swings back and forth where the pipe is screwed into an ell or the flange of an ell.

All engineers know the result when a fitting is screwed up too far and then has to be backed off. We give the fitting another turn and use care next time not to go too far.

Whenever a pipe is put up and the expansion really works the thread back and forth, there will be a leak in a short time. The reason there are not more leaks is because there is spring enough in the pipes so that there is no back and forth movement on the thread.

Expansion joints should be avoided wherever possible, as there is danger of their being misused in several ways. They may be packed with something that sticks

A Big Piping Job.

them; the gland may be screwed up sideways with the same effect; they may not be set up in line with proper guides, and they may not be properly anchored.

An expansion joint has the pressure on the area of the pipe in which it is placed as well as the thrust on the pipe from the steam turning the corner.

There can be no shaking of pipes with expansion joints, as, from necessity, the pipes must be anchored solid.

The ideal way to take care of expansion is to have the branch pipes long enough to have sufficient spring and put in long curves.

A job of piping was put up to carry 160 pounds of steam. The main pipe was 16 inches internal diameter, and to supply steam to the engines there were two 12-inch pipes taken off at right angles to the 16-inch pipe, in which was an expansion joint.

Before the pipe was put up the engineer designing the work was replaced by others who simply bent a piece of flat iron at right angles, put a strut across and bolted it to a rough stone wall with $\frac{7}{8}$ -inch bolts to take the thrust of the end of the pipe.

One thing was inevitable; the pipe let go.

Then came along a pipe man who suggested putting in the thread twisting scheme shown in the cut of the expansion piece. Fig. 23a, page 66.

His idea was that the pipe would twist on the threads at each of the joints. From sheer good luck the pipe did not twist on the threads and set them to leaking, but twisted on the flanges.

Of course, a thing like this cannot be anchored until you get to the point *A*, and the shaking of the pipe together with the expansion soon had the packing worn out in

Don't Use Copper Ells.

the joint that worked the easiest. There was a big leak requiring a shutdown to put in a new gasket.

In a short time a flange on this joint cracked and had to be bound. This joint was finally made sufficiently tight so that the movement was transferred to another one, which was soon in the same condition.

This arrangement was leaking so often and caused so many shutdowns that it was finally taken out, the expansion joint put back in the main pipe, and the end of the pipe securely anchored.

It will be noticed that among the fittings in this hitch up there are nine companion flanges.

It was in use about a year and a half and when taken down there were five of these nine companion flanges broken.

Copper ells for expansion have a way of bursting, and copper is not a safe metal to use for this purpose.

As globe valves were formerly made, it was a nice job to regrind them when leaks occurred.

After a time very ingenious machines were made that would do accurate work. Attempts were made to get valve disks that had a medium soft composition, from a species of hard rubber to babbit metal. These are liable to give out under high pressure. Valves are now made with brass seats and disks, and both removable, so that repairs can be quickly made. These should not be put in with white lead. Some makers put their seats and bonnets together with white lead. The engineer that takes these apart will find a nice job as it will be necessary to get a torch and heat the outside before they can be taken apart. He will then be glad to put them together with black lead.

Valve Openings.

Globe valves should always be used where it is necessary to open and close quickly, or where it is necessary to regulate nicely, like throttle valves, injection valves to condensers, feed valves to boilers, etc. There is not so much loss in pressure through a globe valve as is generally claimed, especially when used for steam.

The difference in an indicator diagram between a globe valve opened one turn and full open is hardly appreciable.

A globe valve should be put in so that the pressure should come on bottom for two reasons: First, if the pressure were on top the current of steam through or past the valve will keep it vibrating and soon pull it off the stem. Second, the valve disk when pressure is on top will be held on its seat until all lost motion is taken up, which will require about a turn of the wheel before the valve moves, thus rendering it useless for close regulation, and it will be no better in this respect than a gate valve.

The throttle valves on straight-line engines are made with one-half of the valve a solid disk and the other half, or moving part, swings around on to it when the valve is open, so that one-half of the diameter is always closed. With this valve there is no wire drawing across the seat.

Professor Sweet told the writer a story of an engineer who wrote him that he had found the trouble with his engine; the valve was never half open, and he had taken it off and put on a valve that could be opened full. Professor Sweet wrote him that if he would take a diagram from his engine with the new valve, then replace the valve he had taken off and take another diagram, should there be any appreciable difference between the two, he (Professor Sweet) would pay for the new valve.

Draining of Pipes.

The engineer admitted there was no difference.

For exhaust and water, gate valves should be used, except as noted above, as these are not as lively as high-pressure steam.

The first gate valves that came out had disks made in two parts with a wedge in between. These wedges have a way of wearing in such a manner that they stick in closing. When this occurs with boiler blow-off valves it causes cold chills.

The introduction of the solid disk saved all concern about the valve closing easily and these have had the largest sale. With the low pressure carried at the time of their introduction it was customary to put in rings of babbitt but it was soon evident that this metal was not durable under heat due to 100 pounds of steam. Babbitt seats have disappeared above a pressure of 70 pounds.

When high pressures of 150 pounds and superheat began to be used it was learned that even brass seats and disks would not stand the temperature and the valves with seats and disks are all made of iron.

The old line of check valves with spindle or wings for guide and vertical lift that, when they had become somewhat worn would stick and require several hard blows with a club before they would seat, have largely gone out of use and been replaced with the swinging check.

Sometimes a man, when connecting a steam pipe to an engine, will incline the pipe towards the boilers as it seems that the proper place for the water is in the boilers and the drain from the pipe should go there. He will learn that the drain will not flow back against a current of steam. He will also learn that when the load is light and the current of steam slow and apparently largely

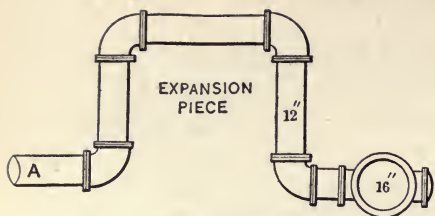
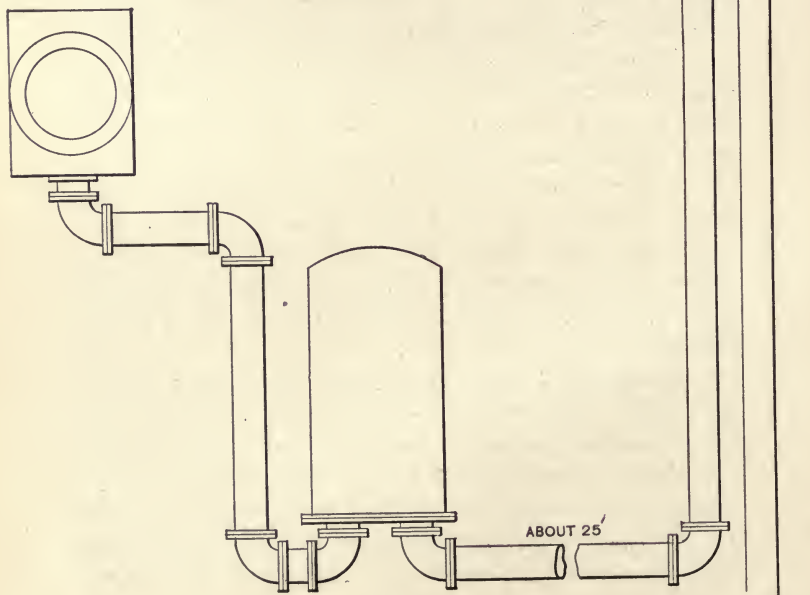

Fig. 23a.

Fig. 24. Action in Pipes of Syphon Condenser.



Water in Steam Pipes.

along the top of the pipe, the water will loaf along the pipe, fill up all pockets, etc., and when a heavy pull comes on the engine it will all come over in body and that it is better to slope towards the engine so as to drain all the time and avoid any accumulation.

There was an excellent opportunity to observe the action of water in pipes by the use of a syphon condenser set up as shown in Fig. 24. The engine had a 28x60-inch cylinder and the exhaust was 8 inches. The engine was doing rolling-mill work and at times was only carrying friction load. When the load was first thrown off the vacuum would go from 23 to 26 or 27 inches. The vacuum would gradually drop back during the light load to 22 inches, when, if there was no increase in the load, there could be heard a rush of water in the pipe and the vacuum would go up to 26 inches again.

The case was diagnosed in this way: When the load was thrown off, the volume of steam in the exhaust was small and the water condensed in the heater, etc., having such a long distance to travel would collect along the bottom of the pipe. As it collected, it would lessen the area of the pipe, thus partially choking the steam passage, causing a drop in the vacuum. The vacuum in the condenser would remain the same, and when the difference in pressure in the condenser and that on top of the water became great enough, or the pipe became choked sufficiently so as to start a wave motion, the water would be forced out of the horizontal pipe, up the vertical and through the condenser without trouble. During a case of high water this pipe and a portion of the heater were under water and ran without trouble.

This condenser would at times get too full and would run water over into the exhaust pipe, but if it was only a

A Better Plan.

small amount and the pump was stopped, the water would go out all right. Twice during its use the pipe was flooded when no one was near the pump, water hammer was set up and the horizontal pipe burst, but in no case did any water get back through the vertical part of the heater. After this had been used for a short time, there was so much trouble with it that it seemed the better plan to change to the one shown in Fig. 25. The exhaust here entered at the top of the heater and passed out at the bottom before it entered the vertical pipe. The passage out of this heater to vertical pipe was so short that there was no chance for an accumulation of water and there was never any trouble of loss of vacuum from this cause. One day, when the engine was stopped and drip open, the engineer noticed a stream of water running from the drip, and investigation showed that a hole had become worn in the coil and water was going from heater coil into the exhaust. The coil was taken out and a double coil put in, consisting of a 2-inch and

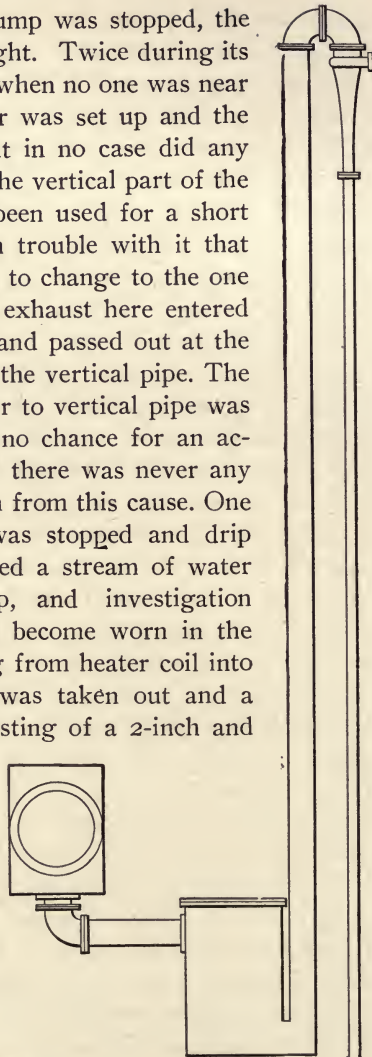

Fig. 25. A Better Plan.

Heaters and Condensing Engines.

1½-inch pipe. These pipes were screwed into headers and one day both pipes pulled out. Feeding these pipes was a pump with a 10-inch water cylinder controlled by a pressure regulator that would keep the pressure up to 100 pounds. This forced water enough into the exhaust to condense all the steam so that there was no pressure to carry it away, and some got into the steam cylinder, though not enough to break anything. Since that time

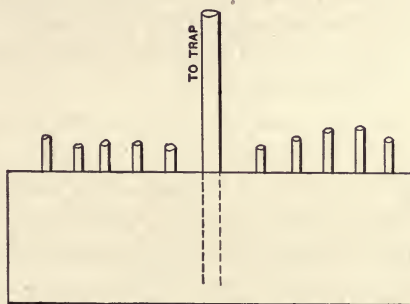

Fig. 26. Pratt and Cady Receiver.

this engineer has never put a heater in the exhaust pipe of a condensing engine. The difference in temperature between the hot well and the vacuum, or the temperature in the exhaust, will not amount to a saving of 2 per cent., which, in many cases, would not pay for the investment, and when the risk is taken into account, he has thought best not to assume it.

When draining, it is necessary in many cases to have

Heating Liquids.

a place that will collect the water in such a manner that steam cannot get by without forcing the water ahead of it. The principle on which this is accomplished is shown in a Pratt & Cady receiver for their old style return traps, something like Fig. 26. Into this receiver the water comes through the various drain pipes. On these pipes should be check valves to prevent any interference one with another.

From this receiver the water passes out through the central pipe. This pipe extends nearly to the bottom of the receiver, and it is evident that no steam can get out until the water has been forced out below the end of this pipe. With such a system, the drip can be forced as high as the pressure will raise water.

When heating liquids in vessels where steam cannot come in contact with the contents, coils are used. If at the end of the coil an ell looking up is used, it will not be possible to get the condensed water out of the pipes and have them do their full work, without forcing a sufficient current through to drive all the water in the pipes ahead of it. This means big coal bills. Immersed coils can be successfully drained by putting a tee at the end of the coil, as shown in Fig. 27, with a very short nipple and cap on one end, a bushing and smaller sized pipe with long thread at the other end. The small pipe reaching into the tee should go below the bottom of the pipe, coming into the side of the tee so as to drain the coil clear to the bottom. The coil should be put in the vessel so that there is a continual incline toward this tee. It will drain thoroughly and a trap can be used.

Another form made with ells is shown in Fig. 28. These pockets, to be effectual, must be short.

Main Steam Pipes.

One method of putting up a main steam pipe is shown in Figs. 29 and 30. This is a good system where there are a number of small engines, and for such a purpose it really requires no separator, for it is itself one form of separator.

Where a main pipe is put up like Fig. 31, the drain from the main pipe can be taken direct into the boiler by the 1½-inch pipe, as shown. In this pipe there should be a stop and swinging check valve and the pipe should

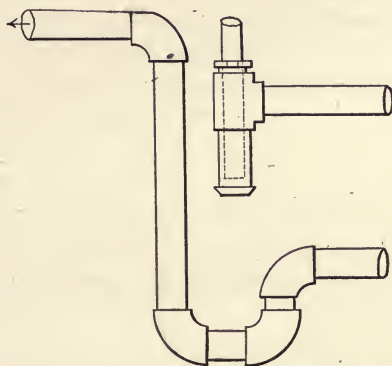

Fig. 27 and 28. Methods of Piping.

enter the boiler below the water line. The pipe from the boiler to the main pipe should never enter the main at the bottom, as when the stop valve is closed it makes a pocket for water. In some cases an extra stop valve is put next to the boiler as an extra precaution. When this is done there should be a ½-inch drip valve just above this valve to drain any water that may collect from leakage through the top valve, and the bottom valve should be opened first. The stop valve at main pipe should never

Main Steam Pipes.

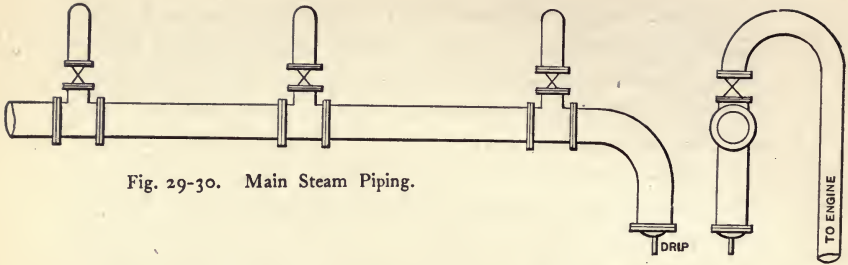

Fig. 29-30. Main Steam Piping.

be omitted. Another method is to put the main pipe at the proper level so that the connecting pipe from the boiler may lie level. This has to be done where there is not sufficient height for the other plan. Fig. 32 is a top view. This is equally as good a plan, but the main pipe may not be high enough to drain back into the boiler. It is claimed that 7 feet elevation above the water is necessary for this, although good work has been done with an elevation of 4 feet.

In large electric stations it is good practice to put in

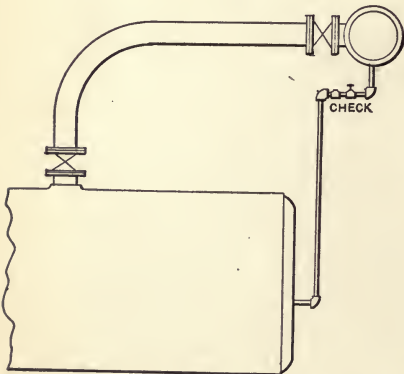

Fig. 31. Another Way.

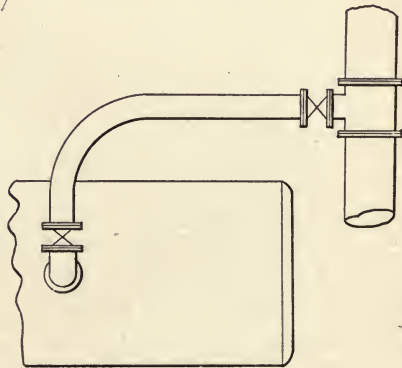

Fig. 32. Top View.

Main Steam Pipes.

two steam pipes and two water pipes. Where this is done and there are two lines of boilers it is usual to run the main lines through the center of the boiler-room. This necessitates the crossing of one of the main lines with a pipe from each boiler. These cross-over pipes should not go under the main pipes, as this forms a pocket on top of the stop valve when closed. The cross-over pipe should go over the main pipe, as shown in Fig. 33.

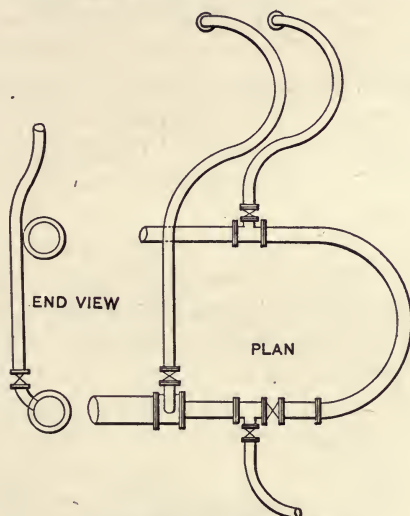

Fig. 33. Plan for Crossing Pipes.

Where the pipes are not too long, the expansion can be taken care of with generous curves in the pipe. Pipes 300 feet long or more require very circuitous routes. When curves like Fig. 34 are put in, they should be laid horizontally to prevent the trapping of water. Curves of this kind should never be put in with fittings or flanges, as they would be leaking in a short time.

Curved Pipes and Slip Joints.

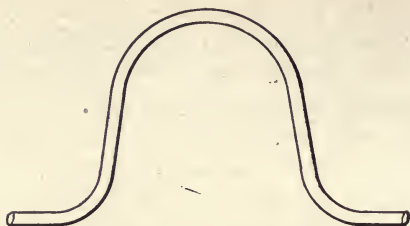

Fig. 34. Curve that might Trap Water.

I

Wrought iron expands $\frac{\text{I}}{150,000}$ of an inch for each degree change in temperature. To determine the expansion of a pipe: $\frac{\text{degrees change} \times \text{length in inches}}{150,000} =$ expansion.

A pipe 300 feet long or 3,600 inches under a steam pressure of 150 pounds becomes, if we take 70 degrees as the temperature of the pipe before steam is admitted, $\frac{3,600 \times 293}{150,000} = 7$ inches expansion.

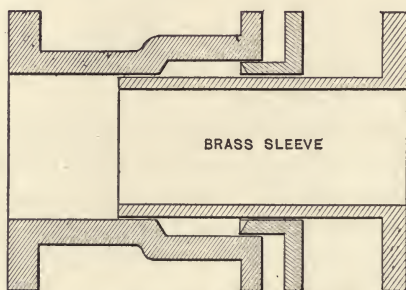

Fig. 35. A Slip Joint.

Water Hammer.

Slip joints are made like Fig. 35. They should be accurately guided, as the sleeve should work as true as a piston rod, and unless guided properly the gland can clamp the sleeve sufficiently tight to prevent it sliding.

The pipe should be rigidly secured at each end, in the first place, to hold the pipe from pulling apart from pressure, and also to slide the joint in when the pipe expands, and, in the second place, to prevent vibration and to pull the joint out when contracting.

Large pipes should never be anchored to buildings, as the vibrations will loosen the brickwork in time. The pressure against the end, or a turn in the pipe, is the area of the pipe multiplied by the pressure per unit of area, and in addition is the momentum of the moving body of steam.

Water hammer in a pipe can occur only where there is a dead end or an abrupt change in direction. It is supposed to be caused by the water condensed in the cold pipe being driven ahead by the steam, then a vacuum being formed and the steam and water rushing together, only to have the water driven forward again. The velocity of steam rushing into a vacuum and there meeting a body of water gives the water a heavy impetus, and should the water meet an obstruction, it receives a blow that will shatter anything of ordinary strength.

Should water hammer occur when steam is turned into a cold pipe, and should there be a valve of ample size that can be opened instantly, the pipe can be saved; if not, there can nothing be done if the steam has traveled any distance so that there is a large volume. Shutting off steam from its source still leaves steam in the pipe, and until the steam is all condensed, the hammer will be maintained until something gives way.

About Traps.

An important item about a piping plant is a trap. A trap is a trap, and it is unfortunate that it is impossible to get along without them.

For large systems, and where live steam is used for heating, some of the return systems are on the side of economy. Where heating factories of more than one story and where the buildings are not too far apart, the engineer was successful in returning the water from the pipes directly by gravity without any trap.

Where the work is not very important and the amount of condensation is not large, an expansion trap of good design will do the work all right.

The important thing about traps for main steam pipes and separators in the same is that the trap shall be quick and sure to operate, not liable to derangement; that it shall have a large opening that can take care of a flood of water should a flood come, and that it shall not close until all the water is gotten rid of.

A trap having a small opening is liable to become plugged. At one place one of these plugged-up with a small piece of packing, not much larger than the lead in a lead pencil, and a smash-up was the result.

At one mill a bell and spigott suction pipe was put in, and the pipe being 10-inch diameter and 200 feet long. This pipe was laid by skilled men and extra precautions were taken in pouring and caulking the lead, and the gravel was thoroughly tamped under it. It leaked badly when the pumps were put to work. It takes but little expansion to draw a pipe with a lead joint sufficient to leak enough air to make trouble in a suction line or in gas mains. For water pipes under pressure, the small leaks are readily absorbed by the ground. Flange pipe with thin rubber gasket inside the bolts will give less

Suction for Pumps.

trouble and can be made absolutely tight with care.

When connecting a number of pumps to one suction pipe, some pumps may have more "pull" than others, and the latter may not be able to get any water. The safer plan is to put in check valves in all the branch pipes, as shown in Fig. 36. Should there be a small pump in connection with large ones, put the connection to this at the bottom of main pipe, or put the end of suction through the top and let it project into the main pipe nearly to the bottom. The large pumps can better take care of the small accumulation of air than the small one.

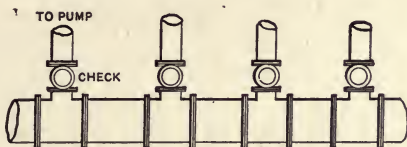

Fig. 36. Check Valves in Branch Pipes.

Drip Pipes for Cylinders.

Drips were laid out for a tandem compound engine having piston valves. The directions were to lead the drips from the steam pipe and the drip from the receiver in separate pipes out of doors, the drip from the receiver to have a check valve and trap. The drips from each cylinder were to be connected with check valve in each end and carried separately to the condenser. The engineer did not see them put up, but after a short time he heard complaints about the large amount of water that came over in the steam pipe and that it took an hour to get the engine started, the trouble being with water

Cylinder Drip Pipes.

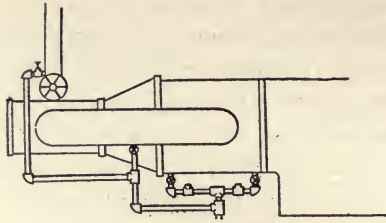

Fig. 37. The Wrong Way to Pipe Cylinder Drips.

in the low pressure cylinder. This seemed strange until an investigation showed the connections made (as in Fig. 37) with all the drips connected together.

The way they worked was this: The pressure in the receiver and from the steam pipe was greater than in the low pressure cylinder; the low pressure cylinder having piston valves on the side, there was no chance of getting rid of the water except through the drips; the pressure in the drip pipes from steam pipe and receiver being greater than the pressure in the cylinder, there was no possible chance for the water to escape. The drip from

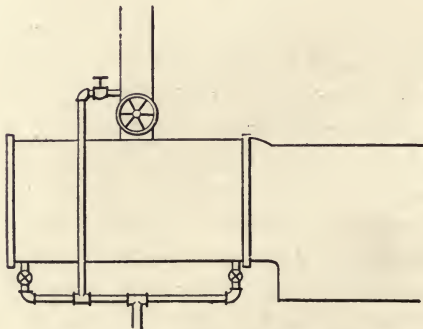

Fig. 38. Another poor way to do it.

Steam Heating.

cylinder and receiver were taken out of the other pipe and were carried away separately and there was an end to the trouble.

Drips are often connected as in Fig. 38, the drip from steam pipe being connected to the cylinder drips, and when starting all are wide open. The result is that the pressure from the steam pipe prevents the water from escaping from the cylinder and the piston slaps in the water for some time. The drip from the steam pipe should never be connected with the cylinder drains, but when so connected the steam pipe drain should always be closed when starting the engine. In one case where the drip from steam led to a receiver on a compound engine, and this pipe had the compound gage connected to it, it was found that by giving the valve one-half turn the pressure on the gage would go up to 50 pounds and yet there would be no pressure on the receiver, the pressure being due to friction in the pipe.

Piping for Steam Heat.

When heating a building with exhaust steam the pipe should go to the top of the building first, and, leading downward, branch out to the radiators. Air is nearly double the weight of steam, and if steam is taken to the radiators on the rise, the air will flow into the radiators instead of ascending. When taken from a descending pipe, a large portion will flow right through to the bottom, and there will be much less trouble with air in the radiators. Fig. 39 is an elevation showing the arrangement of piping followed in a large hotel. The pressure is just below that of the atmosphere. The first radiators that were put in had 1 square foot of surface to 75 cubic feet of space. This was found to be not sufficient. There was

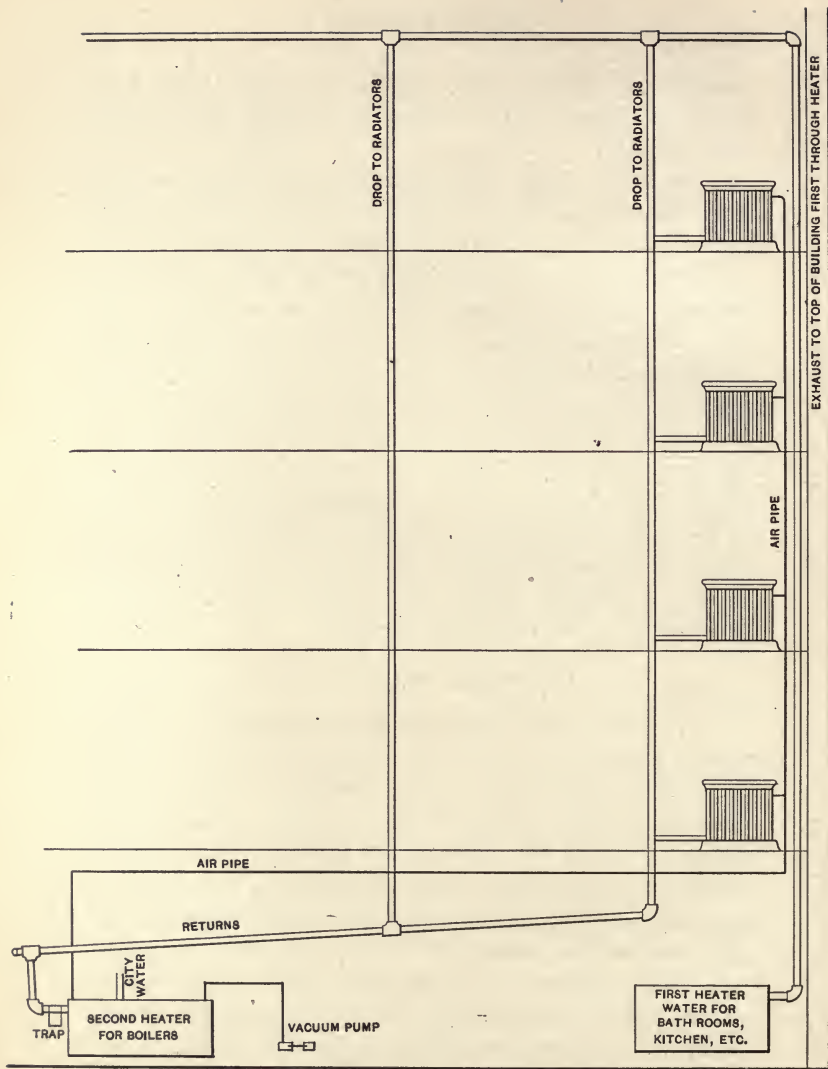

Fig. 39. Plan for Piping a Hotel.

Piping a Receiver.

then put in 1 to 50, except at the northwest corners of the building, where it was made 1 to 35. This was found more than actually necessary, but was a better fault than to have the heating surface small. Steam can be turned on to the radiators at any time, and there is no cracking in the pipes.

When piping up the receiver for a compound engine it is customary to do it something on the plan of Fig. 40. In work of this kind there should be a check between the receiver and the trap to prevent air drawing back, should the pressure in the receiver go below that of the atmosphere. Should this occur and there be water present, it would surely get into the low-pressure cylinder.

Should the trap not open properly the receiver will

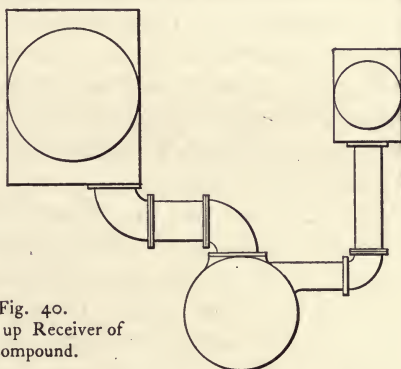

Fig. 40.
Piping up Receiver of
Compound.

fill with water and a large body of water go over into the engine. For this reason some engineers have advocated the taking of steam to low-pressure cylinder directly under the receiver. This method would not furnish so dry steam, but the moisture would be uniform, and not in a body should the trap fail to work.

The better plan is to leave out the receiver. One builder has tried both ways and can find no difference in economy and has given up the receiver.

Mason Work.



The best way to learn how to do mason work is to observe that which is being demolished.

A man was employed in a growing establishment that removed a great many buildings, foundations, etc., and had the opportunity to study the result of different methods. He has seen brick walls pushed over. In some, the bricks have been broken and when these were cleaned it required a large amount of labor. In others, when the wall fell the bricks all separated readily and were cleaned with little trouble.

When the first were laid the bricks were wet, or there was cement in the mortar. In the latter case the bricks were laid dry with lime mortar. In some cases the voids between the bricks were only partially filled and the wall came to pieces easily although the mortar adhered to the bricks. Observing the above, engineers have called for bricks to be wet except during freezing weather, and also are careful that plenty of mortar shall be used and that cement shall be added.

Masons generally, if left to themselves, will sling a little mortar on to the place where the bricks are to be laid, especially in the inside courses, lay in the brick, spread the mortar over the top and smooth off with a

Laying Bricks.

trowel. The brick are held by the small amount of mortar top and bottom, and there will be very little at the sides and ends. When mortar is simply slung over the top, or "slushed," as masons call it, the mortar does not penetrate between the brick more than from 1-16 to 1-4 of an inch.

When laying the inside courses there should be sufficient mortar put in, so that when the brick is pushed into it, it will come up on all sides clear to the top of the brick. It should not be smoothed off even when the inside course is even with the outside except on the last level at night. A wall laid in this manner will be strong and more nearly air tight.

Lime mortar should be made by slacking lime entirely covered with water to prevent burning. It should be mixed some days before using and should consist of about one part lime to five parts sand. When cement is to be used with it, the cement should be mixed thoroughly with water and added to the mortar just before it is used.

Pure lime will not "set." It is only when mixed with impurities that it has "setting" qualities. Should clay be burned with it, it becomes cement, and the more of these impurities the slower it will slacken and the less heat will be given off during the slacking process. Certain clays are made up of silica, alumina and iron oxides. Some lime rocks contain these impurities and are valuable for making cement.

Lime mortar hardens when exposed to the air and will harden in a wall only as fast as the air enters and comes in contact with it. No matter how old lime mortar is, if taken out of a wall and immersed in water, the lime will dissolve and leave the sand free. Quicklime is simply limestone heated or burned in a furnace.

Cements.

Rosendale cement is made from a limestone rock containing, or having added to it in form of clay, about 30 per cent. of silica, 8 per cent. of alumina, 3 per cent. of iron oxide, 33 to 35 per cent. of lime, and the balance made up of magnesia. It is burned in a furnace of brick construction, large at the bottom and ending at the top in a small chimney. A layer of fuel is put on the bottom, then a layer of the stone and clay, then a thin layer of buckwheat coal, and the furnace is filled up in this manner with stone and coal. Some kilns are made to dump the whole amount in the kiln every night, while others are arranged to run continuously, and the stone is taken out as burned. All stone, properly burned, are then ground and the Rosendale cement is ready for the packers. It sets slowly, but will continue to grow hard for years. It is not suitable for work that needs to be used at once, but makes good construction where there is two to four months' time for it to harden. It will not stand frost for a few days after it is laid. It is claimed by some of its advocates that at fifty to one hundred years it will be stronger than the quicker setting Portlands. It is a long time to wait. It has the merit of being cheap.

The manufacture of Portland is a much slower and more expensive process, and requires several times the outlay for buildings and machinery.

The stone is first quarried and run through a crusher and then to a dryer, where it is thoroughly dried. From there it goes to the ball mill, which is a cylinder about 4 feet in diameter and 5 to 6 feet long. These mills are lined with armor plate and partially filled with steel balls, weighing 20 pounds each. Outside of the lining are screens, so arranged that the stone that does not pass the screens is thrown back into the mill. The stone first

Making Cements.

goes through these ball mills and is partially ground while the mills revolve. From the ball mills it goes to the pebble mills, which usually are 5 feet in diameter by 20 feet long, laid horizontally and revolving on trunnions.

These mills are filled half full of imported pebbles, from $1\frac{1}{2}$ to $2\frac{1}{2}$ inches in diameter. These pebbles are very hard and their work severe. When the stone leaves the pebble mill it is so fine that 95 per cent. of it will pass through a sieve having 10,000 meshes per square inch.

From the pebble mill it goes to the kilns. The kilns are $7\frac{1}{2}$ feet in diameter and 60 feet long, placed on an incline, and revolve from one to three revolutions per minute. The fire is at the lower end, and is coal, powdered as finely as the stone and blown in with air. The stone enters at the upper end, and finally is subjected to a temperature of 3,200 degrees. It is all melted, and emerges from the kiln in the form of clinker, very hard and very heavy. In some mills it is cooled and taken direct to the grinding machinery; in others it is placed in storage, where from a day's to a week's supply is kept. The grinding of the clinker is the same process as the grinding of the stone. After the grinding it is taken to the stock house.

Its chemical composition is about 63 per cent. lime, 20 per cent. silica and the balance alumina and iron. There should not be to exceed 2 per cent. of magnesia. The rock is usually carbonate of lime, but during its passage through the kiln the carbonic acid is driven off.

The utmost care must be exercised all the way through. The chemist must examine the rock before it goes to the crushers and see that the right proportions are started, and must follow it all through the various

Properties of Cement.

processes, so that it shall be correct when it finally reaches the storehouse.

After the cement reaches the storehouse its physical properties must be tested. In the laboratory the cement is kept at a uniform temperature, so that all comparisons shall be accurate.

Briquets are made having a cross-section of 1 square inch in area. The amount of water and cement are both weighed and thoroughly mixed with a trowel. This mixing is not simply turning it over, but all the pressure possible is put on to the trowel to make as compact a mass as possible. Some of these briquets are allowed to set in air, and some in water. At one day, seven days and twenty-eight days they are tested by being pulled apart in a testing machine, and a record kept. One set is kept in boiling water twenty-four hours, and must not crack nor disintegrate, and must also undergo the tensile test.

A cement manufacturer keeps a record of the physical and chemical properties of all of the product he sells, and if it is condemned, he can guess pretty nearly the reason.

It is important that a cement should not set too quickly, as it could not be handled fast enough to get it into its place.

To determine the setting, a "pat" is made, this pat being about 2 inches square and $\frac{1}{2}$ inch thick, with thin edges, by thoroughly mixing and strong compression with a trowel. Note the time when the pat becomes hard enough to sustain a wire 1-12 inch in diameter, loaded with $\frac{1}{4}$ pound. When the wire is sustained, the initial set has commenced. It should not be less than 45 minutes.

When it will sustain a wire 1-24 inch in diameter loaded with 1 pound, the set is complete.

Testing Samples.

It should not be less than two hours, nor more than six hours. The water, cement and room should be about 70 degrees Fahr. Much warmer than this the set will be quicker, and colder the set will be slower. The weight of water should be about 20 per cent. of the weight of the cement.

Specifications for cement in many instances are peculiar. Some engineers specify that the cement shall be fresh ground, and then follow that up with the requirement that the initial set shall not be less than 45 minutes. Fresh ground cement will hardly stand this latter test. Cement is improved by having some age, and should stay in the storehouse for at least one month.

A United States engineer advertised for cement and one of the clauses was: "After being mixed neat and filled into a glass bottle, or similar vessel, and struck level at the top, it must not crack the vessel in setting, nor rise out of it, nor become loose in it by shrinking." He got one bid. Cement should expand about one-thousandth of its volume in setting.

It is surprising what different results will be obtained by different men who are skilled in testing.

A sample of cement was taken to a college laboratory, where it failed to fulfill the requirements. The manufacturers sent their representatives and he showed 15 per cent. less than the result of the first test. A representative from a certain testing laboratory made a test, with the result that he showed 50 per cent. better than the first test, and brought the cement beyond the requirements of the specification. All these tests were from the same sample of cement, using the same sand, mixed and molded in the same laboratory and broken by the same machine.

Cement, when set, should be uniform in color and

Mixing with Sand.

free from all blotches or spots. Unless colored, it is usually light in color when hard.

These three substances—lime, Rosendale and Portland cements—are what the engineer must rely upon for holding his masonry structure together.

The next important thing is sand. This should be clean and sharp and free from soil or dirt of any kind. Any loam with it will retard its setting and the completed work will be inferior. When sand is fairly dry, by squeezing a handful of it, it should leave the hand clean. Putting it into a glass of water the water would remain clear.

It is calculated that sand has voids amounting to one-third of its bulk, so that if one part of cement be mixed with three parts of sand the voids will be filled and there will be no increase of volume in the sand, and that to use less cement than the above will leave voids in the sand, depending on the less amount used. This must depend somewhat on the size of sand used. In an engineer's experience he found that one part sand and one part cement made a quicker setting and a stronger mixture than one to three. He also learned that there was a vast difference in the different brands of cement. A specially good brand of cement will carry four parts of sand and make as strong concrete as another brand will when carrying three parts.

When using Rosendale cement, it would be well not to use over two, or at most two and a half, parts of sand. From the above it will be seen that the lower priced cement is not always the cheapest.

Lime, and Rosendale cement will not stand frost. Portland cement of good quality that will stand the boil-

Winter Masonry.

ing test will withstand frost where it does not become frozen before the final set.

Some foundations were put in an open field where the temperature remained from 10 to 18 degrees below zero for a number of days, and the concrete was first class. This concrete was protected only by the forms. In this case boiling water was used on the sand and stone so as to get as much of the frost as possible out of them.

Brick walls have been laid with lime mortar very successfully in winter by the use of hot water in tempering the mortar, and protecting the walls at night.

When mixing concrete in the proportions of one of cement, three of sand, and six of broken stone, it will require $1\frac{1}{2}$ barrels of cement and $\frac{1}{2}$ yard of sand for each yard of concrete. The stone should be broken to pass through a 2-inch ring.

Cement is improved by working and driving down solid, and for this reason the usual manner of writing down specifications is that "only sufficient water shall be used so that when the concrete is well rammed the water will just show on the surface." To do this and make a water-tight job and leave a smooth outside surface, needs extra care in mixing.

As mixed in probably 75 per cent. of cases with the above amount of water, there will be considerable stone in places with very little of the paste between them, and in other places it will be all paste and but little stone.

Because of this sham mixing, it is sometimes the practice to wet the mixture to such an extent that it will be "puddled," and the paste will mix with the stone sufficiently to make a smooth and water-tight job with but little effort. Such a mixture cannot be rammed, and only a thin tool is used to work it down well next the forms

Concrete Work.

so as to make a smooth outside job. This is a favorite plan around a job that must hold water—as dams, head-gates and similar places.

For jobs of any size a good concrete mixer should be used, and care should then be used that the mix is not allowed to heap up in a high pile and the stone allowed to separate, roll to the bottom and be put into the work separately.

The stone used in concrete work should be crushed from a good quality of either granite, a strong limestone or trap rock. Stone of a slaty character of any kind, or limestones similar in form to slate rock, do not make a strong concrete.

Rubble masonry is fast going out of date, but when laid with cement the work should be watched to be sure that the stones are bedded in cement, rather than have the stones laid and cement thrown over them, which is a favorite practice, with many masons.

One way is to have rubble work “grouted.” This consists in laying up the stone dry. The outside is then pointed up with Portland cement, which soon sets.

A box is provided being 12 inches wide at the bottom, 30 inches wide at the top, and 5 to 6 feet long. In one end is a gate about 6 inches wide and 8 inches high to let out the mixture. This rests on top of the stone work. Should there be any leaks either in the pointing up or at the gate in the box, it can be stopped by forcing into them paper taken from the cement barrels.

Rosendale cement is used for this work. Water is put in the tub or box and the cement mixed. Then the sand is put in, one of cement to two of sand. A man stands at either end of the box with a hoe and keeps hoeing up from the bottom so as to keep the sand and cement

Examining Masonry.

from settling and to mix it thoroughly. Sufficient water should be used so that the whole will run freely.

When mixed, the gate is slowly raised and the mixture runs into the stone work, and if properly mixed it will fill everything full, as it runs as freely as water, and will make a thoroughly water-tight job. Such a job, after it is a year or two old, will be a difficult matter to tear down, except by blasting.

An engineer had seen so much of this work done and the work was so solid that he attempted to use it in his practice at different places, but found it exceedingly difficult to teach men to do this very simple mixing. They could not learn to keep the sand in suspension and the sand would run over the top of the work and stop it up. There would be some cement at the bottom of the foundation, a lot of sand on top, and the center empty, so he had to give it up and use concrete.

He found a knife and a two-foot rule handy tools to examine masonry. When brick are laid close, a knife will determine whether there is any mortar between them. Where they are a little wider apart, the end of a rule will soon determine whether the joint is full or whether a little mortar has been thrown over the top. He has found many masonry walls of rubble laid in cement that he could push a two-foot rule through in places after the cement was set.

When commencing a foundation, the first important thing is the nature of the ground. If the foundation is to rest on stone, the surface which is to receive the foundation should be flat, or, if the stone is sloping, it should be cut into steps, otherwise the foundation may slide.

A stone base will transmit vibrations, and sometimes

Foundations.

sound, so that is not desirable for the base of foundations for high-speed machinery where vibrations and noise would be objectionable, as in an office building.

Damp clay is slippery, and will press in all directions, going down at the bottom, in at the sides and bulging up a short distance away. Dry clay has a tendency to draw moisture from the air, and near the surface will expand and contract, depending on the weather.

In many sections it is treacherous. In some sections, where the land is well drained and the surface water runs away quickly, it makes a good base for a foundation when the foundation goes 4 to 5 feet in depth. It will transmit vibrations.

The ideal base is hard pan. This, next to stone, is the nearest to being non-compressible. Next to hard pan is gravel or sand.

If possible, this should be compacted with large quantities of water. Either of these will compress some. The thing to provide for is that the foundation shall be put down in such a manner that the settlement shall be equal in all directions.

The bottom of foundations should be below frost, otherwise the frost may distort them.

Good, compact sand or gravel will sustain 3 tons per square foot. It will sustain 6 tons if a few inches of settlement in a few years are not objectionable.

Clay, when not subject to frequent soakings, may be trusted with from 1 to 2 tons per square foot.

Quicksand, if it is held on all sides so that it will not be forced out and can be kept dry, makes a good base. Should water get in it, however, it will take but a small hole to let it out, provided it has a place to flow.

Where soils are uneven and treacherous and can be

Pile Driving.

kept wet, piles should be resorted to. City laws allow from 25 to 30 tons on a pile. The usual specification calls for a hammer of a pile driver to weigh 2,000 pounds, drop 12 feet, and the last blow to be resisted by a pile sinking only $\frac{1}{4}$ inch. The question has been asked, "What is the weight or force of such a blow?"

A man, having a large number of piles to drive, fell to working on this problem, and found ignorance on all sides. He took it to a young man who analyzed it as follows:

2,000 pounds weight falling 12 feet = 12,000 foot-pounds energy. The pile sinking 1 inch = 1-12 foot of space.

$$\text{Energy} = \text{force} \times \text{space.}$$

$$\text{Force} = \frac{\text{energy}}{\text{space}}$$

$$\frac{\text{Energy}}{\text{space}} = \frac{24,000}{1-12} = \frac{24,000 \times 12}{1} = 288,000 \text{ lbs.}$$

as the force of the blow, or the resistance of the pile, the pile sinking 1 inch from the blow. If the pile sinks only $\frac{1}{4}$ inch, there is no doubt about its being able to sustain the 25-ton load imposed upon it.

The piles should be sawed off not higher than the line of permanent moisture and a concrete base built over them. They are driven $2\frac{1}{2}$ feet center to center, and the concrete commences 6 inches below the top of them, and should be 2 feet thick. This holds the top of them so they cannot spread

Where piles have to go too deep, if there is sufficient room, a base of concrete can be made broad enough so that the weight will not be more than 1 ton or $\frac{1}{2}$ ton

More about Foundations.

per square foot, remembering always that the base should be built so that if there is settling it should settle equally all over. To accomplish this, a sub-foundation or base should be put in, covering the entire ground, and made 2 to 5 feet thick, depending upon the weights that are to be put upon it, and set some distance apart.

When building foundations for machinery, there should be pockets left at the bottom, or a short distance from the bottom, so that the bottom of foundation bolts can be reached at any time. It is rare that foundation bolts break, but when they do, to have a chance to get at the bottom nut is worth a great deal. It is also handy to be able to let a bolt down out of the way during the erection or subsequent handling of the engine. The pockets should be at least 18 inches square. The holes through the foundation for bolts should be larger than the bolt, so that the bolt can be swung around in the hole if necessary.

The anchor bolts should not be grouted in, as there may come a time when it may be necessary to get them out.

Should it be necessary to put new bolts into an old foundation, a hole can be drilled somewhat larger than the bolt, a split with wedge put in the bottom and clean Portland cement, without sand, put in the hole until it is half full. There need be no fear of pulling the bolt out.

The general practice is to build foundations for machinery to within half an inch of the level of the base of the machinery and fill this space with grout. This may fill the space, no one knows. Air pockets may get in and keep out the grout at the most important point.

A good practice is to leave the top of foundation 2 to 3 inches below the machinery and support the latter

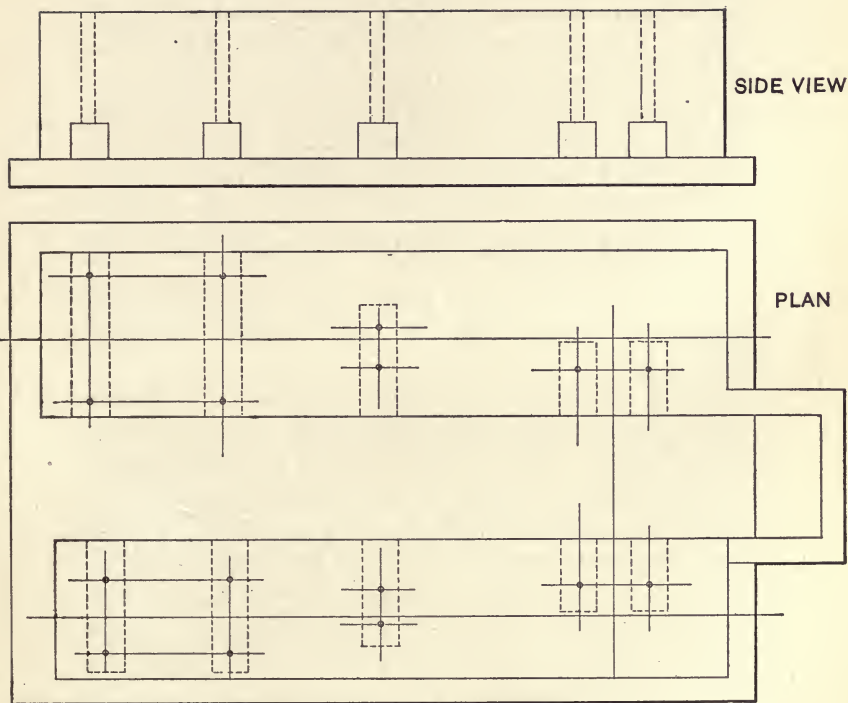

Fig. 41 Foundation for Cross-Compound Engine.

Foundation for Compound.

on iron wedges. When the frame of the engine is leveled and put into line, make a concrete of 1 part Portland, $2\frac{1}{2}$ parts sand and 5 of roofers' gravel or of small crushed stone of the same size. Put just sufficient water in it so that when it is squeezed in the hand it would retain its shape. This is pushed under the machinery with a stick and rammed solid with an iron rammer. If too much water is put in it will not stay in place, but will fall away, so that care should be exercised that it is not too wet. This method takes longer than grouting and is harder work, but there is no doubt that it fits every place, that it is in solid, and makes a filling that is much harder and fits better than grout.

To prevent filling the holes around foundation bolts, fill the top of these holes with waste, excelsior or something similar.

The cut shows a foundation with base covering the entire ground under both foundations for a cross-compound engine. This is a good idea in any case, and especially so if the ground is not of good gravel. This plan shows pockets for getting at the bottom of the foundation bolts so arranged that access can be had from the wheel-pit side, allowing all around the outside to be filled if desirable and a cellar not wanted. The holes for bolts can be made by building in gas-pipe or boiler tubing or square boxes of wood.

Stakes have been used a great deal. They should be tapered, say from 4 inches at top to 2 inches at the bottom, and made smooth. They should be soaked in water for a week before using, so that they will not swell in the masonry. They should be pulled out as soon as possible after the foundation is finished. For this purpose, they should be sufficiently long to project 6 inches above the



Stone and Brick.

top of the foundation. A light chain should be put around the top and a lever of 4x4 timber, 12 feet long, with a good fulcrum, will usually start them. If not, have two or three men put a strain on the lever and hit the stake a good, square blow directly on top with a sledge and it will pop right out.

Foundations are built of brick, stone and concrete. An engineer was building some foundations, for an electric station, of stone according to the terms of the contract, when the civil engineer employed by the owners objected and wanted them built of brick. The M. E. asked for his reasons, and he stated that brick made a better foundation and that all foundations of that character in that vicinity were built of brick. The M. E. asked him what an engine foundation was for, and he replied that it was to hold an engine up. "No," said the M. E., "it's to hold an engine down and have it stay quiet, and to do this requires weight and stability, and stone fills the requirements better than brick, as it is heavier and stiffer."

To this the C. E. took exceptions, but after consulting his books admitted that stone had more weight, but would not agree with the M. E. that stone was stiffer and that brickwork would spring. "Well," said the M. E., "you go to any of the places where they have large engines on brick piers, and if you can find a single one where the engine is well loaded that it does not spring, I will take out the stone foundations and put in brick." The M. E. heard no more about foundations.

Good Portland concrete is getting to be universal for engine foundations, and is rapidly coming into use for making bridges, dams, and buildings. A concrete house costs about one-half as much as a brick one, and

Fig. 42. Plan of Chimney.

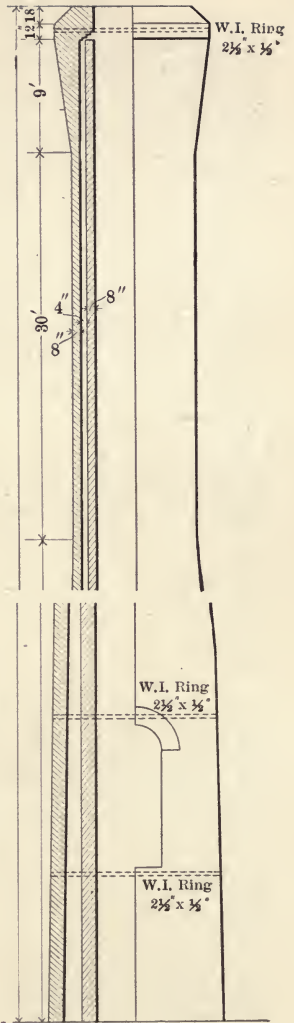
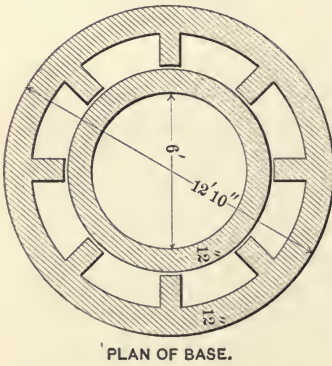

Brick and Steel Chimneys.

the same is true of mills. It can be molded in any form and can be made to represent any kind of cut stone desired at a minimum cost.

Chimney.

When it comes to deciding on draft, and first cost has to be kept down, a steel stack is usually decided upon.

Carbonic acid and carbonic oxide gases are very destructive to steel, and a steel stack corrodes very quickly on the inside. The heavy, self-supporting stack will take longer to rust out than the thin, guyed ones, but they, too, must give way.

Fig. 42 is a brick chimney that costs no more than a self-supporting steel stack. It is very stiff and stands up against wind pressure in good shape. The inside shell is 12 inches thick at the bottom and 8 inches at the top. It does not reach quite through the top. The outside shell is 12 inches thick at the bottom and 8 inches during the latter part, except at the enlargement at the top. Commencing at the top, there are 18 inches for the bevel. This has a cast-iron cap with rabbeted joints, so that no water can get under the plate. Copper bolts, $\frac{7}{8}$ inch diameter, are built into the chimney at the top, and when the cap is in place these are riveted. The cap reaches down 4 inches inside of the chimney and 4 inches over the base of the bevel. The square part is 12 inches and the slope is 9 feet. Below this, for 30 feet, the chimney is straight, and from that point to the bottom the batter is 2-10 of an inch per foot on each side. As shown on the plan at the base, buttresses are built into the outside shell and extend as high as possible. They should not come within 3

Reasons for Plain Designs.

inches of the inner shell at any point. Above and below the opening for the flue and at the top of the chimney there is a $2\frac{1}{2} \times \frac{1}{2}$ -inch iron band built in next to the outer course of brick, and every 10 feet there is a band, $1\frac{1}{2} \times \frac{1}{4}$ inch, built in in the same way, so that the chimney is thoroughly banded, and yet they do not show.

The mortar should be made of one part lime to five parts clean, sharp sand, and when used one part Portland cement to one part lime should be added. When added the cement should be mixed with water before putting it into the mortar, otherwise the cement will be mixed in dry lumps. No more should be mixed than can be used within three hours of the mixing.

The outer course should be laid in what is known as "push joints," viz., the mortar should be put on the laid brick sufficient to fill the joint full, the brick laid in it and pushed to place. This fills the joint completely full. Masons object to this because it makes a little thicker joint. They like to stick a little mortar on the inside corner of the brick and lay it down as in an ordinary straight wall. This makes a very thin joint at the outside, with often no mortar for an inch or two, and a weak construction. All interstices should be well filled with mortar for strength and for tightness.

It will be noticed there are no rings at the top for looks nor any projections. All projections catch snow, ice and rain, and as water is a universal solvent, where there are projections there will be disintegrations.

There should be a ladder built on the outside of the chimney of $\frac{7}{8}$ -inch round iron, the steps being 14 inches apart, 14 inches wide and projecting 9 inches, so that a man can put his leg through to rest. A chimney built as above, 6 feet internal diameter and 125 feet high, cost

Size of Chimneys.

above the foundation \$1,850. One 8½ feet diameter and 150 feet high cost \$2,800, and one 13 feet internal diameter and 200 feet high cost \$8,750. The latter had 16-inch walls for 70 feet.

The formula for area of chimneys:

$$\text{Area} = \frac{120 \times \text{square feet of grate}}{\sqrt{\text{height}}}$$

A table has been prepared by Mr. Wm. Kent and is published in most hand books. Mr. Kent based his table on the consumption of five pounds of coal per horse-power, so as to have it ample during bad weather.

Mr. George H. Babcock's rule of thumb was: "The area of chimney should be ⅛ the area of grate. It should never be less than 1-10."

In a high chimney, the velocity being greater, the area can be smaller than with a low chimney. There is an idea that the chimney should have an area equal to that of all the tubes. This would make the chimney too large. If we have a boiler with 70 tubes 4 inches in diameter we have an area of 500 square inches and a friction surface of 375 inches. A stack 28 inches in diameter would carry that all right, and this would have a friction of only 90 inches. Besides we have seen that a boiler flue is never full of gas at the full velocity of chimney. The flues between the boiler and the chimney should be slightly larger than the chimney, as, like the boiler flues, they are generally horizontal and have bends.

Of late years many owners of steam plants have put in induced draft.

One of the drawbacks to chimney draft is that, when strong, it draws air through all cracks and interstices, as

SIZES OF CHIMNEYS WITH APPROPRIATE HORSE-POWER BOILERS.

Dia. in	HEIGHT OF CHIMNEYS.										Effective Area Square ft.	Actual Area Square ft.	Side of Square of approximate area, Inches.		
	50 ft	60 ft	70 ft	80 ft	90 ft	100 ft	110 ft	125 ft	150 ft	175 ft				200 ft	
	COMMERCIAL HORSE-POWER.														
18	23	25	27	0.97	1.77	16
21	35	38	41	1.47	2.41	19
24	49	54	58	62	2.08	3.14	22
27	65	72	78	83	2.78	3.98	24
30	84	92	100	107	113	3.58	4.91	27
33	..	115	125	133	141	4.47	5.94	30
36	..	141	152	163	173	182	5.47	7.07	32
39	183	196	208	219	6.57	8.30	35
42	216	231	245	258	271	7.76	9.62	38
48	311	330	348	365	389	10.44	12.57	43
54	363	427	449	472	503	551	13.51	15.90	48
60	505	539	565	593	632	692	748	16.98	19.64	54
66	658	694	728	776	849	918	981	...	20.83	23.76	59
72	792	835	876	934	1023	1105	1181	...	25.08	28.27	64
78	995	1038	1107	1212	1310	1400	...	29.73	33.18	70
84	1163	1214	1294	1418	1531	1637	...	34.76	38.48	75
90	1344	1415	1496	1639	1770	1893	...	40.19	44.18	80
96	1537	1616	1720	1876	2027	2167	...	46.01	50.27	86

Induced and Forced Draft.

well as through the brickwork itself, thus diluting the gases and cooling them.

Induced draft has the same drawback. The induced-draft apparatus is made up of steel plates, which must be acted on the same as a steel stack. It is, or a portion of it at least, subject to repairs and breakdowns and a continuous expense for fuel. The products of combustion are discharged into the air that is breathed by the operatives and nearby residents.

If high chimneys are not desired, would it not be better to build a chimney, say, 100 feet high, and put in the air by fan under the grate? It would not draw air through boiler setting to cool off the boiler, and the surrounding air would be purer. The apparatus would be more durable and could be smaller, as the volume of cold air is not so great as the hot air.

Objections have been made to the steam jet for aiding or increasing combustion, on account of the large amount of steam used.

One engineer tried to learn the amount of steam used with steam jets, and the result of his investigation was that the steam jet, as he used it, required 8 per cent. of the fuel burned to operate it. He then took the difference between the amount of fuel used when running with natural draft and with the steam jet, and found the net result was that the jet took 2 per cent. more coal.

Whatever system of draft is used there should be a draft regulator. There are damper regulators made now that are very powerful and will regulate the steam pressure within 2 pounds.

For burning small anthracite and use a steam jet to help out. Put a valve in the steam pipe that leads to the jets and arrange the damper regulator so that when steam

Dampers.

rises it will close this valve first and then the damper in the flue. Of course, when steam lowers, the damper opens first and then the jets.

The Engine Room.



When James Watt took hold of the steam engine it consisted of a cylinder in which steam was admitted under the piston and raised it to the top of the stroke when cold water was admitted and the vacuum, or rather, the pressure of air on top of the piston forced it down, thus doing mechanical work.

Watt built a separate condenser and used steam on both sides of the piston. He also invented and used the indicator. His researches led him to foretell the advantage of using steam expansively and of compounding the same, but he did not live to see it carried out.

Later mathematicians took hold of the matter, and, by figures, showed the saving by expanding steam.

A professor in Providence was looking over these figures, and, becoming interested, took them to a young man who had shown inventive ability while working at the harness maker's trade by inventing the sewing machine for stitching leather. This young man was George H. Corliss. Elias Howe afterwards invented the placing of the eye at the point of the needle, thus making the sewing machine practical for all purposes.

Young Corliss set about making an expansion engine,

What Corliss Did.

the point of cutting off to be determined by the action of the governor so that full boiler pressure should be maintained in the cylinder until expansion commenced.

Expansion of steam had been tried with poppet valves and a fixed cut-off, but had not met with much success. The poppet valve did not appeal to Mr. Corliss, neither did the slide valve with its long ports and large clearance, so he set to work to make something entirely new. His success was so remarkable as to place him as the foremost engineer of his age, with the probability that centuries will go by before his name will be forgotten.

He accomplished four things. He did away with crooked steam passages, placing a valve close to each end of the cylinder, with short, straight ports, thus reducing the clearance to a minimum. He made a valve that while light, was rigid and would keep its shape; that was quickly and inexpensively made, requiring no scraping or grinding, and that would remain tight as long as the slide valve. By the use of the wrist-plate he quickened the motion of the valves at the right time, thus improving on the motion of the eccentric. By the use of his disengaging motion he brought expansion to perfection.

He had the lot of most inventors, and was obliged to force his invention on an unwilling public. He had to take all the responsibility, and in many instances take his pay in what he could save in fuel. This in the end proved fortunate for him, as in most cases he received far in excess of the price he had put on the machine.

At the time Mr. Corliss was selling his automatic cut-off engines for what he could save, the United States Government was spending money in experiments to show there was no economy in using steam expansively.

With Mr. Corliss as draftsman, was a man by name of

Wright and Corliss.

William Wright. Wright always claimed that he was the original designer of the Corliss valve. When a man creates a great thing he is apt to imitate it later. Mr. Wright never afterwards built anything that remotely resembled the Corliss valve. He invented a cam motion—a cam moving around a central cam, its position being determined by the governor. This cam operated poppet steam valves and made an automatic cut-off engine. The exhaust was two slide valves, each valve being placed at the cylinder ends so as to reduce clearance, and as far as possible get the results obtained by Mr. Corliss.

These engines were built for a number of years by Woodruff & Beach, at Hartford, Conn. Mr. Wright made a change in his cam and governor and went into business for himself. After a time he became convinced that the poppet was not a tight valve and built his engines with gridiron valves.

When Mr. Corliss' patents expired, a great many builders started in to build "improved" Corliss engines, and some of them have made rather sad work of it.

In Mr. Corliss' day, piston and rotative speeds were slow, and he did not live to see the enormous amount of work that the steam engine was to do in the generation of electricity, calling for higher pressures, faster speed and large units. In all this work there has been a chance for inventive and constructive talent to meet the entirely new conditions.

When electricity first came into use the Corliss engine was thought entirely too slow. High-speed engines had become partially developed and the new field developed them rapidly, and it was for a time given entirely over to them.

The electric light company at Waterbury, Conn., went

Piston Valves.

to the Corliss Company and asked them to build a cross-compound engine having a stroke of 4 feet and to run at the rate of 80 revolutions per minute. This, at the time, was considered terrific speed, but the engine company undertook the work, which turned out highly satisfactory. Others worked in the same direction, and results showed that for hard work and for economy and long life, the Corliss engine built for the new conditions was still the favorite.

A favorite valve for a long time for the piston valve. This is a straight valve moving in a case. Fig. 13 is a typical piston valve. As the steam passes by the ends and through the center, there is no pressure on the valve seat, and there is only the sliding friction due to its weight and that due to the tightness of the valve in its case. In some cases this valve is put in without any packing rings of any kind, and being frictionless nearly, will be fairly tight for some months if neatly fitted. To use spring rings it is necessary to put bars across the port to prevent the rings expanding into the ports and getting caught. Another method is to make a shell for the outside of the valve and expand it with set-screws. This makes as rigid a valve as one entirely solid, and has the single advantage of being adjustable by hand instead of getting a new valve. One builder for a time made a valve that could be adjusted from the outside when the engine was running, and he had the wrecks incident to such a device.

The piston valves are made to operate at the ends of the cylinder, thus imitating the Corliss in the attempt to get short ports. Of necessity, their ports are longer than the Corliss, because of the shape of the valve, and also the port must go clear around the valve.

Advantages and Objections.

The advantage of the piston valve is that its construction is lathe work and can be quickly and cheaply made; it is nearly frictionless, can be operated at a high rate of speed and requires very little oil; all its mechanism can be light and easily handled by the governor. The objections to it are the considerable clearance, the rather tortuous steam passages and the extreme probability of its leaking in a short time.

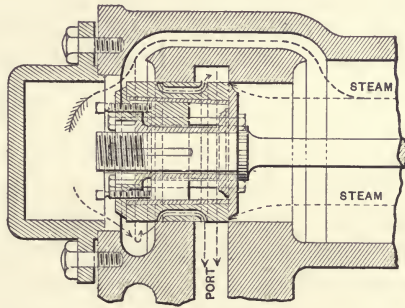

Fig. 43 Double Ported Piston Valve for Valve Engine.

For high rotative speeds the single valve can be made to give as good cards, except the compression, as a four valve with two eccentrics, with the same speed. The four-valve engine, however, will be the more economical under changes of load, because the exhaust valve closure is not disturbed by the governor and does not produce the excessive compression.

The shorter the stroke, the greater the percentage of clearance. This is again increased by the number of times the clearance spaces are filled and emptied per minute.

About Engine Design.

When looking up a medium-speed engine (there are no slow speeds now) sufficient valve area, small clearance, sufficient area for bearings and pins, and one that is easy of access to all parts for repairs, are the points that should be looked after. This also applies to engines of all classes.

In former years engines were designed by practical engineers who had experience with them or who watched the operation of them after they were installed. They were also assembled in the shop by hand or hand tools, and all the mechanics had a taste of putting them together under conditions similar to those of the engineer in the engine-room, and they were made easy to get at, get apart and get together again.

Of late years, altogether too many have been designed by draftsmen who had no knowledge of the practical handling of them after they had once left the shop, with the result that there are some fearful monstrosities. They are also put together with a traveling crane, and many nice points are not noticed by mechanics there. It is true that engines must be heavier than formerly, but there is no excuse for putting a stuffing box in in such a manner that the engineer can just reach it at arm's length through a hot hole that keeps his head and body out.

Some builders put a sheet-steel case over the cylinder, and this case is fitted in such a manner that to put it on or remove it the whole valve motion must be taken off.

One type of engine designed to be direct connected to electric generators has its main bearing so constructed that the armature must be blocked up, fields removed and shaft disconnected to get to the adjustment of the bearing. The builder says he does this to prevent monkeying with it; that it is too often the case that where things

Horizontal vs. Vertical.

are handy to get at they are adjusted out of shape and use in a short time; that these journals will run two or three years without giving trouble if let alone, and that if they will do that, one can afford to be put to a little extra trouble when adjustments are so seldom required.

When purchasing large cross-compound engines the difficulty of lubricating the low-pressure cylinder and the large number of cylinders of this class that have caused endless delays and expense, should be borne in mind.

Another thing is the room they occupy. Said a manufacturer to me: "We have been in the habit of putting in Corliss engines, cross-compound, owing to their durability, small need for repairs, reliability and economy, but they take up too much room. In our business they have to be close to the mill machinery, they are right in the way of our work and reduce the production the mill ought to turn out, so that we have gone to putting in high-speed engines. These engines will have less life, will consume more coal, but our production is increased so much by the extra space that the extra space is worth many times the extra cost of fuel, etc., and we can well afford to put them in, let them wear out and then put in more."

In these cases the vertical engine is the solution. The wear on the cylinders is slight, there is a big saving in cylinder oil and the floor space is small.

There is one drawback—the weight is taken from the bottom of the cylinder and put on the crank pin, and also the engine is unbalanced, as the weight of the moving parts is all downward with the full area of the piston to push them down, and only the area of piston less the area of piston rod to pull them up; also, the jerk that the engine gets at the bottom of the stroke when it takes

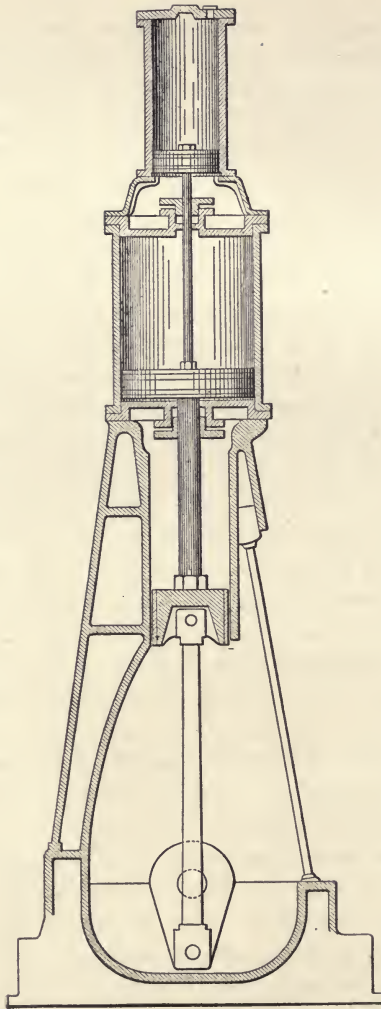

Fig. 44. Cylinder Designed to Balance Moving Parts on Vertical Engine.

Balancing Vertical Engines.

steam at the bottom makes a noisy engine, and on boats gives disagreeable jerks.

It is not possible to balance one of these engines by counterweights in the crank, as when the engine is on the bottom center the counterweight is in equilibrium. Some engineers argue that one side will balance the other through the shaft, but if they will stand by the shaft on a boat with the three-cylinder engines they will see that this is not true.

Builders of engines with two-cylinders and cranks set at 180 degrees argue that in their case one side balances the other through the shaft when they have good counterweights, but to balance such an engine with counterweights would necessitate the putting in of a counterweight in the low-pressure crank to make up the difference between the high and low pressure moving parts, and putting none in the high-pressure crank, surely not a very mechanical device.

Should the attempt be made to put sufficient counterweight in the crank to balance the moving parts, it will be found that there is not sufficient room for the necessary weight. It is necessary to keep the pins and main journal keyed up snug to prevent jar and pound on the bottom, and this means an excessive amount of oil and excessive wear. Even with this, it is cheaper to put in new pins and brasses than new pistons and rebore large cylinders on horizontal engines. Builders of vertical engines will guarantee better economy for them than for the horizontal type.

The writer designed and patented a cylinder to put on top of the steam cylinder of a vertical engine, as shown in Fig. 44. This device is simply a cylinder open at the bottom and with a small relief valve on top to relieve any

Pounds and their causes.

air that may leak in. The weight of all the moving parts is ascertained, as well as the difference between the area of the piston at the bottom and top, and the area of the balancing piston is made to sustain this weight with a pressure of 12 pounds per square inch. Vacuum is formed at the top after the piston has traveled a short distance, and, as the bottom is open to the atmosphere, the whole moving parts are suspended on air and the resistance of the air going down carries the parts back to nearly the end of the stroke, when they are let down easily on the pin going over the top center. As they are supported at the bottom center by the small piston, the jar is removed and the parts can be run looser, with the result of less wear. This arrangement should remove the disagreeable jar on steamers caused by the engines going around the bottom center.

Pounding from various causes.

An engine that is not in line will not run quietly. Sometimes the engine wears out of line or the shaft gets out of level for want of proper adjustment at the right time; it perhaps has been "tinkered" with and gotten out from that cause; some portions may have worn faster than others; the foundation may have not settled uniformly or some parts have been too weak and sprung out of shape.

There are altogether too many cases where the engine was not put in proper alinement when built, or pins were not put in straight.

A self-contained engine had been run for a number of years; one of the wheels had become loose; the cross-head and boxes on both ends of the rod were worn and

Weak Crossheads.

the builders were directed to send new parts and an attempt would be made to get the wheel tight at the side of the engine. To this plan the builders objected, stating that they must have the engine returned to the shop to do a good job. This would necessitate shutting down a large plant, but a breakdown gave them the opportunity.

The shaft, rod and crosshead were sent, but were delayed in returning, so that it was necessary to get it together and start up as quickly as possible. When the engine was started it pounded badly, but as the work

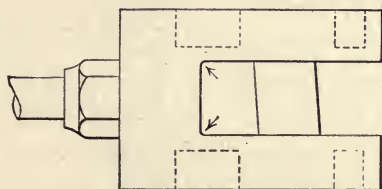

Fig. 45. Weak points in Crossheads.

required this engine to run continuously it meant considerable loss to stop and locate the trouble. Another engine was therefore purchased, so as to have a duplicate engine.

Before this arrived the piston rod let go. New studs for the cylinder head and a new rod were made and hustled in in a few hours, and the engine continued at work. As all the hands were busy with this work, there could be no chance to hunt up the trouble.

Before the spare engine was ready the crosshead let go at points shown by arrows in Fig. 45. This crosshead was cored out, as shown by dotted lines, and was rather weak at the square corners.

Frames out of Line.

The spare engine was gotten together and put into service. A new crosshead was procured by a nearby foundry, and when it was put in the precaution was taken to key the rod up snugly on the crank-pin and drop the other end down on to the crosshead pin. It fitted squarely. The rod was then disconnected from the crank-pin, and keyed up on to the crosshead, and then dropped down onto the crank-pin, and that came square. The engine was then started up, and it ran perfectly quiet.

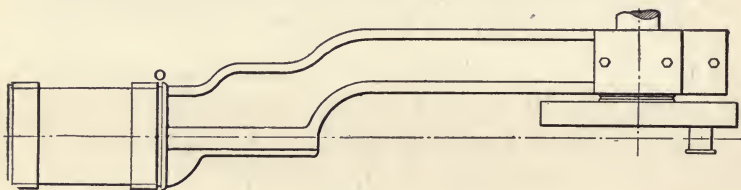

Fig. 46. Frame out of line.

The old crosshead was so badly broken that just what the trouble was could not be determined, but the probability is that the pin was put in something as shown in Fig. 45, though not so crooked.

Had the trial of the connecting rod been made with the first pin in the same manner that it was with the second, the trouble would have been discovered at the outset. When setting up engines it is a good plan to try the connecting rod, as described.

Another error that has been found many times is shown in Fig. 46. A line put through the engine will show that the cylinder is not in line with the guides and will have to be thrown around by putting in shims at either O or E.

Twisted Guides.

A not infrequent defect is shown in Fig. 47, and can be detected by placing a plumb, as shown. This is particularly bad with V-guides. In one factory I have in mind there are four engines from the same builder with V-guides that stand in this manner. Fortunately, the

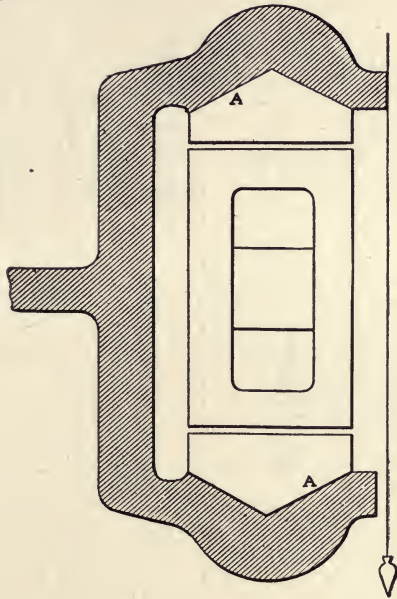

Fig. 47. Guides out of live vertically.

engines run forward and do not make as much trouble as the running backward.

The only remedy is to trim down the shoes at A and A' until the crossheads stand plumb.

There is no excuse for a V-guide. There have been cases where the foundation under a cylinder has settled

Crank Pin not Central.

more under one side than the other and twisted the guides.

Pounding from this cause is a compound noise, and while it takes place on the center the pound will be at

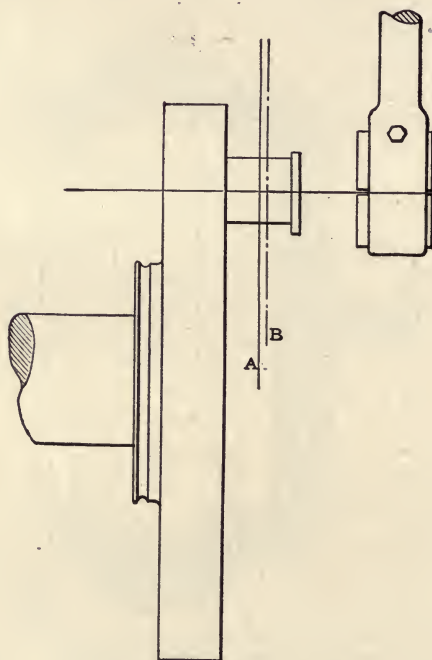

Fig. 48. Crank Pin not Central.

the crosshead and crank-pin both, but not exactly the same time.

Another trouble that sometimes occurs is that the center line through the engine does not come through center of pin, as shown in Fig. 48, where the center of

Crank out of Square.

pin is the line A, while the line through engine is at B.

The remedy for this is to trim down one side of the brasses and add on to the other side, as shown in Fig. 48. When they have to be cut off on the side toward the crank and the rod is round, care must be taken that the

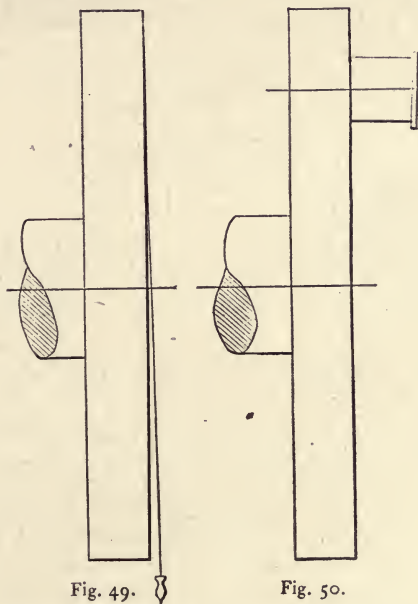

Fig. 49. Crank disk out by plumb.
Fig. 50. Crank pin put in crooked.

large part of the rod does not get too close to the crank disk when the crank-pin is at the forward center. If the crosshead is one-sided, the same course may be pursued.

To determine if the shaft is level, suspend a plumb line, as in Fig. 49. If it is out, as shown, the pound will

Pistons too Small.

not be on the center, but when the crank-pin is nearly half way between. The only remedy is to make the shaft level and with a pin put in crooked, as in Fig. 50, a new pin put in straight will be necessary.

Should a piston be too small, as shown in Fig. 51, and a larger force of the steam strike it on one side, the piston will be forced to the other side and there will be

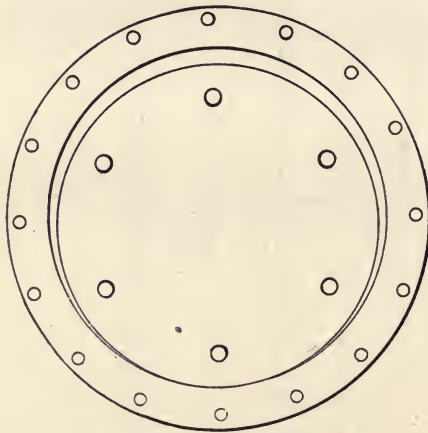

Fig. 51. Piston too Small.

a severe pound. When the cylinder head is taken off, nothing out of the way can be seen. The remedy is a piston with a broader bearing at the bottom.

A cylinder having shoulders will pound. A Corliss or similar valve having end play may pound if the steam impinges just right to force it endwise. The valve will wear smoother if it has end play, and unless the pound is too great it will be better to leave it. It can be eased

Loose Glands or Packing.

somewhat or stopped entirely by putting a little plate and spring at the end and put in a bolt through the valve bonnet to adjust the tension of the spring.

Pounding is sometimes caused by side play in rod brasses, but the engine must be out of line somewhere to make this serious.

A loose gland or loose metallic packing in the stuffing-box will make a disagreeable pound. A loose piston rod, either in the crosshead or the piston, will pound.

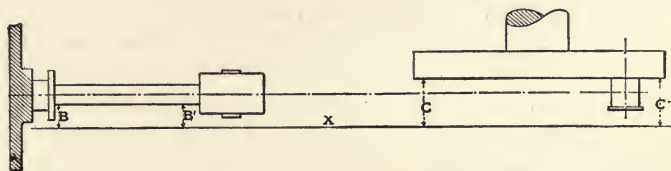

Fig. 52. Lining up from piston rod.

Sometimes, if brasses get loose so as to turn in the straps or stub ends, they will cause a pound. If an engine is working very light and the internal surface of the cylinder is exposed chiefly to low pressure and to the condenser, a large amount of steam will be condensed when the valve opens and will cause a snapping in the cylinder like entrained water. This is sometimes mistaken for pounding, but it is really water. It will wash off the cylinder oil from the wearing surfaces, which might cause cutting, but other than this does no real harm.

When the piston rod runs straight, a line can be strung, as shown in Fig. 52. Put the engine as near the outer center as will allow measurements to be made from both sides of the disk above the rod. Put a stick tightly

Locomotive Pounds.

back of the gland and draw a line X parallel with the piston rod, measuring from B B'. Then take the distance from the disk at C C'.

Should there be a crank instead of a disk, both in this case and in Fig. 48, measure from the end of the pin on one center, turn the engine to the opposite center, and make the same measurements in this position. An engine in perfect alinement with the bearings well fitted and keyed fairly snug will run smoothly with very little compression. All that will be necessary is to have the exhaust valves close quickly enough to have sufficient lap to make them tight on the admission of steam.

A locomotive engineer discovered a pound on one side, and located it in the crosshead. He took out the piston rod, put a thickness of letter-paper around the taper, put the rod back and drew it up with the key, and the trouble was over.

When paper can be drawn down tight and held rigid it makes an excellent packing for this purpose, or for any place that needs filling up, even top of a foundation for supporting an engine.

On a stationary engine a pound at the crosshead was found to be the jam nut had become loosened. When these nuts get loose they give warning by pounding. When the rod gets loose on a key it will do the same thing. Also when a piston gets loose there will be a pound in the cylinder. If it is simply forced on the rod and riveted over it will rarely give warning when loose, but comes off at once.

A pound was located at the crosshead of an engine and the men in charge were unable to find it, as the jam nut and everything about the crosshead was snug and tight. A consulting engineer was sent for, who un-

Set screws don't hold fly-wheels.

screwed the jam nut and the rod was found broken off in the center of the nut.

An engineer was sent for, with the information that on one of the engines the crank pin was heating and pounding. This was caused by the pin being loose in the crank.

Should a crank or wheel become loose on the shaft they will give notice by a creaking noise, sometime before there is any danger. There will also be a slight exudation of oil having a rusty appearance.

A certain engine had a shaft 14" diameter on which was a wheel 20 feet diameter, having a heavy rim.

This wheel had been creaking at the hub for some time. The engineer finally decided it was getting serious. After a talk with some of his engineering friends he submitted the following plan to the management: Have a new shaft and crank made. Borrow some small engines and set them up to do the lighter work and get a sufficient amount of the heavier work ahead, and thus keep up the product. Then take the wheel and shaft out, bore the hub to fit the new shaft and put it in service.

It was estimated that the loss from stoppage of this engine was \$1,000 per day.

Now, in these works there was a machinist who was styled M—. M—, who was a good talker and who had succeeded in getting the management to think there was nothing in mechanics he was not master of. He reported there was no danger with the wheel, but should anything happen he could tighten it without any such expense.

A few weeks after this the engineer left for other fields, and shortly afterwards the wheel slid along the shaft until it brought up against the foundation. This

Where they failed.

meant a shutdown. After a day's delay (\$1,000) the machinist shoved the wheel back to place, and the engine started and ran a few days, when it was again over against the foundation.

The wheel was again shoved back to place, two steel set screws were put in in a slanting direction, as

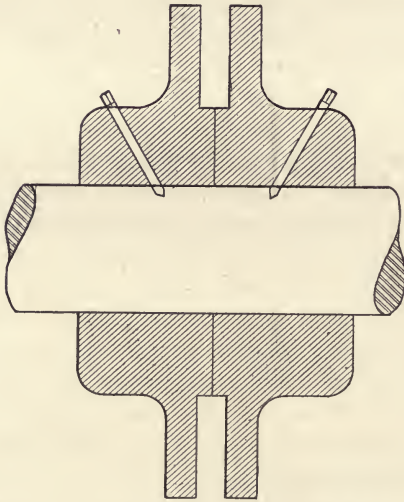

Fig. 53. Set screws that did'nt hold the fly-wheel.

shown in Fig. 53, extending through into the shaft. After a few days' delay (more \$1,000) the engine was again started, and ran a few months, when, as was to be expected, the set screws broke off level with the shaft, and the wheel was again against the foundation. A new shaft was then procured, and the wheel put on in proper shape. This required a shutdown of a month.

Pressing crank pins.

A heavy-rimmed wheel on an engine cannot be held with set screws, but must hug the shaft tightly.

This engine had a crank pin 7" diameter, and three of them had become loose.

A new pin was made, .01 inch larger than the hole, estimated to require 100,000 pounds pressure to force it in place.

When about half way in, taking about 90,000 pounds pressure, one of the straps broke, and by the time another was made and in place it required 150,000 pounds and some persuasion with a hammer. This pin did not come loose. This was at the time when the engineer was looking up the best way to take care of the wheel. At the time there was a mechanic on the premises superintending the erection of machinery built by a large machinery firm and the subject of forced fits came up.

This mechanic was not in favor of building machinery so as to require high pressures to force them on. When asked what he would do if they got loose, he said he would bush them. Asked if his people had ever done that, he replied, "Yes, lots of them." Further discussion seemed useless.

Lining up an Engine.

The writer had the annoying experiences which most engineers encounter with pounding, hot journals, water, etc. He learned that the most fruitful cause of pounding is want of alinement. Keying up an engine out of line makes the trouble worse in many cases.

The old V-guide that holds a cross-head and connecting rod rigid in a straight line when the rest of the engine is in such shape that it wants to turn a little is

Lining up Engines.

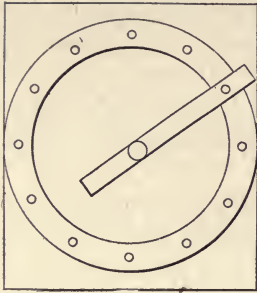

54

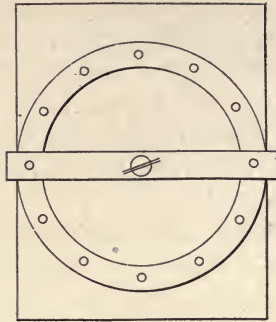

55

Figs. 54-55 Two ways of holding a center line.

one of the annoyances. If the bottom of one of the main journals wears faster than the other the V-guide makes a fuss about it, whereas a round guide would go all right.

In one case where the foundation under the cylinder had settled slightly, so that it threw the guides slightly out of line the struggle between cross-head and crank as to which should be master was noisy. As usual at such times, the shop was too busy to shut down and put in a new foundation without warning, so it was ascertained

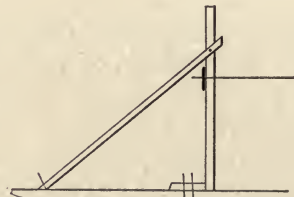
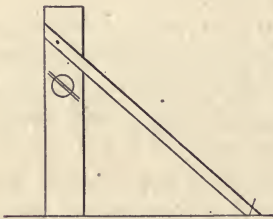

Figs. 56-57. Two views of stake.

Holding the line.

how much was necessary to turn the cross-head so that it stood straight, planed one side of the cross-head at the top and the other at the bottom put in liners alongside the shoes, and the conflict was over. Bored guides would have saved that work.

To ascertain if the engine is in line, take out all the reciprocating parts and put a line through the cylinder reaching to front of the crank. This line should be a fine, braided line, of silk. It can be fastened and centered in the back end of the cylinder with a stick bolted with one

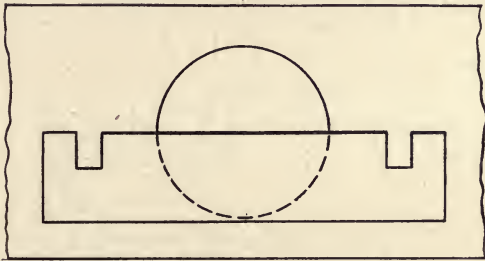

Fig. 58. For holding the line.

bolt, as in Fig. 54, or can reach across and be fastened with two, as in Fig. 55. In front of the crank set a stake that can be adjusted sideways, as shown in front and side views in Figs. 56 and 57. Put the line as near central of the cylinder as possible and draw it tight so that there shall be no sag. Commence at the back end of the cylinder and center the line.

A better way for holding the end of the line is to notch a piece of iron, as shown in Fig. 58, and put screws into the board through the notches. The iron strip can

Shimming the frame.

then be fastened just tight enough to hold it in place and raised or lowered to suit the work. Let the cord lay across the iron strip and suspend a weight on it sufficiently heavy to hold the cord tight.

The best thing to use for caliper is a pine stick nearly sharp at one end and a pin in the other that can be drawn out or pushed in for adjustment. Have one for the end of the cylinder and one for the stuffing-box. After the line is central at the cylinder end, try it through the stuffing-box, moving the line at its support at the stake in front of the crank. When central

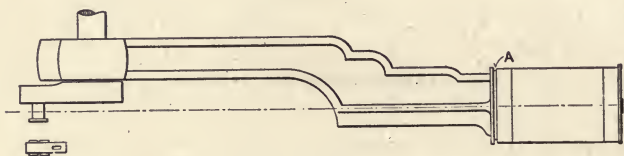

Fig. 59. Lining frame with shims.

here, try the back end of the cylinder and so alternate until the line is central at both points. It is then in line with the cylinder and all other parts should be in line with it. Try the guides. One builder had most of the engines that he built and erected crooked at the point *A*, Fig. 59, and shims were required to throw the cylinder around into line with the guides.

Bring the crank-pin down to the line, or if the crank is down, which is the better position, bring it up to the line and see if the line is central to the pin. Turn the crank around to the other center. If the line is central at both points, it is all right; if the line comes one side of the center on one side and on the other side on the other,

A quick alignment test.

the outside journal wants swinging around, if a single engine; if double, one of the cylinders may have to be moved. If the line comes to the same side of the center of the pin when the crank is in both positions, then the shaft journals are not set right.

The cheapest and quickest way to overcome this is to take off the required amount of metal from one side of

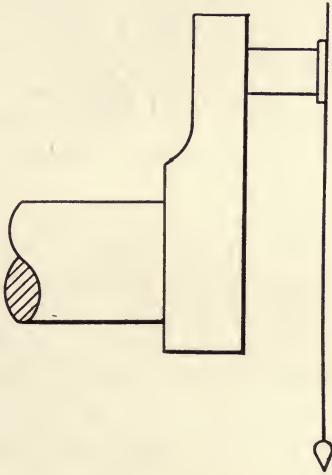

Fig. 60. Leveling shaft by plumb line.

the crank-pin boxes and sweat, or solder an equal amount on the other side.

A temporary alinement can be made without taking the engine apart by putting the engine on the back center and putting a line alongside the engine parallel with the piston rod and then measuring off to the crank-pin or to points on the disk from that line.

Where the belt man was wrong.

To find if the shaft is level, drop a plumb line outside of the crank-pin when it is up, as in Fig. 60, and then turn the engine over until the pin is down. This can be done with steam and without disconnecting anything. Some do it by dropping a line down the side of the wheel.

A foundation for an engine, shafting, etc., was made and the engine was put in place. The shaft man came along and set up the shafting by marks that were given him. The man who was to put on the belt went to line up the pulley on the shaft, and it was out. He sent for the engineer and told him that to get the engine in line with the shaft the back end of the engine would have to be swung around $1\frac{1}{2}$ inches. As the foundation bolts were cemented in, this meant the cutting out of the holes in cylinder feet and a bad job. A transit was procured and the whole job gone over, proving that everything was in line and the work put up correctly. The belt man was asked how he arrived at the conclusion that the engine was out of line with the shaft and he put a line alongside the pulley on the engine and another alongside the pulley on the driven shaft, which showed that one of them was badly out. He was asked to turn the line shaft half way around and when this was done the work was out in the opposite direction.

A pulley may be turned up true, but it is not always put on the shaft true—in fact, seldom is—so that when anything is attempted by line by using the side of a pulley, it should be demonstrated first that the pulley runs absolutely true.

Sometimes a pillow block is not set absolutely level like Fig. 61, and there will be heating on one end, and after a time this bearing will be out of shape, so that the only remedy is re-boring.

About pedestal bearings.

It has been the custom to make crank bearings like Fig. 62, with the base of the bottom shell narrower than the side shells, so that when the cap was screwed down hard the bottom shell was spread out, causing the bearing to heat. The base of the bottom shell should be as wide as the sides.

Eccentrics are usually held in place by set-screws through the hub of the eccentric and against the shaft. This forces one side of the hub away from the shaft, and

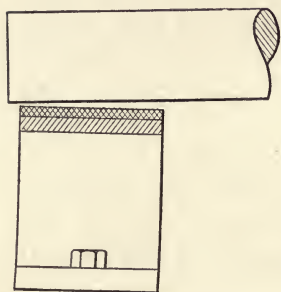

Fig. 61. Shaft out of line,

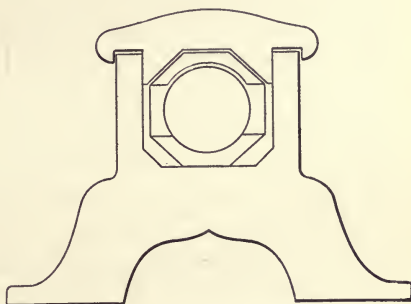

Fig. 62. Poor bottom shell,

light eccentrics are distorted, causing heating. One builder has recognized this evil and his practice is to drill into the shaft and draw the eccentric to the shaft, thus keeping it in true form. There is a slot in the hub at the bolt hole for adjusting the eccentric.

The question of the wear of rings and cylinders of modern engines is an interesting one.

An engineer was interested in having four large engines built and there was a verbal agreement that the last cut should be with a $\frac{5}{8}$ -inch feed and the cylinder left rough. When the engines came the cylinders were

Cylinder Oils.

smooth. He went to the agent and then to the superintendent to know why they were bored smooth. He didn't know and wanted to know "What there was about boring cylinders anyhow." The engineer told him he had started a great many engines and never knew of a cut cylinder. Cutting a new cylinder did not seem to be possible. Since he went into the electric business there was all kinds of trouble with cut cylinders—even one of the superintendent's engines, only a 22-inch cylinder, had been cut while in charge of his own man. He went to investigating and found that with coarse cuts and the cylinders full of little ridges, any clinging, should it start, would only take off the top of the ridge. It took a year to wear a cylinder smooth, but it was tight all the time, and when it did get its surface it was a natural one and there was no trouble. When electricity came into the field it brought a new class of men who thought they should be bored smooth. The trouble with this is that if there was a disposition to cling, a little shaving would start and go the whole length of the cylinder.

Cylinder oils have many times been blamed unjustly for cut cylinders. One builder had a low pressure cylinder cut and there seemed no way to prevent it. He took off the cylinder head of the low pressure cylinder, running with one end and the high pressure side, and had an oil syringe so that oil could be injected to any part of the cylinder. Oil was applied liberally but there were spots all over the cylinder that would get red hot and it was not possible to prevent it with oil. There were two packing rings and he had an idea that possibly these packing rings brushed the oil away. He took out one ring and rounding the edges of the other and the engine went off without any more trouble.

Cylinder Bushings.

One large engine with the cylinder bushed had the bushing cut and another was put in only to go the same way. A third was made. On boring it the iron was found to be soft, but was put in to run until they could get a hard one. When the hard one was ready it was found that the soft one was wearing all right and the trouble there was over.

Babbitt liberally applied to both junk and packing rings has been used in some cases with good results. One builder told of a place where he had trouble and put in babbitt which cured the trouble, and he thought he had a remedy for all such cases. Other engines he put it into were badly cut. Rings of ordinary copper were then tried, and they started off beautifully, but in the next case they proved no better than iron rings. This builder has given up being sure.

Exhaust Pipes for Vertical Engines.

Vertical engines have come into use for various reasons and will be used more when their utility is more generally understood.

The large low-pressure cylinders on compound horizontal engines require an excessive amount of compounded cylinder oil, and even then there is much trouble with many.

Where water is bad, or scarce, or dear, and surface condensers are used, it is very difficult to separate the compounded oil.

Where space is limited the vertical is the only solution.

There are some verticals sold whose builders have

Exhaust passages.

not had practical experience, and as a result the engines give a great deal of trouble. An example of this is shown in Fig. 63. This shows the principle on which the exhaust

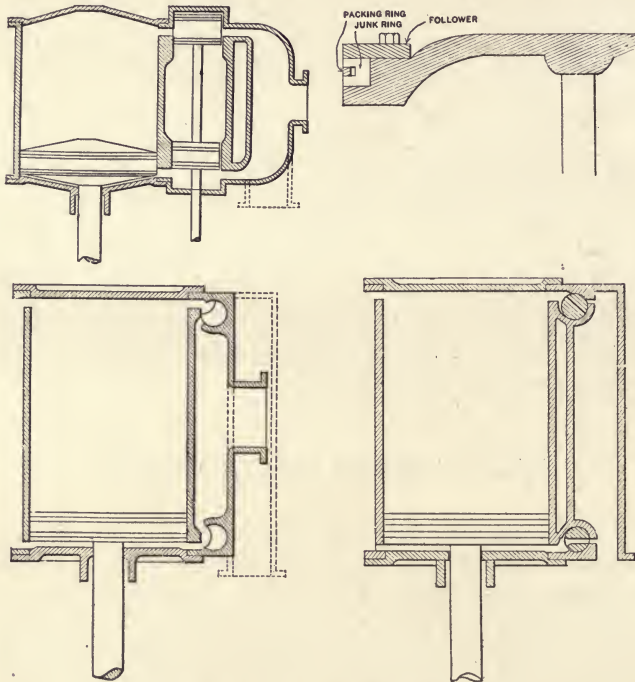

Figs. 63-65-66. Exhaust outlets.

Fig. 64. Low pressure piston.

side of this engine is built. On the opposite side are the steam valves, also piston valves.

This engine has a large clearance, but the chief defect is in the exhaust outlet.

It will be noticed that this is in the center. All the

Water in Cylinders.

condensed water from the top is thrown to the bottom. When the bottom valve opens, the water from both top and bottom must pass upward and turn the right angle with the steam to get out. This it will do if the engine is loaded and the exhaust passages are filled with steam. When the engine has a light load the water falls back, enters the bottom of the cylinder and makes all kind of trouble. This engine has pistons with conical faces, and the bottom head is a beautiful water-pocket. It is a delight for the engineer to take care of the rod packing and scoop up the water that is thrown in all directions. The maker of metallic packing for this engine has little peace in life. The valves being of the piston type, there is no escape for the water except such as has gone down the rods, and there are cracked pistons, and broken journal cap bolts, these apparently being the weaker part of the engine.

A section of the low-pressure piston is shown in Fig. 63. The piston is a single casting with a rebate joint for junk ring, and the follower is a ring of metal held in position with tap bolts. The distress in this cylinder from water showed itself in the loosening and breaking of these tap bolts.

This engine drives a railway generator. The cars are of the 60-seat type, and run at regular railroad speed. The schedule is such that for about one-half hour the cars are at the terminal stations or on down grades. At such times the pistons pounding on the water at the bottom of the cylinders is a delight to mechanical ears. When the cars strike the up grades, which a portion of them do nearly simultaneously, and the engine is loaded, the water will be driven out and quiet reigns until a short time after the light load comes on.

Breaks from Water.

Most of the trouble could be obviated by making the exhaust passage like that shown by the dotted lines. The pockets caused by the conical pistons and at bottoms of valves would give trouble, however, in keeping the rods tight.

An engine was wrecked by the breaking of the cross-head end of the connecting rod. This end was made of ordinary yellow brass screwed on to the end of rod.

The throttle had been closed by an automatic device, and the engineer had unhooked the wrist-plate to stop the engine by hand in the usual manner, when this casting gave way. The question then arose as to the cause of the casting breaking at just that time.

Examination of the break showed that there were two small places where cinder had got in the mixture when poured and there was also evidence of crystallization. The engine was a vertical Corliss type, shown in Fig. 65. The exhaust was the old-fashioned kind, with the exhaust chamber surrounding a portion of the outside of the cylinder. This type is bad enough when horizontal, but when set up on end it is barbarous.

We have here the same feature in a modified form, as mentioned in the piston valve engine, with two exceptions in its favor. It has a flat head, and there is a chance to keep the rod tight. It has Corliss steam valves, and there is a chance for a partial escape of water into the steam pipe.

When the engine runs light, there will be some shock when it strikes the water that in time will cause the weakest part to give way.

This type of engine, either vertical or horizontal, should have the exhaust chamber arranged as shown in Fig. 66, the valves in circular form with port through the

Piston Rods And Follower Bolts.

center and seat on what in this engine is the back of the valve. This brings the steam pressure top of the valve to hold it on its seat, thus doing away with springs, as well as reducing clearance. Vertical engines should have the outlet at bottom as shown, horizontal in center. Water, in these cases, does not flood the cylinder or cause immediate wreck, but it will cause distress on weak parts for future trouble. Engines working with full and continuous load will generally clear themselves of water. It is the irregularly loaded ones that give cause for apprehension.

It may be noticed that in both these cases the valves are shown reversed from the position they would be in when in operation. This is to show the easy path for the water to flow back into the cylinder when the light exhaust has left it and the cylinder is empty.

These are cases where the designer "didn't think."

Piston Rods and Follower Bolts.

An engineer was told one morning that the back cylinder head of one of the engines had gone through the engine-room door and was lying out in the yard.

The rod was what is known as a screwed rod and had broken just outside the jam nut; the piston had taken out head, doors and all. The end of the cylinder was cracked some, but it looked as though it could be strapped if a new rod and piston could be had. The front head was all right. The engineer took the jam nut for size of thread and other necessary dimensions and started for the builders, feeling that a screwed rod was not just the thing. At a place where he changed cars the train he was to take was half

Key or Screw—Which?

an hour late and when it arrived the locomotive had been through his experience.

A piston rod had broken in the key slot in cross-head. Here was a keyed rod broken; at the shop he saw an engine cylinder wrecked by a break in the key. Here were two keyed rods broken to one screwed. Which plan was the safer?

After he arrived at the shop he received a telephone from home that as the cylinder cooled off the cracks extended and new ones showed up; that there was no hope of saving it, and the only thing to do was to get a new cylinder, which was done.

There was this difference between the stationary engine and the locomotive: The bolts holding the head of the stationary engine were made too large, and when the strain came and something had to go, the expensive cylinder took the punishment. On the locomotive the working strain on the bolts had been carefully calculated; they were made strong enough for that and no more, and when the shock came the bolts let go, the cylinder was uninjured as well as the head and piston. All that was necessary was a new rod and a new set of small bolts.

If stationary engine builders would take lessons from locomotive builders in this respect, there would be less disastrous wrecks when there is trouble with the back head.

There is one other trouble that has caused a great many bills of expense, and that is: follower bolts on the piston. With good, tough iron bolts nicely fitted there should be no trouble. Many bolts are not properly fitted and they get loose and come out, and but few engines have clearance enough for them. A follower bolt should be fitted so as to require some pressure of the wrench all

Corliss' Way of Doing It.

the way. It should not stick when part way in. It should be set up snug, but not enough pressure should be put upon it to strain it in any way. A great many follower bolts are strained beyond their elastic limit and they break when at work. Either of these evils is the result of carelessness or incompetency. According to the observation of Mr. Corliss, the most prolific cause of wrecked engines was broken follower bolts, and these broken bolts were caused by screwing them up too hard. It was a rare thing if they got loose. To avoid the possibility of getting too much strain on them, during the latter part of

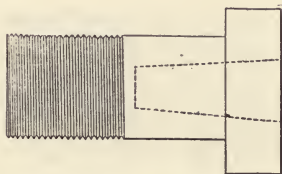

Fig. 67. Corliss follower bolt.



Fig. 68. Tapered plug for screwing in.

his life he had them made like Fig. 67, the bolt large, with fine thread and a tapered socket in the end. This was set up with a tapered plug, Fig. 68, so that when a certain strain was put on the plug it would come out. This worked well for a time, but with some engineers who did not adjust their pistons often the bolts would stick and the tapered plug would not hold, so engineers had to invent something to start the bolts, and the same device that would start them when stuck would also set them up too tight. However, these bolts were so large there was little trouble from breaking.

Prof. Sweet's Plan.

During later years, when the practice has been to make parts interchangeable, some builders have bought machine bolts of steel, and in most cases of this kind the bolts are loose fitting, especially so after they have been in use and have been removed a few times. An old bolt, or a new one put into an old hole, makes a bad job, and generally they are too small. If builders of stationary engines would make the follower bolts on pistons larger and pay more attention to the fitting, and make the back cylinder head bolts smaller, there would be less expense for their customers from breakdowns.

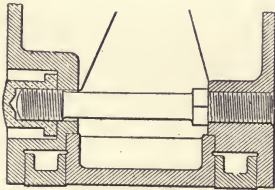

Fig. 69. Sweets' flower bolt.

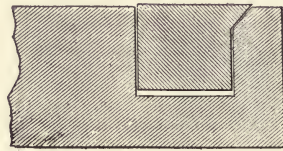

Fig. 70. A slow-acting (?) junk ring.

Prof. John E. Sweet writes:

"We overcome the difficulty perfectly by doing away with that sore of bolt. The drawing shows what we use and the success comes from riveting in the stud and turning down the body to the bottom of the thread. The stud will stretch one-half inch before it will break, and before that takes place the end of the nut will be shoved off, and the man with the long-handled wrench will have a warning.

The elasticity of the long body is so much that it is like putting a spring washer under the nut, and they don't work loose. The nuts we use are Tobin bronze, capped over so as to prevent steam from getting to the thread or

Piston Packing Rings.

leaking. Cost! Yes, but is not the preventing of the trouble—and this does it—worth the cost?

The recesses shown in the piston rings in the drawing are cast eccentric, giving the effect of an eccentric ring and parallel surfaces in the grooves in the piston. The rings are limited expansion—that is, the ends are hooked together so as to prevent their crowding against the surface of the cylinder, but when the whole is up to running temperature they are a mechanical fit in the cylinder. They cost, too, twice or three times as much as ordinary rings, but they are worth it."

For many years pistons were made with rings set out with springs and screws. In one respect this plan was excellent when skill was used in the adjustment. The rings had the same tension at all parts of the cylinder and the cylinder was always the same size the whole length. Later came the self-adjusting steam packing rings, which wore the cylinder large on the ends. Then came the various sectioned packing rings set out with springs and all self-adjusting. Many of this type are ingenious, simple and do good work. The snap ring has probably the most advocates.

The concern an M. E. was with at one time rented a factory and power to another concern. The engine had steam packing in the piston and the cylinder being in bad shape it was decided to rebore it and put in new packing. The engineer wanted steam packing rings and the M. E. proposed to let him have what he wanted with the plea that a man made happy would take better care of the machine. The president said "No. Put in the same packing we have on our own engines," and a pair of snap rings were put in.

The engineer spent several evenings taking off the

“Slow Acting” Piston Rings.

cylinder head trying to find something the matter with the packing. At last he gave up, and one evening wanted the machinist who fitted the packing to come and look at it. He had the wheel blocked, and turned on full head of steam. but not a particle of steam or a drop of water showed. He said nothing of it to the M. E., but was always a little sore because he did not get the steam packing. The steam packing would have cost about 60 per cent. more and the cylinder would have been out of shape much quicker with it.

One maker of steam packing claims that his rings are made in such shape that the steam acts on them slowly. A cross-section is something like Fig. 66, and his claim is that the beveled edge prevents the steam from acting quickly. As well claim that steam acts on a conical piston slowly.

With most packings that are put in junk rings, the junk ring has to be removed to get the rings out, and unless the ports are well blocked up there is trouble with them, and getting rings over the counterbores is at times exasperating.

Some builders—the Bass company being the first—make their rings so that the packing rings can be removed and replaced without removing the junk ring. This makes the examining of the packing and truing up of the piston a quick and easy job. It has been remarked on several occasions that it appears to be the settled policy on the part of some builders to make their engines as unhandy and expensive to take care of as possible. One of these things is a solid piston. A solid piston is heavy, it cannot be centered; if the ring breaks, or if it is thought one is broken, the rod packing must be removed, rod taken from cross-head, the whole arrangement taken out

Stopping a Pound.

and then the whole thing put back. A job that with a proper piston could have been done in an hour takes half a day to a day and lots of extra help. When a man confesses he can build nothing but a solid piston it is a confession that he has not the "know how."

Many engines have a pound at the back end of the cylinder. Some engineers claim to have discovered the cause, which is a pounding piston, and they want a large sum for pointing out the remedy. An engineer had a

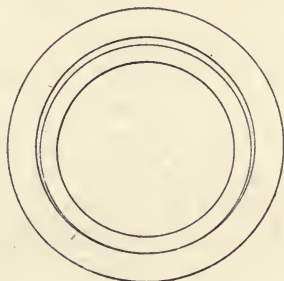

Fig. 67. Junk ring too small.

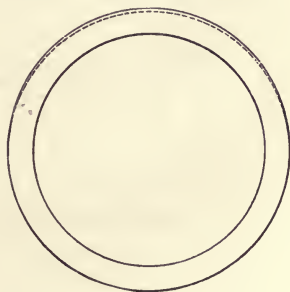

Fig. 68. A remedy for this.

heavy pound in the back end of a cylinder and took off the head and removed packing, but found nothing to indicate that there was any trouble. There was nothing out of the way, except the junk ring was small and the piston could move sideways if the force of the entering steam should strike the piston heavier on one side than the other. Fig. 67 shows this in an exaggerated form. He made a new junk ring with new snap packing rings, the junk ring being turned the exact size of the cylinder, then set off the center so as to turn the top of the ring off to

High Speed Engines.

allow for clearance. This is shown in Fig. 68. A ring turned in this manner will fit the cylinder nearly half of its circumference and there can be no side movement. After this there was no more "pounding piston."

The joints of the packing rings can be anywhere in the lower portion of the junk ring and the piston will be tight, even should they be open for one-fourth of the circumference. This may not be the cause of a pounding piston, but with a junk ring made in this manner there will be no pounding, also the packing will be tight with packing joints on the bottom.

Where High Speed Engines Pay.

There are many cases where light machinery, like fans, small dynamos, etc., is operated where power is wanted when the main engine is shut down. These are required to run at high rotative speed, and in such cases it is a good policy to investigate the small engines running in a case with the moving parts continually slushed with oil and water.

For those who like all parts in plain sight where everything can be examined thoroughly at any time and adjustments easily made, there are a number of high-speed machines of this character that are doing excellent work.

For light work at night it often pays to have these engines so placed that they can be hitched on at any time. For places that belting and shafting costs too much to fit up, these engines are valuable, especially where steam is used about the mill and the cost of piping not great. Many a large engine has been materially injured by running too light a load evenings, to say nothing of the economy.

Electricity in Place of Shafting.

In an electric station an 18-inch cylinder Corliss engine required more coal after 12 o'clock than a high-speed engine doing the same work. The latter engine had a 12-inch cylinder and the load was just a full load and it was doing its best service.

It is becoming the practice to use electricity and thus save the installation and friction of shafting and belts. Large, tight belts can make sufficient friction to consume a great deal of coal. This is the proper thing to do when machines can be grouped so that too small motors are not used. In this case the engine is large, and should there be small loads to be run through the evening it would be a good plan to use a small engine for the purpose rather than run the large engine with the electric equipment.

Turbines have come to stay, but just what can be expected of them is not yet known. So far, one can get as good guarantees for economy from builders of vertical engines, and in some cases horizontal engines, as from turbine builders.

There is one case where the claim is made that the company operating the plant does not know what either system is using, but they do know that when the turbines are in operation but half the fuel is used that is required to operate the same plant with high-grade Corliss engines. Their Corliss engines should produce a mechanical horse-power with not to exceed $13\frac{1}{2}$ pounds of water per hour. This would make the turbines running with $6\frac{3}{4}$ pounds. Evidently something is wrong. The turbine has a tremendous peripheral speed amounting to 30,000 feet per minute.

There are cases where the engine builder makes great promises about the performance of his engines and guarantees great results. The engine is sold f. o. b. factory.

Satisfactory Engines.

After the engine is put in use it is found faulty and does not come up to the guarantee, and when the builder is appealed to to make it good he falls back on the claim that the engine was sold f. o. b. factory, and after it leaves the factory it is the customer's machine and he has nothing further to do with it. He sends a man to erect it and his work is inferior, and when complaint is made he claims that he furnished the man as an accommodation; that the man during the erection was working for the customer and under the customer's direction; that the engine was f. o. b. factory and the customer is at fault if he does not see that the man does his work right.

Two cases of this kind have come to my notice, both of them from one firm. The better plan is to insist that the engine builder shall deliver and erect his own engine and be responsible for his work and his men.

Steam pressures are increasing, which is of advantage in many ways where there is a large amount of power and the work is continuous. Because of this, there are some mill owners who hear of the high pressures and think they must not be outdone, so put in engines of no more than 500 horse-power, that think they must use 160 pounds or more steam pressure, and they only run ten hours per day.

One case that came to my attention was of a man that put in a single 24-inch cylinder and arranged to carry 160 pounds steam pressure, and put in piping, heater, etc., none too heavy for 100 pounds.

The excessively high steam pressures have not yet demonstrated so much economy as to warrant the necessary extra weight, piping and accessories for ordinary small and medium powers for light and medium work.

Hot Boxes and Bearing Metal.

A firm had a new engine which, in common with engines of that time, had all of its bearings of bronze. The outer journal was short for a regular wheel, but this being in a rolling mill, an extra heavy wheel was put on and put close to the outer bearings, and there was a hot journal right off.

Stove blacking—the black lead of those days—sulphur, salt pork, etc., were tried without avail, and cold water was the only reliable thing that would allow work to continue, and cold water was used as long as that engine was run. The crank-pin boxes were also bronze and these had spells of heating. After a trial of several cooling mixtures, white lead, thinned to the consistency of paint with lubricating oil, was found to be the best, cooling the quickest and leaving the pin smooth. This was applied by taking a small funnel, putting the forefinger of the left hand over the bottom until the oil hole was reached and then holding the funnel with the right hand. This, of course, is not possible with high-speed engines, but there are a number of ways that suggest themselves as different conditions arise. There is a mineral called barytes that is used extensively in the adulteration of white lead, and if this is used it will make trouble, but genuine white lead is an excellent cure for hot journals.

Cold water is a sure thing if enough can be used, but there are many places where it cannot, as it would ruin belts or machinery. An M. E. went into an engine-room one afternoon and found them shut down with a hot main journal, and they could only run a few minutes at a time. They could not use water because it would not do to let it run into the wheel-pit. He called for some white lead

Cooling Hot Bearings.

and some ice; mixed up the lead and showed them how to apply it, put the ice on to the cap of the journal and built a fence around it with waste that would absorb nearly all of the water and at the same time keep the melted ice spread over the whole top. The engineer said if he could only run long enough to bring down the goods they were to ship that day they would be satisfied. The M. E. called again in two hours, found everybody happy, journal cool and the engineer did not have to work that night.

Bronze boxes are nearly gone by and their use is very rare, babbitt metal and the cheaper white metals having taken its place. Some of the white lining metals are no better than bronze, and they have a way of melting out that is not pleasant.

One journal, 14x26, used to have spells of heating without any apparent cause. After ten years of service it was thought best to put in some new shells, and in order that they should be all right, the engineer had the lining metal made up and sent to the builder who made the new shells. As there was considerable work to be done, they sent a man from the shop to put them in. This man evidently had had experience with new shells on old journals and was careful to make all preparations for hot work, even having a hose laid.

Everything went off cool and all right and the engineer expressed his astonishment, and the following conversation took place:

Engineer—But those shells have babbitt metal.

Engineman—We put in babbitt metal.

Engineer—What kind?

Engineman—The best we can get.

Engineer—How much do you pay?

Engineman—Twenty-two cents.

Crank Pin and Cross Head Boxes.

Engineer—They cost thirty cents without the labor. Babbitt's receipt called for copper 4 parts, antimony 8 parts, and the best Banca tin 96 parts. This is the same, except it has only 85 parts tin and is a little harder, and you will notice that when first cast it has a slight tinge of yellow. It will stand hammering and at the same time, when chipped, the chips will fly all over the room.

The outer journal of this engine had a way of getting very hot persistently. Taking off the cap revealed a small line about 1-16 of an inch wide that was very bright and there was so much friction that oil fed through the cup would have no effect.

The cap was removed and a wooden box with a lid made, and this was packed with waste, when a very little oil would run it all right. This shaft was made from horseshoe scrap and a piece of steel caulk might have made the hard spot.

It has been the custom for years to line the crank-pin boxes with babbitt and make the crosshead boxes of bronze. An engineer had an engine with crank-pin $7\frac{1}{2}$ inches and crosshead pin 7 inches in diameter.

The crank-pin boxes would run without keying up for months, but the crosshead boxes would need keying twice per week. In the Mechanics' Fair at Boston, in 1883, there was on exhibition what was termed "hardened copper" that was claimed to be superior to any metal for bearings. It was not "hard" but it was treated in some manner so that it would file and work with tools something like cast iron. The engineer got some of this and had some crosshead boxes made. These would go for a longer time without adjusting than the crank-pin. Evidently, the makers of this metal could not make people believe that copper would make good bearings and had

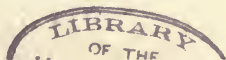

Bearings that Bind.

to give up the business. None of it can be found now.

It is a fact that pure copper is one of our best non-at-trition metals.

One lubricant used in drawing brass and copper is made by boiling together tallow, hard soap and water, putting in water to make it of the proper consistency. This is better than oil for cutting brass and copper pipe.

Soap is a fair lubricant and at one time was extensively used in packing axles on locomotives that heated. A dash of spirits of camphor sometimes has a good effect.

Kerosene, when gummy oils are used, will clear a journal, but not so quickly as potash or ammonia.

The causes for hot journals are many. Of course, a tight journal will heat. A journal in a solid box, if it gets warm, will pretty surely get hot, as it will expand faster than the box; the outside of the box not being hot will not expand and will cause the box to bind. The only place that there is any excuse for using solid boxes is on the parallel rods of a locomotive.

With reciprocating motion a box too loose will heat from the pounding out of the oil.

A bronze box is cause for apprehension. The name "bronze" covers a multitude of sins, and worse. A few are made of good material; many are simply cheap brass with an occasional small percentage of tin. When they get hot they tear the journal and frequently ruin it. A great many of the white lining metals are as bad, so far as heating is concerned, as "bronze." They are made up of cheap material, lead being largely used.

When a man offers cheap lining metal it must be made from cheap ingredients. Sometimes the best lining metal is ruined through improper treatment, and this is more liable to be the case with the better qualities than with

Causes of Heating.

the cheaper. Tin melts at 440 degrees Fahr., and a metal made chiefly from tin should not be overheated. A good rule is that it is sufficiently hot when it will char a pine stick. It should always be covered with a flux when melting to preserve it from oxidation. Charcoal is often used for this purpose.

Heating may be caused by all parts not being lubricated, there being no oil channels to spread the oil; by hard metals made up in the shaft, like pieces of steel, or cast iron, or cinder, or any material that does not wear smoothly and evenly; by the casting not being properly cleaned and sand working out under the lining metal; by the edges of the lining metal not having been trimmed off and the thin edges cracking off; by the work not being in line, or level and the load not distributed evenly; by the journal not being of sufficient size, there being more than 150 pounds pressure to the square inch. In some cases dirt may get in, and in many cases improper lubricants are used. Too tight a belt makes an excess of friction.

Corliss Engines.



This chapter will be to a large extent personal. For a number of years I had tried to get some one interested in putting on an extra eccentric but was unable to do so, and all Corliss engine builders of the time claimed that it was not necessary and would make a needless combination and expense.

In 1872 I had added to my equipment a Corliss engine, 28 x 60, running at 52 revolutions. To this engine was attached a syphon condenser. At that time indicators were scarce, but I had a Richards. I was unable to get a card that suited me. If the attempt was made to get any compression the exhaust was late and would not show full vacuum before half stroke. I tried compression by giving the eccentric a large advance and by lengthening the exhaust connections. By doing this it was necessary to lengthen the steam connections. This made about three-eighths stroke the latest possible cut-off. As the engine was doing rolling mill work, some of the time it meant full stroke. The slowness of the exhaust also troubled me. It was learned after repeated trials that getting compression at the expense of release meant more coal burned, while the earlier the release, the less coal

Corliss Indicator Diagrams.

was required. It finally settled down to the diagram shown in Fig. 69, as the best that could be done and still have the engine run fairly quiet. I began to talk two eccentrics for Corliss engines, but no one would listen to me, all interested parties claiming the extra one was not needed. I tried to induce those having new engines built to insist on it, but all were easily talked out of it.

In 1883 I was in a position to say that the engine should be changed that way. In conversation one day with the superintendent of the engine works, he was told there was going to be another eccentric. Said the superintendent, "We can build it for you," and it was arranged

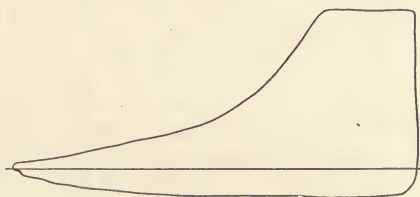

Fig. 69. Single eccentric diagram.

that I should send the dimensions and a sketch of what was wanted and the engine builder would make it. It was made in 1884.

For some reason everyone had the idea that the office of a second eccentric was to give freedom to setting the exhaust valves and the principal thing was to get compression. I wanted to get early release and have the vacuum have effect the full length of the stroke; also a longer range of cutting-off.

With a Corliss engine it is evident that the valve must release at or before the full throw of the eccentric, so the steam eccentric was set at right angles to the crank, which would insure a range of cut-off up to half stroke. Both

Wristplates.

eccentrics were set at right angles to the crank, both wrist plates vertical, the steam valves with 1-16 inch lead and the exhaust with $\frac{1}{8}$ inch lead. The exhaust eccentric was then turned to about 30 degrees angular advance of the steam eccentric.

I have always had the idea that one should never depart from the builder's design of an engine if pos-

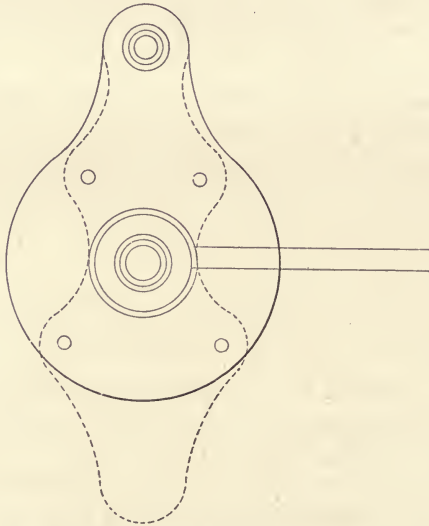

Fig. 70. Old Corliss Wristplate.

sible; that there should be no special parts, so that repairs could be quickly and cheaply made. The wrist plate originally was like Fig. 70. The new wrist plates were made one-half as thick, with the outline shown by dotted lines, and fitted to the same stud. The new rocker arm was the same as its mate, and all valve connections

More Corliss Cards.

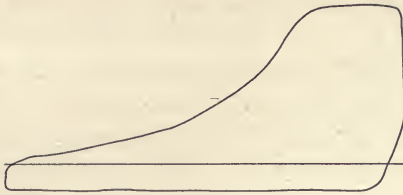

Fig. 71. Diagram from two eccentrics.

were the same. After the new arrangement was started a diagram was like Fig. 71. It will be noticed on this that the cut-off is round. I wrote the builder, sending some cards, and inquired if there was any remedy. The builder suggested that the studs operating the steam valves be set 1 inch nearer the circumference of the wrist plate, which would give the valve more and quicker travel. This was done, and the precaution was taken to work the wrist full throw both ways to see that everything was clear, but when the steam was turned on and the engine was partly up to speed, the dash-pot rod pulled just out of the guide, and the result was a broken wrist plate. As everything was uniform with the old, the old single wrist plate was put back and attached to the steam eccentric set at right angles to the crank, and Fig. 72 was the result.

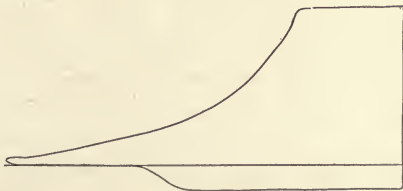

Fig. 72. Another card from one eccentric.

Two Eccentric Corliss Engines.

The round cut-off was not overcome by the longer and quicker travel to the valve, and I have observed since that, with a condensing engine, early release and compression, the cut-off will be round.

There was another thing observed, and that was that the range during which the engine could cut off was extended to three-quarters stroke. At first it did not seem possible, but it was reasoned that the release taking place at half stroke, and the piston being at its highest speed, it must travel the extra quarter stroke while the valve was closing.

The first engine to which it was applied was speeded up two revolutions by the change, owing to the governor in its old position having a longer cut-off. It has largely been the custom on Corliss engines to build the governor with a travel of 4 inches. This was cut down to $2\frac{1}{2}$.

With two eccentrics set in the manner described so that steam can follow three-quarter stroke, and the governor travel reduced to $2\frac{1}{2}$ inches, a Corliss engine is a powerful machine and the regulation is very close.

The wrist plates should be as light and simple as possible. A few builders make small balance wheels for this purpose. It should be remembered that a wrist-plate must be stopped and started twice every revolution, and, when made heavy, brings a severe strain on the whole gearing from wrist plate to eccentric, and means hot eccentrics, shaky rods and a pound in every joint.

Some wrist plates are built like Fig. 73, evidently with the idea that they can be finished all over in the lathe.

Wrist plates like this are very hard to stop and start the other way, and with this type there will always be hot eccentrics. It is not necessary that wrist plates should

Setting Corliss Valves.

be finished and many are made that are left plain castings.

On the end of valves, on the opposite side of cylinder from wrist plates, is a mark showing the edge of the valve, and below on the seat are marks showing port openings. Fig. 74 shows these marks and my method of setting the wrist plates and valves before splining the valve stems for the little jim cranks.

The usual method for setting Corliss valves with one eccentric, with engine on the center, is to give from 1-32 to 1-16 inch lead for cylinders from 12 to 36 inches. With wrist plate on center, steam lap from 3-16 to $\frac{3}{8}$ inch and exhaust lap from 1-32 to $\frac{1}{8}$ inch. According to

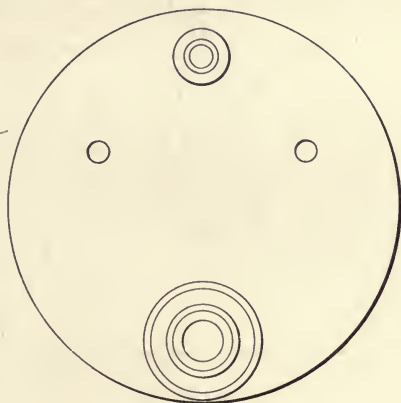

Fig. 73. Round wristplate.

my plan with compound engines, the steam lead on the low-pressure cylinder should be from $\frac{3}{8}$ to $\frac{5}{8}$ inch, depending on size of cylinder.

With cylinders without steam jackets, the corner of steam line on indicator card should be a little rounding. This is caused by initial condensation. To bring this

Marks for Valve Setting.

corner up square means excessive lead, more coal and more oil. With a steam jacket, this corner will be brought up square.

Fig. 75 shows plan of wrist plates and my way of putting in the starting bars. By this method both bars can be taken in one hand and the engine handled the same as with a single wrist plate. Most builders put in round rods, and in such a manner that it is impossible to handle the engine by hand.

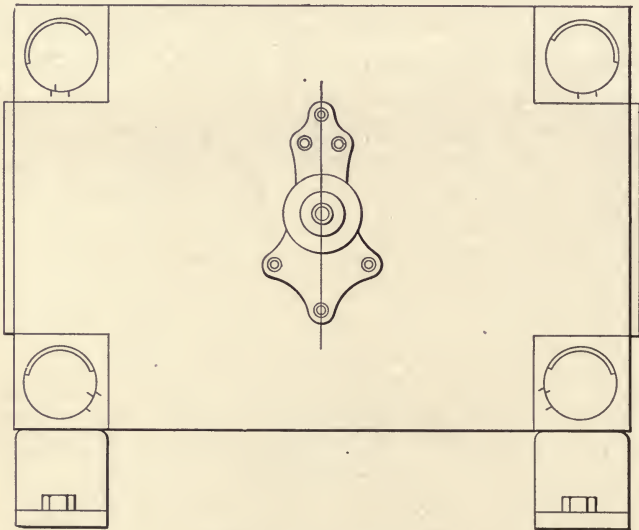

Fig. 74. Valve setting marks.

These bars are struck out in all sorts of directions but the right one. They are usually laid out by draftsmen or someone having no practical knowledge of engineering.

When a Corliss engine, or any other four-valve en-

When Valves Make Trouble.

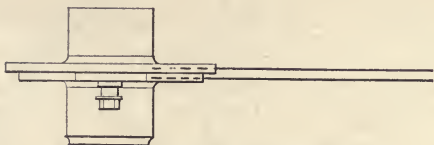

Fig. 75. Both bars handled together.

gine except piston valves, is running light so that the steam expands below the atmosphere on non-condensing single engines, the exhaust valves will lift and rattle. This is particularly noticeable when steam is shut off. Because of this, a very few engine builders have got into the practice of making the ends of the valves solid to prevent them lifting. Valves made in this manner are liable to give trouble when starting the engine. When a valve which is solid on the end, or a piston valve, or any valve that fits tight to case, has steam admitted, the valve will become heated before the surrounding case and will stick and cause something to break. This has caused lots of single pump mechanisms to break, especially when new. Where there are valves of this kind, care should be taken to heat everything thoroughly before attempting to start.

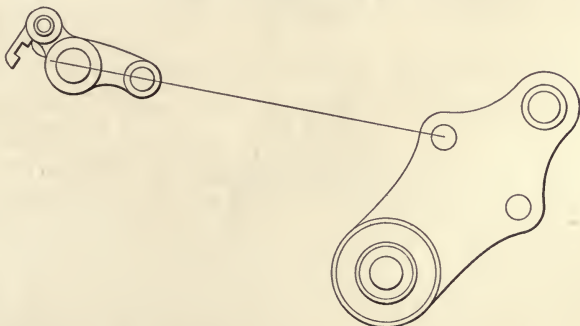

Fig. 76. Not a good plan.

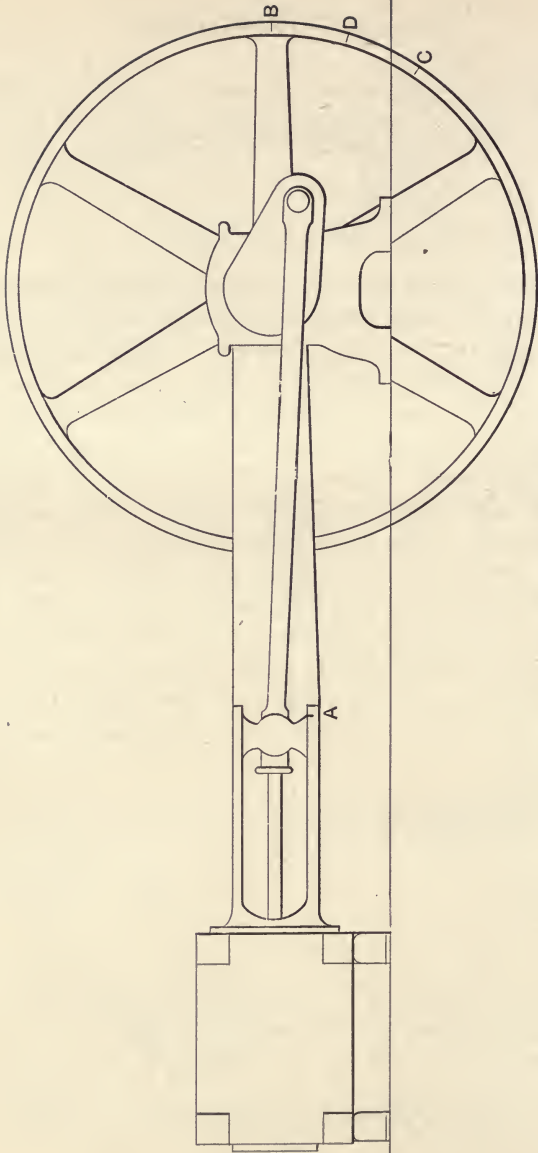

Fig. 77. Putting an engine on the center.

How to Place an Engine on Centre.

Another bad practice some builders have gotten into is to construct the valve mechanism in such a manner as to bring the jim cranks very nearly in the center at full throw of wrist plate—nearly as bad as Fig. 76. A very little shortening up on the connections means a wreck.

To place engine on exact center, turn the crank just past the center and mark the cross-head and guide, as at *A*, Fig. 77. Also measure from the floor to side of wheel rim, say one foot, or two feet, and make a mark upon the wheel, as at *B*, then turn the crank the other way past the center to bring the mark on crosshead and guide and with the same distance from the floor as before make another mark on the wheel, as at *C*. Now make a permanent mark *D* on the wheel just half way between the two marks, and this mark, brought to same distance from the floor, puts the engine exactly on the center, and the mark being permanent can be used at any future time. Mark for the other center in the same manner.

Should it become necessary to alter the steam connections between wrist plate and jim crank, be careful to see that the dash-pot rod is also adjusted properly, so that it will not be pushed to the bottom or lifted so high it will not hook on.

Next give attention to the reach rods from governor, to see that the valve cuts off properly and that the stop motion has not been put out of service.

An engineer had occasion to examine five engineers for a chief engineer's position for an 8,000 horse-power station, and when the question was asked, "When changes have been made in the steam connections, what changes should be looked after in the governor?" not one of them could think of a thing, although, if a governor belt should break, it means a runaway.

An Answer to Criticism.

Cards were sent to the builder, and the superintendent showed them to the head draftsman, who inquired why they had not done it before. "Oh," said the superintendent, "Crane has been after us to build this for the last five years." Being asked why he had not done it he replied, "Because we don't want outsiders to come here and show us how to build engines."

The new arrangement cost \$263. The amount of coal burned two months before it was applied and for two months afterward showed a saving in fuel of \$500 per year.

This engine was not built at the Corliss works, but at the time there was at this place a 30 x 60 engine built at the Corliss shop, and the Corliss company was asked for a price for putting on an extra eccentric, and the reply was, "We will not do it for any price. We do not want our engines run that way."

The extra eccentric went on, nevertheless, and a few years afterward I went to the Corliss works and had a compound built just as I wanted it—two eccentrics and all.

After about 1892 any one could get two eccentrics who asked for them, and by 1897 most Corliss builders claimed they had built them for years.

I have been amused at seeing Corliss engines fitted with two eccentrics and both wrist plates working in unison. There are many engines running this way that would do just as good service with one plate.

Criticism has been made of my method of setting the valves. With 1-16 inch lead on the steam valves and the large lead on the exhaust, it is reasoned that for a short time steam will blow through when the engine is on the center, but this does not occur after the engine is up to speed and the cut-off in operation.

Selecting an Engine.

With some types of Corliss exhaust valves there will be pounding caused by the valve not having the springs put in correctly and the valve dropping a little during the exhaust to be forced against the seat suddenly by the entering steam.

Most automatic cut-off engines have a rattling in the exhaust valves when the engine is working light and running non-condensing caused by the steam in the cylinder expanding below the atmosphere, thus lifting the exhaust valves from their seats. With junk ring fitting the entire lower half of cylinder there are those who will contend that this will add to the friction, arguing that the pressure on top of the ring produces a pressure on every square inch of bottom.

This question is the same as that of the slide valve, whether the pressure is over the total face or over the ports only. No extra coal was burned with this form of junk ring.

When selecting an engine, some people are governed more by scruples than by conditions. There are many who are strictly Corliss men and can listen to nothing but a Corliss engine under any and all circumstances where there is sufficient power to be used that requires even the smallest sizes of this engine. There are others who will listen to nothing but high speed and direct connecting to individual shafts or to generators. When short stroke and high rotative speeds came out the claim was made that they used steam faster, and as a result hotter; there would be less condensation; the engine could be directly coupled to the engine shaft, thus doing away with a big wheel, jack shaft and belts and much power could be saved in that way.

One large manufacturing company put in two of these

What Engine to Buy.

engines, each coupled to a main line of shafting. They advertised extensively their plans and gave glowing accounts of the results after starting. After a time they began to count the cost, and it did not look so flattering. It would not do to make the change to a Corliss engine right away, in view of all they had said, so they kept very quiet for a long time and then put in a Corliss. For their work they did a wise thing finally, and should have done it in the first place. Even with this in view there are many cases where a Corliss is prohibitive.

A person just starting a small business has sufficient money to buy a high-speed engine and small building to put it in. His business pays so that it is enlarged, and he finally gets a Corliss. He did not have sufficient capital in the first place to pay for the Corliss, with the large building required for the engine, belt, pulleys, etc. There are many cases in large, well-established concerns that have use for power, where they have room for a high-speed engine and where the extra amount of coal used would not warrant the extensive changes in the buildings and grounds necessary for the installing of a Corliss. In many new buildings the same conditions exist. Where a small portion of the works run overtime a high-speed engine is a necessity, and, while using more coal per horsepower when the main engine is loaded, will drive the small amount of work required with less coal than the large engine would require.

Many business concerns have got a good start with a high-speed engine that could not have made a beginning had they been obliged to put in its bigger brother at the start.

It is more necessary, however, to have the high-speed engine loaded to about its capacity than for a Corliss. A

Power of an Engine.

Corliss engine changes neither its lead nor compression with change of load. While doing work it has the resistance on the exhaust side to overcome, and this resistance will be the same under a light as under a heavy load. With a non-condensing engine it would appear something like this:

Assuming an engine to have 160 square inches area and 500 feet piston speed per minute, it will give 80 horse-power with 33 pounds mean effective pressure. An engine with the same mean effective pressure will require 50 square inches of piston and the same piston speed to do 25 horse-power. Adding back pressure to the latter case,

we have 49 pounds total pressure, and $\frac{49 \times 50 \times 500}{33000} = 34$ horse-power.

Should the larger engine be only loaded to 25 horse-power it would require but 10 pounds mean effective pressure, and adding the 16 pounds back pressure we have

$$\frac{26 \times 160 \times 500}{33000} = 63 \text{ H. P.},$$

showing that the small engine to overcome all resistance would require coal for 34 horse-power, while the larger engine doing the same work would require coal for 63 horse-power.

Should a condenser be used these results would be materially changed, but there would still be the greater amount of condensation in the larger cylinder.

When we have a high-speed engine with single valve and shaft governor we have the above exaggerated by the compression. When a shaft governor is used, the compression is increased with every reduction in the point of cutting off, so that with light load the piston not only

Highest Possible Economy.

has to displace the resistance that falls to the lot of the four-valve engine, but from half stroke must push this resistance up to nearly boiler pressure in compression.

It is estimated that the highest economy that is possible for an engine to reach is 1 horse-power with 1 pound of coal. The engine that requires or that receives high compression will not be the one to attain it.

Valves.

Among the more prominent valves formerly used were the D slide valve and the single poppet valve. After pressures were increased the latter gave way to the double poppet shown in Fig. 78. This is balanced valve except

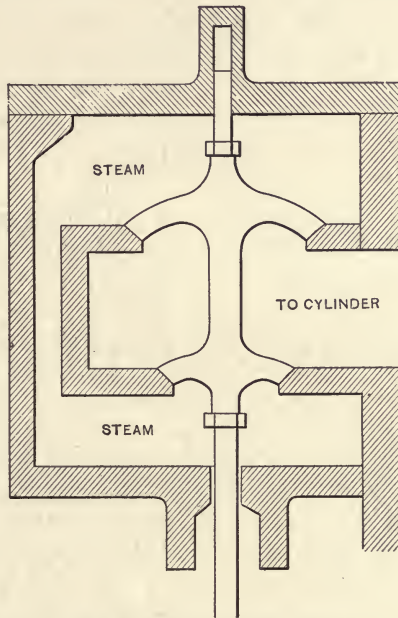

Fig. 78. Double poppet valve.

one end must be made sufficiently small to pass entire through the port of the other.

This is a difficult valve to make tight. In the first place, the seat frames are of iron and the valves brass and the expansion is different, and this difference increases

Slide Valves.

with the increase of pressure. In the second place, these valves must be ground to their seats when cold. It is rare that the same amount of material will be put on each seat. A single poppet valve can be made tight, but it would require heavy machinery to open it.

The slide valve, Fig. 79, can be made tight, and if made so that the valve will always wipe clear over the seat will remain tight for years. Some of these valves and ports are very crudely designed.

At one time lead was supposed to be necessary to

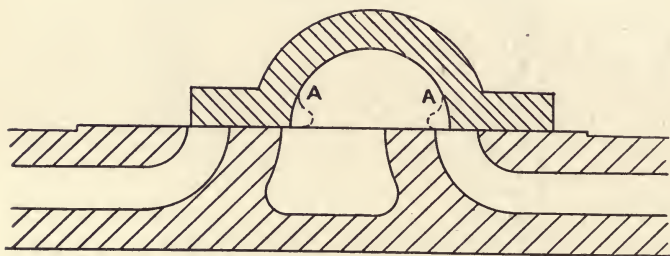

Fig. 79. A typical slide valve.

keep an engine from pounding. After the advent of the high-speed engine, compression was deemed the thing. With some builds of engines, both are thought necessary by the builders with the result that we have some pretty poor results, owing to the design of the valve. Not very intelligent work can be done in valve setting without an indicator, but either with or without an indicator a very clear idea can be got by taking out the valve. Take two parallel strips of pine and on one mark the dimensions of the valve and opening for the exhaust; on the other, the seat with ports, and put them together as shown in Fig. 80. Then find the travel of the valve and move the top stick

Laying Out a Valve.

over the bottom corresponding with the valve travel. The lead, both steam and exhaust, can be plainly seen as well as all the movements of the valve. Builders who have the idea that imperfections in the build and alignment of the engine resulting in a noisy engine can be overcome by compression, are apt to put an inside lap as shown by the dotted portion at *A*, Fig. 79. This, with a fair clearance, will make excessive compression and a late exhaust, both very expensive. An indicator card will tell how much of this should be taken out.

Lead will cause an engine to pound. Steam pressure

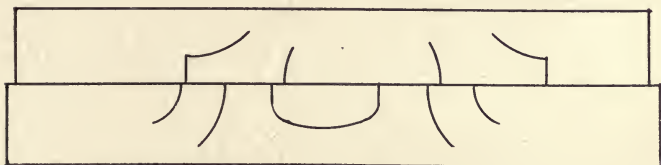

Fig. 80. Wooden valve for experimenting.

admitted to the cylinder raises the pressure suddenly and takes up the lost motion too quickly. An engine properly built, and not run at too high a rotative speed, will run smoothly with a moderate amount of compression. To attempt to get smooth running with an extra amount of compression or of lead means more oil, more coal and more repairs.

The longer the ports the more lead is required, as it takes time for steam to move. With small-sized engines about 1-16 of an inch lead for steam and $\frac{1}{8}$ for exhaust is a fair guess. When setting an eccentric a rule that can be easily remembered is: It should be set far enough ahead of a right angle to the crank to allow for the lap and lead of the valve. When it becomes necessary to run

Setting the Eccentrics.

the engine the other way this rule should not be forgotten. The eccentric would be turned either greater or less than half way, as indicated by the points on the shaft of Fig. 81.

An engineer was at one time called upon to look at the governor of a small engine. The owner said that the engine had run all right until of late, when he could not get speed. The governor was gone over carefully and

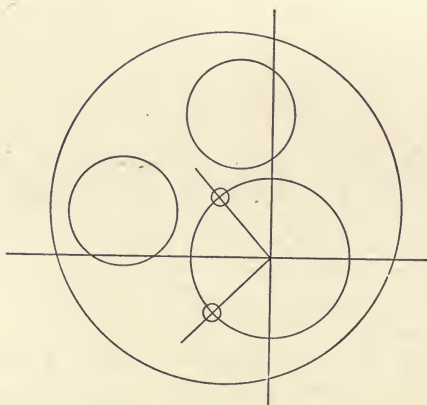

Fig. 81. Setting eccentric to reverse engine.

nothing was found wrong. The owner was asked if anything had been done to the engine, and received a reply that there had not.

The governor pulley was taken off, so as to get at the eccentric, and while looking this over the owner volunteered the information that he had moved the engine from an old location, had had a piper who wrote "M. E." after his name to do the changing, piping, etc., and the piper had an engineer come to set the eccentric. "Yes," said the engineer, who by this time had the steam-chest cover

The Gridiron Valve.

off, "and he turned the eccentric just half-way around." The eccentric was then set, and, by the way, there were marks on the shaft to set it to run the engine either way, and the governor gave no more trouble. Turning the eccentric half-way had delayed the admission of steam about one-third of the stroke; also delayed the exhaust.

There are many modifications of the slide valve. In some cases there are ports through the valve and a loose valve riding on top for a cut-off. In some cases there are two or more steam ports and a corresponding number of ports through the valve, making what is termed a "gridiron" valve. As you add a port you of course add to the surface exposed to the steam and add to the skin friction, so that for the same area there will not be the same amount of steam passing through at the same time. Should you try to lessen this and make the valve thin, if a large one, it will warp under heat and pressure. Some builders try to overcome this by facing off the seat and valve when hot.

A man about to buy an engine was solicited to buy an engine with a gridiron valve. While employing an engineer he took to investigating the subject personally. He paid four visits to a place where they had a very large engine with this type of valve, and on three of his visits they were facing off the valves.

This springing of the valve occurs only in the larger sizes. As ports are added, the travel of the valve is reduced so that the gridiron valve becomes a neat and a necessary design for a releasing valve under moderately high speeds. There are a number of nicely designed balanced slide valves which have the good quality of remaining tight for a long time and requiring much less power than the D valve.

High Speed Engines.

The poppet valve is very little used in mill, factory or electric work. Where met with they are operated by cams. To set the valves, the governor is raised to its highest position and blocked. The cams are brought around to the valve stems; if more cams than one, be sure and get the right cam to the right stem. Set the valve stem at the proper length so that as the cam passes it, it will touch but not open the valve. Then let the governor down, place the engine on the center and bring the cam into position to open the valve for the lead required.

Mention has been made of a small amount of compression necessary for smooth running of a well-built, moderate-speed engine. When it comes to a high-speed engine, these calculations are all upset. A high-speed engine requires nice design, nice workmanship and perfection in balancing. With a slow or moderate-speed engine, the pressure on the pin and main journal will be direct, as the push or pull comes from the piston. On a high-speed engine, the weight of the working parts and relative speed may be so great as to change the thrust on the opposite side. This tendency is increased with the increase of the weight of the working parts and also with light loads. It also increases as the square of the number of revolutions.

With a piston valve in engine or pump, one should be careful when starting up cold if the valve is nearly new, or if it has been recently adjusted, as the valve, when steam is admitted, will heat up much faster than the steam chest and will expand so as to be tight and liable to break something.

The valves for engines therefore are: the *D* slide valve, with its modification, the gridiron valve; the poppet valve, the piston valve, shown in Fig. 43; the balanced slide valve, shown in Fig. 82, and the Corliss valve.

Balanced Valves.

“Imitation is the sincerest flattery,” therefore the valve most imitated is that most desired by the public. The slide, because of the size necessary, is limited to small and medium sized engines where high-pressure steam is used. It is possible to use it on the low-pressure cylinders of compound engines where the heat and pressure are not great.

The poppet valve has largely gone out of use, but, like baggy trousers, may occasionally come in fashion.

The piston valve, because of its small friction, simplicity and cheapness, is very attractive and has considerable demand. Even those that own up to its liability to leak

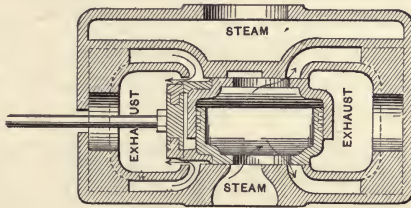

Fig. 82. Balanced slide valve.

will use it on high-pressure cylinders of compound engines, and by using a tight valve on the low-pressure cylinder get, in many cases, very good results.

Steam will blow through stronger into a vacuum than into the atmosphere. George was trying to reduce the coal bill at an electric station where they ran the day load with a single cylinder, piston valve engine. He connected the exhaust to the condenser, and immediately the coal account increased. He had a new valve and complete new chest put on, and, while there was some improvement, it still required more coal with the condenser. When exhausting into the condenser the steam could be plainly heard rushing by the valve.

Runaway Engines.

The balanced slide valve requires skill and time to make a tight fit, but can be made tight and durable. With from 15 to 20 per cent of the pressure to hold the valve in place it is a neat arrangement and vies with piston valve in attractiveness with the advantage of keeping tight. They are easily handled by a shaft governor and are largely used in medium and high-speed engines, and have a large sale. When an engine with shaft governor is attached to a condenser it should be carefully watched when there is no load. A shaft governor is supposed to govern the admission of steam from no steam admitted up to three-quarter stroke. With a single valve, with lead, compression, exhaust and the variable cut-off all to look out for, requires nice calculation, and in many cases the governor has not sufficient range to entirely prevent the admission of steam with no load, and with a vacuum the chances are in favor of a runaway engine. An M. E. attached a condenser to an engine with a shaft governor, and, knowing what he had to expect, explained to the engineer the probability of excessive speed at midnight, when the street lights were thrown off, and cautioned him to jump for his throttle as soon as he threw the switch. The M. E. stood close by the engine so as to be sure to prevent trouble. He, however, wanted the engineer to do the work and see what he had to deal with. He had to close down to save the engine and then let the engineer try and regulate it. The patrons that were using the lights at that time must have wondered a little.

He finally took hold of the throttle, closed it down and then turned it slowly up to the point where the lights were all right and then put a mark on top of wheel of valve. He then threw on the street lights and opened the throttle, counting the number of turns. The switch was then

A Tandem Compound.

thrown out, the valve closed that number of turns and, leaving the wheel with mark on top, brought the speed down, or rather regulated the amount of steam necessary for the proper speed, so that the governor could handle it without the lights fluctuating. This would not do for a railroad load.

An M. E. had a case with a tandem compound engine, piston valves, shaft governor, that was not safe with a condenser, and the builders had a man at work a month before he had the valves and governor so that it would control the engine with light load with a condenser. The builder sent in a bill for \$600, and insisted on its being paid or would bring suit. To avoid a law-suit the M. E. advised the payment of the bill and that not another dollar's worth of goods be ordered from the builders.

So far as the Corliss valve is concerned, there are many that do not like to admit they are imitators and claim to have something just as good or better. The horse-power of the other types are small as compared with the Corliss type. The Corliss type with disengaging valve gear is limited in rotative speed. There are builders that put in double-ported valves with steam closed dash-pots that will get 150 revolutions. The objection (there seems to be but one) to the Corliss engine is the cost of the mechanism for operating the valves, which makes the first cost of the engine large; also the longer stroke must always make this engine more expensive in first cost than the single-valve engines, but not more so than those imitations of the Corliss idea of using four valves at the ends of the cylinder. The valve gear should not be run over 125 revolutions.

Air Pumps and Condensers.

When James Watt separated the condenser from the cylinder of the steam engine, he built his air pump

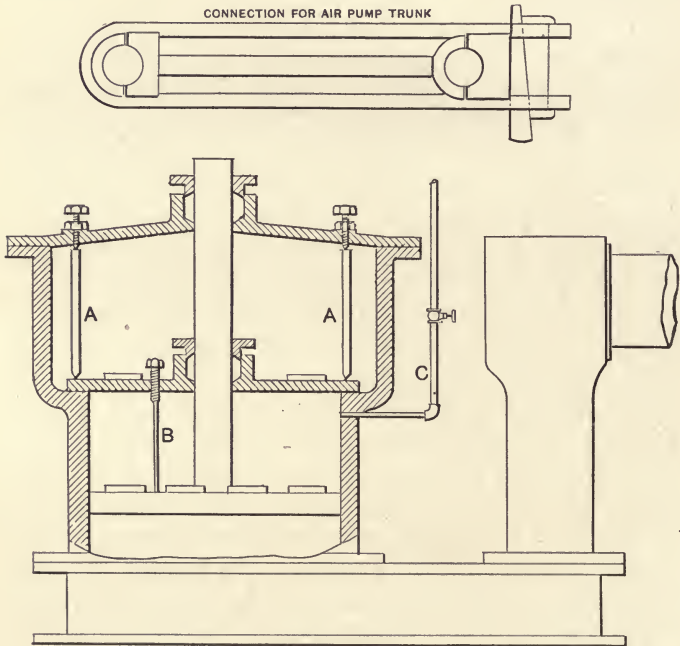

Fig. 83.

similar to Fig. 83. There has been some refinement put on this, but in the main it is the best plan for an air pump ever designed.

Mr. Corliss added something to it of value. He put in iron rods *A A*, with set-screws through cover, to hold

Air Pump Packing.

down the top valve plate. When it is necessary to lift this cover the set-screws can be loosened and the rods taken out. He then put in two holes through this plate, which are closed with plugs when the pump is in operation.

When the plate is to be lifted, the pump is put at its lowest position, these plugs taken out and bolts with an engagement, threaded near the head, shown at *B*. This bolt reaches to the plunger, and by raising the pump to its position the top plate is raised and access had to the plunger.

Mr. Corliss also made an arrangement for driving the pump—that is, the connection to the bottom of the trunk of a long strap with a rod between the top and bottom brasses, so that when the key is driven at the top, both top and bottom brasses are tightened alike.

The usual method for packing the plungers was with hemp, which would last but a short time. A man got a patent for a packing made from maple blocks, the joints rabbeted, and this packing made double. This packing was held against the cylinder by two coils of rubber hose made without canvas, Fig. 84. He sold his patent to Mr. Corliss, and it was the only patent Mr. Corliss ever bought. An engineer had one of these pumps, 26-inch cylinder, in use six years, and thinking the packing must be used up, he procured a new set to replace the old; but upon taking the old out he found it in perfect condition, and replaced it.

These pumps, as generally run, have a pound wher the water on top of the plunger strikes the valve plate. One of Mr. Harris's engineers learned to put in a $\frac{1}{2}$ -inch pipe with globe valve, as shown at *C*, and by opening this valve about one-eighth of a turn, just sufficient

A Patent Corliss Bought.

to let in air enough to cushion the water and open the valves before the water struck them, all pounding from the above cause would be prevented.

This is sure on all properly designed pumps, but as these pumps are lined with bronze, and all the parts of bronze are very expensive, there is too often a temptation to make them too small. When too small, this air cushion is of no avail, and will reduce the vacuum.

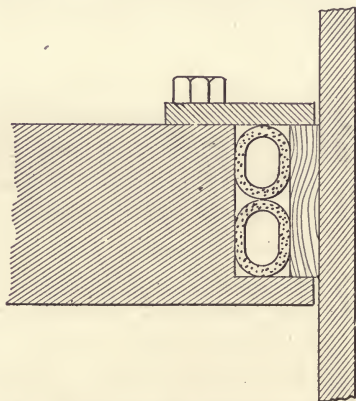

Fig. 84. Air pump packing that Corliss bought.

An air pump cylinder should be of sufficient capacity so that the water to be removed should not fill over 35 per cent., leaving the rest for air and vapor, which at that pressure require a large space.

When boiler pressures were low, condensers were a necessity, but as pressures increased many steam users got along without them, and because of their expense, the percentage of condensing engines was small.

About the year 1870 a man by name of Ransom invented a condenser, a cross-section of which is shown

The First Syphon Condenser.

in Fig. 85. This was the first syphon condenser.
At the top of the condenser was a plate, perforated

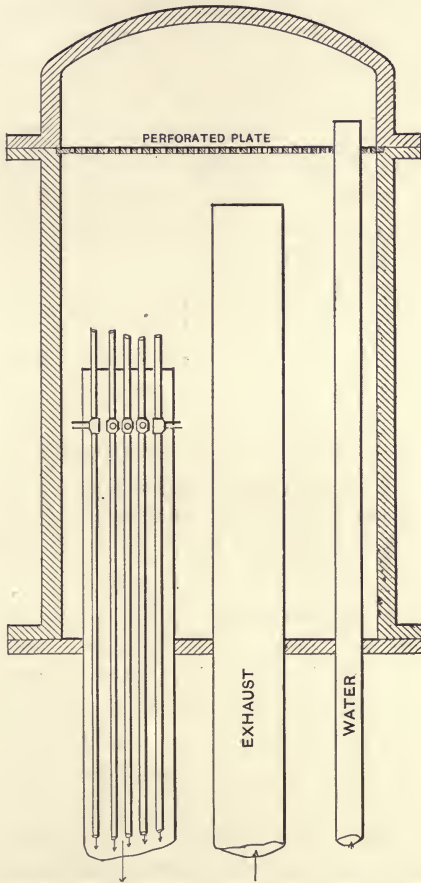

Fig. 85. The first syphon condenser—Ransom's.

except over the end of the exhaust pipe.

The injection pipe reached above the perforated

Trouble with early Condensers.

plate. The discharge pipe was of the same size as the exhaust and filled with 1-inch pipes, as shown. These pipes, near the top, had branches through which the water entered, and as the water passed down the pipes it drew in air and vapor at the top. Of course this condenser must be 34 feet above the hot well.

A great many of these condensers were put in, as they were inexpensive and had nothing about them to need repairs, except a cold water pump.

They would produce from 24 to 27 inches of vacuum, and many of them did good work; but there being no way of telling the height of water in them, and as it was necessary to have the water over the top of the discharge pipe to get the best vacuum, many an engineer pumped the water until it went over the top of the exhaust pipe, and a wreck followed. There were so many of these wrecks that this condenser was short lived.

About the time these condensers were wrecking engines and steam users had awaked to the fact that about 25 per cent. of fuel could be saved with a good condenser, Mr. Henry W. Bulkley came out with his syphon-injector condenser, his patent being for a syphon and injector combined when applied to a condenser.

This condenser is shown in Fig. 86. If we let water flow from the end of a pipe, it will take a tapered form. These condensers are made in that form. They are finished inside so as to give a smooth flow. There is a cone having a small annular space at the end, this annular space being of the right capacity to let a sufficient amount of water through without pressure, and also the throat at the bottom is of the same capacity.

The flange at top of condenser is placed 34 feet above the hot well, and the hot well should be of sufficient size

Bulkley's Condenser.

to hold the water at all times over the lower end of the pipe.

Accidents with this condenser can occur: By allowing the lower end of the discharge pipe to become uncov-

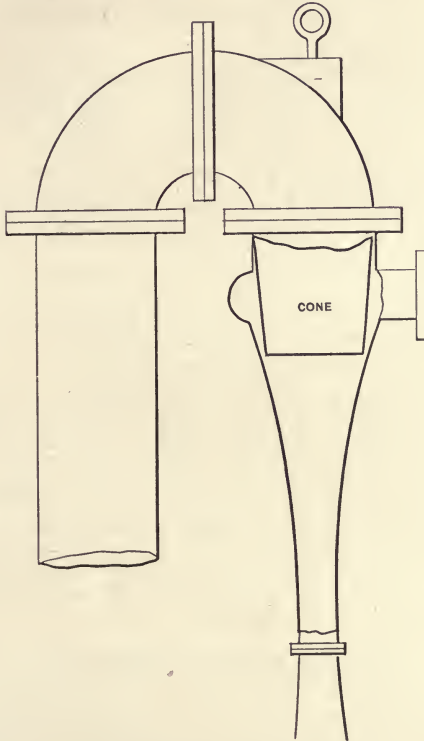

Fig. 86. Bulkley's syphon condenser.

ered and air bubbles to enter, lifting the water after the manner of the air lift in wells; by putting on a heavy pressure of water and forcing more through the end of

Hot Well Capacity.

the cone than will readily pass out of the throat ; by putting on sufficient pressure to collapse the cone ; by the bursting of a tube in a heater in the exhaust pipe.

There is no excuse for any of these mishaps to occur.

The hot well should be double the capacity of the down, or tail pipe, and no water other than the feed should be taken from it.

If necessary to use water from the hot well for other purposes, there should be a second well for that purpose.

An important thing is to have a good strainer over the suction pipe, or there will be the annoyance of taking out the cone to remove obstructions. The objection to this condenser is that it requires a constant water supply to fill the throat regardless of the load. The vacuum produced with not over 300 feet elevation above sea level is 28 inches by mercury gage.

One of these condensers was elevated 20 feet above the water supply, and which, after starting, would draw its own water. In one case a large hole wore through a heater coil, allowing the water to flow direct into the exhaust without giving trouble. This went on for some time and was finally discovered by seeing a large stream of water running out of the drain pipe while the engine was standing.

There have been some modifications of this condenser. Because of the trouble with the cone stopping up, one builder made them with adjustable cones, so that more or less water could be let through and also the cone could be lifted to let out any obstructions. A condenser of this description will not produce a high vacuum.

The Worthington Pump Company, in 1900, commenced building a condenser similar to the Bulkley, which

Worthington's Condenser.

is shown in Fig. 87. This does not have the cone, and if it depended on the condenser alone, would not produce a high vacuum. They put in a pipe in the center of the condenser which leads through a cooler placed in the in-

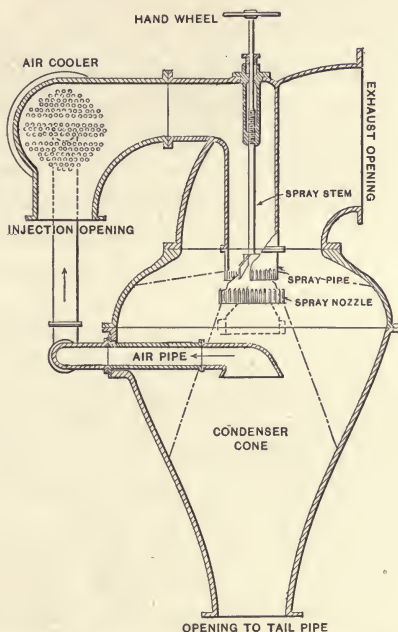

Fig. 87. Worthington's syphon condenser.

jection pipe and then to a dry vacuum pipe. The object is to pump any air not taken out by the water through this dry vacuum pump. The claim is made that a less amount of water is required than with the Bulkley.

The syphon condenser showed steam users that there

Conover's Plan.

was about 25 per cent. saved by the use of condensers. A demand arose for condensing apparatus, and nearly every pump builder commenced building them in connection with their horizontal pumps. Some of them did very good work, but a horizontal pump is not the better plan for an air pump.

In the first place, horizontal direct-acting pumps sometimes stop. They are great consumers of steam. A large horizontal water cylinder has a way of collecting grit in the packing and cutting the lining out. A vertical pump as built by Watt is not so liable to do this.

A duplex pump is an improper pump to use, as it is very liable to take short strokes, which makes large clearance, and is also liable for a time to make so short strokes that the engine cylinder becomes filled with water.

Mr. E. K. Conover, seeing the large amount of steam used for the condenser, took up the Watt air pump and attached it to a special compound engine with Corliss valves and adjustable cut-off. This made an exceedingly economical independent condenser and very compact. As it is driven by an engine with crank and eccentric it does not stop when one is not watching.

If sufficiently large for the work it will maintain the high vacuum of this type of air pump, and as it is vertical, there is very little danger from cut cylinders. It cannot be built as cheaply as the horizontal type.

Since Mr. Conover showed such excellent results, other builders have adopted the practice of building the larger sizes of air pumps vertical, and with compound engines, so that vertical pumps have become universal.

The important thing to look after in a condensing plant is absolute tightness. A small leak of cold air admitted to the exhaust and becoming heated, takes up a

Hot Well Temperature.

great deal of room. Care, therefore, should be taken to have all joints in the exhaust and all rods and stems as nearly tight as possible.

If only a partial vacuum can be obtained and the pointer on the vacuum gage fluctuates, it is a pretty sure sign of an air leak. An excellent way for stopping air leaks is to get as high a vacuum as possible and then paint the whole exhaust system, carefully watching the whole surface to see if any place is found where the paint is drawn in. If the hole is not too large, constant painting will finally stop it. After the whole surface has been gone over carefully, test the exhaust relief valve. The final test is to stop up the outlet from condenser, fasten down the relief valve and turn on steam until 15 or 20 pounds pressure shows. This test should not be tried unless absolutely necessary, as it expands everything, and of itself is liable to induce leaks.

The water in the hot well is sufficiently cool if 100 degrees Fahr. It may be 110 degrees and with a good condenser get 26 inches. 90 degrees for 28½ inches.

With any engine a vacuum will remove the atmospheric resistance and will show economy, except with leaky valves or piston. In such a case the steam will leak faster into a vacuum than into the air, and a condenser may show a loss.

A condenser, however, shows best with a full loaded engine.

When the Ransom condenser came out, a manufacturer put one on a 24-inch cylinder.

The addition of the vacuum showed such a saving that he reasoned that if he had a larger cylinder the vacuum would do more work and he would get still better results, so he took off the 24-inch and put on a 30-inch,

Water for Jet Condenser.

with the result that he consumed more fuel.

His 24-inch cylinder showed a diagram card like the full lines in Fig. 88, while the 30-inch showed one like the dotted lines. The work done by the vacuum was no more with the larger cylinder, because of the earlier cut-off, while the cylinder condensation was largely increased.

A 22 x 42-inch cylinder and 75 pounds of steam with 26 inches vacuum showed much better results than a 38 x 48-inch with 8 pounds of steam and the same vacuum doing the same work.

For determining the amount of water for a jet condenser, the usual approximate rule is 20 times the amount of water that is used to generate the steam.

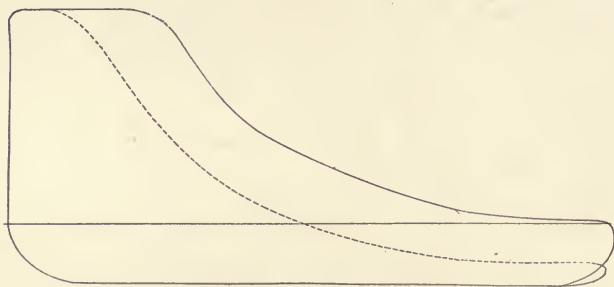

Fig. 88.

One rule to estimate the amount is: Divide 1,000 by the difference between 100 degrees and the injection water; multiply the weight of steam used per hour by the quotient, and the result will be the weight of water required.

Because of the amount of water required for a condenser there are many places where they could not be used. About 1891 H. R. Worthington came out with a cooling tower, shown in Fig. 89. This consists of a steel

Cooling Tower.

shell, open at the top and supported on a suitable foundation. On one side of the shell is a fan to force a current of air through the tower. The filling consists of earthen

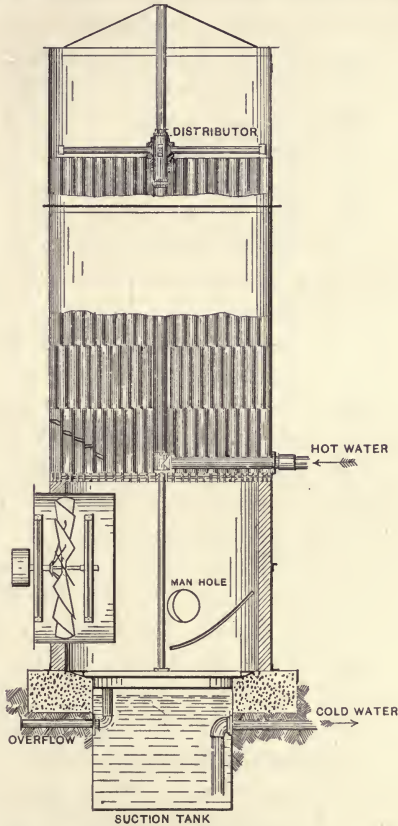

Fig. 89. Worthington cooling tower.

tiling set on end. The water from condenser is carried by pipe to top of tower and distributed by spraying over the ends of the top set of tile, and the water is spread

Action of Cooling Tower.

evenly and in a thin sheet over the outside and inside of the tiles, and is met by the air from the fan. When the writer was first shown one of these, and having some knowledge of the power required to move large bodies of air, he inquired why they did not put a stack on top and save the power required to drive the fan. This has later been done.

Later Mr. Barnard invented a tower that operates with neither fan nor stack, although it will do more work if encased and used as the Worthington. This tower consists of mats made from wire cloth and hung in a vertical position, over the tops of which the water from the condenser is distributed. As the water flows down the mats it turns in and through the interstices and is thoroughly broken up and exposed to the action of the air, and, its progress being so slow, a long time is given the air for contact with it. It is open on all sides to the air; and, to get the best results as a fanless and stackless tower, it should be placed in an exposed position where the wind has free access from all sides.

The action of all these towers is the same—the contact of air and evaporation. The latter is the most important, as the more rapidly the moist air can be driven away the greater will be the evaporation with a consequent reduction of temperature. Other fanless towers have been built of wood with excellent results.

Connected with the cooling tower in many cases, but more often in marine work, is the surface condenser, one form of which is shown in Fig. 90. The circulating water passes through the tubes, and the exhaust steam, coming in contact with the outside of the tubes, is condensed and removed by the air pump. The air pump, in this case, can be smaller than when all water must be handled

Surface Condenser.

by it, and the condensed steam, free from all impurities but oil, can be returned to the boilers. The oil question with large horizontal engines is a serious drawback.

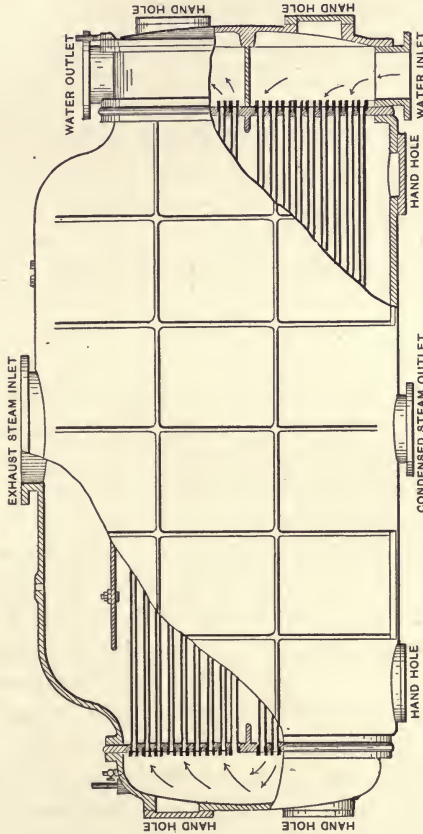

Fig. 90. A typical surface condenser.

The low-pressure cylinders of compound engines of the horizontal type require large quantities of compounded cylinder oil, the worst thing that can be used for

- Using Surface Condenser.

a boiler. In some cases it is absolutely impossible to use the water from condensation.

In the first place, there should be a good oil separator put in the exhaust just as it enters the condensers. This will separate all the water and oil in the form of liquid, but the larger part of the oil has been vaporized, and the animal part has become an emulsion in the steam and becomes a portion of the condensed steam. It is at this point that the great trouble arises in separation.

Salt, hay, excelsior, sponges and various absorbents have been tried. Should sponges be tried, soak them in oil and squeeze them dry. They will then reject water and take up oil. About the best plan is a tank like Fig. 91. This consists of a series of partitions whereby the water goes first under, then over, then under, etc., until it comes to the opposite end, when it is taken out by a pipe, as shown. During all the movement of the water through the tank the oil has every facility to come to the top and stay there. The important thing is that the tank be large and the passage of the water very slow. It is still better if the water can be carried a long distance through a large pipe before coming to the tank and frequently a second tank is necessary.

It is advisable to build a large tank, as large as one can afford, but for 1,000 H. P. capacity not less than 15' square and 12' deep, let the water enter at the top and pass to feed pump from bottom.

When used together, a cooling tower should cool the water below the temperature of the surrounding air and the surface condenser should cool the condensed water to not above 115 degrees. It has been claimed that one foot area of tube surface would cool 10 to 12 pounds of steam, but experience has shown that with water from

Getting the Oil Out.

tower at 98 degrees one could not count on over 6 pounds of water from one foot of tube area.

These condensers are necessary only with bad waters, and with bad water and high temperature in the condenser, the tubes get scaled quickly. In one case a firm had such bad water and the condensing apparatus was so small for the work that the temperature of the water as it went to the tower was so high that the inside of the pipe, valve disc and seats were covered with scale.

Where water is scarce, one reason for putting in a cooling tower has been the idea that most of the water required for the boilers could be saved, but the evapora-

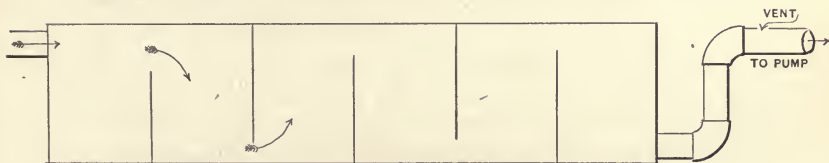

Fig. 91. A good plan for a tank.

tion from the tower amounts to nearly as much as the exhaust from a non-condensing engine.

The idea that some people have as to the nature of a vacuum is surprising. Many consider it a source of power, whereas there is no power in it. It is simply a space devoid of power or resistance. It removes all resistance from the exhaust side of the piston and allows a pressure that equals the pressure of the atmosphere to do mechanical work.

An engineer came across an article that stated that at the dock trial of a steamship, to the engines of which was attached an independent condenser, the valves and pistons of the engines were so tight, and the engines

About Vacuum.

throughout were so perfect, that when the steam was shut off the engines continued to run from the vacuum produced by the independent condenser, and that the vacuum had to be broken before the engines could be stopped.

The engineer wrote an article saying that it did not show perfection; that it simply showed that the throttle leaked.

This was resented by the writer of the article, and it started a discussion that was taken up by the various mechanical papers, that lasted over a year, and it was surprising the number of engineers who actually believed that with an independent condenser a marine engine could turn a propeller in the water indefinitely without any steam being admitted to the cylinders.

He had an engine with steam cylinder, 30 x 60 inches, with tight piston, valves and throttle valve, to which was connected an air pump, 26 x 12 inches. He reasoned that as the steam piston was larger and ran at a higher speed, it must produce a better vacuum on the steam side of the piston when the steam was shut off tight, than the smaller and slower-moving air pump, so he took a card under those conditions. The vacuum on the exhaust side of piston was 27 inches, and on the opposite or steam side was 28½ inches. This any one can verify if he has an engine perfectly tight, including the throttle.

Some men have an idea that the vacuum can lift water out of a condenser into the cylinder. A vacuum can do no work, not even lift water. Take a gage glass, plug one end tight, fill the glass to within 2 inches of the top with water and produce a vacuum at the top, and it will be seen that the water cannot be moved.

Work of a Vacuum.

Admit a little air at the bottom and the water will be raised all right.

Not until water can be raised out of a glass tube plugged tight at the bottom will it ever be possible to raise water out of a condenser into an engine cylinder, unless air be admitted from the outside. The condenser may be flooded and flow back, but never raised.

The writer was in the office of a large engineering firm, and there heard the remark so often made, "When steam is shut off the engine is changed into an air pump."

It seems strange what a large number of engineers believe this. When steam is shut off the engine is not changed into an air pump. The exhaust valve on exhaust end is open to the vacuum on a condensing engine, and the exhaust valve on the other end is closed. Cards taken from an engine with tight throttle, piston and valves, showed about one inch better vacuum on the steam side of the piston than on the exhaust side, but this was immediately lost as soon as the exhaust on that end commenced to open.

An engine can only become an air pump when the valves are reversed. When the engine is driven from some other source, or by the momentum of the wheel, and the valves reversed, the engine will be changed into a pump.

This engineer also made the other remark we hear so frequently, "When the engine is changed into a pump it will 'suck' water out of the condenser."

This shows what confused ideas many men get about the nature of a vacuum. A vacuum is a space that is inert. It has no force or energy of any kind.

We see a non-condensing engine attached to a condenser and noting how much easier it runs it naturally

An Example.

seems that the vacuum has done lots of work. We see steam shut off from an engine with the exhaust open to the atmosphere and note that the engine stops in one minute. We then attach the exhaust to a condenser with a high vacuum and note that when steam is shut off the engine may run five or ten minutes, and it appears as though the vacuum was doing a whole lot of work in that engine.

Suppose a boy is pushing a cart and is applying a force of 30 pounds, but a boy in front of him is holding back with a force of 15 pounds, the cart will be moved forward with a force of 15 pounds. Suppose the obstructing boy drops out of the way. The boy pushing, exerting no more force than at first, can move double the load, or move the same load faster. It is this boy that, while putting forth no more energy, is accomplishing work. It is not the obstructing boy who is doing any work. His case is simply that of resistance removed. He is simply out of the way.

It is the same with a vacuum. It is simply atmospheric resistance removed. A vacuum cannot suck water out of a condenser or out of any other place.

Water has never been raised by a vacuum, even to the extent of one one-thousandth part of an inch. It has always been raised by pressure.

Tools for the Engine Room.

An important item for the engineer is a complement of handy tools. The much-abused monkey-wrench will never be entirely replaced, but, if one can afford it, a set of drop-forged steel wrenches will do much better work, as they do not spring.

Sometimes there will be a large nut or plug that no ordinary wrench will fit, when a square bar of steel can be bent at the end, as shown. The bar should be of sufficient area so that it will not spring open, and as the entire bar can be used for a lever it makes a powerful wrench.

One form of home-made, large monkey-wrench is made like Fig. 92, the key being used to set the jaws for any sized nut. These are made 4 feet long, with a hole at the end of the lever for attaching a small tackle.

Sometimes an obstinate nut can be started by holding it hard against the nut and striking the end of the wrench with the ball of the hand, or a block of heavy wood can be used, striking the wrench with the end of the stick. A stick of wood does not batter the wrench like a hammer and does more effectual work—a hammer strikes too solid a blow and is liable to break something.

Altogether too many wrenches are ruined by the use of hammers, and in screwing up work, too many bolts are broken or are strained to such an extent that they let go in service. A piece of gas pipe over the end of a wrench has been the cause of many disasters.

A handy tool for many uses is the Jimmy. This is made from $\frac{7}{8}$ -inch steel and is 18 inches long. Another form is also shown, the long end being used to put through holes in flanges to bring them into line.

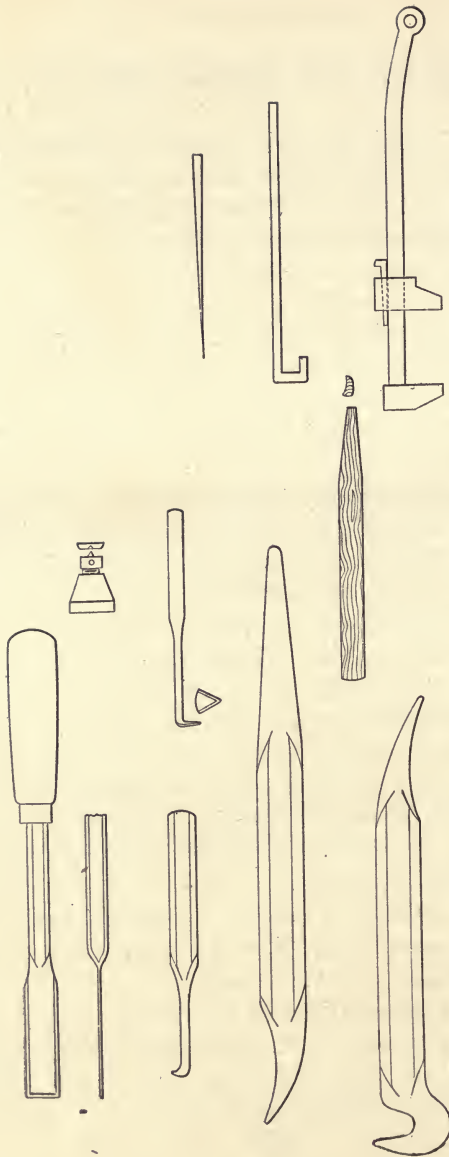

Tool for cleaning flanges.
 Gage glass cutter.
 Small crow bar.
 Special crow bar.

Screw jack wrecking wedge.
 A handy scraper.
 Packing stick.

Wrecking wedge.
 Special wrench of square bar.
 Home made monkey wrench.

Fig. 92. Engine room tools.

Engineers' Handy Tools.

Wrecking wedges, as shown, are used for opening joints of all kinds, being sharp at the end and a long taper. They are easily inserted and very powerful.

For cleaning flanges that can be separated but slightly the thin tools are convenient, the tool being but 1-16 inch thick and the flat part 4 to 5 inches long. A small screw-jack, the jack being 3 inches long, is a convenient tool.

A handy form of scraper in many cases for flange joints is shown, also a hardwood stick for driving packing into stuffing boxes. This does not injure the rod. For removing packing a hook at the end like a corkscrew is the neatest thing, although if the packing is thoroughly rotten, the old-style hook, simply the end of a rod bent over, must be resorted to.

At the present time very neat cutters for cutting glass gages are on the market, but where one finds himself without one he can make the tools shown. In order to do a neat job it is necessary to cut the glass on the inside. This tool is drawn down and bent over as shown, and the point made sharp.

When hardening, be careful not to heat the tool too hot. It is not necessary to draw the temper any, provided it was not too hot. When steel is too hot and plunged into water, the grain is made coarser and the work will be brittle. If heated just right, the grain will be made finer and the tool will be hard and tough and difficult to break. With this tool a scratch can be made around the inside of the glass tube, and, if it does not break of itself, it can be broken by placing the end of the thumbs on each side of the crack and attempting to bend it. It will then break off at the mark made by the tool.

Belting.

I was called upon to examine and report upon a belt, as the claim had been put forth that it was a sham.

I found the belt connecting the engine to line shaft, the engine pulley 20 feet in diameter and shaft pulley about 5 feet.

The belt was made from a fine quality of leather and well put together. It had been stretched so that in many places the leather was actually pulled apart and still the glue held.

The belt was large enough for the work, but the center of shafts were not far apart, making a short belt, and as the pull was on top, it was necessary to keep it taut. There was no idler.

The case was diagnosed as follows: As the belt centers were short and it was necessary that the belt be tight to drive the load, there had been trouble with the belt stretching. When the weather is damp a belt will stretch and will grow short again when the weather is dry.

The belt having given trouble by stretching, it was but natural that the men when taking it up should say that they would take it up so that it would be all right for a long time. Should this be done when there was damp weather and a severe strain be put on it then, when the weather became dry it would be put to a severe test and would probably be in the condition found.

The concern using the belt did not believe in idlers. There are many ideas both for and against idlers. When the belt is long and pull on the bottom, idlers are not necessary. When the belt is short and the pull is on top, an idler saves many anxious moments. An idler should always be put on the slack side of the belt whether the slack side be bottom or top.

Don't Run Belts Too Tight.

An idler should be arranged, in addition to the tightening screws, so that one end of the shaft can be moved back and forth by screws. This will serve to guide the belt and oftentimes save tightening it. It does this on the same principle that a roll can be knocked sideways when moving a load.

Fig. 93 shows one form of tightener with a side adjustment for the end of shaft.

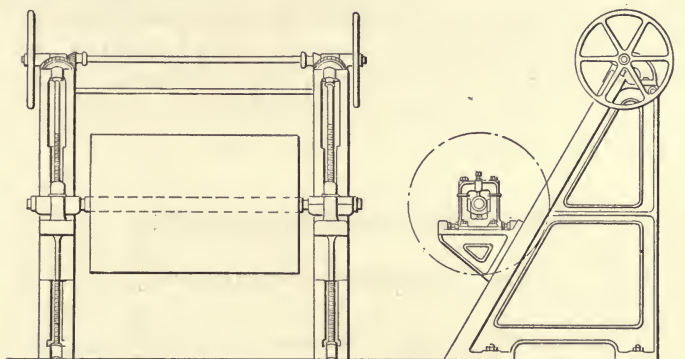

Fig. 93. A substantial tightener.

A belt should never be run tighter than absolutely necessary, both on account of friction of shaft and also the life of the belt.

Where an idler is used the belt can be tightened and save many a shut-down. When screwing up a tightener it is only in rare cases that a man does not get tired and stop when the belt is sufficiently tight. There may be a few cases different, but they are rare. When a belt has to be tightened by shutting down and using belt clamps, the temptation is to overdo things.

A belt, to be of value, should be made of the best

Picking Out a Good Belt.

part of the hide, which is the back. The neck and shoulders are a spongy mass, easily absorbing moisture and stretching in all directions. In the belly, the grain runs different and this is also inferior.

The hide is thick at the center of the back and sloping down thinner for a short distance and then gradually growing thicker to the belly. Fig. 94 is an exaggerated cross section.

The dotted lines on Fig. 95 show all the portion that should be taken from the hide for the manufacture of belts. Fifty-four inches has been settled upon as the longest part that should be put in a belt. There are many hides that will yield longer pieces than this, but if only 54 inches are allowed, one is fairly safe.



Fig. 94. Exaggerated cross section of a hide.

The backs are called "centers." After one has become familiar with the appearance of the center of the back he cannot be deceived. There is no possible way discovered yet of imitating it and one can always tell whether a piece of belting has the center of the back running through it.

A belt larger than 48 inches wide should have more than one center, else it will be encroaching on the belly, with a stretchy belt as the result.

A belt of more than one ply should be made of only solid leather without any filling.

It should be borne in mind that a hide is not uniform in thickness, and that to produce a belt of the same thickness throughout, the hide must have the high portions

Where Belt Leather Should Come From.

shaved down on the flesh side, or the low places must be filled up with leather shavings.

When a belt is put together it should be with glue alone and there is no excuse for stitches, pegs or rivets.

Some belt makers claim that to shave down the high parts of the flesh side so as to make the thickness uniform greatly reduces the strength of the hide, and that a stronger belt can be made by filling the low places and they succeed in getting many of their customers to believe it. This is a matter for the purchaser to decide.

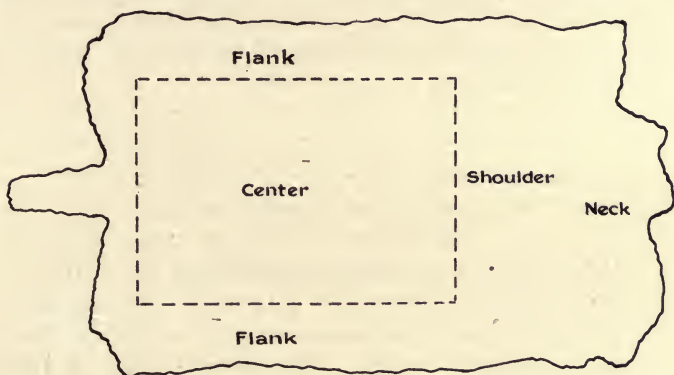

Fig. 95. Shows only part to be used for belts.

It would be a good idea for him to see the belt put together if he elects to have the leather shaved down.

Heavy main belts should weigh not less than 16 ounces per square foot for each single ply without any filling.

A double ply will be a little over $\frac{3}{8}$ of an inch thick and three ply $\frac{5}{8}$ inch thick.

At one time I had the pleasure of putting on a three-ply belt that was plump $\frac{3}{4}$ inch thick, and that without

Making a Wide Belt.

any filling of any kind. The belt maker was two years selecting the hides for this belt.

Hides for a belt should be dried on a stretcher and should be seasoned for several months, so that the order for an important belt should be given as early as possible.

We have here again two ideas. Some makers claim that to take the stretch out of new leather permanently injures it and that a belt will be longer lived if it is stretched in use—and business is shut down to take it up several times. Even if this were so, the interruption of business for taking up a belt frequently would be of more account than the cost of a new belt.

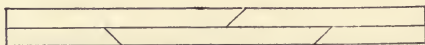

Fig. 96. The best way to make a wide belt.

When pulleys are properly made and the shafts in line, there are two causes for a belt not running true. One is that the belt is not made straight, or the last joint is not put together straight. The other is lack of uniformity in the hides, there being belly leather and one side stretching more than the other.

An excellent way to make a belt 48 inches wide and over is to put three centers on one side and two on the other made with a running splice, or the joints lengthwise lapping about 3 inches instead of butting together. This is a more expensive belt, but fine running. Fig. 96.

To determine the length of a belt, multiply the distance between center of shafts by two, add the diameter of the two pulleys together, divide by two and multiply by $3\frac{1}{8}$. Add this product to the first product.

Horse-power of Belts.

To determine the horse-power of a belt some authorities give the speed of a 1-inch belt as 600 feet equals 1 horse-power, and from that on to 1,000 feet equals 1 horse-power.

If we take the first the rule is:

$$\frac{\text{speed} \times \text{width}}{600} = \text{H.P.}$$

If we have a single belt 12 inches wide and running 5,000 feet per minute, it becomes

$$\frac{5,000 \times 12}{600} = 100 \text{ H.P.}$$

Should we take 1,000 feet as 1 horse-power it would make 60 horse-power.

Another rule takes into account the allowable strain on a belt, which is taken to be 70 pounds as the highest allowable strain on a belt one inch wide.

$$\frac{\text{speed} \times \text{width} \times \text{strain}}{33,000} = \text{H.P.}$$

or

$$\frac{5,000 \times 12 \times 70}{33,000} = 127 \text{ H.P.}$$

By adding another ply will add 75 per cent. to the strength of the belt.

Extra plies add weight, which is also important.

Belts sometimes do not run well because the pulleys are not turned accurately.

At one place an engineer put up some work where the belt ran to one side and the purchaser was very much put out and was saying all sorts of things about the belt

Arc of Contact vs. Speed.

and wanted the maker sent for right away. The engineer admitted that if the belt was the cause of the trouble the maker should be called upon to remedy it, but suggested that before he was called upon that the purchaser should do the first thing the belt maker would do—measure the pulleys. This was done and the engine pulley, 20 feet in diameter, was found $\frac{1}{2}$ inch larger on one side than the other. After this was straightened out there was no further trouble.

There used to be a great account made of the “arc of contact” on the pulley notwithstanding that the belt usually slips on the driving pulley, which is the largest and has the largest “arc of contact.” One strong “arc of contact” man argued that as he had had trouble with the belt slipping on some of his work and as increasing the diameter of his pulleys had remedied the slipping, therefore the larger pulleys, having a larger “arc of contact,” were what was desired. After some talk he finally admitted that the higher belt speed caused by the larger diameter pulleys might have something to do with it.

Belts that run at a high speed frequently get charged with static electricity. This dries out a belt, rendering it dry and brittle.

A copper wire, size from No. 6 to No. 12, with a number of points composed of wire, stretched across the belt at a point where it runs the smoothest, the points of wire being about 1 inch from the belt and the ends of the wire grounded on bearings, or anywhere convenient, will remove all that is harmful.

New belts are dressed with what is termed “waterproof dressing.” Hardly two belt makers use the same preparation. It should be made from ingredients that will keep the belt soft and pliable, and is waterproof only so

A Good Belt Dressing.

far as it has filled the pores of the belt and leaves smaller space for moisture.

One of the best belt dressings is made from 1 part neatsfoot oil and 3 parts castor oil.

Nothing should ever be put on a belt except something that will keep it clean, soft, pliable, etc. No rosin, or like drying or sticky substance should ever be allowed upon a belt, either alone, or in connection with other ingredients. But little should be put on at a time.

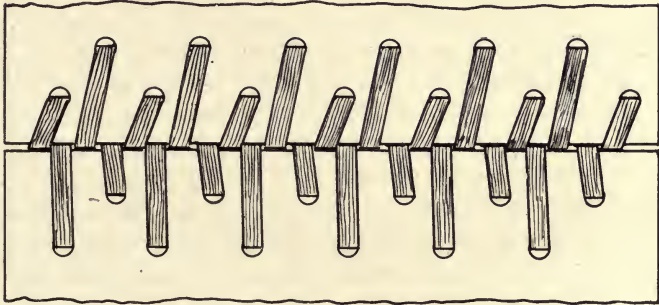

Fig. 97. A good hinge joint.

In dusty places nothing has yet been found that is good for the belt that will prevent the belt from catching the dust. In such places belts should be kept as clean as possible by frequent wiping, and even with the best of care they will have to be changed and thoroughly cleaned frequently.

The best joint for a belt is the cemented joint. This requires time to shave down properly, and about five hours to set. Because it cannot be pressed like the rest of the belt there will be some noise when this joint goes over the pulley, but if properly done there will be no jumping and the speed will be uniform.

Lacing a Belt.

The worst joint is the ordinary laced joint. It has the merit of being quickly made. Another method is the "hinge plan" shown in Fig. 97. An important item in this plan is good lace leather, which should be strong, well tanned and uniform in thickness.

Annealed nickel wire makes a good belt lacing, or what is better a composition wire made especially for this purpose.

Number 18 wire will do for single 3-inch belts and number 10 for double for 6 inch and above.

A single row of holes are used, the holes being no farther from the end than the thickness of belt and $\frac{3}{8}$ inch apart and should be cut with a 3-32 inch belt punch. Cut depression on inside of belt for the wire. Commence lacing at center by passing the ends of the wire through the two center holes to the pulley side of the belt. The lacing should be double on the pulley side; then lace each way to the side, double lacing on the inside, drawing up tightly all the time without kinks or crossing the wire. When finished, flatten down with a hammer on some new surface.

With a proper wire laced joint there is no jar.

There are various patent metallic fastenings, many of them doing first-class service.

A good form of specifications for belt is as follows:

Specification for belt to be put on pulleys 10 feet and 9 feet 6 inches diameter and shaft centers 48 feet:

The belt shall be made from the centers of selected hides, which shall be well seasoned and stretched, shall be from pure oak-tanned leather.

The belt shall be 60 inches wide, shall be three ply, made with running splice, shall have three centers on one face and two on the other, and three in middle ply. No

Belt Specifications.

center shall be longer than 54 inches. The belt shall be made without filling, splits or rivets, and shall weigh when finished 48 ounces to each square foot before any waterproofing is applied.

When the hides are ready to make up the engineer shall be notified in ample time and shall have the opportunity to examine the hides and also see the belt put together.

After putting together the belt shall be thoroughly treated with a waterproof dressing acceptable to the engineer.

The manufacturer shall furnish sample of belt he proposes to furnish with his proposal. This sample shall be 12 inches square and shall show the texture, weight, etc., that are proposed, and the maker agrees that if the belt shall not, in every particular, be equal to the sample in weight, texture, etc., and made according to specifications, he will put the belt on the pulleys and allow it to be used without charge until a suitable belt can be procured. The sample of belt shall not be waterproofed.

The maker shall put the belt on the pulleys and shall take it up once within one year if needed.

Oils.



In the early days tallow was the lubricant for the cylinder, and there were many ingenious devices for feeding it. The cup that gave the best satisfaction was one having a bottom valve for adjusting the feed, a vent to open when filling and a valve at the top under a small cup. This required the tallow to be "tried" out and kept in a pot set where it would keep warm, so the cup could be filled readily.

There was another cup that was filled with "leaf" tallow, and the tallow was cooked out by the steam heat. This plan had the merit of feeding slowly, but one hardly knew when it began to feed or when it ended. Taken as a lubricant alone, there is nothing superior to tallow. It also has the merit of not being expensive. It has in its composition, however, the animal stearic and oleac acids that are set free by heat and change all inside steam surfaces into oxide of iron. A cylinder head made from iron was very porous, and in a few years the acids from the tallow had worked through these pores, making them larger, until the steam leaked through so much that the head was ruined.

There was also a sediment from the tallow, which,

A Good Oil.

mixed with the corroded iron, would form balls that would sometimes clog the steam passages.

Neatsfoot and lard oils were used, and while not forming the balls from sediment as much as tallow, they would corrode about the same.

Sperm oil did very well, when genuine sperm could be obtained, but the trouble with the fish oils of all kinds was the amount of gum they would leave, requiring the valves and piston to be all taken apart and cleaned once in three or four months, and the piston follower bolts that were broken were legion.

An engineer had had his trials with all these lubricants, when one day an oil agent appeared who claimed to have a new oil, made from petroleum with a slight amount of animal oil, that would do better work than the animal oils, would not gum or corrode, and would clean out all the old oil. His story seemed so much like a fairy tale, the engineer was not inclined to deal with him, but he persisted in having a barrel sent for trial, and it was thought an easy way to get rid of him.

When the engineer came to try the oil, he found the agent had not overstated it, and it did elegant work. After this oil had been introduced and it was found that petroleum was a good cylinder lubricant, other manufacturers commenced producing oils from petroleum, the systems and mixtures being different. Some attempted to make cylinder oil from clear petroleum.

One day the treasurer came to the engineer and told him there was an oil firm he would like to purchase from, on account of the price of the goods and also for other business reasons, and they were to send a barrel for trial.

After using the oil two or three days, the engineer reported the oil fully equal to anything they had used.

Oil Agents.

After two weeks he could not lubricate the valves, and reported the manner in which the oil was working, but said he could manage to use it up. The oil was a straight petroleum; a piece of tallow as large as a hen's egg was put in a quart, and it went all right. That proportion of tallow will not show in the cylinder, but use one-half, and the deposit in the cylinder will remind one of the old days of tallow.

When trying different oils it was noticed that after a good oil had been used for some time and a new oil was put in, for a few days the new oil would work better, even though it were an inferior oil. In two or three weeks much larger quantities would be required. It is this peculiarity that has been the undoing of many engineers who have persisted in opposing a change in oils.

An oil agent would come along and want to sell a cheaper oil for a cheaper price, but could not get the consent of the engineer. The agent would then propose to the manager that he deliver to the agent one of his empty oil barrels and he would fill it with his oil, while the engineer, knowing nothing of the trade, would suppose he was using the same oil, and when asked by the manager if the oil was still going all right would reply that it was. This would be deemed proof that the engineer was untruthful, and he would get his discharge. If an inferior oil would always show up within a day or two, many an engineer's reputation would have been saved.

At the time the engineer tried the petroleum product there were no lubricators and he had only an oil pump. In a 28-inch cylinder he would put in about two tablespoonfuls at one and one-half hour intervals. What would be thought of oiling a cylinder in that manner and quantity nowadays, when, if there is an oil pump on a

Oil That Doesn't Lubricate.

cylinder, the man running the engine will pump in a teacupful every half hour in addition to the sight feed.

Shortly after the petroleum oils came in use, the sight-feed lubricators came out. These made possible constant and correct lubrication. Since then have come the mechanical oil pumps, so that engineers can now take their choice of a number of first-class devices.

The requisite for a cylinder oil is that it shall be suited to the temperature, the quality of the steam and the weight of the parts to be lubricated. In the first place the oil should be vaporized.

It will be noticed that when an oil requires large quantities a large amount of the oil will be found in the cylinder in the same condition that it was in before using, while an oil that did efficient service none of it would be found in the cylinder, except in the form of milky water in low places.

The effects of it, however, could be plainly seen. Should an oil not be of sufficient high-flash test, none of it will be found in the cylinder, and the surfaces will appear dry and devoid of lubrication.

For high pressure and light pistons an oil having a high fire test and medium body or viscosity is required, while with low pressure and heavy pistons, a low fire test and heavy body is required.

If an engineer has only the high fire test oil he can sometimes make it right for the low-pressure cylinder by the addition of ordinary lubricating oil, provided there be sufficient animal oil compounded with the cylinder oil. If not properly compounded, if he can get tallow that is clean, he will find it of advantage to put in a tablespoonful of that to a quart of his cylinder oil. This proportion of tallow will have no ill effect in the cylinder.

To Detect Alkali.

In some rare cases, where a high fire test oil is used for high pressure and the body of the oil is so heavy that it will not find its way under light-weight moving parts, the addition of one-quarter of ordinary engine oil will improve it.

For heavy weights and low pressure steam there must be some animal oil. An indication of what this animal oil is is shown by saponifying a sample. Take a 2-ounce bottle, fill half full of water and put in a stick of caustic soda or potash or a little strong ammonia, and then fill nearly full with the oil and shake it well. Petroleum will not make soap, but animal oils will, so that the animal oil will separate and leave the mineral oil intact, except when compounded in special ways with neatsfoot oil, when the whole of it, mineral oil and all, will thicken.

Neatsfoot oil will make a yellow soap, lard oil and tallow a white soap, fish oils a little darker color than lard oil. If you are buying a pure lard, sperm or any animal oil, the saponifying test will indicate whether it is adulterated with the cheaper mineral products

To detect acids or alkali in the oil, wash a sample of oil with distilled water and draw off the water. Take a piece of blue litmus paper and dip in the water, and if it turns red there is acid in the water. If red litmus paper turns blue, there is alkali.

Many engineers have a high regard for graphite and have believed that if it were possible to suspend graphite in oil so that it would feed in an ordinary lubricator without clogging, it would be an ideal cylinder lubricant.

To suspend graphite in oil the question of gravity comes in, and some oil or some substance must be used that is heavier than graphite so that the graphite will float in it. Will such a substance be a good cylinder oil?

Viscosity.

Such a combination has been made and the floating of the graphite is perfect.

I have mentioned viscosity in oils. It is generally supposed to mean, body, or ability to withstand pressure, a highly viscous oil may be valueless.

The test for viscosity is the length of time in seconds it requires for a given quantity of oil to flow through a given opening at a given temperature.

It is the length of time in seconds that it requires for 60 cubic centimeters of the oil at 212° to flow through an opening of about $\frac{1}{8}$ ".

An oil requiring 175 seconds would be 175 deg. viscosity and one requiring 150 seconds would be 150 degrees viscosity.

There should be no pressure but its own weight.

The most viscous oil from petroleum is the tar residue, of no value, while the least viscous is tallow, the highest value as a lubricant known, so that viscosity is an indication, not a proof.

One day an oil agent called on the engineer, but was told that oil was out of date, that a graphite oil had been procured and no more cylinder oil would be needed.

Said the agent: "What is the easiest running bearing made? Is there any bearing that is less frictionless than a ball bearing?" The engineer admitted there was none.

Said the agent: "It is the ball bearing that represents the oil. Oil is made up of globules which roll like a ball bearing. Graphite, to be of value, must be the flake graphite. Flake graphite must cause sliding friction and sliding friction will always be greater than rolling friction. Graphite may do good in filling up low places, but as a lubricant it will not take the place of oil."

The engineer went ahead and tried his graphite, and

Continuous Oiling.

while it fed perfectly it would not do the work of oil and was abandoned. It appeared to work more like the cylinder oil that does not vaporize.

Machine oil can be all mineral oil, and should be for some places. Wherever the oil is in a case with mechanism running in the same, should there be animal oil of any kind compounded with the mineral, the animal oil or fats will form an emulsion and soon get thick and unfit for use. When oil is filtered and continually used it should be all mineral.

The ideal oil is one that can be used in a hot room in summer and will feed in exposed places in winter. This kind is seldom found. There are many good oils that will feed in winter that become so light by warmth that they are valueless in summer for heavy work, and the heavy oil that is necessary for summer use will not feed in winter. There are a few oils that can be used at any time.

With modern systems of catching oil it is possible to keep a continuous stream of oil on the bearings, pipe the drain to an oil filter, raise the oil to a distributing tank and pipe from there to the different journals. Where air pressure is at hand it makes a cheap and efficient method of raising the oil. There are many elaborate systems for doing this. A simple way is to let the oil run into a tank capable of holding sufficient pressure

Here the pipe to take out the oil extends to nearly the bottom of tank and the air inlet opens at the top. When air is turned on, the pressure on top of the oil forces it to a height due to the pressure. There should be two tanks, so that the drain can be kept constant. The filter can be below or above the engine, as most convenient. Where air pressure is not convenient, a small pump can be used and an attachment made to some part of engine.

About Grease.

When a man is obliged to use an oil that thickens by cold he will need to be careful of his drain pipes. These pipes should not be less than 1 inch in diameter. In one case a drain 1 inch in diameter that was laid on the floor alongside the wheel pit the oil would not drain even when the engine-room was warm. It was finally seen that the air set in motion by the wheel was sufficiently cool to chill the pipe, and it became necessary to put a box around the pipe and a $\frac{1}{8}$ -inch steam pipe alongside the drain pipe.

Some engineers prefer grease because it is cleaner. A few claim it is cheaper, but its advantage over oil is problematical. Grease is made from horse oil; a better grease is made from mule oil. Either has a terribly rank smell, and to overcome this they are flavored with oil of mervane, which drowns the bad smell and gives the grease the flavor of a peach pit.

To be of value oil must be manufactured from good stock and by those that understand the business. A first-class cylinder stock just mixed with a lighter oil will not give the results required unless it be put together in proper form.

A good test for oil is to make a bearing for the largest shaft available and line it with babbitt metal. On top of this bearing put a hole for an oil cup and another hole extending through top and nearly through the babbitt, so that it will come to within 3-16 inch of the shaft. This is for a thermometer. Arrange a clamp of wood or iron like Fig. 98, with a weight at the end of the lever. When oil is to be tried, set the oil to feeding and tighten bolts so as to just balance the weight. The oil should have a determined length of time to flow, say one-half hour or one hour. Several trials should be made with a

Testing Oil.

standard oil, so as to be accustomed to its use, before trying oil for comparison.

A heavy oil should not be fed as many drops per minute as a light oil, as there is more oil in a drop of the heavy than in the light.

After becoming accustomed to the machine so as to feed the proper amount, the thermometer will indicate which has the best lubricating properties.

A straight, clean mineral oil can be filtered continuously, and care should be used to save all oil by proper

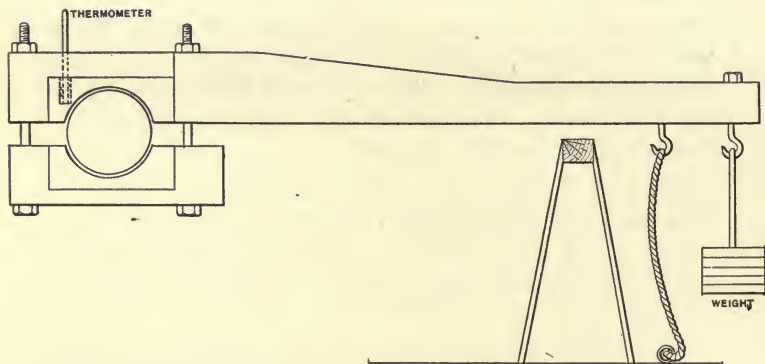

Fig. 98. Oil testing device.

guards and pans, and but a small amount of new oil need be used. With a good filter, filtered oil will cool a hot journal more quickly than new oil.

For shafting, ring oiling bearings should be used, and the rings should be solid and not less than $\frac{1}{2}$ inch in width. Rings made from half-round material, bent into a circle and the ends not closed together securely are liable to get out of shape, the ends catch and the feed be stopped.

Oiling Bearings.

It is not a bad idea to have pockets on the outside of the ring, but these pockets should be smooth on the outside and should not project beyond a true circle, as otherwise they might catch and stop the ring.

The thrust rings should always be in the center of the bearing and the groove should be lined with babbitt. At each end of bearing should be a small collar turned to a sharp edge. This will throw off all oil and prevent it running along the shaft. The babbitt wipers usually used for this purpose do not do the work satisfactorily, and there is a waste of oil as well as an untidy looking shaft and floor.

The oil cellars should be of ample size. For a 5-inch shaft, they should be not less than 2 quarts capacity, and would be still better if they held a gallon.

A few engine builders are getting to building ring or chain oiling bearings for the engine shaft. This, when universal, will be a great improvement.

For oiling crosshead pins the telescope oiling device is a neat thing, as it places the oil cup where it can be filled and adjusted at any time, and there is not the spattering of oil as with the wiper. It also works nicely on the eccentrics.

Cleaning.



Should any part of the machinery get covered with gum, use a strong solution of potash. This can be applied with a piece of waste wrapped around a stick. If the metal is cold it will not be discolored, but if hot, the metal will be blue. A strong ammonia will do the same thing. The work needs polishing afterwards in either case. For this purpose, when cold, get a pepper box and use Rosedale cement on a wet rag. The moisture soon dries out, and the dry cement can be easily wiped off, leaving the work thoroughly clean. As the metal is clean it will rust quickly should it be exposed to dampness.

When cleaning an engine, after it is wiped as clean as possible with waste, a little of this dry cement on a piece of waste will remove the last vestige of oil and leave the work clean and bright. For this latter work rotten stone is better. Use care not to get any of either on the bearings.

Some engineers like their bright work burnished. Those who have the time and inclination can do this as follows: If the finish on the engine is rough, use coarse emery cloth to bring the surface down level and finish with fine. Take a drill rod and heat it to a mild cherry

Cleaning Solutions.

red and dip it in water. Do not draw the temper. Polish the rod with the fine emery and then draw the rod at right angle over the work, using considerable pressure. When the engine is wiped, use a fine powder like rotten stone. Be careful about the bearings.

For cleaning the brasses around the pins, rub with waste until bright. This requires some time at first. After they are once bright it is easy to keep them so.

Oil is good to clean off fresh tarnish, and if the oil is wiped off every day and then a piece of clean waste used to wipe dry and clean, the brass can be made to shine all the time, without the use of any powder or cleaner, and no harm done to the pins. Brass oil cups can be treated in the same manner.

In the days when the dome, sand box and wagon top of a locomotive was covered with brass, as a general thing the firemen had nothing but Rosedale cement to clean with. This was put on with oil to scour the tarnish off and then the polishing was done with dry cement.

The firemen learned that a solution of oxalic acid would remove the tarnish and then the scouring was easy. Some firemen used to get spermaceatic candles, rub the brass over and let it stand a few hours, or over night, when it could be wiped off and the brass was clean.

Since that time a number of polishing pastes have come into use. They require but little labor, leave the brass a nice color, and are also good to clean the hot ironwork. Tripoli is one of the best.

Paint work should be wiped clean every day, paying particular attention to the corners. An engineer's thoroughness can be told by looking at the corners. On work that has not been cleaned for a few days, and also on

Leaving a Film of Oil.

work where the varnish is getting thin, take a piece of waste, get it wet through and squeeze out most of the water and put on some engine oil, about the same quantity as there is water. Wipe the work over with this. In the case of considerable dirt, it should be rubbed until thoroughly clean. It is a good idea to wipe off afterwards with clean waste, especially if the surface was dirty. This leaves just a very thin film of oil, the paint is clean and the work looks nearly like new varnish work. This is a neat way of caring for work that is exposed to the weather.

Notes, Rules and Tables.



One H. P. is 33,000 pounds raised one foot high in one minute, or 33,000 foot pounds per minute.

A heat unit or H. U. or British thermal unit or B. T. U. is the heat required to raise one pound of water at 39.1° one degree.

According to Joule's experiments 1 heat unit was equal to 772 foot pounds, but further experiments have demonstrated that one heat unit is equal to 778 foot pounds, 33,000 foot pounds per minute divided by 778 = 42.62 heat units per H. P. per minute, or $42.62 \times 60 = 2557.20$ heat units per hour.

A pound of carbon contains 14,500 H. U. A pound of coal having 10% of ash will have remaining 13,050 H. U.

A good boiler with a good fireman should get 75% of this into steam, which allows 8% for radiation and losses from air leaks, etc., and 17% loss of heat in gases going up the chimney, which leaves 9787.5 H. U. in steam per pound coal. Of this, 2257.20 is converted into work, the remainder, or 7230.30, going out in the exhaust.

This is providing that 1 pound coal produces 1 H. P. If it requires 2 pounds, then the total H. U. will be

Keep the Boiler Clean.

$9787.5 \times 2 = 19575 - 2557.2 = 17017.8$ H. U. going out in the exhaust.

As the H. U. in 1 pound coal with 10% of ash is 13050, this number divided by $2557.2 = 5.1$ H. P. that would be obtained with one pound coal, if all the heat could be converted into work, or if the heat put into steam, 9787.5 H. U. could be converted into work, it would make

$$\frac{9787.5}{2557.2} = 3.86 \text{ H. P. per pound coal.}$$

The efficiency of the boiler will depend upon the ease with which it can be kept clean, the tightness of its setting in preventing air leaks, the thinness of the heating surface, the draft and the circulation.

The latter point is very important. The greater the difference in temperature between the water within the boiler and the fire the more rapid the absorption of heat. The more rapid the water flows over the heating surface bringing fresh water into contact, the greater will be this difference, and the more rapid the movement of the water the easier will be the disengagement of the steam.

Wrought iron expands 1-150000 of an inch per inch for each degree.

A pipe 300 feet long and 150 lbs. pressure would expand as follows: 300 ft. is 3600 inches. Temperature of room 80° . Temperature of steam at 150 lbs. pressure 366° less the $80^{\circ} = 286^{\circ}$ difference in temperature of

$$\text{pipe. } \frac{3600 \times 286}{150000} = 6.86 \text{ inches the pipe would expand.}$$

Standards of Pressure.

All pressures are measured or standardized by the weight of mercury.

The atmosphere sustains mercury 30" high.

One cubic inch of mercury weighs .49 of a pound.
 $30 \times .49 = 14.7$.

Weight of water.

A pressure of one pound is exerted per square inch by a column of water 2.3093' high, and one atmosphere, or 14.7 pounds, by a column 33.947' high.

The pressure multiplied by 2.3093 will give the height of a column of water due to that pressure.

A column 1' high has a pressure of .433 pounds. Height, multiplied by .433 equals the pressure.

The efficiency of an engine depends upon the small amount of heat required to do a certain amount of work.

The engine that has the lowest terminal pressure in proportion to the mean effective pressure will require the least heat, or, put in another way, the lowest amount of heat will go out in the exhaust.

An engine that requires a large amount of compression to secure quiet running will have a rounded cut-off corner on the diagram, and this, together with the compression, will make the terminal pressure higher.

An engine having a slow piston speed will condense a large amount of steam when it enters the cylinder, and this will be re-evaporated towards the end, bringing the terminal pressure high.

Too slow piston speed will give too much time for a cylinder to cool off and cause cylinder condensation, with consequent re-evaporation.

Should we wish to get a high piston speed we have the problem of rotation speed to contend with.

To get a piston speed of 800' per minute we can

About Clearance.

build an engine with 6' stroke and 66 revolutions. This number of revolutions will require no more compression than is necessary to lap the exhaust valves to have them seated properly when the steam valves open, the indicator card will show nearly square corners all around, which will be the theoretic and practical card for economy.

Should we conclude that this stroke is too long, we can divide it by 4, making it 18" stroke and a rotative speed of 266 revolutions. The piston speed is the same, but the compression required will increase as the square of the number of the revolutions, the card from the engine will have round corners and the terminal pressure will be higher.

Clearance plays an important part.

Clearance is that portion that exists between the piston and cylinder head, between the valves and cylinder in the steam parts and in any depressions in the piston or heads.

The clearance spaces are filled with steam at each stroke and are emptied, doing only the work that the steam in them expands, and are finally emptied, the unexpanded portion doing no work. The effect is to increase the terminal pressure.

The clearance spaces are filled and emptied at each stroke.

The shorter the stroke, the greater the percentage of clearance.

The nearer the valve is to the cylinder, and the shorter and smaller the port, provided it is of ample area for the passage of the steam, the less will be the clearance, which is the reason for the four-valve engine.

The quicker the cut-off valve closes, the sharper will be the cut-off and the lower will be the terminal

Compression—Lap—Lead.

pressure.

The terminal pressure will be the lowest in proportion to the mean effective pressure when the engine is cutting off at about $\frac{1}{4}$ stroke, so that an engine loaded to that amount will be at its most economical load.

Compression is the vapor enclosed within the cylinder by the closing of the exhaust valve before the crank reaches the center.

Its object is to absorb the inertia of the moving parts gradually and allow them to come to a state of rest without jar.

Lap of a valve is the amount that the valve travels beyond the port more than is necessary to cover the same. Its office is to cover the port, or space beyond, sufficiently to insure tightness, and in a steam valve to provide for cutting off the steam.

In an exhaust valve, to give compression.

Lead is the amount the valve opens before the crank reaches the center.

Pre-release is sometimes applied to the exhaust valve and is the same thing as lead on the steam valve.

An eccentric is a wheel placed off the center, and is used to be placed on a shaft to give motion to the valves of an engine.

The distance it will move a rod or valve is the extreme movement between the distance of its circumference on both sides of the shaft, and is termed the throw of the eccentric.

The travel of the valve is the total distance the valve moves.

If the eccentric rod be attached direct to valve the throw of eccentric and travel of valve will be the same.

The travel of the valve should be the width of the

Selecting Size of Feed Pump.

port and the lap.

When it is desired to give a greater travel of the valve than the throw of the eccentric, a rocker arm is placed between, and by attaching the valve rod at a greater distance from the center than the eccentric rod the valve travel is lengthened.

In the Corliss type, the rapidity of opening and closing the valves is increased by the use of a wrist plate.

To determine the size of pump for a set of boilers.

A boiler H.P. is 30 pounds of water evaporated per hour, but it should be capable of evaporating 45 if a call for that should arise.

Find the total amount that would be evaporated by the boiler, or set of boilers, per hour, and divide by 60, which gives the amount per minute. Divide this by 8.33, which reduces the pounds to gallons. Multiply this by 231 will give the amount in cubic inches.

A pump should not exceed a piston speed of 100' per minute. Multiplying $100 \times 12 = 1200''$ piston speed. Divide the cubic inches by 1200 gives the area of piston. To get the diameter extract the square root or find the diameter from a table of areas.

If we have 1000 H.P. and allow for a possible evaporation of 45 pounds per H.P., $1000 \times 45 = 45000$

$$\text{pounds. } \frac{45000}{60} = 750 \text{ pounds per minute. } \frac{750}{8.33} = 90$$

$$\text{gallons. } 90 \times 231 = 20790 \text{ cubic in. } \frac{20790}{1200} = 17.2''$$

area of piston, or 5" diam.

There should be at least 10% allowed for slip and for duplex pump it would not be unwise to allow 20%.

To determine how much water a pump will deliver,

“Powers” Rule for Pumps.

multiply the area of the cylinder in inches by the stroke in inches and by the number of strokes per minute. This gives the cubic inch capacity. Divide this by 231 gives the number of gallons. Gallons multiplied by 8.33 equals the pounds, and by 60 gives the pounds per hour. Deduct the percentage for slip.

To determine the power, multiply the area by the pressure of water and the speed of the piston, allow 20% for friction, etc., and divide by 33000.

“Power” gives the rule. Multiply the number of gallons by 15 times the elevation and divide by 33000 will give the H.P.

To find the H.P. of a boiler from the heating surface, allow 12 square feet of heating surface for a tubular boiler and 10 square feet for a water tube.

In a recent catalog of a well-known maker of engineering specialties the writer noticed the following approximate rules for calculating the horse-power of various kinds of boilers. The rules are intended for use in determining the proper sizes of injectors and other apparatus when the exact dimensions or heating surface of the boiler is unknown or hard to obtain :

Kind	H. P.
Horizontal Tubular	$= \text{Dia.}^2 \times \text{Length} \div 5$
Vertical	$= \text{Dia.}^2 \times \text{Height} \div 4$
Flue Boilers	$= \text{Dia.} \times \text{Length} \div 3$
Locomotive Type. .	$= \text{Dia. of Waist}^2 \times$ $\text{Length over all} \div 6.$

All dimensions to be in feet.

In the first and third cases the length is the length of the tubes or that of a “flush-head” boiler and does not include the extended smoke-box. In the second case, the height is that of a plain vertical boiler in which the upper part of the tubes is above the water line; it is not the

Boiler Ratings.

height of a boiler with submerged tubes.

The extreme simplicity of the rules aroused curiosity as to their accuracy and comparisons were made between manufacturers' ratings and ratings calculated by the formulas above. The results are given below. They agree very closely, except in a few of the larger sizes of tubular boilers, where the calculated rating falls below that of the manufacturer. And in these sizes it will be noticed that the heating surface per horse-power is less than in the smaller sizes where the two ratings practically agree.

It is quite possible that the ratings of other manufacturers would show a better or worse agreement. In any event, the rules prove to be valuable for just what is intended and will save considerable trouble in measuring up and calculating the power of existing boilers when ordering injectors, feed pumps, and the like.

The ratio of grate surface to heating surface varies from 1 to 40, to 1 to 60. At 3 pounds of coal per H.P. and ratio, 1 to 40, the amount of coal burned per square foot of grate will be 12 pounds, while with a ratio of 1 to 60 the consumption will be 19 pounds coal per square foot of grate.

To find the contents of a shell boiler, multiply the area of the head in inches, less the area of all the tubes in inches by the length of the shell in inches. This gives the total capacity of the boiler. From this we must subtract that portion not filled, or the segment of the circle.

There are a number of short rules that are only approximate.

To find the area of the segment of a circle, we first find the area of sector of a circle.

Calculating Steam Room.

The length of the arc of a circle—chord of whole arc is 8 times the chord of half the arc, and taking $\frac{1}{3}$ of the remainder.

The area of the sector of a circle equals length of arc $\times \frac{1}{2}$ the radius.

Area of segment of circle—area of sector of circle—area of triangle when segment is less than a semi-circle.

A boiler 72" diameter filled to within 18" of top will have the dimensions of cut, the radius being 36", the chord of whole arc 63" and chord of half the arc

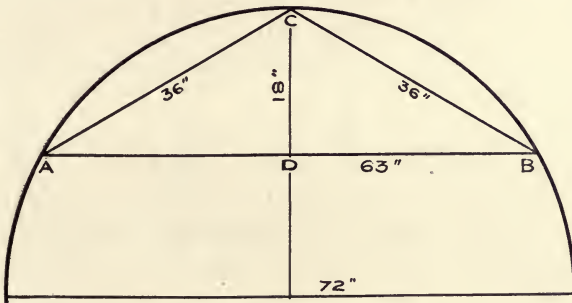

Fig. 99. Boiler calculations.

36". The two sides of triangular arc 36" and base 63.
From the above rule.

$8 \times 36 - 63 = 225$. One-third of this is 75×18
($\frac{1}{2}$ the radius of the circle) = 1350.

The area of the triangle is found by adding the three sides together and dividing by 2. From the half sum subtract each side separately; multiply the half sum and the three remainders continuously together; take the square root of the product.

$$\text{The three sides, } 36, 36, 63. \quad 36 + 36 + 63 = \frac{135}{2}$$

How it is Figured.

$= 67.5$ and $67.5 - 36 = 31.5$; $67.5 - 63 = 4.5$. And $31.5 \times 67.5 \times 31.5 \times 4.5 = 301388$ and the square root 549. $1350 - 549 = 801$ square inches, area of segment.

Another short method is to take the chord of the arc and versed sine, or the rise only.

To $\frac{2}{3}$ of the product of the chord A. B. and rise C. D. of the segment, add the cube of the rise, divided by twice the chord; the remainder is the area nearly.

$$63 \times 18 = 1134 \times \frac{2}{3} = 756.$$

$$18 \times 18 \times 18 = 5832. \quad 63 \times 2 = 126. \quad \frac{5832}{126} = 46$$

$$756 + 46 = 802 \text{ sq. in. area.}$$

To get at the principle requires use of the higher mathematics.

With a copy of Trautwine's tables the result can be obtained accurately with but few figures.

Divide the rise by diameter of circle. In the table find a number opposite the quotient and multiply this number by the square of the diameter.

$$\frac{18}{72} = .25.$$

In the table opposite. '25 is the number 72

$$.153546. \quad 72 \text{ squared} = 5184. \quad .153546 \times 5184 = 795.98 \text{ area. This is the accurate area.}$$

From the same arc can be found the radius of a circle.

Add the square of half the chord A. B. to the square of the rise C. D. and divide by twice the rise, gives the radius of the circle.

This applies to a railroad curve or the arc of a pulley.

Should the occasion arise, where the distance from center to circumference cannot be found, stretch a line

Area of Tubes.

across the circumference at any point and measure from center of line to circumference.

The usual rule to apply for boiler braces is to allow 2" space around the head and tubes that do not need bracing.

To find the area for the braces, find the area of segment of the space above the tubes and subtract the 2".

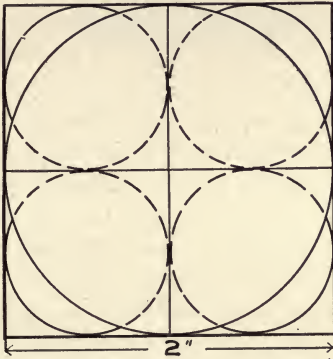

Fig. 100. Showing area of inches.

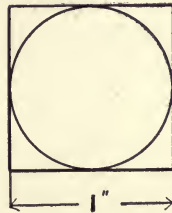

Fig. 101.

The area of a circle is .7854 of the square of the diameter. Fig. 101.

Doubling the diameter increases the area four times, as shown in Fig. 100.

Real Boiler Economy.



When filling a boiler or emptying it without pressure, there should be a vent. Mr. P. H. Bullock puts a check in a vertical pipe $\frac{3}{4}$ inch in diameter, the check opening in. When there is no pressure, the check is always open and prevents a vacuum in the boiler when water is running out, and will let air out when water is running in. It will close itself when steam is raised to about 2 pounds.

When economy, ease of taking care, first cost, etc., are concerned, it is a difficult matter to beat a tubular boiler. When it comes to space occupied, long life, high pressure and large units, it is of necessity supplanted by the water tube. The water tube, correctly designed and honestly built, is also much safer than the tubular.

Where the tubes are put into manifolds, or headers, and suspended from the drums by short tubes, these short tubes should be two sizes heavier than the tubes in boiler.

For instance, a 4-inch tube is made from No. 10 metal, and the short tubes should be No. 8. All of them should be full size in the thinnest part, and should be made from wrought iron.

Grates under a boiler should last as long as the boiler, and this can only be done by keeping them cool.

When a fire is cleaned by shutting the ash pit doors the grates become red hot. This will be more effectually done if the ash and small coal be left in the ash pit, especially at night. When iron is heated to a red heat the grain becomes coarser under expansion and does not return to its original size when cooled. This process continued causes the iron to swell in places where the heat

About Grate Bars.

has been most intense and distortion occurs, bringing some portion up into the fire and the grates then go pretty fast.

It is the better plan to have the ash pit made with a place to hold water 8" to 10" deep and keep water in it during the time there is fire on the grate.



Fig. 102. Forms of grate bars.

The ash pit doors should not be closed so long as there is fire on the grates, and the regulation should all be done by damper in the flues.

It is sometimes necessary to take the ash pit doors off when the firemen persist in closing them.

There are numerous forms of grate bars, but the form shown at *A*, Fig. 102, will give the best distribution of air, while that at *B* will come next. Either of these types can be made lighter, and a furnace full will cost less than with a straight bar.

Bars set with the rear end raised or lowered will give better results than if placed level.

Shaking grates are of service only for relieving the finer ash, while they are valueless for removing clinker and the coarser ash. The better grate is that made after the plan of *A* and put in with front and rear sections, so that the front or rear can be dumped separately.

A soft patch for a boiler is a patch made to fit, and either lead putty with iron borings or some form of sheet packing put under to make a joint after the manner of making a flange joint, and the patch is screwed up with counter-sunk bolts. Generally the piece of boiler

Boiler Patches.

is not cut, which leaves two thicknesses of iron, so that that nearest the fire, not being protected by water, is burned.

A hard patch is a patch where the iron is cut out of the boiler, a piece fitted to cover it, holes drilled and riveted on, chipped and caulked and made tight.

The soft patch is liable to get to leaking and is dangerous. The hard patch is safe, although over the fire it would be better to put in a new fire sheet entire to avoid a double thickness and rivets where the fire is intense.

Drilled holes are better than punched, because the fiber of the iron is not disturbed as in punching.

Laying out Gaskets.

To lay out a gasket for the regular shaped manhole or handhole, find the length of the plate and divide it by three. On the line AB and with $\frac{1}{3}$ as radius and with centers at C and D lay off the two circles.

Should the length be 15", set the dividers at 5" and lay off the two circles. Then with the center at E lay off the arc G , and with the center at the intersection of the circles at F lay off the arc H . With the same centers the outside circle can be laid out. This will make a regular 11" x 15" gasket.

There will sometimes be found a plate, where, instead of the small arcs G and H , there will be a straight line drawn from the same points.

Foaming.

Foaming is the raising of the water with the steam. It is caused by grease or dirt that prevents a free separation of the steam. In one case where the engineer

Foaming Boilers.

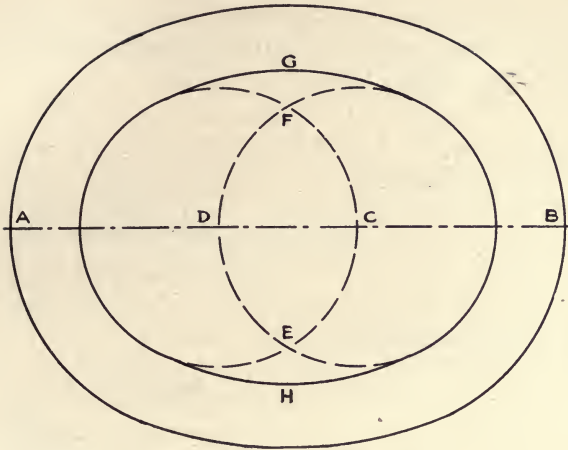

Fig. 103. Laying out a Gasket.

had not kept his boiler clean there was a large amount of deposit. It became necessary to raise the front end three inches and this changed the circulation within the boiler and stirred up the deposit so much as to set up a dangerous foaming until the boiler was cleaned.

Soap, or any substance like an alkaline boiler compound when grease is present, salt water put into fresh water, too little steam room or not sufficient area at top of water, or a strong draft of steam that causes the water to raise, will produce foaming.

It is dangerous by drawing too much water from boiler and also by getting water into the engine which washes off the oil and may break something.

Boiler Braces.

There are two general forms of braces—the crow-foot, where both ends are riveted to the boiler, and the

Boiler Braces.

angle. In the latter there are a pair of angles riveted to head the entire length, and the braces are held to the angles with a tapered pin.

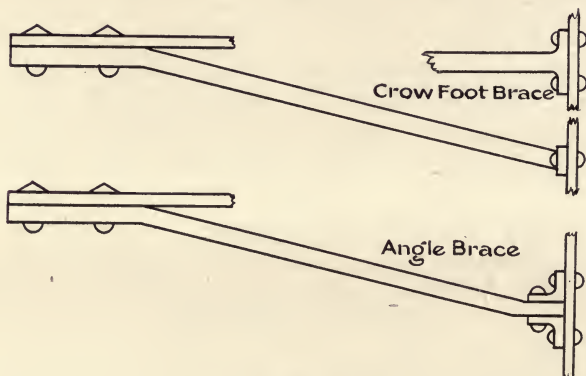

Fig. 104. Boiler braces.

Pumps.

With a non-condensing engine exhausting through a heater it is the more economical to feed water to boiler with a power pump. With a condensing engine or a number of engines the steam pump exhausting through a heater not connected with the engines will be the more economical.

The amount of heat converted into work in moving the plungers will be the same in each case, and the heat

$$\text{at 1 H. U.} = 778 \text{ foot lbs.} = \frac{33000}{778} \times 60 = 2557 \text{ H. U.}$$

per hour per H. P. for driving pump.

Steam Pumps.

The main engine driving the pump and using $1\frac{1}{2}$ lbs. of coal per H. P. will, with 9800 H. U. per lb.,

9800

4900

delivered into the steam, means that $\frac{\quad}{14,700} - 2557 =$

12,443 H. U. per H. P. are loaded on to the condenser and goes out in the discharge and lost. If the pump were driven direct by steam there would be the same amount of heat converted into work, and while the amount of steam required to drive the pump would be more, all the waste heat going into the heater would heat the feed water and all waste heat would return to boiler.

A steam pump is elastic and can be run at any speed to keep the feed regular.

A power pump runs at one speed and must feed the boiler too fast and have the water shut off a portion of the time or there must be a relief valve to waste water through after it has been pumped to a high pressure.

A duplex pump will be easier on piping, etc., than a single pump.

A pump may give trouble from a leak in suction pipe; from a strainer becoming clogged; from the piston packing leaking; from a valve breaking through, or from a portion of the pump filling with air.

A leak in suction will be known from there being larger quantities of air. A clogged strainer from there not being a sufficient amount of water to fill the pump.

An air chamber of ample size should be put in the suction of a pump, as shown in Fig. 105, so that the current of water will flow direct to it. An air chamber put on as indicated by the dotted lines is of no value.

A check valve should be put in the discharge of a

Air Bound Pumps.

pump, and an air or vent valve at the top of pipe between it and the pump. This valve should never be less than $\frac{1}{2}$ inch, and for large pumps much larger.

When a pump gets air-bound it can be quickly relieved. A man tried to syphon spring water over a hill to his house, and the water would flow but a short time.

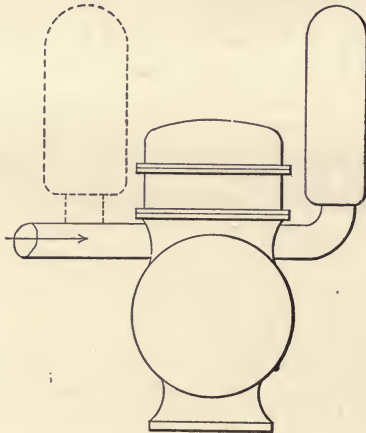

Fig. 105. Air chamber on suction end of pump.

He then put a chamber at the extreme high point for the accumulation of air with a valve to shut the chamber off from the pipe and means to refill it with water driving out the air. This helped matters, but did not insure a constant operation. The pipe was 2-inch. He took out the 2-inch on the downhill side and put in $2\frac{1}{2}$ -inch, and had no further trouble.

Injectors should be used where heaters are not available and are valuable on locomotives, traction and portable engines. All of the heat for driving them is

Injectors.

returned to the boiler, but they use live steam for all this work.

Where a heater can be used they are valuable only as auxiliary for a cheap substitute when the pump is broken. It is the better plan to install two pumps.

The injector must have supply not to exceed 110° . Some will raise their water by suction 15', while others will raise it but a short distance.

The principle reasons for their not working is getting hot (as they must be sufficiently cool to condense the steam). To be sure of this, the water supply must not be too warm; it must be ample and unobstructed, and the strainer must be sufficient to prevent the entrance of anything that will clog the small ports. The check valves may stick, and the inner tubes will wear large and require removal. The better plan is to have the printed directions of the builder on hand if possible. Also do not put an ell or turn within two feet in the discharge line.

A leaky piston can be detected by the noise of a leak through both strokes; a leak through one valve by a noise on one end. If a pump is air bound it can be told by opening the vent cock in valve chamber; also there will be a jerky motion of the plunger, caused by the pump cylinder being partially filled with air.

All pumps should have a check and stop valve in the discharge and a vent not less than $\frac{3}{8}$ ".

When the pump gets air sufficient to cause trouble the quickest method to get rid of it is to stop the pump, open the vent, and as soon as the water is out the air will follow. Leave the vent open for a few strokes.

In the smaller sizes of duplex pumps, where both cylinders are cast together and one plate extends over both heads, it sometimes happens that the gasket in the

Duplex Pump Valves.

partition between the two cylinders gives out, allowing the contents of one cylinder to blow through into the other. This may happen on either end. A duplex pump may sometimes refuse to work from improperly set valves.

To set the valves of a duplex pump place the pistons at center of stroke; place the valves at center of travel. The valve stems have a little play in the valve and this play should also be set central.

With a single cylinder pump it may refuse to work from the supplemental piston on top sticking from want of oil or from dirt, or when new from the piston valve expanding before the chest gets hot, or from some of the small parts getting stopped up.

When high pressures are used and cold water, medium hard rubber should be used for water end. When pumping hot water, hard valves should be used and the pump placed below the supply.

Heaters.

Heaters are of different designs, one being a coil through which the water passes the entire length, the steam being on the outside.

The claim for this type is that the water travels so far, all the time changing direction and all of the water is exposed to the heat. With this type there is no reservoir and no space for deposit of sediment.

Another type has the steam passing through the tubes, the water being enclosed in a shell outside the tubes. In some cases the tubes are expanded into two heads, one of the heads being constructed so as to allow for expansion. In some types the tubes are corrugated,

Using Waste Heat.

and in others the tubes are bent into U shape to allow for expansion.

This type has a reservoir and a space for deposit for sediment but has the drawback where the shells are made from rolled metal that the metal will pit at lower portion of shell where the water is simply warm and no circulation.

In the open type the water is sprayed over and brought in direct contact with the steam.

This type requires watchfulness, will get the water nearly as hot as the steam, will deposit a large per cent. of the impurities in the water ; but care is necessary all of the time to prevent the oil getting into the boilers.

Economizers.

An economizer is composed of cast iron tubes forced into headers, these headers connected together. Outside these tubes are scrapers being continually moved up and down, thus keeping the surface clean from the soot. These economizers are placed in flue from boiler to stack and absorb a portion of the heat from the flue gases.

From whatever source the feed water absorbs waste heat, for every 10° the economy in fuel will be practically 1%. A good heater with sufficient exhaust at pressure of the atmosphere will heat the feed water to 200 to 210° . An economizer will add about 100° more.

The effect of an economizer in a flue is to reduce the temperature of the flue gases, and as the temperature is reduced the draft will be reduced so that where economizers are used the chimney should be higher.

Steam Gauge.

The spring in a steam gauge is a flat tube and is constructed on the principle that "a thin elliptical metal tube if bent into a coil will seek to coil or uncoil itself as subjected to external or internal pressure." A steam gauge should have a coil, bend or some provision to retain water directly under it, so that steam or heat shall be kept from the spring, as heat would expand it and show false.

The spring is connected to pointer by lever and gears. The spring should move but a short distance, as there is a tendency for these tubes to "set" when their traverse is long, and when there comes a permanent "set" a new spring and dial is required.

Rope and Pulleys.

When a rope is put over one pulley the weight will be raised at the same speed as the power at the other end, and power and weight will be equal except the friction.

When another pulley is added the speed of the weight or resistance will be one-half that of the power applied and double the weight can be moved at $\frac{1}{2}$ the former speed, and for every pulley added the speed will be reduced and greater resistance overcome. This is the "law of movable pulleys." The same law applies to the lever and wedge.

Safety Valves.

To find weight to put on safety valve lever, let A represent area \times pressure; l represent " length of lever from fulcrum to center of valve; L, length of lever from fulcrum to weight; W, weight.

Safety Valve Calculations.

$$\text{Then } W = \frac{a \times l}{L}$$

This rule does not include the weight of lever and valve and would slightly overload the valve.

Let L = length of lever from fulcrum to weight.

L' = length of lever from fulcrum to center of valve.

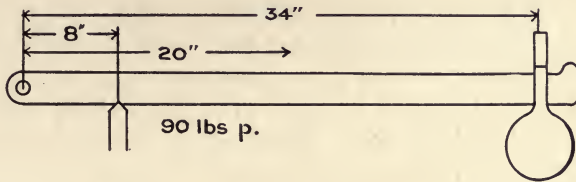

Fig. 106. Safety valve calculations.

L'' = length of lever from fulcrum to center of gravity.

W = weight in pounds.

w = weight of lever.

w' = weight of valve.

a = area of valve.

p = pressure of steam.

$$a \times p - \left(\frac{w \times L''}{L'} + w' \right) \times L'$$

1. Then, $W = \frac{\text{---}}{L}$

2. Weight of a cubic inch of cast iron is .2607.

Cubic inch of wrought iron, .2816.

. Let L = length of lever from fulcrum to weight 34".

L' = length of lever from fulcrum to center of valve 8".

L'' = length of lever from fulcrum to center of gravity 20".

How It Is Done.

w = weight of lever, 10 lbs.

w' = weight of valve, 6 lbs.

a = area of valve, $12\frac{1}{2}$ lbs.

p = pressure in boiler, 90 lbs.

W = weight to be found.

The center of gravity of lever is the point where it would balance and is near the center depending upon the amount of taper.

$$\text{Then } \frac{12\frac{1}{2} \times 90 - \left(\frac{10 \times 20}{8} + 6\right) \times 8}{34}$$

$$10 \times 20 = \frac{200}{8} = 25 + 6 = 31$$

$$\begin{array}{r} 90 \\ 12\frac{1}{2} \\ \hline \end{array}$$

$$1080$$

$$\begin{array}{r} 45 \\ \hline \end{array}$$

$$1125$$

$$\begin{array}{r} 31 \\ \hline \end{array}$$

$$1094$$

$$\begin{array}{r} 8 \\ \hline \end{array}$$

$$34)8752(257 \text{ lbs. weight}$$

$$\begin{array}{r} 68 \\ \hline \end{array}$$

$$195$$

$$\begin{array}{r} 170 \\ \hline \end{array}$$

$$252$$

$$257$$

J. W. HILL.

Pop Valves.

To change the pressure on spring safety valves, known as "pop" valves, remove the lock-up cap and slacken check nut.

To increase the pressure, turn the compression to the left, or down, about one square of the nut for each five pounds pressure. Then secure the check nut and let the valve blow. Note if the pressure is reduced too much after the valve "pops."

A "pop" valve is made with the regular conical valve and outside of this is a lip with sharp edge nearly seating on a movable plate. When the valve commences to blow a small amount will pass out under this lip, but as the amount increases it is retained by this lip and the extra pressure under the increased area causes the valve to "pop" or open fully at once.

From the outside case is a place to reach the plate, or movable ring, generally by removing a plug. After screwing down on the valve and the pressure is reduced too much, insert a pointed instrument and turn this movable ring down three or four notches and let it blow, and repeat until the seating is right. If it seats quickly and the pressure rises too much before it "pops," screw the ring in the opposite direction.

Should it be necessary to reduce the pressure, proceed in the opposite manner.

Fly Wheels.

In fly wheel rims, for a given material there is a definite speed at which disruption will occur, regardless of the amount of material used.

Fly Wheel Problems.

This is expressed by the following formula :

$V = 1.6 \sqrt{\frac{s}{w}}$ in which V is the velocity of rim in feet per second at which disruption will occur, w the weight of a cubic inch of material used, and s the tensile strength of one square inch.

The formula means that if we divide the tensile strength of the material by its weight per cubic inch, extract the square root of the quotient and then multiply by 1.6 the result will be the speed in feet per second.

Instead of the ultimate strength let us take the safe strength.

Cast iron in large castings could be depended upon for a tensile strength of 10,000 lbs., and with a factor of safety of 10 would give us 1000 lbs. per square inch. The weight of a cubic inch of cast iron is .26 of a lb., so that we have for solid cast iron rims $V = 1.6 \sqrt{\frac{1000}{.26}} = 100$ feet per second.

This corresponds to 1.15 miles per minute. There will probably be some shrinkage strains, so that it is considered good practice not to run them faster than a mile a minute.

With jointed rims and joints between the arms it is not considered possible to make a joint to exceed one-fourth the strength of a solid rim.

With steel having a tensile strength of 60,000 lbs., or a safe strength of 6000 and weighing .28 lbs. per cubic inch, we have $V = 1.6 \sqrt{\frac{6000}{.28}} = 146$ feet per second, or 1.66 miles per minute.

Hard maple has a tensile strength of 10,500 lbs. It is made up in segments so that a factor of safety of 20 is taken, and the weight is .0283 per cubic inch. $V = 1.6 \sqrt{\frac{262.5}{.283}} = 1.54$ ft. per second, or 1.75 miles per minute.

W. H. BOEHM.

Right Angle Triangle.

When it is necessary to determine a right angle a distance can be measured off in one direction of 6 feet and another of 8 feet, and from these two points the distance should be 10 feet.

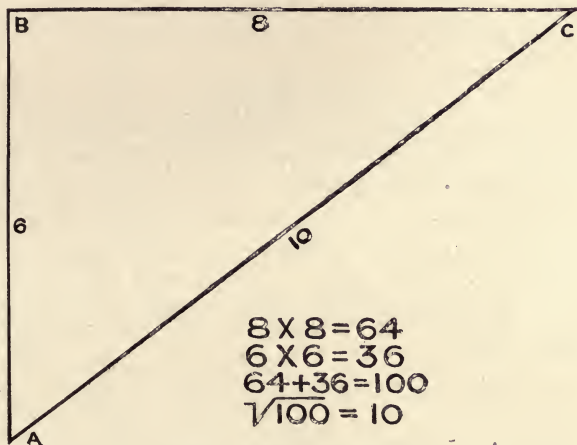

Fig. 107. Right angle triangle.

The cut shows the dimensions and method of finding the third side. Multiply each of the two sides by themselves, add the products together and extract the square root.

Facts About Steam.

Flow of steam in pipes should not exceed 100 ft. per second, or 6000 ft. per minute.

At sea level fresh water boils at 212° . For each degree less estimate the elevation at 550 ft.

Cylinder Pressure.

Discharge of steam through pipes. Trial made at Novelty Iron Works. H. P. at 80 lbs. steam.

1" pipe	140	H. P.
1¼" "	214	"
1½" "	315	"
2" "	560	"
2½" "	875	"

Cylinder Pressure.

To find average mean pressure in cylinder by calculation when cut-off is known:

Divide initial pressure by ratio of expansion and multiply by hyperbolic logarithm increased by 1.

With 100 pounds initial pressure and cutting off at ¼ of the stroke, the ratio will be 4 and the hyperbolic logarithm 1.386.

$$\frac{100}{4} = 25 \qquad 1.386 + 1 = 2.386.$$

$2.386 \times 25 = 59.65$ lbs., mean effective pressure.

The above does not take account of the loss from back pressure, compression, lowering of steam line or rounded corner at release, so that an indicator card would show a result somewhat less.

The following are tables showing points of cutting off at 8ths and 10ths with ratio of expansion and hyperbolic logarithms:

Point of cutting off	$\frac{1}{8}$	$\frac{2}{8}$	$\frac{3}{8}$	$\frac{4}{8}$	$\frac{5}{8}$	$\frac{6}{8}$	$\frac{7}{8}$
Ratio of expansion	8	4	2.66	2	1.6	1.33	1.14
Hyperbolic Logarithms . . .	2.079	1.386	0.978	0.693	0.470	0.285	0.131
Point of cutting off	$\frac{1}{10}$	$\frac{2}{10}$	$\frac{3}{10}$	$\frac{4}{10}$	$\frac{6}{10}$	$\frac{7}{10}$	$\frac{8}{10}$
Ratio of expansion	10	5	3.33	2.5	1.66	1.42	1.25
Hyperbolic Logarithms . . .	2.303	1.609	1.203	0.916	0.507	0.351	0.223

Mean Effective Pressures.

Another table is often convenient. Mean pressure in cylinder when cutting off at

$\frac{1}{4}$	stroke =	boiler pressure	×	.597
$\frac{1}{3}$	“ =	“	×	.670
$\frac{3}{8}$	“ =	“	×	.743
$\frac{1}{2}$	“ =	“	×	.847
$\frac{5}{8}$	“ =	“	×	.919
$\frac{2}{3}$	“ =	“	×	.937
$\frac{3}{4}$	“ =	“	×	.966
$\frac{7}{8}$	“ =	“	×	.992

Buell gives the rule for finding terminal pressure in the cylinder as: “The terminal pressure of steam in a cylinder is the product of the pressure at cut-off multiplied by cut-off.

95 lbs. steam \times .25 cut-off = 23.75, terminal pressure.

POINTS OF CUTTING OFF.

Initial Pressure	$\frac{1}{8}$	$\frac{1}{5}$	$\frac{1}{4}$	$\frac{1}{3}$	$\frac{3}{8}$	$\frac{1}{2}$	$\frac{5}{8}$	$\frac{3}{4}$
10	3.8	5.2	5.9	6.6	7.4	8.4	9.1	9.6
15	5.7	7.8	8.9	10.4	11.1	12.7	13.7	14.4
20	7.6	10.4	11.9	13.6	14.8	16.9	18.3	19.2
25	9.5	13.0	14.9	17.5	18.5	21.1	22.9	24.1
30	11.5	15.6	17.9	20.9	22.2	25.4	27.5	28.9
35	13.4	18.2	20.8	24.4	25.9	29.6	32.1	33.8
40	15.4	20.8	23.8	27.9	29.6	33.8	36.7	37.5
45	17.3	23.4	26.8	31.4	33.3	38.1	41.3	43.4
50	19.2	26.0	29.8	34.9	37.0	42.3	45.9	48.2
55	21.2	28.7	32.8	38.4	40.8	46.5	50.5	53.7
60	23.1	31.1	35.7	41.9	44.5	50.7	55.1	57.8
65	25.0	33.9	38.7	45.4	48.9	54.0	59.7	62.4
70	26.9	36.5	41.7	48.9	52.4	59.2	64.3	67.4
75	28.8	39.1	44.7	52.4	55.6	63.4	68.9	72.5
80	30.8	41.7	47.7	55.9	59.3	67.7	73.5	77.1
85	32.7	44.3	50.7	59.4	63.0	71.9	78.0	81.9
90	34.6	46.9	53.6	62.9	66.7	76.1	82.6	86.7
95	36.6	49.5	56.6	66.4	70.8	80.4	87.0	91.2
100	38.4	52.1	59.6	69.9	74.1	84.6	91.8	96.3
105	40.4	54.7	62.6	73.4	77.8	88.8	96.4	101.1
110	42.5	57.4	65.5	76.4	81.5	93.1	101.0	106.0
120	46.1	63.4	71.5	83.9	89.4	105.5	110.2	115.2
130	50.0	67.8	77.5	90.9	95.3	110.0	119.1	125.4
140	53.8	78.0	83.5	97.9	103.8	118.5	128.6	135.9

About Heat Units.

Average pressure from rule:—Divide the initial pressure by ratio of expansion and multiply quotient by the hyperbolic Logarithm increased by 1

Loss of Heat.

To find loss in the gas going up chimney in heat units:

Weight of flue gas \times specific heat \times temperature above boiler room = heat units.

The weight of air theoretically necessary for the combustion of one pound carbon is 12 lbs, but the usual amount in practice where draft is used is 24 lbs.

The specific heat of air compared with water is .238.

If temperature of gas leaving boiler is 500° and temperature of boiler room 80° , then the coal has put 420° heat units into 24 lbs. air for each lb. of coal.

24 lbs. air \times .238 = 5.732. This multiplied by 420 = 2407.44 heat units.

Should we wish to determine the amount of water it would evaporate from 212° to steam at 212° we divide the heat units by 966. This gives us 2.48 lbs. of water. This is the heat lost in producing draft, or the heat lost in chimney.

It is at this point that the only hope lies in economy in the use of powdered fuel.

With the fuel powdered fine and the air thoroughly mixed and blown in it should require but the theoretic amount of air which would save one-half the above loss. There is another small loss that might be saved.

With draft in the flue at the end of the boiler, either by chimney or by induced draft with exhaust fan, there will be air drawn in through the brick work and through every crack and crevice and has a cooling effect.

Forced Draft.

Air put in by a blower so that the pressure inside of the furnace shall be equal to that of the external air will prevent any air coming in except that which goes through the fuel.

Boiler Tests.

When making a boiler test and it is desired to find what the evaporation is "from and at 212° ," or from 212° of feed water to steam at same temperature, divide the heat units put in by the coal by 966° , which is the latent heat of steam at the pressure of the atmosphere.

Suppose the pressure was 100 lbs. and temperature of feed 96° . The total heat units, taken from Porter's tables, of 100 lbs. steam 1216.9. The temperature in feed was 96° .

$$1216.9 - 96 \div 966 = 1.164.$$

This is called the factor of equivalent evaporation. Multiplying the actual evaporation by this factor will give what the evaporation would have been "from and at 212° ." If the evaporation had been 8.6 lbs. of water, then $8.6 \times 1.164 = 10.01$.

If it is desired to find the H. P., which is recognized as 30 lbs. of water, evaporated per hour from feed at 100° to steam at 70 lbs. pressure.

Find the factor from the above figures which are at 70 lbs. 1210. 32 H. U. — $100^{\circ} = 1110.32 \div 966 = 1.150$.

The factor of equivalent evaporation, 1.164 multiplied by the actual amount evaporated per hour and divided by the factor of 100° feed to steam at 70 lbs., viz.: 1.50 will give the standard H. P.

If the actual evaporation per hour had been 10,000 lbs. of water from 96° of feed water and 100 lbs. pres-

Electrical Terms and Phrases.

sure, then $1.164 \times 10,000 \div 1.150 = 10,121.73$. This number divided by 30, which is 30 lbs. of water per hour; $10,121.73 \div 30 = 337.37$ H. P. with feed at 100° to steam at 70 lbs. pressure.

Piston Speed and Horse Power.

Piston speed of engine \times area of piston \times M. E. P.
 $\div 33,000 =$ H. P.

Piston speed of engine \times area of piston \times M. E. P.
 $\div 44,236 =$ Kilowatts.

Electrical Terms.

In measuring the electric current there is one thing that puzzles the beginner. He cannot understand why the dynamo is not doing work when the switches are thrown out and wonders where the current goes.

He is told that the current must be calculated the same as water and the amperes as volumè, and that throwing out a switch is the same as shutting off a valve. He realizes that shutting off a valve means raising the pressure and this is what puzzles him.

If we look upon the electric current as a volume of air from a fan blower, that when a gate is shut and a portion or all of the air is shut off that none is being moved and that the fan is simply turning in the case it can be better understood.

If it is desired to find the K. W. at switch board with 10% loss, $\div 48,659$ K. W. $\times 1.34 =$ H. P.

Allowing for 10% loss, K. W. $\times 1.47 =$ H. P.

A volt is the measure of electric pressure and corresponds to pounds pressure in hydraulics.

An ampere is the measure of electric quantity and corresponds to gallons, etc., in hydraulics.

Electrical Notes.

Volts \times amperes gives the watts which correspond to energy, 446 of which = 1 horsepower.

The number of watts divided by 446 = horsepower.

An Ohm is the measure of electric resistance in the wire and corresponds to friction in pipes.

A copper wire 1-10" area and 1' long has a resistance of 10.6 ohms.

In determining the size of wire the entire circuit, both the outgoing and the return must be taken into account.

A 16 candle-power lamp at 110 volts requires $3\frac{1}{2}$ watts per candle power or 56 watts.

When estimating the size of wire the first thing to be taken into account is the "drop" or loss in voltage that can be allowed.

For lighting there should be a drop of but 2 volts on a 110 volt service, or 2 per cent.

For some kinds of power service there can be a loss of 5 %. At 500 volts this would mean a drop of 25 volts, and at 10% it would mean 50 volts. The latter is allowed on railway work.

In three phase work the volume of current in each wire, or terminal, will be 58% of total.

If we have a three phase generator of a capacity of 750 K. W. and generating current under 12,000 volts pressure, the amperes in each terminal will be about 37.

750 K. W. is 750,000 watts.

$750,000 \div 12,00 = 62.5$ amperes.

58% of 62.5 = 36.25 amperes per terminal and the volume of current that determines the size of each wire.

If we wish to supply 50 amp. 100 feet distant we have a circuit of 200 feet. If the voltage is 110 and we

Hardened Copper.

want a drop of but 2 volts we proceed as follows:

$$\frac{\text{resistance} \times \text{amp.} \times \text{distance}}{\text{volts loss}} = \text{circular mils, or}$$
$$\frac{10.6 \times 50 \times 200}{2} = 53,000 \text{ circular mils.}$$

We look at a table of circular mils and find this corresponds to No. 2 wire, as, if there is no number of wire that corresponds, the larger number should be taken.

This number is from Brown's & Sharp's gauge.

Brown & Sharp's gauge differs from all others in that all the numbers have a direct relation to each other. If we have a wire and wish to get one just double the area we count up three of the numbers. A No. 000 wire has just double the area of No. 1. No. 4 is one-half the area of No. 1. No. 10 is half the area of No. 7.

Hardened Copper.

Receipt for hardened copper-Blue clay, borax, potash and straw, equal parts; crush fine, mix thoroughly together and let it remain three days preparatory to use. To 1 lb. copper, when melted, take 1 lb. 8 oz. of the mixture; stir well in and let it remain one hour. Remove the slag, then put in a small piece of glass the size of $\frac{1}{2}$ oz. bottle with a teaspoonful of borax; stir well, let it remain 15 minutes and pour.

A patent for the above was granted to a woman. This woman was not a metallurgist, but a clairvoyant, and her story was that during a trance an old Egyptian appeared to her and gave her the above receipt.

Estimating Water Power.

Copper made from the above will be 99% copper and the stuff put into the copper comes out in the form of slag.

From the above receipt copper drills have been made that would drill granite. For bearings it should be made so that it will work about like cast-iron.

A few years since a man in Pennsylvania designed a compound metal having about 85% of copper that could be made so hard that a hatchet made from it will cut nails.

It was suggested by the writer that a trial be made to show its shot resisting qualities compared with steel.

A ball from a Mauser rifle that would perforate a $\frac{1}{2}$ " steel boiler plate would only penetrate the copper plate $\frac{1}{8}$ ".

Points of compass by a watch point the hour hand of the watch to the sun and half way between that point and 12 is due south when north of the equator.

When estimating water power at 75% efficiency, a flow of 705 cubic feet of water per minute equals 1 H. P. for each 1 foot fall.

Other Metals.

Regarding copper as a metal for journals, a maker of seamless tubes had the following experience:

When drawing seamless tubes, the cast shell is put on an arbor and pushed through a die and the friction on the arbor is enormous. He had trouble in getting a lubricant for his arbors that would prevent the brass clinging and cutting the arbor. He noticed that he had no trouble with the copper tubes, so he would draw a copper tube, then three or four brass tubes, then a copper and so on and then he had no trouble with the brass tubes. It was

An Expanding Metal.

shown that a sufficient film of copper was left on the arbor to lubricate the following brass tubes.

Metal that will expand in cooling :

9 parts lead.

2 " antimony.

1 " bismuth.

Examination Questions.

Some time ago the owners of a large building erected in New York City put in an elaborate steam-heating and elevator machinery plant, and they required a good engineer to take charge. They were prepared to pay good salary to a suitable man, and this fact becoming known, a host of applicants became candidates for the place. As a means of helping to indicate what man would best suit the position, the candidates were required to take part in a competitive examination, the subjoined being the questions submitted. Few engineers would be able to answer half of the questions, but the publication of them will give engineers an idea of the range of knowledge required by those favoring the system of appointment through merit alone, and they may serve as a guide to study :

What is your name?

Your age, and where born?

Are you a machinist?

Where were you apprenticed, and number of years you worked at the trade?

What is steam?

What are the properties of steam?

At what temperature does water boil at sea level?

What is the volume of steam from 1 cubic inch of water?

Examination Questions.

What is the temperature of steam, and volume at 1 pound above atmospheric pressure?

What is the temperature of steam at 60 pounds above atmospheric pressure?

What is the proper course to pursue should the water be found low in the boiler?

If a boiler 72" diameter had the tubes to within 30" of the top of the boiler and allowing 2" around the shell and top of the tubes did not call for braces, what would be the area to be braced?

What form of braces are commonly used?

If a boiler 72" diameter were filled with water to within 18" of the top, what would be the area of that portion filled with steam?

What is the largest area allowed between braces?

What types of engines are you familiar with?

What is a slide valve?

What is a piston valve?

What are Corliss valves?

What is an eccentric?

How much throw should an eccentric have?

How should an eccentric be set?

What is lap?

What is lead?

What is compression?

Can this be carried too far?

How would you place an engine on the exact center?

How would you set a slide valve?

How would you set Corliss valves with single eccentric?

How with a double?

What causes an engine to pound?

How can it be remedied?

Examination Questions.

What causes an engine to heat?

What are some of the remedies?

How would you determine the travel of a piston so it should be the same distance from both ends of the cylinder?

Upon what does the efficiency of an engine depend?

What is the effect of too slow a piston speed?

What is the effect of too high a rotative speed?

What is the effect of clearance?

What relation does a four-valve engine bear to clearance?

When re-setting the steam valves on a Corliss engine what is there to look after in relation to the governor?

In what way is a vacuum of benefit to an engine?

What is a heater?

In what way is a heater of benefit?

How many types are there?

What is the object of a surface condenser?

Can oil be separated from the exhaust steam?

What is an economizer?

What are the important points about piping?

What is the cause of water hammer?

Should a pipe incline towards the boiler or towards engine? Why?

What is the expansion of a pipe 300' long with 150 lbs. steam?

How can this expansion be taken care of?

What is the important point about traps?

What is sensible heat?

What is the British unit of heat?

What is the mechanical equivalent of heat?

What is the equivalent of a horse-power?

What is the horse-power of an engine—cylinder,

Examination Questions.

12"x18"; initial pressure, 80 pounds per square inch; cut-off, $\frac{1}{4}$ stroke; revolutions, 100 per minute?

If the initial pressure be 80 pounds per square inch, and cut-off $\frac{5}{8}$ stroke, what will be the terminal pressure?

What will be the point of cut-off to reduce the terminal to atmospheric pressure?

Have you ever used the indicator?

And whose make?

Draw an indicator diagram, and compute the horsepower from it, of an engine 14"x22", initial pressure 75 pounds, cut-off stroke, revolutions 80 per minute.

Have you had any experience with piston valves?

State what other valves you are familiar with, and give a sketch of them.

What is lap and lead?

What is pre-release?

Of what benefit is compression?

What is the tensile strength of iron?

And of steel?

What is the safe working pressure per square inch of a tubular boiler 54" diameter, plates 5-16" thick?

What pressure will be necessary to burst an iron boiler 30" diameter, 5-16" thick, the diameter and pitch of rivets so they will shear off when the plates have reached the limits of their tensile strength?

Give a sketch of what you consider the best boiler stay.

And how a boiler should be stayed.

What grate surface do you allow in square feet per horse-power?

What is a fair allowance of heating surface per horse-power?

How much water will 1 pound of coal evaporate?

Examination Questions.

How much coal would be a fair average per horse-power per hour?

How much water evaporated per horse-power per hour?

Give a rule for computing the diameter of a safety valve for a given boiler.

Where is the best place to introduce the feed water in a boiler?

Where should the blow-off pipe be situated?

When is the best time to remove clinkers from the fire-brick walls with the least injury to the brick?

Where should the connections be made in a boiler for the attachment of steam and water gauges?

Where should the steam and water gauges be situated?

What is your opinion as to the use of Croton water in boilers?

State your objections, if any?

What different make of steam gauges are you familiar with?

State maker's name, and draw a vertical section of them.

Have you had an experience in steam heating?

State where.

Would it be economy to use the exhaust steam for heating purposes, if it should throw a pressure of 2 pounds per square inch on piston?

What weight is required for a safety valve 4" diameter, total length of lever 36", from fulcrum to valve 4", boiler pressure 80 pounds per square inch, weight of valve and connections 12 pounds?

The diameter being 1, what is the area?

Examination Questions.

What is the square of 12?

What is the cubical capacity of a cylinder 4'x10'?

What is the pressure per square inch of a column of water 100' high?

And at what height will it support a column of mercury?

What is a soft patch on a boiler? What is a hard patch?

Which is to be preferred, and why? Which is better, drilled or punched holes? Why?

How should a boiler be cooled off? How should the water in a boiler be changed?

What is the effect of leaving the doors and damper shut?

What is foaming?

What are the causes of foaming? How are boilers injured by it?

How are engines?

How often should water gauges and gauge glasses be blown out?

How would you change the point of blowing off with a spring or "pop" valve?

What pumps are you familiar with?

How would you set the valves for a duplex pump?

What are the causes of a pump not working?

How remedied?

What are the causes for an injector not working?

What is a vacuum?

Where is a vacuum used? How would you determine the amount of water for a condenser?

How would you determine the amount of water a boiler required?

How would you determine the size of pump for it?

About Chimneys.

How much grate area should there be per horse-power of boiler?

How much heating surface?

What are the causes that lead to boiler explosions?

What is external corrosion?

What is internal corrosion or pitting?

What are the causes?

What is grooving and cause?

When are explosions the most destructive?

Upon what does the efficiency of the boiler depend?

Stability of Chimneys.

Stability, or power to withstand the over-turning force of the highest winds, requires a proportionate relation between the weight, height, breadth of base, and exposed area of the chimney. This relation is expressed in the quotation

$$C \frac{d h^2}{b} = W,$$

in which d = the average breadth of the shaft; h = its height; b = the breadth of base, — all in feet; W = weight of chimney in lbs., and C = a co-efficient of wind pressure per square foot of area. This varies with the cross-section of the chimney, and = 56 for a square, 35 for an octagon, and 28 for a round chimney. Thus a square chimney of average breadth of 8 feet, 10 feet wide at base and 100 feet high, would require to weigh $56 \times 8 \times 100 \times 10 = 448,000$ lbs., to withstand any gale likely to be experienced. Brickwork weighs from 100 to 130 lbs. per cubic foot, hence such a chimney must average 13 inches thick to be safe. A round stack could weigh half as much, or have less base.

Areas and Circumferences of Circles

From 1-64th to 100.

Diam.	Area.	Circum.	Diam.	Area.	Circum.
1	.000192	.04909	6 $\frac{1}{2}$	35.7848	21.2058
$\frac{1}{2}$.000767	.09818	7	38.4846	21.9912
$\frac{3}{4}$.003068	.19635	$7\frac{1}{2}$	41.2826	22.7766
$\frac{1}{10}$.012272	.3927	$7\frac{3}{4}$	44.1787	23.562
$\frac{1}{8}$.027612	.589	$8\frac{1}{4}$	47.1731	24.3474
$\frac{3}{10}$.049087	.7854	8	50.2656	25.1328
$\frac{1}{5}$.076699	.98175	$8\frac{1}{2}$	53.4563	25.9182
$\frac{2}{5}$.110447	1.1781	$8\frac{3}{4}$	56.7451	26.7036
$\frac{1}{4}$.15033	1.37445	9	60.1322	27.489
$\frac{3}{8}$.19635	1.5708	$9\frac{1}{4}$	63.6174	28.2744
$\frac{1}{3}$.248505	1.76715	$9\frac{1}{2}$	67.2008	29.0598
$\frac{2}{3}$.306796	1.9635	$9\frac{3}{4}$	70.8823	29.8452
$\frac{1}{2}$.371224	2.15985	10	74.6621	30.6306
$\frac{3}{4}$.441787	2.3562	$10\frac{1}{4}$	78.54	31.416
$\frac{1}{2}$.518487	2.55255	$10\frac{1}{2}$	82.5161	32.2014
$\frac{1}{2}$.601322	2.7489	$10\frac{3}{4}$	86.5903	32.9868
$\frac{1}{2}$.690292	2.94525	11	90.7628	33.7722
1	.7854	3.1416	$11\frac{1}{4}$	95.0334	34.5576
$1\frac{1}{4}$	1.2272	3.927	$11\frac{1}{2}$	99.4022	35.343
$1\frac{1}{2}$	1.7671	4.7124	$11\frac{3}{4}$	103.8691	36.1284
$1\frac{3}{4}$	2.4053	5.4978	12	108.4343	36.9138
2	3.1416	6.2832	$12\frac{1}{4}$	113.098	37.6992
$2\frac{1}{4}$	3.9761	7.0686	$12\frac{1}{2}$	117.859	38.4846
$2\frac{1}{2}$	4.9087	7.854	$12\frac{3}{4}$	122.719	39.27
$2\frac{3}{4}$	5.9396	8.6384	13	127.677	40.0554
3	7.0686	9.4248	$13\frac{1}{4}$	132.733	40.8408
$3\frac{1}{4}$	8.2958	10.2102	$13\frac{1}{2}$	137.887	41.6262
$3\frac{1}{2}$	9.6211	10.9956	$13\frac{3}{4}$	143.139	42.4116
$3\frac{3}{4}$	11.0447	11.781	14	148.49	43.197
4	12.5664	12.5664	$14\frac{1}{4}$	153.938	43.9824
$4\frac{1}{4}$	14.1863	13.3518	$14\frac{1}{2}$	159.485	44.7678
$4\frac{1}{2}$	15.9043	14.1372	$14\frac{3}{4}$	165.13	45.5532
$4\frac{3}{4}$	17.7206	14.9226	15	170.874	46.3386
5	19.635	15.708	$15\frac{1}{4}$	176.715	47.124
$5\frac{1}{4}$	21.6476	16.4934	$15\frac{1}{2}$	182.655	47.9094
$5\frac{1}{2}$	23.7583	17.2788	$15\frac{3}{4}$	188.692	48.6948
$5\frac{3}{4}$	25.9673	18.0642	16	194.828	49.4802
6	28.2744	18.8496	$16\frac{1}{4}$	201.062	50.2656
$6\frac{1}{4}$	30.6797	19.635	$16\frac{1}{2}$	207.395	51.051
$6\frac{1}{2}$	33.1831	20.4204	$16\frac{3}{4}$	213.825	51.8364

Areas and Circumferences of Circles (Continued).

Diam.	Area.	Circum.	Diam.	Area.	Circum.
16	220.354	52.6218	28	615.754	87.9648
17	226.981	53.4072	$\frac{1}{2}$	626.798	88.7502
$\frac{1}{4}$	233.706	54.1926	$\frac{3}{4}$	637.941	89.5356
$\frac{3}{8}$	240.529	54.978	$\frac{5}{8}$	649.182	90.321
$\frac{1}{2}$	247.45	55.7634	29	660.521	91.1064
18	254.47	56.5488	$\frac{1}{2}$	671.959	91.8918
$\frac{1}{4}$	261.587	57.3342	$\frac{3}{4}$	683.494	92.6772
$\frac{3}{8}$	268.803	58.1196	$\frac{5}{8}$	695.128	93.4626
$\frac{1}{2}$	276.117	58.905	30	706.86	94.248
19	283.529	59.6904	$\frac{1}{2}$	718.69	95.0334
$\frac{1}{4}$	291.04	60.4758	$\frac{3}{4}$	730.618	95.8188
$\frac{3}{8}$	298.648	61.2612	$\frac{5}{8}$	742.645	96.6042
$\frac{1}{2}$	306.355	62.0466	31	754.769	97.3896
20	314.16	62.832	$\frac{1}{2}$	766.992	98.175
$\frac{1}{4}$	322.063	63.6174	$\frac{3}{4}$	779.313	98.9604
$\frac{3}{8}$	330.064	64.4028	$\frac{5}{8}$	791.732	99.7458
$\frac{1}{2}$	338.164	65.1882	32	804.25	100.5312
21	346.361	65.9736	$\frac{1}{2}$	816.865	101.3166
$\frac{1}{4}$	354.657	66.759	$\frac{3}{4}$	829.579	102.102
$\frac{3}{8}$	363.051	67.5444	$\frac{5}{8}$	842.391	102.8874
$\frac{1}{2}$	371.543	68.3298	33	855.301	103.673
22	380.134	69.1152	$\frac{1}{2}$	868.309	104.458
$\frac{1}{4}$	388.822	69.9006	$\frac{3}{4}$	881.415	105.244
$\frac{3}{8}$	397.609	70.686	$\frac{5}{8}$	894.62	106.029
$\frac{1}{2}$	406.494	71.4714	34	907.922	106.814
23	415.477	72.2568	$\frac{1}{2}$	921.323	107.6
$\frac{1}{4}$	424.558	73.0422	$\frac{3}{4}$	934.822	108.385
$\frac{3}{8}$	433.737	73.8276	$\frac{5}{8}$	948.42	109.171
$\frac{1}{2}$	443.015	74.613	35	962.115	109.956
24	452.39	75.3984	$\frac{1}{2}$	975.909	110.741
$\frac{1}{4}$	461.864	76.1838	$\frac{3}{4}$	989.8	111.527
$\frac{3}{8}$	471.436	76.9692	$\frac{5}{8}$	1003.79	112.312
$\frac{1}{2}$	481.107	77.7546	36	1017.878	113.098
25	490.875	78.54	$\frac{1}{2}$	1032.065	113.883
$\frac{1}{4}$	500.742	79.3254	$\frac{3}{4}$	1046.349	114.668
$\frac{3}{8}$	510.706	80.1108	$\frac{5}{8}$	1060.732	115.454
$\frac{1}{2}$	520.769	80.8962	37	1075.213	116.239
26	530.93	81.6816	$\frac{1}{2}$	1089.792	117.025
$\frac{1}{4}$	541.19	82.467	$\frac{3}{4}$	1104.469	117.81
$\frac{3}{8}$	551.547	83.2524	$\frac{5}{8}$	1119.244	118.595
$\frac{1}{2}$	562.003	84.0378	38	1134.118	119.381
27	572.557	84.8232	$\frac{1}{2}$	1149.089	120.166
$\frac{1}{4}$	583.209	85.6086	$\frac{3}{4}$	1164.159	120.952
$\frac{3}{8}$	593.959	86.394	$\frac{5}{8}$	1179.327	121.737
$\frac{1}{2}$	604.807	87.1794	39	1194.593	122.522

Areas and Circumferences of Circles (Continued).

Diam.	Area.	Circum.	Diam.	Area.	Circum.
33	1203.958	123.308	50	2002.97	158.651
	1225.42	124.093		2022.85	159.436
	1240.981	124.879		2042.83	160.222
40	1256.64	125.664	51	2062.9	161.007
	1272.397	126.449		2083.08	161.792
	1238.252	127.235		2103.35	162.578
41	1304.206	128.02	52	2123.72	163.363
	1320.257	128.806		2144.19	164.149
	1336.407	129.591		2164.76	164.934
42	1352.655	130.376	53	2185.42	165.719
	1339.001	131.162		2206.19	166.505
	1335.45	131.947		2227.05	167.29
43	1401.99	132.733	54	2248.01	168.076
	1418.63	133.518		2269.07	168.861
	1435.37	134.303		2290.23	169.646
44	1452.2	135.089	55	2311.48	170.432
	1469.14	135.874		2332.83	171.217
	1486.17	136.66		2354.29	172.003
45	1503.3	137.445	56	2375.83	172.788
	1520.53	138.23		2397.48	173.573
	1537.86	139.016		2419.23	174.359
46	1555.29	139.801	57	2441.07	175.144
	1572.81	140.587		2463.01	175.93
	1590.43	141.372		2485.05	176.715
47	1608.16	142.157	58	2507.19	177.5
	1625.97	142.943		2529.43	178.286
	1643.89	143.728		2551.76	179.071
48	1661.91	144.514	59	2574.2	179.857
	1680.02	145.299		2596.73	180.642
	1698.23	146.084		2619.36	181.427
49	1716.54	146.87	60	2642.09	182.213
	1734.95	147.655		2664.91	182.998
	1753.45	148.441		2687.84	183.784
50	1772.00	149.226	61	2710.86	184.569
	1790.70	150.011		2733.98	185.354
	1809.56	150.797		2757.2	186.14
51	1828.46	151.582	62	2780.51	186.925
	1847.46	152.368		2803.93	187.711
	1866.55	153.153		2827.44	188.496
52	1885.75	153.938	63	2851.05	189.281
	1905.04	154.724		2874.76	190.067
	1924.43	155.509		2898.57	190.852
53	1943.91	156.295	64	2922.47	191.638
	1963.5	157.08		2946.48	192.423
	1983.18	157.865		2970.58	193.203

Areas and Circumferences of Circles

(Continued).

Diam.	Area.	Circum.	Diam.	Area.	Circum.
61 $\frac{3}{4}$	2994.78	193.994	73	4185.4	229.337
62	3019.08	194.779	$\frac{1}{4}$	4214.11	230.122
$\frac{1}{4}$	3043.47	195.565	$\frac{1}{2}$	4242.93	230.908
$\frac{1}{2}$	3067.97	196.35	$\frac{3}{4}$	4271.84	231.693
$\frac{3}{4}$	3092.56	197.135	74	4300.85	232.478
63	3117.25	197.921	$\frac{1}{4}$	4329.96	233.264
$\frac{1}{4}$	3142.04	198.706	$\frac{1}{2}$	4359.17	234.049
$\frac{1}{2}$	3166.93	199.492	$\frac{3}{4}$	4388.47	234.835
$\frac{3}{4}$	3191.91	200.277	75	4417.87	235.62
64	3217.	201.062	$\frac{1}{4}$	4447.38	236.405
$\frac{1}{4}$	3242.18	201.848	$\frac{1}{2}$	4476.98	237.191
$\frac{1}{2}$	3267.46	202.633	$\frac{3}{4}$	4506.67	237.976
$\frac{3}{4}$	3292.84	203.419	76	4536.47	238.762
65	3318.31	204.204	$\frac{1}{4}$	4566.36	239.547
$\frac{1}{4}$	3343.89	204.989	$\frac{1}{2}$	4596.36	240.332
$\frac{1}{2}$	3369.56	205.775	$\frac{3}{4}$	4626.45	241.118
$\frac{3}{4}$	3395.33	206.56	77	4656.64	241.903
66	3421.2	207.346	$\frac{1}{4}$	4686.92	242.689
$\frac{1}{4}$	3447.17	208.131	$\frac{1}{2}$	4717.31	243.474
$\frac{1}{2}$	3473.24	208.916	$\frac{3}{4}$	4747.79	244.259
$\frac{3}{4}$	3499.4	209.702	78	4778.37	245.045
67	3525.66	210.487	$\frac{1}{4}$	4809.05	245.83
$\frac{1}{4}$	3552.02	211.273	$\frac{1}{2}$	4839.83	246.616
$\frac{1}{2}$	3578.48	212.058	$\frac{3}{4}$	4870.71	247.401
$\frac{3}{4}$	3605.04	212.843	79	4901.68	248.186
68	3631.69	213.629	$\frac{1}{4}$	4932.75	248.972
$\frac{1}{4}$	3658.44	214.414	$\frac{1}{2}$	4963.92	249.757
$\frac{1}{2}$	3685.29	215.2	$\frac{3}{4}$	4995.19	250.543
$\frac{3}{4}$	3712.24	215.985	80	5026.56	251.328
69	3739.29	216.77	$\frac{1}{4}$	5058.03	252.113
$\frac{1}{4}$	3766.43	217.556	$\frac{1}{2}$	5089.59	252.899
$\frac{1}{2}$	3793.68	218.341	$\frac{3}{4}$	5121.25	253.684
$\frac{3}{4}$	3821.02	219.127	81	5153.01	254.47
70	3848.46	219.912	$\frac{1}{4}$	5184.87	255.255
$\frac{1}{4}$	3876.	220.697	$\frac{1}{2}$	5216.82	256.04
$\frac{1}{2}$	3903.63	221.483	$\frac{3}{4}$	5248.88	256.826
$\frac{3}{4}$	3931.37	222.268	82	5281.03	257.611
71	3959.2	223.054	$\frac{1}{4}$	5313.28	258.397
$\frac{1}{4}$	3987.13	223.839	$\frac{1}{2}$	5345.63	259.182
$\frac{1}{2}$	4015.16	224.624	$\frac{3}{4}$	5378.08	259.967
$\frac{3}{4}$	4043.29	225.41	83	5410.62	260.753
72	4071.51	226.195	$\frac{1}{4}$	5443.26	261.538
$\frac{1}{4}$	4099.84	226.981	$\frac{1}{2}$	5476.01	262.324
$\frac{1}{2}$	4128.26	227.766	$\frac{3}{4}$	5508.84	263.109
$\frac{3}{4}$	4156.78	228.551	84	5541.78	263.894

Areas and Circumferences of Circles (Concluded).

Diam.	Area.	Circum.	Diam.	Area.	Circum.
84 $\frac{1}{2}$	5574.82	264.68	92 $\frac{1}{2}$	6756.45	291.383
$\frac{1}{4}$	5307.95	265.465	93	6792.92	292.169
$\frac{3}{4}$	5641.18	266.251	$\frac{1}{4}$	6829.49	292.954
85 $\frac{1}{2}$	5674.51	267.036	$\frac{1}{2}$	6866.16	293.74
$\frac{1}{4}$	5707.94	267.821	$\frac{3}{4}$	6902.93	294.525
$\frac{3}{4}$	5741.47	268.607	94	6939.79	295.31
$\frac{1}{2}$	5775.1	269.392	$\frac{1}{4}$	6976.76	296.096
86 $\frac{1}{4}$	5808.82	270.178	$\frac{1}{2}$	7013.82	296.881
$\frac{3}{4}$	5842.64	270.963	$\frac{3}{4}$	7050.98	297.667
$\frac{1}{2}$	5876.56	271.748	95	7088.23	298.452
$\frac{1}{4}$	5910.58	272.534	$\frac{1}{4}$	7125.59	299.237
87 $\frac{1}{4}$	5944.69	273.319	$\frac{3}{4}$	7163.04	300.023
$\frac{3}{4}$	5978.91	274.105	$\frac{1}{2}$	7200.6	300.808
$\frac{1}{2}$	6013.22	274.89	96	7238.25	301.594
$\frac{1}{4}$	6047.63	275.675	$\frac{1}{4}$	7275.99	302.379
88 $\frac{3}{4}$	6082.14	276.461	$\frac{3}{4}$	7313.84	303.164
$\frac{1}{2}$	6116.74	277.246	$\frac{1}{2}$	7351.79	303.95
$\frac{1}{4}$	6151.45	278.032	97	7389.83	304.735
$\frac{3}{4}$	6186.25	278.817	$\frac{1}{4}$	7427.97	305.521
89 $\frac{1}{4}$	6221.15	279.602	$\frac{3}{4}$	7466.21	306.306
$\frac{3}{4}$	6256.15	280.388	$\frac{1}{2}$	7504.55	307.091
$\frac{1}{2}$	6291.25	281.173	98	7542.98	307.877
$\frac{1}{4}$	6326.45	281.959	$\frac{1}{4}$	7581.52	308.662
90 $\frac{3}{4}$	6361.74	282.744	$\frac{3}{4}$	7620.15	309.448
$\frac{1}{2}$	6397.13	283.529	$\frac{1}{2}$	7658.88	310.233
$\frac{1}{4}$	6432.62	284.315	99	7697.71	311.018
$\frac{3}{4}$	6468.21	285.1	$\frac{1}{4}$	7736.63	311.804
91 $\frac{1}{4}$	6503.9	285.886	$\frac{3}{4}$	7775.66	312.589
$\frac{3}{4}$	6539.68	286.671	$\frac{1}{2}$	7814.78	313.375
$\frac{1}{2}$	6575.56	287.456	100	7854.	314.16
$\frac{1}{4}$	6611.55	288.242	$\frac{1}{4}$	7893.32	314.945
92 $\frac{3}{4}$	6647.63	289.027	$\frac{3}{4}$	7932.74	315.731
$\frac{1}{2}$	6683.8	289.813	$\frac{1}{2}$	7972.25	316.516
$\frac{1}{4}$	6720.08	290.598

Areas of Segments of a Circle.

D=diameter of circle. H=Height of segment.

Area of segment= $D^2 \times M$. The following table gives values of M corresponding to various values of $\frac{H}{D}$.

$\frac{H}{D}$	M	$\frac{H}{D}$	M	$\frac{H}{D}$	M	$\frac{H}{D}$	M
.001	.000042	.040	.010538	.079	.028894	.118	.052090
.002	.000119	.041	.010932	.080	.029435	.119	.052737
.003	.000219	.042	.011331	.081	.029979	.120	.053385
.004	.000337	.043	.011734	.082	.030526	.121	.054037
.005	.000471	.044	.012142	.083	.031077	.122	.054690
.006	.000619	.045	.012555	.084	.031630	.123	.055346
.007	.000779	.046	.012971	.085	.032186	.124	.056004
.008	.000952	.047	.013393	.086	.032746	.125	.056664
.009	.001135	.048	.013818	.087	.033308	.126	.057326
.010	.001329	.049	.014248	.088	.033873	.127	.057991
.011	.001533	.050	.014681	.089	.034441	.128	.058658
.012	.001746	.051	.015119	.090	.035012	.129	.059328
.013	.001969	.052	.015561	.091	.035586	.130	.059999
.014	.002199	.053	.016008	.092	.036162	.131	.060673
.015	.002438	.054	.016458	.093	.036742	.132	.061349
.016	.002685	.055	.016912	.094	.037324	.133	.062027
.017	.002940	.056	.017369	.095	.037909	.134	.062707
.018	.003202	.057	.017831	.096	.038497	.135	.063389
.019	.003472	.058	.018297	.097	.039087	.136	.064074
.020	.003749	.059	.018766	.098	.039681	.137	.064761
.021	.004032	.060	.019239	.099	.040277	.138	.065449
.022	.004322	.061	.019716	.100	.040875	.139	.066140
.023	.004619	.062	.020197	.101	.041477	.140	.066833
.024	.004922	.063	.020681	.102	.042081	.141	.067528
.025	.005231	.064	.021168	.103	.042687	.142	.068225
.026	.005546	.065	.021660	.104	.043296	.143	.068924
.027	.005867	.066	.022155	.105	.043908	.144	.069626
.028	.006194	.067	.022653	.106	.044523	.145	.070329
.029	.006527	.068	.023155	.107	.045140	.146	.071034
.030	.006866	.069	.023660	.108	.045759	.147	.071741
.031	.007209	.070	.024168	.109	.046381	.148	.072450
.032	.007559	.071	.024680	.110	.047006	.149	.073162
.033	.007913	.072	.025196	.111	.047633	.150	.073875
.034	.008273	.073	.025714	.112	.048262	.151	.074590
.035	.008638	.074	.026236	.113	.048894	.152	.075307
.036	.009008	.075	.026761	.114	.049529	.153	.076026
.037	.009383	.076	.027290	.115	.050165	.154	.076747
.038	.009763	.077	.027821	.116	.050805	.155	.077470
.039	.010148	.078	.028356	.117	.051446	.156	.078194

Areas of Segments of a Circle (*Continued*).

$\frac{H}{D}$	M	$\frac{H}{D}$	M	$\frac{H}{D}$	M	$\frac{H}{D}$	M
.157	.078921	.200	.111824	.243	.147513	.286	.185425
.153	.079650	.201	.112625	.244	.148371	.287	.186329
.159	.080380	.202	.113427	.245	.149231	.288	.187235
.130	.081112	.203	.114231	.246	.150091	.289	.188141
.161	.081847	.204	.115036	.247	.150953	.290	.189048
.162	.082582	.205	.115842	.248	.151816	.291	.189956
.133	.083320	.206	.116651	.249	.152681	.292	.190865
.134	.084060	.207	.117460	.250	.153546	.293	.191774
.135	.084801	.208	.118271	.251	.154413	.294	.192685
.136	.085545	.209	.119083	.252	.155281	.295	.193597
.137	.086290	.210	.119898	.253	.156149	.296	.194509
.138	.087037	.211	.120713	.254	.157019	.297	.195423
.169	.087785	.212	.121530	.255	.157891	.298	.196337
.170	.088536	.213	.122348	.256	.158763	.299	.197252
.171	.089288	.214	.123167	.257	.159636	.300	.198168
.172	.090042	.215	.123988	.258	.160511	.301	.199085
.173	.090797	.216	.124811	.259	.161386	.302	.200003
.174	.091555	.217	.125634	.260	.162263	.303	.200922
.175	.092314	.218	.126459	.261	.163141	.304	.201841
.176	.093074	.219	.127286	.262	.164020	.305	.202762
.177	.093837	.220	.128114	.263	.164900	.306	.203683
.178	.094601	.221	.128943	.264	.165781	.307	.204605
.179	.095367	.222	.129773	.265	.166663	.308	.205528
.130	.096135	.223	.130605	.266	.167546	.309	.206452
.131	.096904	.224	.131438	.267	.168431	.310	.207376
.132	.097675	.225	.132273	.268	.169316	.311	.208302
.133	.098447	.226	.133109	.269	.170202	.312	.209228
.134	.099221	.227	.133946	.270	.171090	.313	.210155
.135	.099997	.228	.134784	.271	.171978	.314	.211083
.136	.100774	.229	.135624	.272	.172868	.315	.212011
.137	.101553	.230	.136465	.273	.173758	.316	.212941
.138	.102334	.231	.137307	.274	.174650	.317	.213871
.139	.103116	.232	.138151	.275	.175542	.318	.214802
.130	.103900	.233	.138996	.276	.176436	.319	.215734
.131	.104686	.234	.139842	.277	.177330	.320	.216666
.132	.105472	.235	.140689	.278	.178226	.321	.217600
.133	.106261	.236	.141538	.279	.179122	.322	.218534
.134	.107051	.237	.142388	.280	.180020	.323	.219469
.135	.107843	.238	.143239	.281	.180918	.324	.220404
.136	.108636	.239	.144091	.282	.181818	.325	.221341
.137	.109431	.240	.144945	.283	.182718	.326	.222278
.138	.110227	.241	.145800	.284	.183619	.327	.223216
.139	.111025	.242	.146655	.285	.184522	.328	.224154

Areas of Segments of a Circle (*Concluded*).

$\frac{H}{D}$	M	$\frac{H}{D}$	M	$\frac{H}{D}$	M	$\frac{H}{D}$	M
.329	.225094	.372	.266111	.415	.308110	.458	.350749
.330	.226034	.373	.267078	.416	.309096	.459	.351745
.331	.226964	.374	.268046	.417	.310082	.460	.352742
.332	.227916	.375	.269014	.418	.311068	.461	.353739
.333	.228858	.376	.269982	.419	.312055	.462	.354736
.334	.229801	.377	.270951	.420	.313042	.463	.355733
.335	.230745	.378	.271921	.421	.314029	.464	.356730
.336	.231689	.379	.272891	.422	.315017	.465	.357728
.337	.232634	.380	.273861	.423	.316005	.466	.358725
.338	.233580	.381	.274832	.424	.316993	.467	.359723
.339	.234526	.382	.275804	.425	.317981	.468	.360721
.340	.235473	.383	.276776	.426	.318970	.469	.361719
.341	.236421	.384	.277748	.427	.319959	.470	.362717
.342	.237369	.385	.278721	.428	.320949	.471	.363715
.343	.238319	.386	.279695	.429	.321938	.472	.364714
.344	.239268	.387	.280669	.430	.322928	.473	.365712
.345	.240219	.388	.281643	.431	.323919	.474	.366711
.346	.241170	.389	.282618	.432	.324909	.475	.367710
.347	.242122	.390	.283593	.433	.325900	.476	.368708
.348	.243074	.391	.284569	.434	.326891	.477	.369707
.349	.244027	.392	.285545	.435	.327883	.478	.370706
.350	.244980	.393	.286521	.436	.328874	.479	.371705
.351	.245935	.394	.287499	.437	.329866	.480	.372704
.352	.246890	.395	.288476	.438	.330858	.481	.373704
.353	.247845	.396	.289454	.439	.331851	.482	.374703
.354	.248801	.397	.290432	.440	.332843	.483	.375702
.355	.249758	.398	.291411	.441	.333836	.484	.376702
.356	.250715	.399	.292390	.442	.334829	.485	.377701
.357	.251673	.400	.293370	.443	.335823	.486	.378701
.358	.252632	.401	.294350	.444	.336816	.487	.379701
.359	.253591	.402	.295330	.445	.337810	.488	.380700
.360	.254551	.403	.296311	.446	.338804	.489	.381700
.361	.255511	.404	.297292	.447	.339799	.490	.382700
.362	.256472	.405	.298274	.448	.340793	.491	.383700
.363	.257433	.406	.299256	.449	.341788	.492	.384699
.364	.258395	.407	.300238	.450	.342783	.493	.385699
.365	.259358	.408	.301221	.451	.343778	.494	.386699
.366	.260321	.409	.302204	.452	.344773	.495	.387699
.367	.261285	.410	.303187	.453	.345768	.496	.388699
.368	.262249	.411	.304171	.454	.346764	.497	.389699
.369	.263214	.412	.305156	.455	.347760	.498	.390699
.370	.264179	.413	.306140	.456	.348756	.499	.391699
.371	.265145	.414	.307125	.457	.349752	.500	.392699

PROPERTIES OF SATURATED STEAM.

Pressure, Temperature, Volume and Density.
(Haswell.)

Pressure per sq. in.	Pressure in Mercury.	Temperature.	Total Heat from Water at 32°.	Volume of 1 Pound.	Density or Wt. of 1 Cubic Foot.
Lbs.	Ins.	Deg.	Deg.	Cu. Ft.	Lb.
1	2.04	102.1	1112.5	330.36	.003
2	4.07	126.3	1119.7	172.08	.0058
3	6.11	141.6	1124.6	117.52	.0085
4	8.14	153.1	1128.1	89.62	.0112
5	10.18	162.3	1130.9	72.66	.0138
6	12.22	170.2	1133.3	61.21	.0163
7	14.25	176.9	1135.3	52.94	.0189
8	16.29	182.9	1137.2	46.69	.0214
9	18.32	188.3	1138.8	41.79	.0239
10	20.36	193.3	1140.3	37.84	.0264
11	22.39	197.8	1141.7	34.63	.0289
12	24.43	202.	1143.	31.88	.0314
13	26.46	205.9	1144.2	29.57	.0338
14	28.51	209.6	1145.3	27.61	.0362
14.7	29.92	212.	1146.1	26.36	.03802
15	30.54	213.1	1146.4	25.85	.0387
16	32.57	216.3	1147.4	24.32	.0411
17	34.61	219.6	1148.3	22.96	.0435
18	36.65	222.4	1149.2	21.78	.0459
19	38.68	225.3	1150.1	20.7	.0483
20	40.72	228.	1150.9	19.72	.0507
21	42.75	230.6	1151.7	18.84	.0531
22	44.79	233.1	1152.5	18.03	.0555
23	46.83	235.5	1153.2	17.26	.058
24	48.86	237.8	1153.9	16.64	.0601
25	50.9	240.1	1154.6	15.99	.0625
26	52.93	242.3	1155.3	15.38	.065
27	54.97	244.4	1155.8	14.86	.0673
28	57.01	246.4	1156.4	14.37	.0696
29	59.04	248.4	1157.1	13.9	.0719

Properties of Saturated Steam (*Continued*).

Pressure per sq. in.	Pressure in Mercury.	Temperature.	Total Heat from Water at 32°.	Volume of 1 Pound.	Density or Wt. of 1 Cubic Foot.
Lbs.	Ins.	Deg.	Deg.	Cu. Ft.	Lb.
30	61.08	250.4	1157.8	13.46	.0743
31	63.11	252.2	1158.4	13.05	.0766
32	65.15	254.1	1158.9	12.67	.0789
33	67.19	255.9	1159.5	12.31	.0812
34	69.22	257.6	1160.	11.97	.0835
35	71.26	259.3	1160.5	11.65	.0858
36	73.29	260.9	1161.	11.34	.0881
37	75.33	262.6	1161.5	11.04	.0905
38	77.37	264.2	1162.	10.76	.0929
39	79.4	265.8	1162.5	10.51	.0952
40	81.43	267.3	1162.9	10.27	.0974
41	83.47	268.7	1163.4	10.03	.0996
42	85.5	270.2	1163.8	9.81	.102
43	87.54	271.6	1164.2	9.59	.1042
44	89.58	273.	1164.6	9.39	.1065
45	91.61	274.4	1165.1	9.18	.1089
46	93.65	275.8	1165.5	9.	.1111
47	95.69	277.1	1165.9	8.82	.1133
48	97.72	278.4	1166.3	8.65	.1156
49	99.76	279.7	1166.7	8.48	.1179
50	101.8	281.	1167.1	8.31	.1202
51	103.83	282.3	1167.5	8.17	.1224
52	105.87	283.5	1167.9	8.04	.1246
53	107.9	284.7	1168.3	7.88	.1269
54	109.94	285.9	1168.6	7.74	.1291
55	111.98	287.1	1169.	7.61	.1314
56	114.01	288.2	1169.3	7.48	.1336
57	116.05	289.3	1169.7	7.36	.1364
58	118.08	290.4	1170.	7.24	.138
59	120.12	291.6	1170.4	7.12	.1403
60	122.16	292.7	1170.7	7.01	.1425
61	124.19	293.8	1171.1	6.9	.1447
62	126.23	294.8	1171.4	6.81	.1469
63	128.26	295.9	1171.7	6.7	.1493
64	130.3	296.9	1172.	6.6	.1516
65	132.34	298.	1172.3	6.49	.1538
66	134.37	299.	1172.6	6.41	.156
67	136.4	300.	1172.9	6.32	.1583
68	138.44	300.9	1173.2	6.23	.1605
69	140.48	301.9	1173.5	6.15	.1627

Properties of Saturated Steam (*Continued*).

Pressure per sq. in.	Pressure in Mercury.	Temperature.	Total Heat from Water at 32°.	Volume of 1 Pound.	Density or Wt. of 1 Cubic Foot.
Lbs.	Ins.	Deg.	Deg.	Cu. Ft.	Lb.
70	142.52	302.9	1173.8	6.07	.1648
71	144.55	303.9	1174.1	5.99	.167
72	146.59	304.8	1174.3	5.91	.1692
73	148.62	305.7	1174.6	5.83	.1714
74	150.66	306.6	1174.9	5.76	.1736
75	152.69	307.5	1175.2	5.68	.1759
76	154.73	308.4	1175.4	5.61	.1782
77	156.77	309.3	1175.7	5.54	.1804
78	158.8	310.2	1176.	5.48	.1826
79	160.84	311.1	1176.3	5.41	.1848
80	162.87	312.	1176.5	5.35	.1869
81	164.91	312.8	1176.8	5.29	.1891
82	166.95	313.6	1177.1	5.23	.1913
83	168.98	314.5	1177.4	5.17	.1935
84	171.02	315.3	1177.6	5.11	.1957
85	173.05	316.1	1177.9	5.05	.198
86	175.09	316.9	1178.1	5.	.2002
87	177.13	317.8	1178.4	4.94	.2024
88	179.16	318.6	1178.6	4.89	.2044
89	181.2	319.4	1178.9	4.84	.2067
90	183.23	320.2	1179.1	4.79	.2089
91	185.27	321.	1179.3	4.74	.2111
92	187.31	321.7	1179.5	4.69	.2133
93	189.34	322.5	1179.8	4.64	.2155
94	191.38	323.3	1180.	4.6	.2176
95	193.41	324.1	1180.3	4.55	.2198
96	195.45	324.8	1180.5	4.51	.2219
97	197.49	325.6	1180.8	4.46	.2241
98	199.52	326.2	1181.	4.42	.2263
99	201.56	327.1	1181.2	4.37	.2285
100	203.59	327.9	1181.4	4.33	.2307
101	205.63	328.5	1181.6	4.29	.2329
102	207.66	329.1	1181.8	4.25	.2351
103	209.7	329.9	1182.	4.21	.2373
104	211.74	330.6	1182.2	4.18	.2393
105	213.77	331.3	1182.4	4.14	.2414
106	215.81	331.9	1182.6	4.11	.2435
107	217.84	332.6	1182.8	4.07	.2456
108	219.88	333.3	1183.	4.04	.2477
109	221.92	334.	1183.3	4.	.2499

Properties of Saturated Steam (*Continued*).

Pressure per sq. in.	Pressure in Mercury.	Temperature.	Total Heat from Water at 32°.	Volume of 1 Pound.	Density or Wt. of 1 Cubic Foot.
Lbs	Ins.	Deg.	Deg.	Cu. Ft.	Lb.
110	223.95	334.6	1183.5	3.97	.2521
111	225.99	335.3	1183.7	3.93	.2543
112	228.02	336.	1183.9	3.9	.2564
113	230.06	336.7	1184.1	3.86	.2586
114	232.1	337.4	1184.3	3.83	.2607
115	234.13	338.	1184.5	3.8	.2628
116	236.17	338.6	1184.7	3.77	.2649
117	238.2	339.3	1184.9	3.74	.2652
118	240.24	339.9	1185.1	3.71	.2674
119	242.28	340.5	1185.3	3.68	.2696
120	244.31	341.1	1185.4	3.65	.2738
121	246.35	341.8	1185.6	3.62	.2759
122	248.38	342.4	1185.8	3.59	.278
123	250.42	343.	1186.	3.56	.2801
124	252.45	343.6	1186.2	3.54	.2822
125	254.49	344.2	1186.4	3.51	.2845
126	256.53	344.8	1186.6	3.49	.2867
127	258.56	345.4	1186.8	3.46	.2889
128	260.6	346.	1186.9	3.44	.2911
129	262.64	346.6	1187.1	3.41	.2933
130	264.67	347.2	1187.3	3.38	.2955
131	266.71	347.8	1187.5	3.35	.2977
132	268.74	348.3	1187.6	3.33	.2999
133	270.78	348.9	1187.8	3.31	.302
134	272.81	349.5	1188.	3.29	.304
135	274.85	350.1	1188.2	3.27	.306
136	276.89	350.6	1188.3	3.25	.308
137	278.92	351.2	1188.5	3.22	.3101
138	280.96	351.8	1188.7	3.2	.3121
139	282.99	352.4	1188.9	3.18	.3142
140	285.03	352.9	1189.	3.16	.3162
141	287.07	353.5	1189.2	3.14	.3184
142	289.1	354.	1189.4	3.12	.3206
143	291.14	354.5	1189.6	3.1	.3228
144	293.17	355.	1189.7	3.08	.325
145	295.21	355.6	1189.9	3.06	.3273
146	297.25	356.1	1190.	3.04	.3294
147	299.28	356.7	1190.2	3.02	.3315
148	301.32	357.2	1190.3	3.	.3336
149	303.35	357.8	1190.5	2.98	.3357

Properties of Saturated Steam (*Concluded*).

Pressure per sq. in.	Pressure in Mercury.	Temperature.	Total Heat from Water at 32°.	Volume of 1 Pound.	Density or Wt. of 1 Cubic Foot.
Lbs.	Ins.	Deg.	Deg.	Cu. Ft.	Lb.
150	305.39	358.3	1190.7	2.96	.3377
155	315.57	361.	1191.5	2.87	.3484
160	325.75	363.4	1192.2	2.79	.359
165	335.93	366.	1192.9	2.71	.3695
170	346.11	368.2	1193.7	2.63	.3798
175	356.29	370.8	1194.4	2.56	.3899
180	366.47	372.9	1195.1	2.49	.4009
185	376.65	375.3	1195.8	2.43	.4117
190	386.83	377.5	1196.5	2.37	.4222
195	397.01	379.7	1197.2	2.31	.4327
200	407.19	381.7	1197.8	2.26	.4431
210	427.54	386.	1199.1	2.16	.4634
220	447.9	389.9	1200.3	2.06	.4842
230	468.26	393.8	1201.5	1.98	.5052
240	488.62	397.5	1202.6	1.9	.5248
250	508.98	401.1	1203.7	1.83	.5464
260	529.34	404.5	1204.8	1.76	.5669
270	549.7	407.9	1205.8	1.7	.5868
280	570.06	411.2	1206.8	1.64	.6081
290	590.42	414.4	1207.8	1.59	.6273
300	610.78	417.5	1208.7	1.54	.6486
350	712.57	430.1	1212.6	1.33	.7498
400	814.37	444.9	1217.1	1.18	.8502
450	916.17	456.7	1220.7	1.05	.9499
500	1018.	467.5	1224.	.95	1.049
550	1119.8	477.5	1227.	.87	1.148
600	1221.6	487.	1229.9	.8	1.245
650	1323.4	495.6	1232.5	.74	1.342
700	1425.8	504.1	1235.1	.69	1.4395
800	1628.7	519.5	1239.8	.61	1.6322
900	1832.3	533.6	1244.2	.55	1.8235
1000	2035.9	546.5	1248.1	.5	2.014

INDEX

Air—weight of.....	250
Alkali in oil.....	212
Ammonia in water.....	51
Ampere.....	252
Anchor bolts.....	94
Anthracite coal.....	9
Area of tubes.....	231
Areas of Circles.....	263-267
Areas of Segments.....	268-270
Atmospheric Pressure.....	223
Average pressures.....	249
Babbitt metals.....	148
Babbitt packing rings.....	133
Banking fire.....	20
Balancing vertical engines.....	113
Balanced valves.....	173
Bearing metal.....	147
Belt dressing.....	205
Belt joints.....	205
Belt leather.....	201
Belting.....	130-198-207
Belts—power of.....	203
Black lead.....	63-147
Blowers.....	12
Home made.....	14
Blow-off valve troubles.....	33
Blow-off pipes.....	44
Boiler braces.....	235
Boiler compounds—Cutch.....	23
Gambier.....	23
Carbonate of Soda.....	23
Japonica.....	23
Kerosene.....	23
Potatoes.....	23
Sal. soda.....	23
Tannic acid.....	23
Boiler—contents of.....	228
Boiler economy.....	221-232
Boiler explosions.....	51
Boiler feeding.....	19
Boiler fittings.....	42
Boiler horse power.....	227
Boiler ratings.....	228
Boiler room.....	7
Boiler settings.....	26-42-44
Boiler tests.....	251
Boilers.....	51

Boilers—material	39
Boilers—strength of	39
Boilers—weakness of	51
Braces	235
Brick foundations	97
Bricklaying	82
Bridge walls	46
Bronze bearings	149
Bulkley's condensers	180
Burnishing	218
Carbonate of soda	23
Caustic soda	23
Cards	152-155-157
Causes of heating	151
Air bound pumps	238
Air chambers	237
Air pumps and condensers	176
Air pump packing	177
Cement and mortar	83
Cement	84
Mixing	88
Portland	84
Rosendale	84
Specifications	87
Testing	86
Centering engine	160
Check valves	65
Chemicals for coal	19
Chimneys	98
Brick or steel	99
Size of	101
Stability of	262
Table of	102
Circles	231
Circles, Areas of	263-267
Circulation	31-43-222
Cleaning Boilers	7-222
Cleaning boiler flues	7
Clean boilers	222
Cleaning engines	218
Cleaning fire	11
Clearance	224
Clinkers	10
Compound engines	111
Compounds for cleaning	218
Compounds—tandem	175
Compression	172-225
Concrete	99
Condensation	223
Condenser troubles	180
Condensers and air pumps	67-176-178
Condensing Engines	69-174

Contents of boiler	228
Continuous oiling	214
Cooling bearings	147
Cooling mixtures	147
Cooling off boilers	27-29
Cooling towers	186-188
Copper elbows—don't use	63
Copper—hardened	254
Copper rings	133
Corliss engines	107-111-120-136-139-145-152
Corliss engine with two eccentrics.....	153-156-162
Corliss, Geo. H.	105-177
Corliss valves	175
Corliss valve setting	158
Corrosion	51
Crank pin and cross head boxes	149
Crank pin not central	118
Crank pins—pressing on	125
Cranks out of square	119
Crossheads—weak	115
Curved pipes	74
Cutch	23
Cut-off	224
Cylinder bushings	133
Cylinder drips	77
Cylinder oils	132
Cylinder pressure	248
Cylinder—smooth or rough	131
Cylinder—water in	135
Cylinder—wear of	131
Dam for water supply	37
Dampers	103
Defective steam gages	32-242
Direct connected engines	110
Dirty streams—feed water from.....	38
Down draft	15
Draft—forced or induced	103-251
Draining of floors	50
Draining of pipes	65
Drip pipes for cylinders	79
Drop of voltage	253
Duplex pumps	21-237-239
Eccentrics	133
Economizers	241
Economy	166
Economy of boiler	232
Efficiency of boiler	221
Efficiency of engine	223
Electric light engines	107-174
Electrical boiler cleaner	24
Electrical terms	252
Electricity or shafting	145

Engine design	110
Engine efficiency	223
Engine room tools	195
Equivalent evaporation	251
Erecting engines	146
Estimating water power	255
Evaporation	250
Examining boards	21-256-261
Examining masonry	91
Examination questions	256-261
Exhaust passages	134
Exhaust pipes	133
Expanding metal	256
Expansions in pipes	61-222
Expansion of steam	248
Expansion of wrought iron	222
Extracting oil from water	191
Factor of evaporation	251
Factor of safety	41
Feeding boilers	19-226
Feed pipes	43
Feed pump—size of	226
Filtering oils	214
Filtering water	8
Fire brick arch	47
Fire—Thickness of	10
Fire tools	10-11
Firing	9-12-14-16-17
Fish oils	209
Fittings for boilers	42
Flanged joints	60
Flash test of oil	211
Floors—draining of	50
Flow of steam	247
Fly wheels	123-245
Foaming	234
Follower bolts	137-139
Foot valves	38
Forced draft	103-251
Foundations	92-94
Stone and brick	97
Strength of	92
Frames out of line	116
Frozen gage pipe	32
Furnace plates	48
Fusible plug	21
Gage cocks may deceive	33
Gage connections	33
Gage glass cutters	197
Gage glass points	33-197
Gage—steam	32-242
Gambier	23

Gaskets—laying out	234
Graphite	212
Grate surface	228
Grates	232
Grease	215
Gridiron valves	171
Grooving	52
Guides	117
Gum	209
Hard patch on boiler	234
Hardened copper	149-254
Heat—latent	53
Sensible	53
Total	53
Heat units	20-53-221
Heaters—feed water	69-239-240
Heating by steam	79
Heating of bearings—causes	151
Heating liquids	70
Heating surface	42-228
High test oils	211
High speed engine	144-164-172
High steam pressure	146
Hinge joint for belt	205
Holding fly wheels	123
Home-made blower	14
Horizontal vs. Vertical engines	111
Horse power	221
Horse power of belts	203
Horse power of boiler	227
Horse power of engine	165-252
Hot boxes and bearing metal	147
Hot well capacity	182
Hot well temperature	185
Howe, Elias	105
Hydraulic piping	58
Idlers or tighteners	198
Indicator cards	152-155-157
Induced draft	103
Inertia	225
Injection water	186
Injectors	238
Japonica	23
Jet condensers	186
Joints for pipe	59
Joule's experiment	221
Junk ring	140-163
Kerosene boilers	23
Keys	122
Kilowatts	252
Lacing a belt	206
Lap	225

Lard oils	209
Latent heat	53
Laying out a valve	169
Lazy bar	12
Lead	154-168-225
Leather for belts	201
Leaky blow-off valve	33
Leaks in a cool boiler	30
Leaky tubes	28
Leveling shaft	119-129
Lime	23
Lining up engine	121-125-128
Locomotive pounds	122
Loose glands or packing	121
Loss by dirt and scale	222
Loss of heat	250
Lubricants	150-208
Mason work	82-89
Examining	91
Mean effective pressure	249
Mercury, weight of	223
Metal for bearings	255
Metal that expands in cooling	256
Mineral oil	214
Mortar and cement	82
Mud in boilers	8
Neatsfoot oil	209
Notes, Rules and Tables	221-231
Ohm	253
Oil agents	210
Oil filters	214
Oil in condensers	189
Oil in water	133
Oil mixtures	210
Oil separators	191
Oils	132-208
Oiling continuously	214
Open heaters	241
Overheating boilers	28
Oxalic acid	219
Packing for air pumps	177
Packing sticks	197
Packing with paper	122
Paper packing	122
Pastes for polishing	219
Patching boilers	233
Pedestal bearings	131
Petroleum	209
Picking out belts	200
Pile driving	93
Pillow block not level	130
Pipes, draining of	65

Pipe joints	59
Pipes—steam	71
Pipe threads	55
Table of	57
Welds	55
Piping	8-54
Piping a hotel	80
Piping a receiver	81
Piping, expansion of	61-222
Piping, hydraulic	58
Pistons	135
Piston packing rings	141
Piston rods and follow bolts	137
Piston rod breaks	115
Piston rod fastenings	138
Piston speed	223-252
Piston too small	120
Piston valves	108-172
Points of compass by watch	255
Polishing metals	219
Pop valves	8-45-245
Poppet valves	106-167
Potatoes as boiler cleaner	25
Pounds and their causes	114-118-120-122-143
Powdered coal	15-250
Powder or steam pump	22
Power of engines	165
Power pumps	236
Power taken by pumps	236
Pre-release	225
Pressing on crank pins	125
Pressure in cylinders	248
Pressure, standards of	223
Properties of steam	271-275
Pulleys and Ropes	242
Pulleys not put on true	130
Pulverized coal	15
Pumps	21-77-226-236-239
Pumps—duplex	237-239
Pumps for boiler feeding	21
Pump, leaking piston	239
Pump, power required	236
Pumps, rule for	226
Pump, slip of	226
Pumps, suction for	77
Pumps that pound	22
Pump valves	240
Putting engine on center	160
Questions for examinations	21-256-261
Ransom's condenser	179
Ratio of grate and heating surface	228
Real boiler economy	232

Receiver piping	81
Reversing an engine	170
Ring oiling	216
Ropes and pulleys	242
Rosendale cement	84
Rough cylinders	132
Rule for pumps	227
Rules for strength of boilers	4
Rules, Notes and Tables	221-231
Runaway engines	174
Safety valves	8-45-242
Safety valve outlet	48
Sal soda	23
Scale and mud	7-23
Scrapers	197
Sector of circle	228
Segment of circle	228
Segment of circle—Area of	268-270
Selecting an engine	163
Sensible heat	53
Separators	190
Set screws in fly wheels	123
Setting eccentrics	169
Settings for boilers	42-44
Shaking grates	233
Shimming the frame	128
Side walls of boiler setting	46
Size of wire	253
Slide valves	168
Slip joints	74
Slip of pump	226
Smoke	12-14-16
Smooth cylinders	131
Soft coal firing	12-17
Soft patches	233
Solutions for cleaning	219
Specifications for belts	207
Specifications for cement	87
Speed of belts	204
Stability of chimneys	262
Standards of pressure	223
Starting bars	159
Starting up a boiler	89
Steam—Facts about	53 247
Steam gage connections	33
Steam gage frozen	32
Steam gage	242
Steam heating	79
Steam jackets	157
Steam packing rings	142
Steam pipes	71
Steam vs. power pump	22

Steam, Properties of	271-275
Steam pumps	237
Steam room	229
Steam traps	76
Steel for boilers	39
Stokers	18
Stone and brick foundations	97
Stove blacking lubricant	147
Strainers	34-36-182
Strength of boilers	39
Strength of boilers, Rules for	40
Stroke	224
Suction for pumps	77
Surface condensers	189
Sweet's follower bolt	140
Syphon condensers	179
Tables—	
Areas of circles.....	263-267
Chimneys	102
Pipe threads	57
Segments of circles.....	268-270
Steam, Properties of.....	271-275
Tables, Notes and Rules	221-231
Tallow	208
Tandem compound	175
Tannic acid	23
Testing alignment	129
Testing cement	86
Testing oils	215
Testing water	8
Temperature of hot well	185
Terminal pressure	225
The engine room	105
Thickness of fire	10-16
Three phase work	253
Tight belts	145-198
Tighteners	199
Tools for engineer	195
Traps	76
Travel of valve	225
Triangles	247
Trying gage cocks	33
Tubes, Cleaning	7
Iron	41
Steel	41
Too many	42
Twisted guides	117
Two eccentrics on Corliss engines.....	153-156-162
Unequal expansion	52
Vacuum	185-192
Valves	167-173
Valves, balanced	173

Valve on Straight Line engine	64
Valve openings	64
Valve setting	158
Valve travel	225
Valves setting, pump	240
Valves that spring	171
Vent valves	238
Vertical engines	111
Vertical engine exhausts	133
Viscosity of oil	211-213
Volt	252
Waste gas boiler	31
Waste heat, using	26-241
Water	54
Water for jet condensers	186
Water from streams.....	34
Water in cylinders	135
Water strainers	34-36
Water in exhaust pipe	68
Water in pipes	42
Water in steam pipes	67
Water hammer	75
Water power, estimating	255
Water, pressure of	223
Water test	8
Water, weight of	223
Watt, James	105
Watts	253
Wear of cylinders	131
Welds in pipe	58
White lead vs. black lead for valves	63
Wide belts	202
Winter masonry	89
Wire, size of	253
Wirthington condensers	182
Wright, William	107
Wrist plates	154-156
Wrought iron, expansion of	222



The Best Flange Packing Made

RAINBOW PACKING

Don't have to use wire and cloth to hold *Rainbow*
Can't blow it out. Thousands of imitators
No equal. Will hold highest pressure



The Color of Rainbow Packing is Red

Three Rows of Diamonds extending throughout the entire length
of each and every roll of Rainbow Packing

We manufacture a complete line of fine mechanical rubber goods, including Belting, Hose, Packings, Mats and Mattings. Metal Inserted Step Treads and Mats, and Sheet Rubber Tiling, Moulded Goods of every description.

Manufactured exclusively by

Peerless Rubber Manufacturing Company

16 Warren Street, New York

THE ECLIPSE SECTIONAL RAINBOW GASKET



Fac-Simile of a 6-inch Section of Eclipse Gasket, Showing
Name and Trade Mark Imbedded

**FOR HAND HOLES
FOR MAN HOLES**

Manufactured from the celebrated *Rainbow*
Packing Compound.

The most economical and convenient
form for making gaskets ever produced.

Absolutely no waste. Will carry in stock
for years.

Manufactured exclusively by

PEERLESS RUBBER MANUFACTURING CO.

**16 WARREN STREET
NEW YORK**

For sale by all first-class Dealers

**CATALOGUE OF
STANDARD
PRACTICAL AND
SCIENTIFIC
BOOKS**



PUBLISHED AND FOR SALE BY

The Norman W. Henley Publishing Co.

132 Nassau St., New York, U. S. A.

INDEX OF SUBJECTS

Brazing and Soldering.....	3
Cams.....	11
Charts.....	3
Chemistry.....	4
Civil Engineering.....	4
Coke.....	4
Compressed Air.....	4
Concrete.....	5
Dictionaries.....	5
Dies—Metal Work.....	6
Drawing—Sketching Paper.....	6
Electricity.....	7
Enameling.....	9
Factory Management, etc.....	9
Fuel.....	10
Gas Engines and Gas.....	10
Gearing and Cams.....	11
Hydraulics.....	11
Ice and Refrigeration.....	11
Inventions—Patents.....	12
Lathe Practice.....	12
Liquid Air.....	12
Locomotive Engineering.....	12
Machine Shop Practice.....	14
Manual Training.....	17
Marine Engineering.....	17
Metal Work—Dies.....	6
Mining.....	17
Miscellaneous.....	18
Patents and Inventions.....	12
Pattern Making.....	18
Perfumery.....	18
Plumbing.....	19
Receipt Book.....	24
Refrigeration and Ice.....	11
Rubber.....	19
Saws.....	20
Screw Cutting.....	20
Sheet Metal Work.....	20
Soldering.....	3
Steam Engineering.....	20
Steam Heating and Ventilation.....	22
Steam Pipes.....	22
Steel.....	22
Watch Making.....	23
Wireless Telephones.....	23

 Any of these books will be sent prepaid to any part of the world, on receipt of price.

REMIT by Draft, Postal Money Order, Express Money Order or by Registered Mail.

GOOD, USEFUL BOOKS

BRAZING AND SOLDERING

BRAZING AND SOLDERING. By JAMES F. HOBART. The only book that shows you just how to handle any job of brazing or soldering that comes along; tells you what mixture to use, how to make a furnace if you need one. Full of kinks. 4th edition. **25 cents**

CHARTS

BATTLESHIP CHART. An engraving which shows the details of a battleship as if the sides were of glass and you could see all the interior. The finest piece of work that has ever been done. So accurate that it is used at Annapolis for instruction purposes. Shows all details and gives correct name of every part. 28 x 42 inches—plate paper. **50 cents**

BOX CAR CHART. A chart showing the anatomy of a box car, having every part of the car numbered and its proper name given in a reference list. **20 cents**

GONDOLA CAR CHART. A chart showing the anatomy of a gondola car, having every part of the car numbered and its proper reference name given in a reference list. **20 cents**

PASSENGER CAR CHART. A chart showing the anatomy of a passenger car, having every part of the car numbered and its proper name given in a reference list. **20 cents**

TRACTIVE POWER CHART. A chart whereby you can find the tractive power or drawbar pull of any locomotive, without making a figure. Shows what cylinders are equal, how driving wheels and steam pressure affect the power. What sized engine you need to exert a given drawbar pull or anything you desire in this line. **50 cents**

WESTINGHOUSE AIR-BRAKE CHARTS. Chart I.—Shows (in colors) the most modern Westinghouse High Speed and Signal Equipment used on Passenger Engines, Passenger Engine Tenders, and Passenger Cars. Chart II.—Shows (in colors) the Standard Westinghouse Equipment for Freight and Switch Engines, Freight and Switch Engine Tenders, and Freight Cars. Price for the set, **50 cents**

CHEMISTRY

HENLEY'S TWENTIETH CENTURY BOOK OF RECEIPTS, FORMULAS AND PROCESSES. Edited by GARDNER D. HISCOX. The most valuable Techno-chemical Receipt Book published, including over 10,000 selected scientific chemical, technological, and practical receipts and processes. See page 24 for full description of this book. **\$3.00**

CIVIL ENGINEERING

HENLEY'S ENCYCLOPEDIA OF PRACTICAL ENGINEERING AND ALLIED TRADES. Edited by JOSEPH G. HORNER, A.M.I., M.E. This set of five volumes contains about 2,500 pages with thousands of illustrations, including diagrammatic and sectional drawings with full explanatory details. It covers the entire practice of Civil and Mechanical Engineering. It tells you all you want to know about engineering and tells it so simply, so clearly, so concisely that one cannot help but understand. **\$6.00** per volume or **\$25.00** for complete set of five volumes.

COKE

COKE—MODERN COKING PRACTICE; INCLUDING THE ANALYSIS OF MATERIALS AND PRODUCTS.

By T. H. BYROM, Fellow of the Institute of Chemistry, Fellow of The Chemical Society, etc., and J. E. CHRISTOPHER, Member of the Society of Chemical Industry, etc. A handbook for those engaged in Coke manufacture and the recovery of By-products. Fully illustrated with folding plates.

The subject of Coke Manufacture is of rapidly increasing interest and significance, embracing as it does the recovery of valuable by-products in which scientific control is of the first importance. It has been the aim of the authors, in preparing this book, to produce one which shall be of use and benefit to those who are associated with, or interested in, the modern developments of the industry.

Contents: Chap. I. Introductory. Chap. II. General Classification of Fuels. Chap. III. Coal Washing. Chap. IV. The Sampling and Valuation of Coal, Coke, etc. Chap. V. The Calorific Power of Coal and Coke. Chap. VI. Coke Ovens. Chap. VII. Coke Ovens, continued. Chap. VIII. Coke Ovens, continued. Chap. IX. Charging and Discharging of Coke Ovens. Chap. X. Cooling and Condensing Plant. Chap. XI. Gas Exhausters. Chap. XII. Composition and Analysis of Ammoniacal Liquor. Chap. XIII. Working up of Ammoniacal Liquor. Chap. XIV. Treatment of Waste Gases from Sulphate Plants. Chap. XV. Valuation of Ammonium Sulphate. Chap. XVI. Direct Recovery of Ammonia from Coke Oven Gases. Chap. XVII. Surplus Gas from Coke Oven. Useful Tables. Very fully illustrated. **\$3.50 net**

COMPRESSED AIR

COMPRESSED AIR IN ALL ITS APPLICATIONS. By GARDNER D. HISCOX. This is the most complete book on the subject of Air that has ever been issued, and its thirty-five chapters include about every phase of the subject one can think of. It may be called an encyclopedia of compressed air. It is written by an expert, who, in its 665 pages, has dealt with the subject in a comprehensive manner, no phase of it being omitted. Over 500 illustrations, 5th Edition, revised and enlarged. Cloth bound; **\$5.00**, Half morocco, **\$6.50**

CONCRETE

ORNAMENTAL CONCRETE WITHOUT MOLDS, By A. A. HOUGHTON. The process for making ornamental concrete without molds, has long been held as a secret and now, for the first time, this process is given to the public. The book reveals the secret and is the only book published which explains a simple, practical method whereby the concrete worker is enabled, by employing wood and metal templates of different designs, to mold or model in concrete any Cornice, Archivolt, Column, Pedestal, Base Cap, Urn or Pier in a monolithic form—right upon the job. These may be molded in units or blocks, and then built up to suit the specifications demanded. This work is fully illustrated, with detailed engravings. **\$2.00**

POPULAR HAND BOOK FOR CEMENT AND CONCRETE USERS, By MYRON H. LEWIS, C.E. This is a concise treatise of the principles and methods employed in the manufacture and use of cement in all classes of modern works. The author has brought together in this work, all the salient matter of interest to the user of concrete and its many diversified products. The matter is presented in logical and systematic order, clearly written, fully illustrated and free from involved mathematics. Everything of value to the concrete user is given. Among the chapters contained in the book are: I. Historical Development of the Uses of Cement and Concrete. II. Glossary of Terms employed in Cement and Concrete work. III. Kinds of Cement employed in Construction. IV. Limes, Ordinary and Hydraulic. V. Lime Plasters. VI. Natural Cements. VII. Portland Cements. VIII. Inspection and Testing. IX. Adulteration; or Foreign Substances in Cement. X. Sand, Gravel and Broken Stone. XI. Mortar. XII. Grout. XIII. Concrete (Plain). XIV. Concrete (Reinforced). XV. Methods and Kinds of Reinforcements. XVI. Forms for Plain and Reinforced Concrete. XVII. Concrete Blocks. XVIII. Artificial Stone. XIX. Concrete Tiles. XX. Concrete Pipes and Conduits. XXI. Concrete Piles. XXII. Concrete Buildings. XXIII. Concrete in Water Works. XXIV. Concrete in Sewer Works. XXV. Concrete in Highway Construction. XXVI. Concrete Retaining Walls. XXVII. Concrete Arches and Abutments. XXVIII. Concrete in Subway and Tunnels. XXIX. Concrete in Bridge Work. XXX. Concrete in Docks and Wharves. XXXI. Concrete Construction under Water. XXXII. Concrete on the Farm. XXXIII. Concrete Chimneys. XXXIV. Concrete for Ornamentation. XXXV. Concrete Mausoleums and Miscellaneous Uses. XXXVI. Inspection for Concrete Work. XXXVII. Waterproofing Concrete Work. XXXVIII. Coloring and Painting Concrete Work. XXXIX. Method of Finishing Concrete Surfaces. XL. Specifications and Estimates for Concrete Work. **\$2.50**

DICTIONARIES

STANDARD ELECTRICAL DICTIONARY. By T. O'CONNOR SLOANE. An indispensable work to all interested in electrical science. Suitable alike for the student and professional. A practical hand-book of reference containing definitions of about 5,000 distinct words, terms and phrases. The definitions are terse and concise and include every term used in electrical science. Recently issued. An entirely new edition. Should be in the possession of all who desire to keep abreast with the progress of this branch of science. Complete, concise and convenient. 682 pages—393 illustrations. **\$3.00**

DIES—METAL WORK

DIES, THEIR CONSTRUCTION AND USE FOR THE MODERN WORKING OF SHEET METALS. By J. V. WOODWORTH. A new book by a practical man, for those who wish to know the latest practice in the working of sheet metals. It shows how dies are designed, made and used, and those who are engaged in this line of work can secure many valuable suggestions. **\$3.00**

PUNCHES, DIES AND TOOLS FOR MANUFACTURING IN PRESSES. By J. V. WOODWORTH. An encyclopedia of die-making, punch-making, die-sinking, sheet-metal working, and making of special tools, subpresses, devices and mechanical combinations for punching, cutting, bending, forming, piercing, drawing, compressing, and assembling sheet-metal parts and also articles of other materials in machine tools. This is a distinct work from the author's book entitled "Dies; Their Construction and Use." 500 pages, 700 engravings. **\$4.00**

DRAWING—SKETCHING PAPER

LINEAR PERSPECTIVE SELF-TAUGHT. By HERMAN T. C. KRAUS. This work gives the theory and practice of linear perspective, as used in architectural, engineering, and mechanical drawings. Persons taking up the study of the subject by themselves, without the aid of a teacher, will be able by the use of the instruction given to readily grasp the subject, and by reasonable practice become good perspective draftsmen. The arrangement of the book is good; the plate is on the left-hand, while the descriptive text follows on the opposite page, so as to be readily referred to. The drawings are on sufficiently large scale to show the work clearly and are plainly figured. The whole work makes a very complete course on perspective drawing, and will be found of great value to architects, civil and mechanical engineers, patent attorneys, art designers, engravers, and draftsmen. **\$2.50**

PRACTICAL PERSPECTIVE. By RICHARDS and COLVIN. Shows just how to make all kinds of mechanical drawings in the only practical perspective isometric. Makes everything plain so that any mechanic can understand a sketch or drawing in this way. Saves time in the drawing room and mistakes in the shops. Contains practical examples of various classes of work. **50 cents**

SELF-TAUGHT MECHANICAL DRAWING AND ELEMENTARY MACHINE DESIGN. By F. L. SYLVESTER, M. E., Draftsman, with additions by Erik Oberg, associate editor of "Machinery." A practical elementary treatise on Mechanical Drawing and Machine Design, comprising the first principles of geometric and mechanical drawing, workshop mathematics, mechanics, strength of materials and the calculation and design of machine details, compiled for the use of practical mechanics and young draftsmen. **\$2.00**

A NEW SKETCHING PAPER. A new specially ruled paper to enable you to make sketches or drawings in isometric perspective without any figuring or fussing. It is being used for shop details as well as for assembly drawings, as it makes one sketch do the work of three, and no workman can help seeing just what is wanted. Pads of 40 sheets, 6 x 9 inches, **25 cents**. Pads of 40 sheets, 9 x 12 inches, **50 cents**

ELECTRICITY

ARITHMETIC OF ELECTRICITY. By Prof. T. O'CONNOR SLOANE. A practical treatise on electrical calculations of all kinds reduced to a series of rules, all of the simplest forms, and involving only ordinary arithmetic; each rule illustrated by one or more practical problems, with detailed solution of each one. This book is classed among the most useful works published on the science of electricity covering as it does the mathematics of electricity in a manner that will attract the attention of those who are not familiar with algebraical formulas. 160 pages. **\$1.00**

COMMUTATOR CONSTRUCTION. By Wm. BAXTER, JR. The business end of any dynamo or motor of the direct current type is the commutator. This book goes into the designing, building, and maintenance of commutators, shows how to locate troubles and how to remedy them; everyone who fusses with dynamos needs this. **25 cents**

DYNAMO BUILDING FOR AMATEURS, OR HOW TO CONSTRUCT A FIFTY WATT DYNAMO. By ARTHUR J. WEED, Member of N. Y. Electrical Society. This book is a practical treatise showing in detail the construction of a small dynamo or motor, the entire machine work of which can be done on a small foot lathe.

Dimensioned working drawings are given for each piece of machine work and each operation is clearly described.

This machine when used as a dynamo has an output of fifty watts; when used as a motor it will drive a small drill press or lathe. It can be used to drive a sewing machine on any and all ordinary work.

The book is illustrated with more than sixty original engravings showing the actual construction of the different parts. Paper. **Paper 50 cents Cloth \$1.00**

ELECTRIC FURNACES AND THEIR INDUSTRIAL APPLICATIONS. By J. WRIGHT. This is a book which will prove of interest to many classes of people; the manufacturer who desires to know what product can be manufactured successfully in the electric furnace, the chemist who wishes to post himself on the electro-chemistry, and the student of science who merely looks into the subject from curiosity. 288 pages. **\$3.00**

ELECTRIC LIGHTING AND HEATING POCKET BOOK. By SYDNEY F. WALKER. This book puts in convenient form useful information regarding the apparatus which is likely to be attached to the mains of an electrical company. Tables of units and equivalents are included and useful electrical laws and formulas are stated. 438 pages, 300 engravings. **\$3.00**

ELECTRIC TOY MAKING, DYNAMO BUILDING, AND ELECTRIC MOTOR CONSTRUCTION. This work treats of the making at home of electrical toys, electrical apparatus, motors, dynamos, and instruments in general, and is designed to bring within the reach of young and old the manufacture of genuine and useful electrical appliances. 185 pages. Fully illustrated. **\$1.00**

ELECTRIC WIRING, DIAGRAMS AND SWITCH-BOARDS. By NEWTON HARRISON. This is the only complete work issued showing and telling you what you should know about direct and alternating current wiring. It is a ready reference. The work is free from advanced technicalities and mathematics. Arithmetic being used throughout. It is in every respect a handy, well-written, instructive, comprehensive volume on wiring for the wireman, foreman, contractor or electrician. 272 pages, 105 illustrations. **\$1.50**

ELECTRICIAN'S HANDY BOOK. By PROF. T. O'CONOR SLOANE. This work is intended for the practical electrician, who has to make things go. The entire field of Electricity is covered within its pages. It contains no useless theory; everything is to the point. It teaches you just what you should know about electricity. It is the standard work published on the subject. Forty-one chapters, 610 engravings, handsomely bound in red leather with titles and edges in gold. **\$3.50**

ELECTRICITY IN FACTORIES AND WORKSHOPS, ITS COST AND CONVENIENCE. By ARTHUR P. HASLAM. A practical book for power producers and power users showing what a convenience the electric motor, in its various forms, has become to the modern manufacturer. It also deals with the conditions which determine the cost of electric driving, and compares this with other methods of producing and utilizing power. 312 pages. Very fully illustrated. **\$2.50**

ELECTRICITY SIMPLIFIED. By PROF. T. O'CONOR SLOANE. The object of "Electricity Simplified" is to make the subject as plain as possible and to show what the modern conception of electricity is; to show how two plates of different metals immersed in acid can send a message around the globe; to explain how a bundle of copper wire rotated by a steam engine can be the agent in lighting our streets, to tell what the volt, ohm and ampere are, and what high and low tension mean; and to answer the questions that perpetually arise in the mind in this age of electricity. 172 pages. Illustrated. **\$1.00**

HOW TO BECOME A SUCCESSFUL ELECTRICIAN. By PROF. T. O'CONOR SLOANE. An interesting book from cover to cover. Telling in simplest language the surest and easiest way to become a successful electrician. The studies to be followed, methods of work, field of operation and the requirements of the successful electrician are pointed out and fully explained. 202 pages. Illustrated. **\$1.00**

MANAGEMENT OF DYNAMOS. By LUMMIS-PATERSON. A handbook of theory and practice. This work is arranged in three parts. The first part covers the elementary theory of the dynamo. The second part, the construction and action of the different classes of dynamos in common use are described; while the third part relates to such matters as affect the practical management and working of dynamos and motors. 292 pages, 117 illustrations. **\$1.50**

STANDARD ELECTRICAL DICTIONARY. By Prof. T. O'CONOR SLOANE. A practical handbook of reference containing definitions of about 5,000 distinct words, terms and phrases. The definitions are terse and concise and include every term used in electrical science. 682 pages, 393 illustrations. **\$3.00**

SWITCHBOARDS. By WILLIAM BAXTER, JR. This book appeals to every engineer and electrician who wants to know the practical side of things. All sorts and conditions of dynamos, connections and circuits are shown by diagram and illustrate just how the switchboard should be connected. Includes direct and alternating current boards, also those for arc lighting, incandescent, and power circuits. Special treatment on high voltage boards for power transmission. 190 pages. Illustrated. **\$1.50**

TELEPHONE CONSTRUCTION, INSTALLATION, WIRING, OPERATION AND MAINTENANCE. By W. H. RADCLIFFE and H. C. CUSHING. This book gives the principles of construction and operation of both the Bell and Independent instruments; approved methods of installing and wiring them; the means of protecting them from lightning and abnormal currents; their connection together for operation as series or bridging stations; and rules for their inspection and maintenance. Line wiring and the wiring and operation of special telephone systems are also treated. 180 pages, 125 illustrations. **\$1.00**

WIRING A HOUSE. By HERBERT PRATT. Shows a house already built; tells just how to start about wiring it. Where to begin; what wire to use; how to run it according to insurance rules, in fact just the information you need. Directions apply equally to a shop. Fourth edition. **25 cents**

WIRELESS TELEPHONES AND HOW THEY WORK. By JAMES ERSKINE-MURRAY. This work is free from elaborate details and aims at giving a clear survey of the way in which Wireless Telephones work. It is intended for amateur workers and for those whose knowledge of Electricity is slight. Chapters contained: How We Hear—Historical—The Conversion of Sound into Electric Waves—Wireless Transmission—The Production of Alternating Currents of High Frequency—How the Electric Waves are Radiated and Received—The Receiving Instruments—Detectors—Achievements and Expectations—Glossary of Technical Work. Cloth. **\$1.00**

ENAMELING

HENLEY'S TWENTIETH CENTURY RECEIPT BOOK. Edited by GARDNER D. HISCOX. A work of 10,000 practical receipts, including enameling receipts for hollow ware, for metals, for signs, for china and porcelain, for wood, etc. Thorough and practical. See page 24 for full description of this book. **\$3.00**

FACTORY MANAGEMENT, ETC.

MODERN MACHINE SHOP CONSTRUCTION, EQUIPMENT AND MANAGEMENT. By O. E. PERRIGO, M.E. A work designed for the practical and every-day use of the Architect who designs, the Manufacturers who build, the Engineers who plan and equip, the Superintendents who organize and direct, and for the information of every stockholder, director, officer, accountant, clerk, superintendent, foreman, and workman of the modern machine shop and manufacturing plant of Industrial America. **\$5.00**

FUEL

COMBUSTION OF COAL AND THE PREVENTION OF SMOKE. By WM. M. BARR. To be a success a fireman must be "Light on Coal." He must keep his fire in good condition, and prevent, as far as possible, the smoke nuisance. To do this, he should know how coal burns, how smoke is formed and the proper burning of fuel to obtain the best results. He can learn this, and more too, from Barr's "Combustion of Coal." It is an absolute authority on all questions relating to the Firing of a Locomotive. Nearly 350 pages, fully illustrated. **\$1.00**

SMOKE PREVENTION AND FUEL ECONOMY. By BOOTH and KERSHAW. As the title indicates, this book of 197 pages and 75 illustrations deals with the problem of complete combustion, which it treats from the chemical and mechanical standpoints, besides pointing out the economical and humanitarian aspects of the question. **\$2.50**

GAS ENGINES AND GAS

CHEMISTRY OF GAS MANUFACTURE. By H. M. ROYLES. A practical treatise for the use of gas engineers, gas managers and students. Including among its contents—Preparations of Standard Solutions, Coal, Furnaces, Testing and Regulation. Products of Carbonization. Analysis of Crude Coal Gas. Analysis of Lime. Ammonia. Analysis of Oxide of Iron. Naphthalene. Analysis of Fire-Bricks and Fire-Clay. Welding and Spent Oxide. Photometry and Gas Testing. Carburetted Water Gas. Metropolis Gas. Miscellaneous Extracts. Useful Tables. **\$4.50**

GAS ENGINE CONSTRUCTION, Or How to Build a Half-Horse-power Gas Engine. By PARSELL and WEED. A practical treatise describing the theory and principles of the action of gas engines of various types, and the design and construction of a half-horse-power gas engine, with illustrations of the work in actual progress, together with dimensioned working drawings giving clearly the sizes of the various details. 300 pages. **\$2.50**

GAS, GASOLINE, AND OIL ENGINES. By GARDNER D. HISCOX. Just issued, 18th revised and enlarged edition. Every user of a gas engine needs this book. Simple, instructive, and right up-to-date. The only complete work on the subject. Tells all about the running and management of gas, gasoline and oil engines as designed and manufactured in the United States. Explosive motors for stationary, marine and vehicle power are fully treated, together with illustrations of their parts and tabulated sizes, also their care and running are included. Electric Ignition by Induction Coil and Jump Sparks are fully explained and illustrated, including valuable information on the testing for economy and power and the erection of power plants.

The special information on PRODUCER and SUCTION GASES included cannot fail to prove of value to all interested in the generation of producer gas and its utilization in gas engines.

The rules and regulations of the Board of Fire Underwriters in regard to the installation and management of Gasoline Motors is given in full, suggesting the safe installation of explosive motor power. A list of United States Patents issued on Gas, Gasoline and Oil Engines and their adjuncts from 1875 to date is included. 484 pages. 410 engravings. **\$2.50 net**

MODERN GAS ENGINES AND PRODUCER GAS PLANTS. By R. E. MATHOT, M.E. A practical treatise of 320 pages, fully illustrated by 175 detailed illustrations, setting forth the principles of gas engines and producer design, the selection and installation of an engine, conditions of perfect operation, producer-gas engines and their possibilities, the care of gas engines and producer-gas plants, with a chapter on volatile hydrocarbon and oil engines. This book has been endorsed by Dugal Clerk as a most useful work for all interested in Gas Engine installation and Producer Gas. **\$2.50**

GEARING AND CAMS

BEVEL GEAR TABLES. By D. AG. ENGSTROM. No one who has to do with bevel gears in any way should be without this book. The designer and draftsman will find it a great convenience, while to the machinist who turns up the blanks or cuts the teeth, it is invaluable, as all needed dimensions are given and no fancy figuring need be done. **\$1.00**

CHANGE GEAR DEVICES. By OSCAR E. PERRIGO. A book for every designer, draftsman and mechanic who is interested in feed changes for any kind of machines. This shows what has been done and how. Gives plans, patents and all information that you need. Saves hunting through patent records and reinventing old ideas. A standard work of reference. **\$1.00**

DRAFTING OF CAMS. By LOUIS ROUILLION. The laying out of cams is a serious problem unless you know how to do it right. This puts you on the right road for practically any kind of cam you are likely to run up against. **25 cents**

HYDRAULICS

HYDRAULIC ENGINEERING. By GARDNER D. HISCOX. A treatise on the properties, power, and resources of water for all purposes. Including the measurement of streams; the flow of water in pipes or conduits; the horse-power of falling water; turbine and impact water-wheels; wave-motors, centrifugal, reciprocating, and air-lift pumps. With 300 figures and diagrams and 36 practical tables. 320 pages. **\$4.00**

ICE AND REFRIGERATION

POCKET BOOK OF REFRIGERATION AND ICE MAKING. By A. J. WALLIS-TAYLOR. This is one of the latest and most comprehensive reference books published on the subject of refrigeration and cold storage. It explains the properties and refrigerating effect of the different fluids in use, the management of refrigerating machinery and the construction and insulation of cold rooms with their required pipe surface for different degrees of cold; freezing mixtures and non-freezing brines, temperatures of cold rooms for all kinds of provisions, cold storage charges for all classes of goods, ice making and storage of ice, data and memoranda for constant reference by refrigerating engineers, with nearly one hundred tables containing valuable references to every fact and condition required in the installation and operation of a refrigerating plant. **\$1.50**

INVENTIONS—PATENTS

INVENTOR'S MANUAL, HOW TO MAKE A PATENT PAY. This is a book designed as a guide to inventors in perfecting their inventions, taking out their patents, and disposing of them. It is not in any sense a Patent Solicitor's Circular, nor a Patent Broker's Advertisement. No advertisements of any description appear in the work. It is a book containing a quarter of a century's experience of a successful inventor, together with notes based upon the experience of many other inventors. **\$1.00**

LATHE PRACTICE

MODERN AMERICAN LATHE PRACTICE. By OSCAR E. PERRIGO. An up-to-date book on American Lathe Work, describing and illustrating the very latest practice in lathe and boring-mill operations, as well as the construction of and latest developments in the manufacture of these important classes of machine tools. 300 pages, fully illustrated. **\$2.50**

PRACTICAL METAL TURNING. By JOSEPH G. HORNER. A work of 404 pages, fully illustrated, covering in a comprehensive manner the modern practice of machining metal parts in the lathe, including the regular engine lathe, its essential design, its uses, its tools, its attachments, and the manner of holding the work and performing the operations. The modernized engine lathe, its methods, tools, and great range of accurate work. The Turret Lathe, its tools, accessories and methods of performing its functions. Chapters on special work, grinding, tool holders, speeds, feeds, modern tool steels, etc., etc. **\$3.50**

TURNING AND BORING TAPERS. By FRED H. COLVIN. There are two ways to turn tapers; the right way and one other. This treatise has to do with the right way; it tells you how to start the work properly, how to set the lathe, what tools to use and how to use them, and forty and one other little things that you should know. Fourth edition. **25 cents**

LIQUID AIR

LIQUID AIR AND THE LIQUEFACTION OF GASES. By T. O'CONNOR SLOANE. Theory, history, biography, practical applications, manufacture. 365 pages. Illustrated. **\$2.00**

LOCOMOTIVE ENGINEERING

AIR-BRAKE CATECHISM. By ROBERT H. BLACKALL. This book is a standard text book. It covers the Westinghouse Air-Brake Equipment, including the No. 5 and the No. 6 E T Locomotive Brake Equipment; the K (Quick-Service) Triple Valve for Freight Service; and the Cross-Compound Pump. The operation of all parts of the apparatus is explained in detail, and a practical way of finding their peculiarities and defects, with a proper remedy, is given. It contains 2,000 questions with their answers, which will enable any railroad man to pass any examination on the subject of Air Brakes. Endorsed and used by air-brake instructors and examiners on nearly every railroad in the United States. 23d Edition. 380 pages, fully illustrated with folding plates and diagrams. **\$2.00**

AMERICAN COMPOUND LOCOMOTIVES. By FRED H. COLVIN. The most complete book on compounds published. Shows all types, including the balanced compound. Makes everything clear by many illustrations, and shows valve setting, breakdowns and repairs. 142 pages. **\$1.00**

APPLICATION OF HIGHLY SUPERHEATED STEAM TO LOCOMOTIVES. By ROBERT GARBE. A practical book. Contains special chapters on Generation of Highly Superheated Steam; Superheated Steam and the Two-Cylinder Simple Engine; Compounding and Superheating; Designs of Locomotive Superheaters; Constructive Details of Locomotives using Highly Superheated Steam; Experimental and Working Results. Illustrated with folding plates and tables. **\$2.50**

COMBUSTION OF COAL AND THE PREVENTION OF SMOKE. By WM. M. BARR. To be a success a fireman must be "Light on Coal." He must keep his fire in good condition, and prevent as far as possible, the smoke nuisance. To do this, he should know how coal burns, how smoke is formed and the proper burning of fuel to obtain the best results. He can learn this, and more too, from Barr's "Combination of Coal." It is an absolute authority on all questions relating to the Firing of a Locomotive. Nearly 350 pages, fully illustrated. **\$1.00**

LINK MOTIONS, VALVES AND VALVE SETTING. By FRED H. COLVIN, Associate Editor of "American Machinist." A handy book that clears up the mysteries of valve setting. Shows the different valve gears in use, how they work, and why. Piston and slide valves of different types are illustrated and explained. A book that every railroad man in the motive-power department ought to have. Fully illustrated. **50 cents.**

LOCOMOTIVE BOILER CONSTRUCTION. By FRANK A. KLEINHANS. The only book showing how locomotive boilers are built in modern shops. Shows all types of boilers used; gives details of construction; practical facts, such as life of riveting punches and dies, work done per day, allowance for bending and flanging sheets and other data that means dollars to any railroad man. 421 pages, 334 illustrations. Six folding plates. **\$3.00**

LOCOMOTIVE BREAKDOWNS AND THEIR REMEDIES. By GEO. L. FOWLER. Revised by Wm. W. Wood, Air-Brake Instructor. Just issued 1910. Revised pocket edition. It is out of the question to try and tell you about every subject that is covered in this pocket edition of Locomotive Breakdowns. Just imagine all the common troubles that an engineer may expect to happen some time, and then add all of the unexpected ones, troubles that could occur, but that you had never thought about, and you will find that they are all treated with the very best methods of repair. Walschaert Locomotive Valve Gear Troubles, Electric Headlight Troubles, as well as Questions and Answers on the Air Brake are all included. 294 pages. Fully illustrated. **\$1.00**

LOCOMOTIVE CATECHISM. By ROBERT GRIMSHAW. 27th revised and enlarged edition. This may well be called an encyclopedia of the locomotive. Contains over 4,000 examination questions with their answers, including among them those asked at the First, Second and Third year's Examinations. 825 pages, 437 illustrations and 3 folding plates. **\$2.50**

NEW YORK AIR-BRAKE CATECHISM. By ROBERT H. BLACKALL. This is a complete treatise on the New York Air-Brake and Air-Signalling Apparatus, giving a detailed description of all the parts, their operation, troubles, and the methods of locating and remedying the same. 200 pages, fully illustrated. **\$1.00**

POCKET-RAILROAD DICTIONARY AND VADE MECUM. By FRED H. COLVIN, Associate Editor "American Machinist." Different from any book you ever saw. Gives clear and concise information on just the points you are interested in. It's really a pocket dictionary, fully illustrated, and so arranged that you can find just what you want in a second without an index. Whether you are interested in Axles or Acetylene; Compounds or Counter Balancing; Rails or Reducing Valves; Tires or Turntables, you'll find them in this little book. It's very complete. Flexible cloth cover, 200 pages. **\$1.00**

TRAIN RULES AND DESPATCHING. By H. A. DALBY. Contains the standard code for both single and double track and explains how trains are handled under all conditions. Gives all signals in colors, is illustrated wherever necessary, and the most complete book in print on this important subject. Bound in fine seal flexible leather. 221 pages. **\$1.50**

WALSCHAERT LOCOMOTIVE VALVE GEAR. By WM. W. WOOD. If you would thoroughly understand the Walschaert Valve Gear, you should possess a copy of this book. The author divides the subject into four divisions, as follows: I. Analysis of the gear. II. Designing and erecting of the gear III. Advantages of the gear. IV. Questions and answers relating to the Walschaert Valve Gear. This book is specially valuable to those preparing for promotion. Nearly 200 pages. **\$1.50**

WESTINGHOUSE E T AIR-BRAKE INSTRUCTION POCKET BOOK CATECHISM. By WM. W. WOOD, Air-Brake Instructor. A practical work containing examination questions and answers on the E T Equipment. Covering what the E T Brake is. How it should be operated. What to do when defective. Not a question can be asked of the engineman up for promotion on either the No. 5 or the No. 6 E T equipment that is not asked and answered in the book. If you want to thoroughly understand the E T equipment get a copy of this book. It covers every detail. Makes Air-Brake troubles and examinations easy. Fully illustrated with colored plates, showing various pressures. **\$2.00**

MACHINE SHOP PRACTICE

AMERICAN TOOL MAKING AND INTERCHANGEABLE MANUFACTURING. By J. V. WOODWORTH. A practical treatise on the designing, constructing, use, and installation of tools, jigs, fixtures, devices, special appliances, sheet-metal working processes, automatic mechanisms, and labor-saving contrivances; together with their use in the lathe milling machine, turret lathe, screw machine, boring mill, power press, drill, subpress, drop hammer, etc., for the working of metals, the production of interchangeable machine parts, and the manufacture of repetition articles of metal. 560 pages, 600 illustrations. **\$4.00**

HENLEY'S ENCYCLOPEDIA OF PRACTICAL ENGINEERING AND ALLIED TRADES. Edited by JOSEPH G. HORNER. A.M.I.Mech.I. This work covers the entire practice of Civil and Mechanical Engineering. The best known experts in all branches of engineering have contributed to these volumes. The Cyclopedia is admirably well adapted to the needs of the beginner and the self-taught practical man, as well as the mechanical engineer, designer, draftsman, shop superintendent, foreman and machinist.

It is a modern treatise in five volumes. Handsomely bound in Half Morocco, each volume containing nearly 500 pages, with thousands of illustrations, including diagrammatic and sectional drawings with full explanatory details. **\$25.00** for the complete set of five volumes, **\$6.00** per volume, when ordered singly.

MACHINE SHOP ARITHMETIC. By COLVIN-CHENEY. Most popular book for shop men. Shows how all shop problems are worked out and "why." Includes change gears for cutting any threads; drills, taps, sink and force fits; metric system of measurements and threads. Used by all classes of mechanics and for instruction of Y. M. C. A. and other schools. Fifth edition. 131 pages. **50 cents**

MECHANICAL MOVEMENTS, POWERS, AND DEVICES. By GARDNER D. HISCOX. This is a collection of 1890 engravings of different mechanical motions and appliances, accompanied by appropriate text, making it a book of great value to the inventor, the draftsman, and to all readers with mechanical tastes. The book is divided into eighteen sections or chapters in which the subject matter is classified under the following heads: Mechanical Powers, Transmission of Power, Measurement of Power, Steam Power, Air Power Appliances, Electric Power and Construction, Navigation and Roads, Gearing, Motion and Devices, Controlling Motion, Horological, Mining, Mill and Factory Appliances, Construction and Devices, Drafting Devices, Miscellaneous Devices, etc. 11th edition. 400 octavo pages. **\$2.50**

MECHANICAL APPLIANCES, MECHANICAL MOVEMENTS AND NOVELTIES OF CONSTRUCTION. By GARDNER D. HISCOX. This is a supplementary volume to the one upon mechanical movements. Unlike the first volume, which is more elementary in character, this volume contains illustrations and descriptions of many combinations of motions and of mechanical devices and appliances found in different lines of Machinery. Each device being shown by a line drawing with a description showing its working parts and the method of operation. From the multitude of devices described, and illustrated, might be mentioned, in passing, such items as conveyors and elevators, Prony brakes, thermometers, various types of boilers, solar engines, oil-fuel burners, condensers, evaporators, Corliss and other valve gears, governors, gas engines, water motors of various descriptions, air ships, motors and dynamos, automobile and motor bicycles, railway block signals, car couples, link and gear motions, ball bearings, breech block mechanism for heavy guns, and a large accumulation of others of equal importance. 1,000 specially made engravings. 396 octavo pages. **\$2.50**

SPECIAL OFFER These two volumes sell for \$2.50 each, but when the two volumes are ordered at one time from us, we send them prepaid to any address in the world, on receipt of \$4.00. You save \$1 by ordering the two volumes of Mechanical Movements at one time.

MODERN MACHINE SHOP CONSTRUCTION, EQUIPMENT AND MANAGEMENT. By OSCAR E. PERRIGO. The only work published that describes the Modern Machine Shop or Manufacturing Plant from the time the grass is growing on the site intended for it until the finished product is shipped. Just the book needed by those contemplating the erection of modern shop buildings, the rebuilding and reorganization of old ones, or the introduction of Modern Shop Methods, Time and Cost Systems. It is a book written and illustrated by a practical shop man for practical shop men who are too busy to read theories and want facts. It is the most complete all-around book of its kind ever published. 400 large quarto pages, 225 original and specially-made illustrations. **\$5.00**

MODERN MACHINE SHOP TOOLS; THEIR CONSTRUCTION, OPERATION, AND MANIPULATION. By W. H. VANDERVOORT. A work of 555 pages and 673 illustrations, describing in every detail the construction, operation, and manipulation of both Hand and Machine Tools. Includes chapters on filing, fitting, and scraping surfaces; on drills, reamers, taps, and dies; the lathe and its tools; planers, shapers, and their tools; milling machines and cutters; gear cutters and gear cutting; drilling machines and drill work; grinding machines and their work; hardening and tempering; gearing, belting and transmission machinery; useful data and tables. **\$4.00**

THE MODERN MACHINIST. By JOHN T. USHER. This book might be called a compendium of shop methods, showing a variety of special tools and appliances which will give new ideas to many mechanics from the superintendent down to the man at the bench. It will be found a valuable addition to any machinist's library and should be consulted whenever a new or difficult job is to be done, whether it is boring, milling, turning, or planing, as they are all treated in a practical manner. Fifth edition. 320 pages, 250 illustrations. **\$2.50**

MODERN MECHANISM. Edited by PARK BENJAMIN. A practical treatise on machines, motors and the transmission of power, being a complete work and a supplementary volume to Appleton's Cyclopaedia of Applied Mechanics. Deals solely with the principal and most useful advances of the past few years. 959 pages containing over 1,000 illustrations; bound in half morocco. **\$4.00**

MODERN MILLING MACHINES: THEIR DESIGN, CONSTRUCTION AND OPERATION. By JOSEPH G. HORNER. This book describes and illustrates the Milling Machine and its work in such a plain, clear, and forceful manner, and illustrates the subject so clearly and completely, that the up-to-date machinist, student, or mechanical engineer can not afford to do without the valuable information which it contains. It describes not only the early machines of this class, but notes their gradual development into the splendid machines of the present day, giving the design and construction of the various types, forms, and special features produced by prominent manufacturers, American and foreign. 304 pages, 300 illustrations. **\$4.00**

"SHOP KINKS." By ROBERT GRIMSHAW. This shows special methods of doing work of various kinds, and reducing cost of production. Has hints and kinks from some of the largest shops in this country and Europe. You are almost sure to find some that apply to your work, and in such a way as to save time and trouble. 400 pages. Fourth edition. **\$2.50**

TOOLS FOR MACHINISTS AND WOOD WORKERS, INCLUDING INSTRUMENTS OF MEASUREMENT.

By JOSEPH G. HORNER. A practical treatise of 340 pages, fully illustrated and comprising a general description and classification of cutting tools and tool angles, allied cutting tools for machinists and woodworkers; shearing tools; scraping tools; saws; milling cutters; drilling and boring tools; taps and dies; punches and hammers; and the hardening, tempering and grinding of these tools. Tools for measuring and testing work, including standards of measurement; surface plates; levels; surface gauges; dividers; calipers; verniers; micrometers; snap, cylindrical and limit gauges; screw thread, wire and reference gauges, indicators, templets, etc. **\$3.50**

MANUAL TRAINING

ECONOMICS OF MANUAL TRAINING. By LOUIS ROUILLION. The only book that gives just the information needed by all interested in manual training, regarding buildings, equipment and supplies. Shows exactly what is needed for all grades of the work from the Kindergarten to the High and Normal School. Gives itemized lists of everything needed and tells just what it ought to cost. Also shows where to buy supplies. **\$1.50**

MARINE ENGINEERING

MARINE ENGINES AND BOILERS, THEIR DESIGN AND CONSTRUCTION. By DR. G. BAUER, LESLIE S. ROBERTSON, and S. BRYAN DONKIN. This work is clearly written, thoroughly systematic, theoretically sound; while the character of its plans, drawings, tables, and statistics is without reproach. The illustrations are careful reproductions from actual working drawings, with some well-executed photographic views of completed engines and boilers. **\$9.00 net**

MINING

MORE DEPOSITS OF SOUTH AFRICA WITH A CHAPTER ON HINTS TO PROSPECTORS. By J. P. JOHNSON. This book gives a condensed account of the ore-deposits at present known in South Africa. It is also intended as a guide to the prospector. Only an elementary knowledge of geology and some mining experience are necessary in order to understand this work. With these qualifications, it will materially assist one in his search for metalliferous mineral occurrences and, so far as simple ores are concerned, should enable one to form some idea of the possibilities of any they may find.

Among the chapters given are: Titaniferous and Chromiferous Iron Oxides—Nickel—Copper—Cobalt—Tin—Molybdenum—Tungsten—Lead—Mercury—Antimony—Iron—Hints to Prospectors. Illustrated. **\$2.00**

PRACTICAL COAL MINING. By T. H. COCKIN. An important work, containing 428 pages and 213 illustrations, complete with practical details, which will intuitively impart to the reader, not only a general knowledge of the principles of coal mining, but also considerable insight into allied subjects. The treatise is positively up to date in every instance, and should be in the hands of every colliery engineer, geologist, mine operator, superintendent, foreman, and all others who are interested in or connected with the industry. **\$2.50**

PHYSICS AND CHEMISTRY OF MINING. By T. H. BYROM. A practical work for the use of all preparing for examinations in mining or qualifying for colliery managers' certificates. The aim of the author in this excellent book is to place clearly before the reader useful and authoritative data which will render him valuable assistance in his studies. The only work of its kind published. The information incorporated in it will prove of the greatest practical utility to students, mining engineers, colliery managers, and all others who are specially interested in the present-day treatment of mining problems. 160 pages. Illustrated. **\$2.00**

MISCELLANEOUS

BRONZES. Henley's Twentieth Century Receipt Book contains many practical formulas on bronze casting, imitation bronze, bronze polishes, renovation of bronze. See page 24 for full description of this book. **\$3.00**

EMINENT ENGINEERS. By DWIGHT GODDARD. Everyone who appreciates the effect of such great inventions as the Steam Engine, Steamboat, Locomotive, Sewing Machine, Steel Working, and other fundamental discoveries, is interested in knowing a little about the men who made them and their achievements.

Mr. Goddard has selected thirty-two of the world's engineers who have contributed most largely to the advancement of our civilization by mechanical means, giving only such facts as are of general interest and in a way which appeals to all, whether mechanics or not. 280 pages, 35 illustrations. **\$1.50**

LAWS OF BUSINESS, By THEOPHILUS PARSONS, LL.D. The Best Book for Business Men ever Published. Treats clearly of Contracts, Sales, Notes, Bills of Exchange, Agency, Agreement, Stoppage in Transitu, Consideration, Limitations, Leases, Partnership, Executors, Interest, Hotel Keepers, Fire and Life Insurance, Collections, Bonds, Frauds, Receipts, Patents, Deeds, Mortgages, Liens, Assignments, Minors, Married Women, Arbitration, Guardians, Wills, etc. Three Hundred Approved Forms are given. Every Business Man should have a copy of this book for ready reference. The book is bound in full sheep, and Contains 864 Octavo Pages. Our special price. **\$3.50**

PATTERN MAKING

PRACTICAL PATTERN MAKING. By F. W. BARROWS. This is a very complete and entirely practical treatise on the subject of pattern making, illustrating pattern work in wood and metal. From its pages you are taught just what you should know about pattern making. It contains a detailed description of the materials used by pattern makers, also the tools, both those for hand use, and the more interesting machine tools; having complete chapters on The Band Saw, The Buzz Saw, and The Lathe. Individual patterns of many different kinds are fully illustrated and described, and the mounting of metal patterns on plates for molding machines is included. **\$2.00**

PERFUMERY

HENLEY'S TWENTIETH CENTURY BOOK OF RECEIPTS, FORMULAS AND PROCESSES. Edited by G. D. HISCOX. The most valuable Techno-Chemical Receipt Book published. Contains over 10,000 practical Receipts many of which will prove of special value to the perfumer, a mine of information, up to date in every respect. Cloth, **\$3.00**; half morocco. See page 24 for full description of this book. **\$4.00**

PERFUMES AND THEIR PREPARATION. By G. W. ASKINSON, Perfumer. A comprehensive treatise, in which there has been nothing omitted that could be of value to the Perfumer. Complete directions for making handkerchief perfumes, smelling-salts, sachets, fumigating pastilles; preparations for the care of the skin, the mouth, the hair, cosmetics, hair dyes and other toilet articles are given, also a detailed description of aromatic substances; their nature, tests of purity, and wholesale manufacture. A book of general, as well as professional interest, meeting the wants not only of the druggist and perfume manufacturer, but also of the general public. Third edition. 312 pages. Illustrated. **\$3.00**

PLUMBING

MODERN PLUMBING ILLUSTRATED. By R. M. STARBUCK. The author of this book, Mr. R. M. Starbuck, is one of the leading authorities on plumbing in the United States. The book represents the highest standard of plumbing work. It has been adopted and used as a reference book by the United States Government, in its sanitary work in Cuba, Porto Rico and the Philippines, and by the principal Boards of Health of the United States and Canada.

It gives Connections, Sizes and Working Data for All Fixtures and Groups of Fixtures. It is helpful to the Master Plumber in Demonstrating to his customers and in figuring work. It gives the Mechanic and Student quick and easy Access to the best Modern Plumbing Practice. Suggestions for Estimating Plumbing Construction are contained in its pages. This book represents, in a word, the latest and best up-to-date practice, and should be in the hands of every architect, sanitary engineer and plumber who wishes to keep himself up to the minute on this important feature of construction. 400 octavo pages, fully illustrated by 55 full-page engravings. **\$4.00**

RUBBER

HENLEY'S TWENTIETH CENTURY BOOK OF RECEIPTS, FORMULAS AND PROCESSES. Edited by GARDNER D. HISCOX. Contains upward of 10,000 practical receipts, including among them formulas on artificial rubber. See page 24 for full description of this book. **\$3.00**

RUBBER HAND STAMPS AND THE MANIPULATION OF INDIA RUBBER. By T. O'CONNOR SLOANE. This book gives full details on all points, treating in a concise and simple manner the elements of nearly everything it is necessary to understand for a commencement in any branch of the India Rubber Manufacture. The making of all kinds of Rubber Hand Stamps, Small Articles of India Rubber, U. S. Government Composition, Dating Hand Stamps, the Manipulation of Sheet Rubber, Toy Balloons, India Rubber Solutions, Cements, Blackings, Renovating Varnish, and Treatment for India Rubber Shoes, etc.; the Hektograph Stamp Inks, and Miscellaneous Notes, with a Short Account of the Discovery, Collection, and Manufacture of India Rubber are set forth in a manner designed to be readily understood, the explanations being plain and simple. Second edition. 144 pages. Illustrated. **\$1.00**

SAWS

SAW FILING AND MANAGEMENT OF SAWS. By ROBERT GRIMSHAW. A practical hand book on filing, gumming, swaging, hammering, and the brazing of band saws, the speed, work, and power to run circular saws, etc. A handy book for those who have charge of saws, or for those mechanics who do their own filing, as it deals with the proper shape and pitches of saw teeth of all kinds and gives many useful hints and rules for gumming, setting, and filing, and is a practical aid to those who use saws for any purpose. New edition, revised and enlarged. Illustrated. **\$1.00**

SCREW CUTTING

THREADS AND THREAD CUTTING. By COLVIN and STABEL. This clears up many of the mysteries of thread-cutting, such as double and triple threads, internal threads, catching threads, use of hobs, etc. Contains a lot of useful hints and several tables. **25 cents**

SHEET METAL WORK

DIES, THEIR CONSTRUCTION AND USE FOR THE MODERN WORKING OF SHEET METALS. By J. V. WOODWORTH. A new book by a practical man, for those who wish to know the latest practice in the working of sheet metals. It shows how dies are designed, made and used, and those who are engaged in this line of work can secure many valuable suggestions. **\$3.00**

PUNCHES, DIES AND TOOLS FOR MANUFACTURING IN PRESSES. By J. V. WOODWORTH. A work of 500 pages and illustrated by nearly 700 engravings, being an encyclopedia of die-making, punch-making, die sinking, sheet-metal working, and making of special tools, subpresses, devices and mechanical combinations for punching, cutting, bending, forming, piercing, drawing, compressing, and assembling sheet-metal parts and also articles of other materials in machine tools. **\$4.00**

STEAM ENGINEERING

AMERICAN STATIONARY ENGINEERING. By W. E. CRANE. A new book by a well-known author. Begins at the boiler room and takes in the whole power plant. Contains the result of years of practical experience in all sorts of engine rooms and gives exact information that cannot be found elsewhere. It's plain enough for practical men and yet of value to those high in the profession. Has a complete examination for a license. **\$2.00**

BOILER ROOM CHART. By GEO. L. FOWLER. A Chart—size 14 x 28 inches—showing in isometric perspective the mechanisms belonging in a modern boiler room. Water tube boilers, ordinary grates and mechanical stokers, feed water heaters and pumps comprise the equipment. The various parts are shown broken or removed, so that the internal construction is fully illustrated. Each part is given a reference number, and these, with the corresponding name, are given in a glossary printed at the sides. This chart is really a dictionary of the boiler room—the names of more than 200 parts being given. It is educational—worth many times its cost. **25 cents**

ENGINE RUNNER'S CATECHISM. By ROBERT GRIMSHAW. Tells how to erect, adjust, and run the principal steam engines in use in the United States. The work is of a handy size for the pocket. To young engineers this catechism will be of great value, especially to those who may be preparing to go forward to be examined for certificates of competency; and to engineers generally it will be of no little service as they will find in this volume more really practical and useful information than is to be found anywhere else within a like compass. 387 pages. — Sixth edition. **\$2.00**

ENGINE TESTS AND BOILER EFFICIENCIES. By J. BUCHETTI. This work fully describes and illustrates the method of testing the power of steam engines, turbine and explosive motors. The properties of steam and the evaporative power of fuels. Combustion of fuel and chimney draft; with formulas explained or practically computed. 255 pages, 179 illustrations. **\$3.00**

HORSE POWER CHART. Shows the horse power of any stationary engine without calculation. No matter what the cylinder diameter or stroke; the steam pressure or cut-off; the revolutions, or whether condensing or non-condensing, it's all there. Easy to use, accurate, and saves time and calculations. Especially useful to engineers and designers. **50 cents**

MODERN STEAM ENGINEERING IN THEORY AND PRACTICE. By GARDNER D. HISCOX. This is a complete and practical work issued for Stationary Engineers and Firemen dealing with the care and management of Boilers, Engines, Pumps, Superheated Steam, Refrigerating Machinery, Dynamos, Motors, Elevators, Air Compressors, and all other branches with which the modern Engineer must be familiar. Nearly 200 Questions with their Answers on Steam and Electrical Engineering, likely to be asked by the Examining Board, are included. 487 pages, 405 engravings. **\$3.00**

STEAM ENGINE CATECHISM. By ROBERT GRIMSHAW. This volume of 413 pages is not only a catechism on the question and answer principle; but it contains formulas and worked-out answers for all the Steam problems that appertain to the operation and management of the Steam Engine. Illustrations of various valves and valve gear with their principles of operation are given. 34 tables that are indispensable to every engineer and fireman that wishes to be progressive and is ambitious to become master of his calling are within its pages. It is a most valuable instructor in the service of Steam Engineering. Leading engineers have recommended it as a valuable educator for the beginner as well as a reference book for the engineer. Sixteenth edition. **\$2.00**

STEAM ENGINEER'S ARITHMETIC. By COLVIN-CHENEY. A practical pocket book for the Steam Engineer. Shows how to work the problems of the engine room and shows "why." Tells how to figure horse-power of engines and boilers; area of boilers; has tables of areas and circumferences; steam tables; has a dictionary of engineering terms. Puts you onto all of the little kinks in figuring whatever there is to figure around a power plant. Tells you about the heat unit; absolute zero; adiabatic expansion; duty of engines; factor of safety; and 1,001 other things; and everything is plain and simple— not the hardest way to figure, but the easiest. **50 cents**

STEAM HEATING AND VENTILATION

PRACTICAL STEAM, HOT-WATER HEATING AND VENTILATION. By A. G. KING. This book is the standard and latest work published on the subject and has been prepared for the use of all engaged in the business of steam, hot-water heating and ventilation. It is an original and exhaustive work. Tells how to get heating contracts, how to install heating and ventilating apparatus, the best business methods to be used, with "Tricks of the Trade" for shop use. Rules and data for estimating radiation and cost and such tables and information as make it an indispensable work for everyone interested in steam, hot-water heating and ventilation. It describes all the principal systems of steam, hot-water, vacuum, vapor and vacuum-vapor heating, together with the new accelerated systems of hot-water circulation, including chapters on up-to-date methods of ventilation and the fan or blower system of heating and ventilation.

You should secure a copy of this book, as each chapter contains a mine of practical information. 367 pages, 300 detailed engravings. **\$3.00**

STEAM PIPES

STEAM PIPES: THEIR DESIGN AND CONSTRUCTION. By WM. H. BOOTH. The work is well illustrated in regard to pipe joints, expansion offsets, flexible joints, and self-contained sliding joints for taking up the expansion of long pipes. In fact, the chapters on the flow of Steam and expansion of pipes are most valuable to all steam fitters and users. The pressure strength of pipes and method of hanging them is well treated and illustrated. Valves and by-passes are fully illustrated and described, as are also flange joints and their proper proportions. Exhaust heads and separators. One of the most valuable chapters is that on superheated steam and the saving of steam by insulation with the various kinds of felting and other materials, with comparison tables of the loss of heat in thermal units from naked and felted steam pipes. Contains 187 pages. **\$2.00**

STEEL

AMERICAN STEEL WORKER. By E. R. MARKHAM. The standard work on hardening, tempering and annealing steel of all kinds. A practical book for the machinist, tool maker or superintendent. Shows just how to secure best results in any case that comes along. How to make and use furnaces and case harden; how to handle high-speed steel and how to temper for all classes of work. **\$2.50**

HARDENING, TEMPERING, ANNEALING, AND FORGING OF STEEL. By J. V. WOODWORTH. A new book containing special directions for the successful hardening and tempering of all steel tools. Milling cutters, taps, thread dies, reamers, both solid and shell, hollow mills, punches and dies, and all kinds of sheet-metal working tools, shear blades, saws, fine cutlery and metal-cutting tools of all descriptions, as well as for all implements of steel both large and small, the simplest, and most satisfactory hardening and tempering processes are presented. The uses to which the leading brands of steel may be adapted are concisely presented, and their treatment for working under different conditions explained, as are also the special methods for the hardening and tempering of special brands. 320 pages; 250 illustrations. **\$2.50**

HENLEY'S TWENTIETH CENTURY BOOK OF RECEIPTS, FORMULAS AND PROCESSES. Edited by GARDNER D. HISCOX. The most valuable techno-chemical Receipt book published, giving, among other practical receipts, methods of annealing, coloring, tempering, welding, plating, polishing and cleaning steel. See page 24 for full description of this book. **\$3.00**

WATCH MAKING

HENLEY'S TWENTIETH CENTURY BOOK OF RECEIPTS, FORMULAS AND PROCESSES. Edited by GARDNER D. HISCOX. Contains upwards of 10,000 practical formulas including many watchmakers' formulas. **\$3.00**

WATCHMAKER'S HANDBOOK. By CLAUDIUS SAUNIER. No work issued can compare with this book for clearness and completeness. It contains 498 pages and is intended as a workshop companion for those engaged in Watchmaking and allied Mechanical Arts. Nearly 250 engravings and fourteen plates are included. **\$3.00**

WIRELESS TELEPHONES

WIRELESS TELEPHONES AND HOW THEY WORK. By JAMES ERSKINE-MURRAY. This work is free from elaborate details and aims at giving a clear survey of the way in which Wireless Telephones work. It is intended for amateur workers and for those whose knowledge of Electricity is slight. Chapters contained: How We Hear—Historical—The Conversion of Sound into Electric Waves—Wireless Transmission—The Production of Alternating Currents of High Frequency—How the Electric Waves are Radiated and Received—The Receiving Instruments—Detectors—Achievements and Expectations—Glossary of Technical Words. Cloth. **\$1.00**





Henley's Twentieth Century Book of Recipes, Formulas and Processes

Edited by GARDNER D. HISCOX, M. E.

Price \$3.00 Cloth Binding

\$4.00 Half Morocco Binding

**Contains over 10,000 Selected Scientific, Chemical,
Technological and Practical Recipes and
Processes, including Hundreds of
So-Called Trade Secrets
for Every Business**

THIS book of 800 pages is the most complete Book of Recipes ever published, giving thousands of recipes for the manufacture of valuable articles for every-day use. Hints, Helps, Practical Ideas and Secret Processes are revealed within its pages. It covers every branch of the useful arts and tells thousands of ways of making money and is just the book everyone should have at his command.

The pages are filled with matters of intense interest and immeasurable practical value to the Photographer, the Perfumer, the Painter, the Manufacturer of Glues, Pastes, Cements and Mucilages, the Physician, the Druggist, the Electrician, the Brewer, the Engineer, the Foundryman, the Machinist, the Potter, the Tanner, the Confectioner, the Chiropodist, the Manufacturer of Chemical Novelties and Toilet Preparations, the Dyer, the Electroplater, the Enameler, the Engraver, the Provisioner, the Glass Worker, the Goldbeater, the Watchmaker and Jeweler, the Ink Manufacturer, the Optician, the Farmer, the Dairyman, the Paper Maker, the Metal Worker, the Soap Maker, the Veterinary Surgeon, and the Technologist in general.

A book to which you may turn with confidence that you will find what you are looking for. A mine of information up-to-date in every respect. Contains an immense number of formulas that every one ought to have that are not found in any other work.

150 ml

2.00

RETURN CIRCULATION DEPARTMENT
TO → 202 Main Library

LOAN PERIOD 1	2	3
HOME USE		
4	5	6

ALL BOOKS MAY BE RECALLED AFTER 7 DAYS

Renewals and Recharges may be made 4 days prior to the due date.

Books may be Renewed by calling 642-3405.

DUE AS STAMPED BELOW

OCT 26 1989

~~AUTO DISC OCT 03 1989~~

FEB 09 1990

AUTO DISC JAN 25 '90

UNIVERSITY OF CALIFORNIA, BERKELEY
 BERKELEY, CA 94720

U.C. BERKELEY LIBRARIES



C006092088

Crane

203790

TJ275

