









COPYRIGHTED 1920 BY  
AMERICAN WOOD WORKING MACHINERY CO  
ROCHESTER, N. Y., U. S. A

FEB - 3 1920



American  
Woodworking Machinery  
*for*  
Vocational Training

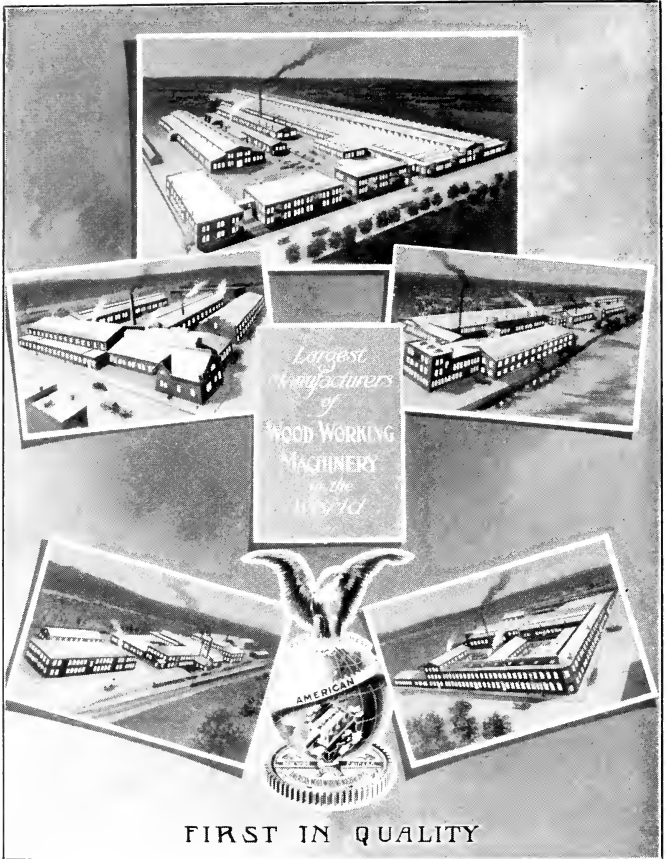
American  
Wood Working Machinery Company

Executive and General Sales Offices

Rochester, N. Y.



FIRST IN QUALITY



American Wood Working Machinery Company

*Executive and General Sales Offices*

591 Lyell Avenue, Rochester, N. Y.

Rochester Works	-	-	-	-	Rochester, N. Y.
Hoyt Works	-	-	-	-	Aurora, Ill.
Houston Works	-	-	-	-	Montgomery, Pa.
R. & H. Works	-	-	-	-	Williamsport, Pa.
Williamsport Works	-	-	-	-	Williamsport, Pa.

©CLA561738



20-2664

300 1

## Introductory

**T**HIS book is divided into three parts. Part I is devoted to the description of American Woodworking machines for vocational schools. Part II has to do with the operation of some of the machines with the view of helping the student to a better understanding of the correct position to take at the various machines he will be called upon to operate. Part III is of primary interest to the teacher or director of vocational work, especially to those on whom fall the responsibility for specifying equipment for their schools.

The guiding principle in the construction of our machines rests solely on the nature of the work they are to perform. Our engineers are constantly seeking the highest requirements of the trade and making improvements accordingly.

We have kept pace with the highest developments in electrical drives. The direct application of both A. C. and D. C. motors to saw arbors and cutter heads, as illustrated in this catalog, are original and exclusive with us. When a motor goes on an American machine it becomes a part of the machine itself (see our Headblock Lathes, Jointers, Saw Benches and Surfacers); you will find no clumsy makeshift arrangements here.

Please file this book where you can get hold of it when you need anything in woodworking machinery.

**American Wood Working  
Machinery Company**

Rochester, N. Y.

District Sales Offices and Representatives  
of the  
American Wood Working Machinery Co.

*District Sales Offices :*

New York, N. Y.  
347 Madison Avenue

Chicago, Ill.  
565 W. Washington Boulevard

New Orleans, La.  
Canal Bank & Trust Co. Building

Rochester, N. Y.  
591 Lyell Avenue

Portland, Ore.  
North 19th and Wilson Streets

San Francisco, Cal.  
525 Market Street

*Canadian Representatives :*

Garlock-Walker Machinery Co.  
32 Front Street West, Toronto, Canada

*Agents for Great Britain :*

The Projectile & Engineering Co., Ltd.  
London, S. W. 8, England

*Agents for Australia :*

L. Scrutton & Co.  
Melbourne, N. S. W.

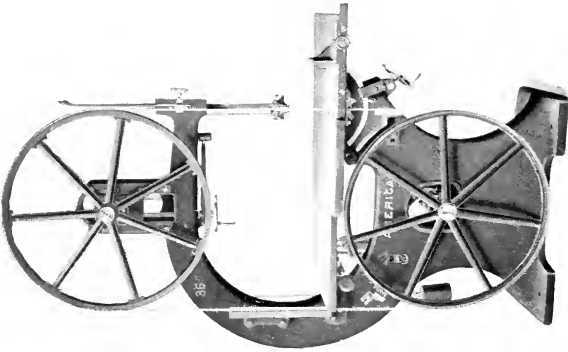
## The Men Who Work in Wood

The men who work in wood!—here is a clan  
    That other workers well may envy—these  
Who serve so much, so well, their fellow man,  
    Who turn to use the tall and sheltering trees.  
The roof of green becomes a roof of gray,  
    The sturdy trunk the pillars of a home.  
They fashion us the infant's cradle, they  
    Are part of every threshold, every room.

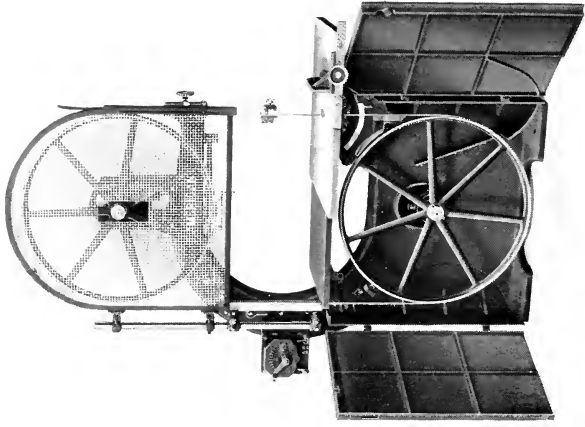
The chair we dream in by the cheery fire,  
    The board at which we gather for the meal,  
The bed to which our weary limbs retire,  
    And everything we know and love and feel  
They shape from fallen forests for our need—  
    Yea, even that last room in which we rest,  
When we lie down to rest at last indeed,  
    The woodland's sainted lily on our breast.

Theirs not the dust of mines, the grime of toil  
    In sweaty shops of steel and molten brass—  
Theirs is the scent of sawdust and of soil  
    The song of waters, wind across the grass.  
In everything they make for us they leave  
    The wooded upland and the quiet shores,  
Yea, into every article they weave  
    Some memory of God's great out-of-doors.

—*Douglas Mallock*  
    *In American Lumberman.*

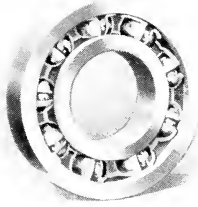


Plain Machine



Iron Doors

American No. 10 Standard 36" Band Saw



## American No. 10 Standard 36" Band Saw

OUR most popular band saw is our standard 36" machine. It is intended for all grades of work in cabinet shops, pattern shops and manual training schools.

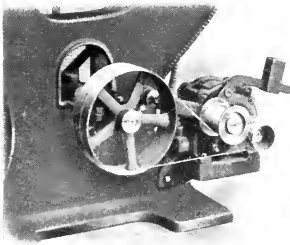
**Capacity**—18" vertically, 36" horizontally. Carries blades from  $\frac{1}{8}$  to  $1\frac{3}{4}$ " wide. One  $\frac{1}{2}$ " blade 19' 3" long regularly furnished, also brazing clamp and tongs. Table tilts 45 degrees to right and 5 degrees to left.

### Technical Features

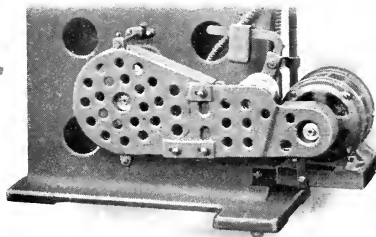
**Wheels**—36" diameter by  $1\frac{3}{4}$ " face and covered with rubber. Babbitt or ball bearing. Lower wheel arm or solid. Upper wheel equipped with Patent Weighing Strain. Both wheels protected as illustrated, at extra cost. **Guides**—Guide bar fitted with Patent Mohawk Dutchman Guide. Lower Guide, adjustable iron plates. **Table**—Size 32"x32". Patent Segment Self-Locking Tilting Device, indexed in degrees. Quick Adjustable Ripping Gauge. **T. & L.**—(Self-oiling loose) pulleys 14"x $1\frac{1}{4}$ "; 500 to 600 R.P.M.

**Extras**—Web Lower Wheel, Iron Doors. Wire Guard, Ball Bearing, Motor Drive are not included in the list price of machine, but are supplied at additional cost.

Fig.	Style	Floor Space	Horse-Power	Weight, lbs.	Boxed for Exp't.		Code
					Wt. lbs.	Cu. ft.	
514	Arm Wheels	3'6"x5'2"	2 to 4	1400	1900	90	<i>Darby</i>
	Ball Bearings, extra						<i>Daric</i>
	Iron doors, lower wheel, extra						<i>Dark</i>
	Wire Guard, for either wheel, extra						<i>Darkful</i>
	Wire Guards, for both wheels, extra						<i>Darking</i>
	Web, lower wheel, extra						<i>Darkle</i>
	Hand Splitting Gauge and Roll, extra						<i>Darleg</i>
	Motor Drive, extra						



Open View



Closed View

### Motor Drive

The illustrations show a belt drive with automatic tightener and with motor mounted on base of machine. This makes a self-contained equipment, altogether neat and desirable. Suitable for either D. C. or A. C. current.

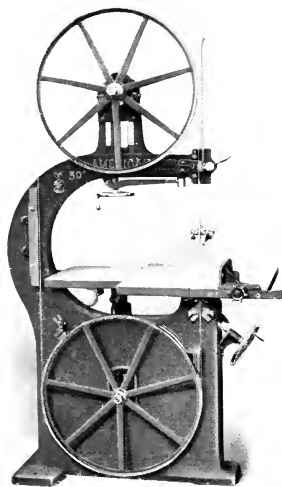


Figure 5190

### American 30'' Band Saw

**O**UR 30'' Band Saw is the lightest we make and the wheels are as small as we would advise for practical use.

**Capacity**—13'' vertically, 29'' horizontally. One blade  $\frac{1}{2}$ '' wide, length blade 17' 2'' is regularly furnished, also brazing clamp and tongs. Table tilts for bevel sawing, 45° to right, 30° to left.

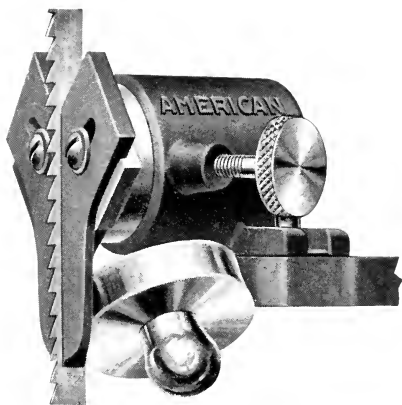
#### Technical Features

**Wheels**—30'' diameter by  $1\frac{1}{2}$ '' face, made entirely of iron, covered with rubber bands. Boxes are adjustable for alignment and wear. Straining device for blade same as on 36''.

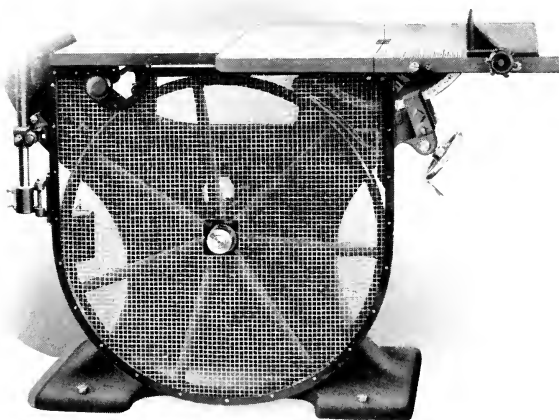
**Guides**—Upper Guide is our Mohawk Dutchman Patent. Lower Guide, adjustable chilled plates. **Table**—Size, 26''x28''. Tilts and locks without the use of a wrench, and has hand rip gauge. **T. & L.**—(Self-oiling loose) pulleys 12''x3 $\frac{1}{2}$ ''; 600 to 650 R. P. M.

Fig.	Style	Floor Space	Horse-power	Weight lbs.	Boxed for Exp't		Code
					Wt., lbs.	Cu. ft.	
5190	With Arm						
	Wheel	3'3''x4'4''x7'10'' high $1\frac{1}{2}$ to 3		1130	1550	67	<i>Dash</i>
	Wire guard for either wheel, extra			....	..	..	<i>Dashing</i>
	Wire guards for both wheels, extra			....	..	..	<i>Dashment</i>
	Web Lower Wheel, extra		.....	....	..	..	<i>Dasy</i>
	Iron Doors, extra		.....	....	..	..	<i>Dasying</i>
	Ball Bearings, extra		.....	....	..	..	<i>Dashet</i>
	Hand Splitting Gauge and Roll, extra		.....	....	..	..	<i>Daszig</i>

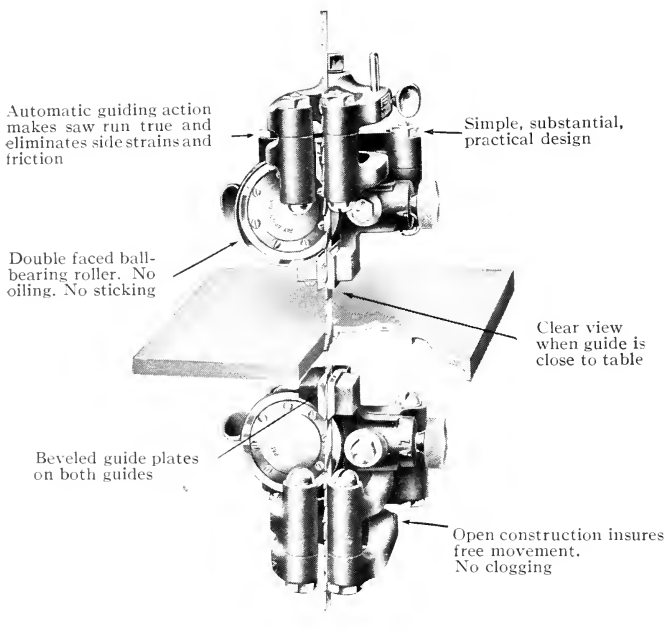




Mohawk Dutchman Saw Guide



Wire Guard for Lower Wheel



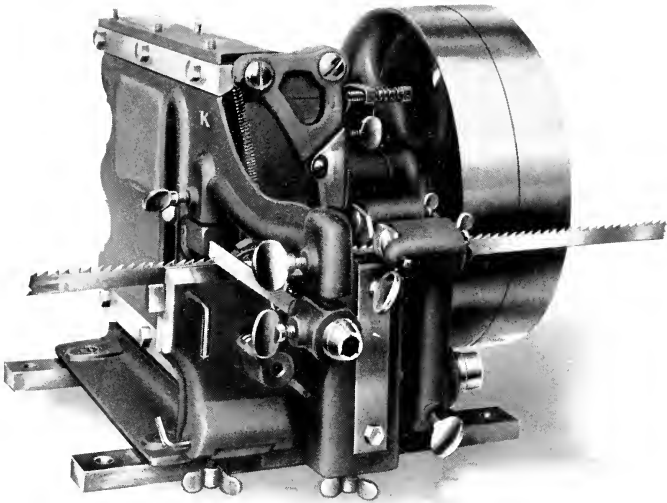
## The Newell Automatic Saw Guide

**I**N the Newell Automatic Saw Guide the grinding members, instead of being rigid as in all other guides, have a swinging movement which allows the back of the saw to swing freely while the teeth are held practically stationary.

With these Guides the operator can force the saw around the shortest curve without kinking or straining it. Deep cuts can be made straight from top to bottom without dishing out, thus enabling the operator to saw close to the line of his work without spoiling it or making a lot of hand finishing necessary.

The swinging movement of the Newell Guide compels the saw to follow true to the line of pressure. Any tendency for the saw to deviate causes the guide to react upon it immediately, thereby correcting the deviation.

There is great economy in the use of the Newell Guide inasmuch as the saw breakage as compared with any other guide is considerably reduced.



## Combination Band Saw Filing, Setting and Jointing Machine

**T**HIS is the only machine made that performs the two operations of filing and setting the band saw at one time. This places it in a class by itself, there being none similar to it on the market.

The powerful elliptical movement of the filing arm, working between heavy adjustable bronze slides, guided by vertical rods set at an angle, is mechanically perfect. It gives each tooth a clean, sharp cut, and can be so delicately adjusted as to leave the teeth without a particle of burr. All teeth are filed and jointed to an exact uniform height and size. It means less breakage of saws, longer life, quicker work, and smoother and better cutting.

The setting device not only sets the teeth perfectly, but also each tooth in such a way as to allow the proper clearance behind the cutting edge.

All wearing parts are made of steel, and the vise, through which the saw passes, is steel lined.

The time it takes to file, set and joint band saws in one operation, is only a fraction of the time occupied in hand filing. Standard files,  $4\frac{1}{2}$ " extra slim taper or 7" slim taper, are used

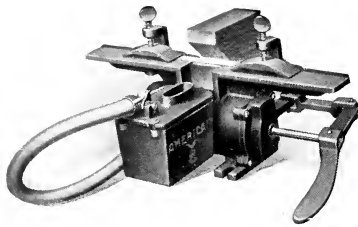


Figure 1260

### American Band Saw Brazer

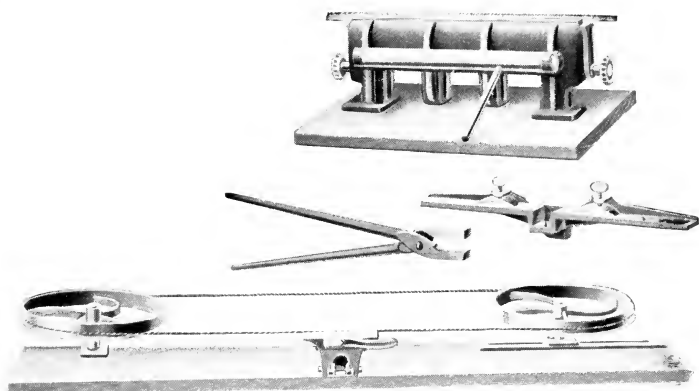
THE illustration shows a new device for heating the joint with a flame and blowpipe, which overcomes the objections to the old method and is proving very satisfactory in practice.

The Saw Blade is beveled or "scarfed" for the lap, on the table, which is machined true on the face and back, and suitable clamps hold it while being operated upon. The Blowpipe is supplied with air from a double-acting pump with receiving chamber, fitted with good leather valves and double-cup piston packing. The capacity of the pump is much greater than the requirements, and very little exertion is needed to get sufficient heat to braze saws 1¼" wide.

The Lamp is attached to the machine, and has a very large elliptical wick, giving a long, steady flame which becomes hottest at the point where it is forced against the saw by the air blast. Kerosene is used for fuel.

The Brazer is made ready for use by simply clamping it or screwing it to a bench and attaching the blast hose. We furnish brazer complete, one piece of hose, a quantity of prepared spelter and pulverized borax, some fine tying wire and full directions for brazing with either spelter or silver solder. The time required for scarfing down the ends of the blade, adjusting it and completing the braze is from eight to fifteen minutes, dependent on the width of the blade and skill of the operator.

Figure	Style	Boxed Wt.	Cubic Feet	Code
1260	Band Saw Brazer	24	2	<i>Dulia</i>
1261	Brazing Clamp for 3" Saws with Rims			<i>Dullard</i>



## American Filing Wheels, Vises and Scarfing Frame

OF the ordinary appliances for keeping saws in order, we have filing wheels and studs, two sizes of filing vises, brazing and scarfing frame with tongs.

The Filing Wheels and studs are made plain but serviceable, and are designed to be attached to a bench, as indicated in cut. We do not furnish the plank shown. The wheels are covered with heavy canvas, and the right-hand one adjusts horizontally to strain the blade.

The Vises are made with jaws either 10" or 18" long. When an outfit is ordered we furnish the one 10" long unless otherwise stated. There are adjustable stops in the vises, so that the blade will not sink when filed. The jaws are planed true and will grip the whole length of the vise.

The Brazing and scarfing frame for holding the saws when they are to be joined can be placed in the vise or screwed to a bench, whichever is the most convenient. The entire outfit is simple and all that is necessary where a small amount of this work is to be done.

Fig.	Style	Weight, lbs.	Boxed for Export		Code
			Wt., lbs.	Cu. ft.	
1255	Filing Wheels and Studs . . .	58	65	2	<i>Dulcet</i>
1256	10" Filing Vise . . . . .	17	25	$\frac{1}{2}$	<i>Dulcify</i>
1257	18" Filing Vise . . . . .	36	55	1	<i>Dulcinea</i>
1258	Scarfing Frame and Tongs . . .	17	30	1	<i>Dulcitan</i>

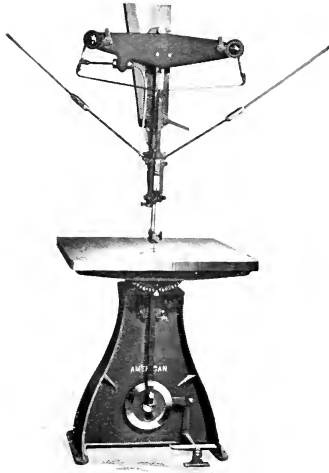


Figure 5221

### American Scroll Saw

**T**HIS machine is intended for furniture, sash, door and blind factories, carriage and pattern shops. It is made with either stationary or tilting table. It runs at a high speed without jar. A brass pump with rubber tube is supplied to keep the saw blade cool and blow the dust away.

**Capacity**—Any thickness up to 12". Four saws  $\frac{1}{4}$ ", 14" long;  $\frac{3}{8}$ ",  $\frac{1}{2}$ " and  $\frac{5}{8}$ ", 16" long.

### Technical Features

**Table**—Made of iron; size, 36"x38". **Strain**—The strain is a new and practical design, permitting a high speed and an even tension on the blade at all points of the stroke. Variation in the amount of tension can be put on the saw by applying a crank (which is furnished) to the square end of shafts. **Under Guide Ways**—These are so constructed that their expansion when warm does not tighten the cross heads, which is an important feature. **Tight & Loose Pulleys**—6"x3"—1200 R.P.M.

Fig.	Style	Floor Space	Horse-power	Weight, lbs.	Boxed for Exp't.		Code
					Wt., lbs.	Cu. ft.	
5221	Tilting Table	36"x39"	2	600	920	50	<i>Daucus Daughter</i>
5231	Stationary Table	36"x39"	2	600	920	50	



Figure 5241

### New American Self-Contained Jig Saw

**T**HE New American Self-Contained Jig Saw is for use in all kinds of woodworking plants where interior and exterior irregular sawing is to be done. Being self-contained, it is more rigid than the usual style of machine where the strain head is fastened to the ceiling.

**Capacity**—Length of stroke 4". 36" from saw to column. 10" can be cut under the guide. Blades from 12" to 20" can be used.

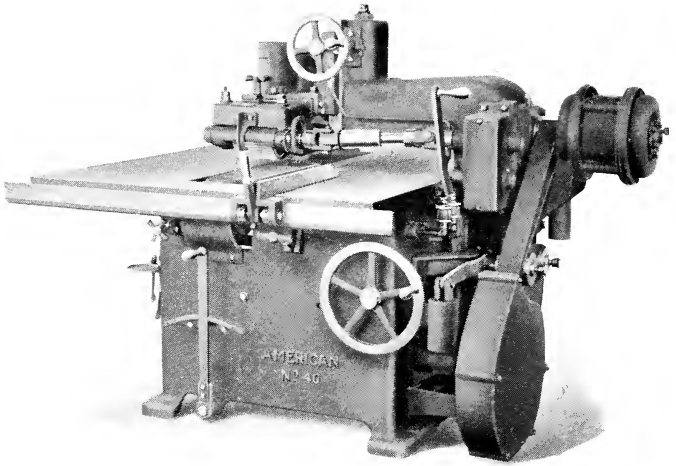
#### Technical Features

Four saws are furnished:  $\frac{1}{4}$ ", 14" long:  $\frac{3}{8}$ ",  $\frac{1}{2}$ " and  $\frac{5}{8}$ ", 16" long.

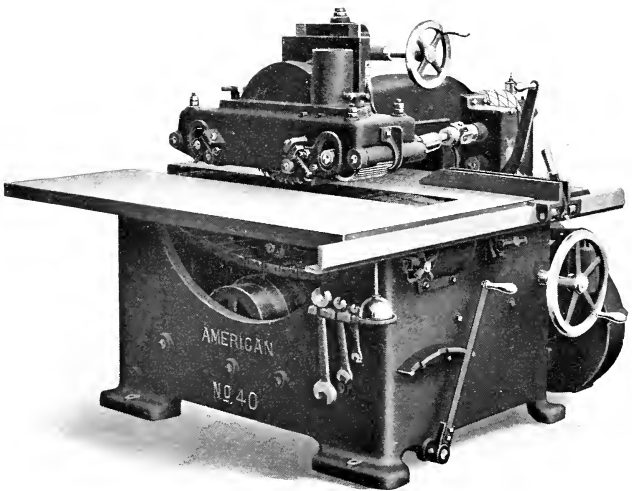
**The Column**—Has wide foot flange and three-point bearing on the floor, insuring rigidity. **The Table**—Is iron, 32" x 38", well ribbed underneath and mounted on a segment, and can be tilted either to the right or left 30 degrees. It is 39" from the floor. The height of the entire machine is 7' 7". It is also provided with iron swinging drawer for extra saws, wrenches, etc. **Straining Head**—

Having no links, pivots or levers to wear and get out of alignment, makes a perfect self-contained strain. There are two large coil springs used for the tension and a wrench is provided to apply to the square ends of the spring shafts to regulate the amount of tension required. A long retracting spring is used to counterbalance the movable part of the head and the straining device can be raised or lowered and locked in position by an eccentric lever for different lengths of saws. It is also provided with a brass plunger pump which furnishes a blast to free the work from dust. All sliding parts are adjustable and the bottom end of the pitman is fitted with babbitt bushing. The brake and shifting device is convenient to the operator for starting and stopping the machine. **Tight & Loose Pulleys**—6" x 3"—1200 R. P. M. Motor Drive can be applied at an extra price.

Fig.	Floor Space	Horse-power	Wgt. lbs.	Boxed for Export		Code
				Wt. lbs.	Cu. ft.	
5241	3' x 5' 4"	2	1200	1500	65	Dauntless



Rear View



*Figure 5620*

American No. 40 Chain Feed Edging Saw



## American No. 40 Chain-Feed Edging Saw

**T**HIS is an extremely rigid and well-designed machine for accurately edging crooked and uneven stock and cutting out checks and imperfections. It will rip to widths leaving the edges perfectly straight at a rate equal to the output of two or three hand-fed saws. All the adjustments are in sight and are made from the front of the machine.

**Capacity**—Will rip stock as short as 8" and to 24" wide. Distance from saw to left hand of table 24". Largest diameter of saw used 14"; smallest, 10". A 14" saw will rip stock 4" thick and under. A 12" saw is furnished with the machine. Hole is 1 $\frac{5}{8}$ " with  $\frac{5}{8}$ " dowel pin 1 $\frac{3}{16}$ " from centre of saw to centre of pin. A jointing stone and holder are furnished.

### Technical Features

**Main Column**—Is the cored type, exceptionally heavy and strong, making a rigid support for the saw and the upper feed works. It is gibbed to the frame in heavy ways in such a manner that when clamped to the frame by the clamp lever it is absolutely free from vibration. It is adjusted by a screw with ball end-thrust bearing operated by a large hand wheel at the front of the machine.

**Arbor**—Is 2" diameter and runs in three self-oiling bearings. Pulley, 8"x7", speed 3000 to 3400 R.P.M. Sight feed oil cups are provided. **Feed Works**—Consist of an endless-feed chain in the table with pressures above to keep the stock in firm contact with the chain. There is an in-feed and an out-feed pressure roll of large diameter. The in-feed roll is driven, thus making it more positive in entering stock for straight ripping. Rolls are horizontally mounted on hinged arms and have independent vertical adjustment with spring pressures applied to each. This affords flexibility that permits the stock to enter the rolls easily. The arms of both the in-feed and out-feed rolls can be adjusted so they can be kept in perfect alignment with the saw and the feed chain. The saw and rolls are entirely enclosed making an efficient suction hood. The hood is adjustable on a screw with ball bearing end-thrust operated by an overhead handwheel and has graduated scale to indicate height of the rolls. There is also a kick-back or sliver guard back of the in-feeding roll which makes a complete protection for the operator. The front of the roll hood is provided with a sight that indicates the location of the saw for sighting the cut. A section of the circular hood for the saw can be removed for changing saws by loosening two hand wheels and the suction pipe does not have to be removed.

Three rates of feed, usually 60, 120 and 160 lineal feet per minute are provided. Quick change of feed is made, without throwing off the power, by lever at the left of operator. Binder lever controlling the feed is at the right of operator. The driving mechanism on the right side of the machine for the endless feed chain and in-feed roll consists of steel roller chain and feed pulley which are entirely enclosed. **Table**—Is fitted with an endless chain which travels on an independent bed plate with the wearing surfaces lined with steel. It can be adjusted vertically to insure perfect contact with the stock on the table. The adjustment is made by hand wheel and screw from the in-feeding end of the machine. The front end of the bed is also adjustable, transversely to and from the saw. This insures perfect alignment with the saw at all times. Sight-feed oil cups are provided at the right-hand side of frame for lubricating the chain. **Countershaft** (furnished as an extra)—Is provided with tightener for drive belt with 12"x8" T. & L. (self-oiling loose) pulleys; speed 1000 R.P.M. **Motor Drive**—Can be supplied by mounting motor on a special bracket which takes the place of the usual outer bearing, a flexible coupling connecting the motor shaft direct to the saw arbor.

Fig.	Floor Space	Horse-power	Wgt., lbs.	Boxed for Exp't.		Code
				Wt., lbs.	Cu. ft.	
5620	6' 5" x 4' 10"	10 to 12	3800	4500	189	<i>Dansalo Danseda</i>



Figure 577

### American No. 1 Iron Frame Rip Saw

**T**HIS is a heavy, well-proportioned machine with large arbor and driving pulley. It is suitable for use in almost any woodworking shop.

**Capacity**—Rips stock up to 4" thick and 21" wide. A 16" saw with  $1\frac{1}{4}$ " hole is furnished regularly. A 12" saw projects  $2\frac{1}{2}$ " above the table. Saws up to 20" diameter may be used.

#### Technical Features

**Arbor**— $1\frac{5}{16}$ " diameter; self-oiling boxes with return channels. Arbor Pulley 6"x6"; speed, 2400 R.P.M. **Table**—Is made of iron 34"x47", hinged at the back of the frame, is raised by a screw and held by clamping segments at both sides, which are tightened by one wheel. **Ripping Gauge**—Made of iron and adjusts on an iron dove-tailed way at the front of the table. Can be made adjustable to rip at any angle from square to miter, when so ordered as an extra. Cut-off gauge and track can be added at an extra cost. **Countershaft**—Has **T. & L.** (self-oiling loose) pulleys, 12"x6 $\frac{3}{8}$ "; speed, 600 R.P.M.

Fig.	Style	Floor Space	Horse-power	Weight, lbs.	Boxed for Exp't. Wt., lbs. Cu. ft.		Code
577	Without Counters'ft	4'x4'6"	5 to 10	875	1200	50	<i>Debark</i>
578	With Countershaft	4'x7'	5 to 10	1150	1500	50	<i>Debate</i>

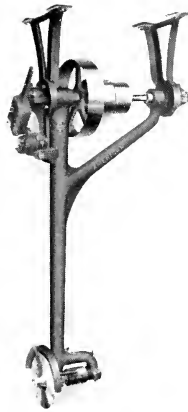


Figure 6154

### American Light Swing Saw

**A** CONVENIENT, quick-acting swing saw for light work, with perfect counterbalance, which is so arranged that the operator is not only relieved from lifting the weight, but is actually assisted in pulling the saw through the lumber. The cut shows right-hand saw, but if specified it may be furnished left-hand. Length from base of hangers to center of arbor, 6'5"; from center of counter to center of arbor, 5'. Cannot be made special length.

**Capacity**—Largest saw recommended is 14" diameter. One 12" saw, 1" hole, regularly furnished.

#### Technical Features

**Saw Arbor**—Runs in babbitted boxes. Pulley is 4"x4". **Frame**—Supported on trunnions on the hangers instead of being hung on the countershaft. Made in one piece with a cored center and tapering. **Hangers**—Arranged to be hung from ceiling or wall, or below a table as ordered. **Countershaft**—Runs in cap boxes with provision for taking up wear. Driving Pulley 16"x3½". **T. & L.** (self-oiling loose pulleys, 8"x4¼", 800 R.P.M.)

Fig.	Style	Floor Space	H. P.	Wt., lbs.	Boxed for Export		Code
					Wt., lbs.	Cu. ft.	
6154	To Hang from Ceiling, right-hand	3'4"x1'6"	3 to 5	500	750	27	<i>Degerm</i>
6155	To Hang from Ceiling, left-hand	3'4"x1'6"	3 to 5	500	750	27	<i>Degest</i>
6156	To Hang from Wall, right-hand	3'4"x1'6"	3 to 5	500	750	27	<i>Degrade</i>
6157	To Hang from Wall, left-hand	3'4"x1'6"	3 to 5	500	750	27	<i>Dehorn</i>
6158	To Work under Table, right-hand	3'4"x1'6"	3 to 5	500	750	27	<i>Deism</i>
6159	To Work under Table, left-hand	3'4"x1'6"	3 to 5	500	750	27	<i>Dejected</i>
	Adjustable Hangers, extra	.....	.....	.....	.....	.....	<i>Delation</i>
	Foot Treadle, extra	.....	.....	.....	.....	.....	<i>Deleble</i>
	Metal Cut-Off Gauge, extra	.....	.....	.....	.....	.....	<i>Delectot</i>

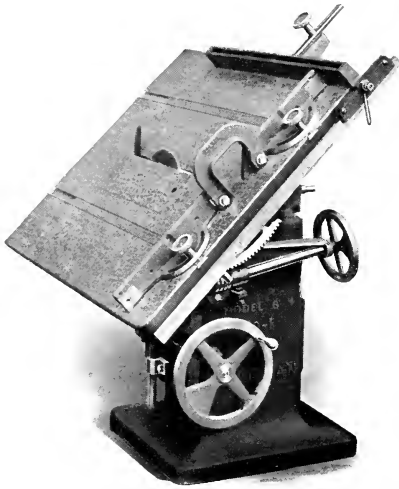
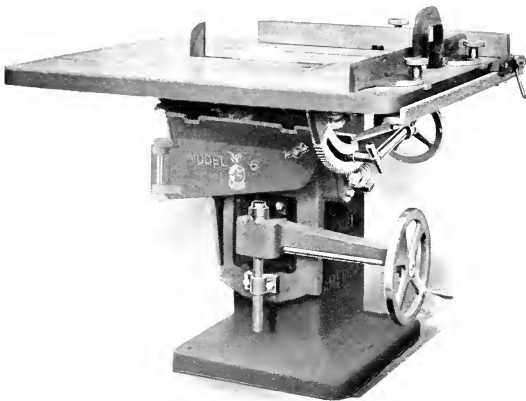
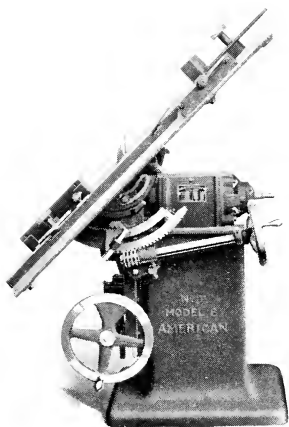


Table Tilted



American No. 1 Variety Saw Bench

*Figure 637*



Showing Special Motor Drive

## American No. 1 Variety Saw Bench Model 6

**D**ESIGNED especially for fine and accurate cutting on all classes of wood in furniture, sash, door and blind, cabinet, pattern and general wood working shops. This machine can be supplied with a special motor driven arbor as shown and with boring or mortising attachment shown on page 25.

**Capacity**—20" wide, 3" thick. An 8" saw projects 1" above the table. Saws up to 14" can be used. A 12" saw, 1" hole, regularly furnished.

### Technical Features

**Table**—Of iron, strongly ribbed, planed true, and scraped. Size 36"x44". Adjusts up and down 3½" in gibbed ways by hand wheel, miter gears and screw. Tilts upward from right hand side to 45 degrees by means of a hand wheel and worm. Has throat plate which is removable to admit of jointing, grooving and rabbeting heads. The table is provided with ripping, cut-off and miter gauges. The ripping gauge can be used either side of the saw, and indexes are provided on both ripping and cut-off gauges. **Arbor**—1¼" diameter, one journal plain, one corrugated. Boxes 5½" long, self-oiling, with circulating channels, lined with genuine babbitt. Ball bearings are applied, when desired, as an extra. Arbor pulley 3½"x5¼"; speed 3000 R.P.M. **Boring Table (Extra)**—Hardwood, mounted on a heavy bracket. Size 14"x28". Grooved and fitted with iron track for fence. Bracket moves up and down in gibbed ways 9". Fence adjustable for angle boring. Bit socket has ½" hole or a Morse taper if desired. **Hollow Chisel Mortising Attachment (Extra)**—Accommodates chisels up to ½". Table supported on a heavy bracket which slides up and down in gibbed ways. Table moves in and out by foot treadle. **Countershaft**—T. & L. (self-oiling loose) pulleys: 8"x5¼", speed 750 R.P.M. Motor attached to base, can be applied as an extra, making a self-contained tool ready for wiring.

Fig.	Style	Floor Space	Horse-power	Wgt., lbs.	Boxed for Exp't.		Code
					Wt., lbs.	Cu. ft.	
637	No. 1 Variety Saw and Counter . . . . .	3'6"x7' 4 to 7½	1000	1500	65	<i>Depicture Dental</i>	
633	With B. A. . . . .	6' x 7' 4 to 7½	1250	1700	70		
	Two End Stop C. O. Gauges, in place of Square and Swivel Gauges, extra . . . . .					<i>Deoculate</i>	
	Mortising Attachment, extra . . . . .					<i>Dentist</i>	
	Self-Centering Chuck, extra . . . . .					<i>Denude</i>	
	Ball Bearings, extra . . . . .					<i>Depassing</i>	
	Jointing Head with Two Knives, extra . . . . .					<i>Depas</i>	
	Saw Guard, extra . . . . .					<i>Depress</i>	

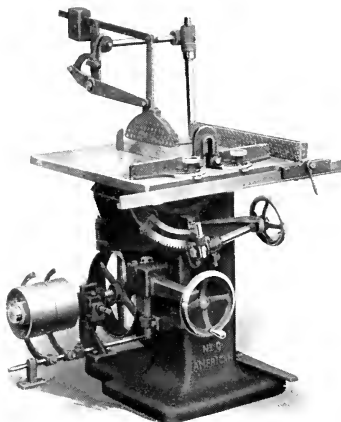


Figure 638

### American No. 0 Saw Bench

**T**HIS is a modern design with tilting table, saw dust chute, graduated gauges and other late improvements, and is especially adapted to pattern, chair, camera, electrotpe and similar small work which needs to be cut accurately and handled quickly.

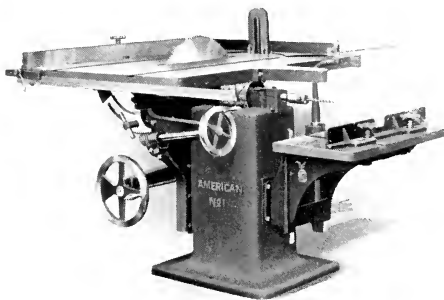
**Capacity**—Rips up to 13" wide, and the gauges will cut off 12" wide. Table angles 45 degrees for bevel sawing. An 8" saw projects  $1\frac{3}{4}$ " above the table. Saws from 6" to 12" may be used. A 12" saw is furnished.

#### Technical Features

**Saw Arbor**— $1\frac{1}{8}$ " diameter in bearings, and 1" where saw is applied. One journal is plain and the other corrugated. The boxes are cast on the frame and are self-oiling. Arbor Pulley is  $3'' \times 3\frac{3}{4}''$ . **Table**—Size, 27" x 30", adjusts vertically  $3\frac{1}{2}''$ , has a movable throat plate surrounding saw, tilts to an angle of 45 degrees by segment and hand wheel and is slotted for the cut-off gauges. The Gauges consist of two swiveled cut-off slides and one ripping gauge with rule graduations. **Countershaft**—Usually attached to the base of machine. Has T. & L. (self-oiling loose) pulleys,  $8'' \times 4\frac{1}{4}''$ ; 750 R.P.M. Countershaft may be separate from the machine. Motor can be attached to base in place of countershaft at an extra price.

Fig.	Style	Floor Space	Horse-power	Weight, lbs.	Boxed for Expt.		Code
					Wt., lbs.	Cu. ft.	
638	Counter attached	3'4"x3'9"	3	680	930	50	<i>Deport</i>
6381	Counter separate	3'4"x3'	3	850	1100	50	<i>Depredate</i>
	Safety Saw Guide, extra...		.....	.....	.....	.....	<i>Depress</i>

## Boring and Mortising Attachments for American Variety Saws



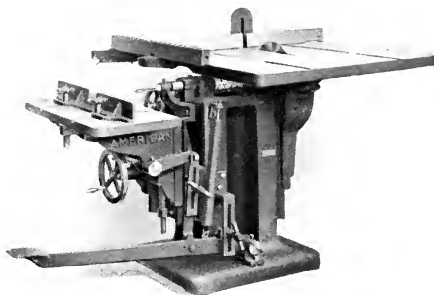
Boring Attachment

THESE attachments can be applied to our No. 1 and No. 10 Variety Saws and also our Student's Precision Saw Bench, all illustrated on the pages immediately preceding.

**Mortising Attachment**—The Mortising Attachment will accommodate chisels up to  $\frac{1}{2}$ " square and will mortise  $3\frac{1}{2}$ " deep. Other chisels with bits are furnished as extras at manufacturer's prices. The chisels are standard and are held in a rigid socket, and the table is adjustable vertically by hand wheel, and horizontally by a foot lever. Table has a depth gauge and there are a socket and sleeves on the arbor to receive bit shanks.

**Boring Attachment**—The Boring Attachment is made with a plain bit socket, with  $\frac{1}{2}$ " hole, or a Morse taper hole, as desired. The table is mounted on a bracket that adjusts vertically in gibbed ways on a support, that is securely fastened to the frame of the machine. The table slide is gibbed to ways on top of the bracket, and adjusts horizontally for depth of boring. The vertical adjustment is by means of crank, shown in cut. The table is of wood,  $14'' \times 28''$ , and has an iron fence, clamped to iron tracks in the table. The fence can be angled either way. A depth gauge is clamped to the table slide. Self-centering chucks can be supplied at an extra cost.

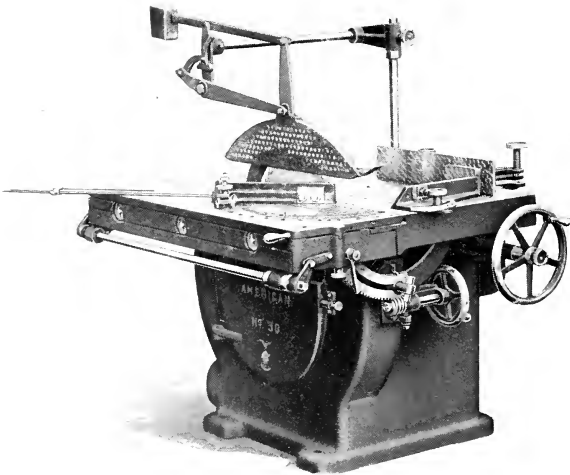
These attachments are given in the schedule underneath each of the Variety Saws to which they apply.



Mortising Attachment



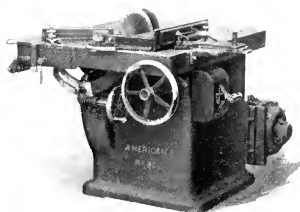
Table Tilts to 45 Degrees



*Figure 6385*

American No. 30 Universal Saw Bench





Showing Motor Drive

## American No. 30 Universal Saw Bench

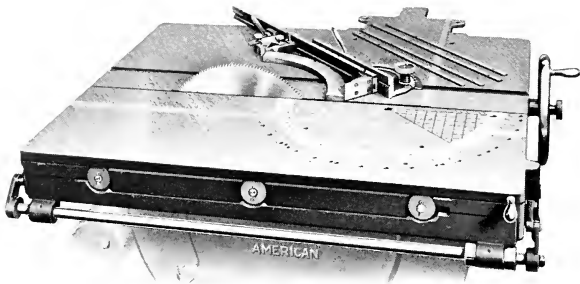
**O**UR No. 30 Universal Saw Bench is a machine that will do ripping, cross-cutting and dadoing in an efficient and thorough manner. It will cut a perfect miter; it will measure any angle instantly and accurately; it will cut off to length or rip to width—all without the operator having to do any previous calculating or even referring to a rule.

**Capacity**—Rips from  $\frac{1}{8}$ " to 27 $\frac{1}{2}$ " and cuts off to 31" wide when saw is set for 2" thick. An 18" saw may project 5 $\frac{3}{4}$ " above the table. The table tilts to 45° for bevel sawing. Two 18" saws 1 $\frac{1}{8}$ " hole are furnished. If necessary one 20" saw (not adjustable) can be used. Dado heads 2 $\frac{1}{2}$ " wide can be used.

### Technical Features

**Frame**—Is a unit casting, massive and rigid, having three points of bearing on the floor. **Table**—Size 40"x48". The movable section is 17" wide, guided by an accurately fitted tongue and groove and supported on adjustable anti-friction rollers. It can be drawn away from the main table 3" for dado work. Main section is 23" wide, and is ruled for ripping up to 27 $\frac{1}{2}$ " wide. The entire table can be tilted to 45° by means of a worm and worm segment. The segment is accurately graduated and can be clamped at any point, and there is a fixed stop on the frame for the horizontal position. **Gauges**—There are four gauges, three for cutting off and one for ripping. The principal cutting off gauge is pivoted to the sliding section and can be stopped at the principal angles with a taper pin, and by a patented attachment all intermediate angles can be quickly found. We apply also in connection with this gauge our patent graduated sector on the table, by which stock can be cut to required angle without calculation when the length is known. The two swivel cut-off gauges move in a slot in each section of the table. The supporting tongues extend the whole length of the table and can be reversed when not in use, maintaining an unbroken table surface. The ripping gauge is adjusted by taper pins and micrometer rack and pinion and can be used on either side of the saw. The stationary table is ruled across its face for accurate ripping. The fence can be tilted to 45°. The entire gauge can be swung to an angle for roughing out core boxes. **Segment Gauge (self-contained)**—Can be supplied as an extra for jointing segments of glued-up rings, gear wheels, pulleys, etc., from 8" diameter with four segments upward. It is attached to the right-hand cut-off gauge. **Arbor Yoke**—Carries two hard steel arbors 1 $\frac{7}{8}$ " diameter with self-oiling boxes and 4 $\frac{1}{2}$ "x6 $\frac{1}{2}$ " pulley between. The yoke revolves on a disk 22" diameter, fitted into a bored bearing in one wall of the frame, and on a supporting gudgeon in rear wall, this bearing being shouldered both ways to prevent end motion. The circular adjustment is made by a worm wheel and worm of quick pitch with adjustment for wear. A special arbor sleeve is furnished to take the place of the nut and collar when a dado head is used. A sawdust chute is cast into the frame and delivers at the rear. **Countershaft**—Has Tight and Loose (self-oiling) pulleys 12"x6 $\frac{1}{2}$ ", 700 R.P.M. It may be placed on or under the floor. Idler jack, pivoted inside the frame, carries two self-oiling guide pulleys. **Motor Drive (extra)**—Takes the place of the countershaft and can be attached directly to the main frame, making a self-contained unit ready for wiring. Safety Guard shown in cuts is an extra.

Fig.	Name	Floor Space	Horse-power	Wgt., lbs.	Boxed for Exp't		Code
					Wt., lbs.	Cu. ft.	
6385	Universal Saw Bench	5' x 7'	7 $\frac{1}{2}$	2400	3100	95	<i>Depring</i>
	Saw Guard, extra		.....	.....	.....	..	<i>Depure</i>
	Belt Shield, extra		.....	.....	.....	..	<i>Deputy</i>
	Segment Gauge, extra		.....	.....	.....	..	<i>Deputiff</i>
	Extended Rip Gauge, extra		.....	.....	.....	..	<i>Deputiff</i>



Segment Gauge



*Figure 6391*

American No. 20 Universal Saw Bench

## American No. 20 Universal Saw Bench

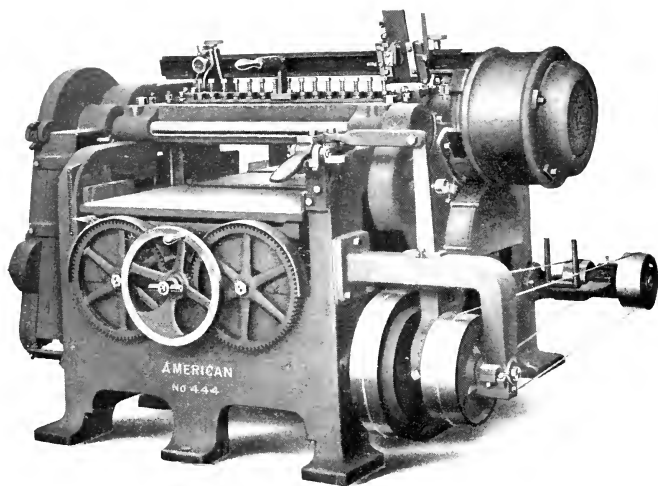
**T**HIS machine is designed for accurate sawing in all kinds of light and medium work as found in pattern, car, interior trim and cabinet shops. It is especially adapted to use in manual training schools. It is made with a frame cast in one piece and is unusually rigid, having three points of bearing on the floor.

**Capacity**—Rips from  $\frac{1}{16}$ " to 22" between saw and ripping fence; table tilts to 45 degrees for bevel sawing; moving table has graduated arc for cutting angles. Dado heads up to 2" wide may be used. Two 14" saws (one rip and one cross-cut) 1" eye, which project  $3\frac{7}{8}$ " above table are furnished.

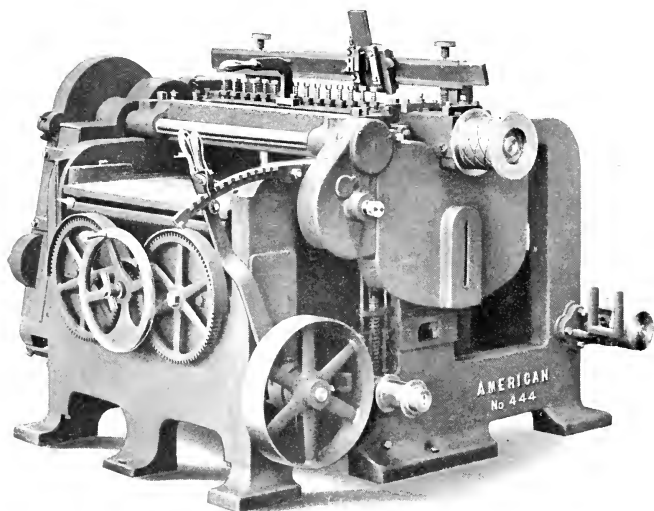
### Technical Features

**Arbor Yoke**—Carries two steel arbors  $1\frac{1}{8}$ " diameter with long self-oiling boxes and pulley between. This yoke revolves on a disk 17" in diameter fitted into a bored bearing in the rigid front wall of the frame and the saws hang outside this disk and wall. The arbor yoke is further supported by a journal having a bored bearing in the back wall of the frame. The circular adjustment is made by worm wheel and worm of quick pitch with adjustment for wear. The arbor pulleys are 4"x5 $\frac{1}{4}$ " face. A special arbor sleeve is furnished to receive dado heads up to 2" wide; this takes the place of the nut and loose saw collar. **Table and Gauges**—Size, 38" long by 36" wide; the movable section is 15" wide, the other 21". The movable section is guided by tongue and groove accurately scraped together and may be slid out to cut off 24" wide. Its operation is made easy by anti-friction rollers. It can be drawn away from the stationary table about 3" for dado heads. The entire table tilts to 45 degrees by screw and worm wheel segment. There is a screw stop for the horizontal position. Table is ruled for ripping up to 22". The Gauges are the same as those used on our heavy Universal Saw Bench and consist of a ripping gauge which can be used on either side of the saw; three cut-off gauges, one swiveled on the movable table and used in conjunction with a protractor arc for quick angle work, two pivoted on sliding tongues let into the table which can be drawn out to cut off 21" wide. These tongues extend the full length of the table and are made to be reversed when not in use which preserves the table surface unbroken. **Countershaft**—Has **T. & L.** (self-oiling loose) pulleys, 10"x6 $\frac{1}{4}$ "; speed, 650 R.P.M. An idler jack is pivoted inside the frame which carries two self-oiling bronze bushed pulleys. This is adapted either to motor drive or countershaft. Motor can be applied to the main frame, making a self-contained unit ready for wiring.

Fig.	Name	Floor Space	Horse-power	Wgt., lbs.	Boxed for Export		Code
					Wgt., lbs.	Cu. ft.	
6391	No. 20 Un. Saw Bench	3'6"x5' with ctr.	4 to 7 $\frac{1}{2}$	2000	2600	80	<i>Depthen</i>
	Un. Saw Grd, extra	.....	.....	.....	.....	..	<i>Depure</i>
	Belt Shield, extra	.....	.....	.....	.....	..	<i>Deputy</i>
	Pulley Seg't. G'ge., extra	.....	.....	.....	.....	..	<i>Deputied</i>
	Ext Rip G'ge	.....	.....	.....	.....	..	<i>Deputiff</i>
	Br'cket, extra	.....	.....	.....	.....	..	<i>Deputiff</i>

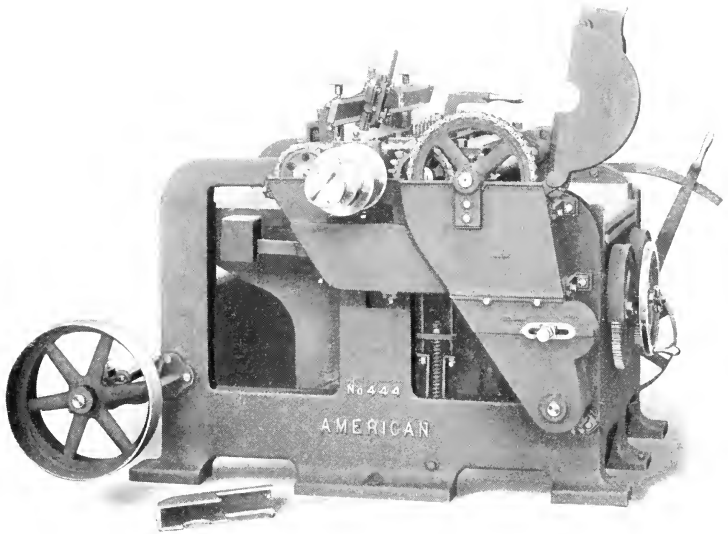


With Variable Feed and Direct-Attached Motor



*Figure 7741*

American No. 444 Single Finishing Planer



### American No. 444 Single Finishing Planer

**T**HIS machine is the latest development of a finishing planer and the fourth in the line of improved designs for this type of surfacer. Our experience dates back over twenty years, and thousands of our planers are in use in many of the leading wood shops in this and other countries. They are in furniture, chair, interior trim, carpenter, pattern, box, sash and door, automobile, wagon and implement factories, and in many of the leading manual training schools.

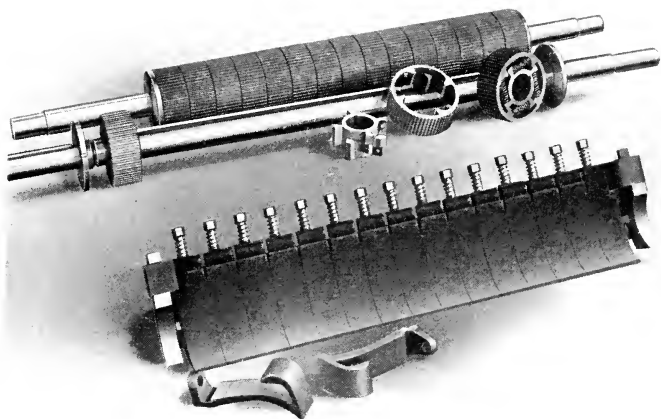
**Capacity**—Made in three widths, 24", 30" and 36", and to 7" in thickness; pieces from 4" long up can be surfaced true. Feed from 18 lineal feet per minute upward according to the requirements of the work. Usually two rates of speed are furnished, 22 ft. and 30 ft., but with the variable feed the maximum can be 85 ft. With our patent sectional roll and chipbreaker, narrow strips of varying thickness can be surfaced simultaneously, thus increasing the capacity of the planer several hundred per cent.

## Technical Features

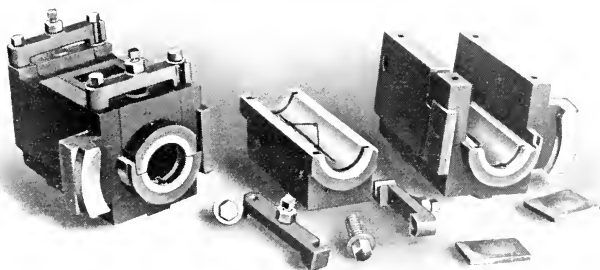
**Feed Rolls**—Are 5" diameter, all driven. and, unless otherwise ordered, turned smooth, except the upper in-feed roll which is corrugated. Our patented sectional in-feed roll has no rival for power, durability and convenience. Each section carries eight tempered tool steel springs 2 $\frac{1}{8}$ " long, and repairs, under reasonable working conditions, are rare. The construction is such that an entire roll can be taken apart and reassembled in a few minutes. Sections and drivers are of hardened steel. Roll shafts are held down by long range tempered steel springs adjustable for tension. **Feed Drive**—Is by belts in the high speed portion of the transmission, hardened steel roller chains for the intermediate, and cut gears for the rolls or slow portion. This makes for simplicity, economy of power and smooth action of the rolls, all necessary conditions for a high grade planer feed. **Cylinder**—Is of hard forged steel, triangular with three knives or round with thin knives if desired. Journals are 2 $\frac{1}{4}$ " diameter, carefully ground and lapped. Boxes are of the side clamping type with automatic circulation of oil and emergency oilers in the caps. Pneumatic cylinder pulleys 5" x 5 $\frac{1}{2}$ " are clamped on to conical bearings. Ball bearings can be furnished at an extra price. They consist of two pairs of bearings to each journal with steady collars between each pair and ample facilities for oiling, the requirements being much less than for the babbitt bearings. **Chipbreaker**—Is made solid or sectional to correspond with the in-feed roll. It adjusts in grooves concentrically to the cylinder and can be lifted out when required. When made solid, it can be lipped with flexible steel. Sections are of hardened steel. **Pressure Bar**—Hangs close to the cylinder and is adjustable at either end by finger wheels; it is ordinarily made yielding, but may be rigid and adjustable in height when so ordered. **Bed Plate**—(In three sections) is machined on entire surface; the center section lies under the cylinder and is removable for any purpose; the in-feed and delivery sections are usually slightly below the line of the cylinder bed, but can be adjusted to suit conditions. **Main Bed**—Is supported on heavy inclines, which move on tracks cast upon the frame. The machined surfaces are scraped to a bearing and ample provision is made for oiling. The adjustment for thickness is made by means of two square threaded screws coupled together and operated by a large central hand wheel and cut gears. **Knife Jointing and Setting Attachments**—Are extra and consist of a permanent slide bar secured to the frame over the cylinder on which the setter and jointing slide move and may be pushed to the end of the slide bar when not in use. When ordered a knife grinder can be put in place of the jointing plate, usually motor driven. **Motor Drive**—For belted planers we can furnish a special motor with extended shaft to receive pulleys at each end to drive the cylinder. This can be located on the floor behind the planer or overhead. For simplicity and economy of room and belting, we recommend our new directly attached motor secured to the cylinder on a taper with holding nut. Motor frame is bolted up to a supporting bracket directly attached to the machine frame and is adjustable to concentricity with the rotor. **Counter-shaft**—Has T. & L. (self-oiling) pulleys 12" x 7 $\frac{1}{4}$ ", speed 850 R.P.M.

Fig.	Style	Floor Space	Horse-power	Wt., lbs	Boxed for Export		Code
					Wgt., lbs.	Cu. ft.	
7741	No. 444, 36x7 Single Surfacer, 4 Rolls, Solid Roll	6'6"x5'4"	7 $\frac{1}{2}$ to 15	5600	6600	200	<i>Di put</i>
7771	No. 444, 30x7 Single Surfacer, 4 Rolls, Solid Roll	6' x 5'4"	7 $\frac{1}{2}$ to 15	5300	6300	180	<i>Di puting</i>
7831	No. 444, 24x7 Single Surfacer, 4 Rolls, Solid Roll	5'6"x5'4"	7 $\frac{1}{2}$ to 15	4100	5100	160	<i>Di puvert</i>
	Variable Feed instead of Single Belt Feed, any size, extra						<i>Di sanchor</i>
	Sectional Roll with Flexible Steel Lip Chipbreaker, extra						<i>Di pylon</i>
	Sectional Roll with 2" Independent Sectional Chipbreakers						<i>Di rem pt</i>
	Ball Bearings, extra						<i>Di face</i>

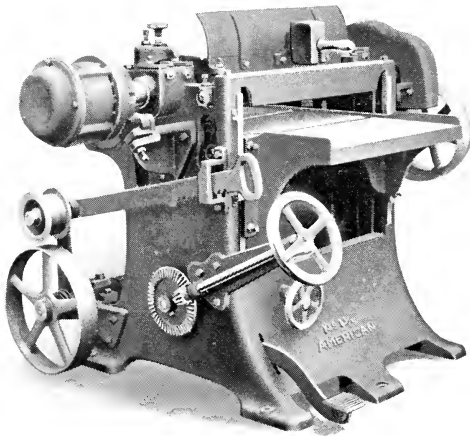
\*Knife Jointing and Setting Attachments are now furnished with machine without extra cost.



Sectional Feed Roll and Chipbreaker  
Applicable to No. 444 Surfacer



Detachable Side Clamping Boxes  
Applicable to No. 444 Surfacer



### American No. 1½ Single Surfacer

**T**HIS is a new design, improved to date, and will do smooth work in furniture, carriage, chair and carpenter shops.

**Capacity**—Works material  $\frac{1}{16}$ " to 7" in thickness and 24" wide. There are usually two rates of feed, 18 and 32 feet per minute. Two knives are regularly furnished.

#### Technical Features

**Feed**—The feed rolls are set as close as possible to the cylinder, and the upper in-feed roll is fluted and is held down by adjustable spring tension attached to equalizer bar. All the rolls are  $3\frac{1}{2}$ " diameter and the two upper ones are driven by gearing. The feed gearing is strong and well arranged and is driven direct from the cylinder; there is a binder pulley and lever for starting and stopping the feed. **Cylinder**—Is a solid steel forging two-sides tapped, with bearings  $1\frac{1}{8}$ " diameter and 8" long, carefully ground and boxes scraped to them, so that they will not heat on starting if properly oiled. If desired a round head can be furnished, without charge, and also a knife setting and jointing attachment, at an extra price. The cylinder boxes are cast on the frame and have patent side clamping caps with self-oiling devices arranged for constant circulation. **Bed**—Is very rigid, the vertical web being 10" deep and strongly ribbed under the cylinder plate; it has six points of support on the frame, four of which are planed ways with suitable gibs to take up wear. There is thus no teetering as the lumber enters the rolls, and no vibration under the cut of the cylinder. **Pressure Bars**—Are carefully fitted, and pieces 4" long can be planed without dubbing the ends; the chipbreaker works concentrically to the cylinder within the limits of the cut, and as close to the knives as is safe; both bars are adjusted to the stock independently, and hang  $2\frac{1}{4}$ " apart at the lips. **Countershaft**—Has T. & L. (self-oiling loose) pulleys,  $10\frac{1}{2}$ "x $5\frac{1}{4}$ "; speed, 800 R.P.M. **Motor Drive**—Can be furnished as an extra and as shown in cut consists of an A. C. motor direct-attached to cylinder. Controlling apparatus "Detroit" Iron Clad Fused Switch. D. C. motor can be applied in the same manner.

Fig.	Size	Floor Space	Horse-power	Weight, lbs.	Boxed for Ex'pt.		Code
					Wt., lbs.	Cu. ft.	
7911	24"x7" Round Cylinder, optional Knife Setting and Jointing	4'6"x4'10"	5 to 10	2300	2850	90	<i>Disavouch Disbaser Disbatel</i>



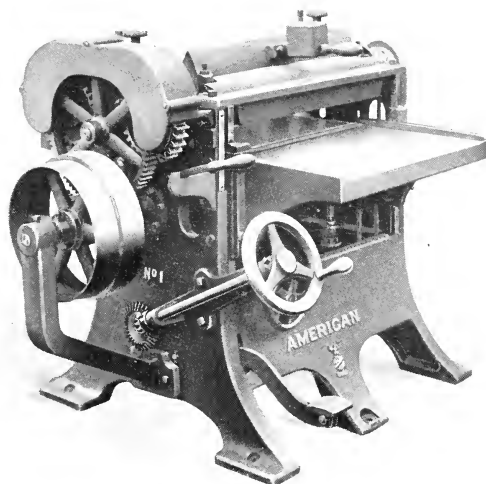


Figure 792

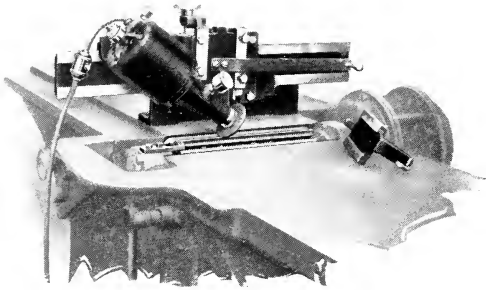
### American No. 1 Single Surfer

**B**UILT with special reference to doing smooth work. The frame is rigid and heavy, and has three points of bearing on the floor. **Capacity**—Works material  $\frac{1}{16}$ " to 6" thick and 16", 20" and 24" wide. There are usually two rates of feed, 18 and 32 feet per minute. Two knives are regularly furnished.

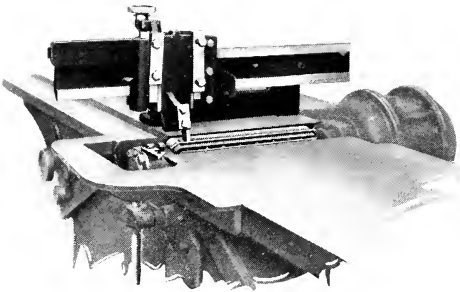
#### Technical Features

**Feed**—The feed works are particularly strong and well arranged, and the gears are extra heavy. They are driven from the countershaft by cone pulleys, and there is a lever to stop the feed, shifting the first pinion out of gear. The feed rolls are set very close to the cylinder, the upper in-feed roll is fluted, and pressure is obtained by adjustable spring tension attached to equalizer bar. All the rolls are  $3\frac{1}{2}$ " diameter and the upper ones are driven by the gearing. **Cylinder**—Is a solid steel forging, two sided tapered, with bearings  $1\frac{1}{8}$ " diameter and 7" long, and is very carefully fitted and balanced. If desired a round head can be furnished without charge, also knife setting and jointing attachments at an extra price. The box-caps are planed into recesses to prevent vibration sideways. **Bed**—Is very rigid, the web being 8" deep, and solidly ribbed under the cylinder, and it has six points of support on the frame, with gibs to take up lost motion. **Pressure Bars**—Are carefully arranged and fitted, and pieces 6" long can be planed smooth without dubbing the ends. The chipbreaker swings concentrically to the cylinder, and both bars work close to the knives and are both adjustable, independently of each other and the feed rolls. **Countershaft**—Has T. & L. (self-oiling loose) pulleys,  $10\frac{1}{2}$ " by  $5\frac{1}{4}$ "; speed, 800 R.P.M. Motor drive can be applied similar to No. 1  $\frac{1}{2}$  Surfer.

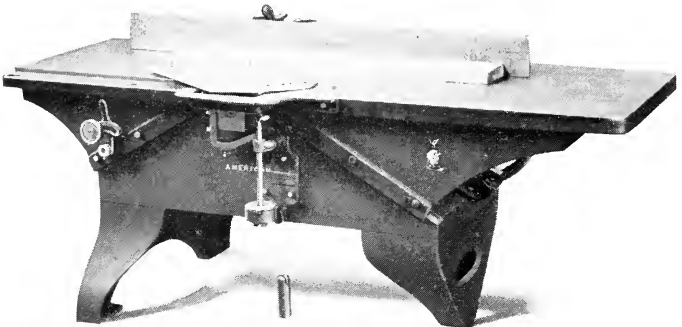
Fig.	Size	Floor Space	Horse-power	Weight, lbs.	Boxed for Expt.		Code
					Wt., lbs.	Cu. ft.	
792	24"x6"	4' 6"x3'8"	5 to 10	1850	2500	85	<i>Disavowed</i>
793	20"x6"	4' 2"x3'8"	5 to 10	1630	2400	76	<i>Disbanded</i>
794	16"x6"	3'10"x3'8"	5 to 10	1400	2200	72	<i>Disbark</i>
Round Cylinder, optional							<i>Disbaser</i>
Knife Setting and Jointing Attachments, extra							<i>Disbatel</i>



Motor Knife Grinder



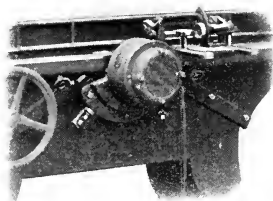
Knife Jointing Attachment



*Figure 802*

American No. 1 Jointer and Buzz Planer

## American No. 1 Jointer and Buzz Planer



NO other buzz planer has the adjustment, solidity of construction and advantages of this one. There are no links, wedges, pin-joints or eccentrics under the table to get out of adjustment or wear slack; by putting the frame on three legs it is impossible to strain or twist it by bolting down or by the

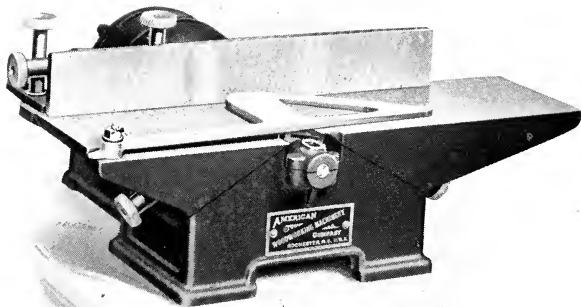
settling of the floor, and there is no projecting flange for the operator to tread upon. By means of the large hand wheel at the right, the working table can be moved instantly either way, without requiring the operator to change his position in the least. The design and method of fitting up is such that the tables must be true and remain so, and they cannot twist, rock, strain or be displaced, no matter how uneven the foundations on which they are placed.

**Capacity**—Made in sizes to work material, 8", 12", 16", 20", 24", 30" and 36" wide. The cross-shaft under the short table can be adjusted by slacking the segment clamp screw, and the rear table will then drop down sufficiently to make a hollow or "spring" glue joint. Furnished with each machine; one pair of plain knives, plain rabbeting bracket, necessary wrenches, and a countershaft, with our improved (self-oiling loose) pulleys and hangers.

### Technical Features

**Cutter Head**—A round safety cutter head with thin knives is the standard equipment; a square head with plain knives will be furnished if desired. Ball bearings for machines up to 24" can be furnished at an extra price. **Adjustable Bevel Gauge**—Is provided, secured to the rear or short table, so as not to interfere with the movement of the working table. The gauge is indexed so as to be set instantly to any bevel desired. **Tables**—The tables are 7' long on all machines. They are heavily ribbed and provided with steel lips. The rear table is grooved  $\frac{5}{8}$ " deep and has an adjustment for making hollow glue joints. Both tables can be drawn away from the cutter head on a level independently of the incline adjustment, so as to leave an opening 7" wide to admit the use of special cutters for beading, moulding, grooving, etc. **Countershaft**.—This is furnished with tight and loose pulleys according to size of machine, as listed below. **Motor Drive**—Can be furnished as an extra and, as shown in the cut above, consists of an A. C. 60 cy. motor mounted directly onto the extended journal of the cutterhead. Motor frame is adjustable to the rotor.

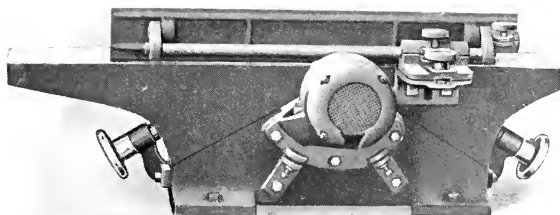
Fig.	Works	Floor Space	Horse-power	Height to Top Table	T. & L Pulleys	Sp.	Wt., lbs.	Boxed for Export		Code	
								Wgt., lbs.	Cu. ft.		
800	8"	2'5"x7'	2 to 3	33"	8"x3 $\frac{3}{4}$ "	900	1200	1800	82	<i>Disbecome</i>	
801	12"	2'9"x7'	2 to 3	33"	8"x4 $\frac{1}{4}$ "	900	1500	2000	86	<i>Disbench</i>	
802	16"	3'1"x7'	3 to 5	32"	8"x4 $\frac{1}{4}$ "	950	1800	2300	94	<i>Disblame</i>	
803	20"	3'5"x7'	3 to 5	32"	9"x4 $\frac{1}{4}$ "	950	2100	2700	96	<i>Disbord</i>	
804	24"	3'9"x7'	3 to 5	31"	10"x5 $\frac{1}{4}$ "	950	2300	3200	104	<i>Disbowel</i>	
805	30"	4'1"x7'	5 to 7 $\frac{1}{2}$	30"	10"x5 $\frac{1}{4}$ "	950	3000	3700	116	<i>Disbranch</i>	
806	36"	4'7"x7'	5 to 7 $\frac{1}{2}$	30"	10"x6 $\frac{1}{4}$ "	950	3500	4200	130	<i>Disurgeon</i>	
		Special Rabbeting Table with Sliding Miter Gauge									<i>Discoideal</i>
		Spring Attachments for Running Mouldings, including four Dovetail Bolts									<i>Discoidean</i>
		American Safety Guard, extra									<i>Discoloring</i>
		Ball Bearings for Machines up to 24", extra									<i>Disblaming</i>



American 4" Bench Jointer



*Figure 8191*  
American 6" and 8" Bench Jointer  
(With Pedestal)



Direct-Attached Motor Drive, 6" and 8" Jointers

## American Bench Jointer

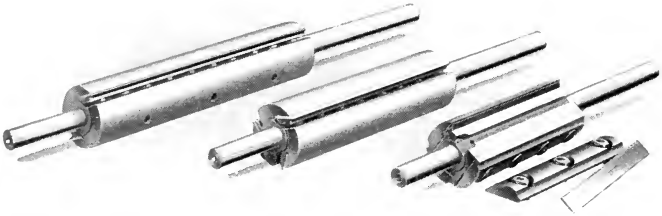
**D**ESIGNED for a great variety of small work such as is found in pattern shops, chair and furniture work, and manual training schools. The frame is a single casting, made amply heavy, with inclines at both ends upon which the tables move. The 6" and 8" machines are made with or without a base, at a difference in price; when without a base it can be set upon a bench. The 4" machine is furnished only as illustrated with motor drive and without pedestal. It is strictly a bench machine.

**Capacity**—Made in three sizes with 4", 6" and 8" heads respectively. Furnished with two thin knives.

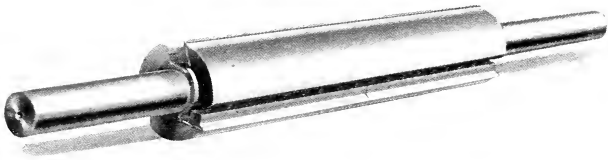
### Technical Features

**Tables**—The tables are each a single casting carefully fitted to the inclines with adjusting screws for the cut and clamping levers to secure rigidity on the frame. Top surface is planed and scraped to exact alignment after the parts are all fitted together and clamped securely; no chance for an error. They are 41" long over all on the 6" and 8" machines. On the 4" machine they are 22". The rear table has a 5/16" rabbeting groove. **Cylinder**—Is a solid steel forging round and provided with two thin knives of either high-grade tool steel or self-hardening steel as ordered; the pulley is 3 1/2" diameter and receives a 2 1/2" belt and may run 3200 to 3600 R.P.M. or higher in some cases. Either babbitted or ball bearings can be supplied; the latter are furnished regularly with machine. The ball bearings are the latest and most perfect radial ball and collar construction, requiring the minimum of power and oil. The 4" machine is furnished with babbitted bearings only. **The Fence**—Is secured to the rear table so as not to interfere with the adjustment of the long table to the cut, and it may be tilted to 45 degrees or any intermediate position, and rigidly clamped at any point. **Countershaft**—Has T. & L. (self-oiling loose) pulleys, 6" x 3 3/8"; speed, 800 R.P.M. **Motor Drive**—Is furnished as an extra. Our direct-attached motor drive is available in either D.C. or A.C. Motor on 4" machine is connected by flexible coupling.

Fig.	Style	Floor Space	Horse-power	Wt., lbs.	Boxed for Exp't.		Code
					Wt., lbs.	Cu. ft.	
8190	4" as illustrated only	23" x 18"	1/2	80	100	5	<i>Discape</i>
8191	6" With C.S. and Base	41" x 18"	1	300	350	24	<i>Discarnate</i>
8192	As Above—No Base	41" x 18"	1	100	150	20	<i>Discede</i>
8193	8" With C. S. and Base	41" x 20"	1	350	400	26	<i>Disceding</i>
8194	8" As Above—No Base	41" x 20"	1	150	200	22	<i>Discept</i>
	Babbitt instead of Ball Bearings						<i>Disceptag</i>



American Safety Jointer Cylinders



American Round Surfacer Cylinder



American High Speed Hard Steel Knives

## American Safety Jointer Cylinders

**O**UR Safety Jointer Cylinders are made in three styles, as illustrated, and are known as our **Standard Two-Knife Cylinder**, **Special Three-Knife Head** and **Special Four-Capped Head**. The first two are of the same construction, the last is simply a square cylinder with the sides capped with bars which give it a round cross section. This cylinder has two sides slotted which permit the use of moulding cutters (by detaching the caps), and two sides with knives. It will be seen that the construction of our two and three-knife safety jointer cylinders is very simple, consisting of a steel forging turned round and with slots planed lengthwise to receive the thin knives and knife clamping blocks with provision for adjusting the knives. In fact, the simplicity and absolute safety of these heads over others have recommended them to many of the best mills everywhere, and they are passed by insurance companies and state inspectors invariably. The Four-Capped Safety Jointer Cylinder with dovetail slots for attaching special knives for variety work is strictly a special head with us, and is furnished on our machines only on special order. The knives furnished with each head depend upon the quality and temper of steel desired. Unless otherwise specified we furnish special steel knives tempered to file or grind. High speed, hard steel knives are extra. The grade of knife should be specified when ordering the cylinder.

## American Patent Round Surfacer Cylinders

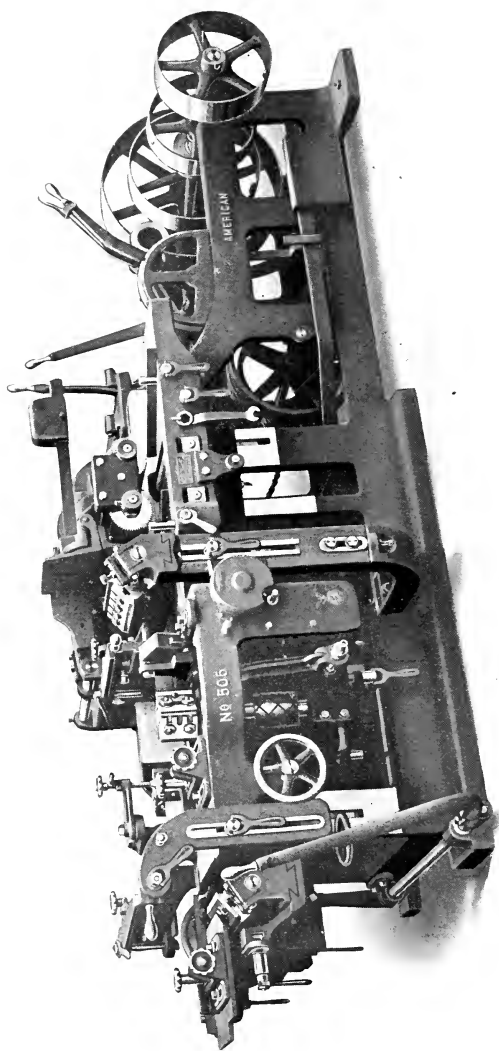
We have been manufacturing Round Surfacer Cylinders for many years and are prepared to supply the most critical users with the best that money can buy. We make them up to 8½" in diameter with two, three, four, six and eight knives, the number of knives depending upon the nature of work to be done and the machine to which the head applies. The construction of these heads is simple, consisting of the same fundamental features described above, varying only in detail as the purpose requires.

## American Thin Special Steel Knives

Our thin jointer knives are ⅛" thick and ground parallel all over. We can furnish them to file or to grind for sharpening.

The best knife for surfacers is made from special steel, heat treated by experts with the most modern equipment and is a product recommended for fast feeds and high speed. These knives are the last word in high grade woodworking knives, and we know from experience will meet all reasonable requirements on hard or soft wood at high speeds. They are strictly guaranteed as to material and workmanship.

All knives are ⅛" thick and usually 8", 12", 16", 20", 24", 27", 30" and 36" long. Standard widths are 1⅜", 1¼", 1⅜", 1½", 1⅞" and 1⅞". Special widths can be made to order.



*Figure 8432*  
American No. 505, 8", 10" and 12" Four-sided Moulder



## American No. 505 Fast Feed Four Side Moulder

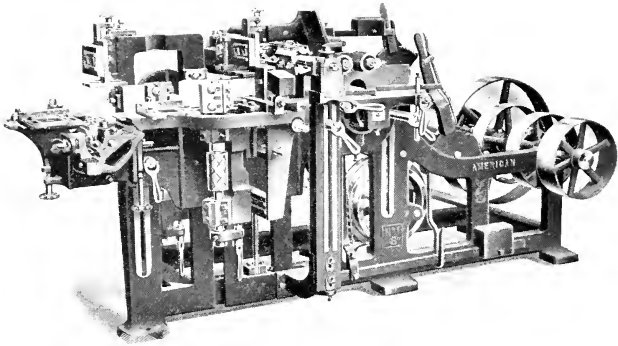
**O**UR No. 505 is an advanced type of American Moulder. It is a strong, rigid and well-built machine with all adjustments and conveniences necessary to a moulder. The machine is fitted to receive straight knife jointing forms for top and bottom and side heads. All parts are easily accessible and one wrench only is needed for set-up.

**Capacity**—Made in three sizes, 8", 10" and 12" wide, each to work 4" thick. Four forged steel, 4-sided, slotted heads, with two knives on each, and knife setting and jointing attachments for all heads with jointing forms for straight knives. Self-centering heads at extra cost. Four-knife round heads at extra cost.

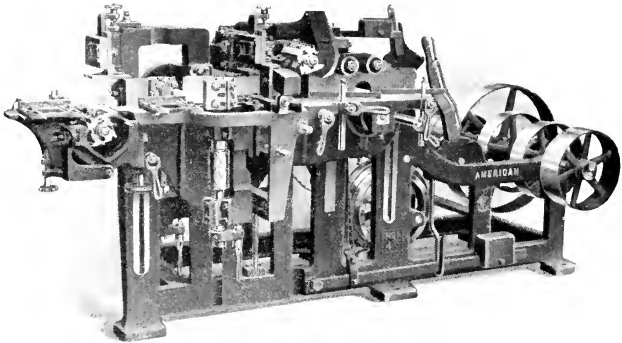
### Technical Features

**Table**—Clamped securely to the frame at three points of contact—gibbed with provision for wear. Adjusts 10" on large screw with ball-bearings and reducing gearing. Reversible plate under top head, grooved on one side to allow for projection of cutters, and adjustable endwise. End platen swings down out of way to give access to knives, and is cushioned by a spring. **Feed**—Consists of four power-driven rolls with cut gears and driven by hardened roller chain and sprockets inside the frame; controlled from either end of machine. Top rolls are 5½" diameter with removable outside bearing. A heavy equalizer bar on inside of frame connects with the top feed roll yokes and keeps the rolls parallel with the face of the bed—preventing any twist or strain on shafts or gears. Top rolls lift by means of lever near operator. Lower feed rolls are 6" diameter and may be removed without dismantling the machine. Rates of feed, 15, 25, 44 and 75' per minute, with lever gear shift controlling two rates at a time. **Cutter Heads**—Top and bottom heads are the slip-off type and the spindles run in heavy side clamping boxes with screw adjustment. Outside bearings for both heads adjustable in gibbed slides and detachable. All heads, including side heads, have cutting circle of 6½". Outside bearing stand securely clamped to frame of machine; adjustable for lining up when necessary. Arbors are crucible steel, 1 13/16" diameter where head goes on, 2¼" diameter in bearings. Chipbreaker adjusts to and from cutters; slides back out of the way to give access to knives. Pressure foot is hinged on the chipbreaker proper, with springs in the hinge, to avoid vibration, and adjusts independently. Pressure Bars, in rear of top head and over bottom head, are sectional; adjust horizontally and vertically; are hinged and swing up over the frame, leaving table and side heads clear. Bearings have dust-proof oilers and compression grease cups. **Side Headstocks**—Both are securely attached to the table—making vibration impossible. Both adjust vertically and laterally. The outside headstock may be set to an angle. The angular adjustment is obtained by a horizontal screw at the lower end of the headstock, which moves the head on a circle, the center of which lies on a plane with the face of the table. The angular adjustment once made, is not affected by the vertical and lateral adjustments of the headstock. Inside head has chipbreaker and take-up. Outside head has weighted, reciprocating matcher clip attached to the movable block carrying the headstock and moves in and out with the headstock. The opening in the bed for the outside head has an adjustable movable plate for carrying wide material. For narrow stock this may be removed. Side spindles are crucible steel 1 13/16" in diameter where heads go on and are mounted in our side clamping boxes and run on self-oiling pivoted steps. **Countershaft**—Size of driving pulleys are as four to one in relation to all cutter head pulleys, giving excellent belt contact. T. & L. pulleys are self-oiling 12"x8", and should make 900 R.P.M.

Fig.	Size	Floor Space	Horse-power	Weight, lbs.	Boxed for Export		Code
					Wgt., lbs.	Cu. ft.	
8432	12"	11'2"x6'0"	10 to 20	7350	9850	355	<i>Disembit</i>
8452	10"	11'2"x5'8"	10 to 20	7300	9650	345	<i>Disembog</i>
8522	8"	11'2"x5'8"	8 to 15	7000	8650	335	<i>Disemburn</i>



*Figure 8601*  
American No. 1, 6" Four-sided Moulder



*Figure 8641*  
American No. 1, 4" Four-sided Moulder

## American No. 1—4" and 6" Moulders

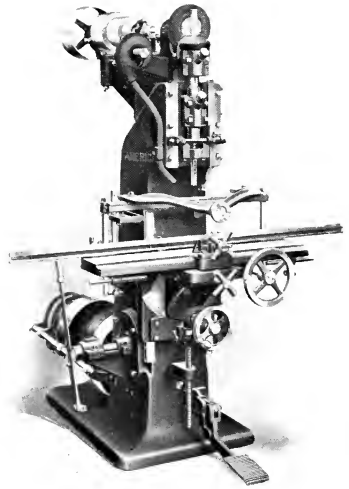
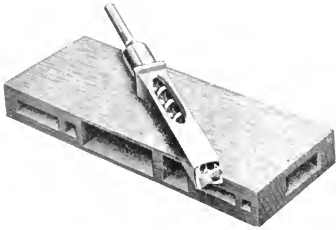
**T**HE American No. 1—4" and 6" Moulders are strong and well-built machines with frames cast in one piece. They are made to work one, two, three or four sides as per code below—and there is little difference between them, except the width of the table. Practically the only difference lies in the fact that the 6" machine has an outside removable bearing for both upper and lower cutter heads while the 4" machine has not. The following description will answer for both.

**Capacity**—Made in two sizes, 6" and 4" wide by 4" thick. Bed drops 16" on 6" machine; 20" on 4" machine. Four rates of feed—12, 23, 30 and 58 feet per minute. Four slotted heads with two knives for each, one steel cap head and a spur feed are regularly furnished.

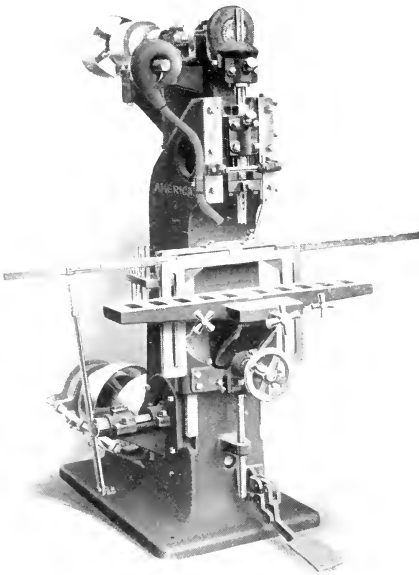
### Technical Features

**Bed**—Of good weight is gibbed to planed ways on the frame with provision for wear. Raised and lowered by screw on ball bearings by a crank. Rear table swings down out of the way giving access to the cutter head. **Cutter Heads**—Top head has lateral adjustment by means of a hand wheel. Under head has both lateral and vertical adjustments with adjustable plates in table and swing. There is a journal box on each side of pulley on under head arbor. Top and bottom heads are of the slip-on type. Arbors are 1½" diameter where heads go on. All journal boxes are set on an incline. **Inside and Outside Headstocks**—Have vertical and horizontal adjustments and may be set to an angle. The inside head is provided with chipbreaker and take-up. The outside head is provided with reciprocating chipbreaker which travels in and out with the adjustment of the head and retains its position when the head is thrown to an angle. Side spindles are provided with self-oiling steps and are 1½" diameter where the heads go on. **Pressure Bars**—They are located in rear of top head and over under head, are sectional and adjustable vertically with and without hand screws. Both are hinged to swing back over the frame. **Feed**—Consists of two 3" top rolls and one 5" bottom roll, all of which are powerfully driven with chains. The top rolls are raised by means of a lever convenient to the operator. The top roll yokes are hinged to rise and fall parallel with the face of the table. **Countershaft**—Has **T. & L.** (self-oiling loose) pulleys, 10½"x5"; speed, 800 R.P.M.

Fig.	Style	Floor Space	Horse-power	Wgt., lbs.	Boxed for Export		Code
					Wt., lbs.	Cu. ft.	
8601	Four Sides	9'x4'	5 to 10	2700	3600	150	<i>Disengulf</i>
8611	Three Sides	9'x4'	5 to 7½	2600	3500	150	<i>Disenmesh</i>
8621	Two Sides	9'x4'	4 to 5	2500	3400	150	<i>Disenroll</i>
8631	One Side	9'x4'	3 to 5	2400	3300	150	<i>Disenlave</i>
8641	Four Sides	9'x4'	5 to 10	2500	3500	140	<i>Disentrail</i>
8651	Three Sides	9'x4'	5 to 7	2400	3400	140	<i>Disentwine</i>
8661	Two Sides	9'x4'	4 to 5	2300	3300	140	<i>Disfame</i>
8671	One Side	9'x4'	3 to 5	2200	3100	140	<i>Disfavor</i>

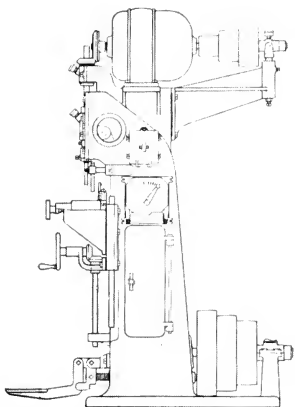


*Figure 902—Clamp Table*



*Figure 901—Plain Table*

American No. 20 Automatic Vertical Hollow Chisel Mortiser



## American No. 20 Automatic Vertical Hollow Chisel Mortiser

**T**HIS machine is compact, well designed and finely fitted for mortising in hard and soft woods for use in carriage, furniture, sash and door, and all wood-working factories, and is especially adapted to work in manual training schools. It is automatic in operation.

**Capacity**—Mortises up to  $\frac{3}{4}$ " square in hardwood or 1" in soft wood by  $3\frac{1}{2}$ " deep. Speeds of the chisel ram are: 10, 20, and 35 strokes per minute. Speed of spindle, 3600 R.P.M. We furnish with each machine: three chisels, one each  $\frac{3}{8}$ ",  $\frac{1}{2}$ " and  $\frac{5}{8}$ " with bits to correspond.

### Technical Features

**Chisel Ram**—Reciprocates with quick return, in gibbed ways with proper provision for taking up wear and is arranged with an adjustable chisel holder. It operates automatically by foot treadle. The stroke is adjustable from 0 to 4". An adjustable hold-down close to the chisel prevents the lifting of the stock on the return stroke. The bit spindle is driven by noiseless mitre gears, doing away with the troublesome idlers for the right angle drive. There is a fan provided on the machine to keep the chisel cool and blow the chips away.

**Table**—Choice is given between a plain table and a clamp table. The latter is furnished as an extra and is described under **Extras** below. This description applies to the plain table which is regularly furnished under Figure 901. Is securely gibbed to the frame and is adjustable vertically by hand wheel. Can be tilted to an angle of 30 degrees to the right or left and will allow a mortise to be made in the center of material  $5\frac{1}{2}$ " wide by 12" deep. It is also adjusted to and from the column. It is provided with a detachable plate under the chisel which can be replaced with wood or soft metal for through mortising. An adjustable back guide and hold-down is provided with spring spacing stop gages which can be set for several mortises and different lengths, thus saving time otherwise consumed in marking off each piece to be mortised. Has a line gage attachment which can be used with or without the spring stop gages, and which will be found to be very convenient when making mortises that have to be marked off as in long material where the spring stop gauges cannot be used. **Counter-shaft**—Driving pulley is  $10" \times 4"$  and should make 1200 R.P.M. Loose pulley bronze bushed and self-oiling.

**Extras**—The clamping table as shown in Figure 902 is furnished as an extra. It is provided with spring stop gages and adjustable locking guide and hold down. It has an extra clamping device for wide stock at the upper edge and which can be easily attached or removed. Motor drive, either direct, or indirect, for belt drive; price according to requirements.

Fig.	Style	Floor Space	Horse-power	Weight, lbs.	Boxed for Expt.		Code
					Wt., lbs.	Cu. ft.	
901	Plain Table	5'3" x 5'	2	1500	2300	117	<i>Dispross</i>
902	Clamp Table	5'3" x 5'	2	1600	2400	117	<i>Dispunct</i>

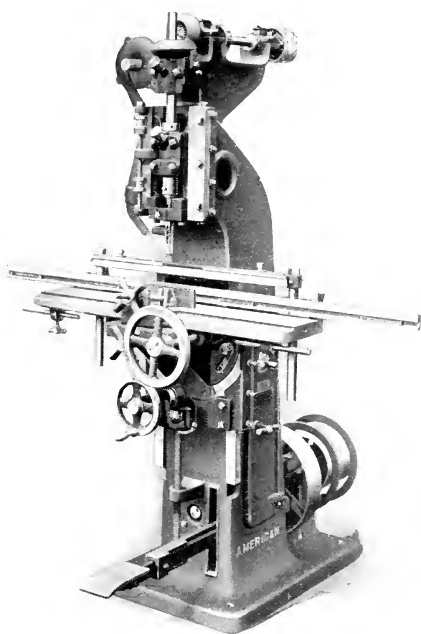


Figure 9032—Clamp Table

### American No. 25 Vertical Hollow Chisel Mortiser with Foot Power Feed

**T**HIS is the latest addition to our large list of mortising machines and we feel sure it will appeal strongly to all woodworkers, especially to those familiar with our *power* hollow chisel mortiser of the same type. For all the lighter grades of work in hard or soft wood, in furniture, sash, door and blind factories, jobbing shops, and especially in manual training schools it is without equal in weight, capacity and workmanship. It is a high grade tool with heavy cored column and broad base flange making it free from vibration. It is capable of a large output in the hands of a good operator.

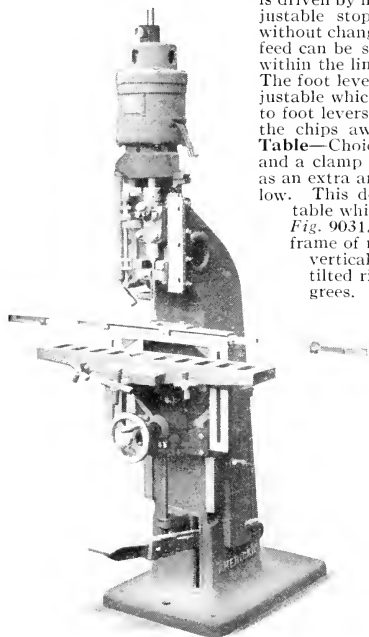
**Capacity**—Mortises up to  $\frac{5}{8}$ " in hardwood and  $\frac{3}{4}$ " square in soft wood, by  $3\frac{1}{2}$ " deep and to the center of a  $6\frac{1}{2}$ " circle.

## Technical Features

**Chisel Ram**—Operates by foot power in gibbed ways with proper provision for taking up wear and is arranged with an adjustable chisel holder. The speed of the bit spindle is 3400 R.P.M. The bit spindle

is driven by noiseless mitre gears and has adjustable stops for different depth of hole without changing height of table. The chisel feed can be speeded according to the work within the limit of the foot lever movement. The foot lever and connections are made adjustable which permits more or less leverage to foot levers. A blower is provided to clear the chips away and keep the chisel cool.

**Table**—Choice is given between a plain table and a clamp table. The latter is furnished as an extra and is described under *extras* below. This description applies to the plain table which is regularly furnished under Fig. 9031. It is securely gibbed to the frame of machine and is adjustable 12" vertically by hand wheel. It can be tilted right or left to an angle of 30 degrees. It adjusts to and from the



column and has a detachable plate directly under the chisel which can be replaced with wood or soft metal for mortising through. An adjustable back guide and hold down is provided with spring spacing stop gauges which can be set for several mortises and different lengths, saving time that would otherwise be consumed in marking off each piece to be mortised.

**Countershaft**—Has T. & L. (self-oiling loose) pulleys 8" x 3½" face and should make 1200 R.P.M.

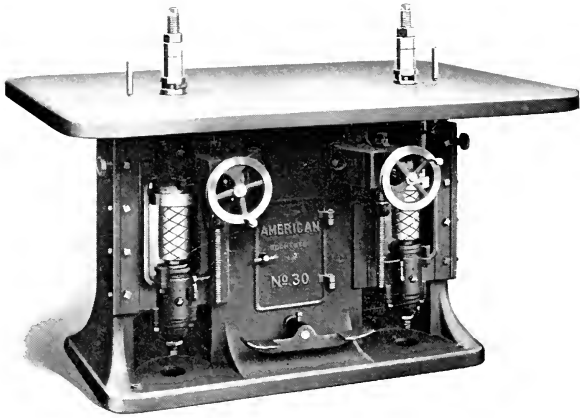
**Equipment**—Three chisels, one each ¾", ½" and ⅝" with bits to correspond.

**Extras**—

### Plain Table—Motor Drive

The clamp table as shown in the small cut on the preceding page is furnished as an extra. It is provided with spring stop gauges and adjustable locking guide and hold-down. It has an extra clamping device for wide stock at the upper edge which can be easily attached or removed. Motor drive, either direct with motor mounted on the boring spindle or indirect for belt to countershaft, can be furnished at prices according to requirements.

Fig.	Style	Floor Space	Horse-power	Weight, lbs.	Boxed for Export		Code
					Wgt., lbs.	Cu. ft.	
9031	Plain Table	4'8"x5'1"	2	820	1400	70	<i>Dispurge</i>
9032	Clamp Table	4'8"x5'1"	2	920	1500	70	<i>Dispurka</i>



## American Nos. 30 and 20 Conical Bronze Bearing Shapers

OUR series 30 and 20 shapers are mechanically alike, the difference being in the depth and width of the frames and in the size of the table. The 30 is the larger and heavier of the two.

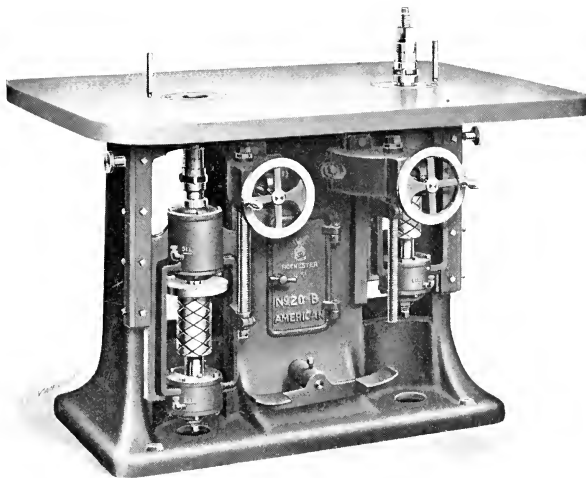
**Capacity**—On the No. 30 the spindles are 30" apart; on the No. 20 they are 24". Two steel slotted collars, two filling-in collars for each spindle and one set of blank knives are regularly furnished.

### Technical Features

**Spindles**—Are made solid of special hard cast steel; they are machined and ground with the greatest care and are hardened at the lower end and run in a well of oil; the end steps are of phosphor bronze. **Spindle Yokes**—are cast in one piece, and they are rigidly held in "V" slides on the frame by means of take-up gibs, and clamping wheels. Slides are carefully machined and hand scraped. The yokes are adjustable vertically by screws and hand wheels which are balanced. **Boxes**—Are of special hard bronze with a steel jacket forced over the outside by hydraulic pressure. They are adjustable vertically to take up wear, and oiling wicks are supplied which bear against the journals for their entire length. **Tables**—Are of iron, 44" x 62" and 38" x 54", well ribbed and very rigid. There are iron rings around the spindles and they can be of any bore within their limits. Detachable guide pins are located just outside the rings. **An Adjustable Countershaft**—With adjustable guide stands is usually supplied. Loose pulley is bronze bushed and self-oiling. Speed 1400 R.P.M. **Motor Drive**—We attach a motor to a countershaft base: the motor is special and furnished by us together with its base as an extra.

Fig.	Name	Floor Space	Horse-power	Wgt., lbs.	Boxed for Exp't.		Code
					Wt., lbs.	Cu. ft.	
925	No. 30 with adj. C. S.	5'3"x8'	3 to 7½	2800	3400	93	<i>Dissoluble</i>
930	No. 20 with adj. C. S.	4'6"x8'	3 to 5	2100	2700	75	<i>Distaind</i>
	Spindles made in sections with detachable stems, optional.						
	Extra stems with one set of collars, per pair, extra . . . . .						
	Special Motor Countershaft extra . . . . .						
	Shaper Guards, per pair, extra . . . . .						
	Top Steady Bearings, per pair, extra . . . . .						
							<i>Distortion</i>
							<i>Distanck</i>
							<i>Distill</i>
							<i>Distrait</i>

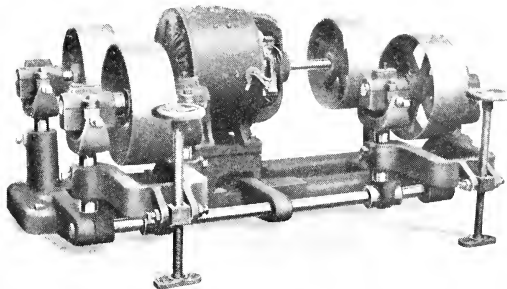




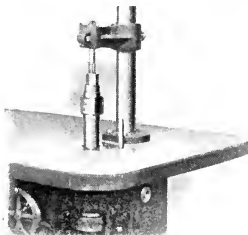
*Figure 9301*

**American Nos. 20-B and 30-B Shapers**

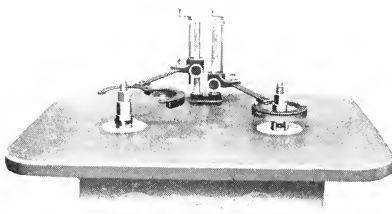
THE feature that distinguishes the type B Shapers from the rest of the series 20 and 30 is that the spindles run in ball bearings. The general description of this type is the same as the rest of the series. For code see opposite page.



Special Motor Countershaft. As applied to Nos. 20 and 30.



Top Steady Bearing



Shaper Guard

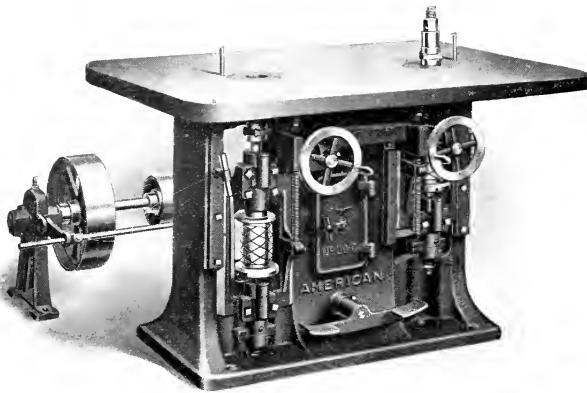


Figure 929

### American Nos. 20-C and 30-C Two Spindle Shapers

**T**HE difference between our No. 20-C and No. 30-C Shapers is in the size of the table, the distance of the spindles apart and the weight of the machines. There is no difference in the construction. Both are made with babbitted bearings and plain countershaft as illustrated above.

**Capacity**—On the No. 20-C the spindles are 24" apart; on the No. 30-C they are 30" apart. Two steel slotted collars, two filling collars for each spindle and one set of blank knives are regularly furnished.

#### Technical Features

**Table**—On the No. 20-C is 38"x54"; on the No. 30-C, 44"x62". The iron rings are 7" and 8" in diameter. The spindles are special hard cast steel, with upper sections 7½" long by 1⅝" diameter on the No. 20-C; 9"x1⅜" diameter on the No. 30-C. Boxes are lined with the best babbitt. The spindles are adjusted vertically by hand wheels shown. The yokes slide in accurately planed hand-scraped gibbed ways. **Countershaft**—Has T. & L. (self-oiling loose) pulleys, 10"x6¼" on the No. 30-C; 8"x5¼" on the No. 20-C. Speed, 1000 R.P.M. for 5000 on spindles.

Fig.	Style	Floor Space	Horse-power	Wgt., lbs.	Boxed for Export		Code
					Wgt., lbs.	Cu. ft.	
9254	No. 30-C Plain Countershaft and Babbitt Bearings	5'3"x8'	5 to 7½	2600	3200	100	<i>Dissomine</i>
9303	No. 20-C Plain CS and Babbitt Bearings	4'6"x8'	3 to 5	1900	2600	80	<i>Dissornet</i>
	Shaper Guards, per pair, extra						<i>Distill</i>
	Spindles made in sections with detachable stems, optional						<i>Distoma</i>
	Extra stems with one set of collars, per pair, extra						<i>Distortion</i>
	Top Steady Bearings, per pair, extra						<i>Distraint</i>

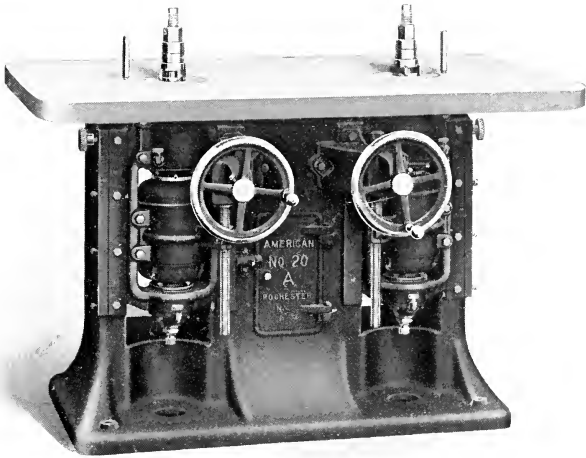


Figure 9300

### Nos. 30-A and 20-A Motor Spindle Shaper

OF our New Line of Shapers, the Type A Motor Spindle Ball Bearing Shaper, is the most prominent one of the group. It is made in both the sizes as the other types of the series are.

As the illustration indicates the rotors of the motors are secured to the spindles in place of the usual pulleys. 7200 R.P.M. is the speed recommended for the spindles, and at this speed the motors develop  $\frac{1}{2}$  H.P. each. In order to obtain this speed, a frequency changer is required which generates 120 cycle. When a number of shapers are located near each other, one frequency changer serves them all. These motors are made specially for these machines and are always for alternating current, 3 phase, 120 cycle, 220 volts. Ample appliances are provided for protecting the parts, together with all conveniences for lubrication, adjustments and manipulation. The electric connection and control are attached to the frame of the machine, making it a unit construction.

The advantages of this construction are: elimination of counter-shafts and belts, saving of much floor space, flexibility of operation and a greater economy of power and operating expense.

The general description of our Type A Shapers is the same as that of the others of the series 20 and 30.

Fig.	Style	Floor Space	Horse-Power	Wgt.. lbs.	Boxed for Exp't		Code
					Wgt..lbs.	Cu. ft.	
9250	No. 30-A Motor Spindle	5'3"x8'	5 to 7½	2300	3000	93	<i>Dissoman</i>
9300	No. 20-A Motor Spindle	4'6"x8'	3 to 5	1975	2650	75	<i>Disspone</i>
9253	No. 30-B Ball Bearing Belt Driven	5'3"x8'	5 to 7½	2550	3200	93	<i>Dissoment</i>
9301	No. 20-B Ball Bearing Belt Driven	4'6"x8'	3 to 5	1900	2600	75	<i>Disspute</i>

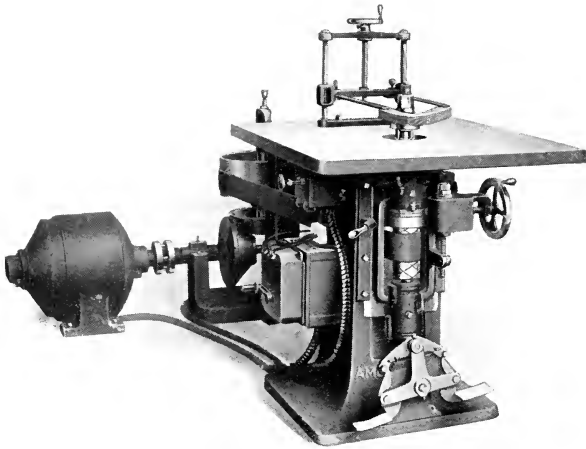


Figure 937

## American No. 1 Reversible Shaper

OUR No. 1 Shaper with reversible counter shaft is a machine that is used generally in furniture factories, vehicle works, pattern shops, etc. It is made with babbitt or conical bearings as ordered. We furnish with each machine: one detachable upper spindle section, nine differential guide collars, one table ring, two steel collars and one pair of plain shaper knives.

### Technical Features

**Spindle**—Is of crucible steel,  $1\frac{1}{8}$ " in diameter and the journals are 6" long and are carefully ground true and finely polished. The boxes are scraped to the journals. Top sections are detachable and may be of any diameter from  $\frac{3}{8}$ " to  $1\frac{1}{8}$ "; standard section  $\frac{5}{8}$ " diameter. **Boxes**—Are cast in a strong yoke, which is carefully scraped to ways on the frame, and the take-up gib is provided with a clamp screw, which binds the yoke to the frame firmly. The caps have automatic oilers and are planed into ledges to prevent side motion. Bearings can be either plain babbitt, conical or ball at different prices. **Table**—Is of iron  $32'' \times 36''$ , and is provided with a movable center plate 6" diameter surrounding the spindle. **Shifter Pedal**—Is self-locking and self-releasing; thus the whole force of the friction is made positive and retained in action as long as desirable, without any effort from the operator. **Countershaft**—Has two compressed paper frictions engaging with an iron wheel on the vertical shaft; the latter has bearings on both sides of the driving pulley and a self-oiling step for end pressure. Driving pulley is  $8'' \times 4\frac{1}{2}''$ ; speed, 1000 R.P.M. for 5000 on spindles.

**Extras**—Safety guard is furnished at an extra price.

**Motor Drive**—Motor drive is extra and consists of a Motor connected to countershaft by flexible coupling and wired to enclosed rheostat and switch by flexible conduit wiring. See Cut.

Fig.	Style	Floor Space	Horse Power	Wgt., lbs.	Boxed for Ex'pt		Code
					Wt., lbs.	Cu. ft.	
937	With Babbitt Bearings	2'9" x 8'	4 to 7½	1100	1500	66	<i>Distribute</i>
9371	With Ball Bearings	.....	.....	.....	.....	..	<i>District</i>
	Jointing Gauge, extra	.....	.....	.....	.....	..	<i>Distrouble</i>



## Perkins Universal Draw Cut Trimmer

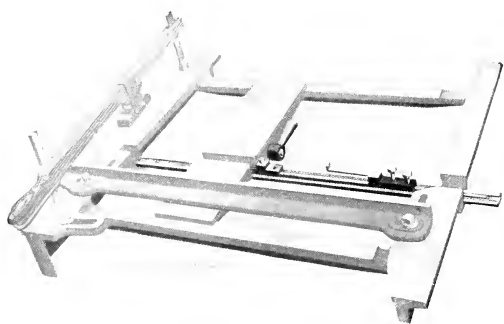
**T**HE Perkins Universal Draw Cut Trimmer is unquestionably the finest hand mitreing machine built. It is made with or without stand.

**Capacity**—It is made in two sizes with beds 20" x 8" and 22" x 13" respectively. Draw of knife on the smaller size is 1 $\frac{1}{8}$ ". The forward mitre 4 $\frac{3}{8}$ ", the backward mitre 5 $\frac{5}{8}$ ", and the length of trim 7 $\frac{1}{2}$ ". The draw of knife on the large machine is 1 $\frac{5}{8}$ ", forward mitre 8", backward 8 $\frac{1}{2}$ ", length of trim 12".

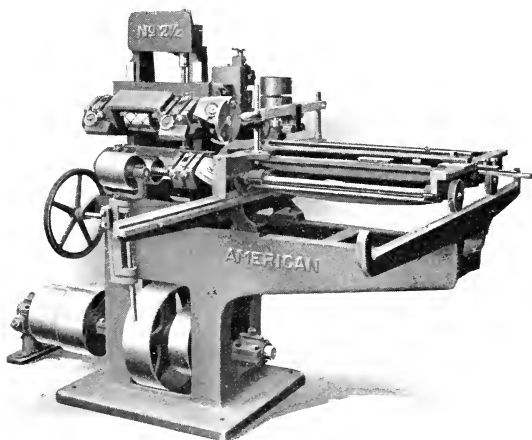
### Technical Features

**Stand**—Is a cored casting and supports the machine proper without vibration. **Knife Head**—The knife head ways are circular giving the knife a draw cut. Ways are universally adjustable for alignment. **Handle**—Is detachable and adjustable to suit work or convenience of operator.

No.	Size of Bed	Weight lbs.	Boxed for Export		Code
			Wt., lbs.	Cu Ft.	
8	20" x 8"	65	80	2	<i>Brave Braid Brand</i>
13	22" x 13"	155	195	5	
	Pedestal extra				



Patent Bridge Bar and Stop Gauge.



*Figure 9431*

American No. 2 1/2 Tenoning Machine

## American No. 2½ Tenoning Machine

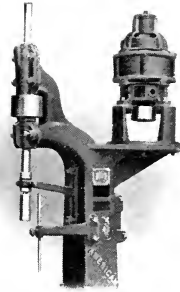
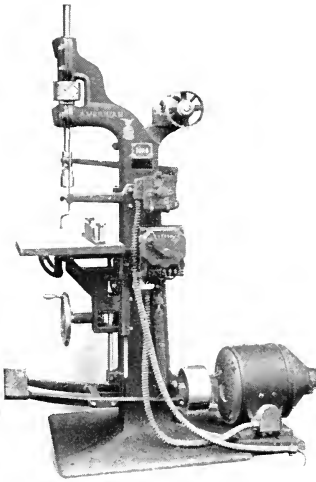
**T**HIS machine is designed for sash, blind, furniture and cabinet work. The machine is heavy and rigid in all its parts, has large base, is convenient in all adjustments, of new design and first-class in construction.

**Capacity:**—It will cut a tenon 3⅞" at one operation and 6¾" long by passing the material through the machine twice. Any thickness of tenon may be cut on stock up to 5¼" thick and 15" wide. One set of heads and knives are furnished with each machine. Cut-off Saw attachment can be furnished at an extra price.

### Technical Features

**The Headstocks**—Are both adjustable vertically by means of two screws. The top headstock has independent vertical adjustment to change thickness of tenon, and has lateral adjustment for cutting tenons with shoulders unequal distance from end of material on opposite sides. Both headstocks being adjustable in conjunction and with one screw enables the operator to center, or place, his tenon instantly. **The Cope Headstocks**—Are attached to the main headstocks and are adjusted with them. Each also has independent vertical and horizontal adjustments. **The Carriage**—Has combination roller movement which greatly facilitates the work, both in ease of operation and as to quantity turned out in a given time. It is properly secured to the ways, provided with guards and cleaning device, constantly retaining a perfect alignment with the cutter heads. The top of table has longitudinal lines to which the guide may be set, for various widths of material, at perfect right angles with the cut of the heads. A pocket is provided with spiral spring to hold a marker to mark the face side of material as the carriage is passed over the ways. The hold-down device is convenient and efficient and the fence may be set to any required angle. The rolls on which the carriage travels are connected from end to end and mounted in a frame, hence the carriage must move perfectly true across the ways. This insures not only an easy movement, no matter where the operator may take hold of the carriage, or how much weight there may be on it, but also perfect work. The carriage is equipped with our Patent Bridge Bar and End Stop Gauge. This effects a large saving of time and insures accurate work. **The Front or Rear Cut-Off Saw Attachment**—Has a lever by means of which the saw may be adjusted to a graduated scale, while in motion, to cut off the tenons at any desired length. This lever is handy to the operator and results in saving much time, especially on job work. This cut-off attachment is driven by a belt running from the cope counter, which belt may be removed when the cut-off saw is not in use. **The Cutter-Head Spindles**—Are 1¼" diameter carrying pulleys 4" diameter by 4¼" face, and run in side clamping boxes 4" long. The cope spindles are ⅞" diameter. **The Guide Pulley**—On the rear of the machine which acts on the belt that drives the cope counter is a decided advantage, because it gives this belt better contact on the pulley on the vertical shaft. **The T. & L.** (self-oiling loose) pulleys are 11"x5¼"; speed, 900 R.P.M.

Fig.	Style	Floor Space	Horse-power	Wgt., lbs.	Boxed for Exp't.		Code
					Wt., lbs.	Cu. ft.	
9431	Sgl. Hds., Two Copes	6'8"x5'	5 to 10	1800	2200	75	<i>Diureid</i>
9432	Sgl. Hds., One Cope	6'8"x5'	5 to 10	1700	2200	75	<i>Diurna</i>
9433	Sgl. Hds., No Cope	6'8"x5'	5 to 10	1600	2200	75	<i>Diva</i>
	Rear Cut-off Saw, extra	.....	.....	....	....	..	<i>Divalent</i>
	Front Cut-off Saw, ext.	.....	.....	....	....	..	<i>Divaricate</i>



## American No. 1 Vertical Borer

**O**UR No. 1 Borer is a substantially constructed machine, having broad base with wide foot flanges and stands free from vibration.

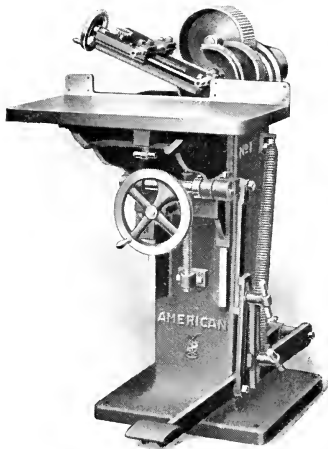
**Capacity**—Five bits are regularly furnished to bore holes,  $\frac{3}{8}$ " ,  $\frac{1}{2}$ " ,  $\frac{3}{4}$ " ,  $\frac{7}{8}$ " and 1" in diameter. The spindle is 10" from the post and has a throw of 10". The bit socket is removable and will receive bits having  $\frac{1}{2}$ " shanks. Self-centering chuck may be furnished at an extra price.

### Technical Features

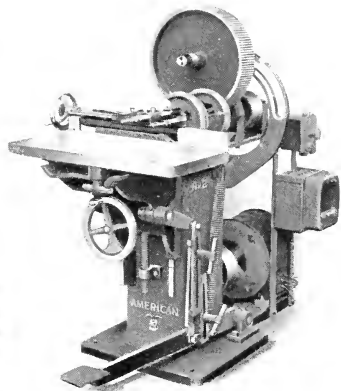
**Spindle**—Is of steel,  $1\frac{5}{16}$ " in diameter splined in a long sleeve which forms the journals for the boxes. Stops are provided to regulate the depth of hole, raising point of spindle, and to hold the stock to the table. **Table**—Has a universal movement and may be tilted forward or to either side; has vertical adjustment 9" by hand wheel and bevel gears. Distance from bit socket to table when raised to its highest point is 11"; when dropped to its lowest point, 20"; maximum distance from front of table to guide,  $15\frac{3}{4}$ "; width of table, 18". **Countershaft**—Has T. & L. (self-oiling loose) pulleys,  $8\frac{1}{2}$ "x  $3\frac{3}{4}$ "; speed, 500 R.P.M. Motor Drives can be furnished as illustrated, but are extra.

Fig.	Floor Space	Horse-power	Weight, lbs	Boxed for Export		Code
				Wgt., lbs.	Cu. ft.	
9721	4'4"x2'6"	3 to 5	900	1300	70	<i>Dividual</i>





No. 1



No. 2

Figures 980-981

## American Double Horizontal Boring Machine With Radial Adjustment

THIS machine is intended for that class of work in which two holes are to be bored at the same time, as in doweling, chair, cabinet, carriage, car and other similar work.

**Capacity**—No. 2 machine has cone pulleys for two speeds. Counter-shaft should be located overhead to equalize wear. Capacity No. 1, 1" to 10" apart and 5" deep; No. 2, 16" apart and 5" deep and from  $\frac{1}{8}$ " to  $\frac{3}{4}$ " in diameter. Bits carry screw shanks usually. We furnish one pair  $\frac{3}{8}$ " or  $\frac{7}{16}$ " bits, as ordered.

### Technical Features

**Two Spindles**—Are mounted in an adjustable head which swivels around one of them, so that they may be set at an angle from the horizontal line of the table, as shown in the cut. The range of adjustment is from a horizontal to a perpendicular line and beyond. The distance between the centers is adjusted by a screw on a gibbed slide independently of the angular adjustment in any position.

**Table**—Has a vertical movement on gibbed ways of 9" and forward and back movements also on gibbed ways of 6".

**The Intermediate Gear**—Is mounted on a radius arm, so that it always retains an even mesh with the central spindle and the arm is held rigidly by a segment bolted to the frame, thus preventing vibration. Both gear and pinions are very carefully cut and matched together, are very wide on the face, insuring durability, and they run without back-lash or rattle. Main gear is 4" face. **Spindles**—Are of steel, and the bearings are carefully scraped and fitted. The proportion of length of bearing to diameter is  $4\frac{1}{2}$  to 1. **The Adjustment Screw**—For the table is worked by a crank under the table, making it very convenient, and a foot lever attachment is applied to the table slide so that the operator has the use of both hands for the work. **The T. & L.** (self-oiling loose) pulleys are 8"x3 $\frac{3}{4}$ "; speed, 600 R.P.M.

Fig.	Style	Floor Space	Horse-power	Weight, lbs.	Boxed for Export		Code
					Wgt., lbs.	Cu. ft.	
980	No. 1	5'x2'4"	1 to 3	900	1160	68	<i>Dizzy</i>
981	No. 2	5'x2'4"	1 to 3	975	1285	68	<i>Djolan</i>

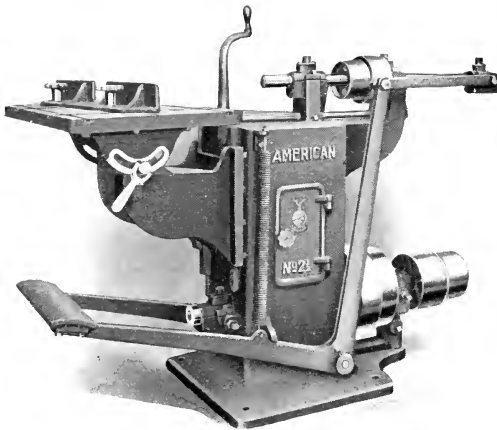


Figure 982

### American No. 2½ Horizontal Boring Machine

**T**HIS is a very strong and rigid machine, made entirely of iron and steel and suitable for furniture, chair, agricultural and general wood work.

**Capacity**—Has a stroke of 12" and will bore holes up to 3" diameter and to the center of 20" vertically. Furnished with each machine, one plain bit socket for ½" shanks, no bits. A self centering chuck can be had as an extra.

#### Technical Features

**Boring Arbor**—Is of steel, 1½" in diameter and is splined in a steel sleeve which runs in a very long bearing of fine babbitt metal, thus all the journals on the boring arbor are of steel. **A Steady Bearing**—Is placed next to the bit socket so that the wear can be readily taken up and the bit prevented from dodging as it enters the work. **The Vertical Lever**—Pulls directly on the center line of the spindle and not with a downward thrust. **Table**—Is iron, 18"x32" surface, and has slots for the fence at right angles so that long work can be bored endwise as well as across, at any required angle. The table tilts to 45 degrees both ways, and the adjustable fence can be clamped in any desired position, square, parallel to or at an angle with the boring spindle. Numerous holes are provided in the fence for the attachment of jigs or stops. **Stop Gauge**—Is easily reached by the operator at his post, and can be adjusted without stopping the machine. **The Foot Lever**—Is arranged to give a good leverage on the boring arbor, and there is a returning spring on each side of the frame to equalize the action. This arrangement gives a quicker and easier movement than a counterweight. The tension may be adjusted when necessary. **The Table Bracket**—Has a vertical adjustment of 10" and is carefully fitted to the ways with an adjustable gib; the screw-crank is removable. **The T. & L.** (self-oiling loose) pulleys are 8"x4½"; speed, 1000 R.P.M.

Fig.	Style	Floor Space	Horse-power	Wgt., lbs.	Boxed for Exp't.		Code
					Wt., lbs.	Cu. ft.	
982	With Plain Bit Socket Self-centering Chuck, extra	5'7"x2'8"	1 to 4 .....	1050 ....	1500 .....	70 ..	<i>Doand Doblin</i>

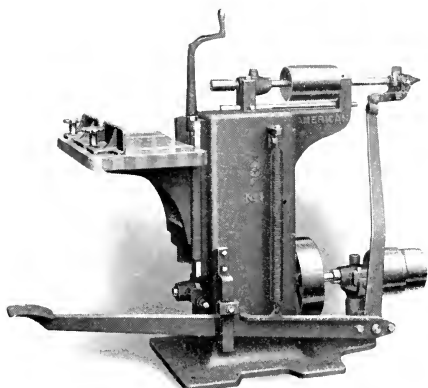


Figure 984

### American No. 1 Horizontal Boring Machine

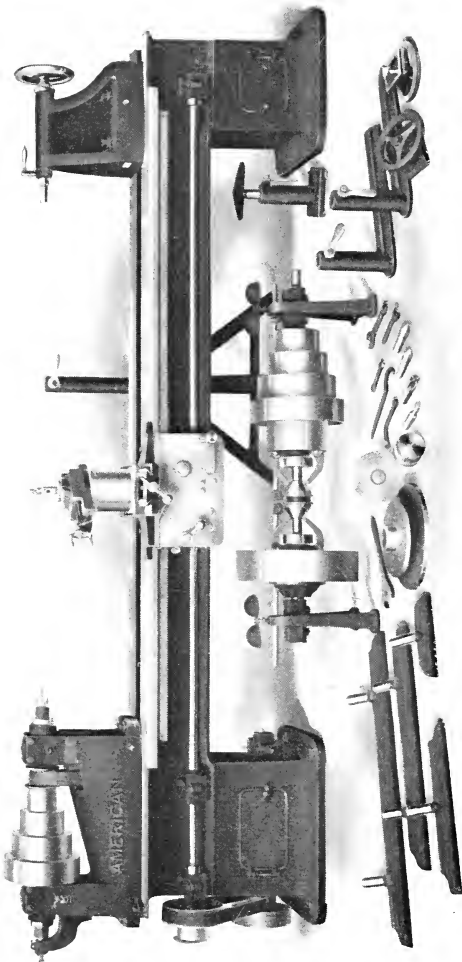
**T**HIS is a neat and practical design for light work in furniture, chair and general woodworking shops. The frame is cored out hollow and is cast in one piece.

**Capacity**— $4\frac{1}{2}$ " deep, up to 2" in diameter, and to the center of 20" vertically. A plain bit socket,  $\frac{1}{2}$ " hole, is regularly furnished.

#### Technical Features

**Spindle**—Of steel,  $1\frac{1}{8}$ " diameter, and slides in its own boxes, which are longer than the stroke. An adjustable stop-rod determines the depth of hole. **Table**—Is of hard wood glued up, 14"x28". Has an iron stop-bar adjustable to any angle, and held by suitable clamp wheels. Has vertical adjustment by a screw and hand crank, with a range of 10". Hand crank is removable when desired. **Rear Spindle Bearing**—Is turned smaller and has bronze end bearing. All bearings are well proportioned and lined with a fine quality of babbitt metal. The foot lever and returning springs are designed for quick and easy operation; there is no downward pull on the rear end of spindle. **Countershaft**—Has T. & L. (self-oiling loose) pulleys, 7"x3 $\frac{1}{4}$ "; speed, 1200 R.P.M.

Fig.	Style	Floor Space	Horse-power	Wgt., lbs.	Boxed for Exp't. Wt., lbs.	Exp't. Cu. ft.	Code
984	With Plain Bit Socket Self-centering Chuck, according to size, extra	5'2"x2'4"	1 to 4	600	800	40	Dobby Dobhash



*Figure 10441*  
American No. 7 Pattern-Makers' Lathe

## American No. 7 Pattern-Makers' Lathe

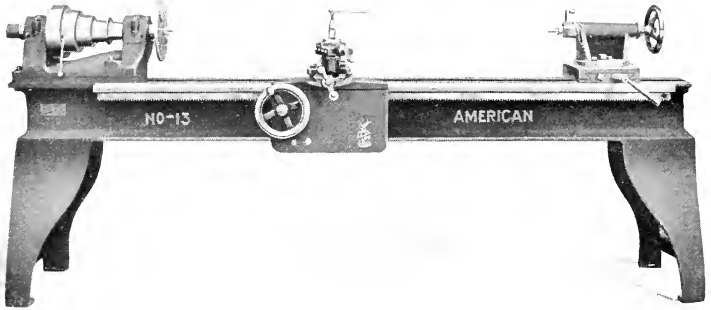
**I**N design and construction this tool has the quality of a modern iron working lathe, and is more convenient and quicker to operate than any other tool of its type.

**Capacity**—Built in three sizes, 20", 26" and 32" swing. For the 20" machine, beds are regularly furnished 10 feet long while for the 26" and 32" swing, beds are 12 feet. Beds of greater or lesser lengths can be furnished at extra prices. We furnish with each machine: one floor rest stand, one rest extension, two driving centers, two cup centers, two conical centers, three face plates, 8", 12" and 18" diameter, one rosette chuck, two rest sockets for bed, one rest socket for carriage, four rests, 12", 24", 36" and 48" long and one right-angle rest 6" long.

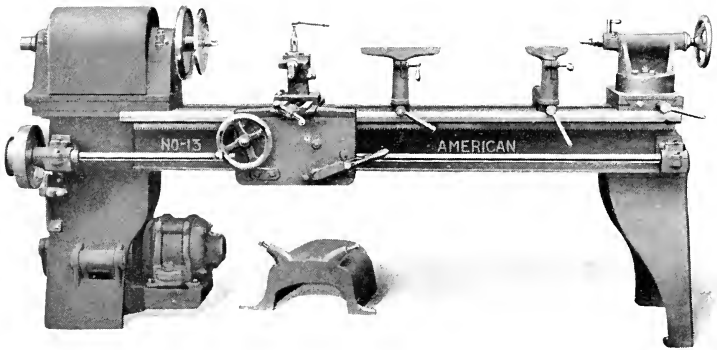
### Technical Features

**Frame**—Is heavy, and rigid, the two cored columns have wide flanges preventing any possible vibration. The ways on the bed are wide. The slide for the carriage is placed on the side of the bed and below the surface, and will not interfere with any tools resting on the bed. **Head Block**—Is extra heavy, having longer and wider base than on any similar machine. It carries a strong hollow spindle, which runs in our patent side-clamping, self-oiling boxes. The head block may be swiveled 5 degrees either way from the center line. The cone pulley is made of cast iron accurately machined both inside and outside. The large end of the cone pulley is closed to prevent dust collecting on the inside. **Spindle**—Has a  $\frac{3}{8}$ " hole running through it and it is made of the best crucible steel, machine ground and is absolutely true. The journals are lined with genuine babbitt metal and are adjustable to wear. An end step or thrust bearing is provided for the spindle so arranged with bronze thrust step, set screw and check nut, as to take up any end play. It is interchangeable and can be placed at either end of the head block. **Tail Block**—Is the open type to permit the cutting tools to be brought close to the centers without interference. The spindle is bored and reamed for centers, having a  $\frac{1}{2}$ " taper in 12"; the largest diameter is  $1\frac{1}{4}$ ", which is the same as the head block, insuring a large and rigid center. The adjusting screw turns in a bronze nut that is securely fastened to the spindle, yet is easily removed when desired. **Carriage**—Can be run either by hand or by power feed and in either direction. It has a 22" bearing on the front side of the bed, is securely gibbed and has a transverse thrust bearing between apron and lower side of bed. The automatic feeding mechanism for the carriage is self-contained in the apron, and consists of a train of metal gears driven by worm wheel, which are driven by a longitudinal feed shaft. This in turn is driven from a subcountershaft contained inside the base, which is driven by belt from the head block spindle. All bearings are self-oiling. There are two changes of feed,  $\frac{1}{16}$ " and  $\frac{1}{8}$ " per revolution of the spindle. This speed can be doubled by reversing the cones on the feed shaft. The cross line screw for moving turret has micrometer dial. **Cross-Slide**—Is neatly fitted and strongly gibbed to the carriage and has an extra long traverse for turning duplicate parts. **Turret Plate**—Is graduated in degrees so that the compound rest can be instantly set to any desired angle. **Countershaft**—Is driven by self-oiling friction clutch pulleys having bronze bushings arranged to run at two different speeds by two belts; namely, 120 and 750 R.P.M., giving the head block spindle a variation in speed from 71 to 2310 R.P.M., in eight speeds. Pulleys 10" and 20"x4 $\frac{3}{4}$ " face.

Fig.	Style	Size	Floor Space	Horse-power	Distance Between Centers	Wgt., lbs.	Boxed for Export		Code
							Wgt., lbs.	Cu. ft.	
10441	No. 7	20"x10'	11'3"x2'10"	4	5'10"	3200	4000	135	<i>Dogma</i>
10442	No. 7	26"x12'	13'3"x3' 3"	4	7' 4"	3700	4500	150	<i>Dogmatist</i>
10443	No. 7	32"x12'	13'3"x3' 3"	4	7' 2"	3800	4600	168	<i>Dogskin</i>
		Each Additional 2' of Bed, extra			.....	.....	.....	.....	<i>Dogwood</i>
		Hand Feed Instead of Power Feed			.....	.....	.....	.....	<i>Doily</i>



American No. 13 Pattern Makers Lathe  
(Hand Feed Carriage)



American No. 13 Pattern Makers Lathe  
(Power Feed Carriage and Motor Drive)  
(Motor extra)

## American No. 13 Pattern Makers Lathe

**O**UR No. 13 Lathe is a machine designed especially for work in pattern shops and for instruction in schools. It is fitted with swivel headblock, set over swivel tailblock and with carriage and tool post, the carriage to move by hand or power. The regular equipment is the hand feed carriage, power feed being an extra.

**Capacity**—Made with 16", 20" and 24" swing over bed; 13", 17" and 21" swing over carriage; 59" between centers, with cone headblock and 8' bed; 5' 2" with motor headblock. Beds may be furnished 10', 12' or 16' at extra price. When hand break wheel is used in connection with cone headblock the distance between centers is 57".

### Technical Features

**Headstock**—Has a hollow steel spindle running in hard metal boxes with ring oilers. Can be swiveled 5 degrees either way from center line. The spindle has a  $\frac{5}{8}$ " hole through it, and end thrust collars with check nuts to take up end motion. Motor headstock is equipt with ball bearings. **Tailblock**—Has set-over and swiveling features, and is graduated 20 degrees either way from center line. **Carriage**—May be operated by hand or by power (as an extra) and in either direction. It has a bearing 18" long on front way of bed, and has transverse bearing 6" long back of the apron. The feeding mechanism is self-contained in the apron of the carriage, consisting of cut gears, steel rack and worm wheel. The feed shaft is driven from a sub-counter on the rear of bed. The sub-counter is driven by a belt from cone spindle or motor. There are two changes of feed,  $\frac{1}{32}$ " and  $\frac{1}{16}$ " per rotation of spindle. The cross slide is gibbed to the carriage. Cross line screw for moving turret has indexed collar. The turret plate is graduated in degrees and may be removed by quarter turn of clamp bolt. The rest sockets are removable without removing hand wheel or clamp screw. **Countershaft**—Has two pairs T. & L. (self-oiling loose) pulleys 8"x3 $\frac{3}{4}$ "; speed 400 and 750 R.P.M. giving 8 speeds on head spindle. **Equipment**—One floor stand with offset rest socket, two driving centers, two cup centers and two conical centers, three face plates 6", 10" and 16" in diameter, one rosette chuck, two rest sockets for bed, one rest socket for carriage, three straight rests 12", 24" and 48" long, one angle rest 4" long. **Motor Drive**—Motor drive is an extra and choice is given between a D.C. and an A.C. headblock; or a D.C. or an A.C. motor mounted on saddle underneath lathe. Starting apparatus will vary according to conditions and for that reason none is illustrated here.

Fig	Swing	Style	Floor Space	Horse-Power	Wt. lbs.	8' Bed		Code	
						Distance Betw'n Centers	Boxed for Exp't		
						Wt. lbs.	Cu. ft.		
10481	16" 8'	8' Bed, Carriage and Comp. Rest	8'6"x2'	3	2400	5' 1"	3200	50	<i>Dolia</i>
10482	20" 8'	8' Bed, Carriage and Comp. Rest	8'6"x2'	3	2500	5' 1"	3400	55	<i>Dolichos</i>
10483	24" 8'	8' Bed, Carriage and Comp. Rest	8'6"x2'	3	2600	5' 1"	3500	60	<i>Dolichorb</i>
						Power Feed Attachment, Extra			<i>Dolichurus</i>
						Each 2' of Bed, extra			<i>Doliolum</i>

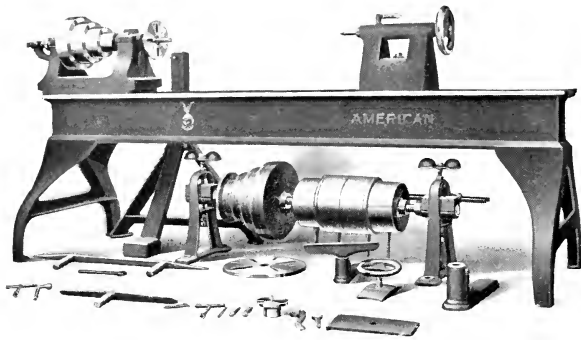


Figure 1050

### American No. 9 Pattern-Makers' Lathe

**O**UR No. 9 Pattern-Makers' Lathe is similar to the No. 8, except that it is not made with a carriage.

**Capacity**—Standard lengths of bed are 8', but beds 10', 12', 14' and 16' long can be furnished at extra price. Width across top flanges, 12½"; spread of legs 2'6". The parts usually furnished are head and tailstocks, one pair of driving centers, one pair of conical centers, rosette chuck, two face plates, two rest sockets, three "T" rests and floor rest stand countershaft.

#### Technical Features

**Bed**—Is cast-iron, mounted on iron legs, and planed perfectly true, with the headstock and tailstock carefully fitted to it and properly secured by clamping bolts. **Head and Tail Spindles**—Screws and all centers are of steel; the tail screw has square threads, and the hand wheel is turned and polished. **Main Bearing Caps**—Are planed into ledges on the headstock and lined with babbitt metal, which is carefully scraped, and the journals nicely fitted, so as not to heat when started. **Headstock Cone**—Is of iron, specially strengthened inside but quite light, and it can be reversed when ordered, to bring the large lift next the head center. The countershaft has kiln-dried wood cone, glued up in layers, with grain crossed, and fastened at both ends to shaft. **Main Arbor**—Extends at both ends with reversed threads as usual, and there is a detachable yoke to take the end thrust, provided with a bronze step and a hardened steel center pin. A large face plate for overhanging end of arbor and heavy floor rest stand, are furnished. **Countershaft**—And hangers with two pairs of T. & L. (self-oiling loose) pulleys, gives eight speeds on spindle; T. & L. pulleys for 20", 9"x4¼"; for 24", 10"x4¼"; speed, 400 to 750 R.P.M.

Fig.	Size	Floor Space	Horse-power	8' Bed Distance Between Centers	Weight, lbs.	Boxed for Export		Code
						Weight, lbs.	Cubic Feet	
1049	20"	2'6"x8' up	2 to 4	4'8½"	1200 to 1500	1600 to 1900	50to100	<i>Dold</i>
1050	24"	2'6"x8' up	2 to 4	4'1½"	1400 to 1600	1700 to 2000	56to120	<i>Dolent</i>
		Each additional 2' of bed, extra						<i>Dolesome</i>



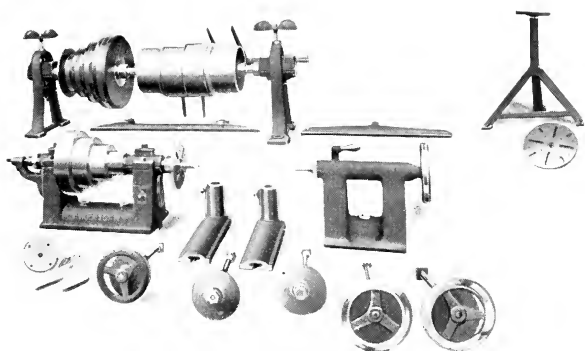


Figure 1052

## American No. 10 Pattern-Makers' Lathes

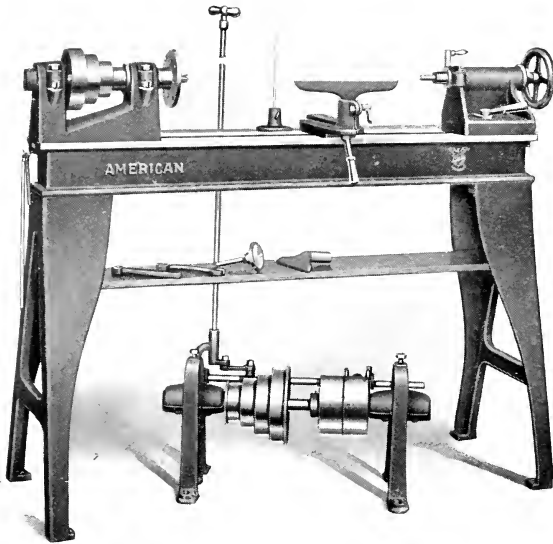
ON these lathes the head and tailstocks are cored hollow and made heavy and rigid so as to resist vibration or "chatter." The head and tail spindles and all centers are of steel; the tail screw has square threads, and the hand wheel is turned and polished.

**Capacity**—Made in three sizes, to swing 16", 20" and 24". The parts furnished include head and tailstocks, one pair of driving centers, one pair of conical centers, rosette chuck, two face plates, two rest sockets, three rests, floor rest stand and clamp bolts with hand wheels for bed 10" to 12" deep and countershaft.

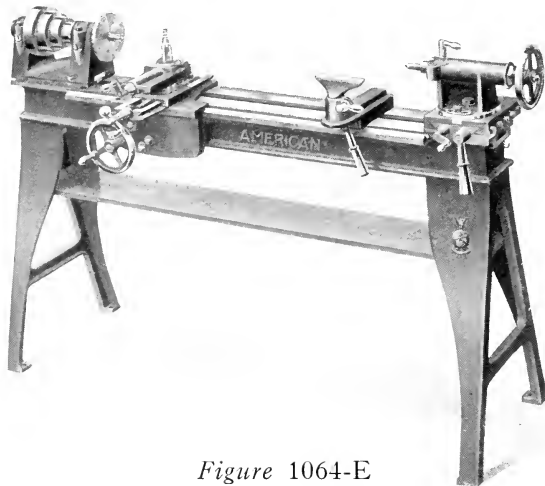
### Technical Features

**Main Bearing Caps**—Are planed into ledges on the headstock and lined with fine babbitt, which is carefully scraped and the journals nicely ground and fitted, so as not to heat when started. All surfaces resting on the bed are planed true and do not require fitting down if the bed is true. **Headstock Cone**—Is of iron, specially strengthened inside but quite light, and it can be reversed, when ordered, to bring the large lift next the head center. The countershaft has kiln-dried wood cone, glued up in layers with grain crossed, and it is fastened at both ends to the shaft. **Main Arbor**—Extends at both ends with reversed threads, as usual, and there is a detachable yoke to take the end-thrust, provided with a bronze step and a hardened steel center pin. A large face plate for the overhanging end of the arbor, and a heavy floor rest stand, are furnished. **Countershaft**—Has T. & L. (self-oiling loose) pulleys as per schedule below. Wood beds to order.

Fig.	Sg.	Dia. Hd. Spin.	Lgt. J'r'l.	Wdt. Cone Belt	H. P.	T. & L.	Speed	Wt., lbs.	Boxed for Export		Code
									Wgt., lbs.	Cu. ft.	
1052	16"	1½"	5½"	2 "	2 to 4	8"x3¾"	400 to 750	600	1000	47	<i>Dollin</i>
1053	20"	1¾"	6 "	2½"	2 to 4	9"x4¼"	400 to 750	800	1200	47	<i>Dolman</i>
1054	24"	2 "	7 "	3 "	2 to 4	10"x4¼"	400 to 750	900	1300	55	<i>Dolorous</i>

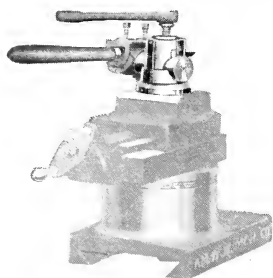


*Figure 1064*  
American 12-inch Speed Lathe  
Plain with Countershaft



*Figure 1064-E*  
American 12-inch Speed Lathe  
With Carriage and Tool Post and Swiveling Headblock and Tailstock

## American 12-Inch Speed Lathe



American Tool Holder

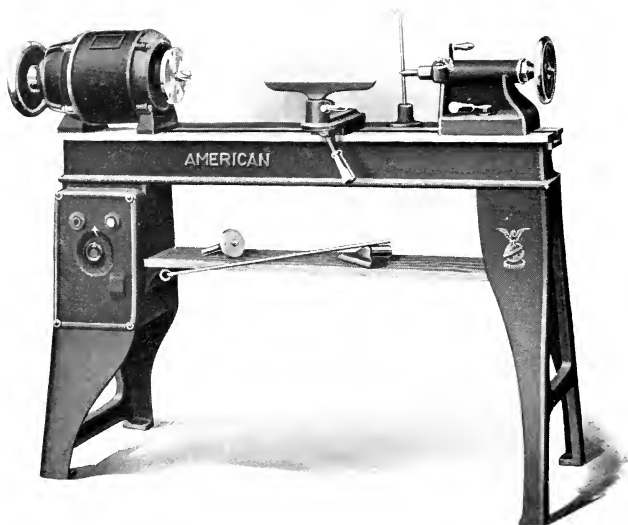
**T**HE American 12-inch Speed Lathe is a strictly high grade tool, designed for manual training work and will be found adequate to every purpose of the class room. It will also meet the requirements of any pattern shop for a lathe with a 12" swing. It is built with or without a movable carriage and set-over tail stock.

**Capacity**—It is made regularly with a 55" bed which gives a maximum distance of 26" between centers. It is also made with 48" and 72" beds, giving a distance between centers, 19" and 43" respectively. It is furnished with headstock and tailstock with swiveling features as an extra. With each machine is furnished a  $\frac{1}{2}$ " cup center, one 6" face plate, one 3" rosette chuck for interchangeable screws, one 6" rest, one 12" rest, one blue pin holder and one center drift for headblock.

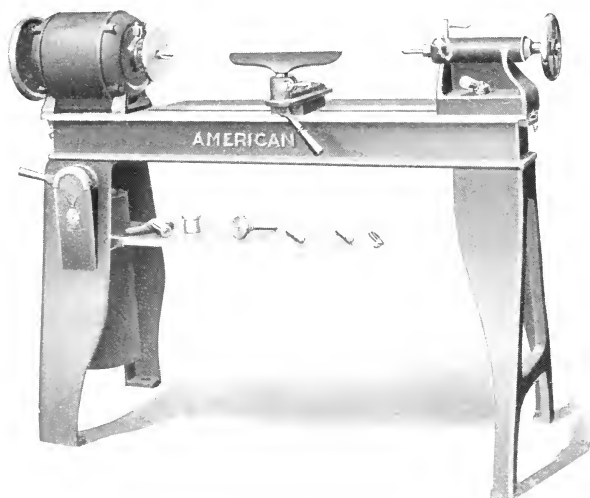
### Technical Features

**Bed**—Is made of cast iron, carefully planed and finished. There are no flanges on the inside to collect dust and chips. **Headblock**—Is nicely fitted on planed ways and secured by clamping bolts. The bearings on the belt driven lathes are ring oiling bronze bush and adjustable for wear. There are ball bearings on the motor headblock lathe. Cone Pulley is made of cast iron and is finished inside and out. The spindle is hollow and is made of high carbon steel. An end step thrust collar takes up all play. **Tailblock**—Is constructed so the cutting tools may be brought close to the centers without interference. Spindle is bored and reamed for centers, having a taper  $\frac{1}{2}$ " in twelve. **Countershaft**—Has self-oiling bearings, four step cone and tight and loose pulleys  $6'' \times 2\frac{3}{4}''$ , 800 R.P.M.

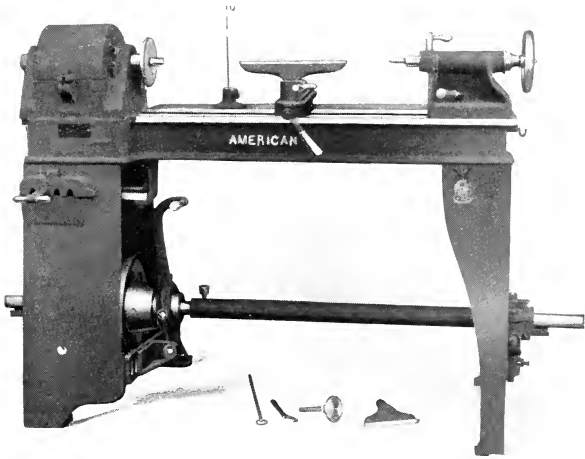
**Motor Drive**—Extra according to type. **D. C. Motor Headblock**—The A. W. C. Motor is a special design for use with our equipment only. Its operation is very simple, consisting of a start and stop push button station, the starting point working in connection with a magnet switch which closes the main circuit to motor. The rheostat handle must always be brought back to the minimum speed point in order to insure the motor starting on full field. The speed can then be regulated between 600 and 3000 R.P.M. by movement of the rheostat handle operating through field circuit of motor, and this provides maximum efficiency at all speeds. It is also provided with overload circuit breaker, low voltage release and dynamic braking which brings the motor down to predetermined speed. The stop button working in connection with the low voltage release, with the dynamic feature, brings the motor to a stop. **A. C. Motor Headblock**—An A. C. Headblock on a Speed Lathe is an entirely new idea; and, the fact that it is new and because we originated it, we are not a little proud of it. Heretofore an A. C. Drive has been obtained by mounting the motor on a saddle underneath lathe and belting from the cone on motor to the one on the headstock. The convenience and safety of our new Motor Headblock idea over the old method will be readily apparent since the use of belts is eliminated. Motor is  $\frac{1}{2}$  H. P. 3 phase, 60 cycle and gives four speeds—570, 1,140, 1,710, 3,420. (A 2-phase installation can be had at a slight additional cost.) The controller, like the motor, is made especially for use after our own specifications. It is mounted in the leg of the lathe and is operated by the lever shown in cut. It is totally enclosed and in the "off" position the motor is entirely disconnected from the line. **Motor Underneath Head Block**—This motor is  $\frac{1}{2}$  H. P. and is mounted on a saddle underneath the headblock and enclosed. To the motor shaft is attached a four-step cone pulley which is belted to the cone pulley in the headstock through an opening in the bed of the lathe. This motor may be a D. C., a single-phase A. C. motor, or again a two or three-phase A. C. motor. The illustration shows a polyphase motor, any voltage, running 1800 R.P.M. The Starting Apparatus, as shown below is an American Iron-Clad Fused Switch which is totally enclosed.



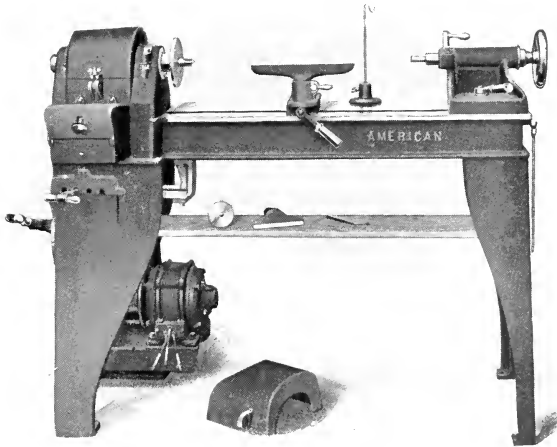
*Figure 1064-B*  
American 12-inch Speed Lathe  
With Motor Headblock and A. W. C. Special Control



*Figure 1064-C*  
American 12-inch Speed Lathe  
With Motor Headblock and A. W. M. Special Control



*Figure 1064-A*  
American Friction Clutch



*Figure 1064-D*  
American 12" Speed Lathe  
A. C. Motor Mounted on Saddle and A. W. M. C. Enclosed Switch

# Details of American 12-Inch Speed Lathe

## GENERAL

Sizes of lathes 12"x48"; 12"x55"; 12"x72". Distance from floor to top of bed, 36".  
 Distance between centers, 19", 26", 43". Depth of bed, 5 1/8".  
 Width of bed, 6 1/2".  
 Distance from floor to center of spindle 42". Width of belt on Tight and Loose pulleys 2".  
 Diameter of driving shaft, 1 5/16".

## HEADSTOCK

Length of headstock, 12 3/8". Size of bearings, 1 7/16" x 3" and 1 3/8" x 3".  
 Width of headstock, 6".  
 Length of spindle over all, 14 1/16". Diameters of cone on spindle, 6 1/4", 5", 3 3/4", 2 1/2".  
 Diameter of spindle, 1 7/16". Rates of speed, 480; 800; 1333; 2400.  
 Diameter of hole in spindle, 1/2".  
 Width of belt used, 1 1/2".

## TAILSTOCK

Length of tailstock, 9". Length of spindle, 8 1/2".  
 Width of tailstock, 6". Diameter of spindle, 1 3/8".  
 Set-over of tailstock, 2" back of center and 1" forward of center. Size of bearings, 1 3/8" x 8".  
 Adjustment of spindle, 5".

## CARRIAGE AND TOOL POST

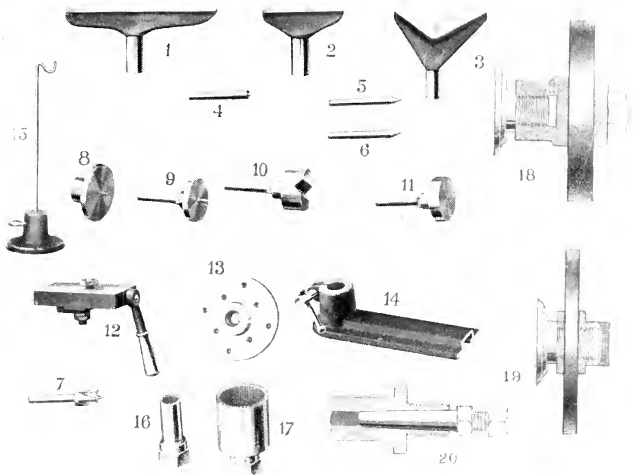
*On the 48", 55" and 72" Lathes respectively.*

Travel on bed, 17 1/2"; 24 1/2"; 41 1/2". Cross feed, 5".  
 Length of bearing on bed, 12". Size of slot in post, 1 9/32" x 1 3/8".

## COUNTERSHAFT

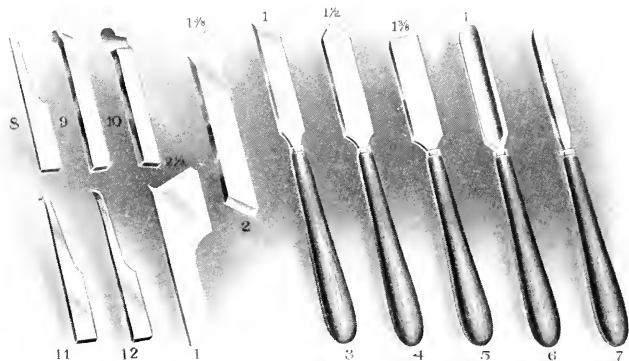
Length of Shaft, 30". Diameter of cone, 3 3/4"; 5"; 6 1/4"; 7 1/2".  
 Diameter of Shaft, 1 5/16". Face of cone, 1 1/2".  
 Drop of hangers, 9". Speed of Shaft, 800.  
 Size of bearings, 1 5/16" x 6 1/4".  
 Size of tight and loose pulleys, 6" x 2 3/8".

Fig.	Style	Horse-power	Wgt., lbs.	Boxed for Export		Code
				Wt., lbs.	Cu. ft.	
1064	12" Speed Lathe, 55" bed without carriage and tool post—with countershaft . . . . .	1/2	500	800	30	<i>Domal</i>
	48" Iron Bed . . . . .	..	...	...	..	<i>Domboc</i>
	72" Iron Bed . . . . .	..	...	...	..	<i>Dome</i>
	90" Iron Bed . . . . .	..	...	...	..	<i>Domert</i>
	Rear End Face Plate and Floor Stand—without rest, extra . . . . .	..	...	...	..	<i>Domesday</i>
	Universal Hand Turning Tool Holder, extra . . . . .	..	...	...	..	<i>Domestic</i>
	Carriage and Compound Rest and Tool Post, extra . . . . .	..	...	...	..	<i>Domett</i>
	Set-over Tailblock, extra . . . . .	..	...	...	..	<i>Domicella</i>
	Cone mounted on American Friction Clutch for shaft above lathe, extra . . . . .	..	...	...	..	<i>Dominant</i>
	Cone mounted on American Friction Clutch for shaft underneath Lathe (no shaft)—extra . . . . .	..	...	...	..	<i>Domine</i>
	D. C. Motor Headblock and Special A. W. C. Control (Conduit Wiring), extra . . . . .	..	...	...	..	
	D. C. Motor Headblock and Ordinary Field Control, extra . . . . .	..	...	...	..	
	A. C. Motor Headstock with Controller and Dynamic Brake, extra . . . . .	..	...	...	..	
	A. C. Motor on Saddle underneath and Iron Clad Fused Switch, extra . . . . .	..	...	...	..	
	A. C. Motor on Saddle underneath and American Enclosed Switch, extra . . . . .	..	...	...	..	



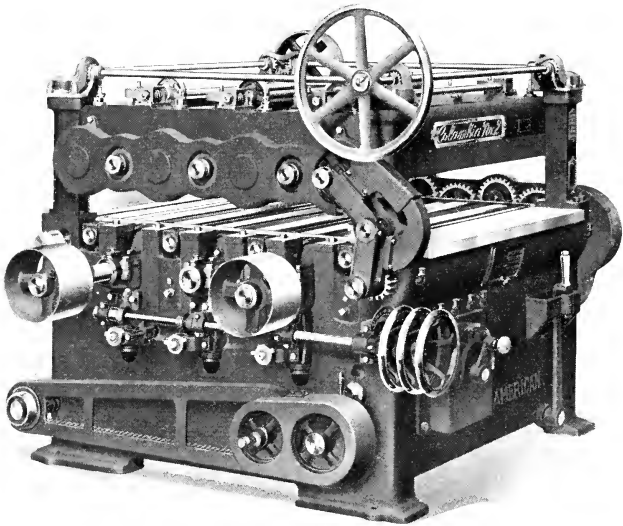
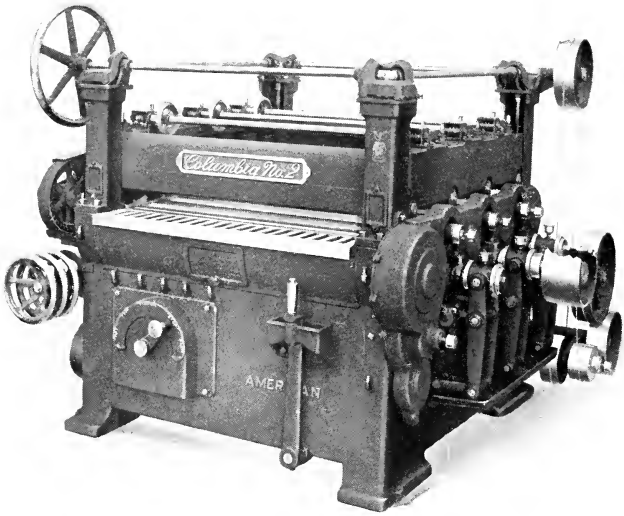
### Auxiliaries used on Lathe in Turning

1, 12" rest. 2, 6" rest. 3 Angle rest. 4, Cup center. 5 and 6, Conical centers. 7, Spur center. 8, Rosette chuck face plate. 9, Rosette chuck with face plate and taper center. 10, Crotch center. 11, Drill pad. 12, Rest socket plate. 13, 6" face plate. 14, Rest socket. 15, Print holder. 16, Small Hollow chuck. 17, Large Hollow chuck. 18, 1"x7" Emery Wheel Attachment, no emery wheel furnished. 19, 1/2"x7" Emery Wheel Attachment, no emery wheel furnished. 20, Speed Lathe Collet.



### American Turning Tools

The above cut shows a few styles of American Gouges or Turning Tools. 1, Roughing and Smoothing Chisel. 2, Double Edge Skew Chisel. 3, Skew Edge Chisel. 4, Spear Point Chisel. 5, Straight Chisel. 6, Gouge. 7, Round Nose Chisel. 8, 9, 10, 11, 12, Tool Post Turning Tools for Carriage.



*Figure 10700*

American No. 2 "Columbia" Three-Drum Sander



## American No. 2 "Columbia" Sander

OUR Columbia Sander was the first machine made with a successful automatic take-up drum. The machine in recent years has undergone many minor improvements, and the product we turn out today we designate our Columbia No. 2.

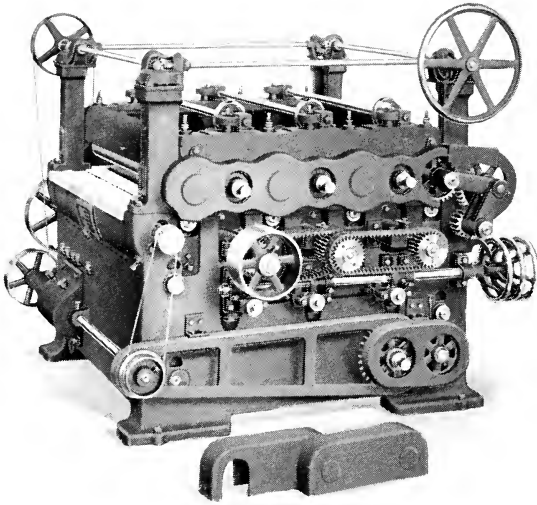
Quite recently we have added a new method of driving the drums; that known as our Silent Chain drive which is furnished at the option of the purchaser. See page 76.

**Capacity**—Made regularly to open 8", but can be made to open 12" thick at an extra price. There are three rates of feed, and the machine is furnished with drums covered with sandpaper ready for use.

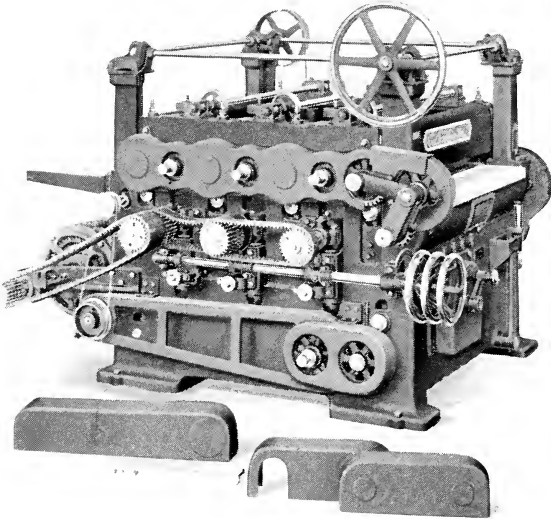
### Technical Features

**The Top Frame**—Is supported on all four corners on posts, and rises and falls on raising screws, which have bearings on top and bottom. All back-lash of the screws is avoided, whereby one of the most common causes of poor work—viz., the rocking of the top frame—is overcome. All operators who have had to contend with back-lash in the raising screws will appreciate our device for overcoming this fault. **The Cylinders**—The most important feature of a sander, are three in number, each made in one piece, of semi-steel casting, turned, ground and balanced on especially constructed machines. They are provided with our patent automatic paper tightener, which takes up all slack in the paper while the machine is doing its work. Tight-fitting paper is the first requisite for good work. On no other make of sander is found this automatic feature, as it is covered by our own patents, and we guarantee that in all instances it will perform just what we claim for it; namely, that the paper on the drums will be kept at an even tension at all times and at all points. The adjustment of the cylinders is regulated by hand wheels, placed together on the working side of the machine in convenient reach of the operator. The raising and lowering is accomplished by wedges, which give the cylindershaft boxes a firm support, avoiding all jumping as is necessarily the case when raising and lowering is accomplished by screws. For re-covering the cylinders with felt or cloth, it is not necessary to take them out of the machine, as is the case with other makes of sanders, since this operation can be performed with little trouble while the cylinders remain in their respective places in the machine. **Feed**—There are three speeds of feed practically instantaneous. The lever and segment for operating the feed are located on the left hand side of the lower front girt. The segment contains five holes—three for the different speeds of feed, and two intermediate holes for instantaneously stopping the feed. The device is accessible through an opening in the front girt of machine. **Power Hoist**—Is provided for the top feed works, which is not only a saving in time but also in labor. Its action is prompt and perfectly reliable. **In The Oscillators**—We have obtained mechanical perfection, and by our device the reciprocal movement is absolutely in the line of the axis of the cylinder, thereby avoiding any lifting or cramping motion. This is imperative to secure good work. **The Boxes**—For cylinder shafts, oscillators and counter-shafts are self-oiling, having oil receptacles and drain plugs; the loose pulley is also similarly arranged.

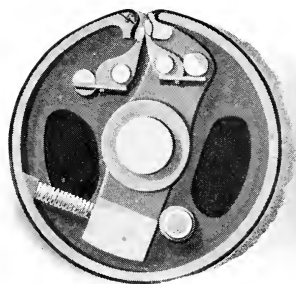
Fig.	Size	Floor Space	T. & L.	Speed	Horse-power	Wt., lbs.	Boxed for Exp't.		Code
							Wt., lbs.	Cu. ft.	
10700	31"	5'2"x 6' 5"	12x 8½	550	10 to 20	7700	8900	256	<i>Dorsiduct</i>
10711	37"	5'2"x 6'11"	12x 8½	550	10 to 20	8200	9500	265	<i>Dorsouluar</i>
10722	43"	5'2"x 7' 5"	14x10½	550	15 to 25	8700	10000	280	<i>Dory</i>
10733	49"	5'2"x 7'11"	14x10½	550	15 to 25	9300	10900	300	<i>Dosage</i>
10744	55"	5'2"x 8' 5"	14x10½	550	20 to 30	9800	11700	320	<i>Dosilthean</i>
10755	61"	5'2"x 8'10"	16x12½	550	20 to 30	10500	12500	345	<i>Dosshouse</i>
10766	67"	5'2"x 9' 5"	16x12½	550	20 to 30	11200	13200	380	<i>Dot</i>
10777	73"	5'2"x 9'11"	16x12½	550	25 to 35	11800	13800	430	<i>Dotation</i>
10788	79"	5'2"x10' 5"	18x14½	550	25 to 35	12700	14900	475	<i>Dotkin</i>
10799	85"	5'2"x10'11"	18x14½	550	25 to 35	13600	15900	520	<i>Dotterel</i>
		Sander any width to open 12" thick on order				.....	...	...	<i>Douar</i>



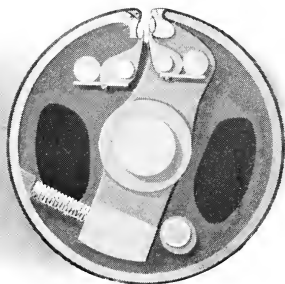
American No. 2 Columbia Three Drum Sander  
(Silent Chain Drive—Belt)



American No. 2 Columbia Three Drum Sander  
(Silent Chain Drive—Motor)



Clamps Closed



Clamps Open

### Automatic Sand-Paper Take-up

**T**HE illustration above shows two transverse sections of the Columbia Sand-paper drum and reveals the operation of our Automatic Take-up, which, we claim, is the simplest and most efficient device of its kind made.

The drums are cast in one piece (not made by short sections set-screwed to the shaft), which greatly enhances the rigidity of the shaft removing from it all trembling.

The Take-up frame or paper stretcher is also cast in one piece, and swings loosely on the drum shaft. Before it is inserted into the cylinder it is carefully balanced.

The clamps consist of an oval steel bar fitting closely in an oval seat. One clamp is fastened to the cylinder casting, the other to the Take-up frame. They are actuated by eccentric clamp shafts. Turning these in one direction closes them, and turning them in the opposite direction opens them.

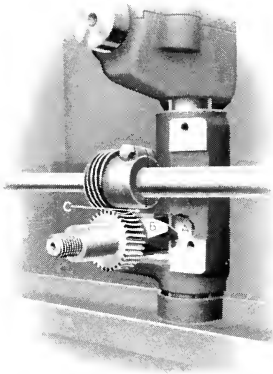
The clamp shafts press on a series of flat springs in order to accommodate different thickness of paper at the same time, furnishing an excess of pressure. The paper being held in oval seats with the aforesaid excess of pressure can never pull out.

The Take-up is held back by a series of eccentrics while the paper is being put on the drum. As soon as these are released the coil springs come into action pushing it towards the other side of the open slot. As it is mounted on the central shaft and moves on the line of the circumference, any slack of paper that may occur will instantaneously be taken up as it appears.

To put the paper on the Columbia drum is the simplest kind of a job and requires but a moment. Place one end of the paper into the set of clamps on the strike side of the drum and close the clamps; then revolve the drum until the other set of clamps appear; insert the other end of the paper into the remaining set of clamps and close them. This done, release the eccentric, and the work is finished.

If it should become necessary to re-cover the drums with felt or canvas the operation is easy and consumes but little time. There is a half-round strip of steel under which is fastened the felt on the strike side of the drum. The other end is simply tucked in and held by the take-up. When it is remembered that there are sanders on which the drums have to be taken from the machine before they can be re-covered, this is no small item in favor of the Columbia.

## Wedge Block Adjustment of Drums



THIS illustration is a broken out view of the wedge block adjustment as applied to the Columbia Sander. By the use of the wedge block we have an absolutely rigid support that will not wear, as is the case where the drums rest on screws. Hence, no lost motion can occur to disturb the parallelism of the drums.

A, represents the drum box stem which fits closely into a reamed hole in the frame. Across this stem is planed deeply a diagonal slot which the wedge block, B, engages. This wedge block slides in a sub-

stantial housing in the frame—represented by C. The wedge blocks on both sides are connected and adjusted by hand wheels at the front of machine.

A careful study of the illustration will clearly show the rigidity that must obtain with this construction, and the superiority over raising screws must be readily apparent.

If it should become necessary to adjust these wedges for an alignment of the drums (which is most unlikely) provision is made for that, and it is simple—requiring nothing but the turning of a screw in the block itself.

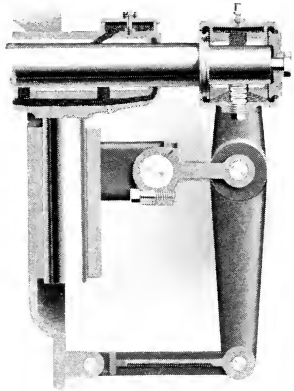
## A Perfectly Central and Non-Cramping Oscillator

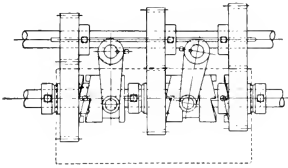
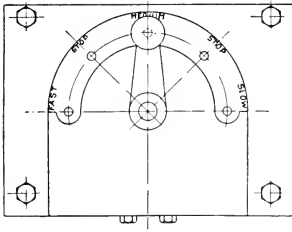
THE oscillator is the most delicate piece of mechanism in the construction of a sander and the most difficult in which to overcome wear and lost motion. As implied in the title, its action must be perfectly central and there must be no cramping. In other words, there must be no pulling up and down.

The flexible joints together with the eccentric and strap illustrated here insure an absolutely central oscillation.

Means for the perfect circulation of oil is an essential feature of the Columbia oscillator, as well as of the drum shaft bearings, and is clearly shown in the illustration.

Provision is made for taking up lost motion in the oscillator bearings as shown by the reversed collar on the end of the drum shaft which is filled with fibre washers. Babbitted washers are located between the collars and the oscillator boxes to prevent any wear there.





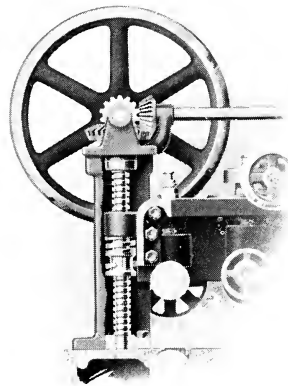
## Quick Change of Feed Speed

ON the Columbia Sander there are three speeds of feed produced quickly by our gear change illustrated here. The principle is about the same as that used in automobiles and is instantaneous. The lever and the segment are located on the left hand side of the lower front girt. The segment contains five holes—three for the different speeds of feed, and two intermediate holes for instantaneously stopping the feed.

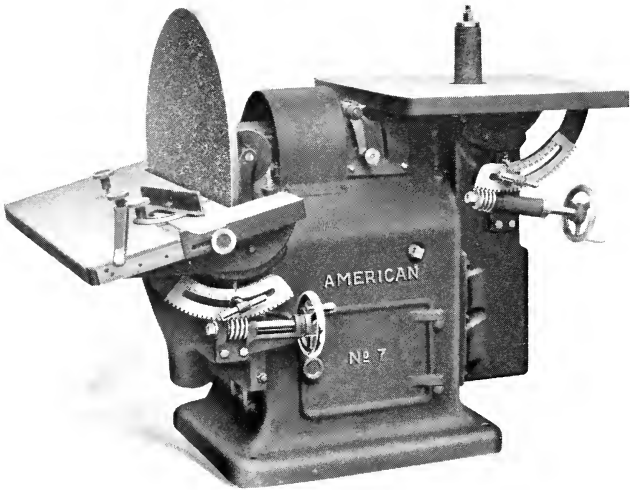
All the component parts of the device may be easily replaced should occasion demand it. The device is accessible through an opening in the front girt of machine.

## Rigid Screw Corner Post for Feed Works

A NOTEWORTHY feature in the construction of the Columbia Sander is found in the method of supporting the upper feed works frame, whereby the greatest rigidity possible is obtained. The four cast iron corner posts contain each a short heavy screw with a bearing top and bottom. To these screws the frame is attached and a coil spring with a take-up nut is placed below it to take up any wear that may appear in the screw.



There are sanders whose only support for the feed roll frame is four long corner screws fastened only at the bottom; with all such the roll frame is never steady and when feeding thick stock it will sway back and forth. Not so with the Columbia—there is absolute rigidity even when the roll frame is up to its highest point.



*Figure 11140*

### **American No. 7 Disk and Spindle Sander**

**WE** have incorporated in this design all the requirements for a combination sanding machine for Pattern, Furniture, Chair, and general woodwork for either flat or curved surfaces. Ball bearings are provided on the operating spindles; all moving parts are driven from the main arbor and provision is made on the base for the attachment of a motor with automatic belt tightener for driving the arbor; or it may be driven from the countershaft which is furnished unless otherwise specified. The machine is made in three forms, viz.: as shown in the engraving with disk and vertical roll spindle; with disk and drum; or with two disks; either form admits of the unit motor drive when ordered as an extra.

## Technical Features

**Main Frame**—Is massive, has a broad base and is a single casting in cored form measuring 26" x 31" on the floor. **The Disks**—Are of semi-steel  $\frac{3}{4}$ " thick, machined to hold the cement and put in exact running balance. Dust hood under the table is arranged to connect with an exhaust pipe. Disks are quickly removable from the main arbor for changing the sand paper. **Disk Table**—Moves vertically on machined and hand fitted ways and is counterbalanced by protected weights; a foot lever linked to the slide and operated from the right hand side of the machine overcomes the friction on the ways and makes the adjustment easy; a clamp screw on the slide gib is located over the lever. The table is also adjustable to and from the disk and can be tilted from 10° up to 45° down by means of a toothed and graduated quadrant operated by a worm and hand wheel. The quadrant can be clamped rigidly at any angle and the table rests on machined rockers—the center line of which lies on the face of the disk. **Roll Spindle**—Has ball-bearings in a vertically moving yoke which gives an end motion to the sand roll while in operation. The spindle is  $\frac{7}{8}$ " diameter where the rolls are attached and the latter are clamped on by cupped collars and held perfectly central. The rolls are made of kiln dried hardwood covered with elastic material and cut in two centrally for easy attachment of the sand paper and a quick change of sizes. **Roll Table**—Is 27" x 27" and can be tilted forward 45° and backward 5°. It is adjusted to any position by a toothed quadrant and worm and hand wheel and after adjustment can be clamped rigidly. Center plates are fitted into the table around the rolls permitting quick changing and also the tilting of the table but with a close clearance around the rolls. **Drives**—May be by a belt to the main arbor through the countershaft; roll spindle can be disconnected from the main drive by a clutch which releases all the operating parts connected with the roll spindle. Motor drive attachment is provided for on the machine frame with an automatic belt tightener, making a unit construction with starting box attached, needing only connection with the power circuit. In ordering a motor drive (extra) state the kind of current required; we recommend and usually carry in stock A. C. 3 phase 220-volt motors. **Countershaft**—Has 10 x 5½ T. & L. pulleys and should run 625 R. P. M. giving main arbor 750 R. P. M. **Equipment**—Consists of three spindle rolls with table plates to correspond, one extra 30" disk, six No. 1½ sand paper circles, one centering slide and one graduated gauge for the disk table, together with necessary wrenches and one can of cement. **Floor Space**—48" x 65" (with motor attached)

Fig	Style	Floor Space	Horse-power	Wt., lbs.	Boxed for Exp't.		Code
					Wt., lbs.	Cu. Ft.	
11130	No. 7 —30" double disk	4' x 5'	5	2800	3500	80	<i>Drainabo</i>
11140	No. 7-A—30" disk and roll spindle	4' x 5'	5	2200	3400	78	<i>Drainacot</i>
11150	No. 7-B—30" disk and drum	4' x 5'	5	2100	3300	78	<i>Drainadad</i>



Figure 1111

### American No. 6 Disk and Drum Sander

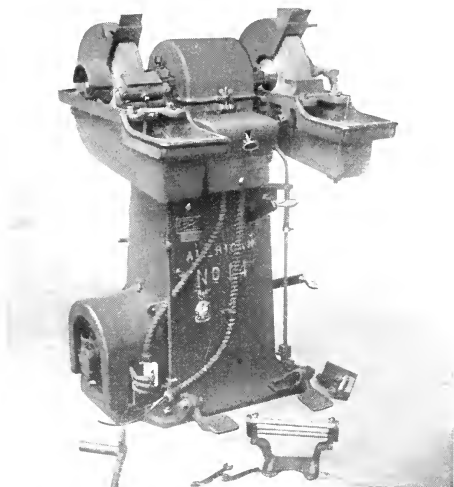
**T**HIS machine is intended for use in furniture, chair and cabinet shops and is peculiarly adapted to manual training school work. It is made with a disk and drum, or with two disks and in range of sizes, per table below.

#### Technical Features

**Disk**—The disk is made of iron, accurately turned and balanced. The clamping ring is made in four sections for convenience in renewing paper. The regular sizes of disks are 30", 36", 42" and 48" in diameter, and the working surface in each case is 2" less. The arbor is of steel accurately ground and runs in babbitted self-oiling boxes. **Drum**—Is built up of kiln-dried wood on iron centers and is made in two sizes 13" x 16" and 16" x 24". It is covered with carpet or felt which makes a proper mounting for the sandpaper. **Tables**—The disk table is adjustable vertically by hand wheel as shown in cut and tilts to an angle. The drum table may be removed if desired. They are made of glued up strips of hardwood, or of iron, if ordered. **Counter-shaft**—T. & L. (self-oiling loose) pulleys are 12" x 4½", and should make 450 to 700 R.P.M. **Motor Drive**—When motor drive is furnished the base is extended to receive the motor as shown in the illustration.

Fig.	Style	Floor Space	Horse-power	Wgt., lbs.	Boxed for Exp't.		Code
					Wt., lbs.	Cu. ft.	
1108	No. 6, Two 48" Disks, Two Tables	4'x5'8"	2	1675	3200	100	<i>Drag</i>
1109	No. 6, Two 42" Disks, Two Tables	4'x5'8"	2	1500	3100	100	<i>Draggy</i>
1110	No. 6, Two 36" Disks, Two Tables	4'x5'8"	2	1350	3000	100	<i>Dragonet</i>
	No. 6, Two 30" Disks, Two Tables	4'x5'8"	2	1200	2900	100	<i>Dragpot</i>
1111	No. 6, Disk and Drum Sander, 36" Disk, 16"x24" Drum, three bearings	4'x5'8"	2	1050	2500	100	<i>Dragsmen</i>
1112	No. 6 Disk and Drum Sander, 30" Disk, 13"x16" Drum	4'x5'8"	2	900	2400	100	<i>Drum</i>





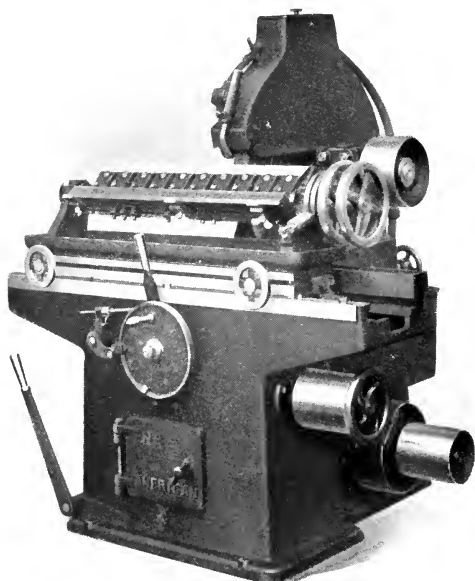
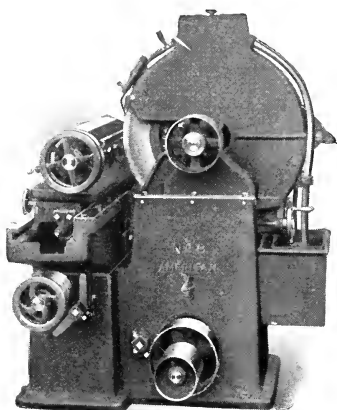
### American No. 14 Grinding Machine

**O**UR No. 14 Grinder is designed especially for manual training schools, pattern and general woodworking shops. It is provided with two 12"x2" alundum wheels, and one 5"x3 $\frac{1}{4}$ " alundum cone for wet grinding. It has an attachment for grinding flat hand-plane bits. Oil stones can be used in place of the alundum wheels, but the latter are preferable because they will not gum up easily and do not have to be frequently dressed off on that account. Two alundum wheels 12"x2" and one alundum cone 5"x3 $\frac{1}{4}$ " are furnished when required. Hole in wheels 1 $\frac{1}{4}$ " diameter.

#### Technical Features

**Frame**—Is a one-piece casting with broad foot flange and stands free from vibration when the wheels are kept in balance. **Arbor**—Is fitted with a two-step cone pulley, giving two speeds for different size of wheels. The driving cone and belt are enclosed in the machine. The arbor bearings are of good length and are self-oiling. Water tanks are located under each wheel and are adjustable vertically by foot treaders at the base of machine. **Motor Drive**—When motor drive is required (as shown in the cut) the base of the machine is extended to receive the motor which takes the place of the tight and loose pulleys, being connected direct to the lower cone shaft. **Countershaft**—(When furnished) has **T. & L.** (self-oiling loose) pulleys, 8"x3 $\frac{1}{4}$ " and should make 1100 R.P.M. for the alundum wheels, or 550 R.P.M. for oil stone wheels. **Motor Drive**—Cut shows A.C. motor mounted directly onto frame of machine and American Iron-Clad Fused Switch. This is an extra.

Fig.	Floor Space	Horse-power	Weight, lbs.	Boxed for Export		Code
				Wgt., lbs.	Cu. ft.	
11401	23"x34"	1 to 2	690	990	48	<i>Drivington</i>



*Figure 1126*

American No. 9 Universal Knife Grinder

## American No. 9 Universal Knife Grinder

**A**N extremely rigid, well designed, finely fitted machine, intended for accurate results by critical users, in grinding thin hard steel knives as well as the ordinary planer knives. The frame is of pedestal form, cast in one piece, and it supports the carriage ways, the adjustable head stock carrying the grinding wheel arbor and all the operative parts of the machine.

**Capacity**—Made in two sizes, 31" and 37".

### Technical Features

**The Carriage**—Moves on gibbed ways by means of a rack and gear- and is extra heavy and rigid. Stops are provided for changing the stroke which can be adjusted when in motion. The actual extreme reciprocation of the carriage is about 3" more than the rated capacity of the machine, so that the wheel clears the knife at both ends while reversing. **The Grinding Headstock**—Is gibbed down to ways planned at right angles to the carriage ways, and the arbor bearings are of the side clamping type, making adjustment easy and accurate. A cross-feed screw is provided to adjust the wheel to the work automatically as the carriage reciprocates, and it has a hand wheel convenient to the operator, for independent adjustments. **The Feed**—Is entirely automatic, the reciprocation of the carriage being continuous, and the forward feed of the grinding wheel is capable of adjustment from 1-1000" to 1-3000" to each reciprocation. This movement is controlled by a stop which can be set so that the wheel will cease grinding at any point, and by means of the vertical hand lever, the reciprocation of the carriage can be varied or stopped at any point. **The Patent Knife Bar**—Is a new departure in machines of this class and enables the operator to grind ordinary slotted knives in the usual way, and also provides a clamping jaw to hold thin hard steel knives, which may be firmly held and ground without a separate attachment to the bar. By a special device, thin knives can be brought up to the wheel at an angle adapted to the work to be done, and they may be back ground without shifting in the clamp; there is also a special duplex index disk on the end of the bar graduated so that the approximate grinding angle may be found quickly and the exact angle afterward determined by the differential position of the two sets of graduations; this device also provides for the changing diameter of the grinding wheel so that the grinding angle may always be determined accurately. **Patent Back Stops**—Are attached to both the slotted knife face and the thin knife clamp, whereby the edge being ground will be kept parallel with the back, and the knife thus always balanced. There are many other important details, which render this machine superior to any now made. **The Grinding Wheel**—Is 26" diameter, and cased, and provided with a water nozzle and return spout so that all emery and steel dust is carried to a settling tank with the water. A rotary pump supplies a large volume of water. **A Countershaft**—Is supplied in the base of the machine, having 10"x4" **T. & L.** (self-oiling loose) pulleys, which should run 300 R.P.M. There is a hand lever shifter for the main driving belt attached to the machine frame.

Fig.	Size	Floor Space	Horse-power	Weight, lbs.	Boxed for Exp't.		Code
					Wt., lbs.	Cu ft.	
1126	31"	4'x6'8"	2 to 4	2150	2750	110	<i>Dreaming</i>
1127	37"	4'x7'8"	2 to 4	2300	2950	130	<i>Deary</i>

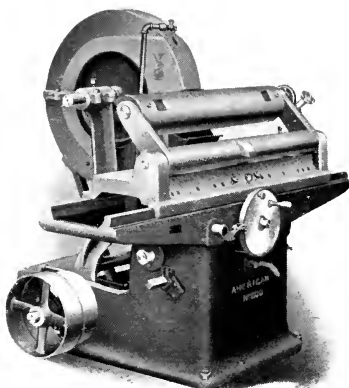


Figure 1130

## American No. 200 Automatic Self-Feed Knife Grinder

A UNIVERSAL automatic machine that will accurately grind any kind of a knife or bar that will lie on a plane surface. The frame is of pedestal form, carrying two planed ways on which the carriage slides. The solidity of this construction insures perfect grinding.

**Capacity**—Made in four sizes, 30", 36", 42" and 50".

### Technical Features

**The Knife Bar**—Is so shaped that the grinding may be performed either to or from the edge of the knife and a screw adjustment is provided for setting the knife at any desired angle. The frame carrying the knife bar is pivoted to the carriage so that the bar may be swung away from the wheel to provide easy access to the knives when changing. **The Feed**—Is entirely automatic; the reciprocating movement of the knife carriage is governed by stops so that any length of knife up to the capacity of the machine may be ground. The movement of the wheel to the knife can be regulated to grind from 1-3000" to 1-1000" to each back and-forth movement of the knife carriage. The movement of the wheel carriage when set is automatically controlled and the wheel will cease grinding at any point desired. We furnish one emery wheel 26" diameter, 1½" face. **A Pump Attachment**—And tank are supplied for use when wet grinding is desired. The tank can easily be removed for cleaning when necessary. If desired the pump and tank can be omitted and an overhanging tank supplied at a slight reduction in price. **Counter-shaft**—Has T. & L. (self-oiling loose) pulleys, 12"x3"; speed, 300 R.P.M.

Figure	Size	Floor Space	Horse-power	Weight, lbs.	Boxed for Exp't.		Code
					Wt., lbs.	Cu. ft.	
1130	30"	6'8"x3'6"	2 to 5	1450	2100	100	<i>Dredge</i>
1131	36"	7'2"x3'6"	2 to 5	1550	2200	120	<i>Dredging</i>
1132	42"	7'8"x3'6"	2 to 5	1650	2300	120	<i>Dreibund</i>
1133	50"	9' x3'6"	2 to 5	1750	2400	130	<i>Drench</i>
If pump attachment is not wanted, suffix code word					Cat		
to regular code word							

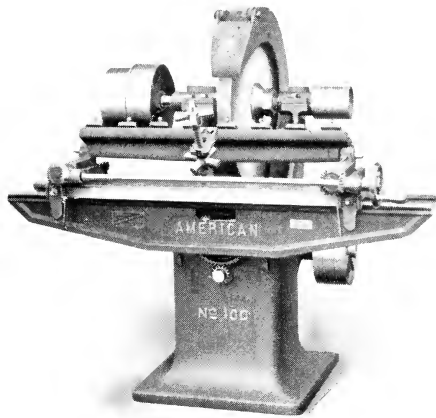


Figure 11341

### American No. 100 Automatic Knife Grinder

**T**HIS machine is designed to meet the demands for a plain semi-automatic knife grinder without the automatic cross feed. It is provided with our patent combination bar for clamping either slotted or hard thin knives. The frame is a heavy cored column, cast in one piece, with broad foot flanges, making it rigid and free from vibration.

**Capacity**—Made in three sizes, 32", 36" and 50".

#### Technical Features

**The Carriage**—Has an automatic transverse movement across the face of the wheel and is provided with adjustable stops for regulating the length of cut, and can be instantly stopped at any desired point.

**The Knife Bar**—For holding the knife is slotted, to receive bolts on one face and has a series of clamps by means of which hard thin knives can be securely held and accurately ground. It is fed to the wheel by a hand wheel, as shown. The knife is ground perfectly true and can be quickly set at any angle or bevel desired.

**The Arbor**—Carrying the wheel is of large diameter and runs in long boxes. **One Wheel**—22" in diameter by 1½" face, is furnished with each machine, and a hood is always furnished with the machine. The machine can be used for wet grinding, in which case we furnish a small water tank attached to top of hood and from which water is dropped onto the wheel. However, the machine when so equipped should not be regarded as a regular wet grinder, as no provision is made to take care of waste water. **T. & L.**—(Self-oiling loose) pulleys, 10"x3"; speed, 350 R.P.M.

Fig.	Size	Floor Space	Horse-power	Weight, lbs.	Boxed for Export		Code
					Wgt., lbs.	Cu. ft.	
11341	32"	6' x3'	2 to 5	800	1200	45	<i>Drilled</i>
11342	36"	6'4"x3'2"	2 to 5	850	1250	50	<i>Drink</i>
11343	50"	7'6"x3'	2 to 5	900	1300	55	<i>Drinked</i>
	Water tank, extra		.....	...	....	..	<i>Drinlap</i>

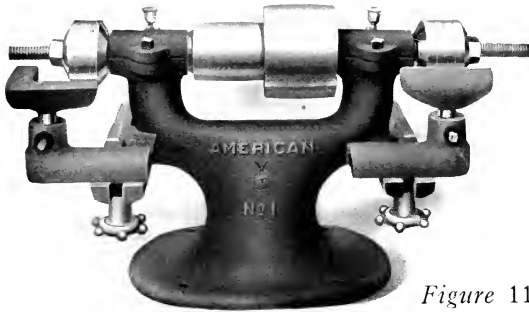


Figure 1142

### American No. 1 Double End Emery Grinder

THE accompanying cut shows our double end emery grinder, a heavy substantial machine, arranged to carry five wheels with knife grinding attachment, and with gumming attachment for small circular saws, when so ordered. The arbor is of steel, running in long boxes. It is fitted with a cone pulley, thus giving two changes of speed. One end is so arranged as to carry two or four 12" wheels varying in thickness, and the other end two 12" wheels, all having a  $7\frac{3}{8}$ " hole. The pulleys on arbor are 4" and 6" in diameter. No wheels are furnished, unless ordered at extra cost. Countershaft is furnished if desired, at extra cost, with T. & L. (self-oiling loose) pulleys, 8"x4"; speed, 750 R.P.M.

Fig.	Style	Horse-power	Wgt., lbs.	Boxed for Export		Code
				Wgt., lbs.	Cu. ft.	
1142	No. 1 With Counter .	1 to 2	285	390	9	<i>Droque.</i>
1143	No. 1 Without Counter	1 to 2	135	235	5	<i>Droit</i>
11431	Saw Gum'ing Attach't., extra					<i>Drollery</i>

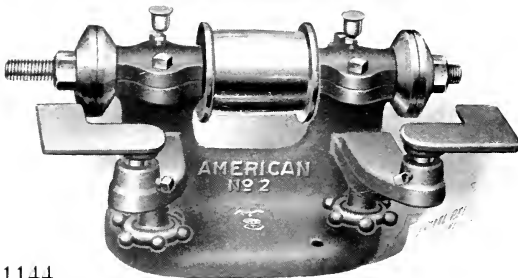


Figure 1144

### American No. 2 Double Emery Grinder

OUR No. 2 Double Emery Grinder is a less expensive rig than the one illustrated above, and is suitable for wheels 12" in diameter, with  $7\frac{3}{8}$ " hole. The arbor is of steel mounted in long boxes, and the arbor pulley is 4" in diameter. No wheels are furnished with the machine unless ordered and they are extra. Countershaft furnished if desired, at extra cost, with T. & L. (self-oiling loose) pulleys, 8"x3"; speed 750 R.P.M.

Fig.	Style	Horse-power	Wgt., lbs.	Boxed for Export		Code
				Wgt., lbs.	Cu. ft.	
1144	No. 2 With Counter .	1 to 2	130	175	5	<i>Dromia</i>
1145	No. 2 Without Counter	1 to 2	65	90	3	<i>Dromos</i>



## American Grindstone Frame

THE American grindstone frame shown in the cut is a very substantial rig and is fitted with a tool rest and water tank. The stone is of a fine quality and is operated by gearing and electric motor. If a belt drive is desired the end of arbor is fitted with a pulley.

We furnish these frames and stones in sizes from 30" up to 48" in diameter as per code below. Motor equipment is furnished as an extra.

Figure	Size of Stone	Floor Space	Horse-power	Wgt. lbs.	Boxed for Export		Code
					Wgts.	Cu. ft.	
11482	48"x6"	6'x3'	1 to 1½	1182	2200	65	<i>Dropping</i>
11483	48"x4"	6'x3'	1 to 1½	1037	2000	65	<i>Dropsy</i>
11486	40"x6"	6'x3'	1 to 1½	915	1800	60	<i>Drown</i>
11487	40"x4"	6'x3'	1 to 1½	815	1700	60	<i>Drowse</i>
	Truing Device, Extra	5'x3'	1 to 1½	250			<i>Drudge</i>
11488	38"x6"	5'x3'	1 to 1½	802	1400	45	<i>Drugger</i>
11489	38"x4"	5'x3'	1 to 1½	745	1300	45	<i>Drummin</i>
11490	36"x6"	5'x3'	1 to 1½	712	1300	45	<i>Drummer</i>
11492	36"x4"	5'x3'	1 to 1½	620	1200	45	<i>Druxy</i>
11493	30"x4"	5'x3'	1 to 1½	520	1200	42	<i>Dryad</i>
11496	30"x3"	5'x3'	1 to 1½	432	1100	42	<i>Dualin</i>
	Truing Device	.....	.....	250	.....	..	<i>Duan</i>
	Automatic Truing and Tool Holding Device, Extra	.....	.....	25	.....	..	<i>Dubbing</i>

Cubical contents for any of above machines, 39 cubic feet.  
Export boxing weight for each machine, 150 pounds extra.

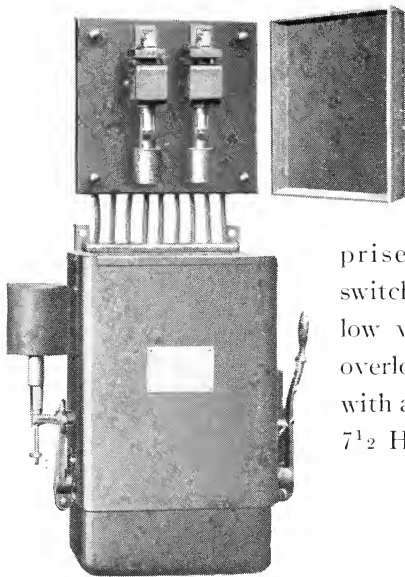
## Motor Drives and Controls for Woodworking Machinery

**T**HE illustrations, throughout this catalog, of machines with motors, show the vast improvement that has been made in electric drives for woodworking machines by this Company. We were the first in the field to apply motors to our machines and the development of successful drives has been largely due to us.

The following pages specify the various types of drive for the machines illustrated in the catalog.

The success of an electric drive depends very largely on the type of control used in connection with it. We illustrate the various types applied to our machines on pages 90 to 96.

### Electric Control Data



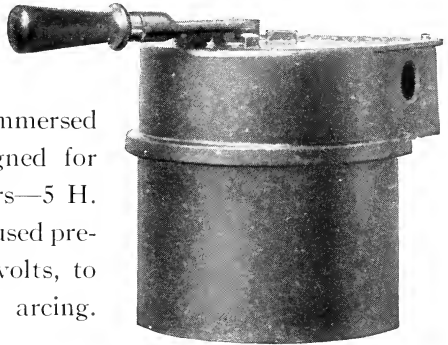
#### Control A

Consists of Hand Starting Compensator which comprises an oil immersed switch with sliding contacts, low voltage protection and overload relays. It is used with all squirrel cage motors, 7<sup>1</sup>/<sub>2</sub> H. P. and over.



### Control B

Consists of an oil immersed starter and is designed for starting small motors—5 H. P. and under, and is used preferably on 440-550 volts, to take up dangerous arcing.



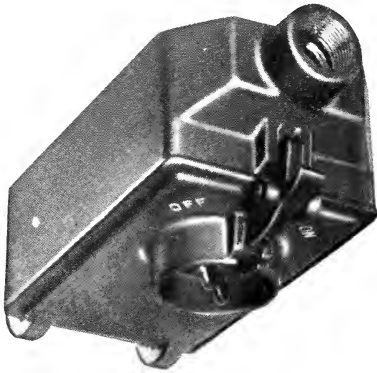
### Control C

Consists of a 3 or 4 pole single throw, quick make and break switch, two protective plugs, two hinged covers, one over-switch and one over-plug. The switch is designed so it is impossible to open unless switch is off. Overload is obtained by two time limit plugs which take care of momentary overload in starting. It is impossible to single phase a motor with this switch.



This switch is used in connection with all motors up to 5 H. P.

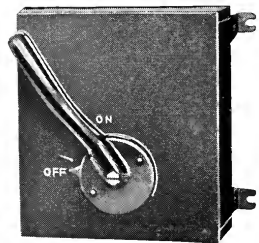
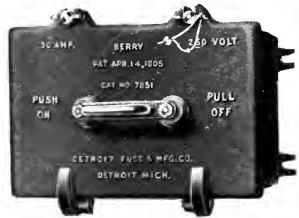
### Control D



Consists of a three pole snap switch mounted on porcelain base with fuses and enclosed in a Crouse-Hinds special conduit. It is used only on 2 H. P., 3 phase motors and under.

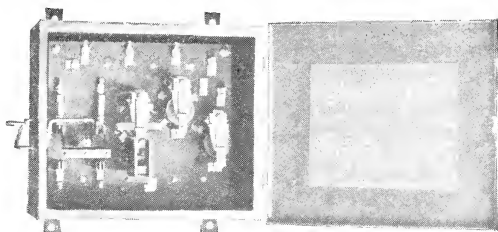
### Control E

Is used for direct current only and consists of a two-pole fused switch for overload and a standard rheostat with low voltage protection enclosed in metal case, making a totally enclosed unit; it is used in connection with all D. C. motors.



## Electric Control Data—Continued

### Control F



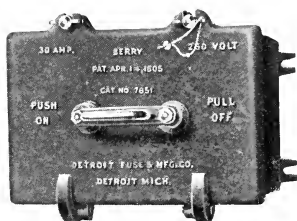
Consists of two-point contactors, magnetic blowout for low voltage and fused switch for overload protection; is used on all D. C. motors up to  $7\frac{1}{2}$  H. P. with push button control.

### Control G

Consists of standard, open rheostat for all D. C. motors and does not include any switch.



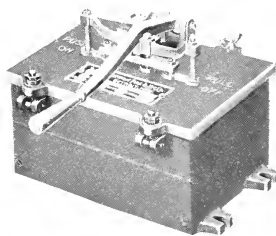
### Control H



Consists of a standard enclosed fused switch, two or three phase, used on all motors up to 5 H. P. in place of time limit if desired.

### Control J

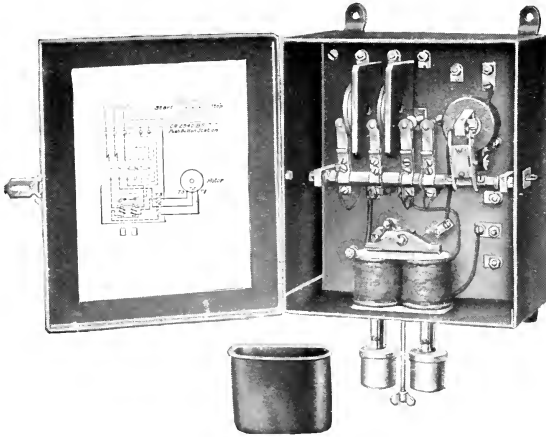
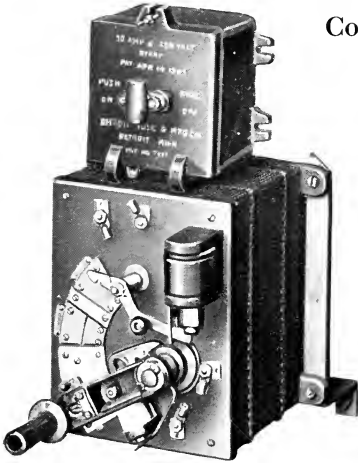
Enclosed fused starter. Its motion is automatic in that the first movement throws the motor directly on the line and holding same for a few moments, then releasing it, automatically cuts off the line and throws the fuses in running. For all A. C. motors up to 5 H. P.



### Control M

Is used on single phase motors, and is included in price on all 7½ H. P. and over.

This control cuts down the starting current from 2½ to 3½ times, running to 1½, and allows the motor to come slower

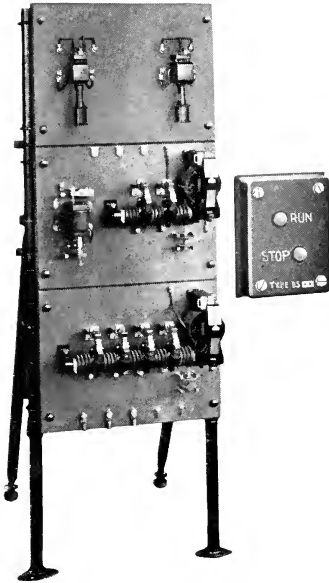
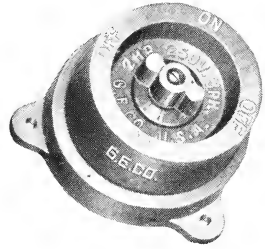


### Control N

Is an automatic A. C. push button type for A. C. motors up to 7½ H. P.

### Control P

Is a 2 or 3 phase snap switch for A.C. motors, 2 H. P. and under.

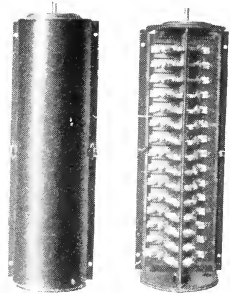


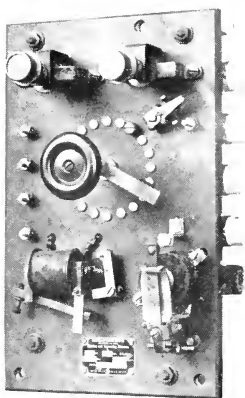
### Control R

Is an automatic compensator with overload relays, triple pole contactors mounted on slate base and one start and stop push button station; it can be used on all A. C. motors.

### Control V

Is a special control for A. C. Motor Head Blocks as applied to lathes.



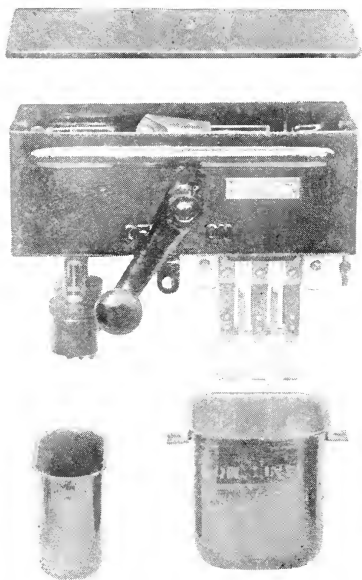


### Control W

Is a special control for use on D. C. Speed Lathe only, consists of a push button type overload, low voltage and dynamo brake.

### Control Y

Consists of a totally enclosed dust proof oil switch with overload and low voltage protection.



# Electric Starting Apparatus

(Illustrated pages 90 to 96)

Controls	Electric Current
<b>A</b> Hand-Starting Compensator	Sin.-Ph. 60 Cy. 110 v.
<b>B</b> Oil Switch	Sin.-Ph. 60 Cy. 220 v.
<b>C</b> Time Limit Fused Switch	3-Ph. 60 Cy. 110 v.
<b>D</b> Enclosed Fused Snap Switch	3-Ph. 60 Cy. 220 v.
<b>E</b> Enclosed Rheostat, Fused Switch,	3-Ph. 60 Cy. 440 v.
<b>F</b> Automatic D. C. Push Button	3-Ph. 60 Cy. 550 v.
<b>G</b> Standard Rheostat	2-Ph. 60 Cy. 110 v.
<b>H</b> Enclosed Fused Switch	2-Ph. 60 Cy. 200 v.
<b>J</b> Enclosed Fused Starter	2-Ph. 60 Cy. 440 v.
<b>M</b> Single-Phase Starter over 5 H. P.,	2-Ph. 60 Cy. 550 v.
<b>N</b> Automatic A. C. Push Button	3-Ph. 25 Cy. 110 v.
<b>P</b> Enclosed Snap Switch	3-Ph. 25 Cy. 220 v.
<b>R</b> Auto. Compensator	3-Ph. 25 Cy. 440 v.
<b>V</b> Multi-Speed A. C. Head Blocks	3-Ph. 25 Cy. 550 v. Sin.-Ph. 25 Cy. 110 v.
<b>W</b> Var.-Speed D. C. Head Blocks	Sin.-Ph. 25 Cy. 220 v. D. C. 115 v.
<b>Y</b> Oil Circuit Breaker and Switch	D. C. 230 v. D. C. 550 v.

## Specifications for Motor Drives

---

**No. 1**—Motor mounted in housing on a special base attached to frame of machine and geared to countershaft or arbor; gears totally enclosed. \*For Alternating Current ..... phase, ..... cycle, ..... voltage.

**No. 2**—Motor mounted on a special base and coupled to countershaft or arbor by flexible coupling. \*For Alternating Current, ..... phase, ..... cycle, ..... voltage.

**No. 3**—Motor mounted attached to frame of machine and armature or rotor shaft extended. \*For Alternating Current ..... phase, ..... cycle, ..... voltage.

**No. 4**—Motor without base and directly attached to countershaft by flexible coupling. \*For Alternating Current ..... phase, ..... cycle, ..... voltage.

**No. 5**—Motor mounted on standard motor base and with pulley of the proper size. \*For Alternating Current ..... phase, ..... cycle, ..... voltage.

**No. 6**—Motor Mounted on special base attached to frame of machine and belted direct to arbor. \*For alternating current ..... phase, ..... cycle, ..... voltage.

**No. 7**—Motor mounted on special base with combination belt and gear connection. \*For alternating current ..... phase, ..... cycle, ..... voltage.

\*For Direct Current ..... voltage.



**No. 8**—Motor mounted on special base with shaft extended on both sides to receive driving pulleys and hangers taking the place of regular countershaft. \*For Alternating Current ..... phase, ..... cycle, ..... voltage.

**No. 9**—Motor attached to frame of machine, rotor mounted on cylinder or arbor.

\*For Alternating Current ..... phase, ..... cycle, ..... voltage.

**No. 10**—Standard motor with shaft extension to take place of countershaft. \*For Alternating Current ..... phase, ..... cycle, ..... voltage.

**No. 11**—Motor on special base, shaft extended, silent chain drive to machine.

**No. 12**—Motor on special base, worm and worm wheel drive.

\*For Direct Current ..... voltage.



## **Part II**

Life is an arrow, therefore you must know  
What mark to aim at, how to use the bow,—  
Then draw it to the head and let it go.

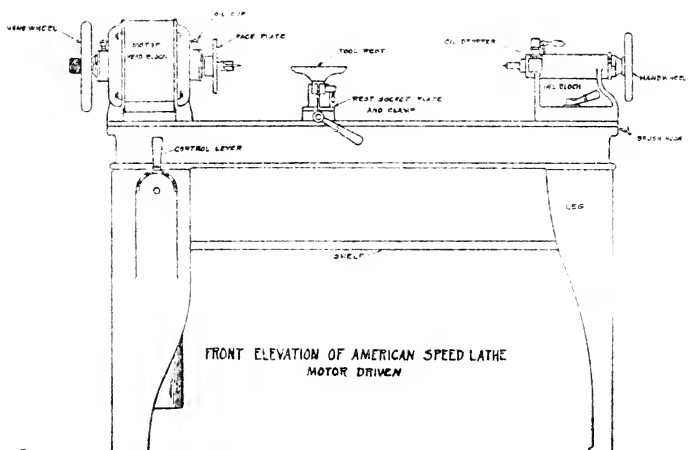
—*Henry Van Dyke*

## The Operation of Woodworking Machines

**T**HE operation of woodworking machines forms the subject matter of Part II of this book.

Sufficient examples are given to enable the student to arrive at a fair understanding of what *is* the correct position to take at some of the principal machines he will be called upon to operate.

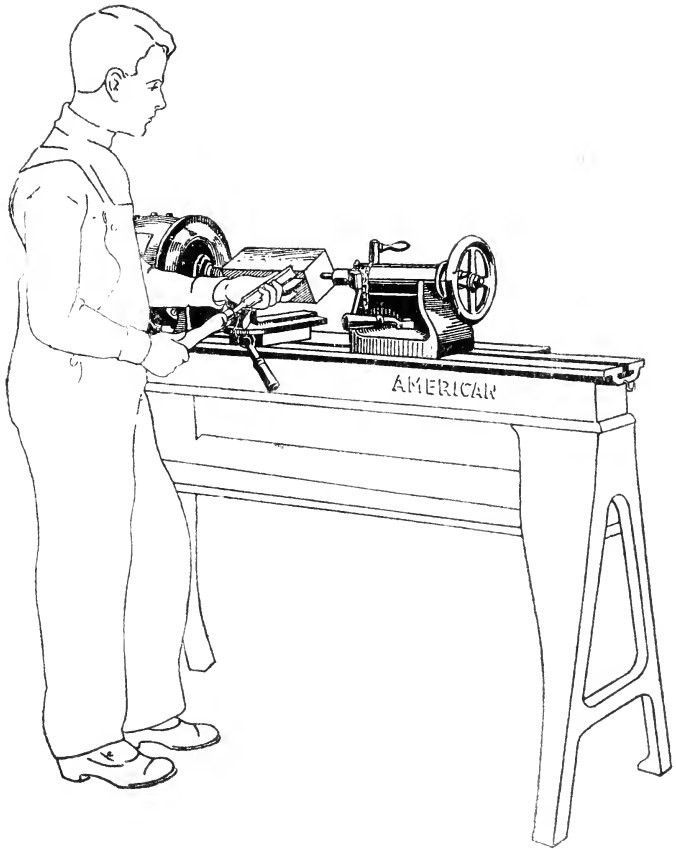
The Lathe, the Universal Saw, the Jointer and the Sander and their operation form the chief source of experimental training in the woodworking department of the manual training school. Consequently we have confined our illustrations to these machines.



Front Elevation of Motor Headblock Lathe  
(American 12-Inch Speed Lathe)

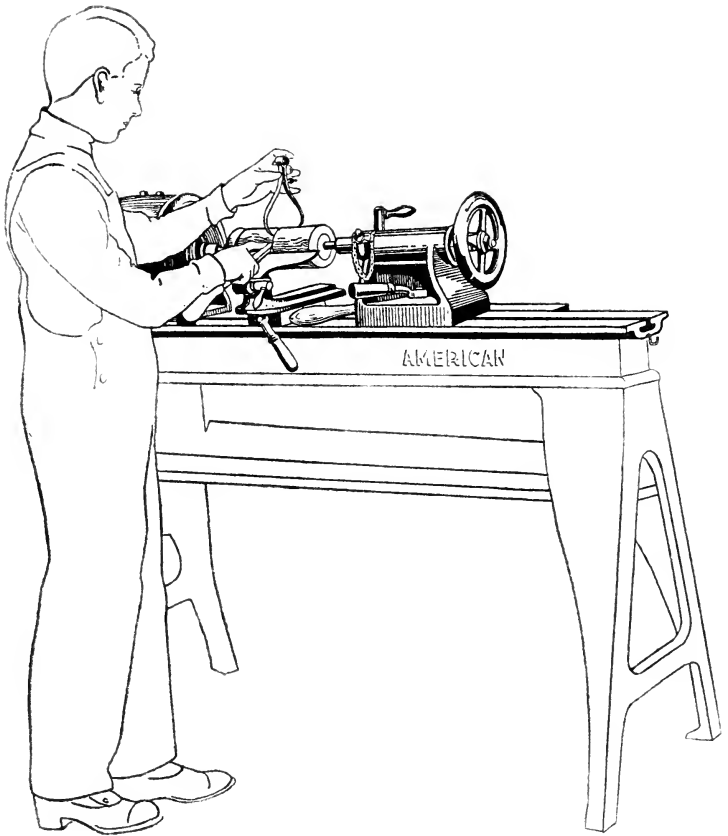
## On Operating the Lathe

The Lathe is perhaps more closely akin to the art side of the student's development than any other wood-working machine. And, for that reason, it claims his highest interest. With it his skill in forming articles of use or beauty is challenged; for what he accomplishes depends almost entirely upon himself. That is what makes the Lathe so interesting and so essential to the equipment of the woodworking department of a vocational school. The process of turning will always form the centre of interest in such a department.



## The Roughing Cut

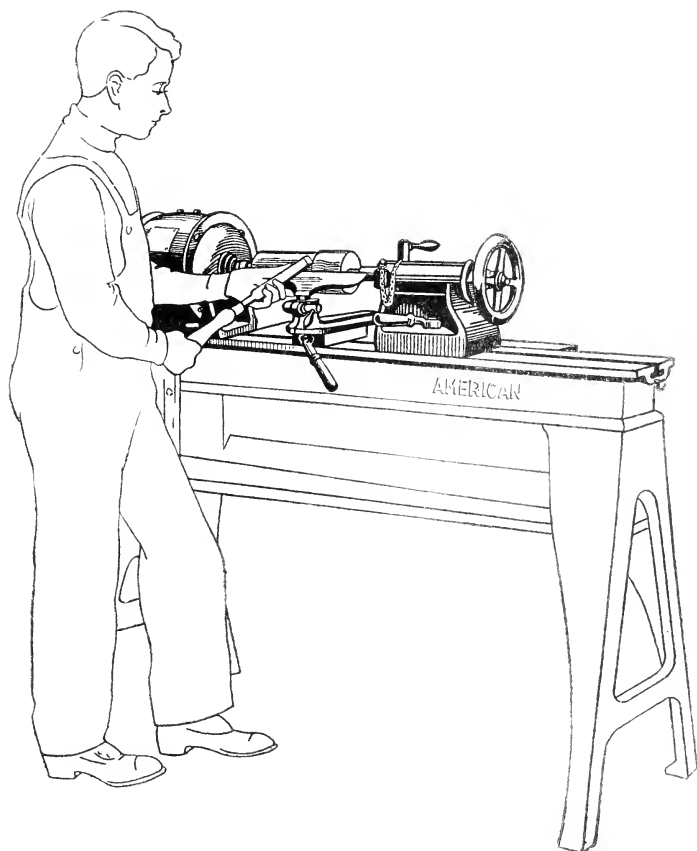
In this illustration the student is preparing to take the *roughing cut* in turning a cylinder. This operation consists in removing the corners of the square piece and is done with the tool known as the gouge.



## The Sizing Cut

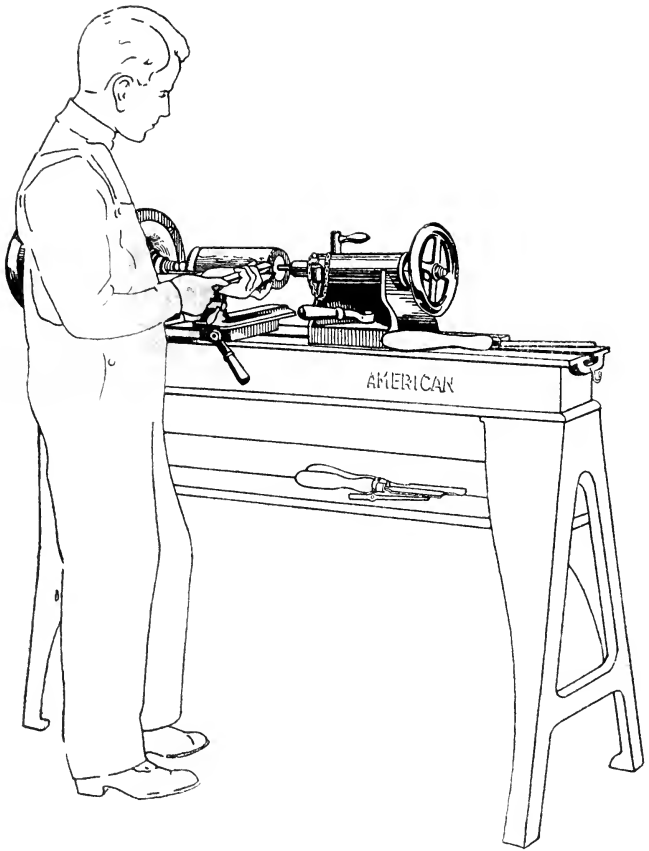
After the roughing cut has been taken, calipers set to the diameter desired will determine the depth of the next cut. The illustration shows the student performing this operation with the cut-off tool.





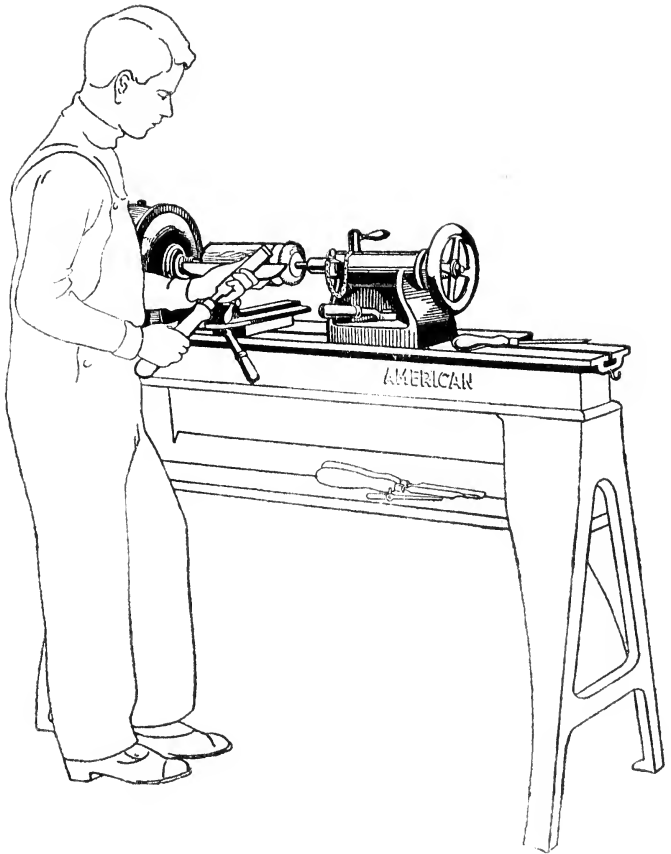
## The Paring Cut

When the correct dimension has been found, as shown in the preceding illustration, the next step in the process of turning a cylinder is the *paring cut* or finishing cut. This is done with the skew or bevel chisel. A very thin shaving is removed by this operation.



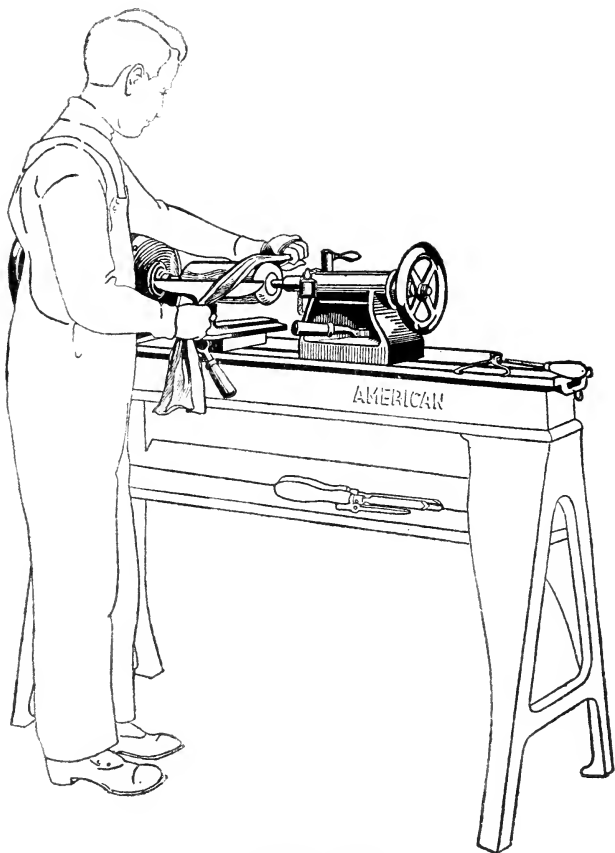
## Cutting the Ends

This operation is performed by using the cut-off tool. It is merely taking a slice off the end. If a very thin slice is to be removed, it is usually made by the long point of the skew chisel. If it is more than a quarter of an inch it should be *sized* and then removed by the skew.



## **Rounding**

If it is desired to round the end of a piece or to produce a convex surface the operation can be done by applying the broad side of the skew chisel. This is perhaps the most difficult operation to perform if accuracy is obtained.

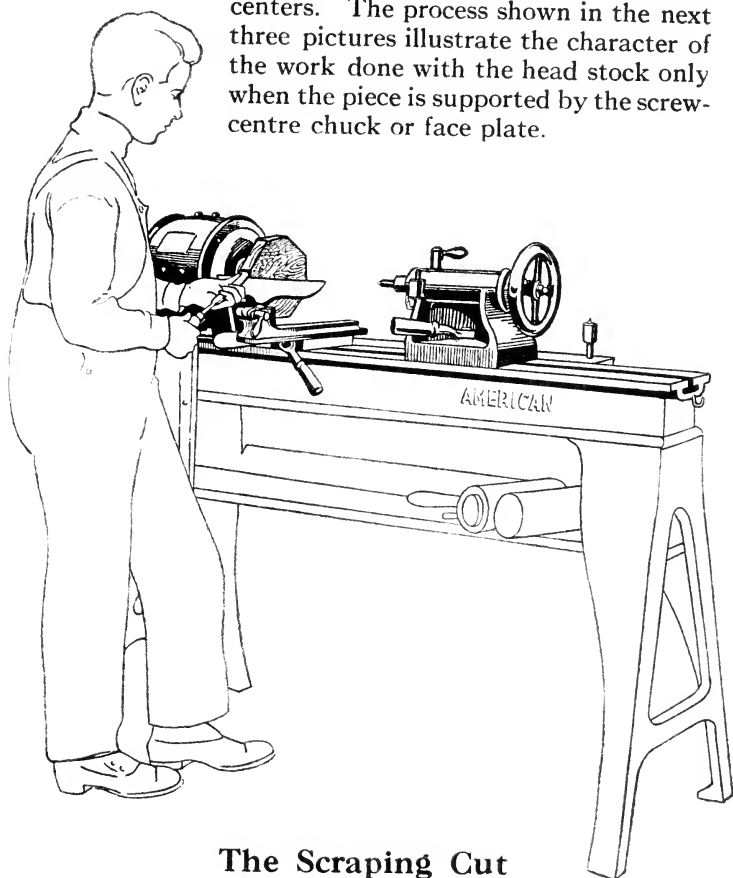


## Polishing

This operation is done with a cloth after the cylinder has been sanded and while rotating in the lathe. In sanding, use first a fairly coarse grade of paper, No. 1 or  $1\frac{1}{2}$ , and afterwards a fine grade, No. 0 or 00. Before applying the cloth the wood may be varnished lightly while the lathe is not running, taking care to wipe off all the surplus varnish. The varnish will assist in giving the surface a fine polish when the cloth is applied.

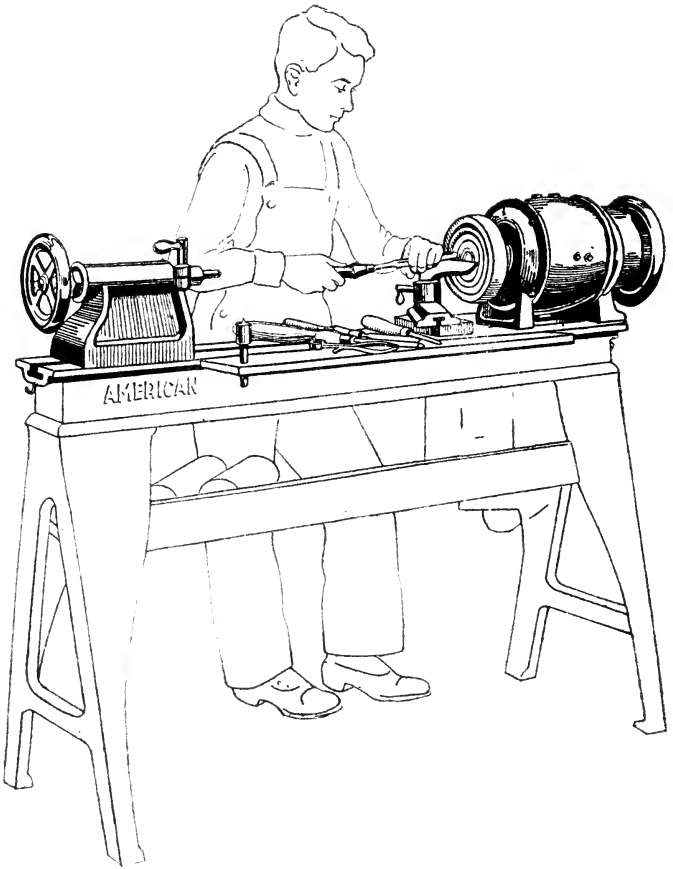
## Face Plate Turning

The preceding illustrations show the process of turning when the piece is supported between the live and dead centers. The process shown in the next three pictures illustrate the character of the work done with the head stock only when the piece is supported by the screw-centre chuck or face plate.



### The Scraping Cut

This cut is properly made with the concave chisel held in such a position as to give a light scraping cut. Care should be exercised not to allow the chisel to extend too deeply, otherwise the material will chip with the grain. After the desired circumference has been obtained the surface should be smoothed with the skew chisel.



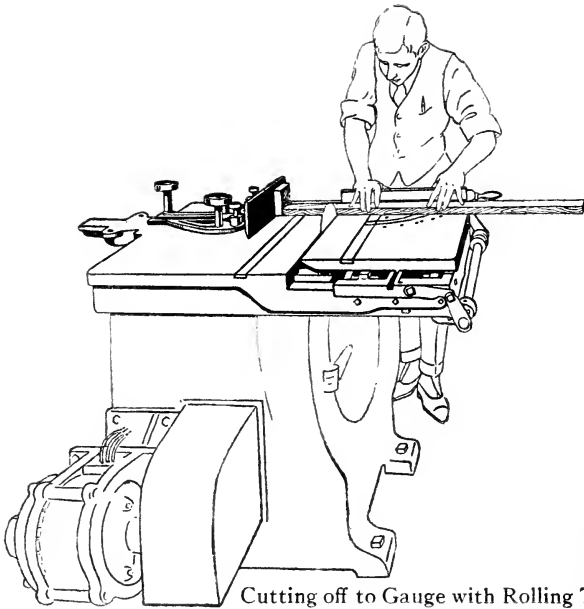
## Modeling a Rosette

This illustration shows the student using the rest, set at right angles with the bed or parallel with the face plate. Prior to the modeling a shearing cut should be taken with the skew chisel to face off the material to an even surface.

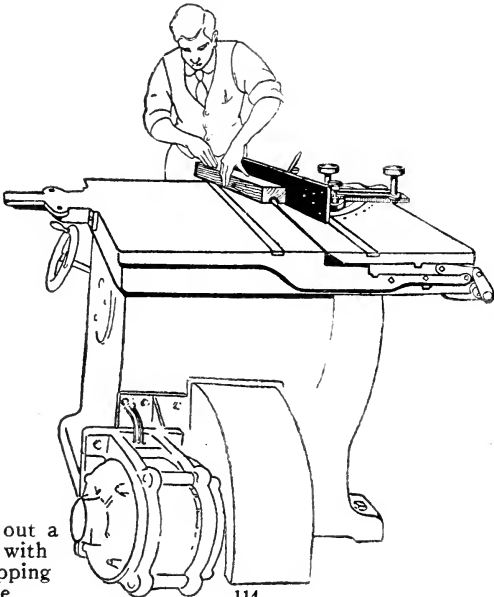


### Use of the Dividers

This illustration shows the use of the dividers. The student is marking off to a uniform scale the position of the various corrugations in the rosette he is turning.

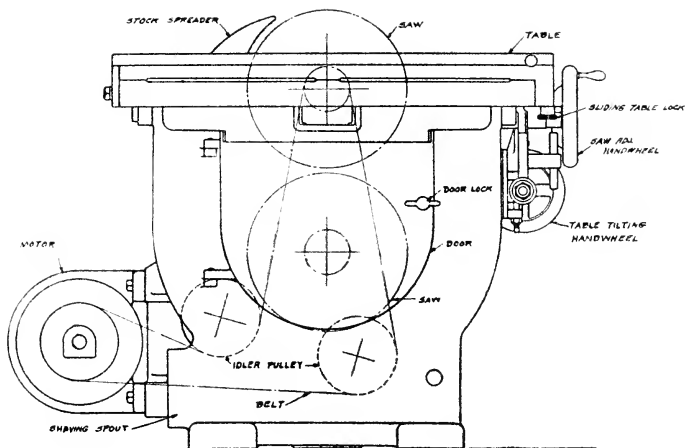


Cutting off to Gauge with Rolling Table



Roughing out a  
Core box with  
use of Ripping  
Gauge



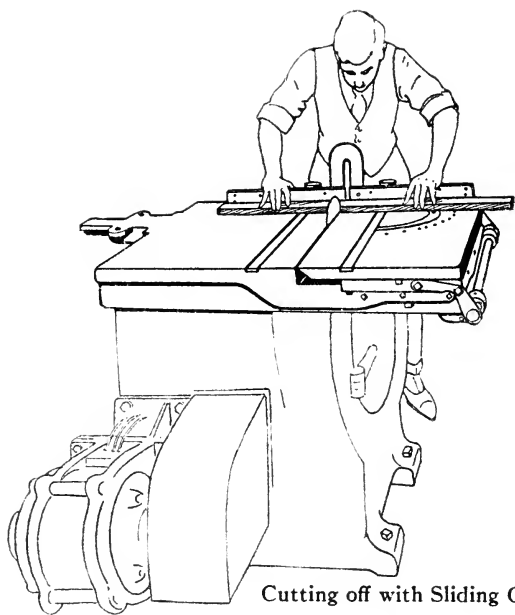


Front Elevation of Universal Saw  
(American No. 20 Universal Saw)

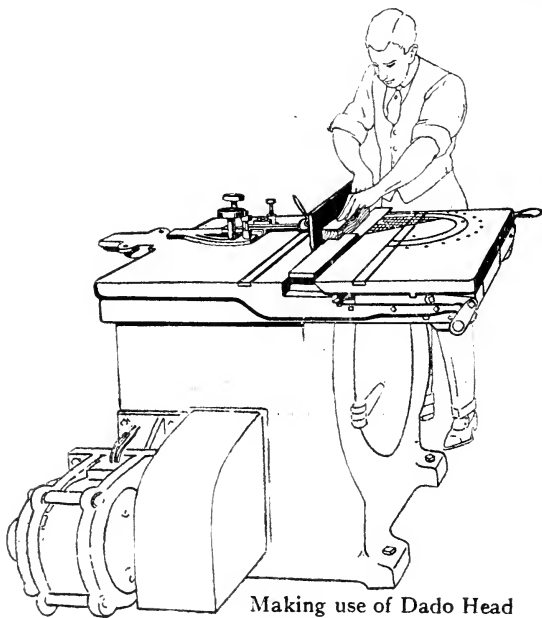
## On Operating the Universal Saw

The operations that can be performed on the Universal Saw are so many that we shall not attempt to illustrate them all here. But enough are given to show the characteristic poses involved in cross-cutting, ripping, and dadoing,—the three basic uses of a Universal Saw.

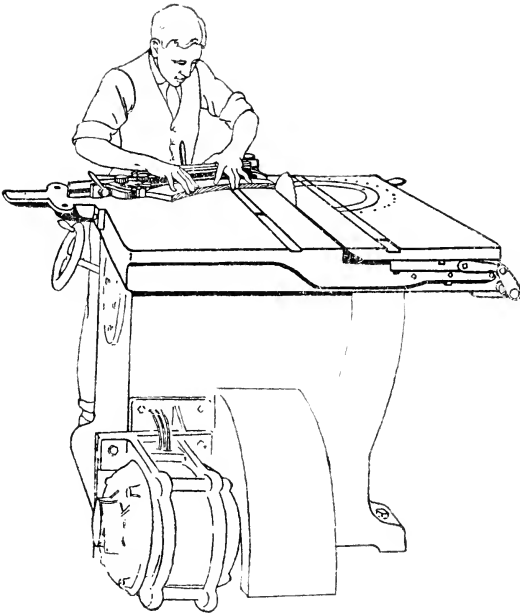
It is a more dangerous tool than the lathe and the guard should be kept over the saw at all times, except of course, in dadoing when it cannot be used.



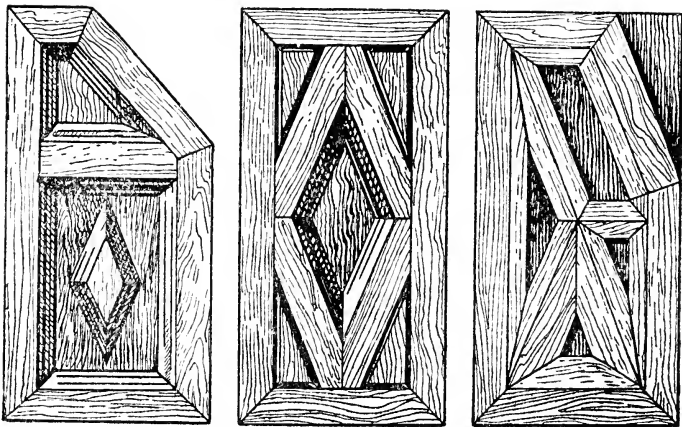
Cutting off with Sliding Gauges



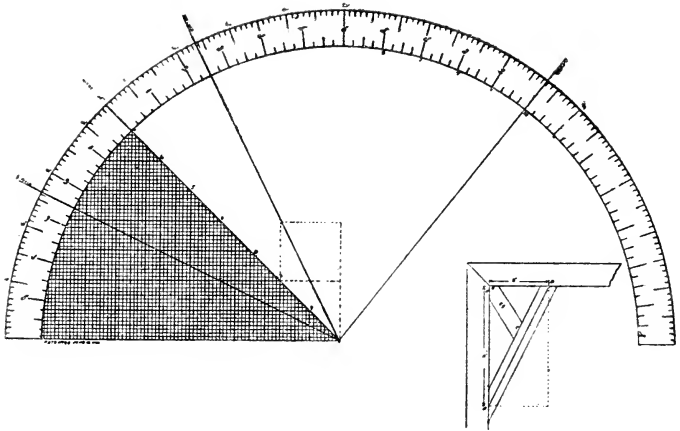
Making use of Dado Head



Using Pulley Segment Gauge



Panels made on the Universal Saw Bench with aid of the Protractor

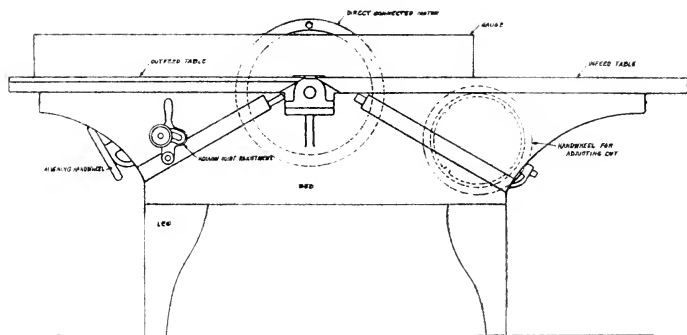


## Use of Patent Bevel Protractor as Applied to American Universal Saw Bench

The drawing shows a brace extending from a point 2" in one direction and 4" in another at right angles, the object being to determine angles, A B and C.

*The Starting Point* of fence is 45 degrees or common mitre. In setting fence for the measurement, viz., 2"x4", the operator starts at 2" on the Cross Graduated Sector and then follows the 2" line, which parallels the travel of the saw until he reaches the 4" line. The intersection is marked with a star in drawing.

*Angles:*—You will note that you are dividing an imaginary block 2" wide by 4" long. The fence, when set, registers an arbitrary graduation in circular arc  $2\frac{1}{2}"$ . This gives you the acute or steep angle A. This setting also gives you the key to all angles that it may be desired to cut, and it is only necessary to remember the one point, viz.,  $2\frac{1}{2}"$ . To determine angle B, set fence  $2\frac{1}{2}"$  to the left of the 45 degree line. To determine angle C, start at 90 degrees and carry the fence forward two lines  $2\frac{1}{2}"$ , viz., 5".



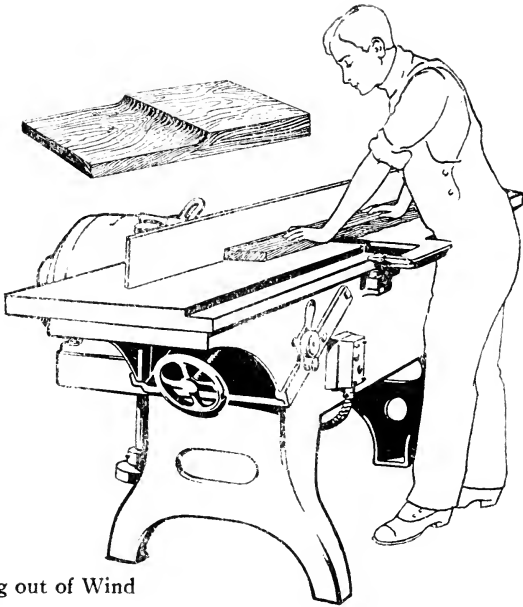
Front Elevation of Hand Jointer  
(American No. 1)

## On Operating the Hand Jointer

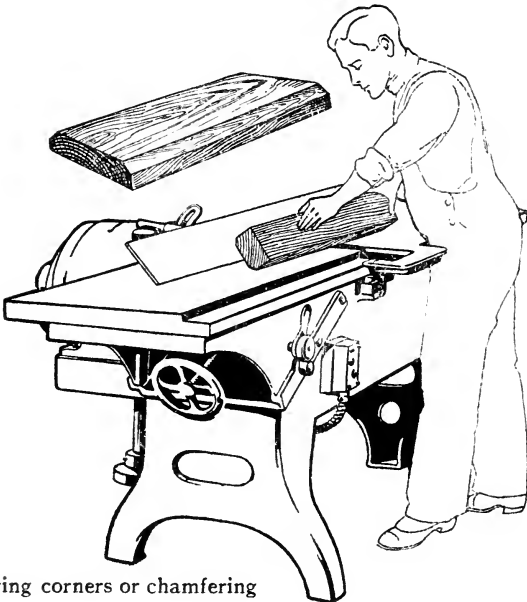
The great variety of work that can be done on a hand jointer depends very largely upon the knowledge and skill of the operator. In this fact lies the value of this tool as a part of a school equipment,—second only to the lathe. It lends itself to so many operations, that the student gains much in knowledge and efficiency.

The five operations following, will give a fair idea of the scope of work that is usually accomplished on a hand jointer and show something of the method by which the work should be done.

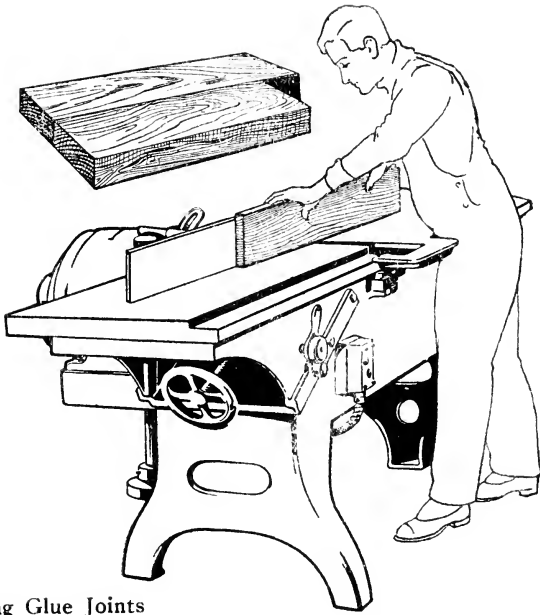
The Jointer is another tool when the use of the guard should never be omitted.



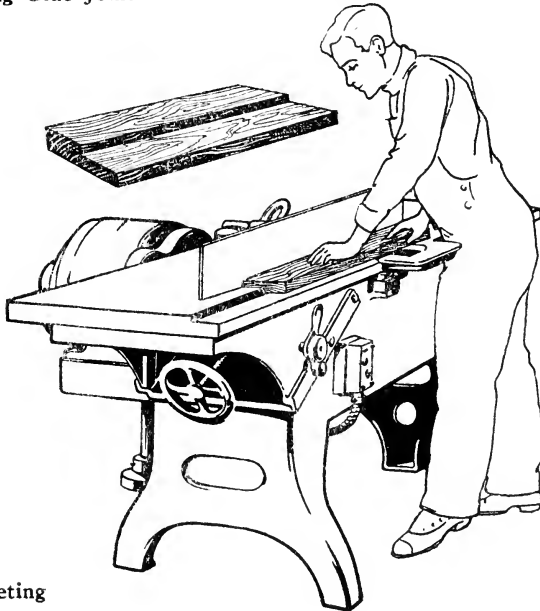
Planing out of Wind



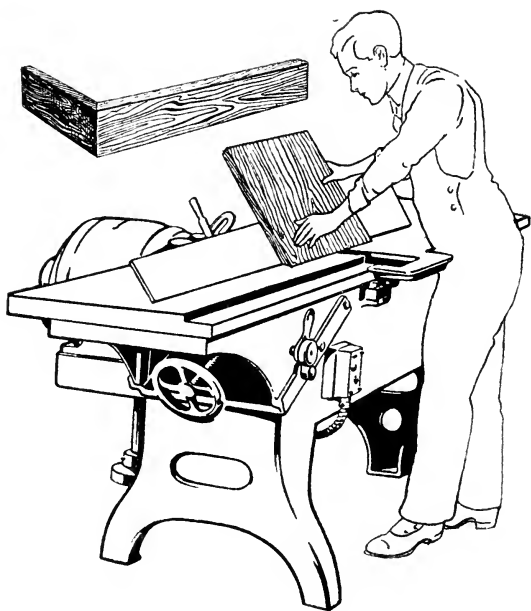
Removing corners or chamfering



Making Glue Joints



Rabbeting



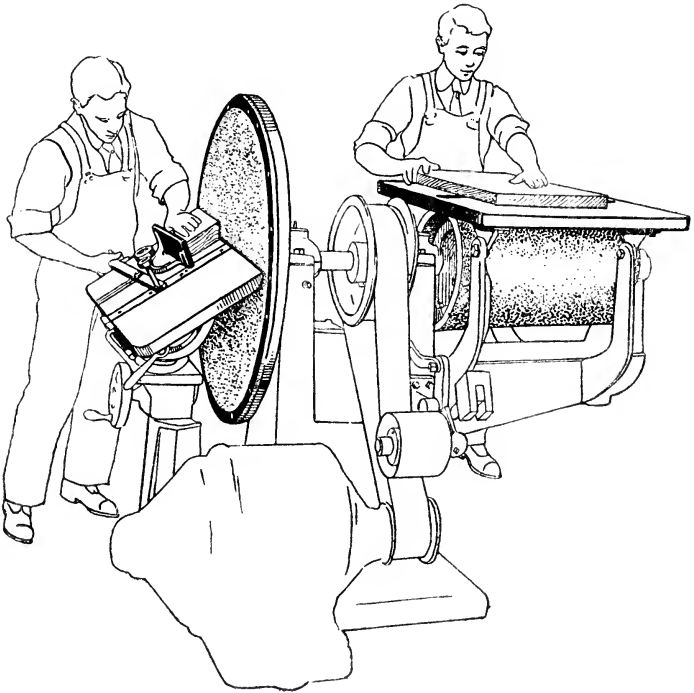
Planing a Bevel for Mitre Work



## On Operating the Sander

The Sander is an interesting machine in the school room for on it considerable "forming" can be done as with the lathe, although its prime use is to make smooth or polish.

In the single illustration following, the boy at the left is forming a mitre while the one at the right is smoothing a surface.





## **Part III**

A literary education is no education. All the classics of the past cannot make men. Experience does, life does.

—*Leonardo da Vinci*

## Machine Specifications for the Cabinet Shop

**I**N order to assist school men charged with the responsibility of writing the machinery specifications for cabinet shop equipment, we append the following pages. Any of these may be copied literally with the assurance that every important item that should enter into the construction of a high grade machine is covered completely.

Of course we have used our machines as the basis for these specifications; but they will cover any other make of high grade woodworking machines as well. They are intended as a protection against the substitution of machines inferior to ours which are known and accepted in the industries as the standard.

The subject *Alternative Specifications* given after each machine refers generally to other ways in which certain parts of American machines may be constructed and particularly to the latest methods of motor drive.

# Specifications for Woodworking Machines

---

## 36-Inch Band Saw

(Illustrated page 8)

**Capacity**—To take 18" under guide at its highest point and 36" horizontally. Adaptable for blades from  $\frac{1}{8}$ " to  $1\frac{3}{4}$ " wide.

**Frame**—To be one piece casting with double column yoke supporting upper wheel shaft.

**Table**—To be of iron 32"x32"; to tilt 5 degrees to left and 45 to right; to be mounted on double saddle with side clamps; equipt with adjustable hand ripping gage. To have hand wheel tilting device, indexed and self-locking.

**Wheels**—Upper wheel to be of iron spoke construction with laminated hardwood rim and \*lower wheel of solid web construction. Both wheels to be crowned with rubber bands. †Wheel shafts to run in babbitted bearings adjustable for wear and alignment. Wheels  $1\frac{3}{4}$ " face. Upper wheel to be equipt with U-spring weighing strain indexed. Upper wheel to adjust vertically  $6\frac{1}{2}$ " in gibbed ways, and to have tilting adjustment for tracking the blade.

**Guards**—‡Upper wheel to be protected by wire screen guard and lower one by iron doors.

**Drive**—§Driven by tight and loose pulleys 14"x4 $\frac{1}{2}$ " at 500 to 600 R.P.M.

**Equipment**—To consist of one  $\frac{1}{2}$ " blade brazed and set ready for use; one set of brazing clamps and tongs.

**Alternative Specifications**—\*Lower wheel to be of cast iron spoke construction with cast iron rim.

†Upper wheel shaft to run in double race ball bearings and lower wheel shaft in single race ball bearings.

‡Both wheels to be protected by wire screen guards.

§Motor driven. (Copy data under motor section page 98 given as drive Nos. 3, 4, 5 or 6. See pages 90 to 97 for control data.)

## 30-Inch Band Saw

(Illustrated page 10)

**Capacity**—To take 13" under guide at its highest point and 29" horizontally. Adaptable for blades from  $\frac{1}{8}$ " to  $1\frac{1}{2}$ " wide.

**Frame**—One piece casting with double column yoke supporting upper wheel shaft.

**Table**—To be of iron 26"x28"; to tilt 30 degrees to left and 45 to right; to be mounted on double saddle with side clamps; equip with adjustable hand ripping gage. To have hand wheel tilting device, indexed and self-locking.

**Wheels**—Upper wheel to be of iron spoke construction with laminated hardwood rim and \*lower wheel of solid web construction. Both wheels to be crowned with rubber bands. †Wheel shafts to run in babbitted bearings adjustable for wear and alignment. Wheels to be  $1\frac{1}{2}$ " face. Upper wheel to be equip with U-spring weighing strain indexed. Upper wheel to adjust vertically  $6\frac{1}{2}$ " in gibbed ways, and to have tilting adjustment for tracking the blade.

**Guards**—‡Upper wheel to be protected by wire screen guard and lower one by iron doors.

**Drive**—§Driven by tight and loose pulleys 12"x $3\frac{1}{2}$ " at 600 to 650 R.P.M.

**Equipment**—To consist of one  $\frac{1}{2}$ " blade brazed and set ready for use; one set of brazing clamps and tongs.

**Alternative Specifications**—\*Lower wheel to be of cast iron spoke construction with cast iron rim.

†Upper wheel shaft to run in double race ball bearings and lower wheel shaft in single race ball bearings.

‡Both wheels to be protected by wire screen guards.

§Motor driven. (Copy data under motor section page 98 given as drive Nos. 3, 4, 5 or 6. See pages 90 to 97 for control data.)

## Band Saw Brazier

(Illustrated page 14)

**Machine**—To be capable of being clamped or screwed to a bench. It is to be furnished complete with one piece of hose, a quantity of prepared spelter and pulverized borax, some fine tying wire and full directions for brazing with silver solder.

**Lamp**—To be attached to the machine, and is to have large elliptical wick, giving a long, steady flame which becomes hot at the point where it is forced against the saw by the air blast. Kerosene is to be used for fuel.

**Blow Pipe**—To be supplied with air from a double-acting pump with receiving chamber, fitted with good leather valves and double-cup piston packing.

## Self-Contained Jig Saw

(Illustrated page 17)

**Capacity**—To take 10" under guide and 36" from saw to column.

**Frame**—To be cored column with wide foot flange having three points of bearing on the floor. Does not require fastening to the ceiling.

**Table**—To be iron 32"x38" mounted on segment to tilt either right or left 30 degrees.

**Straining Head**—To have two large coil springs for tension with means for regulating the amount of tension required. To have long retracting spring to counter-balance the movable part of the head. To have eccentric lever for locking the head in position for different lengths of blades.

**Pitman**—To be adjustable for wear and at lower end to be fitted with babbitt bushing.

**Drive**—\*Driven by tight and loose pulleys 6"x3" at 1200 R.P.M.

**Equipment**—To consist of four saws  $\frac{1}{4}$ ", 14" long;  $\frac{3}{8}$ ",  $\frac{1}{2}$ " and  $\frac{5}{8}$ ", 16" long.

**Alternative Specifications**—\*Motor driven. (Copy data under motor section page 98 given as drive No. 4, 5 or 6. See pages 90 to 97 for control data.)



## Jig Saw

(Illustrated page 16)

**Capacity**—To take any thickness up to 12".

**Frame**—To be one piece casting heavily ribbed to eliminate vibration.

**Table**—To be of iron 36"x38", tilting.

**Straining Device**—To be equipt with crank for varying the tension of the blade.

**Guide Ways**—To be so constructed that their expansion from friction does not tighten the cross heads.

**Blower**—To be provided for removing the dust and keeping saw blade cool.

**Clamping Device**—To be provided for lower end of saw so that it is not necessary to use a pin.

**Foot Brake**—To be provided for control of saw.

**Drive**—\*Driven by tight and loose pulleys 6"x3" at 1200 R.P.M.

**Equipment**—To consist of four saws,  $\frac{1}{4}$ ", 14" long;  $\frac{3}{8}$ ",  $\frac{1}{2}$ " and  $\frac{5}{8}$ " 16" long.

**Alternative Specifications**—\*Motor driven (copy data under motor section page 98 given as drive Nos. 1, 4, 5 or 6. See pages 90 to 97 for control data.)

## Chain-Feed Edging Saw

(Illustrated page 18)

**Capacity**—To rip stock as short as 8" and up to 24" wide.

**Column**—To be gibbed to frame of machine in heavy ways and adjusted by screw with ball-bearing and thrust operated by hand wheel at front of machine, and to have lever locking device

**Feed Works**—To consist of an endless feed chain in table and adjustable pressure rolls above—the front roll driven. Feed works and saw to be enclosed so as to make a suction hood. The hood to be adjustable by screw with ball-bearing end thrust operated by an overhead hand wheel and to have graduated scale to indicate the height of rolls. To have section of hood removable for changing saws. To have three changes of feed 60, 120 and 160 lineal feet per minute all made by lever, at the left of operator, without throwing off the power. The driving mechanism for chain to be totally enclosed.

**Table**—To be fitted with endless chain which travels on independent bed plate with the wearing surfaces lined with steel.

**Drive**—\*Driven by tight and loose pulleys 12"x8" at 1000 R.P.M.

**Equipment**—To consist of one 12" saw.

**Alternative Specifications**—\*Motor driven. (Copy data under motor section pages 98 and 99 given as drive Nos. 5 or 9. See pages 90 to 97 for control data.)

## Hand-Feed Rip Saw

(Illustrated page 20)

**Capacity**—To rip stock up to 4" thick and 21" wide. To take saws up to 20" diameter.

**Frame**—To be made of iron firmly braced and heavily ribbed.

**Table**—To be of iron 34"x37" and hinged at back of frame. To have raising screw in front.

**Rip Saw**—To be made of iron and to adjust on iron dove-tail track at the front of table. \*Not adjustable for mitre work.

**Drive**—†Driven by tight and loose pulleys 12"x6 $\frac{3}{8}$ " at 600 R.P.M.

**Equipment**—To consist of one 16" saw.

**Alternative Specifications**—\*Gauge to be adjustable for angle and mitre work.

†Motor driven. (Copy data under motor section page 98 given as drive No. 5. See pages 90 to 97 for control data.)

## Swing Cut-Off Saw

(Illustrated page 21)

**Capacity**—To take saws up to 14" diameter.

**Frame**—To be round column type and supported on trunnions on the hangers. To be 5 ft. long from center of the countershaft or driving pulley to the center of the arbor and to be 6 ft. 5" long from the base of the hangers to the center of the arbor. To be fitted with counterbalance that assists in drawing the saw through the stock; this counterbalance to be of the chain type.

**Drive**—\*Driven by tight and loose pulleys 8"x4 $\frac{1}{2}$ " at 800 R.P.M.

**Equipment**—To consist of one 12" saw with 1" hole and a 14" shield.

**Alternative Specifications**—\*Motor driven. (Copy data under motor section page 98 given as drive Nos 5 or 6. See pages 90 to 97 for control data )

## Medium Variety Saw Bench

(Illustrated page 22)

**Capacity**—To take up to 20" between saw and rip fence and saws up to 14" diameter.

**Frame**—To be one-piece casting, box form, with broad base, absolutely rigid. Slide ways for the table bracket or yoke are to be a part of the main frame. Sawdust chute to be part of table slide and the front is to be covered by a hinged door, giving free access to the saw.

**Table**—To tilt to 45 degrees by hand wheel and worm gearing for bevel sawing; table to raise and lower by hand wheel, bevel gears and screw, mounted on ball bearing. Table to be 36"x44"; to be fitted with removable throat plate. Ripping fence to slide on graduated track. Mitre cut-off gauges to slide on tongues in T-slots in the table. To have yoke for connecting the two mitre gauges. Table to be lined for the square and the 45 degree positions of mitre gauges.

**Arbor**—To be 1¼" diameter, \*to run in babbitted bearings, one being corrugated to take up end play. Boxes to be 5½" long, self-oiling, with circulating channels.

**Guard**—Automatic, aluminum hood, saw guard with weight counterbalance and ratchet for adjusting the guard to three positions.

**Drive**—†Driven by tight and loose pulleys 8"x5¼" at 750 R.P.M.

**Equipment**—One 12" diameter cross-cut saw with 1" hole.

**Alternative Specifications**—\*To run in ball bearings.

†Motor driven. (Copy data under motor section pages 98 and 99 given as drive Nos 5, 6 or 9. See pages 90 to 97 for control data.)

## Small Variety Saw Bench

(Illustrated page 24)

**Capacity**—To take up to 13" between saw and rip fence and saws up to 12" diameter may be used.

**Table**—To tilt to 45 degrees by hand wheel and worm gearing for bevel sawing. Table is also to raise and lower by hand wheel, bevel gears and screw, mounted on ball bearing. Table is to be 27"x30"; to be fitted with removable throat plate. Ripping fence with scaled track is to be furnished, also pair of mitre cut-off gauges which slide on tongues in T-slots in the table and yoke for connecting the two mitre gauges.

**Frame**—To be one-piece casting, box form, with broad base, absolutely rigid. Slide ways for the table bracket or yoke are to be a part of the main frame. Sawdust chute to be part of table slide and the front is to be covered by a hinged door, giving free access to the saw.

**Arbor**—To be 1 $\frac{1}{8}$ " diameter, to run in babbitted bearings, one being corrugated to take up end play. Boxes to be 5" long, self-oiling, with circulating channels.

**Guard**—Automatic, aluminum hood, saw guard with weight counterbalance and ratchet for adjusting the guard to three positions.

**Drive**—\*Driven by tight and loose pulleys 8"x4 $\frac{1}{2}$ " at 750 R.P.M.

**Equipment**—To consist of one 12" diameter cross-cut saw with 1" hole.

**Alternative Specifications**—\*Motor driven (Copy data under motor section page 98 given as drive Nos. 5 or 6. See pages 90 to 97 for control data.)

## Large Universal Saw Bench

(Illustrated page 26)

**Capacity**—\*To rip from  $\frac{1}{8}$ " to  $27\frac{1}{2}$ " wide; to cut off 31" wide and to swing saws up to 18" diameter. Table to open for dado heads up to  $2\frac{1}{2}$ " wide.

**Frame**—A unit casting, three points of bearing upon the floor, with cast partition for keeping sawdust from the belt chamber. To be provided with swinging door for totally enclosing the saws, and to have sawdust hood connection.

**Table**—40"x48"; left hand section to be movable upon adjustable anti-friction rollers, and top to be accurately fitted by tongue and groove; main section of table to be 23" wide and to have extension ruled for setting ripping gauge. Table to tilt by means of worm and worm segment to an angle of 45 degrees and to be provided with fixed stop on the frame for horizontal position. Lift hand table to be fitted with protractor and accurate taper pin stops for all principle angles; also to be graduated in circular inches to be used in connection with a special cross graduated sector for cutting angles desired without previous calculation or laying out of work.

**Arbor Yokes**—To carry two hard steel arbors, not less than  $1\frac{7}{16}$ " diameter in the bearings. To be provided with self-oiling boxes, arbor yoke to revolve in disks supported in the frame of the machine, inside disk to be not less than 22" diameter and outside to be arranged for locking when one non-adjustable saw is used. Yoke to be adjustable by worm and worm wheel for bringing the saws into action. The pair of boxes for each saw arbor to be yoked in one casting, and each arbor yoke to be a separate casting from the main revolving yoke, each saw arbor yoke to be securely mounted on the revolving yoke, and arranged so each can be independently adjusted in any direction to compensate for slightest wear in bearings—thus maintaining at all times perfect alignment of the saw blades with the accurate pin stops to gauges and fine graduations on table top.

**Gauges**—To be provided with two swivel head gauges with yoke locking the same for double cutting-off

### Large Universal Saw Bench—Continued

gauge, one ripping gauge with micrometric and swivel adjustment and tilting features, to be adjustable for working either side of the saw. The swivel gauge to be pivoted to the left hand table and to swing from zero to 180 degrees; and have adjustment for locking to intermediate angles.

**Drive**—†Driven by tight and loose pulleys 12"x6½" at 700 R.P.M.

**Equipment**—To consist of two saws 18" diameter, 1" hole.

**Alternative Specifications**—\*To rip from ½" to 36" wide.

†Motor driven. (Copy data under motor section page 98 given as drive Nos. 5 or 6. See pages 90 to 97 for control data.)

## Medium Universal Saw Bench

(Illustrated page 28)

**Capacity**—\*To rip from  $\frac{1}{8}$ " to 22" wide; to cut off 21" wide and to swing saws up to 14" diameter. Table to open for dado heads up to  $2\frac{1}{2}$ " wide.

**Frame**—A unit casting, three points of bearing upon the floor, with cast partition for keeping sawdust from the belt chamber. To be provided with swinging door for totally enclosing the saws, and to have sawdust hood connection.

**Table**—38"x36"; left hand section to be movable upon adjustable anti-friction rollers, and top to be accurately fitted by tongue and groove; main section of table to be 21" wide and to have extension ruled for setting ripping gauge. Table to tilt by means of worm and worm segment to an angle of 45 degrees and to be provided with fixed stop on the frame for horizontal position. Lift hand table to be fitted with protractor and accurate taper pin stops for all principle angles; also to be graduated in circular inches to be used in connection with a special cross graduated sector for cutting angles desired without previous calculation or laying out of work.

**Arbor Yokes**—To carry two hard steel arbors, not less than  $1\frac{3}{16}$ " diameter in the bearings. To be provided with self-oiling boxes, arbor yoke to revolve in discs supported in the frame of the machine, inside disc to be not less than 17" diameter and outside to be arranged for locking when one non-adjustable saw is used. Yoke to be adjustable by worm and worm wheel for bringing the saws into action. The pair of boxes for each saw arbor to be yoked in one casting, and each arbor yoke to be a separate casting from the main revolving yoke, each saw arbor yoke to be securely mounted on the revolving yoke, and arranged so each can be independently adjusted in any direction to compensate for slightest wear in bearings—thus maintaining at all times perfect alignment of the saw blades with the accurate pin stops to gauges and fine graduations on table top.

**Gauges**—To be provided with two swivel head gauges with yoke locking the same for double cutting-off gauge, one ripping gauge with micrometric and swivel adjust-



### Medium Universal Saw Bench—Continued

ment and tilting features, to be adjustable for working either side of the saw. The swivel gauge to be pivoted to the left hand table and to swing from zero to 180 degrees; and have adjustment for locking to intermediate angles.

**Drive**—†Driven by tight and loose pulleys 10"x6 $\frac{1}{4}$ " at 650 R.P.M.

**Equipment**—To consist of two saws 18" diameter, 1" hole.

**Alternative Specifications**—\*To rip from  $\frac{1}{8}$ " to 30" wide.

†Motor driven. (Copy data under motor section page 98 given as drive Nos. 5 or 6. See pages 90 to 97 for control data.)

## Medium Single Surfacer

(Illustrated page 30)

**Capacity**—To plane up to 24" wide and 7" thick.

**Feed**—\*To be furnished with variable feed device giving rates of feed up to 85 ft. per minute. There are to be four driven feed rolls 5" diameter. †Infeed roll to be in 2" independent sections with eight driving points in each section and eight springs each  $2\frac{1}{8}$ " long. Sections of the roll shells and drivers to be of hardened steel. Roll shafts to be held down by long range tempered steel springs adjustable for tension. ‡Chipbreaker also to be in 2" independent sections. Feed drive to be by belts, hardened steel roller chains and cut gears.

**Cylinder**—§To be of three-knife round type. Journals to be  $2\frac{1}{4}$ " diameter 11" long. ☐Boxes to be of the side clamping type with automatic circulation of oil and emergency oilers in the caps. To have knife setting and jointing attachments, always on the machine ready for instant use.

**Pressure Bar**—To be adjustable at either end by finger wheel.

**Main Bed**—To be supported on heavy inclines which move on tracks cast upon the frame. The adjustment for thickness to be made by means of two threaded screws coupled together and operated by a large central hand wheel and cut gears.

**Drive**—||Driven by countershaft with tight and loose pulleys  $12" \times 7\frac{1}{4}"$  at 850 R.P.M.

**Alternative Specifications**—\*To be furnished with single belt feed with idler pulley.

†Infeed roll to be solid.

‡Chipbreaker to be solid with steel shoe.

§Cylinder to be 3-knife triangular type.

☐Boxes to be ball-bearing type.

||Motor driven. (Copy data under motor section pages 98 and 99 given as drive Nos. 4, 9 or 10. See pages 90 to 97 for control data.)

## Light Single Surfacers

(Illustrated page 34)

**Capacity**—To take 24" wide, 7" thick.

**Frame**—To be of the cast type, well ribbed, and of rigid construction, and to have three points of bearing on the floor.

**Bed**—To be of rigid construction, with vertical web of not less than 10" deep under the cylinder plate, and to be supported to the frame by six points, four being suitable for take-up in wear and to be adjustable from outside of frame. Bed to raise and lower on screws.

**Feed**—To consist of four feed rolls, two upper ones driven, and rate of feed to be from 18' to 32' per minute. To be provided with four feed rolls.

**Cylinder**—To be forged, bearings to be  $1\frac{5}{8}$ " diameter by 8" long and to be held in side-clamping boxes. Chip-breaker to work concentrically with cutter head.

**Drive**—\*Driven by countershaft with tight and loose pulleys  $10\frac{1}{2}$ "x $5\frac{1}{4}$ " at 800 R.P.M.

**Alternative Specifications**—\*Motor driven. (Copy data under motor section pages 98 and 99 given as drive Nos. 5 or 9. See pages 90 to 97 for control data.)

## Hand Jointer and Buzz Planer

(Illustrated page 36)

**Capacity**—\*Head to be 8" wide.

**Frame**—Main bed casting to be mounted on three legs giving three points bearing on the floor, making the machine practically self-aligning and impossible to get wrenched or twisted out of true.

**Table**—Each section of the table to be mounted on a wedge-shaped casting which is adjustable on two long inclined ways with long locking gibbs and hand wheels for adjusting the tables. Tables to have rabbetting groove and rabbetting bracket. Rear table is to have adjustment for making hollow or spring glue joints. Both tables are to have detachable steel lips next to the cutter head. Tables are to draw out horizontally leaving an opening of 7" around the cutter head. Table to have bevel Protractor fence with quick lever adjustment.

**Cutter Head**—†To be two-knife round type with thin steel knives.

**Drive**—‡Driven by countershaft with tight and loose pulleys 10"x4" at 900 R.P.M.

**Alternative Specifications**—\*Head to be 12" 20" 24" 30" or 36" wide.

†To be three-knife round type with three thin steel knives (*if direct-connected motor driven.*)

‡Motor driven. (Copy data under motor section pages 98 and 99 given as drive Nos. 1, 5, 6 or 9. See pages 90 to 97 for control data.)

## Bench Jointer

(Illustrated page 38)

**Capacity**—\*Head to be 6" wide.

**Frame**—To have two inclining tables, adjustable by hand wheel and from the cylinder, with positive locking devices. †To be mounted on square-cored pedestal.

**Tables**—To be 41" long over all and rear table to be provided with rabbetting groove.

**Cutter Head**—To be two-knife round, ball bearing type. Fence to be adjustable full width of table and to tilt to 45 degrees, and to be lever set, and provided with protractor, for setting at any bevel.

**Drive**—‡Driven by countershaft with tight and loose pulleys 6"x3¼" at 800 R.P.M.

**Alternative Specifications**—\*Head to be 8" wide, or head to be 4" wide.

†Not to be mounted on pedestal.

‡Motor driven. (Copy data under motor section pages 98 and 99 given as drive Nos. 5, 6 or 9. See pages 90 to 97 for control data.)

## 8-Inch Four-Sided Moulder

(Illustrated page 42)

**Capacity**—To work \*8" wide and 4" thick.

**Frame**—To be open type with all parts of machine easily accessible.

**Table**—To adjust 10" on large screw with ball bearing and thrust. To have reversible plate under top head. Rear end table to swing down out of the way to give access to knives on bottom head.

**Feed**—To consist of four power driven rolls with cut gears and driven by hardened steel roller chain and sprockets inside the frame. To have heavy equalizer bar inside the frame connecting with the top feed roll yokes to keep the rolls parallel with face of bed. Top rolls to be not less than 5½" diameter and lower rolls not less than 6" diameter. To have four rates of feed controlled at either end of machine.

**Cutter Heads**—To be of the slip-on type, having outside removable bearings, and adjustable for alignment. To have cutting circle of 6½" diameter. Bearings to be side clamping type.

**Chipbreaker**—To adjust to and from the cutters and to lift out of way to give access to knives. Pressure bars in rear of top head and over bottom head to be sectional; to adjust horizontally and vertically and to be hinged to swing up out of way leaving table and side heads clear.

**Side Headstocks**—To be securely attached to the table and to adjust vertically and laterally. The outside headstock to angle. Inside head to have chipbreaker and take up. Outside head to have weighted matcher clip attached to the movable block carrying the headstock and to move in and out with the headstock.

**Drive**—†Driven by tight and loose pulleys 12"x8" at 900 R.P.M.

**Alternative Specifications**—\*To work 10" or 12" wide.

†Motor Driven. (Copy data under motor section page 98 given as drive Nos. 4 or 5. See pages 90 to 97 for control data.)

## 6-Inch Moulding Machine

(Illustrated page 44)

**Capacity**—\*To work stock 6" wide, by 4" thick, and bed to drop for planing to width at least 16".

**Frame**—To be cast in one piece, bed to raise and lower on gibbed ways attached to the frame by screw, with take-up provision for wear, bed to raise and lower by screw and ball bearings.

**Feed**—To consist of three driven feed rolls.

**Headstock**—To have vertical and horizontal adjustments and side heads to have angular adjustment. All heads to be of the slip-on type and to be four-sided, provided with two knives and bolts for each, and to be bored for  $1\frac{1}{8}$ " arbors where the head goes on.

**Drive**—†Driven by countershaft with tight and loose pulleys  $10\frac{1}{2}$ "x5" at 800 R.P.M.

**Alternative Specifications**—\*To work stock 4" wide by 4" thick.

†Motor driven. (Copy data under motor section page 98 given as drive Nos. 4 or 5. See pages 90 to 97 for control data.)

## 4-Inch Moulding Machine

(Illustrated page 44)

**Capacity**—To work stock two sides 4" wide, by 4" thick, and bed to drop for planing to width at least 20".

**Frame**—To be cast in one piece. Bed to raise and lower on gibbed ways attached to the frame, by screw and ball bearings with take-up provision for wear.

**Feed**—To consist of three driven feed rolls.

**Headstock**—To have vertical and horizontal adjustments and side heads to have angular adjustment. All heads to be of the slip-on type and to be four-sided, provided with two knives and bolts for each, and to be bored for  $1\frac{1}{8}$ " arbors where the head goes on.

**Drive**—\*Driven by countershaft with tight and loose pulleys  $10\frac{1}{2}$ "x5" at 800 R.P.M.

**Alternative Specifications**—\*Motor driven. (Copy data under motor section page 98 given as drive Nos. 4 or 5. See pages 90 to 97 for control data.)

## Automatic Vertical Hollow Chisel Mortiser

(Illustrated page 46)

**Capacity**—To make mortises up to  $\frac{3}{4}$ " square by  $3\frac{1}{2}$ " deep. Speeds of chisel rams to be 10, 20 and 35 strokes per minute, and speed of bit spindle not less than 3500 R.P.M.

**Frame**—To be cast in one piece and heavily ribbed to stand strain.

**Chisel Ram**—To be of the reciprocating type, with quick return, to be operated automatically by foot treadle and the stroke to be adjustable from zero to 4".

**Table**—\*To be provided with clamp for holding stock at top and bottom, table to be recessed so chips will fall thru. To have rack and pinion for lateral movement. To be adjustable crosswise and for height by hand wheel. Table to be provided with wooden throat-plate. Table to be provided with tilting adjustment to any angle from zero to 30 degrees, right or left. Adjustable hold-downs to be provided for holding stock in position. Bit spindle to be gear driven. Machine to be provided with a fan for removal of chips and for keeping chisel cool.

**Drive**—†Driven by countershaft with tight and loose pulleys 10"x4" at 1200 R.P.M.

**Equipment**—To consist of three chisels, one each  $\frac{3}{8}$ ",  $\frac{1}{2}$ " and  $\frac{5}{8}$ " with bits to correspond.

**Alternative Specifications**—\*To be provided with plain table gibbed to frame and adjustable 12" vertically by hand wheel and to tilt 30 degrees to right or left; to have adjustable back guide and hold down with spring spacing stop gauges.

†Motor driven. (Copy data under motor section page 98 given as drive Nos. 5 or 7. See pages 90 to 97 for control data.)



## Vertical Hollow Chisel Mortiser with Foot Power Feed

(Illustrated page 48)

**Capacity**—To use chisels up to  $\frac{5}{8}$ " square by  $3\frac{1}{2}$ " deep. Chisel ram to be operated by foot treadle and to be arranged with adjustable chisel holders. Bit spindle to be gear driven. Machine to be provided with a fan for removal of chips and for keeping chisel cool.

**Frame**—To be cast in one piece and heavily ribbed to stand strain.

**Table**—\*To be provided with clamp for holding stock at top and bottom, table to be recessed so chips will fall thru. To have rack and pinion for lateral movement. To be adjustable crosswise and for height by hand wheel. Table to be provided with wooden throat-plate, also with tilting adjustment to any angle from zero to 30 degrees, right or left. Adjustable hold-downs provided for holding stock in position.

**Drive**—†Driven by countershaft with tight and loose pulleys  $8" \times 3\frac{1}{2}"$  at 1200 R.P.M.

**Equipment**—To consist of three chisles, one each  $\frac{3}{8}"$ ,  $\frac{1}{2}"$  and  $\frac{5}{8}"$  with bits to correspond.

**Alternative Specifications**—\*To be provided with plain table gibbed to frame and adjustable 12" vertically by hand wheel and to tilt 30 degrees to right or left; to have adjustable back guide and hold down with spring spacing stop gauges.

†Motor driven. (Copy data under motor section pages 98 and 99 given as drive Nos. 5, 7 or 9. See pages 90 to 97 for control data.)

## Two Spindle Shaper

(Illustrated pages 50, 51 and 58)

**Capacity**—Distance between spindles to be 24". Table to be 38" wide by 54" long.

**Frame**—To be cast in one piece, solidly ribbed to prevent any vibration, and to have tool closet cast therein.

**Table**—To be of cast iron, accurately scraped and edges rounded, and to be not less than 38" wide by 54" long. To be provided with one set table rings and guide pins.

**Spindle Yokes**—To be cast in one piece and to be held in V-slides in the frame with take-up gibs and clamping wheels. The slides to be carefully machined and hand scraped to fit. The yokes to be adjusted vertically by screws and hand wheel, having a direct lift. All gearing to be totally enclosed.

**Spindles**—Spindles to be made of forgings and to be hardened at the lower end where the end step comes in contact; and to be  $1\frac{1}{8}$ " where the collar goes on and to have detachable stems. \*The journals are to run in ball bearings.

**Drive**—†Driven by countershaft with tight and loose pulleys 8"x5 $\frac{1}{4}$ " at 1000 R.P.M.

**Equipment**—To consist of two steel collars, two filling-in collars for each spindle and one set of blank knives.

**Alternative Specifications**—\*Journals to run in babbitted bearings—or, journals are to run in taper bronze bearings.

†Motor driven. (Copy data under motor section pages 98 and 99 given as drive Nos. 5, 7 or 8. See pages 90 to 97 for control data.)

## Reversible Shaper

(Illustrated page 54)

**Frame**—To be cast in one piece, solidly ribbed to prevent any vibration.

**Table**—To be cast iron, accurately scraped and edges rounded. Table to be not less than 32"x36" with removable centre plate.

**Spindle Yoke**—To be cast in one piece and to be held in V-slides in the frame with take-up gib and clamping device. Slide to be carefully machined and hand scraped to fit. Yoke to be adjustable vertically by screw and hand wheel, having a direct lift. All hoisting gears to be totally enclosed. Spindle to be of crucible steel, not less than  $1\frac{7}{16}$ " diameter in the journals, and not less than 6" long in the bearings. To have detachable top section.

**Drive**—\*Driven by reversible countershaft having two compressed paper frictions engaged with an iron wheel on the vertical shaft, vertical shaft to have bearings at both ends, with take-up for wear. The reversing device to be by foot lever arrangement at the operator's side of the machine, and to have self-locking device for holding it in position, and self-releasing device for clearance of friction when not in duty.

**Equipment**—To be provided with one detachable upper spindle section, nine differential guide collars, one table ring, two steel collars and one pair of plain shaper knives.

**Alternative Specifications**—\*Motor driven. (Copy data under motor section pages 98 to 99 given as drive Nos. 4 or 10. See pages 90 to 97 for control data.)

## Universal Draw Cut Trimmer

(Illustrated page 55)

**Capacity**—Size of bed to be 22"x13". Draw of knife in cut  $1\frac{5}{8}$ ". Forward mitre 8". Back mitre  $8\frac{1}{2}$ ". Trim 12".

**Stand**—\*To be mounted on an iron pedestal easily removable.

**Handle**—To be detachable and adjustable to suit work or convenience of operator.

**Head**—Wear of head in guide ways to be universally for alignment.

**Alternative Specifications**—\*Without pedestal.

## Tenoning Machine

(Illustrated page 56)

**Capacity**—To cut tenons  $3\frac{7}{8}$ " long and 15" wide at one operation.

**Frame**—To be cast in one piece, well ribbed to eliminate vibration.

**Headstocks**—To be adjustable vertically and laterally, both headstocks to be adjustable in conjunction with one screw, and to have side-clamping boxes. Cope attachment to have independent adjustment, vertical, horizontal and angular.

**Carriage**—To have combination roller movement upon ways properly secured, provided with guards and cleaning devices.

**Table**—To be provided with longitudinal lines for setting the gauges and quick adjustable clamp by hand lever for setting the bridge bar and stops.

**Cut-Off Saw**—To be of the rear type and have quick hand lever adjustment for moving the saw laterally.

**Drive**—\*Driven by countershaft having tight and loose pulleys  $11"x5\frac{1}{4}"$  at 900 R.P.M.

**Equipment**—To be provided with one set of cutter heads, cope attachments and rear cut-off saw.

**Alternative Specifications**—\*Motor driven. (Copy data under motor section page 98 given as Drive Nos. 1, 4 or 5. See pages 90 to 97 for control data.)

## Vertical Borer

(Illustrated page 68)

**Capacity**—Machine to take bits up to 1" diameter, with a throw of 10", and a distance of 10" between the spindle and posts. Five bits to be furnished with  $\frac{1}{2}$ " shanks— $\frac{3}{8}$ ",  $\frac{1}{2}$ ",  $\frac{3}{4}$ ",  $\frac{7}{8}$ " and 1" diameter.

**Frame**—To be cast in one piece, of the column type, having a broad base and wide foot flanges.

**Table**—To have universal movement and to tilt forward or sidewise, and to be adjustable to a height of 9" by hand wheel and screw.

**Spindle**—To be not less than  $1\frac{5}{16}$ " diameter, splined in a long sleeve in the journal boxes. Spindle to be operated by a foot treadle adjustable for throw of bit. Adjustable stop for holding down of stock to be provided.

**Drive**—\*Driven by countershaft having tight and loose pulleys  $8\frac{1}{2}$ "x $3\frac{3}{4}$ " at 500 R.P.M.

**Equipment**—To consist of five bits  $\frac{3}{8}$ ",  $\frac{1}{2}$ ",  $\frac{3}{4}$ ",  $\frac{7}{8}$ " and 1" diameter.

**Alternative Specifications**—\*Motor driven. (Copy data under motor section page 98 given as drive Nos. 5 or 6. See pages 90 to 97 for control data.)

# Horizontal Radial Boring Machine

(Illustrated page 59)

**Capacity**—To bore holes \*up to 16" apart and 5" deep and from  $\frac{1}{8}$ " to  $\frac{3}{4}$ " diameter.

**Frame**—To be one piece cored casting.

**Spindles**—To have two spindles mounted in an adjustable head which swivels around one of them so they may be set at an angle from the horizontal line of table. The range of adjustment to be from a horizontal to a perpendicular line and beyond. The distance between centres to be independent of angular adjustment in any position. Both intermediate and pinion gear to be cut, and the former not less than 4" face.

**Table**—To have vertical adjustment of 9" on gibbed ways and forward and backward movement of 6".

**Drive**—†Driven by tight and loose pulleys 8"x3 $\frac{3}{4}$ " at 600 R.P.M.

**Equipment**—To consist of two bits  $\frac{3}{8}$ " diameter.

**Alternative Specifications**—\*To bore holes up to 10" apart.

†Motor driven. (Copy data under motor section page 98 given as drive No. 5. See pages 90 to 97 for control data.)

## Horizontal Boring Machine

(Illustrated page 60)

- Capacity**—To have 12" stroke and to bore holes up to 3" diameter and to centre of 20" vertically.
- Frame**—To be one piece casting with extension to receive counter or motor.
- Spindle**—To be of steel  $1\frac{5}{16}$ " diameter. To have steady bearing close to bit socket so that wear can be readily taken up. Vertical lever to pull directly on centre line of spindle.
- Table**—To be of iron 18"x32" and slotted for fence at right angles so that long work can be bored edgewise as well as across, and at any required angle. Table to adjust vertically 10" and to tilt 45 degrees both ways.
- Foot Lever**—To be equipped with quick returning spring on both sides.
- Drive**—\*Driven by tight and loose pulleys 8"x4 $\frac{1}{2}$ " at 1000 R.P.M.
- Alternative Specifications**—\*Motor driven. (Copy data under motor section page 98 given as drive Nos. 5 or 6. See pages 90 to 97 for control data.)

## Pattern Maker's Lathe

(Illustrated page 64)

**Capacity**—\*To swing 16" over the bed and to take in up to 5' 1" long between centres.

**Bed**—Is to be made of cast iron, carefully planed and finished, and †to be 8' long.

**Headblock**—To be made to swivel 5 degrees either way and to be fitted on planed ways and secured by clamping bolts. Bearings to be ring-oiling, bronze bushed and adjustable for wear. Cone pulley is to be made of cast iron, finished inside and out. Spindle is to be hollow and made of high carbon steel. Step thrust collar to take up end play.

**Tailstock**—To be constructed so cutting tools may be brought close to the centre without interference; to be radial-set overttype swiveling 20 degrees either way and to have taper-pin stop for self-centering alignment.

**Carriage**—To have a bearing not less than 18" long on the bed on the front way, and to have a traverse bearing of not less than 6" long on the back of the apron. Feeding mechanism to be of cut gears, steel rack and worm wheel. Cross line screw for moving turret to be indexed collar type and turret plate to be graduated and arranged for removing by clamp bolt. Rest socket to be of the quick-removable type by lever adjustment.

**Drive**—‡Driven by countershaft with two pairs of tight and loose pulleys 8"x3 $\frac{3}{4}$ " at 400 and 750 R.P.M. giving eight speeds on head spindle

**Equipment**—To consist of one floor stand and offset socket, rear face plate, two driving centres, two cup centres, two conical centres, one face plate each, 6", 10" and 16" in diameter, one rosette chuck, two rest sockets for bed, one rest socket for carriage, three straight rests, 12", 24" and 48" long, and one 4" angle rest, and one hand-turning tool holder.

**Alternative Specifications**—\*To swing 20" or 24" over the bed.

†To be 10', 12' or 16'.

‡Motor driven. (Copy data under motor section pages 98 and 99 given as drive Nos. 6 or 9. See pages 90 to 97 for control data.)



## 12-Inch Speed Lathe

(Illustrated pages 68, 70 and 71)

**Capacity**—To swing 12" over the bed and †to take in up to 26" between centres.

**Bed**—To be \*55" long, made of cast iron, and carefully planed and finished and mounted on iron legs.

**Headblock**—To be made to swivel 5 degrees either way and to be fitted on planed ways and secured by clamping bolts. Bearings to be ring-oiling, bronze bushed and adjustable for wear. Cone pulley to be made of cast iron, finished inside and out. Spindle is to be hollow and made of high-carbon steel. Step thrust collar to take up end play. Spindle to be bored and reamed for centres having a taper  $\frac{1}{2}$ " in twelve.

**Tailstock**—To be constructed so cutting tools may be brought close to the centres without interference; to be radial-set over-type, to swivel either way.

**Carriage**—To be compound type with radial tool post.

**Drive**—‡Driven by countershaft with 4-step cone pulley and tight and loose pulleys 6"x2 $\frac{3}{4}$ " at 800 R.P.M.

**Equipment**—To consist of one spur centre, one  $\frac{1}{2}$ " cup centre, one 6" face plate, one 3" rosette chuck for interchangeable screws, one 6" rest, one 12" rest, one blue-print holder and one centre drift for headblock. Rear face plate, floor stand with straight and angle rests and one extra 48" rest with double rests. Distance from floor to centre of spindle to be 42". Distance from floor to top of bed 36". Depth of bed 5 $\frac{1}{8}$ ". Width of bed 6 $\frac{1}{2}$ ". Length of headstock 12 $\frac{3}{8}$ ". Width of headstock 6". Length of spindle over all 14 $\frac{11}{16}$ ". Diameter of spindle 1 $\frac{7}{16}$ ". Diameter of hole in spindle  $\frac{1}{2}$ ". Length of tailstock 9". Width of tailstock 6". Length of spindle 8 $\frac{1}{2}$ ". Diameter of spindle 1 $\frac{3}{8}$ ". Adjustment of spindle 5".

**Alternative Specifications**—\*Bed to be 48", 72" or 90" long.

†To take in up to 19", 43" or 61" between centres.

‡Motor driven. (Copy data under motor section pages 98 to 99 given as drive Nos. 6 or 9. See pages 90 to 97 for control data.)

## Triple Drum Sander

(Illustrated page 74)

**Capacity**—To work stock 31" wide and up to 8" thick.

**Top Frame**—To be supported on all four corners on posts and to raise and lower on heavy screws with bearings top and bottom.

**Drums**—To be provided with automatic paper take up while machine is in operation. To have wedge type adjustment for raising and lowering them. To be covered with sandpaper ready for use. To be provided with central non-cramping oscillator. Boxes to be side clamping type.

**Feed**—To be provided with three speeds operated by lever and segment at front of machine. To consist of eight rolls—four above with pressure rolls between and four in the table. Feed to be equipped with power hoist.

**Drive**—\*Driven by tight and loose pulleys 12"x8½" at 550 R.P.M.

**Alternative Specifications**—\*Motor driven. (Copy data under motor section pages 98 and 99 given as drive Nos. 5 or 11. See pages 90 to 97 for control data.)

## Disk and Spindle Sander

(Illustrated page 80)

**Frame**—To be cast in one piece with broad foot flange. 26"x31" and tool chest to be in the frame.

**Spindle**—To be  $\frac{1}{8}$ " diameter when the sand rolls are applied and to have ball bearings in a vertical moving yoke which gives an end motion to the sand roll while in operation. Roll table to be 27"x27" and to tilt forward 45 degrees and 5 degrees backward by toothed quadrant and worm and hand wheel.

**Disk**—To be of iron  $\frac{3}{4}$ " thick machined to hold cement and to be in exact running balance. One extra disk to be furnished for change. Disk table to be of iron and adjustable vertically on machined ways and counterbalanced to adjust easily. The table to be adjustable to and from the disk and to an angle of 45 degrees down and 10 degrees up. Angular adjustment to be by toothed quadrant, worm and hand wheel.

**Drive**—\*Driven by belt to main arbor through the countershaft and arranged so that the roll spindle may be disconnected when so desired by the operation of a clutch which permits the disk to be run separately. Counter to have tight and loose pulleys 10"x5 $\frac{1}{2}$ " to run 625 R.P.M giving main arbor 750 R.P.M.

**Equipment**—To consist of three spindle rolls with table plates to correspond, one extra 30" disk, six No. 1 $\frac{1}{2}$  sandpaper circles, one centring slide and one graduated gauge for disk table.

**Alternative Specifications**—\*Motor driven. (Copy data under motor section page 98 given as drive Nos. 5 or 6. See pages 90 to 97 for control data.)

## Disk and Drum Sander

(Illustrated page 82)

**Frame**—To be cast in one piece, box type, and to have wide floor flanges to prevent vibration.

**Disk**—To be made of iron, \*30" diameter accurately turned and balanced, sand paper to be held to the disk by an outside ring in four sections, with hand wheel adjustment for removing same, and to lie in a rabbet with rounded edge turned in the face of the disk.

**Table**—To be not less than 16" wide, full length of the face of the wheel, and to have vertical adjustment of at least 8", and to have an angle adjustment up to 45 degrees.

**Drum**—To be built up of kiln-dried wood with iron centers and to be †13"x16" and covered with felt.

**Drive**—‡Driven by countershaft with tight and loose pulleys 12"x4½" at 500 R.P.M.

**Equipment**—Disk to be covered with sandpaper.

**Alternative Specifications**—\*36", 42" or 48" diameter.

†Drum to be 16"x24".

‡Motor driven. (Copy data under motor section page 98 given as drive Nos. 5 or 6. See pages 90 to 97 for control data.)

## Automatic Knife Grinder

(Illustrated page 87)

**Capacity**—To grind knives up to \*31" long.

**Frame**—To be of the box type, cast in one piece, with heavy flanges to prevent vibration.

**Knife Bar**—To have adjustable swinging movement so that the edge of the knife may be ground to any angle desired, and the frame may be swung away from the wheel to provide easy access for changing knives.

**Carriage**—Carrying the knife bar to be entirely automatic with reciprocating movement of the knife carriage to be governed by stops for various lengths of knives. The cross line movement for grinding to be regulated in adjustments as fine as  $\frac{1}{300}$ " and to have automatic control stops for setting the depth of grinding to the point desired. Pump attachment and tank to be supplied, tank to have three compartments, all to be easily removed for cleaning.

**Drive**—†Driven by countershaft with tight and loose pulleys 10"x4" at 300 R.P.M.

**Alternative Specifications**—\*To grind knife up to 37" long. †Motor driven. (Copy data under motor section page 98 given as drive No. 5. See pages 90 to 97 for control data.)

## Automatic Self-Feed Knife Grinder

(Illustrated page 86)

**Capacity**—To grind knives \*32" long.

**Frame**—To be a one piece casting, cored and with broad foot flange.

**Carriage**—To have automatic transverse movement across the face of wheel and to be provided with adjustable stops for regulating length of cut.

**Knife Bar**—To be slotted to receive bolts on one face and to have clamp for holding hard, thin knives.

**Wheel**—To be 22" diameter by  $1\frac{1}{2}$ " face.

**Drive**—†Driven by tight and loose pulleys 10"x3" at 350 R.P.M.

**Alternative Specifications**—\*To grind knives 36" or 50" long.

†Motor driven. (Copy data under motor section page 98 given as drive No. 5. See pages 90 to 97 for control data.)

## Small Tool Grinding Machine

(Illustrated page 83)

**Capacity**—To grind all sorts of small tools including flat hand plane bits.

**Frame**—To be one piece casting with broad foot flange and to stand free from vibrator.

**Arbor**—To provide for two grinding wheels and to be fitted with two-step cone pulley giving two speeds for different size wheels. The driving cone and belt to be enclosed in the machine.

**Water Tanks**—To be located under each wheel and to be adjustable vertically by foot treadle at the base of machine.

**Drive**—\*Driven by tight and loose pulleys 8"x3¼" at 1100 R.P.M.

**Equipment**—To consist of alundum wheels 12"x2" and one alundum cone 5"x3¼".

**Alternative Specifications**—\*Motor driven. (Copy data under motor section page 98 given as drive Nos. 5 or 6 See pages 90 to 97 for control data.)

## Double Emery Grinder

(Illustrated page 88-bottom)

**Capacity**—Machine is to be suitable for wheels 12" diameter, with 7/8" hole. Machine is to be suitable for mounting on bench. Pulley on arbor to be 4" diameter. No wheels are to be included.

**Arbor**—To be of steel, mounted in long boxes.

**Drive**—\*Driven by countershaft with tight and loose pulleys 8"x3" at 750 R.P.M.

**Alternative Specifications**—\*Motor driven. (Copy data under motor section page 98 given as drive No. 5. See pages 90 to 97 for control data.)

## Grindstone

(Illustrated page 89)

**Frame**—Supporting the stone to be of cast iron with cast iron legs supporting same.

**Arbor**—\*To carry a stone 30" diameter by 4" face. Tool rest is to be furnished, and water tank with drop cock. Tight pulley is to be fitted on the arbor shaft.

**Drive**—†Driven by countershaft with tight and loose pulleys 12"x3 $\frac{3}{8}$ " at 150 R.P.M.

**Alternative Specifications**—\*To carry a stone 36" or 38".  
†Motor driven. (Copy data under motor section page 99 given as drive No. 12. See pages 90 to 97 for control data.)

# INDEX

## PART I

	PAGE
Machine Section . . . . .	8
Band Scroll Saws . . . . .	8
Band Saw Guides . . . . .	11
Boring Machines . . . . .	58
Brazing Machines . . . . .	13
Buzz Planers . . . . .	36
Chain Feed Edging Saw . . . . .	18
Emery Grinders . . . . .	88
Filing and Setting Machines . . . . .	15
Grindstones . . . . .	89
Jointers (Bench) . . . . .	38
Knife Grinders . . . . .	84
Lathes . . . . .	62
Mitre Machines . . . . .	55
Mortisers (Hollow Chisel) . . . . .	46
Moulders . . . . .	42
Planers . . . . .	30
Rip Saw Benches . . . . .	20
Safety Cylinders . . . . .	40
Sanders (Drum) . . . . .	74
Sanders (Drum, Disk and Spindle) . . . . .	80
Scroll Saws . . . . .	16
Shapers (Double) . . . . .	50
Shapers (Single) . . . . .	54
Surfacers . . . . .	30
Swing Saws . . . . .	21
Tenoners . . . . .	56
Tool Grinders . . . . .	83
Trimmer, Universal Draw Cut . . . . .	55
Universal Saw Bench . . . . .	26
Variety Saw Benches . . . . .	22

## PART I

Motor Section . . . . .	90
-------------------------	----

## PART II

On the Operation of Woodworking Machinery . . . . .	101
---	-----

## PART III

Specifications for the Purchasing of Woodworking Machinery . . . . .	125
---	-----





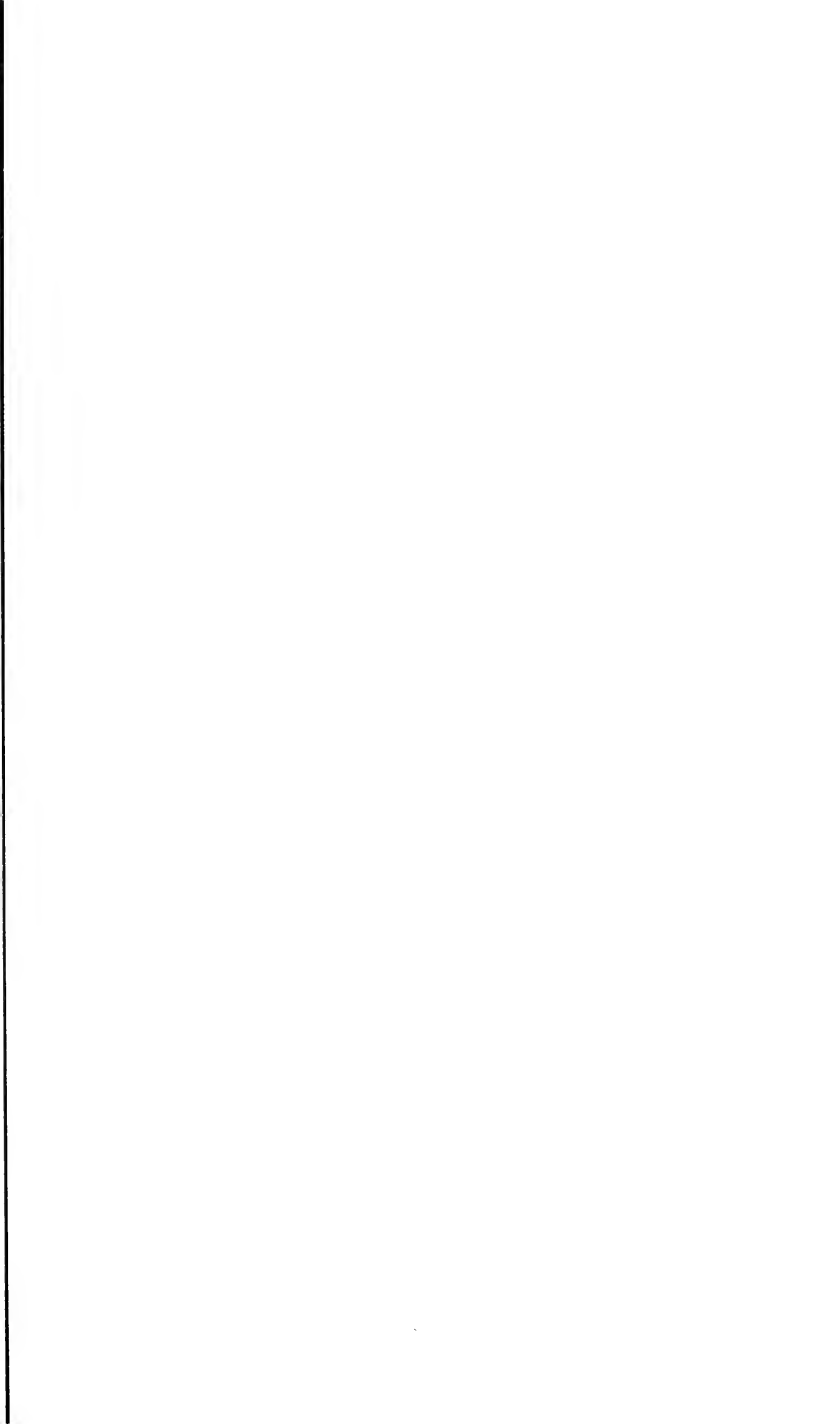
---

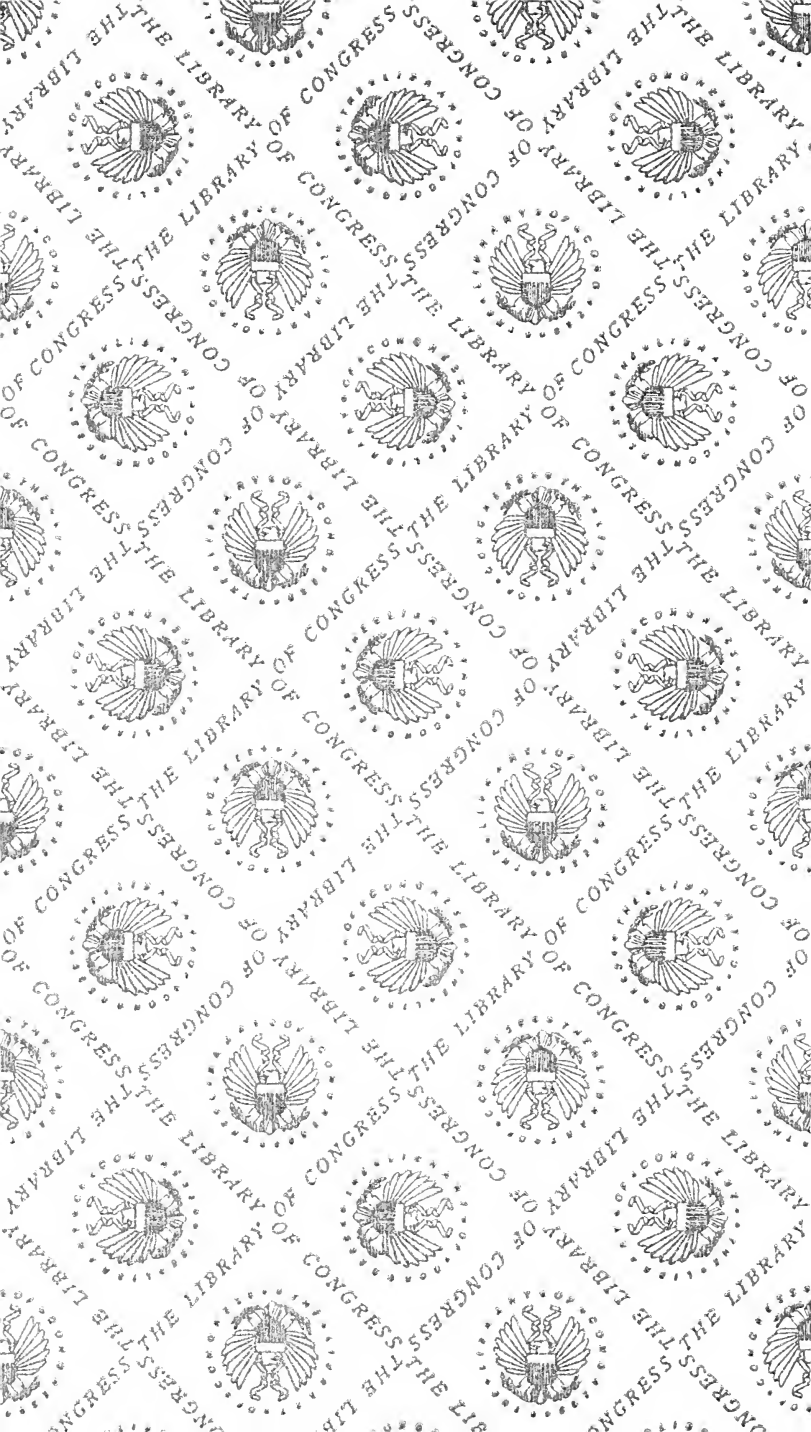
PRESS OF  
HENRY CONOLLY  
COMPANY  
ROCHESTER, N. Y.

---









HECKMAN  
BINDERY INC.

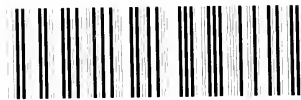


DEC 90

N. MANCHESTER,  
INDIANA 46962



LIBRARY OF CONGRESS



0 016 067 132 4