

ART MAGAZINE

XI

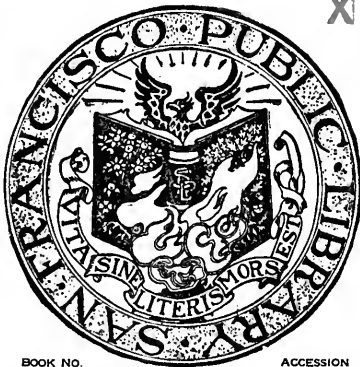

BOOK NO.

ACCESSION

720.5 Ar24 125

422434

NOT TO BE TAKEN FROM THE LIBRARY

Form 37 10M 11-35

Handwritten signature or initials

0





THE ARCHITECT AND ENGINEER

SAN FRANCISCO
PUBLIC LIBRARY
PERIODICAL DEPT.

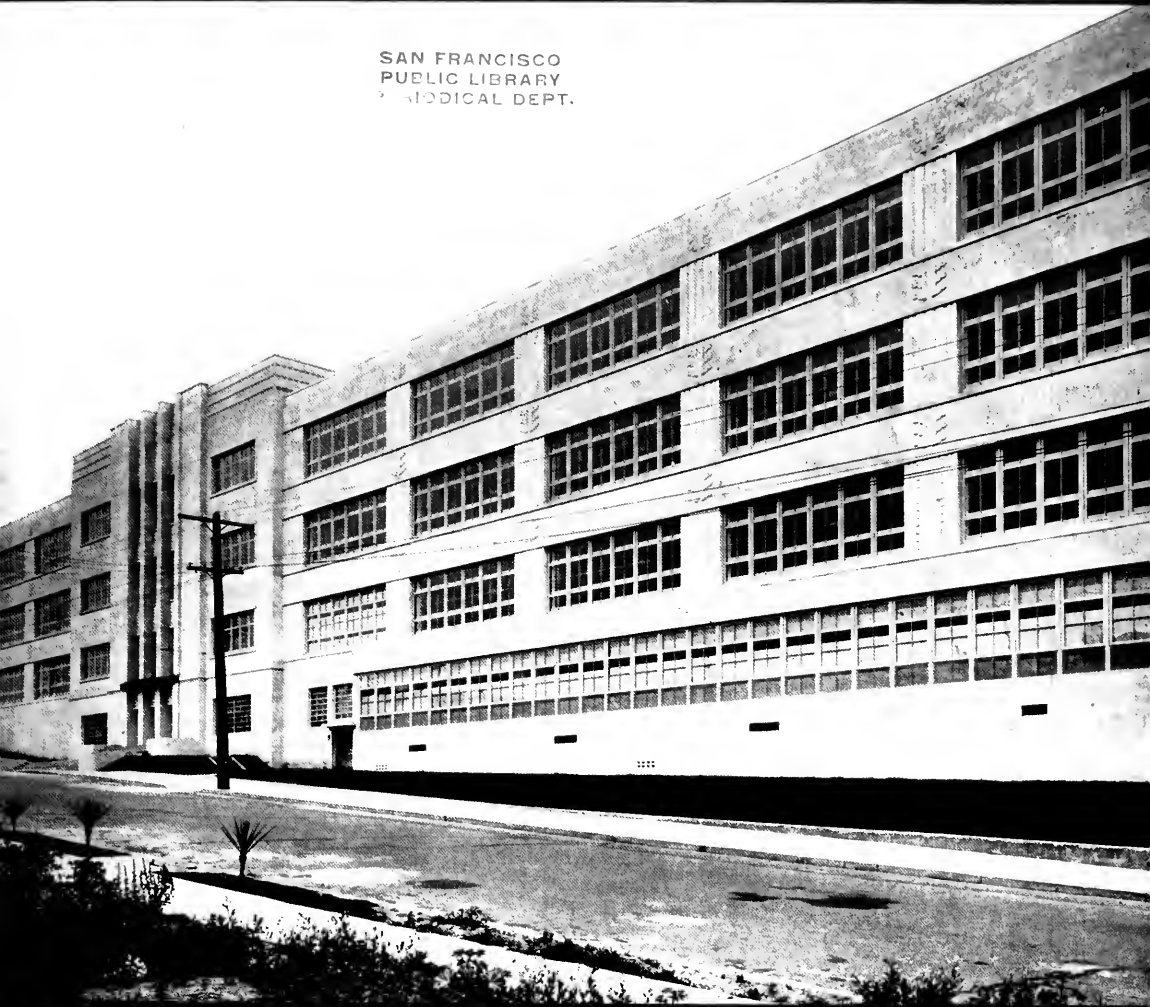

GEORGE WASHINGTON HIGH SCHOOL
R. MILLER & T. L. PFLUEGER

SAN FRANCISCO
ARCHITECTS

APRIL 1936

for
CENTURIES TO COME



GOLDEN
GATE
PORTLAND
CEMENT

LINED with concrete 4 feet thick at the sidewalls and 3 feet at the crown, the Yerba Buena Tunnel takes its place in modern engineering achievement as the largest bore tunnel in the world. It is 76 feet wide, 58 feet high, and 540 feet long. Its double decks provide for 6 lanes of motor traffic, 3 lanes of truck traffic, and 2 interurban tracks.

Appropriate is the fact that the cement chosen for all the concrete is Golden Gate True Portland Cement, produced on San Francisco Bay.

No matter what the job—whether it takes one sack or a trainload—you'll find the right cement for the purpose under the reliable name of Golden Gate.

PACIFIC PORTLAND CEMENT COMPANY
SAN FRANCISCO

FOR SOUND CONSTRUCTION

x 720.5
AN 24 125

THE ARCHITECT AND ENGINEER

FOR · APRIL · 1936

presents

COVER

422434

GEORGE WASHINGTON HIGH SCHOOL, SAN FRANCISCO
J. R. Miller and T. L. Pflueger, Architects

FRONTISPIECE

STREET FACADE, ACADEMIC BUILDING, GEORGE WASHINGTON
HIGH SCHOOL, SAN FRANCISCO
J. R. Miller and T. L. Pflueger, Architects

TEXT

GEORGE WASHINGTON HIGH SCHOOL, SAN FRANCISCO	9
C. H. Sawyer, City Architect	
FRESCOES OF THE GEORGE WASHINGTON HIGH SCHOOL	17
Victor Arnautoff	
ARCHITECTURE AT AN EXPOSITION	27
Irving F. Morrow	
NEW TYPE OF LOW COST SCHOOL BUILDINGS	31
WOOD NO LONGER A FIRE HAZARD	35
B. P. Caldwell, Jr.	
EARTHQUAKE PHENOMENA IN CALIFORNIA	39
Captain R. V. Labarre	
TERMITE CURB IS IN CONFLICTING HANDS	43
A. A. Brown	
MODERN DESIGN FOR THE KITCHEN	45
Mary D. Gillies	
SUMMER AIR CONDITIONING WITH ICE	48
H. L. Lincoln	
WITH THE ARCHITECTS	55

PLATES AND ILLUSTRATIONS

GEORGE WASHINGTON HIGH SCHOOL, SAN FRANCISCO	
J. R. Miller and T. L. Pflueger, Architects	
Detail of Entrance 9	Plan of Complete Project 10
Models 11	Detail of Street Facade 12
Main East Entrance 13	Street Frontage 14
Entrance to Library 15	Administration Corridor 16
Murals Over Stairway 18	
TWO RESIDENCES BY WILLIAM WURSTER, ARCHITECT . 22-26	
1—House of Dr. and Mrs. George H. Sanderson, Stockton	
2—House of Dr. and Mrs. Saxton T. Pope, Burlingame	
MANUAL ARTS HIGH SCHOOL, LOS ANGELES	31-32
John Parkinson and Donald B. Parkinson, Architects	
FIRE TESTS OF HARDWOOD INTERIOR FINISH	36-37
TWO INTERESTING FIREPLACES	38

FREDERICK W. JONES
Editor

HOMER M. HADLEY
ROBERT DENNIS MURRAY
IRVING F. MORROW
L. H. NISHKIAN
A. A. BROWN
Contributing Editors

EDGAR N. KIERULFF
Advertising Manager

J. LESLIE MEEK

Published monthly by THE ARCHITECT AND ENGINEER, INC., 68 Post Street, San Francisco, California. W. J. L. Kierulff, President and Manager; Fred'k. W. Jones, Vice-President; L. B. Penhorwood, Secretary. Los Angeles office, 832 W. 5th Street. Subscriptions, United States and Pan-American, \$3.00 a year; single copy \$.50. Foreign countries, \$5.00 a year.

WOLMANIZED LUMBER

NO EVIDENCE OF TERMITE ATTACK . . .

. . . on Wolmanized wood was found in the installations examined by us in the United States. . . We failed to find or learn of a single case of termite attack upon Wolmanized wood in the survey in Central America, of the Standard Fruit & Steamship Company's properties. This company has used 35,000,000 feet of Wolmanized lumber there during the last nine years.

—From the report of the Pittsburgh Testing Laboratory, a leading fact finding institution.

AMERICAN LUMBER & TREATING CO.
37 West Van Buren St.
CHICAGO, ILL.

San Francisco Sales Office
116 New Montgomery St.
Phone SUHer 1225

Los Angeles Sales Office
1031 South Broadway
Phone PRospect 5558

For **STRENGTH**



CROCKER
FIRST NATIONAL
BANK
OF SAN FRANCISCO

Member Federal Deposit Insurance Corporation

27

HAWS SANITARY FOUNTAINS

Insure Safe DRINKING WATER

for students of the new

George Washington High School

San Francisco

Miller & Pflueger, Architects
Leland & Haley, Mechanical Engineers
Anderson & Rowe, Mechanical Equipment

Manufactured by
HAWS DRINKING FAUCET CO.
1808 Harmon Street
Berkeley, California

GLAZED TILE WALLS

of
(PRECISION SIZED)

ENAMELED WALL UNITS

FOR

GEORGE WASHINGTON HIGH SCHOOL
MILLER AND PFLUEGER ARCHITECTS
SAN FRANCISCO, CALIF.

CORRIDORS & LOBBY
TOILETS
CAFETERIA (Group)

COLORFUL PERMANENT
ECONOMICAL

FURNISHED BY

KRAFTILE COMPANY

Factory & Main Office
NILES, CALIF.

BRANCH: 525 MARKET STREET
SAN FRANCISCO

ENAMELED CLAY PRODUCTS

NOTES AND COMMENTS

THREE elements enter into the building of a house—cost, practicality, and beauty—and each is essential. The cost of motor cars has steadily diminished, while not only their efficiency but their attractiveness has risen. This is the combined result of intelligent quantity production, plus competition, helped by a lively and continuing interest on the part of the public. It seems strange that people do not feel the same excitement over a house that they do over a car. No man can be a good and useful citizen who does not have a good home, and a home to most men, aside from the big cities—and their day is passing—means a house on a plot of ground, a house he knows to be wholly useful, and which he believes to be completely beautiful.

Crowds pay admission each year to see the new motor cars; will they pay in the same number to see new houses? When the design and functioning of the house is a matter of equally absorbing interest, then we will be ready to rebuild this country as it should be built, with a home for every family, in which living will be easy and comfortable and healthful. And the building of these homes and the furnishing of them will boost our present highest production capacity far beyond anything hitherto known.

* * *

THE BATTLE of architectural styles is over, and the result is a draw, according to Louis La Beume, of St. Louis, vice president of the American Institute of Architects. The modernists are retreating from their extreme position, he says. Likewise the traditionalists are moving ahead. Beauty is as avidly sought as comfort, he finds.

"Excess is giving way to common sense," Mr. La Beume points out. "The architect of today realizes, as perhaps never before, the necessity of a fresher and less traditional approach to his problem. Economic forces, no less than esthetic ideals, have always affected the course of design. Such forces must inevitably have their effect on what is called style of architecture. Certain elements and phrases in architectural vocabulary are gradually being sluffed off, and new words and phrases are being coined.

"During the past five years or more the architectural profession has been busy, not in the practice of architecture, but in the discussion of architectural theories. Heated verbal engagements have taken place between the proponents of tradition and the apostles of progress. Both sides have often been eloquent, and sometimes logical.

"There is a vast difference, however, between verbal eloquence and architectural eloquence, and architects must, in the final analysis, be judged by their deeds rather than their words. Now that the fury of the discussion seems to be abating, we may take advantage of the breathing spell and attempt to appraise the net results of the controversy.

"If the functionalists have overstated their case, as must be soberly admitted, they have at least performed a useful service in calling attention to the need for simplification and for clean, outright architectural statement. Material functionalism as the sole attribute of architectural design is an absurdity, for architecture remains an art founded on use, but evoking a response from the spirit which hungers just as avidly for beauty as it does for comfort."

* * *

AMERICAN architects for some years have been working independently and originally, and doing the world's best work in their line. Lately they have been greatly helped by the makers of new building materials. So far, the type of building that seems to exemplify the best work of these originators is the automobile filling and service station. The automotive industry, while revolutionizing our transportation, may also be revolutionizing our architecture.

In the filling station the architects have had entirely new requirements, and so turned naturally to new forms and new materials. They are helped by the bold experimentation of chemists and steel manufacturers, in turning out new substances for construction work. So we find these service stations, meant for what used to be a filthy business, as neat, clean and attractive as modern bathrooms and often as attractive externally and internally as fine stores and homes. They are strong, durable, easy to clean, resistant to cold and heat.

"So far, so good," comments a writer in the *Battle Creek Journal*, "but let it be observed that in these structures not only many customary materials, but many customary labors and services are eliminated. They are built often without lathing, plastering, siding, nailing and sawing. And when built they need no painting or papering, and very little cleaning. Less work to do, more trades eliminated, more unemployment! Must we always pay this price of progress?"

* * *

THE Federal Government recently sent out a press notice warning prospective home builders of the "Jerry Builder." The article appears elsewhere in this issue. It is gratifying to note that agitation against

this type of builder is coming from influential sources. Webster defines Jerry-Builder as "one who builds cheaply and unsubstantially." That is a mild definition.

The price paid by the owner for employing this kind of service is appalling. The loss does not always fall upon the original owner provided he is able to get rid of his investment a year or so after completion. The second owner is the one who pays and pays dearly. Poor workmanship and inferior materials soon become manifest and there is no comeback either for the new owner or the original owner who was inveigled into building on promise of getting the job done at a ridiculously low figure.

IN the August number of *The Octagon*, an official mouthpiece of the A.I.A., appears "A Statement to the Architectural Profession" by the Boston Chapter. The article begins:

"The Architects themselves, and not the public, are responsible today for most of the disabilities under which they are suffering. This has been true for many years past, and tragically true today. They have established in the public mind a definite impression that under certain circumstances professional services for which a substantial fee is legitimately charged, may be secured without any compensation whatsoever."

The article is well worth attention, but is weakened at the end where the opposition thought has contributed a discordant note:

"If he wishes to enter unauthorized competitions or vary from the spirit of professional practice, let him be honest about it and resign from the Institute before so doing. A few architects have done this and their honesty in so acting is respected."

It is not a question of Institute membership—in or out, it is a bad business maneuver, and without doubt reacts adversely on one's own practice as well as injuring the entire profession.

How one thus acting may expect to retain the respect of his fellow practitioners or the public is certainly beyond the comprehension of intelligent men.

In or out of the Institute has no relation to the subject—in either case one may pursue lofty ideals—but remaining out to free oneself from the supposed entanglements of good practice is to admit a lack of straightforward purpose, and is a dubious business course.—Paul A. Davis.

EVERY ARCHITECT in California

will be interested in an important announcement in this magazine next month.



Photo by Moulin

STREET FACADE ACADEMIC BUILDING, GEORGE WASHINGTON HIGH
SCHOOL, SAN FRANCISCO, CALIFORNIA
J. R. MILLER AND T. L. PFLUEGER, ARCHITECTS



Photo by Moutin

DETAIL OF ENTRANCE, GEORGE WASHINGTON HIGH SCHOOL, SAN FRANCISCO
J. R. Miller and T. L. Pflueger, Architects

THE GEORGE WASHINGTON HIGH SCHOOL

By Chas. H. Sawyer, City Architect

OF all the school buildings that have been built in San Francisco since the fire, the George Washington High School is perhaps the most outstanding, not in point of size, for there are others as large. In other respects it is in a class by itself.

To begin with the site is impressive, and is of ample area, covering sixteen acres of high land in the Richmond District. From the building is visible a wide panorama of the city, the Golden Gate and distant mountains.

The site itself was for many years a quarry

and the operations of the quarry men in excavating the so-called "red rock" that was used in so much of the concrete work in earlier days, has left an amphitheatre, that is ideally situated for a football and athletic stadium.

The architects, Messrs. Miller and Pflueger, spent many months in their preliminary studies of the site and its possibilities, preparing some twenty-three plans, studying the problem from every angle and the complete plans that were finally developed and approved by the Department of Education, will, it is hoped,

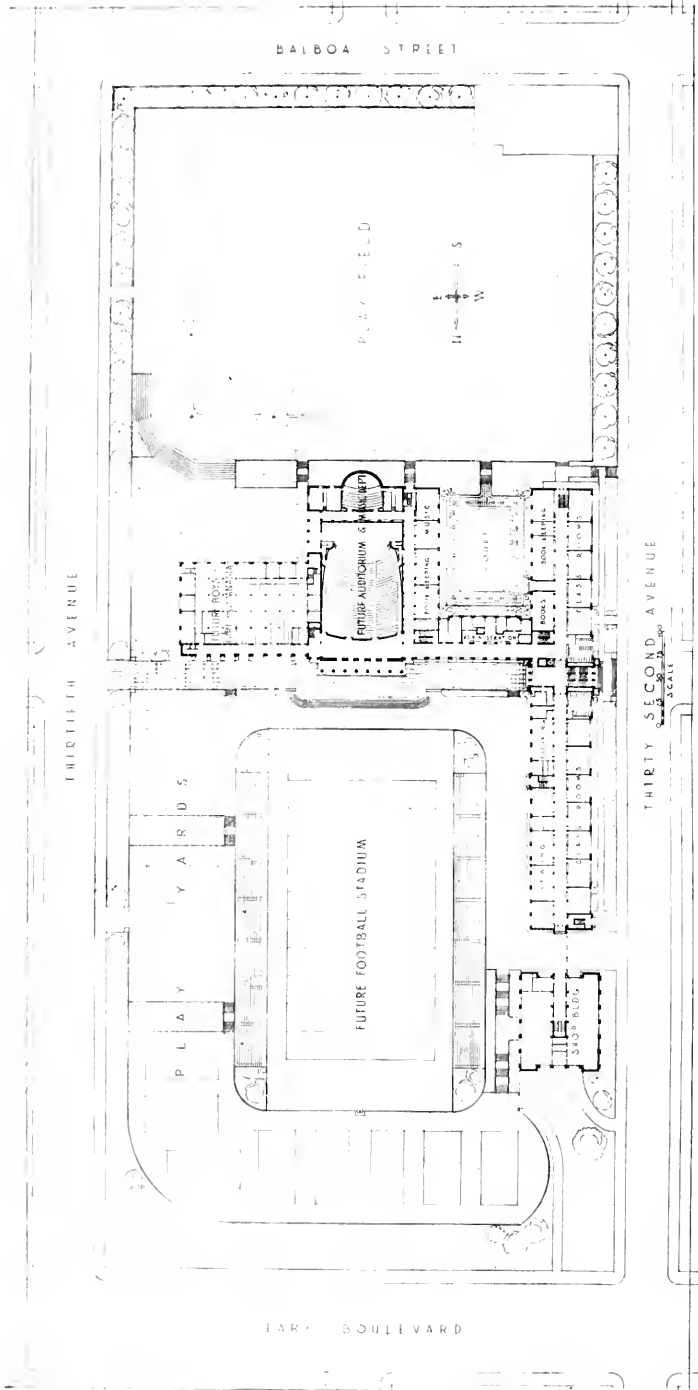

PLANS OF COMPLETE PROJECT, GEORGE WASHINGTON HIGH SCHOOL,
 SAN FRANCISCO
 J. R. MILLER AND T. L. FLUEGER, ARCHITECTS

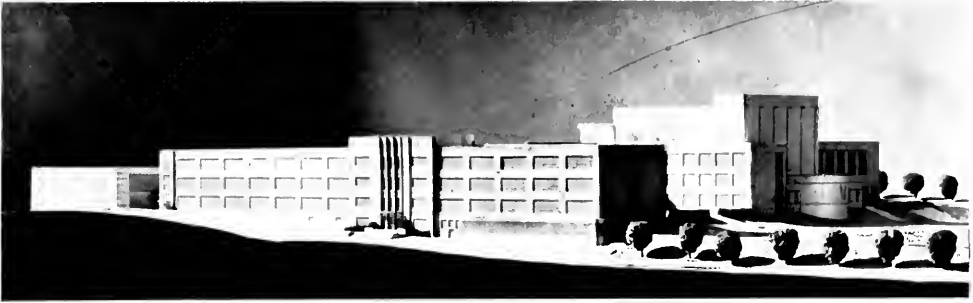

MODEL OF GEORGE WASHINGTON HIGH SCHOOL, SAN FRANCISCO
 J. R. Miller and T. L. Pflueger, Architects

be followed without change.

The present building is but the first unit of the ultimate High School and consists of the Academic building. There are still to be erected, the shop building, gymnasium and auditorium. The shop building is now under construction and the other units will follow in due course.

Design is Modern

The architectural design is modern and well adapted to concrete of which the building is

constructed. The deep spandrels and the main piers are of exposed concrete with a light paint coat for color. Mullions, coping, and certain decorative panels are of pleasingly rough textured terra-cotta. The main entrance on 32nd Street is of tooled cast stone.

A construction feature that assured freedom in the spandrels from the unsightliness of poorly made joints at floor levels was the pouring of the spandrels to their full height



MODEL OF COMPLETE PROJECT, GEORGE WASHINGTON HIGH SCHOOL, SHOWING INTERESTING TREATMENT OF AUDITORIUM PORTICO, RECALLING MT. VERNON RESIDENCE OF GEORGE WASHINGTON



Photo by Monlin

DETAIL OF STREET FACADE, ACADEMIC BUILDING, GEORGE WASHINGTON
HIGH SCHOOL, SAN FRANCISCO, CALIFORNIA

J. P. MILLER AND T. L. PFLUEGER, ARCHITECTS



Photo by Moulin

MAIN EAST ENTRANCE TO ACADEMIC BUILDING, GEORGE WASHINGTON
HIGH SCHOOL, SAN FRANCISCO, CALIFORNIA

J. R. MILLER AND T. L. PFLUEGER, ARCHITECTS

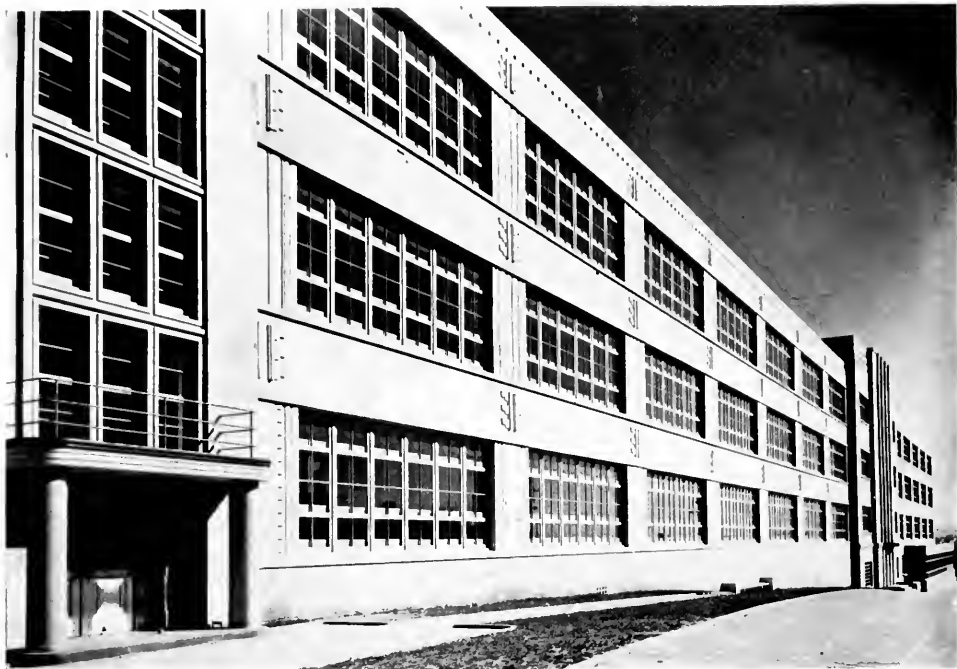

GEORGE WASHINGTON HIGH SCHOOL, SAN FRANCISCO, CALIFORNIA
 J. R. Miller and T. L. Pflueger, Architects
 View gives a splendid idea of the great length of the building—487 feet.

in one operation and making the joint in the piers and mullions come not at the floor but at the top of the spandrels. This construction conformed admirably with the architectural treatment of the spandrels: they are complete and whole and without joints. The tree and leaf conventional design which at intervals stands in relief upon them, is also assured of better execution by this procedure.

The academic building is the first school erected in San Francisco in strict compliance with the new legislation and the Rules and Regulations of the California State Department of Public Works.

Forty-five Classrooms

The building contains forty-five typical classrooms, thirty special class rooms and laboratories, administrative offices, library, cafeteria, and Reserve Officers' training quarters,

and will accommodate two thousand pupils. This unit also contains the power plant for the entire project.

The building is three stories high, except where the contour of the site allows an additional floor containing the cafeteria and Reserve Officers' quarters.

The building has been placed on the east side of Thirty-second Avenue, and serves to cut off the westerly winds from the athletic stadium. The facade is four hundred and eighty-seven feet long, joined near the center by an L shaped wing, forming a court in the rear 138 by 100 feet with a southern exposure.

The building was designed to give a maximum of light, the spacing of the columns on the Thirty-second Avenue facade give an almost unbroken glass area in the class rooms. Tests made by the Municipal Bureau of Arch-



Mural by Gordon Langdon

MAIN ENTRANCE TO LIBRARY, GEORGE WASHINGTON HIGH SCHOOL,
SAN FRANCISCO, CALIFORNIA

J. R. Miller and T. L. Pflueger, Architects

itecture, of light conditions, are extremely gratifying.

Standardized Interior

As the educational requirements of San

Francisco schools are standardized, the interior is typical of other high schools. There are, however, certain features that have been introduced that deserve mention.



Kraffle Walls

ADMINISTRATION CORRIDOR, GEORGE WASHINGTON HIGH SCHOOL, SAN FRANCISCO
J. R. Miller and T. L. Pflueger, Architects

The stairways are a double stairway, permitting circulation either up or down to operate independently. The walls and ceilings are exposed concrete. All stairways are lighted by recessed light units.

Acoustical treatment has been used to minimize the usual noise of the corridors, caused by traffic and the metal locker doors. The library and certain portions of the cafeteria unit are also acoustically treated.

Another feature not used before in San Francisco schools are the murals described elsewhere in this issue. In the main lobby the Life and Era of George Washington was chosen by the architects, and the artists have

spent many months in the execution of this important work. Three other panels, two in the library, and one at the library entrance, are the work of well known San Francisco artists.

Another innovation is the complete broadcasting equipment, allowing the principal to talk, or broadcast incoming radio programs throughout the building.

The cafeteria is complete, and of ample size, well lighted, with all modern equipment.

The Reserve Officers training quarters has a shooting gallery, with the necessary armory, and storage rooms protected by steel doors of tool proof steel.

(Please turn to Page 33)

FRESCOES OF GEO. WASHINGTON SCHOOL

By Victor Arnautoff

IT is impossible to describe the tremendous emotions I felt when I first saw the exciting shape of space that was offered to me by Mr. Pflueger for frescoes in the George Washington School.

A broad stairway,—a high ceiling, massive and strong in its simplicity; walls monumental. There is nothing sweet, nothing trivial in them. A man's job. Am I the man who has to paint those walls? For a moment I was frightened. Could I do it? I decided I could.

Subject—the life of George Washington. For a long time nothing but reading. Then planning and sketching.

Two big walls on the right and left side of the stairway — two periods of Washington's life—formation of personality and personality in action.

South wall — formation of personality. George Washington as surveyor, messenger and scout, officer of militia. Indians here and there.

North wall—action. Burning of the stamps, Boston Tea Party, Boston Massacre, raising of Independence flag pole in Philadelphia, George Washington accepting command of the army.

Small walls of the alcove to the north corridor—War, the moon on the ceiling—symbol of death. On the left George Washington, Congress and Army at Valley Forge. On the right—surrender of British army at Yorktown.

Alcove to the south corridor. The sun and rainbow — symbols of life. On the right — farewell to the army. On the left—George Washington, Jefferson and Hamilton in an endless discussion.

Then the north wall of the lobby—George Washington on his farm—the farm that produced everything. There are the overseer, black slaves and white craftsmen.

In the entrance alcove to the east corridor: On the ceiling—13 stars of liberty. On the left—George Washington bidding farewell to his mother. On the right—donation of the shares of Potomac River Company for education. It was a vain attempt to establish a National University.

The last wall between the entrances to south and east corridors was quite a problem. I had a desire to find some connection between George Washington and California. I could not find that but I did discover that he was one of the first who visualized and discussed



Photo by Moulin

*Mural by Arnautoff, depicting the Life of George Washington
MAIN STAIRWAY, GEORGE WASHINGTON HIGH SCHOOL, SAN FRANCISCO
J. R. Miller and T. L. Pflueger, Architects*

with his friends the tremendous possibility of the west. And there it is—by means of war and peace the 13 states grown up to 48.

The march of the white race from the Atlantic to the Pacific. This is a short story of my struggle with the subject.

The problems of composition, color and scale did not bother me very much. The light and color of the doors and tiles suggested the contrasts of colors—I used the suggestion.

The character of the ceiling tells exactly

how far I can go in intensity at my colors and contrasts of light and dark—I did go as far as it is necessary.

The structural lines of architecture suggested structural lines of my composition—I used them.

I cannot say it is all so easy, but it is always a great joy to anticipate, to analyze and to know when you have finished that you have contributed your bit to the beauty of architecture.

STOLEN — ONE WASHINGTON MONUMENT

Some Strange Facts About Worlds' Highest Stone Structure

GAZING upon the giant stature of the Washington Monument at the National Capital, who would suppose that any gang could steal it! Yet, a gang stole it once—though it was comparatively a little fellow then, only 150 feet high. The thieves not only stole it, but held it for four years despite Congress, the courts and the army and navy of the United States. The period was from February 22, 1855, to February 22, 1859.

Indeed, the Washington Monument is one of the oddest monuments on this erratic globe and has behind it a remarkable history. It has been said that it was built upside down and inside out. It has "tuberculosis" and it "breathes". When the sun shines hottest on its exterior, rain sometimes falls inside so heavily that the attendants have to wear raincoats and rubbers.

An act for the erection of a memorial to George Washington was passed by the Congress that existed under the Articles of Confederation on August 7, 1783. A memorial of some sort might have been put up when the Federal City was laid out in 1791, but President Washington objected to having a memorial erected for him while he was still alive.

Not until 1833, long after the First President had been gathered to his fathers, was an organization formed among patriotic citizens to carry out the purposes of the Act of

1783. This body took the name of the Washington National Monument Association. Its first president was John Marshall, Chief Justice of the Supreme Court. After three years of preliminaries, it began collecting a dollar each from sympathizers in the hope of obtaining a million dollars to erect a monument, the design for which was completed by Robert Mills, in 1836. In 1848, the Association was reorganized with the President of the United States as its president *ex officio*. Thereafter, the country's Chief Executive always held this position in the Association.

Designing the Monument

By 1848, enough money had been collected to start building. The original plans for the Monument provided for an Egyptian shaft to rise 700 feet. A circular Greek temple, 250 feet in diameter and 200 feet high, was to surround the Babylonian conic base. Above the main entrance, a quadriga would have presented a colossal figure of Washington, clad in a Roman toga, standing in a chariot driven by an Etruscan Victory and drawn by Arabian horses.

The temple feature was abandoned before work began and for it was substituted a plain shaft on a stepped pyramidal base. Other alterations of design were introduced as the work proceeded until the present shaft emerged from the confusion in 1879, after the masonry was up 174 feet, with the help

of studies made of obelisks in Egypt by George P. Marsh, our Minister to Italy.

Thus the design for the monument did not finally crystallize until 43 years after the first design had been accepted, and 31 years after building operations had begun.

The most astonishing thing is that the proportions of the Monument are architecturally sound.

Stones Begin to Fly

Six years of building operations cost the Association \$120,000 — about all it had collected, and the shaft still measured only 150 feet in height. Then came a suggestion which led to trouble. Citizens of Alabama asked that they be allowed to quarry stones and contribute them in lieu of cash. This plan seemed to provide a way to keep the shaft rising and the Association grasped it, sending out a general call for building stones. Emperors, kings, states, nations, orders and individuals responded. Each stone bore an inscription with the name of its donor and the date of its presentation. The inscriptions may now be read inside the shaft, where the stones are of all sorts. The exterior of the shaft consists of Maryland marble, except for a band of Vermont marble from 174 to 200 feet above the ground—but the change in material observable to sight-seers is due not to the band of Vermont marble but to the resumption of Maryland marble with weather markings differing from those on the stonework below the Vermont marble band.

One donated stone never reached the niche prepared for it. This was the block contributed by Pope Pius IX, which bore the inscription, "Rome". The American Party, whose members were popularly called "Know-Nothings", saw a chance to make capital out of the Pope's gift.

On the evening of March 5, 1854, a band of masked "Know-Nothings" went to the Monument grounds, overpowered the night watchman and carted off the four-ton stone from Rome. It is supposed that they smashed the stone to bits with sledge hammers; at any

rate it was never seen again. News of this outrage antagonized the entire world and gifts of money and stone ceased abruptly. In despair, the victimized Association turned to Congress for funds with which to continue. A bill was prepared and was scheduled to come before the House on February 22, 1855.

Monument Becomes White Elephant

On the night of February 21, some members of the Know-Nothing group in Washington took a step which branded them before the world as little better than a gang of thieves. Breaking into the offices of the Monument Association, they seized its records and books, set themselves up as the sole members, ousted the old officers and elected new ones from among themselves. Next day, they informed the public that they owned and would build the Monument.

The original officials and members were unable to prove their right to the Association's assets on account of the disappearance of the records. By this time the Monument had become a good deal of a white elephant and perhaps they were not unwilling to let the other fellows bear the burden of the work for a while. The "Know-Nothings" tried, but the public treated their requests for funds and materials with contempt. This Washington Monument fiasco undoubtedly contributed to the subsequent rapid decline of the "Know-Nothing" Party.

Faced by the danger of having the Monument abandoned and ownerless, Congress incorporated the Washington National Monument Association with its original membership on February 22 1859, and returned the property to the ousted officials. This was four years after the "Know-Nothings" had taken violent possession.

Monument Completed in 1888

In 1876, the Democrats had obtained a majority in the House of Representatives, while the Republicans dominated the Senate. This situation for a time was to make the Monument a football of politics. However,

[Please turn to Page 30]

TWO RESIDENCES

by

WILLIAM WILSON WURSTER

Architect



I HOUSE OF DR. AND MRS. GEO. H. SANDERSON
Stockton
California

II HOUSE OF DR. AND MRS. SAXTON T. POPE
Burlingame
California



GARDEN ELEVATION DETAIL, RESIDENCE OF DR. AND MRS. GEORGE H. SANDERSON, STOCKTON, CALIFORNIA
WILLIAM WILSON WURSTER, ARCHITECT



GARDEN ELEVATION, RESIDENCE OF DR. AND MRS. GEORGE H. SANDERSON,
 STOCKTON, CALIFORNIA
 William Wilson Wurster, Architect

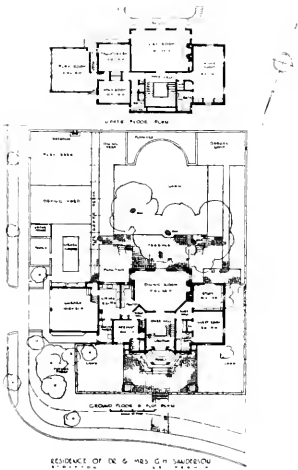

PLANS RESIDENCE OF
 DR. AND MRS. G. H. SANDERSON,
 STOCKTON, CALIFORNIA

Note interesting arrangement of dining room
 and study overlooking terrace and gardens.



DINING ROOM, RESIDENCE OF DR. AND MRS. GEORGE H. SANDERSON,
STOCKTON, CALIFORNIA



ENTRANCE STAIRCASE, RESIDENCE OF
DR. AND MRS. G. H. SANDERSON,
STOCKTON, CALIFORNIA

William Wilson Wurster, Architect



GARDEN ELEVATION, RESIDENCE OF DR. AND MRS. SAXTON T. POPE,
BURLINGAME, CALIFORNIA

Hall and Proetz and William W. Wurster, Associated Architects

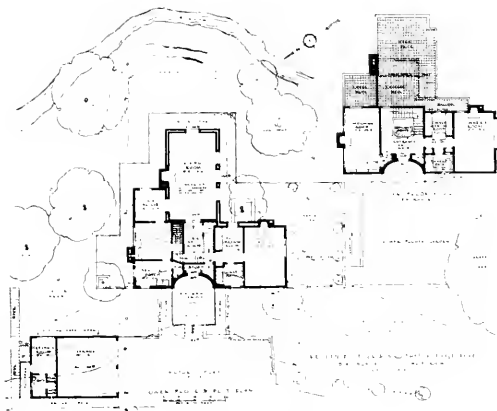

PLANS, RESIDENCE OF
DR. AND MRS. SAXTON T. POPE,
BURLINGAME, CALIFORNIA

Hall and Proetz,
William W. Wurster,
Associated Architects



ROAD ELEVATION, RESIDENCE OF DR. AND MRS. SAXTON T. POPE,
BURLINGAME, CALIFORNIA

Hall and Proetz and William W. Wurster, Associated Architects



DETAIL OF FIREPLACE, HOUSE OF
DR. AND MRS. SAXTON T. POPE,
BURLINGAME, CALIFORNIA

Hall and Proetz and
William Wilson Wurster,
Associated Architects

ARCHITECTURE AT AN EXPOSITION

By Irving F. Morrow A. I. A.

in San Francisco Chronicle

“ARCHITECTURE,” runs a familiar aphorism, “is the mother of the arts.” Expressions of this sort are generally used as figures of speech and with rhetorical intent. Yet in a very literal sense architecture does underlie civilized life. Not only is each of the other arts dependent upon it in one way or another, but the scope and spirit of all our activities are to some degree conditioned by the buildings in and among which they take place.

This being the case, it might seem to follow that architecture, in response to the varied and persistent promptings of society, would be the most mobile and progressive of the arts. But such an expectation overlooks one of the controlling factors.

In every other artistic activity the cost of the materials employed is negligible. Painters can stack pictures behind the piano, and writers and musical composers can cram bureau drawers with manuscripts with essentially no investment but their time. Buildings, on the other hand, even the smallest, can be constructed only at considerable expense. Of course this over-simplifies to some degree. It may be argued, for instance, that music is music only when sounded, and that bringing an elaborate orchestral or operatic manuscript to performance may cost a tidy sum. It may likewise be urged that an architect is free to embody his conceptions in drawings and models as cheaply as do the painter and the sculptor. But architecture in turn is architecture only when built, and no architect

worthy of the name is concerned with drawings save as means to an end.

The fact remains, therefore, that economic conditions are a heavier drag on creative expression in architecture than in the other arts. And be it noted that the discussion is not at all on how the artist himself makes a living, but solely on how his conceptions are physically realized. It is impossible to imagine an architect personally buying land and erecting the buildings of his dreams. He requires clients able and willing to pay the costs. Nor is it a question merely of whether or no a building shall be built. Much that achieves execution is tainted at the core by compromise with financial expediency. Quarters for all sorts of specific activities must be transformable to new uses if the original ones fail; houses must be conceived, not to satisfy the desires and personalities of occupants, but in deference to prudent ideas of resale value, and so on. Buildings cost money; money can not be risked on uncertainties; innovations in either arrangement or appearance present a degree of uncertainty; they can not be blithely scrapped if later regretted. And so it comes about that the art which would seem destined by its social function to play the most forward-looking role turns out to be in fact the most conservative.

Designer Faces Baffling Situation

With economics thus imposing caution, not to say timidity, the designer who is responsive to the changing cultural complex faces a baffling situation. How is he to achieve the progressive adjustments—call them experiments

if you like—by which alone stagnation is to be avoided? To be sure, it is no longer necessary to "play safe" in store fronts and interiors; but most of these partake more of the nature of decoration than of architecture in any serious sense of the word, and should perhaps be classified as super-advertising. Almost the only spacious opportunity offered by modern life which is above this petty prudence is the large exposition. For here there need be no worry over whether it will sell, or whether the style is going to last, or whether it conforms to neighboring buildings, or any of the other anxieties that bother practical people about permanent structures. An exposition is deliberately designed to be transitory. From these secondary economic inhibitions it is free.

What bearing should this almost unique situation have on the architecture of an exposition? To answer this one must go a step further back and ask what is expected of an exposition. It will be assumed without further discussion that the county fair conception—locomotives executed in oranges—is obsolescent if not obsolete, and that thinking people justify an exposition as an opportunity to exploit and take stock of the cultural resources of the community. To architecture this means liberation of the creative impulses which in ordinary life are perforce warped or thwarted by practical considerations. Expositions become society's architectural experiment stations. It should be useless to conduct at them elaborate and costly demonstrations of what we already know. It is difficult to see how a community not resigned to artistic impotence could countenance an architectural retrospective exposition.

So much for the general spirit of architecture in such an enterprise; which should be generous, confident, hopeful. If this architecture is to be really a solicitous mother rather than an indifferent stepmother to the other arts, it has more specific obligations to meet.

First, as to painting and sculpture. The separate pictures and statues displayed in gal-

eries—in a word, the "art exhibits"—lie outside the scope of this discussion. They constitute in effect a museum problem, unrelated to the architectural one beyond the necessary provision of gallery space. Art shows of this kind are generally adequately housed, except that architects still occasionally persist in the perversity of giving the choice picture locations on the middle of the gallery walls to doorways, and relegating the pictures to the less satisfactory corners. But the decorative art—sculpture, painting, mosaic—that is made integral with the buildings is of the essence of the architectural problem.

Meaning of Creative Collaboration

Collaboration between the plastic arts is one of those proprieties which are unfailingly indorsed and rarely tried. We have, alas, almost to relearn what creative collaboration means. In recent times—which is to say, during the last couple of centuries or more (we are taking a long view)—the plastic arts have cooperated on somewhat the following pattern. Architectural ornament is conceived in terms of routine modeling (summed up in the "repeat ornament" commonly noted on the drawings after the appearance of the first unit at the left side of the sheet). This ornament is in fact repeated up to the limits of the budget and the precedent of the best examples. After which—possibly even after the erection of the building—the architect surveys the empty spaces and the remaining funds, and commissions a statue of Civic Virtue here and a painting of Industry Welcoming the Arts there. The resulting assemblage goes currently under the name of collaboration.

For this state of affairs there has been divided responsibility. Artists on their part have not infrequently imposed immoderate prices and conditions for descents from the ivory tower. Architects, on the other hand, have been too commonly untrained in the allied arts, indifferent to their possible contribution, insensitive to the essential nature and values

of decoration, and (consciously or unconsciously) apprehensive, even jealous of the intervention of first rate creative talents on their work.

Take this explanation, or produce one you like better, the fact remains that in recent times (as defined above), in important architectural work, there have been few instances of the employment of significant sculptors and painters under conditions affording reasonable scope for the creative contributions they were prepared to offer.

Collaboration means working together. Of course every project requires direction, and the natural head of an architectural one is the architect. But it does not follow that acquiescence by sculptors and painters in belated dictation from an architect constitutes collaboration between the plastic arts. Imagine an important building worked out in this wise. "Architectural" (perfunctory) ornament is essentially excluded. All decoration is provided by creative sculptors and painters, chosen with a view to their sympathy with the kind of conception the architect is developing. They are called into consultation, not after nothing essential remains for them to do, but while there is still opportunity to profit from the particular abilities which justify their employment. They are not put separately to assembling a number of unrelated items. They work as a team under the direction of the architect. Each not only develops his own particular contribution, but may even influence the total design in the manner and to the extent that are advantageous for the whole.

That would be collaboration. In a workaday world it is seldom realizable in any fullness. An exposition can demonstrate and keep alive the ideal. Failure to do so means more than an opportunity wasted; it means an obligation repudiated.

Since sculpture and painting have been considered as in effect part of the architecture, these conclusions are of general validity, for no exposition can dispense with buildings.

The arts of music, drama and dance, however, are more dependent upon policy. An exposition might conceivably be devoted to a purpose so narrow (commerce or a phase of science) that it would exclude them on principle. But at any exposition organized on general cultural lines, as defined above, it becomes obligatory not only to admit these arts, but to make each the subject of a broadly conceived and carefully planned policy. In this case the function of architecture is to provide appropriate physical facilities and emotional setting for each specific activity. One might be tempted to ask if this is not already general practice outside of expositions, and if anything further remains to be said. But to consider the requirements of these arts at an exposition is to realize that under ordinary circumstances they are left in large degree to shift much as they can.

Ideal Concert Hall Needed

Consider, for instance, the performance of music. San Francisco (to come down to cases) is a large and cosmopolitan city, accustomed to frequent and varied musical events. To how many concert patrons has it occurred that there is not in the city a hall designed expressly for the most favorable presentation of either orchestral music, chamber music or solo recitals? Every public place available to music is something less than ideal, for one or more of the following reasons. Either (1) its design was dictated by preconceptions of architectural effect unrelated to the production and hearing of music, or (2) the necessity of housing a variety of activities imposes compromises on the facilities provided for each (for example, on a theater stage with fly gallery, ideal back and top sounding boards for music are impossible); or (3) its psychological or emotional suggestion is disconcerting. San Francisco is adduced because local conditions will be familiar to the reader. Doubtless a survey would reveal few cities not in a similar position.

The theaters generally available for drama and dance suffer no less from their own par-

ticular inadequacies. Being commonly built as business rather than artistic ventures, they serve business before art. The requirements are determined in the box office rather than by people experienced in doing the things for which a theater is ostensibly built. To advertise the largest switchboard in the world is supposed to dispose of further technical examination. Apparatus of this kind may be costly, but it is less so than land and building for revolving stages, scenery carriages and elevators, rehearsal rooms and the rest.

The economic conditions which impose these compromises and insufficiencies do not operate at an exposition. Concert hall and theater are free to embody both the most up-to-date current practice and the most plausible innovations. There is no dismissing arduous technical study on the ground that after all it is only a temporary building. When working in an experimental laboratory no shortsightedness must be allowed to jeopardize the success of the experiment. With expositions distributed in time and place about as they are, every person should anticipate seeing at least once in his life an ideal concert hall and an ideal theater.

Such in barest outline is the role of architecture at an exposition. It may seem like an exacting order. But being a mother never was an occupation to be taken lightly.

STOLEN—ONE WASHINGTON MONUMENT

(Concluded from Page 20)

within the next four years, \$1,187,700 was provided to carry the work to completion.

The shaft, though completed in 1888, nearly half a century ago, is still the tallest stone structure in the world. Its 100 ounce aluminum tip—the largest solid block of the metal which had been cast at that date—was exhibited by jewelers in New York City and in Washington, D.C. It was less than a foot high, but aluminum was very costly in those days. According to an old-timer, young Washingtonians got the local exhibitor to let them

step over the exhibit, so that they could say later that they "had stepped over the top of the tallest building in the world". The jeweler, it is said, taxed them "two bits" each for their fun.

Queer Quirks

At about the time of the Monument's completion, representatives of the Corps of Engineers, United States Army, reported that it had a regular pulsation, popularly designated as "breathing". It also had a lateral contraction and expansion, so that channel irons had to be employed to support the stairway. Its "tuberculosis" is of the geological variety and is due to the exudations from the rubble masonry of the core, which seep through the interstices of the blocks of stone. Disintegration has been checked by drilling holes from inside the shaft and forcing in fresh cement under hydraulic pressure.

The charge that the monument was built inside out and upside down was made in 1911 by Professor G. E. Merrill, at the time Curator of Geology at the National Museum. In an article published in the Popular Mechanics Magazine, he said: "This gigantic pile . . . is, so far as quality and material is concerned, not only wrong side up but wrong side out as well. The very best and most enduring material of the entire structure lies in the inner courses of the upper portion of the work (which bears least strain). The poorest and weakest of the material is compressed in the outer portion of the first 190 feet, which has to bear the weight of the superincumbent 350 feet and more and has to receive beside the wash from all the rain that falls on the portion above."

Within the Monument, rain falls on warm days after cool spells. The inner walls retain their low temperature long after the outside atmosphere has become superheated. Hence, when the warm air enters the front door and sweeps upward against the cool inner stones, its moisture is condensed and precipitation follows.

NEW TYPE OF LOW COST SCHOOL BUILDINGS

THE Manual Arts High School group in Los Angeles represents a new type of low-cost masonry school house design in California. The original buildings in this group are being replaced by reinforced concrete structures and an entirely new layout.

With limited funds at their command the architects were confronted with the problem of complying with the structural requirements of the state lateral force law and at the same time providing adequate accommodations for the large number of students enrolling in the school. A very plain and simple type of construction was obviously all that could be expected and both the layout and design of the buildings were accordingly shaped to achieve the desired results with the greatest measure of economy.

The first two units of the group are the Science building, which parallels Vermont Avenue, and the Administration and Art building which is laid out at right angles to the street, with the main entrance in the center opposite the east end of the Science building. Both structures are two stories, the general dimensions of the Science building being 64x260 ft. while the approximate dimensions of the Administration and Art buildings are 64x208 ft. This extended rectangular plan for the buildings was adopted for several reasons. In the first place it allowed for maximum effective use of floor space with classrooms and laboratories ranged along either side of long corridors through the middle of the buildings and ample natural light for all from outside windows. In the second place it simplified the

structural design by permitting the repetition of typical sections and at the same time made for economy in construction for the same reason.

There are no basements but the ground floors are about 3½ ft. above the surface to provide space for and give easy access to service pipes and conduits. The height between the main and second floor slabs is 13 ft. and between the second floor and roof slabs the same, but an air space with outside louvres for ventilation is provided under the roof by a suspended ceiling dropped down about 18 inches. The corridors are 12 ft. 6 in. clear width and the classrooms and laboratories range from 23x30 ft. to 23x40 ft. Stairways and toilets are in the ends of the buildings and are lighted by windows back of the grills in the concrete walls.

Structural design of the buildings for resistance to lateral forces, or loads, was simplified by the rectangular plan and its effectiveness promoted by the low center of gravity ob-

Main entrance to Science Building, Manual Arts High School, Los Angeles, with Administration Building in the background. These two extended rectangular buildings are set at right angles to each other.





MANUAL ARTS HIGH SCHOOL GROUP, LOS ANGELES, CALIFORNIA
JOHN PARKINSON AND DONALD B. PARKINSON, ARCHITECTS

The two upper pictures show the Science Building; lower picture the Art Wing of the Administration Building.

tained by eliminating the basement and restricting the height of the structure. The general structural plan consists of a framed corridor with reinforced concrete columns and girders; reinforced concrete outside walls in which the sections between openings are treated as piers and the spandrels as girders with diagonal reinforcements at juncture of vertical wall sections and spandrels, and reinforced concrete floor and roof slabs acting as diaphragms to transmit lateral loads to the transverse walls and the outside walls.

A pan system of floor construction was used with beams running longitudinally and joists transversely, the 3-in. concrete floor slab being reinforced with steel fabric. Footings for the columns and walls are carried down about 6 ft. below the surface into compacted sand and gravel. The footings are continuous under all transverse and bearing walls. Reinforced concrete transverse walls placed at intervals in the length of the buildings further stiffen the structure. Stairways are of steel with cement treads.

In the architectural treatment of the buildings horizontal lines are emphasized by dividing the vertical height of the walls into bands marked by a continuous sill at the bottom of the windows and a continuous 18-inch slab extension at the top of the windows, which serves to break up the intense light at mid-day; also by horizontal channels in the concrete wall surfaces. Exterior wall surfaces are natural concrete treated with waterproof paint in colors, which further emphasizes the horizontal lines. Cream and buff are used in alternate bands with a strip of blue on the edge of the extended slab over the windows. A very pleasing effect is produced by rounding the corners of the buildings.

All floors are finished cement and interior walls are plastered, acoustic plaster being used for ceilings which are all suspended metal lath to conceal the floor joists and beams. Metal lockers are set between the columns in

the corridors with metal lath and plaster furring bringing the wall surfaces out even with them. Oregon pine trim painted is used in all the rooms except the offices in the Administration building where the trim is hardwood. Windows are double-hung with wood sash.

A library room 35x90 ft. is provided on the second floor of the Administration building; chemistry, physics and biology laboratories on the second floor of the Science building.

John Parkinson and Donald B. Parkinson, Los Angeles, are the architects for the Manual Arts High School. Lindgren & Swinerton, Los Angeles, were the general contractors on the first two units, their contract amounting to \$247,583, covering all work. Cost of the completed buildings averages about \$4.00 per sq. ft.

Other new buildings in the group will be a girls' gymnasium and an auditorium.

THE GEORGE WASHINGTON HIGH SCHOOL, SAN FRANCISCO

(Concluded from Page 16)

Shop Building Under Construction

The building is equipped with one passenger elevator, and a book lift from the basement to the library unit.

The shop building that is now under construction will contain automobile, machine, electrical, cabinet and pattern shops, with the necessary appurtenances.

A great many school buildings have been constructed under the supervision of the Bureau of Architecture, and in that long list the George Washington High School is an outstanding example of perfect co-ordination between architects, engineers, contractors, inspectors, the Government resident engineers, and artists, and it is felt that the completed work is a splendid example of good designing, sound engineering, and careful, painstaking workmanship.



STREET SCENE IN SPAIN

WOOD NO LONGER A FIRE HAZARD

By B. P. Caldwell, Jr.

FIREPROOFED lumber, a dream for centuries, is at last a reality.

This recent contribution of science which practically robs wood of its ability to burn and renders it instead an obstacle in the path of fire, is made known after a comprehensive examination just completed by Underwriters' Laboratories, authority on fire and accident characteristics of materials and devices.

The importance of this development in fire protection is at once evident. Ravages of fire in homes, commercial buildings and on ship-board result in an appalling annual loss. In 1935 alone 10,000 lives and \$245,000,000 in property were sacrificed in this country's bon-fire. In this great conflagration the chief fuel is usually wood, man's most widely used building material.

A method of preventing large losses is to limit the amount of available fuel at the point of origin of the fire. This can be done by the extensive use of fire-retarding or incombustible materials. As the majority of fires in buildings, ships and dwellings have their beginnings in the interior of these structures, the use of fireproofed wood for floors and interior trim would be an effective method of combating loss.

"Practically noncombustible and nonflammable" is the evaluation of the effectiveness of the fireproofed wood tested by Underwriters' Laboratories. Walls or floors of this

material, tests show, will act as fire-stops and prevent the passage of fire through them, thus confining the conflagration to its point of origin and preventing its spread. It is further stated in the report approving this material that its fire-resisting properties will last throughout its useful life. These and the other conclusions drawn are the results of a great variety and number of tests.

The material investigated and approved is fireproofed lumber of red oak and maple for flooring and interior trim. The successful fireproofing of this lumber is effected by a method not unlike that used in the treatment of telegraph poles, railroad ties, fence posts, etc., with creosote for protection against decay, except that incombustible salts are used in the case of the fireproofed lumber. The technique of the process is exacting as its success depends largely upon getting just the correct amount of salts into the wood as a greater or lesser amount fails to give the desired results.

Properties of this lumber other than its fire-resisting qualities were also investigated. Its workability was found to be equal in every way to that of untreated lumber. Its ability to take paint and varnish is not altered, its appearance is unchanged and its weight is only slightly greater than that of untreated material.

In the tests actual fire conditions were created. Whole floors of the fireproofed lum-



FIG. 10
FIRE TESTS OF VERTICAL PANELS OF RED OAK—NOT TREATED
EXPOSED FACE WHEN WITHDRAWN FROM FURNACE

ber, and others of untreated lumber, were subjected to a roaring inferno in gas-fired furnaces especially designed for such work. Through windows the behavior under fire of the fireproofed and the untreated floors was observed and compared by one group of engineers, while a hundred feet away other engineers recorded the temperatures of the floors by means of meters connected with thermocouples.

The fireproofed floors came from the furnace at the completion of the tests like a

phoenix rising from the flames—blackened and charred on the exposed surface but intact and otherwise sound, having successfully stood as a barrier against the fire and prevented its passage. The untreated floors did not fare so well. They ignited and, on completion of the tests, were burning on both the exposed and unexposed surfaces, the fire having eaten through them.

Fire spread tests in a horizontal furnace, where the flames were played on one end of the flooring, were also conducted. Chemical



FIG. II
FIRE TESTS OF VERTICAL PANELS OF RED OAK—TREATED
EXPOSED FACE WHEN WITHDRAWN FROM FURNACE

and calorimetric tests were performed on numerous samples conditioned in various ways. Test floors were repeatedly washed to determine the lasting quality of the fireproofing. For thirty days an automatic machine scrubbed them with cleaning compound, flushed with clear water and dried the surface every thirty minutes and then repeated the operations. All of these tests, as well as the Dunlap Fire Tube, Timber and Crib tests conducted on a great number of samples, showed the merits of the fireproofed lumber.

This successful method of fire-roofing wood is a solution to a problem which has attracted the attention of men of science for

centuries. As early as 400 BC, Aeneas, the famous Trojan hero, suggested soaking lumber in vinegar to render it fireproof. Others tried coating with clay, washing with mineral salts and painting with various metallic paints. Some, knowing the protection afforded by charcoal, suggested charring the surfaces of timbers to be used in ship construction. Then the discovery that timbers from salt mines were fire-resistant led to impregnation with common salt. Gay-Lussac, the French chemist, was more successful than most experimenters in his use of borax and ammonium phosphate, but they made a hard, glassy surface on the wood.



TWO INTERESTING FIREPLACES

EARTHQUAKE PHENOMENA, IN CALIFORNIA

ENGINEER URGES INTENSIVE STUDY OF SUBJECT

By Captain R. V. Labarre

"THE only way we know to deal successfully with any natural phenomenon is to get acquainted with it, to find out all we can about it, and thus to meet it on its own grounds. That is the way mankind has succeeded so far, and it is safe to conclude that it is the only way it will ever succeed."

An earthquake is an unusual occurrence, a momentary aberration of the orderly processes of nature. Erosion, sedimentation, shrinkage and tidal strains gradually set up stresses in the earth's crust. When these stresses reach the point where they are greater than the strength of the rocks, a slip occurs, and the consequent disturbance is called an earthquake.

Practically all of the earthquakes that occur in California are those caused by a sudden slip along a geologic fault.

Geologists are well informed as to the structure of the earth's crust underlying California, the location of major faults, and the areas of greatest faulting. The Seismological Society of America has published a Fault Map of California compiled from data secured from authoritative sources, which contributes much information on this subject. The Society Bulletin publishes more live information about earthquake facts and theories than any other technical periodical in America. Observatories have been erected in Pasadena, Mt. Wilson, Mt. Hamilton, Berkeley

and San Jose, where delicate instruments are continually recording earth disturbances ranging from minute microseisms to earthquakes which come within the recording possibilities of these sensitive instruments.

The public also has an instrument for measuring and describing the violence of earthquakes. It is crude, but it is the best scale yet available and is the only one that has been successfully used in historic research. This is called the "Rossi-Forel Scale", and has been well described as a "measure of the man scaling and wall cracking power of the quake."

These agencies and others operating therewith, have furnished valuable information and data on the severe shock in Owens Valley in 1872, the repeated disasters in San Francisco, and those at Petaluma, Stanford, San Jose, Santa Barbara, Long Beach, the minor disasters at Inglewood and Whittier in the Los Angeles District, and shocks in the Imperial Valley at Calexico and Brawley. The published report of 85 earthquakes recorded in the section of California lying north of San Luis Obispo and Kern Counties and West of Inyo and Mono Counties for the year 1933-1934 indicate the great seismicity of this region.

One must not infer from the above statement that it is desired to convey the impression that the remainder of the State of California is considered immune from earthquakes. Tulare County, Kern River, Amador Valley, Honey Lake Valley, Fort Klamath and Merced Falls have experienced quakes of destructive

A message to the Industrial Committee of the California State Chamber of Commerce.

intensity, and it cannot be said that shocks occurring in such regions will be less intense than those occurring elsewhere.

Scientific Data Limited

Considering the geological knowledge acquired, the historical data accumulated and the seismological equipment and competent personnel in charge, we should be in a position to observe and locate accurately every earthquake occurring in California and map its intensity. We have data on the areas in California of great seismic activity, but we are not in a position, nor have we the knowledge to forecast when and where earthquakes will occur, nor their duration or intensity.

With the exception of the Long Beach earthquake of 1933, engineers have no accurate instrumental measure of the period and amplitude or acceleration of any of the earthquakes before mentioned. Nor have we any instrumental data on the dominant period of the ground in these localities, nor of the periods of the buildings that were wrecked or of those which survived the quakes. We have no file of the mapped intensities of earthquakes which have occurred in the past and have no organization set up to compile this data for future ones. A complete file of all these related data would make quickly available information of any particular region, and should be of inestimable value to the industrialist, the engineer, the architect and the insurance underwriters by offering quick access to valuable information as to the seismicity of any region, give some conception as to the type of construction which should be avoided therein, and fix the risk factor for establishing equitable insurance rates.

We have no authoritative data on the structural problems involved in the design of earthquake resistant structures, except such as are contained in scattered articles published by a few competent engineers who have observed and studied earthquakes in this and other countries; and such structural data

as we have borrowed from Japan and other foreign countries.

Earthquake Factor Recommended

There is also but limited data on the accelerations to be anticipated in any future earthquake. The only record we have of accelerations are those recorded by the strong motion seismographs installed in Long Beach and vicinity by the Coast and Geodetic Survey shortly before the earthquake of March 10 1933. From these accelerogram records and from the observed damage in this and other earthquakes which have occurred in California, together with related data of damage in Japan, an earthquake factor of 1/10 gravity was recommended.

This factor may be too high or too low. It is the prevailing opinion of many informed engineers that it is difficult to justify the use of a lower seismic factor than 1/10 gravity. More accurate and detailed information is needed on this subject. We have no organization set up to study these problems. We need an organization composed of competent structural engineers of wide experience who will, with all possible promptness, visit and report the site of each important destructive earthquake in California, study all of the instructive borderline cases between failure and success in resisting the shocks and make notes on the general ratio of damage to sound value in typical structures.

The year 1929 marks the beginning of the study of economic seismology in California. Following a series of conferences held in San Francisco under the auspices of the San Francisco Chamber of Commerce, the United States Coast and Geodetic Survey embarked on a program of instrument development and earthquake study with particular reference to the needs of the engineering and architectural professions.

By the end of 1932 a few newly developed strong motion seismographs were installed in Northern and Southern California, and were

in operation at the time of the Long Beach earthquake of March 10, 1933.

During the years 1932-1935 the Coast Survey has installed and serviced 57 strong motion seismographs located in the most active seismic regions of the state. It has obtained field instrumental data on every shock originating in the state strong enough to set in motion the mechanism of these instruments. It has surveyed and recorded the periods and amplitudes of 200 to 300 buildings, 60 to 70 water tank towers and 10 to 20 other types of structures.

Valuable Records Unpublished

A special survey of the Long Beach area, following the March 10, 1933 earthquake, has been made by the Coast Survey, architects, engineers, and other interested observers. The wealth of data obtained by these is not yet available because it has not been published.

As to the accumulation of the field data obtained by the Survey during 1932 to 1935, a wealth of data is locked in these valuable field records. Although this data has by request been circulated to a limited group, it has not in its present condition been of material assistance to the engineering profession. It should be intensively studied in order to classify structures according to their periods, and the observations checked with existing theories for the purpose of excluding those which are irrelevant or erroneous.

Early in 1934, it became apparent that the appropriation under which this work, being carried out by the Survey, would be exhausted and the program in danger of being seriously curtailed or discontinued entirely. We were informed by Congressman Costello (in a letter to the Los Angeles Chamber of Commerce dated July 16, 1935) that inasmuch as the President was inclined to consider seismological work in California a matter of state consideration, the President had advised the director of the budget, Mr. Oliver, to elimi-

nate from his schedule the appropriation for seismological investigation. Mr. Patton was successful in petitioning Mr. Oliver to restore \$17,000 of the \$30,000 asked for, with the understanding that California was to furnish the remainder, either in money, services, or supplies, etc. Such is the present status of the Federal Seismological Program in California for the fiscal year July, 1935 to June, 1936. Under the curtailed Federal appropriation, much of the valuable work being done by the Survey has been discontinued. With the PWA appropriation, the Survey was able to employ competent civilian employees, but with the transition to Civil Service, required by all annual Federal appropriations, there is a dearth of competent civil service men available and the work of the Survey has been retarded.

On a recent visit to Washington which I made in connection with this seismological program, I have had the opportunity to realize that the future of the seismological activities of the Coast and Geodetic Survey in California depend on the co-operation of California interests, which must include the expenditure of funds raised in this state in order to supplement the Federal appropriation.

Scientist and Engineer Need to Collaborate

In order that the complexity of the problem might be better understood, the following factors inherent to the very nature of the subject are listed:

Seismology is a science of many diverse aspects. It must be studied with respect to its relation to the physical sciences and arts pertinent thereto. The ideal seismologist would be a combination of physicist, geologist, engineer, architect and economist. Such a combination does not exist in single individuals and in consequence the progress over the field of seismology can only be attained through the meeting of minds and the united efforts of the respective leaders in these and

other fields, each specializing in his own field, the efforts of all being co-ordinated toward the common goal.

To some extent this has already been accomplished. There is at present unusually effective co-operation among scientists—on the other hand there does not seem to be an adequate liaison between those interested in the science of seismology and those who would make practical application of the attainments of the scientific worker. It is important to breach this gap between the scientist and the engineer.

The second factor is one of national policy. Earthquakes can not be studied in California and the conclusions applied with assurance to the remainder of the country. As the Federal government is interested in the whole country and as our interests are in California, it naturally follows that investigations of earthquake phenomena in California and the cost thereof can not, as a matter of policy, be borne entirely by the Federal government. Doubt is entertained also as to the possibility of effective Federal leadership in the intensive study required. There seems to be an unwritten law to the effect that the Federal government shall not engage broadly and avowedly in scientific research. Such research is undertaken by the government from time to time, but its objective is always some definite, limited, utilitarian purpose. It would be quite difficult and require a long time to induce the Bureau of the Budget and the Congress to broaden this attitude. Any one familiar with the zealous guardianship which Congress exercises over the expenditures of its appropriations knows that it is contrary to all precedent to hope that any Federal agency would be given permanently the broad blanket authority to enable it to act effectively in an emergency such as, for example, would result from the occurrence of a large earthquake, or to allot Federal funds for expenditure by non-Federal agencies.

The protection of life and property in California demands that a more comprehensive and intelligent understanding of earthquake

phenomena and its related effect on structures be better understood by business and professional agencies. The economic interests involved are so great that a continuance of this seismological research is essential.

Research Program Outlined

With these thoughts in mind, a program of Seismological Investigations and Research has been proposed, covering a period of four years, and which includes cooperation and participation by the U. S. Coast and Geodetic Survey, and the three leading technical educational institutions of the state—the University of California, Stanford University, and the California Institute of Technology; with the State Chamber of Commerce as the statewide organization acting with these institutions in all matters relating to the program as a whole.

At the end of this 4-year period, progress will be appraised and future plans developed.

To finance this program it is assumed that an appropriation of \$27,000 yearly will be made by the Federal Government for expenditure by the Coast and Geodetic Survey, and that \$15,000 yearly will be raised in California and assigned for expenditure equally to the California Institute of Technology, the University of California, and Stanford University. The attitude of the Carnegie Institute of Washington will be one of interest and continued co-operation as in the past.

After many conferences with the heads of the research departments of the three universities, the chief of the San Francisco office of the Coast and Geodetic Survey, and Dr. Patton, director of the Coast and Geodetic Survey at Washington, leading architects and engineers of both the north and the south, the proposed program has been evolved. The participation of the universities in this program has the official approval of Dr. Millikan for the California Institute of Technology, Dr. Sproul for the University of California, and Dr. Wilbur for Stanford University.

The technical end of this proposed coop-

(Please turn to Page 51)

TERMITE CURB IS IN CONFLICTING HANDS

PEST CONTROL BOARD *versus* STRUCTURAL ENGINEERS

By A. A. Brown, C. E.

A MEMBER of the Structural Pest Control Board called up a licensed structural engineer recently and informed him that he was doing work without being properly licensed. In this case the engineer had been employed as a consultant by a prominent firm of San Francisco architects to direct the repairs to a structure damaged in part by termites. It was the contention of the official that neither architects nor engineers are properly licensed to undertake the repair or remodeling of a structure involving termite damage. He stated that they should first become licensed under their Structural Pest Control Board before they would be qualified to act as proficient architects and engineers in such matters.

There appears to be some doubt on the part of the Department of Professional and Vocational Standards of the State of California as to the administration of the two laws enacted at the 1935 session of the Legislature dealing with problems created by termites. A few days ago, a representative from that Department called upon the writer to discuss the administration of the present law and to obtain his views on the same. The views at that time expressed are in substance the basis of this article.

The 1929 Legislature considered the problem of termite control and enacted legisla-

tion placing the responsibility for supervising contractors engaged in this work in the hands of the Agricultural Commissioners of the several counties. This bill was ill-considered, illogical and unenforceable, and, in consequence, was repealed at the request of the County Agricultural Commissioners at the following session of the Legislature. In 1935 the Legislature enacted two laws, neither of which were carefully considered, placing the responsibility in one case in a newly organized Board to be known as the Structural Pest Control Board, and in the other instance with the Contractors License Bureau.

In the August issue of **The Architect and Engineer**, mention was made of this conflict between the new laws, pointing out that as far as buildings and structures were concerned, they appeared to be a function of the Contractors board. In that case, however, the only qualifications required by the Contractors License Law of those to be licensed as specialists in this work, were that they should submit evidence of good character, honesty, and integrity!

Two Groups at Loggerheads

The prevention and control of termite damage has thus become the bastard child of the professional branches of the construction industry. The parentage of this problem-child was first laid at the door of the County Agricultural Commissioners, who promptly dis-

claimed ownership. Now another group, alien to the building industry, has proposed to adopt the orphan. This group's claim to knowledge of the building industry was summarized in a recent statewide examination, as follows:

"What is a mud sill? What do you consider the proper mix for cement in a foundation wall for a two story dwelling? What is a post butt? What is a joist? What is a girder? Would it be practical to cut an opening beneath the first floor line, above the foundation, in a brick wall 20 inches high and four feet long, to remove debris or earth without shoring it up?"

It would seem, however, that under the Contractors License Law they will not be permitted to make off with the child. This latter law as amended by the 1935 Legislature, provides:

"Sec. 3. A contractor within the meaning of this act is a person, firm, copartnership, corporation, association, or other organization, or any combination of any thereof, who in any capacity other than as the employee of another with wages as the sole compensation, undertakes or offers to undertake or purports to have the capacity to undertake or submits a bid to construct, alter, repair, add to, subtract from, improve, wreck, or demolish any building, highway, road, railroad, excavation or other structure, projects, development, or improvement, or to do any part thereof, including the erection of scaffolding or other structures or works in connection therewith, **including the eradication of or the processing against infestation by pests structurally injurious to building or structures: . . .**" (Bold face are the writer's.)

This same act provides:

"Sec. 14. All laws, or parts of laws, in conflict with the provisions of this act shall be, and the same are hereby repealed."

Which would seem very definitely to eliminate the Structural Pest Control Board from activities within the building industry.

Construction Legislation Needed

It seems that by accident and not design the parentage of this questionable child, for

the present at least, rests with contractors and builders. With all the welter of discussion and legislation to date, it should be apparent to the professional members of the building industry that the public wants and is demanding constructive legislation on this important subject; but for some reason the legislation proposed and enacted to date has been poorly conceived, with little or no careful thought given to the subject.

Following the disastrous earthquake in Long Beach there was a public demand for the enactment of legislation governing the construction of schools. The public wanted schools that would be reasonably earthquake proof. In that case, the professional branches of the construction industry gave heed to this demand and prepared legislation in a form which established a minimum requirement, and placed its administration under the department of architecture. The Legislature did not simply pass a law requiring the earthquake-proofing of schools, and stating that contractors building them should earthquake-proof them, but a minimum requirement was laid down as a guide; and so, for a school to be built in the State of California today it is necessary that the designer meet this minimum set of requirements. He may add to those requirements, but he must not subtract from them.

In the case of the Structural Pest Control law no broad principles have been agreed upon as to what constitutes proper measures for prevention and control; no minimum rules or requirements have been established for methods of eradication; and no provisions have been made in the building laws as a minimum guide for termite prevention.

Need Support of the Professions

As the matter now stands every man licensed is a law unto himself. He writes his own standards, and these vary from the crudest type of palliative to the highest standards of workmanship. Thus, those who desire to do first-class work must compete with less scrupulous operators, resulting in an ever-lower-

(Please turn to Page 47)

MODERN DESIGN FOR THE KITCHEN

By Mary D. Gillies

YOU'VE asked me to discuss the subject, "The Place of Color and Knick-Knacks in the Kitchen". Frankly, relating color and kitchen decoration to knick-knacks may suggest too frivolous a point of view on a subject which is very close to women's hearts and is also vital in merchandising equipment.

As a matter of fact, decoration is three quarters color. And color has played an important role in our lives since there was light. For light is color. Only a few weeks ago I heard a well-known colorist, Howard Ketcham, speak before the Home Economics Women in business in New York. To illustrate the importance of color he gave this example: In 1860 Darwin discovered that flowers which are self-fertilizing are colorless; they are sufficient unto themselves. In other words, they require no sex appeal. Whereas those which depend on bees and birds for fertilization are gay and flamboyant in color — use lip stick and rouge, you might say, the better to attract. And thus it has been from the beginning of time. Color has a stronger eye appeal than line, form or mass. And it is color we turn to primarily in developing the background of our kitchens.

In order to clarify our thinking we must visualize the kitchens to be decorated today. Roughly speaking, there are three types — new kitchens, remodeled kitchens, old kitchens.

This year there will be kitchens to plan and decorate in some 200,000 new homes which it is estimated will be built. But even though there is only one city in the whole state of Oregon with more than 200,000 houses in it, these new houses are just a drop in the bucket compared with the millions of old kitchens, some of which will be completely remodeled. Others will be lucky if they get a coat of paint.

From my position in the background it looks as though the outstanding trend in decorating kitchens today is modern. The streamlined functional kitchen came in with the Chicago Century of Progress Fair, 1933-34, and has become identified in the public mind with efficient electrical kitchens. As a matter of fact, those modern kitchens made a deep impression on the visitors at the Fair and were listed with twin beds, air conditioning and Venetian blinds as the most interesting features of the exhibition houses.

This acceptance of modern kitchens conforms with trends in housing and furnishings . . . In the January furniture market in Chicago, we were all startled to discover that 36% of all furniture shown was modern. It's evident from this that a large number of the 200,000 houses which are being built will be modern. The furniture will be modern and naturally the kitchens will be modern also.

Moreover, many remodeled kitchens, in old houses, as well as kitchens in new traditional houses, will be decorated in the modern manner because we have come to look at kitchen decoration and equipment as a thing apart

Part of an address by the Home Furnishing Editor of McCall's Magazine at a Home Service Conference in Mansfield, Ohio.

from the decoration and style of the rest of the house. There is no shock today to find a streamlined modern kitchen in a Georgian house.

We have long looked at bathrooms in this light. Have you ever heard of an Early American or French Provincial bathroom? No, we are quite content to have them **modern**, regardless of the architecture of the house and it is the equipment in the bathroom that has dictated this.

The same thing is true in the kitchen today. Ranges and refrigerators have gone "modern" in a big way. Moreover, they have been welcomed with open arms by the public. And it is the modern lines of this major equipment which is almost forcing us to streamline kitchens.

Modern Kitchens Easy to Decorate

Now how do you go about decorating a modern kitchen? They are really the easiest of all kitchens to plan and decorate. They "do" themselves. First you work out the ideal arrangement, install your streamlined major equipment, fill in the intervening spaces with flush front cabinets and presto your kitchen is three quarters done.

Your color schemes will be keyed to white because white is right for major equipment. The only remaining problem then will be the surfacing of floors and walls.

For modern kitchens plain colored linoleums with display inserts are preferred. Flush panel doors are customary also. It is a clever plan to surface the doors with linoleum and as you can well imagine it is practical too.

At the windows Venetian blinds are attractive with or without tailored curtains.

But the walls are where the excitement comes in. For the modern kitchen today there are a fascinating array of washable permanent finish materials, including micarta, formica, carrara glass, flexwood, linoleum and the newcomer to the field—glass bricks. And of all mediums these glass bricks are the most fascinating. I've been dreaming nights and days about a kitchen with one whole wall of this intriguing

stuff. Moreover, when it is used for an inside wall the installation is comparatively inexpensive.

For the most part the materials I've mentioned come in sheets and can be applied in horizontal bands joined with metal moldings.

One modern smart kitchen I've seen recently was developed in grey and copper. The floor was black with grey inserts indicating traffic lines. The walls were formica grading through three values of grey from floor to ceiling—with copper joinings. The curtains were copper-toned Revolite fabric and the ceiling was covered in copper foil. It was very nice and as efficient and pleasing to the eye as a new automobile.

Another kitchen very much simpler had a black floor. The walls were white carrara, the doors black but the ceiling and cupboard linings were vermilion. Can you imagine what that did to the room? The lustrous white carrara reflected the color from the ceiling making it an indescribably lovely luscious pink.

In doing many modern kitchens there is a tendency to make the walls too dark. And there's no question about it, dark blue, cocoa brown and empire green combined with white equipment and cabinets, make a dramatic combination, but a kitchen is essentially a utilitarian room occupied—notwithstanding electrical equipment—for fairly long periods of time. Therefore, even though the lighting is handled expertly, the too strong contrast of large areas is apt to be just a little trying.

* * *

I was working on two kitchens in December last year and in my search for red knickknacks for the red and white kitchen I spotted some funny red wooden Swedish candlesticks which I used on a shelf over the range. And I have been simply besieged by women who wanted those exact candle holders only to discover that the Swedish shop in question displays them just for Christmas—the rest of the year they are stored with the customs to avoid paying duty on the unsold items. It was only after a diligent search that I found

a shop which would supply them the year round.

In doing trick kitchens, and by a trick kitchen I mean any kitchen which is not modern and functional in its decoration, the sky is the limit. Usually I find such kitchens easier to plan and decorate if I follow some particular theme. I may want to do an Early American one, a Spanish or Mexican kitchen or again I may get my idea from a piece of chintz or wallpaper or even a shop window. In a kitchen I have just finished, a plate served as my inspiration and supplied the color scheme as well as the motif.

I have assembled here other accessories which help illustrate the method I use in building up color schemes.

- Plan 1. Vegetable Wallpaper
Black linoleum floor
Red curtains
White equipment
Red doors
- Plan 2. Strawberry chintz
Pink walls
Plank floor
Milk glass, pewter
Wedgewood strawberry plates
- Plan 3. Brown chintz
Peach walls
Plank floor
Brown pottery
- Plan 4. Green plaid plates
Yellow walls
Green door
Green floor
Rust draperies
- Plan 5. Pink plates
White walls
Blue doors and pale pink ceiling
Black floor. Pink curtains
- Plan 6. Musical chintz
Black and white scheme

To Summarize

It has been clear, I'm sure, throughout my discussion that in planning any kitchen, equipment comes first; then arrangement, and finally a color scheme which in most cases must be keyed to the white equipment. This is

made comparatively simple because the trend in kitchen planning today is definitely toward modern, and white fits the modern mode. However, there are those who still cling to trick kitchens. Such kitchens are easier to assemble if you key them to some amusing knick-knack. When you select your theme be sure it is appropriate for kitchen use and having decided on it—carry it through carefully and completely to a successful conclusion.

TERMITE CURB IN CONFLICTING HANDS

(Concluded from Page 44)

ing standard of quality. In view of all this, it seems time, does it not, for the professional members of the construction industry—represented by architects and engineers—to admit parentage of the problem-child, and to aid in the formulation of constructive legislation to govern the same?

It cannot be denied that the demand exists for such legislation, after the two miscarriages of purpose mentioned above. In fact, three unsuccessful attempts have been made by the Legislature to deal with the termite problem. This has not been due to lack of available information on the subject, since extensive research studies have been made and scientific data is at hand for those in the field of applied science to use in setting up standards of construction.

Is this to go by default to an organization alien to the building industry? This is an opportunity for the professions to be of service to millions of citizens. The time elapsing between now and the meeting of the Legislature in 1937 is ample to allow for a constructive study of the problem by a committee composed of architects and engineers representative of the state as a whole, which can be used as a guide by the Legislature and the Department of Professional and Vocational Standards in revising existing laws so as to provide the public with the protection and assistance they are so persistently demanding.



AN ENGLISH TUDOR HOUSE IN BURLINGAME

SUMMER AIR CONDITIONING WITH ICE

By H. L. Lincoln

INTERESTING news items in recent discussions of summer air conditioning have been the reports of performance of extended surface units, often using ice water for cooling. In many ways they are similar to the unit heaters that for a number of years have been giving good service in shops, stores and clubs.

Several California manufacturers have introduced the principle of circulating cold water through these fin coil conditioners placed in front of a blower. This adapts the idea to installations of considerable size, that is, when the blower is moving more than 5000 CFM, and where the air is distributed through a more or less extensive duct system. For the simpler and smaller uses for local cooling of individual rooms, a propeller fan can be mounted in the radiator housing.

One particularly attractive feature is the convenience of providing many parts of a building with conditioned air drawing its heating or cooling effect from a central plant. Ordinary water pipes, that any plumber can install, are used for the distribution systems at great saving in space as compared to the duct system, formerly required when the air conditioning equipment for an entire building was concentrated in a single plant.

Installations can now be found in offices, restaurants, theaters and residences. The experience of these users shows that when ice is used, it is possible to control temperature, humidity and motion, and at the same time

provide ventilation, including filtering of fresh air when desired.

Not only is there equipment available that does that which the ventilating engineer wants, but also the manufacturer is able to state what it will do—as the heat removal in Btu's per hour under stated conditions. In many instances, this is further supported by the engineers of the ice and cold storage industry, who find that there is little difference between the analysis of the cooling required for air conditioning a building at 72 degrees and 50 per cent relative humidity, and that



This equipment takes air in through filters at the top with a blower placed in the floor.

EDITOR'S NOTE—The author is an executive of the Union Ice Company of San Francisco.

for a cold storage warehouse specifying 33 degrees with 85 per cent relative humidity, combined with a definite and controlled circulation of air.

When the object is to make rooms comfortable for human occupancy, the selection of the desirable temperature to be maintained is dependent first on the outside temperature, then on the length of time people will remain in the air conditioned room, and finally, on the extent to which humidity is controlled. Whatever cooling or dehumidifying may be required to obtain about 70 degrees and 50 per cent humidity, can be supplied by using cold water. Moreover, this is the safest and most easily handled cooling agent.

Methods of Control

The system may be controlled in several ways as by varying the amount of air; by varying the amount of water; or by varying the temperature of the water. When it is desired to remove moisture from the air, the water temperature should not be over 50 degrees. That temperature being above the freezing point, ordinary tap water is entirely satisfactory, and there is no occasion to use brine or other chemicals. Furthermore, the system is easily adapted to a heating system by merely circulating hot instead of cold water.

The cold water supply is naturally a tank at some central point, and whether the cooling is developed by a refrigerating machine or by melting ice depends on many factors, perhaps the principal one being the number of hours per season that the full capacity of the plant will be used. When plant capacity is required for only four or five hundred hours a year, melting ice takes only the simplest and most carefree equipment, and at the same time is economical to operate. When the cooling load is 1200 hours or more a year, the cost per hour of operating the refrigerating plant may be sufficiently low to make up for the difference in investment and maintenance. When the period of operation is between these two, in order to determine which cooling medium is preferable, it is de-

sirable to make a careful study of local conditions, particularly including the presence of mechanics competent to handle the inevitable maintenance work.

From the operation of installations now in use, it appears that the actual load on the air conditioning system for many restaurants, most of the community theaters and many office buildings in California, only requires the use of the refrigerating plant a small part of the time. This is particularly true when 65-degree water is available to do a large part of the cooling in a preliminary coil. This water may come from the city supply or from a cooling tower. In many California localities, such water can be expected to do something like half of the total cooling required during the season. Little ice is required in cool weather. In warm or humid weather, a thermostat can be provided to start and stop the ice water pump, thus automatically maintaining a comfortable room.

Operation of System Explained

The fundamental element of the system as now used consists of a blower, preferably with a variable-speed motor, that delivers into the building a supply of fresh air that is cooled as is necessary. This is done in a two-stage cooler consisting of three coils, the first two for the 65-degree water from the city supply, well or cooling tower; the third for ice water, circulated from a melting tank. When a cooling tower is required, it may be either of the atmospheric or forced-draft type and placed on the roof of the building or elsewhere, as convenient. The designer of such a unit, with a capacity to produce a cooling effect equivalent to six tons of refrigeration, 72,000 Btu per hour, would probably equip it with a 15 GPM ice water pump, driven by a 1/4 HP motor and a 25 GPM cooling tower pump, driven by a 1/3 HP motor. For ordinary operation, the system would be controlled by a panel carrying first a starting switch for the fan, which may be push-button control, and second, a starting switch on the cooling tower pump, which would have in parallel with it the ice pump, started and

stopped by the thermostat as required.

In the last three years, a number of these two-stage coolers have been developed. Some have the cooling tower built into the device; others of somewhat larger size, place the cooling tower on the roof. They have the advantage over the straight evaporative cooling or air washer system in that they will meet the load of extremely hot days, and also, the ice water acts to dehumidify the air on humid days or when a room is fully occupied.

Ordinarily, the system should be designed to do four things:

1. Supply fresh air in a quantity appropriate to the average number of people in the room;

2. When a water supply is available at a temperature of not over 70 degrees, as from a well or cooling tower, use that to cool the incoming air and meet the requirements for moderately warm days;

3. Supply ice water at about 45 degrees to provide additional cooling and particularly to dehumidify humid rooms, to be controlled by a thermostat that starts on ice water pump when the temperature of the room occupied exceeds a selected figure.

4. Provide a source of hot water to convert the system to an all year air conditioner, thus making a combination system that will meet the requirements of both summer and winter.

The equipment illustrated, which is built in three sizes to handle 1800, 3600 or 7200 CFM, is assembled to take air in through filters at the top, with a blower placed on the floor. Three sections of coils are placed between the filters and fan, the first two are to be connected to the cooling tower, the third to the ice tank. It can as easily be assembled with the intake at the bottom and fan discharge at the top; or, horizontally, so that the entire unit can be placed on the floor or close to the ceiling. In addition to this attractive feature of the unit is the fact that the several parts used in the assembly are all of standard manufacture and hence prompt de-

liveries can be made of equipment selected to meet the conditions of any particular building.

EARTHQUAKE PHENOMENA

(Concluded from Page 42)

erative project will consist of the study of earthquake phenomena in relation to the design of safe and economical structures, and will be divided into four parts as represented by the efforts of the three educational institutions and the United States Coast and Geodetic Survey. All four will direct their efforts toward studies of fundamental principles underlying a rational treatment of earthquake building construction. Each will direct its effort along a different phase of the problem. Each university has assumed certain specific duties and the United States Coast and Geodetic Survey is to act as general coordinator of all technical work, in addition to the field work with respect to placing and servicing seismographs over the state, and the development of new instruments and equipment.

The California State Chamber of Commerce is asked to sponsor and co-operate in this program; to be the central coordinating agency, governing the public policy of the program — to hold before the state for all time a clear vision of the results to be achieved in the seismological field.

The prestige resulting from its unquestioned pre-eminence in state representation and from the far-reaching resources at its command, will enable it by counsel and guidance, to put forth the necessary efforts with dispatch in case of a major earthquake; to guide the trend of existing effort, to bolster it up at weak points, disseminate information to the public, and thus insure an accelerated and uniform progress over the entire range of this proposed seismological program.

If we are to have further knowledge of earthquake phenomena, which is vital to our progress as a state, it is up to California to act. The Federal government will do its part, if California does hers.

YESTERDAY AND TODAY — A COMPARISON

By Harold C. McLaughlin, A. I. A.

A FEW years ago a book was published under the title of "Only Yesterday," which cataloged in a vivid style the manners and customs, the deeds and gossips that had comparatively recently shaped our lives and dominated our thoughts, but which were already fading into the twilight of the past. The book had the charm of a chance meeting with a childhood friend or of an old picture album found in an attic on a rainy day.

Today I wish to recall for you certain other manners and customs that also have faded, thank God. Only yesterday architects took the whole afternoon for lunch to get away from the morgue-like atmosphere of their offices. Only yesterday professional conversation was as cheerful as the moans from the mourners' bench at an A. M. E. funeral. Only yesterday processions of hungry draftsmen wore trails from office to office.

But times are changing. Quite recently we have seen processions of harassed architects searching frantically for draftsmen. Today—for the first time in this decade—we can compare the present with the past without sighing, and the future with the present without fear. Today—for the first time in this decade—we are facing a dawn rather than a sunset. This new day is still little more than a flush on the horizon. It is still pretty murky where most of us are, but hope has displaced despair or apathy. Life is once more a game that's worth the candle.

But this New Day, like all other new days, holds a challenge, a challenge for all of our institutions. For man's creations are no more exempt from the law of the survival of the fittest than Nature's own. Facism and Nazism, New Deals and Square Deals, Capitalism and Bolshevism, Towsendism, Chiropody and the profession of architecture may some day be under glass along with the stuffed carcasses of

outmoded species in time's great Smithsonian Institute. No institution, not even the church, can close its eyes and count on the inertia of the past to carry it through. The position which our honored profession shall hold in the future will depend upon the intelligence, energy, and clarity with which we meet our problems of today.

One of the problems that faces us is that of the mass production house. To some this seems an ogre, to others a blessing. It may well be that before we die we will find ourselves not only eating out of tin cans, drinking out of tin cans, and riding in tin cans, but living in the damn things. If so, where does architecture fit into the picture?

Prefabrication, the advent of new materials, and the development of factory technique are playing an increasingly important part in the building industry. Ultimately they will revolutionize building procedure, office practice and even our relations with our clients. Are we keeping step?

Only recently has the country begun to dimly perceive the tremendous economic losses due to absence of group or community planning; and still dimmer is its idea of what can be done about it. The solution of this problem will be slow and difficult, but progress here will be what may keep architecture a respected profession rather than the concubine of the jerry builder and the belt-line house producer.

Government subsidized housing for the poor is another matter that vitally affects our profession. Most of our clients, being of the propertied classes, are strongly opposed to this, but there is a real social and economic problem causing the outcry for slum-clearance. Offhand, government subsidization of housing seems a policy that would only be fair and effective if carried to its logical extreme of Socialisation of all housing—which inflates the

solution to such tremendous proportions that it would be comparable to taking the axe to the fly on baby's head. There is, however, a real problem at the base and our profession, with its knowledge of building and its trained analytic minds, will be shirking its opportunity if it does not contribute materially to finding a real solution.

Not the least of the problems facing us is that of learning to design buildings that are logical and beautiful expressions of present day life and materials. This is the "better-mouse-trap" that may bring a path through all these foregoing jungles of ideas right up to our own door. But who knows which is the best mouse trap?

I have here touched on more or less abstract problems. Problems which will not be solved in this year or this decade. But there will be many concrete and immediate problems to face in the year before us. Problems such as the recent school program presented. Problems which will require a united effort for the common good. The first of these definite problems is that of repairing our implement for united action. During the past five years the Institute, though with limited funds and reduced personnel, has ably demonstrated its value to the profession. It has been our point of contact with the various Federal programs, our representative in Washington. Through its efforts the architect has escaped being the completely forgotten man. But the Institute can retain its prestige only if it continues to represent the majority of the qualified members of the profession. During the past five years the Institute has lost many of its old members through retirement, death and financial disability. During this same period of lull in building, the new graduates have not been able to establish themselves in the profession, and hence our membership has not been replenished from this source. Thus has been produced a crisis in Institute affairs, grave enough for me to desire to leave with you in closing the earnest recommendation to the ensuing administration that energetic action be taken not only to retain those of our members who have accumulated a delinquency during these last years, but to enroll with us the new members that are a vital necessity for the continuance of the Institute.

SOCIAL SECURITY LAW AND THE ARCHITECT

AT THE request of Mr. William Stanley Parker, chairman, Committee on Construction Industry Relations, the following statement by A.I.A. Counsel, concerning the relation of the Social Security Law to the members of the profession, is printed for the information of Institute members.

"Articles in the press have doubtless made known to the members of the profession the fact that operative January 1, 1936, and with taxes payable some time after January 1, 1937, there has come into force the Federal Social Security Law dealing in 1936 with unemployment insurance and prospectively in 1937 with old age and other social compensations. For the current year architects need only concern themselves with the unemployment insurance which is paid by employers at the rate of 1% for 1936 upon the payrolls of any person or corporation employing eight or more people. This tax is not to be deducted from employees.

"In various states supplementary state legislation has been passed in order to enable the citizens of such states to get the benefits later on of the Federal unemployment insurance. Where no state laws have been passed the Federal tax is payable, but people in such states will get no benefit from the Federal fund. Where state legislation has been passed, and has been approved by the Federal Social Security Board, a credit against the 1% tax payable to the government is allowed up to 90%.

"There are a great many variations of application of both the Federal and the various state laws so far enacted and we suggest to the members of the profession that they keep in active touch with their local situation in respect to these laws. Particular attention should be paid, in drawing contracts, to the liability placed upon contractors and others for seeing to it that proper payments are made of these insurance taxes by subcontractors. We understand generally that the passing on of these taxes through the operations of builders has increased the cost of structural contracts from 7 to 8%. This percentage will vary in different localities and under different State laws but is a cost factor which architects must now carry actively in mind."

ORIGIN OF NAMES OF CALIFORNIA COUNTIES

This is the seventh article in the series giving derivation of the names of California counties:

MERCED COUNTY—Created April 19, 1855. This county derived its name from the Merced River, which originally was named by the Spanish "Rio de Nuestra Senora de la Merced," meaning "the river of Our Lady of Mercy."

Merced occupies a most strategic location. It is approximately in the center of the state and in the heart of the San Joaquin Valley. The county has 3830 farms with a total acreage of 829,377. Highways and roads total 2000 miles. Diversity of agricultural products, fine cattle, the largest peach and apricot orchards, largest seedless raisin vineyards, abundance of water and a natural gateway to Yosemite National Park, are features for which the county is noted.

Merced has more than 318,722 acres under irrigation, ranking fourth in the state. More than 1500 miles of canals carry water to rich and productive soils, the systems representing an investment of \$25,000,000. Dairying accounts for 50 per cent of the county's income. One lumber mill at Merced Falls, near Merced, has an annual lumber cut of over 50,000,000 feet annually, with a payroll in excess of \$1,000,000. In addition to rail lines, Merced has 237 miles of hard-surfaced highways, while 1750 miles of good, graded roads reach every section of the county. Population: 36,748. Area: 1995 square miles.

MODOC COUNTY—Created February 17, 1874. This county derived its name from a fierce tribe of Indians by that name, which means "the head of the river," and who lived at the headwaters of the Pit River. General O. O. Howard, in an article in the St. Nicholas magazine for May, 1908, page 624, states that the Indian name of the tribe of which Modoc is a corruption is "Maklaks", and means "The People."

Famed for its hunting, fishing and scenic attractions, Modoc also boasts of 450,139 acres under cultivation, 70,325 of which are under irrigation, and is noted for its fine strains of cattle and sheep. The county has 53,193 head of cattle and more than 125,000 sheep. Dairy products are increasing in importance.

Modoc is one of the few remaining sections of the state whose virgin timber resources remain practically untouched. It is estimated that 1,000,000 feet of lumber could be cut daily for 200 years, at the end of which time reforestation would have provided a new growth for cutting.

During the gold rush to California's Mother Lode far to the south, many pioneers traversed this country

which was known to the Indians as "The Smiles of God." The warlike Piutes on the east and the still fiercer Modocs on the west discouraged the white man and settlements were not in evidence until the late sixties. The Modoc Lava Beds was the scene of the Modoc War of 1872-73. Soon after the Modocs had been removed against their will to the Klamath Reservation, some 150 braves led by Captain Jack, young Modoc chief, left the reservation, secreted themselves in the lava beds and began depredations against the whites. Troops sent against them were routed. Washington ordered a peace parley and a commission headed by Brig. General Edward S. Canby met Captain Jack and his subchiefs under a flag of truce. The general was shot and killed and Captain Jack, who escaped, but finally was captured and hanged at Fort Klamath on October 4, 1873. Population: 8,038. Area: 3823 square miles.

MONO COUNTY—Created April 24, 1861. This county derived its name from the Monache Indians, as the Yokuts, their neighbors, called the tribes of this region. In Spanish, the name is interpreted as "mon-key". The Monaches were closely related to the northern Piutes of Nevada and the Bannocks of Idaho. Two branches of these tribes now are locally recognized—the Piutes of Bridgeport and Mono Lake and the Washoes of Carson Valley and regions to the north.

Forming the northern section of the Inyo-Mono playground, this county combines extraordinary scenic, recreational, hunting and fishing attractions with industries centered on sheep, cattle and poultry raising, mining, the growing of apples and other hardy fruits. Here are snow-capped mountains reaching a height of twelve and thirteen thousand feet, great forests, beautiful lakes, volcanic Mono Craters, the unusual Mono Lake, the "Dead Sea of America", Bodie, famous mining camp of pioneer days, and many other places of interest. No fish swim in Mono Lake, the only life in it, due to intensive mineralization, being a species of brine shrimp. Several cones of the Mono Craters are 3000 feet high.

The charm of the vast Mono National Forest draws many tourists and vacationists. A total of 796,034 acres of its 1,260,536 acres lie in Mono and Alpine counties.

Mono has rich mineral deposits. Its arable lands are subject to extensive cultivation. The county is capable of supporting many times its present population. Excellent highways now make it easily accessible. Population: 1360. Area: 3030 square miles.

Next—Monterey, Napa, Nevada

VISITS CALIFORNIA

Frederick V. Lockman, architect, recently resumed active practice at his office, 420 Douglas Building, Seattle, after an extended stay in California.

With the Architects

JOSEPH J. RANKIN

The death of Joseph J. Rankin, architect, San Francisco, occurred at Fort Miley Hospital, April 6th, following a brief illness. Mr. Rankin was 49 years of age. He graduated from the School of Architecture, University of California, and prior to practicing the profession for himself, was associated with W. C. Hays in the design of Berkeley and other school buildings. Mr. Rankin is survived by a widow and three sons.

ARCHITECTS ARE BUSY

Architects throughout the state are busier than at any time since the beginning of the depression. There is such a scarcity of draftsmen—some are working day and night. There is a preponderance of residence work with encouraging signs for a revival of apartment houses, store buildings, and industrial structures.

HOSPITAL ADDITION

Masten & Hurd, 233 Post Street, San Francisco, have been commissioned to prepare plans for a \$100,000 addition to the Merritt Hospital at Webster and Hawthorne Streets, Oakland.

HAS MUCH WORK

New work in the office of Chester H. Treichel, Oakland, includes alterations to the City Market, Oakland, estimated to cost \$7000; residence in San Mateo for A. E. Evans to cost \$11,000; a Monterey Colonial dwelling in Oakmore Highlands and a house in Redwood City.

MILLER & WARNECKE ACTIVE

In the office of Miller & Warnecke, Financial Center Building, Oakland, plans have been completed for a large residence on Pershing Drive, Oakland, for C. C. Gibson, and a house in St. James Wood, Oakland, for Dr. Whitfield Crane.

\$50,000 RESIDENCE

Clarence A. Tantau is preparing plans for a \$50,000 country house in Orinda, Contra Costa County, for R. F. Rheem. The builders are Charles Stockholm & Sons. The same architect is completing drawings for a clubhouse for Miss Marion Hollins at the Paso Tiempo Country Club, Santa Cruz.

HILLSBOROUGH RESIDENCE

A two-story stucco residence is to be built in Hillsborough for Mr. and Mrs. Decker McAllister, from plans by Gardner A. Dailey, who has also prepared plans for a guest house at Woodside for William Lowe.

PERSONAL

Merrill W. Baird, architect, is opening a new office at 1300 N. Vergudo Road, Glendale, California, and desires manufacturers' catalogues and specifications for A.I.A. filing system.

J. C. Johnson, President of the S. T. Johnson Company, is in the East attending the oil burners' convention in Detroit. Before returning Mr. Johnson will visit the company's eastern office in Philadelphia.

Frank P. Schemmel of San Jose, formerly of Solon & Schemmel now Solon & Larkin, San Jose, is making a six months tour of Europe, returning about October 1st.

William L. Higgins announces his association with Chester Root, architect, who will carry on the long established architectural practice of the late William E. Higgins, formerly Wolfe & Higgins, as William L. Higgins, Chester Root, architect, associates. The new organization announces the removal of its offices from 19 North Second Street to the Security Building, First and San Fernando Streets, San Jose.

W. F. Herbert, architect, formerly associated with C. A. Calkins, is continuing practice with offices in the Rosenberg Building, Santa Rosa. Mr. Herbert will be pleased to receive building material samples and literature.

Rhenisch, Wilson & Waterman, engineers and architects, 612 North Grove Avenue, Oak Park, Ill., would like to receive catalogs and building material samples from Pacific Coast and Middle West manufacturers.

RESIDENCE WORK

Clarence Mayhew, 6026 Acacia Avenue, Oakland has completed drawings for a Provincial style residence in Piedmont Estates, Oakland, for Harriot Small; also a Venetian style residence in Piedmont for Mrs. A. G. Steltzner and a Modern-Japanese style house in the Taylor Gardens, Berkeley, for John Rowell.

ENGLISH DWELLING

Arnold S. Constable has completed working drawings for a two-story and basement English style dwelling for Dr. B. M. Campbell of San Francisco. The house will be built in Sea Cliff, San Francisco, at an estimated cost of \$8000.

HOLLYWOOD HIGH SCHOOL

Myron Hunt and H. C. Chambers of Los Angeles, have completed plans for a new building for the North Hollywood High School. The estimated cost of the 21-room academic building is \$102,000.

PROGRAM OF INSTITUTE CONVENTION IN EAST

PACIFIC COAST delegates to the Annual Convention of the American Institute of Architects at Williamsburg, Va., the week of May 5 will be leaving for the East in a few days. All the Coast Chapters will be represented. Following is the tentative program:

TUESDAY, MAY FIFTH

(The Chamberlin Hotel, Old Point Comfort)

Morning Session

The President, Stephen F. Voorhees, Presiding

9:00 A.M. Registration continued.

10:00 A.M. Opening of the Convention.

The President's Address—

By Stephen F. Voorhees

The Report of the Treasurer—

By Edwin Bergstrom

* The Report of the Board of Directors—

By Charles T. Ingham

Luncheon

1:00 P.M. Luncheon and Joint Meeting with The Producers' Council.

Afternoon

The President Presiding

2:30 P.M. Board and Committee Reports.

Consideration of By-law Amendments.

5:00 P.M. Reception by the President and Mrs. Voorhees.

6:00 P.M. Registration closes.

Evening

The President Presiding

8:00 P.M. Report of Committee on Credentials.

8:15 P.M. Nominations of Officers and Directors.
Adoption of By-law Amendments.

WEDNESDAY, MAY SIXTH

Morning Session

(Phi Beta Kappa Hall, in Williamsburg)

The President Presiding

10:30 A.M. Opening of the Session.

Address—By Dr. William Stewart Bryan, President, College of William and Mary.

Address—By Kenneth Chorley, Vice-President, Colonial Williamsburg, Inc.

Address—By William G. Perry, Architect.

12:00 Noon—At Bruton Parish Church.

Services and Address—

By Dr. W. A. R. Goodwin.

Luncheon

1:30 P.M. At the College Refectory.

(At this luncheon all attending the Convention will be the guests at the College of William and Mary.)

Afternoon

2:30 P.M. Visiting at Williamsburg.

Evening

No meetings scheduled.

THURSDAY, MAY SEVENTH

Morning Session

(Phi Beta Kappa Hall, in Williamsburg)

The Second Vice-President, Francis P. Sullivan,

Presiding

10:30 A.M. Opening of the Session.

Discussion of Housing—led by R. H. Shreve, Chairman of Committee on Housing.

12:00 M. Discussion of Public Works Program—led by Francis P. Sullivan, Chairman, Committee on Public Works.

Luncheon

1:30 P.M. At the College Refectory.

(Each person must have a ticket)

Afternoon

2:30 P.M. Visiting in Williamsburg.

Joint Planning Conference—

Under the auspices of three national planning groups.

All attending the Convention of The Institute are cordially invited to this Conference.

Evening

(The Chamberlin Hotel, Old Point Comfort)

The First Vice-President, Louis LaBeaume, Presiding

8:00 P.M. Polls Open.

8:15 P.M. Unfinished Business.

Discussion of Educational Program—led by William Emerson, Chairman, Committee on Education.

Discussion of Construction Industry Relations—led by William Stanley Parker, Chairman, Committee on Building Industry Relations.

11:00 P.M. Polls close.

FRIDAY, MAY EIGHTH

Morning Session

(Phi Beta Kappa Hall, in Williamsburg)

The President Presiding

10:30 A.M. Opening of the Session.

New Business.

Report of Committee on Resolutions.

Open Forum Discussion.

Announcement of Elections.

Luncheon

1:30 P.M. At the College Refectory.

(Each person must have a ticket).

Afternoon

2:30 P.M. Visiting in Williamsburg.

Evening

(The Chamberlin Hotel, Old Point Comfort)

The President Presiding

8:00 P.M. Dinner of the Institute.

Presentation of Medals.

Presentation of Fellowship Certificates.

Presentation of Tributes.

Adjournment.

SATURDAY, MAY NINTH

Visit to the James River Plantations

CONTRACTORS LICENSE BOARD

Organization of the State Constructors' License Board, established by the 1935 Legislature to direct the activities of the State License Bureau, was accomplished in Sacramento the past month with the election of Warren A. Bechtel, Jr., of San Francisco, as chairman and Ralph E. Homann, of Los Angeles, as vice chairman. Standing committee chairmen elected were S. G. Johnson, Oakland, rules and procedure; William Nies, Los Angeles, finance and budget, and Ralph E. Homann, Los Angeles, personnel.

The Board, whose appointment was recently announced by Governor Merriam, consists of Warren A. Bechtel, Jr., general engineering contractor of San Francisco; Roy M. Butcher, electrical contractor of San Jose; Ralph E. Homann, general building contractor of Los Angeles; S. G. Johnson, general building contractor of Oakland; William Nies, plumbing contractor of Los Angeles; Hugh McNulty, general building contractor of Fresno, and Stephen L. Ford, plasterer contractor of Long Beach.

William G. Bonelli, Registrar of Contractors, was re-appointed to the same position, which he holds jointly with the directorship of the State Department of Professional and Vocational Standards.

The Board, which serves without pay, is a division of the State Department of Professional and Vocational Standards. Licentiates under its jurisdiction total 22,579. The Board has the power to control the issuance of licenses to construction contractors of all classes, and to suspend or revoke licenses for various acts inimical to the public welfare.

ANOTHER EXPOSITION

A committee of prominent Cleveland architects has been appointed by Alexander G. Robinson III, president of the Cleveland Chapter of the American Institute of Architects, to cooperate with the officials of the Great Lakes Exposition in planning the architecture of a huge industrial show to be held next summer on Cleveland's downtown lakefront. The committee, headed by Abram Garfield, will have final authority on all questions involving architecture, the general theme of which is now under consideration. Serving with Mr. Garfield on the committee are J. Byers Hays, Frank B. Meade, F. R. Walker, and Antonio Dinardo.

HOLTZER-CABOT ELECTRIC DEVICES

As Northern California distributors for The Holtzer-Cabot Electric Company of Boston, the F. A. Thomas Company will handle and install their signal and communicating equipment, including electric clock and program systems, fire alarm systems, nurses call systems, telephone systems, and electric distribution panels. Headquarters are maintained at 47 Second Street, San Francisco.

FIVE-ROOM STEEL HOUSE FOR \$2,000

(Condensed from Iron Age)

Low-cost home construction is expected to stimulate the building industry. Many experiments have produced houses available for small incomes, attractive, well insulated and lighted, fireproof and vermin-proof. A five-room steel house, costing \$1,350 at factory, brings total investment down to \$2,000. It includes wiring and lighting, plumbing and fixtures, hardware and all other accessories. With FHA financing as high as 80%, all cash needed would be for cost of site, plus first installment payment, which would average \$15 to \$17 a month. A 1-car steel garage costs \$235; for two cars, \$400. A week-end cottage or tourist cabin with garage, likewise steel, may be put up for \$500. Concrete slabs form house foundations, but other materials may be used, or a basement included. Walls, roof and incidental parts may be bought separately. They are interlocking, self-framing, made of 20-gage heavily galvanized armco sheets. Wall panels have flanged sides fitting into the adjoining panel. They are fastened with simple hook belts, the flanges carrying furring strips for finishing in side walls. This strip serves also for nailing and insulation, making temperature control easier. The structural joint provides for expansion and contracting with temperature changes.

FREDERICK HARRISON MOVES

Frederick S. Harrison, who has been practicing architecture in Sacramento for twenty years, has opened new offices in Suite 307 of the Old Elks Building at 824 J Street. His offices formerly were at 1005 Tenth Street, that city.

Mr. Harrison is a consulting architect for the Federal Housing Administration. Twenty-five years ago, he was Sacramento's building inspector.

BOOK REVIEW

ELEMENTS OF DIESEL ENGINEERING:—by Orville Adams; The Norman W. Henely Co., #2 West 45th Street, New York; Price:—\$4.00.

A manual-introductory to the subject, and easily understandable. This volume should appeal to the engineer and to the engineering student. Format is exceptionally good for a text book or manual; illustrations excellent.

The contents embrace chapters on fuels, lubricating oils, combustion, parts, repairs, maintenance, etc., etc., as well as a thorough exposition of combustion chambers, injection pumps, and spray valves for solid injection engines.

This is the first book of its kind to reach the reviewer's desk since the start of the depression.

Chapter and Club Meetings

NORTHERN CALIFORNIA CHAPTER

The regular monthly meeting of Northern California Chapter, A.I.A., was held at the St. Germain Restaurant, San Francisco, at 6:30 P.M., March 31, President Will G. Corlett presiding.

Guests present included Mr. Keffer, A.I.A., Iowa, and 15 students of the School of Architecture, University of California at Berkeley.

Mr. Allen gave an interesting account of the report which was made to the Institute on Small House Study.

Messrs. Albert J. Evers and Wm. I. Garren were elected delegates to the 68th Annual Convention to be held in Williamsburg, Va., May 5, 6, 7, 8. The remaining membership were elected alternates.

Mr. Allen moved that the delegates be un instructed in keeping with the usual custom but that the directors, independently or assisted by a committee, gather opinions on matters to come before the convention and report these to the Chapter; and further, that any action taken thereon be sent to the delegation for its information.

The motion was seconded by Mr. Frick and unanimously carried. President Corlett appointed the following committee to fulfill the instruction: Messrs. Meyer, Evers and Mitchell.

Discussion on competitions for Federal buildings and other matters was deferred until the April meeting on motion of Mr. Dailey.

During the remaining portion of the evening Arthur Brown, Jr., told of his recent European trip. In the course of his stay it had been his privilege to attend the XIIIth International Congress of Architects in Rome as a member of the American delegation. His account of its functioning and entertainment and the impressions gathered from his observation of current European architecture was exceedingly interesting. —J.H.M.

APRIL CHAPTER MEETING

Southern California Chapter, American Institute of Architects, met Tuesday, April 14, at 6:30 p.m. in Casa de Rosas Inn, 2608 S. Hoover Street, Los Angeles. Reginald D. Johnson described the restoration of Williamsburgh, Virginia, where the next Institute convention will be held. Henry F. Withey made a report on the Federal Writers Project for the American Guide Manual to be produced by the WPA. This was the annual preconvention meeting of the Chapter and various matters to come before the convention were discussed.

SOUTHERN CALIFORNIA CHAPTER

Housing needs was the subject of the March 10th meeting of Southern California Chapter, A. I. A.

Two papers were read, one by Eugene Weston, Jr., vice-president of the Chapter, and the other by George Adams, secretary, following which the meeting was thrown open to a discussion of housing.

Mr. Weston's paper, accompanied by key plans, perspectives and building layouts of fourteen European projects, dealt principally with what has been accomplished abroad in the way of modern housing, which he termed the science of planned community units.

Europe has housed, since the war, 6,000,000 people in housing projects as compared to a possible 10,000 people in this country, according to Mr. Weston. The British government has assisted in financing 55 per cent of the 2,112,000 dwelling units built in England from 1919 to 1933, he stated. The illustrations used were those of the Becontree and Welwyn projects in England, one in Stockholm, Sweden, and another in Helsingfors, Finland, the latter known as the best planned city in the world.

Progress made in housing during the past three years was described by Mr. Adams, who called attention to the fact that of the government-assisted projects built in the United States, but two were located west of the Mississippi river.

Miss Helen Alfred of New York City, secretary and director of the National Public Housing Conference, stated that the British had set an example by their successful interpretation of this problem to the public. She suggested an organization of various interests to stimulate action and work out a program.

Collective ownership of land is one of the basic reasons for the success of these projects in England, according to Charles H. Cheney. He advised relating our programs to those in that country, where the family buys a leasehold, occupies the house as owner and contributes monthly a small sum to a community fund used for upkeep and repairs, thereby insuring the proper maintenance of all houses in the group.

Ralph C. Flewelling, who presided at the meeting, introduced Capt. W. G. Bingham, associate director of the Federal Housing Administration in Southern California; Walter Alley, executive director of the Los Angeles Municipal Housing Commission, and Col. Charles A. Lindner, member of the Los Angeles City Planning Commission and co-ordinator for the Municipal Housing Commission.

Colonel Lindner spoke briefly of the Utah Street housing project which he still has hopes of bringing to maturity, even though the government has withdrawn its offer of financial assistance.

In the absence of Sumner Spaulding, chairman of the Chapter committee on education, C. Raimond Johnson spoke on the mentorship program, whereby the National Council of Architectural Registration Boards requests that various Chapters select members to act as mentors for the graduates from architectural schools. The plan is to guide the novice through his course of training, preliminary to taking his examination to practice architecture.

Mr. Flewelling stated that the Chapter had been asked to report to the Institute in Washington its attitude on the so-called Buffalo plan and the question of rendering architectural services on small houses costing under \$5,000.

After reviewing the problem, he said, the executive committee decided that a minimum fee of 10 per cent should be charged on architectural services for work of this character, and approved the Institute short form document.

BUILDERS' EXCHANGE OF SAN FRANCISCO

The annual meeting of The Builders' Exchange of San Francisco showed that the Exchange is in a flourishing condition despite the depression and has gained new members the past year.

The following Board of Directors was elected to serve for the ensuing year:

J. W. Bender, Chas. W. Carle, R. J. H. Forbes, W. H. George, Wm. G. Gilmour, Emil Hogberg, E. M. Hundley, Jos. B. Keenan, J. D. McGilvray, H. N. Patterson and A. H. Wilhelm.

GRANTED ARCHITECTS' CERTIFICATES

Provisional certificates were granted by the State Board of Architectural Examiners, Southern District, at their meeting March 31, to the following: Thornton M. Abell, 454 East Rustic Road, Santa Monica; Randall Duell, 9441 Wilshire Boulevard, Beverly Hills; Harry Widman, 1850 Sycamore Street, and Frederick Hastings Walis, 5243 Lockhaven Avenue, Los Angeles.

EXPOSITION BUILDING

The first contract to be let in connection with the 1938 Bridge Exposition is a three-story reinforced concrete administration building at Bush and Stockton Streets, San Francisco. Here will be quartered the executive offices of the Fair and the architectural engineering department where the plans will be turned out for the various buildings. The Federal government has given the Exposition management substantial financial support.

VICTORY FOR REGISTERED ENGINEERS

"Holding that a person who is not a registered civil engineer in California cannot prepare plans and specifications for small bridges, although no charge is made for such plans, Deputy Attorney General Hession sounded a warning, in a letter to the District Attorney of El Dorado county, that has a far "reaching effect," says The Registered Civil Engineer, news bulletin of the California board of Registration for Civil Engineers. "He emphasized the fact that the intent and purpose of the Civil Engineers' Registration Act is to safeguard life, health, property and public welfare, and as a matter of safety to the public, only qualified (registered) engineers are authorized to prepare plans for bridges, regardless of the cost."

In his letter to District Attorney Harry S. Lyon of El Dorado county Deputy Attorney General Jess Hession says:

"When you were last in the office you submitted to me a problem confronting your board of supervisors wherein that board contracted with one Hestor Williamson for the construction of bridges where the price was under \$500.00, and that they have been having him prepare plans and specifications without charge; and that the county surveyor who is a civil engineer, has raised the question that such a practice is illegal in that Williamson is not a civil engineer, and can not prepare plans and specifications for the board.

"I am of the opinion that the county surveyor's contention is right.

"I am sending you herewith a pamphlet containing the Civil Engineers' Registration Act, wherein section 1(a) defines the term 'civil engineer' as meaning that branch of professional engineering which deals with the economics of, the use and design of, materials of construction and the determination of their physical qualities; and section 16 of the act containing the exemptions from the provisions of the act, which do not cover a person preparing plans and specifications.

"The purpose and intent of the act is to have qualified persons prepare the plans and specifications as a matter of safety, and which would, of course, apply to a contractor preparing his own plans without charge, the same as to a person who prepared them for another with a charge."

JOHNSON ZONE CONTROL

Johnson Service Company, Milwaukee, Wis., have a new pamphlet just off the press. It is called "Johnson Zone Control Systems" and explains in detail automatic heat control with special reference to zone heating. Charts, diagrams and fine illustrations make the book valuable to the busy architect and mechanical engineer.

REPLANNING OF CITIES IS ARCHITECT'S CONCERN

Architects are urged to make the replanning of cities a part of their professional concern, in a report to the American Institute of Architects by Arthur Peabody, president of the Madison, Wis., Chapter.

Railroads, motor cars, and airplanes have resulted in the haphazard development of cities, and sections which have deteriorated in the process must be reclaimed and their values restored, declares Mr. Peabody, who is State Architect of Wisconsin.

Future city residents will not continue to live on streets thronging with traffic, he predicts, but will move some distance from the center of the town, necessitating at least two cars per family, and raising the problem of parking and garaging them. Plans for rebuilding cities should, Mr. Peabody suggests, include ten-story garages at regular intervals along the street, and hangars for family airplanes.

"Certain towns in Wisconsin have doubled in size and population during the past thirty years," he says. "If they were well conditioned at one time, they are not quite that now. What was at least endurable then has become difficult and wasteful. Older portions are now outmoded, and the new portions do not fit in nicely, or at all, with the originals. Certain districts have been invaded by industry or commerce. Fine old residences have become boarding houses and a few have been torn down to avoid taxation. The section has lost prestige.

"One might say that a clean sweep would be the best solution. But could not a skilled city planner bring back old time values by some magic touch?"

"How much attention does the architect pay to the item of town development? Does he concern himself at all or is his mind occupied with the immediate design and erection of some building upon a certain plot of ground? Of course, he is not in the real estate business, and to give expression to this or that could get him 'in wrong' in ways he might not expect.

"Take for example the effect of changing a residence street into a business street. Would that better be left to men in the city hall? But the method of making the change should be of great interest to the owner of a proposed business structure.

"If the entire street is given over to trade, travel will be greatly increased and congestion may very well ensue to an extent which will affect the success of buildings fronting upon it. The standard residence street is usually provided with a narrow roadway inadequate for the traffic of a business thoroughfare.

"Time was when towns were rather well arranged. There were two principal features, the common—a pasture ground, convenient and safe—and at a cer-

tain distance, the market place. The common, surrounded by dwellings of solid citizens, was presently improved by shade trees and a white painted fence. The market place, afterward known as the square, developed into the main business center. Here the court house or the city hall was presently erected. Other important buildings were the post office, the hotel, the church, the general store and the blacksmith shop.

"Between these two principal items, the common and the square, there extended Main Street, lined with dwellings, and from it at right angles, other streets and lanes of indefinite extent. Beyond all this, cow pastures, farms and the cemetery. The town was complete.

"If the world had stood still, as we have imagined it to have done in ancient days, all would be well."

The advent of the railroad destroyed the essential unity of this plan, Mr. Peabody continues. "What had been principal became secondary. Main Street, which had occupied first place, sank in general opinion. The public square was in the wrong location. The city park, far from being the very center, was left to one side, and being rather near the railway, was exposed to the noise and smoke of locomotives.

"Besides this, there came presently tall factory chimneys and the clatter of machines. The most serious matter was the enlarged scale on which the town began to be carried along. Everything about the place became suddenly too small. New elements fitted badly into the old containers.

"If railways were the sole means of transportation, there might be less confusion. But here come three other elements to disturb the town—the motor bus, the freight truck and the airplane. They are a burden upon the community that must become a more usual and every day matter.

"The next generation may find most traveling done by air. Shall we see, presently, small one-man airplanes landing in our streets, spreading their wings from curb to curb? Why not? Once resting upon the ground, they may fold up and proceed quietly to their destination."

STRUCTURAL ENGINEERS VISIT THE MINT

The April 14th meeting of the Structural Engineer's Association of Northern California, was well attended with two subjects of interest contributing to the entertainment of the members.

A trip to the new U. S. mint under construction in San Francisco was followed by dinner at the Engineer's Club and then an evening on bridges, with Frederick W. Panhorst the principal speaker. During inspection of the structural steel being erected at the mint H. A. Schirmer of Oakland made an interesting talk describing briefly the design and construction progress. H. B. Hammill acted as chairman of the program committee.

Estimator's Guide

Giving Cost of Building Materials, Wage Scale, Etc.

Amounts given are figuring prices and are made up from average quotations furnished by material houses to San Francisco contractors.

NOTE—3% Sales Tax on all materials but not labor.

All prices and wages quoted are for San Francisco and the Bay District. There may be slight fluctuation of prices in the interior and southern part of the state. Freight cartage, at least, must be added in figuring country work.

Bond—1/2% amount of contract.

Brickwork—

Common, \$35 to \$40 per 1000 laid, (according to class of work).

Face, \$75 to \$90 per 1000 laid, (according to class of work).

Brick Steps, using pressed brick, \$1.10 lin. ft.

Brick Walls, using pressed brick on edge, 60c sq. ft. (Foundations extra.)

Brick Veneer on frame buildings, \$.75 sq. ft.

Common f.o.b. cars, \$12.00 job cartage. Face, f.o.b. cars, \$45.00 to \$50.00 per 1000, carload lots.

HOLLOW TILE FIREPROOFING (f.o.b. job)

3x12x12 in. \$ 84.00 per M

4x12x12 in. 94.50 per M

6x12x12 in. 126.00 per M

8x12x12 in. 225.00 per M

HOLLOW BUILDING TILE (f.o.b. job)

carload lots.

8x12x5/2 \$ 94.50

6x12x5/2 73.50

Discount 5%.

Composition Floors—18c to 35c per sq. ft.

In large quantities, 16c per sq. ft. laid.

Mosaic Floors—80c per sq. ft.

Duraflex Floor—23c to 30c sq. ft.

Rubber Tile—50c per sq. ft.

Terazzo Floors—45c to 60c per sq. ft.

Terazzo Steps—\$1.60 lin. ft.

Concrete Work (material at San Francisco bunkers)—Quotations below 2000 lbs. to the ton. \$2.00 delivered.

No. 3 rock, at bunkers.....\$1.80 per ton

No. 4 rock, at bunkers..... 1.75 per ton

Elliott top gravel, at bunkers..... 2.10 per ton

Washed gravel, at bunkers..... 2.10 per ton

Elliott top gravel, at bunkers 2.10 per ton

City gravel, at bunkers..... 1.75 per ton

River sand, at bunkers..... 1.80 per ton

Delivered bank sand..... 1.20 cu. yd.

Note—Above prices are subject to discount of 10c per ton on invoices paid on or before the 15th of month, following delivery.

SAND

Del Monte, \$1.75 to \$3.00 per ton.

Fan Shell Beach (car lots, f.o.b. Lake Majella), \$.275 to \$4.00 per ton.

Cement, 2.50 per bbl. in paper sks.

Cement (f.o.b. Job. S. F.) \$3.00 per bbl.

Cement (f.o.b. Job. Oak.) \$3.00 per bbl.

Rebate of 10 cents bbl. cash in 15 days.

Calaveras White\$6.00 per bbl.

Medusa White\$6.00 per bbl.

Forms, Labors average \$30.00 per M.

Average cost of concrete in place, exclusive of forms, 35c per cu. ft.

4-inch concrete basement floor

.....12/2c to 14c per sq. ft.

4 1/2 inch Concrete Basement floor.....

.....14/2c to 16c per sq. ft.

2-inch rat-proofing7/2c per sq. ft.

Concrete Steps\$1.40 per lin. ft.

Dampproofing and Waterproofing—

Two-coat work, 15c per yard.

Membrane waterproofing—4 layers of saturated felt, \$4.00 per square.

Hot coating work, \$1.80 per square.

Medusa Waterproofing, 15c per lb., San Francisco Warehouse.

Electric Wiring—\$12.00 to \$15.00 per outlet

for conduit work (including switches).

Knob and tube average \$7.00 per outlet, including switches.

Elevators—

Prices vary according to capacity, speed and type. Consult elevator companies.

Average cost of installing an automatic elevator in four-story building, \$2800;

direct automatic, about \$2700.

Excavation—

Sand, 50 cents; clay or shale, 80c per yard.

Teams, \$10.00 per day.

Trucks, \$18 to \$25 per day.

Above figures are an average without water. Steam shovel work in large quantities, less; hard material, such as rock, will run considerably more.

Fire Escapes—

Ten-foot balcony, with stairs, \$75.00 per balcony, average.

Glass (consult with manufacturers)—

Double strength window glass, 15c per square foot.

Quartz Lite, 50c per square foot.

Plate 75c per square foot.

Art, \$1.00 up per square foot.

Wire (for skylights), 35c per sq. foot

Obscure glass, 26c square foot.

Note—Add extra for setting

Heating—

Average, \$1.90 per sq. ft. of radiation, according to conditions.

Iron—Cost of ornamental iron, cast iron, etc., depends on designs.

Lumber (prices delivered to bldg. site).

No. 1 common \$33.00 per M

No. 2 common 28.00 per M

Selection O. P. common 38.00 per M

2x4 No. 3 form lumber 24.00 per M

1x4 No. 2 flooring VG 60.00 per M

1x4 No. 3 flooring VG 50.00 per M

1x6 No. 2 flooring VG 60.00 per M

1/4x4 and 6, No. 2 flooring 65.00 per M

Slash grain—

1x4 No. 2 flooring \$45.00 per M

1x4 No. 3 flooring 38.00 per M

No. 1 common run T. & G. 31.00 per M

Lath 7.00 per M

Shingles (add cartage to price quoted)—

Redwood, No. 1 \$1.10 per bdle.

Redwood, No. 290 per bdle.

Red Cedar 1.00 per bdle.

Hardwood Flooring (delivered to building)—

13-16x3/4" T & G Maple.....\$120.00 M ft.

1-11x2/4" T & G Maple 132.00 M ft.

7/8x3/2 sq. edge Maple 140.00 M ft.

13-16x2/4" 3/8x2" 5-16x2" T&G T&G Sq.Ed.

Clr. Otd. Oak\$200.00 M \$150.00 M \$180 M

Sel. Otd. Oak 140.00 M 120.00 M 135 M

Clr. Pla. Oak 135.00 M 107.00 M 120 M

Sel. Pla. Oak 120.00 M 88.00 M 107 M

Clear Maple 140.00 M 100.00 M

Laying & Finishing 13c ft. 11 ft. 10 ft.

Wage—Floor layers, \$7.50 per day.

Building Paper—

1 ply per 1000 ft. roll\$3.50

2 ply per 1000 ft. roll 5.00

3 ply per 1000 ft. roll 6.25

Brownskin, 500 ft. roll 5.00

Brownskin Pro-tect-o-mat, 1000 ft. roll 10.00

Sisalcraft, 500 ft. roll 5.00

Sash cord com. No. 7\$1.20 per 100 ft.

Sash cord com. No. 8 1.50 per 100 ft.

Sash cord spot No. 7 1.90 per 100 ft.

Sash cord spot No. 8 2.25 per 100 ft.

Sash weights cast iron, \$50.00 ton.

Nails, \$3.50 base.

Sash weights, \$45 per ton.

Millwork—

O. P. \$100.00 per 1000. R. W., \$106.00

per 1000 (delivered).

Double hung box window frames, average,

with trim, \$6.50 and up, each.

Doors, including trim (single panel, 1 3/4

in. Oregon pine) \$8.00 and up, each.

Doors, including trim (five panel, 1 3/4 in.

Oregon pine) \$6.50 each.

Screen doors, \$4.00 each.

Patent screen windows, 25c a sq. ft.

Cases for kitchen pantries seven ft. high,

per lineal ft., \$6.50 each.

Dining room cases, \$7.00 per lineal foot.

Labor—Rough carpentry, warehouse heavy framing (average), \$12.00 per M.

For smaller work average, \$27.50 to \$35.00

per 1000.

Marble—(See Dealers)

Painting—

Two-coat work	29c per yard
Three-coat work	40c per yard
Cold Water Pointing	10c per yard
Whitewashing	4c per yard
Turpentine, 80c per gal., in cans and 75c per gal. in drums.	
Raw Linseed Oil—80c gal. in bbls.	
Bolled Linseed Oil—85c gal. in bbls.	
Medusa Port-land Cement Paint, 20c per lb.	

Carter or Dutch Boy White Lead in Oil (in steel kegs). Per Lb.

1 ton lots, 100 lbs. net weight	103 1/2c
500 lbs. and less than 1 ton lots	11c
Less than 500 lb. lots	11 1/2c

Dutch Boy Dry Red Lead and Litharge (in steel kegs).

1 ton lots, 100 lb. kegs, net wt.	103 1/2c
500 lb. and less than 1 ton lots	11c
Less than 500 lb. lots	11 1/2c

Red Lead in Oil (in steel kegs)

1 ton lots, 100 lb. kegs, net. wt.	12 1/2c
500 lb. and less than 1 ton lots	12 1/2c
Less than 500 lb. lots	13c

Note—Accessibility and conditions cause wide variance of costs.

Patent Chimneys—

6-inch	\$1.00 lineal foot
8-inch	1.50 lineal foot
10-inch	1.75 lineal foot
12-inch	2.00 lineal foot

Plastering—Interior—

1 coat, brown mortar only, wood lath	Yard \$0.60
2 coats, lime mortar hard finish, wood lath ..	.70

2 coats, hard wall plaster, wood lath	\$.80
3 coats, metal lath and plaster	1.25
Keene cement on metal lath	1.30
Ceilings with 3/4 hot roll channels metal lath ..	.75
Ceilings with 3/4 hot roll channels metal lath plastered	1.50
Single partition 3/4 channel lath 1 side85
Single partition 3/4 channel lath 2 sides 2 inches thick	2.75
4-inch double partition 3/4 channel lath 2 sides	1.30
4-inch double partition 3/4 channel lath 2 sides plastered	3.00

Plastering—Exterior—

2 coats cement finish, brick or concrete wall	\$1.10
2 coats Atlas cement, brick or concrete wall	1.35
3 coats cement finish, No. 18 gauge wire mesh	1.50
3 coats Medusa finish, No. 18 gauge wire mesh	2.00

Wood lath, \$6.00 per 1000.
 2 1/2-lb. metal lath (dipped)

25-lb. metal lath (galvanized)

Plumbing—

From \$65.00 per fixture up, according to grade, quantity and runs.

Roofing—

"Standard" tar and gravel, \$6.00 per sq. for 30 sqs. or over.
 Less than 30 sqs. \$6.50 per sq.
 Tile, \$20.00 to \$35.00 per square.

Redwood Shingles, \$11.00 per square in place.
 Cedar Shingles, \$10 sq. in place.
 Recoit, with Gravel, \$3.00 per sq.
 Slate, from \$25.00 to \$60.00 per sq. laid according to color and thickness.

Sheet Metal—

Windows—Metal, \$2.00 a sq. foot.
 Fire doors (average), including hardware, \$2.00 per sq. ft.

Stylights—

Copper, 90c sq. ft. (not glazed).
 Galvanized iron, 25c sq. ft. (not glazed).

Steel—Structural

\$100 ton (erected), this quotation is an average for comparatively small quantities. Light truss work higher. Plain beams and column work in large quantities \$80 to \$90 per ton cost of steel; average building, \$89.00.

Steel Reinforcing—

\$85.00 per ton, set, (average).

Stone—

Granite, average, \$6.50 cu. foot in place.
 Sandstone, average Blue, \$4.00, Boise, \$3.00 sq. ft. in place.
 Indiana Limestone, \$2.80 per sq. ft. in place.

Store Fronts—

Copper sash bars for store fronts, corner, center and around sides, will average 75c per lineal foot.

Note—Consult with agents.

Tile—Floor, Wainscot, Etc.—(See Dealers).

SAN FRANCISCO BUILDING TRADES WAGE SCALE

Established by The Impartial Wage Board November 9, 1932. Effective on all work January 1, 1933, to remain in effect until June 30, 1933, and for so long thereafter as economic conditions remain substantially unchanged.

This scale is based on an eight-hour day and is to be considered as a minimum and employees of superior skill and craft knowledge may be paid in excess of the amounts set forth herein.

CRAFT	Journeyman Mechanics	CRAFT	Journeyman Mechanics	CRAFT	Journeyman Mechanics
Asbestos Workers	\$6.40	Iron Workers (Bridge and Structural)	\$9.60	Stair Builders	\$7.20*
Bricklayers	9.00	Iron Workers (Hoisting Engineers)	10.00	Stone Cutters, Soft and Granite	6.80
Bricklayers' Hodcarriers	5.60	Laborers (6-day week)	5.00	Stone Setters, Soft and Granite	8.00
Cabinet Workers (Outside)	7.20*	Lathers, Chasing Iron	8.00	Stone Derricksmen	7.20
Caisson Workers (Open) Water Work	8.00	Lathers, All Other	6.80	Tile Setters	8.00
Carpenters	9.00	Marble Setters	8.00	Tile Setters' Helpers	5.00
Cement Finishers	7.20	Marble Setters' Helpers	5.00*	Tile, Cork and Rubber	7.20
Cork Insulation Workers	7.20	Millwrights	7.20*	Welders, Structural Steel Frame on Buildings ..	9.60
Electrical Workers	8.00	Mosaic and Terrazo Workers (Outside)	7.20	Welders, All Others on Buildings	8.00
Electrical Fixture Hangers	7.00	Mosaic and Terrazo Helpers	5.00	Auto Truck Drivers—Less than 4,500 lbs.	5.50
Elevator Constructors	8.68	Painters	7.00	Auto Truck Drivers—2,500 lbs. to 4,500 lbs.	6.00
Elevator Constructors' Helpers	6.08	Painters, Varnishers and Polishers (Outside) ..	7.00	Auto Truck Drivers—4,500 lbs. to 6,500 lbs.	6.50
Engineers, Portable and Hoisting	8.00	Pile Drivers and Wharf Builders	8.00	Auto Truck Drivers—6,500 lbs. and over	7.00
Glass Workers (All Classifications)	6.80	Pile Drivers Engineers	9.00	General Teamsters, 1 Horse	5.50
Hardwood Floormen	7.20*	Plasters and Hodcarriers (See wage scale under Plastering)		General Teamsters, 2 Horses	6.00
Housemovers	6.40	Plumbers	8.00	General Teamsters, 4 Horses	6.50
Housemovers, Architectural Iron (Outside) ..	7.20	Roofers (All classifications)	6.40	Plow Teamsters, 4 Horses	6.50
Housemovers, Reinforced Concrete, or Rodmen ..	7.20	Sheet Metal Workers	7.20	Scraper Teamsters, 2 Horses	6.00
		Sprinkler Fitters	9.00	Scraper Teamsters, 4 Horses	6.00
		Steam Fitters	8.00		

*Established by Special Board

GENERAL WORKING CONDITIONS

- Eight hours shall constitute a day's work for all crafts, except as otherwise noted.
- Where less than eight hours are worked pro rata rates for such shorter period shall be paid.
- Plasterers' Hodcarriers, Bricklayers' Hodcarriers, Roofers' Laborers and Engineers, Portable and Hoisting, shall start 15 minutes before other workmen, both at morning and at noon.
- Five days, consisting of not more than eight hours a day, on Monday to Friday inclusive, shall constitute a week's work.
- The wages set forth herein shall be considered as net wages.
- Except as noted the above rates of pay apply only to work performed at the job site.
- Transportation costs in excess of twenty-five cents each way shall be paid by the contractor.
- Traveling time in excess of one and one-half hours each way shall be paid for at straight time rates.
- Overtime shall be paid as follows: For the

- first four hours after the first eight hours, time and one-half. All time thereafter shall be paid double time. Saturday (except Laborers), Sundays and Holidays (from 12 midnight of the preceding day shall be paid double time. Irrespective of starting time, overtime for Cement Finishers shall not commence until after eight hours of work.
- On Saturday Laborers shall be paid straight time for an eight-hour day.
- Where two shifts are worked in any twenty-four hours, shift time shall be straight time. Where three shifts are worked, eight hours' pay shall be paid for seven hours on the second and third shifts.
- All work, except as noted in paragraph 13, shall be performed between the hours of 8 A. M. and 5 P. M.
- In emergencies, or where premises cannot be vacated until the close of business, men reporting for work shall work at straight time.

- Any work performed on such jobs after midnight shall be paid time and one-half up to four hours of overtime and double time thereafter (provided that if a new crew is employed on Saturdays, Sundays or Holidays which has not worked during the five preceding working days, such crew shall be paid time and one-half. No job can be considered as an emergency job until it has been registered with the Industrial Association and a determination has been made that the job falls within the terms of this section).
- Recognized holidays to be: New Year's Day, Decoration Day, Fourth of July, Labor Day, Armistice Day, Thanksgiving Day, Christmas Day.
- Men ordered to report for work for whom no employment is provided shall be entitled to two hours' pay.
- This award shall be effective in the City and County of San Francisco.

NOTE: Provision of paragraph 13 appearing in brackets () does not apply to Carpenters, Cabinet Workers (Outside), Hardwood Floormen, Millwrights, or Stair Builders.

PRODUCERS COUNCIL CLUB

New officers were elected at the recent annual meeting of the Producers' Council Club of Northern California, a chapter of the Producers' Council, Inc., headquarters in New York City, an association of outstanding national manufacturers of building materials, affiliated with the American Institute of Architects.

The broad objectives of the organization are the promotion of a better mutual understanding between architects, engineers, contractors and manufacturers of building products, and the encouragement of production of dependable materials, good construction, meritorious architecture and sound trade practices.

At present there are but two chapters of the Producers' Council on the Pacific Coast, one in San Francisco, known as the Northern California Club, and one in Los Angeles, known as the Southern California Club. Steps are being taken by the Council to establish other chapters in the West in representative locations.

The newly chosen officers are as follows:

President, A. W. Scott, National Lead Company; Vice president, J. G. Mackenzie, Libbey-Owens-Ford Glass Co.; Secretary-treasurer, H. E. Root; Directors, A. W. Scott, J. G. Mackenzie, H. E. Root, Clarke E. Wayland, Ben F. Blair, F. K. Pinney, R. W. Beard, A. W. Sperry and Arthur Skaife; Representatives,

American Institute of Architects, Chas. F. Masten, Wilbur D. Peugh and Harry M. Michelson.

BAKERSFIELD ARCHITECT BUSY

Clarence Cullimore, architect, 104 Olander Avenue, Bakersfield, reports the following new work in his office:

"Plans are now in preparation for a Southern Colonial residence for Dr. and Mrs. Keith S. McKee, Bakersfield to cost \$30,000; a residence for Mr. and Mrs. Malcolm Brock, Bakersfield, for \$15,000; an adobe residence for Dr. and Mrs. Irvin H. Betts, Visalia, for \$15,000; an adobe residence for Fred E. Vanderhoof, Woodlake, \$15,000, and a residence for Mr. and Mrs. Asa C. Dimon, Bakersfield, part frame and part adobe, to cost \$10,000."

THE ART OF ARCHITECTURE

The University of California at Los Angeles will have on its summer session faculty Richard Neutra, architect, who will instruct a class in the Art of Architecture. Also of interest to architects will be a summer session course in acoustics, which Dr. Vern O. Knudsen, professor of physics at the University, will conduct. Lectures and demonstrations on sound and the theory of sound with applications to architectural and physical acoustics will be included in this course.

The University of California at Los Angeles summer session opens June 27 and closes August 7.

THE HOUSE THAT IS DESIGNED FOR LIVING

The architect's plans for this house include provision for **adequate** electrical wiring, because that is the basis of comfort and convenience for those who will live in it.

Adequate electrical wiring is the architect's concern because wiring is an integral part of the structure. It must provide plenty of outlets for appliances in use at present and new ones as they are acquired, as well as lighting.

If it does not, it will be a source of inconvenience and annoyance. If the building has to be rewired after it is completed, it will be much more expensive than if it had been done correctly in the first place.

Specify **RED SEAL** wiring in your plans, and be assured a sound foundation for adequate electrical convenience both now and for the future.

RED SEAL information, plans, and consultation without cost or obligation.

PACIFIC COAST ELECTRICAL BUREAU

SAN FRANCISCO
447 Sutter Street

• CALIFORNIA •

LOS ANGELES
601 W. 5th Street

MONEL METAL

[High Nickel Alloy]

is the accepted material for soda fountains and lunch-room equipment, just as it is the universal metal for food service equipment in leading hotels and restaurants throughout the country.

CORROSIRON

[Acid Resisting Iron]

is the accepted material for draining waste lines. CORROSIRON meets all State and Municipal specifications for drain lines from school laboratories and chemistry rooms.

Pacific Foundry Company Ltd.

Pacific Metals Company Ltd.

1400 South Alameda St.
LOS ANGELES

3100 Nineteenth St.
SAN FRANCISCO

551 Fifth Ave.
NEW YORK

ARCHITECTS TO DIRECT NATIONAL HOUSING PROGRAM

PONSORED by a coalition of architects, builders, government agencies, banking and other groups, a movement to achieve a higher national housing level has been launched, it is announced by Stephen F. Voorhees, president of the American Institute of Architects.

A major objective is to bring architectural service, hitherto largely confined to costlier structures, into the small house field. Another aim, with the aid of the Federal Home Loan Bank System, building and loan associations, and other lending agencies, is to raise building and mortgage standards.

Three million new and four million modernized homes are said to be needed and it is planned to enlist the entire architectural profession in directing their construction and design.

"Many powerful forces of the country are moving toward vastly increasing the number of small houses to be built in the near future," the announcement declares. "Architects, faced with the charge that they are neglecting a sphere in which great social and economic developments are impending, have, with the sanction of the Board of Directors of the Institute, assumed the responsibility of correlating the diverse interests involved to a common end."

Heading the activities is a housing committee of the Institute of which Richmond H. Shreve of New York has been named chairman. Housing groups in each of the Institute's sixty-eight Chapters will carry on the work in every section of the United States in co-operation with the field representatives of the Federal Housing Administration.

"Considerable study has been given to plans for co-operation between the Federal Home Loan Bank System and the architectural profession," the committee explains. "An authorized plan for government and professional co-operation in raising building and mortgage standards is being developed.

"A number of local professional groups have been organized to test the possibility of working in the small house field through prepared plans and collaborative service.

"Efforts are being made at a number of points to educate local lending institutions as to the added value of competent architectural service. In New York City an important group of savings banks has established requirements which they deem minimum standards for new construction.

"This bank group has given notice that adequate plans and specifications will be required from the borrower and thus has set up real opportunity for architectural service.

"The Committee for Economic Recovery, a non-federal group, is broadly organized, and is advocating a country-wide home building program 'as a most important social and economic objective.' Greatest emphasis is placed upon the need of homes in range of

Hollywood
ROOSEVELT

Redecorated all of their
superb suites with

WALLCOVER
FLAT

A tribute by a
famous hotel to
a famous paint.

Use Coupon
for Sample



GENERAL PAINT

GENERAL CORPORATION

San Francisco • Los Angeles • Oakland • Portland • Seattle • Spokane • Tulsa

Use This Coupon for
FREE SAMPLE
of
Wall Cover Flat

Check color WHITE IVORY ORCHID SEAFOAM SILVER GRAY APRICOT TURQUOISE

Mail coupon to nearest Division
Office—print name and address clearly or attach business card.

Name _____

Street and Number _____

City and State _____

cost up to \$4,000. It is recognized by this committee that group planning must be properly related to the community in which the development is to be made. Adequate technical service is recognized and urged as essential to successful planning.

"Nationwide industrial corporations are instituting advertising and construction programs based on the certification of quality standards of building. The intention is to build up in this way a public recognition of the increased value of a building operation based on sound plans and specifications. The need of architectural service is pointed out.

"Two purposes are emphasized by the American Institute of Architects: 1—to increase the value of the service of the architect by adding supervision to preparation of plans and specifications; and 2—to secure and employ government aid in lifting and maintaining building and mortgage standards.

"Both of these steps are calculated to bring the architect more fully into the small house field by emphasizing the value of architectural service as compared with the use of plans only.

"A 'short form' of agreement and general conditions suitable for use in connection with small house work has been prepared and approved by the Institute. The Federal Housing Administration co-operated in its preparation, and the document is now being sent to all FHA field officers.

"The Federal Housing Administration reports receiving many inquiries from the building public for architectural service. Prospective owners and builders will be referred by the Administration to Officers of the Institute's Chapters. The local representative of the FHA will be instructed to help in bringing together the prospective builder and owner and the architect."

CURLETT NAMED PROJECT ENGINEER

Aleck Curlett, architect of Los Angeles, and formerly of San Francisco, has been appointed project engineer of the PWA in charge of the Los Angeles city school reconstruction program which is being put through with the co-operation of the PWA. Announcement of his appointment was made by A. D. Wilder, acting state director of the PWA following Mr. Curlett's return from a trip to Washington. For the last two years Mr. Curlett has been chief of the inspection division of the PWA in Southern California. Dwight W. Stephenson, state legal advisor, who was temporarily in charge of the Los Angeles Office of the PWA has returned to his regular duties.

NAVAL HANGAR

William Wills, partner in the Pioneer Construction Co., Lloyd Building, Seattle, recently returned from the Hawaiian Islands, where he had spent a year superintending the construction of a huge steel hangar for the U. S. Navy on Ford Island. The building is 400x300 feet and is built to accommodate planes with 120 foot wing spread.

ALL AROUND THE WORLD
you'll find

SLOAN
FLUSH VALVES

There are installations in every civilized country, in every kind of building, and on ships that travel the water highways of the world. To carry SLOAN Flush Valves to the far places of the earth not once, but repeatedly, indicates a genuine buying preference, not mere salesmanship. Today the vast majority of all flush valves installed carry the name SLOAN, the standard of flush valve comparison around the world.

SLOAN VALVE CO. — CHICAGO

BUILD WELL~

A PROPERLY designed and well constructed building is a credit to any city and a profitable investment for its owner.

Such structures are the STANDARD OIL BUILDING, MATSON BUILDING, FOUR-FIFTY SUTTER STREET, STOCK EXCHANGE, S. F. BASE BALL PARK, MILLS TOWER, OPERA HOUSE and VETERANS' MEMORIAL, San Francisco, OLYMPIC CLUB ALTERATIONS, SANTA ANITA RACING PLANT and other notable structures — all built or supervised by —

Lindgren & Swinerton, Inc.

Standard Oil Building 605 W. Tenth Street
San Francisco Los Angeles

We Maintain a Termite Control Department

Architects . . .

S a f e g u a r d
y o u r b u i l d i n g s
a g a i n s t d e c a y
o r t e r m i t e
a t t a c k b y
s p e c i f y i n g

**WOLMANIZED or CREOSOTED
LUMBER and TIMBER**

E. K. WOOD LUMBER CO.

*"Goods of the Woods" is your guarantee for
Quality and Service*

NO. 1 DRUMM ST., SAN FRANCISCO

LOS ANGELES

OAKLAND

KRAMER

FLUSH VALVES

● ARE INSTALLED IN THE
● GEORGE WASHINGTON HIGH SCHOOL

J. R. MILLER & T. L. PFLUEGER
A R C H I T E C T S

Simplicity of Construction
for Positive Performance
and Low Maintenance



● THE
LEADER
ON THE
PACIFIC COAST

●
DALMO SALES CORPORATION

CONCRETE

By F. W. Reynolds

Assistant Director of Procurement, Washington, D.C.

CONCRETE, as we know it today, is a vastly superior product to that produced 35 to 40 years ago. Commencing about 1900, great steps have been made, not only in the theories of concrete mix, but in improvement of cements. In this earlier period, concrete was mixed very dry and tamped into place. Little was known at that time of the theory of water-cement ratio and scientific methods of designing concrete mixes, since adopted. This dry-mix period was followed with a concrete deluged with water, the chief consideration being given to placing only.

The theories of concrete mixes were not well established and the preparations were generally indicated in abstract amounts. One of the methods that found wide acceptance was to determine the volume of voids in the coarse aggregate by means of immersion in water, and add to it an amount of sand equal to these voids, plus 10%. The combined aggregate was then analyzed for voids, and sufficient cement was added to fill these voids, plus 10%. This method produced generally a fair concrete when the aggregates were properly graded. The amount of water to be added was considered of no great importance, except that enough water was added to make the concrete workable, but not too sloppy. Tests on concrete cylinders, however, showed a wide range of results, and indicated the necessity of extensive tests to determine what makes concrete good concrete. At the same time, research was being carried forward in the production of cements to provide finer grinding and greater uniformity of product.

The results of studies by various investigators finally developed the theory of water-cement ratio as we know it today. This theory presupposes that the strength of the concrete mass is dependent upon the richness of the cement paste, which latter, of course, is a mixture of cement and water. The richness of the cement paste has such a preponderant effect upon the strength of the concrete that, from a theoretical standpoint, any gradation of durable aggregates may be used so long as the workability is maintained. It is, therefore, possible to provide excellent concrete by using sand alone, or by using coarse aggregate alone; and we can even go so far as to say that the coarse aggregate may be of one size. From the viewpoint of economics, however, the use of aggregates as just described would be ruinous to the concrete industry as so little of the coarse aggregate could be used and still retain workability of concrete.

This, therefore, brings us to the question of the selection of combined aggregate to produce maximum economy. These aggregates should be properly graded from the smallest to the largest particles, and the nearer they approach a thoroughly correct gradation, the less the cost with equal strength of the

concrete. The point in this discussion, however, is that the richness of the paste, or the proportion of water to cement, assuring workability, determines the strength of the concrete.

Moving forward on the premise that a minimum of water produces maximum strength, various methods have been studied to develop equipment whereby drier mixes may be placed. As a result, various forms of mechanical vibrators have been developed. It is not possible in hand placed concrete, where the concrete sections are thin and there is a high percentage of reinforcement, to pour concrete with a slump of much less than 4". It has been found, however, that by the use of internal vibrators concrete having a slump as low as 1½" can be properly placed. This means that with equal amounts of cement and coarse aggregate, and decreased water, the resulting concrete is very much stronger than with the 4" slump concrete. If it is determined that the cement-water ratio in the hand placed concrete produces sufficient strength, cement may be saved if the vibration methods are employed.

Another development of importance in the making of concrete has been the introduction of equipment to weigh rather than measure the aggregates for each batch. The weighing of aggregates undoubtedly produces a more uniform concrete. Where measurement is permitted (especially wheelbarrow measurement) the tendency is to overload the wheelbarrows in the early part of the day, and to gradually lighten the loads in the latter part of the day when the men are tired. This can be overcome, of course, by inspection, but requires an inspector to be constantly at the mixer in order to get the proper results. One of the difficulties with measurement of aggregates is the determination of the bulking of sand with different proportions of water content. Sand is known to bulk as much as 30%, when wet, over dry-rodded material, but this high factor is not usually recognized. The result is that if the sand is decidedly moist, especially after a heavy rain, and the inspector does not immediately change to the proper amounts of sand, the mixture is under-sanded. This results not only in decreased strength of the concrete, but also increased cost to the contractor. For various reasons stated above, most contractors today who have had experience with weighing of aggregates prefer that method over volume measurements; and certainly all engineers with field experience prefer measurement by weight.

In the manufacture of concrete, too little attention is given in the specifications, and on the work, to the proper construction of forms. This applies particularly to architectural concrete. On all exposed work it should be a part of the specifications that the joints of the form lining should be truly horizontal and truly vertical and without quilt-work patching. It is impossible to completely cover up these joint marks



HOUSE OF NEW IDEAS

Sponsored by Woman's Home Companion

H. Roy Kelley, Architect

equipped with

PAYNE

WINTER AIR CONDITIONER

Designed for comfortable living it seemed only natural that a Payne Winter Air Conditioner should be selected in National Competition for the Modern California HOUSE OF NEW IDEAS in Westwood, California. Specifications for the completely modern home of today should include Payne Winter Air Conditioning.

PAYNE FURNACE & SUPPLY COMPANY

338 No. Foothill Road . . . Beverly Hills, California

Stanley Ball Bearing Hinges

FOR smooth, trouble-free operation of doors for the life of the building.

You will find our "Architect's Manual of Stanley Hardware" very useful in making up hardware specifications. Send for a copy.

THE STANLEY WORKS
New Britain, Conn.

SAN FRANCISCO
576 Monadnock Bldg.
LOS ANGELES
407 American Bank Bldg.
SEATTLE
619 Mutual Life Bldg.

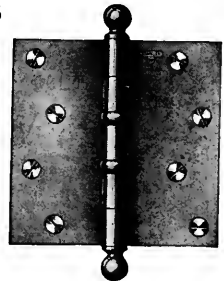

BAXCO
Pressure Creosoted Lumber
FOR TERMITE AND DECAY PROOF
BUILDING CONSTRUCTION
CREOSOTED AND UNTREATED
PILING

Exclusive Sales Agents in California for
WEST COAST WOOD PRESERVING CO.
 Seattle, Wash.

J. H. BAXTER & CO.
 333 Montgomery St. San Francisco
 601 West Fifth St. Los Angeles

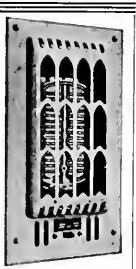

APEX
AIR ELECTRIC WATER
HEATERS

Send for Architect's Catalogue
 Bathroom Heaters in the Standard
 Colors, 1000 to 2500 Watts
 \$14.00 to \$27.50

APEX MANUFACTURING CO.
 1501 Powell Street
 Emeryville, Oakland, Calif.

Distributors
 Sandoval Sales Co.
 Phone KEarny 7010
 557 Market Street, San Francisco, Calif.
 Apex Sales Co.
 1855 Industrial Street, Los Angeles, Calif.
 Phone MUtual 9141



Product of
CALIFORNIA SHADE CLOTH CO.
 210 Bayshore Blvd., San Francisco
 Manufacturers of
QUALITY HAND MADE SHADE CLOTH
IN ALL GRADES

Wholesale Distributors
SLOANE-BLABON LINOLEUM
AMBASSADOR VENETIAN BLINDS

STRUCTURAL STEEL

For Class A Buildings,
 Bridges, etc.

JUDSON PACIFIC CO.

609 MISSION STREET
 SAN FRANCISCO

Plants: San Francisco - Oakland

in concrete without excessive rubbing of the concrete. This should be considered architecturally. This indicates the wisdom of showing on the drawings where the joint should come with respect to windows, doors, etc. Another matter in form work which is not given sufficient consideration is the location and method of forming construction joints. These should, likewise, be truly horizontal and truly vertical, and their location carefully predetermined. This is often neglected on building construction. The drawings should show the manner of making these construction joints. A good method for horizontal joints is to tack a 1" to 2" strip on the exposed face of the concrete, and state in the specifications that the concrete is to be poured approximately 1" above the bottom of the strip. At the expiration of approximately an hour the surface of the concrete should be worked to bring the concrete back up over the bottom of the strip and all concrete above that point be removed in preparation for the next pour.

Decided progress, as previously mentioned, has been made in the manufacture of better cements. Considerable attention has been given recently to the manufacture of a Puzzolan Portland cement. It is generally recognized that concretes exposed to extreme sulphate and alkaline conditions have not proven entirely satisfactory. Experience in foreign countries has demonstrated the value of Puzzolan cements under these conditions, and laboratory tests now being made in this country are showing very promising results. The Procurement Division has under consideration a specification designed specifically to meet extreme adverse sulphate conditions.—
Federal Architect.

JOBS FOR COLLEGE MEN

College graduates looking for "jobs" should fare better this year.

Such is the conclusion reached by Miss Vera Christie, head of the University of California Bureau of Occupation, an organization that probably places more college students and graduates in contact with prospective employers than any other like body in the country.

Miss Christie finds, "a 100 per cent increase for full-time graduate positions in the last six months, indicating that business conditions have obviously picked up." Furthermore, she notes that representatives from eastern concerns who have not interviewed senior students for approximately five years, are again in correspondence with the Bureau and planning to select seniors for training.

The Bureau of Occupations places self-supporting students in part-time work during the semester and attempts to find full-time employment for them during the summer.

SUSPENSION OF LICENSE UPHELD

Another victory for the State Contractors' License law in the appellate division of the Supreme Court, which upheld a departmental decision handed down over two years ago, suspending the license of Philip Karz of Los Angeles.

The decision of the registrar was set aside in the Superior Court of Los Angeles county by Judge Emmet H. Wilson in February, 1934. The reversal was carried to the higher court with Eugene M. Elson, deputy attorney general, representing the department. After more than two years the appellate court has reversed the judgment of the superior court in a decision which is a complete victory for the state department.

"I am highly gratified," Retired State Registrar of Contractors Wm. G. Bonelli stated. "Our record as to reversals is, in my opinion, rather remarkable, due to the fact that the Contractors' License Bureau probably takes punitive action against more licentiates than any other similar body in the state of California. Our reversals to date can be numbered upon the fingers of one hand, with space left over. I believe this case and our general record prove conclusively that our method of procedure in complaint cases is soundly conceived and carried out by a well qualified personnel. In view of the Karz decision, the department feels very confident it may expect splendid support from the higher courts as long as we continue to proceed in our established manner."

The new State Registrar of Contractors is Earl S. Anderson of Los Angeles.

PROPOSE COURT HOUSE COMPETITION

Open competition between architects in Los Angeles County will govern the selection of the architect to design the proposed new \$6,000,000 County Court-house in the Civic Center, it has been decided by the Board of Supervisors, according to a press dispatch.

Preliminary to the beginning of the competition, which is expected to be conducted in accord with a general plan recommended by the American Institute of Architects, county officials are now gathering data upon which the contest will be predicated.

"Whether we get an honestly constructed edifice and whether we obtain truly competitive bidding depends so much on getting the right type of architect, one fully qualified for his job in every sense of the word and above political influence, that a fair competition is the best way of selecting the architect," the board members were told by Supervisor John Anson Ford, who proposed the competitive method of selection.

IN LARGER QUARTERS

William J. Bain, Seattle architect, and his associate, Ivan W. Meyer, recently moved their architectural studio from 704 to 314 Textile Tower in order to get more space to handle increased practice.

SAN JOSE AUDITORIUM

A municipal improvement outstanding for its splendid design and construction.

Binder & Curtiss,
Architects

Completely illustrated in The
Architect and Engineer for May.

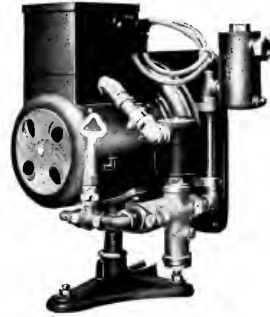

*The luxury of efficiency
at the price of economy!*

JOHNSON Oil Burners . . . all of them . . . are famed for efficiency, for economical operation. Here, for smaller homes, is the Johnson Type B, low in first cost as well as in cost of operation. Available in various models according to radiation required up to 1385 square feet and for either gravity or pump feed, it represents a recommendation that can be made with the same confidence felt in commending any Johnson burner to the home-owner.

S. T. JOHNSON CO.

940 Arlington Street

Oakland, California

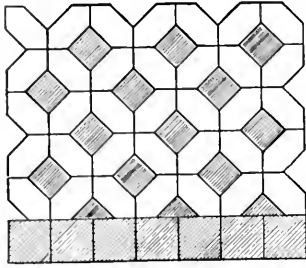

POMONA TILES

FOR

**Bathrooms and Kitchens
in over 60 colors**

Warehouses and Display Rooms

135 Tenth St. . . . San Francisco
629-33 North La Brea Ave.
Los Angeles
6106 Roosevelt Way . . . Seattle

POMONA TILE MFG. CO.
PLANT—POMONA, CALIF.

THE

BUILDING MATERIAL EXHIBIT

• •

LOS ANGELES

We offer a complete service to Architects and Engineers with information on manufacturers' representatives and details of materials.

FIFTH at FIGUEROA
M U t u a l 6 3 0 6

WARNS AGAINST "JERRY BUILDER"

"Jerry Builders", the racketeers of the construction industry, have again become active with the upturn in residence building.

Aroused by reports from various sections of the country to the effect that there has been a recent increase in the use of poor materials and inferior home construction methods by some few unscrupulous builders, the Federal Housing Administration has issued warnings to all persons using the Modernization Credit Plan or the Mutual Mortgage Insurance Plan to "give careful scrutiny to all bids for work submitted to them by contractors and builders".

The bait is an exceedingly low bid against which the legitimate contractor has little or no defense. Such low bids are made possible by evasion of the statutory obligation that the contractor carry compensation insurance and by use of inferior materials where the specifications call for products of good quality.

It is pointed out that the Federal Housing Administration has set up certain well defined standards as one of its requirements for mortgage insurance, one condition of which is that no materials of an inferior quality be used.

The average person is unfamiliar with construction problems and therefore may be an easy victim when he gets a bid much lower than others submitted to him and lower than he expected.

All persons are warned to be careful in signing contracts for either repairs or new homes. If they go ahead with an incompetent or dishonest builder they may expect poor materials and workmanship from which they will suffer material loss within a few years. One of the best safeguards is to demand proof of a contractor that he carries compensation insurance.

Among the properties thrown back on mortgages during the depression have been hundreds which were not worth the price of the mortgage because the work had been shoddy and dishonestly done. This has

SISALKRAFT

REG. U. S. PAT. OFF.

"More than a
building paper"

THE SISALKRAFT CO.

205 West Wacker Drive
(Canal Station) Chicago, Ill.
55 New Montgomery Street
San Francisco, Calif.

F. A. THOMAS CO., INC.

47 Second Street
San Francisco, California

Distributors

Holtzer-Cabot Electric Company
Boston, Massachusetts

•
Electric Clock Systems
Fire Alarm Systems
Telephone Systems
Bank Signal Equipment
Hospital Signal Systems
Experimental Laboratory Panels
Bells - Buzzers - Horns

ESTIMATES FURNISHED

borne heavily on the owners because it has prevented them from getting back any portion of their equity.

Among the glaring faults of "jerry building" which sooner or later necessitate expensive repairs, is the poorly constructed foundation, which on settling cause plaster walls and ceilings to crack. When natural drainage is disregarded in the placing of the house, and the foundation walls are not protected by drain tile, basements become unduly damp and to some extent cause structural difficulties.

Never should masonry walls of any description or chimneys rest on wood framing. This has been the cause of many masonry troubles, as the wood shrinks and pulls away from the masonry and, consequently, the walls settle and become fractured. Chimneys do the same, producing a fire hazard.

The use of green lumber is another factor that becomes the cause of later expense. The fault caused by the shrinkage of lumber cannot later be cured by good craftsmanship or design.

THE ARCHITECT AND ENGINEER

White Brothers

Hardwood Headquarters

LUMBER
FLOORING
VENEERS
PANELS

5TH AND BRANNAN . . . SAN FRANCISCO
500 HIGH STREET OAKLAND

LIGHTING FIXTURES

GEORGE WASHINGTON
HIGH SCHOOL

MILLER & PFLUEGER, ARCHITECTS

by

ALFRED J.
CASELLA

1507 SUTTER STREET
SAN FRANCISCO

Poorly applied paint is another sin of the "jerry builder". Often damp surfaces have been painted or the work has been done in the dead of winter. Both practices necessitate a new paint job a few months later.

Inadequately designed houses with trick angles and chopped-up roofs add a hazard that should be avoided as the broken roof lines produce valleys, saddles, and pockets in which water or snow collect, thereby causing expensive maintenance.

In New York State the Department of Labor and the Attorney General's office in Albany have requested aid of the Federal Housing Administration in that state in stamping out unscrupulous practices in the building field.

ART GALLERY ARCHITECT

John Russell Pope, New York architect, has been selected to plan the building of the National Gallery of Art in Washington, which will house the paintings given to the nation by Andrew W. Mellon.

WORLD'S LARGEST SIGN

Picture a ten-story building one block long and you get some idea of the biggest sign in the world which flashed across Times Square for the first time on the evening of March 28. The mammoth spectacular, representing a million-dollar investment of the Wm. Wrigley Jr. Company, follows their record-breaking display atop the old Putnam Building, which dominated Times Square from 1917 to 1924.

The new site is a commanding one, occupying the entire block on Broadway from 44th to 45th Street on the east side of Times Square, where hundreds of thousands throng the sidewalks of the heart of New York, and where daily more people pass through one subway station than actually reside in Toledo or Dayton. The height from the sidewalks to the top of the structure exceeds the height of the Statue of Liberty.

This massive spectacular which will illuminate Broadway with a skyscraper of color, is a bold departure in advertising technique. In direct contrast to the other quick-flashing, eye-jerking electric signs, to the hurrying crowds and the speeding traffic, the Wrigley display is keyed to a slow-motion tempo. Gigantic multi-colored fish, largest of which measures 42 feet in length, appear to glide about among rhythmic waves of sea green light, in gentle, unhurried movement. Bubbles rise lazily to the top of the sign. And to complete the soothing psychological effect is the message "Steadies the Nerves." In the center of this electrical sea, perched on a package of Spearmint bigger than a box-car, the traditional "Spearman" dominates the scene.

Behind the scenes, animating the tropical display which is spread across a spider-web of steel, are intricate flashing mechanisms rivaling the ingenuity of stage lighting devices, and of a magnitude never before attempted in an outdoor electrical picture. The electric current



PACIFIC Gas Heating Appliances

- ⊙ Circulator Heaters
- ⊙ Radiant Wall Heaters
- ⊙ Gas Steam Radiators
- ⊙ Floor Furnaces
- ⊙ Gravity Furnaces
- ⊙ Blower Furnaces
- ⊙ Unit Heaters
- ⊙ Forced Air Units
- ⊙ Water Heaters

Write for Catalog No. AE-3

PACIFIC GAS
RADIATOR CO.

Huntington Park, California,
U. S. A.



Make the old stucco colorful and water tight by applying one or more coats of

BAY STATE Brick and Cement Coating

Manufactured by a company whose products have been on the market for over half a century.



Distributors

CALIFORNIA SALES
COMPANY, INC.

444 MARKET STREET
SAN FRANCISCO

IT'S HERE!

Perfected
by
ELECTRIC HEATING
WESIX



BEFORE YOU INSTALL
ANY HEATING SYSTEM

... ask us about WESIX *automatic* electric heaters—proven in thousands of installations in homes, buildings, hospitals, schools—even entire cities! WESIX patented *double-action* principle of *circulating* and *radiating* provides quick, efficient, economical heat. You know it's *healthful*. NO FANS to stir up breeze and drafts—no moving parts

WESIX ELECTRIC HEATER CO.
380 First Street San Francisco

**Melrose Lumber
& Supply Co.**

LUMBER AND
MILL WORK

46th Ave. and E. 12th St.
Oakland
Phones: FRuitvale 0240 — 0251

**JOSEPH MUSTO
SONS-KEENAN
COMPANY**

MARBLE
and
ONYX

535 NORTH POINT STREET
SAN FRANCISCO
1801 S. SOTO STREET
LOS ANGELES

required would serve all the needs of a city of ten thousand, while the annual wattage consumed is sufficient to operate all the radios in the United States for a period of two hours. To give some idea of the size of the figures, it has been estimated that if a six-foot man were enlarged in the same proportion as the smallest fish on the sign, the 86th story of the Empire State Building would barely reach his shoulders.

The sign contains 1,084 feet of neon tubing and almost seventy miles of insulated wire, enough neon to put the red stripes in an American flag running the entire breadth of between the cities of Washington and Baltimore. Some 29,508 lamp receptacles are used, which, if stacked end to end, would make six piles the height of the Eiffel tower. Eight tons of galvanized sheet metal are used in the sign proper, and the total weight of the sign is 110 tons. Housed in the specially built control-room, which compares in area to the size of a 3-room city apartment, are seven and a half tons of electrical apparatus and equipment.

Dorothy Shepard, young California artist, created the design for this novel spectacular.

OHIO STATEHOUSE

Musty plans which have lain hidden nearly 100 years shows that Ohio's statehouse was not completed according to the architect's design.

The Capitol dome, dubbed the "cheesebox" by some, should have been surrounded by fluted Doric columns of stone, and the west side of the building should have had a double row of stone columns instead of one.

John Schooley, state architect who took possession of the crumpled plans found in the statehouse basement by a carpenter, could only guess at the reason for not completing the building according to design. He said that construction was interrupted several times and added the legislature probably got tired of

P. F. REILLY

*Building
Contractor
and Manager of
Construction*

730 ELLIS STREET
San Francisco
UN DERHILL 5829

MARBLE
AMERICAN MARBLE
COMPANY



P. O. Box 578
South San Francisco, Calif.
Phones: SUTter 2840
South City 161

**ANDERSON
&
RINGROSE**

General Contractors

320 Market Street, San Francisco
Phone GARfield 2245

MURALS

for Hotel Cocktail Rooms,
Theaters, etc.

**HEINSBERGEN
DECORATING CO.**

7415 Beverly Boulevard, Los Angeles
401 Russ Building, San Francisco

Pacific Manufacturing Company

High Class Interior Finish
Quality Millwork

454 Montgomery St. 641 Merrill Ave.
San Francisco Los Angeles
GARfield 7755 AXridge 9011

1315 Seventh Street, Oakland
GLenroust 7850

Smith

Lumber Company

WHOLESALE - JOBBING - RETAIL
FACTORY AND BUILDING LUMBER
PLYWOODS - ROOFING
DISTRIBUTING YARDS

San Francisco	Oakland
•	19th Ave. &
4th & Channel	Estuary
MArket 0103	FRuitvale 3174

YOUR INQUIRIES SOLICITED

DUNNE'S

SASH & TRIM COLORS

are the Nth Degree in
Color Permanence so des-
irable when color is nec-
essary to set off a particu-
lar style of architecture.

FRANK W. DUNNE CO.
41st and Linden
Oakland

TRANSIT-MIX CONCRETE

A Perfect Blend
Material

Golden Gate Atlas
Materials Co.

Sixteenth and Harrison Streets
San Francisco
Phone HEmlock 7020

the tinkering with its place of busi-
ness and adopted a resolution de-
claring the building completed.

The plans were so mutilated that
Schooley is having them restored.
Then they will be placed on exhibi-
tion in the Columbus Gallery of Fine
Arts before being stored permanent-
ly in a fire-proof filing cabinet.

AMERICAN ACADEMY IN ROME

The Alumni Association of the
American Academy in Rome has an-
nounced the winners of prizes and
medals in the annual collaborative
competition for students of architec-
ture, landscape architecture, paint-
ing, and sculpture. The First prize
of \$300 was awarded to a team from
The College of Architecture, Corn-
ell University, of which the mem-
bers were B. J. Rabe, architect;
A. Briggs, painter; J. C. Lawrence,
sculptor; and R. S. Kitchen, land-
scape architect. The Second prize
of \$150 was won by a University of
Pennsylvania team in collaboration
with the Pennsylvania Academy of
Fine Arts—W. S. Allen, architect;
Mary Louise Lawsen, painter; Kath-
erine Blackman, sculptor; Katrina
Haines, landscape architect. The
Third prize of \$75 went to a Yale
University team, A. N. Daniel, archi-
tect; M. Lauretano, painter; G. Ka-
trina, sculptor.

Medals were also awarded to
teams from several schools, and
criticisms of each design were re-
corded at the judgment to be sent
to the competitors.

The problem was "A Community
Recreation Center for a Town of
about Twelve Thousand People."

MONSON BROS.

•
General
Contractors
•

475 SIXTH STREET
San Francisco
DOuglas 1101

Alumilite

by

Kawneer

•

Store Fronts - Windows

and

Architectural Castings

in

Polished Satin

or

Anodic Finish

THE

Kawneer

COMPANY
OF CALIFORNIA
BERKELEY

"BROWNSKIN"

RESILIENT WATERPROOF
BUILDING PAPER

THE BUILDING PAPER WITH
A FACTOR OF SAFETY

Angier Corporation

Framingham, Mass.

PACIFIC COAST DIVISION
564 HOWARD STREET
SAN FRANCISCO

DOuglas 4416
350 South Anderson St.
Los Angeles

LUXOR

WINDOW SHADES

Translucent Shading
of highest count
cambric

William Volker & Co.

631 Howard Street
San Francisco



Pump Governors	Oil Heaters
Safety Pump Governors	Relief Valves
Automatic Gas Regulating Valves	Oil-Burner Governors
Gas Burners	Little Giant Improved Oil Burners
Gas Burning Equipment	Oil Pumping Sets
Vacuum Pump Governors	Oil Valves
Vacuum Regulating Valves	Oil Strainers
Continuous Flow Steam Traps	Steam Oil Strainers
Thermostats	Duplex Oil Pumps
Reducing Valves	Rotary Oil Pumps
Boiler Feed-Water Regulators	Boiler Feed Pumps
	Water Heaters
	Oil Meters

VAUGHN-G. E. WITT Co.
ENGINEERS

C. W. Vaughn, President and Manager

MANUFACTURERS AND DISTRIBUTORS

4224-28 Hollis St. Phone Olympic 6084
Emeryville, Oakland, Calif.

CONSTRUCTION LEAGUE MEETING

Alex. Linn Trout, architect of Detroit, recently attended the fifth annual assembly of the Construction League of the United States at Washington, D.C. The meeting was composed of delegates from the various organizations of the League and its state representatives. His report, printed in the Bulletin of the Michigan Society of Architects, gives an intelligent review of the activities of the League:

"The League has more to its credit than is generally realized. Much of its work has been propaganda, and much of its effort has been a quiet but powerful backing of the work of its constituent organizations. The American Institute of Architects and the American Society of Civil Engineers have provided most of the individual leaders, but there has been able support from the Associated General Contractors, the Producer's Council, and the various sub-contracting organizations comprising the League; not forgetting the American Road Builders' Association and related interests.

"The success of the organization has not been due to heavy budget expenditures. In fact, we feel that some more systematic contribution must be forthcoming if the construction industry is to extend its gains. Heavier financial support not only to the Construction League, but to all our business and professional groups, must be worked out if professional standings and private business is to be maintained.

"Apparently many who have benefited do not realize how much effort has been made to hold the ground already gained. The early slogan that work relief is better than idleness has been generally accepted, and the handling of construction work through organized business channels has made considerable progress.

"The question of further Federal aid for housing was debated briefly, and a housing committee was appointed. A prominent administrative leader, speaking off the record,

FORDERER Cornice Works

Manufacturers of
Hollow Metal Products
Interior Metal Trim
Elevator Fronts and Cabs
Metal Wall Plugs, Anchors, Etc.
Sheet Metal Products
Sanitary Metal Base
Commercial Refrigerators
Building Paper
Metal and Wire Accessories for Concrete
269 POTRERO AVENUE
San Francisco, Calif.
HEMLOCK 4100
CONSULT OUR ENGINEERING DEPARTMENT

MacDonald & Kahn

General Contractors



Financial Center Bldg.
405 Montgomery St.
San Francisco

Robert W. Hunt Company
ENGINEERS

Inspection - Tests - Consultation
Schools and Other Structures
Are Built as Designed

When Construction Materials are Inspected at point of Manufacture and during Erection by

ROBERT W. HUNT COMPANY

Cement, Concrete, Chemical, Metallurgical, X-Ray and Physical Laboratories

Chicago - New York - Pittsburgh
Los Angeles - All Large Cities
San Francisco, 251 Kearny Street

G. P. W. JENSEN & SON

Building Construction

320 Market Street, San Francisco
Phone 2444

THE TORMEY COMPANY

GENERAL PAINTERS
AND DECORATORS

Phone UNDERhill 1913

563 FULTON STREET
San Francisco

CRANE

High Class Plumbing Fixtures



ALL PRINCIPAL COAST CITIES

Bethlehem Steel Company

General Offices:  Bethlehem, Pa.

STEEL BRIDGES and BUILDINGS

San Francisco
20th and Illinois Sts.

Seattle
W. Anderson Street

Portland
American Bank Bldg.

Los Angeles
Stauson Ave.

Salt Lake City
Kearns Bldg.

Honolulu, T. H.
Schuman Bldg.

MULLEN MFG. COMPANY

BANK, STORE AND OFFICE
FIXTURES—CABINET WORK
OF GUARANTEED QUALITY
CHURCH SEATING

Office and Factory:
60-80 RAUSCH ST., Bet. 7th and 8th Sts.
San Francisco
Telephone UNDERhill 5815

COMMON BRICK

If you like good brick and good service, phone us for information, you will find that it always pays to be our patron.

Remillard-Dandini Co.

Phone TEmplebar 8133
Office, 569 - 3rd Street, Oakland
Plants
San Jose Pleasanton Greenbrae

DINWIDDIE CONSTRUCTION COMPANY

BUILDERS OF
GOOD BUILDINGS

CROCKER BUILDING
SAN FRANCISCO

predicted that further Federal funds would not be forthcoming for this purpose because of the necessity of balancing the budget. A further study of the recently published report of the housing committee of the United States Chamber of Commerce was suggested.

"To the writer, the most interesting part of the meeting came through the comments of individuals of the present situation. It was freely expressed that some sort of zoning would be inevitable as a result of the Federal Housing Administration's insurance requirements. Whatever the political attitude of those discussing the situation, there was unanimous agreement that the procedures worked out by that body were most progressive and worthy of study and support.

"Financial surveys and more systematic mortgage investigation seem to be the order of the day. The Mutual Savings Banks of New York are making this type of city planning survey and extending loans similar to FHA requirements, but without the insurance. The various insurance companies are giving the matters of neighborhood and city planning most careful thought. Their real estate holdings are enormous and they do not want to be stung again.

"Out of the chaos of the past five years, things seem to be shaping up. When we consider the tremendous accomplishments of Europe in the housing field, and the splendid architectural leadership which characterizes the movement, there certainly seems to be an unlimited field of opportunity for the coordination of the political, social, and financial requirements that will set up the stage for activity in our own country and state. There seems to be abundant opportunity for the type of cooperative effort that is possible through such organizations as the state and national Construction Leagues."

LOT SALES INCREASE

Of 20 western and southwestern cities, 16 report sharp increases in sales of residential lots already this year, with special activity in Oklahoma City, Tulsa, Dallas, Houston, Fort Worth, San Francisco, Beverly Hills, Cal., Spokane, and Seattle.

San Francisco Bay Bridge

Contracts Completed

U. S. Marine Hospital
Ford Assembly Plants,
Seattle, Long Beach and
Richmond
Oakland Approach to
Bay Bridge

Contracts Awarded

U. S. Mint, San Francisco
Administration Building and
To!! Plaza, Bay Bridge,
Oakland

Clinton Construction Co.

of California
923 Folsom Street
San Francisco
SUtter 3440

Specify DICKEY CLAY PRODUCTS

Dickey Mastertile	Face Brick
Partition Tile	Fire Brick
Drain Tile	Paving Brick
Fireproofing Tile	Wall Coping
Floor Tile	Flue Lining
Common Brick	Dickey Flashing Blocks

W. S. DICKEY CLAY MFG. COMPANY

116 New Montgomery St.,
San Francisco, Calif.
105 Jackson St., Oakland, Calif.

REPUBLIC STEEL CORPORATION



Manufacturers of

ENDURO Stainless Steel; TON-
CAN Copper Molybdenum Iron
Sheets and Pipe; and Steel Pipe,
Sheets and Reinforcing Bar for
every building purpose.

Write for information

Rialto Building, San Francisco, Calif.
Edison Building, Los Angeles, Calif.
White-Henry-Stuart Bldg., Seattle, Wash.

Our linoleum installation
in the new
**GEORGE WASHINGTON
HIGH SCHOOL**
San Francisco

MILLER & PFLUEGER, ARCHITECTS
is typical of the Quality Material and
Superior Service performed by

WEST COAST
LINOLEUM and CARPET
STORES

2703 MISSION STREET, SAN FRANCISCO

**Independent
Iron Works**

Structural Steel
Ornamental Iron
Steel Service Stations
Steel Tanks
Standard Steel Mill Buildings
Bridges

821 Pine Street Oakland

**JOHN
CASSARETTO**

—Since 1886—And Still Active—

Building Materials

READY MIX CONCRETE
ROCK - SAND - GRAVEL - LIME
CEMENT - PLASTER - MORTAR
METAL LATH - WOOD LATH
STUCCO - WIRE NETTING

Service Unexcelled

Bunkers
Sixth and Channel, San Francisco
Phones: GARfield 3176, GARfield 3177

Carl T. Doell Co.

**Plumbing
Heating**

Plumbing Contractor
Veterans Memorial Building
Oakland

467 21ST STREET
OAKLAND

Telephone GLencourt 8246

GOOD NEWS

Good news for the building industry and for prospective home builders in the low income brackets was contained in a recent announcement by Stewart McDonald, Federal Housing Administrator, of an arrangement made whereby the Reconstruction Finance Corporation Mortgage Company will purchase mortgages given for construction of new homes and insured by the Federal Housing Administration.

While financial institutions have heretofore found a ready market for insured mortgages, this arrangement is tantamount to the establishment of a national mortgage association or a mortgage discount bank and supplies to lending institutions an additional outlet for such of their insured mortgages as they wish to convert into cash.

One of the beneficial effects expected to result from this arrangement is that it will enable banks or other lending institutions to turn over several times the limited amount of money they are permitted to invest in mortgages. Particularly is this of advantage in localities and sections where the available funds for mortgage investment are limited.

COUNTRY PLANNING

C. A. McClure writes in the Planning News:

A practical example of planning on a county basis is the undertaking, sponsored by the Washington State Planning Council, of a careful study of a typical, going irrigation project, to determine its status in relation to the social and financial picture of the state, region, and nation. The Yakima Valley project in eastern Washington was chosen for such a study. The fact that Yakima County was active in planning and research was an element in making the selection. The Bureau of Reclamation and the Washington State College will cooperate in the survey, to determine what annual contribution this, as well as other going projects, makes to the wealth of the nation; what

their trade value is; what their return to the government has been, not only in repayment of funds advanced but by the creation of new wealth subject to federal income tax. The social, educational, physical, and financial status of persons on irrigation projects will also be analyzed in the study.

WORLD'S FAIR SITE

Work by four United States Army dredges in filling the 430 acre Yerba Buena Shoals' site for the 1939 World's Fair is progressing "ahead of schedule", according to Lt. Colonel J. A. Dorst, district engineer for the United States Army.

A total of 945,000 cubic yards of material have been deposited at the fill, representing nearly 6 per cent of the total required. The foundation of the south wall is now 60 per cent complete.

Pile driving to provide triangulation stations, range piles and shore connections for pipe lines, has been started under a contract awarded by the Army to Ben C. Gerwick, Inc.

**MONEL
METAL**

For the Modern Kitchen

Heaters, boilers, storage tanks, water softeners, cabinet tops, "Streamline" or "Straitline" Kitchen Sinks

See our display rooms, arranged for your convenience

**MODERN METAL
APPLIANCE CO.**
4238 Broadway Oakland, Calif.

**RICHMOND
TILE
CO**

3421 GEARY STREET
San Francisco
Telephone BAview 9187

TILE CONTRACT ON
Geo. Washington High School
Miller & Pflueger, Architects

Classified Advertising Announcements

All Firms are Listed by Pages, besides
being grouped according to Craft or Trade.
Star (*) indicates alternate months.

AIR CONDITIONING	
The Union Ice Company, 354 Pine Street, San Francisco.....	5
ARCHITECTURAL TERRA COTTA	
N. Clark & Sons, 116 Natoma Street, San Francisco.....	*
Gladding McBean & Co., 660 Market Street, San Francisco; 2901 Los Feliz Boulevard Los Angeles; 1500 First Avenue South, Seattle; 79 S. E. Taylor St., Portland; 22nd and Market Streets, Oakland; 1102 N. Monroe Street, Spokane; Vancouver, B. C.	*
BANKS	
Crocker First National Bank, Montgomery and Post Streets, San Francisco.....	2
BATHROOM HEATERS	
Wesix Electric Heater Company, 390 First Street, San Francisco; 631 San Julian Street, Los Angeles; 2008 Third Avenue, Seattle, Wash.	72
BRICK—FACE, COMMON, ETC.	
N. Clark & Sons, 116 Natoma Street, San Francisco.....	*
Gladding McBean & Co., 660 Market Street, San Francisco; 2901 Los Feliz Boulevard Los Angeles; 1500 First Avenue South, Seattle; 79 S. E. Taylor St., Portland; 22nd and Market Streets, Oakland; 1102 N. Monroe Street, Spokane; Vancouver, B. C.	*
W. S. Dickey Clay Mfg. Co., 116 New Montgomery Street, San Francisco; factory, Niles, Calif.; yards, 7th and Hooper Streets, San Francisco, and 105 Jackson Street, Oakland; Factory in Livermore	75
Remillard-Dardini Co., 569 Third Street, Oakland.....	75
BUILDERS HARDWARE	
The Stanley Works, New Britain, Conn.; Monadnock Bldg., San Francisco; Los Angeles and Seattle	67
BUILDING MATERIALS	
Building Material Exhibit, Architect's Building, Los Angeles.....	70
BUILDING PAPERS	
The Sisalkraft Company, 205 W. Wacker Drive, Chicago, Ill., and 55 New Montgomery Street, San Francisco	70
"Browskin," Angier Corporation, 370 Second Street, San Francisco	73
CEMENT	
Portland Cement Association, 564 Market Street, San Francisco; 616 West Fifth Street, Los Angeles; 146 West Fifth Street, Portland; 518 Exchange Building, Seattle	Back cover
"Golden Gate" and "Old Mission," manufactured by Pacific Portland Cement Co., 111 Sutter Street, San Francisco; Portland, Los Angeles and San Diego.....Second cover	
CEMENT TESTS—CHEMICAL ENGINEERS	
Robert W. Hunt Co., 251 Kearny Street, San Francisco.....	74
CEMENT—COLOR	
"Golden Gate Tan Cement," manufactured by Pacific Portland Cement Co., 111 Sutter Street, San Francisco; Portland, Los Angeles and San Diego	Second cover
W. S. Dickey Clay Mfg. Co., 116 New Montgomery Street, San Francisco	75
CEMENT PAINT	
General Paint Corporation, San Francisco, Los Angeles, Oakland, Portland and Seattle	64
California Sales Company, 444 Market Street, San Francisco.....	71
CONCRETE AGGREGATES	
Golden Gate Atlas Materials Company, Sixteenth and Harrison Streets, San Francisco	73
John Cassaretto, Sixth and Channel Streets, San Francisco	76
CONCRETE CURING & PROTECTION	
The Sisalkraft Company, 205 W. Wacker Drive, Chicago, Ill., and 55 New Montgomery Street, San Francisco	70
CONTRACTORS—GENERAL	
MacDonald & Kahn, Financial Center Bldg., San Francisco.....	74
Lindgren & Swinerton, Inc., Standard Oil Building, San Francisco	68
Dinwiddie Construction Co., Crocker Bldg., San Francisco.....	75
Clinton Construction Company, 923 Folsom Street, San Francisco.....	75
Anderson & Ringrose, 320 Market Street, San Francisco.....	72
NEW THIS MONTH	
Crocker First National Bank... 2	
Krafttile Company	2
Union Ice Company	5
Payne Furnace & Supply Co. 66	
Dalmo Sales Co.	6-66
Alfred J. Casella	71
F. A. Thomas Co., Inc.	70
West Coast Linoleum	76
Stanley Works	67
W. P. Fuller & Co.	3
Richmond Tile	76

	Page
CONTRACTORS—GENERAL	
G. P. W. Jensen, 320 Market Street, San Francisco.....	74
Monson Bros., 475 Sixth Street, San Francisco.....	78
P. F. Reilly, 730 Ellis Street, San Francisco.....	72
Wm. Martin & Son	79
DAMP-PROOFING & WATERPROOFING	
"Golden Gate Tan Plastic Waterproof Cement," manufactured by Pacific Portland Cement Co., 111 Sutter Street, San Francisco; Portland, Los Angeles and San Diego	Second page of cover
The Sisalkraft Company, 205 W. Wacker Drive, Chicago, Ill., and 55 New Montgomery Street, San Francisco	70
Bay State Brick & Cement Coating, sold by California Sales Company, 444 Market Street, San Francisco.....	71
DOORS—HOLLOW METAL	
Forderer Cornice Works, Potrero Avenue, San Francisco.....	74
Kawneer Mfg. Co., Eighth and Dwight Streets, Berkeley.....	73
DRAIN PIPE AND FITTINGS	
"Corrosion" Acid Proof, manufactured by Pacific Foundry Co., 3100 Nineteenth Street, San Francisco, end 470 E. Third Street, Los Angeles.....	64
DRINKING FOUNTAINS	
Haws Drinking Faucet Co., 1808 Harmon Street, Berkeley; American Seating Co., San Francisco, Los Angeles and Proenix.....	2
ENGINEERS—MECHANICAL	
Hunter & Hudson, 41 Sutter Street, San Francisco.....	78
ELECTRIC AIR AND WATER HEATERS	
Sandoval Sales Company, 557 Market Street, San Francisco.....	71
West Electric Heater Company, 390 First Street, San Francisco; 631 San Julian Street, Los Angeles; 2008 Third Avenue, Seattle, Wash.	72
ELECTRICAL ADVICE	
Pacific Coast Electrical Bureau, 447 Sutter Street, San Francisco, and 601 W. Fifth Street Los Angeles.....	63
ELEVATORS	
Pacific Elevator and Equipment Company, 45 Reusch Street, San Francisco.....	78
HOLLOW TILE AND BRICK FENCES	
W. S. Dickey Clay Mfg. Co., 116 New Montgomery Street, San Francisco	75
FIXTURES—BANK, OFFICE, STORE	
Mullen Manufacturing Co., 64 Rausch Street, San Francisco.....	75
Pacific Manufacturing Company, 454 Montgomery Street, San Francisco; 1315 Seventh Street, Oakland, Los Angeles and Santa Clara.....	73
GAS FUEL	
Pacific Gas Association, 447 Sutter Street, San Francisco.....	Third Cover
GAS BURNERS	
Vaughn-G. E. Witt Company, 4224-28 Hollis Street, Emeryville, Oakland.....	74
GAS VENTS	
Payne Furnace & Supply Co., Beverly Hills, California.....	76
GLASS	
W. P. Fuller & Co., 301 Mission Street, San Francisco. Branches and dealers throughout the West	*
Libbey-Owens-Ford Glass Co., Toledo, Ohio; 633 Rialto Bldg., San Francisco; 1212 Architects Bldg., Los Angeles; Mr. C. W. Holland, P. O. Box 3142, Seattle.....	2
Pittsburgh Plate Glass Company, Grant Building, Pittsburgh, Pa. W. P. Fuller & Co., Pacific Coast Distributors	*
HARDWARE	
The Stanley Works, Monadnock Building, San Francisco; American Bank Building, Los Angeles	67
HARDWOOD LUMBER	
White Bros., Fifth and Brannan Streets, San Francisco; 500 High Street, Oakland.....	71
HEATING—ELECTRIC	
Apex Air and Water Electric Heaters, Sandoval Sales Company, 557 Market Street, San Francisco.....	68
West Electric Heater Company, 390 First Street, San Francisco; 631 San Julian Street, Los Angeles; 2008 Third Avenue, Seattle, Wash.	72
HEATING EQUIPMENT	
Payne Furnace & Supply Co., Beverly Hills, California.....	67
Pacific Gas Radiator Co., 7615 Roseberry Ave., Huntington Park; Sales Office, H. C. Stoeckel, 557 Market Street, San Francisco.....	71
HEAT REGULATION	
Johnson Service Company, Milwaukee, represented on the Pacific Coast by the following branch offices: 814 Rialto Bldg., San Francisco; 153 West Avenue, 34, Los Angeles; 1312 N.W. Raleigh St., Portland, and 473 Coleman Bldg., Seattle	*
HOLLOW BUILDING TILE (Burned Clay)	
N. Clark & Sons, 116 Natome Street, San Francisco.....	*
Gladding, McBean & Co., 660 Market Street, San Francisco; 2901 Los Feliz Boulevard, Los Angeles; 1500 First Avenue South, Seattle; 79 S. E. Taylor Street, Portland; Twenty-second and Market Streets, Oakland; 1102 N. Monroe Street, Spokane; Vancouver, B. C.	*

Phone GAfield 1164

Hunter & Hudson

Consulting Engineers

**DESIGNERS OF HEATING
AIR CONDITIONING
VENTILATING AND WIRING
SYSTEMS, MECHANICAL
AND ELECTRICAL EQUIP-
MENT OF BUILDINGS**

41 SUTTER STREET
ROOM 710

San Francisco California

T R E E

"INSURANCE"
b y D A V E Y

DESTRUCTIVE forces threaten your investment in trees just the same as in other property. The need for "protection" is equally as great. While you can't insure the value in the ordinary sense, you can protect against severe losses and restoration bills by having Davey Tree Surgery keep them at par.

"A stitch in time saves nine." Regular Davey inspection nips in the bud the destructive forces that work unseen and often unsuspected.

Davey Tree Service includes pruning, cavity work, root-work, moving, bracing and washing. Phone or write for free inspection and estimate. You'll find the cost no higher than "taking a chance."

INSIST ON GENUINE



DAVEY

TREE

SURGERY CO., LTD.

SAN FRANCISCO

Russ Bldg.
SUTter 3377

LOS ANGELES

Story Bldg.
TUcker 1929

FRESNO: Mattei Bldg. Phone: 2-2817

Local phones in: Pasadena, Palo Alto, Oakland, San Rafael, Burlingame

SKILL . . KNOWLEDGE . . EXPERIENCE

**William Martin
& Son
Builders**

666 Mission Street
San Francisco
Telephone SUtter 6700
Evenings: GARfield 9456

ELEVATORS

**Pacific Elevator and
Equipment Company**

45 Rausch Street, San Francisco
HEmlock 4476

A. KNOWLES

*Contracting
Plasterer*

982 Bryant Street
San Francisco

UNderhill 4048

"The Only Pacific Coast Factory"

**THE HERMANN
SAFE COMPANY**

Manufacturers and Dealers

**FIRE AND BURGLAR PROOF
SAFES, VAULTS, SAFE
DEPOSIT BOXES**

**Howard & Main Sts.
San Francisco**

Telephone GARfield 3041

W. S. Dickey Clay Mfg. Co., 116 New Montgomery Street, San Francisco; factory, Niles, Calif.; yards, 7th and Hooper Streets, San Francisco, and 105 Jackson Street, Oakland	Page 75
INSPECTION AND TESTS	
Robert W. Hunt Co., 251 Kearny St., San Francisco.....	74
LACQUERS	
General Paint Corp., San Francisco, Los Angeles, Oakland, Portland, Seattle and Tulsa W. P. Fuller & Co., 301 Mission Street, San Francisco. Branches and dealers throughout the West	64 3
LINOLEUM	
Sloan-Blabon linoleum, sold by California Shade Cloth Co., 210 Bayshore Boulevard, San Francisco	70
LUMBER	
Pacific Mfg. Co., 454 Montgomery Street, San Francisco; 1315 Seventh Street, Oakland; Los Angeles and Santa Clara	73
Smith Lumber Company, Nineteenth Avenue and Estuary, Oakland.....	73
Melrose Lumber & Supply Co., Forty-sixth Avenue and E. Twelfth Street, Oakland.....	72
E. K. Wood Lumber Company, 4701 Santa Fe Avenue, Los Angeles; I Drumm Street, San Francisco; Frederick and King Streets, Oakland	66
MARBLE	
Joseph Musto Sons-Keenan Co., 535 N. Point Street, San Francisco.....	72
MILLWORK	
E. K. Wood Lumber Company, No. 1 Drumm Street, San Francisco, Oakland, Los Angeles	66
Melrose Lumber & Supply Company, Forty-sixth Avenue and E. Twelfth Street, Oakland Pacific Mfg. Co., 454 Montgomery Street, San Francisco; 1315 Seventh Street, Oakland; Los Angeles and Santa Clara	72 73
Smith Lumber Company, Nineteenth Avenue and Estuary, Oakland	73
MONEL METAL	
"Inco" brand, distributed on the Pacific Coast by the Pacific Foundry Company, Harrison and Eighteenth Streets, San Francisco, and Eagle Brass Foundry, Seattle Kitchen sinks, heaters, storage tanks—Modern Metal Appliance Company, 4238 Broadway, Oakland	64 76
MURALS	
Heinsbergen Decorating Co., Los Angeles and 401 Russ Building, San Francisco	72
OIL BURNERS	
S. T. Johnson Co., 585 Potrero Avenue, San Francisco; 940 Arlington Street, Oakland; 1729 Front Street, Sacramento, and 230 N. Sutter Street, Stockton	69
Vaughn-G. E. Witt Co., 4224-28 Hollis Street, Emeryville, Oakland.....	74
ONYX	
Joseph Musto Sons-Keenan Co., 535 No. Point Street, San Francisco.....	72
ORNAMENTAL IRON	
Independent Iron Works, 821 Pine Street, Oakland.....	76
PAINTS, OIL, LEAD	
W. P. Fuller & Co., 301 Mission Street, San Francisco. Branches and dealers throughout the West	3
Frank W. Dunne Co., 41st and Linden Streets, Oakland	73
General Paint Corp., San Francisco, Los Angeles, Oakland, Portland, Seattle and Tulsa	64
PAINTING, DECORATING, ETC.	
The Tormey Co., 563 Fulton Street, San Francisco.....	74
Heinsbergen Decorating Co., 401 Russ Building, San Francisco	72
PARTITIONS—MOVABLE OFFICE	
Pacific Mfg. Co., 454 Montgomery Street, San Francisco; 1315 Seventh Street, Oakland; factory at Santa Clara	73
W. S. Dickey Clay Mfg. Co., 116 New Montgomery Street, San Francisco	75
PILES—CREOSOTED WOOD	
J. H. Baxter & Co., 333 Montgomery Street, San Francisco and 601W Fifth Street, Los Angeles	68
PLASTER	
"Empire" and "Reno Hardware Plaster," manufactured by Pacific Portland Cement Co., 111 Sutter Street, San Francisco; Portland, Los Angeles and San Diego.....	Second cover
PLASTERING	
A. Knowles, 982 Bryant Street, San Francisco.....	79

	Page
PLATE GLASS	
Libbey-Owens-Ford Glass Co., Toledo, Ohio; 633 Rialto Bldo., San Francisco; 1212 Architects Bldg., Los Angeles; Mr. C. W. Holland, P. O. Box 3142, Seattle.....	*
PLUMBING CONTRACTORS AND MATERIALS	
Carl T. Doell Co., 467 Twenty-first Street, Oakland.....	76
Crane Co., all principal Coast cities.....	74
PRESSURE REGULATORS	
Vaughn-G. E. Witt Co., 4224-28 Hollis Street, Emeryville, Oakland.....	74
ROOF MATERIALS	
Gladding, McBean & Co., 660 Market Street, San Francisco; 2901 Los Feliz Boulevard, Los Angeles; 1500 First Avenue South, Seattle; 79 S. E. Taylor Street, Portland; Twenty-second and Market Streets, Oakland; 1102 N. Monroe Street, Spokane; Vancouver, B. C.	*
N. Clark & Sons, 112-116 Natoma Street, San Francisco; works, West Alameda.....	*
SAND, ROCK AND GRAVEL	
John Cassaretto, Sixth and Channel Streets, San Francisco	76
SHADE CLOTH	
California Shade Cloth Co., 210 Bayshore Boulevard, San Francisco.....	68
SHEET METAL WORK	
Forderer Cornice Works, Potrero Avenue, San Francisco.....	74
STANDARD STEEL BUILDINGS	
Independent Iron Works, 821 Pine Street, Oakland.....	76
STEEL—STAINLESS	
Republic Steel Corporation, Rialto Bldg., San Francisco; Edison Bldg., Los Angeles; White-Henry-Stuart Bldg., Seattle	75
STEEL, STRUCTURAL	
Independent Iron Works, 821 Pine Street, Oakland.....	76
Judson Pacific Company, C. F. Weber Bldg., Mission and Second Streets, San Francisco shops, San Francisco and Oakland	68
Pacific Coast Steel Corp.—See Bethlehem Steel Company, Twentieth and Illinois Streets, San Francisco; Slauson Avenue, Los Angeles; American Bank Building, Portland, Ore.; West Andover Street, Seattle, Wash.	75
STORE FIXTURES	
Mullen Mfg. Co., 60 Rausch Street, San Francisco.....	75
STORE FRONTS	
Kawneer Mfg. Co., Eighth and Dwight Streets, Berkeley.....	73
TEMPERATURE REGULATION	
Johnson Service Company, Milwaukee, represented on the Pacific Coast by the following branch offices: 814 Rialto Bldo., San Francisco; 153 West Avenue, 34, Los Angeles; 1312 N.W. Raleigh St., Portland, and 473 Coleman Bldg., Seattle	*
TERMITE CONTROL—WOOD PRESERVATIVE	
E. K. Wood Lumber Company, No. 1 Drumm Street, San Francisco; 4701 Santa Fe Ave., Los Angeles; Frederick and King Streets, Oakland.....	66
J. H. Baxter & Co., 333 Montgomery Street, San Francisco, and 601 W. Fifth Street, Los Angeles	68
American Lumber & Treating Company, Rialto Bldg., San Francisco; 1031 S. Broadway Los Angeles	2
TREE SURGERY	
Davey Tree Surgery Co., Ltd., Russ Building, San Francisco; Story Building, Los Angeles	78
TILE—DECORATIVE, ETC.	
Pomona Tile Mfg. Co., plant, Pomona, Cal.; Sales Rooms, 135 Tenth St., San Francisco; 217 S. La Brea Ave., Los Angeles; 6106 Roosevelt Way, Seattle.....	70
Gladding McBean & Co., 660 Market St., San Francisco; 2901 Los Feliz Boulevard, Los Angeles	*
VALVES	
Sloan Valve Co., manufacturers of Sloan flush valves, 4300 West Lake St., Chicago, Ill.	65
VAULT DOORS	
Hermann Safe Co., Howard and Main Streets, San Francisco	79
WATERPROOFING	
Bay State Brick & Cement Coating, California Sales Co., 444 Market Street, San Francisco	71
WINDOWS	
Kawneer Mfg. Co., Eighth and Dwight Streets, Berkeley.....	73
Dalmo Sales Co., San Francisco.....	6 and 66
WINDOW SHADES	
California Shade Cloth Co., 210 Bayshore Boulevard, San Francisco.....	68
Wm. Volker & Co., 631 Howard Street, San Francisco.....	73

UNREGISTERED ARCHITECTS

From "The Voice of the People" in the Detroit News

To the Editor: I am a prospective home builder. In searching for ideas, my wife and I visited several model homes open for inspection. We visited only houses built by reputable firms. Several years ago we had a bitter experience with one of these fly-by-night contractors, so this time we are going to be mighty careful. While inspecting a house recently a stranger approached and introduced himself as an architect. He gave us several good references and showed us specimens of his drawings. He wanted us to let him draw the plans for our home.

Once stung, twice shy; however, I looked up this man's references and found them to be worthless. I also discovered this man was not a duly registered architect. I am writing this letter to warn others, but I do wish some registered architect would explain why persons of this type are permitted to solicit business.

(Signed) Prospective Builder.

William D. Cuthbert, A.I.A., Detroit, volunteers the following answer:

"I read with interest and understanding a recent letter in The News headed 'Unregistered Architect', and shall try to make a worth-while reply. "The state law providing for the registration of architects requires that any person who represents himself to be an architect shall be duly registered. Probably the main reason why unregistered or unlicensed individuals in any of the professions at times ply their trade is because of a certain apathy and often lack of information on the part of the public.

"The various professional organizations welcome the receipt of accurate data as to violation of registration laws and will actively prosecute all such cases. Unfortunately, most organizations are not able to maintain any sort of investigating staff and must rely on their own members and on the public for such reports. A registered architect is stamped by the state as a technically competent person and is legally responsible for his action and advice."

THE ARCHITECT AND ENGINEER

SAN FRANCISCO
PUBLIC LIBRARY
PERIODICAL DEPT.



E SAN JOSE MUNICIPAL AUDITORIUM
NDER AND CURTIS, ARCHITECTS

MAY 1936

High and Dry for all time

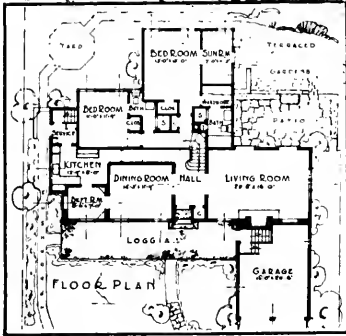

Home of Geo. M. Dufton under construction in hills back of Oakland.

WM. I. GARREN, A.I.A.,
Architect

J. R. ARMSTRONG, Oakland,
Contractor

"To assure smooth, dense concrete that will seal out moisture, Tan Plastic waterproof cement was specified and is being used in all the concrete work in this home. With both the heating plant and laundry in the basement, a watertight job was imperative. Tan Plastic is also specified for the stucco because of its pleasing color and moisture resistant qualities."

Wm. I. Garren.



for
STUCCO
•
POOLS
•
MONOLITHIC
CONCRETE
•
BASEMENTS
•
MORTAR
•
CAST STONE

You too should take the precaution to seal out moisture on your jobs with TAN PLASTIC. Rightly used, it will never disappoint.

THE ARCHITECT AND ENGINEER

FOR • MAY • 1936

presents

COVER	MUNICIPAL AUDITORIUM, SAN JOSE Binder and Curtis, Architects	
FRONTISPIECE .	GARDEN VIEW MUNICIPAL AUDITORIUM, SAN JOSE Binder and Curtis, Architects	
TEXT	SAN JOSE CIVIC AUDITORIUM	9
	Donald Powers Smith	
	SCHOOL UNDERGOES "FACE LIFTING"	27
	William T. Wright, S.E.	
	WELL-PLANNED MEDICO-DENTAL BUILDING	29
	AUSTRALIA SHOWS WAY TO MODERNISM	31
	EARTHQUAKES DESCRIBED BY STUDENT	33
	Byron Nishkian	
	67 YEAR OLD BUILDING MODERNIZED	35
	William I. Garren, Architect	
	PROGRESS IN DOMESTIC ARCHITECTURE	39
	Wills I. Bennett	
	DISTINGUISHED SAN FRANCISCO ARCHITECT GIVES HIS IMPRESSIONS OF INTERNATIONAL PROGRESS	43
	STRUCTURAL PEST CONTROL ACT	45
	Glen V. Slater	
	INSTITUTE CONVENTION WELL ATTENDED	49
	WITH THE ARCHITECTS	55
PLATES AND ILLUSTRATIONS—		
	SKETCHES BY DONALD P. SMITH	9-12
	SAN JOSE MUNICIPAL AUDITORIUM	10-26
	Binder and Curtis, Architects	
	Plans	Main Auditorium
	Details of Organ Screen	Montgomery Hall
	Exterior View	Auditorium Stage
	Exterior Loggias	Garden View
	Detail	Main Lobby
	ETCHING BY WILLIAM WOOLLETT	26
	FINE ARTS BUILDING, INGLEWOOD	28
	T. C. Kistner, Architect	
	MEDICO-DENTAL BUILDING, LOS ANGELES	30
	Gene Verge, Architect	
	McPHERSON'S BUILDING, MELBOURNE, AUSTRALIA	31
	Reid & Pearson, Architects	
	VICTORY THEATER BUILDING, SAN JOSE	35-37
	Wm. I. Garren, Architect	
	ARTHUR BROWN, JR., ARCHITECT	43

FREDERICK W. JONES
Editor

HOMER M. HADLEY
ROBERT DENNIS MURRAY
IRVING F. MORROW
L. H. NISHKIAN
A. A. BROWN

Contributing Editors

EDGAR N. KIERULFF
Advertising Manager

J. LESLIE MEEK

Published monthly by THE ARCHITECT AND ENGINEER, INC., 68 Post Street, San Francisco, California. W. J. L. Kierulff, President and Manager; Fred'k. W. Jones, Vice-President; L. B. Penhorwood, Secretary. Los Angeles office, 832 W. 5th Street. Subscriptions, United States and Pan-American, \$3.00 a year; single copy \$.50. Foreign countries, \$5.00 a year.

What's Going on
in

YOUR TREES

You take no chances on termites damaging your house—you insure against loss from fire—but what about your tree investment?

Destructive forces may be working in your trees right now—unseen and unsuspected. Why not find out?

A free Davey Tree inspection reveals true conditions and enables you to nip trouble in the bud and set corrective forces to work. Pruning, cavity work, root work, bracing, and washing.

It costs no more for genuine



SAN FRANCISCO Fresno LOS ANGELES
Russ Bldg. Mattel Bldg. Story Bldg.
SUtter 3377 Phone 2-2817 Tucker 1929

Local phones in: Pasadena, Palo Alto,
Oakland, San Rafael, Burlingame

Skill • Knowledge • Responsibility

PAYNE



The choice of discriminating buyers of Gas-Fired Heating and Air-Conditioning Equipment. A catalog showing complete Payne line sent upon request.



PAYNE FURNACE
& SUPPLY COMPANY
Beverly Hills California

Notes and Comments

Editor's Note—The important announcement to architects scheduled to be made this month has been delayed until the June issue.

HERR HITLER has turned to the architects for one of his latest reformations. You may not believe it but this fellow Hitler is opposed to modernism as applied to the design of buildings. He wishes to make German architecture distinctly characteristic of their national style. True, the modern trend got its start in Germany but today it has become so international that Hitler thinks its about time his country returned to traditional German forms.

As a result of his reactionary ideas two of Germany's leading exponents of modern design have been forced to leave the country and are now in London. They are Eric Mendelsohn, well known as one of the foremost protagonists of modernism and responsible for many outstanding structures in Germany, and Dr. Walter Gropius of Bauhaus fame. Although the latter was not forced to leave the country he found that he could no longer carry on his work at Bauhaus, which is a modern system of technical education, and be consistent with the reactionary ideals put forward by the present German administration.

* * *

THE ARCHITECTS of the new \$400,000 Civic Auditorium in San Jose are to be congratulated. It is one of the best things that has been done architecturally in that city in recent years. The building shows careful study of the needs of a growing community and capable handling in the development of a design at once dignified and beautiful. Mr. Curtis, the architect, was fortunate in having as his associate, Mr. Lotz, to whom was assigned the task of developing an ideal engineering layout.

* * *

RETURNING from a trip around the world, Emil Sodersteen, Australian architect recently submitted to an interview by the Editor of Building, who sought to gather Mr. Sodersteen's impressions of architectural development in countries other than his own.

Sweden impressed him as the outstanding country in modern architectural design.

Not only was he delighted in the buildings, both ancient and modern, which he saw in Sweden, but he was also much impressed by the innate good taste and artistic appreciation which was evinced by the Swedish people. The architect in this country was held in similar esteem to the medical profession in other lands, and during his whole sojourn in Sweden, he said with a smile, "I was referred to as Herr Arkitekt."

While in Sweden, Mr. Sodersteen decided he would fly across to Russia and see for himself the state of affairs in that country. After landing at the aerodrome in Leningrad, he was furnished with a girl guide—not in the sense as we understand girl guides—but a feminine interpreter and guide to the city. These girls, he explained, are specially trained for this work, and are able to intelligently converse on pictures in the Art Gallery, give historical outlines of the various palaces, and are generally most enlightening. He saw few instances of dire poverty, though, generally speaking, the populace were some-what shabbily dressed.

Mr. Sodersteen was rather disappointed in the present day architecture in England. While admitting that the British architect was a cultured man and generally a good business man, he was of the opinion that the design and conception of most of the work was uninspired.

In our own country he was impressed with New York, but was disappointed in American architecture generally, which he said he had always looked up to as the acme of efficiency and perfection. This he found in many instances not to be the case.

It was impossible, however, to regard the magnificent Empire State Building without a feeling of awe and admiration. Its streamlined silhouette towering into the skies seemed to symbolize human aspiration. Although he admired many of the buildings he saw in New York, as a city he did not like it at all, and he found the people rather nerve-racking.

"I have never been so cold in my life, as I was in Chicago," he said, "and on several occasions when I ventured from my hotel I had only walked a few yards before I was forced to return by that fierce icy blast which sweeps across the Lake, and seems to paralyze one's face as it touches it, I was thoroughly miserable in Chicago—outside I was frozen and inside I was nearly stifled owing to the steam heating of the buildings which apparently take a lot of getting used to."

* * *

Kansas City, Missouri, is building a huge municipal auditorium without a single window. It will cost \$5,000,000. How will this windowless auditorium be ventilated? That's easy. It will be not only ventilated but kept warm in winter and cool in summer by an electrical air conditioning system, one of the largest ever constructed.

V
E
R
T
I
C
A
L

T
R
E
A
T
M
E
N
T

I
S

W
E
L
L

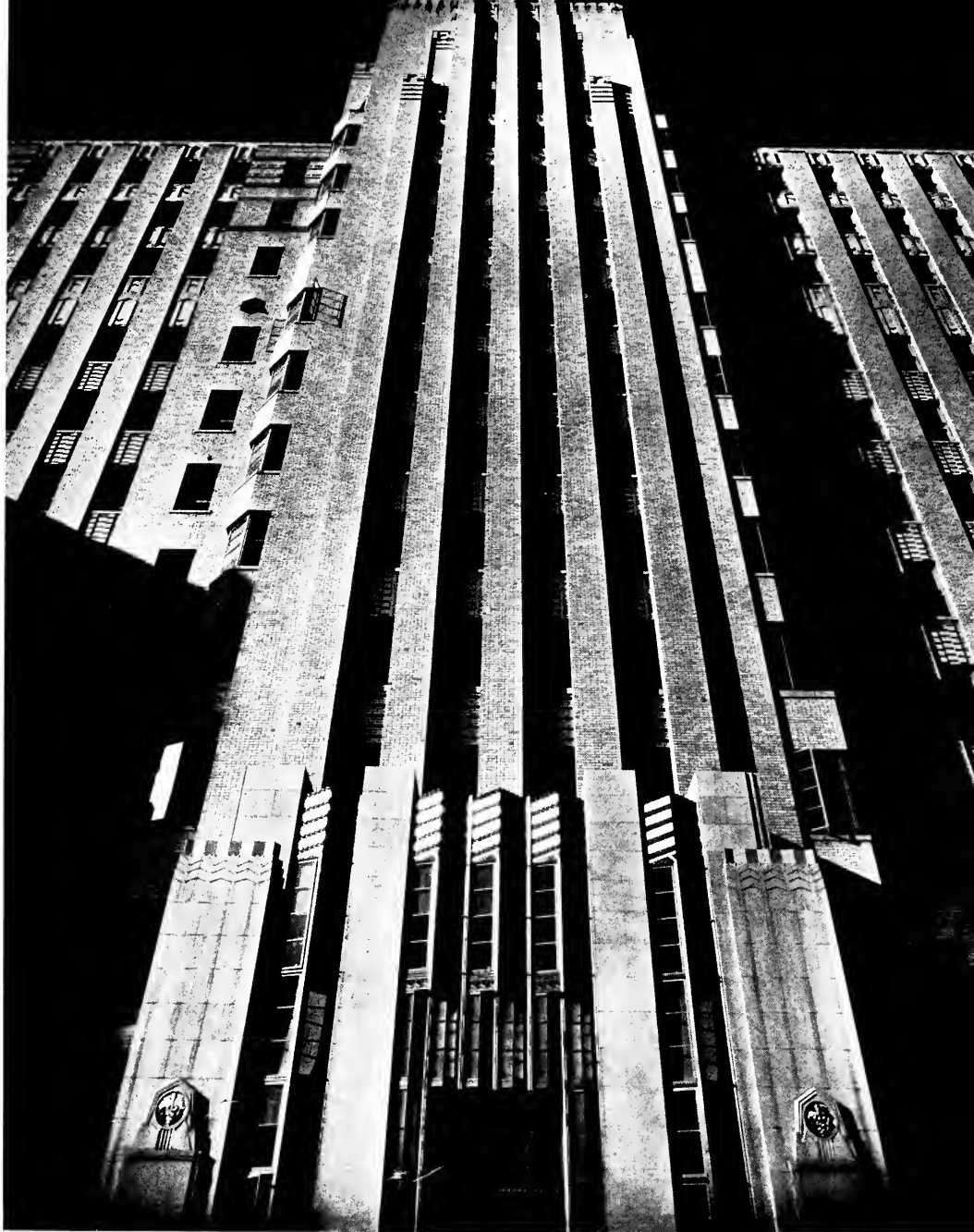

L EXPRESSED IN BRICK AND TERRA COTTA

U. S. MARINE HOSPITAL, SEATTLE, WASHINGTON
BEBB & GOULD AND JOHN GRAHAM, ASSOCIATE ARCHITECTS

GLADDING, McBEAN & CO.

Manufacturers of Clay Products

SAN FRANCISCO

LOS ANGELES

SEATTLE

PORTLAND

OAKLAND

SFOYANE

VANCOUVER B. C.

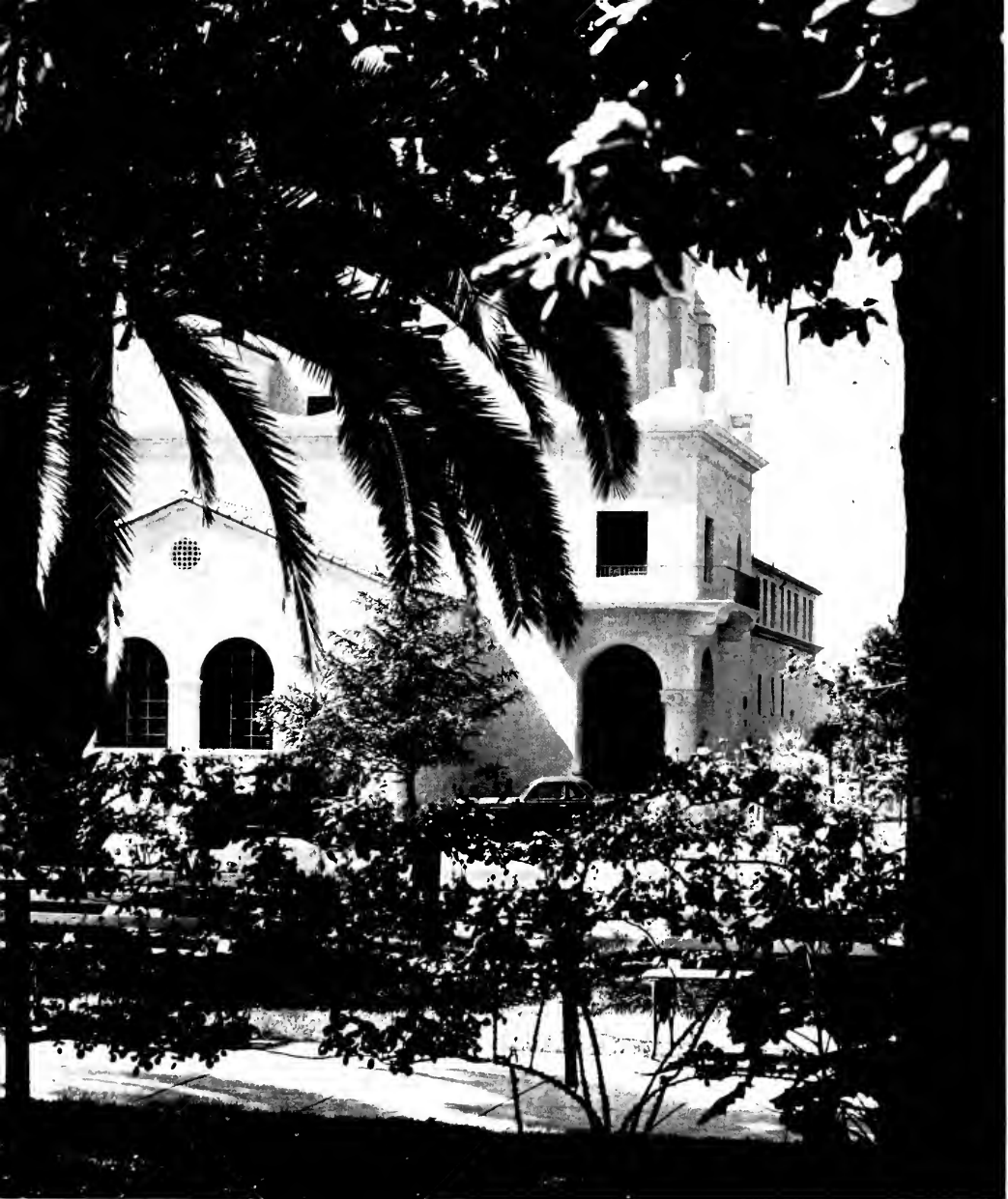

Photo Gabriel Moulin Studios

GARDEN VIEW OF MUNICIPAL AUDITORIUM, SAN JOSE, CALIFORNIA
BINDER AND CURTIS, ARCHITECTS

SAN JOSE CIVIC AUDITORIUM

BUILDING HAS THREE ASSEMBLY HALLS

By Donald Powers Smith

VITRUVIUS said that architectural "well building" required "Commodity, Firmness, and Delight", but happy Vitruvius didn't have to dodge automobiles, depressions, or Le Corbusier. The architect who breathed the troubled air of the past decade probably goes Vitruvius one better, and adds "Economy" before being able to produce any building whatsoever. So, from the haze of pencil dust that surrounds the conception of all good projects, the architects of the San Jose Municipal Auditorium must emerge with a design that is at once commodiously flexible, structurally fitted to unusual conditions, and pleasing to the eyes and purse of a tax-skeptical populace.

No demand for cumbersome regard of authoritative precedent stunted the efforts of the designers; still there was an attempt to respect those intrinsic qualities which make a style distinguished. From the gold-burned walls, so reminiscent of local missions, to the impertinent finial atop the tower, there is a fusion of tradition and color which makes the new Municipal Auditorium distinctly San Jose's own. A decided suggestion of the California Mission style was demanded by popular preference; yet as the forms of this architecture became limited we find introduced into the resultant work an illusive something that we associate with the hills of Ravello, the gardens of Majorca, or the silhouettes by the gorge of the Quadalevin at Ronda. Withal, the problem resolved itself into finding a happy elevational interpretation of the plan, the struc-

tural system, and the materials to present an unsophisticated and sincere quality which throughout the ages has made building "Architecture". The designers, ever mindful of the essence of charm in our mission architecture, played upon the natural expression of masses, forms, and color of the building to produce interest, rather than finesse of ornament and detail.

Simplicity and dignity were very desirable; but the intrigue of cool shadowed loggias and the heights of a tower, which is distinctly characteristic of the valley's Franciscan architecture, couldn't be resisted; so we find them



SKETCH BY DONALD P. SMITH

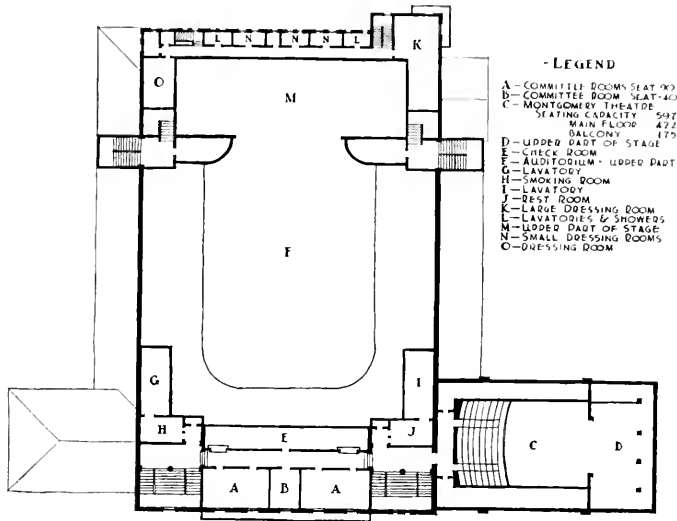

- LEGEND

- A - COMMITTEE ROOMS SEAT 70
- B - COMMITTEE ROOM SEAT 40
- C - MONTGOMERY THEATRE SEATING CAPACITY 507 MAIN FLOOR 472 BALCONY 175
- D - UPPER PART OF STAGE
- E - CHECK ROOM
- F - AUDITORIUM - UPPER PART
- G - LAVATORY
- H - SMOKING ROOM
- I - LAVATORY
- J - REST ROOM
- K - LARGE DRESSING ROOM
- L - LAVATORIES & SHOWERS
- M - UPPER PART OF STAGE
- N - SMALL DRESSING ROOMS
- O - DRESSING ROOM

MEZZANINE FLOOR

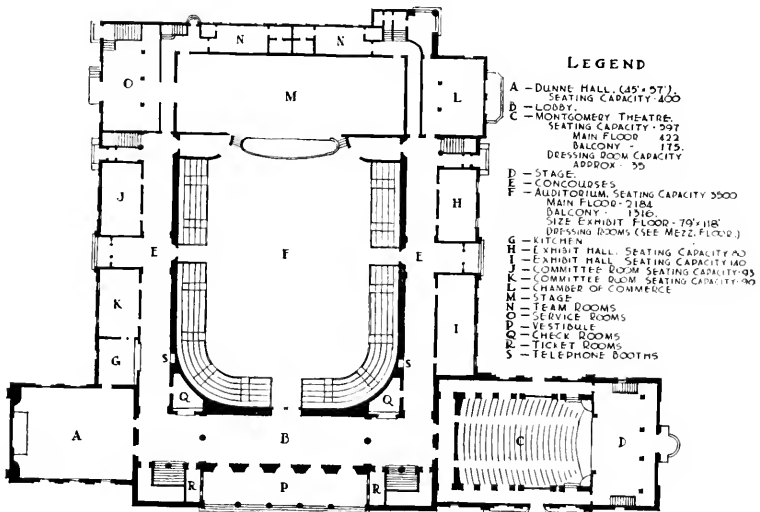

LEGEND

- A - DUNNE HALL (45'x57') SEATING CAPACITY 400
- B - LOBBY
- C - MONTGOMERY THEATRE SEATING CAPACITY 507 MAIN FLOOR 472 BALCONY 175 DRESSING ROOM CAPACITY APPROX 50
- D - STAGE
- E - CONCOURSES
- F - AUDITORIUM SEATING CAPACITY 3500 MAIN FLOOR 2180 BALCONY 1320 SEE EXHIBIT FLOOR 70'x118' DRESSING ROOMS (SEE MEZZ FLOOR)
- G - KITCHEN
- H - EXHIBIT HALL SEATING CAPACITY 10
- I - EXHIBIT HALL SEATING CAPACITY 10
- J - COMMITTEE ROOM SEATING CAPACITY 70
- K - COMMITTEE ROOM SEATING CAPACITY 70
- L - CHAMBER OF COMMERCE
- M - STAGE
- N - TEAM ROOMS
- O - SERVICE ROOMS
- P - VESTIBULE
- Q - CHECK ROOMS
- R - TICKET ROOMS
- S - TELEPHONE BOOTHS

FIRST FLOOR

PLANS, MUNICIPAL AUDITORIUM, SAN JOSE, CALIFORNIA
BINDER AND CURTIS, ARCHITECTS

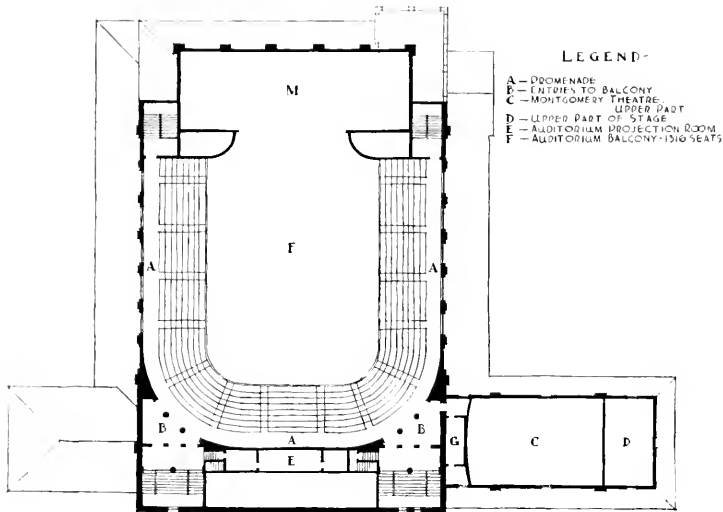

BALCONY
 PLAN OF BALCONY FLOOR, MUNICIPAL AUDITORIUM, SAN JOSE
 Binder and Curtis, Architects

dominating the principle facade. The tower, dressed in apparent extravagance, proves a necessity not only in composition, but as a housing for the large exhaust fans, and the crowning belfry provides sheltered space for the exhaust. Smiling little architectural concrete gentlemen poke their bald heads thru the grapes and leaves of the vestibule loggia column capitals. Sprightly bits of an artisan's wrot iron work, colored the rich green of old brass tarnished by salty breezes from low waters; and shadows from bold mouldings and deep window reveals, were depended upon to complete the main block of the auditorium.

Flanking this block on the left side, the Dunne Hall, and on the tower side, the somewhat larger Montgomery Hall, complete the three hundred and seventeen foot expanse of the facade.

Secondary elevations presented equal problems; but most interesting was the study of the loft over the stage. Because of an unusual site beside the main business section, the contour

of roofs against the hills will probably never be belittled by taller buildings. What an opportunity to take that loft tower, which could so easily become a misfortune on the skyline, and mould the romantic possibilities of buttressed serene walls into a centre of charm rather than regret!

Come with us for a moment into the auditorium thru the studded heavy oak doors, with their sparkling leaded transoms, to the inviting vistas of the lobby. A happy awakening to rich color awaits us, with a ceiling which, unashamed of its structural form, has been decorated by a master who could suggest a riot of hue and yet keep his pigments so in place and subdued that the passage from the lobby to the other parts of the building does not leave us with that jolted feeling so commonly felt in the contrast between the rich plan frontispiece and the colder utility portions of an edifice. Over a back ground of chalky white, designs, such as the Indians of California and the southwest have left us in abundance,

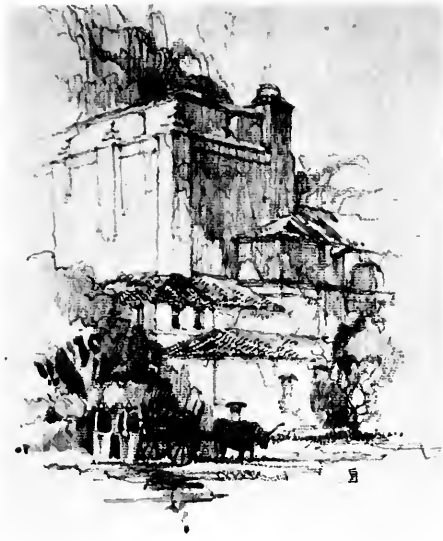

SKETCH BY DONALD P. SMITH

recall early days of natives who, guided by the mission fathers, recreated old Spain on the treasure lands of the Pacific. White walls above a tile topped wainscot, footed by a quarry tile floor, give life and color to the lobby that mark it as a fitting introduction to a palace of happiness, pleasure, and learning.

From the lobby we may pass immediately into the main auditorium, or at the ends of the lobby commodious side galleries provide further access; or opposite these on the front wall, we find a stair system literally lifts us to the level of the promenade back of the auditorium balcony. The coffered auditorium ceiling glows in the effusion of natural light from side lunettes. Even during the grayest of days the cream color of acoustical tile on the ceiling reflects an abundance of daylight from the clerestory windows. The hall is in the form of a "U" with balcony on three sides. So happy were the heights and proportions of the balcony that it was not found necessary to resort to vomitory access, but a wide promenade provides adequate circulation and distribution of the incoming crowd behind the seats. This

feature, which is seldom attainable where balcony elevations make it impossible to approach from the top, is a marked economy in construction and space. Under the main balcony area five tiers of raised fixed seats overlook the polished maple floor of the central hall.

The designers felt that the interior of an auditorium for a city such as San Jose should hardly partake of the artificial exhibition of detail such as is so redolent of past decades of theaters. Consequently thruout the building there is an attempt to achieve a simplicity and "bigness" of character, so that in passing thru the various elements our discerning citizen would not feel a lack of uniformity of scale. Rather, he would feel an almost "out-of-doors" expression in the sweeping moulds and pierced grills of the fifty-foot proscenium, or the profusion of sunlight in the stairs and halls, and the various interesting forms logically resulting from the structure. In the main auditorium the only bits of applied decoration are the clay-like pots at the stage wall exits, and the low relief plaques from the workshop of a sympathetic modeler. These plaques tell a story of the days when San Jose was the first state

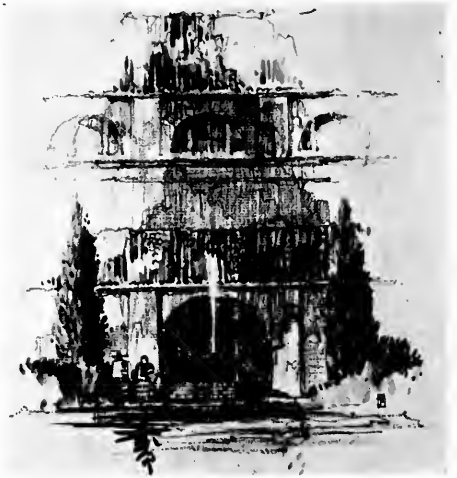

SKETCH BY DONALD P. SMITH

capitol, and when the mission at Santa Clara was building tradition for future generations.

Back again in the main lobby: at one end we can enter directly to the foyer of one of the memorial halls — the Montgomery Hall, named in honor of the donor of the principle piece of property on which the Auditorium stands. This little theater, seating six hundred persons, is fully equipped with stage, dressing rooms and projection room. Its columned loggias for side aisles, and a warm wall color, reflect the mahogany of the velour curtains and drapes.

At the opposite end of the entrance lobby is the Dunne Hall, which commemorates one who induced community thinking toward this civic project by means of a generous legacy for the purpose. Smaller than the two larger halls, it serves for banquets, lectures, or like activities. Adjoining is a well equipped kitchen and concession room. Off the side concourses, which in themselves can house sizable exhibits, are a number of committee rooms and exhibit halls which, combined with the Dunne and Montgomery Halls, and the main auditorium, give San Jose an outstandingly flexible building fitted for any purpose to which it may be called upon to serve. Herein lies the kernel of thought behind the plan. A building which might house anything from an opera to a circus, a basketball or tennis game to a great convention, or art exhibits and flower shows. This problem has been solved by a succession of readily accessible halls, varying in seating capacities from thirty-five to thirty-five hundred people.

The utilities, lavatories, phones, checking rooms, ticket booths and the like are disposed of in convenient yet not obnoxiously obvious locations. Stages are complete and fully equipped. The main auditorium stage is 114 feet wide, 36 feet deep with proscenium opening of 50 feet. Dressing rooms for individual stars, chorus groups, or athletic teams are provided, also adequate and convenient storage and property rooms. The level main floor in the auditorium has removable sections at the stage end which when removed provide an ample orchestra pit.



DETAIL OF ORGAN SCREEN, MUNICIPAL AUDITORIUM, SAN JOSE, CALIFORNIA

Binder and Curtis, Architects

Doors to all exhibit areas are specially constructed to fold back and provide a width sufficient to allow automobiles to pass through. The ceiling in the auditorium has a network of six inch bronze rimmed holes which allow any hangings to be made directly to hook fittings on the bottom of the large trusses. Acoustical treatment of acoustical tile or plaster have proven very satisfactory in all circulation and gathering spaces.

The hand wrought electric fixtures throughout the building reflect the character of the architectural style, and also combine that factor of utility requisite to good illumination. Built into the bottom of the auditorium fixtures are large spot lights which brilliantly illuminate the floor area.

The entire structure is of reinforced concrete with a steel frame, including floor,



Photo Gabriel Moulin Studios

MUNICIPAL AUDITORIUM, SAN JOSE, CALIFORNIA
Binder and Curtis, Architects; Wm. D. Lotz, Structural Engineer

balcony and roofs. Interior walls surrounding the auditorium are also of concrete. All of the interior and exterior architectural columns were poured in waste moulds including the capitals and left in their natural state. The ceiling of the lobby which forms the mezzanine floor was poured over finished forms and the decoration applied directly on the concrete.

The heating and ventilating system is housed in deep basements away from the stage and meeting rooms. Fans, filters, heaters, etc., are so arranged that certain zones may be served at will.

The architects of the building were Binder and Curtis, the structural engineer was Wm. D. Lotz and the mechanical engineers were Leland and Haley of San Francisco.



Photo Gabriel Moulin Studios

"Cool shadowed loggias dominate the principle facade. . . . A decided suggestion of the California Mission is apparent—a style which was adopted by popular preference."

THE SAN JOSE MUNICIPAL AUDITORIUM
Binder and Curtis, Architects

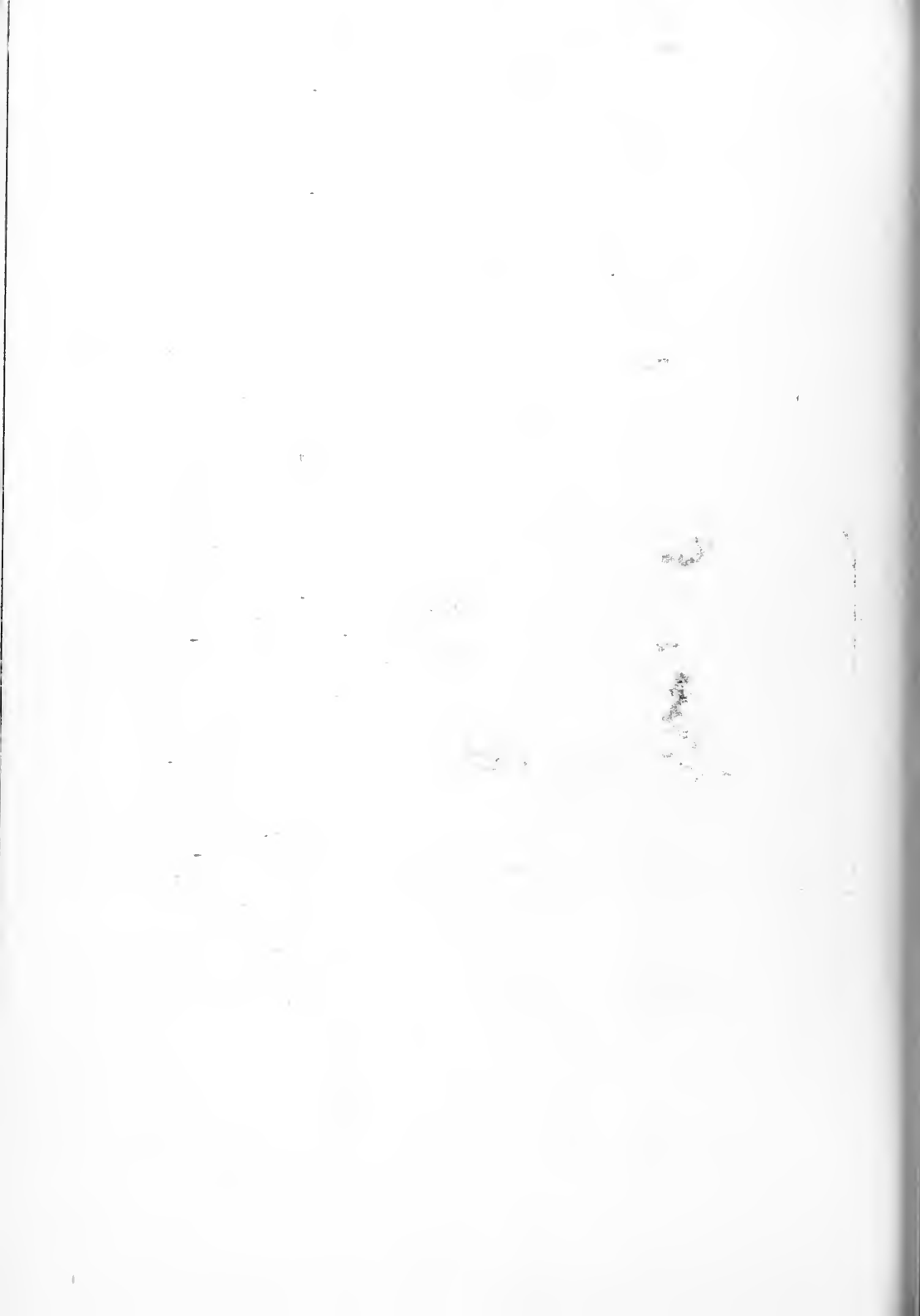



Photo Gabriel Moulin Studios

Garden View of Market Street Elevation

THE SAN JOSE MUNICIPAL AUDITORIUM
Binder and Curtis, Architects

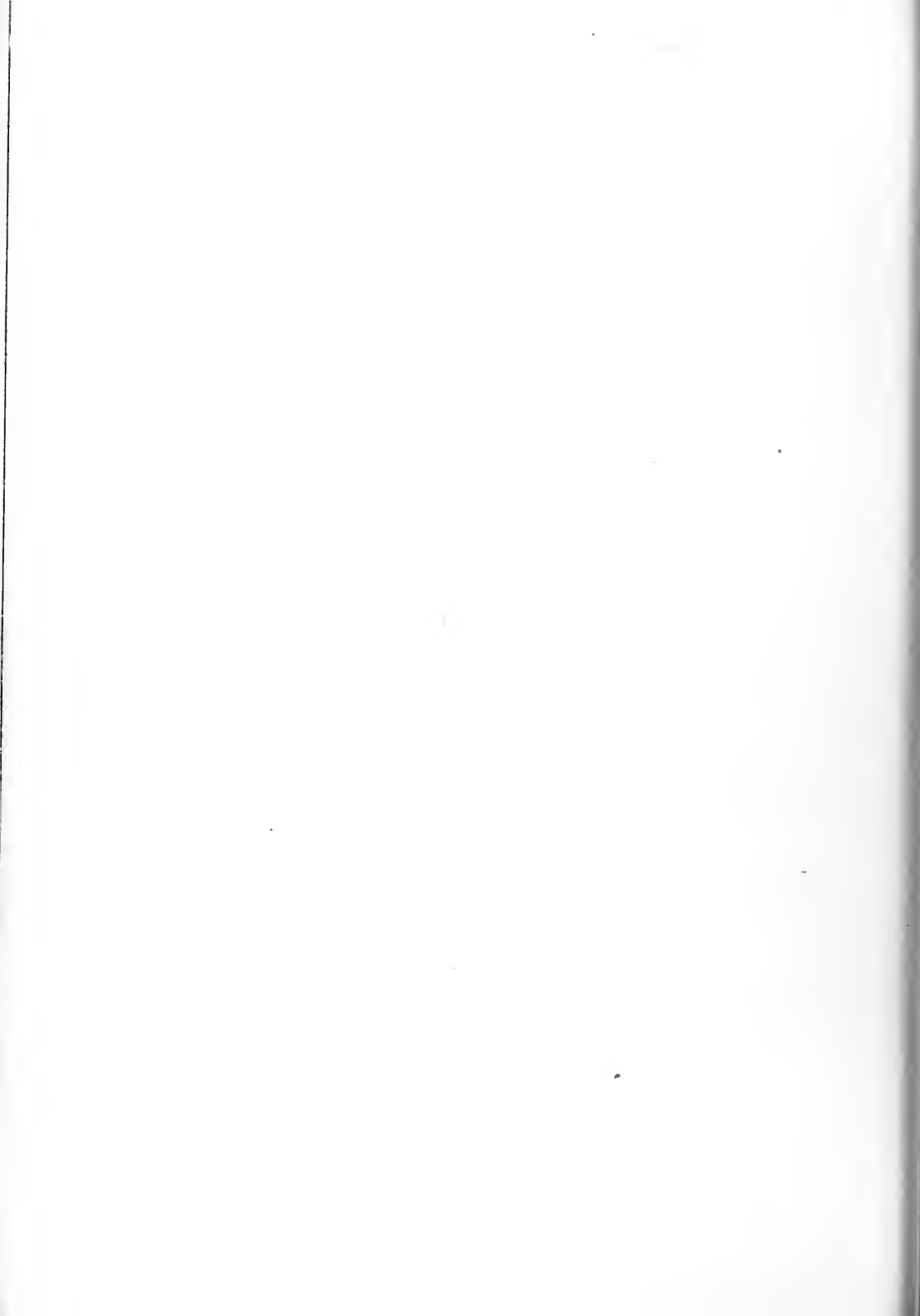



Photo Gabriel Moulou Studios

Cream colored walls and red roof tiles make an effective contrast to the surrounding evergreen foliage.

THE SAN JOSE MUNICIPAL AUDITORIUM
Binder and Curtis, Architects





Tile by Solon & Larkin

Photo Gabriel Moulin Studios

"White walls above a tile topped wainscot, footed by a quarry tile floor, give life and color to the main lobby."

THE SAN JOSE MUNICIPAL AUDITORIUM
Binder and Curtis, Architects





Photo Gabriel Moulin Studios

"The coffered auditorium ceiling glows in the effusion of natural light from side lunettes. The ceiling is cream colored acoustical tile. Under the main balcony five tiers of raised fixed seats overlook the polished maple floor. The only applied decoration in the auditorium, with its 3500 seats, are the terra cotta pots at the stage wall exits and the low relief plaques reminiscent of early mission days."

THE SAN JOSE MUNICIPAL AUDITORIUM
Binder and Curtis, Architects



Photo Gabriel Moulin Studios

The Montgomery Memorial Hall. This little theater seating 600, is fully equipped with stage scenery, curtains, dressing rooms and projection equipment for movies. . . . "Its columned loggias for side aisles and a warm wall color, reflect the mahogany of the velour curtains and drapes."

THE SAN JOSE MUNICIPAL AUDITORIUM
Binder and Curtis, Architects

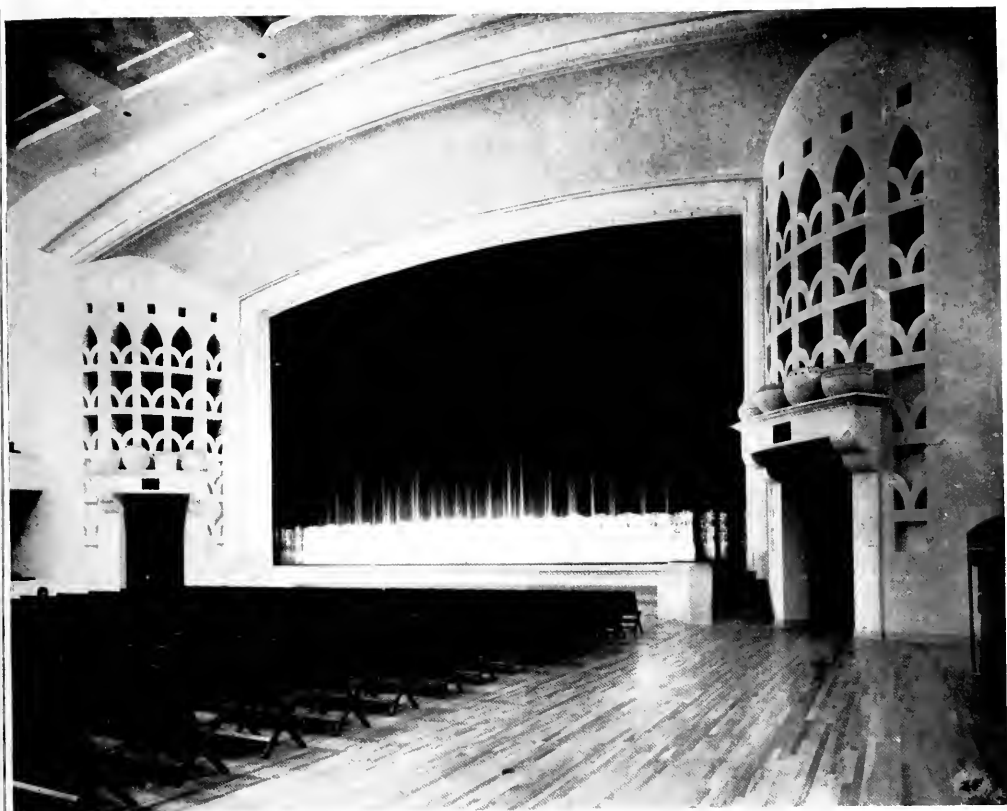

A close up of the Main Auditorium stage. Note unusual design of organ screens and effective placing of terra cotta jars over stage wall exits.

THE SAN JOSE MUNICIPAL AUDITORIUM
Binder and Curtis, Architects

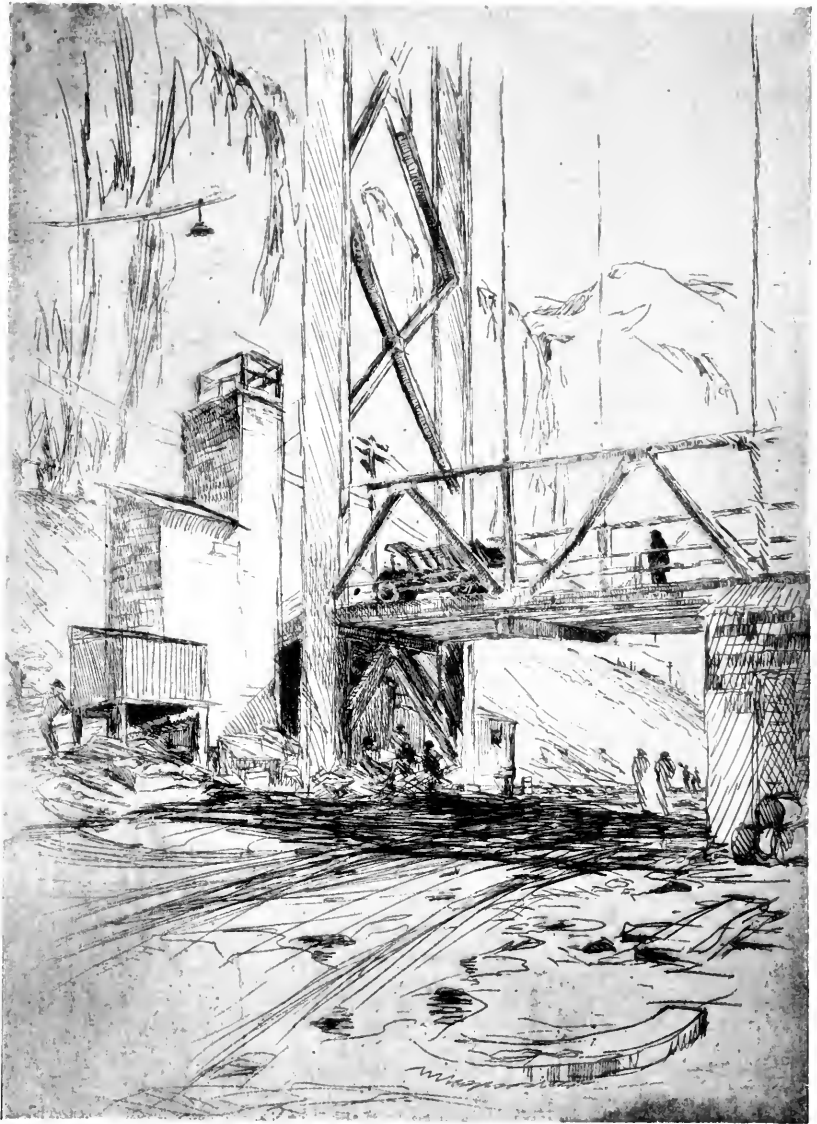

ETCHING BY WILLIAM WOOLLETT

SCHOOL UNDERGOES "FACE LIFTING"

INGLEWOOD UNION HIGH IS SUCCESSFULLY TREATED

By William T. Wright, Structural Engineer

THE reconstruction of an existing building is often looked at from a structural viewpoint only—strengthening the damaged or structurally deficient parts but leaving the architectural design unchanged. There are many buildings in which this is necessary in order to keep the reconstruction cost from being extravagant or even prohibitive to the owners. In such buildings, the general features of the design can be left intact or can be repaired in place with the least expense. Some buildings, however, are of a nature that by changing the architectural design and remodeling the building as well as strengthening it, an actual saving in ultimate cost may result, or at least no extra expense would be involved. The Fine Arts Building of the Inglewood Union High School in Inglewood, California, is an example in point of discussion.

In the reconstruction of this building, the architect was confronted with many varied problems. "Face lifting" or removing the exterior four inches of brickwork to make way for the application of a corresponding thickness of gunite membrane, was one of the problems involved. Others were: installation of new columns and beams in the brick walls to carry the vertical loads; construction of new fireproof stairway to replace the wood stairs to the second floor; installation of a system of horizontal diaphragms to transmit the lateral earthquake or wind loads to the foundation along with the necessary interior vertical resisting elements; strengthening the

existing roof trusses for vertical loads; re-arrangement of windows to give proper light in rooms and re-arrangement of some class rooms to improve instruction facilities; correction of the faulty and inefficient heating system; and a general refinishing and reconditioning of the interior.

Two things had to be kept in mind in deciding on the scheme of reconstruction—first to keep the ultimate cost down as much as possible, and second to arrange the work so that it could be handled by the "relief labor" to be employed. The C.W.A. had already started removing parapets and face brick before the plans were begun.

After considerable study of the exterior in its original state and the possible changes which would involve no extra expense, the design was settled upon as a modern adaptation of classic architecture. This meant plain surfaces with simple ornamentation properly arranged to enhance the beauty of the structure. The name "Fine Arts" alone would bring such a style to one's mind and the designer carried this thought throughout his work. The economy of the work is found in the use of materials that could readily be incorporated into the strengthening program with as little extra cost for ornamentation as possible.

The designer always encounters difficulty in fitting the window fenestration and general shape of the facade into a new design, but here the problem was simplified by the choice of a new style. The curved window heads were changed to square and all extruding ornament was removed. The slight projecting



BEFORE ALTERATIONS—BUILT IN 1924
FINE ARTS BUILDING, INGLEWOOD UNION HIGH SCHOOL, INGLEWOOD, CALIFORNIA



AFTER ALTERATIONS—COMPLETED 1936
FINE ARTS BUILDING, INGLEWOOD UNION HIGH SCHOOL, INGLEWOOD, CALIFORNIA
T. C. Kistner, Architect

surfaces on each face of the building were accentuated or subdued to fit the design and the entrances were remodeled in accordance with their importance.

One of the interesting features of the completed building lies in the arrangement of the materials used for the exterior finish. Backed by a general over all surface of "sack finished" gunite, the smooth run-plaster flutings, rough sand finished spandrels, and ornamental exposed concrete entrances and copings make the facade most attractive. The entire surface is covered with two coats of cement paint to give a light gray color on which the shadows bring out the features of the design. Polished cast aluminum grills light the new stairways while all doors and windows are painted with a grayish green color that blends so well with the rest of the finish.

The horizontal diaphragms for transmitting the lateral forces to the vertical resisting elements are composed of light I-beam and H-column section welded together to form a system of continuous trusses around the building. The vertical resisting elements are reinforced concrete walls varying from 8 to 16 inches in thickness and carried on new foot-

ings to the hard soil beneath. The new stairways are of metal, supported between concrete walls and are placed next to the exterior wall where natural light is available for lighting the wells. The existing roof trusses are strengthened with bolts and steel plates where extra nailing and bracing was not sufficient.

The large study hall is given extra light by the addition of two new windows in the rear wall where the old fireplaces had been. Several lecture rooms have been re-arranged to afford better teaching facilities and the old gas fireplace heating system is supplanted by a steam system connected to the existing boiler plant. The ceilings of all rooms throughout the building are finished with acoustical plaster and all wood work, windows and floors have been refinished to make the building "practically new".

The entire construction work was carried on by C.W.A. and S.E.R.A. "relief labor", with the exception of the gunite, structural steel, and steel stair work, which was under separate contracts. The project was handled by a competent contractor employed by the school district to supervise the work.

WELL PLANNED MEDICO-DENTAL BUILDING

THE Dr. F. J. Gaspard Medical Building in Los Angeles, designed by Gene Verge, illustrates good modern planning for working space, equipment, heating and ventilating, for both medical and dental needs. Every possible convenience for patients, as well as efficient and enjoyable working conditions for physicians and nurses, has been provided.

The building has a large and well-appointed reception room and carefully planned business office. There are three private doctors' offices and consultation rooms, with steriliz-

ing and scrub-up rooms in connection; a complete laboratory and drug room; sterile and non-sterile linen rooms; dressing rooms and recovery rooms. The radiographic department embraces X-ray and fluoroscopic equipment, a developing department and facilities for plaster-cast work, a lounge and a viewing room.

The second floor is occupied by completely modern dentists' quarters. There is a patio adequately furnished for the convenience of patients, a feature consistent with the California-Italian architecture of the building.

Of prime importance in equipping this

building, in which the maintenance of health is naturally the essential motive, was the design of a modern heating and ventilating system that would insure proper temperature and atmospheric conditions at all times. This has been accomplished with a gas-fired, forced-air, semi-air conditioning system placed in the center of the building. The furnace is connected to a main trunk line leading into two plenums located in the attic. From the plenums branches are taken off at right

angles to registers located high in the walls, thus assuring complete circulation of air without objectionable drafts and a thorough diffusion within the rooms.

A blower provides delivery of air under slight pressure for proper circulation. Filters assure clean, pure air at all times. Control is by means of a thermostat located in the main corridor, with a toggle switch for operating the blower independently of the gas heating unit for ventilation.



DR. F. J. GASPARD MEDICO-DENTAL BUILDING, LOS ANGELES
Gene Verge, Architect

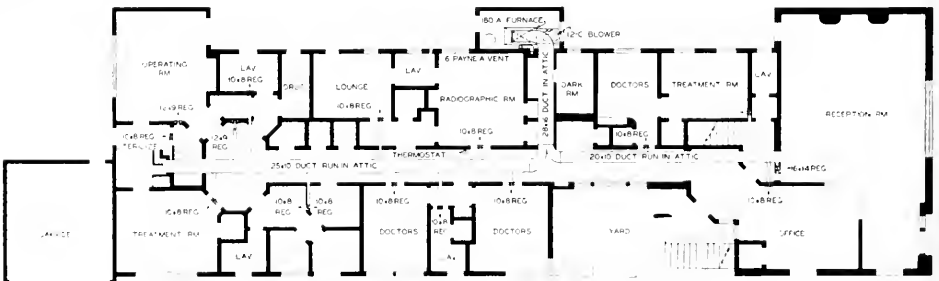

GROUND FLOOR PLAN, DR. F. J. GASPARD MEDICO-DENTAL BUILDING

AUSTRALIA SHOWS WAY TO MODERNISM

MELBOURNE BUILDING GOOD EXAMPLE OF TREND



McPHERSON'S BUILDING, MELBOURNE, AUSTRALIA
Reid & Pearson and Stuart P. Calder, Joint Architects

THE ultra-modern movement has reached Australia and one of the most recent examples of architectural treatment in this manner is a most interesting two story mercantile building at Melbourne for McPherson's, Ltd., and designed by Reid and Pearson and Stuart P. Calder, associated

architects. Architects in this country could follow this style without injuring their reputations. The following paragraphs, reprinted from the June issue of *Building*, published in Sydney, Australia, give some salient details of the structure:

"The science of building of to-day eschews such words as solidity, dinginess and stuffiness, substituting instead the quality of spa-

sciousness, the penetration of an abundance of light and air, enclosed in an architectural style in which horizontality is featured.

"'Walls of Glass' described the cathedrals of mediaeval days, when magnificently colored glass was woven into pictures of immense size and height and extraordinary beauty to depict biblical stories and create the dim religious atmosphere essential to impress the worshipper with the awe-inspiring majesty of the structure, as well as to contribute to peacefulness and thoughtfulness. How such vast areas of glass were supported became the subject of conversation among the populace unversed in the scientific manipulation of materials to resist the stresses and strains of the very tall buildings for verticality or the aspiring tendency of architecture, was the then keynote of the theme.

"'Walls of Glass' can still be said to describe the modern building, but they are placed on their sides instead of on their ends, for horizontality has given place to verticality as an architectural feature, and the purpose of the building is to house human activity in the process of everyday life, and for this white light and clarity have supplanted the dim religious lighting.

"The layman still ponders on the why and wherefore, as he seeks to find some evidence of structural members to support such huge walls of glass as those worked into the modern building, but the problem is as baffling to him now as it was to his brothers in mediaeval days, and just as it would be Double Dutch to prate about a parallelogram of forces in buttresses of old, so also would it be Double Dutch today to talk about cantilevered floors and suspended members and their strains, and even the secondary strains set up in materials that, all unseen, silently and faithfully carry out the function of producing a highly scientific and stabilized structure.

"Along the entire length of McPherson's shop front of 160 feet to Collins Street, Melbourne, there appears to be no supports, for it is a sensible commercial requirement that every inch of frontage shall be used for the

display of goods. It is a very expensive and foolish idea to pay hundreds or, in some cases, thousands of pounds per frontage foot of ground to cover it with a solid pier when its function is for the display of goods. So we find that other than the end vertical members which face up the dividing walls, no such intrusion as a pier of story post appears on this frontage, and where structural members exist, they are kept back a little. From these the shop fronts are supported. This may be noted in the cantilevered stallboards to the shop windows, which sail over to afford the pavement lights their full scope, and from which the slender but extraordinarily strong sections of Birmabrite rise to carry their loads. A small base of possibly 6 in. or 8 in. of Birmabrite running around the shop windows and above the frieze of black Carrara glass, contribute to the horizontality. On the frieze is placed the firm's name in neat lettering in "Stayn-proof" stainless steel, possibly 18 in. deep with a projection 2 in. by 1 in. face, resting against the black glass, as a most dignified, restrained and important function of the facade.

"Above the lettering comes an unbroken stretch of windows into which a pattern is made by the regular occurrence of certain sized panes of glass. These windows are also exceedingly strong. The divisions are painted green, contrasting nicely with the black marble. A few rows of terra cotta in pale browns with purple veinings and mottlings make the next tier, and after that comes another row of windows and then the top member of terra cotta. At one end of the building a private entrance and small tower for supporting a Neon sign have been provided, and here the architect is to be congratulated for making the sign an integral part of the design, and not allowing it to come in later as an afterthought to interfere with the architectural ensemble. So far only the projections, onto which the Neon lights were intended to hang, are visible, as the Neon sign was not permitted to be erected by the Council, which is amazing.

(Please turn to Page 52)

EARTHQUAKES DESCRIBED BY STUDENT

GROWING GENERATION NEEDS FACTS ABOUT PHENOMENA

By Byron Nishkian

The following article was written as an essay in an English course at the University of California by Byron Nishkian, son of L. H. Nishkian, structural engineer of San Francisco. It is not without interest to architects and engineers and should be a source of information to students in our public schools whose knowledge on the subject is generally admitted to be limited. The suggestion has been made that papers similar to this be read to students to better inform them about earthquake phenomena. On account of its clarity and simplicity of presentation the paper is presented here in full:



WHEN one speaks of an earthquake the average layman immediately thinks of some supernatural power that is intent on destroying humanity. Of course, to anybody who has the slightest knowledge concerning earthquakes and their causes this thought is absurd. An earthquake is, contrary to most beliefs, a phenomenon that is as natural to the earth as rain. It is merely the result of one of the many processes which shape the earth's surface. It is due to these processes that many of the earth's mountains, valleys, lakes and even the ocean, deeps have been and are being formed. It was due to these processes that Tomales and Bolinas Bays were shaped. If a person took the time to look at a map of the regions above named, he would find that it is possible to draw a straight line through the Spring Valley Lakes, Tomales Bay and Bolinas Bay. This is what is known as the San Andreas fault. It was due to repeated slippages on this line that these places were formed. Although there is no place on the surface of the earth that is immune to an earthquake, there are regions which are more subject to them than others.

In order to understand the actions which cause an earthquake, one must have a clear

picture of the earth in his mind. I don't mean a picture of the earth as shown on maps, but the entire globe. In other words, one must picture the earth as a solid sphere. It must be understood that the earth is composed of a thin, hard shell of a thickness that is estimated to be about one hundred miles. This is not what is usually thought of as thin, but, in comparison with the diameter of the earth, it is relatively thin. From this depth the interior of the earth gradually changes from solid condition to a plastic state. It is in this shell that the earthquake originates, so hereafter whenever the crust is referred to, this solid, one hundred mile thick crust is meant.

There are regions of the earth's crust which are composed of rocks that are much heavier, as an average, than other regions of the crust. The regions which are composed of the heavier rocks, gradually sink down into the plastic interior, which in turn causes the regions composed of the lighter rocks to be bouyed up. It is in this manner that our mountains and ocean beds are formed. The heavy regions gradually sink deeper and deeper into the plastic interior to form the ocean beds, and the lighter regions are gradually pushed higher and higher to form the mountain plateaus. One corroboration that this is the manner in which our ocean beds are formed is found in the

fact that generally the rocks beneath the ocean beds are heavier than the rocks underlying mountain ranges. As this process goes on, a strain is placed on the regions between the upheaving and sinking portions of the earth's crust. This region is finally so highly stressed that rupture occurs in some approximately vertical plane of weakness. This plane of rupture is known as a fault plane and the surface line of this plane is called the fault line.

Fault Lines on Pacific Coast

Here on the Pacific Coast, there are a great number of these fault lines which form what one might call a net-work over the state. The San Andreas fault, which is the longest one in California, is also one of the longest in the world. It extends nearly the entire length of the state. Because of the weakened condition of the crust along these lines these are generally where future earthquakes will occur.

After one has listened to the foregoing he asks himself why this action wouldn't stop after a length of time. It seems only natural that it would stop, because after a due amount of shifting about, the mountains and ocean beds should finally gain equilibrium. This action would stop after a length of time; that is, if there were no other forces to interfere with the aforementioned process. However, there are other processes going on at the same time which must be taken into consideration. One of the most important of these is the cooling of the earth. In the cooling of the earth the part where the effect is most marked is on the surface of the earth. As the surface of the earth cools, it shrinks, with the effect that stresses and strains gradually accumulate. Finally the resulting stresses exceed the strength of the materials in which they are taking place. When they exceed the strength of the material, there is a movement which causes a rupture of the material. Some scientists state that this is one of the causes of earthquakes also. Another process or action which also contributes to the occur-

rence of earthquakes is erosion. The rivers are constantly washing sand and gravel down from the mountains and depositing them on the ocean beds. As these depositions continue, the ocean beds get heavier which upsets the equilibrium that has been established; thereby causing adjustments to be made, resulting in further earthquakes.

Two Distinct Types of Vibration

When a sudden movement occurs on the fault plane, vibrations are set up in the surrounding materials. These vibrations, which travel in all directions, are what we feel during an earthquake. The vibrations have vertical and horizontal components. The movements along the fault line range from a few inches to many feet. For example, during the earthquake of 1906 in San Francisco, where the San Andreas fault line passes near Point Arena, the extreme observed movement at the surface was twenty-two feet. Although these movements are on the surface of the earth's crust, the center of the disturbance, which is known as the focus, is many miles below, sometimes as much as forty or more miles down.

When an earthquake occurs there are two types of vibration; longitudinal which is parallel to the direction of propagation of the wave, and transverse which is at right angles to the direction of propagation of the wave. A good example of a longitudinal wave is a long coil-spring vibrating lengthwise. A good example of a transverse wave is a violin string vibrating transverse to the length of the string. It is a known fact that in a given material longitudinal waves travel about 1.7 times faster than transverse waves. By a knowledge of the velocities of the two it is possible to compute the distance between the seismograph and the origin of the disturbance by measuring on the seismograph record, the interval of time between the arrival of the two waves.

When a fault line is near or under a large body of water, and there is a large vertical

(Please turn to page 52)

67 YEAR OLD BUILDING MODERNIZED

IMPROVEMENTS TRIPLE INCOME OF PROPERTY

By William I. Garren, Architect

AFTER sixty-seven years in the life of a structure have passed, it probably can be said without dispute that complete obsolescence has set in and that, unless the properties or buildings have been re-modeled and altered from architectural generation to generation, these properties will have outlived their commercial uses.

This is the situation that confronted the owners of 230 feet of building frontage on the main business thoroughfare of San Jose, one hundred feet from the busiest traffic corner in this important industrial and commercial city. Somewhere around the year 1868, a large brick structure with a wood interior, at that time somewhat defiant of our present known earth forces, was built. Its first use was perhaps that of a large hotel where governors and presidents and visiting European aristocracy might stay during their visit in San Jose. Later these hotel suites gave way to office uses and through fifty years or more they accumulated files, safes, shelves, stoves, wall paper,—until 1935 found the building at a point where tenancy income was negligible and approached or had passed tax- and up-keep-cost.

Another important, devastating feature in the life of this structure was the settling or dehydrating (according to engineers) condition prevailing throughout the Santa Clara Valley which is lowering the water table and



VICTORY
THEATER
BUILDING,
SAN JOSE,
BEFORE
ALTERATIONS



VICTORY THEATER BUILDING, SAN JOSE,
AFTER ALTERATIONS
William I. Garren, Architect



NIGHT VIEW OF VICTORY THEATER BUILDING,
SAN JOSE, AFTER MODERNIZATION
Wm. I. Garren, Architect

causing settlement of many of the buildings in spite of good or bad construction, leaving its toll of cracks, through walls, footings and other parts of the structure.

With 20% of the street frontage rented and less than 10% of the upper floor offices rented, there was undertaken the complete restoration or rehabilitation of this structure. The walls and floors were completely tied, anchored and braced with the insertion of steel anchors at all floor levels to hold the entire building together. The whole structure as to outer walls and floors was saved which represented probably well over 50% of the cost of a new building. The money expended in modernizing represented largely the mechanical and electrical installations that had been lacking in the original structure. The cast iron pipes in the building were completely gone and a great deal of the galvanized steel piping which had not been replaced in recent years was practically useless. The original timbers in

the building — both redwood and pine — where they had not been subjected to lack of ventilation or dry rot, were in perfect condition with the only weakening due to shrinkage of joists from their moorings on the basement sills.

The entire store fronts of the building of course were out dated and completely obsolete, and required a modern installation as indicated in the photographs.

Another feature of the building which was completely obsolete was that the second floor of the building had been lighted on its interior through open corridors at the third floor in ship fashion, so that all inside rooms on the second floor were, for all modern purposes, obsolete and without light. The removal of the third floor of the building was found by the owners to be a better procedure than to attempt the introduction of light wells. This change not only improved the architectural composition but provided a full floor of offices with excellent light.

The street, through a period of many years of neglect in modernization, had suffered a loss of traffic. The public were not accustomed to pass or enter the stores in this structure, and had turned away from this street so that the problem became one not only of modernizing the building but of inducing the public back to the property and the use of its stores.

With the above problem in mind, the Phelan heirs, owners of the property, set out to make this block as attractive as possible architecturally, both day and night. Fortunately, a large theater, now the Victory Theater and formerly the opera house of San Jose, existed on the block. The Victory Theater was completely remodeled structurally and certain features which were hold-overs from the "foot-light" days were torn out and remodeled to the necessities of the "silver-screen". This change immediately affected the traffic to the property, to the theater, and accomplished the result of bringing many persons to the property that had not bothered to pass before.



CORRIDOR OF SECOND FLOOR OFFICES, VICTORY BUILDING, SAN JOSE, BEFORE ALTERATIONS.

Note stairway to third floor.

The completion of the new Post Office on First Street, the remodeling of the Court House and the removal of the car tracks, have all assisted materially in bringing back to the property a traffic use that was obstructed in the past, so that the building itself probably merely enters into the planning of the city in the above respects.

To further increase the usability of this street for traffic, the building has been completely lighted at night with flood lights and, in addition, between each two stores there are pilasters which are lighted with indirect Neon.

The building today represents, insofar as the stores are concerned, a new structure completely modernized and remodeled, with well arranged shops, all properly equipped with lighting and wiring for every type of busi-

ness. The offices above are, as well, completely modernized and in every way they offer the finest facilities for light, space, heat.

The building was completed on January 1, 1936 and on April 1, 1936, 70% of the stores were rented and negotiations were in process for the remaining 30%. The offices were about 40% rented. The income from the entire structure has been approximately tripled and the upkeep losses have been largely removed.

The building was designed by William I. Garren, A. I. A., architect. W. M. Caldwell of San Jose was the general contractor. Jas. A. Clayton Company were the agents in charge of tenants and leasing. Norman W. Green was the consulting structural engineer. The sculptural ornament on the building was modeled by Raymond Pucinelli.

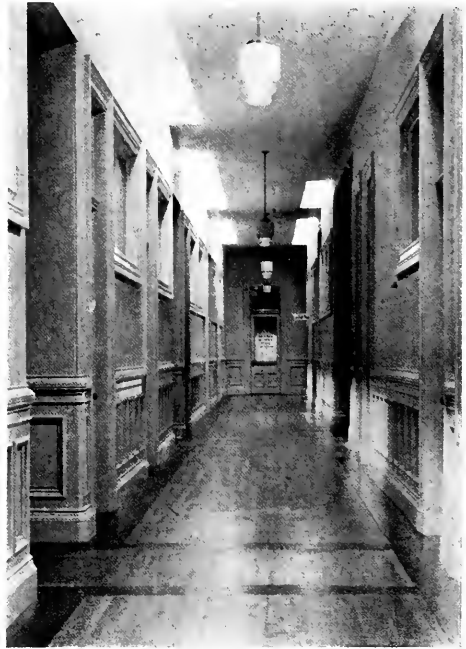

CORRIDOR OF SECOND FLOOR OFFICES, VICTORY BUILDING, SAN JOSE, AFTER REMOVAL OF THIRD STORY

William I. Garren, Architect



GARDEN APPROACH TO CHARLES CHAPLIN'S FORMER HOME IN HOLLYWOOD

PROGRESS IN DOMESTIC ARCHITECTURE

PUBLIC IS DEMANDING BETTER HOUSING VALUES

By Wills I. Bennett, Professor of Architecture, University of Michigan

TILL some five years ago progress in domestic architecture was uneventful and largely without direction. Structural improvements came gradually into use, and houses were made more comfortable than formerly. Taste as to style had certainly improved since the days of the scroll saw and the turning lathe and we had survived such innovations as the sleeping porch. House equipment had made particular progress and if other factors had kept pace with it we should have arrived more quickly at the modern house. Perhaps in time to come we shall thank the depression for better housing. This lull in building has roused us to action. We now question some of the one-time verities, and we are starting out on a new line. For this reason housing is now a particularly live subject.

In the boom days now gone beyond recall the old ideal of housing as individual self-expression in one's chosen style—English, Colonial, or whatnot—lined countless suburban streets with assorted specimens of domestic architecture. Individual dwellings were often in good taste and had a fine homelike character. Considerable emphasis was placed on keeping up with the Joneses or surpassing them but rarely was there any architectural unity or harmony for the whole neighborhood.

And this is the best phase of pre-depression housing. Houses for workers varied all the way from the company towns of miserable shacks in our mining districts, to such fine developments as Kohler, Wisconsin. This is also

essentially a company town in that it was built for the employees of the Kohler Manufacturing Company. There are not many Kohlers. The general level of workmen's dwellings stands forth in the typical speculative subdivision of jerry-built houses in our outlying industrial districts.

Then there are the multiple dwellings. Where these have been fine apartments we have been proud of them as evidence of mass wealth and luxurious living. Where they are poor we have gladly left them to the social worker, for there were pleasanter things to think about. There appeared to be no way in which good design and good construction could be put into these cheap dwellings.

Probably the traditional technique of producing housing facilities will continue to serve a portion of the housing market. In this process we shall see the present variety of styles supplemented by what is called "modern"—flat roofs, corner windows and straight lines. Thus applied this so-called style means neither more nor less than Norman or Spanish. It is merely a vogue in surface treatment and has no particular reflection in the plan or in construction. Aggressive manufacturers will continue to urge the introduction of new structural and decorative materials. Many of these are excellent and they are very attractively presented by modern publicity. So the possibilities in leisurely progress are interesting. We might explore this or that material, or this or that trick in planning, or construction, or decoration. But so long as the time-honored set-up involving the speculative builder persists, and so long as good building is a luxury, the progress of housing is likely to be slow.

A talk before the Michigan Engineering Society, Ann Harbor.

The failure of our traditional housing methods lies precisely in their economic inadequacy. Public opinion is becoming convinced that the poor man and even the man on moderate salary has had to pay too much for what he got in housing.

In outlining the new prospect for better housing values there are several factors familiar to you all — land, finance, and actual production. These affect all kinds of housing. It will be necessary here to pass over the important subjects of land and financing for there will be just time to briefly survey the technological problems. We shall have to assume that an understanding of proper land use will hold the value of sites to a reasonable proportion of building costs, and that building money will become available on the basis of stable investment.

The dissatisfaction which urges a new attack on housing has its greatest force in social unrest. The American dream of a competence and an owned home for every family has not come true. Perhaps people are now unduly pessimistic that it ever will come true. Certainly they are becoming more and more conscious of class distinctions. The great mass of people called "The Havenots" are becoming more vocal. They are talking this and that about social justice. They are beginning to demand better housing values, and the experience of England, Holland, France, and Germany shows that they will get them by one means or another.

Technological Activity

Another force that concerns us here directly is that of technological activity. This, I think, is, like the other, an instinctive demand for better housing values. To professional men this expression will seem the more realistic. You have then two types of housing planner. The one who is preoccupied with social unrest is apt to be concerned mainly with the production of large quantities of housing, probably at public cost. The technological type of mind is interested primarily in producing better housing at **lower** cost. Both would agree on certain principles. The outstanding one is that

of thinking and working at large scale. If better housing is going to be coordinated with better living and more stable real estate values, community planning is essential.

Group construction is the first step toward efficiency in production. It will probably assume an increasing part in housing activity.

Mass production is as yet in the background. It is, however, an intriguing idea, and conceivably might turn the trick economically for the small house in making a stand against the multi-family dwelling. I should like briefly to discuss modern housing under the heads just mentioned — community planning, group construction, and mass production. They are already beginning to influence the character of home architecture and we can begin to see something of what may develop.

Community planning admits of certain principles such as the interdependence of people in a modern group, and the existence of certain conditions of modern living. Our planners have based their ideas on the English garden cities. The gridiron plan is avoided and the whole treatment is open and informal. The unity of the whole effect controls the slight variations in form and treatment of the single dwellings. Designs are repeated many times but the types are so alternated as to avoid the appearance of monotony. In Radburn, New Jersey, Henry Wright has adapted an English ideal to American requirements. The unit of subdivision is the "superblock" whose nucleus is the school, and of course the playground group. Children do not have to cross any main street or highway in school or recreation hours, and in the whole plan particular thought has been given to traffic control because modern traffic is part of modern living. Recreation areas instead of being separate and rectangular parks are made almost a part of the living area. Stores are somewhat removed from the houses yet they are convenient and on the homeward path of commuters from New York. In relation to parks each family has its own yard but they also have ready access to the public space for recreation and circulation. House design is controlled and al-

though the dwellings are modest there is variety with a fine harmony in the whole effect.

Better Architecture

Group construction has long been used in apartment structures. Usually it does not produce low-cost housing but this may in part be attributed to the land costs involved. Apartment development has often been a high-pressure method of extracting returns from high-priced land. Certain economies inherent in the mere act of large-scale construction are available here for housing. With the present movement toward large-scale projects the architect is able to do more architecturally with these structures. Instead of the great grid facades with barren inner courts, lower structures are more freely articulated so as to offer a greater variety of exposure and a more interesting pattern of open spaces. In these projects the architect finds a new opportunity. Good group planning is followed by unit dwelling planning based on proper orientation, efficiency as to cost and operation; attractiveness of the whole building complex as well as attractiveness in the various apartments.

As to the single house there is a desperate need for a better commodity at a lower cost. Large-scale operations such as the building of an entire community in one season under one contract should be helpful here. Data on such projects as the Couzens settlement in Michigan, now under way should, when the work is finished, give us something to go on. Architecturally the prospects here are good, with a whole community planned as one design and carried out with sufficient variety in the units that make up the pattern. The margin of profit, however, is so slight in the well-built small house that there may not be much real gain in this kind of production.

The other way is through increased factory production and new fabrication of parts for dwellings. It is only natural that in an industrial age we should endeavor to apply industrial methods to the production of housing. That is what the prefabricators are trying to do. Thus far their efforts go only part way and

their success has been modest. Insofar as I know no fully prefabricated house in rooms or sections has been placed on the market, and I know of none in which all the parts are brought to the site requiring only rapid assembly. The term prefabrication is therefore only one of convenience. In spite of its tentative character, however, the arrival of the completely fabricated dwelling to be merely assembled at the site would have such a decisive effect on architectural practice and appearance, and on the whole housing industry, that I should like to indicate the possibilities.

Prefabrication is not exactly new. Before the War, at Forest Hills, Long Island, Grosvenor Atterbury, the New York architect, was building houses of prefabricated concrete slabs cast in a plant at the site. These dwellings were tentative in design for at that time no one, at least in the vicinity of New York, dared depart from a conventional style to make a more consistent use of a new material. These houses proved to be costly and instead of a settlement for workingmen as intended, Forest Hills became a rather exclusive suburb, though not entirely due to building costs. This type of construction of room-sized slabs has also been tried elsewhere with some success. Where such slabs are used for walls without added finishes they are often difficult to seal against moisture. For these systems casting and assembly require heavy setting machinery in the field and total costs appear to be high, although at Frankfort in Germany, where this method was used, a considerable economy is claimed. Perhaps if the scale of operations were large enough savings would be well worth while. Such a construction encourages an architecture of substantial appearance, with flat roofs, simple planes, broad color effects, and uniform windows.

Prefabricated Houses

Another series of prefabricated systems can be grouped under the heading of Framed Structures. These, modifying traditional skeleton construction with steel studs and floor joists, have won considerable acceptance. This

is probably because they adapt themselves more readily to conventional plans and architectural treatments. Such gradual penetration of the market does not produce startling results but in the end it may achieve the purpose better than would the shock of a more direct attack. On these steel frames, often of stamped sheet metal rather than rolled shapes, conventional exterior and interior finishes may be applied, or panels of metal, wood or plastic may be secured to the frame. This latter possibility enables the architect to play with the various new materials if he so desires. In these new framed systems we are easily convinced as to the superiority of the job where good exterior and interior finishes and adequate insulation are used. We remain to be convinced as to costs. When the steel frame becomes the basis of a panel construction thoroughly developed and efficiently fabricated, we may see some real price reductions.

The lumber interests are by no means asleep and in the Forest Products Laboratory at Madison, Wisconsin, a prefabricated wood construction has been devised and extensively tested. This system is based on the principle of making thin veneered outer and inner surfaces part of the working structure by gluing them to light studs or beams as the case may be. The sections made in the factory are light and rigid panels, filled with insulation. Much is claimed for the new synthetic glues and this whole construction appears to depend upon them. Wood is always attractive as a surface whether for the natural grain of the wood or as a base for finishes. The experiments of the lumber industry in eliminating the faults of wood as a building material while featuring its good qualities, and in producing units of construction which can be readily assembled by hand labor in the field, will be awaited with interest. At the Century of Progress Exposition the house of wood was one of the most attractive.

This wood system at Madison might be called a frameless house, and several other frameless systems of metal or of wood and metal, are being developed. I know of none

in production. The unit here is likely to be cellular rather than panel, for the third dimension, the thickness, is included in each wall or floor unit. These systems are perhaps the most difficult in their first development. The unit of wall surface or of floor surface must be most carefully chosen. It must permit of good architectural proportions for the building and for the separate rooms. It must be of such size that it can readily be handled in transit and in assembly. The joining of the units must be simple yet rigid; tight, and susceptible of pleasing architectural treatment. The joining of stories also seems to present a difficulty not encountered in framed structures. If, however, such systems can be perfected and sufficiently simplified, they permit a flexibility in planning and in assembly not available to others, and the frank development and expression of a module system is a challenge to architectural skill. A high degree of standardization and complete fabrication seem, with the other features, to offer the best bet for new values in housing. The possible savings in prefabrication will lie largely in mass production, factory control of manufacture, and the limiting of field work to simple assembly. Other things being equal, the system that lends itself best to this organized production will obtain the best results.

Sloped roofs are possible with prefabricated houses and they will no doubt continue to be available to those who want them and can afford to pay for them. Flat roofs have been used since the days of ancient Egypt and we can take it for granted that the present day architect will be able to do something pleasing with them. The issue, I think, will finally be decided on the basis of economics rather than sentiment. In planning a modern house the owner will weigh the cost of a sloping roof with its attic against more usable space which could be added on the first or second floor. There need be no fear for the loss of home appeal in the modern house. It can be made as attractive as now in fundamental proportions, and infinitely more pleasing in surface textures

(Please turn to Page 52)

Distinguished San Francisco Architect Gives His Impressions of International Progress

AFTER spending nearly a year abroad, Arthur Brown, Jr., F.A.I.A., architect of a number of notable buildings here and in Washington, D.C., has returned to San Francisco, happy to be home and favorably impressed with building conditions in California in comparison with construction work in other parts of the country. When Mr. Brown and his wife and daughters departed for the East last summer, San Francisco was just beginning to recover from the depression. Building recovery, too, was on the move. Returning, the noted architect was pleasantly surprised

to find architects and draftsmen busy, contractors with plenty of work to figure and new buildings, particularly residences, going up in numbers.

The two bridges looked good to the Brown family. And besides the bridges there was the new Federal Building in the Civic Center, designed by Mr. Brown himself, and which showed signs of early completion, thanks to the competent hands who were in charge of the

construction work. In all his travels here and abroad there were no new structures more outstanding in design or importance than the San Francisco improvements just referred to, Mr. Brown commented.

Asked for an interview, the San Francisco architect consented with characteristic modesty.

Referring to travel abroad Mr. Brown's party found conditions very agreeable. "The hotels," Mr. Brown said, "are excellent and greatly improved in so far as their equipment is concerned. They compare favorably with our own best hotels.

"In France and Italy there were apparently very few Americans or any

other foreigners travelling, but that was probably accounted for by the lateness of the season.

"So far as I could see, the foreign cities seemed normally prosperous, although I had the feeling that they were not a little worried by their internal affairs; so much so that one heard little discussion of our own country.

"Most of the new architecture that I saw



ARTHUR BROWN, Jr., ARCHITECT

was of a sociological and popular character. In the larger cities there was a certain amount of new commercial work, but very little monumental construction, excepting in Italy where their popular programs take on a monumental character. In Paris the modern architecture is of a progressive type and much of it is very pleasing. There are a number of new churches in Paris which are interesting and refreshing to look at. In the larger cities there are quite a few new hotels, including the Majestic in Rome, the George V in Paris and the Plaza in Brussels. All of these hostelrys are of a conservative modern character and equipped with the latest devices for the comfort of guests.

"In regard to the modern trend abroad, Italy is almost universally modernistic. The buildings, while simple in form, are monumental, and apparently their design is influenced quite strongly by their engineering viewpoint. French modernism seems to be improving and the tendency is to eliminate exaggeration.

"The International Congress in Rome, which I attended as a Federal delegate, was extremely interesting. I enjoyed meeting our confreres from other countries. In fact I found them far more absorbing than some of the heavy papers that were read. There were many well-known architects present — most of them European. Mr. Voorhees, President of the American Institute of Architects, was there with Mr. Zantzinger and also Chester Aldrich and Mr. Hewlett of the American Academy. The French were strongly represented by Mr. Pontremoli of the Ecole des Beaux Arts, Mr. Maigrot, Mr. Tournaire, Mr. Chedanne, and other well-known French architects. Mr. Robert Fan represented the Chinese architects, and I was pleased to meet my old friend, Basile Couremenos, from Athens.

"The Italian architects outdid themselves in hospitality. They staged several imposing parties, one on the Capitoline Hill and a garden

party at the villa d'Este. There was also a reception at the Farnese Palace, which gave one a chance to see it under the most favorable circumstances.

"In Paris I spent much of my time seeing old friends and renewing acquaintances. I also went to the weekly meetings of the Academy of Fine Arts and had the opportunity of hearing discussions on many topics of aesthetic interest. Many of the better known architects are actively occupied with the preparations for an Exposition in 1937, which promises to be brilliant, and I believe it will reflect a fairly good picture of present day architectural opinion in France.

"Going through the East I did not get the impression that there was much private work in progress. The development of Radio City, however, is continuing on a big scale. In Washington there is still great activity in Government building.

"I was happy to get back to San Francisco, which I found prosperous looking, and the progress on the bridges was astonishing. I did not hear much of our proposed Exposition while away, but upon my return to San Francisco I was delighted to find that the Fair is progressing in such an encouraging manner."

Arthur Brown, Jr., de l'Institut de France, F.A.I.A., L.L.D., . . . Graduated with a degree of B.S. in Civil Engineering, University of California, in 1896 and of the Ecole des Beaux Arts, Paris, in 1901. . . . Awarded the Architecte Diplome by the French Government. . . . For a number of years a member of the firm of Bakewell and Brown, nationally known as the architects of the San Francisco City Hall, the design for which was won in competition. . . . This firm also designed the Berkeley City Hall, the Horticultural Building at the Panama Pacific International Exposition, various buildings for the Stanford University and the Pacific Gas & Electric office building, San Francisco. . . . Mr. Brown served as associate architect for the Panama Pacific International Exposition; lecturer in Architecture at Harvard University, 1918; Professor in Theory of Architecture, 1918. . . . Appointed a member of the Board of Architectural Consultants of the Treasury Department, Washington, D. C., in 1927. . . . Designed the Department of Labor and Interstate Commerce Building, Washington, D. C., the Veterans Memorial Building and new Federal Building in San Francisco Civic Center, and the Infirmary Building, University of California, Berkeley. . . . He was a member of the Architectural Commission of the Chicago Worlds Fair Centennial Celebration, 1933, and is also a member of the San Francisco Bay Exposition and a member of the Exposition Consulting Board of Architects. . . . Member of the A.I.A., Beaux Arts Society, Societe des Architectes Diplomes par le Gouvernement, de l'Institut de France, Beta Theta Pi, Officier Legion d'Honneur (France), University Club, Pacific Union, Olympic, Cercle de l'Union and Burlingame Clubs.

STRUCTURAL PEST CONTROL ACT

EXTENT OF ARCHITECT AND ENGINEER'S RESPONSIBILITY

By Glen V. Slater, State Registrar of Pest Control Board

THE April number of The Architect and Engineer published an article by A. A. Brown, C.E., the title of which was "Termite Curb Is In Conflicting Hands — Pest Control Board versus Structural Engineers."

This article seems to call for a reply in view of the fact that many statements were worded in such a manner as to be misleading, in that it does not present a true picture of the activities of the exterminating industry, nor of the function of the State Structural Pest Control Act as experienced today. The first questions that arise are: "What is the Structural Pest Control Act? What is the purpose of such legislation? What does the Act require? What is the definition of Structural Pest Control as defined in the Act and what are the exemptions?"

It is the consensus of those who have been familiar with the enforcement of the Structural Pest Control Act, and the studying of the Act as passed, that the above questions are answered in plain, understandable language within the wording of the law. However, since the question has been brought up as to its validity and practicability, the following interpretations may serve as an index as to what enforcement agents consider the true analysis of the Act in question:

(a) The Structural Pest Control Act is a law which is intended to regulate, by licensing, the physical operations of exterminating pests, parasites, insects, fungi, rodents, etc., or preventing the habitation of such pests by the use of chemicals or deadly poisons.

(b) The purpose of the law is to safeguard the public by requiring that those persons who apply chemicals are cognizant of the danger to human life in the improper use of insecticides, fumigants, or allied chemicals.

(c) The law requires that every person who engages in the practice of Structural Pest Control shall be licensed unless specifically exempt.

(d) Section one defines Structural Pest Control as follows: "As used in this Act, Structural Pest Control includes the use of insecticides, fumigants, or allied chemicals for the purpose of eliminating, exterminating, or preventing infestation of vermin, rodents, parasites, fungi, insects, and any other pests which infest or damage household or other structures."

(e) Certain persons, utilities and agencies are exempt from provisions of the Act, all of which are recited in Section two, Paragraph E of this section which reads, "Licensed architects or licensed civil or structural engineers acting solely within their professional capacity."

Now, having stated the scope of the law and salient points relating thereto, we can discuss the next question: "To what extent can an architect or engineer practice Structural Pest Control?" — and for the sake of argument we may include the contractor. Neither the architects', engineers', nor contractors' laws authorize, either directly or indirectly, the engaging in any other profession than the one for which he is certified, registered, or licensed. Nor do any of the laws prohibit him from engaging in some other business. However, if he is interested in any other activity which is regulated by a state law, then he is legally

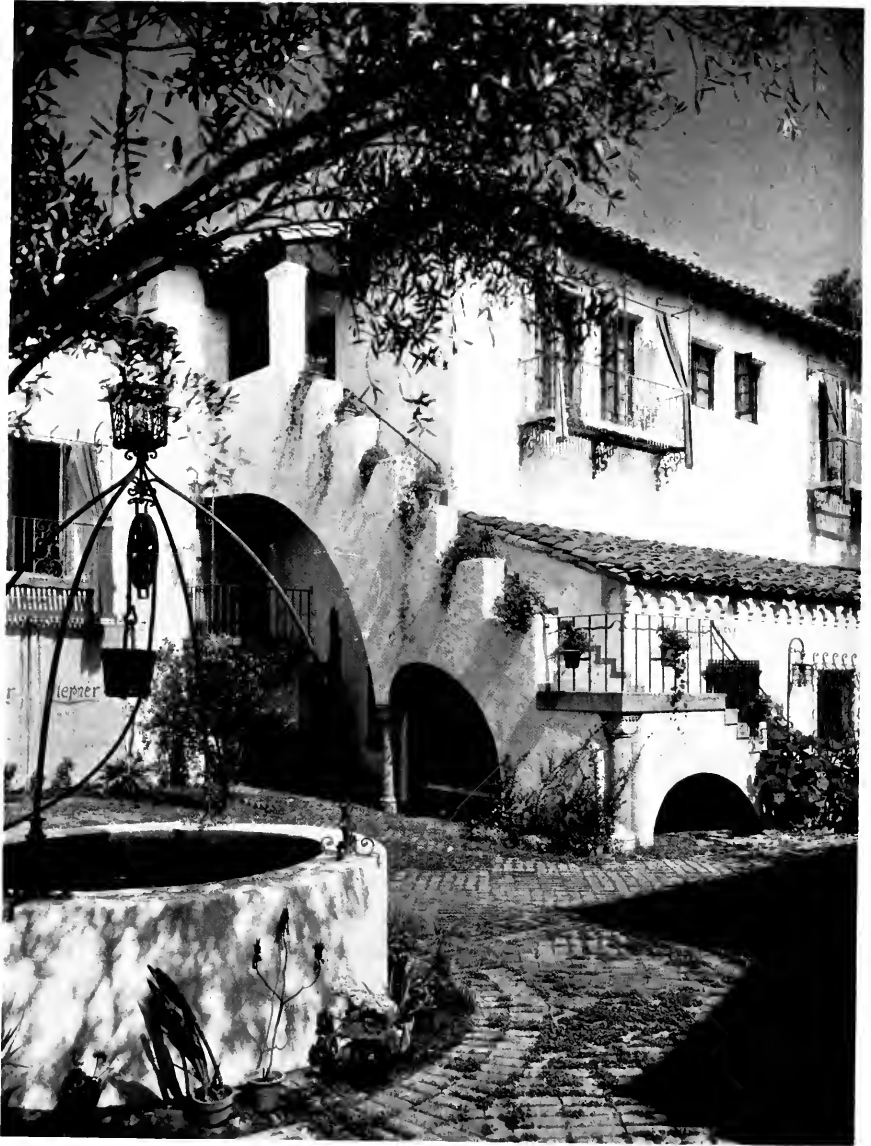

WISHING WELL, PAVED WALKS, CLINGING VINES AND FLOWER POTS, CONTRIBUTE TO THE CHARM OF THIS SPANISH HOME

obligated to respect and comply with any and all requirements regulating the business or profession, regardless of whether he holds an architect's or engineer's certificate or a contractor's license.

The assumption that architects and engineers are exempt in Section two has been broadened beyond their true field of activity, for the law specifically states, "when acting solely within their professional capacity." The professional capacity of an architect or engineer is generally accepted by the ethical members of the profession as the planning and designing of buildings and structures or civil engineers' projects, and it is the contractor's function to erect or build. Certainly, if it had been intended that the control of pests was the function of the architect or engineer, such would have been included in the definition recited in each Act.

In the definition of Structural Pest Control, the words "eliminating, exterminating, or preventing infestation" are used.

The architect or engineer is employed by a client for the purpose of designing a structure that will be structurally safe. In doing this he must take into consideration all factors, such as loads, either vertical or horizontal, kind and strength of material, etc. If, in his opinion, a treated timber, regardless of how or with what it may be treated, or some particular method of construction is advisable as a precautionary measure against infestation of termites, he is morally obligated, to his client, to exercise his judgment in this regard, and certainly he is legally authorized to do so under the exemption provision, but it is not agreed that an architect or engineer has a right, nor is within the scope of his professional practice, to advise or specify the use of chemicals or poisons to rid a structure of existing destructive pests or insects, etc.

An architect may plan a hospital, the engineer may design it structurally, and the contractor may build it, but that does not give any of them the right to treat the patients confined therein. It would be just as logical for any of them to step over into the medical

profession as it would be for them to prescribe the use of insecticides, chemicals, or deadly poisons in or around a home or structure, since in both cases human life is at stake. Briefly, the law, as contemplated, was not enacted in order that engineers, architects, or contractors should practice Structural Pest Control as defined by the Act, unless such persons held a certificate issued by the Pest Control Board.

The statement is made in the article published that exterminators claim that knowledge of the building industry was summarized in a recent State-wide examination as follows: "What is a mud sill? What do you consider the proper mix for cement in a foundation wall for a two-story dwelling? What is a post butt? What is a joist? What is a girder? Would it be practical to cut an opening beneath the first floor line, above the foundation, in a brick wall 20 inches high and four feet long, to remove debris or earth without shoring it up?"

The impression is given that this was the entire set of questions that had to do with the construction problems in exterminating, which is very misleading, for there were, in addition to these questions, diagrams in which the examinee described the practical way of caring for infestation found in structures under certain conditions, and for the information of the readers it might be well to state that many of these questions originated in the University of California at Berkeley, and were authored by a recognized authority on the subject of termite prevention.

There never has been any conflict between divisions in the Department of Professional and Vocational Standards in the administration of the Structural Pest Control Act.

The Structural Pest Control Act was sponsored by a very representative State-wide group of exterminators who are desirous of putting the industry on a basis that would command the respect that is its due, and at the same time protect the public from unethical practices that were creeping into the business. This law is without question the most compre-

hensive regulatory measure in force anywhere in the United States today, and is being used as a model for several other states in proposed legislation in order that these commonwealths may realize benefits similar to those being experienced in California. In the matter of termite control alone it is estimated that a saving of five hundred dollars a day is being made for the property owners of the State of California solely through the Structural Pest Control Act, in that it is eliminating poor practice, itinerant operations, fraudulent claims at the time of inspection, and inadequate work after contracts have been consummated. It might be well, perhaps, to call attention to the fact that the article in question was based entirely on the subject of termites. The Structural Pest Control Act, however, regulates all types of exterminating, and anyone taking an examination for class A, which embraces all classes of

the work, writes tests in eleven subjects, termites constituting only one subject in the test.

Standardization of methods is a granted need. Standardization of chemicals is already taken care of by the Economics Poisons Act.

There is no question but what the Structural Pest Control Act has, in the short time of its operation, proven very beneficial to both property owners and honest exterminators throughout the State. Most individuals, banks, and loaning organizations now require an inspection of structures and a report of same by an experienced and competent termite operator before loans will be considered.

In summarizing, it is safe to say that any individual interested in the welfare of the State will assist in enforcing any present law that has been passed for the good of the people and will assume a helpful attitude rather than a position of destructive criticism.



GARDEN DECORATION

INSTITUTE CONVENTION WELL ATTENDED

HIGHER STANDARDS OF PLANNING - - HOUSING DISCUSSED

(Special to The Architect and Engineer)



LD POINT COMFORT, VA.,

May 10. — The 68th Convention of The American Institute of Architects at Williamsburg, Va., was the most successful meeting held by the Institute in recent years. The attendance was large and the enthusiasm all that could be desired.

Higher standards of planning, design, and construction in public buildings of the nation are being sought by Secretary of the Treasury Henry Morgenthau, Jr., through coöperation with the Institute, it was revealed in a special committee report at the convention.

Francis P. Sullivan of Washington, was chairman of the committee whose report was unanimously accepted by Directors of the Institute.

The problem approached involves not only theories and concepts of designs and motifs, but the detailed consideration of the necessary relationships between government agencies and architects. One of the questions on the agenda is whether permanent governmental architectural agencies are necessary, and if so what their organization and functions should be.

The method of selection of private architects, where they are engaged on government work, as well as of materials, are questions before the conference. What, if any, obstacles to architectural advance are raised by unnecessary governmental restrictions also are the subject of study.

The report stated that "distinct progress has been made toward a mutual understanding of the points of view of the architectural profession and the officials concerned with public buildings.

"The Secretary's action," the report continued, "in initiating the conference has placed the Institute in a position where it can materially advance the cause of good architecture. There is little doubt that the result will be to clear away many of the obstacles which have, in the past, hampered the architects of public buildings in the endeavor to attain the high level of planning, design, and construction which is appropriate for them.

"While the progress of these discussions may appear to some to be unduly deliberate, it must be realized that the situation which now exists is a development of many years and cannot be remedied in a day.

"Reports received from the public works representatives of the various Chapters indicate that much effective work has been done in the states and municipalities along lines parallel to those which have been pursued by the Institute Committee on Public Works in its contacts with the Federal Government.

Regional Plan for Washington

As chairman of the committee on the National Capital, Mr. Sullivan reported that "a project for a regional plan comprising the area between Washington, Baltimore, and Annapolis, long advocated by the Baltimore Chapter, has assumed concrete form and a study has been initiated under the auspices of the Maryland State Planning Commission and National Resources Committee."

"During the past year," he added, "this committee has been active in advocating a study of the approaches to the United States Capitol Building, and the development of a plan for the north, south and east axis of the City of Washington, to supplement and harmonize with the treatment of the Mall area.

The committee is working toward the establishment in the National Gallery of Art in Washington, D.C., of a permanent national collection of architectural drawings under the sponsorship of the Institute. This is in accordance with a resolution adopted by the Institute's Board of Directors.

Opposition to centralized control of housing by the Federal Government was voiced by the Committee on Housing, in a survey report made public at the convention.

Public apathy was blamed by the committee, headed by Richmond H. Shreve of New York, for "indecision" delaying the adoption of a national plan of action. Housing, it was suggested, should be recognized as a social problem equally as vital as hospitalization, education, police service, or fire protection.

Development of separate housing plans for families of low-income and for those able to pay an economic rent was advocated. Public aid, it was held, must supplement private enterprise in providing dwellings for low-income groups. Unwavering adherence to "standards" below which housing may not be occupied, even though low at first, was asked.

Oppose Government Control

"The American Institute of Architects should oppose any course of action setting up Federal control through a central agency to coerce localities into the execution of plans subject to Federal approval, or placing in the hands of Government control of the financing of all housing developments," the report said.

"Federal agencies should exercise only such nationwide functions as guide and aid all localities and inter-relate one region with another in accordance with a national plan of action. Decentralization of activities with respect to specific projects is recommended.

"Remote control is impossible. It is necessary to concentrate as close to each locality as possible, to study its problems and to initiate projects. These developments should be related to regional and community planning, without which any improvement, however well conceived and executed in itself, risks failure through death of its locality. What is needed

is neighborhood insurance against depreciation.

"It is essential that there be a measure of minimum dwelling sufficiency, however low, as a beginning, and that it be enforced. The importance of proper relation of housing to transportation, employment, recreation, and educational facilities must be recognized. For the solution of the problems in each community, coöperation of local social and economic agencies such as chambers of commerce, merchants' associations, welfare organizations, and churches is needed."

No housing procedure, whether social or governmental, will be clearly indicated until public opinion or political expediency is ready to go beyond present indecision, the report declared.

The Problem of Domestic Shelter

"As yet there does not exist an organized majority with a social purpose to deal with shelter as we have dealt with hospitalization, education, water supply and sanitation, police service, or fire protection," it states.

"It is clear that the whole question of domestic shelter is part of a vastly greater problem of social progress not alone in the United States, but over the world. It is clear, too, that while the problem involves many more considerations than the mere provision of shelter, it must be attacked primarily as a social problem and not as a means of stimulating industry or reducing employment.

"It is a long-time problem and not an emergency condition to be dealt with through temporary expedients, although at this time its difficulties are made more evident in the high light of social and political experiment viewed against the dark shadow of the depression.

"In facing the problem of housing, there must be considered the unbalanced distribution of national income; the public and private debt structure; a decreasing rate of population growth; and an economic state in which the construction industry must be mostly concerned with replacement.

"Innumerable State Housing Boards and Housing Authorities were legally created in the

last three years, but apparently we are as far from having any effective procedure, much less results, as we are from having any agreement on the functions in housing of Federal, State, or Municipal Governments or that of private producers aided, guided, regulated, or left alone to their own sweet ways.

"As realization of responsibility and opportunity develops, there will be an acceptance of the principle that the demands on the part of those having ability to pay an economic rent will be met by private enterprise, but that need caused by inability to pay must be relieved by public aid.

Housing the Non-Economic Group

"The bill with respect to housing for the non-economic group introduced by Senator Wagner and now before Congress is significant as an indication of a possible Government program. It is clear, however, that Government agencies not active in the relief housing field are not agreed as to common procedure and that the country at large is not prepared to express a united or even preponderant opinion favoring any one of many plans.

"Effective action of permanent value is to be obtained only as communities take back and exercise their initiative and do not depend on a central bureau for local relief."

The economic group comprising families able to own homes or to pay an adequate rent, covers the widest possible range from the great cities to the simplest country home and the farm houses, the report points out.

"No rule of average income can be justly applied because incomes which in a city must be recognized as low may in the country constitute a modest competence. In this field there has been less discussion of public policy, but much active effort to extend the range of professional service into the lower levels of ownership, the small house as contrasted with the home of the successful 'rugged individualist'.

"No effort can be broadly successful unless directed toward the greatest bulk of home building, the low-priced small house."

Foreign Architects Honored

Election of five foreign architects to honorary membership in the American Institute of Architects was announced by Charles T. Ingham, Secretary of the Institute, on the closing day of the convention.

Mr. Ingham also announced that Edward Bruce, Secretary of the Advisory Committee on Fine Arts to the Treasury and head of the Federal Public Works of Art Project, was voted an honorary member "in recognition of his unselfish efforts to further the creation and appreciation of art in America."

"Mr. Bruce's encouragement of young artists has brought hope and opportunity for creative work, as he has helped to make the government and the people of the country conscious of art as a factor in our social economy," the citation said. "His own talents as a painter have brought recognition from his fellow artists, from museums, and from connoisseurs."

The foreign architects and their citations are as follows:

SIR IAN MACALISTER Kt., M.A. Merton College, Oxford, Secretary of the Royal Institute of British Architects since 1908.

PERCY EDWARD THOMAS, O.B.E., F.R. I.B.A., President of the Royal Institute of British Architects, the first Welshman and the youngest architect to hold that office.

EMILE MAIGROT of Paris and of Rheims, France, President of the Societe des Architectes Diplomes par le Gouvernement and Secretary-General of the Comite Permanent International des Architectes, an architect of great industry and ability.

ALBERTO CALZA BINI of Rome, Italy, architect, active in the educational professional and political rebuilding of Italy as well as in the town planning of Rome and the restoration of its historical monuments.

Dr. ADOLFO MORALES de LOS RIOS, educator, writer and distinguished architect of Rio de Janeiro. Dr. Morales has been active in improving professional standards in Brazil and has rendered service in the promotion of international relations.

EARTHQUAKES

(Concluded from Page 34)

component in the movement, a tidal wave is caused. Often these vertical movements are of a great height, sometimes causing islands to disappear and new ones to appear. When there is a vertical movement, the water will rush into it and then recede or vice versa. It is this rushing and receding of the water that causes the tidal wave.

Earthquakes have been known as far back as historic records go. However, it is only during the period of more recent civilization where man has congregated in large congested areas and in buildings that are not adequately designed for earthquake resistance that it has become a menace to life and property. The Federal Government is placing instruments in various localities to determine the severity, characteristics and probable periods of recurrence of earthquakes. When this information has been obtained and compiled, structural engineers will be able to construct earthquake resistant structures and thus remove the fear of earthquakes as well as the hazard to life and property.

AUSTRALIA SHOWS WAY TO MODERNISM

(Concluded from Page 32)

"The doors are of single sheets of plate glass with bevelled edges neatly framed in two leaves and fitted with a chromium kicking plate.

"The shop windows are lined with dark toned plain walnut relieved with horizontal strips of metal or black mahogany.

"The corners of the shop windows are of curved glass, which further adds to the "absence of support" idea, particularly after what we have been accustomed to see—a vertical member coming on the angle. Above these, single storeyed windows flood the interior with light, which is as bright as day.

"The facade is virtually undecorated, if we

except the exaggerated keystones that come over the entrances. Yet a distinctly modern character is obtained from the materials and the disposition of the openings and lighting features.

"The structure is of steel and concrete, and covers an area of 160 ft. frontage, both to Collins and Francis Streets, by a depth of 140 feet. The interior is kept severely plain and devoid of all excesses, everything being useful. A feature is made of a two-way stairs in the center of the shop leading to a mezzanine floor, whilst beneath this a small flight of stairs leads to a basement, thus converting the two stories in the front to a three story structure inside."

PROGRESS IN DOMESTIC ARCHITECTURE

(Concluded from Page 42)

and colors, in ready cleanability, in convenience and comfort, and in adaptability to the installation of modern equipment.

Some of you may wonder why this paper was not confined to a pleasant discussion of the qualities of fine houses of traditional character. For men interested in the house-building field it seems to me that the opportunity lies not in building elaborate houses but in giving better housing values. The automobile industry found its opportunity and its profits, not in Cadillacs, Imperial Chryslers, and Lincolns, but in Chevrolets, Plymouths and Fords. Everyone agrees today that these small cars of whatever make are truly remarkable values in fine transportation. There can be no great progress in housing without more efficient production. No house however skillfully fabricated can expect consumer acceptance unless it is good to look at and comfortable to live in. The housing industry is just beginning a new day in the production of homes. Successful new methods will result in tremendous activity in building and better homes for people everywhere.

WILLIAM H. WEEKS, ARCHITECT

California lost one of its pioneer architects April 29 when William H. Weeks, known from one end of the state to the other for his work in school architecture, passed away at his beautiful home in Piedmont. Mr. Weeks had been ailing for some time, having suffered a heart attack last November. Prior to that time, in spite of his advanced age, 72, he continued to be actively engaged in the practice of his profession, maintaining offices in the Underwood Building, San Francisco, with his son, Harold Henry Weeks, as associate.

It was said of Mr. Weeks that practically every city and town in Northern and Central California claimed one or more buildings which he had designed. A story is told about a competitor of Mr. Weeks who invited a number of school trustees to accompany him on an auto tour of Northern California to inspect school houses he had built. The board was about to select an architect to design a new building for its community and this architect was in line for the commission.

Coming to the first town the officials noticed an attractive school house along the highway and were somewhat surprised that their architect host did not proffer any information about it.

"Who designed that good looking building?" one of the officials asked finally.

"That building, why 'er, I think W. H. Weeks was the architect," he replied somewhat reluctantly.

Further along they passed another school. "And who was the architect of that structure?" the trustee again asked. Once more the answer was "W. H. Weeks." As other towns were visited similar questions and identical answers were given until finally the board is said to have agreed that it had seen enough and returning home speedily sent for Mr. Weeks and offered him the job.

Among the outstanding school buildings designed by the W. H. Weeks office are the Piedmont High School, the "million dollar" high school at Santa Barbara, the Pomona High School, the Palo Alto High School and schools in Santa Rosa, Napa, San Jose, Cambell, Saratoga, Mountain View, Sunnyvale, Gilroy, Morgan Hill, Pacific Grove, Monterey, Paso Robles and San Leandro. Before the depression Mr. Weeks' architectural activities included the Madison-Lake Apartments in Oakland, the Hotel Leamington, the Jackson Hotel, Piedmont Hotel, Oakland, Durant Hotel, Berkeley, De Anza Hotel, San Jose, Hotel Appleton, Watsonville, and a number of apartment and office buildings.

All told, Mr. Weeks is said to have designed more than 1200 school houses besides about 50 churches, as many banks and at one time all of the Carnegie libraries in this part of the State.

Born in Charlottetown, Prince Edward Island, Mr. Weeks came to this country at the age of 12. He received his architectural education at the Berger

Institute in Denver, and soon moved to Watsonville, where he first established himself.

With his family, he moved to Oakland in 1915, and in 1924 established his home in Piedmont.

He is survived by his widow, Mrs. Maggie H. Weeks, whom he married in Charlestown, Ind., in 1891, and five children, Harold H. Weeks, associated with him as an architect and who will carry on the business, Foster H. Weeks, Arthur E. Weeks, Miss Margaret Weeks, and Mrs. Jack Norris. Also surviving are two sisters and a brother, Mrs. Jean Steinhauer and Mrs. Ida Covell of Watsonville, and Hammond Weeks, architect.

Mr. Weeks was a member of Northern California Chapter, A.I.A., a Mason and member of various other fraternal orders. He was one of the first architects to resume practice in San Francisco after the earthquake and fire of 1906. His office at that time was in the Embarcadero Building at the foot of Market Street.

BURGESS J. REEVE

Burgess J. Reeve died at his home, 1829 West Adams Street, Los Angeles, the latter part of April, aged 90 years. In the sixty years he was actively engaged in business he designed many important buildings in the southern city, most of which have, in recent years been razed to make way for new structures. Among them were the Pro-Cathedral on the site of the Biltmore hotel; St. Vincent's church at Grand Avenue and Washington Boulevard, and the Phillips block on North Spring Street.

CHARLES ALLERTON COOLIDGE

Charles Allerton Coolidge of Boston, nationally known architect, died suddenly April 1 at the home of his daughter, Mrs. Gordon S. Rentschler, wife of the president of the National City Bank of New York. Mr. Coolidge designed the Stanford University buildings at Palo Alto, several Harvard University halls and numerous other important structures throughout the country.

BOOK REVIEWS

By Edgar N. Kierulff

CITY PLANNING AND HOUSING:— 1st Volume; Historical and Sociological; by Doctor Werner Hegeman; Architectural Book Publishing Co., New York City. Price: \$3.75.

This is the first of three volumes, and if the other two are as complete, and contain data of corresponding interest, they should constitute a valuable group covering the subject.

The historical sections of this present volume bring to light some interesting facts relative to programs for public works, housing and zoning laws advocated by the early founders of the country.

Eighteen chapters comprise the format and cover the periods of city planning development.

SAN FRANCISCO ARCHITECTURAL CLUB

WALTER C. CLIFFORD, President
H. WALTER RUPPEL, Vice-President
RICHARD E. AUDSLEY, Secretary A. N. GRANISH, Treasurer

TRUSTEES
WALDON B. RUE OTTO G. HINTERMANN HARRY C. NYE
DIRECTORS
ALBERT KAHL IRA H. SPRINGER CHARLES J. CONTI

Atelier Interests Members

The new set-up of the Atelier is producing some very fine results as shown by the recent problems that have been on display in the club quarters. The new system, briefly, consists of projects done conjunctively by the Atelier students and the students of the School of Architecture at the University of California. Our students use the same program as the college men, and there is no difference in the duration of the problem.

Club men are ably criticized by their two patrons, Mario J. Ciampi and E. Preston Ames. After the

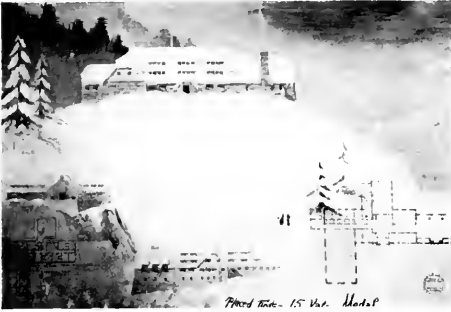

SUBMITTED BY WORLEY WONG AND
AWARDED FIRST MENTION

rendu date, and the college judgment, the best California problems are sent to the club to be judged by a jury of local architects, appointed by the Committee of Education of the Northern California Chapter, American Institute of Architects. The work pub-

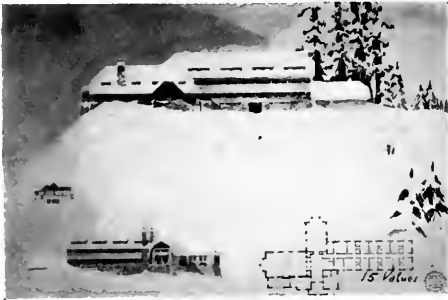

SUBMITTED BY JAN WILKING AND
AWARDED SECOND MENTION

lished herewith are the winners of the first problem, "A Ski Club in the Sierra Nevadas." The jury consisted of Messrs. Edward Frick, Clarence Tantau and Winfield

Scott Wellington, representing the Institute; Raymond Jeans, representing the University of California, and Messrs. Ames and Ciampi, for the Club.

The April meeting of the club brought many old timers to the festive board. It is interesting to note that with new life in the architectural profession, the older men are once more renewing their friendships formed in the club. There were 63 members present. Nedd Joyner has been admitted to regular membership. Instructive and hair-raising movies were shown by the Champion Spark Plug company, depicting the contributions to modern automobiles and their safety appliances, by the racing drivers of the day.

* * *

The annual Spring Frolic was held at the Club Lido, Friday evening, May 15. The affair, given in response to the many requests that the club duplicate its very successful event of last December, was a huge success and largely attended. H. Walter Ruppel was in charge of the ticket sales.

"R. E. A."

LOS ANGELES NATIONAL HOME SHOW

The Building Material Exhibit, Architects' Building, Los Angeles, is housing the "Los Angeles National Home Show" this month.

In addition to regular and special displays of all materials for new home construction and modernization, the Federal Housing Administration employed a large staff of experts to answer questions and give authoritative information regarding financing. An exact duplicate of the material used in the 1936 Housing Show at the San Diego Exposition was set up as part of the educational exhibit of the Federal Housing Administration.

The Building Material Exhibit itself has just been completely modernized and includes many innovations in the attractive display and demonstration of various building materials and equipment.

1936 BUILDER'S EXCHANGE MEETING

Santa Barbara has been selected as the place for holding the 1936 convention of the California State Builders' Exchange. The time of meeting to be announced later will be the latter part of September or early in October. Thirteen of the 17 state directors attended the Fresno meeting, April 4, which was presided over by State President C. W. Pettifer of Long Beach. State Registrar of Contractors Earl S. Anderson and Deputy Registrar Glen V. Slater attended the meeting and there was a discussion of the operation of the Contractors' License Act which resulted in a general agreement that the law can be made completely effective by strict enforcement.

With the Architects

STORE ALTERATIONS

Plans have been completed by Albert F. Roller, Crocker-First National Bank Building, San Francisco, for alterations to the Post Street store of the Allied Properties Company. J. Salzman, furrier, is the lessee. Mr. Roller has also made plans for a new elevator front and improvements to the lobby of the Alaska Commercial Building, San Francisco.

SACRAMENTO STORE BUILDING

Moore & Roberts, 693 Mission Street, San Francisco, have been awarded a contract by the Capital Company to build a one-story brick and concrete store building at 1009 11th Street, Sacramento. This same firm also has a contract to build a two-story dwelling for Edgar Meakin in San Francisco from plans by Miller & Warnecke.

SCHOOL AUDITORIUM

St. Matthew's Parish will build a \$75,000 parochial school auditorium at San Mateo. The hall will seat 500. Plans were prepared by H. A. Minton, 525 Market Street, San Francisco, who has also made drawings for an addition to St. Brigid's Parochial School at Broadway and Franklin Street, San Francisco.

SAN JOSE LIBRARY

Extensive alterations are to be made to the old Post Office Building at Market and San Fernando Streets, San Jose. Upon completion the building will be used as the central library, the old library building having been disposed of to the State College. Ralph Wyckoff is architect for the proposed improvements.

NINE STORY HOTEL ADDITION

W. Adrian, 417 Market Street, San Francisco, has completed the structural plans for a nine-story steel frame and reinforced concrete addition to the Oxford Hotel, Turk and Mason Streets, San Francisco. Arnold Haase is the owner of the property.

FACTORY FOR SAN LEANDRO

The Friden Calculating Machine Company will build a one-story steel frame and brick office building and factory in San Leandro from plans by Frederick H. Reimers, 233 Post Street, San Francisco.

TWO BERKELEY DWELLINGS

Plans have recently been completed by John B. Anthony for two Berkeley dwellings, one for Dr. Kellogg, and the other for S. W. Shear. Both houses will cost in the neighborhood of \$8500 each.

PERSONAL

Professor Harry W. Shepherd, associate professor of landscape architecture at University of California, Berkeley, and consultant to the State Park Commission, has been engaged to make the planting plan and select the plant material for the Old Mission gardens and LaPurissima State Park at Lompoc.

Fred Confer has moved his office from Russell street to a studio home at Brookside and Claremont Avenue, Berkeley.

Fred J. Rogers, of Seattle, has moved his architectural office to Suite 1106 Textile Tower, Seattle, from room 1504 in the same building. He has engaged as his assistant Harry E. Nordquist, graduate in architecture from the U. of W., class of 1933.

THEATER PLANS COMPLETED

John H. Ahnden, 822-39th Avenue, San Francisco, has completed working drawings for a reinforced concrete theater to be built at Chestnut and Scott Streets, San Francisco, at an estimated cost of \$75,000. L. H. Nishkian is the structural engineer.

PAROCHIAL SCHOOL

A two-story and basement reinforced concrete parochial school is to be built at Howard and Walnut Streets, Petaluma, for St. Vincent's Parish, from plans by Arnold S. Constable, 580 Market Street, San Francisco. Improvements will cost \$60,000.

ST. JAMES WOOD HOUSE

Clarence Mayhew, 6026 Acacia Avenue, Oakland, is busy on plans for several new houses in the Bay District, including a \$10,000 dwelling for Allen Schutter in St. James Wood, Oakland, and a house in the Taylor Gardens Tract, Berkeley, for Mr. Rowell.

SAN FRANCISCO RESIDENCE

Hyman & Appleton of San Francisco are architects of the two-story frame residence for Otto Rosenstein. The house will occupy a view lot on Francisco Street, near Polk, San Francisco.

MARIN COUNTY RESIDENCE

REDDICK H. BICKEL, 9 Geary Street, San Francisco, has prepared plans for a two-story residence in Kentfield for J. Marmur, 51 Walnut Avenue, Larkspur. Approximate cost \$10,000.

BANK BUILDING

A one-story reinforced concrete bank building is being erected at Colusa for the Bank of America from plans by L. J. Hendy, 625 Market Street, San Francisco.

FEDERAL RECOGNITION

The United States Senate has accorded the 1939 World's Fair the official recognition of the United States Government.

By unanimous vote, the Senate passed Senator Hiram W. Johnson's bill authorizing President Roosevelt to invite all foreign nations to participate in the Exposition in San Francisco three years hence.

The Senate's unanimous vote presaged similar action by the House of Representatives, in the opinion of Exposition leaders.

Senator Johnson's bill will be introduced in the House of Representatives by Representatives Florence P. Kahn and Richard J. Welch.

Passage of the bill in the House will mean that the Exposition can at once begin plans for international participation.

More than that, it was pointed out, it means that the San Francisco Bay Exposition is the only 1939 Fair to be given official governmental sanction and approval.

ARCHITECTS GRANTED CERTIFICATES

Certificates to practice architecture in the State of California were granted at the last meeting of the State Board of Architectural Examiners, Northern California Section, to the following: Curtis Tobey, 1022 East 28th Street, Oakland; William Franklin Baxter, 1040 Norwood Avenue, Oakland; William Arthur Newman, 402 Post Office Building, San Francisco.

BERKELEY FIRE HOUSE

James W. Plachek of Berkeley, has completed plans for a new fire station on Cedar Street, between Eighth and Ninth Streets, Berkeley, to replace the old station at Sixth and Camelia Streets. The City Council is advertising for bids.

ST. JAMES WOOD HOUSE

Geo. Gerken, manager of the Sunset Lumber Company, Oakland, will build an Early California Spanish style residence in St. James Wood, Oakland, Williams & Wastell, architects. F. A. Kurtz will be in charge of construction.

SPANISH STYLE RESIDENCE

Charles R. Lindley, Monadnock Building, San Francisco, has completed plans for a Spanish style residence in St. Francis Wood, San Francisco, for Dr. John Mott Rector. The estimated cost is \$18,000.

ENGLISH DWELLING

Charles E. J. Rogers, Phelan Building, San Francisco, has completed plans for a \$9000 dwelling to be built facing El Camino Real in Vallejo for Robert E. Clark.

ARCHITECTURAL EXHIBIT

An exhibition of the architectural work of Sacramento architects was held during the month in the gallery of the Womens Building on the California State Fair Grounds, Sacramento. The affair was sponsored by the Sacramento District Society of the State Association of California Architects.

Sketches and plans of Sacramento's outstanding construction projects — completed, under construction and proposed — were exhibited.

Herbert E. Goodpastor, attached to Harry J. Devine's office, is the president of the local society, while W. K. Bartges and R. C. Younger of the State Division of Architects are the vice president and secretary, respectively.

CURRENT BUILDING COSTS IN LOS ANGELES AREA

Compilation of unit building costs for various types of buildings in Southern California, has just been completed by the Construction Industries Committee of the Los Angeles Chamber of Commerce with the cooperation of architects and contractors.

Covering such structures as steel frame buildings, Class A reinforced concrete structures, Class C buildings, and residential construction, the report compares current building costs with similar costs in the years from 1927 to 1933. The report was not compiled in the years 1934 and 1935. Unit building costs for the Class A and Class C buildings are figured in cubic feet, while those for residential construction are indicated in square feet.

It is interesting to note that the committee does not recommend that a unit cost of less than \$3.00 per square foot be estimated in the construction of residences. This cost includes architectural fees.

The unit building costs given in the report of the committee were arrived at as a result of a study by a sub-committee. "The committee received a wide range of current building costs", the report says. "In every instance some costs were submitted indicating that such types of structures can be constructed for less than the amount indicated, and the same is true with reference to more expensive construction. After study, however, it is felt that the committee cannot recommend lower unit costs than those indicated. Furthermore, the costs are effective at this time, with the likelihood of an early increase.

"In considering these costs the following factors were used by the committee:

"Volume in cubic feet is average floor area times the total height from the lowest basement floor to high point of roof.

"Area in square feet is total floor space, including porches but not light courts.

"Cost is contractor's price plus architect's fee."

BUILDING COSTS IN LOS ANGELES AREA

TOTAL UNIT VALUES PER CUBIC FOOT

	1927		1929		1930	
Class A Steel Frame Buildings						
Office buildings	\$.50	\$.70	\$.47	\$.68	\$.45	\$.65
Hotels55	.70	.53	.67	.51	.64
Apartments55	.70	.50	.65	.48	.62
Lofts20	.35	.20	.35	.19	.34
Warehouses20	.30	.19	.30	.18	.29
Class A Reinforced Concrete						
Hotels45	.65	.48	.64	.46	.62
Apartments50	.65	.46	.62	.45	.60
Lofts17	.30	.17	.30	.16	.30
Warehouses15	.25	.15	.25	.15	.25
Class C Brick Buildings						
Stores on ground, apartments above25	.45	.20	.42	.20	.40
Apartments30	.50	.30	.50	.27	.50
Hotels25	.45	.25	.45	.23	.45
1-story garages per sq. ft.	1.50	2.00	1.50	2.00	1.46	2.00
1-story stores per sq. ft.	2.00	3.25	1.80	3.25	1.75	3.20
Markets

TOTAL UNIT COSTS PER SQUARE FOOT—FRAME BUILDINGS

Residences—Two-story						
Good	6.00	8.00	6.00	8.00	5.75	8.00
Medium	4.00	5.00	4.00	5.00	3.90	4.90
Residences—One-story						
Good	3.40	3.75	3.40	3.75	3.25	3.60
Medium	2.75	3.25	2.75	3.25	2.50	3.15
Four Flat Building, Two-Story						
Good	4.25	5.00	4.00	5.00	3.80	4.75
Medium	3.75	4.25	3.50	4.50	3.30	4.25

TOTAL UNIT COSTS PER CU. FT.—CLASS "A" AND CLASS "C" BUILDINGS

	1931		1933		1936	
Office buildings	\$.42	\$.64	\$.32	\$.44	\$.55	\$.66
Hotels50	.63	.38	.47	.60	.70
Apartments45	.60	.34	.45	.55	.70
Lofts18	.33	.14	.21	.20	.30
Warehouses16	.26	.12	.20	.20	.30
Class A Reinforced Concrete						
Hotels45	.61	.34	.46	.50	.60
Apartments44	.60	.33	.45	.50	.60
Lofts15	.29	.11	.18	.20	.28
Warehouses14	.24	.11	.18	.20	.28
Class C Brick Buildings						
Stores on ground, apartments above19	.39	.14	.30	.17	.40
Apartments25	.50	.19	.38	.22	.44
Hotels22	.45	.17	.34	.22	.44
1-story garages per sq. ft.	1.40	2.00	1.05	1.50	1.75	2.25
1-story stores per sq. ft.	1.65	3.00	1.25	2.28	1.75	2.25
Markets	2.65	3.50

TOTAL UNIT COSTS PER SQ. FT.—FRAME BUILDINGS

Residences—Two-story						
Good	5.50	7.80	4.13	5.85	5.00	7.50
Medium	3.80	4.75	2.85	3.56	4.00	5.00
Residences—One-story						
Good	3.05	3.50	2.29	2.63	4.00	6.50
Medium	2.25	3.05	1.69	2.29	3.00	4.50
Four Flat Building, Two-Story						
Good	3.75	4.65	2.80	3.50	3.50	4.00
Medium	3.10	4.05	2.33	3.04	3.00	3.75

Chapter and Club Meetings

SOUTHERN CALIFORNIA CHAPTER

Anticipating the annual Institute convention at Williamsburgh, Virginia, the April 14th Chapter meeting in Los Angeles was addressed by Reginald D. Johnson who described the colorful background and historical associations of the Virginia city in the early era, touched upon the state of deterioration to which many of its buildings and landmarks had fallen in the ensuing years, and later, with the aid of illuminated projection slides, depicted various results of the work of restoration. Scenes of homes, verdant gardens, and buildings, notably the Wren building of William and Mary College, Bruton Parish church, Raleigh Tavern and the palace and capitol buildings, were presented, all aptly portraying the striking manner in which the architectural and historical authenticity has been adhered to.

George Adams, secretary of the Chapter, read excerpts from a letter published in the Octagon which contained instructions to the Chapters regarding convention delegates.

A review of proposed amendments to the A.I.A. constitution and by-laws to be presented to the national convention was presented by S. B. Marston, S. E. Lunden and Eugene Weston, Jr., and passed upon by the chapter.

In the absence of Roland E. Coate, chairman of the ethics committee, a letter on a code of ethics for A.I.A. sketches was read by A. C. Zimmerman, a co-member of the committee.

F. J. Miller, who is retiring as assistant secretary to the Chapter, was presented with a handsome gold watch in appreciation of his services to the Chapter during the past eight years, and his successor, Howard Walker, was introduced to the Chapter members present. The presentation and introduction were made by Ralph C. Flewelling, president, who presided at the meeting.

Henry F. Withey reported completion of the organization of the Federal Writers' Project whereby descriptions of buildings of outstanding interest and significance will be recorded by writers of that group.

STATE BOARD OF EXAMINERS

Frederick H. Meyer, architect, of San Francisco, has been elected president of the California State Board of Architectural Examiners, an honor conferred upon him at the annual joint meeting of the Northern and Southern sections of the board held last month in Los Angeles. Mr. Meyer succeeds Warren C. Perry as president of the Northern section.

Harold Chambers of Los Angeles was elected president of the Southern section and becomes vice-president of the State Board. G. Stanley Wilson, Riverside, was elected state secretary, succeeding C. J. Ryland of Monterey. Harry J. Devine, Sacramento, was named secretary of the Northern section, the other members being Mr. Meyer, Warren Perry, C. F. B. Roeth and C. J. Ryland. Mr. Roeth temporarily retains his place on the board due to the failure to date of Arthur H. Memmler, recent appointee of Governor Merriam, to qualify.

WASHINGTON STATE CHAPTER

Domestic architecture is occupying the chief attention this spring of the Washington State Chapter, A. I. A., under the leadership of President Lance E. Gowen, Seattle.

Good results were achieved by the architectural exhibit, dealing particularly with domestic construction, held in the lounge room of the Olympic Hotel, Seattle, in conjunction with the Pacific Northwest regional meeting of the National Association of Real Estate Boards. Representing the Washington Chapter, John Ted Jacobsen had complete charge. Exhibitors included: Edwin J. Ivey, Elizabeth Ayers, J. Lister Holmes, Floyd A. Naramore, Smith, Carroll and Johanson, Arthur L. Loveless and Lester P. Fey, William J. Bain and Ivan W. Meyer, William Mallis, Richard E. Lytel and LaMonte Shorett, Thomas, Grainger and Thomas, Fred B. Stephen, all of Seattle; and Mock and Morrison of Tacoma. Sculptor Dudley Pratt displayed several examples of tin sculpture.

"Home Financing" was explained by F. S. McWilliams, president of the Fidelity Savings and Loan Association, Spokane, and chairman of the Federal Home Loan Bank for the Eleventh District, which includes Oregon, Washington, Idaho, Montana and Wyoming. Frank Compton, Seattle, presided, and Norman Dickison, Seattle, served as toastmaster.

G. Grant La Farge, architect of New York City, addressed a special meeting of the Chapter held Thursday, April 16, in the Gold Room of the New Washington Hotel, Seattle.

SEATTLE SOCIETY OF ARCHITECTS

Organization of the Seattle Society of Architects to facilitate the handling of small house projects under professional supervision was recently effected under the sponsorship of the Washington State Chapter, A. I. A.

The Society is making arrangements with home finan-

cing institutions to promote the construction of high quality, medium-sized residences under the long-term amortized mortgage initiated by the FHA. This plan provides for a monthly payment ranging from \$30 to \$60 to cover all costs following an original down payment running 10% to 40%. Some financial institutions are making contracts with prospective owners without any down payment. The arrangement with the architects provides for design and supervision on a percentage basis. Construction is done under general contract.

Architect members of the society include Lance E. Gowen, Arthur L. Loveless, Clyde Grainger, Richard E. Lytel, Donald P. Thomas, Arthur P. Herrman, Frederick Bockerman, Henry Olschewsky, Sam Chinn, Alban A. Shay and LaMonte Shorett.

ENGINEERS INSPECT MINT

At the April 14th meeting of the Structural Engineers of Northern California, a visit was paid the U. S. mint, under construction in San Francisco. The excursion was made doubly interesting by an explanatory talk by H. A. Schirmer, Works Engineer of the Bethlehem Steel Company, who said in part:

"The contract for the structural steel for the United States Mint was awarded to Bethlehem Steel Company on August 19, 1935, by the Clinton Construction Company, the general contractors for the project. It required from January 27 to March 20 to erect the 1243 tons for this structure. The frame was erected by Steel Erectors Consolidated using two guy derricks having 100 foot timber booms and 150 foot mast operated by steam engines. All of the material was delivered to the site by truck, being hauled from the railroad yards. The structure is rectangular in plan, measuring 270' 9" by 185' 1" with a central court that is 183' 0" by 79' 4". This court is entered through a drive way from the north side of the building. The court is primarily an enclosure for loading and unloading gold and silver bullion and is heavily guarded from especially constructed guard rooms. The structure is four stories in height, the stories varying from 15' to 18' 3". There are three small pent houses for elevator equipment constructed with special provisions for future shooting galleries and rifle ranges.

"The material for the structure was rolled by the Bethlehem Steel Company at their Bethlehem, Lackawanna, Sparrow Point, Seattle, and South San Francisco plants. 1194 tons were fabricated at the Alameda plant. The shop details for the structure were also made at Alameda but approval of all details was made by the Procurement Division at Washington.

"There are a total of 129 slabs, varying from 2" to 5 1/4". The heaviest slab weighed 3743# and was approximately 4' square. These slabs were anchored by means of four 1 1/4" O/ anchor bolts and after erection the columns were welded to the slabs by a continuous 3/8" fillet weld. The slabs were leveled by

means of three 7/8" O/ leveling bolts and set upon 2" grout cushion. The slabs for the structure weighed 49 tons and were rolled and planed at the Sparrow Point plant of the Bethlehem Steel Company.

"There was a total of 1029 beams, the largest section being 36" B at 300#, while the heaviest beam weighed four tons. The beams have the usual standard top and bottom connections with framed webs. These top and bottom connections were angles in place of beam tees. Beam tees were used only in exceptional cases for eccentric connections. All rivets were 7/8" O/.

"The columns were fabricated in two tiers, the largest section being 14" B at 300# weighing a total of seven tons. Typical column splices with butt plates were used, all columns being milled to bear at top and bottom and splice plates provided to develop the column section. There were a total of 251 columns.

"The structure is designed in accordance with the San Francisco building code for 2% gravity and 20# per square foot wind pressure, being designed by the Procurement Division at Washington. The four corners have exceptionally heavy K shape bracing for resisting earthquake and wind stresses. The members of this bracing are primarily 14" B at 87# and 12" B at 53#. The lateral forces are distributed from the upper three stories by structural steel bracing to the diagonally reinforced concrete walls of the first story. The horizontal struts also form an integral part of the bracing, varying from 24" B at 100# to 33" B at 240#."

Scott Fullerton, Construction Engineer for the Treasury Department, commented upon the utility of the structure and summarized, in a very interesting manner, the location and use of the various parts of the building as related to the coining of the money.

ATTEND CONVENTION

W. I. Garren and Albert Evers were the San Francisco architects to attend the Institute convention in Williamsburgh, Virginia. Mr. Garren went as delegate from the State Association and Mr. Evers represented the Northern California Chapter.

Before leaving for the East Mr. Evers tendered his resignation as Chief Architectural Adviser for the Federal Housing Administration, which position he has occupied since the department was established by the Federal Government. Mr. Evers' time will be largely occupied on Exposition work.

STRUCTURAL ENGINEERS MEET

The May meeting of the Structural Engineers Association of Northern California was held at the Engineers Club, San Francisco, May 5. The principal speaker was Dr. Perry Byerly, Associate Professor of Seismology at the University of California, who spoke on the subject: "Seismology — in Relation to Structural Engineering."

ORIGIN OF NAMES OF CALIFORNIA COUNTIES

This is the eight article in the series giving derivation of the names of California counties:

MONTEREY COUNTY—Created February 18, 1850. One of the original twenty-seven counties of the state. It derived its name from the bay of Monterey. The word itself is composed of the Spanish words "monte" and "rey", and literally means "king of the forest." The bay was discovered by Sebastian Vizcaino in 1630, and named in honor of his friend and patron, Gaspar de Zuniga, Count of Monterey and Viceroy of Mexico.

The old city of Monterey in this county has been the capital of California under three flags, was the birthplace of the state's first constitution, the first constitutional assembly met there and Monterey claims California's first newspaper, first frame and first brick house, the first theater and the first jury empaneled in the state.

Historic Monterey, a place of beautiful homes, of mountains, valleys, seashore and harbors, has the slogan "The Land of Enchantment." The county offers a wide range in economic opportunities and recreational resources, the cities and towns are progressive and the rural communities afford unlimited possibilities in diversified farming.

For 124 miles the Monterey shore is washed by the waters of the Pacific. To the east are the picturesque Diablo mountains and to the south the Gabilan range. In between are fertile valleys, particularly the great Salinas Valley. The county has 1891 farms totalling 1,305,001 acres. Farming heads the list of leading industries, followed by cattle raising, dairying, fruit and berry raising, poultry, growing of guayule for rubber, and commercial fishing in Monterey Bay. Some 20,500 acres are in lettuce which leads all crops in value of output. Attractions for tourists are the famed Del Monte, old Monterey, Pacific Grove, the Seventeen Mile Drive, Big Sur Redwoods, Carmel, Pebble Beach, King City and Salinas, "Rodeo City" of California. Population: 53,705. Area: 3330 square miles.

NAPA COUNTY—Created February 18, 1850. One of the original twenty-seven counties of the state. The word "Napa" means, in the language of a large and powerful tribe of Indians that lived in that section of California, "fish." Myriads of fish inhabited the Napa river and other streams of this section. This tribe of Indians was nearly exterminated by smallpox in 1838, and now the only evidence of their ever having existed is the name given to the county.

Picturesque mountains, cool canyons, fishing retreats, wooded hills, green valleys, spouting geysers and freaks of nature, together with great wealth in agricul-

tural products, place Napa in an enviable position among California counties.

Agricultural production may be divided into three main classifications: grapes, fruits and nuts; alfalfa and hay; and field crops, such as barley, oats, wheat, vegetables and berries. Hills provide feed and range for stockraising and the poultry industry is increasing rapidly. Napa is famous for its vineyards and wineries and an historic flour mill built in 1846.

Geysers near Calistoga spout at regular intervals, some of them shooting 300 feet in the air. Nearby is the Petrified Forest and a fine highway leads to the summit of Mount St. Helena which towers to a height of 4343 feet. It was a signalling point for the Russians when they were endeavoring to get a foothold in California by extending their operations from Fort Ross on the Sonoma coast. In 1841 the Russian naturalist, Wosnersemsky, named the mountain in honor of a Russian empress. Robert Louis Stevenson resided near the summit in 1880 while writing the "Silverado Squatters". A monument has been erected there to his memory. Population: 22,897. Area: 783 square miles.

NEVADA COUNTY—Created April 25, 1851. The word "Nevada" in Spanish means "snowy." The county derived its name from the perpetual snow-capped mountains within its boundaries.

This county has given to the world \$300,000,000 in gold and produces oranges at one end and ice at the other. It is one of the state's richest counties in scenic attractions, farming, mining and lumbering. In the western section, roses bloom the year around while at Donner Lake, near its eastern boundary, the annual snowfall is from ten to twenty feet. Its golden era dates from 1848. The rocker was the first machine used for washing gold, followed by the long-tom which in turn gave place to the sluice. Hydraulic mining was first undertaken in 1852 and by 1876 \$100,000,000 was invested in plants, equipment and property for this form of mining. In 1884 hydraulic mining was prohibited by law. Within a radius of six miles from Grass Valley are 110 gold mines, while within a radius of five miles from Nevada City are 120 mines with more than one-tenth of the population engaged in this industry. Here are the Empire, North Star, Maryland-Idaho, Malahoff and other famous mines.

Dry farming is successful, but most growers rely upon irrigation. More than 1,000 miles of ditches and flumes, costing \$4,250,000 furnish water for orchards and farms. Leading fruits are pears, apples, plums and prunes with a large harvest of oranges. Dairying and stock and poultry raising are major industries.

In the eastern section of the county is historic Donner Lake, where George and Jacob Donner with a company of emigrants were imprisoned by snow from November until February 19, 1846. Most of them perished before the first relief party from California

Estimator's Guide

Giving Cost of Building Materials, Wage Scale, Etc.

Amounts given are figuring prices and are made up from average quotations furnished by material houses to San Francisco contractors. 3% Sales Tax on all materials but not labor.

Note—Mechanics are demanding higher wages due to scarcity of skilled labor. Present scale may be advanced in 30 days.

All prices and wages quoted are for San Francisco and the Bay District. There may be slight fluctuation of prices in the interior and southern part of the state. Freight cartage, at least, must be added in figuring country work.

Bond—1½% amount of contract.

Brickwork—

Common, \$35 to \$40 per 1000 laid, (according to class of work).

Face, \$75 to \$90 per 1000 laid, (according to class of work).

Brick Steps, using pressed brick, \$1.10 lin. ft.

Brick Walls, using pressed brick on edge, 60c sq. ft. (Foundations extra.)

Brick Veneer on frame buildings, \$.75 sq. ft.

Common f.o.b. cars, \$12.00 job cartage. Face, f.o.b. cars, \$45.00 to \$50.00 per 1000, carload lots.

HOLLOW TILE FIREPROOFING (f.o.b. job)

3x12x12 in. \$ 84.00 per M

4x12x12 in. 94.50 per M

6x12x12 in. 126.00 per M

8x12x12 in. 225.00 per M

HOLLOW BUILDING TILE (f.o.b. job)

carload lots.

8x12x5½ \$ 94.50

6x12x5½ 73.50

Discount 5%.

Composition Floors—18c to 35c per sq. ft.

In large quantities, 16c per sq. ft. laid.

Mosaic Floors—80c per sq. ft.

Duraflex Floor—23c to 30c per sq. ft.

Rubber Tile—50c per sq. ft.

Terazzo Floors—45c to 60c per sq. ft.

Terazzo Steps—\$1.60 lin. ft.

Concrete Work (material at San Francisco bunkers)—Quotations below 2000 lbs. to the ton, \$2.00 delivered.

No. 3 rock, at bunkers.....\$1.80 per ton

No. 4 rock, at bunkers..... 1.75 per ton

Elliott top gravel, at bunkers 2.10 per ton

Washed gravel, at bunkers.... 2.10 per ton

Elliott top gravel, at bunkers 2.10 per ton

City gravel, at bunkers..... 1.75 per ton

River sand, at bunkers..... 1.80 per ton

Delivered bank sand..... 1.20 cu. yd.

Note—Above prices are subject to discount of 10c per ton on invoices paid on or before the 15th of month, following delivery.

SAND

Del Monte, \$1.75 to \$3.00 per ton.

Fen Shell Beach (car lots, f.o.b. Lake Majella), \$2.75 to \$4.00 per ton.

Cement, 2.50 per bbl. in paper sks.

Cement (f.o.b. Job, S. F.) \$3.00 per bbl.

Cement (f.o.b. Job, Oak.) \$3.00 per bbl.

Rebate of 10 cents bbl. cash in 15 days.

Calaveras White\$6.00 per bbl.

Medusa White\$8.00 per bbl.

Forms, Labors average \$40.00 per M.

Average cost of concrete in place, exclusive of forms, 35c per cu. ft.

4-inch concrete basement floor

.....12½c to 14c per sq. ft.

4½ inch Concrete Basement floor.....

.....14½c to 16c per sq. ft.

2-inch rat-proofing7½c per sq. ft.

Concrete Steps\$1.50 per lin. ft.

Dampproofing and Waterproofing—

Two-coat work, 15c per yard.

Membrane waterproofing—4 layers of saturated felt, \$4.00 per square.

Hot coating work, \$1.80 per square.

Medusa Waterproofing, 15c per lb., San Francisco Warehouse.

Electric Wiring—\$12.00 to \$15.00 per outlet

for conduit work (including switches).

Knob and tube average \$7.00 per outlet, including switches.

Elevators—

Prices vary according to capacity, speed and type. Consult elevator companies.

Average cost of installing an automatic elevator in four-story building, \$2800; direct automatic, about \$2700.

Excavation—

Sand, 50 cents; clay or shale, 80c per yard.

Teams, \$12.00 per day.

Trucks, \$20 to \$25 per day.

Above figures are an average without water. Steam shovel work in large quantities, less; hard material, such as rock, will run considerably more.

Fire Escapes—

Ten-foot balcony, with stairs, \$85.00 per balcony, average.

Glass (consult with manufacturers)—

Double strength window glass, 15c per square foot.

Quartz Lite, 50c per square foot.

Plate 75c per square foot.

Art, \$1.00 up per square foot.

Wire (for skylights), 35c per sq. foot

Obscure glass, 26c square foot.

Note—Add extra for setting

Heating—

Average, \$1.90 per sq. ft. of radiation, according to conditions.

Iron—

Cost of ornamental iron, cast iron, etc., depends on designs.

Lumber (prices delivered to bldg. site).

No. 1 common \$34.00 per M

No. 2 common 29.00 per M

Selection O. P. common 39.00 per M

2x4 No. 3 form lumber 24.00 per M

1x4 No. 2 flooring VG 60.00 per M

1x4 No. 3 flooring VG 50.00 per M

1x6 No. 2 flooring VG 60.00 per M

1¼x4 and 6, No. 2 flooring 65.00 per M

Slash grain—

1x4 No. 2 flooring \$48.00 per M

1x4 No. 3 flooring 40.00 per M

No. 1 common run T. & G. 33.00 per M

Lath 7.00 per M

Shingles (add cartage to price quoted)—

Redwood, No. 1 \$1.10 per bdle.

Redwood, No. 290 per bdle.

Red Cedar 1.00 per bdle.

Hardwood Flooring (delivered to building)—

13-16x¾" T & G Maple \$120.00 M ft.

1-16x¾" T & G Maple 132.00 M ft.

7/8x¾" sq. edge Maple 140.00 M ft.

13-16x2½" ¾x2" 5-16x2" T&G Sq.Ed.

Clr. Qtd. Oak \$200.00 M \$150.00 M \$180 M

Sel. Qtd. Oak 140.00 M 120.00 M 135 M

Clr. Fla. Oak 135.00 M 107.00 M 120 M

Sel. Fla. Oak 120.00 M 88.00 M 107 M

Clear Maple 140.00 M 100.00 M

Laying & Finishing 13c ft. 11 ft. 10 ft.

Wage—Floor layers, \$7.50 per day.

Building Paper—

1 ply per 1000 ft. roll \$3.50

2 ply per 1000 ft. roll 5.00

3 ply per 1000 ft. roll 6.25

Brownskin, 500 ft. roll 10.00

Brownskin Proctexomat, 1000 ft. roll 5.00

Sisalcraft, 500 ft. roll 5.00

Sash cord com. No. 7 \$1.20 per 100 ft.

Sash cord com. No. 8 1.50 per 100 ft.

Sash cord spot No. 7 1.80 per 100 ft.

Sash cord spot No. 8 2.25 per 100 ft.

Sash weights cast iron, \$50.00 ton.

Nails, \$3.50 base.

Sash weights, \$45 per ton.

Millwork—

O. P. \$100.00 per 1000. R. W., \$106.00 per 1000 (delivered).

Double hung box window frames, average, with trim, \$6.50 and up, each.

Doors, including trim (single panel, 1¾ in. Oregon pine) \$8.00 and up, each.

Doors, including trim (five panel, 1¾ in. Oregon pine) \$6.50 each.

Screen doors, \$4.00 each.

Patent screen windows, 25c a sq. ft.

Cases for kitchen pantries seven ft. high, per lineal ft., \$6.50 each.

Dining room cases, \$7.00 per lineal foot.

Labor—Rough carpentry, warehouse heavy framing (average), \$14.00 per M.

For smaller work average, \$32.50 to \$40.00 per 1000.

Marble—(See Dealers)

Painting—

Two-coat work	29c per yard
Three-coat work	40c per yard
Cold Water Painting	10c per yard
Whitewashing	4c per yard
Turpentine, 80c per gal. in cans and 75c per gal. in drums.	
Raw Linseed Oil—80c gal. in bbls.	
Boiled Linseed Oil—65c gal. in bbls.	
Medusa Portland Cement Paint, 20c per lb.	

Carrier or Dutch Boy White Lead in Oil (in steel kegs).

1 ton lots, 100 lbs. net weight	Per lb. \$1.03 ³ c
500 lbs. and less than 1 ton lots	11c
Less than 500 lb. lots	11 ¹ / ₂ c

Dutch Boy Dry Red Lead and Litharge (in steel kegs).

1 ton lots, 100 lb. kegs, net wt.	10 ³ / ₄ c
500 lb. and less than 1 ton lots	11c
Less than 500 lb. lots	11 ¹ / ₂ c

Red Lead in Oil (in steel kegs)

1 ton lots, 100 lb. kegs, net. wt.	12 ¹ / ₂ c
500 lb. and less than 1 ton lots	12 ¹ / ₂ c
Less than 500 lb. lots	13c

Note—Accessibility and conditions cause wide variance of costs.

Paten Chimneys—

6-inch	\$1.00 lineal foot
8-inch	1.50 lineal foot
10-inch	1.75 lineal foot
12-inch	2.00 lineal foot

Plastering—Interior—

1 coat, brown mortar only, wood lath	Yard \$0.65
2 coats, lime mortar hard finish, wood lath	75

2 coats, hard wall plaster, wood lath	\$ 80
3 coats, metal lath and plaster	1.25
Keene cement on metal lath	1.20
Ceilings with 3/4 hot roll channels metal lath	.75
Ceilings with 3/4 hot roll channels metal lath plastered	1.50
Single partition 3/4 channel lath 1 side	.85
Single partition 3/4 channel lath 2 sides 2 inches thick	2.75
4-inch double partition 3/4 channel lath 2 sides plastered	1.30
4-inch double partition 3/4 channel lath 2 sides plastered	3.00

Plastering—Exterior—

2 coats cement finish, brick or concrete wall	Yard \$1.10
2 coats Atlas cement, brick or concrete wall	1.35
3 coats cement finish, No. 18 gauge wire mesh	1.50
3 coats Medusa finish, No. 18 gauge wire mesh	2.00
Wood lath, \$6.00 per 1000.	
2.5-lb. metal lath (dipped)	.17
2.5-lb. metal lath (galvanized)	.20
3.4-lb. metal lath (dipped)	.22
3.4-lb. metal lath (galvanized)	.28
3/4-inch hot roll channels, \$72 per ton.	
Finish plaster, \$18.90 ton; in paper sacks.	
Dealer's commission, \$1.00 off above quotations.	
\$13.85 (rebate 10c sack)	
Lime, f.o.b. warehouse, \$2.25 bbl.; cars, \$2.15	
Lime, bulk (ton 2000 lbs.), \$16.00 ton.	
Wall Board 5 ply, \$50.00 per M.	
Hydrate Lime, \$19.50 ton.	
Plasterers Wage Scale	\$1.25 per hour
Lathers Wage Scale	1.25 per hour
Head Carriers Wage Scale	1.10 per hour

Composition Stucco—\$1.60 to \$2.00 sq. yard (applied).

Plumbing—

From \$65.00 per fixture up, according to grade, quantity and runs.

Roofing—

'Standard' tar and gravel, \$6.00 per sq. for 30 sqs. or over.
Less than 30 sqs. \$6.50 per sq.
Tile, \$20.00 to \$35.00 per square.

Redwood Shingles, \$11.00 per square in place.
Cedar Shingles, \$10 sq. in place.
Roocat, with Gravel, \$3.00 per sq.
Slate, from \$25.00 to \$60.00 per sq. laid according to color and thickness.

Sheet Metal—

Windows—Metal, \$2.00 a sq. foot.
Fire doors (average), including hardware, \$2.00 per sq. ft.

Skylights—

Copper, 90c sq. ft. (not glazed).
Galvanized iron, 25c sq. ft. (not glazed).

Steel—Structural

\$100 ton (erected), this quotation is an average for comparatively small quantities. Light truss work higher. Plain beams and column work in large quantities \$80 to \$90 per ton cost of steel; average building, \$89.00.

Steel Reinforcing—

\$90.00 per ton, set, (average).

Stone—

Granite, average, \$6.50 cu. foot in place.
Sandstone, average Blue, \$4.00. Boise, \$3.00 sq. ft. in place.
Indiana Limestone, \$2.80 per sq. ft. in place.

Store Fronts—

Copper sash bars for store fronts corner, center and around sides, will average 75c per lineal foot.
Note—Consult with agents.

Tile—Floor, Wainscot, Etc.—(See Dealers).

SAN FRANCISCO BUILDING TRADES WAGE SCALE

Established by the Impartial Wage Board November 9, 1932. Effective on all work January 1, 1933, to remain in effect until June 30, 1933, and for so long thereafter as economic conditions remain substantially unchanged.

This scale is based on an eight-hour day and is to be considered as a minimum and employees of superior skill and craft knowledge may be paid in excess of the amounts set forth herein.

CRAFT	Journeyman Mechanics
Asbestos Workers	\$6.40
Bricklayers	9.00
Bricklayers' Hodcarriers	8.00
Cabinet Workers (Outside)	7.20*
Gaißon Workers (Open) Water Work	8.00
Carpenters	9.00
Cement Finishers	7.20
Cork Insulation Workers	7.20
Electrical Workers	8.00
Electrical Fixture Hangers	7.00
Elevator Constructors	8.68
Elevator Constructors' Helpers	6.08
Engineers, Portable and Hoisting	8.00
Glass Workers (All Classifications)	6.80
Hardwood Floormen	7.20*
Housemovers	6.40
Housemiths, Architectural Iron (Outside)	7.20
Housemiths, Reinforced Concrete, or Rodmen	7.20

*Established by Special Board

CRAFT	Journeyman Mechanics
Iron Workers (Bridge and Structural)	\$9.40
Iron Workers (Hoisting Engineers)	10.00
Laborers (6-day week)	5.00
Lathers, Channel Iron	8.00
Lathers, All Other	8.00
Marble Setters	8.00
Marble Setters' Helpers	5.00
Millwrights	7.20*
Mosaic and Terrazzo Workers (Outside)	7.20
Mosaic and Terrazzo Helpers	5.00
Painters	7.00
Painters, Varnishers and Polishers (Outside)	7.00
Pile Drivers and Wharf Builders	8.00
Pile Drivers Engineers	9.00
Plasterers and Hodcarriers (See wage scale under Plastering).	
Plumbers	8.00
Roofers (All classifications)	8.00
Sheet Metal Workers	7.20
Sprinkler Fitters	9.00
Steam Fitters	8.00

CRAFT	Journeyman Mechanics
Stair Builders	\$7.20*
Stone Cutters, Soft and Granite	6.80
Stone Setters, Soft and Granite	8.00
Stone Derrickmen	7.20
Tile Setters	8.00
Tile Setters' Helpers	5.00
Tile, Cork and Rubber	7.20
Welders, Structural Steel Frame on Buildings 9.40	
Welders, All Others on Buildings	8.00
Auto Truck Drivers—Less than 2,500 lbs.	5.50
Auto Truck Drivers—2,500 lbs. to 4,500 lbs.	6.00
Auto Truck Drivers—4,500 lbs. to 6,500 lbs.	6.50
Auto Truck Drivers—6,500 lbs. and over	7.00
General Teamsters, 1 Horse	5.50
General Teamsters, 2 Horses	6.00
General Teamsters, 4 Horses	6.50
Plow Teamsters, 4 Horses	6.50
Scraper Teamsters, 2 Horses	6.00
Scraper Teamsters, 4 Horses	6.00

GENERAL WORKING CONDITIONS

- Eight hours shall constitute a day's work for all crafts, except as otherwise noted.
- Where less than eight hours are worked pro rata rates for such shorter period shall be paid.
- Plasterers' Hodcarriers, Bricklayers' Hodcarriers, Roofers' Laborers and Engineers, Portable and Hoisting, shall start 15 minutes before other workmen, both at morning and at noon.
- Five days, consisting of not more than eight hours a day, on Monday to Friday inclusive, shall constitute a week's work.
- The wages set forth herein shall be considered as net wages.
- Except as noted the above rates of pay apply only to work performed at the job site.
- Transportation costs in excess of twenty-five cents each way shall be paid by the contractor.
- Traveling time in excess of one and one-half hours each way shall be paid for at straight time rates.
- Overtime shall be paid as follows: For the

- first four hours after the first eight hours, time and one-half. All time thereafter shall be paid double time. Saturday (except Laborers), Sundays and Holidays from 12 midnight of the preceding day, shall be paid double time. Irrespective of starting time, overtime for Cement Finishers shall not commence until after eight hours of work.
- On Saturday Laborers shall be paid straight time for an eight-hour day.
- Where two shifts are worked in any twenty-four hours, shift time shall be straight time. Where three shifts are worked, eight hours' pay shall be paid for seven hours on the second and third shifts.
- All work, except as noted in paragraph 13, shall be performed between the hours of 8 A. M. and 5 P. M.
- In emergencies, or where premises cannot be vacated until the close of business, men reporting for work shall work at straight time.

- Any work performed on such jobs after midnight shall be paid time and one-half up to four hours of overtime and double time thereafter (provided, that if a new crew is employed on Saturdays, Sundays or Holidays which has not worked during the five preceding working days, such crew shall be paid time and one-half. No job can be considered as an emergency job until it has been registered with the Industrial Association and a determination has been made that the job falls within the terms of this section).
- Recognized holidays to be: New Year's Day, Decoration Day, Fourth of July, Labor Day, Admission Day, Thanksgiving Day, Christmas Day.
 - Men ordered to report for work, for whom no employment is provided shall be entitled to two hours' pay.
 - This award shall be effective in the City and County of San Francisco.

NOTE: Provision of paragraph 13 appearing in brackets () does not apply to Carpenters, Cabinet Workers (Outside), Hardwood Floormen, Millwrights, or Stair Builders.

reached them. The horrible suffering they endured is a tragic part of early California history. East of Donner Lake is Truckee, one of the state's most popular winter playgrounds. Population: 10,596. Area: 975 square miles.

ORANGE COUNTY—Created March 11, 1889. This county was given its name by the legislature because of the orange groves for which it is justly famous. It was "carved" out of the southeastern portion of Los Angeles County.

This county is one of the richest in the United States per cultivated acre. The total annual agricultural production is approximately \$52,000,000. Here is the home of the Valencia orange, which ripens early in May and will hang upon the tree until November without deterioration. On account of its highly productive oil fields, Orange stood for many years as the second county in the state in the production of minerals. Annual production of oil, gasoline and other oil products has reached the high sum of \$50,000,000 a year, and yet that production now is surpassed by the Valencia orange in valuation.

Orange county is entering upon a period of intensive development. It is less than 35 miles from Los Angeles, San Diego is 90 miles south, while San Bernardino, Redlands, Riverside and other cities may be reached in an hour's drive. It has more than 1000 miles of hard surfaced highways and less than 50 miles of arteries commonly known as dirt roads.

Citrus fruits and tropical and semi-tropical fruits are raised in abundance. Over 51,000 acres are devoted to citrus fruits alone. The county has 40 miles of ocean shore line with many attractive beaches. Newport Bay is the only land-locked harbor for hundreds of miles. Here is the noted Marine Research branch of the California Institute of Technology. At San Juan Capistrano is the mission of that name founded in 1776.

With its beautiful homes, delightful beaches, vast orange groves, oil fields and growing industries, Orange is one of California's greatest counties. Population: 118,674. Area: 795 square miles.

Next: Placer, Plumas and Riverside—Editor.

FRATERNITY HOUSE

Newsom & Newsom, Russ Building, San Francisco, are preparing working drawings for a two-story and attic frame and stucco fraternity house at Palo Alto for the Delta Tau Delta. The cost is estimated at \$25,000.

Another fraternity house at Stanford is for the Delta Epsilon, Leslie I. Nichols, architect.

VALLEJO ELKS' BUILDING

Preliminary drawings are in progress in the office of Dodge A. Riedy, Pacific Building, San Francisco, for a \$50,000 lodge building at Vallejo for the B.P.O.E. The structure will replace the old Elks Building destroyed by fire some time ago.

A construction schedule for the 1939 World's Fair involving the expenditure of \$4,209,609 in funds under allocations of the Public Works Administration has been announced by Leland W. Cutler, president of the San Francisco Bay Exposition, Inc.

Besides this, several million dollars will be spent during the current year as reclamation of the Exposition site at Yerba Buena Shoal progresses under allocations made by the Works Progress Administration.

The PWA program, approved in final form by Federal authorities, includes construction of an administration building, ferry slips, two airplane hangars, airport terminal building, ferry terminal, five large exhibit buildings and paving of the site. All the airport structures will be used by the Exposition for exhibit and service buildings, and will conform in appearance to the general architecture of the Fair.

Of the \$4,209,609 involved in this program, 45 per cent or \$1,894,324 will be furnished by the PWA, and \$2,315,285, or 55 per cent, by the Exposition Company, Mr. Cutler pointed out.

The items included in the program follow:

1. Administration building at Bush and Stockton Streets in San Francisco, already under construction. To be finished June 15, 1936. Cost \$157,700.
2. Ferry slips at the Exposition site for both passenger and freight traffic. Contract awarded May 1, 1936. Cost \$457,300.
3. Two permanent airplane hangars, to be used during Exposition for exhibit purposes. Contract to be awarded July 1, 1936. Cost \$685,300.
4. Permanent airport terminal building, also to be used for Exposition purposes. Contract to be awarded August 1, 1936. Cost \$715,300.
5. Five major exhibit palaces. Contract to be awarded September 1, 1936. Cost \$1,399,607.
6. Ferry terminal building on Exposition site. Contract to be awarded September 1, 1936. Cost \$274,900.
7. Paving for walks, driveways, et cetera. Contract to be awarded September 1, 1936. Cost \$441,400.

The balance of the \$4,209,609 represents preliminary engineering, and architectural expenses.

Wholly in addition to the PWA program, Mr. Cutler pointed out, there will be spent between now and the opening of the Exposition a total of \$7,937,491 for physical construction of the Fair. This includes the

“AIR CONDITION WITH ICE”

A suggestion that may save your clients

20% to 50% on this vital building feature.

Air conditioning—the novel luxury of yesterday—has become the expected comfort of today. A feature that no owner can afford to overlook in a building where public patronage counts.

But does this necessarily mean a heavy year-round investment to meet a mere summertime need? Not if

you air condition with ice. For ice provides the hot weather comfort that store, hotel, theatre, and office building patrons have come to demand . . . and does it often at only half the cost of more elaborate installations.

Let our engineers supply the data to fit your particular air conditioning job.

The **UNION ICE** Company

354 PINE STREET

SAN FRANCISCO

DON'T WAIT FOR YOUR CLIENT TO DEMAND ELECTRICAL ADEQUACY

Provide for it in your plans. If he refuses to authorize it, then you are relieved of responsibility for any inconvenience and expense he may be put to later for rewiring. You did your part when you included adequate wiring in your plans and specifications.

We offer to architects and engineers RED SEAL plans, specifications, or consultation without obligation.

You can not be held negligent if the client does not follow your suggestions.

By using RED SEAL minimum specifications as a guide, you insure both yourself and your client against an inferior wiring job.

PACIFIC COAST ELECTRICAL BUREAU

SAN FRANCISCO
447 Sutter Street

• CALIFORNIA •

LOS ANGELES
601 W. 5th Street

reclamation of the site, landscaping and horticultural work; construction of roads, bridges and trestles linking the site with the San Francisco-Oakland Bay bridge, and for installation of water, sewerage, drainage and other utilities. This total is exclusive of operating overhead.

Meanwhile, United States Army engineers, at work on filling in the 430 acre site, report that enough land will be wholly reclaimed so that construction of airplane hangars can be started on July 1.

STUDENTS SUBMIT BRIDGE DESIGNS

Students of engineering and architecture in eighteen technical schools throughout the country submitted eighty-three designs in the eighth annual students' bridge design competition of the American Institute of Steel Construction. A jury of nationally-known engineers and architects selected the ten best from the preliminary drawings for entry into the final judging. All of the entrants in the competition are actively engaged in studying engineering or architecture.

The students who will submit final renditions are:

Messrs. Lawrence F. Côté of the University of Maine; Russell E. Madsen, A. W. Millington and Henry H. Wiss of Rensselaer Polytechnic Institute; Maurice Lubin and Arthur A. Unger of New York University; John A. Grove and Frank R. Streba of Carnegie Institute of Technology, and Clarence H. Rosa of the University of Michigan.

From these designs, this month, the jury will select a prize winner.

The subject of the competitive design was a steel highway bridge having a span of 300 feet, with 30 foot minimum vertical clearance over a river.

"HOME TALENT" INDUSTRIES

Stimulation of "home talent" industries under the leadership of the architectural profession was urged at the 68th convention of the American Institute of Architects at Old Point Comfort, by Ely Jacques Kahn of New York, chairman of the Committee on Allied Arts of the American Institute of Architects.

Outlining a national program of development for creative community industries, Mr. Kahn asserted that the rediscovered crafts would inspire fresh styles in home decoration and create new uses for building materials.

Local arts and crafts, including glass, metals, pottery, textiles, and furniture, present an unexplored avenue of research and advancement which promises to enrich American life, Mr. Kahn declared. His program calls for nationwide exhibitions of inherently American materials of outstanding characteristics to be sponsored by architects in a campaign to guide builders to higher standards of design and decoration.

"In every section some industry or craft is active," Mr. Kahn pointed out. "It should be the task of

Hollywood ROOSEVELT

Redecorated all of their
superb suites with

WALLCOVER

FLAT

A tribute by a
famous hotel to
a famous paint.

Use Coupon
for Sample



GENERAL PAINT
CORPORATION

San Francisco • Los Angeles • Oakland • Portland • Seattle • Spokane • Tulsa

Use This Coupon for
FREE SAMPLE
of
Wall Kover Flat

Mail coupon to nearest Division Office—print name and address clearly or attach business card.

Name

Street and Number

City and State

Check color wanted: WHITE IVORY ORCHID SEAFOAM SILVER GRAY APRICOT TURQUOISE

MONEL METAL

[High Nickel Alloy]

is the accepted material for soda fountains and lunch-room equipment, just as it is the universal metal for food service equipment in leading hotels and restaurants throughout the country.

CORROSIRON

[Acid Resisting Iron]

is the accepted material for draining waste lines. CORROSIRON meets all State and Municipal specifications for drain lines from school laboratories and chemistry rooms.

Pacific Foundry Company Ltd.

Pacific Metals Company Ltd.

1400 South Alameda St.
LOS ANGELES

3100 Nineteenth St.
SAN FRANCISCO

551 Fifth Ave.
NEW YORK

Architects . . .

S a f e g u a r d
y o u r b u i l d i n g s
a g a i n s t d e c a y
o r t e r m i t e
a t t a c k b y
s p e c i f y i n g

**WOLMANIZED or CREOSOTED
LUMBER and TIMBER**

E. K. WOOD LUMBER CO.

*"Goods of the Woods" is your guarantee for
Quality and Service*

NO. 1 DRUMM ST., SAN FRANCISCO
LOS ANGELES OAKLAND

BUILD WELL~

A PROPERLY designed and well constructed building is a credit to any city and a profitable investment for its owner.

Such structures are the STANDARD OIL BUILDING, MATSON BUILDING, FOUR-FIFTY SUTTER STREET, STOCK EXCHANGE, S. F. BASE BALL PARK, MILLS TOWER, OPERA HOUSE and VETERANS' MEMORIAL, San Francisco, OLYMPIC CLUB ALTERATIONS, SANTA ANITA RACING PLANT and other notable structures — all built or supervised by —

Lindgren & Swinerton, Inc.

Standard Oil Building 605 W. Tenth Street
San Francisco Los Angeles
We Maintain a Termite Control Department

architects to investigate and sponsor evidences of good local work. By arranging exhibitions, a tradition of fine designs in every field could be built up. What Sweden and other countries have done under the direction of successful artists can be accomplished in the United States.

"Toledo, Cincinnati, and other cities in the Middle West are turning out much that is interesting in glass and china. Yet from the angle of building possibilities and uses in design, what does the architectural profession know about glass construction, and other glass production, pottery, and china?

"In Pittsburgh the metal industries provide a wide field of opportunity. Controlling and directing ideas of local manufacture is a healthy manner of dominating local artistic standards. The exhibitions can be both of building materials and manufactured articles, either handicraft or mass manufacture, in which good design appears.

"Where a high standard has been set, the reaction will affect the public, resulting in a demand for similar standards in its buildings. We hear many complaints that a great deal of building is done without benefit of architectural advice. The misguided element of the community must be trained to finer appreciation through the things which it buys and uses. Swedish experience has proved that manufacturers can be made conscious of the value of design and that the public will automatically support such a movement."

International ramifications of the movement were predicted by Mr. Kahn. America, he said, should be represented in world displays of design and manufactured articles, particularly at the 1937 Exhibition of Industrial Arts in Paris, and the 1939 World's Fair in New York. (and San Francisco.)

The architect of a home or building should be responsible for its design "down to the flowers on the table", Mr. Kahn asserted. Without eliminating decorators and those engaged in allied fields, centralized control of design in the hands of the architect must be stimulated, he added.

"Some architects feel that their work is not complete unless they handle all of the details that enter into their buildings. Others wish to know what is destined to affect the appearance of their structure. Inspection of many decorative objects will reveal that they have been designed by architects, under the theory that a man trained to design and knowing his materials is an ideal person to direct such enterprises. The day is not far distant when a real field in designing will be opened to architects, allowing them to measurably broaden their activities."

PALO ALTO DWELLING

John K. Branner has completed and is taking bids for a stucco house to be built in Palo Alto for W. H. Thayer at an estimated cost of \$8500.

A LETTER FROM TEXAS

Editor The Architect and Engineer,
San Francisco.

Viva Mr. Jones. Viva The Architect and Engineer.
Viva Mr. Johnson. Viva California. Viva Texas. Viva.
Viva.

Mr. Editor I think you are my caballero. Very good of you to give the modernists a special number and then let Mr. Johnson blow them to bits. I am flattered to be allowed a voice in such a chorus.

You may be sure that I read Mr. Johnson's article with more than ordinary interest. As you know he is one of my heroes.

Mr. Johnson's article has been a great help to me. And I want to thank you a lot for the manner in which you presented my views.

In seeing how terrible so much of the architecture of the country really is I once thought that the colleges of architecture and philosophy should be combined, and no architect allowed to practice that couldn't set his buildings upon as sound a philosophy as that required by law for foundations. And that no philosopher be allowed to peep that couldn't reduce his philosophy to a workable plan.

So I am pleased to note Mr. Johnson's reference to philosophy. I am pleased to read that he has architecture as neatly classified in a few divisions as Havelock Ellis has us subdivided in others.

I have been intending to write that I enjoyed the Robert Stacy Judd articles very much and hope we have more of them.

Thanks a lot for the invitation to send a picture or two of my recent work. I am going to try for at least one decent picture. But owing to local custom it is going to be difficult to get pictures this argument should have. Laredo people don't want their homes photographed. They employ watchmen to keep their neighbors off the premises during construction. And thereafter you are admitted by appointment. Nothing is built for sale so its all the opposite to Los Angeles.

And therein hangs a tale. Suffice to say this is the largest all-Mexican town in the United States and some day may look the part. Right now a good earthquake would help a lot. The termites are busy, but being Mexican termites, work very slow. . . .

Again thanking you for all favors and wishing you continued success, I am

Yours very truly,

L. S. Sanderson

Laredo, Texas, April 3, 1936

ENGINEER FOR WASHINGTON SCHOOL

Walter Hueber, of San Francisco, was the structural engineer of the new George Washington High School, Miller and Pflueger, architects, illustrated in the April number of The Architect and Engineer. The design is in conformity with the new California earthquake law.

For
COMMERCE



CROCKER
FIRST NATIONAL
BANK
OF SAN FRANCISCO

Member Federal Deposit Insurance Corporation

WOLMANIZED LUMBER THIRTY YEARS OF SERVICE

Wolmanized lumber has proven, over a period of more than thirty years, under the widest variety of service conditions, that it is permanently protected against the attacks of termites and decay.

AMERICAN LUMBER & TREATING CO.
37 West Van Buren St.
CHICAGO, ILL.

San Francisco Sales Office
114 New Montgomery St.
Phone SUtter 1225

Los Angeles Sales Office
1031 South Broadway
Phone PRespect 5588



Remodeled No. 7A
Illustrated

HAWS DRINKING FAUCET CO.

1808 Harmon Street

Berkeley, Calif.

DO YOU KNOW

that HAWS ANGLE
STREAM DRINKING
FOUNTAINS meet with
the requirements of the
American Public Health
Association?

Catalog P details these
requirements and illus-
trates our complete line.
Copy on request.

APEX AIR ELECTRIC WATER HEATERS

Send for Architect's Catalogue
Bathroom Heaters in the Standard
Colors, 1000 to 2500 Watts
\$14.00 to \$27.50

APEX MANUFACTURING CO.

1501 Powell Street
Emeryville, Oakland, Calif.

Distributors

Sandoval Sales Co.

Phone KEarny 7010

557 Market Street, San Francisco, Calif.

Apex Sales Co.

1855 Industrial Street, Los Angeles, Calif.

Phone MUtual 9141

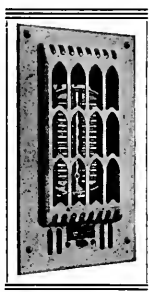

-Product of

CALIFORNIA SHADE CLOTH CO.

210 Bayshore Blvd., San Francisco

Manufacturers of

QUALITY HAND MADE SHADE CLOTH
IN ALL GRADES

Wholesale Distributors

SLOANE-BLABON LINOLEUM
AMBASSADOR VENETIAN BLINDS

STRUCTURAL STEEL

For Class A Buildings,
Bridges, etc.

JUDSON PACIFIC CO.

609 MISSION STREET
SAN FRANCISCO

Plants: San Francisco - Oakland

AN ARCHITECTURAL EXCURSION IN MAGAZINES OF THE PROFESSION

By Robert H. Orr

in Southwest-Builder and Contractor

Within the confines of your own office take a trip from the Atlantic to the Pacific. An architectural excursion, if you please, through The Architectural Forum, the Architectural Record, Architecture, American Architect, Architect and Engineer, Pencil Points and others. That the trip may be taken at the same time of the year we will for convenience choose March. The suburbs from the front cover in and the outskirts from the last cover back contain advertising matter about the same in all, in great profusion, adequately illustrating the materials and equipment that go into buildings, and set out in the most acceptable form known to printers, publishers and illustrators. And yet one is astounded by the general lack of knowledge that the average architect possesses upon these matters aside from plan, design, details and customary construction; brick, stone, tile, concrete, steel, wood, plaster and other common commodities. The whole portrayal astounds one when it comes to a decision, when from coast to coast from the Canadian border to Mexico, environment, climatic conditions, seasonal length, available resources should and must have some bearing upon one's choice. The duty demanded must necessarily vary from extremes of heat and cold, dry or wet variances.

Passing to those parts which an architect should more reasonably understand, his imagination is just as baffled in grasping the great array of presentation. Speaking in the order in which this journey is taken: There was a time when the frontispiece was a choice illustration of some masterpiece in architecture but subtle the array of poses leads one to believe that there is a drift from buildings to personalities. Being laudatory it creates a disinterest in the subject matter quickly passed over in search for something genuinely architectural in character. When we come to the historic setting, the charm and beauty of the past "Historic American Buildings", the New England churches in the Georgian Type, there is some compensation for the deeds done to the flesh. Then once more to be led hither and yon by the ultra moderne house sprinkled to the end with outlooks, graphs, clinic planning and modernization, the scene changes.

An architectural exhibit is always interesting. A room full of the period of 1886, another with the standards of 1936. "As the League (The Architectural League of New York) is a private club, it was deemed unfair to try to use the submissions to tell any particular story of stylistic expression. The only criterion of judgment by the various committees was excellency in achievement of the exhibitor's aims." This would be a fine way to award an architectural competition. "Special Building Types" is well chosen, dealing with special occupancy and conditions met with more frequency as conditions change.

With practically no attempt to portray the so-called trend in architecture, the charm, beauty and vantage point from whence these illustrations were taken, compel admiration unrestricted nor stinted. Frankly an architectural journal, interesting from cover to cover with a continued portfolio of useful subjects.

So old, so useful, so declined, so restored and turning to the plate illustrations, which at one time in the past were the pride of every architectural magazine but now a lost art, the focus is brought to the center from whence one may turn right or left and retain a thorough interest. It has been said that some are architectural plate followers. Perhaps that is not a bad accusation for, after all, we profit by one another's achievements. Why not more good plate illustrations? They have a real place in the training of young men and the older men have not gotten beyond the desire for the practical, concise and direct method of illustrating.

Given more particularly to speaking the voice of the architect, punctuating it with the work he has done, avoiding playful enterprises, taking advantage of the present with no reflection to the past, it maintains a tempered standard of endeavor for which there can be nothing but admiration.

One of the younger. The draftsmen's friend. The imaginative rather than the real; the rendering that precedes the actual; the talented that gather from the four corners of the nation; the works of those who have closed life's scene; the useful information everyone needs; having some faults but not many, and quoting Ralph Walker in part: "I firmly believe that the only way architecture can develop is through local process, a process in which the whole community must share.

"The machine, as a labor-saving device, has only a small part in making architecture.

"It has been one of the false quantities of modern American life that so large an interest has been devoted to the gadget, for as the interest in the gadget increased the interest in beauty diminished. Life and its accessories are in need of regeneration into beauty.

"As this country left the eighteenth century and entered the nineteenth, it possessed a beautiful architecture, a civilization in which most things were harmonious, and it is interesting to remember that those years in which architecture and community were beautiful were longer than the years when ugliness became so common a sight to all.

"The architect cannot be successful when divorced from his community. He becomes merely imitative."

FURNISHED GLASS FOR AUDITORIUM

All the glass in the new San Jose Civic Auditorium was furnished and installed by the Le Deit Glass Company, 762 Lenzen Avenue, San Jose. One of the leading glass firms in the Santa Clara Valley, the Le Deit Company has completed many notable installations in that territory and besides plate and window glass it handles art glass and mirrors.

THE

BUILDING MATERIAL EXHIBIT • • LOS ANGELES

We offer a complete service to Architects and Engineers with information on manufacturers' representatives and details of materials.

FIFTH at FIGUEROA

M U T U A L 6 3 0 6



*The luxury of efficiency
at the price of economy!*

JOHNSON Oil Burners . . . all of them . . . are famed for efficiency, for economical operation. Here, for smaller homes, is the Johnson Type B; low in first cost as well as in cost of operation. Available in various models according to radiation required up to 1385 square feet and for either gravity or pump feed, it represents a recommendation that can be made with the same confidence felt in commending any Johnson burner to the home-owner.

S. T. JOHNSON CO.

940 Arlington Street

Oakland, California

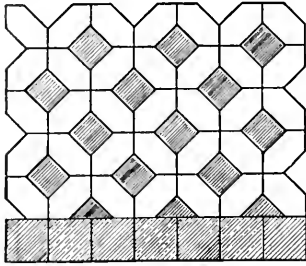

POMONA TILES

FOR

**Bathrooms and Kitchens
in over 60 colors**

Warehouses and Display Rooms

135 Tenth St. . . . San Francisco
629-33 North La Brea Ave. . . . Los Angeles
6106 Roosevelt Way . . . Seattle

**POMONA TILE MFG. CO.
PLANT—POMONA, CALIF.**

THE LANDSCAPE ARCHITECT

Emerson wrote "We ascribe beauty to that which is simple; which has no superfluous parts; which exactly answers its end; which stands related to all things; which is the mean of many extremes." The wise landscape architect could well use these lines as a definite rule to follow in the creation of his living pictures, for truly living pictures they are, painted with the forms and colors provided by nature. Yet how very often do they become grotesque monstrosities due to the ignorance of the would-be landscape gardener or the over zealous nursery stock salesman, both of whom, obsessed with the one idea of greater profits through the sale of more shrubs and trees, are inclined to plant and over-plant until the average home grounds resemble a badly planted public park. The foundation areas are choked with trees and shrubs that in a few years overgrow themselves to completely swallow up the building and also most successfully destroy the architectural beauty that the architect strived to create. This condition being prevalent there seems every good reason for the ethical architect being loathe to call for or recommend the services of one who, ignorantly, of course, yet none the less deleterious, plays havoc with his carefully designed home.

This naturally brings up the question of the Landscape Architect. What is he and where does he fit into the picture in co-operation with the architect? He is not the man who, after working several days with a grading and sodding contractor, has some cards printed "Landscape Gardener" and starts out flim-flaming the public. This type has no more conception of design and proportion than has the high school draftsman of French Directoire style in architecture. The nursery stock salesman who promises free landscape plans as a premium for purchasing the plant material from his concern is no more a landscape architect than the former. This deal is the same as a building supply house offering to design and build a home for the party buying the material from them. True, they could build a house but by

LIGHTING FIXTURES

for

San Jose's
New
Auditorium

*Manufactured and installed
by*

**ART FIXTURE
SHOP**

Paul D. Cambiano

789 So. 2nd St., San Jose, Cal.

To the

**ARCHITECTURAL
PROFESSION!**

GIVE

your clients

COMFORT

and

SATISFACTION

by including

"AIR-LITE"

VENETIAN

BLINDS

in your specifications

NUFF SAID

GUNN, CARLE & CO.

20 Potrero Ave. UNDERhill 5480
SAN FRANCISCO

SISALKRAFT
REG. U. S. PAT. OFF.

"More than a
building paper"

THE SISALKRAFT CO.

205 West Wacker Drive
(Canal Station) Chicago, Ill.
55 New Montgomery Street
San Francisco, Calif.



**DALMO
WINDOW
PRODUCTS**

DALMO SALES CORPORATION
511 Harrison St., San Francisco

THE ARCHITECT AND ENGINEER.

Electrical Installation

in the

San Jose Auditorium

and the

Remodeled Victory Theater Building

illustrated in this issue

by

GUILBERT BROS. ELECTRIC CO.

286 W. Santa Clara Street
San Jose

no stretch of the imagination would it come close to fitting the needs of the owner. Nowhere would it reflect the personality of the people who were to live within it nor would it possess any individuality. These most necessary factors along with many others can only be taken care of by the architect having exclusively his client's interest at heart and no outside connections advising him as to just what to specify.

The landscape architect must have a complete knowledge of design, proportion and perspective. He is thoroughly informed on the different styles of architecture and knows the proper treatment for each. He knows soils and the correct materials to plant in them, also the methods of changing soil conditions to fit the stock available. He knows the weather of the locality and the effect on plants to be used. He is thoroughly familiar with countless numbers of trees, plants and shrubs; knows their habits, blooming period, ultimate height, colors, texture of foliage, manner of growth and seasonal changes. He also knows the available sources of supply (for example: In our office are listed over 20,000 varieties of plants from nearly 2,000 sources. These listings are the result of years of surveillance and are so arranged that any required item can be located on a moment's notice).

The garden designer is an expert in color harmony and values. He knows just what to use to make a cold wall warm or a hot corner cool. By the adroit use of perspective he makes the grounds appear smaller or larger according to its needs. He frames pleasing vistas and blocks out displeasing areas. He accentuates the good points in the design created by the architect and blends the house artfully with the surrounding countryside. He is not only willing but eager to co-operate at all times with the architect and many annoying problems can be quickly cleared up by a few simple suggestions. It is a good plan to have the assistance of the garden designer from the very first plans. By knowing what and where the planting are located much unnecessary work will be eliminated.

HARDWOOD LUMBER FLOORING VENEERS PANELS

Exotic Woods for Modernistic Trim

White Brothers
Hardwood Headquarters

Since 1872

5TH AND BRANNAN . . . SAN FRANCISCO
500 HIGH STREET OAKLAND

Mechanical Work Including HEATING AND VENTILATING

in San Jose
Civic Auditorium

Installed by

HATELEY & HATELEY
Sacramento, California



PACIFIC Gas Heating Appliances

- ⊙ Circulator Heaters
- ⊙ Radiant Wall Heaters
- ⊙ Gas Steam Radiators
- ⊙ Floor Furnaces
- ⊙ Gravity Furnaces
- ⊙ Blower Furnaces
- ⊙ Unit Heaters
- ⊙ Forced Air Units
- ⊙ Water Heaters

Write for Catalog No. AE-3

**PACIFIC GAS
RADIATOR CO.**
Huntington Park, California,
U. S. A.



Make the old stucco colorful and water tight by applying one or more coats of

BAY STATE Brick and Cement Coating

Manufactured by a company whose products have been on the market for over half a century.



Distributors

**CALIFORNIA SALES
COMPANY, INC.**

444 MARKET STREET
SAN FRANCISCO

IT'S HERE!

Perfected
by
**ELECTRIC
HEATING
WESIX**



BEFORE YOU INSTALL
ANY HEATING SYSTEM

... ask us about WESIX *automatic* electric heaters—proven in thousands of installations in homes, buildings, hospitals, schools—even entire cities! WESIX patented double-action principle of *circulating* and *radiating* provides quick, efficient, economical heat. You know it's *healthful*. NO FANS to stir up breeze and drafts—no moving parts.

•
WESIX ELECTRIC HEATER CO.
380 First Street San Francisco

**Melrose Lumber
& Supply Co.**

•
**LUMBER AND
MILL WORK**

•
46th Ave. and E. 12th St.
Oakland
Phones: FRuitvale 0240 — 0251

**JOSEPH MUSTO
SONS-KEENAN
COMPANY**

—
**MARBLE
and
ONYX**

—
535 NORTH POINT STREET
SAN FRANCISCO
1801 S. SOTO STREET
LOS ANGELES

The grades will not have to be changed once they are finished; there will be no rubbish to be dug out once the planting has actually been started and material can be leisurely compared and selected which will result in a better job all the way round.

A house can be beautiful or commonplace; it can be ordinary or possess untold charm and character. Catalogs, flower shows and nursery salesmen can all help to buy plants but only the skilled designer can assist in perfecting the picture of the architect's true objective. After all a home can be no better than its landscape and the landscape architect is never happier than when assisting the architect in the attainment of artistic perfection.—Bulletin Michigan Society of Architects.

ENGINEERING PROGRESS

• Many new engineering conceptions of the past year show truly advancing civilization, in spite of social and international problems. Scientists and engineers proceed like explorers and pioneers, forever breaking new trails. What will come next? New high-creep-strength steel leads to stronger turbines, high steam temperatures, better station efficiencies, lower power costs, accelerated power-plant construction. New cobalt-beryllium-copper alloy lengthens the life of current-carrying springs and mechanisms. The quantum theory of the reflection of electrons at potential barriers leads to a fresh field. So do analogies between the behavior of electrons and electrical machinery through the general language of tensor analysis. Progress with more powerful, economic and varied apparatus for power and communication purposes, linked to devices for measuring and controlling its electrical and mechanical performance, is directed by highly talented engineers to the ingenious, economical use of materials, study of systems of interconnected apparatus and highly specialized, delicately controlled equipment. Immense development of vacuum and gas-filled electronic devices follows research in atoms and electrons, chemists and metallurgists producing many materials of great

P. F. REILLY

*Building
Contractor
and Manager of
Construction*

—
730 ELLIS STREET
San Francisco
UN DERHILL 5829

**Quarry Tile
Floor**

in Main Lobby of
San Jose Auditorium

•
Manufactured by
SOLOMON AND LARKIN
1881 S. First Street
SAN JOSE

**ANDERSON
&
RINGROSE**

—
General Contractors

—
320 Market Street, San Francisco
Phone GARfield 2245

MURALS

for Hotel Cocktail Rooms,
Theaters, etc.

**HEINSBERGEN
DECORATING CO.**

7415 Beverly Boulevard, Los Angeles
401 Russ Building, San Francisco

Pacific Manufacturing Company

High Class Interior Finish
Quality Millwork

454 Montgomery St. 641 Merrill Ave.
San Francisco Los Angeles
GARfield 7755 AXridge 9011

1315 Seventh Street, Oakland
GLencourt 7850

Smith

Lumber Company

WHOLESALE - JOBBING - RETAIL
FACTORY AND BUILDING LUMBER
PLYWOODS - ROOFING
DISTRIBUTING YARDS

San Francisco	Oakland
•	19th Ave. &
4th & Channel	Estuary
MARKet 0103	FRuitvale 3174
YOUR INQUIRIES SOLICITED	

CEMENTEX!

Specified for

Stucco and Concrete
Will water-proof and
beautify!

Recent users

Hayward High School
Shenstone Apartments
470 Mandana Blvd., Oakland

TAKE A LOOK!

FRANK W. DUNNE CO.
41st and Linden Oakland

TRANSIT-MIX CONCRETE

A Perfect Blend
Material

Golden Gate Atlas
Materials Co.

Sixteenth and Harrison Streets
San Francisco
Phone HEmlack 7020

electrical utility, like pyranols, fernico and high-creep-strength steels. With psychologists, they unfold air-conditioning, noise meters, a science of seeing, radio equipment for two-way communication, sodium lamps and other means for highway safety.

—General Electric Review.

COMPETITION WINNERS

Following is a list of the winners of prizes and honorable mentions in the '1936' Pencil Points—Portland Cement Association's Architectural Competition.

Problem A—A House Suitable for Northern Climates.

First Prize (\$1500) Walter J. Thies, Dayton, Ohio.

Second Prize (\$750) George D. Conner and Robert S. Loney, Washington, D. C.

Third Prize (\$500) Owen Lau Gowman, New York.

Special Mention (\$50) Richard Powers, Chicago.

Mentions (\$50 each) Thomas S. Acuri, Laurelton, N. Y.; Manson Bennett, Portland, Oregon; Malcolm P. Cameron and Howard A. Topp, Los Angeles; Allen R. Congdon, Nantucket, Mass.; Joseph G. Durant, Boscobel, Wisconsin; Robert V. Goldsborough, Chicago; Harry Jones Harman, Urbana, Illinois; Edward H. Hicks, Clarendon, Virginia; Robert I. Hillier, Brooklyn, N. Y.; Hudson and Hudson, Buffalo, N. Y.; Clarence W. Jahn and Edwin A. Wagner, Milwaukee, Wisconsin; Russel Krob, Jan Ruhtenberg, and Walter Sanders, New York; Elmo K. Lathrop, Detroit; Amedeo Leone, Detroit; A. Martini and J. Pendlebury, Flushing, N. Y.; E. Manson and C. V. Northrup, Massena, N. Y.; J. P. Margon, Philadelphia; Joseph A. Parks, Bethesda, Md.; Lester Beach Scheide, Hartford, Conn.

Problem B—A House Suitable for Southern Climates.

First Prize (\$1500) Harris A. Kemp and David G. Connally, Dallas, Texas.

Second Prize (\$750) Don E. Hatch and Carl Landefeld, New York.

Third Prize (\$500) Frederick Hodgson, Chicago.

Special Mention (\$50) Hays and Simpson, Cleveland.

Alumilite

by

Kawneer

•

Store Fronts - Windows

and

Architectural Castings

in

Polished Satin

or

Anodic Finish

THE

Kawneer
COMPANY
OF CALIFORNIA
BERKELEY

"BROWNSKIN"

RESILIENT WATERPROOF
BUILDING PAPER

THE BUILDING PAPER WITH
A FACTOR OF SAFETY

Angier Corporation

Framingham, Mass.

PACIFIC COAST DIVISION

544 HOWARD STREET

SAN FRANCISCO

DOuglas 4416

350 South Anderson St.
Los Angeles

LUXOR

WINDOW SHADES

*Translucent Shading
of highest count
cambric*

William Volker & Co.

631 Howard Street
San Francisco



Pump Governors
Safety Pump Governors
Automatic Gas Regulating Valves
Gas Burners
Gas Burning Equipment
Vacuum Pump Governors
Vacuum Regulating Valves
Continuous Flow Steam Traps
Thermostats
Reducing Valves
Boiler Feed-Water Regulators

Oil Heaters
Relief Valves
Oil-burner Governors
Little Giant Improved Oil Burners
Oil Pumping Sets
Oil Valves
Oil Strainers
Steam Oil Strainers
Duplex Oil Pumps
Rotary Oil Pumps
Boiler Feed Pumps
Water Heaters
Oil Meters

VAUGHN-G. E. WITT Co.
ENGINEERS

C. W. Vaughn, President and Manager
MANUFACTURERS AND DISTRIBUTORS

4224-28 Hollis St. Phone OLYmpic 6084
Emeryville, Oakland, Calif.

Mentions (\$50 each) H. Hall Van Vleck Bradley, Greenwich, Conn.; George D. Conner and Robert S. Loney, Washington, D. C. (2); Richard E. Collins and Charles Hood Helmer, Tacoma Park, Maryland; Joseph J. De Brita and Herbert A. Magoon, New York; John E. Fortune, Los Angeles; E. W. Genter, Jr., Glendale, Calif.; John Hironimus, New York; Rudolph A. Matern, Bloomfield Hills, Michigan (2); Emil J. Minx, Chicago; Trevor R. Milligan and Kenneth E. Wischmeyer, St. Louis; M. Righton Swicegood, New York; Joseph Shilowitz, Jersey City, New Jersey; F. Talbott Wilson, Houston, Texas; Harry Wijk, Boston; Royal Barry Wills and Hugh A. Stubbins, Boston, Massachusetts; Robert E. West, Tulsa, Oklahoma; J. Floyd Yewell, New York.

The Judges were: Atlee B. Ayres, F. A. I. A., San Antonio, William D. Crowell, A. I. A., St. Louis, Edmund B. Gilchrist, A. I. A., Philadelphia, Carl F. Gould, F. A. I. A., Seattle, C. Herrick Hammond, F. A. I. A., Chicago, Robert D. Kohn, F. A. I. A., New York, Howard Major, A. I. A., Palm Beach.

**FORDERER
Cornice Works**

Manufacturers of
Hollow Metal Products
Interior Metal Trim
Elevator Fronts and Cabs
Metal Wall Plugs, Anchors, Etc.
Sheet Metal Products
Sanitary Metal Base
Commercial Refrigerators
Building Paper
Metal and Wire Accessories for Concrete
269 POTRERO AVENUE
San Francisco, Calif.
HEMtoek 4100
CONSULT OUR ENGINEERING DEPARTMENT

MacDonald & Kahn

*General
Contractors*



Financial Center Bldg.
405 Montgomery St.
San Francisco

Robert W. Hunt Company
ENGINEERS

Inspection - Tests - Consultation
Schools and Other Structures
Are Built as Designed

When Construction Materials are Inspected at point of Manufacture and during Erection by

ROBERT W. HUNT COMPANY

Cement, Concrete, Chemical, Metallurgical, X-Ray and Physical Laboratories

Chicago - New York - Pittsburgh
Los Angeles - All Large Cities
San Francisco, 251 Kearny Street

BUILDING MATERIAL ANALYSIS

Practical materials must take precedence over the merely new. Prefabricated housing has not reached a stage of demand to make its manufacture profitable. Its parts, however, come into wide use, such as steel framings — walls, studs, joists, ceilings. They increase durability, ease of assembling, fireproofing, insulation, vermin-proofing. Cement floors come with precast concrete joists, now made by 120 plants. Kitchens and bathrooms have been fashioned into single units, combining all latest advances in plumbing, fittings and decoration. Oil-burners, gas-burners and coal stokers mark great progress in heating. Air-conditioning becomes a science, with its own specific apparatus, covering temperature, purification, ventilation, humidification. Insulation assumes prime importance. Decorations and wall finishes join the novelty parade. Structural glass takes a strong start. Floors of oak and other woods become better with new finishes. Copper and zinc for roofing

**THE TORMEY
COMPANY**

**GENERAL PAINTERS
AND DECORATORS**

Phone UNDERhill 1913

563 FULTON STREET
San Francisco

**G. P. W.
JENSEN & SON**

Building Construction

320 Market Street, San Francisco
Phone 2444

CRANE

*High Class Plumbing
Fixtures*

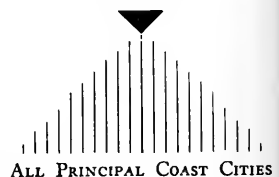

THE ARCHITECT AND ENGINEER

Bethlehem Steel Company

General Offices:  Bethlehem, Pa.

STEEL BRIDGES and BUILDINGS

San Francisco
20th and Illinois Sts.

Seattle
W. Andover Street

Portland
American Bank Bldg.

Los Angeles
Stauson Ave.

Salt Lake City
Kearns Bldg.

Honolulu, T. H.
Schuman Bldg.

MULLEN MFG. COMPANY

BANK, STORE AND OFFICE
FIXTURES—CABINET WORK
OF GUARANTEED QUALITY
CHURCH SEATING

Office and Factory:
60-80 RAUSCH ST., Bet. 7th and 8th Sts.
San Francisco
Telephone UNderhill 5815

COMMON BRICK

If you like good brick and good service, phone us for information, you will find that it always pays to be our patron.

Remillard-Dandini Co.

Phone TEmplebar 8133
Office, 569 - 3rd Street, Oakland
Plants
San Jose Pleasanton Greenbrae

DINWIDDIE CONSTRUCTION COMPANY

BUILDERS OF
GOOD BUILDINGS

CROCKER BUILDING
SAN FRANCISCO

advance in common use, while beautiful effects appear with antiqued clay tiles, cement shingles simulating age-old woods and stone slabs. Electric fixtures and appliances take leadership in the modernization movement, as is proven by new high volume records in current output. Lighting becomes a science, replacing a vast amount of old equipment with latest devices.—National Real Estate Journal.

ITEMS OF ARCHITECTURAL INTEREST

By A Critic

Windows were originally merely openings in the walls, and although glass windows were used, it is believed, at Pompeii, they did not come into general use in England before the 12th century. Later on in 1695 a window tax was imposed, and at intervals for revenue purposes it was renewed until the year 1850, when the sum of £1,832,684, was obtained from this source. In 1851 the tax was repealed.

* * *

Sir Christopher Wren, the most famous of English architects, died 212 years ago at the age of 91, and although he had no previous special architectural training, the great Fire of London provided him with an opportunity which he was capable of dealing with in a way that made his fame as an architect.

The cost of the churches he built, or rebuilt, in or around London alone, amounted to more than £1,000,000, besides which he built many others in other parts of England, as well as colleges, mansions, public buildings, business premises, and other places, estimated roughly at £2,000,000, so that on a 5 per cent commission his income would have averaged about £3,000 a year during the whole 50 years of his career without any allowance for slumps, or trade depressions such as modern architects have to put up with. But they didn't pay that way then; on the contrary he was treated shockingly and asked to take a hundred or two a year for constructing St. Paul's.

San Francisco Bay Bridge

Contracts Completed

U. S. Marine Hospital
Ford Assembly Plants,
Seattle, Long Beach and
Richmond
Oakland Approach to
Bay Bridge

Contracts Awarded
U. S. Mint, San Francisco
Administration Building and
To!! Plaza, Bay Bridge,
Oakland

Clinton Construction Co.

of California
923 Folsom Street
San Francisco
SUtter 3440

Specify Dickey Clay Products

Dickey Mastertile	Face Brick
Partition Tile	Fire Brick
Drain Tile	Paving Brick
Fireproofing Tile	Wall Coping
Floor Tile	Flue Lining
Common Brick	Dickey Flashing Blocks

W. S. DICKEY CLAY MFG. COMPANY

116 New Montgomery St.,
San Francisco, Calif.
105 Jackson St., Oakland, Calif.

REPUBLIC STEEL CORPORATION



Manufacturers of

ENDURO Stainless Steel; TON-CAN Copper Molybdenum Iron Sheets and Pipe; and Steel Pipe, Sheets and Reinforcing Bar for every building purpose.

Write for information

Rialto Building, San Francisco, Calif.
Edison Building, Los Angeles, Calif.
White-Henry-Stuart Bldg., Seattle, Wash.

**Contract floor covering
is our business.**

**Quality materials and
superior service
is our specialty.**

**Samples and estimates
gladly submitted.**

WEST COAST

**LINOLEUM and CARPET
STORES**

2703 MISSION STREET, SAN FRANCISCO
Telephone VAencia 4909

Independent Iron Works

Structural Steel
Ornamental Iron
Steel Service Stations
Steel Tanks
Standard Steel Mill Buildings
Bridges

821 Pine Street Oakland

JOHN CASSARETTO

—Since 1886—And Still Active—

Building Materials

READY MIX CONCRETE
ROCK - SAND - GRAVEL - LIME
CEMENT - PLASTER - MORTAR
METAL LATH - WOOD LATH
STUCCO - WIRE NETTING

Service Unexcelled

Bunkers

Sixth and Channel, San Francisco
Phones: GARfield 3176, GARfield 3177

Carl T. Doell Co.

Plumbing Heating

Plumbing Contractor
Veterans Memorial Building
Oakland

467 21ST STREET
OAKLAND

Telephone GLencourt 8246

The Phares Lighthouse at Alexandria was included in the list of the "Seven Wonders of the World." It was 450 feet high, and was started by King Ptolemy of Egypt, and finished by his son, King Ptolemy Philadelphus. The architect was Sostratus, who put on it an inscription which when translated read, "King Ptolemy to the Gods the Saviours for the benefit of sailors."

ARCHITECTS AS APPRAISERS

The architect is fitted by training and experience to make appraisals of existing buildings.

It is a part of the every day routine of an architect's practice to analyze the requirements of the buildings he designs, so that the finished building will fully provide all the facilities needed in the proper relation to each other.

The arrangement of the plan is of first importance, for if this does not provide economical use of the space suitable for the intended use, the value of the building is materially lessened. An architect examining a building to be appraised, can, because of wide experience, determine how well suited the building is to the use for which it was built.

The architect, because of his familiarity with the details of construction and the use of materials, can by an inspection of a building, learn more of its exact condition structurally than would be possible for one with less experience in building operations.

If the examination of the building shows it is substantially constructed and that there is evidence throughout of good quality of workmanship without extravagance, then a low maintenance cost with resulting higher returns on the investment is assured. The design of a building has an important bearing on its value, for if the design gives the building character that is suitable to its use, location and environment, it will materially add to the sale value of the building. The successful use of materials, the skillful selection of color and texture and the fitness of design give a quality to a building that will add to its desirability for rental or purchase. The architect is able to

appreciate and appraise this value. He would, however, realize that an estimate of the replacement cost, less depreciation, would not represent the true value of a building. He would, in addition to the features mentioned, give consideration to obsolescence, operating cost, changing neighborhood conditions, taxation, and the useful life of the improvement.

The well-informed architect, after making this kind of an analysis of an existing building, will be able to make an appraisal that will represent the real investment value of a building.

—Melville Clark Chatten.

DELEGATES TO CONVENTION

The Los Angeles delegates who attended the convention of The American Institute of Architects at Old Point Comfort and Williamsburg, Virginia, were: George Adams, A. M. Edelman and Samuel E. Lunden; Edwin Bergstrom, treasurer; David J. Witmer, regional director Sierra Nevada Division.

M O N E L M E T A L

For the Modern Kitchen

Heaters, boilers, storage tanks,
water softeners, cabinet tops,
"Streamline" or "Straitline"
Kitchen Sinks

See our display rooms, arranged for
your convenience

**MODERN METAL
APPLIANCE CO.**
4238 Broadway Oakland, Calif.

MONSON BROS.

•
**General
Contractors**
•

475 SIXTH STREET
San Francisco
Douglas 1101

Classified Advertising Announcements

All Firms are Listed by Pages, besides
being grouped according to Craft or Trade.

Star (*) indicates alternate months.

		NEW THIS MONTH
AIR CONDITIONING		
The Union Ice Company, 354 Pine Street, San Francisco.....	64	
ARCHITECTURAL TERRA COTTA		
N. Clark & Sons, 116 Natoma Street, San Francisco.....	4	
Gledding McBean & Co., 660 Market Street, San Francisco; 2901 Los Feliz Boulevard Los Angeles; 1500 First Avenue South, Seattle; 79 S. E. Taylor St., Portland; 22nd and Market Street, Oakland; 1102 N. Monroe Street, Spokane; Vancouver, B. C.	7	Art Fixture Shop 70
BANKS		
Crocker First National Bank, Montgomery and Post Streets, San Francisco.....	67	
BATHROOM HEATERS		
Wesix Electric Heater Company, 390 First Street, San Francisco; 631 San Julian Street, Los Angeles; 2008 Third Avenue, Seattle, Wash.	72	Davey Tree Surgery 2
BRICK—FACE, COMMON, ETC.		
N. Clark & Sons, 116 Natoma Street, San Francisco.....	4	Johnson Service 3
Gledding McBean & Co., 660 Market Street, San Francisco; 2901 Los Feliz Boulevard Los Angeles; 1500 First Avenue South, Seattle; 79 S. E. Taylor St., Portland; 22nd and Market Street, Oakland; 1102 N. Monroe Street, Spokane; Vancouver, B. C.	7	Gunn-Carle & Co. 70
W. S. Dickey Clay Mfg. Co., 116 New Montgomery Street, San Francisco; factory, Niles, Calif.; yards, 7th and Hooper Streets, San Francisco, and 105 Jackson Street, Oakland; Factory in Livermore.....	75	Libbey-Owens-Ford 5
Remillard-Dardini Co., 569 Third Street, Oakland.....	75	Hateley & Hateley 71
BUILDERS HARDWARE		
The Stanley Works, New Britain, Conn.; Monadnock Bldg., San Francisco; Los Angeles and Seattle	*	Solon & Larkin 72
BUILDING MATERIALS		
Building Material Exhibit, Architect's Building, Los Angeles.....	69	Guilbert Bros. Electric Co. 71
BUILDING PAPERS		
The Sisalkraft Company, 205 W. Wacker Drive, Chicago, Ill., and 55 New Montgomery Street, San Francisco	70	Sloan Valve Co. 6
"Brownskin," Angier Corporation, 370 Second Street, San Francisco	73	
CEMENT		
Portland Cement Association, 564 Market Street, San Francisco; 816 West Fifth Street, Los Angeles; 146 West Fifth Street, Portland; 518 Exchange Building, Seattle	Back cover	
"Golden Gate" and "Old Mission," manufactured by Pacific Portland Cement Co., 111 Sutter Street, San Francisco; Portland, Los Angeles and San Diego.....	Second cover	
CEMENT TESTS—CHEMICAL ENGINEERS		
Robert W. Hunt Co., 251 Kearny Street, San Francisco.....	74	
CEMENT—COLOR		
"Golden Gate Tan Cement," manufactured by Pacific Portland Cement Co., 111 Sutter Street, San Francisco; Portland, Los Angeles and San Diego	Second cover	
W. S. Dickey Clay Mfg. Co., 116 New Montgomery Street, San Francisco	75	
CEMENT PAINT		
General Paint Corporation, San Francisco, Los Angeles, Oakland, Portland and Seattle	65	
California Sales Company, 444 Market Street, San Francisco.....	71	
CONCRETE AGGREGATES		
Golden Gate Atlas Materials Company, Sixteenth and Harrison Streets, San Francisco	73	
John Cassaretto, Sixth and Channel Streets, San Francisco	76	
CONCRETE CURING & PROTECTION		
The Sisalkraft Company, 205 W. Wacker Drive, Chicago, Ill., and 55 New Montgomery Street, San Francisco	70	
CONTRACTORS—GENERAL		
MacDonald & Kehn, Financial Center Bldg., San Francisco.....	74	
Lindgren & Swinerton, Inc., Standard Oil Building, San Francisco.....	66	
Dinwiddie Construction Co., Crocker Bldg., San Francisco.....	75	
Clinton Construction Company, 923 Folsom Street, San Francisco.....	75	
Anderson & Ringrose, 320 Market Street, San Francisco.....	72	

	Page
CONTRACTORS—GENERAL	
G. P. W. Jensen, 320 Market Street, San Francisco.....	74
Monson Bros., 475 Sixth Street, San Francisco.....	78
P. F. Reilly, 730 Ellis Street, San Francisco.....	72
Wm. Martin & Son	79
DAMP-PROOFING & WATERPROOFING	
"Golden Gate Tan Plastic Waterproof Cement," manufactured by Pacific Portland Cement Co., 111 Sutter Street, San Francisco; Portland, Los Angeles and San Diego	Second page of cover
The Siskrafft Company, 205 W. Wecker Drive, Chicago, Ill., and 55 New Montgomery Street, San Francisco	70
Bay State Brick & Cement Coating, sold by California Sales Company, 444 Market Street, San Francisco.....	71
DOORS—HOLLOW METAL	
Forderer Cornice Works, Potrero Avenue, San Francisco.....	74
Kawneer Mfg. Co., Eighth and Dwight Streets, Berkeley.....	73
DRAIN PIPE AND FITTINGS	
"Corrosion" Acid Proof, manufactured by Pacific Foundry Co., 3100 Nineteenth Street, San Francisco, and 470 E. Third Street, Los Angeles.....	65
DRINKING FOUNTAINS	
Haws Drinking Faucet Co., 1808 Harmon Street, Berkeley; American Seating Co., San Francisco, Los Angeles and Phoenix.....	68
ENGINEERS—MECHANICAL	
Hunter & Hudson, 41 Sutter Street, San Francisco.....	78
ELECTRIC AIR AND WATER HEATERS	
Sandoval Sales Company, 557 Market Street, San Francisco.....	71
West Electric Heater Company, 390 First Street, San Francisco; 631 San Julian Street, Los Angeles; 2008 Third Avenue, Seattle, Wash.	72
ELECTRICAL ADVICE	
Pacific Coast Electrical Bureau, 447 Sutter Street, San Francisco, and 601 W. Fifth Street, Los Angeles	64
ELEVATORS	
Pacific Elevator and Equipment Company, 45 Rausch Street, San Francisco.....	78
HOLLOW TILE AND BRICK FENCES	
W. S. Dickey Clay Mfg. Co., 116 New Montgomery Street, San Francisco	75
FIXTURES—BANK, OFFICE, STORE	
Mullen Manufacturing Co., 64 Rausch Street, San Francisco.....	75
Pacific Manufacturing Company, 454 Montgomery Street, San Francisco; 1315 Seventh Street, Oakland, Los Angeles and Santa Clara.....	73
GAS FUEL	
Pacific Gas Association, 447 Sutter Street, San Francisco.....	Third Cover
GAS BURNERS	
Vaughn-G. E. Witt Company, 4224-28 Hollis Street, Emeryville, Oakland.....	74
GAS VENTS	
Payne Furnace & Supply Co., Beverly Hills, California.....	2
GLASS	
W. P. Fuller & Co., 301 Mission Street, San Francisco. Branches and dealers throughout the West	*
Libbey-Owens-Ford Glass Co., Toledo, Ohio; 633 Rialto Bldg., San Francisco; 1212 Architects Bldg., Los Angeles; Mr. C. W. Holland, P.O. Box 3142, Seattle.....	5
Pittsburgh Plate Glass Company, Grant Building, Pittsburgh, Pa. W. P. Fuller & Co., Pacific Coast Distributors	*
HARDWARE	
The Stanley Works, Monadnock Building, San Francisco; American Bank Building, Los Angeles	*
HARDWOOD LUMBER	
White Bros., Fifth and Brannen Streets, San Francisco; 500 High Street, Oakland.....	71
HEATING—ELECTRIC	
Apex Air and Water Electric Heaters, Sandoval Sales Company, 557 Market Street, San Francisco.....	68
West Electric Heater Company, 390 First Street, San Francisco; 631 San Julian Street, Los Angeles; 2008 Third Avenue, Seattle, Wash.	72
HEATING EQUIPMENT	
Payne Furnace & Supply Co., Beverly Hills, California.....	2
Pacific Gas Radiator Co., 7615 Roseberry Ave., Huntington Park; Sales Office, H. C. Stoeckel, 557 Market Street, San Francisco.....	71
HEAT REGULATION	
Johnson Service Company, Milwaukee, represented on the Pacific Coast by the following branch offices: 814 Rialto Bldg., San Francisco; 153 West Avenue, 34, Los Angeles; 1312 N.W. Raleigh St., Portland, and 473 Coleman Bldg., Seattle	3
HOLLOW BUILDING TILE (Burned Clay)	
N. Clark & Sons, 116 Natoma Street, San Francisco.....	4
Gladding, McBean & Co., 660 Market Street, San Francisco; 2901 Los Feliz Boulevard Los Angeles; 1500 First Avenue South, Seattle; 79 S. E. Taylor Street, Portland; Twenty-second and Market Streets, Oakland; 1102 N. Monroe Street, Spokane; Vancouver, B. C.	7

Phone GARfield 1164

Hunter & Hudson
Consulting Engineers
**DESIGNERS OF HEATING
 AIR CONDITIONING
 VENTILATING AND WIRING
 SYSTEMS, MECHANICAL
 AND ELECTRICAL EQUIP-
 MENT OF BUILDINGS**
CS
41 SUTTER STREET
 ROOM 710
San Francisco California

SAN FRANCISCO'S

FIRST

SKYSCRAPER

to be Erected

Since the Depression

THE LURIE

10 Story

Office Building

W. D. Peugh,

Architect

Plate and Drawings

in the June

ARCHITECT and

ENGINEER

**William Martin
& Son
Builders**

666 Mission Street
San Francisco
Telephone Sutter 6700
Evenings: GARfield 9456

ELEVATORS

**Pacific Elevator and
Equipment Company**

45 Rausch Street, San Francisco
HEmlock 4476

A. KNOWLES

*Contracting
Plasterer*

982 Bryant Street
San Francisco

UNderhill 4048

"The Only Pacific Coast Factory"

**THE HERMANN
SAFE COMPANY**

Manufacturers and Dealers

**FIRE AND BURGLAR PROOF
SAFES, VAULTS, SAFE
DEPOSIT BOXES**

**Howard & Main Sts.
San Francisco**

Telephone GARfield 3041

	Page
W. S. Dickey Clay Mfg. Co., 116 New Montgomery Street, San Francisco; factory, Niles, Calif.; yards, 7th and Hooper Streets, San Francisco, and 105 Jackson Street, Oakland	75
INSPECTION AND TESTS	
Robert W. Hunt Co., 251 Kearny St., San Francisco.....	74
LACQUERS	
General Paint Corp., San Francisco, Los Angeles, Oakland, Portland, Seattle and Tulsa W. P. Fuller & Co., 301 Mission Street, San Francisco. Branches and dealers through- out the West	65
LINOLEUM	
Sloan-Blabon linoleum, sold by California Shade Cloth Co., 210 Bayshore Boulevard, San Francisco	70
LUMBER	
Pacific Mfg. Co., 454 Montgomery Street, San Francisco; 1315 Seventh Street, Oak- land; Los Angeles and Santa Clara.....	73
Smith Lumber Company, Nineteenth Avenue and Estuary, Oakland.....	73
Melrose Lumber & Supply Co., Forty-sixth Avenue and E. Twelfth Street, Oakland.....	72
E. K. Wood Lumber Company, 4701 Santa Fe Avenue, Los Angeles; 1 Drumm Street, San Francisco; Frederick and King Streets, Oakland.....	66
MARBLE	
Joseph Musto Sons-Keenan Co., 535 N. Point Street, San Francisco.....	72
MILLWORK	
E. K. Wood Lumber Company, No. 1 Drumm Street, San Francisco, Oakland, Los Angeles	66
Melrose Lumber & Supply Company, Forty-sixth Avenue and E. Twelfth Street, Oakland Pacific Mfg. Co., 454 Montgomery Street, San Francisco; 1315 Seventh Street, Oak- land; Los Angeles and Santa Clara.....	72
Smith Lumber Company, Nineteenth Avenue and Estuary, Oakland	73
MONEL METAL	
"Inco" brand, distributed on the Pacific Coast by the Pacific Foundry Company, Harrison and Eighteenth Streets, San Francisco, and Eagle Brass Foundry, Seattle Kitchen sinks, heaters, storage tanks—Modern Metal Appliance Company, 4238 Broad- way, Oakland	94
76	
MURALS	
Heinsbergen Decorating Co., Los Angeles and 401 Russ Building, San Francisco	72
OIL BURNERS	
S. T. Johnson Co., 585 Potrero Avenue, San Francisco; 940 Arlington Street, Oakland; 1729 Front Street, Sacramento, and 230 N. Sutter Street, Stockton	69
Vaughn-G. E. Witt Co., 4224-28 Hollis Street, Emeryville, Oakland.....	74
ONYX	
Joseph Musto Sons-Keenan Co., 535 No. Point Street, San Francisco.....	72
ORNAMENTAL IRON	
Independent Iron Works, 821 Pine Street, Oakland.....	76
PAINTS, OIL, LEAD	
W. P. Fuller & Co., 301 Mission Street, San Francisco. Branches and dealers through- out the West	65
Frank W. Dunne Co., 41st and Linden Streets, Oakland	73
General Paint Corp., San Francisco, Los Angeles, Oakland, Portland, Seattle and Tulsa	65
PAINTING, DECORATING, ETC.	
The Tormey Co., 563 Fulton Street, San Francisco.....	74
Heinsbergen Decorating Co., 401 Russ Building, San Francisco	72
PARTITIONS—MOVABLE OFFICE	
Pacific Mfg. Co., 454 Montgomery Street, San Francisco; 1315 Seventh Street, Oak- land; factory at Santa Clara.....	73
W. S. Dickey Clay Mfg. Co., 116 New Montgomery Street, San Francisco	75
PILES—CREOSOTED WOOD	
J. H. Baxter & Co., 333 Montgomery Street, San Francisco and 601W Fifth Street, Los Angeles	6
PLASTER	
"Empire" and "Reno Hardware Plaster," manufactured by Pacific Portland Cement Co., 111 Sutter Street, San Francisco; Portland, Los Angeles and San Diego.....Second cover	
PLASTERING	
A. Knowles, 982 Bryant Street, San Francisco.....	79

	Page
PLATE GLASS	
Libbey-Owens-Ford Glass Co., Toledo, Ohio; 633 Rialto Bldg., San Francisco; 1212 Architects Bldg., Los Angeles; Mr. C. W. Holland, P.O. Box 3142, Seattle.....	5
PLUMBING CONTRACTORS AND MATERIALS	
Carl T. Doell Co., 467 Twenty-first Street, Oakland.....	76
Crane Co., all principal Coast cities.....	74
PRESSURE REGULATORS	
Vaughn-G. E. Witt Co., 4224-28 Hollis Street, Emeryville, Oakland.....	74
ROOF MATERIALS	
Gladding, McBean & Co., 660 Market Street, San Francisco; 2901 Los Feliz Boulevard, Los Angeles; 1500 First Avenue South, Seattle; 79 S. E. Taylor Street, Portland; Twenty-second and Market Streets, Oakland; 1102 N. Monroe Street, Spokane; Vancouver, B. C.....	7
N. Clark & Sons, 112-116 Natoma Street, San Francisco; works, West Alameda.....	4
SAND, ROCK AND GRAVEL	
John Cassaretto, Sixth and Channel Streets, San Francisco.....	76
SHADE CLOTH	
California Shade Cloth Co., 210 Bayshore Boulevard, San Francisco.....	68
SHEET METAL WORK	
Forderer Cornice Works, Potrero Avenue, San Francisco.....	74
STANDARD STEEL BUILDINGS	
Independent Iron Works, 821 Pine Street, Oakland.....	76
STEEL—STAINLESS	
Republic Steel Corporation, Rialto Bldg., San Francisco; Edison Bldg., Los Angeles; White-Henry-Stuart Bldg., Seattle.....	75
STEEL STRUCTURAL	
Independent Iron Works, 821 Pine Street, Oakland.....	76
Judson Pacific Company, C. F. Weber Bldg., Mission and Second Streets, San Francisco shops, San Francisco and Oakland.....	68
Pacific Coast Steel Corp.—See Bethlehem Steel Company, Twentieth and Illinois Streets, San Francisco; Slauson Avenue, Los Angeles; American Bank Building, Portland, Ore.; West Anover Street, Seattle, Wash.....	75
STORE FIXTURES	
Mullen Mfg. Co., 60 Rausch Street, San Francisco.....	75
STORE FRONTS	
Kewneer Mfg. Co., Eighth and Dwight Streets, Berkeley.....	73
TEMPERATURE REGULATION	
Johnson Service Company, Milwaukee, represented on the Pacific Coast by the following branch offices: 814 Rialto Bldg., San Francisco; 153 West Avenue, 34, Los Los Angeles; 1312 N.W. Raleigh St., Portland, and 473 Coleman Bldg., Seattle.....	3
TERMITE CONTROL—WOOD PRESERVATIVE	
E. K. Wood Lumber Company, No. 1 Drumm Street, San Francisco; 4701 Santa Fe Ave., Los Angeles; Frederick and King Streets, Oakland.....	66
J. H. Baxter & Co., 333 Montgomery Street, San Francisco, and 601 W. Fifth Street, Los Angeles.....	*
American Lumber & Treating Company, Rialto Bldg., San Francisco; 1031 S. Broadway Los Angeles.....	2
TREE SURGERY	
Davey Tree Surgery Co., Ltd., Russ Building, San Francisco; Story Building, Los Angeles.....	2
TILE—DECORATIVE, ETC.	
Pomona Tile Mfg. Co., plant, Pomona, Cal.; Sales Rooms, 135 Tenth St., San Francisco; 217 S. La Brea Ave., Los Angeles; 6106 Roosevelt Way, Seattle.....	70
Gladding McBean & Co., 660 Market St., San Francisco; 2901 Los Feliz Boulevard, Los Angeles.....	7
VALVES	
Sloan Valve Co., manufacturers of Sloan flush valves, 4300 West Lake St., Chicago, Ill.....	6
VAULT DOORS	
Hermann Safe Co., Howard and Main Streets, San Francisco.....	79
WATERPROOFING	
Bay State Brick & Cement Coating, California Sales Co., 444 Market Street, San Francisco.....	71
WINDOWS	
Kawneer Mfg. Co., Eighth and Dwight Streets, Berkeley.....	73
Dalmo Sales Co., San Francisco.....	70
WINDOW SHADES	
California Shade Cloth Co., 210 Bayshore Boulevard, San Francisco.....	68
Wm. Volker & Co., 631 Howard Street, San Francisco.....	73

ARCHITECT SEN-MUT

How Architect Sen-Mut, self-made Egyptian and queen's favorite, buried his not very important father and mother, is revealed in a new tomb discovered at Thebes and announced by the Metropolitan Museum of Art.

The tomb, which escaped plundering by robbers for over 3,400 years, was intact when the archaeologist entered, says the first report from Ambrose Lansing, director of the Museum's Egyptian Expedition.

Although Sen-Mut held a long string of titles and honors as favorite of the feminist Egyptian Queen Hatshepsut, the tomb of his father and mother shows that they had no official titles. From this, the Egyptologist infers that ambitious Sen-Mut won Egypt's highest honors as a self-made man.

Limestone chips, thrown into the ravine, deeply covered the entrance to the elderly couple's burial, thus protecting it from vandalism that wrecked so many Egyptian tombs.

The tomb that Sen-Mut built for himself, on the hilltop, is almost completely destroyed. The Egyptian Expedition is now reinvestigating this tomb and its surroundings, since Sen-Mut's funerary arrangements have proved to be extraordinary. In 1927, the expedition found a second and secret tomb that the queen's favorite built for himself under the very court of a great temple he was building for his sovereign.—Bulletin, Illinois Society of Architects.

LOOK CLOSELY

Look at the following sentence and then state how many times the letter f, either large or small, occurs:

The Federal national fishes are the result of scientific study combined with the experience of years.

Did you answer three right off the bat? Somebody says four! It is said that out of twenty people of intelligence not more than two will get it right the first time, and many will not find more than three after being told there are five.—Exchange.

THE ARCHITECT AND ENGINEER

SAN FRANCISCO
PUBLIC LIBRARY
MUSICAL DEPT.



JUNE 1936

SAN FRANCISCO SCHOOL BUILDINGS



Recreation Room in Basement of Home of Mr. and Mrs. R. F. LeMon, Pines, Oakland, California.
 Architect, Frederick L. Confer, Berkeley • Contractor, F. W. Confer, B.

How

TAN PLASTIC *pourability* made this basement room IMPERVIOUS TO MOISTURE

"Hillside construction usually presents more than one foundation problem. The play room in this home was built in an excavation below the main floor. Consequently the high surrounding foundation walls HAD to be watertight. To overcome the risk of seepage through walls of this room, Golden Gate TAN PLASTIC Waterproof Cement was specified for foundation work. It has proven eminently satisfactory."

{Signed} Frederick L. Confer, Architect

for
 STUCCO
 POOLS
 MONOLITHIC
 CONCRETE
 BASEMENTS
 MORTAR
 CAST STONE



This free folder
 tells how to use TAN
 PLASTIC to get best results.

The ARCHITECT and ENGINEER

presents for June, 1936 —

	COVER	ARCHITECT'S PERSPECTIVE, MARINA JUNIOR HIGH SCHOOL BUILDING, SAN FRANCISCO Geo. W. Kelham and W. P. Day, Architects	
	FRONTISPIECE .	DETAIL OF THE LAWTON SCHOOL BUILDING, SAN FRANCISCO Dodge A. Riedy and Chas. E. J. Rogers, Architects	
	TEXT	MODERN DESIGN FOR SAN FRANCISCO SCHOOLS 9 Frederick W. Jones	
W. J. L. KIERULFF	President	PROBLEMS OF COLOSSAL SCULPTURE 17 Warren Cheney	
FRED'K. W. JONES	Vice President and Editor	TRENDS IN BUILDING PRODUCTION 29 K. Lonberg-Holm and C. Theodore Larson	
LOUISE B. PENHORWOOD	Secretary	INSTITUTE AND STATE ASSOCIATIONS 35 William I. Garren, Architect	
EDGAR N. KIERULFF	Advertising Manager	FURTHER STUDY OF 'QUAKE PHENOMENA 45 Professor Perry Byerly	
J. LESLIE MEEK	Advertising	EQUIPMENT FOR SUMMER AIR CONDITIONING 51 H. L. Lincoln	
VERNON S. YALLOP	Architects' Reports	PLANS FOR 1939 WORLDS FAIR OUTLINED AT ARCHITECTS' BANQUET 55 WITH THE ARCHITECTS 57	
	PLATES AND ILLUSTRATIONS	MARINA JUNIOR HIGH SCHOOL BUILDING, SAN FRANCISCO 9-10 Geo. W. Kelham and W. P. Day, Architects	
		LAWTON SCHOOL BUILDING, SAN FRANCISCO 11-13 Dodge A. Riedy and Chas. E. J. Rogers, Architects	
		FRANCIS SCOTT KEY SCHOOL BUILDING, SAN FRANCISCO 14 William Mooser, Edard A. Eames and Douglas D. Stone, Architects	
		PATRICK HENRY SCHOOL BUILDING, SAN FRANCISCO 15 W. D. Peugh, Architect	
		SCULPTURE BY WARREN CHENEY 16-20	
		RECENT HOUSES BY EDWIN LEWIS SNYDER, ARCHITECT 21-28	
		MAISON-PAUL RESTAURANT, SAN FRANCISCO 34 Dodge A. Riedy, Architect	
		DESIGNS FOR A FIRE SAFE HOUSE 37-44	
		GARDEN FOUNTAIN 53	
		MODERN KITCHENS 60	

Notes and Comments

THE upward tendency of rents, combined with a shortage of single-family dwellings and apartments in most sections of the country, should have an appreciable effect on homebuilding during this and the next several years, says a statement issued by the Federal Housing Administration.

"A country-wide survey in 212 cities made by the National Association of Real Estate Boards shows an up-trend in rents of single-family dwellings, detached and semi-detached. Of these, 36 cities show the increase as approximately 5 per cent; 109 cities show it as approximately 10 per cent; 22 show it at 15 per cent; 34 show it at 20 per cent; and 11 show it 25 per cent or over. The aggregate showing an increase of 10 per cent or over is thus 83 per cent of the cities. The aggregate showing a 15 per cent increase or over is 32 per cent of the cities.

"Only seven cities still have a downward trend in rents, ranging all the way from 5 per cent to 25 per cent and over.

"Of 187 cities reporting increased rental rates in heated apartments, 53 cities show the rise as approximately 5 per cent; 73 cities show it as approximately 10 per cent; 35 show it at 15 per cent; 19 show it 20 per cent; 7 show it 25 per cent or over. Thus 72 per cent of the cities report these rates have gone up 10 per cent or more, and 33 per cent say they have advanced 15 per cent or more.

"As to apartment structures, six cities still have a downward trend of rents. Three had a decrease of approximately 5 per cent, and but two went 25 per cent or over.

"In unheated duplexes or flat buildings, 162 cities showing rent increases, 45 cities reporting it approximately 5 per cent; 73 cities give it as 15 per cent; 18 cities as 20 per cent; and six report it 25 per cent or over. Thus an aggregate of the cities show the gain as 10 per cent or more, and 27 per cent show it as 15 per cent or more.

"The upward trend in rents invariably follows a decrease in vacancies. While increase in rents is usually paralleled by an increase in building costs, that does not seem to be the case at present, for building costs are as yet comparatively low."

* * *

TO architects, one of the most interesting features of H. G. Wells' sensational film "Things To Come", is the lavish use of glass predicted for the home of tomorrow. According to the Wellsian study of modern trends, we are fast moving toward a day when our homes, factories, and office buildings will be constructed mainly of glass. In the latter stages of the picture, the plot action is supposed to be laid in

the year 2036 and the sets designed to portray life in that distant day fill the eye with a simple, unique splendor. Giant columns of glass support the high ceilings, and each room is flooded with illumination from hidden lights. Couches, armchairs, settees, and tables are all made of glass, as are the huge mirrors which decorate the walls. Even the walls and floors themselves are built of glass.

Architects, interior decorators, and designers have all shown particular interest in the Wells' film because of this conception of tomorrow's developments. That it is a shrewd interpretation of existing trends is emphasized by the following comment from Morris Sanders, one of the country's leading architects:

"We are on the threshold of a true glass era, certainly," he declared, "and while Mr. Wells may have erred in one or two small details, he has undoubtedly given us a significant picture of the future building. My belief is, however, that we are progressing much more rapidly toward the Glass Age than the film indicates. Glass as a material, always emphasized in modern European structures, is now coming into its own in America. Glass brick walls and partitions are an increasing solution to present day construction problems. In a thousand different ways, this material is coming to play a highly important part in the modern building."

Mr. Sanders was recently awarded a medal by the Architectural League for the design of his own home in New York City, in which he has made extensive use of modern glass material.

* * *

ABOUT a year ago a 13-story building in Los Angeles was literally cut in two and five feet removed to make it conform with a newly aligned street. More recently at New Orleans, a 5000 ton reinforced concrete hospital was moved 112 feet to make room for a new dental building. The project was carried out successfully due to the unusual care that was exercised in providing smooth roller paths. The foundations being on compressible material it was found necessary to employ 45-ft. piles driven to reach a sufficiently firm stratum. The building had been similarly supported when constructed but an increase of 15 per cent, was made in the number of piles on the new site in order to make provision for the effects of a suddenly applied load.

In preparing the building for its transfer to the new site 18-inch steel beam sills were placed on each side of the longitudinal column rows. On these were set up short steel columns carrying the 18-inch runway beams. The column loads were

transferred to 24-inch beams in pairs on either side of the columns which were bolted and grouted to the columns. In place of plain rollers steel reels 6 inches in net diameter were turned out of lengths of 7-inch shafting leaving bevelled flanges at each end. These reels were inserted between the 24-inch cradle beams and the runway beams, a total of 600 being required, the building being supported on 342 rollers at any one time. Transverse beams and diagonal bracing were added above the cradle beams. To transfer the column loads to the cradle beams, steel wedges were driven under the sill beams thus forcing the runway beams and rollers up against the upper beams. The columns were then cut away and the runway outside the building brought up to the level of the runway beams inside.

In all there were four pairs of runways. For motive power a steam driven winch exerted a pull through a pair of 8 sheave blocks, one block being secured to the cradle near the rear end, and the other to the continuous footings on the new site. A pull of 615,000 lbs. was required to start the building rolling and afterwards a pull of 338,000 lbs. The new runway structure was observed to subside about one eighth of an inch. The footings on the new site settled a total of three-quarters of an inch before coming to rest after ten days. The old foundations also rose a quarter of an inch when relieved of their load. The total time occupied in moving was 1 hour 58 minutes, the actual travelling time being about 20 minutes.

When Your Trees Need
PRUNING • ROOT WORK
BRACING • CAVITY WORK
MOVING • WASHING

Phone for free inspection and estimate . . Reasonable prices.

It costs no more for genuine

DAVEY
TREE
SURGERY CO., LTD.

SAN FRANCISCO Fresno LOS ANGELES
Russ Bldg. Mattei Bldg. Story Bldg.
SUHar 3377 Phone 2-2817 TUCKER 1929

Local phones in: Pasadena, Palo Alto, Oakland, San Rafael, Burlingame

Skill • Knowledge • Responsibility

THE ARCHITECT AND ENGINEER

ARCHITECTS REPORTS NOW OWNED and PUBLISHED by THE ARCHITECT and ENGINEER

WITH this issue The Architect and Engineer becomes more vitally interested in the advancement of the architectural profession in California than at any time in its 32 years of continuous and useful service. After many months of negotiation, the State Association of California Architects (Northern Section) and the publishers of this magazine, have reached an agreement whereby Architect's Reports, sponsored by the State Association, become a unit of The Architect and Engineer and will, for a period of years, be published from this office as a part of the magazine's service to its advertisers. For many years The Architect and Engineer has issued its own Building Reports and now, with the merging of the two, subscribers are assured an ideal service, complete and dependable in every detail.

The State Association of California Architects has made remarkable progress in the last four or five years and its close affiliation with the Institute Chapters, has helped to make its influence felt in the profession. All Institute members are automatically members of the State Association and such membership also applies to all registered architects in good standing. Working closely with the architects and building industry is the Producer's Council, a national body with local Clubs, like the Chapters of the Institute, and devoted also to the cause of good architecture, good materials and good building construction. And here is where The Architect and Engineer comes into the picture, joining with these organizations in a mutual understanding to advance the interests of the profession and the building industry.

The following is the official announcement of the Association by its President, William I. Garren:

"The State Association of California Architects wishes to make the following announcement to the building industry and to the subscribers of Architect's Reports:

"By agreement between the State Association of California Architects, Northern Section, and THE ARCHITECT AND ENGINEER, the publishers of the latter have purchased and are now the owners of Architect's Reports, Inc.

"Architect's Reports have been merged with THE ARCHITECT AND ENGINEER'S daily news service, and in the future will be published and distributed by THE ARCHITECT AND ENGINEER.

"The State Association of California Architects, through its member architects, will cooperate in furnishing THE ARCHITECT AND ENGINEER advance information pertaining to work in architects' offices, and this information will be given out as early as is consistent with the interests of the architects' clients and themselves.

"The State Association of California Architects recommends to the building industry the use of this daily building report service.

"In addition the State Association of California Architects will cooperate in assisting THE ARCHITECT AND ENGINEER in its task of gathering suitable material for publication in its magazine.

"With this new set up THE ARCHITECT AND ENGINEER Daily Architects' Reports will become the largest advance daily news service in the building industry on the Pacific Coast.

(Signed) "WILLIAM I. GARREN,

"President State Association
of California Architects."

The State Association of California Architects is a Member
of The American Institute of Architects.

Executive Board Northern Section: President, Wm. I. Garren; Vice-President, Harry M. Michelsen; Secretary, Ellsworth E. Johnson; Treasurer, Otto G. Hintermann; Directors, J. K. Ballantine, Jr., Chas. F. E. Roeth, Harry J. Devine, Roland I. Stringham.





Photo Mouth Studios

DETAIL OF ENTRANCE, LAWTON SCHOOL BUILDING, SAN FRANCISCO
DODGE A. RIEDY AND CHAS. E. J. ROGERS, ARCHITECTS

MODERN DESIGN FOR SAN FRANCISCO SCHOOLS

SPLENDID PROGRESS OF A \$3,500,000 PROGRAM

By Frederick W. Jones

IN striking contrast to some of the other cities and towns in California, San Francisco's new school buildings, architecturally and structurally, are outstanding for their improved design. Two months ago several pages of this magazine were given to illustrating the new George Washington High School by Miller and Pflueger. This number contains a generous showing of pictures of the Marina Junior High School by Geo. W. Kelham and W. P. Day; the Lawton School, by Dodge A. Riedy and Charles E. J. Rogers; The Francis Scott Key School, Wm. Mooser, Edward A. Eames and Douglas D. Stone, and the Patrick Henry School by W. D. Peugh. All four buildings reflect the modern influence and are the last word in earthquake design, a requirement made mandatory by the Field Act.

* * *

All of the school buildings illustrated are part of a building program inaugurated in the spring of 1934 when the City of San Francisco approved a \$3,500,000 bond issue providing for the erection of nine new structures and modernization of two older ones. This program, now nearing completion, marks the fulfillment of a long-time plan by which San Francisco has kept its school system progressively in step with the need for new educational facilities.

In keeping with previous practice, all the new school buildings were designed for reinforced concrete with architectural concrete exterior walls. This type of construction provides



DETAIL, MARINA JUNIOR HIGH SCHOOL,
SAN FRANCISCO
Geo. W. Kelham and W. P. Day, Architects



ARCHITECT'S DRAWING, MARINA JUNIOR HIGH SCHOOL, SAN FRANCISCO
Geo. W. Kelham and W. P. Day, Architects



Photo Moulin Studios

STREET FACADE, MARINA JUNIOR HIGH SCHOOL, SAN FRANCISCO
Geo. W. Kelham and W. P. Day, Architects

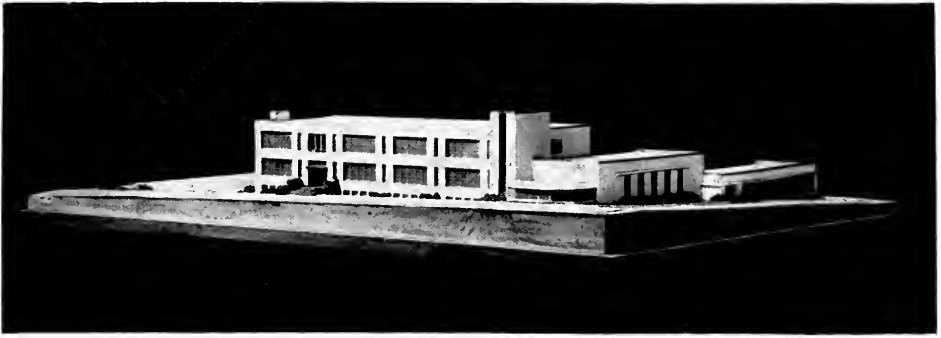

MODEL, LAWTON SCHOOL BUILDING, SAN FRANCISCO
Dodge A. Riedy and Chas. E. J. Rogers, Architects

maximum safety in earthquakes and conforms to all requirements of the recently enacted California laws for design of school buildings.

At present, all but two of the schools in the program have been completed. Their costs range from 32 to 37 cents a cubic foot—most economical for modern school buildings.

School	Contract Price	Cu.Ft. Cost
George Washington High	\$734,000	\$0.32
Marina Junior High	555,565	0.35
Francis Scott Key	174,600	0.37
Patrick Henry	94,397	
Glen Park	203,978	0.32
Agassiz	126,000	
Lawton	169,788	0.34
Visitacion Valley	162,096	0.34
Sunshine-Buena Vista	265,423	

Marina Junior High School

An excellent site was chosen for the Marina Junior High School, facing Fillmore Street to the west, Chestnut Street to the south and Bay Street to the north, and Point Lobos Park and Playground to the east. Diagonally across the street from the corner of Bay and Fillmore Streets is Cervantes Avenue, forming an interesting axis with the tower of the Golden Gate Bridge at one end, and the auditorium building of the school at the other.

The exterior design of the building is bold and massive in character, but no sacrifice has been made insofar as ample light to the class rooms is concerned. The center unit of the Fillmore Street frontage, the academic building, contains the administrative offices, class rooms and specialty departments, such as cooking, sewing, laboratories, library, business and

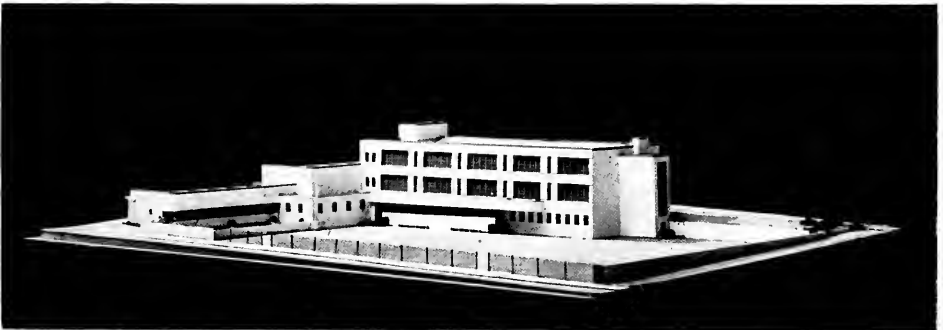

MODEL, LAWTON SCHOOL BUILDING, SAN FRANCISCO
Dodge A. Riedy and Chas. E. J. Rogers, Architects

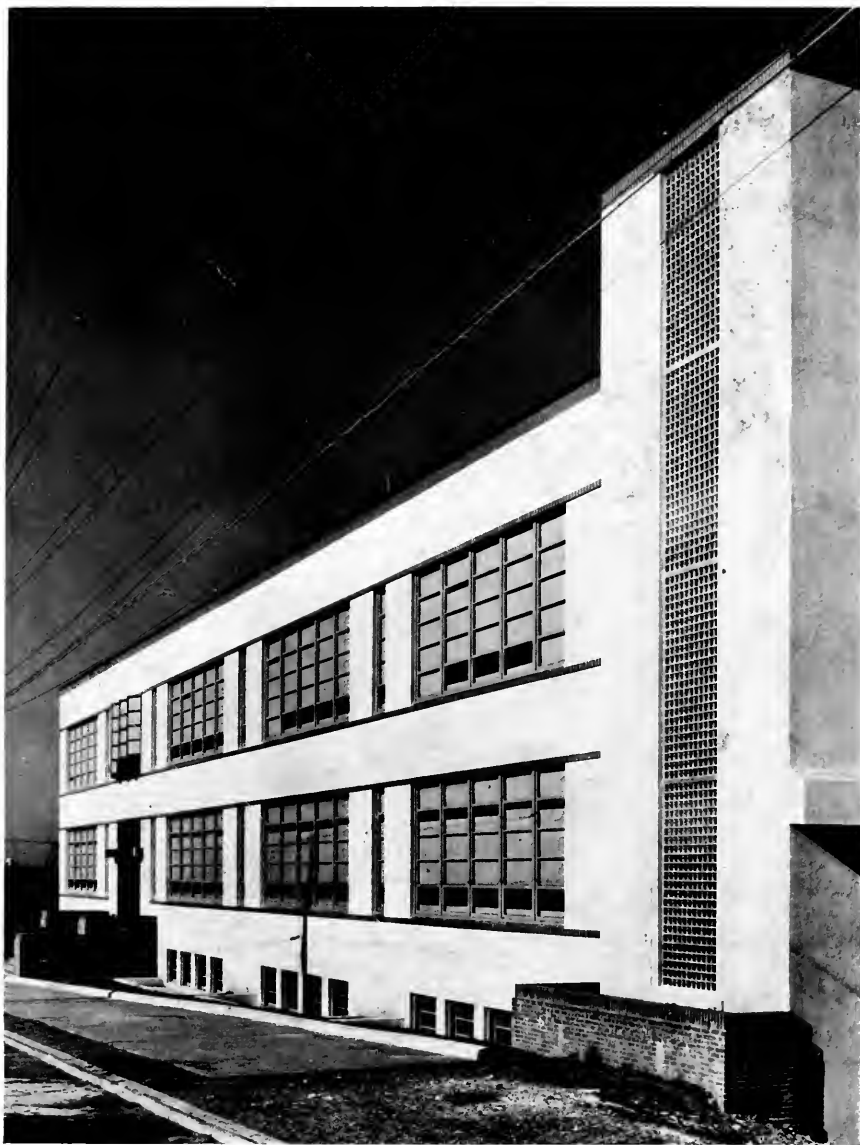
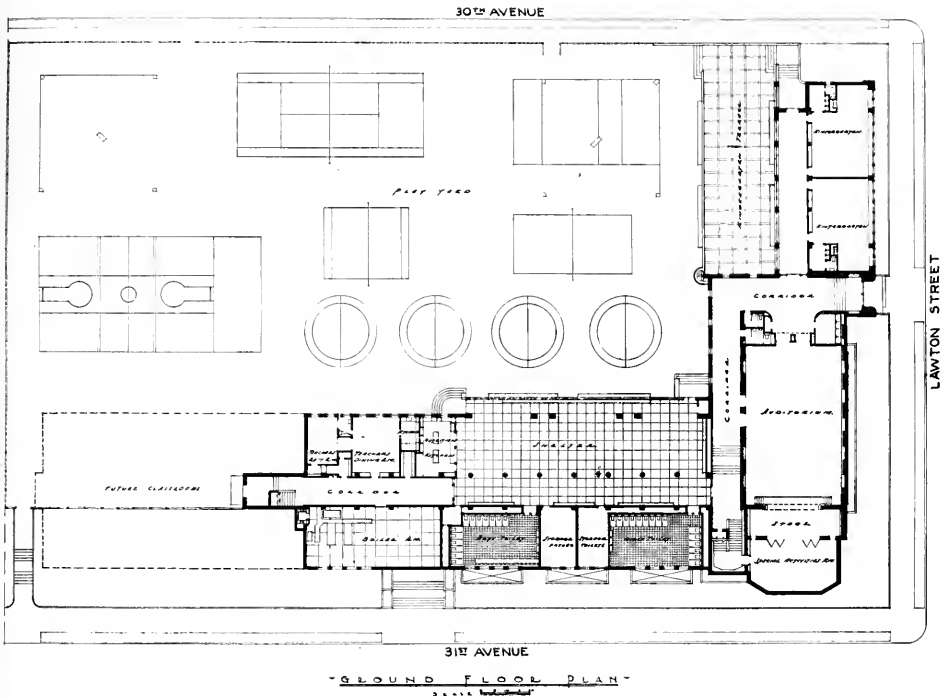

Photo Moulm Studios

LAWTON SCHOOL BUILDING, SAN FRANCISCO, CALIFORNIA
Dodge A. Riedy and Chas. E. J. Rogers, Architects



drawing rooms. An outstanding feature of this unit of the group is the distribution of the rooms. Class rooms were located to the east, farthest away from Fillmore Street, with its more or less noise from traffic. The specialty rooms face on Fillmore Street. A double stairway in the center of the building and an additional stairway at each end make vertical circulation easy of accomplishment.

The gymnasium, which is connected to the south end of the academic building, is located at the corner of Fillmore and Chestnut Streets. On the first floor of this unit are located the boys' and girls' locker and shower rooms, with exposure to the south. The corridor to the north gives easy access to the play yard. The gymnasium rooms for boys and girls respectively are located on the second floor. A balcony extends along the northerly side with seating arrangements for spectators during exhibition games and drills.

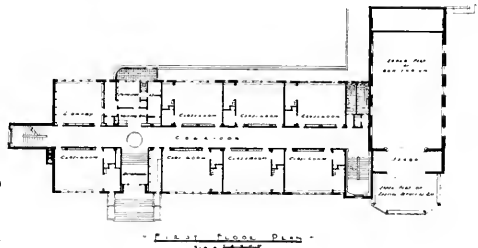
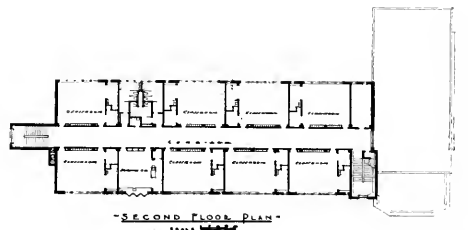

PLANS, LAWTON SCHOOL BUILDING,
SAN FRANCISCO
Dodge A. Riedy and Chas. E. J.
Rogers, Architects



Photo Moudin Studios

FRANCIS SCOTT KEY SCHOOL BUILDING, SAN FRANCISCO
William Mooser, Edward A. Eames and Douglas D. Stone, Architects

The interior of the auditorium will have a simple treatment harmonizing with the exterior design. It was given careful consideration from the standpoint of acoustics. The main floor will have direct access to the academic and shop buildings, and also separate entrances and exits to and from the streets. The foyer, which is to be used as an art gallery, will be located on the second floor and directly connected to the academic building. From the foyer, direct access may be had to the balcony. The stage will be suitable for any theatrical performance which might be desired by the school.

The shop building, now under construction, is located east of the auditorium and faces north on Bay Street. Because of the character of the proposed activities in this building, it was located as far as possible from the academic unit. On the south wing of the first floor, there will be located a cafeteria with direct access to the yard. On the north wing will be the electrical, machine and sheet metal shops, with ample provision for offices, stock and locker rooms. Specially designed band practice and choral rooms, with windows near



DETAIL OF ENTRANCE, FRANCIS SCOTT KEY SCHOOL BUILDING, SAN FRANCISCO
William Mooser, Edw. A. Eames and Douglas D. Stone, Architects

the ceiling facing north, for minimum sound disturbances, will be located on the second floor. The mechanical drawing room, wood-working and printing shops are located on Bay Street facing north.

The interior color treatment of the completed units is distinctive. The woodwork is stained a light tan and finished with a warm light gray. The walls in class and specialty rooms in the academic building are a light buff, except where cork carpet occurs. The latter is left natural. The corridor walls, including the lockers and tile, are a light gray. The gymnasium was finished in clear tones of light silver gray and buff.

The Lawton School

The Lawton School is on the north side of Lawton Street, between 30th and 31st Avenues.

The exterior treatment of this school is distinctive in that the facades have been developed to express the functions of the building. Economic considerations (costs, etc.), were important factors in its simple, dignified design. Each unit — academic wing, auditorium and kindergarten — was designed to express its purpose; the whole composition being coordinated into a pleasing study in mass.

Color has been judiciously used. Colorful tile has been used at the entrances, on the

parapet copings, and at the head and sill of the windows.

Flowers in variegated colors, adding to the building's inviting appearance, are planned in large brick flower boxes at the main entrance, the stair towers, along the auditorium windows, and the kindergartens.

Another unusual feature is the introduction of vacuum glass building blocks in the stair towers. These glass blocks are set in cement mortar like ordinary bricks, and are reinforced with round metal rods — forming virtually a solid wall of glass.

The school plant contains fifteen class rooms, two kindergarten rooms, special activities room, auditorium, science room, large clinic, covered play space, library, teachers' rest and lunch rooms.

The kindergartens strike a new note in planning. Given a southern exposure, the south walls are virtually all windows to allow maximum sunlight. An alcove, off each kindergarten, forms a work project space where the youngsters can express themselves in various projects, whether it be by crayon, blocks or scissors. A large corridor, separated from the main corridor by doors, provides a covered play space during inclement weather. A commodious terrace is provided for these young

(Please turn to Page 51)



Photo Moulin Studios

PATRICK HENRY SCHOOL BUILDING, SAN FRANCISCO
W. D. Peugh, Architect



MODEL FOR A PYLON OF PEACE

WARREN CHENEY, SCULPTOR

(Photographed out-of-doors against San Francisco Bay;
actual height to be 80 feet)

PROBLEMS OF COLOSSAL SCULPTURE

PYLON OF PEACE EXPRESSES SPIRIT OF UNDERSTANDING

By Warren Cheney

HLE who has stood in front of a well modeled colossal sculpture and sensed the enormous power of such a figure, has had a unique art experience. Such a person will agree with the sculptor that when a figure is made five times or more the size of a six foot man, it acquires an impressiveness which smaller sculptures never quite achieve.

San Franciscans are able to imagine the effect of a colossus, perhaps, through their familiarity with the Stock Exchange Pylons which include figures nearly three times life size. To envision the size of the "Pylon of Peace", imagine the figures at the base as the same size as the Stock Exchange sculptures. Then, standing at the foot of the colossus and looking upward you would see the great six foot hands fifty feet above, extended in a gesture of celestial gentleness and sympathy. This immense figure might easily be a visual equivalent of the poetic concept of a University, "... spreading light and goodness — over all the West," to quote from that stirring song, "Hail to California."

In order to explain some of the problems to be solved in the creation of a colossus such as the "Pylon of Peace,"

let us consider some of the outstanding colossi we have inherited from the past: Japan's Daibutsu at Kamakura, China's great rock-cut figures at L'ung Men, Yung Kang, and T'ien-lung Shan, Indo-China's enormous masks on the towers of the Bayon at Angkor Thom, India's monolithic Jain colossus of Gomata at Sravana Belgola in Mysore State, Egypt's amazing rock-cut colossi of Ramses II at Abu Simbel, and Europe's little known Völkerschlacht Denkmal at Leipzig with the XXth century colossi by Franz Metzner (inside the monument).

When we contemplate the spiritual significance, the meaning, content or expression of these various colossi, we perceive two distinct elements carrying the sculptural conception: first, the pose and gesture, and second, the creative handling of the form, proportion, and volume organization or design.

After studying human emotional reactions, the sculptor discovers that the physical body instinctively reflects the state of the human spirit. He realizes that the way a person moves, (the gestures and poses unconsciously assumed) reveals the emotional state, especially when the emotion is intense. In other words, certain body movements are actually the external



DETAIL "MOTHER AND CHILD"
Warren Cheney, Sculptor



"ESPERE"

Sculpture by
Warren Cheney

"THE TRANSFIGURATION"

Sculpture by
Warren Cheney



manifestations of an emotional stress, and it is upon these that the arts of expressive painting, dance and sculpture are built.

An essential part of every emotion, however, is made up of inner sensations that are not visible: the quickened pulse, the surge of feeling, the sense of nervous strain, and so on. Consequently, when the visual artist would create a work of profound emotional expression he must find a way to add to expressive body movement these non-visual internal manifestations.

In sculpture, this can only be done through a conditioning or distortion of naturalistic form and proportion, which explains why all great sculptures contain more or less obvious distortions. For the sculptor, the problem of expression means finding a pose and gesture not ambiguous in meaning, and then adding conditioned form and proportion that will complete the spiritual significance of the art work. I believe twentieth century sculptors are more keenly aware of this dual problem than were sculptors of numerous other epochs, and this is borne out by inspection of the before-mentioned colossi.

With the seated Kamakura Daibutsu, as well as with the seated rock-cut figures at Abu Simbel and a L'ung Men, only the heads are significant in pose and expression. If the heads were knocked off, the poses would become meaningless or ambiguous, and would deprive the statues of their emotional content. Buddhist sculptures, as well as Hindu and Jain sculptures are usually given symbolic poses rather than the universally expressive poses found in the non-symbolic art of the dance. The great masks of the Bayon towers are so frankly disconnected with any body-forms that they gain in significance, becoming faces in the clouds, as it were, easily imagined as the heads of supernal beings. Metzner's colossi have, on the other hand, very expressive pose and gesture in addition to sensitive creative handling of form and proportion.

Another vital problem of the colossus is that of scale. In order to give an enormous



DETAIL "AMOR CAELESTIS"
by Warren Cheney, Sculptor

statue relationship to the human being, proper transition elements must be introduced. Abu Simbel gains immensity as well as relationship to man through the use of small figures of Ramses' Queens which fill spaces beside the lower legs. On the other hand, the Kamakura Daibutsu, the Jain colossus, and the Metzner colossi lose in scale and in relationship to man due to the lack of such transition elements.

* * *

In the model for the "Pylon of Peace," the figures at the base were studied from the standpoint of their relationship to the size of a man. This relationship was worked out so carefully that to increase or decrease the planned size of the total Pylon would necessi-



Sculpture by Warren Cheney

tate a re-organization of the figures which act as the transition element. In determining the proportions of the large figure, my objective was to create the effect of a superhuman Being, a nameless, non-sectarian kind of Great Spirit. In studying other colossi, I felt their proportions to be heavy and earthy, giving the feeling of Giants rather than Gods, due to their stocky, weighty bodies.

To avoid this earthy quality, I began working with the tall, vertical kind of figure that the twelfth century Europeans did so well at Chartres, Moissac and Autun. When I finally arrived at the present proportion of the Pylon, it seemed to give the effect of a soaring, unbroken figure whose impersonal face looked down on Mankind far below, and whose gesture of extended arms and hands emanated the spirit of Peace and Understanding.

* * *

The group of works reproduced herein, along with the "Pylon of Peace," are extremely varied in treatment, and logically so, I feel, since they express varied emotions.

The marble, "Opus 5," whose rhythmic movements and related forms appeal to the

aesthetic sense, has a pose and gesture of no particular spiritual significance.

The contrast between the "Mother and Child" and the "Amor Caelestis" is the contrast between the primitive intensity of a woman's apprehension for her child's life and health, and, the quiet, benign love of a great Spirit for a human-being. In the former, the expression is carried by the uplifted, intense face, and in the latter by the immense power of the arms which are so gentle.

"Espere" is a figure moving on into life with longing and hope, while the "Transfiguration" is a spirit in torment, struggling to escape out of the body.

EDITOR'S NOTE—Since his work was reproduced in *The Architect and Engineer* in February 1933, Mr. Cheney has received national recognition. In 1934 he was invited by the Metropolitan Museum to execute a sculpture especially for the 1935 American Industrial Arts Exhibition. The piece was "Amor Caelestis", one exemplar of which is owned by the San Francisco Museum of Art as part of the Albert M. Bender collection. One-man exhibitions of Mr. Cheney's work were held at the Gump Galleries, San Francisco, in 1934, and at the Marie Sterner Galleries, New York, in 1936. The latter was especially well received, reviews appearing in the *New York Times*, *New York World-Telegram*, *New York Sun*, and in the *Art News* which latter publication reproduced "Opus 5". The *Art Digest* carried a very favorable article and also reproduced a view of "Opus 5", while the *Survey-Graphic* ran a two-page spread with reproductions of "Amor Caelestis", "Mother and Child", "Famine" and "Mater Dolorosa". For the past five years Mr. Cheney has been a member of the Art Faculty of Mills College, Oakland, California.

Recent Houses

by

Edwin Lewis Snyder, Architect



HOUSE FOR LLOYD BRADLEY, HILDALE AVENUE,
BERKELEY, CALIFORNIA

EDWIN LEWIS SNYDER, ARCHITECT

Style: California Farm House.

Seven rooms, two baths and two-car garage; wood and stucco exterior; cedar shake roof; glass brick exterior walls in bath rooms; all interior trim pickled pine; textured walls stained.

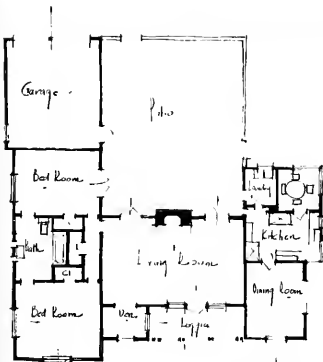

Edwin Lewis Snyder
Architect

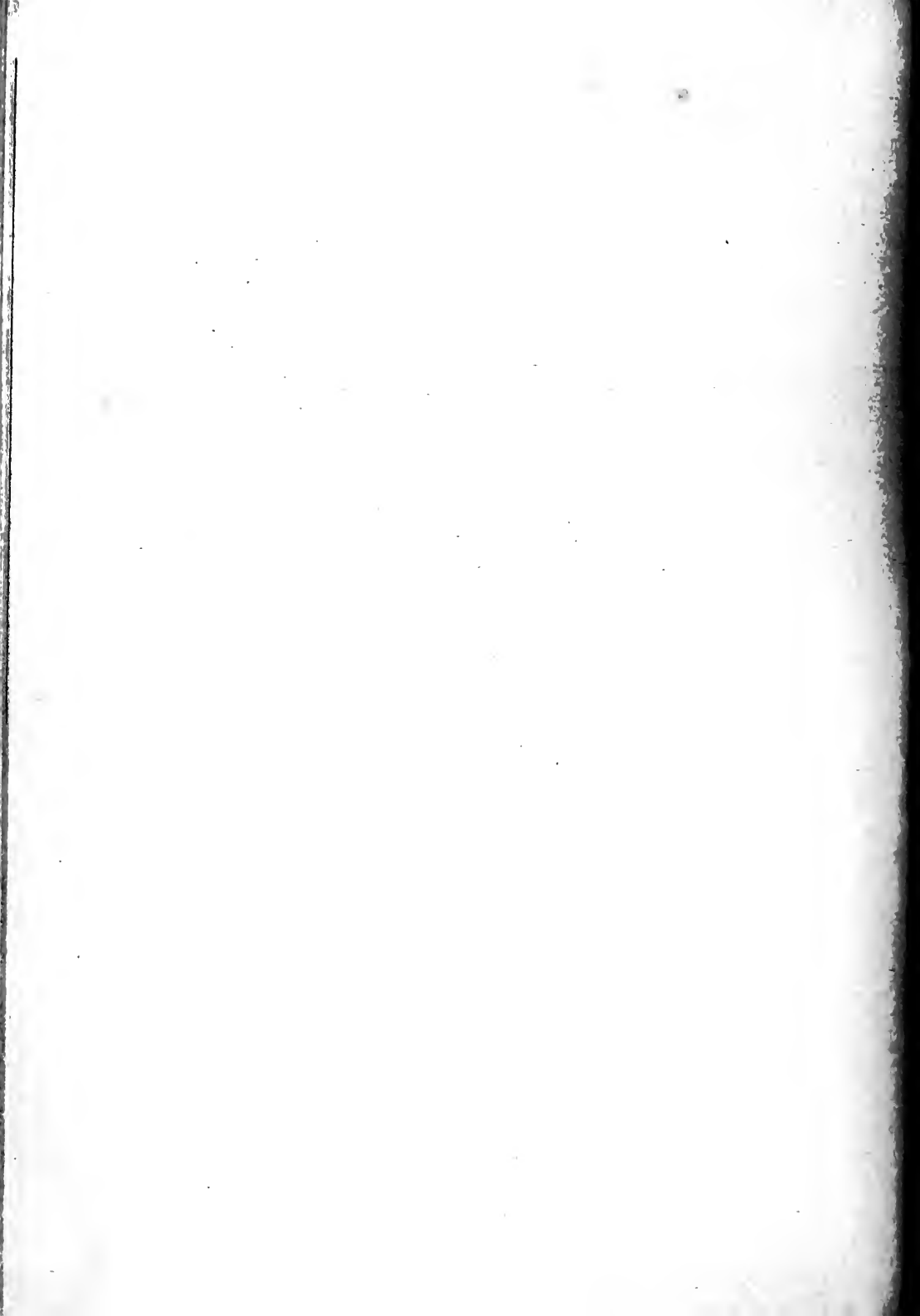



HOUSE FOR GEORGE PRIFOLD, JR., ARLINGTON ESTATES,
BERKELEY, CALIFORNIA

EDWIN LEWIS SNYDER, ARCHITECT

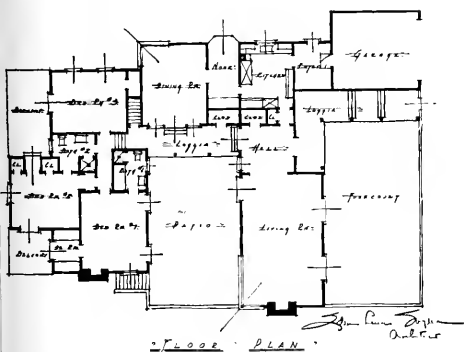

Style: California Ranch House. Eight rooms, three baths and two car garage.

Rustic exterior painted an off-white with colonial yellow shutters; hand-split cedar shake roof, left natural; steel sash; textured plaster and pine interiors (acid stained); oak plank floors in living and dining rooms; brick floors in loggias and entrance hall; brick paving in patio and forecourt. The house is air-conditioned.

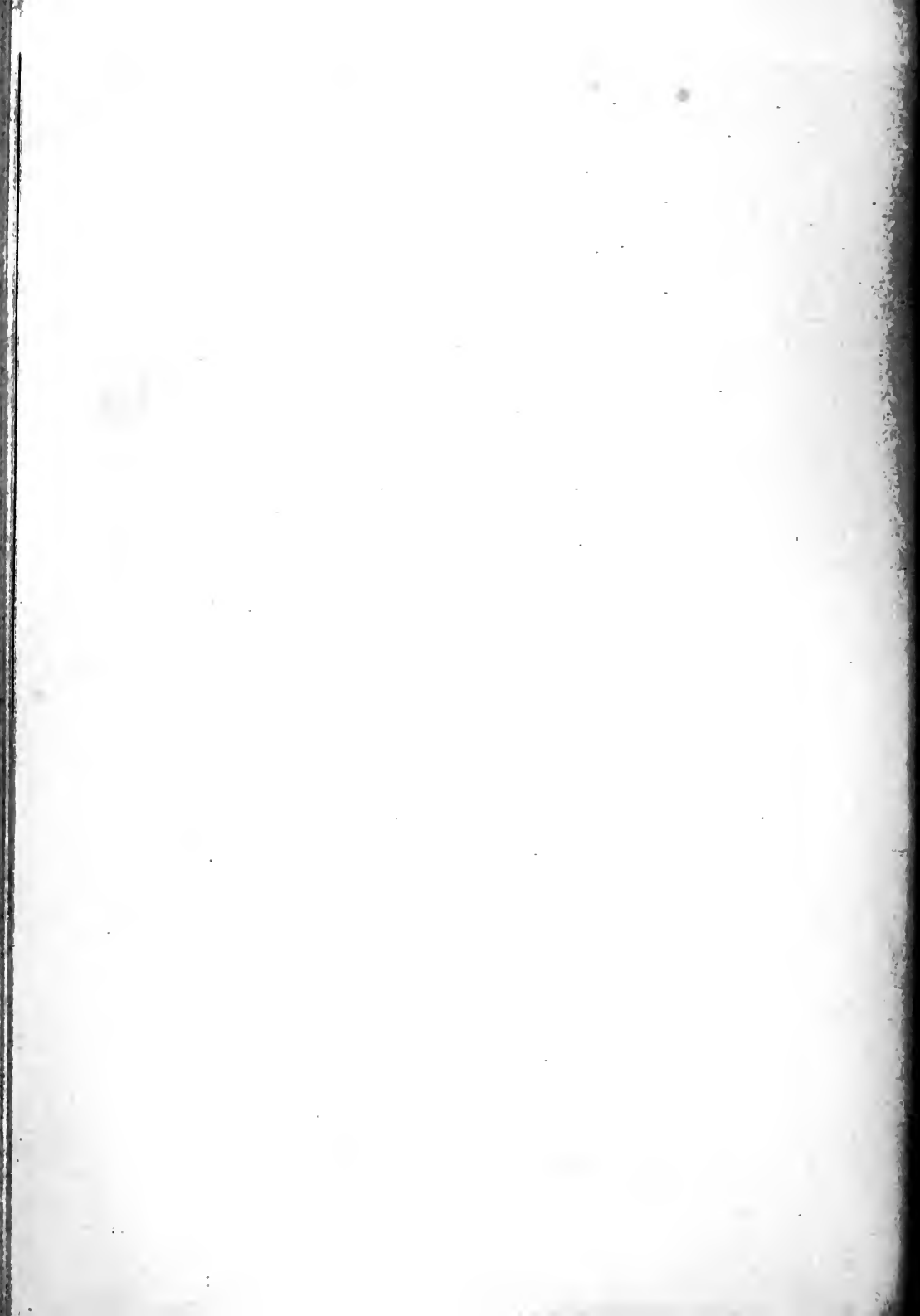



HOUSE FOR GEORGE FREDERICK BRUNS, MORAGA ROAD,
OAKLAND, CALIFORNIA
EDWIN LEWIS SNYDER, ARCHITECT

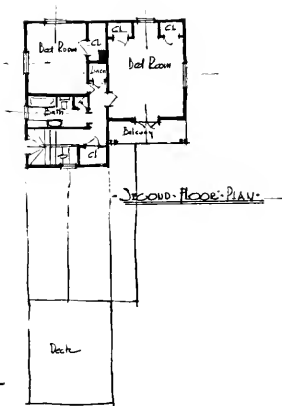
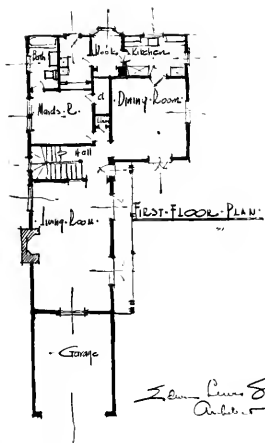

Style: New Orleans Plantation.

Seven rooms, two baths and two-car garage; rustic and brick exterior; white color scheme; cedar shake roof; double hung windows; brick chimneys and fire place; interior textured plaster walls painted; pickled pine wood ceilings; oak plank floors; wall paper in bedrooms.

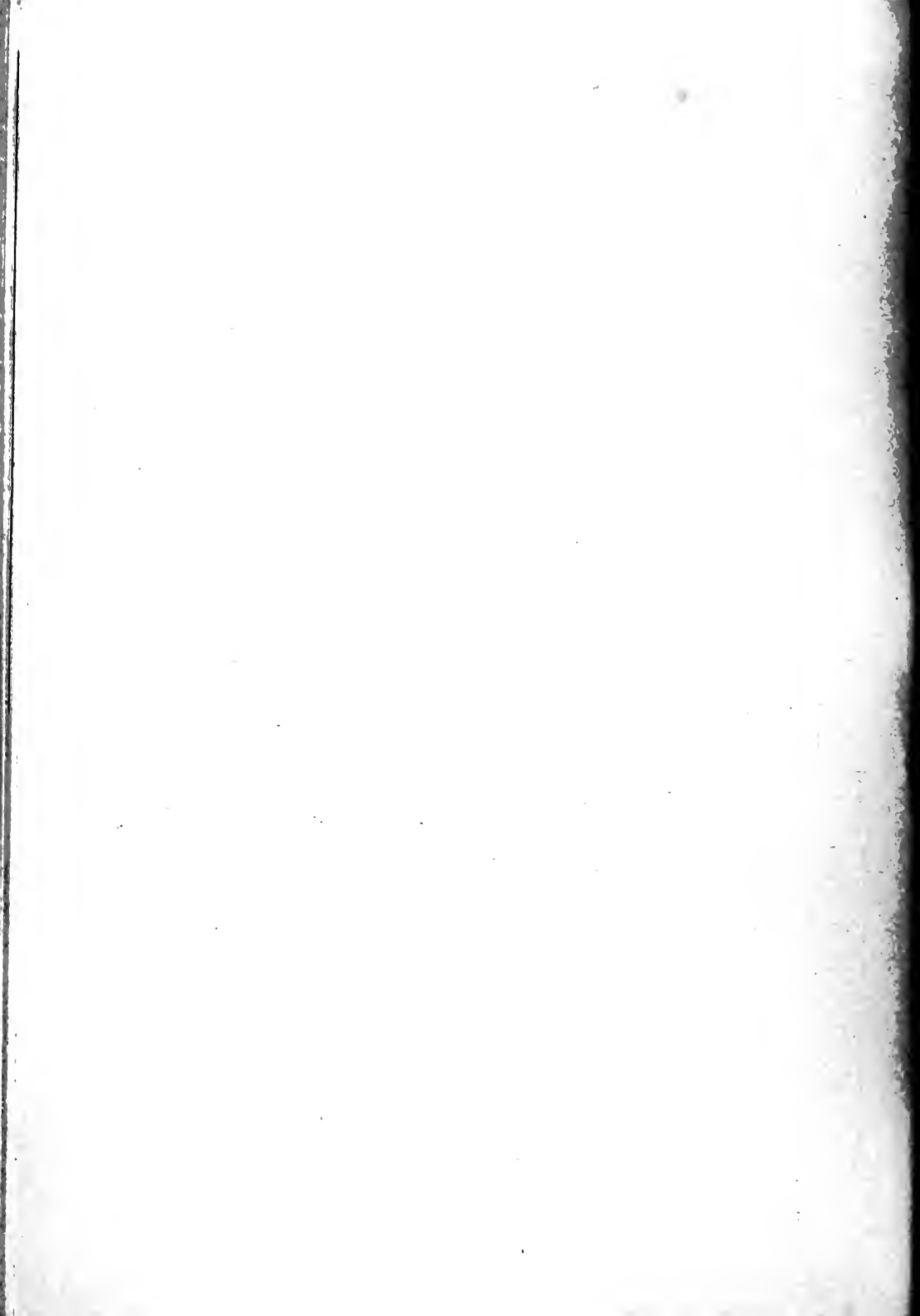

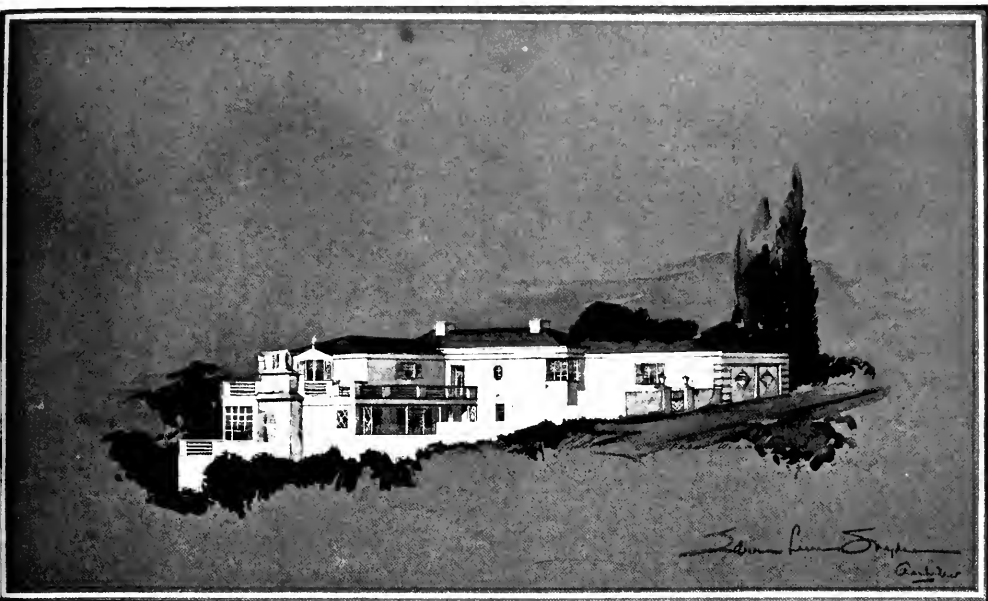

HOUSE FOR DR. WILLIAM A. S. McGRATH, PIEDMONT, CALIFORNIA
(See over page)
EDWIN LEWIS SNYDER, ARCHITECT



HOUSE FOR LIEUT. COL. WILLIAM F. C. JEPSON, ST. PAUL'S COURT,
OAKLAND, CALIFORNIA
EDWIN LEWIS SNYDER, ARCHITECT

HOUSE FOR DR. WILLIAM A. S. McGRATH,
PIEDMONT

Edwin Lewis Snyder, Architect

Style: Semi-modern.

Eleven rooms, four baths and two car garage. White stucco exterior . . . blue glazed tile roof . . . exterior trim painted Mediterranean blue . . . steel sash . . . living room and hall, painted pine dado . . . Oregon pine ceilings . . . texture plaster walls . . . dining room finished in Philippine mahogany treated with acid . . . den finished with acid treated Oregon pine panels . . . recreation room and bar paneled with wall board . . . Monel metal sink and drain boards in kitchen . . . air conditioned . . . gas heat.

HOUSE FOR LIEUT. COL. WILLIAM F. C.
JEPSON, OAKLAND

Edwin Lewis Snyder, Architect

Style: California-Colonial

Seven rooms, two baths and garage.

Exterior finish — lower part stucco, upper part rustic . . . exterior color scheme, beige and Mediterranean blue . . . Oregon pine interior trim . . . pickled pine ceilings . . . texture plaster walls . . . oak floors . . . color tile bath rooms . . . gas furnace.

TRENDS IN BUILDING PRODUCTION

LIQUIDATION OF OBSOLETE STRUCTURES IS NEEDED

By K. Lonberg-Holm and C. Theodore Larson in *Real Estate Record*

THE potential demand for new buildings increases with each advance made by science and industry. Power generation and new means of communication and transportation have merged city and country into production networks. The old neighborhoods and districts have lost their economic advantages and become blighted. Electrification and achievements in sanitation and atmospheric control have raised desirable standards of living to the point where structures lacking these new essentials are considered obsolete and become unprofitable.

The effective demand, on the other hand, defines the building market. This has been shrinking because of the lack of purchasing power. (Between 1929 and 1933 the average family income declined 35 per cent for home owners and 35 per cent for tenants in 52 cities reporting average incomes of \$1,500 and more, according to the 1934 Financial Survey of Urban Housing.)

Around the effective consumer demand has been organized various business relationships: (1) real estate; (2) mortgage finance; (3) building design, fabrication and use — architects and engineers, contractors, manufacturers, dealers, trades and labor, building services. From a business standpoint a centralized control of building production has not been nec-

essary, or even desirable, so long as profits could be made in each of the many ramifications of this complex set-up. The building field is lacking in centralized organization because it has been found profitable to be so.

In contrast, the automobile industry is concentrated in the three big producers — General Motors, Ford and Chrysler — who sold 91.6 per cent of all passenger cars in 1935. The building field produced only about 60,000 new houses and about 20,000 new apartment units in the 37 Eastern states in 1935 (estimate based on F. W. Dodge Corporation statistics), whereas the automobile industry produced 3,400,000 passenger cars in the United States and Canada in the same year.

The varying interests of business are reflected in the uneven development of building types. Residential construction, largely a speculative market, is technologically backward compared to the industrial field where buildings are designed primarily as instruments for production and therefore have been less subject to ownership restrictions in their development.

With an expanding market the different business relationships have been able to get their proportionate shares of the building dollar. The various groups have not been in conflict; they have functioned together. Competition has been chiefly within the same group

— between rival real estate dealers or rival financiers or rival designers or rival builders or rival manufacturers merchandising much the same product or service.

New Marketing Forces

Conditions of limited selling have broken the old building relationships. A new set of forces is coming into existence.

1. **A changing land economy:** Formerly any depreciation in the value of a building because of deterioration or obsolescence was expected to be more than offset by an increase in land values. An inflation of land prices which occurred first with the pushing out of the American frontier, then with population growth and a migration to the cities, served to encourage this belief; at the same time it concealed an increasing obsolescence arising from advances in science and industry.

Recent social and economic changes have caused these prices to be deflated, leaving in distress many communities that had capitalized an enormous "planned" expansion of their populations. The old mortgage structure is stranded by the real estate deflation and exposed to the double threat of revealed obsolescence and potential obsolescence.

2. **Reforms in mortgage finance:** Outlets are needed for the excess of new credit funds piling up in the lending institutions. An important instrument set up to facilitate a credit flow into building production is the Federal Housing Administration, which insures private lenders against loss. Interest rates have been somewhat reduced, and the need for expensive second mortgages and frequent refinancing is eliminated by the availability of larger loans and by the principle of long-term amortization. Such measures represent a further development of installment buying. The extension of purchasing power has been partly successful in easing conditions, as shown by the current upturn in building modernization and residential construction.

Both the real estate deflation and the financial reforms represent concessions, which as

savings to the consumer cannot be carried very far, for the nearer a complete negation of land prices and interest rates is approached, the more difficult becomes the making of profits. It is the business of real estate and mortgage finance, therefore, to oppose advances which may speed up the rate of obsolescence in building production.

3. **Technological advances:** An increasing abundance and diversity of products, all seeking new uses and competing for buyers, has resulted in a still more intensive struggle for market supremacy. Better materials (examples: plastics, alloys, plymetals) and more efficient fabrication methods (examples: shot-welding, die-casting) have been developed. More than 400 new chemical compounds were produced and marketed in 1935.

Technical applications of new laboratory discoveries provide increased production capacities. Current plant modernization is forced by competition for business supremacy. Obsolete equipment is replaced by labor-saving devices and high-speed automatic machinery offering enlarged output. Last year the steel industry spent nearly \$150,000,000 on plant modernization. Orders totaling approximately \$94,000,000 were booked by the machine tool industry in 1935, a gain of 88 per cent over 1934.

These developments represent accelerated production, unlimited except for an increasing amount of **unused** capacities. (See studies by Brookings Institution on potential capacities.) Industrial demands force expansion into new markets. Business competition is stepped up from a struggle between rivals in the same line to a struggle between major industries for as many markets as possible.

In the steel industry, for example, continuous rolling mills built during the past few years have increased production capacity of sheets and tin mill black plate to more than 16 million tons. The 1935 output did not exceed 6,400,000 tons. Even should 1936 establish a new record, some 9 million tons of sheet capacity may remain idle. The steel industry sees hous-

ing as a tonnage-builder — "a market for steel worth **fighting for**" (*Iron Age*, January 2, 1936). Only mass production will be profitable, since the steel used in a single house is too small to interest either the steel mill or the structural steel fabricator. Steel systems have been developed for house designs for the low-income groups where a real mass market is seen. This field has hitherto been held closely by the lumber industry, which is forced by the intensified competition to improve its own production technique. Similarly, the electrical industry sees housing as a power load-builder; sales of appliances have increased steadily.

Effects on Production

The highly mechanized industries see the building field (housing in particular) as an outlet for excess production. The non-mechanizable groups are at a disadvantage, and find it their business to obstruct industrial advances. The conflict between the mechanizable and non-mechanizable groups resolves itself into a conflict between profits through production and profits through possession — change versus permanence.

Control over liquidation of obsolete structures is lacking. This restricts new production. The obsolete buildings which should be liquidated in order to make way for more desirable structures tend to persist and to glut the market. Between 1921 and 1933 the replacement rate of homes and apartments was 7/10 of 1 per cent a year; this means that the American home at the present rate of turnover will remain in use for 142 years. (**Housing Problems**, Frank Watson). In the mechanized industries replacements are exceedingly rapid by comparison. The Ford Motor Co. systematically junks obsolete equipment; old machines are removed as rapidly as more productive tools become available. Certain automobile producers pay their dealers for scrapping old cars.

Obsolescence in structural parts of buildings is comparatively slow, in mechanical parts

comparatively rapid. For this reason the manufacturers of readily installed mechanical equipment have been promoting building modernization as a major market. The relative importance of such accessory equipment (refrigeration, air conditioning, lighting, labor-saving devices) has increased steadily and can be expected to increase even more rapidly.

Construction statistics show that alterations and repairs have become an important category of work. This signifies, however, a subtraction from new construction.

Distribution Control

Increasing competition makes distribution the primary problem in business. Costs of marketing have been increasing. Competitive selling implies the continued growth of horizontal and vertical corporations for economies in distribution through increased production control. The fight for profits through production resolves itself into a struggle for control of markets through control of the different factors in distribution.

Sales promotion involves three factors — buyers, selling tools, products. Technically, the degree of control over each of these factors can be measured by the extent of specialization, standardization and integration.

1. **Buyers:** The growing importance of the consumer demands sales research to discover who the buyers are and what they want so that sales resistance may be reduced.

Through advertising or propaganda the general public or any specific consumer group is conditioned for the reception of new commodities. Specific appeal is made to women as a major purchasing factor in home building. The industries have taken the aggressive in sponsoring such educational programs (modernization campaigns, better lighting campaigns, model home demonstrations).

Buyer education increases the potential demand and stimulates new needs. Through sales promotion, such as that of the Federal Housing Administration, consumers become aware

of deficiencies in existing housing, obsolescence is accelerated and potential standards of living are advanced.

2. **Selling tools:** Selling has been stepped up from a local basis to a national basis through the media of advertising — magazines, radio hook-ups. In the building field specific tools have been developed for coordinated and timed sales effort — building reports, catalog files.

An increasing number of building products (especially equipment for cooking, lighting, sanitation, air conditioning) are marketed direct to the consumer. Selling by telephone is facilitated by the establishing of decentralized warehouses for immediate local deliveries. Visual or dramatic presentations (portable movies, charts, trial use) make possible direct demonstrations to individual buyers.

3. **Products:** Efforts are made to stimulate sales by changes in the merchandise. These changes range from superficial "styling" to increased serviceability (better space utilization, more conveniences) and reduced costs through simplification and standardization. In the building field this is reflected in an increasing specialization according to structural types.

Collective Marketing

Selling is made easier when buying is simplified. Industrial producers are combining structural and mechanical parts into complete systems (packages). Standard kitchens and bathrooms are produced in single units. Optional systems of electrification, heating and air conditioning are available.

The development of special structural and mechanical equipment (examples: communications, sound control, air conditioning) has led to an increasing complexity in building specifications. In addition to specifying the structural assembly in terms of materials, the building designer is required to specify the use performance of the completed building in terms of equipment.

Architects and builders have not been trained to perform in this direction. As a ser-

vice in collective selling this function passes to the industries or manufacturers and their trained experts who obviously know most about their own products. The prospective purchaser of a home (or his architect) no longer has to specify individual parts; instead, he prescribes his desired requirements and it is then up to the industry or manufacturer to specify and to produce the units or systems which will perform according to selected standards.

Better building performance is promoted as increasing competition, facilitated by business mergers, forces inclusion of still more products into the structural and mechanical systems. For example, the successful operation of an air conditioning system depends not only on the air conditioning equipment, but also on the thermal conductivity and the specific behavior of the structural assembly. The manufacturer therefore must assume design control of the structure in order to be able to guarantee the use performance of his air conditioning system.

Collective marketing also shows a shift from the sale of tangibles to the rendering of services. (Examples: renting of mechanical equipment; communicational and protective services like telephones and fire alarm systems; apartment hotels with full community services.) Service selling shows its greatest advance in the field of commercial building.

Unit Fabrication

As building production becomes integrated the industrial producers take over more marketing functions — financing, design, fabrication, servicing. The implied objective is the marketing of complete functional units such as dwellings, and the setting up of new controlled distribution systems in competition with the old trade outlets.

This trend toward collective marketing is demonstrated in the many experiments with "prefabricated" houses. The technological differences between these houses and more conventional houses are quantitative only. They are not truly prefabricated structures, but standardized assemblies of prefabricated parts usually obtainable by any builder in the open

market. All contemporary building involves the use of prefabricated parts. Portable roadside diners, house boats and automobile trailers represent a more advanced form of prefabrication.

Prefabricated houses have not yet become important in competitive building. Major factors opposing their development:

1. **Existing mortgage structure.** Urban mortgages, about 58 per cent of the 1933 value of all urban real estate and 21.7 per cent of all total long-term national debts, are the largest single class of outstanding indebtedness. (**The Internal Debts of the United States**, survey by the Twentieth Century Fund.) A sudden influx of mass-produced cheap modern dwellings would subtract so substantially from the market value of existing structures that their value might fall below the debt outstanding against them.

2. **Existing trade relationships:** The opposition of groups who would be displaced economically is expressed in building code restrictions and in boycotts by dealers and building crafts, also by imposed restrictions in some real estate developments.

On the other hand prefabrication is promoted by the competition between the various manufacturing and raw material industries for major shares of the building dollar. The steel and power industries cut across the pattern. Outlets are sought for specific products through mass production of low-cost dwellings (examples: the all-steel, the all-wood, the all-electric-appliance houses). Manufacturers in other industries have also entered the market; for example, the Briggs Manufacturing Co., producer of automobile bodies, now markets standard kitchen and bathroom equipment.

Different marketing approaches are attempted. Conventional outlets (dealers, corporation subsidiaries, department stores) are used, or new companies are formed for this specific purpose (examples: General Houses, American Houses). In some instances existing building trades are used for the structural assembly; in other cases complete shop-fabrication is tried.

In between are various compromise procedures, like that of the Reynolds Corporation, which combines a coordinated system of materials and equipment items with a sales plan that continues the services of local architect, builder and dealer.

Commercially, the companies marketing prefabricated houses, particularly those which are backed by the big manufacturers, are important as the first evidence of new distribution systems. Technologically, they represent the last evidences of an architecture which has been developed within the limitations of hand labor and the deficiencies of natural materials.

Further Implications:

1. Prefabrication requires mass production, the economic advantages of which can be gained only through integration and control of the different phases of production (research, design, fabrication, distribution, use, liquidation). The big manufacturers who need a housing industry as an outlet for their products hesitate to take over these additional functions at the risk of antagonizing their present business relationships.

2. The traditional organization of the building field is no longer compatible with the new productive forces, so with industrial growth a destruction of the old trade and handicraft relations can be expected. Small enterprises are at a disadvantage. Professional workers are squeezed out or absorbed into corporations. The labor unions have the strength of their own protective organization, but this relative security can be maintained only by shifting from trade unions to industrial unions.

3. This industrial development — corresponding to current developments in the transportation, communication and entertainment fields — implies an increasing degree of centralized control. Such control is determined by the extent of integration in use, distribution, fabrication, design, research, and (most important at present) liquidation. Building production becomes the integration of systems of services, a conception which presupposes planning of all production activities.



MAISON-PAUL RESTAURANT, SAN FRANCISCO
Dodge A. Riedy, Architect
View before remodeling



MAISON-PAUL RESTAURANT, SAN FRANCISCO
Dodge A. Riedy, Architect
View after remodeling

INSTITUTE AND STATE ASSOCIATIONS

AMENDMENTS TO BY-LAWS DEFERRED BY CONVENTION

A Report By Wm. I. Garren, Delegate

 ON Monday, May 4, there assembled at the New Chamberlain Hotel, Point Comfort, a meeting of the representatives of the State Associations that were present at the convention, together with those Associations that are members affiliated with the A.I.A.

A secretary was named from the Pennsylvania Society and he will in due time probably forward to our societies the regular minutes of this and other meetings. J. R. Fugard of Chicago, member of the Illinois Society, acted as chairman of the meetings.

There were present at the Association meetings the representatives of the member Associations, namely—California, Wisconsin, Oklahoma and Illinois; also representatives of Pennsylvania, Florida, New York and one or two others.

At the meeting the first day the discussions centered about the proposals of the Los Angeles Chapter A.I.A. to oppose the proposed amendments to the A.I.A. constitution and by-laws. In the course of the discussions, it developed that New York was strenuously opposed to the complication, as they termed it, of involving the Institute with the State Associations. Some of the objections were due to misinterpretation of the existing and proposed by-law amendments. Many of the objections voiced were from Institute members who were also Association

members and sought to defend the integrity of the Institute, at the same time keeping their State Associations independently operative.

New York apparently wished to delegate authority on national problems and subjects to the Institute while retaining state rights on all state affairs.

Los Angeles Chapter apparently had desires similar to New York in that they did not wish to make Institute members bound to be members of State Societies, to pay dues, and they further did not wish to demand that Institute members agree to accept draftsmen's organizations as a part of the set-up.

There were objections raised that representatives of State Societies, had to be Institute members and that this precluded the right of independent representatives from State Associations to Institute conventions.

The discussions on the whole were extremely friendly and there was a very definite and apparent earnest desire on the part of the State Associations who were not affiliated with the A.I.A. to become affiliated as soon as possible, but on terms other than those which were contained in the present by-laws and the proposed amendments.

There was a very general feeling at the meeting that it was unnecessary to complicate the Institute by-laws to the extent that was suggested in the printed convention documents, and many thought that a simple

amendment or set of rules could be developed that would bind the Associations together in a national affiliation with the Institute where they might have national representation on national problems, leaving them with extreme freedom of action within their states. As a result of all the discussion, it was considered best to ask the A.I.A. convention not to vote upon or pass any of the amendments to the A.I.A. by-laws which had been printed for the convention, and not to consider any amendments at this session of the convention, but rather to leave the by-laws as they now stand with the following program for the future.

A resolution was adopted by the convention the following day in which it was agreed to set up a new committee to represent the Institute, the affiliated State Society members and the non-affiliated State Societies, to make a study of the whole problem for presentation to the next convention. A copy of this resolution will probably be forwarded by the secretary of the A.I.A.

As your delegate to the convention, I believe that the report of the meetings and the actions to be published later will be a better description of what was done and accomplished than I can hope to offer in a report.

After meeting the men from many states and hearing their problems aired and discussed, the most interesting conclusion that I can come to is that the old problem of State's Rights is just as alive today as it was when the constitution was written for this country.

Each state has a different problem. Each state arrives at the realization of its problem at a different time. Many of the eastern states and Middle-western states are now at a point in their problems and their thinking where we in California were from four to six years ago, and it is impossible to have these states span the gap of years and experience which we conceitedly think we have accomplished and settled in California. It is, therefore, necessary that each group of architects in each section of the country shall come about their own problems in their own manner and at the time that they believe the emergency exists. We can offer our help and our suggestions when it is requested but there is nothing to be gained by attempting to be missionaries in forcing other states to accept our ideas which are not always the proper solutions for other sections of the country.

I would suggest that California permit the eastern states to take the leadership in the committee which will be formed to study this problem and that we only go so far as to cooperate fully to preserve what we have already accomplished and to help in arriving at a national affiliation that will be satisfactory to more of the states and to the Institute. The relations between the Institute and the State Association in California have been perfect. Both organizations have profited. The architects as a group have profited and we should continue to enlarge upon and build up the spirit of cooperation which has existed since the State Association was formed.

AWARDED MENTIONS IN CONCRETE HOUSE COMPETITION

The page on the right and the three pages which follow show designs by three California and one Oregon contestant for a firesafe concrete house, submitted in the recent Pencil Points and Portland Cement Association Architectural Competition. Comments of the jury are printed on the overpage of each plate.

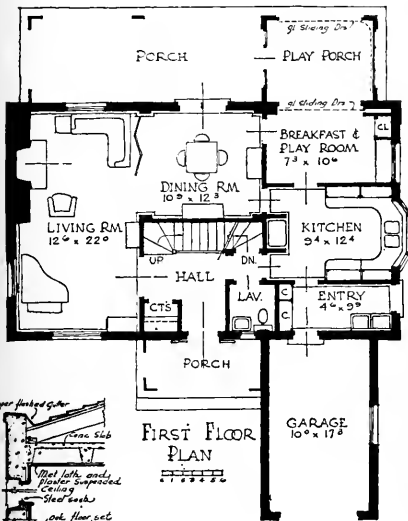

FIRST FLOOR PLAN

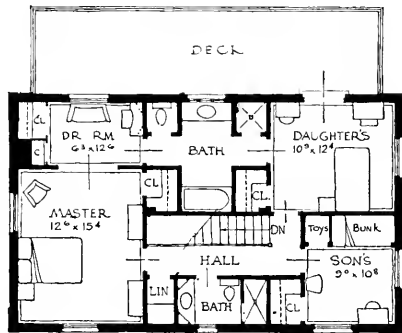

SECOND FLOOR PLAN

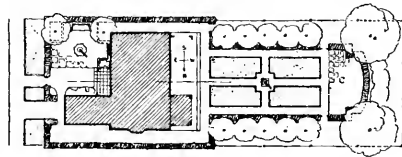

PLOT PLAN

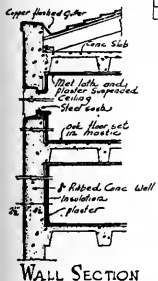

WALL SECTION

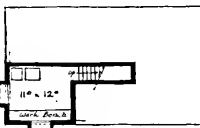

BASEMENT



North Elevation

CUBAGE	
1225.00 SQ. FT.	16,782.00
115.00	1,440.00
10.00	120.00
8.00	96.00
6.00	72.00
4.00	48.00
2.00	24.00
1.00	12.00
0.50	6.00
TOTAL	20,700.00



East Elevation

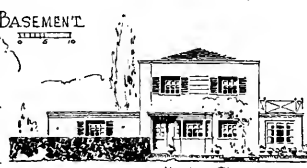

North Elevation



West Elevation

DESIGN FOR A FIRESAFE CONCRETE HOUSE
 Pencil Points - Portland Cement Association. Architectural Competition

MENTION DESIGN

John E. Fortune

A house for Southern California but with many of the characteristics of a Northern house. A good workable plan with complete circulation and easy accessibility for all purposes. The second story bath between master's and daughter's rooms is unusual and interesting. The entrance hall is ample and the exterior design is in good taste and suitable for concrete.

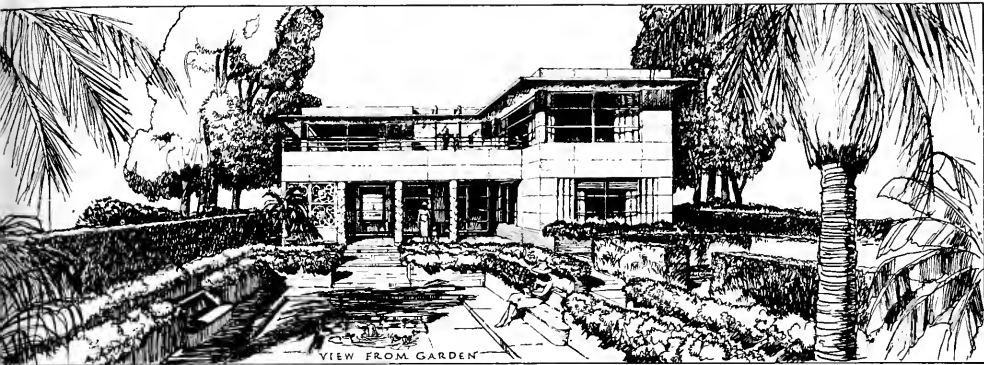

DESIGN FOR A FIRE-SAFE CONCRETE HOUSE

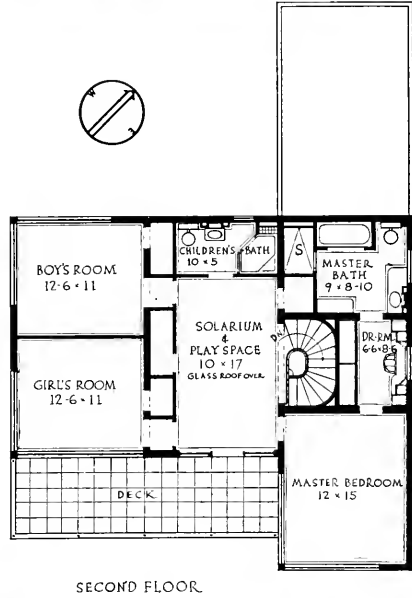
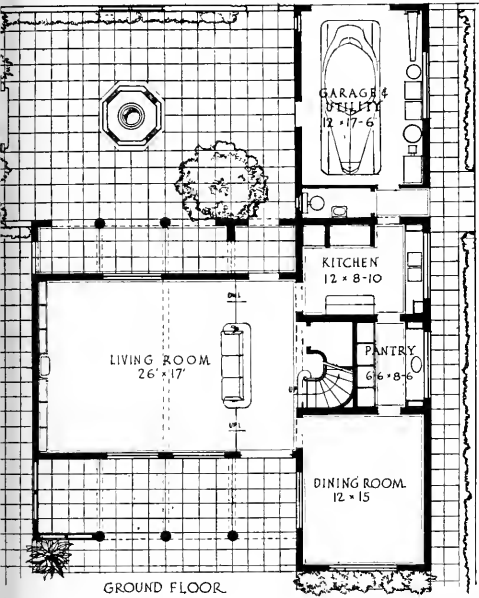

A	71-6 x 15-4 x 9-6	2202	GRF
B	15-4 x 15-4 x 18-6	874	-
C	26-8 x 24-0 x 18-6	11837	-
D	7-6 x 8-0 x 9-0 x 4	482	-
TOTAL CUBAGE 23738 GRF			

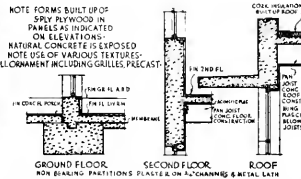
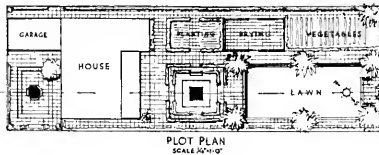
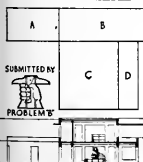

PRECAST PORTLAND CEMENT ASSOCIATION ARCHITECTURAL COMPETITION

MENTION DESIGN

E. W. Genter, Jr.

Here is a florid type of house, designed for execution in concrete with the natural surface exposed. It is frankly placed with the garage right on the street so that the whole rear of the property is usable. The living room is comfortable and nicely related to out-of-doors. The winding stair is bad but it is well lighted from the skylight above.

Mention

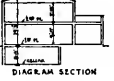
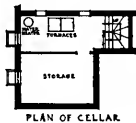
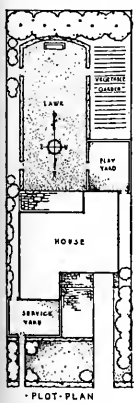
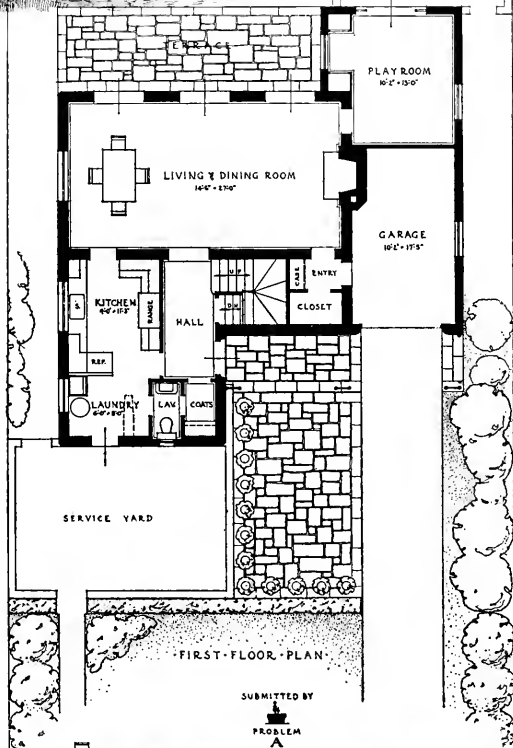
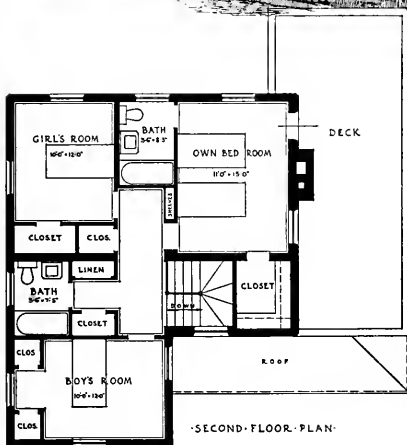
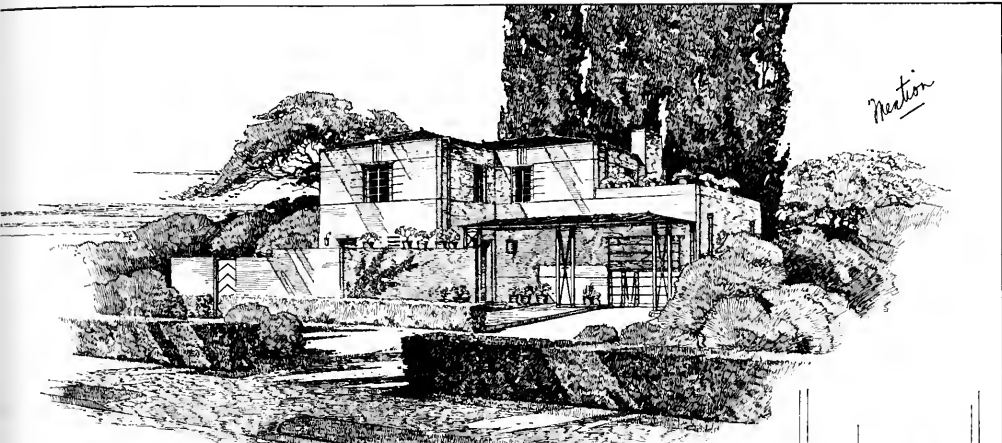

SURFACE

A	10' x 11' 0"	2444
B	2' x 2' 0"	1544
C	10' x 10' 0"	211
D	10' x 10' 0"	211
E	10' x 10' 0"	211
F	10' x 10' 0"	211
G	10' x 10' 0"	211
H	10' x 10' 0"	211
I	10' x 10' 0"	211
J	10' x 10' 0"	211
K	10' x 10' 0"	211
L	10' x 10' 0"	211
M	10' x 10' 0"	211
N	10' x 10' 0"	211
O	10' x 10' 0"	211
P	10' x 10' 0"	211
Q	10' x 10' 0"	211
R	10' x 10' 0"	211
S	10' x 10' 0"	211
T	10' x 10' 0"	211
U	10' x 10' 0"	211
V	10' x 10' 0"	211
W	10' x 10' 0"	211
X	10' x 10' 0"	211
Y	10' x 10' 0"	211
Z	10' x 10' 0"	211
CELLAR (TOTAL)		3015
TOTAL CU. FT.		25358

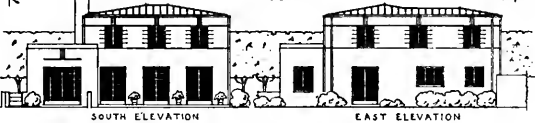
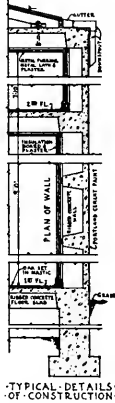

DESIGN FOR A FIRESAFE CONCRETE HOUSE

PENCIL POINTS-PORTLAND CEMENT ASSOCIATION ARCHITECTURAL COMPETITION

Malcolm P. Cameron and Howard A. Topp, Architects Building, Los Angeles, California

Mention

MENTION DESIGN

Malcolm P. Cameron and

Howard A. Topp

A smart, compact plan with no waste space. The play room is so placed that it may be used for other purposes as soon as the children outgrow the need for a play room. The garage has been retained in the main mass of the first story and the importance of the large opening has been cleverly subdued by the shadow of the front porch. The two bathrooms, though only one is required, are desirable for a three bedroom house. The handling of the exterior shows imagination as well as good taste and an understanding of concrete. The perspective rendering is drawn with skill.

Mention

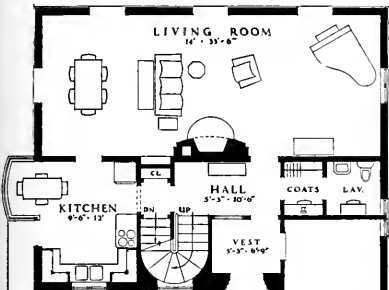
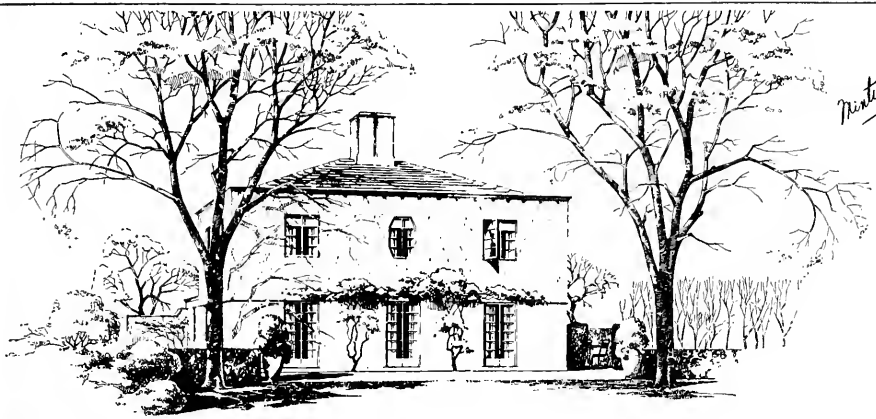

FIRST FLOOR PLAN



CUBAGE

A	38' - 31" x 31" x 8" = 31200
B	30' - 11" x 31" x 8" = 23520
C	11' - 11" x 31" x 8" = 2880
D	11' - 11" x 8" x 8" = 784
E	20' - 11" x 8" x 8" = 1344
F	11' - 11" x 8" x 8" = 784
G	11' - 11" x 11" x 8" = 10648

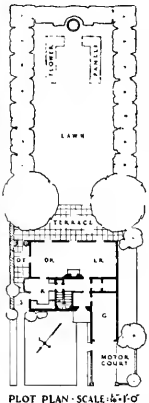

PLOT PLAN - SCALE 1/4" = 1'-0"

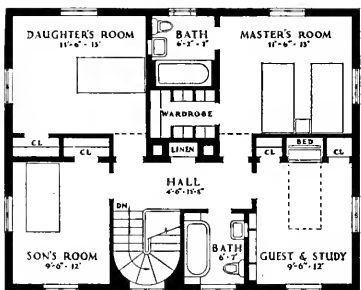

SECOND FLOOR PLAN

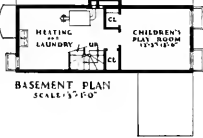

BASEMENT PLAN SCALE 1/4" = 1'-0"

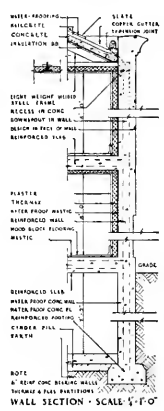

WALL SECTION - SCALE 1/4" = 1'-0"

NON DE FLAME
PROBLEM 'A'



DESIGN • FOR • A • FIRESAFE • CONCRETE • HOUSE
PENCIL POINTS • PORTLAND CEMENT ASSOCIATION ARCHITECTURAL COMPETITION

MENTION DESIGN

Manson Bennett

Simple exterior design, restrained and in good taste. The walled-in motor court screens the narrow projection of the garage. This plan also is adapted to the needs and income level of the hypothetical client. The direct access to garage through the vestibule is convenient and nicely placed. The combined living and dining room offers a desirable spaciousness. With terrace to the south and a simple garden, it is well placed.

FURTHER STUDY OF 'QUAKE PHENOMENA

BEST DESIGNED BUILDINGS LEAST LIABLE TO DAMAGE

By Perry Byerly



SINCE very early times man has mistrusted his personal reactions to earthquakes and has sought to create instruments which will tell him more. The seismologist of today frequently receives telephone calls from anxious citizens. The message is likely to be: "My house has just been shaken sharply, throwing a picture from the wall and disturbing furniture. The same is true in the houses of my neighbors. Has there been an earthquake?" Only when we can tell the individual that the instruments on the campus have recorded earth motion is he satisfied that there has been an earthquake. The interest of the layman in the recording of an instrument has always been a mystery to me. It would appear that the breakage of the picture would be more important, but frequently this is not so.

The ancient Chinese were the first to build contrivances which would indicate earthquakes. The first one on record was built in the year 136. The inventor was wise in that he did not disclose the interior of his seismoscope. Simple instruments do not appeal, and there is little doubt that the inside of this instrument was simple—the rod extending above the sphere being hinged within—a pendulum, in fact. When the pendulum swung in a certain direction it knocked the ball out of the mouth of the dragon on that side of the sphere. The ball fell into the mouth of the frog. There is little doubt that earthquakes recorded on this seismoscope were also felt. But inward satisfaction was given to the lay public in knowing that an instrument also had recorded the shock. This instrument is called a seismoscope since

it indicates that there has been an earthquake without giving any measurement of it.

Some Early Seismoscopes

Other early seismoscopes were bowls of liquid with the sides above the liquid powdered. Any rocking of the bowl caused the liquid to wash away the powder and an earthquake was inferred, although again probably in such cases the earthquake was also felt.

There seems to be a general feeling among many people that the instrument responds in a different way to artificial earthquakes than to natural earthquakes. This of course is not the case. The records of a small earthquake and a large blast from the same distance look much the same. However, we many times feel vibration in the house due to air waves, and to these the instruments are insensitive if properly housed.

One of the earliest forms of seismoscope was the column. In early days the falling of columns of various dimensions was expected to give a good measure of the earthquake. It was Professor West who first used, for the computation of the acceleration of the earthquake motion, the simple formula which assumed a steady force acting on a column.

Prince Galitzin, reasoning by West's formula, built a series of prisms of various heights which were set up on a metallic base. His theory was that the maximum acceleration of the earthquake could be computed by West's formula using the shortest prism which had fallen. These columns were never satisfactory and are no longer used.

Professor Kirkpatrick improved the theory of falling columns by developing a formula for their reaction to simple harmonic motion.

Abstracts of a talk given May 5, 1936, before the Structural Engineers Association of San Francisco.

The Horizontal Pendulum

Modern seismometers began with the use of ordinary pendulums in Italy. To the bottom of the mass of the pendulum was attached a writing pen. In order to obtain a pendulum of sufficiently long period, it was necessary to have a very long suspension, and in such cases where the center of oscillation of the pendulum is far from the center of suspension, the problem of getting sufficient magnification is a serious one. So the use of the horizontal pendulum came in.

Outside of Japan very long period instruments, i.e., instruments of period greater than 25 seconds, have not been found practicable. In Japan, however, horizontal pendulums with periods of one minute are employed. The new wave seismograph being developed at Pasadena will probably enable us to procure instruments of effectively long period with a great stability.

Any pendulum gives a magnified picture of the true earth motion as long as that earth motion has a period very much less than the free period of the seismometer. When the period of the earth motion approaches that of the seismometer, the record is very much warped unless the seismometer is well damped. Modern seismographs are all damped — some with vanes moving in oil — some by copper plates moving in a magnetic field. The most modern electromagnetic instruments are damped by a suitable shunt in the recording circuit. When the period of earth motion exceeds greatly the period of the seismometer, the mass of the instrument moves with the earth and no record is obtained. If the period of the earth motion is less than that of the free period of the instrument, a suitably damped seismometer gives a response proportional to the displacement of the earth. In the region where the two periods are approximately equal, the response is proportional to the velocity of the earth. In the region where the earth period is greater than that of the seismometer period, the response is proportional to the acceleration of the earth. From these facts have arisen the terms accelerometer and displace-

ment-meter used to distinguish short period from long period seismometers. I consider this an unfortunate usage of the words, since whether or not an instrument is an accelerometer or displacement-meter depends entirely on the periods of the waves being recorded. And to date we have found that with increased magnification there appears to be no limit in either direction to the periods of waves which may be recorded. The fault of the accelerometer is that it neglects waves of periods long relative to its own. Its record may, of course, be integrated in order to find out the actual earth displacement, whereas, the earth acceleration may be immediately computed by dividing the amplitude of the waves by the magnification of the instrument.

The displacement-meter has the disadvantage that, although the displacements may be computed directly by dividing the trace amplitude by the magnification, the determination of the maximum accelerations is difficult since they normally accompany very short periods of relatively low amplitude, and when these ride upon waves of much greater amplitude and longer period they are hard to decipher correctly. Although we are speaking here of accelerometers and displacement-meters, we must remember that usually any one instrument is acting as both during an earthquake.

Instruments for Measuring Motion

Just recently the United States Coast and Geodetic Survey has developed very insensitive instruments for the measurement of motion during very strong earthquakes. Its most successful instrument is called the accelerometer. It operates with a period of one-tenth of a second, and is thus a displacement-meter only to waves of period shorter than this. Good records of earthquakes have been obtained by the Survey for the Long Beach and Helena earthquakes, and we are now on the point of obtaining much more exact information as to how the earth shakes in the regions where it does damage. It is to be hoped that the Survey will be able to establish instruments of longer period which will give us further knowledge of the earthquake waves of longer period. Only

by use of a number of different seismometers of different free period may we hope to obtain a complete picture of all the motions.

We come now to what has appeared to be one of the most troublesome problems of engineering seismology. With what physical qualities of the motion, as indicated by the strong motion seismograph, may we correlate the destruction to man-made structures which accompanies the shock? The early workers seemed to feel that acceleration was the factor. If we had the maximum acceleration due to an earthquake, we should then be able to tell what the damage was without going out to look around. The records of the U. S. Coast and Geodetic Survey made at Long Beach indicated that the maximum acceleration was about one-third gravity. If we had seen these records before we saw the city of Long Beach, I feel sure that most of us on visiting the city would have been amazed at the small amount of damage done. The point is, of course, that these accelerations accompanied periods of about three-tenths of a second and were not repeated for a very long time. We see, therefore, that frequency and duration are also factors. If the motion were purely simple harmonic, the acceleration and frequency would describe the waves completely. Even if the earthquake motion were simple harmonic, we would need three quantities to describe it—the amplitude and the frequency (from which we could compute the velocity and the acceleration), and the duration.

Studies of human susceptibility to vibration have been made in the past. Some have attempted to correlate the threshold of perceptibility and the annoyance level with the velocity of the motion, which varies with the product of the amplitude and the frequency; others have correlated it with the acceleration, which varies with the product of the amplitude and the square of the frequency; still others have felt that it depends both on the acceleration and the number of times this changes direction, the function depending on the product of the amplitude and the cube of the frequency. No one has suggested in

seismology, as far as I know, that the damage done by an earthquake was a linear function of the maximum velocity. And the maximum displacement often accompanies fairly low frequencies. . . .

Picture of Earth's Motion in Quake

It should be recognized that an earthquake can never be described by one number. What the seismologist some day should be able to give to the structural engineer is the exact picture of the motion of the earth during the entire earthquake. This will require the records from more than one instrument, if both the accelerations and the displacements throughout the shock are to be known accurately. This will necessarily be the picture of that motion at some particular point, and may not even closely approximate the motion at a point not far away on different geologic foundation, witness the difference in effects on filled ground on the bay side and on Russian Hill in 1906. Filled ground may be actually ruptured, thrown about, and permanently displaced. We occasionally hear the statement made that loose fill is a good absorber, and therefore should be a good foundation on which to build. But a building built on loose fill must participate in the process of absorbing, and such buildings have done exactly that in California earthquakes. This process of absorption is a painful one. Good solid rock is a good transmitter, and it is on a good transmitter that it is best to build. The energy passes by instead of being absorbed in the locality of the building. The 1906 earthquake showed us quite clearly that a loose foundation was a bad one.

It is interesting to note that certain German seismologists have come to the conclusion that such foundation is better than rock. I think this is because the German earthquakes are always small. It is quite true that the ideal location for a building would be on rock in a locality such that the medium transmitting the waves from the source to the building was loose mud. This mud would then absorb practically all of the energy. One can conceive of a loose material between the

source and the building of such thickness that practically all of the energy was absorbed before the building was reached. This might very well happen in small shocks, but in a very large earthquake such thicknesses do not exist.

The damage which will be done to a building by a vibration of a given frequency depends quite obviously on the free period of the building, the harmonics thereof, and the free periods of the various parts of the building. Even if we could apply a single number giving the destructivity of an earthquake, it would apply only to a certain type of building, i.e., destruction is intimately linked with the type of structure. Some day we may be able to give the complete picture of an earthquake centering in a desert. It will be impossible to say what this earthquake might have done to a city in that locality until every structure in the city is described in equally great detail, and to date the application of such data regarding earthquake motion to the design of projected structures is not a solved problem by any means. It is in this direction that shaking table experiments are so valuable.

An interesting result of the study of periods of structures is the effect of two adjacent structures on each other. I observed, some years ago, the Pacific Gas and Electric Company Building in San Francisco had the same free period as that of the adjoining Matson Building. Dr. Carder of the U.S. Coast and Geodetic Survey told us recently in Pasadena that he had observed the same thing, but that on some days the period had one value and on other days another. Presumably one of these values is that controlled by one building, and the other value that controlled by the other building. It will be interesting to know whether this linking of the structures is strong enough to hold during an earthquake and to prevent any battering. It was interesting to me to note in Dr. Carder's talk that the Alameda County Court House with the walls completed has a much lower period than did the frame. The Campanile on the University campus, built with the idea of flex-

ibility, has, as a finished structure, the same period as did the steel frame. It must be remembered, however, that in the case of the Campanile, a set of very heavy chimes has been added to the stop of the structure.

Well Built Buildings Important

For any building our hope is that no periods of the building or of part of it be repeated many times during a large earthquake. Field observation of how well built buildings have withstood earthquakes, as well as the study of seismograms, indicates that we do not need to fear repetition of the given period for a time long enough to wreck a correctly designed and constructed building. The significance of a period of a building seems to lie largely in its relationship to the periods to be expected in earthquake waves. Although we know in the case of the Long Beach and the Montana earthquakes the frequencies with which the maximum acceleration was associated, we need also to know more about the longer periods present, since to each structure the most dangerous periods are most probably those of the building and of its parts. We must have detailed strong motion records, written on instruments of different periods, for many large earthquakes in the same region before we can feel certain that there are ranges of building frequencies which are relatively safe, and that we can build buildings of these periods with less care than those of other periods.

Recently there has been considerable discussion as to whether or not certain areas of the earth's crust have free periods of their own. Certain observations in Germany seem to indicate that such might well be the case. There is no theoretical ground for suspecting this at present, although the idea that a basin of loose material lying between hill slopes might have a free period much as a basin of liquid, seems not hard to imagine. There seems to be little reason to think that certain rock strata will have free periods. I have spoken with geophysical prospectors — men who fire explosions and observe the artificial seismic waves set up thereby. One experi-

enced man told me that once and only once he had observed such a case—a layer of sandstone underlain by gravels shook for so long with approximately simple harmonic motion that he was unable to observe waves reflected from below.

If the immediate surface layer of a locality has a certain free period, it would seem reasonable to me that a regional layer of much greater thickness might also have its free period, and that we might have a large number of free periods of a region—that one which is predominate depending on the disturbance acting. It is very desirable that this problem be studied further and this is being done by the Coast and Geodetic Survey with its shaker. If it be found that this shaker is able to set up a free vibration, it should not be concluded from this that any building of longer period will necessarily be safe during an earthquake. It may be the case, if free periods exist, that a large earthquake will set a deeper layer into vibration. Only after many earthquakes, including large ones, can definite conclusions be drawn regarding the existence and importance of free periods. The frequency set up at the source is, no doubt, a very important factor and we know that the larger earthquakes set up, in addition to high frequencies, much lower ones than do smaller earthquakes.

Advantage of Field Study of 'Quakes

Let me again return to the question of the field study of earthquakes—the actual observation in the field of what the damage has been. Field study has come into disrepute with seismologists in recent years because of the great development of instruments. The old idea of the purpose of field studies being to locate epicenters only, has a tendency to persist, and since we can locate epicenters by instruments, some say, "Why the field study?" In the first place, even from the viewpoint of epicenters, field study is valuable. We must in seismology distinguish two types of epicenters—the instrumental and the field. The instrument records waves sent out from the point where the fault starts to break,

and the instrumental epicenter will be above this point. Since our instrumental epicenters frequently do not lie in the region of greatest damage, it seems reasonable to say that the fault breaks with greater violence under the region of greater destruction than it does where it started to break, i.e., under our instrumental epicenter. It is to the field epicenter that isoseismal maps lead us. But the great advantage of the field study is in the indication of safe and unsafe regions.

The old idea of the use of isoseismal maps to locate epicenters is well shown in the practice of seismologists of referring to what actually happened as due to "apparent intensity," and saving the words "real intensity" for what might have happened if the city had been built on rock and if the buildings had been well designed and constructed. I have noted in some engineers also a zealous interest in this type of real intensity. I have been asked what was the intensity of an earthquake centering in the desert. I have answered that to an engineer the earthquake had no intensity, and I have been called a philosopher. It seems to me rather inconsistent from a scientific and engineering viewpoint to preserve this dualism which forever speaks of the facts of life as apparent and leaves the word "real" to describe things which cannot be determined. Of course the answer is, suppose we decide later to build a city in this desert, we must know for what earthquake hazards to design. I will grant that when American practice becomes such that before the location of a city the earthquake hazard of a site is deeply considered, and the buildings are designed accordingly, then the question of the intensity of an earthquake in a desert will come to have more practical significance.

Field study is criticized sometimes because it does not require great skill and is, therefore, a menial task. I am of the opinion, however, that a field study done in the proper way possibly requires more skill than making an instrumental study. Instruments are respected far more than personal impressions, and of

course this has good foundation. Nevertheless, I do not agree with those who say that the location of a suitable instrument (not yet invented) in each city in California would eliminate the need of field studies, because in any city of moderate size there exist a number of different geologic foundations and the effects of these foundations is quite different. For instance, the proposed instrument placed on Russian Hill in 1906 would not have given a true picture of what happened throughout the city. I feel that it is absolutely necessary to use the methods of field observation in addition to the instrumental measure of the motion and shaking table applications of that measured motion. The latter methods are most necessary, but also is the field study where the motion is directly applied to the building already constructed. We must not confine ourselves to reproducing on the shaking tables the motion obtained from seismographs and observing the effects on the models of structures.

Accumulation of Information Urged

Recently, as many of you know, there has been envisaged a project for the study of seismology in California from the engineering viewpoint. The project which I proposed, although it could no doubt only be accomplished partially without large funds, was this: an able young geologist should be sent throughout the cities of California to study from old maps and city records the nature of the geologic foundation of these cities—which regions are filled in (naturally and artificially)—what the near surface geology is as indicated by wells and excavations. I should like to see detailed maps of the soil conditions in our large cities. In addition, an able young engineer should keep track of these towns, watching new structures, studying the plans of the old structures, picking out particular types, of course, with reference to their foundation as well as to their design. This data should be kept with the data regarding the geologic foundation. I think that these two men could well be employed for several years in accumulating this information.

After any large earthquake, a group of competent men should be sent into the field to observe the damage to buildings, particularly those picked out as types. Surely then we should be able to know why certain buildings, apparently like others, fail, whereas, the others stand.

I think that after every small shock a man should be sent into the field to study the minor intensity effects. The latter work would keep us clearly in touch with all California earthquakes, and I think it would be very helpful in the long run for us to know just where and when small earthquakes are occurring. Our instruments cannot do all of this for us. The pattern of small shocks is a necessary part of the picture of California earthquakes and may yet lead to a better knowledge of when and where large shocks may be expected. Maxwell Allen has pointed out that certain parts of the San Andreas Fault have frequent moderately large shocks, whereas, other portions are free from small shocks, but occasionally feel one of the first magnitude. In Humboldt County there are frequent moderately large shocks. In Mendocino, Sonoma and Marin Counties there are very few earthquakes. This, however, was the region of the maximum intensity of the 1906 shock. From the Bay district south through San Luis Obispo County there are a great number of small and moderate shocks. Then in the region of the Fault from Ventura to Riverside Counties there are a less number of small shocks, this region being the center of the great 1857 earthquakes. Again, down in Imperial County we have a great number of moderately large earthquakes. It is very remarkable in the study of local earthquakes from the instrument records in this region to note the freedom of Marin, Sonoma, and Mendocino Counties from small shocks. It is particularly from the region south of San Jose that we record the vast number of little earthquakes.

It is dangerous to claim that any part of our western region is safe from earthquakes. The country around Mina, Nevada, seemed quite safe until 1932. Helena also seemed to

have very little hazard until last year. In California our great valley towns, although not very close to our Coast Range faults, need fear the effects of their deep alluvial foundation. And we have no assurance that the east side of the valley will remain quiescent. I have hopes that by careful observation and listing of small shocks, county by county, we may be able to convince the people in the valley that schools even there should be well constructed.

A program of field study should appeal to engineers. The instrumental studies and the laboratory experiments are essential and must be carried out, but in doing so we must not forget the value of field studies.

MODERN DESIGN FOR SAN FRANCISCO SCHOOLS

(Concluded from Page 15)

children which is separated from the main play field by a low wall.

The ground floor contains the teachers' rest and lunch rooms, a large nutrition kitchen, together with commodious and well lighted play space. The principal boys' and girls' toilets are adjacent to this covered play ground, which is accessible from the playing field.

The auditorium, seating 400 people, is approached from Lawton Street, besides being accessible from the academic wing, so that this unit can be isolated from the academic wing in the event the auditorium is being used by an outside organization.

The special activities room is located immediately behind, and on the same level with the auditorium stage, so that in the event of large pageants or plays requiring an unusually deep stage, this room may be thrown open by means of folding doors to provide the additional depth.

The first floor, facing 31st Avenue, contains class rooms, the clinic and principal's office. The principal's office, immediately facing the main entrance, is well located, and, on the play field side a balcony has been provided, so that the principal has control over the play area from his office.

The second floor contains more class rooms and a well-equipped science room. Auxiliary toilets are provided on both floors of the academic wing.

The academic wing was built at a cost of \$169,788. The auditorium and kindergarten units will be constructed at a later date, bringing the total cost to \$263,000.

EQUIPMENT FOR SUMMER AIR CONDITIONING

By H. L. Lincoln

BECAUSE of the popular interest that has responded to the advertising of air conditioning, all kinds of devices are now on the market, each one of them making some contribution to the general objective. The subject is alluring, and the promise held out by the advertising generally stimulates a desire to enjoy the new development. Then follows the question of what to buy.

Until someone makes a reasonably thorough review of what air conditioning is and what is required to produce it, most anything may be offered — from exhaust fans to small vaporizers. The confusion has prompted various groups, such as the branches of the American Society of Heating and Ventilating Engineers of Chicago and Los Angeles, to suggest standards of air conditioning, summer as well as winter. Ordinarily, the requirements are that at least four of the nine listed functions shall

be supplied by equipment offered for air conditioning. For summer air conditioning this means as a minimum cooling and dehumidification, with provision for ventilation, such as fresh air as required by those occupying the room. Even a superficial study shows that this fresh air must be so distributed that there will be no drafts and the range of temperature controlled in a way appropriate to the service.

The amount of cooling required depends not only on the outside temperature but also on what the people who are in the room are or have been doing and how long they expect to remain. If the occupants of the air conditioned room stay there more than one hour, the optimum condition is lower than in a store where the customers' visits are short.

The following standards, subject to certain modifications depending on local requirements, have been set up by ventilating engineers:

OUTSIDE DRY BULB	INSIDE DRY BULB*	
	Over one hour	Less than one hour
105	83	85
100	81	83
95	79	81
90	76	79
85	75	77

*Desirable relative humidity to be about 55%, dropping to 40% for higher temperatures.

Surveys of California climate made by the University of California develop very clearly that there are two distinct loads imposed on any building. They are typified by the conditions in Los Angeles and Fresno. The Los Angeles climate has many days moderately hot, frequently with high humidity. The Fresno climate has a summer season of very high temperatures with low humidity. In Fresno a considerable amount of cooling can be done by using evaporation. This is particularly effective if cooling tower water is circulated through a radiator, thus preventing any increase in humidity in the rooms cooled. In Los Angeles, on the other hand, a large part of the time dehumidification is required, together with cooling. In both cases, if the system is to satisfactorily meet the requirements of summer air conditioning, a source of refrigeration must be available, for even evaporative cooling fails to produce satisfactory conditions if

the humidity is moderately high or with rooms full of people.

There are two distinct sources of refrigeration that are now successfully used in this state. For many years the larger buildings and theaters have used mechanical refrigeration. In the last four years a considerable number of installations are using ice and are finding it economical when the hours of cooling per season are from 300 to possibly not over 1000.

The selection of any equipment is a problem of economics. The investment of the equipment must be written off and the equipment maintained, as well as the direct operating cost, including the purchase of electricity, water and ice. Both factors must be considered in determining the year round economy, and it should be recognized at the start that the cost of ice per hour of operation is several times greater than the cost of electricity required to run a compressor. On the other hand, the difference in cost of the equipment will pay for many hours use of ice each year. The relationship is well illustrated by an economic analysis of contrasting types of air conditioning systems of equal capacity.

Any comparison of bids may easily develop three basic designs of equipment required for a particular building, where there is a load of 18 tons refrigeration (216,000 BTU per hour). One group develops the cooling effect with a mechanical refrigeration machine of 18 tons rated capacity, driven by a 20 H. P. motor. Such equipment is likely to cost in the neighborhood of \$7,000. A second type would supply the refrigeration by melting ice with a capacity to melt 1500 lbs. of ice per hour to give the same refrigeration rating. The investment required would be very much less, perhaps \$1,800. A third type would combine a cooling tower to provide evaporative cooling with an ice tank, and would cost installed about \$3,200.

Naturally, the operating cost per hour is more or less inversely proportional to the investment. The electricity to run a refrigerating compressor is much less than the cost of ice per hour, but far more must be considered than merely the cost of electricity. Some

allowance must be made for refrigerant, supplies, water, repairs, and attendance during the operating season and an appreciable bill for electric service even when the air conditioning system is not in use.

When the purchaser has been trained in the selection of machinery, he will consider not only the capacity purchased but also the amount of time per year he is going to use it. The greater the number of hours per year, the lower must be the operating cost per hour. If a comparison of air conditioning equipment be made, for use in a small theatre or restaurant in Fresno for instance, where experience shows that satisfactory conditions require less than 400 hours operation per year, the importance of this basic comparison becomes evident. For the short hour load of the 18 ton cooling system under consideration, the mechanical unit shows the highest cost per year,

being somewhat more than the straight ice plant and considerably more than the cooling tower equipped with an ice tank. Furthermore, the cost of the mechanical installation is established for all time, cool summers as well as hot; whereas, when the refrigeration is supplied by melting ice, there is practically no cost when it is not necessary to cool the air.

If the installation were to cool a Los Angeles theater, where for 1000 to 1200 hours a year it is required to keep a crowded house comfortable, even during a warm humid afternoon, the effect of a low hourly operating cost dominates.

These contrasting examples of climate and usage indicate the necessity for real thrift in selecting or advising the installation of air conditioning equipment, particularly wherever there is occasion to give consideration to the most effective use of available capital.



GARDEN FOUNTAIN

SAN FRANCISCO ARCHITECTURAL CLUB

WALTER C. CLIFFORD, President
H. WALTER RUPPEL, Vice-President
RICHARD E. AUDESLEY, Secretary A. N. GRANISH, Treasurer

TRUSTEES
WALDON B. RUE OTTO G. HINTERMANN HARRY C. NYE
DIRECTORS
ALBERT KAHL IRA H. SPRINGER CHARLES J. CONTI

FINAL PROBLEM TILL FALL

The second and last group of this semester's conjunctive design problems between the University of

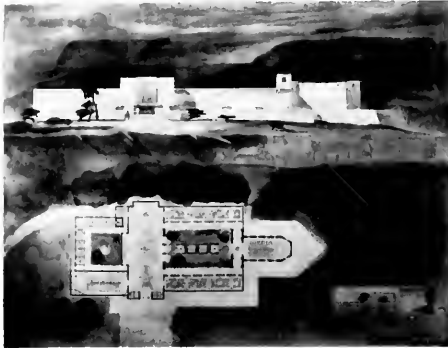

MUSEUM OF LOCAL ANTIQUITIES

Submitted by Clement Mullins, San Francisco Architectural Club, and placed First

California and the San Francisco Architectural Club was judged recently.

The projects, "A Museum of Local Antiquities" bore a wealth of ideas and originality both in planning and design of facades and required considerable debate and deliberation on the part of the jury to finally select the winners. The two problems ranking highest in the competition were those of Clement Mullins of San Francisco Architectural Club and C. Holser of the University of California, being placed in the order named.

The jury for the evening consisted of W. W. Wur-

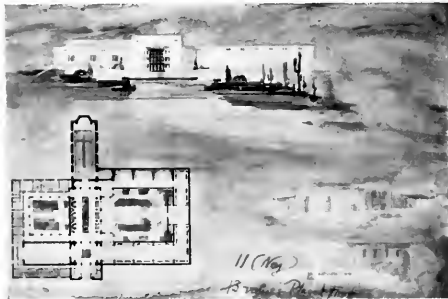

MUSEUM OF LOCAL ANTIQUITIES

Submitted by C. Holser and placed Second

ster, E. Frick, Professors H. Moise and M. Goodman of U. C., M. Ciampi and E. Ames of S.F.A.C.

The exhibition of the work during the week following

the judgment stimulated much interest and comment by the visitors and club members.

Indications point to an even more successful series of projects in the early fall, when conjunctive competition between the University of California and the San Francisco Architectural Club will be resumed.

STRUCTURAL ENGINEERING CLASS

Plans are under way for organization of an elementary class in structural engineering to start the latter part of August. The structural design course as given by Mr. Chew particularly fills the requirements of the State Board of Architectural Examiners. No previous experience or engineering schooling is necessary for enrollment.

OREGON STATE CAPITOL

The jury in the Oregon State Capitol competition has awarded first prize—the commission to prepare the plans for the building—to Goodhugh Livingston of the firm of Trowbridge & Livingston, associated with Francis Keally, New York. Second choice of the jury were the drawings of W. P. Day, architect of San Francisco. Others who received honorable mention and prizes of \$1,500 each, were Wesley Sherwood Berrell, New York; De Young & Mascowitz, New York, associated with Karl W. Rosenberg, of Oregon, John A. Thompson and Gerald A. Holmes, New York, and Walter T. Karcher and Livingston Smith, Philadelphia.

Under terms of the contract Mr. Livingston will employ a local architect to act as resident supervisor of construction.

The Capitol will be rectangular in shape, about 400 feet long by 164 feet wide, with a cylinder tower rising from the center section to a height of 166 feet. The tower will have a flat roof and will be topped by a large statue of a pioneer.

Three stories high, the rectangular portion of the building will provide space for administrative offices on the first floor, two legislative chambers with allied offices and committee rooms on the second floor, the assembly halls extending upward through the third floor level with balconies for spectators also at that level. In the basement will be a barber shop, cafeteria and work-rooms for state departments.

BERKELEY ARCHITECT BUSY

New work in the office of Edwin L. Snyder, 2101 Addison Street, Berkeley, includes a residence in the Arlington Estates, for George Prifold, Jr., a California Colonial dwelling on Keeler Avenue, Berkeley, for F. W. Hiatt; a residence on Hilldale Avenue, for Lloyd Bradley; alterations to the Hillside Club, Berkeley; a two-story dwelling designed in the New Orleans Plantation style on the Moraga Road, Oakland, for George F. Bruns, and a California Colonial dwelling in St. Paul's Court, Oakland, for Lieutenant William F. C. Jepson.

Plans For 1939 World's Fair Outlined At Architects Banquet

PROGRESSIVE developments in the designing and construction of the 1939 World's Fair in San Francisco Bay were revealed at a joint meeting of the American Institute of Architects, Northern California Chapter, the Producers' Council, Northern California Club, and executives of the Exposition, headed by Leland W. Cutler, president, held on May 26, at the St. Francis Hotel, San Francisco.

First important session of leading California architects, engineers and building industry officials with executive directors of the Exposition, the meeting further substantiated the unity of enterprise that is marking the preliminary activities of the 1939 International Exposition.

The speakers, introduced by Will G. Corlett, president of the Northern California Chapter, A.I.A., were: George W. Kelham, chairman of the Exposition's Architectural Commission; W. P. Day, director of works; Brigadier General William E. Gillmore, executive officer, and Leland W. Cutler, president.

That the 1939 World's Fair has been designed to create a happy medium between "thrilling pageantry and structural beauty" was the message of George W. Kelham to the 350 architects, engineers and civic leaders gathered for the occasion.

Kelham, who was also head of the architectural commission for the memorable 1915 Panama-Pacific International Exposition, said:

"Expositions are a dual personality in that they must both entertain and yet inspire a love for beauty and the finer things of life. In the creation of the 1939 World's Fair, we will not imitate the 1915 Exposition, nor will we present any of the modernistic tendencies of Chicago's and other cities' Fairs to the millions of visitors who will come to California three years from now.

"The architect must blend the highest degree of art in his design with the required utilitarian value in the creation of a great World's Fair, such as the one we plan for 1939.

"Our Exposition problem was threefold. The people must be able to turn from serious exhibits of natural or industrial wonders to the most trivial amusement, for that is the public mood. Therefore the amusement zone must have a centralized and easily available setting. Second, the architecture must have an appeal to the senses, with emphasis on illumination, or decorative lighting, and California flora. Third, not the slightest physical annoyance of clash in harmony of design and accessibility of the Exposition site by various routes approaching, or within, the grounds must interfere with the visitors' repeated desire to return."

"When the gates of the 1939 World's Fair open on February 18th, three years hence, there will be a structural unity, a completed design in architectural beauty, that will epitomize all that man has lived for down the ages — —"

In a progress report of the Exposition works project, Mr. Day declared:

"Reclamation work on the 430-acre site of the 1939 World's Fair is approximately one-eighth completed.



WILL G. CORLETT, President Northern California Chapter, A.I.A., and J. C. MacKENZIE, Vice-President San Francisco Club, Producers Council

Plans for the roads and bridges are almost complete. There will be connections with both the upper and lower decks, and a structure 64 feet wide, handling six lanes of auto traffic, will extend from the westerly portal of Yerba Buena Island over the causeway to the Exposition site, now under construction.

"Water supply plans and specifications, being prepared by the Public Utilities Commission of the City and County of San Francisco, call for Fair site reservoir accommodations holding 1.4 millions gallons. Water capacity will be 2½ million gallons per day peak load, pumped over the San Francisco-Oakland Bay Bridge from a pump plant on the San Francisco shore and through a 10 or 12-inch pipe line to the storage location."

Day also stated that work is well under way on the three-mile long rock seawall, costing \$728,000, to surround the Exposition site to a level 13-feet above Bay water; that approximately \$500,000 will be expended on the horticultural plans for trees, plants and

flowers, now being planted for Exposition purposes in a nursery in Balboa Park; and that the new World's Fair Administration Building at Stockton and Bush streets will be completed on July 8.

Other construction plans call for immediate start of work on two ferry slips on the San Francisco side of the Fair site, and one freight slip on the Oakland side, and the award of contracts shortly for three permanent Fair buildings — two hangars and an airport terminal building, to be later converted to airdrome purposes following the Exposition period.

Potential importance of the World's Fair site on Yerba Buena shoals was emphasized by Brigadier General Gilmore, Executive Officer of the Exposition, and former Chief of Staff, of the U. S. Army Air Corps.

Summarizing the future of the San Francisco Bay area as a Western aviation center, Gen. Gilmore said:

"The importance of the reclamation project at Yerba Buena shoals that will be the Exposition site of 1939 cannot be over-estimated. While we think in terms of the World's Fair we must also think in terms of the future of the San Francisco Bay region as one of America's foremost air transport centers.

"While it is wonderful to plan this great World's Fair in 1939 in San Francisco Bay, this community will, long afterward, reap the benefits of the Exposition project in developing the future airport site and seaplane base on Yerba Buena shoals."

The program, which was especially planned to cover the construction and architectural scope of the Exposition, closed with a summary tribute by President Cutler to the engineering and architectural staffs, to the Federal, State and City governments, and to the hard-working citizen committees who made the Exposition's development possible.

"The 1939 World's Fair is on its way," he said, "and nothing can stop it! This will be an International Exposition in every sense of the word, as the nations of Europe, Asia, Africa and North and South America — and their peoples — will be invited to participate.

"This will be California's, and all America's, World's Fair — and one of such enduring grandeur that we can all be proud of its memory in the years to come."

Arrangements for the joint session were made by Mr. Corlett, J. A. Mitchell, secretary of the American Institute of Architects, J. C. MacKenzie, vice-president of the Producers' Council, and H. Root, secretary-treasurer of the Producers' Council.

HOSPITAL ADDITIONS

Additions costing more than \$60,000 are planned to the French Hospital, San Francisco. There will be a brick Maternity Ward and other improvements. Fabre & Hildebrand, are the architects.

KELHAM AND DAY THE ARCHITECTS

"White Cement — a California Product" is the title given a recently published pamphlet by the Calaveras Cement Company, San Francisco, Los Angeles and Seattle, Wash. The booklet is A.I.A. standard size for filing and contains a number of pictures of buildings on which Calaveras Cement and Calaveras White Cement have been used. One illustration shows the Marina Junior High School, San Francisco, designed by Geo. W. Kelham and W. P. Day. In giving credit for the design, Mr. Kelham's name was printed as the architect and Mr. Day was mentioned as the engineer. While it is true the engineering was done by Mr. Day credit also should have been given Mr. Day as one of the architects of the structure.

MORE HEINSBERGEN MURALS

From May 25 to May 30 the Heinsbergen Decorative Company, Los Angeles and San Francisco, held a preview of its murals in the Cocktail Room of the Sir Francis Drake Hotel, San Francisco, and the Rendezvous Room in the Biltmore Hotel, Los Angeles. The ten murals in the San Francisco Hotel have been greatly admired for their marvelous coloring and matchless technique.

SAN FRANCISCO APARTMENT HOUSE

An \$85,000 apartment house will be erected on Jackson Street near Laguna, San Francisco, by A. Penzinger, 750 Taylor Street. Plans have been prepared by E. H. Denke and call for a seven-story steel frame and reinforced concrete building of twenty-eight apartments. Colored tile baths, stall showers, hardwood floors and a steam heating plant, are among features of the structure.

\$60,000 SAN FRANCISCO THEATER

R. E. Sbarboro and H. L. Detjen have been granted a permit to build a one-story steel and concrete theater on Chestnut Street, near Scott, San Francisco. Cost of the structure, which is to seat 900 persons, is listed at \$60,000. John Ahnden is the architect.

SANTA ROSA DEPARTMENT STORE

Plans are being completed by C. A. Caulkins of Santa Rosa for remodeling the three-story reinforced concrete Rosenberg Building, Santa Rosa, which was badly damaged by fire a month ago. The plans call for new store fronts, new interior finish and improved elevator equipment.

\$30,000 OAKLAND RESIDENCE

A contract has been awarded for the construction of a French style dwelling in St. James Wood, Oakland, for Henry Jackson, from plans by Miller & Warnecke, Financial Center Building, Oakland. More than \$30,000 will be expended on the improvements.

With the Architects

INDUSTRIAL PLANT

Construction is expected to go forward this month on a group of industrial buildings at Fruitvale and Alameda Avenues, Oakland, for the Owens-Illinois-Pacific Glass Company. There are to be four buildings of steel, concrete, corrugated iron and glass brick. A. R. McLaren, 611 Howard Street, San Francisco, is the mechanical engineer and the P. J. Walker Company, will be managers of construction.

SORORITY AND FRATERNITY HOUSES

W. W. Wurster, 260 California Street, San Francisco, is preparing working drawings for a two-story sorority house for the Delta Delta Delta at Leroy Avenue and Bancroft Way, Berkeley, estimated to cost \$50,000.

At Palo Alto, the Delta Tau Delta will spend \$25,000 on alterations and additions from plans by Noble and Archie T. Newsom.

SUGAR REFINERY

One of the largest industrial projects of the year will be the construction of a sugar refinery two and one half miles from Woodland, Yolo County, by the Spreckels Sugar Company, 2 Pine Street, San Francisco. George W. Kelham, is the architect. More than \$2,000,000 will be expended on buildings and equipment.

SACRAMENTO WAREHOUSE

A two-story reinforced concrete warehouse is to be built at Sacramento for the Thompson-Diggs Company. The building will be flat slab reinforced concrete and will be equipped with automatic fire sprinklers. T. Ronneberg, of San Francisco, is the structural engineer.

BERKELEY RESIDENCE

Plans have been completed by Messrs. Dragon and Schmidts, architects of Berkeley, for the construction of a residence on Berdue Avenue, Berkeley, for John W. Gibbons, estimated to cost \$11,500.

DALY CITY SCHOOL

Plans are being prepared by Resing and McGuiness, 488 Pine Street, San Francisco, for a gymnasium and swimming pool at the Jefferson High School, Daly City. L. H. Nishkian is the structural engineer. The estimated cost of the improvements is \$125,000.

C. A. Balch, Los Angeles, has opened a branch office at 514 Bank of America Building, Visalia. Judson Steele is manager of the Visalia branch.

OAKLAND HOSPITAL

Plans have been completed by Masten & Hurd, 233 Post Street, San Francisco, for new administration quarters and a maternity ward annex to Merritt Hospital at Webster and Hawthorne Streets, Oakland. Estimated cost is \$100,000. The same architects are completing plans for a \$10,000 residence in St. Francis Wood, San Francisco, for D. H. Hughes.

SPANISH VILLAGE

Carleton M. Winslow, Architects' Building, Los Angeles, is preparing plans for a Spanish village consisting of ten bungalows and a replica of a Spanish cathedral to be built on Wilshire Boulevard, between Alexander and Mariposa Avenues, Los Angeles, for the Chapman Estate. The owners will spend in excess of \$600,000 on the project.

SAN MATEO DWELLINGS

Gordon B. Kaufmann of Los Angeles, is the architect of a group of twenty or more frame and stucco dwellings to be built in one of the new residence tracts in San Mateo for the Merner interests. Each house will have from five to seven rooms with all modern conveniences.

BRANCH LIBRARIES

Plans are being completed by Frederick H. Meyer, Kohl Building, San Francisco, for a reinforced concrete branch library for the City of San Francisco on West Portal Avenue; also a branch library on Courtland Avenue, Bernal Heights. The structures will cost \$42,000 each.

HOTEL IMPROVEMENTS

Extensive improvements will be made to the Arrowhead Springs Hotel, in San Bernardino County from plans by Earl T. Heitschmidt, 808 Subway Terminal Building, Los Angeles. There will be a \$250,000 guest room building; a \$60,000 bathhouse and a \$75,000 casino.

STORAGE WAREHOUSE

F. Eugene Barton has completed plans for a warehouse at 20th and R Streets, Sacramento, for the Bekin Van and Storage Company to cost \$30,000. Mr. Barton is also preparing plans for two residences to be built in the Bay District.

SACRAMENTO STORES

Extensive remodeling to ten stores at 12th and K Streets, Sacramento, will be done this summer from plans by Harry J. Devine. The building at present is occupied by Sears, Roebuck Company.

Chapter and Club Meetings

NORTHERN CALIFORNIA CHAPTER

University Night" was the stated occasion for the members of Northern California Chapter, A.I.A., to assemble at the Faculty Club, University of California, Berkeley, on Tuesday evening, April 28.

The custom of holding one meeting a year on the campus was started some years ago so that a closer bond might be established between the practicing members of the profession and the students in architecture. The splendid attendance which has always been attracted to it is indication of the interest which the members hold for the students in their work and development.

Members present included John Bakewell, Jr., C. Geoffrey Bangs, Morris Bruce, Will G. Corlett, John J. Donovan, Albert J. Evers, Edward L. Frick, Henry H. Gutterson, William C. Hays, Lester Hurd, Raymond W. Jeans, Ellsworth E. Johnson, Thomas J. Kent, Frederick H. Meyer, Chester H. Miller, Leffler B. Miller, James H. Mitchell, Howard Moise, Robert Stanton, Stanton D. Willard, Alfred C. Williams, Wm. Wilson Wurster, Raymond Yelland and John Davis Young.

A brief after-dinner business session was directed by President Will G. Corlett and the meeting then adjourned to the School of Architecture Building.

Mr. Meyer reported for the committee delegated to review proposed revision of the By-Laws of the Institute, and stated that no provision was found therein to necessitate instruction to the delegates. His report was accepted.

Mr. Bakewell spoke on Competitions and moved that the Chapter place itself on record as favoring competitions for important Federal Public Works. The motion was seconded and carried without dissent.

Mr. Donovan urged that the Chapter initiate action to press for the disbursement of public funds direct to municipalities and boards of education instead of through PWA and WPA. No action was taken in the matter.

C. Grant La Farge, F.A.I.A., was introduced and heartily welcomed. Making a tour of the Schools of Architecture throughout the country in the special interest of the Institute, his time at Berkeley happily coincided with the meeting and permitted his being present.

Mr. La Farge spoke on the registration system and membership and the reaction which he had encountered on his tour with respect to these, explaining that in addition to the educational mission he had undertaken for the Institute, he also was making observations for the National Council of Registration Boards.

When again called upon at the "Ark" where members and students were assembled together, Mr. La

Farge directed his remarks to the students with an entertaining analysis of wiles and weaknesses in the so-called modern style. The students were urged to be sincere and real in their designs and cautioned to avoid features by which modern design is too often expressed, if the adoption of these otherwise would be for banal effect and not pertinent or of value in the particular problem.

Other speakers were Mr. Perry, Director of the School of Architecture; Mr. Corlett, President of the Chapter, and Mr. Ratcliff, President of the "Ark" student body. Student work on display in the Exhibit Hall was also of special interest.—J.H.M.

WASHINGTON STATE CHAPTER

R. C. Erskine, Seattle realtor, addressed the Washington State Chapter, A.I.A., at its May meeting.

Mr. Erskine, commenting on the improved conditions in the building industry, offered the advice that if the boom now starting is to benefit the architect, he must evolve a method to sell the home owner on the value of architectural service.

"The architect is the poorest of all professional and business men in promoting his own business," said Mr. Erskine. "You should overcome your modesty. The public should learn that the architect is needed not only for beauty, but that the architect also is a purveyor and advocate of utility and economy. When the home owner understands that the architect can save him money, give him comfort and make his home convenient as well as attractive, the architect who is active in the design of dwellings will have more than he can do."

Following addresses by Carl Gould, F.A.I.A., and Walter Averill, editor of Pacific Builder and Engineer, the Chapter adopted a motion by President Lance Gowen which precipitated a series of telegrams urging the Washington Congressional delegation to support an effort headed by Congressman Beiter, New York, to earmark for PWA projects \$700,000,000 of the proposed \$1,500,000,000 Federal works fund.

F. A. Naramore presided.

The June meeting was held in Tacoma — with golf and other recreations featuring the program.

BIRTHDAY ANNIVERSARY

The 75th birthday anniversary of Frederick Heath, senior member of Heath, Gove and Bell, architects, of Tacoma, was the occasion of a special meeting of the Tacoma Society of Architects Wednesday, April 15. Special ice cream dessert in the form of "Heath Cubes," replica of the tile product he invented, was served.

PLANNING THE MODERN KITCHEN

IN modern home design, it has become necessary to plan the kitchen with as much care and study as any other part of the house. No longer does the conscientious architect leave a square hole in the back part of the house, to be filled in afterward with miscellaneous cooking equipment. Manufacturers have perhaps provided the principal stimulus to better kitchen planning by developing improved gas and electric appliances and built-in features such as sinks, cabinets, ranges, refrigerators, etc.

Public utilities have also been universally active in bringing design-consciousness into the kitchens of new and modernized homes. Home economics and architectural services, conducted by utilities all over the country, have contributed by spreading valuable information and knowledge of modern appliances, their correct use and installation.

The kitchen designs appearing herewith are illustrations from a color booklet, "Today, Kitchens are

Planned." Regardless of the differences in taste of individual home owners, or their preferences in regard to kitchen work, there have been developed definite principles of design and layout which contribute to facility, convenience and efficiency.

These particular designs feature the all-gas kitchen, — gas range, Electrolux gas refrigerator and automatic gas water heater. In all of these appliances, automatic operation has been carried to a new degree of performance. Hot water supply is regulated automatically, range temperatures are controlled by clock or thermostat, and the refrigerator provides continuous freezing with a tiny gas flame.

Compactness is the dominating keynote of the best kitchen arrangement, particularly in homes of smaller size. Another fundamental is the placing of appliances to provide continuous working surfaces. A logical sequence of operation — from refrigerator, to sink, to range, to dining room — saves many unnecessary steps and reduces kitchen labor.



THE ALL GAS KITCHEN, FINISHED IN LUSTROUS STRUCTURAL GLASS



ALL GAS KITCHEN WITH WHITE ENAMEL FIXTURES



A MODERN ALL-GAS KITCHEN

Designed by H. E. Shoemaker and interpreted by Fred Heckman

Estimator's Guide

Giving Cost of Building Materials, Wage Scale, Etc.

Amounts given are figuring prices and are made up from average quotations furnished by material houses to San Francisco contractors. 3% Sales Tax on all materials but not labor.

Note—Mechanics are demanding higher wages due to scarcity of skilled labor. Present scale may be advanced in 30 days.

All prices and wages quoted are for San Francisco and the Bay District. There may be slight fluctuation of prices in the interior and southern part of the state. Freight cartage, at least, must be added in figuring country work.

Bond—1½% amount of contract.

Brickwork—

Common, \$35 to \$40 per 1000 laid, (according to class of work).
Face, \$75 to \$90 per 1000 laid, (according to class of work).

Brick Steps, using pressed brick, \$1.10 lin. ft.

Brick Walls, using pressed brick on edge, 60c sq. ft. (Foundations extra.)

Brick Veneer on frame buildings, \$.75 sq. ft.

Common f.o.b. cars, \$12.00 job cartage. Face, f.o.b. cars, \$45.00 to \$50.00 per 1000, carload lots.

HOLLOW TILE FIREPROOFING (f.o.b. job)

3x12x12 in. \$ 84.00 per M
4x12x12 in. 94.50 per M
6x12x12 in. 126.00 per M
8x12x12 in. 225.00 per M

HOLLOW BUILDING TILE (f.o.b. job)

carload lots.
8x12x5½ \$ 94.50
6x12x5½ 73.50

Discount 5%.

Composition Floors—18c to 35c per sq. ft. In large quantities, 16c per sq. ft. laid.

Mosaic Floors—80c per sq. ft.

Duraflex Floor—23c to 30c sq. ft.

Rubber Tile—50c per sq. ft.

Terazzo Floors—45c to 60c per sq. ft.

Terazzo Steps—\$1.60 lin. ft.

Concrete Work (material at San Francisco bunkers)—Quotations below 2000 lbs. to the ton. \$2.00 delivered.

No. 3 rock, at bunkers.....\$1.80 per ton
No. 4 rock, at bunkers..... 1.75 per ton
Elliott top gravel, at bunkers 2.10 per ton
Washed gravel, at bunkers... 2.10 per ton
Elliott top gravel, at bunkers 2.10 per ton
City gravel, at bunkers..... 1.75 per ton
River sand, at bunkers..... 1.80 per ton
Delivered bank sand..... 1.20 cu. yd.

Note—Above prices are subject to discount of 10c per ton on invoices paid on or before the 15th of month, following delivery.

SAND

Del Monte, \$1.75 to \$3.00 per ton.
Fan Shell Beach (car lots, f.o.b. Lake Ma-jella), \$2.75 to \$4.00 per ton.

Cement, 2.50 per bbl. in paper sks.
Cement (f.o.b. Job, S. F.) \$3.00 per bbl.
Cement (f.o.b. Job, Oak.) \$3.00 per bbl.
Rebate of 10 cents bbl. cash in 15 days.
Calaveras White\$6.00 per bbl.
Medusa White\$8.00 per bbl.
Forms, Labors average \$40.00 per M.
Average cost of concrete in place, exclusive of forms, 35c per cu. ft.
4-inch concrete basement floor12½c to 14c per sq. ft.
4½ inch Concrete Basement floor.....14½c to 16c per sq. ft.
2-inch rat-proofing7½c per sq. ft.
Concrete Steps\$1.50 per lin. ft.

Dampproofing and Waterproofing—

Two-coat work, 15c per yard.
Membrane waterproofing—4 layers of saturated felt, \$4.00 per square.
Hot coating work, \$1.80 per square.
Medusa Waterproofing, 15c per lb., San Francisco Warehouse.

Electric Wiring—\$12.00 to \$15.00 per outlet for conduit work (including switches).
Knob and tube average \$7.00 per outlet, including switches.

Elevators—

Prices vary according to capacity, speed and type. Consult elevator companies.
Average cost of installing an automatic elevator in four-story building, \$2800; direct automatic, about \$2700.

Excavation—

Sand, 50 cents; clay or shale, 80c per yard.
Teams, \$12.00 per day.
Trucks, \$20 to \$25 per day.

Above figures are an average without water. Steam shovel work in large quantities, less; hard material, such as rock, will run considerably more.

Fire Escapes—

Ten-foot balcony, with stairs, \$85.00 per balcony, average.

Glass (consult with manufacturers)—

Double strength window glass, 15c per square foot.
Quartz Lite, 50c per square foot.
Plate 75c per square foot.
Art, \$1.00 up per square foot.
Wire (for skylights), 35c per sq. foot
Obscure glass, 26c square foot.

Note—Add extra for setting

Heating—

Average, \$1.90 per sq. ft. of radiation, according to conditions.

Iron—Cost of ornamental iron, cast iron, etc., depends on designs.

Lumber (prices delivered to bldg. site).

No. 1 common\$34.00 per M
No. 2 common 29.00 per M
Selection O. P. common 39.00 per M
2x4 No. 3 form lumber..... 24.00 per M
1x4 No. 2 flooring VG..... 60.00 per M
1x4 No. 3 flooring VG..... 50.00 per M
1x6 No. 2 flooring VG..... 60.00 per M
1¼x4 and 6, No. 2 flooring 65.00 per M

Slash grain—

1x4 No. 2 flooring\$48.00 per M
1x4 No. 3 flooring 40.00 per M
No. 1 common run T. & G. 33.00 per M
Lath 7.00 per M

Shingles (add cartage to price quoted)—

Redwood, No. 1\$1.10 per bdle.
Redwood, No. 290 per bdle.
Red Cedar 1.00 per bdle.

Hardwood Flooring (delivered to building)—

13-16x3¼" T & G Maple.....\$120.00 M ft.
1 1-16x2¼" T & G Maple 132.00 M ft.
7x3½ sq. edge Maple 140.00 M ft.
13-16x2¼" ¾x2" 5-16x2" T&G T&G Sq.Ed.
Clr. Qtd. Oak\$200.00 M \$150.00 M \$180 M
Sel. Qtd. Oak 140.00 M 120.00 M 135 M
Clr. Pla. Oak 135.00 M 107.00 M 120 M
Sel. Pla. Oak 120.00 M 88.00 M 107 M
Clear Maple 140.00 M 100.00 M
Laying & Finishing 13c ft. 11 ft. 10 ft.
Wage—Floor layers, \$7.50 per day.

Building Paper—

1 ply per 1000 ft. roll\$3.50
2 ply per 1000 ft. roll 5.00
3 ply per 1000 ft. roll 6.25
Brownkin, 500 ft. roll 5.00
Brownkin Protect-o-mat, 1000 ft. roll10.00
Sisalcraft, 500 ft. roll 5.00
Sash cord com. No. 7\$1.20 per 100 ft.
Sash cord com. No. 8 1.50 per 100 ft.
Sash cord spot No. 7 1.90 per 100 ft.
Sash cord spot No. 8 2.25 per 100 ft.
Sash weights cast iron, \$50.00 ton.
Nails, \$3.50 base.
Sash weights, \$45 per ton.

Millwork—

O. P. \$100.00 per 1000. R. W., \$106.00 per 1000 (delivered).
Double hung box window frames, average, with trim, \$6.50 and up, each.
Doors, including trim (single panel, 1¾ in. Oregon pine) \$8.00 and up, each.
Doors, including trim (five panel, 1¾ in. Oregon pine) \$6.50 each.
Screen doors, \$4.00 each.
Patent screen windows, 25c a sq. ft.
Cases for kitchen pantries seven ft. high, per lineal ft., \$6.50 each.
Dining room cases, \$7.00 per lineal foot.
Labor—Rough carpentry, warehouse heavy framing (average), \$14.00 per M.
For smaller work average, \$32.50 to \$40.00 per 1000.

Marble—(See Dealers)

Painting—

Two-coat work 29c per yard
 Three-coat work 40c per yard
 Cold Water Painting 10c per yard
 Whitewashing 4c per yard
 Turpentine, 80c per gal., in cans and 75c per gal. in drums.
 Raw Linseed Oil—80c gal. in bbls.
 Boiled Linseed Oil—85c gal. in bbls.
 Medusa Pe-tland Cement Paint, 20c per lb.

Carter or Dutch Boy White Lead in Oil (in steel kegs).

Per Lb.
 1 ton lots, 100 lbs. net weight.10 3/4
 500 lbs. and less than 1 ton lots.11c
 Less than 500 lb. lots.11 1/2c

Dutch Boy Dry Red Lead and Litharge (in steel kegs).

1 ton lots, 100 lb. kegs, net wt.10 3/4
 500 lb. and less than 1 ton lots.11c
 Less than 500 lb. lots.11 1/2c

Red Lead in Oil (in steel kegs)

1 ton lots, 100 lb. kegs, net. wt. 12 1/2c
 500 lb. and less than 1 ton lots 12 1/2c
 Less than 500 lb. lots13c
 Note—Accessibility and conditions cause wide variance of costs.

Potat Chimneys—

6-inch \$1.00 lineal foot
 8-inch 1.50 lineal foot
 10-inch 1.75 lineal foot
 12-inch 2.00 lineal foot

Plastering—Interior—

1 coat, brown mortar only, wood lath. \$0.65
 2 coats, lime render hard finish, wood lath. 75c

2 coats, hard plaster, wood lath. \$.80
 3 coats, metal lath and plaster 1.25
 Keene cement on metal lath 1.30
 Ceilings with 3/4 hot roll channels metal lath
 Ceilings with 3/4 hot roll channels metal lath
 plastered 1.50
 Shingle partition 3/4 channel lath 1 side.85
 Single partition 3/4 channel lath 2 sides 2
 inches thick 2.75
 4-inch double partition 3/4 channel lath 2
 sides plastered 1.30
 4-inch double partition 3/4 channel lath 2
 sides plastered 3.00

Plastering—Exterior—

2 coats cement finish, brick or concrete
 wall \$1.10
 2 coats Atlas cement, brick or concrete
 wall 1.35
 3 coats cement finish, No. 18 gauge wire
 mesh 1.50
 3 coats Medusa finish, No. 18 gauge wire
 mesh 2.00
 Wood lath, \$6.00 per 1000.17
 2.5-lb. metal lath (dipped)20
 3.4-lb. metal lath (dipped)22
 3.4-lb. metal lath (galvanized)28
 3/4-inch hot roll channels, \$72 per ton.
 Finish plaster, \$18.90 ton; in paper sacks.
 Dealer's commission, \$1.00 off above quotations.
 \$13.85 (rebate 10c sacks)
 Lime, 1-cub. warehouse \$2.25 bbl.; cars, \$2.15
 Lime, bulk (ton 2000 lbs.), \$16.00 ton.
 Wall Board 5 ply, \$50.00 per M.
 Hydrate Lime, \$19.50 ton.
 Plasterers' Wage Scale \$1.25 per hour
 Hod Carriers' Wage Scale 1.10 per hour
Composition Stucco—\$1.60 to \$2.00 sq. yard
 (applied).

Plumbing—

From \$65.00 per fixture up, according to
 grade, quantity and runs.

Roofing—

"Standard" tar and gravel, \$6.00 per sq.
 for 30 sqs. or over.
 Less than 30 sqs. \$6.50 per sq.
 Tile, \$20.00 to \$35.00 per square.

Redwood Shingles, \$11.00 per square in
 place.
 Cedar Shingles, \$10 sq. in place.
 Recotat, with Gravel, \$3.00 per sq.
 Asbestos Shingles, \$15 to \$25 per sq.
 laid.
 Slate, from \$25.00 to \$60.00 per sq. laid
 according to color and thickness.

Sheet Metal—

Windows—Metal, \$2.00 a sq. foot.
 Fire doors (average), including hardware
 \$2.00 per sq. ft.

Skylights—

Copper, 90c sq. ft. (not glazed).
 Galvanized iron, 25c sq. ft. (not glazed).

Steel—Structural

\$100 ton (erected), this quotation is an
 average for comparatively small quantities.
 Light truss work higher. Plain
 beams and column work in large
 quantities \$80 to \$90 per ton cost of steel,
 average building, \$89.00.

Steel Reinforcing—

\$90.00 per ton, set, (average).

Stone—

Granite, average, \$6.50 cu. foot in place.
 Sandstone, average Blue, \$4.00. Boise,
 \$3.00 sq. ft. in place.
 Indiana Limestone, \$2.80 per sq. ft. in
 place.

Store Fronts—

Copper sash bars for store fronts, corner,
 center and around sides, will average
 75c per lineal foot.
 Note—Consult with agents.

Tile—Floor, Wainscot, Etc.—(See Dealers).

Asphalt Tile—18c to 28c per sq. ft. in-
 stalled.

SAN FRANCISCO BUILDING TRADES WAGE SCALE

Established by The Impartial Wage Board November 9, 1932. Effective on all work January 1, 1933, to remain in effect until June 30, 1933, and for so long thereafter as economic conditions remain substantially unchanged.

This scale is based on an eight-hour day and is to be considered as a minimum and employees of superior skill and craft knowledge may be paid in excess of the amounts set forth herein.

CRAFT

Asbestos Workers \$8.00
 Bricklayers 9.00
 Bricklayers' Hodcarriers 5.60
 Cabinet Workers (Outside) 7.20
 Caisson Workers (Open) Water Work 8.00
 Carpenters 8.00
 Cement Finishers 7.20
 Cork Insulation Workers 7.20
 Electrical Workers 8.00
 Electrical Fixture Hangers 7.00
 Elevator Constructors 8.68
 Elevator Constructors' Helpers 6.08
 Engineers, Portable and Hoisting 8.00
 Glass Workers (All Classifications) 6.80
 Hardwood Floormen 7.20
 Housemovers 6.40
 Housesmiths, Architectural Iron (Outside) 7.20
 Housesmiths, Reinforced Concrete, or Rodmen 7.20

*Established by Special Board

CRAFT

Iron Workers (Bridge and Structural) \$9.60
 Iron Workers (Hoisting Engineers) 10.00
 Laborers (6-day week) 5.00
 Lathers, Chateaus 6.00
 Lathers, All Other 6.80
 Marble Setters 8.00
 Marble Setters' Helpers 5.00
 Millwrights 7.20
 Mosaic and Terrazzo Workers (Outside) 7.20
 Mosaic and Terrazzo Helpers 5.00
 Painters 7.00
 Painters, Varnishers and Polishes (Outside) 7.00
 Pile Drivers and Wharf Builders 8.00
 Pipe Drivers Engineers 9.00
 Plasterers and Hodcarriers (See wage scale
 under Plastering).
 Plumbers 8.00
 Roofers (All classifications) 6.40
 Sheet Metal Workers 7.20
 Sprinkler Fitters 9.00
 Steam Fitters 8.00

CRAFT

Stair Builders \$7.20*
 Stone Cutters, Soft and Granite 6.80
 Stone Setters, Soft and Granite 8.00
 Stone Derrickmen 8.00
 Tile Setters 8.00
 Tile Setters' Helpers 5.00
 Tile, Cork and Rubber 7.20
 Welders, Structural Steel Frame on Buildings 9.60
 Welders, All Others on Buildings 8.00
 Auto Truck Drivers—Less than 2,500 lbs. 5.50
 Auto Truck Drivers—2,500 lbs. to 4,500 lbs. 6.50
 Auto Truck Drivers—4,500 lbs. to 6,500 lbs. 6.50
 Auto Truck Drivers—6,500 lbs. and over 7.00
 General Teamsters, 1 Horse 5.50
 General Teamsters, 2 Horses 6.50
 General Teamsters, 4 Horses 6.50
 Plow Teamsters, 4 Horses 6.50
 Scraper Teamsters, 2 Horses 6.00
 Scraper Teamsters, 4 Horses 6.00

GENERAL WORKING CONDITIONS

- Eight hours shall constitute a day's work for all crafts, except as otherwise noted.
- Where less than eight hours are worked pro rata rates for such shorter period shall be paid.
- Plasterers' Hodcarriers, Bricklayers' Hodcarriers, Roofers' Laborers and Engineers, Portable and Hoisting, shall start 15 minutes before other workmen, both at morning and at noon.
- Five days, consisting of not more than eight hours a day, on Monday to Friday inclusive, shall constitute a week's work.
- The wages set forth herein shall be considered as net wages.
- Except as noted the above rates of pay apply only to work performed at the job site.
- Transportation costs in excess of twenty-five cents each way shall be paid by the contractor.
- Traveling time in excess of one and one-half hours each way shall be paid for at straight time rates.
- Overtime shall be paid as follows: For the

- first four hours after the first eight hours, time and one-half. All time thereafter shall be paid double time. Saturday (except Laborers), Sundays and Holidays from 12 midnight of the preceding day shall be paid Double time. Irrespective of starting time, overtime for Cement Finishers shall not commence until after eight hours of work.
- On Saturday Laborers shall be paid straight time for an eight-hour day.
- Where two shifts are worked in any twenty-four hours, shift time shall be straight time; Where three shifts are worked, eight hours pay shall be paid for seven hours on the second and third shifts.
- All work, except as noted in paragraph 13, shall be performed between the hours of 8 A. M. and 5 P. M.
- In emergencies, or where premises cannot be vacated until the close of business, men reporting for work shall work at straight time.

- Any work performed on such jobs after midnight shall be paid time and one-half up to four hours of overtime and double time thereafter (provided that if a new crew is employed on Saturdays, Sundays or Holidays which has not worked during the five preceding working days, such crew shall be paid time and one-half. No job can be considered as an emergency job until it has been registered with the Industrial Association and a determination has been made that the job falls within the terms of this section).
- Recognized holidays to be: New Year's Day, Decoration Day, Fourth of July, Labor Day, Christmas Day, Mission Day, Thanksgiving Day, Christmas Day.
 - Men ordered to report for work, for whom no employment is provided shall be entitled to two hours' pay.
 - This award shall be effective in the City and County of San Francisco.
 - (Outside), Hardwood Floormen, Millwrights, or Stair Builders.

SILICOSIS AN EMPLOYER PROBLEM



APPOINTMENT of four committees in the cooperative campaign for prevention of silicosis has been announced by Secretary of Labor Frances Perkins as an outgrowth of the recent national conference held at Washington. Employers, workers, insurance companies, engineers and physicians, government and technical societies, were represented at the conference and all of them indicated a desire to cooperate in the movement.

Warren A. Cook of the State Department of Health of Connecticut, is chairman of the committee on prevention of silicosis through engineering control and one of his aides is C. H. Fry, chief of the California Bureau of Industrial Accident Prevention. Surgeon R. R. Sayers of the U. S. Public Health Service, is chairman of the committee on prevention through medical control; V. P. Ahearn of the National Sand & Gravel Association, chairman of the committee on economics, legal and insurance phases of the problem, and L. Metcalfe Walling, labor commissioner of Rhode Island, chairman of the committee on regulatory and administrative phases of the problem.

Silicosis is caused by breathing very small particles of dust containing silica. Symptoms of the disease are not very well known and it can only be determined by X-ray examination. The malady is insidious and is often a long time developing. Although known to industry for years and the subject of study and research resulting in preventive measures in some industries, silicosis was not brought to public attention until a recent epidemic of litigation for recovery of damages by alleged victims of the disease swept the country. At that time silicosis was not even known to some of the employers against whom suits were brought.

Speaking at the recent national conference on "Silicosis as an Employer Problem", Alfred C. Hirth of the Air Hygiene Foundation of America, said in part:

"Since its inception, the National Safety Council has been interested in occupational diseases. It undertook a study of silicosis in 1928, the results of which were made available by publication in the American Journal of Hygiene.

"The American Standards Association has appointed a special committee who have been active on this problem for the past year and a half. This committee includes representatives of twenty-five organizations and through its subcommittees on fundamentals is giving a great deal of study to the question of toxic limits and other phases of the matter. Almost every trade association which includes dusty industries has conducted some work on the subject.

"The Air Hygiene Foundation of America is now engaged in collecting and coordinating available

information concerning pneumoconiosis. The Foundation is composed of approximately a thousand companies and has adopted a program almost identical with that of the Department of Labor as revealed by its committee set-up.

"As a direct result of this great mass of research, we have been able to design and fabricate mechanical appliances and equipment to such a degree that the existence of a dust hazard is already on its way out.

"The current demand for mechanical methods which will prevent silicosis and other dust diseases has led to an opinion held by some that engineering control of dust is a novel idea. This, however, is contrary to fact.

"We have found that one of the fundamental methods of dust elimination is the substitution of wet for dry processes. Very effective work along this line has been accomplished in the mining industry in the use of wet drills. Similarly, wet grinding has quite generally superseded the old dry processes, batching operations are often performed with materials that are damp to start with or with the addition of water at some stage in the process; mine rooms and passageways are often sprayed with water or some chemical such as salt solution to allay dust during and after blasting; water instead of air is used in cleaning castings. One of the most inexpensive and effective means of dust control that we have found is the isolation of dust producing processes from the rest of the plant. This procedure is used today in almost all sand blast operations, which heretofore have been one of our most serious sources of dust.

"It has been our experience that the simple expedient of avoiding 'bad practices' in management of factory and mine operations is a time tested preventive of dust diseases. Well supervised mines, for example, schedule their blasting for periods when men are not in the vicinity and do not permit that room to be worked until after the lapse of a specified period. Better managed foundries make it a practice to shakeout in the early morning or at other times when most of the workmen are absent. Many plants require strict adherence to rules for cleaning and sweeping. They prohibit the blowing off of dusty machinery or clothing with air hose. Sweeping in dusty working rooms is usually done only after working hours and after first sprinkling the floor. Vacuum cleaning either by a portable machine or by a central system has been used in factories and foundries of all descriptions.

"We have not been able to eliminate all dust hazards by the comparatively simple procedure outlined above, and in some cases have found it necessary to install exhaust ventilation. By this means we have been able to remove dust laden air from the dust producing process at its point of generation. It is frequently a very expensive installation but in some operations is indispensable.

ARCHITECTS REPORTS

Sponsored and Endorsed by
STATE ASSOCIATION OF
CALIFORNIA ARCHITECTS

Write for samples to
THE ARCHITECT AND ENGINEER
68 Post Street, San Francisco

ENDURING SATISFACTION

The successful architect must include human values in his planning.

Modern human beings are to live in the house he plans. If that house is to give enduring satisfaction it must be equipped for modern living. This means, more than any other one thing, electrical adequacy.

Plans must make provision for good lighting and plenty of convenience outlets to permit the enjoyment of all the electrical appliances that are necessary to modern living.

Electrical adequacy insures enduring satisfaction to the client and enduring success to the architect.

RED SEAL plans, information, or consultation without charge or obligation.

PACIFIC COAST ELECTRICAL BUREAU

SAN FRANCISCO
447 Sutter Street

• CALIFORNIA •

LOS ANGELES
601 W. 5th Street

"The principles of exhaust ventilation have been applied by the mining industry very effectively. One of the most outstanding illustrations has been their development of the so-called dust trap on drills, whereby they have been able to reduce dust in dry drilling to a level equal to or less than that attained in wet drilling.

"I might go on almost indefinitely in discussing what has been done in industry and what industry proposed to do. I have referred to the subject quite briefly, with the thought in mind that it might be heartening to Madam Secretary if she realized how much had already been done.

"The elimination of the dust hazard is inseparably connected with the physical examination of employees. The finest engineering talent is now employed in purifying the air in our plants, but whether or not the hazard has in fact been removed will be finally demonstrated by the fact that the lungs of workmen are not being affected and this can be determined only by an X-ray examination. No effective program of dust elimination can be inaugurated that does not provide for a medical check-up as an acid test of the effectiveness of the work of the engineers.

"The careful employer is also concerned with the fitness of the men whom he employs. So long as the human element remains in our industrial life, we will have some negligent employers, just as we will always have some careless workmen. Society penalizes these individuals by the passage of laws and by awarding compensation to those who have been injured as a consequence, but society certainly does not want the careful employer to suffer, for, if it does, it will leave greatly reduced the inducement to be careful.

"In brief, the employer who has gone to great expense to maintain a safe plant does not want to employ a man whose health has been undermined while in some other employment but whose disability does not occur until some time later with the natural consequence that claim is brought against the employer for whom he was working at the time of disability rather than the employer who caused the disability. We do not believe, however, that when such an examination demonstrates that an individual may have some fibrosis present in his lungs that he should then be either deprived of his means of livelihood or should be placed at other work at a reduced income. We sympathize with the employees' objection to physical examination, when such examination results in their being cast out of employment. We simply point out here the value of a physical examination in connection with the elimination of dust hazards, and we assure our employees that some fair plan will be worked out whereby they will not be caused to suffer.

"However well we may do our work, there are now, and in the future will be, some men who become disabled from silicosis. The manner in which these men

Hollywood ROOSEVELT

*Redecorated all of their
superb suites with*

WALLCOVER FLAT

A tribute by a
famous hotel to
a famous paint.

*Use Coupon
for Sample*



Use This Coupon for
FREE SAMPLE
of
Wall Cover Flat

Mail coupon to nearest Division Office—print name and address clearly or attach business card.
Name _____
Street and Number _____
City and State _____

Check color wanted: WHITE IVORY ORCHID SEASIDE SILVER GRAY APRICOT TURQUOISE

MONEL METAL

[High Nickel Alloy]

is the accepted material for soda fountains and lunch-room equipment, just as it is the universal metal for food service equipment in leading hotels and restaurants throughout the country.

CORROSIRON

[Acid Resisting Iron]

is the accepted material for draining waste lines. CORROSIRON meets all State and Municipal specifications for drain lines from school laboratories and chemistry rooms.

Pacific Foundry Company Ltd.
Pacific Metals Company Ltd.

1400 South Alameda St. 3100 Nineteenth St. 551 Fifth Ave.
LOS ANGELES SAN FRANCISCO NEW YORK

Architects . . .

S a f e g u a r d
y o u r b u i l d i n g s
a g a i n s t d e c a y
o r t e r m i t e
a t t a c k b y
s p e c i f y i n g

**WOLMANIZED or CREOSOTED
LUMBER and TIMBER**

E. K. WOOD LUMBER CO.

*"Goods of the Woods" is your guarantee for
Quality and Service*

NO. 1 DRUMM ST., SAN FRANCISCO

LOS ANGELES

OAKLAND

BUILD WELL ~

A PROPERLY designed and well constructed building is a credit to any city and a profitable investment for its owner.

Such structures are the STANDARD OIL BUILDING, MATSON BUILDING, FOUR-FIFTY SUTTER STREET, STOCK EXCHANGE, S. F. BASE BALL PARK, MILLS TOWER, OPERA HOUSE and VETERANS' MEMORIAL, San Francisco, OLYMPIC CLUB ALTERATIONS, SANTA ANITA RACING PLANT and other notable structures — all built or supervised by —

Lindgren & Swinerton, Inc.

Standard Oil Building 605 W. Tenth Street
San Francisco Los Angeles

We Maintain a Termite Control Department

are to be compensated presents a perplexing problem. Within the past two years, various interests have rushed in and secured legislation on the subject without giving sufficient thought to its formulation and in some cases have done more harm than good. In some instances they have failed utterly to make any provision for the creation of medical boards to determine the existence or extent of disability. In others, they have been content to provide for compensation without giving any thought to the question of accrued liability.

"Our problem is not solved if we simply succeed in passing the buck along to someone else. It is essentially a joint undertaking, and if the insurance companies are to be asked to assist, we must so phrase our laws that they can do so on a basis having some relation to fact and not to be asked to buy a pig in a poke. Some groups believe that no change should be made in the existing order; others are of the opinion that silicosis should be made compensable in the same manner that traumatic injuries are now compensated under Workmen's Compensation Acts. There is no such thing as unanimity of opinion.

"The question of whether silicosis should be compensable or whether it should remain the subject of common law actions, in those states recognizing a common law cause of action for occupational disease, is squarely before us.

"In England and many of her dominions which I have had extensive experience with silicosis and kindred diseases, the disabilities have been made compensable under Occupational Disease Acts. I think it will be agreed that under such acts, the vicious situation with which we are now faced, the filing of thousands of actions for damages by ambulance chasing lawyers would be largely, if not entirely, eliminated. The shyster lawyer will foment litigation only so long as he will receive a substantial portion of the recovery. As soon as his fees become a negligible quantity, then, and then only, will his interest cease. Under many of the better drawn Compensation Acts, legal fees are strictly limited. The elimination of large legal fees is of real benefit to the employee. Under such a plan the injured man or his dependents are those who receive the benefits—not the lawyers and expert witnesses used in the prosecution of the case. This benefit, of course, is also shared by the employer.

"The problem is not solved by simply including silicosis as an accidental injury under existing Workmen's Compensation Acts or as an occupational disease under acts covering disability arising from this source. It is peculiar unto itself and should be the subject of special handling. Properly drawn compensation laws embracing silicosis should recognize accrued liability on a basis that will not cripple industry and thus cause unemployment, should provide for periodic physical examinations in the interest of workers, should establish adequate medical boards for the

determination of medical questions, should make provisions against stale claims, and should provide for assignment of partially disabled workers to more fitting jobs.

"It should be borne in mind that in the interests of all concerned the burden of cost must be kept below that point which will cripple any industry, thereby crippling the community in which such industry is located because of the resulting unemployment.

"Industry appreciates the fact that the medical aspect of the silicosis problem is a very intricate one and that, unfortunately, few doctors are capable of making a correct diagnosis. Through ignorance and sensational publicity, the popular belief is rapidly growing that to inhale silica is to have silicosis. The question of disability seems to be ignored entirely, whereas it is really the meat of the question.

"I think it would be helpful if our medical experts could furnish us with some usable information as to the relationship between silicosis and disability and give us some yardstick for measuring the extent of disability where it exists. I may be asking the impossible, and it may require considerable research at no small expense to determine finally that it is impossible, but I do believe that it is worth both the time and the money. If we talked more about disability and less about silicosis, we would be more accurately expressing our ideas.

"To repeat and emphasize a thought previously expressed herein, a consideration of the many aspects of the silicosis problem, clearly indicates that the interests therein of employees, employers and the general public proceed along parallel lines. The employers of the country can be counted upon to cooperate and whole-heartedly work with the Labor Department, with the Public Health Service, with The Bureau of Mines, with other pertinent public authorities, and with labor itself, to reach a solution of this problem along sane, constructive and effective lines."

SACRAMENTO SCHOOL

Plans have been completed by Starks & Flanders and bids will be received up to June 25th for the main academic building and gymnasium of the new Sacramento Senior High School. The cost of the main building is estimated at \$467,000 and the gymnasium, \$90,000.

TAFT SCHOOL IMPROVEMENTS

The office of William H. and Harold Weeks, 525 Market Street, San Francisco, has plans for two new reinforced concrete units to the administration building of the Taft Union High School. They are to replace old units which are to be razed. The estimated cost is \$90,000.

For Western Business



CROCKER FIRST NATIONAL BANK OF SAN FRANCISCO

Member Federal Deposit Insurance Corporation

WOLMANIZED LUMBER HAS ALL THE ATTRIBUTES OF UNTREATED LUMBER

Strength, cleanliness, paintability, no corrosive effect on metals, resilience, high insulating value. WITH POSITIVE PROTECTION AGAINST TERMITES AND DECAY.

Specified by leading architects and engineers.

AMERICAN LUMBER & TREATING CO. 37 West Van Buren St. CHICAGO, ILL.

San Francisco Sales Office
116 New Montgomery St.
Phone SUtter 1225

Los Angeles Sales Office
1031 South Broadway
Phone PRospect 5558

BAXCO
Pressure Creosoted Lumber
FOR TERMITE AND DECAY PROOF
BUILDING CONSTRUCTION
CREOSOTED AND UNTREATED
PILING

Exclusive Sales Agents in California for
WEST COAST WOOD PRESERVING CO.
 Seattle, Wash.

J. H. BAXTER & CO.
 333 Montgomery St. 601 West Fifth St.
 San Francisco Los Angeles

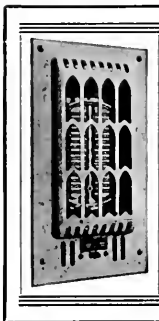

APEX
AIR ELECTRIC WATER
HEATERS

Send for Architect's Catalogue
Bathroom Heaters in the Standard
 Colors, 1000 to 2500 Watts
 \$14.00 to \$27.50

APEX MANUFACTURING CO.
 1501 Powell Street
 Emeryville, Oakland, Calif.
 Distributors
Sandoval Sales Co.
 Phone KEarny 7010
 557 Market Street, San Francisco, Calif.
Apex Sales Co.
 1855 Industrial Street, Los Angeles, Calif.
 Phone MUtual 9141



Product of
CALIFORNIA SHADE CLOTH CO.
 210 Bayshore Blvd., San Francisco

Manufacturers of
QUALITY HAND MADE SHADE CLOTH
IN ALL GRADES

Wholesale Distributors
SLOANE-BLABON LINOLEUM
AMBASSADOR VENETIAN BLINDS

STRUCTURAL STEEL

For Class A Buildings,
 Bridges, etc.

JUDSON PACIFIC CO.

609 MISSION STREET
 SAN FRANCISCO

Plants: San Francisco - Oakland

BOOK REVIEWS

By Edgar N. Kerulff

A SMALL HOUSE IN THE SUN: — By Samuel Cham-berlin; Hastings House, 110 West 42nd Street, New York City, New York. Price: \$10.00.

As a portion of the title indicates, this book is "The Visage of Rural New England in Photographs" and so it is, and a visage of surpassing beauty.

The book itself in the manner of which it's subject matter is treated is superlative. It is without a fraction of a doubt, regardless of how trite the statement is, the most charming and delightful book to come to the writer's attention in recent years.

The photography leaves nothing to be desired and serves to give those of us who have never, and may never see New England, a glimpse into that land which is so typically American, so thoroughly our own, yet reflecting that Mother-country from which we began our national existence.

The book should send more than one American on a pilgrimage to the New England States, particularly those coastal regions which are graphically shown in it's photography.

ARCHITECTURAL GRAPHIC STANDARDS: — (For Architects, Engineers, Decorators, and Draftsmen.) By Charles George Ramsey, A.I.A., and Harold Reeve Sleeper, A.I.A. John Wiley & Sons, Inc., New York City, New York. Price: \$6.00.

A book that should prove of inestimable value to the professions named in the title.

The entire volume consists of details, well drawn and very explicit, and covering the field of construction as no other book has done since the first edition published in 1921.

All drawings and architectural details are clear and the book contains an excellent index, which is essential in such a type volume.

WOMAN SCULPTOR HONORED

The President, Timothy L. Pflueger, architect, and the Board of Directors of the San Francisco Art Association announce the first award of the Phelan Traveling Scholarship of \$2,000, to Miss Helen Phillips, sculptor.

Miss Phillips is 23 years old, fair haired, blue eyed with the short stocky build so often associated with the famous sculptors of history. She was born in Fresno, California, attended high school in San Francisco but graduated from Fresno High. To her knowledge there have never been any artists or sculptors in the family.

She has studied for the past three and one-half years at the California School of Fine Arts under the direction of Ralph Stackpole.

SIXTY-EIGHTH A.I.A. CONVENTION
Report of Delegates
from Northern California Chapter

THE CONVENTION, beginning May 5, and ending May 9, was held in two places, Old Point Comfort and Williamsburg, about 40 miles apart, in that historical "Tidewater Virginia," between the York and James Rivers.

To tell much of the trip, either going or returning, would be beyond the scope of this report. Suffice it to say en route an interesting day at Chicago and one in Washington were well spent. The Chicago Lakefront Park and Buildings are tremendously interesting and, of course, Washington, is filled with architectural wonders, even on a "muggy" day featured by a cloudburst.

The first day in Old Point was May 4, practically all of which your delegates spent with the meeting of State Societies. By the exchange of viewpoints it became obvious that in the different States, A.I.A. Chapters and State Societies have diverse problems — almost as varied as the States themselves. It was concluded that a broader study should be given to "Unification", and a resolution was passed requesting that the relationship of the Institute to State Societies be further considered by a general committee and brought up again at the next convention. This resolution was later adopted in substance by the convention.

Tuesday, May 5, found most of the delegates at hand and the Chamberlain Hotel was filled to overflowing with architects, producers, guests and their families.

The routine of the various reports was quickly passed over, and afternoon saw the convention reconvened to consider the amendments to Constitution and By-Laws, sitting as a "Committee of the Whole". One of the most important changes, in addition to that mentioned regarding State Societies, was one which denied to the individual member any ownership in the property of the Institute. Due to tax requirements, this seemed logical and wise.

In the evening, nominations for officers and directors were made without developing any spirited contests, and the By-Law Amendments as recommended were finally adopted.

The next day's sessions were in Williamsburg, featured by luncheon for the delegates at William and Mary College and a service at noontime in the old Bruton Parish Church.

It was a delightful experience to see for the first time the interesting restoration of old Williamsburg and to admire the competence and ability of the architects of the restoration, as well as that of the

original Colonial architects who first produced the remarkable government buildings and Governor's palace. Williamsburg is being transformed to the atmosphere and reality of pre-revolutionary times. It is a most inspiring and delightful experience to find the ideal combination of authentic research and archeology, architectural restoration and landscape design which is everywhere evident. Even the smaller dwellings are charming and real in their unaffected simplicity. Great honor is due to those who conceived the "Restoration" and to John D. Rockefeller, Jr., who has himself supplied the necessary funds.

At succeeding sessions held in Phi Beta Kappa Hall at William and Mary College, the discussions of Housing were of considerable length but developed no outstanding points or progress. Each section of the nation appears to have particular problems and must solve them as seems best.

Of particular interest was the discussion on Competitions on May 8, at Williamsburg. A resolution offered stated in effect that competitions offer the best means of selecting architects for public buildings. The opposition was vigorous and the proponents did not seem numerous. Argument disclosed the feeling from most sections of the nation that an open endorsement of the competitive method of selecting architects would bring with it a host of unauthorized competitions and result in undoing the progress of many years. A substitute resolution was finally passed, which requested the Board of Directors to consider carefully the competitive method as a suitable one for selecting architects on public buildings.

The President's reception and the convention dinner were attended by about six hundred delegates and others. Both were hugely successful socially and the personal presentation of Fellowship awards at the dinner with the reading of a citation to each recipient, was especially impressive.

The last day was devoted to visiting three beautiful old houses on the James River; all date from the early eighteenth century: "Carter's Grove," "Westover" and "Shirley." They proved to be beautiful examples; the first two restored and Shirley seemingly untouched except by age.

To visit this part of Virginia with countless towns and buildings famous in our history was a most enjoyable experience. Yorktown, Jamestown, Williamsburg, Fort Monroe and other famous spots proved delightful, especially with the courtesies of the Virginia Chapter and the Williamsburg Holding Corporation.

The last day was marred by the unfortunate accident to President Voorhees' car, in which he, Ralph Cameron and Charles Klander were overturned at high speed. Fortunately, although all were painfully bruised and cut, aside from broken ribs, no major injuries seemed to develop.

Respectively submitted

ALBERT J. EVERS and WM. I. GARREN.

For a general summary of the proceedings of the convention, the June issue of the Octagon gives far more than is possible in a report of your delegates.

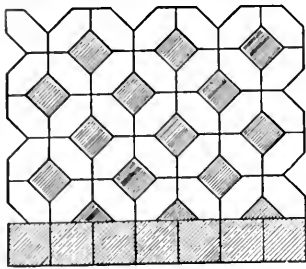

POMONA TILES

FOR

**Bathrooms and Kitchens
in over 60 colors**

Warehouses and Display Rooms

135 Tenth St. . . . San Francisco
629-33 North La Brea Ave.
Los Angeles
6106 Roosevelt Way . . . Seattle

POMONA TILE MFG. CO.
PLANT—POMONA, CALIF.

To the

**ARCHITECTURAL
PROFESSION!**

GIVE
your clients
COMFORT
and
SATISFACTION

by including

**"AIR-LITE"
VENETIAN
BLINDS**

in your specifications
NUFF SAID

GUNN, CARLE & CO.
20 Potrero Ave. UNDERHILL 5480
SAN FRANCISCO

TILE

by E. B. Morris in
The Federal Architect

A word to explain why it is that an architect is going to make a discourse on tile. There had been some discussion about it on account of the fact that both ceramics and architecture are involved, and the question was whether it would be better to have an architect talk on the art of ceramics or to have a ceramist talk on the art of architecture; so it was decided, perhaps as the greater of two evils, to have the architect do the work.

As you know, practically all architectural materials fall under two general classifications: one, the classification in which the interior structure of the material is not changed by making it ready for building purposes, such as granites and marbles and so on. The interior structure of the material has in this case been all taken care of by nature. The other is the type of material in which not only the surface is arranged by man, but also the color and the whole texture. These are, of course, the ceramic materials.

The first of these is very much closer to the drafting board. In the matter of stone, granite, marble, and wood you draw what you expect to get and there is always a machine that will give it to you. However, when you get into ceramic things, before they are burned, they start out all wrong; they are wrong as to size, wrong as to color, wrong as to texture. They go into a kiln and are burned, and they come out as desired, which is all the result of experience. The man who is working on the drafting board has a little different problem, a more extended problem of design, in the ceramic materials, because he himself has to enter into designing the color and the appearance which, in the case of the marbles and stones, had been taken care of by Mother Nature, saving him that trouble.

So there is this more extended responsibility of design for the architect when he is working with ceramic materials than when he is working



REYNOLDS METALLATION

ALUMINUM foil for
permanent home
INSULATION

REYNOLDS ECOD

welded wire fabric
plaster base—
prevents cracks,
provides thermal
insulation

*Northern California
Distributors—*

WESTERN ASBESTOS CO.
675 TOWNSEND STREET
SAN FRANCISCO

SISALKRAFT
REG. U. S. PAT. OFF.

**"More than a
building paper"**

THE SISALKRAFT CO.
205 West Wacker Drive
(Canal Station) Chicago, Ill.
55 New Montgomery Street
San Francisco, Calif.



**DALMO
WINDOW
PRODUCTS**

DALMO SALES CORPORATION
511 Harrison St., San Francisco

A WESTERN PRODUCT FOR WESTERN USE



The only white cement made on
the Pacific Coast is

CALAVERAS WHITE PORTLAND CEMENT

A California Product
San Francisco, Los Angeles, Seattle

HARDWOOD

LUMBER
FLOORING
VENEERS
PANELS

Exotic Woods for Modernistic Trim

White Brothers
Hardwood Headquarters

Since 1872

5TH AND BRANNAN . . . SAN FRANCISCO
500 HIGH STREET OAKLAND

PAYNE



The choice of discriminating buyers
of Gas-Fired Heating and Air-
Conditioning Equipment. A cata-
log showing complete Payne line
sent upon request.



**PAYNE FURNACE
& SUPPLY COMPANY**

Beverly Hills

California

with tile, and for that reason it is felt that there should be a little review of tile classifications.

No architect needs to have a very keen and extended knowledge of ceramics and of the physics and chemistry that go into the manufacture of tile, but he should and usually does have a great deal of information pertaining to the matter, but not in a deeply ceramic manner; so I would like to bring to mind several classifications in the tile field.

The first two classifications are in obtaining the clay body; the first, the plastic method; the second, the dust-pressed method. The next classification, the manner of obtaining the finish; one, the finish which is inherent in the tile, and the other the glaze applied to the tile. Then the two methods of burning the tile which, so far as an architect is concerned, produce the same result; the older beehive kiln method and the newer tunnel method. And then, finally, the two methods of setting the tile, one the method of floating the tile individually on the cement and the other the method of floating tile mounted on paper.

As to the first classification, the dust-pressed tile and the plastic tile, it may be pointed out that clay, which is nothing more than a rock-like piece of mud, is not at all suited for architectural purposes. It has first of all to be separated from impurities and ground up into a powder. The problem is to get cohesion of this powdered substance.

Of course, the oldest method is mixing it with water to obtain a more or less stiff mud, which is in designing with the glazed dust-pressed tile you have always to bear in mind that there is a certain sheen on it which, for monumental purposes, has to be treated very carefully. Also, it is a very uniform product, because there is not much chance for variation on the tile, and if you need variation it has to be a very careful selection of range of tile in order to give you any movement in the pattern and the color.

The same two methods of finish apply to the plastic tile. In most of the plastic tile the color is inherent



PACIFIC GAS Heating Appliances

- ⊙ Circulator Heaters
- ⊙ Radiant Wall Heaters
- ⊙ Gas Steam Radiators
- ⊙ Floor Furnaces
- ⊙ Gravity Furnaces
- ⊙ Blower Furnaces
- ⊙ Unit Heaters
- ⊙ Forced Air Units
- ⊙ Water Heaters

Write for Catalog No. AE-3

**PACIFIC GAS
RADIATOR CO.**

Huntington Park, California,
U. S. A.



Make the old stucco color-
ful and water tight by ap-
plying one or more coats of

BAY STATE Brick and Cement Coating

Manufactured by a company whose
products have been on the market
for over half a century.



Distributors

**CALIFORNIA SALES
COMPANY, INC.**

444 MARKET STREET
SAN FRANCISCO

IT'S HERE!

Perfected
by
WESIX



**BEFORE YOU INSTALL
ANY HEATING SYSTEM**

... ask us about WESIX *automatic* electric heaters—proven in thousands of installations in homes, buildings, hospitals, schools—even entire cities! WESIX patented double-action principle of circulating and radiating provides quick, efficient, economical heat. You know it's *healthful*. NO FANS to stir up breeze and drafts—no moving parts.

•
WESIX ELECTRIC HEATER CO.
380 First Street San Francisco

**Melrose Lumber
& Supply Co.**

•
**LUMBER AND
MILL WORK**

•
46th Ave. and E. 12th St.
Oakland
Phones: FRuitvale 0240 — 0251

**JOSEPH MUSTO
SONS-KEENAN
COMPANY**

—
**MARBLE
and
ONYX**

—
535 NORTH POINT STREET
SAN FRANCISCO
1801 S. SOTO STREET
LOS ANGELES

in the tile. It is extruded and the various mixes of clay which can be put in it fix the color. You put in a certain amount of red-burning clay and you have a red tile, or you put the gray-burning clay in and you have a gray tile, with the exception, of course, that you have sometimes a fireflash on it, giving it a little over-tone, which makes a very beautiful tile.

The plastic tile which has a glaze is what we know as a faience tile, and that tile is frost-proof, can be used out-of-doors, and is a very beautiful product. It is usually a hand-made tile.

I was in Trenton a couple of weeks ago and saw them make a hand-made tile, which was very interesting to me. They took the little wooden mold, and a man picked up the clay, which was the only time he touched it with his hands, put it in the mold and whanged it down with a mallet. Then he took a piece of tin, scraped it off to give it the proper surface, and then by a lever pushed the tile out. In order to give it a rounded edge he used a little metal thing. As a matter of fact, he made a hand-made tile without touching his hands to it at all, which was rather amusing to me.

I think that you must bear in mind, in designing tile, that you have, as I said before, a product in which you have to give some consideration to the formation of the tile. You have to study the thing. The thing to think about always is that you should call for the result that you expect to obtain, and not for the process by which you expect it to be obtained. Let the manufacturer decide that, and you work up your scheme and find out from the tile people whether the colors which you want to put in that scheme are obtainable as you wish them.

Don't use trade color names, because that is apt to be confusing as you go from one company to another. Make your own description of the colors that you would like to have there but find out first if it is possible to get them. If it is possible to get them, call for them, have them in the contract, and then insist on getting them. I think that the tile

Phone GARfield 1164

Hunter & Hudson
Consulting Engineers
DESIGNERS OF HEATING
AIR CONDITIONING
VENTILATING AND WIRING
SYSTEMS, MECHANICAL
AND ELECTRICAL EQUIP-
MENT OF BUILDINGS

41 SUTTER STREET
ROOM 710
San Francisco California

HIGH GRADE MILLWORK
AND INTERIOR FINISH
SASH AND DOORS

**LANNOM BROS.
MFG. CO.**

FIFTH AND MAGNOLIA STREETS
OAKLAND, CALIFORNIA
Telephone: LAkeside 3663

**ANDERSON
&
RINGROSE**

General Contractors

320 Market Street, San Francisco
Phone GARfield 2245

MURALS

for Hotel Cocktail Rooms,
Theaters, etc.

**HEINSBERGEN
DECORATING CO.**

7415 Beverly Boulevard, Los Angeles
401 Russ Building, San Francisco

Pacific Manufacturing Company

High Class Interior Finish
Quality Millwork

454 Montgomery St. 641 Merrill Ave.
San Francisco Los Angeles
GARfield 7755 AXridge 9011

1315 Seventh Street, Oakland
GLencourt 7850

Smith

Lumber Company

WHOLESALE - JOBBING - RETAIL
FACTORY AND BUILDING LUMBER
PLYWOODS - ROOFING

DISTRIBUTING YARDS

San Francisco	Oakland
•	19th Ave. &
4th & Channel	Estuary
MARKet 0103	FRuitvale 3174

YOUR INQUIRIES SOLICITED

Proven Finishes

Dunne's Satin Wall
Dunamel
Dunne Non-fading Sash
Colors
Cementex

Satisfaction assured when these
products are specified

FRANK W. DUNNE CO.
41st and Linden Streets
Oakland

TRANSIT-MIX CONCRETE

A Perfect-Blend
Material

Golden Gate Atlas
Materials Co.

Sixteenth and Harrison Streets
San Francisco
Phone HEmlock 7020

people will, in most cases, be able to work along with you so that all you have to do is to call for results and you will get them.

MORE FAIR DIRECTORS

Thirty-five more names have been added to the long list of World's Fair Directors.

World-wide in character and participation, the Exposition will lay emphasis upon the history, trade, industry and culture particularly of the Pacific nations, according to a formal resolution adopted by the directors. The resolution follows:

"That the San Francisco Bay Exposition shall be a world's Exposition, to be participated in by all nations in the Eastern and Western Hemispheres —

"That emphasis shall also be placed upon the Pacific Ocean, and the countries and peoples adjacent thereto, their history, their achievements, and their future —

"That the Exposition shall symbolize and promote peace, unity and coöperation among the nations of the Pacific and the World —"

Election of the 35 additional directors raised the membership of the board to 95. There still exists a number of vacancies to be filled. The new directors are as follows:

Frank Belgrano, President, Pacific National Fire Insurance Company;

S. Belither, President, Shell Oil Company;

Albert M. Bender, Insurance broker
James B. Black, President, Pacific Gas & Electric Company;

W. W. Crocker, President, Crocker First National Bank;

Robert Stanley Dollar, President, Dollar Steamship Lines;

Sidney Ehrman, Heller, Ehrman, White & McAuliffe;

J. E. French, J. E. French Co.;
Edward T. Ford, Vice President and Manager, W. R. Grace & Co.;

Don Gilman, National Broadcasting Company;

A. Crawford Greene, Attorney;
Henry Q. Hawes, Vice President and General Manager McCann, Erickson Co.;

William Randolph Hearst, publisher;

Alumilite

by

Kawneer

Store Fronts - Windows

and

Architectural Castings

in

Polished Satin

or

Anodic Finish

THE

Kawneer

COMPANY
OF CALIFORNIA
BERKELEY

"BROWNSKIN"

RESILIENT WATERPROOF
BUILDING PAPER

THE BUILDING PAPER WITH
A FACTOR OF SAFETY

Angier Corporation

Framingham, Mass.

PACIFIC COAST DIVISION
564 HOWARD STREET
SAN FRANCISCO
DOuglas 4416
350 South Anderson St.
Los Angeles

LUXOR

WINDOW SHADES

*Translucent Shading
of highest count
cambric*

William Volker & Co.

631 Howard Street
San Francisco



Pump Governors
 Safety Pump Governors
 Automatic Gas Regulating Valves
 Gas Burners
 Gas Burning Equipment
 Vacuum Pump Governors
 Vacuum Regulating Valves
 Continuous Flow Steam Traps
 Thermostats
 Reducing Valves
 Boiler Feed-Water Regulators

Oil Heaters
 Relief Valves
 Oil-Burner Governors
 Little Giant Improved Oil Burners
 Oil Pumping Sets
 Oil Valves
 Oil Strainers
 Steam Oil Strainers
 Duplex Oil Pumps
 Rotary Oil Pumps
 Boiler Feed Pumps
 Water Heaters
 Oil Meters

VAUGHN-G. E. WITT Co.
 ENGINEERS

C. W. Vaughn, President and Manager
 MANUFACTURERS AND DISTRIBUTORS

4224-28 Hollis St. Phone OLYmpic 6084
 Emeryville, Oakland, Calif.

Robert W. Hunt Company
 ENGINEERS

Inspection - Tests - Consultation
 Schools and Other Structures
 Are Built as Designed

When Construction Materials are Inspected at points of Manufacture and during Erection by

ROBERT W. HUNT COMPANY

Cement, Concrete, Chemical, Metallurgical, X-Ray and Physical Laboratories

Chicago - New York - Pittsburgh
 Los Angeles - All Large Cities
 San Francisco, 251 Kearny Street

**G. P. W.
 JENSEN & SON**

Building Construction

320 Market Street, San Francisco
 Phone 2444

R. B. Henderson, President, St. Francis Investment Company;

Charles S. Howard, President, Howard Automobile Company;

William L. Hughson, automobile dealer;

A. M. Kemp, President, Mutual Life Insurance Company;

Charles Kendrick, President, Schlage Lock Company;

Gus Lachman, Lachman Brothers; Leonard S. Levy, Controller, City and County of San Francisco;

James K. Lohead, Vice-President, American Trust Company;

Charles K. McIntosh, President, Bank of California, N. A.;

Robert Miller, Pacific Lighting Corporation;

S. F. B. Morse, President, Del Monte Properties;

A. J. Mount, Berkeley; John A. O'Connell, Secretary, San Francisco Labor Council;

Fred Pabst, Columbia Broadcasting Company;

Stuart L. Rawlings, Executive Vice President, Calaveras Cement Co.;

William P. Roth, President, Matson Navigation Company;

Robert Sproul, President, University of California;

L. P. St. Claire, President, Union Oil Company;

Don Tresidder, Yosemite Park and Curry Company;

E. A. Vandeleur, Secretary, California State Federation of Labor;

Ray Lyman Wilbur, President, Leland Stanford University;

A. Emory Wishon, President, Yosemite Portland Cement Company;

Leonard E. Wood, President, California Packing Corporation and Alaska Packers Association.

The State Corporation Commissioner has accorded the Exposition Company permission to market \$7,500,000 in non-interest bearing subscription certificates. This is the sum which will be raised from private sources to complete the Exposition.

The directors also elected Henry Q. Hawes, local advertising man and prominent in Community Chest affairs, as vice-chairman of the Exposition's finance committee which is

**FORDERER
 Cornice Works**

Manufacturers of
 Hollow Metal Products
 Interior Metal Trim
 Elevator Fronts and Cabs
 Metal Wall Plugs, Anchors, Etc.
 Sheet Metal Products
 Sanitary Metal Base
 Commercial Refrigerators
 Building Paper
 Metal and Wire Accessories
 for Concrete
 269 POTRERO AVENUE
 San Francisco, Calif.
 HElock 4100
 CONSULT OUR ENGINEERING DEPARTMENT

MacDonald & Kahn

*General
 Contractors*



Financial Center Bldg.
 405 Montgomery St.
 San Francisco

**THE TORMEY
 COMPANY**

**GENERAL PAINTERS
 AND DECORATORS**

Phone UNDERhill 1913

563 FULTON STREET
 San Francisco

CRANE

*High Class Plumbing
 Fixtures*

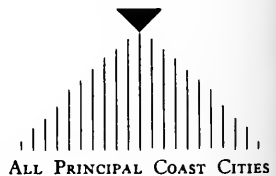

THE ARCHITECT AND ENGINEER

Bethlehem Steel Company

General Offices:  Bethlehem, Pa.

STEEL BRIDGES and BUILDINGS

San Francisco
20th and Illinois Sts.

Los Angeles
Stanton Ave.

Seattle
W. Anderson Street

Salt Lake City
Kearns Bldg.

Portland
American Bank Bldg.

Honolulu, T. H.
Schuman Bldg.

headed by Kenneth R. Kingsbury, President of the Standard Oil Company of California.

Prompt measures to win representation from all foreign nations at the 1939 Exposition will be undertaken, Mr. Cutler announced.

J. CHESTER ALLISON

J. Chester Allison, for many years identified with the development of the Imperial Valley and control of the Colorado river in the Delta region, died at Scripps Memorial hospital, La Jolla, May 28, of heart disease.

Mr. Allison was graduated from Stanford University in 1902 and joined his father and Thomas H. Silsbee on their cattle camp in the Colorado river delta below Volcano Lake. Later he secured a position under Chief Engineer C. N. Perry of the California Development Company, afterwards known as the Imperial Irrigation District, working as rod and chain man with a surveying crew until 1905. During that period the first network of canals was constructed. For the next two years he helped to design, locate and build the system of levees which held the Colorado river in check. He advanced to the post of assistant engineer and to chief engineer under Receiver W. H. Holabird.

After sale of the California Development Company's interests to the Imperial Irrigation District Mr. Allison opened an office in Calexico for practice as a consulting engineer for the Chandler interests, the Palo Verde Mutual Water Company and the Palo Verde Joint Levee District in Riverside county. In 1920 he secured an option on 100,000 acres in Mexico but it was not until 1924 that he found time to incorporate the Delta Canal Company and construct a water system to irrigate his land.

In 1916 he moved his office to La Jolla where he resided up to the time of his death.

Mr. Allison was one of the earliest advocates of flood control on the Colorado river and was a member of the first committee sent to Washington in 1917 seeking Federal assistance

Progress

Contracts in Execution

U. S. Mint, San Francisco

Administration Building and Toll Plaza, Bay Bridge, Oakland

Yerba Buena Crossing, Bay Bridge

Figueroa^a Street Overhead Crossing, Los Angeles

Clinton Construction Co. of California

923 Folsom Street
San Francisco
SUtter 3440

MULLEN MFG. COMPANY

BANK, STORE AND OFFICE FIXTURES—CABINET WORK OF GUARANTEED QUALITY CHURCH SEATING

Office and Factory:
60-80 RAUSCH ST., Bet. 7th and 8th Sts.
San Francisco
Telephone UNDERhill 5815

COMMON BRICK

If you like good brick and good service, phone us for information, you will find that it always pays to be our patron.

Remillard-Dandini Co.

Phone TEmplebar 8133
Office, 569 - 3rd Street, Oakland
Plants
San Jose Pleasanton Greenbrae

DINWIDDIE CONSTRUCTION COMPANY

BUILDERS OF GOOD BUILDINGS

CROCKER BUILDING
SAN FRANCISCO

Specify DICKY CLAY PRODUCTS

Dickey Mastertile	Face Brick
Partition Tile	Fire Brick
Drain Tile	Paving Brick
Fireproofing Tile	Wall Coping
Floor Tile	Flue Lining
Common Brick	Dickey Flashing Blocks

W. S. DICKEY CLAY MFG. COMPANY

116 New Montgomery St.,
San Francisco, Calif.
105 Jackson St., Oakland, Calif.

REPUBLIC STEEL CORPORATION



Manufacturers of
ENDURO Stainless Steel; TON-CAN Copper Molybdenum Iron Sheets and Pipe; and Steel Pipe, Sheets and Reinforcing Bar for every building purpose.

Write for information

Rialto Building, San Francisco, Calif.
Edison Building, Los Angeles, Calif.
White-Henry-Stuart Bldg., Seattle, Wash.

LAWTON SCHOOL

SAN FRANCISCO
DODGE A. REIDY and CHAS. J. ROGERS
ARCHITECTS

ANOTHER LINOLEUM CONTRACT INSTALLED

BY

WEST COAST LINOLEUM and CARPET STORES

2703 MISSION STREET, SAN FRANCISCO
Telephone VAencia 4909

Independent Iron Works

Structural Steel
Ornamental Iron
Steel Service Stations
Steel Tanks
Standard Steel Mill Buildings
Bridges

821 Pine Street

Oakland

JOHN CASSARETTO

—Since 1886—And Still Active—

Building Materials

READY MIX CONCRETE
ROCK - SAND - GRAVEL - LIME
CEMENT - PLASTER - MORTAR
METAL LATH - WOOD LATH
STUCCO - WIRE NETTING

Service Unexcelled

Bunkers

Sixth and Channel, San Francisco
Phones: GArfeld 3176, GArfeld 3177

Carl T. Doell Co.

Plumbing Heating

Plumbing Contractor
Veterans Memorial Building
Oakland

467 21ST STREET
OAKLAND

Telephone GLencourt 8246

AVIATION CENTER

"The San Francisco Bay region is destined to be one of the World's foremost aviation centers, and the 1939 World's Fair has an unprecedented opportunity to show the modern progress of civil and military aeronautics — "

This statement, made by Brigadier-General H. H. Arnold, Assistant Chief of the United States Army Air Corps, on a flying inspection tour of Pacific Coast army air bases, was indicative of Federal interest in the Exposition's development.

"San Francisco Bay, shipping and transportation hub of the West Coast, has a definite future in aviation development. The trans-Pacific airline, and expansion of commercial airports at Oakland and Mills Field, have been paralleled by recent U. S. Army development projects at Sunnyvale and Hamilton Field, in Marin, and the \$7,000,000 project, at Sacramento to create a Western Army Supply and Repair Air base. In addition, the U. S. Navy is proceeding with plans for its \$15,000,000 Alameda Air base.

"California and the cities of San Francisco Bay should start the ball rolling toward the greatest aeronautical pageant in history, to be held in conjunction with the 1939 International Exposition, and its major theme — Transportation. Spectacular mobile and static displays of commercial and military flying, the National Air Races, and international flying meets, should provide attractions for millions of visitors.

"It is possible, that with well-laid plans, the U. S. Army Air Corps may hold its annual maneuvers, held at Sacramento in 1930, in the San Francisco Bay area in Exposition year. The World's Fair site, which will become San Francisco's official airdrome following the Fair period, deserves a fitting tribute in the way of a dedication that will herald its opening to the world."

BUILDING INSPECTOR RESIGNS

Joseph C. Longueville, building inspector of Alhambra for the last three years, resigned June 1 to enter the office of A. C. Martin, architect of Los Angeles.



*I*ncandescent understands the Architect's problems — and knows how to help solve them. As exclusive distributors for Lightolier fixtures we can offer your clients the charm and distinction of outstanding lighting equipment.

INCANDESCENT SUPPLY CO.
San Francisco Oakland Fresno Los Angeles

M O N E L M E T A L

For the Modern Kitchen

Heaters, boilers, storage tanks, water softeners, cabinet tops, "Streamline" or "Straitline" Kitchen Sinks

See our display rooms, arranged for your convenience

**MODERN METAL
APPLIANCE CO.**
4238 Broadway Oakland, Calif.



HERRICK IRON WORKS

STRUCTURAL STEEL

18TH AND CAMPBELL STS.
OAKLAND, CALIF.

Phone GLencourt 1767

P. F. REILLY

Building Contractor

Builders Exchange
San Francisco

Classified Advertising Announcements

All Firms are Listed by Pages, besides
being grouped according to Craft or Trade.
Star (*) indicates alternate months.

ACOUSTICAL AND SOUND CONTROL	
Western Asbestos Co., 675 Townsend Street, San Francisco.....	70
AIR CONDITIONING	
The Union Ice Company, 354 Pine Street, San Francisco.....	*
ARCHITECTURAL TERRA COTTA	
N. Clark & Sons, 116 Natoma Street, San Francisco.....	*
Gladding McBean & Co., 660 Market Street, San Francisco; 2901 Los Feliz Boulevard Los Angeles; 1500 First Avenue South, Seattle; 79 S. E. Taylor St., Portland; 22nd and Market Street, Oakland; 1102 N. Monroe Street, Spokane; Vancouver, B. C.	*
Crocker First National Bank, Montgomery and Post Streets, San Francisco.....	67
BATHROOM HEATERS	
Wesix Electric Heater Company, 390 First Street, San Francisco; 631 San Julian Street, Los Angeles; 2008 Third Avenue, Seattle, Wash.	72
Apex Electric Heaters, sold by Sandoval Sales Co., 557 Market Street, San Francisco	68
BRICK—FACE, COMMON, ETC.	
N. Clark & Sons, 116 Natoma Street, San Francisco.....	*
Gladding McBean & Co., 660 Market Street, San Francisco; 2901 Los Feliz Boulevard Los Angeles; 1500 First Avenue South, Seattle; 79 S. E. Taylor St., Portland; 22nd and Market Street, Oakland; 1102 N. Monroe Street, Spokane; Vancouver, B. C.	*
W. S. Dickey Clay Mfg. Co., 116 New Montgomery Street, San Francisco; factory, Niles, Calif.; yards, 7th and Hooper Streets, San Francisco, and 105 Jackson Street, Oakland; Factory in Livermore	75
Remillard-Derdini Co., 569 Third Street, Oakland.....	75
BUILDERS HARDWARE	
The Stanley Works, New Britain, Conn.; Monadnock Bldg., San Francisco; Los Angeles and Seattle	4
BUILDING MATERIALS	
Building Material Exhibit, Architect's Building, Los Angeles.....	4
BUILDING PAPERS	
The Sisalkraft Company, 205 W. Wacker Drive, Chicago, Ill., and 55 New Montgomery Street, San Francisco	70
"Brownskin," Angier Corporation, 370 Second Street, San Francisco	73
CEMENT	
Calaveras Cement Company, 315 Montgomery Street, San Francisco	5-71
Portland Cement Association, 564 Market Street, San Francisco; 816 West Fifth Street, Los Angeles; 146 West Fifth Street, Portland; 518 Exchange Building, Seattle	Back cover
"Golden Gate" and "Old Mission," manufactured by Pacific Portland Cement Co., 111 Sutter Street, San Francisco; Portland, Los Angeles and San Diego.....	Second cover
CEMENT TESTS—CHEMICAL ENGINEERS	
Robert W. Hunt Co., 251 Kearny Street, San Francisco.....	74
CEMENT—COLOR	
"Golden Gate Tan Cement," manufactured by Pacific Portland Cement Co., 111 Sutter Street, San Francisco; Portland, Los Angeles and San Diego	Second cover
W. S. Dickey Clay Mfg. Co., 116 New Montgomery Street, San Francisco	75
CEMENT PAINT	
General Paint Corporation, San Francisco, Los Angeles, Oakland, Portland and Seattle	65
California Sales Company, 444 Market Street, San Francisco.....	71
CONCRETE AGGREGATES	
Golden Gate Atlas Materials Company, Sixteenth and Harrison Streets, San Francisco	73
John Cassaretto, Sixth and Channel Streets, San Francisco	76
CONCRETE CURING & PROTECTION	
The Sisalkraft Company, 205 W. Wacker Drive, Chicago, Ill., and 55 New Montgomery Street, San Francisco	70
CONTRACTORS—GENERAL	
MacDonald & Kehn, Financial Center Bldg., San Francisco.....	74

NEW THIS MONTH

Calaveras Cement Co.....	5-71
Crocker First National Bank	67
Herrick Iron Works	76
Lannom Bros.	72
American Lumber & Treating Co.	3
Incandescent Supply Co.	76
Western Asbestos Co.	70

	Page
CONTRACTORS—GENERAL	
Lindgren & Swinerton, Inc., Standard Oil Building, San Francisco.....	66
Dinwiddie Construction Co., Crocker Bldg., San Francisco.....	75
Clinton Construction Company, 923 Folsom Street, San Francisco.....	75
Anderson & Ringrose, 320 Market Street, San Francisco.....	72
G. P. W. Jansen, 320 Market Street, San Francisco.....	74
Monson Bros., 475 Sixth Street, San Francisco.....	78
P. F. Reilly, 730 Ellis Street, San Francisco.....	72
Wm. Martin & Son, Builders' Exchange, San Francisco.....	79
DAMP-PROOFING & WATERPROOFING	
"Golden Gate Ten Plastic Waterproof Cement," manufactured by Pacific Portland Cement Co., 111 Sutter Street, San Francisco; Portland, Los Angeles and San Diego.....	Second page of cover
The Sisalkraft Company, 205 W. Wacker Drive, Chicago, Ill., and 55 New Montgomery Street, San Francisco.....	70
Bay State Brick & Cement Coating, sold by California Sales Company, 444 Market Street, San Francisco.....	71
DOORS—HOLLOW METAL	
Forderer Cornice Works, Potrero Avenue, San Francisco.....	74
Kewneer Mfg. Co., Eighth and Dwight Streets, Berkeley.....	73
DRAIN PIPE AND FITTINGS	
Corrosion—Acid resisting pipe, fittings, exhaust pumps, etc., Pacific Foundry Co., 3100 19th Street, San Francisco; 1400 S. Alameda Street, Los Angeles.....	65
DRINKING FOUNTAINS	
Haws Drinking Faucet Co., 1808 Harmon Street, Berkeley; American Seating Co., San Francisco, Los Angeles and Phoenix.....	4
ENGINEERS—MECHANICAL	
Hunter & Hudson, 41 Sutter Street, San Francisco.....	72
ELECTRIC AIR AND WATER HEATERS	
Sandoval Sales Company, 557 Market Street, San Francisco.....	68
Wesix Electric Heater Company, 390 First Street, San Francisco; 631 San Julian Street, Los Angeles; 2008 Third Avenue, Seattle, Wash.....	72
ELECTRICAL ADVICE	
Pacific Coast Electrical Bureau, 447 Sutter Street, San Francisco, and 601 W. Fifth Street, Los Angeles.....	64
ELEVATORS	
Pacific Elevator and Equipment Company, 45 Rausch Street, San Francisco.....	78
FLOORING	
Asphalt Tile, Western Asbestos Company, 675 Townsend Street, San Francisco.....	70
HOLLOW TILE AND BRICK FENCES	
W. S. Dickey Clay Mfg. Co., 116 New Montgomery Street, San Francisco.....	75
FIXTURES—BANK, OFFICE, STORE	
Mullen Manufacturing Co., 64 Rausch Street, San Francisco.....	75
Pacific Manufacturing Company, 454 Montgomery Street, San Francisco; 1315 Seventh Street, Oakland, Los Angeles and Santa Clara.....	73
GAS FUEL	
Pacific Gas Association, 447 Sutter Street, San Francisco.....	Third Cover
GAS BURNERS	
Vaughn-G. E. Witt Company, 4224-28 Hollis Street, Emeryville, Oakland.....	74
GAS VENTS	
Payne Furnace & Supply Co., Beverly Hills, California.....	71
GLASS	
W. P. Fuller & Co., 301 Mission Street, San Francisco. Branches and dealers throughout of the West.....	6
Libbey-Owens-Ford Glass Co., Toledo, Ohio; 633 Rialto Bldg., San Francisco; 1212 Architects Bldg., Los Angeles; Mr. C. W. Holland, P.O. Box 3142, Seattle.....	*
Pittsburgh Plate Glass Company, Grant Building, Pittsburgh, Pa. W. P. Fuller & Co., Pacific Coast Distributors.....	5
HARDWARE	
The Stanley Works, Monadnock Building, San Francisco; American Bank Building, Los Angeles.....	4
HARDWOOD LUMBER	
White Bros., Fifth and Brannen Streets, San Francisco; 500 High Street, Oakland.....	71
HEATING—ELECTRIC	
Apex Air and Water Electric Heaters, Sandoval Sales Company, 557 Market Street, San Francisco.....	68
Wesix Electric Heater Company, 390 First Street, San Francisco; 631 San Julian Street, Los Angeles; 2008 Third Avenue, Seattle, Wash.....	72
HEATING EQUIPMENT	
Payne Furnace & Supply Co., Beverly Hills, California.....	71
Pacific Gas Radiator Co., 7615 Roseberry Ave., Huntington Park; Sales Office, H. C. Stoeckel, 557 Market Street, San Francisco.....	71
HEAT REGULATION	
Johnson Service Company, Milwaukee, represented on the Pacific Coast by the following branch offices: 814 Rialto Bldg., San Francisco; 153 West Avenue, 34, Los Angeles; 1312 N.W. Raleigh St., Portland, and 473 Coleman Bldg., Seattle.....	.

NEW STATE BUILDING

How the California State Department of Public Works is able to construct a \$750,000 building to house its various divisions without any extra cost to taxpayers, was revealed by Governor Frank F. Merriam at the ceremonies attending the laying of the cornerstone of the new building in Sacramento, the past month.

The Governor called the working out of the plan whereby the Department of Public Works will erect an edifice out of its own funds without a legislative appropriation or use of any tax monies or gas tax funds, a bit of skillful financial planning, which will enable not only the Department of Public Works, but the Department of Motor Vehicles as well, to pay for two splendid buildings in less than five years.

Both these departments have outgrown their present quarters and the need for new housing facilities for them has been recognized for two years. Director Earl Lee Kelly of the Department of Public Works broached the plan for a new building to Governor Merriam and as a result of conferences between these two and Arlin E. Stockburger, Director of Finance, there developed the plan which led up to the laying of the cornerstone for the future Public Works headquarters building.

The new structure will be financed in part from the sale of the Department's equity in the present Public Works Building, and the remaining cost will be amortized over a period of years by means of a rental charge, which, including operating expenses, will be considerably less than half the rate per square foot which normally would apply on buildings of the type of the new structure.

In September, 1926, the State agreed to lease for ten years the present Public Works Building at a monthly rental of \$7,415.02, or a total rental of \$889,802.40. It also was provided that the State would have the privilege of purchasing the building and site at a cost of \$669,-

**William Martin
& Son
Builders**

666 Mission Street
San Francisco
Telephone Sutter 6700
Evenings: GARfield 9456

ELEVATORS

**Pacific Elevator and
Equipment Company**

45 Rausch Street, San Francisco
HEmlock 4476

A. KNOWLES

*Contracting
Plasterer*

982 Bryant Street
San Francisco

UNderhill 4048

"The Only Pacific Coast Factory"

**THE HERMANN
SAFE COMPANY**

Manufacturers and Dealers

**FIRE AND BURGLAR PROOF
SAFES, VAULTS, SAFE
DEPOSIT BOXES**

**Howard & Main Sts.
San Francisco**

Telephone GARfield 3041

HOLLOW BUILDING TILE (Burned Clay)	Page
N. Clark & Sons, 116 Natoma Street, San Francisco.....	75
Gladding, McBean & Co., 660 Market Street, San Francisco; 2901 Los Feliz Boulevard, Los Angeles; 1500 First Avenue South, Seattle; 79 S. E. Taylor Street, Portland; Twenty-second and Market Streets, Oakland; 1102 N. Monroe Street, Spokane; Vancouver, B. C.	75
W. S. Dickey Clay Mfg. Co., 116 New Montgomery Street, San Francisco; factory, Niles, Calif.; yards, 7th and Hooper Streets, San Francisco, and 105 Jackson Street, Oakland	75
INSULATING MATERIALS	70
Western Asbestos Co., 675 Townsend Street, San Francisco	70
INSPECTION AND TESTS	74
Robert W. Hunt Co., 251 Kearny St., San Francisco.....	74
LACQUERS	65
General Paint Corp., San Francisco, Los Angeles, Oakland, Portland, Seattle and Tulsa W. P. Fuller & Co., 301 Mission Street, San Francisco. Branches and dealers throughout the West	5
LIGHTING FIXTURES	76
Incandescent Supply Co., 726 Mission Street, San Francisco; Oakland, Fresno	76
LINOLEUM	70
Sloan-Blabon linoleum, sold by California Shade Cloth Co., 210 Bayshore Boulevard, San Francisco	70
LUMBER	73
Pacific Mfg. Co., 454 Montgomery Street, San Francisco; 1315 Seventh Street, Oakland; Los Angeles and Santa Clara.....	73
Smith Lumber Company, Nineteenth Avenue and Estuary, Oakland.....	73
Melrose Lumber & Supply Co., Forty-sixth Avenue and E. Twelfth Street, Oakland.....	72
E. K. Wood Lumber Company, 4701 Santa Fe Avenue, Los Angeles; 1 Drumm Street, San Francisco; Frederick and King Streets, Oakland.....	66
MARBLE	72
Joseph Musto Sons-Keenan Co., 535 N. Point Street, San Francisco.....	72
MILLWORK	66
E. K. Wood Lumber Company, No. 1 Drumm Street, San Francisco, Oakland, Los Angeles	66
Lannom Bros. Mfg. Co., Fifth and Magnolia Streets, Oakland.....	72
Melrose Lumber & Supply Company, Forty-sixth Avenue and E. Twelfth Street, Oakland	72
Pacific Mfg. Co., 454 Montgomery Street, San Francisco; 1315 Seventh Street, Oakland; Los Angeles and Santa Clara.....	73
Smith Lumber Company, Nineteenth Avenue and Estuary, Oakland	73
MONEL METAL	65
"Inco" brand, distributed on the Pacific Coast by the Pacific Metals Company, 3100 19th Street, San Francisco, and 6400 So. Alameda Street, Los Angeles.....	65
Kitchen sinks, heaters, storage tanks—Modern Metal Appliance Company, 4238 Broadway, Oakland	76
MURALS	72
Heinsbergen Decorating Co., Los Angeles and 401 Russ Building, San Francisco	72
OIL BURNERS	4
S. T. Johnson Co., 585 Potrero Avenue, San Francisco; 940 Arlington Street, Oakland; 1729 Front Street, Sacramento, and 230 N. Sutter Street, Stockton	4
Vaughn-G. E. Witt Co., 4224-28 Hollis Street, Emeryville, Oakland.....	74
ONYX	72
Joseph Musto Sons-Keenan Co., 535 No. Point Street, San Francisco.....	72
ORNAMENTAL IRON	76
Independent Iron Works, 821 Pine Street, Oakland.....	76
ORNAMENTAL LIGHTING	76
Incandescent Supply Co., 726 Mission Street, San Francisco, Oakland, Fresno.....	76
PAINTS, OIL, LEAD	6
W. P. Fuller & Co., 301 Mission Street, San Francisco. Branches and dealers throughout the West	6
Frank W. Dunne Co., 41st and Linden Streets, Oakland	73
General Paint Corp., San Francisco, Los Angeles, Oakland, Portland, Seattle and Tulsa	65
PAINTING, DECORATING, ETC.	74
The Tormey Co., 563 Fulton Street, San Francisco.....	74
Heinsbergen Decorating Co., 401 Russ Building, San Francisco	72
PARTITIONS—MOVABLE OFFICE	73
Pacific Mfg. Co., 454 Montgomery Street, San Francisco; 1315 Seventh Street, Oakland; factory at Santa Clara	73
W. S. Dickey Clay Mfg. Co., 116 New Montgomery Street, San Francisco	75
PLASTER	79
"Empire" and "Reno Hardware Plaster," manufactured by Pacific Portland Cement Co., 111 Sutter Street, San Francisco; Portland, Los Angeles and San Diego.....Second cover	79
PLASTERING	79
A. Knowles, 982 Bryant Street, San Francisco.....	79

	Page
PLATE GLASS	
Libbey-Owens-Ford Glass Co., Toledo, Ohio; 633 Rialto Bldg., San Francisco; 1212 Architects Bldg., Los Angeles; Mr. C. W. Holland, P.O. Box 3142, Seattle	*
PLUMBING CONTRACTORS AND MATERIALS	
Carl T. Doell Co., 467 Twenty-first Street, Oakland.....	76
Crane Co., all principal Coast cities.....	74
PRESSURE REGULATORS	
Vaughn-G. E. Witt Co., 4224-28 Hollis Street, Emeryville, Oakland.....	74
ROOF MATERIALS	
Gladding, McBean & Co., 660 Market Street, San Francisco; 2901 Los Feliz Boulevard, Los Angeles; 1500 First Avenue South, Seattle; 79 S. E. Taylor Street, Portland; Twenty-second and Market Streets, Oakland; 1102 N. Monroe Street, Spokane; Vancouver, B. C.	*
N. Clark & Sons, 112-116 Natoma Street, San Francisco; works, West Alameda.....	*
SAND, ROCK AND GRAVEL	
John Cassaretto, Sixth and Channel Streets, San Francisco	76
SHADE CLOTH	
California Shade Cloth Co., 210 Bayshore Boulevard, San Francisco.....	68
SHEET METAL WORK	
Forderer Cornice Works, Potrero Avenue, San Francisco.....	74
STANDARD STEEL BUILDINGS	
Independent Iron Works, 821 Pine Street, Oakland.....	76
STEEL—STAINLESS	
Republic Steel Corporation, Rialto Bldg., San Francisco; Edison Bldg., Los Angeles; White-Henry-Stuart Bldg., Seattle	75
STEEL, STRUCTURAL	
Independent Iron Works, 821 Pine Street, Oakland.....	76
Judson Pacific Company, C. F. Weber Bldg., Mission and Second Streets, San Francisco shops, San Francisco and Oakland.....	68
Pacific Coast Steel Corp.—See Bethlehem Steel Company, Twentieth and Illinois Streets, San Francisco; Slauson Avenue, Los Angeles; American Bank Building, Portland, Ore.; West Andover Street, Seattle, Wash.	75
Herrick Iron Works, 18th & Campbell Streets, Oakland.....	76
STORE FIXTURES	
Mullen Mfg. Co., 60 Rausch Street, San Francisco.....	75
STORE FRONTS	
Kawneer Mfg. Co., Eighth and Dwight Streets, Berkeley.....	73
TEMPERATURE REGULATION	
Johnson Service Company, Milwaukee, represented on the Pacific Coast by the following branch offices: 814 Rialto Bldg., San Francisco; 153 West Avenue, 34, Los Angeles; 1312 N.W. Raleigh St., Portland, and 473 Coleman Bldg., Seattle.....	*
TERMITE CONTROL—WOOD PRESERVATIVE	
E. K. Wood Lumber Company, No. 1 Drumm Street, San Francisco; 4701 Santa Fe Ave., Los Angeles; Frederick and King Streets, Oakland.....	66
American Lumber & Treating Company, Rialto Bldg., San Francisco; 1031 S. Broadway Los Angeles	3
TREE SURGERY	
Davey Tree Surgery Co., Ltd., Russ Building, San Francisco; Story Building, Los Angeles	2
TILE—DECORATIVE, ETC.	
Pomona Tile Mfg. Co., plant, Pomona, Cal.; Sales Rooms, 135 Tenth St., San Francisco; 217 S. La Brea Ave., Los Angeles; 6106 Roosevelt Way, Seattle.....	70
Gladding McBean & Co., 660 Market St., San Francisco; 2901 Los Feliz Boulevard, Los Angeles	*
VALVES	
Sloan Valve Co., manufacturers of Sloan flush valves, 4300 West Lake St., Chicago, Ill.	*
VAULT DOORS	
Hermann Safe Co., Howard and Main Streets, San Francisco	79
WATERPROOFING	
Boy State Brick & Cement Coating, California Sales Co., 444 Market Street, San Francisco	71
WINDOWS	
Kawneer Mfg. Co., Eighth and Dwight Streets, Berkeley.....	73
Dalmo Sales Co., San Francisco	70
WINDOW SHADES	
California Shade Cloth Co., 210 Bayshore Boulevard, San Francisco.....	68
Wm. Volker & Co., 631 Howard Street, San Francisco.....	73

692. The State, through the Division of Highways, exercised this option in September, 1927, and by February, 1929 had completed purchase of the structure, the final cost being \$597,-716.67.

Other state agencies rented offices in the building, including the Department of Motor Vehicles. Equities of this agency in the building accumulated to such an extent that by the end of this month its equity will amount to \$283,592.71. At this rate, with its rentals accruing as equity, the Department of Motor Vehicles within a few years would have owned the building and the Department of Public Works would have had to begin paying rent to its sister organization.

Foreseeing this situation, Director Kelly proposed to the Governor that his Department erect its own building and pay for it out of the sale of its equity in its present structure and the savings in rentals which would be effected. The Department of Motor Vehicles decided to do likewise and also own its own building.

BANISH BILLBOARDS

Looking to the future when San Francisco will invite the world to view the marvels of its great bridges and the beauties of its island exposition, the City and County Federations of San Francisco is taking the leadership in a move to prevent defacement of these structures by outdoor advertising signs and placards.

In a resolution the Federation goes on record as opposing the erection of any signs, billboards, placards or advertising matter of any kind on the plaza that will face the approach to the San Francisco - Oakland Bay Bridge or the bridge itself and its approaches, except directional signs, time tables or schedules of trains or other information necessary for public convenience.

Copies of the resolution have been sent to the California Toll Bridge Authority, San Francisco - Oakland bridge division of public works, Golden Gate Highway District and Mayor Rossi, San Francisco.

THE ARCHITECT AND ENGINEER

SAN FRANCISCO
PUBLIC LIBRARY
MEDICAL DEPT.

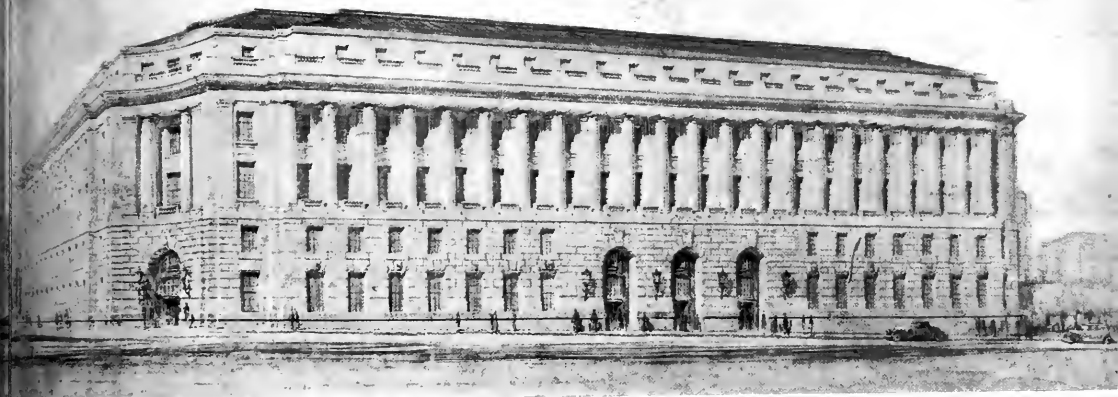

JULY 1936

NEW FEDERAL BUILDING, SAN FRANCISCO CIVIC CENTER
COMMENTS ON THE OREGON STATE CAPITOL COMPETITION

PACIFIC PRODUCTS

give

PERMANENCE

to the



W. D. PEUGH, *Architect*

CAHILL BROS., *Contractors*

W. A. & G. GILMOUR, *Plaster Contractors*

NATIONAL LATHING CO., *Lathing Contractors*

"PACIFIC" PRODUCTS USED

GOLDEN GATE PORTLAND CEMENT

STANDARD GYPSUM PLASTER

MILCOR METAL LATH

AMES STEEL STUDS *and* PARTITIONS

The largest office building to be built in the West since 1929, the Lurie Building in San Francisco reflects the best in modern architectural practice.

Modern design is expressed in sound construction. Materials were selected on the basis of recognized standards and proven merit. "Pacific" Products were used throughout. Golden Gate True Portland Cement, Standard Gypsum Plaster, Milcor Metal Lath and other products of Pacific Portland Cement Company contribute to the Lurie Building's permanence.

No matter what the structure, large or small, you invest with certainty when you specify time-tested "Pacific" Products.

AT BUILDING SUPPLY DEALERS

PACIFIC PRODUCTS

Manufactured and Distributed by

PACIFIC PORTLAND CEMENT COMPANY

SAN FRANCISCO • LOS ANGELES

COASTWIDE SERVICE

PORTLAND • SEATTLE

The ARCHITECT and ENGINEER

presents for July, 1936 —

	COVER	ARCHITECT'S PERSPECTIVE, FEDERAL OFFICE BUILDING, SAN FRANCISCO Arthur Brown, Jr., Architect	
	FRONTISPIECE .	DETAIL OF FACADE, FEDERAL OFFICE BUILDING, SAN FRANCISCO Arthur Brown, Jr., Architect	
	TEXT	NEW FEDERAL BUILDING, SAN FRANCISCO Frederick W. Jones	11
W. J. L. KIERULFF President		OREGON STATE CAPITOL COMPETITION Arthur Brown, Jr.	13
FRED'K. W. JONES Vice President and Editor		U. S. HOUSING SHORTAGE OVER MILLION William C. Bober	31
LOUISE B. PENHORWOOD Secretary		ARCHITECTS MUST RESIST USURPATION Howard J. White, Architect	35
EDGAR N. KIERULFF Advertising Manager		BRIDGE ENGINEERS CONTRIBUTE TO PROGRESS Glenn B. Woodruff	37
J. LESLIE MEEK Advertising		ATTORNEY GENERAL RULES ON PEST CONTROL A. A. Brown, C.E.	41
VERNON S. YALLOP Architects' Reports		WORLD'S FAIR SITE AS FUTURE AIRPORT Brigadier General Wm. S. Gilmore	45
ARTHUR BROWN, JR. HARRY MICHELSEN W. G. CORLETT Advisory Editors		HEATING THE HOME HAS MANY NEW ANGLES ARCHITECTS' BULLETIN Harris C. Allen, Architect	47 51
		WITH THE ARCHITECTS	53
	PLATES AND ILLUSTRATIONS—		
		FEDERAL OFFICE BUILDING, CIVIC CENTER, SAN FRANCISCO Arthur Brown, Jr., Architect	11-12
		OREGON STATE CAPITOL COMPETITION Elevations and Plans by the following Architects: Trowbridge & Livingston and Francis Keally, W. P. Day, Warren C. Perry and Stafford L. Jory, William Mooser and Chas. F. Maury, Henry T. Howard, J. R. Miller and T. L. Pflueger, Frederic F. Amandes, Hervey P. Clark, John Davis Young, John Bakewell and Ernest E. Weihe, Arthur Brown, Jr., Dodge A. Reidy and Mario J. Ciampi.	13-30
		PUBLIC WORKS BUILDING, SACRAMENTO	40
		STAIR APPROACH TO HOLLYWOOD HOME	44
		MISS HELEN PHILLIPS, SCULPTOR	55
		TOURING SERVICE BUREAU	56

Notes and Comments

THE Institute, at its last convention, did not mince matters in taking a firm stand on the subject of free promotional sketches. A resolution was unanimously passed requesting the Board of Directors to consider the advisability of amending Article 7 of the Principles of Professional Practice to express definitely the Institute's position, which is negative, on free promotional sketches.

That the Institute has a bone to pick also with manufacturers, distributors of materials and contractors who undertake to perform the services and functions of the architect was disclosed when resolutions discouraging such practice were passed. One paragraph:

"It is believed that The Institute in taking a strong stand in this matter will best serve not only the public but the young architects who must depend largely upon the class of work thus handed by non-professional services."

EVERY business seems to divide itself into two functions: one concerned with the actual ability to do the work, the other with the aim to convince others that you can do the work.

The ability to do the work comes under the head of architectural talent or genius and, naturally, is the quality most respected and revered in this profession. The other ability, from a practical standpoint, is the more important. Our own great H. H. Richardson named the three important things in architecture, "Get the job. Get the job, and Get the job."

All jobs are obtained by means of pictures presented to the prospective client; sometimes by pictures on paper, more often by pictures in the thin air painted by a silver tongue and a persuasive personality.

Let no one inveigh against the silver tongue and the persuasive personality. They are the legitimate instruments of salesmanship the world over. They are also the potential guarantee to the client that after the project is under way discussion on the basis of mutual understanding will be possible.

But the architect whose silver tongue is the point of his pencil, whose persuasive personality spreads itself in the form of sketches on paper is the person who appeals to the imagination of all architects. He is the person who combines the ability to erect beautiful buildings with the ability to picture them in advance for the actual consideration of others. The man talks best who has conviction and if he has before him sketches showing what his performance actually is to be, he must feel conviction.

Golf is sometimes used to convince of architectural ability. Bridge, too, is used. But there is a feeling in the breast of most

architects that if an architect can prove his ability by means of his pencil, he has adopted the best technique possible in his profession.—The Federal Architect.

Which again brings up the mooted question: "Shall the client pay for these sketches?"

ARCHITECTS all over the country are still divided upon the wisdom of holding architectural competitions for Federal and other public buildings. At the Institute Convention a resolution was offered to the effect that "The Architectural Competition is the best method of obtaining designs for and architects to supervise the erection of all buildings and monuments where the expenditure of public funds is involved." After heated debate, a substitute resolution was offered by Irwin S. Porter, of the Washington, D. C., Chapter, and carried, as follows:

"Resolved, That the Sixty-eighth Convention does not express itself concerning methods of selecting architects for public work."

A later resolution asking for "thoughtful consideration" of the subject by the Board of Directors was passed as follows:

"Resolved, That the architectural competition, conducted under suitable safeguards, is a method for the selection of the architect for public buildings which should receive thoughtful consideration from The Board of Directors, as being a possible solution to some of the difficulties facing the Government, the private architect and The Institute."

IN opposition to the suggestion that architectural competitions be held for public buildings, Robert A. Eckles, A.I.A., argues quite sensibly:

"To introduce a public competition method with the approval of the A. I. A. will cause great confusion in the public mind, and do much to put the profession back where it was thirty years ago. It is my understanding that it was a very common belief on the part of building committees, school boards, etc., that the way to select an architect was to have a 'competition' by submission of 'pictures.' This very undignified proceeding has been gradually eliminated as far as my observation goes and the selection of an architect has been based on better procedure. Politics and salesmanship no doubt enter into many selections of architects but the mere recommendation of a public competition will not eliminate either. For every A. I. A. sponsored competition which is actually put into effect there may be a hundred informal competitions put out by building committees and similar bodies in small communities. They will understand the suggestion

that a competition is desirable but will not agree to the regulations which are necessary to have any A. I. A. sponsored competition based on merit.

"The competition system (properly sponsored) may, in certain cases, help individual architects but in small communities it will probably be a great set back in prestige for the architectural profession and may actually be worse than that. The publicity will be damaging rather than helpful."

A Seattle building paper publishes this "sign of the times":

"Several Washington architects who moved their studios to their homes during the trend of the depression now find themselves too busy to set up downtown offices again."

It don't seem possible!

The Berkeley Building Department has devised a sensible way of protecting property owners from becoming victims of unlicensed and incompetent designers of buildings. Every set of plans filed is stamped and must be properly signed by the applicant before a permit is issued. The stamp reads:

"I hereby certify that the plans and specifications used in making the application hereon for a building permit were prepared by _____ and that the Laws of the State of California governing the practice of architecture, civil engineering and structural engineering, have not been violated in so doing." In brief the plans must contain the name of a licensed architect or engineer or they go back to the applicant unapproved.

Don't Neglect your TREES

• The value of your trees, like any other asset should be preserved. Call Davey Tree Surgery for a free inspection and estimate.

It costs no more for genuine



SAN FRANCISCO Fresno LOS ANGELES
Russ Bldg. Mattei Bldg. Story Bldg.
SUtter 3377 TUCKER 1929

Local phone in: Pasadena, Pala Alto,
Oakland, San Rafael, Burlingame

Skill • Knowledge • Responsibility

HERMOSA TILES



LOS ANGELES SHOWROOM

Select THE BEAUTIFUL COLORED TILES FOR YOUR BATHS AND KITCHENS AT THE HOME OF HERMOSA TILES

660 MARKET STREET SAN FRANCISCO

2901 LOS FELIZ BLVD. LOS ANGELES

1500 FIRST AVENUE SOUTH SEATTLE

America's outstanding tile showrooms, where individual booths, modern and up-to-date in their appointments, provide comfort and privacy, as well as every facility for the developing of color schemes and the displaying of tiles.

GLADDING, McBEAN & CO.

MANUFACTURERS OF CLAY PRODUCTS

SAN FRANCISCO
PORTLAND

LOS ANGELES
SEATTLE SPOKANE

OAKLAND
VANCOUVER, B. C.



DETAIL OF FACADE, FEDERAL OFFICE BUILDING, SAN FRANCISCO
ARTHUR BROWN, JR., ARCHITECT
General Direction of the Treasury Department

NEW FEDERAL BUILDING, SAN FRANCISCO

SPLENDID ADDITION TO CIVIC CENTER GROUP

By Frederick W. Jones



THE limited number of views of San Francisco's new Federal building shown in this issue will be followed later with a more extensive presentation, including plans and detail drawings. In designing the structure, the architect, Arthur Brown, Jr., gave close attention to the neighboring buildings in the Civic Center so that there might be a harmonious blending of the several public structures. With this thought in mind it was decided to adopt a classical colonnade, without a center motif,

as leading up to the Plaza and its dominating feature, the City Hall dome.

An interesting point about the building is the reentrant curve at the corner — an original and effective treatment.

The building is entirely devoted to housing government officials and is essentially an office structure, having no monumental interior treatment, except the vestibule. Construction of the building was started in November, 1933, with the dedication taking place in May of this year. Its cost to the Government was under \$3,000,000.



MAIN VESTIBULE, FEDERAL OFFICE BUILDING, SAN FRANCISCO
ARTHUR BROWN, JR., ARCHITECT
General Direction of the Treasury Department

OREGON STATE CAPITOL COMPETITION

COMMENTS ON SCHEMES OF SAN FRANCISCO ENTRANTS

By Arthur Brown, F. A. I. A.



WINNING DESIGN, OREGON STATE CAPITOL BUILDING, SALEM, OREGON
Trowbridge and Livingston and Francis Keally, Associate Architects

FOLLOWING the recent Oregon State Capitol Competition, the members of the San Francisco Architectural Club had the very excellent idea of exhibiting the drawings of the San Francisco architects who participated in the affair. The competition brought out designs from ten of our local people, and W. P. Day is to be congratulated on upholding the prestige of the local group by winning one of the awards.

The State of Oregon, through its Capitol Commission, deserves the thanks of the profession for having conducted this important

competition according to the most approved procedure of the A.I.A.

Much has been said, pro and con, on competitions in general, but the efforts of the Institute, over a period of many years, in spite of obstacles and much apathy, have established in the minds of officials and the public generally, the idea that, if competitions are to be held, the procedure suggested in the competition code of the A.I.A. may be accepted as standard. This is really a great achievement.

There is work, however, still to be done by the Competition Committee of the A.I.A. on technical problems connected with the drafting of programs by the professional advisers.

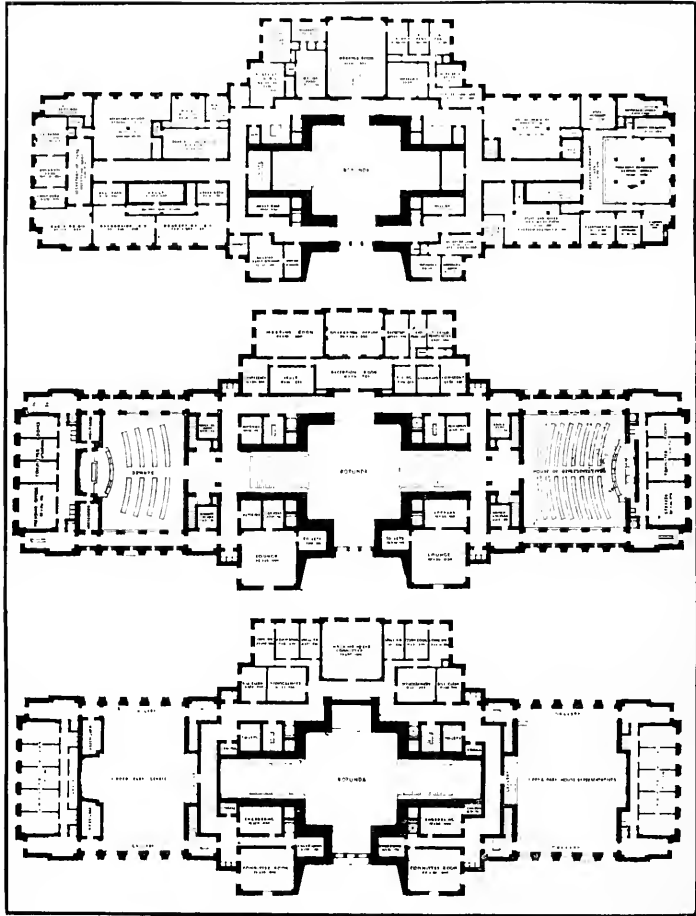

FLOOR PLANS, WINNING DESIGN, OREGON STATE CAPITOL COMPETITION

TOP—First floor. Central rotunda with wide steps leading up to second floor. On south side board of control offices at left and tax commission offices at right; hearing room between. East wing devoted to offices of secretary of state and budget division. West wing, the state land board of treasurer's office and the state tax commission work room.

CENTER—Second floor. Governor's office in south wing. Senate chamber in east wing with office of president of senate and committee rooms in rear. House chamber in west wing, with speaker's office and committee rooms in rear. Private entrances for legislators in corners of the building at south, for governor at center, with private elevators to serve them.

BOTTOM—Third floor. Ways and means committee rooms in south wing; other rooms for legislature. Each legislative chamber has central and side galleries. Committee rooms at each end; above them, committee rooms on fourth floor.

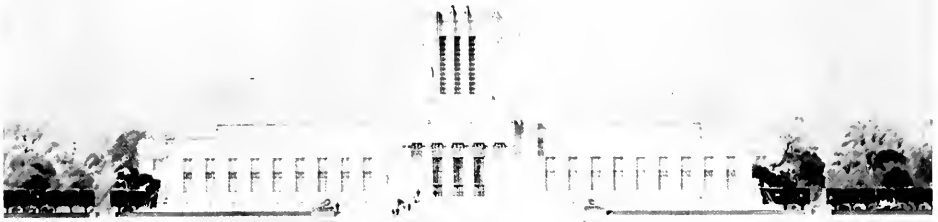

OREGON STATE CAPITOL BUILDING

PRIZE AWARD DESIGN, OREGON STATE CAPITOL BUILDING
W. P. Day, Architect

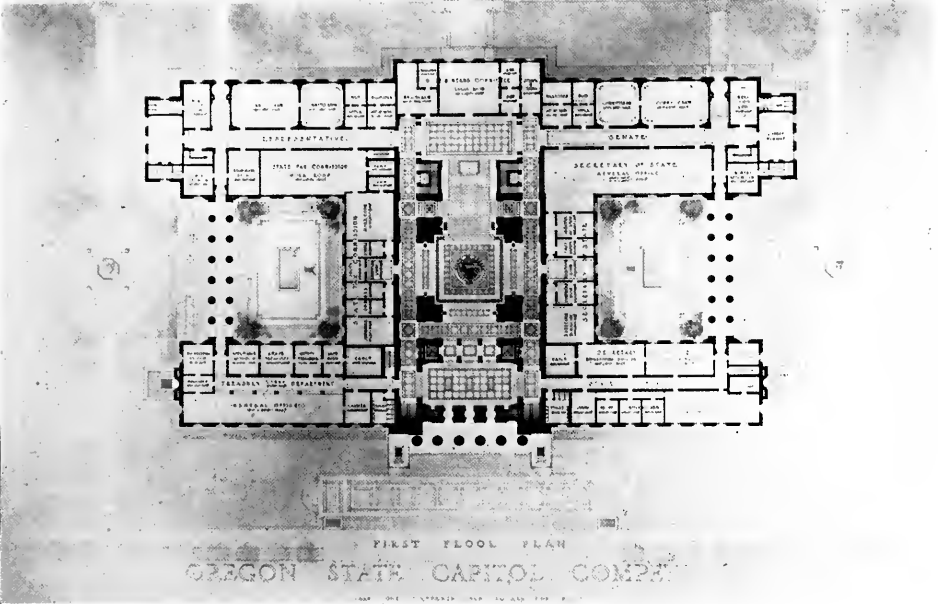

FIRST FLOOR PLAN, OREGON STATE CAPITOL BUILDING
W. P. Day, Architect



WARREN C. PERRY AND STAFFORD L. JORY, ARCHITECTS

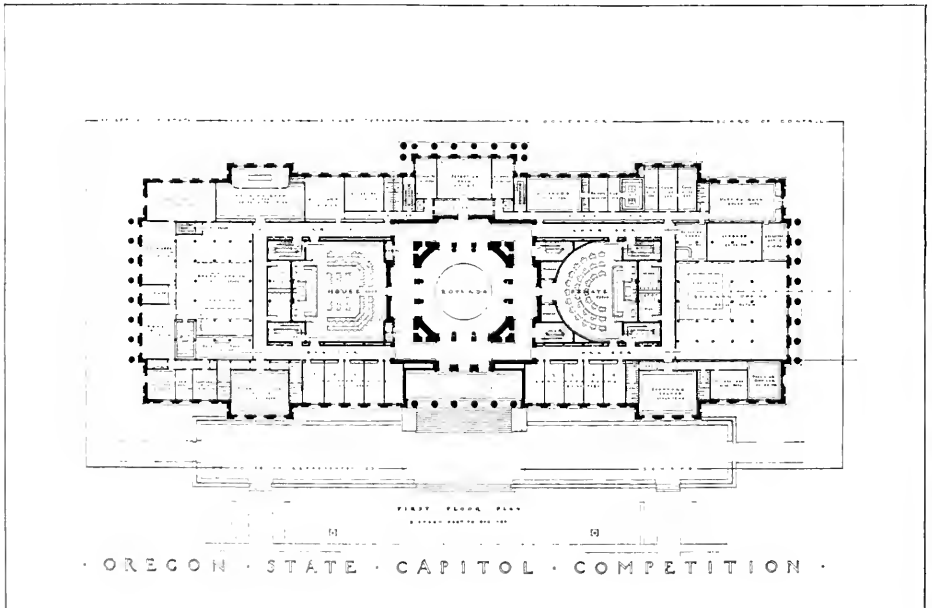

There exist many unnecessary nuisance clauses which have become more or less stereotyped and which, with attention, could be eliminated from the standard competition forms. But much more serious and fundamental is the tendency, which seems to prevail of late, to make the space requirements so complicated and inelastic that the architectural problem becomes a sort of Chinese puzzle, and very seriously cramps creative imaginative effort. The principle enunciated by Guadet that the architect should control his proportions becomes very difficult of accomplishment. This result seems to me to defeat the object of competitions from the standpoint of the client, who presumably seeks by this means to stimulate creative effort and bring out different ideas for his choice. Since in practice the detailed arrangement of the smaller units is almost invariably re-studied by the winner after a competition is decided, it would seem reasonable that over-elaboration of requirements is not essential. Laloux used to say that the essence of a program should be expressed in the title, and that reading the title was all that was necessary for the creation of a respectable design. This, of course, was an exaggeration to accentuate the point.

With due respect to the practical requirements of floor space and cost of the Oregon State House problem, I believe a program could have been devised which would have given much more liberty for the imaginative treatment of space, line, mass, and coherence, granting that architecture should involve more than strict functionalism and structural stability. To be specific, all those who have studied the present program felt the inadequacy of the cube. The unit price of 80c per cubic foot would seem to be too ample, and I venture to guess that somewhat less would be sufficient. This would have increased the allowable cubic limit and removed to a degree one of the blights that bedeviled the competitors.

Furthermore, if the area requirements of the various departments had been limited to prescribing the floor space required for each department as a whole, and adjusted with regard

to their numerical relation, the competitors would not have exhausted their ingenuity on unnecessary detail. Also the suggested relation of the groups to one another was perhaps unnecessary, as it is by no means certain that some other grouping would not have been just as good from the standpoint of the operation of the building and would have had advantages from the point of view of monumental design.

Should Announce Jury in Advance

The fact that the names of the jurors were not revealed before the judgment was a brake on the free expression of the designers, since there is always the feeling of danger of possible offense to the prejudice of some of our more fanatical confreres by the use of a classical column, however appropriate, or, on the other hand, to the intolerant attitude of some of our traditionalists in regard to modernistic forms. The knowledge of the personnel of the jury could do no possible harm, but would serve to partially eliminate one of the uncertainties confronting the competitors.

A study of the various schemes on exhibition has suggested that many of the competitors have consciously or unconsciously been fettered by the restraints which I have just mentioned. In spite of these conditions, one cannot but be strongly impressed by the excellent showing of the projects presented. All the competitors have bravely and intelligently attacked the difficulties of the problem and have presented very defendable solutions. Some of the renderings also are extremely successful, as the reproductions will show.

There was evidence everywhere of the ability to simplify the complications of the program and a determined effort to satisfy literally its implications. The circulations are usually good, and the effort to attain airiness is generally present. The facades show a tendency toward a commendable simplicity. The literal interpretation of the program has led to some questionable dispositions, such as, placing important elements on the ground floor, et cetera. In many cases there has been a lack of clear grouping for the same reason. It is per-



WILLIAM MOOSER AND CHAS. F. MAURY, ARCHITECTS

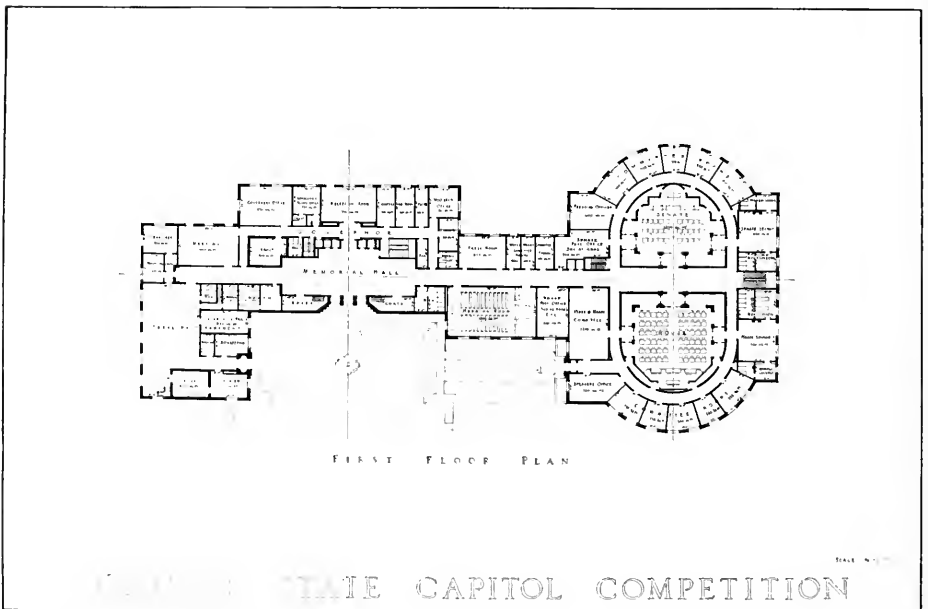

haps debatable to compose, as the program requires, the more utilitarian services of the executive offices in the same building as the more monumental elements of the legislative group.

The limited cube has served to restrain the free search for pleasing mass and silhouette, which seem desirable in such a building and on such a site. Several designs have, to a certain degree, overcome this difficulty.

Many of the authors have consciously avoided traditional forms and combinations of space elements, depending on function and structure alone to attain character. Others have used traditional compositions and have avoided traditional forms of expression.

These self-imposed restrictions, in addition to the conditions of the program, have had a tendency to eliminate the full attainment of character.

Viewing most of the facades, without knowing the subject of the competition, one might have some difficulty in discovering that they represented a State Capitol.

In fact, it might be observed that the quality of character is very generally neglected by present day designers.

The pursuit of purely esthetic values by the play of light and shade, rhythm and the free use of a broad vocabulary of form, seems to have been dampened by the mood of the day.

Comments on Individual Schemes

I have noted a few impressions of the various individual schemes, gathered at the Club exhibition.

Messrs. Perry and Jory present a scheme closely respecting the implications of the program. These entrants possessed the courage to intensify the character of the subject by a traditional reference.

Messrs. Mooser and Maury present a disymmetric plan, clearly segregating the legislative groups from the administrative, and giving possibilities of picturesque effects in facade.

Mr. Howard has a clever, well-balanced plan which develops fine monumental elements both in plan, section, and facade. The latter

has imposing and finely proportioned masses and contrasts of the utilitarian parts with the more monumental parts, together with interesting rhythms.

Messrs. Miller and Pflueger present a rigorously simple interpretation of the program, well-balanced and logically arranged in plan and cleanly expressed in facade, with severe reserve in detail.

Mr. Amandes presents a clear, well-balanced plan and a skilfully massed, severely simple rhythmic facade.

Hervey Clark submits a plan clearly segregating the legislative and executive branches by means of interior courts, and accentuating the legislative branch by a monumental vestibule developed into a dominating motive on the exterior.

Messrs. Bakewell and Weihe offer a well-arranged and proportional plan, respecting the program and permitting the development of an ample rotunda. The facade is severely simple and well massed with a traditional suggestion in the dome.

Messrs. Riedy and Campi present an imaginative scheme characterized by a sustained search for the monumental both in the interior and the exterior, placing the executive offices in the upper stories to obtain an imposing height. There is also a preoccupation for rhythmic arrangement.

Mr. Young presents an ingenious plan based on a system of interior courts, to achieve the plan relations, and depending on a long, ample vestibule for monumental effect.

No comments have been made on the winning design because of the fact that elevations and plans were not available at the time of writing.

* * *

Report of Jury

Your Jury begs to report as follows:

That it convened at 9 a. m. May 25, 1936, in the assembly room of the Salem Chamber of Commerce;

That it received its instructions from your technical adviser as to its duties;

That a total of 123 designs were received, of which two were excluded as having been



HENRY T. HOWARD, ARCHITECT

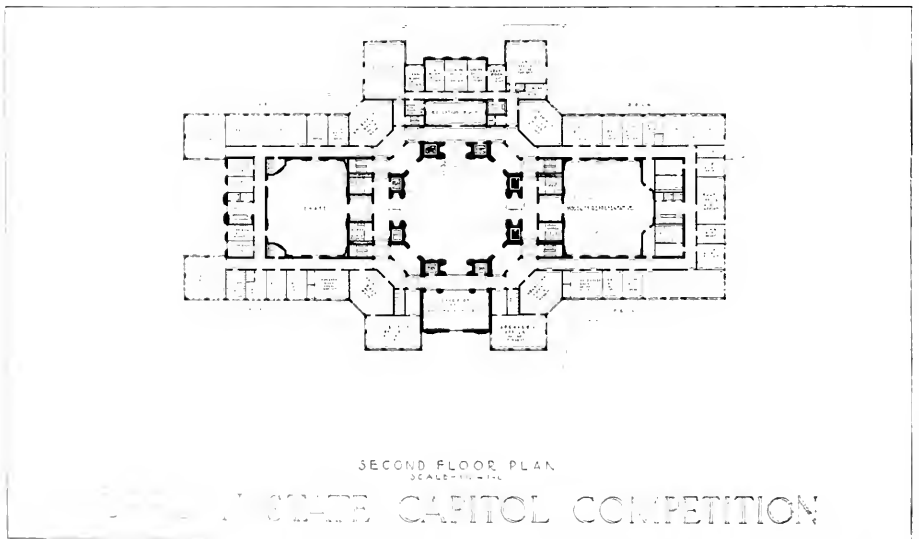

received after the designated date, and ten were disqualified for excess cubage and one of which did not contain the requisite envelope;

That the remaining 110 designs have been carefully analyzed by us and our unanimous conclusion is as follows:

We have placed the design numbered 89 for identification as first; and recommend that you accept this design and make the award accordingly, subject to the examination and approval of the competitor's credentials by your technical adviser;

That we recommend the five additional awards be given to the authors of the following numbered designs, to wit: No. 32, No. 23, No. 100, No. 99, No. 7, which order does not indicate the order of preference. (Editor's Note — * indicates winner of first award, ** one of the five additional awards.)

Salem, Oregon, May 26, 1936.

E. B. MACNAUGHTON
Chairman of Jury
WALTER H. THOMAS
DAVID C. ALLISON
MRS. GORDON VOORHIES
T. H. BANFIELD

Winning Design in Greco-Egyptian

The winning design is the work of Goodhue Livingston and George W. Jacoby of Trowbridge & Livingston, and of Francis Keally, associated with Trowbridge & Livingston in the competition. The architecture is described by Mr. Jacoby as reflecting "Greek refinement and Egyptian simplicity, without the classical details of the former."

"We didn't look at the temples of the past in designing the Oregon Building," Mr. Keally is quoted as saying. "We can't tag the style of architecture. It was built for Oregon, and was based on early Oregon history."

The building will be three stories high and 400' long. The design is distinctive, modern, of good architectural ancestry.

Thirty cities from Coast to Coast were represented in the competition. Among the 123 architects are firms who have written and are writing architectural history.

It is significant that the greatest number of entries came from east of the Mississippi, and that New York City, with 28, furnished the largest number of contestants. New York won five of the six prizes, the sixth going to San Francisco.

Goodhue Livingston, member of the winning firm, received his Ph.B. in architecture from Columbia University in 1892 and has been practicing architecture ever since. He was awarded an honorary M.A. degree by Columbia in 1914.

Francis Keally began practice in New York nine years ago after 10 years of teaching architectural departments of the University of Minnesota, New York University and other schools. He received a B.S. degree from the School of Architecture of the University of Pennsylvania in 1916.

Livingston & Trowbridge have designed such buildings as the Chemical National Bank, St. Regis Hotel, New York Stock Exchange, Knickerbocker Hotel, Bankers Trust Co. Building, Ardsley Club, Equitable Trust Building, the J. P. Morgan & Co. offices and the B. Altman & Co. Building, all of New York City; the Mellon National Bank, U.S. Postoffice and Courthouse in Pittsburg; the famous Palace Hotel of San Francisco; the Mitsui Bank Building in Tokio and the Rickers Island penitentiary, the Red Cross memorial to women of the civil war, and the memorial to world war women. The Mitsui Building is a \$100,000 building designed to be earthquake proof.

Architects Who Submitted Designs

- Amandes, F. Frederic—414 Dewey Blvd., San Francisco, Cal.
- Bakewell & Weihe—251 Kearny Street, San Francisco, Cal.
- Barrett & Logan—302 N. Broadway, Portland, Oregon
- Brown, Arthur, Jr.—251 Kearny Street, San Francisco, Cal.
- **Bessell, Wesley Sherwood—16-E. 52nd Street, New York, N. Y.
- Bottomley, William Lawrence—112 E. 55th Street, New York, N. Y.
- Beidler, Herbert B.—925 N. Michigan Avenue, Chicago, Ill.

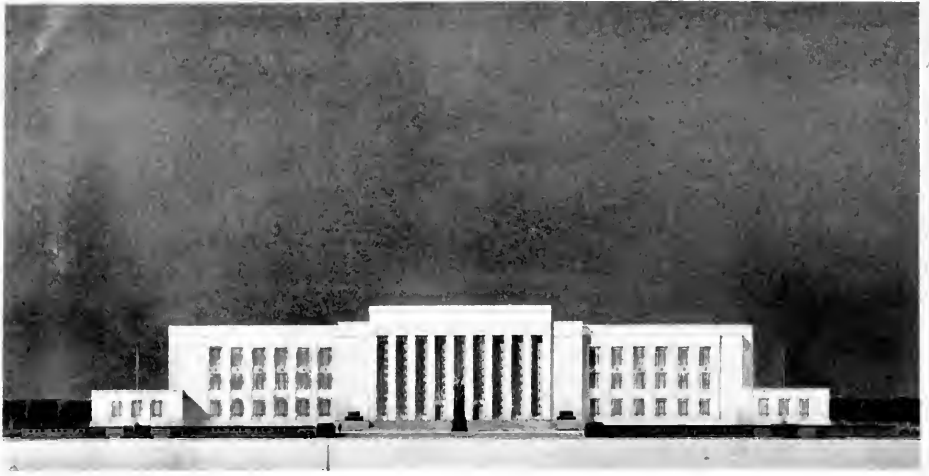

J. R. MILLER AND T. L. PFLUEGER, ARCHITECTS

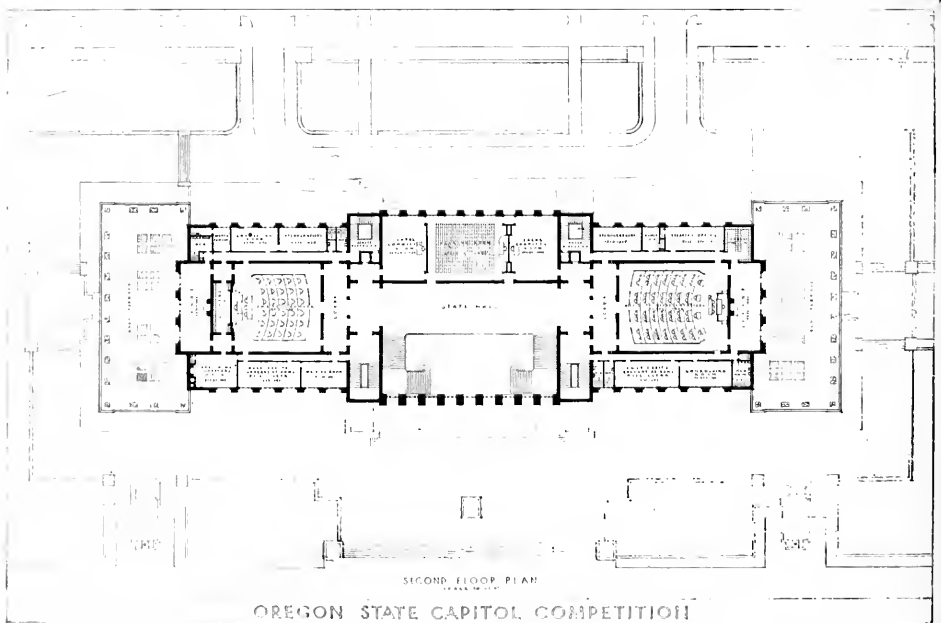

- Blair, Walter Dabney—154 E. 61st Street, New York, N. Y.
- Buell, Temple Hoyne—Buell Bldg., 14th and Stout Streets, Denver, Colorado.
- Brown, Archibald Manning—140 E. 39th Street, New York, N. Y.
- Cunningham, Harry Francis—Washington, D. C.
- Cinner, Louis L.—480 Lexington Avenue, New York, N. Y.
- Corlett, Will G. and Wm. A. Rich—Bank of America Bldg., Oakland, Cal.
- Cram & Ferguson—248 Boylston Street, Boston, Mass.
- Clark, Hervey P.—210 Post Street, San Francisco, Cal.
- Doyle, A. E. & Associate—Pacific Bldg., Portland, Oregon.
- Dougan, L. L.—Studio Bldg., Portland, Oregon
- Doane, Ralph Harrington, John F. G. Gunther, Lawrence B. Anderson, John Reed—60 Battery March Street, Boston, Mass.
- Drury, C. F. & Vahlberg, Walter T.—819 Hightower Bldg., Oklahoma City, Oklahoma.
- **Day, William Peyton—1502 Financial Center Bldg., San Francisco, Cal.
- **deYoung & Moscovitz, Architects, Karl W. Rosenberg, R. A. Oregon, associated—205 E. 42nd Street, New York, N. Y.
- DeWitt & Washburn & Donald Barthelme—1013 Prætorian Bldg., Dallas, Texas.
- Ellett, Thomas Harlan, T. A. Fransioli, Jr., associate—101 Park Avenue, New York, N. Y.
- Evans, Randolph & Carl C. Braun—140 Nassau Street, New York, N. Y.
- Associated Architects—186 E. End Avenue, New York, N. Y.
- Fellheimer, Alfred & Stewart Wagner, associate—155 E. 42nd Street, New York, N. Y.
- Flewelling, Ralph C.—614 Architects Bldg., Los Angeles, Cal.
- Gugler, Eric C.—101 Park Avenue, New York, N. Y.
- Gilbert, Cass, Jr.—41 E. 42nd Street, New York, N. Y.
- Gillam, W. C. F.—1470 Broadway, Burlingame, Cal.
- Ganster & Deeter, Deam, Ganster & Deeter—305 W. Oregon Street, Urbana, Ill.
- Grillo, Salvatore—96 McDougal Street, New York, N. Y.
- Garfield, Harris, Robinson & Schafer—National City Bank Bldg., Cleveland, Ohio.
- Gilchrist, Edmund B. & Lloyd Malkus, associate—225 S. 15th Street, Philadelphia, Pa.
- Gallion, Arthur B.—2926 Porter Street, N. W. Washington, D. C.
- Graham, John—Dexter Horton Bldg., Seattle Wash.
- Honnold, Douglas & George Vernon Russell—1918 Grace Avenue, Los Angeles, Cal.
- Holland & White, Architects—101 Park Avenue, New York, N. Y.
- Harrison, W. K. & J. A. Foulhoux—45 Rockefeller Plaza, New York, N. Y.
- Hayslip, Sydney B., Lawrence, Holford, & Allen, associates—925 Failing Bldg., Portland, Oregon.
- Hutchins, Robert S. & L. Bancel LaFarge, Alexander D. Knox, John C. B. Moore—11 E. 44th Street, New York, N. Y.
- Hirons, Frederic C. & Horace G. Foulkes, David L. Foulkes—Railway Exchange Bldg., Portland, Oregon.
- Heitschmidt, Earl T.—417 S. Hill Street, Los Angeles, Cal.
- Howard, Henry Temple—580 Market Street, San Francisco, Cal.
- Hatton, John Matthews—420 Madison Avenue, New York, N. Y.
- Hays & Simpson, Harry A. Herzog, associate—71 Euclid Bldg., Cleveland, Ohio, 311 Guaranty Bldg., Portland, Oregon.
- Hornbostel, Henry—233 Oliver Avenue, Pittsburgh, Pa.
- Hansen, Ramm—McCornick Bldg., Salt Lake City, Utah.
- Justement, Louis—744 Jackson Place N. W. Washington, D. C.
- Jallade, Louis E. & Maurice Gauthier, associates—597 5th Avenue, New York, N. Y.
- James, Charles D.—Couch Bldg., Portland, Oregon.
- Jones & Marsh—701 Woodlark Bldg., Portland, Ore.
- Johnston, Hollis & Robert W. Turner, associates—847 Pittcock Block, Portland, Oregon.
- Jacobsen, John T., associated with Heath, Gove & Bell and associate.—3305 E. Thomas, Seattle, Wash., 1701 Puget Sound Bank Bldg.
- Kamphoefner, Henry L.—506 Insurance Exchange Bldg., Sioux City, Iowa.
- Kimball, Edgar Rollins—968 Madison Avenue, Birmingham, Mich.
- Knighton & Howell—U. S. National Bank Bldg., Portland, Oregon.
- Keast, Morton—1501 Commonwealth Bldg., 12th and Chestnut Streets, Philadelphia, Pa.
- **Karcher, Walter T. & Livingston Smith—1520 Locust Street, Philadelphia, Pa.
- Lawrence, Holford & Allyn—925 Failing Bldg., Portland, Oregon.
- Lunden, Samuel E.—400 Rowan Bldg., Los Angeles, Cal.
- Linde, Carl & George M. Post—1121 Failing Bldg., Portland, Oregon.
- Link, J. G. & Co.—317 Electric Bldg., Billings, Mont.
- Lescaze, William—211 E. 48th Street, New York, N. Y.
- Landreth, Wallace & Norman Alpaugh—Baker, Oregon; Los Angeles, Cal.



FREDERIC F. AMANDES, ARCHITECT

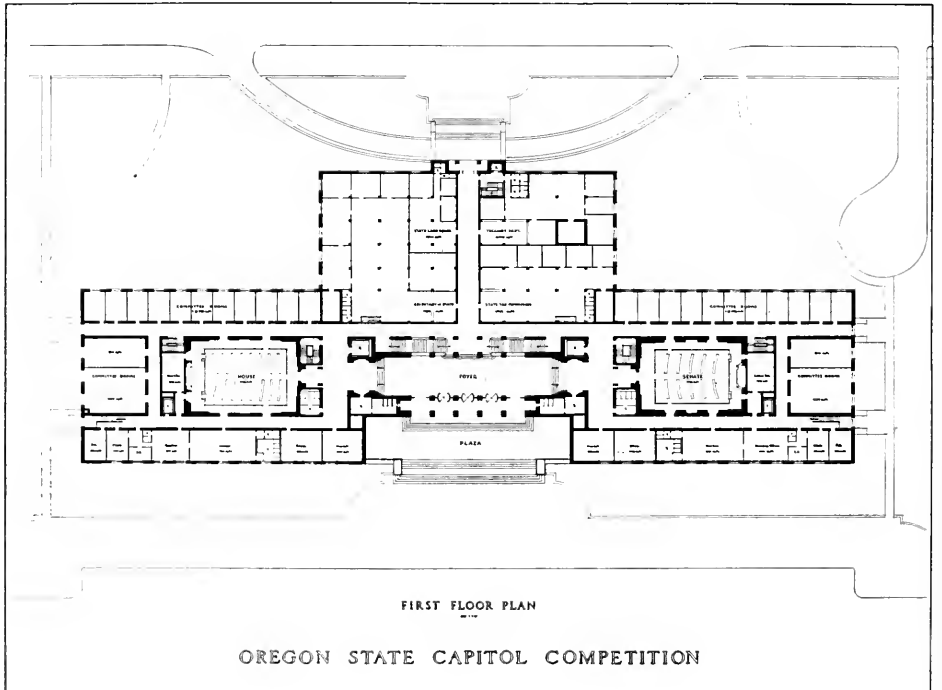

- Morin, Roi L.—Public Service Bldg., Portland, Oregon.
- Miller, John Edward—University of Notre Dame, Notre Dame, Indiana.
- Morris & O'Connor—101 Park Ave., New York, N. Y.
- Mooser, William and Charles F. Maury and William Mooser, Jr.—681 Market Street, San Francisco, Cal.
- Murphy, Frederic Vernon—1413 H. Street, N. W. Washington, D. C.
- Marston & Maybury—25 S. Euclid Avenue, Pasadena, Cal.
- McClelland & Jones—501-504 Republic Bldg., Seattle, Wash.
- Miller, J. R. & T. L. Pflueger—580 Market Street, San Francisco, Cal.
- Milano, Joseph—225 Cummins Highway, Roslindale, Mass.
- Morrison, Earl W.—Textile Tower, Seattle, Wash.
- Magoon, Herbert A.—21 E. 14th Street, New York, N. Y.
- Nedved, Rudolph J. & Charles M. Goodman—220 N. Royal Street, Alexandria, Va.
- Nelson, Donald & Hubert Burnham & C. Herrick Hammond—4524 Live Oak, Dallas, Texas.
- Perry, Warren Charles—260 California Street, San Francisco, Cal.
- Pope & Burton—2012 Buckingham Rd., Los Angeles, Cal.
- Poor, Alfred Easton—101 Park Ave., New York, N. Y.
- Pennington, Lewis & Churchill & Harold Steiner—250 Park Avenue, New York, N. Y.
- Post, George B. & Sons—101 Park Avenue, New York, N. Y.
- Rixford, Loring P.—1977 Broadway, New York, N. Y.
- Riedy, Dodge A. & Mario J. Ciampi—821 Market Street, San Francisco, Cal.
- Roald & Schneider—Spalding Bldg., Portland, Oregon.
- Summo, Don A.—271 North Avenue, New Rochelle, N. Y.
- Schmidt, Garden & Erikson—104 S. Michigan Avenue, Chicago, Ill.
- Smith, Alfred H.—1806 S. W. High Street, Portland, Oregon.
- Shaw, Stanley T.—Washington Bldg., Tacoma, Wash.
- Smythe, Richard Haviland—681 Fifth Avenue, New York, N. Y.
- Simonds, George Patton—80 Main Street, Hayward, Cal.
- Sisson, Ralph C. & A. J. Dreyer, associate—3409 N. E. Oregon, Portland, Oregon., R.F.D. No. 1, Box 755, Berkeley, Cal.
- Starrett & Van Vleck—267 Fifth Avenue, New York, N. Y.
- Shilling & Shilling—Springfield, Ohio.
- Smyth, J. H.—Chestnut & Smith Bldg., Tulsa, Okla.
- Sternfeld, Harry—1610 Architects Bldg., 17th & Sansom Streets, Philadelphia, Pa.
- Sutton, Whitney & Aandahl Herman Brookman & Jamieson Parker, associates—Portland, Oregon.
- Tourtellotte, J. E. & Truman E. Phillips—311-312 Postal Bldg., Portland, Oregon.
- Totten, George Oakley, Jr.—2633 16th N. W. Washington, D. C.
- Thayer, William Greenough—101 Park Avenue, New York, N. Y.
- Thomas, Harlan, Lance Gowan, Arthur Herrman, Henry Olschewsky, associates—304 Textile Tower, Seattle, Wash.
- *Trowbridge & Livingston & Francis Keally, associates—101 Park Avenue, New York, N. Y.
- **Thompson, John A. & Gerald Holmes—101 Park Avenue, New York, N. Y.
- Thomas, Lee—Weatherly Bldg., Portland, Oregon.
- Underwood, Gilbert Stanley—408 Spring Street, Los Angeles, Cal.
- Upjohn, Hobart & Otto F. Langmann—Grand Central Terminal, New York.
- Vitzthum, Karl M.—1 N. La Salle Street Bldg., Chicago, Ill.
- Vassilieve, Nicholas B. and Aymar Embury II.—150 E. 61st Street, New York, N. Y.
- Walker & Eisen—437 S. Hill Street, Los Angeles, Cal.
- Wooten, A. Mitchell—114½ E. Gordon Street, Kingston, N. C.
- Wade, John J.—728 Marine Trust Bldg., Buffalo, N. Y.
- Whitehouse & Church—Railway Exchange Bldg., Portland, Oregon.
- Wallwork, Johnson & Dukehart—422 U. S. Bank Bldg., Portland, Oregon.
- Young, John Davis—2002 California Street, San Francisco, Cal.
- Zantzing & Borie & Kneedler & Zantzing—1602 Architects Bldg., & 1801 Spruce Street, Philadelphia, Pa.

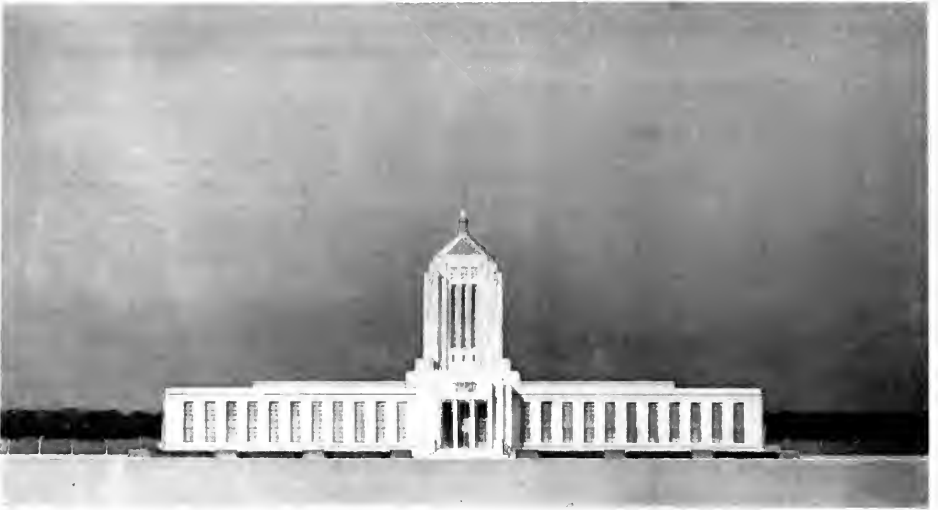

HERVEY P. CLARK, ARCHITECT

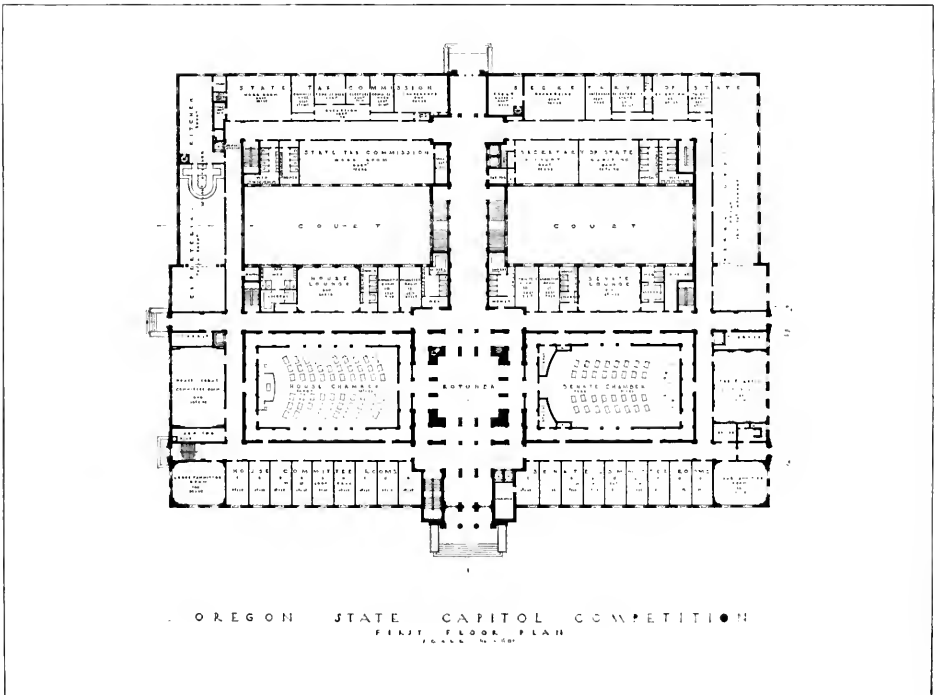

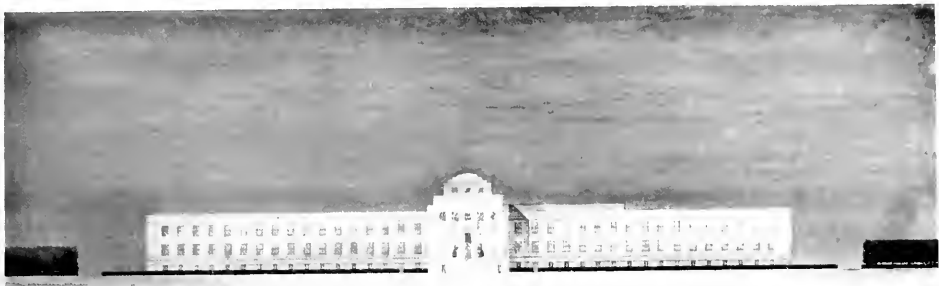

JOHN DAVIS YOUNG, ARCHITECT

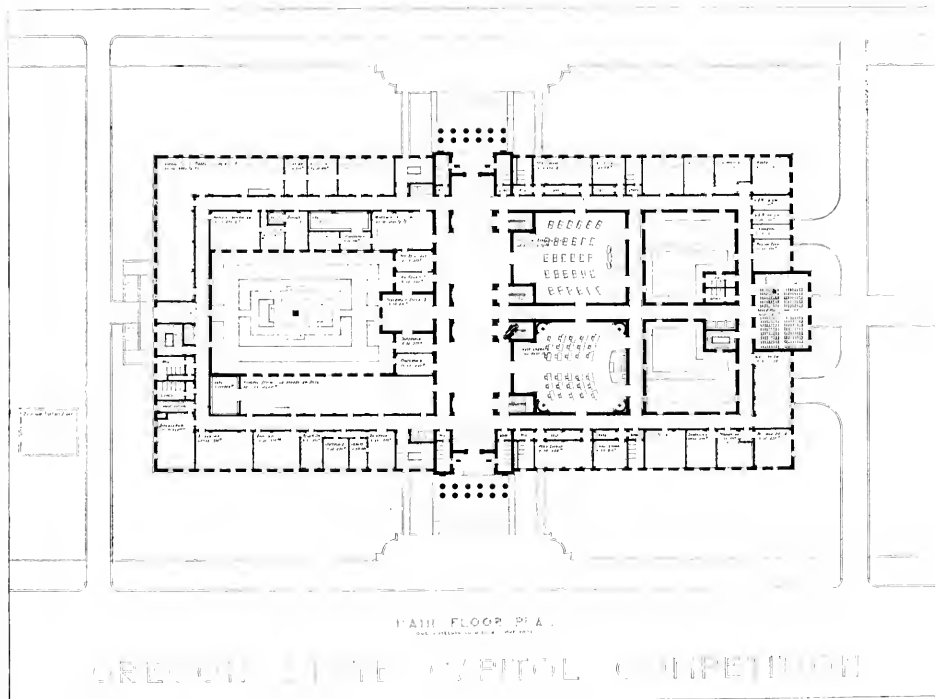

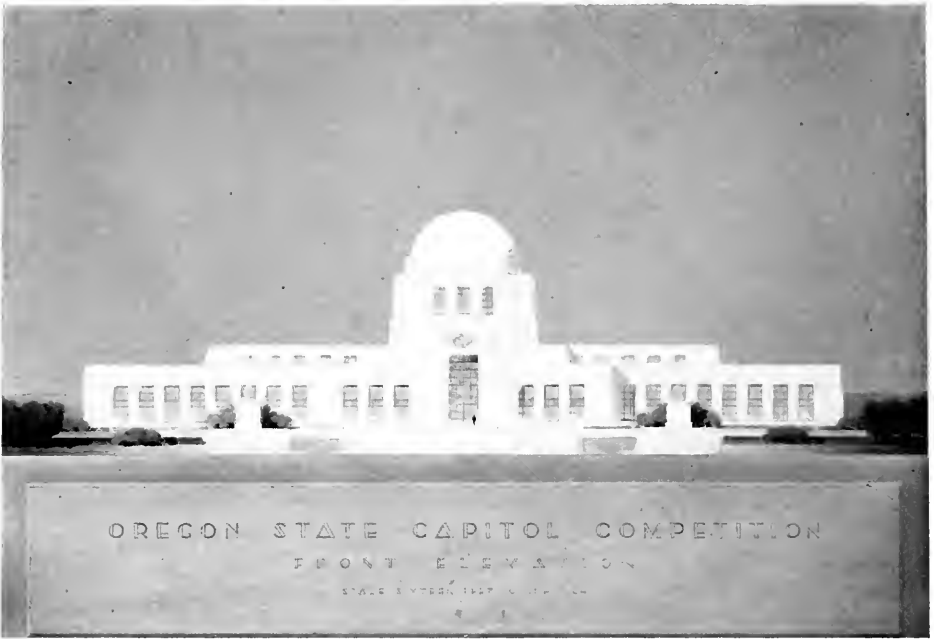

JOHN BAKEWELL AND ERNEST E. WEIHE, ARCHITECTS

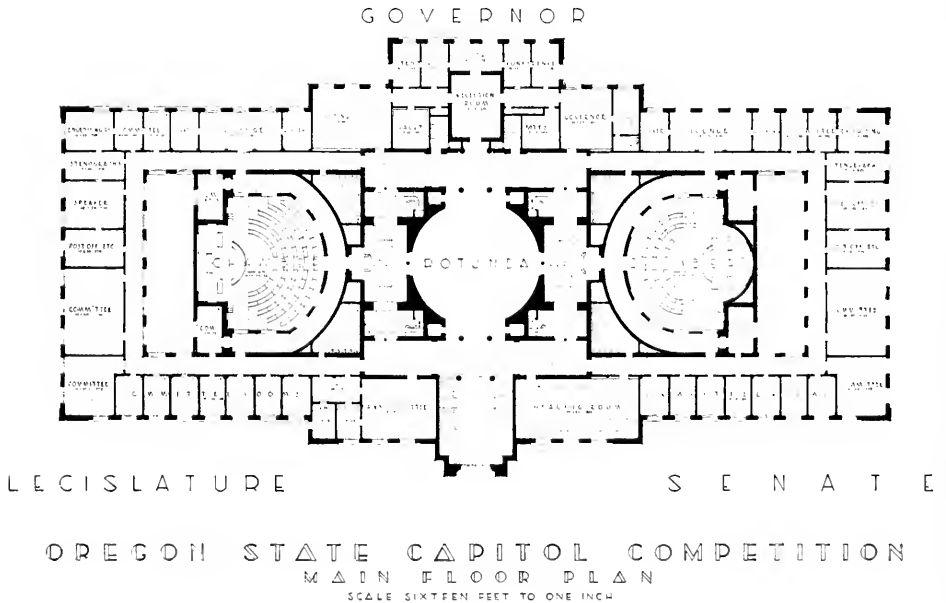



ARTHUR BROWN, JR., ARCHITECT

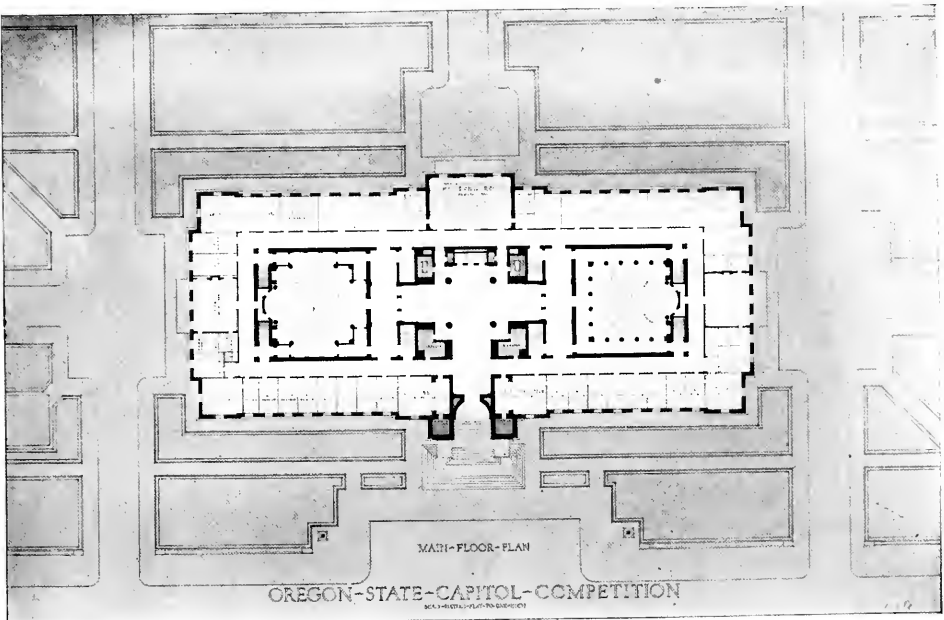

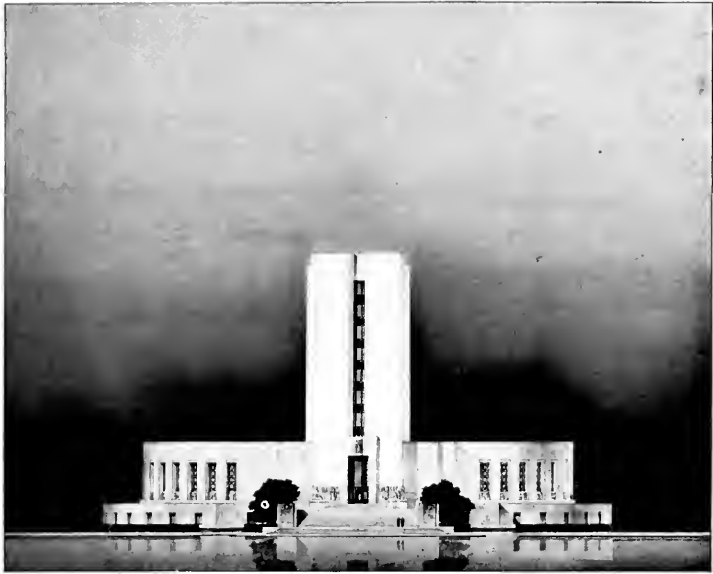

DODGE A. RIEDY AND MARIO J. CIAMPI

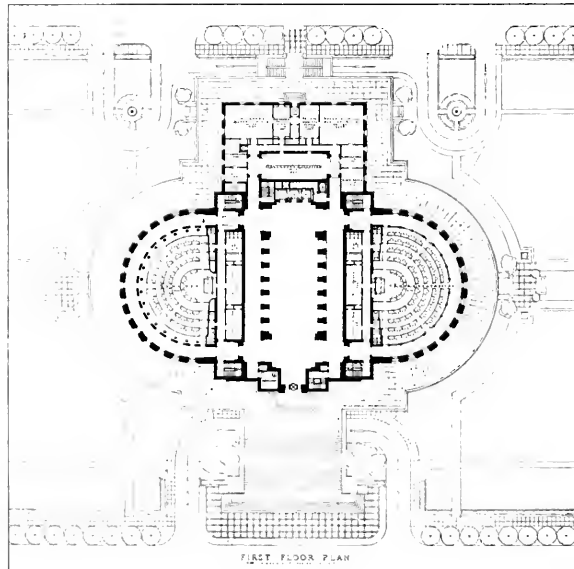

U. S. HOUSING SHORTAGE OVER MILLION

ANALYSIS SHOWS DEFINITE NEED OF MORE BUILDING

By William C. Bober

A direct shortage of roughly, 1,200,000 housing units faces the United States at the present time, almost 700,000 more call for outright replacement and approximately 4,800,000 more require such drastic structural changes to make them livable that they would practically become new homes.

These figures are a portion of a comprehensive study just completed by the author, who is head of the Statistical Research Department of the Johns-Manville Corporation. He carries his analysis from 1925 through to the beginning of 1936.

In the last 10 years, he points out, some 3,000,000 housing units were built. But during that period approximately 700,000 homes were destroyed by fire and natural calamities, such as floods, tornadoes and the like. These homes had to be replaced and constituted part of the 3,000,000 homes built. This left only about 2,300,000 new homes built to satisfy an increase in the number of families of approximately 3,500,000, and an initial deficit of new construction of about 1,200,000 homes.

The complete text of the survey follows:

THE housing shortage has been a perennial matter of debate ever since the beginning of the depression. At that time it dawned on informed people that not only was the decline in home building contributing a disproportionately large share to the general decline in business, but that the residential building slump had started much further back than 1929. The greatest number of homes ever built in this country was probably in 1925 and the research of recent years has proved abundantly that warning signals, almost wholly disregarded at that time, developed in 1926 and ushered in the second phase of the building boom—the stage of over-building. One of the most significant signals was the failure of the rent index to advance further in 1926 after its long upward march from the war days.

It can therefore perhaps be assumed that effective commercial demand and supply of home space were very roughly in balance at the beginning of 1926. We can therefore begin our calculations of the housing shortage

from that year. Obviously we must know three factors: (1) the number of homes required since 1926 to take care of new families caused by population growth (2) the number of new homes required for replacement and (3) the number of homes actually built in the years since 1926.

When we start figuring the new homes required each year, we run up against a "time lag" that is widely ignored and has caused some of the most misleading published figures on the home shortage. It is known that we are increasing at the rate of only about 900,000 people per year in the early part of this decade. As the American family now averages very close to four people, this would seem to call for only 225,000 new homes per year in this decade. But this reasoning is defective because new families are created thru marriages and the people who are marrying in this year 1936, for instance, average around 24 years of age. Obviously they were born, not in this decade or even in the last, but around 1912 in the first decade of the 20th century. It is therefore the rate of increase in a past decade and not in this that determines how many people will marry at the

present time and thereby create a demand for new homes.

The above is important because our rate of growth of population has varied from decade to decade. It was around 710,000 per year from 1860 to 1870, rose to 1,600,000 in 1900 to 1910, dropped to 1,370,000 from 1910 to 1920 because of the suspension of immigration during the war years, rose to a peak of 1,700,000 from 1920 to 1930 because of the revival of immigration on a large scale up to 1924 and on a very much smaller scale after that because of the quotas, and finally will be anywhere between 800 and 900,000 per year in the present decade.

The people who will marry all thru this decade will not have been born in it; therefore the rate of growth from 1920 to 1930 is for the present wholly irrelevant. The very large decline in growth of population after 1924 or so is also immaterial to our present calculations. If we continue to assume that the average age of marriage is around 24 and we are dealing with the housing demand from 1925 to 1935 then, — we are interested in the rate of growth of population between 1902 and 1911, a period during which we grew, roughly, at the rate of 1,600,000 a year.

But our entire growth of population during the period 1902 to 1911 did not manage to survive to marry in the years 1926 to 1935. We must take deaths into account and we must also allow for compensating factors. For instance, a good deal of our increase in population from 1902 to 1911 was caused, not by births, but by immigrants who had already survived the high death rate of childhood. Furthermore, people who reach the age of 24 in 1936 may have immigrated to this country in (say) 1924 at the age of 12 and are not the product of the rate of increase of this country for the above decade. To make matters short, we can roughly estimate that around 1,400,000 people per year reached marriageable age in the period 1926 to 1935 and represented approximately 350,000 new families per year. This called for building around

3,500,000 new homes in the years 1926 to 1935 to provide for population increase. How many homes did we actually build?

1926 to 1935 Calculations

In answering the above question we run up against the exceedingly inadequate building statistics of the earlier years of the above 10 year period. In 1926 Dodge contract figures were just beginning to get underway. The Department of Labor at that time published residential construction data for only 257 cities. Considerably later, cities of approximately 25,000 were added but it was not until 1932 that home building data was published for most of the cities over 10,000. But even the latter group comprises only 45% of our population although it accounts for a far greater percentage of our total construction. At the same time, a great deal of building has been going on since 1926 in small suburban towns below 10,000. Beginning with January 1, of this year, the Department of Labor added another group for which to report building activity — that is, towns and cities above 2500 but below 10,000 population. This will be a big help for future calculations but not for the period 1926 to 1935. But even at that, there is still a considerable gap in our information — that is, for towns under 2500 and the strictly rural areas where considerable home building is known to take place.

Because of this great inadequacy of information, we are driven to use the only series of cities for which information on an identical unchanged basis is available as far back as 1921 — that is, the series of 257 identical cities. This data is based on permits and is therefore subject to considerable inaccuracy but it is the best we have for back years. How many new home units were built in these 257 cities? The record is as follows:

1926—	462,214	1932—	27,381
1927—	406,095	1933—	25,879
1928—	388,678	1934—	22,063
1929—	244,394	1935—	55,810
1930—	125,322		
1931—	98,178	Total—	1,856,014

We therefore built 1,856,014 new home units (each apartment in a multi-family structure counts as a home unit) in the 257 cities in the 10 year period 1926 to 1935. These cities comprise about a third of our population, but as the boom-day building was disproportionately of a multi-family apartment type, we are entitled to assume that a disproportionate amount of homes were built in the big cities which are covered by the group of 257. All research proves the latter, but at the same time, building in the small suburbs also developed at a disproportionate rate. How many homes were built outside of the 257 cities which include no cities under 25,000? The only true answer is that no one knows, but we can make a fair estimate.

In the three years, 1933 to 1935, for which we have such information, 138,610 homes were reported built in cities over 10,000. This group included the 257 above cities in which 103,752 homes were built during the same three years. The number of homes built in the former group is therefore larger than the other by 1.34. We must therefore increase our grand total of 1,856,014 homes built from 1926 to 1935 in the 257 cities by 1.34 in order to include cities of over 10,000. (All cities over 10,000 not reported). This works out at 2,487,200 homes built in the 10 year period in cities over 10,000.

How many homes were built in cities from 10,000 to 2,500? Information for this group only began with January 1, 1936. So far we have nothing but a three months period to guide us, that is January 1 to March 31, 1936. Besides, by no means all of these smaller cities are reported. In that period 27,337 new homes were reported to have been built, of which 23,325 were in cities of over 10,000 and 4,012 in cities from 10,000 down to 2,500. If we assume (a very reckless assumption which I very much hesitate to make) that this proportion applies all the way from 1926 to 1935, then we have to increase our figure of 2,487,000 homes by 1.17 and we get a total of 2,909,000 homes built in all towns and cities above 2500.

How many were built in towns, villages and in open country below 2500 population, as well as in unreported cities above that size? On that we have absolutely no information. We can merely make a complete guess and add about 180,000 home units. Our final estimate (or, rather guess) is therefore that about 3,090,000 home units were built in the entire country in the 10 year period 1925 to 1936.

As we have seen, mere growth in population called for building roughly 3,500,000 new homes in the above 10 year period. As we only built around 3,000,000 we seem to have a shortage of only about 500,000. But at this point we must not forget that a certain part of our 3,000,000 home units were built not for growth of population, but for replacement of homes destroyed by fire, flood, hurricanes, tornadoes and earthquakes. How many of such destroyed homes were there?

Home Replacements Due to Fire Loss

This again is largely a matter of guess but fire loss data shows that approximately \$150,000,000 of dwellings are destroyed by fire on the average per year in non-rural areas alone. This roughly works out at 35,000 homes. We can easily add another 35,000 per year to cover farm houses burnt and homes in farms and cities destroyed in other ways than fire. This gives a total of around 700,000 homes built in the above 10 year period, not for growth of population, but to make good the ravages of fire and natural calamities. Subtracting this amount from the 3,000,000 homes built, we have left only 2,300,000 homes erected in 1926 to 1935 to satisfy a demand for 3,500,000 caused by population growth. Assuming that the building boom from the end of the war to end of 1925 merely made good the war and pre-war shortages of space, and that demand and supply were roughly in balance at end of 1925, we therefore had a shortage of about 1,200,000 home units at the beginning of 1936.

In our calculations, we have, however, not allowed for any replacement of homes except those destroyed by fire and natural calamities.

As the Real Property Inventory in 64 cities showed, 2.2% of all dwelling units were recorded as unfit for human habitation and 15.4% required major structural changes to make them safe and livable according to the survey investigators. If we assume 31 million home units as existing throughout the entire country and apply the above percentages, we would have to assume that 682,000 homes should be replaced at once and that over 4,774,000 home units require major structural changes. If we take these figures at their face value, it would seem we now have a total direct shortage of around 1,900,000 homes (1,200,000 plus 682,000) and that almost 4,800,000 homes must be altered so drastically that they will practically become new homes. If we add these together, it might be said we are short 6,700,000 new or rebuilt homes.

Prefer Autos to New Homes

But needless to say, the above is a highly theoretical shortage figure. It must never be forgotten that a new home is one of the most postponable of all wants. Almost everyone already has some kind of a home. A person may live in the poorest slum, be doubled up with in-laws or strange families and no doubt would very much like a new home. But that is very far from being an actual effective commercial demand for a new home. If the home is not actually ready to fall apart, it is still serviceable in the sense that it at least provides shelter and the dwellers cannot or will not place an order for a new home or move into a new home built by others until their economic status has improved suffic-

iently and other more immediate wants have been satisfied. As to the latter, the early recovery years proved that many an American family prefers to remain doubled-up and spend new or increased income on a new automobile rather than a new home.

The need for homes, however, is obvious. It therefore appears that the actual demand depends largely upon how aggressively the building industry competes with every other industry for its share of the consumer's dollar. Seldom has the building industry had so many natural forces on its side. To take advantage of them it must actively merchandise its products in a concerted effort to stimulate the home building desire.

Included under the estimate for dwellings that should be destroyed or require major repair, are of course home units inhabited by people who will perhaps never have the income to move into higher-rent dwellings, let alone buy a home specially erected for them. This particular demand for homes is therefore especially theoretical. It may be satisfied only by subsidy of some kind from the public purse and no one at present is in a position to say to what extent the more fortunate will be willing to be taxed for the sake of providing subsidized homes for the lowest income population. Obviously, as our population rate of growth declines, the replacement market will become progressively more important. But few existing homes absolutely demand replacement. The extent of the latter will depend on incomes, building costs and prosperity generally plus the public's willingness to be taxed for subsidized low-rent homes.

ARCHITECTS MUST RESIST USURPATION

CONTRACTORS "CUT IN" TO DETRIMENT OF PROFESSION

By Howard J. White, Architect

The practice of some contractors, sub-contractors and material houses in attempting to compete with the architect and engineer in the preparation of plans and specifications for a building or alterations to a building has grown to such an extent that architects are alarmed. Constructive methods to stamp out the evil have been started in various localities where offenses of this nature have become acute. "The Architect Must Resist Usurpation," is the title of a frank expose of the evil in the July issue of the Monthly Bulletin of the Illinois Society of Architects. The author, Howard J. White, is a member of the firm of Graham, Anderson, Probst & White of Chicago. The quantity and variety of work performed by his firm make Mr. White an authority on the subject he discusses.

WHILE architects have not had a New Deal, their professional place is very generally accepted by the public, both in residential and industrial building work. In the "horse and buggy" age, it was common practice to construct different kinds of buildings without the service of architects. Happily, this is not true today and advancement in education and state registration of architects has raised their practice to a high plane.

The advice "consult an architect" frequently seen in newspaper and magazine articles and in paid advertisements and literature of manufacturers, is but one indication of the acceptance. Another important indication is that many insurance companies and building and loan associations do not make building loans unless an architect is engaged for the operation. It is now commonly accepted that residential and industrial buildings have a greater sale value if architects' services have been used, and the time may arrive when a statement from an architect certifying that the building was planned and the construction supervised by him, will be a necessary document in the sale of the property.

In view of these facts, it is surprising to find some contractors and building material producers still resorting to "horse and buggy" methods and taking advantage of the depression to secure the services of architectural draftsmen to render architectural services for small compensation. In some cases the illegal practice of having a licensed architect stamp the plans is being resorted to.

These concerns seem to lose sight of the fact that one of their valuable assets should be to cultivate good will among architects, instead of subjecting them to unfair competition, and that the added business to be gained by their methods is small compared to the amount they may lose when the facts are made known to the profession.

An architectural firm having a large practice in store front modernization and remodeling has advised that its business has been considerably curtailed by glass manufacturers furnishing free drawings and specifications of not only the glass work but also of the accompanying work in other materials. There are many large manufacturing concerns that encroach on the architect's province — firms that solicit business from the architect — and for their

own building programs hire a draftsman and do their planning.

A national paint manufacturer is doing just this in the Chicago vicinity at the present time. Another case is a large corporation allied with a building supply manufacturer that does all of its own planning of branch stores and buildings. Such companies surely are not entitled to consideration of their materials by the architect.

Much work has been lost to the profession by certain companies selling direct to the owner new and modernizing equipment and having fixtures designed by a manufacturer.

The ends to which material manufacturers will go in the matter of furnishing architectural services can best be illustrated by quoting several letters which are on file in the secretary's office. The first letter is written on what is apparently a letterhead of a national building supply company. The letter is addressed to a member of the Illinois Society. It reads:

"Dear Sir: As a building manager, trustee or receiver, you are vitally interested in maintaining your buildings for 100% occupancy at a minimum cost.

"We have been contracting and executing general building reconditioning in all its various phases for the past forty years, and can meet your every requirement, no matter how small or large, speedily, efficiently and to your entire satisfaction.

"FULL ARCHITECTURAL SERVICE AND COUNSEL REGARDING ANY TYPE OF BUILDING, REMODELING OR ALTERATION WILL BE FURNISHED.

"In contacting us you incur no obligation whatsoever, and we will give immediate attention to your inquiries. References furnished on request.

Respectfully yours,

"All designs by (Manufacturer's Name) for every architectural need."

The building supply company was communicated with and they sent the Society a copy of their letter to their Chicago Manager. We quote:

"We were very much disturbed to receive in this morning's mail a letter addressed by your company on our letterhead, supposedly to contractors, but through error no doubt, one of these was received by an architect. In your letter you propose to do contracting and general building reconditioning and offer your 'full architectural service and counsel' in connection with this remodeling.

"As you undoubtedly know, this company has enjoyed the confidence of the architects throughout the country for a good many years and we have always worked with them, and it is not our intention to have this letterhead showing (manufacturer's name) cuts and designs used in this manner because of the unfavorable reaction on the part of the architects as a whole.

"Will you, therefore, please cease advertising full architectural service and counsel, with our request that you work through the architects.

"May we hear from you?"

Very truly yours,"

From the above letter, particularly that part which we have capitalized, the manufacturer seems to feel that his only error was that one of the letters was received by an architect. However, we think good has been accomplished in this case and that the manufacturer's prompt action in the matter is commendable.

It might be interesting to some of our younger members to go back for a time to an occurrence which only our older members will recall. The case is the Columbus Memorial Building. The architect was W. W. Boyington; the general contractor, George A. Fuller Company; the marble contractor, William Henry Burke. Burke was an Englishman and was brought to this country by McKim. He was a great friend of D. H. Burnham and Henry Ives Cobb. He was a real designer, but not an architect. The owner of the building was Henry J. Furber. Burke, by clever manipulation, discredited the architect in the mind of

(Please turn to Page 43)

BRIDGE ENGINEERS CONTRIBUTE TO PROGRESS

DEVELOPMENT OF DESIGN VALUABLE AID TO PROFESSION

By Glenn B. Woodruff, Chief Designer

IF VERY major structure should contribute its bit toward the increase of engineering knowledge. This contribution may take the form of new methods of stress analysis, the development of new materials, and new construction methods. There is opportunity on every project for observing, recording and disseminating results that have been obtained. To this end, some of the design and construction problems on the Bay Bridge are described.

I. DESIGN

(a) EARTHQUAKE. The effects of seismic forces have been considered throughout the design. In some cases provision for these forces controlled the span layout. For example, to secure adequate longitudinal anchorage in the East Bay Structure, the 2400-ft. cantilever structure is held at its west end and the five 508-ft. spans at their east end, the expansion for this entire distance being taken up at the split tower, E-4. The earthquake stresses were reduced by considering the spring effect resulting from the elongation of the truss members.

The earthquake stresses in the flexible West Bay suspension structure are comparatively small. In a longitudinal direction, the cables act as guys. During an earthquake the tower bases will move with the piers and the tops will remain in a nearly constant position. The suspended structure acts to a large degree as the pendulum of a seismograph so that the effect of these loads is comparatively small.

Editor's Note—Abstract of a talk before the San Francisco Section, American Society of Civil Engineers, at the Engineers Club, San Francisco.

It is only in the massive foundations that seismic forces become of great importance. The height of the piers, measured to rock, is large. The earthquake forces result from the horizontal acceleration on the mass of the superstructure, the mass of the piers and from the surrounding water and mud. The effect of the water was calculated from the formulae developed by Westergaard for earthquake forces on dams. The effect on a pier is double that on a dam since water is present on both sides. The pressure from the mud was calculated on the assumption that the mud was a viscous liquid weighing 100 pounds per cubic foot. In this case the mud may be acting in phase opposite to the pier.

(b) MODELS. The use of models in stress analyses of engineering structures is becoming more common. At the outset of this project, three models of possible designs for the West Bay Crossing were made at the University of California. Since these models were made prior to the final span layout, they had no direct application to this project. The results did, however, confirm the deflection theory of suspension bridges and Moisseiff's wind theory.

During the erection of the West Bay suspended structure, it was essential that the deflections of the towers be kept within reasonable limits. An arbitrary figure was also set as the maximum unbalanced pull on the center anchorage. Since these sections were being erected on an assembly line, it was essential that the contractor should plan his program for some periods ahead. The analytical solution

of the problem, involving many variables, would have been most tedious. With the model it has been possible to follow each step in sequence. The results predicted by the model have been confirmed by field observations on the structure.

Model analysis was also used in checking the design of the towers.

(c) RIGID FRAMES. Extensive use has been made of rigid frames. In concrete the 82½-ft. clear spans on the San Francisco section and the 65-ft. spans west of the anchorage form typical examples. This type of construction is also being used in steel. It requires less depth than the usual truss, has less detail to maintain and presents a more clean-cut appearance. The roof framing of the garage at the Administration Building, the roof of and the street crossings at the Interurban Terminal form typical examples.

II. DETAILS OF DESIGN

Some of the details of design may be briefly mentioned.

Box, rather than laced sections, have been used extensively.

Eyebars have been used in all heavy tension members except those where stress reversal exists.

Pin joints have been used at points of high secondary stress.

A circular cable saddle was developed at Bent 1. In case of redesign, all saddles would be made circular.

Insofar as practicable, roller nests have been eliminated, and expansion taken by flexure or long rocker posts.

III. SAFETY IN DESIGN

Insofar as possible, the design has been such as to eliminate possible accidents. The following details are illustrative:

The calculated stresses required 8-in. timber sheeting on the West Bay Crossing. The design provided 10-in. vertical and 4-in. diagonal.

The preliminary grouting over the tunnel roof, where 10,000 sacks of cement were forced into the voids of the rock, was primarily to insure safety during construction.

The steel ribs in the tunnel were entirely

for the purpose of holding the roof until the concrete lining could be placed.

IV. CONSTRUCTION METHODS

In several cases the design called for new construction methods or the extension of past methods. As examples may be mentioned:

The dome caissons for the West Bay piers;

The 24-ft. diameter open wells, 150 ft. in depth, for supporting Pier YB-1;

The use of vibrators in placing all but underwater methods.

Many of the new construction methods have been developed by the contractors. A tribute is due all the contractors on the project. The fact that the work has run smoothly and according to schedule throughout has been largely due to perfect cooperation between these contractors and the State organization. Among the methods developed by the contractors may be mentioned:

East Bay Cofferdams reducing the interior bracing to a minimum;

Concrete plant for the piers;

Hammer heads for erecting the towers;

Cable stringing methods;

The cable compacting machine, which reduced the voids to 18 per cent rather than the 20 per cent normally expected in a cable of this diameter;

The method of erecting the suspended structure;

Cantilever methods of truss erection in the East Bay.

V. INVESTIGATIONS

Throughout the work an effort has been made to accumulate data and to investigate results that would aid to engineering knowledge and lead to better practice.

1. The control of the concrete on this work has included:

Inspection of aggregates and cement at source;

A concrete technician in charge of the mixing plants;

Accurate proportioning equipment;

Investigation of mixing and placing procedure.

Believing that a great deal of the troubles

with concrete are due to shrinkage, the following steps have been taken to reduce it a minimum:

- a. Use of low-heat cement;
- b. Pouring of large masses in comparatively small blocks;
- c. Limiting the amount of cement to 5.2 sacks per cubic yard;
- d. A grading of aggregate and with more fines than commonly used.

With this procedure there is obtained a workable mix using 5 sacks of cement to the yard with 28-day strengths of over 3500 pounds, and strengths at one year of 5500 pounds.

2. At the outset of driving heavy joints on the cantilever, the calipering of "cut-outs" disclosed that the rivets were not filling the holes. While the following conclusions are by no means new, they are frequently violated. The following points are essential to good rivets:

- Proper bolting,
- Proper rivet heating,
- Fit of rivets.

3. Tests on Riveted Joints. A large amount of the information that gave confidence in proportioning members on this bridge has been experimental work done in connection with other large structures. In order to repay this debt, arrangements were made to provide funds to test riveted joints at the Universities of California and Illinois. Those at California are static tests on joints running up to the full capacity of the machine. Those at Illinois are repeated-load tests on smaller specimens.

In neither University have the results been reduced so as to permit definite conclusions. There is no question, however, but that they will furnish a large amount of new information as to the action of riveted joints and riveted members.

4. Repeated Loads. It has been demonstrated by tests on small specimens that the yield point of structural steel can be raised by repeated stressing beyond such point. The American Bridge Company made a similar

test on one of the 16 x 2-in. heat-treated test eyebars by this projects. Under repeated stress the yield point was raised nearly to the ultimate.

In the time available, it has been impossible to describe more than a few of the details, in which it is believed that this project is contributing to engineering progress. The speaker desires to emphasize that the observation and recording of these results has added practically nothing to the cost of the project. In the present art or science of construction, there is more need of improvements and refinements in construction methods than in stress analysis. Every engineer should consider it a duty to the profession to record and disseminate similar information.

STATE BUILDING, SACRAMENTO

The new State Building at Sacramento, (See over page) will provide 155,000 square feet of floor area which will care for the requirements of the Department of Public Works.

Due to the nature of the underground conditions it was necessary to construct on concrete pile foundations, some of the piles extending down to a depth of 40 feet below basement floor area.

Five thousand seven hundred eight cubic yards of concrete will be used to complete the structure exclusive of pile foundation.

The building will be practically fireproof and will withstand earthquake shock in so far as it is structurally possible.

Two high speed elevators are provided to meet the demands of the public. An additional elevator is provided for departmental use.

One important feature is that all offices and work spaces will be air conditioned for proper cooling in the summer and warming in the winter. Scientific acoustical treatment will be applied throughout.

The architectural design is in the modern manner and has been planned in the form of the capital letter "H."



Courtesy California Highways and Public Works

PUBLIC WORKS BUILDING, SACRAMENTO, CALIFORNIA
Drawing by A. W. Eichler

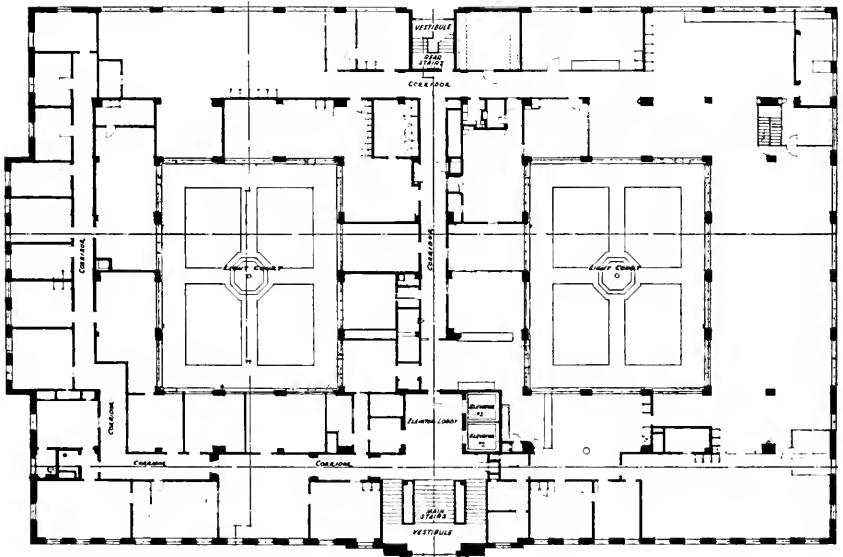

GROUND FLOOR PLAN shows a width of 226 feet 6 inches and depth of 146 feet, providing 26,200 square feet of floor space, and two light courts each 48 feet wide and 61 feet deep.

ATTORNEY GENERAL RULES ON PEST CONTROL

TWO CONFLICTING LAWS SHOULD BE CONSIDERED JOINTLY

By A. A. Brown C. E.

FROM time to time abortive attempts are made by groups alien to the construction industry to assume responsibilities in that field without the qualifications of training and experience. Likewise, members of the contracting fraternity at times are desirous of assuming some of the functions of the professional branches of the building industry. The construction business has become highly specialized not only in the professional branches, but also in the contracting and material-supply phases. Each new problem created by the march of human progress has been successfully solved by one or more groups within the industry. The attempt on the part of the pest-control operators to partition for their special benefit that part of the building business concerned with preventing damage to wood in structures by pests, received a deserved rebuke at the hands of Attorney General U. S. Webb in a ruling dated May 16, 1936, in which he says:

"As Chapter 816, amending the Contractors' License Law, and Chapter 823, creating a Structural Pest Control Board and regulating the business of structural pest control, were enacted at the same session of the Legislature, approved by the Governor on the same day, and became effective at the same time, they may properly be considered in pari materia in so far as they relate to structural pest control. For this reason these two chapters should be considered together and, if

possible, harmonized to the end that all of their provisions may be given effect.

"Construing these two statutes in this manner, I think it is unreasonable to ascribe to the Legislature an intention to require for the doing of a particular act that a structural pest control operator shall be licensed by two different boards and subjected to two different sets of regulations.

"This result can be avoided by construing the words

'including the eradication of or the processing against infestation by pests structurally injurious to building or structures', which were added to Section 3 and incorporated in Subdivision (c) of section 3 $\frac{1}{2}$ of the Contractors' License Law, as applying only to construction work — that is to say, the fabrication into a building or structure of structural members to replace members damaged by pests, or the processing of mechanical means of structural members for the purpose of eliminating pests. Limiting the application of the words in this manner, one who is licensed as a 'specialty contractor' under Subdivision (c) of Section 3 $\frac{1}{2}$ of the Contractors' License Law is in my opinion authorized to conduct operations in structural pest control only in connection with or incidental to construction work. Processing by such licensee may not include the use of insecticides, fumigants or allied chemicals for the purpose of eradicating, eliminating, exterminating or preventing the infestation of a house or other structure by pests infesting the same. I am of the opinion also that in order to practice pest control work to this limited extent, he is not required to be licensed by the Structural Pest Control Board. I am further of the opinion that one who is

licensed by the Structural Pest Control Board may practice structural pest control only in so far as it does not involve construction work or work incidental thereto as hereinbefore defined, and that in so operating he is not required to have a contractor's license. Should he undertake, however, to do any construction work in connection with pest control, he must obtain a contractor's license. In other words, should a person undertake to eradicate or prevent infestation of buildings by pests, both by construction work and by the use of insecticides, fumigants and allied chemicals, he must have both types of licenses.

"There is nothing in either the Civil Engineering Registration Act (Statutes 1929, Page 1645, as amended) or in the Act Regulating the Practice of Architecture (Statutes 1901, page 641, as amended), relating to structural pest control. I am of the opinion that either a civil engineer or an architect who supervises work upon a building, including structural pest control work, is acting solely within his professional capacity so long as he does not actually engage in doing the pest control work himself, and is not required to be licensed under either the Contractors' License Law or the Structural Pest Control Act."

The writer has no quarrel with those engaged in the pest control business outside the construction field, but when their Registrar says: "It is not agreed that an architect or engineer has a right, nor is within the scope of his professional practice, to advise or specify the use of chemicals or poisons to rid a structure of existing destructive pests or insects, etc.," one cannot fail to recognize that an organized group is attempting to partition the construction industry for their special benefit.

Experiments were carried on both in England and in America as early as 1756 on the use of vegetable tars and creosote-like materials for wood preservatives. The manufacture of wood preservatives and the preservative treatment of wood and its products constitutes an important branch of the construction industry.

To advise and prepare specifications to rid waterfront structures of marine borers, or to protect wood against the ravages of fungi, has for decades been recognized as an important phase of civil engineering.

In the long battle waged against Typhoid fever the civil engineer played an important part in providing a pure water supply. He also directs the operation of sewage disposal and mosquito abatement work. To do this, it is necessary for them to specify and direct the use of chemicals. By education, training, and experience, engineers have demonstrated their ability to use chemicals in the everyday practice of their profession.

The Attorney General has now ruled that pest control operations must become part and parcel of the construction industry by registering as specialty contractors before undertaking pest control work in construction. The Contractors' License Board has the necessary personnel to supervise specialty contractors engaged in structural pest control, and to avoid future conflicts the responsibility so far as buildings and structures are concerned, should be concentrated with their board.

The termite racket has provided an outlet for questionable products manufactured by pest-control operators. In a letter received in the past month from such an operator, (spelling and phraseology his) the writer was asked:

"Can you advise us how solids of the Orthi-Dichlorbenzene Mixture and the Orthophenylphenol make up and in what proportions make up. Some of the people is using the solids and to 1# to the Gal of Keresene. It is a combination, Fumigant, Poison, and wood preservative. We want to make up this material ourselves but buy the raw material and resale to other firms."

The material-supply phase of the construction industry is highly competitive. One would not expect the W. P. Fuller Company, The Paraffine Co., Inc., nor the General Paint Corporation to place on the market a product for use in termite control with no more research or fundamental understanding of the problem than is indicated by the above inquiry. The professional branches of the construction industry habitually subject new materials to searching inquiry. Material dealers know this

only too well, and in consequence jealously guard their reputations for marketing only scientifically tested products. At the present writing too many manufacturers of toilet accessories, perfume, etc., are finding the termite control field a lucrative one for the distribution of products of doubtful merit.

It is altogether probable that the practice of eliminating, exterminating and preventing infestation of vermin, rodents, parasites, insects and other pests which infest or damage households, is in need of regulation and control —

ARCHITECTS MUST RESIST USURPATION

(Concluded from Page 36)

the owner with the result that he, Burke, in addition to his contract for furnishing and setting the marble was given the designing of all the corridors, stores, the main lobby and even the bronze store fronts. He employed our old friend Trost as designer for the bronze work. We do not recall the amount of money involved, but it was a considerable amount even in those days. The net result of the operation, which was carried out without any architectural supervision or check, was a grand lawsuit.

The architects meekly submitted to the government action in the matter of public work. It is manifest that the great majority of the men employed by the government in this work received their training in offices of the pro-

which would properly constitute functions of the Structural Pest Control Board. Certainly the construction industry historically has demonstrated its ability to meet the problems which are continually arising, and provide solutions that are both logical and economical.

The published report of the San Francisco Termite Survey* lists many common mistakes made in building construction, and points to the need for a comprehensive study and revision of building codes in the light of this menace.

*Printed report of the San Francisco Termite Survey available at the Department of Public Works, City Hall, San Francisco.

fession. It may be that we have lost our sense of humor and need a Gilbert and Sullivan to bring before us, in words and music, the comedy of the present situation.

The "I, Aye, I" articles by Lewis Horowitz published in the "Saturday Evening Post" during the last few months do not lend any particular dignity to the profession.

To what conclusion does all this bring us? Does it not demand of us zealotry, vigilance, ethics, and — in every way — dignity worthy of our profession?

This is not a one-sided question. The architects have a responsibility as well, and they should refrain from asking any contractor to make drawings for them. There is a willingness on the part of some material people to furnish rendered drawings of store fronts and alteration work which when furnished are submitted as the architect's own work! Surely, there can be little difference, from an ethical standpoint, whether the architect with a contractor's presentation or a contractor with his own presentation sells the owner.



VINE CLAD STAIR APPROACH TO HOLLYWOOD HOME

WORLD'S FAIR SITE AS FUTURE AIRPORT

IMPORTANCE OF PROJECT CITED BY ARMY OFFICER

By Brigadier General Wm. S. Gilmore

BECAUSE the San Francisco Bay Region is bound to be one of the world's greatest aviation centers, the building of an airport on Yerba Buena Shoals, on the site of which we will hold a World Exposition in 1939, is a matter of tremendous importance to this community.

The development of the Yerba Buena Shoals as an airport was made possible by the splendid work initiated by the San Francisco Junior Chamber of Commerce. Early in 1931, the City and County of San Francisco secured this site from the State of California, the grant of the shoals to the city being for airport purposes.

Long before that time, however, men of the Junior Chamber of Commerce, who were especially interested in aviation, felt that a terminal airport should be provided of sufficient size to serve adequately the rapidly growing air traffic requirements of the Bay Region. Transport companies operating in San Francisco had been obliged to allow from thirty to ninety minutes for the conveyance of their passengers by ordinary means from San Francisco to the various airports in the Bay Area, thus resulting in the loss of valuable flying time.

In the selection of Yerba Buena Shoals as the site for an airport, it was apparent that the most accessible site in the entire Metropolitan Bay Area had been secured. This site also had the following advantages as an airport:

Because of its location in the Bay, there is a minimum hazard and nuisance to people

living in the Bay cities. It has favorable meteorological conditions, good approaches, ample room to allow expansion, and is suitable for the operation of both land and sea planes. It has splendid transportation connections to the adjacent cities. These conditions are all important in the location of an air terminal and this site more nearly met the fundamentals that must be considered in the selection of an airport site than any other that it was possible to acquire.

But in spite of all this, it would undoubtedly have taken many years for the City of San Francisco to have built the airport if the Golden Gate International Exposition had not come into being.

There will be an actual expenditure of approximately seven million dollars on airport facilities at the site. These include construction of sea wall and sand fill, roadways and trestles, water supply and drainage, paving, and permanent airport buildings. The funds for this construction are furnished by the Golden Gate International Exposition with very substantial aid from the Federal Government through its Work Progress Administration and Public Works Administration agencies.

Many people ask, "Why is it necessary to build another airport here in San Francisco?" — That is best answered by saying that it is manifest that the first requisite of an airport terminal is easy accessibility to the people it serves. People who fly usually do so to save time and this airport site is located in almost the geographical center of the Metropolitan Bay Area, and by the bridge, one may reach

the airport in approximately ten minutes from down town San Francisco and only a little longer time from down town Oakland.

The tremendous increase in air travel and in the amount of express, mail and freight carried, has made it wise to develop the most accessible site for an airport to serve our Metropolitan Bay Area.

Unless the reader has studied the question of aviation development, I am sure he will be interested in a few statistics on this subject. Going back only to the period of six months, from January to June, inclusive, of 1934, our commercial aircraft companies flew in the United States, seventeen million, seven hundred thousand miles and carried one hundred ninety-one thousand passengers. In the six months from July to December, inclusive, of the following year, 1935, this travel had increased to thirty million, seven hundred thousand miles flown, and to four hundred twenty-seven thousand passengers carried. From January to June, 1934, the express carried was nine hundred and sixteen thousand pounds. From July to December, 1935, it was two million, four hundred thousand pounds.

We often hear of the immense amount of air travel in Europe. It might interest you to know that during the periods from January to December, inclusive, of 1935, when we flew thirty million, seven hundred thousand miles in the United States, all foreign travel on commercial lines amounted to four million, seven hundred thousand miles. Passengers carried in that period in the United States were four hundred twenty-seven thousand as against eighty-five thousand nine hundred on foreign lines. From the San Francisco airport alone, from January 1, 1934 to December 31, 1935, there were carried eighty thousand, five hundred twenty passengers, in and out of the airport. In this same period, five hundred thousand pounds of express and six hundred thousand pounds of mail were carried out. All figures quoted are furnished by the department of Commerce, and, of course, are authentic. These figures definitely establish San Francisco Airport as one of the main airport

terminals in our country. The comparison of Domestic and Foreign Air Commerce is certainly very impressive. The enormous strides that have been made in the development of Air Transportation and Air Commerce in the United States in the past year alone, compared to the development in all foreign countries, is a high tribute to American Engineering skill, the American air lines, and in general, to the Aviation Industry. These figures certainly show why we are justified in spending money and effort in the development of the air terminal site for the San Francisco Bay Area.

The Traffic Representative of United Air Lines, E. F. Johnson, estimates the future local traffic for us, and bases his estimate on the progress made since 1933 — says that there will be carried from the San Francisco Bay Area, in 1940, the year after the Exposition closes, one hundred fifty-four thousand passengers, the minimum being in January, of eleven thousand, the maximum in the month of September, fourteen thousand. These figures do not take into account what Pan American may develop in its great line out to China.

During our exposition, in 1939, it is going to be possible to have here, as a great attraction to thousands of people, the most spectacular and interesting aeronautical exhibits ever held. Plans call for holding Army and Navy Air maneuvers, National Air Races, International Flying Meets, and the most complete exhibit of all aeronautical equipment ever assembled at any exposition.

Here are some real reasons why we can all say that San Francisco Bay Region is destined to be one of the really great Aviation Centers of our Country!

Hamilton Field in Marin County near San Rafael, where the Army has its great bombing base, has been built at a cost of \$5,000,000. This site is capable of and will undoubtedly be further developed.

Sunnyvale Air Base, built by the United States Navy, and now used by the Army Air Service, cost \$5,500,000.

(Please turn to Page 49)

HEATING THE HOME HAS MANY NEW ANGLES

INSULATION, AIR CONDITIONING, THERMOSTATIC CONTROL

WHEN planning a home, it is important that special attention be paid to the equipment to be used. It should be selected for the work that it is supposed to perform; it should be adequate in capacity and strength for the service required. First cost should never be the controlling factor in making the selection; after all it is performance and service that you are buying. Be sure that the company you are dealing with is financially responsible and enjoys a reputation for doing good and careful work, that it is in a position to render satisfactory service in the future.

The home may be beautiful from the standpoint of exterior design, interior decoration, and convenient in its general arrangement, but if not provided with a suitable, efficient and adequate heating system, together with some form of air conditioning equipment to at least supply sufficient moisture to maintain proper relative humidity, it may be a very uncomfortable and unpleasant place to spend many years of your life. Happiness and an uncomfortable home do not go hand in hand. You are building a permanent residence, who not make it comfortable, convenient, and healthy?

When designing the heating plant it should be remembered that its size or capacity is determined by taking into consideration and allowing for all the items that effect the quantity of heat that must be supplied to the

house in order to maintain a proper room temperature. Only by doing this is it possible to provide a heating plant that will be economical in its operation and produce satisfactory results.

Some of the important items to be considered are:

1. Type of wall construction
2. Square feet of exposed wall surface
3. Type of windows
4. Square feet of exposed window surface
5. Type and square feet of ceiling surface exposed to a temperature lower than room temperature
6. Type and square feet of floor surface exposed to a temperature lower than room temperature
7. Outside temperature to be assumed—zero degrees in this locality
8. Inside or room temperature—usually assumed as 70°
9. Quantity of air leakage from various sources
10. Direction of exposure of the various rooms

The heating plant should supply only the heat that is lost from the house through the walls, windows, ceilings, floors, and the leakage from various sources. If the heat supplied is less than the quantity required to maintain an inside temperature of 70 degrees, the house will be cold and uncomfortable; on the other hand, if more than the required quantity of heat is supplied, the house will be over-

heated and fuel wasted. In either case the plant will not operate economically.

It should be understood that the type of heating plant used, has very little, if any, effect on the quantity of heat lost from the house, and further that the quantity of heat lost from the house depends, in a large degree, on the kind of materials used and the type of wall construction. It is possible to materially reduce the heat loss by using proper materials and a proper type of wall and window construction. A few examples will suffice to illustrate this point: Assume 100 square feet of wall surface area with an outside temperature of zero degrees and an inside temperature of seventy degrees. Under these conditions the ordinary frame wall, consisting of siding, sheathing, building paper, lath and plaster — the type found in many houses — will lose 1834 heat units per hour. The same area of concrete wall, 20 inches thick, and plastered inside, will lose 1939 heat units per hour. The same area of stucco wall, with wood lath and plastered inside, will lose 2114 heat units per hour. The same area of brick wall 12 inches thick and plastered inside, will lose 1939 heat units per hour. The same area of stone wall 16 inches thick, with lath and plaster inside will lose 1750 heat units per hour.

Now suppose we take the frame wall that had a loss of 1834 heat units and fill the space between the studs (about 4 inches) with a good insulating material. The loss for the same area and under the same conditions of temperature will be reduced to 680 heat units per hour, or a saving in this case of 1154 heat units. Similar savings would be made in the other types of walls by using proper insulating material. Storm windows or weather strips will also reduce the heat loss.

Reducing the heat loss from the house reduces the heat to be supplied by the heating plant and naturally reduces the amount of fuel burned. It can also be said that a house easy to heat in the winter will be a cool house in the summer. Thus proper insulating serves two purposes.

In my opinion, the first step in planning the

heating system is to build the house so that the heat loss will be reduced to a minimum.

There are three general types of heating systems suitable for the home, namely hot water, low pressure steam (often called vapor system) and warm air. We are frequently asked, "Which is the best system," or "What system shall I use?" This is always difficult to answer, and it cannot be answered intelligently without knowing and studying all the conditions to be met in each particular home. They are most always different. Generally speaking, any one of the three systems, when properly designed, installed, and efficiently operated, will produce equally good results. The type finally selected should be the one that best satisfies all requirements and conditions, including the desires of the owner, who perhaps has very definite ideas of what should or should not be done.

The location of the furnace should receive more than casual attention. It should not occupy more space than necessary; it should be near the chimney and fuel supply; the fuel storage should be located, if possible, near the driveway. Basement space is valuable; do not use more than necessary for the heating plant.

Fuels may be classified into three divisions:

1. Solid — such as coal and coke.
2. Liquid — such as oil.
3. Gas — either artificial or natural.

The selection of the kind of fuel depends on the cost and the owner's preference. To insure cleanliness and convenience and to provide full automatic operation, many owners are willing to pay the price necessary for gas or liquid fuel.

Whatever may be the final selection of the type of furnace and fuel to be used, the house should be provided with automatic temperature control, obtained by the use of a reliable thermostat.

During the past four or five years, real progress has been made in the important field of air conditioning as applied to the home. The term, "air conditioning," or "conditioned air" seems to be surrounded with some sort of mystery; many think of it as a new and startling

discovery. It is not. In fact, our fathers, grandfathers, and great grandfathers knew something about and made use of it to a limited extent. In the earlier days homes were heated with stoves burning wood or coal, and it was not uncommon to find placed on the top of the stove a tea kettle or some other type of container filled with water, with vapor rising from its surface and being quickly absorbed by the air in the room. This, though crude, was one method of conditioning air, in cold weather, by introducing moisture, thus providing a higher relative humidity. Today we do the same thing by different and more efficient methods.

Fundamentally, air conditioning means the introduction of sufficient moisture into the air circulated through the house during the heating season to maintain a proper relative humidity — 45 to 55 per cent — thereby producing, together with proper temperature, comfortable and healthy living conditions.

Every new home should include as an essential part of the heating system, a recognized and acceptable method of introducing moisture into the air, thereby maintaining, during the winter, a relative humidity of not less than 45%. While it is more difficult to obtain satisfactory results in a house that did not, when constructed, take this into consideration,

equipment is available that would greatly improve the dry condition of the air. In addition to the healthier and more comfortable living conditions, there are many other advantages — the furniture will not dry out, windows will not shrink and rattle, floors will not creak and the doors will fit as they should.

Due to lack of time, it has not been possible to discuss many of the important details so necessary in planning a successful heating and air conditioning plant. In conclusion, let me summarize the important points mentioned in this talk:

1. Build your home in such a way that the heat loss will be reduced to a minimum. It will save many dollars in cost of fuel.
2. A house that is easy to heat in the winter is usually cool and comfortable in the hot summer days.
3. Pay particular attention to the location of the equipment in the basement; it is valuable space.
4. Provide automatic temperature control; it is not very expensive and will save fuel.
5. Provide a method of introducing moisture into the air and maintain a relative humidity of not less than 45%.
6. Artificial cooling provides comfortable living conditions during the summer, but at the present time it is expensive.

WORLD'S FAIR SITE AS
FUTURE AIRPORT
(Concluded from Page 46)

Mills Field at South San Francisco has been developed and is being further improved at a cost of \$4,800,000.

Oakland, Alameda and Benton Field Airports, cost approximately \$3,200,000.

It is proposed to expend at Yerba Buena Shoals \$7,000,000, and \$15,000,000 more for a Naval Air Base at Alameda.

There will be a total expenditure of \$35,000,000 for the development of aviation projects in the San Francisco Bay Area.

Of course, it is wonderful to have the 1939 World's Fair here in the San Francisco Bay Area, but long after the ordinary layman ceases to think about the Exposition, this community will, every day, reap the benefits of the work of developing the airport site on Yerba Buena Shoals.



CHARCOAL DRAWING BY BISHOP

ARCHITECTS' BULLETIN

Issued For

THE STATE ASSOCIATION OF CALIFORNIA ARCHITECTS Northern Section

STATE ASSOCIATION MEMBER OF THE AMERICAN INSTITUTE OF ARCHITECTS

Harris C. Allen
Editor

Address all communications for publication in the Bulletin to the Editor (Harris C. Allen) 557 Market Street, Room 218, San Francisco, California.

Board of Control

Harris C. Allen Otto G. Hintermann
Harry Michelsen Ellsworth E. Johnson

State Association Officers

William I. Garren..... President
Lester H. Hibbard..... Vice-President
H. C. Chambers..... Secretary
Otto G. Hintermann..... Treasurer
Albert J. Evers
Regional Director, A.I.A.

Executive Board — Northern Section

William I. Garren..... President
Harry Michelsen..... Vice-President
Ellsworth Johnson..... Secretary
Otto G. Hintermann..... Treasurer

Directors

Harry Devine J. K. Ballantine
Roland I. Stringham Chas. F. B. Roeth

Executive Board — Southern Section

Lester H. Hibbard..... President
George D. Riddle..... Vice-President
H. C. Chambers..... Secretary
Robert H. Orr..... Treasurer

Directors

A. M. Edelman Louis J. Gill
Wm. S. McCary Henry C. Newton

District Advisors—Northern Section

Harris C. Allen Wm. K. Bartges
J. H. Mitchell Gwynn Officer
J. K. Ballantine C. A. Caulkins
Thos. Kent Frank Mayo
C. F. Maury Chas. E. Butner
Wilbur D. Peugh Ralph Wyckoff
Will Toeplek Leslie I. Nicols
Dodge Riedy Wallace A. Stephen
Edward Frick W. E. Baumberger
S. L. Hyman F. T. Georgeson
Ralph E. Westell Casebolt C. Dakin
Earl R. MacDonald Ralph D. Taylor
Jas. T. Narbett Edward W. Peterson
Herbert G. Goodpastor

EDITORIAL ANNOUNCEMENT

In the June issue of THE ARCHITECT & ENGINEER there appeared a statement by William I. Garren, President of the State Association of California Architects, (also appearing elsewhere in this issue) announcing the purchase of "Architect's Reports" by THE ARCHITECT & ENGINEER, and the consequent transfer of the Association's contracts to the purchaser. Incidental to this "New Deal" comes the establishment of a department for the Association, to appear in this journal monthly. Through this medium the profession may receive such notices, news items and general information as may properly be published, confining direct communications to members to matters of internal business in process of determination.

The "Bulletin" of the Association, therefore, which has appeared somewhat irregularly of late, will be renewed in this regular form, coming to the profession in a journal which has for many years recorded the progress of the building industry on the Pacific Coast. Now that a new stimulus has been given to construction activities, this new relationship is auspicious. It is not too much to say that the science and art of architecture are undergoing a renaissance; and it is consistent, even necessary, that both the private and the public relations of architects take on new life.

* * *

In accordance with custom, the Executive Board of the Northern Section has responsibility for this year's Convention of the State Association. The Board has determined the place to be Del Monte Hotel, the time to be October 16 and 17, the Convention Committee to consist at present of Harris Allen, Chairman; J. K. Ballantine and Otto Hintermann. This will be enlarged and sub-committees will be appointed in due course. As regards the program, it is not possible to make any specific announcement as yet; but in view of the outstanding success of the 1934 Convention, something similar in the way of Forums or Group Conferences may probably be expected. There are several important, timely subjects (or problems) suitable for consideration with participating representatives of various outside organizations or interests. Slowly but steadily, we are approaching a closer organization of the great, sprawling, unwieldy mass of agencies which make up the building industry, and consciously or unconsciously these all look to the architectural profession to lead the way, just as it must direct and co-ordinate them in actual building operations.

That almost equally important phase of a convention — the cultivation of acquaintance and fellowship — will certainly not be overlooked in this third Del Monte re-union. Entertainment and recreation naturally accompany that environment. We will not ape the radio and command you to buy your tickets tomorrow; but we do urge you to plan ahead for a short vacation in October.



JOINT CONFERENCE

This San Francisco Board, consisting of officially appointed representatives from organizations of architects, engineers, contractors and producers, has been meeting fairly frequently, and its meetings have been to some purpose. Its attention is given to conditions, mainly public, which concern the entire group. An instance: as the result of representations made to the city authorities, the staff of building inspectors will be almost doubled. Progress is being made toward the improvement of other conditions.

EMPLOYMENT BUREAU

Our office secretary, Miss Kragen, reports "Land-office business" in registering and placing draftsmen. This service furnished by the Association is becoming more widely known and utilized. If you need a draftsman — or a job — get in touch with Miss Kragen at the Association office (557 Market Street, phone DOuglas 4561) and specify your needs or your qualifications. The office is a natural clearing house for this business.

SUBSCRIPTIONS

Treasurer Otto Hintermann calls attention to the fact that membership subscriptions are still needed for the current year — and the number of subscribers to date is not up to our average. These five dollar subscriptions form a larger part of the Association revenue than formerly, and there are regular and special activities and services to which the Association is committed by the will of the membership. Are architects too busy to remember this small contribution to the organized defence of the profession and its standards? If you have not sent in your subscription please give this your earnest and early consideration.

ARCHITECTS

REPORTS

Now Owned and

Published by

THE ARCHITECT

AND ENGINEER

"The State Association of California Architects wishes to make the following announcement to the building industry and to the subscribers of Architect's Reports:

"By agreement between the State Association of California Architects, Northern Section, and THE ARCHITECT AND ENGINEER, the publishers of the latter have purchased and are now the owners of Architect's Reports, Inc.

"Architect's Reports have been merged with THE ARCHITECT AND ENGINEER'S daily news service, and in the future will be published and distributed by THE ARCHITECT AND ENGINEER.

"The State Association of California Architects, through its member architects, will cooperate in furnishing THE ARCHITECT AND ENGINEER advance information pertaining to work in architects' offices, and this information will be given out as early as is consistent with the interests of the architects' clients and themselves.

"The State Association of California Architects recommends to the building industry the use of this daily building report service.

"In addition the State Association of California Architects will cooperate in assisting THE ARCHITECT AND ENGINEER in its task of gathering suitable material for publication in its magazine.

"With this new set up THE ARCHITECT AND ENGINEER Daily Architects' Reports will become the largest advance daily news service in the building industry on the Pacific Coast.

(Signed) "WILLIAM I. GARREN,

"President State Association
of California Architects."

With the Architects

HYMAN AND APPLETON BUSY

One of the busiest architectural firms in San Francisco is Hyman and Appleton, 68 Post Street. Contracts have been let for a \$35,000 warehouse for the Pacific Can Company at Carroll Avenue and Newhall Street, San Francisco; a \$12,000 residence in Atherton for Sidney Herzog; alterations to the house of M. Hirsch and a reinforced concrete factory for Lawrence A. Meyers on Folsom Street, San Francisco. Plans have been completed for a \$25,000 residence on Camino Del Mar, near 27th Avenue, for Harry E. Fisher; an \$18,000 residence in Seacliff for Harry B. Allen, and a \$25,000 house on 30th Avenue for Louis E. Goodman.

BURLINGAME APARTMENTS

A two-story frame and stucco apartment house has been planned for Anita Road, Burlingame, by Angus D. McSweeney for Mrs. Anita Reed of 15 Park Road, Berkeley. There will be ten apartments. G. W. Williams Company will build the \$22,000 structure. Mr. McSweeney has also made plans for remodeling the office building at 604 Mission Street, owned by the Bothin Realty Company.

CENTERVILLE RESIDENCE

Birge M. Clark, 310 University Avenue, Palo Alto, has awarded contracts for the construction of an eight-room house in Centerville, Alameda County, California, for Allen G. Norris. Stucco exterior, shake roof and gas heating are specified. Contracts call for an expenditure of about \$12,000.

C. E. BUTNER BUSY

New work in the office of C. E. Butner, architect, 51 Maple Avenue, Salinas, includes an addition to the Pajaro Grammar School; addition to the King City grammar school; earthquake strengthening to the same building; a store and apartment building in Salinas for Earl Wilson and an addition to the Monterey County Hospital.

HOSPITAL ADDITION

Charles F. Dean of Sacramento is preparing preliminary drawings for a maternity ward at the Sutter Hospital, 52nd and F Streets, Sacramento, estimated to cost \$90,000. The building will be air conditioned.

WHARF REMODEL

Henry T. Howard, 580 Market Street, San Francisco, has completed drawings for reconstructing the Howard Terminal wharf at First and Market Streets, Oakland, estimated to cost \$10,000.

SACRAMENTO ARCHITECT ACTIVE

The office of Frederick S. Harrison, 824 J Street, Sacramento, reports working drawings completed for a \$23,000 residence at Sierra Oaks for P. G. Layth; a \$5,000 house at Walnut Grove for which a contract has been awarded; a residence in Clarksburg for Ray Burdy and a house at Walnut Grove for Reed Henderson.

MORE RESIDENCES

Wallace A. Stephen, Belle Haven City, Santa Clara County, has prepared plans for a \$10,000 eight-room house for the David D. Bohannon Organization on Embarcadero Road, near Palo Alto, also a \$13,000 Colonial house in San Mateo and a five-room house at Belle Haven City for Mr. Derico.

W. I. GARREN BUSY

Considerable new work is reported in the office of William I. Garren, 233 Post Street, San Francisco, including more modernization for the Phelan Estate in San Jose, store alterations, and a \$14,000 English house in Claremont Pines and other residence work in the Bay Region.

ELEVATOR INSTALLATION

Six new elevators are to be installed in the Merchants Exchange Building, San Francisco, which is another step on the part of the owners to modernize the structure not only in general appearance but in its mechanical equipment. The Westinghouse Company has the elevator contract.

TWO SAN FRANCISCO DWELLINGS

Plans have been completed by C. O. Clausen, 746 46th Avenue, San Francisco, for two speculative houses to be built on 19th Avenue, north of Wawona Street, San Francisco, for S. F. Johnson. The owner will be in charge of construction which will represent an investment of \$10,000.

SIX SAN FRANCISCO DWELLINGS

Edward Denke, 1317 Hyde Street, San Francisco, is the architect of six one-story frame and stucco dwellings which R. F. Galli will build for speculation on the west side of 23rd Avenue, south of Ocean, San Francisco. They will cost \$6,000 each.

PALO ALTO RESIDENCE

Charles K. Sumner has completed plans for a seven-room residence to be built on the campus at Stanford University for Prof. Carl F. Brand, a member of the University faculty.

SAN FRANCISCO ARCHITECTURAL CLUB

Kearny Street, San Francisco
WALTER C. CLIFFORD, President
H. WALTER RUPPEL, Vice-President
RICHARD E. AUDSLEY, Secretary A. N. GRANISH, Treasurer

TRUSTEES
WALDON B. RUE OTTO G. HINTERMANN HARRY C. NYE
DIRECTORS
ALBERT KAHL IRA H. SPRINGER CHARLES J. CONTI

Vacation Time

With the lure of mountain streams, blue Pacific waters, and other vacation attractions, the San Francisco Architectural Club brings to a close an active spring season. During the summer months the executive board will labor on plans for an interesting program to round out the year's activities.

The June meeting brought forth many old faces. Among the past presidents in attendance were Messrs. Harry Nye, Lawrence Keyser, Jack Sly, Donnell Jaekle, and several other real 'old timers'. It is interesting to note that with increasing activity in the profession, the old esprit de corps is again prevalent.

* * *

May Increase Dues

Among the more important items of business at the June meeting was the question of raising the yearly dues. During the depression the annual dues were decreased to meet the then existing conditions and expenses were curtailed to a minimum, but it was the opinion of the board of directors that the time was ripe for an increase. Increasing operating expenses, and enlargement of several activities for the membership makes this increase imperative.

The first monthly social meeting was a pronounced success. About forty-five members were in attendance to enjoy card games, billiards, pool, etc. These social evenings are in the nature of an experiment, it being felt that the club should conduct two separate meetings a month, the first, a business meeting and the second a social night.

* * *

Two Exhibitions

The club was extremely fortunate, through the courtesy of the San Francisco entrants, in being able to show the various solutions of the recent Oregon State Capitol Competition, as submitted by the local architects. Another interesting exhibition was the Richard Gosline show of water-colors, pencil sketches and etchings, made during a recent archaeological tour through Mexico, Yucatan and Central America.

R.E.A.

WORLD'S HIGHEST BRIDGE

It looks as if Canada will soon be able to claim the distinction of having the highest bridge in the world, if the negotiations of a group of British capitalists bear fruit. These men are interested in the construction of a bridge across the narrow entrance to Vancouver Harbor at an estimated cost of £1,200,000. The plans provide for a structure 1500 feet in length with a clearance of 200 feet.

WINDOWLESS AMERICAN BUILDINGS

(From Buildings, Sydney, Australia)

The extent to which air conditioning has been developed in the United States is evident from the recent trend in design of some industrial buildings. For instance in one case the walls are entirely of masonry, there being no windows whatever in the structure, whilst another is built entirely of glass blocks without windows. The owner is depending upon the installation of air-conditioning plant for the supply of fresh air and upon artificial lighting for light.

We question, however, whether air conditioning and artificial lighting will ever become developed to such an extent in Australia. In addition to the extra cost of installing air conditioning plants, it would be hard to convince Australians that conditioned air is preferable to the natural fresh air and artificial lighting to natural lighting.

However, the development that has taken place in America is none the less interesting.

CHURCH ARCHITECTURE

The next meeting of the North American Conference on church architecture will be held October 9 in the Cathedral of Saint John the Divine, New York City.

The following have been invited to address the conference: The Right Reverend Bishop William T. Manning, Dr. Ralph Adams Cram, Dr. John Angel, Dr. Francis S. Onderdonk, University of Michigan, who will speak on Ferro-Concrete Construction, and give an illustrated lecture on architectural services for smaller churches; Prof. Leopold Arnaut, of the School of Architecture of Columbia University, and Joseph G. Reynolds, Jr., of Boston. All architects, building contractors and others interested in modern American architecture are invited to be present.

GRASS VALLEY RESIDENCE

Plans have been completed and construction is progressing for a \$15,000 residence in Grass Valley for H. B. Snyder of that city. Jens C. Peterson of Sacramento is the architect. There will be seven rooms, two baths and a double garage.

ALBERT J. EVERS HONORED

Albert J. Evers, architect of San Francisco, has been elected regional director of the Sierra Nevada Division of The American Institute of Architects.

Mr. Evers time is now largely occupied on 1939 Exposition work.

\$15,000 RESIDENCE

Eldridge T. Spencer, Claus Spreckels Building, San Francisco, has completed plans for a \$15,000 residence to be built in Upper Piedmont Estates, Alameda County, for A. S. Olofson of 1100 Norwood Drive, Oakland.

APPRAISING THE CONTROVERSY

By Louis La Beaume, F. A. I. A.

During the past five years or more the architectural profession has been busy, not in the practice of architecture, but in the discussion of architectural theories. Heated verbal engagements have taken place between the proponents of tradition and the apostles of progress. Both sides have often been eloquent, and sometimes logical. However, there is a vast difference between verbal eloquence and architectural eloquence, and architects must, in the final analysis, be judged by their deeds rather than their words. And now that the fury of the discussion seems to be abating, we may take advantage of our breathing spell and attempt to appraise the net results of the controversy.

There seem to be signs that some of the modernists are retreating from their extreme position; likewise some of the traditionalists seem to be moving ahead. Excess is giving way to common sense. Economic forces, no less than esthetic ideals, have always affected the course of design. Such forces must inevitably have their effect on what is called style in architecture. The battle of the styles is over and the architect of today realizes, as perhaps never before, the necessity of a fresher and less traditional approach to his problem. Certain elements and phrases in his architectural vocabulary are gradually being sluffed off, and some new words and phrases are being coined.

If the functionalists have overstated their case, as must be soberly admitted, they have at least performed a useful service in calling attention to the need for simplification and for clean, outright architectural statement. Material functionalism as the sole attribute of architectural design is an absurdity, for architecture remains an art founded on use, but evoking a response from the spirit which hungers just as avidly for beauty as it does for comfort. — The Octagon.

SACRAMENTO ARCHITECT BUSY

One of the busy architect's offices in Sacramento is that of Herbert E. Goodpastor in the Mitau Building. Mr. Goodpastor was formerly with Harry J. Devine and prior to then was associated with Chester H. Treichel in Oakland. Following is a list of some of the work he has on the boards:

Mortuary building for L. R. Jefford, Grass Valley, \$20,000; residence for R. Miller, College Tract, Sacramento, \$8,000; residence in Orinda, Oakland, \$7,500; residence for J. J. Judson, Hillsborough; remodeling of store building in Sacramento; residence for T. Lindblad, College Tract, Sacramento, \$11,000.

Mr. Goodpastor is consulting architect for the Land Drive Terrace promoted by the McClatchy Realty Company, Sacramento. Sixteen new houses are under construction.

WOMAN SCULPTOR TO STUDY ABROAD

Miss Helen Phillips, sculptor, who was recently awarded the Phelan Traveling Scholarship by the San Francisco Art Association, is planning to go to Europe this summer to study the old masters and the modern trend in sculpture. She plans to see the Gothic sculpture in France, the Romanesque on the Adriatic and



MISS HELEN PHILLIPS, SCULPTOR

Mediterranean coasts, the Renaissance in Italy. In the great museums of Europe she will have the opportunity to view examples of Assyrian, Byzantine and Egyptian sculpture from the best periods.

Miss Phillips has never been out of California. This opportunity she states, will permit her to study in a manner she never dreamed possible, and by going to Europe gather a broader perspective of her chosen profession.

Thus far her own tenacity, the idealization on the part of her sisters and mother, have made possible her present achievements. Miss Phillips resides at 1365 Greenwich Street, San Francisco.

The Phelan Traveling Scholarship is limited to past and present students of the California School of Fine Arts, San Francisco, who have completed two years of consecutive study, and who are under 30 years of age. Provision was made for this scholarship under the terms of the bequest left the San Francisco Art Association by the late Senator James D. Phelan.

SAN FRANCISCO MUSEUM OF ART

Exhibitions for August: International watercolor exhibition, July 23 - August 23. Exhibition of abstract art, July 27 - August 28.

Exhibitions for September: Paintings by Gauguin, September 4 - October 4. Survey of Oriental and European rugs during four centuries, September 6 - October 4. Paintings by American Indians, Sept. 6.

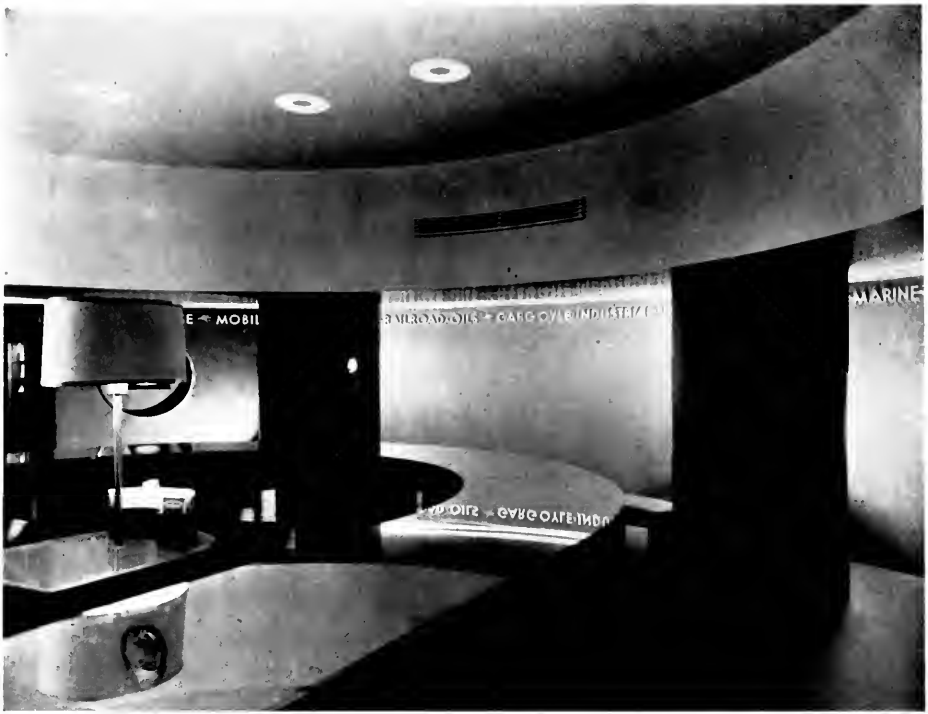

MODERN TREATMENT OF TOURING SERVICE BUREAU, NEW YORK

TOURING BUREAU OF MODERN DESIGN

The new Socony-Vacuum Touring Service Bureau by Henry Dreyfuss is distinctively modern in design and appointments, in fact the bureau is said to be one of the most modern of its kind in the country.

Mr. Dreyfuss handled the design in a way that best emphasized the U shape of the room. The corners of the columns were cut off, making them round and three of the existing columns and one other built-in column form a colonnade around the circular end of the bureau.

The service counter is U-shaped and gives a maximum amount of counter work space.

The ceiling over the colonnade was lowered, covering some of the existing duct work and allowing new duct work to be installed, while the ceiling over the central part of the room was left at a higher level.

The entrance to the building elevator lobby passage has been made with splayed sides so as to meet the curved walls at a good angle and present a wide inviting doorway.

The street entrance at the other side of the bureau has been set at an angle to the walls of the new room in such a way that people coming into the building from the street get a vista through the door, as do people from the bank located in the building. A wall



STRIKING DESIGN AND DECORATIVE TREATMENT OF TOURING SERVICE BUREAU, NEW YORK

set back from the flat end of the U divides the bureau from the office space but allows passage into it at either side.

The general color scheme of the room is green-blue and white with brilliant red accents.

The main walls and columns and floor are blue linoleum. This gives an interesting decorative treatment and also provides for exceptional ease of maintenance in that the only cleaning necessary is washing.

The ceiling is off-white, with various small wall spaces painted similarly to give a bright touch to the general scheme. The front of the counter is of white linoleum.

Large photo-murals cover the walls on either side of the counter. These show a long parade of cars against a cloud filled sky.

A semi-circular bench upholstered in brilliant red leather is set between the two central columns.

Two continuous movies are set in niches in the curved wall. Show cases with brilliant red backgrounds are set in the entrance passageway to the building.

A number of brilliant louvred lights are set in the ceiling over the counter and a large specially built lamp placed on the desk behind the counter throws a brilliant ray of light on the ceiling.

The room is made to seem larger by a trough of light running around the entire space back of the colonnade, which throws a halo of light around the room.

FAIR SITE CONNECTED WITH BRIDGE

The site of the 1939 Golden Gate International Exposition is now connected directly with Yerba Buena Island and the San Francisco-Oakland Bay Bridge, the foundation of a 110-foot wide causeway leading from the island to the southern end of the Exposition area having been completed.

Powerful dredges will continue depositing rock and sand on the causeway to form what will ultimately be a six-lane roadway leading from the island down to the Exposition. This roadway will be a three per cent grade.

First to officially cross the stretch of land from Yerba Buena Island to the Exposition site was the Exposition's Director of Works, William P. Day, and San Francisco's Chief Administrative Officer, Alfred J. Cleary, who is a member of the Exposition's Executive Committee.

The causeway also is the first step in creating a protected basin which will eventually serve as the 1939 World's Fair Yacht Harbor, lying between the Exposition site and the island.

With the Exposition project approximately 15 per cent complete, work is being speeded on the rock seawall, which is now 1200 feet long. A fourth derrick barge will join the dike construction fleet this week, which will raise the rock deposit schedule to approximately 40,000 tons a month.

TILE MAN IN SHIP COLLISION

The many acquaintances of Frank P. Schemmel, formerly of Solon and Schemmel, manufacturers of S & S tile, San Jose, will be interested to read of his exciting experience on the first lap of his journey around the world. In a letter to **The Architect and**



BUILDING WITH BRICK AND HOLLOW TILE IN SAN SALVADOR

Engineer, dated Hamburg, Germany, and written May 8 on board the steamship New York, Mr. Schemmel writes:

"After being ship-wrecked on the coast of Sar Salvador and then taken inland through the jungles to the city of San Salvador, I noticed while there, that most of the structures are built of brick and hollow tile. In building they first run up the walls of brick and tile, then place steel rods in space and finish by pouring the concrete. This was new to me, possibly old to you, nevertheless took a picture which you can enlarge if you wish.

"Last night on the North Sea, about twelve hours run from the Holland coast, we ran into a Dutch freighter and sank it. We stood by and rescued twenty-six men of the crew.

"It was densely foggy and both boats kept their whistles going.

"I heard the oncoming boat but it could not be seen until with a crash we stove in her side. Eight men crawled onto our bow; the rest we picked up, their boat sinking in three hours. The impact made a large hole in our bow."

ROME PRIZE IN ARCHITECTURE

Richard Ayers, architect, now residing in New York, was awarded the Daniel H. Burnham fellowship in architecture this year.

The final problem was "A Community Mausoleum." The jury of award consisted of John Russell Pope, chairman; Louis Ayres, Benjamin W. Morris, and James Kellum Smith.

Mr. Ayers was born in Jefferson, Georgia, in 1910. He received his B.F.A. in 1932 and M.F.A. in 1934, both from Yale University. He works in the office of Frederick A. Godley, New York, N. Y.

The ten finalists were chosen from ninety entrants. Honorable Mentions were given to John J. Brust and Max O. Urbahn, both from Milwaukee, Wisconsin.

DECORATIVE PAINTING

The purpose of decorative painting is probably the least understood of any of the work that is used in the interiors of buildings, and few comprehend its value and necessity, particularly in public and semi-public buildings.

The lack of understanding of this character of work and its too frequent improper application, has prejudiced many against it. Not being a structural material (in a literal sense) it is too often considered only as a protective medium and immaterial whether done at all or how executed. This, however, is an erroneous conception which should be corrected.

Decorative painting in its true sense is a fine art—as much so as sculpture or other allied arts. It has a real necessity wherever plaster surfaces are used, and in many cases is more effective and economical than the use of other materials or forms of treatment.

Its purpose when used with judgment is to enhance the room; to give restfulness and balance, with that degree of contrast or relationship in color as will best suit the architectural scheme. Its purpose as to effect is similar to the use of stone, marble, bronze, wood or other materials of a textural and color value.

Its possibilities in obtaining effects goes much further than other mediums of expression, due to the innumerable combinations of tone and color that can be used.

It acts as a medium to blend and pull together other materials that enter into the construction of the room. Textures and self tones can be employed to great advantage, where both character and simple effects are desired. There are cases where creative design and color may prove the best and most economical method of expression, such as in rooms that have a functional purpose. There are still other rooms of a monumental character, where great richness in subdued colors or gold are essential to give the proper accentuation, as in ornamental coffered ceilings.

The possibilities of decorative painting are endless, and whether done in the simplest neutral tone or on a highly decorative manner, it is one of the most essential factors in the successful treatment of an interior.

It is evident that great judgment and study should be devoted to this branch of architecture to insure the desired results. The work cannot be given out in a haphazard manner, and whoever is entrusted with the commission must be thoroughly capable of handling it.

Decorative painting is a specialized field of art, and should not be confused with the work of the plain or mural painter, these being separate fields of endeavor just as much so as those of the mason, the stone cutter or modeler. One could not expect the mason to give the same result as a stone cutter or modeler,

and for the same reason one cannot procure decorative painting from a plain or mural painter who has not been trained for this type of work or has no organization for its execution.

The decorative painter to direct and execute this work should be one who has had training in art and architecture, with an understanding of the architect's and owner's viewpoints, and results to be achieved. He must have creative ability and a technical knowledge as to the best methods for the execution of the work, together with a broad experience and an organization of competent and trained artisans. He should know when and how to suggest changes, additions or eliminations in the scheme as the work progresses, that will lead to its successful completion.

It can be readily seen that it is impossible to overcome this lack of knowledge in the mind of a decorator or painter who may have the best of intentions but is lacking in the training and understanding of this type of work. Even the most complete and adequate drawings, specifications and supervision will be useless in his hands. For these reasons it is impossible to have work of this character carried out successfully by open competitive bidding.

In order to obtain the proper service and results as outlined, a method has been used by a number of architects and owners which has proved most economical and satisfactory in its attainments. This method eliminates the necessity for indiscriminate competitive bidding.

1. The architect to insert in his specifications an allowance sufficient to cover the decorative painting, this to form a part of the general contract and subject to the control of the architect, or handled by the architect and owner as a separate item.

2. To select by invitation a decorative painter (or not more than three of repute and standing to review the work in question, who is to give his credentials in writing to the owner and architect of their consideration.

3. The owner and architect if satisfied with this information, to request the decorator (or any one of the three) to prepare a preliminary scheme without prejudice or cost to the owner.

4. The scheme to consist of such color drawings and descriptive specifications as will give a general idea of the work proposed, together with a budget of cost that shall not exceed the amount specified.

5. If this preliminary work is not satisfactory to the architect and owner they may take up the work with some one else in the same manner without obligation.

6. If the preliminary work is satisfactory, the decorator to be commissioned to prepare the following data, for which he may make a service charge to be agreed upon in advance with the architect and owner.

7. To prepare all color or line drawings to fully

illustrate the work intended, together with detail specifications in which latitude is given to make changes as the work progresses. From these drawings and specifications, a detailed budget to be prepared based on the cost of each space and further analyzed to give the cost of the various elements that go to make up the amount of the budget, such as working drawings and layouts, cartoons, samples, decorative painting labor, decorative ornamental painting labor, overhead and profit.

8. If the foregoing is generally satisfactory to the architect and owner, an agreement to be entered into with the decorative painter for the execution of the work which shall also include all costs under items 6 and 7.

9. If a working basis cannot be agreed upon, the decorative painter to be paid the amount for service in item 6, and the matter closed. The drawings, specifications, etc., being the property of the owner.

The method outlined herein will give the basis for a fair and impartial contract, will enable the architect and owner to keep a check on the work both in labor and execution, and will give latitude for changes as may be deemed necessary as the work progresses without extra cost to the owner.

SOUTHERN CALIFORNIA CHAPTER

The June meeting of Southern California Chapter, The American Institute of Architects, was held at the Clark Hotel, Los Angeles, Tuesday evening, June 16.

Reports on the 1936 Institute convention were made by A. M. Edelman and George J. Adams.

Inaugurating a symposia on the lives and works of architects of the past, three speakers combined to present a very inspiring picture of the life and achievements of Bertram Grosvenor Goodhue, noted American architect. The speakers were Winchton L. Risley, Carelton M. Winslow and Dr. Hartley Burr Alexander, the last named a member of the faculty of Scripps College and guest speaker of the evening. The three men, all formerly associated with Goodhue, with the introduction of anecdote, correspondence and a serious appraisal of his character, aims and the significance of his work, brought to the members present a figure who should indeed at all times stand high in American art and architecture.

Ralph C. Flewelling, president, announced that the next session would be held at Palos Verdes Estates July 14.

NEW ADVERTISING MANAGER

Bennett Chapple, vice-president and director of publicity of The American Rolling Mill Company, Middletown, Ohio, recently announced the appointment of Harry V. Mercer as advertising manager, a newly created office at Armco. Mr. Mercer has been associated with Armco since May 1, 1916. During 14 of his 20 years of service he has been identified with practically all phases of the company's publicity and advertising.

WHAT'S NEW IN HOUSES

By G. Frank Corder, A. I. A.

Interest in home building never seems to wane, in spite of setbacks. Those of us who haven't one, want one. Those who have want a better one or else they want to change neighborhoods. Thanks to the Federal Housing Administration system of mortgage insurance and its Better Housing Campaign we see very definite signs of renewed activity in house building. Let's visit some of these new houses and see what's going on, see what's new in houses.

The results of a recent nation-wide competition among architects for designs for a medium size house indicate that not alone the house, but the lot and the neighborhood now form the basis of planning and design. Architects are pointing the way to better living through houses that consider all these phases I have just mentioned. Houses and their garages are being consolidated into one structure with the garage frequently on the street side and the living room looking over the beautiful rear garden, where local conditions make this feasible.

We find an increasing number of houses that are being built firesafe. Light forms of steel and of concrete seem to be leading in popularity. More and larger windows, both of wood and steel, are being provided and where the view warrants, the large stationary, plate glass panorama window has reappeared.

Because so many people take most of their meals in a room other than the dining room, the latter is slowly disappearing or is becoming a part of an enlarged living room. The breakfast nook or dining alcove, as you please, has come to stay because of its practicality.

There is much evidence that the full basement is on its way out because modern air conditioning plants, laundry equipment and play rooms may just as well be put above ground. In the case of play and recreation rooms they are infinitely better out of damp basements.

Kitchens are smaller but are receiving more care in their planning and equipment. Electric fans for removing heat and odors are now common. Longer counters and work places are being recognized as necessities. Linoleum in special colors is seen on walls for ready washing, and also on drainboards. The newer sinks have metal cabinets and drawers below and a wide range of colors is available. Less food storage space is needed now. As a nation we are eating less and stores are nearby to store it for us.

Heat insulation has become the common requirement in outside walls and topmost ceiling. There is no insulating value in ordinary building paper, contrary to what you may be told by those interested in selling you a house. Investigate. In no one thing does the modern house show greater progress over its predecessors than in attention to physical comfort. Insulation, weatherstripping, better windows, lower ceilings and better heating systems all combine to

make us comfortable. Air conditioning systems are gaining impetus as costs gradually decline and broaden the market.

The average air conditioning plant warms the air, generally with oil as the fuel but now and then using coal, circulates it under pressure from a blower to the rooms, returns it to the heater, filters it, adds moisture and then repeats the cycle. Not many are yet cooling it in summer nor removing excess moisture as occasion demands not because these are impossible of accomplishment but because the added cost is usually more than the homebuyer of modest means can afford to pay. Room temperatures are controlled by automatic regulators as is usually but not always the percentage of humidity.

Large, accessible attics are disappearing from two story houses, although they are still seen over the one floor bungalow type.

Exterior design of residences is slow to respond to new types so one may come upon a very modern plan or layout having its exterior done in the details of one of the conventional or period styles. It is the same with interiors. Entire interiors in the modern style are rare in small houses as yet but one will find single rooms, decoration here and there and other features that indicate the trend. One influence that will speed this up is the more rapid spread of furniture done in the modern manner. Movable equipment is always more quick to respond to new influences than fixed matters like buildings.

Surprisingly enough, there are but few really new materials to be found on the new houses. Older materials being used in new ways are much more common. Except for windows and mirrors, glass has still to be used in other ways as it has been used in commercial buildings. Even in bathrooms where it is highly suitable it has made little inroad on the old familiar tile. And, speaking of bathrooms, have you seen the new pressed steel plumbing fixtures with beautiful porcelain enameled finishes in many colors? And the new bathtub, four feet square, provided with angular seats and a diagonal tub depression?

In artificial lighting there is a trend toward softer, non-glare types and with more general ceiling lighting. Forests of bridge lamps giving next to no light are very lovely but are ruinous to eyes. Have them if you must but provide general lighting as well. The modern type of standing lamp which directs most of its light to the ceiling is very good.

These are some of the things that you have seen today.—Bulletin, Michigan Society of Architects.

DISAPPEARING SKYSCRAPERS

Skyscrapers are economic absurdities, said a speaker at the convention of the American Institute of Architects in Williamsburg, Va. They will disappear within two generations.

The skyscraper would not have attained such heights if good sense had prevailed. It is no longer news that excessively tall buildings, like the superliners on the ocean, are chiefly the result of pride and rivalry, tremendously costly, and not profitable. The giant buildings complicate traffic and other problems. The depression checked the race for height.

The recent trend, supported by improved transportation facilities, is away from crowded centers into outlying communities. Cities full of parks and gardens and individual homes have become the American ideal.

But we thought the skyscrapers would be left as an example of a special building era. Will the ones already built really disappear in this country? What will New York and Chicago do without their famous skylines.—Berkeley Gazette.

AIR CONDITIONING—Design and construction of ducts; by Thomas J. Brett; Engineer, Board of Education, Chicago; American Technical Society, Drexel Ave., at 58th Street, Chicago, Ill. Price: \$2.50.

This is a new and practical text on the requirements design, installation and operation of air ducts for the distribution of air for air-conditioning systems in various buildings and in railway cars.

The book deals with its subject in a very easy-to-understand manner. It is well illustrated, and contains many practical questions with answers worked out in considerable detail.

In the table of contents may be found such subject matter and treatment as—Duct requirements; Calculations for duct design and construction; Inlet and exit duct openings; Air circulation, etc., etc.

The book offers an excellent guide and handy reference for the air conditioning expert and for the further guidance of the architect or engineer confronted with the problems of today in that very important phase of modern building, air conditioning.

"SLOCO-GRAMS"

The May-June issue of "Sloco-grams" by the Sloan Valve Company merits the attention of architects and engineers, as well as general and specialized contractors. They will find in the book data of interest on installations of valve equipment in some of the foremost buildings in the United States. The photography is high class, views of the city of Philadelphia being particularly attractive.

Estimator's Guide

Giving Cost of Building Materials, Wage Scale, Etc.

Amounts given are figuring prices and are made up from average quotations furnished by material houses to San Francisco contractors. 3% Sales Tax on all materials but not labor.

Note—Mechanics are demanding higher wages due to scarcity of skilled labor. Present scale may be advanced in 30 days.

All prices and wages quoted are for San Francisco and the Bay District. There may be slight fluctuation of prices in the interior and southern part of the state. Freight cartage, at least, must be added in figuring country work.

Bond—1½% amount of contract.

Brickwork—

Common, \$35 to \$40 per 1000 laid, (according to class of work).

Face, \$75 to \$90 per 1000 laid, (according to class of work).

Brick Steps, using pressed brick, \$1.10 lin. ft.

Brick Walls, using pressed brick on edge, 60c sq. ft. (Foundations extra.)

Brick Veneer on frame buildings, \$.75 sq. ft.

Common f.o.b. cars, \$12.00 job cartage. Face, f.o.b. cars, \$45.00 to \$50.00 per 1000, carload lots.

HOLLOW TILE FIREPROOFING (f.o.b. job)

3x12x12 in.	\$ 84.00 per M
4x12x12 in.	94.50 per M
6x12x12 in.	126.00 per M
8x12x12 in.	225.00 per M

HOLLOW BUILDING TILE (f.o.b. job)

carload lots.	
8x12x5½	\$ 94.50
6x12x5½	73.50

Discount 5%.

Composition Floors—18c to 35c per sq. ft.

In large quantities, 16c per sq. ft. laid.

Mosaic Floor—80c per sq. ft.

Duraflex Floor—23c to 30c sq. ft.

Rubber Tile—50c per sq. ft.

Terazzo Floors—45c to 60c per sq. ft.

Terazzo Steps—1.60 lin. ft.

Concrete Work (material at San Francisco bunkers)—Quotations below 2000 lbs. to the ton, \$2.00 delivered.

No. 3 rock, at bunkers.....	\$1.80 per ton
No. 4 rock, at bunkers.....	1.75 per ton
Elliott top gravel, at bunkers 2.10 per ton	
Washed gravel, at bunkers....	2.10 per ton
Elliott top gravel, at bunkers 2.10 per ton	
City gravel, at bunkers.....	1.75 per ton
River sand, at bunkers.....	1.80 per ton
Delivered bank sand.....	1.20 cu. yd.

Note—Above prices are subject to discount of 10c per ton on invoices paid on or before the 15th of month, following delivery.

SAND

Del Monte, \$1.75 to \$3.00 per ton.
Fan Shell Beach (car lots, f.o.b. Lake Matella), \$2.75 to \$4.00 per ton.

Cement, 2.50 per bbl. in paper sks.	
Cement (f.o.b. Job, S. F.) \$3.00 per bbl.	
Cement (f.o.b. Job, Oak.) \$3.00 per bbl.	
Rebate of 10 cents bbl. cash in 15 days.	
Calaveras White	\$6.00 per bbl.
Medusa White	\$8.00 per bbl.
Forms, Labors average	\$40.00 per M.
Average cost of concrete in place, exclusive of forms, 35c per cu. ft.	
4-inch concrete basement floor	12½c to 14c per sq. ft.
4½ inch Concrete Basement floor.....	14½c to 16c per sq. ft.
2-inch rat-proofing	7½c per sq. ft.
Concrete Steps	\$1.50 per lin. ft.

Dampproofing and Waterproofing—

Two-coat work, 15c per yard.
Membrane waterproofing—4 layers of saturated felt, \$4.00 per square.
Hot coating work, \$1.80 per square.
Medusa Waterproofing, 15c per lb., San Francisco Warehouse.

Electric Wiring—\$12.00 to \$15.00 per outlet for conduit work (including switches). Knob and tube average \$7.00 per outlet, including switches.

Elevators—

Prices vary according to capacity, speed and type. Consult elevator companies. Average cost of installing an automatic elevator in four-story building, \$2800; direct automatic, about \$2700.

Excavation—

Sand, 50 cents; clay or shale, 80c per yard.
Teams, \$12.00 per day.
Trucks, \$20 to \$25 per day.
Above figures are an average without water. Steam shovel work in large quantities, less; hard material, such as rock, will run considerably more.

Fire Escapes—

Ten-foot balcony, with stairs, \$85.00 per balcony, average.

Glass (consult with manufacturers)—

Double strength window glass, 15c per square foot.
Quartz Lite, 50c per square foot.
Plate 75c per square foot.
Art, \$1.00 up per square foot.
Wire (for skylights), 35c per sq. foot
Obscure glass, 26c square foot.

Note—Add extra for setting

Heating—

Average, \$1.90 per sq. ft. of radiation, according to conditions.

Iron—Cost of ornamental iron, cast iron, etc., depends on designs.

Lumber (prices delivered to bldg. site).

No. 1 common.....	\$34.00 per M
No. 2 common.....	29.00 per M
Selection O. P. common.....	39.00 per M
2x4 No. 3 form lumber.....	24.00 per M
1x4 No. 2 flooring VG.....	60.00 per M
1x4 No. 3 flooring VG.....	50.00 per M
1x6 No. 2 flooring VG.....	60.00 per M
1½x4 and 6, No. 2 flooring.....	65.00 per M

Slash grain—

1x4 No. 2 flooring.....	\$48.00 per M
1x4 No. 3 flooring.....	40.00 per M
No. 1 common run T. & G.....	33.00 per M
Lath.....	7.00 per M

Shingles (add cartage to price quoted)—

Redwood, No. 1.....	\$1.10 per bdle.
Redwood, No. 2.....	.90 per bdle.
Red Cedar.....	1.00 per bdle.

Hardwood Flooring (delivered to building)—

13-16x3¼" T & G Maple.....	\$120.00 M ft
1-16x2¼" T & G Maple.....	132.00 M ft
7/8x3½ sq. edge Maple.....	140.00 M ft.
13-16x2¼" T&G.....	5-16x2" Sq.Ed.
Clr. Qtd. Oak.....	\$200.00 M \$150.00 M \$180 M
Sel. Qtd. Oak.....	140.00 M 120.00 M 135 M
Clr. Pla. Oak.....	135.00 M 107.00 M 120 M
Sel. Pla. Oak.....	120.00 M 88.00 M 107 M
Clear Maple.....	140.00 M 100.00 M
Laying & Finishing.....	13c ft. 11c ft. 10c ft.
Wage—Floor layers, \$7.50 per day.	

Building Paper—

1 ply per 1000 ft. roll.....	\$3.50
2 ply per 1000 ft. roll.....	5.00
3 ply per 1000 ft. roll.....	6.25
Brownskin, 500 ft. roll.....	10.00
Brownskin Pro-ecto-mat, 1000 ft. roll.....	10.00
Sisal-kraft, 500 ft. roll.....	5.00
Sash cord com. No. 7.....	\$1.20 per 100 ft.
Sash cord com. No. 8.....	1.50 per 100 ft.
Sash cord spot No. 7.....	1.90 per 100 ft.
Sash cord spot No. 8.....	2.25 per 100 ft.
Sash weights cast iron, \$50.00 ton.	
Nails, \$3.50 base.	
Sash weights, \$45 per ton.	

Millwork—

O. P. \$100.00 per 1000. R. W., \$106.00 per 1000 (delivered).
Double hung box window frames, average, with trim, \$6.50 and up, each.
Doors, including trim (single panel, 1¾ in. Oregon pine) \$8.00 and up, each.
Doors, including trim (five panel, 1¾ in. Oregon pine) \$6.50 each.
Screen doors, \$4.00 each.
Patent screen windows, 25c a sq. ft.
Cases for kitchen pantries seven ft. high, per lineal ft., \$6.50 each.
Dining room cases, \$7.00 per lineal foot.
Labor—Rough carpentry, warehouse heavy framing (average), \$14.00 per M.
For smaller work average, \$32.50 to \$40.00 per 1000.

Marble—(See Dealers)

Painting—

Two-coat work	29c per yard
Three-coat work	40c per yard
Cold Water Painting	10c per yard
Whitewashing	4c per yard
Turpentine, 80c per gal., in cans and 75c per gal. in drums.	
Raw Linseed Oil—80c gal. in bbls.	
Boiled Linseed Oil—85c gal. in bbls.	
Medusa Portland Cement Paint, 20c per lb.	

Carter or Dutch Boy White Lead in Oil (in steel kegs). Per Lb.

1 ton lots, 100 lbs. net weight.....	103 1/4c
500 lbs. and less than 1 ton lots.....	11c
Less than 500 lb. lots	11 1/2c

Dutch Boy Dry Red Lead and Litharge (in steel kegs).

1 ton lots, 100 lb. kegs, net wt.....	103 1/4c
500 lb. and less than 1 ton lots.....	11c
Less than 500 lb. lots	11 1/2c

Red Lead in Oil (in steel kegs)

1 ton lots, 100 lb. kegs, net. wt. 12 1/2c	
500 lb. and less than 1 ton lots 12 1/2c	
Less than 500 lb. lots	13c

Note—Accessibility and conditions cause wide variance of costs.

Patent Chimneys—

6-inch	\$1.00 lineal foot
8-inch	1.50 lineal foot
10-inch	1.75 lineal foot
12-inch	2.00 lineal foot

Plastering—Interior—

1 coat, brown mortar only, wood lath.....	Yard \$0.65
2 coats, lime mortar hard finish, wood lath .75	

2 coats, hard wall plaster, wood lath.....	\$.80
3 coats, metal lath and plaster	1.25
Keene cement on metal lath	1.30
Ceilings with 3/4 hot roll channels metal lath75
Ceilings with 3/4 hot roll channels metal lath plastered	1.50
Shingle partition 3/4 channel lath 2 sides 2 inches thick	2.75
4-inch double partition 3/4 channel lath 2 sides	1.30
4-inch double partition 3/4 channel lath 2 sides plastered	3.00

Plastering—Exterior—

2 coats cement finish, brick or concrete wall	Yard \$1.10
2 coats Celaveras cement, brick or concrete wall	1.35
3 coats cement finish, No. 18 gauge wire mesh	1.50
3 coats Celaveras finish, No. 18 gauge wire mesh	2.00
Wood lath, \$6.00 per 1000	5.00
2.5-lb. metal lath (dipped)17
2.5-lb. metal lath (galvanized)20
3.4-lb. metal lath (dipped)22
3.4-lb. metal lath (galvanized)28
3 1/2-inch hot roll channels, \$72 per ton. Finish plaster, \$18.90 per, in paper sacks. Dealer's commission, \$1.00 off above quotations. \$12.85 (retails 10c sack). 1 side.....	
Lime, f.o.b. warehouse, \$2.25 bbl.; cars, \$2.15	
Lime, bulk (ton 2000 lbs.), \$16.00 ton.	
Wall Board 5 ply, \$50.00 per M.	
Hydrate Lime, \$19.90 ton.	

Plasterers Wage Scale\$1.25 per hour
 Lathers Wage Scale 1.25 per hour
 Hod Carriers Wage Scale 1.10 per hour
Composition Stucco—\$1.60 to \$2.00 sq. yard (applied).

Plumbing—

From \$65.00 per fixture up, according to grade, quantity and runs.

Roofing—

"Standard" tar and gravel, \$6.00 per sq. for 30 sqs. or over.
 Less than 30 sqs. \$6.50 per sq.
 Tile, \$20.00 to \$35.00 per square.

Redwood Shingles, \$11.00 per square in place.
 Cedar Shingles, \$10 sq. in place.
 Recoat, with Gravel, \$3.00 per sq.
 Asbestos Shingles, \$15 to \$25 per sq. laid.
 Slate, from \$25.00 to \$60.00 per sq. laid according to color and thickness.

Sheet Metal—

Windows—Metal, \$2.00 a sq. foot.
 Fire doors (average), including hardware, \$2.00 per sq. ft.

Skylights—

Copper, 90c sq. ft. (not glazed).
 Galvanized iron, 25c sq. ft. (not glazed).

Steel—Structural

\$100 ton (erected), this quotation is an average for comparatively small quantities. Light truss work higher. Plain beams and column work in large quantities \$80 to \$90 per ton cost of steel; average building, \$89.00.

Steel Reinforcing—

\$90.00 per ton, set, (average).

Stone—

Granite, average, \$6.50 cu. foot in place.
 Sandstone, average Blue, \$4.00, Boise, \$3.00 sq. ft. in place.
 Indiana Limestone, \$2.80 per sq. ft. in place.

Store Fronts—

Copper sash bars for store fronts, corner, center and around sides, will average 75c per lineal foot.
 Note—Consult with agents.

Tile—Floor, Wainscot, Etc.—(See Dealers).

Asphalt Tile—18c to 28c. per sq. ft. installed.

SAN FRANCISCO BUILDING TRADES WAGE SCALE

Established by The Imperial Wage Board November 9, 1932. Effective on all work January 1, 1933, to remain in effect until June 30, 1933, and for so long thereafter as economic conditions remain substantially unchanged.

This scale is based on an eight-hour day and is to be considered as a minimum and employees of superior skill and craft knowledge may be paid in excess of the amounts set forth herein.

CRAFT	Journeyman Mechanics
Asbestos Workers	\$8.00
Bricklayers	9.00
Bricklayers' Hodcarriers	5.40
Cabinet Workers (Outside)	8.00*
Caisson Workers (Open) Water Work	8.20
Carpenters	9.00
Cement Finishers	7.20
Cork Insulation Workers	7.20
Electrical Workers	8.00
Electrical Fixture Hangers	7.00
Elevator Constructors	8.68
Elevator Constructors' Helpers	6.08
Engineers, Portable and Hoisting	8.00
Glass Workers (All Classifications)	6.80
Hardwood Floormen	7.20*
Housemovers	6.40
Housemiths, Architectural Iron (Outside).....	7.20
Housemiths, Reinforced Concrete, or Rodmen 7.20	

*Established by Special Board

CRAFT	Journeyman Mechanics
Iron Workers (Bridge and Structural)	\$9.40
Iron Workers (Hoisting Engineers)	10.00
Laborers	8.00
Lathers, Channel Iron	8.00
Lathers, All Other	6.80
Marble Setters	8.00
Marble Setters' Helpers	7.20*
Millwrights	8.00
Mosaic and Terrazzo Workers (Outside).....	7.20
Mosaic and Terrazzo Helpers	5.00
Painters	7.00
Painters, Varnishers and Polishers (Outside).....	7.00
Pile Drivers and Wharf Builders	8.00
Pile Drivers Engineers	9.00
Plasters and Hodcarriers (See wage scale under Plastering).	
Plumbers	8.00
Roofers (All classifications)	6.40
Sheet Metal Workers	7.20
Sprinkler Fitters	9.00
Steam Fitters	8.00

CRAFT	Journeyman Mechanics
Stair Builders	\$7.20*
Stone Cutters, Soft and Granite	6.80
Stone Setters, Soft and Granite	7.00
Stone Derricksmen	7.20
Tile Setters	8.00
Tile Setters' Helpers	5.00
Tile, Cork and Rubber	7.20
Welders, Structural Steel Frame on Buildings 9.40	
Welders, All Others on Buildings	8.00
Auto Truck Drivers—Less than 2,500 lbs.	5.50
Auto Truck Drivers—2,500 lbs. to 4,500 lbs.	6.50
Auto Truck Drivers—4,500 lbs. to 6,500 lbs.	6.00
Auto Truck Drivers—6,500 lbs. and over	7.00
General Teamsters, 1 Horse	5.50
General Teamsters, 2 Horses	6.00
General Teamsters, 4 Horses	6.50
Plow Teamsters, 4 Horses	6.50
Scraper Teamsters, 2 Horses	6.00
Scraper Teamsters, 4 Horses	6.00

GENERAL WORKING CONDITIONS

- Eight hours shall constitute a day's work for all crafts, except as otherwise noted.
- Where less than eight hours are worked pro rata rates for such shorter period shall be paid.
- Plasterers' Hodcarriers, Bricklayers' Hodcarriers, Roofers' Laborers and Engineers, Portable and Hoisting, shall start 15 minutes before other workmen, both at morning and at noon.
- Five days, consisting of not more than eight hours a day, on Monday to Friday inclusive, shall constitute a week's work.
- The wages set forth herein shall be considered as net wages.
- Except as noted the above rates of pay apply only to work performed at the job site.
- Transportation costs in excess of twenty-five cents each way shall be paid by the contractor.
- Traveling time, in excess of one and one-half hours each way shall be paid for at straight time rates.
- Overtime shall be paid as follows: For the

- first four hours after the first eight hours, time and one-half. All time thereafter shall be paid double time. Saturdays (except Laborers), Sundays and Holidays from 12 midnight of the preceding day, shall be paid double time. Irrespective of starting time, overtime for Cement Finishers shall not commence until after eight hours of work.
- On Saturday Laborers shall be paid straight time for an eight-hour day.
- Where two shifts are worked in any twenty-four hours, shift time shall be straight time; Where three shifts are worked, eight hours' pay shall be paid for seven hours on the second and third shifts.
- All work, except as noted in paragraph 13, shall be performed between the hours of 8 A. M. and 5 P. M.
- In emergencies, or where premises cannot be vacated until the close of business, men recruited for work shall work at straight time.

Any work performed on such jobs after midnight shall be paid time and one-half up to four hours of overtime and double time thereafter (provided, that if a new crew is employed on Saturdays, Sundays or Holidays which has not worked during the five preceding working days, such crew shall be paid time and one-half. No job can be considered as an emergency job until it has been registered with the Industrial Association and a determination has been made that the job falls within the terms of this section).

- Recognized holidays to be: New Year's Day, Decoration Day, Fourth of July, Labor Day, Admission Day, Thanksgiving Day, Christmas Day.
- Men ordered to report for work, for whom no employment is provided shall be entitled to two hours' pay.
- This award shall be effective in the City and County of San Francisco.

NOTE: Provision of paragraph 13 appearing in brackets () does not apply to Carpenters, Cabinet Workers (Outside), Hardwood Floormen, Millwrights, or Steam Builders.

ORIGIN OF NAMES OF CALIFORNIA COUNTIES

This is the ninth article in the series giving derivation of the names of California counties:

PLACER COUNTY — Created April 25, 1851. "Placer" probably is a contraction of the words "plaza de oro," the place of gold, and means in Spanish liberally translated "a place near a river where gold is found." The county derived its name from the numerous places therein where the method of extracting gold from the ground, called placer mining, was practiced.

Placer is one of California's most historic counties and is the location of the second gold discovery in the state. Its mines have yielded nearly \$100,000,000 and the county still ranks fairly high in mining. It is estimated a potential gold production of over one billion dollars remains in ancient river channels where mining can be carried on by the drifting process. In May, 1848, gold was discovered in Auburn Ravine, at a point where the state highway now crosses the ravine and enters the city of Auburn. For six or eight years, mining was the principal industry and then settlers began planting fruit trees and barley.

No other county has such a wide range of resources, and diversity of climate and soil products. The U. S. Department of Agriculture has separated the soil groups into 18 series, 22 types and nine phases. Placer is a center for deciduous fruits of high quality. It is the largest shipper in California of ripe table fruits to eastern markets. The county has thousands of acres of virgin timber. Oranges, olives, plums, peaches, pears, cherries and figs are raised abundantly in the foothills while the flat country has immense fields of wheat, oats, barley and alfalfa. Hunting, fishing and scenic attractions lure thousands of visitors. Population: 24,468. Area: 1,411 square miles.

PLUMAS COUNTY—Created March 18, 1854. The Spanish originally called one of the tributaries of the Sacramento river, Rio de las Plumas, or the "River of the Feathers." It was in 1820 that a bold Spanish exploring expedition headed by Don Luis Arguello, came upon the stream and because its surface was covered with bright feathers of countless waterfowl named it Rio de las Plumas. The Americans subsequently robbed this river of its beautiful name by changing its euphonious Spanish title to the English equivalent, the Feather River, but the legislature, in creating this county, gave thereto the name of "Plumas" because of the fact that all of the numerous branches of the Feather River have their origin in the county.

While missions were being built along the California coast and explorers were pushing into unknown territories, the mountainous regions to the north remained

unpenetrated. Native Californians never pushed into the heart of the mountains skirting the Sacramento Valley on the east. Residents of the valley gazed upon the snowy crests of the Sierra Nevada, but beyond this they did not go. As a result the territory now known as Plumas county had no part in the early history of California. It is believed Peter Lassen and Isadore Meyerwitz were the first two white men to set foot there. In the fall of 1849 a man named Stoddard and his party arrived at Big Meadows. He and a companion were lost while hunting and in their wanderings discovered chunks of gold on the lake shore. Stoddard escaped after his companion was killed by Indians and reached Nevada City. In 1851 gold discoveries were made in many other places.

Plumas is known as "The Recreation County of California." Its mountain scenery is unsurpassed. Of a total of 1,659,520 acres, approximately 1,300,000 are non-tilable and mountainous. Despite the mountainous character of Plumas, agricultural activity has been a major development. Its valleys are fertile and productive. Hay Crops alone cover 19,449 acres. The county rates ninth in mineral production. It is one of the leading hydro-electric power sections in the state. Portola, Quincy, Beckwith and Greenville are noted vacation resorts and Keddie is the junction of the Great Northern Railroad from Klamath Falls with the Western Pacific. Population: 7,913. Area: 2,593 square miles.

RIVERSIDE COUNTY—Created March 11, 1893. This county was formed from portions of San Diego and San Bernardino counties and derived its name from the town of Riverside.

This county is the fourth largest in California. Its scenic attractions are many and varied, ranging from desert to snow-capped mountains. Its resorts are internationally known, notably Palm Springs, playground of the wealthy. In the city of Riverside is the world-famous Riverside Inn.

Riverside has 4,746 farms embracing 633,932 acres. Crops produced, headed by oranges, have an annual valuation amounting into many many millions of dollars. In a land where water is essential to soil cultivation, Riverside has an abundant supply and has approximately 125,000 irrigated acres. Every plant known to the temperate and semi-tropic zones can be grown successfully. Production of oranges and lemons is the leading industry while hay, barley, wheat, oats and alfalfa crops are produced in enormous quantities. Fruits, melons, walnuts, vegetables and dairy and poultry rank high. In one year, Riverside produced 1,812,023 pounds of dates. The county also is a great honey producing center and boasts 40,000 colonies of bees. In this county is located the Citrus Experiment Station and graduate School of Sub-Tropical Horticulture. The soil is a rich silt, the entire region having once been the bed of an inland sea.

From the Salton Sea, 216 feet below sea level, to the pine-studded summit of old Mount San Jacinto

ICE CUTS AIR CONDITIONING COSTS

from 1/5 to 1/2

ICE provides ideal, modern, air conditioned comfort for hotels, stores, theatres, offices—

—and in many cases does the job at a saving of 20% to 50%, as compared to more complex installations.

Ask our engineering department for data to meet your particular problem. You'll find that air conditioning with ice is simpler and more dependable . . . as well as outstandingly thrifty.

The UNION ICE Company

354 PINE STREET

SAN FRANCISCO

“DATED” HOUSES

A house is old when it fails to provide convenience and comfort to those living in it. A house with a score or more useful years behind it may yet be young, and one built yesterday may not be modern.

The electrical age is here, and electrical convenience is increasingly important. Antiquated lighting or an insufficient number of convenience outlets definitely place a house in the “pre-electrical” age.

RED SEAL plans, information, or consultation without charge or obligation.

The house which provides for the convenient use of appliances will remain modern indefinitely. The house in which few outlets are available, requiring unsightly and dangerous extension cords run under rugs or festooned around the room is unnecessarily out of date.

Guard against premature obsolescence of the homes you design by including adequate electrical specifications.

PACIFIC COAST ELECTRICAL BUREAU

SAN FRANCISCO
447 Sutter Street

• CALIFORNIA •

LOS ANGELES
601 W. 5th Street

with an altitude of nearly 11,000 feet, there is almost a limitless range of climatic conditions.

Riverside County has mineral resources so vast and varied that they have as yet been but meagerly developed. Population: 81,024. Area: 7,223 square miles.

SONOMA COUNTY—Created February 18, 1850. One of the original twenty-seven counties. "Sonoma" is an Indian word meaning "valley of the moon," because of the resemblance of this valley to the shape of that orb. In 1824, when Padre Jose Actimira baptized the chief of the Cho-cuy-en Indians, he gave him the baptismal name of Sonoma, and from this source the county derived its name.

In 1812, a band of Russians landed on the coast of Sonoma and, with permission from Spain, established a colony at the port of Bodega for the purpose of maintaining fisheries and hunting for furs. As early as 1815 they had ranchos in the interior, purchased cattle from the Spaniards and devoted themselves to the raising of stock and the production of wheat. During the revolutionary troubles in Mexico they contended they had become the actual owners of the territory they occupied and claimed practically all the country north of San Francisco Bay. A fort was erected which was called Stawianski, but which the Mexicans designated as the fort of the Russians. The Americans corrupted the name to Fort Ross. Over this the Russian flag was raised and a military governor was appointed by the Czar. This establishment was maintained until 1840, when the Russian sold to John A. Sutter, who had, in August of 1839, established his fort and settlement at Sacramento. Historic Fort Ross has been restored by the Native Sons. A few years after the Russians landed, Sonoma county witnessed the founding of Mission San Francisco de Solano in 1823, the twenty-first and last mission of Father Junipero Serra's chain of California missions. Spanish settlers began colonizing Sonoma in 1853 and year after year the county developed its now famous reputation as one of the greatest agricultural districts in the world.

On June 14, 1846 Ezekial Merritt and a party of thirty-three raised the Bear Flag of California at what now is the mission town of Sonoma.

For fifty years, the late Luther Burbank, noted horticulturist, made Sonoma his home and in Santa Rosa and Sebastopol carried on his horticultural wizardry. He found there the rich soil which has made Sonoma outstanding in the production of fruit and farm crops.

Sonoma is noted for its Gravenstein apples and its prunes, its two leading crops, ranks among the highest of California counties in farm products, is first in the sale of poultry and eggs and third in the value of domestic animals and bees. Petaluma is known as the "Egg Basket of the world" and has an estimated 12,000,000 chickens.

The county is in the heart of the Redwood Empire and its Russian River resorts, widely known springs, its

Hollywood ROOSEVELT

Redecorated all of their
superb suites with

WALLCOVER FLAT

A tribute by a
famous hotel to
a famous paint.

Use Coupon
for Sample



GENERAL PAINT
of
GENERAL PAINT CORPORATION

San Francisco • Los Angeles • Oakland • Portland • Seattle • Spokane • Tulsa

Use This Coupon for
FREE SAMPLE
of
Wall Cover Flat

Mail coupon to nearest Division Office—print name and address clearly or attach business card.
Name.....
Street and Number.....
City and State.....
Check color wanted: WHITE IVORY ORCHID SAGEBANK SILVER GRAY APRICOT TURQUOISE

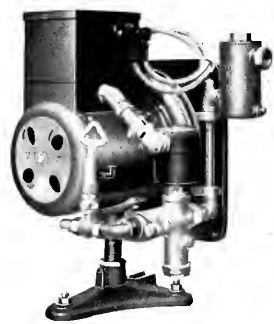

*The luxury of efficiency
at the price of economy!*

JOHNSON Oil Burners . . . all of them . . . are famed for efficiency, for economical operation. Here, for smaller homes, is the Johnson Type B, low in first cost as well as in cost of operation. Available in various models according to radiation required up to 1385 square feet and for either gravity or pump feed, it represents a recommendation that can be made with the same confidence felt in commending any Johnson burner to the home-owner.

S. T. JOHNSON CO.
940 Arlington Street Oakland, California

Architects . . .

S a f e g u a r d
y o u r b u i l d i n g s
a g a i n s t d e c a y
o r t e r m i t e
a t t a c k b y
s p e c i f y i n g

**WOLMANIZED or CREOSOTED
LUMBER and TIMBER**

E. K. WOOD LUMBER CO.

*"Goods of the Woods" is your guarantee for
Quality and Service*

NO. 1 DRUMM ST., SAN FRANCISCO
LOS ANGELES OAKLAND

BUILD WELL~

A PROPERLY designed and well constructed building is a credit to any city and a profitable investment for its owner.

Such structures are the STANDARD OIL BUILDING, MATSON BUILDING, FOUR-FIFTY SUTTER STREET, STOCK EXCHANGE, S. F. BASE BALL PARK, MILLS TOWER, OPERA HOUSE and VETERANS' MEMORIAL, San Francisco, OLYMPIC CLUB ALTERATIONS, SANTA ANITA RACING PLANT and other notable structures — all built or supervised by —

Lindgren & Swinerton, Inc.

Standard Oil Building 605 W. Tenth Street
San Francisco Los Angeles
We Maintain a Termite Control Department

geysers east of Cloverdale, the Sonoma Petrified Forest, Glen Ellen, home of the late Jack London, and seaside vacation spots have made it widely known. Hunting and fishing are prominent attractions. Santa Rosa is the county seat and a prosperous California city. Cloverdale, Cotati, Geyserville, Guerneville, Healdsburg, Monte Rio, Petaluma, Sebastopol and Sonoma are names known throughout the country. Population: 66,222. Area: 1,582 square miles.

STANISLAUS COUNTY—Created April 1, 1854. Chief Estanislao, of a powerful tribe of Indians living on what now is known as the Stanislaus River, but by the Indians called the La-Kish-um-na, was educated at the Mission San Jose. He became a renegade and incited his tribe against the Spaniards, but was defeated in 1826 in a fierce battle on this river, which afterwards was called Stanislaus for the defeated Indian chief. It is from this river that the county derived its name.

Primarily an agricultural county, Stanislaus is one of the wealthiest in the state. Its rich, sandy soil gives exceptional productivity to farm and orchard crops. Its water resources are important. The San Joaquin River crosses the county from south to north, the Stanislaus forms the northern boundary, the Tuolumne flows through the middle and the Merced River is the southern watershed. The irrigation districts are known to engineers the world over. The La Grange dam on the Tuolumne, costing \$550,000; the Goodwin Dam on the Stanislaus, costing \$350,000, and the Don Pedro and Melones dams impound a tremendous water reserve which is released for irrigation purposes.

Stanislaus is one of the leading counties in the United States in number of dairy farms and value of dairy products. Creameries of national reputation are located here. Approximately 62,000 acres are devoted to alfalfa. The county has about 2,000,000 bearing fruit trees. Grain and forage are important crops. Cantaloupes, watermelons and like crops run in annual value from \$2,500,000 to almost \$3,000,000. Beans and juice grapes bring in about \$1,800,000 each annually. Poultry and eggs return a yearly income of approximately \$1,500,000.

Modesto is one of the most prosperous cities in the State. The Turlock, Modesto, Waterford, Oakdale, Patterson, Newman and West Stanislaus irrigation districts attract international attention and irrigate approximately 250,000 acres.

Knights Ferry and La Grange are historic mining towns and Modesto is not far from Yosemite Valley. Ceres, Newman, Oakdale, Patterson, Riverbank and Turlock, the latter famous for its melons, reflect the prosperity of Stanislaus. Population: 56,641. Area: 1,450 square miles.

(Next: Sutter, Sierra, Santa Clara)

MODERNIZATION OF KITCHENS AND BATHROOMS

IN apartment modernization, kitchens and bathrooms are items of such great importance that they deserve separate and special consideration. Great strides have been made during recent years by manufacturers of kitchen and bathroom equipment, and fashions here have changed more rapidly than any other apartment features. Out-of-date living room and bedroom arrangements may not be insuperable handicaps in renting, but outmoded kitchens and bathrooms are likely to be.

From the renting standpoint, kitchens carefully planned as to conveniences and equipped with the most modern appliances, are one of the chief factors which influence the feminine prospect's decision and, as managers well know, the wife's choice is quite often the final one. No less important is the proper arrangement and equipment of bathrooms, which are subject to the critical inspection of both men and women.

Changing fashions are perhaps even more noteworthy in bathrooms than in kitchens, although in both cases there is a vast difference between the equipment available five or six years ago and that which may be obtained today. The resulting contrast between new and old makes these two spaces keynotes in the determination of the suites' modernity by the prospect.

In considering kitchen modernizations, the owner or agent has to think of all of the following major points though not necessarily in order listed:

- (a) General appearance.
- (b) Arrangement of various facilities in order to secure greatest possible convenience for housewife.
- (c) Size.
- (d) Location in relation to dining space.
- (e) Light and ventilation.
- (f) Durable floor coverings that are easily maintained and cleaned with the minimum of difficulty.

The problem of the modernizer who is simply replacing obsolete equipment with new equipment in a space formerly devoted to kitchen use is somewhat easier than that of the owner who has to create kitchen space out of space formerly devoted to other purposes. However, the latter may have considerable advantage over the former in thorough modernizations owing to the fact that he can often arrange space to suit current demand in the locality, whereas the former may be in the position of having to utilize a space that doesn't quite suit the demands.

In either case the provision of good stoves, of automatic refrigeration, of sinks and trays, and adequate cabinet space is absolutely necessary in nearly all types of housing space today. Great improvements in this respect are being made in the reconditioning of even low-rent tenement space. Such investment of equipment is well worth while to the

Leadership



General Fremont, California Pioneer

CROCKER FIRST NATIONAL BANK OF SAN FRANCISCO

Member Federal Deposit Insurance Corporation

WOLMANIZED LUMBER HAS ALL THE ATTRIBUTES OF UNTREATED LUMBER

Strength, cleanliness, paintability, no corrosive effect on metals, resilience, high insulating value. WITH POSITIVE PROTECTION AGAINST TERMITES AND DECAY.

Specified by leading architects and engineers.

AMERICAN LUMBER & TREATING CO.
37 West Van Buren St.
CHICAGO, ILL.

San Francisco Sales Office
116 New Montgomery St.
Phone SUtter 1225

Los Angeles Sales Office
1031 South Broadway
Phone PRospect 5558

How about more business?

ARCHITECTS' REPORTS
offer the Building
Trade dependable
Leads for new
Business.

Published by THE ARCHITECT and ENGINEER
68 Post Street, San Francisco

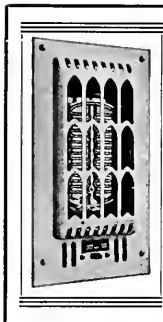

APEX AIR ELECTRIC WATER HEATERS

Send for Architect's Catalogue
Bathroom Heaters in the Standard
Colors, 1000 to 2500 Watts
\$14.00 to \$27.50

APEX MANUFACTURING CO.
1301 Powell Street
Emeryville, Oakland, Calif.

Distributors
Sandoval Sales Co.
Phone KEarny 7010
557 Market Street, San Francisco, Calif.
Apex Sales Co.
1855 Industrial Street, Los Angeles, Calif.
Phone MUtual 9141



Product of
CALIFORNIA SHADE CLOTH CO.
210 Bayshore Blvd., San Francisco

Manufacturers of
QUALITY HAND MADE SHADE CLOTH
IN ALL GRADES

Wholesale Distributors
SLOANE-BLABON LINOLEUM
AMBASSADOR VENETIAN BLINDS

STRUCTURAL STEEL

For Class A Buildings,
Bridges, etc.

JUDSON PACIFIC CO.

609 MISSION STREET
SAN FRANCISCO

Plants: San Francisco - Oakland

owner for the simple reason that modern kitchen equipment is now becoming a commonplace and the apartments that do not have it are definitely handicapped in competition with their neighbors.

Some detailed points which it is well to consider when purchasing and installing equipment are:

(a) Size of oven in the stove and number of burners on the stove.

(b) Efficient and noiseless refrigeration which furnishes adequate amount of ice.

(c) Installation of adequate cabinet space, with easy access to shelves.

(d) Space for milk bottles somewhere in the kitchen either on the floor or in the cabinets.

(e) Provision of vegetable freshener in refrigerator.

(f) Broom closet.

(g) Sufficient wall plugs for all necessary electrical conveniences such as waffle iron, percolators, electric irons, etc.

(h) Such built-in conveniences as ironing boards.

It is surprising how frequently one finds that stoves are inadequate in size. This is a very important factor to the housewife, who quite often refuses to take an apartment simply because the oven is not large enough to cook a turkey or a large roast and there are not enough burners available for cooking a real meal. The size of the kitchen itself is similarly a matter of great interest to the housewife, though this is a matter of individual preference. Some prefer large kitchens and others prefer the small efficiency type. The same may be said of the points just raised about stove size. A great deal depends on the locality and general preference in a given city.

A number of manufacturers are now supplying beautiful combination sinks and trays of metal or composition material that are attractive in looks and make few demands on the housewife for upkeep. Whatever type is selected, the materials should be good, for sinks and trays are subject to rough usage. Quality here is economical in the long run. The type of refrigeration supplied is again largely a matter of personal preference. Some prefer electric refrigerators and some gas.

Light and ventilation are two factors which must be adequate in nearly all classes of housing space. The housewife who has suffered from lack of proper light in her kitchen or from excessive temperatures due to poor ventilation will be a poor prospect for removal. Similarly, if she has been handicapped in her culinary work by lack of sufficient cabinet space to store groceries, dishes, glassware and kitchen utensils, it is very likely that she will look elsewhere at the end of the year. Large cabinet space in the lower part of the stove to use for kitchen utensils is especially to be recommended, since pots and pans take up an inordinate amount of space on shelves.

Provision of what might be called extras, such as a single swinging faucet to provide either hot or cold

water or both, is an added advantage, and deep sinks for washing dishes and clothing are usually welcome to the feminine prospect. The extent to which owners go to provide extras depends, of course, on the class of property. In all events the kitchen must promise value both in appearance and in serviceableness.

The same is quite true of bathrooms. No other single feature, not even the kitchen, so thoroughly dates an apartment unit as the appearance of its bathroom. The desolate effect of so many of the old time bathrooms with their poor arrangement, their old fashioned tubs and their lack of color in decoration is passe.

The large bathroom is no longer necessary. Even a space 5 x 5 ft. in size can be effectively used these days, although 6 x 8 ft. is perhaps better in the higher class of apartment properties. In modernization so much depends on whether the owner has proper spaces for bathrooms or whether he must create the rooms out of other space. Sometimes it is possible to utilize a very small space for the lavatory and closet section and put in a shower compartment in an adjoining space. Needless to say, the inclusion of all services in one room is much better.

Not only has the bathroom equipment changed a great deal in appearance and effectiveness but there is a growing trend to more bathrooms per apartment unit. In reconditioning units larger than four rooms, it is always advisable to consider the possibility of adding an extra bathroom.

Location of the bathroom is also of much importance in renting the space. Generally speaking, it is much better to place the room between the living room space and bedroom space or between bedrooms, with the door opening into a corridor, than to place it so that access to it must be through a bedroom. The provision of exterior light and air is not, however, so important, perhaps as it was once considered. Given adequate ventilation through a shaft which really functions as a draft producer, it is often possible to use interior space for this purpose.

In the matter of general appearance the bathroom must be cheerful. It should have a floor of a material easily cleaned and, of course, waterproof. Tile, either as wainscoting or as total wall surface, is a primary requisite of most modern bathrooms. Whatever material is used in the remainder of the interior surface, whether plaster with glazed paint finish or wall paper, should carry out the note of cheerfulness and luxurious simplicity. A point often overlooked by those who prefer wall paper is that the paper should not be so placed as to be exposed to dampness from the shower fixture.

Here are a few further points which are generally important in all types of space, though the extent to which they are utilized again depends a great deal on the returns from the unit

(a) Modern medicine cabinets with good mirrors and adjustable glass shelves. There should be large and deep in order to provide room for the large number of medicines, toilet accessories, etc., that the average family uses. A glass shelf below the medicine cabinet is a good practical feature also.

(b) Built-in tub of modern vitreous china or similar material that cleans easily and wears well. Should be flat bottomed to prevent accidents from slipping and should have a large faucet and large drain to facilitate rapid filling and emptying of tub.

(c) Efficient modern plumbing throughout, with faucets and other metal fixtures of the latest design, and equipped with washers that can be relied upon over a period of time.

(d) Lavatories and water closets of the same high type of materials as are used in the tubs. Great improvements have been made during recent years in the flush action of the water closets, a siphon jet being especially popular in the better class space. Seats and covers are now obtainable in very attractive composition materials.

(e) Efficient lighting. If possible, the electric fixtures should be so placed as to throw a good light on the face of a person standing at the lavatory and using the medicine cabinet mirror. This is very important in shaving or, for the feminine contingent, in applying creams or make-up. Where shower curtains are furnished, the fabrics should be of material impervious to stains and mildew.

(f) Additional convenience such as built in clothes hamper and linen cabinets are excellent sales points if the size and arrangement of the bathroom make them possible. Such conveniences are highly valued by tenants.

(g) The radiator should be inconspicuous but should by all means be large enough to furnish sufficient heat. In the endeavor to save space some, even of the most modern apartments, have adopted very small radiators under the lavatories or in other nooks. Often these cannot adequately heat the room, which of course is irritating to the tenants.

(h) Soap niches should be handy to both tub and shower users and should be of size sufficient to hold both soap and brushes. There should be at least two towel racks.

One of the most common rearrangements of bathroom equipment in modernization is to change position of the tub from the long side of a room to the short to fill the entire space at one end. However, this arrangement has certain disadvantages. Often the tub is thus placed beneath the window, which makes it difficult to open the window without stepping into the tub and also exposes the tub to soot drift from the window. When an interior space is used for the bathroom these disadvantages are of course obviated. — Buildings and Building Management.

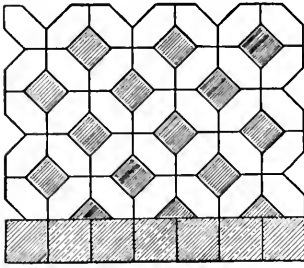

POMONA TILES

FOR

**Bathrooms and Kitchens
in over 60 colors**

Warehouses and Display Rooms

135 Tenth St. . . . San Francisco

629-33 North La Brea Ave.

Los Angeles

6106 Roosevelt Way . . Seattle

**POMONA TILE MFG. CO.
PLANT—POMONA, CALIF.**

To the

**ARCHITECTURAL
PROFESSION!**

GIVE

your clients

COMFORT

and

SATISFACTION

by including

"AIR-LITE"

VENETIAN

BLINDS

in your specifications

NUFF SAID

GUNN, CARLE & CO.

20 Potrero Ave. UNderhill 5480
SAN FRANCISCO

SIX COMPANIES QUIT TUNNEL WORK

Six Companies of California, Inc., contractors on the Broadway low-level vehicular tunnel and approaches, providing a new feeder for the San Francisco-Oakland Bay Bridge, discontinued work on the project June 13, and has entered suit to recover money claimed to be due.

This action by the contractors is the culmination of a dispute between them and Joint Highway District No. 13, the contracting authority, arising when difficult ground conditions developed and a cave-in caused the death of three workers, and was precipitated by the District assessing a penalty of \$500 a day against the contractors for failure to complete the work within the time limit specified in the contract, May 24, 1936. This penalty, provided for in the contract, was deducted from the progress payments to the contractors for the period from May 24 to May 31. Directors of Six Companies of California refused to accept the penalty and notified the District they would discontinue work.

Supervisor Thomas E. Caldecott speaking for the District said the work, now about 70 per cent completed, will be finished under the direction of the District and paid for with the funds now on hand. The contract price, based on the low bid submitted by the Six Companies, Inc., May 23, 1934, was \$3,683,931, and progress payments have been made totalling \$2,170,000. The District is assured against loss by a surety bond for \$1,842,000 given by the contractors.

Henry J. Kaiser, president of Six Companies of California, Inc., attributes the difficulties on the job to information said to have been given by the District's geologist who reported the ground through which the tunnel was to be driven was of a self-sustaining character. "The plain fact is that no portion of the ground encountered is self-sustaining", President Kaiser asserts.

In a statement for the District Mr.



REYNOLDS METALLATION

ALUMINUM foil for
permanent home
INSULATION

REYNOLDS ECOD

welded wire fabric
plaster base—
prevents cracks,
provides thermal
insulation

*Northern California
Distributors—*

WESTERN ASBESTOS CO.

675 TOWNSEND STREET
SAN FRANCISCO

SISALKRAFT
REG. U. S. PAT. OFF.

**"More than a
building paper"**

THE SISALKRAFT CO.

285 West Wacker Drive
(Canal Station) Chicago, Ill.
55 New Montgomery Street
San Francisco, Calif.



**DALMO
WINDOW
PRODUCTS**

DALMO SALES CORPORATION
511 Harrison St., San Francisco

FERRO — PORCELAIN

Words to conjure
with—for porce-
lain is here to
stay.

**Building
Exteriors**

**Building
Interiors**

Every inquiry promptly
answered

FERRO ENAMELING CO.

1100 - 57th Ave., Oakland, Calif.

HARDWOOD LUMBER FLOORING VENEERS PANELS

Exotic Woods for Modernistic Trim

White Brothers
Hardwood Headquarters

Since 1872

5TH AND BRANNAN . . . SAN FRANCISCO
500 HIGH STREET OAKLAND

PAYNE



The choice of discriminating buyers
of Gas-Fired Heating and Air-
Conditioning Equipment. A cata-
log showing complete Payne line
sent upon request.



**PAYNE FURNACE
& SUPPLY COMPANY**

Beverly Hills

California

Caldecott asserts "delays have been due to construction methods pursued by the contractors which permitted cave-ins and required reinforcing of construction timbering. These delayed completion of the work many months and added to the contractor's costs. These conditions were created by the contractor. They would not have occurred had proper methods of construction been followed before the permanent concrete lining was placed. The present tunnel lining is amply strong in design and where in place, stands firm and adequate to meet all the conditions found.

"Six Companies of California is seeking to be relieved of its obligation to perform the work, which it bid for in competition with other contractors, on the grounds that it did not know the conditions which would be met in construction, and that it was misled by a preliminary report of a geologist and the specifications."

1939 FAIR RESOLUTIONS

President Roosevelt has signed the joint Congressional bill according the 1939 Golden Gate International Exposition the official recognition of the United States Government.

This action means that President Roosevelt will invite, through the Department of State, all foreign nations to participate in the 1939 World's Fair in San Francisco.

The resolution, signed by President Roosevelt, reads:

"Authorizing the President to invite foreign countries to participate in the San Francisco Bay Exposition of 1939 at San Francisco, California.

"WHEREAS, there is to be held at San Francisco, California, during the year 1939 an International Exposition which has for its purpose the celebration of the completion of the San Francisco-Oakland Bridge and the Golden Gate Bridge, and which is designed to depict and exhibit the progress and accomplishments of the Pacific area of the United States in science, industry, business, transportation, and culture, and which, because of its world character, will

Modernize with White Cement

One Sack



Covers 100 square yards
of concrete, stucco or masonry
surface with 2 brush coats.

To brighten old exteriors
use Calaveras White Portland
Cement mixed with water and
apply with a dutch brush to
damp surface.

For further details write

CALAVERAS CEMENT CO.

315 Montgomery St., San Francisco

Los Angeles

Seattle

Make the old stucco color-
ful and water tight by ap-
plying one or more coats of

**BAY STATE
Brick and Cement
Coating**

Manufactured by a company whose
products have been on the market
for over half a century.



Distributors

**CALIFORNIA SALES
COMPANY, INC.**

444 MARKET STREET

SAN FRANCISCO

IT'S HERE!

Perfected
by
**ELECTRIC
HEATING
WESIX**



BEFORE YOU INSTALL
ANY HEATING SYSTEM

... ask us about WESIX *automatic* electric heaters—proven in thousands of installations in homes, buildings, hospitals, schools—even entire cities! WESIX patented *double-action* principle of *circulating* and *radiating* provides quick, efficient, economical heat. You know it's *healthful*. NO FANS to stir up breeze and drafts—*no moving parts*

WESIX ELECTRIC HEATER CO.
380 First Street San Francisco

Alumilite
by
Kawneer

Store Fronts - Windows
and
Architectural Castings
in
Polished Satin
or
Anodic Finish

THE
Kawneer
COMPANY
OF CALIFORNIA
BERKELEY

contribute to cordial relations among the nations of the world; and

"WHEREAS, because of its location and purpose, its scope and aims, said Exposition is deserving of the support and encouragement of the Government of the United States of America:

"THEREFORE BE IT RESOLVED by the Senate and House of Representatives of the United States of America in Congress assembled,— That the President of the United States be, and he is hereby, authorized and respectfully requested by proclamation, or in such manner as he may deem proper, to invite all foreign countries and nations to such proposed Exposition with a request that they participate therein."

STRUCTURAL PEST CONTROL

Licenses of the Structural Pest Control Board may also be required to have State Contractors' licenses, reported by Earl S. Anderson, State Registrar of Contractors and Glen V. Slater, Registrar for the Structural Pest Control Board, at which time a recent opinion of the Attorney General relating to the subject was discussed.

The legal opinion, the State officers report, states "I am further of the opinion that one who is licensed by the Structural Pest Control Board may practice structural pest control only insofar as it does not involve construction work or work incidental thereto as hereinabove defined, and in so operating he is not required to have a contractor's license. Should he undertake, however, to do any construction work in connection with pest control, he must obtain a contractor's license. In other words, should a person undertake to eradicate or prevent infestation of buildings by pests, both by construction work and by the use of insecticides, fumigants and allied chemicals, he must have both types of licenses.

"I am of the opinion that either a civil engineer or an architect who supervises work upon a building, including structural pest control work, is acting solely within his professional capacity as long as he does not

Phone GARfield 1164

Hunter & Hudson
Consulting Engineers
DESIGNERS OF HEATING
AIR CONDITIONING
VENTILATING AND WIRING
SYSTEMS, MECHANICAL
AND ELECTRICAL EQUIP-
MENT OF BUILDINGS

41 SUTTER STREET
ROOM 710
San Francisco California

HIGH GRADE MILLWORK
AND INTERIOR FINISH
SASH AND DOORS

**LANNOM BROS.
MFG. CO.**

FIFTH AND MAGNOLIA STREETS
OAKLAND, CALIFORNIA
Telephone: LAte side 3663

**ANDERSON
&
RINGROSE**

General Contractors

320 Market Street, San Francisco
Phone GARfield 2245

CRANE
*High Class Plumbing
Fixtures*

ALL PRINCIPAL COAST CITIES

Pacific Manufacturing Company

High Class Interior Finish
Quality Millwork

454 Montgomery St. 641 Merrill Ave.
San Francisco Los Angeles
GAfield 7755 AXridge 9011

1315 Seventh Street, Oakland
GLencourt 7850

FORDERER Cornice Works

Manufacturers of

Hollow Metal Products
Interior Metal Trim
Elevator Fronts and Cabs
Metal Wall Plugs, Anchors, Etc.
Sheet Metal Products
Sanitary Metal Base
Commercial Refrigerators
Building Paper
Metal and Wire Accessories
for Concrete

269 POTRERO AVENUE
San Francisco, Calif.

HEmlock 4100
CONSULT OUR ENGINEERING
DEPARTMENT

• INSPECT •

THE FOLLOWING WALL JOBS
IN ALAMEDA COUNTY
AND

YOU TOO WILL SPECIFY
**DUNNE SATIN WALL
FINISH**

VETERAN MEMORIAL BLDGS.
HIGHLAND HOSPITAL
LATHAM SQUARE BUILDING,
OAKLAND

FRANK W. DUNNE CO.
41st and Linden Sts., Oakland

actually engaged in doing the pest control work himself, and is not required to be licensed under either the Contractors' License Law or the Structural Pest Control Act."

In commenting upon the above quotations from the ruling of the Attorney General, Mr. Slater states, "Attorney General Webb has found there is no conflict between the laws licensing structural pest control operators, contractors, architects or engineers. There are certain cases where the Pest Control Act and the Contractors' Law both apply, however, and in such cases double jurisdiction requires that the operator be licensed by two different bodies."

Mr. Slater further points out that the officials who have discussed the ruling of the Attorney General have reached a decision that it is necessary that a definite line be drawn between pest control operations without structural features and structural work of replacement or fabrication, unless the individual doing such work is licensed for each class.

LOW TAXES AND HOME BUILDING

It has been a practically universal argument in this country that low taxes encourage home building. Yet in California there are some people who believe, or at least profess to believe, that the present system of taxation is wrong and that a single tax on land should be substituted, which means that taxes on homes would be increased after a period of years to the point of actual confiscation by the state. This single tax is put forward in the guise of a proposal to abolish the sales tax, on which the people will vote next November. To those who may be inclined to favor a single tax and a consequently higher tax on homes the following from The Improvement Bulletin will be illuminating:

"It is readily apparent that taxes are a pronounced factor in determining the percentage of citizens who own the homes they occupy. Everyone has heard the casual remark 'it's cheaper to rent than to

"Ask the National Lead Man!"

Special attention is given to architects' inquiries on paint materials and painting procedure by our technical staff.

SPECIFY

DUTCH BOY

Painter Products

BASS - HUETER

Paints and Varnishes

NATIONAL LEAD COMPANY

San Francisco Seattle
Portland Los Angeles

Branches and dealers in all principal cities

"BROWNSKIN"

RESILIENT WATERPROOF
BUILDING PAPER

THE BUILDING PAPER WITH
A FACTOR OF SAFETY

Angier Corporation

Framingham, Mass.
PACIFIC COAST DIVISION
564 HOWARD STREET
SAN FRANCISCO
DOuglas 4416
350 South Anderson St.
Los Angeles

TRANSIT-MIX CONCRETE

A Perfect-Blend
Material

Golden Gate Atlas
Materials Co.

Sixteenth and Harrison Streets
San Francisco
Phone HEmlock 7020

LUXOR

WINDOW SHADES

Translucent Shading
of highest count
cambric

William Volker & Co.

631 Howard Street
San Francisco

THE

BUILDING MATERIAL EXHIBIT

LOS ANGELES

We offer a complete service to Architects and Engineers with information on manufacturers' representatives and details of materials.

FIFTH at FIGUEROA
M U t u a l 6 3 0 6

REPUBLIC STEEL CORPORATION



Manufacturers of

ENDURO Stainless Steel; TON-CAN Copper Molybd num Iron Sheets and Pipe; and Steel Pipe, Sheets and Reinforcing Bar for every building purpose.

Write for information

Rialto Building, San Francisco, Calif.
Edison Building, Los Angeles, Calif.
White-Henry-Stuart Bldg., Seattle, Wash.

Specify DICKEY CLAY PRODUCTS

Dickey Mantertile	Face Brick
Partition Tile	Fire Brick
Drain Tile	Paving Brick
Fireproofing Tile	Wall Coping
Floor Tile	Flue Lining
Common Brick	Dickey Flashing Blocks

W. S. DICKEY CLAY MFG.
COMPANY

116, New Montgomery St.,
San Francisco, Calif.
105 Jackson St., Oakland, Calif.

own a home', and pressed for a more definite statement, the man who expresses a preference for a rented home says that 'taxes are so high I can't afford to own.'

"Now, very definitely, it is not cheaper to rent than to own. Figuring depreciation, upkeep and taxes, it is cheaper to own, in most localities, at least. And, furthermore, there is a pleasure in home ownership that the renter never knows.

"But, nevertheless, taxes are a big factor in determining the volume of home building. They put the brakes on home-ownership. The prospective home owner doesn't build, or buy, if he is at all cautious, until he is thoroughly familiar with tax probabilities.

"Taxes should be low to encourage home ownership in America as they are in other countries. It is stated, and it is probably true, that homes and farms in the United States carry a larger share of the tax load than in any other country in the world.

"Professor Paul Studenski of New York University has just published a comparative survey giving the facts. He shows that in the United States the general property tax bears 57 per cent of all the costs of national, state and local governments.

DO YOU KEEP A TERMITE?

(San Fracisco Chronicle)

Do you keep a termite? The question is given a great deal of point by the report of the San Francisco Termite Survey, a relief workers' project for which the City of San Francisco employed a director A. A. Brown, the engineer who had been chairman of the Termite Investigations Committee.

According to the survey report the householder who does not keep a termite is almost the exception. Of a total of 1710 buildings inspected by the survey, 81 per cent of the wood frame structures were found to be infested by wood destroying insects, chiefly termites. Of the Class C buildings 33 per cent were infested; of the Class B build-



Pump Governors	Oil Heaters
Safety Pump Governors	Relief Valves
Automatic Gas Regulating Valves	Oil Burner Governors
Gas Burners	Little Giant Improved Oil Burners
Gas Burning Equipment	Oil Pumping Sets
Vacuum Pump Governors	Oil Valves
Vacuum Regulating Valves	Oil Strainers
Continuous Flow Steam Traps	Steam Oil Strainers
Thermostats	Duplex Oil Pumps
Reducing Valves	Rotary Oil Pumps
Boiler Feed-Water Regulators	Boiler Feed Pumps
	Water Heaters
	Oil Meters

VAUGHN-G. E. WITT Co. ENGINEERS

C. W. Vaughn, President and Manager

MANUFACTURERS AND
DISTRIBUTORS

4224-28 Hollis St. Phone Olympic 6084
Emeryville, Oakland, Calif.

Robert W. Hunt Company ENGINEERS

Inspection - Tests - Consultation
Schools and Other Structures
Are Built as Designed

When Construction Materials are Inspected at point of Manufacture and during Erection by

ROBERT W. HUNT COMPANY

Cement, Concrete, Chemical, Metallurgical, X-Ray and Physical Laboratories

Chicago - New York - Pittsburgh
Los Angeles - All Large Cities
San Francisco, 251 Kearny Street

G. P. W. JENSEN & SON

Building Construction

320 Market Street, San Francisco

Phone 2444

Progress

Contracts in Execution

U. S. Mint, San Francisco

Administration Building and
Toll Plaza, Bay Bridge,
Oakland

Yerba Buena Crossing,
Bay Bridge

Figueroa Street Overhead
Crossing, Los Angeles

Clinton Construction Co. of California

923 Folsom Street
San Francisco
SUtter 3440

ings 37 per cent and of the Class A buildings 36 per cent. It should be explained that the number of Class A and Class B buildings inspected was much smaller than that of the Class C and wood frame structures.

The survey comprised inspection of buildings taken at random through the city and an inspection of all the buildings in one area covering about 662 acres. In this area where the inspection was 100 per cent the percentages of infection ran a little lower among the buildings taken at random—78 per cent for wood frame buildings, 31 per cent for Class C, 34 per cent for Class B and 27 per cent for Class A.

Thus the survey has demonstrated a more widespread termite infestation than had been supposed. Similar surveys of other cities throughout the United States would probably demonstrate the same thing—that the inhabitants do not realize the extent to which they harbor termites.

The report emphasizes the fact that

The "State"



Model No. 75

When there are more beautiful and efficient drinking fountains HAWS will make them.

This new model is made of Vitreous China—Semi-Recessed—obtainable with ice-water faucet on special order with or without bubbler. Lots of head room.

HAWS DRINKING FAUCET CO.
1803 Harmon Street Berkeley, Calif.

COMMON BRICK

If you like good brick and good service, phone us for information, you will find that it always pays to be our patron.

Remillard-Dandini Co.

Phone TEmplebar 8133
Office, 569 - 3rd Street, Oakland
Plants
San Jose Pleasanton Greenbrae

Bethlehem Steel Company

General Offices:  Bethlehem, Pa.

STEEL BRIDGES and BUILDINGS

San Francisco
20th and Illinois Sts.

Seattle
W. Anderson Street

Portland
American Bank Bldg.

Los Angeles
Slauson Ave.

Salt Lake City
Kearns Bldg.

Honolulu, T. H.
Schuman Bldg.

NOW... Any Size Building Can Have Modern Forced Air Heat!

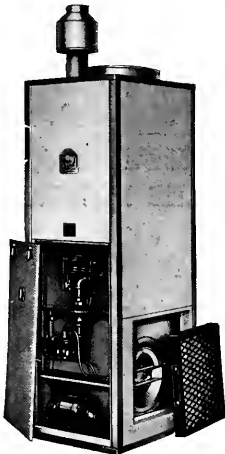

Quiet, compact, efficient heating and ventilating unit supplies filtered air—warm in winter! Cool in summer.

PACIFIC Forced Air Unit

MODEL A-11

Easily installed in kitchen, closet or screened porch. NO BASEMENT REQUIRED. Automatic controls maintain constant, uniform temperature, guard against overheating, save fuel.

Write for catalog AE-7

PACIFIC GAS RADIATOR CO.
Huntington Park, Calif., U. S. A.

Pacific
GAS HEATING HEADQUARTERS

LAWTON SCHOOL
 SAN FRANCISCO
 DODGE A. REIDY and CHAS. J. ROGERS
 ARCHITECTS

**ANOTHER LINOLEUM
 CONTRACT INSTALLED**

BY
WEST COAST
 LINOLEUM and CARPET
 STORES

2703 MISSION STREET, SAN FRANCISCO
 Telephone VAleria 4909

**Independent
 Iron Works**

Structural Steel
 Ornamental Iron
 Steel Service Stations
 Steel Tanks
 Standard Steel Mill Buildings
 Bridges

821 Pine Street Oakland

these termites do not represent an invasion from other lands. The termites we have now were here, all over the United States, ages before the white man came. They used to live exclusively in the wilds, where they were the scavengers of dead timber of all sorts. They have now moved to town because the white man has set up for them large stores of inviting food.

The value of the report, aside from the jolt it gives to apathy about termites, is its store of useful information to building owners. One who has studied this report should be less blind to termite presence and should go less blindly about the job of guarding against or getting rid of the destructive wood devourers. It has been printed by the city for public distribution.



LIGHTING OF LASTING DISTINCTION

• The kind your clients are demanding. Lifetime charm is added to a new or modernized home with Lightolier quality fixtures. Write for Home Owners Booklet.

INCANDESCENT SUPPLY CO.
 San Francisco Oakland Fresno Los Angeles

**M O N E L
 M E T A L**

For the Modern Kitchen
 Heaters, boilers, storage tanks, water softeners, cabinet tops, "Streamline" or "Straitline" Kitchen Sinks

See our display rooms, arranged for your convenience

**MODERN METAL
 APPLIANCE CO.**
 4238 Broadway Oakland, Calif.

CORROSIRON
 MADE IN U.S.A.
HIGH SILICON ACID RESISTING IRON

REDUCE COST OF HANDLING CORROSIVE GASES
 with CORROSIRON

**EXHAUST FANS for
 ACID FUMES**

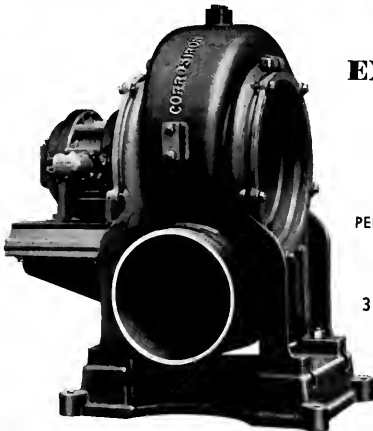

Write for
 BULLETIN No. 130
 SHOWING
 PERFORMANCE DATA—DESCRIPTIONS
 and
 DIMENSIONAL BLUE PRINTS
 SIZES

3 in.—6 in.—8 in.—12 in.—15 in.
 CAPACITIES
 50 C.F.M. to 5000 C.F.M.

TYPE DM.

PACIFIC FOUNDRY COMPANY, Ltd.

551 Fifth Avenue
 NEW YORK

3100 Nineteenth St.
 SAN FRANCISCO

1400 South Alameda St.
 LOS ANGELES



**HERRICK
 IRON WORKS**

STRUCTURAL STEEL

18TH AND CAMPBELL STS.
 OAKLAND, CALIF.
 Phone G-Lencourt 1767

P. F. REILLY

Building Contractor

Builders Exchange
 San Francisco

Classified Advertising Announcements

All Firms are Listed by Pages, besides
being grouped according to Craft or Trade.
Star (*) indicates alternate months.

ACOUSTICAL AND SOUND CONTROL		NEW THIS MONTH	
Western Asbestos Co., 675 Townsend Street, San Francisco.....	70		
AIR CONDITIONING			
The Union Ice Company, 354 Pine Street, San Francisco.....	64		
ARCHITECTURAL TERRA COTTA			
N. Clark & Sons, 116 Natoma Street, San Francisco.....	7		
Gladding McBean & Co., 660 Market Street, San Francisco; 2901 Los Feliz Boulevard Los Angeles; 1500 First Avenue South, Seattle; 79 S. E. Taylor St., Portland; 22nd and Market Street, Oakland; 1102 N. Monroe Street, Spokane; Vancouver, B. C.....	9	Bethlehem Steel Co.	6
BANKS			
Crocker First National Bank, Montgomery and Post Streets, San Francisco.....	67	Calaveras Cement Co.	71
BATHROOM HEATERS			
Wesix Electric Heater Company, 390 First Street, San Francisco; 631 San Julian Street, Los Angeles; 2008 Third Avenue, Seattle, Wash.....	72	Ferro Enameling Co.	71
Apex Electric Heaters, sold by Sandoval Sales Co., 557 Market Street, San Francisco.....	68		
BLINDS—VENETIAN			
Gunn-Carle & Co., 20 Pittreiro Ave., San Francisco.....	70	Libbey, Owens, Ford	8
BRICK—FACE, COMMON, ETC.			
N. Clark & Sons, 116 Natoma Street, San Francisco.....	7	Pacific Foundry Co., Ltd.	73
Gladding McBean & Co., 660 Market Street, San Francisco; 2901 Los Feliz Boulevard Los Angeles; 1500 First Avenue South, Seattle; 79 S. E. Taylor St., Portland; 22nd and Market Street, Oakland; 1102 N. Monroe Street, Spokane; Vancouver, B. C.....	9	Pacific Gas Radiator	75
W. S. Dickey Clay Mfg. Co., 116 New Montgomery Street, San Francisco; factory, Niles, Calif.; yards, 7th and Hooper Streets, San Francisco, and 105 Jackson Street, Oakland; Factory in Livermore	74	Sloan Valve Co.	5
Remillard-Dardini Co., 569 Third Street, Oakland.....	75	Union Ice Co.	64
BUILDERS HARDWARE			
The Stanley Works, New Britain, Conn.; Monednock Bldg., San Francisco; Los Angeles and Seattle	Western Asbestos Co.	70
BUILDING MATERIALS			
Building Material Exhibit, Architect's Building, Los Angeles	74		
BUILDING PAPERS			
The Sisalkraft Company, 205 W. Wacker Drive, Chicago, Ill., and 55 New Montgomery Street, San Francisco	70		
"Brownskin," Angier Corporation, 370 Second Street, San Francisco	73		
CEMENT			
Calaveras Cement Company, 315 Montgomery Street, San Francisco.....	71		
Portland Cement Association, 564 Market Street, San Francisco; 816 West Fifth Street, Los Angeles; 146 West Fifth Street, Portland; 518 Exchange Building, Seattle	Back cover		
"Golden Gate" and "Old Mission," manufactured by Pacific Portland Cement Co., 111 Sutter Street, San Francisco; Portland, Los Angeles and San Diego.....	Second cover		
CEMENT TESTS—CHEMICAL ENGINEERS			
Robert W. Hunt Co., 251 Kearny Street, San Francisco.....	74		
CEMENT—COLOR			
"Golden Gate Ten Cement," manufactured by Pacific Portland Cement Co., 111 Sutter Street, San Francisco; Portland, Los Angeles and San Diego	Second cover		
W. S. Dickey Clay Mfg. Co., 116 New Montgomery Street, San Francisco	74		
CEMENT PAINT			
General Paint Corporation, San Francisco, Los Angeles, Oakland, Portland and Seattle	65		
California Sales Company, 444 Market Street, San Francisco.....	71		
CONCRETE AGGREGATES			
Golden Gate Atlas Materials Company, Sixteenth and Harrison Streets, San Francisco	73		
John Cassaretto, Sixth and Channel Streets, San Francisco	78		
CONCRETE CURING & PROTECTION			
The Sisalkraft Company, 205 W. Wacker Drive, Chicago, Ill., and 55 New Montgomery Street, San Francisco	70		
CONTRACTORS—GENERAL			
MacDonald & Kahn, Financial Center Bldg., San Francisco	79		

	Page
CONTRACTORS—GENERAL	
Lindgren & Swinerton, Inc., Standard Oil Building, San Francisco.....	66
Dinwiddie Construction Co., Crocker Bldg., San Francisco	79
Clinton Construction Company, 923 Folsom Street, San Francisco.....	75
Anderson & Ringrose, 320 Market Street, San Francisco.....	72
G. P. W. Jensen, 320 Market Street, San Francisco.....	74
P. F. Reilly, 730 Ellis Street, San Francisco	76
Wm. Martin & Son, Builders' Exchange, San Francisco.....	79
DAMP-PROOFING & WATERPROOFING	
"Golden Gate Tan Plastic Waterproof Cement," manufactured by Pacific Portland Cement Co., 111 Sutter Street, San Francisco; Portland, Los Angeles and San Diego	Second page of cover
The Sisalkraft Company, 205 W. Wacker Drive, Chicago, Ill., and 55 New Montgomery Street, San Francisco	70
Bay State Brick & Cement Coating, sold by California Sales Company, 444 Market Street, San Francisco.....	71
DOORS—HOLLOW METAL	
Forderer Corncove Works, Potrero Avenue, San Francisco	72
Kawneer Mfg. Co., Eighth and Dwight Streets, Berkeley.....	73
ACID PROOF DRAIN PIPE AND FITTINGS	
Corrosion—Acid resisting pipe, fittings, exhaust fans, pumps, etc., Pacific Foundry Co., 3100 19th Street, San Francisco; 1400 S. Alameda Street, Los Angeles.....	76
DRINKING FOUNTAINS	
Haws Drinking Faucet Co., 1808 Harmon Street, Berkeley; American Seating Co., San Francisco, Los Angeles and Phoenix	75
ENGINEERS—MECHANICAL	
Hunter & Hudson, 41 Sutter Street, San Francisco.....	72
ELECTRIC AIR AND WATER HEATERS	
Sandoval Sales Company, 557 Market Street, San Francisco.....	68
West Electric Heater Company, 390 First Street, San Francisco; 631 San Julian Street, Los Angeles; 2008 Third Avenue, Seattle, Wash.	72
ELECTRICAL ADVICE	
Pacific Coast Electrical Bureau, 447 Sutter Street, San Francisco, and 601 W. Fifth Street, Los Angeles	64
ELEVATORS	
Pacific Elevator and Equipment Company, 45 Rausch Street, San Francisco	79
PORCELAIN ENAMELING	
Ferro Enameling Company, 1100 57th Street, Oakland.....	71
FLOORING	
Asphalt Tile, Western Asbestos Company, 675 Townsend Street, San Francisco.....	70
HOLLOW TILE AND BRICK FENCES	
W. S. Dickey Clay Mfg. Co., 116 New Montgomery Street, San Francisco.....	74
FIXTURES—BANK, OFFICE, STORE	
Mullen Manufacturing Co., 64 Rausch Street, San Francisco	79
Pacific Manufacturing Company, 454 Montgomery Street, San Francisco; 1315 Seventh Street, Oakland, Los Angeles and Santa Clara.....	73
GAS FUEL	
Pacific Gas Association, 447 Sutter Street, San Francisco.....	Third Cover
GAS BURNERS	
Vaughn-G. E. Witt Company, 4224-28 Hollis Street, Emeryville, Oakland.....	74
GAS VENTS	
Payne Furnace & Supply Co., Beverly Hills, California.....	71
GAS RADIATORS	
Pacific Gas Radiator Company, Huntington Park, Cal.....	75
GLASS	
W. P. Fuller & Co., 301 Mission Street, San Francisco. Branches and dealers throughout of the West	6
Libbey-Owens-Ford Glass Co., Toledo, Ohio; 633 Rialto Bldg., San Francisco; 1212 Architects Bldg., Los Angeles; Mr. C. W. Holland, P.O. Box 3142, Seattle.....	8
Pittsburgh Plate Glass Company, Grant Building, Pittsburgh, Pa. W. P. Fuller & Co., Pacific Coast Distributors
HARDWARE	
The Stanley Works, Monednock Building, San Francisco; American Bank Building, Los Angeles
HARDWOOD LUMBER	
White Bros., Fifth and Brannan Streets, San Francisco; 500 High Street, Oakland.....	71
HEATING—ELECTRIC	
Apex Air and Water Electric Heaters, Sandoval Sales Company, 557 Market Street, San Francisco.....	68
West Electric Heater Company, 390 First Street, San Francisco; 631 San Julian Street, Los Angeles; 2008 Third Avenue, Seattle, Wash.	72
HEATING EQUIPMENT	
Payne Furnace & Supply Co., Beverly Hills, California.....	71
Pacific Gas Radiator Co., 7615 Roseberry Ave., Huntington Park; Sales Office, H. C. Stoeckel, 557 Market Street, San Francisco.....	75
HEAT REGULATION	
Johnson Service Company, Milwaukee, represented on the Pacific Coast by the following branch offices: 814 Rialto Bldg., San Francisco; 153 West Avenue, 34, Los Angeles; 1312 N.W. Raleigh St., Portland, and 473 Coleman Bldg., Seattle.....	3

JOHN CASSARETTO

—Since 1886—And Still Active—

Building Materials

READY MIX CONCRETE
ROCK - SAND - GRAVEL - LIME
CEMENT - PLASTER - MORTAR
METAL LATH - WOOD LATH
STUCCO - WIRE NETTING

Service Unexcelled

Bunkers
Sixth and Channel, San Francisco
Phones: GARfield 3176, GARfield 3177

Carl T. Doell Co.

Plumbing Heating

Plumbing Contractor
Veterans Memorial Building
Oakland

467 21ST STREET
OAKLAND

Telephone GLencourt 8246

DINWIDDIE CONSTRUCTION COMPANY

●
BUILDERS OF
GOOD BUILDINGS

●
CROCKER BUILDING
SAN FRANCISCO

MULLEN MFG. COMPANY

—
BANK, STORE AND OFFICE
FIXTURES—CABINET WORK
OF GUARANTEED QUALITY
CHURCH SEATING

—
Office and Factory:
60-80 RAUSCH ST., Bet. 7th and 8th Sts.
San Francisco
Telephone UNDERhill 5815

**William Martin
& Son
Builders**

666 Mission Street
San Francisco

Telephone SUtter 6700
Evenings: GARfield 9456

ELEVATORS

**Pacific Elevator and
Equipment Company**

45 Reusch Street, San Francisco
HEmlock 4476

MacDonald & Kahn

*General
Contractors*

Financial Center Bldg.
405 Montgomery St.
San Francisco

"The Only Pacific Coast Factory"

**THE HERMANN
SAFE COMPANY**

Manufacturers and Dealers

**FIRE AND BURGLAR PROOF
SAFES, VAULTS, SAFE
DEPOSIT BOXES**

**Howard & Main Sts.
San Francisco**

Telephone GARfield 3041

HOLLOW BUILDING TILE (Burned Clay)

N. Clark & Sons, 116 Natoma Street, San Francisco.....	Page 7
Gladding, McBean & Co., 660 Market Street, San Francisco; 2901 Los Feliz Boulevard, Los Angeles; 1500 First Avenue South, Seattle; 79 S. E. Taylor Street, Portland; Twenty-second and Market Streets, Oakland; 1102 N. Monroe Street, Spokane; Vancouver, B. C.	9
W. S. Dickey Clay Mfg. Co., 116 New Montgomery Street, San Francisco; factory, Niles, Calif.; yards, 7th and Hooper Streets, San Francisco, and 105 Jackson Street, Oakland	74

INSULATING MATERIALS

Western Asbestos Co., 675 Townsend Street, San Francisco.....	70
---	----

INSPECTION AND TESTS

Robert W. Hunt Co., 251 Keerny St., San Francisco.....	74
--	----

LACQUERS

General Paint Corp., San Francisco, Los Angeles, Oakland, Portland, Seattle and Tulsa	65
W. P. Fuller & Co., 301 Mission Street, San Francisco. Branches and dealers throughout the West	5

LIGHTING FIXTURES

Incandescent Supply Co., 726 Mission Street, San Francisco; Oakland, Fresno.....	76
--	----

LINOLEUM

Sloan-Blabon linoleum, sold by California Shade Cloth Co., 210 Bayshore Boulevard, San Francisco	70
--	----

LUMBER

Pacific Mfg. Co., 454 Montgomery Street, San Francisco; 1315 Seventh Street, Oakland; Los Angeles and Santa Clara.....	73
Smith Lumber Company, Nineteenth Avenue and Estuary, Oakland.....	80
Melrose Lumber & Supply Co., Forty-sixth Avenue and E. Twelfth Street, Oakland.....	80
E. K. Wood Lumber Company, 4701 Santa Fe Avenue, Los Angeles; 1 Drumm Street, San Francisco; Frederick and King Streets, Oakland.....	66

MARBLE

Joseph Musto Sons-Keenan Co., 535 N. Point Street, San Francisco.....	80
---	----

MILLWORK

E. K. Wood Lumber Company, No. 1 Drumm Street, San Francisco, Oakland, Los Angeles	66
Lannom Bros. Mfg. Co., Fifth and Magnolia Streets, Oakland.....	72
Melrose Lumber & Supply Company, Forty-sixth Avenue and E. Twelfth Street, Oakland	72
Pacific Mfg. Co., 454 Montgomery Street, San Francisco; 1315 Seventh Street, Oakland; Los Angeles and Santa Clara.....	73
Smith Lumber Company, Nineteenth Avenue and Estuary, Oakland	80

MONEL METAL

"Inco" brand, distributed on the Pacific Coast by the Pacific Metals Company, 3100 19th Street, San Francisco, and 1400 So. Alameda Street, Los Angeles.....	76
Kitchen sinks, heaters, storage tanks—Modern Metal Appliance Company, 4238 Broadway, Oakland	76

MURALS

Heinsbergen Decorating Co., Los Angeles and 401 Russ Building, San Francisco	72
--	----

OIL BURNERS

S. T. Johnson Co., 585 Potrero Avenue, San Francisco; 940 Arlington Street, Oakland; 1729 Front Street, Sacramento, and 230 N. Sutter Street, Stockton.....	65
Vaughn-G. E. Witt Co., 4224-28 Hollis Street, Emeryville, Oakland.....	74

ONYX

Joseph Musto Sons-Keenan Co., 535 No. Point Street, San Francisco.....	72
--	----

ORNAMENTAL IRON

Independent Iron Works, 821 Pine Street, Oakland.....	76
---	----

ORNAMENTAL LIGHTING

Incandescent Supply Co., 726 Mission Street, San Francisco, Oakland, Fresno.....	76
--	----

PAINTS, OIL, LEAD

W. P. Fuller & Co., 301 Mission Street, San Francisco. Branches and dealers throughout the West	5
Frank W. Dunne Co., 41st and Linden Streets, Oakland	73
General Paint Corp., San Francisco, Los Angeles, Oakland, Portland, Seattle and Tulsa	65
National Lead Company, 2240 24th Street, San Francisco. Branch dealers in principal Coast cities	73

PAINTING, DECORATING, ETC.

The Tormey Co., 563 Fulton Street, San Francisco	80
Heinsbergen Decorating Co., 401 Russ Building, San Francisco	72

PARTITIONS—MOVABLE OFFICE

Pacific Mfg. Co., 454 Montgomery Street, San Francisco; 1315 Seventh Street, Oakland; factory at Santa Clara	73
W. S. Dickey Clay Mfg. Co., 116 New Montgomery Street, San Francisco	75

PLASTER

"Empire" and "Reno Hardware Plaster," manufactured by Pacific Portland Cement Co., 111 Sutter Street, San Francisco; Portland, Los Angeles and San Diego.....Second cover	79
---	----

PLATE GLASS		Page
Libbey-Owens-Ford Glass Co., Toledo, Ohio; 633 Rialto Bldg., San Francisco; 1212 Architects Bldg., Los Angeles; Mr. C. W. Holland, P.O. Box 3142, Seattle	7	
PLUMBING CONTRACTORS AND MATERIALS		
Carl T. Doell Co., 467 Twenty-first Street, Oakland	78	
Crane Co., all principal Coast cities	72	
PRESSURE REGULATORS		
Vaughn-G. E. Witt Co., 4224-28 Hollis Street, Emeryville, Oakland	74	
ROOF MATERIALS		
Gladding, McBean & Co., 660 Market Street, San Francisco; 2901 Los Feliz Boulevard, Los Angeles; 1500 First Avenue South, Seattle; 79 S. E. Taylor Street, Portland; Twenty-second and Market Streets, Oakland; 1102 N. Monroe Street, Spokane; Vancouver, B. C.	9	
N. Clark & Sons, 112-116 Natoma Street, San Francisco; works, West Alameda	7	
SAND, ROCK AND GRAVEL		
John Cassaretto, Sixth and Channel Streets, San Francisco	78	
SHADE CLOTH		
California Shade Cloth Co., 210 Bayshore Boulevard, San Francisco	68	
SHEET METAL WORK		
Forterer Cornice Works, Potrero Avenue, San Francisco	72	
STANDARD STEEL BUILDINGS		
Independent Iron Works, 821 Pine Street, Oakland	76	
STEEL—STAINLESS		
Republic Steel Corporation, Rialto Bldg., San Francisco; Edison Bldg., Los Angeles; White-Henry-Stuart Bldg., Seattle	74	
STEEL, STRUCTURAL		
Independent Iron Works, 821 Pine Street, Oakland	76	
Judson Pacific Company, C. F. Weeber Bldg., Mission and Second Streets, San Francisco shops, San Francisco and Oakland	68	
Pacific Coast Steel Corp.—See Bethlehem Steel Company, Twentieth and Illinois Streets, San Francisco; Slauson Avenue, Los Angeles; American Bank Building, Portland, Ore.; West Andover Street, Seattle, Wash.	6 and 75	
Herrick Iron Works, 18th & Campbell Streets, Oakland	76	
STORE FIXTURES		
Mullen Mfg. Co., 60 Rausch Street, San Francisco	78	
STORE FRONTS		
Kawneer Mfg. Co., Eighth and Dwight Streets, Berkeley	72	
TEMPERATURE REGULATION		
Johnson Service Company, Milwaukee, represented on the Pacific Coast by the following branch offices: 814 Rialto Bldg., San Francisco; 153 West Avenue, 34, Los Angeles; 1312 N.W. Raleigh St., Portland, and 473 Coleman Bldg., Seattle	3	
TERMITE CONTROL—WOOD PRESERVATIVE		
E. K. Wood Lumber Company, No. 1 Drumm Street, San Francisco; 4701 Santa Fe Ave., Los Angeles; Frederick and King Streets, Oakland	66	
American Lumber & Treating Company, Rialto Bldg., San Francisco; 1031 S. Broadway Los Angeles	67	
TREE SURGERY		
Davey Tree Surgery Co., Ltd., Russ Building, San Francisco; Story Building, Los Angeles	2	
TILE—DECORATIVE, ETC.		
Pomona Tile Mfg. Co., plant, Pomona, Cal.; Sales Rooms, 135 Tenth St., San Francisco; 217 S. La Brea Ave., Los Angeles; 6106 Roosevelt Way, Seattle	70	
Gladding McBean & Co., 660 Market St., San Francisco; 2901 Los Feliz Boulevard, Los Angeles	8	
VARNISHES		
National Lead Company, 2240 24th Street, San Francisco. Branches and dealers in all principal Coast cities	73	
W. P. Fuller Company, San Francisco and principal Coast cities	4	
VALVES		
Sloan Valve Co., manufacturers of Sloan flush valves, 4300 West Lake St., Chicago, Ill.	5	
VAULT DOORS		
Hermann Safe Co., Howard and Main Streets, San Francisco	79	
WATERPROOFING		
Bay State Brick & Cement Coating, California Sales Co., 444 Market Street, San Francisco	71	
WINDOWS		
Kawneer Mfg. Co., Eighth and Dwight Streets, Berkeley	72	
Dalmo Sales Co., San Francisco	70	
WINDOW SHADES		
California Shade Cloth Co., 210 Bayshore Boulevard, San Francisco	68	
Wm. Volker & Co., 631 Howard Street, San Francisco	73	

Melrose Lumber & Supply Co.

LUMBER AND MILL WORK

46th Ave. and E. 12th St.
Oakland

Phones: FRuitvale 0240 — 0251

JOSEPH MUSTO SONS-KEENAN COMPANY

MARBLE
and
ONYX

535 NORTH POINT STREET
SAN FRANCISCO
1801 S. SOTO STREET
LOS ANGELES

Smith

Lumber Company
WHOLESALE - JOBBING - RETAIL
FACTORY AND BUILDING LUMBER
PLYWOODS - ROOFING
DISTRIBUTING YARDS

San Francisco	Oakland
4th & Channel	19th Ave. & Estuary
MARKet 0103	FRuitvale 3174
YOUR INQUIRIES SOLICITED	

THE TORMEY COMPANY

GENERAL PAINTERS AND DECORATORS

Phone UNderhill 1913

563 FULTON STREET
San Francisco

THE ARCHITECT AND ENGINEER

SAN FRANCISCO
PUBLIC LIBRARY
PERIODICAL DEPT.



1939 THE GOLDEN GATE INTERNATIONAL EXPOSITION, A PAGEANT OF THE PACIFIC 1939

August 1936

HOW TAN PLASTIC

pourability



Home of E. O. McCormick, Jr.
Hillsborough, California
William Wilson Wurster, Architect
D. B. Gladstone, Contractor

Makes

VERANDAS WEATHERPROOF

The veranda, a great American institution, calls for special architectural consideration in the choice of materials.

First, the floor and walls must be pleasing to the eye, both in the searching sunlight and the cool, deep shadows. Next, it must be practical and that means *weatherproof*.

TAN PLASTIC pourability assures solid, smooth-surfaced concrete that repels moisture and assures permanent satisfaction. Its warm, pleasing tan color blends harmoniously with the landscape and the furnishings.

For any project where protection as well as appearance counts, specify TAN PLASTIC. Used right it never disappoints.

Ask Your Building Material Dealer.

"Smoothness and color shade led us to specify Golden Gate Tan Plastic Cement for this porch. No trowel work was needed. Neither was it necessary to add any coloring material to the cement."

*{Signed} William Wilson Wurster,
Architect*



for
STUCCO
•
POOLS
•
MONOLITHIC
CONCRETE
•
BASEMENTS
•
MORTAR
•
CAST STONE



This free folder
tells how to use TAN
PLASTIC to get best results.

PACIFIC PORTLAND CEMENT COMPANY

SAN FRANCISCO • LOS ANGELES

COASTWIDE SERVICE

PORTLAND • SEATTLE

The ARCHITECT and ENGINEER

presents for August, 1936—Vol. 126, No. 2—

	COVER	AIRPLANE VIEW OF THE GOLDEN GATE INTERNATIONAL EXPOSITION	
	FRONTISPIECE .	DETAIL OF ENTRANCE TO LURIE BUILDING, SAN FRANCISCO Wilbur D. Peugh, Architect	
	TEXT	SAN FRANCISCO HAS CUSTOM MADE BUILDING Frederick W. Jones	11
		MODERNIZING BOOSTS RENTAL VALUES	15
		NEW DECORATIVE MEDIUM FOR ARCHITECTS Oscar B. Bach	23
		THE FUNCTION OF FUNCTIONALISM	25
		Leicester B. Holland, F.A.I.A. GUEST HOUSE ON THE RANCH OF JAMES ROLPH, III	33
		NATIONAL PRAISE FOR SACRAMENTO BRIDGE .	43
		Everett L. Walsh NEW SCALE AND CODE FOR ENGINEERS	45
		MACHINE TABULATION—'35 BUSINESS CENSUS .	49
		ARCHITECTS' BULLETIN	51
		WITH THE ARCHITECTS	55
	PLATES AND ILLUSTRATIONS—		
		LURIE BUILDING, SAN FRANCISCO	11-12
		Wilbur D. Peugh, Architect WEST PORTAL BRANCH, SAN FRANCISCO BANK	13
		Wilbur D. Peugh, Architect BUILDING FOR NATIONAL CASH REGISTER CO. .	14
		Albert F. Roller, Architect COTTAGE BAKERY, HAYWARD, CALIFORNIA .	16
		FILLMORE STREET BRANCH, SAN FRANCISCO BANK	17
		Wilbur D. Peugh, Architect J. W. ROBINSON BUILDING, LOS ANGELES . .	18
		Edward L. Mayberry and Allison and Allison, Architects HOUSE FOR DR. R. G. FLOOD, SAN FRANCISCO	19
		Farr and Ward, Architects BUILDING FOR GARLOCK PACKING COMPANY	20
		Dodge I. Riedy, Architect DOORS FOR AN ENTRANCE TO A BUILDING DEVOTED TO INDUSTRY	27
		Oscar B. Bach PUEBLO COTTAGES FOR LOS ANGELES HOTEL	32
		Carlton Monroe Winslow, Architect GUEST HOUSE FOR FORMER GOVERNOR JAS. ROLPH, JR., SAN MATEO COUNTY	33-38
		Noble Newsom and Archie T. Newsom, Architects RESIDENCE OF JOHN M. HOLMES, HILLS- BOROUGH	39-41
		Noble Newsom and Archie T. Newsom, Architects TOWER BRIDGE, SACRAMENTO	42
		Geo. B. McDougall, Architect THEATRICAL PICTURE STUDIO, SAN FRANCISCO	48
		Bliss and Fairweather, Architects	
W. J. L. KIERULFF	President		
FRED'K. W. JONES	Vice President and Editor		
LOUISE B. PENHORWOOD	Secretary		
EDGAR N. KIERULFF	Advertising Manager		
J. LESLIE MEEK	Advertising		
VERNON S. YALLOP	Architects' Reports		
ARTHUR BROWN, JR			
HARRY MICHELSEN			
W. G. CORLETT	Advisory Editors		

Notes and Comments

IT is unfortunate that there is to be a conflict of dates for the San Francisco and New York Worlds Fairs—both scheduled for 1939—but there would appear to be no disposition on the part of either of the promoters to change the time, hence both must trust to good fortune for the success of their ventures. San Francisco has made better progress to date and the unusual setting that is promised our own Exposition, is likely to prove a considerable drawing card. 'Twill be like a Venice at home. The possibilities are without limit. The East already admits this. Here is a recent comment in the American Architect and Architecture:

"Press releases from San Francisco related, in glowing terms, what Brigadier-General Arnold visualized as California's aeronautical future. One report said: 'California and the cities of San Francisco Bay should start the ball rolling toward the greatest aeronautical pageant in history, to be held in conjunction with the 1939 International Exposition, and its major theme—Transportation. Spectacular mobile and static displays of commercial and military flying, the National Air Races, and international flying meets, should provide attraction for millions of visitors.'

"'It is possible,' the Brigadier-General continued, 'that with well-laid plans the U. S. Army Air Corps may hold its annual maneuvers in the San Francisco Bay area in Exposition year.'

"Important as the Brigadier-General's remarks were, chief interest to outsiders lay in the obvious fact that California promoters aren't 'missing a trick' in selling the 1939 venture to the world. With New York planning a similar exposition in 1939, it can be expected that the press will be full of glowing reports, that each organization will attempt to outdo the other in magnificence, originality and exhibits.

"Despite the scope of activities that the San Francisco Exposition undoubtedly will undertake, there is absolutely no reason to believe that the New York World's Fair Committee is letting any grass grow under its feet. Some of the biggest 'names' in architectural circles got together recently with George McAneny, Chairman of the Board of the World's Fair, and there was plenty of evidence that this group does not plan to be outdone."

THE change of our nation from one dominantly agricultural to one of dominant importance industrially, with the consequent massing of people in small congested areas in cities, has created many problems new to the technical professions. Polluted water supplies, and the recurring epidemics of typhoid fever, are no longer

front page news. The disposal of human waste constituted a hazard to health prior to development of our modern sewage disposal works. At the spring meeting of the American Society of Civil Engineers, the work of engineers in controlling insect-borne diseases, such as yellow fever and malaria, occupied a place of prominence on the program. The massing of buildings in cities and towns, principally constructed of wood, a large percentage of which are now infested by one or more types of wood-destroying organisms, is a relatively new problem requiring the attention of the professional branches of the construction industry. This is a subject that vitally interests every home owner. It should be considered in two distinct phases: One concerns existing buildings, their repair and prevention of future damage by termites, etc., and the other deals with new construction and the Building Code.

To date no standard of workmanship or materials to be used has been established as a guide by which the public can judge the proposals submitted by pest control operators and others for the eradication and repair of infested structures. The public has little specific knowledge of the materials used for the purpose, and no time or opportunity to acquire such knowledge. It has been the common practice among pest control operators to go from house to house offering free inspection service in the expectation of finding an infestation and selling their own specially prepared "solutions" (often worthless), for the purpose of eradication. This has been commonly referred to as the "Termite racket." When the recent session of the State Legislature created the Structural Pest Control Board, it was hoped by many that the licensing of pest control operators by a board appointed by the Governor would stop the "racketeer methods" and raise the standard of business ethics to those prevailing in the building industry. The Structural Pest Control Board has not stopped the abuses which led to its creation. Instead, the board has energetically opposed every effort on the part of the City of San Francisco to assemble the facts on the subject through a termite survey. It would seem, therefore, that the board has abdicated the functions for which it was created, making it not only expedient but necessary that architects and engineers advise the public on this important subject.

The printed report of the San Francisco Termite Survey issued by the Board of Public Works makes available a large amount of basic data for use in reconstructing the Building Code. It strikingly illustrates that no type or kind of building

as now constructed, is free from infestation—which is to say that our Building Codes are inadequate. The responsibility for recommending additions and changes in the Code to meet this new problem properly rests with architects and engineers. Each of these professions should appoint a committee to jointly study the problem and sponsor such changes in the Code as will afford the prospective builder the security he has a right to enjoy. Such constructive action will no doubt aid in creating public interest in home ownership.

CULMINATING the joint exhibition of Architectural League and American Institute of Decorators, felicitous correspondence between the presidents symbolizes an ideal collaboration which the public has been quick to welcome. Architects and decorators now work together with mutual common interests, says a writer in the Interior Decorator. The unified trend of architecture and decoration, as illustrated in the exhibits, was accepted with general approval. This was revealed especially by the "Room of 1936," in which seven members of the Institute collaborated to express the taste of a cultured family, with some reflection of modern influences but more particular emphasis on comfort and intrinsic beauty in line and color, bringing objects of interests charming in themselves but more effective in giving life to the ensemble.

SOME people will resort to about everything but murder to avoid paying a legitimate architect's fee. In one middle west city where the state law prohibits the erection of a building costing \$7500 or over unless it has been designed by a licensed architect, a lawyer advised his client to split the building into parts, building one unit at a time for which a permit was issued for each unit as the work progressed, at an estimated cost of under \$7500 per unit. And by thus manipulating things the owner was able to put up a structure that eventually represented an investment of over \$50,000 without the services of a licensed architect.

Undoubtedly the recent depression has worked in many different ways to injure the architectural profession. Scarcity of money has prompted owners to try and save the architect's fee by employing hungry draftsmen. And unemployed draftsmen for a while were so numerous that they were willing to work for a living wage just to keep off the dole. With improved conditions, architects getting busy and good draftsmen difficult to find, it would seem to be a splendid time for both architects and draftsmen to get together in some mutual understanding about employment

(Please turn to Page 76)



THEATRICAL PICTURE STUDIO, SAN FRANCISCO
Bliss and Fairweather, Architects

TERRA COTTA UNIT TILE, because of its flexibility, colors and permanence, proved the ideal material for this modernization project . . . Shapes are available to form various styles of architectural designs for stores, office buildings, banks, hotels, etc.

GLADDING, McBEAN & CO.

Manufacturers of Clay Products

SAN FRANCISCO
PORTLAND

LOS ANGELES
SEATTLE

SPOKANE

OAKLAND
VANCOUVER, B. C.

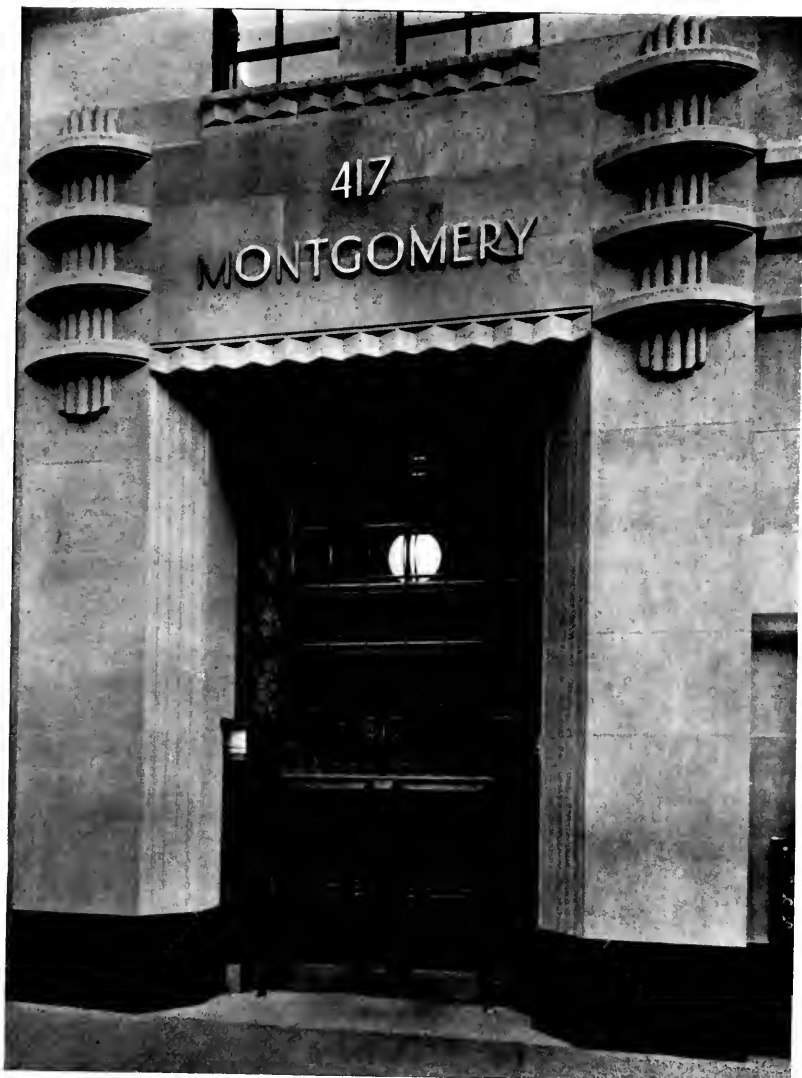

Photo by Wesley Swadley

DETAIL OF ENTRANCE, LURIE BUILDING, SAN FRANCISCO
WILBUR D. PEUGH, ARCHITECT

SAN FRANCISCO HAS CUSTOM MADE BUILDING

FIRST OFFICE STRUCTURE BUILT SINCE THE DEPRESSION

By Fred'k W. Jones

WE HAVE been hearing about custom made clothes for many years. Custom made office buildings, however, are a development of today. In the recently completed Lurie Building in San Francisco we have an outstanding example of this new type of "made to order" building. The preliminary drawings provided ten floors of open areas. As construction progressed and tenants were signed, the arrangement of each floor became an individual problem to be worked out according to the needs of the client, just as a tailor cuts a suit or overcoat to satisfy the whims of the customer. Every tenant is provided with a layout and equipment to meet his particular requirement. All utilities, such as telephones, electricity, mail chutes, elevator service, etc., were anticipated and ample provision was made to provide them when and where needed. A staggered system of toilet facilities between floors provides convenience without depending upon elevator service. The toilets may be reached from each floor by walking down a half story flight of stairs. Only one other building in San Francisco, the Pacific National Bank Building, enjoys a similar arrangement and it was designed by the same architect, who planned the Lurie Building, W. D. Peugh.

The Lurie is the first and only office building to be erected in San Francisco since the beginning of the depression, while the Pacific National just referred to, was the last office structure to be completed prior to the let down in building.

When the design of the building was in its early stages it was discovered that no office

LURIE BUILDING, SAN FRANCISCO
Wilbur D. Peugh, Architect





ENTRANCE LOBBY, LURIE BUILDING,
SAN FRANCISCO
Wilbur D. Peugh, Architect

structure had been built in the United States since 1930. Nor has an office building been built in San Francisco any later (excluding, of course, the Lurie Building) although there has been considerable remodeling of office structures, both large and small. The cost of the Lurie Building was based on 1927-28 prices. Actual building costs, however, were considerably less than estimates, offsetting in a measure, reduced rental values prevailing today. It was possible too, to obtain land during the depression period at a price greatly under realty values in the days of nation-wide prosperity.

The Lurie Building is of the Class B type with reinforced concrete walls, floors and roof. The street facade is faced with limestone set in a series of vertical panels which extend from the second to the tenth floors. The entrance lobby is of red marble, bronze and gold and lends an effect of richness and solidity. Plain but dignified, the building reflects the character of

its tenants whose names read like a page torn from the blue book of industry. The roster includes the Hammond Lumber Company, General Petroleum Company, Federal Hardware Mutual Insurance Company, Northwestern Mutual Fire Insurance Company, Fire Association of Philadelphia, National Ice & Cold Storage Company, Hunt Bros. Packing Company, the Western Union Telegraph Company and the State of California, which latter occupies two floors devoted to the Insurance Commission and Department of Parks.

The building was leased 100% long before completion.

Branch Bank Building

The West Portal Branch of the San Francisco Bank, situated on West Portal Avenue and Ulloa Street, San Francisco, occupies a frontage of 103 feet on West Portal Avenue and 83 feet on Ulloa Street.

The building is modern in design and is faced



ENTRANCE LOBBY, LOOKING OUT,
LURIE BUILDING, SAN FRANCISCO
Wilbur D. Peugh, Architect



Photo by Scaulley

WEST PORTAL BRANCH, SAN FRANCISCO BANK
 Wilbur D. Peugh, Architect

entirely with imported Italian Travertine marble. A unique feature of the construction is the location of the heating system on the mezza-

nine floor at the rear of the banking room, from which air at high velocity is used for both heating or cooling.



INTERIOR, WEST PORTAL BRANCH, SAN FRANCISCO BANK
 Wilbur D. Peugh, Architect
 Note interesting treatment of ceiling



This thirty year old building on Mission Street, San Francisco, still structurally sound, was given a new front of reinforced concrete and faced with enamel terra cotta unit tile. . . The color scheme is cream for the main surface with peach trimmings. . . The vertical ribs, designed to flank a Neon display, is Redwood brown. . . The interior was completely rearranged to conform with the needs of the tenant.

Albert F. Roller, Architect



MODERNIZING BOOSTS RENTAL VALUES

ARCHITECTS FIND OPPORTUNITY IN ALTERATION WORK

Some Recent California Examples

IN SPITE of the fact that the astounding sum of one billion one hundred and fifty millions of dollars was spent last year on modernization and remodeling (figures furnished by FHA) this class of work would appear to be still in its infancy. Insofar as it affects domestic architecture the remodeling program may be said to have reached its peak but applied to income-producing property, such as stores, flats, apartments, hotels and theaters, modernization has only just begun. Owners of buildings of the types listed are just beginning to realize that if they expect profits on their investments they must meet obsolescence squarely in the face and overcome the inevitable. A building is no different than an automobile, or the human body for that matter. Age will take its toll. Just as the motor car needs replacement or tuning up so one's property, if it has served the average years of usefulness, must be revamped and reconditioned if it is to continue to produce an income.

In this issue is presented a number of recent examples of modernization work. In every instance the improvements that have been made have been justified since immediate occupancy at increased rentals has followed. These are not exceptional cases. Instances are rare, indeed, of an owner spending any considerable sum of money improving his property and failing thereafter to find a good tenant. Which explains why owners are becoming more and more receptive to architects' suggestions to modernize.

Walter C. Johnson, managing agent of a large insurance building in Omaha, speaking before the Dallas Convention of the National

Association of Building Owners and Managers recently, offered three reasons why so much interest is today being shown by property owners and the public in general in reconstruction work:

(1) "So many properties have been 'milked' and 'starved' during the last few years in an attempt in some way to meet other obligations. (2) Passage of a large number of properties into institutional hands—insurance companies, banks, trust companies, etc. (3) Realization by many owners that modernizing is an attractive alternative to ruinous 'price' competition."

Continuing with his address, which was published in full in the July issue of *Buildings and Building Management*, Mr. Johnson said:

"Discussion, naturally, must be general in character. Each building is very much an individual problem. The building manager must make a careful analysis of several factors controlling nature and extent of remodeling—(1) amount of vacancy in their city (2) rent level of their class of property (3) competition in their field (4) location (5) structure, design and efficiency of plan (6) class of present tenants (7) financing (8) cost of improvements (9) new schedule of rents and operating costs. Of course in event of extensive remodeling a competent architect must be relied upon for design and execution.

"Modernization should not be confused with the present abuse of the word to mean 'modern'. Rather it should mean to correct as far as possible encroachment of obsolescence—to provide comfortable, efficient and attractive accommodations meeting the most enlightened present day requirements—at a fair price.



Upper picture shows Cottage Bakery in Hayward, Calif., before the architects, Miller and Warnecke, undertook to modernize the structure. Picture on the right indicates a remarkable transformation by using a dark maroon Ferro-porcelain for the first story while the upper portion is finished in plaster with painted wood strips to relieve the flat surface. The sign has a cream background with maroon letters. Stainless steel snap-on moulding was used at the top of the first story while the door leading to the bakery proper has a Ferro-porcelain panel relieved with small strips of stainless steel.

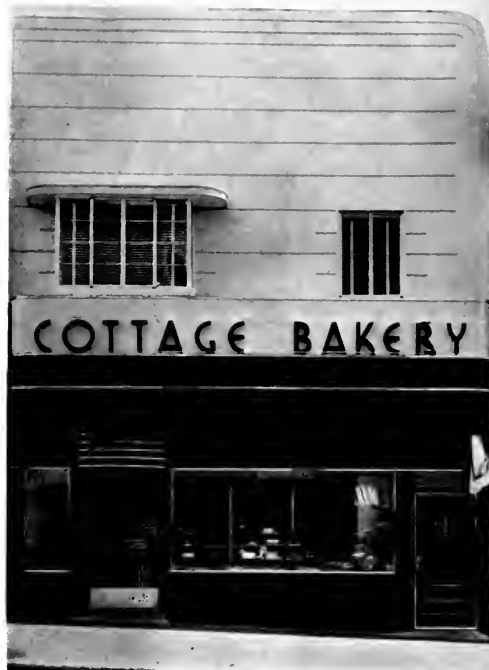

"First, attention is directed to the exterior of the building—not always as important as first thought. The tenant lives on the inside of the building and, except in the case of monumental structures, the public very seldom sees anything above the first or second floor level. Less expensive treatment can be, of course (1) painting (2) washing, steam cleaning, sand blasting or other suitable cleaning (3) removal of excess and obsolete ornamentation, particularly, outmoded and dangerous cornices. In some cases it will be economically sound to provide new store fronts, removing projecting show windows and bringing them flush with the building, treatment with ornamental glass, etc. Where more extensive treatment is warranted, consideration can be given to facing the building with limestone, terra cotta, structural glass or combinations of these materials. Very often such treatment means new window frames.

"The path taken by the tenant and the public

on entering or leaving a building—main entrance, lobby, elevators, floor corridors—should be given very careful thought. Impressions and opinions of the character of the building are most often formed in the public spaces.

"Very often an excellent impression of the building as a whole can be given by a change in appearance of the main entrance, without refacing the whole front.

"Entrance doors should be examined with a critical eye. Utility in ease of access to the public, both summer and winter is, of course, of first importance. Worn kick plates, battered push bars, scarred doors and frames should claim continuous attention.

"Stained marble in the lobby can be polished, paint freshened up, lighting changed, mail boxes and directory boards replaced, new decorative floor mats laid, unkempt lobby cigar or news stands removed or cleaned up, with telling effect without great expenditure.

Where more extensive treatment is warranted new marble floors or terrazzo with colorful pattern can be installed. Linoleum, rubber tile, asphalt, cork and similar floor treatments are not generally considered practical for the main lobby.

"It is difficult for many owners to see the wisdom of considerable expenditure usually required on elevators, but nothing stamps the age of a building more definitely.

"In the matter of corridors much can be accomplished. 'Borrowed light' into the corridors is just as passe as the open elevator shaft. Much of the heavy effect of all the wood trim and ornamental glass can be relieved by painting the trim of the 'borrowed' light the color of the wall. In a complete job it should be taken out and the wall plastered or treated like the balance of the wall. Light fixtures and hardware in the corridors should be examined. Attention should be given to the floors especially where the old 'hex' tile, chipped and worn ceramic tile, or wood is found. Many floor treatments have been found satisfactory. Terrazzo, considering cost of installation and maintenance, is favored. Less expensive treat-



FILLMORE STREET BRANCH OF
SAN FRANCISCO BANK
Wilbur D. Peugh, Architect



This building was at one time occupied by a savings and loan society. Both exterior and interior were completely remodeled. The street frontage is cast stone with ornamental mar- quise.

Photo by Scudlery



The J. W. Robinson Department Store Building, Los Angeles, was originally designed by Neuman and Richards, Architects. The old exterior was like many exteriors fifteen or twenty years ago — faced with pressed brick and terra cotta.

In designing the new facade the architects, Edward L. Mayberry and Allison and Allison, selected a pleasing modern treatment of terra cotta Hermosa tile which adapts itself nicely to the verticle treatment of the street frontages.



ment with rubber tile, asphalt tile, linoleum, or cork produce an attractive effect. In a few buildings pattern and color combinations for the floors have been adopted with favorable reaction from the public.

This is true particularly in the floor lobbies. The elevator door opens, the tenant sees a red and green floor and says 'Oh! This isn't my floor. I'm on the blue and yellow floor.' Where present wainscoting is unsuitable, it can be removed and replaced with marble, linoleum or some other suitable covering, or eliminated entirely with a 4 inch to 6 inch base substituted. I have found the latter attractive and absolutely feasible—less expensive to install, less expensive when doors are to be cut in and not prohibitive in maintenance.

"Really an important place to look for modernization is the toilet room. The great American public has been made 'bathroom conscious' in the home and now expects modern, attractive facilities in office buildings. This may be a result of the great influx of women into business offices in the last twenty years. At any rate, a dirty, smelly, dark, dingy toilet room is 'out'. Absolute cleanliness, of course, is first; then good ventilation, good light, modern fixtures and even bright cheerful colors. Marble or tile floors and wainscoting seem most suitable. Stall partitions can be metal, structural glass or marble depending very much on the particular building. Paper towels or electric hand driers are acceptable. The latter have this to recommend them—(1) economy, and (2) an appearance of tidiness and cleanliness at all times.

"Doors and Trim—Woodwork in our buildings gets old—scratched, banged up, dented, grimy and smoky. In many of our older buildings the trim is light oak, with fancy filagree design and upper panel of glass in corridor doors. This is indeed a problem. We can borrow a suggestion from the house interior decorators and paint the window frames to match the tenant's walls, but paint on doors and base is not very practical. American walnut seems the most popular woodwork at present, with mahogany next preferred. Where



HOUSE OF DR. R. G. FLOOD, FILBERT AND
BRODERICK STREETS, SAN FRANCISCO

Albert Farr and J. Francis Ward, Architects

Upper picture before alterations

Lower picture, after alterations



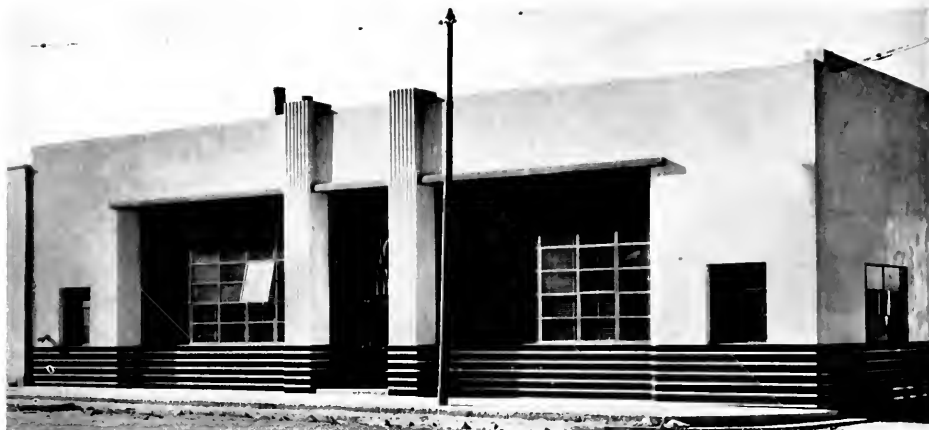

BUILDING FOR GARLOCK PACKING COMPANY, SAN FRANCISCO
Dodge I. Riedy, Architect



DETAIL OF ENTRANCE, BUILDING FOR GARLOCK
PACKING COMPANY, SAN FRANCISCO

Dodge I. Riedy, Architect

warranted a change to modern style and material of trim works wonders.

"Shades and Blinds—Venetian blinds have caught the public's fancy and are regarded as strictly modern. Even though expensive to install and somewhat expensive to clean and maintain, their permanence and modern appearance recommend them. If not blinds, the removal of old cracked shades and replacement with new clean light colored shades goes far to giving a neat, trim appearance to the windows and creates a favorable impression with prospective tenants.

"Floors—If wood floors are uniform and in fair condition they can be sanded and treated with a penetrating stain. Floor covering to be furnished by the building is another solution. There is one disadvantage—floors should be typical and run under all partitions to avoid patching or further expense at the time of future tenant alterations. It is difficult also to settle on color or pattern of floor covering that will harmonize with all color schemes of the different tenants."

* * *

Foresight and aggressiveness on the part of a lessee, together with good judgment and a willingness on the part of an owner to spend sufficient to salvage a declining property, made possible the recent consummation of a long term lease with one of the world's larg-

est specialty manufacturers for a building on Mission Street, in the heart of San Francisco, that had outlived its economic usefulness, although well located and still structurally sound.

The lessee's requirements were manifold, the local branch operating a service and repair department in conjunction with its distribution over a large sales territory.

Therefore an entire rearrangement of the interior was necessary as well as a new facade. From the survey of requirements it developed that only the side and rear walls, floors, roof and interior structural supports could be salvaged and incorporated into the new scheme. But even on this basis a lease satisfactory to both parties was possible.

The entire Mission Street facade is new, of reinforced concrete, faced with reddish brown terra cotta unit tile, selected because of its flexibility and adaptability and because it answered the demands for color permanency.

The lower floor which originally was divided into two stores and a building lobby was transferred into one large sales space with commodious demonstrating rooms. The second floor houses a sales division and a sales auditorium, and the third floor, three private offices and service and repair department.

At the rear an adjoining building was connected by protected openings, the added space serving as a garage, shipping and receiving entrance.

The building, while over 30 years old, and before remodelled, totally unappealing and unrentable, is today outstanding for its attractive appearance—a splendid example of what can, within the bounds of economic practicality,

be accomplished to restore a fast depreciating piece of property to new revenue producing interests.

* * *

Other examples of modernization is the Fillmore Street Branch of the San Francisco Bank. The building was formerly designed for and occupied by the Pacific States Savings and Loan Association. W. D. Peugh, the architect, was called upon to completely remodel the structure to meet the needs of a banking institution. The exterior was given an attractive face of cast stone with an ornamental marquise and the interior was enlarged and completely redecorated.

The J. W. Robinson Department Store Building at Seventh and Grand Avenue, Los Angeles, originally designed by Neuman and Richards, was recently modernized from cellar to roof from plans by Edward L. Mayberry and Allison and Allison, and the expenditure is said to have already been justified. The old exterior facing of brick has been replaced with colorful terra cotta tile.

An example of store front improvement is found in a small bakery establishment in Oakland. The architects, Miller and Warnecke, used Ferro-porcelain to brighten up the exterior of the first story, selecting a dark maroon for the color. The sign is in maroon letters with cream color background. Stainless steel snap-on moulding was used at the top of the first story to dress up the front of the store while the door leading to the bakery proper has a Ferro-porcelain panel relieved with small strips of stainless steel. The upper part of the building is finished in plaster with painted wood strips to relieve the flat surface.

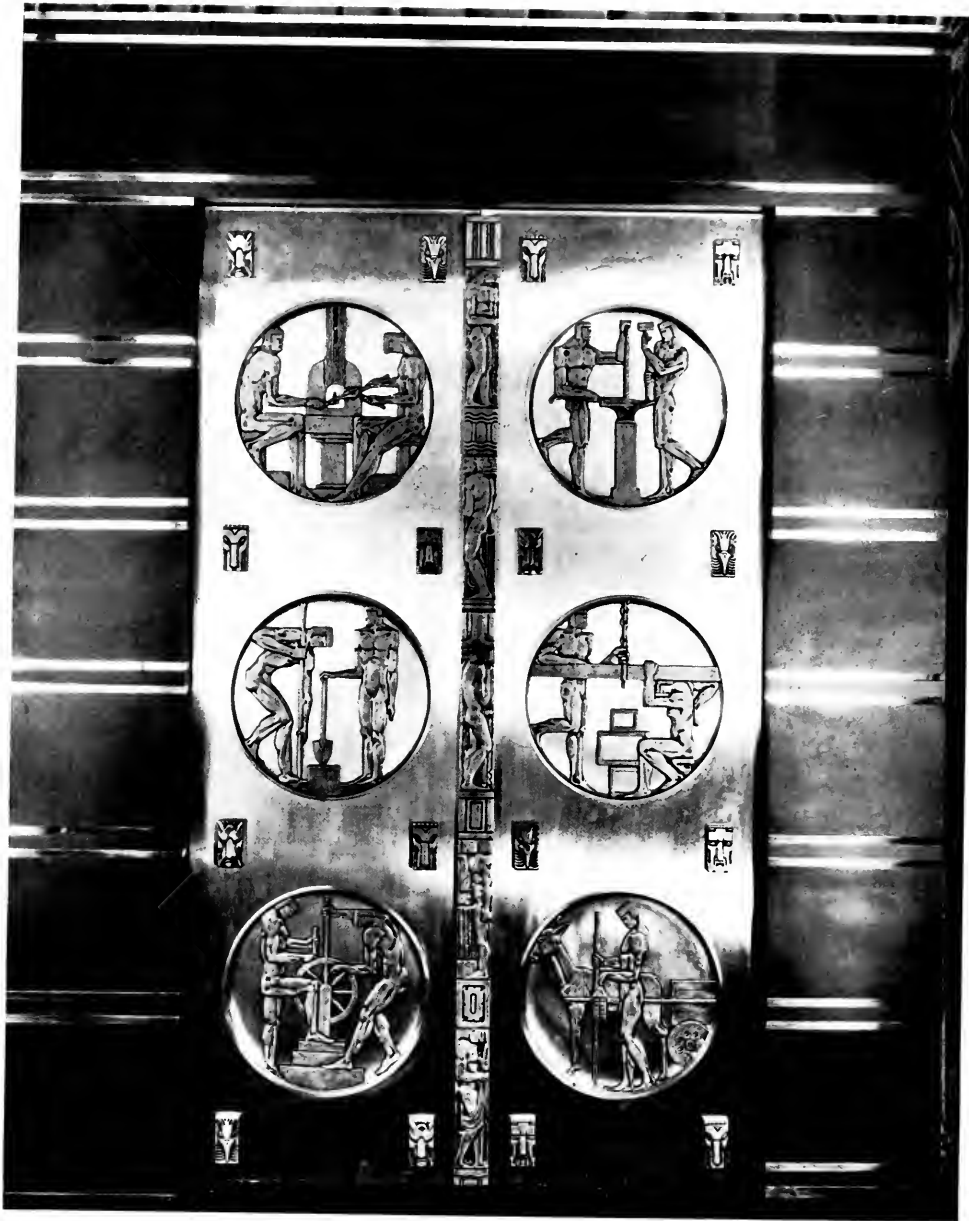

DOORS FOR AN ENTRANCE TO A BUILDING DEVOTED TO INDUSTRY
DESIGNED AND EXECUTED BY OSCAR B. BACH

Plaques represent Mining, Smelting, Fabrication, Machinery, Building and Transportation. The broad, silvery expanse is framed in glazed black sheets, the joints marked with bands of stainless steel colored red and double ribbons of bright steel.

NEW DECORATIVE MEDIUM FOR ARCHITECTS

STAINLESS STEEL FOR INTERIOR AND EXTERIOR FACADES

An Interview With Oscar B. Bach

AMERICAN artists have discovered a new medium for their creative work which has attractive possibilities for exterior and interior architectural facades. It is stainless steel. In an interview with Oscar B. Bach, internationally known artist in decorative metal work, he gives his views of this new medium, and the following excerpts, published in the June Issue of *Metal Progress*, will be found of interest:

"Other materials—stone, marble, terracotta, tile, bronze, iron, lead and zinc—have left their marks on respective periods in our civilization. So will this new material set its everlasting mark on our century and future civilization.

"Just as we look back at the old times and modes of construction with their stone walls and wonder at the progress that has since been made in steel skeleton building construction and its mechanical wonders, so will generations to come look back upon the construction of the coming era and marvel at the innovations that stainless steel made possible.

"Stainless steels bring to the arts and sciences an entirely new medium of expression—whether for artistic purposes or for the almost limitless utilitarian uses where a permanent metal is needed.

"Early sculptors expressed themselves in three dimensions through the use of marble, granite and other materials such as the softer metals—all that were then available. The natural characteristics of these materials created limitations in their use. For decorative purposes, most large sculpturing, even when in low relief, necessitates a tremendous amount



Oscar B. Bach

of bracing and support, as the material used can seldom carry any structural load. Now the stainless steels make it possible for artists to work in a material that is as strong and dependable as it is beautiful.

"Stainless steel store fronts, vestibules, railings, bank cages and fixtures, vaults, grilles and furniture are increasingly used in the more modern buildings."

Answering a query as to what features of the new material are of outstanding importance to the artist, Mr. Bach said:

"Corrosion resistance has usually been regarded as the outstanding characteristic. I do not want to detract from this feature, for it enables the artist to gain immortality for his work—it will be everlasting. We all have felt that rust is the great destroyer of the steel age, just as verdigris was the destroyer of the bronze age. It has menaced the purity of our chemicals from which come medicines and



BRILLIANTLY COLORED REPOUSSE PLAQUE SYMBOLIC OF DRAMA
One of three on the exterior walls of Music Hall, Rockefeller Center, New York

dyes and has stood as a bar to progress in all fields of applied science. It has jeopardized our foods by the constant threat of contamination. It has eaten into the choicest productions of the craftsmen and ruined their pristine beauty.

"For centuries we have been looking for a steel that would not rust. Any other metal less strong than steel would not do. Only kings and emperors could afford to command an artist to work in gold, yet we yearned for a truly noble metal. Protective coverings, even the very modern electroplating, were far from satisfactory—they were so very temporary. The real solution and the real success to overcome this destroyer, rust, is found in stainless steel.

"Important though this matter of perma-

nence is, both from the standpoint of inspiration and economics, I would like to impress the thought that the artist must keep in mind the new values and principles of this material.

"The most important feature is its great tensile strength and ductility. When working in thin sheets of stainless steel of the chromium-nickel varieties it is actually possible to increase its strength approximately four times by the simple process of hammering to develop the details of a design in relief. Where previously tremendous thicknesses—I mean tremendous by comparison with sheet metal—had to be considered, the designer learns to think in the terms of manifold and new fabricating processes made possible by the present knowledge of this material, always keeping in mind the

(Please turn to Page 47)

THE FUNCTION OF FUNCTIONALISM

EXTREMISTS ADOPT GANGSTER'S CRY, "GIVE 'EM THE WORKS"

By Leicester B. Holland, F. A. I. A.

WHEN Professor Emerson suggested that I should speak to you this evening, I asked if he had any especial topic in mind. "Why not give a thought to beauty," said he. Now, I would gladly do so, there are few things I would do more willingly, but Beauty is too mutable a flame to be portrayed in words of mine. So I have chosen instead, her sister goddess, perhaps to some degree her rival, Functionalism:

"Skin deep and valued at a pin
Is beauty such as Venus owns,
Her beauty is beneath the skin
And lies in layers on the bones."

If I were talking tonight to any but a group of architects, or on any subject save architecture, I should not dare approach a topic such as I have set myself. For Functionalism is not simply a scientific or philosophic subject, but has assumed somewhat the aspect of a religion, or at least a cult. And as there is no use arguing about taste, there is still less use in arguing about religion. Either you believe in a given doctrine or you don't, and you will listen to what any speaker says about it with approbation or disgust, from the word go, and will end with the same approbation or disgust, perhaps slightly heightened, at the word stop. Were I to ask you individually, point blank, yes or no, are you a functionalist?—some would doubtless answer energetically with the fervor of the faithful or the hatred of the heresy hunter. But the majority, I think would answer, "What do you mean, a functionalist?" They are the wiser ones, I think, who through years

over the drawing board have learned that in our work cults are invariably valueless, and that while faith may move mountains, it cannot produce architecture. We shall never find a quick and easy road to Paradise.

For this reason I dare face that fact that Functionalism is a cult, and further, I dare discuss it as a cult, and hope to discover by consideration of its formulae and practices what value may lie in the philosophy on which it rests. For Functionalism has its philosophy, of that I am sure, though I am not wholly sure what it is; it has its dogma, which should proclaim that philosophy. Further it has its practices which, based on dogma, may depart considerably from its philosophy, and finally it has its apparent theory popularly deduced from its cult practices. Let us consider these phases in the reverse order, starting with the surface phenomena familiar to all of us, and work backward toward the truth that may be at the bottom of it all.

As it expresses itself in current building, Functionalism aims to create plans which will provide functional relations between rooms arranged to suit present day modes of living, while permitting an economical use of materials. It aims further to provide an exterior treatment dictated primarily by plan, with little or no regard for traditional concepts, and with elimination of all purely decorative features. That, I think, is an unprejudiced summary of functionalist expression in modern architecture.

The Ancients and Honorables

But architecture so conceived is by no means new, it has a long and honorable history in this country, and tagging it by a new name does not make it revolutionary. A generation ago

*A paper read at the 68th convention of the American Institute of Architects, May, 1936.

the city of Philadelphia was known affectionately as "the city of homes." These homes were, for the major part, so much alike that but for the number on the door it would have been difficult for an owner to identify his own. They were of excellent red brick, carefully laid, and had flat roofs. There was a door and two windows on the ground floor, two windows in each upper story. Lintels and door steps were of white marble—the most functional material available, in spite of the fact that the steps had to be constantly scrubbed and whitened. Within, a narrow hall led from the front door to the stairway, with the parlor at the side, and dining room and kitchen in a rear extension. Above, there was a sitting room in the extension, two bed rooms and a bath in front, and so on up. I do not believe a city residence could be more functionally planned or executed; there was no waste space at all, no exterior decoration, no queer corners or oddities, almost no closets, and the construction was simplicity itself. At a guess I should say that most of these houses were built between 1820 and 1860. Those which have not been torn down are still standing, as strongly, as efficiently as ever. They are as good today as they were a hundred years ago, but no better. Perhaps this might be called Quaker architecture, for the large brick meeting houses of Philadelphia show the same complete devotion to functional efficiency. And as, with the Quakers, rich and poor wore clothes of a common cut, so the brick row houses of the well to do differed little from those of "mechanic" class, except in size and location.

"Relic and Type of Our Ancestors' Worth"

The so-called "Philadelphia blocks" were not the only structures of the early nineteenth century that showed this rigid functionalism. The farm houses of New England obey the same compulsion, though the form is different. Here the buildings are isolated and sheathed with wood instead of brick, but the construction is as direct and economical, the plan as stereotyped on a basis of rational efficiency. In the main house the parlor—functioning chiefly for funerals—bed-room and roomy

kitchen cluster around the single central chimney and stairway to the attic; from the kitchen the closed woodshed leads to the barn, so that the stock can be tended and the wood brought in, regardless of stormy weather. Nothing could be simpler, there is no waste, no excess in any part.

Of course these old houses are not exactly as their builders would build them today, for methods of construction and manners of living have changed. Today concrete and steel may be more economical than brick and timber, the old fashioned kitchen where the mistress sat in a rocking chair to shell the peas, would be waste space now, when the can opener does the trick in half a minute. What was functional then is not functional now, but the principle remains, and we should expect the devotees of the modern cult to hail these works of our grandfathers as forerunners of the new gospel. Actually I have never heard one do so.

The reason, I suspect, is that there would be no glory at all in admitting that one was trying to do today simply what had been so well done by the commercial builders of the past. For such architecture was not formerly the work of architects at all, it was simply an architecture of necessity. It is undeniable that a strict limitation to efficient minima makes for speed and economy in building, though I doubt if by itself it helps in any other way. But speed that kills and economy at any price are only excusable as the dictates of stark need. It may be that we cannot afford to build in any other way, if so, good-bye to the architects. For the architect has no reason to exist if he cannot choose how he shall build.

The best face saver, of course, when confronted with a necessity, is to make a virtue of it, embrace it with open arms, and claim the glory of self-sacrifice. Poverty which one cannot avoid is deplorable; poverty voluntarily and ostentatiously assumed in the name of faith is highly honorific. Hence the Hindu fakir, the self-immolating ascetic. "When," says the story, "Orberose found she was no longer pleasing to men, she turned to God." So the more enthusiastic devotees of functionalism naturally

embrace excessive and artificial servitude and proudly expose the meagre nakedness of their buildings as a rebuke to more fleshly design. It is not sufficient, for the adept, that a building shall function well, that would be simply common sense; to draw the praises of the world, the world must be made function conscious, and every functional element be flaunted in its face. Hence the extremist brings forward with a flourish steam pipes, drain pipes, air ducts and radiators, thin wiry spiral stairs and mass construction brutal in its directness. His motto seems to be the gangster's cry, "Give 'em the works!"

Distractions of St. Anthony

Personally, I find such wanton exhibitionism distressing, even as a profession of faith. If one can afford no shoes or hat, bare feet and head are no disgrace. For unusual efforts, clothes are encumbering, and may be wisely laid aside, and no one can deny the beauty of a well formed naked body in action. But it is disturbing to be surrounded by buildings that seem all set to speed away at the starting gun. And it is certainly one thing for an athlete to slough his restricting garments, and quite another to have a visitor take off his overcoat, and then all his other clothes and skin, as well.

A quiet chat with an anatomical convive, lolling, as it were, in his viscera, would be very difficult for me. I wonder why. We all accept anatomy, we esteem the bones, the nerves, the muscles, even the ductless glands, and often like to discuss them, but the sight of them is undoubtedly distracting. And so with the vital organs of a building; we like to know they are there, technicians like to operate on them, but their insistent display in the common round of life is distracting. It hinders the mind in its current consideration of men and things. A philosophic outlook requires a decent integument for architectural surroundings, as well as for human beings.

I grant I am presenting functionalism in its extreme phase; not all functionalists worship the apotheosis of the non-siphoning trap. Instead, one may reasonably aim at **expression** of construction rather than **exposure** of con-

struction, for certainly all objects in nature express their construction, though it is rarely literally exposed. And we have all been taught that a good deal of the fascination of Gothic architecture springs from the frank declaration of its structural system. But the details of Gothic construction are not all obvious, they sometimes require the elaborate demonstration a Viollet-le-duc before we apprehend them. All the casual observer recognizes is a fabric of piers and vaulting ribs closed by a secondary tissue of stone and glass, and held stable at a daring height by obvious external props. But there can be little doubt that the mediaeval builder enjoyed the display of his engineering skill as such, and whether consciously or not he habitually distributed his ornament so as to accentuate the anatomy of his building. Instead of yielding to the baroque barbarism of facial tattooing, as practiced by the Maoris, he limited his decoration to the civilized and strictly structural emphasis of the lip-stick and eyebrow pencil.

Unfortunately, with modern methods of construction it is very difficult to emphasize the anatomy of a building. For the patterns of straight forward steel and concrete work are simple in the extreme. One can hardly emphasize the repeated rectangularity of post and lintel, when there are no significant points on which to center emphasis. No one would attempt, I think, to express the reinforcing rods within a concrete beam, even though they are the heart and life of its strength, and the walls which shut the weather out are merely so much wrapping paper.

In this regard I should like to quote that great evangelist of structural expressionism just mentioned, Viollet-le-duc. [Discourses on Architecture, p. 394.] "The exterior decoration of Greek architecture," he says, "was merely structure refined into beautiful forms by the strictest application of reason; the elements of structure always appeared under the architecture, as the bones of a man are evident under his muscles. The decorative interior fragments, remaining to us from this beautiful architecture, are always in accordance with

this principle. Under the Roman Empire, if the decoration was sometimes distinct from the basis of structure, it nevertheless frankly confessed its own structure as a parasite. We have seen that the Roman monument, made of rubble and brick, received a decoration of marble, without any absolutely necessary relation in character with the structure to which it was applied; but this decoration was, as it were, a second structure whose treatment belied neither its material nor its workmanship . . . Greek architecture is a naked body, whose beauty is the result of the perfect adaptability of its form to its structure and functions, while Roman architecture is a body clothed; but whether this clothing fitted the body well or ill, as a clothing it was always reasonable and appropriate to its material; it was rich if the material was rich, and simple if the material was poor."

Obviously modern architecture is allied to the Roman rather than the Greek, for the exteriors and interiors of our buildings can not limit themselves to their naked skeleton construction if the building is to have any function as a whole, and instead of trying so to clothe his building that it will look naked, the expressive care of the modern architect should be primarily concerned with the frank confession of the parasitic nature of his walls. Granted they are but textile garments, it makes no logical difference what the pattern of them may be, broadcloth or plaid, brocade or flowered gingham. If the wall is wall-paper, what matter whether the lines are horizontal or vertical or crisscross? So long as the architect respects his floor levels and his columnar supports, he is absolutely free to do whatever he likes with his facade, only he must remember to make it patently parasitic.

But does it follow that all facades that adhere to this functional canon are equally good? I need no reply, for everyone knows that facades have functions of form itself, quite apart from any question of structure.

"Backward, Turn Backward, Oh Time"

When I was a youngster I was given one Christmas, a nickel watch. That was not the

price of the watch but the material of the case. This was really long ago, before the Ingersoll had made the dollar famous. My watch, like all cheap watches then, was Swiss, not unduly large, and quite a presentable time-piece. But much as I loved my watch, it did not get all the care it deserved, and at last gave up the struggle. Something essential was broken; the cost of reconditioning was unwarranted, and the watch was tenderly laid aside in a bureau drawer. In time another Christmas brought another watch exactly like the first, and this too, in due course was dropped or hit by a bat or something, and declined to function further. One day—still later—I was now in my teens and passionately given to tinkering—I came across the two watches and started to investigate. I took them all apart, and put them together again, and then I made a synthesis, and found that by combining the sound elements of the one with the other I could make of the two a single watch that would run. You can imagine my pride at the achievement. But now, having plumbed the intricacies of watchwork, I had lost the timid reverence which I think is normal toward such things, and felt that this synthetic watch was my own creation to do with as I pleased. What pleased me most was to see the wheels go round—I was a thorough functionalist—and as one is hindered from seeing the works in the customary disposition of a watch, I reversed them in the case, so that the ticking balance wheel was visible through the glass, while to see the dial, the back had to be removed. This arrangement properly astonished my playmates and amused me greatly for awhile, but it had its practical inconveniences in telling time. So I made another shift, turning the works right side about again, but removing the face. The hands were left in place, and by proper orientation one could estimate the hour fairly well, while behind the two black indicators the whole delightful intricacy of brass wheels was perfectly exposed.

I have no recollection of what happened after that. Perhaps in time the mechanism died again, perhaps my plaything bored me and was

put aside, perhaps I restored the face. I only remembered that when my mechanical exposition lost its novelty it lost its charm. For thirty-five years I have carried a perfectly normal—if not always well regulated—time-piece. And with thinning hairs the consciousness has grown in me that in removing the dial of my nickel watch I devitalized it almost as effectively as if I had trod it under foot. For the truth I see now is, that the purpose of a watch is not simply to run, but to tell the time, and for this ultimate function the formal facade is just as important as all the machinery it conceals.

And likewise, of all architecture—save that of the dreariest necessity, that hardly deserves the name—it may be said that the form has a function of its own, not dependent on but often dictating the functioning of the mechanism it conceals. Indeed it sometimes occurs that a work of architecture has no function whatever except that fulfilled by its form. Witness the Arc de l'Etoile and the Washington monument, than which nothing could be more strictly functional, though plan and construction are not of the least concern.

This brings us to a consideration of the functionalist dogma which serves as the expressed basis for the various manifestations in practice we have been reviewing. For dogma is the crystallized ideology of any cult, and should serve as clue to the underlying philosophy, which is sometimes quite erroneously represented in the surface manifestations. There may be many dogmas to functionalism. I have found but one sententiously announced. It is "Form follows function," enunciated first, I believe, by Louis Sullivan. A catchy phrase, tripping with alliteration proper to any cantrip. The mere sound leads one on; elaboration, with or without sense, is almost irresistible.

Form follows function, without the least compunction,

Form follows function, fiction follows fact.

Form is a fiction that flowers out of function

While function is a factor that founded on a fact.

And so on and so forth.

But resisting elaborations which the functionalist may not accept, let us analyze the slogan and see just what it means and what it holds of worth. There is no need to define "form" to an architect, the word speaks for itself. "Function" is harder, for there are various sorts of functions outside of calculus. Buildings as units have functions, parts of buildings have functions subsidiary to the total function but distinct in themselves, and structural elements have functions of a character independent of those of the building as a whole, or of its parts. Let us assume, in default of specification, that it is meant that each sort of function has its following form.

The hard knot still remains, what is meant by the non-architectural word "follows"?

Are we to understand the doctrine to assert that form should be considered only consequent to and dependent on a consideration of functions? Can we express it more clearly as a command to reach for a function instead of a form? Or is it meant that form develops spontaneously out of function, and follows it blindly and inevitably, uncontrolled and effortless as the morning after follows the night before? With this meaning form is an act of Providence, quite beyond the architect's concern, and the doctrine becomes "Save the function and you save all."

Either interpretation may be intended. Either or both may be sound philosophy, or either or both may be false. It all depends I fear, on how broad a significance one attaches to the elastic word function.

Out of the Mouth of Grand Rapids

Recently I happened on a very penetrating observation in a most unlikely place, a gaudy catalogue of interior arrangements. Furniture, draperies, floor coverings, and what not, were shown in full, almost fulsome, color. Each dazzling composition had an appropriate code name and caption. One was a bed room christened "Modern." The caption ran "Modern is functional, the function of this bedroom is to induce repose."

I cannot guarantee that this particular lay-

out would induce repose—that is beside the point—but profound truth lies in the observation that a bed room does not wholly fulfill its function by being an economical and efficient sleeping place, it must before all, induce a psychologic state in accord with its use. Functionally a dining room is not simply a place to eat in, a library a place to read in, an office a place to work in. To function fully such rooms must be designed to eat, to read, to work in well, and cheerfully and comfortably. The architect must be a psychologist in design, and oh, there are so many rooms—and exteriors—that need to be psycho-analyzed. Sometimes I fear that the basic complaint of modern architecture is an inferiority complex.

This comes, I think, from a too rigid adherence to the canon of efficiency. As a therapist I would recommend a practice of the canon of liberality. There is a prevalent tendency to calculate scientifically just how much space is required for this or that, just how many steps it takes to go from here to there, just how the furniture or equipment may be disposed so as to interfere least with the necessary circulation. And then, having figured a set of minima for maximum efficiency, to let those figures control the design. The system is much too rigid. The slightest alteration in any factor may result in failure of the whole, and gadgets do not a palace make, nor chromium a home. Our friends, the engineers, for all their figures, are far more liberal. To be sure, they calculate their loads and strains most carefully, and study the breaking point of the materials, their strength in tension, compression and shear, but then, what does the engineer do? He allows a **factor of safety** of four or five times the minimum requirement. The architect would be well advised, likewise, when he has calculated his efficient minima, to allow a **factor of comfort**, not necessarily of four or five, but at least of two.

For architecture, since it is made for sensuous and temperamental man, can never be a strict mathematical calculation. To the mathematician six plus two amounts to just as much as five plus three; to the architect it may be

considerably less, while four plus four may total up to a great deal more. Why it should be that the whole is sometimes so much greater than the sum of all the parts I cannot say, except that architecture is an art, and that is the nature of art.

"And I know not if, save in this, such gift be allowed to man,
That out of three sounds he frame, not a fourth sound, but a star."

All Art Is Divided Into Three Parts

From these considerations I maintain that no building which is merely efficiently planned and scientifically constructed can be ipso facto considered functional architecture at all. Ever since architecture has been analyzed philosophically it has been recognized as a unity consisting of three parts, not of two. These components, as stated by Vitruvius, are durability, convenience and beauty. Or in the quaint phraseology of the ever memorable Sir Henry Wotton, knight, we have, "In architecture, as in all other Operative Arts, the End must direct the Operation. The End is to build well. Well-building hath three Conditions, Commodity, Firmness, and Delight."

"In all other operative arts"; the rule of the trinity is very wide, you see, by no means limited to architecture. I recall dimly, that in school or college we were taught, perhaps from Genung's Rhetoric (?) that the desiderata of literary composition were Clearness, Force, and Beauty. The same three elements rephrased for a different art. No one or two complete without the rest, and no one following inevitably from another. Even though, in sequence of time one might say that clearness must be assured before one thinks of force, and force before beauty, as foundations must precede walls and roof, yet always "the end must direct the operation," as the roof is the functional epitome of the habitation.

It may be, I am uncertain in this, that the primal doctrine of Functionalism as a cult, is that Plan and Construction, Commodity and Firmness, are alone essential to Well Building, and that Form or Delight is not in itself functional. If so, the doctrine is diabolic, of that I

am very sure. Or it may be that the doctrine merely prescribes a procedure in design, advocating first a study of the plan, then of the construction and only at the last of form. In this case the doctrine is at least human, though perhaps not divine—but it is not new at all. May I read you another passage from Viollet-le-duc which I happened on by chance when looking for the bit I read before? It appeared in 1863 when American architecture was approaching its lowest ebb, about to succumb to the fascination of the Napoleonic mansard, and the romantic Gothic frivolities inspired by Pugin. [Discourses on Architecture pp. 188 ff.]

"When an architect," says the practical Frenchman, "has an edifice to construct, a hospital, perhaps, a public office or a palace, his first task is to deduce some order from the programme which is given him, as this, like all written programmes, is apt to be confused and contradictory. He must satisfy himself regarding its real requirements and their relative importance, without occupying himself with any consideration of architecture, in the ordinary use of the term; that is to say, with the decorative envelope in which the structure is to be enclosed. He is content for the present simply to get everything in place; he takes care to subordinate those parts of each division of the programme which seem to him, on examination, to be mere accessories; by slow degrees, its intricate and complicated conditions thus become simplified; for to reduce an elaborate problem to its elements needs careful analysis and judicious distribution. Then, having arranged the different wings or divisions of his edifice satisfactorily, when he proceeds to unite them in a grand whole, he finds he must recur once more to the work of simplification; the whole wants unity, the connections between the different divisions are awkward and artificial and require adjustment. He again applies himself to the task of arranging the plan, changes from left to right, puts that in front which was behind, and returns a hundred times to the disposition of details in his design. Then the conscientious architect pauses and lays aside the sheets covered with the results of his

studies, when suddenly he believes that he has discovered in his programme a principal idea, subordinating every other consideration. Light breaks upon him; instead of examining the proposition before him in detail, to arrive at the general combination of the whole, he reverses the operation; he discovers that until then he has had but a glimpse of the true requirements of the structure, and finds that its various apartments and dependencies should be submitted to a new general disposition on a larger scale, affecting all their mutual arrangements and communications. Thus the details of the plan, the study of which had severally taxed the resources of his mind, assume their natural positions. The leading idea found, the accessories arrange themselves without difficulty. The architect has become the master of his programme, he reviews his interpretation of it with deliberation, he completes it and brings it to perfection. . . . His plan settled upon, his elevations are a part and expression of them; he sees how he should construct them, and the dominating idea of the plan becomes the principal feature of the facades. Considerations of stability and of the most economical methods of construction suggest to him the character of his exteriors. . . . Then arises under his hand a sort of carcass or frame, a combination of masses, in which he proceeds to make the exterior appearance a manifestation of the interior dispositions, to cause the idea of the plan to frankly reappear in the elevation, and to decorate or subordinate the various parts according to its suggestions. At this point the artistic capacities of the architect begin to be tested; for, to have a clear head, a practical mind, a power of expressing ideas with neatness and precision, is not enough; if he would be appreciated, he must gratify the eye and clothe his truthful expressions with graceful and attractive forms."

How Old the New

Is this a new doctrine? It was not invented by Viollet-le-duc. It was old when Suger laid the corner stone of the apse of St. Denis, it was old when the baths of Caracalla were designed. If the function of functionalism is

to re-emphasize such architectural philosophy, it follows in the footsteps of the mighty; if its function is just to combat a popular hankering after period decoration, it is fighting a losing battle against straw men, for it can only substitute one fashion for another. It becomes the trivial plaything of magazine advertisements.

In a recent book by Rebecca West, the author speaks of "a stupendous apartment, designed" as she says "in that modernist style which represents the last attempt of bad taste to escape the criticism of good taste. Having been reproached so often for excessive and ill conceived and executed ornamentation and poor design, it has set about getting rid of all ornamentation, and as much design as possible."

There is one point I would emphasize in Viollet-le-duc's account, which I have seen nowhere else brought out. That is the turning point in the organization of the plan; when the dry analysis of the elements is completed, the efficient organization of the parts worked out, there comes all at once a crystallization, a revelation, as it were, of the meaning of the

whole.—What is it? The plan takes **form**, the organism lives, it has a soul. For form is the soul of architecture, as plan is its intellect and structure its body. And it seems as if the form had been there all the while, and so it has; for plans are not simply lines on paper, but symbols for areas enclosed, of definite cubic form, and back of all the forms of all the parts is the ideal concept of the formal whole, the spirit of a hospital, perhaps, a public office, or a palace. If the architect has no such subconscious vision of his building from the start, be sure it will never come alive.

If we must have a dogma, would substitute for "Form follows Function," Sir Henry's version,

"The End must direct the Operation."

The End is the enclosure of space, satisfactorily from every point of view, and enclosed space is form, whether viewed from within or without, the form whose creation is peculiarly the architect's study. Such form is no derivative or parasite of function. It is a twin-born guide and fellow, and the ultimate proclamation of the goal achieved.



PUEBLO COTTAGES FOR CHAPMAN PARK HOTEL, LOS ANGELES
Carlton Monroe Winslow, Architect



A GUEST HOUSE ON THE RANCH OF JAMES ROLPH III SAN MATEO, CALIFORNIA

AMONG the various buildings on the Rolph Ranch in San Mateo County, California, is a guest house, originally intended for the use of the late Governor, James Rolph, Jr., and built as a present from his son. An effort was made to include in this building details that would recall to the Governor much of his interesting personal life; such as ranching, hunting, horses, and his sea-faring experiences. To accomplish this last effect, much of the equipment and interior cabin finish of the old flag ship of the former mayor's fleet was actually removed from the vessel and incorporated into the house. The bedrooms were lined with the ship's paneling and even the ceilings reproduced the beams and curves of the cabins. The original bunks were included, as were the built-in dressers, mirrors, and seats.

Most of the lighting fixtures were the old oil cabin and deck lamps, wired for electricity. Bells, floor gratings, water casks, and various instruments were fitted into the scheme.

The design of the house is typical of the California ranchos as developed by the Yankee settlers. Exterior walls are of boards and wide heavy battens painted white, with a blue wainscot around the interior of the porch. The roof is of hand made tile in various dark shades. Rafters are white with the exposed roof boards painted turquoise. There is a great heavy front door of moss colored planks, with an old type latch string and crude wood handle. Floors throughout are of tile, waxed to a rich brown. The living room carries out the ranch feeling with a wood trussed ceiling and mantle of local stone. An old fashioned kitchen extends across one end of the house with ample space for dining. The color scheme in this room is quite brilliant, almost Mexican in spirit, with a generous use of red, yellow, and green.

THE PORCH, ROLPH RANCH HOUSE

(See plate on the right)

Rafters, beams, and porch posts are white-washed . . . The roof boards are turquoise . . . A wainscot of dull glazed blue with a border of terra cotta extends around the walls in the porch . . . There is a heavy plank door, studded, and moss colored, with an old type latch string and crude wood handle . . . The two ranch silhouettes are terra cotta color on buff background panels . . . Lamps are from the flag ship as are the water casks, the binnacle, floor gratings and spars . . . A mixture of flagstones, tiles, marble, and shells pave the terrace and steps.

RANCH HOUSE OF FORMER GOVERNOR JAMES ROLPH, JR.
Noble and Archie T. Newsom, Architects

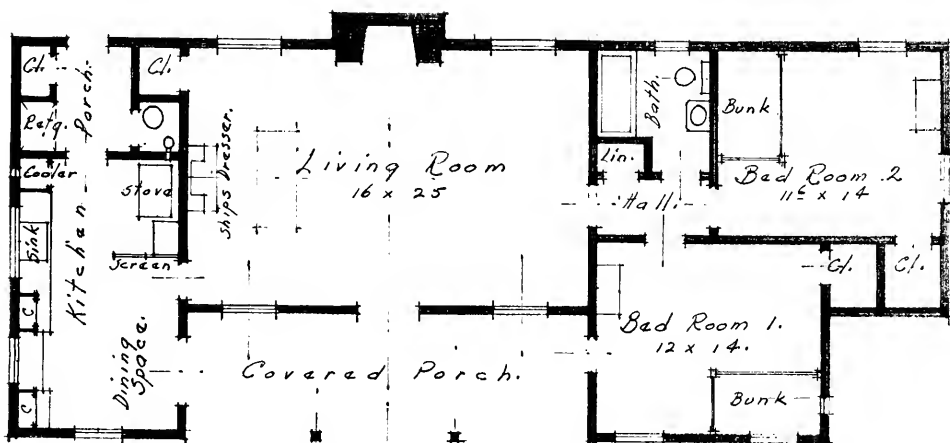

Floor Plan.
 Scale $\frac{1}{8}'' = 1'-0''$



BEDROOM, ROLPH RANCH HOUSE

The room was completely furnished from articles and finish taken from the old flag ship of the Rolph fleet. Wall panels are of fine woods with the original hand rubbed surface . . . Even the doors, dresser, and mirror, (not all shown here) came from the same sailing vessel.



RESIDENCE OF JOHN M. HOLMES, HILLSBOROUGH, CALIFORNIA
Noble Newsom and Archie T. Newsom, Architects

THE John M. Holmes residence is built on a large wooded property and sits well back from the street.

It is approached along a private road that winds through the trees, allowing several vistas of the house before reaching the wide parking terrace.

The design is based on New England Colonial, with the white painted wood of the exterior glistening against a background of deep foliage. There are the typical shutters, a front door enameled dark green with brass hardware, and a roof that shows deep shadows from heavy split shakes.

Inside, Colonial details are found throughout, with a varied color scheme. The living room walls are of a pale green blue, with white trim and panels, while the dining room has a complete wall-paper picture of "The Landing of the Pilgrims." A feature of the children's bedrooms is the floor of cork carpet with inserted motives such as "Little Bo Peep" and a cowboy riding a bucking pony.

The owners have furnished the rooms with many original Colonial pieces, including heirlooms and other antiques brought from the Eastern coast.



GARDEN VIEW, RESIDENCE OF JOHN M. HOLMES, HILLSBOROUGH, CALIFORNIA
Noble Newsom and Archie T. Newsom, Architects

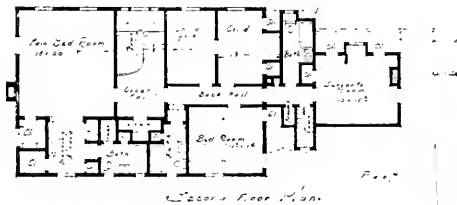
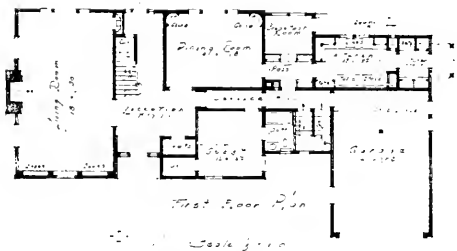

PLANS, RESIDENCE OF JOHN M. HOLMES,
THE CAROLANDS ESTATES, HILLSBOROUGH,
SAN MATEO COUNTY, CALIFORNIA

Noble Newsom and Archie T. Newsom, Architects

The residence of Royce C. Clerk, pictured on the right, is influenced by the California Colonial style, and is planned to take advantage of a broad view of the entire San Francisco Bay. The exterior is partly of light flesh colored stucco, and partly of brick veneer washed with the same color. A dark hand made tile is used on the roof, with the ridges bedded in white cement.



LIVING ROOM, RESIDENCE OF JOHN M. HOLMES, HILLSBOROUGH, CALIFORNIA
 Noble Newsom and Archie T. Newsom, Architects

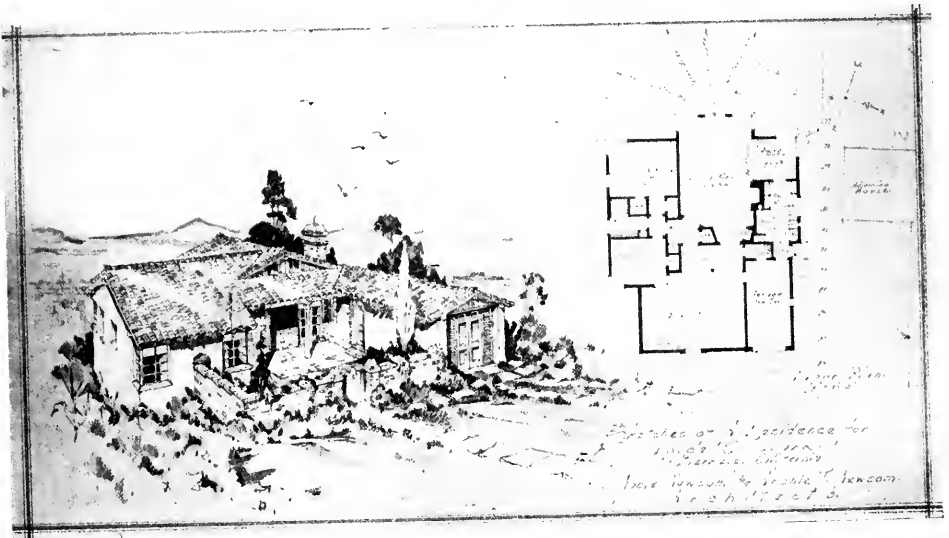

RESIDENCE FOR ROYCE C. CLARK, BERKELEY, CALIFORNIA
 Noble Newsom and Archie T. Newsom, Architects

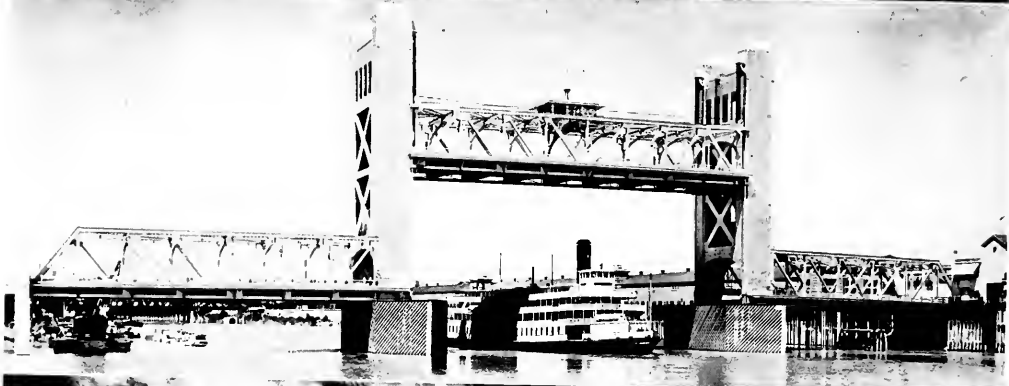

Courtesy California Highways and Public Works

TOWER BRIDGE, SACRAMENTO, AWARDED HONOR MENTION FOR BEAUTY IN NATIONAL COMPETITION

NATIONAL PRAISE FOR SACRAMENTO BRIDGE

RECEIVES JURY'S VALUE FOR ARCHITECTURAL BEAUTY

By Everett L. Walsh

FOR THE second time in as many years a California bridge, designed by the State Division of Highways and built by the Department of Public Works, has won an award in the annual national competition held in New York by the American Institute of Steel Construction, Inc., for the most beautiful bridge built during the past year.

This honor was won by the Tower Bridge, spanning the Sacramento River at Sacramento, which was accorded second place in Group B, including bridges costing between \$250,000 and \$1,000,000. Group A included bridges costing \$1,000,000 or more, and Group C those costing less than \$250,000. A total of thirty-one bridges entered the contest.

A similar award in 1935 was won in Group C by the Eel River Bridge, a continuous steel girder structure on State Route No. 1, Redwood Highway, at Smith Point in Humboldt County.

The Tower Bridge award brings additional honor from the fact that this lift spar structure entered into competition with bridges of all other types, and never before has a lift bridge been judged comparable in harmony of outline and proportion with arch and suspension bridges because the inherent graceful and symmetrical lines of the latter types have always been considered the most beautiful.

Californians may well be proud, therefore, in having the most beautiful lift bridge in the United States. The awards were made by a

jury of nationally known engineers and architects consisting of Messrs. Robert D. Kohn and Arthur Loomis Harmon, architects of New York; Professor William J. Krefeld of the College of Engineering, Columbia University; Mr. Howard C. Baird, consulting engineer of New York; and Mr. Kenneth Hayes Miller of New York, one of America's best known artists.

Records on the early Egyptian monuments prove that bridges were built during the time of Rameses II, 1350 B. C. In the days of King Arthur and his Knights of the Round Table, movable bridges were used as a protection against attack, by having drawbridges over moats around the castles.

The earliest lift bridges in the United States were located along the Erie Canal and were constructed in 1874. As population and water bourne commerce increased, it became necessary to increase the size and efficiency of movable bridges. The design of such bridges has kept pace with the development of steam, gasoline and electric power until today we have large fast moving types of bridges which meet the needs of modern necessity.

The Tower Bridge at Sacramento represents all that is modern in engineering skill and bridge design. The bridge is 737 feet long with a roadway width of 52 feet and two sidewalks four feet wide. A roadway thirteen feet wide, protected by concrete curbs, is provided for the Sacramento Northern Railroad tracks.

The bridge consists of steel spans resting on concrete piers and abutments. The center lift span is 209 feet long and is supported by

towers 160 feet high. West of the lift span is one 193-foot steel truss span and four 34-foot steel girder spans. East of the lift span is one 167-foot steel truss span and one 30-foot steel girder span. The overhead clearance of the lift span provides a maximum clearance above high water of 100 feet and a vertical clearance between fenders of 172 feet.

An advantage of this type of bridge is that it is very seldom necessary to raise the lift span to its fully raised position. The majority of vessels can pass under the structure when the lift span is only partially raised and thus avoid undue delay. The bridge can be fully opened and closed in approximately one and one-half minutes. The old bridge which was replaced at this location required six minutes to open and close completely.

The lift span mechanism is operated by power transmitted to the operator's house on the lift span by submarine cables placed at a minimum depth of 10 feet below the streambed. Flexible cables with sufficient slack to provide for the continuous flow of electrical energy when the lift span is raised to its maximum height are located in the towers.

In addition to the electric motors which provide the power for lifting the bridge, there is also an auxiliary gasoline motor which operates an electric generator. In case of a power failure, or if the electrical transmission line is broken for any reason, the gasoline motor will be ready to furnish power at a moment's notice.

The old bridge was built in 1910 at the same location, at the foot of M Street. It had long been an eyesore to the people of the State who entered Sacramento from the west. M Street, the Pennsylvania Avenue of California, runs directly into the State Capitol, which is flanked by the new Capitol extension buildings and Capitol Park. It was unimpressive, to say the least, to have such an antiquated structure as the gateway to the beautiful capitol buildings and grounds. When the need for a new bridge became an absolute necessity due to traffic requirements, popular sentiment demanded that every effort be expended to

design a structure which would be unexcelled in architectural and engineering beauty and thus conform to its natural setting.

Simplicity is the chief characteristic of the bridge architecture. The principle departure from ordinary practice is the plating or covering of the tower truss members with steel plates which give the appearance of simplicity in mass. The plates cover the intricate lacing and cross members and produce a modernistic straight line effect which is pleasing to the eye.

To produce the illusion of artistically adequate pier size in the substructure and continue the simple straight line effect, the fender structure protecting the main pier has been offset a considerable distance back from the channel and extended the proper distance beyond the edge of the tower. The pier itself is not visible through the fender as the fender extends above the pier and effectively conceals it, thus giving the tower an apparent support of ample size.

This treatment of the fender system was handled in this manner because the plating of the towers creates such an appearance of massive strength that it indicates the need of a massive supporting structure. Actually the pier is much smaller than appearance indicates as the greater part of the tower loads come on the front leg of the tower and no pier or pedestal is used under the rear tower leg. All loads coming at that point are taken by the approach truss span. This arrangement of the fender system gives the proper balance and symmetry of design when viewed from the side.

The curved portals over the roadway and at each intermediate panel point are a unique feature of the structure and add greatly to the aesthetic effect of the bridge from the viewpoint of the motorist as he travels over the roadway.

The massive abutments and pylons at each end of the bridge blend fittingly with the general proportions, color and natural surroundings of the structure. All steel members

(Please turn to Page 47)

NEW SCALE AND CODE FOR ENGINEERS

MINIMUM WAGE PROPOSED FOR EACH CLASSIFICATION

IN SOUTHERN California a tentative scale and code for engineers has been drawn up by the Engineers and Architects Association, and the Los Angeles Chapter, American Association of Engineers, and will be submitted to 40 other engineering organizations in the same territory for endorsement.

The code and scale apply to San Diego, Imperial, Orange, Riverside, San Bernardino, Los Angeles, Kern, Ventura, Santa Barbara and San Luis Obispo counties.

A letter sent out with the code and scale by President Marsh and Secretary C. H. Kiehl says:

"One of the important objectives of the American Association of Engineers is a complete classification of all engineering positions and a minimum salary schedule for each classification. The Los Angeles Chapter of the Association believes there is a great need for this at the present time in Southern California.

"There are, as you probably know, great differences in wages paid for similar positions by various organizations and employers. In some instances the rates of one employer are only one-half that of another. Great differences also occur in working hours per week, working conditions, provisions for board, lodging, transportation, sickness, vacation, etc. These differences are the result of having no established wage code and scale. The employer may want to do the fair thing, may even think he is being fair, but of several fair-minded men probably no two would arrive at the same figures for a schedule of wages. It necessarily becomes an organization matter if we are to have any real fairness and uniformity of wages. Some organizations must work out a schedule that is fair, just, and reasonable,

for the use of all of us. We believe that all fair-minded employers and employees in the engineering field will welcome such a solution.

"Our Association is organized to promote and accomplish the above objectives. It is peculiarly fitted to do so as it is composed of both employers and employees, and a loyal friendship and fraternalism exists between them. This fraternalism is general throughout the entire engineering field. It creates such active interest in the welfare of each other that we believe fair and just schedules of wages and fees can be established and will be welcomed by all groups.

"We would much appreciate your indorsement, adoption, and use of this wage code and scale. Please bear in mind that there will never be a code that will perfectly satisfy every individual. This code will be of great value to the profession as a whole, and we ask that you weigh your share of this general good against your individual disadvantage, if any.

"In order to effectuate the policy of the American Association of Engineers; to reduce unemployment; to improve the standards of labor; to eliminate competitive practices, destructive of the interests of the public, employers, and employees; and to increase the consumption of industrial and agricultural products, by increasing purchasing power; this wage code and scale is hereby established by the Engineers and Architects Association, Los Angeles Chapter, American Association of Engineers, for the adoption by, and use of, the employers and employees of Southern California.

Wage Code

1. The right of the employer to employ, promote, or discharge employees shall not be abridged.

- " 2. A working day shall consist of eight hours with overtime paid at the same rate.
- " 3. A working week shall consist of forty hours, except in cases of emergency. Such emergency overtime shall be compensated by allowing a corresponding amount of regular time off, with pay, within thirty days after the emergency, or at any other time mutually agreeable to both parties.
- " 4. When the work is away from headquarters, transportation shall be provided by the employer and wages allowed for the time spent enroute to and from work.
- " 5. Board and lodging, near the job, may be furnished by the employer, if he desires. In such event, transportation and transportation time shall be to and from such lodging.
- " 6. When headquarters are so located that lodgings or living quarters are not easily obtainable, transportation and transportation time shall be allowed to the nearest place where such may be obtained.
- " 7. When an employee is used for a day, or any fraction thereof, in a position higher than that for which he is employed, he shall be paid the wage of the higher position for that day, in lieu of the wage at which he was employed. For monthly employees, the monthly rates to be prorated in each case.
- " 8. When employed by the day, one day notice of discharge or resignation is required, except at the conclusion of a particular piece of work for which the employee had been hired.
- " 9. When employed by the month, or year, two weeks notice of discharge or resignation is required.
- " 10. Not less than one-half day of wages shall be paid for any work done, and one day's wages shall be paid if more than four hours have been worked.
- " 11. No deductions shall be made from the

salary of a monthly employee because of bad weather or other interference with the progress of the work.

- " 12. Vacation time on pay shall accumulate at the rate of one working day per month, to be taken annually at a time approved by the employer, or at any other time mutually agreeable to both employer and employee. If not taken, pay shall be allowed for the same at the termination of employment.
- " 13. Sick leave shall accumulate indefinitely, at the rate of one working day per month. No pay is to be allowed for sick leave not used.
- " 14. Transportation and reasonable traveling expenses shall be paid by the employer, when an employee is hired for a job that is more than one hundred miles from the place of hiring.

Wage Scale

Proposed minimum salaries are contained in the wage scale which covers 150 individual positions under ten group classifications. Salaries are designated as (A) minimum beginning salary; (B) minimum after 1 year and (C) minimum after three years of employment. Following are the group classifications and salary ranges for three years:

Property Appraiser—(A) \$180 for junior to \$375 for chief real estate appraiser; (B) \$190 to \$400; (C) \$200 to \$425.

Regional or City Planning—(A) \$175 for junior planning draftsman to \$200 for chief engineer in cities under 15,000 population and graded up to \$500 for cities over 1,000,000; (B) \$185 to \$600; (C) \$200 to \$700.

Architectural Engineer—(A) \$110 per month for student and \$175 for junior architectural draftsman to \$350 for chief architect; (B) \$115 and \$185 to \$375; (C) \$120 and \$200 to \$400.

Building Inspector—(A) \$180 per month for deputy inspector up to \$400 for chief engineer; (B) \$190 to \$500; (C) \$205 to \$600.

Cartographer—(A) \$130 per month for assistant and \$175 for cartographer; (B) \$140 and \$185; \$150 and \$200.

Civil Engineer—\$130 per month for chain-

man and \$225 for junior engineer to \$700 for chief engineer, ranging up to \$2000, depending on size of project; (B) \$140 and \$235 up; (C) \$150 and \$250 up. For county surveyor salary range is \$300 to \$400 for counties up to 50,000 population; for counties from 50,000 to 150,000, \$400 to \$500; counties 150,000 to 2,000,000, \$500 to \$1000; over 2,000,000, \$1000. Same schedule applies to road commissioner. For city engineer, salary range is: cities up to 15,000 population, \$200 to \$300 per month; 15,000 population, \$200 to \$300 per month; 15,000 to 50,000, \$300 to \$400; 50,000 to 100,000, \$400 to \$500; 100,000 to 300,000, \$500 to \$600; 300,000 to 500,000, \$600 to \$700; 500,000 to 1,000,000, \$700 to \$1000; over \$1,000,000, \$1000.

Electrical Engineer—(A) \$175 per month for junior draftsman to \$500 for chief electrical engineer; (B) \$185 to \$600; (C) \$200 to \$700.

Landscape Architect—(A) \$180 per month for junior and \$225 for landscape architect; (B) \$190 and \$235; (C) \$205 and \$250.

Mechanical Engineer—(A) \$175 per month for junior draftsman to \$500 for chief engineer; (B) \$185 to \$600; (C) \$200 to \$700.

Road and Sewer Construction Superintendent—(A) \$155 per month for foreman paved ways to \$250 for road and sewer construction superintendent; (B) \$165 to \$260; (C) \$180 to \$275.

NEW DECORATIVE MEDIUM

(Concluded from Page 24)

much greater tensile strength and hardness in comparison with more ordinary metallic alloys.

"Flat strips, 16 gage or lighter, can be drawn through mechanical rolls and then formed into any desired shape and profile, as for instance in the fabrication of stainless steel windows and architectural trim: Stainless steel can be welded, wrought, forged, repoussed, spun, stamped, rolled, cold drawn. It lends itself especially to cold treatment since working it thus increases its tensile strength. However, for many forging operations it is necessary to work it hot in a manner similar to steel or iron. This, however, is readily done.

"Graceful grilles and doors no longer have to be cast in heavy materials, but can be light enough to be carried and erected by the average workman. They will, on the other hand, have a strength and endurance out of all proportion to so-called hollow bronze doors or even the massive cast bronze doors."

"About two years ago," he continued, "I was asked to suggest a method of coloring the natural finish of stainless steel, with the proviso that it must not be painted nor anything applied to the metal or added to the metal that would cause it to deteriorate.

"I experimented along these lines and eventually succeeded in adding an apparent improvement by coloring the surface of this metal.

"Many architectural and sculptural masterpieces from ancient to modern times indicate that enduring results can be achieved when the artist utilizes to the fullest extent the natural characteristics—even limitations—of the material of construction. This I am sure will be the case with this new and precious metal."

TOWER BRIDGE

(Concluded from Page 44)

of the bridge, including the towers, are painted with aluminum paint which gives them a metallic luster.

For a distance of 2000 feet on the west approach to the bridge a beautification project was initiated to improve the appearance of that approach. This consisted of leveling all the area within the State right of way, installing a sprinkler system, planting small park areas immediately adjacent to the bridge and landscaping the approach by planting shrubs.

The Tower Bridge, only bridge in the West to win an award, was built by the State Department of Public Works, in cooperation with the city and county of Sacramento and the Federal Government, at a cost of \$994,000. The design and construction was under the direction of C. H. Purcell, State Highway Engineer, and F. W. Panhorst, Acting Bridge Engineer.

Editor's Note—Geo. B. McDougall, head of the Division of Architecture, and Alfred Eichler, Chief Architectural Designer, planned the architectural features of the structure.



THEATRICAL PICTURE STUDIO, SAN FRANCISCO
Bliss and Fairweather, Architects
Exterior white and black unit tile

MACHINE TABULATION - '35 BUSINESS CENSUS

GROWTH OF CITIES AND STATES WILL APPEAR IN DETAIL

By Fred A. Gosnell

Some months ago this magazine published an article describing certain of the details in handling the nationwide Business Census. The article was received enthusiastically and following requests for additional information on this subject the Department of Commerce has prepared an explanatory article dealing chiefly with the mechanical operations involved in handling the three million schedules for the 1935 Census of Business. The article follows:

THE robot stage of the 1935 Census of Business has been reached at the Census Bureau's Philadelphia branch office. As the processing of the construction schedules progresses wider use is made of mechanical methods.

Three types of machines are used for the mechanical stage of the Census—"punchers", "sorters", and "tabulators". The first of these, the punchers, are hand operated. The other two are powered by electricity which moves the innumerable little brushes, wheels, metal arms and counters of their intricate mechanism.

Before the schedules come to the machine tabulation division, they are bound in folios by States, for each branch of business covered by the Census—construction, retail trade, wholesale trade, bus transportation, trucking and warehousing, radio broadcasting, services and amusements, hotels, banking and finance, insurance and real estate, advertising agencies, and miscellaneous. Thus all of the construction schedules for New York are bound in one package; all for Ohio are bound in another; all for California are bound in another; and so on for each State. The schedules, before they were sorted and folioed, were all checked for consistency and accuracy, and each item on each schedule was coded.

The punch-card machine does just what its name indicates. It punches or perforates cards.

The cards are rectangular, $3\frac{1}{4}$ by $7\frac{1}{4}$ inches, lined off in much the same manner as a statistical table, with rows of serial numbers under each heading. Each perforation has a meaning of its own, translating facts into figures.

When all of the information from the schedules has been transferred to cards, the schedules are filed away, and used only for checking inconsistencies. The cards contain all of the information which was on the schedules, and the individual identity of each company is thereafter concealed completely.

Several different cards are required to take off all the data. For instance, the first construction card, in addition to nearly 20 columns needed to describe the concern for classification purposes (kind of business, type, location, etc.), contains columns punched to indicate total value of construction performed, number of active proprietors, total number of paid employees October 26, 1935, total 1935 pay roll, total man-months of employment, and cost of materials and equipment installed.

Another card is arranged to provide such additional data as orders from owners, orders from contractor, total orders received, total of work sublet, number of proprietors and firm members, number of Negroes employed, and value of merchandising activities. A third card covers an analysis of the work performed, either public or private, by new construction and additions and remodeling, repainting and maintenance. There are seven different cards needed for the construction schedules.

An entire floor at Census headquarters is taken up by the card-punching section of the division of machine tabulation. The machines are smaller than a typewriter and have a fourteen-keyboard, which looks something like the keyboard on a small adding machine. To record all of the information gathered for all branches of business covered by the Census, approximately 35,000,000 punch cards are needed.

The operator works the machine by pushing down one of the keys, which punches the first column. The card then moves automatically to second-column position. Another punch and it moves to third position, and so on. It is a one-handed operation, but surprising speed is attained by the operators who read off the code symbols like a piano player reads music. Skilled operators of these machines average about two hundred cards (of 45 columns each) per hour.

The floor occupied by the card punchers sounds like an old time newspaper office when the machines are all in operation. The clicking of keys and the punching mechanism sounds like the old time telegraph sets which were used before the advent of the teletype machine.

The cards are assembled in wooden boxes in the same geographical groupings in which the schedules were sent to the tabulating division. They then go to the sorting machines. These machines are electrically powered, stand on legs about table height and are much larger than the card punching machines. They are about four feet long. The cards travel over a series of wheels against which a brush, making contact through the perforation, does the sorting. This brush is similar to the brush in an automobile generator. Under this top set of sorters are twelve compartments or bins, into which the cards are sorted. The machine can sort between three and four hundred cards a minute, dropping each into its proper bin. A separate sort is required on each identification column.

The sorting machine will pick out from thousands of cards only those for certain classifica-

tions. The machine is wired in a certain manner and cards for a given area are inserted. When the cards have all been through the machine all of the building contractor cards are found in one bin, highway construction in another, sheet metal in a third, and so on. If the code has two digits the cards have to go through twice. Each classified pack of cards is then put through the tabulator for automatic count and a total of each amount-column.

The tabulator is a much more intricate machine than either the sorter or puncher. This is the machine into which the sorted cards are placed and out of which come printed "result slips", which contain totalled data, arrayed by the classification of the cards.

They are larger than the sorting machines, weighing nearly a ton each. The cards are placed on a rack on the left side of the machine, and drop down over rotating shafts, which turn against brushes, just as in the sorting machines. The contacts made in this manner transmit a circuit to the right side of the machine, where the adding apparatus is located. Thus the data are totalled. The totals are transferred to the result slips with an elaborate typewriting mechanism. When a tabulating machine is placed in operation it sounds very much like a linotype machine. It will tabulate 150 cards each minute.

A look into the inside of one of these machines reveals a maze of wires, registers, fuses and other electrical and mechanical apparatus. It is as complicated as an elaborate telephone switchboard. Each morning before the machines are used for tabulating Census data, they are checked for accuracy.

Two types of tabulators are being used for the Business Census. One will total statistics up to nine figures, the other up to ten figures. Revenue and expense totals are usually expressed in thousands of dollars, to save unnecessary digits.

The result slips produced by the tabulating machines are then sent to construction division of the Census. When they have been carefully checked and analyzed the data are transferred by hand, to final tables.

ARCHITECTS' BULLETIN

Issued For

THE STATE ASSOCIATION OF CALIFORNIA ARCHITECTS

Northern Section

STATE ASSOCIATION MEMBER
OF THE
AMERICAN INSTITUTE OF ARCHITECTS

Harris C. Allen
Editor

Address all communications for publication in the Bulletin to the Editor (Harris C. Allen) 557 Market Street, Room 218, San Francisco, California.

Board of Control
Harris C. Allen Otto G. Hintermann
Harry Michelsen Ellsworth E. Johnson

State Association Officers
William I. Garren.....President
Lester H. Hibbard.....Vice-President
H. C. Chambers.....Secretary
Otto G. Hintermann.....Treasurer
Albert J. Evers
Regional Director, A.I.A.

Executive Board — Northern Section
William I. Garren.....President
Harry Michelsen.....Vice-President
Ellsworth Johnson.....Secretary
Otto G. Hintermann.....Treasurer

Directors
Harry Devine J. K. Ballantine
Roland I. Stringham Chas. F. B. Roeth

Executive Board — Southern Section
Lester H. Hibbard.....President
George D. Riddle.....Vice-President
H. C. Chambers.....Secretary
Robert H. Orr.....Treasurer

Directors
A. M. Edelman Louis J. Gill
Wm. S. McCary Henry C. Newton

District Advisors—Northern Section
Harris C. Allen Wm. K. Bartges
J. H. Mitchell Gwynn Officer
J. K. Ballantine C. A. Caulkins
Thos. Kent Frank Mayo
C. F. Maury Chas. E. Butner
Wilbur D. Peugh Ralph Wyckoff
Will Toepke Leslie I. Nicols
Dodge Riedy Wallace A. Stephen
Edward Frick W. E. Baumberger
S. L. Hyman F. T. Georgeson
Ralph E. Wastell Casebolt C. Dakin
Earl R. MacDonald Ralph D. Taylor
Jas. T. Narbett Edward W. Peterson
Herbert G. Goodpastor

1936 ASSOCIATION CONVENTION

Committee personnel has been selected (for the Northern Section) for the annual convention of the State Association to be held at Del Monte in October. Sub-committee chairmen will act on the General Convention Committee with Messrs. Allen, Hintermann and Ballantine, previously appointed. The committees are as follows:

RECEPTION, REGISTRATION AND INFORMATION

Chairman, Ellsworth E. Johnson, San Francisco; Charles H. Sawyer, San Francisco; John J. Donovan, Berkeley; Henry C. Collins, Palo Alto; Howard Bissell, Stockton; Ralph Wyckoff, San Jose; Robert Stanton, Del Monte.

PROGRAM AND ENTERTAINMENT

Chairman, Harris C. Allen, San Francisco; A. Appleton, San Francisco; J. K. Ballantine, Jr., San Francisco; Albert J. Evers, San Francisco; Henry H. Gutterson, San Francisco; William O. Raiguel, Monterey.

GOLF

Chairman: Harry M. Michelsen, San Francisco; Wilbur D. Peugh, San Francisco; William G. Corlett, Oakland; Milton Latham, Carmel; Herbert E. Goodpastor, Sacramento.

PUBLICITY

Chairman, Roland I. Stringham, San Francisco; Chester H. Miller, Oakland; L. F. Starks, Sacramento; Rafael Lake, Fresno; C. A. Caulkins, Jr., Santa Rosa; Peter Sala, Stockton; Ralph Wyckoff, San Jose; F. T. Georgeson, Eureka.

TRANSPORTATION

Chairman, Dodge Riedy, San Francisco; William E. Schirmer, Oakland; Gwynn Officer, Berkeley; James T. Narbett, Richmond; H. J. Devine, Sacramento; E. L. Norberg, Burlingame; Victor Galbraith, Stockton.

HOTEL RATES

Very reasonable rates have been made by Hotel Del Monte. They are on the American Plan, which includes meals (and How!) and are as follows:

	PER DAY
BOTH WINGS	
Single Room without bath—1 person	\$7.00 each
Double room without bath—2 persons	6.50 each
Single Room with bath—1 person	8.00 each
Double Room with bath—2 persons	7.00 each
2 Single Rooms, bath between—2 persons	7.50 each
2 Double Rooms, bath between—4 persons	6.50 each

	Per Day
Main Building, Cottages, and Remodeled Wing Rooms	
Single Room with bath—1 person	\$9.00 each
Double Room with bath—2 persons	8.00 each
Sitting Room	6.00



BUILDERS' EXCHANGE

Our members are reminded that the floor of the San Francisco Builders' Exchange is open to them—which is often a great convenience. Go in some day, introduce yourself (if necessary) and extend your acquaintance.

* * *

PUBLICITY

Our office has received a number of "coupons" clipped from a monthly publication requesting information about architects, all of which have been answered, giving names of local or adjacent architects, and other data.

* * *

A TRIP TO SAN DIEGO

The State Association officers of the Southern District visited San Diego the afternoon and evening of June 27th and were pleasantly entertained in the office of one of the distinguished architectural firms which has a roof garden that is a garden and a view that is enchanting. The scheme of the Civic Center engrossed attention, those having it in charge deploring the loss of elevation to the tower due to its proximity to Lindberg Field.

The appearance of the genial councilman, John S. Siebert, imbued with the grace of a matured architect, now supplemented by political science, lent dignity to the occasion. Spurred by the recent victory at the polls for city officers, the architect's eyes look now askance at control of county officers.

With our hosts to the Fair Grounds the indulgence was that which strengthens the body and nothing more. The after dinner speeches were informative and the occasion rounded out an hour of felicitations that were enjoyable.

Those in attendance were: Joseph W. Potter, John S. Siebert, Robert Halley, Jr., H. Lewis Bodmer, Charlie H. Salyers, Sam W. Hamill, Ralph E. Swearingen, Frank L. Hope, Jr., Robert R. Curtis, A. O. Treganza, Louis J. Gill, George A. Pallister, Jack Lyman, Charles H. Holmstrom, G. A. Hanssen, architects. Bruce Rick, Fred Burtzmer, and Harrold Shaw, draftsmen. Clarence Cullimore of Bakersfield, Scott Quintin, Alhambra, A. M. Edelman, Lester H. Hibbard, and Robert H. Orr of Los Angeles.

HISTORIC ARCHITECTURE

The following excerpts are from an article in "The Octagon" by

Charles E. Peterson, A.I.A.

"On November 13, 1933, a memorandum proposing 'the relief employment under the Civil Works Administration of a substantial number of the architectural profession in a program recording interesting and significant specimens of American architecture' was submitted to the National Parks Service. The subjects for measurement and photographing were to be * * * almost a complete resume of the builders' art. It should include public buildings, churches, residences, bridges, forts, barns, mills, shops, rural outbuildings, and any other kind of structure of which there are good specimens extant. The lists should be made up from the standpoint of academic interest rather than of commercial uses. The largest part of individual effort spent so far in measuring antique buildings and recording them seems to have been with an eye to adapting historic styles to modern commercial architectural practice and * * * whole classes of structure have been neglected. Also to be included were 'other structures which would not engage the special interest of an architectural connoisseur * * * the great number of plain structures which by fate or accident are identified with historic events.'

"The idea was well received, and within four days it had been approved by the Director of the Bureau and the Secretary of the Interior. It was then submitted to the Civil Works Administration, supplemented by elaborate 'breakdowns.' The plan was suited to the requirements of the new relief program, and on November 29—less than three weeks after it was written—it was approved in its original form.

"A nation-wide organization was soon functioning, and shortly after the first of the year there were measuring parties in the field.

"The project was carried on with the gratifying support of the profession and the public at large. By April it was possible to hold an exhibition at the National Museum in Washington, including drawings and photographs from all parts of the country. The quality of the work was excellent, and the exhibition was well received. The proven feasibility of the whole idea encouraged the National Parks Service, The American Institute of Architects, and the Library of Congress to effect, on July 23, 1934, an agreement to carry on the work as a permanent activity.

"The project has now been carried through the stormy seas of two emergency programs—the Civil Works Administration and the Federal Emergency Relief Administration—and it is well on its way through the third—the Works Progress Administration. The funds through which the Historic American Buildings Survey is operated are scheduled to expire on July 1, 1936, although the work will be extended beyond that

date if it is possible to do so. The policy of the Administration in regard to the financing of various relief projects must continually change to meet changing conditions of unemployment. Over a large part of the South, it is already difficult to secure draftsmen to work on the Survey, and it is probable that, through general business recovery, in a year or two the project can no longer be conducted as an unemployment relief measure.

"While the Historic American Buildings Survey receives its initial impetus from relief funds, it was designed so it could be made permanent. There are many possible sources which might supply the funds to carry on the work, and the historic material which should be recorded is nearly inexhaustible. In only a few areas of the country have all the worthy buildings been measured, and with the passing of time many more will become eligible.

"On August 21, 1935, there was approved an important Act of Congress 'to provide for the preservation of historic American sites, buildings, objects and antiquities of national significance, and for other purposes.' This act declares this form of conservation to be a policy of the Federal Government.

"Among other things, the Act of 1935 directs that the Secretary of the Interior shall perform the following duties:

'(a) Secure, collate, and preserve drawings, plans, photographs, and other data of historic and archaeological sites, buildings and objects.

'(b) Make a survey of historic and archaeological sites, buildings, and objects for the purpose of determining which possess exceptional value as commemorating or illustrating the history of the United States.

'(c) Make necessary investigations and researches in the United States relating to particular sites, buildings or objects to obtain true and accurate historical and archaeological facts and information containing the same.

"The Historic American Buildings Survey had made an impressive start in these activities, beginning nearly two years before the Act of August 21, 1935, under the broad authority of the NIRA. It might be appropriate here to define the nature of the Survey, since its name, selected in the beginning for its trademark value, has always been something of a misnomer. The product of the Historic American Buildings Survey consists of four parts:

"(a) A master list of American buildings, significant for their historic or architectural value, available in the Library of Congress. The list is in the form of a card catalogue, with one card for each building. So far as

is possible up to the present time, each card contains a bibliography of the building represented. The list contains at this date nearly two thousand entries, only a small fraction of the number needed to make it really comprehensive.

"(b) A collection of measured drawings of these buildings on standard sheets. 5589 sheets of drawings, representing 788 buildings, have been deposited in the Library of Congress, and approximately 3706 more sheets have been completed for this purpose. Prints are available at a nominal fee, so that architects can add to their libraries selected subjects at a minimum cost. The original field notebooks become a part of the collection.

"(c) A collection of photographs of these buildings which becomes a part of the Pictorial Archives of Early American Architecture. Prints can be studied in the Library, and copies are available at cost. 4205 Historic American Building Survey negatives have been filed in the Library.

"(d) A collection of historical notes deposited with the graphic material. The writings submitted are not exhaustive, and their accuracy is not vouched for. They were collected by architects on their visits to the buildings measured, with the idea of making available additional information. This collection of essays is in such form that it can be supplemented at any time from documentary sources.

"Architectural schools near historic buildings have a good opportunity to contribute records executed as a part of the regular training of the students. At the present time students of the University of Virginia are recording four of the original pavilions on the Old Lawn of the University campus. Thomas Jefferson had intended these buildings to be examples of classic architecture, and they will now become available to students everywhere.

"The National Parks Service is ready to furnish supplies for such work, provided it is done according to the standard specifications. The important thing is that there is now a proper repository where drawings made according to a uniform and established technique are preserved and made accessible for general distribution.

"Private architectural firms may, with very little additional work, make contributions to the Historic American Buildings Survey by submitting measured drawings made in connection with remodeling or restoring important old buildings. Such data will be accepted by the Library of Congress through the local officer of the Survey. Such officer, if unknown to an architect desiring to submit data or drawings, may be located by addressing the National Parks Service of the Department of the Interior. While complete drawings of a building are desirable, drawings of parts of a building will also be received by the Survey.

With the Architects

G. A. LANSBURGH BUSY

Besides a large San Francisco project, details of which will not be available for a while, G. A. Lansburgh, San Francisco and Los Angeles, reports considerable activity in his office. The Hotel Plaza on Post Street, San Francisco, is undergoing a new facade which will give the big hostelry a modern appearance. The plans were made by Mr. Lansburgh who is also at work on drawings for extensive alterations to the Hollywood Plaza Hotel to include a cocktail lounge, new cafe, kitchen, etc. Another Los Angeles improvement in charge of Mr. Lansburgh is remodeling and decorating the Sunset Tower Apartments.

DEPARTMENT STORE, SANTA ROSA

Working drawings are well along for a two story reinforced concrete department store building at Santa Rosa for Fred S. Rosenburg. The architect, C. A. Caulkins, reports that the building will cover a ground area 145 by 240 feet and will be semi-modern in design.

Mr. Caulkins is also preparing drawings for an early California house for Dr. H. H. Wolfe of Fort Bragg where the residence will be built.

BEACH COTTAGE

Harris C. Allen, architect of San Francisco, has completed plans for an \$8,000 beach cottage for Paul W. Wood of San Francisco. The house will occupy an attractive marine view site at Rio Del Mar, Aptos, Santa Cruz County, and will have nine rooms and four baths. Mr. Allen has also completed drawings for remodeling the mortuary of V. G. Caporgno at 1727 Grove Street, Oakland.

SCHOOL ADDITION AND RESIDENCE

Plans have been approved by the State Department of Engineering for a four room addition to the Roache Grammar School, near Watsonville, the drawings having been made by A. W. Story. Plans by the same architect provide for a \$13,000 hollow tile residence on the Hecker Highway in Santa Cruz County, for E. W. McSherry of Watsonville.

STORE REMODEL WORK

At Sacramento \$35,000 will be expended by Mrs. Kate H. Remick and Geo. C. Bassett on a 12 store remodeling project at 12th and K Streets, from plans by Harry J. Devine. The work will include new store fronts and interior remodeling.

PERSONAL

Vernon B. McClurg, architect of Los Angeles, has been appointed head of the architectural, engineering and cartographic work of the Resettlement Division. Mr. and Mrs. McClurg are making their home at the Parkway Manor, Los Angeles.

Edwin Snyder, architect of Berkeley, has moved to adjoining quarters in the Mason McDuffey Building at 2104 Addison Street, Berkeley. An attractive studio has been fitted up with a well lighted and commodious drafting room, private office and general reception room.

Douglas Dacre Stone has moved to larger offices at 381 Bush Street. Mr. Stone's new quarters take up an entire floor and are most attractive. Glass brick, special lighting fixtures, Venetian blinds, with a pleasing color scheme, combine to make the studio outstanding for convenience and good taste.

Clarence J. Smale has moved his office from 1126 S. Western Avenue to 309 S. Orlando Street, Los Angeles.

A partnership for the practice of architecture has been formed by Louis L. Dorr, Charles R. Selkirk and Dwight Gibbs under the firm name, Dorr, Selkirk & Gibbs. Their offices are at 906 Architects' Building, Los Angeles.

Normand W. Mohr, formerly city architect of San Francisco, at present structural engineer for Federal C. S., has recently returned to San Francisco from the South where he was a guest of his brother, Hal Mohr, ace cameraman, and wife of Evelyn Venable. While in Los Angeles Mr. Mohr conferred with Hon. H. S. Payne, secretary of the Board of Public Utilities regarding transportation problems, and Mayor Ben Cole of San Diego on Exposition and Municipal planning.

SCHOOL OF EDUCATION

Arthur Brown, Jr., and John Bakewell have been commissioned to prepare plans for a \$525,000 building to house the Stanford School of Education at Palo Alto. The structure is made possible by a trust fund created by Dr. and Mrs. Elwood Cubberley. The building will form part of a three unit group which includes the present library and enlarged art gallery. Construction will be of reinforced concrete and stone.

VALLEJO LAUNDRY BUILDING

Messrs. Miller and Warnecke of Oakland, have completed drawings for a one story frame and stucco laundry building at Vallejo for the Vallejo Steam Laundry Company. The cost is estimated at \$15,000.

HONORARY MEMBER OF HORUS

Geo. M. Rasque, architect of Spokane, was recently made an honorary member of Horus, Temple of Scarab, national professional fraternity of architects, by Washington State College. This distinction was given him because of his contributions to national architecture. He has designed and directed construction of more than 90 schools in the Northwest and has also been architect for several courthouses and other public buildings.

Honorary membership in Horus has in the past been conferred upon three other practicing architects in the State of Washington: Julius Zittel and Harold Whitehouse, Spokane, and George Gove, Tacoma.

GARAGE AND WAREHOUSE

A. H. Knoll, Hearst Building, San Francisco, has finished plans for a \$30,000 warehouse and office building to be erected on the west side of Folsom Street, between 15th and 16th Streets, San Francisco. It will be 75 by 245 feet and constructed of structural steel and corrugated iron. Mr. Knoll has also made plans for a garage building on York Street, San Francisco, for the Sunset Scavenger Corp.

WILLIAMS AND WASTELL BUSY

New work in the office of Messrs. Williams and Wastell, architects of Oakland, includes an early California style residence in Piedmont for H. M. Thomas; a \$6500 house on LeConte Avenue, Berkeley, for an unnamed client; a \$10,000 English style residence in Alameda for J. R. Parkinson, and a \$6,000 house in Oakland for F. E. Sorisio.

CHURCH ADDITION

Extensive remodeling and an addition of several class rooms is planned to the Church of Jesus Christ of Latter Day Saints at Moss Avenue and Webster Street, Oakland, from plans by Theo. G. Ruegg, 751 Dolores Street, San Francisco. The improvements will cost \$12,000.

DESIGNING TWO RESIDENCES

Two residences to be built in the neighborhood of Jackson and Locust Streets, San Francisco, are being designed in the office of Frederic F. Amandes, 414 Dewey Boulevard, San Francisco. One will cost \$22,000 and the other \$18,000.

APARTMENT BUILDING

Chester Treichel, 696 Cleveland Avenue, Oakland, has completed plans for a two story frame and stucco apartment building for W. T. Seawell to be built on El Camino Real, San Mateo County. There will be four three-room apartments. Estimated cost of the improvements is \$15,000.

HELENA RECOVERING

Outstanding in Montana's building activity is Helena's earthquake rehabilitation program which has reached a volume aggregating a million and a half dollars, according to Oscar Baarson, city engineer. Construction has been maintained at a record pace since Jan. 1. The high mark in building permits for this year was reached in June with an official total of \$197,772, or several times that of June, 1935. Permits during the first six months totaled \$674,396.

GYMNASIUM AND AUDITORIUM

Construction will go forward at once on a one-story frame and stucco gymnasium and auditorium at Covelo for the Round Valley Union High School District. Covelo is in Mendocino County, California. C. A. Caulkins of Santa Rosa is the architect. The estimated cost of the improvement is \$50,000.

\$18,000 HILLSBOROUGH RESIDENCE

Henry C. Smith, Humboldt Bank Building, San Francisco, has completed working drawings for an \$18,000 eight room residence on Robles Road, Hillsborough, for J. C. Musser. The exterior will be brick veneer with shingle roof, steel sash and gas heat.

CERTIFICATE TO PRACTICE

A provisional certificate to practice architecture in the State of California has been issued by the California State Board of Architectural Examiners, Northern District, to John Henry Devitt, 279 14th Avenue, San Francisco.

FLORAL FIESTA

Home appliance, building materials and industrial products exhibits will be featured in connection with the second annual products and floral fiesta to be held for four days starting October 8, at the Bay Meadows racing course, San Mateo.

STORE ALTERATIONS

Contracts have been let to the Mullen Manufacturing Company of San Francisco for remodeling the interior of Roos Bros. store in Berkeley, from plans by Albert R. Williams, architect, 251 Post Street, San Francisco.

MARIN COUNTY RESIDENCE

Plans are in a preliminary stage in the office of Albert J. Evers and Roland I. Stringham, 525 Market Street, San Francisco, for a \$15,000 two story frame residence at Del Mesa in Marin County for an unnamed client.

PIEDMONT RESIDENCE

W. E. Schirmer has completed plans and awarded a contract for a \$15,000 residence in Piedmont for A. M. Upton, 6149 Buena Vista, Piedmont.

USURPATION OF ARCHITECTS' SERVICES

To the Editor:

Your magazine I enjoy more than any other architectural journal; particularly I endorse the article entitled "Architects Must Resist Usurpation" by Mr. Howard J. White, published in your July number.

The writer, while starting life in the strictly professional line, has been both an architect and a contractor but never both at the same time, and this has given him an opportunity to see the two points of view. If we as architects must do business with contractors and material dealers, it helps us to know both sides as well as being a benefit to our clients. The practice of contractors offering architectural service free is not only usurpation but a great swindling game for those engaged in that kind of business, and we have had such here in Seattle.

An example of how such games are worked, which came to my notice, is pertinent to this subject. A contractor-architect secured a building to erect for a client, giving a price of \$25,000, at the same time agreeing with his client that if the client got any competitive bids and awarded the construction to another, that he should be paid the usual architect's fee for plans. The owner of the building was on the verge of letting the contract for \$25,000 when he took a friend's advice and got bids and let the construction contract for \$17,000 and the builder made a profit of \$2,000. The contractor got the usual architect's fee. This happens many times on residences and small buildings and I know several architect-contractors who are operating that way. While I was Superintendent of Buildings of the City of Seattle, this game was brought to my attention. I believe the architects owe it to themselves to bring this to the attention of the public generally.

Mr. Horowitz's articles in the Saturday Evening Post, I have read with a good deal of interest, but the average architect does not have many clients like his Mr. Kahn, who said, "Go ahead with the house, I don't care a d— what it costs."

Architects make one serious mistake and that is the predominating desire to be artists without the necessary knowledge to produce artistic, livable and practical buildings and this has let another set of men "horn in" on us, the structural engineer and engineers for heating, ventilating, wiring, acoustics, etc. These men are essentially craftsmen, not architects, and they are already fighting architects, demanding on public work that architects employ men belonging to their particular unions.

Now, this brings me to what we architects should do—advertise just what we are and what our functions are; go slow on ethics; the public cares nothing for them, they belong solely to the profession. Do I hear someone object to advertising? True, it does not do much good, but we can advertise professionally as a class and not as individuals, and sometimes in the daily as

well as professional papers. Advertising used to be considered unethical by some architects, but not any more; the public does not consider it the same as law or medicine.

We are not at the end of our road yet; here in the West even 40 years ago, a man did not think of an architect but of a carpenter, when he wanted to build a house. The modern trend of design and the millions of new gadgets may give the engineer an opening to suggest that the architect is not as necessary as he is; true, we need specialists. This is an age of specialists, but the architects are not quite in the fix of the doctors, who have so many specialists that one never knows whether he has the right kind or not.

Yours very truly,

James E. Blackwell
Architect.

Seattle, July 22, 1936.

NINE-STORY BUILDING

A nine-story reinforced concrete mercantile building will be erected at once at Tenth and Market Streets, San Francisco, for the Western Furniture Exchange and Mercantile Mart. The plans are being prepared by the architectural department of the Bank of America. L. H. Nishkian will be the structural engineer and Leland and Haley will have charge of the mechanical lay out.

Mahogany and glass partitions are incorporated in the plans which provide for a thoroughly modern treatment.

TO REMODEL RESIDENCE

From plans by Messrs. Farr and Ward the residence of Mrs. Stanley Fay at 2130 Vallejo Street, San Francisco, will undergo extensive remodeling at an estimated cost of \$7,000. One of Farr and Wards' residence alteration projects is illustrated elsewhere in this issue.

TO REBUILD NAPA SCHOOL

The Napa Union High School which was partially destroyed by fire is to be rebuilt immediately from plans by William Herbert of Santa Rosa and W. Adrian, structural engineer, of San Francisco. An entire new auditorium is planned.

PIEDMONT RESIDENCE

W. W. Wurster, Newhall Building, San Francisco, has drawn plans for an early California style house to be built in Piedmont for Milo T. Gates. There will be twelve rooms.

NINE ROOM RESIDENCE

H. W. Higbie, 518 South Second Street, San Jose, is architect of a nine room \$16,000 residence to be built in San Jose for W. S. Clayton, banker, of that city.

FOR EXCELLENCE IN ARCHITECTURE

For "general excellence in architecture", thirty graduates of American architectural schools have received the School Medal of the American Institute of Architects, it is announced.

The awards, made by the Institute's Committee on Education, of which Dean William Emerson of the Massachusetts Institute of Technology is chairman, went to the following:

Logan Stanley Chappell, Columbia University.

Herman C. Litwack, New York University.

Serge P. Petroff, Cornell University.

William James Taylor, Syracuse University.

Joseph Donald Mochon, Rensselaer Polytechnic Institute.

Melville C. Branch, Jr., Princeton University.

Adrian Nathan Daniel, Jr., Yale University.

John A. Valtz, Massachusetts Institute of Technology.

Eustis Dearborn, Harvard University.

Paul Lucien Gaudreau, Catholic University of America.

Alexander Hamilton Van Keuren, University of Pennsylvania.

Eugene Joseph Mackey, Carnegie Institute of Technology.

Joseph Frank Belis, Pennsylvania State College.

Hollie W. Shupe, Ohio State University.

Cyrus L. Baxter, University of Cincinnati.

Leon Clement Hufnagel, University of Notre Dame.

Paul Bradley Brown, University of Michigan.

Ivar Viehe-Naess, Jr., Armour Institute of Technology.

Edward Hale Fairbank and

Arthur Richard Williams, University of Illinois.

Raymond Edwin Lippenberger, Kansas State Agricultural College.

Curtis Besinger, University of Kansas.

George Viotor Davis, Washington University.

Robert W. Auvinen, University of Minnesota.

Albert C. Martin, University of Southern California.

Wendell Ross Spackman, University of California.

Yoshio Iwanaga, University of Washington.

Richard Nichols Hoar, Alabama Polytechnic Institute.

James Lanier Doom, Georgia School of Technology.

CELEBRATES 10TH ANNIVERSARY

The American Institute of Quantity Surveyors is this year celebrating the Tenth Anniversary of its organization, which took place at Chicago on June 7-8-9, 1926.

To commemorate this event, as well as to provide a means of certifying the character and calibre of surveys prepared by the members of this Institute, a stamp of the Institute seal, in attractive colors, will be issued this year, and hereafter yearly, for the identification of professional surveys.

A program for the establishment of stabilized employment and economic compensation to assure construction analysts, appraisers, estimators, and supervisors a minimum of \$3,000 yearly for 2000 hours, is now being formulated.

ILLUMINATING ENGINEERING SOCIETY CONVENTION

The thirtieth annual convention of the Illuminating Engineering Society will be held at the Hotel Statler, Buffalo, N. Y., August 31 to September 3.

The leading authorities on illumination design, sight conservation and lighting practice will attend, presenting papers of interest to industrial executives, engineers, architects, lighting specialists and all others interested in better illumination of the home, office, industrial plant and outdoor locations.

The new mercury vapor light sources will be dealt with in several excellent papers by leading research scientists.

Modern lighting, particularly in relation to architecture, will be discussed by several authorities in lighting and design fields.

Exhibits of leading manufacturers of lighting equipment will show the latest development in light sources, lighting equipment and lighting practices.

Dr. Halbertsma of the Phillips Company, Holland, will address the convention. Dr. Halbertsma is one of the leading European authorities on lighting.

MELVIN EARL CUMMINGS

Melvin Earl Cummings, internationally known sculptor, died August 21 at St. Luke's Hospital, San Francisco, following a brief illness. He was 59.

Mr. Cummings' genius for design and execution of monuments and portraits spread his fame to many lands.

His contributions to San Francisco art and beauty include the Becker and Rideout fountains in Golden Gate Park; La Sois fountain in Washington Square; the sundial memorial in front of the de Young Memorial Museum; the Ruben Lloyd monument and pool of enchantment memorial in Golden Gate Park, and the entrances to the park at First and Eighth Avenues, San Francisco.

Mr. Cummings served as artist member of the San Francisco Park Commission since 1904. He was also artist life member of the board of trustees of the California Palace of the Legion of Honor.

In 1904 he was appointed professor of modeling at the University of California, a position he held until his death.

Born in Salt Lake City, Cummings studied at the Mark Hopkins Institute of Art in San Francisco, then, in 1900, went to Paris, where he continued his studies under Mercie at l'Ecole des Beaux Arts. After three years he returned to San Francisco, to become professor at the Mark Hopkins Institute.

ARCHITECTS MOVE

W. Asa Hudson has moved his office from 9562 Wilshire Boulevard, Beverly Hills, to 450 N. Beverly Drive, Beverly Hills.

Wilfred B. Verity has moved his offices from suite 612 Pershing Square Building to suite 820 W. M. Garland Building, Los Angeles.

Secretary of the Interior Harold L. Ickes has announced award of the contract for construction of Bartlett Dam on the Verde River in Arizona, to Barrett and Hilp of San Francisco and Macco Corporation of Clearwater, California, on their joint bid of \$2,228,272.

Bartlett Dam will be the highest multiple arch structure in the world. It will serve the Salt River Federal Reclamation Project through storing 200,000 acre-feet of water to supplement the supply of project and Indian lands.

Bartlett Dam will be 270 feet high, 14 feet higher than the Lake Pleasant dam on the Agua Fria River, also in Arizona, which is at present the highest multiple arch dam. Outside the United States the 239-foot Tirsó dam in Italy is the highest of this type of construction.

The successful bid was the lowest of eight received by the Bureau of Reclamation at its office in Phoenix, Arizona.

The dam will have a crest length of 750 feet. It will have ten reinforced concrete arches, supported by nine hollow reinforced concrete buttresses spaced 60 feet apart. It will have a short gravity section at each abutment.

A concrete-lined, open-channel spillway controlled by three 50 by 50-foot gates will be located in the right abutment. The outlet works will pass through one of the arches. Among the principal items of work involved in construction of the dam are the following: 337,000 cubic yards of excavation; placement of 163,000 cubic yards of concrete; installation of 9,200,000 pounds of gates and hoists, valves, trash-tracks, pipes, reinforcement bars and miscellaneous metalwork.

Approximately 6,300 acres of land allocated to Indians on the Salt River Indian Reservation will receive water from the reservoir to be created by Bartlett Dam. Otherwise the water will be used on lands already within the Salt River Project.

STRUCTURAL ENGINEERS MEET

The August meeting of the Structural Engineers Association of Northern California was held at the Engineers' Club, 206 Sansome Street on Tuesday evening, August 4th.

The principal speaker was S. S. Gorman, engineer for the San Francisco-Oakland Bay Bridge Authority who gave an illustrated address on "San Francisco Interurban Terminals and Related Facilities."

\$40,000 ALTERATION WORK

From plans by Henry H. Meyers, 2021 Alameda Avenue, Alameda, work has started on earthquake strengthening of the Livermore Grammar School. The estimated cost is \$40,000.

People who pay rent each month can expect a further rise of approximately 8.9 per cent during the coming year and those living in the middle west will experience the largest increase, one of 9.9 per cent, while the gain in the far western and mountain states should be the smallest, one of 8.1 per cent, according to data obtained by the Mortgage Bankers' Association of America from facts supplied by its members located in 36 states who replied to the organization's fourth poll on various public and business questions. The average increase for the next year in the eastern states will be about 8.8 per cent and in the southern states 9 per cent, George H. Patterson, secretary of the Mortgage Bankers' Association, said in disclosing the results of the survey.

"Our tabulations also show," said Mr. Patterson, "that the average increase in rents of apartments for the country as a whole in 1935 as compared with 1934 amounted to approximately 8.2% as against an average rise of 8.3% in 1934 over 1933. Increases in the four broad geographical sections of the country segregated in making our compilations shows that in 1935, as compared with the previous year, apartment rents gained 8% in the southern states, 5% in the eastern states, 10.40% in the mountain and far western states and 9.5% in the middle western states.

"As to private dwellings, our members estimate that the average increase in rents in this type of housing now over a year ago is about 10.7%, while the gain in 1935 over 1934 was about 7.6%. This fact can be better appreciated when it is stated that every member of our Association without exception pointed out that the lack of single-family homes was becoming a problem in his community. This is undoubtedly the greatest and most important single item in the entire housing problem—a shortage of single-family homes."

The Mortgage Bankers poll also revealed that 98% of the members replying said that families in their communities that had "doubled up" during the depression years were "undoubling" and that this situation alone will create a housing problem in itself because of the fact that so little building has gone on since 1924. Thirteen per cent of the Association's members stated that there was some surplusage of apartment space in their communities, but that it was not large and that it would undoubtedly be taken up in the very near future. The remainder stated that apartments were "well-filled". Ninety-five per cent of the replying members said that no more office space was required in their communities at the present time, indicating, Mr. Patterson said, that no important amount of new construction in this field can be expected for some time.

"Our query to members as to when a housing shortage might be expected brought many varied answers, some setting the date as the fall of 1937-38, others in 1939, and some as five years away. The most

significant fact revealed in our poll, however, was the almost unanimous belief among the members that most single-family houses are needed all over the country. A member in New York said that city needed from 10,000 to 15,000 new houses, and two members in Salt Lake City declared that between 500 and 600 houses were needed there, with 3000 over the next three years. Tulsa needs 150, and the outlook in Cleveland is for 20,000 units within the next few years. An Omaha member estimated that city's needs as 4500. Three hundred is indicated for Duluth and the same number for Des Moines. Ft. Wayne, said a member there, needs 1000 new houses, and Rockford, Illinois, 300. New Orleans needs at least 1000 new houses, Charlotte, N. C., 250, Atlanta, 2000, and Birmingham, 1000.

"The composite opinion of our members is to the effect that the United States is rapidly entering into the greatest phase of real estate activity and new construction it has ever seen, and on the most favorable terms from the construction, financial and labor viewpoints."

LIGHT BECOMES ARCHITECTURAL

Light is becoming architectural, functional and scientific as well as decorative. As soon as scientists, engineers, architects and decorators began asking themselves if light couldn't be measured and adjusted to its uses, they conceived the idea of building light right into the house just as doors and windows are.

No longer does room lighting come only from an obvious source, such as a chandelier, lamp or bracket. It may be spilled from a cornice or from behind glass panels or mirrors. Each light introduced into a room is placed with a definite purpose to which it is exactly suited. The placement is not haphazard and the quantity of illumination is scientifically calculated for every occasion.

The general illumination of a room is the first thing to be considered. When that has been decided upon, the local or directed light for reading, sewing and other particular tasks is chosen. Decorative lighting, such as projector lights which will outline specific objects on special occasions, can be considered when the final plans are made.

General illumination often comes from panels of glass which are built into the ceiling. These may be rectangular strips or ovals of opal glass set flush. Cylinders of glass fastened together with chromium bands, shed diversified light in long hallways. Floor lamps with indirect lighting systems, are still another method.

Cove lighting is used in many new houses. In this architectural lighting arrangement bulbs, which are concealed in a recess in the ceiling, throw the light against the adjoining wall from which it is diffused through the room. Dressing table alcoves often are

lighted from behind panels of frosted glass which are built at either side of the mirror. To achieve a soft glow in any room, tubular wall lights of metal and glass are used.

For specific lighting there are cylindrical lights with chromium shades which may be installed above desks, stoves, beds or dressing mirrors. Cove lighting can be used in the library bookshelves. It not only brings out the titles of the books but makes them a decorative feature at night as well as in the daytime.

The secret behind the projector light, used to illuminate many famous paintings and statues in museums, is an inner stencil of the object to be outlined with light. This is made by taking a photograph of the particular object through the lens to be used on the projector light and from the spot where it is to be placed. A cutout is made from this picture and placed within the light so that the rays, passing through the outline, are directed in that pattern.

The dining room table is one spot where the projector light may be used to advantage. One of these stenciled lights illuminates the table top but spills no farther. Diners are left in the comfortable glow of the general room lighting, just outside the projected rays. Famous paintings in hall or living room also may be accented with this type of illumination.—Bulletin, Michigan Society of Architects.

AMERICAN ARCHITECT FOR ENGLAND

Mario Corbett, San Mateo architect residing at the Benjamin Franklin Hotel, is preparing preliminary plans for an Andalusian farm house in the Cornwall country, England. The residence will be erected for Colonel Truman of London and South Africa.

Colonel Truman, who has lived many years in the Moorish atmosphere of Southern Spain and Africa, believes that California architects have created the finest designs of this style in the modern manner. The buildings will be of native stone, plastered to resemble adobe, with tiles imported from Spain. They will be equipped with American plumbing and heating facilities.

SANTA CRUZ COURT HOUSE

Albert F. Roller, architect of San Francisco, has been commissioned to prepare plans at once for the first unit of a \$500,000 group of county buildings at Santa Cruz. The first building will house the sheriff's quarters and jail. The unit will be of reinforced concrete, three stories and basement and will cost \$180,000. Construction will start in 90 days.

PUBLIC UTILITY BUILDING

A \$40,000 public utility building for Santa Cruz has been designed by Alben Froberg, architect, 1955 Webster Street, Oakland, who has also made plans for a service station for J. J. McElroy of Oakland.

Estimator's Guide

Giving Cost of Building Materials, Wage Scale, Etc.

Amounts given are figuring prices and are made up from average quotations furnished by material houses to San Francisco contractors. 3% Sales Tax on all materials but not labor.

All prices and wages quoted are for San Francisco and the Bay District. There may be slight fluctuation of prices in the interior and southern part of the state. Freight cartage, at least, must be added in figuring country work.

Bond—1½% amount of contract.

Brickwork—

Common, \$35 to \$40 per 1000 laid, (according to class of work).

Face, \$75 to \$90 per 1000 laid, (according to class of work).

Brick Steps, using pressed brick, \$1.10 lin. ft.

Brick Walls, using pressed brick on edge, 60c sq. ft. (Foundations extra.)

Brick Veneer on frame buildings, \$.75 sq. ft.

Common f.o.b. cars, \$12.00 job cartage. Face, f.o.b. cars, \$45.00 to \$50.00 per 1000, carload lots.

HOLLOW TILE FIREPROOFING (f.o.b. job)

3x12x12 in.	\$ 84.00 per M
4x12x12 in.	94.50 per M
6x12x12 in.	126.00 per M
8x12x12 in.	225.00 per M

HOLLOW BUILDING TILE (f.o.b. job)

carload lots.	
8x12x5½"	\$ 94.50
6x12x5½"	73.50

Discount 5%.

Composition Floors—18c to 35c per sq. ft.

In large quantities, 16c per sq. ft. laid.

Mosaic Floors—80c per sq. ft.

Duraflex Floor—23c to 30c sq. ft.

Rubber Tile—50c per sq. ft.

Terazzo Floors—45c to 60c per sq. ft.

Terazzo Steps—\$1.60 lin. ft.

Concrete Work (material at San Francisco bunkers)—Quotations below 2000 lbs. to the ton. \$2.00 delivered.

No. 3 rock, at bunkers.....	\$1.80 per ton
No. 4 rock, at bunkers.....	1.75 per ton
Elliott top gravel, at bunkers.....	2.10 per ton
Washed gravel, at bunkers.....	2.10 per ton
Elliott top gravel, at bunkers.....	2.10 per ton
City gravel, at bunkers.....	1.75 per ton
River sand, at bunkers.....	1.80 per ton
Delivered bank sand.....	1.20 cu. yd.

Note—Above prices are subject to discount of 10c per ton on invoices paid on or before the 15th of month, following delivery.

SAND

Del Monte, \$1.75 to \$3.00 per ton.
Fen Shell Beach (car lots, f.o.b. Lake Majoella), \$2.75 to \$4.00 per ton.

Cement, 2.50 per bbl. in paper sks.
Cement (f.o.b. Job, S. F.) \$3.00 per bbl.
Cement (f.o.b. Job, Oak.) \$3.00 per bbl.
Rebate of 10 cents bbl. cash in 15 days.
Calaveras White\$6.00 per bbl.
Medusa White\$8.00 per bbl.
Forms, Labors average \$40.00 per M.

Average cost of concrete in place, exclusive of forms, 35c per cu. ft.
4-inch concrete basement floor12½c to 14c per sq. ft.
4½ inch Concrete Basement floor.....14½c to 16c per sq. ft.
2-inch rat-proofing7½c per sq. ft.
Concrete Steps\$1.50 per lin. ft.

Dampproofing and Waterproofing—

Two-coat work, 15c per yard.
Membrane waterproofing—4 layers of saturated felt, \$4.00 per square.
Hot coating work, \$1.80 per square.
Medusa Waterproofing, 15c per lb., San Francisco Warehouse.

Electric Wiring—\$12.00 to \$15.00 per outlet for conduit work (including switches).
Knob and tube average \$7.00 per outlet, including switches.

Elevators—

Prices vary according to capacity, speed and type. Consult elevator companies.
Average cost of installing an automatic elevator in four-story building, \$2800; direct automatic, about \$2700.

Excavation—

Sand, 50 cents; clay or shale, 80c per yard.
Teams, \$12.00 per day.
Trucks, \$20 to \$25 per day.
Above figures are an average without water. Steam shovel work in large quantities, less; hard material, such as rock, will run considerably more.

Fire Escapes—

Ten-foot balcony, with stairs, \$85.00 per balcony, average.

Glass (consult with manufacturers)—

Double strength window glass, 15c per square foot.
Quartz Lite, 50c per square foot.
Plate 75c per square foot.
Art, \$1.00 up per square foot.
Wire (for skylights), 35c per sq. foot
Obscure glass, 26c square foot.
Note—Add extra for setting

Heating—

Average, \$1.90 per sq. ft. of radiation, according to conditions.

Iron—Cost of ornamental iron, cast iron, etc., depends on designs.

Lumber (prices delivered to bldg. site).

No. 1 common.....	\$34.00 per M
No. 2 common.....	29.00 per M
Selection O. P. common.....	39.00 per M
2x4 No. 3 form lumber.....	24.00 per M
1x4 No. 2 flooring VG.....	60.00 per M
1x4 No. 3 flooring VG.....	50.00 per M
1x6 No. 2 flooring VG.....	60.00 per M
1½x4 and 6, No. 2 flooring.....	65.00 per M

Slash grain—

1x4 No. 2 flooring.....	\$48.00 per M
1x4 No. 3 flooring.....	40.00 per M
No. 1 common run T. & G.....	33.00 per M
Lath.....	7.00 per M

Shingles (add cartage to price quoted)—

Redwood, No. 1.....	\$1.10 per bdle.
Redwood, No. 2.....	.90 per bdle.
Red Cedar.....	1.00 per bdle.

Hardwood Flooring (delivered to building)—

13-16x3¼" T & G Maple.....	\$120.00 M ft
1-1½x2¼" T & G Maple.....	132.00 M ft
7½x3½ sq. edge Maple.....	140.00 M ft
13-16x2¼" T & G Sq. Ed.	5-16x2"
Clr. Old. Oak.....	\$200.00 M \$150.00 M \$180 M
Sel. Old. Oak.....	140.00 M 120.00 M 135 M
Clr. Pla. Oak.....	135.00 M 107.00 M 120 M
Sel. Pla. Oak.....	120.00 M 88.00 M 107 M
Clear Maple.....	140.00 M 100.00 M
Laying & Finishing.....	15c ft. 11 ft. 10 ft.

Wage—Floor layers, \$7.50 per day.

Building Paper—

1 ply per 1000 ft. roll.....	\$3.50
2 ply per 1000 ft. roll.....	5.00
3 ply per 1000 ft. roll.....	6.25
Brownskin, 500 ft. roll.....	5.00
Brownskin Protect-o-mat, 1000 ft. roll.....	10.00
Sisalcraft, 500 ft. roll.....	5.00
Sash cord com. No. 7.....	\$1.20 per 100 ft.
Sash cord com. No. 8.....	1.50 per 100 ft.
Sash cord spot No. 7.....	1.90 per 100 ft.
Sash cord spot No. 8.....	2.25 per 100 ft.
Sash weights cast iron, \$50.00 ton.	
Nails, \$3.50 base.	
Sash weights, \$45 per ton.	

Millwork—

O. P. \$100.00 per 1000. R. W., \$106.00 per 1000 (delivered).
Double hung box window frames, average, with trim, \$6.50 and up, each.
Doors, including trim (single panel, 1¾ in. Oregon pine) \$8.00 and up, each.
Doors, including trim (five panel, 1¾ in. Oregon pine) \$6.50 each.
Screen doors, \$4.00 each.
Patent screen windows, 25c a sq. ft.
Cases for kitchen pantries seven ft. high, per lineal ft., \$6.50 each.
Dining room cases, \$7.00 per lineal foot.
Labor—Rough carpentry, warehouse heavy framing (average), \$14.00 per M.
For smaller work average, \$32.50 to \$40.00 per 1000.

Marble—(See Dealers)

Painting—

Two-coat work	29c per yard
Three-coat work	40c per yard
Cold Water Painting	10c per yard
Whitewashing	4c per yard
Turpentine, 80c per gal., in cans and 75c per lb. in drums.	
Raw Linseed Oil—80c gal. in bbls.	
Boiled Linseed Oil—85c gal. in bbls.	
Medusa Portland Cement Paint, 20c per lb.	

Carrier or Dutch Boy White Lead in Oil (in steel kegs).

1 ton lots, 100 lbs. net weight.....	10 $\frac{3}{4}$ c
500 lbs. and less than 1 ton lots.....	11c
Less than 500 lb. lots	11 $\frac{1}{2}$ c

Dutch Boy Dry Red Lead and Litharge (in steel kegs).

1 ton lots, 100 lb. kegs, net wt.....	10 $\frac{3}{4}$ c
500 lb. and less than 1 ton lots.....	11c
Less than 500 lb. lots	11 $\frac{1}{2}$ c

Red Lead in Oil (in steel kegs)

1 ton lots, 100 lb. kegs, net. wt. 12 $\frac{1}{2}$ c	
500 lb. and less than 1 ton lots 12 $\frac{1}{2}$ c	
Less than 500 lb. lots	13c

Note—Accessibility and conditions cause wide variance of costs.

Patent Chimneys—

6-inch	\$1.00 lineal foot
8-inch	1.50 lineal foot
10-inch	1.75 lineal foot
12-inch	2.00 lineal foot

Plastering—Interior—

1 coat, brown mortar only, wood lath.....	Yard \$0.65
2 coats, lime mortar hard finish, wood lath ..	.75

2 coats, hard well plaster, wood lath.....	\$.80
3 coats, metal lath and plaster	1.25
Keene cement on metal lath	1.30
Ceilings with $\frac{3}{4}$ hot roll channels metal lath ..	1.50
Ceilings with $\frac{3}{4}$ hot roll channels metal lath plastered75
Single partition $\frac{3}{4}$ channel lath 1 side.....	.85
Single partition $\frac{3}{4}$ channel lath 2 sides 2 inches thick	2.75
4-inch double partition $\frac{3}{4}$ channel lath 2 sides	1.30
4-inch double partition $\frac{3}{4}$ channel lath 2 sides plastered	3.00

Plastering—Exterior—

2 coats cement finish, brick or concrete wall	Yard \$1.10
2 coats Celaveras cement, brick or concrete wall	1.35
3 coats cement finish, No. 18 gauge wire mesh	1.50
3 coats Celaveras finish, No. 18 gauge wire mesh	2.00
Wood lath, \$6.00 per 1000.	
2.5-lb. metal lath (dipped)17
2.5-lb. metal lath (galvanized)20
3.4-lb. metal lath (dipped)22
3.4-lb. metal lath (galvanized)28
$\frac{3}{4}$ -inch hot roll channels, \$72 per ton.	
Finish plaster, \$18.90 ton; in paper sacks.	
Dealer's commission, \$1.00 off above quotations. (\$13.85 rebate 10c sack).	
Lime, f.o.b. warehouse, \$2.25 bbl.; cars, \$2.15 lbf., bulk (ton 2000 lbs.), \$16.00 ton.	
Wall Board 5 ply, \$50.00 per M.	
Hydrate Lime, \$19.50 ton.	
Plasterers Wage Scale	\$1.25 per hour
Lathers Wage Scale	1.25 per hour
and Carriers Wage Scale	1.10 per hour
Composition Stucco—\$1.60 to \$2.00 sq. yard (applied).	

Plumbing—

From \$65.00 per fixture up, according to grade, quantity and runs.

Roofing—

"Standard" tar and gravel, \$6.00 per sq. for 30 sqs. or over.
Less than 30 sqs. \$6.50 per sq.
Tile, \$20.00 to \$35.00 per square.

Redwood Shingles, \$11.00 per square in place.
Cedar Shingles, \$10 sq. in place.
Recoat, with Gravel, \$3.00 per sq.
Asbestos Shingles, \$15 to \$25 per sq. laid.
Slate, from \$25.00 to \$60.00 per sq. laid according to color and thickness.

Sheet Metal—

Windows—Metal, \$2.00 a sq. foot.
Fire doors (average), including hardware, \$2.00 per sq. ft.

Skylights—

Copper, 90c sq. ft. (not glazed).
Galvanized iron, 25c sq. ft. (not glazed).

Steel—Structural

\$100 ton (erected), this quotation is an average for comparatively small quantities. Light truss work higher. Plain beams and column work in large quantities \$80 to \$90 per ton cost of steel; average building, \$89.00.

Steel Reinforcing—

\$90.00 per ton, set. (average).

Stone—

Granite, average, \$6.50 cu. foot in place.
Sandstone, average Blue, \$4.00, Boise, \$3.00 sq. ft. in place.
Indiana Limestone, \$2.80 per sq. ft. in place.

Store Fronts—

Copper sash bars for store fronts, corner, center and around sides, will average 75c per lineal foot.
Note—Consult with agents.

Tile—Floor, Wainscot, Etc.—(See Dealers).

Asphalt Tile—18c to 28c per sq. ft. installed.

SAN FRANCISCO BUILDING TRADES WAGE SCALE

Recommended by the Impartial Wage Board, June 18, 1936. Effective July 1, 1936

This scale is based on an eight-hour day and is to be considered as a minimum and employees of superior skill and craft knowledge may be paid in excess of the amounts set forth herein. This scale applies only to work on buildings and does not include inside or shop workers.

CRAFT	Journeymen Mechanics
Asbestos Workers	\$ 8.00
Bricklayers	12.00
Bricklayers' Hodcarriers	8.00
Cabinet Workers (Outside)	9.00
Carpenters	9.00
Cement Finishers	9.00
Cork Insulation Workers	9.00
Electrical Workers	10.00
Electrical Fixture Hangers	8.00
Elevator Constructors	10.40
Engineers, Portable and Hoisting	9.00
Glass Workers (all classifications)	8.50
Hardwood Floormen	9.00
Housesmiths, Architectural Iron (outside)	9.00
Housesmiths, Reinforced Concrete, or Rodmen	9.00
Iron Workers (Bridge and Structural)	11.00
Iron Workers (Hoisting Engineers)	11.00

CRAFT	Journeymen Mechanics
Laborers (six-day week)	\$ 5.50
Lathers, Channel Iron	9.00
Lathers, all others	9.00
Marble Setters	10.00
Millwrights	9.00
Masons and Terrazzo Workers (outside)	9.00
Painters	9.00
Painters, Varnishers and Polishers (outside)	9.00
Pile Drivers and Wharf Builders	9.00
Pile Drivers Engineers	10.00
Plasterers	12.00
Plasterers' Hodcarriers	8.00
Plumbers	10.00
Roofers (all classifications)	8.00
Sheet Metal Workers	9.00
Steam Fitters	10.00
Stair Builders	9.00

CRAFT	Journeymen Mechanics
Stone Cutters, Soft and Granite	9.00
Stone Setters, Soft and Granite	12.00
Stone Erectors	9.00
Tile Setters	10.00
Tile, Cork and Rubber	9.00
Welders, Structural Steel Frame on Buildings	11.00
Welders, All Others on Buildings	9.00
Dump Truck Drivers, 2 yards or less	6.00
Dump Truck Drivers, 3 yards	6.50
Dump Truck Drivers, 4 yards	7.00
Dump Truck Drivers, 5 yards	7.00
Dump Truck Drivers, 6 yards	7.50
Truck Drivers of Concrete Mixer Trucks:	
2 yards or less	6.50
3 yards	7.00
4 yards	7.50
5 yards	7.50
6 yards	8.00

GENERAL WORKING CONDITIONS

- Eight hours should constitute a day's work for all crafts, except as otherwise noted.
- Where less than eight hours are worked pro rata rates for such shorter period should be paid.
- Plasterers' Hodcarriers, Bricklayers' Hodcarriers, Roofers' Laborers and Engineers, Portable and Hoisting, shall start 15 minutes before other workmen, both at morning end at noon.
- Five days, consisting of not more than eight hours a day, on Monday to Friday, inclusive, should constitute a week's work, except for building laborers.
- The wages set forth herein should be considered as net wages.
- Except as noted the above rates of pay apply only to work performed at the job site.
- Transportation costs except for intra-city fares should be paid by contractor.

- Traveling time in excess of one hour each way should be paid for at straight time rates.
- Overtime should be paid as follows: For the first four hours after the first eight hours, time and one-half. All time thereafter should be paid double time, Saturdays (except for Laborers), Sundays and Holidays from 12 midnight of the preceding day, should be paid double time. Irrespective of starting time, overtime for Cement Finishers should not commence until after eight hours of work, except that after 12 midnight overtime for cement finishers should be paid at the rate of time and one-half for the first four hours and double time thereafter. Shift work for cement workers should be subject to the provisions of paragraph 11.
- On Saturday Laborers should be paid straight time up to eight hours. Overtime rates should be paid as specified in paragraph 9.
- Where two shifts are worked in any twenty-four hours, shift time should be straight time. Where three shifts are worked, eight hours' pay should be paid for seven hours on the second and third shifts.

- All work, except as noted in paragraph 13, should be performed between the hours of 8 A. M. and 5 P. M.
- In emergencies, or where premises cannot be vacated until the close of business, men then reporting for work should work at straight time. Any work performed on such jobs after midnight should be paid time and one-half up to four hours of overtime and double time thereafter.
- Recognized holidays to be: New Year's Day, Decoration Day, Fourth of July, Labor Day, Admission Day, Thanksgiving Day, Christmas Day.
- Men ordered to report for work, for whom no employment is provided should be entitled to two hours' pay.
- This award should be effective in the City and County of San Francisco.

HOT WATER HEATING—GAS FUEL

Successful heating with hot water as the circulating medium and gas fuel as the heat source, carried to the point of complete efficiency and satisfaction, has for many years been the dream and vision of the heating industry. Countless experiments and speculations have been devoted to hot water heating theory, and several types of equipment have been manufactured and used for its application.

Radiation of heat by circulating hot water through the house has long been regarded by heating experts as the ultimate and logical method of heating. The advantages are obvious to anyone familiar with heating practice—absolute cleanliness; entire use of heat energy through eliminating heat losses due to flues or steam condensation; smaller and more compact equipment; and finally, the greatly reduced cost, both of purchase and operation.

However, with most of the hot water systems which have been in use, the principal difficulty has been in the large volumes of water requiring heat for circulation. At least thirty gallons has been the minimum, necessitating approximately 45,000 B.t.u.'s to raise this quantity to a temperature sufficient to heat a home. Also, the length of time necessary to heat this volume of water has been unfavorable.

That these obstacles have now been overcome, and that hot water heating in its full development is now available for general use, is current news for the architectural, building and heating trades. It has recently been presented in the form of a compact unit designed to provide both domestic space heating and water heating from the same source. The unit may be installed anywhere in the house, and requires no basement.

Compared with the thirty gallon minimum required by previous hot water systems, this new system uses only one and a half gallons of water to heat a home, and only 2,400 B.t.u.'s of heat input are required to bring this water to the proper heating temperature. Instead of the normal steam delivery of 240 B.t.u.'s per square foot, this system delivers up to 280 B.t.u.'s for each square foot of radiation. Whereas a large gallonage means a lengthy wait at each starting cycle, the new heater performs this operation instantaneously. The water content of one and a half gallons speeds through a closed system of small copper tubing and delivers its heat to the rooms of a home through the medium of concealed copper convactor radiation which is installed in the walls of the building.

It can easily be seen that this type of heating is simply the most logical adjunct to the automatic gas water heater. As in other kinds of heating, including warm air and steam, where the greatest satisfaction is desired, gas fuel is used because of its controllability, cleanliness and low cost.

The principles involved in the new system have proved both simple and sound, and are fully approved

by such authorities as the American Gas Association. The unit is applicable to heating and water heating requirements in any climate. It lends itself readily to air conditioning and may be so arranged that through the centralizing of convectors, warm air is emitted into each and every room. In summer these same convectors may be employed as cooling coils and through the air conditioning system reduce the room temperatures to the point desired.

Through this new development, engineering science has brought house heating and water heating to a new high point of simplicity, high efficiency and economy.

BUILDING IN BAY AREA IMPROVES

A rise of 163 per cent in San Francisco building construction in June as compared with the same month in 1935, is announced by the Bureau of Labor Statistics. In Oakland, however, the volume dropped more than 25 per cent in June but picked up materially in July.

The San Francisco rise was part of a national trend, found in eight out of nine geographical districts, that sent the volume of construction last June zooming to a level 97 per cent higher than in June, 1935.

In June of last year there were issued 325 permits in San Francisco, calling for construction estimated at \$486,178. Last month the number of permits issued was 524, the bureau announced, and the estimated value of buildings covered was \$1,278,184. The latter figure was subdivided as follows: Residential buildings, 161 permits, \$775,111; nonresidential, 27 permits, \$192,356; alterations, additions and repairs to existing structures, 336 permits, \$310,717.

In Oakland there were issued 491 permits last month totaling \$1,900,056, of which 73 covered nonresidential construction amounting to \$1,213,371, and 67 residential construction totaling \$287,966. In June of last year Oakland permits numbered 300 and totaled \$2,691,577.

One hundred and forty cities and towns in the Pacific States, the bureau stated, reported \$18,738,778 in building construction last month, as compared with \$18,026,127 in June, 1935.

OREGON CAPITOL PLANS

Oregon's new \$2,200,000 State Capitol at Salem will be erected under a single general contract, the Capitol Commission deciding that centralization of responsibility for the project would simplify supervision and probably reduce construction costs. Plans are being completed on a schedule which will permit advertising for bids within about 40 days. The building is being designed by Architects Goodhue Livingston of New York, and Whitehouse & Church, associates, of Portland.

HOBSON'S CHOICE

There is no alternative, buildings **MUST** be artificially lighted.

Somebody is going to light the buildings you design, and that lighting can be friend or foe to the effect you wish to produce.

Lighting left to others or added as an afterthought may ruin the most perfect architectural effect, while lighting planned as an integral part of the structure will bring out lines and textures, tones and colors.

Lighting **CAN** be practical as well as aesthetically effective, but the combination doesn't just happen—it requires careful planning.

In planning, you have many things to consider. We are concerned only with the electrical service of which lighting is a part. We will be glad to check or help plan the details to assure the effect you want.

PACIFIC COAST ELECTRICAL BUREAU

447 Sutter Street
SAN FRANCISCO

601 W. 5th Street
LOS ANGELES

MUCH BUILDING AHEAD

The "New Deal" is ready to swing into the second phase of its big new work-relief program—distributing \$300,000,000 throughout the country to spur a \$650,000,000 public improvement construction program.

The building drive, directed by Harold L. Ickes, Public Works Administration, will back up the Works Progress Administration's \$1,425,000,000 worth of quick job-making projects.

It will be some time before Ickes can release all of the \$300,000,000. Money for the Federal gifts will be available only as the Reconstruction Finance Corporation sells the municipal bonds PWA took as security for past project loans.

The initial allotment list was expected, however, to be around \$100,000,000.

Ickes has determined to make his part of the program move as rapidly as possible to create jobs and send millions coursing to heavy industries through purchases of steel, cement, bricks and lumber.

PWA officials revealed that about 2000 projects, some in every State, have been approved. They will be announced as fast as stenographers can list them on typewritten stencils and mimeograph operators reproduce them.

A sizeable number of municipal power plant applications were reported on Ickes' approval list—the New Deal's notice to the private utility interests that it will not abandon its campaign for decreased electricity rates.

Coupled with the \$50,000,000 he had still unallocated from past programs, Ickes has mapped a new \$300,000,000 building campaign. He estimated it would produce some \$650,000,000 in construction because project applicants will more than match Federal contributions.

INTERNATIONAL STEEL CONFERENCE

The fifth International Conference on Steel Construction will be held in Berlin October 2, 5 and 7 next. This is an organization composed of the various national steel associations. The American Institute of Steel Construction, Inc., is the member from the United States.

On October 2, there will be several papers on "The Influence of the Recent Progress of Science and Technique in the Use of Steel."

On October 5, will be a discussion on "The Use of Steel in the Construction of Protected Areas from Air Raids" and a discussion on "The Relations between the Architect, Engineer and Contractor in the Various Member Countries."

On October 7, will be a review of the European specifications for the use of steel in buildings. The standard specification of the American Institute of Steel Construction which was this year raised to 20,000 pounds unit stress, is just being brought into conformity with the specification that has already been in use in European countries for some time.

BUILDING REVAMPS ELEVATORS TO MEET TRAFFIC DEMANDS

To meet the increasing demand of elevator traffic, owners of the 15-story Merchants Exchange Building, San Francisco, have completed arrangements to replace existing hydraulic lifts with six ultra modern electric Westinghouse passenger elevators.

The Merchants Exchange Building, designed by the late D. H. Burnham and Willis Polk, is one of the best known office structures on the Coast. It has a total rentable area above the ground of approximately 137,000 square feet and includes among its tenants the Chamber of Commerce and the Commercial Club of San Francisco. The latter occupies the entire 13th and 14th floors and has an average daily luncheon attendance of 300 which often, on special occasions, runs up to 1,000 or 1,500. Naturally this rush overloads existing elevator service, since the 15 minute peak demand sometimes reaches a total of 600 in one direction and 275 in the other. For this and other reasons, the six old hydraulic elevators are being replaced with new equipment under the direction of Bliss and Fairweather, architects. The contract recently awarded to the Westinghouse Electric Elevator Company calls for completion of the work in two sections; three of the elevators are to be changed over between September and December of this year and the other three between January and April, 1937.

The new electric elevators will consist of six 800 FPM passenger cars running from the basement to the 15th floor. These new full automatic control elevators will represent the last word in today's vertical transportation and will be provided with Westinghouse instant signals and quota control so as to better cope with the severe "down" peaks mentioned above. Each car will have solid car and hatch doors running on silent gearless hangers and controlled by electric power operators. The openings will be protected by the Westinghouse Safe-T-Ray.

The equipment for each car will also include a call indicator for night service, an electric car position indicator, dispatching lights and a complete intercommunicating telephone system, together with Westinghouse cable equalizers and inertia type guide rail lubricators. Up and down lanterns with single stroke bells will also be provided in the corridors of the intermediate floors.

In the lobby of the ground floor there will be installed a starter's station with starter's call back, a convertible quota dispatcher and a panel position and motion indicator with telltale annunciator, all so grouped as to give the starter immediate and accurate information concerning any abnormal traffic peaks and to provide, if necessary, instant and easy adjustment of the automatic dispatcher to effectively meet these conditions.

Achievement

EVERY INDUSTRY strives to achieve a worth while position...to make the most dependable products...to render surpassing service and build enduring goodwill among its customers. That these objectives have been achieved by General Paint Corporation is attested by our thousands of satisfied customers *everywhere*. The prudent architect will specify GENERAL paints...the paints without a competitor.



Engineers are invited to send for our new brochure "PIPE PROTECTION" just off the press. A request on your letterhead will bring you a copy.

GENERAL PAINT
CORPORATION

San Francisco • Los Angeles • Oakland
Portland • Seattle • Spokane • Tulsa
Honolulu • Manila, P. I.

BIG in **VALUE** and **PRODUCTION**
LOW in **COST** and **OPERATING EXPENSE**



The Oil Burning
JOHNSON

"LADDI" DU-ALL

Boiler Burner Unit furnishes either heat, domestic hot water or both at new records in low costs!

For homes of from 4 to 9 rooms.

Fully Automatic

Burns Low Cost Diesel Fuel Oil

3 sizes, 4½, 5, and 5½ feet in height, each 24 inches in diameter

Phone or write for full details

JOHNSON
OIL BURNERS

S. T. JOHNSON
Since 1904
ARLINGTON AVENUE,
OAKLAND

Architects . . .

S a f e g u a r d
y o u r b u i l d i n g s
a g a i n s t d e c a y
o r t e r m i t e
a t t a c k b y
s p e c i f y i n g

**WOLMANIZED or CREOSOTED
LUMBER and TIMBER**

E. K. WOOD LUMBER CO.

*"Goods of the Woods" is your guarantee for
Quality and Service*

NO. 1 DRUMM ST., SAN FRANCISCO
LOS ANGELES OAKLAND

**BUILD
WELL~**

A PROPERLY designed and well constructed building is a credit to any city and a profitable investment for its owner.

Such structures are the STANDARD OIL BUILDING, MATSON BUILDING, FOUR-FIFTY SUTTER STREET, STOCK EXCHANGE, S. F. BASE BALL PARK, MILLS TOWER, OPERA HOUSE and VETERANS' MEMORIAL, San Francisco, OLYMPIC CLUB ALTERATIONS, SANTA ANITA RACING PLANT and other notable structures — all built or supervised by —

Lindgren & Swinerton, Inc.

Standard Oil Building 605 W. Tenth Street
San Francisco Los Angeles
We Maintain a Termite Control Department

NEW RULES FOR CALIFORNIA CONTRACTORS

Moving to tighten the requirements as to character and competency of applicants for state contractors licenses in California, the State Contractors' License Board at a meeting in San Francisco, July 24, adopted new rules which will hereafter govern the issuance of licenses by the registrar of contractors. These rules require:

1—Applications to be attested by a notary.

2—Applicants to have as sponsors (a) Architects, civil or structural engineers or licensed contractors; (b) owners for whom they have acted as contractor, superintendent or foreman; (c) building supply firms; and (d) banks. For an individual contractor 7 sponsors are required, for each member of a co-partnership 4, and for each principal officer of a corporation 4.

3—Oral examination if registrar is not satisfied with information contained in application.

It is also provided in the rules that inspectors may file original complaints of violations of the law with the registrar after investigation; must report violations of state workmen's compensation act and will advise applicants in procedure for filing applications. All complaints against licensed contractors must be in writing, state facts which are claimed to be a violation of the law and inspectors must present all information obtained impartially at the hearing.

Registrar Earl Anderson advised the board the rules had been approved by the state attorney general's office and that they were as stringent as they could be made under the present law. Further amendments to the law will be sought by the board at the next session of the Legislature permitting amplification of the rules to determine competency of applicants, it was indicated.

Registrar Anderson reported that 21,600 licenses had been renewed for the fiscal year beginning July 1, 1936, and that 950 new licenses had been issued. About 48 per cent of the contractors reported they had compensation insurance in effect, about 40 per cent reported they were not carrying insurance because they had no employees to cover, while 12 per cent made no report on insurance. A complete check of operations of contractors not reporting insurance will be made to determine if they are complying with the law.

Roy M. Butcher of San Jose, was elected chairman of the state board for the ensuing year and Ralph E. Homann of Los Angeles, was re-elected vice-president. W. A. Bechtel, Jr., engineering contractor member, notified the board he had submitted his resignation to the governor because private business would not allow time for his duties as a member. Vice-president Homann presided at the meeting in the absence of Mr. Bechtel. Other members present were: Roy M. Butcher, San Jose; S. G. Robinson, Oakland; William Nies, Los Angeles and Stephen L. Ford, Long Beach.

PROTECTIVE LINING FOR PIPE INTERIOR

The art of applying protective coatings to the outside of pipes has been known for many years. The mechanical application of hot or cold bituminous enamels to the interior surfaces of pipes is a recent development.

The inside coating is heated to a given temperature in thermostatically controlled, mechanically agitated kettles. It passes through an electrically heated feed line to the point of application inside the pipe. A weir, or container, also electrically heated is attached to the feed line and the hot coating material is stored in this container until the lining process is ready to begin. The hot coating then flows out through a valve, overflowing a heated apron which carries it to the inside wall of the pipe. The pipe is then revolved, the coating being applied automatically as the weir and feed pipe are withdrawn with a slow spiral motion, the speed of withdrawal being governed by the inside diameter of the pipe.

The rate of withdrawal is also governed by the length of the weir and apron. If the weir and apron are 24 inches long, the rate of withdrawal is 12 inches per revolution. Thus with each revolution a 24 inch width of coating is applied, but since the weir is withdrawn only 12 inches the next revolution applies a second coat over the first—in shingle fashion. The double application at the pipe ends is accomplished by revolving the pipe at the beginning and end of the operation, two complete revolutions without moving the weir and apron.

ORIGIN OF NAMES OF CALIFORNIA COUNTIES

This is the tenth article in the series giving derivation of the names of California counties:

SANTA CLARA COUNTY—Created February 18, 1850. One of the original twenty-seven counties. On January 12, 1777, Mission Santa Clara was established, and named for Saint Clara of Assissi, Italy, the first Franciscan nun and founder of the Order of Saint Clara. Her name "Clara" means "clear" or "bright," and according to the Roman Book of Martyrs, as Hortalana, the pious mother of this nun, was once kneeling before a crucifix, praying earnestly, that she might be happily delivered of her unborn babe, she heard a voice whispering, "Fear not, woman, thou wilt safely bring forth;" whereupon a brilliant light suddenly illumined the place, and the mother, inspired by the mysterious prediction, baptized her child Clara, which is the feminine of the word meaning clear or bright. Clara afterwards was sanctified on account of her many eminent virtues, and accordingly venerated by the Catholics in all Roman Catholic churches, and canonized under the name Saint Clara. The Franciscan padres de La Pena and Murguia founded the Mission Santa Clara and it was from this mission the county derived its name.

For Western INDUSTRY



CROCKER FIRST NATIONAL BANK OF SAN FRANCISCO

Member Federal Deposit Insurance Corporation

WOLMANIZED LUMBER

**WHERE THERE IS
A CHANCE OF DECAY
OR TERMITE ATTACK . . .**

Insures freedom from the destructive action of rot, and the weakening tunnels of wood-eating insects. Thirty years of service prove its efficiency. Specify Genuine WOLMANIZED LUMBER.



AMERICAN LUMBER & TREATING CO.
37 West Van Buren St.
CHICAGO, ILL.

San Francisco Sales Office
116 New Montgomery St.
Phone SUtter 1225

Los Angeles Sales Office
1031 South Broadway
Phone PRospect 5558



**FASTER, MORE ECONOMICAL
WARM AIR DELIVERY**

Here is a furnace that delivers warm air in any desired quantity. Where winter heating and air conditioning comfort, at its best, is desired, select a Pacific Everlast Gas Furnace—built to last a lifetime.

PACIFIC GAS RADIATOR CO.

HUNTINGTON PARK, CALIF., U. S. A.



Write for
Catalog No. AE-8

APEX Electric Heat

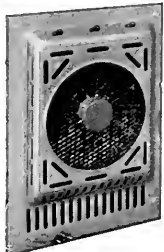

BLO-AIR HEATERS
for living rooms, bedrooms and
commercial installations

RADIANT CONVECTION HEATERS
for bathrooms and breakfast nooks

APEX Manufacturing Co.

Oakland, California
SANDOVAL SALES CO.
Distributors for
Northern California and Nevada
557 Market St., San Francisco



Product of
CALIFORNIA SHADE CLOTH CO.
210 Bayshore Blvd., San Francisco

Manufacturers of
**QUALITY HAND MADE SHADE CLOTH
IN ALL GRADES**

Wholesale Distributors
**SLOANE-BLABON LINOLEUM
AMBASSADOR VENETIAN BLINDS**

STRUCTURAL STEEL

**For Class A Buildings,
Bridges, etc.**

JUDSON PACIFIC CO.

609 MISSION STREET
SAN FRANCISCO

Plants: San Francisco - Oakland

Santa Clara's natural beauty and commercial wealth make it one of California's outstanding counties. Mountain ranges on the west act as a barrier against coast fogs and winds and eastern ranges which shut out the heat of the San Joaquin Valley in summer make for an ideal climate. In the spring and early summer, Santa Clara's famous orchards present a scene of gorgeous colors.

The county is a heavy producer of all farm and orchard crops. A total of approximately 70,000 acres of prunes produce annually more than \$9,808,000 worth of this crop. About 19,000 acres of apricots produce to the extent of \$3,500,000 annually, the pear crop is valued at more than \$2,000,000 and cherries bring in about \$1,190,000 a year. The average fruit acreage is 119,676 with an annual crop valuation exceeding \$15,000,000. Agricultural products account for numerous canneries and packing plants.

Santa Clara is noted for its educational advantages. Public school buildings are valued at more than \$10,000,000. The San Jose State Teachers College was established in 1862. In 1891 the famous Stanford University at Palo Alto was opened. The University of Santa Clara was created by the mission fathers in 1777 and now is one of California's better known institutions of learning. Lick Observatory was established in 1888 on the summit of Mount Hamilton.

San Jose, county seat of Santa Clara, was founded in 1777. Here the first American flag was raised in the pueblo of San Jose in July, 1846, and the first California legislature convened there December 15, 1849. At Sunnyvale is the \$5,000,000 dirigible base, now under Army control. Gilroy, a charming city in the southern end of Santa Clara Valley, is known as "The Home of the Prune." Here are 15,000 acres of prune trees and an enormous acreage of apricots, pears, grapes, tomatoes and lettuce. The county boasts the beautiful cities of Los Altos, Los Gatos, Palo Alto, Santa Clara and Saratoga. Population: 145,118. Area: 1,328 square miles.

SANTA CRUZ COUNTY—Created February 18, 1850. One of the original twenty-seven counties. "Santa" is the Spanish feminine of "Saint" or "holy"; "Cruz" is the Spanish for "cross", and Santa Cruz signifies "holy cross", which emblem was to the devout explorers of California what it was to the Crusaders. Those who fell by the wayside had a crude cross erected over them to mark their last resting place. If anything notable occurred in any of the expeditions, a cross was set up, and all that marked the site of the mission which was founded by Padres Lopez and Salazar on September 25, 1791, was the memorial cross erected to mark this site. From this the county derived its name.

Highly productive fruit orchards and farms, a wealth of natural scenery and beaches that lure thousands of vacationists, combine to make this little county one of the most attractive spots in California. The site of

Santa Cruz, county seat, is known as "The Atlantic City of the West."

Twenty-one distinct soil types are in evidence throughout the county. Pajaro Valley claims a soil fertility comparing favorably with any area in the United States. It is famous for its apple production. Santa Cruz harvests over one-third of the State's apple crop. More than 54,000 tons of this fruit are produced annually.

With 200 miles of trout streams, Monterey Bay fishing, splendid mountain camping sites, Felton Grove, or Santa Cruz County Big Trees, one of the finest groves of redwoods in California, the California Redwood Park and wonderful beach resorts, the county is a paradise for lovers of the out-of-doors.

Few farming communities can boast a proximity to beach and mountain resorts of such a character as offered by Santa Cruz county. Within a radius of 30 miles lie Del Monte, Monterey, Santa Cruz, Capitola, Rio del Mar, Seacliff, Rob Roy, Pebble Beach, Pacific Grove, Ben Lomond, Brookdale, Boulder Creek, Felton, the Big Trees and California Redwood Park.

Watsonville is the center of the apple growing district. It is the third largest shipping point between Los Angeles and San Francisco. Its huge packing houses and canneries are impressive. Population: 37,433. Area 435 square miles.

SHASTA COUNTY—Created February 18, 1850. One of the original twenty-seven counties. The derivation of the name of the county, which was taken from the mountain of that name, is in doubt. Some authorities claim the name "Shasta" is derived from Shas-ti-ka, the name of a tribe of Indians that lived at the base of Mt. Shasta. The word "Shas-ti-ka" means "stone house or cave dwellers." Other authorities claim that the word "Shasta" is a corruption of the French word "chaste", and was applied by explorers because of the wonderful whiteness or chasity of the eternal snow that caps the summit of this wonderful peak.

This county is the twelfth largest in the State. Stock raising, agricultural and mineral production, lumbering and a mecca for sportsmen, make Shasta a land of many attractions. While millions in gold, copper and other ores have been mined, geologists believe the surface merely has been scratched. McCloud River, Rising River and Fall River and Burney, Cottonwood, Battle and Hat Creeks enable the county to rank high in potential hydro-electric power. Here is located one of the world's largest single units for power generation.

Redding, the county seat, was established in the gold rush days, but Shasta, a few miles to the west, was the main community and in 1851 and 1852 was the largest city north of San Francisco. In 1888, county offices were moved from Shasta to Redding. Shasta, now in ruins, is a historic and romantic spot. This town is considered the cradle of Masonry in California. The old Masonic building has defied time and the elements since its erection in 1853. Population: 13,927.

(Next: Sierra, Siskiyou and Solano)

Stanley Ball Bearing Hinges

FOR smooth, trouble-free operation of doors for the life of the building.

You will find our "Architect's Manual of Stanley Hardware" very useful in making up hardware specifications. Send for a copy.

THE STANLEY WORKS
New Britain, Conn.

SAN FRANCISCO
576 Manadnock Bldg.

LOS ANGELES
407 American Bank Bldg.

SEATTLE
568 First Avenue, South

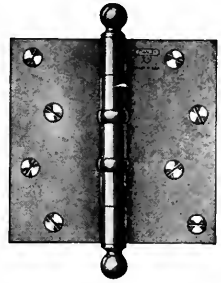

Another Notch

D. Zelinsky & Sons, Inc. was chosen to do the painting of San Francisco's newest skyscraper, the ten-story building at 417 Montgomery Street, owned by Louis R. Lurie, W. D. Peugh, Architect.

This job was done *the practical way* on a fixed fee basis, eliminating expenses for owner, contractor and architect.

Our staff organization offers this same plan for similar building projects.

D. ZELINSKY & SONS, INC.

Painters—Decorators

SAN FRANCISCO

• LOS ANGELES

PORTLAND • SEATTLE • WASHINGTON, D. C.

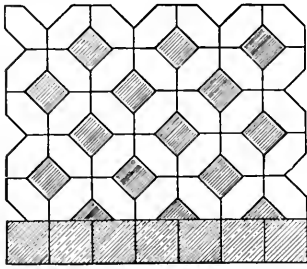

POMONA TILES

FOR

**Bathrooms and Kitchens
in over 60 colors**

Warehouses and Display Rooms

135 Tenth St. . . . San Francisco
629-33 North La Brea Ave.
Los Angeles
6106 Roosevelt Way . . . Seattle

POMONA TILE MFG. CO.
PLANT—POMONA, CALIF.

To the

**ARCHITECTURAL
PROFESSION !**

GIVE
your clients

COMFORT
and

SATISFACTION
by including

“AIR-LITE”

**VENETIAN
BLINDS**

in your specifications
NUFF SAID

GUNN, CARLE & CO.
20 Potrero Ave. UNDERHILL 5480
SAN FRANCISCO

REPORT OF IMPARTIAL WAGE BOARD FOR BUILDING INDUSTRY

THE Seventh Impartial Wage Board was appointed on May 6, 1936, to survey wages and working conditions in the building industry of San Francisco and to recommend minimum wage rates for the crafts involved. The Board submits herewith its report and recommendations.

In January of the present year a duly constituted Board of Arbitration acting on behalf of the Associated General Contractors, Central California Chapter, and the Bay Counties District Council of Carpenters handed down an award fixing the wage scale and working hours for carpenters. This award was arrived at through the customary and accepted processes of arbitration. Representatives of both employers and employees were given a full and impartial hearing. The facts and views bearing upon the questions at issue were thoroughly canvassed. The resulting award has been accepted by all parties concerned and now governs the working conditions for the carpenters' craft in San Francisco.

The undersigned Board's own studies have served to confirm the soundness of this award with respect to carpenters' wages and working conditions. The new wage scale of \$9.00 per day now in effect compares favorably with that prevailing for union carpenters in the United States generally. When allowance is made for differences in the cost of living and for differences in employment, the new scale appears to provide San Francisco carpenters with a slightly more adequate real wage than is typical of the rest of the United States.

The undersigned Board has arrived at the conclusion that the carpenters' award, resulting as it has from the orderly processes of arbitration with both employers and employees adequately represented, should be taken as a proper basis for the determination of wage rates in the other related crafts of the building industry. The same fundamental conditions that affect the carpenters' craft also affect



REYNOLDS METALLATION

ALUMINUM foil for
permanent home
INSULATION

REYNOLDS ECOD

welded wire fabric
plaster base—
prevents cracks,
provides thermal
insulation

*Northern California
Distributors—*

WESTERN ASBESTOS CO.

675 TOWNSEND STREET
SAN FRANCISCO

SISALKRAFT
REG. U. S. PAT. OFF.

“More than a
building paper”

THE SISALKRAFT CO.
205 West Wacker Drive
(Canal Station) Chicago, Ill.
55 New Montgomery Street
San Francisco, Calif.



**DALMO
WINDOW
PRODUCTS**

DALMO SALES CORPORATION
511 Harrison St., San Francisco

FERRO — PORCELAIN

is used in every building and has been used for years.

New uses are being found for it, continually.

Your inquiries regarding this material will be promptly answered.



FERRO ENAMELING CO.

1100 - 57th Ave., Oakland, Calif.

HARDWOOD

LUMBER
FLOORING
VENEERS
PANELS

Exotic Woods for Modernistic Trim

White Brothers
Hardwood Headquarters

Since 1872

5TH AND BRANNAN . . . SAN FRANCISCO
500 HIGH STREET OAKLAND

PAYNE



The choice of discriminating buyers of Gas-Fired Heating and Air-Conditioning Equipment. A catalog showing complete Payne line sent upon request.



**PAYNE FURNACE
& SUPPLY COMPANY**

Beverly Hills

California

the other crafts. This Board has accordingly undertaken as its primary obligation, so far as wage rates are concerned, to bring the recommended wage rates of the other crafts into proper relationship with the new wage scale for carpenters.

The Board has made every effort to obtain as much information as possible to assist it in arriving at sound conclusions with respect to the proper differentials between the present carpenters' wage and the wage scales in other crafts of the industry, and with respect to the related problems of the length of the working week and working day. The Board has employed independent economists and statisticians who have prepared careful studies of the history of wages and hours in the building trades in San Francisco, of the historical relations between these wages and hours with those in other cities, and of variations in the cost of living, building activity and other significant factors bearing upon the general problem. In addition, the Board has made a point of discussing the situation with employer representatives of all of the different crafts in the industry, and has thereby been enabled to obtain significant first-hand information with regard to the present situation in the several branches of the industry. The Board keenly regrets that representatives of organized labor in the industry did not see fit to accept an invitation to furnish information and to present their views.

The following are the Boards recommendations with regard to:

- (1) the number of days to be worked per week;
- (2) the number of hours to be worked per day;
- (3) the scale of wages for the different crafts.

(1) The five-day week is recognized in the industry as a suitable working week, and has been generally adopted in San Francisco and throughout the principal cities of the United States for all occupations in building except common laborers. This is a signal accomplishment for the industry and has been achieved within a relatively short time without serious disturbance of its economic position relative to

MODERNIZE WITH WHITE CEMENT



ONE SACK covers 100 square yards of concrete, stucco or masonry surface with 2 brush coats.

To brighten old exteriors use Calaveras White Portland Cement mixed with water and apply with a dutch brush to damp surface.

For further details write

CALAVERAS CEMENT CO.
315 Montgomery St., San Francisco
Los Angeles Seattle

Make the old stucco colorful and water tight by applying one or more coats of

BAY STATE Brick and Cement Coating

Manufactured by a company whose products have been on the market for over half a century.



Distributors

**CALIFORNIA SALES
COMPANY, INC.**

444 MARKET STREET
SAN FRANCISCO

IT'S HERE!

Perfected
by
ELECTRIC HEATING
WESIX



BEFORE YOU INSTALL ANY HEATING SYSTEM

... ask us about WESIX *automatic* electric heaters—proven in thousands of installations in homes, buildings, hospitals, schools—even entire cities! WESIX patented *double-action* principle of *circulating* and *radiating* provides quick, efficient, economical heat. You know it's *healthful*. NO FANS to stir up breeze and drafts—*no moving parts*.

WESIX ELECTRIC HEATER CO.
380 First Street San Francisco

Alumilite

by

Kawneer

Store Fronts - Windows

and

Architectural Castings

in

Polished Satin

or

Anodic Finish

THE

Kawneer
COMPANY
OF CALIFORNIA
BERKELEY

the community as a whole. Any further reduction in the working week would, however, be impractical at this time in the opinion of this Board on account of the impossibility of maintaining the earning power of the workman.

(2) A more difficult problem that confronted the Board was the question of the hours per day to be worked in the different crafts. At the present time four important crafts are working six hours, one is working seven hours and the remainder, numbering some 36 crafts, are working eight hours per day. The Board has found evidence to show that these differences in the length of the working day in different crafts are a source of considerable disruption in the industry. The successive steps involved in building construction are to such a degree inter-dependent that when the several crafts work varying hours the length of time taken to complete a building is prolonged, there occur more frequent delays and interruptions, some crafts lose more time due to these delays, and the cost of building is greater than it would be if all of the crafts adopted a standard working day. Accordingly the Board has concluded that a uniform working day should be established for all building trades.

The Board has further concluded that this uniform working day should be an eight-hour day. It is true that there has been a tendency for the length of the working day and the working week gradually to decrease. According to the United States Bureau of Labor Statistics, the average hours per week prevailing in the building trades in the United States as a whole declined from 44.7 in 1914 to 38.7 in 1935. But the Board does not believe that present conditions in the building industry of San Francisco would justify the adoption of a general six-hour or even seven-hour day at this time.

In the first place the six-hour or seven-hour working day where it has been adopted by some crafts since the advent of the depression, has been accepted primarily as a means of spreading work and not because

Clinton Construction Co.
of California
General Contractors

923 Folsom Street
San Francisco
SUtter 3440

HIGH GRADE MILLWORK
AND INTERIOR FINISH
SASH AND DOORS

LANNOM BROS.
MFG. CO.

FIFTH AND MAGNOLIA STREETS
OAKLAND, CALIFORNIA
Telephone: LAkeside 3663

ANDERSON & RINGROSE

General Contractors

320 Market Street, San Francisco
Phone GARfield 2245

CRANE

High Class Plumbing
Fixtures

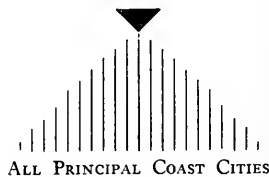

ALL PRINCIPAL COAST CITIES

THE ARCHITECT AND ENGINEER

Pacific Manufacturing Company

High Class Interior Finish
Quality Millwork

454 Montgomery St. 641 Merrill Ave.
San Francisco Los Angeles
Garfield 7755 AXridge 9011

1315 Seventh Street, Oakland
GLEncourt 7850

FORDERER Cornice Works

Manufacturers of

Hollow Metal Products
Interior Metal Trim
Elevator Fronts and Cabs
Sheet Wall Plugs, Anchors, Etc.
Metal Wall Products
Sanitary Metal Base
Commercial Refrigerators
Building Paper
Metal and Wire Accessories
for Concrete

269 POTRERO AVENUE
San Francisco, Calif.
HEmlock 4100
CONSULT OUR ENGINEERING
DEPARTMENT

PEELING?

Then
on your next job specify

H&D CEMENT PAINT

for Stucco

Look These Over!

HIGHLAND HOSPITAL
LAKE MERRITT HOTEL
BERKELEY FIRE STATIONS

FRANK W. DUNNE CO.
41st & Linden Oakland

Carl T. Doell Co.

*Plumbing
Heating*

Plumbing Contractor
Veterans Memorial Building
Oakland

467 21ST STREET
OAKLAND

Telephone GLEncourt 8246

of any increased efficiency of labor. This fact makes it impossible to accept the view that the recent adoption of the shorter working day by five crafts is representative of an historical tendency which can be justified by the economic conditions of the industry.

In the second place, it is the view of the Board that the shortening of the working day as a permanent measure could only be economically justified if at the same time, the hourly rate of wages could properly be so increased as to make it possible for the worker to earn enough to maintain his previous standard of living. But it is clear that because of the character of the building market at this time, such an increase in hourly wage rates would so increase the cost of building as seriously to affect the volume of construction. Such an increase would, under prevailing conditions, be contrary to the best interests of the workers, the employers, and the general public.

On the other hand, if the length of the working day were to be generally reduced without a corresponding increase in hourly wage rates, the result would be a reduction in weekly and yearly income per worker and in his standard of living. A shorter working day would therefore impose a real injustice upon the workers until such time as the industry can clearly afford to pay a proportionately higher hourly rate of wages so that the individual worker's standard of living can be at least maintained. Accordingly the Board recommends the adoption of a uniform working day of eight hours throughout the industry.

However, the Board recognizes that it may be desirable to permit temporary exceptions to this general rule. Workers in some of the crafts are willing and anxious, as a temporary expedient in order to spread the burden of unemployment, to work a shorter day than eight hours. There is evidence to show that, except in a few crafts, unemployment has recently declined considerably, and there is good reason to expect continued improvement. In fact, in some trades there already appears to be a scarcity of trained men. One important

"Ask the National Lead Man!"

Special attention is given to architects' inquiries on paint materials and painting procedure by our technical staff.

SPECIFY

DUTCH BOY

Painter Products

BASS - HUETER

Paints and Varnishes

o

NATIONAL LEAD COMPANY

San Francisco Seattle
Portland Los Angeles
Branches and dealers in all principal cities

We suggest for
dependable

SUMMER OR WINTER

AIR CONDITIONING

that you investigate

Delco Frigidaire's

"Conditionair"

A Product of General Motors

Call

A L A D D I N Heating Corp.

5107 BROADWAY

OLYMPIC 5424

OAKLAND CALIFORNIA

T/N ONE-PIECE WATER CLOSET



The first and finest one-piece water closet. No elevated tank and not attached to wall. Can be installed in corners, under stairs or windows. Simplified fittings assuring positive, quiet performance. Special regulating stop, designed for either angle or straight supply, permitting volume regulation of water under all pressures. Sold only by Master Plumbers.

Distributed by

TAY HOLBROOK, INC.

SAN FRANCISCO

OAKLAND
SACRAMENTO

SAN JOSE
FRESNO

RUBBERCEPTOR

SOLID RUBBER — SLIP PROOF
SHOWER RECEPTOR

Available in all regular sizes and popular colors, designed for easy fitting, making a permanent leak-proof joint with any materials used in construction of stall showers. Approved by Departments of Building and Safety and Plumbing Inspection Divisions wherever presented.

Distributors



1930 VAN NESS AVE., SAN FRANCISCO
2335 BROADWAY, OAKLAND

VENETIAN BLINDS
LINOLEUM • AWNINGS
RUGS • CARPETS
HARDWOOD FLOORS

craft has recently returned to an eight-hour day after operating on a seven-hour day basis for a number of years. But in those few crafts in which unemployment is still a serious problem, and in which both workers and employers are agreed upon the desirability of continuing a shorter working day than eight hours as a temporary relief measure, this Board feels that it would be unwise to insist upon an immediate return to the eight-hour day. However, while the right of the workmen in any trade, by agreement with their employers, to curtail the length of the working day is not to be denied, it must be recognized that the same income that would accrue to that trade if it worked forty hours per week could be obtained for a thirty or thirty-five hour week only if its wage rate were to be correspondingly increased. If one trade were to receive the same income for thirty or thirty-five hours as it formerly received for forty hours, then all trades should have the same right, and all wage scales would have to be advanced accordingly. Such an advance is not feasible at the present time in the judgment of this Board. Hence, if any craft elects, by agreement with its employers, to continue the six-or seven-hour day, its members should expect a proportionate reduction in income.

(3) Having accepted the award of the Special Board of Arbitration in the case of the carpenters, the undersigned Board has regarded the problem of determining wage rates for the other crafts as one of fixing the differentials between the carpenters' wage rate and that of each of the other crafts. Here the Board recognizes the fact that differentials are the cumulative result of years of historical development in the building industry. They may properly be said to represent allowances for, (1) differences in regularity of employment, (2) differences in the degree of skill and training required, (3) differences in the degree of arduousness and risk involved in the different crafts and, (4) to a limited degree, differences in tool investment and depreciation. The Board has not found justification



Pump Governors	Oil Heaters
Safety Pump Governors	Relief Valves
Automatic Gas Regulating Valves	Oil-Burner Governors
Gas Burners	Little Giant Improved Oil Burners
Gas Burning Equipment	Oil Pumping Sets
Vacuum Pump Governors	Oil Valves
Vacuum Regulating Valves	Oil Strainers
Continuous Flow Steam Traps	Steam Oil Strainers
Thermostats	Duplex Oil Pumps
Reducing Valves	Rotary Oil Pumps
Boiler Feed-Water Regulators	Boiler Feed Pumps
	Water Heaters
	Oil Meters

VAUGHN-G. E. WITT Co.

ENGINEERS

C. W. Vaughn, President and Manager

MANUFACTURERS AND DISTRIBUTORS

4224-2B Hollis St. Phone Olympic 6084
Emeryville, Oakland, Calif.

Robert W. Hunt Company

ENGINEERS

Inspection - Tests - Consultation

Schools and Other Structures
Are Built as Designed

When Construction Materials are
Inspected at point of Manufacture
and during Erection by

ROBERT W. HUNT COMPANY

Cement, Concrete, Chemical, Metallurgical,
X-Ray and Physical Laboratories

Chicago - New York - Pittsburgh
Los Angeles - All Large Cities
San Francisco, 251 Kearny Street



HERRICK IRON WORKS

STRUCTURAL STEEL

18TH AND CAMPBELL STS.
OAKLAND, CALIF.
Phone GLencourt 1767

THE ARCHITECT AND ENGINEER



No longer a problem
for the Architect

TRANSIT MIX CONCRETE AND MORTAR

makes delivery of material
to the job swift and in-
expensive . . . minimizing the
architect's supervision costs
and assuring his client a de-
pendable mix.

Speed . . . Reliability . . . Economy

Let us co-operate with you

Golden Gate-Atlas Materials Co.

16th and Harrison Streets
San Francisco
UNderhill 3650

COMMON BRICK

If you like good brick and good
service, phone us for informa-
tion, you will find that it always
pays to be our patron.

Remillard-Dandini Co.

Phone TEMplebar 8133

Office, 569 - 3rd Street, Oakland

Plants

San Jose Pleasanton Greenbrae

Bethlehem Steel Company

General Offices:  Bethlehem, Pa.

STEEL BRIDGES and BUILDINGS

San Francisco
20th and Illinois Sts.

Seattle
W. Anderson Street

Portland
American Bank Bldg.

Los Angeles
Stauson Ave.

Salt Lake City
Kearns Bldg.

Honolulu, T. H.
Schuman Bldg.

for making any material changes in
the differentials that have prevailed
in the past between the wage rates
of the different crafts. It has endeav-
ored merely to adjust the wage rates
of the other crafts to the new wage
rate for carpenters, preserving as far
as possible the traditional differen-
tials. It has, however, compared the
differentials prevailing in San Fran-
cisco against those in other important
cities and against the average figures
for the United States.

Acting on these considerations, this
Board recommends that the accom-
panying scale of wages be established
for the building trades in San Fran-
cisco, effective July 1, 1936.

(Signed) B. F. Haley
" H. M. Walker
" A. I. Esberg, Chairman,
Impartial Wage Board.

BILLBOARD LAW UPHELD

Efforts of the State Department of
Public Works to enforce the provi-
sions of the Outdoor Advertising Act
receive deserved support from the
decision of Superior Judge Welsh at
Sacramento upholding the Act.

Judge Welsh has ruled that the
regulation of roadside signs is clearly
within California's police power to
preserve the public peace, safety,
morals and general welfare. The de-
cision accords with rulings of courts
in other States which have similar
laws, and with decisions of United
States courts in which such laws have
been tested.

HIGHWAY ENGINEERS TO MEET

State highway engineers from all
over the United States will convene
in San Francisco December 7 to 10
inclusive, when the American Associa-
tion of State Highway Officials holds
its annual meeting.

This was the announcement made
by C. H. Purcell, chief engineer of
the San Francisco-Oakland Bay Bridge,
who is a member of the executive
committee of the highway officials'
association.

Mr. Purcell said that W. C. Mark-
ham, executive secretary of the Asso-
ciation, will arrive in San Francisco
next month to complete arrangements
for the convention.

Modern Design Dignified and Good Looking



Model No. 75

This new semi-recessed HAWS DRINKING
FOUNTAIN is made of Vitreous China and
answers a demand for an attractive, well
built fixture for public and semi-public
buildings.

HAWS DRINKING FAUCET CO
1808 Harmon Street Berkeley, Calif.

"BROWNSKIN" RESILIENT WATERPROOF BUILDING PAPER

THE BUILDING PAPER WITH
A FACTOR OF SAFETY

Angier Corporation

Framingham, Mass.

PACIFIC COAST DIVISION

564 HOWARD STREET

SAN FRANCISCO

Douglas 4416

350 South Anderson St.

Los Angeles

LUXOR

WINDOW SHADES

*Translucent Shading
of highest count
cambric*

William Volker & Co.

631 Howard Street
San Francisco

REPUBLIC STEEL CORPORATION



Manufacturers of

ENDURO Stainless Steel; TON-CAN Copper Molybdenum Iron Sheets and Pipe; and Steel Pipe, Sheets and Reinforcing Bar for every building purpose.

Write for information

Rialto Building, San Francisco, Calif.
Edison Building, Los Angeles, Calif.
White-Henry-Stuart Bldg., Seattle, Wash.

Independent Iron Works

Structural Steel
Ornamental Iron
Steel Service Stations
Steel Tanks
Standard Steel Mill Buildings
Bridges

821 Pine Street

Oakland

Two major highway projects, the San Francisco - Oakland Bay Bridge (which will be open to automobile traffic at convention time) and the Golden Gate Bridge, were powerful factors that influenced the executive committee at its midyear meeting to select San Francisco for the convention.

NOTES AND COMMENTS

(Concluded from Page 2)

and wages that would work for the interests of both and make it impossible for a company to lure a draftsman or an owner to procure suitable plans except through legitimate channels.

The architects, too, could soon put a stop to firms supplying customers with free plans and specifications by blacklisting these companies and refusing to permit them to bid on any of their work.

The article in last month's Architect and Engineer by Howard J. White, a prominent Chicago architect, describing conditions in that city which indicated a lamentable state of affairs in shyster competition, was read with intense interest by Pacific Coast architects who are fast beginning to realize that legislation and organization must eventually be the answer in clearing up a menacing situation.



Early fixture-planning brings you more surely to your goal: the beauty and charm of an effectively-lighted home! Don't delay selection until the house is completed. Even at the blue-print stage, assure yourself the matchless distinction and proved efficiency of famous Lightolier equipment.

Booklet "The Charm of a Well Lighted Home" available upon request

INCANDESCENT SUPPLY CO.
San Francisco Oakland Fresno Los Angeles

MONEL METAL

For the Modern Kitchen
Heaters, boilers, storage tanks, water softeners, cabinet tops, "Streamline" or "Straitline" Kitchen Sinks

See our display rooms, arranged for your convenience

MODERN METAL APPLIANCE CO.
4238 Broadway Oakland, Calif.

CORROSIRON

MADE IN U.S.A.

HIGH SILICON ACID RESISTING IRON

REDUCE COST OF HANDLING CORROSIVE GASES

with CORROSIRON

EXHAUST FANS for ACID FUMES



Write for

BULLETIN No. 130

SHOWING

PERFORMANCE DATA—DESCRIPTIONS

and

DIMENSIONAL BLUE PRINTS

SIZES

3 in.—6 in.—8 in.—12 in.—15 in.

CAPACITIES

50 C.F.M. to 5000 C.F.M.

TYPE DM.

PACIFIC FOUNDRY COMPANY, Ltd.

551 Fifth Avenue
NEW YORK

3100 Nineteenth St.
SAN FRANCISCO

1400 South Alameda St.
LOS ANGELES

MAKING DOLLARS GROW ON TREES

Money invested in genuine Davey Tree Surgery comes back to you twofold—in satisfaction and enjoyment, and in enhanced value. Write or phone nearest office for free inspection.

It costs no more for genuine



SAN FRANCISCO Russ Bldg. SUTTER 3377
Fresno Mattei Bldg.
LOS ANGELES Story Bldg. TUCKER 1929
Local phones in: Pasadena, Palo Alto, Oakland, San Rafael, Burlingame

Skill • Knowledge • Responsibility

Classified Advertising Announcements

All Firms are Listed by Pages, besides
being grouped according to Craft or Trade.

Star (*) indicates alternate months.

ACOUSTICAL AND SOUND CONTROL	
Western Asbestos Co., 675 Townsend Street, San Francisco.....	70
AIR CONDITIONING	
The Union Ice Company, 354 Pine Street, San Francisco.....	*
ARCHITECTURAL TERRA COTTA	
N. Clark & Sons, 116 Natoma Street, San Francisco.....	*
Gladding McBean & Co., 660 Market Street, San Francisco; 2901 Los Feliz Boulevard Los Angeles; 1500 First Avenue South, Seattle; 79 S. E. Taylor St., Portland; 22nd and Market Street, Oakland; 1102 N. Monroe Street, Spokane; Vancouver, B. C.	9
BANKS	
Crocker First National Bank, Montgomery and Post Streets, San Francisco.....	67
BATHROOM HEATERS	
Wesix Electric Heater Company, 390 First Street, San Francisco; 631 San Julian Street, Los Angeles; 2008 Third Avenue, Seattle, Wash.	72
Apax Electric Heaters, sold by Sandoval Sales Co., 557 Market Street, San Francisco	68
BLINDS—VENETIAN	
Higgins Co., 1930 Van Ness Ave., San Francisco; 2335 Broadway, Oakland	74
Gunn-Carle & Co., 20 Pitrero Ave., San Francisco.....	70
BRICK—FACE, COMMON, ETC.	
N. Clark & Sons, 116 Natoma Street, San Francisco.....	*
Gladding McBean & Co., 660 Market Street, San Francisco; 2901 Los Feliz Boulevard Los Angeles; 1500 First Avenue South, Seattle; 79 S. E. Taylor St., Portland; 22nd and Market Street, Oakland; 1102 N. Monroe Street, Spokane; Vancouver, B. C.	9
Remillard-Dardini Co., 569 Third Street, Oakland.....	75
BUILDERS HARDWARE	
The Stanley Works, New Britain, Conn.; Monadnock Bldg., San Francisco; Los Angeles and Seattle	69
BUILDING MATERIALS	
Building Material Exhibit, Architect's Building, Los Angeles	74
BUILDING PAPERS	
The Sisalkraft Company, 205 W. Wacker Drive, Chicago, Ill., and 55 New Montgomery Street, San Francisco	70
"Browskin," Angier Corporation, 370 Second Street, San Francisco.....	75
CEMENT	
Galaveras Cement Company, 315 Montgomery Street, San Francisco.....	71
Portland Cement Association, 564 Market Street, San Francisco; 816 West Fifth Street, Los Angeles; 146 West Fifth Street, Portland; 518 Exchange Building, Seattle	Back cover
"Golden Gate" and "Old Mission," manufactured by Pacific Portland Cement Co., 111 Sutter Street, San Francisco; Portland, Los Angeles and San Diego.....	Second cover
CEMENT TESTS—CHEMICAL ENGINEERS	
Robert W. Hunt Co., 251 Kearny Street, San Francisco.....	74
CEMENT—COLOR	
"Golden Gate Tan Cement," manufactured by Pacific Portland Cement Co., 111 Sutter Street, San Francisco; Portland, Los Angeles and San Diego	Second cover
CEMENT PAINT	
General Paint Corporation, San Francisco, Los Angeles, Oakland, Portland and Seattle	65
California Sales Company, 444 Market Street, San Francisco.....	71
CONCRETE AGGREGATES	
Golden Gate Atlas Materials Company, Sixteenth and Harrison Streets, San Francisco	75
John Cassaretto, Sixth and Channel Streets, San Francisco	78
CONCRETE CURING & PROTECTION	
The Sisalkraft Company, 205 W. Wacker Drive, Chicago, Ill., and 55 New Montgomery Street, San Francisco	70
CONTRACTORS—GENERAL	
MacDonald & Kahn, Financial Center Bldg., San Francisco.....	79

NEW THIS MONTH

Bethlehem Steel Co.	6
Celotex Corporation	5
Pittsburgh Glass Co.	7
Gladding, McBean & Co.	9
Golden Gate Atlas Mater- ials Co.	75
Aladdin Heating Corp.	73
Pacific Gas Radiator Co.	68
The Stanley Works	69
D. Zelinsky & Sons	69
Smoot-Holman Co.	8
National Lead Co.	73
Tay-Holbrook, Inc.	74
Westinghouse Electric Elevator	8
Higgins Co.	74

	Page
CONTRACTORS—GENERAL	
Lindgren & Swinerton, Inc., Standard Oil Building, San Francisco.....	66
Dinwiddie Construction Co., Crocker Bldg., San Francisco.....	79
Clinton Construction Company, 923 Folsom Street, San Francisco.....	72
Anderson & Ringrose, 320 Market Street, San Francisco.....	72
G. P. W. Jensen, 320 Market Street, San Francisco.....	*
P. F. Reilly, 730 Ellis Street, San Francisco.....	76
Wm. Martin & Son, Builders' Exchange, San Francisco.....	79
DAMP-PROOFING & WATERPROOFING	
"Golden Gate Tan Plastic Waterproof Cement," manufactured by Pacific Portland Cement Co., 111 Sutter Street, San Francisco; Portland, Los Angeles and San Diego.....	Second page of cover
The Siskalcraft Company, 205 W. Wacker Drive, Chicago, Ill., and 55 New Montgomery Street, San Francisco.....	70
Bay State Brick & Cement Coating, sold by California Sales Company, 444 Market Street, San Francisco.....	71
DOORS—HOLLOW METAL	
Forderer Cornice Works, Potrero Avenue, San Francisco.....	72
Kawnear Mfg. Co., Eighth and Dwight Streets, Berkeley.....	73
ACID PROOF DRAIN PIPE AND FITTINGS	
Corrosion—Acid resisting pipe, fittings, exhaust fans, pumps, etc., Pacific Foundry Co., 3100 19th Street, San Francisco; 1400 S. Alameda Street, Los Angeles.....	76
DRINKING FOUNTAINS	
Haws Drinking Faucet Co., 1808 Harmon Street, Berkeley; American Seating Co., San Francisco, Los Angeles and Phoenix.....	75
ENGINEERS—MECHANICAL	
Hunter & Hudson, 41 Sutter Street, San Francisco.....	80
ELECTRIC AIR AND WATER HEATERS	
Sandoval Sales Company, 557 Market Street, San Francisco.....	68
Wesix Electric Heater Company, 390 First Street, San Francisco; 631 San Julian Street, Los Angeles; 2008 Third Avenue, Seattle, Wash.....	72
ELECTRICAL ADVICE	
Pacific Coast Electrical Bureau, 447 Sutter Street, San Francisco, and 601 W. Fifth Street, Los Angeles.....	64
ELEVATORS	
Pacific Elevator and Equipment Company, 45 Rausch Street, San Francisco.....	79
Westinghouse Electric Elevator Company, Crocker First National Bank Bldg., San Francisco.....	8
PORCELAIN ENAMELING	
Ferro Enameling Company, 1100 57th Street, Oakland.....	71
FLOORING	
Asphalt Tile, Western Asbestos Company, 675 Townsend Street, San Francisco.....	70
FIXTURES—BANK, OFFICE, STORE	
Mullen Manufacturing Co., 64 Rausch Street, San Francisco.....	79
Pacific Manufacturing Company, 454 Montgomery Street, San Francisco; 1315 Seventh Street, Oakland, Los Angeles and Santa Clara.....	73
GAS FUEL	
Pacific Gas Association, 447 Sutter Street, San Francisco.....	Third Cover
GAS BURNERS	
Vaughn-G. E. Witt Company, 4224-28 Hollis Street, Emeryville, Oakland.....	74
GAS VENTS	
Payne Furnace & Supply Co., Beverly Hills, California.....	71
GAS RADIATORS	
Pacific Gas Radiator Company, Huntington Park, Calif.....	68
GLASS	
W. P. Fuller & Co., 301 Mission Street, San Francisco. Branches and dealers throughout the West.....	7
Libbey-Owens-Ford Glass Co., Toledo, Ohio; 633 Rialto Bldg., San Francisco; 1212 Architects Bldg., Los Angeles; Mr. C. W. Holland, P.O. Box 3142, Seattle.....	*
Pittsburgh Plate Glass Company, Grant Building, Pittsburgh, Pa. W. P. Fuller & Co., Pacific Coast Distributors.....	7
HARDWARE	
The Stanley Works, Monadnock Building, San Francisco; American Bank Building, Los Angeles.....	69
HARDWOOD LUMBER	
White Bros., Fifth and Brannan Streets, San Francisco; 500 High Street, Oakland.....	71
HEATING—ELECTRIC	
Apex Air and Water Electric Heaters, Sandoval Sales Company, 557 Market Street, San Francisco.....	68
Wesix Electric Heater Company, 390 First Street, San Francisco; 631 San Julian Street, Los Angeles; 2008 Third Avenue, Seattle, Wash.....	72
HEATING EQUIPMENT	
Payne Furnace & Supply Co., Beverly Hills, California.....	71
Pacific Gas Radiator Co., 7615 Roseberry Ave., Huntington Park; Sales Office, H. C. Stoeckel, 557 Market Street, San Francisco.....	68
Aladdin Heating Corp., 5107 Broadway, Oakland.....	73
Tay-Holbrook, Inc., San Francisco, Oakland, Sacramento, Fresno, San Jose.....	74
HEAT REGULATION	
Johnson Service Company, Milwaukee, represented on the Pacific Coast by the following branch offices: 814 Rialto Bldg., San Francisco; 153 West Avenue, 34, Los Angeles; 1312 N.W. Raleigh St., Portland, and 473 Coleman Bldg., Seattle.....	*

JOHN CASSARETTO

—Since 1886—And Still Active—

Building Materials

READY MIX CONCRETE
ROCK - SAND - GRAVEL - LIME
CEMENT - PLASTER - MORTAR
METAL LATH - WOOD LATH
STUCCO - WIRE NETTING

Service Unexcelled

Bunkers
Sixth and Channel, San Francisco
Phones: GARfield 3176, GARfield 3177

LAWTON SCHOOL

SAN FRANCISCO
DODGE A. REIDY and CHAS. J. ROGERS
ARCHITECTS

**ANOTHER LINOLEUM
CONTRACT INSTALLED**

BY
**WEST COAST
LINOLEUM and CARPET
STORES**

2703 MISSION STREET, SAN FRANCISCO
Telephone VAleria 4909

**DINWIDDIE
CONSTRUCTION
COMPANY**

●
**BUILDERS OF
GOOD BUILDINGS**

●
CROCKER BUILDING
SAN FRANCISCO

**MULLEN MFG.
COMPANY**

**BANK, STORE AND OFFICE
FIXTURES—CABINET WORK
OF GUARANTEED QUALITY
CHURCH SEATING**

Office and Factory:
60-80 RAUSCH ST., Bet. 7th and 8th Sts.
San Francisco
Telephone UNderhill 5815

**William Martin
& Son
Builders**

666 Mission Street
San Francisco
Telephone SUtter 6700
Evenings: GARfield 9456

ELEVATORS

**Pacific Elevator and
Equipment Company**

45 Rausch Street, San Francisco
HEmlock 4476

MacDonald & Kahn

*General
Contractors*

Financial Center Bldg.
405 Montgomery St.
San Francisco

"The Only Pacific Coast Factory"

**THE HERMANN
SAFE COMPANY**

Manufacturers and Dealers
FIRE AND BURGLAR PROOF
SAFES, VAULTS, SAFE
DEPOSIT BOXES

**Howard & Main Sts.
San Francisco**
Telephone GARfield 3041

HOLLOW BUILDING TILE (Burned Clay)	Page
N. Clark & Sons, 116 Natoma Street, San Francisco	9
Gladling, McBean & Co., 660 Market Street, San Francisco; 2901 Los Feliz Boulevard, Los Angeles; 1500 First Avenue South, Seattle; 79 S. E. Taylor Street, Portland; Twenty-second and Market Streets, Oakland; 1102 N. Monroe Street, Spokane; Vancouver, B. C.	9
INSULATING MATERIALS	70
Western Asbestos Co., 675 Townsend Street, San Francisco	70
INSPECTION AND TESTS	74
Robert W. Hunt Co., 251 Kearny St., San Francisco	74
LACQUERS	65
General Paint Corp., San Francisco, Los Angeles, Oakland, Portland, Seattle and Tulsa	65
W. P. Fuller & Co., 301 Mission Street, San Francisco. Branches and dealers throughout the West	7
LIGHTING-FIXTURES	76
Incandescent Supply Co., 726 Mission Street, San Francisco; Oakland, Fresno	76
LINOLEUM	70
Sloan-Blabon linoleum, sold by California Shade Cloth Co., 210 Bayshore Boulevard, San Francisco	70
Higgins Co., 1930 Van Ness Ave., San Francisco; 2335 Broadway, Oakland	74
LUMBER	73
Pacific Mfg. Co., 454 Montgomery Street, San Francisco; 1315 Seventh Street, Oakland; Los Angeles and Santa Clara	73
Smith Lumber Company, Nineteenth Avenue and Estuary, Oakland	80
Melrose Lumber & Supply Co., Forty-sixth Avenue and E. Twelfth Street, Oakland	80
E. K. Wood Lumber Company, 4701 Santa Fe Avenue, Los Angeles; 1 Drumm Street, San Francisco; Frederick and King Streets, Oakland	66
MARBLE	80
Joseph Musto Sons-Keenan Co., 535 N. Point Street, San Francisco	80
MILLWORK	66
E. K. Wood Lumber Company, No. 1 Drumm Street, San Francisco, Oakland, Los Angeles	66
Lannom Bros. Mfg. Co., Fifth and Magnolia Streets, Oakland	72
Melrose Lumber & Supply Company, Forty-sixth Avenue and E. Twelfth Street, Oakland	72
Pacific Mfg. Co., 454 Montgomery Street, San Francisco; 1315 Seventh Street, Oakland; Los Angeles and Santa Clara	73
Smith Lumber Company, Nineteenth Avenue and Estuary, Oakland	80
MONEL METAL	76
"Inco" brand, distributed on the Pacific Coast by the Pacific Metals Company, 3100 19th Street, San Francisco, and 1400 So. Alameda Street, Los Angeles	76
Heaters, storage tanks—Modern Metal Appliance Company, 4238 Broadway, Oakland	76
MURALS	*
Heinsbergen Decorating Co., Los Angeles and 401 Russ Building, San Francisco	*
OIL BURNERS	65
S. T. Johnson Co., 585 Potrero Avenue, San Francisco; 940 Arlington Street, Oakland; 1729 Front Street, Sacramento, and 230 N. Sutter Street, Stockton	65
Vaughn-G. E. Witt Co., 4224-28 Hollis Street, Emeryville, Oakland	74
ONYX	72
Joseph Musto Sons-Keenan Co., 535 No. Point Street, San Francisco	72
ORNAMENTAL IRON	76
Independant Iron Works, 821 Pine Street, Oakland	76
ORNAMENTAL LIGHTING	76
Incandescent Supply Co., 726 Mission Street, San Francisco, Oakland, Fresno	76
PAINTS, OIL, LEAD	73
W. P. Fuller & Co., 301 Mission Street, San Francisco. Branches and dealers throughout the West	7
Frank W. Dunne Co., 41st and Linden Streets, Oakland	73
General Paint Corp., San Francisco, Los Angeles, Oakland, Portland, Seattle and Tulsa	65
National Lead Company, 2240 24th Street, San Francisco. Branch dealers in principal Coast cities	73
PAINTING, DECORATING, ETC.	80
The Tormay Co., 563 Fulton Street, San Francisco	80
Heinsbergen Decorating Co., 401 Russ Building, San Francisco	*
PARTITIONS—MOVABLE OFFICE	73
Pacific Mfg. Co., 454 Montgomery Street, San Francisco; 1315 Seventh Street, Oakland; factory at Santa Clara	73
PLASTER	
"Empire" and "Reno Hardware Plaster," manufactured by Pacific Portland Cement Co., 111 Sutter Street, San Francisco; Portland, Los Angeles and San Diego	Second cover

	Page
PLATE GLASS	
Libbey-Owens-Ford Glass Co., Toledo, Ohio; 633 Rialto Bldg., San Francisco; 1212 Architects Bldg., Los Angeles; Mr. C. W. Holland, P. O. Box 3142, Seattle	*
PLUMBING CONTRACTORS AND MATERIALS	
Carl T. Doell Co., 467 Twenty-first Street, Oakland	73
Crane Co., all principal Coast cities	72
Tay-Holbrook, Inc., San Francisco, Oakland, Sacramento, Fresno, San Jose	74
PRESSURE REGULATORS	
Veughn-G. E. Witt Co., 4224-28 Hollis Street, Emeryville, Oakland.....	74
REFRIGERATION	
Kelvinator Electric Refrigerators, Aladdin Heating Corp., 5107 Broadway, Oakland ..	73
REINFORCING STEEL	
Gunn, Carle & Company, 20 Potrero Ave., San Francisco	70
ROOF MATERIALS	
Gladding, McBean & Co., 660 Market Street, San Francisco; 2901 Los Feliz Boulevard, Los Angeles; 1500 First Avenue South, Seattle; 79 S. E. Taylor Street, Portland; Twenty-second and Market Streets, Oakland; 1102 N. Monroe Street, Spokane; Vancouver, B. C.	9
N. Clark & Sons, 112-116 Natoma Street, San Francisco; works, West Alameda	*
SAND, ROCK AND GRAVEL	
John Cassaretto, Sixth and Channel Streets, San Francisco	78
SHADE CLOTH	
California Shade Cloth Co., 210 Bayshore Boulevard, San Francisco.....	68
STANDARD STEEL BUILDINGS	
Independent Iron Works, 821 Pine Street, Oakland.....	76
STEEL—STAINLESS	
Republic Steel Corporation, Rialto Bldg., San Francisco; Edison Bldg., Los Angeles; White-Henry-Stuart Bldg., Seattle	76
STEEL, STRUCTURAL	
Independent Iron Works, 821 Pine Street, Oakland.....	76
Judson Pacific Company, C. F. Weber Bldg., Mission and Second Streets, San Francisco shops, San Francisco and Oakland.....	68
Pacific Coast Steel Corp.—See Bethlehem Steel Company, Twentieth and Illinois Streets, San Francisco; Slauson Avenue, Los Angeles; American Bank Building, Portland, Ore.; West Anover Street, Seattle, Wash.	6 and 75
Herrick Iron Works, 18th and Campbell Streets, Oakland.....	74
STORE FIXTURES	
Mullen Mfg. Co., 60 Rausch Street, San Francisco	78
STORE FRONTS	
Kawneer Mfg. Co., Eighth and Dwight Streets, Berkeley	72
TEMPERATURE REGULATION	
Johnson Service Company, Milwaukee, represented on the Pacific Coast by the following branch offices: 814 Rialto Bldg., San Francisco; 153 West Avenue, 34, Los Angeles; 1312 N.W. Raleigh St., Portland, and 473 Coleman Bldg., Seattle....	*
TERMITE CONTROL—WOOD PRESERVATIVE	
E. K. Wood Lumber Company, No. 1 Drumm Street, San Francisco; 4701 Santa Fe Ave., Los Angeles; Frederick and King Streets, Oakland.....	66
American Lumber & Treating Company, Rialto Bldg., San Francisco; 1031 S. Broadway Los Angeles	67
TREE SURGERY	
Davey Tree Surgery Co., Ltd., Russ Building, San Francisco; Story Building, Los Angeles	76
TILE—DECORATIVE, ETC.	
Pomona Tile Mfg. Co., plant, Pomona, Cal.; Sales Rooms, 135 Tenth St., San Francisco; 217 S. La Brea Ave., Los Angeles; 6106 Roosevelt Way, Seattle.....	70
Gladding McBean & Co., 660 Market St., San Francisco; 2901 Los Feliz Boulevard, Los Angeles	9
VARNISHES	
National Lead Company, 2240 24th Street, San Francisco. Branches and dealers in all principal Coast cities	73
W. P. Fuller Company, San Francisco and principal Coast cities.	7
VALVES	
Sloan Valve Co., manufacturers of Sloan flush valves, 4300 West Lake St., Chicago, Ill.	*
WATERPROOFING	
Bay State Brick & Cement Coating, California Sales Co., 444 Market Street, San Francisco	71
WATER HEATERS	
Tay-Holbrook, Inc., San Francisco, Oakland, Sacramento, Fresno, San Jose	74
WINDOWS	
Kawneer Mfg. Co., Eighth and Dwight Streets, Berkeley	72
Dalmo Sales Co., San Francisco	70
WINDOW SHADES	
California Shade Cloth Co., 210 Bayshore Boulevard, San Francisco.....	68
Wm. Volker & Co., 631 Howard Street, San Francisco	75

Phone GARfield 1164

Hunter & Hudson

Consulting Engineers
**DESIGNERS OF HEATING
 AIR CONDITIONING
 VENTILATING AND WIRING
 SYSTEMS, MECHANICAL
 AND ELECTRICAL EQUIP-
 MENT OF BUILDINGS**

41 SUTTER STREET
 ROOM 710
 San Francisco California

JOSEPH MUSTO SONS-KEENAN COMPANY

MARBLE
and
ONYX

535 NORTH POINT STREET
 SAN FRANCISCO
 1801 S. SOTO STREET
 LOS ANGELES

Smith

Lumber Company
 WHOLESALE - JOBBING - RETAIL
 FACTORY AND BUILDING LUMBER
 PLYWOODS - ROOFING

DISTRIBUTING YARDS
 San Francisco Oakland
 • 19th Ave. &
 4th & Channel Estuary
 Market 0103 FRuitvale 3174
 YOUR INQUIRIES SOLICITED

THE TORMEY COMPANY

**GENERAL PAINTERS
 AND DECORATORS**

Phone UNDERhill 1913

563 FULTON STREET
 San Francisco

THE ARCHITECT
AND ENGINEER

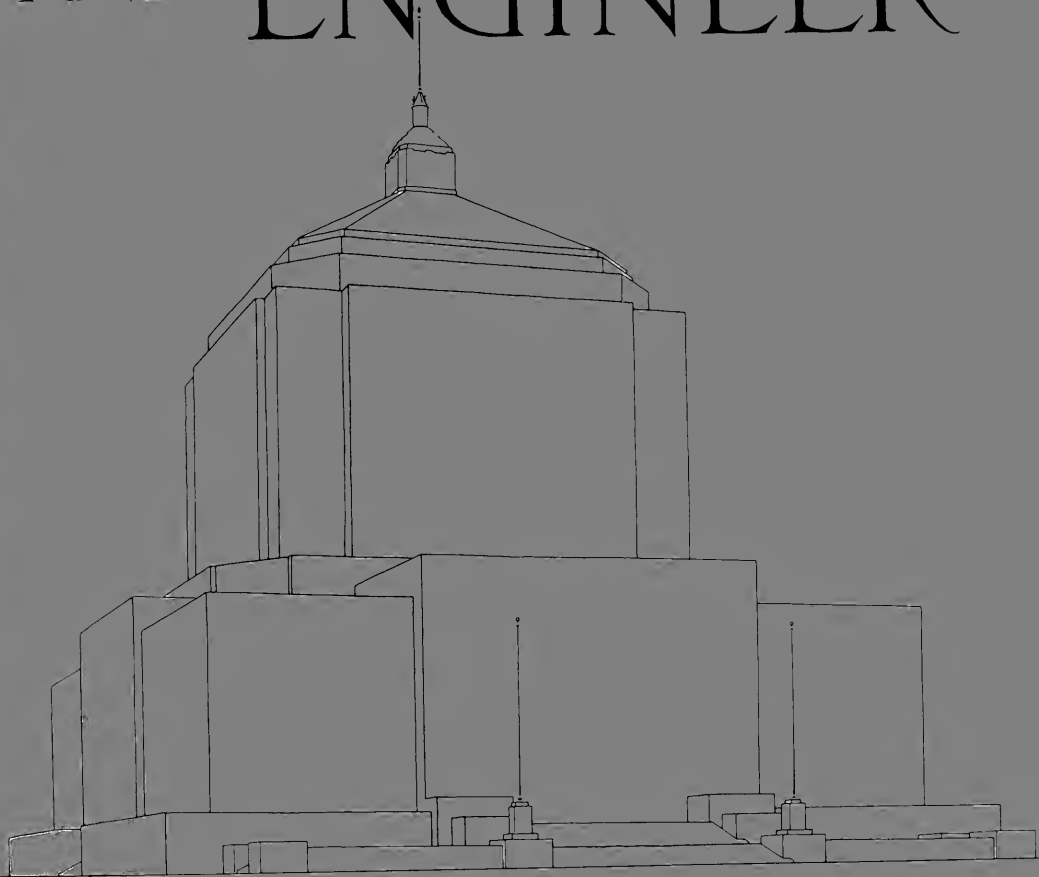

THE · ALAMEDA · COUNTY · COURT · HOUSE

SEPTEMBER 1936

Plan for PROTECTION

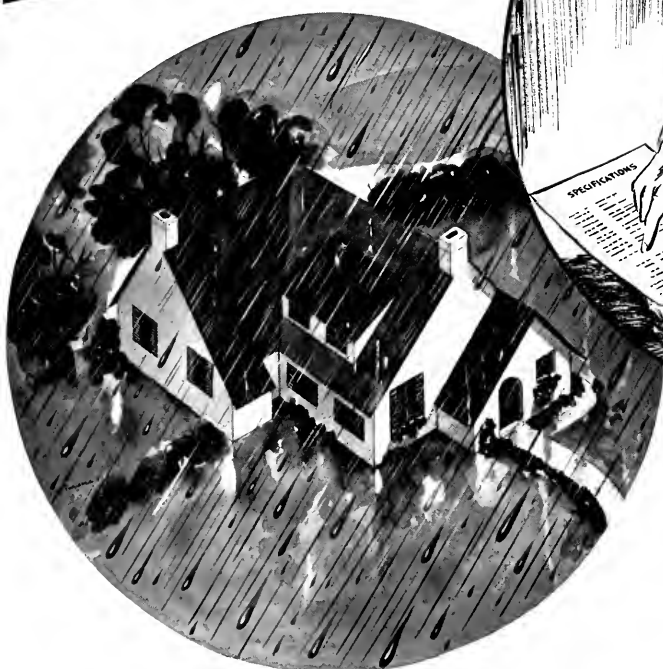

When you plan that new home, plan it so moisture and dampness will be sealed out forever. One of the surest precautions is to specify TAN PLASTIC and see that it is used right.

TAN PLASTIC *pourability* assures a solid impervious concrete with even, smooth surfaces. TAN PLASTIC color assures pleasing appearance.

Whether it's architectural concrete... foundation... basement or stucco... make sure the specifications include "TAN PLASTIC." Used right it never disappoints.

PACIFIC PORTLAND CEMENT COMPANY

SAN FRANCISCO • LOS ANGELES

COASTWIDE SERVICE

PORTLAND • SEASIDE

THE ARCHITECT AND ENGINEER

*Presents
for September
1936*

Cover

ALAMEDA COUNTY COURT HOUSE

W. J. L. KIERULFF
President

Frontispiece

FRED'K. W. JONES
Vice President and Editor

COURT HOUSE AND HALL OF RECORDS, OAKLAND, CAL. 18
Corlett, Plachek, Minton, Schirmer and Werner, Architects

LOUISE B. PENHORWOOD
Secretary

Text

EDGAR N. KIERULFF
Advertising Manager

OAKLAND'S MONUMENTAL COURT HOUSE 19
Homer M. Hadley

J. LESLIE MEEK
Advertising

NOBLE STRUCTURE DOMINATES CITY SKYLINE 25
Fredrick Williams

VERNON S. YALLOP
Architects' Reports

COURT HOUSE STRUCTURAL DESIGN 33
Will G. Corlett

ARTHUR BROWN, JR.
HARRY MICHELSEN

MECHANICAL AND ELECTRICAL EQUIPMENT 37
G. M. Simonson, Consulting Engineer

W. G. CORLETT
Advisory Editors

ARCHITECTS' FEE A SAVING TO THE OWNER 41
Howard J. White

SPINNING CABLES OF GOLDEN GATE BRIDGE 43
Robert G. Broch

ACOUSTICS IN REMODELED STRUCTURES 49

MORE STATE PARKS AND BEACHES 51
William E. Colby

ARCHITECTS' BULLETIN 53

WITH THE ARCHITECTS 59

Plates and Illustrations

COURT HOUSE AND HALL OF RECORDS, OAKLAND, CAL. 18-36
W. G. Corlett, J. W. Plachek, H. A. Minton, W. E. Schirmer and Carl Werner,
Architects. George Wagner and K. E. Parker Co., General Contractors

HOTEL DEL MONTE 54-55
Garden View, Lounge and Roman Plunge

THE ARCHITECT AND ENGINEER, INC., 68 Post Street, San Francisco, EXbrook 7182. Los Angeles office, 832 W. 5th Street. New York representative, Chas. W. Barton, 551 Fifth Avenue, New York City, N. Y. Chicago representative, Harry B. Boardman, 123 West Madison Street, Chicago, Ill. Published on the 12th of each month. Entered as second class matter, November 2, 1905, at the Postoffice at San Francisco, California, under the Act of March 3, 1897. Subscriptions, United States and Pan America, \$3.00 a year; Foreign countries, \$5.00 a year; single copy, \$.50.

Notes and Comments

NEXT month the State Association of California Architects will gather in annual convention at Del Monte—a beautiful spot in which to dream and play. Architects from all points of the State will assemble there for a few days rest, comradeship and entertainment. Fussy clients, bothersome contractors and financial worries will be temporarily, at least, cast to the winds. And after it is all over who shall say these fellows who contribute so much to the beauty and comfort of our existence, are not that much better to go on with their noble work. The October issue of the Architect and Engineer will be dedicated to the architects of the State with the wish that it may cement a closer unity of purpose among the members of the Association who seek to accomplish bigger and better things for the profession. A full report of the Del Monte meeting will be published in November.

* * *

THE new Alameda County Court House which is so profusely illustrated in this issue, is a splendid example of what a public building can be when capable architectural and engineering service is engaged. So that there might be no cry of favoritism the Supervisors appointed a board of five representative architects to design the building, each possessed of sufficient training and experience to warrant his commission. The five members have conferred on all matters pertaining to the design and construction of the building and unity of action has marked the board's activities throughout the undertaking... Differences in policy have been conspicuous by their absence and if there has been any lack of harmony it has not appeared.

To Messrs. Corlett, Plechek, Minton, Schirmer and Werner, the community owes its appreciation. The work of these architects speaks for itself. Alameda County has a public edifice equal if not superior to any similar structure in the country—a building both monumental and utilitarian, a building structurally permanent, specious, massive and satisfying architecturally.

* * *

THERE appears to be a wide difference of opinion to the decision of the jury in connection with the Oregon State Capitol competition. No doubt some good will come out of this competition for the profession has learned a few things because of it—and the layman, too, for that matter. Arthur Brown's comment in the July issue of The Architect and Engineer was read with widespread interest, the reaction being that it was fair and constructive. Under the sub-title "Capitol Design Unpopular" the Oregon Journal published the following:

Public reaction to the decision of the judges in the Capitol design contest varied from emphatic disapproval to approval . . . Comment by State officials for public consumption was highly favorable to the design, but "off the record" comment was not so complimentary.

From The Federal Architect, Washington, D.C., we learn that the winning design offers "one of the big opportunities to tie the stream-line modern back to architecture." "It is to be hoped," this paper says, "that in the Salem Capitol inspirational achievement may be realized without throwing everything into the discard.

"In the endeavor to achieve the freshness and newness similar to that which characterizes this winning design, our architects of the present decade have thrown into the garbage heap everything in their frenzied sighing for newness."

From Portland, Oregon, we have received quite a few comments and some of the Oregon architects who took part in the competition, have asked that their designs be published in The Architect and Engineer. This will be done in an early issue with suitable comments by Roi L. Morin, prominent Portland architect, and an entrant in the competition.

* * *

EVERY thinking architect should read Mr. Holland's article in last month's issue of The Architect and Engineer on "The Function of Functionalism". Those who have read it have expressed pleasure and gratification. Mr. Holland writes constructively, logically, scholarly. Alfred Busselle, A.I.A. in a letter to the Institute's official paper, The Octagon, praises Dr. Holland for his thought provoking statement on the practice of architecture and adds:

"Far beyond its nominal scope it suggests the status of a true architect.

"We cry aloud for recognition. My feeling is that many of us are more concerned with being recognized than we are with being architects. There is no reason, other than in ourselves, why we should have to battle for our jobs with commerce, with industry, with home builders, and with government itself, quite apart from emulation among ourselves.

"Let us ask ourselves searchingly, 'Are we master craftsmen?' If we are not, we are not architects. We may be great designers in a limited sense, good business-getters or golf-players, but not architects.

"A master-craftsman sees his whole problem; the creation of a thing of use, convenience and beauty, made to serve its whole purpose. The client can employ no other without at least partial failure of his purpose. There should be no question about it in the public mind.

"The master-craftsman concerns himself with his clients' interests from every point of view. He may incidentally build a personal monument, in fact he should do so, but only as a by-product, not as an objective. Great men there have been and doubtless are, who seem to have built such personal monuments consciously. But this has happened mostly when the problem itself was monumental.

"The master-craftsman knows of himself how things are done, how buildings and their several parts go together and as he designs he constructs. I am afraid too many of us are not sufficiently scourged by the comment: 'He's a good architect, but he's an impractical fellow.' Such comment illuminates the popular conception. It means that the speaker does not expect very much from an architect, and that if the client had a really important piece of work to do, the architect would have as small a place and as small a fee as possible.

"The master-craftsman feels that he is responsible for good work and he refuses to take as his tools those who cannot or will not produce it. He is not plagued by 'the lowest bidders,' or any considerable number of bidders. He selects those he wants. That this statement should be called Utopian merely shows how far we have fallen.

"Let us try to raise ourselves by realizing that our highest praise is to be worthy of the full rich meaning of the term 'master craftsmen'."

* * *

LAST month we said something about the layman who would accept most any kind of draughting service just so long as he could avoid paying an architect's fee. Particular reference was made in the article to gratuitous plans by contractors and large corporations that have something to sell besides blue prints.

Appros to the discussion of "service without pay," the following editorial by Frederick E. Towndrow, F.R.I.B.A., in Design and Construction for July and reprinted in The Octagon under the caption: "Sans Roof: Sans Architect," is most timely:

* * *

THE Ottawa correspondent of The Observer has provided me with a two-point topic. A new Canadian Housing Act provides that where a prospective house-purchaser can furnish 20 per cent of the cost of building his own home, the loan companies will furnish 80 per cent, of which 20 per cent is loaned or guaranteed by the Dominion Government. But this Act lays down rigid regulations as to standards of construction and materials, and it was found—when they came to it—that the creations of the ordinary builders

(Please turn to Page 75)

Welcome to DEL MONTE!



California Architects' Association Convention, Hotel Del Monte October 15 to 18

DEL MONTE extends a cordial invitation to the architects of California, meeting at Hotel Del Monte from October 15 to 18.

Situated on the historic Monterey Peninsula, eight hours north of Los Angeles and three hours south of San Francisco, Del Monte combines the niceties of modern living with a romantic, old-world background.

Within easy driving distance are many reminders of early California—historic adobes, the house where Robert Louis Stevenson lived, the old whaling station, California's first customs house, Mission San Carlos Borromeo where Fra Junipero Serra lived and where today he lies buried.

From Los Angeles, there is through Pullman service to Del Monte on the *Sunset Limited*, an easy, overnight trip.

A 20,000 ACRE PLAYGROUND

It is difficult to mention any sport that Del Monte does not provide. There's golf on the Del Monte course or the beautiful Pebble Beach links. Swimming in the surf or the magnificent Roman Plunge in the Hotel grounds. Tennis on your choice of many courts. Riding on a hundred miles of private bridle trails. Dinner dancing in the lovely Bali Room. Badminton. Bicycle riding. Sightseeing on the Seventeen Mile Drive.

HOTEL DEL MONTE

Carl S. Stanley, Manager

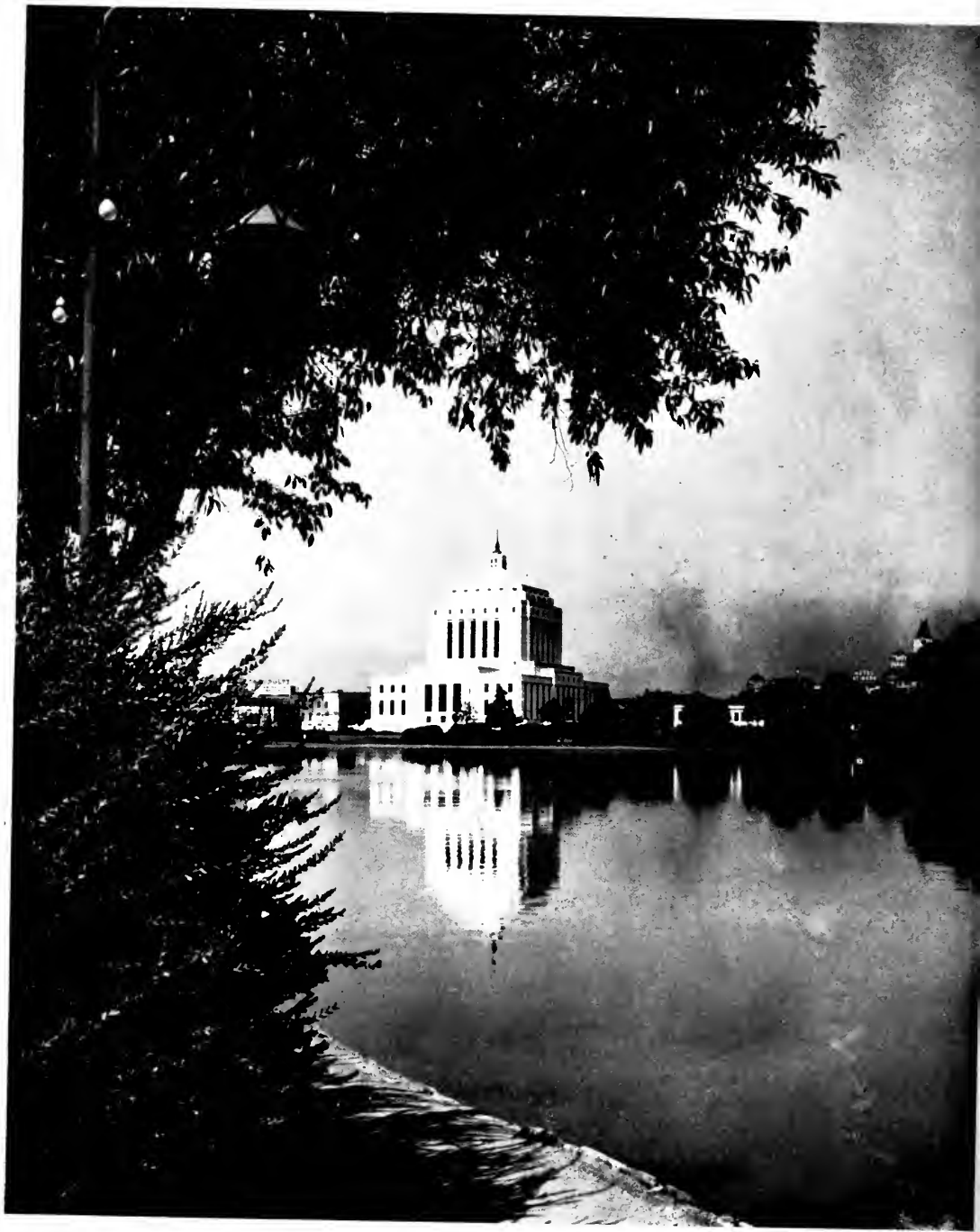

COURT HOUSE AND HALL OF RECORDS, OAKLAND, CALIFORNIA,
LOOKING ACROSS LAKE MERRITT

W. G. CORLETT, J. W. PLACHEK, H. A. MINTON, W. E. SCHIRMER AND
CARL WERNER, ARCHITECTS.

OAKLAND'S MONUMENTAL COURT HOUSE

PLEASING DESIGN IN REINFORCED CONCRETE AND STONE

By Homer M. Hadley



WHEN one reviews the many excellent features of Alameda County's monumental Court House and Hall of Records, Oakland, California, he is left with two outstanding impressions.

The first is a feeling of strength and power which the great square central superstructure, rising from its broad wide base, creates in the mind of the beholder. "The hills rock-ribbed and ancient as the sun" find here their counterpart: simple, unfeigned, dignified.

The second impression is good American efficiency, created by the building's interior arrangement and appointments. Space has been fully utilized. Circulation is direct and open. Light and ventilation are the best. Furnishing and trim are of excellent quality, sound and serviceable, but are neither over-

ornate nor costly. It appears a good place to work in. And its top stories' jail promises to function most effectively—let him escape who can!

This building results from the inadequacy and obsolescence of Alameda County's old court house and from the need for proper facilities for conducting the county's business. It has been financed by a bond issue, supplemented by two P.W.A. grants totaling \$481,000. The general contract, purchase of site, furnishings, architectural and engineering fees, etc., combine to give a final cost of \$2,195,000.

The main facade is the easterly one, overlooking Lake Merritt. Broad sweeping flights of granite steps reach to the grey-toned granite entrances. One enters through bronze doors into a spacious vestibule, ascending more steps to the main floor level and pro-

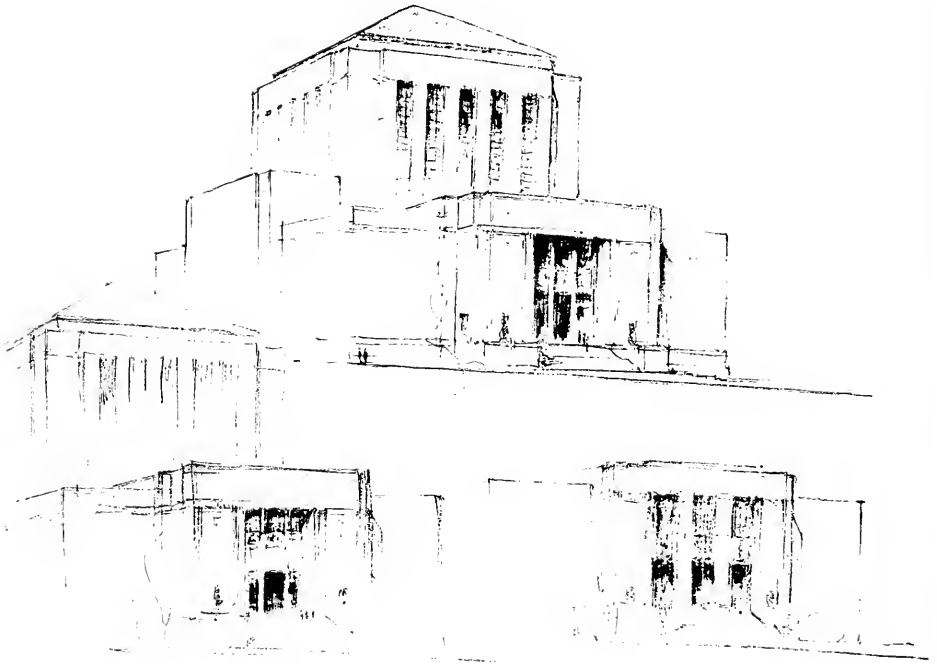
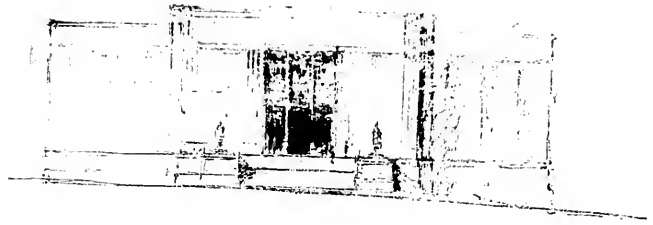

PRELIMINARY STUDIES
ALAMEDA COUNTY
COURT HOUSE,
OAKLAND, CALIFORNIA

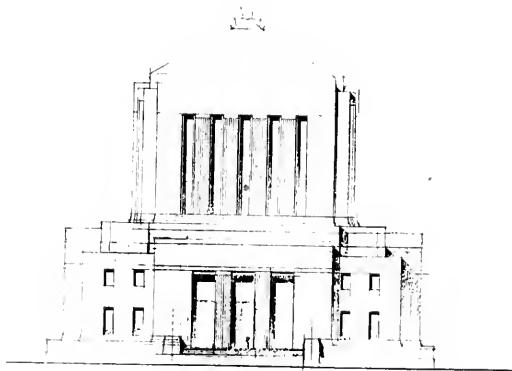



FINAL PROGRESS STUDIES AND
ARCHITECTS' PERSPECTIVE OF
ACCEPTED DESIGN, ALAMEDA COUNTY
COURT HOUSE AND HALL OF RECORDS,
OAKLAND, CALIFORNIA

Rendering below by Edward H. Gehrke
W. G. Corlett, J. W. Plachek, H. A. Minton,
W. E. Schirmer, and Carl Werner,
Architects

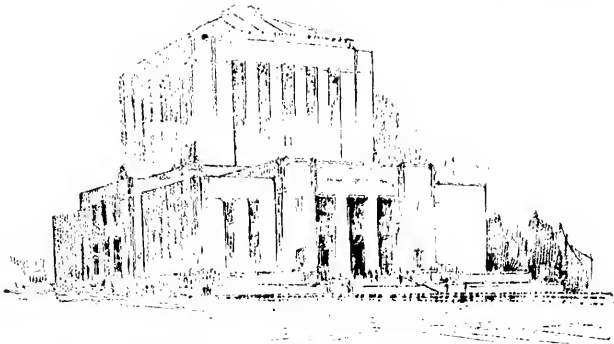

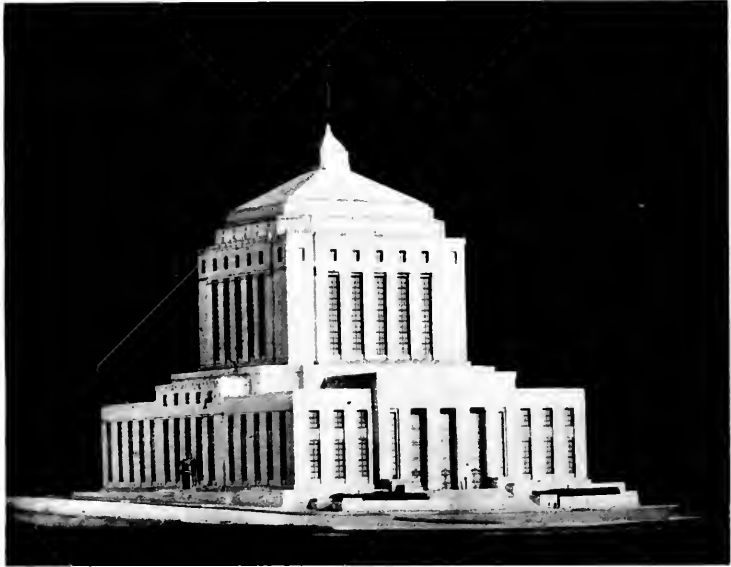

CARDBOARD MODEL OF COURT HOUSE MADE PRIOR TO WORKING DRAWINGS
Scale 16" to foot



VIEW OF COMPLETED COURT HOUSE
Note similarity to model

ceeding to the central lobby space where the bank of elevators is found. The transverse north-south corridor naturally is located to pass through this focal point. The corridors are faced with beautiful Appalachian Roseal marble, the soft tints and tones of which are most pleasing. Corridor ceilings are of cast and run plaster with Holograph directed lights placed along the axes of the corridors. No hanging chandeliers are used here.

11th stories of the tower. One is impressed with the varied and manifold uses to which this building is put.

Structurally it is a great monolith, a framework of steel encased in reinforced concrete. At every story there is the full horizontal plate or diaphragm of the floor framing while vertically the whole extensive system of exterior walls together with certain interior walls are of reinforced concrete. Walls, floors, and frame



ANOTHER INTERESTING VIEW OF THE COURT HOUSE FROM ACROSS LAKE MERRITT, OAKLAND, CALIFORNIA

On this main floor and in the upper stories are located the offices and quarters of various county officials and courts. The board of supervisors, the treasurer, the clerk, the recorder, the engineer, the district attorney and others, are now furnished with adequate space and facilities which have long been lacking. Ten court rooms, judges' chambers, jury rooms, witness rooms, large law library and other rooms will provide for the legal and judicial processes of the county. A jail for prisoners awaiting trial occupies the 10th and

are tied together with detailed reinforcement and every effort has been made to achieve structural unity and rigidity and consequent earthquake resistance.

These aims and objectives have been realized and there has resulted a building of such efficient strength that it is difficult to conceive of danger or serious damage from an earthquake. Buildings like this will acquit themselves so well when put to the test that they will largely dissipate the fears now entertained of earthquake harm. If there is no damage what then is the harm?



GEORGE WAGNER AND K. E. PARKER COMPANY, GENERAL CONTRACTORS
COURT HOUSE AND HALL OF RECORDS, OAKLAND, CALIFORNIA
W. G. CORLETT, J. W. PLACHEK, H. A. MINTON, W. E. SCHIRMER
AND CARL WERNER, ARCHITECTS

NOBLE STRUCTURE DOMINATES CITY SKYLINE

OAKLAND COURT HOUSE HAS ARCHITECTURAL BEAUTY

by Fredrick Williams

ALAMEDA County's new Court House and Hall of Records, in its beautiful setting on the shores of Lake Merritt, in Oakland, California, is rapidly nearing completion and will be finished and ready for occupancy October first.

Its two hundred feet of height rises from a base which, with its areaways and approaches, occupies a full city block of two hundred by three hundred feet, bounded by Fallon Street, Twelfth Street, Oak Street and Thirteenth Street. The structure dominates the skyline and surroundings of this portion of the city and is placed to group with present and future public buildings around the south end of Lake Merritt.

The building is massive and dignified in form with uniformity of treatment and finish on all four frontages. Simplicity and directness have been achieved without the use of expensive materials or elaboration of ornament, decoration and detail.

Structurally permanent, fireproof and earthquake resistive, it has a complete structural steel frame fireproofed with concrete and reinforced concrete walls, floors and roofs. Above this the exterior is trimmed with belt courses, copings, and spandrels of granitex terra cotta. The base, approaches, steps and ground floor area walls are of California granite.

The ground floor, or lowest floor level, is

higher than the sidewalk grade at Thirteenth and Fallon Streets, above which there are twelve more floor levels. The lower three floors are one acre each in area, and there is a total building area of five and one half acres. The building is planned to have the simplicity and efficiency of a practical office structure in economy of space devoted to circulation, with careful attention given to the convenience of the public, including accessibility to the various departments, adequate day-lighting and economical and durable design for economic operation of the building as a whole. Congestion is avoided and directness of approach to various departments is provided, with a consequent saving of space and cost and economy in operation of the building.

The departments where large numbers of people transact business are all on the lower floors,—(first and second). Court rooms and their adjuncts are on the upper floors,—(third to eighth) devoted exclusively to court uses apart from other county departments. The district attorney's office occupies the entire ninth floor while a complete jail with the necessary adjuncts for prisoners awaiting trial, is provided on the tenth and eleventh floors. Accommodations are provided for one hundred and ten prisoners with day rooms, kitchen, visitors' corridors, attorneys' consultation rooms, as well as quarters for the jailer, bureau of identification, physician, photographer, etc. Four large passenger elevators and a jail eleva-

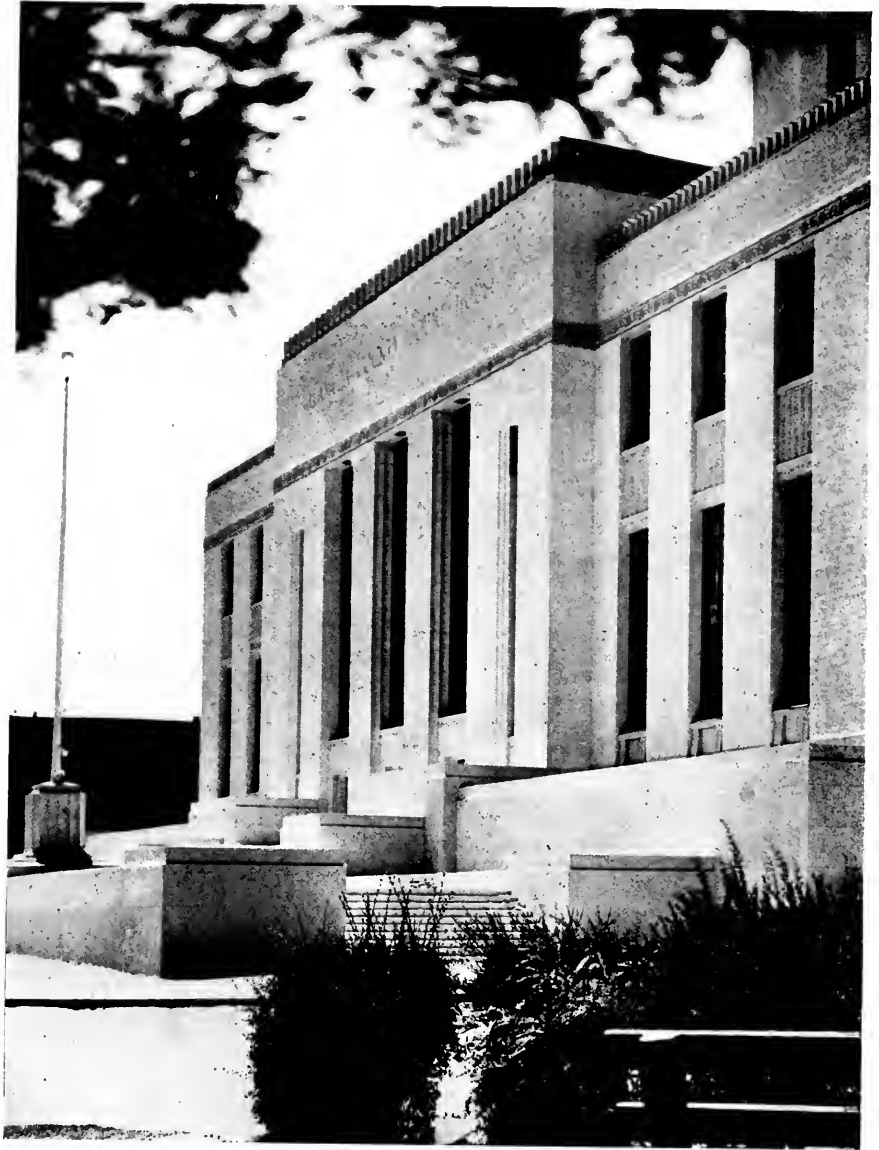

FALLON STREET FACADE, COURT HOUSE AND HALL OF RECORDS,
OAKLAND, CALIFORNIA

W. G. CORLETT, J. W. PLACHEK, H. A. MINTON, W. E. SCHIRMER AND
CARL WERNER, ARCHITECTS

tor serve the upper floors. The special elevator, exclusively for service to the jail is accessible from a vehicular under-pass through the building at the ground floor level and provides access to all court rooms from above or below, entirely out of view of the public.

Space is provided for all county elective offices and superior courts, as well as other necessary adjuncts, including treasurer, tax collector, auditor, county superintendent of schools, county development commission, assessor and recorder, on the main floor and main floor mezzanine; building superintendent, adult probation officer, weights and measurers department, mosquito abatement district, county library, county agricultural commissioners, storage rooms, boiler room, fan room, carpenter shop, paint shop, and under-pass driveway, on the ground floor; supervisors' chamber, large committee room and public office, county clerk, county surveyor, civil service commission, county purchasing agent,

sheriff, and law library on the second floor; with mezzanines for county clerk, surveyor, and private offices and storage room for supervisors on the third floor level connecting directly to the second floor; four court rooms each on the third and fifth floors and two court rooms on the seventh floor, all with jury rooms, judges chambers, witness rooms, ante rooms, vestibules, court reporters and transcribing rooms on the intermediate floors (fourth, sixth and eighth); public defender and public administrator's offices on the seventh floor; district attorney's office on the ninth floor; jail cells, day rooms, kitchen, visitor's lobby, etc., on the tenth floor; jail cells, day rooms, bureau of identification, doctor, etc., on the eleventh floor; and elevator and mechanical equipment on the twelfth floor. A cupola atop the roof is accessible for extensive observation in all directions over Oakland, adjacent cities, the hills and bay.

All procedure has been under the direction

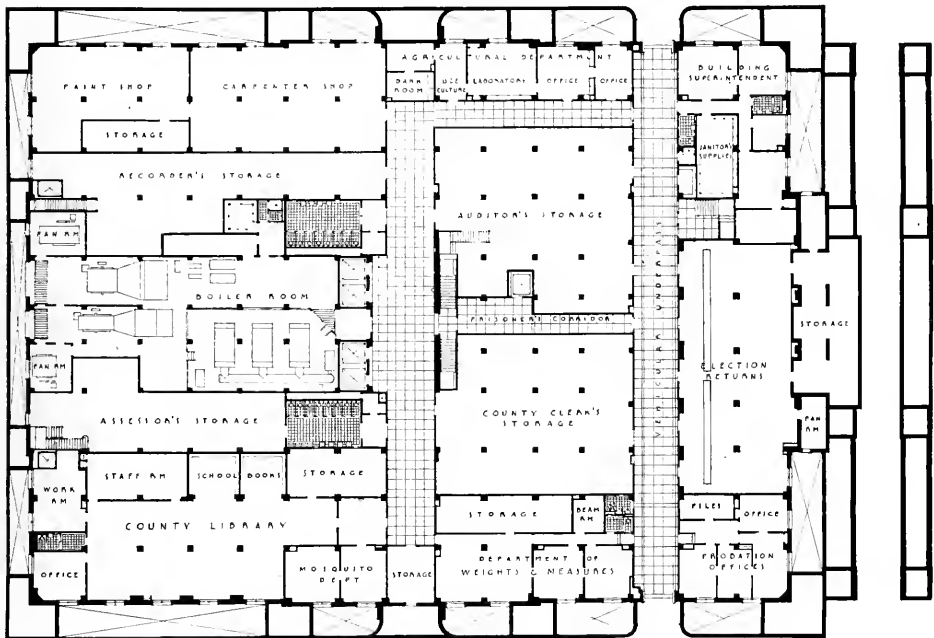

GROUND FLOOR PLAN, COURT HOUSE AND HALL OF RECORDS, OAKLAND, CALIFORNIA



DETAIL OF FALLON STREET FRONT, COURT HOUSE AND
HALL OF RECORDS, OAKLAND, CALIFORNIA

W. G. CORLETT, J. W. PLACHEK, H. A. MINTON, W. E. SCHIRMER AND
CARI. WERNER, ARCHITECTS

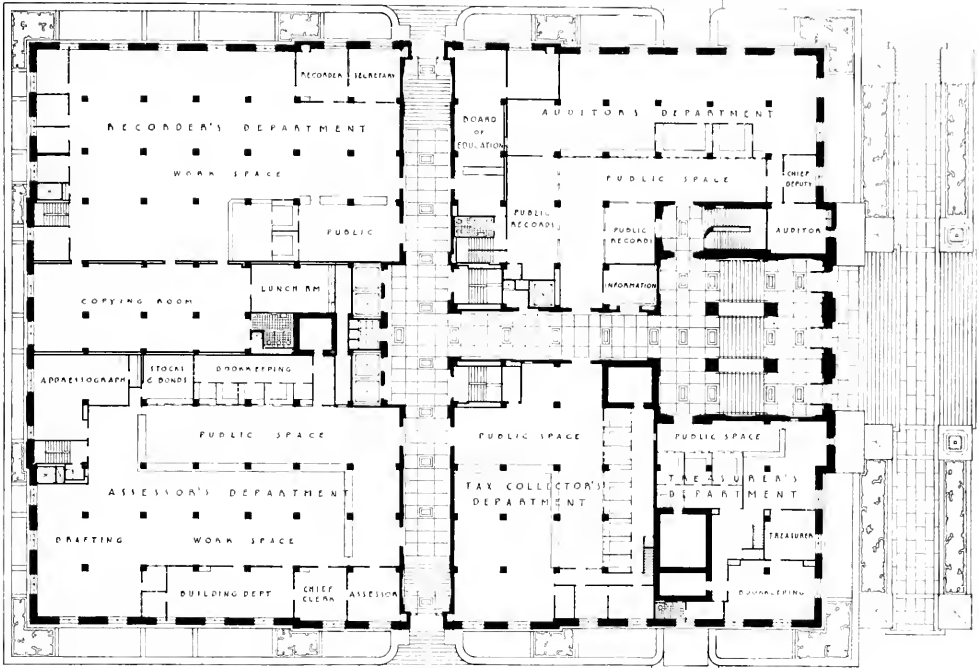

FALLOON STREET

FIRST FLOOR PLAN, COURT HOUSE AND HALL OF RECORDS, OAKLAND, CALIFORNIA

of the Board of Supervisors,—Wm. J. Hamilton, Ralph V. Richmond, Geo. A. Janssen, Thos. E. Caldecott and Clifford Wixson.

Total costs including land, building, expenses, architecture, engineering, tests, inspections, furnishings and equipment will be \$2,195,000 which is within the amount of bonds voted plus Federal grants. Cost of building only was approximately \$1,700,000.

Architectural, structural and mechanical design and supervision have been by Will G. Corlett, Henry A. Minton, James W. Plachek, Wm. E. Schirmer and Carl Werner, architects. J. Harry Blohme has acted as engineer inspector for the P.W.A. and Alfred L. Vezina, chief inspector and G. M. Simonson, mechanical engineer.

SOME COURT HOUSE DATA

Site: 200 ft. x 300 ft.
 Building Dimensions: 176 ft. x 244 ft. plus areas and approaches.
 Contents: 4,000,000 cu. ft.
 Area: 235,000 sq. ft. or 5.4 acres; Ground, First and Second Floors, 1 acre each.

Building Funds:

Bond Issue	\$1,712,000.00
Sale of Old Buildings	1,700.00
Federal Grants	481,350.00
	<hr/>
	2,195,050.00

Costs:

Purchase of Site	\$ 268,000.00
Preliminary Expense, Surveys, Borings, Bond Expense, etc.	13,944.38
Architecture, Engineering, Inspection and tests	140,087.61
Building Contracts	1,634,609.11
	<hr/>
Reserve for Contingencies and Furnishings	\$2,056,641.13
	138,408.87
	<hr/>
	\$2,195,050.00

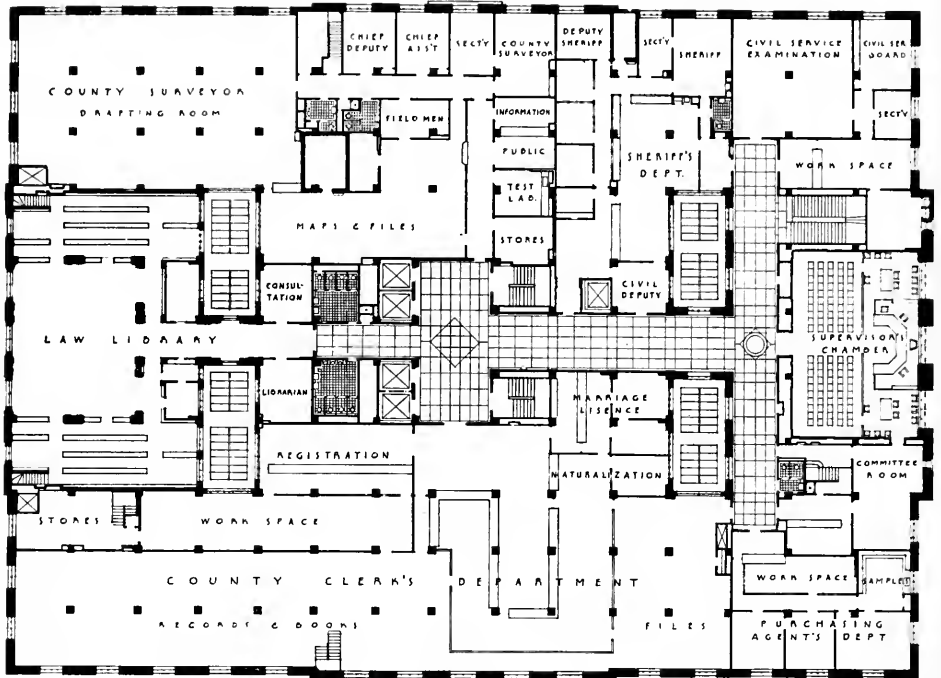

SECOND FLOOR PLAN, COURT HOUSE AND HALL OF RECORDS, OAKLAND, CALIFORNIA

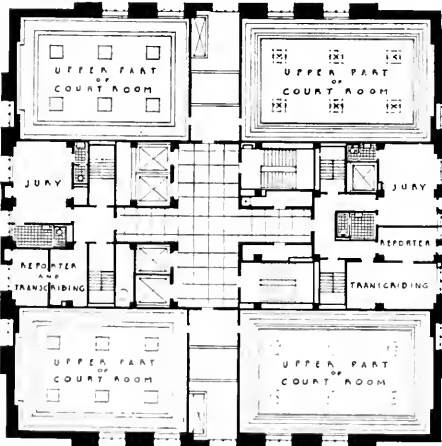

TYPICAL COURT ROOM FLOOR
(Third, Fifth and Seventh)

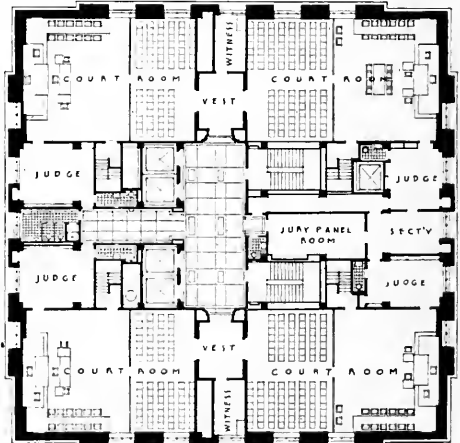

TYPICAL INTERMEDIATE COURT ROOM FLOOR
(Fourth, Sixth and Eighth)

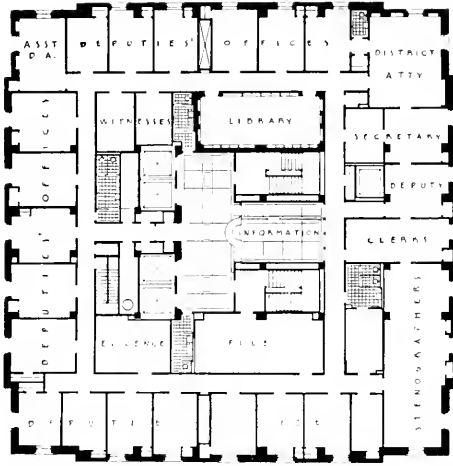

DISTRICT ATTORNEY'S OFFICE
(Ninth Floor)

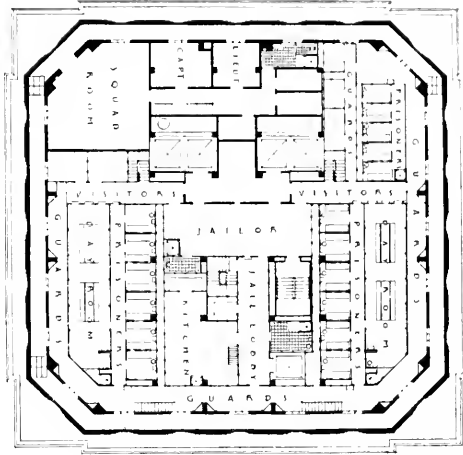

JAIL QUARTERS
(Tenth and Eleventh Floors)



TYPICAL COURT ROOM ENTRANCE



ENTRANCE DOOR TO SUPERVISORS' CHAMBER



MAIN ENTRANCE LOBBY FROM
SUPERVISORS' STAIRWAY



ELEVATOR DOOR, FIRST FLOOR LOBBY



LOBBY, COURT ROOM FLOOR



CORNER OF LAW LIBRARY

COURT HOUSE STRUCTURAL DESIGN

BUILDING BUILT TO RESIST LATERAL FORCES

by W. G. Corlett

THE new Alameda County Court House has a complete structural steel frame with reinforced concrete floor and roof slabs and reinforced concrete walls. Exterior finish of walls is waterproofing and white cement and sand dash.

Foundations are individual spread footings of reinforced concrete with square pedestals to the approximate ground floor level with the tops of all footing pedestals interconnected with 12 inch by 14 inch reinforced concrete tie beams in both directions. All footings are square, there being no combined or cantilever footings.

A thorough investigation of foundation soil conditions was made, consisting of sub-surface geologic exploration, penetrometer tests, laboratory tests and field tests for bearing values. Eight exploration shafts were sunk,

averaging over forty (40) feet in depth, and sufficient in diameter for a man to descend for accurate observation and measurements. Complete geologic sections for the entire area were plotted. Field bearing tests were made with load-settlement curves plotted up to 21,000 pounds per square foot and Time-Load-Settlement graphs up to 108 hours and 12,000 lbs. per square foot. Character, density and moisture conditions of soil were carefully considered in place as well as in the laboratory.

Footing levels in the deeper portion, approximately thirteen feet six inches below the ground floor level, were established,—locating the footings in the lenses of the more consolidated clay and coarse sand and gravel. The tests indicated six thousand pounds per square foot as a conservative bearing value. Footings were designed on a basis of 5200

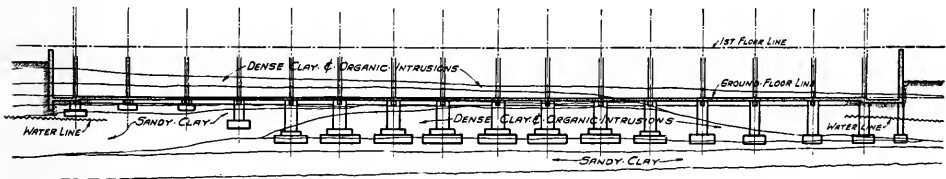

SECTION THRU FOUNDATIONS

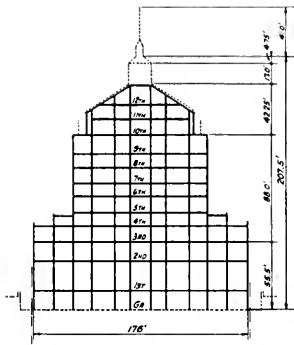

TRANSVERSE SECTION

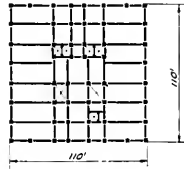
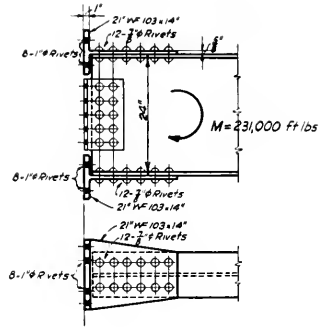

PLAN AT 7TH FLOOR STEEL

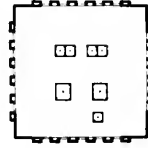

PLAN AT 7TH FLOOR CONCRETE

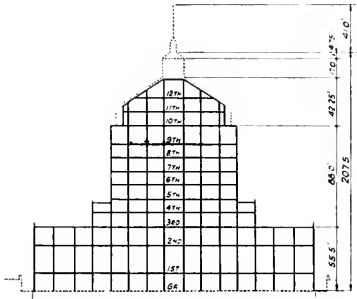

LONGITUDINAL SECTION STEEL

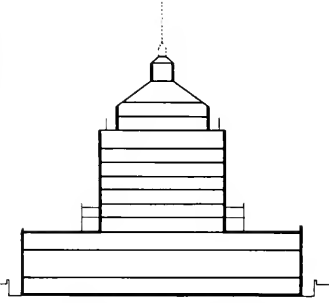

LONGITUDINAL SECTION CONCRETE

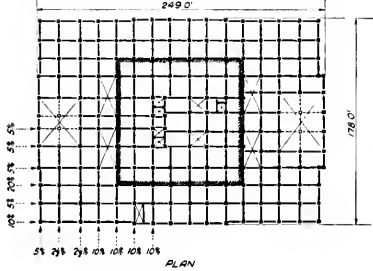

PLAN

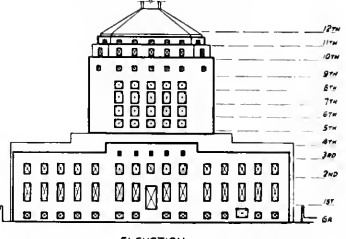

ELEVATION

STRUCTURAL DIAGRAMS, COURT HOUSE AND HALL OF RECORDS, OAKLAND, CALIFORNIA

pounds per square foot per dead load only. Live load being small in proportion to dead load, full live load will keep pressures within 6000 pounds per square foot. All steps, approaches, area walls, etc. are carried on isolated footings to the same soil strata.

Execution of the work of excavation and foundations verified predetermined geologic data and it was not found necessary to change pre-established footing levels.

The structural steel frame, including all beams, girders and columns, was fabricated entirely of rolled sections. No built-up sections, plate girders or trusses were required. Careful architectural planning made it unnecessary to offset beams and columns. All columns carry through directly to the foundation and practically all main beams and girders, including wall and spandrel beams, are on column centers. All steel is encased in concrete fireproofing. Beams 21 inches and over in depth are fireproofed with pneumatic concrete to a thickness of two inches to eliminate dead weight. The total tonnage of structural steel in the frame was 2158 tons or 18.5 lbs. per square foot of floor or 1.1 lbs. per cubic foot of building.

Recognizing the probability of earthquakes due to the proximity of the Hayward Fault, approximately five miles to the east, and the San Andreas Fault, approximately 15 miles to the west, a careful analysis of lateral forces and design therefore was made. The structural steel frame was designed for a lateral force equivalent to 2% of the Dead plus Live Load of the completed structure, which for parts of the building is equivalent to a 43 pound wind pressure. It is of interest to note that the design for 2% of gravity increased the steel tonnage by approximately 10% over a design for 15 pound wind pressure. In the superstructure the wall bents alone were used to resist lateral forces. At the third floor, or the base of the superstructure, a heavy concrete slab was used as a

diaphragm to distribute lateral forces. Forces were distributed to the various bents in proportion to their rigidities and the usual approximate methods were used in the analysis. In all cases cut beam connections, top and bottom, of the general type shown were adequate, all rivets being $\frac{7}{8}$ " diameter. The allowable working stresses used in the lateral analysis were normal working stresses with 1/3 increase.

It was recognized that the steel frame, designed for a lateral force of 2% of gravity would have adequate strength to resist large lateral forces, but would prove much more flexible than the relatively rigid exterior concrete walls. The building was therefore considered as a rigid structure and walls are designed to resist a lateral force equivalent to 20% of the Dead Load with allowable design stresses within the elastic limit of the reinforced concrete. Shears were proportioned to the piers according to their relative rigidities considering both bending and shearing deflections and spandrels and piers were adequately reinforced to resist this bending and shear. Exterior wall thicknesses range from 14" in thickness to a minimum of 8" and all walls in the lateral force systems were of high strength concrete (3000# in 28 days design assumption) with two (2) layers of reinforcement in all walls.

The lateral force design as a rigid structure with a high lateral force was a departure from the usual design for buildings of this height (200 feet) but was practical and possible because of the relative broadness, large symmetrical wall areas, regular framing, good horizontal diaphragms, good materials and unity of materials. No difficulties were encountered during construction and the added cost of reinforcement was not reflected materially in the total concrete cost. There was a total of 15,300 cu. yds. of concrete in the building and 926 tons of reinforcing steel or 16.5 cu. yds. of concrete per ton of reinforcing steel. The amount of concrete per each cu. ft.



ARCHITECTS—Reading from Left to Right: (Top) William E. Schirmer, Henry A. Minton, (Below) Carl Werner, Will G. Corlett and Jas. W. Plachek.

of building was .0039 cu. yards. The average cost of all concrete including forms, cement finish, reinforcing steel and pneumatic concrete was \$24.70 per cu. yd. in place.

The mix for the concrete in the exterior walls from the 1st floor to the 10th floor and 3rd floor diaphragm was designed to produce a strength of 3000# per sq. in. in 28 days. Test cylinders of this concrete taken during construction showed an average strength of approximately 4000# per sq. in. in 28 days. The mix for all other structural concrete was

designed to produce a strength of 2000# per sq. in. in 28 days and tests gave an average strength of 2800# per sq. in. in 28 days.

The structural design was made simultaneously with the architectural planning and designing in the office of the architects and under their direction. The group of structural engineers were Will G. Corlett, Arthur W. Anderson, Chas. N. Bley, M. V. Pregnoff and Searle B. Nevius. Labarre and Converse were foundation and testing engineers for foundation investigations.

MECHANICAL AND ELECTRICAL EQUIPMENT COURT HOUSE AND HALL OF RECORDS AIR CONDITIONED

by G. M. Simonson, Consulting Engineer

THE mechanical and electrical installations of the new Alameda County Court House and Hall of Records have been designed to provide modern and efficient equipment to insure the health, comfort and safety of the public and the county officers and employees.

The importance of the mechanical and electrical equipment was recognized by the architects and their co-operation and support made the installation possible.

The size of the building and the type of construction have been fully described in preceding articles. The heating, ventilating and air conditioning systems and the illumination system were designed to meet the conditions of occupancy and exposure to the weather in the various areas in the building. The lower floors of the building, being approximately one acre in area and which house the general county offices, present a far different problem from the upper tower section, in which are located the ten court rooms, the district attorney and the jail.

Heating System

The boiler room is located on the ground floor in the rear of the building. In this space are installed the heating boilers, house pumps, fire pumps, bilge pumps, large ventilating fans for ground, first and second floors, refrigeration compressors for air conditioning system and boiler room auxiliaries.

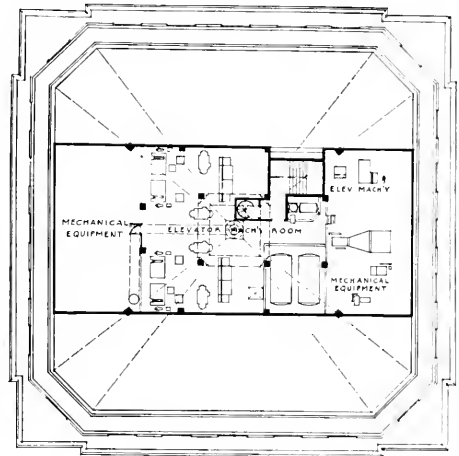

LAYOUT FOR MECHANICAL EQUIPMENT,
COURT HOUSE, TWELFTH FLOOR

The boilers consist of three 160 horse power and one 25 horse power low pressure welded steel heating boilers with rotary type fuel oil burners. The three large boilers are provided with hydraulic type combustion control system and are to carry the heating and hot water load. The small boiler is to be used for the night heating load of the jail and summer water heating.

The system is a two pipe vacuum system supplying steam to eight zones of direct radiators and to the ventilating and air conditioning heating stacks, and to steam coils for water

heating. The direct radiation zones are provided with mechanical control of automatic steam valves with temperature responsive elements operating from a combination of radiator temperature and outdoor temperature. The zones are provided on the north and south sides of the lower floors, all four sides of the tower section and north and south sides of the jail.

The system for the lower floors is a split system with direct radiation for the wall, window and roof losses and constant temperature air supply from the ventilating fans. The supply fans are arranged with tempering and heating stacks and by-pass dampers controlled by pneumatic duct thermostats in supply ducts to the various parts of these floors.

Ventilating System

The ventilating system is composed of twenty-two fan systems, eighteen of which have both supply and exhaust fans while four are exhaust systems only. The ten individual court room systems, the supervisors' chamber system and the law library system are all air conditioned.

The fans systems for the lower floors consist of three systems: No. 1—71,000 CFM for the north side and interior of the ground floor, first floor and first floor mezzanine; No. 2—50,000 CFM for the south side of the ground floor, first floor, first floor mezzanine and second floor; No. 3—27,700 CFM for the north side and interior of the second floor. Both supply and exhaust fans for the first two systems are located in the basement adjacent to the boiler room. Fresh air is admitted through louver dampers to each supply fan and recirculation dampers are provided for heating the building in the morning. The supply and exhaust fans for the third system are located on the third floor level at two corners of the tower. All three of these systems are provided with two pass oil type continuous curtain automatic air filters with synchronous motor control timers, tempering coils, heating coils and double dampers dividing the fan discharges into eight, six and three sections respectively.

All other supply systems, including air conditioning, have dry type air filters.

One supply and exhaust system serves the election returns department of the county clerk's office, one system the interior rooms from the third to ninth floors inclusive and one system the jail.

The motors for System 1 and System 3 are two speed and the motors for System 2 are three speed. The motors for all other systems are constant speed. All motors for ventilating systems, except the jail supply and exhaust system and the jail kitchen exhaust system, are controlled from a fan panel in the boiler room. The motor starters for supply and exhaust fans of the same system are electrically interlocked so that one push button station controls both fans. The multi-speed motors have selector switches on the control panels to control speeds of supply and exhaust fans simultaneously. Running pilot lamps and trouble lamps to indicate systems that have shut down due to overload have been provided on this panel. A common trouble bell on a relay circuit gives warning to the operator.

Air Conditioning

The ten court rooms, the supervisors' chamber and the law library are provided with separate air conditioning systems for heating and cooling.

The refrigerating equipment consists of three motor driven, direct connected six-cylinder 21-ton compressors producing chilled water for the air conditioning units and installed in the boiler room. The condenser water cooling system consists of a condenser water pump, pumping the water to an air washer type cooler on the third floor level at one corner of the tower. The fan for this air washer has a capacity of 49,000 CFM. The chilled water to the air conditioning units is pumped by a circulating pump in the boiler room. All of the above equipment is controlled by thermostat in the chilled water line with a multi-step wheat-stone bridge type motor operated controller starting or stopping the equipment in proper sequence, also starting or stopping compressors as required by the load on the air conditioning units. Switches are provided to vary

the sequence of operation of the compressors.

The air conditioning equipment for the court rooms and supervisors' chamber consists of specially designed vertical units with heating coils and by-pass dampers, and blast-type cooling coils with a capacity of 3,500 CFM each. The air conditioning units and their exhaust fans for the court rooms are located on the fourth, sixth and eighth floors in fan rooms over the lobbies to two adjacent court rooms, with units and exhaust fans for two court rooms in each fan room. Fresh air is admitted through screened openings in exterior windows and discharged above the ninth floor. Dampers are provided so that the exhaust air may be recirculated through the air conditioning units.

The air conditioning unit for the law library consists of a centrifugal fan with heating and cooling coils in two sections for the upper and lower floor of the library, and is located with its exhaust fan on the third floor level at one corner of the tower.

The heating and cooling coils of all air conditioning units are controlled by pneumatic dual thermostats installed in the rooms to be air conditioned. A control panel is provided in the boiler room with pneumatic control switches which shift these thermostats from heating to cooling by changing the air pressure in the system. Switches are also provided on this panel to control the recirculation dampers for the air conditioning systems as well as the dampers for systems No. 1 and No. 2.

The pneumatic control switches and the electrical fan control in the boiler room enables the engineer to control each court room, the supervisors' chamber and the law library individually.

Plumbing Installation

Adequate toilet rooms and lavatories have been provided as can be seen from the floor plans.

The water system consists of house pumps in the boiler room and pressure tanks in the



WILLIAM J. HAMILTON

FORESIGHT AND DIPLOMACY BIG SAVING TO TAXPAYERS

TO William J. Hamilton, Chairman of the Alameda County Board of Supervisors, is due no little credit for his indefatigable work in securing Federal aid which made possible the financing of the Court House project. After the people had petitioned for a bond election, feeling as they did, that the city and county were in sore need of a modern structure to replace an antiquated building, the electors on April 3, 1934 voted \$1,712,000 and immediately thereafter delegated Mr. Hamilton to go to Washington for an additional \$462,200 needed to cover cost of the improvement.

Refused at first, Mr. Hamilton declined to take no for an answer, and when he returned to his home city it was to advise his fellow townsmen that the needed funds had been pledged. Later a still further grant of \$19,150 was allowed.

Construction of the new building was started February 1, 1935 and on October 12, 1935 the corner stone was laid. The building was dedicated by the Native Sons and Daughters of the Golden West September 6 of this month. It will be fully completed and occupied October 1 next. Since contracts were let on the structure building costs and labor have increased to the extent that an award today for the same structure would cost an additional \$600,000 at least. So with the Federal aid added to this the county is over one million dollars to the good in addition to having one of the finest court houses in the country.

roof of the tower section. Hot water is generated in heaters in the boiler rooms and distributed in a gravity circulation system.

The fire protection system consists of an automatic fire pump of 500 gallons a minute capacity with hose racks distributed thruout the building. Dry stand pipes are also provided with steamer connections on the thirteenth street side of building.

A chilled drinking water system circulating to wall drinking fountains with a compressor unit located in the tower roof, has been provided.

Electrical System

The electrical system is fed from the power company's net work transformers in a vault under Oak Street to the main switchboard located adjacent to the boiler room. The service and system of distribution for both light and power is three phase, four wire, 120/208 volts.

The main light and power switches are carbon type air circuit breakers mounted above the main switchboard and connected thereto with flat copper busses. The main switchboard is a front connected board builtup of panels with thermal type circuit breakers.

Three phase four wire feeders for light and power are run to power distribution and lighting panels thruout the building.

Power panels are made up of circuit breakers similar to the main switchboard. Lighting panels are made up of single pole circuit breakers with three phase, four wire mains. Branch lighting circuits are three phase, four wire with a neutral common to three circuit wires.

All wire is 30% performance compound rubber covered, except the service cables which are paper insulated, lead encased.

The illumination of the building has been designed to produce the best possible working conditions and the intensity has been kept at a uniformly high level.

The entrance lobby, corridors, main stair-

ways, supervisors' chamber, law library and court rooms are illuminated by means of inbuilt fixtures utilizing prismatic control lenses. In the corridors multi-light units are used to conform to the shape of corridor and to provide group control. In the supervisors' chamber the lense units are arranged symmetrically around the glass ceiling light. In the court rooms the lenses are arranged in six groups of four each in a specially designed semi-flush mounting with opal glass panels and decorative bars. Thus there is a total absence of the ponderous hanging fixtures usually in monumental public buildings. The ceilings present a clean appearance and the illumination is scientifically distributed by accurate selection of lamp positions with respect to the control lenses.

The offices thruout the building are illuminated with total indirect fixtures except in the low ceiling areas where semi-indirect units are used. The intensity of illumination is from 18 to 20 feet candles except in drafting rooms where the intensity is 35 foot candles.

The front entrance of the building is illuminated by means of four flood lights concealed in the granite base at either side of the entrance. The entire building has been provided with conduits, outlets and panel cabinets for future flood lighting.

Conduits and outlets have been provided for a semi-automatic telephone system. A dictograph intercommunicating telephone system has been provided for the district attorney's department and a manual system for the jail and sheriff's office.

Resetting impulse type clocks provide uniform time thruout the building. A combined fire alarm and watchman's system has been installed with connections to the city fire alarm system and to the police system.

The treasurer's vaults are protected by a special system with sound detecting devices inside of vault and connections to the police system. A separate closed hold up alarm system is provided with connections to the sheriff's office.

ARCHITECT'S FEE A SAVING TO THE OWNER

COMPETITION HINDERED IF CONTRACTORS FURNISH PLANS

by Howard J. White

THERE are firms of contractors operating especially in the industrial field who secure contracts direct with the owners based upon plans and specifications that are prepared in their own organizations.

Some owners apparently are willing to take the chances of having the contract faithfully performed without the protection of the services of an architect. With this practice, the profession can do nothing if the contractors keep within the law. The profession does owe a duty to the owners, however, to make clear what the service of an architect means in the protection of their interests, and the advantages to be gained from the architect's skill and accumulated experience, contrasted with the skill of an unknown architect or draftsman in the contractor's employ and control.

With an honest contractor and with everything going well during construction, the objections from the owner's standpoint may be minimized, but if the market rises or with other emergencies occurring, errors in estimating or unlooked for conditions of soil, weather, etc., the general contractor and his sub-contractors are confronted with the temptation to "take it out of the job." They are, after all, human and do not relish doing work without a profit.

Plans and specifications of operations herein described are brief skeletons as compared with those usually employed by the architect and the owner's risk is thereby greatly enlarged.

The irony of this situation is that some of these contractors expect to keep the good will of the architects while they are subjecting him to unfair competition, and are resorting to practice which does not square with high professional practice.

The owner, by choosing a contractor to supervise his work and make his plans and specifications, loses a very important function of the architect's service—that of obtaining legitimate competition among a number of qualified builders.

We have in mind a building where there were no unusual foundation conditions and where a complete set of architectural, structural, plumbing, heating and wiring drawings were furnished. The low bid was \$629,000—the high bid \$817,000. For another similar building the low bid was \$665,000—the high \$899,000. By what system of magic could an owner hope, without a definite set of plans and specifications, to pick the contractor whose price would approximate the low bid obtained by competition?

There is the artistic side of this problem also. A traveler saw in a central New York town a strange structure. He was interested and hunted up the owner. "What is it that

you are building?" he asked. "Oh, just an idea of mine. I am going to have a chap come over from Boston next month and put the architecture on." Now the owner, by selecting an architect, has the advantage of good architectural design.

Supervision is very important. There is a case today of a building built by a contractor from his own plans and under his own supervision. He was unable to finance the completion of the building and the new owner found that the structural slabs, by reason of lumber, straw and other refuse left in the concrete, had to be reinforced. This correction was performed at a cost of approximately \$5,000 and was required in order to make the structure safe. Some men even cheat at solitaire!

Supervision by a qualified architect is vital.

We have a word which we use very often that tells a story centuries old. When the Roman architects specified marble, they said it must be sincere, that is, without wax. So when you sign a letter "Yours sincerely" you are reminded of an architect's specification of 2000 years ago.

In the final analysis the architect's FEE might well be architect's FREE because a capable architect will save the owner as much or more than his fee.

Now to summarize, the owner—by the selection of a capable architect—obtains: 1. A complete study of his problems by numerous sketches. 2. A complete set of plans and specifications. 3. An architectural treatment in keeping with the use to which the building is put. 4. Full competition with a number of contractors. 5. A complete budget of the cost before making any commitments. 6. Qualified supervision of the work, including checking of extras and credits.

A service of this kind is certainly worth the architect's fee. Possibly some of you will recall a campaign started some time ago by the general contractors in which the slogan was "Select your General Contractor First." The general contractor would then be in a position to name an architect who in this case would be obligated to the general contractor and not to the owner. This campaign has died a natural death.

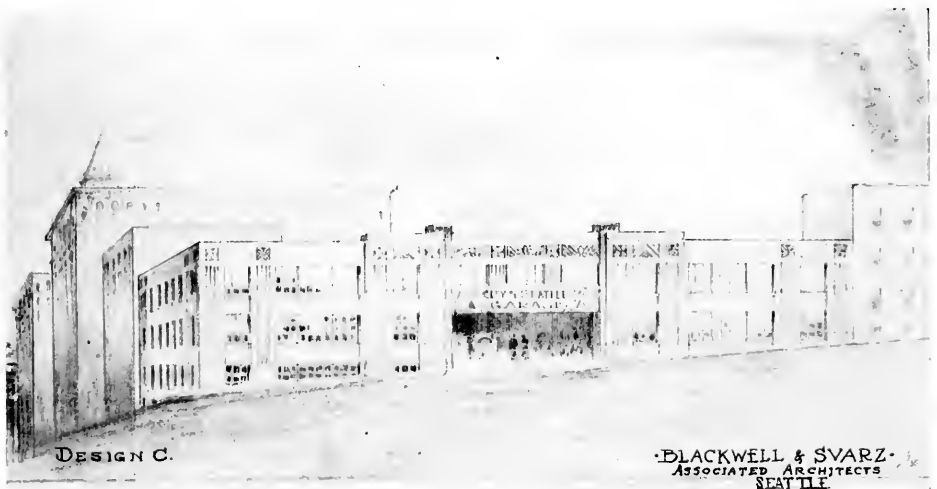

PRELIMINARY STUDY FOR A PUBLIC GARAGE, SEATTLE, WASHINGTON
Blackwell & Svarz, Associated Architects

SPINNING CABLES OF GOLDEN GATE BRIDGE

STEEL WIRES COMBINED INTO STRANDS, MODERN IDEA

By Robert G. Brock

THE invention of the suspension bridge cannot be credited to any one man. Rather it is the result of a constant development down the years from the time of earliest civilization. Vegetable fibers and vines were the original supporting strands, and are even used by certain primitive people today to support crude bridges across ravines and narrow gorges.

The use of steel wires made up into strands and cables is a relatively modern development and is rightfully credited to John A. Roebling who in 1844 first used this material in the construction of an aqueduct over the old Pennsylvania Canal in Pittsburgh, Pennsylvania.

The success of this small structure indicated that much development of the idea was possible, and in the years that followed increasingly large and long structures were successfully built. Only eleven years after the aqueduct was built, Roebling erected a suspension bridge across the Niagara Gorge that was regarded universally as an eighth wonder of the world.

The climax to suspension bridge building during the nineteenth century was the completion in 1883 of the Brooklyn Bridge. The methods of erection used for the first time on this structure are basically the same as those used today. Development of electric and hydraulic machinery, and the enormous amount of empirical data that has been sys-

tematically gathered since that time, have only led to refinements and increased efficiency in machines and methods.

The Golden Gate at its narrowest point is about a mile wide, and is the logical location for a bridge linking the Peninsula with Marin and the other counties to the North. Due to the strategic value of San Francisco Bay commercially, as well as in time of war, it is imperative that the Golden Gate be unimpeded by such a structure. A suspension bridge is for this reason peculiarly well suited to this location.

The San Francisco Peninsula helps to form one of the greatest harbors in the world, but at the same time the fact that it is a Peninsula results in geographical isolation of this city from the rest of Northern California.

To meet this condition, the Golden Gate Bridge and Highway District was organized to undertake the financing and later the operation of the bridge when completed. The Bridge District is composed of the five Northern Counties, including San Francisco, Marin, Napa, Sonoma, Del Norte and parts of Mendocino County.

The Strauss Engineering Corporation was commissioned to prepare plans and specifications for the structure and in 1931 these plans were sent out for bids.

The Bethlehem Steel Company were awarded the superstructure, Barrett and Hilp the anchorages and pylons, Pacific Bridge Company the piers and fenders, and John A. Roebling's Sons Company of California the main

cables, cable bands, suspender ropes and accessories.

The Roebling Company has from the beginning of modern suspension bridge building, been foremost in developing the erection technique and equipment peculiar to this type of structure. The Golden Gate Bridge was the first of its size to be built on the West Coast, all of its predecessors having been in or near New York and thus near to Trenton, New Jersey, where the factories and engineering offices of the Roebling Company are located.

It was clearly evident that a depot of operations on the West Coast would be required to properly perform the contract work, located somewhere on San Francisco Bay, if such a site could be obtained. We eventually purchased a nine acre site in Marin County that was called California City, and that was only seven miles by water from the bridge site. California City offered the area, the deep water, the docks and the ready accessibility that we required.

The procedure that we decided upon was to manufacture the wire in Trenton complete with the galvanizing coat, and ship it in coils to California City. There it was to be stored and reeled and then shipped by barge to the bridge site as required. The California City plant also was intended to be the repair base and assembly plant for the special equipment used in the actual cable erection.

Shipment of the bridge wire from the East Coast was to be by way of intercoastal boats that would tie up at California City and unload from their holds directly onto our dock. A trial shipment of 50 coils of wire showed that it would be necessary to protect the wire from sweating in the holds of these vessels while enroute. A coating of special wax was found to be the most effective preventative, and so all the wire was wax coated before shipment.

This wax had to be completely removed from the wire before it could be spun into the main cables, and for this reason we included dewaxing equipment in addition to

the reeling machines, machine shop and material handling equipment, within the building that we erected on the California City site.

The coils of bridge wire received at California City averaged 400 lbs. each and contained about 4,000 feet of wire. In the reeling operation about 45 coils of wire were placed on each reel, in other words, 9 tons of wire in one continuous length. This required 45 splices per reel. The splicing operation is interesting because it is accomplished with hydraulic pressure, requires no heat, and the resulting splice develops over 100% of the wire strength. In making the splice the ends from two coils of wire are cleaned in carbon tetrachloride, then threaded by hydraulic pressure on a two piece die. Following this a nipple, threaded inside, is slipped on in such a way that the two wire ends meet in the middle of the nipple. Then the assembly is placed in another three plunger hydraulic press that exerts 150 tons pressure per square inch forcing the metal in the nipple to flow around the two wire ends. Under tension these splices are so remarkably efficient that breaks always occur outside the splice. The breaking strength of the bridge wire averaged 7,000 lbs. and in all cases exceeded by 10% or more the strength of 225,000 lbs. per square inch cross section required in the specifications. Actually the wire averaged 245,000 lbs. per square inch. Both ends from every coil were tested for breaking strength and each coil was identified by a number by which reference to the entire history of the steel from the raw material to the finished product could be made if necessary.

The special steel of which the bridge wire is made, is a Roebling development based on 50 years of suspension bridge building experience. It is made from raw materials selected for their purity and melted in small heats under closely controlled conditions that insure the uniformity of the product. The wire is cold drawn to .195" diameter and is then double galvanized by passing it through a zinc bath allowing it to retain all the zinc that will adhere to it.

All material movements from California City to the bridge site were to be by water and so we purchased two barges and chartered a powerful tug to provide a dependable transportation service that would be available to us at any time. Docks were already available at both terminals of the bridge on which we could discharge materials carried there by barge from California City. So there, in outline, is the story of the preparations and planning that preceded any of our field work on the bridge proper.

Largest Suspension Bridge in World

In many ways the Golden Gate Bridge is the largest suspension bridge ever attempted. Its main span is 4200 feet, its total length between approaches is over 9000 feet, its towers are 746 feet high and its main cables are $36\frac{1}{2}$ inches in diameter. The clearance of the bridge at midspan is 220 feet, which is enough to allow any ship afloat to pass through the Golden Gate.

There is nearly as much steel in either of its towers as there is in all of the towers on the Bay Bridge, and either of these towers is 313 feet taller than the Russ Building.

The concrete used in the anchorages, piers, fenders and pylons would make a ten foot sidewalk 1032 miles long, while the total length of #6 acid steel galvanized bridge wire in the main cables would more than encircle the earth three times at the equator.

These main cables are the largest and longest yet attempted. The story of their erection is one of new and revolutionary ideas and equipment that have produced a rate of spinning in tons of wire per day 444 per cent greater than ever before attained. Briefly, by the use of triple spinning wheels and double tramways it was possible to place 24 wires with each trip of the wheels compared with only four wires on the George Washington Bridge and the San Francisco-Oakland Bay Bridge.

The first step in fabrication of the main cables is the erection of a temporary footbridge and the storm system which gives it stability. The prevailing wind at the Golden Gate is westerly and thus at right angles to

the bridge. It averages above 20 miles per hour and attains a velocity at times of 60 miles per hour. Such a wind offers a serious difficulty that must be overcome if the footbridge is to be held in its normal position providing accessibility to the main cables during their erection.

The supporting ropes for the footbridge were erected in the main-span in the usual manner. They were first accurately cut to the required length, then placed on reels and hauled to the bridge site. An end from the reel was made fast at the base of the Marin tower and the reel placed on a barge that was then towed across the gate by tugs, paying out the rope as it went. When the barge reached the San Francisco tower fender, the reel was lifted off by a derrick located at the San Francisco tower top. A set of falls from a similar derrick on the Marin tower top was then attached to the end fastened at the Marin tower base and both derricks working simultaneously then lifted the rope clear of the water and up to the prepared attachment points at the tower tops. Twenty-five ropes were erected in this manner for the footbridge.

The footbridge consists of two walkways located on 90 ft. centers directly beneath the main cables with crossbridges located at the quarterpoints and at midspan.

The west walkway, under the western main cable has 12 supporting footbridge ropes each $1\text{-}9/16$ " diameter, and the east walkway has 13 such ropes. On former bridges the practice has been to bunch these ropes and use members between them heavy enough to provide sufficient stiffness in the walkway. On the Golden Gate Bridge the ropes were equally spaced beneath the walkway, in this way materially reducing the required size of the stiffening members and, therefore, the overall weight of the footbridge.

The footbridge under the east cable was two feet wider than the west walkway to provide room for an escalator by which the men were helped up the incline on either side of both towers.

The footbridge floor was assembled in the anchorages, for each side-span, and hauled up the footbridge ropes in trains. For the main-span the floor was assembled at both tower tops and allowed to slide down the footbridge ropes to midspan and erected symmetrically from midspan back to each tower.

The footbridge floor was prefabricated by a local contractor and delivered to us in sections about 12 x 16 ft. each. In actual erection, a steel section was placed about every tenth section to serve as a firebreak. In that portion of the footbridge directly beneath the main cables, wire mesh was used, which will later be removed to allow the main cables to sag below the footbridge during the erection of floor steel, which temporarily distorts the true catenary curve of these cables. The wire mesh also materially reduces the area exposed to the wind and thus helps for stability in the footbridge.

Following the completion of footbridge erection, our electricians installed an elaborate communications, power and lighting system on it using over 200 miles of copper conductor for this purpose alone. Simultaneously, crews at both anchorages placed the unreeling machines, tension towers and tramway drive engines while other crews on the footbridge erected the tramways and the mid-span transfer station.

Tramway System Supported by Ropes

On former suspension bridge jobs, the tramway system has been supported by regularly spaced structural steel bents located on the footbridge. This in itself has placed a considerable additional load on the footbridge. On the Golden Gate Bridge the tramway system was supported entirely by a separate system of supporting ropes, stabilized by guy ropes fastened at intervals to the footbridge and by boom spreaders located at 400 ft. intervals. These booms each had two sets of split sheaves through which the tramway ropes passed, spaced correctly to allow the hanger of the spinning carriage to pass between them freely. The load of the tramway system was thus not only completely removed from the

footbridge but also provided it an actual additional support. The impedance of structural steel bents was also completely eliminated from the walkway, and the tendency of the loaded spinning carriage to produce a longitudinal wave motion in the walkway was effectively prevented. In addition the rope supporting system was adjustable so that any desired vertical clearance between the spinning carriages and the footbridge could be attained.

The main cables on all major suspension bridges are of parallel wire construction. In this type of cable the strands and the individual wires composing each strand are parallel with each other from anchorage to anchorage. There is always an odd number of strands in such a cable. In each cable of the Bay Bridge there are 37 strands while in each Golden Gate Bridge cable there are 61.

Before the compacting process a complete cable of this type has a hexagonal cross section. The standard practice in all previous bridges has been to place the strands during erection in horizontal rows with each successive layer of strands in the same horizontal plane. This results in a hexagonal cross section with a flat bottom. During actual spinning, difficulty was always experienced due to the tendency of the cable to rotate 30 degrees or more out of position between the control points, which are the tower top saddles, during the temperature cycle of each day. This rotation was caused by temperature differences between the strands which resulted in their unequal expansion or contraction with respect to each other.

When such a cable was being compacted to a round cross section, it was found that a perfect circle could not be attained as considerable vertical displacement of certain strands, particularly those in the top row was required and could only be approximated. This vertical displacement also tended to produce an unbalanced stress within the cable resulting in increasing the load on some strands while reducing it in others. Another difficulty was the tendency of the strands to

slump, actually producing an oval instead of a circular cross section in the finished cable. The tendency to slump was increased by the fact that the slope of the outside strands on the upper half of the hexagon was 60° with the horizontal, which, in itself, was an unstable condition for these strands and made them difficult to control.

On the Golden Gate Bridge a deliberate attempt was made to overcome all these difficulties and attain the perfect cable, with uniform stresses throughout, and a perfectly circular cross section when compacted.

The first step toward attainment of this goal was to rotate the hexagonal section built up during spinning through 30° thus producing a hexagon with straight sides and a pointed top and bottom.

Next a study of wire distribution by strands through the cable showed that contrary to standard practice, it would be desirable to increase the number of wires in some strands and reduce it in others. Redistribution of the wires per strand practically eliminated the potential vertical displacement required during compacting.

The rotation of the hexagonal section placed the strands in vertical instead of horizontal rows and permitted the use of cable formers used for the first time on these cables. The cable formers were frames that were spaced at several points along the cables that helped shape the cable and at the same time provided rod spacers between the vertical rows of strands during spinning. These spacers permitted air to flow freely through the cable at all times. This flow of air tended to equalize temperature differences through the cable and for this reason prevented the tendency of the cables to rotate out of position during any heat cycle.

The number of wires in the top and bottom strands of the cable was reduced to a point where the vertical axis of the hexagon was exactly equal to the diameter of the compacted cable. A ten foot full scale model of the cable was then made and compacted. It

was found that the pressure necessary to compact the cable to the required diameter was less than that required to compact the George Washington Bridge cables, the only other cables of comparable size. This indicated less resistance to flow and a more natural or direct travel of the wires into the voids between strands which in turn demonstrated that vertical displacement of wires was not taking place.

The Golden Gate Bridge cables have a diameter of 36½" and are each approximately 7650 feet long and each weigh 7125 tons. The erection of the Golden Gate Bridge cables and the hanging of suspender ropes ready to receive the floor steel must be accomplished in 14 months. Deducting a reasonable time for erection of footbridges and the necessary control and communication equipment for spinning, and additional time for erection of cable bands and suspender ropes, the time left for actual spinning is reduced to about 9 months. This time limit made it imperative to develop new ideas designed to increase the tonnage of wires spun per day. Working five days per week and allowing a reasonable amount of lost time due to weather conditions that would prevent spinning it became apparent that we would need to spin 265 tons of wire per day if we were not to exceed the contract time. The best previous record per cable was established on the George Washington Bridge and was 61 tons per day.

The speed of the tramways hauling the spinning wheels was known to have reached their practical limit at 750 feet per minute. Speeds beyond this would only invite disaster to both men and equipment. Two wire spinning had been tried on the final strand of one of the George Washington Bridge cables and proven practicable. This, however, would theoretically only double the spinning speed of 61 tons per day.

Spin 271 Tons of Cable Per Day

This theoretical speed was again doubled by the revolutionary idea of using two sepa-

rate tramway systems, each carrying wire to the midpoint of the mainspan instead of all the way from anchorage to anchorage as in all previous erection jobs. This would necessitate a transfer of wires at midspan from one tramway to the other, but would allow two spinning carriages to carry wire in the same direction at the same time. Using two wire spinning and double tramways, the potential production per day would be 244 tons, still short of the required rate of 265 tons. Practically this potential speed was even less as we fully realized that delays caused by wind and fog conditions would be far worse on the Golden Gate Bridge than those experienced on any previous suspension bridge.

In order to attain the required production we, therefore, used three spinning wheels on each carriage and actually were able to spin 271 tons per day thus exceeding the requirements.

The use of three spinning wheels on 4 carriages made it possible to spin 24 wires per trip. Since the wheels carried a bight or loop of wire, this called for 6 unreeling machines with their supplementary apparatus in each anchorage.

In the spinning operation, all wire must be adjusted to proper deflection, or sag, before a succeeding trip of the carriages may begin. This necessitates ready identification of the wires so that their adjustment may be not only fast but accurate.

The spinning operation was divided into two work units, based on position relative to the cable itself. Thus three unreeling machines in each anchorage were to pay wires out to work unit #1 and the other three to work unit #2 located on the opposite side of the cable.

Each work unit, therefore, at a given moment had six wires either not yet adjusted or in process or adjustment. Before leaving the unreeling machines, two of the wires were given a color, one of them green, the other red, while the third wire was white, the color

of the galvanizing. Each work unit spun two strands, thus four strands were being spun simultaneously.

Spinning at such a prodigious rate is very similar to the operation of a complex railroad system and requires the same close and accurate timing to realize full efficiency. A dispatcher was, therefore, absolutely required in order to properly coordinate the work. In order to be effective, elaborate communication and indicating equipment was provided in the dispatcher's office, the actual nerve center of the job, located at midspan.

For the first time in cable fabrication a device called a Selsyn Unit was used, that indicated on a dial, in the dispatcher's office, the exact position of the spinning wheels at all times. These units are self synchronous motors, that follow exactly the forward or reverse rotation of the master drive unit which in turn is coupled to the tramway engine in each anchorage.

Telephone and annunciator equipment offering instant contact with every point on the footbridge was also located in the dispatching office. In the event of trouble of any sort it was possible for the dispatcher to learn at once its nature and cause and take immediate steps to remedy it.

Actual spinning began November 11, 1935, and was completed on both cables May 20, 1936, in a total elapsed time of six months and nine days.

Cable compacting started May 25th and was completed on both cables on June 16th.

We are at present wrapping the main cables from each anchorage to the hold-down pylons and preparing to erect the cable bands and suspender ropes. This will be completed during the last week of August at which time Bethlehem Steel Company will start erection of floor steel. Six months later we will again be active in the field finishing the wrapping of main cables.

Shortly thereafter, probably in May 1937, the Golden Gate Bridge will be officially completed and opened to traffic.

ACOUSTICS IN REMODELED STRUCTURES

STUDY GIVEN TO SOUND CONDITIONS IN SMALL ROOMS

DURING the past few years the changes in architectural design have been such as to create unprecedented activity in remodelling what are now out of date buildings. These changes have been very largely the result of advantages in modern science and conditions of living. In the days of the old silent films, for instance, no consideration was given to the acoustical properties of a theater, but now the acoustics of a talkie theater is one of the most important features to be studied. In fact such have been the advances made in the science that it is being studied even in its application to small rooms where dinner speeches, etc., are likely to be held.

The remodelling of old premises to make them acoustically up to date is something upon which G. W. Stewart and R. V. Lindsay have to say in their book upon acoustics.

"It is hard to over-emphasize the great importance of adequate attention to the acoustic properties of a room or auditorium during the process of designing it and before the actual construction. The main purpose of the hall should be carefully considered and an approximate value of the desired reverberation time agreed upon. The actual absorbing power for a hall of the desired size should then be calculated from a knowledge of the area and the absorption co-efficients of the various absorbing materials that will enter into it, viz., the walls, ceiling, floor, seats and audi-

ences. The last will naturally be a variable factor, but in general it is sufficient to allow for an absorption corresponding to from $1/3$ rd to $1/2$ the maximum audience. After all these factors have been accounted for, the residual necessary absorption must be introduced in a manner best suited to the architectural plan of the room. There are certain common materials for this purpose such as hair felt, plaster, cork board and various fibres. The greatly increased interest in architectural acoustics has led to the development of many varieties of patented sound-absorbing material, references to which may be found in current literature. If the total absorbing power of the necessary room equipment proves to be too great, it is possible to reduce it by painting, varnishing or otherwise treating some of the surfaces.

In the case of a hall already constructed, the acoustic properties of which are found to need correction, the above sufficiently indicates the general procedure. The employment of the services of an experienced acoustical engineer is generally an economy.

The transmission of sound through the partitions of a building is often a matter of great importance and has been the subject of extensive investigation. It is not our purpose here to enter into details but rather to point out a few fundamental facts. When sound waves strike a wall, a portion of the energy is reflected into room and we say the rest is absorbed. Of the "absorbed" energy, a

part suffers viscous damping in the pores of the wall and is dissipated into heat. If there are cracks or holes, a part of the energy will travel through these as sound waves in air. Another part of the energy will set up true waves in the wall which will be transmitted through it as through any medium. But it must be emphasized that, because the wall is in general very much more dense than air, the amount of sound energy conveyed through the wall in this way is negligibly small. Lastly, the incident sound and generate sound in the air on the other side. It is in this way that most of the sound energy is transmitted from the air of one room to that of the next. The actual determination of the amount transmitted in a given case is a problem of some difficulty, for a discussion of which reference may be made to Buckingham. But it seems clear that to reduce the transmission in this way the walls should be made as massive and rigid as possible and that the use of real sound-absorbing material in the construction is of little value in comparison.

Sabine has demonstrated that for masonry partitions ranging in weight from 10 to 45 pounds per square foot the reduction in sound intensity, or the ratio of incident to transmitted intensity, is proportional to the five-halves power of the weight in pounds per square foot. Another interesting experiment by Sabine showed that the drumskin action of a wall is clearly in evidence in a double walled partition. Two walls each of single gypsum tile, were separated by an air space of two inches. The effect of bridging and filling in the space with wood was tried. Then

the ratio was measured. It was greatest for no filling at all, and the other conditions, slag-filled, bridged with wood, sawdust-filled. The reduction for the empty space was four times that for the sawdust-filled space and eighty times that for a single wall.

Investigations of essentially similar nature have been carried out by Davis and Littler, whose results parallel those of Sabine to a large extent. In particular they emphasize the characteristic drumskin action. Of course it should be emphasized that the transmission about which we are here speaking is from air to air through the wall. The transmission of sound which originates in the wall or floor is naturally a different matter. In this case there may be considerable wave transmission through the partitions and the more rigid the construction the greater the transmission. Hence it arises that a room may be proof against sounds which arise in the air of the adjoining room (such as conversation or music), while it is not proof against sounds which arise by pounding on the floor or walls or the throbbing of machinery fixed rigidly to the floor. These facts must be considered in the practical application of sound proofing.

Absorbing material placed in wooden floors are somewhat disappointing because the drumskin action occurs. Nevertheless in home building, if precautions are taken to prevent the top floor from having solid contact with the under floor, through nails or otherwise, and if the top flooring rests upon a half inch or more of absorbent material, fairly good results are obtainable.—Building.

MORE STATE PARKS AND BEACHES

CALIFORNIA COMMISSION SPONSORS INITIATIVE MEASURE

By William E. Colby

The following article is contributed by the California State Park Commission, sponsors of the initiative prohibiting tideland oil drilling and authorizing slant-drilling from the uplands and which will appear on the election ballot in November. The bill will enable by other than tax-increasing methods the completion of California's magnificent system of state parks.

The initiative creates entirely new revenue for the State, half of which will go to acquire and maintain more state parks and beaches. It is imperatively needed if the commission's program, which is attracting millions of dollars in tourist money to California annually, is to be continued.

BEAUTY and attraction of the beaches fronting our seacoast communities frequently is a factor in their growth or decay. California's shoreside towns for decades have capitalized on this knowledge.

Instances are on record tracing a definite slowing up of development and loss of business in such places directly to beach pollution or damage from causes beyond their control. Preservation of the natural beauty of their beaches therefore has become of vital concern to every town and county on the California coast.

Witness the recent action at certain points where fine beach vistas have been marred by forests of unsightly oil rigs. The Huntington Beach City Council and Chamber of Commerce, the Orange County Coast Association and the Venice Commercial Board were

among the first of hundreds of organizations throughout the state to endorse an initiative measure appearing on the November ballot as Proposition 4. It is proposed to meet the situation by forever prohibiting surface drilling on tidelands or through coastal waters.

Engineers and elected officials of coast towns will find much to interest them in the measure. The Attorney General has titled it: "Prohibiting Tideland Surface Oil Drilling, Authorizing Slant Drilling from Uplands."

It stops the defacement of beaches and pollution of tidal waters through uncontrolled drilling for oil. It is also a revenue measure. Without increasing the tax rate one penny it will provide funds through attractive royalties on oil extracted from pools known to be submerged beneath our beaches and coastal waters and therefore in the public domain. It permits only slant wells drilled from the uplands behind the beaches to penetrate these pools.

Geologists say the formation of at least half the California coast line is of a nature indicating the possibility of such submerged oil deposits. It is impossible to estimate the potential income to the state from the orderly tapping of these resources, but statisticians have guessed that it will start at about two million dollars a year.

Proposition 4 provides that half of such revenue will go to the State Park Commission

for the protection, maintenance and extension of its splendid system of state - owned parks, beaches and monuments. The other half will be devoted to the reduction of taxes.

The Park Commission needs this new revenue. The six million dollar bond issue voted to its uses in 1928 is exhausted. It has gone to the acquisition and upkeep of close to fifteen million dollars worth of property. Obviously this is not the time for another bond issue, and adequate legislative appropriations for the purpose would increase taxes.

Chief interest in the measure for the architect, contractor, building supply house and planning commission centers in its potential influence on communities close by beaches overlying submerged oil pools. Funds will be available to the state to acquire and improve more of these public playgrounds. Tideland

oil drilling will be forever prohibited. Slant drilling into state oil deposits will be legalized under rigid restrictions. Revived confidence in the future of affected communities would be reflected in a surge of construction activities. Buildings to accommodate a growing population and increased tourist traffic will be an immediate need. Through the channels of trade everyone will share in the influx of new tourist money attracted by clean and sightly beaches maintained under state supervision.

Proponents of the measure assert that it solves many pressing problems at one stroke. It promises benefits to every section of California and hardships to none, they say. Recognition of that factor has resulted in its endorsement by hundreds of conservation, civic, business, fraternal, professional and technical organizations in all parts of the state.



SKETCH FOR A HOME IN LOS ANGELES

ARCHITECTS' BULLETIN

Issued For

THE STATE ASSOCIATION OF CALIFORNIA ARCHITECTS

Northern Section

STATE ASSOCIATION MEMBER
OF THE
AMERICAN INSTITUTE OF ARCHITECTS

Harris C. Allen
Editor

Address all communications for publication in the Bulletin to the Editor (Harris C. Allen) 557 Market Street, Room 218, San Francisco, California.

Board of Control

Harris C. Allen Otto G. Hintermann
Harry Michelsen Ellsworth E. Johnson

State Association Officers

William I. Garren..... President
Lester H. Hibbard..... Vice-President
H. C. Chambers..... Secretary
Otto G. Hintermann..... Treasurer
Albert J. Evers
Regional Director, A.I.A.

Executive Board — Northern Section

William I. Garren..... President
Harry Michelsen..... Vice-President
Ellsworth Johnson..... Secretary
Otto G. Hintermann..... Treasurer

Directors

Harry Devine J. K. Ballantine
Roland I. Stringham Chas. F. B. Roeth

Executive Board — Southern Section

Lester H. Hibbard..... President
George D. Riddle..... Vice-President
H. C. Chambers..... Secretary
Robert H. Orr..... Treasurer

Directors

A. M. Edelman Louis J. Gill
Wm. S. McCay Roy C. Mitchell

District Advisors—Northern Section

Harris C. Allen Wm. K. Bartges
J. H. Mitchell Gwynn Officer
J. K. Ballantine C. A. Caulkins
Thos. Kent Frank Mayo
C. F. Maury Chas. E. Butner
Wilbur D. Peugh Ralph Wyckoff
Will Toepke Leslie I. Nicols
Dodge Riedy Wallace A. Stephen
Edward Frick W. E. Baumberger
S. L. Hyman F. T. Georgeson
Ralph E. Wastell Casebolt C. Dakin
Earl R. MacDonald Ralph D. Taylor
Jas. T. Narbett Edward W. Peterson
Herbert G. Goodpastor

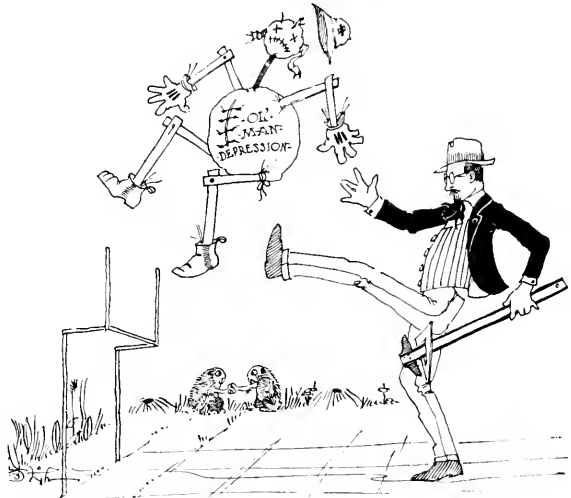

~ ONE - FOOT - TO - THE - SPECTRE
~ CONVENTION ~ 1936 ~

ALL roads will lead to Del Monte next month when the State Association of California Architects meets in annual convention at the world famous Del Monte Hotel. An unprecedented attendance is expected from both the Northern and Southern Sections. One of the features of the meeting will be the Convention Number of The Architect and Engineer in which will be illustrated some of the more recent work of architects in the Monterey and Peninsular Bay Regions, together with messages from the Presidents of the Northern and Southern Divisions and the official program.

Program Has Many Features

The convention will open Friday morning, October 16, with appointment of committees and the report of the Executive Board. This will be an executive session. On Friday afternoon there will be an open meeting in co-operation with the Producers' Council, devoted to three "Forums" or short addresses with limited time allotted for questions and answers. The subjects will be:

"More Permanent Building Values" (talks by a prominent banker and a representative of the Federal Housing Administration).

"The influence of Modern Developments on Californian Architecture" (talks by selected architects).



"Building Industry Relationships" (talk by representative of the Building Trades).

The convention dinner will take place Friday evening, preceded by the usual pleasant "hospitality hour" in the tower room. There will be a short talk at the dinner by a distinguished guest speaker, together with an excellent musical program. Saturday morning there will be an executive session devoted to action on the executive board's report and resolutions presented by the resolutions committee.

On Saturday afternoon the convention "blind bogey" golf tournament will be held, after which a very informal family party will join for good cheer, food and prize-giving under the genial direction of our one-and-only Abe Appleton as father of the family.

Notable Artists to Entertain

A few words about the artists who are to present the musical program Friday night. Marsden Argall, dramatic baritone, is one of the rising stars of San Francisco. He created a furore at this summer's jinks of the Bohemian Club, and has sung several leading roles in San Francisco opera seasons. Mildred Baldwin is a beautiful young soprano who also has a promising future, is in demand for concert appearances, and will be heard in opera. Frederic Saatman is an accomplished pianist who has toured with great success in Europe, South America and Australia, and has but recently settled in California. The fine standard set by previous convention entertainment will be maintained, and perhaps surpassed, at Del Monte this year.

A word to the wise—it is usually prudent to make reservations at the hotel in advance of a convention. Those preferring to stay at a European plan hotel will find excellent accommodations and low rates at the Mission Inn, Monterey.

Hotel Rates

Very reasonable rates have been made by Hotel Del Monte. They are on the American Plan, and are as follows:

BOTH WINGS		PER DAY
Single Room without bath—1 person	\$7.00 each
Double Room without bath—2 persons	6.50 each
Single Room with bath—1 person	8.00 each
Double Room with bath—2 persons	7.00 each
2 Single Rooms, both between—2 persons.	7.50 each

GARDEN VIEW, HOTEL DEL MONTE

2 Double Rooms, bath between—4 persons 6.50 each
Main Building, Cottages, and Remodeled

	Per Day
Wing Rooms	
Single Room with bath—1 person \$9.00 each
Double Room with bath—2 persons 8.00 each
Sitting Room 6.00

Committees in Charge

The following committees from the North will serve:

Reception, Registration and Information—Chairman, Ellsworth E. Johnson, San Francisco; Charles H. Sawyer, San Francisco; John J. Donovan, Berkeley; Henry C. Collins, Palo Alto; Howard Bissell, Stockton; Ralph Wyckoff, San Jose; Robert Stanton, Del Monte.

Program and Entertainment—Chairman, Harris C. Allen, San Francisco; A. Appleton, San Francisco; J. K. Ballantine, Jr., San Francisco; Albert J. Evers, San Francisco; Henry H. Gutterson, San Francisco; William O. Raiguel, Monterey.

Golf—Chairman, Harry M. Michelsen, San Francisco; Wilbur D. Peugh, San Francisco; William G. Corlett, Oakland; Milton Latham, Carmel; Herbert E. Goodpastor, Sacramento.

Publicity—Chairman, Roland I. Stringham, San Francisco; Chester H. Miller, Oakland; L. F. Starks, Sacramento; Rafael Lake, Fresno; C. A. Caulkins, Jr., Santa Rosa; Peter Sala, Stockton; Ralph Wyckoff, San Jose; F. T. Georgeson, Eureka.

Transportation—Chairman, Dodge Riedy, San Francisco; William E. Schirmer, Oakland; Gwynn Officer, Berkeley; H. J. Devine, Sacramento; E. L. Norberg, Burlingame; Victor Galbraith, Stockton.

The Executive Board, Southern Section, has appointed the following members to serve on convention committees:

Reception, Registration and Information—Robert H. Orr, Los Angeles; William S. McCay, Pasadena.

Program and Entertainment—H. C. Chambers, Los Angeles; Joseph W. Potter, San Diego.

Golf Tournament—Gordon B. Kaufmann, Los Angeles; Winsor Soule, Santa Barbara.

Publicity—Louis N. Crawford, Santa Maria; Breo Freeman, Pasadena.

Transportation—Lester H. Hibbard, Los Angeles; Roy C. Mitchell, Los Angeles.

A Word About Del Monte

Del Monte has long been known as an ideal convention center. Situated in the midst of a 20,000 acre estate the hotel is far removed from the distractions of city meeting places yet there are facilities for every sport and recreation.

At Del Monte, too, there is much of interest to the architect. The tap-rooms at the hotel and Del Monte Lodge and at the Monterey Peninsula Country Club have all been remodeled and rooms in the old wings of the hostelry are being renovated and modernized under the direction of Robert Stanton, A.I.A.

Within a radius of five miles of Del Monte there are five golf courses. One, the Del Monte No. 1 course, was the first constructed in the state and is but a short distance from the hotel.

Three others, the sea-side Pebble Beach course, where Bobby Jones played his spectacular match with Johnnie Goodman in 1929, the exclusive Cypress



THE ROMAN PLUNGE, HOTEL DEL MONTE



LOUNGE, LOOKING TOWARD THE DINING ROOM, HOTEL DEL MONTE

Point course and the dunes course of the Monterey Peninsula Country Club, are within the confines of the Del Monte forest. There is also a municipal course at Pacific Grove.

Through the Del Monte forest runs the world famous Seventeen Mile Drive which is one of the most scenic roads in the country.

Then there is the historic town of Monterey to explore. It was here that California history began and many of the old adobe houses dating back to the days of the dons are still in a fine state of preserva-

tion giving interesting sidelights on the architecture of those days. Monterey is a city of firsts—the first theater in California still stands—the first house of milled lumber—the first brick house—the first custom house (which has been under the flag of three nations)—Colton Hall where the first Constitution of California was drafted. Monterey's new City Hall adjoins Colton Hall and harmonizes with the architecture of the older building.

* * *

DISTRICT ADVISORS

The San Francisco District (S. F. Society of Architects) met August 19 for nominating new advisors, and is holding a postcard ballot at this writing. Palo Alto District has elected Dole Ford Thomson as Advisor. Sacramento District has elected Edward Flanders and Arthur Dudman, Advisors, with Alden W. Campbell as secretary. Other districts are planning meetings.

* * *

COMMUNICATIONS

Members are urged to send to the editor of this Bulletin any items of news or special information, as well as any questions, criticisms or suggestions. These columns are open as a Forum to all architects—including (please take notice) our brothers in the warm sunny south. What we want is circulation—to even up the heat in the South and the frost in the North.

* * *

LIGHTING DEMONSTRATION

A few San Francisco architects were hurriedly assembled on August 18 for a demonstration of new lighting methods, prepared by the Gen-

eral Electric, the Westinghouse and the Pacific Gas & Electric Companies. The exhibit was brought here for the benefit of western lighting experts, and consisted of the new method of producing colored light with ultra-violet radiation; the new sodium light—which will be used on the Bay Bridge; the new high intensity mercury lamp; the capillary lamp; and the fluorescent treatment. Some of these systems will not be completely perfected for perhaps two years; but we can look forward to much greater efficiency, longer life and closer approximation to daylight in the near future.

* * *

BUILDING MATERIALS

The office of the Association is in the Building Material Exhibit Building, 557 Market Street, San Francisco. At the suggestion of some of our members, we print a list of the materials here on exhibition. Mailed or wired inquiries about any product, addressed to the Building Material Exhibit, will receive prompt attention.

- A**
- Aluminum—tubing—sheets—strips
- Acoustical materials
- Air Conditioning units
- B**
- Bathroom cabinets—steel and wood
- Blackboards
- Brass—tubing—sheets—strips
- Brick
- Bronze—tubing—sheets—strips
- Built-in kitchen fixtures (sectional)
- Built-in kitchen fixtures (custom built)
- C**
- Chairs—office—restaurant—school—coffee shops, etc.
- Chimes—Electric door
- Clay tile
- Clothes vaults—metal
- Concrete waterproofing
- Coolers—revolving and stationary type
- Copper—tubing—sheets—strips
- Cabinets—wood and metal—bath and lavatory
- D**
- Drainboards—linoleum—composite—metal
- Dampers—fireplace
- Desks—school
- Door grilles
- Door openers
- Doors—folding and sliding—overhead garage
- Draperies—for school and church auditoriums, etc.
- E**
- Electric appliances for kitchen and household
- Electric heaters
- Electric chimes
- Electric house numbers
- Electric irons
- Electric washers
- Electric controlling devices
- Electric plate warmers
- Enameled metal signs
- F**
- Fans—electric
- Fireplaces—patented circulating type
- Flooring—magnesite—rubber
- Floor hardening treatments—colors or plain
- Floor surfacing and polishing machines
- Folding doors
- Folding partitions
- Furnaces—gas and oil fired
- G**
- Gas heaters—wall type and circulators
- Gas water heaters—storage and instantaneous
- Gas fired floor and basement furnaces
- Gas ranges
- H**
- Hollow clay tile

- I**
- Incandescent lamps
- Imitation marble
- Imitation pressed clay tile
- Incinerators
- Insulating materials
- Ironing boards
- K**
- Kitchen cabinets—tables—etc.
- Kitchen ventilator fans
- L**
- Linoleum drainboards
- Linoleum wall coverings
- M**
- Magnesite floors
- Marble—imitation
- Mercury vapor lamps
- Metal clothes vaults
- Metal enamel signs
- O**
- Oil burners
- Overhead garage doors
- P**
- Paints—interior
- Plate warmers
- Plywood
- Pressed brick
- R**
- Roller screens
- Roofing—patented and tile—shingles and snakes
- Rubber flooring
- S**
- Septic tanks
- Shutter awnings
- Signs—pressed metal, enameled
- Sliding doors
- Stainless steel—tubing—sheets—strips
- Shoe racks
- T**
- Termite and pest control chemicals
- Terrazzo—stairs and floor
- Textures for walls and ceilings
- Telephones and telephone equipment
- Tile—hand made clay
- Tile—imitation
- Tubing—brass—bronze—copper—aluminum
- V**
- Varnishes—interior
- Venetian blinds
- Ventilating fans—domestic and commercial
- W**
- Window roller shades
- Wall and Roller beds
- Window ventilators
- Weatherstrips
- Waterproofing for concrete

STRUCTURAL ENGINEERS ANNUAL MEETING

The annual gathering of California structural engineers in the North and South will be held at Santa Maria Inn Oct. 16-17th and an attendance larger than that of two years ago is expected. Last year the meeting was held in Fresno. An attractive program is being arranged by the entertainment committee.

The September meeting of the association was held at the Engineers' Club, 206 Sansome Street, on Tuesday evening, September 1st. After dinner an interesting program was carried out, the subject for the evening being, "Rapid Transit Plan for the City of San Francisco". Paul J. Ost, Chief Electrical Engineer of the Public Utilities Commission, City of San Francisco, was principal speaker.

LARGE SPANISH HOME

El Camino Real, Berkeley, is the site for a large Spanish style home which A. J. Regino will build from plans by Edwin L. Snyder, architect, 2104 Addison Street, Berkeley.

ENGINEERS HONOR NATIONAL OFFICERS

The San Francisco Section, Am. Soc. C. E., held a special dinner meeting at the Engineers' Club, Friday evening, July 14, to greet President D. W. Mead and Secretary George T. Seabury. Seventy members and guests were present.

Secretary Seabury gave the members an intimate picture of the working details of the organization. In line with the advancement of the Society affairs a grade of Student Member is proposed and will be submitted to the membership for vote this fall, the dues to be \$3.00 annually. On the subject of welfare the board of directors has committees working on registration, salaries, fees, engineering and public education.

President Mead recalled the fact that his first visit to San Francisco was made just 40 years ago when he was searching for a manufacturer of centrifugal pumps.

He requested members to send suggestions to the Society, as to how it may better serve its members.

His talk was stimulating and he closed with two pertinent thoughts, one that engineers give out more information about projects that were not successful and in that way assist engineers when carrying out new developments; and also that a Code of Ethics be prepared telling one what should be done, instead of the type which is based upon what you "shall not do."—C.J.C.

APARTMENT HOUSE ADDITION

John M. Cooper, 6241 W. Sixth Street, Los Angeles, has prepared plans for adding to and completing a class A apartment building at 410 N. Rossmore Ave. for Rossmore-Beverly, Inc. Construction work may be handled by the owner on a segregated contract basis. The building, a reinforced concrete structure, 135x140 feet, was started eight or nine years ago by Harry Feigenbaum and was poured up to the fifth floor level. Three more stories will be added, making it eight stories instead of thirteen as originally proposed. Completion of the building will require a further expenditure of \$325,000.

WE WOULD LIKE TO HAVE IT!

Editor The Architect and Engineer:

Mexico has just passed a law against further inroads of "pack box" architecture, (modern). Together with other laws that will preserve all notable buildings from alterations that would in any way change their appearance.

If it is not convenient for you to get the story there I will be glad to get full information in Mexico.

Yours very truly,

L. S. Sanderson.

Laredo, Texas, Aug. 24, '36.

SAN FRANCISCO ARCHITECTURAL CLUB

Kearny Street, San Francisco
WALTER C. CLIFFORD, President
H. WALTER RUPPEL, Vice-President
RICHARD E. AUDSLEY, Secretary A. N. GRANISH, Treasurer
TRUSTEES
WALDON B. RUE OTTO G. HINTERMANN HARRY C. NYE
DIRECTORS
ALBERT KAHL IRA H. SPRINGER CHARLES J. CONTI

UNIVERSITY NIGHT

With vacation season drawing to a close, the San Francisco Architectural Club once more resumes its regular activities, both academic and social.

One of the most enjoyable affairs in many months (at least in the mind of your correspondent) was the "University of California Night" on August 19th. A large delegation of pencil pushers from the "Ark" and many grads., assembled in a spirit of fellowship with the club members.

After a speech of welcome by H. Walter Ruppel, chairman of the evening, dynamic Jack Sly, ably assisted at the console by Sid Colton, led the assembly in a few rounds of a "Community Singing".

Wendell Ross Spackman, recent A. I. A. medalist, on behalf of the "Ark", gave a spirited talk emphasizing the value of closer cooperation and mutual understanding between the club members and Department of Architecture at the University.

The speaker of the evening, Albert J. Evers, gave a most enlightening and instructive talk on the Federal Housing Administration and its effects upon the architectural profession; prefacing his talk with an informal account of the recent A.I.A. convention in restored historic Williamsburg.

Atelier Season Starts Soon

The Atelier season is scheduled to open this month and an increasing number of students is anticipated. The club will continue to work to the program of the School of Architecture, U. of C., last year's cooperation having worked out very successfully. Patrons will be Irving Morrow, Mario J. Ciampi, and one other yet to be announced.

Engineering Classes

Architectural Engineering classes will again be under the tutelage of R. S. Chew, structural engineer. Many men have signified their intentions of entering one or more of these classes.—"REA".

BOOK REVIEW

TECHNICAL DRAWING: By Frederick E. Giesecke; Henry C. Spencer, Alva Miloctue; The Macmillan Company, 60 Fifth Avenue, New York. Price:—\$3.00.

This book is an addition and a valuable one to the popular and excellent engineering science series.

The book is primarily intended as a class text and ready reference and though it should not be thought of strictly as a manual it is of such type that it has a very definite place in the drafting room. Engineers will find it more than valuable as a reference volume.

THE NEW DEAL IN ARCHITECTURE

The New York Times in its Magazine Section of June 7 calls attention with an intimation of approval, to the New Deal's set-up of a centralized system of design for public buildings. "The new centralized system has naturally invited criticism—sometimes touched with considerable acid," writes H. I. Brock, author of The Times' article that "is illustrated with drawings of buildings proposed or constructed in all parts of the country for which the Treasury Department furnished the money. "Thus," the article says, "a centralized government agency is directly, and no longer indirectly responsible for what the country gets in the way of postoffices, whether in Oshkosh or New York City."

Does this centralized bureau of the Treasury Department, under the guise of Supervising Architect, accomplish anything that the architects in private practice could not and did not accomplish prior to this injection of bureaucracy into architecture? Mr. Brock insists that the chief purpose of the central bureau "is to produce buildings, whatever their scale, which fit into the modern picture, urban or rural, with no lack of variety; yet which in each case bear the distinct and distinguished stamp of a government building." This was something, he argues, that was not generally achieved under the old system with "its tendencies, outside of a few important buildings, to makeshift and haphazard designs, often reflecting vagaries or lapses of taste in local architects assigned to a very special task with very special requirements."

As proof that the new system of centralized design is giving the country a new architecture, the author of this article calls attention to what cannot be termed in any other light than an unfair comparison. For example Mr. Brock cites the ancient granite pile in Lower New York City, known as the Old Postoffice and long condemned by public and architects alike as a design of a period and style of the past.

Standardization of design, called "rubber stamp" by architects has followed local conditions, adopted sectional styles, and otherwise conformed to the work of private architects, who set the pace to begin with and who now see their work copied enmasse, pigeon-holed and revised by draftsmen to meet requirements of plot and adjoining buildings. It is hardly possible that a Southern California architect charged with designing a postoffice for a small city in his territory would seek to impose upon his public a Colonial Georgian type of the Eastern seaboard. It would indeed be difficult to imagine that a Boston architect would design a small Massachusetts postoffice building after the Spanish Colonial style. But under this New Deal bureau at Washington local architects are out of the picture. The fees that they might have earned during the depression and might earn in the future, if this bureau continues to function, are lost to every community that gets a new government building. Only for the largest projects are local archi-

tects called upon to furnish the designs and under central bureau control the job must be fraught with unpleasant supervision of details, including the selection of materials, that takes all of the joy out of the fees.

America was not raised to heights of greatness by bureaucracy and if the practicing architects are deprived of the rights to design public buildings, architecture will suffer. Human nature, as such, militates against the observance of bureau rules and submergence of individuality in design into the melting pot of standardization. Only dire necessity will force really great architects to work like machines to see their work designated for the files under some such mark as XYZ—B—99. This same design can be used in a dozen cities of the same state or district and unless the public has other landmarks to go by, innumerable instances of wandering in a strange town may result. Can public architecture attain a really high level under bureau control? Will architects submerge ideals and their right as individuals and bury self respect in the cauldron of standardization?

It may be true, as charged by The New Deal, that the old system of making the Supervising Architect the paymaster for public jobs designed by local architects, had glaring faults. Will the new system stand the acid test of public approval? Will it satisfy the demands for an American architecture in keeping with the growing inclinations of the public for more permanent public buildings of distinctive types as models for privately constructed structures. Will the oncoming, architecturally inclined youths of the country be able to carry on under a system that stifles artistic ability!—Stone.

200 "NEW AMERICAN" HOMES

With more than 200 homes already completed and opened for public inspection this year, General Electric's "New American" demonstration home building program is by far exceeding the quota realization for the similar period last year. Moreover, it is expected many more homes are yet to be contracted for during 1936. Last year approximately 600 "New American" homes were erected in the United States.

In addition, the general features of the program have been adapted to Canada by the Canadian General Electric Company and already 32 of the homes have been constructed in the dominion.

STORE BUILDING

Wilfred B. Verity, 820 W. M. Garland Building, Los Angeles, is completing plans for a one-story, basement and mezzanine store building, 57x120 feet in area, to be built at 8521-23 S. Vermont Avenue, Los Angeles, for Edward L. McClain. The building will have a concrete frame, reinforced brick walls, wood trusses, composition roofing, structural steel, cement and maple floors, basement sprinkler and steel sash.

With the Architects

OREGON ARCHITECTS LICENSED

Four new licenses to practice architecture were granted applicants by the Oregon State Board of Architects Examiners July 16.

Two were issued by reciprocity, both from New York City. One was for Francis Keally, associate with Trowbridge and Livingston, architects for the new Oregon State Capitol Building, and the other to Horace G. Foulkes. Two were to successful applicants who took the recent state examinations namely, Donald W. Hayes and Donald W. Edmundson, both of Portland.

Officers elected by the examining board to serve during the ensuing year were as follows: President, J. E. Wicks, Astoria; vice-president, Francis B. Jacobberger, Portland; treasurer, Kenneth Legge, Portland; and secretary, Margaret G. Fritsch, Portland. Other board members are: Frank C. Clark, Medford; and John B. Bennes, Portland.

CLARENCE CULLIMORE BUSY

Clarence Cullimore architect of Bakersfield, is commencing construction of two Southern Plantation type residences. One is for Mr. and Mrs. Malcolm Brock and will cost \$20,000 and the other is for Mr. and Mrs. Monroe Homer to cost \$15,000. Work is progressing on an abode ranch house for Swift and Company of Chicago on the McKittrick ranch, one of their holdings in Kern County, California.

Mr. Cullimore also has on the boards an adobe house for Mr. and Mrs. E. B. Daniel of Bakersfield and an early California ranch house for Dr. Earl Johnson of Taft, California.

PERSIAN COCKTAIL ROOM

The new Persian cocktail and dance room at the Sir Francis Drake Hotel, San Francisco, was opened to the public the latter part of August. The opening night was a society event. The room is without doubt the most beautiful of its kind on the Pacific Coast and Douglas Stone, the architect, has received many favorable comments for his work. The lighting effects and murals are outstanding for their brilliance and color. Pictures of the room will be shown in this magazine in an early issue.

NAPA UNION HIGH SCHOOL

Plans have been completed for rebuilding the burned portion of the Napa Union High School, the work to include a new gymnasium and second floor to the class room unit. William Herbert of Santa Rosa is the architect and W. Adrian of San Francisco, the engineer. The improvements will cost \$75,000.

WILL TEACH ARCHITECTURE

Further increasing the curriculum in architecture and fine arts for the fall quarter of University College, adult evening division of the University of Southern California, 35 classes will open for registration on September 21. Headed by Arthur C. Weatherhead, dean of the U. S. C. College of Architecture and Fine Arts, a staff of 17 faculty members, including Paul Sample, Glen Lukens, Daniel Lutz, Robert M. Gage, Paul Frankl, Mildred Bateson, George J. Carpenter, Edgar Wileman, Frank B. Greene and Robert M. Fox, will conduct classes.

MODESTO MARKET BUILDING

A one story frame and brick market building has been designed by Russell Guerne De Lappe for Carl W. Shannon of Modesto. The building will be erected at 12th and J Streets and will cost \$26,000.

Mr. De Lappe has working drawings in progress for a 22 bed two story hollow tile building for the Newman Hospital Corporation. Cost \$32,000.

TWO HISTORICAL EVENTS

Two events that will be history in years to come, were celebrated by residents of the Bay Region the past month. On Friday, August 24 over 1500 people attended ground breaking ceremonies at the Exposition site on Yerba Buena Shoal, and a few days later the Exposition administration building in San Francisco, was formally occupied.

W. W. WURSTER HAS MUCH WORK

New work in the office of W. W. Wurster, Newhall Building, San Francisco, includes an early California style residence of twelve rooms for Milo T. Gates in Piedmont; a residence in Oakland for an unnamed client and a seven room house at Walnut Creek, Contra Costa County, for H. Allyn Wood.

STORES AND APARTMENTS

Mrs. Sarah J. Klett, 145 Harvest Street, Salinas, has had plans prepared by Charles E. Butner for a \$30,000 Spanish style store and apartment building on South Main Street, Salinas. The building will be two stories and basement. There will be a terra cotta tile roof.

WM. I. GARREN BUSY

Residence work is keeping the office of William I. Garren, San Francisco, on the qui vive. Recent projects include a house in Los Altos for Gerald Eaton; a residence in San Francisco for Alfred Schulz and a dwelling in Berkeley for an unnamed client.

NEWSPAPER EXPOSITION IN 1939

Staged by the National Editorial Association, an exposition of the American newspaper from the birth of journalism in New England in the 17th Century to its present indispensable place in national life will be presented at the Golden Gate International Exposition here in 1939. Clayton Rand, NEA president, declared that the exhibit will show the world the place the modern newspaper occupies "as a protector of democracy and an invaluable servant of organized society."

WATSONVILLE GRAMMAR SCHOOL

The Watsonville Grammar School District has had preliminary plans prepared by A. W. Storey, architect, for an ambitious grammar school unit to cost \$150,000 and to include 14 class rooms, auditorium and gymnasium.

Mr. Storey is also architect of a \$20,000 grammar school addition, plans for which have been completed.

STORES AND OFFICES

Messrs. Fabre and Hildebrand, French Bank Building, San Francisco, have completed plans for a two story reinforced concrete store and office building in San Mateo. They also made drawings and awarded contracts for an addition to the French Hospital in San Francisco.

PALO ALTO HIGH SCHOOL

Working drawings are being completed by Birge M. Clarke for a \$350,000 Junior High School group at Palo Alto. The location is the Middlefield Road and Santa Rita. Besides 27 class rooms there will be administrative offices, gymnasium, shops, library and cafeteria.

ROSE BOWL ADDITION

The City of Pasadena has applied to the WPA for \$205,089 to complete improvements at the famous Rose Bowl. New work calls for constructing four pedestrian tunnels, installing a sprinkler system, grading and planting.

TAFT UNION HIGH SCHOOL

From plans by Harold Weeks of San Francisco, construction will start shortly on a one story reinforced concrete addition to the Union High School building at Taft, Kern County. Two new wings will be built at an approximate cost of \$90,000.

ARCHITECTS IMPRISONED

One city architect committed suicide and seven others were arrested on June 9 as King Carol acted to punish those responsible for the Bucharest grandstand collapse which killed 20 and injured 500 on June 8.

CONTRACTORS AND ARCHITECTURAL SERVICE Editor The Architect and Engineer:

Once more the old subject of unfair competition by contractors and builders in connection with architectural services seems to be to the fore. The very fact that this subject bobs up perennially shows that no satisfactory solution has yet been reached. As one who has gone through numerous stages of this battle, allow me to suggest a possible solution or, at least, an approach to one.

If contractors are going to combine the services of architect and builder, let the architects say to the contractors:—Either you control your men through your organizations or the architects will urge their clients to build by segregated contracts, eliminating the contractors entirely. Of course in this case the architect would charge the client the usual fee for segregated work but even so to the average owner the proposed method would seem to promise a material saving.

Personally, I have not been in favor of segregated contracts, feeling not only that the contractor has a valuable and legitimate function to perform and that it is much simpler and better for an architect to deal with one responsible head than to try and coordinate a half dozen crafts on the job but also that there are many contractors who play a square game and want to cooperate with the architect in every way.

Things have come to such a pass that some drastic action is necessary and it may be that with such a reprisal in the offing, the various contractors' associations would lend a willing and efficient hand to help us with remedial legislation.

San Diego, August 17, 1936.

John S. Siebert.

HONOR FOR LOUIS SKIDMORE

Louis Skidmore, Chicago architect, has been appointed Director of the Department and Professor in charge of senior design, Armour Institute of Technology, Chicago.

Mr. Skidmore succeeds Earl H. Reed, who has resigned in order to give full time to his architectural practice. Mr. Reed lays down his duties as director with the sincere appreciation of the president and board of trustees for the untiring patience with which he has carried on the responsibilities for the department during an extremely difficult period.

Mr. Skidmore will be assisted by Jerrold Loebel, of Loebel and Schlossman, who will serve as assistant director. Mr. Loebel, a graduate of Armour in 1921, has served during the past year on the advisory committee of architects, and is in close contact with the work of the department.

PERSONAL

Eugene Weston, Jr., architect, has been appointed a member of the Municipal Art Commission of Los Angeles to succeed William Lee Woollett.

Estimator's Guide

Giving Cost of Building Materials, Wage Scale, Etc.

Amounts given are figuring prices and are made up from average quotations furnished by material houses to San Francisco contractors. 3% Sales Tax on all materials but not labor.

All prices and wages quoted are for San Francisco and the Bay District. There may be slight fluctuation of prices in the interior and southern part of the state. Freight cartage, at least, must be added in figuring country work.

Bond—1 1/2% amount of contract.

Brickwork—

Common, \$35 to \$40 per 1000 laid, (according to class of work).
Face, \$75 to \$90 per 1000 laid, (according to class of work).

Brick Steps, using pressed brick, \$1.10 lin. ft.

Brick Walls, using pressed brick on edge, 60c sq. ft. (Foundations extra.)

Brick Veneer on frame buildings, \$.75 sq. ft.

Common f.o.b. cars, \$12.00 job cartage. Face, f.o.b. cars, \$45.00 to \$50.00 per 1000, carload lots.

HOLLOW TILE FIREPROOFING (f.o.b. job)

3x12x12 in. \$ 84.00 per M
4x12x12 in. 94.50 per M
6x12x12 in. 126.00 per M
8x12x12 in. 225.00 per M

HOLLOW BUILDING TILE (f.o.b. job)

carload lots.
8x12x5 1/2 \$ 94.50
6x12x5 1/2 73.50

Discount 5%.

Composition Floors—18c to 35c per sq. ft.

In large quantities, 16c per sq. ft. laid.

Mosaic Floors—80c per sq. ft.

Duraflex Floor—23c to 30c sq. ft.

Rubber Tile—50c per sq. ft.

Terazzo Floors—45c to 60c per sq. ft.

Terazzo Steps—\$1.60 lin. ft.

Concrete Work (material at San Francisco bunkers)—Quotations below 2000 lbs. to the ton. \$2.00 delivered.

No. 3 rock, at bunkers.....\$1.80 per ton
No. 4 rock, at bunkers..... 1.75 per ton
Elliott top gravel, at bunkers 2.10 per ton
Washed gravel, at bunkers.... 2.10 per ton
Elliott top gravel, at bunkers 2.10 per ton
City gravel, at bunkers..... 1.75 per ton
River sand, at bunkers..... 1.60 per ton
Delivered bank sand..... 1.20 cu. yd.

Note—Above prices are subject to discount of 10c per ton on invoices paid on or before the 15th of month, following delivery.

SAND

Del Monte, \$1.75 to \$3.00 per ton.
Fen Shell Beach (car lots, f.o.b. Lake Majella), \$2.75 to \$4.00 per ton.

Cement, 2.50 per bbl. in paper sks.
Cement (f.o.b. Job, S. F.) \$3.00 per bbl.
Cement (f.o.b. Job, Oak.) \$3.00 per bbl.
Rebate of 10 cents bbl. cash in 15 days.
Calaveras White\$6.00 per bbl.
Medusa White \$8.00 per bbl.
Forms, Labors average \$40.00 per M.

Average cost of concrete in place, exclusive of forms, 35c per cu. ft.

4-inch concrete basement floor12 1/2c to 14c per sq. ft.

4 1/2 inch Concrete Basement floor..... 14 1/2c to 16c per sq. ft.

2-inch rat-proofing7 1/2c per sq. ft.
Concrete Steps\$1.50 per lin. ft.

Damproofing and Waterproofing—

Two-coat work, 15c per yard.
Membrane waterproofing—4 layers of saturated felt, \$4.00 per square.
Hot coated work, \$1.80 per square.
Medusa Waterproofing, 15c per lb., San Francisco Warehouse.

Electric Wiring—\$12.00 to \$15.00 per outlet for conduit work (including switches).

Knob and tube average \$7.00 per outlet, including switches.

Elevators—

Prices vary according to capacity, speed and type. Consult elevator companies.
Average cost of installing an automatic elevator in four-story building, \$2800; direct automatic, about \$2700.

Excavation—

Sand, 50 cents; clay or shale, 80c per yard.
Teams, \$12.00 per day.
Trucks, \$20 to \$25 per day.

Above figures are an average without water. Steam shovel work in large quantities, less; hard material, such as rock, will run considerably more.

Fire Escapes—

Ten-foot balcony, with stairs, \$85.00 per balcony, average.

Glass (consult with manufacturers)—

Double strength window glass, 15c per square foot.
Quartz Lite, 50c per square foot.
Plate 75c per square foot.
Art, \$1.00 up per square foot.
Wire (for skylights), 35c per sq. foot
Obscure glass, 26c square foot.

Note—Add extra for setting

Heating—

Average, \$1.90 per sq. ft. of radiation according to conditions.

Iron—Cost of ornamental iron, cast iron, etc., depends on designs.

Lumber (prices delivered to bldg. site).

No. 1 common\$34.00 per M
No. 2 common 29.00 per M
Selection Q, P, common 39.00 per M
2x4 No. 3 form lumber 24.00 per M
1x4 No. 2 flooring VG 60.00 per M
1x4 No. 3 flooring VG 50.00 per M
1x6 No. 2 flooring VG 60.00 per M
1 1/4x4 and 6, No. 2 flooring 65.00 per M

Slash grain—

1x4 No. 2 flooring \$48.00 per M
1x4 No. 3 flooring 40.00 per M
No. 1 common run T. & G. 33.00 per M
Lath 7.00 per M

Shingles (add cartage to price quoted)—

Redwood, No. 1 \$1.10 per bdle.
Redwood, No. 290 per bdle.
Red Cedar 1.00 per bdle.

Hardwood Flooring (delivered to building)—

13-16x3 1/4" T & G Maple\$120.00 M ft
1 1-16x2 1/4" T & G Maple 132.00 M ft
7/8x3/2 sq. edge Maple 140.00 M ft
13-16x2 1/4" 3/4x2" 5-16x2 1/4" T & G \$120.00 M ft

Clr. Qtd. Oak\$200.00 M \$150.00 M \$180 M
Sel. Qtd. Oak 140.00 M 120.00 M 135 M
Clr. Pla. Oak 135.00 M 107.00 M 120 M
Sel. Pla. Oak 122.00 M 98.00 M 107 M
Clear Maple 140.00 M 100.00 M
Laying & Finishing 13c ft. 11 ft. 10 ft.
Wage—Floor layers, \$7.50 per day.

Building Paper—

1 ply per 1000 ft. roll\$3.50
2 ply per 1000 ft. roll 5.00
3 ply per 1000 ft. roll 6.25
Brownkin 500 ft. roll 5.00
Brownkin Pro-fo-mat, 1000 ft. roll 10.00
Sikalraft, 500 ft. roll 5.00
Sash cord com. No. 7\$1.20 per 100 ft.
Sash cord com. No. 8 1.50 per 100 ft.
Sash cord spot No. 7 1.90 per 100 ft.
Sash cord spot No. 8 2.25 per 100 ft.
Sash weights cast iron, 550.00 ton.
Nails, \$3.50 base.
Sash weights, 44c per ton.

Millwork—

O. P. \$100.00 per 1000. R. W., \$106.00 per 1000 (delivered).
Double hung box window frames, average, with trim, \$6.50 and up, each.
Doors, including trim (single panel, 1 3/4 in. Oregon pine) \$8.00 and up, each.
Doors, including trim (five panel, 1 3/4 in. Oregon pine) \$6.50 each.
Screen doors, \$4.00 each.
Patent screen windows, 25c a sq. ft.
Cases for kitchen pantries seven ft. high, per lineal ft., \$6.50 each.
Dining room cases, \$7.00 per lineal foot.
Labor—Rough carpentry, warehouse heavy framing (average), \$14.00 per M.
For smaller work average, \$32.50 to \$40.00 per 1000.

Merble—(See Dealers)

Painting—

Two-coat work	29c per yard
Three-coat work	40c per yard
Cold Water Painting	10c per yard
Whitewashing	4c per yard
Turpentine, 80c per gal., in cans and 75c per gal. in drums.	
Raw Linseed Oil—80c gal. in bbls.	
Boiled Linseed Oil—85c gal. in bbls.	
Medusa Portland Cement Paint, 20c per lb.	

Carter or Dutch Boy White Lead in Oil (in steel kegs).

	Per Lb.
1 ton lots, 100 lbs. net weight.....	10 $\frac{3}{4}$ c
500 lbs. and less than 1 ton lots.....	11c
Less than 500 lb. lots	11 $\frac{1}{2}$ c

Dutch Boy Dry Red Lead and Litharge (in steel kegs).

1 ton lots, 100 lb. kegs. net wt.....	10 $\frac{3}{4}$ c
500 lb. and less than 1 ton lots.....	11c
Less than 500 lb. lots.....	11 $\frac{1}{2}$ c

Red Lead in Oil (in steel kegs)

1 ton lots, 100 lb. kegs. net. wt. 121 $\frac{1}{2}$ c	
500 lb. and less than 1 ton lots 12 $\frac{1}{2}$ c	
Less than 500 lb. lots	13c

Note—Accessibility and conditions cause wide variance of costs.

Patent Chimneys—

6-inch	\$1.00 lineal foot
8-inch	1.50 lineal foot
10-inch	1.75 lineal foot
12-inch	2.00 lineal foot

Plastering—Interior—

1 coat, brown mortar only, wood lath.....	Yard \$0.65
2 coats, lime mortar hard finish, wood lath ..	.75

2 coats, hard wall plaster, wood lath.....	\$.80
3 coats, metal lath and plaster	1.30
Keene cement on metal lath75
Ceilings with $\frac{3}{4}$ hot roll channels metal lath plastered	1.50
Single partition $\frac{3}{4}$ channel lath 1 side.....	.85
2 inches thick	2.75
4-inch double partition $\frac{3}{4}$ channel lath 2 sides	1.30
4-inch double partition $\frac{3}{4}$ channel lath 2 sides plastered	3.00

Plastering—Exterior—

2 coats cement finish, brick or concrete wall	Yard \$1.10
2 coats Celoveras cement, brick or concrete wall	1.35
3 coats cement finish, No. 18 gauge wire mesh	1.50
3 coats Celoveras finish, No. 18 gauge wire mesh	2.00
2.5-lb. metal lath, \$6.00 per 1000.....	.17
2.5-lb. metal lath (galvanized)20
3.4-lb. metal lath (dipped)22
3.4-lb. metal lath (galvanized)28
$\frac{3}{4}$ -inch hot roll channels, \$72 per ton.....	
Finish plaster, \$18.99 per ton in paper sacks, Dealer's commission, \$1.00 off above quotations, \$13.85 (rebate 10c sack)	
Lime, l.o.b. warehouse, \$2.25 bbl.; cars, \$2.15	
Lime bulk (ton 200 lbs.), \$16.00/ton.	
Wall Board 5 ply, \$50.00 per M.	
Hydrate Lime, \$19.50 ton.	
Plasterer's Wage Scale	\$1.25 per hour
Lather's Wage Scale75 per hour
Ho'd Carriers Wage Scale	1.10 per hour
Composition Stucco—\$1.60 to \$2.00 sq. yard (applied).	

Wood lath, \$6.00 per 1000.....	.17
2.5-lb. metal lath (galvanized)20
3.4-lb. metal lath (dipped)22
3.4-lb. metal lath (galvanized)28
$\frac{3}{4}$ -inch hot roll channels, \$72 per ton.....	
Finish plaster, \$18.99 per ton in paper sacks, Dealer's commission, \$1.00 off above quotations, \$13.85 (rebate 10c sack)	
Lime, l.o.b. warehouse, \$2.25 bbl.; cars, \$2.15	
Lime bulk (ton 200 lbs.), \$16.00/ton.	
Wall Board 5 ply, \$50.00 per M.	
Hydrate Lime, \$19.50 ton.	
Plasterer's Wage Scale	\$1.25 per hour
Lather's Wage Scale75 per hour
Ho'd Carriers Wage Scale	1.10 per hour
Composition Stucco—\$1.60 to \$2.00 sq. yard (applied).	

Plumbing—

From \$65.00 per fixture up, according to grade, quantity and runs.

Roofing—

"Standard" tar and gravel, \$6.00 per sq. for 30 sqs. or over.
 Less than 30 sqs. \$6.50 per sq.
 Tile, \$20.00 to \$35.00 per square.

Redwood Shingles, \$11.00 per square in place.
 Cedar Shingles, \$10 sq. in place.
 Recoit, with Gravel, \$3.00 per sq.
 Asbestos Shingles, \$15 to \$25 per sq. laid.
 Slate, from \$25.00 to \$60.00 per sq. laid according to color and thickness.

Sheet Metal—

Windows—Metal, \$2.00 a sq. foot.
 Fire doors (average), including hardware \$2.00 per sq. ft.

Skylights—

Copper, 90c sq. ft. (not glazed).
 Galvanized iron, 25c sq. ft. (not glazed).

Steel—Structural

\$100 ton (erected), this quotation is an average for comparatively small quantities. Light truss work higher. Plain beams and column work in large quantities \$80 to \$90 per ton cost of steel, average building, \$89.00.

Steel Reinforcing—

\$70.00 per ton, set, (average).

Stone—

Granite, average, \$6.50 cu. foot in place.
 Sandstone, average, Blue, \$4.00, Boise, \$3.00 sq. ft. in place.
 Indiana Limestone, \$2.80 per sq. ft. in place.

Store Fronts—

Copper sash bars for store fronts, corner, center and around sides, will average 75c per lineal foot.
 Note—Consult with agents.

Tile—Floor, Wainscot, Etc.—(See Dealers).

Asphalt Tile—18c to 28c per sq. ft. installed.

SAN FRANCISCO BUILDING TRADES WAGE SCALE

Recommended by the Impartial Wage Board, June 18, 1936. Effective July 1, 1936

This scale is based on an eight-hour day and is to be considered as a minimum and employees of superior skill and craft knowledge may be paid in excess of the amounts set forth herein. This scale applies only to work on buildings and does not include inside or shop works.

CRAFT	Journeymen Mechanics	CRAFT	Journeymen Mechanics	CRAFT	Journeymen Mechanics
Asbestos Workers	\$ 8.00	Laborers (six-day week)	\$ 5.50	Stone Cutters, Soft and Granite	9.00
Bricklayers	12.00	Lathers, Channel Iron	10.00	Stone Setters, Soft and Granite	12.00
Bricklayers' Hodcarriers	8.00	Lathers, all others	9.00	Stone Derrickmen	9.00
Cabinet Workers (Outside)	9.00	Marble Setters	10.00	Tile Setters	10.00
Carpenters	9.00	Millwrights	9.00	Tile, Cork and Rubber	9.00
Cement Finishers	9.00	Mosaic and Terrazzo Workers (outside)	9.00	Welders, Structural Steel Frame on Buildings	11.00
Cork Insulation Workers	9.00	Painters	9.00	Welders, All Others on Buildings	9.00
Electrical Workers	10.00	Painters, Varnishers and Polishers (outside)	9.00	Dump Truck Drivers, 2 yards or less	6.80
Electrical Fixture Hangers	8.00	Pile Drivers and Wharf Builders	9.00	Dump Truck Drivers, 3 yards	6.50
Elevator Constructors	10.40	Pile Drivers Engineers	10.00	Dump Truck Drivers, 4 yards	7.00
Engineers, Portable and Hoisting	9.00	Plasterers	12.00	Dump Truck Drivers, 5 yards	7.50
Glass Workers (all classifications)	8.50	Plasterers' Hodcarriers	8.00	Dump Truck Drivers, 6 yards	7.50
Hardwood Floorman	9.00	Plumbers	10.00	Truck Drivers of Concrete Mixer Trucks:	
Housemiths, Architectural iron (outside)	9.00	Roofers (all classifications)	8.00	2 yards or less	6.50
Housemiths, Reinforced Concrete, or Rodmen	9.00	Sheet Metal Workers	9.00	3 yards	7.00
Iron Workers (Bridge and Structural)	11.00	Sprinkler Fitters	10.00	4 yards	7.50
Iron Workers (Hoisting Engineers)	11.00	Steam Fitters	10.00	5 yards	7.50
		Stair Builders	9.00	6 yards	8.00

GENERAL WORKING CONDITIONS

- Eight hours should constitute a day's work for all crafts, except as otherwise noted.
- Where less than eight hours are worked pro rata rates for such shorter period should be paid.
- Plasterers' Hodcarriers, Bricklayers' Hodcarriers, Roofers' Laborers and Engineers, Portable and Hoisting, shall start 15 minutes before other workmen, both at morning and at noon.
- Five days, consisting of not more than eight hours a day, on Monday to Friday, inclusive, should constitute a week's work, except for building laborers.
- The wages set forth herein should be considered as net wages.
- Except as noted the above rates of pay apply only to work performed at the job site.
- Transportation costs except for intra-city taxes should be paid by contractor.
- Traveling time in excess of one hour each way should be paid for at straight time rates.
- Overtime should be paid as follows: For the first four hours after the first eight hours, time and one-half. All time thereafter should be paid double time, Saturdays (except for Laborers), Sundays and holidays from 12 midnight of the preceding day, should be paid double time. Irrespective of starting time, overtime for Cement Finishers should not commence until after eight hours of work, except that after 12 midnight overtime for cement finishers should be paid at the rate of time and one-half for the first four hours and double time thereafter. Shift work for cement workers should be subject to the provisions of paragraph 11.
- On Saturday Laborers should be paid straight time up to eight hours. Overtime rates should be paid as specified in paragraph 9.
- Where two shifts are worked in any twenty-four hours, shift time should be straight time. Where three shifts are worked, eight hours pay should be paid for seven hours on the second and third shifts.
- All work, except as noted in paragraph 13, should be performed between the hours of 8 A. M. and 5 P. M.
- In emergencies, or where premises cannot be vacated until the close of business, men then reporting for work should work at straight time. Any work performed on such jobs after midnight should be paid time and one-half up to four hours of overtime and double time thereafter.
- Recognized holidays to be: New Year's Day, Decoration Day, Fourth of July, Labor Day, Admission Day, Thanksgiving Day, Christmas Day.
- Men ordered to report for work, for whom no employment is provided should be entitled to two hours' pay.
- This award should be effective in the City and County of San Francisco.

CONTRACTOR MAKES HIS WILL

The following comes from J. C. Elliott at Pueblo, Colorado:

"Judge," said the contractor to his lawyer, "doctor says I got about a month to live. I want to make my will."

"Fix it so my overdraft in the bank goes to my wife— she can explain it to them . . . My equity in my automobile I want to go to my son. He will have to go to work then to meet the payments . . . Give my unpaid bills to the bonding company; they took some awful chances on me and are entitled to something . . . That new-fangled machine on the job, I want the resident engineer to have. He made me buy it; maybe he can make it work. My retained percentage give to the state. I never expected to get it anyway. My equipment, give to the junk man. He has had his eye on it for several years . . . My keg, I want to go to my bootlegger, I hope it costs him as much to keep it wet as it has me . . . I want you to handle the funeral for me, judge. Any undertaker will do, but I want these six materialmen for pallbearers. They have carried me so long they might as well finish the job."

TWO SAN FRANCISCO DWELLINGS

D. E. Jaekle, 126 Post Street, has completed working drawings for two dwellings to be built on Sloat Boulevard, San Francisco, for A. J. Herzig. They will cost \$6,000 each.

Other work in Mr. Jaekle's office includes an \$8,000 flat building for Eric Lundgren on Fifteenth Street, and alterations to stores and apartments at 517 Cortland Avenue, San Francisco, for E. Iudice.

OAKLAND HALL BUILDING

The Teamsters and Auto Truck Drivers Union of Oakland will have an office and hall building at Ninth and West Streets, Oakland, plans having been prepared by J. B. Anthony, 2014 Shattuck Avenue, Berkeley. The building will be constructed of reinforced concrete and will cost \$30,000.

NEW THEATER FOR RODEO

Rodeo, birthplace of Lefty Gomez, who was the pitching wonder of the New York Yanks last year, but is somewhat of a flop this season, is to have a new theater and store building. It will be of reinforced concrete and will seat 700 persons.

SAN MATEO RESIDENCE

Messrs. Schuetz and Dakin, 544 Market Street, San Francisco, have prepared plans for a one story frame residence for J. B. Roepolo at San Mateo.

ATHERTON RESIDENCE

Douglas D. Stone has completed plans for a six room residence to be built in Atherton for W. A. Dobel, Jr. Bids have been taken and construction will start shortly.

ELLIS W. TAYLOR CALLED ABROAD

Ellis Wing Taylor, architect and structural engineer of Los Angeles, left by airplane August 3 for New York City whence he sailed August 5 for England.

Mr. Taylor was called to England by the Rootes Motor Car Company, Ltd., of Devonshire House, London, to act as consulting engineer on a large airplane factory that company is preparing to construct. He will be abroad from six to eight weeks.

Mr. Taylor has been in business with his brother, Edward Cray Taylor, since 1910. During the past year he has designed several manufacturing units and a large hangar that were added to the Douglas Aircraft Company plant in Santa Monica.

SAN LEANDRO GRAMMAR SCHOOL

Bids taken last month for an eight class room and auditorium building at San Leandro ran high and were rejected. Plans are being revised by Geo. R. Klinkhardt, architect, and H. J. Brunner, engineer, and it is probable the gymnasium will be omitted for the present. Funds available are under \$50,000.

SANTA ROSA ARCHITECT BUSY

New work in the office of C. A. Caulkins of Santa Rosa includes a \$50,000 gymnasium, auditorium and shop building, for the Round Valley Union High School District at Covelo, California, and an English style residence in Santa Rosa for H. Eicker.

TRAIN TERMINAL DEPOT

The Key System will have a new train terminal depot at 41st and Piedmont Avenue, Oakland, to be constructed of steel and concrete with a clock tower as a feature. Messrs. Kent and Hass of San Francisco, are the architects of the \$20,000 building.

PIEDMONT RESIDENCE

Clarence W. Mayhew, architect, has awarded a contract for the construction of a \$11,000 Colonial residence in Piedmont for Allen Shuetter. There will be seven rooms, two baths and a two car garage.

BRANCH LIBRARY COMPLETED

Berkeley's new branch library on The Alameda has been completed and is now open to the public. It is an attractive building, well planned and conveniently located. The architect was J. W. Plachek.

BERKELEY RESIDENCE

Chester H. Treichel, 696 Cleveland Street, Oakland, has completed drawings for a one story Spanish style residence to be built on Ada Street, Berkeley, for J. A. Stroud, Jr.

SAN JOSE RESIDENCE

A \$10,000 residence is being designed for an unnamed client in San Jose by Ralph Wyckoff, architect, of that city. Construction will be frame and stucco with shake roof.

SEEING IS BELIEVING

Every structure worthy of the architect's signature deserves to be correctly lighted, both inside and out.

In the commercial field, for example, people want their offices in well lighted, comfortable buildings. The owner of such a building never has any trouble renting space.

The architect who has the reputation of designing buildings which are always occupied and in which space is at a premium, need not worry about a clientele. His services are always in demand.

Progressively improving light sources are simplifying the lighting problem and making possible working conditions which encourage faster, easier, more accurate work with greater ease than ever before practicable.

Some of the new lighting sources require that special attention be given the wiring.

This bureau offers advisory service and assistance in planning lighting and wiring, without cost or obligation.

PACIFIC COAST ELECTRICAL BUREAU

447 Sutter Street
SAN FRANCISCO

601 W. 5th Street
LOS ANGELES

COIN FOR BAY BRIDGE

Monarch II, last of the California Valley grizzly bears, born and bred in San Francisco, 26 years of age and son of the famous Monarch of Woodward's Gardens, Mid-Winter Fair and Golden Gate Park, is the model for the obverse of the commemorative coin which will be minted this fall in San Francisco as part of the celebration of the completion of the San Francisco-Oakland Bay Bridge.

The grizzly bear is the official animal totem of California and appears on the state shield and on the grizzly bear flag, the official banner of the state.

The reverse of the coin shows the Bay Bridge foreshortened, stretching from San Francisco to Yerba Buena Island, and East Bay hills, the historic Ferry Tower in the foreground and several types of ship-ping in the waters beneath the bridge.

The design for the coin, which has been dispatched to the Director of the Mint at Washington, D.C., for final approval, was made by Jacques Schnier, famous young San Francisco sculptor who has won many prizes for his work in important exhibits recently in the Bay region.

The coin was sponsored in the Senate by Hiram W. Johnson of California and approved by the President on June 26, 1936.

When the bas relief in plaster has been completed by the sculptor following the approval of the sketches, the cast will be sent to the mint where the intaglio dies will be made and forwarded to the San Francisco Mint where the coins will be actually minted.

The coins will be of half-dollar denomination and will be sold by the celebration committee through the various banks and the San Francisco Clearing House as part of the celebration activities, November 12, 13 and 14 of this year.

COURT HOUSE ELEVATORS

The elevator equipment in the Alameda County Court House consists of four public passenger elevators and one prisoners' elevator serving the jail section of the building.

The four public elevators, two on each side of the entrance lobby are Otis gearless traction signal control with automatic self-leveling and high speed electrically operated doors of the center parting type.

This type of operation is as nearly entirely automatic as is possible. The pressure of a button starts and stops the cars and the attendant merely closes the doors and presses car buttons as directed by the passengers, resulting in rapid and safe service.

The specially designed cars are of a laminated wood-metal construction of alternate layers of steel and wood, resulting in a rigid fireproof construction, while the interior is of beautifully finished walnut with metal canopies.

The cars are of generous size each capable of transporting twenty passengers per trip at a speed of 600 ft. per minute, and provided with power oper-

For Progress



CROCKER
FIRST NATIONAL
BANK
OF SAN FRANCISCO

Member Federal Deposit Insurance Corporation

Achievement

EVERY INDUSTRY strives to achieve a worth while position...to make the most dependable products...to render surpassing service and build enduring goodwill among its customers. That these objectives have been achieved by General Paint Corporation is attested by our thousands of satisfied customers *everywhere*. The prudent architect will specify GENERAL paints...the paints without a competitor.



Engineers are invited to send for our new brochure "PIPE PROTECTION" just off the press. A request on your letterhead will bring you a copy.

GENERAL PAINT
CORPORATION

San Francisco · Los Angeles · Oakland
Portland · Seattle · Spokane · Tulsa
Honolulu · Manila, P. I.

WOLMANIZED LUMBER

**ASK YOUR LUMBER
DEALER**

Wolmanized Lumber is sold through recognized lumber dealers. Many reliable lumber yards carry this modern decay and termite protected material in stock. All lumber dealers can supply Wolmanized Lumber on short notice.



AMERICAN LUMBER & TREATING CO.
37 West Van Buren St.
CHICAGO, ILL.

San Francisco Sales Office
116 New Montgomery St.
Phone SUtter 1225

Los Angeles Sales Office
1031 South Broadway
Phone PRospect 5558

THE

BUILDING MATERIAL EXHIBIT

• •

LOS ANGELES

We offer a complete service to Architects and Engineers with information on manufacturers' representatives and details of materials.

FIFTH at FIGUEROA
M U t u a l 6 3 0 6

BUILD WELL~

A PROPERLY designed and well constructed building is a credit to any city and a profitable investment for its owner.

Such structures are the STANDARD OIL BUILDING, MATSON BUILDING, FOUR-FIFTY SUTTER STREET, STOCK EXCHANGE, S. F. BASE BALL PARK, MILLS TOWER, OPERA HOUSE and VETERANS' MEMORIAL, San Francisco, OLYMPIC CLUB ALTERATIONS, SANTA ANITA RACING PLANT and other notable structures — all built or supervised by —

Lindgren & Swinerton, Inc.

Standard Oil Building 605 W. Tenth Street
San Francisco Los Angeles
We Maintain a Termite Control Department

Roofing Waterproofing

Alameda County Court House



GENERAL ROOFING CO.

Harry Hennings
OAKLAND, CALIFORNIA

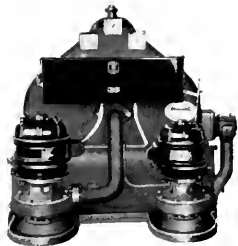

**"AMERICAN
MARSH"
REDI-VAC
VACUUM
HEATING
PUMP**

Send for Bulletin 441

SIMONDS MACHINERY CO.
San Francisco Los Angeles
816 FOLSOM ST. 522 EAST 4TH ST.

ated doors to insure the safety of the passengers.

The entrances are of bronze and hollow steel and specially designed signal fixtures harmonize with the lobby and corridor treatment.

SHASTA COUNTY

The State of California has undertaken the construction of the \$7,500,000 Kennett Dam which will hold in storage the flood waters of the Sacramento River and develop an almost unlimited kilowatt hours of electrical energy annually.

Anderson, Happy and Fall River valleys are exceptionally fertile and noted for their agricultural production.

Shasta has the only active volcano in the United States, Lassen Peak, which is in Lassen Volcanic National Park. The last eruption was in 1915, but the lava flow was not sufficient to cause much damage.

The county is famous for its vacation resorts and thousands of tourists are attracted to Burney Falls, Castle Crags, the Ice Caves on Hat Creek and the California Caves.

BOOK REVIEW

HOUSES FOR MODERATE MEANS—By R. Randal Phillips, A.R.I.B.A.; Chas. Scribners Sons, New York, N. Y. London, Country Life Ltd. Price: \$2.75.

The chief aim of the author is to demonstrate what may be accomplished in the way of small but dignified and livable houses within the means of the average salaried person.

The illustrations are well done and plans are given together with costs and construction details.

While the majority of the houses shown are really more suitable to the British Isles, several of them could be made adaptable to the United States.

PERSONAL

Major K. Charles Bean of the U. S. Engineers' office, has been named by the Los Angeles Board of Public Utilities and Transportation as chief engineer to succeed J. Ogden Marsh, who resigned, effective August 15, to engage in private business.

Raphael Nicolais, architect, has moved his office from the Clem Wilson Building to 5670 Wilshire Boulevard, Los Angeles.

SANITARIUM IMPROVEMENTS

Two new buildings are being designed by W. G. Corlett of Oakland for the Arroyo Sanitarium at Livermore. There will be a dormitory for employees and a central heating plant. The total cost is estimated at \$110,000.

OAKLAND FLAT BUILDING

A \$12,000 frame flat building has been designed by J. K. Ballantine, Jr., for E. J. Fisher of 972 Grosvenor Place, Oakland.



MONOLITHIC CONCRETE



Owl Drug Store, corner of Hollywood and Caluenga Blvds., Hollywood, Calif.
Architects: Morgan, Walls and Clements. Builder: W. M. Simpson Construction Co.

*for outstanding effects
on bread-and-butter jobs!*

EMPHATICALLY this is not just another drug store. Passers-by realize that the designer has architecturally lifted a commonplace business out of the crowd. One more example of how monolithic concrete is helping architects to create distinction in routine work.

Especially noteworthy here is the iridescent surface effect achieved by casting the concrete in smooth lined forms, and painting and spraying with mica before the paint dried.

Architectural concrete is enabling daring moderns, and conservative architects as well, to give form and permanence to their ideas and welcome cost savings to their clients.

Before you plan any new building or modernization, however small, learn the possibilities of

architectural concrete. Fire-safe, earthquake resistant, economical! Practical data are available in monographs covering specifications, form work, and other details. You will also want our new booklet, *Beauty in Walls of Architectural Concrete.*

Paste this coupon on a postal card. Mail to address nearest you.

Please send:

- Monographs on Architectural Concrete.
- "Beauty in Walls of Architectural Concrete."

Name.....

Business Address.....

City..... State.....

PORTLAND CEMENT ASSOCIATION

564 Market Street
San Francisco

816 West Fifth Street
Los Angeles

903 Seaboard Bldg.
Seattle, Wash.

There's a PACIFIC Gas Heating Appliance for Every Need

- Gas Steam Radiators
- Circulator Heaters
- Forced-Air Units
- Blower Furnaces
- Gravity Furnaces
- Floor Furnaces
- Unit Heaters
- Water Heaters

The Pacific name on gas heating appliances is your guarantee of Clean, Odorless, Safe, Dependable and Economical heat. A.G.A. Approval.

Ask for Catalog AE9

Pacific Gas Radiator Co.
Huntington Park, Calif., U.S.A.

The following communication appeared in a recent issue of the Architectural Forum:

I am inclined to be absent minded, and so when I attend conventions of architectural societies I sometimes blunder into a business meeting. Before I can collect my faculties and escape I have to listen to a portion of the speech then being given. Frequently this speech has to do with Advertising the Profession. In general, architects who make speeches on this subject are committed to two hypotheses that leave me cold; they believe (a) that advertising the architectural profession should be financed by using somebody else's dough, and (b) that the advertising should be dignified.

Regarding (a) I can only remark that an extensive survey of the advertising field leads me to suspect that the manufacturer who will spend any serious money advertising something for somebody else has not yet appeared on the horizon and that when he does his relatives will probably start thumbing through the telephone directory in search of a good psychiatrist.

Now for (b). Dignity is an excellent thing in advertising but it has the minor disadvantage that it doesn't sell anything. If you will analyze the advertising done by many of our most successful manufacturers you will note that their display advertising is based on the good old theory of scaring the customer half to death. A customer well frightened is at least half way to the drug store to buy your product.

We will assume that your name is Ezekiel W. Zunk (God forbid), and that you manufacture the Zunk Electric Ironer. You harbor the ambition to sell these useful products in large numbers to the nobility and gentry of this republic, so you hire an advertising agency to get to work for you.

What is the first thing your advertising counsel does? Well, not the first thing; of course the first thing they do is to ask for a retaining fee, but the second thing they do is to put their art department at work preparing a lay-out of an advertisement to be run in four colors in six or seven magazines. The most noticeable feature of the advertisement is a "strip," a series of four pictures.

The first picture is captioned "Don't Let 'Ironing-Board Itch' Destroy Your Home," and shows a housewife bending wearily over an ironing board, scratching herself with a flat iron.

The second picture introduces the housewife's husband; he is saying to her, "How come you are always too tired to attend the annual oratorio of the 14th Street Chopin & Chowder Club with me?" He is accompanying his question with a dirty look and the housewife is weeping bitterly.

The third strip shows one of the neighbor women putting in her five cents' worth. "Why don't you get a Zunk Electric Ironer on dignified deferred payment terms and end this drudgery?" she wants to know.

The fourth and last strip is captioned, with chaste simplicity, "Sweethearts Again." The housewife looks at least 25 years younger; her husband is handing her \$11 worth of orchids across the new ironer and remarking passionately, "Phooey on Claudette Colbert! You are far more beautiful than she since the Zunk Electric Ironer entered our little love nest."

Under the strip is a restrained sales talk in 36 point Bodoni Bold pointing out that living in a house that lacks a Zunk Electric Ironer is socially on a par with camping out on the city dump.

You see how it goes?

By adopting this technique and spending a small sum, say \$6,000,000, we architects could launch a campaign that would strike terror to the hearts of every American living in a house that was not designed by an architect. Imagine a strip showing the whole family coming down with "Contractor's Coryza"

APEX Electric Heat



BLO-AIR HEATERS
for living rooms, bedrooms and commercial installations

RADIANT CONVECTION HEATERS
for bathrooms and breakfast nooks

APEX Manufacturing Co.
Oakland, California
SANDOVAL SALES CO.
Distributors for
Northern California and Nevada
557 Market St., San Francisco



Product of
CALIFORNIA SHADE CLOTH CO.
210 Bayshore Blvd., San Francisco

Manufacturers of
**QUALITY HAND MADE SHADE CLOTH
IN ALL GRADES**

Wholesale Distributors
**SLOANE-BLABON LINOLEUM
AMBASSADOR VENETIAN BLINDS**

STRUCTURAL STEEL

For Class A Buildings,
Bridges, etc.

JUDSON PACIFIC CO.

609 MISSION STREET
SAN FRANCISCO

Plants: San Francisco - Oakland

or "Lumber Dealer's Lumbago" as the result of living in a house that was brought into the world without an architect to assist at the accouchement! The effect would be little short of terrific.

Any smart copy writer (me, for instance) could produce startling effective advertisements based on the accepted theory that women, who are the potential purchasers of all homes (or at least the instigators of all such purchases) can be divided into two classes: those who want to get married and those who want to stay married (a possible third class, the members of which are saving up for a divorce, is temporarily out of the market).

Does it seem far-fetched to you that architectural services should be held out as a means whereby any single gal can be assured of a husband who owns a valuable collection of etchings and some expensive bridgework? Or, if the lady is married, that architectural services will infallibly prevent her husband from smirking at waitresses or, in Winchellese, "three-alarming over one of the French Casino choristers?" If it does, let me assure you that many more far-fetched tie-ups than this have frequently gone to town.

The possibilities of such a campaign are endless. The expense would be endless, too. ROGER ALLEN.

SOUTHERN CALIFORNIA CHAPTER

The regular monthly meeting of Southern California Chapter, The American Institute of Architects, was held at the Little Theater in Padua Hills August 11. Dances and songs were presented by the Padua Hills players, a group of young Mexican artists.

George Adams, secretary of the Chapter, informed the members of a letter written by Myron Hunt protesting the construction of a county law library building on the site of the old county courthouse. It is Mr. Hunt's contention that the library should be incorporated in the proposed county courts building and the site of the old courthouse used for a park.

Manfred DeAhna, new associate member of the Chapter, was introduced. Several guests, including H. R. Smith of the Colorado Chapter, were also introduced.

Plans for the September meeting, at the Clark Hotel in Los Angeles, were outlined by President Ralph Flewelling.

The October meeting will be held at the Flintridge Country Club and has been designated as the annual guest evening. At that time Sumner Hunt will be presented with a life membership in the Chapter. Another feature will be an exhibition of the work of Paul Craig.

The following members and guests attended the meeting: A. M. Edelman, Ralph C. Flewelling, A. C. Zimmerman, Henry Davis, S. B. Marston, Samuel E. Lunden, Ernest Wilson, G. Stanley Wilson, J. Robert Harris, Roy C. Mitchell, Wm. M. Clarke, Robert H. Orr, Douglas McLellan, Henry F. Withey, R. Germain Hubby, R. B. Stacy-Judd, George Allison.

Paul Robinson Hunter, Ben H. O'Connor, H. R. Smith, Reginald D. Johnson, Walter Davis, J. J. Bac-kus, Wm. McCay, Breo Freeman, Edgar Maybury, Tom Elston, George J. Adams, Manfred M. DeAhna, Gates Burrows.

DECORATIVE MICARTA THE MODERN MATERIAL

FOR INTERIORS AND EXTERIORS

WESTINGHOUSE MICARTA is the Architect's choice for wall surfaces in homes, offices, stores, hospitals, restaurants, bar rooms, and on store fronts; also for tops of counters, tables, and desks, because MICARTA is:

Stronger than cast iron.

One-half the weight of aluminum.

Resilient and flexible.

Tougher than fine hard wood and easier to saw and fit into place.

Unaffected by water, oil, dilute mineral acids and alkalis.

Not injured by heat up to 250°F.

Glass-smooth.

Available in 32 standard designs, colors, and patterns.

Send for descriptive and application data.

Westinghouse



Here is a delightful inn, replete with the charm of Old Monterey and the atmosphere of true early California hospitality . . . yet modern to the last detail in comfort and convenience. Courtyard car space . . . accommodations for all family requirements at moderate rates . . . Sherman Rose Dining Room in conjunction.

MISSION INN * Monterey

456 TYLER STREET

TELEPHONE MONTEREY 4164

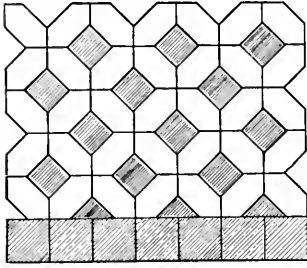

POMONA TILES

FOR

**Bathrooms and Kitchens
in over 60 colors**

Warehouses and Display Rooms

135 Tenth St. . . . San Francisco

629-33 North La Brea Ave.

Los Angeles

6106 Roosevelt Way . . . Seattle

POMONA TILE MFG. CO.
PLANT—POMONA, CALIF.

GOOD BRICKWORK

Frank M. Weakley writes for The Federal Architect what he thinks of brick, why specifications for brick construction should be clear and explicit and why good masonry work is dependent upon not only the quality of the bricks but the jointing and the labor. Mr. Weakley submits the following answers to questions anent good and poor brickwork.

1. Is it more lime? No. Lime makes for a whiter joint and a more plastic mortar. A Portland cement mortar is rather harsh and should have some lime in it, but this is only incidental.

2. Is it tighter specifications? Partially so, but only to the extent of being explicit as to just what is wanted.

3. Is it a special construction engineer? In general, no. If a construction engineer is worth employing, he should be able to get reasonably good results without having to call in someone else. I have more trouble with bricklayers and plasterers than any of the other trades; they get careless. The contractor's superintendent and the brick foreman do not inspect the work the mechanics do. I insist that both of these men watch the work carefully and find that it is a constant fight to get them to do so.

4. Is it through flashing? No. In my opinion, most of the through flashing can be omitted as being useless. In some cases it definitely weakens the wall.

5. Is it the type of joint? Yes, very much so. I consider this is a matter of architecture. The architectural designer should know how to get the best appearance with the various kinds and colors of mortar joints. This matter of joints should be studied concurrently with the kind of bricks.

6. Is it the type of bricks? Yes, emphatically, but here the type of joints have a great bearing on the results. Where bricks vary materially in size, it is almost impossible to get a good looking job with struck or weathered joints, as the joints will



REYNOLDS METALLATION

ALUMINUM foil for
permanent home
INSULATION

REYNOLDS ECOD

welded wire fabric
plaster base—
prevents cracks,
provides thermal
insulation

*Northern California
Distributors—*

WESTERN ASBESTOS CO.

675 TOWNSEND STREET
SAN FRANCISCO

To the

ARCHITECTURAL PROFESSION!

GIVE

your clients

COMFORT

and

SATISFACTION

by including

"AIR-LITE"

VENETIAN

BLINDS

in your specifications

NUFF SAID

GUNN, CARLE & CO.

20 Potrero Ave. UNDERHILL 5480
SAN FRANCISCO

SISALKRAFT
REG. U. S. PAT. OFF.

**"More than a
building paper"**

THE SISALKRAFT CO.

205 West Wacker Drive
(Canal Station) Chicago, Ill.
55 New Montgomery Street
San Francisco, Calif.



**DALMO
WINDOW
PRODUCTS**

DALMO SALES CORPORATION
511 Harrison St., San Francisco

THE ARCHITECT AND ENGINEER

EYE APPEAL

That is what every architect is striving for — and getting — if he is specifying FERRO-PORCELAIN for the exterior of his jobs.



Inquiries promptly answered.



FERRO ENAMELING CO.

1100 - 57th Ave., Oakland, Calif.

HARDWOOD LUMBER FLOORING VENEERS PANELS

Exotic Woods for Modernistic Trim

White Brothers
Hardwood Headquarters

Since 1872

5TH AND BRANNAN . . . SAN FRANCISCO
500 HIGH STREET OAKLAND

PAYNE



The choice of discriminating buyers of Gas-Fired Heating and Air-Conditioning Equipment. A catalog showing complete Payne line sent upon request.



PAYNE FURNACE & SUPPLY COMPANY

Beverly Hills California

vary and give bad lines. I have seen some very nice looking walls of common brick laid with special jointing.

Good brickwork depends upon the bricks, the jointing and the labor. It is up to the construction engineer to attend to the last; the first two is the business of the designer.

I believe that the architectural designer should be very much of an artist. He should be able to get the effects he wants, call them texture, character, color, atmosphere, feel, etc., etc., by the proper combination of bricks, mortars, jointing and bond.

The specifications should be quite clear as to what the designer intends. If he wants a particular job, he should describe it definitely. I see no good reason why this cannot be done.

If the specifications are explicit, the construction engineer should be able to get the proper workmanship. Some bricklayers cannot do decent work. Such should be weeded out, in a diplomatic manner, of course. If enough sloppy work is condemned, the contractor will usually take the needed action.

Where careful bonding is required, and the bricks vary in size, they should be gauged and separated into piles according to size, the different sizes being used in different walls.

I recommend keeping away from struck or weathered joints in exterior face work. The principal objection I have to this jointing is that it looks ragged. The vertical joints do not fit into the horizontal joints. I much prefer the concave joints.

Trim has much to do with the appearance of brickwork. I have seen some very attractive buildings of Georgian period design with common brick and relatively cheap wood trim. The character and type of openings in a brick wall affect the appearance.

To sum up the above, I think it is the business of the architectural designer to get out a creditable design for a brick building. Then the construction engineer will not have much trouble in getting good looking brickwork.

*For the new
Alameda County
Court House —*

CALAVERAS White CEMENT

For beauty and durability Calaveras white cement was selected for the exterior of the building.

A thin dash coat of Calaveras white cement stucco was applied over monolithic concrete walls, producing interesting shadow effects but still retaining form marking.

Read the text of this magazine for full details and illustrations of the construction of this splendid new building.



CALAVERAS CEMENT COMPANY

315 Montgomery St., San Francisco

Pre-Convention Number of the Architect & Engineer

will be published in connection with the annual meeting of the State Association of California Architects at the Del Monte Hotel October

- Recent work on the Monterey Peninsula by well known architects will make this an outstanding number. Complete program and full advance information about the convention.

IT'S HERE!

perfected
by
ELECTRIC HEATING
WESIX

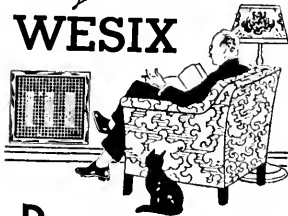

BEFORE YOU INSTALL ANY HEATING SYSTEM

... ask us about WESIX *automatic electric heaters*—proven in thousands of installations in homes, buildings, hospitals, schools—even entire cities! WESIX patented *double-action principle of circulating and radiating* provides quick, efficient, economical heat. You know it's *healthful*. NO FANS to stir up breeze and drafts—*no moving parts*.

WESIX ELECTRIC HEATER CO.
380 First Street San Francisco

HOW TO IMPROVE STEEL STRUCTURES
By H. L. Whittemore

IT seems reasonably certain that in the future engineers will use less material and more skill in designing and fabricating structures. It seems to be agreed that this country has passed the pioneer period of abundant material and a shortage of labor, particularly skilled workmen and competent engineers. Europe has for years been working under the conditions which we are now facing but we should not adopt without question the methods which they are using.

If the cost of material is low compared with the other costs, it is practicable to use sufficient material to insure a safe and satisfactory structure. In the future the cost of material will certainly increase greatly compared with the other costs, making it necessary to use as little as possible. There will then be a great economic advantage in using materials having high strength or other unusual properties. To avoid failures in service the fabricator will then be obliged to make adequate tests to make sure that the material has the required properties. Specifications will then become more rigid and the necessity for adequately testing each lot of material will increase very greatly. Reliance on the manufacturer to supply satisfactory material will more and more prove inadequate unless the fabricator makes his own inspection and tests before acceptance.

When the aluminum alloy duraluminum came into use for aircraft structures it did not have the background of 100 years of satisfactory service possessed by iron and steel. The producers of "dural" therefore very wisely made sure that the material complied with the specifications. We have found that the "dural" tubing for our investigations always complied with the military aircraft specifications under which it was obtained while for chromium-molybdenum steel tubing it was often necessary to re-

Clinton Construction Co.
of California
General Contractors

923 Folsom Street
San Francisco
SUtter 3440

HIGH GRADE MILLWORK
AND INTERIOR FINISH
SASH AND DOORS

LANNOM BROS. MFG. CO.

FIFTH AND MAGNOLIA STREETS
OAKLAND, CALIFORNIA
Telephone: LAkeside 3663

ANDERSON & RINGROSE

General Contractors

320 Market Street, San Francisco
Phone GARfield 2245

CRANE
High Class Plumbing Fixtures

ALL PRINCIPAL COAST CITIES

Alumilite

by

Kawneer

Store Fronts - Windows

and

Architectural Castings

in

Polished Satin

or

Anodic Finish

THE
Kawneer
COMPANY
OF CALIFORNIA
BERKELEY

Pacific Manufacturing Company

High Class Interior Finish
Quality Millwork

454 Montgomery St. 641 Merrill Ave.
San Francisco Los Angeles
GARfield 7755 AXridge 9011

1315 Seventh Street, Oakland
GLencourt 7850

FORDERER Cornice Works

Manufacturers of

Hollow Metal Products
Interior Metal Trim
Elevator Fronts and Cabs
Metal Wall Plugs, Anchors, Etc.
Sheet Metal Products
Sanitary Metal Base
Commercial Refrigerators
Building Paper
Metal and Wire Accessories
for Concrete
269 POTRERO AVENUE
San Francisco, Calif.
HEmlock 4100
CONSULT OUR ENGINEERING
DEPARTMENT

Melrose Lumber & Supply Co.

•
LUMBER AND
MILL WORK
•

46th Ave. and E. 12th St.
Oakland

Phones: FRuitvale 0240 — 0251

Carl T. Doell Co.

*Plumbing
Heating*

Plumbing Contractor
Veterans Memorial Building
Oakland

467 21ST STREET
OAKLAND

Telephone GLencourt 8246

ject many of the tubes, and the replacements did not always comply. I believe this has been due to a fundamental difference in the mental attitude of the producers. In this respect the steel industry has been much more backward than its competitors. It is needless to point out that, to this extent, the steel industry promoted the use of "dural".

If the maker recommends a commodity for a particular purpose, such as a bolt or I-beam which is used in the condition it is received, he should supply the engineering data regarding the commodity needed by the designer or user.

After the World War this government dumped large quantities of nitro-cellulose at sea but the duPont Company investigated other methods of disposing of its surplus. Among other uses was the manufacture of cellophane. It was necessary, however, for the sales force and the laboratory to study possible uses, alter the composition to meet new requirements and particularly to increase the tensile strength and resistance to water. The phenomenal increase in the use of cellophane could not possibly have taken place without the thorough work on this phase of the problem. Now cellophane is even used for women's dresses.

When planning a 10-inch pipe line in the hydraulic laboratory at the Bureau, a thin-wall pipe was necessary to avoid overloading the supporting structure. The spans were 17 feet, and because of the high compressive stress on the upper portion of the pipe it seemed possible that the pipe would fail by local buckling although the pipe manufacturer had recommended the pipe for this span without giving the results of actual tests or even the method of computing the strength of the pipe under these conditions. Although the pipe was installed because there was no other practicable solution, the pipe manufacturer should have furnished satisfactory evidence that the pipe was safe when used in this way.

We are particularly interested in the development of improved meth-

"Ask the National Lead Man!"

Special attention is given to architects' inquiries on paint materials and painting procedure by our technical staff.

SPECIFY

DUTCH BOY

Painter Products

BASS - HUETER

Paints and Varnishes

NATIONAL LEAD
COMPANY

San Francisco Seattle
Portland Los Angeles

Branches and dealers in all principal cities

We suggest for
dependable

SUMMER OR WINTER

AIR CONDITIONING

that you investigate

Delco Frigidaire's

"Conditionair"

A Product of General Motors

Call

A LADDIN Heating Corp.

5107 BROADWAY

OLYMPIC 5424

OAKLAND

CALIFORNIA

T/N ONE-PIECE WATER CLOSET



The first and finest one-piece water closet. No elevated tank and not attached to wall. Can be installed in corners, under stairs or windows. Simplified fittings assuring positive, quiet performance. Special regulating stop, designed for either angle or straight supply, permitting volume regulation of water under all pressures. Sold only by Master Plumbers.

Distributed by

TAY HOLBROOK, INC.

SAN FRANCISCO

OAKLAND

SAN JOSE

SACRAMENTO

FRESNO

FLOOR COVERING
AND

LINOLEUM WALLCOVERING
FOR THE NEW

**ALAMEDA COUNTY
COURT HOUSE**

W. G. Corlett, J. W. Plachek, W. E. Schirmer,
H. A. Minton, Carl Werner, Architects

Installed by

HIGGINS CO.

1930 VAN NESS AVE., SAN FRANCISCO
2335 BROADWAY, OAKLAND

VENETIAN BLINDS
LINOLEUM • AWNINGS
RUGS • CARPETS
HARDWOOD FLOORS

ods of design and fabrication of steel structures because such advances will widen the market for structural steel. Although for many structures the conventional designs have proved safe and satisfactory, it seems to the casual observer that there has been less progress in the designing of steel structures during the past 25 years than in other branches of engineering, such as power plants, automobiles, etc. Probably much of this conservatism has been due to the inflexible requirements of the building codes in our cities which, although necessary to protect the public, have been applied in such a way as to seriously handicap progress in the construction industry. Apparently the steel industry has been content with the code requirements which apply to steel.

It seems to me that in this country less attention is paid to research on metal structures than to any other branch of engineering.

Too often computations based upon simplifying assumptions or the results of photo-elastic analysis are considered conclusive when tests of actual structures are needed. The recent investigations on aircraft structures show what can be done in this field if the problems are studied energetically. The fact that structural problems have received comparatively little attention only increases the chances that investigations in this field will not only increase the use of steel structures but benefit the public by making them safe and economical.

NEW YORK'S NEWEST APARTMENTS

Cautious resumption of apartment construction, after six years of inaction, reveals many striking advances. In the fashionable West End district of New York City, a 20-story house replaces one of 10 stories, built in 1900, containing suites of eight to 12 rooms. Not only did the room layout of the old house make good modernization impractical, but income from the site is increased greatly by doubling height. Improvements over old houses are so notable, the



Pump Governors	Oil Heaters
Safety Pump Governors	Relief Valves
Automatic Gas Regulating Valves	Oil Burner Governors
Gas Burners	Little Giant Improved Oil Burners
Gas Burning Equipment	Oil Pumping Sets
Vacuum Pump Governors	Oil Valves
Vacuum Regulating Valves	Oil Strainers
Continuous Flow Steam Traps	Steam Oil Strainers
Thermostats	Duplex Oil Pumps
Reducing Valves	Rotary Oil Pumps
Boiler Feed-Water Regulators	Boiler Feed Pumps
	Water Heaters
	Oil Meters

VAUGHN-G. E. WITT Co. ENGINEERS

C. W. Vaughn, President and Manager

MANUFACTURERS AND
DISTRIBUTORS

4224-28 Hollis St. Phone OLympic 6084
Emeryville, Oakland, Calif.

Robert W. Hunt Company ENGINEERS

Inspection - Tests - Consultation
Schools and Other Structures
Are Built as Designed

*When Construction Materials are
Inspected at point of Manufacture
and during Erection by*
ROBERT W. HUNT COMPANY

*Cement, Concrete, Chemical, Metallurgical,
X-Ray and Physical Laboratories*

Chicago - New York - Pittsburgh
Los Angeles - All Large Cities
San Francisco, 251 Kearny Street



HERRICK IRON WORKS

STRUCTURAL STEEL

187B AND CAMPBELL STS.
OAKLAND, CALIF.

Phone GLencourt 1767



No longer a problem
for the Architect

TRANSIT MIX CONCRETE

AND MORTAR

makes delivery of material to the job swift and inexpensive . . . minimizing the architect's supervision costs and assuring his client a dependable mix.

Speed . . . Reliability . . . Economy

Let us co-operate with you

Golden Gate-Atlas Materials Co.

16th and Harrison Streets
San Francisco
UNDERhill 3650

COMMON BRICK

If you like good brick and good service, phone us for information, you will find that it always pays to be our patron.

Remillard-Dandini Co.

Phone TEmplebar 8133

Office, 569 - 3rd Street, Oakland

Plants

San Jose Pleasanton Greenbrae

Bethlehem Steel Company

General Offices:  Bethlehem, Pa.

STEEL BRIDGES and BUILDINGS

San Francisco
20th and Illinois Sts.

Seattle
W. Andover Street

Portland
American Bank Bldg.

Los Angeles
Slouson Ave.

Salt Lake City
Keorns Bldg.

Honolulu, T. H.
Schuman Bldg.

builders found ample security in the realty axiom that best buildings fill promptly with the neighborhood's most desirable tenants, the shift leaving rundown competitors with more vacancies. Suites of one to four rooms predominate, a few containing five, only one seven. Studio corner windows make the outside look much different—an impossible feature for old structures with corner columns. Gray is the color scheme, with black, vermilion and silvery touches, window frames being steel. The same colors carry through the lobby. A circular gallery at floor entry leads to most rooms of each suite, all of which get more light from the larger windows. Living rooms are dropped two steps below suite floor level, a dining foyer being marked off only by an ornamental iron railing. Reinforced concrete floors are surfaced with woods, the slabs carrying electrical conduits. Bathroom floors and walls are tiled in colors. They contain everything of the latest, as do kitchens, where all hardware is chromium-plated and equipment all electric. Water pipes, drains and electric outlets in each suite provide for air-conditioning apparatus to be put in by tenants, if wanted.—Buildings & Building Management.

NOTES AND COMMENTS

(Concluded from Page 2)

were not up to this standard. It was found, also that the small home-owners could not afford architects. So, 'to avoid the marring of the landscape which has taken place in England,' the Government—through the Ministry of Finance—instituted a competition in which 526 architects submitted designs for a small, compact, low-cost house. A committee of architects were the judges. From the entries they selected the best five, and these with the next best fifty will be published in book form and sold at fifty cents the lot. This is my first point.

"The second point is that the judges actually selected as the best design of all a house with a flat roof, because it was proved to them beyond doubt that the flat roof was eminently suitable to the rigorous of the Canadian climate and that it substantially reduced costs.

"The thoughts that arise out of this are these: it is important that a Government,

Modern Design Dignified and Good Looking



Model No. 75

This new semi-recessed HAWS DRINKING FOUNTAIN is made of Vitreous China and answers a demand for an attractive, well built fixture for public and semi-public buildings.

HAWS DRINKING FAUCET CO
1808 Harmon Street Berkeley, Calif.

"BROWNSKIN"

RESILIENT WATERPROOF
BUILDING PAPER

THE BUILDING PAPER WITH
A FACTOR OF SAFETY

Angier Corporation

Framingham, Mass.

PACIFIC COAST DIVISION

544 HOWARD STREET

SAN FRANCISCO

DOUGLAS 4416

350 South Anderson St.

Los Angeles

MacDonald & Kahn

General
Contractors



Financial Center Bldg.

405 Montgomery St.

San Francisco

especially when it is lending part of the money, should insist on the proper assistance of trained architects. But here, in Canada, when they come to face up to the problem, they find that people always say that they cannot afford architects.

"Yet they do not altogether dispense with them, because the choice work of some 526 architects is examined and fifty-five of them have the honor of having their designs put into a book and sold for fifty cents—which the builders and house-purchasers may copy.

"I do not know what happens to the architects after their designs have been so honored. Perhaps the speculative builders who cannot afford a few guineas for an architect's services send a small subscription to a Canadian Architects' Benevolent Fund; for one good turn deserves another. But more likely the builders and prospective owners discover that no one design is quite what they want, but by knocking two of them into one they can make a design of their very own; and, the design being their very own, they are under no obligation whatever. Or perhaps there is some system of royalties under which an architect is allowed to travel round all the suburbs of all the towns of Canada, and if he can recognize his design he is allowed to write to the builder or owner and ask for a copyright fee; only, of course, if the

builder has improved on the design it would be rather bad form for an architect to expect any consideration. In short, picking the architect's brain is an interesting and profitable occupation, and one which we can recommend to all sound business men.

"Yet, somehow, something ought to be done to preserve such a body of men who can show the builders and the public how money can be saved. And, considering that they have saved the whole cost of a roof, could we not give a small proportion of the money saved to them as fees, and thus buy their personal services? The problem is how to preserve this species of money-savers and yet at the same time avoid paying their fees.

REPUBLIC STEEL CORPORATION



Manufacturers of

ENDURO Stainless Steel; TON-CAN Copper Molybdenum Iron Sheets and Pipe; and Steel Pipe, Sheets and Reinforcing Bar for every building purpose.

Write for information

Rialto Building, San Francisco, Calif.
Edison Building, Los Angeles, Calif.
White-Henry-Stuart Bldg., Seattle, Wash.

CORROSIRON

MADE IN U.S.A.

HIGH SILICON ACID RESISTING IRON

REDUCE COST OF HANDLING CORROSIVE GASES

with CORROSIRON

EXHAUST FANS for ACID FUMES

Write for BULLETIN No. 130 SHOWING PERFORMANCE DATA—DESCRIPTIONS and DIMENSIONAL BLUE PRINTS SIZES

3 in.—6 in.—8 in.—12 in.—15 in.

CAPACITIES

50 C.F.M. to 5000 C.F.M.

TYPE DM.



PACIFIC FOUNDRY COMPANY, Ltd.

551 Fifth Avenue
NEW YORK

3100 Nineteenth St.
SAN FRANCISCO

1400 South Alameda St.
LOS ANGELES

★ ★ ★ ★ ★

Traditional and contemporary designs of Lightolier fixtures are on display in our showrooms. Whether you are working on a new or modernized home you'll find the very designs you want at Incandescent.

Booklet, "The Charm of a Well Lighted Home" available upon request.

INCANDESCENT SUPPLY CO.
San Francisco Oakland Fresno Los Angeles

★ ★ ★ ★ ★

MONEL METAL

For the Modern Kitchen
Heaters, boilers, storage tanks, water softeners, cabinet tops. "Streamline" or "Straitline" Kitchen Sinks

See our display rooms, arranged for your convenience

MODERN METAL APPLIANCE CO.
4238 Broadway Oakland, Calif.

"THANK YOU Mr. Architect."

That's what your clients will say for suggesting genuine Davey Tree Surgery. And remember—

It costs no more for genuine



SAN FRANCISCO Fresno LOS ANGELES
Russ Bldg. Mattai Bldg. Story Bldg.
SUtter 3377 Tucker 1929
Local phones in: Pasadena, Palo Alto, Oakland, San Rafael, Burlingame

Skill • Knowledge • Responsibility

Classified Advertising Announcements

All Firms are Listed by Pages, besides
being grouped according to Craft or Trade.
Star (*) indicates alternate months.

ACOUSTICAL AND SOUND CONTROL	
Western Asbestos Co., 675 Townsend Street, San Francisco.....	70
AIR CONDITIONING	
The Union Ice Company, 354 Pine Street, San Francisco	*
ARCHITECTURAL TERRA COTTA	
N. Clark & Sons, 116 Natoma Street, San Francisco.....	11
Gladding McBean & Co., 660 Market Street, San Francisco; 2901 Los Feliz Boulevard Los Angeles; 1500 First Avenue South, Seattle; 79 S. E. Taylor St., Portland; 22nd and Market Streets, Oakland; 1102 N. Monroe Street, Spokane; Vancouver, B. C.....	*
BANKS	
Crocker First National Bank, Montgomery and Post Streets, San Francisco.....	65
BATHROOM HEATERS	
West Electric Heater Company, 390 First Street, San Francisco; 631 San Julian Street, Los Angeles; 2008 Third Avenue, Seattle, Wash.	72
Apex Electric Heaters, sold by Sandoval Sales Co., 557 Market Street, San Francisco	68
BLINDS—VENETIAN	
Higgins Co., 1930 Van Ness Ave., San Francisco; 2335 Broadway, Oakland	74
Gunn-Carle & Co., 20 Potrero Ave., San Francisco.....	70
BRICK—FACE, COMMON, ETC.	
N. Clark & Sons, 116 Natoma Street, San Francisco.....	11
Gladding McBean & Co., 660 Market Street, San Francisco; 2901 Los Feliz Boulevard Los Angeles; 1500 First Avenue South, Seattle; 79 S. E. Taylor St., Portland; 22nd and Market Streets, Oakland; 1102 N. Monroe Street, Spokane; Vancouver, B. C.	*
Remillard-Dardini Co., 569 Third Street, Oakland.....	75
BUILDERS HARDWARE	
The Stanley Works, New Britain, Conn.; Monadnock Bldg., San Francisco; Los Angeles and Seattle	*
BUILDING MATERIALS	
Building Material Exhibit, Architect's Building, Los Angeles....	65
BUILDING PAPERS	
The Sisalkraft Company, 205 W. Wacker Drive, Chicago, Ill., and 55 New Montgomery Street, San Francisco	70
"Brownskin," Angier Corporation, 370 Second Street, San Francisco	75
CEMENT	
Calaveras Cement Company, 315 Montgomery Street, San Francisco.....	71
Portland Cement Association, 564 Market Street, San Francisco; 816 West Fifth Street, Los Angeles; 146 West Fifth Street, Portland; 518 Exchange Building, Seattle	Back cover
"Golden Gate" and "Old Mission," manufactured by Pacific Portland Cement Co., 111 Sutter Street, San Francisco; Portland, Los Angeles and San Diego.....	Second cover
CEMENT TESTS—CHEMICAL ENGINEERS	
Robert W. Hunt Co., 251 Kearny Street, San Francisco.....	74
CEMENT—COLOR	
"Golden Gate Tan Cement," manufactured by Pacific Portland Cement Co., 111 Sutter Street, San Francisco; Portland, Los Angeles and San Diego	Second cover
CEMENT PAINT	
General Paint Corporation, San Francisco, Los Angeles, Oakland, Portland and Seattle	65
CONCRETE AGGREGATES	
Golden Gate Atlas Materials Company, Sixteenth and Harrison Streets, San Francisco	75
John Cassareto, Sixth and Channel Streets, San Francisco	78
CONCRETE CURING & PROTECTION	
The Sisalkraft Company, 205 W. Wacker Drive, Chicago, Ill., and 55 New Montgomery Street, San Francisco	70
CONTRACTORS—GENERAL	
MacDonald & Kahn, Financial Center Bldg., San Francisco	79
CHEMICAL ENGINEERS	
Abbott A. Hanks, Inc., 624 Sacramento Street, San Francisco.....	79

NEW THIS MONTH

American Brass Company 10-11	•
Johnson Service	3
General Roofing Co.	66
Libbey-Owens-Ford	17
Del Monte Hotel	18
Frank W. Dunne	16
National Mill & Lumber Co. ...	16
E. K. Wood Lumber Co.	14
N. Clark & Son	13
Sloan Valve Co.	12
Westinghouse Electric & Mfg. Co.	15
S. T. Johnson Co.	4-5
Abbott A. Hanks, Inc.	79

CONTRACTORS—GENERAL		Page
Lindgren & Swinerton, Inc., Standard Oil Building, San Francisco.....		66
Dinwiddie Construction Co., Crocker Bldg., San Francisco.....		79
Clinton Construction Company, 923 Folsom Street, San Francisco.....		72
Anderson & Ringrose, 320 Market Street, San Francisco.....		72
G. P. W. Jensen, 320 Market Street, San Francisco.....		78
DAMP-PROOFING & WATERPROOFING		
"Golden Gate Tan Plastic Waterproof Cement," manufactured by Pacific Portland Cement Co., 111 Sutter Street, San Francisco; Portland, Los Angeles and San Diego.....		Second page of cover
The Sisalkraft Company, 205 W. Wacker Drive, Chicago, Ill., and 55 New Montgomery Street, San Francisco.....		70
DOORS—HOLLOW METAL		
Forderer Cornice Works, Potrero Avenue, San Francisco.....		72
Kawneer Mfg. Co., Eighth and Dwight Streets, Berkeley.....		73
ACID PROOF DRAIN PIPE AND FITTINGS		
Corrosion—Acid resisting pipe, fittings, exhaust fans, pumps, etc., Pacific Foundry Co., 3100 19th Street, San Francisco; 1400 S. Alameda Street, Los Angeles.....		76
DRINKING FOUNTAINS		
Haws Drinking Faucet Co., 1808 Harmon Street, Berkeley; American Seating Co., San Francisco, Los Angeles and Phoenix.....		14
ENGINEERS—MECHANICAL		
Hunter & Hudson, 41 Sutter Street, San Francisco.....		80
ELECTRIC AIR AND WATER HEATERS		
Sandoval Sales Company, 557 Market Street, San Francisco.....		68
Wesix Electric Heater Company, 390 First Street, San Francisco; 631 San Julian Street, Los Angeles; 2008 Third Avenue, Seattle, Wash.....		72
ELECTRICAL ADVICE		
Pacific Coast Electrical Bureau, 447 Sutter Street, San Francisco, and 601 W. Fifth Street, Los Angeles.....		64
ELECTRICAL EQUIPMENT		
Westinghouse Electric & Mfg. Co., 1 Montgomery Street, San Francisco.....		66
ELEVATORS		
Pacific Elevator and Equipment Company, 45 Rausch Street, San Francisco.....		*
Westinghouse Electric Elevator Company, 1 Montgomery Street, San Francisco.....		8
PORCELAIN ENAMELING		
Ferro Enameling Company, 1100 57th Street, Oakland.....		71
FLOORING		
Asphalt Tile, Western Asbestos Company, 675 Townsend Street, San Francisco.....		70
FIXTURES—BANK, OFFICE, STORE		
Mullen Manufacturing Co., 64 Rausch Street, San Francisco.....		79
Pacific Manufacturing Company, 454 Montgomery Street, San Francisco; 1315 Seventh Street, Oakland, Los Angeles and Santa Clara.....		73
GAS FUEL		
Pacific Gas Association, 447 Sutter Street, San Francisco.....		Third Cover
GAS BURNERS		
Vaughn-G. E. Witt Company, 4224-28 Hollis Street, Emeryville, Oakland.....		74
GAS VENTS		
Payne Furnace & Supply Co., Beverly Hills, California.....		71
GAS RADIATORS		
Pacific Gas Radiator Company, Huntington Park, Calif.....		68
GLASS		
W. P. Fuller & Co., 301 Mission Street, San Francisco. Branches and dealers throughout of the West.....		*
Libbey-Owens-Ford Glass Co., Toledo, Ohio; 633 Rialto Bldg., San Francisco; 1212 Architect's Bldg., Los Angeles; Mr. C. W. Holland, P.O. Box 3142, Seattle.....		15
Pittsburgh Plate Glass Company, Grant Building, Pittsburgh, Pa. W. P. Fuller & Co., Pacific Coast Distributors.....		*
HARDWARE		
The Stanley Works, Monednock Building, San Francisco; American Bank Building, Los Angeles.....		*
HARDWOOD LUMBER		
White Bros., Fifth and Brannan Streets, San Francisco; 500 High Street, Oakland.....		71
HEATING—ELECTRIC		
Apex Air and Water Electric Heaters, Sandoval Sales Company, 557 Market Street, San Francisco.....		68
Wesix Electric Heater Company, 390 First Street, San Francisco; 631 San Julian Street, Los Angeles; 2008 Third Avenue, Seattle, Wash.....		72
HEATING EQUIPMENT		
Payne Furnace & Supply Co., Beverly Hills, California.....		71
Pacific Gas Radiator Co., 7615 Roseberry Ave., Huntington Park; Sales Office, H. C. Stockel, 557 Market Street, San Francisco.....		68
Aladdin Heating Corp., 5107 Broadway, Oakland.....		73
Tay-Holbrook, Inc., San Francisco, Oakland, Sacramento, Fresno, San Jose.....		74
HEAT REGULATION		
Johnson Service Company, Milwaukee, represented on the Pacific Coast by the following branch offices: 814 Rialto Bldg., San Francisco; 153 West Avenue, 34, Los Angeles; 1312 N.W. Raleigh St., Portland, and 473 Coleman Bldg., Seattle.....		3

**JOHN
CASSARETTO**
—Since 1886—And Still Active—

Building Materials

READY MIX CONCRETE
ROCK - SAND - GRAVEL - LIME
CEMENT - PLASTER - MORTAR
METAL LATH - WOOD LATH
STUCCO - WIRE NETTING

Service Unexcelled
Bunkers
Sixth and Channel, San Francisco
Phones: GARfield 3176, GARfield 3177

**G. P. W.
JENSEN & SON**

Building Construction

320 Market Street, San Francisco
Phone 2444

**DINWIDDIE
CONSTRUCTION
COMPANY**

•

**BUILDERS OF
GOOD BUILDINGS**

•

CROCKER BUILDING
SAN FRANCISCO

**MULLEN MFG.
COMPANY**

BANK, STORE AND OFFICE
FIXTURES—CABINET WORK
OF GUARANTEED QUALITY
CHURCH SEATING

Office and Factory:
60-80 RAUSCH ST., Bet. 7th and 8th Sts.
San Francisco
Telephone UNderhill 5815

Independent Iron Works

Structural Steel
Ornamental Iron
Steel Service Stations
Steel Tanks
Standard Steel Mill Buildings
Bridges

821 Pine Street Oakland

MURALS

for Hotel Cocktail Rooms,
Theaters, etc.

HEINSBERGEN
DECORATING CO.

7415 Beverly Boulevard, Los Angeles
401 Russ Building, San Francisco



*American Plan
Cuisine Par Excellence
Comfortable Rooms*

SANTA MARIA INN
FRANK J. MCCOY
Santa Maria, California

ABBOT A. HANKS, INC. Engineers & Chemists

INSPECTING — TESTING — CONSULTING
CONCRETE • STEEL • MATERIALS
CHEMICAL AND TESTING
LABORATORIES
• RESEARCH AND INVESTIGATION •

TESTS OF STRUCTURAL MATERIALS
DESIGN OF CONCRETE MIXES
SHOP AND ERECTION INSPECTION OF
STRUCTURES AND EQUIPMENT
INVESTIGATION OF STRUCTURES
AND MATERIALS
TESTS AND INVESTIGATION OF
FOUNDATION SOILS
FIRE RESISTANCE AND INSULATION
TESTS

624 Sacramento Street, San Francisco

HOLLOW BUILDING TILE (Burned Clay)	Page
N. Clark & Sons, 116 Natoma Street, San Francisco	11
Gladding, McBean & Co., 660 Market Street, San Francisco; 2901 Los Feliz Boulevard, Los Angeles; 1500 First Avenue South, Seattle; 79 S. E. Taylor Street, Portland; Twenty-second and Market Streets, Oakland; 1102 N. Monroe Street Spokane; Vancouver, B. C.	.
INSULATING MATERIALS	70
Western Asbestos Co., 675 Townsend Street, San Francisco	
INSPECTION AND TESTS	
Robert W. Hunt Co., 251 Kearny St., San Francisco	74
Abbott A. Hanks, Inc., 624 Sacramento Street, San Francisco	79
LACQUERS	
General Paint Corp., San Francisco, Los Angeles, Oakland, Portland, Seattle and Tulsa	65
W. P. Fuller & Co., 301 Mission Street, San Francisco. Branches and dealers throughout of the West	.
LIGHTING FIXTURES	
Incandescent Supply Co., 726 Mission Street, San Francisco; Oakland, Fresno	76
LINOLEUM	
Sloan-Blabon linoleum, sold by California Shade Cloth Co., 210 Bayshore Boulevard, San Francisco	70
Higgins Co., 1930 Van Ness Ave., San Francisco; 2335 Broadway, Oakland	74
LUMBER	
Pacific Mfg. Co., 454 Montgomery Street, San Francisco; 1315 Seventh Street, Oakland; Los Angeles and Santa Clara	73
Smith Lumber Company, Nineteenth Avenue and Estuary, Oakland	80
Melrose Lumber & Supply Co., Forty-sixth Avenue and E. Twelfth Street, Oakland	80
E. K. Wood Lumber Company, 4701 Santa Fe Avenue, Los Angeles; I Drumm Street, San Francisco; Frederick and Kings Streets, Oakland	.
MARBLE	
Joseph Musto Sons-Keenan Co., 535 N. Point Street, San Francisco	80
MACHINERY—PUMPS, ETC.	
Simonds Machinery Company, 816 Folsom Street, San Francisco	66
MILLWORK	
E. K. Wood Lumber Company, No. I Drumm Street, San Francisco, Oakland, Los Angeles	12
Lannom Bros. Mfg. Co., Fifth and Magnolia Streets, Oakland	72
Melrose Lumber & Supply Company, Forty-sixth Avenue and E. Twelfth Street, Oakland	78
Pacific Mfg. Co., 454 Montgomery Street, San Francisco; 1315 Seventh Street, Oakland; Los Angeles and Santa Clara	73
Smith Lumber Company, Nineteenth Avenue and Estuary, Oakland	80
MONEL METAL	
"Inco" brand, distributed on the Pacific Coast by the Pacific Metals Company, 3100 19th Street, San Francisco, and 1400 So. Alameda Street, Los Angeles	76
Heaters, storage tanks—Modern Metal Appliance Company, 4238 Broadway, Oakland	76
MURALS	
Heinsbergen Decorating Co., Los Angeles and 401 Russ Building, San Francisco	.
OIL BURNERS	
S. T. Johnson Co., 585 Potrero Avenue, San Francisco; 940 Arlington Street, Oakland; 1729 Front Street, Sacramento, and 230 N. Sutter Street, Stockton	4-5
Vaughn-G. E. Witt Co., 4224-28 Hollis Street, Emeryville, Oakland	74
ONYX	
Joseph Musto Sons-Keenan Co., 535 No. Point Street, San Francisco	72
ORNAMENTAL IRON	
Independent Iron Works, 821 Pine Street, Oakland	76
ORNAMENTAL LIGHTING	
Incandescent Supply Co., 726 Mission Street, San Francisco, Oakland, Fresno	76
PAINTS, OIL, LEAD	
W. P. Fuller & Co., 301 Mission Street, San Francisco. Branches and dealers throughout the West	.
Frank W. Dunne Co., 41st and Linden Streets, Oakland	14
General Paint Corp., San Francisco, Los Angeles, Oakland, Portland, Seattle and Tulsa	65
National Lead Company, 2240 24th Street, San Francisco. Branch dealers in principal Coast cities	73
PAINTING, DECORATING, ETC.	
The Tormey Co., 563 Fulton Street, San Francisco	80
Heinsbergen Decorating Co., 401 Russ Building, San Francisco	.
PARTITIONS—MOVABLE OFFICE	
Pacific Mfg. Co., 454 Montgomery Street, San Francisco; 1315 Seventh Street, Oakland; factory at Santa Clara	73
PLASTER	
"Empire" and "Reno Hardware Plaster," manufactured by Pacific Portland Cement Co., 111 Sutter Street, San Francisco; Portland, Los Angeles and San Diego	Second cover

	Page
PLATE GLASS	
Libbey-Owens-Ford Glass Co., Toledo, Ohio; 633 Rialto Bldg., San Francisco; 1212 Architects Bldg., Los Angeles; Mr. C. W. Holland, P. O. Box 3142, Seattle	17
PLUMBING CONTRACTORS AND MATERIALS	
Carl T. Doell Co., 467 Twenty-first Street, Oakland	73
Crane Co., all principal Coast cities	72
Tay-Holbrook, Inc., San Francisco, Oakland, Sacramento, Fresno, San Jose	74
PRESSURE REGULATORS	
Vaughn-G. E. Witt Co., 4224-28 Hollis Street, Emeryville, Oakland	74
PUMPS	
Simonds Machinery Company, 816 Folsom Street, San Francisco	66
REFRIGERATION	
Kelvinator Electric Refrigerators, Aladdin Heating Corp., 5107 Broadway, Oakland	73
REINFORCING STEEL	
Gunn, Carle & Company, 20 Potrero Ave., San Francisco	70
ROOF MATERIALS	
Gladding, McBean & Co., 660 Market Street, San Francisco; 2901 Los Feliz Boulevard, Los Angeles; 1500 First Avenue South, Seattle; 79 S. E. Taylor Street, Portland; Twenty-second and Market Streets, Oakland; 1102 N. Monroe Street, Spokane; Vancouver, B. C.	*
N. Clark & Sons, 112-116 Natoma Street, San Francisco; works, West Alameda	11
SAND, ROCK AND GRAVEL	
John Cassaretto, Sixth and Channel Streets, San Francisco	78
SHADE CLOTH	
California Shade Cloth Co., 210 Bayshore Boulevard, San Francisco	68
STANDARD STEEL BUILDINGS	
Independent Iron Works, 821 Pine Street, Oakland	76
STEEL—STAINLESS	
Republic Steel Corporation, Rialto Bldg., San Francisco; Edison Bldg., Los Angeles; White-Henry-Stuart Bldg., Seattle	76
STEEL STRUCTURAL	
Independent Iron Works, 821 Pine Street, Oakland	76
Judson Pacific Company, C. F. Weber Bldg., Mission and Second Streets, San Francisco shops, San Francisco and Oakland	68
Pacific Coast Steel Corp.—See Bethlehem Steel Company, Twentieth and Illinois Streets, San Francisco; Slauson Avenue, Los Angeles; American Bank Building, Portland, Ore.; West Andover Street, Seattle, Wash.	6 and 75
Herrick Iron Works, 18th and Campbell Streets, Oakland	74
STORE FIXTURES	
Mullen Mfg. Co., 60 Rausch Street, San Francisco	78
STORE FRONTS	
Kawneer Mfg. Co., Eighth and Dwight Streets, Berkeley	72
TEMPERATURE REGULATION	
Johnson Service Company, Milwaukee, represented on the Pacific Coast by the following branch offices: 814 Rialto Bldg., San Francisco; 153 West Avenue, 34, Los Angeles; 1312 N.W. Raleigh St, Portland, and 473 Coleman Bldg., Seattle	3
TERMITE CONTROL—WOOD PRESERVATIVE	
E. K. Wood Lumber Company, No. 1 Drumm Street, San Francisco; 4701 Santa Fe Ave., Los Angeles; Frederick and King Streets, Oakland	12
American Lumber & Treating Company, Rialto Bldg., San Francisco; 1031 S. Broadway Los Angeles	65
TREE SURGERY	
Davey Tree Surgery Co., Ltd., Russ Building, San Francisco; Story Building, Los Angeles	76
TILE—DECORATIVE, ETC.	
Pomona Tile Mfg. Co., plant, Pomona, Cal.; Sales Rooms, 135 Tenth St., San Francisco; 217 S. La Brea Ave., Los Angeles; 6106 Roosevelt Way, Seattle	70
Gladding McBean & Co., 660 Market St., San Francisco; 2901 Los Feliz Boulevard, Los Angeles	*
VARNISHES	
National Lead Company, 2240 24th Street, San Francisco. Branches and dealers in all principal Coast cities	73
W. P. Fuller Company, San Francisco and principal Coast cities	*
VALVES	
Sloan Valve Co., manufacturers of 5loan flush valves, 4300 West Lake St., Chicago, Ill.	10
WATER HEATERS	
Tay-Holbrook, Inc., San Francisco, Oakland, Sacramento, Fresno, San Jose	74
WINDOWS	
Kawneer Mfg. Co., Eighth and Dwight Streets, Berkeley	72
Dalmo Sales Co., San Francisco	70
WINDOW SHADES	
California Shade Cloth Co., 210 Bayshore Boulevard, San Francisco	68
Wm. Volker & Co., 631 Howard Street, San Francisco	75

Phone GARfield 1164

Hunter & Hudson

Consulting Engineers

DESIGNERS OF HEATING
AIR CONDITIONING
VENTILATING AND WIRING
SYSTEMS, MECHANICAL
AND ELECTRICAL EQUIP-
MENT OF BUILDINGS

41 SUTTER STREET
ROOM 710
San Francisco California

JOSEPH MUSTO SONS-KEENAN COMPANY

—
MARBLE
and
ONYX

535 NORTH POINT STREET
SAN FRANCISCO
1801 S. SOTO STREET
LOS ANGELES

Smith

Lumber Company

WHOLESALE - JOBBING - RETAIL
FACTORY AND BUILDING LUMBER
PLYWOODS - ROOFING
DISTRIBUTING YARDS

San Francisco | Oakland
• | 19th Ave. &
4th & Channel | Estuary
MARket 0103 | FRUITvale 3174

YOUR INQUIRIES SOLICITED

THE TORMEY COMPANY

GENERAL PAINTERS
AND DECORATORS

—
Phone UNDERhill 1913
—
563 FULTON STREET
San Francisco

