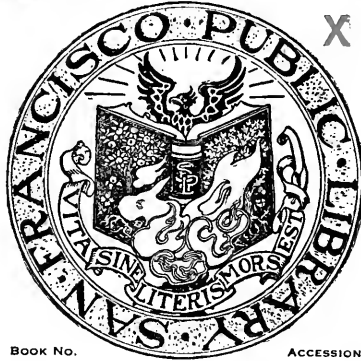




ART MAGAZINE



Book No.

ACCESSION

\*720.5 Ar24<sup>147</sup>

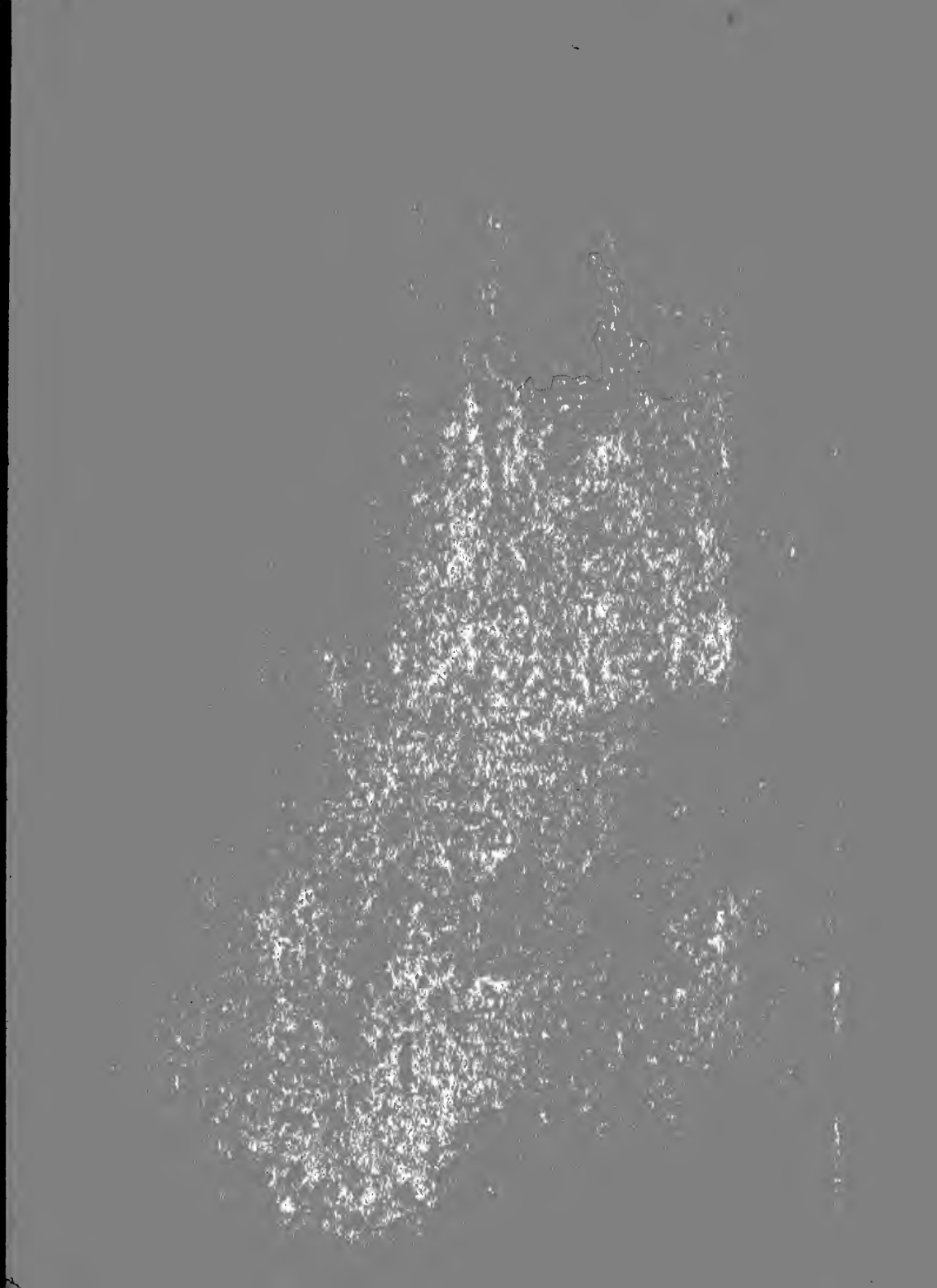
526929

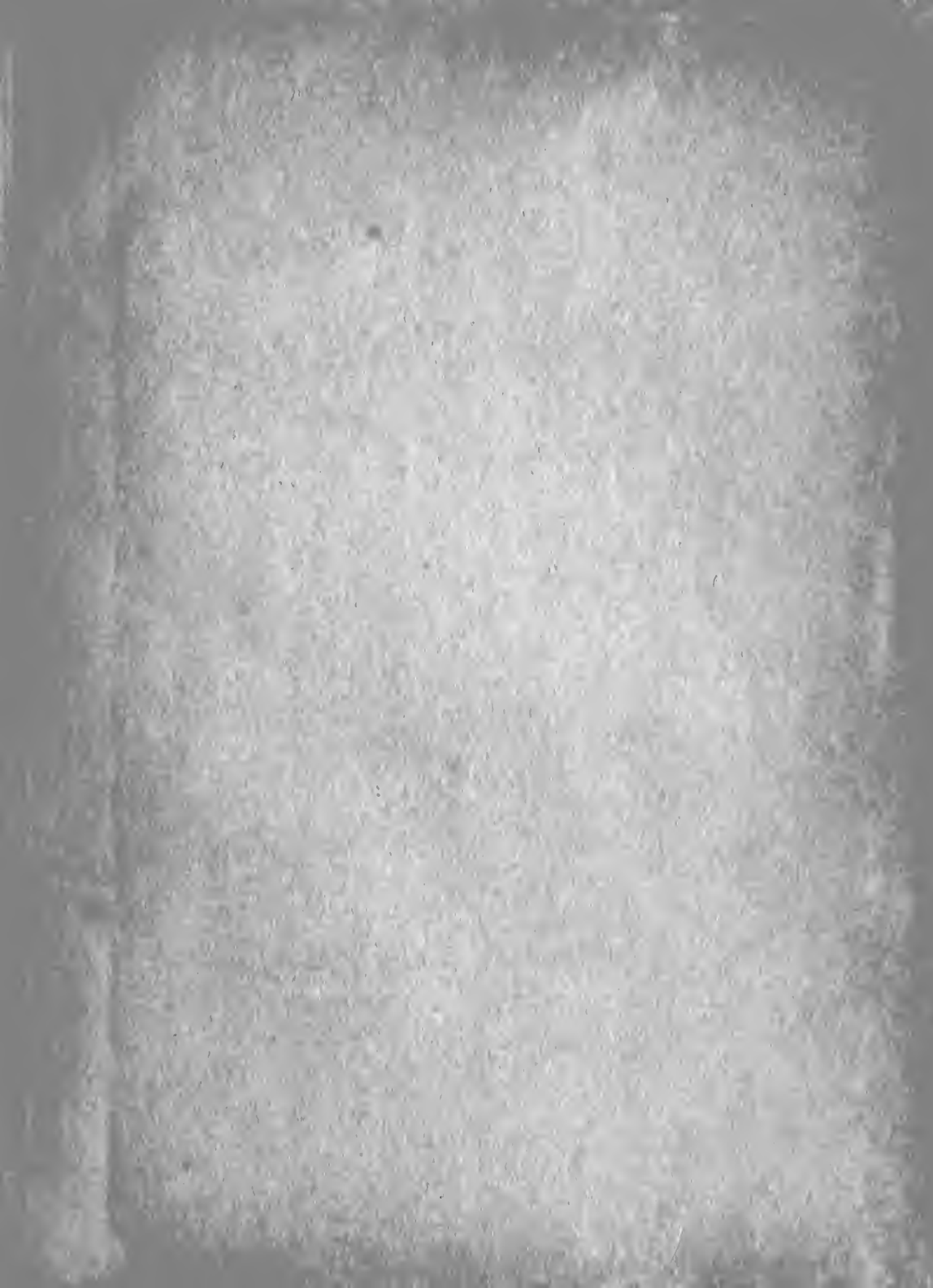
NOT TO BE TAKEN FROM THE LIBRARY

FORM 3427—SM—12-39

C









ARCHITECT  
AND  
ENGINEER

**OCTOBER 1941**

USE "Pennvernon" . . .  
NOT JUST "WINDOW GLASS"



**ATTRACTIVE** windows deserve a quality window glass.  
A window glass like Pennvernon. It is clear. Unusually free from flaws.  
Brilliant and reflective on both sides of the sheet. Each light is paper-packed.

DISTRIBUTED BY

**W • P • FULLER & CO**

BRANCHES AND DEALERS THROUGHOUT THE WEST



## PRIVATE BUILDING WILL CONTINUE

**Architects** will do well to stem their fear over building conditions resulting from the Government's priority orders. It is true the construction industry, in so far as costly residence work is concerned, is beginning to feel the pinch, but the situation is one subject to early correction, and does not call for unnecessary alarm.

It appears at this writing that the Government's priority plan has been handed some premature publicity that has evoked rumors of building curtailment right and left; in fact all types of building would appear to be doomed, except emergency work. Actually, however, such is not the case, nor is it likely to be. Fact is the Government is not prohibiting or restricting the building of any type of structure. While there are tight spots at present in certain metals, which have made it necessary to enforce a priority program, American production capacity is so vast that there is bound to be a reasonable amount of material available for civilian requirements, even after defense needs have been satisfied.

The present tightening up will probably not last more than sixty or ninety days, following which will come a gradual improvement. It is unthinkable that the Government would see the disorganization of so large and important an industry. Well aware of conditions and with a view to easing the minds of alarmists, many of the architects' associations and Chapters are appointing special committees and passing resolutions. The following, by the Michigan Society of Architects, is typical:

Whereas the architects of the State of Michigan are greatly concerned about the impression which has been created in the building industry, and in the minds of the building public generally that construction of new work must be restricted to defense building or to residential construction not to exceed \$6000 in cost, and whereas this impression is altogether erroneous, nevertheless it has had the effect of discouraging private building enterprises, and

Whereas, the building industry is one of the largest in the nation, and such curtailment of work will impose a serious hardship upon that industry, and will deprive several million men of needed employment, and also will deprive the Government of the considerable tax revenues which this industry supplies, and,

Whereas to date the architectural profession has experienced little difficulty in obtaining required materials for building construction, and whereas the architect, by proper study of every building project, can use materials which are not needed for defense,

Therefore, be it resolved that the Michigan Society of Architects deplores the erroneous impression which has been created, and urges that every possible means be used to encourage normal private building enterprise, and be it further resolved that copies of this resolution be furnished to the public press, the building industry and public officials.

\* \* \*

Here is an example of the kind of press dispatches that are being sent out from Washington, this one dated October 10:

"In a drastic move to conserve critical defense materials, the supply priorities and allocations board ruled today that no new public or private construction projects can be started unless they are essential for defense or the health and safety of the people.

"This applies not only to public projects, Federal, State and local, but it applies to the construction of factories, lofts, warehouses, office buildings and all other commercial construction. It even applies to residential construction and to construction for public utilities."

If we are to take this news dispatch literally, it means the closing down of the building industry for an indefinite period.

If, on the other hand, we take it figuratively, and that's the way we are disposed to take it, then we need not be unduly alarmed—conditions will not be as bad as they may appear momentarily.

*A handsome, long-lived floor of Nairn Linoleum in a ward of St. Agnes Hospital, White Plains, New York.*



*The new trend in the hospital  
field—more modernization  
less new construction*

● Realizing the growing scarcity of many building materials for new construction, hospital authorities feel that now is the time to concentrate on the renovation of existing buildings. A frequent disadvantage of older buildings is their worn wood floors. In Nairn Linoleum architects find a floor specification that fulfills every modern hospital requirement.

For one thing, Nairn Linoleum reduces foot-traffic noises to a minimum, providing the quiet so necessary for patients. And its resiliency makes it easy on the feet. (Lessens foot-fatigue of the staff and increases efficiency.) Nairn Linoleum more than gives the

sanitary features that hospitals require. Authorities find its proven germicidal property (unobtainable in other types of flooring) a valuable asset. And its smooth surface has no cracks to collect dirt and germs . . . Keeps spick and span with a minimum of cleaning and waxing.

From an economy standpoint too Nairn Linoleum is ideal. Moderate in first cost, negligible in upkeep expense, this modern linoleum "takes" years of long hard foot-traffic with hardly a sign of wear. For wards, rooms, offices and corridors alike, Nairn Linoleum gives hospitals a permanent, trouble-free specification.

When installed by Authorized Contractors, Nairn Linoleum is fully guaranteed.

CONGOLEUM-NAIRN INC., KEARNY, N. J.

**NAIRN**

**Linoleum Floors and Walls**

# ARCHITECT AND ENGINEER

x720.5  
Ar24 141  
526929



## NEXT MONTH

¶ For more than 35 years Albert Farr, architect, of San Francisco, has been designing beautiful homes in California. For the last six or eight years Mr. Farr has had an able team mate in J. Francis Ward, a native of New Zealand who started with Mr. Farr as a draughtsman, and has been a member of the firm for the last 15 years.

¶ Only the old timers in the profession will recall Albert Farr's brilliant early career. A pupil of F. A. Barker, noted English architect, Mr. Farr's rise was rapid and soon he was designing many of the more prominent residences in the San Francisco Bay District. His English Tudor houses were outstanding for their fine feeling for this style of architecture and many of them are still objects of interest in the exclusive residence district of Piedmont. Some of the owners of Piedmont homes designed by Mr. Farr are Messrs. Dawson, Cavalier, Walton Moore, General Long and Arthur King.

¶ Ecclesiastical and commercial work from the Farr office is also to be found in the Piedmont environs.

¶ One of the firm's largest commissions was the George Lewis house in Beverly Hills. Mr. Lewis is head of the well known retail jewelry house of Shreve & Company. Probably no home in the southern part of the State has been more frequently used as background for moving pictures than the Lewis house.

¶ Readers of Architect and Engineer are definitely going to find this Farr and Ward issue next month a real treat.

Volume 147

October, 1941

Number 1

<b>MAIN ROTUNDA, NATIONAL GALLERY OF ART, WASHINGTON, D.C.</b>	18
JOHN RUSSELL POPE, EGGERS & HIGGINS, Architects	
<b>FEATURE, HOUSE IN PIEDMONT</b>	19
FRED'K W. JONES	
<b>N.B.C. BUILDING, SAN FRANCISCO</b>	25
<b>IS MODERN ARCHITECTURE REALLY NECESSARY?</b>	27
ARTHUR BROWN, JR., F.A.I.A.	
<b>THE CASE FOR MODERNISM</b>	30
RICHARD J. NEUTRA, Architect	
<b>THE FINE ARTS IN AMERICA</b>	35
ELMER GREY, F.A.I.A.	
<b>DEFENSE HOUSING IN SAN DIEGO</b>	47
<b>STATE ASSOCIATION CONVENTION</b>	50

### PLATES AND ILLUSTRATIONS

<b>RESIDENCE OF STATE ASSEMBLYMAN ARTHUR W. CARLSON, PIEDMONT, CALIFORNIA</b>	19-23
WILLIAMS & WASTELL, Architects	
<b>N.B.C. BUILDING, SAN FRANCISCO</b>	24-25
ALBERT F. ROLLER, Architect	
<b>MODERN HOUSES BY RICHARD J. NEUTRA</b>	32-33
<b>NATIONAL GALLERY OF ART, WASHINGTON, D.C.</b>	35
JOHN RUSSELL POPE, EGGERS & HIGGINS, Architects	
<b>HUNTINGTON ART GALLERY, SAN MARINO</b>	36-38
MYRON HUNT AND ELMER GREY, Architects	
<b>LINCOLN SHRINE, REDLANDS, CALIFORNIA</b>	40
ELMER GREY, Architect	
<b>HOUSE IN PALM SPRINGS CALIFORNIA</b>	46
RICHARD J. NEUTRA, Architect	

EDITOR, FRED'K W. JONES; ASSISTANT EDITOR, E. N. KIERULFF; CONSULTING AND CONTRIBUTING EDITOR, MARK DANIELS; ADVERTISING MANAGER, R. W. WALKER. REGULAR CONTRIBUTING EDITORS: Harris C. Allen, Harry Sanders, Ben H. O'Connor, Glenn Stanton, Roi L. Morin, Chas. H. Alden, Irving F. Morrow. HONORARY EDITORS: Arthur Brown, Jr., Timothy L. Pflueger, Lewis P. Hobart, Wm. W. Wurster, Will G. Corlett, Frederick H. Meyer, Thos. J. Kent, Gordon B. Kaufmann, Paul R. Hunter, Michael Goodman, Harry Michelsen.

ARCHITECT AND ENGINEER is published on the 15th of the month by The Architect and Engineer, Inc., 68 Post Street, San Francisco. President, K. P. Kierulff; Vice President, Fred'k W. Jones; Secretary and Business Manager, L. B. Penhorwood.

Entered as second class matter, November 2, 1905, at the Post Office in San Francisco, California, under the Act of March 3, 1897. Subscriptions, United States and Pan America, \$3.00 a year; foreign countries \$5.00 a year; single copy \$ .50.

Los Angeles office: 1709 W. 8th street, Wentworth Green, Manager, Phone EXposition 8292. ARCHITECTS REPORTS are published daily from this office and are sponsored by the Northern Section, State Association of California Architects; Vernon S. Yallop, Mgr.

Getting down to

# BRASS TACKS

about this

## ADEQUATE WIRING STORY



The "functional" theme is paramount in the architectural profession today. The architect who is building his future, aware of the demand for comfort, convenience, and utility, provides these in the homes he plans.



As the electrical equipment is in constant use in any home today, the electrical wiring **MUST** furnish service conveniently at any point where it is needed. At the time of building, enough outlets and enough switches should be installed in the right places, and thoughtful attention should be given to locating them for smooth service.



The architect planning the electrical service for modern living is assured that no one, especially his client, will ever have cause to criticize him about that planning.



Copies of "Electrical Symbols for Architectural Plans" and "Minimum Requirements for Certification as Red Seal Wiring Installations," will be sent **FREE** upon request.



NORTHERN CALIFORNIA

ELECTRICAL BUREAU

447 Sutter Street

San Francisco

## NEW LINE OF GAS FIRED HEATERS

A new line of gas-fired unit heaters is announced by Utility Fan Corporation, Los Angeles, manufacturer of forced-air furnaces, floor furnaces, blowers and evaporative air coolers. These suspended heaters are being widely used in military and naval buildings and factories occupied with defense contracts, as well as many types of commercial and industrial structures.

The heating element in Utility unit heaters has corru-



gated sections shown by test to give maximum heat transfer for space occupied. There are no interior baffles in the heating element.

Highly streamlined design and installation close to the ceiling are gained by the use of a built-in draft diverter, also the compact arrangement of the motor and fan assembly in the intake air chamber. Uniform air distribution over the entire heat transfer surface is obtained by the design of this air chamber and the type of fan used.

## VENETIAN BLIND PATENT GRANTED

Valuable new patents applying to both metal and wood Venetian blinds have recently been granted to C. W. Morse, president of Lifetime Products Corporation, Los Angeles.

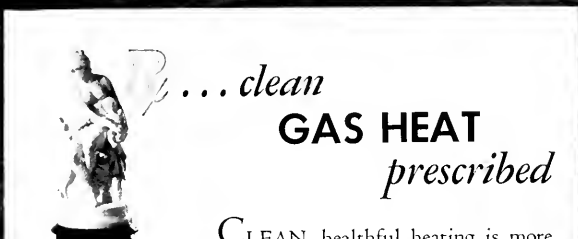
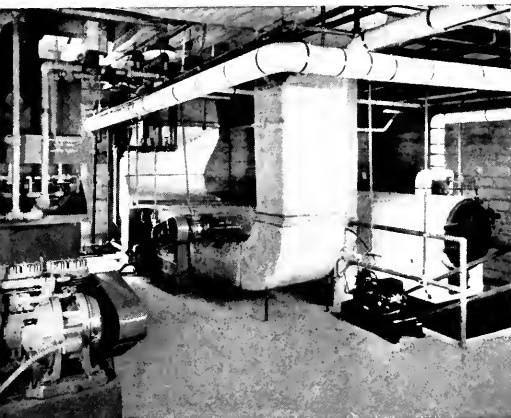
These new patents eliminate the greatest single objection to Venetian blinds, that is the difficulty of closing the blind completely so that no light shines through. The new device also permits the easy raising and lowering of blinds when closed, which hitherto had been impossible. In other words, the cords used under the new Morse patents operate as freely when the blinds are closed as when they are open. Another advantage is the fact the life of the cord is greatly increased.

In commenting on this new development, Mr. Morse stated he regarded his invention the greatest next to his development of flexible steel Venetian blinds. The licensing of qualified blind manufacturers to use the new patents is contemplated.

*from Surgery to Nursery*



SUTTER MATERNITY HOSPITAL • SACRAMENTO • ARCHITECT, CHAS. F. DEAN



*... clean*

**GAS HEAT**  
*prescribed*

CLEAN, healthful heating is more than desirable, it's *necessary* in a hospital. At Sutter Maternity Hospital, above, Gas heating — specified by Architect Chas. F. Dean — provides a mild, uniform "indoor climate" — automatically regulated — free of dust, soot, smoke or odor. ☆ As in large installations, so too for the home, gas equipment appears more and more in specifications. Not alone for heating, but for cooking that's "revelation-ary" in the ease it brings . . . for refrigeration that's revolutionary in silent, trouble-free operation. And finally, for water heating that places luxury "on tap" at low cost. ☆ Yes, this is the trend. And directing it are the architects, builders and owners themselves. They've discovered that there's no substitute for Gas equipment.

**GAS**  
FIRST CHOICE

**4**  
FOR YOUR BIG JOBS



**COOKING \* WATER HEATING \* HEATING \* REFRIGERATION**

## BILL TO ELIMINATE CHISELING

Editor, Architect and Engineer,  
San Francisco, California:

I am enclosing a copy of Assembly Bill No. 1731, relating to bids on public works. This bill, with which you are no doubt familiar, is a measure in which the California State Builders Exchange and its member exchanges have been greatly interested. The measure also had the support, in principle at least, of the two sections of the State Association of California Architects and the several Chapters of the American Institute of Architects.

Many people believe that the listing of sub-contractors' names at the time bids are submitted will aid materially in eliminating chiseling and retain the business for the sub-contractor whose economy has made it possible for the general contractor to be low bidder.

If it is not asking too much, we would like to see this bill appear in your publication at your earliest convenience, so that architects and contractors may become familiar with its provisions. Those of us who believe in this policy hope to see the practice extended into private work wherever possible.

Very truly yours,

DONALD BEACH KIRBY, A.I.A.,

First Vice-President, California State Builders Exchange.

Secretary, Southern California A.I.A.

*An act relating to bids for the construction of public works and improvements.*

(Approved by Governor July 19, 1941. Filed with Secretary of State July 19, 1941.)

*The people of the State of California do enact as follows:*

SECTION 1. Any officer, department, board or commission taking bids for the construction of any public work or improvement shall provide in the specifications prepared for the work or improvement or in the general conditions under which bids will be received for the doing of the work incident to the public work or improvement that any person making a bid or offer to perform the work, shall, in his bid or offer, set forth the name and the location of the mill, shop or office of each sub-contractor who will perform work or labor or render service to the contractor in or about the construction of the work or improvement and the portion of the work which will be done by each sub-contractor.

If a contractor fails to specify a sub-contractor for any portion of the work to be performed under the contract, he shall be deemed to have agreed to perform such portion himself, and he shall not be permitted to subcontract that portion of the work except under the conditions hereinafter set forth.

No contractor whose bid is accepted shall, without the consent of the awarding authority, either:

(a) substitute any person as sub-contractor in place of the subcontractor designated in the original bid, or

(b) permit any subcontract to be assigned or transferred or allow it to be performed by anyone other than the original subcontractor, or

(c) sublet or subcontract any portion of the work as to which his original bid did not designate a subcontractor.

Subletting or subcontracting of any portion of the work as to which no subcontract was designated in the original bid shall only be permitted in cases of public emergency or necessity, and then only after a finding reduced to writing as a public record of the awarding authority setting forth the facts constituting such emergency or necessity.

Should the contractor violate any of the provisions of this act, his so doing will be deemed a violation of his contract and the awarding authority shall have the right to cancel the contract. The contractor shall not, after any such violation, recover thereon for any of the work done or materials furnished on such public work or improvement.

The failure on the part of a contractor to comply with any provision of this act shall not constitute a defense to such contractor in any action brought against him by a subcontractor.

This act shall not apply to contracts for the construction or improvement or repair of State highways, including bridges, nor to city or county projects financed in whole or in part with motor vehicle fuel funds.

Nothing in this act contained shall be deemed to limit or diminish any rights or remedies, either legal or equitable, which either an original or substituted subcontractor may have against the contractor, his successors or assigns, nor any such rights or remedies (including the right to take over and complete the contract) which the State of California, or any municipal corporation, county, body politic, or public corporation, or public agency may have against the contractor, his successors or assigns.

## A FEW TAX FIGURES

The \$700,000,000 annual income of the State of California and its local governments is collected from the people by way of many taxes, licenses, and other income producers. However, it may be divided into three classes: (1) local taxes levied on property; (2) taxes which are levied on a uniform statewide basis; and (3) reve-

nue other than taxes. All told, these three sources of revenue brought \$693,800,000 into California's governmental treasuries during the fiscal year 1939-40.

Largest item in the production of revenue was the property tax, which is levied for local governmental purposes only and which produced \$307,601,000, or 44 per cent of the total. Statewide taxes are numerous and their total yield exceeds that of property taxes, as they amounted to \$330,166,000, which was 48 per cent of the total. Not nearly so productive as taxes, but substantial in receipts, are non-tax revenues, which amounted to \$56,026,000 and were 8 per cent of state and local government income.

## E-Z MIX TINTING SYSTEM

"Because architects are so frequently called upon to furnish suggestions for the complete job of interior decorating—or color-styling," says Frank J. Schulte, Advertising Manager of Acme White Lead and Color Works of Detroit, Michigan, "they will find—as many have already found—the Acme E-Z Mix Color Tinting System of immeasurable assistance in working out color-styling plans and suggestions."

"Color preference," he continues, "is largely a matter of individual taste. One person will like a deep shade of blue, for example, while her neighbor may prefer a delicate orchid. And therein lies the beauty of the Acme E-Z Mix Tinting System as far as its help to the architect is concerned. First of all, this new system provides him with large-sized color chips showing actual samples of seventy-two different colors and tints that are available to him through the E-Z Mix System. There are six base colors and three intermix colors which can be made by intermixing base colors to our formulas. Then, these six base colors and three intermix colors can each be let down seven times with our No-Lustre Flat Wall White or Big 6 Master Painters Flat Wall White. There is a color chip for each let-down, and we provide the painter with exact formula for making each one. There is no guesswork about it."

GRAYSON

GRAYSON



**BRONZE**

C. F. Rosborg, Arch.

## FOR PERMANENCE

Long famous for beauty, dependability and lifetime service, bronze has again become one of the most popular

metals for store front members. Fortunately, too—for this durable metal lends an air of richness and permanence that means increased sales and prestige to any establishment.

Equally important, Kawneer bronze members offer many possibilities for distinctive store front design. And, when Kawneer Rolled Construction (with fully resilient sash) is used throughout, architect and contractor can safely assure the owner low maintenance, and trouble-free service.

Get latest data from the Kawneer distributor, from SWEETS, or by writing THE KAWNEER COMPANY, NILES, MICH.



IT'S EASY TO DESIGN AND INSTALL

**Kawneer**

**STORE FRONTS**



NEW FULL-SIZE DETAILS on Kawneer Rolled Construction—simplified for present day requirements. Write for your copy today.

# Sloan Flush Valves - ?



*Above is shown a section of the River Rouge Plant of the Ford Motor Company—one of the largest industrial plants in the world. Here, where more than 85,000 men are employed, working conditions are so excellent that Ford's cost of workmen's compensation is less than 50c on each \$100.00 of payroll. It is only natural that where quality, cleanliness and safety are cardinal principles, there should be found Sloan Flush Valves—not only at River Rouge but throughout the vast Ford empire.*



# TAKE

# Geared

# FOR EXAMPLE

Only since 1923 has the Ford Motor Company used Sloan Flush Valves. *But*—since that date, when Ford discovered the superiority of Sloan Flush Valves, they have used them exclusively in all their *replacement* work, as well as in the vast building program constantly in progress. To date more than 1900 Sloan Valves have been installed in the River Rouge Plant alone—and in addition, there are many hundreds more installed in Ford plants and buildings throughout the entire United States.

## Why Sloan Flush Valves?

**They Save Water . . .** In one installation where Sloan Flush Valves replaced other equipment, there resulted a saving of 50,000,000 gallons of water per year. Nation-wide—Sloan Flush Valves save water *all* the time because their adjustment is *permanent*.

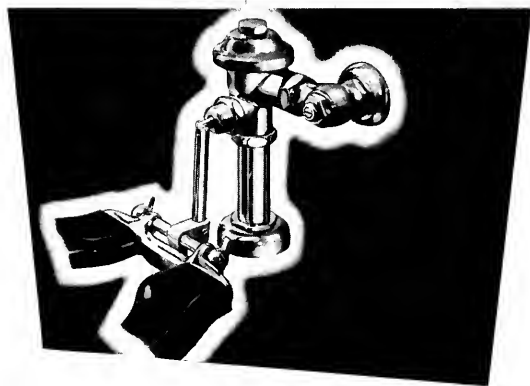
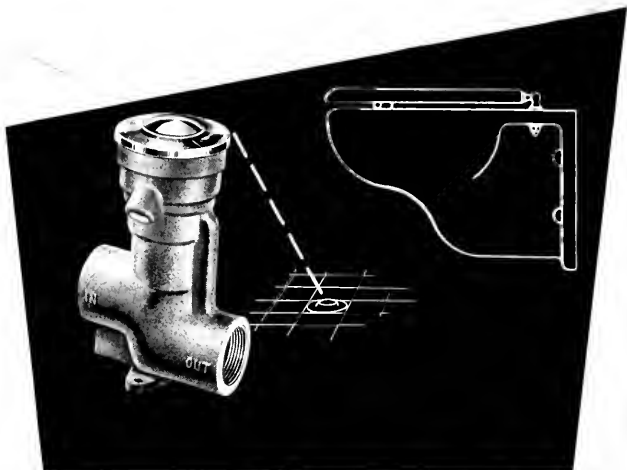
**They Save Replacement . . .** Sloan Valve durability can be verified in *your* locality. Installations fifteen, twenty or twenty-five years old are common to every section of the country and to every type of building.

**They Reduce Maintenance Expense . . .** Sloan Flush Valves cost but  $\frac{1}{2}\text{¢}$  to  $1\frac{1}{2}\text{¢}$  per valve per year to maintain. Entire installations in service for years without being touched are constantly reported.

**That's Why . . .** In schools, hospitals, office buildings, hotels, institutions, factories, apartments or public buildings, the vast majority of flush valves are SLOAN. Indeed—*throughout the entire building field more SLOAN Flush Valves are sold than all other makes combined.*

## SLOAN VALVE COMPANY

4300 W. Lake St., Chicago



**Sloan Floor Valve.** The illustration at the top shows the type of floor valve used by the hundreds in the River Rouge Plant. This unit affords the utmost in sanitary conditions—the valve being operated by the pressure of the foot on the floor button. Installed in the floor this flush valve is fool-proof and virtually cannot get out of order.

**Sloan Seat-Action Valve.** This automatically operated valve eliminates all possibility of thoughtless failure to flush the toilet. Sloan Seat-Action Valves are especially popular in schools, public buildings, terminals and large industrial plants.

1. Records prove repair costs for Sloan Valves to be only  $\frac{1}{2}\text{¢}$  to  $1\frac{1}{2}\text{¢}$  per valve per year.
2. Sloan Valves frequently pay their installation cost in water-saving the first year.
3. Because of precision manufacture, Sloan Flush Valves are an investment in enduring satisfaction.

**YET—Sloan Flush Valves cost no more than others.**

# SLOAN Flush VALVES

# NEWS AND COMMENT ON ART

## DALI

Last month's small exhibition of Salvador Dali at the Courvoisier Galleries was another reminder that this painter, as indeed the whole Surrealist movement which he typifies to the public at large, is more concerned with subject matter than with artistic values properly speaking. In short, his interests and his procedure are essentially literary. In this he and his movement are at one with the late nineteenth and early twentieth century academic painting against which they reacted. For the earlier sentimentalism's dogma of conformity, the later inverted sentimentalism substitutes the dogma of heresy. But the pedantry of the obvious and the pedantry of the precious are only obverse and reverse of the same coin.

Dali's color is not infrequently agreeable, without constituting in any sense a particularly arresting experience. Beyond that his pictures are quite lacking in distinction or significance of formal organization. The enthusiasms and antipathies which they excite spring from the spectators' attitudes toward the objects depicted. Even these can be accepted neither at face value nor on the recommendation of any accessible scheme of symbolism. To suggest abandoning one's self to an aesthetic reaction is fatuous, because we are dealing with literature graphically presented, not with visual aesthetic phenomena. One is driven to intellectual calculation not unlike the decoding of a code telegram, with the added obstacle that the code, instead of being available, is a secret invention of the author.

In an interview with Dali published in This World of the San Francisco Chronicle of August 24 last, Alfred Frankenstein quotes the painter as saying, "It is the business of the scientist to explain things; it is the business of the artist to create enigmas." The aphorism illustrates how tenuous may be the line which separates truth from fallacy. Up to the last word he is voicing a fundamental and incontrovertible fact; the addition of "enigmas" injects the blight of calculating self-consciousness which vitiates his intellectual as well as his aesthetic contribution. To the controversy over obscurity in art there will be no end. Its cause may lie on the receiving end as well as on the sending end of the artistic circuit. Doubtless the sincere artist will not shrink from obscurity which the work in hand seems to impose. But the artistic progeny of a person who assumes obscurity as an obligation is born tainted.

Irving F. Morrow.

## AT THE MUSEUMS

The following activities will continue beyond the publication date of the Architect and Engineer:

### CALIFORNIA PALACE OF THE LEGION OF HONOR

#### EXHIBITIONS

Oils, Watercolors and Drawings by Daniel Rhodes; through October 22.

Watercolors by Edward Johnson and Richard Allman; opening October 1.

Paintings by Manuel J. Tolegian; opening October 6.

Old Master Drawings from the Collection of Le Roy M. Backus; opening October 13.

Manners and Modes of Yesterday: a Pageant of Fashion from Pre-Civil War Days to 1890—Fifty Wood Engravings; opening October 13.

Caricatures by Arthur Szyk; opening October 20.

#### LECTURES

"Styles in Furniture," Dr. Elizabeth Moses, Curator of Decorative Arts, M. H. de Young Museum; Sunday, October 26, at 4:00 p.m.

#### FILMS

Motion Pictures every Saturday at 2:30 p.m. Admission free.

October 25—"The Smiling Madame Beudet," a psychological study (1923). "Menilmontant" (1925). "Ballet Mecanique," produced and directed by Fernand Leger (1924). "Entr'acte," directed by Rene Clair (1924).

#### COURSES

Admission free.

Art Courses—Each Wednesday at 11:00 a.m. Children's Art Class—Each Saturday, 10:30-12:00 a.m. Gallery Tours for Schools, Clubs and Social Groups by appointment. BAyview 4611.

#### ORGAN RECITALS

Uda Waldrop, Organist—Each Saturday and Sunday at 3:00 p.m.

### SAN FRANCISCO MUSEUM OF ART

#### EXHIBITIONS

Paintings by Loren MacIver; through October 26.

Paintings by Barbara Stevenson; through October 26.

The California School of Fine Arts Alumni Association Exhibition—Painting, Sculpture, Decorative Arts, Commercial Art and Illustration and Graphic Arts; through October 26.

Gouaches by Mine Okubo; through November 2. Sculpture by Mary Erckenbrack; through November 5.

Paintings of the Gold Rush; through November 6.

Artists of the Upper Mississippi; through November 15.

American Sculpture Today; through November 16.

First Annual West of the Rockies Photographic Salon; through November 16.

#### LECTURES

"British Art Today," Douglas MacAgy; Wednesday evening, October 22, at 8:30.

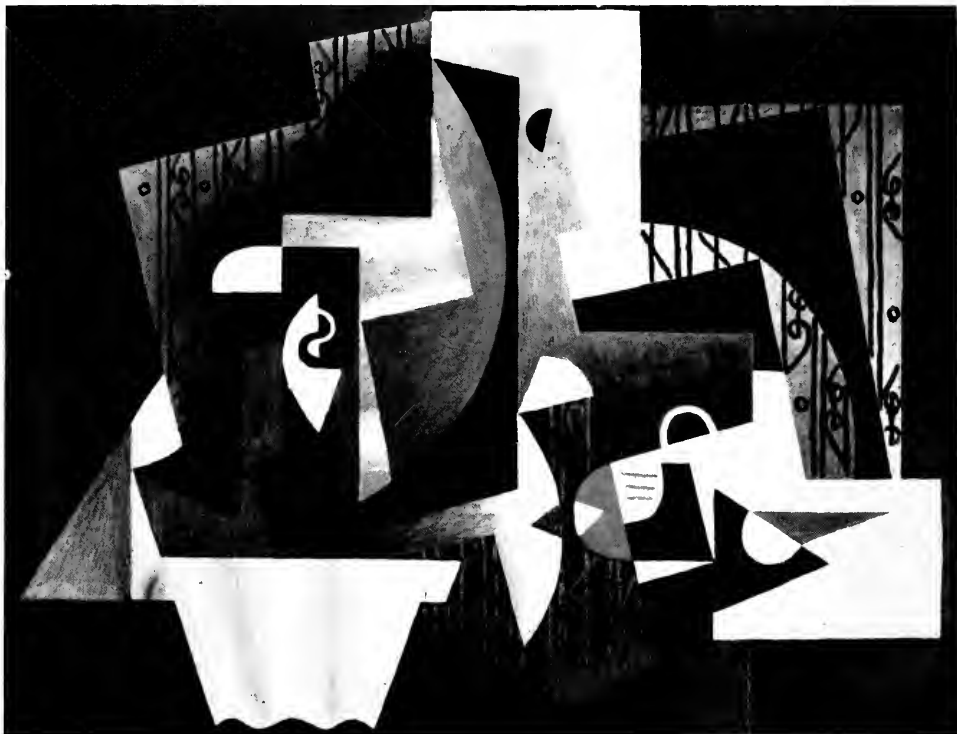
"What Is the Value of Primitive Art?" by Ellen H. Bransten; Sunday afternoon, October 26, at 3:00.

"Constructivism and Surrealism," by Guest Lecturer Charles Howard; Wednesday evening, October 29, at 8:30.

#### COURSES

"The Language of Art," illustrated lectures and experiments in the principal art mediums and factors for art enjoyment. The course requires no skill or previous experience in any branch of art whatever. It is a course in appreciation, not in practice, but frequent experiments will be made for more direct experience. It will be conducted by Charles Lindstrom and Douglas MacAgy. Teachers may arrange for salary increment credit.

# IN AN EVER CHANGING WORLD



COMPOSITION

by Alexander Corazza

The artist's business is not the reproduction of material, but the organization of material. In this picture from the San Francisco Art Association's sixty-first annual at the San Francisco Museum of Art the artist has pushed abstract organization to the point where the material as such is recognized only vaguely if at all. Naturally the artistic value of a pattern of this kind is really incomprehensible when the element of color is omitted.

Meetings will be held on Thursday afternoons from 2:30 to 4:00 or Thursday evenings from 8:00 to 9:30, beginning October 2.

1.—What You See and What You Think You See. 2.—Ways of Drawing; try the principal drawing mediums yourself. 3.—What Makes Art Work? 4.—Print-making; experiment with etching, dry-point, linoleum cut. 5.—Color and Design; design in watercolor and montage. 6.—Painting in Oil; try an oil painting. 7.—Form and Expression. 8.—Painting in Tempera and Fresco; demonstrated. 9.—Sculpture; model in clay and see other methods demonstrated. 10.—Art Judgment; how may art be evaluated?

For the course, \$4.00.

## SURVEY OF LANDSCAPE PAINTING

Advanced course open to those who have had a Museum introductory course or its equivalent. Monday afternoons at 2:30 or Monday evenings at 8:00, beginning October 6. Conducted by Grace L. McCann Morley, Charles Lindstrom and Douglas MacAgy. Fee for the course is \$4.00; for Museum members, \$2.00. Credit is available on these two courses for school teachers.

## PHOTO FORUM

Instructive and entertaining programs on photography every Monday evening at 8:00. Conducted by Thomes Hughes. Photographers are invited to exhibit stills, slides and movies. Expert advice and helpful suggestions given by various authorities in the field. Members of the Museum admitted free; 25c to non-members. The Photographic Society of San Francisco will be guest participant October 6.

## FALL CLASSES IN FLOWER ARRANGEMENT

Conducted by Helen Van Cleave Park. Beginning Classes—Alternate Wednesdays, October 8, 22, November 5, 19; mornings, afternoons and evenings. Fee is \$2.50.

## FILMS

Friday afternoons and evenings at 2:30 and 8:00 p.m. Admission, 25c.

October 24—"Carnival in Flanders" (1926). J. Feyder's refreshing and witty comedy of seventeenth century Flanders, which won world-wide acclaim. Afternoon, 2:30; evening, 8:00.

October 31—"The Four Horsemen of the Apocalypse" (1921), with Rudolph Valentino. The famous film which made Valentino the most popular screen idol of all time. Afternoon, 2:30; evening, 8:00.



*Depend on*  
**UTILITY**

For heating equipment that has been tested in the laboratory and proven in actual operation—heating equipment that is efficient, economical and dependable.



MODEL MFD  
DUAL REGISTER  
FURNACE

From all departments of the huge Utility plant, completed parts move steadily to the modern assembly lines, where Utility Heating Equipment is assembled, inspected and tested by capable, experienced workmen.

MANUFACTURERS OF FORCED-AIR BASEMENT AND CLOSET FURNACES, FLOOR AND DUAL REGISTER FURNACES, CIRCULATING HEATERS AND UNIT HEATERS

**UTILITY FAN CORPORATION**  
4851 SO. ALAMEDA STREET • LOS ANGELES, CALIFORNIA

5

San Francisco's Finest

*The New*

**N.B.C. BROADCASTING BUILDING**

Taylor and O'Farrell Streets

is rapidly reaching completion stage

**BARRETT & HILP**

*Builders*

918 HARRISON STREET • SAN FRANCISCO

# PORCELAIN ENAMEL GIVES NEW BANK

## *Lasting Beauty* AT LOW COST



*The Farmers and Merchants Bank at Long Beach, California. Porcelain enamel on U·S·S VITRENAMEL Sheets fabricated and installed by the U. S. Porcelain Enamel Co. of Los Angeles.*

THE exterior of the new branch of the Farmers and Merchants Bank at Long Beach, California is finished in ivory porcelain enamel. Window sills, door trim and sign letters are of the same material in a harmonious dark brown. The soft, attractive colors give a pleasing effect of quiet dignity.

These colors will remain fresh, because porcelain enamel is fade-proof and weather resistant. Easily cleaned with soap and water, maintenance is

negligible. But this is only one of the economies of porcelain enamel. Low in first cost, it is easy and inexpensive to erect, and will give years of trouble-free service.

The versatility of porcelain enamel on U·S·S VITRENAMEL is practically unlimited. Any design is easily reproduced at low cost, because the steel base is inexpensively formed. Striking and pleasing effects can be obtained from a full range of colors. And porcelain enamel is adaptable

to almost any purpose—interior or exterior. It is equally good for new work or remodeling; on masonry, wood or steel construction.

To be sure of quality work always specify the base metal. U·S·S VITRENAMEL Sheets are specially made for fine porcelain enameling. They are uniformly flat and have the necessary ductility for shaping to almost any form that may be desired. Their prepared surface assures better enameling.

## U·S·S VITRENAMEL SHEETS

COLUMBIA STEEL COMPANY

*San Francisco*

CARNEGIE-ILLINOIS STEEL CORPORATION, Pittsburgh and Chicago

Scully Steel Products Company, Chicago, Warehouse Distributors · United States Steel Export Company, New York



# UNITED STATES STEEL

# AMERICAN ACADEMY IN ROME

## NEW YORK CITY

### Announces Competitions for Cash Prizes in Painting and Sculpture Totaling \$3850.00

Under present international conditions the Academy cannot send Fellows to Rome for study, travel and creative work. In order to carry on the policy of aiding and stimulating American Art, the Trustees therefore have decided to offer certain competitive cash prizes to outstanding young artists and students.

For this purpose preliminary competitions will be held in a regional center of each of six districts embracing the United States.

The final competitions will be held in New York City.

In each preliminary competition a prize of \$25.00 will be offered for each of the best ten submissions, five in painting and five in sculpture. After a week's exhibition of all work submitted at each center, the sixty prize-winning designs will be shipped to New York for the final judgment and exhibition.

In the final competitions four prizes will be offered in each subject.—First prize of \$1000; and Second, Third and Fourth prizes of \$100., \$50. and \$25. respectively.

#### GENERAL REGULATIONS

The awards will be made after competitions which are open to *unmarried male* citizens of the United States who will be under 31 years of age on June 1st, 1942.

The Academy reserves the right to withhold any prize in case the jury decides that the work submitted is not of sufficient merit to justify an award.

All work is submitted at the owner's risk. The Academy will not assume responsibility for any loss or damage while the designs are in its custody or in transit.

For each subject in the final competitions there will be a jury of artists of national reputation chosen from different parts of the country. For the preliminary competitions the juries will be selected from among well-known artists of the several districts.

#### SPECIAL REGULATIONS

##### Prize in Painting

Any man desiring to compete for a Prize in painting must fill in the enclosed application and file it with the Supervisor for his District *before January 1st* (See the following list of Supervisors and Districts).

Each candidate accepted as a competitor must then submit *before April 20th*:

One painting in any medium, 32"x40", framed in a plain moulding not to exceed 1 inch in width.

The submission must be a figure composition but the artist will choose the subject matter.

Landscapes, portraits and still life cannot qualify.

A photographic record of work previously done must also be submitted.

##### Prize in Sculpture

Any man desiring to compete for a Prize in sculpture must fill in the enclosed application and file it, together with six or more photographs of his previous work, with the Supervisor for his District *before January 1st* (See the following list of Supervisors and Districts).

If accepted as a competitor on the merit of his photographs, each candidate must submit *before April 20th*:

A figure or group of figures in uncolored plaster not to exceed 24 inches in any dimension.

A photographic record of work previously done must also be submitted.

#### Requirements in Painting and Sculpture

The painting, sculpture and photographs submitted must bear, not the name of the artist, but a pseudonym, and must be accompanied by a sealed envelope bearing on its face the pseudonym and containing within the name and address of the artist.

#### Supervisors and Districts

Grace L. McCann Morley, Director,  
San Francisco Museum of Art, San Francisco, California.

Center For: Alaska, California, Hawaii, Idaho, Montana,  
Nevada, Oregon and Washington.

Fred S. Bartlett, Curator of Fine Arts,  
The Denver Art Museum, Denver, Colorado.

Center For: Arizona, Colorado, Kansas, Nebraska, New Mexico,  
North Dakota, South Dakota, Utah and Wyoming.

James Chillman, Jr., Director,  
The Museum of Fine Arts of Houston, Houston, Texas.

Center For: Arkansas, Louisiana, Mississippi, Oklahoma  
and Texas.

Daniel Catton Rich, Director of Fine Arts,  
The Art Institute of Chicago, Chicago, Illinois.

Center For: Illinois, Indiana, Iowa, Michigan, Minnesota,  
Missouri, Ohio and Wisconsin.

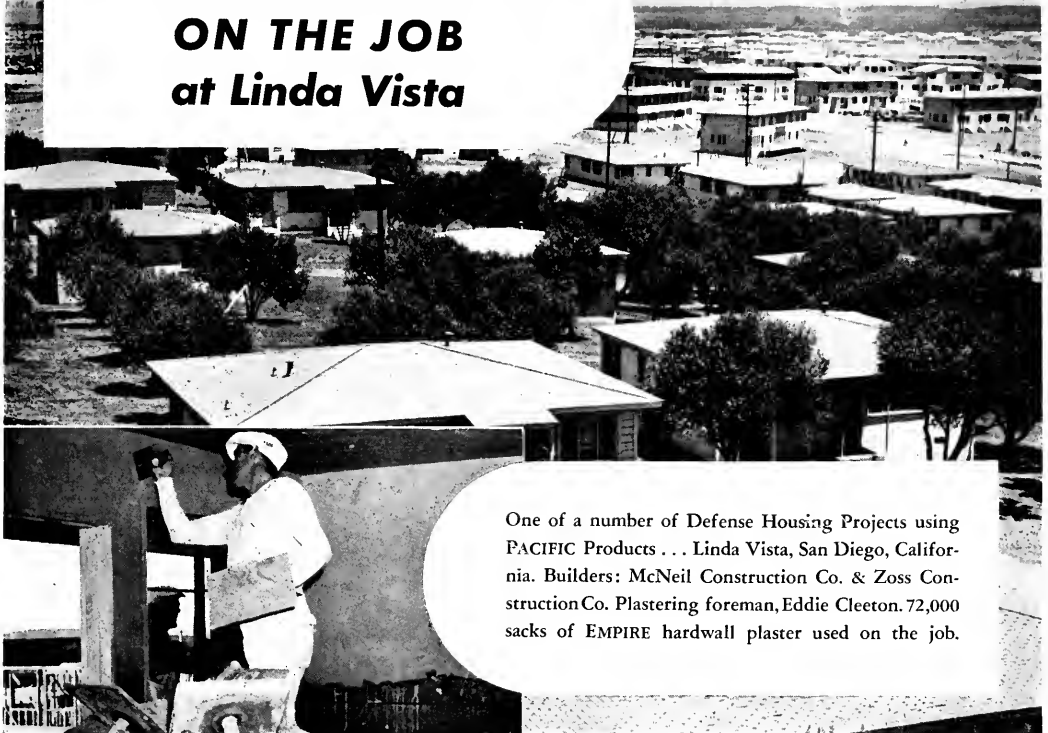
Hans Schuler, Director,  
The Maryland Institute, Baltimore, Maryland.

Center For: Alabama, District of Columbia, Florida, Georgia,  
Kentucky, Maryland, North Carolina, South Carolina, Tennessee,  
Virginia and West Virginia.

Hobart Nichols, President,  
National Academy of Design, Room 1432,  
101 Park Avenue, New York, N. Y.

Center For: Delaware, New Jersey, New York, Pennsylvania  
and the six New England states.

# EMPIRE PLASTER ON THE JOB at Linda Vista



One of a number of Defense Housing Projects using PACIFIC Products . . . Linda Vista, San Diego, California. Builders: McNeil Construction Co. & Zoss Construction Co. Plastering foreman, Eddie Cleeton. 72,000 sacks of EMPIRE hardwall plaster used on the job.

**Ask Your Building Materials Dealer**

**EMPIRE**  
Hardwall Plaster

**STANDARD**  
Hardwall Plaster

**GOLDEN GATE**  
Portland Cement

**OLD MISSION**  
Portland Cement

Products of



San Francisco • Los Angeles • Portland • Seattle

**COASTWIDE SERVICE**

In plastering the houses at Linda Vista...“one finished every 15 minutes” . . . there’s no time for second chance. Every batch, every sack has to be of the same high *uniform* quality. For over a third of a century, the name EMPIRE has stood for dependability in Gypsum products. Whether your next job be large or small, specify EMPIRE or STANDARD hardwall plaster...both made by Pacific Portland Cement Company.

**F O R S O U N D C O N S T R U C T I O N**



# Imitation OR THE Real Thing?

Art experts can tell a genuine "old master" from a cheap copy at a glance. The texture of the painting, its richness, its deep toned beauty and the way it lasts through the centuries, all distinguish the real from the imitation.

So it is with tile! REAL tile ALONE gives you permanent beauty. REAL POMONA TILE gives your home the enduring charm, the delightful, clean appearance you expect . . . now . . . or twenty years from now. Demand REAL POMONA TILE. Accept no inferior substitutes.

**Only REAL Pomona Tile Has All These Advantages**

- Absolutely fireproof
- Surface immune to cigarette burns
- Practical for use on floors, walls, ceiling
- Colorfast for life
- Waterproof, stainproof, easy-to-clean
- True color balance
- Patented "Stone-ite" feature assures permanence



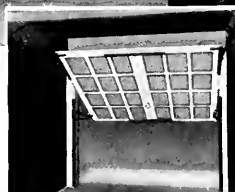
**POMONA TILE MANUFACTURING COMPANY**  
 427-33 N. LA BREA AVENUE • LOS ANGELES  
 157H TENTH STREET—SAN FRANCISCO    5176 ROOSEVELT WAY—SEATTLE  
 PLANT: POMONA, CALIFORNIA    MINES: DEATH VALLEY

## Something New An AUTOMATIC Garage Door



Turn the handle and *up it goes*—no tugging, no lifting.

**THAT'S STANLEY**  
**Econ-O-matic**  
 Economical • Automatic



A Stanley "Swing-Up" Hardware Set with new attractions. For old and new doors from 8' x 6'6" to 8' x 7' weighing not over 150 lbs. The low price will please you. Ask your dealer. The Stanley Works, New Britain, Connecticut.

**STANLEY**  
 TRADE MARK  
 HARDWARE FOR CAREFREE DOORS

*If you plan to keep bicycles, garden tools, hose, etc. in your garage be sure to make it large enough—about 12' x 24' (single garage).*



## FULL-TIME ECONOMY!

Small, day-to-day fuel wastes make monthly fuel bills higher than they should be. Such losses are generally caused by incomplete combustion, especially when starting with heavy-bodied oil. The JOHNSON 30 AVH ROTARY OIL BURNER and Vis-flo-trol make it possible to use heavier, low-grade oils high in BTU content, in any climate. It is always easy to start, with even firing under all temperatures and viscosities.

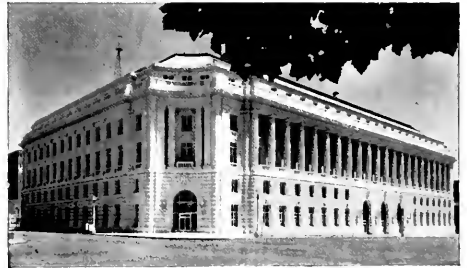
For ease of installation and lasting satisfaction, specify the JOHNSON 30 AVH ROTARY OIL BURNER. Specifications and operating data are yours, free for the asking, at our authorized dealers.

**S. T. JOHNSON CO.**  
 940 Arlington Avenue • Oakland, Calif.  
 401 N. Broad Street • Philadelphia, Pa.

## No Worry for the Architect

*"—All acid proof drain pipe and fittings shall be Ferro-silicon—CORROSIRON—"*

(Write for above specification)



FEDERAL BUILDING • CIVIC CENTER • SAN FRANCISCO

Arthur Brown, Jr., Architect

**CORROSIRON DRAIN LINES and FITTINGS** and LABORATORY EQUIPMENT was specified because of its superior resistance to corrosion and wear.

**Pacific Foundry Company, Ltd.**  
 NEW YORK • 3100 NINETEENTH ST., SAN FRANCISCO • LOS ANGELES



KRAFTILE OFFERS—

# Immediate Delivery on Wall Units!

Delays on private industrial construction avoided  
... building time and labor costs drastically cut  
—by using Kraftile Structural Wall Units



“Construction As Usual!”  
Another load of Kraftile arrives and another job keeps on schedule

Kraftile Wall Unit installation (Ceramic Glaze finish) in the Paper Container Division of the American Can Company, San Francisco

**I**N ADDITION to vast tonnage for government contracts, the Kraftile plant today is regularly producing ample supplies of structural wall units for private construction.

But it is not only to solve the material priority problem that Western architects and contractors are using more and more Kraftile Wall Units.

There are these other important advantages:

**Speed of construction.** Kraftile Wall Unit partitions go up in about half the time it takes for ordinary frame construction. Pre-tiled on one or both sides, they require no finishing. Labor cost is reduced considerably.

**Strength and permanency.** High-fired Kraftile stands up under the hardest abuse... has 10 times State-required seismic resistance. And there's no danger of decay or termite destruction.

**No upkeep costs.** Kraftile surfaces are jewel-hard — stain-resistant, vermin-proof, scratchproof, water and fireproof. Colors cannot fade... no repainting or plastering.

All types of Kraftile Wall Units — Ceramic Glaze (precision-sized), Ceramic Glaze (unsized), and “Salt-Glaze” offer these advantages. For further information write KRAFTILE COMPANY, Niles, California or mail coupon.

## KRAFTILE STRUCTURAL WALL UNITS



*Kraftile Company is a member of the Producers' Council, Inc., the national organization of manufacturers of quality building materials*

### FREE HANDBOOK

KRAFTILE COMPANY, Niles, California

Please send me without cost or obligation “Handbook of Specifications and Suggestions on Glazed Structural Wall Units.”

Name \_\_\_\_\_

Address \_\_\_\_\_

City \_\_\_\_\_ State \_\_\_\_\_



**MAIN ROTUNDA, NATIONAL GALLERY OF ART, WASHINGTON, D. C.**  
**John Russell Pope, Eggers and Higgins, Architects**

(See Elmer Grey's article on Page 35)

# FEATURE HOUSE IN PIEDMONT

By FRED'K W. JONES

**The** architect's mission is not only to design a building well but to anticipate the needs of its owner, be they commonplace or extraordinary. When a client demands features not embodied in the average dwelling the architect must be equal to the task. Usually he enjoys it because it gives him an opportunity to use his talents and ingenuity. A case at point is the residence of State Assemblyman Arthur W. Carlson in Piedmont, California, Williams and Wastell, architects. Here a number of unusual problems intrigued the designers and builders.

Site of the 12 room house overlooks the city of Oakland and distant bay. The lot has quite a drop in the rear. Concrete and stone retaining walls and terraces take care of this. One of the natural beauties of the site was a grand, century-old oak tree which the owner wished to preserve. Unfortunately, the tree stood on a small knoll which had to be leveled. How to change the grade and save the tree was a real problem. It was finally decided to excavate down to the roots of the tree, after which the roots were boxed and raised slightly by means of movers' jacks. Then followed more excavating under the crate to permit the insertion of cakes of ice. The tree was now virtually riding on ice. As the cakes melted, the oak gradually settled to the desired level and if you will look at the photograph you will see what a splendid job the architects did. The huge oak with its 70-foot spread appears always to have been in its present position, though actually it is five feet lower.

Another feature of the Carlson house is the installation of a pipe organ. The pipes are in the basement, while the console is in the music room on the first floor. Screens





Waters and Hainlin Studios





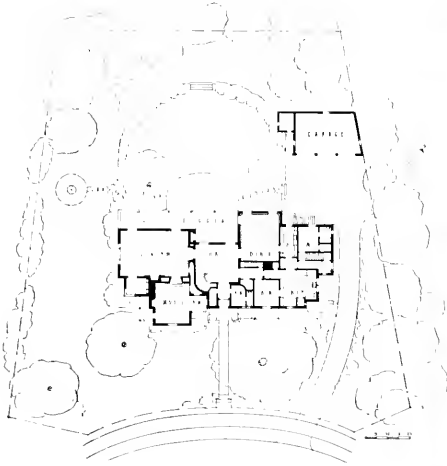
## HOUSE IN PIEDMONT, CALIFORNIA

WILLIAMS AND WASTELL, ARCHITECTS

This California Colonial home of State Assemblyman Arthur W. Carlson is replete with interesting features. Real problems, one after another, faced the architects, not the least of which was to save a beautiful live oak that the owner wished to have preserved. The tree (at right of house in the picture) originally stood on a five foot knoll. It was dropped to grade by excavating beneath the roots and dumping cakes of ice into the hole. As the ice melted the tree gradually sank to the desired level.

The house has a sound proof rifle range in the basement and a pipe organ with pipes kept at an even temperature by means of a domestic hot water heater.

The picture on the lower left (opposite page) shows the entrance hall and front staircase. The mural is a combination of hand painting and wall paper and is a rare example of adjusting standard wall paper to an incline. The other picture on the same page is the dining room, panelled in birch.





**LIVING ROOM, LOOKING INTO MUSIC ROOM; NOTE ORGAN CONSOLE  
OPPOSITE PAGE, UPPER: BREAKFAST ROOM; LOWER: RIFLE RANGE**

in the music and living rooms provide an outlet for the organ notes. Inasmuch as the pipes have to be kept at an even temperature it was necessary to provide a special heating system, accomplished by means of an automatic hot water heater.

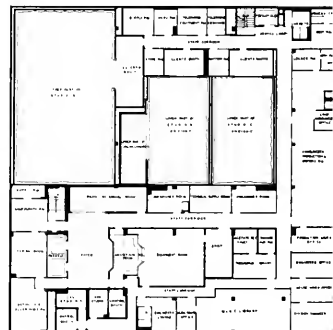
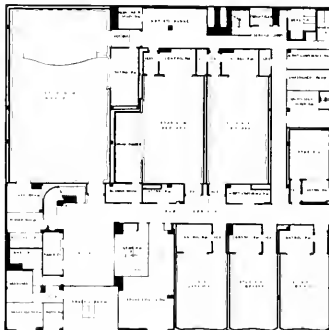
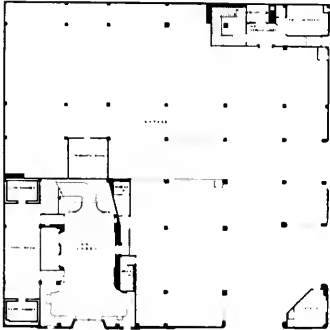
Somewhat of a novelty for a private home is a sound proof rifle range in the basement. Target practice is a hobby with the owner. So the architects conceived the idea of building a 50-foot range beneath the living room. Concrete walls and insulated sheet steel ceiling

shut out the noise so successfully that one may sit quietly in any room in the house without being disturbed.

The house has white-washed brick exterior walls, Gladding, McBean shingle tile roof and stone terraces. Various varieties of hard woods are used in the interior, including birch, cedar, spruce and knotty pine. There is a low pressure steam heating plant with thermostatic control and concealed radiators. A secret closet for the safe keeping of valuables is in one of the second floor rooms.



# NEW STREAMLINED BUILDING IN SAN FRANCISCO





# FOR NATIONAL BROADCASTING COMPANY



**San Francisco's** new NBC Building, rapidly nearing completion at Taylor and O'Farrell Streets, will be the most perfect plant of its kind, according to veteran executives and engineers of broadcasting. The improvement will definitely establish San Francisco as one of the four great radio centers of the United States.

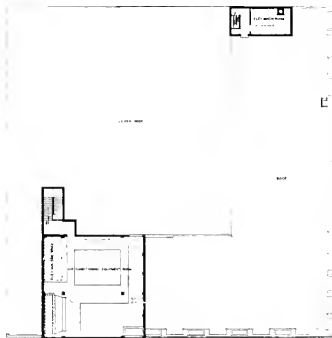
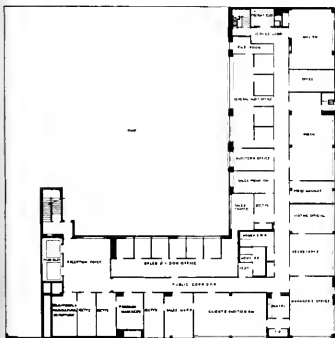
The architect is Albert F. Roller and the builders are Barrett & Hilp, 718 Harrison Street, San Francisco.

Five stories high, the building is being constructed of reinforced concrete, trimmed with bands of glass brick. These will admit daylight but will not be transparent and they will be illuminated at night from within to give the structure a dramatic appearance.

There will be windows in the building and it will be air-conditioned throughout. Architecture is modern, streamlined, but not freakish, fantastic nor faddish. It will give KGO and KPO 52,800 square feet of floor space, more than double the area of present quarters. A larger percentage of the footage will be devoted to studios and not wasted in unnecessary office and hallway area.

The main entrance will be on Taylor Street, near the Clift Hotel, and will be beneath a dignified, inviting marquee. An 80-foot tower will rise above the entrance, the most dramatic feature of which will be a great mural panel, 14 by 40 feet. While the details of this feature will not be revealed until it is unveiled at the dedication, it will symbolize the vast extent of radio and the unlimited service it gives to all the lands and all the peoples of the earth.

Ten studios will provide adequate facilities



## LARGE PICTURE— ARCHITECT'S MODEL

BELOW, from left to  
right—FIRST, SEC-  
OND, THIRD,  
FOURTH AND PENT  
HOUSE PLANS

for all broadcasts, rehearsals and auditions. The largest of these studios will accommodate audiences of 500 people. All studios open to the public will be on the second floor, easily accessible from elevators and stairway.

Show windows at either side of the entrance and others inside the main lobby will tell the story of radio, will publicize programs and radio-advertised products.

Such interesting activities as the master control room, news room, traffic, radio recording, will be visible from the foyers on different floors through large windows, making it possible for visitors to see what goes on "back stage" in a broadcasting plant.

There will be a million feet—that's 190 miles—of wire in the building, most of it being of a special design to meet the requirements of broadcasting. Much other technical equipment is now being assembled and constructed in the engineering field office.

Nerve center of the plant, of course, will be the master control desk, so designed that one man will have complete control over every studio, every line in and out of the building, all the switches and operations. He will be like a train dispatcher who directs the movements of all trains.

There will be a special PAX system to make all house monitoring possible and to enable executives to dial in any studio, any program or any other local broadcasting station direct from their desks.

Chances of error in switching operations will be reduced to a minimum by means of a master pre-set. At present individual buttons must be punched for all stations that are to carry the next program and this must be done in five seconds. By use of the pre-set this work is all set-up in advance. When chimes ring, only one button will need to be pushed. The pre-set will do the rest, instantly and accurately.

Following the best accepted practice, every studio will be set on springs with the walls and ceiling suspended by springs—the box within a box idea. In this way it will be impossible for any outside sound or vibration to reach the studios. All wall surfaces will have scientifically correct acoustical treatment and will be set at angles that will make echoes and sound reflec-

tion impossible.

Steam heat will be combined with the air conditioning system to maintain ideal temperature and moisture control under any atmospheric conditions. Controls and equipment will be located on the fifth or pent house floor.

Office and studio layout and the arrangement of departments received much serious study by the architects and engineers and the result will be a series of floor plans conducive to absolute efficiency of operation. Convenience of the public also was kept in mind.

From the moment they pass through the beautiful entrance doors into the exquisite lobby, every detail of design and decoration will welcome and interest the visitors. Broad stairway and the elevators will invite them on to the second or studio floor.

Facing this foyer will be the newsroom with its teletype machines bringing news from the four corners of the earth over the wires of all three of the great news syndicates. Editors will be there preparing news broadcast material while in the center will be a triangular news desk from which broadcasts will originate.

Through another large window visitors will see the traffic department where program schedules are worked out, corrected and kept posted on huge boards.

Studio A will open directly off of this foyer through double doors and a vestibule. At the far end of the large room will be a stage and to the right the control room. This studio will be 41 by 70 feet, capable of seating 500 people.

Studios B and C will be just a few steps down a public corridor and will each be 24 by 44 feet. Control rooms will be at the far ends of these studios and the pipe organ will be located in Studio B. Studios A, B and C will all be two stories high and clients' observation booths will be above the control rooms.

Studios D, E and F will be across the public corridor from B and C and will each be 20 by 30 feet in size. Studio G will open off the end of the corridor and will be used chiefly by individual speakers or for forums or programs not of particular interest to visible audiences.

Other occupancy of the second floor will

(Turn to Page 49)

# IS MODERN ARCHITECTURE REALLY NECESSARY?

By ARTHUR BROWN, JR., F.A.I.A.

When Irving Morrow asked me the other day to act as the Devil's advocate to his Section's report, I was appalled, as well as flattered. I was appalled by the task of discussing a subject so confused by present conditions, and so refractory to clear analysis. He told me that his findings were in favor of Modernism, and that he wanted me to represent the opposition, as a Classicist—a recalcitrant one, presumably. I told him I was not consciously an appointed Classicist, and furthermore was not violently opposed to any work of architecture that was really pleasing—a broad reservation, however. I said if he wanted me to, I would gladly comment on his report to the best of my ability, but that I would like to confine my discussion to the text of his report.

As to the background of this highly controversial subject, there is no doubt that the garden of American architecture has become full of ugly weeds, but in the process of weeding, it is highly desirable that other weeds do not flourish in their stead.

I have felt, personally, that modern progress should be in the effort to eliminate abuses and cultivate a clearer understanding of those fundamentals that have always guided the traditional current.

The system of education has yet some work to do in regard to fully grasping the fundamentals, and human weakness makes the application strangely bewildering.

After following the succession of fiery polemics that has raged continually since I can remember—Romanesque—Art Nouveau—and all the personal "isms" of the self-appointed prophets, I am inclined to borrow the words of the Frenchman who said somewhere, "Plus ça change plus c'est la meme chose," or words to that effect.

---

Editor's Note: Conclusion of a copyrighted report of the Section on Architecture of the Commonwealth Club of California, presented to the Club on April 17, 1941. The first installment of the report, "Why Modern Architecture?," by Irving F. Morrow, appeared in the September Architect and Engineer.

But that should not eliminate the constant search for the elusive truth. This might be done by sober analysis and a sincere, disinterested approach. We have been bored too much by the aggressive rationalizing of their fallacies by pompous "lone wolves."

Mr. Morrow's report is, to my way of thinking, a disinterested effort to clarify a confused situation, and my comment is just as sincerely an effort to assist in that clarification.

The title of the report, "Why Modern Architecture?," does not appear to state the case that Mr. Morrow wishes to establish—nor is his conclusion more clearly defined. Does he mean to ask what were the conditions which brought about the "Modernistic" philosophy, or does he mean to undertake to demonstrate that the "Modernistic" mode is the only true gospel to the exclusion of all other contemporary modes? Then again, if he has sought to prove that thorny proposition, just where has he defined the inclusive and exclusive characteristics of the modernistic creed? It would be interesting to compare this creed with the guiding principles of the traditional stream it seeks to displace. These points I think should be strongly defined before the general discussion is undertaken.

I have in my hand a copy of the report that I have annotated. Many, if indeed not most of the paragraphs I have marked with an "O.K." However, there are other paragraphs which I think might reasonably be challenged. Some of the postulates proposed are open to question, such as the notion attributed to the middle-aged man in the street that all architecture must be done according to arbitrary formulas and rules, presumably essential to the traditional styles.

Then again the contention that the "modernistic" mode is not a fad, simply because of its measure of present popularity. This same phenomenon has characterized the many revolutionary movements of the past hundred years.



**ARTHUR BROWN, JR., Architect**

The Gothic revival, for example, and the various previous "mechanistic" movements.

Also, that the younger men seem infatuated by the "new architecture," is neither surprising nor convincing. The system of education has been for several years strongly influenced by aggressive theorists, who are particularly attracted by abstract and radical dogmas. I think that it might be argued that they and their pupils are dupes of the recrudescence of the cunningly plausible notions of the "mechanistic" movement of the middle of the 19th century. Geoffrey Scott has advanced a very strong argument as to the fallacy of this theory. I refer to his chapter in his "Essay on the History of Taste."

Communism and fascism, also, often attract the young as a promised panacea for the maladjustments they see about them. Nor am I prepared to think that the search for novelty has not been, consciously or otherwise, a very powerful impulse. I have no quarrel with novelty per se, but only when it seeks to displace fundamentals.

In the modernistic movement, certainly much sincere and able effort has been expended by the partisans of a "new architecture," but less admirable motives have also been present, as they sometimes have in other movements—exaggerated egotism, a necessity for publicity, the need of "selling talk," an unbalanced desire for novelty and excitement. The architectural press, hungry for news, has given to it exaggerated importance, due to the news value of novelty. Also the need for advertising from

industry has had its part in the policy of the press. The protagonists have been very eager and aggressive, and have sought to destroy in their own interest. This is freely admitted by one of the principal prophets. Nor has a campaign of trick slogans been absent.

As an expression of time and place, I am much inclined to think that in the current domestic architecture of our region, is a better reflection than the products of the Bauhaus or the Scandinavian Schools, however appropriate they may be in their home countries.

The "new architects," too, often look to the unexplored past for inspiration: the "Perisphere," the form of which Ledoux had already thought of applying in the 18th century, for example. One is inclined to ask if some of the "new" theory is not based on an unconscious desire to rationalize a particular novelty, rather than based on a necessity for a complete change of mode.

Again, is it a valid postulate to assume that Tradition is essentially static? Progress, on the contrary, is one of the avowed aims of the tradition in which I was reared. The statement by Gromort of the tenets of contemporary tradition is clear on that point.

That craftsmanship is dead would be a cruel thought, were it reasonable to admit. That some of the drudgery has been eliminated is not proof that the human urge to use the hands will not always exist. The music of the masters does not depend solely on whether it is reproduced by the pianola or interpreted by a Paderewski.

In Mr. Morrow's paper, in my opinion, the fundamental factors of architectural activity have been admirably analyzed and expressed. The social, technical and emotional factors have been very well described. Another factor also (which might, I suppose, be a sub-head under social or technical) would seem to be of importance—the economic factor—which has been given little attention, and yet I believe it sometimes to be of almost more influence than any one of the other factors. It may, indeed, be the governing factor in the development of any new trend, as it has often been in the past.

However, the conclusions implied in the discussion of these factors do not seem to

establish the pretention that the necessities can be better met by a radical and complete abandonment of the traditions of the building craft that have gradually unfolded since the beginning of history.

The crux of the argument in this report is probably contained in the discussion of these three factors, social, technical and emotional—and they should be examined more in detail. I would accentuate this point as being the important one of the whole report. It is in the relative values involved in these three factors that an agreement should be sought. I thoroughly disagree with the relative weights which Mr. Morrow seems to imply. It can easily be shown by a definition and interpretation of what characterizes Architecture in relation to Engineering, that vastly too much weight is given the technical factor. Most of the new materials, so much talked of, are in reality in the nature of improvements on old materials, which do not affect the fundamentals of design. Certainly the execution of a design is rendered easier and cheaper, and new possibilities are opened thereby, but it is not clear how those factors radically change the processes of creative composition. Also I think I spy a number of "non sequiturs"—but time does not permit.

In all of this I have seen no valid argument that the traditional point of view is unable to cope naturally with the needs that the "new architecture" pretends exclusively to satisfy. The absence of the highly essential Q.E.D. is my strongest impression after reading this paper. I wonder if others feel the same way.

In further comment, on the implications of the report, it specifically implies that complete satisfaction of architectural needs is attained by buildings embodying the qualities of:

1. Simplicity
2. Concision

3. Openness
4. Lightness and poise
5. Rejection of superfluous detail
6. Insistence on essential relationships

Very good! Would it not be pertinent to ask ourselves if those qualities are not gloriously embodied, and with numerous other qualities in addition, by examples picked at random from the great stream of Greco-Latin culture, such as:

1. The Parthenon
2. Sancta Sophia
3. The National Library, Paris
4. The Pennsylvania Station — anathema to the modern purists
5. The typical 18th century house in America, or France and England
6. A house in Pomeii
7. The Garabit Viaduct
8. London Bridge
9. The interior at Perigueux
10. Chartres Cathedral
11. The great mosque of Kairouan
12. The Golden Gate Bridge

It would be illuminating to cite achievements of the "new architecture" in comparison to these.

I venture to suppose that before convincing arguments are possible on "Why Modern Architecture?" it would be useful to consider the words of Arthur Upham Pope discussing the controversy over the Jefferson Memorial: "Beyond these issues lies one deeper and more essential. What constitutes architectural excellence? Whence come the canons of Architectural Beauty? What is the aim and justification of architecture, and what can it express properly?"

(A continuation of the Report by Mr. Neutra follows on next page.)

# THE CASE FOR MODERNISM

By RICHARD J. NEUTRA

That there is something wrong in our environment is familiar to us, although we might not always be conscious what we are ailing of. But known to psychopathology are cases where people break down under the strains of this disorderly, disharmonized, disintegrated environment of ours.

I will read you a short paragraph from the "New Yorker":

"Mildred Gottfried, a seventeen-year-old high school student, went around her family apartment in Flatbush setting fire to the furniture, because it all seemed perfectly disgusting to her. 'Something must have snapped in Mildred,' said her mother apologetically. But we don't think so for a minute. This determined girl, one of the great destructive critics of our time, simply did a thing that has lurked in the background of everyone's head. Equipped only with a dream and a box of matches, she destroyed an otherwise indelible old world and created an inescapable necessity for a new one. We hope she beats an arson rap that is facing her as we write this. There is a place for Mildred in society, as well as the one she already possesses in our heart."



RICHARD J. NEUTRA, Architect

So, you see people all over the country are suffering from the thing which progressive pioneering spirits in our profession try to analyze and to solve. This has been going on for a long time, for a much longer time than anyone here present could have experienced within the span of his own life. There is no one so old in this room that he can look back to the beginning of what is now called "modern architecture." I will read a few quotations from an interview I gave a few years back.

"New architecture is not an official fad of today. 'In 1849,' a man named Gobard writes in the 'French Journal,' 'a glass is determined to be the fundamental architecture in lieu of heavy walls where strength and safety is accomplished in spite of many perforations. Our houses will have practically continuous openings with single and double translucent and transparent glass.'

"In 1850 Theophile Gautier, the novelist, wrote in 'La Paris,' 'One will create a new architecture in that moment when someone makes use of the new means offered by industry.'

"In 1867, with the Civil War just over in the United States, the 'Journal de Beaux Arts' states, 'But the architect one day will be replaced by the engineer.'"

You see it is an old story. Slowly it has crystallized into solutions which are irreversible regardless of all the ripples in fashion.

I quote Mr. Morrow: "As long as mankind is free to confront new situations with unimpaired spirit, new architectural style will be possible." This conception of mankind is in sharp contrast with that of the man who thinks everything was finished before he was born. If there are air raids overhead, would we try to combat them with "muzzle loading guns?" No, we must have air defense guns of the newest type, with devices that can aim in a fraction of a second. When the air raids are over and our buildings are a shambles, are we going to re-erect them with obsolete methods

—in some medieval fashion, slowly and uneconomically?

According to computations of my own, checked by architects in England, the houses destroyed by bombs are worth less than the bombs and the replacement cost of destroyed aggressor planes. A family dwelling is a cheap article compared to a heavy bomber, or even to the bombs weighing 500 to 2500 pounds, all of which must be built with the highest precision.

We would have to create communities and neighborhoods of an entirely different character, because no peace treaty will prevent for good a repetition of this destruction, long before our modernization period is over.

Mr. Morrow has made it clear that architecture is not a stage setting. "Novelty" is dangerous in architecture, because amortization periods are so extended. A lady's gown is often worn two or three times only; so it may be of a passing kind of novelty. But if you indebt yourself for 20 or 25 years to pay back a mortgage, you can't afford to become fatigued by the style of your building after six months or even six years.

Novelty has to do with nervous fatigue. We must design buildings, so sound and so clean-cut that they do not cause us fatigue. Yet they must be sufficiently flexible that varying furnishings, hangings and carpets, in other words, accessories more quickly paid off, may be added and again abolished during the amortization period. Styles which are revived are not "traditional;" these revivals are much more fashionable, fatiguing, they change more quickly than anything we do in contemporary work.

As Mr. Morrow said, some people still doubt that our new designs will fit into old settings. If mankind could have sustained such a notion, we wouldn't have had any progress during the past fifty thousand years!

Perhaps millions of dollars have been spent by amateurs to buy passage to Italy and see the Piazza di San Marco in Venice. It is a fine, perhaps the best, outdoor-indoor room. When, about 1520, Jacopo Sansovino was given a job by the Signoria of Venice to build a new library,

he was given a site just opposite the Palazzo Ducale, a Gothic structure built in the 14th century. Adjoining the Palazzo, just across the street stands St. Marks' Cathedral, an 11th century building of Byzantine architecture. But Sansovino did not for a moment consider construction of a Byzantine or a Gothic building to "match" or imitate the neighbors. Why not? Because he was intelligent—and knew his limitations. He was ambitious to do the best in his time, to speak the language he actually knew. He wouldn't have tried to speak Egyptian or Arabian or Chinese. I don't think his library is one of the best examples of Italian Renaissance, but it was at any rate the best building of that decade in Venice.

Mr. Morrow foretold that coming ages will not be interested in us if we are not interested in ourselves! It is indeed more important to be loyal to one's own time than to one's own town, because if you do try to escape the feeling for your own time, you escape into nothing but insincerity.



**HOUSE IN PALM SPRINGS, CALIFORNIA**  
Richard J. Neutra, Architect  
Peter Pfisterer, Collaborator



# TWO PAGES OF MODERN HOUSES

By RICHARD J. NEUTRA, ARCHITECT

Collaborating with Mr. Neutra in many of his houses is  
Peter Pfisterer



Left—House in Glendale, California

Below—Residence in North Hollywood

Opposite Page—Home in Portland, Oregon

Below—House in North Hollywood







## MODERN ARCHITECTURE AND MODERN LIVING

On the subject of "Modern Architecture and Modern Living," Louis Christian Mullgardt spoke as follows:

In reviewing mentally world progress in its national phases, we get two kinds of expression.

One fundamental is to be found in every country, oriental or occidental, and that is the first principle, simplicity, in what we term "architectural expression." The front of a building for example, may be perfectly plain and punctured simply with windows designed so as not to be offensive to the eye. Perhaps it was not actually designed for "aesthetic expression," but as a result of interior need.

A punctured wall serves one of two purposes, either as an entrance or as a window for interior light. There are all sorts of ways of doing that thing, and we merely have to look about in our own community to see what has been done by those who have produced buildings.

It doesn't follow that a thing is architecturally charming because it is ornate. In our communities, we see altogether too many houses with features that are extraneous, unnecessary and merely done for effect. Many people, including architects, are not really sympathetic to the fundamental we term "truth in architecture."

Architecture, above all things, must be expressive of truth in its aesthetic quality if it is to have significance. Of course, you can't take a facade or, say, four sides of a residence, and indicate thereon where the children's room is. But, in its entirety, you would find a good design for a home looking like a good design for a home, a real home which the owner is fond of, which is really his life. For, in the last analysis, there isn't anything that surpasses the home as an expression of love, affection and sympathy; it becomes a part of and is the enclosure, the shell, of a human family, just as the physical body is the cocoon of the spirit of the individual. Unless this is so of the exterior, and the interior too, it cannot be considered good architecture, and perhaps not architecture at all. It may be merely fantastic, and of that we have a great deal now.

Design begins with the requirements and the

purpose for which the structure is to be used. That is the governing factor. When the plan has been agreed upon between architect and owner in a preliminary form, the work drawings are made and such essentials as foundation and form of construction come next.

Next comes the aesthetic, the spirit of the thing, the expression of visible things as to whether they are good, pleasing or displeasing. That depends upon a quality we will call ingenuity. All of us feel more or less the presence of an incongruity, whether it be in architecture or paint, medicine, engineering or whatever you may consider. A man who doesn't conduct his grocery business in a satisfactory way finds himself being criticized and perhaps loses his business. You need, first, the foundation of good judgment and added thereto comes the "display of charm." It may be done ever so simply, and it may be overdone and crude and inconsistent.

Now, the second kind of expression is evidenced when it comes to building large structures, pretentious in that they have not been merely constructed but possess the quality of "aesthetic expression." The Parthenon, for instance, has a simple design in a specific style. In its original it was both beautiful and elaborate in its architecture and color scheme. I need not mention other buildings, but it is just the difference between exceeding simplicity and the maximum of glory in architecture.

Then we have all the in-between phases, and where architecture begins and where it ceases, I think, usually depends on individual taste. Whether it is good, bad or indifferent is a personal thing. But there is something in art that is indescribably indefinable. A child of five years may be composing music, and that has happened. Now, that is innate in the child. The child's talent is to be acknowledged but the child is not to be congratulated for possessing remarkable talent at an early age. People of that kind if they grow up and are cared for usually become great, as musicians, and often times lead short and very sad lives. At least that is the way history portrays so much of human life.

And there is a great, a decided relationship between human life and the things which man does; the things which he creates.



**NATIONAL GALLERY OF ART (MELLON GALLERY), WASHINGTON, D. C.**  
**John Russell Pope, Eggers and Higgins, Architects**

## THE FINE ARTS IN AMERICA

By **ELMER GREY, F.A.I.A.**

To make any just appraisal of the fine arts in America it is necessary to compare them in some respects with those of the rest of the civilized world. In doing this we should remember that American civilization is much younger than that of European countries. Art is the flowering of certain well developed social and economic conditions and it would be unfair to compare our art with that of foreign countries without noting the differing periods of time in which the two have had to prepare.

The art of London's National Gallery, of France's Louvre, or of Italy's Uffizi would never have been had there not gone before it centuries of preparation when culture was being developed and wealth to support art was being accumulated. Our colonists brought some cul-

---

**Editor's Note:** This is the first publication of Mr. Grey's essay, which was offered in the recent competition sponsored by The Atlantic Monthly and the American Institute of Architects.

Prize winners and finalists cited for mention in the competition have been announced as follows: First Prize of \$1000, given by the trustees of the Waid Educational Fund of the A.I.A., to John A. Kouwenhoven of Dorset, Vermont, for his essay, "Arts in America." The Second Prize of \$500, also furnished by the Waid Fund, went to George Boas of Johns Hopkins University, for his essay, "Art in Education."

ture with them from Europe but the necessary wealth had to be made here. Fortunately we have had men who realized that.

After the landing of the pilgrims America was busy for more than two hundred years getting its economic life raised to an art strata. First came settlement of the Atlantic coast, then external and internal wars of adjustment, then more settlement and pushing of the railway further west. Finally rails were laid along the steep sides of the Sierra Nevadas, the last spikes were driven, and the continent was spanned. When the best minds of the country were busy with such enterprises there was little time for art. But that is a short range view of the matter.

For the process of building the railroad over the mountains yielded to one of its promoters the nucleus of a fortune which many years later in one of its ramifications found expression in the erection of the Huntington Art Gallery at San Marino, California, and the purchase of many priceless works of art to fill it. Other galleries had long existed in the east, but this was the first of its kind in the far west; and since it is typical of what men of wealth have done in other parts of the country it will be dwelt upon



Copyright, Keystone Photo Service

**HUNTINGTON ART GALLERY, SAN MARINO, CALIFORNIA**  
**Myron Hunt and Elmer Grey, Architects**

in some detail here. If we have in our mind's eye a clearer picture of such an institution some of us may be better able to follow the further discussion.

In its collection are many magnificent portraits by painters such as Gainsborough, Romney, Sir Joshua Reynolds and the like and some gorgeous Beauvais tapestries. Whether you classify English paintings as first, second, third or fourth in rank among those of the world, it remains true that those in this gallery are the very flower of the British school when it was at its height. Mrs. Siddons, Lady Hamilton, the Duchess of Devonshire and a host of other celebrities of that day appear here life-size, and they all but speak to us out of the frames in which their distinguishing features are perpetuated. We picture to ourselves more vividly Lord Nelson and his compatriots off duty and surrounded by the beautiful women who occupied so large a part of their lives. Aided in this way our minds reach back into history and re-live some of the stirring events of a past age. Even George Washington smiles benignly down from his frame as if to remind us that after these lords and duchesses, in another land, came another day.

Previous to their purchase by Mr. Huntington the pictures had been in private galleries, mostly in England, where few could see them—here they are made available to all. Mr. Huntington felt that the cultural influence of such a gallery in a community where wealth was pouring in from oil and other natural resources, and where the danger of materialism was consequently great, would be incalculable.

The gallery has an attendance of something like 200,000 annually, showing that great numbers are interested in its kind of art—and they cannot fail to have their mental horizons enlarged by it. Furthermore they get much more when visiting it than just the pictures, for its surroundings are those of great beauty. It is situated in the midst of what was once Mr. Huntington's large private estate in a part of California where scenery and climate combine in making possible an ideal setting. One approaches along a drive shaded with spreading oak trees and a path lined with palms and semi-tropical shrubs. On the south is a wide terrace

upon which stand superb bronzes and from which one looks out over the entire San Gabriel valley. Below this and accessible to all visitors is a remarkable garden where, from South Africa, South America, Mexico and other remote parts of the globe are gathered different varieties of cacti. Many of these are of gigantic size and weird shape and would make a suitable background for any Alice in Wonderland. Closely adjacent, but separated by a wide expanse of lawn, is the Huntington Library, where many precious manuscripts and many first editions of rare books are kept. Toward the north a long, broad sward extends away from the building, flanked with numerous marble statues set in niches of shrubbery and interspersed with magnificent oaks. Beyond, in the near distance, are the Sierra Madre mountains. Who would not prefer visiting an art gallery amidst such surroundings as these!

When Mr. Huntington was once asked why he confined his collection almost exclusively to 18th century portraits he answered, "Because I like to surround myself with good-looking, well-fed men and women!" Whether that was said in jest or in earnest the fact remains that the portraits in this gallery would fail of their full mission if they did not remind us that the artists who made them were also in all probability well-fed—for they were bountifully supplied with cash by their patrons and in a country and time when knighthood was in flower titles were conferred upon some of them.

If we would expect much from our artists today we should remember this; and we might also think how, in these times where there is so much that is sordid in the world, the valuable art spirit may best be kept alive. We cannot see the wisdom of subsidizing artists, even assuming that it could be done. But there are other ways of helping art. Business is doing its part—and can do more. And motion pictures have done a very great deal—and can do more.

The remarkably beautiful effects one frequently sees on the screen do not just happen—the initial impulse for many of them was created by artists who turned away from painting because they could not make a living at it and who do this kind of work for a liveli-



**HUNTINGTON ART GALLERY, SAN MARINO, CALIFORNIA**  
**Myron Hunt and Elmer Grey, Architects**

Copyright, Keystone Photo Service

hood. "Sketch artists," they are called in the studios, and they are responsible for the composition of some of our most beautiful screen scenes. The studios have also provided work for others inclined toward art. Art directors are men of wide knowledge of affairs who sort out the work of the sketch artists and determine which are most suitable to reproduce. They also coordinate these conceptions with work of set designers and set constructors.

But artists have to be very proficient before they can be used by the movies. How are younger men of talent to obtain such proficiency? Here is where governmental aid comes in. At the National Gallery in London the copying of masterpieces by students was in times of peace a regular thing. At the South Kensington Museum in London the students who came there to study were so numerous that a cafeteria was provided for them in the building. Similar privileges are now extended to students in most American galleries, but to just what extent they also offer life-classes, a most important part of such training, we do not know.

Of course, something has been done for artists under the WPA programme, but that supply of work cannot be permanent. It would seem that continued public demand for high class scenic and musical productions on the screen would supply a good deal of what is wanted. Therein is a permanent field of demand and the fine things that have already been provided and have been well patronized indicate what the public wants.

When we see and hear productions on the screen such for instance as that in which Heifetz plays with almost the same clarity as though he were in the room, we are apt to forget what it typifies in inventive genius, in the rapid progress of the art, and in its frequent foreign derivation. We look at the picture before us but are apt to be unmindful of the panorama of past events that brought it into being—the settlement of a virgin country, the growth of an idea from a toy into an intricate and marvelous combination of mechanics, artistry and business; and the hope which this success held out to gifted men and women abroad who are now here contributing to our happi-

ness! We see the actors on the screen, but we do not see the sketch artists, the directors, the sound technicians, the camera-men and others, who made their presentation possible. In some respects these pioneers in art—who are usually self-taught, because no university turns out such experts, and who are often subjected to long nerve-wracking pressure—are quite as much to be admired as the men more commonly called artists who paint with a brush on canvas. The painter's reputation has been built up by centuries of laudation and is well-deserved; but here in only about thirty years has grown up a cooperative activity that makes pictures that move and talk and whose claims to art are so well assured that already the world would be bleak without it! Sir Joshua Reynolds when he painted Mrs. Siddons, or Romney when he painted Lady Hamilton—what would they have thought had they been told that some day pictures would be painted that showed people walking about and talking; and that on larger canvases dramas would be enacted on such pictures that vast congregations of people could watch and enjoy? Yet that is the most popular art of our day and is capable of bringing to us—and yet will do so, we predict—the world's best architecture, sculpture, drama and music in single concords of cultural delight.

Forty years ago the whole section of country west of Chicago was virtually devoid of any institution furthering the cause of art. In Los Angeles at that time a purported art school that had a peculiar odor about it was found to be over a place where they were selling fertilizer! Its idea of nature study was to have the pupils sit on green leaves during recitations so they would be flat for copying afterward! When Melba came there the only place for her to sing was in the prize-ring of Hazard's Pavilion where there had been a prize-fight the night before!

However, while all this was going on prenatal influences for art were hard at work. For example, in 1880 there came over from England as an emigrant a young man named Robert Watchorn. He worked in the underground coal mines of Pennsylvania for awhile, meanwhile attending night school; but soon rose to posi-



**LINCOLN SHRINE, REDLANDS, CALIFORNIA**  
Elmer Grey, Architect



**INTERIOR OF LINCOLN SHRINE, REDLANDS, CALIFORNIA**  
Elmer Grey, Architect; Geo. G. Barnard, Sculptor; Dean Cornwell, Murals



tions of more importance. In some way he became interested in the production of oil and in that activity amassed several fortunes. His public benefactions since have been many and a small part of them was a gift to the city of Redlands, California, of a Shrine to Abraham Lincoln. Architecture, sculpture, painting and literature were called upon in this building to pay homage to a national hero. The architectural part consists of an octagonal pavilion flanked on two sides by open terraces, in the centers of which are sculptured fountains by Merrell Gage. On the interior, opposite the entrance is a niche containing a marble bust of Lincoln by George Grey Barnard.

The walls and domed ceiling are covered with murals by Dean Cornwell, and because the subject of murals seems to be somewhat shrouded in the public mind they will be spoken of in detail here. It might be supposed that they would have taken the form of realistic scenes depicting Lincoln engaged in various public acts, but if that had been done it would have occasioned numerous painted portraits which would have competed one with another and with the marble portrait bust. Besides, Lincoln did not himself go about freeing the slaves, but it was the spiritual idea of freedom for the colored race which he stood for so valiantly and succeeded in spreading over the land which finally accomplished the purpose. So Lincoln's achievements were portrayed instead in an allegorical manner. "What Lincoln did can best be ascertained in books," it was stated at the time, "let us have murals that inspire us to read the books."

If a similar idea were oftener followed in murals it would be for the betterment of many of them. Realism in them does not compliment the beholder. It often tells him what he already knows; overlooking the fact that he has an imagination that it would please him to be allowed to exercise. Many murals have also suffered by not being sufficiently subdued as unobtrusive backgrounds. Puvic de Chavannes showed us how this should be done years ago in his decorations in the Boston Public Library, and admirable examples since are those of Scott Williams in the Indiana State Library and Historical Building at Indianapolis, the murals

by Dean Cornwell in the Los Angeles Public Library, and the very recent work by Andre Durenceau in the ocean liner "America." All three of these artists are also very painstaking in their draftsmanship—a point frequently slighted, especially by some of the ultra-modernists. Cornwell's Los Angeles Library work is crowded with figures required by his subjects, yet every one is a personage carefully drawn from a model.

There is much controversy these days about modern versus older schools of art and it would be sidestepping an important issue if the subject were not touched upon here. Some may say that it is all a matter of taste—and undoubtedly it is—so the question becomes one of which is good and which poor taste. No attempt will be made here to decide that point; rather we will endeavor to take the stand of a neutral observer and report the world of art as we find it.

Generally speaking, the modernist believes in breaking away from tradition for the reason that it hampers the timeliness of creative impulse; that the purpose of art is to express ideas, and that one should take any measures he sees fit to convey the ideas. He looks upon the ornament of the past as belonging only to the past and endeavors to evolve new forms of ornament to suit the altered purposes of a later day. Prevailing taste he considers to be incumbered by the incubus of tradition and that this should be largely shaken off to allow new taste to be formed which will better fit the conditions of a new world. Of course such a doctrine often results in over-enthusiastic adherents taking the bit in their teeth so to speak, and running off into extremes the value of which is questionable.

The conservative, on the other hand, maintains that good taste is formed by the discriminating majority over periods of time; that certain standards of taste have thus been established in comparison with which new work may be judged; that while it is true that one purpose of art is the expression of ideas it is also true that these should be expressed in terms of beauty, and that the majority have in the course of time established certain standards of beauty which it is folly to ignore. In

architecture, for instance, the conservative maintains that there are certain classes of buildings that have come to be universally admired and so can be used as models in designing new buildings. In this category he puts such as the great Gothic cathedrals, the baronial halls of England, the lovely domestic architecture of England, the beautiful chateaus of the Loire valley, the imposing halls of the burgomasters and guilds of Holland and Belgium, the civic buildings and palaces of the Renaissance in Italy and the temples of ancient Greece.

Now between these two ideologies, if they may be so called, there are those who follow a middle course which values the historic buildings, believes that a suggestion of them in present-day work lends romantic flavor that is too valuable to be lost, but feels that they should be followed only in so far as they are applicable; and that the principles governing their designs should be studied rather than their forms copied intact. This group numbers in its fold many brilliant men, and by such we see the old models followed in a general way but often modified in delightful details to suit new requirements or altered trends of public thought. Two splendid illustrations of such work are the Folger Shakespeare Library and the Academy of Sciences recently added to the Mall at the National capital. Both follow the general composition of their classic neighbors but are distinctly modern in treatment.

The modern trend has also influenced sculpture, but there is not space here to go into its many ramifications. When it is not free-standing, but forms an integral part of the building, and particularly when the architecture of the building has much flat wall surface in its composition there is a recent treatment (not new but borrowed from the ancient Egyptians and Assyrians) that has been very successfully used. It consists of a flattening out of the front faces of the sculpture which seems to tie it in better with the flat faces of the surrounding walls. One of its most successful exponents is Lee Lawrie and the most conspicuous example of his work is on the Nebraska State Capitol at Lincoln. Its message there takes on almost the aspect of religion.

On the tops of the pylons of the south facade the sculpture emerges gradually from the stone walls below into huge, majestic figures representing great law givers of the western world. The gradual emergence of these figures seems to emphasize their intended message. It is as though the structural stone below gradually grew in intelligence under the sculptor's chisel until finally it comes forth as great comprehending Beings having beneficent purpose and power. It makes one feel stronger to look upon them. But it has been truly said that, "it takes more than figures growing out of a pylon, with their lower parts uncarved, to make architectural sculpture" and it was Lee Lawrie's genius and his aptness in collaborating with the architectural intent that made his work on this building so fine.

The Nebraska Capitol, designed by Bertram Grosvenor Goodhue, is also a fine example of the architectural trend toward the modern, but by one who was thoroughly steeped in traditional values and broke away to the extent of applying their principles in new and brilliant ways. Although unusual in composition the building is nevertheless not in the least bizarre. Goodhue's works, of which there have been an abundance, illustrate the truth of what Alexander Sterling Calder has said, that the sources of art are rooted within man himself. The creative artist must either act on passionate conviction founded on intuition, or on a reasoned conclusion based on intelligence and taste. Goodhue's exceptional genius enabled him to act on both.

In the art of easel painting, landscapes of the older schools recall to us Nature's happiest or most dramatic moods. Portraits depict the beauty or character of their subjects. Time alone will tell how departure from these ideals by certain painters of the present day will finally be judged by the public.

It is unfortunate that the differing viewpoints of these various schools of art have created so much feeling. Newspapers and magazines have been replete of late with articles written by adherents of one, condemning the work of another, and often in no uncertain terms. That kind of criticism cannot help the cause of art. The public looks to art for an uplift of thought,

and when artists are in disagreement among themselves bringing their differences before the public in such ways cannot contribute to any kind of betterment.

In the colleges of today, instructors who are adherents of one or the other school should not impose their viewpoints upon students. Differences of opinion regarding art are inevitable and students should know that they are free to form their own tastes. This point is brought up because in some private schools today students are helped along in reaching conclusions which, outside of the schools are not those of the majority. We do not instruct pupils in political economy what presidential candidate to vote for, and neither should we tell those studying art whether the work of Goya is better for their taste than that of Abbey. The point is important too because the life of art is dependent fully as much upon a patron class as upon artists, and the former in embryo constitute a portion of those receiving instruction in schools.

The extent to which artists themselves should be controlled in their work is a matter deserving some attention. There have been those engaged in WPA or U. S. Treasury Department mural projects who, we are told, were communistically inclined and looked forward to the time when a revolution in America will upset the existing order of things. They have been inclined to do what they could to incorporate in the subject matter of their paintings ideas that would further that end. To prevent such things from happening well chosen committees should pass upon all preliminary sketches for such work and also upon final results. In the case of WPA work this can be and is being done to a certain extent by civic art commissions, but in Treasury Department work if reports are correct there is room for improvement.

What we need more than anything else in art is a more widespread appreciation of its benefits by all classes and especially by the patron class. We have no clergy to initiate and support art projects to any such extent as was done in the middle ages—nor any princes or kings—so we must rely upon private initiative. Fortunately there is much promise in this.



**NEBRASKA STATE CAPITOL  
Sculpture Detail by Lee Laurie**

Robert Watchorn, the erstwhile emigrant and miner, when asked if he would give \$25,000, to a worthy building project, answered, "I will give \$250,000!" Arthur Fleming gave \$4,000,000 to the California Institute of Technology and left for himself scarcely enough to live on. Andrew Mellon, as we all know, left his countrymen a fifteen million dollar art gallery and a collection of pictures far exceeding that in value—but we will have more to say about that further on.

Even when money is apparently not available the cause of art is not hopeless. In 1897 Milwaukee wanted a soldier's monument. A resourceful woman, by means of an ingenious and systematic method, obtained the autographs of prominent people all over the world accompanied by a sketch, verse, or other insignia characteristic of their vocations. These were bound in a handsome volume and sold at auction. Mr. Gustave Pabst paid \$30,000 for it and the monument was built.

Business is realizing more and more that art is an aid to salesmanship. Frank Bowers made fifty sketches for the screen production of "Gone With the Wind" but alternated these with murals for automobile salesrooms, sandwich shops and cocktail bars! Hugo Ballin, who has been associated as an artist with over one hundred screen presentations, has also done splendid murals for the Los Angeles Times building and other business institutions.

Great responsibility lies with the architects. In the case of public buildings it has been wisely said, "The general public does not discriminate where architecture leaves off and decoration begins. If you (the architect) have mediocre decorations in your building the public will pronounce the building mediocre. If you have outstanding decorations they will say it is a masterpiece!" That is just about true! And since the public does not know what kind of decorations should go in public buildings, nor how much to allow for them in the budget, it is the architect's opportunity and also his duty to see that the right appropriation is allowed and the right kind of decorators and sculptors are employed.

Geography or race we cannot see having any appreciable effect upon our art. Modern

transportation facilities make it too easy to get from place to place. For the same reason we cannot see the development of a distinctively American style. If it were good it would immediately be copied abroad, and if it were poor it would not long prevail here. What we need to strive for is simple, unaffected beauty as the outgrowth of natural conditions, and it seems to us that then style will take care of itself.

If our homes and our public buildings were all objects of great beauty and we stopped at that, there would still be missing a vital factor which contributes greatly to happiness, namely music. From an old picture postal card mailed at Budapest I read: "The blue Danube is flowing past my window. All night, when both shores are illuminated, gypsy bands play on the water. Wherever you go you can hear such a band and for a few coins they will play almost any tune you ask for." In Venice a man walking through the streets and over one of the bridges sings at the top of his voice, utterly unaware of doing anything that might seem strange to another. In Paris, in times of peace, one may sit every day at an inexpensive restaurant in the Palais Royale and listen to a band playing in the court outside. And so, the world over, we find lovers of music. Because of this wide appeal America, like other countries, has had to make provisions for public music. Forty years ago there were no public concerts to speak of west of Chicago, and music in the schools as an accredited study was then unthought of. Now all that is changed. Free public concerts have become a common thing in most of our large cities. All public schools and junior colleges have their courses of music study; many include the teaching of violin, piano, music appreciation, theory and harmony. Almost all schools of any size have their orchestra, band and chorus. It is safe to say that this development is now general throughout the country. Also, musically inclined people used to look to Europe for advanced education—now we take the lead. Professorships in music are established in all the principal colleges and universities; and degrees given out that are akin to those of the sciences. There has also been very widespread improvement in music

appreciation through the use of the radio and from musical screen productions. The whole trend has been to raise the standard of music in school, home and university life.

In attempting to say more about the new National Gallery of Art in Washington, D. C., the gift of the late Andrew W. Mellon, we are confronted with difficulty because of the vastness of the subject. As the Baltimore Sun once put it, "both the building and the art treasures it contains can be described only in superlatives!" "The largest marble edifice of its kind in the world!"—"eighty million dollars worth of art housed in the building at the outset!"—"the Mellon collection alone appraised at \$50,000,000! Add to this the Samuel H. Kress collection, pronounced one of the greatest private assemblages of Italian art in existence!" These are some of the superlatives, but even they carry us only so far. The building has been pro-

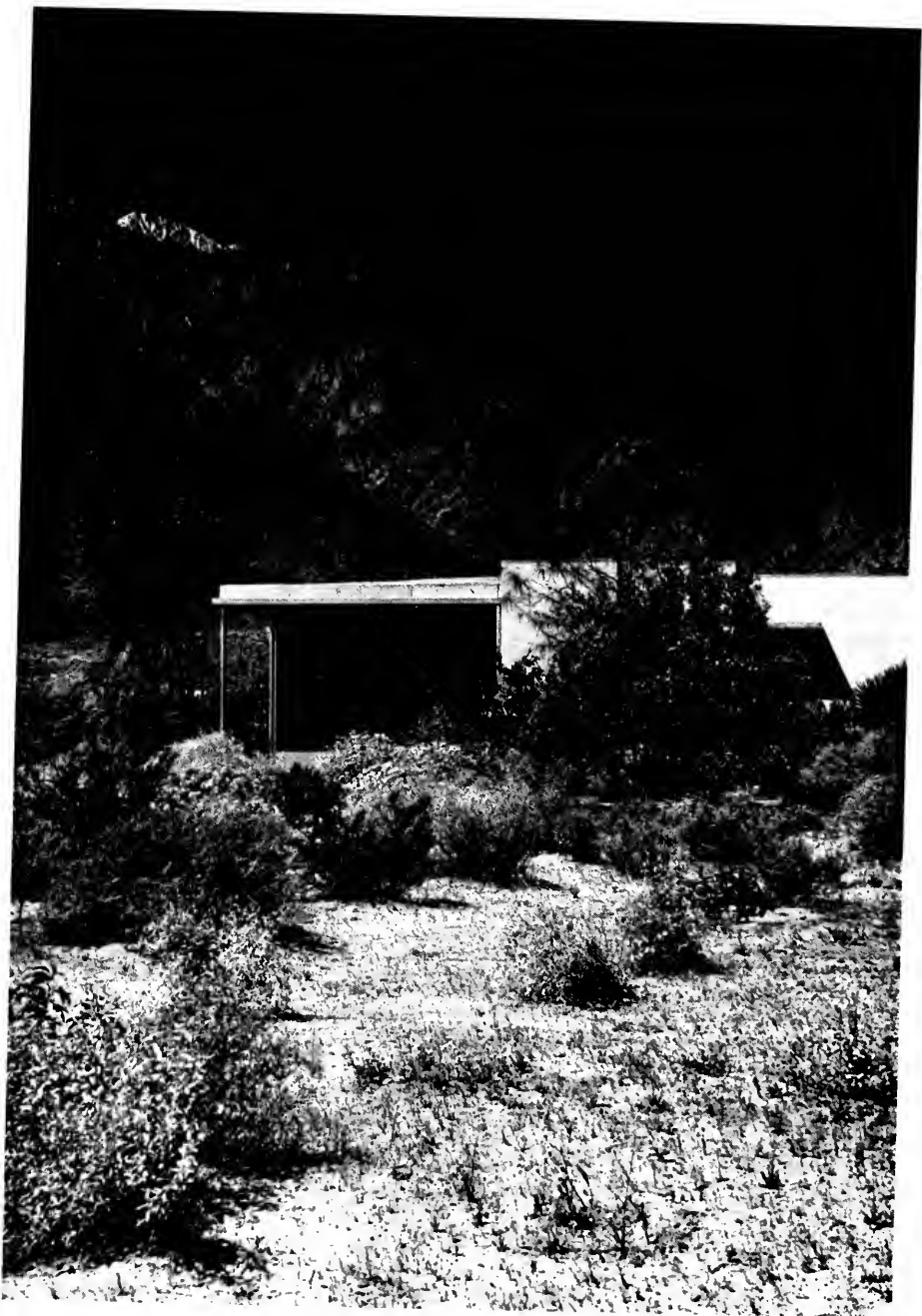
nounced by competent critics to be a masterpiece in design, a structure as noble and inspiring as the wealth of pictures it contains. Its architect was the late John Russell Pope and associates. Mr. Pope died in 1937, just twenty-four hours after Mr. Mellon expired! Since then the work has been carried on by his associates, Messrs. Otto C. Eggers and Daniel Paul Higgins. That a man of Mr. Mellon's extremely practical mind should have allotted such an enormous sum of money to an institution of that nature constitutes the very strongest possible testimony that could be offered for the value of art in the community. What the building and the pictures are really like can only be appreciated by seeing them. We can only hope here to create a desire for that experience. All who realize it will, we know, be proud of being Americans because America no longer need look to Europe for a Gallery of Art which ranks among the greatest in the world.



**NIGHT LIGHTED POOL AND SCREEN PORCH, HOUSE IN PALM SPRINGS, CALIFORNIA**  
(exterior on next page)

**Richard J. Neutra, Architect; Peter Pfisterer, Collaborator**

The living room, built on a 'quake proof concrete slab on the ground, opens onto the porch with a sliding glass steel frame door



**PERSPECTIVE, HOUSE IN PALM SPRINGS, CALIFORNIA**

**Richard J. Neutra, Architect**  
**Peter Pfisterer, Collaborator**

# DEFENSE HOUSING IN SAN DIEGO

**One** of the nation's largest defense housing projects is taking concrete form at Kearney Mesa, San Diego, better known as the Linda Vista Project. Some idea of its size may be had from the statement that there are 3,000 housing units involved, with 1200 acres of ground reserved for development. The site was chosen for its natural advantages as well as its accessibility to aircraft industries and "downtown" San Diego.

All of the houses have been placed so that

each unit may share the beauty of the natural vistas. West view from the project is the ocean. On the south is San Diego Bay and the city itself. On the north and east are the San Bernardino Mountains.

The main axis of the project is two miles long and follows the north-south ridge of the plateau. The strip utilized for the housing is a mile wide. Land areas west, south, and east surrounding the site are too steep to encourage encroachment of speculative developments



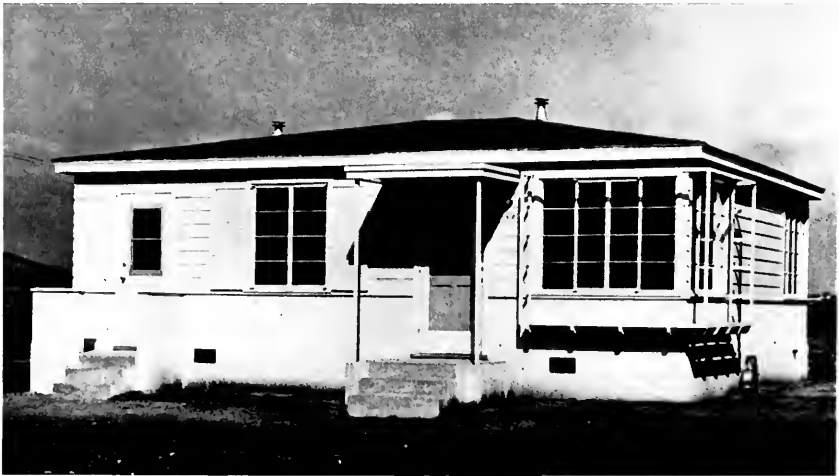
**Air view of huge defense housing project at San Diego, California. More than 1700 buildings will house 3,000 families of industrial workers employed in nearby aircraft plants.**



**One of the completed two family dwellings**



**Progress picture of 5,000,000 gallon reservoir for water supply**



**One of the completed single family dwellings**



that would endanger property values and cause blight.

The gently rolling topography of the site made it possible for the planners to avoid a regimented house plan. Main circulatory roads follow the general contours and form super blocks. Access to units within the blocks is made by local streets and cul-de-sacs. Kearney Mesa soil is shallow and through skillful planning the amount of cut and fill necessary in the allocation of houses was held to a minimum.

Site development will include a commercial area located in the geographical center of the project. Plans now in progress call for stores, theater, receiving hospital, administration buildings, and maintenance shops. Other facilities needed by this 13,000-person community and to be provided for by the government on other locations within the site are:

Three thousand housing units, with individual overall dimensions of 24 by 30 feet; large living rooms with dining alcove; kitchens completely furnished with stove, sink and washtub, electric refrigerator and metal storage cabinets. Bathroom and kitchen floors will be covered with linoleum. Bedrooms will contain generous closet space. House heat will be supplied by circulating gas heaters.

For the first time in such a major project, the best oak hardwood flooring is being used throughout. The houses are of wood frame with exteriors of sturdy and lasting redwood, or of the best stucco that is available. Low pitched roofs are covered with asbestos shingles. Spacious windows have steel sash. Interior walls are mostly plastic, some of them having an interior stucco finish.

To accomplish the tremendous task of building a community for 3,000 families in a contract period of 300 calendar days, the McNeil and Zoss construction companies adapted mass production methods. Speed and economy were effected by the purchase of materials in large quantities and processing them in a system of shops at the center of the project. Many parts of each building—wall, flooring, ceiling sections, plumbing units and standard electric systems—are pre-fabricated before being trucked to house sites. There they are quickly

assembled by crews of workers each of whom has become a specialist in one phase of the assembly. This system became effective to a point in production so that 40 houses could be completed each working day.

The immensity of the project is indicated by figures which show that it is requiring 45 miles of water and sewer pipe, 24,000,000 board feet of lumber, 24,000 doors, 20,000 lighting fixtures, 2,500,000 square feet of the finest hardwood oak flooring, 96,000 gallons of paint, 315,000 pieces of glass, 810,000 square yards of lathing and plastering, 3,500,000 square feet of roofing and 20,000 kegs of nails, weighing more than 2,000,000 pounds.

---

### N.B.C. BUILDING, SAN FRANCISCO

(Continued from Page 26)

include sound effects room, two script conference rooms, musicians' room, artists' lounge and the necessary store rooms, lockers, service lobbies and wash rooms. Freight elevator and second stairway will be at the rear of the building, available from O'Farrell Street.

Visible from the foyer of the third floor will be the master control room directly opposite the elevators. To the left will be the radio recording room while at the right will be studios H and J, used chiefly for the presentation of transcribed programs.

Also on this floor will be offices for the division engineer, supervisors and secretaries, the equipment room and engineers' lounge, music rights, music library, continuity acceptance department, typing, mimeographing, Thesaurus library, record audition room and record vaults.

Announcers, writers and producers will share one large room on the O'Farrell Street side of the third floor while at the rear will be the telephone switchboard, photographer's dark room, supply and locker rooms.

Administrative offices will occupy the fourth floor. These will include the general manager, sales manager, program manager, press manager, sales promotion, their staffs and secretaries. The educational and agricultural department, clients' audition room, kitchen, mail room and general files also will be on four and an office will be reserved for visiting officials.

# STATE ASSOCIATION CONVENTION

The Fourteenth Annual Convention of the State Association of California Architects was held at the Hollywood - Roosevelt Hotel in Hollywood October 9, 10 and 11 with a record attendance from the South and a very fair representation from the North. Round table discussions brought out some interesting reports on "Public Relations" and "Defense Projects." Norman Blanchard, chairman of the Northern Section Public Relations Committee, submitted an interesting report on "Public Relations and Radio." The following is a summary prepared by Mr. Blanchard for the press:

"A number of architects' organizations throughout the country are working out public relations programs and several programs are now in operation. The question of finance—how much money is required and in what ways can it most beneficially be spent—is, in all cases, a paramount issue.

"Publicity, whether through newspapers, radio, exhibits or bulletins is valuable and all of these media can and should be utilized to insure a well-balanced program of public education. Several architectural groups are concentrating on the use of radio and some of these are undertaking paid programs.

"This raises a thorny question of (1) finance and (2) professional policy, as our own experience shows. Last year the State Association of California Architects, Northern Section, undertook a paid radio series with a leading San Francisco station. The series dealt with house design, planning and construction, and was named 'What, No Architect?' Our original budget for a 15-minute broadcast, given each Sunday, was \$150 (radio time, talent and mailing (but excluding clerical work and stationery). Each of our members was asked to contribute \$3.00 a month to meet operating costs.

"As our series developed, costs rose rapidly to a figure of \$180.00 a broadcast. We found that we could not possibly maintain this rate of expenditure without running into debt. The burden on our contributors was too heavy, and

yet to give the program variation, additional expense was inevitable. So, before our funds ran out, we cut expenses and concluded the series with an eighth and final broadcast. We had spent a total of over \$1,200.00 in eight weeks.

"It is true that a number of inquiries or business 'leads' developed. These were 'valued' at \$400,000. Unfortunately, several architects to whom these leads were distributed did not follow them up and those who did proceed further failed to achieve any practical result.

"At the same time, the series did arouse considerable public interest in a general way and this encouraged us to continue with our public relations work, though along different lines. We now know that paid radio does not suit the budgets of not too affluent professional groups, though it may suit those of commercial sponsors. We also know that we could have achieved a great deal more for that expenditure of \$1,200.00.

"Under our present public relations program, we employ a professional publicist who aids us in working out a program of public activity (planning, civil defense, etc.), secures publicity for our exhibits, meetings and statements on civic and national affairs, and arranges broadcasts in which our members appear as guest speakers on sustaining radio programs.

"These radio discussions cost us nothing apart from the effort involved in arranging material, as they are of a strictly educational or 'general interest' type. The Architect participating is accepted by the station as an expert in his field. He does not have to pay for the privilege of speaking over the air.

"This is as it should be. The radio and press of Northern California have indicated they agree with us that architecture and the architectural profession are of sufficient public interest to merit this recognition.

"Other local professional organizations, including the American Institute of Decorators, Northern California chapter, hold the same view and enjoy similar privileges with local radio stations. They consider that it is unprofessional for a non-commercial group to employ paid radio and that the fact that a broadcast is paid for makes it a 'commercial' rather than an educational feature. 'After all, we're not in the same category as soap and soup manufacturers,' said one professional man. 'We can expect better consideration than that.'

"In the past four months our members have participated in 12 general interest broadcasts given over the three major networks. These broadcasts have covered various subjects such as women and architecture, architects and defense, exhibits of residential work (we had four broadcasts for one exhibit), house design and community planning. Women's afternoon sessions are specially utilized.

"To secure better representation for architects under the defense and post-defense program, we are laying special stress on the architect's complete function in national preparedness. In recent weeks, we were invited by the Office for Emergency Management (U. S. Government) and the California State Council of Defense, to aid in presenting an air raid shelter exhibit, first in Sacramento, the State capital, and later in other California cities. Defense officials have arranged a complete radio and press publicity program for this exhibit, with due credit to our association as co-sponsors. At the same time, we are involved in no expense apart from the contribution of our services as technical experts. More than 170,000 people visited the exhibit during the eight days of its presentation in Sacramento.

"Our present public relations costs, including publicist's fees and office expenses are only one-third of our last year's budget for paid radio and we are getting a far wider spread of activity. At this rate we can continue to pay our way—which after all, is important. We are asking members to contribute a minimum of \$1.00 a month each to the program;

present contributions are slightly above this average.

"As our funds develop, we plan to spend moderate sums with newspapers and radio in paid announcements for exhibits, forums, etc. But these will be occasional and will come within the category of 'special events.'

"Our experience is paralleled by that of several other professional organizations which have undertaken paid media on a continual basis. Radio is a valuable instrument if utilized in the right way and in accordance with our professional standing. But attempts to achieve the financially impossible will, if persisted in, inevitably lead to disappointment, indebtedness and the discouragement of future effort.

"We realize that problems resulting from years of neglect by our profession cannot be solved within a day. We do not expect any staggering results from our activity; our program is not a sales drive. Our real concern is to build up a long-range public relations program which will be financially solvent, will be of lasting value and will have the confidence of our members, of the building industry and the general public. We are confident that this can be done."

"Defense Projects" was the subject of an interesting and informative talk by Colonel Edwin C. Kelton, U. S. A., who confined himself largely to "The Design of Airports."

Friday's business session was conducted by President Fred Reimers. Samuel Lundeen led a discussion of the subject of "Priorities and the Effect on the Profession." Others to join in were Earl Anderson and Neil Haggerty, the latter Priorities Director in the Southern California District. Cedric Gibbons discussed "Architecture in the Motion Picture Industry" and again in open forum "Defense Housing" was outlined by Eugene Weston with remarks by Commander Godwin on "Defense Construction."

## STATE CONVENTION

President Walter R. Hagedohm's annual report follows, in part:

To All Architects:

The year just passed has brought the greatest

changes the world has ever known. In a much greater proportion, perhaps, than any other business or profession, has architecture run the scale of ups and downs. Many who have been working on government projects, either as architects for the whole project as a practicing architect, or on a salary basis, have been well taken care of, and have had their most prosperous years since the roaring twenties. Likewise, those who have tried to keep busy on private work, small homes and other work, have suddenly found themselves without real work and business to carry on.

The policy, therefore, of the State Association of California Architects has been a flexible one. A policy which has striven to keep up with the fluctuations of the times, and to fit in with the program of all our defense with which the country has been concerned. That the architect, with his special training as a planner, as a designer, as one who takes all conditions into consideration, is a valuable asset to the governmental agencies, goes without saying. Without doubt, many who are now practicing architecture will find themselves engaged in very different pursuits in the near future. How many will be engaged in the practice of their chosen work will depend to a large extent, first, on how well they are equipped to handle the vast defense work problems, whether it be in housing or other branch of military construction, and secondly, it will depend upon how this Association, with the unanimous support of all its members, will make it possible through state and national bodies to bring before those in authority the value of the architect.

The time of great crisis is especially one in which we, as an organization, should bind ourselves closer together. Put our own houses in order. Be prepared! Have something to offer, and then let the world know that we can do things!—Do the things that are necessary for successful carrying out of the government's plans.

During the past year the State Association has been active on many fronts.

While it was agreed upon between the Northern and Southern Sections that no legislation would be introduced at the last session of the State Legislature, we found ourselves confronted by the necessity of going into a fight to retain the laws, weak as they are, we now have for the registration and the qualifying of architects.

While the Association had no money to spend on these activities, it was fortunate in having willing and unselfish members who gave of their time and money to aid in defeating this legislation. We received a great aid from the other professions, the medical, the dental, and the bar associations. This aid was given after careful consideration of our problem, and it is a recommendation of your president that this pleasant relationship, so auspiciously begun, be continued. The members of the Association, both North and South, answered the plea of your Legislative Committees

and wrote to the members of the Senate and Assembly. For the first time our numbers began to be felt. It is recommended that for the following year the Legislative Committees, both of the North and South, work together on a program for legislation to be presented the next Legislature. It is recommended that in arranging for the due for the next two years, that a certain amount be budgeted as going to legislative costs. We were fortunate this time, but next time, those who opposed us and who have felt our strength will make better plans to obtain their end. So it will be well for us to be even better prepared than they. To do this requires money, it requires a representative who can look out for our interests, not only in the bills we present, but much more important, the bills which others present, with jokers in them detrimental to the profession.

The Professional Betterment Committee has carried out a program within the organization that has been one of the mainsprings of progress. The effort to bring an end to plan signing, poor construction, and helping in the prosecuting of those trespassing the law to practice, was one which produced results. The survey covering a period of twenty years, which was made to bring out just exactly what has happened to the profession of architecture here in California, particularly in Southern California, brought out facts which we can now use to put our own house in order. The fact that the average age of the practicing architect has risen from 42 to 54 and a fraction in twenty years, and that the new blood entering the profession each year is less than three per cent bodes ill for our group, means that we must look more closely into the education of the architect in the schools and his acceptance in the ranks of the public. We must bring him into more direct contact with the practical side of architecture, make him better equipped to take up his work immediately after securing his degree; making it possible, in other words, to secure his practical training while securing his theory and design. In turn, the State Board of Architectural Examiners must work out an arrangement whereby they have a more direct policy for the registration of architects. A policy that will encourage the younger men to enter the ranks of the profession, instead of practicing as "architects without portfolio," or becoming a member of a plan factory instead of working with the architect.

Probably the greatest advance has been made in the direction of educating the public to the use of the architect. Public Relations—or our relations to the public—not only to our clients or prospects, but the material dealers, the contractors—to the man in the street—and last but not at all least, our relations between the brethren of the profession is of vital importance. In fact, public relations enters into the work of all the committees formerly mentioned. The effect of the programs inaugurated in the North and South were definitely felt in our legislative effort. In civilian

defense, the display of the bomb-proof shelter in San Francisco and Sacramento, and the active participation by members in both sections on the State and County Civilian Defense Councils are part of public relations.

In the Northern Section a well rounded public relations program has been developed, and is being carried on with continuing effectiveness. Press notices are becoming more numerous. Architects are asked to take part in public affairs, broadcasts—lectures—etc. In the Southern Section the first year on the air was concluded—speakers' bureau members lectured at schools, colleges, libraries, department stores—colored slides were shown in illustrated talks—series of newspaper articles were written in local as well as eastern papers. Stories regarding the profession on items of interest to the public have been set up in press releases for all papers in the various communities. These programs are live—growing—actual happenings. We know that thousands of people have a better understanding of what an architect is, what he does, and why he is necessary to the public. We have also found that the architect is not always equipped to give the public the service he should be able to, as a certificated architect. We also have observed that the architect is not always conscientious about his work—and in fact—sometimes most impolite.

If the radio program of Southern California had done nothing more than arouse the national interest it has aroused, and crystalized the wordy discussions into action as it has—it has more than served its purpose for the profession.

During this past year, the Association has been active in working with the Southern California Chapter of the A.I.A. at its convention activities. It has co-operated at every opportunity. The Association in both sections has been active in working with all governmental agencies, city, state, county and national for the benefit of the public and the profession. It has at numerous times offered its services to the President of the United States in any capacity where it members could be of service—likewise to the Governor of the State.

Whenever individual architects have encountered difficulties, it has endeavored to help them out with these governmental agencies, through committees or directly through your president or board. Being an organization with a different motive than the individual, the Association, besides carrying the weight of numbers, has a better ground on which to discuss the problems which concern the profession as a whole, than the individual. It is, therefore, recommended that members present their problems dealing with various governmental agencies to their district boards, who will gladly work with them.

In all this the shoulders of the Association always seem broad when difficulties beset us—but let us not forget to take part in and support all the activities of

the Association—so that when help is needed the Association will be in a position to really do something. An organization is as strong as its members. The usual excuse is lack of time—still it's a very true saying, "If you want to get a thing done—give it to a busy man to do!" So help out willingly, make the load lighter for your officers and executive boards, and they will be able to increase the service to you a thousand fold.

In order to make architecture a household word, and good architecture appreciated, we must humanize it. We must make it easier for the layman to understand through our own actions and work—through becoming more human ourselves.

It has been a pleasure to work with the officers, committees and the individual architects during the past year. Their co-operation has made the work worthwhile. Many things have been accomplished—but there is still so much to be done that we have hardly made a dent in it. During these next months it is going to be more necessary than ever that the architects unite as one group. These times will not last forever—things might change quite suddenly—and we, as a profession, should not be caught napping. Let us, therefore, face the coming year with a unity of purpose and desire to be of service to the profession, to our country, and to the public. May we continue to advance.

Respectfully submitted,

Walter R. Hagedohm, President.

#### CO-ORDINATING COMMITTEE REPORT

The following report was submitted by the Co-ordinating Committee, Robert H. Orr, chairman:

The appointment of this committee by the president was the result of numerous complaints being made to the State Association when the public became more conscious of the architectural profession through the publicity of the radio.

Its purpose was to adjudicate disputes between architect and owner in an amicable manner and to co-operate with the State Board of Architectural Examiners in matters which appeared to be within their jurisdiction to handle. The committee had no power of its own other than to hear both sides of a disputable nature and make a recommendation to the parties involved.

Twelve formal charges were made in writing to the State Association, Southern Section, involving architects and their methods of practice. Ten of these were examined by the committee, both sides were heard, and the committee's recommendations rendered.

One case was ignored by the architect, and no decision was reached.

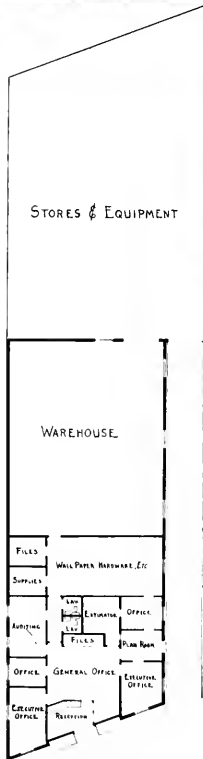
Two cases were referred to the State Board of Architectural Examiners. One of these was prosecuted and the defendants found guilty and fined \$50.00 or 10 days jail sentence.

One case, which has reached the stage of going to trial, was referred to the committee by the court for arbitration, and the committee's findings were approved by the court.

Two cases are yet pending settlement and both seem in a fair way to be settled upon the recommendation of the committee.

In addition to these formal cases, there were many that were received over the telephone and the parties advised that their complaint had no fundamental foundation to base charges upon and they would have to make the best of their misunderstanding.

# BUILDER OF FINE RESIDENCES IN NEW HOME



**Having** established an enviable reputation as builders of better type houses in the exclusive residential districts on the San Mateo Peninsula, the G. W. Williams Co. faced the necessity of constructing a home for itself that would not only reflect the company's standing in the community but would enable it to better serve an increasing clientele. The building illustrated is the answer to the aforementioned needs. Pictures show a general view of the exterior, one corner of the general business office and a plan.

Designed by Chester Root, architect of San Jose, along modern lines, the building is located at 10 California Drive in close proximity to the residence districts of Burlingame and San Mateo. Attractive from the outside, it is equally interesting and pleasant within. All of the interior walls and partitions are lined with Firtex to insure good insulation and sound deadening. From the general business office in front radiate smaller rooms, including President Williams' office, superintendent of construction, estimator's, blue print and consulting rooms, and in the rear is a commodious warehouse for storage of building materials and equipment. Structurally the building is fire proof and quake resistant. Walls are reinforced concrete. The building is well lighted, heated and air conditioned.

# CAMDEN PLAN AND ITS POST-WAR POSSIBILITIES

**Much** is being written about the Camden Plan, a new approach to the rapid and efficient construction of defense houses. It provides for the building of prominent homes in stable communities, thereby relieving the immediate shortage and looking forward after the emergency to demolishing not new homes but old slums. The California Housing and Planning Association has indorsed the plan which is described in the organization's official paper "Agenda" as follows:

The Camden Plan is one of the most significant developments in American housing, perhaps also a significant development in American culture. It is what Americans, long divided fifty-fifty between owning and renting, have been looking for—a system with the advantages of both, the drawbacks of neither. For the Camden Plan of cooperative housing—or "mutual housing," as its originator, Colonel Westbrook terms it—provides for the flexibility of renting and the incentive of ownership. And in addition something neither system has offered most people, good site planning.

Because the Government has furnished the initial capital for the Camden project, it is not a true cooperative at present. It is a combination of the housing cooperative idea—which has worked so well and widely in Europe, especially Sweden—and the well-known American mutual insurance system. Needless to say the experience of the USHA in designing and maintaining large communities has also been utilized.

The Camden Plan represents a serious attempt to save Americans from re-traveling two roads that turned into blind alleys. One of these roads we raced along in the twenties pursuing the "own-your-own-home bubble" which finally burst and disappeared beneath a sea of mortgages. FHA has lately resurrected this dream like Venus from the sea, but the fact remains that home-ownership is essentially costly and inflexible for most industrial workers and middle-income white-collar workers. The other road was the "road back" from the last emergency when the Government dumped its housing on the open market and the whole huge, costly effort was thereby wasted.

The idea behind the Camden Plan was revived a year ago after John Green, President of the Shipyard Workers' Union, testified before the House Lanham Committee describing the housing shortage, "extortionate rent increases in a rapidly-shrinking market," and the necessity of a sound housing program. Colonel Westbrook, working under John Carmody of FWA, contacted Green and Audubon Village, first of the Camden Plan projects, was the result. Fully occupied already, Audubon Village contains 500 families in three-, four-, and five-room houses. There are no down payments on them and monthly payments range from \$21.50 to \$33.50. Through careful maintenance and minimum vacancy losses these payments can be re-

duced by 30 per cent at the end of the second year. No other housing scheme so encourages and rewards the initiative of the occupants.

John Green's union has long been actively interested in housing. One of the reasons was Yorkship Village, one of the few good housing projects built by the Government during the last war, which is also at Camden, New Jersey. Green headed the first real local labor committee on housing, which was started in 1934 and persisted as a unified labor committee even after the AFL and CIO split.

The Camden Plan is operating under the Lanham Act at present, which means that the occupants must be workers in defense industries. The entire Government investment is to be repaid by the occupants, probably in twenty-five years. This plan is so much the best development to emerge from the confusion of defense housing that it is surprising that more projects are not under way, even though its application does have limitations. Source of the delay has been partly a naive faith in the beguiling charms of Title Six and partly real-estate's opposition, not only to cooperative housing but to all permanent housing. Charles Palmer, Coordinator of Defense Housing, has thrown his weight on the side of the real estate boys and has opposed the Camden Plan.

The real estate ideal is to delay until there is a housing shortage, then build only temporary homes for defense migrants, and after the emergency tear these homes down, leaving the real estate market as before.

The Camden Plan as adapted by FWA, is an attempt to build permanent homes in stable communities, thus relieving the immediate shortage and looking forward after the emergency to demolishing not new homes but old slums.

It is thus more than a mere emergency measure, and it is usable not only by labor but by many other groups. A large scale building program after the war of low-income housing by USHA and middle-income housing under variations of the Camden Plan could prevent depression, wipe out slums, and raise the standard of living.

Richard Neutra, architect for the Camden Plan Project in Dallas, Texas, says:

"The government low-rent housing projects have stimulated large-scale site planning and skill, in contrast to the speculative subdivision where strings of disjointed ownerships are sold. In the latter community facilities can rarely be provided and even the smallest playground for a little company of toddlers creates almost unsurmountable maintenance problems.

"Now comes Colonel Westbrook's Camden Plan projects, offering the advantage of large-scale site planning plus the incentive of ownership. This ownership is

qualified, for it holds no promise of speculative profit, but it is enriched by a most valuable neighborhood control.

"I had the opportunity to join Colonel Westbrook in his original and persistent effort, and, consulting with David Williams, developed the site and unit plans for a project in 1938. The psychological significance of this **mutually insured and mutually conditioned ownership** with control and enjoyment of community facilities—day nursery, shops, pools, playgrounds—filled us with enthusiasm."

Catherine Bauer, in her basic research work, has shown early European precedents for this urge to extend dwelling benefits beyond the enclosure of the unit and the boundaries of the individual ground allotment. Colonel Westbrook's Camden Plan is in this tradition and was from the beginning not merely a financial set-up but was born with its own architectural physiognomy.

### PROCEDURE FOR PRIORITY ON SCARCE MATERIALS

This proposed plan is to be used in securing a steady flow of necessary materials for building construction, repairs and remodeling essential to defense and will apply only to sales which can be identified as necessary to a defense area.

When the distributor finds it impossible to obtain a particular material he shall proceed as follows:

1. Make an analysis of sales for the ninety-day period prior to the request for priority number and determine as accurately as possible the percentage of item or items going into construction, remodeling or repairs essential to a defense area.

2. The distributor shall file with his request for priority number the estimated percentage in sales together with a statement of the amount of stock on hand, and an estimate of the amount of the essential material required for the next ninety-day period.

3. Each distributor shall maintain a record of sales classified as necessary to a defense area, such records to be open for inspection by any person designated by the Federal Government, and the percentage of necessary sales in each three-month period shall determine the distributor's rating for the next three-month period.

4. Should there be any question as to the need of essential materials ordered, the distributor shall require his customer to furnish a signed statement showing the location and kind of building, its use or proposed use, so that this information might be available to the Priorities Division.

5. In the case of a distributor who sells for re-sale and finds it necessary to secure a priority number on any item or items, it shall be necessary for the distributor to obtain signed statements from his customer giving the percentage of their sales going to necessary or defense construction, and such statements submitted by the customers shall accompany the distributors' request for priority number.

6. After a priority number is issued to a distributor, he may extend such priority number to his supplier, who may in turn re-extend such number to his source of supply for securing materials.

7. In order that a definite record of the materials from the manufacturer to the job may be available, any supplier or distributor who thus extends a priority number and preference ratings, shall keep such records as may be required by the Priorities Division.

8. In case a distributor finds, after making his request or estimate of goods required for the next ninety-day period, that such request or estimate will not cover his requirement for that period, he shall execute an interim report for the materials, sending it to the proper authority with a full letter of explanation.

### HOMES FOR DEFENSE WORKERS

One thousand four hundred and thirty-six additional homes for the families of workers in defense industries and enlisted personnel and civilian employees of the Army and the Navy were reported as available for occupancy September 5. This makes a total of 22,373 homes made available for occupancy under the FWA defense housing program.

In addition to the homes occupied or made available for occupancy during the month, contracts for 5,152 more dwelling units were reported, making a total of 71,709 presently under contract. Summary of buildings completed, occupied or under contract:

Homes made available for occupancy.....	22,373
Homes occupied .....	16,320
Homes under contract.....	71,709
Total estimated project cost of homes under contract .....	\$278,117,979

As of September 5 a total of 91,873 homes had been approved for construction.

### NEW MAGAZINE(?)

Washington State Chapter of Architects has been asked to endorse a new architectural publication to be called *Western Architecture*. It is to be launched by the publisher of a skiing paper in the Northwest. The plan is to issue a bi-monthly magazine, this in the face of the fact that most of the existing architectural journals are having their troubles coming out once a month, let alone twice. Oregon Chapter, too, has been asked to endorse the paper.

Features of the October 2 meeting of Washington State Chapter were addresses by William D. Shannon on "Priority" and John D. McLaughlan on "Community Fund to the Defense Program."

### ON THE SCREEN

Architects, interior designers and others concerned with the home building and furnishing field will likely be interested in seeing and using the new sound-color motion picture entitled, "American Walnut," which has just been released by the American Walnut Manufacturers Association.



# WITH THE ARCHITECTS AND ENGINEERS

## ARCHITECTS AND CIVILIAN DEFENSE

Details of a nationwide organization which will enable America's 17,000 architects to participate directly in civilian defense were made public recently by Frederick H. Reimers, president of the State Association of California Architects, Northern Section.

"The organization is being formed under the direction of Fiorello H. La Guardia, U. S. Director of Civilian Defense, and Richmond H. Shreve, president of the American Institute of Architects," Reimers declared. "Seventy-one Institute Chapters, 22 State Associations affiliated with the Institute and other architectural groups will participate in the movement.

"Horace W. Peaslee, chairman for the Air Raid Protection Committee of the Washington, D. C., Chapter, American Institute of Architects, has been appointed to head the program. With him will be named nine regional directors corresponding with the regional directors of Mr. La Guardia's program, and local architects' committees to work with state and city defense councils."

Reimers said that California architects are already forming committees to work with civil defense councils in San Francisco, Oakland, Berkeley, San Jose, Fresno and Los Angeles.

The State Association of California Architects is meanwhile planning a series of civilian defense exhibits in cooperation with the California State Council of Defense. The first of these, a comprehensive air raid shelter exhibit, was presented at the State Fair, Sacramento, recently and was viewed by 175,000 people.

## FOR ARCHITECTURAL DRAFTSMEN

Classes for experienced architectural draftsmen began functioning at the University of Southern California with the opening of the fall quarter, September 22.

Roy G. Johnston, University lecturer, is teaching the course, "Architectural Engineering," classes being held each Monday from 7 to 9:20 p. m. in room 103 of the Harris College of Architecture and Fine Arts Building.

The course is a study of the general principles of mechanics, strength of materials, and graphic statics, with problems in structural design involving wood, steel and reinforced concrete.

Four courses in architectural design, one in the history of architecture and one in "Estimating and Construction Costs" also are on the University College curriculum in architecture for the fall quarter.

## S. F. TRAFFIC PROBLEM

The city of San Francisco has engaged Messrs. Madigan and Hyland, New York, specialists in traffic and transportation problems, to study conditions in the Bay city and make a report on a master plan to improve the present situation.

## SEPTEMBER CHAPTER MEETING

The September meeting of Southern California Chapter, A. I. A., was held at the Clark Hotel, Los Angeles, with guests present including Al Martin, an absentee for some time. Murray Erick, structural engineer, spoke on government construction procedure. C. J. Haggerty outlined the position of labor and the great activity in public and private construction in this area. Mr. Haggerty is an enlightened spokesman and it will be men of his caliber who will solve intelligently the problems of labor.

Earl Anderson of the Construction Industries Division, Los Angeles Chamber of Commerce, presented a most informative picture of Federal priorities and production control in connection with construction.

Mrs. Purves, assistant secretary, was present, attending a Chapter meeting for the first time. It would be interesting to know what her reactions really were! William Pereira, affiliated with the Chicago Chapter, now connected with Paramount Studios, was also a guest.

## PERSONAL

Ivan W. Meyer, Seattle, architect, is doing his bit in the service with a rank of captain of the headquarters company, 66th Field Artillery Brigade, 41st Division, U. S. Army.

Francis J. Heusel has moved his office from the Kress Building, Long Beach, to 441 E. First Street, Long Beach.

Ralf E. Decker announces the opening of an office for the practice of architecture at 1411 Fourth Avenue Building, Seattle, Washington. Mr. Decker's college training was obtained at the Universities of Idaho and Washington. He will specialize in commercial and residential work, is associate member of the A. I. A.

## ENGINEERS AND ARCHITECTS DINE

Engineers and Architects Association of Southern California celebrated a successful year by holding a jubilee meeting at the Cabrillo Hotel, Los Angeles, the evening of September 25. A fine dinner preceded an evening of entertainment, which included moving pictures in charge of Samuel Hobbs, field engineer of the Portland Cement Association. There was also an educational film illustrating the Grand Canyon.

## JOINT MEETING OF CHAPTERS

The annual joint meeting of Oregon and Washington State Chapters, A. I. A., will be held on Mt. Hood November 15-16, Roi Morin, president of the Oregon Chapter, Portland, announced while in San Francisco recently attending a Federal Housing conference.

Spokane Chapter will also participate and Glenn Stanton of Portland will be master of ceremonies.

## ARCHITECTS REORGANIZE STATE BOARD

The California State Board of Architectural Examiners, which in the past has operated as two district groups, Northern California and Southern California, on Saturday, September 13th, took office as a single organization for the whole State.

Combination of the two groups as a single board consisting of nine architects was authorized by the State Legislature this year to assure more uniform procedure. Functions of the board are to conduct examinations, issue licenses and maintain standards of practice among California's 1200 architects.

The board will be limited to five members after 1945.

## ARCHITECT HEADS BUILDING EXCHANGE

At the Sixteenth Annual Convention of the California State Builders Exchange a resolution was adopted, very strongly favoring compulsory arbitration, and urged immediate State and Federal Legislation. The Exchange delegates felt that the best interests of the public are not served by strikes and shut down of production.

Officers for the new year are: Donald Beach Kirby, Orange County, President; W. T. Drury, Bakersfield, First Vice-President; Charles G. Connors, Fresno, Second Vice-President; William McGrath, Oakland, Third Vice-President; Harry Cayford, Fresno, Secretary-Treasurer; G. W. Bassett, Orange County, Secretary to the President.

The new president is a well known Southern California architect who has taken considerable interest in the Builders Exchange movement throughout the state. Kirby is also Secretary of the Southern California Chapter of the American Institute of Architects.

The Executive Board will consist of W. G. Thornally, Oakland; Charles W. Pettifer, Long Beach; A. H. Davies, Stockton; George Haddix, San Pedro; Roy Butcher, San Jose.

The 1942 Convention will be held in Bakersfield.

## COMPULSORY ARBITRATION FAVORED

At the recent convention of the California State Builders' Exchange, Ltd., held in Oakland, the following resolution was adopted:

"WHEREAS, it is apparent that in many instances collective bargaining has failed, and where arbitration has been refused, compulsory arbitration is advisable,

"THEREFORE, BE IT RESOLVED, that this 16th Annual Convention of the California State Builders' Exchange go on record urging the Federal Government and the State Government to pass necessary laws so that in these kind of cases we may have compulsory arbitration to settle differences so that the best interests of the public, the employer and the employee be served, and

"BE IT FURTHER RESOLVED that a copy of this

Resolution be sent to all Federal and State officials who are concerned with this kind of legislation."

## STEEL BRIDGE COMPETITION

The American Institute of Steel Construction announces another annual bridge design competition, open to bona fide registered students of structural engineering and architecture in recognized technical schools of the United States and its possessions, and offers three cash prizes of \$200, \$100 and \$50 respectively, for the designs placed first, second and third. Certificates, signed by a jury of award and officers of the Institute, will be awarded to the prize winners and to those whose designs are given honorable mention.

The subject of the competitive design is a steel highway bridge to carry a highway over a river crossing. The structure shall provide a clear width of 42 feet between curbs. Steel railings are to be provided of a total height above the roadway surface of 3 feet 2 inches. The axial alignment is on a level grade the full length of the structure. A vertical clearance of 25 feet above water level must be provided for a width of 75 feet at the center of the river, and a horizontal clearance at water level of the entire width of the river. The structure is assumed to be located in unsettled country and no provision for lighting is to be made. The design may be based upon any bridge type suitable to its purpose and location.

The student may assume that ample funds are available with which to build an efficient structure of good appearance, but no money is available for expensive decoration or masonry. It is suggested that appearance shall be obtained by a proper use of form. The structure must be of steel, including the railings, but not including the abutments. The piers may be of steel or masonry, or a combination of both.

The execution of the design must be entirely the work of one competitor. No other person may work on the design except to criticize and give advice. The drawing must be a line drawing in black ink only. The use of color is prohibited but shadows may be indicated in black ink or a monotone wash. Only one drawing is to be submitted by each student.

A jury of nationally known engineers and architects will judge the competition on February 18, 1942. Drawings must be received at the Executive Offices of the American Institute of Steel Construction, 101 Park Avenue, New York City, not later than February 10, 1942.

## NO MORE EXPENSIVE HOMES

From inside sources it is learned the government will clamp down on expensive private home construction until after the war. Houses costing around \$6,000 may be built if the buyer is in sight. Just what is going to happen to the building industry from now on is troubling a lot of people. However, since the above was written it is reported steps are being taken to ease up on the pressure.

## H. & V. EXPOSITION

The need for improving working conditions and speeding industrial production in plants engaged in National Defense operations lends special importance to the 7th International Heating & Ventilating Exposition to be held in Philadelphia January 26 to 30 next. The exposition will also stress the importance of greater efficiency and economy of operation, with a view to lower costs and fuel conservation in the heating, ventilating and air conditioning of all types of buildings.

Manufacturers of heating, ventilating and air conditioning equipment view the exposition as a meeting ground and forum for discussion and revision of plans in order to make adjustments for current contingencies and also to reveal the trend of planning for the post-war economy, which is already beginning to take form.

The essential services which their products perform afford pressing need for consultation and counsel with customers, which many manufacturers recognize as a first claim on their attention, since theirs is a business of continuing service as well as the production of new apparatus and supplies. This function, the exposition enables them to satisfy effectively and promptly.

Means for stepping up the efficiencies of existing plants are best explained with the aid of practical demonstrations of the latest modifications and adjuncts to familiar systems. New and supplementary devices are readily demonstrated by means of samples, models, and illustrative apparatus.

Defense plants are productive of many exacting requirements for controlled atmospheres, essential to production efficiency, and the established manufacturers are able to disclose numerous innovations in the industrial applications of their products, actuated by the new demands. New and interesting trends are also disclosed in both detailed methods and in the extent of air conditioning for human comfort, essential to living and working under pressure for maximum accomplishment.

In the no less essential field of domestic heating are several new systems using rapid heat transfer and forced circulation, for which claims of lower installation and operating costs are made. Offsetting these innovations, higher efficiencies have been achieved by improvements applied to many of the older-established systems.

The net result of these and other items of change is a marked stimulation of interest in the exposition for engineers, contractors, builders, distributors, buyers and users of equipment.

## CLEARING SHASTA RESERVOIR SITE

A contract has been awarded by Secretary of the Interior Harold L. Ickes for clearing brush and timber from part of the 13,000 acres of the Shasta reservoir site.

The work of clearing this large area was divided into 15 schedules. E. L. Gates on his low bid of \$381,-

000 was awarded the contract for three schedules, covering the clearing of an area east of the Sacramento River and north of O'Brien Creek, an area west of the Sacramento River, and an area north of the Pit River. The remaining 12 schedules will be readvertised.

Bids were opened by the Bureau of Reclamation at its Sacramento, California, office on August 27. Two other contractors submitted bids on all of the 15 schedules.

Clearing work is completed or under way on about 5,600 acres, of which 3,200 acres have been under contract and 2,400 acres done by Civilian Conservation Corps.

Shasta reservoir will cover a total of 29,500 acres in the canyons of the Sacramento, Pit and McCloud rivers. The entire area above dead storage level—or almost 25,000 acres—is to be cleared of trees, stumps, and brush.

## AMERICAN ACADEMY IN ROME COMPETITIONS

This year the American Academy in Rome will award cash prizes to young artists of talent. In previous years the Academy has awarded Fellowships for travel, creative work, and study in Rome. While present international conditions prevail, the trustees of the Academy have decided to continue their policy of aiding and stimulating American art by offering competitive cash prizes to young artists for study in the Americas.

For this purpose preliminary competitions in painting and sculpture will be held at a regional center in each of six districts embracing the United States.

In each of these regional competitions a prize of \$25 will be offered for each of the best ten submissions, five in painting and five in sculpture. After a week's exhibition of all work submitted at each center the sixty winning designs will be shipped to New York for the final judgment and exhibition.

In the final competitions four prizes will be offered in each subject, first prize of \$1,000 and second, third and fourth prizes of \$100, \$50 and \$25, respectively.

The Academy reserves the right to withhold any prize in case the jury decides that the work submitted is not of sufficient merit to justify an award.

The juries for the preliminary competitions will be selected from among well-known artists of the several districts and for the final competitions, from among artists of national reputation.

The competitions are open to unmarried male citizens of the United States who are under 31 years of age.

This district includes the states of California, Idaho, Montana, Nevada, Oregon and Washington; also Alaska and Hawaii. The regional center is San Francisco and the Supervisor is Grace L. McCann Morley, director of San Francisco Museum of Art, from whom circular of information and application form may be obtained on request. Applications must be filed with the supervisor before January 1st.

# MODERNIZED PRODUCTS

Brief Notes on New Materials and Equipment in the Building Industry.

## 613. GARAGE DOOR

Turn the handle and up it goes—no tugging, no lifting. That's the Stanley Econ-o-matic garage door hardware that will please your clients. And the price is low. Send for literature.

## 614. PLASTICS

"Lustron, a Monsanto Plastic" is the title of a late booklet on this all-interesting subject of plastics. It's illustrated in beautiful colors and gives a certain amount of technical information on how plastic materials are made.

## 615. ARC WELDING

A new 38-page catalog describing the complete line of Hobart "Simplified" arc welders and accessories will be sent to our readers. There are many things to know about welding in these times and this is an important presentation on the subject.

## 616. AIR CONDITIONING

The Trane Company, who issues this catalog, known as "Bulletin S290" makes the most complete line of heating, cooling and air conditioning equipment in the country. This one should be added to your A.I.A. File 30. Well illustrated.

## 617. ELECTRIC WALL HEATER

This one has a quiet, motor-driven fan, a modern grille, which blends gracefully into any setting, a low operating cost, and has no exposed hot wires or glowing elements. The warm air is delivered downwards. Complete details will be sent.

## 618. COMPOSITION SHINGLES

Here is variety in roofing—a roof that looks like a million dollars at a price your client can afford to pay. The United States Gypsum Company will tell you about their "Random Tab" shingles in a full-color folder, showing various shades and designs available in this attractive composition roofing.

## 619. DRAFTING MACHINES

The manufacturers do not claim accuracy for their machines. They guarantee accuracy. L. G. Wright, Inc. make a full line of precision instruments in this field and their catalog should be found interesting.

## 620. BUILDING PAPER

Once in place, it's an expensive operation to repair or replace building paper. That's why it's so important to use a paper that will give effective service for the life of the building. Here's another folder on the subject by Sisalkraft, and an interesting one.

## 621. GLAZING

Constant failure proves that putty doesn't do the job, so states the bulletin on "Tremglaze," a glazing compound manufactured by Tremco Manufacturing Co. It is pointed out that the first cost is only slightly higher, but the results much more lasting and satisfactory.

## 622. INVISIBLE HINGES

They permit the streamlining of a door by eliminating the unsightly butt. Catalog No. 10 of Soss Manufacturing Co. describes precision workmanship in invisible hinges and points out their many advantages. Complete with blueprints and directions for installation, it is very worthwhile.

## 623. MOVIE SCREENS

Whether you are called upon to give your advice and write specifications for motion picture screens, or whether a client in building his home makes provision to show home movies, you ought to know all about the subject of motion picture screens. Here is a very valuable booklet identified as "Catalog 41" issued by Da-Lite Screen Co., Inc.

## 624. WOOD CASEMENTS

Steel casements are fast disappearing from the market, owing to our de-

fense program. What is more natural then, than to turn to wood? Here is described the famous "Pella" line. These casements are modern, and have many advantages in appearance and cost.

## 625. TILE ADHESIVE

Tile beauty and durability, developed by tile manufacturers at great expense, are offset a great deal by the unsatisfactory, cumbersome methods of wet-mortar installations. Miracle Adhesives Corporation describes a newer, modern method of tile setting. Good information.

## 626. FIRE PREVENTION

The instant, smothering action of CO<sub>2</sub> gas, stored in centralized tanks ready to release at any one of many locations, is recognized as one of the most effective and efficient ways to overcome fires. Here is an unusually informative booklet on the subject, issued by the Cardox Corporation.

## 627. GAS EQUIPMENT

Seven attractive folders and leaflets packed with facts have just been issued by American Radiator & Standard Sanitary Corporation on gas-fired equipment. We'll send you a set if you wish.

Architect and Engineer  
68 Post Street  
San Francisco, Calif.

Please send me literature on the following items as checked below. This request places me under no obligation.

613	<input type="checkbox"/>	620	<input type="checkbox"/>
614	<input type="checkbox"/>	621	<input type="checkbox"/>
615	<input type="checkbox"/>	622	<input type="checkbox"/>
616	<input type="checkbox"/>	623	<input type="checkbox"/>
617	<input type="checkbox"/>	624	<input type="checkbox"/>
618	<input type="checkbox"/>	625	<input type="checkbox"/>
619	<input type="checkbox"/>	626	<input type="checkbox"/>

627

My Name.....

Name of Company.....

Street.....

City..... State.....

# ARCHITECTS' BULLETIN

Issued For

## THE STATE ASSOCIATION OF CALIFORNIA ARCHITECTS Northern Section

STATE ASSOCIATION MEMBER  
OF THE  
AMERICAN INSTITUTE OF ARCHITECTS

Editor  
Harris C. Allen

Address all communications for publication in the Bulletin to the Editor (Harris C. Allen) 557 Market Street, Room 218, San Francisco, California.

### STATE ASSOCIATION OFFICERS

President.....Walter R. Hagedohm  
Vice-Pres.....Fred'k H. Reimers, San Francisco  
Secretary.....Vincent G. Raney, San Francisco  
Treasurer.....Robert H. Orr, Los Angeles

Regional Director—Southern Section  
Gordon B. Kaufmann, Los Angeles

Regional Director—Northern Section  
Harry M. Michelsen, San Francisco

Executive Board—Northern Section  
Officers

President.....Fred'k H. Reimers, San Francisco  
Vice-Pres.....Wayne S. Hertzka, San Francisco  
Secretary.....Vincent Raney, San Francisco  
Treasurer.....Mario Ciampi, San Francisco

### Directors

David Horn and Robert Stanton  
Ernest E. Weihe  
Harry J. Devine and F. H. Reimers

Executive Board—Southern Section

President.....Walter R. Hagedohm  
Vice-Pres.....E. Allan Sheet  
Secretary.....Winsor Soule, Santa Barbara  
Treasurer.....Robert H. Orr, Los Angeles

### Directors

Winsor Soule, William Templeton Johnson,  
Ben H. O'Connor, Edward Allan Sheet,  
Walter R. Hagedohm

Northern Section Advisory Council

San Francisco District:  
Clarence W. Mayhew, President  
Edward J. Maher, Secretary  
Henry H. Gutterson  
Lester W. Hurd  
Ellsworth Johnson  
William Henry Rowe  
Clyde F. Trudell  
Harold H. Weeks  
John Davis Young

North Bay:  
J. C. Felciano  
Lower San Joaquin:  
Russell G.  
de Lappe  
Santa Clara:  
Chester Root  
San Mateo:  
Leo J. Sharps  
Upper Sacramento:  
C. C. Dakin  
Sacramento:  
W. E. Manhart  
Upper San Joaquin:  
D. H. Horn  
Monterey Bay:  
Robert Stanton  
Palo Alto:  
David B. Clark  
Marin:  
J. W. Bertenshaw  
East Bay:  
J. H. Anderson,  
Chairman  
A. C. Williams,  
Secretary  
T. N. Thompson  
Berkeley:  
C. R. Schmidt  
Redwood Empire:  
F. T. Georgeson  
Lassen:  
Ralph D. Taylor

## 1941 CONVENTION

A report of the convention will be published in the November Bulletin. Although the results of convention voting will doubtless be made public in the meantime, an account of discussions and activities will be of interest to our members—to those members, that is, who are interested in the common problems and ambitions of the profession. And we believe that includes most of our membership.

### The State Board

California's two State Boards of Architectural Examiners have become a single organization for the whole State.

Amalgamation of the northern and southern offices was authorized by recent State legislation to assure more uniform control over California's 1200 architects. The new office will include nine members until 1945, when the number will be reduced to five.

The new Board, appointed by Governor Olson, includes Frederick H. Reimers, San Francisco, president; David J. Witmer, Los Angeles, vice-president; Ernest E. Weihe, San Francisco, secretary; Frederick H. Mayer and Warren C. Perry, San Francisco; Harry J. Devine, Sacramento; Louis J. Gill, San Diego; Ben H. O'Connor, Los Angeles; and Winsor Soule, Santa Barbara.

### City Planning

The Association (especially the San Francisco District Society) has been keenly interested in the problem of securing a scientific Master Plan for San Francisco, for which a City Planning Commission was provided in the City Charter. Space in these columns has been devoted to the subject, on several occasions. And progress has been made. One of our members, Douglas Dacre Stone, was appointed to fill a vacancy on the Commission; authority was given to engage expert help and to proceed with a definite survey and study. And recently an expert consultant, Ernest P. Goodrich, was engaged.

An editorial page in one of the city's leading papers presented the opinions of several individuals on the subject. Serious criticism was expressed. One writer (known chiefly as a student of low-cost public housing) questioned the standing and experience of the expert engaged by the Commission, and compared him unfavorably with California planners.

All of this publicity, and the comments both critical and constructive, are valuable. The city authorities and the Commission should, and probably will, be stimulated and assisted thereby.

In all fairness, the public should also hear the Commission's side in this so far one-sided controversy. We are informed by the Secretary that in addition to the consultant already engaged, it is proposed to secure a full time city-planning engineer to act as field man, with gradual increase of office staff to an efficient active organization. The following is a greatly condensed account of the career of Mr. Goodrich:

Member of: American Society of Civil Engineers; American Institute of Consulting Engineers; American Society of Terminal Engineers; Institute of Traffic Engineers (past president); Institute of City Planning (director); American Transit Association; National Safety Council; New York Traffic Committee; etc.

Chief Engineer, Bush Terminal Co.; Consulting Engineer, New York City Government; Port Engineer, Albany; Commissioner Department of Sanitation, New York City; Chairman of Traffic Statistics of First U. S. Transportation Conference.

Private practice as City Planning and Traffic Engineer for 25 years. Author of many treatises on traffic and transit. Lecturer at Harvard, Columbia, Michigan, etc. Retained for city or regional planning, traffic and transit work and study in 50 American and some foreign cities or countries. Prepared complete regional plans for New York City, Cincinnati, Newark and many other cities; for Nanking, Champoa, and a new part of Canton; China; special studies for Stockholm, Sweden; Antwerp, Belgium and Canberra, Australia. Designed the Los Angeles Harbor.

From this brief resumé of Mr. Goodrich's record, it would appear that his reputation as a planning authority is well established and of international character. If the City Planning Commission proceeds with its indicated program, with the coordination of the other city departments, with requisite funds and authority, and with wise replacements of personnel on occasion, its usefulness will justify its place in the City Charter.

**Air Raid Shelter** More than 170,000 people inspected the air raid shelter exhibit which was presented at the California State Fair, Sacramento, by the State Defense Council and the State Association of California Architects, Northern Section, during the week ending September 7.

The exhibit, believed to be the first of its kind in the United States, represented the type of shelter which British factory owners are required to provide for their employees—large enough to accommodate 50 people during a prolonged raid. Thirty feet long, 12 feet wide and 8 feet high, the shelter was sunk half underground and covered with two feet of earth and sandbags. Corrugated steel provided the lining and sandbag baffle walls gave protection at entrance and exit.

Exhibit equipment included gas masks, steel helmets, stretchers, first aid set, fire extinguishers, emergency tools and a selection of 35 vivid British civil defense posters displayed on panels running lengthwise through the exhibit. Air raid sound effects, recorded during an actual raid on London, gave an added touch of realism.

Governor Culbert L. Olson and U. S. Army Air Corps officials visited the exhibit and were greatly impressed. We also learn that Washington civilian defense executives were keenly interested and are desirous of seeing similar exhibits presented in other cities in coastal areas.

The Public Relations Committee of the Northern Sec-



CALIFORNIA ARCHITECTS' AIR RAID SHELTER AT STATE FAIR

tion of the Association originally planned this exhibit and carried out a great part of the work in organizing and directing it at Sacramento. We congratulate them on a really remarkable pioneering effort which looks like winning national attention.

**1942 Advisors** At the Advisory Council meeting called in San Francisco on September 16th, a quorum was not present and, therefore, the election of two new members of the Executive Board was postponed to the October Convention. It was hoped that on this account a good representation from the Northern Section would attend the Convention. If any member feels that the Board does not consult the profession sufficiently on matters of general policy, he may well reflect that the Advisory Council is the medium for discussion of such matters, and he is partly responsible if his District is not represented at such a meeting. The Executive Board welcomes comments and suggestions at all times, but the Advisory Council meeting expresses the major opinion of the members, upon which policies and actions are based.

**Women's Auxiliary** The fall club season was officially opened for members of the Women's Auxiliary of the State Association of California Architects when the group met Wednesday, September 3rd, at the Women's City Club, San Francisco. No meetings were held in July and August, due to the summer vacation period.

Suggestions were presented by members of the Executive Board, for immediate social and educational activities, with the prediction that, with the cooperation of each architect's wife, California architects will greatly benefit through the many activities planned.

The executive board includes the following: Mesdames Harold H. Weeks, Dodge A. Riedy, Mario J. Ciampi, Rudolph Igaz, J. Francis Ward, Donnell E. Jaekle, Vincent Raney, William A. Rowe, John Davis Young, Ernest Born and Harry Michelsen.

"Art in Architecture" was the subject of a very interesting address, by the guest speaker, Lucien Labaudt, well known mural artist and director of the Labaudt School of Custom Design.

# Estimator's Guide

## Giving Cost of Building Materials, Wage Scale, Etc.

Amounts given are figuring prices and are made up from average quotations furnished by material houses to San Francisco contractors. 3% Sales Tax on all materials but not labor.

All prices and wages quoted are for San Francisco and the Bay District. There may be slight fluctuation of prices in the interior and southern part of the state. Freight cartage, at least, must be added in figuring country work.

**Bond**—1½% amount of contract.  
Government work ¾%.

**Brickwork**—

Common, \$40 to \$45 per 1000 laid, (according to class of work).  
Face, \$90 to \$100 per 1000 laid, (according to class of work).  
Brick Steps, using pressed brick, \$1.00 lin. ft.  
Brick Veneer on frame buildings, \$1.00 sq. ft.  
Common f.o.b. cars, \$14.00 at yard. Cartage extra.  
Face, f.o.b. cars, \$40.00 to \$80.00 per 1000, carload lots.

**Building Paper**—

1 ply per 1000 ft. roll	\$3.50
2 ply per 1000 ft. roll	5.00
3 ply per 1000 ft. roll	6.25
Siseltkraft, 500 ft. roll	5.00
Sash card com. No. 7	\$.120 per 100 ft.
Sash card com. No. 8	1.50 per 100 ft.
Sash card spot No. 7	1.90 per 100 ft.
Sash card spot No. 8	2.25 per 100 ft.
Sash weights cast iron, 550.00 ton.	
Nails, \$3.50 base.	
Sash weights, \$45 per ton.	

**Concrete Aggregates**—

**GRAVEL** (all sizes) \$1.45 per ton at bunker; delivered to any point in S. F. County \$1.85.

	Bunker	Delivered
Top sand	\$1.45	\$1.85
Concrete mix	1.45	1.85
Crushed rock, ¾ to ¾	1.60	2.00
Crushed rock, ¾ to 1½	1.60	2.00
Roofing gravel	1.60	1.85
City gravel	1.45	2.00
River sand	1.50	1.90
Bank sand—\$1.00 per cubic yard at bunker or delivered.		

**SAND**—

	Bunker	Delivered
River sand	\$1.50	\$1.85
Lapis (Nos. 2 & 4)	2.00	2.40
City (Nos. 1 & 2)	1.80	2.20
Healdsburg plaster sand	1.80	\$1.80 and \$2.20
Del Monte white	50c per sack	

Common cement (all brands, paper sacks) carload lots \$2.52 per bbl. f.o.b. cars; delivered, \$2.70; less than carloads delivered, 70c per sack.  
Cash discount on carload lots, 10c a barrel, 10th Prox.; cash discount less than carload lots, 2%.

Atlas White } 1 to 100 sacks, \$2.00 sack,  
Calaveras White } warehouse or delivery;  
Medusa White }

Forms, Labors average \$40.00 per M.  
Average cost of concrete in place, exclusive of forms, 35c per cu. ft.; with forms, 60c.  
4-inch concrete basement floor .....12½c to 14c per sq. ft.  
Ret-roofing .....7½c  
Concrete Steps .....\$1.25 per lin. ft.

**Dampproofing and Waterproofing**—

Two-coat work, 20c to 30c per yard.  
Membrane waterproofing—4 layers of saturated felt, \$4.50 per square.  
Hot coating work, \$2.00 per square.  
Medusa Waterproofing, 15c per lb., San Francisco Warehouse.  
Tricoat waterproofing.  
(See representative.)

**Electric Wiring**—\$12.00 to \$15.00 per outlet for conduit work (including switches).  
Knob and tube average \$3.00 per outlet.

**Elevators**—

Prices vary according to capacity, speed and type. Consult elevator companies.  
Average cost of installing an automatic elevator in four-story building, \$2800; direct automatic, about \$2700.

**Excavation**—

Sand, 60 cents; clay or shale \$1 per yard.  
Teams, \$12.00 per day.  
Trucks, \$22 to \$27.50 per day.

Above figures are an average without water. Steam shovel work in large quantities, less; hard material, such as rock, will run considerably more.

**Fire Escapes**—

Ten-foot galvanized iron balcony, with stairs, \$150 installed on new buildings; \$160 on old buildings.

**Floors**—

**Composition Floors**—22c to 40c per sq. ft. In large quantities, 18c per sq. ft. laid.  
**Mosaic Floors**—80c per sq. ft.  
**Dureflex Floor**—23c to 30c sq. ft.  
**Rubber Tile**—50c to 75c per sq. ft.  
**Terazzo Floors**—45c to 60c per sq. ft.  
**Terazzo Steps**—\$1.60 lin. ft.

**Hardwood Flooring** (delivered to building)—

	1½x2¼"	¾x2"	¾x2"
	T&G	T&G	Sq. Ed.
Clr. Qtd. Oak	\$144.00 M	\$122.00 M	\$141.00 M
Sel. Qtd. Oak	118.00 M	101.00 M	114.00 M
Clr. Pla. Oak	120.00 M	102.00 M	115.00 M
Sel. Pla. Oak	113.00 M	92.00 M	107.00 M
Clr. Maple	125.00 M	113.00 M	

Wage—Floor layers, \$11.00.  
Note—Above quotations are all board measure except last column which is sq. ft.

**Glass** (consult with manufacturers)—

Double strength window glass, 20c per square foot.  
Plate 80c per square foot (unglazed) in place, \$1.00.  
Art, \$1.00 up per square foot.  
Wire (for skylights), 40c per sq. foot.  
Obscure glass, 30c to 50c square foot.  
Glass bricks, \$2.50 per sq. ft., in place.  
Note—If not stipulated add extra for setting.

**Heating**—

Average, \$1.90 per sq. ft. of radiation, according to conditions.  
Warm air (gravity) average \$48 per register.  
Forced air, average \$68 per register.

**Iron**—Cost of ornamental iron, cast iron, etc., depends on designs.

**Lumber** (prices delivered to bldg. site)

No. 1 common	\$43.00 per M
No. 2 common	41.00 per M
Select O. P. common	46.00 per M
2x4 No. 3 form lumber	32.00 per M
1x4 No. 2 flooring VG	70.00 per M
1x4 No. 3 flooring VG	85.00 per M
1x6 No. 2 flooring VG	76.00 per M
1¼x4 and 6, No. 2 flooring	75.00 per M

**Slash grain**—

1x4 No. 2 flooring	\$55.00 per M
1x4 No. 3 flooring	62.00 per M
No. 1 common run T. & G.	48.00 per M
Lath	7.50 per M

**Shingles** (add cartage to price quoted)—

Redwood, No. 1	\$1.20 per bble.
Redwood, No. 2	1.00 per bble.
Red Cedar	1.45 per bble.

**Plywood—Douglas Fir** (add cartage)—

"Plyscord" sheathing (unsanded)  
¾" 3-ply and 48"x96" \$39.75 per M  
"Pitwall" (wallboard grade)—  
¼" 3-ply 48"x96" \$43.70 per M  
"Pitform" (concrete form grade)—  
¾" 5-ply 48"x96" \$117.30 per M  
Exterior Plywood Siding—  
¾" 5-ply Fir \$132.00 per M  
Redwood (Rustic) 1"x8" clear heart \$95.00 per M  
\$5 less per M for A grade.

**Millwork—Standard.**

O. P. \$100 per 1000. R. W. rustic \$120.00 per 1000 (delivered).  
Double hung box window frames, average, with trim, \$6.50 and up, each.  
Complete door unit, \$10.00.  
Screen doors, \$3.50 each.  
Patent screen windows, 25c a sq. ft.  
Cases for kitchen pantries seven ft. high, per lineal ft., \$8.00 each.  
Dining room cases, \$8.00 per lineal foot. Rough and finish about 75c per sq. ft.  
Labor—Rough carpentry, warehouse heavy framing (average), \$17.50 per M.  
For smaller work average, \$35.00 to \$45.00 per 1000.

**Marble**—(See Dealers)

**Painting**—

Two-coat work	per yard 50c
Three-coat work	per yard 70c
Cold water painting	per yard 10c
Whitewashing	per yard 4c

Turpentine, 65c per gal., in 5 gal. cans, and 55c per gal. in drums.

Raw Linseed Oil—95c gal. in light drums. Boiled Linseed Oil—98c gal. in drums and \$1.08 in 5 gal. cans.

**White Lead in oil**

	Per Lb.
1 ton lots, 100 lbs. net weight.....	11 1/4c
500 lbs. and less than 1 ton.....	12c
Less than 500 lb. lots.....	12 1/2c

**Red Lead and litharge**

1 ton lots, 100 lbs. net weight.....	11 3/4c
500 lbs. and less than 1 ton.....	12c
Less than 500 lb. lots.....	12 1/2c

**Red Lead in oil**

1 ton lots, 100 lbs. net weight.....	12 3/4c
500 lbs. and less than 1 ton.....	13c
Less than 500 lb. lots.....	13 1/2c

Note—Accessibility and conditions cause some variance in costs.

**Patent Chimneys—**

6-inch.....	\$1.25 lineal foot
8-inch.....	1.50 lineal foot
10-inch.....	2.25 lineal foot
12-inch.....	3.00 lineal foot

**Plastering—Interior—**

1 coat, brown mortar only, wood lath.....	Yard \$0.50
2 coats, lime mortar hard finish, wood lath.....	.85
2 coats, hard wall plaster, wood lath.....	.72
3 coats, metal lath and plaster.....	1.25
Keene cement on metal lath.....	1.30
Ceilings with 3/4 hot roll channels metal lath (lathed only).....	.90
Ceilings with 3/4 hot roll channels metal lath plastered.....	1.80
Single partition 3/4 channel lath 1 side lath only.....	.85
Single partition 3/4 channel lath 2 inches thick plastered.....	\$2.90
4-inch double partition 3/4 channel lath 2 sides (lath only).....	1.70
4-inch double partition 3/4 channel lath 2 sides plastered.....	3.30
Thermax single partition; 1" channels; 2 1/4" overall partition width. Plastered both sides.....	2.50
Thermax double partition; 1" channels; 4 1/4" overall partition width. Plastered both sides.....	3.40

3 coats over 1" Thermax nailed to one side wood studs or joists.....	1.25
3 coats over 1" Thermax suspended to one side wood studs with spring sound isolation clip.....	1.45

**Plastering—Exterior—**

2 coats cement finish, brick or concrete wall.....	1.00
3 coats cement finish, No. 18 gauge wire mesh.....	1.75
Wood lath, \$5.50 to \$6.50 per 1000.....	
2.5-lb. metal lath (dipped).....	.19
2.5-lb. metal lath (galvanized).....	.21
3.4-lb. metal lath (dipped).....	.22
3.4-lb. metal lath (galvanized).....	.24
3/4-inch hot roll channels, \$72 per ton. Finish plaster, \$18.90 ton; in paper 1 sacks. Dealer's commission, \$1.00 off above quotations. \$13.85 (rebate 10c sack).	
Lime, f.o.b. warehouse, \$2.25 bbl.; cars, \$2.15	
Lime, bulk (ton 200 lbs.), \$16.00 ton. Wall Board 5 ply, \$50.00 per M. Hydrate Lime, \$19.50 ton.	
Plasterers Wage Scale.....	\$1.67 per hour
Lathers Wage Scale.....	1.40 per hour
Hod Carriers Wage Scale.....	1.40 per hour

Composition Stucco—\$1.80 to \$2.00 sq. yard [applied].

**Plumbing—**

From \$100.00 per fixture up, according to grade, quantity and runs.

**Roofing—**

"Standard" tar and gravel, \$7.00 per sq. for 30 sqs. or over. Less than 30 sqs. \$7.50 per sq. Tile, \$20.00 to \$35.00 per square. Redwood Shingles, \$7.50 per square in place.

Copper, \$16.50 to \$18.00 per sq. in place.	
5/2 # 1-16" Cedar Shingles, 4 1/2" Exposure.....	8.00 Square
5/8 x 16" — #1 Cedar Shingles, 5" Exposure.....	9.00 Square
4/2 # 1-24" Royal Shingles, 7 1/2" Exposure.....	9.50 Square
Re-coat with Gravel, \$3 per sq. Asbestos Shingles, \$15 to \$25 per sq. laid.	
Slate, from \$25.00 per sq., according to color and thickness.....	
1/2 x 25" Resawn Cedar Shakes, 10" Exposure.....	10.50
3/4 x 25" Resawn Cedar Shakes, 10" Exposure.....	11.50

1 x 25" Resawn Cedar Shakes, 10" Exposure.....	12.50
--	-------

Above prices are for shakes in place.

**Sheet Metal—**

Windows—Metal, \$1.75 a sq. foot. Fire doors (average), including hardware \$1.75 per sq. ft.

**Skylights—(not glazed)**

Copper, 90c sq. ft. (flat). Galvanized iron, 40c sq. ft. (flat). Vented hip skylights 60c sq. ft.

**Steel—Structural (None available except for defense work)**

\$150 ton (erected), this quotation is an average for comparatively small quantities. Light truss work higher. Plain beams and column work in large quantities \$140 per ton.

**Steel Reinforcing (None available except for defense work)**

\$150 to \$200 per ton, set.

**Stone—**

Granite, average, \$6.50 cu. foot in place. Sandstone, average Blue, \$4.00, Boise, \$3.00 sq. ft. in place. Indiana Limestone, \$2.80 per sq. ft. in place.

**Store Fronts—**

Copper sash bars for store fronts, corner, center and around sides, will average \$1.00 per lineal foot. Note—Consult with agents.

**Tile—Floor, Wainscot, etc.— (See Dealers)**

Asphalt Tile—18c to 28c per sq. ft. installed.

**Wall Tile—**

Glazed Terra Cotta Wall Units (single faced) laid in place—approximate prices:	
2 x 6 x 12.....	\$1.00 sq. ft.
4 x 6 x 12.....	1.15 sq. ft.
2 x 8 x 16.....	1.10 sq. ft.
4 x 8 x 16.....	1.30 sq. ft.

**Venetian Blinds—**

40c per square foot and up. Installation extra.

**Windows—Steel**

Factory type sash 30c ft. Ventilators for steel sash \$5.00 each.

**1941 BUILDING TRADES WAGE SCALES FOR NORTHERN CALIFORNIA**

\*6-hour day \*\*7-hour day

CRAFT	Alameda	Fresno	Marin	Sacramento	San Jose	Stockton	Watsonville	San Francisco
ASBESTOS WORKERS.....	\$1.25	\$1.25	\$1.25	\$1.12 1/2	\$1.25	\$1.25	\$1.12 1/2	\$1.25
BRICKLAYERS.....	.75	.50	.75	.75	.75	.75	.50	.75
BRICKLAYERS' HODCARRIERS.....	.125	.87 1/2	.75	1.05	.35	.106	1.12 1/2	.125
CARPENTERS.....	.75	1.12 1/2	1.25	1.18 1/4	1.25	1.18 1/4	1.12 1/2	1.25
CEMENT FINISHERS.....	.25	.25	.25	.18 1/4	.25	.25	1.00	.25
ELECTRICIANS.....	1.50	** 1.37-4/7	1.37 1/2	1.37 1/2	1.50	.....	1.12 1/2	1.50
ELEVATOR CONSTRUCTORS.....	1.56	1.50	1.50	1.10	* 1.21-3/7	.....	1.40	1.50
ENGINEERS: Material Hoist Piledriver.....	1.37 1/2	1.25	1.37 1/2	1.37 1/2	1.48	.....	1.25	1.37 1/2
..... Structural Steel.....	1.60	1.60	1.60	1.60	1.60	1.60	1.50	1.60
..... Mason.....	1.25	1.50	1.25	1.25	1.25	1.60	1.60	1.60
GLASS WORKERS.....	1.25	1.00 1/4	1.25	1.10	* 1.21-3/7	.....	1.12 1/2	1.25
IRONWORKERS: Ornamentals.....	1.31 1/4	1.25	1.25	1.37 1/2	1.31 1/4	.....	1.25	1.31 1/4
..... Reinf. Rodmen.....	1.31 1/4	1.31 1/4	1.31 1/4	1.31 1/4	1.31 1/4	.....	1.25	1.31 1/4
..... Structural.....	1.60	1.60	1.50	1.60	1.60	1.37 1/2	1.37 1/2	1.60
LABORERS: Building.....	.81 1/4	.75	.81 1/4	.75	.75	.81 1/2	.75	.85
..... Concrete.....	.87 1/2	.....	.....	.91 1/4	.....	.87 1/2	.80	.87 1/2
LATHERS.....	* 1.60	* 1.50	* 1.50	* 1.50	* 1.60	* 1.50	* 1.12 1/2	* 1.60
MARBLE SETTERS.....	1.25	1.25	1.31 1/4	1.31 1/4	1.25	.....	1.25	1.31 1/4
MOSAIC AND TERRAZZO.....	1.25	** 1.12 1/2	1.25	1.15 1/2	1.25	.....	1.25	1.25
PAINTERS.....	1.25	** 1.14-2/7	.....	1.18 1/4	.....	* 1.18 3/4	** 1.15	** 1.25
PILEDRIVERS.....	1.40	.....	1.40	1.40	1.40	.....	.....	1.40
PLASTERERS.....	* 1.66-2/3	* 1.50	* 1.66-2/3	* 1.57 1/2	* 1.75	* 1.50	1.50	* 1.66-2/3
PLASTERERS' HODCARRIERS.....	1.45	1.25	1.40	* 1.18 3/4	* 1.35	* 1.50	1.12 1/2	1.40
PLUMBERS.....	1.50	1.40-5/8	1.50	1.50	1.50	1.50	1.25	1.52 1/2
ROOFERS.....	1.25	1.00	1.25	1.18 1/4	1.25	1.12 1/2	1.25	1.25
SHEET METAL WORKERS.....	1.31 1/4	1.31 1/4	1.25	1.37 1/2	1.37 1/2	1.37 1/2	1.25	1.25
SPRINKLER FITTERS.....	1.37 1/2	.....	.....	1.37 1/2	1.37 1/2	.....	1.25	1.37 1/2
STEAMFITTERS.....	1.37 1/2	1.50	1.50	1.50	1.50	1.50	1.50	1.50
STONESETTERS (MASONS).....	* 1.75	1.40-5/8	1.25	1.50	1.50	* 1.50	1.50	* 1.50
TILESETTERS.....	1.37 1/2	1.25	1.37 1/2	1.31 1/4	1.37 1/2	1.25	1.25	1.37 1/2

Prepared and compiled by CENTRAL CALIFORNIA CHAPTER, ASSOCIATED GENERAL CONTRACTORS OF AMERICA with the assistance and cooperation of secretaries of General Contractors Associations and Builders Exchanges of Northern California.



## PRODUCTION CLINICS PLANNED

California's small industries, faced with shutdown or extinction through defense production pressure, were thrown a lifeline by the California State Council of Defense.

Governor Culbert L. Olson announced in Los Angeles that the State Council, in cooperation with the Office of Production Management, would sponsor a four-day "National Defense Production Clinic." Sessions will be held in San Francisco October 28 and 29; in Los Angeles October 30 and 31.

The clinics will have a two-fold purpose, the Governor said, first, to bring together the prime contractors and potential sub-contractors in a concerted effort to spread the work and speed up defense production. Second, to solve the problems of those "little business men" whose plants and offices are being squeezed by priorities, price controls and other defense measures.

"The small business man," Governor Olson said, "wants work and not conversation. The object of these clinics will be to get that work, to keep all our plants busy. We must harness all our productive resources and keep all our men and machines in high gear. And it is important to have the big plants with big orders find ways of spreading the work. Idle tools and idle men are wasted opportunity."

Governor Olson said he had been assured by Donald Nelson, director of OPM's Priorities Division, and Floyd B. Odum, director of the Division of Contract Distribution of OPM, that they would be represented at the clinics by Washington staff executives.

Details of the clinics will be worked out by State Defense Council members with Colonel Frank M. Smith, newly-appointed area manager for the Division of Contract Distribution. Colonel Smith and his staff, already busy on defense contract problems in the Los Angeles and San Francisco field offices, will attend the meetings.

## PASSING OF JOHN J. NESBITT

John J. Nesbitt, pioneer in the heating and ventilating of school buildings, and a widely recognized authority in the field of heating, piping, ventilating and air conditioning, died September 11, aged 74.

Mr. Nesbitt was president of John J. Nesbitt, Inc., State Road and Rhawn Street, Holmesburg, manufacturers of unit ventilators, and lived at Rockfield Farm, Ambler.

Born in Dublin, Ireland, Mr. Nesbitt came to this country at the age of 15, and became a citizen upon reaching his majority.

He devoted his entire business career to the field of heating, piping, ventilating and air conditioning, and in 1917 invented a schoolroom unit ventilator which met with wide acceptance.

In 1938 he was elected a life member in the American Society of Heating and Ventilating Engineers, to which he had belonged for 17 years.



## RICHMOND Form-Tying Methods for Concrete Work are Hours Ahead of Profit-Eating "Make-Shift" Devices!

You could puddle your concrete, right on the job, but you don't! Why, then, struggle through your concrete form work with methods equally old fashioned? You don't have to! Richmond patented pre-fabricated form-tying devices are specifically engineered for tying and anchoring concrete forms of every kind — from light walls to heavy structures. Richmond products save money, save time, do a better job. Prove it? Gladly! Just ask.

**RICHMOND 10-WAY PROFIT PLAN**

- 1—Over 67 different form-tying devices meet in every condition.
- 2—Cost less to use than usual "House-Made" wire, hand or rod ties.
- 3—Engineered for safe working loads of 1500 lb. 2500 lb. Post.
- 4—Faster erecting and stripping, saves time and lumber.
- 5—Provides perfect wall alignment, plus uniform thickness.
- 6—1 to 2 inch "No id back", protects job against rust staining.
- 7—Weight scientifically cut to save shipping and handling costs.
- 8—Delivery right in the job, saves work-time.
- 9—Job section labels save time.
- 10—No cost for working parts. You pay only for ties used.
- 11—Job planning bureau specifies types, quantities, methods, free.

**FASTER FORM WORK!**

See point 4. Because Richmond specifies, supplies, and shows you how, there is no waste of time, money or materials. Your job goes faster. Your profits bigger.

11 pages of buying data for Architects, Engineers, Builders, Contractors.

SHOW CATALOG IN SWEETS

**RICHMOND SCREW ANCHOR COMPANY, INC.**

816 LIBERTY AVENUE, BROOKLYN, N. Y.

THE RICHMOND SCREW TYING CONSTRUCTION DIVISION OF THE RICHMOND SCREW ANCHOR COMPANY, INC.

## COATINGS FOR EXTERIOR SURFACES THAT LAST. CABOTS COLLOPAKES

IN  
BLUES  
GREENS  
REDS  
AND  
A WIDE COLOR  
RANGE



**GUNN, CARLE & CO.**

SAN FRANCISCO  
20 Potrero Avenue  
Underhill 5480



## QUALITY AND DEPENDABLE *Service*

are the factors that influence architects and contractors when selecting lumber and mill work — Quality of merchandise — Integrity and Ability of the firm—Service in physical equipment — Experience and Personnel — All these factors contribute to a speedy and satisfactory completion of construction with minimum of time and expense.

### MANUFACTURER OR DEALER IN

Douglas Fir—Redwood—Sugar and Ponderosa Pine — Plywood and Concrete Form Panels — Sash and Doors — Millwork — Insulation — Builders' Hardware.

## E. K. WOOD LUMBER CO.

"Goods of the Woods" ©

LOS ANGELES • SAN FRANCISCO • OAKLAND

## *Our Sincere Appreciation*

TO MANY CALIFORNIA ARCHITECTS THAT INCLUDE G. W. WILLIAMS CO. IN THEIR LIST OF BIDDERS.

EACH OF THE 18 YEARS THAT WE HAVE BEEN BUILDING APARTMENTS, RESIDENCES, CHURCHES, SCHOOLS AND BUSINESS BUILDINGS OF ALL KINDS FOR YOU HAS ADDED FURTHER TO OUR EXPERIENCE AND RESPONSIBILITY.

WE HOPE TO BUILD MANY MORE BUILDINGS FOR YOU IN THE YEARS TO COME.

## **G·W·WILLIAMS CO.** *General Contractors*

10 CALIFORNIA DRIVE

BURLINGAME

### BUILDING COSTS IN UPWARD TREND

Building costs of a standard six-room house continued a steady rise with 1.1 per cent increase in July over June, Federal Home Loan Bank Board economists revealed. This brings the cumulative increase for the year—July, 1940, through July, 1941—of construction costs to 11.4 per cent.

With the average month of 1935-1939 taken as the base month of construction cost index, equaling 100, the figure for July of this year reached 113.6, as compared to 102.0 for July a year ago.

Labor costs in recent years have risen more rapidly than those of materials, and show 15.4 per cent increase since July, 1940. The labor index now stands at 119.3. Building supplies, on the other hand, increased but 9.4 per cent during the past year, and show a current index figure of 110.7.

Adjusted to normal seasonal variations in home building, the index indicates also that while building costs were rising, residential construction increased in even greater proportion—5.4 in July over June, and 17.7 per cent over July, 1940.

### OREGON SURVEYS CHROMITE DEPOSITS

Because chromite is needed by defense industry, WPA workers under the direction of the Oregon State Department of Geology and Mineral Studies are surveying the chromite resources of that State along the southwest coastline in Coos and Curry counties. Chromite is used to toughen steel and in the manufacture of stainless steel products. Practically all of the chromite used in this country is imported. Chief sources of supply are Africa, the Philippines, Egypt, India, and Turkey, in the order named. Of the 300,000-odd tons of chromite normally used here in a year, less than 3300 tons on the average have been produced domestically. Oregon chromite attracted attention during World War No. 1, when plans were made to tap the deposits. The survey work includes drilling, collecting samples, laboratory analysis, and determination of depth and extent of chromite sand as well as its chromite content.

### SEARCH FOR DOMESTIC RUBBER

Scientists at California Institute of Technology are experimenting with the sage-brush-like guayule plant of the desert as a possible domestic source of rubber. WPA workers are growing 500 of these native Mexican shrubs. The botany department of the college is sponsoring the project. One large rubber concern has spent over a million dollars in an attempt to grow the shrub on California plantations, but the cost has remained too high to compete with imported rubber. There is a 1,000-acre experimental plantation of guayule at Salinas (California), and the seedlings for the Cal-Tech tests came from there.

### FIRST WOMAN TO WIN SCHOLARSHIP

A \$1,000 scholarship for postgraduate work in the field of architecture and civic design has been awarded to Miss Ann Sirotenko, 22, of 101 Forest Hill Road, West Orange, N. J., by the Advisory Council of the Cooper Union Art Schools. Miss Sirotenko, who was graduated from Cooper Union's Day School of Art in June, begins a year of advanced study at Cranbrook Academy of Art, Bloomfield Hills, Mich., this fall.

The first girl ever to receive a postgraduate architectural scholarship at Cooper Union, Miss Sirotenko was given the honor in recognition of the excellence of her designs for large buildings, modern interior decoration, plumbing and sewage systems, and heating and ventilating units. At Cranbrook Academy she will continue her study of large-scale construction. Miss Sirotenko, blond and only five feet tall, aspires to build skyscrapers, bridges, and public buildings.

Born in New York City in 1919, Miss Sirotenko is the daughter of the late Vladimir Sirotenko, Russian-American artist and writer. She painted with her father from the time she was old enough to hold a brush.

Miss Sirotenko was the winner of the 1940 Architectural Prize at Cooper Union, where she also was awarded the Pictorial Composition Prize in 1939. She ranked first in a poster contest sponsored by the American Society for the prevention of Cruelty to Animals in 1936, and in a sculpturing competition held by the Classical League of New York in 1937.

### PROTECTIVE DEFENSE MEASURES

Managers of industrial plants and local defense authorities are being urged by Charles R. Page, Regional Director of Civilian Defense, in San Francisco, to begin planning for protection against air raids.

Planning guides titled "Protection of Industrial Plants and Public Buildings" have been sent to the various headquarters of the OCD and defense councils.


These guides warned the nation that "even though the possibility of an enemy air attack may be remote it is essential that protective organization be developed at once to guard against the disruption of normal activities and the safety of the personnel."

The organization for each plant or public building, as outlined by the guide, calls for a coordinator, an engineering chief and four division heads—fire, police, medical and maintenance. The guide gives detailed instructions for the activities of these leaders.

The OCD called attention to the desirability of dispersal of industrial operations, so far as it is economically possible, and declared that each plant be prepared to protect itself, independent of outside assistance.

### WHITE MARBLE BANK FACADE

The beautiful exterior of the remodeled Morris Plan Building in Oakland, illustrated in last month's Architect and Engineer, is Yuhl-Colorado white marble, quarried and installed by the Vermont Marble Company, Underwood Building, San Francisco.



Follow the sun  
to the DESERT INN...  
33rd season. Send for a  
"Sands of Time" magazine

35 acre estate . . . swimming pool, tennis and  
badminton courts, riding, golf, all sports.  
Delightful accommodations . . . delicious food.

**THE  
DESERT  
INN**

**PALM SPRINGS, CALIFORNIA**



### California's Hotel Beautiful

- like a country estate yet in the heart of a throbbing metropolitan area.
- a matchless view—
- comfortable, luxuriously furnished rooms, excellent cuisine.
- in an atmosphere of quiet and gracious living.

Rooms, with bath, \$2.50 to \$5.00 per day.

*Attractive monthly rates*

**HOTEL CLAREMONT • BERKELEY**

**BAXCO**  
CHROMATED ZINC CHLORIDE

**GLC**

**PRESSURE TREATED LUMBER**  
● **PROTECTS AGAINST DECAY**  
**AND TERMITE ATTACK**

*Specify it in your home*  
*Available through Lumber Dealers*

LOS ANGELES 601 W. 5th Street Phone Michigan 6294	SAN FRANCISCO 333 Montgomery Street Phone DOuglas 3883
---	--

**J.H. Baxter & Co.**

AGENTS FOR WEST COAST WOOD PRESERVING CO., SEATTLE, WASH.

**The Most Complete Line of**  
**STEELS and BUILDING MATERIALS**  
**Made by a Single Producer**



*See Sweet's Catalog File or write us for  
full information.*

**REPUBLIC STEEL CORPORATION**  
GENERAL OFFICES: CLEVELAND, OHIO

DENVER, COLORADO . . . . .	CONTINENTAL OIL BUILDING
LOS ANGELES, CALIFORNIA . . . . .	EDISON BUILDING
SALT LAKE CITY, UTAH . . . . .	WALKER BANK BUILDING
SAN FRANCISCO, CALIFORNIA . . . . .	RIALTO BUILDING
SEATTLE, WASH. . . . .	WHITE-HENRY-STUART BUILDING

**HOGAN LUMBER CO.**  
*Wholesale and Retail*

**LUMBER**

---

**MILL WORK • SASH & DOORS**

---

*Office, Mill, Yard and Docks*  
**SECOND AND ALICE STREETS • OAKLAND, CALIF.**  
**Telephone GLencourt 6861**

**HOME FINANCING AT LOW COST**

How an increase as small as one per cent in interest may mean a difference of ten per cent or more in the total cost of a home, is pointed out by the Federal Housing Administration in support of its contention that home financing today is less costly than ever before.

The maximum charge which may be made on an FHA-insured mortgage, according to Federal Housing Administrator Abner H. Ferguson, now is 4 1/2 per cent interest, plus one-half per cent mortgage insurance premium, both computed on outstanding declining balances.

"Few people realize that an apparently trifling difference in interest rates makes a very considerable difference in the final cost of home ownership," declared Administrator Ferguson. "Rates most frequently quoted for this form of financing are fractional, ranging from six per cent down to 4 1/2 per cent, an inconsequential variation in the opinion of many borrowers.

"However, a little figuring clearly shows that a difference of only one per cent in the rate a home buyer pays for his money may mean a difference of ten per cent or more in the total cost of his home.

"For example, assume a mortgage amounts to \$5000 and the charge is five per cent, which is the maximum cost under the Federal Housing plan. On a monthly amortized, direct reduction loan carrying FHA insurance, the borrower will pay \$7920 over a period of 20 years.

"With exactly the same kind of loan, without FHA insurance, and at six per cent interest, he would pay \$8604. The \$684 difference is more than 13 per cent of his principal commitment, and would mean an increase of more than 8 1/2 per cent in the total eventual cost of his home."

A similar transaction consummated before FHA-insured mortgages were made available through approved local lending institutions six years ago was handled about as follows, according to FHA officials:

First mortgage for \$2400 at six per cent, or more, interest; second mortgage for \$1850 at seven or more per cent, and a third mortgage for \$750, on which interest might range from seven to ten per cent. Usually they were written on one-year notes, which required complete refinancing, with title search and accumulating charges, at least every five years.

In both instances, it was declared, the down payment is assumed to be \$600. In contrast to multiple mortgages, high interest rates and repetition of financing charges, it was pointed out that a single long term FHA-insured mortgage may be completely paid off and the entire \$5000 indebtedness wiped out with payments averaging less than a dollar a day, without secondary financing or ever renewing the mortgage loan.

In War-time Building Bulletin No. 1 the Building Research Station of the Department of Scientific and Industrial Research put forward economical type designs in steelwork for single-story open shed factories. These, however, are not suitable for exclusive use in factories which require to be camouflaged, and in War-time Building Bulletin No. 4 (H.M. Stationery Office, price 1/-) which has just been issued, the range of roof types has been extended by supplementary designs which, suitably combined with the others in the factory structure, will facilitate camouflage.

The principal difference between the two types of structure lies in the roof glazing; in the first case the glazed areas were placed vertically on the roof trusses, while in the supplementary designs the roof and glazing are sloped, and the roof trusses are symmetrical, of a double-pitched design. The extended range of type designs has been prepared for use by themselves or in conjunction with the original type designs, depending on the camouflage requirements for the factory concerned.

Shuttering could be saved, also, by the use of promising systems of precast construction, although the cost would be correspondingly higher. It is intended in future Bulletins to put forward a number of type designs which represent so far as possible the most economical and efficient use of reinforced concrete for factory construction.

The object of Wartime Building Bulletin No. 3 (H. M. Stationery Office, price 1s. 0d.) which has just been issued, is to consider the hut type of building for which a big demand has arisen as a result of the war. The details of huts to be used for different purposes may vary to some extent, but the general requirements remain very similar in all cases, and in this Bulletin the normal Army living hut has been taken as a basis.

Certain requirements are demanded by planning, loads and working stresses, conditions of comfort, such as heat insulation and rain penetration, and the availability of materials and labor. These are discussed in the first part of the Bulletin, and two tables are given, the first of which shows the estimated heat loss per hour for varying types of floors, walls and roofs, while the second shows the comparative total heat loss for huts erected from combinations of these components.

#### CELOTEX HAS NEW CLIP SYSTEM

A complete clip system for securing gypsum lath to the studding, producing crack-resisting, floating plastered walls and ceilings at a cost not exceeding that for ordinary nailed-on walls in most markets, is announced as the latest addition to the Celotex line.

Simplicity is said to be the outstanding feature of this system as only three forms of clips are necessary in constructing walls and ceilings, with open frontal nailing of the clips to the studs for easy application.

## MODERN STORE FIXTURE MANUFACTURING CO.

762 - 100th Ave., Oakland • TRinidad 4864

*Manufacturers of Fixtures for*

T A V E R N S  
DEPARTMENT STORES  
JEWELRY STORES  
CLOTHING STORES  
MILLINERY STORES  
SHOE STORES  
C O U N T E R S  
OFFICE FIXTURES  
P A R T I T I O N S  
STORE FRONTS  
RESTAURANTS  
FOOD MARKETS  
BEAUTY SALONS  
CONFECTIONERS  
CIGAR STORES  
R E M O D E L I N G  
SPECIAL WOOD WORK

## SISALKRAFT

REG. U. S. PAT. OFF.

~~~~~  
"More than a building paper"  
~~~~~

**THE SISALKRAFT CO.**

205 West Wacker Drive  
(Canal Station) Chicago, Ill.

55 New Montgomery Street  
San Francisco, Calif.

## CLINTON CONSTRUCTION CO.

OF CALIFORNIA

**General Contractors**

923 FOLSOM STREET • SAN FRANCISCO

SUtter 3440

## ACOUSTI-CELOTEX

for office-quieting provides . . .

- PAINTABILITY
- PERMANENT LIGHT-REFLECTION
- HIGH EFFICIENCY

*Acoustical Engineers & Contractors*

**WESTERN ASBESTOS CO.**

*Building Materials*      *Mechanical Specialist*  
SACRAMENTO      OAKLAND  
SAN FRANCISCO

## STRUCTURAL STEEL

For Class A Buildings,  
Bridges, etc.

**JUDSON PACIFIC CO.**

1200 SEVENTEENTH STREET  
SAN FRANCISCO

Plants: San Francisco - Oakland

## FRANK J. McCOY HOTELS

**SANTA MARIA INN**—Santa Maria, California • Orville E. Sammann, Mgr.  
WORLD FAMOUS STOP-OVER, BETWEEN  
SAN FRANCISCO AND LOS ANGELES

**EL ENCANTO HOTEL & VILLAS**—Santa Barbara, California • Fred E. Pimentel, Mgr.  
AMERICA'S HOTEL BEAUTIFUL, IN A  
MATCHLESS SETTING ON THE RIVIERA

## BASALITE

CAMBERED SHINGLE TILE

PERMANENT • FIREPROOF • STORM-  
SAFE • COLORFUL • ECONOMICAL

Manufactured by  
**BASALT ROCK CO., INC.**  
NAPA, CALIFORNIA

The "float" is provided through the ability of the clips to compensate for the swelling, shrinking, warping, and twisting of the wooden framework of the house. While walls built with these clips by the inventor, Harry Burson, during the past two years have proved eminently satisfactory to owners, various tests have been made to determine the degree of "float" provided. It is reported that twisting a stud in a finished wall section 45 deg. out of line, as well as spreading studs a full two inches with a mechanical jack, failed to produce cracks in the finished plastered side of the wall. Similarly, the corner of a ceiling section of the test panels had to be jacked up to equal 7½" of settlement in a ten foot wide room before a fine hairline crack appeared in the plaster in one corner.

The perfected system will be marketed by The Celotex Corporation under the brand name Anchor Clip System.

### INFORMATION ON BUILDING PRODUCTS

The Producers' Council Bulletin 40 is ready for distribution. Detailed information may be found therein on the following:

American Lumber & Treating Co.—Presents information on **Wolmanized Lumber** for guarding against decay and termites, including a list of items to be protected and short specifications.

Crane Co.—Presents a **modern one-pipe hot water heating system** for small homes, and may be installed in homes without basements; also the new **Crane Closets—Sewelco and Delmar** of improved design, and including dimensions and prices.

Richmond Screw Anchor Co.—Presents **A. C. Form Tys** for monolithic architectural concrete walls, economical and easily applied. All working parts are returnable for credit.

Sisalkraft Company—Applications in sound building construction of **Sisalkraft**, a reinforced, weatherproof building paper of remarkable strength and resistance, and especially treated to resist shrinkage and dry rot.

The Stanley Works—Announce a **new improved non-rising pin**, which requires no twisting or turning to find the proper position. Snaps into place and will not rise through action of the door.

Vermont Marble Co.—Presents **toilets and showers of marble**, rich in individuality, durable and competitive in price, with no expensive maintenance costs.

### OREGON CHAPTER NOTES

The first fall meeting of Oregon Chapter was held at Lloyd's club house September 16.

Morgan Homer Hartford has made application to be raised from Chapter Associate status to full Institute membership.

The annual picnic meeting held in July is still a matter for remembrance. It was the hottest day of the year—103 in some places and as high as 110 in others.

# VERMONT MARBLE COMPANY

Producers and Finishers  
of  
Domestic and Imported Marbles

San Francisco, Los Angeles and Tacoma, Wash.  
San Francisco phone: SUiter 6747

# ALADDIN Heating Corp.

Specializing in  
QUALITY HEATING EQUIPMENT  
2222 San Pablo Avenue, Oakland  
TWinoaks 1022

## "AMERICAN MARSH" Redi-Vac Vacuum Heating Pump



Send for  
Bulletin 441

**SIMONDS MACHINERY CO.**

San Francisco  
816 Folsom St.

Los Angeles  
455 East Fourth St.

**S**LOANE has worked with architects,  
designers and decorators for years.  
▶ We interpret intelligently . . . and  
we know what it is to be up against  
deadlines and strict budgets. ▶ Let  
us prove this!

FURNITURE • FABRICS • WALLPAPERS  
LAMPS AND FLOOR COVERINGS  
WHOLESALE CONTRACT DIVISION

W & J **SLOANE**  
Sutter near Grant • San Francisco


U.S.  
PRODUCTS  
**VAN ARSDALE - HARRIS CO.**  
ENGINEERS & CONTRACTORS

**ACOUSTICAL TREATMENT  
INSULATION • SOUND CONTROL**

Fifth and Brannon Streets • San Francisco, Calif.  
Telephone GArdfield 3600

Division  
VAN ARSDALE - HARRIS LUMBER CO., INC.

## INSIST on the FINEST



Only LIFETIME steel slat Venetian  
blinds offer these exclusive features:  
The finest steel electrogalvanized  
and LIFE-ERIZED to assure adhe-  
sion of the two coats of baked  
enamel: STA-WAXED to preserve  
the beautiful lustre; Finished in 24  
eye-pleasing colors. Carried by  
better Venetian blind dealers and  
manufacturers.

**LIFE TIME**  
Products Corporation

631 East Florence Avenue  
Los Angeles, California

## PACIFIC MANUFACTURING CO.

HIGH CLASS INTERIOR FINISH  
QUALITY MILLWORK

142 SANSOME ST., SAN FRANCISCO  
GARfield 7755

6820 MCKINLEY AVE., LOS ANGELES  
THornwall 4196

BUILDERS EXCHANGE, OAKLAND

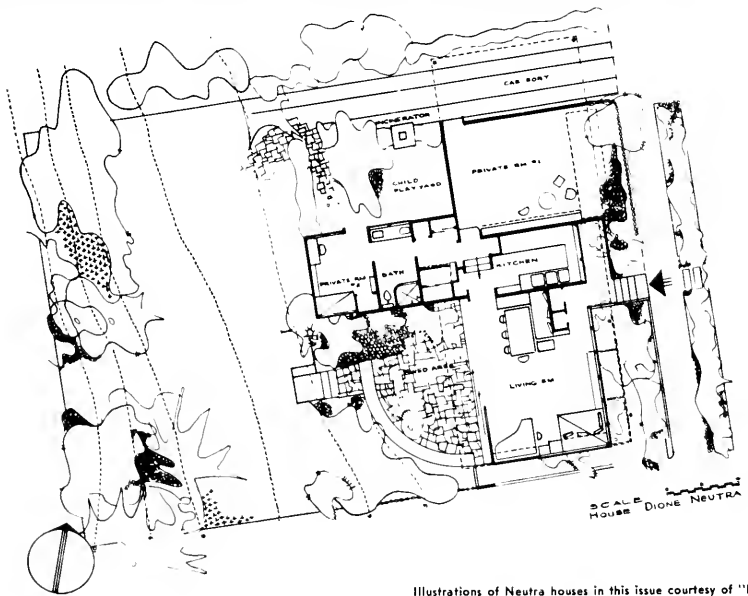
Fine Water Colors and Papers  
For Architectural Renderings

**H. S. CROCKER  
COMPANY, Inc.**

720 MISSION STREET  
Market Street at Second • San Francisco



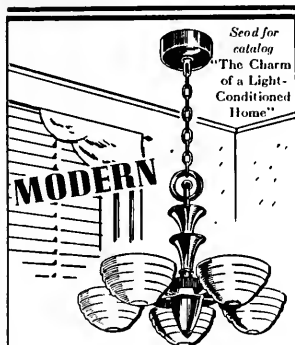
**HOUSE IN LOS ANGELES, CALIFORNIA**  
Richard J. Neutra, Architect



Illustrations of Neutra houses in this issue courtesy of "Housing"



Send for catalog  
"The Charm  
of a Light-  
Conditioned  
Home"



**MODERN**

No furnishings you can buy for so little will give you as much long term satisfaction as a new Lightolier fixture.

**INCANDESCENT  
SUPPLY COMPANY**  
726 MISSION STREET, SAN FRANCISCO

## ARCHITECTS VS. GOVERNMENT WORK

Although the participation of government and industry in building operations is desirable, the actual work of design and construction should be delegated to private architects, says a statement by Albert Kahn of Detroit, Fellow of the American Institute of Architects.

A stereotyped architecture and the loss of professional initiative are the consequences of regimentation, Mr. Kahn, designer of many notable industrial structures, points out.

"There can be no question about the desirability, even necessity of Governmental — both Federal and State — participation in the preparation of plans and the carrying out of building operations," Mr. Kahn says. "This statement applies equally to private enterprise.

"Familiarity with requirements, the result of repeatedly solving the same or similar projects is invaluable in the development of plans, and the Government as well as private industry would fail in their duties if proper agencies for directing the planning and construction of buildings were not provided.

"Whether, however, Government bureaus or industrial organizations may undertake the actual preparation of plans — the supervision, even the construction of the work, in the hope of producing the best results, is a very serious question. The objections to such a plan in Government work are:

"First, there is too much work to be done for any one department to handle successfully. The Procurement Division of the Treasury Department, for instance, employs many hundreds of men; the Army, Navy and other divisions, many more hundreds. It is utterly impossible to manage such groups with certain regimentation which must interfere with creative work.

"Then, the red tape that necessarily obtains in such organizations is another objection. It is apt to destroy initiative.

"Standardization must be the rule, and this makes for stereotyped results. The best incentives are lacking for individuality and men grow into a rut,

*Here's how  
Easy it is to*  
**BANK WITH US  
BY MAIL**

- 1 Write for simple instructions on opening a mail account.
- 2 Mail us deposits in special envelopes which we provide.
- 3 We send by return mail a receipt for every deposit and forms for the next mailing.
- 4 Statements are sent monthly, and additional check books as requested.

*Why don't you avail yourself  
of this convenient banking  
service today?*

**CROCKER FIRST  
NATIONAL BANK**  
OF SAN FRANCISCO  
*California's Capital National Bank*

Member Federal Deposit Insurance Corporation

Phone GARfield 1164

## Hunter & Hudson

*Consulting Engineers*

DESIGNERS OF HEATING  
AIR CONDITIONING  
VENTILATING AND WIRING  
SYSTEMS, MECHANICAL  
AND ELECTRICAL EQUIP-  
MENT OF BUILDINGS

41 SUTTER STREET  
ROOM 110

San Francisco California

## Robert W. Hunt Company ENGINEERS

Inspection - Tests - Consultation  
Schools and Other Structures  
Are Built as Designed

*When Construction Materials are  
Inspected at point of Manufacture  
and during Erection by*

ROBERT W. HUNT COMPANY

*Cement, Concrete, Chemical, Metallurgical,  
X-Ray and Physical Laboratories*

Chicago - New York - Pittsburgh  
Los Angeles - All Large Cities  
San Francisco, 251 Kearny Street

## THE TORMEY COMPANY

GENERAL PAINTERS  
AND DECORATORS

Phone UNderhill 1913

563 FULTON STREET  
San Francisco

## G. P. W. JENSEN & SON

Building Construction

320 Market Street, San Francisco  
Phone: GARfield 2444

**ABBOT A. HANKS, INC.**  
**Engineers & Chemists**

INSPECTING — TESTING — CONSULTING  
CONCRETE • STEEL • MATERIALS  
CHEMICAL AND TESTING  
LABORATORIES

- RESEARCH AND INVESTIGATION •

TESTS OF STRUCTURAL MATERIALS  
DESIGN OF CONCRETE MIXES  
SHOP AND ERECTION INSPECTION OF  
STRUCTURES AND EQUIPMENT  
INVESTIGATION OF STRUCTURES  
AND MATERIALS  
TESTS AND INVESTIGATION OF  
FOUNDATION SOILS  
FIRE RESISTANCE AND INSULATION  
TESTS

624 Sacramento Street, San Francisco

**MULLEN MFG.  
COMPANY**

**BANK, STORE AND OFFICE  
FIXTURES—CABINET WORK  
OF GUARANTEED QUALITY  
CHURCH SEATING**

Office and Factory:  
60-80 RAUSCH ST., Bef. 7th and 8th Sts.  
San Francisco  
Telephone UNderhill 5815



**HERRICK  
IRON WORKS**

**STRUCTURAL STEEL  
REINFORCING STEEL**

18TH AND CAMPBELL STS.  
OAKLAND, CALIF.  
Phone Glencourt 1767

**FORDERER  
CORNICE WORKS**

Manufacturers of  
Hollow Metal Products  
Interior Metal Trim  
Elevator Fronts and Cabs  
Metal Plaster Accessories  
Sanitary Metal Base  
Metal Cabinets  
Flat and Roll Metal Screens  
Commercial Refrigerators

269 POTRERO AVE.  
San Francisco, Calif.  
HEmlock 4100

often become indifferent, and do not keep informed on the advances of the profession."

In private industry where smaller architectural departments often exist, many of the same objections apply, Mr. Kahn holds. "The technical knowledge concerning the particular product to be housed and acquaintance with detailed requirements are, of course, of prime importance in planning, but the men engaged by these private concerns are generally of limited capacity or little versed in the advances made in the profession. On the other hand, men successfully engaged in private practice must be on their toes, as it were, and keep fully informed if they are to meet competition.

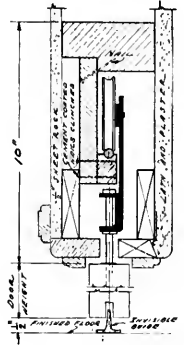
"They are, therefore, in a position to materially contribute to and greatly benefit the work. The employment of a competent private practitioner should result in a fresh attack upon problems, a greater enthusiasm in solving their intricacies, and above all, furnish the assistance of men often more skilled in design and construction than the groups gathered in Government bureaus or by individual organizations.

"Then, too, we must voice the complaint that unnecessary competition on the part of Government with private practice works a hardship on the individual architects, who often, in times of stress such as of recent years, would be wonderfully heartened and uplifted by the opportunity to share in the work carried on by the Government and would in numerous cases be enabled to keep their offices open and their employees at work.

"Nor is the statement that the employment of private practitioners results in delay in the preparation of plans entirely tenable. Such delays when they occur are generally traceable to improper choice of private architects, politics too often playing an important part.

"Any well organized private office should with the very efficient cooperation of officials and staffs of government agencies produce superior results practically, artistically, as well as economically. That Government offi-

**Pitcher  
DOOR SYSTEM**



Includes Closet Doors, Interior Disappearing Doors, Exterior French and Screen Doors, Tandem Doors for Wide Openings, Sliding Partitions, Folding Doors, Garage Doors. Send for Details.

**E. C. Pitcher Co.**

557 Market St., San Francisco  
Phone YUkon 1543

**Independent  
Iron Works**

Structural Steel  
Ornamental Iron  
Steel Service Stations  
Steel Tanks  
Standard Steel Mill Buildings  
Bridges

821 Pine Street      Oakland

**ANDERSON  
&  
RINGROSE**

General Contractors

320 Market Street, San Francisco  
Phone GARfield 2245



## Wm. Penn Hotel

2208 West 8th St.  
Los Angeles, Calif.

200 Rooms  
200 Baths

One in Room..... \$200  
Two in Room..... \$250

Attractive weekly and monthly rates.

Professional men will appreciate the good food at moderate prices in our Quaker Grill.

## JOHN CASSARETTO

—Since 1886—And Still Active—

### Building Materials

READY MIX CONCRETE  
ROCK - SAND - GRAVEL - LIME  
CEMENT - PLASTER - MORTAR  
METAL LATH - WOOD LATH  
STUCCO - WIRE NETTING

### Service Unexcelled

Bunkers

Sixth and Channel, San Francisco  
Phones: GARfield 3176, GARfield 3177

## VAUGHN - G. E. WITT Co.

Manufacturers and Distributors

Pump Governors	Oil Heaters
Safety Pump Governors	Relief Valves
Automatic Gas Regulating Valves	Oil Burner Governors
Gas Burning Equipment	Oil Burners
Vacuum Pump Governors	Oil Pumping Sets
Vacuum Regulating Valves	Oil Valves
Continuous Flow Steam Traps	Oil and Steam Strainers
Thermostats	Duplex Oil Pumps
Reducing Valves	Rotary Oil Pumps
	Boiler Feed Pumps
	Water Heaters
	Boiler Feed-Water Regulators

4224-28 Hollis St., Emeryville, Oakland

ciels recognize the advantages of employing outside engineers is proven by the fact that when an emergency arises, such are often called upon to help."

Preparation of working drawings by private enterprise, also generally proves a mistake, though the fact is not always realized, Mr. Kahn explains. "Comparison of work done in this manner with that produced by competent private practitioners definitely proves this," he continues.

"In most instances, the former employs a small group of men usually for maintenance work. This then is increased by such assistants as are available. This rarely means the best for they are, as a rule, employed. A mixed group of this kind can hardly be expected to produce results equal to those of a competent experienced organization.

"The plan is generally adopted to effect economies in both preparation of plans and in construction, but usually the opposite obtains. Where problems involve building around secret processes, there may be reason for undertaking their own work, but ordinarily the work of the private concern can not compare with that of the experienced professional.

"One particularly unfortunate system often employed by private enterprise is to have contracting firms render architectural service, such being entrusted with the working up of preliminary sketches prepared by the owners. Little do the latter appreciate the risk involved.

"Properly equipped architectural organizations with carefully prepared plans and specifications will produce infinitely better results and through competitive bidding, lower costs; besides which, the employer of the private architect places someone disinterested in charge of the work, thereby protecting the interests of the owner.

"The problem of the participation of the Government as well as private enterprise in the practice of architecture is doubtless not confined to the United States alone. It is possible that a satisfactory solution of the questions



**WOMEN** go into raptures over this new Wesix "Perfect Thirty-Six" electric bathroom heater. Its instant, head-to-foot heat, they exclaim, "is simply marvelous!" You will like it because it fits perfectly into 42-inch wainscots. For details write Dept. 206, Wesix Electric Heater Co., 390-1st St., San Francisco.

**WESIX**

World's Largest Manufacturers of Major Electric Heaters

## F E R R O - PORCELAIN

A permanent and beautiful exterior finish . . . particularly adaptable to modern design. Eliminates upkeep costs . . . such as painting . . . choose your own color.

The entire fronts of the Chestnut Tree restaurants in San Francisco are Ferro-Porcelain Enamel.

We will be pleased to work out details for Ferro-Porcelain construction in connection with most any type of building.

**FRANK ALLEN CO.**  
Ferro-Porcelain Constructors

320 Market St.  
San Francisco

832 W. 5th St.  
Los Angeles

## INCLUDE TREES IN YOUR PLANS

DAVEY, ORIGINATOR OF TREE SUR-  
GERY, OFFERS FREE INSPECTION  
AND ESTIMATE.



**DAVEY**  
**TREE**  
SURGERY CO., LTD.

SAN FRANCISCO Sutter 3377  
Russ Bldg.

FRESNO  
Mottei Bldg.

LOS ANGELES Tucker 1929  
Story Bldg.

Local phones in: Pasadena, Palo Alto,  
Oakland, San Rafael, San Mateo

**SKILL - KNOWLEDGE -  
RESPONSIBILITY**

## DINWIDDIE CONSTRUCTION COMPANY

•

## BUILDERS

•

CROCKER BUILDING  
SAN FRANCISCO

HIGH GRADE MILLWORK  
AND INTERIOR FINISH  
SASH AND DOORS

## LANNOM BROS. MFG. CO.

FIFTH AND MAGNOLIA STREETS  
OAKLAND, CALIFORNIA  
Telephone: TEmploer 3663

involved has been reached in other countries. It is equally probable that the nature of the relations between the Government, private enterprise and the private practitioner, differs in other countries, that perhaps in some places the questions raised do not exist."

### CITIES OF THE FUTURE

Cities of the future will be "fortified," Michael Rosenauer, Fellow of the Royal Institute of British Architects, declares in a survey of "The Architect's Position in the Present Period of Emergency" prepared for the American Institute of Architects.

"Just as the plan of a medieval town with its fortified surrounding walls reflects in its defense precautions the kind of attack to which it was exposed, so the future planning of our cities will be directed by defense precautions against attacks from the air," Mr. Rosenauer says.

"A wide field of interesting prospects opens here for the planner, not only with regard to construction problems, but also with regard to social, urbanistic and design problems."

Public shelters should be constructed as dormitories, Mr. Rosenauer points out in comparing American and British conditions. "According to actual experiences of London, the time people have to spend in shelters extends over a longer period than originally anticipated when indiscriminate bombing was not calculated with," he explains. "Any shelters offered to the public should consequently be regarded as dormitories with the safety degree of bomb-proof shelters.

"The protective qualities of a bomb-proof construction allow the assembling of people and permit a centralized organization in its design. Such organization facilitates the installation of adequate plants for air conditioning, protective measures against gas attacks, the proper arrangement of first-aid and cleansing stations which form an integral part of shelter constructions.

"Bomb-proof shelters can be planned on a sufficiently spacious scale to offer numerous possibilities for peacetime use, thus balancing the greater

capital outlay. Their design should take advantage of the fact that the effect of bomb explosions on shelter walls above and below ground indicate lower construction costs for shelter space above ground than for basement floors.

"The provision of shelters in large individual buildings requires careful survey of existing structural conditions, as well as elaborate studies of possible shelter locations inside the buildings. The British regulations make the buildings owner responsible for these provisions and grant a subsidy for work in this connection. The planning of this category of shelters was usually entrusted to private architects. Private architects also planned and supervised the construction of individual shelters in private houses.

"The adaptation of hospitals for war-time use is a precautionary measure of major importance. Only timely preparation of work based on comprehensive schemes can help to avoid disruption and tragedy. Even if hospitals in large cities might only be considered as clearing stations for patients to be evacuated to country hospitals, the proper function of medical services during a period of emergency has to be secured.

"Selected parts of hospital buildings have to be structurally strengthened to a degree which gives a certain number of wards shelter-proof quality. It will, in most cases, be found advisable to add to existing buildings one new bomb-proof wing and house there a group of operating theatres with attached accident and surgical wards, installed with entirely independent plants for mechanical services."

"These problems caused by the vulnerability of our cities from the air are, in their first appearance, of mere technical nature, but when we visualize them as linking elements to future construction, their architectural properties at once become clear to us. The fact that we are confronted with the possibility of air attack is bound to direct not only the method of protection in case of emergency, but also the whole system of future constructions, as well as the organization of our cities."

ARCHITECT  
AND  
ENGINEER

**NOVEMBER 1941**

**RECENT WORK OF ALBERT FARR AND J. FRANCIS WARD**

USE "PENNVERNON" . . .  
NOT JUST "WINDOW GLASS"



**ATTRACTIVE** windows deserve a quality window glass.  
A window glass like Pennvernon. It is clear. Unusually free from flaws.  
Brilliant and reflective on both sides of the sheet. Each light is paper-packed.

DISTRIBUTED BY

**W • P • FULLER & CO**

BRANCHES AND DEALERS THROUGHOUT THE WEST

# **RUNNING FIRE** — By **MARK DANIELS, A. I. A.**

## • **MODERNISM**

John Dewey, professor of philosophy at Columbia University, wrote:

"Man differs from the lower animals because he preserves his past experiences. . . . With the animals, an experience perishes as it happens . . . but man lives in a world where each occurrence is charged with echoes of other things. . . . And all this marks the difference between bestiality and humanity, between culture and mere physical nature, is because man remembers, preserving and recording his experiences." Traditional architecture, so called only to lug it into a useless argument, embodies elements of past cultural motifs. We see in them, here and there, bits of ornament, masses and shadows, angles and reveals that flash before our unconscious minds pictures that recall past evolutions that have transpired to develop us from a mollusk to a man. Most intellectuals like these flashbacks of development; all of us need them. Professor Dewey's analysis of philosophy has fairly well presented one phase of tradition in architecture. The increasing number of discussions of the comparative merits of modern as against traditional architecture seem to me to be predicated upon an ambiguous premise, for modern architecture can be traditional, and vice versa. Further, good architecture was always modern, but the reverse cannot be truthfully said.

Confusion of the issue is largely the result of the contentions of certain extremists that if the traditional element is strongly brought out in a structure it cannot be good; that it can only be good when the traditional element has been ignored and the modern method of handling certain elements, such as fenestration, is employed. The late Francis McComas, whose paintings and charcoals have been acclaimed by the moderns, finally built himself a house and studio in the Spanish style. He said that while it was not modern, it exactly fitted what he needed; and until his death, he was completely satisfied with it as a home and studio, wherein he executed some of the world's finest modern charcoal studies. Some men have weak eyes and do not like too much light in their houses. One famous writer does his best work where he cannot see out of a window. There is no logical reason why these existing requirements of today cannot be satisfied in either modern or traditional style.

As to the overworked expression, "functional," good architecture has been, and always will be functional—whether it was Hotientot, Egyptian, Chinese, Greek, Roman, Gothic, or 1941. In the last issue of the ARCHITECT & ENGINEER this column pointed out a possibility of over-modernizing to the extent that men might live underground and condemn convicted criminals to live in the open air as a punishment for their crimes. These reductio ad absurdum are not proper to any discussion but they do throw some light upon the subject. Some of our leading architects who are ardent exponents of the modern government have lately adopted almost in toto, structural designs that were used in Egypt more than 1,000 years ago and in China 500 years ago. Where they

fill the requirements of today they are as appropriate as ever; where they do not, they should not be used, and other methods of satisfying present-day conditions should be devised, whether they be in the modern style or not.

Most of these discussions are occasioned by the use of the misnomer, "modern architecture." To my way of thinking, what is usually meant is architecture in the modern style and when so considered is as reasonable as architecture in any other style, if it is good. After all, it is more important to know whether the work is "architecture" or not, rather than whether it is "modern" or not.

## • **PUBLISHERS' GRIEF**

The publishers have their own dilemmas, and it is not always easy for them to get off the horns. When the publisher decides to show pictures of the work of an architect whom he particularly admires, he is confronted with the problem of whether to publish that work as examples of the architect's ability or to run pictures that redound to the credit of the architect's client. Sometimes the best pictures sent in are of minor work, and some of the worst are of important buildings done for the architect's biggest client. If the publisher shows the pictures of structures for their sheer beauty and does not build up on the work for the important client, he may be helping the architect's reputation but hurting his practice. Added to this, if the publisher is not advised as to which is of importance to the architect, he is in a still worse position.

It's a fix. What would you do?

## • **ANOTHER PARADOX**

It is universally conceded that the principles of the relation between labor and government in the totalitarian states is more inimical to the interest of labor than in any other form of government. It would seem, therefore, that a common-sense procedure on the part of labor would be to bend every effort toward assistance to those countries that are fighting the totalitarians.

But the contrary seems to be the case, at least in this country; for here we find the unions, supposedly representing labor, putting forth great effort in effective attempts to block steps of our government toward producing materials that are essential to the defeat of the greatest of all totalitarian governments.

But this is not the first time, nor will it be the last, when the action of the unions appears to be an effort to defeat themselves. No doubt it is a form of blind expediency under the guise of the misdirected belief that "they will get theirs first" and fight out any disastrous consequences after they have "got theirs." 4

## • **AN ARCHITECTS' UNION**

Some months ago at a meeting of the State Association of California Architects, a member brought up for discussion the advisability of organizing an architects' union. In general, the plan was to develop a

(Turn to Page 71)

*A handsome, long-lived floor of Nairn Linoleum in a ward of St. Agnes Hospital, White Plains, New York.*



*The new trend in the hospital  
field—more modernization  
less new construction*

● Realizing the growing scarcity of many building materials for new construction, hospital authorities feel that now is the time to concentrate on the renovation of existing buildings. A frequent disadvantage of older buildings is their worn wood floors. In Nairn Linoleum architects find a floor specification that fulfills every modern hospital requirement.

For one thing, Nairn Linoleum reduces foot-traffic noises to a minimum, providing the quiet so necessary for patients. And its resiliency makes it easy on the feet. (Lessens foot-fatigue of the staff and increases efficiency.) Nairn Linoleum more than gives the

sanitary features that hospitals require. Authorities find its proven germicidal property (unobtainable in other types of flooring) a valuable asset. And its smooth surface has no cracks to collect dirt and germs . . . Keeps spick and span with a minimum of cleaning and waxing.

From an economy standpoint too Nairn Linoleum is ideal. Moderate in first cost, negligible in upkeep expense, this modern linoleum "takes" years of long hard foot-traffic with hardly a sign of wear. For wards, rooms, offices and corridors alike, Nairn Linoleum gives hospitals a permanent, trouble-free specification.

When installed by Authorized Contractors, Nairn Linoleum is fully guaranteed.

CONGOLEUM-NAIRN INC., KEARNY, N. J.

**NAIRN**

**Linoleum Floors and Walls**



# ARCHITECT AND ENGINEER



## NEXT MONTH

With the American public's growing appetite for liquor the demand for attractive drinking establishments and cocktail lounges has given architects opportunity to display their versatility by designing bars that are different. One such lounge has recently been completed in San Francisco from plans by J. Lloyd Conrich, architect. It is called "Zanzibar" and is a combination of Chinese and Polynesian architecture with a dash of modern and native African to relieve the monotony. The interior is virtually a South Sea village composed of seven small native huts, a Chinese temple and a bar. The bar is bamboo and over it is draped a tappa cloth canopy. Some interesting photos and a plan in Architect and Engineer for December will give you a better idea of this unique project.

The modern trend in architecture is emphasized in a group of buildings for the California Institution for Men at Chino in San Bernardino County. This much-publicised project, involving the expenditure of large sums of public moneys, appears to have been successfully completed after some unpleasant newspaper publicity, and the illustrations bear out the assertion that the State is about to put in operation "the most scientific penal program of rehabilitation in the country."

The Federal Works Agency has recently completed a new City Hall for the city of Fullerton in Southern California. It is a two-story reinforced concrete structure of early Spanish design. You will be astonished at the low cost of this WPA project.

A. L. Brinckman, formerly Building Inspector of the City of Berkeley, now a member of the faculty of the University of Hawaii, has prepared a special article for Architect and Engineer presenting an original idea for the design of small retaining walls. Drawings and tables are used to illustrate.

Volume 147

November, 1941

Number 2

<b>Running Fire</b> . . . . .	<b>1</b>
Mark Daniels, Architect	
<b>News and Comment on Art</b> . . . . .	<b>10-11</b>
Irving Morrow, Architect	
<b>Work of Farr and Ward</b> . . . . .	<b>19</b>
Mark Daniels, Architect	
<b>Substitution in Building Codes</b> . . . . .	<b>43</b>
Anson Boyd, State Architect	
<b>Material Shortages and National Defense</b> . . . . .	<b>48</b>
<b>Planning For Post-War Housing</b> . . . . .	<b>53</b>
Leon H. Keyserling	
<b>With the Architects and Engineers</b> . . . . .	<b>57</b>
<b>Architects Bulletin—Convention Report</b> . . . . .	<b>61</b>
Harris Allen, Architect	

### PLATES AND ILLUSTRATIONS

<b>Residence of Walter E. Buck, Woodside, Calif.</b> . . . . .	<b>18</b>
<b>Work of Farr &amp; Word, Architects</b> . . . . .	<b>20-40</b>
Studio for A. W. Woodruff	
Ski Lodge for Frank S. Hanlon	
Residence of W. E. Jason	
Residence of Felix Kahn	
Milton Hess Estate, Los Altos	
Residence of Maurice L. Goldman	
Offices of Consolidated Chemical Industries	
House of Eugene Elkus, Marin County	
Residence of R. B. Robinette, Jr., Los Altos	
<b>House in Orinda, California</b> . . . . .	<b>42</b>
Reynolds & Chamberlain, Architects	
<b>House in Oakland</b> . . . . .	<b>52</b>
Reynolds & Chamberlain, Architects	

EDITOR, FRED'K W. JONES; ASSISTANT EDITOR, E. N. KIERULFF; CONSULTING AND CONTRIBUTING EDITOR, MARK DANIELS; ADVERTISING MANAGER, R. W. WALKER. REGULAR CONTRIBUTING EDITORS: Harris C. Allen, Harry Sanders, Ben H. O'Connor, Glenn Stanton, Roi L. Morin, Chas. H. Alden, Irving F. Morrow. HONORARY EDITORS: Arthur Brown, Jr., Timothy L. Pflueger, Lewis P. Hobart, Wm. W. Wurster, Will G. Corlett, Frederick H. Meyer, Thos. J. Kent, Gordon B. Kaufmann, Paul R. Hunter, Michael Goodman, Harry Michelsen.

ARCHITECT AND ENGINEER is published on the 15th of the month by The Architect and Engineer, Inc., 68 Post Street, San Francisco. President, K. P. Kierulff; Vice President, Fred'k W. Jones; Secretary and Business Manager, L. B. Penhorwood.

Entered as second class matter, November 2, 1905, at the Post Office in San Francisco, California, under the Act of March 3, 1897. Subscriptions, United States and Pan America, \$3.00 a year; foreign countries \$5.00 a year; single copy \$ .50.

Los Angeles office: 1709 W. 8th street, Wentworth Green, Manager. Phone EXposition 8292. ARCHITECTS REPORTS are published daily from this office and are sponsored by the Northern Section, State Association of California Architects; Vernon S. Yallop, Mgr.

# Livability



Residence of Mr. and Mrs. W. E. Jason, Jr., Atherton, California.  
Albert Farr and J. Francis Ward, Architects

*Farr & Ward,*

SAN FRANCISCO ARCHITECTS SPECIFY

**BILTWEL and  
TORIDAIRE**

**GAS HEATING UNITS**

These well constructed  
gas furnaces make for bet-  
ter livability in any home.

*Manufactured by*

**FRASER AND JOHNSTON CO.**

725 POTRERO AVENUE . . SAN FRANCISCO  
CALIFORNIA

# HEATING

in all Farr and Ward Buildings

illustrated in this issue by

**DAVISON  
SHEET METAL WORKS**

Lowell Davison

1250 Ninth Avenue, San Francisco

Overland 9061

**TEAMWORK**  
for  
**SECURITY**

**GOLDEN GATE • OLD MISSION**  
PORTLAND CEMENT      PORTLAND CEMENT

**MILCOR**

METAL LATH PRODUCTS

**EMPIRE**

GYPSUM PLASTER

**STANDARD**

GYPSUM PLASTER

**PACIFIC**  
PORTLAND CEMENT COMPANY

**FOR SOUND CONSTRUCTION**

# Specification" for

# CAREFREE LIVING . . .



HOME OF MR. AND MRS. F. C. WEST  
Menlo Park, California

Designed by Architect Chester Root, Higgins & Root, San Jose, this attractive home is built around the family's needs. ☆ Contributing to household ease and freedom are a modern gas range, gas water heater and gas furnace. They make life smoother, simpler and more healthful.

## . . . MODERN GAS EQUIPMENT

*Livability* marks the modern home and *gas equipment* marks the plan that best achieves it. As architects and owners agree, all-gas specifications mean *liberation* from the 4 Big Jobs. ☆ Then cooking, refrigeration, water heating, space heating . . . all become merely four easy steps in better living. For *gas* is the fastest, most flexible fuel and . . . as budgets eloquently testify . . . the most economical. ☆ To architects and builders, all-gas planning means *prestige* . . . the extra bonus of client satisfaction; to the owner, years of trouble-free service. ☆ Your Gas Company offers technical consultation, free upon request. Ask for this helpful advisory service on your next job, large or small.

# GAS

FIRST CHOICE



# 4

COOKING \* WATER HEATING \* HEATING \* REFRIGERATION

# If IT WERE YOUR HOME

●

If you were building a home for your self today, wouldn't you give serious thought to the wiring? Wouldn't you have enough outlets to serve all the appliances you might want to use? Wouldn't you plan the placing of outlets carefully so that you could attach appliances without resorting to calisthenics?

Would you leave to chance your lighting, which has power to enhance or destroy the atmosphere of the room you created? Wouldn't you plan the permanent lighting so that your most important architectural effects were properly emphasized regardless of the lamps that might be added?

Wouldn't you locate switches so that you would not have to walk twenty or thirty feet to turn off the living room light and then make a hazardous return trip in the dark?

Wouldn't you specify in your plans plenty of circuits of ample sized wire to serve all the outlets and lighting fixtures you may have operating at once?

Your client wants the same livability in his home. He may not know how vital good electric service is, but you do know. You know how completely the comfort and convenience of the people occupying the house depend upon smooth electrical service—because you want that kind of service for yourself.

Include electrical adequacy in the plans for every home you design.



## NORTHERN CALIFORNIA ELECTRICAL BUREAU

447 Sutter Street

San Francisco

## STATIC ELECTRICITY IN HOSPITALS

[Bulletin, Illinois Society of Architects]

We built a fish hatchery a number of years ago and one of the requisites was that the pipe be non-corrosive. It was salt water, right on the sea coast. The pipe was available at very great expense; it was composition pipe, non-metallic. It worked perfectly, absolutely resisted salt water. It had only one fault; it killed the fish. There was just enough formaldehyde in the composition to kill the fish.

I was discussing with a sanitary engineer the problem of static electricity in a hospital operating room. It had been thought that air conditioning, that is, a fairly high moisture content or relative humidity would solve the problem of static electricity. For many years hospital operators have worn conductors, chains fastened to the end of their trousers, and so on, and floors have had grids of brass which have been circuited to the water pipes in order to prevent electrolysis, or sparks which are extremely dangerous in the case of many anesthetics. Many of the anesthetics are highly explosive.

It was thought, as I said, that the high humidity of an air conditioning system would overcome this, but the last thesis on the subject published by the American Medical Society shows that there were cases which baffled them for a long time, and that the static was developed by the gas running from the container down the rubber hose to the mouth of the patient and it exploded just at the worst point. High humidity will not prevent that. Wrapping the hose with wire is so far thought to do it.

I think the medical profession, over a period of two years, had a record of about an average of two hundred explosions a year due to static in operating rooms, two of them fatal due to explosion in the lungs, the others running from zero damage up to burns or fright.

—Ernest E. Weihe, Architect, San Francisco.

It is not only necessary to ground the various items mentioned by Mr. Weihe, but also every person and all other things in and about the operating room. There should be a grounded floor grid; surgeons and nurses should not wear shoes with soles of ordinary rubber. However, when persons are grounded there is danger of injury by electric shock from the lighting current when holding or touching a defective fixture.

Light cord extensions should be fixed, that is non-removable; ordinary switches will not do; non-sparking extension sockets and plugs and switches are commercial articles; extension cord sockets and all other lamp sockets should be switches, and lamps should be protected against breaking.

The use or installation of anything and everything that can produce a spark must be avoided. The surgeon's cauting instrument will cause an explosion if explosive mixtures are present; that motors often do spark is common knowledge.

—Richard E. Schmidt, Architect, Chicago.

# *The Advertising Pull of National vs. Regional Magazines*

ONE of these days the so-called regional or sectional publication will come into its own with deserved recognition as the **most important** advertising medium for national advertisers.

If regional publications are the weaker secondary form of advertising media, pray tell what are the daily newspapers, the local radio stations (witness the growth of spot radio), local billboards, streetcar placards, etc.?

The facts are . . . the regional publication has more influence, is more carefully read, is a better advertising medium **because** it is localized or sectional in coverage . . . and because its contents are of direct interest and value to the reader . . . in the case of *Architect and Engineer*, it offers its subscribers who are largely Western—Western architecture for Western requirements. *Architect and Engineer* has been published for thirty-five years, month in and month out, without interruption. It is read by practically every practicing architect in the Western States, is the recognized mouth-piece and authority for the building industry on the Pacific Slope.

Advertisers who wish to get their message to West Coast architects and allied building interests make no mistake when they select *Architect and Engineer* as their medium . . . a fact that has been proven time and again.

## **INDORSED BY STATE ASSOCIATION OF CALIFORNIA ARCHITECTS**

"We have extreme confidence in ARCHITECT AND ENGINEER since it has served beneficially the architectural profession during the many years of its existence. It has kept the entire industry well informed about news of design and building construction. We suggest you give it preference to any other publication of a similar nature for any advertising or promotional work that you wish to convey to the public or the building industry on the Pacific Coast. This magazine should be far more effective for promoting your business than a national publication, because it retains a close contact with the local industries."

*—From a resolution by the State Association of California Architects.*

# DEFENSE DIRECTORY

---

## DIVISION OF INFORMATION — OEM

San Francisco—Dean S. Jennings, Regional Officer; Harry E. Flanagan, Assistant; 260 California Street.

## DIVISION OF PRIORITIES — OPM

San Francisco—Andrew L. Kerr, District Manager, Federal Reserve Bank Building.  
Housing Priorities: James Whiteside

Los Angeles—G. Howard Hutchins, District Manager, 1151 South Broadway.  
Housing Priorities: Kelvin Vanderlip

Seattle—William D. Shannon, District Manager, Stuart Building.  
Housing Priorities: Louis Scarbrough

Portland—J. Fred Bergesch, District Manager, Bedell Building.

## DIVISION OF CONTRACT DISTRIBUTION — OPM

San Francisco—Colonel Frank M. Smith, Area Manager, Federal Reserve Bank Building.

Los Angeles—H. M. Craft, District Manager, Federal Reserve Branch Bank Building.

Seattle—Fred Bold, District Manager, Federal Reserve Bank Building.

Portland—S. A. MacEachron, District Manager, Federal Reserve Bank Building.

Spokane—T. Wilber Weger, District Manager, Old National Bank Building.

## DIVISION OF DEFENSE HOUSING — OEM

Berkeley, Calif.—O. W. Campbell, Associate Regional Co-ordinator, 2121 Allston Way.

Seattle—Louis Scarbrough, Assistant Regional Co-ordinator, Stuart Building.

Los Angeles—Raymond Brummett, Field Adviser, Homes Registration Office, 4185 Leimert Boulevard.

## DIVISION OF TRAINING WITHIN INDUSTRY — OPM

San Francisco—Alexander Heron, District Representative, 260 California Street.

Los Angeles—William K. Hopkins, District Representative, Roosevelt Building.

Seattle—General H. G. Winsor, District Representative, Stuart Building.

Portland—Laurin E. Himman, Representative, Public Service Building.

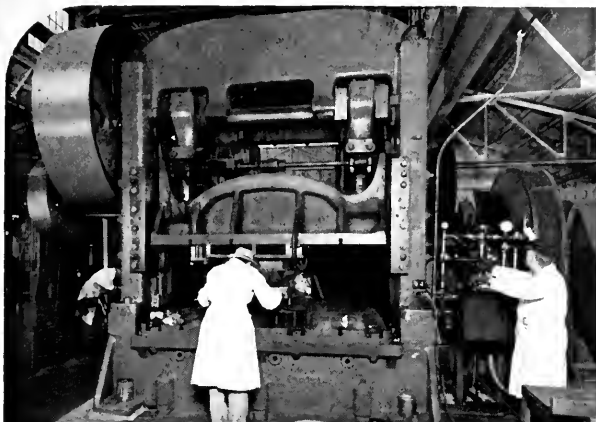
## OFFICE OF CIVILIAN DEFENSE — OEM

Ninth Corps Area

San Francisco—Jack H. Helms, Acting Regional Director, 233 Sansome Street.

## DIVISION OF HEALTH AND WELFARE SERVICES — OEM

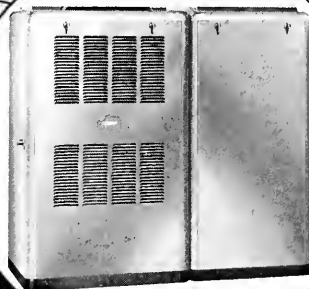
San Francisco—Richard Nenstadt, Co-ordinator, 785 Market Street.



This press, with a capacity of 375 tons, is one of many that make Utility die-formed parts—parts that are uniform, smoothly finished and attractive. This is only one of the many pieces of equipment that give Utility Fan Corporation the largest and most complete sheet-metal facilities in the West.

*Depend on*  
**UTILITY**

*For modern design and sound engineering... accurate testing in complete laboratories... mass production on modern equipment and efficient assembly lines... helpful factory and sales service.*



## **UTILITY FAN CORPORATION**

4851 SO. ALAMEDA STREET • LOS ANGELES, CALIFORNIA

MANUFACTURERS OF FORCED-AIR BASEMENT AND CLOSET FURNACES,  
FLOOR AND DUAL REGISTER FURNACES, CIRCULATING HEATERS AND UNIT HEATERS

## Homes of Outstanding Beauty

Farr & Ward, Architects

OWNERS: A. B. MARCH, EUGENE ELKUS, RICHARD ELKUS, FELIX KAHN AND R. B. ROBINETTE, JR.

*(All illustrated in this issue)*

## Apartment Houses of Distinction

Farr & Ward, Architects

OWNERS: MRS. F. W. L. TYDEMAN AND DR. FRANCIS TORREY

*(Not illustrated)*

# **D. B. GLADSTONE**

*Builder*

557 MARKET STREET • SAN FRANCISCO

# NEWS AND COMMENT ON ART

## FRENCH PAINTING

The small and informal exhibition of nineteenth and twentieth century French painting during October at the Gump Galleries—only some thirty to thirty-five small pictures all told—although quite fortuitous in content and obviously organized with a view to nothing more than showing a few canvases which chanced to be available, became none the less an agreeable and instructive reminder of the vitality and continuity of French art. By no means every important painter was present, and those who figured were represented by pictures generally unknown, and in many cases of minor importance. Yet above the fragmentary and miscellaneous spotting of personalities, subjects and treatments it was gratifying to be able to sense again some of the qualities whose persistence has made French painting one of the significant traditions of modern times—design, objectivity of vision, respect for medium.

Whether the ostensible purpose has been anecdotal, sentimental, didactic or decorative, whether the compelling mood has been submission to or defiance of the subject as such, the force actually motivating French painting has consistently been the pursuit of formal organization. That this pre-occupation need imply neither monumental size and scale nor "serious" subject matter was amply apparent in, among others, the small recumbent nude by Matisse, a firmly organized pattern in yellow, gray and terra-cotta red.

The characteristic French objectivity of vision was felt almost throughout the show. Indeed, the one exception and pointed contrast was Rouault, in whose three small stained-glass-like patterns, be the subject persons or flowers, the painter's eye seemed unaware of an external world and obscurely searching for one within. How objectivity of vision may coincide with variety and independence of attitude was demonstrated by the three flower pieces of Manet, Seurat and Renoir respectively. Each painting had been preceded by a clear visual experience, but in each case that experience acquired a different significance by refraction through a different mind.

French technical ingenuity has devised numberless ways of handling paint. Here, even in the small compass noted, many manners were exemplified—the meticulous brushing-out of Courbet and early Corot; the fond stroking of Renoir; the confident dabbing of Cezanne; the alert and restless spotting of Pissarro and Van Gogh; the casual smearing of Matisse; the prodigal, not to say profligate trailing of Vlaminck. Yet whatever the manner, one sensed the "paintiness" of paint—again excepting Rouault, whose surfaces seemed encumbered with something less fluent than paint, applied with something less tractable than a brush.

The juxtaposition of five Vlamincks prompted the reflection that, whereas there are painters (Renoir, for instance) who have painted literally numberless pictures in a fairly constant style, here is a painter who enjoys the distinction of having never painted but one picture.

To an artist concerned with organization of his materials as an architect must perforce be con-

cerned, every new contact with Cezanne, however slight the motive, becomes a revealing and arresting experience. Cezanne's handling of his materials (both subject matter and medium) resembles Debussy's orchestration in its passionate rejection of everything which does not clearly further the purpose in hand.

## PAINTINGS OF THE GOLD RUSH

One does not habitually look to the general run of art exhibits for excitement, but the paintings of the gold rush at the San Francisco Museum of Art furnished at least one first-rate surprise. To the erudite A. D. O. Browere may have been old stuff, but to me, at least, he came as not only a new experience, but a refreshing one as well. His eight or more pictures varied in interest and in quality, but their technical competence was almost uniformly high. One wonders why they have remained in obscurity, and when we shall see more—merits of the kind and degree encountered in the better ones are not likely to be flashes in the pan.

In reviewing work of the early California painters one is often constrained to admit that historical interest and community pride count for much in a very enthusiastic judgment. Also, one is led to speculate on why paintings of spectacular scenery seldom afford more than very limited artistic satisfaction. Browere's Falls of the San Joaquin and Rocky Mountain Landscape come closer to organizing scenery into satisfying paintings than any of the efforts I can recall off-hand of his better known contemporaries. They are also interesting in that western topographical structure and characteristic feeling unmistakably emerge above a technique and manner developed for the exploitation of landscape of a quite different stamp. His Lone Prospector is a sort of latter-day altar piece wherein the familiar apparatus of early mining replaces the usual trappings of saints and tempters. His Flower Spray, a highly formalized arrangement of lilies and irises against a dark, inert background, impressed me as astonishingly modern in its purely decorative effectiveness.

J. A. Bergner's Front Street—a San Francisco block presented in direct elevation—requires only translation into subtly inbred perspective to make a capital Utrillo. But doubtless San Francisco of the gold rush never provided Bergner a good press.

Irving F. Morrow.

## AT THE GALLERIES

The following announcements have been received from museums and private galleries of events continuing beyond the publication date of the Architect and Engineer:

### CALIFORNIA PALACE OF THE LEGION OF HONOR

#### EXHIBITIONS

History in the Making; One Hundred Wood Engravings by American Artists of the Nineteenth Century; opening November 15.

Thirteen Watercolors; opening November 15.  
Eugene Berman: "Time and the Monuments" (A Decorative Mural with Preliminary Sketches); opening November 17.



# IN AN EVER CHANGING WORLD

## LECTURES

"Color and Form," Rudolph Schaeffer, Director, Schaeffer Studios; Sunday, November 16, at 4:00 p.m.

"Eugene Berman: Painter of Nostalgia," Dr. Jermaine MacAgy; Sunday, November 23, at 4:00 p.m.

"Some Parallels Between Great Art and Great Music," Alexander Fried, Music and Art Critic, San Francisco Examiner; Sunday, November 30, at 4:00 p.m.

## MOTION PICTURES

(Every Saturday at 2:00 p.m. Admission free.)

November 15—"Rien Que Les Heures," directed by Alberto Cavalcanti (1926). "Berlin, the Symphony of a Great City," directed by Walter Ruttmann (1927).

November 22—"Chang," directed and photographed by Merian C. Cooper and Ernest B. Shiedsack (1927).

November 29—"Night Mail," produced by Basil Wright and Harry Watt (1936). "Rhapsody in Steel," directed by F. Lyle Goldman (1935).

## EDUCATIONAL ACTIVITIES

Art Courses—Each Wednesday at 10:30 a.m.

Children's Art Classes—Each Saturday at 10:30 a.m. to 12:00 m.

Gallery Tours for Schools, Clubs, Social Groups. By appointment; Bayview 4611.

## ORGAN RECITALS

Uda Waldrop, Organist. Each Saturday and Sunday at 3:00 p.m.

## RADIO BROADCASTS

"The Art of Eugene Berman," by Dr. Robert Neuhaus; Station KJBS, Sunday, November 23 at 4:00 p.m.

## CITY OF PARIS

Color Woodcuts by Meta C. Hendel, through November 20.

## SAN FRANCISCO MUSEUM OF ART

### EXHIBITIONS

Artists of the Upper Mississippi—Through November 15.

American Sculpture of Today—Through November 16.

First Annual Photographic Salon: West of the Rockies—Through November 16.

Paintings and Prints by Marion Holden Pope—Through November 16.

Mobiles by Alexander Calder—Through November 19.

Junior League Portrait Exhibition—Through November 30.

Drawings and Prints by John Stoll—Through November 30.

Sixteenth Annual Exhibition of the San Francisco Society of Women Artists—Through December 7.

California Watercolor Society Annual Exhibition: San Francisco Showing—Through December 9.

Fine News Photographs of the War—Dates to be announced.

## LECTURES

Decorative Arts Review—The San Francisco Society of Women Artists Annual. Guest Lecturer:



MOTHER AND CHILD by Raymond Puccinelli

Marian Simpson; assisted by other member artists active in the crafts. Sunday afternoon, November 16, at 3:00.

The Venetian Tradition in Painting—Douglas MacAgy. Sunday afternoon, November 23, at 3:00.

Portraits of the Junior League Exhibition. Guest Lecturer: Yvonne Dane. Wednesday evening, November 26, at 8:30.

Painting for Pleasure—John Humphrey. Sunday afternoon, November 30, at 3:00.

The Composers' Forum will present a program of compositions by Ernest Bloch, performed by distinguished artists. Monday evening, December 1, at 8:00.

No public lectures during December and holiday season. Lectures will be resumed January 11, 1942.

## EDUCATIONAL ACTIVITIES

Painting for Pleasure—A Museum Painting Workshop conducted by David Park, Tuesday evenings from 7:00 to 10:00. Adults may stop in any time during the evening to explore for themselves the pleasure of painting, with assistance from a well known painter, under informal and reassuring conditions. All materials are provided for 25 cents an evening.



*Balcony Detail, Residence of Felix Kohn, Seacliff, San Francisco  
Farr & Ward, Architects*

CAST IRON BALCONY and  
WINDOW GRILLS executed by

**FAIR MANUFACTURING COMPANY**

*Miscellaneous and Ornamental  
Iron and Structural Steel*

617 Bryant Street

San Francisco

**FOR THE U. S. A.**  
**Experts Specify AQULUX**

**F**OR DEFENSE and encampment housing—both for heating and for hot water—experts have chosen the Johnson AQULUX for installations all over the country. Note the natural beauty of line and the functional design of AQU-LUX — which is an indication of the competent engineering that has won such wide acceptance.



*Aqulux 85*

See our exhibit, Air  
Conditioning Show,  
Philadelphia, January,  
26-30.

**S. T. JOHNSON CO.**

940 Arlington Ave., OAKLAND, CALIF.  
401 N. Broad St., PHILADELPHIA, PA.

THE HIGH GRADE MILLWORK  
IN MANY OF THE FINE HOMES  
BY ALBERT FARR & J. FRANCIS  
WARD, ARCHITECTS, AND  
ILLUSTRATED IN THIS ISSUE,  
FURNISHED BY

**LANNOM BROS. MANUFACTURING CO.**

Fifth and Magnolia Streets  
OAKLAND, CALIFORNIA



**BETTER LIGHTING FIXTURES**

The picture shows one of our recent  
Farr and Ward installations

**ALFRED J. CASELLA**

*Designers and Manufacturers  
of Period Lighting Fixtures*

1507 Sutter Street, San Francisco

Phone ORdway 4610

# Clay Products and NATIONAL DEFENSE ★ ★

*The clay products of N. Clark & Sons have been used in the following defense projects:*

This country's job today is defense. It is the job both of today and tonight. And as night rolls around at the huge clay products plant of N. Clark & Sons at Alameda, California, men toil while furnaces glow, so that the clay products needs of the United States Army and Navy on the Pacific Coast may be supplied.

These needs have been great. The country's armed forces are large users of clay products. For defense covers much more than airplanes, battleships, tanks and guns. Six and one-half million men are at present employed in the country's building industry. A good percentage of these men are busy constructing barracks, ammunition depots, supply depots and naval and air bases. And of these new facilities, the Pacific Coast is getting a great share.

Each of these units needs various kinds of clay products — Sewer Pipe, Ceramic Glazed Wall Units, Quarry Tile, Special Ventilators, Brick and Ceramic Veneer.

While serving national defense, N. Clark & Sons is not unmindful of the needs of civilian building too. Happily, our facilities are large enough to meet today's broad requirements.



The Army Arsenal at Benecia; Army Air Base, Hamilton Field; Army Air Base, Moffett Field; Army Aviation Cadet Training Field, Stockton; Fort Cromkite, Marin County, Calif.; Fort Scott, San Francisco; Presidio of San Francisco; Letterman Hospital, San Francisco; Fort Ord, Monterey; Camp Clayton, Watsonville; Mare Island Navy Yard; Naval Air Station, Alameda; Naval Supply Depot, Oakland; Navy Ammunition Depots, Hawthorne, Nevada



and Fallbrook, Calif.; Navy Ammunition Depots in various Pacific Islands; Naval Station at Bremerton; Naval Training Station, Yerba Buena Island; Naval Air Station, Sand Point, Washington; Todd-California Shipbuilding Corporation, Richmond; Moore Drydock Corporation, Oakland; Defense Housing projects, Richmond and Vallejo — plus a number of others.



## N. Clark & Sons

116 Natoma Street

San Francisco, Calif.

**LOS ANGELES · SALT LAKE CITY · PORTLAND**



**Producers of Quality Architectural Clay Products for the Western Building Industry**

# AMERICAN ACADEMY IN ROME

NEW YORK CITY

## Announces Competitions for Cash Prizes in Painting and Sculpture Totaling \$3850.00

Under present international conditions the Academy cannot send Fellows to Rome for study, travel and creative work. In order to carry on the policy of aiding and stimulating American Art, the Trustees therefore have decided to offer certain competitive cash prizes to outstanding young artists and students.

For this purpose preliminary competitions will be held in a regional center of each of six districts embracing the United States.

The final competitions will be held in New York City.

In each preliminary competition a prize of \$25.00 will be offered for each of the best ten submissions, five in painting and five in sculpture. After a week's exhibition of all work submitted at each center, the sixty prize-winning designs will be shipped to New York for the final judgment and exhibition.

In the final competitions four prizes will be offered in each subject,—First prize of \$1000; and Second, Third and Fourth prizes of \$100., \$50. and \$25. respectively.

### GENERAL REGULATIONS

The awards will be made after competitions which are open to *unmarried male* citizens of the United States who will be under 31 years of age on June 1st, 1942.

The Academy reserves the right to withhold any prize in case the jury decides that the work submitted is not of sufficient merit to justify an award.

All work is submitted at the owner's risk. The Academy will not assume responsibility for any loss or damage while the designs are in its custody or in transit.

For each subject in the final competitions there will be a jury of artists of national reputation chosen from different parts of the country. For the preliminary competitions the juries will be selected from among well-known artists of the several districts.

### SPECIAL REGULATIONS

#### Prize in Painting

Any man desiring to compete for a Prize in painting must fill in the enclosed application and file it with the Supervisor for his District *before January 1st* (See the following list of Supervisors and Districts).

Each candidate accepted as a competitor must then submit *before April 20th*:

One painting in any medium, 32"x40", framed in a plain moulding not to exceed 1 inch in width.

The submission must be a figure composition but the artist will choose the subject matter.

Landscapes, portraits and still life cannot qualify.

A photographic record of work previously done must also be submitted.

#### Prize in Sculpture

Any man desiring to compete for a Prize in sculpture must fill in the enclosed application and file it, together with six or more photographs of his previous work, with the Supervisor for his District *before January 1st* (See the following list of Supervisors and Districts).

If accepted as a competitor on the merit of his photographs, each candidate must submit *before April 20th*:

A figure or group of figures in uncolored plaster not to exceed 24 inches in any dimension.

A photographic record of work previously done must also be submitted.

### Requirements in Painting and Sculpture

The painting, sculpture and photographs submitted must bear, not the name of the artist, but a pseudonym, and must be accompanied by a sealed envelope bearing on its face the pseudonym and containing within the name and address of the artist.

### Supervisors and Districts

Grace L. McCann Morley, Director,  
San Francisco Museum of Art, San Francisco, California.

Center For: Alaska, California, Hawaii, Idaho, Montana,  
Nevada, Oregon and Washington.

Fred S. Bartlett, Curator of Fine Arts,  
The Denver Art Museum, Denver, Colorado.

Center For: Arizona, Colorado, Kansas, Nebraska, New Mexico,  
North Dakota, South Dakota, Utah and Wyoming.

James Chillman, Jr., Director,  
The Museum of Fine Arts of Houston, Houston, Texas.

Center For: Arkansas, Louisiana, Mississippi, Oklahoma  
and Texas.

Daniel Catton Rich, Director of Fine Arts,  
The Art Institute of Chicago, Chicago, Illinois.

Center For: Illinois, Indiana, Iowa, Michigan, Minnesota,  
Missouri, Ohio and Wisconsin.

Hans Schuler, Director,  
The Maryland Institute, Baltimore, Maryland.

Center For: Alabama, District of Columbia, Florida, Georgia,  
Kentucky, Maryland, North Carolina, South Carolina, Tennes-  
see, Virginia and West Virginia.

Hobart Nichols, President,  
National Academy of Design, Room 1432,  
101 Park Avenue, New York, N. Y.

Center For: Delaware, New Jersey, New York, Pennsylvania  
and the six New England states.

# Clay Products and NATIONAL DEFENSE ★ ★

*The clay products of N. Clark & Sons have been used in the following defense projects:*

This country's job today is defense. It is the job both of today and tonight. And as night rolls around at the huge clay products plant of N. Clark & Sons at Alameda, California, men toil while furnaces glow, so that the clay products needs of the United States Army and Navy on the Pacific Coast may be supplied.

These needs have been great. The country's armed forces are large users of clay products. For defense covers much more than airplanes, battleships, tanks and guns. Six and one-half million men are at present employed in the country's building industry. A good percentage of these men are busy constructing barracks, ammunition depots, supply depots and naval and air bases. And of these new facilities, the Pacific Coast is getting a large share.

Each of these units needs various kinds of clay products — Sewer Pipe, Ceramic Glazed Wall Units, Quarry Tile, Special Ventilators, Brick and Ceramic Veneer.

While serving national defense, N. Clark & Sons is not unmindful of the needs of civilian building too. Happily, our facilities are large enough to meet today's broad requirements.



Cronkite, Marin County, Calif.; Fort Scott, San Francisco; Presidio of San Francisco; Letterman Hospital, San Francisco; Fort Ord, Monterey; Camp Clayton, Watsonville; Mare Island Navy Yard; Naval Air Station, Alameda; Naval Supply Depot, Oakland; Navy Ammunition Depots, Hawthorne, Nevada and Fallbrook, Calif.; Navy Ammunition Depots in various Pacific Islands; Naval Station at Bremerton; Naval Training Station, Yerba Buena Island; Naval Air Station, Sand Point, Washington; Todd-California Shipbuilding Corporation, Richmond; Moore Drydock Corporation, Oakland; Defense Housing projects, Richmond and Vallejo — plus a number of others.



## **N. Clark & Sons**

116 Natoma Street  
San Francisco, Calif.

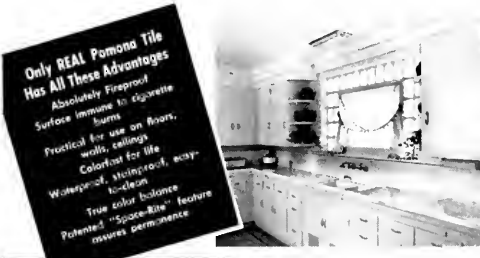
**LOS ANGELES · SALT LAKE CITY · PORTLAND**

**Producers of Quality Architectural Clay  
Products for the Western Building Industry**



# Imitation OR THE Real Thing?

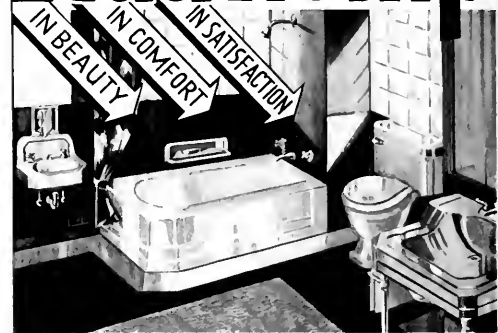
Connoisseurs can tell a genuine "Ming Dynasty" Vase from a copy at a glance. The rich beauty of color and design plus the exquisite workmanship puts it far above inferior imitations. These and other gorgeous art treasures have often been copied but never duplicated. Tile too has its imitators. But never has the permanent beauty, the enduring charm and delightful appearance of REAL POMONA TILE been successfully duplicated. DEMAND REAL POMONA TILE and be assured of lasting beauty in your home. Accept no inferior substitutes.



**Only REAL Pomona Tile Has All These Advantages**  
 Absolutely Fireproof  
 Surface immune to cigarette burns  
 Practical for use on floors, walls, ceilings  
 Colorfast for life  
 Waterproof, stainproof, easy-to-clean  
 True color balance  
 Patented "Space-Rite" feature assures permanence

**POMONA TILE MANUFACTURING COMPANY**  
 629-33 N. LA BREA AVENUE • LOS ANGELES  
 135TH TENTH STREET—SAN FRANCISCO  
 PLANT: POMONA, CALIFORNIA  
 6106 ROOSEVELT WAY—SEATTLE  
 MINES: DEATH VALLEY

# Leadership



## Quality Plumbing Fixtures Since 1896 . . .

- For more than 45 years WASHINGTON-ELJER has produced a complete, fully guaranteed line of vitreous china and porcelain enameled plumbing fixtures. They offer the utmost in modern design, comfort, convenience and quality. Made in the West Exclusively for Western users, WASHINGTON-ELJER fixtures are the logical choice for Western architects.

# Washington-Eljer Co.

4100 South Alameda Street Los Angeles, Calif.

the

# LIVABLE KITCHEN

Architects today are not only designing the kitchen for convenience and efficiency but they are making a livable room of it. To this end Paramount Built-in Fixtures meet the most exacting requirements. Their "Deluxe," "Moderne" and "Economy" cabinet fixtures are distinctive in design and construction and may be had in stock sizes or built to order.

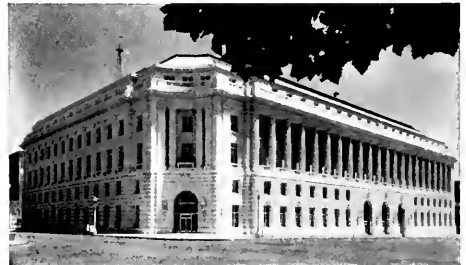
Catalog for the asking

**Paramount**  
 BUILT-IN FIXTURE COMPANY  
 5407 Broadway, Oakland, California  
 Phone PLedmont 3100

## No Worry for the Architect

"—All acid proof drain pipe and fittings shall be ferro-silicon—CORROSIRON—"

(Write for above specification)



FEDERAL BUILDING • CIVIC CENTER • SAN FRANCISCO

Arthur Brown, Jr., Architect

**CORROSIRON** DRAIN LINES and FITTINGS and LABORATORY EQUIPMENT was specified because of its superior resistance to corrosion and wear.

## Pacific Foundry Company, Ltd.

NEW YORK • 3100 NINETEENTH ST., SAN FRANCISCO • LOS ANGELES

**HERE'S A U. S. ARMY AIR CORPS PHOTO OF CALIFORNIA'S LARGEST CANTONMENT**



**FOR NATIONAL DEFENSE — FORT ORD, CALIFORNIA**

29,000 men stationed here are provided with sanitary drinking facilities through the medium of HAWS FOUNTAINS, thus helping materially to maintain the health of those in the service.

Other defense projects equipped with HAWS FOUNTAINS are listed below:

- |   |  |   |  |   |
|---|--|---|--|---|
| <p><b>CALIFORNIA</b><br/>Camp Clayton<br/>Camp Nacimiento<br/>Camp Roberts<br/>Camp McQuaide<br/>Camp San Luis Obispo<br/>Camp Torrey Pines<br/>Camp Haan<br/>Fort Rosecrans<br/>Fort McArthur<br/>Fort McDowell<br/>McClellan Field<br/>Hamilton Field</p> | <p>March Field<br/>Presidio, San Francisco<br/>Stockton Airport<br/>Santa Barbara Hospital<br/>Fresno Airport<br/><b>ALASKA</b><br/>Anchorage<br/>Fairbanks<br/><b>ARIZONA</b><br/>Tucson Municipal Airport<br/>Fort Huachuca<br/><b>FLORIDA</b><br/>Tallahassee Airport</p> | <p><b>GEORGIA</b><br/>Savannah Airport<br/>Fort Sill<br/><b>NEW MEXICO</b><br/>Albuquerque Airport<br/><b>OREGON</b><br/>Columbia Airport<br/><b>SOUTH CAROLINA</b><br/>Charleston General Hospital<br/><b>TEXAS</b><br/>Camp El Paso</p> | <p>Abilene, Texas<br/>Camp Barkeley<br/><b>UTAH</b><br/>Salt Lake City Airport<br/><b>IDAHO</b><br/>Boise Airport<br/><b>WASHINGTON</b><br/>Camp Murray<br/>Fort Lewis<br/>Fort Casey<br/>Fort Worden<br/>Vancouver Hospital</p> | <p><b>NAVAL PROJECTS</b><br/>Supply Depot, Alameda<br/>Supply Base, Alameda<br/>Air Bases, Alameda<br/>Mare Island<br/>San Diego<br/>Sumatra<br/>Pearl Harbor<br/>Maui<br/>Midway</p> |
|---|--|---|--|---|

**HAWS DRINKING FAUCET COMPANY**

1808 HARMON STREET • BERKELEY • CALIFORNIA

Agents in the following cities:

New York • Los Angeles • San Francisco • Seattle • Salt Lake City • Portland



**RESIDENCE OF WALTER E. BUCK, WOODSIDE, CALIFORNIA**  
**Albert Farr and J. Francis Ward, Architects**

Photo F. W. Tjdenan



# WORK OF FARR & WARD

By MARK DANIELS

**As an** example of a firm of non-crusading architects, Farr and Ward justify considerable emulation. By non-crusading I mean that they are not out tilting at windmills of prejudice with their triangle and T-square in the thought that only they can be right, but rather their efforts are directed to rendering the best service their excellent training and wide experience enable them to perform.

Their work indicates that they are not concerned with molding every commission into a preconceived pattern with the trade-mark "Farr and Ward," but rather that they are influenced in the choice of style and the solution of the problem by the consideration of the location and nature of the site, the client's personality and the relative importance of the subject. Although they naturally recognize and endeavor to meet the purely functional problem involved, they have, as opposed to the views of certain of the modernists, striven to maintain a domestic character in their residential work, accompanied by the human and accidental values inherent in the best examples of traditional architecture.

They have practiced architecture without "isms" for over twenty years, with jobs following one another in a continuous uninterrupted stream. They might be called chain architects, for they seem to light one job off another much as Bert Farr (Albert to you, please) lights one cigarette off another. By practicing without "isms" I mean that they are free from the curse of styles and seem to be as much at home with source material drawn from Tudor, Renaissance and French examples as in a frankly modern

solution. The wide variety of styles developed in their structures which, incidentally, fall in an equally wide range of cost, is ample evidence of Farr and Ward's freedom from "isms." From the small house in the Corte Madera hills to the stately Tudor Buck mansion in San Mateo County, the problem seems always to have been approached from the angle of satisfying the client in the most practical manner possible, consistent with good taste. Francis Ward told me that they had a sort of slogan in the office which was, in effect, "Do the job right. Please the client, but do it right." How this policy worked out in one instance is clear from a brief note written by Felix Kahn in reply to a request from me. "There is no information I can give you on my house that will be of interest to anyone; it is just a plain house designed for plain people to live in and it answers this purpose beautifully." Some architects might question the plainness of the house and possibly the plainness of the Kahns. They could not question the satisfaction of the client.

One of the most interesting and unusual problems that I have known to be handed to an architect was the one on which Farr and Ward were engaged to erect a reproduction of the leaning tower of Pisa in Ilgair Park, Chicago. It was unique in that the shell was all but a replica while it serves as a water storage tank and a landmark to be seen from a considerable distance. Like the original, the building stands on the edge of swampy land and the architects, with the help of Thomas Chace, engineer, devised a stable foundation from the vision of a duck bracing itself with web feet stuck out on a

(Turn to Page 31)



**STUDIO FOR A. WILBUR WOODRUFF  
SAN FRANCISCO**



At the left is a replica of the famous leaning tower of Pisa. The 110-ft. tower is in Ilgair Park, Chicago. It is built of precast reinforced concrete and houses the park's high pressure water tank. A circular staircase is for the convenience of romantic view lovers. The original plans provided for a tea room in the lantern at the top.

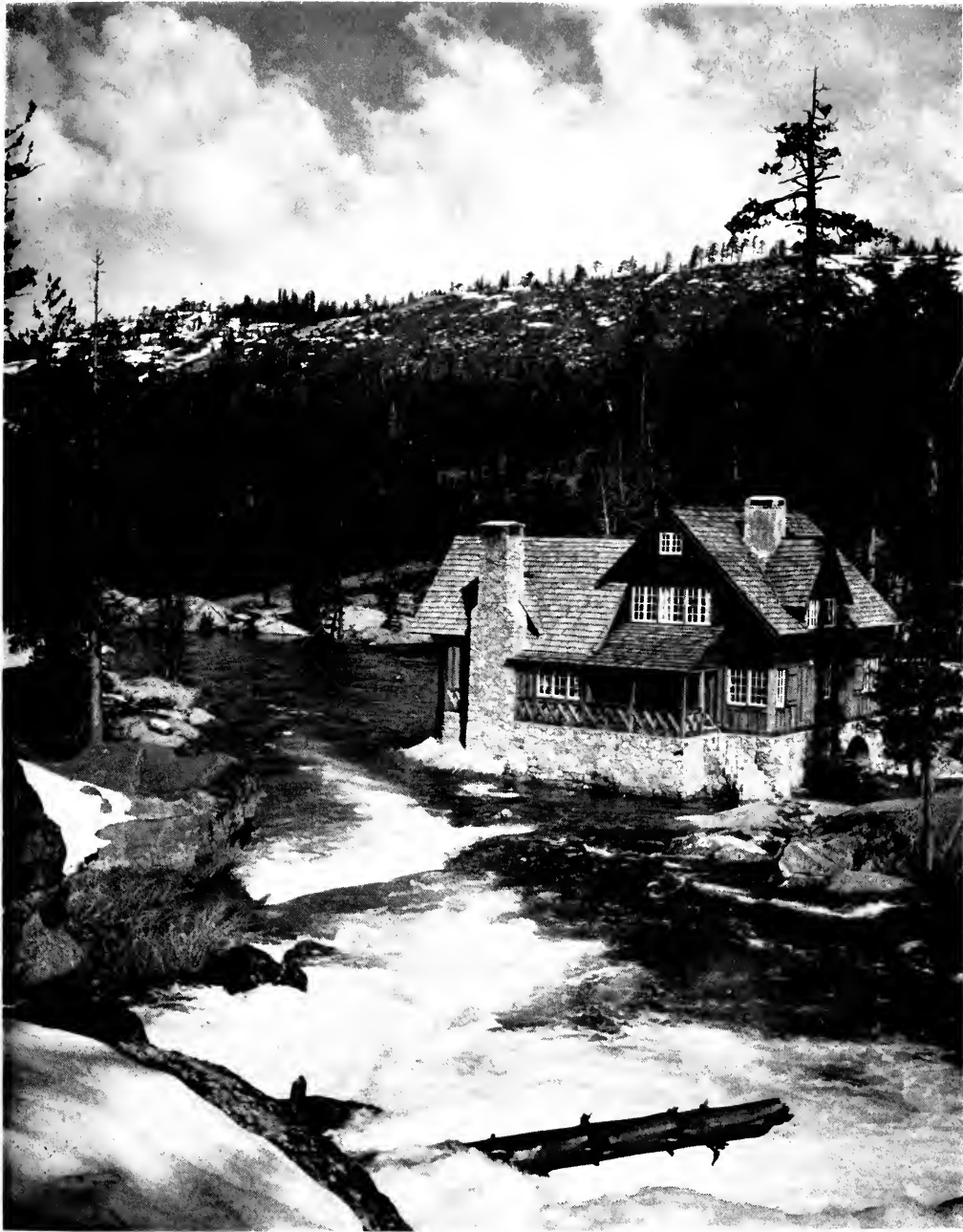


Photo Max Heinegg

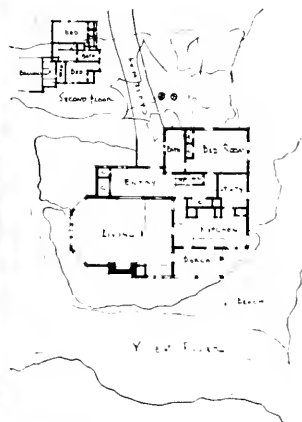
**SKI LODGE FOR FRANK S. HANLON ON THE YUBA RIVER, NEAR CISCO, CALIFORNIA**



**VIEW OF THE FRANK S. HANLON SKI LODGE FROM SOUTH BANK OF YUBA RIVER  
GLACIER GAP, NEAR CISCO, CALIFORNIA**



**LIVING ROOM**

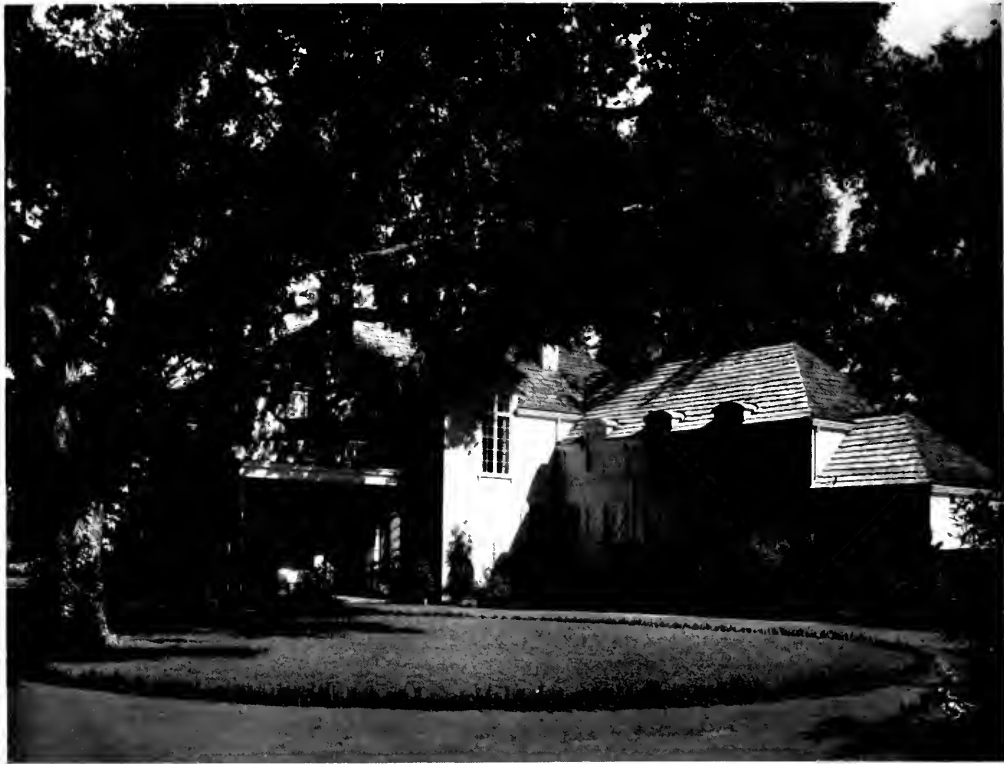


**PLANS**

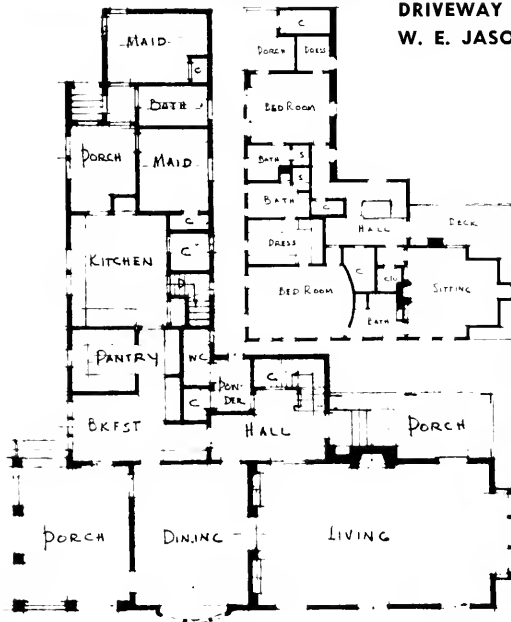


Photo Henry Seutter

**ENTRANCE DETAIL, RESIDENCE OF W. E. JASON, JR., ATHERTON, CALIFORNIA**



**DRIVEWAY APPROACH TO RESIDENCE OF  
W. E. JASON, JR., ATHERTON, CALIFORNIA**

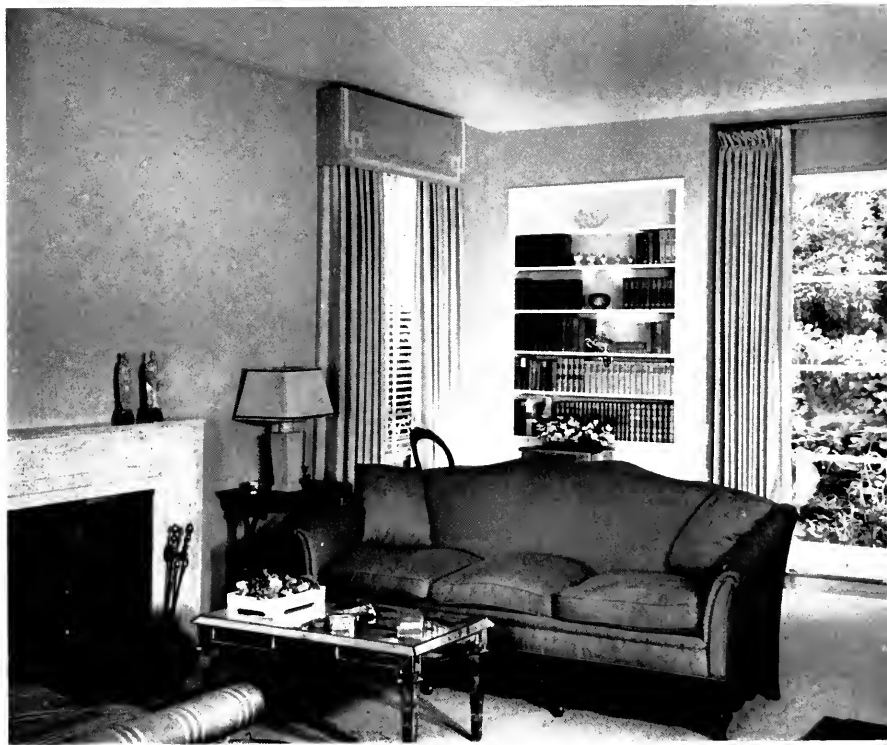


**STAIRWAY DETAIL BELOW**





**ABOVE:**  
**LIVING ROOM**  
**FIREPLACE,**  
**HOUSE OF**  
**RICHARD E.**  
**ELKUS,**  
**SAN FRANCISCO**

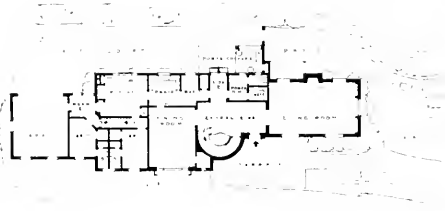
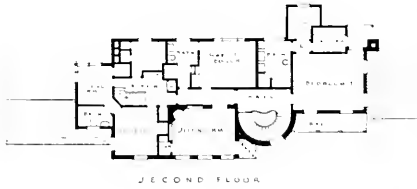


**BELOW:**  
**LIVING ROOM,**  
**RESIDENCE OF**  
**MONROE J.**  
**ROSENSHINE,**  
**SAN FRANCISCO**

Photos Helen H. Ward

# Residence of Felix Kahn, Sea Cliff, San Francisco

ALBERT FARR AND J. FRANCIS WARD,  
ARCHITECTS



The house stands on a long, shallow lot fronting the beach and overlooking the Golden Gate. It is a modern solution of the site with a suggestion of New Orleans manifested in the lacy iron and patio detail. This blending of the old and new is noticeable also in the circular staircase and modern wall treatment of living and dining rooms.

The Pictures:

Above—General view and plans.

Left—Detail of patio.

Right—Staircase and corner of sitting room. Latter has blond mahogany flush paneled walls, plate glass bookshelves.





Photo Helen H. Ward





**FELIX KAHN RESIDENCE,  
San Francisco**

**STREET FRONT**



**LIVING ROOM**



**DINING ROOM**



## FELIX KAHN RESIDENCE, San Francisco

The bathrooms and kitchen are finished in a combination of modern materials: Vitrolite walls, glass brick, aluminum sash, stainless steel sinks and rubber floors.



## RESIDENCE OF E. H. WALTER, HILLSBOROUGH, CALIFORNIA

Photos Helen H. Ward





Photo by Moulin

**ENTRANCE GATE TO MILTON HAAS ESTATE, LOS ALTOS, CALIFORNIA**



**CLUBHOUSE, MILTON HAAS ESTATE, LOS ALTOS, CALIFORNIA**

(Continued from Page 19)

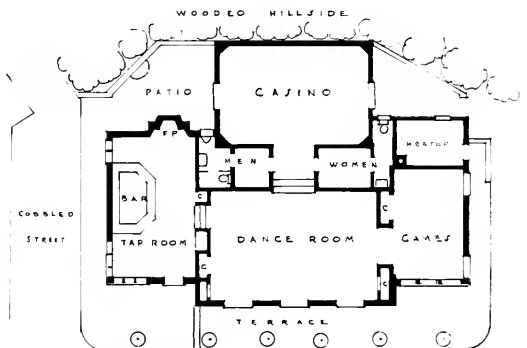
muddy bank. The structure was on a scale 75 per cent of the old "Pisa project." Whether there were any ducks squatting around in Tuscany in the 12th century is not recorded, but since Galileo was born in Pisa about four centuries later, a sense of balance might have been in the air when Pisa's great university was started.

The private casino on the Haas estate is another example of the unusual jobs that have fallen to the lot of Farr and Ward. This pavilion is part of an estate where the idea of providing separate buildings for each activity has been carried out very completely. There are the owner's house, guest house, servant's quarters, a self contained section consisting of bath house, pool and tennis court, and finally the private casino where the guests can dance, and otherwise amuse themselves without disturbing the domestic tranquility of the house. It is to be hoped that the doors in the casino

were padded for decorative effect rather than in anticipation of gaming disputes.

The planning of the Ski Lodge on the Yuba River presented some unusual problems. The owner, I am told, having pointed to an enormous granite boulder lying in the swirling waters of the river said, "Build me a house

[Turn to Page 41]



**PLAN OF CLUBHOUSE**

# THE MILTON HAAS ESTATE, LOS ALTOS, CALIFORNIA



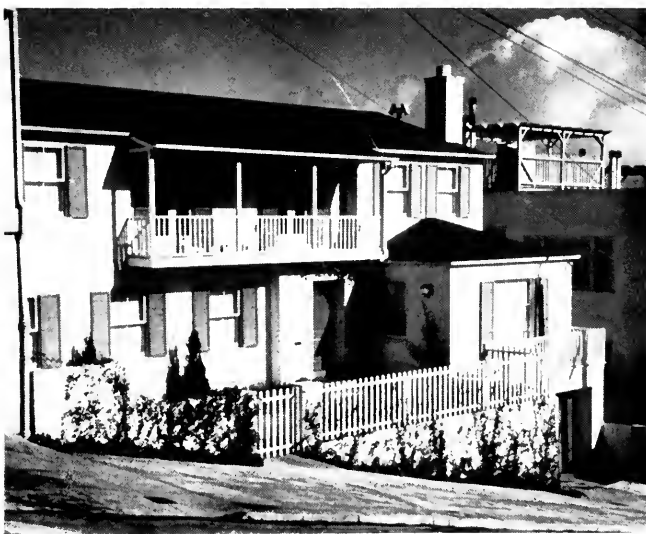
**TAP ROOM AND BAR DONE IN ANTIQUED OAK, FRENCH PROVINCIAL FEELING**

**CASINO GAMING ROOM  
THE PANELS ARE BY  
LELAND HYDE**

**ALBERT FARR AND J. FRANCIS WARD, ARCHITECTS**



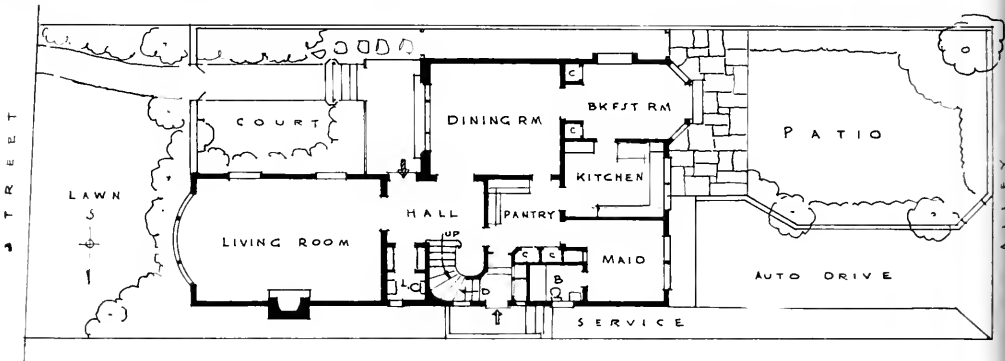
**SWIMMING POOL AND  
BATHING PAVILION**



**RESIDENCE OF  
JULIUS LITTMAN  
SAN FRANCISCO, CALIFORNIA**

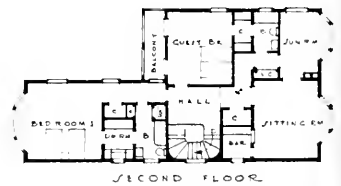


Photo Helen H. Ward

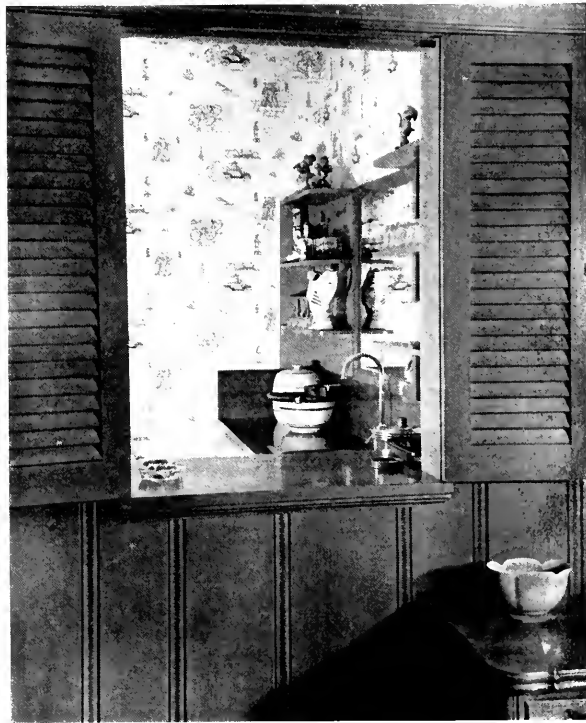


**RESIDENCE OF A. B. MARCH, SAN FRANCISCO**

Details of the lower and upper halls are illustrated on the opposite page, also breakfast room and bar in sitting room.









Photos Helen H. Ward



**RESIDENCE OF MR. AND MRS.  
MAURICE L. GOLDMAN,  
SAN FRANCISCO**

Full advantage is taken of one of San Francisco's typical hillside lots. Entrance is at first floor level with garage accessible a few feet further down the street at basement level. Dining room opens onto a sheltered south garden.

A detail of the Colonial staircase is shown at the left.



**OFFICES OF THE CONSOLIDATED  
CHEMICAL INDUSTRIES,  
SAN FRANCISCO**

All the offices and lobbies are finished in Flexwood veneers. . . . The entrance lobby is bleached maple; the other rooms, figured mahogany, Prima Vera and English oak. Lobby frieze is decorated with murals of the different plants of the company in the United States and Argentina.



# HOUSE OF EUGENE ELKUS, MARIN COUNTY



LIVING ROOM

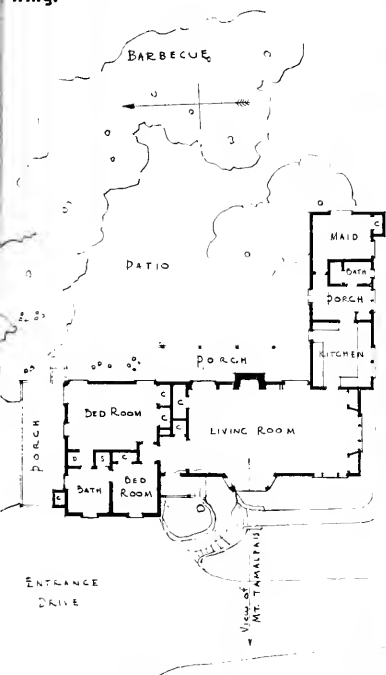


FIREPLACE DETAIL



**VIEWS IN PATIO**

The Elkus house occupies a gently sloping knoll with superb view of Mt. Tamalpais and the San Francisco Bay. Sheltered patios insure outdoor living with convenient access to kitchen wing.



Photos Helen H. Ward



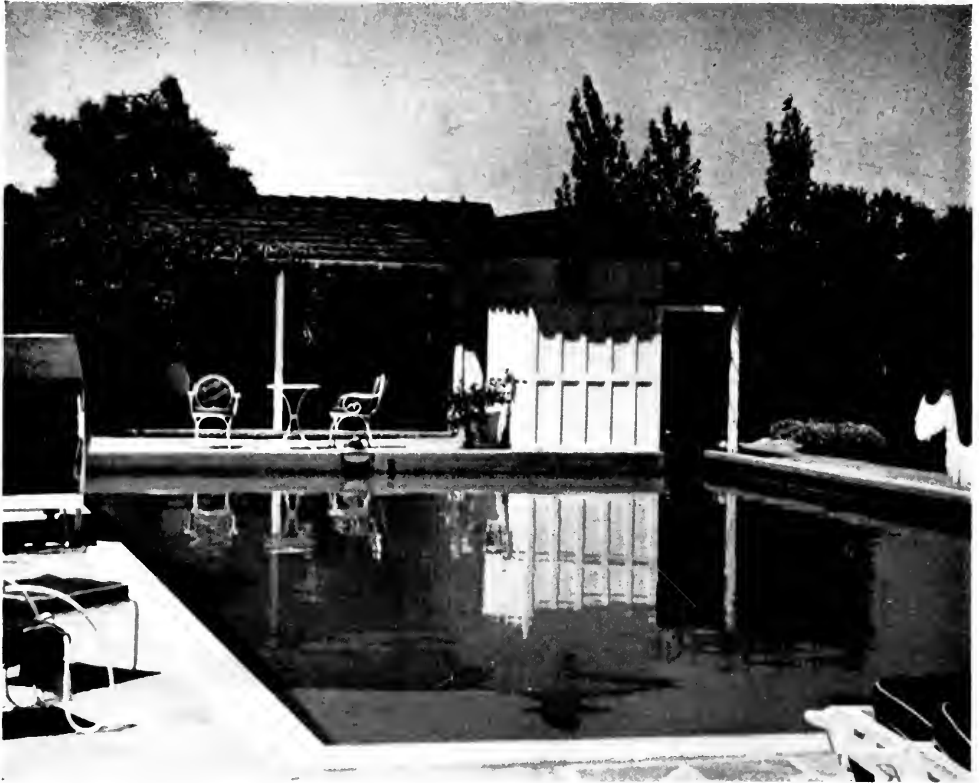


Photo Helen H. Ward

**SWIMMING POOL AND CORNER OF  
PATIO, RESIDENCE OF  
R. B. ROBINETTE, JR.,  
COUNTRY CLUB GROUNDS,  
LOS ALTOS, CALIFORNIA**

The estate includes, besides the owner's home, a private bathing solarium, guest cottage, garage, tennis courts, etc.



on that, with a view of the waterfall above, with access at all times, either in high spring flood or when the snow is piled ten feet high." Pockets were blasted in the boulder and the building walls doveled into the rock, with tunnels for the spring floods to get away and a stone causeway built to the highway and the automobile shelter, where the obliging snow ploughs provide access throughout the High Sierra winter, to this Biblical jumble of Noah's Ark on the whale's back.

For the last several years I have passed by and admired the Jason House in Atherton and paid the, until now, unknown architect tribute to his good taste. It is really very lovely and, though comparatively large, it is wedded to its immediate environment. The interiors are in exquisite taste as is the exterior with its balcony supported on small steel pipes. The French cast iron settee on the front porch seems to add just the touch that is needed.

I have a feeling that Farr and Ward both

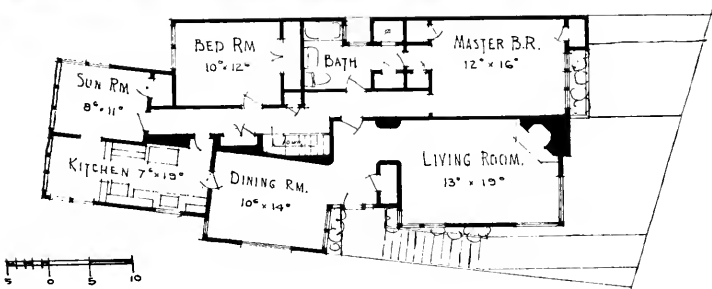
have fond memories of a dashing creole maiden in New Orleans, for in many of their houses are introduced elements of typical New Orleans exterior iron work. The small place of business of Mr. Wilbur Woodruff in Pacific Avenue is made one of the loveliest jobs in San Francisco by the use of this iron work. If a creole lady is the secret of this sort of success, it might be advisable for many of us to travel south more often.

The interior work of the Consolidated Chemical Company is an excellent example of Farr and Ward's ability to get into the atmosphere of the modern treatment. Their consistency in using a circular, or coin, motif in the treasurer's office may have been accidental but I doubt it. The A. B. March home in Sea Cliff is good straightforward American architecture with another touch of New Orleans iron work around the balcony. But it is needless to go on in mere words. The photographs tell a better story than can my feeble pen.



## HOUSE IN SAN FRANCISCO

Reynolds & Chamberlain,  
Architects





**HALL AND LIVING ROOM, HOUSE IN ORINDA, CALIFORNIA**  
Reynolds and Chamberlain, Architects

*Courtesy Housing*



# SUBSTITUTIONS IN BUILDING

By ANSON BOYD, State Architect

**This word** "substitution" may be considered from two points of view, one of which has to do with the non-structural elements of a building and how well it will perform its utilitarian purposes; the other point of view has to do with the structural stability of a building and its ability to withstand the stresses acting within it or the forces which may be exerted against it. In broad terms, and for the purposes of new construction not yet designed, the Uniform Building Code has within it for the purposes of this **second** point of view, the design standards for substitutions and until stark necessity may force a general lowering of the standards of construction set up within this code, the basic problem appears to be one of ingenuity in plan and design rather than one of the lowering of structural quality. The codes drawn up and the practices established by this Pacific Coast Building Conference represent the accumulated experience and conscientious effort toward safe, stable, and durable construction over a number of decades. This set of standards, which although far from perfect, represent the advances in good architecture and sound engineering which we are loathe to see junked in any substantial part, with the prospect of commencing once again more years of hard fought battles to bring construction back once more to the standards which we now have in this building code.

## SUBSTITUTIONS THREATEN TO LOWER STANDARDS

Let us consider what the prospects would appear to be, by either a general lowering of construction standards, or by their general maintenance as outlined in the five types of

Editor's Note—This is part of an address before the Pacific Coast Building Officials Conference at Santa Barbara, September 30, 1941.

construction defined in the Uniform Building Code as they relate to individual and collective safety of the communities in which new construction will stand. In proposing in the first place to make use of substitutions, there is inherent in the word the implication of the lowering of standards. This lowering of standards may, in broad terms, take the form of expanding the field in which non-fire-resistive types of construction may be erected accompanied by the expansion of the forms of protection equalizing or reducing the consequent risk. In properly selected community areas, consideration of this item might produce some merit. However, in so far as the general matter of priority bottlenecks is concerned, the effects of such a widening of non-fire-resistive construction and a general lowering of fire ratings would have a negligible effect. A reconsideration might be given to the increasing of general design stresses for fire-resistive construction types. A survey of the risks involved in the general raising of stress allowances would indicate that the background of supply does not carry the necessary guarantees of quality. Naturally during a period of intense shortages the tendency is toward the acceptance for use of border line steel in lieu of no steel at all, or border line cement in lieu of no cement at all. This tendency is one which is difficult to counteract and does not constitute an opportune situation for a consideration of designing more engineered work for these materials to do.

According to briefed statistics which I have obtained within the last few days, the four basic metals, steel, copper, zinc, and aluminum show a general shortage for military and civilian needs of approximately 35% over and

above the amount we can now produce for the year 1941 within the United States. For the year 1942 in each of these materials the shortage is slightly **increased** with the exception of aluminum in which the shortage may be slightly decreased. However, the percentage is still well above being one-third short of our total requirements. It is, therefore, evident that emergency measures, whatever they may be, as they relate to these particular materials, refer only to inventory stocks on hand or such inventories as may be obtained in the immediate future but do not provide any answer to the problem for the next two years at least.

It would appear to me from the foregoing that the broad implications of priority shortages, as they relate to the building codes excluding for the present detailed considerations of what materials and gadgets can actually be bought from day to day to put together any particular job, that these broad considerations of the design standards of the Uniform Building Code taken together with the building materials which are going to be obtainable, do not indicate that a revision of the codes downward is going to be any more of a solution than is the obtaining of a priority number from the Office of Production Management for, for instance, reinforcing steel in a district where there isn't any steel to be had.

#### **BUILDINGS AFFECTED BY PRIORITY ORDER**

So, therefore, for a moment or two until we take up detailed considerations, let us leave the design standards of the code undisturbed until better proof is offered that these codes do not have within them the necessary flexibility for planning and designing with the materials which are or may be available, and let's take a look at the prospects of what kind of building may need emergency measures in order to permit it to proceed. From this point, if you will permit me, I will digress for a moment and recall to you the budget message of the Governor of California to the State Legislature, which outlines the **State's policy** during this defense emergency. Relating to capital outlays, the Governor stated: "Capital outlays recommended in this budget include only those 'must' items requiring immediate attention.

There are many others which would be highly desirable and which should be undertaken at the proper time. . . .

"The State Government is badly in need of additional buildings, but whether we should enter upon a construction program at this time in competition with the Federal Government's program of defense construction, is a question meriting your immediate and serious study. . . . The time will come when peace shall again prevail in the world and we shall then have to face the probability that unemployment will become as burdensome, as acute in all of its manifestations as ever before and perhaps more so.

"I am, therefore, recommending that the State undertake a study of its long-term building needs and that, so far as possible, provision be made to time the construction of public buildings and the performance of public works to coincide with the work needs of our citizens."

Such a building program was drawn up in the Department of Public Works and submitted to the Legislature for approval. At the present time there is under way an expanding building program including all types of improvements throughout the State. This program is being prepared for the purpose of providing a foundation for a widespread construction era to aid in maintaining the standards of living and business in California. The administration of this State under the direction of Governor Olson, contends that the "four freedoms" which have been stated by the President of these United States as the foundation and reason for the greatest re-arming effort of all time, shall not, in California, drift through a mirage of war prosperity and on into the jeopardy of a post war depression, when sound business planning can forestall the disastrous consequences of do-nothing policies. How long the heavy and expanding volume of defense production on the Pacific Coast will last is not only difficult but impossible to determine. It is obvious what will happen if it recedes abruptly. Before detailed consideration of any drastic changes in the State's building standards are undertaken, the future implications should be well considered.

## 27 MILLION DEFENSE WORKERS

In broad terms, and according to the generally assembled figures of the National Resources Planning Board, there were during the year of 1939 about two and one-half million persons at work on all phases of defense, including military. This was just about two years ago. Not much over two short years ahead—in 1944—plans call for employment in all defense industries, including the military service, of about twenty-seven million persons, 90% of whom will be engaged in doing things that were not even in existence as organized occupations just a little over two years ago. These figures are, of course, the kind of statistics which allow for wide variation in their eventual totals. By allowing this wide variation the staggering overall dimensions of a post-war transition are not substantially reduced. Allowing for a very broad interpretation, and assuming that between 15 and 30 million people in these United States, and probably a higher percentage in the States on the West Coast are or will be in defense work than in many other States—15 to 30 million people will be engaged in defense industries and must, therefore, at some undetermined time move over from full employment for defense to full employment for that kind of peace which must continue to make the West Coast and the United States a healthy place in which to raise our children.

Let's take a quick look at what this means—In the United States during the best year of the booming 1920's, three million people went back to work from a status of unemployment during the previous year. During the best four years of the 20's the average was about 2,200,000 people per year above the previous year. Germany, in the vast re-arming expansion which built the military machine which has torn Europe into shreds, absorbed from unemployment in no single year more than 1,800,000 people. Proportioning this to the population of the United States, we would require that 2,800,000 persons per year be taken into full employment to match Germany's effort. Referring back to the 27 millions, you will see that our efforts must far exceed the greatest that Germany accomplished. However, for the

United States to rearrange its life following the period of defense building in which we are now engaged, and provided we accomplish this rearrangement at a speed no greater than the best year during the booming "twenties," or at no greater speed than Germany did during its best years, would require a period of from five to ten years for its accomplishment, with the consequent disastrous downward plunge of the standards of living, paralysis of business, and the probable loss or restriction of some of those very things which we are arming now to defend.

In view of these facts, there will necessarily be a great expansion of public and private building following the defense effort, and any lessons learned from the results of engineering ingenuity which has been stimulated by the defense building program, should be used to full advantage. The trend of our codes should be continually forward along the lines of design so well commenced in the Uniform Building Code, namely, that design standards and technical requirements should be criteria rather than the specification of materials or setting up of arbitrary minimums, in so far as this is possible.

Within the State Division of Architecture and in contemplation of the situation in which we now find ourselves, with the approval of the Director of Public Works, I instructed our Schoolhouse Section, which enforces the laws governing structural safety of public school construction throughout California, to revise and bring up to date the Rules and Regulations and Appendix "A," relating to school construction, with the basic idea in mind of removing, in so far as possible, arbitrary requirements and placing the entire Appendix "A" upon the basis of design within such limits as are reasonable. This Appendix "A" and the Rules and Regulations, which have recently been revised, have been reprinted and reissued on this basis.

Relating to the enforcement of the laws relating to structural stability and earthquake stresses by the Division of Architecture, the detailed matter of substitutions for priority materials is a constant and increasing problem. The Schoolhouse Section has been instructed,

in relation to buildings now under construction, and in co-operation with the local authorities, engineers, and architects, to make those necessary adjustments which are required to bring a project to completion and which fall within the limits of sound engineering practice. If a contractor is unable to obtain the sizes of steel required, rearrangement of the design to fit the sizes which can be obtained, is made. This policy continues throughout the building and the Division's engineers exercise their judgment therein. There is, however, no substitute for reinforcing steel once the project is well under way and no steel is obtainable. Re-design, however, for, for instance, gravity walls, provided the necessary proper footing are also designed and built, will be approved by the Division of Architecture, provided that this design for gravity walls is within the limits of sound engineering as defined in Appendix "A."

The Division of Architecture follows the policy in relation to schoolhouse construction as well as State construction, that the shortage of materials indicates that within proper limits a different bracket of the code should be followed, with proper protective measures, and not that risks should be taken with the lives or safety of the occupants of the building.

#### SUGGESTIONS FOR BUILDING CODE ENFORCEMENT

For those persons engaged in enforcing building codes in cities, towns, and other political sub-divisions there are perhaps four principal means of meeting the problem:

First: Is the broadening of code interpretations as has been done by the Division of Architecture in enforcing its Appendix "A." This can be done to good effect in many instances without the reduction of standards below the limits of sound practice. The building inspector is generally empowered by code to use judgment in administering its regulations and in the present emergency he should take advantage of this power, as, for instance, grouted brickwork may be considered as good or in some cases even preferable to mortar jointed brickwork even though not specifically mentioned in a code. With due respects to the fire hazards of a particular project, wood might be substituted for steel sash regardless of fire zone, as well as similar variations which, in the judgment of the building inspector, based on the merits of the particular project, do not constitute practical or unreasonable risk.

Second: "Actual Revision of Code Requirements": The actual changing of code provisions and the raising of the working stresses or reduction of live loads involve the risks to which I have referred earlier and, in general, do not produce, for the aggregate of building on the West Coast, a sufficient tonnage to materially affect the general shortage. Revisions of these working limits, when and if made, should be based on meritorious data and not upon emergency shortages.

For non-structural materials a consideration of certain existing limitations in view of recent research might yield some advantage. In plumbing installations, for instance, the new Manual issued by the Bureau of Standards (Report No. BMS66) may be used to advantage and may result in the use of less material with safety to health and durability.

Third: "Changes in Structural and Architectural Design": Walls may be designed as gravity type as I have mentioned before. In general, two methods can be considered in design, in one of which, although all materials are used as before, there may be involved much less of each kind than usual. Under this class would be some of the proposed modern methods now being promoted for light roofs and buildings. The other might be designs in which there would be less necessity for the scarce materials, thus, in concrete design, sections purely in compression, avoiding the use of reinforcing steel might with ingenuity be devised. Although concrete and reinforcing have been cited as examples, the same principles apply to other structural materials—brick, wood, structural steel, etc. These, however, do not apparently call for materially changing the design standards of the codes. They do call for ingenuity in design within safe working limits and this fact brings into clear profile the fact that we have as yet not offered substitutions in the building code for priority materials as the title of this discussion requires, but have suggested that by ingenuity in the use of those materials we can obtain within the limits of sound and proven engineering, design which is for both emergency and long-term purposes the soundest policy.

Fourth: "Substitutions of Materials": Browsing through in very recent days some current publications, technical and magazines of general circulation, brought out the following: Magazines such as "Business Week" referred to the general subject of priorities with a jovial grimness. Commencing along about June and in successive issues they refer to the difficulties of the organization of the priorities office, with but little, if any, helpful comment about what business was going to do about it. In one magazine I found a general summary of the priority situation with one whole paragraph devoted to "substitutions" and from this paragraph the information was distilled that there is an artificial silk being produced in quantities which will tend to alleviate the silk shortage—but not the "building short-

age." The "Engineering News Record" carried a bulletin of developments, priorities division notes and an occasional suggestion. The architectural magazines devoted themselves largely to the technique of defense construction and very recently to some surveys of post war conditions. The general zone of silence around this matter of substitution indicates that there have not been developed standard methods which are better or even approaching being good enough to substitute for current architectural and engineering practice, and upon surveying various state and other affected agencies I received detailed suggestions, all of which go under the general heading "The judgment of the building inspector" and which do not require substantial alteration of the Uniform Building Code, excepting where materials are described by specification making their particular specification mandatory and thereby eliminating other methods which may be, for practical purposes, generally equal. As, for instance, asphalt dipped mesh might be used for stucco reinforcing instead of galvanized. There are conditions where black iron pipe might be satisfactorily substituted for galvanized. Glued wood arches have proven successful and plywood is being extensively used structurally. Pressure concrete for plumbing fixtures; composition materials for vents, pipes and electrical installations. All of these, as has been mentioned before, do not require basic alterations of the codes in so far as design standards are concerned but require a technical description of requirement in lieu of a specification requirement as well as the use, by the building inspector, of his discretionary powers, implied or stated in the codes.

#### NEW TYPE OF DESIGN MAY BE OFFERED

Some revision of policy on the part of building inspection offices may be advantageous, as has been done within the State Division of Architecture, toward a co-operative attitude in the matter of submission of new types of designs or materials which take into consideration the urgency and the need of the investor. Under urgent conditions it is not possible for an investor to go through extensive laboratory tests or underwriter's approvals, and on an emergency basis the judgment of the inspector represents ample experience to be relied upon. It is infrequent that the results of laboratory tests arrive at conclusions materially and practically different from those which the experienced building inspector has formed after proper investigation by his own methods of analysis and on an emergency basis the inspector should exercise his discretionary powers.

Recalling certain of the abuses following the last war in revision of existing codes, ample

consideration should be given to the fact that brick veneer unanchored,, sand substituted for cement in mortar or concrete, insufficient anchorage and attachment methods in metal lathing, and other similar inferior standards of workmanship or materials should not be the results of an intensive building program.

It would appear that a general policy of co-operation under emergency discretionary powers by the City and State agencies enforcing building codes, taking into consideration the merits of the projects involved and within limits of the design standards of the Uniform Code revised to technical definitions where necessary, accomplish all that can be expected in the way of aiding building construction to continue under shortage conditions; in that the general lowering of design limitations would not obtain materials where none exist, nor would they spread the existing supply or the supply in sight by a percentage which would make any perceptible dent in the problem.

One other consideration which should be set aside for future thought may be economic pressure in the event that a shortage of space requirements of a particular type develops in the face of an acute shortage of materials with which to build new buildings. There may be a tendency to spread occupancies into formerly blighted or semi-blighted areas bringing about modernizing or reconditioning projects. In view of these emergency conditions, some thought might be given to existing code requirements in order that this avenue of expansion may not be blocked. This tendency, however, is not at present clearly discernible in this region.

*I wish to leave with you as public officials, returning to your various communities, the imperative necessity not only for the preparation of the legal structure of building law, but also the legal and detail plan structure of each community's post-emergency construction and improvement program.*

Within the State of California, the Department of Public Works is now engaged in negotiations to secure financing toward the detailed planning of the State's needed building construction in order that this program of improvement may be ready to go at the time when the State's citizens need this work for the support

of their business and general employment. The earnest activity of every citizen on the Coast not specifically involved in the defense program should be toward a completed plan in cooperation with the community in which he lives, the region in which his community is located, the State, and the Works Reserve

being drawn up under the leadership of the National Administration, bearing in mind the fact that an enormous number of people must be re-trained and business must be re-tooled and re-expanded at a rate of speed hitherto unachieved and in a volume hitherto uncompleted.

## MATERIAL SHORTAGES AND NATIONAL DEFENSE

**Building**, like many other industries, is beginning to feel the ill-effects of our national defense movement.

An idea of the impact of this activity on the building industry is given by the fact that defense construction has recently totaled over \$250,000,000 a month — more than half the 1939-40 average for civil construction of all types. Building has been called upon to expand its output more than 50 per cent almost overnight. Even more important, this increase has been concentrated in certain areas and on particular building types. Industrial construction, for example, is scheduled to reach a peak of \$140,000,000 this month, an increase of 700 per cent over the 1939 average in a class of work distinguished by its uniform use of a relatively small number of basic materials. Cantonment construction, relying heavily on lumber, sheet materials and millwork, touched an even higher figure in February—and both the cantonment and industrial building programs, now largely completed, are scheduled for early repeat performances.

Thus, from within the industry, defense construction demands have been such as to exhaust reserve supplies of many building materials and to exceed—in some instances temporarily, in some instances for longer periods—existing productive capacity and the available supply of skilled building workers in certain areas.

When to these facts is added the probability of transportation bottlenecks and fuel shortages which may affect still other materials, the conclusion is inescapable that the building industry faces materials and labor shortages of important dimensions — shortages in some

cases temporary and localized, but in others general and likely to continue for some time, if not indeed for the duration of the emergency.

Nevertheless, it is just as false to exaggerate the priorities problem as it is to adopt a head-in-the-sand attitude. In almost no cases are such shortages likely to be absolute; that is, to cut off civilian supply entirely. In most instances they will arise not out of a complete exhaustion of normal sources of supply for direct defense uses but rather out of a combined military and civil demand which exceeds present productive facilities. This means that if and when predicted shortages do occur, there will still be available limited quantities of most materials for those civilian uses where their fundamental properties are most essential. Particular types of material or equipment are more likely to be hard to obtain than whole general categories. Acute shortages and government regulation of strategic materials will develop gradually, as existing reserves are used up.

Moreover, even the most pessimistic prognostications do not place all or even most building materials among those that will probably be short. Many of the most basic materials are described as "abundantly available." And few, indeed, are the materials of modern building for which there are no alternatives in common use. The question of the effect of military priorities on private, non-defense building is not, therefore, as some have posed it—one of whether non-defense building will stop—but rather a question of how much of it will change.

To estimate with any accuracy exactly when such changes are going to prove necessary is, at least at the present time, virtually impossible.

Nobody knows just how soon—or how late—threatened shortages will actually develop. The important thing is to understand the basic causes behind supply failures, the nature and operation of government controls and, in general, what steps may be taken to alleviate the effects of such shortages or to prevent their developing at all.

Architects and builders must realize that it remains within their power to control the ultimate result, given sufficient understanding of the problem: that the very "tailor-made" character of building, so often bemoaned in the past, in this instance provides flexibility to meet changing conditions.

Material shortages arising out of the defense program may be classified under two headings: primary and secondary. By primary shortages are meant those such as have developed in imported materials like rubber and cork, where the supply has been cut off or curtailed by interruption of normal international trade and lack of ships, and domestic materials such as aluminum, where productive capacity has not kept pace with expanding demand. Primary shortages are fairly easy to predict and may be anticipated if needs are reasonably well established.

Secondary shortages include those arising out of transportation bottlenecks which may cut off the supply of raw materials or fuel necessary to process these materials, or which may affect the distribution of finished products (as is beginning to be the case with structural steel on the Pacific Coast). Also under this heading should be included local shortages resulting from unusually heavy local demands, and shortages of fabricated products due to the conversion of existing productive facilities to direct defense production, such as are likely in certain classes of building equipment. Secondary shortages are obviously harder to predict than primary shortages, may (as in World War I) play an important part in the building picture. Several shortages of the first type are already apparent.

Raw materials used in building which have been placed under "industry-wide mandatory control" include aluminum, nickel (monel metal),

nickel-bearing steel (stainless), copper, zinc and cork. This, the most drastic form of government control, indicates an "acute" shortage and probably means that no further supplies of these materials will be available for any but the most essential building purposes, if at all. It does not mean, however, that the supply of fabricated products employing these materials will be cut off immediately, since it will be some time before reserve stocks are exhausted. At such time as this takes place, it seems probable that items like monel metal sinks and hot water tanks, stainless steel trim and aluminum windows will be virtually unobtainable. Whether the shortage of copper and zinc (for galvanized iron) means that neither will be available for essentials like flashing gutters, piping, etc., remains to be seen but it seems clear that their use as roofing materials will be frowned upon if not prohibited entirely.

Other primary materials which, while not yet on the mandatory control list, show equally acute shortages are chromium and rubber (rubber is subject to a special import control of its own).

The shortage of chromium will affect future production of hardware, plumbing fixtures, lighting equipment and metal trim, which will probably not be obtainable in this finish, once present stocks have been used up.

Steel, as a primary material, is in a special category by itself. Obviously essential to the defense effort at every stage, it is nevertheless available in huge quantities certainly in excess of direct defense demands. The question is whether there will be enough to fill all civilian needs and if not—as is seemingly the case—which needs will be placed first. Since iron and steel products are being substituted for non-ferrous metals in many instances, it is almost impossible to forecast future demand. Structural steel has undeniably been hard to get during the past few months, yet the American Institute of Steel Construction insists that fabrication is not being used to capacity.

For the present, at least, steel probably belongs among those materials which have been all but used up by the first phase of the defense program. Other materials in this group are

electrical equipment, fabricated sheet materials and other items used in the cantonment and industrial building programs now drawing to a close. Such shortages are difficult to analyze and even harder to predict, since they depend on a complex of factors including raw materials, fabricating facilities, and transportation, and vary from month to month and locality to locality. About all that can be said with assurance is that they have applied to particular items rather than whole lines, that they depend almost entirely on the defense building program, and that they are likely to be less and less important as this program nears completion.

Future defense building, it is promised, will be planned more with an eye towards availability of material, now that the initial objectives have been achieved. As to long-term shortages, that which threatens in non-ferrous metals, is clearly one of the most serious facing building as a whole, especially since the shortage of copper and nickel is accompanied by a shortage of zinc which may prevent the use of galvanized iron as a substitute. Just when such shortage will take effect depends, as has been said, on the existing supply of already fabricated materials. Naturally, they will be felt first in areas where defense and non-defense construction have been particularly active, and retail stocks are low. Even in such areas they are not likely to have an immediate effect upon individual, small scale operations for some time, but may be felt immediately in the case of large scale projects requiring wholesale quantities of material.

#### THE PROBLEM OF SUBSTITUTES

First reaction to the possibility of a shortage in a particular material is naturally to look around for a suitable substitute. Under wartime conditions, this approach is not likely to prove as fruitful as might be expected. For many essential raw materials, no suitable substitutes have been developed. Where true substitutes exist, they are likely to be just as scarce as the material they replace, or, in any event, not available in sufficient quantities to supply wholly new demands.

Plastics already have been substituted for a

great many materials. But they are not a cure-all. In the first place, the supply of plastics is not infinite but is limited, like every other material, by productive capacity, which cannot be doubled overnight. (Production of some plastics will be limited by the supply of formaldehyde, which is used in making smokeless powder.) Plastic manufacturers will be reluctant to expand into new fields unless there is a reasonable certainty that demand will continue, and not slack off when other materials are again available.

Nevertheless, substitutions of various kinds will undoubtedly be made. In addition to plastics (trim, hardware), porcelain enamel seems a good bet in place of galvanizing and non-ferrous metals. It is already being used extensively by stove and refrigerator manufacturers to replace aluminum and stainless steel, and (in contrasting colors) chromium trim.

Not strictly substitutes, but potent safety valves for building, are the various alternative structural and finish materials already in use. Thus concrete, for example, in many uses replaces wood (and vice versa). If, as seems probable, cork and rubber flooring are curtailed, asphalt tile, quarry tile, terrazzo, wood, and many other available materials can take their place.

Plaster board may be substituted for metal lath.

Even more potent should be the architect's ability to adopt entirely new solutions, if necessary, to meet a dearth of materials of a particular type. If flashing and gutters are hard to obtain, roofs can be designed which require neither; if window sash are no longer available, fixed glass and louvered ventilators may be used instead. Even in larger structures the same principle applies: where structural steel is hard to get, reinforced concrete (or reinforced brickwork) can be used in its place: for wide spans, suspension cables—as used at the Chicago fair—or laminated wood arches may be the solution. It would not be difficult, by this method to replace 90 per cent of the materials in any particular building. Should anything so drastic be required, an entirely new concept of shelter could be devised to meet the needs



and potentialities of a war-torn world.

With talk of an oil shortage due to lack of tankers on the East Coast, and other dislocations of the transportation system possible, architects and builders are bound to be asked questions regarding the best type of fuel burning equipment to install in new homes. Since the answer—in so far as it depends upon the question of priorities—rests upon government policies yet to be announced, it is not easy to make. One thing is sure: with the number of domestic burners already in use well above the two-million mark, any attempt to cut off entirely, or sharply curtail the supply of domestic liquid fuel would create more drastic problems than it could possibly solve, and is exceedingly unlikely for this reason if for no other. Much more likely is a program of domestic fuel conservation, which will probably apply to fuels of all types since all depend on transportation in one form or another and all forms of transportation will be overtaxed. Already, the Oil Burner Institute has launched such a program, calling for a check-up on existing burners, enforcement of Commercial Standards in new installations of all types, and more adequate insulation, and aimed at fuel savings upward of 25 per cent.

The priority system of ratings for purchase of critical materials such as steel, iron, copper, zinc, etc., required for defense purposes, and articles and appliances in which those materials have heretofore been freely used, is designed for the conservation of materials of which there is a present or prospective shortage.

Because the system has not been generally understood there has been much confusion in the minds of many persons as to their immediate effect on construction.

The ratings given apply only to the order in which purchases of materials may be made. It is a mistake to say or to infer that because defense construction has first call in purchase of materials that they cannot be obtained or used if obtainable. The immediate problem is one of distribution to which too little attention has been given by defense agencies and authorities and which has been complicated by the increasing ramification of priority ratings issued by the Priorities Division of the OPM.

#### MATERIALS AFFECTED AND NOT AFFECTED

**ALUMINUM** and aluminum scrap have become precious metals, every bit of which is needed for defense uses. Non-ferrous metals of all kinds are short and both copper and zinc (used for galvanizing) are under industry control. Chromium for trim may eventually disappear entirely.

**CONCRETE.** Local production of cement, sand and gravel assures ample supplies of materials for concrete, although reinforcement may become harder to obtain. During World War I fuel shortages shut down some cement plants and transportation difficulties created gravel famines in areas where military construction was particularly heavy. Lumber forms may be used if metal forms or sheet materials become unobtainable.

**DUCTWORK** and other essential uses of metal will doubtless receive preferential treatment although some substitute for galvanizing may be necessary.

**FLUE TILE, BRICK** and other clay products are locally produced and available in abundance. Defense demands on this group of materials have not been heavy and they constitute a reliable "standby" if shortages in other lines develop.

**FLASHING** should be used sparingly and painted iron or impregnated fabrics may have to be substituted for other materials. Avoid complicated roofs which require more flashing than the simple gable type.

**FIXTURES** should not be tight, unless existing productive facilities are converted to other uses. Materials for enameling are abundant. Chrome trim, as in other lines, may disappear.

**GUTTERS AND DOWNSPOUTS** may be hard to obtain with rationing of non-ferrous metals and zinc for galvanizing. If the situation becomes acute, generous overhangs and splash slabs offer one solution, porcelain enamel on steel, another.

**HARDWARE**, like wiring, seems slated for restrictions. Iron may replace non-ferrous metals and certain finishes, such as chromium, will probably be unobtainable.

**HEATING**, like plumbing, uses strategic materials. However, its greater flexibility (the chance to use substitute materials, methods, etc.) should relieve any strains which may develop.

**INSULATION**, in general, should be available in abundance, although aluminum foil may disappear entirely for a time. Use of insulation of other types will be officially encouraged, both in new and old construction, to save fuel.

**KITCHEN CABINETS** in metal, which require mechanical fabrication, should be replaced by wood if shortages develop. Monel metal, chromium and stainless steel are out of the kitchen picture once present stock is used up.

**LUMBER**, despite demands totaling several million board feet for Army cantonments, is not considered a tight spot in the defense material picture. Timber stands and sawmill capacity are more than adequate.

Army buying, which in the past is said to have caused local shortages of particular items, will be better distributed as the second cantonment program gets under way. The big question seems to be shipping from West Coast mills and this is not yet acute.

**MILLWORK AND FINISH LUMBER** are available in adequate quantities despite heavy demand due to cantonment construction. More than ample local productive facilities and stocks of suitable materials assure domestic supplies for an indefinite period, except in areas where unusual building activity causes temporary shortages. There is no shortage of glass.

**PLASTER AND PLASTER BOARD**, with an abundant supply assured, should regain much of the ground lost to other materials if shortages in other lines develop.

**PLUMBING**, a heavy consumer of both ferrous and non-ferrous metals, is in for changes and restrictions of various kinds. Official plans call for discouraging second bathrooms, simplified practices to save pipe. Hot water tanks are already hard to obtain.

**PAINT** supplies will continue to be ample. Tung oil, an import, can be replaced by a synthetic substitute.

**ROOFING** materials, such as wood and asphalt shingles, slate and tile, are plentiful. Building paper supplies are adequate at present, with some question as to the future because of the anticipated shortage of paper of all types. Galvanized and copper nails may become hard to obtain.

**SHEET METAL WORK**, such as metal roofs and other non-essential applications, will be discouraged in order to conserve non-ferrous metals.

**STRUCTURAL STEEL** for residential purposes should be replaced by timber whenever possible. Although there is as yet no shortage of junior sizes, further fabrication will probably be discouraged to conserve metal.

**SHEET MATERIALS** have been subjected to heavy demands by the cantonment program, which for a time absorbed almost the entire production of some types. Army buying has now slacked off and future purchases will be better distributed.

**WIRING** and electrical equipment in general is one of the tight spots in the residential building picture. Program calls for restrictions all along the line, but no absolute curtailment.



**HOUSE IN OAKLAND**

**Reynolds and Chamberlain, Architects**

# PLANNING FOR POST-WAR HOUSING

By LEON H. KEYSERLING, Deputy Administrator U. S. H. A.

It is my firm conviction that the first task of the present, for housers, for planners, and for all who think and live as we do, is to concentrate upon the eventual defeat and overthrow of the Nazi regime—for the end of Hitler is indispensable to any sense of hope or aspiration for the future of housing or planning or any other manifestations of the democratic spirit.

How can housers and planners contribute to the defense of democracy? The obvious answer is that they can help to build houses for defense workers quickly and economically and soundly. But if we define defense workers narrowly as the army and the navy and those producing the primary implements of war, this answer is far simpler than the truth. For the truth is that the ground crews who set the airplanes in motion are as much defense workers as the pilots who fly them. The workers in the factories manufacturing the thousands of parts which go into the making of an airplane are as much defense workers as the ground crews. And so on down the line, until we are drawn inescapably to the conclusion that everyone who is assisting in the quickening of production and the development of our total resources is a defense worker.

Wherever plans are operating more slowly because there is insufficient housing for an adequate supply of workers, wherever the workers in these plants find their efficiency lowered because they are living under bad housing conditions, wherever the general level of health and morale of the population is impaired by slum conditions, wherever anti-social resentment or anti-democratic activities are encouraged by such evil conditions—in all such in-

stances there is a defense housing emergency.

More than that. The magnitude of the defense housing problem can be realized only when we ask ourselves the further question: "What are we defending?" Surely we must be defending, against the totalitarian systems, that system which we believe offers better prospects and opportunities not only for political democracy, but also for its economic and social equivalents. We must be defending the practical opportunities which our country affords to raise standards of living and to enlarge the economic and social advantages of the presently submerged portions of our population. To abandon these efforts during the so-called defense period would deprive the average man of something to fight for, and thus weaken the vast reserve strength and morale which are the real power of a modern Nation. It would mean forgetting our objectives while seeking to defend them.

So do not let anyone tell you that we cannot have guns and housing too. Do not let anyone tell you that France fell because of her social reforms. Do not let anyone put you on the defensive. It is your responsibility to plan and to organize and to agitate for better housing **now**. That is your unique contribution toward the successful outcome of the defense effort.

And through this action **now**, you will also be taking the most effective steps to prepare for the economic and social problems of incomparable size which will beset us when the defense period is over.

What are these problems, moving toward intersection at the end of the defense period?

First, there is the general trend of the business cycle. We had a minor depression commencing in 1920, and then a major depression

Editor's Note—The principal address delivered at Santa Barbara before 300 people from 59 California cities and towns interested in the activities and post-war aims of the California Housing and Planning Association.

commencing in 1929, and a minor depression commencing in 1937, and we can discern with reasonable assurance the presence of factors indicating another major depression when the defense boom subsides.

Second, there is the general trend of technological change and the displacement of men by machines. During the past ten years, for example, the "hot strip mill" has been introduced into the steel industry. It is estimated that 127 men in an automatic steel mill can produce as much as 4,512 men in the old hand style type of mill. Between 1920 and 1940, the physical volume of industrial production increased 63 per cent, while factory employment increased less than one-half of one per cent.

Third, there is the maladjustment of working skills. Millions of workers have lost all skills through years of idleness. Equally important, but less commonly recognized, millions of workers are now being trained for jobs that will become obsolescent when the defense emergency is over. The peace-time equivalent for dive-bombing and operating 16-inch naval guns has not yet been revealed. Of the skilled workers being drawn into our shipbuilding program, at least 300,000 will have no conceivable place there when the war is over and the vessels of the whole world are again available for commercial pursuits. Thus at the end of the defense boom the overskilled and the underskilled will be pooled in one great army of those inadequately trained for the work at hand.

Fourth, and by far the most important of all, there is the awful certainty of the abrupt subsidence, if not the complete collapse, of our tremendous primary defense industries as soon as the need for them is over. The tragic paradox of today is that the more millions of men and the more billions of dollars of capital there are employed in the defense program, the more millions of men and the more billions of dollars of capital will suddenly become idle when the defense program is over—unless we do something about it now.

Let us look at a few overall figures.

The defense program now under way, including British purchases and private investment in defense plants, involves expenditures of about 57 billion dollars.

Defense expenditures for the year 1941 alone will run from 13 to 14 billion dollars.

Due largely to the defense effort and its ramifying effects, the national income, which stood at 76 billion dollars in 1940, will rise to around 90 billion dollars in 1941, and perhaps 100 billion dollars in 1942.

Due also to the defense program and its ramifying effects, non-agricultural employment, which stood at about 35 million people at the beginning of 1940, will rise to about 42 million people in 1941.

These figures of gain and progress all along the economic line have their dismal counterpart. They mean that when the defense period is over, whether it be in one year or two years or three years, we shall face a drop in our annual national income, taking into account the secondary effects of reduced government expenditures, ranging from a minimum of 15 billion dollars to a maximum that may easily run as high as 30 billion dollars. They mean that we shall face a drop in employment ranging from a minimum of about 7 million to a maximum that may run to over 15 millions—unless something is done to prevent it.

If nothing is done now, we shall have at the end of the defense boom a depression incomparably more serious than that which commenced in 1929. More than this, the repetition on a grander scale of the last depression would bring into focus forces of disillusion and discontent, elements of political adventuresomeness, and factors of racial and religious intolerance, the seeds of which are not unsown today. Neither life nor liberty nor property will be secure unless we can employ our traditional democratic technique and our demonstrated capacity for organization and foresight to forestall these evils.

Basically, the problem is an economic one—to create peace-time industries to supplant defense activities when the war is over. And by common consent, this should move housing to the center of the stage.

Production of goods that create and recreate wealth will be needed, after the drain and strain of armament production—and the building of homes represents the optimum of social utility.

Programs that distribute our existing wealth in the interests of social justice will need to be reinforced by programs that make everyone richer by adding to the total store of goods. Housing does that.

Methods of creating employment for men, money and materials will be needed, and there is more room for such employment in housing than anywhere else. A private and public housing program — mostly private — of 1,000,000 homes a year for 15 years, representing the conservative needs to cover obsolescence and population growth alone, would involve capital investments of from 4 to 5 billion dollars a year. Including allied forms of rebuilding, rehabilitation and redevelopment, the figure might easily be raised to 6 to 7½ billion dollars a year. When we multiply this by 2½, to allow for the indirect effects of constructive activity, we arrive at a figure running above 15 billion dollars a year, which is just about enough to cover the minimum figure I cited for the threatened drop in our annual national income when the boom is over—unless we prevent it.

Most of such a program would be done by private enterprise. Not more than 300,000 units a year, or 4,500,000 units in 15 years, should be done by public housing agencies. The public subsidy cost of such a program would not reach its peak until the end of the 15 year period, when the 4,500,000 units of public housing would be occupied. Even then, I estimate that the annual subsidy cost, Federal and local, would be less than 1/30 of our Federal defense expenditures for 1942 alone!

The housing program can become the key to unity for peaceful progress after our unity for defense.

But the supreme test of any program, seeking to assert its claim to utility when the defense boom is over, is the speed with which it can get started. A nation-wide housing program is not simply a matter of overall estimates of need or standard blueprints. Preparations must be carried forward in the form of specific requirements of hundreds of individual localities—each with its unique problems of industry, of transportation, of social conditions, of income distribution, of housing facilities. Blueprints must be adapted to the topography, the

climate, the habits, the social customs and the artistic modes of these hundreds of communities. This adaptation can be effected only through trained and active local housing groups, with the knowledge, the experience, the incentives and the money to do the work.

There are now several hundred local housing authorities reaching to the four corners of the country. These are not made up of theorists or visionaries. They represent practical, hard-headed local citizens drawn from every walk of life. They have gained perspective and vision through the work already done.

Now is the time to keep these local groups alive and active. Now is the time to enlarge their number and broaden their scope. Now is the time to organize complementary activities—all to the end that specific and definite housing programs can grow and take shape as an integral part of community planning and community life. These programs should embrace private housing, public housing and all related activities. They should be ready to go the moment the defense boom ends.

I believe that your primary job is to use your technical skills to design local rebuilding programs as large as your imagination, time and resources will permit. Your primary job is to utilize your proximity to the people themselves, to make them aware of their housing needs in the context of their general economic and social problems, to help them reflect their awareness and desires through all the channels of expressions available in a democracy. Only when the people are active in the pursuit of common objectives, rather than passive in the receipt of easy benefits, can genuine democracy thrive and prosper.

I want to congratulate this new and vital organization—the California Housing and Planning Association—for the work being done. May you prove the pattern for similar action in every state, because the varied life and enterprise of this great area affords so broad an example to the nation. You have been successful, and you will be more so, just so long as you continue to be aggressive, to be concrete and realistic, and, above all, to do things on a big scale.

# Temporary Housing for 374,000 in Event of Disaster

A detailed plan to house 374,000 men, women and children in San Francisco in event of fire, bombardment or earthquake has been submitted to Fiorello H. LaGuardia, U. S. Director of civilian defense, by Thomas Larke, Jr., chairman of the city's Red Cross Disaster Relief Commission.

The plan, prepared by executives of the commission's shelter division and members of the San Francisco Society of Architects, was drawn up in two parts.

1. A survey of schools, hotels, apartment houses and garages which could accommodate 374,000 persons, or 57 per cent of the city's population, immediately following a disaster.

2. Specially planned relief shelter camps, built for 1000 persons each, to provide housing over a longer period for those whose homes had been destroyed.

Commenting on the thoroughness of the plan, A. L. Schafer, Pacific Coast manager of the American National Red Cross, said:

"This is undoubtedly the most comprehensive shelter plan which has come to my attention from any city in America. We are submitting it to defense authorities in Washington for consideration by other coastal cities such as New York, Boston, New Orleans, Los Angeles and Seattle.

"The survey is worthy of note because it shows that emergency housing is immediately available for nearly 60 per cent of San Francisco's population," Shafer added.

"British defense experts have found that an industrial city threatened with attack—or under attack—must provide for around 60 per cent of its normal population if it is to keep and maintain defense production. Evacuation of more than 40 per cent of the population has proved impractical."

Requiring four months for completion, the plan was drawn up by Albert Jason, shelter division chairman; Harry J. Oser, engineer and shelter division vice-chairman; Col. W. P. Bear, statistician; Alfred P. Fisher, engineer; Norman E. Curtis, insurance executive, and the following architects:

W. Clement Ambrose, Norman K. Blanchard, Samuel L. Hyman, Irving F. Morrow, William H. Rowe, J. Francis Ward and Harold H. Weeks.

The survey shows that beds could be provided for 99,974 people in 101 public and 29 parochial schools, while 111,278 more could be accommodated in tents on school grounds. The city's 3000 hotels and 10,000 apartment houses would house a minimum of 100,000 refugees, and 166 garages would house 59,000 more.

"Schools are a basic part of the plan, since they are strategically located throughout the city and they have large-scale toilet facilities and kitchens," Jason, shelter division chairman, pointed out.

Meals for the disaster stricken populace would be prepared at a central depot, then trucked to the schools and other housing centers. They would be prepared and distributed by the food and fuel division under the direction of Raymond B. Hayward, chairman.

The relief shelter camps planned by the architects for prolonged emergency would be divided into two, four and six-person family units, with separate accommodations for single men. Constructed either in the city's parks or in close-by rural areas, the camps would have heated dormitories, mess hall and kitchens, toilet and shower facilities, laundries, hot and cold water, store houses and fire-fighting equipment.

## STRUCTURES FOR DEFENSE HOUSING

Standard defense housing warranting 40-year amortization can be developed out of existing structures in many key defense cities, at a cost far below that of comparable new housing, according to Fred W. Catlett, a member of the Federal Home Loan Bank Board.

His statement is based on a preliminary report by Arthur Goodwillie, head of the Bank Board's Neighborhood Rehabilitation Section, that recent surveys have proved feasible "a program which will develop a large pool of standard low-cost housing, having a low economic rent level, which can be leased to low-income families both during and after the emergency at a price representing little or no subsidy."

The Goodwillie report, centered largely on surveys made in Washington, D. C., and Norfolk, Va., added that the program would "as a by-product, eliminate numerous decrepit neighborhoods and slum areas without direct cost."

Briefly, these surveys showed that selected sub-standard areas could be made into livable quarters for defense workers at 50 per cent to 60 per cent of the cost of new construction; that in many instances the number of housing units could be increased 25 per cent to 35 per cent; that such a program would halt the migration of resident workers whose increasing incomes would otherwise soon cause them to compete for newly-built defense housing; and that areas contributing increasingly to disease and crime would be reclaimed.

Under the program developed by Mr. Goodwillie, an important factor is the projected amortization over a period of 40 years or less. The projects would be structurally good enough to last that period of time and the lower cost of rehabilitation—as against the higher cost of new housing—would make 40-year amortization feasible.

"The program would be another step in utilizing community assets—such utilities as water, gas and light systems, sewage disposal, paved streets, schools, stores and churches," said Mr. Catlett.

# WITH THE ARCHITECTS AND ENGINEERS

## OCTOBER S. F. CHAPTER OUTING

The October meeting of the Northern California Chapter, A.I.A., was held at Stag's Leap Manor, in Napa County. Following the precedent established last fall, when the usual evening meeting in San Francisco was changed (in October) to a Saturday afternoon trip to Sonoma to view the interesting old adobes there, with dinner at the Swiss Hotel, this year another "departure" was taken and in spite of threatening rain (which materialized) about thirty members climbed aboard a big bus at 12:30 on Saturday, November 1, for another trip to the interior country.

The journey included a quick tour of the gigantic new defense housing projects at Vallejo and visits to two of the old wineries built in the 1870's, both in and out of the ground—either tunneled out of the rocky hillside, or with heavy groined walls of concrete supported on curious cast iron columns brought from France.

Traveling on past the old world towers of the St. Helena Asylum, the bus climbed up the Silverado Trail and to the roomy old stone mansion built by Horace Blanchard Chase, now well known as the Stag's Leap Hotel. There the adventurous architects and several of their friends from the Producers' Council dined a hearty country dinner, surrounded by the lofty remnants of late Victorian grandeur whose elaborate elegance was only equaled by the late ornate eloquence of President Appleton, surely master of both toasts and hosts.

These Chapter excursions bid fair to become a regular annual tradition, for there are still a number of interesting trips that can be made to points of interest in the development of California, according to those who know.

---

## THE BUTTERFLY MAP

The Butterfly Map, an invention of B. J. S. Cahill, retired Alameda architect, has been adopted by W. G. Paden, Superintendent of the Alameda School System, as "far superior to the world maps now in use."

"Obviously," says Mr. Cahill, "what is best for one school system is best for all but as no political map is possible until the war is over, the schools can only use a physical world map which also explains the principles of the new projection and prepares teachers for the big colored wall maps to follow when peace comes."

---

## FRED MEYER HONORED

Frederick H. Meyer has been appointed to succeed the late Harold K. Crane as chairman of the street and highway committee of the San Francisco Chamber of Commerce. Mr. Meyer was a former chairman of the committee and past director of the Chamber.

## ARCHITECT WRITES A BOOK

"Old Adobes of Forgotten Fort Tejon," by Clarence Cullimore, architect, A.I.A., of Bakersfield, will be off the press shortly, it is announced by the Secretary of Kern County's Historical Society. The book will be profusely illustrated with drawings and photographs. The text recounts the early history of the Upper San Joaquin Valley, recites legends surrounding the trapper, Peter Lebeck, and records interesting details of the inception and operation of Fort Tejon and the adobe brick construction and architectural flavor of the twenty-one original buildings which once comprised United States Army posts.

The romance of the early "Fifties" should make this book fascinating reading as well as an authentic historical document. The book approaches the subject from an architectural point of view.

---

## PHILLIP E. JOSEPH

Phillip E. Joseph, one of San Francisco's promising young architects, died at St. Joseph's Hospital, October 15, following a nervous breakdown. Young Joseph was 30 years old and a native of Ukiah. He only recently was awarded the Arthur W. Wheelwright traveling fellowship by Harvard University. The fellowship carried a stipend of \$3,500. He was preparing a year's trip through Latin America. Mr. Joseph was a graduate of the University of California and had been a member of the Stanford faculty for the past three years. He practiced his profession in the office of John Ekin Dinwiddie, San Francisco, which firm, only recently, was awarded first prize for the second consecutive year for the best house design in the House Beautiful Competition.

---

Edwin J. Peterson, architect and secretary-treasurer of Spokane Chapter, A.I.A., has been assigned to Fort Monmouth, N. J., with the U. S. Army Signal Corps. His ranking title is first lieutenant.

A. L. Brinckman, former building inspector for the city of Berkeley and now a member of the faculty of the University of Hawaii, is giving a course of instruction in building codes, pest control and fire and accident prevention.

---

## OREGON CHAPTER'S OCTOBER MEETING

The regular October meeting of Oregon Chapter, A.I.A., was held Tuesday, October 21, with Regional Director Harlan Thomas of Seattle guest of the evening. Mr. Thomas stopped over on his way East for the mid-year directors' meeting of the A.I.A. at Washington, D. C.

## GIVE YOUTH A CHANCE!

William Wilson Wurster, architect, makes a plea for the young architects of San Francisco, in a contribution to the Chronicle's weekly forum of present-day problems, Wurster's offering being an answer to the query: "Would you say that the older generation in San Francisco's business and social life is giving the younger generation a chance to move in and play an adequate role in vital decisions?" We quote Mr. Wurster:

Parents are often maddeningly unaware that their children have become adults. It is an age-old difficulty to know just when youth has developed to the point of full participation and even leadership in the decisions of the day—in the business world, in civic and national affairs.

Here is one example from our recent history. In 1935 and 1936 the younger group of architects in San Francisco gradually realized that the coming 1939 Exposition was being planned and that we had no participation in the great general scheme—that in the main it was being done by the very people who at our age had made the decisions in the 1915 Panama Pacific Exposition. Trying to bring this matter to a head, I wrote the Chamber of Commerce asking them, as representing broad objective leadership, to see what could be done to include the younger group. But to no avail.

In the letter I stated that in New York the Architectural Board of the Fair had made the rule that none of the official buildings could be done by members of their own body. Out here, all of the official buildings were done by members of the Architectural Board. This situation I felt to be bad on two counts:

(a) The younger men were deprived of their very legitimate right to participate; and, of more importance,

(b) The Exposition was deprived of the modern thinking and fresher enthusiasm which might have given added zest and enrichment to the whole thing.

It would seem, on looking back, that the younger group might have prevented one thing—the debacle of placing the auto parking out at the bleak north end where you sneaked in under guy wires of the "Cavalcade of the Golden West." And perhaps if a full acknowledgment of the motor car needs had been made, the whole story of the Exposition might have been different. Think how changed it would have been if you could have parked at the Federal Building when you wanted to see the Indian Exhibit; or at the Palace of Fine Arts, or at the Brazil Building to drink coffee, or at the Yerba Buena Club when you only wanted a place to eat dinner.

That is past history. But now there is another younger generation coming along—and even more important civic problems which, if they are not new, at least are newly faced and require energy and imagination for their solution. Don't make the old mistake once more. Support your young group of eager planners—Telesis

—and give them a leading part in all this debate on the city plan. Listen to them talk of the city's needs. Support the young people in the San Francisco Housing and Planning Association, and in the California Housing and Planning Association. I name these because I know them—probably every profession and field of civic interest has similar youthful elements. Give them their chance. They have something to give to the life of the city.

## A VOICE FROM LONDON

Bulletin of the Michigan Society of Architects prints the following from the Detroit News, which no doubt will be read with interest by Pacific Coast architects: "C. Howard Crane, world-famous Detroit architect, is home for a brief visit from London, where he has been for several years designing and building vast structures. He came home with some very decided views.

"If the United States had made good on that slogan, 'Every aid to Britain short of war,' the war would have been over by now and Germany would have been defeated," was one of his statements.

"There are three classes in the United States—the so-called America First group, which is clearly a German-inspired propaganda group; the All Aid Short of War group, and the people who realize what Adolf Hitler has planned for us and are anxious to go full-length. The Short of War group is doing about 10 per cent of what could be done. When we read of the increase in sales of automobiles over 1940 we can be sure every other manufacturing group is doing the same thing, or has been.

"If we really had done everything short of war in the last two years, England would have been able to make a continental invasion. She can not do it now because of shortages of tanks and ammunition and all sorts of things. Don't think she isn't grateful for what the United States has done. She appreciates every little effort. She isn't asking for an army, just materials.

"The boys—and they are boys, pink-cheeked young fellows you might think were a lot of sissies—who are manning the RAF are doing a tremendous job. The bombing of Germany isn't the important thing they are doing. The important thing is that they are bombing night and day the ports of the continent, because right now the Germans are building boats and submarines in every spot along the coast they can find available. It was only the lack of those things that halted the invasion long ago.

"I belong to an American unit of the Home Guard. There are about 60 of us, of all ages and all degrees. Some have a million dollars and some haven't a dime. We have our own officers but we are drilled by English sergeants-major. I think we are the only mobile unit of the million or more Home Guards. We are used mostly for driving English officers and others to points where there is immediate need.



"There has been no bombing worth mentioning since last May. I live in the heart of London and we have had a dozen or more bombs dropped pretty close—so close that our ceilings are all cracked and dishes have been shaken off the table. But everyone goes along as if nothing much had happened.

"The restaurants and theatres are crowded and all sorts of parties are on at all times. They dropped bombs into Earls Court a few times but no great damage was done. (Crane built Earls Court, the largest recreational center in the world and an architectural feat which was said by British authorities to be impossible.)

"I'm busy these days building factories and I don't have a lot of rest. My last job will house about 500 women and 200 men working on shell casing. The women are the better workmen, by the way, and get less money. But that will be adjusted. I don't know how long I'll be here. I'm really on some war business.

"England is very optimistic about the final outcome. If the United States really makes good on that slogan, "Everything short of war," Hitler will be defeated, you may be sure. If it doesn't—I hate to think of what will happen then."

---

### PRIORITY RATINGS

The importance of securing priority ratings before starting construction of new homes, and for materials necessary to remodel and rehabilitate existing dwellings, is stressed in a statement issued by D. C. McGinness, district director of the Federal Housing Administration.

Some contractors, the housing director pointed out, appear unaware of the fact that priority numbers are essential not only to assure delivery of certain critical materials, but that dealers must maintain records of such numbers in order to replace their depleted stocks. Thus a complete cycle is created between builder, dealer, jobber and manufacturer to perpetuate an even flow of building materials from factories to defense housing projects.

"The Federal Housing Administration does not issue or assign priority ratings," said Mr. McGinness, "but for the convenience of contractors concerned with residential construction, it serves as a clearing house to accept, review and submit applications to the Office of Production Management, which issues priority certificates direct to the applicant.

"Necessary forms are available at the FHA office and in order to expedite the production of needed housing, preference ratings are being graduated. Highest rating is granted projects under construction as of September 1, 1941, and to remodeling and rehabilitation. Lower ratings are granted new construction for rent or for sale at rental or sales prices within reach of defense workers for whose occupancy the housing is intended."

Mr. McGinness declared that FHA is accepting ap-

plications for priority rating on all housing projects, regardless of type or kind of financing to be used.

"It is not required that the dwelling be financed through FHA in order to enjoy this service," he said. "It is available to all alike. It is important, however, to secure priority ratings before construction is started on any dwelling to assure the availability of all materials necessary to complete the structure or rehabilitation project."

The housing director branded as erroneous rumors that FHA has clamped stringent restrictions on the amount for which mortgages are insurable.

"There have been no changes in our regulations in that regard," he declared. "The OPM has ruled that priority preference will be given homes not exceeding a cost of \$6000, and rental properties not to exceed \$50 a month per family unit, but no such limitations have been placed in FHA regulations.

"The Federal Housing Administration still is insuring mortgages in amounts up to \$16,000 on houses containing one to four family units, applying both to existing structures and new construction. In the case of new houses, the contractor needs only assurance of the availability of all materials necessary to complete the buildings, and if they meet FHA construction requirements and property standards, they become eligible for mortgage insurance."

Mortgages on new homes built under FHA inspection from approved plans and specifications with appraisal values up to \$6000 were said to be eligible for 90 per cent mortgage insurance, with a repayment period of 25 years.

New homes in the higher brackets may secure 90 per cent mortgage insurance up to \$6000 appraisal, plus 80 per cent on additional value up to \$10,000. On new homes appraised at more than \$10,000, and existing dwellings not built under FHA inspection but which meet FHA requirements, mortgages were said to be insurable for as much as 80 per cent of the appraised value, up to \$16,000, and monthly payments may extend over any convenient period up to 20 years.

---

### WILL MAJOR IN REGIONAL PLANNING

As a result of a successful six-year experiment in offering courses in city and regional planning as a field of undergraduate study, the Graduate School at Cornell University announces that, beginning this fall, graduate students may elect to major in this field of endeavor, leading to the degree of Master in Regional Planning.

---

### APPLICATIONS FOR CIVIL SERVICE

The U. S. Civil Service Commission, Washington, D. C., will receive applications for civil service examinations for engineering draftsmen, with salaries ranging from \$1620 to \$2600 a year, until December 31.

# MODERNIZED PRODUCTS

Brief Notes on New Materials and Equipment in the Building Industry.

## 628. GLASS INSULATION

Those interested in the use and potentialities of glass as an insulating material will find useful coordinated information and data in "The Dielectric Strength of Glass—An Engineering Viewpoint." This recent study, by E. B. Shand, is now available in reprint form from Corning Glass Works.

## 629. SHEET METAL

With sheet metal becoming scarce because of defense requirements, architects, contractors and sheet metal workers want to make every pound go as far as possible. An aid to this is the corrugated roofing slide rule and roof leader selector offered by the American Rolling Mill Co. One of these valuable rules may be obtained without cost.

## 630. SANITATION

This handbook on sanitation, issued by Huntington Laboratories, covers the subject as applied to industrial and institutional establishments literally from A to Z. Indexed by sections and starts with liquid soaps, touches on floor finishing and winds up with chapters on deodorants, disinfectants and cleaning specialties.

## 631. DUMB WAITERS

This pamphlet for your No. 33 A.I.A. file covers the subject of dumb waiters very well, but it does much more than that. Various types of lifts and elevators for institutional establishments are discussed, even hand-powered elevators. Issued by Sedgwick Machine Works.

## 632. VENTILATORS

This one is manufactured on the "squirrel cage" principle and is described as highly efficient when put to the use for which it is intended—kitchen ventilation. The folder describes several models. Manufactured by Trade-Wind Motorfans, Inc.

## 633. MAIL CHUTES

The old standby, Cutler Mail Chute Co., has some interesting late material on their boxes and chutes. Their catalog, "Cutler Model G," describes the systems in working drawings and

provides photographs of the models available. Yours for the asking.

## 634. LIGHTING FIXTURES

It's always well to keep abreast of literature on lighting fixtures. So we gladly present a handy reference pamphlet recently received from the Northern California Electrical Bureau, entitled, "Lighting Fixtures for the Home." Well illustrated, showing what should go into every room in the house.

## 635. FLUORESCENT LIGHTING

Two pamphlets are available from the Frink Corporation. One, "It Started One Night in a Howling Gale," traces the development of lighting from 84 years ago and the other is Circular BF-1004 describing the complete modern line of fluorescent lighting fixtures. The Frink Corporation has been a leader in this field.

## 636. REVOLVING DOORS

We've just received "Door of the Month" issue No. 4 from International Revolving Door Co. Modern architecture is demanding doors with more glass and this literature gives all the answers. Featured is a door with glass covering 90 per cent of its vertical surfaces.

## 637. INTERCOMMUNICATION

Here's interesting reading providing you're looking for a voice amplifying system. Made by Webster Electric Co., the Electric "Teletalk" comes in a number of models, picks up your voice and takes it into the next room, or the adjoining building, or wherever it is that you need to have your voice heard quickly.

## 638. SAFETY TREAD

Long lasting safety and comfort under foot, best describes the stair tread manufactured by the Ohio Rubber Co., and an attractive booklet is available upon request. Made of hard, tough rubber base, reinforced with galvanized wire, the tread comes in four standard colors.

## 639. WALL COVERING

"Beauty Pays a Bonus" and in this case we believe it. That's the title of

a booklet recently issued by Standard Coated Products Corporation, describing a really beautiful line of fabric wall coverings. Rich designs go hand in hand with permanency when these coverings are used.

## 640. WEATHERSTRIPPING

We read recently where a ton of weatherstripping would save several carloads of fuel oil or coal during a cold winter, so building minded persons should be more concerned about saving heat. Here's an interesting brochure on weatherstripping, which is issued by Master Metal Strip Service, Inc.

## 641. ORNAMENTAL IRON

Never in one booklet have we run across so many different presentations on ornamental cast iron work. It is called "Cast Iron Verandas and Railings" and is issued by the manufacturer—Smyser-Royer Co. It belongs in A.I.A. file No. 15-C and is a valuable addition. Fill in the coupon.

## 642. HOUSE INSULATION

"How to Live in Comfort" is the apt title of a booklet on insulation recently issued by the Eagle Picher Co. Eagle insulation is a material similar in structure to pellets of fine wool. It's full of tiny dead air cells and is applied by the efficient pneumatic method.

Architect and Engineer  
68 Post Street  
San Francisco, Calif.

Please send me literature on the following items as checked below. This request places me under no obligation.

628 <input type="checkbox"/>	635 <input type="checkbox"/>
629 <input type="checkbox"/>	636 <input type="checkbox"/>
630 <input type="checkbox"/>	637 <input type="checkbox"/>
631 <input type="checkbox"/>	638 <input type="checkbox"/>
632 <input type="checkbox"/>	639 <input type="checkbox"/>
633 <input type="checkbox"/>	640 <input type="checkbox"/>
634 <input type="checkbox"/>	641 <input type="checkbox"/>

642

My Name.....

Name of Company.....

Street.....

City..... State.....

# ARCHITECTS' BULLETIN

Issued For

THE STATE ASSOCIATION OF CALIFORNIA ARCHITECTS

Northern Section

STATE ASSOCIATION MEMBER  
OF THE  
AMERICAN INSTITUTE OF ARCHITECTS

Editor  
Harris C. Allen

Address all communications for publication  
in the Bulletin to the Editor (Harris C.  
Allen) 557 Market Street, Room 218, San  
Francisco, California.

## STATE ASSOCIATION OFFICERS

President. Wayne S. Hertzka, San Francisco  
Vice-Pres. Walter R. Hagedohm, Los Angeles  
Sec'y..... Rowland H. Crawford, Beverly Hills  
Treasurer.....David H. Horn, Fresno

## Regional Director—Southern Section

Gordon B. Kaufmann

## Regional Director—Northern Section

Harry M. Michelsen

## Executive Board—Northern Section

President Wayne S. Hertzka, San Francisco  
V.-Pres., Norman K. Blanchard, San Francisco  
Secretary ..... Andrew T. Hass, San Francisco  
Treasurer .....David H. Horn, Fresno

## Directors

Russell G. de Lappe, Modesto; Clarence W.  
Mayhew, Harry M. Michelsen, Frederick  
H. Reimers, Ernest E. Weihe, San Francisco

## Executive Board—Southern Section

President, Walter R. Hagedohm, Los Angeles  
Vice-Pres.....E. Allen Sheet, Los Angeles  
Sec'y., Rowland H. Crawford, Beverly Hills  
Treasurer..... George E. Gable, Los Angeles  
(The Northern Section Advisory Council  
will appear in the next Bulletin.)

## Northern Section Advisory Council

San Francisco District:  
Clarence W. Mayhew, President  
Edward J. Maher, Secretary  
Henry H. Gutterson  
Lester W. Hurd  
Ellsworth Johnson  
William Henry Rowe  
Clyde F. Trudell  
Harold H. Weeks  
John Davis Young

North Bay: Palo Alto:  
J. C. Felciano David B. Clark  
Lower San Joaquin: Marin:  
Russell G. J. W. Bertenshaw  
de Lappe East Bay:  
Santa Clara: J. H. Anderson,  
Chairman  
Chester Root A. C. Williams,  
Secretary  
San Mateo: Leo J. Sharps  
Upper Sacramento: T. N. Thompson  
C. C. Dakin Berkeley:  
Sacramento: C. R. Schmidt  
W. E. Manhart Redwood Empire:  
Upper San Joaquin: F. T. Georgeson  
D. H. Horn Lassen:  
Monterey Bay: Ralph D. Taylor  
Robert Stanton

## CONVENTION REPORT

The 1941 Convention should be recorded in the history of our Association as one of its most important and timely meetings, both for discussion and for action.

Both internal and external problems were presented, and the occasion was notable for the amount of information presented on critical subjects by members and by guest speakers; the amount of general participation in "Round-table" discussions; and the amount of unity attained in final agreements.

Complete text of resolutions adopted is not yet available, and publication of these must be delayed to the next issue of the Bulletin. However, a general account of the Convention's activities may be made.

The recommendation adopted at the 1941 Convention, to establish dues-paying as a qualification for voting, was not accepted. Our established system of voting-membership to include all licensed architects is maintained and strengthened.

One amendment requires the election of officers and Directors-at-large of the Executive Board, by the entire membership through letter ballot. This ballot can be mailed together with the usual pre-convention notices, not entailing a separate mailing; and the appointment of Directors to represent the State Board and the A.I.A. Chapters will be requested a month earlier than the Convention, so that information necessary for the nomination by the Advisory Council may be available in time.

The Delegate system for representation of Districts at Conventions and other official S.A.C.A. meetings was adopted, including allotment of votes to which each District shall be entitled (one to each ten members or fraction thereof), using the A.I.A. system as a model. This assures all members of vote representation at all meetings.

The Executive Board is increased to provide five "Directors-at-large" in each Section (instead of four) and decreased to provide one Director from each A.I.A. Chapter (instead of two from Northern and two from Southern Chapters).

Certain subjects and events were of special interest. These may be mentioned in order of their presentation—

1. PUBLIC RELATIONS. This report included the most comprehensive practical program, for work done and contemplated, in both Sections, that has ever been presented to one of our Conventions. The complete report should be available to all members; it is too detailed to include in these comments, other than to say that it emphasized the educational character of the whole program, and the professional character of its execution. This was further emphasized by the accompanying address given by Mr. Richard Gandy, Vice-President of the State Bar of California, in which he described the publicizing of their own public services, the process of self-discipline by which they

improve their professional integrity and public confidence therein, and in which he expressed the interest of the State Bar in our Association's efforts along these same lines and its desire to cooperate in every possible way.

It should be obvious to our members what the active cooperation of the State Bar will mean to our Association. This talk by a guest speaker was certainly one of the highlights of the Convention.

2. AIRPORTS. An interesting account of the design of airports was given by Colonel E. C. Kelton, in which he intimated that architects may well be engaged in this ever-increasing line of activity—outside of Army posts, naturally. There is no question that the most able studies of airports have been made by architects—and doubtless studied with advantage by Army and Navy Bureaus.

3. PRIORITIES. This subject developed much discussion, with many questions addressed to the speakers, who included Mr. E. S. Anderson from the Los Angeles Chamber of Commerce, Mr. Carl Dumbolton from the Priorities Board, Mr. George Riddle and Mr. Richard Willis from the F. H. A. Lightening the serious vein of this discussion was the account by Mr. Willis of one applicant who interpreted a "B-4" rating as meaning that "all the materials would be gone B-4 his turn came."

4. STATE CONTROL. Mr. Dwight Stephenson, Director of Professional and Vocational Standards, presented an unexpectedly sympathetic point of view; plans to further improve State protection for architects, and requests for questions and suggestions. Mr. Stephenson was "on the spot" but kept his equanimity and good temper, and probably will profit by both commendation and criticism. As he is himself a professional man (a lawyer) he understands our standards.

5. DEFENSE HOUSING. George Gable and Eugene Weston cleared up various items about this huge program—which holds much of promise to the private architect—and provided an interesting talk by Commander Godwin on Navy Housing. Commander Godwin revealed that the Navy needs more architects on its staff, for its future program, and intimated his readiness to assist architects to join the Navy Reserve Corps for active duty in this emergency.

6. SOCIAL ACTIVITIES. The annual banquet departed from precedent by furnishing no speakers, no vaudeville, no entertainment in fact, except dining and dancing—and, of course, the traditional pours of "hospitality." Social relations between architects and their guests were eminently successful and no casualties were reported. As a highlight to this phase of Convention atmosphere, perhaps we should mention the appearance of our handsome Secretary, Vincent Raney, at the banquet—a vision of sartorial elegance in fawn-colored double-breasted dinner coat, with tie and carnation of deep Burgundy shade. The gals reeled over in columns, or shoals or what have you. It was a knock-out.

7. EDUCATION. Dean A. C. Weatherhead (Architecture, USC) and Sumner Spaulding presented a thoughtful report on present problems both as to students and practitioners, of which perhaps the outstanding suggestion was for a series of conferences, or clinics, or round-tables, to enable the practicing architect to keep abreast of latest developments in the building field. This included a plan for financing a year's program for monthly meetings. But there seems to be no reason why such a practical and valuable idea should not be realized without financing.

8. CIVILIAN DEFENSE. Mr. C. D. Griffin presented a picture of plans for air raid shelter defense (if, as and when) with the able assistance of Lt. D. E. Andrews of the Los Angeles police force. Quoting *La Guardia*: "If you are prepared and nothing happens, nothing is lost; but if you are not prepared and anything happens, everything may be lost."

This brief summary of the 1941 Convention ought to show that the Association is a valuable medium for joining forces, comparing notes, acquiring information, hearing the results and recommendations of committee investigations and study, agreeing and deciding on policies, initiating activities and actions, getting a broad perspective on the conditions of the profession and the industry and a broad outlook on the future, so far as that may be possible. And it should also make clear that any positive progress will come in proportion to the unity we achieve in bettering our own human relationships.

### New Officers

A few words are not amiss in comment on officers for the coming year. Although no specific place on the Convention program was given to Legislative work (since no immediate legislation is expected) the report of our Legislative Committee shows energy and thoroughness, during the past year, of great value to the Association. Hence it is a real pleasure to announce the election of that Committee Chairman, Wayne S. Hertzka, as State President. His service will redound to the good of the Association.

The new Secretary of the Northern Section, Andrew T. Hass, comes newly into Association office, but has been active in Chapter work, and is well and favorably known to local architects. He possesses ability and energy and an agreeable personality, and is a welcome addition to the workers of the Association.

David Horn, as Treasurer, will be continuing his service to the Association in an increased form. As a Northern Section Director last year he brought new viewpoints into the Board, as well as intelligent interest and enthusiasm.

Last, but not least, Norman Blanchard, as Vice-President, will continue to guide the work of Public Relations which he has organized so vitally, and contribute to the other agenda of the Board his good judgment and progressive ideas.

# Estimator's Guide

## Giving Cost of Building Materials, Wage Scale, Etc.

Amounts given are figuring prices and are made up from average quotations furnished by material houses to San Francisco contractors. 3% Sales Tax on all materials but not labor.

All prices and wages quoted are for San Francisco and the Bay District. There may be slight fluctuation of prices in the interior and southern part of the state. Freight cartage, at least, must be added in figuring country work.

**Bond**—1/2% amount of contract.  
Government work 3/4%.

### Brickwork—

Common, \$40 to \$45 per 1000 laid, (according to class of work).  
Face, \$90 to \$100 per 1000 laid, (according to class of work).  
Brick Steps, using pressed brick, \$1.00 lin. ft.  
Brick Veneer on frame buildings, \$1.00 sq. ft.  
Common f.o.b. cars, \$14.00 at yard. Cartage extra.  
Face, f.o.b. cars, \$40.00 to \$80.00 per 1000, carload lots.

### Building Paper—

1 ply per 1000 ft. roll	.....\$3.50
2 ply per 1000 ft. roll	.....5.00
3 ply per 1000 ft. roll	.....6.25
Star-kraft, 500 ft. roll	.....5.00
Sash cord com. No. 7	.....\$1.20 per 100 ft.
Sash cord com. No. 8	.....1.50 per 100 ft.
Sash cord spot No. 7	.....1.90 per 100 ft.
Sash cord spot No. 8	.....2.25 per 100 ft.
Sash weights cast iron, \$50.00 ton.	
Nails, \$3.50 base.	
Sash weights, \$45 per ton.	

### Concrete Aggregates—

GRAVEL (all sizes) \$1.45 per ton at bunker; delivered to any point in S. F. County \$1.85.

	Bunker	Delivered
Top sand	.....\$1.45	\$1.85
Concrete mix	.....1.45	1.85
Crushed rock, 3/4 to 3/8	.....1.60	2.00
Crushed rock, 3/4 to 1 1/2	.....1.60	2.00
Roofing gravel	.....1.60	2.00
City gravel	.....1.45	1.85
River sand	.....1.50	1.90
Bank sand—\$1.00 per cubic yard at bunker or delivered.		

### SAND—

	Bunker	Delivered
River sand	.....\$1.50	\$1.85
Lapis (Nos. 2 & 4)	.....2.00	2.40
Olympic Nos. 1 & 2	.....1.80	2.20
Healdsburg plaster sand	.....\$1.80	\$2.20
Del Monte white	.....50c per sack	
Common cement (all brands, paper sacks) carload lots \$2.52 per bbl, f.o.b. car; delivered, \$2.70 less than carloads delivered, 70c per sack.		
Cash discount on carload lots, 10c a barrel, 10th Prox.; cash discount less than carload lots, 2%.		

Atlas White  
Calaveras White } 1 to 100 sacks, \$2.00 sack,  
Medusa White } warehouse or delivery;

Forms, labor average \$40.00 per M.  
Average cost of concrete in place, exclusive of forms, 35c per cu. ft.;  
with forms, 60c.  
4-inch concrete basement floor  
.....12 1/2c to 14c per sq. ft.  
Ret-proofing .....7 1/2c  
Concrete Steps .....\$1.25 per lin. ft.

### Dampproofing and Waterproofing—

Two-coat work, 20c to 30c per yard.  
Membrane waterproofing—4 layers of saturated felt, \$4.50 per square.  
Hot coating work, \$2.00 per square.  
Medusa Waterproofing, 15c per lb., San Francisco Warehouse.  
Tricocel waterproofing.  
(See representative.)

**Electric Wiring**—\$12.00 to \$15.00 per outlet for conduit work (including switches).  
Knob and tube average \$3.00 per outlet.

### Elevators—

Prices very according to capacity, speed and type. Consult elevator companies.  
Average cost of installing an automatic elevator in four-story building, \$2600; direct automatic, about \$2700.

### Excavation—

Sand, 60 cents; clay or shale \$1 per yard.  
Teams, \$12.00 per day.  
Trucks, \$22 to \$27.50 per day.

Above figures are an average without water. Steam shovel work in large quantities, less; hard material, such as rock, will run considerably more.

### Fire Escapes—

Ten-foot galvanized iron balcony, with stairs, \$150 installed on new buildings; \$160 on old buildings.

### Floors—

**Composition Floors**—22c to 40c per sq. ft.  
In large quantities, 18c per sq. ft. laid.  
**Mosaic Floors**—80c per sq. ft.  
**Duraflex Floor**—23c to 30c sq. ft.  
**Rubber Tile**—50c to 75c per sq. ft.  
**Terazzo Floors**—45c to 60c per sq. ft.  
**Terazzo Steps**—\$1.60 lin. ft.

### Hardwood Flooring (delivered to building)—

	3 1/2" x 2 1/4"	3 1/2" x 2"	3 1/2" x 1 3/4"
	1 1/8" S.G.	1 1/8" S.G.	S.G. Ed.
Clr. Otd. Oak	.....\$144.00 M	\$122.00 M	\$141.00 M
Sel. Otd. Oak	.....118.00 M	101.00 M	114.00 M
Clr. Pils. Oak	.....120.00 M	102.00 M	115.00 M
Sel. Pils. Oak	.....113.00 M	92.00 M	107.00 M
Clr. Maple	.....125.00 M	113.00 M	

Wage—Floor layers, \$12.00.  
Note—Above quotations are all board measure except last column which is sq. ft.

### Glass (consult with manufacturers)—

Double strength window glass, 20c per square foot.  
Plate 80c per square foot (unglazed) in place, \$1.00.  
Art, \$1.00 up per square foot.  
Wire (for skylights), 40c per sq. foot.  
Obscure glass, 30c to 50c square foot.  
Glass bricks, \$2.50 per sq. ft., in place.  
Note—If not stipulated add extra for setting.

### Heating—

Average, \$1.90 per sq. ft. of radiation according to conditions.  
Warm air (gravity) average \$48 per register.  
Forced air, average \$68 per register.

**Iron**—Cost of ornamental iron, cast iron etc., depends on designs.

### Lumber (prices delivered to bldg. site)

No. 1 common	.....\$43.00 per M
No. 2 common	.....41.00 per M
Select O. P. common	.....46.00 per M
2x4 No. 3 form lumber	.....32.00 per M
1x4 No. 2 flooring VG	.....90.00 per M
1x4 No. 3 flooring VG	.....85.00 per M
1x6 No. 2 flooring VG	.....96.00 per M
1 1/4x4 and 6, No. 2 flooring	.....95.00 per M

### Slash grain—

1x4 No. 2 flooring	.....\$45.00 per M
1x4 No. 3 flooring	.....42.00 per M
No. 1 common run T. & G.	.....48.00 per M
Lath	.....7.50 per M

**Shingles (add cartage to price quoted)**—  
Redwood, No. 1 .....\$1.20 per edg.  
Redwood, No. 2 .....1.00 per edg.  
Red Cedar .....1.45 per edg.

### Plywood—Douglas Fir (add cartage)—

"Plycord" sheathing (unsanded)  
3/4" 3-ply and 48"x96" .....\$39.75 per M  
"Plywell" (wallboard grade)—  
1/2" 3-ply 48"x96" .....\$43.70 per M  
"Plyform" (concrete form grade)—  
3/8" 5-ply 48"x96" .....\$117.30 per M  
**Exterior Plywood Siding**—  
1/2" 5-ply Fir .....\$132.00 per M  
Redwood (Rustic) 1 1/8" clear heart. \$ 95.00 per M  
\$5 less per M for A grade.

### Millwork—Standard.

O. P. \$100 per 1000. R. W. rustic \$120.00 per 1000 (delivered).  
Double hung box window frames, average with trim, \$6.50 and up each.  
Complete door unit, \$10.00.  
Screen doors, \$3.50 each.  
Patent screen windows, 25c a sq. ft.  
Cases for kitchen pantries seven ft. high per lineal ft., \$8.00 each.  
Dining room cases, \$8.00 per lineal foot.  
Rough and finish about 75c per sq. ft.  
Labor—Rough carpentry, warehouse heavy framing (average), \$17.50 per M.  
For smaller work average, \$35.00 to \$45.00 per 1000

### Marble—(See Dealers)

### Painting—

Two-coat work .....per yard 50c  
Three-coat work .....per yard 70c  
Cold water painting .....per yard 10c  
Whitewashing .....per yard 4c

Turpentine, 65c per gal., in 5 gal. cans, and 55c per gal. in drums.  
 Raw Linseed Oil—95c gal. in light drums.  
 Boiled Linseed Oil—98c gal. in drums and \$1.08 in 5 gal. cans.

**White Lead in oil** Per Lb.  
 1 ton lots, 100 lbs. net weight.....1 1/4c  
 500 lbs. and less than 1 ton.....12c  
 Less than 500 lb. lots.....12 1/2c

**Red Lead and litharge**  
 1 ton lots, 100 lbs. net weight.....1 1/4c  
 500 lbs. and less than 1 ton.....12c  
 Less than 500 lb. lots.....12 1/2c

**Red Lead in oil**  
 1 ton lots, 100 lbs. net weight.....12 3/4c  
 500 lbs. and less than 1 ton.....13c  
 Less than 500 lb. lots.....13 1/2c

Note—Accessibility and conditions cause some variance in costs.

**Patent Chimneys—**  
 6-inch.....\$1.25 lineal foot  
 8-inch.....1.50 lineal foot  
 10-inch.....2.25 lineal foot  
 12-inch.....3.00 lineal foot

**Plastering—Interior—**  
 Yerd  
 1 coat, brown mortar only, wood lath.....\$0.50  
 2 coats, lime mortar, hard finish, wood lath......55  
 2 coats, hard wall plaster, wood lath......72  
 3 coats, metal lath and plaster.....1.25  
 Keene cement on metal lath.....1.30  
 Ceilings with 3/4 hot roll channels metal lath (lath only)......90  
 Ceilings with 3/4 hot roll channels metal lath plastered.....1.80  
 Single partition 3/4 channel lath 1 side (lath only)......85  
 Single partition 3/4 channel lath 2 inches thick plastered.....\$2.90  
 4-inch double partition 3/4 channel lath 2 sides (lath only).....1.70  
 4-inch double partition 3/4 channel lath 2 sides plastered.....3.30  
 Thermax single partition; 1" channels; 2 1/2" overall partition width, Plastered both sides.....2.50  
 Thermax double partition; 1" channels; 4 1/2" overall partition width, Plastered both sides.....3.40

3 coats over 1" Thermax nailed to one side wood studs or joists.....1.25  
 3 coats over 1" Thermax suspended to one side wood studs with spring sound insulation clip.....1.45

**Plastering—Exterior—** Yerd  
 2 coats cement finish, brick or concrete wall.....\$1.00  
 3 coats cement finish, No. 16 gauge wire mesh.....1.75  
 Wood lath, \$5.50 to \$6.50 per 1000......19  
 2.5-lb. metal lath (dipped)......21  
 2.5-lb. metal lath (galvanized)......21  
 3.4-lb. metal lath (dipped)......22  
 3.4-lb. metal lath (galvanized)......24  
 3/4-inch hot roll channels, \$72 per ton. Finish plaster, \$18.90 ton; in paper sacks. Dealer's commission, \$1.00 off above quotations. \$13.85 (retake 16 sack).  
 Lime, f.o.b. warehouse, \$2.25 bbl.; cars, \$2.15  
 Lime, bulk (ton 2000 lbs.), \$16.00 ton.  
 Wall board 5 ply, \$50.00 per M.  
 Hydrate Lime, \$9.50 ton.  
 Plasterers Wage Scale.....\$1.67 per hour  
 Lathers Wage Scale.....1.40 per hour  
 Hod Carriers Wage Scale.....1.40 per hour

**Composition Stucco—**\$1.80 to \$2.00 sq. yard (applied).  
**Plumbing—**  
 From \$100.00 per fixture up, according to grade, quantity and runs.

**Roofing—**  
 "Standard" tar and gravel, \$7.00 per sq. for 30 sqs. or over.  
 Less than 30 sqs. \$7.50 per sq.  
 Tile, \$20.00 to \$35.00 per square.  
 Redwood Shingles, \$7.50 per square in place.  
 Cooper, \$16.50 to \$18.00 per sq. in place.  
 5/2 #1-16" Cedar Shingles, 4 1/2" Exposure.....8.00 Square  
 5/8 x 16"—#1 Cedar Shingles, 5" Exposure.....9.00 Square  
 4/2 #1-24" Royal Shingles, 7 1/2" Exposure.....9.50 Square  
 Re-coat with Gravel, \$3 per sq.  
 Asbestos Shingles, \$15 to \$25 per sq. laid.  
 Slate, from \$25.00 per sq., according to color and thickness.  
 1/2 x 25" Resawn Cedar Shakes, 10" Exposure.....10.50  
 3/4 x 25" Resawn Cedar Shakes, 10" Exposure.....11.50

1 x 25" Resawn Cedar Shakes, 10" Exposure.....12.50  
 Above prices are for shakes in place.

**Sheet Metal—**  
 Windows—Metal, \$1.75 a sq. foot.  
 Fire doors (average), including hardware, \$1.75 per sq. ft.

**Skylights—**(not glazed)  
 Copper, 90c sq. ft. (flat).  
 Galvanized iron, 40c sq. ft. (flat).  
 Vented hip skylights 60c sq. ft.

**Steel—Structural** (None available except for defense work)  
 \$150 ton (erected), this quotation is an average for comparatively small quantities. Light truss work higher. Plain beams and column work in large quantities \$140 per ton.

**Steel Reinforcing** (None available except for defense work)  
 \$150 to \$200 per ton, set.

**Stone—**  
 Granite, average, \$6.50 cu. foot in place.  
 Sandstone, average Blue, \$4.00, Boise, \$3.00 sq. ft. in place.  
 Indiana Limestone, \$2.80 per sq. ft. in place.

**Store Fronts—**  
 Copper sash bars for store fronts, corner, center and around sides, will average \$1.00 per lineal foot.  
 Note—Consult with agents.

**Tile—Floor, Wainscot, etc.—** (See Dealers)  
 Asphalt Tile—18c to 28c per sq. ft. installed.

**Wall Tile—**  
 Glazed Terra Cotta Wall Units (single faced) laid in place—approximate prices:  
 2 x 6 x 12.....\$1.00 sq. ft.  
 4 x 4 x 12.....1.15 sq. ft.  
 2 x 8 x 16.....1.10 sq. ft.  
 4 x 8 x 16.....1.30 sq. ft.

**Venetian Blinds—**  
 40c per square foot and up. Installation extra.

**Windows—Steel**  
 Factory type sash 30c ft.  
 Ventilators for steel sash \$5.00 each.

## 1941 BUILDING TRADES WAGE SCALES FOR NORTHERN CALIFORNIA

\*6-hour day \*7-hour day

CRAFT	Alameda	Fresno	Marin	Sacramento	San Jose	Stockton	Watsonville	San Francisco
ASBESTOS WORKERS	\$1.25	\$1.25	\$1.25	\$1.12 1/2	\$1.25	\$1.25	\$1.12 1/2	\$1.25
BRICKLAYERS	*1.75	*1.50	*1.75	*1.75	*.75	*.75	*.75	*1.75
BRICKLAYERS' HODCARRIERS	*1.25	*.87 1/2	*1.25	*1.05	*.35	*.06	*1.12 1/2	*1.25
CARPENTERS	1.25	1.12 1/2	1.25	1.18 3/4	1.25	1.18 3/4	1.12 1/2	1.25
CEMENT FINISHERS	1.25	1.25	1.25	1.25	1.25	1.25	1.00	1.25
ELECTRICIANS	1.50	**1.37-4/7	1.37 1/2	1.37 1/2	1.50	.....	1.12 1/2	1.50
ELEVATOR CONSTRUCTORS	1.56	1.50	1.56	1.56	1.50	.....	1.40	1.50
ENGINEERS: Material Hoist	1.37 1/2	1.25	1.37 1/2	1.37 1/2	1.48	.....	1.25	1.37 1/2
Electric Hoist	1.60	1.60	1.60	1.60	1.72	.....	1.50	1.60
Structural Steel	1.60	1.60	1.60	1.60	1.60	.....	1.60	1.60
GLASS WORKERS	1.25	1.06 1/4	1.25	1.10	*1.21-3/7	.....	1.12 1/2	1.25
IRONWORKERS: Ornamental	1.31 1/4	1.25	1.25	1.37 1/2	1.31 1/4	.....	1.25	1.31 1/4
Reinf. Rodman	1.31 1/4	1.31 1/4	1.31 1/4	1.31 1/4	1.25	.....	1.25	1.31 1/4
Structural	1.60	1.60	1.50	1.60	1.60	.....	1.37 1/2	1.60
LABORERS: Building	.81 1/4	.75	.81 1/4	.75	.75	.....	.81 1/4	.75
Concrete	.87 1/2	.....	.....	.91 1/4	.....	.....	.87 1/2	*.87 1/2
LATHERS	*1.60	*1.50	*1.50	*1.50	*1.60	.....	*1.50	*1.60
MARBLE SETTERS	1.25	1.25	1.31 1/4	1.31 1/4	1.25	.....	1.25	1.31 1/4
MOSAIC AND TERRAZZO	1.25	1.12 1/2	1.25	1.15 1/2	1.25	.....	1.00	1.00
PAINTERS	**1.25	**1.14-2/7	**1.25	**1.25	**1.21-3/7	1.18 3/4	**1.15	**1.25
PILEDRIVERS	1.40	1.40	1.40	1.40	1.40	.....	1.40	1.40
PLASTERERS	*1.66-2/3	*1.50	*1.66-2/3	*1.57 1/2	*.75	.....	*1.50	*1.66-2/3
PLASTERERS' HODCARRIERS	*1.45	*1.25	*1.40	*1.18 3/4	*.35	.....	*1.35	*1.12 1/2
PLUMBERS	1.50	1.40-5/8	1.50	1.50	1.50	.....	1.25	1.52 1/2
ROOFERS	1.25	1.00	1.25	1.18 3/4	1.25	.....	1.12 1/2	1.25
SHEET METAL WORKERS	1.31 1/4	1.31 1/4	1.25	1.37 1/2	1.37 1/2	.....	1.25	1.25
SPRINKLER FITTERS	1.37 1/2	.....	.....	.....	1.50	.....	.....	1.37 1/2
STEAMFITTERS	1.37 1/2	1.40-5/8	1.25	1.50	1.50	.....	1.25	1.37 1/2
STONESETTERS (MASONS)	*1.75	1.25	*1.75	*1.75	*1.50	.....	*1.50	*1.50
TILESETTERS	1.37 1/2	1.25	1.37 1/2	1.31 1/4	1.37 1/2	.....	1.25	1.37 1/2

Prepared and compiled by  
 CENTRAL CALIFORNIA CHAPTER, ASSOCIATED GENERAL CONTRACTORS OF AMERICA  
 with the assistance and cooperation of secretaries of General Contractors Associations and Builders Exchanges of Northern California.

## FIXING UP THE RUN-DOWN HOUSE

"That run-down house across the street" is attracting more attention in several communities today than it seems to warrant from appearances.

A lot of people would like to know if the owner doesn't want to make it into living quarters for defense workers. As it stands, it's not only an eyesore to the community but a neglected piece of a "national defense area" that might be converted into the use of families looking for homes.

"Government agencies and private industry are prepared to help turn such properties into defense homes," according to Donald H. McNeal, Deputy General Manager in charge of the Home Owners' Loan Corporation's reconditioning division. "What's needed now is the cooperation of their owners."

He explained that homes registration offices have been established by the Defense Housing Coordinator in key defense centers to list vacant houses and to accept applications from property owners who are willing to convert vacant space in their properties—or entire houses—into quarters for defense workers. These applicants are offered the free counsel of experienced technicians in planning conversion jobs, estimating costs and advising as to the possibilities of revenue from rent.

The provision of "free advice" is where the HOLC comes into the picture. Its technicians have reconditioned some 550,000 homes, directing an expenditure of nearly \$175,000,000 in the last several years. Under an arrangement with the Defense Housing Coordinator, the services of these technicians are available to the public at large to speed homes for defense workers. The President has advanced \$100,000 from his emergency funds for the hiring of fee architects and technicians where the HOLC salaried staff can't do the job alone.

"If a property owner contacts a local homes registration office, he will be furnished with the necessary advice on financing," said Mr. McNeal. "Thousands of home-financing institutions have funds available for reconditioning and repair work and are cooperating in this program. And the technical assistance will be furnished by the HOLC."

"The preliminary service is entirely without charge. If the job requires detailed working drawings and supervision of construction, the HOLC will provide a technician at a reasonable fee."

"The speediest and most economical way to provide defense housing is through the use of existing structures," he said. "Homes registration offices and our technical men are ready to act on applications as fast as they come in. Property owners who cooperate in this movement not only are aiding in the defense effort but in many cases will obtain revenue from properties which have been only a burden to them in recent years."



## RICHMOND Form-Tying Methods for Concrete Work are Hours Ahead of Profit-Eating "Make-Shift" Devices!

You could puddle your concrete, right on the job, but you don't! Why, then, struggle through your concrete form work with methods equally old fashioned? You don't have to! Richmond patented pre-fabricated form-tying devices are specifically engineered for tying and anchoring concrete forms of every kind—from light walls to heavy structures. Richmond products save money, save time, do a better job. Prove it? Gladly! Just ask.

**RICHMOND 10-WAY PROFIT PLAN**

- Over 60 different form-tying devices meeting every condition.
- Can be used on new or old ties.
- Engineered for safe working loads of 1500 to 2500 lbs.
- Faster erecting and stripping, saves time and lumber.
- Form-sets perfect wall alignment, plus uniform thickness.
- 1 in. x 2 in. "J" face protects job against rust staining.
- Weight scientifically cut to save shipping and handling costs.
- Delivery right to the job saves warehousing.
- Job section labels save time.
- No cost for working parts. You pay only for ties used.
- J-5 planning bureau specifies types, quantities, methods, free.

**FASTER FORM WORK!**

See point 4. Because Richmond specifies, supplies, and shows you how, there is no waste of time, money or materials. Your job goes faster. Your profits bigger.

11 pages of buying data for Architects, Engineers, Builders, Contractors.

**1100K CATALOG \$5 W.P.E.**

**RICHMOND SCREW ANCHOR COMPANY, INC.**

816 LIBERTY AVENUE, BROOKLYN, N. Y.

THE RICHMOND WAY TO SAVER CONSTRUCTION COSTS  
FOR ALL CONCRETE CONSTRUCTION

## THE 3 POPULAR METHODS OF TREATING EXTERIOR REDWOOD are

CABOT'S #230—which holds the NATURAL COLOR OF THE WOOD for MANY YEARS.

CABOT'S #241 CREOSOTE BLEACHING OIL which gives an old WEATHER-BEATEN SILVER-GREY EFFECT.

or

CABOT'S #344 Creosote SILVER-GREY STAIN.

## GUNN CARLE & CO.

20 Potrero Ave. Underhill 5480  
SAN FRANCISCO



## QUALITY AND DEPENDABLE *Service*

are the factors that influence architects and contractors when selecting lumber and mill work — Quality of merchandise — Integrity and Ability of the firm—Service in physical equipment — Experience and Personnel — All these factors contribute to a speedy and satisfactory completion of construction with minimum of time and expense.

### MANUFACTURER OR DEALER IN

Douglas Fir—Redwood—Sugar and Ponderosa Pine — Plywood and Concrete Form Panels — Sash and Doors — Millwork — Insulation — Builders' Hardware.

## E. K. WOOD LUMBER CO.

"Goods of the Woods" ©

LOS ANGELES • SAN FRANCISCO • OAKLAND



for a High Quality Tile Job

- PERMANENT
- SANITARY
- COLOR-BALANCED

### THE CAMBRIDGE TILE MFG. CO.

Factory: Cincinnati, Ohio  
Pacific

Los Angeles • Branches • San Francisco

**PUT THIS NEW MODERN WINDOW IN YOUR PLANS!**

ROLL-O-SEAL double hung windows make for greater satisfaction for architect, builder and home owner. Unique roller-bearing construction gives smooth, finger-light operation, eliminates sticking, binding or jamming. Water tight, dust free. Units are factory fitted ready to install. Write for folder or phone . . . .

# ROLL-O-SEAL

TELEPHONE LTD. Richmond 1141  
1518 SO. CENTRAL • LOS ANGELES, CALIF.

### PRESENT AND FUTURE OF THE ARCHITECT

On August 20, 1941, there appeared in the Chicago Daily News an article captioned "Get Your Architect Free." It stated, "Defense housing officials announced that the government would provide free architectural service to prepare estimates for remodeling old homes for defense workers."

This brings to my mind the question: "How far will the architect allow the public to be disillusioned, without in any way trying to explain his side of this situation?" Neither professional ethics nor modesty should deter him from bringing to the attention of the government, the industrialist, the business man and the home owner the facts that the architect alone, through his education and training, is prepared to give them the utmost in values and service, in the designing and planning of their buildings and that these services can not be given free.

They should also understand that in the employment of an architect the greatest assurance of economical construction and practical design is obtained, which safeguards their investments, and the fee for the architect's services is as necessary an expenditure as the cost of the foundations of the structure.

Professional ethics will not pay the salaries, rents and many other expenses of the present-day architect's office. In the collection of money for the maintenance of the office the architect receives no consideration for his professional status from the parties to whom he is indebted. The engineer - contractors and speculative builders have recognized the reticency of the architect to demand the position of authority which he is educated to hold because of his artistic and technical schooling and they are endeavoring to convince both the government and the public that they alone merit responsibility for the construction of any project.

Much of the defense work is turned over to bureaus which absorb the architects, or to contractors who immediately assume the authority of the architect. In many instances, where awards are made direct to contractors, the architect is employed by the contractor just as he employs his construction superintendent, and the architect has no executive authority nor can he control the construction or the type or character of the materials used.

The government has not made wide use of the architectural profession in awarding the contracts for defense work and it has explained that, due to the emergency, it was necessary to award the contracts to firms capable of handling the work expeditiously and having in their employ structural and mechanical engineers sufficient in number to handle all the work in their offices—which only the larger firms of architects have.

Many of the architects have offices large enough in personnel to handle projects costing several millions of dollars and they have available structural and mechanical engineers whom they can employ, to increase their



regular force, if the urgency of turning out the work in a limited time should require it.

These architects and their organizations stand ready and willing to do their parts in the defense program, should a commission be awarded them.

The government has overlooked these men entirely and has awarded many contracts to contractors who make subordinate arrangements for the necessary technical services.

The government has advanced money to build plants. This has been an inducement to manufacturers to expand their facilities and receive defense work and with this thought in mind, the owners have allowed the work to be awarded as the government dictates.

With priorities taking effect, private work is being halted because of the fact that without a priority rating no owner has any assurance as to when his building will be completed. This condition leaves many architects' offices with their personnel idle.

Now, the government advertises, "Get Your Architect Free." This means only that the government will hire and pay architects and donate their services and charge this expense to the defense program. The public can not be asked to make an analytical study of who pays the architect, but the public must know that they are paid and must reason that the government is subordinating the architectural profession.

What his relation to the building and economic post-war situation will be, depends upon what is done by the architect to familiarize the public with the work he performs in the practice of his profession and with the fact that no one else has the education or ability to function as he does in the construction of a building.

The architect alone possesses the knowledge of design, the ability to plan practically the physical functions of the building, and the technical knowledge to supervise the construction, so as to assure the use of all materials at the proper time and in a manner to best serve the purpose for which they were intended.

When the public fully understands the many ways in which an architect serves it in its building investment, it will know the need for first consulting him, then following his advice, thereby obtaining the greatest security on its investment.

Understanding these facts, no one would consider building without proper guidance and then the architect would control the project from its inception until its completion, being free to use unbiased judgment in design and use of materials, so that the completed building will be practical in arrangement, pleasing to the eye and safely and economically built.

After the defense program is over, the government will expect the architect in private practice to re-employ the designers, draftsmen, stenographers, etc. and proceed as in the past. This will not be possible if the public, through government education, expects free service, and this condition, together with the paucity



Follow the sun  
to the **DESERT INN**. .  
33rd season. Send for a  
"Sands of Time" magazine

35 acre estate . . . swimming pool, tennis and  
badminton courts, riding, golf, all sports.  
Delightful accommodations . . . delicious food.

**PALM SPRINGS, CALIFORNIA**



### *California's Hotel Beautiful*

- like a country estate yet in the heart of a throbbing metropolitan area.
- a matchless view—
- comfortable, luxuriously furnished rooms, excellent cuisine.
- in an atmosphere of quiet and gracious living.

Rooms, with bath, \$2.50 to \$5.00 per day.

*Attractive monthly rates*

**HOTEL CLAREMONT • BERKELEY**

**BAXCO**  
CHROMATED ZINC CHLORIDE

**GLC**

**PRESSURE TREATED LUMBER**  
● **PROTECTS AGAINST DECAY  
AND TERMITE ATTACK**

*Specify it in your home  
Available through Lumber Dealers*

LOS ANGELES 601 W. 5th Street Phone Michigan 6294	SAN FRANCISCO 333 Montgomery Street Phone DOuglas 3883
---	--

**J. H. Baxter & Co.**

AGENTS FOR WEST COAST WOOD PRESERVING CO. SEATTLE, WASH.

**The Most Complete Line of  
STEELS and BUILDING MATERIALS  
Made by a Single Producer**



*See Sweet's Catalog File or write us for  
full information.*

**REPUBLIC STEEL CORPORATION**  
GENERAL OFFICES: CLEVELAND, OHIO

DENVER, COLORADO . . . . .	CONTINENTAL OIL BUILDING
LOS ANGELES, CALIFORNIA . . . . .	EDISON BUILDING
SALT LAKE CITY, UTAH . . . . .	WALKER BANK BUILDING
SAN FRANCISCO, CALIFORNIA . . . . .	RIALTO BUILDING
SEATTLE, WASH. . . . .	WHITE-HENRY-STUART BUILDING

**HOGAN LUMBER CO.**  
*Wholesale and Retail*

**LUMBER**

---

**MILL WORK • SASH & DOORS**

---

*Office, Mill, Yard and Docks*  
**SECOND AND ALICE STREETS • OAKLAND, CALIF.**  
*Telephone GLencourt 6861*

of work and the low income of the architects in general, brought about by the present emergency, will result in a peak of unemployment in the architectural profession.  
—William J. Ryan, President,  
Illinois Society of Architects, in Monthly Bulletin.

#### PLASTICS FOR DEFENSE

The Sixth Annual Modern Plastics Competition, recently concluded, had more than 2,000 objects entered in 18 classifications encompassing the following categories: Architecture, Business and Office Equipment, Displays, Furniture, General Housewares, Major Household Appliances, Lighting, Industrial, Jewelry and Novelty, Military and Defense, Objects of Art, Packaging and Closures, Radio and Musical Instruments, Scientific, Sporting Goods, Games and Toys, Transport, Wearing Apparel, and Extruded Plastics.

The bulk of plastic productions in this year's competition and the bulk of major awards was not for "novelties" but for productions in the serious business of military and defense, industrial, scientific, transport, major household appliances and business equipment.

Plastics to defend America—for bombing planes, lighter than metals, swift, powerful, efficient; plastics for gun turrets, for transparent observation hatches, for shatterproof windows; plastics for fluorescent panels for the cockpits of planes to minimize the hazards of night flying by making the panel visible to the pilot alone.

Plastics have moved into the vanguard of industrial development not only for use as housings but for the vital structural parts of the working unit and precious metals have been released by the ton load as a result of the competent substitution of plastics for industrial uses.

Plastics have come to the rescue of major household necessities whose production has been imperiled by the metal shortage. Plastics for refrigerators, for complete shower stalls, for washing machines and for fruit-juicers, knives, vacuum cleaners, upholstery fabrics, window blinds and textiles of such bewitching beauty and fragility of appearance that their almost miraculous sturdiness is completely overlooked.

Major awards were given for extraordinary architectural achievements with plastics; for upholstery fabrics to be used in the subways, buses and theaters, and for new black-out lighting devices.

#### PLASTIC WIRING SYSTEM

A new residential and industrial type surface wiring system, using plastic as its basic material, is announced. This new development is the result of eight years of extensive research and experimentation to develop an economical wiring system that provides more adequate outlets at a cost commensurate with conventional installations.

Engineering tests made by Electrical Testing Labora-

tories for the John B. Pierce Foundation conclusively confirm the fact that electricity can be more efficiently distributed, with less copper, when the conductors are in bare, rather than insulated form. This is made possible for the first time by the successful use of thermo-setting plastic housings in a surface wiring system.

The wiring system employs only two basic materials: (a) Metal for conducting the current. (b) Non-current conductive plastic housings.

This method effects a saving of essential materials such as steel, zinc, brass, rubber, etc., which are necessary in conventional wiring systems, which usually provide an inadequate number of outlets.

The significant advantages of this new system are: (a) Ample capacity. (b) Electrically non-conductive plastic housings. (c) Adequate mechanical protection. (d) Lower initial installation cost. (e) Rapid assembly or installation. (f) Simple disassembly and reassembly. (g) Equivalent electrical facilities with a substantial reduction in the volume of essential materials used.

The residential system is smaller in dimensions than the industrial type, has No. 12 copper conductors and provides 30 ampere capacity with duplex outlets at 12-inch intervals. The industrial type employs tubular copper conductors and provides 45 ampere capacity with outlets at 8-inch intervals.

The combined advantages of economy, efficiency, reallocation of important metals and a good-looking, inconspicuous appearance are all inherent in this new system.

#### SPECIFICATION NO. 1000

The one thousandth set of construction specifications for irrigation works in the West—specifications which have covered such record-breaking engineering accomplishments as Boulder and Grand Coulee dams, the All-American Canal and the Continental Divide Tunnel—has been issued by the Bureau of Reclamation.

Appropriately enough the specification which ran the total number issued during the past 39 years of Bureau of Reclamation activity to four digits was written for the Friant-Kern Canal on the Great Central Valley California Reclamation Project.

The Friant-Kern Canal, with a flow capacity of 3500 cubic feet a second, will be one of the largest modern irrigation canals ever built. It is the longest canal on the project which itself is one of the most difficult and most complex jobs of water, power, flood control and irrigation engineering ever undertaken by the Bureau.

During its 39 years of existence the Bureau has written specifications for and built 180 storage and diversion dams, 28 hydroelectric power plants, more than 20,000 miles of canals, ditches and drains. It has built nearly 800 miles of tunnels, 300 miles of dikes, 14,000 bridges, 21,000 culverts, 6000 flumes, 3000 buildings and over 200,000 other structures.

## THE OAKLAND PLANING MILL INC.

MILLWORK, SASH AND DOORS  
HARDWOODS

105 Washington Street  
Oakland, California      TEmplebar 5503

## PAINTING AND DECORATING of the

M. L. Goldman residence in San Francisco  
and the Glacier Gap residence on the  
Yuba River. Farr and Ward, architects, by

## VICTOR E. SWEDBERG

Painting Contractor

2215 - 10TH AVENUE, OAKLAND  
Phone MErritt 1924

## SISALKRAFT

REG. U. S. PAT. OFF.

~~~~~  
"More than a building paper"  
~~~~~

## THE SISALKRAFT CO.

205 West Wacker Drive  
(Canal Station) Chicago, Ill.

55 New Montgomery Street  
San Francisco, Calif.

## CLINTON CONSTRUCTION CO. OF CALIFORNIA

## General Contractors

923 FOLSOM STREET • SAN FRANCISCO

SUtter 3440

## ACOUSTI-CELOTEX

for office-quieting provides . . .

- PAINTABILITY
- PERMANENT LIGHT-REFLECTION
- HIGH EFFICIENCY

*Acoustical Engineers & Contractors*

**WESTERN ASBESTOS CO.**

*Building Materials*      *Mechanical Specialties*  
SACRAMENTO      OAKLAND  
SAN FRANCISCO

## STRUCTURAL STEEL

For Class A Buildings,  
Bridges, etc.

**JUDSON PACIFIC CO.**

1200 SEVENTEENTH STREET  
SAN FRANCISCO

Plants: San Francisco - Oakland

## FRANK J. McCOY HOTELS

**SANTA MARIA INN**—Santa Maria,  
California • Orville E. Sammann, Mgr.  
WORLD FAMOUS STOP-OVER, BETWEEN  
SAN FRANCISCO AND LOS ANGELES

**EL ENCANTO HOTEL & VILLAS**—Santa  
Barbara, California • Fred E. Pimentel, Mgr.  
AMERICA'S HOTEL BEAUTIFUL, IN A  
MATCHLESS SETTING ON THE RIVIERA

## BASALITE

CAMBERED SHINGLE TILE

PERMANENT • FIREPROOF • STORM-  
SAFE • COLORFUL • ECONOMICAL

Manufactured by  
**BASALT ROCK CO., INC.**  
NAPA, CALIFORNIA

This construction has brought water, power and light to western areas with a population of 4,500,000. A million farmers and townspeople make their livelihood from reclamation-irrigated land and 3,500,000 more get half of their power and light from reclamation hydroelectric developments. The farms, homes and towns created on reclamation projects represent a taxable investment of \$750,000,000.

About \$2,750,000,000 worth of crops have been produced on reclamation projects. Annual crop production amounts to more than \$100,000,000. Reclamation projects provide a \$200,000,000 annual market for the products of eastern manufacturers.

The five greatest concrete dams ever designed—larger than any in the world—have been constructed under specifications issued by the Bureau. Grand Coulee, most massive, with 10,500,000 cubic yards, was completed this year. Shasta Dam, on the Central Valley project, the second largest, with 6,000,000 cubic yards, is more than a third finished. Boulder Dam, only third in size with 3,250,335 cubic yards but the highest of the five, was completed in 1935. Friant Dam, fourth largest, also on the Central Valley project, will be finished next year. And Marshall Ford Dam on the Colorado River in Texas will be completed late this year or next.

Successively through the years Bureau of Reclamation specifications have called for construction of the highest dam in the world. In 1910 the Bureau completed Shoshone Dam in Wyoming, on the Shoshone Reclamation Project. Its 328 feet exceeded the height of any dam in the world.

In 1915 Arrowrock Dam on the Boise Reclamation Project exceeded Shoshone by 17 feet, taking first place in height. In 1932 Owyhee Dam on the Owyhee Reclamation Project in Oregon-Idaho was built to a height of 417 feet and three years later the Bureau completed Boulder Dam—whose towering height of 726 feet from bedrock to crest is likely to remain unsurpassed for years to come.

Power, main byproduct of irrigation construction by the Bureau, has seen vast advance. Specifications have been written for 28 plants in 17 states—two of them the largest hydroelectric power plants in the world. At Boulder Dam, whose first generator went into operation in 1936, today's installed capacity of 787,300 kilowatts exceeds that of any other hydroelectric plant in existence, with seven more generators still to come. At Grand Coulee Dam, whose first giant 108,000-kilowatt generator went into action recently, the completed power plant will be a third larger than Boulder's. Total capacity will be 1,974,000 kilowatts—enough energy to light a 60-watt lamp in every home in the United States.

### S. F. STRUCTURAL ENGINEERS

The Structural Engineers Association of Northern California dined at the Dawn Club restaurant the evening of November 18. Following the dinner Major Arthur L. Enger, connected with the State Architect's office in Sacramento, gave an informative discussion on the "Revised Appendix A" and Franklin P. Ulrich, Secretary-Treasurer, gave a brief talk on "Recent California Earthquakes." Annual meeting and election of officers will be held Tuesday, December 2.

### RUNNING FIRE

(Concluded from Page 1)

relationship between contractors, draftsmen, and architects that would result in the refusal of any union labor organization to work on a project, the plans and specifications for which have not been drawn, executed and signed by a certified union architect of the State of California. At first the thought was most repugnant to me, and I more or less ridiculed it. Since then I have given it considerable thought, and the more I ponder over such an arrangement the more attractive it appears.

With conditions that seem to be directed toward the doom of the smaller architects as professional men developing in the manner and with the speed with which we are all familiar, it does seem that something of this sort will have to be done eventually. The government's basis for computing architectural fees is running along the line of diminishing returns for the architect. More and more buildings are being erected without the plans of a certified architect. The cost of producing good plans and specifications and supervising construction is increasing daily. The cost of living is jumping like a Mexican bean. Yet, in spite of all this, there seems to be little or no hope for anything but a reduction in fees to the architect. As an example of pure sophistry, the argument that because the building materials have gone up in price, therefore the architect's fee is increased sufficiently to offset reductions in his percentage, is one of the best since the days of the Greeks.

Unionizing the architects may not be the answer, but it is apparent that something should be done.

#### • CLARITY

There is an element in architectural and engineering plans that is altogether too often overlooked by architects and engineers. That element is clarity. It is possible to make a set of drawings that contain somewhere on the various sheets every bit of information that is necessary to the construction of a structure, and yet it might take a battery of Philadelphia lawyers weeks to find this information. And as far as the work of the estimator is concerned, he might throw up his hands in despair. On the other hand, by proper arrangement, organization and sequence of units, even a very complicated set of plans can be so drawn as to present clearly the intention of the architect or the engineer and the requirements for construction. This might add a few sheets of drawing but it will invariably save both the architect and the contractor time and money in the long run.

## ALADDIN Heating Corp.

Specializing in  
QUALITY HEATING EQUIPMENT

2222 San Pablo Avenue, Oakland  
TWinoaks 1022

**S**LOANE has worked with architects, designers and decorators for years.  
► We interpret intelligently . . . and we know what it is to be up against deadlines and strict budgets. ► Let us prove this!

FURNITURE • FABRICS • WALLPAPERS  
LAMPS AND FLOOR COVERINGS  
WHOLESALE CONTRACT DIVISION

W & J **SLOANE**  
Sutter near Grant • San Francisco

## Painting and Decorating

of the Edwin Walter Residence,  
Hillsborough, California, by

**ALFRED SORENSEN**

523 Corbitt Drive  
Burlingame, California

Fine Water Colors and Papers  
For Architectural Renderings

**H. S. CROCKER  
COMPANY, Inc.**

720 MISSION STREET  
Market Street at Second • San Francisco

# VERMONT MARBLE COMPANY

Producers and Finishers  
of  
Domestic and Imported Marbles

San Francisco, Los Angeles and Tacoma, Wash.  
San Francisco phone: SUiter 6747

## "AMERICAN MARSH" Redi-Vac Vacuum Heating Pump



Send for  
Bulletin 441

**SIMONDS MACHINERY CO.**

San Francisco  
816 Folsom St.

Los Angeles  
455 East Fourth St.



**VAN ARSDALE - HARRIS CO.**  
ENGINEERS & CONTRACTORS

**ACOUSTICAL TREATMENT  
INSULATION • SOUND CONTROL**

Fifth and Brannan Streets • San Francisco, Calif.  
Telephone GAfield 3600

Division  
VAN ARSDALE - HARRIS LUMBER CO., INC.

## PACIFIC MANUFACTURING CO.

HIGH CLASS INTERIOR FINISH  
QUALITY MILLWORK

142 SANSOME ST., SAN FRANCISCO  
GARfield 7755

6820 MCKINLEY AVE., LOS ANGELES  
THornwall 4196

BUILDERS EXCHANGE, OAKLAND



Balcony Detail, Residence of Felix Kahn, Seal Cliff, San Francisco  
Farr & Ward, Architects

CAST IRON BALCONY and  
WINDOW GRILLS executed by

**FAIR MANUFACTURING COMPANY**

Established 1916

Miscellaneous and Ornamental  
Iron and Structural Steel

617 Bryant Street

San Francisco

### BANK RESOURCES JUMP 14 PER CENT

The 163 California savings and loan associations that are members of the Federal Home Loan Bank System increased their resources by 14 per cent in the fiscal year recently ended, James Twohy, Governor of the System, said recently. He paid tribute to the home-financing associations in California, recalling that the district Federal Home Loan Bank of Los Angeles, serving California, Nevada, Arizona and Hawaii, began operations nine years ago.

"Assets of all the member thrift and home-finance institutions in California now total \$397,533,000," said Mr. Twohy, "but this increase in size does not fully express the growing usefulness of these associations—extending their services to larger numbers of savers, investors and home owners and cooperating with the Government in many of its defense efforts. Savings and loan associations are currently making about 18.4 per cent of the total of home loans in California."

He based his statement on reports from M. M. Hurford, President of the Federal Home Loan Bank of Los Angeles, which has advanced a total of \$76,075,376 to its member institutions in California since it was established as a central credit reservoir for this district in 1932. On August 31, its outstanding advances to members in this state totaled \$14,728,036.

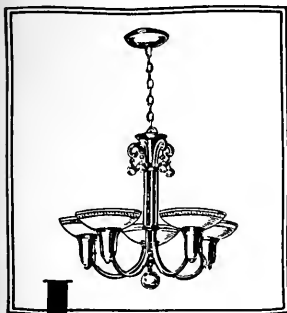
## DEFENSE INDUSTRIES

According to figures recently released by the Committee for Conservation of Manpower in Defense Industries, industrial accidents are rapidly increasing. In 1940, when the National Defense production was getting under way, accidents, many of which could have been avoided, caused 1,350,000 temporary disabilities, left 93,000 workers permanently disabled, and took the lives of 17,000 valuable skilled and semi-skilled laborers. Turned into labor hours, the total stands at one and a half billion man hours. In 1941, these figures are still on the rise and, on the Pacific Coast, as elsewhere in the nation, the Committee for Conservation is working to check the wastage of manpower by reduction of preventable accidents.

Co-operating with the U. S. Department of Labor, the committee and its 400 volunteer safety experts are in reality a service organization. The safety experts and national and regional committeemen are contributing their own and their companies' time for one dollar a year. Their purpose is to eliminate conditions which cause wasteful accidents, and to educate labor, industry, state and city, private and public enterprises to the needs of preservation of laboring life and limb.

Remembering the high accident rate in World War I industrial boom, experienced industrialists decided to do something before the same situation became apparent in the present crisis. New men working in unfamiliar surroundings on full speed production schedules were the most fertile source of minor and serious time loss accidents. Through carelessness, ignorance and often through inadequate safety precautions on the part of a management, accident rates inevitably rise alarmingly during emergency periods. Accordingly, industry and the Department of Labor are co-ordinating activities in the Committee for Conservation work.

The national committee accordingly organized its regional and state chairmen and in 1940 came the first efforts of the 300 leading national safety experts functioning under the



## INDIRECT

A fixture to impress your guests with its beauty and your good taste. Your home is only as lovely as its lighting.

So—may we offer the assistance of our "lighting stylists" in selecting the correct fixtures on your limited budget?

**INCANDESCENT  
SUPPLY COMPANY**  
726 MISSION ST., SAN FRANCISCO

Phone GARfield 1164

## Hunter & Hudson

*Consulting Engineers*

DESIGNERS OF HEATING  
AIR CONDITIONING  
VENTILATING AND WIRING  
SYSTEMS, MECHANICAL  
AND ELECTRICAL EQUIP-  
MENT OF BUILDINGS



41 SUTTER STREET  
ROOM 710

San Francisco California

## Robert W. Hunt Company

ENGINEERS

Inspection - Tests - Consultation

Schools and Other Structures  
Are Built as Designed

*When Construction Materials are  
Inspected at point of Manufacture  
and during Erection by*

ROBERT W. HUNT COMPANY

*Cement, Concrete, Chemical, Metallurgical,  
X-Ray and Physical Laboratories*

Chicago - New York - Pittsburgh  
Los Angeles - All Large Cities  
San Francisco, 251 Kearny Street



Every year more and more doctors, lawyers, engineers, dentists are using our Bank-by-Mail Service. It enables them to do their banking when most convenient, day or night, at home or in the office

Write today for information.

**CROCKER FIRST  
NATIONAL BANK**  
OF SAN FRANCISCO  
*California's oldest National Bank*

Member Federal Deposit Insurance Corporation

## THE TORMEY COMPANY

GENERAL PAINTERS  
AND DECORATORS

Phone UNDERhill 1913

563 FULTON STREET  
San Francisco

G. P. W.  
JENSEN & SON

Building Construction

320 Market Street. San Francisco  
Phone: GARfield 2444

**ABBOT A. HANKS, INC.**  
**Engineers & Chemists**

INSPECTING — TESTING — CONSULTING  
 CONCRETE — STEEL — MATERIALS  
 CHEMICAL AND TESTING  
 LABORATORIES

● RESEARCH AND INVESTIGATION ●

TESTS OF STRUCTURAL MATERIALS  
 DESIGN OF CONCRETE MIXES  
 SHOP AND ERECTION INSPECTION OF  
 STRUCTURES AND EQUIPMENT  
 INVESTIGATION OF STRUCTURES  
 AND MATERIALS  
 TESTS AND INVESTIGATION OF  
 FOUNDATION SOILS  
 FIRE RESISTANCE AND INSULATION  
 TESTS

624 Sacramento Street, San Francisco

**MULLEN MFG.  
 COMPANY**

BANK, STORE AND OFFICE  
 FIXTURES—CABINET WORK  
 OF GUARANTEED QUALITY  
 CHURCH SEATING

Office and Factory:  
 60-80 RAUSCH ST., Bet. 7th and 8th Sts.  
 San Francisco  
 Telephone UNDERhill 5815



**HERRICK  
 IRON WORKS**

STRUCTURAL STEEL  
 REINFORCING STEEL

18TH AND CAMPBELL STS.  
 OAKLAND, CALIF.  
 Phone GLEncourt 1767

**FORDERER  
 CORNICE WORKS**

Manufacturers of  
 Hollow Metal Products  
 Interior Metal Trim  
 Elevator Fronts and Cabs  
 Metal Plaster Accessories  
 Sanitary Metal Base  
 Metal Cabinets  
 Flat end Roll Metal Screens  
 Commercial Refrigerators

269 POTRERO AVE.  
 San Francisco, Calif.  
 HEMlock 4100

committee. Operating under no com-  
 pulsion from the government, its  
 agents have no authority to use force  
 in carrying out safety recommenda-  
 tions. The whole plan is one of edu-  
 cative co-operation based on a study  
 of each factory's individual safety  
 and health needs. The emphasis is be-  
 ing placed especially on small indus-  
 tries which before the defense boom  
 had relatively no safety program be-  
 cause their production was geared for  
 normal schedules and their plants rel-  
 atively uncrowded.

To facilitate operations and because  
 each geographical division of our  
 country has individual problems, the  
 nation was divided into eight admin-  
 istrative zones, the eleven western  
 states comprising the eighth zone.  
 Each state has a chairman and every  
 region a director.

In California, the chairman is B. O.  
 Pickard, of the San Francisco Water-  
 front Employers Association. The re-  
 gional director is R. E. Donovan, safe-  
 ty engineer for Standard Oil Com-  
 pany. Under these two men function  
 the special agents, industrial safety  
 experts drawn from such leading  
 Coast industries as The Paraffine  
 Companies, Inc., Shell Oil Company,  
 Columbia Steel Company, Pullman  
 Company and American Smelting and  
 Refining Company.

Upon the awarding of a govern-  
 ment contract, the National Commit-  
 tee, through its regional heads, as-  
 signs one of the special agents to the  
 contracting manufacturer. This spe-  
 cial agent is to volunteer his services  
 as technical safety adviser. There is  
 no charge for his service and no gov-  
 ernment report is sent back to Wash-  
 ington.

Best interests of the Defense Pro-  
 gram is the primary concern of in-  
 dustry, labor and the public. The sys-  
 tem under which the Committee for  
 Conservation of Manpower in De-  
 fense Industries (CCMDI) operates is  
 one of domestic help through educa-  
 tion, recommendation of safety im-  
 provements, advice to employers and  
 laborers, but never one of compulsion.  
 The program is growing increasingly  
 comprehensive, now embracing all

**Save 20% Space**

Specify

**PITCHER**

IMPROVED DISAPPEARING  
 DOORS

Send for prices and details on our new  
 wood frame sliding doors

**E. C. Pitcher Co.**  
 557 Market Street, San Francisco

Phone Fruitvale 0443

**Eureka Mill &  
 Lumber Co.**

**Lumber and  
 Millwork**

38th Ave. and San Leandro St.  
 Oakland, California

**Independent  
 Iron Works**

Structural Steel  
 Ornamental Iron  
 Steel Service Stations  
 Steel Tanks  
 Standard Steel Mill Buildings  
 Bridges

821 Pine Street Oakland

**ANDERSON  
 &  
 RINGROSE**

General Contractors

320 Market Street, San Francisco  
 Phone GARfield 2245





## Wm. Penn Hotel

2208 West 8th St.  
Los Angeles, Calif.

**200 Rooms**  
**200 Baths**

One in Room..... **\$200**  
Two in Room..... **\$250**

*Attractive weekly and monthly rates.*

Professional men will appreciate the good food at moderate prices in our Quaker Grill.

## PARKER BUILDING SPECIALTIES INCORPORATED

BARBER COLMAN OVERDOORS & RADIO CONTROL

Open and close your garage doors by touching a button on the instrument board of your car! Enjoy the great convenience and safety features that only RADIO CONTROL can give.

Selected by Architects Albert Farr and J. Francis Ward for discriminating clients.

991 BRYANT STREET  
SAN FRANCISCO, CAL.  
UNDERHILL 4612

areas which impinge on industrial efficiency and well being: psychology of the laborer, his health, safety equipment, traffic conditions when he leaves his shift to drive home, and, lastly, the education of all state, civic, fraternal and industrial organizations in an all-out campaign against wastage of America's vital productive manpower.

### LOCAL PRIORITY SITUATION

Protesting "loose and misleading" statements from Washington which have caused "undue alarm over Government priority orders and unnecessary stoppages in building construction," the Building Industry Conference Board has declared that with proper planning by Government and industry, materials can be readily made available for practically all forms of private building.

The board, composed of Northern California architects, engineers, contractors and material manufacturers, has appointed an emergency committee to present solutions on priority rulings; study uses for substitute materials; and collect information on new design methods to minimize utilization of other materials critically needed under the defense program.

"Recent Washington statements have created the impression that many building materials are unprocureable and have thus scared the public into postponing much essential residential and commercial construction," declared Frederick H. Reimers, architect, and president of the board.

"Actually there is no Government ban on any type of construction. Neither is there any shortage of the great majority of materials used for general building. As for critical materials, these represent a comparatively small item in general construction and in most cases can be secured if they are contracted for before a building is started.

"Hoarding by Government agencies has meanwhile induced hoarding by industry groups, all of which is unnecessary. Confirming this is the report that considerable steel may be released for private construction by



**WOMEN** go into raptures over this new Wesix "Perfect Thirty-Six" electric bathroom heater. Its instant, head-to-foot heat, they exclaim, "is simply marvelous!" You will like it because it *fits perfectly into 42-inch wainscots*. For details write Dept. 206, Wesix Electric Heater Co., 390-1st St., San Francisco.

**WESIX**

*World's Largest Manufacturers of Major Electric Heaters*

## FERRO-PORCELAIN

A permanent and beautiful exterior finish . . . particularly adaptable to modern design. Eliminates upkeep costs . . . such as painting . . . choose your own color.

The entire fronts of the Chestnut Tree restaurants in San Francisco are Ferro-Porcelain Enamel.

We will be pleased to work out details for Ferro-Porcelain construction in connection with most any type of building.

**FRANK ALLEN CO.**  
*Ferro-Porcelain Constructors*

320 Market St.  
San Francisco

832 W. 5th St.  
Los Angeles

## INCLUDE TREES IN YOUR PLANS

DAVEY, ORIGINATOR OF TREE SUR-  
GERY, OFFERS FREE INSPECTION  
AND ESTIMATE.



SAN FRANCISCO  
Russ Bldg. Sutter 3377

FRESNO  
Metz 81 Bldg.

LOS ANGELES  
Story Bldg. Tucker 1929

Local phones in: Pasadena, Palo Alto,  
Oakland, San Rafael, San Mateo

SKILL - KNOWLEDGE -  
RESPONSIBILITY

## DINWIDDIE CONSTRUCTION COMPANY

•  
**BUILDERS**

•  
CROCKER BUILDING  
SAN FRANCISCO

HIGH GRADE MILLWORK  
AND INTERIOR FINISH  
SASH AND DOORS

**LANNOM BROS.  
MFG. CO.**

FIFTH AND MAGNOLIA STREETS  
OAKLAND, CALIFORNIA

Telephone: TEmplebar 3663

the end of the year. There is said to be about 30,000,000 tons available in excess of immediate defense requirements.

"To defer the erection of a needed building is speculating with the future, both as to building costs and interest rates," Reimers added.

The board's emergency committee has meanwhile conferred with local OPM officials and is in touch with a similar committee recently organized in New York by the American Standards Association, the American Institute of Architects and the Producers Council. Members of the local committee are: James H. Mitchell, American Institute of Architects, chairman; Norman K. Blanchard, State Association of California Architects; John J. Gould and Henry C. Powers, Structural Engineers Association; William C. Tait, Associated General Contractors; Raymond H. Brown and William F. Anderson, Producers Council.

## JOHN CASSARETTO

—Since 1886—And Still Active—

### Building Materials

READY MIX CONCRETE  
ROCK - SAND - GRAVEL - LIME  
CEMENT - PLASTER - MORTAR  
METAL LATH - WOOD LATH  
STUCCO - WIRE NETTING

### Service Unexcelled

Bunkers  
Sixth and Chennal, San Francisco  
Phones: GARfield 3176, GARfield 3177

## VAUGHN - G. E. WITT Co.

Manufacturers and Distributors

Pump Governors	Oil Heaters
Safety Pump Governors	Relief Valves
Automatic Gas Regulating Valves	Oil Burner Governors
Gas Burning Equipment	Oil Burners
Vacuum Pump Governors	Oil Pumping Sets
Vacuum Regulating Valves	Oil Valves
Continuous Flow Steam Traps	Oil and Steam Strainers
Thermostats	Duplex Oil Pumps
Reducing Valves	Rotary Oil Pumps
	Boiler Feed Pumps
	Water Heaters
	Boiler Feed-Water Regulators

4224-28 Hollis St., Emeryville, Oakland

## STATEMENT OF THE OWNERSHIP, MANAGEMENT, CIRCULATION, ETC., REQUIRED BY THE ACT OF CONGRESS OF AUGUST 24, 1912 AND MARCH 3, 1933.

Of the Architect and Engineer, published monthly at San Francisco, Calif., for October 1, 1941.

State of California  
City and County of San Francisco } SS.

Before me, a notary public in and for the state and county aforesaid, personally appeared L. B. Penhorwood, who, having been duly sworn according to law, depose and say that she is the Business Manager of The Architect and Engineer, and that the following is, to the best of her knowledge and belief, a true statement of the ownership, management (if daily paper, the circulation), etc., of the aforesaid publication for the date shown in the above caption, required by the Act of August 24, 1912, as amended by the Act of March 3, 1933, embodied in section 537, Postal Laws and Regulations, printed on the reverse of this form, to wit:

1. That the names and addresses of the publisher, editor, managing editor, and business managers are:

Publisher, The Architect and Engineer, Inc., 68 Post St., San Francisco, Calif.

Editor, Fred W. Jones, 68 Post St., San Francisco, Calif.

Managing Editor—None.

Business Manager, L. B. Penhorwood, 68 Post St., San Francisco, Calif.

2. That the owner is: (If owned by a corporation, its name and address must be stated and also immediately thereunder the names and addresses of stockholders owning or holding one per cent or more of total amount of stock. If not owned by a corporation, the name and address of the individual owners must be given. If owned by a firm, company, or other unincorporated concern, its name and address, as well as those of each individual member, must be given.)

The Architect and Engineer, Inc., 68 Post St., San Francisco, Calif.

K. P. Kierulff, 68 Post St., San Francisco, Calif.

Fred W. Jones, 68 Post St., San Francisco, Calif.

L. B. Penhorwood, 68 Post St., San Francisco, Calif.

V. S. Yallop, 68 Post St., San Francisco, Calif.

E. J. Cardinal, 942 Howard St., San Francisco, Calif.

3. That the known bondholders, mortgagees, and other security holders owning or holding one per cent or more of total amount of bonds, mortgages, or other securities are: (If there are none, so state.) E. J. Cardinal, 942 Howard St., San Francisco, Calif.

4. That the two paragraphs next above, giving the names of the owners, stockholders, and security holders, if any, contain not only the list of stockholders and security holders as they appear upon the books of the company but also, in cases where the stockholder or security holder appears upon the books of the company as trustee or in any other fiduciary relation, the name of the person or corporation, for whom such trustee is acting, and also that the said two paragraphs contain statements embracing affiant's full knowledge and belief as to the circumstances and conditions under which stockholders and security holders who do not appear upon the books of the company as trustees, hold stock and securities in a capacity other than of a bona fide owner; and this affiant has no reason to believe that any other person, association, or corporation has any interest or indirect in the said stock, bonds, or other securities than as so stated by him.

5. That the average number of copies of each issue of this publication sold or distributed, through the mails or otherwise, to paid subscribers during the twelve months preceding the date shown above is: (This information is required from daily publications only.)

L. B. Penhorwood, Business Mgr.

Sworn to and subscribed before me the 23rd day of September, 1941.

(Seal) CHAS. F. DUISENBERG

Notary Public in and for the City and County of San Francisco, Calif.

(My commission expires May 22, 1945.)

ARCHITECT  
AND  
ENGINEER

**DECEMBER 1941**

MANUFACTURERS OF THE MOST DIVERSIFIED  
LINE OF QUALITY *Burned Clay*  
*Products* ON THE PACIFIC COAST



The 40 acre plant of Gladding, McBean & Co. on Los Feliz Blvd., is one of ten on the Pacific Coast manufacturing the following products:

ACID BRICK \* ACID PROOF CEMENT \* ACOUSTICAL AND INSULATION PRODUCTS  
ASBESTOS \* BRICK \* CERAMIC VENEER (Terra Cotta) \* CHIMNEY PIPE \* DRAIN  
TILE \* ELECTRICAL CONDUIT \* FIRE BRICK \* FLUE LINING \* GAS FLUES \* GLAZED  
BLOCK \* GROUND PRODUCTS \* INDUSTRIAL INSULATION PRODUCTS \* MORTAR  
COLORS \* MODELING CLAY \* POTTERY \* REFRACTORIES \* ROOFING TILE  
STRUCTURAL CLAY TILE \* HERMOSA Bath and Kitchen TILE \* FRANCISCAN  
WARE POTTERY \* VERMICULITE PRODUCTS \* VITRIFIED CLAY SEWER PIPE

★ ★ **GLADDING, McBEAN & CO.** ★ ★

2901 LOS FELIZ BLVD.

Olympic 2121

# RUNNING FIRE — By MARK DANIELS, A. I. A.

## • *SUBSTITUTES—EQUAL OR BETTER*

With priorities running around off leash, biting innocent people indiscriminately, the problem of finding substitutes for those materials which the Government will only let you purchase when you have a priority slip in each hand is becoming critical. It has, however, the merit of developing the ingenuity of the architects in their struggle to find something as good or better than the materials banned by the "Critical List" and priority regulations.

Many materials have already found their way into use and some have proven better than those formerly employed for the same purpose. Lucite, and similar product of the du Pont de Nemours, is one of these. There is a Lucite tubing sufficiently flexible to be inserted through holes that are not straight, which can be substituted for other tubings which are not flexible.

But one of the most practical substitutes and one which definitely replaces previous materials is the Celotex form of board which can be used to take the place of expanded metal lath in solid partition construction for partitions in rooms of ceiling height up to nine feet. Celotex boards are rapidly taking the place of metal lath. The advantages claimed by the Celotex manufacturers is the speed with which the partition can be installed, the economy in plaster due to the fact that it is spread upon a more or less solid surface, the saving of metal, the insulation against heat and sound, and in fact a total slightly lower cost. It looks as if one of the great problems of the architect, the plastering problem, is on its way to a practical solution.

## • *PEGLERIZED*

Day by day, ever more frequently, you hear people say "Oh, if I could only write like Pegler I would certainly show these crooks!" Whether it is a question of soapstone being substituted for jade, a canoe being sold to the Government as a submarine, or a toothpaste that proves to be a metal polish, people say "If I could only write like Pegler."

I feel the same way, not because I want to show anybody up but because I wish to God I could write like Pegler. But in years of effort it has finally seeped through my more or less ossified brain pan that you cannot write like Pegler until you can think like Pegler and that takes a lot of brains.

## • *ADDENDUM*

In an item above on the subject of substitutes, I neglected to include one that would be particularly appropriate as a substitute for plaster but, on second thought, to mention it would be more or less useless because it seems impossible to make the average layman understand that we do not sleep under "sheet-rock."

## • *MODERNISM*

At the meeting of the northern section of the California State Architects the dog-eared subject of modernism in architecture became more or less heated between two members. In an effort to change the subject one of them drifted to "humor" and said that he thought the pun was the lowest form. The anti-modernist replied, "Keep on with your modern designs and you may find a lower one."

To the list of paradoxes, such as the man who contends that free ornament is not only useless but almost criminal and yet spends two hours selecting a necktie, should be added a recent confession of Ernest Weihe, Master of Moderns, that he cannot bear to see a woman smoking on the streets. That particular prejudice does not seem to be very modern.

## • *WHOLESALE PICKETING*

When you walk the streets of San Francisco, if it were not for the arm emblems of the pickets striking against almost every other shop and place of business, one would think that San Francisco is a very thriving village. With thirteen hotels patrolled by pickets, the Emporium and similar old institutions patrolled by pickets, and innumerable other places of business picketed one day and not the next in a manner that shows the devotion of a union laborer to the prosperity of our city, it is apparent that union dues have accumulated to a point where something must be done with the money.

But the time will come when that money will run short and as a suggestion as to how to meet this emergency I offer the following as a practical alternative: Just picket the whole city of San Francisco. Put five pickets at the Golden Gate Bridge terminal, five at the Bay Bridge terminal, and five at Third and Townsend. With fifteen men you can picket the whole damn town which would reduce the cost from the amount necessary to support two or three hundred to the small number of fifteen.

The City of Ontario in Southern California has put up to the citizens for a vote, the proposition of charging each picket \$3.00 per day license fee for enjoying the privilege of picketing, the principle being that the city charges peddlers and similar people a fee per day for plying the trade in the public streets. Whether this will result in additional strikes to increase the wages on all labor by \$3.00 per day is a question, but at least the City of Ontario is trying to work out some remedy for this movement that spells tragedy.

## • *T. L. M.*

The little man stood with his elbow crooked for stability behind the bar rail, holding an old fashioned in each hand. He seemed to be in some doubt as to which one to drink first, but being a man of quick decisions he gulped them down practically as one.

"You must always feel rotten the day after Thanksgiving," he said, "no matter how well you feel. It is a good New England custom which is at variance with others of that dear old country. For instance in the old days 'crooked' was a fine old word descriptive of that delightful feeling that steals over one after a number of old fashions. Then came 'tight,' then 'jagged,' then 'soused,' then 'pickled.' The English language is a living thing and grows in different forms with usage, but I deplore this cursed habit of changing good old words to fit modern conditions. 'Streamlined' was one of these obnoxious modern words which is still being over-done and now they are calling that delightful condition following the consummation of a bottle of Bourbon a 'black-out.' Personally I am unalterably opposed to the adoption

(Turn to Page 58)

# OUR SHOULDER TO THE WHEEL

Today the entire building industry faces a challenge in meeting the unprecedented demands of national defense. Here at Pacific Portland Cement Company wheels are turning as never before in attempting to meet this challenge. Obviously defense orders come first, taking the major part of our output. As rapidly as possible our production is being expanded to help meet the needs of all our customers. In the meantime, bear with us—please—our shoulder is at the wheel.



## COASTWIDE SERVICE

# ARCHITECT AND ENGINEER



Volume 147

December, 1941

Number 3

<b>Running Fire</b> . . . . .	<b>1</b>
Mark Daniels	
<b>"Zanzibar"—a Cocktail Lounge</b> . . . . .	<b>19</b>
<b>Fullerton, California, City Hall</b> . . . . .	<b>23</b>
<b>A Garden and Two Swimming Pools</b> . . . . .	<b>27</b>
Mark Daniels	
<b>Plastics Release Materials for Defense</b> . . . . .	<b>31</b>
<b>A New Venture in Art Instruction</b> . . . . .	<b>35</b>
Antonin Heythum	
<b>Prison Without Walls</b> . . . . .	<b>39</b>
<b>Small Retaining Walls</b> . . . . .	<b>45</b>
Al Brinckman, C.E.	
<b>New Era in Architecture</b> . . . . .	<b>47</b>
<b>Priority Aid for Private Homes</b> . . . . .	<b>49</b>
<b>Standardization of Building Products</b> . . . . .	<b>55</b>

**PLATES AND ILLUSTRATIONS**

<b>"Zanzibar" Cocktail Lounge, San Francisco</b> . . . . .	<b>18-21</b>
J. Lloyd Conrich, Architect	
<b>Fullerton City Hall</b> . . . . .	<b>23-25</b>
G. Stanley Wilson, Architect	
<b>Two Swimming Pools at Burlingame, California</b> . . . . .	<b>26-30</b>
<b>House in Menlo Park, California</b> . . . . .	<b>34</b>
Mario Corbett, Architect	
<b>State Institution for Men, Chino, California</b> . . . . .	<b>39-41</b>
<b>Yuletide Decorations</b> . . . . .	<b>42-43</b>

EDITOR, FRED'K W. JONES; ASSISTANT EDITOR, E. N. KIERULFF; CONSULTING AND CONTRIBUTING EDITOR, MARK DANIELS; ADVERTISING MANAGER, R. W. WALKER. REGULAR CONTRIBUTING EDITORS: Harris C. Allen, Harry Sanders, Ben H. O'Connor, Glenn Stanton, Roi L. Morin, Chas. H. Alden, Irving F. Morrow. HONORARY EDITORS: Arthur Brown, Jr., Timothy L. Pflueger, Lewis P. Hobart, Wm. W. Wurster, Will G. Corlett, Frederick H. Meyer, Thos. J. Kent, Gordon B. Kaufmann, Paul R. Hunter, Michael Goodman, Harry Michelsen.

**NEXT MONTH**

¶ One of the more interesting U.S.H.A. projects in Southern California is Avalon Gardens, located actually within the city limits of Los Angeles, and therefore unlike many of the other housing projects in the South which are mostly situated in outlying districts. Avalon Gardens is surrounded by built-up areas and improved streets and consists mostly of one-story units with a low ratio of persons per acre. Architect Roland F. Coate says the project embodies some very sound fundamental factors for housing in a typical California setting. Models and drawings will accompany the text.

¶ Progress in store and shop design is reflected in several recent examples from the office of Gruenbaum & Krummeck of Hollywood. An interesting alteration job of a downtown Broadway store is included in the series of exceptionally good photo views.

¶ Wallace Neff, architect of Los Angeles, whose residences for prominent members of the movie colony in Hollywood have several times been illustrated in this magazine, is receiving national recognition as originator of a new construction technique now being successfully tried out in a Virginia housing project near Washington, D. C. Balloon forms are used in place of wood and steel. The possibilities for this type of construction for housing, farm buildings, barracks, dormitories, hangars, factories, etc., are said to be almost unlimited. ARCHITECT AND ENGINEER next month will tell you all about it.

ARCHITECT AND ENGINEER is published on the 15th of the month by The Architect and Engineer, Inc., 68 Post Street, San Francisco. President, K. P. Kierulff; Vice President, Fred'k W. Jones; Secretary and Business Manager, L. B. Penhorwood.

Entered as second class matter, November 2, 1905, at the Post Office in San Francisco, California, under the Act of March 3, 1897. Subscriptions, United States and Pan America, \$3.00 a year; foreign countries \$5.00 a year; single copy \$ .50.

Los Angeles office: 1709 W. 8th street, Wentworth Green, Manager. Phone EXposition 8292. ARCHITECTS REPORTS are published daily from this office and are sponsored by the Northern Section, State Association of California Architects; Vernon S. Yallop, Mgr.



Model No. 7A — June

# HAW'S DRINKING FAUCET CO.

and its Representatives  
extend Christmas and  
New Year's Greetings  
to their many patrons

**the high efficiency of Haws  
Drinking Fountains is empha-  
sized by their extensive use  
in U. S. Army Cantonments  
throughout the nation.**

#### REPRESENTATIVES

A. Torres, Howard Clark Bldg., Chicago, Illinois; Claude W. Cornelius, P. O. Box 1112, Glenn Bldg., Atlanta, Georgia; Rex Williams, 625 Dooly Bldg., Salt Lake City, Utah; George H. Killits, 711 Dekum Bldg., Portland, Oregon; Sam Anderson, 3440 Walnut Ave., Seattle, Wash- ington; Eric Roberts, 320 Market St., San Francisco, California; Wallace Mitchell, 171 - 2nd St., San Francisco, California; Leonard E. Shaffer Co., 1340 East Sixth St., Los Angeles, California.

## HAW'S DRINKING FAUCET COMPANY

1808 HARMON STREET • BERKELEY • CALIFORNIA

Agents in the following cities:

New York • Los Angeles • San Francisco • Seattle • Salt Lake City • Portland



# THE MIRACLE OF DEFENSE CONSTRUCTION

by Frazier Hunt



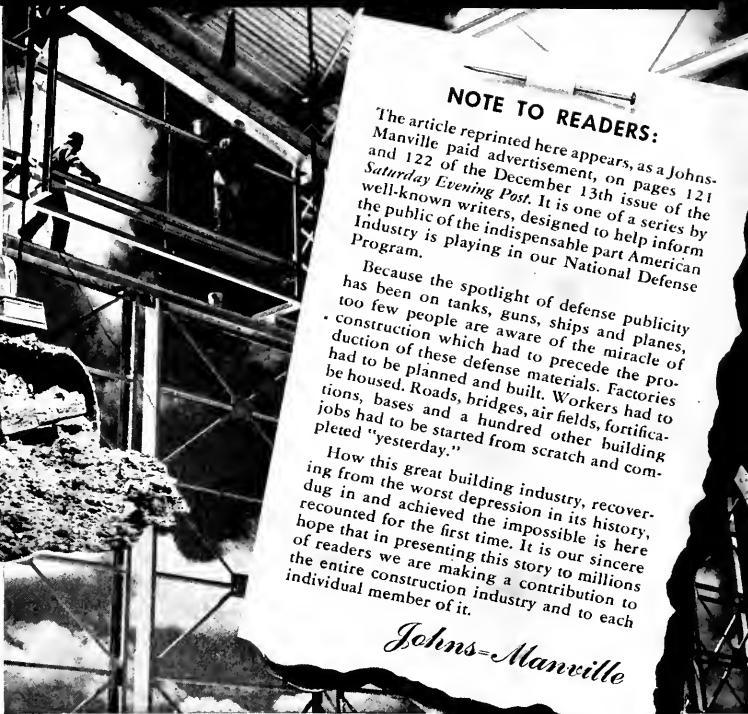
**FOUNDATIONS FIRST.** Before the airplane hangar (right) could go up, the hard-working bulldozer (above) had to dig up and level out the foundation. The bulldozer, with its tractor tread and colossal roar, is the building industry's private "tank."

**A**MONG THE UNSUNG HEROES of America are the "bulldozers"—those giant machines which, like faith, can move mountains.

The whole story of American preparedness starts with those snorting monsters and with men with blueprints and steam shovels, cement mixers, pile drivers, and the thousand and one other tools that are used on any kind of a building job.

Because bombers don't grow on trees. And tanks don't bloom on rose bushes. And you don't dig TNT out of the ground as you do potatoes. All those weapons are made in great factories, giant plants—in buildings that have to be planned by engineers and architects, and built by carpenters, riveters, welders and roofers, working from sunup to sundown.

Before the tank, before the bomber, before the army, had to come the bulldozer-operators, the masons, the steel workers, the electricians, the plumbers, the painters and the whole construction gang . . . And what an almost inconceivable number of buildings are needed for National Defense! Around 1400 separate housing units in an average cantonment; close to a thousand separate buildings in a powder factory; hundreds of sheds and storage bins at a Navy Yard; houses for the workers near many new plants—ground to be cleared, streets to be laid out, roads built, water mains installed, whole cities built from the ground up. What is the construction business? Brother, it's everything you *don't* see—multiplied by ten! You see the tank on the ground or the plane up in the air, but if the construction industry hadn't done *its* job, there wouldn't be any tank and there wouldn't be any plane, either.



## NOTE TO READERS:

The article reprinted here appears, as a Johns-Manville paid advertisement, on pages 121 and 122 of the December 13th issue of the *Saturday Evening Post*. It is one of a series by well-known writers, designed to help inform the public of the indispensable part American Industry is playing in our National Defense Program.

Because the spotlight of defense publicity has been on tanks, guns, ships and planes, too few people are aware of the miracle of construction which had to precede the production of these defense materials. Factories had to be planned and built. Workers had to be housed. Roads, bridges, air fields, fortifications, bases and a hundred other building jobs had to be started from scratch and completed "yesterday."

How this great building industry, recovering from the worst depression in its history, dug in and achieved the impossible is here recounted for the first time. It is our sincere hope that in presenting this story to millions of readers we are making a contribution to the entire construction industry and to each individual member of it.

*Johns-Manville*

has performed miracles, you must realize that this industry had to start from scratch. Particularly was this true of those architects and large construction companies which, during the great American building era of the twenties, had sent beautiful edifices of steel, stone and cement soaring high into the sky. These builders of great new cities, of office buildings, of mammoth factories, of power plants, of bridges and transportation arteries that were the wonder of the world—these builders and the architects, designers and engineers had faced a famine since 1930. The genius was there. The will to build was there. But only through digging deep into their bank accounts had they been able to keep even a skeleton organization together. Only the courage born of free enterprise could have sustained them. About all they had left was one shirt to their backs . . . Yet these same men are performing the miracle of defense construction for America today.

These men might well have said, "Give us a year to get ready. Our staffs are scattered, our equipment rusty." But there wasn't any year. **THE TIME WAS NOW!**

### The Building Materials Dealer

It wasn't only the big boys who rolled up their sleeves and went to work, either. The local building industry responded, too. The building materials dealers, many hard hit by the depression, instantly made their services available for National Defense housing and other construction. They did this often at a sacrifice because they were already short of materials for civilian needs (that's you and me). Despite the fact that building materials manufacturers have been working their plants

are finding it increasingly difficult to furnish supplies with the speed the public has been educated—up to now—to expect.

These smaller companies have shown typical American initiative in meeting their difficulties despite delay in getting materials and shortage of skilled workers. They are particularly deserving of sympathetic understanding on the part of the American public at this time, and it is certainly to their credit that they are not only finding ways around their present difficulties, but are also planning for the future. For these are the men on whom Mr. and Mrs. Homeowner, U. S. A., must depend for the type of housing which will express the true American way of living when peace has come.

We writers and talkers are too deep in the forests of finished products that American genius has built, to be able to see the individual trees. We forget, sometimes, that Uncle Sam didn't furnish the bulldozers and the thousand and one necessary tools when

(Continued on next page)

This is the sixth of a series of advertisements sponsored and paid for by Johns-Manville. For more than 80 years this company has been serving America's basic industries.

How indispensable these industries are to the American Way in time of peace is generally recognized. This series is to help inform the public of the indispensable job these industries are doing in this time of great National Emergency.

Johns-Manville is proud of the contributions its products are making in helping the Construction Industry accomplish "The Miracle of Defense Construction" quickly and at

# THE MIRACLE OF DEFENSE CONSTRUCTION

(Continued from preceding page)

the defense rush struck. These tools were furnished by the great and small building concerns and contractors who had kept alive for ten years only through their courage and ingenuity. Someday they knew they would be needed, and needed desperately. That day came when France fell, and America awoke to her peril. Overnight America demanded adequate defense—armies, training camps, guns, tanks, planes, shells, ships, TNT and powder. And when that call to duty came, not one miracle occurred, *but a thousand!* In a year—in two at the most—the builders HAD to do what Germany had taken seven, in some cases ten years to do.

And they did it! They are saving America by literally building a NEW America. They have conquered Time—they have laughed at Fate. They are winning! Today the bombers and the tanks and the big guns are rolling out of the factories which these men—these builders of the NEW America—have built.

The other day I stood on a spot where for a hundred years tall corn had grown. It was the heart of the broad Corn Belt of this rich land of ours—a single plot of 22,000 acres lying between the Kankakee and the Des Plaines Rivers, a few miles out of Joliet, Illinois. In this single great triangle, where for generations 146 Illinois families had grown corn, were all the basic requirements for a giant plant to make the high explosives for our bombs, shells and torpedoes. Here was plenty of water, excellent transportation, hard roads, safety from enemy bombing attacks and rolling land for protection against inside explosions.

## One Miracle Among Many

So *this* was the spot for "the miracle of the corn fields." The construction company which did the job asked few questions when the government gave them the nod. Quietly they shipped in their key men, and then added workmen at the rate of 100 a day. The bulldozers grunted, the cement mixers groaned, the men sweated and swore—but where the tall corn had grown, there now sprouted chimneys, pipelines, buildings and shops. The sum total of these adds up to one of the biggest, most efficient and safest TNT plants in the world—all done ahead of schedule. That's easy to write about, but these men on the job, just as a starter, had to build 51 miles of standard-gauge railroad, with 117 loading and unloading stations; 44 miles of heavy-duty roads and 80 miles of ordinary highways; 85 miles of pipelines that ran from 4 inches to 42 inches—with 15 miles of sewage pipe thrown in for good measure (and good sanitation). Before this mighty TNT plant was completed, the construction company had put up 460 separate buildings.

The building of this plant is but one example of the job being done. So vast, so widespread is our defense construction a writer despairs, in a short article like this, of ever getting across to you its true magnitude. Maybe this would help: In the first nine months of 1941, we have used enough concrete in airport pavements alone to equal almost all the concrete used in road building in these 48 states in the same period. To pave these urgently needed airports, we have laid enough concrete to build a single-lane transcontinental highway from Charleston, South Carolina, to Los Angeles and back again East as far as Indianapolis, Indiana, or more than 5,000 miles.

## America Does It Again

The blue eyes of hard-working, super-efficient, 49-year-old Brigadier General Brehon Somervell, Chief of the Construction Division of the Army Quartermaster Corps, twinkled with pride when he talked to me in his Washington office about the all-important part the building industry is playing. "You can't exaggerate what has already been accomplished," he said to me. "It's like the statement made by the great General Goethals about the building of the Panama Canal, '*Birds were singing in the trees one week and ships sailing by the next.*' Americans, working for America, have done it again! The whole building industry has come forward in unbelievably fine shape. . . . The results speak for themselves. The efficiency and patriotism of these splendid men have been inspiring. They have tackled what looked to be impossible jobs and they have driven them through, and in many cases ahead of schedule. Labor, too, has, on the whole, been fine. . . . We have almost completed our first great program and are deep in our second now. I can't say too much for these men of this fundamental industry."

I don't want to bog you down with figures, but it is fascinating to take hold of one or two items involved in the single business of Army-cantonment construction. We've used enough lumber in our Army camps to nail a 12-inch plank, 1 inch thick, eight and three-quarters times around the world. In building camps and Army cantonments alone we've employed more than 490,000 workers, and a billion dollars' worth of lumber. A score and more of our great civilian building contractors simply rolled up their sleeves, spat on their brawny hands, and dared bad weather and hard luck in their drive to get finished, in time, camps that would be snug and habitable for our expanding army.

## How the Job Was Laid Out

The whole enormous job really breaks up into three separate divisions—and behind each stands the vast civilian building industry, with its trained men, its tools and its high patriotism. The Army & Navy Corps and Bureaus developed their specifications and then turned them over to the trained civilian architects and engineers of the country. These men, with their firsthand knowledge of materials and design, did the original planning. They worked night and day, adapting civilian methods and techniques to the new field of construction necessary to our national defense.

All of them did—and are doing—their work in three main divisions because all military construction was split into three parts. *First:* To the Construction Division of the Quartermaster Corps went the job of building the plants for Army training, and ordnance and soldier supplies. *Second:* To the Army Corps of Engineers went the task of laying out the construction of fortifications, camouflage works and all Army Air Corps projects and bases, including the nine great air bases acquired in the Atlantic from the British and the new Alaskan air fields. *Third:* To the Bureau of Yards and Docks of the Navy went the complicated job of building naval air bases in the Pacific and Atlantic, as well as at home, and the whole varied and multiple tasks of Navy construction, from shipyards to training schools.

Behind each of these three divisions stood, in phalanx, the great building indus-

try. Architects, engineers and contractors furnished the brains and the muscle to drive the nails in our far-flung fortresses of safety. Also, hundreds of our finest construction brains were willingly drafted to serve as reserve Army and Navy engineers and Constructing Quartermaster officers. From the Philippines to Puerto Rico is ten thousand miles; from Dutch Harbor, Alaska, to Samoa, in the South Seas, is roughly five thousand miles. So the picture of our preparedness program covers a canvas five thousand by ten thousand mile square. Over this great expanse of land and sea, American engineers, builders with saw and hammers, contractors with fantastic bulldozers and pile drivers, have swarmed like busy bees.

A billion dollars was assigned to the Engineer Corps of the Army. There were bomber and fighter factories and assembly plants to be constructed, air bases to be rushed to completion. . . . Altogether 54 great groups of buildings and bases.

Almost overnight a new base is born; a new pearl added to our priceless necklace of national defense—Guam, Wake, Midway, Palmyra, Johnson—these are a few of the names.

Groups of sturdy, daring contractors banded together on most of these jobs, and they found they had to build from the coral and sand up. These new Magellans, modern Vasco de Gamas had to tote everything with them, including drinking water!

## People Back Home

And (to get back home) in this year of 1941, despite the heavy demands of war, our builders have found time somehow to build many of the new homes needed in defense areas. Next year they will build more. But many materials that might go into homes will have to go to defense plants, powder mills, air schools and shipyards, and so we the People must be patient. When our nation is fully armed and strong we can go ahead and build our new homes once again, without let or hindrance.

And in the meantime we can also thank our building-material manufacturers for having the courage, good sense and patriotism to keep intact their organizations, their research laboratories and their staffs when the going was tough and uncertain. Many had to draw deeply on their reserves, but when the crisis came and the building industry had to really perform "the miracle of defense construction," it was ready with new products, more efficient production, to tackle and finish the job. Once again, private industry had proved it could "take it."

So why should any of us complain if, during this coming year, the great effort and the continued need of turning out vast quantities of war goods leave us short-handed in men and materials for home building? The sacrifice and the temporary hardships will be well worth the cost, it seems to me. For what is a home worth if it be not secure, free and decent?

That's what we're struggling for and arming for, isn't it? And, when we get there, don't forget the defense job had to be done *from the ground up*—that private industry was ready to do it—and that the roar of the bulldozers was the first signal of ultimate victory for our democratic way of life.

*This is the sixth of a series of advertisements sponsored and paid for by Johns-Manville and designed to tell the American people how indispensable our basic industries are for National Defense.*

The attractive Nairn Linoleum walls and floor make this living-room in the boys' cottage at the Southbury Training School a very pleasant place. The outstanding durability of Nairn Linoleum will keep the room in good condition for years, in spite of the "wear and tear" of a houseful of boys.



## Here's a specification that meets every "endurance" test for public buildings

—and provides color and beauty, too!



Exterior of the Southbury Training School of the Connecticut State Department of Public Works, Southbury, Connecticut.

**N**AIRN LINOLEUM is the architect's answer for the floors and walls of public buildings, where long-lived, hard-wearing materials are "musts."

Exceptionally durable against heavy daily foot traffic, Nairn floors can take it for years with hardly a sign of wear. Nairn walls are practically *permanent*. Under normal conditions they will last as long as the building itself!

But Nairn Linoleum does more than wear well. It is sound-deadening, easy on the feet, and easy to maintain. Nairn floors need only regular clean-

ing and waxing. A damp cloth removes dust or spatters from Nairn walls.

In addition to its sturdiness, Nairn Linoleum brings new beauty. Obtainable in a wide variety of colors and patterns, it makes possible charming decorative effects through the use of contrasting insets and borders.

Add moderate first cost and negligible upkeep to the other Nairn features and you have the perfect public building specification for both floors and walls. When installed by

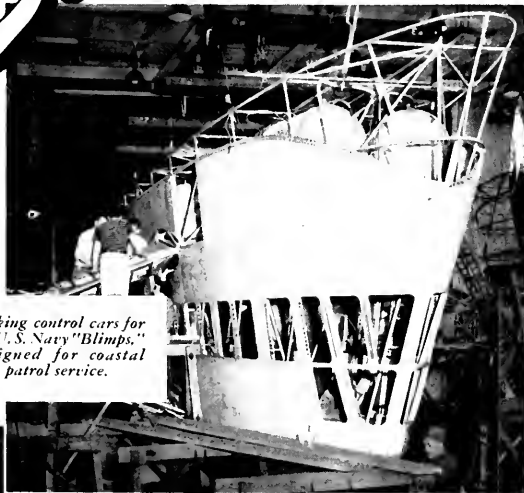
Authorized Contractors, Nairn Linoleum is fully guaranteed.

CONGOLEUM-NAIRN INC., KEARNY, N. J.

**NAIRN**  
LINOLEUM FLOORS & WALLS

# Sloan Flush Valves?

-take



*Making control cars for the U.S. Navy "Blimps," designed for coastal patrol service.*



*View of final inspection conveyors as every Goodyear tire is carefully checked.*



*General view of Goodyear Plant No. One, Akron, Ohio. In Akron there are three such Goodyear plants besides the airship dock—all Sloan equipped.*



America's commercial progress took a long step forward when Charles Goodyear discovered the secret of vulcanizing rubber, back in 1839. From that discovery grew the giant enterprise of the Goodyear Tire and Rubber Company which today not only includes rubber goods factories around the world, but seven large textile mills throughout the United States and Canada, plus innumerable district headquarters, branch offices, sales and service stations. It seems most significant that practically all of these factories and buildings are Sloan equipped.

### Why Sloan Flush Valves?

**WHY** should Goodyear, in common with hundreds of other large organizations and institutions, depend almost entirely upon Sloan for flush valves? The answer is simple: Sloan Flush Valves give the greatest dollar value.

**THEY SAVE WATER . . .** In one installation where Sloan Flush Valves replaced other equipment, there resulted a saving of 50,000,000 gallons of water per year. And of course such a saving means *more* than water; it means saving electricity, coal, man-power. Sloan Flush Valves save their owners money *all* the time because their adjustment stays put.

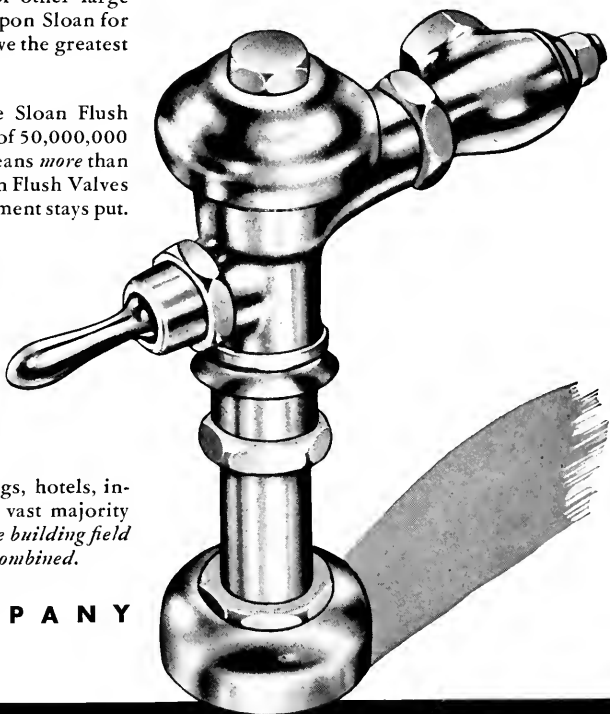
**THEY SAVE REPLACEMENT . . .** Sloan Valve durability can be verified in *your* locality. Installations fifteen, twenty or twenty-five years old are common to every section of the country and to every type of building.

**THEY REDUCE MAINTENANCE EXPENSE . . .** Sloan Flush Valves cost but  $\frac{1}{2}$ c to  $1\frac{1}{2}$ c per valve *per year* to maintain. Entire installations in service for years without being touched are constantly reported.

**THAT'S WHY . . .** In schools, hospitals, office buildings, hotels, institutions, factories, apartments or public buildings, the vast majority of flush valves are SLOAN. Indeed—*throughout the entire building field more SLOAN Flush Valves are sold than all other makes combined.*

**S L O A N   V A L V E   C O M P A N Y**

4300 West Lake Street, Chicago



**SLOAN Flush VALVES**

# NEWS AND COMMENT ON ART

## MAYNARD DIXON

**Significant** painting rests upon design; and pre-occupation with design not infrequently entices a painter through varying degrees of distortion and abstraction, at times even to the complete obliteration of subject matter itself. So characteristic of current art is this attitude that it is often assumed that design can be achieved only by a rather aggressive degree of abstraction, and that anything in which the resemblance is more than approximate must be "old hat."

Maynard Dixon's recent paintings at Gump's therefore came as a salutary reminder that a vigorous sense of design may go along with the most exacting realism. The geologist and the meteorologist and the botanist might almost use his cliffs and his skies and his trees as scientific documents. Yet in their purely formal organization of lines, shapes, values and colors his pictures afford real aesthetic satisfaction, along with a degree of active excitement not always present in what we are asked to accept as the aesthetic experience.

Sunlight is the ever-present protagonist, sometimes felt as light, sometimes even as heat. It submerges whole landscapes, and makes monumental luminaires of the yellowing trees through

CARVED WOOD RELIEF, "THE GARDENER,"  
by Jacques Schnier



which it pours. Even where the greater part of a picture is in shadow, it is not so much a passive absence of sunlight as a vigorous and positive shadow, the reverse of an active and unremitting sun.

On the technical side his mastery, always skirting the futility of pure virtuosity, adds the thrill of exuberance and the assurance of confident dexterity turned to specific account. Perhaps no painter among us has possessed so keen an instinct for the exact impact of every area of color on every other color in the field of vision.

Although Dixon's subjects are often scenically arresting, his pictures invariably escape that curious blend of physical unreality and aesthetic triviality which so frequently characterizes paintings of spectacular scenery. He could probably make a satisfying painting of Yosemite Valley from Artists' Point. Study of his success might possibly lead to a clue as to why "scenery" is generally fatal to an artist.

## THAT MASTER PLAN

**Now** that the idea of a master plan for San Francisco has received its political baptism, the man in the street begins to evince his interest by asking, When will it be finished? and, How much will it cost to build it? To the big public, city planning still connotes grandiose Burnham projects—avenues converging upon statues of generals, and the job done once and for all when the sculpture contracts have been completed.

The Citizens' Committee organized on November 24 under the auspices of the Chamber of Commerce's Committee on City and Regional Planning therefore is in a position to assume a much-needed function. That function, of course, is not to make the master plan. But in the nature of things the planning office will be unable to engage in public relations activities and propaganda. It is a technical organization with a technical job to do, and a combined professional and political position to maintain. The results of its labors, as they emerge from time to time, must nevertheless be explained, interpreted, justified to the man in the street. Public contact and interest as the work progresses will be essential. And the modicum of steam which will inevitably have to be blown off, had far better be blown off in the Citizens' Committee than in the offices of the Planning Commission. The Committee will have amply justified itself if it accomplishes no more than to inculcate the ideas that planning is a process; that the master plan is not a set of drawings and specifications to send to contractors for bids, but a declaration of the principles upon which logical future development should proceed; and that the master plan will never be finished until the community is dead.

Irving F. Morrow.

## PORTRAIT

**H. K. S. Williams** has just presented to the California Palace of the Legion of Honor a portrait of the Duchess of Hamilton and Argyll by Sir Joshua Reynolds. The portrait is a sketch for the large painting of the Duchesse which was painted in

# AN EVER CHANGING WORLD



WATER COLOR, "OLEMA," BY MILLARD SHEETS  
From the Albert M. Bender Collection

1760, and is now in the Lady Lever Art Gallery at Port Sunlight, England.

The sketch painting, which represents Elizabeth Gunning, the famous beauty who married first the 6th Duke of Hamilton, and secondly, the 5th Duke of Argyll, was formerly in the collection of the late Duchess of Argyll, who was Princess Louise, a daughter of Queen Victoria. It was recently sent to this county in one of two separate consignments of pictures acquired from the trustees of the Duchess' estate. The first consignment was temporarily stored in a warehouse at a Liverpool dock. The warehouse was destroyed by incendiary bombs dropped by a German plane and all of the paintings were lost. The second consignment, which included this sketch by Sir Joshua Reynolds, reached New York unscathed.

The portrait is now on exhibition in the section of the Mildred Anna Williams Collection devoted to English painting.

Another recent gift from Mr. Williams is a Dutch painting, "Landscape at Sunset," by Aert van der Neer. Although small, measuring only 12 x 16 inches, the landscape is an excellent example of the painter's work.

## AT THE GALLERIES

The following announcements have been received from museums covering events after the publication date of the ARCHITECT AND ENGINEER.

## CALIFORNIA PALACE OF THE LEGION OF HONOR

### EXHIBITIONS

Exhibition of Paintings and Sculpture Sponsored by the Society for Sanity in Art. Through January 4.

The Art of Children: An Exhibition of the Work of Children in the Saturday Morning Classes. Opening December 13.

Photographs of the Madonna and Child in Famous Paintings and Sculpture, by George E. Stone. Opening December 16.

Days of Real Sport: Sixty Wood Engravings Illustrating the Sports of the Victorian Period. Opening December 16.

### PERMANENT EXHIBITIONS

The Mildred Anna Williams Collection of Paintings, Sculpture, Tapestries and Furniture.

The Collis Potter Huntington Memorial Collection of 18th Century French Paintings, Sculpture, Tapestries, Furniture and Porcelain.

The Alma Spreckels Awl Collection of Sculpture and Drawings by Auguste Rodin.

## SAN FRANCISCO MUSEUM OF ART

### EXHIBITIONS

Paintings by Pauline Ivanovich. Through December 28.

Memorial Exhibitions: Fine California Printing assembled and presented by the Roxburghe Club. Albert M. Bender Collection. Through January 7.

# ECONOMY! SMARTNESS!

*that satisfies*  
**YOUR CLIENTS**

● For performance that pays dividends to the architect and his client, specify the Johnson AQUALUX 150. It gives completely automatic hot-water heat for domestic or industrial purposes — using low cost fuel oil. Provides abundant hot-water and also heat for a 6 to 8 room house. Compact, easy to install, smart, economical!

AQUALUX 150



FREE! Write for details on the complete Johnson line. Engineering counsel given on your problems.

See our exhibit at Air Conditioning Show, Philadelphia, January 26-30

## S. T. JOHNSON CO.

940 Arlington Avenue • Oakland, Calif.  
401 N. Broad Street • Philadelphia, Pa.

*Yes...* **ANY SIZE JOB**

**BETTER  
10 WAYS**

**Specifically engineered products and especially planned methods makes the RICHMOND way in concrete form work.**

Erect a wall section or complicated engineering structure, Richmond helps you do the job better, faster and with more profit.

Richmond gives you the widest range of form-tying devices, specifically engineered for your job. See the panel! 10 distinctive ways to make money and save money!

Let's get the simple arithmetic of these savings down on paper. Ask.

**THE NAME SNAP-TY IS COPY-RIGHTED BY US! In 1930—11 years ago—Richmond, alone, coined and copyrighted the name Snap-Ty as the brand name for one of our tie products.**

### RICHMOND 10-WAY PROFIT PLAN

- 1—Over 50 different form-tying devices meeting every condition.
- 2—Cost less to use than usual "H. one-Made" wire, bamboo, or studs.
- 3—Engineered for safe working loads of 1500 to 2500 lbs.
- 4—Easier erecting and stripping.
- 5—Saves time and labor.
- 6—Precision, perfect wall alignment, plus uniform thickness.
- 7—Lighter weight.
- 8—Ties 2 inch "in d" back" protects job against rust staining.
- 9—Weight scientifically cut to save shipping and handling costs.
- 10—Delivers right to the job area warehousing. Job section labels save time.
- 11—No cost for working parts. You pay only for ties used.
- 12—Job planning Bureau specifies types, quantities, methods... free.

## RICHMOND SCREW ANCHOR COMPANY, INC.

816 LIBERTY AVENUE, BROOKLYN, N. Y.



# ELECTRICAL PLANNING SERVICE FREE TO ARCHITECTS

Probably no architect ever carried a home to completion without making plenty of last-minute changes and additions requested by the client. These seem inevitable.

But in one department of home building you can eliminate this annoyance — and that is the electric system. It's our job to keep up to date on the changes continually taking place in wiring and lighting practice. The information we have is available to architects, without charge or obligation.

We like to recommend Red Seal wiring standards, because they have developed out of more than a score of years of experience and they are practical. They are established at an absolute minimum for satisfactory home electrical service.

However, if the consumer wants more than the bare minimum requirements, if he wants to include heavy duty wiring for dish washer, garbage disposal, or any other special equipment, plans will be drawn for you without charge.

A note addressed to us, or a 'phone call to DOuglas 1556, will bring your free copy of "Electrical Symbols for Architectural Plans" and "Minimum Requirements for Certification as Red Seal Installation."

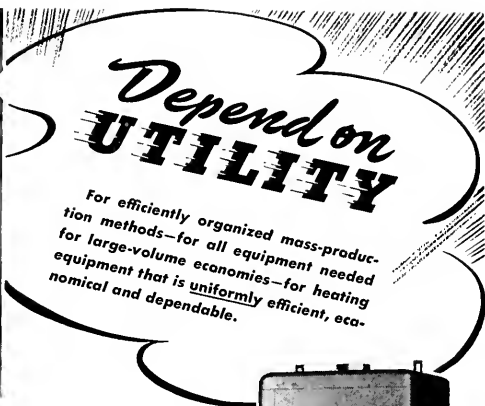
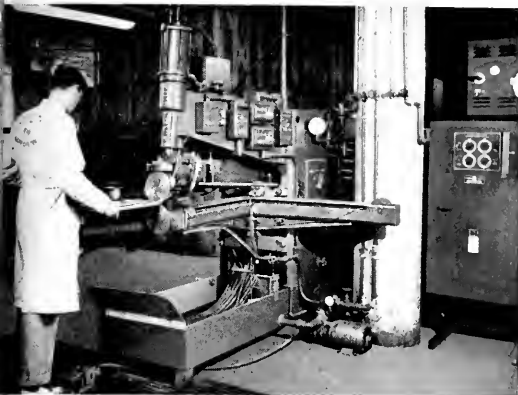


## NORTHERN CALIFORNIA ELECTRICAL BUREAU

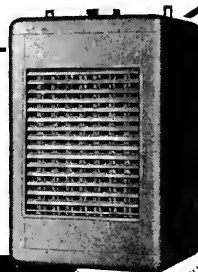
447 Sutter Street

San Francisco





This electric seam welder exerts a pressure of 2 tons, to make continuous gas-tight welds at the rate of 3 to 18 feet per minute, on heat exchangers and other parts of Utility Heating Equipment. These products are made faster, with better appearance and complete assurance against leaks, by electric welding.



MODEL HUF  
UNIT HEATER

MANUFACTURERS OF FORCED-AIR  
BASEMENT AND CLOSET FURNACES,  
FLOOR AND DUAL REGISTER  
FURNACES, CIRCULATING HEATERS  
AND UNIT HEATERS

**UTILITY FAN CORPORATION**  
4851 SO. ALAMEDA STREET • LOS ANGELES, CALIFORNIA

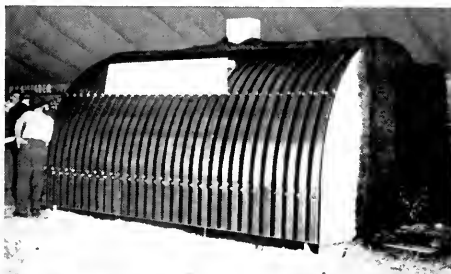
## AIR-CONDITIONED BOMB SHELTER

First air-conditioned bomb shelter ever exhibited in the United States was shown to throngs of visitors attending the Hamilton-Butler county sesquicentennial celebration recently. Built of steel, the bomb shelter has been equipped with a Chrysler Airtemp 3 h.p. air-conditioning system for the safety and comfort of occupants.

In order to resist shock, the shelter is built of 7-gauge corrugated steel of high flexibility, and is designed to be buried under at least 3 feet of earth. Actually, it fits into a built-up steel box, which leaves an insulating space between the box and the rounded parts of the shelter, thus providing additional protection.

To provide proper drainage, a pit is dug at the bottom and filled with gravel and a drainage pipe is installed. The air-conditioning duct enters the air-raid shelter through a stack at the center.

The bomb shelter is equipped with a little stove, a cupboard of dishes, a water cooler, fire extinguisher, spade and other digging tools and a toilet. The shelter has one entrance door, and may be equipped with an escape tunnel at the other end. According to present estimates the shelter will cost about as much as a good automobile.



Upper—Exterior of corrugated steel bomb shelter.  
Lower—Interior view; completely air conditioned.

# AMERICAN ACADEMY IN ROME

NEW YORK CITY

## Announces Competitions for Cash Prizes in Painting and Sculpture Totaling \$3850.00

Under present international conditions the Academy cannot send Fellows to Rome for study, travel and creative work. In order to carry on the policy of aiding and stimulating American Art, the Trustees therefore have decided to offer certain competitive cash prizes to outstanding young artists and students.

For this purpose preliminary competitions will be held in a regional center of each of six districts embracing the United States.

The final competitions will be held in New York City.

In each preliminary competition a prize of \$25.00 will be offered for each of the best ten submissions, five in painting and five in sculpture. After a week's exhibition of all work submitted at each center, the sixty prize-winning designs will be shipped to New York for the final judgment and exhibition.

In the final competitions four prizes will be offered in each subject,—First prize of \$1000; and Second, Third and Fourth prizes of \$100., \$50. and \$25. respectively.

### GENERAL REGULATIONS

The awards will be made after competitions which are open to *unmarried male* citizens of the United States who will be under 31 years of age on June 1st, 1942.

The Academy reserves the right to withhold any prize in case the jury decides that the work submitted is not of sufficient merit to justify an award.

All work is submitted at the owner's risk. The Academy will not assume responsibility for any loss or damage while the designs are in its custody or in transit.

For each subject in the final competitions there will be a jury of artists of national reputation chosen from different parts of the country. For the preliminary competitions the juries will be selected from among well-known artists of the several districts.

### SPECIAL REGULATIONS

#### Prize in Painting

Any man desiring to compete for a Prize in painting must fill in the enclosed application and file it with the Supervisor for his District *before January 1st* (See the following list of Supervisors and Districts).

Each candidate accepted as a competitor must then submit *before April 20th*:

One painting in any medium, 32"x40", framed in a plain moulding not to exceed 1 inch in width.

The submission must be a figure composition but the artist will choose the subject matter.

Landscapes, portraits and still life cannot qualify.

A photographic record of work previously done must also be submitted.

#### Prize in Sculpture

Any man desiring to compete for a Prize in sculpture must fill in the enclosed application and file it, together with six or more photographs of his previous work, with the Supervisor for his District *before January 1st* (See the following list of Supervisors and Districts).

If accepted as a competitor on the merit of his photographs, each candidate must submit *before April 20th*:

A figure or group of figures in uncolored plaster not to exceed 24 inches in any dimension.

A photographic record of work previously done must also be submitted.

### Requirements in Painting and Sculpture

The painting, sculpture and photographs submitted must bear, not the name of the artist, but a pseudonym, and must be accompanied by a sealed envelope bearing on its face the pseudonym and containing within the name and address of the artist.

### Supervisors and Districts

Grace L. McCann Morley, Director,  
San Francisco Museum of Art, San Francisco, California.

Center For: Alaska, California, Hawaii, Idaho, Montana,  
Nevada, Oregon and Washington.

Fred S. Bartlett, Curator of Fine Arts,  
The Denver Art Museum, Denver, Colorado.

Center For: Arizona, Colorado, Kansas, Nebraska, New Mexico,  
North Dakota, South Dakota, Utah and Wyoming.

James Chillman, Jr., Director,  
The Museum of Fine Arts of Houston, Houston, Texas.

Center For: Arkansas, Louisiana, Mississippi, Oklahoma  
and Texas.

Daniel Catton Rich, Director of Fine Arts,  
The Art Institute of Chicago, Chicago, Illinois.

Center For: Illinois, Indiana, Iowa, Michigan, Minnesota,  
Missouri, Ohio and Wisconsin.

Hans Schuler, Director,  
The Maryland Institute, Baltimore, Maryland.

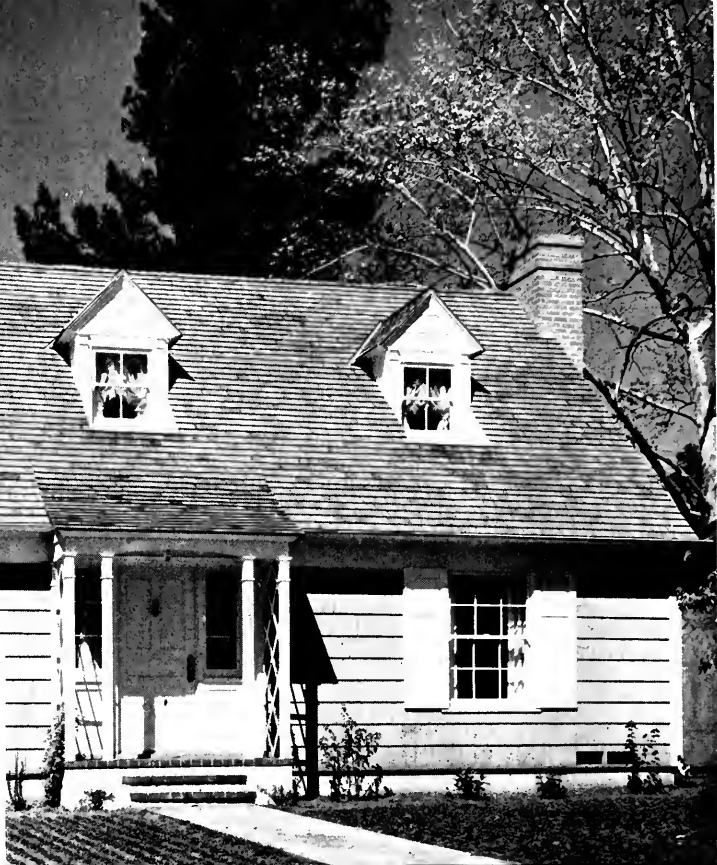
Center For: Alabama, District of Columbia, Florida, Georgia,  
Kentucky, Maryland, North Carolina, South Carolina, Tennes-  
see, Virginia and West Virginia.

Hobart Nichols, President,  
National Academy of Design, Room 1432,  
101 Park Avenue, New York, N. Y.

Center For: Delaware, New Jersey, New York, Pennsylvania  
and the six New England states.

RESIDENCE OF MR. AND MRS. A. A. MAXFIELD, JR.  
Pasadena ☆ Architect, Richard H. Pleger

Outside, this two-story home blends harmoniously with the conservative, "built-up" neighborhood. Inside, all-gas planning creates a new departure from old-fashioned homemaking. A modern gas range, gas refrigerator, gas water heater and gas furnace—these are things that make the difference!



## a "2-story" true story

### ... OF ALL-GAS PLANNING

Write "all-gas" in the specifications and a true story of modern ease and comfort begins. ☆ No other type of equipment is so readily adapted to every style of home . . . so easily masters the 4 Big Jobs. Cooking, refrigeration, water heating, space heating . . . all are done with speed and dispatch! ☆ Clean and controllable, gas is the high efficiency fuel, yet low in cost. It requires no storage, creates no soot or smoke. ☆ Naturally, such exclusive advantages are not lost on architects, builders and owners. Notice how many homes, new and modernized, are all-gas today! ☆ Your Gas Company offers technical consultation without cost.

Note convenient kitchen (left) with gas refrigerator opposite gas range.



**GAS**  
BEST CHOICE



COOKING WATER HEATING HEATING REFRIGERATION



# Imitation OR THE Real Thing?

For years violin makers have tried without success to duplicate the deep richness and tone quality of a genuine Stradivarius Violin.

So it is with tile. REAL POMONA TILE defies imitation. The permanent beauty . . . the enduring charm . . . the lasting quality of POMONA TILE has never been successfully duplicated. DEMAND GENUINE POMONA TILE AND BE ASSURED OF THE BEST.

**Only REAL Pomona Tile Has All These Advantages**

- Absolutely Fireproof
- Surface immune to cigarette burns
- Practical for use on floors, walls, ceilings
- Colorfast for life
- Waterproof, stainproof, easy-to-clean
- True color balance
- Patented "Spice-Rite" texture assures permanence



## POMONA TILE MANUFACTURING COMPANY

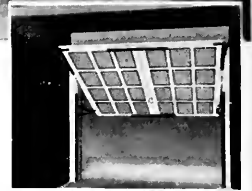
629-33 N. LA BREA AVENUE • LOS ANGELES  
135TH TENTH STREET—SAN FRANCISCO    6106 ROOSEVELT WAY—SEATTLE  
PLANT: POMONA, CALIFORNIA    MINES: DEATH VALLEY

## Something New An AUTOMATIC Garage Door



Turn the handle and *up it goes*—no tugging, no lifting.

THAT'S STANLEY  
*Econ-O-matic*  
Economical • Automatic



A Stanley "Swing-Up" Hardware Set with new attractions. For old and new doors, weighing not over 150 lbs. The low price will please you. Ask your dealer. The Stanley Works, New Britain, Connecticut.

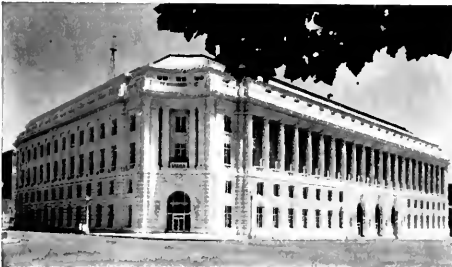
# STANLEY

TRADE MARK  
HARDWARE FOR CAREFREE DOORS

## No Worry for the Architect

*"—All acid proof drain pipe and fittings shall be ferro-silicon—CORROSIRON—"*

(Write for above specification)



FEDERAL BUILDING • CIVIC CENTER • SAN FRANCISCO

Arthur Brown, Jr., Architect

**CORROSIRON** DRAIN LINES and FITTINGS and LABORATORY EQUIPMENT was specified because of its superior resistance to corrosion and wear.

**Pacific Foundry Company, Ltd.**  
NEW YORK • 3100 NINETEENTH ST., SAN FRANCISCO • LOS ANGELES

## THE 3 POPULAR METHODS OF TREATING EXTERIOR REDWOOD

are

CABOT'S #230—which holds the NATURAL COLOR OF THE WOOD for MANY YEARS.

CABOT'S #241 CREOSOTE BLEACHING OIL which gives an old WEATHER-BEATEN SILVER-GREY EFFECT.

or

CABOT'S #344 Creosote SILVER-GREY STAIN.

## GUNN CARLE & CO.

20 Potrero Ave.

UNderhill 5480

SAN FRANCISCO

# For Sale—Business Leads —at One Cent Each!

A DAILY advance building news service, reporting construction projects for the Northern California area, comes to its subscribers in the form of handy, individual slips, giving name of project, location, architect, proposed cost and other pertinent and valuable data.

ARCHITECTS' REPORTS, as the service is called, is mailed daily, and the average number of these reports runs over ONE THOUSAND MONTHLY, based on our current count.

At a cost of \$10 per month, the reports actually reach the subscriber at less than ONE CENT EACH.

Building material houses and contractors in the San Francisco Bay region use ARCHITECTS' REPORTS to help their salesmen round out a profitable day. This service is sponsored and endorsed by the State Association of California Architects. Its compilation cost runs into the thousands of dollars, yet the service is made quickly available to subscribers for a most nominal charge. If you want YOUR share of this daily big business in building materials, subscribe now to ARCHITECTS' REPORTS. Samples sent on request; phone EXbrook 7182.

## ARCHITECTS' REPORTS

*Published by*

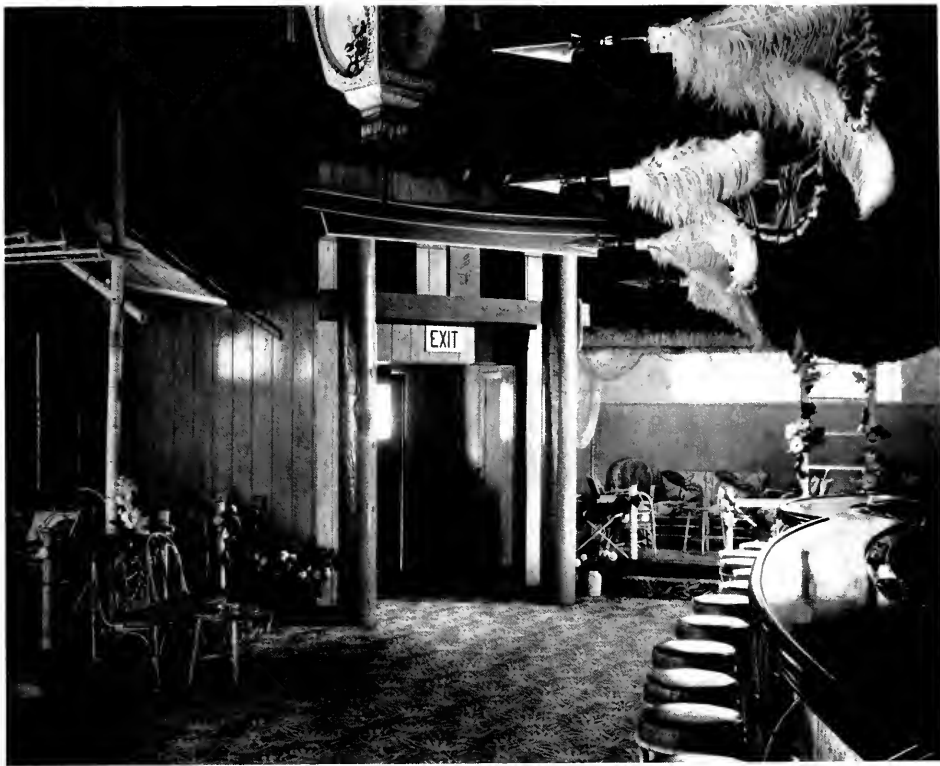
**THE ARCHITECT AND ENGINEER, INC.**

68 Post Street, San Francisco



**"ZANZIBAR" COCKTAIL LOUNGE, SAN FRANCISCO, CALIFORNIA**  
J. Lloyd Conrich, Architect

*Exterior is sheathed in California wood stained a rich mahogany, trim is bright red*



**ENTRANCE—VERTICAL MEMBERS OF THE TORII GATE ARE PAINTED A BRIGHT RED AGAINST A WARM BROWN BACKGROUND**

## **ZANZIBAR — A COCKTAIL LOUNGE**

**"Zanzibar,"** San Francisco's newest cocktail lounge, successfully combines an unusual treatment of Chinese and Polynesian architecture with which is added a semblance of modern and native African, just to confuse the purists. The design is unlike any previous attempt of San Francisco architects to popularize the South Sea Island motif. While the exterior reflects the Chinese influence very definitely the interior has all the color and decorative features of a South Pacific village.

The exterior finish of "Zanzibar" is a rich, mahogany stained California wood with bamboo trim. The soffit of the canopy and the entrance doors are a bright red. Kick and push plates of the doors are hammered copper with brass rivets. Within, Architect Conrich has created a miniature South Sea village comprising seven small native huts, a Chinese temple and a bar, the latter being the prime purpose of the project. The huts are used as booths while the temple serves as a dance floor. Each hut is distinctly different, reflecting the mood of the country it represents. The temple walls are done in imitation teak wood and a highly decorative black Chinese wall paper.

At the end of the temple is a circular fireplace, the front of which, as well as the wood wainscot, is stained black. The fireplace screen is made of delicately modeled sheet metal flowers wired to metal mesh. A red lacquered Torii gate frames the inside of the main entrance.



Bamboo and matting, Economy Shade Company

DETAIL OF BAR, SHOWING WOVEN BAMBOO FRONT AND TAPA CLOTH CANOPY WITH ITS OSTRICH PLUMED SUPPORTING SPEARS





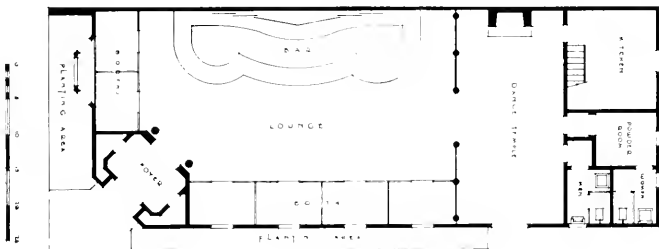
**"ZANZIBAR," A COCKTAIL LOUNGE**

San Francisco

J. LLOYD CONRICH, ARCHITECT

This unique bar on the outskirts of San Francisco's business center, is a modern adaptation of Chinese and South Sea Island architecture. It is arranged inside like a native village with a bamboo bar the dominating point of interest.

The picture at the upper right shows a detail of the circular fireplace with screen of delicately modeled sheet metal flowers wired to metal mesh and executed by Metalcraft Shop, San Francisco. Above the screen is a Chinese dragon painted on compo board.



# A CRIPPLED BUILDING INDUSTRY IS A DEFENSE MENACE

By **TRAVIS G. WALSH, Architect**

**The** policies of the Federal Government threaten to cripple the construction industry and to weaken the economic structure as well as the morale of the nation.

The construction industry, like agriculture, represents one of the most important national activities. In drying up the source of this activity without the demonstrated capacity to absorb it, the Government is depriving employables of work; it is stifling the circulation of willing and available capital, thereby contributing to the misery of vast sections of the population at a time when the national morale should be strengthened rather than impaired.

A successful defense program should recognize the necessities of that large segment of the American public whose sole effort, by virtue of not being definitely absorbed by governmental activities, becomes that of contributing to the national income tax structure. And a very important effort it is, when considered in relation to the prodigious appropriations to be accounted for.

The rank and file of the people are resigned to sacrifices in connection with the defense effort, and do not question the necessity when it is justified, but there are indications that certain of the governmental departments have hoarded tremendous stocks of steel and other materials (including nails) which cannot be used for several years to come.

The construction industry has been called upon to play a leading role in the present emergency and the records so far are favorable. But the records also indicate that only a limited percentage of the industry can be absorbed by the defense program, leaving a formidable balance to be accounted for. A cynical viewpoint is one which disregards the ominous implications of this situation.

There is no question about the paramount importance of accelerating defense measures in every conceivable way but national defense consists of more than ordnance, equipment or supplies. It is entirely within the bounds of reason to regard the developed tax structure, the national economy as a vital part of the defense effort.

The British government completely dislocated the technical professions "in the interests of alleged expediency." This process, which Britain has since been attempting to rectify, is now under way in this country.

The present national policies wherein restrictions are unscrupulously imposed on private activities without the ability of the government to absorb those activities is basically unsound arithmetic.

# FULLERTON, CALIFORNIA, CITY HALL

**A two-story** structure of early Spanish design to house the city officials and departments of Fullerton, California, completed by the Work Projects Administration, was formally occupied October 1. The building replaces the former quarters of the city administration in the Fullerton fire house.

Built of reinforced concrete, the design is Spanish with features quite similar to the Santa Maria City Hall. The tower, tile roof and arcade are familiar outside aspects, and the Spanish motif is further carried out in the interior by use of metal-studded doors, tiled sunken garden and corridors and artificially-aged beamwork and ceilings skillfully tinted to create contrasting illusions of height and depth.

Fullerton has felt the need of a new city hall for 25 years, but it was not until WPA funds were made available that any solution was found. Cost of the project was about \$180,000.

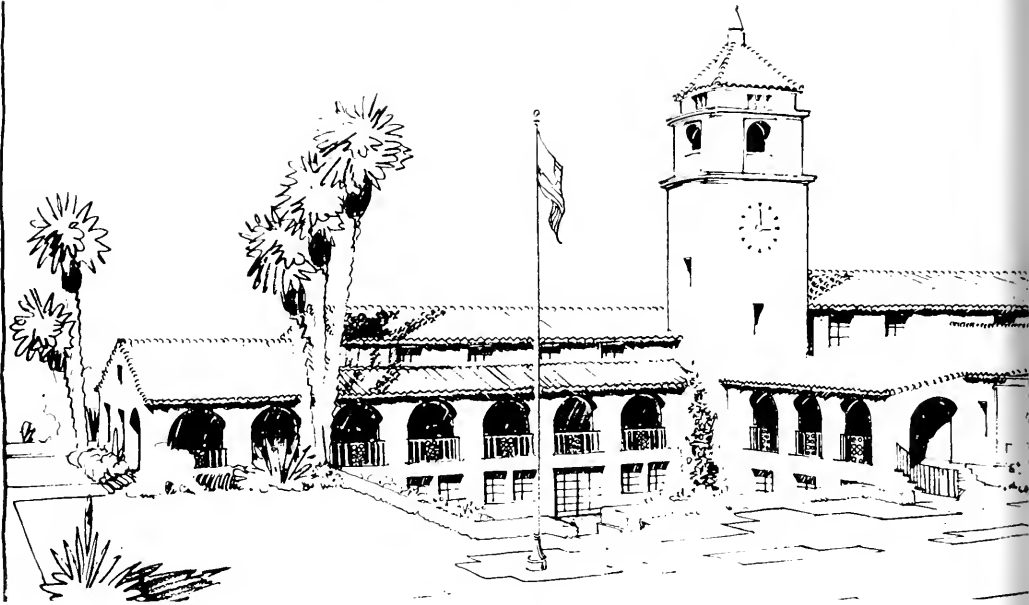
Included in the program was construction of a basement, beautification of the grounds and provision for a modern drainage system to eliminate flooded areas in the spring.

Major items of construction included 2400 cubic yards of excavation, 1,654 cubic yards of reinforced concrete, 115 squares of tile roof, 12,000 board feet of framing, 600 square yards of linoleum, 2800 square feet of steel sash, 3,000 square yards of plaster, 890 square feet of tile and 6,000 square yards of painting.

Designs for three huge mural panels depict-



GENERAL VIEW OF FULLERTON CITY HALL, FULLERTON, CALIFORNIA



## FULLERTON CITY HALL

Fullerton, California

G. STANLEY WILSON, ARCHITECT

The photo on the left was taken from the same angle as the architect's sketch, shown below. The two murals will be hung in the assembly room. They are by Miss Helen Lundeberg, revised by Miss Miriam Ferrington.



ing early Southern California history will soon be ready for transfer to the walls of the hearing room. The murals were created by Miss Helen Lundeberg and her collaborator, Miss Miriam Ferrington, as a project of the WPA Art Program in Los Angeles. They will be traced and executed in soft, harmonious coloring, giving the effect of a tapestry.

Miss Lundeberg has distinguished herself in the American art world in the creation of large monumental decorations for numerous Southern California communities.

The Fullerton decorations will consist of three panels, two of them nine and a half by 24 feet, and the third, ten and a half by 35 feet. Installation will require about two months. The murals are applied thinly over the acoustic plaster walls in a manner to preserve their special properties.

The various groups included in the three panels depict Cabrillo landing at San Diego, or False Bay, 1542; California under the rule of the Mexican republic, 1822; the Boston hide and tallow trade locally, 1830; first overland pioneers from the United States, 1841; Mexican war in California, 1846; California horsemen and the famous "Cannon of the White Mule"; treaty of Cahuenga, 1847; gold mining around Mint Canyon; Los Angeles-San Pedro railroad, 1869; development of Southern California resources; modern industry.



**Titles of murals — Extreme left:** Group 1, Los Angeles-San Pedro Railroad, 1869; Group 2, Development of Southern California resources, cattle raising, oil, etc.; background, first school in Orange County; Group 3, Modern industry in Southern California.

**Left, Father Serra and Portola establish missions, 1769.**



**SWIMMING POOL ON THE ESTATE OF MRS. DOROTHY SPRECKELS-McCARTHY, HILLSBOROUGH, CALIFORNIA**



**GARDEN AND SWIMMING POOL PAVILION, ESTATE OF MRS. DOROTHY SPRECKELS-McCARTHY, HILLSBOROUGH, CALIFORNIA**

**Mark Daniels, Architect**



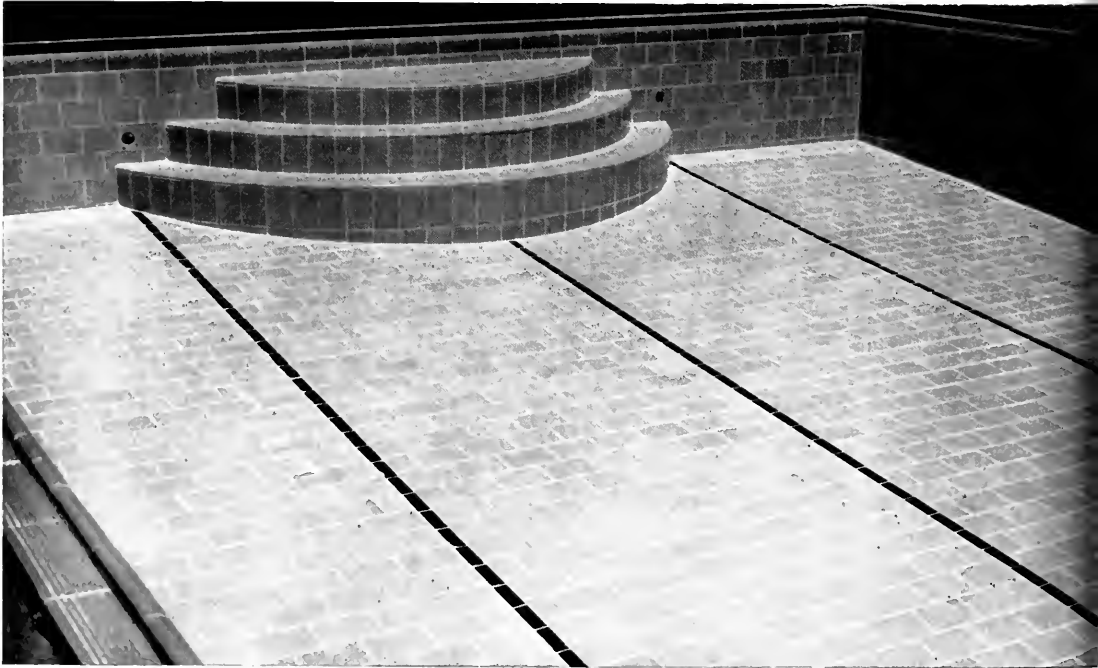
## A GARDEN AND TWO SWIMMING POOLS

By MARK DANIELS, A.I.A.

**Over** in San Mateo County, ten miles from San Francisco, Mrs. Dorothy Spreckels-McCarthy has a very definite idea about a garden, at least her own. By that I do not mean she tells her gardener exactly where to set out his cineraria, just where to place the fuchsias or how to do his topiary work. On the contrary, she merely orders that these things be done properly and when necessary. Nevertheless, her conception of a garden is very clear — it is a place of



**TENNIS PAVILION, ESTATE OF MRS. DOROTHY SPRECKELS-McCARTHY, HILLSBOROUGH, CALIFORNIA**



**SWIMMING POOL AT THE WALTER F. FOSTER RESIDENCE, BURLINGAME, CALIFORNIA**  
**Angus McSweeney, Architect**



beauty to be used and enjoyed. So, when Mrs. McCarthy, then Mrs. Dupuy, purchased the famous and very beautiful old Newhall estate in Hillsborough she immediately set about making it more usable and enjoyable. Little could be done to make it more beautiful.

In the center of the great central formal parterre was a reflection pool, ninety feet in length by forty-two feet in width. It was a magnificent reflection pool, but that was all. Mrs. McCarthy ordered it converted into a swimming pool. Without altering the beautifully designed coping, the work of Lewis Hobart, as were the building and the entire estate, the pool was deepened from 2½ feet to ten feet in the central portion, with shallow water at each end. A filter and purifying plant was installed behind the distant hedges. No visible alterations were made. No springboards, slides or other paraphernalia were installed to mar the garden. It was still a beautiful reflection pool with the addition of crystal clear, deep water

which immeasurably improved the reflecting quality of the water surface. Now it served two purposes; it was still a reflection pool but also a glorious swimming pool. For night swimming a series of submerged lights was installed on the side nearest the house so that only the glow could be seen from there, not the light sources.

It was a real task, this building so large a pool without disturbing existing walls and copings, one that taxed the ingenuity of Paddock Engineering Company, builders of most of the better swimming pools in the state. It is doubtful whether there is another like it, with its deep portion in the center; certainly none like it in charm, beauty and utility. It is an old pool with a new purpose.

To carry out the idea of using and enjoying this lovely garden to the fullest, a garden pavilion obviously was needed. This at once suggested a pool pavilion as well. So a combination garden and pool pavilion was fitted into



FLOOR AND SIDES OF POOL ARE 6X9 LAGUNA GREEN KRAFTILE. STEPS ARE A LIGHTER SHADE GREEN. THE 3-INCH LANE MARKERS ARE NIGHT BLACK.

the picture on the cross axis of the pool. The design is in keeping with the French architecture of the house. The central rotunda is open to the garden. On either side are the women's and men's dressing rooms, showers and toilets. Between these and back of the rotunda is a completely equipped bar, with connections for garden, pool lighting and telephone. The only trouble is that whether you are in the drawing room or the pavilion the other beckons you across the reflections in the pool.

To all this Mrs. McCarthy added, in another part of the grounds, a full championship tennis court completely equipped with lights for night playing. Here again the old was given a new purpose and use. A former guest house was moved to the west side of the court and converted into a tennis pavilion, with a kitchen shower, store rooms and canopied terrace.

And so the old is new and the new is old. The old garden with its clipped hedges, its pleached walks and its terraces, is all there, but

it has new uses, new purposes. The owner's idea has made her garden into a place where you can spend the entire day without having to go back to the house to rest.

The second pool illustrated is at the Hillsborough residence of Walter F. Foster, Angus Mc Sweeney, architect. Fitting handsomely into its woodland surroundings the pool is constructed of Krafftile 6 x 9's Laguna green. It is 25 x 50 feet and ranges in depth from three to 8 feet. The one-piece overflow gutter is the same color as the pool which has night black lane markers of 3-inch stripping. The circular pool steps are a seafoam green, a shade lighter than the other tile. Installation by the Paddock Engineering Company included filtering, heating and a unique system of under-water illumination.

An unusual feature of the design is the one-piece overflow gutter, a detail of which is illustrated, and which shows one-piece internal angles in place of the usual mitered corners.



**Detail of swimming pool constructed of Krafftile by Paddock Engineering Company at residence of Walter F. Foster, Hillsborough. In place of the usual mitered corners, one-piece internal angles were specified for the gutter.**



"PLASDECOR," A LAMINATED PLASTIC USED AS A PERMANENT FINISH FOR HAND PAINTED DECORATIONS FOR MERCHANDISE DISPLAY

## PLASTICS RELEASE MATERIALS FOR DEFENSE

A new architectural use for a plastic has been developed for blocking off sections of terrazzo, a marble and cement composition commonly used for flooring in large buildings.

Strips of plastic tenite attached to ribbons of galvanized iron are used as an outline of the design to be followed in laying terrazzo floors. The tenite part remains visible after the terrazzo has been ground and polished. The strips localize minor cracks which occur when terrazzo floors settle or contract in hardening. Instead of appearing as an irregular split, the cracks tend to run evenly along the strips.

Since the plastic can be produced in an unlimited number of colors, architects are allowed a correspondingly greater freedom in design. Terrazzo strips have hitherto been made almost

exclusively of metals. The shortage of zinc and brass for non-defense purposes drew the attention of designers to the possibilities of applying tenite. Tests were conducted, and as a result the plastic strips have permanently replaced metal ones in a number of applications.

The tenite pieces are more economical to manufacture than brass or zinc strips. They are installed in the same manner as metal ones and when in place will not wear faster than the flooring. Common tin shears may be used to cut the pieces into the desired lengths. They can be bent into various designs with ease.

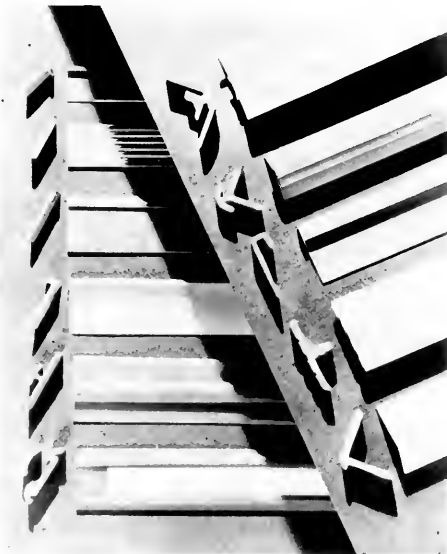
Moisture does not affect the strips to an appreciable degree, nor is the material hazardous in the presence of fire. In one test, a welding flame of approximately 3,000 degrees



**Plastic tenite for blocking off terrazzo floors and steps.**

Fahrenheit was placed directly on the plastic inlaid in the floor. The material melted but did not catch fire.

The plastic is molded by the extrusion method, which forces heated material from a mold much as toothpaste is squeezed from a tube. Small rivets are used to fasten the tenite strips to the iron base. The plastic part that shows in the finished floor is five thirty-seconds of an inch wide, and the assembled piece is one and one-fourth inches deep.



**Colorful plastic strips for moldings and interior trim.**

A top award winner in the architectural classification at the recent Modern Plastics Competition was "Lumitile," a development that makes possible for the first time the architectural use of the beauty and color of plastics.

The open pan design or coffer principle allows identical units to be welded or clipped together into panels of any required size. These panels when used with tube type or fluorescent illumination enable entire walls, ceilings, partitions, columns or other areas to become the source of colorful, shadowless illumination. The intensity and color of this lighting can be controlled in the preparation of the molding powder.

Lumitile may be made more transparent than glass or completely opaque. They are waterproof, acid, alcohol and alkali resistant and will not warp. They are unaffected by age, are very sturdy and shock-resistant, yet amazingly light in weight.

\* \* \*

"Plasdecor" is a unique and effective method of displaying merchandise and represents a distinct departure from the conventional vehicles previously employed. Plasdecor is a laminated plastic developed by Alice Donaldson. The design was executed on a filler paper which was painted and applied, and then laminated with Bakelite Formaldehyde Urea Resin to become an integral part of the plastic sheet. The resultant sheet is impervious to humidity or temperature changes; it is stainproof, hard-surfaced, and assured of a permanent finish for the original hand-painted decoration.

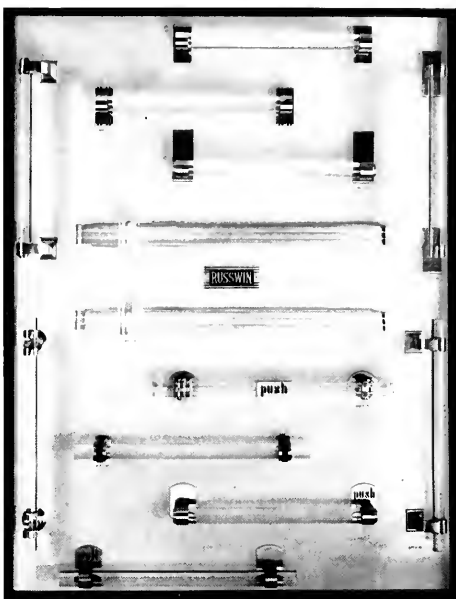
Entrance bars for doors in the home, at the office, and in large buildings are manufactured of transparent "Lucite," a DuPont plastic material, used as a decorative accessory with a utilitarian purpose, as a happy choice. These push and pull bars are designed especially for tempered glass doors, but they are equally effective on metal and wooden doors.

The "Lucite" is extremely durable, practically unbreakable, and will not color or tarnish in either interior or exterior applications.

And most significant of all in the present emergency, the use of Lucite for these items,



"Lumitile" may be used with fluorescent illumination for walls, ceilings, partitions, columns, etc.



Transparent "Lucite" for push and pull bars, replacing brass and bronze.

will release quantities of precious metals such as brass and bronze for defense purposes.

\* \* \*

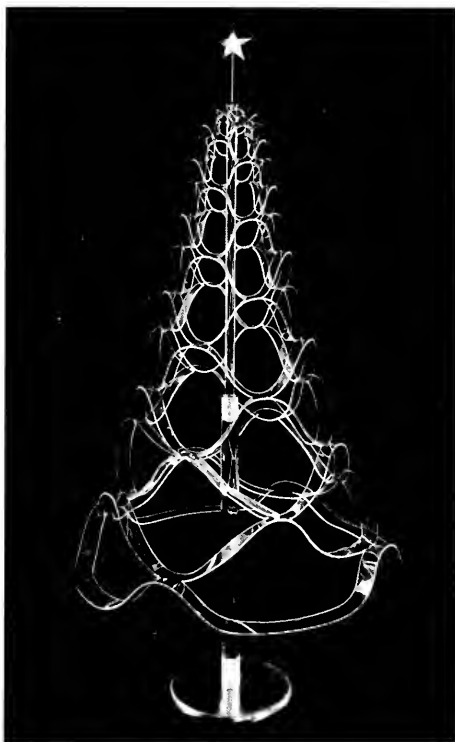
The Christmas tree illustrated here is fashioned from Rohm & Haas Plexiglas. The clear, transparent plastic branches, sparkling in the light, lend themselves to artful decorations for a very Merry Christmas.

Economy is achieved because the cone is made from a flat, one-piece unit which eliminates waste, and imparts an unusually rhythmic and pleasing quality to the design of the tree.

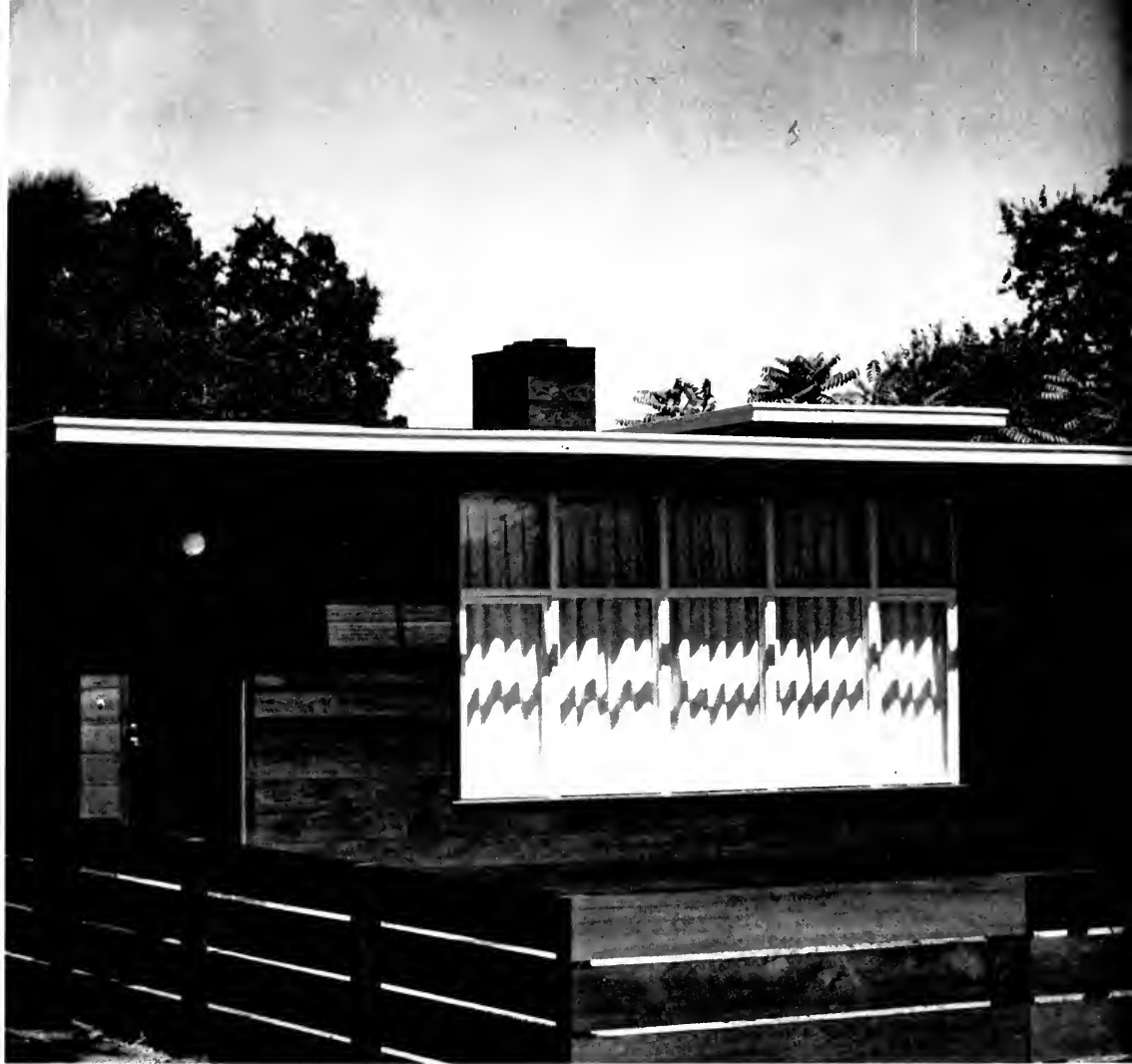
A departure from the conventional and perishable fir, it may well be that plastic trees will take their place as traditional symbols of the yuletide spirit in the not too distant future.

\* \* \*

Wernco Plastiktrim with its extensive color range, utility, and ease of application provides a new decorative touch of visual appeal for use by architects, builders, and linoleum distributors. It is particularly appropriate for use in kitchens, bars, bathrooms, playrooms, showrooms, or wherever creative originality is desired and where interesting and stimulating color effects are in order.

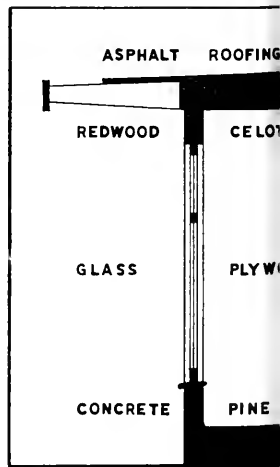
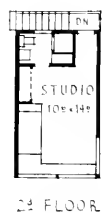
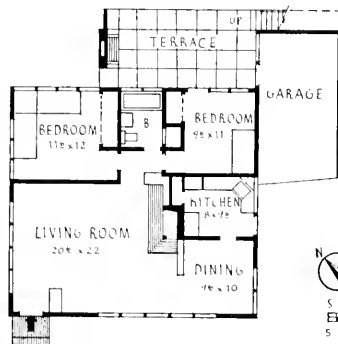
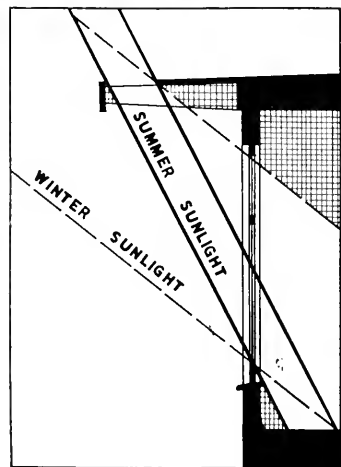


A permanent Christmas tree of Plexiglas obtainable in almost any color.



Courtesy House of

HOUSE IN MENLO PARK, CALIFORNIA  
 Mario Corbett, Architect



# A NEW VENTURE IN DESIGN INSTRUCTION

By ANTONIN HEYTHUM

The most flagrant deficiency in architectural and industrial design in this country has been a kind of drafting-board abstractionism—or, less diplomatically stated, the designer's ignorance of precisely how the objects he was designing were to be made. "Art" has been popularly regarded as something aloof from and above the contaminations of practicality, attainable by the spirit alone. To importune the artist with questions of execution was not only irrelevant; it was materialistic. Probably no other single cause has been more responsible for the peculiar lack of reality which has characterized our design as compared with European.

In the face of this vitiating preconception and its results, the Industrial Design Section recently announced by the California Institute of Technology at Pasadena takes on unusual significance and promise. For the first time in this country, to our knowledge, instruction in design will be attempted against the objective habits of mind of a technical and engineering institution, instead of in the vacuum of the ordinary art school. Scheduled courses embrace history of art, industrial design, shop practice, design techniques, design trends, non-metallic materials, social and buying psychology, business economics, and cost analysis. Any or all of these subjects might doubtless be duplicated in other curricula; the unusual point here is that, as stated above, all this is organized within a technological discipline. Courses will be presented by a regular staff of some eight instructors, supplemented at intervals by visiting designers and engineers.

The inauguration lecture by Antonin Heythum follows. Mr. Heythum is an architect-engineer, stage designer and industrial designer who was born in Czechoslovakia and has worked extensively in these fields in Europe. He came to this country as designer of the Czechoslovak exhibits at the recent San Francisco Exposition in 1939 and New York Exposition in 1940. The simplicity, ingenuity, and decorative effectiveness of the former will be readily recalled in these parts.—I. F. M.

**It is** a logical step forward in education in industrial design when, with the ever-increasing mechanization of production and construction, the need for technologically trained designers makes—for obvious reasons—the technological institute a more adequately equipped place for training than an art school can ever be. This, however, does not mean that the training of aesthetic faculties is considered of secondary importance.

While the accumulation of the necessary practical and scientific knowledge means hard work, it can be obtained to a satisfactory degree by any technically minded individual. But it is his creative imagination that will always determine the quality and success of the industrial designer. This, although it can be trained and developed, cannot be taught unless there is already in existence a definite talent and aptitude for creative work and an inborn feeling and appreciation for aesthetic values.

Of today's manifold requirements for industrial designers, I will enumerate three principal

ones: the first, creative imagination based upon a sound instinct for the needs and desires of men, nourished by an open receptive mind that takes pleasure in research and discovery in the past, present, and future phases of the evolution of mankind; the second, a well trained craftsmanship in the techniques of design as well as workshop techniques; the third, thorough knowledge of materials, technological, economical, sociological, and psychological facts concerning production, promotion and sales processes. The second and third are essential as a realistic ground upon which idealistic conceptions of the first may be based safely. The inventive spirit controlled by scientific exactitude that prevails in a technological institute will soundly balance the artistic fantasy of the industrial design student.

Industrial Design is a peculiar new form of aesthetic expression. Its creations are not only susceptible to aesthetic judgment, but have to be functionally efficient. Their manufacturing is not only a complicated technical process, but

involves social and economic problems as well.

When you decided to choose the profession of industrial design, you may or may not have fully realized these facts. Perhaps there was somewhere in the back of your minds the remembrance of a slogan that challenged your imagination—the slogan attributed to Walter Dorwin Teague of "Designing anything from a match to a city." This is an ambitious scope for a single profession, and even if its large field of possible activities is subdivided, it still calls for a training that is much more diversified than is necessary for almost any other profession.

Before the time of power-driven tools—which made possible mass production, and thereby changed not only the appearance of man's surrounding, but his whole life and attitude toward life—creative imagination, skill, and the knowledge of a few basic materials and tools brought forth the individualized beauty of products of the artist-craftsman or builder. Industrial designers are the men who decide upon the appearance of our standardized visual surroundings of today. To fulfill their task well, they need more than creative imagination and skill and knowledge of a few basic materials and simple tools.

In addition to basic materials there is an ever growing number of synthetic materials. In addition to simple tools there is a variety of the most intricate machinery. Selling and marketing have grown into a complex system which involves economical, sociological, psychological, and international political problems. If we consider these complications and accept the slogan of designing "Anything from a match to a city," it may seem at first sight that adequate training which would prepare for the manifold tasks in such a wide field would call for an almost superhuman effort. But so it seems with quite a number of other professions which call for extensive practical, as well as theoretical, training. What our profession needs more than any other, is open-mindedness; not so much specialized training and preparedness for special tasks as general preparedness in the widest possible sense; not only skill and knowledge, but constant interest

in, and awareness of, facts which influence and shape civilization.

"Anything from a match to a city" may perhaps not come actually as a design project into your office or your employer's, but it is of vital interest to you. Anything you design is, or becomes, a part of a larger whole; and it is your—or our, the Industrial Designer's—responsibility to bring back into everyday life the beauty that not the machine, but the misuse of the machine, has destroyed and is still destroying. Beauty in the truest sense is not at all a superficial element that may be stressed or suppressed without an influence upon efficiency. Quite the contrary. It is a factor of considerable importance in the achievement of complete functional efficiency, as we find it most perfect in nature and in those man-made objects which we honor with a place in our museums. Interdependence of beauty and efficiency is the principal theme of my work with you. We shall study it most carefully in theory as well as in practice. We shall look for it in man's creations of the past and present as well as in nature's appearances and we shall strive for convincing expressions of its eternal truth in our own special experiments.

In the search for the solutions of problems in our field we shall consider, to a reasonable extent, the restrictions which lie in existing technical and economic conditions. Above this, however, we shall set as a guiding principle the consciousness of our personal responsibility for logic and truthfulness in appearance qualities. We shall not support the widespread attempts to streamline anything from a match to a city. We shall streamline neither ashtrays nor radio cabinets, nor baby carriages for the sake of a powerful advertising slogan. We shall confine streamlining strictly to the instances where it means increased efficiency, as in airplane design and anything else that is to move at high speed and has to overcome the resistance of the medium in which it moves.

I wish to stress the importance of a courageous and deeply moral attitude toward our work which I believe is more decisive in our profession than in any other.

To arrive at really worthwhile achievements



in our field of activities it is essential that we consider nothing as being superficial, take nothing for granted, approach every problem whether small or large with equal sincerity and a deep sense of responsibility, that we go down not only to the root of a problem, but to the seed and even the ground. We cannot take it "just easy" if we want to be more than mere fashion designers or stylists and if we want to establish ourselves safely and forever as an important and influential professional group in this industrialized world of ours. We must realize that some so-called industrial designers, including advertising artists, misused their talents or allowed them to be misused in a shameless process of betrayal of the public, covering imperfections, or blowing up artificially the appearance of products to make up for the lack of quality. We must fight such misuse and educate the public to recognize and appreciate quality and logic in product design.

The background of a thorough technical and scientific training is a privilege that so far has seldom been granted to industrial design students. It is a privilege which puts upon you the obligation of proving and demonstrating its worth through the quality of your own work. Architects, stage designers, graphic artists and some imaginative engineers were the pioneers who prepared the way for the recognition of the profession you have chosen and in which you are among the first to be offered a really adequate training. These pioneers have cleared the way for you of some formidable obstacles as represented in the stubbornly backward looking spirit that for a long time governed industrialists' attitudes toward all appearance problems or in the irresponsible piracy in design ideas. More and more often the industrial designer is given credit for his share in the success of a product, and stealing design ideas is becoming equally as illegal as stealing material goods.

Your task will be to widen and deepen the meaning and value of industrial design—to rescue it from today's trend that in many instances lowers it to mere styling. Intimate technical knowledge will best guide you in this endeavor. You must, however, keep in mind that your task is not completed in designing

well. Good design is not always automatically successful design. You have to popularize and advertise it with convincing arguments. That means not only to know that you are right, but to know how to convince others and make them support and follow you. The full realization of all these implications will greatly help you to find and follow a working method that will protect you from failures.

Once you have won control over your creative abilities, learned how to train your technical and practical skill, and accumulated a reasonable amount of general knowledge through several years of school and self-education, you ought to be able to find a way of approach to almost any problem in your field. It should be clear though, that it is neither necessary nor advisable and practicable to try to solve alone any complex problems. A sound sense of cooperation and collaboration or an ability to organize work is an essential requirement in our profession as in many others.

What is most important is a thorough understanding of the basic elements common to all design problems, whether large or small. To promote this understanding and train your minds and senses to keep it dear and clear is what I personally shall be aiming at most intensely throughout our common work.

In order to be able to take full advantage of everything that school or life offers you for your training, you should keep in mind what Le Corbusier, leading French architect and industrial designer, formulated once in an address to English students, saying: "I beg you to keep your eyes open. Do you keep your eyes open? Have you been trained to keep your eyes open? Do you know how to keep your eyes open? Do you keep them open continually and usefully? What do you look at when you go out for a walk?" Open eyes and an open mind are the safeguards that protect you from being led too far astray by your fantasy. The profession you have chosen calls for a spirit that is imaginative and poetic as well as realistic.

We live in a time of crisis, but critical times have often brought forth decisive constructive results in art and science. One of the greatest men of all ages, Leonardo da Vinci, proved that

he was more realistically minded in a time of crisis and war than most of us are today. I will quote from one of his letters which I have found a most reassuring as well as amusing document. It may help anybody who still has some doubtful feelings about today's defense slogan to overcome those doubts. In our profession a realistic attitude towards the problems of our time is most essential in order to find a market for our creative abilities.

In 1482 Leonardo da Vinci offered his services to the Duke of Milan, saying: "Having seen and considered the experiments of all those who profess to be masters in the art of invention of the apparatus of war, and having found that their instruments do not differ materially from those in general use, I venture, without wishing injury to anyone, to make known certain secrets of my own. . . .

"I have a process for the construction of very light bridges, capable of easy transport, by means of which the enemy may be pursued and put to flight; and of others more solid, which will resist both fire and sword, and which

are easily lowered or raised. I know also of a means to burn and destroy hostile bridges.

"I know also how to make light cannons easy of transport, capable of ejecting inflammable matter, the smoke from which would cause terror, destruction and confusion among the enemy. . . .

"I can make cannon, mortars, and engines of fire, etc., of form both **useful and beautiful, and different from those at present in use . . .** [Note: This sounds almost like a definition of industrial design.—A. H.]

"In times of peace, I believe that I can compete with anyone in architecture, and in the construction of both public and private monuments, and in the building of canals. I am able to execute statues in marble, bronze, and clay; in painting I can do as well as anyone else."

This letter expresses a creed formulated by da Vinci elsewhere shortly and strikingly in the words: "War is a bestial madness," but, "when besieged by ambitious tyrants, I find a means of offense and defense in order to preserve the chief gift of Nature, which is Liberty."



Many homes, like the one pictured here, will reflect the spirit of peace and good fellowship, symbolized by light, during the approaching Yuletide season.



ADMINISTRATION BUILDING, STATE INSTITUTION FOR MEN, CHINO, CALIFORNIA

## PRISON WITHOUT WALLS

*A California Institution for the Detention of "First Offenders"*

**Locking** the wire mesh gates to the 2600 acres of the highly publicized, harassed, and investigated "Prison without walls" at Chino, California, the new California Institution for Men has accepted its quarters from the State Department of Public Works, writes Anson Boyd, State Architect, in "California Highways and Public Works." Mr. Boyd classifies the project as "the most scientific penal program of rehabilitation in the country."

Six years ago this project was launched with a \$400,000 appropriation to purchase land for a prison for "the rehabilitation" of "first offenders." Six hundred seventy-one thousand dollars was spent for land.

The plans for the buildings were originally drawn by the architects employed by the old Prison Board and were completed with certain internal rearrangements by the Division of Architecture to conform to the policy of the newly appointed Prison Board.

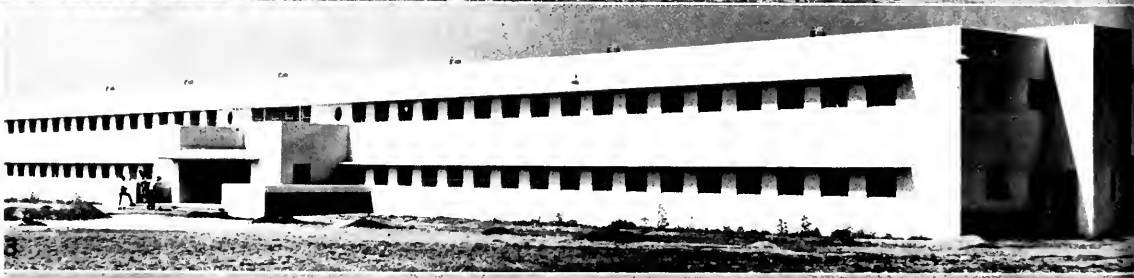
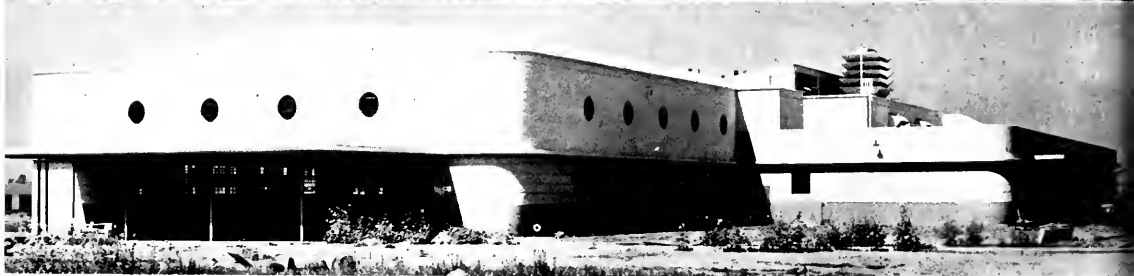
Situated about two miles south of the town of Chino in Los Angeles County, Southern California, the institution is in the center

of one of the two 1300-acre blocks making up its lands. The block occupied by the buildings is surrounded by a cyclone type chain link fence with barbed wire guard along its upper member. There are mushroom type guard posts surrounding the entire plot, which under the present policy of operation are not in use.

The Administration Building faces the main entrance road and looks south toward a range of low hills below Chino, over the acreage which is to be used for farming. This Administration Building is a 3-story, reinforced concrete structure, built in large part by the Works Progress Administration, together with civil service employees of the State, and a number of individual contracts.

Its first floor houses the warden's office and clerical staff to the left of the entrance; the visitors' section, supervisors' dining room and commissary to the right. On the east half of the second floor are clerical offices and board rooms. The remainder of the second and third floors provide housing for unmarried supervisors.

# SCIENTIFICALLY PLANNED BUILDINGS



# R THE REHABILITATION OF MAN

The Administration Building is huge and monumental in design, is air-conditioned throughout, as are the other structures, and contains a most elaborate equipment for the handling of prisoners in a maximum security institution.

Across the rear of the Administration Building, facing what is now the recreation yard, is a 20 foot reinforced concrete wall surmounted by guards' walks and bullet proof gun towers. The remainder of this maximum security wall, estimated to cost \$140,000, was not erected.

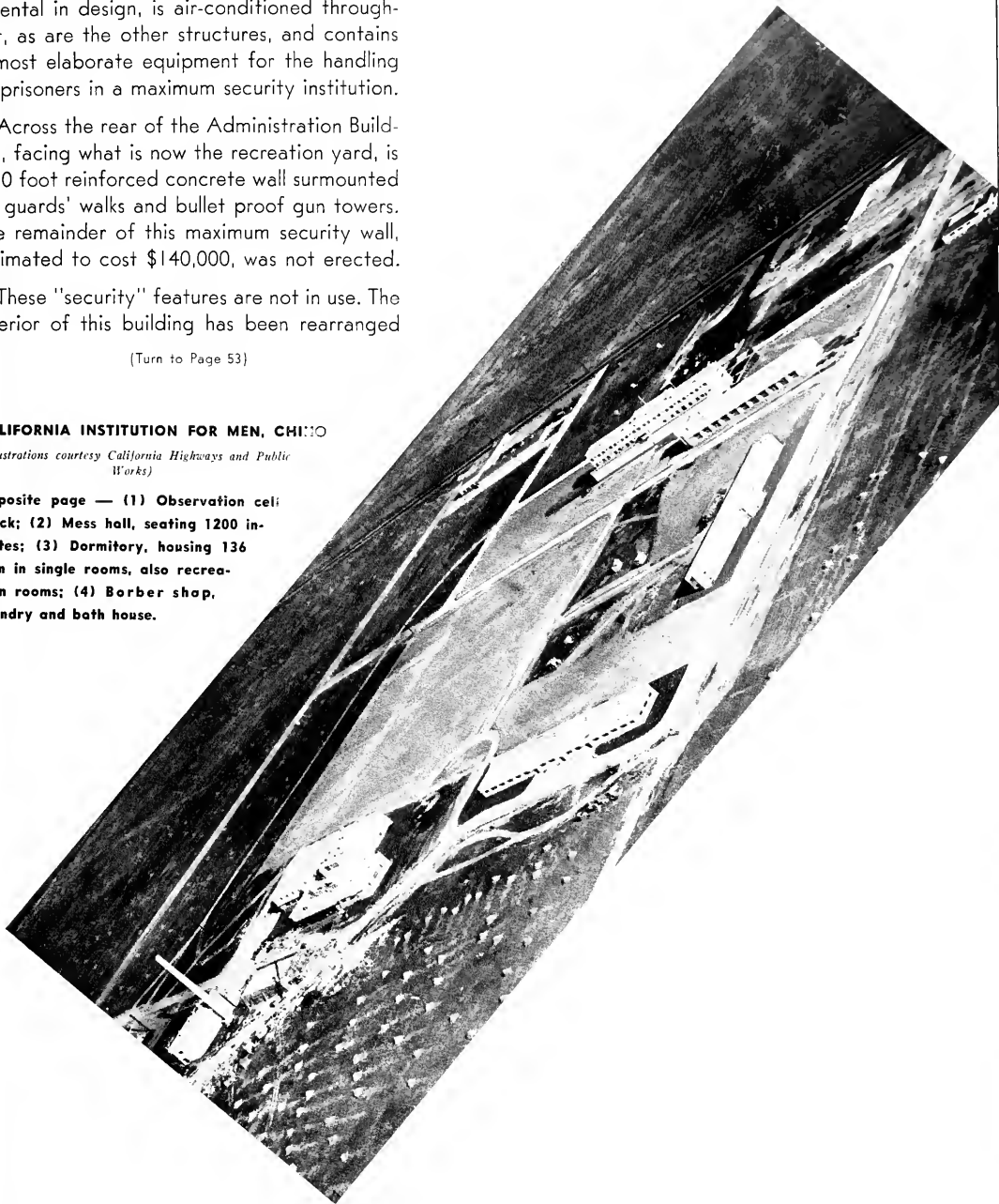
These "security" features are not in use. The interior of this building has been rearranged

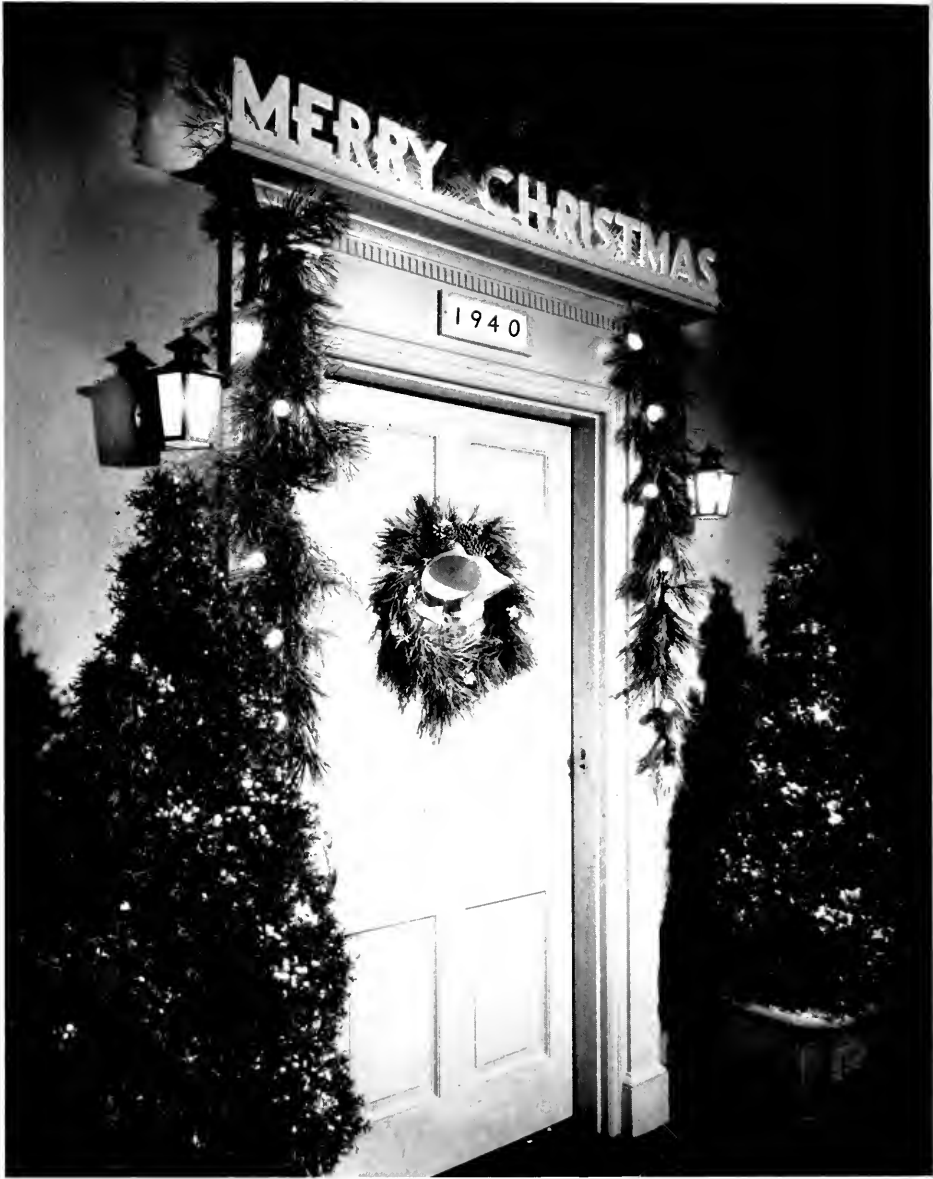
(Turn to Page 53)

## CALIFORNIA INSTITUTION FOR MEN, CHICO

(Illustrations courtesy California Highways and Public Works)

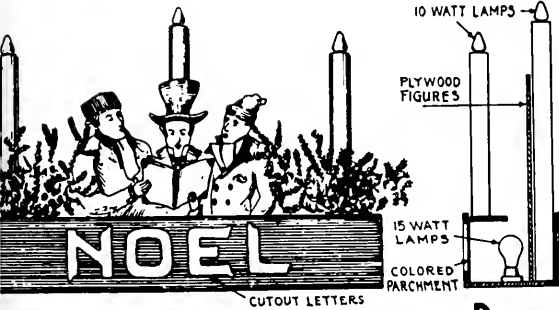
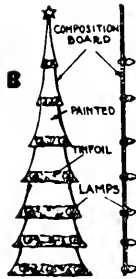
Opposite page — (1) Observation cell block; (2) Mess hall, seating 1200 inmates; (3) Dormitory, housing 136 men in single rooms, also recreation rooms; (4) Barber shop, laundry and bath house.



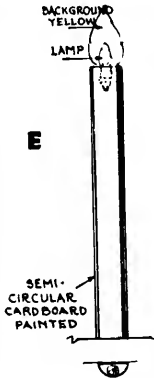


This festive doorway is typical of the Yuletide season in California. Outdoor lighting of cities and towns, public buildings and homes has become general since the Christmas Tree Association first began to encourage the idea fifteen years ago. Awards made by the Association for the best looking trees and house illuminations add yearly interest to the movement. Cash awards are also made to amateur photographers for the best pictures of trees and outdoor decorations.

Sketch B: Conventional Christmas tree. Trees cut out of plywood, painted green, crinkled foil trim. Lamps project through holes in surface.

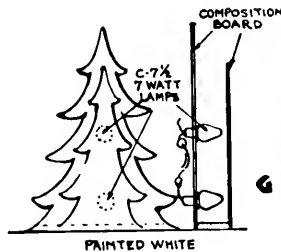


Sketch D: Noel sign of wood and composition board, cutout letters backed with colored diffusing material. Light from inside-frosted lamps on 6" to 8" centers also illuminates composition board figures painted in bright colors.



Sketch E: Candles may be made of cylinders, such as cardboard mailing tubes and metal stove-pipe. Top with a flame-shaped lamp.

Sketch G: Small trees made of two planes of composition board, lighted by C-7½ Christmas tree lamps.





Three modern designs of lighting fixtures  
(fluorescent and incandescent) by Paul Pry.  
Photos by Jo Kim



# SMALL RETAINING WALLS

By AL C. BRINCKMAN, C.E.

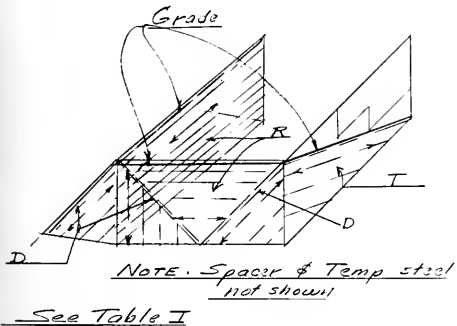
A suggested concept of design for small retaining walls, wing-walls, side-hill garages, vaults, pits, and cellars is hereby presented as being both economical and practical in many such cases.

The field wherein this method of design seems to be most readily applicable is in the small one, two, or three-car "side-hill" garage; the "buried" cellar, and furnace vault or pit under or adjoining frame residential structures, and garden (lot-line) retaining walls, where intermediate cross-walls or buttresses are not desired.

Assumptions of hydrostatic equivalents, bearing values, angle of repose, surcharge, drainage efficiency, coefficients, and so on are matters which are best left to the judgment of the engineer in charge of design.

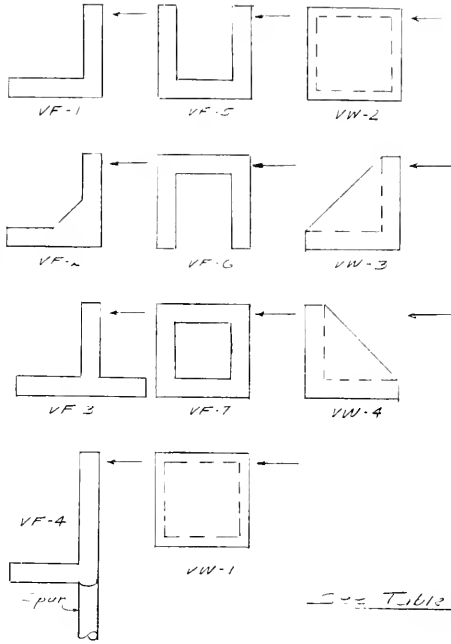
The whole idea is to so place the working steel that it will function most efficiently as the tension element in the beam-walls.

The following tabulation and sketches are self-explanatory, and although not complete, serve to illustrate the wide choice of design elements thus made available.



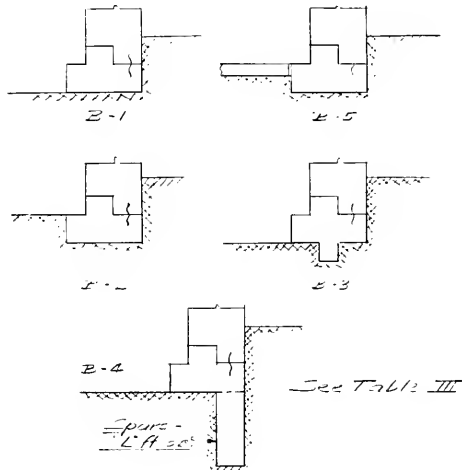
## I. Vertical Distributing Elements

Type	Description
R	Rectangular—continuous between vertical and horizontal supports.
T	Triangular—ordinary "stepped" wall, continuous between vertical supports only.
D	Diagonal wall-beam. (Note: A "fan-shaped" end area may be assumed as resisting shears, and an integral one-half or full "T-beam" section may be assumed as resisting moments.)



## II. Vertical Resisting Elements

Frames		Walls	
Type	Description	Types	Description
VF-1	Open cantilever	VW-1	Solid cross wall
VF-2	Filled Cantilever	VW-2	Pierced cross-wall (see VF-7)
VF-3	Balanced cantilever	VW-3	Buttress
VF-4	Side—"T" Cantilever	VW-4	Counterfort
VF-5	"U" frame cantilever		
VF-6	Inverted "U" frame		
VF-7	Closed rectangle, or "box"		



### III. Horizontal Resisting Elements

Top		Bottom	
Type	Description	Types	Description
T-1	Rectangular slab	B-1	Footing beam
T-2	Triangular (corner) slab	B-2	Trenched footing beam
T-3	Cross-beams:	B-3	Footing beam and shear key
	a—rectangular	B-4	Footing beam and shear spurs ("post-hole piles")
	b—diagonal (see VF-6, VF-7)	B-5	Footing beam and floor slab

Thus, in general, on "side-hill" walls, where the finished grade slopes up or down, as the case may be, the tension steel is placed as **nearly parallel as possible to such grade**. This naturally results in longer relative **spans**, but makes use of definite reaction supports.

In the case of long cellar or retaining walls, of say, over twenty feet, and of 6", 8" or 10" thickness, the following is proposed:

1. Use a 30° to 60° triangular lower corner slab, placing the tension steel so that it is run diagonally from the vertical resisting element to the bottom resisting element.

2. The central "triangular" vertical slab is designed so that its tension steel runs horizontally to the intersecting diagonal strips or beams.

3. The intersecting diagonal strips should be designed as diagonal beams to resist both the horizontal reactions from the central triangular slab, and the earth-pressure along the beam itself.

4. A variation is to provide single "**diagonal**" beams, and then design them to resist the horizontal reactions from the central slab and the vertical or horizontal reactions from the lower (enclosed) corner triangular slabs.

5. When a practical limit has been reached, both as to length, depth of bury, and thickness of wall, the proposed method can be further extended by introducing a cross-buttress, or a counterfort; or a box-frame with the top concealed in the floor system, and the bottom placed under the cellar floor as either a functional strut or as a combined slab and wall footing.

6. Variations of 5 are: (a) introduce an upright cantilever, or (b) introduce an upright "pole-cantilever" by running a deeply-seated spur below the footing level. (The latter system usually involves the use of post-hole or well-drilling outfits.)

The actual moments, shears, reactions and deflections can be readily determined by use of the usual design formulae.



## NEW ERA IN ARCHITECTURE

**How** will the present emergency program affect the future of architecture? What are the prospects for the architectural students who are the architects of tomorrow?

Industrial architecture has been the keynote of the American scene. It has influenced design and set a new standard, and the present era will undoubtedly mark an even greater change. What are the characteristics of this trend? asks a writer in the *Weekly Bulletin* of the Michigan Society of Architects. Architects who are doing large defense work tell us that it is totally different, with concentration on production, and little attempt at eye appeal—yet results are most pleasing, perhaps the birth of something new and more beautiful than ever before. Emphasis has been placed on movement, rather than the static—and that movement must be swift. Trucks, automobiles and airplanes and their assembly lines have been the inspiration. Autos, like buildings, must have less bright work, and who knows but that this will be a blessing? We have confidence enough in our architects to believe that it will be, and as for our industrialists, it's a foregone conclusion. The set-back of skyscrapers forced upon architects by the New York zoning ordinance is an example. The late Raymond Hood said that "automobile design is the highest art in the world today," and it's a healthy sign to see the design of buildings taking on some of those attributes.

These large industrial offices, marvels of organization, masterful in the assembly of the elements of production, have attained the dramatic in functional quality. Like the skyscraper, these streamlined plants attain breathtaking aspects by their very immensity. Instead of height they employ horizontal movement, sweeping the countryside, and measured by acres instead of by square feet. Their designers have made distinct contributions to the profession by making it known around the world as

the moving spirit in the most gigantic undertakings of history. They and their clients, our Government, have had the courage to try for new records. Some mistakes have been made, to be sure, but we learn by doing.

Speed has been attained in a measure never before dreamed of. A marvel of co-ordination, these firms have dovetailed the preparation of plans and specifications with letting contracts and proceeding with construction, so that all operations go along together. Upon receiving the go-ahead, ground is broken almost immediately, structural steel ordered and fabricated while plans are evolved by stages. When one realizes the difficulties ordinarily confronting the architect on modern buildings, it is all the more remarkable to contemplate this added accomplishment, when new and unusual conditions of speed are imposed. It is said that there are many forms and reports to fill out. No wonder there is a shortage of paper.

We don't like regimentation, we don't like too much governmental regulation, but there is no doubt that in the present emergency it has been a tremendous force in pushing the architect into new and advanced methods of production akin to that of industry. And should architecture be put on a factory basis, you ask? Perhaps the answer is that architecture must rise to meet the need of the country—and rise it has. That we are in a new era, there can be no denying; that after the emergency it is going to be still further from the processes we have known, there can be no doubt.

By far the great majority of those in charge of government work are intelligent, forward-thinking men of the most capable type, and that they have succeeded in mobilizing the large architectural offices of the nation in their present advanced state of smooth functioning is evidence enough of their ability. The influence will remain after government has withdrawn. Government has led the way in housing

by setting examples for private enterprise. They are doing the same in the defense program.

One fact is significant. No charge of politics in the selection of architects can be justified. In fact, it isn't even made. Selections are made on the basis of past performance in handling big work. Perhaps the well formed pre-conceived plan of the Institute in making an inventory of architectural offices throughout the nation formed the basis for these selections. It is absolutely necessary for such jobs to go to large established offices, already equipped to function quickly. How then can the remainder of the profession be fitted into the program? It has been said that small, individual offices should band together, forming groups of competent architects and engineers, equipped to handle jobs of any magnitude. This is not quite the answer, for even with the very best individual architects so combined you still haven't got an Albert Kahn, a S. H. & G., a G. & V. or S. L. and H., etc., etc. There is one thing for which there is no substitute—the years of background in a big office that has successfully completed big work.

What, then, is the answer? Many architects, some long established in their own practices, have gone to work for the large firms. This is one solution, though not always the happiest for the one who gives up his own practice. Could it be that a system of farming out might be developed, or a plan of sub-contracting to newly formed groups, under the direction of large offices? This is being worked out in industry, and has much merit in that it does not mean complete disorganization of small business. Certainly the architect must cease to be so much of an individualist, for this is an age of production, and by "farming" for the big offices may the small become large.

This small business—the backbone of the Nation—must be preserved, if we are not to see disastrous results later. Little business, fearful of such dire results, is converging on Washington, and right here at home our own State Administration is even now conducting hearings to devise ways and means of preserving our great heritage of small industry. The picture, though heroic, is not a pretty one. The

major miracle of the age is taking place before our eyes. Where refrigerators were made, guns will grow, and where gadgets were made will come forth cartridge clips, and so on.

We are told to tighten our belts, that the well-known American standard of living is in for a shock. This will no doubt have a tremendous influence on the future of architecture, and who knows but that it will be a good influence? Practically every great change in history has so proven. Maybe this will mean that Americans will find how simply they can live, and architects how simply they can design.

Few people have heretofore stopped to think what the magnitude of American Industry, fully tuned to a specific job, could be. No one thought it possible to turn out 4500 airplane engines a month, much less the 8000 estimated for six months from now. And if you had been given a preview of all the immense plants already come into being it would have seemed like a dream.

And what of the building industry when the building part of the defense program is finished, and what of the major part of it now—those not engaged on actual defense work? The answer to this would seem to lie within the priorities situation. Hopeful signs have come out of Washington recently, and more are expected shortly. Influence is being brought to bear from every quarter—and already its effects can be seen. It is unthinkable that those who understand so well could be so blind as not to see the disastrous results of closing down the Nation's second largest industry, upon which it is fairly estimated that twelve million people are dependent for a livelihood. A priorities committee was speculating on whether or not it would do any good to send a copy of their recommendations to the President. Some felt it would not, that he probably knew little about the building industry. Another said, "No, he doesn't know anything about building, he's just an architect."

The President has gone all out for the defense program. It is safe to say that he will go all out to save the building industry.

It is estimated that a national income of one hundred billion dollars will be attained during

(Turn to next column)

## PRIORITY AID FOR PRIVATE HOMES

**Details** of a broad plan to grant priority assistance for the construction of 200,000 privately financed defense housing units were announced by Donald M. Nelson, Director of Priorities, following approval of the plan in principle by the Council of the Office of Production Management.

The new procedures, worked out by OPM officials in collaboration with Charles F. Palmer, Defense Housing Coordinator, will assure priority aid for 200,000 privately financed homes for defense workers. Other arrangements have already been made for granting priority assistance to 100,000 publicly financed units.

To expedite the building of essential defense housing, project preference ratings will be assigned to defense projects which are already under construction and for remodeling and rehabilitation, which create living accommodations for additional defense workers. Lower ratings will be granted to new construction for rent, and a still lower rating for new construction for sale. All defense housing ratings, however, will be in the defense or "A" class. Certificates of rating will be extended in the field

for privately-financed projects by the field offices of the Priorities Division, upon the recommendation of the Defense Housing Coordinator.

By the use of project ratings, the Division of Priorities can assign **one** rating which can be used to secure delivery of scarce building materials (which appear on the Defense Housing Critical List), and which will go into any **one** defense housing project.

This procedure eliminates the need for many different individual applications for different materials.

A list of defense areas [California is one] has been developed in which there is an acute shortage of housing for defense workers. Defense housing within these areas, both public and private, may be granted priority assistance.

The Defense Housing Critical List includes a number of materials, products, and items essential to housing construction. The project ratings will apply only to items which appear on the list, and in such quantities as the Director of Priorities authorizes. The purpose is to stimu-

---

the defense program, and that this can be maintained, labor absorbed and plants converted to peacetime production if planning is started now. Air transportation is in for a tremendous jump. Bomber plants will be producing commercial planes. Every small town should have air service, and many more individuals will be owning and flying planes. The last war gave a boost to aviation but it was too young then to receive the impetus that it will now.

Reduced construction during the emergency will mean a dearth of civilian building after the war. Housing seems to be the biggest best bet. We will also have a large part in rehabilitating European countries, for they will not be able to do so alone. A bank of new inventions,

meaning new industries, should come into being, with many needed projects such as highways, waterways, slum clearance, city planning.

The teaching profession will see marked evidences of the new trend, and of interest to students will be the structural forms developed in a manner that is fresh and new. Students beginning an architectural training now should find a big assignment awaiting upon graduation. But the world has not changed, and is not likely to change, with regard to preparation for a profession. There are no short cuts and more than ever before will there be temptations to accept a larger income at some trade, with less future.

late and expedite the production of the greatest possible number of dwelling units, which the economical use of available limited quantities of critical materials will permit.

To obtain a preference rating for defense housing projects, the private builder should file an application with the local office of the Federal Housing Administration.

To qualify for the priority assistance extended under the new plan, construction must be confined to family units of a value not in excess of \$6,000, if for sale, or for which the monthly shelter rental does not exceed \$50. These figures represent top prices for housing to receive assistance under the plan. Construction in lower brackets to meet the economic situations of workers in different categories will be encouraged, and it is expected that in most cases the costs involved will be substantially lower. Exception to the limits set will be permitted only in special circumstances, and then only on the basis of individual consideration.

No application for aid will be considered by the priorities officials until it has been demonstrated that the homes involved are designed for and are readily available to defense workers, at prices within their reach, at locations convenient to their employment. It must also be demonstrated that such housing is being, or will be, built in such a way as to use minimum quantities of scarce materials.

Before any specific privately-financed project can be given a rating, it must qualify as defense housing and be approved by the Office of the Defense Housing Coordinator.

When this has been done, and the Defense Housing Coordinator has recommended the project, a rating may be assigned in the field by the Priorities Division to the particular job involved on a project rating form.

This rating will be given to the builder of private housing. The builder can extend the rating by executing (signing) a copy of the order and serving it on his suppliers. The suppliers in turn can extend the rating to their own suppliers in the same way.

With the impact of the defense program upon the national economy, housing operations in every field have been affected by the short-

ages in the products manufactured from critical metals, without which livable housing cannot be produced.

Copper, for example—used for wiring, roofing, gutters and in plumbing supplies—has become increasingly tight. Zinc—used for galvanizing—is also short. Steel and iron products also have been subject to delayed deliveries, and the materials used in hardware are likewise scarce. These difficulties, of course, have been due to the greater need of armament for national defense.

Yet plants manufacturing tanks, guns, shells, and other essentials of national defense, cannot be operated, and ships cannot be built without workers, and workers must have places to live. The production of housing has been in competition with the production of other defense essentials, and was delayed because the scarce materials needed for both were diverted by priorities from housing into other uses.

Because of this, a decision had to be made to regulate the flow of critical materials to insure the necessary supply for housing.

The construction of new defense plants and the development of new industrial areas have shifted the centers of employment; decreased the demand for housing in some areas, and increased it rapidly in others.

#### DEFENSE HOUSING CRITICAL LIST

(Official and subject to change)

1. This list is based upon the critical position of the materials involved as of the date of issue hereof and since that position may change at any time this list is subject to revision whenever affecting circumstances warrant such action.

2. Herein included are all items for which priorities assistance will be given for the construction of defense housing, including Government owned, or assisted, and privately financed. Any materials under priority control not listed herein and which may be deemed essential in a given project by those constructing it, shall be handled as an independent item for priority consideration and will be considered on its merits in relation to that project.

3. Any material not requiring priority assistance may be used in any defense housing project at the discretion of those constructing the project, provided such use of the material is consistent with any other regulation that may govern the project.

4. The preference rating granted to a project will apply only to the materials listed herein and only in such quantities as the Office of Production Management may permit under the order granted. This limi-

tation, unless otherwise defined shall lie within the limits of good practice.

**STEEL AND IRON—to include only:**

1. Reinforcing steel, including rods, mesh, fabric, tie wire and accessories, for concrete and masonry construction.
2. Structural members—to include only:
  - a. Bearing plates, under 6 pounds.
  - b. Joist hangers—multi-family dwellings only.
  - c. Anchors, bolts, tie rods, dowels and cleats.
  - d. Angle lintles—over openings in veneer masonry walls only.
3. Steel stairs, rails, etc. — only for multi-family dwellings where necessary for fire hazard protection — concrete preferred. Uncoated ferrous metal.
4. Insect screen mesh— **made only of:**
  - a. Painted steel.
  - b. Thin coat galvanized and lacquered.
5. Fire doors and their frames for multi-family dwellings only—wood cored with terneplate covers.
6. Roofing devices, flashings, half-round gutters, hangers and downspouts—to include only:
  - a. Steel not heavier than 26 gauge, uncoated or phosphated treated and painted, or zinc coated by electrical process and phosphate treated and painted, or 2 lb. lead.
  - b. Gravel stop, as for item "a" or asphalt dipped steel.
  - c. Roof ventilators (aspirator type) as for item "a."
  - d. Termite shields for infested areas only—as for item "a."
  - e. Wire basket strainers only for downspouts connected to sewer lines—zinc coated.
  - f. Scuppers, and downspout connections for flat roofs—ferrous metal zinc coated.
7. Lath—to include only:
  - a. Ferrous metal, paint dipped. Limited to fire-resisting partitions, ceilings and soffits, and to wall tile bed base, and where gypsum lath and gypsum plaster is not permitted.
  - b. Corner reinforcing—ferrous metal, paint dipped. Limited to not more than 2½ inch lap on each surface of internal angles and on each surface where different kinds of plaster base abut each other. Corner beads for vertical corners only, paint dipped ferrous metal generally, zinc coated only where exposed to moisture or extreme conditions of humidity.
  - c. Exterior stucco base, woven or welded fabric, non-metallic coated; zinc coated before fabrication, optional in California coastal district only.
8. Builders and Cabinet Hardware—with parts of steel or iron only except necessary bushings and pin tumblers of brass or bronze and, optionally,

latch bolts, dead bolts, and stop buttons in exterior lock assemblies of brass or bronze; knobs, push plates, drawer and other pull of glass or other non-metallic material. Exposed steel parts for exterior use, Japanned or primed for painting, lacquered over phosphate coating or cadmium coated, and excluding finishes of zinc coating, nickel or chromium plating except as below noted.

- a. Nails, screws, bolts, nuts and washers ferrous metal generally uncoated; zinc coated, optional, for roof coverings and wall ties only.
- b. Wall ties zinc coated for masonry veneer over frame construction.
- c. Pulleys and sash balances.
  - (1) Uncoated Japanned or primed for painting, ferrous metal.
  - (2) Electroplated zinc on ferrous metal spiral and similar sash balances.
  - (3) Weights, cast iron.
- d. Self-releasing fire exit-devices, as for builders hardware above.
- e. Wood venetian blind hardware and shade fixtures, ferrous metal, primed for paint or lacquered.

NOTE: Hardware used exteriorly under extreme exposure conditions—as in salt air, zinc coated in lieu of as above listed.

9. Glazing points, zinc.

**ELECTRICAL—to include only:**

NOTE: Roughing in material limited to the recommendations of the electrical supplies industry on file in the Priorities Section, Office of Production Management.

1. Underground materials.
2. Overhead materials.
3. Entrance (main) service switch and meter pan or receptacle.
4. Meter.
5. Circuit breaker type distribution panels.
6. Fuse type distribution panels including fuses.
7. Interior wiring method.
  - a. For Non-fireproof construction:
    - (1) Knob and tube, wire and fittings.
    - (2) Wire, and non-metallic sheathed cable.
    - (3) Flexible conduit and armored cable, zinc coating limited in thickness to that of standard electroplate for this material.
  - For fireproof construction:
    - (1) Wire.
    - (2) Rigid steel conduit, enameled.
    - (3) Flexible metallic conduit or armored cable, coated as above noted.
8. Conduit fittings, outlet boxes and wiring devices —number limited, see Note.
9. Plates—switches and convenience outlets, non-metallic.
10. Lighting Fixtures — except aluminum and solid

brass or bronze, copper and brass plating permitted.

- a. Indoor fixtures, light gauge spinings, stampings and drawings; non-metallic (glass, plastics, porcelain, etc.) wherever practicable.
  - b. Outdoor fixtures and standards, cast and wrought ferrous metal only.
11. Electrical accessories.
- a. Wiring, bells, buzzers, push buttons and transformers—multi-family dwellings only.
  - b. Lock releases—multi-family dwellings only.
  - c. Entrance Door Communication — multi-family dwellings only.
  - d. Public telephone systems.

**PLUMBING AND GAS DISTRIBUTION SYSTEMS—to include only:**

1. Cast or stamped ferrous metal, enameled and vitreous ware plumbing fixtures, the latter wherever practicable.
2. Fixture Fittings and Trimmings—Base metal limited to ferrous metal, yellow brass and zinc die castings with plating of flashed copper and nickel or unplated.
3. Drainage and Venting Systems—to include only:
  - a. Cast iron pipe and fittings.
  - b. Galvanized steel pipe, wrought iron pipe and malleable fittings generally non-metallic coated.
  - c. Ferrous metal and brass tubing traps, clean-cuts and connections for fixtures (Brass limited to minimum necessary).
4. Water Distribution Systems—to include only:
  - a. Galvanized steel or wrought iron pipe and malleable fittings, or cement lined cast iron pipe and fittings—lead wherever practicable **inside buildings only.**
  - b. Valves—iron and brass (brass limited to minimum necessary and used for seats only wherever practicable).
5. Water Heaters (storage type) and Hot Water Storage Tanks—**made only of:**
  - a. Galvanized sheet—only where local conditions necessitate
  - b. Black steel, painted
  - c. Coated steel (Enamel or glass lined)
  - d. Brass valves, connections and controls for water heaters:
  - e. Copper coils for storage type hot water generators and heat exchangers — multi-family systems only.
6. Water Softeners for multi-family dwellings only, to have painted steel exteriors, interiors as for water heaters, etc.
7. Gas Distribution System — **only for items noted below:**
  - a. Black steel pipe and fittings.
  - b. Valves as for water distribution systems.

**HEATING AND VENTILATING EQUIPMENT—to include only:**

1. Boilers—**Furnaces only for items noted below:**
  - a. Boilers — ferrous metal with brass safety devices and cocks, limited to minimum practicable.
  - b. Furnaces—ferrous metal with zinc coated casings, interliners and baffles for gravity furnaces and with zinc coated interliners where used in forced warm air furnaces.
  - c. Breechings—ferrous metal non-metallic coated.
  - d. Floor furnaces, space heaters, stoves and other similar heating devices, wherever practicable and where they may replace the above.
  - e. Vents for heating equipment in demountable houses—ferrous metal, non-metallic coated.
2. Accessories—**consisting only of:**
  - a. Pumps.
    - (1) Water Circulators
    - (2) Condensation
    - (3) Vacuum R.L.
  - b. Fans, Blowers and Motors — Centrifugal — Forced warm air systems only — Propeller — large exhaust on large multi-family units.
  - c. Oil Storage Tanks, ferrous metal—non-metallic coated, size limited to minimum necessary, for example, not to exceed 275 gallons capacity for plants serving less than five families.
  - d. Expansion tanks for hot water systems—ferrous metal, non-metallic coated.
3. Distribution Materials—**consisting only of:**
  - a. Piping—ferrous metal, uncoated
  - b. Fittings—Cast ferrous metal, uncoated
  - c. Valves
    - (1) Vent—ferrous metal wherever practicable, yellow brass elsewhere, no plating
    - (2) Gate—ferrous metal wherever practicable, yellow brass elsewhere, no plating
    - (3) Globe—ferrous metal wherever practicable, yellow brass elsewhere, no plating
    - (4) Cocks—ferrous metal wherever practicable, yellow brass elsewhere, no plating
  - d. Traps—central steam systems for multi-family dwellings only.
    - (1) Boiler return
    - (2) Blast
    - (3) Bucket
    - (4) Float and thermostatic.
  - e. Ducts and connections.
    - (1) Ferrous metal phosphate treated and painted or untreated
    - (2) Bright tin.
  - f. Hangers and brackets.
    - (1) Strap iron
    - (2) Cast iron.



## PRISON WITHOUT WALLS

(Continued from Page 41)

### 4. Radiators, Convectors and Registers—only for items noted below

- a. Radiators and convectors of cast iron, without metal enclosure.
- b. Valves.
  - (1) Radiator, yellow brass unplated
  - (2) Air Valves, yellow brass unplated.
- c. Traps—Radiator, for multi-family dwellings only, yellow brass unplated.
- d. Registers and Grilles.
  - (1) Stamped or cast ferrous metal
  - (2) Fabricated steel optional for large units in floor.

### 5. Firing Equipment—only for items listed below:

- a. Oil, gas and coal burners.

NOTE: Oil burners eliminated from eastern seaboard area.

### 6. Control Equipment—only for items listed below:

- a. Damper Regulators
- b. Thermostats
- c. Pressure Controls
  - (1) Pressure Reducing Valves — **Multi-family only**
  - (2) Pressure stats
  - (3) Pressure Relief Valves
- d. Relays.

NOTE: Above items to be reduced to minimum and plating eliminated.

### HOUSEHOLD EQUIPMENT—to include only:

1. Ranges and Refrigerators (As available in the industry)
2. Incinerator hardware and fittings—ferrous metals, non-metallic coated multi-family dwellings only. Incinerator proper, of non-metallic material only.
3. Refuse receptacles — metal cans, zinc coated, modified as per Federal specifications or phosphate treated and painted.

### LAND DEVELOPMENT ITEMS—only as noted below:

1. Wells—Reinforcing Mesh for dug well slabs only.
2. Wells Casings—Ferrous metal, zinc coated only where local conditions make necessary.
3. Pipe Lines and Connections for water and gas distribution systems, as below:
  - a. Pipe and Fittings, ferrous metal; zinc coated pipe only in smaller sizes or where local conditions require.
  - b. Fire Hydrants—ferrous metal with brass limited to minimum necessary for working parts.
  - c. Valves and stop cocks—ferrous metal where possible, otherwise with brass working parts.
  - d. Valve boxes, small—cast ferrous metal.
4. Storage Reservoirs—only for items listed below:
  - a. Reinforcing steel
  - b. Elevated Steel Tanks and Supports.
5. Manholes—Ferrous metal covers and frames and step bars—for streets only.
6. Water and Sewage Treatment Plants to include only:

by the Division of Architecture, reducing materially the luxurious quarters proposed for the Prison Board and including vitally needed facilities which had been omitted by the shrinkage of the funds.

Immediately to the northwest of the Administration Building is the Observation Cell Unit, a reinforced maximum security disciplinary structure. In it are the much publicized cell doors. This building and the other major units, excepting the Administration Building, were built under general contracts.

North of the Observation Cell Unit is the Westerly Dormitory, a medium security cell block housing 136 men, a reinforced concrete, 2-story structure. The entrance, in accordance with the original plans under which the building was erected, is controlled by a guards' booth with customary gun ports. On the first and second floors are dayrooms for recreation and each wing of the building contains single room cells closed with steel cell doors.

Beyond the dormitory building are the laundry and the kitchen and mess hall buildings. The laundry provides shower facilities for the inmates, as well as laundry equipment sufficient for an institution of the size proposed for this group. In the mess hall and kitchen unit, as illustrated in the photograph, seating is available for 1200 inmates.

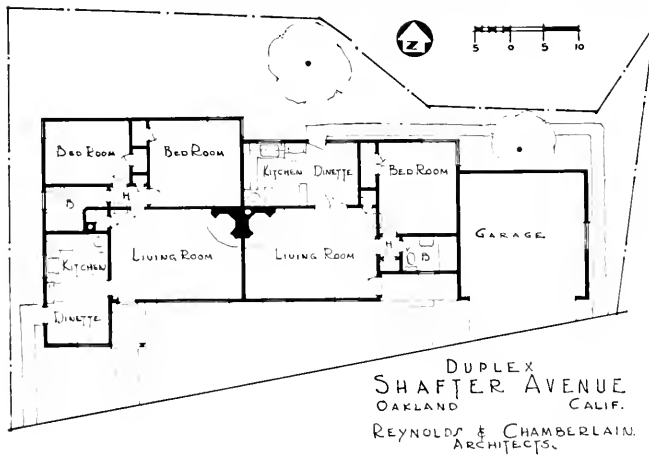
On the grounds, to the northeast of the mess hall building, is a powerhouse and electric substation of sufficient capacity to care for this institution for a number of years to come.

At the extreme northeast corner of the 1300 acre plot is a water distribution system with elevated tank and storage reservoirs, and in the southeast corner is an adequate sewage disposal plant.

Under construction at the present time and not illustrated, is an institutional hospital adequate for the needs of this group of buildings for several years. It is being built at approximately 60 per cent of the cost originally proposed and out of savings due to the rearrangement of funds available.



Courtesy of House



**DUPLEX INCOME DWELLING  
OAKLAND, CALIFORNIA**

**Reynolds and Chamberlain,  
Architects**

# STANDARDIZATION OF BUILDING PRODUCTS

**Organization** of a project to end the present "chaos of sizes and dimensions" has opened the way to broad advances in building economy and efficiency.

Proved economies in labor and materials are immediately available, according to M. W. Adams, secretary of a sectional committee of the American Standards Association, which, under the sponsorship of the American Institute of Architects and the Producers' Council, aims to co-ordinate dimensions of building materials and equipment.

"The most substantial economies of co-ordination will be found in the standardization of sizes for the component parts of the building structure and the use of these sizes without alteration during field erection," Mr. Adams points out. "It is the cutting and fitting of the structural materials and parts in the field that is so wasteful of time, labor, and material.

"The design of special details and the custom manufacture of special sizes for each building involves an even greater waste of time and increase in manufacturing cost, and affords no solution. Any complete solution seems to require standard sizes for these parts and a convenient method of using them. What is needed is a simple method of building layout which creates dimensions that are consistent with available sizes of structural materials and parts.

"A proposed basis for co-ordination has been studied. This basis, in addition to providing a uniform method for determining sizes for all building products and details for their assembly, also greatly simplifies the work of the building designer. It makes available all the economies inherent in a better standardization of individual parts without sacrificing a practical and essential flexibility for building layout and design.

"This simplified method of layout is now much more than a theory on paper. It has been used successfully during the last few years for the layout of a large number of small houses. It has been demonstrated, time and again, that any building designed by an architect can be made to conform to this method with no appreciable alteration in the original layout. The advantages of the method as a new tool for the architect are established.

"A demonstration of the application of this layout to a larger building has recently been completed at Sorel, Quebec, with great success. This two-story, wood-frame building, containing about 280,000 cubic feet, was originally designed by the National Housing

Administration of Canada. By very slight and minor changes in the layout, dimensions were co-ordinated with lengths of frame members which were cut rapidly and accurately by simple 4-inch jig methods.

"Walls and ceilings were assembled in sections, using both fibreboard and plywood for covering. All millwork was completely pre-cut. Within seven working days after the sills were laid on the foundation, the roof was completely closed in. The economies of this job and particularly the speed of erection have caused the authorities in Canada to adopt the method and the standard details for other emergency building."

Many examples in present practice of a partial and limited co-ordination of dimensions are cited by Mr. Adams. "Widths of frames for wood windows and doors are co-ordinated with thicknesses of walls made of standard 2x4 wood studs and conventional finish," he explains. "Widths of wallboard generally are consistent with the 16-inch spacing of studs.

"Medicine cabinets are made in sizes to fit in between studs. Such instances of co-ordination between a limited number of materials or between sizes of materials and customary building dimensions afford definite economies and advantages.

"On the other hand there are numerous instances of materials which are assembled and need a co-ordination which has not been available. An outstanding example is the combination of various masonry facing and back-up materials, particularly where large back-up units are used in combination with a variety of facing materials produced in smaller units and used in a variety of mortar joint thicknesses.

Another example is the use of stock sizes of steel casements in masonry openings and, particularly, with a glazed tile wall finish. These instances will suffice to indicate the lack of and need for a uniform basis for determining sizes for the multitude of materials that are assembled in many different combinations."

Probably the most extensive use of a complete standardization of building products and assembly methods that has yet been made has been in Germany, Mr. Adams says. "Standards, together with a considerable degree of co-ordination, were adopted over ten years ago and apparently have been used exclusively since then for many types of building. It is reported that an over-all economy of at least 25 per cent has resulted, although this cannot be verified at present.

# Regulating War Time Building Construction

**Methods** of regulating building construction under a war economy are detailed in the ninth edition of the World Economy Survey of the League of Nations, now being distributed in this country by the International Documents Service of the Columbia University Press.

Analyzing the problems to be met in the United States, the survey cites different programs which have been adopted to facilitate the expansion of the armament industry. "Simultaneously with the restriction of ordinary building activity, the direct control of essential construction has tended to become centralized," the survey points out.

"The expansion of plant to meet maximum requirements particularly in the heavy industries, much of which is not likely to yield a profit in peace conditions, presents obvious financial problems.

"In some cases the Government itself provides the plants to be operated by private management, particularly when the plant has no peace-time value; in others, plant, etc., financed and run by the Defense Plant Corporation, a subsidiary to the Government's Reconstruction Finance Corporation, is leased to private manufacturers; in others, private construction is encountered under the Emergency Plant Facilities Contract by which the Government undertakes to reimburse the contractor in monthly installments over a period of five years. Finally, the cost of additions to existing plants for defense purposes can be amortized out of earnings over a five-year period."

Building construction in Germany has been under State control since 1936, and non-essential construction has been prohibited in the Reich since 1938, according to the survey. "Previous to 1936, building control in Germany had been indirect, resulting from the priorities of raw material, labor, and so on. A special Building Control Office was set up licensing new construction; repairs and civil building activities were severely restricted; in December, 1939, an order prohibited the initiation of any construction which was not deemed essential by the Building Controller.

"In Great Britain curtailment of private and municipal building originally resulted from shortage of timber and building steel even though at the outbreak of war subsidies for slum clearance and rehabilitation schemes were stopped.

"Further curtailment resulted from the raw material controls. In October 1940 a Works and Building Priority Committee was formed to license and control all civil buildings. Since then regulation has constantly grown, and the Ministry of Works and Buildings has been given power to co-ordinate and control all building activity for the duration of the war.

"In Great Britain, as in the United States, various measures have been adopted to expand essential production facilities, and in June, 1941, plans for a large-scale construction program were announced to cover

airfields, war factories, defense works and emergency hospitals at an estimated yearly cost of 360 million pounds.

"In Germany, under the Second Four-Year Plan inaugurated in 1936, private firms were ordered to erect factories for specified purposes, financed directly through the state or through semi-voluntary or compulsory contributions from industry itself. Concurrently, indirect methods of encouraging expansion in desired directions, such as cheap credit, tax exemptions, and so on, were adopted. Later, a special Government agency, the Todt Organization, was formed to repair transport and other essential facilities damaged by the war."

---

## SUBSTITUTES FOR CRITICAL MATERIALS

In its constant efforts to cut down the use of strategic and critical materials formerly used in the many articles of supplies and equipment it procures for the Army, the Quartermaster Corps is developing as many substitutes as possible, the War Department announced recently.

In a great many items procured by the Quartermaster Corps, tentative specifications have been established which permit contracting officers to accept them in whole or in part if the substitutes will be suitable for the particular job to be done.

As an example of these substitutions, canvas field bags have as component parts, buckles, snaps and rings which were formerly made of solid bronze metal with bronze finish. Four substitutes have now been made available for these items: malleable iron or stamped steel, parkerized finish; the same materials with black baked enamel finish or with black japan finish; and malleable iron, brass plated, oxidized finish.

To date, malleable iron and steel have been substituted in 96 items of equipment procured in large quantities by the Quartermaster Corps for the Army. In place of nickel, the Corps has turned to wood, vitrified clay, cast iron, galvanized iron, steel and glass. These substitute materials receive a special finish to make them suitable for use in all sorts of table tops used in Army kitchens and hospital laboratories, in electric fixtures, kettles and many other items.

Zinc has been replaced by substitutes in the method of galvanizing and copper has given way to such materials as porcelain, glass and corrosive resisting steel. Cooking utensils and many other common items made of aluminum are no longer purchased by the Quartermaster Corps. In the case of cooking utensils, enamelware and steel are being used in its place.

Plastics are being developed rapidly and many new uses are being found for them in the Army procurement program. Such diverse items as salt and pepper shaker tops and uniform buttons are possible future uses.

Fibre glass and rock cork are being substituted for cork in many instances. Wood and concrete are replacing steel in construction specifications wherever possible. In 17 Army items of supply containing silk, substitutes have been found for 14 of them.

#### WINDOW REPLACEMENTS IN WAR TIME

Few glass windows smashed in London air raids are replaced by glass, says the London correspondent of "Industrial and Engineering Chemistry," publication of the American Chemical Society. As a rule, a special window fabric, consisting of wire mesh or cotton net impregnated with cellulose acetate plastic, is nailed on wooden battens and fixed in the window frame.

It has become general practice with large broken plate-glass windows to fill the window with ply, in which a small glass window is inserted to give prospective customers a view of the wares within.

"The general method of manufacturing window replacement fabric," it is explained, "consists in the passage of a loosely woven fabric, suitably prepared to give it rigidity, etc., through a dope of cellulose acetate and plasticizers. The fabric is immersed in the dope and is withdrawn at a slow rate. Preliminary drying of the solvent takes place while the fabric is held vertically in a warm-air tower. Later the finished fabric is more fully dried or seasoned by a protracted drying on cloth while being passed slowly over heated cans.

"The material used is a loosely woven type with an open or network structure. It is bleached and finished with either starch or dextrin in order to dress it properly and to give it sufficient rigidity or structure during the later impregnation process. It is also advisable that the fabric be as dry as possible at this stage as any residual moisture tends to give rise to blushing during drying of the dope.

"Cellulose acetate is the usual basis for the plastic film which is applied to the fabric. If this material be used alone—i.e., without the addition of softeners or plasticizers—a very hard, brittle film results which shows poor aging properties. Consequently additional material is added to give the finish a certain amount of flexibility and good aging properties."

#### UNSIGHTLY BILLBOARDS

"Will California Outsmart Florida?" is the title of an article in a recent issue of a Florida magazine. The article says that Californians are beginning to be smart enough to protect their valuable scenery from defacement by billboards. California does have an active and well-established organization known as the California Roadside Council, which for several years has been carrying on an energetic campaign to accomplish this purpose. Recently a new organization, known as the California Counties Civic League, has been organized. The League points out that "while public funds are expended through the All-Year Club and the Chamber of Commerce, to extol our beautiful highways and

#### PRIVATE BUILDING MUST GO ON

The Building Industry Conference Board of Northern California is asking national organizations of architects, engineers, contractors and material manufacturers to take joint action with the Federal Government to maintain private building through revision of the priorities system.

"Private building needs only a small percentage of critical materials to keep it going," declared James H. Mitchell, architect, and chairman of the board's priorities committee. "Maintenance of the industry will not impair the defense program, but aid it.

"With its allied industries, the building industry employs 6,500,000 people and supports over 250,000 independent businesses. Three million workers face unemployment through curtailment of construction by priorities. Only a portion of the industry's skilled forces can be absorbed into defense work.

"National morale and economy, both essential to total defense, will be undermined if the situation continues. The private building industry must be kept healthy, not only for the present emergency, but to function properly in the critical post-war period."

Members of the board are: American Institute of Architects, Northern California Chapter; State Association of California Architects, Northern Section; San Francisco Society of Architects; Structural Engineers Association of Northern California; American Society of Civil Engineers, San Francisco Section; American Society of Heating and Ventilating Engineers, Golden Gate Chapter; Air Conditioning Society, San Francisco; Associated General Contractors, Central California Chapter; Producers' Council Club of Northern California.

Each member group wrote its national organization urging formation of an industry-wide board "to integrate the dis-organized efforts of the industry's single bodies." This board would

cooperate with the Government in the adoption of substitutes and other means to maintain private building

study the supply and demand of critical materials and furnish full information to permit adequate allocations of these for defense and private building needs

continue as a unifying body to aid reconstruction during the post-war period

Local board members are also submitting the plan to OPM executives, members of the Senate Defense Investigating Committee and to organizations of architects, engineers, contractors, material manufacturers, building trades employees and real estate groups throughout the country.

scenery to tourists, meanwhile a maze of billboards strung along the roads is destroying this great asset of the state—its natural beauty."

## BOOK REVIEWS

By E. N. Kierulff

**STUDIES IN ARTS AND ARCHITECTURE**, University of Pennsylvania Bi-Centennial Conference; Univ. of Pennsylvania Press, Philadelphia, Pa. Price, \$1.25.

An interesting series of studies presented by the University of Pennsylvania at the Bi-Centennial Conference. The section devoted to architecture contains some remarks and criticisms well worth the reading.

The architect of today will find this little book refreshing and in keeping with his trend of thought.

**THE INTENT OF THE ARTIST**, by Sherwood Anderson, Thornton Wilder, Roger Sessions, and William Lescaze, with an introduction by Augusto Centeno; Princeton University Press, Princeton, N.J. Price, \$2.50.

With a galaxy of writers such as the above list, a book has to be good. This one is . . . decidedly, and is an outstanding contribution to the artist and his work in this modern world.

Augusto Centeno, who has written the introduction, is the Associate Professor of Modern Languages at Princeton and has a brilliant record as a student of art, philosophy, language and literature from the standpoint of their humanistic relationship and their significance in the world in this particular era. The thinking architect and artist will find in this book warm and human experience which will be welcome in the mad turmoil of this present year.

**THIS BUSINESS OF ARCHITECTURE**, by Royal Barry Wills; Reinhold Publishing Co., New York. Price, \$2.50.

A book for the young men in the profession and it will do no harm for the older ones to read it. The author is nationally known, has enjoyed a wide and varied practice and his reputation as a designer began from the bottom in the proper manner.

With information gained from dealing with thousands of clients, the author writes with the practical approach to his problems. The book is most readable, has a fluent style and a certain pointed humor.

**THE ENGINEERING PROFESSION**, by Theodore Jesse Hoover, John Charles L. Fish; Stanford University Press, Palo Alto, California. Price, \$5.00.

Presents a detailed description of the qualifications as well as the duties of the professional engineer. The book touches upon his habit of mind and presents an extended analysis of the sphere and status of the engineering profession and its capacities for development in the future.

This study will prove of great value to the young men entering the field and will be also a guide to the vocational counselor when he is called upon to supply needed professional information and advice.

Some fourscore engineers have been contributors to the contents of this very remarkable work.

**ARCHITECTURAL GRAPHIC STANDARDS** (Third Edition), by Charles G. Ramsey, A.I.A., Harold Reeve Sleeper, A.I.A.; Macmillan Company, New York. Price, \$6.00.

A new edition of a book long popular with the architectural profession. The Architect and Engineer has carried reviews of each of the editions as they have come from the press and is happy to again give its endorsement. Seventy-two new sheets have been added to this third edition, while all the old sheets have been brought up to date. Forty-eight percent larger than the original edition, this new volume is one of the "must" books for today's architect and builder.

## J.-M. AND OUR NATIONAL DEFENSE

The part Johns-Manville is taking in National Defense from a constructive angle, is revealed in a series of well thought out articles by eminent writers appearing in leading periodicals, including the Saturday Evening Post. The articles are intended to help inform the public of the indispensable part American industries are playing in the National Defense Program. The series has included a story on the Steel Industry by Lowell Thomas, Oil by Fulton Lewis, Jr., and Shipbuilding by Frazier Hunt.

In this issue of Architect and Engineer Mr. Hunt has a second contribution to the series, "The Miracle of Defense Construction," which is a reprint from the Saturday Evening Post of December 13th. While the two pages of text and illustrations appear as a paid advertisement, the only reference to Johns-Manville is the brief sponsorship note.

It is a fine job J-M is doing in informing the public of the vital part the building industry is playing in the Nation's preparedness program.

## RUNNING FIRE

(Continued from Page 1)

of these modern expressions as a substitute for good old English words. I shall never be a party to the practice of using the modern substitutes. I shall 'stay on the beam.'"

### • S. F. KNOWS HOW—SOMETIMES

—But not always! The House and Garden exhibit at the Auditorium last month was one of the few examples of the perfect flop in this city with the reputation of knowing how. Rural visitors from up state and elsewhere have sent in criticisms that would shame a town even as small as Decoto for the paucity of its display. One man stated that if the town of Dunsmuir were to put on such an exhibit those responsible would be run out of town. Of course, one way to get around this is to hold the exhibit in a municipal building so that the City Fathers can be held responsible, and everyone knows how difficult it would be to run them out of town.

# WITH THE ARCHITECTS

## NO LONGER A FELLOW

Editor, Architect and Engineer:

I was delighted with the receipt of the November issue containing the very beautiful topographical layout of my article on "The Fine Arts in America." I thought the first page particularly fine with the marvelous Mellon gallery at the top and the explanatory editorial note inserted.

As a matter of fact, I have no longer the right to use the F.A.I.A. after my name, having resigned from the Institute several years ago. If it appeared on the proof sent me I overlooked it. But I don't believe it makes any difference. I have written an apology to the secretary of the A.I.A., asking him to extend it also to the officers and directors, and that ought to suffice, it seems to me.

I have sent one of the reprints to the architects of the Mellon Gallery, one to Dean Cornwell, one to Lee Lawrie—and a host of other people.

I thank you heartily for your kindly interest in the whole matter.

Yours truly,

Elmer Grey.

Since publication of Mr. Grey's paper in *Architect & Engineer*, a number of interesting comments have come from various readers throughout the United States. One is from a prominent A.I.A. officer, another from Hugo Ballin, moving picture producer, mural painter and movie art director, and another is from Mrs. Lee Phillips, writer and author of several popular books.

## SAN FRANCISCO GETS OPA OFFICE

Headquarters have been established in San Francisco to oversee administration and enforcement of the iron and steel scrap price schedule in California, Oregon, Washington and adjacent states.

William S. Whitehead, representing the Price Division, and Harold Swope of the Legal Division's Enforcement Section, are in charge of the preliminary work.

Test checks made over the past several weeks have disclosed numerous cases of evasion of the price schedule, it is said. The San Francisco officers of OPA are in the Newhall Building, 260 California Street.

## EDWARD LANGLEY SCHOLARSHIPS

The American Institute of Architects from January 1 to March 1, 1942, will receive proposals of candidates for Edward Langley Scholarships for the year 1942.

Awards will be announced in June, 1942.

Awards may be made to residents of the United States or Canada.

Complete details and proposal blanks may be had without obligation at the office of Architect and Engineer.

## WOMEN'S AUXILIARY ACTIVE

Architects in San Francisco and the Bay region gathered in considerable numbers at the Hotel Claremont the afternoon of December 13th to pay their respects to the younger members of the profession granted certificates to practice during the past year. Cocktails were served on the Lido Porch. The affair was in charge of the Women's Auxiliary of the State Association. The Auxiliary has an active board of officers which is accomplishing the purpose of the organization, namely, to better acquaint the public with architect designed homes and to make the public architect minded. To this end, the Auxiliary recently sponsored a tour of outstanding homes in San Francisco. Houses selected for inspection included those designed by the following architects: Gardner A. Dailey, William W. Wurster, William H. Rowe, Mark Daniels, Vincent Raney, Farr & Ward, Donnell E. Jaekle, and J. Lloyd Conrich.

At the regular monthly meeting of the Auxiliary, held at the Women's City Club, San Francisco, Mrs. William W. Wurster (Catherine Bauer) gave an interesting talk.

## RICHMOND H. SHREVE HONORED

Richmond H. Shreve, president of the American Institute of Architects, has been elected an honorary corresponding member of the Royal Institute of British Architects. Mr. Shreve's election was announced in a communication from Sir Ian MacAlister of London, secretary of the Royal Institute.

Mr. Shreve, member of the New York architectural firm of Shreve, Lamb and Harmon, is active in defense construction and has been identified with the design and execution of many notable buildings, including the Empire State. Mr. Shreve and his associates, together with Fay, Spofford, and Thorndike, Chicago engineers, are carrying out construction operations at the outlying defense base of the United States Government and Newfoundland.

## HARRY MICHELSEN HONORED

Harry M. Michelsen, architect of San Francisco, has been appointed vice-chairman of the Committee on Industrial Relations of the American Institute of Architects, it is announced by Richmond H. Shreve of New York, president of the Institute.

Mr. Michelsen, who is one of a group of Pacific Coast architects named to administer the affairs of the Institute during 1942, succeeds Ralph M. Rice of New York.

The aim of the committee is "to foster and promote an ever closer, amicable, cooperative, and practical relationship between architects and contractors and the labor used in the construction and erection of buildings."

# MODERNIZED PRODUCTS

*Brief Notes on New Materials and Equipment in the Building Industry.*

## 643. PUMPS

Practical information concerning pump adaptation for a wide range of duties under varying conditions, is the theme of the new industrial catalog just published by Pomona Pump Company. Contains a profusion of illustrated case histories of varied applications.

## 644. DOOR HOLDER

This attractive new door holder consists of just two parts—a metal plunger and a rubber insert encased in a metal socket, each part held firmly in place by two screws. Has quiet operation and is especially recommended wherever doors should be occasionally kept open. Booklet available from Bassick Co.

## 645. AIR RAID SHELTER

"Five Minutes in an Air Raid Shelter" is the title of this one. If this brings the war too close to home for comfort, don't ask for it, but if you want to learn how our steel companies are preparing for all possibilities, get it. It's from American Rolling Mill Co.

## 646. WALL PANELING

Like house organs? We know of a rather interesting one published six times a year on the subject of wall paneling, published by Marsh Wall Products, Inc. Tells of many uses of this practical material, which puts color and snap into bathrooms and kitchens. Title is "Marlite Dealer."

## 647. WATER LOSSES

This booklet will interest our engineering readers. It states that remarkable engineering results are being attained by using "Volclay" bentonite for stopping water losses occurring in foundations, pools, reservoirs, mines, bulkheads, etc., and goes on to prove this. Booklet will be sent by American Colloid Co.

## 648. INSTITUTIONAL SYSTEMS

Clocks, paging and signaling systems, and a very complete line of

them too, are described in bulletin No. 5070, issued by Stanley & Patterson, which is available to our readers upon request. Very valuable for any specification writer.

## 649. METAL PRODUCTS

This brochure describes a full line of cabinet sinks and tops, shower bath cabinets, etc., which are made by Elkay Manufacturing Co. It is replete with plan detail and many drawings and photographs and will be a valuable addition to your A.I.A. file 29-H-6.

## 650. INSULATION

The rugged bark of giant California redwoods—trees preserved through centuries—is shredded into fibre, is baled after flame-proofing and the result is one of the finest insulation materials known to man. A new booklet describes one of its major uses—in freezing plant construction. Available from Pacific Lumber Co.

## 651. METAL DOORS, WINDOWS

This should prove to be not only a valuable book for specification men, but draftsmen will find in it a world of detail on metal windows, doors and door and window hardware. It is issued by Druwhit Metal Products Co. and is available to our readers.

## 652. STEEL STUDS

Not perhaps as yet in a universal manner, but many architects think of future home building in terms of steel frame construction. And when the war effort is over plenty of steel will be available. Here is a valuable booklet on the subject, issued by Penn Metal Company, Inc., which is yours for the asking.

## 653. WALL FURRING SYSTEMS

This file of information, issued by Simplon Products Corp. for your A.I.A. file No. 20a describes the only complete mechanical system designed scientifically to meet the many requirements for exterior wall furring.

The system assures a clear air space between masonry and plaster.

## 654. FLOORING AND WALLS

Three products are featured in the booklet available from Thos. Mounding Floor Mfg. Co., namely, tile floors and walls, plastic floors and maintenance materials. Some of the pages are in full color and typical of the illustrations are institutional and office building work. A good addition to your files.

## 655. DRAFT

The subject has nothing to do with an enlistment with Uncle Sam; on the contrary, the literature offered by the Hays Corporation contains valuable engineering data on the subject of what we refer to as air movement, but what they call "static force." Mainly it dwells on industrial plant combustion control. It's excellent.

## 656. METAL LATH

Here, between two covers, is presented the story of expanded metal lath—its saving of space and reduction of construction costs and its contributions to the defense program. "Making America Strong" is its title and it is issued by Metal Lath Manufacturers Association.

Architect and Engineer  
68 Post Street  
San Francisco, Calif.

Please send me literature on the following items as checked below. This request places me under no obligation.

643	<input type="checkbox"/>	650	<input type="checkbox"/>
644	<input type="checkbox"/>	651	<input type="checkbox"/>
645	<input type="checkbox"/>	652	<input type="checkbox"/>
646	<input type="checkbox"/>	653	<input type="checkbox"/>
647	<input type="checkbox"/>	654	<input type="checkbox"/>
648	<input type="checkbox"/>	655	<input type="checkbox"/>
649	<input type="checkbox"/>	656	<input type="checkbox"/>

My Name.....

Name of Company.....

Street.....

City.....State.....



# ARCHITECTS' BULLETIN

Issued For

THE STATE ASSOCIATION OF CALIFORNIA ARCHITECTS

Northern Section

STATE ASSOCIATION MEMBER  
OF THE  
AMERICAN INSTITUTE OF ARCHITECTS

Editor  
Harris C. Allen

Address all communications for publication in the Bulletin to the Editor (Harris C. Allen) 557 Market Street, Room 218, San Francisco, California.

## STATE ASSOCIATION OFFICERS

President.....Wayne S. Hertzka, San Francisco  
Vice-Pres., Walter R. Hagedohm, Los Angeles  
Sec'y.....Rowland H. Crawford, Beverly Hills  
Treasurer.....David H. Horn, Fresno

## Regional Director—Southern Section

Gordon B. Kaufmann

## Regional Director—Northern Section

Harry M. Michelsen

## Executive Board—Northern Section

President.....Wayne S. Hertzka, San Francisco  
V.-Pres., Norman K. Blanchard, San Francisco  
Secretary.....Andrew T. Hass, San Francisco  
Treasurer.....David H. Horn, Fresno

## Directors

Russell G. de Lappe, Modesto; Clarence W. Mayhew, Harry M. Michelsen, Frederick H. Reimers, Ernest E. Weihe, San Francisco

## Executive Board—Southern Section

President, Walter R. Hagedohm, Los Angeles  
Vice-Pres.....E. Allen Sheet, Los Angeles  
Sec'y., Rowland H. Crawford, Beverly Hills  
Treasurer.....George E. Gable, Los Angeles

## Northern Section Advisory Council

San Francisco District:  
Clarence W. Mayhew, President  
Edward J. Maher, Secretary  
Henry H. Guttererson  
Lester W. Hurd  
Ellsworth Johnson  
William Henry Rowe  
Clyde F. Trudell  
Harold H. Weeks  
John Davis Young

North Bay: Palo Alto:  
J. C. Felciano David B. Clark  
Lower San Joaquin: Marin:  
Russell G. J. W. Bertenshaw  
de Lappe East Bay:  
Santa Clara: J. H. Anderson,  
Chester Root Chairman  
San Mateo: A. C. Williams,  
Leo J. Sharps Secretary  
Upper Sacramento: T. N. Thompson  
C. C. Dakin Berkeley:  
Sacramento: C. R. Schmidt  
W. E. Manhart Redwood Empire:  
Upper San Joaquin: F. T. Georgeson  
D. H. Horn Lassen:  
Monterey Bay: Ralph D. Taylor  
Robert Stanton

## PLANS FOR 1942

In presenting the list of committees for 1942, with outlines of their proposed activities, some comments are in order.

First, all members should study this program carefully, both to realize the scope and value of the work contemplated and to determine how best they can participate. The Executive Board will be glad to add any member's name to any committees in whose work he may be especially interested. Appointments are obviously made without this specific information, for the most part, and to a large extent on a geographic basis. It may be conceived as an ideal situation to have all members serving on committees—where the real progress of the profession is determined.

Second, the immediate prospects appear to offer more spare time for architects. This condition will produce hardships, and will call for patience; but it is certainly a temporary condition and it is the part of wisdom to utilize this spare time in forward-looking efforts for the improvement of the profession. To this end, committee activities should become more active than ever before. And this activity should not be confined to the Chairmen, who will direct and coordinate the work but who should not be expected to shoulder all the burdens and responsibilities.

Third, the Executive Board will welcome constructive suggestions and criticisms from members. The more contributions of thoughtful plans and methods, the greater the progress.

The architectural profession struggled along as individuals, against many difficulties, until it united as an Association. It has improved many conditions by this increased united strength. Today it stands at the cross-roads, and the need for unity and combined effort is greater than ever. And now we may hope for the invaluable cooperation of other professional groups.

The coordinating committee of all others, meeting with them, obtaining and making suggestions, gathering material and information, the Association's VOICE TO THE PUBLIC. This Committee should work with the Director of Public Relations in developing and carrying out a Public Relations Program of gathering material for public information and disseminating it through various media such as newspapers, radio, speakers committee, etc. A separate sufficient fund of money to promote its work is to be obtained from the architects and the various building and material associations who would benefit most from greater public and official recognition of sound architectural standards of planning and building construction. Supervising the issuance of monthly News Letters to the associations is also part of this Committee's work. It should also cooperate with the Southern Section in their public relations work with the ultimate goal of a state-wide public relations program.

This Committee should also study the feasibility of having a Planning and Building Center for its and the Association's work. It should also see that

## Public Relations

architects are represented on all City Service Clubs, Improvement Clubs, and City and State Planning Commissions, so the public will always be cognizant of the fact that the architects are desirous of taking their part in civic affairs.

The members of the Public Relations Committee are: J. Francis Ward, Chairman; Harris C. Allen, James Anderson, Hervey P. Clark and Michael Goodman.

**Legislative Committee** One of the main functions of the Association since its inception has been to carry out a legislative program of benefit not only to the architects but to the public. This Committee should review previous legislative work in order to learn from past experience the type of legislative program to follow for the ensuing year. A study of other States' Practice Acts such as New York's, would be of value.

It has been suggested many times that the architects study the California State Bar Act with the idea that the architects might have a similar type of governing body. This Committee should also meet with other groups in the Building Industry, such as the Engineers, the Contractors, and the Cabinet Makers Associations, and discuss with them mutual legislative problems. This Committee should consult with the Southern Section's Legislative Committee so that a unified program and methods of procedure may be formulated. A study of the City and the State Division of Architecture to determine how more of this type of work could be done by architects in private practice is also suggested.

The members of the Legislative Committee are: Vincent G. Raney, Chairman; Clarence A. Caulkins, Jr., Mario J. Ciampi, Fred L. Confer, Harry J. Devine, John J. Donovan, E. J. Maher, Frank V. Mayo, Frederick H. Meyer, Wilbur D. Peugh, Fred L. Swartz and Harold H. Weeks.

**Professional Practice** The main function of this Committee shall be to improve and promote the standards of practice in the architectural profession, and be an information committee for the profession. This work shall be done in cooperation with the AIA committees. One service would be to study a workable Code of Ethics, supplemented with a study of the standard documents such as the General Conditions, Architect & Owner Contracts, Contractor & Owner Contracts, etc. Study should also be made of the possibility of setting up an "appeal board" to which architects and owners could bring their problems of fee adjustments and other disputed points for settlement.

Consultations with the State Board of Architectural Examiners should be made regarding cooperation in enforcing the Practice Act, and the problem of the eligibility and qualifications of candidates for the State Board Examinations. This committee should also consult with the Southern Section regarding some of the work

they have done on this matter.

The members of the Professional Practice Committee are: William W. Wurster, Chairman; William C. Ambrose, Charles H. Franklin, Ellsworth E. Johnson, Lawrence A. Kruse, Chester H. Miller, Peter L. Sala, Norman W. Sexton, Eldridge T. Spencer, Leonard F. Starks and Ralph Wyckoff.

**Education** The function of this committee shall be to act as a liaison group between the Association and the State and City schools. It should cooperate with these institutions and inform them as to the Association, its purposes, methods of operation and problems. Distribution of educational material prepared by the Public Relations and other committees should be arranged. Educational lectures on Architecture, building operations, materials, etc., should be arranged in conjunction with the Speakers Committee. This committee will work with the AIA Educational Committee.

The members of the Education Committee are: Michael Goodman, Chairman; Howard G. Bissell, Harry A. Bruno, Samuel Heiman, Charles F. Maury, Virginia Moran, Irving F. Morrow, Warren C. Perry and William R. Yelland.

**Building Industry** This committee shall represent the Association in the city and state building industry associations, such as:

Building Industry Conference Board,  
California State Chamber of Commerce, Construction Industries Section,  
San Francisco Chamber of Commerce, Construction Industries Section,  
San Francisco Chamber of Commerce, Industrial Committee,  
Producers Council Club of Northern California, etc.

The functions of this committee shall be to see that the Association's interests are protected in these various groups and to cooperate with them in promoting better relations and cooperation in the building industry, particularly in the commercial and industrial field.

The members of the Building Industry Committee are: Frederick H. Reimers, Chairman; Harris C. Allen, Norman K. Blanchard, Will G. Corlett, William B. Glynn, Harry M. Michelsen, James H. Mitchell, Timothy L. Pflueger, Albert F. Roller, Harry A. Thomsen, Jr., and Albert R. Williams.

**Governmental Agencies** This committee shall acquaint itself with the various city, state and Federal agencies which have been formed or will be formed and which affect the practice of architecture. These would include such agencies as the FHA, PWA, OPM, Defense Agencies and Priorities Boards. Information and new developments regarding them, their set-ups, their aims and purposes, how to use them, etc., should be sent to the membership. Where possible this committee should urge the various government

# Estimator's Guide

## Giving Cost of Building Materials, Wage Scale, Etc.

Amounts given are figuring prices and are made up from average quotations furnished by material houses to San Francisco contractors. 3% Sales Tax on all materials but not labor.

All prices and wages quoted are for San Francisco and the Bay District. There may be slight fluctuation of prices in the interior and northern part of the state. Freight cartage, at least, must be added in figuring country work.

and—1/2% amount of contract.  
Government work 3/4%.

### Brickwork—

Common, \$40 to \$45 per 1000 laid, (according to class of work).  
Face, \$90 to \$100 per 1000 laid, (according to class of work).  
Brick Steps, using pressed brick, \$1.00 lin. ft.  
Brick Veneer on frame buildings, \$1.00 sq. ft.  
Common f.o.b. cars, \$14.00 at yard. Cartage extra.  
Face, f.o.b. cars, \$40.00 to \$80.00 per 1000, carload lots.

### Roofing Paper—

1 ply per 1000 ft. roll	.....\$3.50
2 ply per 1000 ft. roll	.....5.00
3 ply per 1000 ft. roll	.....6.25
Asphalt, 500 ft. roll	.....5.00
Asphalt com. No. 7	.....1.20 per 100 ft
Asphalt com. No. 8	.....1.50 per 100 ft
Asphalt spot No. 7	.....1.90 per 100 ft
Asphalt spot No. 8	.....2.25 per 100 ft
Asphalt weights cast iron, 550.00 ton.	
Nails, \$3.50 base.	
Asphalt weights, \$45 per ton.	

### Concrete Aggregates—

GRAVEL (all sizes) \$1.45 per ton at bunker; delivered to any point in S. F. County \$1.85.

	Bunker	Delivered
Top sand	.....\$1.45	.....\$1.85
Concrete mix	.....1.45	.....1.85
Crushed rock, 3/4 to 3/8	.....1.60	.....2.00
Crushed rock, 3/8 to 1/2	.....1.60	.....2.00
Roofing gravel	.....1.60	.....2.00
City gravel	.....1.45	.....1.85
River sand	.....1.50	.....1.90

Bark sand—\$1.00 per cubic yard at bunker or delivered.

ND—	Bunker	Delivered
River sand	.....\$1.50	.....\$1.85
Opis (Nos. 2 & 4)	.....2.00	.....2.40
Olympia Nos. 1 & 2	.....1.80	.....2.20
Helsburg plaster sand	.....\$1.80 and \$2.20	
Del Monte white	.....50c per sack	

Common cement (all brands, paper sacks) carload lots \$2.52 per bbl. f.o.b. car; delivered, \$2.70; less than carloads delivered, 70c per sack.  
Cash discount on carload lots, 10c a barrel, 10th Prox.; cash discount less than carload lots, 2%.

As White } 1 to 100 sacks, \$2.00 sack,  
Delivers White } warehouse or delivery;  
White }  
White }

Forms, Labors average \$40.00 per M.  
Average cost of concrete in place, exclusive of forms, 35c per cu. ft.; with forms, 60c.  
4-inch concrete basement floor .....12/2c to 14c per sq. ft.  
Rat-proofing .....7/2c  
Concrete Steps .....\$1.25 per lin. ft.

### Dampproofing and Waterproofing—

Two-coat work, 20c to 30c per yard.  
Membrane waterproofing—4 layers of saturated felt, \$4.50 per square.  
Hot coating work, \$2.00 per square.  
Madusa Waterproofing, 15c per lb., San Francisco Warehouse.  
Tricoel waterproofing.  
(See representative.)

Electric Wiring—\$12.00 to \$15.00 per outlet for conduit work (including switches).  
Knob and tube average \$3.00 per outlet.

### Elevators—

Prices vary according to capacity, speed and type. Consult elevator companies.  
Average cost of installing an automatic elevator in four-story building, \$2800; direct automatic, about \$2700.

### Excavation—

Sand, 60 cents; clay or shale \$1 per yard.  
Teams, \$12.00 per day.  
Trucks, \$22 to \$27.50 per day.

Above figures are an average without water. Steam shovel work in large quantities, less; hard material, such as rock will run considerably more.

### Fire Escapes—

Ten-foot galvanized iron balcony, with stairs, \$150 installed on new buildings; \$160 on old buildings.

### Floors—

Composition Floors—22c to 40c per sq. ft. In large quantities, 18c per sq. ft. laid.  
Mosaic floors—80c per sq. ft.  
Duraflex Floor—23c to 30c sq. ft.  
Rubber Tile—50c to 75c per sq. ft.  
Terezo Floors—45c to 60c per sq. ft.  
Terezo Steps—\$1.60 lin. ft.

### Hardwood Flooring (delivered to building)—

Clr.	Otd.	Oak	1 1/2"	1 3/4"	2"	3/4"x2"
Sel.	Otd.	Oak	.....\$144.00 M	.....\$122.00 M	.....\$141.00 M	Sq. Ed.
Clr.	Pla.	Oak	.....120.00 M	.....102.00 M	.....115.00 M	
Sel.	Pla.	Oak	.....113.00 M	.....92.00 M	.....107.00 M	
Clr.	Maple	.....125.00 M	.....113.00 M			

Wage—Floor layers, \$12.00.  
Note—Above quotations are all board measure except last column which is sq. ft.

Glass (consult with manufacturers)—  
Double strength window glass, 20c per square foot.  
Plate 80c per square foot (unglazed) in place, \$1.00.  
Art, \$1.00 up per square foot.  
Wire (for skylights), 40c per sq. foot.  
Obscure glass, 30c to 50c square foot.  
Glass bricks, \$2.50 per sq. ft., in place.  
Note—If not stipulated add extra for setting.

### Heating—

Average, \$1.90 per sq. ft. of radiation, according to conditions.  
Warm air (gravity) average \$48 per register.  
Forced air, average \$68 per register.

Iron—Cost of ornamental iron, cast iron, etc., depends on designs.

### Lumber (prices delivered to bldg. site).

No. 1 common	.....\$43.00 per M
No. 2 common	.....41.00 per M
Select O. P. common	.....46.00 per M
2x4 No. 3 form lumber	.....32.00 per M
1x4 No. 2 flooring VG	.....90.00 per M
1x4 No. 3 flooring VG	.....85.00 per M
1x6 No. 2 flooring VG	.....96.00 per M
1 1/4x4 and 6, No. 2 flooring	.....95.00 per M

### Slash grain—

1x4 No. 2 flooring	.....\$65.00 per M
1x4 No. 3 flooring	.....62.00 per M
No. 1 common run T. & G.	.....48.00 per M
Lath	.....7.50 per M

Shingles (add cartage to price quoted)—  
Redwood, No. 1 .....\$1.20 per bale.  
Redwood, No. 2 .....1.00 per bale.  
Red Cedar .....1.45 per bale.

### Plywood—Douglas Fir (add cartage)—

"Plyscord" sheathing (unsanded)  
3/4" 3-ply and 48"x96" .....\$39.75 per M  
"Plywall" (wallboard grade)—  
1/4" 3-ply 48"x96" .....\$43.70 per M  
"Plyform" (concrete form grade)—  
5/8" 5-ply 48"x96" .....\$117.30 per M  
Exterior Plywood Siding—  
3/4" Sply Fir .....\$132.00 per M  
Redwood (Rustic) 1/2" clear heart \$93.00 per M \$5 less per M for A grade.

### Millwork—Standard.

O. P. \$100 per 1000. R. W. rustic \$120.00 per 1000 (delivered).  
Double hung box window frames, average with trim, \$6.50 and up, each.  
Complete door unit, \$10.00.  
Screen doors, \$3.50 each.  
Patent screen windows, 25c a sq. ft.  
Cases for kitchen pantries seven ft. high per lineal ft., \$8.00 each.  
Dining room cases, \$8.00 per lineal foot.  
Rough and finish about 75c per sq. ft.  
Labor—Rough carpentry, warehouse heavy framing (average), \$17.50 per M.  
For smaller work average, \$35.00 to \$45.00 per 1000

### Marble—(See Dealers)

### Painting—

Two-coat work	.....per yard 50c
Three-coat work	.....per yard 70c
Cold water painting	.....per yard 10c
Whitewashing	.....per yard 4c

Turpentine, 65c per gal., in 5 gal. cans. and 55c per gal. in drums.  
 Raw Linseed Oil—95c gal. in light drums.  
 Boiled Linseed Oil—98c gal. in drums and \$1.08 in 5 gal. cans.

**White Lead in oil**

Per Lb.  
 1 ton lots, 100 lbs. net weight.....1 1/4 c  
 500 lbs. and less than 1 ton.....12c  
 Less than 500 lb. lots.....12 1/2 c

**Red Lead and litharge**

1 ton lots, 100 lbs. net weight.....1 1/4 c  
 500 lbs. and less than 1 ton.....12c  
 Less than 500 lb. lots.....12 1/2 c

**Red Lead in oil**

1 ton lots, 100 lbs. net weight.....12 3/4 c  
 500 lbs. and less than 1 ton.....13c  
 Less than 500 lb. lots.....13 1/2 c

Note—Accessibility and conditions cause some variance in costs.

**Patent Chimneys—**

6-inch ..... \$1.25 lineal foot  
 8-inch ..... 1.50 lineal foot  
 10-inch ..... 2.25 lineal foot  
 12-inch ..... 3.00 lineal foot

**Plastering—Interior—**

Yard  
 1 coat, brown mortar only, wood lath.....\$0.50  
 2 coats, lime mortar hard finish, wood lath .85  
 2 coats, hard wall plaster, wood lath.....72  
 3 coats, metal lath and plaster.....1.25  
 Keene cement on metal lath.....1.30  
 Ceilings with 3/4 hot roll channels metal lath (lath ed only)......90  
 Ceilings with 3/4 hot roll channels metal lath plastered.....1.80  
 Single partition 3/4 channel lath 1 side (lath only)......85  
 Single partition 3/4 channel lath 2 sides plastered.....\$2.90  
 4-inch double partition 3/4 channel lath 2 sides (lath only).....1.70  
 4-inch double partition 3/4 channel lath 2 sides plastered.....3.30  
 Thermax single partition; 1" channels; 2 1/4" overall partition width. Plastered both sides.....2.50  
 Thermax double partition; 1" channels; 4 1/2" overall partition width. Plastered both sides.....3.40

3 coats over 1" Thermax nailed to one side wood studs or joists.....1.25  
 3 coats over 1" Thermax suspended to one side wood studs with spring sound isolation clip.....1.45

**Plastering—Exterior—**

Yard  
 2 coats cement finish, brick or concrete wall.....\$1.00  
 3 coats cement finish, No. 18 gauge wire mesh.....1.75  
 Wood lath, \$5.50 to \$6.50 per 1000  
 2.5-lb. metal lath (dipped)......19  
 2.5-lb. metal lath (galvanized)......21  
 3.4-lb. metal lath (dipped)......22  
 3.4-lb. metal lath (galvanized)......24  
 3/4-inch hot roll channels, \$72 per ton.  
 Finish plaster, \$18.90 in; in paper sacks.  
 Dealer's commission, \$1.00 off above quotations.  
 \$13.85 (retake 10c sack).  
 Lime, f.o.b. warehouse, \$2.25 bbl.; cars, \$2.15  
 Lime, bulk (ton 2000 lbs.), \$16.00 ton.  
 Wall Board 5 ply, \$50.00 per M.  
 Hydrate Lime, \$19.50 ton.  
 Plasterers Wage Scale.....\$1.67 per hour  
 Lathers Wage Scale.....1.60 per hour  
 Hod Carriers Wage Scale.....1.40 per hour  
 Composition Stucco—\$1.80 to \$2.00 sq. yard (applied).

**Plumbing—**

From \$100.00 per fixture up, according to grade, quantity and runs.

**Roofing—**

"Standard" tar and gravel, \$7.00 per sq. for 30 sqs. or over.  
 Less than 30 sqs. \$7.50 per sq.  
 Tile, \$20.00 to \$35.00 per square.  
 Redwood Shingles, \$7.50 per square in place.  
 Cooper, \$16.50 to \$18.00 per sq. in place.  
 5/2 #1-16" Cedar Shingles, 4 1/2" Exposure.....8.00 Square  
 5/8 x 16" #1 Cedar Shingles, 5" Exposure.....9.00 Square  
 4/2 #1-24" Royal Shingles, 7 1/2" Exposure.....9.50 Square  
 Re-coat with Gravel, \$3 per sq.  
 Asbestos Shingles, \$15 to \$25 per sq. laid.  
 Slate, from \$25.00 per sq., according to color and thickness.  
 1/2 x 25" Resawn Cedar Shakes, 10" Exposure.....10.50  
 3/4 x 25" Resawn Cedar Shakes, 10" Exposure.....11.50

1 x 25" Resawn Cedar Shakes, 10" Exposure.....12.50  
 Above prices are for shakes in place.

**Sheet Metal—**

Windows—Metal, \$1.75 a sq. foot.  
 Fire doors (average), including hardware \$1.75 per sq. ft.

**Skylights—(not glazed)**

Copper, 90c sq. ft. (flat).  
 Galvanized iron, 40c sq. ft. (flat).  
 Vented hip skylights 60c sq. ft.

**Steel—Structural** (None available except for defense work)

\$150 ton (erected), this quotation is an average for comparatively small quantities. Light truss work higher. Plain beams and column work in large quantities \$140 per ton.

**Steel Reinforcing** (None available except for defense work)

\$150 to \$200 per ton, set.

**Stone—**

Granite, average, \$6.50 cu. foot in place  
 Sandstone, average Blue, \$4.00. Boise \$3.00 sq. ft. in place.  
 Indiana Limestone, \$2.80 per sq. ft. in place.

**Store Fronts—**

Copper sash bars for store fronts, corner center and around sides, will average \$1.00 per lineal foot.  
 Note—Consult with agents.

**Tile—Floor, Wainscot, etc. — (See Dealers)**

Asphalt Tile—18c to 28c per sq. ft. installed.

**Wall Tile—**

Glazed Terra Cotta Wall Units (single faced) laid in place—approximate prices:  
 2 x 6 x 12.....\$1.00 sq. ft.  
 4 x 6 x 12.....1.15 sq. ft.  
 2 x 8 x 16.....1.10 sq. ft.  
 4 x 8 x 16.....1.30 sq. ft.

**Venetian Blinds—**

40c per square foot and up. Installation extra.

**Windows—Steel**

Factory type sash 30c ft.  
 Ventilators for steel sash \$5.00 each.

**1941 BUILDING TRADES WAGE SCALES FOR NORTHERN CALIFORNIA**

\*6-hour day \*7-hour day

CRAFT	Alameda	Fresno	Marin	Sacramento	San Jose	Stockton	Watsonville	San Francisco
ASBESTOS WORKERS	\$1.25	\$1.25	\$1.25	\$1.12 1/2	\$1.25	\$1.25	\$1.12 1/2	\$1.25
BRICKLAYERS	*1.75	*1.50	*1.75	*1.75	*1.75	*1.75	1.50	*1.75
BRICKLAYERS' HODCARRIERS	*1.25	*.87 1/2	*1.25	*1.05	*1.35	*1.06	1.12 1/2	*1.25
CARPENTERS	1.25	1.12 1/2	1.25	1.18 3/4	1.25	1.18 3/4	1.12 1/2	1.25
CEMENT FINISHERS	1.25	1.25	1.25	1.25	1.25	1.25	1.25	1.25
ELECTRICIANS	1.50	**1.37-4/7	1.37 1/2	1.37 1/2	1.50	1.50	1.12 1/2	1.50
ELEVATOR CONSTRUCTORS	1.56	1.50	1.50	1.56	1.50	1.50	1.40	1.50
ENGINEERS: Material Hoist	1.37 1/2	1.25	1.37 1/2	1.37 1/2	1.48	1.25	1.25	1.37 1/2
Pile Driver	1.60	1.60	1.60	1.60	1.72	1.50	1.50	1.60
Structural Steel	1.60	1.60	1.60	1.60	1.60	1.60	1.60	1.60
GLASS WORKERS	1.25	1.06 1/4	1.25	1.10	*1.21-3/7	1.25	1.12 1/2	1.25
IRONWORKERS: Ornamental	1.31 1/4	1.25	1.25	1.37 1/2	1.31 1/4	1.25	1.25	1.31 1/4
Reinf. Rodmen	1.31 1/4	1.31 1/4	1.31 1/4	1.31 1/4	1.31 1/4	1.25	1.31 1/4	1.31 1/4
Structural	1.60	1.60	1.50	1.60	1.60	1.37 1/2	1.37 1/2	1.60
LABORERS: Building	.81 1/4	.75	.81 1/4	.75	.75	.81 1/4	.75	.85
Concrete	.87 1/2			.91 1/4		.87 1/2	.80	.87 1/2
LATHERS	1.25	*1.50	*1.50	*1.50	*1.60	*1.50	*1.12 1/2	*1.60
MARBLE SETTERS	1.25	1.25	1.31 1/4	1.31 1/4	1.25	1.25	1.25	1.31 1/4
MOSAIC AND TERRAZZO	1.25	1.12 1/2	1.25	1.15 1/2	1.25	1.25	1.00	1.25
PAINTERS	**1.25	**1.14-2/7	**1.25	1.18 3/4	**1.21-3/7	1.18 3/4	**1.15	**1.25
PILEDRIVERS	1.40	1.40	1.40	1.40	1.40	1.40	1.40	1.40
PLASTERERS	*1.66-2/3	*1.50	*1.66-2/3	*1.57 1/2	*1.75	*1.50	1.50	*1.66-2/3
PLASTERERS' HODCARRIERS	*1.45	*1.25	*1.40	*1.18 3/4	*1.35	*1.35	1.12 1/2	1.40
PLUMBERS	1.50	1.40-5/8	1.50	1.50	1.50	1.25	1.25	1.52 1/2
ROOFERS	1.25	1.00	1.25	1.18 3/4	1.25	1.12 1/2	1.25	1.25
SHEET METAL WORKERS	1.31 1/4	1.31 1/4	1.25	1.37 1/2	1.37 1/2	1.37 1/2	1.25	1.25
SPRINKLER FITTERS	1.37 1/2			1.50	1.50	1.50		1.37 1/2
STEAMFITTERS	1.37 1/2	1.40-5/8	1.25	1.50	1.50	1.50	1.25	1.37 1/2
STONESETTERS (MASONS)	*1.75	*1.50	*1.75	*1.75	*1.50	*1.50	*1.50	*1.50
TILESETTERS	1.37 1/2	1.25	1.37 1/2	1.31 1/4	1.37 1/2	1.25	1.25	1.37 1/2

Prepared and compiled by  
 CENTRAL CALIFORNIA CHAPTER, ASSOCIATED GENERAL CONTRACTORS OF AMERICA  
 with the assistance and cooperation of secretaries of General Contractors Associations and Builders Exchanges of Northern California.

agencies, such as those mentioned, to employ architects in private practice for this government work.

The members of the Government Agencies Committee are: Andrew T. Hass, Chairman; G. Frederick Ashley, Irving F. Brown, Russell G. de Lappe, Vernon de Mars, Edward R. French, Jr., Eric Johnson, Charles F. Maury, Ernest L. Norberg, Perry T. Poage, Charles S. Pope, Dodge A. Riedy, George P. Simonds and Dole F. Thompson.

**Civilian Defense** This committee shall have representatives on civilian defense committees in all municipalities, and on the American Red Cross, offering the Association's cooperation in this work and keeping the membership informed as to the latest developments. It shall work with the Exhibit Committee if air raid shelter exhibits are built as part of the civilian defense work.

The members of the Civilian Committee are: William G. Merchant, Chairman; Elmore G. Ernst, Clarence J. Felciano, David H. Horn, Samuel L. Hyman, Wallace E. Manhart, Keith O. Narbett, Chester Root, William H. Rowe and Chester H. Treichel.

**Technical Relations** This committee should study the possibility and feasibility of the Association forming a Bureau of Standards similar to the American Medical and Dental Associations, Good Housekeeping Institute, etc., which could test various building materials and stamp them with the Association seal of approval. This could possibly be done in conjunction with the testing laboratories of the University of California and Stanford University.

Meetings of the various Building Code organizations, such as the Pacific Building Officials Conference Board, and the various city building departments in an effort to work with them on any needed changes, revisions or additions to the building laws should be arranged. Under this committee should also come the preparation of educational information regarding the Riley and Field Acts which the Public Relations and the Professional Relations Committees could distribute to the public and profession to acquaint them with necessary public safety measures. This committee should cooperate with the Public Relations Committee in preparing a monthly technical news letter to the profession regarding good methods of building construction and the proper use of materials.

The members of the Technical Relations Committee are: Russell G. de Lappe, Chairman; Edward O. Blodgett, J. U. Cloudsley, Will G. Corlett, Harry W. de Haven, George E. Ellinger, A. Lewis Koue, Frederick H. Meyer, Malcolm D. Reynolds, Walter T. Steilberg and Harold H. Weeks.

**Housing** This committee shall represent the Association on the various City and State Housing Associations for the purpose of keeping the membership informed as to the actions,

purposes, etc., of these groups, and also to act in an advisory capacity with them when necessary. This committee should cooperate with any defense housing projects or agencies controlling this type of work, obtaining all necessary information regarding these projects and informing the membership about them. The Housing Committee should also keep itself informed as to the various apartment house associations, home builders, and other groups of similar nature in an effort to improve relations between these groups and the architects.

The members of the Housing Committee are: John E. Dinwiddie, Chairman; E. Geoffrey Bangs, Ernest Born, Elizabeth Boyter, Loy Chamberlain, Henry C. Collins, Victor Galbraith, Howard Moise, Warren C. Perry and Hugh T. White.

**Exhibits** This committee's work shall be to gather material and arrange for and exhibit architectural work. It shall work in cooperation with the Public Relations Committee. Civilian defense exhibits, air raid shelters, housing and city planning exhibits are all part of this committee's program.

The members of the Exhibit Committee are: Hervey P. Clark, Chairman; Reddick H. Bickel, Ernest Born, Loy Chamberlain, Gardner A. Dailey, Henry T. Howard, Joseph Losekann and Keith E. Ponsford.

**Speakers** This Committee shall cooperate with other committees such as the Public Relations, Educational, etc., to provide speakers at meetings of clubs, schools, civic groups, etc., to talk on various architectural and building subjects. Speeches should be outlined with the speaker.

The members of the Speakers Committee are: James Anderson, Chairman; Hervey P. Clark, Michael Goodman, William H. Knowles, Harry M. Michelsen, Vincent G. Raney, William H. Rowe, Chester H. Treichel and Alfred C. Williams.

**Program** Responsibility for all programs at the general meetings of the Northern Section throughout the year is placed upon this committee which shall be in charge of the 1942 State Association Convention. Its members are: William H. Knowles, Chairman; John F. Beuttler, Lawrence W. Gentry, Edward L. Frick, Irwin Johnson, Robert Jones, Thomas J. Kent, Edward B. Page, C. Jefferson Sly and Robert Stanton.

**Draftsmen** This Committee shall represent the Association on the Board of Directors of the California Society of Architectural Draftsmen, and cooperate with it in all ways possible in their relationship with the Association. The members of this committee are: George P. Simonds, Chairman; Edmund P. de Martini, W. A. Talley, Clyde F. Trudell and Ralph N. Pollack.

**Women's Auxiliary** This shall represent the Association on all Women's Auxiliaries, cooperating with them in all ways possible in their work as part of



## QUALITY AND DEPENDABLE *Service*

are the factors that influence architects and contractors when selecting lumber and mill work — Quality of merchandise — Integrity and Ability of the firm—Service in physical equipment — Experience and Personnel — All these factors contribute to a speedy and satisfactory completion of construction with minimum of time and expense.

### MANUFACTURER OR DEALER IN

Douglas Fir—Redwood—Sugar and Ponderosa Pine — Plywood and Concrete Form Panels — Sash and Doors — Millwork — Insulation — Builders' Hardware.

## E. K. WOOD LUMBER CO.

"Goods of the Woods" ©

LOS ANGELES • SAN FRANCISCO • OAKLAND

# SAVE up to HALF on LABOR TIME!

Immediate Delivery, too!



THE U. S. Government, demanding speed, speed, and more speed, has already used Kraftile Wall Units in 9 public buildings...49 army projects...and 22 navy jobs.

*Kraftile Wall Unit partitions go up in about half the time it takes for ordinary frame construction. These wall units come pre-tiled on one or both sides—thus require no surfacing. Costs are now surprisingly low.*

For complete information, phone or write to Kraftile Company, at Niles, California.

## KRAFTILE STRUCTURAL WALL UNITS

the Association. The members of the Committee are: Ernest E. Weihe, Chairman; Edward D. Cerruti, Jr., and Mildred S. Meyers.

### Architect & Engineer

The Editorial Advisory Committee shall represent the Association on the Advisory Board of THE ARCHITECT & ENGINEER and ARCHITECTS REPORTS, cooperating in all ways necessary and possible in connection with editorial and advertising policies. The members of the committee are: Harris C. Allen, Chairman; Mark Daniels, Andrew T. Hass, David H. Horn, Harry M. Michelsen, Irving F. Morrow and C. Jefferson Sly.

### Membership

This shall work in cooperation with the Treasurer in stimulating the paying of dues by the entire membership. The members of this committee are: Mario J. Ciampi, Chairman; Otto G. Hintermann, David H. Horn and all District Advisors.

### Convention Resolutions

### "Pertaining to Defense"

WHEREAS: The Federal Government of these United States have found it necessary to contribute the resources of the Nation, for the preservation of democracy and carry out an extensive National Defense Program, and

WHEREAS: For the present the officials of the Federal Government have found it necessary to discourage construction which is not directly connected to national defense, due to the shortage of critical building materials, and

WHEREAS: This will affect the livelihood and existence of architects who are now maintaining a professional business, and

WHEREAS: On account of the broad and diversified training and experience of architects in the construction field,

THEREFORE, BE IT RESOLVED: That the State Association of California Architects assembled in convention in Los Angeles, on October 9th, 10th and 11th, 1941, recommend to all federal agencies that they assign defense projects within their jurisdiction to architects in private practice.

### "Code for Craftsmanship"

WHEREAS: It is not beyond the province of possibility, nor is it excluded from the code of ethics for the architects to act in the interest of the public good to undertake to bring about ways and means by which they can join forces in implementing the building industry with some clear cut delineation of facts by which the client could be assured of receiving that grade of work for which they have contracted,

THEREFORE, BE IT RESOLVED: That the Executive Board of the State Association of California Architects be empowered to appoint a standing committee to call upon the Building Trades of the State of California to enlist their cooperation in analyzing the situation and upon basic findings bring into existence such a code. A code that every craftsman in every branch of the building industry could assimilate and use in the guidance of his work whether it be for good, medium or poor.

### "Pertaining to the Riley Act"

WHEREAS: The recent amendments to the Riley Act will require more expert services in the preparation of plans and specifications, and

WHEREAS: The building departments and county surveyors throughout the State of California are responsible for the enforcement of the provisions of this act,

THEREFORE, BE IT RESOLVED: That the State Association of California Architects institute measures to bring to the attention of those responsible for the enforcement of the Riley Act that the

California architects, through their State Association do offer their fullest support in effecting compliance with this law and further offer the services of the Public Relations Committee in educating the citizens of the State to the value of this progressive bit of legislation.

#### "Employment of Local Attorneys"

WHEREAS: Local District Attorneys hesitate to cooperate with enforcement officials non-resident to their district, and

WHEREAS: Local attorneys are better qualified to appraise local situations and act in accordance therewith, and

WHEREAS: The California State Bar Association in the interests of promoting the public good do offer services on a most modest basis even to the extent of rendering gratuitous services in special instances,

THEREFORE BE IT RESOLVED: That the State Association of California Architects through the channels available to their executive officers urge the State Board of Architectural Examiners to employ local attorneys to prosecute local violations of the Architects' Practice Act and to institute the ways and means for the practicing architects in the locality involved to approve the attorney to be employed.

#### "Conferences with the Public"

WHEREAS: Educational conferences bring architects into closer relation with each other and afford them an opportunity to exchange knowledge of mutual interest and professional benefit, and

WHEREAS: The holding of such conferences more readily acquaints the architects with advanced contemporary trends, and

WHEREAS: The public could jointly participate with the Profession in holding such conferences,

THEREFORE BE IT RESOLVED: That the State Association of California Architects undertake a program for the holding of such conferences at more frequent intervals and at locations and at times where and when such conferences would accomplish the greatest professional and social good.

#### "Vote of Thanks"

WHEREAS: Outstanding accomplishments of individuals in the Association in working for the betterment of the Association deserve special recognition, and

WHEREAS: The recent amendment to the Riley Act is such an achievement,

THEREFORE BE IT RESOLVED: That Mr. Harry Michelsen be given a vote of gratitude for his achievement in effecting the amendment to the Riley Act.

#### "Priorities"

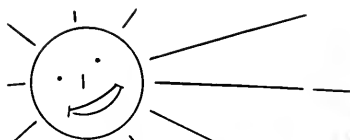
WHEREAS: Lacking priorities on materials, the low-rent housing program of the USHA will necessarily be brought to a standstill in the very near future, and

WHEREAS: These housing projects will contribute to the successful operation of our national defense effort, and

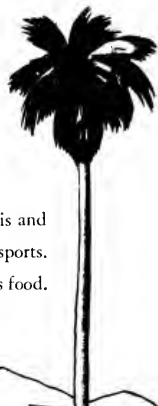
WHEREAS: All these projects require and receive the services of architects,

THEREFORE BE IT RESOLVED: That the State Association of California Architects assembled in Convention at Hollywood, California on this 11th day of October, 1941, does hereby petition the various federal officials and agencies entrusted with the responsibilities of granting priorities, to grant such priorities to all USHA aided projects in conformity with the housing needs of the community in which they are located, and

BE IT FURTHER RESOLVED: That copies of this resolution be sent to the federal officials and agencies having jurisdiction, to the President of the United States, and to the Administrator of the United States Housing Authority, and that as far as possible all housing authorities and other housing organizations in the Western Region and in the United States be asked to cooperate in placing the matter before representatives in Congress and that the officers of this Association be empowered to take any additional steps necessary and proper in an effort to secure favorable consideration of this resolution.



Follow the sun  
to the DESERT INN. . .  
33rd season. Send for a  
"Sands of Time" magazine



35 acre estate . . . swimming pool, tennis and  
badminton courts, riding, golf, all sports.  
Delightful accommodations . . . delicious food.



## PALM SPRINGS, CALIFORNIA



### California's Hotel Beautiful

- like a country estate yet in the heart of a throbbing metropolitan area.
- a matchless view—comfortable, luxuriously furnished rooms, excellent cuisine.
- in an atmosphere of quiet and gracious living.

Rooms, with bath, \$2.50 to \$5.00 per day.

*Attractive monthly rates*

### HOTEL CLAREMONT • BERKELEY

**BAXCO**  
CHROMATED ZINC CHLORIDE

**CZC**

**PRESSURE TREATED LUMBER**  
● **PROTECTS AGAINST DECAY**  
**AND TERMITE ATTACK**

*Specify it in your home*  
*Available through Lumber Dealers*

LOS ANGELES 601 W. 5th Street Phone MIchigan 6294	SAN FRANCISCO 333 Montgomery Street Phone DOuglas 3883
---	--

***J. H. Baxter & Co.***

AGENTS FOR WEST COAST WOOD PRESERVING CO. SEATTLE, WASH.

**The Most Complete Line of**  
**STEELS and BUILDING MATERIALS**  
**Made by a Single Producer**



*See Sweet's Catalog File or write us for full information.*

**REPUBLIC STEEL CORPORATION**  
GENERAL OFFICES: CLEVELAND, OHIO

DENVER, COLORADO . . . . .	CONTINENTAL OIL BUILDING
LOS ANGELES, CALIFORNIA . . . . .	EDISON BUILDING
SALT LAKE CITY, UTAH . . . . .	WALKER BANK BUILDING
SAN FRANCISCO, CALIFORNIA . . . . .	RIALTO BUILDING
SEATTLE, WASH. . . . .	WHITE-HENRY-STUART BUILDING

**HOGAN LUMBER CO.**  
*Wholesale and Retail*

**LUMBER**

---

**MILL WORK • SASH & DOORS**

---

*Office, Mill, Yard and Docks*

**SECOND AND ALICE STREETS • OAKLAND, CALIF.**

**Telephone GLencourt 6861**

**"Pertaining to Public Relations"**

WHEREAS: It is agreed by representatives of the Northern and Southern Sections, State Association of California Architects, meeting in joint conference, that there is urgent need for a program to educate the public as to the full value of the architects' services and his complete function in the community, and WHEREAS: Individual programs of public relations activity have already been initiated by the Northern and the Southern Sections with encouraging success,

THEREFORE BE IT RESOLVED: That the State Association of California Architects, its executive officers and district advisors combine their efforts in a program, first, to educate the Association's members as to the need for such public relations activity, and the material value to each architect of a fully planned public relations program, with the object of securing the support of the full membership, and

BE IT FURTHER RESOLVED: That the Northern and the Southern Sections together work out a uniform program of public relations activity, to be conducted by professional public relations counsel, and

BE IT FURTHER RESOLVED: That each member of the Association be instructed to participate in this program through his everyday relationship with his fellow architects, with the building industry and the general public, and

BE IT FURTHER RESOLVED: That in this statewide public relations program the cooperation of other professional bodies, as well as of groups within the building industry be enlisted, on grounds of mutual interest, to insure the security and advancement of the architectural profession on a broad, stable and lasting basis.

**Office Note** Members visiting the Association office recently must have noticed the good understanding that now prevails there. By the courtesy of the Bigelow-Sanford Carpet Company a new rug covers the bare pine floor, of such warm thickness that no loiterer may be accused of having cold feet. Into its pale green pile are inlaid four symbols of the draftsman—triangles, French curve, and a T-square, so realistic that more than one visitor has thought to pick it up. Comfort and quiet now improve our office efficiency.

**Dues for 1942** Russ de Lappe reports that 58% of members in his district society (the Lower San Joaquin) paid their State Association dues for 1941. He wishes to know whether other district groups have done as well as this. Records show that the great majority have not, and that if other societies emulated Lower San Joaquin, the Association would be much better off financially.

Of the Northern Section's total membership of 500, only 170, or 34%, paid their dues for 1941. As it happens, that was the best level recorded in the Association's history. But it can easily be exceeded in 1942, for which dues notices are being sent out this month. A profession which does not support its own Association to the tune of \$5.00 per member annually deserves to get exactly nowhere.

**Civil Service** Appointment of Frederick H. Meyer to succeed the late Harold K. Crane as Chairman of the Street and Highway Committee of the San Francisco Chamber of Commerce was made recently by President



Walter A. Haas. A former chairman of the committee, and past director of the San Francisco Chamber, Mr. Meyer, nationally renowned architect, has long been active in civic affairs of San Francisco. He was a member of a three-man consulting board of architects named by the late Mayor James Rolph, Jr., to design the Civic Center.

In 1930 Mr. Meyer was chairman of a special San Francisco Chamber committee which investigated feasibility of a bridge across the Golden Gate. More recently he served as chairman of a San Francisco Chamber committee which recommended an amendment to the San Francisco building code increasing the permissible floor area of buildings used for manufacturing, mercantile or office purposes. Sponsored by the San Francisco Chamber, the amendment was passed for second reading by the Board of Supervisors last Monday.

The public service of our likeable Fred Meyer has been a source of pride to the Association. The announcement above was publicly released by the San Francisco Chamber of Commerce.

#### BOOKLET FOR HOME-SEEKERS

Small home-seekers are urged to take advantage of architectural and technical services to protect their investments, "which often represent the savings of a lifetime," in a new booklet published under the sponsorship of the Federal Home Loan Bank Board and entitled "If You Plan to Build or Buy a Home."

To the layman, the booklet addresses the message:

"If you know a poor cement mix when you see it . . . if you know when wood is properly protected and when it's exposed . . . if your eagle eye can detect improper joints, poor soldering, defective wiring, small cracks, loose nails and poor-grade lumber . . . if you know all about weatherproofing, termites, good ventilation and a hundred little items of home-building—then perhaps you can afford to neglect technical advice.

"Otherwise it's a very wise precaution for the most important investment of your life."

The booklet points out that home-seekers now are able to obtain the most liberal, long-term loans, with the lowest home mortgage interest rates, in the nation's history—and that homes can be paid for as conveniently as they can be rented.

The emphasis laid on low-cost homes under the defense housing program adds to, rather than detracts from, the importance of the booklet, Bank Board officials point out. Architectural services always have been available on higher-cost homes but the Bank Board hopes to broaden their use in the small-home field.



**CLIENT:** "My house must be warm, dry and tight. What is the best permanent wall-protection I can get for \$25.00?"

**ARCHITECT:** "Air-Seal with Brownskin. It gives basic built-in 'insulation'—so long as your house lasts. Keeps cold air out; warm air in. Says a big 'NO' to the passage of wind, water, moisture, vapor."

**ANGIER CORPORATION**  
75 WIDDELL STREET FRAMINGHAM, MASS.



Send for AIA folders and Brownskin Sample Catalog.



**Brownskin** Far superior to ordinary "sealing papers" because (1) Resilient with a stretch of 15%; (2) Specially treated to resist deterioration and highly Waterproof; (3) Extremely tough; (4) Windproof; (5) Dustproof; (6) Most effective economical Vapor-Seal.

**SISALKRAFT**  
REG. U. S. PAT. OFF.

"More than a building paper"

**THE SISALKRAFT CO.**

205 West Wacker Drive  
(Canal Station) Chicago, Ill.

55 New Montgomery Street  
San Francisco, Calif.

**CLINTON  
CONSTRUCTION CO.  
OF CALIFORNIA**

**General Contractors**

923 FOLSOM STREET • SAN FRANCISCO

SUtter 3440

## ACOUSTI-CELOTEX

for office-quieting provides . . .

- PAINTABILITY
- PERMANENT LIGHT-REFLECTION
- HIGH EFFICIENCY

*Acoustical Engineers & Contractors*

**WESTERN ASBESTOS CO.**

*Building Materials*      *Mechanical Specialties*  
S A C R A M E N T O      O A K L A N D  
S A N F R A N C I S C O

## STRUCTURAL STEEL

For Class A Buildings,  
Bridges, etc.

**JUDSON PACIFIC CO.**

1200 SEVENTEENTH STREET  
SAN FRANCISCO

Plants: San Francisco - Oakland

## FRANK J. McCOY HOTELS

SANTA MARIA INN—Santa Maria,  
California • Orville E. Sammann, Mgr.

WORLD FAMOUS STOP-OVER, BETWEEN  
SAN FRANCISCO AND LOS ANGELES

EL ENCANTO HOTEL & VILLAS—Santa  
Barbara, California • Fred E. Pimentel, Mgr.

AMERICA'S HOTEL BEAUTIFUL, IN A  
MATCHLESS SETTING ON THE RIVIERA

## BASALITE

CAMBERED SHINGLE TILE

PERMANENT • FIREPROOF • STORM-  
SAFE • COLORFUL • ECONOMICAL

*Manufactured by*  
**BASALT ROCK CO., INC.**  
NAPA, CALIFORNIA

## NEW GLASS BUILDING BLOCK

A new transparent glass building block that affords almost window-like vision is the product of the Pittsburgh Corning Corporation, subsidiary of the Pittsburgh Plate Glass Company.



"VUE" GLASS BRICK WINDOW

The new block, called the "Vue" glass block, was developed for specific needs where some outside vision is desired through panels of non-transparent glass blocks. It permits sufficient general vision of large objects or movement beyond the panel to prevent a "shut-in" feeling, although the visibility of sharp detail is not possible under most conditions.

The Vue block combines the high insulation properties of the usual glass block. It contains a partial vacuum, a dead air space, which results in the glass block panels having approximately the same insulation value as a solid masonry wall eight inches thick, and more than twice the insulation value of ordinary single-glazed windows.

## ARMY RECREATION HALLS

USO recreation centers for soldiers which may be converted into town halls and municipal auditoriums when the emergency is over, are being designed by architectural students at Cooper Union.

"Recreation halls now being built in connection with army cantonments are of necessity hastily constructed of inexpensive materials," Michael Radoslovich, architectural instructor at Cooper Union, points out. "Appropriations have already been made for more than 200 buildings expected to last only twenty years at a maximum.

"Cooper Union students, following a seminar on current building problems, have undertaken to demonstrate that permanent units may be erected without too great an additional outlay of time and money. Detailed drawings and scale models of their final plans will be submitted to USO headquarters.

"Town and city governments could give private or-

ganizations financial assistance in establishing recreation centers made of durable materials. The buildings, situated within city limits, could be utilized as town halls, summer theaters, auditoriums, or high school gymnasiums, after this country's large standing army is reduced to peacetime proportions."

The students are basing their designs on the requirements set for recreation centers by the USO. Their aim is to evolve a building plan which satisfies all the temporary needs of off-duty soldiers and yet has lasting value for post-war civilians. The problem has become their major project of the year.

#### OFFICE EQUIPMENT FACES SHORTAGE

Many of the office worker's tools are fabricated from essential materials. For example, white paper requires chlorine, an acid used in defense work. Pencils require restricted brass, rubber and graphite. The silk shortage is and will continue to affect the production of type-writer ribbons and carbon paper manufacturers are said to be using materials faster than they can be replaced. Rubber bands and paper clips are also destined to be in the shortage bracket. One large manufacturer uses eleven million clips and staples annually, or the equivalent to four thousand pounds. When one multiplies this by all businesses the total represents a staggering sum.

#### ANENT SCARCITY OF NAILS

Nails will be the bottleneck of 1942 building, unless OPM allocates enough steel to make nails, without which no building can be carried on, according to an editorial appearing in the December issue of Building Supply News. With sufficient nails, the building industry can keep most of its thousands of local business organizations and its several million workers functioning. Without them, the alternative will be widespread and unnecessary unemployment and privation affecting every village and hamlet in America, the editorial says.

#### STATE ASSOCIATION AT L. A.

The first general meeting of the State Association of California Architects, Southern Section, since the State Convention, was held Friday evening, November 28, at the Los Angeles Athletic Club. The subject under discussion: "A job for every architect in the defense construction of our country and the method by which the State Association of California Architects may aid in bringing this about."


#### MANUAL OF ENGINEERS

The American Institute of Steel Construction has just published the fourth edition of the Manual of Steel Construction, a handbook for engineers and architects. This new edition contains considerable new data useful to designers and detailers of steel structures.

This Manual is sold by the American Institute of Steel Construction at cost for \$2.00 per copy.

## ALADDIN Heating Corp.

Specializing in  
**QUALITY HEATING EQUIPMENT**  
**2222 San Pablo Avenue, Oakland**  
TWinoaks 1022

 **SLOANE** has worked with architects, designers and decorators for years.  
▶ We interpret intelligently . . . and we know what it is to be up against deadlines and strict budgets. ▶ Let us prove this!

FURNITURE • FABRICS • WALLPAPERS  
LAMPS AND FLOOR COVERINGS  
WHOLESALE CONTRACT DIVISION

W & J **SLOANE**  
Sutter near Grant • San Francisco

## Painting and Decorating

of the Edwin Walter Residence,  
Hillsborough, California, by

### ALFRED SORENSEN

523 Corbitt Drive  
Burlingame, California

Fine Water Colors and Papers  
For Architectural Renderings

## H. S. CROCKER COMPANY, Inc.

720 MISSION STREET  
Market Street at Second • San Francisco

# VERMONT MARBLE COMPANY

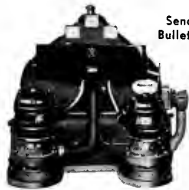
Producers and Finishers  
of

**Domestic and Imported Marbles**

San Francisco, Los Angeles and Tacoma, Wash.

San Francisco phone: SUiter 6747

## "AMERICAN MARSH" Redi-Vac Vacuum Heating Pump



Send for  
Bulletin 441

**SIMONDS MACHINERY CO.**

San Francisco  
816 Folsom St.

Los Angeles  
455 East Fourth St.



PRODUCTS

## VAN ARSDALE - HARRIS CO.

ENGINEERS & CONTRACTORS

**ACOUSTICAL TREATMENT  
INSULATION • SOUND CONTROL**

Fifth and Brannan Streets • San Francisco, Calif.  
Telephone GAfield 3600

Division

VAN ARSDALE - HARRIS LUMBER CO., INC.

## PACIFIC MANUFACTURING CO.

HIGH CLASS INTERIOR FINISH  
QUALITY MILLWORK

142 SANSOME ST., SAN FRANCISCO  
GARfield 7755

6820 MCKINLEY AVE., LOS ANGELES  
THornwall 4196

**BUILDERS EXCHANGE, OAKLAND**

### SOUTHERN CALIFORNIA CHAPTER

An educational exhibit of suggested planning for the Los Angeles regional community was visited by members of Southern California Chapter, The American Institute of Architects, following the regular Chapter meeting at Carl's Drive-In cafe, Los Angeles, November 12. The exhibit, which is housed in the art gallery at Los Angeles County Museum in Exposition Park, opened October 22 and continues through January 15, 1942.

Report of the nominating committee was read by S. B. Marston, who presided. The nominees for next year are: Samuel E. Lunden, president; Herbert J. Powell, vice-president; Donald B. Kirby, secretary; Walter Wurdeman, treasurer; William H. Harrison, director for one year, and Robert Derrah, director for three years.

The Chapter was thanked by Mel Scott, publicity director for the Telesis group, for its contribution to the building of the planning exhibit. Mr. Scott said that the Civic Center plan, developed by the Chapter several years ago, was the kernel of the ultimate exhibit idea.

"And Now We Plan" is the title given to the exhibition dealing with problems of planning for the Los Angeles Region which was assembled under the direction of Roland McKinney and an advisory committee consisting of Palmer Sabin, chairman; Richard J. Neutra, Sumner Spaulding, John Entenza, Samuel Lunden, and Paul Hunter. The actual designing of installation and the gathering of material was in the hands of the Telesis group of Los Angeles.

### POST-WAR BUILDING

Post-war building activity exceeding in magnitude and importance the present defense construction program is predicted by Dean Leopold Arnaud, School of Architecture, Columbia University, in his recent annual report to the president of the University. Plans for rehabilitation must go forward with plans for defense, he stated, pointing out that without a well-planned and well-executed post-war program obsolescence will break down to deterioration of catastrophic proportions.

The architect has occupied a position of importance in the past, Dean Arnaud declared, but his position in the future will be incalculably greater.

### STATUE OF LIBERTY LIGHTING

By utilizing recent developments, the lighting system for the Statue of Liberty in New York Harbor will be remodeled to include brighter beacon lamps for the torch and additional floodlighting with a battery of powerful spotlights. Much of the equipment will be presented as a gift by the Westinghouse Electric and Manufacturing Company in order that this monument symbolizing freedom and tolerance might burn even brighter in a world blacked out by dictatorship and war.

Send for catalog  
"The Charm of a Light-Conditioned Home"

**MODERN**

No furnishings you can buy for so little will give you as much long term satisfaction as a new Lightolier fixture.

**INCANDESCENT SUPPLY COMPANY**  
726 MISSION STREET, SAN FRANCISCO

### S. F. CHAPTER MEETING

The regular monthly meeting of Northern California Chapter, A.I.A., was held at the St. Francis Yacht Club in San Francisco on Tuesday, November 25, President A. Appleton presiding.

Guests present included Messrs. Norman K. Blanchard, Michael Goodman, Albert Henry Hill, Henry T. Howard, Stafford Jory and Francis Joseph McCarthy.

Announcement was made of the Christmas Jinx of the Producers' Council Club at the Lakeside Country Club December 9.

Mr. Mitchell, Chairman of the Committee on Priorities of the Building Industries Conference Board, discussed the resolution being drafted by that group.

Mr. Hertzka read the resolution in its final form, and upon motion of Mr. Mitchell, seconded by Mr. Hertzka, the Chapter endorsed the resolution as read. Substance of this document was the suggestion that action requesting the revision of priority rulings now in effect be instituted at one time by all organizations related to the construction industry, thus unifying all these groups and lending added weight to the appeal.

The meeting was then turned over to Hervey Clark, who called upon several members and various guests for short discourses on subjects pertaining to present day affairs.

Henry Howard gave a very interesting talk on "Working Around Priorities," discussing possible construction methods to save critical materials.

Defense housing in the south was described by Albert Henry Hill, President of the "Telesis" group.

Michael Goodman, Professor of Architecture at the University of California, delivered a very well prepared dissertation on "Air Raid Protection." He presented many of the very complex problems to be solved in providing protection for the civilian population, and discussed the tremendous task of evacuating civilians from danger areas.

Norman K. Blanchard, of the State Association of California Architects,



**O**ur Bank-by-Mail Service is a big convenience to salesmen, office workers, travelers ... all who can't go to the bank whenever they wish. Let us send you the simple instructions for doing your banking safely and efficiently in your spare time, wherever you may be. Overnight service to most places in California.



Phone GARfield 1164

## Hunter & Hudson

*Consulting Engineers*  
DESIGNERS OF HEATING  
AIR CONDITIONING  
VENTILATING AND WIRING  
SYSTEMS, MECHANICAL  
AND ELECTRICAL EQUIP-  
MENT OF BUILDINGS

41 SUTTER STREET  
ROOM 710

San Francisco California

## Robert W. Hunt Company

ENGINEERS

Inspection • Tests • Consultation  
Schools and Other Structures  
Are Built as Designed

*When Construction Materials are  
Inspected at point of Manufacture  
and during Erection by*

ROBERT W. HUNT COMPANY

*Cement, Concrete, Chemical, Metallurgical,  
X-Ray and Physical Laboratories*

Chicago - New York - Pittsburgh  
Los Angeles - All Large Cities  
San Francisco, 251 Kearny Street

## THE TORMEY COMPANY

GENERAL PAINTERS  
AND DECORATORS

Phone UNderhill 1913

563 FULTON STREET  
San Francisco

## G. P. W. JENSEN & SON

Building Construction

320 Market Street, San Francisco  
Phone: GARfield 2444



**WOMEN** go into raptures over this new Wesix "Perfect Thirty-Six" electric bathroom heater. Its instant, head-to-foot heat, they exclaim, "is simply marvelous!" You will like it because it fits perfectly into 42-inch wainscots. For details write Dept. 206, Wesix Electric Heater Co., 390-1st St., San Francisco.

**WESIX**

*World's Largest Manufacturers of Major Electric Heaters*



**HERRICK IRON WORKS**

**STRUCTURAL STEEL  
REINFORCING STEEL**

18TH AND CAMPBELL STS.  
OAKLAND, CALIF.  
Phone GLencourt 1767

**FORDERER  
CORNICE WORKS**

*Manufacturers of*  
Hollow Metal Products  
Interior Metal Trim  
Elevator Fronts and Cabs  
Metal Plaster Accessories  
Sanitary Metal Base  
Metal Cabinets  
Flat and Roll Metal Screens  
Commercial Refrigerators

**269 POTRERO AVE.**  
San Francisco, Calif.  
HEmlock 4100

spoke briefly on "Civilian Defense." He told of a telegram sent to the British Broadcasting Company by the State Association, inquiring about British plans for Post War building in England. He read the reply, which was most interesting, and discussed several of the plans under way for civilian defense.

"Post War Building in the United States," was the subject chosen by Clarence W. Mayhew, President of the San Francisco Society of Architects. He suggested that the architects begin planning now to secure the work to be done after the war, stressing the need for a definite plan now, as being the best way to carry on work later.

"Architects in Government Positions" was the subject discussed by Henry C. Collins, who described several of the agencies in existence and spoke of the need for architects to recognize that these agencies may be here to stay.

Francis Joseph McCarthy, a member of "Telesis," described a project now under way in that group as an approach to a Regional Plan for the Bay Area. He mentioned many of the serious difficulties encountered in attempting to plan for the Bay Region.

Hervey Clark thanked the speakers for their efforts, and returned the meeting to President Appleton, who expressed the appreciation of the Chapter for the fine program arranged by Mr. Clark.—J. D. Y.

**HEATING ENGINEERS**

The week of Jan. 26, 1942, will be important to those engaged in the heating, ventilating, air conditioning field as it will mark the occasion of the 48th Annual Meeting of the American Society of Heating and Ventilating Engineers at the Bellevue-Stratford Hotel, the 7th International Heating and Ventilating Exposition, at the Commercial Museum, 28th National Convention of the National Warm Air Heating and Air Conditioning Association at Benjamin Franklin Hotel, Philadelphia, Pa.

**Save 20% Space**

*Specify*

**PITCHER**

**IMPROVED DISAPPEARING  
DOORS**

Send for prices and details on our new wood frame sliding doors

**E. C. Pitcher Co.**

557 Market Street, San Francisco

Phone Fruitvale 0443

**Eureka Mill &  
Lumber Co.**

**Lumber and  
Millwork**

38th Ave. and San Leandro St.  
Oakland, California

**Independent  
Iron Works**

Structural Steel  
Ornamental Iron  
Steel Service Stations  
Steel Tanks  
Standard Steel Mill Buildings  
Bridges

821 Pine Street      Oakland

**ANDERSON  
&  
RINGROSE**

General Contractors

320 Market Street, San Francisco  
Phone GARfield 2245

## JOHN CASSARETTO

—Since 1886—And Still Active—

### Building Materials

READY MIX CONCRETE  
ROCK - SAND - GRAVEL - LIME  
CEMENT - PLASTER - MORTAR  
METAL LATH - WOOD LATH  
STUCCO - WIRE NETTING

### Service Unexcelled

Bunkers

Sixth and Channel, San Francisco  
Phones: GARfield 3176, GARfield 3177

## ARCHITECTS FOR DEFENSE HOUSING

A nationwide campaign to make the services of trained technicians available to Civilian Defense Committees in every major city has been recommended to the American Institute of Architects by Ben Nash, Chairman of the New York Chapter of the American Designers Institute. The program would be undertaken jointly by the two Institutes.

Architects and designers should integrate themselves more actively into civilian defense efforts of their local communities, Mr. Nash declares.

"At this crucial point when so many changes are being initiated which are to affect the normal ways of living, there is a definite need for architects and designers, the technicians who are especially trained in solving the newly arising problems of civilian health, safety, and economics through proper planning and creative ingenuity," he points out.

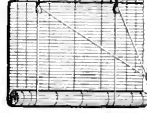
"The environments in which we are to live in the future and the commodities we are to live with are to undergo definite change. They can be simply changed, or changed for the better to benefit community life, individual welfare and to advance our industrial progress.

"Every local Civilian Defense Committee throughout the country should conscript the services of an architect and a designer so that every change affecting the civilian's welfare will be made with planned foresight as to the future.

"America has the opportunity to make itself anew for better living under seemingly adverse circumstances if it uses the experience and ingenuity which is already available. America can do this now under this cycle of drastic change which the national defense program is forcing upon us. It can make the necessary changes in a botched patchwork manner, or in a soundly, planned way.

"The background of training and experience of the architect and the designer are particularly well fitted to move into this, the biggest and most vital task affecting the way of living in America."

## BAMBOO



the dominating decoration at "Zanzibar" Cocktail Lounge, illustrated in

this issue, furnished and installed by Economy Shade Co.

## Distinctive TROPICAL INTERIORS

BAMBOO POLES  
SHADES • MATTING  
FLOOR SCREENS  
PICTURE FRAMES  
MOULDING AND NOVELTIES

Unusual wall and floor coverings, including China grass and woven palm leaf matting.

## ECONOMY SHADE COMPANY

557 Market Street  
San Francisco DOuglas 0691

## VAUGHN - G. E. WITT Co.

Manufacturers and Distributors

Pump Governors	Oil Heaters
Safety Pump Governors	Relief Valves
Automatic Gas Regulating Valves	Oil Burner Governors
Gas Burning Equipment	Oil Burners
Vacuum Pump Governors	Oil Pumping Sets
Vacuum Regulating Valves	Oil Valves
Continuous Flow Steam Traps	Oil and Steam Strainers
Thermostats	Duplex Oil Pumps
Reducing Valves	Rotary Oil Pumps
	Boiler Feed Pumps
	Water Heaters
	Boiler Feed-Water Regulators

4224-28 Hollis St., Emeryville, Oakland

## ABBOT A. HANKS, INC. Engineers & Chemists

INSPECTING — TESTING — CONSULTING  
CONCRETE • STEEL • MATERIALS  
CHEMICAL AND TESTING  
LABORATORIES

- RESEARCH AND INVESTIGATION •
- TESTS OF STRUCTURAL MATERIALS
- DESIGN OF CONCRETE MIXES
- SHOP AND ERECTION INSPECTION OF STRUCTURES AND EQUIPMENT
- INVESTIGATION OF STRUCTURES AND MATERIALS
- TESTS AND INVESTIGATION OF FOUNDATION SOILS
- FIRE RESISTANCE AND INSULATION TESTS

624 Sacramento Street, San Francisco

## MULLEN MFG. COMPANY

BANK, STORE AND OFFICE  
FIXTURES—CABINET WORK  
OF GUARANTEED QUALITY  
CHURCH SEATING

Office and Factory:

60-80 RAUSCH ST., Bet. 7th and 8th Sts.  
San Francisco  
Telephone UNderhill 5815

## F E R R O - PORCELAIN

A permanent and beautiful exterior finish . . . particularly adaptable to modern design. Eliminates upkeep costs . . . such as painting . . . choose your own color.

The entire fronts of the Chestnut Tree restaurants in San Francisco are Ferro-Parcelain Enamel.

We will be pleased to work out details for Ferro-Parcelain construction in connection with most any type of building.

## FRANK ALLEN CO.

Ferro-Parcelain Constructors

320 Market St.  
San Francisco

832 W. 5th St.  
Los Angeles

## INCLUDE TREES IN YOUR PLANS

DAVEY, ORIGINATOR OF TREE SURGERY, OFFERS FREE INSPECTION AND ESTIMATE.



SAN FRANCISCO  
Russ Bldg. 5Utter 3377

FRESNO  
Mattei Bldg.

LOS ANGELES  
Story Bldg. Tucker 1929

Local phones in: Pasadena, Palo Alto,  
Oakland, San Rafael, San Mateo

**SKILL - KNOWLEDGE -  
RESPONSIBILITY**

## DINWIDDIE CONSTRUCTION COMPANY • BUILDERS

CROCKER BUILDING  
SAN FRANCISCO

HIGH GRADE MILLWORK  
AND INTERIOR FINISH  
SASH AND DOORS

## LANNOM BROS. MFG. CO.

FIFTH AND MAGNOLIA STREETS  
OAKLAND, CALIFORNIA  
Telephone: TEmplebar 3663

### UNIQUE SAMPLE KIT

A unique sample and color kit, featuring Marlite Pre-finished Wall Paneling, is being distributed to architects and contractors by Marsh Wall Products, Inc., Dover, Ohio.

In view of the considerable range of materials included in the kit it is amazingly compact and easy to handle. Measuring 8½ inches by 11½



THE MARLITE SAMPLE KIT

inches by 1 inch deep, the kit contains sixteen 2"x2" samples and four 4"x8" samples of Marlite which include plain-colors, tile-patterns, marble-patterns and genuine wood veneers. Each sample is labeled according to color, pattern and finish.

### BAN PREFABRICATED HOUSES

The attention of those branches of the building industry concerned with housing has been directed to the requirements of the California Housing Law by Carey McWilliams, Chief of the Division of Immigration and Housing, who states:

"Our agency and local enforcement departments are particularly concerned with maintaining the present standards of construction for habitations, as an insurance against future shack towns and slums that would have their inception in poorly-built and laid-out dwellings hurriedly assembled and lacking adequate plumbing and sanitary equipment.

"There has been a decided tendency of late to place on the market, under the guise of meeting defense housing needs, prefabricated housing—mostly of the one-room type—that is far below the standards of our state housing law, the law regulating auto courts in unincorporated areas, and local building ordinances. In some instances, originators of these mass pro-



## Wm. Penn Hotel

2208 West 8th St.  
Los Angeles, Calif.

200 Rooms  
200 Baths

One in Room.....	\$200
Two in Room.....	\$250

*Attractive weekly and monthly rates.*

Professional men will appreciate the good food at moderate prices in our Quaker Grill.

duction units have presented their plans for review and comment to the State Division of Immigration and Housing, and have sought to correct their deficiencies, but in other cases they have neglected to consult law enforcement officials and gone ahead with production. They later found, to their financial discomfort, that their product would not be acceptable because it failed to meet existing minimum housing requirements.

"Existing building standards for small permanent habitations to be found in local ordinances, and the present state law, were enacted after careful study for a period of years in California. They are minimum requirements and it is most advisable that these standards, such as they are, should be maintained throughout the period of the present emergency so that California communities will not be confronted in the future with a type of flimsy dwelling construction which, once established in the possession of countless owners, would be extremely difficult to eradicate or to bring into compliance with the law."



ARCHITECT  
AND  
ENGINEER

**JANUARY 1942**

# Defense Savings Pay-Roll Allotment Plan

*Now company heads can help their country, their employees, and themselves*

voluntary pay-roll allotment plan

- helps workers provide for the future
- helps build future buying power
- helps defend America today

This is no charity plea. It is a sound business proposition that vitally concerns the present and future welfare of your company, your employees, and yourself.

During the post-war period of readjustment, you may be faced with the unpleasant necessity of turning employees out into a confused and cheerless world. But you, as an employer, can do something *now* to help shape the destinies of your people. Scores of business heads have adopted the Voluntary Pay-roll Allotment Plan as a simple and easy way for every worker in the land to start a *systematic* and *continuous* Defense Bond savings program.

**Many benefits . . . present and future.** It is more than a sensible step toward reducing the ranks of the post-war needy. It will help spread financial participation in National Defense among all of America's wage earners.

The widespread use of this plan will materially retard inflation. It will "store" part of our pyramiding national income that would otherwise be spent as fast as it's earned, increasing the demand for our diminishing supply of consumer goods.

And don't overlook the immediate benefit . . . money for defense materials, quickly, continuously, *willingly*.

**Let's do it the American way!** America's talent for working out emergency problems, democratically, is being tested today. As always, we will work it out, without pressure or coercion . . . in that old American way; each businessman strengthening his *own* house; not waiting for his neighbor to do it. That custom has, throughout history, enabled America to get things done *of its own free will*.

**In emergencies, America doesn't do things "hit-or-miss."** We would get there eventually if we just left it to everybody's whim to buy Defense Bonds when they thought of it. But we're a nation of businessmen who understand that the way to get a thing done is to *systematize* the operation. That is why so many employers are getting back of this Voluntary Savings Plan.

Like most efficient systems, it is amazingly simple. All you have to do is offer your employees the convenience of having a fixed sum allotted, from each pay envelope, to the purchase of Defense Bonds. The employer holds these funds in a separate bank account, and delivers a Bond to the employee each time his allotments accumulate to a sufficient amount.

Each employee who chooses to start this savings plan decides for himself the denomination of the Bonds to be purchased and the amount to be allotted from his wages each pay day.

**How big does a company have to be?** From three employees on up. Size has nothing to do with it. It works equally well in stores, schools, publishing houses, factories, or banks. This whole idea of pay-roll allotment has been evolved by businessmen in cooperation with the Treasury Department. Each organization adopts its own simple, efficient application of the idea in accordance with the needs of its own set-up.

**No chore at all.** The system is so simple that A. T. & T. uses exactly the same easy card system that is being used by hundreds of companies having fewer than 25 employees! It is simple enough to be handled by a check-mark on a card each pay day.

**Plenty of help available.** Although this is your plan when you put it into effect, the Treasury Department is ready and willing to give you all kinds of help. Local civilian committees in 48 States are set up to have experienced men work with you just as much as you want them to, and no more.

Truly, about all you have to do is to indicate your willingness to get your organization started. We will supply most of the necessary material, and no end of help.

**The first step is to take a closer look.** Sending in the coupon in no way obligates you to install the Plan. It will simply give you a chance to scrutinize the available material and see what other companies are already doing. It will bring you samples of literature explaining the benefits to employees and describing the various denominations of Defense Savings Bonds that can be purchased through the Plan.

Sending the coupon does nothing more than signify that you are anxious to do *something* to help keep your people off relief when defense production sloughs off; *something* to enable *all* wage earners to participate in financing Defense; *something* to provide tomorrow's buying power for your products; *something* to get money *right now* for guns and tanks and planes and ships.

France left it to "hit-or-miss" . . . and *missed*. *Now* is the time for *you* to act! Mail the coupon or write Treasury Department, Section A, 709 Twelfth St. NW., Washington, D. C.



**FREE - NO OBLIGATION**

Treasury Department, Section A,  
709 Twelfth St. NW., Washington, D. C.

Please send me the free kit of material being used by companies that have installed the Voluntary Defense Savings Pay-Roll Allotment Plan.

Name \_\_\_\_\_

Position \_\_\_\_\_

Company \_\_\_\_\_

Address \_\_\_\_\_

# RUNNING FIRE — By MARK DANIELS, A. I. A.

## THE SAMURAI

During the feudal period in Japan the military class were called Samurai, or two-sword men. They did the fighting and as a symbol of their authority and evidence of their courage they carried two swords.

In the 12th century the right to bear arms was restricted to the Samurai, the two sword men. They did not come by this right through race or caste, but solely by usurpation and force of arms.

In the beginning the two-sword men were paid for their services, a commodity that was difficult to hoard or to transport a man of in the streets. As time brought into use objects of value smaller in size, the two-sword man began to come into his own. What with the sole right to bear arms coupled with the exclusive custom of carrying two sticks at a time, he probably deteriorated into a real stick-up man.

In the United States we went through a comparable development, although it occupied an incomparably shorter time. In our country the two-sword man became the two-gun man. The great difference is that we kicked out the two-gun man in a few years while the Japanese have had their two-sword men for over a thousand years and are still being stuck up by them.

## BLESSINGS IN DISGUISE

It's an ill wind that blows no good. Perhaps this war may also bring a vagabond blessing here and there. While I would never transgress the blackout laws, I might be tempted otherwise to guide a bomb my way in the hope that it would fall on the howling occupant of the dog house next door.

Also it might result in a tempering of the exaggerations in the radio announcer's jargon. These jargoniers are beginning to get out a rubber stamp form of superlatives and exaggerations, leaving the name of the commodity to be filled in when the contract is signed. Of course, when you use nothing but superlatives all announcements will be the same except the name. The other night I listened to the radio while preparing a special salad. Foolishly I did not note what particular article was described in the standard announcements and found I had put lipstick in the dressing.

## BOMB SHELTERS

What's the best bomb shelter? Well, one thing certain is that a solid skull is not. Common sense will save more lives than will common brick. Dashing out into the open in search for a shelter more bomb-proof than your own house doesn't give evidence of such sense unless a better one is only one step away.

But there may be time to build some sort of a structure that is more bomb-proof than your own, if you have the land, can get it past the building ordinances and can secure priorities. If you start early, can get the permits and priorities and can get away from the office, you may yet build one of the new bomb-proof designs before the bombs or union laborers strike. Wallace Neff has worked out a design that seems to develop many of the desired qualities. It is de-

scribed elsewhere in this issue and while it is not unlike the witch's gingerbread house in appearance, it might fill the bill, until a bomb hits it, with the advantage of being convertible into a playhouse for the children, if and when.

But all these plans to create a new type of house designed entirely upon bomb resistance seems to me to be predicated upon the thought that the war will last a decade or more. Otherwise it would seem to be more sensible to take the most practical steps possible to protect what we have.

## • FUTURE, FATE AND FAITH

What is the future of the architectural students who hope to be the architects of tomorrow? What will be the fate of the modest architects of today, the architect who works in a small office but in a big way? Only faith will carry him through. Faith in his ability to deliver a service that will ever be vital to civilization.

Contrary to the feeling of many, worried amounting almost to despair, the placing of government work in offices of large organizations does not mean the ultimate extermination of the architect of a small organization. The man who, like the cricket, prefers to sing on a lonely hearth, is often the balance wheel who pulls back the great organizer from his headlong flight in economics. Temporarily he may be in the slough of despair, but he should retain his faith in the general common sense of mankind and the eventual need for his particular kind of work when things are normal again.

One partial remedy for the present condition is the system of "Farming Out." If offices that have taken on large amounts of Government, and perhaps other work, could be shown that much of their emergency work could be farmed out, sub-contracted, as it were, the lot of the smaller architects could be more acceptable. The other alternative seems to be to close the office and give up a practice that, while it may not have been very remunerative in the past, was nevertheless, a happy and honorable occupation. Let us all have faith and pull together.

## • THE ARCHITECTS AND CIVILIAN DEFENSE

The California State Association of Architects has set up an advisory committee of Architects and Engineers who have been working on the problem of Civilian Defense with the appointed committee of that organization. Such cooperation will go a long way on the road of efficiency and economy. The architects and engineers are posted on the subject of materials, their costs, where they can be secured, what should be used, the supplies and kinds of labor involved and can save much time that would be lost in experiment.

## • A REMINDER

I rose and gave her my seat;  
I could not let her stand—  
She made me think of mother, with  
That strap held in her hand.

# A SPIRITUAL AND MORAL WAR

**NOW** that the United States is in the war it is essential that we should realize what total war means to us. It means that the enemy will strain every resource, will exhaust the last ounce of energy of every man, woman and child to defeat us; and it means that he will fight not only our armies and navies but that he will make war on us and our families at home wherever and whenever he can.

TO meet this formidable menace, we are now beginning to mobilize our full material resources. But more is required. We must also mobilize our moral resources. We must steel ourselves and we must recapture the spirit of the pioneers so that no matter how severe the hardships, how great the disappointments, we will not flinch nor waver until victory is won.

IN the end, it is the spirit of men that will decide this war. We should be conscious of and make the most of the tremendous advantage we have over our enemies spiritually and morally. We are fighting for the right of law against the right of might; for good faith against treachery; for tolerance against intolerance; for decency and goodwill against ruthlessness and brutality; and we are fighting so that freedom may not perish from the earth. Let us remember our spiritual heritage, and we cannot help but win.

BUT let us not merely profess these ideals to one another, or to our enemies; let us also remember them in our daily conduct. The outbreak of war with Japan, Germany and Italy has brought tragedy to many of the nationals of these countries living in the United States and they are exposed to indignities and injustices simply because of their nationalities.

LET us by no means relax our vigilance against fifth column activities. The large majority of foreign nationals living in this country, however, are entirely innocent of any hostile intentions; let us, as individuals, show them the decency and tolerance which are among our moral assets in this fight.

LET us fight hard, let us fight with everything we have, but let our side of the fight be clean, if there is such a virtue in war.

# ARCHITECT AND ENGINEER



Volume 148

January, 1942

Number 1

<b>Bomber and Hangar</b> . . . . .	<b>14</b>
<b>Avalon Gardens, Los Angeles</b> . . . . .	<b>15</b>
<b>Bubble Houses for Defense</b> . . . . .	<b>20</b>
Fred'k W. Jones	
<b>Wartime Factory Design</b> . . . . .	<b>25</b>
<b>H. S. Gymnasium at Phoenix, Arizona</b> . . . . .	<b>27</b>
<b>Air Raid Shelters for San Francisco</b> . . . . .	<b>29</b>
<b>The Question of Air Raid Shelters</b> . . . . .	<b>31</b>
Michael Goodman, Architect	
<b>Soundstacks for Noise Absorption</b> . . . . .	<b>33</b>
<b>American Architect Describes London Air Raids</b> . . . . .	<b>35</b>
C. Howard Crane	
<b>Giving Youth a Chance</b> . . . . .	<b>40</b>

**PLATES AND ILLUSTRATIONS**

<b>Avalon Gardens, Los Angeles</b> . . . . .	<b>15-19</b>
Carleton M. Winslow, Roland E. Coate and Samuel E. Lunden, Architects	
<b>Balloon Form Houses for Defense</b> . . . . .	<b>20-23</b>
Wallace Neff, Architect	
<b>Structural Plans for War Time Factories</b> . . . . .	<b>24-25</b>
<b>Union High School Gymnasium, Phoenix, Arizona</b> . . . . .	<b>26-27</b>
Lescher and Mahoney, Architects	
<b>Air Raid Shelters for San Francisco</b> . . . . .	<b>29-30</b>

EDITOR, FRED'K W. JONES; ASSISTANT EDITOR, E. N. KIERULFF; CONSULTING AND CONTRIBUTING EDITOR, MARK DANIELS; ADVERTISING MANAGER, R. W. WALKER. REGULAR CONTRIBUTING EDITORS: Harris C. Allen, Harry Sanders, Ben H. O'Connor, Glenn Stanton, Roi L. Marin, Chas. H. Alden, Irving F. Morrow. HONORARY EDITORS: Arthur Brown, Jr., Timothy L. Pfueger, Lewis P. Hobart, Wm. W. Wurster, Will G. Carlett, Frederick H. Meyer, Thos. J. Kent, Gordon B. Kaufmann, Paul R. Hunter, Michael Goodman, Harry Michelsen.

ARCHITECT AND ENGINEER is published on the 15th of the month by The Architect and Engineer, Inc., 68 Post Street, San Francisco. President, K. P. Kierulff; Vice President, Fred'k W. Jones; Secretary and Business Manager, L. B. Penhorwood.

Entered as second class matter, November 2, 1905, at the Post Office in San Francisco, California, under the Act of March 3, 1879. Subscriptions, United States and Pan America, \$3.00 a year; foreign countries \$5.00 a year; single copy \$.50.

Los Angeles office: 1709 W. 8th street, Wentworth Green, Manager. Phone EXposition 8292. ARCHITECTS REPORTS are published daily from this office and are sponsored by the Northern Section, State Association of California Architects; Vernon S. Yallop, Mgr.

# Watrous Completes World's Largest Flush Valve Contract



An airview of Parkchester taken in January, 1941.

• The Board of Design for the amazing development which the Metropolitan Life Insurance Co. has completed on a site covering 46 city blocks in the Bronx consisted of: R. H. Shreve, Chairman, Shreve, Lamb and Harmon, Architects; Andrew J. Eken, President, Starrett Brothers and Eken, Inc., Contractors; Gilmore D. Clarke, City Planning and Landscape Engineer; Irwin Clavan, Architect; Robert W. Dowling, Vice-President, Starrett Brothers and Eken, Inc., Contractors; George Gove, Manager of Housing Projects, Metropolitan Life Insurance Co.; Henry C. Meyer, Jr., Meyer, Strong & Jones, Inc., Consulting Engineers. Plumbing Contractor, J. L. Murphy, Inc., New York City.

## 12,273 WATROUS FLUSH VALVES installed in the Parkchester Project of Metropolitan Life Insurance Company

IMAGINE building the housing and recreational facilities for a city of 42,000 people as a single project! That's almost as many people as live in cities such as Jamestown, New York, Joliet, Illinois, or San Bernardino, California.

This gives some idea of the giant size of Parkchester—the world's largest housing project—built and owned by the Metropolitan Life Insurance Company.

The flush valves for this huge project made up the largest single order of this

type ever placed. In selecting the valves, every care had to be taken that they would deliver a maximum of efficient service, long life and freedom from maintenance.

It is significant that Watrous Flush Valves were selected.

This is further evidence of the growing trend toward Watrous. You will find complete specification information in Catalog 48—Section 27 of Sweet's Catalog File.



There are 12,273  
Watrous Flush Valves in  
Parkchester just like the  
one shown here.

THE IMPERIAL BRASS MFG. CO.  
1237 West Harrison Street, Chicago, Illinois

# Watrous Flush Valves

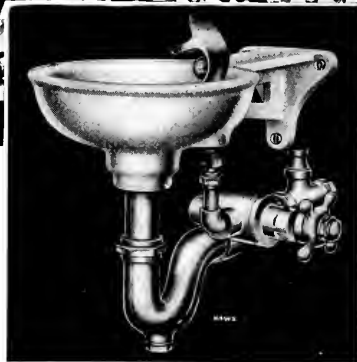
DIAPHRAGM and PISTON TYPES . . . also furnished with SILENT ACTION equipment



AIRPLANE VIEW OF CANTONMENT

# *Haws Fountains*

**Are used by more than  
15,000 recruits in training  
at Camp San Luis  
Obispo, California**



Model 8D5  
CANTONMENT FOUNTAIN

The sanitary features of HAWS DRINKING FOUNTAINS meet the exacting requirements of both Army and Navy construction engineers, as evidenced by their wide use in camps and cantonments throughout the United States.

## HAWS DRINKING FAUCET COMPANY

1808 HARMON STREET • BERKELEY • CALIFORNIA

Agents in the following cities:

New York • Los Angeles • San Francisco • Seattle • Salt Lake City • Portland  
Chicago • Atlanta

# NEWS AND COMMENT ON ART

## A CENTURY AND A HALF OF FRENCH PAINTING

**Commenting** a couple of months ago on the small collection of French pictures shown at the Gump galleries in San Francisco during October, I referred to French painting as one of the significant cultural traditions of modern times. But if this impression could emerge from a handful of canvases scattered through two small rooms, what is to be said of the monumental exhibition now at the de Young Museum, which fills half a dozen or so large galleries, and has been deliberately and aptly assembled for the specific purpose of illustrating the course of French painting through the last century and a half?

This exhibition of the Paintings of France Since the French Revolution was shown at the same museum about a year ago, and now returns substantially as before. I say substantially because, although I have had no opportunity to compare the catalogues of the former and the present occasions, there are a few changes, if memory serves me aright. A few canvases in the original exhibition seem to be absent now—as I write, Ingres' "Turkish Bath" comes to mind, and there are probably some few others of importance. On the other hand, I can not recall Monet's cool, oboe-like "View in Brittany"—perfect companion to his subtle "Cliff at Etretat"—in the former show, and there may be other additions.

But any changes in the contents do not alter the fact that this remains one of the most impressive demonstrations of a prolonged cultural development we have been privileged to see for many a day. Here is a conscientious diagramming of the continuity and the vitality of the tradition of French painting since the beginning of what, in a long view, we might call modern times. The merest novice in this realm of culture, passing through these galleries with care and intelligent attention, should leave with some glimmer of an idea as to how contemporary painting got that way—or at least with some conception as to how to go about solving the mystery. For the adept it is a veritable series of fuses, as it were, touching off long trains of association and memory.

A century and a half of living, growing tradition, summarized, made tangible, is an experience not vouchsafed during every afternoon's stroll. And in judging our good fortune at enjoying this experience, it should not be forgotten that these pictures come from a variety of scattered sources. In other words, even in a normal Europe it would be impossible to indulge such an experience within the walls of one building.

It is impossible to close an appreciation of this exhibition without voicing irritation over a matter which has really nothing to do with the show as such, but concerns a detail of the museum's installation. I refer to the small-town ballyhoo streamer strung across the central motif of the wing of the building which houses the exhibit. Not only is this grotesquely and irreverently inappropriate to the

place and the occasion, but its scale relationship to the architecture on which it is imposed is devastating.

**Irving F. Morrow.**

## AN OLD FRIEND IN A NEW JOB

**Charles Lindstrom**, who was formerly Curator of the San Francisco Museum of Art, has accepted the position of Director of Education at the M. H. de Young Museum. A staff member of the San Francisco Museum of Art for the past six years, Mr. Lindstrom filled successively the posts of Publicity Director, Director of Education, Assistant Curator and Curator there. His transfer from the West's museum of modern art to the West's largest general art museum marks plans for an intensification of the de Young Museum's activities.

For a considerable period Mr. Lindstrom contributed monthly art notes and criticisms to the **Architect and Engineer**.

## ARTISTS AND THE WAR

**Every** American knows that in this hour he must do his job better than ever. With determination and calm all must produce the work that will accomplish most for our country.

Like all of us the artist has two general functions: His work as an artist and citizen.

The Division of Information in the Office of Emergency Management, Washington, D. C., proposes to purchase a group of drawings, water colors and prints for an initial record of our war activities. They will be used for public information.

The subjects are many. The artist is advised to limit himself to those subjects which have a vital, visual appeal to him. He should also select material readily available in his own locality.

All work will be judged in Washington by the following jury and the jury's decision on the work to be recommended to the Office of Emergency Management for purchase will be final: Olin Dows, Consultant, Office of Civilian Defense; Charles Coiner, Consultant in Design, Office for Emergency Management; Holger Cahill, Director, W.P.A. Art Program; Forbes Watson, Consultant, Section of Fine Arts, Public Buildings Administration; Edward B. Rowan, Assistant Chief, Section of Fine Arts, Public Buildings Administration.

All communications **must** be addressed to Olin Dows, Consultant, Office of Civilian Defense, Room 417, 7th and D Streets, S. W., Washington, D. C.

## AMERICAN PRINT EXHIBITION

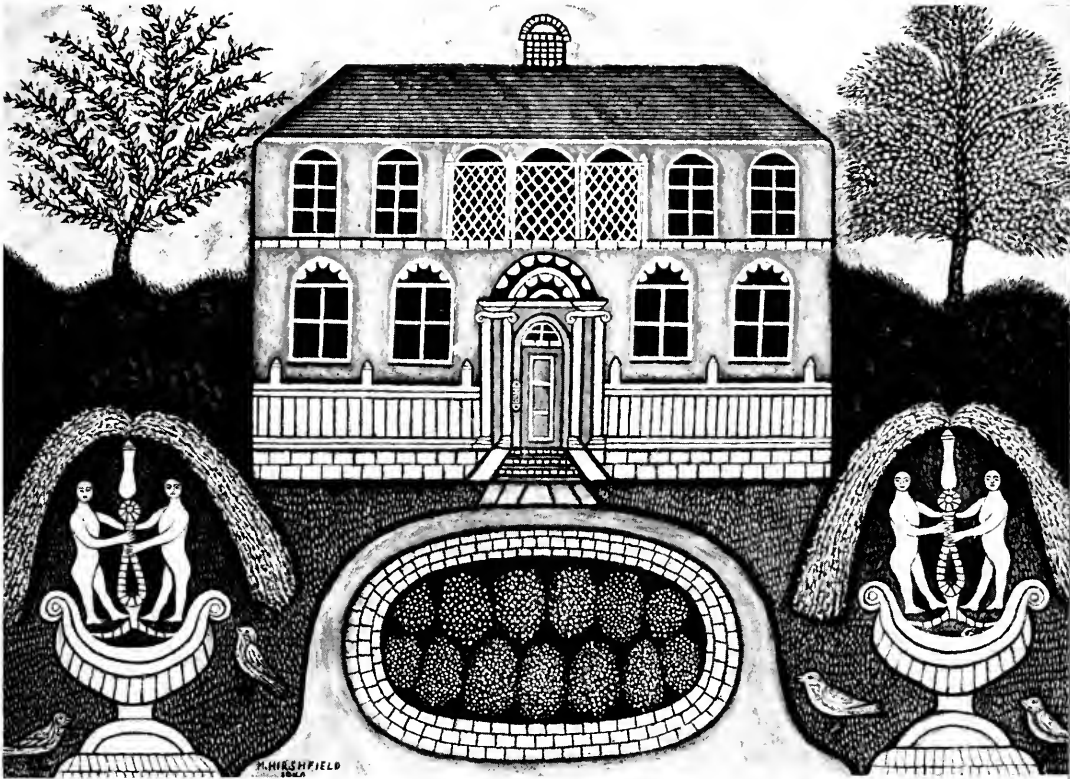
**The 26th** Annual Exhibition of the Society of American Etchers, Inc., is presented this year in combination with an exhibition of Miniature Prints—February 11 to February 28, inclusive, at the galleries of The National Academy of Design, 3 East 89th Street, New York City.

## AT THE MUSEUMS

The following announcements have been received of events after the publication date of the **Architect and Engineer**:



# IN AN EVER CHANGING WORLD



HOUSE WITH TWO FOUNTAINS by M. Hirschfield

## California Palace of the Legion of Honor Special Exhibitions

DRAWINGS AND MONOTYPES by FRANK VAN SLOUN—Opening January 15.

PRINTS AND DRAWINGS by SAUL RABINO—Opening January 15th.

PAINTERS AS BALLET DESIGNERS (Circulated by the Museum of Modern Art)—Opening January 19th.

ANIMALS IN ART—Through January.

DAYS OF REAL SPORT: SIXTY WOOD ENGRAVINGS ILLUSTRATING THE SPORTS OF THE VICTORIAN PERIOD—Through January.

## Permanent Exhibitions

The Mildren Anna Williams Collection of Paintings, Sculpture, Tapestries and Furniture.

The Collis Potter Huntington Memorial Collection of 18th Century French Paintings, Sculpture, Tapestries, Furniture and Porcelain.

The Alma Spreckels Aul Collection of Sculpture and Drawings by Auguste Rodin.

## Organ Recitals

Uda Waldrop, Organist—Each Saturday and Sunday at 3:00 p.m.

## Little Theatre

Motion Pictures—admission free. On each Saturday at 2:00 p.m., from January 10th through June 27th, the Museum will show a series of films selected for their artistic and historical importance. Part of this series has been chosen from the Museum of Modern Art Film Library, the foremost library of its kind in America.

Art Courses—admission free. "Know Your Exhibitions" (Discussions on the Special Exhibitions held at the Museum)—Every Wednesday morning at 10:30, beginning January 7th—Dr. Jermayne MacAgy.

"The Collectors' Club" (Collectors, whether of art-objects, sea-shells, driftwood, bric-a-brac, or what-have-you, are invited to bring in their items to these meetings for critical discussion on their artistic worth and personal value. Everyone, collector or not, is invited to attend.) Every Friday morning at 10:30, beginning January 9th. Dr. Jermayne MacAgy.

GALLERY TOURS—Schools, club or social groups may arrange for privately conducted tours of the Museum's permanent collections and special exhibitions by communicating with the Educational Department, BAYview 5610.

# SPECIFY -

## AQULUX OIL BURNING WATER HEATING UNITS

● Is this what you are looking for . . . a compact boiler burner unit to provide hot water for duplex houses, clubs, apartments and numerous commercial uses? The S. T. Johnson AQULUX #85 and #150 . . . with rated output capacities of 85,000 and 150,000 Btu an hour respectively . . . will take care of most jobs. Their powerful Bankheat Oil Burners give unusually rapid recovery . . . eliminating the need for storage tanks except on extremely large installations. They are soundly made, too, with hot dipped galvanized 10 gage copper steel shell and  $\frac{1}{2}$ " steel heads; refractory firebox; master control and aquastat; draft adjuster; and many other exclusive Johnson engineering features.

See these popular units at the 7th International Heating & Ventilating Exposition, Philadelphia, Jan. 26-30.

FREE  
COMPLETE  
SPECIFICATIONS

### S. T. JOHNSON CO.

940 Arlington Avenue • Oakland, Calif.  
401 N. Broad Street • Philadelphia, Pa.

## TEAMWORK for SECURITY

**GOLDEN GATE • OLD MISSION**  
PORTLAND CEMENT PORTLAND CEMENT

**MILCOR**  
METAL LATH PRODUCTS

**EMPIRE**  
GYPSUM PLASTER

**STANDARD**  
GYPSUM PLASTER

**PACIFIC**  
PORTLAND CEMENT COMPANY

FOR SOUND CONSTRUCTION

### MASTER PLAN FOR BOMBED CITY

Members of the State Association of California Architects have undertaken a study by shortwave radio of the replanning of Britain's bombed towns to aid them in developing San Francisco's Master Plan.

The British Broadcasting Corporation is presenting the broadcasts, in which architects in various British cities are participating.

Norman K. Blanchard, vice president and member of the San Francisco Citizens' Master Plan Committee, had asked the B.B.C. to have an English architect describe the replanning of British cities in Mutual Broadcasting System's "Answering You, from Britain" series.

From the home of Irwin W. Goldstine, radio amateur, three San Francisco architects listed to Donald Gibson, Coventry's city architect, describe his planning program.

The British Government War Damage Commission and the Coventry city council, Gibson declared, had granted the city's planners powers to prevent building on former "pre-blitz" sites. Plans include a "green belt" of open space around Coventry, with industrial zones outside the green belt; wide streets, with shops on one side only, to minimize accidents to pedestrians; parking spaces in front of downtown buildings; division of residential areas into units  $\frac{1}{4}$ -mile square, each with surrounding gardens; a community cultural center in each suburb.

The British Government will loan funds after the war for Coventry's reconstruction.

Goldstine is arranging to utilize his radio unit as a general listening post for the San Francisco study group.

### HAMLIN PRIZE AWARD

The Hamlin Prize, highest award bestowed by the Columbia University School of Architecture for a decorative design, has been won for 1941-42 by Paul Pippin of Severna Park, Md., for the best rendition of a fountain in a housing development.

The winning design provides for a structure of brick and reinforced concrete which combines as a unit a bus stop, public toilets, and a fountain. Planned as a feature of a central plaza surrounded by stores, the edifice includes enclosed waiting rooms that face the water sprays. Sun dials on top of the fountain indicate the time throughout the day.

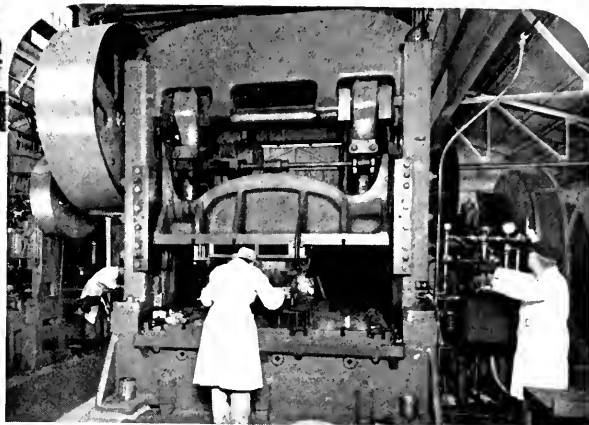
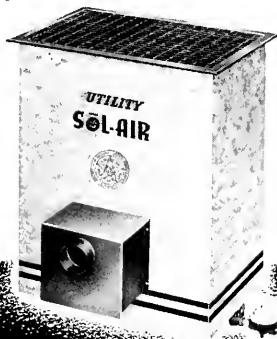
Pippin, a fourth-year student in the School of Architecture, was born in Chestertown, Md., in 1912. For the past three years, Pippin has conducted a column called "Critical Youth Wields the Flail" in Pencil Points.

### A-10 PREFERENCE RATING

An A-10 preference rating will be made available for materials necessary to complete homes and apartment buildings now under construction. Officials of the Division of Civilian Supply estimate that approximately 70,000 private dwelling units are now under construction.

# Depend on UTILITY

For completely modern, gas-fired heating equipment, that is compact in design, efficient in operation, attractive in appearance and dependable in service.



This press, with a capacity of 375 tons, is one of many that make Utility die-formed parts—parts that are uniform, smoothly finished and attractive. This is only one of the many pieces of equipment that give Utility Fan Corporation the largest and most complete sheet-metal facilities in the West.

## UTILITY FAN CORPORATION

4851 SO. ALAMEDA STREET • LOS ANGELES, CALIFORNIA

MANUFACTURERS OF FORCED-AIR BASEMENT AND CLOSET FURNACES, FLOOR AND DUAL REGISTER FURNACES, CIRCULATING HEATERS AND UNIT HEATERS



Small picture (upper left) shows neighborhood one story tire shop in Oakland, prior to converting into upholstery studio with Krafftile front.

# 1942 ELECTRICAL WIRING PROBLEMS

☆

Clients are sometimes unreasonable in blaming inadequate wiring on the architect, even in normal times. And this may happen more than ever today when government regulations limit the amount of wiring materials that may be used.

For your own protection against such unfair attitudes, you will need more than ever now to give special attention to the wiring plans. Now it is necessary that wiring be more accurately planned to take full advantage of every foot of wire and every switch and outlet.

By submitting a carefully worked out wiring plan for your client's approval, you will eliminate those annoying revisions and time-wasting arguments.

Your utility company has men whose sole job is to know the last word on wiring regulations and efficient planning. There is no charge for this service. Phone your local utility office and ask the wiring specialist to call, or write us and we will see that wiring consultation service is provided.

☆

NORTHERN CALIFORNIA  
ELECTRICAL BUREAU

447 SUTTER ST. • SAN FRANCISCO

# Lamella Roof ADAPTABILITY

Shown at  
PHOENIX HIGH SCHOOL



• AN INTERESTING EXAMPLE of the clear floor space and good lighting facilities afforded by Lamella Roofs is the Athletic Building and Auditorium of Phoenix Union High School and Junior College District of Maricopa County, Arizona. This roof is a "4-Way Broach" Lamella, 140'x140', with a 23' rise. Lescher and Mahoney of Phoenix were the Architects, and all construction was by WPA.



**SUMMERBELL**  *The Strength of the Bow*

☆ **ROOF STRUCTURES**

LOS ANGELES • OAKLAND • PORTLAND • SEATTLE  
SAN DIEGO • PHOENIX • SALT LAKE CITY

# WIN HOMES — that "double in gas"

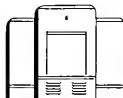


*Architect*—CURTIS CHAMBERS  
*Owners*—FRANK AND FRED POLLY

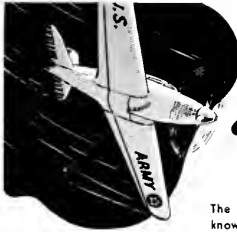


**S**UBTLE variations in the ranch-house style; gas equipment throughout — a delightful combination in these new homes for twin brothers. ★ In specifying gas for the 4 big jobs, Pasadena architect Curtis Chambers assured his clients of lifetime satisfaction; himself, of priceless good will. ★ Such happy results invariably follow the selection of a CP gas range, silent gas refrigerator, automatic gas water heater and gas fuel for space heating. ★ On *your* next job — whatever the size or architectural style — make your plans complete, keep your client-contact "sweet" by specifying gas throughout. ★ Your Gas Company's engineers are available for free consultation — a helpful technical service.

**GAS**  
BEST CHOICE  
4



COOKING + WATER HEATING + HEATING + REFRIGERATION



*Substitutes  
won't do!*

The makers of Uncle Sam's fighting planes know that only the finest of materials and workmanship can be used in their manufacture if they are to give the service and performance expected of them.

This is also true of tile. Only REAL POMONA TILE will give you the permanent beauty, the lasting charm and delightful appearance you expect. To avoid disappointments DEMAND REAL POMONA TILE.

**Only REAL Pomona Tile Has All These Advantages**  
 Absolutely fireproof  
 Surface immune to cigarette burns  
 Practical for use on floors, walls, ceilings  
 Colored for life  
 Waterproof, stainproof, easy-to-clean  
 True color balance  
 Patented "Space-Bite" feature assures permanence



**POMONA TILE MANUFACTURING COMPANY**  
 629-33 N. LA BREA AVENUE • LOS ANGELES  
 135TH TENTH STREET—SAN FRANCISCO 6106 ROOSEVELT WAY—SEATTLE  
 PLANT: POMONA, CALIFORNIA MINES: DEATH VALLEY

**Uncle Sam Uses Corrosiron**



Drain pipes and fittings in many Federal buildings, including the San Francisco Mint, pictured above, are protected with **Corrosiron** — a positive guarantee of long life and sure resistance to corrosion.

**Corrosiron** is used extensively for acid drain lines in hospitals, universities, high schools, laboratories. Is manufactured by —

**Pacific Foundry Company, Ltd.**  
 NEW YORK • 3100 NINETEENTH ST., SAN FRANCISCO • LOS ANGELES

*Biltwel  
Furnaces*  
 are  
**Built  
Well**



A mammoth 200-ton press forms the sections of the heating element out of heavy heat-resisting steel. The *Biltwel* Gas Furnace is built up of multiple sections welded into one piece. Air flow is split into thin streams for closer contact with the large amount of heating surface, resulting in high efficiency.

**FRASER & JOHNSTON Co.**  
 725 POTRERO AVE.  
 SAN FRANCISCO, CALIF.

**BRIGHT ENDURING COLORS  
 —FOR EXTERIOR SURFACES—  
 IN A WIDE COLOR RANGE**

**Cabots  
 Non-Fading  
 Gloss  
 Collopakes**



**GUNN, CARLE & CO.**  
 SAN FRANCISCO  
 20 POTRERO AVE.  
 UNDERHILL 5480

# To Serve a Great Industrial—Defense Area



*New home of Contra Costa County Title Company, Martinez, California. Faced with N. Clark & Sons' Ceramic Veneer. Ed Musson Sharpe, Architect. Ceramic Veneer installation by White & Gloor.*

Thousands of new homes for workmen who are building ships and making petroleum derivatives in the great Contra Costa County industrial-defense area will be cleared through the magnificent new home of the Contra Costa County Title Company in Martinez, California. fittingly, just as the clay products of N. Clark

& Sons are already serving defense in many more direct ways, our Ceramic Veneer was chosen to face this new building.

We are proud indeed to be doing our part in serving the Nation's gigantic defense effort — proud too, to be able to take care of the present needs of civilian requirements.



**N · CLARK AND SONS**

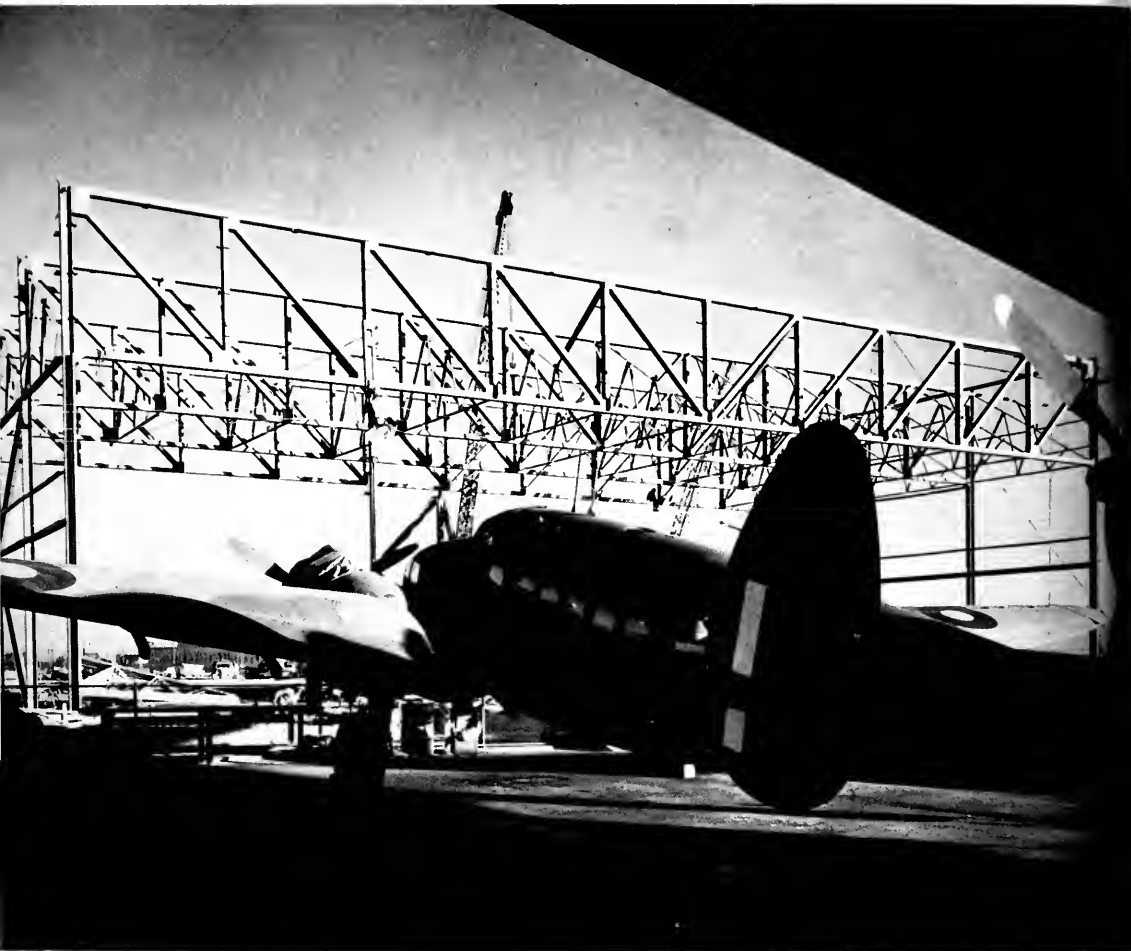
116 Natoma Street • San Francisco

LOS ANGELES

• SALT LAKE CITY

• PORTLAND

**PRODUCERS OF QUALITY ARCHITECTURAL CLAY PRODUCTS**



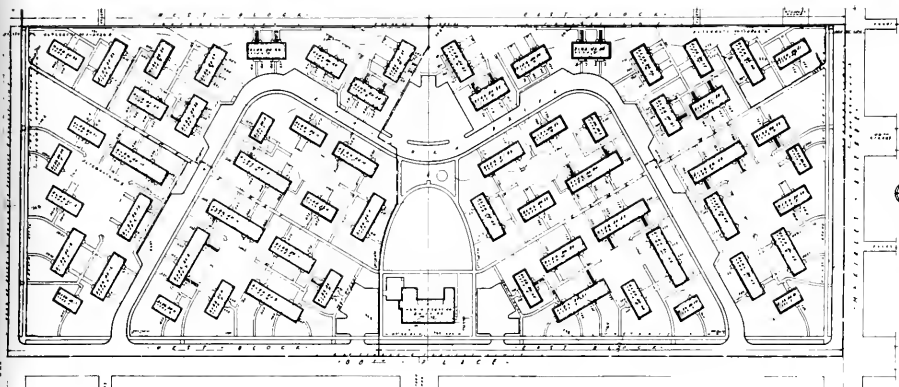
This impressive photo is typical of American preparedness—regretfully a little late getting under way, but, thank God, today advancing full speed ahead. In the foreground is a huge Lockheed and Vega bomber and in the background may be seen the framework of one of the nation's largest service hangars at Burbank, California. Constructed entirely of steel, the hangar will cover an area equivalent to one and one half city blocks. It is to be used exclusively for servicing warplanes before they are turned over to the United States and British air forces. The photo is a dramatic reminder that war is upon us and that it is every man and woman's duty to do his or her part to bring this calamity to a victorious end—to make sure, once and for all time, that we and our children and their children shall have the continued privilege of that freedom for which our fathers fought one hundred and fifty years ago.

Individual liberty and freedom under the guarantees of the Constitution of the United States have produced a mighty and wealthy nation and a standard of living unexcelled in the world. Holding safe these great blessings for future generations justifies all the sacrifices that we may be called upon to make now and in the future.





**AVALON GARDENS**  
 THE HOUSING AUTHORITY OF THE CITY OF LOS ANGELES  
 CALIFORNIA HOUSING AUTHORITY  
 CARLETON M. WINSLOW      ROLAND E. COATE  
 SAMUEL E. LUNDEN



Architects'  
 Model and  
 Plot Plan,  
 Avalon  
 Gardens,  
 Los  
 Angeles

# AVALON GARDENS

## A Los Angeles Housing Project of Unusual Interest

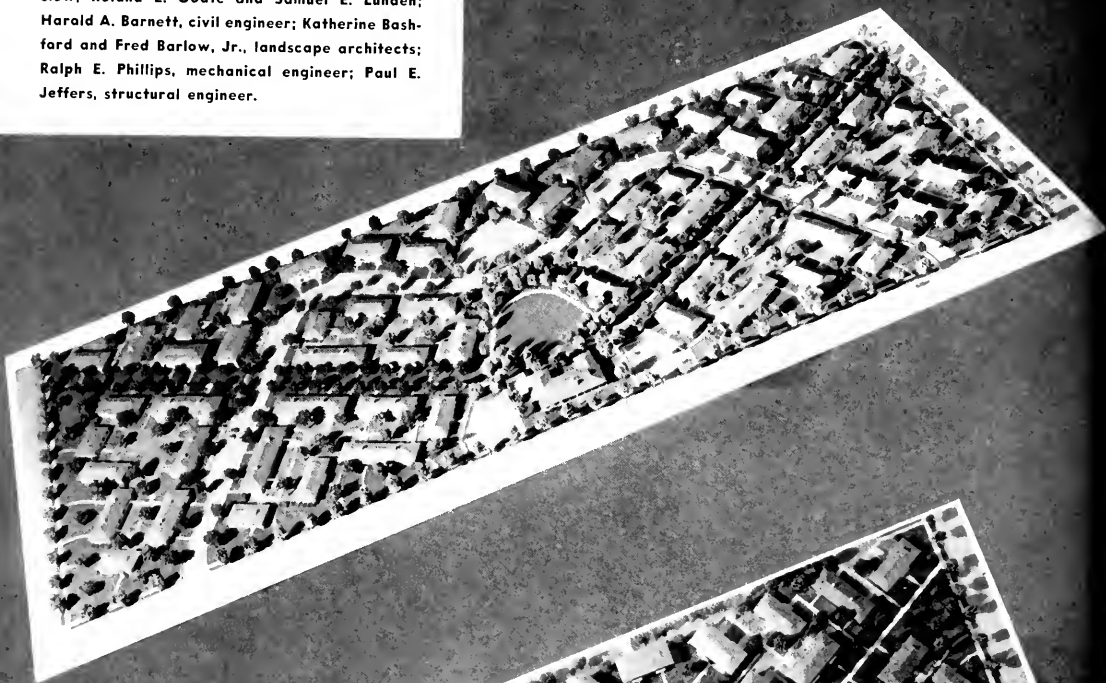
**One** of the most recent contracts for actual construction work let by the Housing Authority of the City of Los Angeles was for a group of low rent houses known as the Avalon Gardens. Smaller in size than most of the other projects, it provides some features which may prove to be significant in the future development of low cost housing.

This project, designated as CAL 4-9, USHA, is located at the intersection of Avalon Boulevard and 88th Place, in a district largely built up with small single family houses and small commercial developments—a district typical of vast areas of most of our cities. The site contains some fifteen acres, bounded by city streets laid out in the familiar gridiron pattern.

## AVALON GARDENS

Photos of two color perspectives of one of Los Angeles' latest housing projects.

California Housing Architects—Carleton M. Winslow, Roland E. Coate and Samuel E. Lunden; Harold A. Barnett, civil engineer; Katherine Bashford and Fred Barlow, Jr., landscape architects; Ralph E. Phillips, mechanical engineer; Paul E. Jeffers, structural engineer.



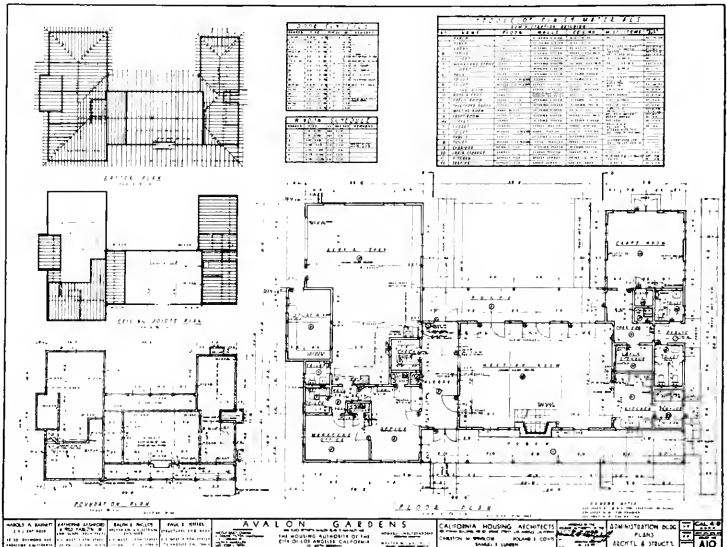
**Perspective and Plans of Administration Building, Avalon Gardens Project, Los Angeles, California**

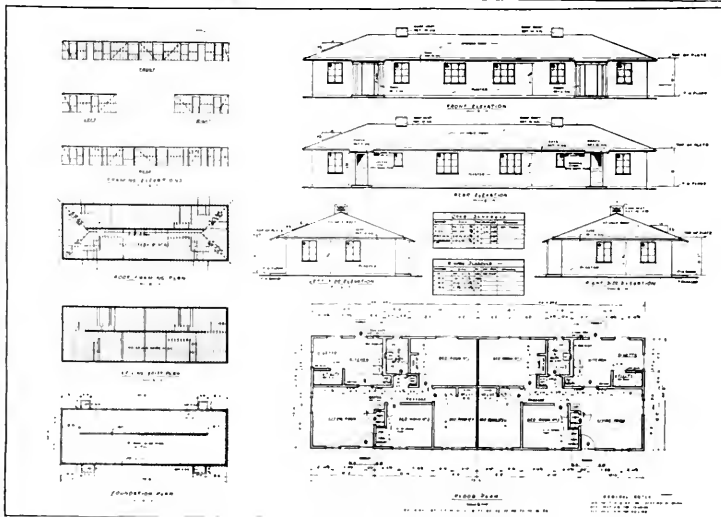
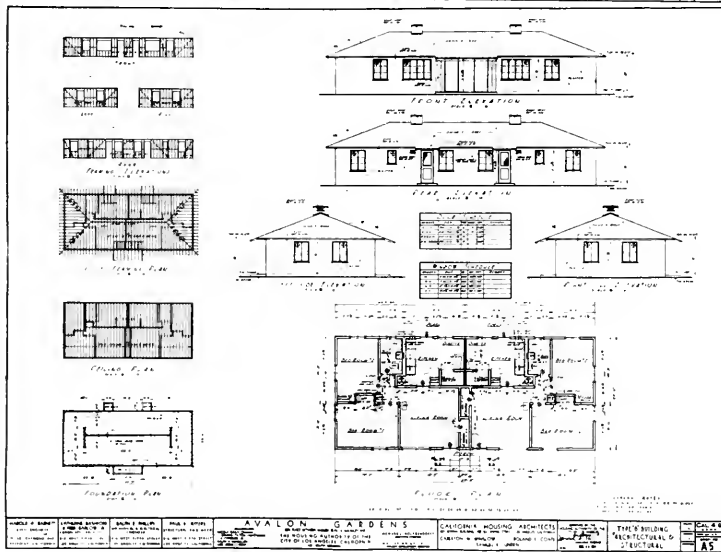
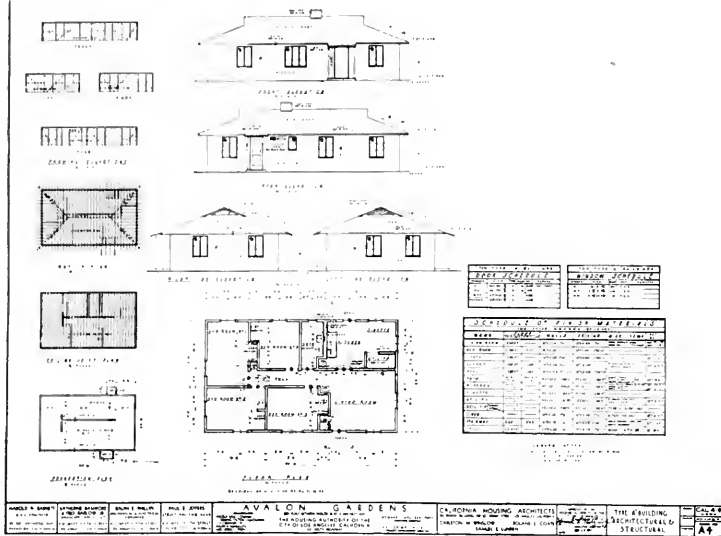


If this acreage had been developed the usual way, by individual houses on forty foot lots, there would ultimately have been less than a hundred single dwellings of the usual heterogeneous character, part of them facing due north and part of them facing due south. Less than a hundred families would have been accommodated in rows facing on narrow streets. This would have resulted in the old familiar pattern which, from any standpoint, has little to recommend it yet continues in use.

By planning the site as a whole there will be dwellings for one hundred and sixty four families in sixty two buildings, each placed at the proper angle to obtain the best exposure to the sun and each surrounded by generous open spaces of attractively landscaped gardens and recreation areas for children and adults. In addition there will be room for an attractive Administration Building containing a large meeting room, a craft room and kitchen facilities, as well as offices and shop space for administration.

It is interesting to observe that all except fourteen of the buildings will be one story in height and that no building will contain more than four families. Actually there will be eight single family houses and thirty of the buildings will contain but two families





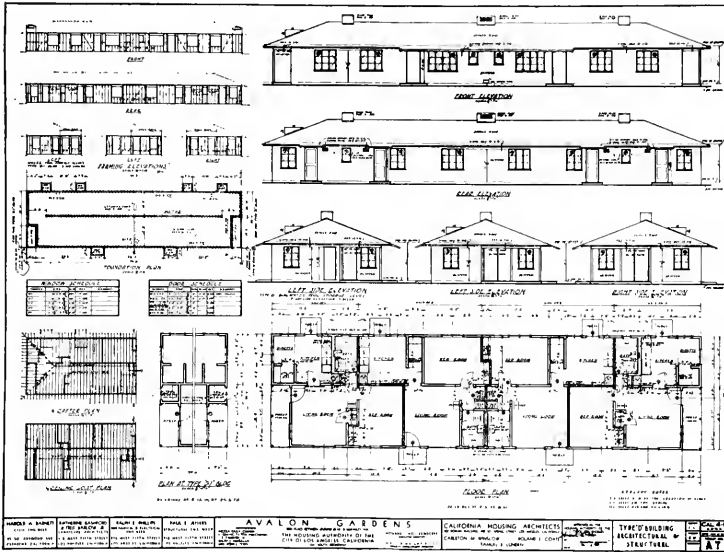
each. The two story buildings are located farthest away from the public streets.

The site as now planned will give maximum privacy to the occupant and there will be one continuous roadway, known as Caliburn Drive which will give easy access to all the buildings and to well distributed and commodious parking areas. The houses are located so that they form courts, with service and laundry yards in the most convenient yet inconspicuous positions, and at the same time the houses will face the landscaped areas containing private walks.

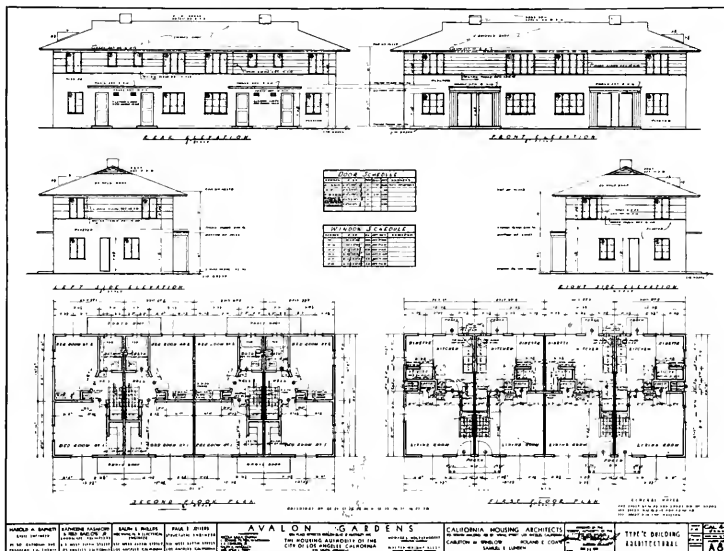
The dwelling units themselves will vary in size, offering the choice of one, two, three or four bedrooms besides the living room, kitchen and bathroom. Each kitchen will be equipped with an electric refrigerator, gas range and a sink and laundry tray set in a tile drainboard. Buildings of the Avalon Gardens Project will be constructed with wood frame walls and single roofs. The exterior walls will be colored stucco with horizontal wood siding on the upper parts of the two story units only. Window areas are unusually generous and will provide light and ventilation to a degree seldom found in living quarters of unsupervised low cost homes. The architects have stressed the importance of privacy, domestic character of design and neighborhood and site appropriateness.

Where is there a neighborhood of low cost houses that would not be improved by a model group of this kind? Where is there a neighborhood that would not welcome such a development as a visual example in community planning?

Associated in the preparation of plans for this neighborhood housing project are Carleton M. Winslow, Roland E. Coate and Samuel E. Lundén, architects.



The three drawings on the opposite page are Architectural and Structural Details and Plans for Types A, B and C Buildings. Plans for Type D Building are shown above.



Architectural Plans for Type E Building, Avalon Gardens Housing Project, Los Angeles.



National Defense Homes Corporation of which Jesse Jones is head, is experimenting with this novel type of home at Falls Church, Va., from a patent applied-for design by Wallace Neff, architect, of Los Angeles.

## BUBBLE HOUSES FOR DEFENSE

By FRED W. JONES

**New** construction technique employing the combination of inflatable rubberized cotton fabric balloon forms, over which concrete is shot by the gunite process, currently is being demonstrated on a Defense Homes Corp. project at Falls Church, Va., near Washington.

The balloons, which may be made in either hemispherical or semi-cylindrical shape of any practical size desired, may be removed after the initial layer of gunite has hardened for 24 hours and be used again for subsequent units. Possibilities of application of this new building process to farm houses, stables, granaries, all other types of farm buildings as well as city dwellings, warehouses, ammunition magazines and countless other construction jobs immediately suggest themselves.

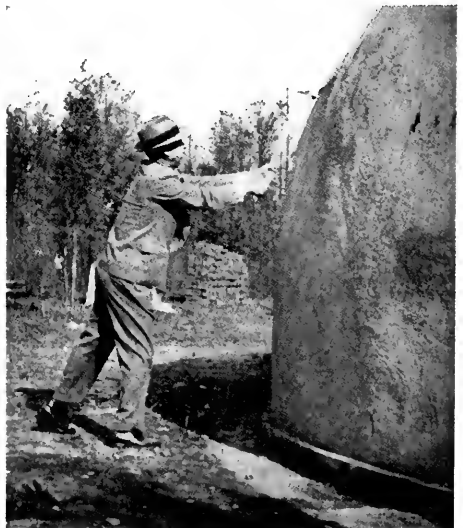
### ARCHITECT NEFF SAYS—

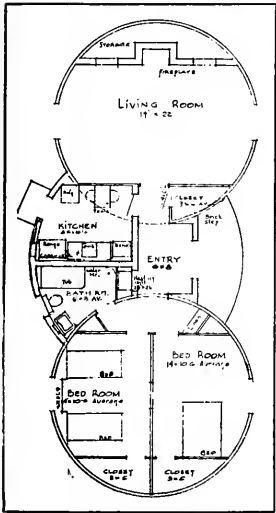
—We are experimenting with various shaped balloons, including one with a square bottom and one with a rectangular bottom, with a semi cylindrical top. How far we can go with different shapes I will not know for some time.

—One of the interesting phases of this type of construction is the fact, that by using only  $\frac{3}{4}$  pounds per square inch air-pressure in the balloon, and working from the top down, the ceiling height is dropped and more head room gained at the side walls. A section through the finished shell is somewhat of an ellipse.

—We are figuring now on powder magazines, gas and oil storage tanks, and small hangars built with the same system.

Testing the strength of gunite shell of Neff System house by hammering it with an ax. Contour of the shell affords head clearance on the interior very close to the wall as may be noted by the figure of the man swinging the hammer.





Upper picture is rear view of Wallace Neff's "Bubble House." Below it is the plan and at the right a model of one hemisphere. Architect Neff is an expert on fireplaces. All bubble houses have one like that illustrated.



# INFLATED BALLOON PROVIDES FORM



**Construction methods: Pictured from top down—(1) Laying out the balloon form; (2) Method of anchoring; (3) Inflating canvas with compressed air; (4) Mounting window frames and dusting balloon so cement won't stick to it.**

The Falls Church Defense Homes project is devoted to the production of attractive, inexpensive dwellings, each comprised of two hemispherical sections erected several feet apart and connected with covered areaway divided into entrance hall, bath and kitchen.

One of the hemispheres is divided by a wall into two ample bedrooms and the other is a spacious living room with fireplace. A surprising amount of closet space is obtained by taking advantage of the corner areas wherever vertical walls are joined to the arc of the outer shell, or dome.

Originator of the balloon building process and designer of the houses under construction at Falls Church, is Wallace Neff of Los Angeles, whose residence work for some of Hollywood's best known movie stars, has been shown from time to time in this magazine. The balloons, or inflatable hemispheres, were especially designed for the purpose by Goodyear Tire & Rubber Co.

Vern D. Case, head of the Case Construction Company of San Pedro, California, and builders of the balloon houses, estimates that concrete houses identical or similar to those now being erected at Falls Church could be produced at the rate of 100 in 60 days or 200 in 90 days, using only four balloon forms in the construction cycle.

Outline of the building processes employed on the initial project gives best insight to the almost unlimited possibilities for this type of construction for housing, farm buildings, barracks, dormitories, hangars, warehouses, and various other building enterprises.

First step is preparation of a circular concrete floor, or base, approximately 23 feet in diameter. Spaced at frequent intervals around the outer perimeter and imbedded in the concrete are steel hooks which are used to anchor sections of small pipe bent to the same arc as the circular base's circumference.

Flat side of the uninflated balloon is laid out on the concrete base. Entirely around the base, or flat side of the balloon is a series of grommets, or eyelets and these are tightly laced to the hook-anchored pipes with stout cord to hold the balloon firmly in place. The balloon is now ready for inflation from an air line to a pressure of approxi-



# OR NOVEL DEFENSE HOUSE

mately one and one-half pounds to the square inch.

When fully inflated the balloon is dusted with a compound to prevent concrete from sticking to it. The whole hemisphere next is covered with two-inch, 16-gauge welded wire mesh, to serve as a bond for the concrete which is shot over the entire balloon to a thickness of approximately one inch by the gunite process. Framework for doors, windows and other desired apertures are fixed in place before applying the gunite, so concrete can be shot around them, making the frame an integral part of the shell.

The concrete used has a high strength factor and dries quickly. The gunite mixture's strength factor is approximately 7,000, compared with a strength factor of 2,000 for ordinary concrete.

It takes between two and one-half to three hours to shoot the concrete for the shell and 24 hours later the balloon may be removed and set up for the next section.

The outer surface of the resultant inner-shell is vapor-sealed with an asphaltic base compound, applied by stiff brush and the structure is ready immediately for application of insulation. Insulation in the form of ground pulp in an asphalt emulsion may be sprayed on to a thickness of approximately one and one-half inches, or a specially prepared blanket of the same thickness of balsam wool may be applied in even shorter time.

Over the insulation again is placed a covering of wire mesh and the final coat of gunite is applied to a thickness of between two and three inches. After the outer layer dries, the building may be painted any desired color with paints which permit breathing so that any trapped moisture may escape.

Interior fitting and decorating proceeds in the conventional manner.

Gunite consists of standard Portland cement and sand mixed dry and carried from the mixer by a conveyor into a cement gun. The mixture is forced through rubber hose to the nozzle in dry form. Another hose brings water to the nozzle and hydration takes place as the concrete ingredients are emitted together.

The balloons are of tough rubberized cotton fabric construction, quite similar to that employed in the production of automobile and truck tires.



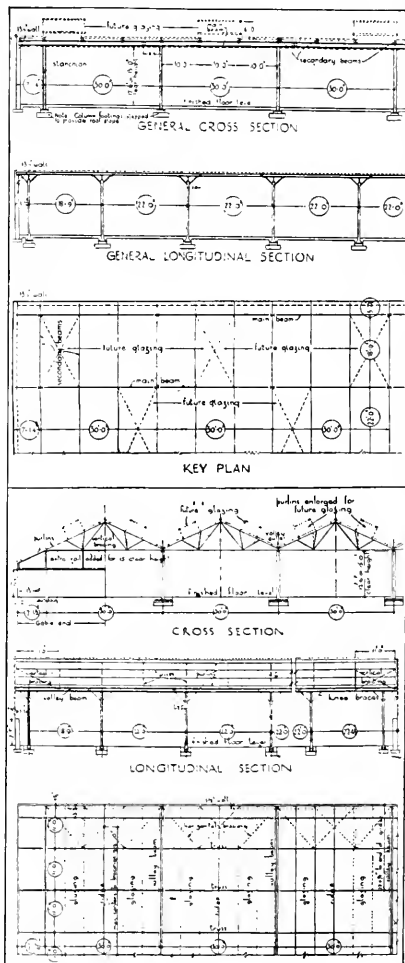
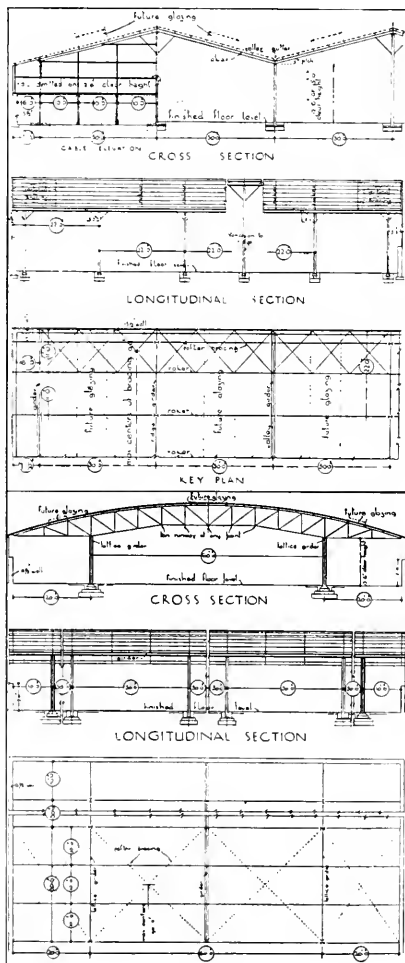
**Construction methods: Pictured from top down—(1) Gunite or concrete shooting unit at left in background. Concrete base for half of housing unit in foreground; (2) Shooting Gunite onto chicken wire; (3-4) Front and side views of completed house.**

# WARTIME FACTORY DESIGN

## As now practiced in England

The design of factories in wartime introduces many problems that are of no account in days of peace. During the first two years of war in England, architects and engineers have been giving special study to these problems and the information which follows only recently has

been assembled in a special wartime bulletin which should be of considerable value to architects and engineers in this country. The bulletin is from the British Building Research Station. Right now new factories are springing up in England in great numbers, to replace those



that have been bombed or to provide increased capacity for those that have been unharmed. The new construction is marked by some radical changes in design which our own engineers may find it expedient to study.

The designs have been prepared in the light of experience of air attacks and offer not only the advantages of standardization as regards economy in the use of steel, but also are so planned as to make the best possible use of effective camouflage.

In order to render the buildings inconspicuous from the air the roofs are either flat, with concrete roof slabs graded slightly to discharge rain water, or are double-pitched at 15 degrees.

The saw-tooth roof is apparently abandoned entirely.

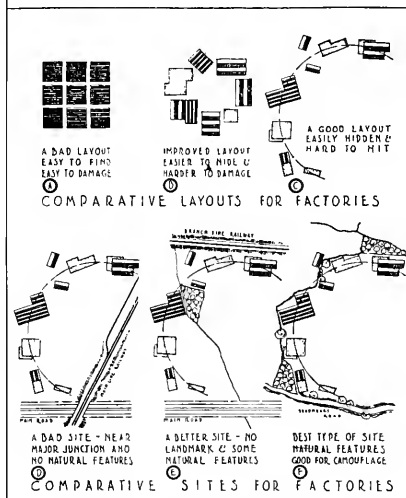
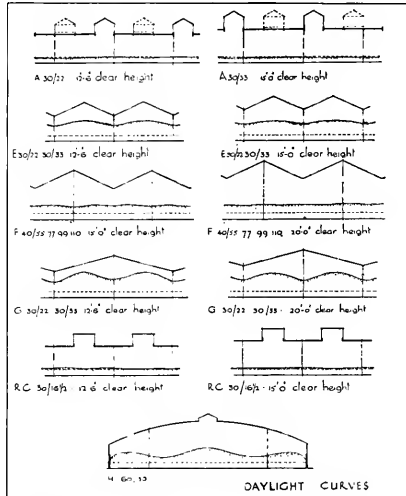
Another alternative is a low curved roof truss for the spanning of wide bays. All roof glazing is omitted but provision is made for the insertion of roof lights if the factories ultimately revert to peace-time production. In the case of the concrete roof slab, low upstands are built in place for this purpose and temporarily covered with precast slabs. Artificial lighting is required under wartime conditions.

In the designs with sloping roofs light corrugated steel sheeting is used for the roof covering. The stanchions are of standard rolled beam sections and the roof girders, rafters and purlins are also standard sections requiring a minimum of fabrication. The stanchion footings vary slightly in elevation so as to provide graded flat roofs or valley gutters as the case may be. The spans of end bays are reduced so that the same roof girder sections may be used throughout.

The outer walls are brick masonry, the roofs are cantilevered outwards to provide wide overhanging eaves. Beyond the outside roof lines on one or more sides are built irregular earth banks from material excavated from the floors. The outer slopes of the banks are flattened and turf-covered, and camouflage netting connects the edges of the roofs with the banks. The same care in the provision of camouflage is displayed during the building operations, each day's work and all necessary plant and materials being suitably covered or

otherwise masked. The access roads are made to resemble rural roads, and every advantage is taken of natural features such as hedges and trees. The buildings are not sited in a regular pattern but in an apparently haphazard fashion.

The factory group may include buildings of different standard types, according to their practical purpose or functions. Some processes may be satisfactorily served in buildings of relatively small bays where assembly operations may require wide clear spans. Where



The top drawings show the daylight curves of different types of factory construction, now being used in England. Below, comparative layouts for factories and their relation to natural objects.

there is considerable danger from fire, caused by incendiary bombs, the concrete slab roof types are used. Design type A employs steel stanchions and roof girders in bays of 30 ft. x 22 ft. or 30 ft. x 33 ft. and design type R.C. covers precast reinforced concrete column and beam construction in bays of 30 ft. x 16½ ft. Protection against the spread of fire in all types of buildings is obtained by interior brick walls carried right up to the roof covering. Door openings carry manually-operated fire-proof doors on both sides. Roof slabs are of continuous construction even when precast units are incorporated.

Design type E comprises steel stanchions and light double-pitched trusses of 30 ft. span, the valley gutters being placed over the stanchions and valley girders. The trusses are spaced at 11 ft. centers to give bay lengths of 22 ft and 33 ft. Design type F is also a double-pitched roof system with bays 40 ft. wide, but the trusses have their apexes over the column lines and the valleys at the centers of the span. The roof trusses are cantilevered each way from the supporting lattice girders running over the columns and providing bay lengths in spans from 55 ft. to 110 ft. Roof truss lines are connected throughout and, as in all trussed roof designs, there is a liberal use of lateral bracing to prevent spreading collapse due to damage in any section.

Factory type G utilizes alternate lines of tall and short columns carrying roof girders on which rest raking rafters, giving another type of double-pitched roof. The bays again follow the standards of 30 ft. x 22 ft. and 30 ft. x 33 ft. In factory type H a curved chord roof truss provides a central bay width of 60 ft. and two side aisles of 20 ft. covered by the cantilevered

ends of the trusses. The stanchion and truss spacing is 30 ft.

Recommendations are also made as to the provision of air-raid shelters for the personnel of the factory. Such shelters are independent self-contained units of either the surface or the sub-floor type, depending upon the nature of the ground and the depth to the water table. As it is recommended that the factory buildings should not exceed 200 feet in any one dimension it would not be necessary to move more than 100 ft. to reach one or other of a series of shelters arranged around the perimeter of the building. For larger floor spaces island shelters may be constructed on the factory floor where they do not interfere with the flow of production. Surface island shelters, however, should not be used in places where the inmates might be trapped by a fire. On the other hand a series of sub-floor shelters with inter-connecting passages could be used by firemen to gain access to the center of a fire. Separate shelters are required for all buildings, including canteens, the size being designed to accommodate the greatest number of persons likely to be engaged, at one time, in the vicinity.

Surface shelters are recommended to be monolithic units of reinforced concrete including floor walls and roof slab. Alternatively reinforced brick walls may be used; when built over the factory floor the two floors should be separated by a sand course or by a layer of bituminous fabric. This will enable the shelter to move bodily without collapse. Sub-surface shelters, also in monolithic concrete units, are separated from the factory floor. Stairs are in two flights, preferably at right angles with a landing between, so that workers can jump down with safety.



UNION HIGH SCHOOL GYMNASIUM, PHOENIX, ARIZONA

Lescher and Mahoney, Architects

## H. S. GYMNASIUM AT PHOENIX, ARIZONA

*Laminated truss arch eliminates all columnar supports*

**A large** high school gymnasium-auditorium of architectural concrete, with a four way broach lamella roof and other ultra-modern features, has been completed by the Work Projects Administration for the Union High School at Phoenix, Arizona, and is now being used by the sponsor.

Of first importance among various unusual features of the building is the domed roof, which rises to a height of fifty-seven feet above the floor and covers the 14,000 square feet of gymnasium floor without any columnar supports.

A patented process, the laminated truss arched dome roof rises from all four walls and is made up of many pre-cut pieces of 18-inch timber held together with bolts. It covers a roof area 144 feet square and weighs an esti-

mated 500,000 pounds, with the entire weight resting on specially designed reinforced concrete beams along the top of the four walls. The horizontal thrust is taken by long two and one-half inch tie rods.

The outside covering of the dome is sheet metal, except for a large area around the periphery which contains a skylight system of diamond shaped metal frames and double panes of wire glass, which admit ample daylight. Floodlights provide night-time illumination, and a movable monorail car suspended underneath the dome permits repairs to the skylight and replacement of floodlight bulbs.

The laminated truss arch was installed by private contract and is among the largest of its type in the United States.

Covering an area 140 feet by 200 feet, with



**Interior of Union High School Gymnasium, Phoenix, Arizona, showing Lamella type of roof construction.**

a height of 34 feet from floor to eaves, the gymnasium-auditorium monolith includes a concrete slab flat deck roof area 30 feet by 140 feet, covered with composition roofing, at each end of the long way of the building.

In addition to the gymnasium floor area 100 feet by 140 feet and two overhanging tiered balconies 14 feet above the floor, the structure contains spacious shower, locker and toilet rooms each 30 feet by 36 feet. One of these is a hospital room and the other are for radio, electrical, photograph, and industrial arts, health and other classes, and for band, orchestra and glee club use.

Designed for the use by conventions as well as a gymnasium, the building has a balcony seating capacity of 3,000 or more and a space on the main floor underneath the projecting part of the balconies for telescoping seats to accommodate 1,500 persons. This capacity can be increased to 8,000 by use of the entire main floor for seats. The wood and steel seats of the balcony are bolted solely to the back of

each successive concrete tier, thereby leaving the under part of the seats free of supports, to provide more aisle room and ample space for spectators' feet and legs.

Another distinguishing feature is the arrangement of the main entrances in each of the four corners of the building, which were designed to conserve floor space. A marquee projects over the double-door entrances on the outside and on the inside of each there is a small lobby. From each lobby there leads upward to the balconies a ramp or incline, instead of stairways, which are illuminated in daytime by a liberal use of glass bricks inserted in the walls above each entrance. There are eight ground-floor exits in addition to the four main entrances.

The floor of the gymnasium-auditorium is six and one-half inches thick. The base floor contains 14,000 square feet of concrete three and one-half inches thick, or enough concrete to lay a sidewalk five feet wide and more than

[Turn to Page 54]

# AIR RAID SHELTERS FOR SAN FRANCISCO

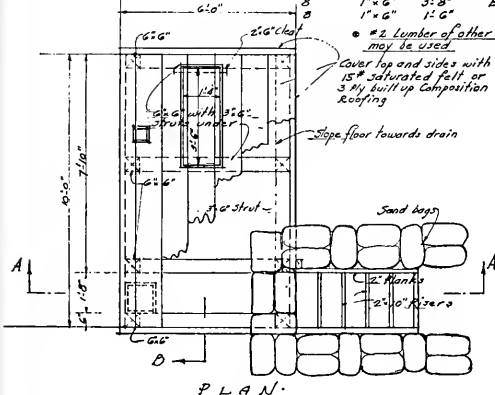
The Air Raid Shelter Committee of the San Francisco Civilian Defense Council believes that bombing, if any, would be sporadic in character, and that the information available does not warrant the construction of residential air raid shelters. However, the Committee feels that each individual citizen should have the opportunity of deciding the extent of his protection for himself, and in order that the public may be informed regarding some of the various types of unit air raid shelter construction, the Committee presents the following information as to methods that may be followed at the option of the citizen. It should be noted that in case of a frame house having no masonry wall construction, a reasonably safe protection from splinters is found by lying on the floor of an interior hallway. In case sand sacks are used around this hallway, these should not be more than two sacks high in order not to overload the floor construction. It should be noted that books held by boxes can be used instead of sand

Size	Length	Location	No. Pieces	Size	Length	Location
6" x 6"	6'-0"	Cap	1	2" x 4"	10'-0"	Side
3" x 6"	5'-0"	Strut	6	2" x 12"	6'-0"	"
6" x 6"	5'-10"	Post	1	2" x 4"	8'-0"	"
2" x 8"	10'-0"	Sill	7	2" x 12"	6'-0"	End
4" x 4"	5'-0"	Strut	1	2" x 12"	8'-0"	"
3" x 6"	3'-2"	"	1	2" x 12"	9'-0"	"
3" x 6"	1'-8"	"	1	2" x 12"	10'-0"	"
3" x 6"	3'-0"	Wedge for Roof	1	2" x 12"	11'-0"	"
3" x 12" (Cut)	10'-0"	Top	19	1" x 12" size	10'-0"	Fiber
3" x 4"	10'-0"	Side	2	2" x 12"	6'-0"	Bench
2" x 12"	10'-0"	B	8	2" x 4"	1'-6"	"
			5	2" x 10"	2'-2"	Steps
			4	1" x 12"	2'-0"	Well
			4	1" x 6"	3'-0"	Vent
			8	1" x 6"	1'-6"	Exit

• #2 Lumber of other widths may be used

Cover top and sides with 15# Saturated Felt or 3 Ply built up Composition Roofing

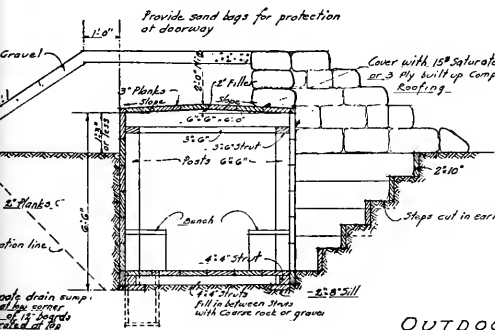
Slope floor towards drain



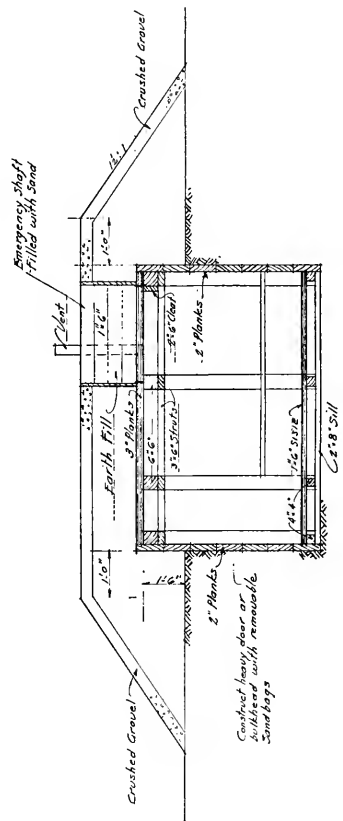
PLAN

Provide sand bags for protection at doorway

Cover with 15# Saturated Felt or 3 Ply built up Composition Roofing



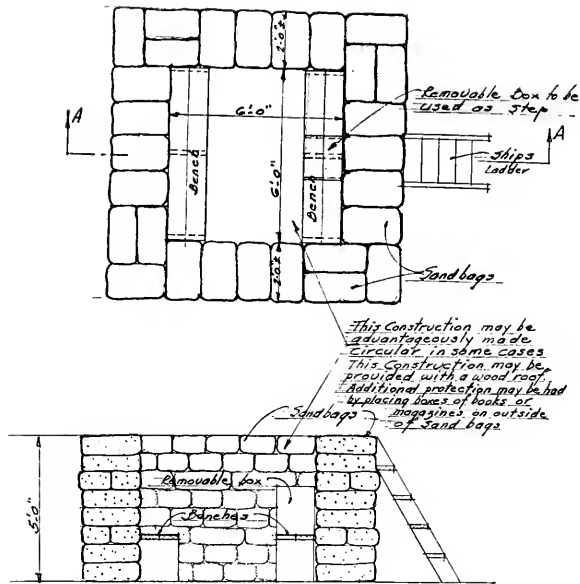
SECTION A-A



SECTION B-B

OUTDOOR AIR RAID SHELTER - SAND FORMATION FOR EIGHT PERSONS TYPE 3

Scale 1/8" = 1'-0"



**Plan and Section, a shelter for six persons prepared by the San Francisco Civilian Defense Council**

bags; also that a well-built table covered with books located in such a hall can be utilized as a protection against any vertically falling splinters.

Protection against direct hits of explosive bombs is impossible to provide, as the force of such explosions cannot be resisted by ordinary construction. The methods described herein are for the purpose of affording some protection against the impact of flying bomb splinters, glass, and other lateral impact.

For protection inside the house, a space on the ground floor may be selected. This space, if provided with masonry walls on four sides, would give reasonable protection. If all four sides of this space be not protected with masonry walls, then the sides not so protected may be protected by sand bag construction.

A type of outdoor shelter is shown here. But the interior shelters are in general considered more advantageous than the outdoor type. The outdoor type is more expensive and has disadvantages of dampness and unhygienic conditions.

In all air raid shelters there should be kept tools such as an axe, a small crow bar, a shovel, and a supply of water and sand.

Further information will be developed on this subject, and this Committee will continue its investigations and will probably issue additional bulletins giving further data from time to time for the information of the public.

The National Civil Defense Committee is working on the technical study of design of shelters of this type, and when the results of their studies become available, an additional bulletin will probably be issued.



# THE QUESTION OF AIR RAID SHELTERS

By MICHAEL GOODMAN, Architect

Let's see what a lay person observes from the easy-chair entourage of Harpers magazine.—"Everyone is excited about the local defense program, and there is a pleasing confusion in all quarters—the sort of confusion which makes democracy so lovable and so frightening. The absence of the enemy, the unlikelihood of his soon appearing in military guise; these give the whole thing a certain incredibility without lessening its intensity."

Why not! Democracy creates in its own image. At least up to last December 7th when the "business as usual" attitude in a politically organized country couldn't mobilize the machinery of production of the so called feudal industrial set-up.

A letter from London's breathing spell concludes by saying that one has to go on as "usually" as one can. This is not the old attitude, which, as the Chinese see it, is only a "treasured trait of forgetfulness inherited from our ancestors."

A maze of information was published on the subject of civilian air raid defense by the countries striving to devise means and methods of passive defense.

It became evident, according to authoritative conclusions, that as long as there is no effective scheme of defense against aggression from the air (other than by defending the air) the citizens of the countries at war will have no other choice but to dig deeper and deeper into their native soil; in fact at a rate of about 10 ft. per year, since China and Spain. "Air raid defense should be planned with a view on the air raids of tomorrow," said Wachtel in his book.

In Europe, after a long process of adjustment during the Renaissance, knowledge developed among the nations that means of defense should match those of the offense. Urban populations were bled white to pay for adequate protection of the cities. Incidentally, the huge post-war housing schemes projected in Germany lay much stress on bomb-shelter

provisions.

What is the cost of safety? This question comes up in view of the possibility that Government authorities may regard, at least for the present, as out of order the building of air raid shelters on any large scale. Labor and materials may be diverted too much from the essential defense effort for widespread public shelters.

Does it mean that it is to be left to the duty of every resigned householder to protect his home and family to the fullest extent of his ability? It must be kept in mind that whereas the total war plans, as envisioned by the Prussians and the Italian General Drouhet, marked civilian populations for a prize or for destruction, the military of the democracies do not take into account the problem of protection of civilians; at least not until recently.

General Groves stated "It is clear that the ability of a country successfully to withstand modern air attack may, in the last analysis, depend upon a well organized and determined passive defense."

In order to provide reasonably safe protection per dollar for the city of San Francisco, a sum of about \$35,000,000 may have to be spent. Who knows, perhaps it may be cheaper to learn to maneuver with the armies involving entire city populations as it has been exemplified in Russia.

The legislative period after the Santa Barbara earthquake concerned itself with matters of reasonably safe construction practice in order to protect life and limb in the future. At no time was it regarded feasible to consider the cost of absolute safety of buildings, since such safety was held economically impossible. The present reminds me of those controversial days. The Japanese, however, build with extravagant looking bracing methods in metropolitan districts, for safety, despite economy.

It must be said in passing that with only hind-sight to draw upon, it is difficult to define what techniques of construction and type of materials may be involved in shelter design.

Editor's Note—This general discussion of air raid shelters by Mr. Goodman is in response to the Editor's request immediately following the declaration of war.

Construction design is a factor of machines and tactics of warfare. The military say that San Francisco and the Bay Region is an ideal target. As to whether it may be bombed, there is an argument raging and involving the question of air power. One side claims that we are probably witnessing an all-time high in city bombing, and may reasonably expect the effectiveness of baby-killing to decline rapidly in the future. By the way, deaths by accident have diminished in England since the war; and casualties due to suffocation and hits by debris run into a high percentage compared to those caused by falling bombs. Since the problem of air raid shelters, or resisting mediums against bombs, is essentially a problem of location, design and construction of such shelters, we need an intelligently authoritative organization, legally implemented, instead of several groups fruitlessly hindered by lack of coordination.

In fact we have one, a committee appointed by the State Association of California Architects, which we must support, since we are thrown on our own initiative. This committee is to advise on air raid protection.

When the Tecton group in London went after public attention, they pointed out in their excellent book that the problem cannot be limited strictly to the actual protection of life. There are also many psychological, political and organizational aspects. That the public should be given the fullest confidence by means of complete technical elucidation which would allow them to satisfy themselves that the proposed protective measures are adequate.

The fate of architects in modern society is rather odd. In time of peace architects are abandoned almost without any organizational check to the free play of their fantasy, imagination and inventiveness. The public holds them to no accounting but limits itself to collecting, at the unexpected hour, whatever benefits architects bring it. When war is at hand, although architects (or engineers) remain not one bit better organized than before, the nation, as in the case of France or England, suddenly expects them to produce something overnight. Let us hope that the public does not ask indignantly: "What are the architects

and engineers doing? Is this the failure of their arts?"

We, as members of the profession with the coordination of the A.R.P. Advisory Board of the S. A. of C. A., must make our own deductions and tend to work out regional conditions to fit our pattern. It is not enough to be a diligent reader of past research.

Such agencies as the U. C. testing laboratories and others may be given grants for experimental tests of available building techniques and materials with a kind of labor devised not to detract from the defense effort.

There are methods of solidification of earth when other materials are not available.

We know that hills and open spaces are helpful. We ought to look closer into the methods of blast wall construction of powder factories.

In England this influenced construction of new factories. We may employ concrete cribbage construction whenever possible.

The Chinese are successfully using a method of bamboo construction against heavy splintering. Except for the incendiary aspect, the wood agglomerate of our cities may offer fair shelter possibilities. Some of the A.R.P. Advisory Board Bulletins are dealing with the outdoor, indoor and refuge room shelters.

We must have an organization of architects and engineers that could give professional advice to the public and render estimates of construction through reliable contractors in the course of a day's work. Insurance must be made available as well as loans of cheap money.

To quote from Bulletin No. 2 on professional policy for architects and engineers, published by the Air Raid Protection Advisory Board:

Architects and engineers should first consider what policy they, as professional men, can best adopt when consulted by householders, building owners or industrialists on air raid protection. High pressure salesmanship is, of course, "out." Nor is it the function of the architect or engineer to urge the need of air raid precautions. That is the function of official bodies and, in the last resort, the individual will decide for himself the degree of protection he should have.

(Turn to Page 39)

## SOUND STACKS FOR NOISE ABSORPTION

In connection with defense activities construction of effective sound stacks for the absorption of noises set up by airplane engines and propellers while they are being tested, presents a number of problems. In the case of several recent sound stack installations the use of Fiberglas thermal insulating wool as the sound absorbing material is said to have proven most effective.

Among installations in which this material has been used are the sound stacks at Patterson Field, Dayton, Ohio; the naval air bases at Cavite, P. I., and the Midway Islands.

Sound stacks are regarded as much more than research gadgets. They are necessities because modern airplane engines are so highly powered that under testing they develop intense noise vibrations. Moreover, they are needed to prevent deafness among workers and annoyance to nearby residents.

A test stand for aircraft engines usually consists of a test cell in which the engine is mounted, a control room directly connected to the test cell, and two sound stacks through which air enters and leaves the cell. The sound stacks serve to admit and discharge air put in motion at high velocity by the engine propeller, and, at the same time, must absorb a large percentage of the noises generated by the engine and propeller in action.

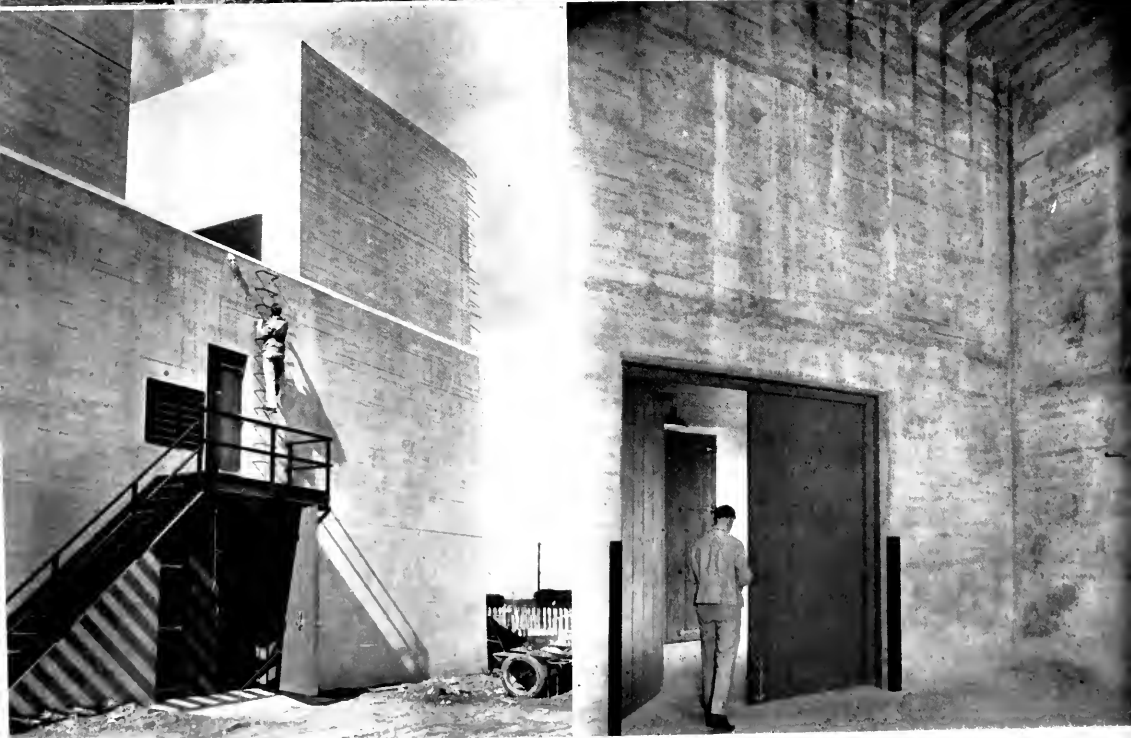
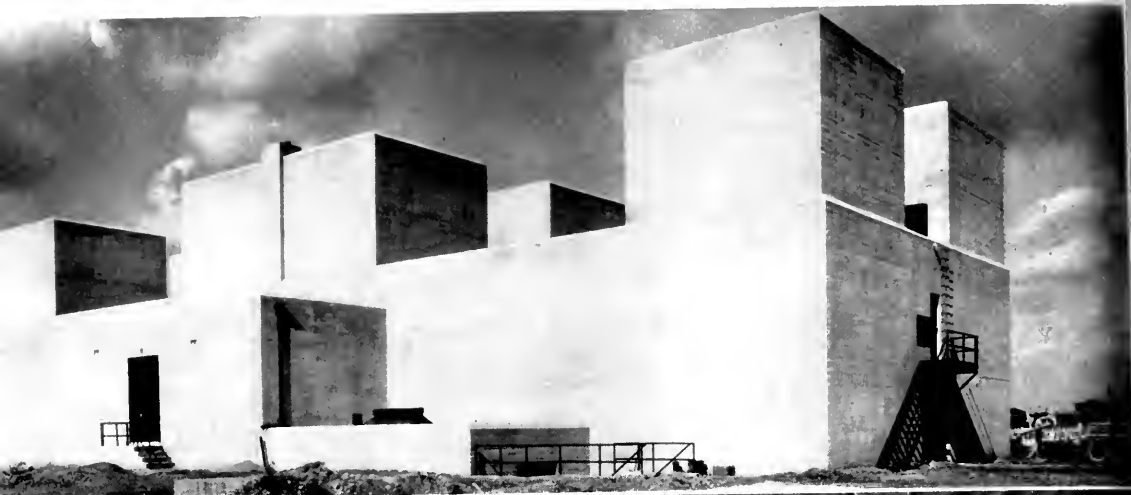
The stacks may be above the test cell, or they may be at the test cell level. One typical installation employs vertical sound stacks about 40 feet high with a 20-foot square opening. In each stack, space is provided for 15 sound absorbing panels, each measuring 20 by 20 feet.

A horizontal stack about 30 feet deep with a 45-foot square opening provides space for 33 sound absorbing panels, each 45 by 24 feet.

The usual practice is to install bats of the Fiberglas insulating material between perforated metal sheets in the form of pans or other similar units. The pans are installed as baffle plates. Exact methods of assembly, details of the size and disposition of the perforations, spacing of the panels, etc., are all matters within the control of the designer.



Interior view of inlet stack, looking up through the stack from a test cell floor, showing how Fiberglas bats are installed between metal sheets, and spacing of baffle plates.



(Top) Exterior view of test stand building. Inlet stacks for the four test cells are on the corners of the structure; outlet stacks in the center each serve two test cells. (Above—left) Exterior view of inlet stacks. (Above—right) Interior view of test cell, showing height from the cell floor that sound-absorbing baffles of Fiberglas pads are installed in an inlet stack.

# AMERICAN ARCHITECT DESCRIBES LONDON

## AIR RAIDS

**Architects**, engineers and members of the building industry generally will doubtless find much of timely interest in a recent talk before the Detroit Chapter, A. I. A., by C. Howard Crane, distinguished architect of Detroit and London, here on war business. Reporting Mr. Crane's address, Talmage C. Hughes, editor of the Weekly Bulletin of the Michigan Society of Architects, comments that when war was declared in Britain Mr. Crane expected his practice to cease but on the contrary it greatly increased, due to the fact that he had been identified with a number of industrial projects prior to the outbreak of hostilities and with the need of additional structures of this type his services were at once in demand. One of the interesting points brought out by Mr. Crane in giving details of his experiences, was the discovery that one half inch asbestos has proved to be the best bomb proof roof, the reason being that the bomb goes right through it but does little damage to the roof structure proper.

The British are wasting few bombs on the civilian population of Germany, he said, but are concentrating on military objectives. Berlin could be bombed easily, but in the words of Mr. Churchill, "Business before pleasure."

Architect's fees are good, Mr. Crane says; they want you to make a lot of money so you can pay a lot of taxes. He believes the quantity survey system, paid for by the owner, in England is a good one. The chief difference between an English office and an American office, he said, was the fact that the English are always eating, a spot of tea, coffee, etc. English architects are more like artists, and not so commercial. One refused to have a telephone because it would disturb him when he was making a perspective.

"The thing that is going to be most interesting to architects, I believe, is an idea of the general living conditions at the moment, the

effects in London and in England of the bombings and just what plans are being made in connection with post war reconstruction. I have been asked many times just how London looks after the Blitz' have knocked down so many of the buildings. When a building is bombed the site is usually cleared up and made nice and tidy and becomes what looks like a parking lot. We have very little use for parking lots in England due to the fact that the use of automobiles is very restricted. Petrol rationing is extremely severe and for ordinary pleasure driving a person is allowed ten gallons per month. If one can prove his car is necessary to defense work, additional coupons are issued but never to the extent that it pays to own and drive your own car.

"I have been in London now for six years and during that time I must say I have seen history in the making. The first year we had the Jubilee celebration of King George the Fifth and, as you know, his death followed soon afterwards. For a short period we had Edward the Seventh on the throne, followed by his abdication which was indeed a most interesting period. The Coronation of the present King George the Sixth was another great celebration that I witnessed. Soon after this event international affairs took on a very serious aspect and in September, 1938 we experienced the first crisis. Everyone expected that war would be declared at that time, but as you all remember, Mr. Chamberlain came back from Munich waving his umbrella and a piece of paper and announced that 'There will be no war in our time.' This message of course was a great relief but I think it was taken with quite a grain of salt because England really did start to work at that time to prepare, although I must say it was rather a half hearted effort because everyone who believed in preparedness was accused of being a war monger. September, 1939 was the most dramatic of all times, when the Germans entered Poland and war was declared. Since that

time my experiences have been varied and most interesting.

"During the few years prior to the war I had been most fortunate in building up a very comfortable practice. My work was varied but I made a real effort to obtain industrial work and had secured quite a foothold in this field. When war was declared I had visions of folding my tent, like the Arabs, and returning to this country, because I could not foresee how the architects in England were going to exist, nor did I realize that my services (being an American) would be very much in demand, but as it turned out things happened just the reverse. My industrial clients began to secure war contracts which meant additions to their factories and when the government decided to disburse the industries it meant the designing and building of new plants in different sections of England, and I became very busy indeed.

"As a rough guess I would estimate that about 80% of the English architects' offices are closed. The reasons for this are several, the main one being that private building ceased entirely and those who were not used to industrial work, had no outlook. The younger draftsmen were all called into service and in a great many instances the architects themselves who held commissions in different branches of the service, quickly gave themselves to the war effort. Other architects were drafted into the Ministries to assist in the building programs as advisers and experts. The result was that the firms remaining, and especially those that were industrial architects, were flooded with work. I have no doubt that owing to the fact that I was an American and therefore presumably more advanced in matters of this kind, that I received my share.

"Special construction has to be used in connection with all vital plants and by vital I mean boiler rooms, compressor houses, transformers and switch gear and all equipment that is really necessary to the plant operation. These sections have to be protected and built to withstand bombs. We also have to consider the building of proper air raid shelters handy to the men and quick of access, first aid and decontamination centers, special fire precaution and watch towers which latter are usually on

the roofs. All factories have to be designed with blast walls. These walls are usually constructed of 14" reinforced brickwork to a height of 8' and no matter how much the area of the factory, the walls are laid out to subdivide the areas into spaces of not over 10,000 sq. ft. each. The walls not only protect the workmen but the machinery and localize the effect of bombs. All of these precautions naturally made the plants cost more and the time involved in building is longer than it would ordinarily take. At the outset of the war, when the Germans started to bomb industrial areas, the workmen left their places immediately the sirens sounded. In most cases the planes never did reach these particular factories, therefore many man hours were lost, so a roof spotter system was inaugurated, which meant that although the sirens had sounded the men would not leave their posts until the second signal or alert was given from the roof spotters themselves, which meant the planes had been sighted. This was the signal for the men to go to the shelters. This new system, of course, resulted in the saving of millions of man hours.

"With these plants working, in many cases three shifts a day, it has been necessary to build very large and efficient canteen buildings to feed the workers. This is really a war of machines, which means production must be kept at its peak, so everything is being done to cater to the workmen. In these canteens every man and woman is given one hot meal during each shift.

"The blackout, of course, is another big problem and a great deal of study has been given to this subject. Very few windowless buildings are being built but where windows are being used only about one third of the area of the sash is being glazed, the remainder of the panes being filled in with steel sheets or asbestos, so that after the war these panels can be removed and glazed and the buildings used in a normal manner.

"They tell a good blackout story—they tell it about drunks too—anyhow I think it will bear repeating. 'It seems that two men were driving in the country one very dark night. No lights of any kind were showing and as their headlights are reduced to a spot the size of a quar-

ter, their visibility was very poor. Finally one man said to the other, 'I think we are coming near to a city,' and the other asked, 'How can you tell?' and the first man replied, 'we are killing more people.' "

"There was a period last winter when we had ninety straight nights of bombing that was anything but pleasant, but we went to bed every night hopeful and woke up thankful. There is not much one can do evenings like these except to stick close to the fireside and do a bit of fancy dodging when things get too close. My house was a sort of rendezvous for other American men whose families have evacuated to America, with the result that it became sort of an annex to the American Club and we play a lot of bridge and do a little fancy drinking to keep our minds occupied. You can catch up on your reading also, if you can concentrate during the barrage. Shrapnel from the guns is wicked stuff and it comes down like rain when the guns are really going.

"You all no doubt have read stirring accounts of the London raids and have even heard them on the radio, but I assure you it is all quite different when you are actually there. When the first daylight raids commenced, which resulted in the Battle of Britain, everybody was keyed to a great pitch. What was the score at one o'clock?—German planes 119, English 17, that's better than yesterday—jolly good show! The ticker services ran the scores almost hourly. As Mr. Churchill so ably said, 'Never was so much owed to so few by so many.' One really had to be there to fully realize the import of those words.

"When the Germans realized that they couldn't lick our handful of fighters, even with their greatest number of planes, they started their indiscriminate night bombing to terrorize the civilian population. Here is where they made another great mistake because those people just don't get terrorized or panicky. People just dug themselves in and said, 'Let 'em come,' and they surely did. For months you could set your watch each night at 7:00 o'clock by the first sirens and rarely did we get 'all clear' until 4 or 4:30 in the morning.

"The theatres all closed except the day-time shows and very few cafes and restaurants were

in operation because people just couldn't get out. When those Ack Ack guns start, traffic stops because the resulting shrapnel will penetrate taxicab roofs and just ruin buses. Wherever you are, you stay put, so it was very wise in those days to get home early. Each month the death rate ran around 7,000 and the casualties about 15,000 in London alone. 50% of these were women and children and hospital patients, so it was at that time a real civilian war. When a man was called up into the service, his friends would give him a white feather, saying, 'So you can't take it—you're getting into the army where it's safe.'

"It's the civilian, too, who is rationed for food and clothing and it's this same civilian who is working in the factories and offices of the Ministries to win this war. No doubt the soldier will get his chance, and let's hope it will be soon.

"The Navy is, of course, doing a grand job too and it was amusing to see the newspaper headlines when the English Navy drove the Italian Navy out of the Mediterranean. They read, 'English win Boat Race.' You can't beat people with that kind of sense of humor.

"I would like just to mention the Home Guard Army and the part a few Americans are playing in it and the activities of the American Eagle Club.

"With the Dunkirk incident, everyone in England expected an immediate invasion and that is when the Home Guard came into being. A civilian army sprung up over night and with clubs, pitch forks and an occasional musket—just like our Minute Men at Lexington—they drilled on the village greens and they were a real determined lot. The invasion didn't come but these men have not let up. Today the home guard is a very well equipped and trained army of one and a half million men—trained to guard their homes, their castles. They know every inch of the ground each division is assigned and they are hoping and praying for an invasion. Would they like to get a real crack at those Jerrys?

"In London a group of about 60 American business men (I was one of them) formed a unit of this Home Guard. We all wanted to be in this thing. We at first found that we were quite

out of order and that we might even lose our citizenship in the United States if we persisted in joining up with an army of another country, with our own country a neutral. There are many ways of skinning a cat, however, and legal ways were found. The King, by a special act, legalized our squadron and concessions were also made by our own government. We became pets too—full equipment was issued us and an armory with large drill hall, rifle range, lecture and club rooms, were placed at our disposal and a garage to house our cars. We became a mobile outfit—the only one really operating in the London area. Monday nights we have rifle practice, map reading and lectures. Thursday night we either drill or have kit inspection, and every Saturday, regardless of the weather, we go on maneuvers. Brig. Gen. Wade Hayes (who in the last war was on Gen. Pershing's staff) is our commanding officer.

The Eagle Club is a service club for all men in uniform, regardless of their nationality. You will see Polish, Dutch and Free French soldiers in London as well as Canadians, Australians and New Zealanders. Most of those men are on leave—most of them have their own service clubs to go to—but we discovered about a year ago that there were then over 5000 American boys in the Canadian forces, in England, and that something should be done to supply them with a home where hot dogs, hamburgers, coca-cola and other high-class American food and drinks could be served. The result was that a few of us got together the necessary funds and now at 28 Charing Cross Road is the American Eagle Club. It is a six story building with our flag flying on the flagpole. There are few clubs that can boast of more amenities. A fellow can take a shower bath, have his uniform cleaned, pressed and mended, get an excellent full course meal for a shilling (a quarter to you) and have the use of the lounges, reading and writing rooms and games rooms. A real efficient information department is in operation at all times and free theatre tickets are available for some of the boys. We have seventy-five volunteer workers. When I left England October first I learned that there were then 13,000 Americans in the Canadian forces. I like to tell this story—

Every Thursday we have a broadcast for the boys when they can say 'Hello Mom' and 'Hello Pop' and as they are introduced over the air the comper usually says 'And what part of Canada are you from, my lad,' the answer usually is Tucson, Arizona, or Mobile, Alabama, or some other 'Canadian' city.

"I am afraid I have digressed and really haven't told you what you came to hear, and that is England's plans for her post-war development.

"Lord Reith, a very able man indeed, is the Minister in charge of this gigantic task and already he has set up a great machine, but like all machines, before they can actually turn out the goods, tools, dies and jobs have to be made.

"In a speech at a luncheon that I attended not long ago, his Lordship made a statement that I took slight issue with and later on I was urged to write a little article on the subject.

"He said at this luncheon that before a real start could be made in the reconstruction plans of London or England, that one great question must be answered: 'Are we to build for a future of peace or a future of war?' I thought this was being a little extreme, and in my article I suggested that the country be rebuilt for a future of peace as far as living and working conditions of the people were concerned and a future of war as far as the services and safety of the people were concerned. I made many suggestions to bring about this condition, none of which were of an experimental nature and many of which had been successfully tried out in this country and others for years.

"In the rebuilding of London in particular, a great deal is going to depend on one major development—that is the electrification of all railroads entering the city, bringing the trains in underground. To definitely do this would solve so many problems. If all trains were put in tunnels and operated without steam, the fourteen major terminals now existent in London could be reduced to possibly four, thus centralizing traffic. The land acquired over the tracks would be of such value as to more than pay for such development and could be used for special housing and super-highways leading to the urban districts. The smoke and noise



nuisance would be reduced and the slum clearance problems solved. All this was done in New York thirty years ago when the railroads along Park Avenue were electrified and covered in, thus eliminating a great cancerous growth through that city, a breeder of slums. It resulted in one of the most attractive streets in the world and one of the most successful real estate developments. The problem in London is the same, only greater.

"A committee of British architects is going to visit this country in the near future in order to study post war development problems. Someone over there suggested that they visit San Francisco in order to see what they did after the earthquake. I was made a minister without portfolio to discuss this subject with members of the Institute here and I have already laid before Mr. Shreve, your president, my ideas of a program and I hope to return to England with a formal invitation to the British architects from the American Institute. Perhaps I'll return with them.

"The damage to London is not too great. A person, I am sure, could list all of the buildings that have been wrecked or destroyed in a few weeks, while it would take centuries to list the buildings still standing. It is true that certain areas are wiped out just like a big fire will do to any city. The replanning of the City of London, and by the city I mean the old financial area, would have been easier, had more buildings been leveled. As a rough estimate I would say that ninety-five per cent of the buildings that have been destroyed, should have been.

"The modern skeleton frame building, either steel or concrete, stands up to bombing very well, and the damage is usually local. Walls are knocked in or sucked out and the structure still

stands. When the same thing happens to wall bearing buildings, they of course collapse and are a total loss.

"The subject that is going to receive the most attention with the replanning and rebuilding scheme is the subject of traffic and the parking and storage of cars. Every building will be required to have garage facilities in its basement and lower floors. Large underground public parking garages will be built, which can be used in war times as shelters and first aid stations and broad super-highways will have to be constructed to direct traffic from the central areas to urban districts.

"The main hospitals will be located far out on these main arteries. They will be fairly easy of access, have better light and air and be subject to less noise. Emergency hospitals and clinics will, no doubt, remain central.

"All services such as sewers, gas, water, steam, electricity and telephone lines, should be placed in large tunnels 50 to 60 feet below the surface. This would protect these most important arteries of civil life against bombing and there again these tunnels could be so constructed that they would form deep shelters.

"London's services certainly have suffered from the bombings. It was amazing to see the masses of pipes and wires that would become exposed after a bomb had hit the center of a road and to me one of the most remarkable things about this war is the fact that outside of a district being without gas for a few days, or perhaps a few telephones out of commission for a while, there has been a minimum of discomfort, due to this cause. It certainly speaks well for the efficiency of the public utilities staffs."

---

## THE QUESTION OF AIR RAID SHELTERS

(Continued from Page 32)

The architect's or engineer's best course of action at this time is to impress upon the layman that he, as a technician in the construction field, should be the appropriate person to provide the best solution of the problem and that there is no formula or design which is applicable in all cases. He should point out that his profession is in the process of receiving information from all available sources and is

making its recommendation on the latest data available.

He can safely explain the advisability of individual surveys now so that the building owner will be prepared to execute the technician's recommendations speedily, and minus the delay and confusion that would occur without previous study of the problem.

## GIVING YOUTH A CHANCE

Editor, Architect and Engineer,  
San Francisco

Sir: I read with interest Mr. William Wurster's remarks on the subject of giving youth a chance. I am entirely in accord with his main thesis, but would like to qualify it by asking when youth stops being youth and becomes middle age. Osler recommended that everyone past the age of 40 should be chloroformed as having already become senile and useless. This would place youth as terminating at about 35 years and if this is what Mr. Wurster means, I endorse his remarks without qualifications. If, however, he wishes to extend the period beyond that 35 year line, I think his statements should be made to apply only to such younger men as really need a boost to put them on their feet.

As between the man under 45 and the man over that age, I believe the older man is the one who most needs help if we are going to make age the criterion. After a man has passed his middle thirties he should certainly be able to stand on his own feet and any attempt to load the dice in his favor more than nature has already done, would seem to be a little unnecessary.

In his remarks about the recent exposition I am inclined to think that Mr. Wurster wishes to include as youths men who have already passed their 35th birthday. Probably in this case he would have liked to see men of his own age included as he uses the first person plural in his dissertation. If this is so, his selection of the Exposition Board of Architecture to point his remarks is a very poor one since the exposition authorities definitely adopted the policy that both younger and older men should be chosen. Messrs. Pflueger, Merchant and Weihe represented the younger men of about Mr. Wurster's age classification, and Messrs. Kelham, Brown and Hobart, the older men whose experience and prestige were qualities that it was felt should also be represented. In other words, Mr. Wurster's recommendation to the Chamber of Commerce, which he quotes, seems to have been followed to the letter.

Continuing his criticism of the exposition, Mr. Wurster states that in the main the general scheme was being done "by the very people who at our age (Mr. Wurster's) had made the decisions in the 1915 Panama Pacific Exposition." Apparently Mr. Wurster has been misinformed about the 1915 exposition. The members of the 1915 Architectural Commission were Willis Polk, Chairman, George Kelham, Henry Bacon, W. B. Faville, W. S. Richardson, R. D. Farquhar, T. Hastings, Louis Mullgardt, and Clarence Ward. In other words, Mr. Kelham was the only member of the old Commission represented in the recent one. It seems unfair that his participation should be begrudged as it was largely due to his investigations and preliminary work that it was decided to create Treasure Island and build the exposition on it. He was the chief promoter of the whole idea.

As to the statement that the exposition was deprived

of "the modern thinking and fresher enthusiasm, etc.", I think that very few will agree with Mr. Wurster's premise that there was any lack of enthusiasm and modern thinking. It would be hard to excite the three young men who were actually employed on the Commission in either modern thinking or fresh enthusiasm.

The assumption on Mr. Wurster's part that a better solution could have been found for the parking facilities, if some other young men had been employed in the place of Messrs. Pflueger, Weihe and Merchant, is far from convincing. His suggestion that it would have been possible to place parking facilities so that one could park his car at any place in the grounds where he might wish to be, shows a lack of understanding of the problem that was actually present or of the conditions that prevailed, such as dates when the fill of different areas would be completed and ready for buildings and the dates when it was necessary for the different building units to be started.

When we consider the relatively small proportion of the many thousands attending the exposition who could afford cars and parking fees, one is inclined to wonder whether, provided proper parking facilities were available, the matter was important enough to call for a sacrifice of other requirements much more important. Surely it is not suggested that cars should have circulated through the crowds on the grounds, or have been parked in areas inside the system of inter-building circulation. Here again the instance used as an illustration does not seem very well chosen.

Another reference that should be challenged is the implication that the set-up for the design of the New York exposition would have been applicable here. That scheme was adapted to the enormous New York scheme, but would not have been practical nor suitable in our much smaller undertaking. It would have been unwieldy and out of all proportion to the scale and size of our exposition. The Directors did not have the funds at their disposal for any such duplication of effort even had it been practical.

There is a sort of veiled assumption in this whole reference to the exposition that, under other direction with a different selection of younger men, the exposition would have been more successful architecturally. This is, of course, possible, but it is highly improbable, as in the first place it would be hard to find three more talented men, and in the second place the exposition as designed was a very great architectural success, and has been so considered by the architectural profession of the whole country, no matter to what school of thought they may belong.

I have not referred in this discussion to the older members of the Commission selected in the proportion of three to three, nor to the important part which they had in the design, since this discussion refers to youth and the part played by the younger men. While as one of their contemporaries I may be prejudiced in their favor, I think that no better selections could have been made.

JOHN BAKEWELL, JR.

# WITH THE ARCHITECTS

## ARCHITECTS NAMED FOR DEFENSE AID

An advisory board of architects and engineers to aid Northern California civilian defense councils and technicians on air raid protection problems has been established by the State Association of California Architects.

"The board will collect all available information on ARP from European and domestic sources, adapt it to local conditions and present it in bulletin form to technical and civilian defense agencies," said Wayne S. Hertzka, Association president. "Architects and engineers are already serving on civilian defense councils throughout the State and formation of this board was inspired by the survey and other work they have so far accomplished."

Subjects to be studied will include regional planning for ARP; advice on how to conduct preliminary surveys of buildings; how to correct deficiencies in buildings surveyed; plans of outdoor and indoor shelters for residences and other buildings; group shelters; demolition and repair of damaged structures; special features, such as camouflage and fire protection, to be incorporated in new buildings and plants.

The board has established offices at 57 Post Street, San Francisco, with this personnel: William G. Merchant, J. Francis Ward, Timothy L. Pflueger and W. Clement Ambrose, architects; Thomas F. Chace and Harold M. Engle, structural engineers; G. M. Simonson, mechanical engineer.

Consulting architects are Walter T. Steilberg, Vincent G. Raney, Mario J. Ciampi and Michael Goodman. J. Francis Ward will serve as full-time director and Philip L. Soljak as secretary.

---

## COCKTAIL PARTY

Honoring the newly certificated architects and their wives, the San Francisco Architects' Auxiliary and the Alameda County Architects' Auxiliary staged an enjoyable cocktail party on December 13, on the Lido Porch, Claremont Hotel in Berkeley.

Among those honored were Miss Virginia Moran, the only woman architect to receive a certificate this year. Miss Moran is a graduate of the University of California (1933) and for the last six years has been employed in the office of a San Francisco architect.

Among Bay Region residents to pass the state examination this year are: John Bolles, Loring P. Rixford, Jr., Burnett Colburn Turner, Siberius Saito, Paul Clarence Overmire, Virginia Marsh Moran, Alfred William Johnson, Ernest Winkler, San Francisco; Henry Morgan Stedman, George Jackson Paulus, Walter Swanson Stromquist, Palo Alto; Herbert Theodore Johnson, Richard Gosline and Frank Wilke, Oakland.

Auxiliary members from San Francisco assisting in the arrangements were: Mrs. Cris Runge, general chairman; Mrs. Mark Daniels, Mrs. Edmund De Martini, Mrs.

Mario Ciampi, Mrs. Harold Weeks, Mrs. J. Francis Ward. Assisting to receive were Mrs. A. Appleton, Mrs. Ernest Born, Mrs. William Rowe, Mrs. Vincent Raney, Mrs. Rudolph Igaz and Mrs. Dodge Reidy.

---

## 1942 L. A. CHAPTER OFFICERS

Election of officers for 1942 featured the December meeting of Southern California Chapter, American Institute of Architects.

The new officers are: Samuel E. Lunden, president; Herbert J. Powell, vice-president; Donald B. Kirby, secretary; Walter Wurdeman, treasurer; William H. Harrison, director for one year, and Robert V. Derrah, director for three years. Ulysses F. Rible is the hold-over director.

---

## FRANCIS J. PLYM FELLOWSHIP

The twenty-ninth competition in architecture and the nineteenth competition in architectural engineering of the Francis J. Plym Fellowships are announced by the committee in charge by authority of the Board of Trustees, University of Illinois. The competition in architecture will be held in two parts; the preliminary during January, and the final probably during February and March. It is open to all graduates of the Department of Architecture in the curriculum in architecture of the University of Illinois, who are American citizens and under thirty years of age on June 1, 1942.

The Architectural and Engineering Fellowship is open to all graduates of the Department of Architecture in the curriculum in architectural engineering.

---

## MARK T. CANTELL

Mark T. Cantell, architect, engineer and author of text books on concrete design and construction, died at his home, 2256 Flores Avenue, Los Angeles, November 21. Mr. Cantell, born in England, was 72. He came from Manitoba, Canada, to Los Angeles where, in 1927, he founded the Pacific Coast University, College of Fine Arts and Sciences, of which he was the head up to the time of his death.

---

## LOUIS C. MULLGARDT, F.A.I.A.

Louis C. Mullgardt, 76, internationally famous architect, and a resident of San Francisco since the 1915 Fair when he designed one of the main courts, died unexpectedly January 13th. The first his friends knew of his passing was a brief notice posted in the Bohemian Club of which he was a member. Mr. Mullgardt was architect of the De Young Museum in Golden Gate Park and the Juvenile Court and Detention Home in San Francisco. He was also architect of the Davies Building, one of the outstanding business structures in Honolulu.

# MODERNIZED PRODUCTS

Brief Notes on New Materials and Equipment in the Building Industry.

## 657. REFRACTORY PRODUCTS

So far as we know it has been some time since any company has produced a catalog giving anywhere as near a complete list of all the refractory products available today as the General Refractories Co. Industrial and plant designers will be particularly interested in this booklet, which is available for the asking.

## 658. PROTECTIVE COATINGS

Protective Coatings, Inc. has a new booklet describing its complete line of materials designed for numerous uses against the ravages of rust, abrasion and corrosion, generally applied by either dipping, brushing or spraying to raw materials, plants and equipment. Very informative.

## 659. SHOWER DOORS

Plastic takes the place of scarce and expensive metal frames for shower doors and in the case of American Shower Door Company they can be made to any size by the extruding process. Glass is pressure-set in non-deteriorating rubber. A catalog showing styles is available.

## 660. EXTRUDED PLASTICS

Decorative trim of extruded plastics for sink well frames, linoleum edgings and nosings and many other uses is available from the R. D. Werner Co. and their attractive booklet, all in color is of especial interest to architects. Contains many interesting detail drawings and sketches, and in these days of metal scarcity, is a valuable addition to your file.

## 661. PLASTICS

Here is another booklet, in full color, on plastics and while it does not contain material of specific interest to builders or architects, it is a work so well done that it is recommended reading. Available from the Monsanto Chemical Co. and titled "Resinox—A Monsanto Plastic."

## 662. CONTROL INSTRUMENTS

Charts and scales, cutaway drawings and photographs adorn this catalog No. 9004, recently issued by the Brown Instrument Co., on the subject of resistance thermometers, control accessories, rotary switches, switch cabinets, etc. A copy will be sent to any of our readers who desire it, and will be found to be a valuable addition to your data file.

## 663. AIR REDUCTION

Industrial engineers should have this book, issued by Air Reduction Co., Inc. Purpose is to describe the five companies which comprise Air Reduction, the products they manufacture and some of the more important applications of these products. It is well illustrated throughout.

## 664. BLACKOUT PAINT

Most of the larger paint companies now make blackout paint. However, one made in paste form, to which 50 per cent water is added for application, has been called to our attention by the American-Marietta Co. It can be sprayed or brushed on windows and dries within 40 minutes, providing a non-flash, non-glare surface.

## 665. EXPANSION JOINTS

A line of asphalt, fibre and cork expansion joints designed to meet all requirements of monolithic concrete construction, including floors, pavements and similar applications has been announced by Keystone Asphalt Products Co. Material is supplied in a wide range of sizes and thicknesses.

## 666. WATERPROOFING

Just off the press is a new bulletin issued by the Primoid Products Corporation, describing its various rubber-base compounds, designed to stop leaks or seepage through brick, concrete, stucco or other types of masonry. When applied to metal, rust and corrosion is prevented. Available to our readers.

## 667. PLASTERING

A comprehensive new reference chart which describes the uses and advantages of all types of interior plaster has been prepared by the U. S. Gypsum Co. Also included in the chart is a glossary of 112 plastering terms. The chart is free to all who request it and is recommended.

## 668. WATER SYSTEMS

When a rural home owner or one living beyond the city water mains considers using or acquiring a water system, he wants to have several things explained to him—what it is, what it does and how it works. To answer these questions, Fairbanks, Morse & Co. have a new book, entitled, "Manual on the Selection, Installation and Operation of Home Water Systems."

## 669. AIR CONDITIONING

When we received this book from Chrysler Airtemp, it came to us with the following comments: "This report is sent to you in the belief that it represents the most comprehensive study of the applications and benefits of air conditioning ever published." Its title is "How Air Conditioning Builds Business Profits."

Architect and Engineer  
68 Post Street  
San Francisco, Calif.

Please send me literature on the following items as checked below. This request places me under no obligation.

657	<input type="checkbox"/>	663	<input type="checkbox"/>
658	<input type="checkbox"/>	664	<input type="checkbox"/>
659	<input type="checkbox"/>	665	<input type="checkbox"/>
660	<input type="checkbox"/>	666	<input type="checkbox"/>
661	<input type="checkbox"/>	667	<input type="checkbox"/>
662	<input type="checkbox"/>	668	<input type="checkbox"/>
		669	<input type="checkbox"/>

My Name.....

Name of Company.....

Street.....

City.....State.....

# ARCHITECTS' BULLETIN

Issued For

THE STATE ASSOCIATION OF CALIFORNIA ARCHITECTS  
Northern Section

STATE ASSOCIATION MEMBER  
OF THE  
AMERICAN INSTITUTE OF ARCHITECTS

Editor

Harris C. Allen

Address all communications for publication  
of the Bulletin to the Editor (Harris C.  
Allen) 557 Market Street, Room 218, San  
Francisco, California.

## STATE ASSOCIATION OFFICERS

President.....Wayne S. Hertzka, San Francisco  
Vice-Pres., Walter R. Hagedohm, Los Angeles  
Secretary.....Rowland H. Crawford, Beverly Hills  
Treasurer.....David H. Horn, Fresno

## Regional Director—Southern Section

Gordon B. Kaufmann

## Regional Director—Northern Section

Harry M. Michelsen

## Executive Board—Northern Section

President.....Wayne S. Hertzka, San Francisco  
Vice-Pres., Norman K. Blanchard, San Francisco  
Secretary.....Andrew T. Hass, San Francisco  
Treasurer.....David H. Horn, Fresno

## Directors

Russell G. de Lappe, Modesto; Clarence W.  
Mayhew, Harry M. Michelsen, Frederick  
H. Reimers, Ernest E. Weihe, San Francisco

## Northern Section Advisory Council

San Francisco District #1:  
Clarence W. Mayhew, President  
Elizabeth Boyter Henry Collins  
Francis Chinn Edmund de Martini  
Rudolph Igaz Mark Daniels  
Charles W. Masten Vincent G. Raney  
Noble Newsom

East Bay District #2:  
Theo N. Thompson, Chairman  
A. C. Williams  
Loy Chamberlain

Berkeley District #3:  
Gwynn Officer, Berkeley

North Bay District #4:  
William F. Herbert, Santa Rosa

Marin District #5:  
John S. Bolles, Ross

Lower San Joaquin District #6:  
Russell G. de Lappe, Modesto

Upper San Joaquin District #7:  
David H. Horn, Fresno

Santa Clara District #8:  
Gifford E. Sobay, San Jose

Palo Alto District #9:  
William F. Hempel, Palo Alto

San Mateo District #10  
Leo J. Sharps, Burlingame

Sacramento District #11:  
Herbert E. Goodpastor, Sacramento

Upper Sacramento District #12:  
Clarence C. Dakin, Redding

Lassen District #13:  
Ralph D. Taylor, Susanville

Monterey District #14:  
Thomas B. Mulvin, Del Monte

Redwood Empire District #15:  
F. T. Georgeson, Eureka

## PRIVATE BUILDING

The most important question before the architectural profession today is "What is going to happen to the private building industry?" Our Association officers realize that while public construction and defense construction provide a certain amount of work for some architects, the bulk of the profession depends upon private building for its employment.

The Association, therefore, is taking an active part through, and coordinating with, the San Francisco Building Industry Conference Board. All of the organizations represented on this Board are presenting to their national headquarters a plan for united action by the entire building industry toward a reasonable minimum continuance of private building. This can only be accomplished by the efforts in Washington of a strong joint committee, which can present facts and arguments, and represent the vital interests of this great industry and of the general public as well. For the ramifications of private building extend throughout the "Body Politic."

The American Institute of Architects is already taking steps toward this getting together of the elements of the industry. In the last Octagon a meeting was announced, to be held in Washington, for this purpose. The plan proposed by our local Board (and printed in fairly large quantity for distribution) may be of real assistance in this movement. It reads as follows:

### THE SITUATION TODAY

The Defense Program stands uppermost as a national endeavor, wherefore this proposed Plan is intended not to impair, but rather to aid it. America's largest industry, Private Building, is virtually paralyzed in all of its many branches. Millions face unemployment while only a portion of its skilled forces can be absorbed into defense work.

The Nation's morale and economy, both essential to total defense, will become demoralized if the situation continues.

The Private Building Industry must be kept healthy, not alone in aid of the present crisis, but to function properly in the critical post-war period.

### CAUSES OF THE SITUATION

The Government was compelled to take a hurried and drastic course wherein lack of united action prevented the Building Industry from furnishing it quickly with responsible data.

This course then might have been averted and now can be moderated by proper counsel, wherefore, the proposed Plan:

### PROPOSED PLAN

A coordinating Board, representative of all groups within the Building Industry, should be set up immediately to integrate the disorganized efforts of its single bodies.

This Board should be empowered to deal on behalf of the Industry with appropriate public agencies in Washington.

This Board should collaborate with the Government toward means for the resumption of private building, without jeopardy to the Defense Program.

This Board should study the supply and demand of critical materials and furnish true information to permit adequate allocations of these for both Defense and Private Building needs. This Board should function broadly to create a course for united action which will be lasting within the Industry for the current and post-war periods.

### CONCLUSION

Under the proposed Plan, Private Building will spring, as it should, into cadent stride with the Defense Program, in whole, a sound structure to fortify the Nation's economy and morale.

### Defense Projects

In the same issue of the Octagon is published a letter from President Hertzka urging the assignment of large defense projects to individuals or groups of architects whose functions will be to develop the site plan, direct the engineers, lay out and supervise the roads, utilities and other extraneous elements, and act as coordinators; architects with small organizations to be assigned one or more buildings included in the projects.

### Defense Councils

Throughout northern California, architects are taking an active part in local Defense Councils. In San Francisco about twenty architects and a like number of engineers are serving under the general chairmanship of John Cahill on "Public Works for Defense," with Past-President Fred Reimers as Chairman of the Shelter Survey Committee. The Air Raid Protection Advisory Board has an office in the Mechanics Institute Building, with J. Francis Ward of our Association as Director. This is a volunteer service by our profession, self-financed; it will assemble information and issue bulletins from time to time. It was formed as the result of a meeting held December 18, 1941 at which some 130 architects were present. Subscriptions to this fund are coming in steadily, and will be welcomed by the Association.

### Association Finances

Demands upon the Association treasury are heavy these days, while its income, aside from dues, will probably be somewhat reduced this year. It is all the more urgent, therefore, that our members support this all-important work. Dues, it will be remembered, are voluntary. They are set at the modest figure of \$5.00. It is clear that architects are helpless as individuals to protect their livelihood under present conditions; only through a unified organization is this even possible. By contributing the annual "subscription dues" the individual members can play their part.

### City Plans

San Francisco has made a start toward its Master Plan by engaging Mr. Ernest Goodrich as consultant. The next step is the appointment of a technical staff to start the actual surveys and studies, including the use of information already assembled. This staff should be as large as promised finances permit, and should include trained, experienced architects, for the ability of the architectural profession to assemble and coordinate has been demonstrated beyond need of further proof. The Association will keep a watchful eye upon eventualities—and upon their absence. The probable decrease in construction activities, due to war and defense emergencies, offers a real opportunity to secure competent personnel, and time to make efficient studies before definite action is taken.

It is noticed that the Berkeley Chamber of Commerce is moving for the formation of a Berkeley Master City Plan. The same advice may be extended to Berkeley, as to the inclusion of adequate architectural service in such studies. And it may be added that the members of our Association in Berkeley owe it to their community and their profession to insist upon a share in this public undertaking.

### City Architecture

Recently re-reading an essay on Edinburgh by Robert Louis Stevenson we cannot resist a quotation which seems to us even more appropriate for certain American cities within our ken:

"Upon the subject of our recent villa architecture, I am frankly ready to mingle my tears with Mr. Ruskin's and it is a subject which makes one envious of his large declamatory and controversial eloquence.

"Day by day, one new villa, one new object of offense, is added to another; the smallest structures keep springing up like mushrooms; the pleasant hills are loaded with them, each impudently squatted in its lot, each roofed and carrying chimneys like a house, and yet a glance of an eye discovers their true character. . . . They are not buildings; for you can scarcely say a thing is built where every measurement is in clamant disproportion with its neighbor. They belong to no style or art, only to a form of business much to be regretted.

"Why should it be cheaper to erect a structure where the size of the windows bears no rational relation to the size of the front? Is there any profit in a misplaced chimney-stack? . . .

"Indifferent buildings give pain to the sensitive; but these things offend the plainest taste. It is a danger which threatens the amenity of the town. . . . If the population of Edinburgh were a living, autonomous body, it would arise like one man and make night hideous with arson; the builders and their accomplices would be driven to work, like the Jews of yore, with the trowel in one hand and the defensive cutlass in the other; and as soon as one of these masonic wonders had been consummated, right-minded iconoclasts would fall thereon and make an end of it at once."

### LEGISLATION AFFECTING ARCHITECTS

At the last session of the California State Legislature the Governor signed the following bills affecting the architectural profession:

**A. B. 363**, by Bennett: Provides that architects' fees must be paid by January 31. A penalty will be charged to July 1st and on July 1st of each year the licenses of architects whose fee remains unpaid, will be automatically suspended and can only be reinstated upon application to the Board. This bill was amended into A. B. 577.

**A. B. 540**, by Robertson: An amendment to the Architects' Act; provides for disciplinary proceedings

# Estimator's Guide

## Giving Cost of Building Materials, Wage Scale, Etc.

Amounts given are figuring prices and are made up from average quotations furnished by material houses to San Francisco contractors. 3% Sales Tax on all materials but not labor.

All prices and wages quoted are for San Francisco and the Bay District. There may be fluctuation of prices in the interior and other part of the state. Freight cartage, east, must be added in figuring country work.

—1/2% amount of contract.  
Government work 3/4%.

### Work—

Common, \$40 to \$45 per 1000 laid, (according to class of work).  
Face, \$90 to \$100 per 1000 laid, (according to class of work).  
Brick Steps, using pressed brick, \$1.00 lin. ft.  
Brick Veneer on frame buildings, \$1.00 sq. ft.  
Common f.o.b. cars, \$14.00 at yard. Cartage extra.  
Face f.o.b. cars, \$40.00 to \$60.00 per 1000, carload lots.

### Building Paper—

ply per 1000 ft. roll	.....\$3.50
ply per 1000 ft. roll	.....5.00
ply per 1000 ft. roll	.....6.25
Kelkraft, 500 ft. roll	.....5.00
sh cord com. No. 7	.....\$1.20 per 100 ft.
sh cord com. No. 8	.....1.50 per 100 ft.
sh cord spot No. 7	.....1.90 per 100 ft.
sh cord spot No. 8	.....2.25 per 100 ft.
sh weights cast iron, \$50.00 ton.	
sh weights, \$3.50 base.	
sh weights, \$45 per ton.	

### Concrete Aggregates—

RAVEL (all sizes) \$1.45 per ton at bunker; delivered to any point in S. F. County \$1.85.

	Bunker	Delivered
op sand	.....\$1.45	.....\$1.85
ashed rock, 1/4 to 3/4	.....1.60	.....2.00
ashed rock, 3/4 to 1 1/2	.....1.60	.....2.00
loofing gravel	.....1.60	.....2.00
ly gravel	.....1.45	.....1.85
ver sand	.....1.80	.....2.20
nk sand—\$1.00 per cubic yard at bunker or delivered.		

	Bunker	Delivered
ver sand	.....\$1.50	.....\$1.85
ps (Nos. 2 & 4)	.....2.00	.....2.40
lypta No. 1 & 2	.....1.80	.....2.20
eldsburg plaster sand	.....\$1.80	.....\$2.20
l Monte white	......50c per sack	
ommon cement (all brands, paper sacks) carload lots \$2.52 per bbl. f.o.b. car; delivered, \$2.70; less than carloads delivered, 70c per sack.		

Cash discount on carload lots, 10c a barrel, 10th Prox.; cash discount less than carload lots, 2%.

White  
vers White } 1 to 100 sacks, \$2.00 sack,  
use White } warehouse or delivery;

Forms, Labors average \$40.00 per M.  
Average cost of concrete in place, exclusive of forms, 35c per cu. ft.; with forms, 60c.  
4-inch concrete basement floor .....12 1/2c to 14c per sq. ft.  
Rat-proofing .....7 1/2c  
Concrete Steps .....\$1.25 per lin. ft.

### Dampproofing and Waterproofing—

Two-coat work, 20c to 30c per yard.  
Membrane waterproofing—4 layers of saturated felt, \$4.50 per square.  
Hot coating work, \$2.00 per square.  
Medusa Waterproofing, 15c per lb., San Francisco Warehouse.  
Tricocel waterproofing.  
(See representative.)

Electric Wiring—\$12.00 to \$15.00 per outlet for conduit work (including switches).  
Knob and tube average \$3.00 per outlet.

### Elevators—

Prices vary according to capacity, speed and type. Consult elevator companies.  
Average cost of installing an automatic elevator in four-story building, \$2800; direct automatic, about \$2700.

### Excavation—

Sand, 60 cents; clay or shale \$1 per yard.  
Teams, \$12.00 per day.  
Trucks, \$22 to \$27.50 per day.

Above figures are an average without water. Steam shovel work in large quantities, less; hard material, such as rock, will run considerably more.

### Fire Escapes—

Ten-foot galvanized iron balcony, with stairs, \$150 installed on new buildings; \$160 on old buildings.

### Floors—

Composition Floors—22c to 40c per sq. ft.  
In large quantities, 18c per sq. ft. laid.  
Mosaic Floors—80c per sq. ft.  
Duraflex Floors—23c to 30c sq. ft.  
Rubber Tile—50c to 75c per sq. ft.  
Terazzo Floors—45c to 60c per sq. ft.  
Terazzo Steps—\$1.60 lin. ft.

### Hardwood Flooring (delivered to building)—

	1 1/2" x 2 1/4" T&G	3/4" x 2" T&G	3/4" x 2" Sq. Ed.
Clr. Otd. Oak	.....\$144.00 M	.....\$122.00 M	.....\$141.00 M
Sel. Otd. Oak	.....118.00 M	.....101.00 M	.....114.00 M
Clr. Pla. Oak	.....120.00 M	.....102.00 M	.....115.00 M
Sel. Pla. Oak	.....113.00 M	.....92.00 M	.....107.00 M
Clr. Maple	.....125.00 M	.....113.00 M	

Wage—Floor layers, \$12.00.  
Note—Above quotations are all board measure except last column which is sq. ft.

Glass (consult with manufacturers)—  
Double strength window glass, 20c per square foot.  
Plate 80c per square foot (unglazed) in place, \$1.00.  
Art, \$1.00 up per square foot.  
Wire (for skylights), 40c per sq. foot.  
Obscure glass, 30c to 50c square foot.  
Glass bricks, \$2.50 per sq. ft. in place.  
Note—if not stipulated add extra for setting.

### Heating—

Average, \$1.90 per sq. ft. of radiation, according to conditions.  
Warm air (gravity) average \$48 per register.  
Forced air, average \$68 per register.

Iron—Cost of ornamental iron, cast iron, etc., depends on designs.

### Lumber (prices delivered to bldg. site)—

No. 1 common	.....\$43.00 per M
No. 2 common	.....41.00 per M
Select O. P. common	.....46.00 per M
2x4 No. 3 form lumber	.....32.00 per M
1x4 No. 2 flooring VG	.....90.00 per M
1x4 No. 3 flooring VG	.....85.00 per M
1x6 No. 2 flooring VG	.....96.00 per M
1 1/4" x 4 and 6, No. 2 flooring	.....95.00 per M
Slash grain—	
1x4 No. 2 flooring	.....\$45.00 per M
1x4 No. 3 flooring	.....62.00 per M
No. 1 common run T. & G.	.....48.00 per M
Lath	.....7.50 per M

Shingles (add cartage to price quoted)—  
Redwood, No. 1 .....\$1.20 per bble.  
Redwood, No. 2 .....1.00 per bble.  
Red Cedar .....1.45 per bble.  
Plywood—Douglas Fir (add cartage)—  
"Plyscord" sheathing (unsanded)  
3/4" 3-ply and 48"x96" .....\$39.75 per M  
"Plywell" (walboard grade)—  
1/4" 3-ply 48"x96" .....\$43.70 per M  
"Plyform" (concrete form grade)—  
5/8" 5-ply 48"x96" .....\$117.30 per M  
Exterior Plywood Siding—  
3/4" 5-ply Fir .....\$132.00 per M  
Redwood (Rustic) 1 1/8" clear heart. \$ 95.00 per M  
\$5 less per M for A grade.

### Millwork—Standard.

O. P. \$100 per 1000. R. W. rustic \$120.00 per 1000 (delivered).  
Double hung box window frames, average with trim, \$6.50 and up, each.  
Complete door unit, \$10.00.  
Screen doors, \$3.50 each.  
Patent screen windows, 25c a sq. ft.  
Cases for kitchen pantries seven ft. high, per lineal ft., \$8.00 each.  
Dining room cases, \$8.00 per lineal foot.  
Rough and finish about 75c per sq. ft.  
Labor—Rough carpentry, warehouse heavy framing (average), \$17.50 per M.  
For smaller work average, \$35.00 to \$45.00 per 1000.

### Marble—(See Dealers)

### Painting—

Two-coat work .....per yard 50c  
Three-coat work .....per yard 70c  
Cold water painting .....per yard 10c  
Whitewashing .....per yard 4c

Turpentine, 65c per gal., in 5 gal. cans, and 55c per gal. in drums.  
 Raw Linseed Oil—95c gal. in light drums.  
 Boiled Linseed Oil—98c gal. in drums and \$1.08 in 5 gal. cens.

**White Lead in oil**

Per Lb.  
 1 ton lots, 100 lbs. net weight.....11 3/4c  
 500 lbs. and less than 1 ton.....12c  
 Less than 500 lb. lots.....12 1/2c

**Red Lead and litharge**

1 ton lots, 100 lbs. net weight.....11 3/4c  
 500 lbs. and less than 1 ton.....12c  
 Less than 500 lb. lots.....12 1/2c

**Red Lead in oil**

1 ton lots, 100 lbs. net weight.....12 3/4c  
 500 lbs. and less than 1 ton.....13c  
 Less than 500 lb. lots.....13 1/2c

Note—Accessibility and conditions cause some variance in costs.

**Patent Chimneys—**

6-inch.....\$1.25 lineal foot  
 8-inch.....1.50 lineal foot  
 10-inch.....2.25 lineal foot  
 12-inch.....3.00 lineal foot

**Plastering—Interior—**

Yard  
 1 coat, brown mortar only, wood lath.....\$0.50  
 2 coats, lime mortar hard finish, wood lath......75  
 2 coats, hard wall plaster, wood lath......72  
 3 coats, metal lath and plaster.....1.25  
 Keene cement on metal lath.....1.30  
 Ceilings with 3/4 hot roll channels metal lath (lathed only)......90  
 Ceilings with 3/4 hot roll channels metal lath plastered......90  
 Single partition 3/4 channel lath 1 side (lath only)......85  
 Single partition 3/4 channel lath 2 inches thick plastered.....\$2.90  
 4-inch double partition 3/4 channel lath 2 sides (lath only).....1.70  
 4-inch double partition 3/4 channel lath 2 sides plastered.....3.30  
 Thermax single partition; 1" channels; 2 1/2" overall partition width. Plastered both sides.....2.50  
 Thermax double partition; 1" channels; 4 3/4" overall partition width. Plastered both sides.....3.40

3 coats over 1" Thermax nailed to one side wood studs or joists.....1.25  
 3 coats over 1" Thermax suspended to one side wood studs with spring sound isolation clip.....1.45

**Plastering—Exterior—**

Yard  
 2 coats cement finish, brick or concrete wall.....\$1.00  
 3 coats cement finish, No. 18 gauge wire mesh.....1.75  
 Wood lath, \$5.50 to \$6.50 per 1000......00  
 2.5-lb. metal lath (dipped)......19  
 2.5-lb. metal lath (galvanized)......21  
 3.4-lb. metal lath (dipped)......22  
 3.4-lb. metal lath (galvanized)......24  
 3/4-inch hot roll channels, \$72 per ton.  
 Finish plaster, \$18.90 ton in paper sacks.  
 Dealer's commission, \$1.00 off above quotations.  
 \$13.85 (rebate 10c sack)  
 Lime, f.o.b. warehouse, \$2.25 bbl.; cars, \$2.15  
 Lime, bulk (ton 2000 lbs.), \$16.00 ton.  
 Wall Board 5 ply, \$50.00 per M.  
 Hydrate Lime \$19.50 ton.

Plasterers Wage Scale.....\$1.67 per hour  
 Lathers Wage Scale.....1.60 per hour  
 Hod Carriers Wage Scale.....1.40 per hour  
 Composition Stucco—\$1.80 to \$2.00 sq. yard (applied).

**Plumbing—**

From \$100.00 per fixture up, according to grade, quantity and runs.

**Roofing—**

"Standard" tar and gravel, \$7.00 per sq. for 30 sqs. or over.  
 Less than 30 sqs. \$7.50 per sq.  
 Tile, \$20.00 to \$35.00 per square.  
 Redwood Shingles, \$7.50 per square in place.  
 Copper, \$16.50 to \$18.00 per sq. in place.  
 5/2 # 1-16" Cedar Shingles, 4 1/2" Exposure.....8.00 Square  
 5/8 x 16" — # 1 Cedar Shingles, 5" Exposure.....9.00 Square  
 4/2 # 1-24" Royal Shingles, 7 1/2" Exposure.....9.50 Square  
 Re-coat with Gravel, \$3 per sq.  
 Asbestos Shingles, \$15 to \$25 per sq. laid.  
 Slate, from \$25.00 per sq., according to color and thickness.  
 1/2 x 25" Resawn Cedar Shakes, 10" Exposure.....10.50  
 3/4 x 25" Resawn Cedar Shakes, 10" Exposure.....11.50

1 x 25" Resawn Cedar Shakes, 10" Exposure.....12.50  
 Above prices are for shakes in place.

**Sheet Metal—**

Windows—Metal, \$1.75 a sq. foot.  
 Fire doors (average), including hardware \$1.75 per sq. ft.

**Skylights—(not glazed)**

Copper, 90c sq. ft. (flat).  
 Galvanized iron, 40c sq. ft. (flat).  
 Vented hio skylights 60c sq. ft.

**Steel—Structural** (None available except for defense work)

\$150 ton (erected), this quotation is an average for comparatively small quantities. Light truss work higher. Plain beams and column work in large quantities \$140 per ton.

**Steel Reinforcing** (None available except for defense work)

\$150 to \$200 per ton, set.

**Stone—**

Granite, average, \$6.50 cu. foot in place  
 Sandstone, average Blue, \$4.00, Boise \$3.00 sq. ft. in place.  
 Indiana Limestone, \$2.80 per sq. ft. in place.

**Store Fronts—**

Copper sash bars for store fronts, corner center and around sides, will average \$1.00 per lineal foot.  
 Note—Consult with agents.

**Tile—Floor, Wainscot, etc.—** (See Dealers)  
 Asphalt Tile—18c to 28c per sq. ft. installed.

**Wall Tile—**

Glazed Terra Cotta Wall Units (single faced) laid in place—approximate prices:  
 2 x 6 x 12.....\$1.00 sq. ft.  
 4 x 4 x 12.....1.15 sq. ft.  
 2 x 8 x 15.....1.10 sq. ft.  
 4 x 8 x 16.....1.30 sq. ft.

**Venetian Blinds—**

40c per square foot and up. Installation extra.

**Windows—Steel**

Factory type sash 30c ft.  
 Ventilators for steel sash \$5.00 each.

**1941 BUILDING TRADES WAGE SCALES FOR NORTHERN CALIFORNIA**

\*6-hour day \*7-hour day

CRAFT	Alameda	Fresno	Marin	Sacramento	San Jose	Stockton	Watsonville	San Francisco
ASBESTOS WORKERS	\$1.25	\$1.25	\$1.25	\$1.12 1/2	\$1.25	\$1.25	\$1.12 1/2	\$1.25
BRICKLAYERS	* 1.75	* 1.50	* 1.75	* 1.75	* 1.75	* 1.75	\$1.50	* 1.75
BRICKLAYERS' HODCARRIERS	* 1.25	* .87 1/2	1.25	* 1.05	* 1.35	* 1.06	1.12 1/2	* 1.25
CARPENTERS	1.25	1.12 1/2	1.25	1.18 3/4	1.25	1.18 3/4	1.12 1/2	* 1.25
CEMENT FINISHERS	1.25	1.25	1.25	1.25	1.25	1.25	1.00	1.25
ELECTRICIANS	1.50	** 1.37-4/7	1.37 1/2	1.37 1/2	1.50	—	1.12 1/2	1.50
ELEVATOR CONSTRUCTORS	1.56	1.50	1.56	1.56	1.50	—	1.40	1.50
ENGINEERS: Material Hoist	1.37 1/2	1.25	1.37 1/2	1.37 1/2	1.48	1.25	1.25	1.37 1/2
Piledriver	1.60	1.40	1.60	1.60	1.72	1.60	1.50	1.60
Structural Steel	1.60	1.60	1.60	1.60	1.60	1.60	1.60	1.60
GLASS WORKERS	1.25	1.06 1/4	1.25	1.10	* 1.21-3/7	—	1.12 1/2	1.25
IRONWORKERS: Ornamental	1.31 1/4	1.25	1.25	1.37 1/2	1.31 1/4	1.25	1.25	1.31 1/4
Reinf. Rodmen	1.31 1/4	1.31 1/4	1.31 1/4	1.31 1/4	1.31 1/4	1.25	1.31 1/4	1.31 1/4
Structural	1.60	1.60	1.50	1.60	1.60	1.37 1/2	1.37 1/2	1.60
LABORERS: Building	.81 1/4	.75	.81 1/4	.75	.75	.81 1/4	.80	.85
Concrete	.87 1/2	—	—	.91 1/4	1.00	.87 1/2	.80	.87 1/2
LATHERS	* 1.60	* 1.50	* 1.50	* 1.50	* 1.60	* 1.50	* 1.12 1/2	* 1.60
MARBLE SETTERS	1.25	1.25	1.31 1/4	1.31 1/4	1.25	1.25	1.25	1.31 1/4
MOSAIC AND TERRAZZO	1.25	1.12 1/2	1.25	1.15 1/2	1.12 1/2	—	—	1.00
PAINTERS	** 1.25	** 1.14-2/7	** 1.25	1.18 3/4	** 1.21-3/7	1.18 3/4	** .15	** 1.00
PILEDRIVERS	1.40	—	1.40	1.40	1.40	—	—	1.40
PLASTERERS	* 1.66-2/3	* 1.50	* 1.66-2/3	* 1.57 1/2	* 1.75	* 1.50	1.50	* 1.66-2/3
PLASTERERS' HODCARRIERS	* 1.45	* 1.25	* 1.45	* 1.18 3/4	* 1.35	* 1.50	* 1.12 1/2	* 1.40
PLUMBERS	1.50	1.40-5/8	1.50	1.50	1.50	1.25	1.25	1.52 1/2
ROOFERS	1.25	1.00	1.25	1.18 3/4	1.25	1.12 1/2	1.12 1/2	1.25
SHEET METAL WORKERS	1.31 1/4	1.31 1/4	1.25	1.37 1/2	1.37 1/2	1.25	1.25	1.25
SPRINKLER FITTERS	1.37 1/2	—	—	—	1.50	—	—	1.37 1/2
STEAMFITTERS	1.37 1/2	1.40-5/8	1.25	1.50	1.50	1.25	1.25	1.37 1/2
STONESETTERS (MASONS)	* 1.75	* 1.50	* 1.75	* 1.75	* 1.50	* 1.50	* 1.50	* 1.50
TILESETTERS	1.37 1/2	1.25	1.37 1/2	1.31 1/4	1.37 1/2	1.25	1.25	1.37 1/2

Prepared and compiled by  
 CENTRAL CALIFORNIA CHAPTER, ASSOCIATED GENERAL CONTRACTORS OF AMERICA  
 with the assistance and cooperation of secretaries of General Contractors Associations and Builders Exchanges of Northern California.



and amplifies the present grounds for revocation or suspension of licenses. Approved June 24, 1941, Chapter 831, Statutes of 1941.

**A. B. 577, by Burns:** An amendment to the Architects' Act which consolidates the District Boards into one State Board and provides as the terms of the present members of the district boards expire, only one appointment be made for every two terms expiring, so that by 1944 the Board will be five members. It further provides for the collection of renewal fees by the Department rather than by the Board. Also provides a \$3.00 penalty for delinquent fees. This bill is now Chapter 255 of the Statutes of 1941.

The two District Boards have already coordinated their functions into a single Board and the Board's headquarters, which was formerly in the State Building, Los Angeles, for the Southern District, has been moved to Sacramento.

**A. B. 624, by Bennett:** This bill was amended to allow architects who wish to retire from active practice to do so upon written application to the Board, exempted from paying the annual fee. Approved June 21, 1941, Chapter 783, Statutes of 1941.

**A. B. 698, by Green:** Provides for the issuance of a building permit for buildings to be constructed which come under the provisions of the Riley Act. It further provides that the enforcement of the provisions of this Act shall be handled by either the County Engineer or the County Surveyor when such Counties have no building department. It further provides that it is a misdemeanor for any one to accept plans and specifications for the construction of any building in violation of the aforesaid Act. This bill is now Chapter 301 of the Statutes of 1941.

**A. B. 1541, by Hawkins:** Clarifies the "Riley Act" and provides that unless specifically exempted, every building to be constructed in this state shall have a minimum of structural requirements, as defined.

**A. B. 2164 and 2165, by Knight:** Dilworth and others: Add an amendment to the Health and Safety Code, defining buildings unfit for human habitation, and provide for the demolition, closing or repair thereof. A. B. 2164 is now Chapter 807 of the Statutes of 1941.

## OUR STAKE IN THE PACIFIC

The United States has vast and vital interests in the Pacific, so vital that our lifeline to the Orient must be kept open with all possible energy. Our interests are in raw materials that are not obtainable elsewhere in the quantities we need.

The nation was prepared—materials-wise—when the Japanese blow came. For many months we have been building stockpiles. We have lots of the stuff we need—and we are going to get more, which will insure our ability to press the fight for democracy on all fronts.

Best known of these vital imports are tin and rubber, but they are not by means the only materials for which we look to this far corner of the world. Chromite, man-

ganese and tungsten for hardening steel; kapok for making life preservers; graphite for lubricating the machines of modern war; mica for insulation; manila fiber for making rope; the tea that we drink and pig bristles for brushes—these and countless other things required for our national welfare we intend to get from the Far East and the Pacific.

Tin is probably the most important of our Pacific imports, and the one hardest to replace. We consume more than 100,000 tons of tin a year; produce practically none. Singapore and the Netherlands Indies provide us with our supply.

Canned food, a staple of American life, for soldiers as well as civilians, uses most of the tin imports. While glass can be substituted to some extent, and studies have been made of the use of silver as a lining for cans, tin is the most practical.

We have a good stockpile of tin on hand in this country; we are building a smelter in Texas to refine Bolivian tin ore. Careful conservation of our supply and possible expansion of the Texas smelter will help us get through the emergency. Nevertheless, the best solution is to keep the Pacific sea lanes open.

Our situation in rubber parallels that of tin. Ninety-eight per cent of our crude rubber supply, and we are consuming more than 600,000 tons a year, comes from the Orient. In no other part of the world are the quantities we obtain available.

Fortunately for us, we have a "second line of defense" in rubber. Rubber is reclaimable. We now are using about 30 per cent reclaimed rubber to 70 per cent crude. We can double that use of reclaimed rubber within a few months.

While reclaimed rubber has certain disadvantages, for inner tubes particularly, it and our reserve supply of rubber will carry the nation for many months. Meantime, we have embarked on an ambitious synthetic rubber production program, that probably could be expanded to fill military demands.

Manganese, chromite and tungsten are also drawn from the Pacific area. If steel is the bone of modern warfare, these alloying elements are its marrow. They make tough, hard steel, the kind that is used for armor plate and for projectiles that will pierce armor. They make possible modern tanks and fighting ships, war planes and guns. We need these minerals, all of them we can get.

We can facilitate the manganese problem by increasing imports from Brazil, Cuba and South Africa, and by rapid expansion of domestic production from low-grade ores. Molybdenum, plentiful here, may be substituted for tungsten in many cases.

Approximately a third of our chromium supply comes from the Philippine Islands and New Caledonia, the remainder from Africa, Turkey and Cuba. This makes freedom of the seas in the Pacific all the more important.

Low-grade chromite deposits in the United States are now being worked, so that we can increase our



## QUALITY AND DEPENDABLE *Service*

are the factors that influence architects and contractors when selecting lumber and mill work — Quality of merchandise — Integrity and Ability of the firm—Service in physical equipment — Experience and Personnel — All these factors contribute to a speedy and satisfactory completion of construction with minimum of time and expense.

### MANUFACTURER OR DEALER IN

Douglas Fir—Redwood—Sugar and Ponderosa Pine — Plywood and Concrete Form Panels — Sash and Doors — Millwork — Insulation — Builders' Hardware.

## E. K. WOOD LUMBER CO.

"Goods of the Woods" ©

LOS ANGELES • SAN FRANCISCO • OAKLAND

## SAVE up to HALF on LABOR TIME!

**Immediate Delivery, too!**



THE U. S. Government, demanding speed, speed, and more speed, has already used Kraftile Wall Units in 9 public buildings...49 army projects...and 22 navy jobs.

*Kraftile Wall Unit portions go up in about half the time it takes for ordinary frame construction. These wall units come pre-tiled on one or both sides—thus require no surfacing. Costs are now surprisingly low.*

For complete information, phone or write to Kraftile Company, at Niles, California.

## KRAFTILE STRUCTURAL WALL UNITS

domestic supply as much as possible. But we must keep the sea lanes open to get the chromite we require.

Japan's threat to the Burma Road is a direct threat to tungsten, for down its wandering curves come the bulk of our supply. Domestic production increased sharply in 1941, and South America also is producing tungsten in quantity. Nevertheless, we imported twice as much as we produced last year and we need all we can get. Priority control exercised by the Office of Production Management has resulted in an increased use of molybdenum alloy in place of tungsten, but for certain military uses tungsten steel is the best. Molybdenum is produced in the United States in sufficient quantity to free us of any dependence on imports.

We depend upon Madagascar and Ceylon for graphite, particularly the higher grade. Deposits in Alabama, Texas and Pennsylvania, however, will serve the purpose in the emergency and loss of all imports of graphite would not seriously impair our military production.

Mica, particularly mica splittings, also are involved in the Pacific. We get 90 per cent of our present supplies of this vital material from India, the remainder from Madagascar. Mica splittings provide the insulation necessary for electrical equipment and we cannot do without it. While we have a goodly supply on hand, we do not have enough to be independent of imports. This is partly a question of training labor in this country if we have to.

All of the world's supply of Manila fiber, from which rope is made, comes from the Philippines area. There is no substitute for it and nothing takes the place of rope where rope is needed.

While these are the most important materials we get from the Orient they are by no means all. Palm oil, for instance, is important for tin plating. We get it from the Netherland Indies, the Philippines and the other islands of the East Indies. Coconut oil, from which we make glycerin, comes from the same area.

We probably can get along without hides from Australia and New Zealand and Australia's lead. But the various tanning agents, such as mangrove bark, we get from the Far East are vital to our welfare. Then there are a world of things of lesser importance, such as sisal, burlap and jute, tapioca, tea, antimony, cobalt, tung oil, copra, mahogany, camphor, nutmegs and pepper.

Many of these products have queer names and they come from strange places. But what happens in Sarawak and Semarang, in Rangoon and Davao, in Singapore and Noumea, will have a direct and vital effect on the life of every one. American industry, American people, depend on a free Pacific.

### STEEL FABRICATION FOR DEFENSE

During the past year more than two thousand defense factories have been built or added to. In addition the volume of construction at Army stations and Navy bases has been tremendous. The fabricators of struc-

tural steel furnished and erected the larger volume of that defense construction. The structural steel fabricators are today turning out on an average more than 200,000 tons of fabricated structural steel a month, and to back up the war effort this work will be expedited and shipments will flow as rapidly as the hot steel can be produced at the mills.

The defense plants have been speeded and the volume of work yet to be completed will be expedited. In this emergency nothing will be permitted to interfere with the Victory program. As indicative of the willingness of this industry to serve our country in this emergency, the American Institute of Steel Construction has dispatched the following telegram to Washington as pledge of its intentions:

"The structural steel fabricating industry, through the American Institute of Steel Construction and with a sober realization of the tremendous national task ahead of us, pledges all of its resources in man-power, trained organization, technical skills and equipment to the greatest possible effort in the fight for final victory. Vital as the industry has been in the defense program to date, its resources have not been taxed more than 60% of its demonstrated capacity production. It stands ready and eager for one hundred percent participation in the vast increase of production—not only in the construction of military structures and additional manufacturing plants, but in shipbuilding, munitions manufacture and any other war production requiring the fabrication of metals—which is now so vitally important in the fight to preserve our freedom and the American way of life."

#### TO COMPLETE HOUSES BEING BUILT

Two moves were made the past month to obtain materials to complete houses now under construction in the San Francisco Bay region.

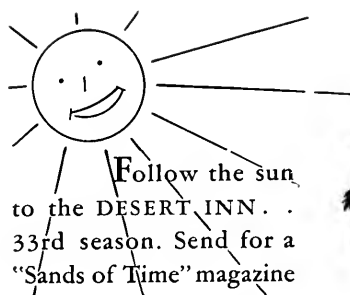
Donald M. Nelson, Director of Priorities, stated that his division was ready to extend priority assistance to complete low-cost dwellings now under construction with USHA funds.

Leon Henderson, Director of the Division of Civilian Supply, has announced that a broad plan will be put into effect shortly to make materials available to complete privately financed dwellings for which foundations were in place October 9. The Director of Priorities is expected to issue a formal order carrying out the program shortly.

#### ART, AND THE ARCHITECT'S WIFE

Mrs. Jeannette Dyer Spencer, decorator and expert on stained glass, gave an interesting talk on "Art and the Architect's Wife"—both subjects which she knows a great deal about—at the January luncheon meeting of the Architects' Auxiliary, at the Women's City Club, San Francisco.

Mrs. Spencer received her M.A. in architecture from the University of California in 1920.



35 acre estate . . . swimming pool, tennis and badminton courts, riding, golf, all sports. Delightful accommodations . . . delicious food.



## PALM SPRINGS, CALIFORNIA



### *California's Hotel Beautiful*

- like a country estate yet in the heart of a throbbing metropolitan area.
- a matchless view—
- comfortable, luxuriously furnished rooms, excellent cuisine.
- in an atmosphere of quiet and gracious living.

Rooms, with bath, \$2.50 to \$5.00 per day.

*Attractive monthly rates*

### **HOTEL CLAREMONT • BERKELEY**

**BAXCO**  
CHROMATED ZINC CHLORIDE

**CZC**

**PRESSURE TREATED LUMBER**  
● **PROTECTS AGAINST DECAY**  
**AND TERMITE ATTACK**

*Specify it in your home*  
*Available through Lumber Dealers*

LOS ANGELES 601 W. 5th Street Phone Mlchigan 6294	SAN FRANCISCO 333 Montgomery Street Phone DOuglas 3883
---	--

***J. H. Baxter & Co.***

AGENTS FOR WEST COAST WOOD PRESERVING CO. SEATTLE, WASH.

**CLINTON**  
**CONSTRUCTION CO.**  
OF CALIFORNIA

**General Contractors**

**923 FOLSOM STREET • SAN FRANCISCO**  
SUtter 3440

**HOGAN LUMBER CO.**  
*Wholesale and Retail*

**LUMBER**

---

**MILL WORK • SASH & DOORS**

---

*Office, Mill, Yard and Docks*  
**SECOND AND ALICE STREETS • OAKLAND, CALIF.**  
Telephone GLencourt 6861

## PEARL HARBOR LACKED PLANNING

The disaster at Pearl Harbor reveals with poignant clarity the tragic results of a lack of protective planning. Frederick J. Woodbridge of New York, chairman of the Committee on Architectural Services of the American Institute of Architects, declares in a statement calling upon the government to utilize the vast reservoir of unused technical skill in the architectural and allied planning professions.

"Hickam Field was as obvious a target or more so than any commercial airport," Mr. Woodbridge points out. "The hangars were lined up to make it as easy as possible to do the maximum damage with the least effort. In fact it is obvious that many planes must have been destroyed not by bombs, but by collapsing roofs of hangars adjacent to a hit. The great barracks shown in the newspapers seem designed to afford the greatest destructive power to a single hit."

Members of the architectural and allied professions throughout this country have for many months been giving of their time and skill to studies connected with defense in time of war, Mr. Woodbridge says.

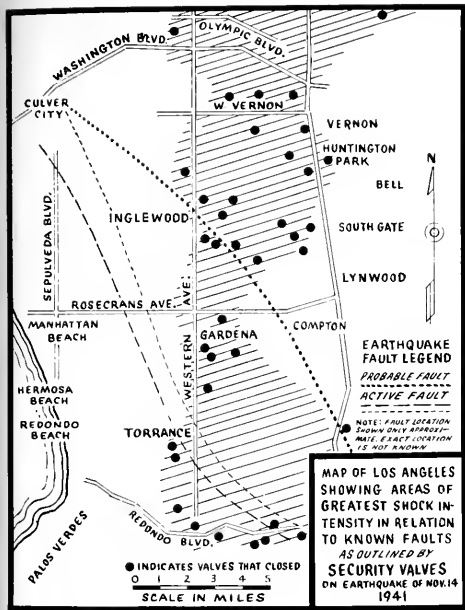
"As a profession primarily concerned with planning," he continues, "architects have emphasized over and over again the importance of planning for most successful protection, both civilian and military. In spite of repeated tenders of service and repeated urging that planning with an eye to protection is of vital importance in view of the development of aerial warfare, very little use has been made of this great body of talent which is eager to do its part in the service of our country.

"Architects have struggled in vain with authorities to consider natural concealment or scattered and staggered plans to avoid such catastrophes. Various excuses have been given, some, in the light of recent events, are ludicrous—such as 'a certain air post is not in a danger zone; it is 250 miles from a border.'

"Usually any extra cost is frowned upon. But surely it would be cheaper to spend half as much again on an installation that would escape destruction than to have to replace an entire establishment, not to mention irreplaceable loss of life.

"Any suggestion that we are not going to be attacked has certainly been blown to the winds by the astonishing stabs made by Japan. We are in an all-out war and all-out means must be adopted to win it. There exists in the country a large body of highly trained technicians who are able and willing, nay impatient, to make their important contribution to the war effort.

"These men are experts fundamentally equipped to deal with camouflage and planning for protection. The services of the architects of this country should now be used as extensively as possible. It makes little difference in what capacity architects are used. The all important fact is that the nation truly cannot afford not to use them."



### SECURITY VALVES FOR EARTHQUAKES

Earthquake-operated gas shut-off valves, installed throughout California to prevent explosions or fire following shocks, came into a new scientific role early in November. Following a relatively severe earthquake in the Los Angeles area, a record was made of the valves that had been closed, and this map forms the first accurate picture of the fault along which the temblor moved, as well as a record of its intensity.

Both the Seismological Laboratory at California Institute of Technology and the Seismological Survey of the U. S. Coast and Geodetic Survey have recognized the value of maps based on the valve operations, and have requested that similar reports be prepared for all future shocks.

Heretofore, the only method available, without too expensive and elaborate equipment, was to gather the indefinite scattered reports from areas where "dishes rattled," others where "plaster fell" or "chimneys toppled." "There has been a scientific need," said John P. Buwalda, head of the Cal-Tech Geology Department, "for some simple, supplementary instrument scattered over a given area to report the local intensity of temblors. This is the nearest thing to it we have yet had."

In addition to its contribution to earthquake fire protection the shock-operated valve is also equipped with a diaphragm control that serves as a defense against a common form of sabotage in industrial plants. In case of any serious leak or tampering with the gas supply line the valve automatically shuts off the flow of gas, to prevent it from reaching pressures that are either dangerously high or low.

the

## LIVABLE KITCHEN

Architects today are not only designing the kitchen for convenience and efficiency but they are making a livable room of it. To this end Paramount Built-in Fixtures meet the most exacting requirements. Their "Deluxe," "Moderne" and "Economy" cabinet fixtures are distinctive in design and construction and may be had in stock sizes or built to order.

Catalog for the asking

Paramount  
 BUILT-IN FIXTURE COMPANY  
 5107 Broadway, Oakland, California  
 Phone PLedmont 3300

## SISALKRAFT

"Building Paper for Every Purpose"

USED IN ALL TYPES OF DEFENSE WORK

THE SISALKRAFT CO.

55 New Montgomery St.

San Francisco

LOS ANGELES  
 CHICAGO

SEATTLE  
 NEW YORK

The Most Complete Line of  
 STEELS and BUILDING MATERIALS  
 Made by a Single Producer



See Sweet's Catalog File or write us for full information.

REPUBLIC STEEL CORPORATION  
 GENERAL OFFICES: CLEVELAND, OHIO

DENVER, COLORADO . . . . . CONTINENTAL OIL BUILDING  
 LOS ANGELES, CALIFORNIA . . . . . EDISON BUILDING  
 SALT LAKE CITY, UTAH . . . . . WALKER BANK BUILDING  
 SAN FRANCISCO, CALIFORNIA . . . . . RIALTO BUILDING  
 SEATTLE, WASH. . . . . WHITE-HENRY-STUART BUILDING

## ACOUSTI-CELOTEX

for office-quieting provides . . .

- PAINTABILITY
- PERMANENT LIGHT-REFLECTION
- HIGH EFFICIENCY

*Acoustical Engineers & Contractors*

## WESTERN ASBESTOS CO.

*Building Materials*      *Mechanical Specialties*  
SACRAMENTO      OAKLAND  
SAN FRANCISCO

## STRUCTURAL STEEL

For Class A Buildings,  
Bridges, etc.

### JUDSON PACIFIC CO.

1200 SEVENTEENTH STREET  
SAN FRANCISCO

Plants: San Francisco - Oakland

## FRANK J. McCOY HOTELS

**SANTA MARIA INN**—Santa Maria, California • Orville E. Sammann, Mgr.  
WORLD FAMOUS STOP-OVER, BETWEEN  
SAN FRANCISCO AND LOS ANGELES

**EL ENCANTO HOTEL & VILLAS**—Santa Barbara, California • Fred E. Pimentel, Mgr.  
AMERICA'S HOTEL BEAUTIFUL, IN A  
MATCHLESS SETTING ON THE RIVIERA

## BASALITE

CAMBERED SHINGLE TILE

PERMANENT • FIREPROOF • STORM-  
SAFE • COLORFUL • ECONOMICAL

Manufactured by  
**BASALT ROCK CO., INC.**  
NAPA, CALIFORNIA

## KITCHEN LAYOUT SPECIALISTS WANTED

Among the unusual types of persons the Government is trying to find now are those who are qualified to design galleys on ships, and kitchen and cafeteria spaces and equipment in buildings.

A four-year college course leading to a bachelor's degree in engineering or architecture is required plus important experience in design, layout, and specification of space arrangements and equipment for galleys of large ships, or for kitchens and cafeterias for large institutions. The amount of experience required increases with the grade of the position. Experience, above the amount required, may be substituted for the college work.

Applicants must not have passed their 60th birthday unless they are entitled to veteran preference. Persons over the age limit may apply, although they can not be certified for permanent appointment. Their names will be listed, if they meet all except the age requirements, for possible use in meeting defense needs which can not be met through the usual means.

Persons who can qualify are urged to apply at once. Application forms, with Announcement No. 190 giving further information, may be obtained from the Secretary, Board of U. S. Civil Service Examiners at any first- or second-class post office, or the United States Civil Service Commission, Washington, D. C.

Applications must be on file at the Washington office of the Commission not later than March 2, 1942.

## BRITISH ARCHITECTS OUTLINE PLANS

Norman K. Blanchard, vice-president of the State Association of California Architects, Northern Section, recently wrote the British Broadcasting Corporation, asking them to have an architect describe the work of Britain's architects in post-war planning.

E. G. Carter, librarian of the Royal Institute of British Architects, London, described this activity in a reply which was broadcast over the Mutual network. The following is Mr. Carter's reply as it was heard over station KFRC, San Francisco, in its "Answering You, from London" program:

"We architects are agreed that we are not yet at the stage when we can put on paper complete and realistic plans for any city. There are many basic technical and social studies which have to be made first. And until we have made those studies we can't plan realistically. Unrealistic planning is just expensive dope. The future of our cities depends on how long we take to win the war.

"All our thinking and all our doing has to be aimed at shortening the war, and rightly so. At the present time, architects are engaged in planning and building camps, defense housing and health services, ARP services, factories and military buildings. And it's in such daily work that we are making the best scientific and imaginative contribution to the rebuilding of Britain.

"That field of work is the ground where the solutions

to many of our post-war architectural problems will germinate. And I can assure you that in their present activities architects are promoting radical changes.

"Britain swarms with official, as well as voluntary, planning research groups. The RIBA has two of its own. There is a Reconstruction Section attached to the Ministry of Works and Buildings, largely started by architects. Moreover most cities have architect-planners already. You may have heard of the work of Donald Gibson of Coventry. And Professor Patrick Abercrombie has recently been appointed to the post of adviser to the London County Council.

"Let me say too, how vitally necessary it is for us to share our fundamental research problems with you, in the States. The British architects are grateful for the help you are giving us already. The American Institute of Architects sends us gifts of American technical and scientific publications, which are widely consulted. And again, Pilgrim Fund money has been made available for architectural exhibitions. There's one going around at present called 'Living in Cities,' which has caused great interest.

"Rockefeller money, too, has been given to the National Buildings Record—ordinarily available for scientific research into architectural problems. And so, Mr. Blanchard, I can give you a fairly optimistic answer, only don't look too soon for paper plans—they'll come in time, from the architects of Great Britain."

#### STRUCTURAL ENGINEERS AND THE WAR

A well attended meeting of the Structural Engineers Association of Northern California was held at the Engineers' Club, San Francisco, the evening of January 6th when leaders of the profession conducted a symposium on Air Raid Shelters. The speakers were Professor Bruce Jameyson of the University of California, Professor J. Bertrand Wells of Stanford University and Mac D. Perkins, a member of the Civilian Defense Council. Motion pictures of air raid effects were announced as a feature of the evening.


The Daily Main Street News, publicity organ of the Northern Section, Structural Engineers Association, will continue publication during the duration of the war, under the capable handling of William H. Popert of the Columbia Steel Company.

Where They Are: H. J. Brunnier at Cristobal, the Canal Zone; Will G. Corlett, back in Oakland after visiting his son who is with the U. S. Army Engineers in Honolulu; Fred W. Crocker, with the Pacific Bridge Company in Hawaii; W. H. Ellison, designing factories for National Defense in San Francisco; A. L. Brinckman, who contributed an interesting article in the December Architect and Engineer on Small Retaining Walls, writes from Honolulu that he and Mrs. Brinckman are safe and sound; Franklin P. Ulrich, still in San Francisco doing active war work. His son, Bob, is on the firing line as an Ensign on a U. S. Destroyer.

## ALADDIN Heating Corp.

Specializing in  
**QUALITY HEATING EQUIPMENT**

**2222 San Pablo Avenue, Oakland**  
TWin Oaks 1022

 **SLOANE** has worked with architects, designers and decorators for years.  
▶ We interpret intelligently . . . and we know what it is to be up against deadlines and strict budgets. ▶ Let us prove this!

FURNITURE • FABRICS • WALLPAPERS  
LAMPS AND FLOOR COVERINGS  
**WHOLESALE CONTRACT DIVISION**

W & J **SLOANE**  
Sutter near Grant • San Francisco

#### ADVERTISING

Dear Mr. Jones:

The intention of the Price Control Bill was that regular items of expense, such as advertising, should not be curtailed due to the price control. It was specifically understood that advertising was a normal item of expense.

I cannot understand why any large corporations should cut down in their advertising.

With every good wish, I am  
Cordially, THOMAS ROLPH,  
House of Representatives.

Washington, D.C., Dec. 16, '41.

## Fine Water Colors and Papers For Architectural Renderings

### H. S. CROCKER COMPANY, Inc.

720 MISSION STREET  
Market Street at Second • San Francisco

# VERMONT MARBLE COMPANY

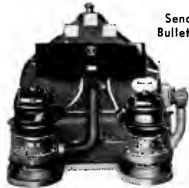
Producers and Finishers  
of

**Domestic and Imported Marbles**

San Francisco, Los Angeles and Tacoma, Wash.

San Francisco phone: SUtter 6747

## "AMERICAN MARSH" Redi-Vac Vacuum Heating Pump



Send for  
Bulletin 441

**SIMONDS MACHINERY CO.**

San Francisco  
816 Folsom St.

Los Angeles  
455 East Fourth St.



PRODUCTS

## VAN ARSDALE - HARRIS CO.

ENGINEERS & CONTRACTORS

**ACOUSTICAL TREATMENT  
INSULATION • SOUND CONTROL**

Fifth and Brannan Streets • San Francisco, Calif.  
Telephone GRanfield 3600

Division

VAN ARSDALE - HARRIS LUMBER CO., INC.

## PACIFIC MANUFACTURING CO.

HIGH CLASS INTERIOR FINISH  
QUALITY MILLWORK

142 SANSOME ST., SAN FRANCISCO  
GRanfield 7755

6820 MCKINLEY AVE., LOS ANGELES  
THornwall 4196

**BUILDERS EXCHANGE, OAKLAND**

## RAID SHELTERS

Under the provisions of the National Emergency Act in England the Government makes it mandatory for the owners of all buildings in which more than 30 people are accommodated, to prepare plans and specifications for air raid shelters. This, therefore, would seem to call for architectural and engineering advice by the owners of these buildings. The plans in all instances are subject to the approval of the Building Authority of the area in which such building is situated. Owners of adjoining buildings may submit proposals for provisions of a joint shelter.

Where an owner fails to construct a shelter the Authority, after seven days notice, may enter the premises or land and construct a shelter, the cost of which will be borne by the owner of the property.

## H. S. GYMNASIUM AT PHOENIX

(Continued from Page 28)

one-half a mile long. The concrete was coated with tar, as a waterproofing, over which was placed a one-inch thickness of dry sand, then there was laid a soft wood subfloor covered with a layer of building paper, and the top surface is of matched hard wood. This "floating floor" provides qualities particularly useful in a gymnasium-auditorium building. Three basketball games can be played upon the floor simultaneously.

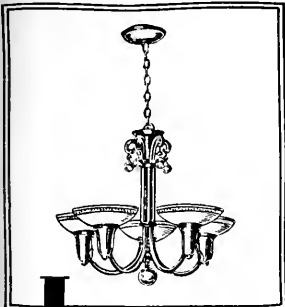
Due to the type of construction, the building required no plastering either inside or outside, but instead was painted a soft green color on the interior and a buff tone on the outside to match the shade of the eight other buildings on the campus. The paint was developed at the school.

Other facilities are a movable stage, a radio booth, a public address system and a press box.

Cost of the building was approximately \$386,113, of which the sponsoring school district provided 44 per cent or \$170,000. Federal funds actually expended accounted for 56 per cent of the total or \$216,113.

The sponsoring school district provided for the major part of its contribution with a \$134,000 bond issue, which it plans to retire with box office receipts for athletic events and rentals of the gymnasium-auditorium. This procedure made it unnecessary to levy additional taxes upon the school district.





# I NDIRECT

A fixture to impress your guests with its beauty and your good taste. Your home is only as lovely as its lighting. So—may we offer the assistance of our "lighting stylists" in selecting the correct fixtures on your limited budget?

**INCANDESCENT  
SUPPLY COMPANY**  
726 MISSION ST., SAN FRANCISCO

Phone GARfield 1164

## Thomas B. Hunter

*Consulting Engineer*  
DESIGNER OF HEATING  
AIR CONDITIONING  
VENTILATING AND WIRING  
SYSTEMS, MECHANICAL  
AND ELECTRICAL EQUIP-  
MENT OF BUILDINGS

41 SUTTER STREET  
ROOM 710  
San Francisco California

## Robert W. Hunt Company

ENGINEERS

Inspection - Tests - Consultation  
Schools and Other Structures  
Are Built as Designed

*When Construction Materials are  
Inspected at point of Manufacture  
and during Erection by*

**ROBERT W. HUNT COMPANY**

*Cement, Concrete, Chemical, Metallurgical,  
X-Ray and Physical Laboratories*

Chicago - New York - Pittsburgh  
Los Angeles - All Large Cities  
San Francisco, 251 Kearny Street

### BUILDING COSTS RISING

Building costs of a standard six-room house rose sharply during October with a 1.7 per cent increase over September, economists of the Federal Home Loan Bank Board announced.

With the exception of but few 30-day periods during recent years, labor costs have gained more rapidly than those of building supplies—in October 2.2 per cent as against a materials cost increase of 1.4 per cent. Since October, 1940, labor costs have increased 15.3 per cent as against 12.2 per cent for materials.

The combined increase in construction costs for labor and materials on the standard dwelling over the last 12-month period totals 13.3 per cent, and now stands nearly 19 per cent above the average month of 1935-1939, which is used by the Bank Board's Division of Research and Statistics as a cost-index of 100.

Since August, the cost of the standard house has risen more than \$500 in seven of the 24 cities reporting building cost figures to the Bank Board—San Antonio, \$923; Dallas, \$709; Houston, \$694; Albuquerque, \$668; Philadelphia, \$598; Harrisburg, \$578; and San Diego, \$570. All except four of the cities reporting show increases of more than \$100 from August to November.

### BUILDING MUST GO ON

The construction industry should be allowed to operate at least at 40 or 50 per cent of its normal rate, Peter Brust of Milwaukee, director of the Illinois-Wisconsin District of the American Institute of Architects, declares in a statement deploring the announced policy of the SPAB which in effect practically halts private building.

"The building industry carries with it activities in other fields such as real estate, furniture, and landscaping," Mr. Brust points out. "I cannot visualize the automobile industry fostering similar accessory activities, yet the construction industry is expected to fold up completely while the automobile industry is curbed only 40 per cent of normal.

"The automobile industry can cur-

**BUSINESS FIRMS**  
*Save Time  
and money*  
**BANKING WITH US**  
**BY MAIL**



Nine out of every ten banking transactions should take no more effort than is needed to mail a letter. That's why more and more neighborhood merchants, business and professional people are using our Mail Service. We supply special envelopes and forms which make banking by mail easy and safe.

*Write for information today.*

**CROCKER FIRST  
NATIONAL BANK**  
OF SAN FRANCISCO  
*California's Oldest National Bank*  
Member Federal Deposit Insurance Corporation

## THE TORMEY COMPANY

GENERAL PAINTERS  
AND DECORATORS

Phone UNDERhill 1913

563 FULTON STREET  
San Francisco

## G. P. W. JENSEN & SON

Building Construction

320 Market Street, San Francisco  
Phone: GARfield 3444



**WOMEN** go into raptures over this new Wesix "Perfect Thirty-Six" electric bathroom heater. Its instant, head-to-foot heat, they exclaim, "is simply marvelous!" You will like it because it *fits perfectly into 42-inch wainscots*. For details write Dept. 206, Wesix Electric Heater Co., 390-1st St., San Francisco.

**WESIX**

*World's Largest Manufacturers of Major Electric Heaters*



**HERRICK  
IRON WORKS**

**STRUCTURAL STEEL  
REINFORCING STEEL**

18TH AND CAMPBELL STS.  
OAKLAND, CALIF.  
Phone GLencourt 1767

**FORDERER  
CORNICE WORKS**

*Manufacturers of*  
Hollow Metal Products  
Interior Metal Trim  
Elevator Fronts and Cabs  
Metal Plaster Accessories  
Sanitary Metal Base  
Metal Cabinets  
Flat and Roll Metal Screens  
Commercial Refrigerators

**269 POTRERO AVE.**  
San Francisco, Calif.  
HEMlock 4100

tail extensive unemployment because the mechanics in this field live in large industrial centers where most of the defense equipment is being manufactured, and where they can switch to defense employment without change of residence or character of work.

"The 80 per cent of building trades mechanics who have never worked in metals would need long periods of training before they could work on defense equipment. In addition, they live in small communities, as well as large areas, and it would require mass migration to bring them to places of employment on defense equipment."

\* \* \*

In non-defense areas the construction industry is already "in the coma that precedes death," according to Clement R. Newkirk of Utica, director of the New York District of the American Institute of Architects, who urges modification of the recent SPAB priority ruling discouraging private building.

"While no one connected with building would selfishly suggest that materials needed for defense uses should be released for other construction purposes, it does seem that re-examination of the priority requirement might suggest a modification so that the entire building industry would not be crippled," Mr. Newkirk declares.

"While many workers previously employed in the building industry have been, or will undoubtedly be, absorbed on government projects in defense areas, the vast majority of workers in this industry will be thrown out of employment unless some means of keeping alive the building industry is devised.

"The roots of this enormous industry spread much further than the actual employment upon a building itself. Those engaged in the real estate business, in the manufacture or selling of types of building materials, those in the planning professions find their livelihood in this industry — a vast army that contributes to the national income tax structure.

"In normal times private construction requires only a relatively small amount of what become critical materials in a national emergency. It would

**Save 20% Space**

*Specify*

**PITCHER**

**IMPROVED DISAPPEARING  
DOORS**

Send for prices and details on our new wood frame sliding doors

**E. C. Pitcher Co.**

557 Market Street, San Francisco

Phone Fruitvale 0443

**Eureka Mill &  
Lumber Co.**

**Lumber and  
Millwork**

38th Ave. and San Leandro St.  
Oakland, California

**Independent  
Iron Works**

Structural Steel  
Ornamental Iron  
Steel Service Stations  
Steel Tanks  
Standard Steel Mill Buildings  
Bridges

821 Pine Street Oakland

**ANDERSON  
&  
RINGROSE**

General Contractors

320 Market Street, San Francisco  
Phone GAfield 2245

## JOHN CASSARETTO

—Since 1886—And Still Active—

### Building Materials

READY MIX CONCRETE  
ROCK - SAND - GRAVEL - LIME  
CEMENT - PLASTER - MORTAR  
METAL LATH - WOOD LATH  
STUCCO - WIRE NETTING

### Service Unexcelled

Bunkers

Sixth and Channel, San Francisco  
Phones: GARfield 3176, GARfield 3177

## VAUGHN - G. E. WITT Co.

Manufacturers and Distributors

Pump Governors	Oil Heaters
Safety Pump Governors	Relief Valves
Automatic Gas Regulating Valves	Oil Burner Governors
Gas Burning Equipment	Oil Burners
Vacuum Pump Governors	Oil Pumping Sets
Vacuum Regulating Valves	Oil Valves
Continuous Flow Steam Traps	Oil and Steam Strainers
Thermostats	Duplex Oil Pumps
Reducing Valves	Rotary Oil Pumps
	Boiler Feed Pumps
	Water Heaters
	Boiler Feed-Water Regulators

4224-28 Hollis St., Emeryville, Oakland

## ABBOT A. HANKS, INC.

### Engineers & Chemists

INSPECTING — TESTING — CONSULTING  
CONCRETE • STEEL • MATERIALS  
CHEMICAL AND TESTING  
LABORATORIES

• RESEARCH AND INVESTIGATION •

TESTS OF STRUCTURAL MATERIALS  
DESIGN OF CONCRETE MIXES  
SHOP AND ERECTION INSPECTION OF  
STRUCTURES AND EQUIPMENT  
INVESTIGATION OF STRUCTURES  
AND MATERIALS  
TESTS AND INVESTIGATION OF  
FOUNDATION SOILS  
FIRE RESISTANCE AND INSULATION  
TESTS

624 Sacramento Street, San Francisco

## MULLEN MFG. COMPANY

BANK, STORE AND OFFICE  
FIXTURES—CABINET WORK  
OF GUARANTEED QUALITY  
CHURCH SEATING

Office and Factory:

60-80 RAUSCH ST., Bet. 7th and 8th Sts.  
San Francisco  
Telephone UNderhill 5815

seem that upon examination, a proper allocation of material, a correct distribution, and the studied substitution of old methods or the use of new materials would save this industry from starvation.

"Only a small proportion of the building industry can actually be absorbed on defense projects, and in non-defense areas, the industry is already in the coma that precedes death. The question to be determined is whether the industry is to be kept alive and in the end of the 'emergency' are we to have an industry sufficiently vigorous to make its potent contribution to the restoration of national prosperity."

The SPAB ruling, Mr. Newkirk points out, has had a more unfortunate effect upon the general public than it has had upon those engaged with the building industry itself.

"Those connected with this industry, Mr. Newkirk says, "had discovered before this announcement that the scarcity of vital defense materials would, upon the exhaustion of present stocks held by material suppliers, practically prevent the construction of projects not connected with the defense program. It did not materially change the situation as it existed, but in the mind of the public it seemed to mean prohibition of all non-defense construction. As a matter of fact, however, unless the ruling is modified, eventually it means just that."

### BAN ON CHROMIUM STEEL

Andrew L. Kerr, District Manager of the Division of Priorities, advises that the civilian use of high grade chromium steel, except in fabricated articles, has been prohibited by the Director of Priorities.

Supplementary Order M-21-D provides that no person shall consume, use, fabricate or deliver corrosion or heat resistant alloy iron or steel containing more than 4 per cent chromium after 10 days from the date of issuance of the order, except on ratings of A-10 or higher.

The order does not apply to fully fabricated chrome steel articles, but to all such material in any stage of fabrication.



## Wm. Penn Hotel

2208 West 8th St.

Los Angeles, Calif.

200 Rooms

200 Baths

One in Room..... \$2.00

Two in Room..... \$2.50

Attractive weekly and monthly rates.

Professional men will appreciate the good food at moderate prices in our Quaker Grill.

## F E R R O - PORCELAIN

A permanent and beautiful exterior finish . . . particularly adaptable to modern design. Eliminates upkeep costs . . . such as painting . . . choose your own color.

The entire fronts of the Chestnut Tree restaurants in San Francisco are Ferro-Porcelain Enamel.

We will be pleased to work out details for Ferro-Porcelain construction in connection with most any type of building.

### FRANK ALLEN CO.

Ferro-Porcelain Constructors

320 Market St.  
San Francisco

832 W. 5th St.  
Los Angeles

## INCLUDE TREES IN YOUR PLANS

DAVEY, ORIGINATOR OF TREE SUR-  
GERY, OFFERS FREE INSPECTION  
AND ESTIMATE.



SAN FRANCISCO 3377  
Russ Bldg. SUtter

FRESNO  
Maffei Bldg.

LOS ANGELES 1929  
Story Bldg. Tucker

Local phones in: Pasadena, Palo Alto,  
Oakland, San Rafael, San Mateo

**SKILL - KNOWLEDGE -  
RESPONSIBILITY**

## DINWIDDIE CONSTRUCTION COMPANY

•  
**BUILDERS**  
•

CROCKER BUILDING  
SAN FRANCISCO

HIGH GRADE MILLWORK  
AND INTERIOR FINISH  
SASH AND DOORS

## LANNOM BROS. MFG. CO.

FIFTH AND MAGNOLIA STREETS  
OAKLAND, CALIFORNIA  
Telephone: TEmplebar 3663

### "REPAIR FOR DEFENSE"

The "Repair for Defense" program of the Federal Housing Administration will rescue many of the valuable old properties which are a part of the nation's estimated eighty billion dollar investment in homes. Howard Leland Smith, chief of the architectural section, technical division, FHA, reports to the American Institute of Architects. This program, Mr. Smith points out, provides a promising field for the talents of architects in defense areas.

"It now appears certain," says Mr. Smith, "that non-defense construction—together with other 'business as usual' activities—will be sharply curtailed in the near future. Consequently, it behooves the architect who wishes to continue practicing to explore every avenue still open where his services can and should be employed.

"The need for defense housing in rapidly expanding defense areas has become a major national problem. To help meet this need in the least possible time and to use as little critical materials as are consistent with sound construction, encouragement is being given to the rehabilitation of old houses suitable for conversion into multi-family use in designated defense areas.

"Rehabilitation will not only conserve vital and strategic materials but will furnish considerable activity for the building trades and its allied industries during the emergency period. Perhaps the most beneficial effect of the FHA repair program will be the conservation and preservation of many of the valuable old properties which are a part of the nation's estimated eighty billion dollar investment in homes.

"Critical materials needed for housing in defense areas will receive favorable action by the priorities officials having jurisdiction, if and when the project has been properly designated as such. Wherever possible, avoid the use of critical material listed on the Defense Housing Critical List to prevent possible delays. The use of substitute materials wherever feasible is required.

"In estimating the possible income and the economic soundness of a pro-

posed rehabilitation job, priorities are limited by a general ruling to units having a shelter rental not in excess of \$50 a month.

"Every encouragement in both financing and priorities is being offered to rehabilitation at the present time. To encourage this type of work, Congress recently amended the FHA Title I terms. Lending institutions are now insured against loss on Title I loans up to \$5,000 (with repayment up to five years) for financing alterations and repairs which create additional defense housing units.

"Priority preference is given to materials which are to be used for improvements which add to the supply of needed defense housing. Furthermore, the Federal Reserve Board's new Regulation "W," which places restrictions on most types of consumer credit, specifically exempts the financing of property alterations which create additional housing for defense workers.

"An amended Title I, priorities preference rating, and lack of credit restrictions add up to favorable 'climate' for a considerable volume of repairs and rehabilitation work.

"Intelligent leadership combined with exceptional vision and technical skill will be necessary, if real and lasting benefits are to be obtained. It seems logical, therefore, that the architect, by reason of his experience and training, should assume a large share of this leadership.

"He can act as counselor and guide through various phases of the operation, since many owners of deteriorating properties are not aware of the possibilities for financing made available through new FHA terms. Cooperation from banks and realtors may be anticipated, because both groups are vitally interested in any movement which tends to arrest the decline of real estate values.

"The architect who actively devotes his time and energy to this program will find himself contributing to the National Defense effort while he is being remunerated for professional services rendered. It is an opportunity for service in a time when architectural help is most needed."

ARCHITECT  
AND  
ENGINEER





AIRPLANE VIEW OF CANTONMENT

## *For Thirsty Recruits*

**HAWS FOUNTAINS are in  
use in practically every large  
cantonment in the Western States**



Model 8D5  
CANTONMENT FOUNTAIN

The sanitary features of HAWS DRINKING FOUNTAINS meet the exacting requirements of both Army and Navy construction engineers. Besides Camp San Luis Obispo, pictured above, the following are a few of the many other cantonments equipped with Haws Fountains: Camps Roberts, Rosecrans, McArthur, McQuaide. Hamilton Field, March Field, Presidio of San Francisco, Mare Island, Alameda Air Bases, San Diego, etc.

# HAWS DRINKING FAUCET COMPANY

1808 HARMON STREET • BERKELEY • CALIFORNIA

Agents in the following cities:

New York • Los Angeles • San Francisco • Seattle • Salt Lake City • Portland  
Chicago • Atlanta • Houston

# RUNNING FIRE — By MARK DANIELS, A. I. A.

## • AIR RAID PROTECTION

The State Association of California Architects is beginning to get its stride in the matter of advice on Air Raid Protection. Bulletin No. 4, of the Association, which came out on January 19, has much of real practical advice and helpful instruction. It has aroused the interest of many non-professional people who are beginning to realize that a better knowledge of explosives and their action under varying conditions may mean life or death to them. I have been asked by several laymen whether they can secure copies of the entire series as they come out and where they can get them. The Association, with headquarters at 57 Post St., phone EXbrook 2241, is preparing to sell subscriptions at a nominal figure.

But, it would seem to me, that more could be said about how to protect one's self and family in a frame dwelling. Nearly all of us live in such a structure and even if we had the money and could get the material to build a bomb proof shelter we may not have the time. The theory of high explosives and their effect on steel and concrete is very fascinating but 99 per cent of us live in frame houses and would like to know what we can do, if anything, to protect ourselves when bombs begin to fall. Should we run to the basement or go to the attic? Should we get under the bed or in the ice box? No doubt the Association will come out more fully on this subject in subsequent bulletins.

## • NEW USES FOR OLD WORDS

It is only natural that war should develop the use of superlatives and other words which, while not superlatives, carry about the same effect. For a time everyone seemed to be getting "annihilated," but the novelty wore off to some extent. Now we are "hurling." We never "throw" or "toss." I hope the habit does not reach the stage where you may hear someone say, "I hurled my cigarette stub into the grate."

## • THE AUTO SALESMAN AND THE ARCHITECT

The position of the auto dealer and salesman is serious indeed. He has built up a business and the government has been forced to take it away from him. He has been left standing with outstretched hands ready to make a delivery, and suddenly, as if by magic, his hands are empty. He is all dressed up with nowhere to go. But, after all, is his position any worse than that of the architect?

The architect has been left with nowhere to go for quite some time now. The necessary priority regulations have taken his jobs right out of his office. There was other work that might have helped but the government has bureauequed it out of reach. There is plenty of work that a well trained architect can do, probably better than any other professional man, and perhaps the government will finally call upon us. In the meantime the problem confronting most architects is whether to close the office, lose their identity and await eventualities or struggle on under a load of accumulating debts. The automobile salesman can change his occupation, but the architect, who has spent 20 years and most of his father's money learn-

ing his, finds that avenue of escape from destitution all but impossible.

## • T. L. M.

The Little Man stood unsteadily with an old fashion in one hand and a book in the other, seemingly in a quandary as to whether to drink the book or open the drink. It was a sizable tome as books go so he tossed off the drink and said:

"The erudite Mr. Henry L. Mencken has done a masterful piece of work in his 'The American Language.' I don't believe I could read it clearly, so I will tell you about it. Mr. Mencken points out that language is an ever-changing medium of expression. By usage nouns become verbs, slang becomes good English, and some phrases disappear through disuse. One of these latter I also have found dead. In all my visits here at this bar the only man I have ever heard use the singularly obsolete phrase, 'No, thank you,' is Mr. Fred Solari himself. Thank you. I don't care if I do."

## • WE STOOP TO CONQUER

Shinto is the indigenous religion of Japan. It embodies no ethical code, no doctrinal system, and no public worship, all of which, viewed from the standpoint of the Christian, is essential to a moral and civilized existence.

If, according to this religion, contact with the dead is a defilement, the last four years in China must have defiled the entire population of Japan. However, with a set form for purification consisting of washing with water and a sacrifice of valuables removing all pollution resulting from any wrong-doing whatsoever, it is easy to understand how the Japanese think they can rectify their errors with a dishpan and a bag of marbles.

These are the highlights of the indigenous religion of the Japanese, which has been growing in patronage in Japan for the past few hundred years. It is a religion of a people who wash out their memory of crime and perfidy with a bowl of water. It is the religion of a people who make professional prostitutes mothers of their children.

Truly, we stoop to conquer!

## • THE DAILY DOZEN

It always amuses me to see the imitation health fans go through their exercises. Arms extended languidly, bending over that is little other than a nod, deep breathing that is hardly a sigh, blinking their eyelids, and a mad dash for a cigarette and a highball.

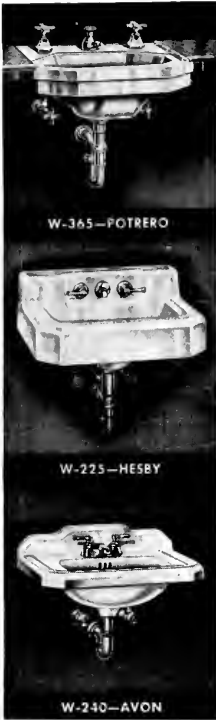
I watched one such athlete at the club. He has a home in the country where he raises a few cattle, sheep and chickens. "Great stuff, this," he said. "Keeps you fit." I asked him why he didn't do a little work on the ranch and he looked at me in such blank amazement that I refrained from telling him he could get push-handled picks. I was afraid he'd do it.

## • LIFE'S TREASURE

Seek not for gold at the rainbow's end.

Gold will be found in the hearts that you mend.

Know that the treasure  
of life is the measure  
of love that you give to a friend.



## WASHINGTON-ELJER FIXTURES MEET FEDERAL SPECIFICATIONS

Washington-Eljer plumbing fixtures have been selected for use in many defense housing developments, cantonments, training stations, etc.

There are special Washington-Eljer fixtures designed to meet the special requirements of all these users. All of them meet Federal specifications.

Defense requirements, of course, receive first call, and Western architects and builders prefer Washington-Eljer fixtures for many essential defense construction projects as well as for today's industrial expansion for defense.

Write or phone for details regarding these special fixtures.

Quality Plumbing Fixtures  
Since 1896

**WASHINGTON-ELJER CO.**  
4100 South Alameda Street  
Los Angeles, California

# PROOF *of the* PUDDING

Daily occupancy is the relentless test of a building's efficiency. Under this test the weaknesses in planning stand revealed.

Nowhere is inefficiency so quickly apparent and so constantly irritating as in inadequate electrical wiring.

Any commercial building especially, must have a wiring system so comprehensive that the electrical demands of a wide variety of tenants can be met. Wiring changes after a building is completed are expensive. They are unnecessary if the original wiring system is sufficiently extensive and properly installed.

If the useful life of the building is to continue over a reasonable period of years, that usefulness must not be strangled by inadequate wiring. Allowance must be made for the constantly increasing use of electrically driven office equipment.



NORTHERN CALIFORNIA  
ELECTRICAL BUREAU

447 SUTTER ST. • SAN FRANCISCO

## TEAMWORK for SECURITY

**GOLDEN GATE • OLD MISSION**  
PORTLAND CEMENT PORTLAND CEMENT

**MILCOR**  
METAL LATH PRODUCTS

**EMPIRE**  
GYPSUM PLASTER

**STANDARD**  
GYPSUM PLASTER

**PACIFIC**  
PORTLAND CEMENT COMPANY

FOR SOUND CONSTRUCTION



# ARCHITECT AND ENGINEER



Volume 148

February, 1942

Number 2

<b>Grayson's Women's Ready-To-Wear Shop, Seattle, Washington . . . . .</b>	<b>14</b>
Gruenbaum, Krummick & Auer, Designers	
<b>Some Notes on Modern Store Design . . . . .</b>	<b>15</b>
Victor Gruenbaum	
<b>Architect and War . . . . .</b>	<b>23</b>
J. Francis Ward, A.I.A.	
<b>Albert Kahn—Defense Builder . . . . .</b>	<b>25</b>
<b>Kahn's Views on Factory Design . . . . .</b>	<b>33</b>
<b>Why Not Union Now? . . . . .</b>	<b>35</b>
Ellis F. Lawrence, F.A.I.A.	
<b>Architectural Education Tomorrow . . . . .</b>	<b>38</b>
Michael Goodman, Architect	
<b>Prevention and Control of Decay in Buildings . . . . .</b>	<b>40</b>

### PLATES AND ILLUSTRATIONS

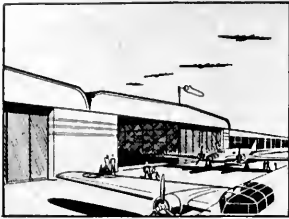
<b>Stores and Apartment House Interiors by Gruenbaum, Krummick &amp; Auer . . . . .</b>	<b>15-21</b>
<b>Work of Albert Kahn, Associated Architects and Engineers, Inc. . . . .</b>	<b>25-32</b>
<b>Twin Houses at Downey, California . . . . .</b>	<b>8</b>
Curtis Chambers, Architect	

EDITOR, FRED'K W. JONES; ASSISTANT EDITOR, E. N. KIERULFF; CONSULTING AND CONTRIBUTING EDITOR, MARK DANIELS; ADVERTISING MANAGER, R. W. WALKER. REGULAR CONTRIBUTING EDITORS: Harris C. Allen, Harry Sanders, Ben H. O'Connor, Glenn Stanton, Roi L. Morin, Chas. H. Alden, Irving F. Morrow. HONORARY EDITORS: Arthur Brown, Jr., Timothy L. Pflueger, Lewis P. Hobart, Wm. W. Wurster, Will G. Corlett, Frederick H. Meyer, Thos. J. Kent, Gordon B. Kaufmann, Paul R. Hunter, Michael Goodman, Harry Michelsen.

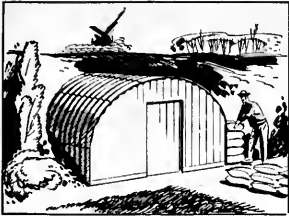
ARCHITECT AND ENGINEER is published on the 15th of the month by The Architect and Engineer, Inc., 68 Post Street, San Francisco. President, K. P. Kierulff; Vice President, Fred'k W. Jones; Secretary and Business Manager, L. B. Penhorwood.

Entered as second class matter, November 2, 1905, at the Post Office in San Francisco, California, under the Act of March 3, 1897. Subscriptions, United States and Pan America, \$3.00 a year; foreign countries \$5.00 a year; single copy \$ .50.

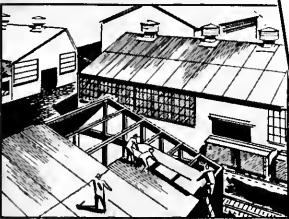
Los Angeles office: 1709 W. 8th street, Wentworth Green, Manager. Phone EXposition 8292. ARCHITECTS REPORTS are published daily from this office and are sponsored by the Northern Section, State Association of California Architects; Vernon S. Yallop, Mgr.



**MOVABLE AIRPLANE HANGARS** can be designed with U·S·S Steel Sheets so they can be moved quickly without damage.



**AIR-RAID SHELTERS** are being made from U·S·S Sectional Plate Arches. These are strong and can be quickly erected with ordinary labor.



**MORE PLANT CAPACITY** is quickly put under roof with U·S·S plain corrugated Steel Sheets.



**PORTABLE BUILDINGS** for the fighting forces can be made of U·S·S Steel Sheets and insulated to keep out heat and cold.

**FOR SPEEDY  
ERECTION**  
*...design with*  
**U·S·S Steel Sheets**

**P**LANT expansions, army camps, air-raid shelters, defense housing, are just a few of the jobs that have to be built literally overnight. But, there's no need to sacrifice durability for speed if you build with U·S·S Steel Sheets.

Look carefully at the illustration. This is a permanent building designed for fast erection by being made in sections. It will stand the ravages of lightning, fire, weather and time. Buildings like this are low in first cost, economical to build, free from expensive maintenance.

They can be moved from place to place and set up without serious loss.

U·S·S Galvanized Sheets are ideal for these applications. In most cases base metal of plain steel or pure iron is satisfactory, but where extra corrosion resistance is required, U·S·S Copper Steel is recommended.

Where immediate painting is important specify U·S·S Dul-Kote, which has a superior surface for painting. Paint holds tighter—does not flake off—protects the surface longer.

**STEEL BUILDINGS** can be set up in hours rather than days when the design is right. Ask for further details on this type of construction.

## U·S·S ROOFING AND SIDING SHEETS



COLUMBIA STEEL COMPANY, San Francisco  
CARNEGIE-ILLINOIS STEEL CORPORATION, Pittsburgh and Chicago  
TENNESSEE COAL, IRON & RAILROAD COMPANY, Birmingham  
Scully Steel Products Company, Chicago, Warehouse Distributors  
United States Steel Export Company, New York

UNITED STATES STEEL



# Living in a Big Way

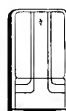
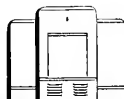
With Emphasis On  
**ALL-GAS COMFORT**



William Wilson Wurster, Architect for the Federal Works Agency.  
Harrett & Hilp, Robert McCarthy, General Contractors.

**I**N JULY, 1941, just another hillside; today the site of 1,667 all-gas equipped, prefabricated homes . . . that's the streamlined story of the newly completed Carquinez Heights Defense Housing Project. \* In fact, in every California defense housing project, modern gas appliances are meeting the challenge of speed and economy, yet doing their part, as always, to maintain America's unmatched living standards.

**GAS**  
BEST CHOICE  
4



**COOKING \* WATER HEATING \* HEATING \* REFRIGERATION**

# NEWS AND COMMENT ON ART

## MURALS AND DRAWINGS BY CORRADO CAGLI (1910- )

The **M. H. de Young Memorial Museum** is showing murals from the Day Room at Camp San Luis Obispo, and seventy drawings of camp life by Corrado Cagli.

Cagli was born in Ancona, Italy. He was successful as a muralist in Rome and other cities of his native land before coming to America. His first exhibition in this country was in the Carnegie International in Pittsburgh, 1936. Cagli has since exhibited at the Julian Levy Gallery, New York; Zeitlin Gallery, Los Angeles, and the Wadsworth Atheneum, Hartford, Connecticut.

When, in the spring of 1941, Cagli was inducted into the United States Army, he was persuaded by a number of officers and men of Battery B of the 143rd Field Artillery to paint these mural panels for their Day Room. The Day Room is the recreational or social hall of a battery. As suggested in this exhibition the buildings at Camp San Luis Obispo were built in simple frame construction of unfinished lumber but with a definite architectural emphasis created by the intersecting vertical and horizontal studs. In order to preserve the architectural feeling of the framework and at the same time to enhance the structural design the artist worked out a system of panels in geometric forms—circle, lunette, triangle, rectangle—that would architecturally and decoratively function within the space they occupied.

The subject matter of the paintings is martial throughout and ingeniously combines phases of ancient combat with present-day life. Some symbolize the spirit of victory or allegorically express the idea of battle. All heroically convey the theme of military life, its ancient heritage, its spirit, interests and modern activities.

Apart from their technical and artistic significance, the most fundamental and worthwhile aspect of Cagli's murals is the social circumstances under which they were created. Although the pictorial scheme and execution of the panels were the artist's, the need and desire for them were the soldiers'.

Other battery units were enthusiastic about the project and there is little doubt that if the war had not suddenly uprooted the 143rd Field Artillery, other camps would have sought to emulate the art of Battery B. As it is, these panels set an example, which, when they are restored to permanent quarters cannot help but have fruitful results both socially and artistically.

Inasmuch as these panels are of considerable artistic significance as well as being representative of an important phase of American military life, arrangements were made with the artist and with Dr. Walter Heil, Director of the de Young Museum, for the exhibition of these murals together with seventy of Cagli's drawings of camp life.

## WILL CARRY ON

The **San Francisco Museum of Art** plans to carry on its work despite the war. It believes that under war conditions there is even more need for art and art museums than in ordinary times—people need now more than ever the refreshment of spirit, the

reaffirmation of faith in civilization, the reminder of the eternal values of life which art is. The Museum is, as well, a center of recreation open to every one in its exhibitions at no charge, and carrying on varied activities at nominal expense or for members at no charge at all.

The Museum also provides exhibitions and activities which convey information of vital importance. Clear examples are the series of Latin-American exhibitions and the accompanying lectures illustrated by slides and motion pictures which can do so much to build understanding of our Southern neighbors.

## ROSENBERG TRAVELING SCHOLARSHIP

The **President** and the Board of Directors of the San Francisco Art Association announce they will receive written applications for the third Abraham Rosenberg Traveling Scholarship Award.

To foster art in America, the late Abraham Rosenberg generously bequeathed in trust to the Board of Directors of the San Francisco Art Association, an endowment fund to be given in Scholarships (amounting to \$1500.00 annually) to gifted students for extended study in the fine arts. Its purpose is to assist exceptional persons who have already demonstrated their ability to accomplish distinguished creative work of professional standing.

Although the Scholarship is intended for study abroad, it is not strictly limited to this field. Applicants desiring to pursue special research in this country will be considered.

General terms of the Scholarship require that the applicant shall have been registered in the California School of Fine Arts for at least two semesters, and shall have completed original work in the fine arts. Applicants shall be between 25 and 35 years of age, although exceptional persons over 35 years will be considered.

Applicants must apply for Scholarships in accordance with instructions contained in a form which will be supplied by writing to the San Francisco Art Association, 800 Chestnut Street, San Francisco. The closing date for receiving applications will be March 31.

## COMPOSERS' FORUM

Another in the series of extremely fine musical programs organized by Ashley Pettis for the Composers' Forum will be presented at the San Francisco Museum of Art on Sunday, February 22, at 3:00 p.m. Compositions by Louis Gruenberg, Frank Denke and Ellis Kohs, will be performed by distinguished artists. These programs are open free to the public.

## YOUNG AMERICAN SCULPTORS EXHIBIT

Until February 24 the San Francisco Museum of Art is exhibiting work by Fifteen American Sculptors. The unusual variety and wealth of creative talent which exists, particularly among the younger sculptors today, has received little recognition throughout the country, principally because of the difficulties involved in shipping. New York's Museum of Modern Art has assembled and circuted this group of fifteen sculptures to fill the need for such exhibitions. Work by John Flannagan, Bernard Walsh, Herbert Ferber, Chaim Gross are

# IN AN EVER CHANGING WORLD



**FIRST WAR WINTER** (oil on canvas) By **CHARLES HOWARD**

This picture won the purchase prize of the 60th Annual Exhibition of Painting and Sculpture of the San Francisco Art Association.

representative of these men who, typical of today's sculptors, work directly in stone—rather than casting—thus retaining the surface quality and nature of the original material.

## **ART ASSOCIATION OFFICERS FOR 1942**

**At the January meeting** of the Board of Directors of the San Francisco Art Association, Eldridge T. Spencer, architect, was unanimously re-elected to serve as President. New members of the Board, elected in December, are Ray Bethers and Donald Gregory; elected to continue in office are Helen Forbes and Worth Ryder.

## **ROSENBERG TRAVELING SCHOLARSHIP**

**The President** and the Board of Directors of the San Francisco Art Association announce the third Abraham Rosenberg Traveling Scholarship Award. While the Scholarship formerly was given only in painting and sculpture, the Scholarship for 1942 will include any subjects taught at the California School of Fine Arts. Among these are painting, sculpture, mural painting, mosaic, design, crafts, lithography and decoration.

Applicants must apply for scholarships in accordance with instructions contained in a form which will be supplied by writing to the San Fran-

cisco Art Association, 800 Chestnut Street, San Francisco. The closing date for receiving applications will be March 31, 1942.

The museums contribute the following announcements of events occurring after the publication date of the Architect and Engineer.

## **CALIFORNIA PALACE, LEGION OF HONOR Exhibitions**

**DRAWINGS** by WILLIAM LITTLEFIELD—Opening February 16th.

**CALIFORNIA MISSIONS: LINOLEUM BLOCKS** by FRIEDOLIN KESSLER—Opening February 16th.

**THE GORDON BLANDING COLLECTION**—Through February.

**ORGAN RECITALS**—Uda Waldrop, Organist—Each Saturday and Sunday at 3:00 p.m.

## **Art Broadcast**

By Dr. Jermayne MacAgy—Station KJBS, February 22, 5:00 p.m.

## **M. H. DE YOUNG MEMORIAL MUSEUM**

### **Exhibits**

Murals from the Day Room at Camp San Luis Obispo and Drawings of Camp Life by Corrado Caqli (1910- ). Through February.

(Turn to Page 39)

*Sloan Flush Valves?*  
*take*



# Rockefeller Center



*for example*

ROCKEFELLER CENTER, probably the largest real estate development in recent history, stands as both a monument to the genius of the late John D. Rockefeller and a symbol of American enterprise. Its fourteen

buildings house more than 25,000 tenants and accommodate over 100,000 visitors daily. Its 5,000,000 square feet of floor space afford services ranging from the famous Music Hall with a seating capacity of 6,200 to twenty-four restaurants, eleven foreign consulates, the press and radio center of the world, and schools which teach everything from shorthand to dancing.

This hundred million dollar project is completely Sloan equipped. Why should this property, in common with literally thousands of other large companies and institutions, give such recognition to Sloan Flush Valves? Simply because Sloan Flush Valves give the greatest dollar value.

## Why SLOAN Flush VALVES?

**THEY SAVE WATER.** Because of the accuracy and permanence of adjustment Sloan Valves save their owners water *all of the time*. And Saved water is saved money—not only in reduced consumption of water but in reduced pumping and man-power costs.

**THEY REDUCE MAINTENANCE EXPENSE.** Sloan Flush Valves cost but  $\frac{1}{2}\%$  to  $1\frac{1}{2}\%$  per valve per year to maintain. Entire installations in service for years without being touched are constantly reported.

**THEY SAVE REPLACEMENT.** Sloan Valve durability may be verified in your locality. Installations 15, 20 and 25 years old are common to every section of the country and every type of building.

*that's why* in office buildings, schools, hospitals, hotels, institutions, factories, apartments or public buildings, the vast majority of flush valves are Sloan. Indeed, there are more Sloan Flush Valves sold than all other makes combined.

SLOAN VALVE COMPANY, 4300 W. LAKE STREET • CHICAGO



Aerial Photo by  
Fairchild Aerial Surveys, Inc.

# SLOAN Flush VALVES

# TWIN HOUSES FOR TWIN BROTHERS



**THIS IS THE FRED POLLEY HOUSE AT DOWNEY, CALIFORNIA**

**Twin** houses for twin brothers was the unique architectural assignment recently accomplished by Curtis Chambers, Pasadena architect, for Frank and Fred Polley of Downey, California. Although the houses were to be built on one lot, 350 feet in width, the planning problem could not be met by designing one house and duplicating it. The brothers were identical twins, but their wives were not. Thus, while the architect adhered to a common style, he worked subtle variations into the arrangement and decorative scheme which give the two homes both distinction and distinctiveness.

The brothers are in business together in Huntington Park and entertain extensively. Consequently, a cozy den, conveniently placed in relation to an outdoor patio and equipped with a built-in bar, is an interesting feature of both homes. Outdoor living potentialities of a deep lot which was originally an orange grove are fully realized in the room placement of the homes. In both

cases, a centrally located living room gives ready access to the rear patio. The ranch house style of architecture is thoroughly in keeping with the suburban character of the district.



**AND THIS IS THE FRANK POLLEY RESIDENCE, ALSO AT DOWNEY**

**Both houses designed by Curtis Chambers, Architect**



# "Why settle for 75¢ when you can have \$1.00?"



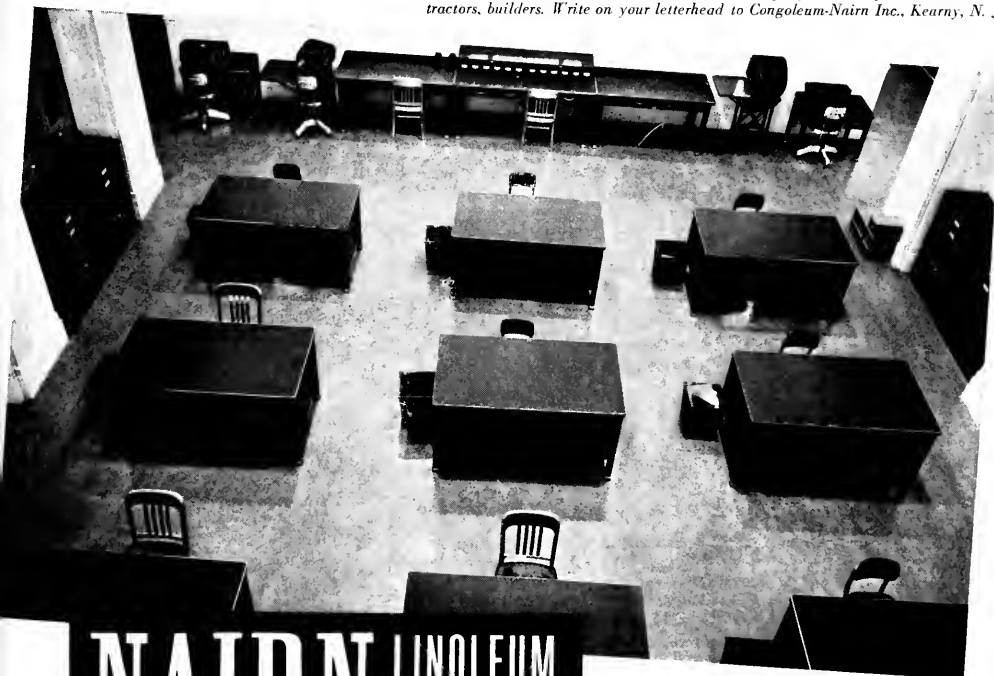
It gives you something to think about when you compare the advantages of Nairn Linoleum with other floor materials. For Nairn Linoleum alone meets *all four* of the basic specifications for the modern floor.

1. **EYE APPEAL**—Unequaled beauty and wide variety of color offer unlimited freedom of design. Patterns that are Color Correlated—with each other and other decorating materials.
2. **LONGER WEAR**—Nairn commercial linoleums not only meet, they *exceed* U. S. Government specifications on *every* point. Built-in ruggedness that spells long-range economy.
3. **RESILIENCE**—Quiet, "foot-easy" Nairn Floors are sound absorbing, sound deadening . . . "come-back" with a minimum of marring after indentation.
4. **CLEANLINESS AND EASY MAINTENANCE**—One-piece construction leaves no dirt-catching cracks and joints . . . reduces maintenance time and cost to a minimum. Positive germicidal properties. No splinters! No "dusting"!

Why be satisfied with a floor that gives you only two or three of these advantages—a 50% or 75% value for your money? In times like these especially—it's important to get "all 4"—100% for every dollar you spend—with Nairn Linoleum!

**EXTRA VALUE IN NAIRN WALL LINOLEUM, TOO.** It lasts as long as the building. It won't fade, crack, discolor, stain or dent. And—with its amazing variety of patterns and colors—it offers more decorating possibilities than any other permanent wall material. Both Nairn Floor and Wall Linoleum are fully guaranteed when installed in accordance with specifications.

**FREE—200 PAGE BOOK** of installation aids and specifications—for architects, contractors, builders. Write on your letterhead to Congoleum-Nairn Inc., Kearny, N. J.

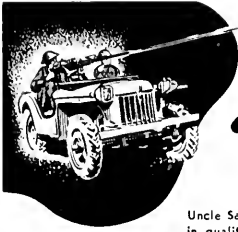


# NAIRN LINOLEUM

FLOORS AND WALLS

*The Federal Reserve Bank of Atlanta, Atlanta, Ga., used a handsome Nairn Veltone pattern. An ideal choice—for quiet, comfortable Nairn Linoleum hushes footsteps—lessens nerve strain.*

**Nairn Linoleum—the floor that gives you "all 4"**



*Substitutes  
won't do!*

Uncle Sam's implements of war have no equal in quality and performance. Time after time they have proven their superiority in combat with the enemy. POMONA TILE is also unequalled, in quality. Only REAL POMONA TILE will give you the permanent beauty, the lasting charm and delightful appearance you expect. DEMAND REAL POMONA TILE AND GET THE BEST.

Only REAL Pomona Tile Has All These Advantages

- Absolutely Fireproof
- Surface immune to cigarette burns
- Practical for use on floors, walls, ceilings
- Colorfast for life
- Waterproof, stainproof, easy to clean
- True color balance
- Patented "Spice-Rite" feature assures permanence



**POMONA TILE MANUFACTURING COMPANY**  
 629-33 N. LA BREA AVENUE • LOS ANGELES  
 135TH TENTH STREET—SAN FRANCISCO 6106 ROOSEVELT WAY—SEATTLE  
 PLANT: POMONA, CALIFORNIA MINES: DEATH VALLEY

## Uncle Sam Uses Corrosiron



Drain pipes and fittings in many Federal buildings, including the San Francisco Mint, pictured above, are protected with **Corrosiron** — a positive guarantee of long life and sure resistance to corrosion.

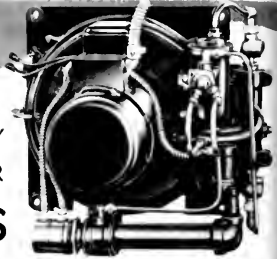
**Corrosiron** is used extensively for acid drain lines in hospitals, universities, high schools, laboratories. Is manufactured by —

**Pacific Foundry Company, Ltd.**  
 NEW YORK • 3100 NINETEENTH ST., SAN FRANCISCO • LOS ANGELES

30 AVH

ROTARY  
OIL BURNER

LOWERS  
FUEL COSTS!



• PATRIOTISM today demands that all types of fuel be conserved. American architects all over the country stake their reputations on the Johnson 30 AVH Rotary Oil Burner using less fuel oil, yet giving superior performance. Important Army and Navy installations of Johnson 30 AVH Burners are being made in all parts of the world because of its efficient handling of heavier, low-grade oils in any climate; positive automatic starting under all conditions; easy adjustments and dependability. Get the facts on modern fuel-saving possibilities. Write us, now, for complete specifications and operating data.

FREE  
COMPLETE  
SPECIFICATIONS

**S. T. JOHNSON CO.**

940 Arlington Avenue • Oakland, Calif.  
 401 N. Broad Street • Philadelphia, Pa.

BRIGHT ENDURING COLORS  
 —FOR EXTERIOR SURFACES—  
 IN A WIDE COLOR RANGE

Cabots  
 Non-Fading  
 Gloss  
 Collopakes



**GUNN, CARLE & CO.**

SAN FRANCISCO  
 20 POTRERO AVE.  
 Underhill 5480

---

---

☆ ☆ **NATIONAL DEFENSE DIRECTORY** ☆ ☆

---

---

**CENTRAL ADMINISTRATIVE SERVICES—O.E.M.**

**SAN FRANCISCO:** Ralph B. Thompson, Regional Administrative Officer; L. F. Gentner, Regional Service Operations Officer; R. W. Scott, Regional Fiscal Officer; Boynton S. Kaiser, Regional Personnel Officer; 1355 Market Street.

**LOS ANGELES:** Philip F. Bauman, Administrative Service Officer, 1031 South Broadway.

**SEATTLE:** Frank W. Burr, Administrative Service Officer, White-Henry-Stuart Building.

**PORTLAND:** Donald Parker, Administrative Service Officer, Bedell Building.

**DIVISION OF INFORMATION—O.E.M.**

**SAN FRANCISCO:** Dean S. Jennings, Regional Information Officer; Harry E. Flanagan, Assistant; 1355 Market Street.

**LOS ANGELES:** H. R. Washburne, Branch Manager, 1031 South Broadway.

**SEATTLE:** Howard MacGowan, Branch Manager, White-Henry-Stuart Building.

**WAR PRODUCTION BOARD**

Division of Industrial Operations  
(Priorities)

**SAN FRANCISCO:** Andrew L. Kerr, District Manager; Gilbert Kneiss, Assistant; 1355 Market Street.

**LOS ANGELES:** Phillip McCullough, Acting Manager, 1031 Broadway.

**SEATTLE:** William D. Shannon, District Manager, Stuart Building.

**PORTLAND:** J. Fred Bergesch, District Manager, Bedell Building.

**PRODUCTION DIVISION**

Contract Distribution Branch

**SAN FRANCISCO:** Colonel F. M. Smith, State Manager; E. F. Halloran, Assistant; 1355 Market Street.

**LOS ANGELES:** District Manager, Western Pacific Building, 1031 South Broadway.

**SEATTLE:** Harry J. Martin, State Director, 3314 White Building.

**SPOKANE:** T. Wilber Weger, District Manager, Old National Bank Building.

**PORTLAND:** John G. Barnett, State Director, 815 Bedell Building.

**FRESNO:** C. E. Bourne, District Manager, Mattei Building.

**OAKLAND:** W. P. Collins, District Manager, Financial Center Building.

**SACRAMENTO:** Orlando McCraney, Acting District Manager, Farmers and Mechanics Building.

**SAN DIEGO:** Paul C. Farmer, Acting District Manager, Union Building.

**PHOENIX:** Fred F. Schalmo, Acting Manager, 406 Security Building.

**BOISE:** H. W. Bogie, Acting Manager, 409 Capital Securities Building.

**RENO:** E. S. Bender, Acting State Director, Saviers Building.

**DIVISION OF LABOR**

**SAN FRANCISCO:** James G. Bryant, Chairman of the Regional Labor Supply Committee; George W. Davis, Executive Officer of Northern California Industrial Area Committee; Lee R. Smith, Regional Labor Representative, Labor Supply Committee; Humboldt Bank Building, 785 Market Street.

**LOS ANGELES:** H. R. Harnish, Executive Officer of Southern California Industrial Area Committee, 1100 South Flower Street.

**WASHINGTON AND OREGON:** James E. Carroll, Executive Officer of the Industrial Area Committee, Oregon State Employment Department, 202 Old Post Office, Portland, Oregon.

**DIVISION OF TRAINING-WITHIN-INDUSTRY**

**SAN FRANCISCO:** Alexander Heron, District Representative; Aylwin Probert, Assistant; 260 California Street.

**LOS ANGELES:** William K. Hopkins, District Representative; Charles K. Fishburne, Assistant; Roosevelt Building.

**SEATTLE:** General H. G. Winsor, District Representative; Leighton Steele, Assistant; Stuart Building.

**PORTLAND:** Laurin E. Hinman, Representative, Public Service Building.

**OFFICE OF CIVILIAN DEFENSE—O.E.M.**

Ninth Corps Area

**SAN FRANCISCO:** Jack H. Helms, Acting Regional Director; Louis Ashlock, Senior Civilian Defense Representative; 1355 Market Street.

**DIVISION OF HEALTH AND WELFARE SERVICES—O.E.M.**

**SAN FRANCISCO:** Richard Neustadt, Co-ordinator; Pearce Davies, Assistant to the Co-ordinator; 785 Market Street.

**DIVISION OF DEFENSE HOUSING CO-ORDINATION  
—O.E.M.**

**SAN FRANCISCO:** O. W. Campbell, Associate Regional Co-ordinator; Raymond Brummet, Field Adviser, Homes Registration Office, 1355 Market Street.

**LOS ANGELES:** Kelvin Vanderlip, Housing Priorities, 1031 South Broadway.

**SEATTLE:** Louis Scarbrough, Assistant Regional Co-ordinator, Room 908, White Building.

**OFFICE OF PRICE ADMINISTRATION**

**SAN FRANCISCO:** Harry Camp, Regional Director; Frank Marsh, Executive Officer; Ben Duniway, Regional Attorney; Thomas W. Sullivan, Regional Inspector; N. S. Buchanan, Regional Price Executive.

Consumer Division

**CALIFORNIA:** Brownie Lee Jones, 260 California Street, San Francisco.

**WASHINGTON:** Beryl S. Gridley, 956 Stuart Building, Seattle.

**OREGON:** Nan Wood Honeyman, Bedell Building.

**TRANSPORTATION DIVISION—O.E.M.**

**SAN FRANCISCO:** Emery A. Boudreau, Deputy Co-ordinator of Civilian Motor Transportation; Richard T. Eddy, Regional Chairman, Central Motor Transportation Committee, California, Arizona and Nevada; Monadnock Building, 681 Market Street.

**PORTLAND:** Frank Landsburg, Regional Chairman, Central Motor Transportation Committee, Washington and Oregon; Pittock Block.

**SALT LAKE CITY:** Bert L. Penn, Regional Chairman, Central Motor Transportation Committee, Idaho; Continental Bank Building.



**GRAYSON'S WOMEN'S READY-TO-WEAR SHOP, SEATTLE, WASHINGTON**

The Arcade. Photographed from one of the entrance doors. Note unusual height which makes possible a spacious show room area and a commanding front. Gruenbaum, Krummeck & Auer, Designers.

# SOME NOTES ON MODERN STORE DESIGN

By VICTOR GRUENBAUM, with Gruenbaum, Krummeck and Auer, Hollywood and New York

**Designing** stores on the West Coast has presented new problems and new possibilities. California's tempered climate makes solutions possible that are prohibitive in the East — features that contribute in no small measure to the attractiveness of a store. The wide open arcade front and the slightly parking lot entrance, for example, could not be carried out anywhere so well as in California. The fact that entrance doors may be kept open all day has left a still closer connection between interior and exterior design.

Another factor influencing store planning in California is the existence of definite shopping centers which are less subject to heavy pedestrian traffic but are magnets for people who enjoy their window shopping. On the other hand, there exists in these shopping centers a heavy automobile traffic which necessitates featuring the advertising factor of the store so it will lure the people who drive by.

The average store is divided into two main portions: (1) the exterior, often enlarged to a vestibule or arcade, and (2) the interior. The functions of the exterior are to serve as advertising poster and exhibit. The interior functions as a "sales factory." There are, of course, great variations within this theme, depending on size, location, merchandise and price category of the enterprise, but for all of them the desired effects of the store design on the neutral passerby are:

1. To arouse his interest by a characteristic and impressive exterior and then awaken his curiosity to the point where he feels impelled to take a second look.

2. This exhibit is gratis but arranged with a very specific aim in mind, namely, to arouse the desire to possess some of the exhibited goods. Aim of the design has to be the most favorable frame and background for this exhibit.

3. Once the desire for possession has been excited, the purpose is to make its fulfillment as easy as possible. This can be done by making the step from the outside to the inside

(Turn to Page 22)



**PRIVATE BAR IN AN APARTMENT**

Here an entrance hall was made to do double duty. Upon opening the doors of a closet the roof, normally in a vertical position behind the doors, swings out and bar counter is rolled forward. The bar stools are stored under the counter when the doors are closed.

# GRAYSONS



## GRAYSON'S STORE

Crenshaw Blvd., Los Angeles

The store has two fronts of equal importance, one (left) directed towards the street, and the other (below) facing a parking lot. The top photograph was taken at night and shows the sweeping canopy floodlighted by concealed reflectors. The wall between arcade and interior is entirely of polished plate glass with frameless herculite doors, giving a complete view of the interior from the street.

The parking lot entrance is curtained to protect the interior during hours of direct sun exposure, but when this front becomes shaded the curtains are drawn, giving the appearance of a tremendous show window.

The lower photograph was taken from the far edge of the credit office and shows the quadruple desk in the center, with its fluted glass partitions and the circular bench for waiting customers. The hosiery counter island is in the background.



GRUENBAUM, KRUMBECK  
AND AUER  
Designers



*ho*

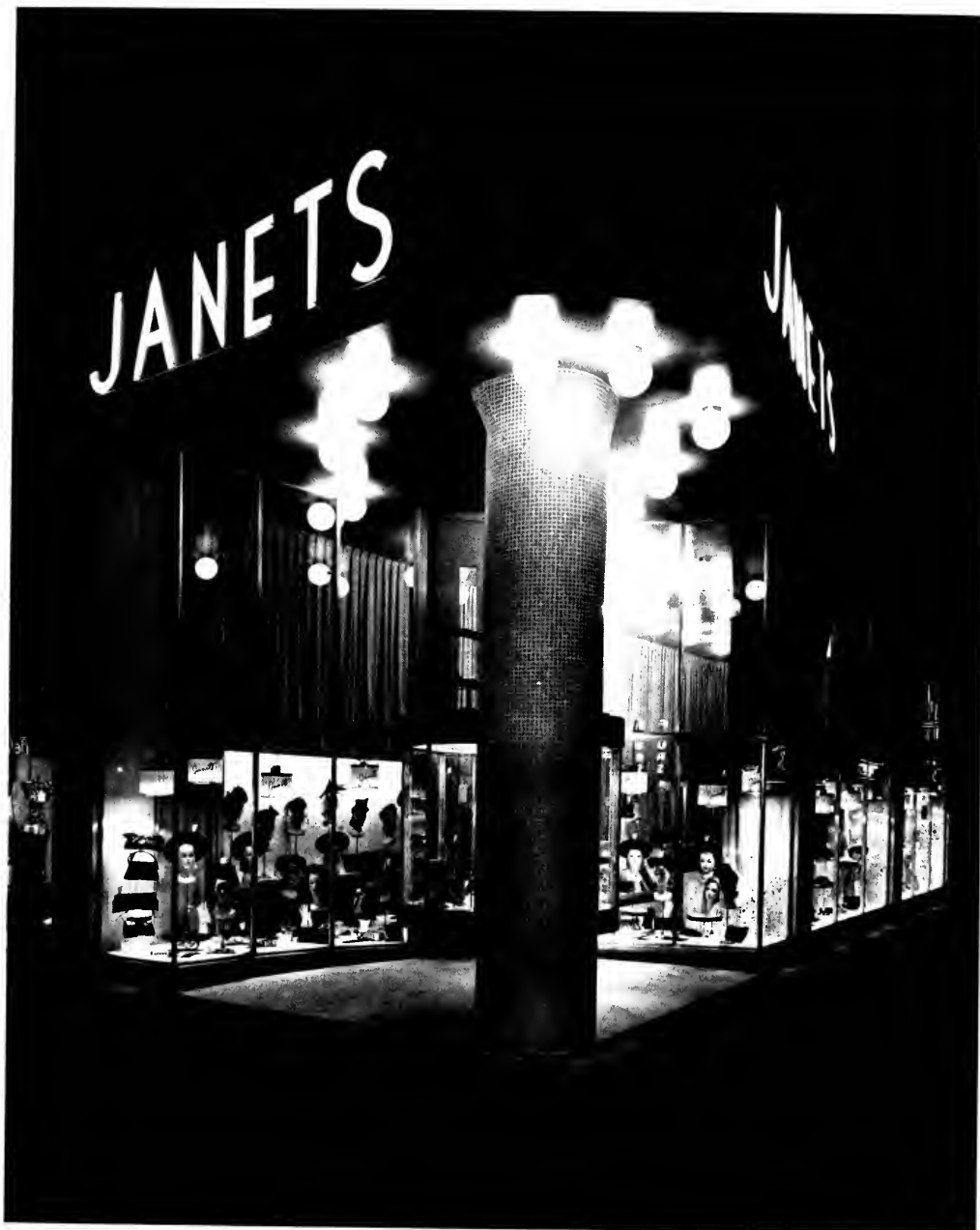
**SO. BROADWAY**  
Los Angeles

is an old store com-  
pletely remodeled. Walls  
and ceiling are covered  
with black patent leather,  
set in big squares, with  
small light bulbs making  
stars at the intersections.  
Light troughs run along  
the ceiling and down the  
long rear wall, throw-  
ing a mild light against  
the dusty rose back-  
ground.

The picture on the right  
is a detail of the same store  
showing treatment of  
the ceiling and ceiling at the ele-  
vator entrances. The old ex-  
isting elevator doors are re-  
placed with "plum pud-  
ding" mahogany. Lettering  
on the doors is white fluores-  
cent neon.



**ENBAUM, KRUMBECK**  
**AUER**  
Architects



**JANET'S MILLINERY STORE, OKLAHOMA CITY, OKLAHOMA**  
**GRUENBAUM, KRUMMECK AND AUER, Designers**

Meyers Photo Shop

Another example of a store in which the entire interior becomes a show-window. Upper picture on the right shows entrance hall to a small apartment. Below is the same room converted into a dining room.





Gruenbaum, Krummeck and Auer, Designers



Photo: Samuel Gottscho



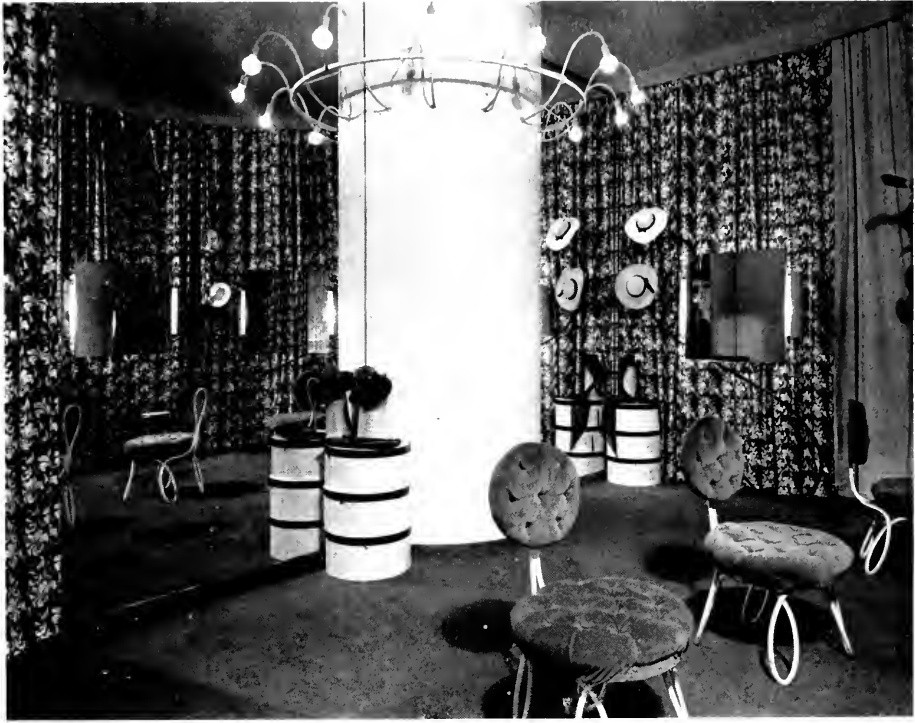
**TWO VIEWS OF A LIVING ROOM IN A METROPOLITAN APARTMENT HOUSE**

The walls are greyish green and white, dark red settees, silver grey carpet. The large arm chairs are covered with grey fabric with yellow print; small chairs are natural pigskin. Interior finish is dark brown walnut.

Upper picture on the opposite page shows the interior of a small millinery shop. Space lacking, the entire left wall is mirrored giving the room an appearance twice its size. A disturbing column within this left wall is covered with a half round shell of plywood and the mirrors complete the circular effect. The lower picture is a continuation of the interior of Grayson's Los Angeles Store.



**GRUENBAUM, KRUMBECK AND AUER, Designers**



agreeable and inviting, psychologically as well as physically. This desire can be increased by making the interior visible from the outside and by assuring the prospective buyer that he will not only get what he has seen on display but will enjoy his purchasing visit.

Main characteristic of the "sales factory" is the fact that the visitor shall not see the machinery; all the smoothly functioning gears and levers must be hidden. The buyer must feel "at home," and even better than at home. Great effort is made to create this feeling: air conditioning, elaborate lighting schemes, acoustically perfect walls and ceilings, warm and friendly colors, sound-absorbing floor coverings and comfortable furniture, all are means to this end. They are all intended to make the buyer feel so well and enjoy being in this room so much that he is ready to pay for this privilege by buying more than he originally intended. Besides this, the interior continues the exhibit of the exterior: displays are grouped in glass showcases, in niches and on tables. The purpose of this is to arouse new desire to buy, in addition to that which made the buyer enter the store in the first place.

In our work we have tried to solve these problems in various ways. Though designer and client usually agree upon the aims of the design, it is very often difficult to convince the client of the propriety of the means necessary to fulfill these aims. The typical store on our main streets all over the country shows clearly the mistakes which are made through lack of able

advice and design. The mistakes made in the layout of the store fronts result usually from improper knowledge of exhibit technique. The gaudiness of materials and trimmings will kill the effect of the exhibited goods. Glass show windows are often, especially in the case of the arcade front, arranged in such a manner that they block access to the rest of the arcade and hence into the store; this is usually due to a desire to show more goods than the exhibit area allows. Other mistakes result from insufficient knowledge of lighting and color effects. Glaring lights on outside or inside make it impossible to enjoy either looking or buying. In the same way, cold or distracting colors destroy comfort.

More and more, retail merchants are learning the value to their business of good store design. Of course, store design alone cannot be the key to success; much depends on location, merchandise and management, but it can be said and it has been proved (as in the case of alterations to existing stores illustrated) that the influence of design is tremendous and that earnings can be increased to twice or three times their original volume by the successful application of this one factor alone.

If the needs and necessities of store design become widely acknowledged and a thorough understanding of all technical factors is achieved, good store design should follow. There is, of course, still a step from a "good" store to an "outstanding" creation. How to make a store-design outstanding is a matter to which theoretical considerations just don't apply. What makes the design outstanding is the finding of an imaginative scheme which governs the entire lay-out like a musical theme, heightening the effect of the technical and psychological devices and assuring their success.

Editor's Note—Victor Gruenbaum and Elsie Krummeck began their collaboration as designers in November, 1939. Michael Auer joined the firm in 1940. Before joining forces Miss Krummeck worked in the exhibit field (metal sculpture, Chicago and New York Fairs), while Mr. Gruenbaum practiced architecture in Vienna, up to the time of the Anschluss. Mr. Auer was educated in the Universities of Budapest, Zurich, and Michigan, and gained his experience in both the architectural and exhibit fields. From two offices, one in New York and one in Hollywood, the firm has extended its activity over a great part of the country, as evidenced from the selection of their work illustrated. Commercial work, however, is not their only field of activity. Apartment interiors, residences, as well as the design of packaging materials, china, glassware, and furniture have all been handled by the new firm.

# ARCHITECT AND WAR

By J. FRANCIS WARD, Architect \*

In all past wars the impact on civilian life has been considerable. Due to the character of the "total" war in which we are now engaged, this influence is being greatly intensified. This is expressed not only in all normal civilian activity but, due to the character of aerial warfare and the very nature of its attack far beyond the first line of defense, it has made necessary a second line of defense in which the civilian is actively engaged. Moreover, we have to deal with these problems not only for the duration of the war but for the period of reconstruction that will follow. Our interest must accordingly be based upon a long range viewpoint.

All walks of life are affected but the architects are feeling the effects to a greater degree than most other groups. The change is not entirely calamitous but it is very essential that the architect re-set his sights. In past years the architect has withdrawn himself to a great degree from participating in public life. In common with all sections of the community, he is now called upon to enter fully into the wartime tasks that are being placed upon the civilian.

Civil or passive defense as it might be termed, to distinguish it from the work of the armed forces, calls for utilization of the specific qualifications and experience of all classes. As a primary purpose in civil defense is to maintain the normal life of the community and so assure the fullest effort in production, it might almost be said that the protection of buildings and equipment is equally as important as the protection of life.

Albert Emil Davies, Chairman of the London County Council in the year of the "blitz," stated in San Francisco on January 23, that loss of life in air raids was less than had been expected but damage to buildings was far greater.

The problem of air raid protection therefore places a great responsibility on the architect who, by training and experience, should be in a position to attack the problem from a broad gauge standpoint. He should participate in all possible activities, serve on Civilian Defense Councils and equip himself with all available information on air raid protection. To be forewarned is to be forearmed and the value of preparation will quickly manifest itself when and if the American mainland is attacked.

This necessity was recognized by us previous to the outbreak of the war and at a mass meeting of the State Association of California Architects on December 18, 1941, it was decided to set up an Air Raid Protection Advisory Board. Members were assessed \$5.00 each to initiate the Board's work. A list of specific functions of the Board was drawn up and published in the Board's first bulletin.

Since then four bulletins have been sent out covering a great number of phases of air raid protective work. Incorporated in these bulletins was an expression of policy to be followed by all members of the profession. A number of standards have been published, such as definition of refuge rooms, splinter-proof and bomb-proof construction. Residential buildings have been classified as to type with the emphasis placed upon the necessity of surveys and various forms of shelters described.

Realizing the necessity of some basic knowledge of aerial warfare, we have given a brief but comprehensive explanation of the various types of bombs, analysis of blast and suction, the action of bomb splinters and the relative hazards of high explosive bombs, incendiary bombs and other factors. The Board has endeavored to collect not only as large a bibliography as possible but is also engaged in securing information on the availability of materials,

\* Director, Air Raid Advisory Board, S.A.C.A.

and publishing the relative values of different local materials for protective purposes. In addition to fact gathering and dissemination of information, the Board has undertaken various other activities and proposes to expand them wherever possible within the framework of the State Association's public relations program. These activities may be summarized as follows:

1. To aid in the drafting of a regional Civil Defense Code. Preliminary meetings have already been held, attended by representatives of the State Defense Council, State Division of Architecture and Building Officials' Conference.

2. To consider the organization of camouflage efforts. This seems a logical development of the architect in wartime as the work of camouflage covers almost every factor in the construction field. Although camouflage also requires the services of landscape architects, mechanical, structural and illuminating engineers, sign painters and artists, the architect, by his training, should be best equipped to prepare plans for camouflage with necessary specifications, call for bids and supervise construction.

3. To collaborate with the A.I.A., engineering societies, and official groups for the exchange of information and standardization of methods. The Board has already received inquiries from all over the country for its bulletins and these have been sent accompanied by a request for material in return. According to present information the work being carried out by the Advisory Board does not seem to have its counterpart in any other section either of the State or of the country generally.

4. The Board is in touch with leaders of the architectural profession in England and hopes to get up-to-the-minute information on methods being used abroad in the light of more recent experience. The Board also hopes, through the State Association's public relations program, to obtain financial assistance for its work and has already approached several foundations. In addition, the Producer's Council Club has subscribed to the program and has

appointed a representative as consultant to the Board so that information on materials may be speedily obtained and included in our bulletins.

5. Every possible effort is being made to bring the name of the architect before the public. Through the efforts of the Advisory Board and its public relations counsel, Philip L. Soljak, many columns of publicity have been obtained in the press throughout the State and in all cases the word "architect" has been emphasized. It is hoped through our Speaker's Bureau that architects can be persuaded to give talks to groups, clubs and service organizations on air raid protective work and other matters of public interest. Radio is also being utilized. A full hour's discussion on A.R.P. was given in the California Council Table program over KSFO on February 1. Participating in the discussion were J. Francis Ward, Harold M. Engle and Philip L. Soljak of the Board and Major Harold F. Osborne, Army O.C.D. representative; Dr. Milton Silverman, Science editor, San Francisco Chronicle; Lester Goodman, chairman of the San Francisco Civilian Defense Council Blackout Committee, and Stuart Ward, program moderator.

6. One of the most important functions that the State Association's public relations committee can undertake is to explore possibilities of employment for architects whose practices have been disrupted by the war. We hope that through the agency of the "A.R.P. News" much valuable information on this subject will be transmitted.

7. The Board's program also includes study of post-war reconstruction and wartime building methods. Architects should be equipped with all available information on these problems to assure for them the leadership in the building industry which they once enjoyed but have largely lost in recent years. The Board hopes with the concerted cooperation of the profession and of allied groups, to aid in reversing a social trend which is to the detriment not only of the profession but of the community at large.



MAP SHOWING LOCATION OF ALBERT KAHN DESIGNED FACTORIES

Wherever the name of a city or place is indicated there are one or more Kahn buildings, including naval bases, tank factories, arsenals, commercial structures and hospitals.

## ALBERT KAHN—DEFENSE BUILDER

Since this country became "Defense Minded," no architect in the nation has achieved greater recognition as a builder of war-time structures, than Albert Kahn of Detroit, and a brother, by the way, of Felix Kahn of San Francisco. To Pacific Coast architects, the mention of Kahn's name is to recount, if such a feat is possible, an astounding list of factories and munition plants he has built, all in record time, within the last two or three years. Employing hundreds of draughtsmen, the Albert Kahn Associated Engineers and Architects, Inc., is reputed to have designed and completed many of those huge structures costing millions of dollars, in less time than is often required to build an eight-room residence. Before the Kahn office began designing defense structures, it built some of the nation's largest automobile plants, including 127 buildings for General Motors, Packard and Ford Motor Companies.

Recently, the Weekly Bulletin of the Michigan Society of Architects, Talmage C. Hughes, architect and editor, published a special de-

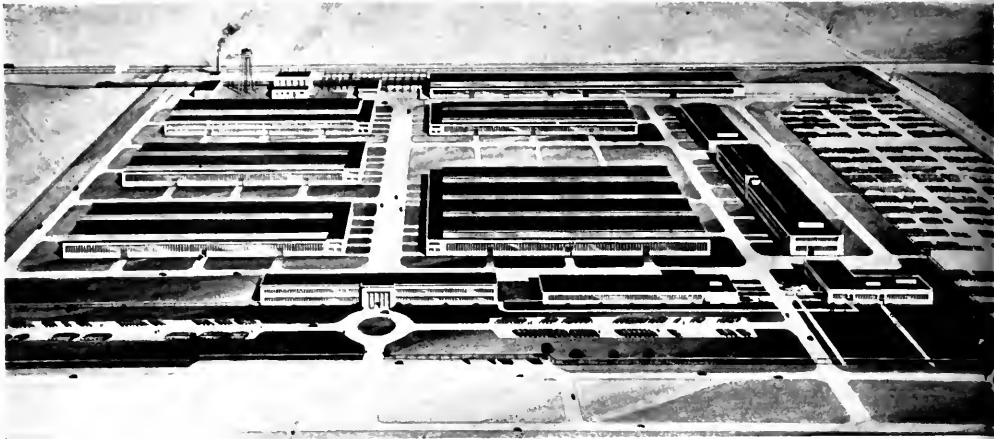
fense number, devoted to the work of Mr. Kahn and his associates. A selection of photographs from this issue is presented in the following pages:

Adrian Fuller, writing in the Detroit Free Press under the caption "Detroit's Key to Defense Speed," says:

"When America's vast defense program was launched, the great factories necessary had first to be designed. It was inevitable that Albert Kahn and his organization should be called in, for long ago Kahn had become recognized as the 'architect of the automobile industry.'

"Kahn's achievements in creating vast industrial plants for Soviet Russia brought him world wide fame. From these same buildings, scores of them costing millions of dollars, have come the vast supplies of munitions Stalin has used in his valiant stand against Germany.

"Utilizing this reservoir of experience, Albert Kahn has met the challenge of defense in the



**ARCHITECTS' PERSPECTIVE OF HUGE HUDSON NAVAL ORDNANCE PLANT, DETROIT**

**Albert Kahn, Associated Architects and Engineers, Inc.**

same way that his long time associates in the automobile industry have done. Kahn expanded his organization overnight to include 500 people, and with the energy and organizational ability characteristic of this seventy-two-year-old veteran, delivered structural steel drawings

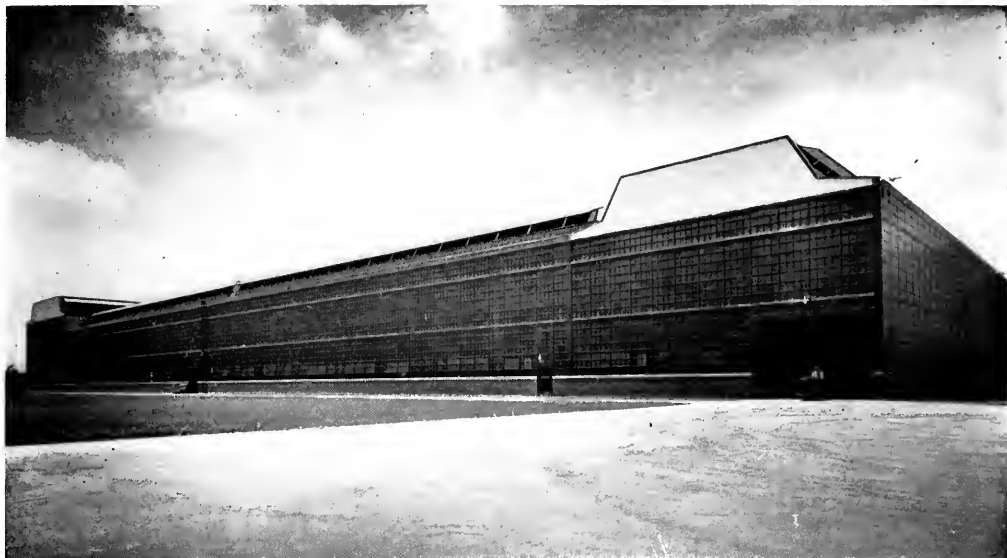
for plants costing millions of dollars in less than a week after they were ordered. Albert Kahn—the man who came to America when he was a boy, who deserted the study of piano for the drawing board and rose to world wide fame for his contribution to industrial architecture—



**CENTRAL WING OF FORD PRESS SHOP, DETROIT, MICHIGAN**

**Albert Kahn, Associated Architects and Engineers, Inc.**





**CHRYSLER TANK ARSENAL, DETROIT, MICHIGAN**

**This immense plant of steel, glass and brick, is more than a quarter mile long and 520 feet wide.**

nas, like other titans of achievement, turned his efforts to all-out defense.

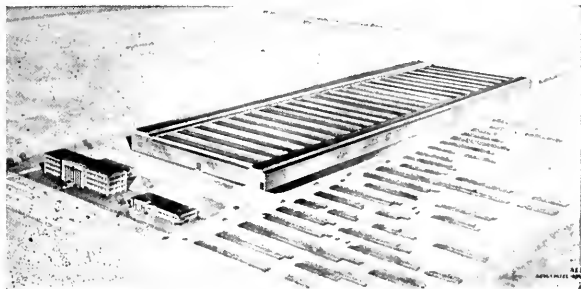
"Kahn learned his profession as a junior employee in architects' offices. A scholarship in architectural design enabled him to spend two years in Europe studying, and, as Kahn puts it, 'my education was furthered by association with men of high attainments.' Today Kahn still does, as he says, 'most of the preliminary lay-out work' on the vast architectural and engineering projects that his organization executes.

"How effective his contribution to defense has been, when speed and more speed has been needed, can be better understood by following the growth of one of the many mammoth structures. We'll illustrate by taking the great Wright Aeronautical Corp. Engine plant near Cincinnati, rather than the greatest of them all—the Ford Willow Run Bomber Plant near Ypsilanti, for the latter is still uncompleted.

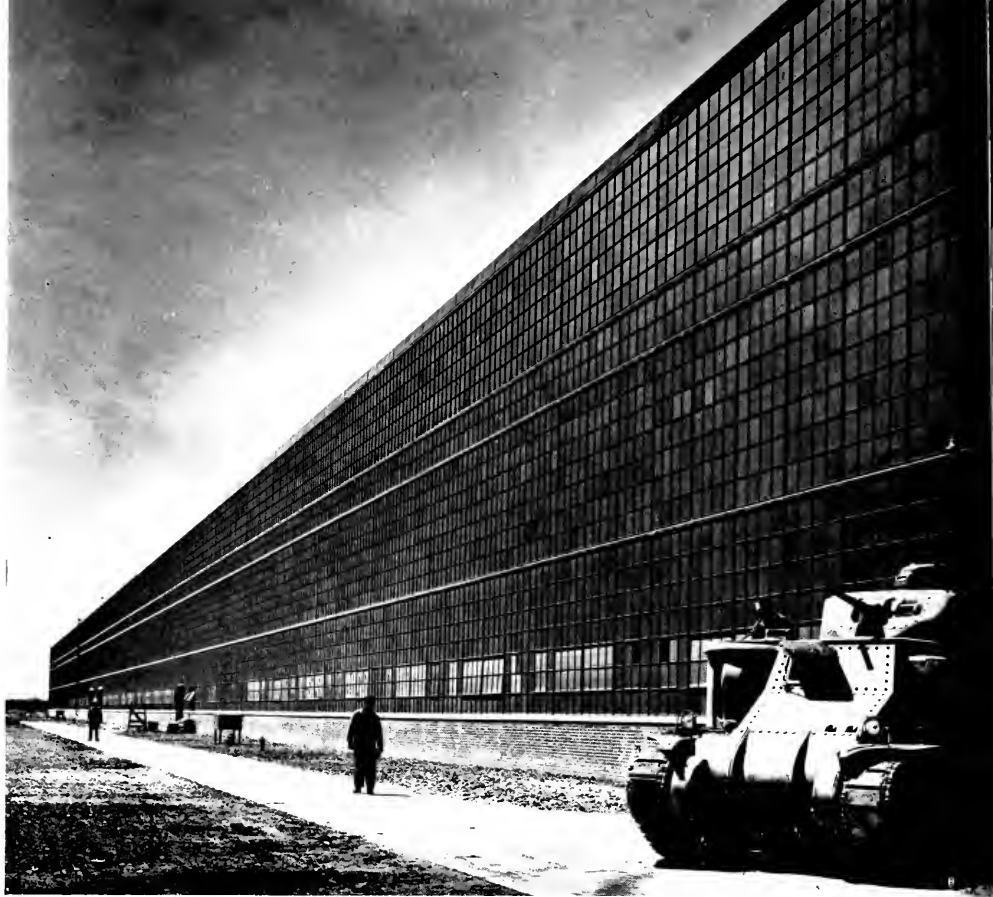
"Wright engineers started work on the Cincinnati lay-out even before it was known just where the fifty-acre plant would be located.

Then, in rapid sequence, land near Cincinnati was purchased and Kahn was called in. Structural steel plans were prepared with great rapidity and the architectural specifications were developed simultaneously.

"Steel bids were taken, and contracts let while excavation was under way. Contracts for the architectural trades were awarded while steel work was being fabricated. Foundations were ready by the time the steel was delivered for erection. Ground was broken Oct. 23, 1940. Steel erection began Jan. 3, 1941 and installation of machinery was started Feb. 15.



**ARCHITECTS' PERSPECTIVE OF CHRYSLER TANK ARSENAL**



**CLOSE UP OF CHRYSLER TANK ARSENAL,  
DETROIT, MICHIGAN. INTERIOR SHOWS  
PLANT IN OPERATION.**

**Albert Kahn, Associated Architects and  
Engineers, Inc.**





AIRPLANE PLANT OF THE TAYLORCRAFT CORPORATION AT ALLIANCE, O.:10



INTERIOR, PLANT OF THE TAYLORCRAFT CORPORATION, ALLIANCE, OHIO

Albert Kahn, Associated Architects and Engineers, Inc.



OFFICE, ENGINEERING & FACTORY BUILDINGS, CURTISS-WRIGHT CORPORATION, BUFFALO, N. Y.

Albert Kahn, Associated Architects and Engineers, Inc.



INTERIOR OF CURTISS-WRIGHT FACTORY, BUFFALO, N. Y.



**CURTISS-WRIGHT CORPORATION, AIRPLANE DIVISION, BUFFALO, N. Y.**  
Corridor in basement of factory with doors to cafeteria, locker rooms, toilet rooms and stairs.

"All major construction work was completed in June, when the first engines rolled off the line two months ahead of schedule. It was just 142 days after ground-breaking, that manufacturing operations were under way.

"The amazing thing about these defense structures that are springing up is that despite the speed many new features are included. In the Curtiss-Wright plant at Cincinnati, for instance, there is an unusually large basement space of 225,000 square feet.

"The basement accommodates corridors through which employees pass too and from their jobs. Stairways take them to their positions at convenient intervals. This saves time and promotes efficiency. Originally they were not intended as bomb shelters, yet, because of their concrete construction, they would serve that purpose if the need should arise.

"In many different parts of the country, the same rate of speed, the same efficiency and the same results, are being duplicated by Kahn's organization.

"But, what of the future? What purpose will be found for these great buildings which have been erected for abnormal defense needs? Not alone is this question asked by the man in the street. It is occupying the thoughts of those in high places as well.

"Only close inspection of these plants gives any sort of clue. Into these buildings have gone facilities that make them readily convertible for peace-time production. But, there remains the question as to how they can possibly be utilized when even before the war there occurred periods when many of our great industries fell into slack periods?

"For the answer to this and other questions the writer turned to Albert Kahn.

"The architect was deliberate in his replies. It was evident that he, too, perhaps more than any other person, has pondered this problem of the future.

" 'Undoubtedly our country will not again be caught in a condition of unpreparedness,' Kahn said. 'Therefore, the defense plants being erected today will continue in use—not, perhaps, 24 hours a day, but, say, eight hours a day, to replenish and repair armaments and other equipment for the standing army of reasonable size which I believe we will maintain. In my opinion, there is no doubt that America will be called upon for many years to come to supply the urgent needs of all other countries.

" 'Being fully prepared and equipped, American manufacturers will be in splendid position to handle this vast volume of business that must



be supplied from some source. To meet competition, to measure up to advanced manufacturing standards, to turn out new products that will be developed, it may even be necessary to rebuild (old) existing plants, as well. This may be over-optimism, but I am fairly convinced that it is not.

"Of course there will be a period of readjustment. But, with so many products unavailable just now, there must come a tremendous rush to supply needed automobiles, commercial airplanes, mechanical refrigerators, radios, talking machines, and all sorts of apparatus, and I feel that the period of readjustment will be much shorter than many persons realize."

**Clean-cut lines, characteristic of modern-day tempo, mark the Kahn work on entrance detail of new Buick Aviation Engine Plant, Buick Motor Division, General Motors Corporation, Melrose Park, Ill.**



**MAIN MANUFACTURING BUILDING, BUICK AVIATION ENGINE PLANT, MELROSE PARK, ILL.**

**In this plant Pratt & Whitney 1020 horsepower plane engines are turned out for the Army Air Corps.**

## KAHN'S VIEWS ON FACTORY DESIGN

**Recently** the Publicity Department of the American Institute of Architects sent out the following timely comments by Albert Kahn on war time industrial expansion:

"The rapid expansion of war plants has created a new type of industrial architecture in the United States. It is but natural that the present opportunities for building anew from scratch produce new ideas in plan and structure. Emphasis has been placed upon the need for speed and little has been said regarding external appearance. Elimination of non-essentials and of all else save the purely utilitarian is imperative. In the very observance of these requirements, however, lies an element which itself makes for attractive external effect. It makes for grandeur and dignity in these mammoth structures.

"Most manufacturing plants today are one-story structures, with occasionally a second floor for certain departments. Many-storied manufacturing buildings, except in special instances and for special purposes—and then only where building areas are limited, are things of the past. For warehouse purposes and the like, they prove economical, but rarely for manufacturing.

"The 'windowless' type of building has been adopted in a number of instances. With fluorescent lighting recently developed, and with air conditioning now quite reliable, certain advantages are rightfully claimed for the windowless building. It affords simpler and speedier construction and it provides a uniformity of light and temperature scarcely obtainable in the daylighted plant. While manufacturing is carried on twenty-four hours per day, the cost of operation should be no higher.

"It will be higher, though, when we return to the normal eight-hour day. For this reason, manufacturers who are building their own plants, and expecting to meet keen competition sooner or later, are adhering largely to the older type. Then, too, many question the psychological effect upon workers entirely shut off

from daylight. This can be determined only by experience.

"The Government rather favors the windowless building because of possible blackouts. The importance of this, however, would seem to be overstressed. Even on moonless nights, plants are easily located by dropping flares or incendiary bombs. And for that matter, blacking out a daylighted structure is a simple and easy task.

"The buildings constructed for the present emergency differ from those of the first World War in that the current ones are of permanent construction, as against the temporary structures built in 1917 and 1918. Most of the latter have since been torn down.

"It is obviously the intent of the Government to continue operation of many of the new plants, if not twenty-four hours of the day as now, at least enough to replenish material and keep equipment in proper order. This would seem the answer to questions often asked about what is to happen after the duration.

"Just as the mere clothing of the modern airplane by designers with an eye for line and a sense of fitness produces an object of beauty, so the direct and frank expression of the functional, the structural element of the industrial building automatically makes for impressive results. External beauty as such is never achieved by application of useless decoration, but rather by good planning, grouping, massing, and proportion. None of these need add to the cost of structure or entail delays. Size itself is an important element in design which is fully recognized by the skilled architect."

No two problems are ever alike, even though the requirements are often the same, Mr. Kahn says, in discussing the defense projects which he has carried out. "We, of course, observe standardization as much as possible, but rarely can a scheme or plant be duplicated in its entirety or without major differences," he explains. Even in such comparatively minor details as location or types of locker rooms and

toilet rooms, there is a wide variation among operating men. Some prefer such in lean-tos, others in balconies or on raised platforms; still others insist on distributing them throughout the plant or placing them right on the main floor.

"What we have done in this regard lately, and with outstanding results, is the providing of an excavated basement with a wide general walkway, through which employees enter and leave the plant. From this passageway, we open locker rooms, cafeterias, lunch rooms, also toilet rooms. Stairways at numerous points lead to the working floor above.

"Many advantages are gained by this arrangement. First of all, those utilities are where they never interfere with future expansion—indeed they are automatically expanded as the plant grows. What is equally important, much travel of employees is avoided on the main floor, since the respective departments are reached direct from below. This is just one detail. There are naturally innumerable others.

"The column spacing is an important one. We used to build plants with columns twenty feet apart—at least in one direction. Now we aim to have them not less than forty feet apart. By careful study and design, we have been able to do this at little, if any, additional cost. Every column loses not less than four square feet of floor space—counting the useless area immediately surrounding it—and every added column interferes just that much with the economical placing of machine tools and also obstructs the flow of materials. Furthermore the additional floor space gained is considerable.

"The all-important point of planning for possible future expansion has been observed and to good advantage, for even now with plants barely completed, extensions are being built. With all necessary provisions for expansion made at the outset, enlargement becomes a simple matter, whereas, with lack of foresight, it is bound to prove difficult. We provide for expansion, not only horizontally for one-storied structures, but also vertically for multi-storied buildings, such as administration, engineering, and heating structures.

"In the building of new defense plants, there has been a minimum of Governmental interference. In most instances, the respective operators have been permitted to build as they believed best for their purpose, which has made possible employment of the latest practice and experience in industrial planning.

"These new plants are to serve just one purpose; namely, to produce in the shortest possible time and at reasonable cost the material needed to put Hitler and his gang where they belong. And, let me tell you, our manufacturers are certainly doing their part in a manner which leaves no doubt in anyone's mind as to their intent."

---

#### DEFENSE PROJECTS OF ALBERT KAHN

**Airplane Engine Plant**—Buick Motor Division, General Motors Corporation, Melrose Park (Chicago), Illinois.

**Airplane Engine Plant**—Chevrolet Motor Division, General Motors Corporation, Tonawanda, New York.

**Airplane Engine Plant**—Wright Aeronautical Corporation, Paterson, N. J.

**Airplane Engine Plant**—Wright Aeronautical Corporation, Lockland (Cincinnati), Ohio.

**Airplane Engine Test Cells**—Packard Motor Car Company, Detroit, Michigan.

**Aircraft Engine Parts Plant**—Thompson Products, Inc., Cleveland, Ohio.

**Airplane Plant**—Curtiss-Wright Corporation, Buffalo, N. Y.

**Airplane Plant**—Curtiss-Wright Corporation, Columbus, Ohio.

**Airplane Plant**—Curtiss-Wright Corporation, St. Louis, Mo.

**Airplane Plant**—Fairchild Aircraft Division, Fairchild Airplane & Engine Corporation, Hagerstown, Md.

**Airplane Plant, Buildings and Additions**—Glenn L. Martin Company, Baltimore, Md.

**Airplane Plant**—Ranger Aircraft Division, Fairchild Airplane & Engine Corporation, Farmingdale, Long Island, N. Y.

**Airplane Plant**—Republic Aviation Corporation, Farmingdale, Long Island, N. Y.

**Airplane Plant**—Taylorcraft Aviation Corporation, Alliance, Ohio.

**Bomber Plant**—Ford Motor Company, Ypsilanti, Michigan.

**Bomber Plant**—Glenn L. Martin Company, Omaha, Nebraska.

**Airplane Propeller Plant**—Curtiss-Wright Corporation, Caldwell, N. J.

(Turn to Page 37)



# WHY NOT UNION NOW?

## *A Proposal for the Planning Professions*

By **ELLIS F. LAWRENCE** in *Pencil Points*

**William** Orr Ludlow, member of Committee on Public Information, A. I. A., in his recent article in *The Octagon*, "Are Architects Slipping?", challenges the profession to action. He quotes, "The profession is held in low esteem by the public. The public has not much use for architects because it thinks they are just fellows who draw pretty pictures." He says, "Many don't see what they can do, especially under war conditions, when the public is little interested in architects because the government is doing most of the building."

But people are interested in defense—in wastage of the taxpayers' money—in interference with individual enterprise, and with inadequate foresight in planning the vast program which the government is undertaking. The profession is doing too little to convince the public and its government of the value of its services in this emergency. Mr. Ludlow ends his article with—"If we want individually to take our part when there is so much dire need, we have got to make use of every opportunity to gain and to hold the respect and confidence of the public by public service."

The writer here offers a program by which the "Public Information" suggested by Mr. Ludlow as a need, may have a maximum of force and perhaps gain, through united efforts, the privilege of serving the government to the limit of our abilities as a profession of planners, and not "picture makers."

In the same issue of *The Octagon* appears the informative article on "Planning for Civilian Defense" by Harvey Stevenson, President of the New York Chapter, A. I. A. We can, if we will, profit much by the experience of the pro-

fession in England which he gives us. As he says, our Government began by imitating the cart-before-the-horse method England adopted until October 1940 when a "proper Ministry of Works and Buildings was finally created and private architects found a field of real service therefrom."

We already have a shortage of trained technicians in certain fields, as England had, and yet the draft boards continue to take our senior students in architecture for the Army, regardless of temperament and training, leading some of us to the conclusion that the draft is not as selective as we had hoped.

We note, also, that "the British government is encouraging and even allowing priorities for desirable private, municipal, and semi-public construction and reconditioning. Most of all it is undertaking long-range planning of the broadest scope. They feel, as we should feel already, that an emergency must not be allowed to breed conditions as bad as or worse than they were before."

Mr. Stevenson ends his article with the following:

"It would be ingenuous in the extreme to assume that all creative artists could be molded at once into a united front for their mutual good, but I believe that the trend of the times demands the most intense efforts in that direction. It does not seem to make sense that those who create the machinery for a product should have one set of principles, those who design the plant another, those who try to provide, if anyone does, for the physical needs of the workers a third, and so on. Until such time as

it is realized that all those people who use vision and imagination in a creative effort, making better things for human use, can join together to protect and strengthen their creative ideals, they will never attain a position commensurate with their efforts."

Here is suggested that collaboration which we must have if the natural emergency is to be solved and post-war days are not to be disastrous. Here is a picture of the planners—"joining together to protect and strengthen their creative ideals"—for the cause of humanity.

But Mr. Stevenson calls the planners "creative artists!" For popular consumption, perhaps it might have better been "creative engineers." One local OPM director has warned that beauty can expect no place in priorities these days and more than one critic has stated that the great architecture of the day is done by engineers.

The writer, in the past, has pleaded for the creative approach. To him architecture is engineering plus beauty. But he has lived long enough to know the architect, as such, has no monopoly on beauty or the comprehensive art and science of planning. He knows engineers, social workers, home economists — yes — and bankers that are planners and good planners, as well as the architects and landscapers. If we are not cultists, we must admit that good site planners, good housing experts, good city planners may come from training and experience in any of the above fields. We should, by this time, know architecture itself is a collaborative social function in which the architect can well be the coordinator and designer.

Therefore, is it not time to bring the planners of the country together in the common undertaking, knowing that "In Union There Is Strength?"

The engineer does, just now, have more popular appeal than does the architect and his opportunities are relatively greater. However, one branch of the government, for reasons best known to itself, uses the Architect-Engineer private practitioners to do much of its work. Is it not significant, this new use of the term Architect-Engineer? Perhaps it might be well

to capitalize on this and to consider how, if the strength of the planners were enough, it might be sold to all other governmental agencies to use the Architect-Engineer. To qualify, the practitioner would have to organize a group of associates including experts in the lines in which he did not qualify—but why not? We know no man can master all phases of the planning problem.

Perhaps there are landscape architects, or housing experts, or city planners who would deny they were architects or engineers—were in fact a new breed of planners—but if such there be, they are few in number. Even to these it should be apparent that they are too weak to push off the stage those other planners—the engineers and architects.

The first step at this time, it appears to the writer, is for all planners to form an alliance, strong enough in finance and numbers to make their message heard by the public, industry, and especially by government, in both the executive and legislative branches.

As Mr. Stevenson writes in his Octagon article: "In summary, then, policies must be planned, projects must be planned, and the work must be planned, all with the full utilization and advantages of all technical skills available."

The writer suggests, therefore, that a Federation of all planning groups be formed from which a National Council of Planners would be chosen to direct a campaign of publicity and education to sell the idea that industry, cities, housing, and governmental defense projects must be planned to avoid waste and to be efficient; and that we, the planners of the country, know and can prove the values to be offered by us in this national emergency. The big idea of planning must be the dominant note. The rivalries between the professions are hurting the cause.

What would the engineers think of such an approach? The writer believes from his experience that they would be friendly to it. The attitude of many engineers is shown in their attacks on the narrowness of their education. Professor Baldwin Woods of the University of California (Mechanical Engineer) writes in the August number of *Architect and Engineer*, "It

is not mentioned often enough that engineering is first an art, and second a science." And, "There is often a hiatus between design and production because the designer doesn't know how the production man must make a thing. There should be a combination of emphasis on power of analysis and ability to do."

In the same magazine is an article on "Engineer Needs Greater Vision." Professor William S. Lynch, Head of the Department of Humanities, warned against entrusting power to men who, though technically skilled, are lacking in vision. He pleads for the humanities in engineering education, and warns that more and more the engineer will be called upon to operate the social controls, as well as machines. He says, "Industry has balked at the personnel material trained in the applied sciences."

In the article, Dr. Edwin S. Burdell, director of Cooper Union, is also quoted along much the same lines.

This shows at least a trend in the thinking of the engineers—the strongest unit among the planners of the country. Engineers, like the architects, are humbled these days. In few cases can either have the freedom necessary to deliver their maximum skill or serve as their knowledge and wisdom permits.

Already the national associations of Engineers and Architects and Landscapers have established friendly relations through conferences and association with governmental agencies. It seems reasonable, then, that this suggestion to form a more formal Alliance of Planners, might succeed in time to contribute much to society in the emergency and guide future destinies in the post-war period.

The writer suggests, therefore, that the American Institute of Architects take the initiative and invite the planning groups for a conference, to perfect plans for a "Union Now" of the planners of the country, where a National Council of Planners might represent strength sufficient to properly advance the cause of Planning in defense and post-war problems. This is no surrender of the prerogatives of any group involved. It strengthens every one of them for there is a place and a need for all.

## DEFENSE PROJECTS OF ALBERT KAHN

(Continued from Page 34)

**Airplane Propeller Plant**—Curtiss - Wright Corporation, Beaver (Pittsburgh), Pa.

**Airplane Plant Additions**—Hamilton Standard Propeller Division, United Aircraft Corporation, East Hartford, Conn.

**Airplane Plant Additions**—Pratt & Whitney Aircraft Division, United Aircraft Corporation, East Hartford, Conn.

**Airplane Plant Additions**—Vought Sikorsky Aircraft Division, United Aircraft Corporation, Stratford, Conn.

**Gun Parts Plant**—Chrysler Division, Chrysler Corporation, Detroit, Michigan.

**Gun Parts Plant**—DeSoto Division Chrysler Corporation, Detroit, Michigan.

**U. S. Army Tank Arsenal**—Chrysler Corporation, East Detroit, Mich.

**Aluminum Forge Plant**—Dodge Division, Chrysler Corporation, Detroit, Michigan.

**Naval Ordnance Plant**—Hudson Motor Car Company, Detroit, Mich.

**Ordnance Plant**—Pontiac Motor Division, General Motors Corporation, Pontiac, Michigan.

**Foundry**—American Steel Foundries, East Chicago, Illinois.

**Chemical Plant**—B. F. Goodrich Company, Louisville, Ky.

**Tool-Making Plant**—City Machine & Tool Company, Toledo, Ohio.

**Manufacturing Building**—New Departure Division, General Motors Corporation, Bristol, Conn.

**Machine Shop**—Pratt & Whitney Division, Niles-Bement-Pond, West Hartford, Conn.

**Plant Additions**—Robins Dry Dock & Repair Company, Erie Basin, Brooklyn, N. Y.

**Magnesium Foundry**—Wright Aeronautical Corporation, Fairlawn, N. J.

**Air Base**—United States Navy, Kaneohe, Oahu, Hawaii.

**Air Base**—United States Navy, Kodiak, Alaska.

**Air Base**—United States Navy, Midway Island.

**Air Base**—United States Navy, Quonset Point, R. I.

**Air Base**—United States Navy, San Juan, Puerto Rico.

**Air Base**—United States Navy, Sitka, Alaska.

**Portions of Air Base**—United States Navy, Squantum, Mass.

**Portions of Air Base**—United States Navy, Chatham, Mass.

**Portions of Air Base**—United States Navy, Banana River, Florida.

**Portions of Air Base**—United States Navy, Key West, Florida.

# ARCHITECTURAL EDUCATION TOMORROW

By MICHAEL GOODMAN, Architect\*

**The** question of the future education of architects is not only bound up with the future of society of which we are members, but also with the form of educational disciplines in the schools of architecture in this country. An articulate engineer of foreign birth told me that no question pertaining to architects will be solved until a plausible definition is found for the word "architect." It eludes definition in the same manner as that of the "intelligentia."

As I encounter various graduates in discussions, I must confess, it is as difficult for me to remain a respectable professor in the present, as it is to retain a prophetic insight into the future.

I am quite aware that the democratic states and institutions are striving to devise what one would call "crisis techniques" as an answer to the need of modification in the present emergency. There is, of course, no time to rock the boat for anything but constructive criticism. Judgments must be suspended, notions withheld, and, in fact, let's revise the critics themselves. Especially, educational panaceas offered by "educators" visiting this country, should be held up for further scrutiny under the compulsion of the present-day reality.

The reason why some newly suggested educational disciplines for architects could not stand the test of reality, may be in the fact that such systems come from a world of ideas at large, (sometimes imported, or read out of a new book) and are uttered by men who never took into account the object in question—the students in the class whom they intend to benefit. Not knowing the background of the college and university structure in this country, they, the critics, add much to the mind's confusion and vogueishness.

Colleges in this country, under the simpler conditions of the early days, were vocational schools opened mostly under grants. Today,

in all major sciences, colleges get men well started toward jobs in Industry.

Corporations absorb the graduating classes of the engineering schools for various specialized branches of service. Supply equals the demand. They do not like cultured prima donnas, or young engineers with theoretical knowledge encyclopedic in scope. In the new, well grooved routines of some corporations there is no more need for the type of engineer or scientist formerly drawn from Switzerland, Germany or Sweden. The routine needs clerical workers, almost all of them. In fact, it is said some corporations ceased to advance creatively.

Apparently no such thing is happening with the graduates of architectural schools. We are concerned with talk relating to the value of liberal education as preparation for life, rather than for making a living; and, as some critics attempted to prove, much of it is rationalization and a defense of existing conditions.

Scientists complain that there is an anarchy in academic research due to the tradition of unbridled individualism and freedom, much as in industry. Fashions rule in science, evidently as in everything else. Research is done in watertight compartments. This sprawling of scientific activity has a pronounced effect on technical education and results in severe criticism from the science and engineering graduates.

Until recently young graduates were complaining that college training contributed to their weakened faith, disillusionment and in discrediting of tradition. They pointed that schools they attended were out of step with the changed social and economic conditions. They discovered once again that the central fact of the 20th century is the impact of technological change upon existing forms and ways of life. There is talk and plans for a program of taking concrete steps in free countries for the purpose of such organization as to assure the greatest yield of intellectual capital for the emergency.

\* Member of the Faculty of the School of Architecture, University of California.

Whereas the engineering and science graduates are narrowly circumscribed in their preparation, architectural students are subjected to a kaleidoscopic procession of influences: The pre-war "Munich" ease of cosy planning; from stark Functionalism to various excursions into aesthetics; the rapid leaving of machine-age aesthetic to a subordinate place in recent competitions. As one reviewer pointed out, "the new drawings resemble those of cavemen rather than engineers; the forms appearing fanciful and random, rather than geometrical and rigidly calculated, more from that strange coherence that wells up into imagination from the unconscious."

Lately, architectural school work exhibits show a confused combination of the recent International style with such "tweedy" and Regional influences as the Finnish wood design, to cite one case.

Possibly a future historian of architecture will observe that such was the work in design attending the fall of Europe.

Significant was a statement by the Princeton School of Architecture on a travel exhibit mount. While the display was babbling in grade, the slogans read in part—"School exhibits show only immature solutions. The only means for perfection, or practice, is life work, a job"—as if they were completely unhappy with themselves.

Possibly this utterance is in line with the general revival of interest in vocational education, and in the complex question of how college should help to earn a living.

The education of students in architecture, and the type of the schools in the near future will depend mainly on the wisdom with which the schools will face the changed conditions after the war.

The students, as the future architects, must be trained for co-operative effort and responsible action in a democracy, which is the hard task to be done. To quote from the current architectural press, reporting on clinical conferences and conventions, the need of learning the use of collaboration is emphasized everywhere.

". . . The background of training and experience of the architect and engineer (with the aid of research scientists) will form a particularly fitting combination to move into this vital task affecting the way of living in America." . . . "to solve newly arising problems of defense, problems of health, economic planning and creative ingenuity—for the present as well as post-war uses."

Budgets after the war are expected to be large. Who is going to absorb them by getting ready plans and ideas? If we fail to educate for that purpose, who will?

---

## NEWS AND COMMENT ON ART

(Continued from Page 8)

Line Drawings, Water Colors and Monotypes, by Peter Takal (1905- ). Through February. Paintings, Water Colors and Prints, by members of the Chinatown Artists' Club. Through February.

Eighteenth Century Meissen—the earliest European porcelain. Through February.

Concert Life in Old San Francisco. Documents from the Pioneer Study Collection (in the Pioneer Study Room). Through February.

### Lectures

The Art of Corrado Cagli, by Dr. Robert Neuhaus. Saturday, February 21, at 3:00 p.m.

California Paintings in the Museum's Collection, by Ninfa Valvo. Wednesday, February 25, at 3:00 p.m.

Masters of Portrait Painting, by Charles Lindstrom. Saturday, February 28, at 3:00 p.m.

## SAN FRANCISCO MUSEUM OF ART

### Exhibitions

Retrospective Exhibition of Eugene Berman. Through March 10.

Contemporary Prints of Latin American, Section II. Through February 22.

15 American Sculptors. Through February 24. San Francisco Art Association Exhibition of Drawings and Prints. Through March 1.

British War Posters. Through February 17.

Cincinnati-Carnegie Exhibition of Art Principles: Color. Through February 15.

Line, Drawing and Perspective. Through March 1.

### Lectures

Ellen Bransten. Sunday, February 22, 3:00-3:20 p.m.; 3:40-4:00 p.m.

### Motion Pictures

"Birth of a Nation" with Lillian Gish, Wallace Reid, Henry B. Walthal. February 20, 2:30 and 8:00 p.m.

# PREVENTION AND CONTROL OF DECAY IN DWELLINGS\*

**Decay** of wood is caused by minute threads (hyphae) of plants known as fungi growing in the wood. The most conspicuous part of these fungi are the fruiting bodies (conks, mushrooms, toadstools, etc.) which liberate spores in the air from which new fungus growths start wherever conditions are favorable.

There are two ways in which fungi can be kept from growing in wood: (1) Poison the wood by injecting a preservative into it; surface treatment is not sufficient; and (2) deprive the decay fungi of water. Wood kept dry is a permanent building material.

Wood must contain more than 20 per cent of moisture before fungi can grow in it. This is considerably less moisture than is found in green wood, but it is more than is recommended for wood in a building for reasons other than those associated with decay. There is no form of decay that is really a dry rot. The rot most aptly called "dry rot" is limited to that caused by a few fungi which carry the necessary water through rootlike strands from the soil or other source to wood that would otherwise be too dry for fungus growth.

The cardinal principles of good building practice to avoid decay can be summarized in the following rules:

1. Build on a well-drained site. This requires the avoidance not only of marshy locations where the water table is at or near the surface, but also of the more common error of poor grading which, especially in the case of houses without basements, causes drainage from the home site or from surrounding areas to seep under the house. Rain water and melting snow should be carried away from the building and the drainage of the general area should be sufficient to keep the ground beneath and around the structure dry. Moisture sources, such as fish ponds, close to the house, should be recognized as dangerous.

2. From lumberyards where the stock is kept off the ground and protected from rain, select

only decay-free lumber that is dry, and keep it dry between delivery and installation. Most lumberyards make a conscientious attempt to deliver lumber at the building site at such a moisture content as to prevent decay and give minimum trouble from shrinking and swelling after installation. Once delivered, however, lumber is often handled with an apparent disregard of its value and the swelling, shrinking, and decay that may result if it is allowed to become wet. During temporary storage on the building site, all lumber should be protected from rain or other moisture sources and should never be piled directly on the ground. For the parts of the building in which the decay hazard is high, select decay-resistant species, such as bald-cypress, cedar, and redwood.

3. Maintain sanitary conditions with respect to foundation, basement, and masonry. All wood scrap and debris that might furnish food for fungi should be removed. A tree stump left beneath a building without a basement has been known to furnish an entrance point for fungus infection resulting in hundreds of dollars worth of damage to floors and woodwork. For the same reason, all concrete forms and form stakes should be removed.

If dirt-filled porches or terraces are used, the wooden sill back of the fill should be completely isolated from the soil by a noncorrosive metal flashing extending between the sill and the foundation upon which it rests, bent upwards over the outside face of the sill, and extending upwards beyond the porch floor and under the siding or other surfacing of the building.

4. As a rule, place no untreated wood within 18 inches of the ground. The wide variations in temperature, rainfall, prevalence of extremely destructive fungi, and availability of the more decay-resistant woods in different sections of the country permit considerable latitude in the application of this rule with respect to contact with the ground. In warm, humid regions, 18 inches may not be enough. In the colder and drier parts of the country, however, wood may

\* Prepared by the Forest Products' Laboratory, U. S. Forest Service, Madison, Wisconsin.

be placed considerably closer to the ground. The 18-inch clearance should always be observed, however, unless ample local experience over a long period has definitely demonstrated that there is no risk in violating it. In some localities, so far as decay is concerned, buildings may be safely supported on piers or posts of decay-resistant wood, such as dense baldcypress, cedar, or redwood, if they are provided with concrete footings extending above the soil. Whenever there is uncertainty as to the safety of using unprotected material in any particular location in a building, the lumber should be thoroughly impregnated with a suitable preservative.

Although decay does not always follow, it is bad practice to lay a wood floor or any untreated wood directly on a brick, cinder, or concrete base at or below the soil grade line, because the wood may absorb sufficient moisture to bring about rapid decay. The floor sleepers should be treated with a preservative and any concrete subfloor should be thoroughly dried before the wood floor is laid. To obtain maximum service the concrete or other base should be waterproofed.

Partition plates, stair carriages, and wood pillars should be on concrete bases and preferably separated from the concrete by some water-resisting material such as roofer's felt mopped on with asphalt.

Similarly, embedding the ends of girders in masonry or concrete walls is not good practice unless the point of contact is well above the outside grade line so that the wall does not become damp and transmit dampness to the wood. Where necessary to seal wood in a wall close to the grade line, preservative-treated or all-heartwood stock of a naturally decay-resistant wood should be used.

5. Beneath all buildings that are not provided with basements or in which the basements are so damp that exposed woodwork will absorb considerable quantities of moisture from the air, provide adequate cross ventilation so that no dead air pockets exist. Buildings without basements should be supported on foundations of adequate height with at least 2 square feet of openings per 25 linear feet, to insure ample air circulation. The ventilators

may be grilled holes left in otherwise solid foundations, latticed brick in brick walls, unenclosed or wood-latticed spaces between supporting masonry piers or between the ends of floor joists above the foundation plate. Dense bushes or other plants should not be placed directly in front of ventilators, as they will greatly reduce the effectiveness of these openings. In cold climates it is desirable to install special vents which may be closed during the winter months to avoid unnecessary cooling of the ground floor. However, the vents should always be opened in the spring. Porches elevated above the ground should be so built as to insure ample circulation of air beneath them.

6. Make all exterior joints tight enough to keep moisture from accumulating in the adjacent wood. The most critical places are at the corners of the building, and around windows, doors, and porches. Unless shutters and garage doors are made from naturally decay-resistant heartwood or properly preserved wood, avoid outside battens and cross rails, which frequently create decay hazards. Provide drainage through bases of porch columns and at the bottom rails of porch screens to avoid trapping water back of these members.

In general, architectural frills or novel forms of construction should be studied carefully to determine whether they provide entrance points or pockets in which moisture may remain long enough to make wood susceptible to decay. Avoid all forms of construction that will trap moisture in the wood.

7. Paint only well-dried wood. Keep exteriors well painted to avoid localized decay that might occur because of moisture absorbed through checks in the paint coat.

8. Avoid the accumulation of moisture condensed from the atmosphere. In many parts of the country, the water vapor in the air within the walls of a house may condense on the back of the sheathing or the under side of the roof during cold weather and even freeze there. When this happens, more water vapor moves into the wall space from within the house, and this, in turn, is condensed until, if the process is continued long enough, the amount of moisture taken up by the wood may be sufficient to permit decay as well as to cause swelling and

paint difficulties. This condition may be aggravated if the air in the house is artificially humidified and if the walls are insulated.

The most positive and least expensive method of preventing condensation within the wall structure of new houses is the use of vapor-resistant barriers at or near the inner face of the wall. Among the materials that are highly resistant to the passage of water vapor are: (1) light-weight asphalt roofing materials; (2) asphalt-impregnated and surface-coated sheathing paper, glossy surfaced, weighing 35 to 50 pounds per roll of 500 square feet; (3) laminated paper made of two or more sheets of kraft paper cemented together with asphalt, 30-60-30 grade; and (4) double-faced reflective insulation mounted on paper.

In houses already erected, painting the inner plastered surfaces of exterior walls with aluminum paint will provide a moisture barrier, although not quite so effectively as the use of the papers recommended for new construction.

During warm, humid weather, there may be so much condensation of moisture on cold-water pipes that a considerable quantity of water drips on the woodwork. This may raise the moisture content of the wood to such a point that the wood is liable to serious localized decay. Such difficulty may be avoided either by insulating the cold surfaces or by making some provision for preventing the condensed moisture from reaching the wood. During cold weather, water may condense on window panes in sufficient quantity to run down over the sash or sills and soak into the wood. The installation of storm windows will greatly reduce the danger of decay in such cases. Reduction of the humidity within the building will also help materially. Chemically treated sash is available and should be used unless the sash can be kept dry.

In repairing a building damaged by decay the primary job is to determine the source of the moisture and remove it. Ordinarily, if adequate ventilation and soil drainage are provided and if all contacts of untreated wood with the soil or moist concrete or masonry are broken, the decayed wood will dry out and further decay will be prevented. In making replacement, it is a good plan to cut out at least a foot beyond the rotten area because wood is

usually infected beyond the point where the rot is apparent. New, green, untreated lumber should never be nailed against old infected material, since this exposes the new wood to immediate attack, with the result that decay may be much more rapid than it was in the original construction.

---

### LOUIS CHRISTIAN MULLGARDT 1876-1942

SOCIAL criticism which arises out of human, as distinguished from narrowly economic interests, generally turns upon the question of injustice to persons. Yet however painful must be the spectacle of human injustice, it seems to me that the most serious indictment of our present order is its failure to utilize the vast reservoirs of human capacity for social ends. The lowliest member of the community who is not definitely subnormal has something to contribute to the common weal. The present frustration of any generous degree of self-realization constitutes a disconcerting sum of personal tragedy, but even this must appear secondary to the resulting impoverishment of society itself. Copy-book morality may be content with the comfortable assurance that ability will always come to the top. But any person who goes about his daily work with open eyes must wince at society's waste of human resources. And if this is true for the nameless individuals who constitute the mass, what is to be said when exceptional endowment is thwarted by what we are pleased to call whims of fate?

On January 16 San Francisco newspapers carried an announcement which should have brought home to each citizen a regret for communal loss, and yet which, through one of those whims of fate, probably passed quite unnoticed by people at large, and brought the twinge of personal poignancy to the barest handful. I refer to the obituary of Louis Christian Mullgardt. Here ended a paradox at once personal and social—the seclusion and obscurity of a generously social nature, and the frustration of an exuberant creative endowment.

My association with Louis Mullgardt began in the early spring of 1913, when I took up work on his Court of the Ages for San Francisco's Panama-Pacific International Exposition of 1915. At that time his public recognition



was ascendant and his powers were at their height. I had myself but recently emerged from a somewhat protesting submission to the current academic routine in this country and in Europe. To be suddenly confronted by the creative urgency, the buoyant inventiveness, the confident realism, the straight-line determination, the imaginative insight and control, which were Louis Mullgardt at the height of his activity, was an experience whose equivalent I still believe is vouchsafed to but few, and which unquestionably was the turning point of my own career.

Dec. 1917  
X  
Much might be said of Louis Mullgardt's extraordinary imagination, his sense of form, his range of thought, his qualities as draftsman. This is not the place to attempt in detail either a recital of his activities or an appraisal of his qualities. It is enough to record that while I readily grant certain shortcomings in his architectural equipment, I still am convinced that he was touched with genius. Some time in the neighborhood of 1920—that is to say, at the top of his career—The Architect and Engineer published a special number devoted to his work. I have not looked the copy up. I only recall that it was profusely illustrated with both photographs and his own very personal draftsmanship, including some of the masterly charcoal drawings which resulted from his first visit to the Hawaiian Islands, and that in an accompanying essay I undertook an extended appraisal of his qualities as architect and artist. The tragic thing is that that magazine, as nearly as I can recall, contained, either in finished or in project form, substantially his entire architectural accomplishment.

It will, of course, be asked how it came about that a mind endowed with an almost painfully intense creative urge passed its best years in almost complete unproductiveness, and that a man exceptionally gifted for intercourse among his fellows lived his maturest years in practical seclusion. No complex phenomenon yields to a single explanation; but essentially I think it may be said that, if ever the much used expression was justified, Louis Mullgardt was the victim of the defects of his virtues.

We live in what Veblen called a pecuniary culture. That is to say, all human activities proceed by leave of and on the terms of financial accountancy, and all human achievement is evaluated by monetary standards. In such a situation lack of humility is a privilege accorded to none but the economic masters. Louis Mullgardt was possessed by vision and conviction so intense that, in the face of incomprehension or opposition, he was powerless even to simulate the petty adjustments and shifts by which men are constrained to live. He was crushed between his own vision and conviction, and the indifference of an incommensurate society, with scarcely a gesture of protest or resistance, because he knew he was right. And I think the greatest tragedy is that that society remains unaware it has rejected the gift of one of its rarest spirits.

IRVING F. MORROW.

## RED CROSS POSTER COMPETITION

An open national competition for Red Cross posters and realistic visual records is announced by the Section of Fine Arts, Public Buildings Administration, Federal Works Agency, Washington, D. C. For works purchased for nation-wide display the Red Cross will pay \$300 for each item. For works not to be used for display purposes but to be reproduced in the press, sums varying from \$10 to \$40 per print will be paid. Entries close March 18. For details address "The Section of Fine Arts, Public Buildings Administrator, Washington, D. C."

## DEFENSE HOUSING FOR TACOMA

Construction of an additional 350 permanent housing units in the state of Washington has been recommended by Charles F. Palmer, Coordinator of Defense Housing, according to advices received in San Francisco from Washington, D. C.

Two hundred units will be built at Tacoma for the families of non-commissioned army officers and 150 will be constructed at Bremerton for the families of civilian shipyard workers.

Defense Homes Corporation is the construction agency for both projects.

## OREGON CHAPTER 1942 OFFICERS

Oregon Chapter, A.I.A., has named the following officers for 1942: President, Roi L. Morin; vice-president, Harry A. Herzog; secretary, Clarence H. Wick; treasurer, Burke R. Morden; trustee, Pietro Belluschi.

At the December meeting it was announced that Morgan Hartford had been elected to Institute membership.

## ENGINEERS AND CIVILIAN DEFENSE

An informal meeting of the Structural Engineers Association of Northern California was held at El Jardin Restaurant, San Francisco, the evening of February 3, to discuss further participation of the engineers in the local civilian defense program. A lively discussion featured the meeting, which was well attended.

## SUGGESTED TOPICS FOR CHAPTER DEBATE

The Architect's Part in the Defense Program  
The Architect's Part in Post-War Planning  
Defense Housing  
Bomb Shelters  
Antiquated Building Codes  
Slum Clearance  
Mass Production  
Architects in Government Work  
Standardization  
City Planning  
Zoning  
Regional Planning.

# MODERNIZED PRODUCTS

*Brief Notes on New Materials and Equipment in the Building Industry.*

## CIVILIAN DEFENSE SCHOOL

A permanent civilian defense school for the training of key personnel in civilian protection matters has been inaugurated at Stanford University, Palo Alto.

The school is offering a series of nine-day courses in civilian protection training in the handling of incendiary and high explosive bombs, fire fighting, the air raid warning system, the control center, and protection against gas. The courses for the present will be given at Sequoia Hall under the direction of Major W. A. Johnson and a staff of officers from the U. S. Army's Chemical Warfare School at Edgewood Arsenal.

"As far as the civilian defense training program is concerned, this school will be the Edgewood civilian defense school of the West," Helms said. "Exactly the same course will be given at the Palo Alto school as is given at Edgewood. It is being established here by the Office of Civilian Defense to expedite the training of civilian protection personnel in the western states.

"It is the intention of the Office of Civilian Defense to offer this course only to key personnel and instructors in the various local councils of the western states," Helms said.

Each class will be limited to approximately 50 individuals selected from the western states. It is necessary that those who receive training at the Palo Alto civilian defense school will return to their local councils and instruct the volunteers in the civilian protection program, spreading the program as rapidly as possible to all parts of the combat zone. Candidates for these courses must be cleared through the State Defense Council and then through the Ninth Regional United States Office of Civilian Defense in San Francisco.

The new school is one of four throughout the nation authorized by Congress.

## 670. FLOODLIGHTING

A timely and interesting folder entitled "Plant Protection Begins with Floodlighting" has just been released by the Goodrich Electric Company. Dealing with the present and urgent need for protective lighting around industrial plants it illustrates various styles of equipment available.

## 671. SUBCONTRACTING

"Subcontracting for Defense," issued by Metropolitan Life Insurance Co., is not of prime interest to architects and engineers, but it contains so much valuable information on manufacturing-subcontracting for armament and other defense work that it is recommended reading. Check the coupon.

## 672. BLACKOUT GLUE

Midland Glue Products Company recommends first black paint on the window, then glue, followed by waterproof paper, cardboard or fibre. In this way the glue will also act as a shatterproofing agent in the event of bombings. Details will be sent if you check the coupon.

## 673. FIRE FIGHTING

The latest design in foam mixing chambers is described in literature available from American-La France-Foamite Corporation. Those concerned with safeguarding petroleum supplies and other flammable liquids will find this material interesting. Check the coupon.

## 674. CONSTRUCTION GLUES

This bulletin details the various important ways in which glue is now be-

ing utilized in the building field: in prefabrication, dri-built construction and in laminated arches and beams. In each case wood is used, releasing important metals for vital war work. I. F. Laucks, Inc., has prepared the bulletin.

## 675. ZINC IN WAR

The contents of this booklet, issued by the New Jersey Zinc Company, contain much information of interest and the title well expresses the subject matter. Prepared primarily with the thought in mind that it would be of most interest to users of zinc, it should also find favor among our readers.

## 676. CONCRETE FORM TIES

Latest addition to the Richmond Screw Anchor Company's line of concrete form tying devices is called the "Flex-Ty." Literature describing it states that it offers a number of very specific engineering advantages to contractors engaged in concrete form work and goes on to explain these advantages.

**Architect and Engineer**  
68 Post Street  
San Francisco, Calif.

Please send me literature on the following items as checked below. This request places me under no obligation.

670  673

671  674

672  675

676

My Name.....

Name of Company.....

Street.....

City.....State.....

# ARCHITECTS' BULLETIN

Issued For

## THE STATE ASSOCIATION OF CALIFORNIA ARCHITECTS Northern Section

STATE ASSOCIATION MEMBER  
OF THE  
AMERICAN INSTITUTE OF ARCHITECTS

Editor

Harris C. Allen

Address all communications for publication in the Bulletin to the Editor (Harris C. Allen) 557 Market Street, Room 218, San Francisco, California.

### STATE ASSOCIATION OFFICERS

President...Wayne S. Hertzka, San Francisco  
Vice-Pres., Walter R. Hagedorn, Los Angeles  
Sec'y.....Rowland H. Crawford, Beverly Hills  
Treasurer.....David H. Horn, Fresno

### Regional Director—Southern Section

Gordon B. Kaufmann

### Regional Director—Northern Section

Harry M. Michelsen

### Executive Board—Northern Section

President...Wayne S. Hertzka, San Francisco  
V.-Pres., Norman K. Blanchard, San Francisco  
Secretary.....Andrew T. Hass, San Francisco  
Treasurer.....David H. Horn, Fresno

### Directors

Russell G. de Lappa, Modesto; Clarence W. Mayhew, Harry M. Michelsen, Frederick H. Reimers, Ernest E. Weihe, San Francisco

### Northern Section Advisory Council

San Francisco District #1:  
Clarence W. Mayhew, President  
Elizabeth Boyter Henry Collins  
Francis Chinn Edmund de Martini  
Rudolph Igaz Mark Daniels  
Charles W. Masten Vincent G. Raney  
Noble Newsom  
East Bay District #2:  
Theo N. Thompson, Chairman  
A. C. Williams  
Loy Chamberlain  
Berkeley District #3:  
Gwynn Officer, Berkeley  
North Bay District #4:  
William F. Herbert, Santa Rosa  
Marin District #5:  
John S. Bolles, Ross  
Lower San Joaquin District #6:  
Russell G. de Lappa, Modesto  
Upper San Joaquin District #7:  
David H. Horn, Fresno  
Santa Clara District #8:  
Gifford E. Sobey, San Jose  
Palo Alto District #9:  
William F. Hempel, Palo Alto  
San Mateo District #10:  
Leo J. Sharps, Burlingame  
Sacramento District #11:  
Herbert E. Goodpastor, Sacramento  
Upper Sacramento District #12:  
Clarence C. Dakin, Redding  
Lassen District #13:  
Ralph D. Taylor, Susanville  
Monterey District #14:  
Thomas B. Mulvin, Del Monte  
Redwood Empire District #15:  
F. T. Georgeson, Eureka

## WAR DEFENSE

The architectural profession of Northern California is being served in a unique manner with authentic information and advice on the whole field of Air Raid Protection, assembled and disseminated by the Air Raid Protection Advisory Board, Room 802, 57 Post Street, San Francisco.

Suggestions and queries will be welcome and architects are invited to consult the file of information which the Board has compiled. Architects are requested to forward on loan to the Board any information (literature, plans, etc.) which they may accumulate or create.

Members of the Board, as appointed by your Association President, are: William G. Merchant, J. Francis Ward, Timothy L. Pflueger and W. Clement Ambrose, architects; Thomas F. Chace and Harold M. Engle, structural engineers; G. M. Simonson, mechanical engineer. Consulting Architects are Walter T. Steilberg, Vincent G. Raney, Mario J. Ciampi and Michael Goodman. J. Francis Ward is Director and Philip L. Soljak, Secretary.

Three bulletins have been issued by the Board, covering a large field of technical information for public and private, indoor and outdoor, shelter against air raid damage. Many publications are on file at the Board office, compiled both in England and the United States to record various methods used in the present active war zone. The bulletins progress from two, to five, to ten pages, profusely illustrated with handsome line drawings—but our tongue is running away with us when we start discussing architectural publications. Suffice it to say that the Board is doing a bang-up job. And the last bulletin ends with a quotation which is too good to be overlooked:

"News columnist Ernie Pyle, who experienced some of London's worst air raids, gave some excellent advice to householders in the San Francisco News of January 3, 1942. We quote him in part:

"If I lived in a wooden house and had a back yard, I'd build me something approximating an Anderson shelter, and fix it up with electric lights and an electric heater and a good system of drainage.

"If I lived in a strong brick house, I'd brick up the windows of one room, provide for ventilation and heat, brace the ceiling with some steel piping, and have plenty of picks and axes so you could get out if it caved in on you.

"If I lived in an apartment house, I'd get together with the landlord and other tenants and see that the basement was converted into a sound habitable shelter.

"Yessir, that's just what I'd do. But before I did that, I'd get myself the damndest array of private, homegrown fire-fighting equipment that any citizen ever stalked the streets with, for I think that if the Japs ever set out to destroy the citizens of San Francisco instead of the actual military objectives, they'll do it with fire bombs."

**Financing** The construction of private air raid shelters may be financed on good terms—see your banker.

**Honor To Architect** In this year's New Year's honors list, King George VI of Great Britain gave the most treasured honor, the Order of Merit (only 24 holders) to Sir Edwin Landseer Lutyens, distinguished architect and President of the Royal Academy. British lands are starred with the high lights of Lutyens' genius, among them the Whithall Cenotoph "to an Unknown Soldier" and the British Embassy in Washington.

**Scholarships** Any architect in the United States or Canada may propose any other architect or architectural draftsman residing in the same country as a candidate for an award in the Edward Langley Scholarships for 1942. Competitive examinations will not be used, as the awards will be determined by the A.I.A. Committee on Awards and Scholarships on the basis of character, purpose and need. The awards will provide funds for advanced work in architecture, for study, travel, or research.

Every proposal shall be made (in duplicate) on A.I.A. Form S 70, available from the Institute headquarters, 1741 New York Avenue, Washington, D.C. Proposals will be received up to March 1, 1942, and awards announced in June, 1942.

**State Code Urged** One hundred members and guests met at the Veneto Restaurant, San Francisco, January 16, to hear reports on the work of our Air Raid Protection Advisory Board and see five British official films on ARP.

Establishment of statewide standards for the construction of shelters and protection of buildings was urged by several speakers.

"At least 20 cities throughout California are preparing shelter plans, all of them different," said J. Francis Ward, director of the A.R.P. Advisory Board. "To avoid confusion and assure maximum safety, a uniform building code is needed for civilian defense, with uniform supervision throughout the State."

Ward also urged research tests on local material for use in structural defense. "Much of the European information on these problems does not apply in California, where we have different building designs, methods and materials," he added.

President Wayne S. Hertzka reported that he had conferred with officials of the Regional Office of Civilian Defense, State Defense Council and State Division of Architecture on a uniform A.R.P. code.

Anson Boyd, State Architect and D. C. Willett, Supervising Structural Engineer, pledged the support of the State Division of Architecture in establishing such a code. Other speakers were Dr. Milton Silver-

man, Science Editor of the San Francisco Chronicle, and Henry C. Powers, President of the Structural Engineers Association of Northern California.

The British films shown at the meeting illustrated factory protection, shelters, blackouts and defense against incendiary bombs.

#### ANOTHER YEAR FOR ABE APPLETON

The annual meeting of Northern California Chapter, A.I.A., was held at the St. Francis Yacht Club in San Francisco at 6:30 p.m. on Tuesday, January 27, President A. Appleton presiding.

This being the annual meeting, reports of the various officers and committees were made to the membership.

The report of the Secretary-Treasurer indicated that the Chapter is in a good position both as to membership and finances, and that attendance at meetings has increased considerably during the past year.

Upon motion of Mr. Evers, seconded by Mr. Knowles, the sum of one hundred dollars was appropriated for transfer from the yearly balance to the educational fund. More advantageous investing of this fund was discussed at length, the matter finally being left to the incoming Board of Directors for further study.

The President gave a fine report on Chapter activities of the past year, which has been an unusually eventful one in which the Chapter was represented at the national conventions of several kindred organizations in addition to the national Institute Convention held in the Yosemite Valley in May.

Reports of the various committees and delegates to allied groups indicated that the Chapter has been taking an active part in professional betterment and civic affairs. Upon motion of Mr. Mitchell, seconded by Mr. Hass, the reports were accepted.

Mr. Evers spoke briefly on plans for housing and urban development, indicating the enormous possibilities in this field for architects in post-war planning.

Messrs. Sala and Mayo, of Stockton, were introduced, and Mr. Mayo told of plans now in progress for the formation of a Central Valley Chapter, A.I.A. President Appleton assured these gentlemen of all possible support and assistance from Northern California Chapter.

Officers for the current year were elected as follows: President, A. Appleton (second year); Vice-President, Ernest E. Weihe; Secretary-Treasurer, Wm. H. Knowles; Director (to serve three years), Hervey P. Clark. The other directors are Andrew Hass, Jas. H. Mitchell and Eldridge T. Spencer.

President Appleton mentioned plans for a joint office of the Chapter and the State Association of California Architects, promising definite information in the near future.

Upon motion of Mr. Hass, seconded by Mr. Stringham, the incoming secretary was instructed to address a letter of appreciation from the Chapter to the retiring secretary for his efforts.

—J. D. Y.

# Estimator's Guide

## Giving Cost of Building Materials, Wage Scale, Etc.

Amounts given are figuring prices and are made up from average quotations furnished by material houses to San Francisco contractors. 3% Sales Tax on all materials but not labor.

All prices and wages quoted are for San Francisco and the Bay District. There may be slight fluctuation of prices in the interior and southern part of the state. Freight cartage, at least, must be added in figuring country work.

**Bond**—1½% amount of contract.  
Government work ¾%.

### Brickwork—

Common, \$40 to \$45 per 1000 laid, (according to class of work).  
Face, \$90 to \$100 per 1000 laid, (according to class of work).  
Brick Steps, using pressed brick, \$1.00 lin. ft.  
Brick Veneer on frame buildings, \$1.00 sq. ft.  
Common f.o.b. cars, \$14.00 at yard. Cartage extra.  
Face, f.o.b. cars, \$40.00 to \$80.00 per 1000, carload lots.

### Building Paper—

1 ply per 1000 ft. roll.....	\$3.50
2 ply per 1000 ft. roll.....	5.00
3 ply per 1000 ft. roll.....	6.25
Starcraft, 500 ft. roll.....	5.00
Sash cord com. No. 7.....	\$1.20 per 100 ft.
Sash cord com. No. 8.....	1.50 per 100 ft.
Sash cord spot No. 7.....	1.90 per 100 ft.
Sash cord spot No. 8.....	2.25 per 100 ft.
Sash weights, cast iron, \$50.00 ton.	
Nails, \$3.50 base.	
Sash weights, \$45.00 per ton.	

### Concrete Aggregates—

GRAVEL (all sizes) \$1.45 per ton at bunker; delivered to any point in S. F. County \$1.85.

	Bunker	Delivered
Top sand.....	\$1.45	\$1.85
Concrete mix.....	1.45	1.85
Crushed rock, ¼ to ¾.....	1.60	2.00
Crushed rock, ¾ to 1½.....	1.60	2.00
Roofing gravel.....	1.60	2.00
City gravel.....	1.45	1.85
River sand.....	1.50	1.90
Bank sand—\$1.00 per cubic yard at bunker or delivered.		

	Bunker	Delivered
River sand.....	\$1.50	\$1.85
Lapis (Nos. 2 & 4).....	2.00	2.40
Olympia Nos. 1 & 2.....	1.80	2.20
Hazelsburg plaster sand.....	\$1.80 and \$2.20	
Del Monte white.....	30c per sack	
Common cement (all brands, paper sacks) carload lots \$2.52 per bbl. f.o.b. car; delivered, \$2.70; less than carloads delivered, 70c per sack. Cash discount on carload lots, 10c a barrel, 10th Prox.; cash discount less than carload lots, 2%.		

Atlas White }  
Calaveras White } 1 to 100 sacks, \$2.00 sack,  
Medusa White } warehouse or delivery.

Forms, Labors average \$40.00 per M.  
Average cost of concrete in place, exclusive of forms, 35c per cu. ft.; with forms, 60c.  
4-inch concrete basement floor.....12½c to 14c per sq. ft.  
Rat-proofing.....7½c  
Concrete Steps.....\$1.25 per lin. ft.

### Dampproofing and Waterproofing—

Two-coat work, 20c to 30c per yard.  
Membrane waterproofing—4 layers of saturated felt, \$4.50 per square.  
Hot coating work, \$2.00 per square.  
Medusa Waterproofing, 15c per lb., San Francisco Warehouse.  
Tricocel waterproofing.  
(See representative.)

**Electric Wiring**—\$12.00 to \$15.00 per outlet for conduit work (including switches).  
Knob and tube average \$3.00 per outlet.

### Elevators—

Prices vary according to capacity, speed and type. Consult elevator companies.  
Average cost of installing an automatic elevator in four-story building, \$2800; direct automatic, about \$2700.

### Excavation—

Sand, 60 cents; clay or shale \$1 per yard.  
Teams, \$12.00 per day.  
Trucks, \$22 to \$27.50 per day.

Above figures are an average without water. Steam shovel work in large quantities, less; hard material, such as rock, will run considerably more.

### Fire Escapes—

Ten-foot galvanized iron balcony, with stairs, \$150 installed on new buildings; \$160 on old buildings.

### Floors—

**Composition Floors**—22c to 40c per sq. ft.  
In large quantities, 18c per sq. ft. laid.  
**Mosaic Floors**—80c per sq. ft.  
**Duraflex Floor**—23c to 30c sq. ft.  
**Rubber Tile**—50c to 75c per sq. ft.  
**Terazzo Floors**—45c to 60c per sq. ft.  
**Terazzo Steps**—\$1.60 lin. ft.

### Hardwood Flooring (delivered to building)—

Clr. Qtd. Oak.....	\$144.00 M	\$122.00 M	\$141.00 M
Sel. Qtd. Oak.....	118.00 M	101.00 M	114.00 M
Clr. Pla. Oak.....	120.00 M	102.00 M	115.00 M
Sel. Pla. Oak.....	113.00 M	92.00 M	107.00 M
Clr. Maple.....	125.00 M	113.00 M	

Wage—Floor layers, \$12.00.  
Note—Above quotations are all board measure except last column which is sq. ft.

**Glass** (consult with manufacturers)—  
Double strength window glass, 20c per square foot.  
Plate 80c per square foot (unglazed) in place, \$1.00.  
Art, \$1.00 up per square foot.  
Wire (for skylights), 40c per sq. foot.  
Obscure glass, 30c to 50c square foot.  
Glass bricks, \$2.50 per sq. ft. in place.  
Note—if not stipulated add extra for setting.

### Heating—

Average, \$1.90 per sq. ft. of radiation, according to conditions.  
Warm air (gravity) average \$48 per register.  
Forced air, average \$68 per register.

**Iron**—Cost of ornamental iron, cast iron, etc., depends on designs.

### Lumber (prices delivered to bldg. site)—

No. 1 common.....	\$43.00 per M
No. 2 common.....	41.00 per M
Select O. P. common.....	46.00 per M
2x4 No. 3 form lumber.....	32.00 per M
1x4 No. 2 flooring VG.....	90.00 per M
1x4 No. 3 flooring VG.....	85.00 per M
1x6 No. 2 flooring VG.....	96.00 per M
1½x4 and 6, No. 2 flooring.....	95.00 per M

Slash grain—  
1x4 No. 2 flooring.....\$65.00 per M  
1x4 No. 3 flooring.....62.00 per M  
No. 1 common run T. & G.....48.00 per M  
Lath.....7.50 per M

Shingles (add cartage to price quoted)—  
Redwood, No. 1.....\$1.20 per bdle.  
Redwood, No. 2.....1.00 per bdle.  
Red Cedar.....1.45 per bdle.

### Plywood—Douglas Fir (add cartage)—

"Plyscord" sheathing (unsanded)  
¾" 3-ply and 48"x96".....\$39.75 per M  
"Plywall" (wallboard grade)—  
½" 3-ply 48"x96".....\$43.70 per M  
"Plyform" (concrete form grade)—  
½" 5-ply 48"x96".....\$117.30 per M  
Exterior Plywood Siding—  
½" 5-ply Fir.....\$132.00 per M  
Redwood (Rustic) 1½x6" clear heart. \$ 95.00 per M  
\$5 less per M for A grade.

### Millwork—Standard.

O. P. \$100 per 1000. R. W. rustic \$120.00 per 1000 (delivered).  
Double hung box window frames, average with trim, \$6.50 and up, each.  
Complete door unit, \$10.00.  
Screen doors, \$3.50 each.  
Patent screen windows, 25c a sq. ft.  
Cases for kitchen pantries seven ft. high, per lineal ft., \$8.00 each.  
Dining room cases, \$8.00 per lineal foot.  
Rough and finish about 75c per sq. ft.  
Labor—Rough carpentry, warehouse heavy framing (average), \$17.50 per M.  
For smaller work average, \$35.00 to \$45.00 per 1000.

### Marble—(See Dealers)

### Painting—

Two-coat work.....	per yard 50c
Three-coat work.....	per yard 70c
Cold water painting.....	per yard 10c
Whitewashing.....	per yard 4c

Turpentine, 65c per gal., in 5 gal. cans, and 55c per gal. in drums.  
 Raw Linseed Oil—95c gal. in light drums.  
 Boiled Linseed Oil—98c gal. in drums and \$1.08 in 5 gal. cans.

**White Lead in oil**

Per Lb.  
 1 ton lots, 100 lbs. net weight.....113/4c  
 500 lbs. and less than 1 ton.....12c  
 Less than 500 lb. lots.....12/2c

**Red Lead and litharge**

1 ton lots, 100 lbs. net weight.....113/4c  
 500 lbs. and less than 1 ton.....12c  
 Less than 500 lb. lots.....12/2c

**Red Lead in oil**

1 ton lots, 100 lbs. net weight.....123/4c  
 500 lbs. and less than 1 ton.....13c  
 Less than 500 lb. lots.....13/2c

Note—Accessibility and conditions cause some variance in costs.

**Patent Chimneys—**

6-inch.....\$1.25 lineal foot  
 8-inch.....1.50 lineal foot  
 10-inch.....2.25 lineal foot  
 12-inch.....3.00 lineal foot

**Plastering—Interior—**

Yard  
 1 coat, brown mortar only, wood lath.....\$0.50  
 2 coats, lime mortar hard finish, wood lath......85  
 2 coats, hard wall plaster, wood lath......72  
 3 coats, metal lath and plaster.....1.26  
 Keene cement on metal lath.....1.30  
 Ceilings with 3/4 hot roll channels metal lath (lathed only)......90  
 Ceilings with 3/4 hot roll channels metal lath plastered.....1.80  
 Single partition 3/4 channel lath 1 side (lath only)......85  
 Single partition 3/4 channel lath 2 inches thick plastered.....\$2.90  
 4-inch double partition 3/4 channel lath 2 sides (lath only).....1.70  
 4-inch double partition 3/4 channel lath 2 sides plastered.....3.30  
 Thermax single partition; 1" channels; 2 1/4" overall partition width. Plastered both sides.....2.50  
 Thermax double partition; 1" channels; 4 1/2" overall partition width. Plastered both sides.....3.40

3 coats over 1" Thermax nailed to one side wood studs or joists.....1.25  
 3 coats over 1" Thermax suspended to one side wood studs with spring sound isolation clip.....1.45

**Plastering—Exterior—**

Yard  
 2 coats cement finish, brick or concrete.....\$1.00  
 3 coats cement finish, No. 18 gauge wire mesh.....1.75  
 Wood lath, \$5.50 to \$6.50 per 1000......21  
 2 1/2-lb. metal lath (dipped)......19  
 2 1/2-lb. metal lath (galvanized)......21  
 3 1/4-lb. metal lath (dipped)......22  
 3 1/4-lb. metal lath (galvanized)......24  
 3 1/4-inch hot roll channels.....\$72 per ton  
 Finish plaster, \$18.90 ton; in paper sacks. Dealer's commission, 1% off above quotations. \$13.85 (rebate 10c sack)  
 Lime, f.o.b. warehouse, \$2.25 bbl.; cars, \$2.15  
 Lime, bulk (ton 2000 lbs.), \$16.00 ton  
 Wall Board 5 ply, \$50.00 per M.  
 Hydrate Lime, \$19.50 ton  
 Plasterer's Wage Scale.....\$1.67 per hour  
 Lathers Wage Scale.....1.60 per hour  
 Hood Carriers Wage Scale.....1.40 per hour  
**Composition Stucco—**\$1.80 to \$2.00 sq. yard (applied).

**Plumbing—**

From \$100.00 per fixture up, according to grade, quantity and runs.

**Roofing—**

"Standard" tar and gravel, \$7.00 per sq. for 30 sqs. or over.  
 Less than 30 sqs. \$7.50 per sq.  
 Tile, \$20.00 to \$35.00 per square.  
 Redwood Shingles, \$7.50 per square in place.  
 Copper, \$16.50 to \$18.00 per sq. in place.  
 5/2 #1-16" Cedar Shingles, 8.00 Square  
 4 1/2" Exposure.....  
 5/8 x 16" #1 Cedar Shingles, 9.00 Square  
 4/2 #1-24" Royal Shingles, 9.50 Square  
 7 1/2" Exposure.....  
 Re-coat with Gravel, \$3 per sq.  
 Asbestos Shingles, \$15 to \$25 per sq. laid.  
 Slate, from \$25.00 per sq., according to color and thickness.  
 1/2 x 25" Resawn Cedar Shakes, 10" Exposure.....10.50  
 3/4 x 25" Resawn Cedar Shakes, 10" Exposure.....11.50

1 x 25" Resawn Cedar Shakes, 10" Exposure.....12.50  
 Above prices are for shakes in place.

**Sheet Metal—**

Windows—Metal, \$1.75 a sq. ft.  
 Fire doors (average), including hardware, \$1.75 per sq. ft.

**Skylights—(not glazed)**

Copper, 90c sq. ft. (flat).  
 Galvanized iron, 40c sq. ft. (flat).  
 Vented hip skylights 60c sq. ft.

**Steel—Structural (None available except for defense work)**

\$150 ton (erected), this quotation is an average for comparatively small quantities. Light truss work higher. Plain beams and column work in large quantities \$140 per ton.

**Steel Reinforcing (None available except for defense work).**

\$150 to \$200 per ton, set.

**Stone—**

Granite, average, \$6.50 cu. foot in place.  
 Sandstone, average Blue, \$4.00. Boise, \$3.00 sq. ft. in place.  
 Indiana Limestone, \$2.80 per sq. ft. in place.

**Store Fronts—**

Copper sash bars for store fronts, corner, center and around sides, will average \$1.00 per lineal foot.  
 Note—Consult with agents.

**Tile—Floor, Wainscot, etc. — (See Dealers)**

Asphalt Tile—18c to 28c per sq. ft. installed.

**Wall Tile—**

Glazed Terra Cotta Wall Units (single faced) laid in place—approximate prices:  
 2 x 6 x 12.....\$1.00 sq. ft.  
 4 x 6 x 12.....1.15 sq. ft.  
 2 x 8 x 16.....1.10 sq. ft.  
 4 x 8 x 16.....1.30 sq. ft.

**Venetian Blinds—**

40c per square foot and up. Installation extra.

**Windows—Steel**

Factory type sash 30c ft.  
 Ventilators for steel sash \$5.00 each.

**1942 BUILDING TRADES WAGE SCALES FOR NORTHERN CALIFORNIA**

\*6-hour day \*\*7-hour day

CRAFT	San Francisco	Alameda	Fresno	Marin	Sacramento	San Jose	San Mateo	Vallejo	Stockton
ASBESTOS WORKERS	\$1.50	\$1.25	\$1.25	\$1.37 1/2	\$1.12 1/2	\$1.25	\$1.25	\$1.25	\$1.25
BRICKLAYERS	1.75	1.75	1.50	1.75	1.75	2.00	1.79-1/6	1.75	1.75
BRICKLAYERS' HODCARRIERS	1.35	1.25	1.05	1.25	1.05	1.35	1.35	1.40	1.14
CARPENTERS	1.37 1/2	1.37 1/2	1.25	1.37 1/2	1.25	1.25	1.37 1/2	1.25	1.25
CEMENT FINISHERS	1.37 1/2	1.37 1/2	1.25	1.25	1.25	1.50	1.50	1.25	1.25
ELECTRICIANS	1.50	1.50	1.50	1.37 1/2	1.50	1.50	1.50	1.50	1.37 1/4
ELEVATOR CONSTRUCTORS	1.61	1.56	1.50	1.61	1.61	1.50	1.50	1.56	1.56
ENGINEERS: Material Hoist	1.50	1.50	1.50	1.50	1.37 1/2	1.52	1.37 1/2	1.37 1/2	1.25
Piledriver	1.75	1.60	1.60	1.75	1.75	1.75	1.62 1/2	1.75	1.75
Structural Steel	1.75	1.60	1.60	1.75	1.75	1.75	1.75	1.60	1.60
GLASS WORKERS	1.25	1.25	1.12 1/2	1.25	1.12 1/2	1.21	1.25	1.25	1.25
IRON WORKERS: Ornamental	1.50	1.31 1/4	1.37 1/2	1.31 1/4	1.37 1/2	1.31 1/4	1.25	1.31 1/4	1.31 1/4
Reinf. Rodmen	1.50	1.31 1/4	1.31 1/4	1.31 1/4	1.31 1/4	1.40	1.31 1/4	1.31 1/4	1.25
Structural	1.75	1.60	1.60	1.60	1.60	1.75	1.50	1.60	1.60
LABORERS: Building	.85	.87 1/2	.82 1/2	.81 1/4	.85	.81 1/4	.81 1/4	.81 1/4	.80
Concrete	.87 1/2	.93 3/4	.90	.81 1/4	.92 1/2	.85	.85	.90	.90
LATHERS	1.75	1.75	1.50	1.75	1.60	1.75	1.75	1.50	1.50
MARBLE SETTERS	1.43 3/4	1.25	1.15	1.31 1/4	1.37 1/2	1.25	1.31 1/4	1.31 1/4	1.31 1/4
MOSAIC & TERRAZZO	1.00	1.25	1.12 1/2	1.12 1/2	1.15-5/8	1.12 1/2	1.12 1/2	1.12 1/2	1.12 1/2
PAINTERS	1.37 1/2	1.47	1.28-4/7	1.37 1/2	1.25	1.35-5/7	1.42-6/7	1.50	1.25
PILEDRIVERS	1.47	1.40	1.40	1.40	1.40	1.47	1.40	1.40	1.40
PLASTERERS	1.66-2/3	1.46-2/3	1.75	1.66-2/3	1.75	2.00	2.00	1.75	1.83-1/3
PLASTERERS' HODCARRIERS	1.50	1.45	1.40	1.40	1.40	1.35	1.75	1.50	1.50
PLUMBERS	1.52 1/2	1.50	1.53-1/8	1.50	1.58 1/4	1.62 1/2	1.50	1.50	1.37 1/2
ROOFERS	1.37 1/2	1.37 1/2	1.12 1/2	1.25	1.25	1.37 1/2	1.25	1.25	1.25
SHEET METAL WORKERS	1.37 1/2	1.37 1/2	1.43 3/4	1.37 1/2	1.50	1.50	1.37 1/2	1.37 1/2	1.37 1/2
SPRINKLER FITTERS	1.50	1.37 1/2	1.25	1.25	1.25	1.62 1/2	1.50	1.50	1.50
STEAMFITTERS	1.50	1.50	1.53-1/8	1.50	1.56 1/4	1.62 1/2	1.50	1.50	1.50
STONESETTERS (Masons)	1.50	1.75	1.50	1.75	1.75	1.50	1.75	1.75	1.50
TILESETTERS	1.50	1.37 1/2	1.37 1/2	1.37 1/2	1.37 1/2	1.50	1.50	1.37 1/2	1.37 1/2

Prepared and compiled by  
 CENTRAL CALIFORNIA CHAPTER, ASSOCIATED GENERAL CONTRACTORS OF AMERICA  
 with the assistance and cooperation of secretaries of General Contractors Associations and Builders Exchanges of Northern California.

## ARC WELDING MINIMIZES BOMB DAMAGE

James F. Lincoln, president of the Lincoln Electric Company, Cleveland, Ohio, left January 12 on a war industry speaking tour after stating that most New York skyscrapers are not bomb proof and urging arc-welded construction to minimize bombing damage wherever possible.

Lincoln, who heads the world's largest manufacturer of war industry welding equipment, will travel to seventeen cities to speak before production men, manufacturers and engineers on methods of speeding war production by means of arc welding.

His itinerary includes Phoenix, Arizona; Los Angeles and San Francisco, California; Portland, Oregon; Seattle, Washington; Vancouver, British Columbia; Salt Lake City, Utah, and Denver, Colorado.

"The vast majority of New York skyscrapers are not bomb proof," Lincoln said before leaving. "The most nearly bomb proof city of the future will be one in which the frameworks all will be of arc-welded construction."

The executive pointed out that steel frameworks with concrete or stone are "a step in the right direction in the saving of lives and property," but added that this step is not enough.

"A steel structure, like a chain, is only as strong as the weakest point," he said. "The weakness in the type of structure now dominating the New York skyline is the riveted joint."

Lincoln pointed out that riveted joints shear under severe strain.

"This probably would result in extensive damage to the most celebrated New York buildings in case of a direct bomb hit," he said. "It is doubtful whether these structures would stand even a 2,000-pound land type bomb such as have been used by the Nazis over London. Experiences in London and Hawaii through reinforced concrete structures have demonstrated that rigid arc welded steel construction is far superior.

"In many present buildings the girders either are not anchored at all at the corners or at best were riveted.

"In arc-welded construction the strength of the joint actually exceeds that of the original metal—resulting in a strong, shock-resisting frame which will not tear apart at the joints.

"Furthermore, the speed and ease of repair of a welded steel frame which may have suffered some damage is an important factor," he said.

Lincoln explained that it was the suction following a bomb blast, rather than the blast itself, which generally does the greatest damage.

"The walls or roofs usually do not blow inward under the much greater blast pressure because the framework holds them," he said. "However, they may be torn loose and the suction following the blast, which lasts much longer, may force them outward.

"Damage from either the blast or the suction would be reduced to a minimum with arc-welded construction."

## WM. WURSTER HONORED

Appointment of Dean Walter R. MacCormack of the Massachusetts Institute of Technology as chairman of the Committee on Urban and Rural Land Use of the American Institute of Architects is announced by Richmond H. Shreve of New York, president of the Institute. Dean MacCormack, who is vice-president of the Institute and who has long been active in the field of housing, succeeds Frederick Bigger of Pittsburgh.

The Institute, according to the announcement, plans to develop a forward-looking policy in the field of city and rural rehabilitation.

J. Frazer Smith of Memphis, Tenn., has been named vice-chairman of the committee. Other members are: Raymond J. Ashton of Salt Lake City; John E. Burchard of Princeton, N. J.; Miles L. Colean of Washington, D. C.; Jean Hebrard of Ann Arbor, Mich.; Arthur C. Holden, Frederick Mathesius and Clarence S. Stein of New York City; James Lawrence, Jr., of Brookline, Mass.; Charles Dana Loomis of Baltimore; C. Julian Oberwarth of Frankfort, Ky.; William Wilson Wurster of San Francisco.

## MOHR SAYS BALLOON TYPE BUILDING HIS

Editor Architect and Engineer,  
San Francisco, Calif.

I beg to direct your attention to my article published in *Architect and Engineer* of August, 1933 (page 4) fully illustrating and describing balloon building process and which I originated and my attorney found patentable May, 1920.

However, in your same publication of this month, January 1, 1942 (page 22) credit is erroneously given Architect Wallace Neff as "originator of balloon building process."

Therefore, I earnestly request that you accordingly make proper correction.

Very respectfully,

NORMAND W. MOHR,

Former San Francisco City Architect.

## KATE N. KINLEY MEMORIAL FELLOWSHIP

The Board of Trustees of the University of Illinois announce that the 11th Annual Kate Neal Kinley Memorial Fellowship, established in 1931, will be renewed following an examination May 30. The fellowship yields the sum of \$1,000, to be used for advanced study of the fine arts in America or abroad. Applications should reach the committee by May 1, 1942. Rexford Newcomb, Urbana, Illinois, chairman.

## PRODUCERS' COUNCIL CLUB

Officers for the year 1942 have been elected by the Producers' Council of Northern California as follows: President, Gano R. Baker, Westinghouse Elevator Company; vice-president, C. W. ("Chuck") Kraft, Kraftile Company; secretary, John Schaumberger, Libbey-Owens-Ford Glass Company; treasurer, Louis D. Saylor, Vermont Marble Company.



## QUALITY AND DEPENDABLE *Service*

are the factors that influence architects and contractors when selecting lumber and mill work — Quality of merchandise — Integrity and Ability of the firm—Service in physical equipment — Experience and Personnel — All these factors contribute to a speedy and satisfactory completion of construction with minimum of time and expense.

### MANUFACTURER OR DEALER IN

Douglas Fir—Redwood—Sugar and Ponderosa Pine — Plywood and Concrete Form Panels — Sash and Doors — Millwork — Insulation — Builders' Hardware.

## E. K. WOOD LUMBER CO.

"Goods of the Woods" ©

LOS ANGELES • SAN FRANCISCO • OAKLAND

# PRE-FABRICATED

Today, Form-Tys too, come ready to use . . . and the RICHMOND way is the profitable way —better . . . faster . . . less costly.



### RICHMOND 10-WAY PROFIT PLAN

- 1—Over 50 different form-tying devices meeting every condition.
- 2—Cut less to one than usual.
- 3—The "One-Made" wire, band, or clips.
- 4—Engineered for safe working loads of 1500 to 2500 lbs.
- 5—Faster erecting and stripping saves time and lumber.
- 6—Promotes perfect wall alignment, 200 uniform thickness.
- 7—1 to 2 inch "ball back" protects job against rust staining.
- 8—Weight scientifically cut to save shipping and handling costs.
- 9—Delivery right to the job saves warehousing. Job section labels save time.
- 10—No cut for working parts. You pay only for ty used.
- 11—Job planning bureau specifies types, quantities, methods . . . free.

Richmond provides you with form-tying devices and methods specifically engineered for concrete work of every kind—light

### 10 ways to profit!

wall construction or heavy engineering structures. Richmond provides basic advantages definitely superior to anything you may have used. Also, Richmond offers you 10 different ways to profit. See that panel!

THE NAME SNAP-TY IS COPYRIGHTED BY US! In 1930—11 years ago—Richmond, alone, coined and copyrighted the name Snap-Ty as the brand name for one of our tie products.

## RICHMOND SCREW ANCHOR COMPANY, INC.

816 LIBERTY AVENUE, BROOKLYN, N. Y.



### ARE ARCHITECTS SLIPPING?

"Architects are slipping." "The profession is held in low esteem by the public." "The prestige of architects has suffered immensely." "The public has not much use for architects because it thinks that they are just fellows who draw pretty pictures of buildings."

Some of these statements are true and some are not true, but enough of them are true to make perfectly reasonable the demand by architects everywhere that we must do something about it and do it now.

Let us bring it right home to the average architect. Are you willing personally to do something about it now? The trouble with most of us is that we think that the Institute or the Chapter should do something about it but are not willing to give our time and our services; many don't see what they can do, especially under the present conditions, when the public is little interested in architects because the government is doing most all of the building.

The standing of the profession does not rest alone on the quality of our professional services, nor on the number of jobs we can get. I believe that architects are entirely right in saying, "What we need most now and must have is 'Public Information.'" Unfortunately, however, most of the commonly used means of public information are not now as effective as they were before nine-tenths of the thinking American people were occupied by war and defense. It is harder to get people to listen to radio talks about architects and architecture; the papers are not as willing as formerly to carry articles by architects unless the articles have a war significance.

But although these and other usual means of getting our message over to the public are not as easy as they were, we must not neglect them as conditions permit their use. The opportunity for the most effective kind of public information is yet open to us—wide open. Let us ask ourselves: How well known are we personally in our community; what do people think of us as citizens; as men interested in civic and social work in our city or town? Do our neighbors consider us just nice fellows who don't count very much and who most of our neighbors and people in our town have never heard of anyhow?

It seems to me that at this time when many of us are out of a job, or soon will be, at this time when our communities and our nation are in need of the personal support of every citizen—at this time, when we have the time and have every incentive as well—this is the time to do Red Cross work, to take a hand in good government, in clean politics, in social betterment, slum clearance, in church work, in education. I believe that right now, if we want our profession to have its place when peace comes again—and if we want individually to take our part when there is so much dire need—we have got to make use of every opportunity to gain and to hold the respect and the confidence of the public by public service.—William Orr Ludlow.



## ARCHITECTS' DUTIES AFTER A BOMBING

More than 1,200 New York City architects have mobilized as a technical auxiliary force to survey every building in the metropolitan area and determine the safest places for civilians during an air raid.

The architects also volunteered to stand by, in eight-hour shifts, at police headquarters in each of the New York's eighty-five precincts and, in the event of an air raid, assist the Department of Housing and Buildings in inspecting the foundation, walls and floors of every structure in a bombed district before re-occupancy of the property is permitted.

Within thirty days a safety report on every building in the five boroughs of New York should be on file in the organization headquarters being established in the Municipal Building and in each of the Borough Halls, Mr. Del Gaudio declares. Each architect will survey one block a day, seven days a week, until the entire area has been covered.

"The function of the architect during an air raid," Mr. Del Gaudio says, "is to go immediately to the police station to which he has been assigned and assist the building inspectors as soon as the all-clear signal has been sounded. The architects will determine the condition of each building in the bombed area and decide whether the structure is safe for occupancy or should be vacated or totally demolished."

A chief architect will be stationed day and night in each of the borough headquarters and at least three men will be close by the precinct officers. In the event that severe damage in any one section of the city requires the services of many inspectors, a "pool" of four hundred architects has been formed. A reserve supply of inspectors can be rushed to any area in distress.

"New York City architects have been anxious to aid in the nation's wartime efforts in any way possible," Mr. Del Gaudio reports, "and they responded eagerly to the committee's plan of cooperating with the Department of Housing and Buildings. Because of their training and experience, architects are ideally equipped to make safety surveys and analyze the strength and weaknesses of a building. There is still a need for more architects, however, and the assistance of every man in the profession is sought."

In making a study of the safety areas in the five boroughs, each architect will enlist the aid of the local air warden. Accompanied by the warden, the architect will inspect structures ranging from skyscrapers to private residences. In the larger buildings the architect will point out to the warden and to the building superintendent the floors and rooms where persons may stay most safely and also instruct the superintendent in the fastest methods of cutting off electricity, gas and other utility services.

In the residential areas, the architects will give individual instruction to house owners on air raid precautions. Until identification badges have been prepared for the architects, their authority will be verified by the

**Quiet** . . . for offices,  
schools, banks, hospitals,  
radio stations, with . . . . .

## **CELOTEX** ACOUSTICAL MATERIALS

*High sound absorption . . . easily  
cleaned . . . paintable . . . low in cost!*

## **WESTERN ASBESTOS CO.**

*Acoustical Engineers and Contractors*

San Francisco . Oakland . Sacramento



### *California's Hotel Beautiful*

—like a country estate  
yet in the heart of a throbbing  
metropolitan area.  
—a matchless view—  
comfortable, luxuriously furnished  
rooms, excellent cuisine.  
—in an atmosphere of quiet  
and gracious living.

Rooms, with bath, \$2.50 to \$5.00 per day.

*Attractive monthly rates*

**HOTEL CLAREMONT · BERKELEY**

**BAXCO**  
CHROMATED ZINC CHLORIDE

**CZC**

**PRESSURE TREATED LUMBER**  
● **PROTECTS AGAINST DECAY  
AND TERMITE ATTACK**

*Specify it in your home  
Available through Lumber Dealers*

LOS ANGELES 601 W. 5th Street Phone Michigan 6294	SAN FRANCISCO 333 Montgomery Street Phone DOuglas 3883
---	--

***J. H. Baxter & Co.***

AGENTS FOR WEST COAST WOOD PRESERVING CO. SEATTLE, WASH.

**CLINTON  
CONSTRUCTION CO.**  
OF CALIFORNIA

**General Contractors**

923 FOLSOM STREET • SAN FRANCISCO  
SUtter 3440

**HOGAN LUMBER CO.**  
*Wholesale and Retail*

**LUMBER**

---

**MILL WORK • SASH & DOORS**

---

*Office, Mill, Yard and Docks*  
**SECOND AND ALICE STREETS • OAKLAND, CALIF.**  
*Telephone GLencourt 6861*

air raid wardens. Information obtained by the architects will be written in triplicate. One copy will be filed at the main headquarters of the organization in the Municipal Building, the second in the local borough office and the third will be kept in the precinct office. The data will be available for the use of all authorized defense groups.

#### RECIPE FOR MAJOR DEFENSE PLANT

Major items of materials required for the construction of Buick Chicago division's big plane engine plant at Melrose Park, Illinois, were listed by the architects, Albert Kahn and Associates, as follows:

- 410,000 bags of cement.
- 115,000 tons of sand and stone.
- 5,500,000 cubic feet of excavation.
- 1,200,000 cubic feet of reinforced concrete.
- 2,500 tons of reinforcing steel.
- 690,000 square feet of wire mesh reinforcing.
- 10,000 tons of structural steel.
- 3,000,000 bricks.
- 820,000 pieces of facing tile.
- 8,600 cubic feet of cut limestone.
- 1,158,000 square feet of cement roof tile.
- 7,000,000 cresote wood flooring blocks, or 123,000 square yards.
- 12,000 squares of composition roofing.
- 150,000 panes of glass.
- 186,000 square feet of steel sash.
- 79,000 feet or 15 miles of heating pipes.
- 575 motor driven fans for ventilation.
- 75 miles of electric conduit.
- 150 miles of electric wire and cable.
- 300,000 pounds of copper for power wiring.
- 9,500 fluorescent light fixtures.
- 10 transformer sub-stations.
- 1 master sub-station providing 30,000 kilowatts.
- 8,000 feet of railroad siding.
- 6 miles of concrete pavement.
- Cafeteria to accommodate 2,000 at one sitting.
- 13,000 lockers for men and women.
- Additional lunchrooms to handle 1,200 more.
- Parking space for 3,500 cars.
- 125 acres of land.

#### THE 1942 BUILDING OUTLOOK

War has modified the 1942 construction program and it is probable that the year will witness greater building activity than was looked for before the United States entered the world conflict on an all-out scale, according to the Producers' Council, national organization of manufacturers of building materials and equipment affiliated with the American Institute of Architects.

"While no official announcements have been made respecting 1942 defense construction, it seems likely that military and naval construction and industrial facilities will be in much greater volume than an-

icipated in releases by OPM during the fall of 1941," the Council says.

"Indications are that total construction in 1942 will be at least equal to the 1941 record volume. There is now in prospect additional cantonments for an expanded army, air fields and other kinds of military facilities, industrial plants, ordnance depots and naval shore establishments. Necessary production of war material apparently cannot be produced within existing or authorized plants and more will have to be built.

"While record volume of construction will continue, distribution of work will still be spotty and normal construction will be further curtailed. It is not necessary to put a stop-order on non-defense construction; it is only necessary to tighten up regulations to carry out the SPAB announcement of October 9.

"This implies that there will be a reduction in the assistance expected to be given to non-defense construction. No possible loosening up which private industry had hoped might be the case in 1942 is probable. War policies will bar new construction deemed non-essential to winning the war.

"Essential civilian construction will be largely hospitals, schools and public service facilities vital to health and safety, and necessary repairs to existing non-defense buildings. It can be taken for granted that every such proposal will be scrutinized most carefully now that war is on.

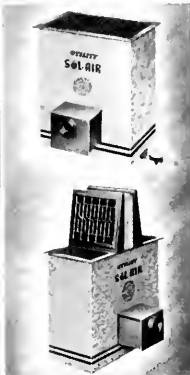
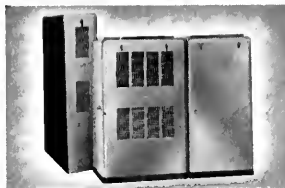
"All funds for Government-built defense housing under the Lanham Act and its early supplements were exhausted several weeks ago. The defense housing agencies are looking to the supplementary legislation providing \$300,000,000 additional funds. Even this is not considered to be sufficient to care for all the new needs which will arise.

"Emphasis now is being placed on temporary housing. A \$10,000,000 program as passed by the House was increased by the Senate to \$300,000,000, so that apparently a substantial fund will be provided.

"Dormitories, trailers and portable houses are planned. These are favored on the basis of speed and flexibility. Prefabrication will doubtless play a major role in this program.

"Of the 200,000 family units originally assigned to private enterprise in the defense housing priorities plan, more than half have already been allotted. Defense officials are disturbed that the great majority of these are being built for sale rather than for rent.

"There is even talk that defense housing priorities might be limited to rental housing. This would provide a major obstacle to private endeavor. Private home builders naturally prefer to get their money out of construction and use it to build more houses. Few builders, it is believed, will be willing to tie up



## A Dependable Source of Supply **UTILITY**

### Gas-Fired Heating Equipment

Scientifically designed by experienced engineers —  
Thoroughly tested in complete laboratories — Built to  
precision specifications, by mass-production methods,  
in a completely modern new plant.

See your Western States A-EC Catalog

## UTILITY FAN CORPORATION

4851 S. Alameda

Los Angeles

Manufacturers of a complete line of Industrial Exhausters,  
Blowers and Fans.

## Something New An **AUTOMATIC** Garage Door



Turn the handle and up it goes — no tugging, no lifting.

**THAT'S STANLEY**  
**Econ-O-matic**  
Economical - Automatic



A Stanley "Swing-Up" Hardware Set with new attractions. For old and new doors, weighing not over 150 lbs. The low price will please you. Ask your dealer. The Stanley Works, New Britain, Connecticut.

# STANLEY

TRADE MARK

HARDWARE FOR CAREFREE DOORS

## ACOUSTI-CELOTEX

for office-quieting provides . . .

- PAINTABILITY
- PERMANENT LIGHT-REFLECTION
- HIGH EFFICIENCY

*Acoustical Engineers & Contractors*

## WESTERN ASBESTOS CO.

*Building Materials*      *Mechanical Specialties*  
S A C R A M E N T O      O A K L A N D  
S A N F R A N C I S C O

## STRUCTURAL STEEL

For Class A Buildings,  
Bridges, etc.

## JUDSON PACIFIC CO.

1200 SEVENTEENTH STREET  
SAN FRANCISCO

Plants: San Francisco - Oakland

Fine Water Colors and Papers  
For Architectural Renderings

## H. S. CROCKER COMPANY, Inc.

720 MISSION STREET

Market Street at Second • San Francisco

## BASALITE

CAMBERED SHINGLE TILE

PERMANENT • FIREPROOF • STORM-  
SAFE • COLORFUL • ECONOMICAL

*Manufactured by*  
**BASALT ROCK CO., INC.**  
NAPA, CALIFORNIA

funds in rental housing and continue to assume the equity risk.

"Builders are now required to state sale or rental prices on OPM applications and to post them prominently on the project.

"Apparently there is urgent need for some additional means under which rental housing for defense workers can be produced by private industry. Such proposals have been advanced as Government subsidy or Government insurance of equity investment, or Government yield insurance.

"A major item in the Government program to provide living facilities for defense workers is more intensive use of existing residential properties through remodeling to provide either additional family units or rooms for rent. The Defense Housing Coordinator has set up an organization under the Defense Homes Registration Service to promote this type of work which will be given preference in priority assistance for critical materials.

"With the collaboration of the HOLC, property owners are offered free assistance in preliminary examination of properties by qualified architects and engineers such as have controlled HOLC's gigantic reconditioning program over the past seven years. Special funds were made available to cover the expense of this preliminary service from defense appropriations to the President. These projects originating through the Homes Registration Bureaus should provide many opportunities for small contractors and for building material manufacturers' salesmen."

### ENGINEERS CLUB OF SAN FRANCISCO

L. A. Elsener, district manager of the Chicago Bridge & Iron Company, is the new president of the Engineers Club of San Francisco, succeeding H. H. Hall, chief engineer of Standard Oil Company of California.

Other new officers for 1942 are J. Marshall Evans of the Standard Oil Company of California, vice-president; Russell P. Hastings, retired civil engineer of San Francisco, secretary; and J. W. Mahoney of the General Electric Company, treasurer.

Besides these officers, the following will serve on the board of directors for 1942: E. F. Maryatt of the Pacific Gas & Electric Company; R. A. Kinzie, consulting engineer of San Francisco; H. W. Gould of H. W. Gould & Co.; W. C. Smith of the General Electric Company; Granville S. Borden of the Standard Oil Company of California; F. H. Fowler, consulting civil engineer of San Francisco; H. A. Sawin of the Yuba Manufacturing Company; H. H. Hall, retiring president; and Denistoun Wood, engineer of tests for the Southern Pacific Company.

### ENGINEERS DISSOLVE PARTNERSHIP

Thomas B. Hunter announces the withdrawal of Robert A. Hudson as junior partner and the dissolution of the firm of Hunter & Hudson, practicing consulting

and mechanical engineers in San Francisco for many years. Mr. Hunter will continue the practice, with offices at 41 Sutter Street, San Francisco. Mr. Hudson has been in poor health for some time.

#### DEMAND FOR OLD HOMES

"If it cannot buy new cars, the public will buy homes already built and close to transportation. For the duration of the war, at least, the scarcity of new automobiles and tires may slow down—and in some instances reverse—the migration of city dwellers to the suburbs," Fred W. Catlett, member of the Federal Home Loan Bank Board, declared in a recent interview.

"We're just beginning to realize that we may have to change a lot of our habits," said Mr. Catlett. "But there may be basic changes, too. Will people turn their 'installment buying' toward acquiring homes when they can't get autos? I think a great many will and I believe transportation restrictions may bring a movement to stay 'close to town'."

He predicted greater activity in residential sales and rentals in the older central sections of cities which have suffered from decentralization in the past 15 years. This should mean a heavy call for homes built for some time and for which there has been little demand, due to a desire to buy new homes in the suburbs.

"Restricted in the use of cars of their own, many employees of centrally located defense plants, as well as other persons, will want to live near their work—near to the business and recreational centers," Mr. Catlett said.

#### SOUTHERN CALIFORNIA CHAPTER ELECTS

New officers and directors for 1942 were installed at the annual meeting of the Southern California Chapter, American Institute of Architects, Tuesday, January 15, at the Clark Hotel, Los Angeles. A large group of the leaders in the architectural and planning professions attended the meeting and saw the following members take office: President, Samuel E. Lunden, Los Angeles; vice-president, Herbert J. Powell, Los Angeles; secretary, Donald Beach Kirby, Los Angeles; treasurer, Walter Wurdeman, Hollywood; directors, U. Floyd Rible, Beverly Hills, Wm. H. Harrison, Los Angeles, and Robert Derrah, Beverly Hills.

The retiring president, Sylvanus B. Marston of Pasadena, told of accomplishments and activities of the past two years during his term of office.

Samuel E. Lunden, new Chapter president, is best known as the architect of the Stock Exchange Building, Hancock Hall and Doheny Library at U. S. C., and many commercial, public and school structures. He is a graduate of the Massachusetts Institute of Technology.

New President Lunden responded to the remarks of the retiring president and outlined policies and a program for the new year. Particular emphasis was placed on the architect's place in civilian defense and in long-range, post-war community planning.

## ALADDIN Heating Corp.

Specializing in  
**QUALITY HEATING EQUIPMENT**  
2222 San Pablo Avenue, Oakland  
TWinoaks 1022

**SLOANE** has worked with architects, designers and decorators for years.  
▶ We interpret intelligently . . . and we know what it is to be up against deadlines and strict budgets. ▶ Let us prove this!

FURNITURE • FABRICS • WALLPAPERS  
LAMPS AND FLOOR COVERINGS  
WHOLESALE CONTRACT DIVISION

W & J **SLOANE**  
Sutter near Grant • San Francisco

## SISALKRAFT

REG. U. S. PAT. OFF.

"More than a building paper"

**THE SISALKRAFT CO.**

205 West Wacker Drive  
(Canal Station) Chicago, Ill.

55 New Montgomery Street  
San Francisco, Calif.

The Most Complete Line of  
**STEELS and BUILDING MATERIALS**  
Made by a Single Producer



See Sweet's Catalog File or write us for full information.

**REPUBLIC STEEL CORPORATION**  
GENERAL OFFICES: CLEVELAND, OHIO

DENVER, COLORADO . . . CONTINENTAL OIL BUILDING  
LOS ANGELES, CALIFORNIA . . . EDISON BUILDING  
SALT LAKE CITY, UTAH . . . WALKER BANK BUILDING  
SAN FRANCISCO, CALIFORNIA . . . RIALTO BUILDING  
SEATTLE, WASH. . . . WHITE-HENRY-STUART BUILDING

# VERMONT MARBLE COMPANY

Producers and Finishers  
of  
Domestic and Imported Marbles

Write for new pamphlet describing our  
Marble Toilets and Showers

San Francisco and Los Angeles  
San Francisco phone: SUTTER 6747

## "AMERICAN MARSH" Redi-Vac Vacuum Heating Pump



Send for  
Bulletin 441

### SIMONDS MACHINERY CO.

San Francisco  
816 Folsom St.

Los Angeles  
455 East Fourth St.

## A BREAK —



for your motor trip  
going north or south  
via Coast Highway

STAY OVER NIGHT AT  
**SANTA MARIA  
INN**

FRANK J. McCOY, *Owner*  
O. E. SAMMANN, *Mgr.*

*Friendly atmosphere  
Excellent meals  
New tap room*

**SANTA MARIA INN** Santa Maria  
California

## PACIFIC MANUFACTURING CO.

HIGH CLASS INTERIOR FINISH  
QUALITY MILLWORK

142 SANSOME ST., SAN FRANCISCO  
GARfield 7755

6820 MCKINLEY AVE., LOS ANGELES  
THornwall 4196

**BUILDERS EXCHANGE, OAKLAND**

## COLUMBIA STEEL AND NATIONAL DEFENSE

Columbia Steel Company, subsidiary of United States Steel Corporation, has announced details of a building program to increase the capacity of its Pittsburg, California, plant to include the addition of a semi-continuous rod mill together with billet heating furnaces, rod cooling and handling equipment. The rod mill will be built east of the plant's open hearth building. Another unit will be capable of producing 500,000 tons of steel plates and 30,000 tons of steel castings annually.

The wire and nail mill will be improved and extended to include additional wire drawing and nail machines, and new facilities for the manufacture of some wire products, the production of which was formerly confined to Eastern mills. Warehousing facilities of the wire mill also will be increased.

Some changes will be made to the primary rolling mills, allowing production of longer rod billets.

## MARBLE TOILETS AND SHOWERS

Marble toilets and showers are featured in a four-page illustrated pamphlet recently issued by the Vermont Marble Company whose Pacific Coast offices are in the Underwood Building, San Francisco, and 727 West 9th Street, Los Angeles. According to H. C. Fawcett, Pacific Coast manager, these brochures are available to the profession on request. The Vermont Company has developed a typical toilet stall of marble which dispenses with all exposed hardware, except what is required for doors. In view of the shortage of metal the all-marble toilet and shower will undoubtedly fill a need at this time. By standardizing the sizes and omitting the hardware, it is possible to keep costs at very reasonable figures and, furthermore, the expense of replacing or painting rusty metal is saved.

## BECOMES CITY OFFICE MANAGER

Paul J. Sheppard, who for the past four years has been handling wall tile sales for Kraftile Company, has taken over the managership of the San Francisco office of the company.

Besides the complete line of Kraftile structural clay products, the office handles sales promotion on building material specialties, including Miracle Adhesives, now used in setting tile; Minwax waterproofings and wood-finishes; Belmont Copper Alundum Tile, the non-slip tile impregnated with germicidal properties.

Mr. Sheppard transfers from Niles, head office of Kraftile Company and location of its kilns.

## LOWE IN NEW YORK

Willis Lowe, architect, formerly residing at 1056 Hubert Road, Oakland, is airport engineer for the Panama American Airways in New York City. He requests that the building trade discontinue sending literature and building material samples to his former Oakland address until after the duration of the war.

## LAKE 136 MILES LONG

Eight years in the building, Grand Coulee Dam, world's largest masonry structure, was almost completed in 1941 and now has formed a lake 136 miles long, John C. Page, Commissioner, Bureau of Reclamation, has reported to Secretary of the Interior Harold L. Ickes.

Transmutation, by the dam's first generators, of the power of the Columbia River into electrical energy for use in industries manufacturing materials and equipment to gird the nation in its fight for liberty was another outstanding event of the year, Mr. Page said.

All mass concrete is in place and only minor clean-up operations remain to be finished. The contractor added 64,540 cubic yards to the dam and appurtenant structures to bring the volume to 10,251,789. Mass pouring ended on December 12, 1941, six years and two weeks after the first bucket was opened on the bedrock.

In the west powerhouse, on the dam's downstream face, Bureau engineers rushed to completion two 10,000 kilowatt station-service generators and on March 22 last year they began transmitting energy over the Bonneville Power Administration's Pacific Northwest grid to aluminum plants near Vancouver, Washington.

Seven months later, on October 4, the first of the plant's 108,000 kilowatt giants began humming its song of power. With the demand for electrical energy growing by leaps and bounds at every turn in world events, Grand Coulee Dam's contribution to America's arsenal was both timely and significant.

At the end of the year, the Bureau had its second "Big Bertha" nearly ready for action and was making rapid progress on unit No. 3. It will join the other two musketeers next month. Three additional machines for installation in 1943 were in varying stages of manufacture and equipment was ordered for still another set of three.

Although construction of the dam, to all intents and purposes, can be considered completed, the year 1942 will not lack for intense building activity. Construction of the east power-



## INDIRECT

A fixture to impress your guests with its beauty and your good taste. Your home is only as lovely as its lighting.

So—may we offer the assistance of our "lighting stylists" in selecting the correct fixtures on your limited budget?

## INCANDESCENT SUPPLY COMPANY

726 MISSION ST., SAN FRANCISCO

Phone GARfield 1164

## Thomas B. Hunter

Consulting Engineer

DESIGNER OF HEATING  
AIR CONDITIONING  
VENTILATING AND WIRING  
SYSTEMS, MECHANICAL  
AND ELECTRICAL EQUIP-  
MENT OF BUILDINGS

41 SUTTER STREET  
ROOM 710

San Francisco California

## Robert W. Hunt Company

ENGINEERS

Inspection - Tests - Consultation

Schools and Other Structures  
Are Built as Designed

When Construction Materials are  
Inspected at point of Manufacture  
and during Erection by

ROBERT W. HUNT COMPANY

Cement, Concrete, Chemical, Metallurgical,  
X-Ray and Physical Laboratories

Chicago - New York - Pittsburgh  
Los Angeles - All Large Cities  
San Francisco, 251 Kearny Street



## BANK WITH US BY MAIL

You don't waste time running around to every store to pay your bills . . . you just mail your check. Then why don't you save additional time and trouble in handling your bank affairs by using our Bank-by-Mail Service? It's the same idea. Write today for simple instructions for banking by mail.

**CROCKER FIRST  
NATIONAL BANK**  
OF SAN FRANCISCO

*California's Oldest National Bank*

Member Federal Deposit Insurance Corporation

## THE TORMEY COMPANY

GENERAL PAINTERS  
AND DECORATORS

Phone UNderhill 1913

563 FULTON STREET  
San Francisco

G. P. W.  
JENSEN & SON

Building Construction

320 Market Street, San Francisco

Phone: GARfield 2444



**WOMEN** go into raptures over this new Wesix "Perfect Thirty-Six" electric bathroom heater. Its instant, head-to-foot heat, they exclaim, "is simply marvelous!" You will like it because it fits perfectly into 42-inch wainscots. For details write Dept. 206, Wesix Electric Heater Co., 390-1st St., San Francisco.

**WESIX**

*World's Largest Manufacturers of Major Electric Heaters*



**HERRICK  
IRON WORKS**

**STRUCTURAL STEEL  
REINFORCING STEEL**

18TH AND CAMPBELL STS.  
OAKLAND, CALIF.  
Phone GLencourt 1767

**FORDERER  
CORNICER WORKS**

*Manufacturers of*  
Hollow Metal Products  
Interior Metal Trim  
Elevator Fronts and Cabs  
Metal Plaster Accessories  
Sanitary Metal Bases  
Metal Cabinets  
Flat and Roll Metal Screens  
Commercial Refrigerators

**269 POTRERO AVE.**  
San Francisco, Calif.  
HEmlock 4100

house and relocation of county roads near the Kettle River and near Hawk Creek, and relocation of isolated sections of Indian Service roads on the Spokane River will be major work projects. On January 1, 1942, the Bureau took over from the contractor and will do the remaining work on the dam.

**SMALLER HOMES IN PROSPECT**

Homes of the future will be smaller, because families are shrinking in size and the proportion of older persons in the household is rising, according to the forthcoming report of the Federal Home Loan Bank Board to Congress for the fiscal year 1941, ended last June 30.

"Of all population trends, probably none has greater significance to the housing market than the number and size of families, for housing demand is largely determined by these two factors," the report says. "On April 1, 1940, the number of private households, which corresponds closely to the number of families, was 34,860,000. It is, therefore, estimated that during the Thirties, there was a net gain of some 5,000,000 families, or 16.6 per cent, as compared with an increase in total population of only 7.2 per cent.

"Over half of the increase in the number of families during the Thirties resulted from a decrease in the average size of family from 4.1 to 3.8 persons. A drop in family size has been revealed by each Census since 1890 and further declines are likely because of a steadily decreasing birth rate. Just as the number of families is a major determinant of the number of dwelling units needed, the number of persons in the average family decides, in the main, the size of units to be built.

"In April, 1940, the number of persons aged 65 or over was 8,960,000, or 6.8 per cent of total population, as compared with 6,630,000, or 5.4 per cent in 1930. Statistics on younger age groups show that the number of persons approaching retirement will continue to increase in the future. Thus, in 1940 there were 25,947,000 persons, or 19.7 per cent of total, in the age group from 45 to 64 years in

**Save 20% Space**

*Specify*

**PITCHER**

**IMPROVED DISAPPEARING  
DOORS**

Send for prices and details on our new wood frame sliding doors

**E. C. Pitcher Co.**

557 Market Street, San Francisco

**Next Month's**

**ARCHITECT and ENGINEER**

will feature the new

**Bank of America Building.**

**San Francisco.**

25 illustrations . . . Special articles by L. H. Nishkian, G. M. Simonson and others.

**Independent  
Iron Works**

Structural Steel  
Ornamental Iron  
Steel Service Stations  
Steel Tanks  
Standard Steel Mill Buildings  
Bridges

821 Pine Street                      Oakland

**ANDERSON  
&  
RINGROSE**

**General Contractors**

320 Market Street, San Francisco  
Phone GARfield 2245



## JOHN CASSARETTO

—Since 1886—And Still Active—

### Building Materials

READY MIX CONCRETE  
ROCK - SAND - GRAVEL - LIME  
CEMENT - PLASTER - MORTAR  
METAL LATH - WOOD LATH  
STUCCO - WIRE NETTING

### Service Unexcelled

Bunkers

Sixth and Channal, San Francisco  
Phones: GARfield 3176, GARfield 3177

## VAUGHN - G. E. WITT Co.

Manufacturers and Distributors

Pump Governors	Oil Heaters
Safety Pump Governors	Relief Valves
Automatic Gas Regulating Valves	Oil Burner Governors
Gas Burning Equipment	Oil Burners
Vacuum Pump Governors	Oil Pumping Sets
Vacuum Regulating Valves	Oil Valves
Continuous Flow Steam Traps	Oil and Steam Strainers
Thermostats	Duplex Oil Pumps
Reducing Valves	Rotary Oil Pumps
	Boiler Feed Pumps
	Water Heaters
	Boiler Feed-Water Regulators

4224-28 Hollis St., Emeryville, Oakland

## ABBOT A. HANKS, INC. Engineers & Chemists

INSPECTING — TESTING — CONSULTING  
CONCRETE • STEEL • MATERIALS  
CHEMICAL AND TESTING  
LABORATORIES  
• RESEARCH AND INVESTIGATION •

TESTS OF STRUCTURAL MATERIALS  
DESIGN OF CONCRETE MIXES  
SHOP AND ERECTION INSPECTION OF  
STRUCTURES AND EQUIPMENT  
INVESTIGATION OF STRUCTURES  
AND MATERIALS  
TESTS AND INVESTIGATION OF  
FOUNDATION SOILS  
FIRE RESISTANCE AND INSULATION  
TESTS

624 Sacramento Street, San Francisco

## MULLEN MFG. COMPANY

BANK, STORE AND OFFICE  
FIXTURES—CABINET WORK  
OF GUARANTEED QUALITY  
CHURCH SEATING

Office and Factory:  
60-80 RAUSCH ST., Bet. 7th and 8th Sts.  
San Francisco  
Telephone UNderhill 5815

contrast with 21,415,000, or 17.4 per cent, in 1930. Such changes as these in the age structure of our population have a direct influence on the need for housing. We may, for example, expect a greater demand for small, compact dwelling units to house older people."

### BLACKOUT BULB

Designed for blackout lighting in air raids, the new Wabash Blackout bulb just announced by the Wabash Appliance Corporation, Brooklyn, N. Y., provides downlighting in a soft



beam of blue light that is safe for indoor visibility during blackouts. The bulb is lined inside with a pure silver reflector lining that hides all filament glare and projects the light downward. Light leaks are prevented by a black silicate coating that covers the bulb up to the extreme lighting end, which is a deep blue. The new bulb consumes 25 watts.

### CHINATOWN HOUSING PROJECT APPROVED

Tentative approval of architects' plans for the Chinatown, San Francisco, low-rent housing development has been made by the five non-paid commissioners who direct the activities of the San Francisco Housing Authority.

Purchase of the 2½ acre site on Pacific Avenue has been completed by the Authority. Mark Daniels and Howard are the architects.



## Wm. Penn Hotel

2208 West 8th St.  
Los Angeles, Calif.

200 Rooms  
200 Baths

One in Room..... \$2.00  
Two in Room..... \$2.50

Attractive weekly and monthly rates.

Professional men will appreciate the good food at moderate prices in our Quaker Grill.

## F E R R O - PORCELAIN

A permanent and beautiful exterior finish . . . particularly adaptable to modern design. Eliminates upkeep costs . . . such as painting . . . choose your own color.

The entire fronts of the Chestnut Tree restaurants in San Francisco are Ferro-  
Porcelain Enamel.

We will be pleased to work out details for Ferro-  
Porcelain construction in connection with most any type of building.

**FRANK ALLEN CO.**  
Ferro-  
Porcelain Constructors

320 Market St.  
San Francisco

832 W. 5th St.  
Los Angeles

## INCLUDE TREES IN YOUR PLANS

DAVEY, ORIGINATOR OF TREE SUR-  
GERY, OFFERS FREE INSPECTION  
AND ESTIMATE.



SAN FRANCISCO  
Russ Bldg. SUtter 3377

FRESNO  
Mattei Bldg.

LOS ANGELES  
Stary Bldg. Tucker 1929

Local phones in: Pasadena, Palo Alto,  
Oakland, San Rafael, San Mateo

SKILL - KNOWLEDGE -  
RESPONSIBILITY

## DINWIDDIE CONSTRUCTION COMPANY

## BUILDERS

CROCKER BUILDING  
SAN FRANCISCO

HIGH GRADE MILLWORK  
AND INTERIOR FINISH  
SASH AND DOORS

## LANNOM BROS. MFG. CO.

FIFTH AND MAGNOLIA STREETS  
OAKLAND, CALIFORNIA  
Telephone: TEmplebar 3663

## BUILDING MATERIAL SUBSTITUTES

Effective co-operation in the De-  
fense program through the use of  
substitutes for building materials on  
the critical list is urged by the Home  
Owners' Loan Corporation. Follow-  
ing are some of the substitutes the  
HOLC suggests:

Wood for gutters and downspouts  
in lieu of metal.

Wood frame screens for metal  
frames.

Wood louver ventilators in lieu of  
metal.

Wood sash for metal sash.

Wood or composition shingles for  
metal shingles.

Composition flashings in lieu of  
metal.

Lead alloy, wood shingles or com-  
position roofing in place of metal  
roofing.

Masonry piers or wood columns in  
lieu of pipe columns.

Plain concrete walls of greater  
thickness or masonry walls in lieu of  
reinforced concrete.

Masonry or plain concrete piers or  
columns in lieu of reinforced concrete.

Thicker concrete driveways, walks  
or floors in lieu of wire mesh rein-  
forced concrete.

Plain concrete footings of greater  
dimensions in lieu of reinforced con-  
crete.

Soapstone or cast cement laundry  
trays in lieu of enameled iron.

Vitreous ware plumbing fixtures in  
lieu of enameled iron.

Glass door knobs and escutcheon  
plates instead of metal.

Plastic or glass switch and outlet  
plates in lieu of metal.

Wood or reinforced lintels in lieu  
of steel lintels.

Wood cabinets in place of metal.  
Wood girders in place of steel  
beams.

Wood hand-rails in place of pipe  
or other metal.

Wood fences in lieu of metal.

### 400 FAMILIES AT SUNNYDALE

More than 400 families embracing  
1450 adults and children are now liv-  
ing at the Sunnydale low rent housing  
development in South San Francisco.  
Final touches are now being made on

the balance of the 772 homes and new  
families are moving in daily.

## NO COMPROMISE

How long will the war last? Recent  
reports from Germany would have us  
believe that the country is in bad  
shape, that dissatisfaction and dissen-  
sion are rife and that the morale of  
the German people is breaking down.

It would be nothing less than stupid  
for us to take these reports at their  
face value. Underestimating the en-  
emy has been the curse of the democ-  
racies in this war. Now that we are at  
last beginning to throw our war effort  
into high gear, nothing of whatsoever  
nature must be allowed to interfere  
with it. There can be no doubt, there  
can be no compromise; only one end  
can be enough—the complete and un-  
equivocal defeat of the Axis.

## Poster COMPETITION National Hospital Day Poster

### Awards:

\$200.00 FIRST PRIZE  
\$ 50.00 Honorable Mention  
\$ 50.00 Honorable Mention  
\$ 50.00 Honorable Mention

Prestige and Cash Awards Await the  
Artists who Submit Entries Selected as  
the best National Hospital Day Posters.

### SUBMIT YOUR ENTRIES NOW

Any size proportionate to 14x22, any  
medium, as many as you may wish to  
enter. All entries will be acknowl-  
edged.

American artists have taken world  
leadership in the field of poster crea-  
tion; the American Hospital Associa-  
tion wants to find the poster best  
suited to direct attention to the hospi-  
tals of the Nation as service centers  
for the care of our people. A distin-  
guished jury will consider every entry;  
winners will be selected on the basis  
of thought and rendition best fitted to  
commemorate National Hospital Day.

### Committee of Judges:

DANIEL CAYTON RICH, *Chairman*  
*Director, The Art Institute of Chicago*  
JOHN AYRELL, *Well-known Designer*  
STANLEY EKMAN, *Free-lance Illustrator*  
WILLIAM A. KITTRIDGE, *Director of Design*  
& *Typography, K. K. Donnelly & Sons Co.*

### Closing Date—March 20th

March 20th is the closing date for  
acceptance of entries; awards an-  
nounced March 30, 1942.

AMERICAN HOSPITAL  
ASSOCIATION  
NATIONAL HOSPITAL DAY COMMITTEE  
18 East Division Street Chicago, Ill.

ARCHITECT  
AND  
ENGINEER

**MARCH 1942**

# HAWS FOUNTAINS AGAIN

ON EVERY FLOOR OF THIS BEAUTIFUL  
12 STORY BANK AND OFFICE BUILDING  
THERE ARE HAWS FOUNTAINS



BANK OF AMERICA HEAD OFFICE BUILDING, SAN FRANCISCO

CAPITOL COMPANY, L. J. HENDY, ARCHITECT

- . . . Bank of America, with its 495 branches, is a consistent user of HAWS DRINKING FOUNTAINS.
- . . . In its new San Francisco building, pictured above, there are no less than 48
- . . . Haws Models, 7D Wall Type and 12A Pedestal Type.

## HAWS DRINKING FAUCET COMPANY

1808 HARMON STREET • BERKELEY • CALIFORNIA

Agents in the following cities:

New York • Los Angeles • San Francisco • Seattle • Salt Lake City • Portland  
Chicago • Atlanta • Houston

# RUNNING FIRE — By MARK DANIELS, A. I. A.

## ● *AMBULANCE CHASERS*

There are, and always have been, many people who will do nothing unless they are paid for it. There are others who will not do anything at all if they can help it. There are some with complexes who will work twice as hard to be cruel as they will to be kind. But it takes a war to bring out those who will not join the forces of mercy unless they get a uniform.

The recent squabble between the women had a very pitiful, almost contemptible angle to it. Unless they could wear a uniform, one group would not help the afflicted as they came in from Pearl Harbor. They seemed to think that only in a uniform could they do the work effectively, or that almost any sort of uniform would transform an Apache into a Good Samaritan. Almost any design would do but it was essential to the relief of the suffering of the wounded soldier.

Soon this difference developed into a bitter argument as to who should care for the Hawaiian evacuees. It began to look as if the women were going to accomplish what the bombs failed to do. They would tear the maimed into halves and each would nurse the half she got—that is, if she had a uniform. Finally, one of the factions planned to lay in wait for ships bringing in the victims in order that they might be first to lay hands on them. And so, the first Ambulance Chasers of this war were born. Thank Heaven that ghost has been laid, but let us bear it in mind, for others are coming along seeking notoriety—and uniforms.

## ● *SUFFERING*

Does a man who has been bomb-maimed in a city of one hundred suffer only one-tenth as much as one who has met the same fate in a city of one thousand? That is a silly question, you say, and yet our sympathies go out in proportion to the numbers involved in a calamity. This seems only natural. Still, we should feel as deeply sympathetic with one bereaved sufferer in an Igorot village as we do for a hundred in London. Ten thousand men cannot suffer more than one. Only more men suffer.

## ● *IMAGINATION*

Imagination, in one form or another, has often been the subject of items in this column. Heretofore, the burden of my song along this line has been the value of imagination in creative or constructive work. This war has brought out some of the tragedies that can result from a lack of imagination.

It has been said, by higher military authorities, that one trouble with the officers of the British Army is their lack of imagination. The reply invariably has been, "tactics and strategy are not sciences in the field of imagination. They are predicated upon cold, hard facts." This line of reasoning is fallacious.

Unquestionably one of the contributing factors to the downfall of Singapore was that the British military authorities could not "imagine" a land attack from the north; but it actually happened. Our own war department brought out statements from high officials that our army and navy in Hawaii could not "imagine" an air attack on Pearl Harbor; but it actually happened. Imagination is essential to the accom-

plishment of all things for we cannot act until we have a mental picture of what we are to do. Likewise, we can do little to prevent disaster unless we have a mental image of what is impending. I have heard several high officers of the army say that what sets General Douglas MacArthur high above his contemporaries is that he has imagination. Thank God, he has a vivid one!

## ● *CHEERIO*

A letter just received from a friend in London carried the usual tone of cheerfulness and confidence but he allowed himself to become slightly sarcastic in his humor. One paragraph stated that, "Word that another platoon of British soldiers had shown their willingness to give their lives for the Empire had greatly cheered the fat men at home."

## ● *WHAT UNION?*

Mr. Ellis F. Lawrence, whose article in Pencil Points, the Architect and Engineer printed in the February issue, has presented a subject of union for architects in a light somewhat different from that in which I presented it quite some months ago in this journal. Nevertheless, both articles pointed in the same direction.

On some minor items I do not agree with Mr. Lawrence. I do not agree that the public has little use for us nor that they think we just draw pretty pictures. I believe that the public is abandoning the architectural ship because the builders and contractors have convinced them that our work is superfluous, that the contractors can accomplish the same result and save the architect's fee. It seems impossible to make the public realize that the architect's fee is in the cost somewhere. However, as I said, this is minor. The fact that the public more or less are off of us remains.

Mr. Lawrence's idea to form a union of planners is a good one. In fact any sort of a union will be a good one if it is done right, but I believe that his is only a step toward an out and out union allied with and endorsed by the labor unions. The implication of Mr. Lawrence's article is principally that we organize to get Government work all of which is a good idea if we can get it, but when the war is over we will be right back in the position of trying to convince the public that they do not save money by letting the contractors do all the work of planning.

Why not take the bit in our teeth, swallow our pride, and come out in a manly sort of way with a proposal to unionize along the lines of labor union and start to work. Labor is on the march and it is because it is unionized that it may, and probably will, eventually rule this Nation. If the architects could forget their misconception of aesthetic superiority (which does not set well on the shoulders of those who cannot write grammatical letters), organize themselves into a proper union and get on the boat with labor, so that no labor union man would work on a job where the plans have not been executed by a certified and licensed architect, that might get us a break. We all know of some labor union men who are getting \$150.00 a week, an amount that would be affluence to many architects.

(Turn to Page 56)



# SAVE

your clients MONEY  
on BOTH heating and hot water

SAVE ON installation—you don't need a whole basement—often a "clothes closet" space is large enough. They will save on operation costs, too, by getting heat and hot water *both* from the same unit.

## AQULUX

LOW COST—TROUBLE-PROOF—TWO SIZES

A HIGH efficiency "engineered" oil burner and boiler in one unit—plenty of heat for a 6-room house. The Army uses it for hot water. Your choice of two sizes—85,000 Btu or 150,000 Btu output—with famous "Bankheat" oil burner—10 gauge Coproy shell—3/16" heavy-dipped galvanized steel heads—every unit tested and guaranteed. You should have details on hand. Ask for them.

**FREE**  
COMPLETE  
SPECIFICATIONS

### S. T. JOHNSON CO.

940 Arlington Avenue • Oakland, Calif.  
401 N. Broad Street • Philadelphia, Pa.

# TEAMWORK for SECURITY

**GOLDEN GATE • OLD MISSION**  
PORTLAND CEMENT    PORTLAND CEMENT

**MILCOR**  
METAL LATH PRODUCTS

**EMPIRE**  
GYPSUM PLASTER

**STANDARD**  
GYPSUM PLASTER

# PACIFIC

PORTLAND CEMENT COMPANY

**FOR SOUND CONSTRUCTION**

## NOBLESSE OBLIGE

In the days when the phrase "Noblesse Oblige" was coined, it was taken for granted that members of the nobility owed certain obligations to those of lesser rank. Of course we have no such class distinctions in America, but we do have the learned professions and the doctrine of Noblesse Oblige applies just as much to them as to the nobility.

Clients trustfully take for granted that a doctor or an architect is omniscient at least in his own field, and few would question his judgment.

Justifiably or not, a client loses his complete faith in his architect's abilities if he finds, for instance, that the architect has neglected detailed plans for the electrical service.

If the client finds that suitable switches have not been provided for turning lights on and off without traversing dark areas, if outlets have not been provided at every point they are needed, or if suitable lighting is not included in the plans, his faith in the architect is badly shaken.

Electrical service today is the vital life-blood of a home, and has assumed a more important place than ever before. Adequate electrical service is now a necessity, and if the architect is to hold his client's regard and good-will, he must include proper wiring in his plans.

Even with curtailed wiring, it should still be planned so that it is convenient.

Your utility or this Bureau will be glad to show you how to provide the utmost service.



## NORTHERN CALIFORNIA ELECTRICAL BUREAU

447 SUTTER ST. • SAN FRANCISCO

# ARCHITECT AND ENGINEER



Volume 148	March, 1942	Number 3
<b>Running Fire</b> . . . . .		1
Mark Daniels, Architect		
<b>News and Comment on Art</b> . . . . .		10
I. F. Morrow, Architect		
<b>Bank of America Building, San Francisco</b> . . . . .		19
Fred'k. W. Jones		
<b>A Few Notes on the Bank of America Structural Design</b> . . . . .		37
L. H. Nishkian, C.E.		
<b>Mechanical and Electrical Installation, Bank of America Building</b> . . . . .		38
G. M. Simonson, M.E.		
<b>More About Air Raid Shelters</b> . . . . .		41
<b>New Type of Wall Construction</b> . . . . .		44
<b>Automobile "Graveyards" Yield Tons of Scrap Iron</b> . . . . .		46
<b>Aerial Attacks on School Buildings Studied</b> . . . . .		47
<b>PLATES AND ILLUSTRATIONS</b>		
<b>Bank of America Building, San Francisco</b> . . . . .		18-33
L. J. Hendy, Architect; H. A. Schery, Consulting Architect		
<b>Two Drawings for Air Raid Shelters</b> . . . . .		42-43
<b>Gallatin County Court House, Shawneetown, Ill.</b> . . . . .		45

---

EDITOR, FRED'K W. JONES; ASSISTANT EDITOR, E. N. KIERULFF; CONSULTING AND CONTRIBUTING EDITOR, MARK DANIELS; ADVERTISING MANAGER, R. W. WALKER. REGULAR CONTRIBUTING EDITORS: Harris C. Allen, Harry Sanders, Ben H. O'Connor, Glenn Stanton, Roi L. Marin, Chas. H. Alden, Irving F. Morrow. HONORARY EDITORS: Arthur Brown, Jr., Timothy L. Pfeuger, Lewis P. Hobart, Wm. W. Wurster, Will G. Carlett, Frederick H. Meyer, Thos. J. Kent, Gordon B. Kaufmann, Paul R. Hunter, Michael Goodman, Harry Michelsen.

ARCHITECT AND ENGINEER is published on the 15th of the month by The Architect and Engineer, Inc., 68 Post Street, San Francisco. President, K. P. Kierulff; Vice President, Fred'k W. Jones; Secretary and Business Manager, L. B. Penhorwood.

Entered as second class matter, November 2, 1905, at the Post Office in San Francisco, California, under the Act of March 3, 1879. Subscriptions, United States and Pan America, \$3.00 a year; foreign countries \$5.00 a year; single copy \$ .50.

Los Angeles office: 1709 W. 8th street, Wentworth Green, Manager. Phone EXposition 8292. ARCHITECTS REPORTS are published daily from this office and are sponsored by the Northern Section, State Association of California Architects; Vernon S. Yallop, Mgr.

# PLAN NOW FOR POST WAR BUILDING

**Most of us** know there is a considerable surplus of architectural and engineering talent that has not been utilized to date in Defense work. True, there are a few who have been fortunate enough to receive building commissions; a few others are doing draughting work for some of the big construction companies, and, yes, a small number of younger members have been inducted into the service, either the Army or Navy.

But there remains at the moment some of our best architectural talent going to waste. Truly, a lamentable situation which calls for action! According to Dow Service and other authorities, post-war building, both public and private, will exceed in volume any previous construction era.

Waiting until the war is over before starting to plan for this building activity means to court chaos. It means a potential loss of many thousand man hours to the building trades; it means a slowing up of employment at the outset of at least 500,000 men on the actual construction of buildings; it means months of delay in the manufacture and delivery of building materials.

A substantial appropriation now by Congress for making surveys, investigations, legal studies, architectural and engineering plans and specifications, would put the present unemployed professional talent at work, keep it busy for the duration and with the war over, the nation would find itself prepared to proceed with its rehabilitation plans. How much better this would be than to have conditions go on as they are, with no substantial outlet for our architectural skill.

As conjectured by Pencil Points, "suppose this vast demand for building construction, that is sure to come with the end of the war, bursts upon the nation without plans already prepared for a sufficient volume of construction to absorb the high peak productive capacity and the return of labor to peace time pursuits . . . the time required then for planning a sufficient volume of construction, so that the change over could be made without interruption, would have far reaching and damaging effects on employment in the building trades and in the manufacture and sale of products. The repercussions would reach into every branch of our national economy."

On the opposite page is printed an amendment to the Employment Stabilization Act (Bill S. 1617, U. S. Senate) which every architect, engineer, building contractor, building material manufacturer and salesman, should read, then write or wire his Congressman immediately, urging its passage. This bill provides an appropriation for post-war planning. It is the first step towards a program of preparing **now** to eliminate a possible bottle-neck of building activity after the war.

Passage of this bill will insure mobilization of unused architectural and engineering skill for post-war planning **NOW!**



# S. 1617

[Report No. 961]

IN THE SENATE OF THE UNITED STATES

JUNE 10, 1941

Mr. BROWN (for Mr. WAGNER) introduced the following bill; which was read twice and referred to the Committee on Education and Labor

JANUARY 16, 1942

Reported by Mr. THOMAS of Utah, with amendments

[Omit the part struck through and insert the part printed in *italics*]

## A BILL

To amend the Employment Stabilization Act of 1931.

*Be it enacted by the Senate and House of Representatives of the United States of America in Congress assembled,* That the Employment Stabilization Act of 1931 is amended by adding the following section:

"SEC. 9. There is hereby authorized to be appropriated annually such sums as may be necessary for allotment to agencies of the United States and for advances to the States, Territories, and island possessions, and the agencies and political subdivisions thereof, by the President, through the ~~Federal Works Agency~~ or such agencies as he may designate, and under such rules and regulations as he may prescribe, for the making of such examinations, surveys, investigations, legal studies, comprehensive plans and programs, *architectural and* engineering plans and specifications, and forms of legal proceedings, as may be necessary to facilitate and expedite the selection, financing, and inauguration of public improvements, works, *services*, and related activities: *Provided*, That advances to States, Territories, and island possessions, and political subdivisions thereof, shall be subject to such requirements as to reimbursement, or with respect to contribution of funds, services, or materials, as the President may determine."

This page reproduced by courtesy of  
Pencil Points

WATCH FOR FURTHER DETAILS  
IN SUCCEEDING ISSUES OF

PENCIL POINTS

and

ARCHITECT AND ENGINEER

# HERE IS THE FIRST STEP

A start in some phases of planning for post-war readjustment has already been made. The bill in Congress to amend the Employment Stabilization Act of 1931 is the first step in this program of preparing now to eliminate the bottle-neck of building activity after the war.

You can help. Write or telegraph your Senators and Representative today—now! Get every man you know in the building industry—builders, contractors, building material salesmen—to do the same. Post-war planning is the concern of every man whose future is linked with a healthy building market. Get the message below to your Congressmen immediately.

## Telegram

NAME	
ADDRESS	
CITY	
STATE	
ZIP	

Send the following message, subject to the Company's rules, regulations and rates set forth in its tariff, and use file with regulatory authorities.

SENATOR.....  
WASHINGTON D C  
EMPHATICALLY URGE PASSAGE OF SENATE  
BILL SIXTEEN SEVENTEEN AS AMENDED  
YOUR NAME



# The FINK & SCHINDLER Co.



MANUFACTURING CONTRACTORS  
COMPLETE INSTALLATIONS  
STORE • BANK • BAR • RESTAURANT • OFFICE  
FIXTURES

GENERAL ALTERATION  
WORK  
LODGE AND CHURCH  
FURNITURE  
SPECIAL SCHOOL  
FURNITURE  
HARDWOOD  
INTERIORS  
SPECIAL  
FURNITURE  
STORE FRONTS  
SHOW CASES  
COUNTERS  
REFINISHING  
OF CABINET WORK  
AND FURNITURE  
ESTIMATES  
FURNISHED

All walnut paneling for the executive offices and private rooms, also all special fixture work throughout the new Bank of America Building, San Francisco, were manufactured and installed by us.

**THE FINK & SCHINDLER CO.**  
552 Brannan Street, San Francisco  
Telephone EXbrook 1513



**PRESSURE TREATED LUMBER**  
● **PROTECTS AGAINST DECAY  
AND TERMITE ATTACK**

*Specify it in your home  
Available through Lumber Dealers*

LOS ANGELES  
601 W. 5th Street  
Phone Michigan 6294

SAN FRANCISCO  
333 Montgomery Street  
Phone DOugles 3883

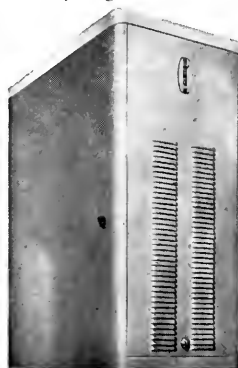
## J. H. Baxter & Co.

AGENTS FOR WEST COAST WOOD PRESERVING CO. SEATTLE, WASH

## Your Client...

may not see his *Biltwel Furnace* every day; but he will be conscious of its presence and always thankful for your foresight in assuring his whole family of warm, healthful room temperature at low cost.

*Biltwel Furnaces* are not only designed for economy and efficiency; they have "eye appeal" as well. They're good to look at — and good to the owner's pocket-book.



Why not ask your heating contractor for more information on the *Biltwel Air Conditioning Gas Furnace*? ... or write to address below for literature.

**Fraser & Johnston Co.**  
725 POTRERO AVE.  
SAN FRANCISCO

Manufacturers of  
**BILTWEL**  
and  
**TORIDAIRE**  
GAS FURNACES

# It Is Our Privilege to Have Furnished the *Sound-Conditioning for San Francisco's New* **BANK OF AMERICA BUILDING**



*Above: Celotex Sound Conditioning provides perfect acoustics in the directors' room atop San Francisco's new 12-story Bank of America Building. Below: The imposing exterior of the Bank of America's new home.*

## **LET CELOTEX SOUND-CONDITIONING HELP SOLVE YOUR ACOUSTICAL PROBLEMS**

SAN FRANCISCO is justly proud of this new Bank of America Building. Nothing has been left undone to make it right in every regard—an efficient home for the two-billion-dollar institution which makes its headquarters here.

It is our privilege to have furnished the sound-conditioning—not only for the beautiful penthouse directors' room, but throughout the twelve general office floors.

In availing yourself of Celotex sound-conditioning experience, you are sure of (1) Proved engineering practice, (2) Uniformly dependable acoustical products, and (3) Guaranteed results. If you have not yet received your copy of our new text, "Less Noise, Better Hearing," please let us have your name.



# **CELOTEX**

REG. U.S. PAT. OFF.

## **SOUND CONDITIONING**

In Canada: Dominion Sound Equipments, Ltd.

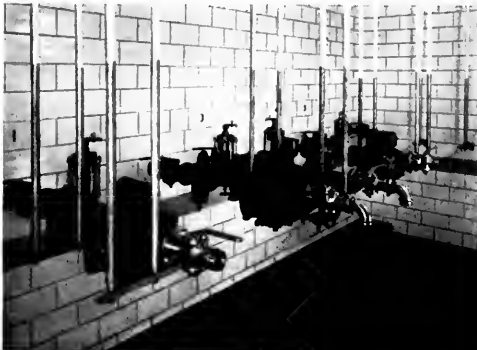
**THE CELOTEX COMPANY • CHICAGO**

America's newest streamlined bottling plant shows

# HOW KRAFTILE LICKS TODAY'S "BUILDING"



**Government Cellar** contains four 100-barrel and eleven 250-barrel glass lined tanks. The Wall Units are Kraftile Ceramic Glazed, Cellular, they are ideal for a refrigerated room like this. Kraftile Vitreous 8 x 8 Quarry Tile is used to finish the floor here, in the Meter Room, and the entire working area of Machinery Hall. 13,300 square feet were used—the largest quarry tile installation in San Francisco last year



*11,340 square feet of Kraftile Structural Wall Units helped Acme Breweries SAVE on steel. CUT labor time. SLASH maintenance costs.*

**W**HAT CAN private industrial construction do these days? There's a good answer in Acme Breweries' new \$750,000 five-story bottle bottling plant. Kraftile Structural Wall Units, Acme found, are a "natural" for modern design — a solution to major building problems, too. For example,

For many partitions, Acme used Kraftile Structural Wall Units in place of steel stud construction. They prove these wall units have 10 times the required seismic resistance. High-fired, they stand up under the hardest abuse. They resist fire, decay and termite destruction.



**Above: Employees' Locker Room** (before locker installation). Partitions for personnel rooms and offices, employees' dressing room, lunch room are 6" x 12" Kraftile "Salt-Glazed" Structural Wall Units thick with vertical cellular construction reinforced with steel grout where necessary. Partitions are glazed from floor to ceiling.

**Left: Government Meter Room** is done in Kraftile Ceramic Wall Units (unsized). These triple-glazed surfaces are available in a variety of colors—bright, mat or mottled. Colors used here are Acme Tery Buff with Tuolomme Green feature strip. Note also Kraftile Quarry Tile which is used on the floor

# OME OF EADACHES”

ile Wall Units helped overcome labor short-  
too. Pre-tiled on one or both sides they go  
one operation. One craft does the work of  
nters, lathers, plasterers and painters. Thus  
uction time is cut about half . . . labor cost  
atly reduced.

d Kraftile Structural Wall Units have given  
’s new plant an attractive, sanitary finish  
*permanent and maintenance-free*. Kraftile  
ces are jewel-hard, stain-resistant and scratch-  
l. Colors cannot fade. There’s no repainting  
astering. Kraftile is kept clean by occasional  
g with a damp cloth.

ou are working on new industrial construc-  
or expansion plans, Kraftile might make an  
rtant difference. For further details, write  
RAFTILE COMPANY, Niles, California.



**Architect:** William Gladstone Merchant; **Structural Engineer—** James M. Smith; **Contractor—** Richard J. H. Forbes; **Masonry Contractor—** Emil Hogberg; **Floor Tile Contractors—** Malott and Peterson



**Corner of lunchroom** (with glass blocks “blacked out”) shows interesting architectural details possible with Kraftile. Here, 2” thick furring tile is used on interior of the outside walls



**Over Partitions of Kraftile “Salt-Glazed” Wall Units, glazed on faces. These are the lowest-priced in the Kraftile line. Available in all range of buff shades, they are laid with a nominal 1/4-inch joint. Ideal for jobs where decorative effects are unnecessary**

## KRAFTILE STRUCTURAL WALL UNITS

Also manufacturers of Quarry Tile—New 6x9  
Master Kraftile—Ceramic Facings—Enameled Brick  
—Swimming Pool Ladder Steps and Overflow  
Gutters—Bathroom Accessories

Kraftile Company is a member of the Producers’ Council, Inc., the national organization of manufacturers of quality building materials



# NEWS AND COMMENT ON ART

## EUGENE BERMAN

Eugene Berman's neo-baroque fantasies at the San Francisco Museum of Art remind once again how unconnected may be the intellectual and the aesthetic interests in art. As comments on a still uncompleted cultural disintegration they are piquant and at times eloquent. The agitation of the forms, important to convey the faintest illusion of purpose or activity; the aimless particularity of the numberless details, leaving the embarrassing voids only too pathetically unfurnished; the people subsiding into listless dejection, apparently unaware of each other's presence and waiting apathetically for the artist to be done; all this probes relentlessly into a spiritual sickness which began with the Renaissance and for which the antidote still remains to be found. Particularly mordant is a picture such as "Nobilissima Visione." It would seem difficult, through any medium, to convey with greater succinctness the futility of the characteristically Baroque preoccupation with frames that are sumptuous, however devoid of content; and with facades that are grandiloquent, even though specious in substance and preceding nothing.

But if the intellectual content of Berman's pictures may be cogent and even revealing, their aesthetic contribution seems meagre and unrewarding. Their form is generally undistinguished when not aggressively irritating; their color finds no equilibrium between drabness and stridency. It may be a question if these negative aesthetic attributes do not inhere in Berman's attitude. It may be that a satire on spurious nobility would be less mordant in terms of aesthetic satisfaction. Perhaps the diagnosing physician has not been immune to the spiritual infection. I suspect that great art must proceed from a degree of enthusiasm, however oriented. Indignation, protest, bitterness even, may be valid motivation; but negation is not enough.

Irving F. Morrow.

## RODIN AT THE LEGION OF HONOR

The permanent collection of the California Palace of the Legion of Honor has been enriched by fourteen celebrated Rodins, the gift just made by Mrs. Alma Spreckels Awl. Eleven bronzes and three marbles, comprising the new acquisition, include the following: St. John the Baptist (miniature study), Sculptor and the Muse, Youth and Old Age, Bust of Henri Rochefort, Head of Balzac, The Negress, Japanese Head, The Kiss, Mignon, Man with the Broken Nose, Burgers of Calais, The Siren of the Sea, La Nature (Head of Woman), and Greek Head.

## FANTASTIC WAR MACHINES

Profoundly moved by the War, Clay Spohn, San Francisco artist known for his tongue-in-cheek humor, finds relief at times by inventing elaborate and fantastic war machines which work only in imagination. In this he follows a distinguished line of artists, not the least of whom is Leonardo. Spohn has prepared a series of gouache paintings of these fantasies for an exhibition at the San Francisco Museum, closing March 29. Spohn's dreams of war take other turns as well. His show includes a series of designs for which he has

coined the word "Guerragraphs." In them the evil forces of war are symbolized in his own demonology which harks back in kind to medieval times. Spohn's imagination has conceived a number of war devices which have been submitted to the War Office at Washington.

## UNIQUE SHOWS AT S. F. MUSEUM OF ART

The San Francisco Museum of Art has planned two unique exhibitions for April: First, an exhibition of the work of five Western architects who were chosen by Eastern authorities for outstanding work in American architecture, and second an exhibition of the Arts of the Circus titled "Hey Rubel." Such a title has real meaning for a display of the development of circus art and of art with a circus theme, for "Hey Rube" is circus vernacular for the protection and preservation of the circus. This exhibition is the first of a series the Museum plans which will offer an artistic analysis of a popular activity of American life. Art of the circus is represented by early posters and a model by Norman Bel Geddes for the recently streamlined Ringling Brothers Barnum and Bailey Combined Shows. Great care and ingenuity is being given the collection and presentation of many prints and paintings which, through art, trace various departments of the present day circus back to its source and later forms. The exhibition opens at the Museum in mid April.

The architectural exhibition will present recent important contributions made to American architecture by Western architects in the field of small house planning. A new technique for such displays has been employed. In place of the usual photographs and plans, models, actual materials of the houses themselves, are so arranged that one may touch and look inside them. The exhibition will be shown at the San Francisco Museum of Art, April 7 to 27, before going on a tour of other cities.

## AT THE GALLERIES

The museums contribute the following announcements of events occurring after the publication date of the Architect and Engineer:

### CALIFORNIA PALACE OF THE LEGION OF HONOR

#### EXHIBITIONS

An Exhibition of Modern Architecture in California, by Raphael Soriano, opening March 16.

An Exhibition of Mexican Prints, opening March 22.

Britain at War (circulated by the Museum of Modern Art), opening March 29.

Belgian Paintings From the 1939 Exposition, through March.

Contemporary American Painting, through March.

#### MOVING PICTURES

March 21—Cavalcade. Directed by Frank Lloyd. A film of British history during the time of Queen Victoria. Sound. (1933.)

March 28—Repeat of the program of March 21.

### SAN FRANCISCO MUSEUM OF ART

#### EXHIBITIONS

Group From the Carnegie Institute, through April 12.

# IN AN EVER CHANGING WORLD



*J. Rivera. 25.*

Ink on paper by Diego Rivera

**FARM WORKMEN**

One hundred-Print Traveling Salon of the Photographic Society of America, through March 31.  
 Fantastic War Machines and Guerragraphs, by Clay Spohn, through March 29.  
 Red Cross Posters, through March 29.  
 Emilie S. Weinberg, through March 22.  
 Allela Cornell, through April 5.

**LECTURES ON CONTEMPORARY MUSIC**  
 Sunday afternoons at 3:00 p.m.—Wesley La MARCH, 1942

Violette, April 5; Charles Jones, April 26; Godfrey Turner, May 3.

M. H. de YOUNG MUSEUM

**EXHIBITIONS**

One-man show (Peter Takal) held over through March.  
 Private Corrado Cagli's drawings of camp life, to March 25.  
 Exhibit of photos, etc., depicting "Concert Life in Old San Francisco," through March.

**S**LOANE has worked with architects, designers and decorators for years. ► We interpret intelligently . . . and we know what it is to be up against deadlines and strict budgets. ► Let us prove this!

FURNITURE • FABRICS • WALLPAPERS  
LAMPS AND FLOOR COVERINGS  
WHOLESALE CONTRACT DIVISION

W & J **SLOANE**  
Sutter near Grant • San Francisco

## The Desert Inn

*33rd Season*

PALM SPRINGS  
CALIFORNIA

**A BREAK—** for your motor trip going north or south via Coast Highway



STAY OVER NIGHT AT

**SANTA MARIA INN**

FRANK J. MCCOY, Owner  
O. E. SAMMANN, Mgr.

*Friendly atmosphere  
Excellent meals  
New tap room*

**SANTA MARIA INN** Santa Maria California

## PACIFIC MANUFACTURING CO.

HIGH CLASS INTERIOR FINISH  
QUALITY MILLWORK

142 SANSOME ST., SAN FRANCISCO  
GARfield 7755

6820 MCKINLEY AVE., LOS ANGELES  
THornwall 4196

BUILDERS EXCHANGE, OAKLAND



**A Dependable  
Source of Supply**

**UTILITY**

**Gas-Fired Heating Equipment**

Scientifically designed by experienced engineers — Thoroughly tested in complete laboratories — Built to precision specifications, by mass-production methods, in a completely modern new plant.

See your Western States A-E-C Catalog

**UTILITY FAN CORPORATION**

4851 S. Alameda

Los Angeles

Manufacturers of a complete line of Industrial Exhausters, Blowers and Fans.



*California's Hotel Beautiful*

—like a country estate yet in the heart of a throbbing metropolitan area.  
—a matchless view— comfortable, luxuriously furnished rooms, excellent cuisine.  
—in an atmosphere of quiet and gracious living.

Rooms, with bath, \$2.50 to \$5.00 per day.

*Attractive monthly rates*

**HOTEL CLAREMONT • BERKELEY**



# Snug

WITHIN a picket fence  
and wartime restrictions



AS A DEMONSTRATION of what can be achieved within war-imposed cost limits, architect Stone cites this appealing small home. Proof again that charm and dignity are not measured by cost, and that the convenience of all-gas housekeeping is not dependent upon income. For this snug little house so neatly fits a snug budget, that renting seems extravagant. ☆ Note the clever use of small space in the kitchen, with its gas range and refrigerator in a streamlined food "production line." ☆ Clean, healthful gas heat and hot water service contribute their share to happy living, and modest gas bills attest sound judgment in writing the specifications. ☆ Many architects today are meeting the challenge of wartime restrictions by "lowering their sights" without compromising their standards. Even installations temporarily prohibited can be provided for, to be added by owners later.



An all-gas cottage that meets requirements for designated "Defense Areas." Owners, Mrs. Mary Stone and Miss Emily Stone, Altadena, Calif. Architect, William J. Stone.



**GAS**  
THE  
VICTORY  
FUEL

*In war industries, camps, bases, defense housing projects and millions of homes, Gas Fuel is doing its part . . . safeguarding health, speeding production, saving money. ☆ The facilities and materials of appliance manufacturers are of*

*course being diverted to war production; but every effort is being made to meet essential requirements. ☆ Your Gas Company will cooperate in every possible way to solve allocation and specification problems. Consultation is invited.*



THE GAS INDUSTRY HAS "ENLISTED" FOR THE DURATION

**Q**uiet . . . for offices,  
schools, banks, hospitals,  
radio stations, with . . .

**CELOTEX**  
**ACOUSTICAL MATERIALS**

*High sound absorption . . . easily  
cleaned . . . paintable . . . low in cost!*

**WESTERN ASBESTOS CO.**  
*Acoustical Engineers and Contractors*  
SAN FRANCISCO • OAKLAND • SACRAMENTO



**QUALITY AND DEPENDABLE**  
*Service*

are the factors that influence architects and contractors when selecting lumber and mill work — Quality of merchandise — Integrity and Ability of the firm—Service in physical equipment — Experience and Personnel — All these factors contribute to a speedy and satisfactory completion of construction with minimum of time and expense.

**MANUFACTURER OR DEALER IN**

Douglas Fir—Redwood—Sugar and Ponderosa Pine — Plywood and Concrete Form Panels — Sash and Doors — Millwork — Insulation — Builders' Hardware.

**E. K. WOOD LUMBER CO.**

*"Goods of the Woods" ©*

LOS ANGELES • SAN FRANCISCO • OAKLAND

**BUILDINGS OF THE FUTURE**

Before a group of Government officials and manufacturers, architects and builders assembled in Washington, D. C., at the annual Construction Industry Conference of the Chamber of Commerce of the United States, Harvey Wiley Corbett, well known New York architect, prophesied design and building changes that would come with the post-war period.

Mr. Corbett says that the great factories, built for war products production, should be turned quickly to production of products needed in peace time building. This has revolutionary implications since labor, engaged in war production, will be unwilling to return to part-time, seasonal employment as it prevails in the building world.

Rapid defense housing construction will have demonstrated the economy of mass production building elements completely finished in the factory, assembled in the field, 100 per cent demountable. This means greater standardization of parts with resultant economies inherent in mass production and a better quality of goods. Mr. Corbett thinks with plans properly made the shift from war to peace production could be handled overnight.

Mr. Corbett's mind picture of future building comprises: (1) No more skyscrapers. They are unnecessary from any point of view and cause undue congestion in streets; in an air raid it is easier for people to get to earth from a five story building than from a fifty story one. (2) Buildings will weigh about one-third what they do now. Masonry—brick, stone, cement—will not be used. Walls three or four inches thick are ample to make a complete division between in and out doors. Premade synthetic materials will replace the usual things now employed.

**BANK OF AMERICA PLUMBING CONTRACT**

With the completion of the Bank of America Building in San Francisco, there have been many favorable comments anent its splendid design and construction. In the matter of materials and equipment, commendation has been equally pronounced.

Without question one of the outstanding installations in this \$2,000,000 structure, is the plumbing system by Alexander Coleman, a pioneer San Francisco man whose important contracts in the past doubtless influenced the bank officials to name him to do the work, on a cost plus basis. That the bank job matches up well with some of Mr. Coleman's past undertakings is quite apparent. We refer to the San Francisco City Hall, the general office building of the Pacific Telephone & Telegraph Company and St. Joseph's Hospital, all Coleman contracts.

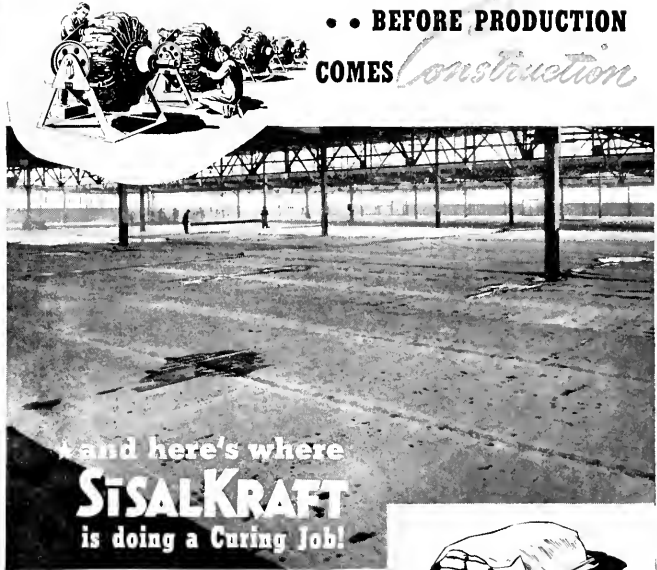
Noticeable features of the plumbing installation in the bank building are the superior type of fixtures, excellence of style and workmanship, reflecting the expert efficiency of the Coleman organization. Besides the plumbing system, Mr. Coleman's contract included installation of the fire protection equipment.

**DEMOUNTABLE CITIES**

What will follow the skyscraper era in American architecture? The American Institute of Architects quotes Harvey Wiley Corbett in criticism of tall buildings, of which, on Mr. Corbett's own word, he "used to be a strong advocate." The war in the air has changed the thinking of those who plan our offices, homes, factories and public buildings. Indeed, some authorities may assert that the era of skyscrapers ended when the depression made tall buildings costly because the general curtailment of business led to a period of expensive vacancies in some of the city's skyscrapers. In other cities a skyscraper era has only begun.

Mr. Corbett foresees buildings of lighter construction, but the most interesting part of his prediction concerns the flexibility of the buildings we may have in the post-war period. These will be fashioned of prefabricated materials that can be assembled and dismantled rapidly.

The relation of design to safety in air raids has, of course, been more intensely studied in this country in recent months, but many an architect has long considered necessary and even radical departures from present practice. Recently Konrad F. Wittman in Architectural Record wrote of the need to disguise buildings in ways not commonly included in the art of camouflage. It is easier to spot from the air buildings designed in geometrical shapes that throw straight shadows than buildings so constructed that their outlines cast irregular curves on the ground. Roof gardens may become more popular—indeed, perhaps small golf courses can be laid out on the roofs of factories.—N. Y. Sun.



**C**URING concrete factory floors, airport runways, access roads and structures — closing in — protecting materials, equipment and finished work — in these and numerous other ways, tough, waterproof SISALKRAFT paper is right in the thick of America's tremendous program of war construction. \* Quickly rolled out over freshly finished concrete, SISALKRAFT assures thorough curing and effective protection without further attention, saving time, man-power and money. For speed, efficiency and economy in concrete curing — specify SISALKRAFT. Available for essential war construction needs in rolls, blankets and covers to suit every job. Convenient distributors' stacks throughout the country.

Write for engineering data.

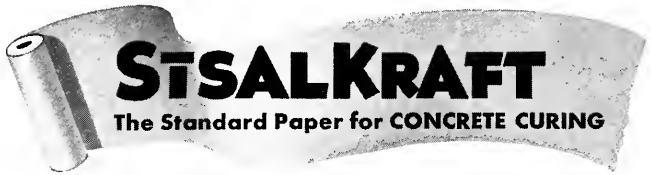
**The SISALKRAFT Co.**  
205 W. Wacker Dr. Chicago, Ill.  
NEW YORK SAN FRANCISCO



**PROTECTING . . . material and equipment**



**. . . for faster, better DEFENSE HOUSING**



*The Beautiful*  
**HALFTONES**  
in this issue of  
**Architect and Engineer**  
Made by  
**POOR RICHARD PHOTO ENGRAVING CO.**  
**HALFTONES • LINE CUTS • COLOR PLATES • ART**  
324 Commercial St., San Francisco GARfield 3225



OUR GREATEST PLEASURE IS  
**WORKING WITH ARCHITECTS**

OFFICE PLANNING AND OFFICE FURNITURE REQUIREMENTS ARE OUR SPECIALTY — WE HAVE THE KNOW-HOW AND THE KNACK!

TO SEE AND ENJOY THE BEAUTIFUL NEW BANK OF AMERICA HEADQUARTERS IS TO SEE ANOTHER RUCKER - FULLER INSTALLATION VERY WELL PLANNED AND EXCEEDINGLY WELL DONE.

**Rucker-Fuller Co.**  
OFFICE FURNITURE  
SAN FRANCISCO  
539 MARKET ST. SACRAMENTO

OAKLAND

**THE** *Beauty* OF REAL TILE  
*is more than Skin Deep!*



Shrewd shoppers know that the imitations of quality products, no matter how closely they resemble the original, usually have extremely short lives when exposed to the wear and tear of normal use.

Don't take a chance and use substitutes for tile.

ONLY REAL POMONA TILE offers these advantages: ENDURING BEAUTY . . . A WATER-PROOF, STAINPROOF, EASY TO CLEAN SURFACE . . . COLOR-FAST FOR LIFE . . . PRACTICAL FOR FLOORS, WALLS and CEILINGS . . . TRUE COLOR BALANCE . . . PATENTED SPACE-RITE FEATURE.

"DEMAND REAL POMONA TILE AND GET THE BEST"



**POMONA TILE MANUFACTURING COMPANY**  
629-33 N. LA BREA AVENUE • LOS ANGELES

125TH TENTH STREET—SAN FRANCISCO  
PLANT: POMONA, CALIFORNIA

6936 BUCKEVELT WAY—SEATTLE  
MINES—DEATH VALLEY

## Uncle Sam Uses Corrosion



Drain pipes and fittings in many Federal buildings, including the San Francisco Mint, pictured above, are protected with **Corrosion** — a positive guarantee of long life and sure resistance to corrosion.

**Corrosion** is used extensively for acid drain lines in hospitals, universities, high schools, laboratories. Is manufactured by —

**Pacific Foundry Company, Ltd.**

NEW YORK • 3100 NINETEENTH ST., SAN FRANCISCO • LOS ANGELES

*the*

## LIVABLE KITCHEN

Architects today are not only designing the kitchen for convenience and efficiency but they are making a livable room of it. To this end Paramount Built-in Fixtures meet the most exacting requirements. Their "Deluxe," "Moderne" and "Economy" cabinet fixtures are distinctive in design and construction and may be had in stock sizes or built to order.

*Catalog for the asking*

**Paramount**  
BUILT-IN FIXTURE COMPANY  
5107 Broadway, Oakland, California  
*Phone Piedmont 8409*

**SAVE THOSE OLD PAINT BRUSHES  
WITH  
CABOTS LIQUID BRUSH CLEANER  
THEY ARE VALUABLE**

Ready To Use  
●  
Will Not Evaporate  
●  
Non-Inflammable  
●  
Will Not Injure  
Bristles or Rubber Settings



**GUNN, CARLE & CO.**

SAN FRANCISCO  
20 POTRERO AVE.  
Underhill 5480



## USE "PENNVERNON"... NOT JUST "WINDOW GLASS"

**T**ODAY, windows are larger, more numerous, better designed than ever before. That is why it is increasingly important that they be glazed with a quality glass. The selection of Pennvernon Window Glass is the simplest way to make certain of quality glass. Pennvernon is clear, bright of surface, reflective. For a sheet glass, it exhibits a remarkable freedom from distortion. And as a result, it assures good vision.

*Distributed by*

# W • P • FULLER & CO

BRANCHES AND DEALERS  
THROUGHOUT THE WEST



PLATE GLASS • MIRRORS • PAINTS • VARNISHES



**CAMERA SHOOTING UPWARDS CATCHES DRAMATIC VERTICAL VIEW OF BANK OF AMERICA'S  
NEW BUILDING AT MONTGOMERY AND PINE STREETS, SAN FRANCISCO**

Photo by Moulin



Haig Patigian's carved limestone panel in entrance lobby, Bank of America Building. Center is a portrait of A. P. Giannini flanked by symbolical figures representing Agriculture and Commerce.

## BANK OF AMERICA BUILDING SAN FRANCISCO

by FRED'K. W. JONES

At California and Montgomery Streets — heart of San Francisco's financial district, Bank of America has built a new office building from which a staff of 1000 people direct the policy and operation of a financial institution the fourth largest in the nation, with 495 branches and combined resources in excess of two billion dollars. It is the first skyscraper (12 stories) to be erected in San Francisco since the 1932 depression and it is probably the last structure of its type that will rise on the Pacific Coast for some years to come, since authorities have predicted that the day of building height-limit office buildings has passed. Completion and occupancy of this \$2,000,000 "monument to finance" marks the turning of another important milestone for San Francisco's 38-year-old institution.

Strength and stability, ideals of the bank's founder, are expressed in the structural and architectural details of the building. Of Roman Classic style the first three stories are gray California



THE BANK'S OFFICIAL SEAL

granite while the remaining nine stories are Granitex terra cotta. Modeled ornamentation below the cornice line adds a modern note of contrast to the classic columns which dominate the exterior of the lower floors.

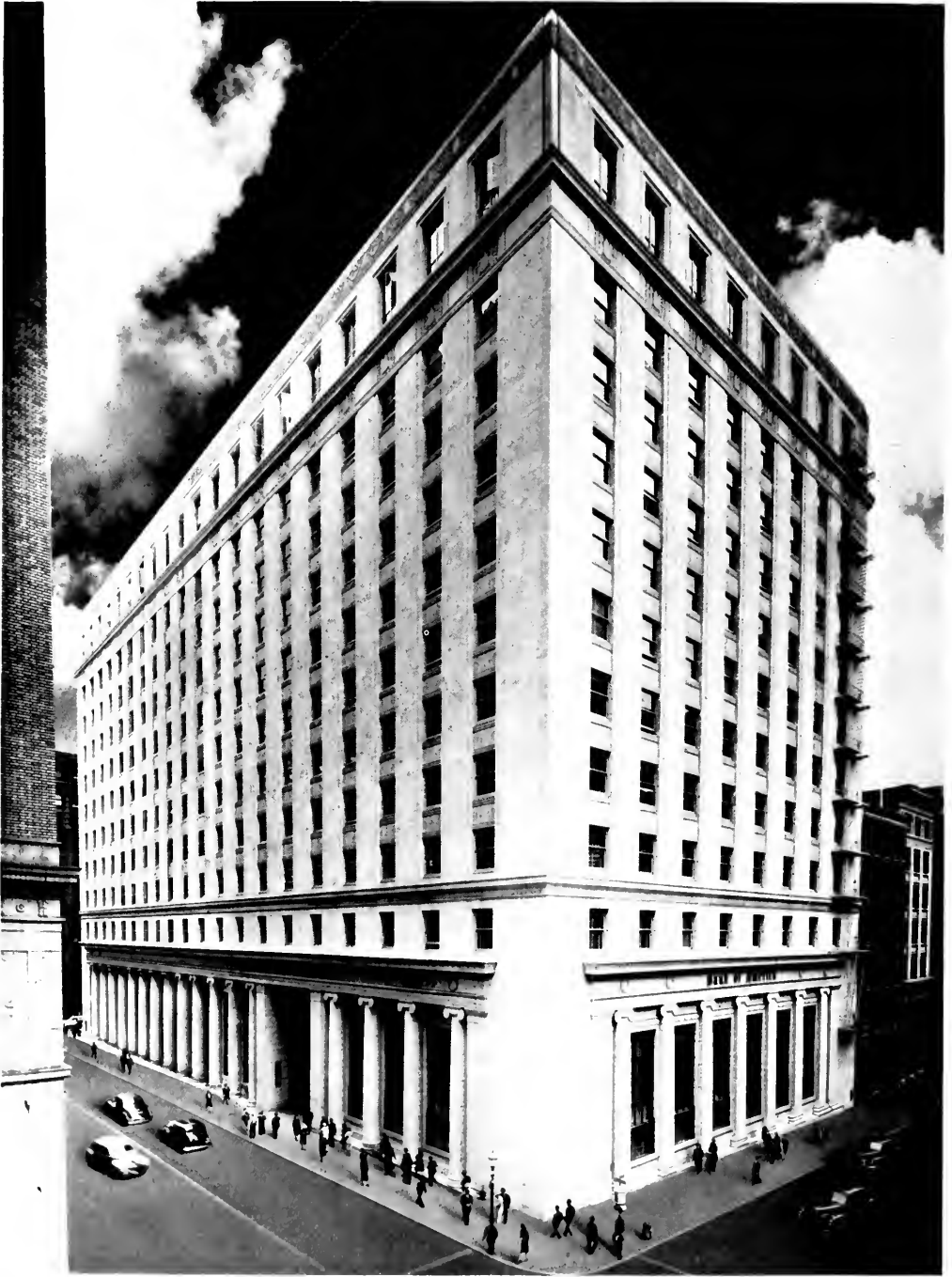
Engineers say there is no building in San Francisco better designed to resist earthquake and fire. Structural trends over a period of years are reflected in the frame of steel, the reinforced concrete

floors and walls and the reinforced concrete cylindrical caissons, the latter sunk 43 feet below sidewalk level.

In the deep basement are the bank's huge vaults constructed of steel plates and concrete and protected by one 35-ton and two 10-ton chrome steel doors, all so delicately balanced they can be swung open by a child.

One of the architectural problems was to retain the old building facing California Street and tie it to the new wing in a manner that would give

(Turn to Page 35)



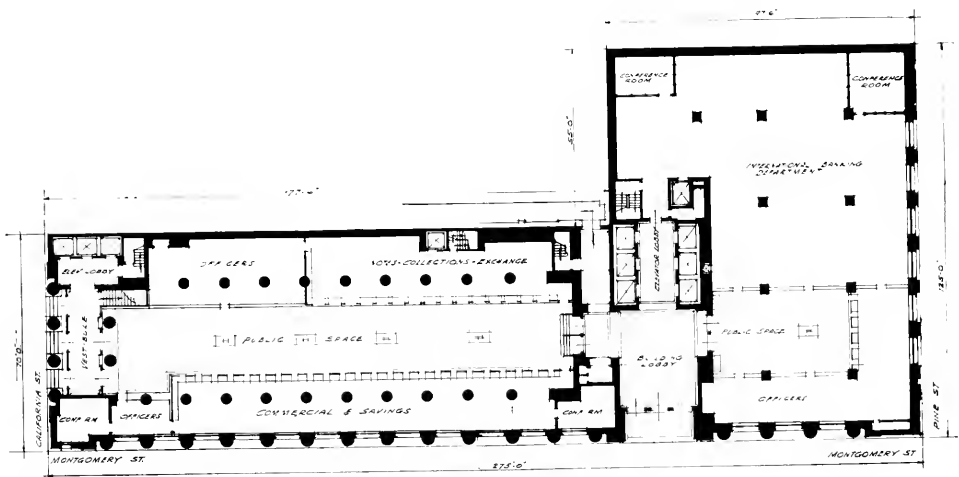
**BANK OF AMERICA BUILDING, LOOKING NORTH FROM PINE AND MONTGOMERY STREETS, SAN FRANCISCO**  
Capital Company, L. J. Hendy, Architect and H. A. Schery, Consulting Architect

Moulin





ARCHITECT'S PERSPECTIVE MADE FROM THE SAME VIEWPOINT AS PHOTOGRAPH SHOWN ON OPPOSITE PAGE



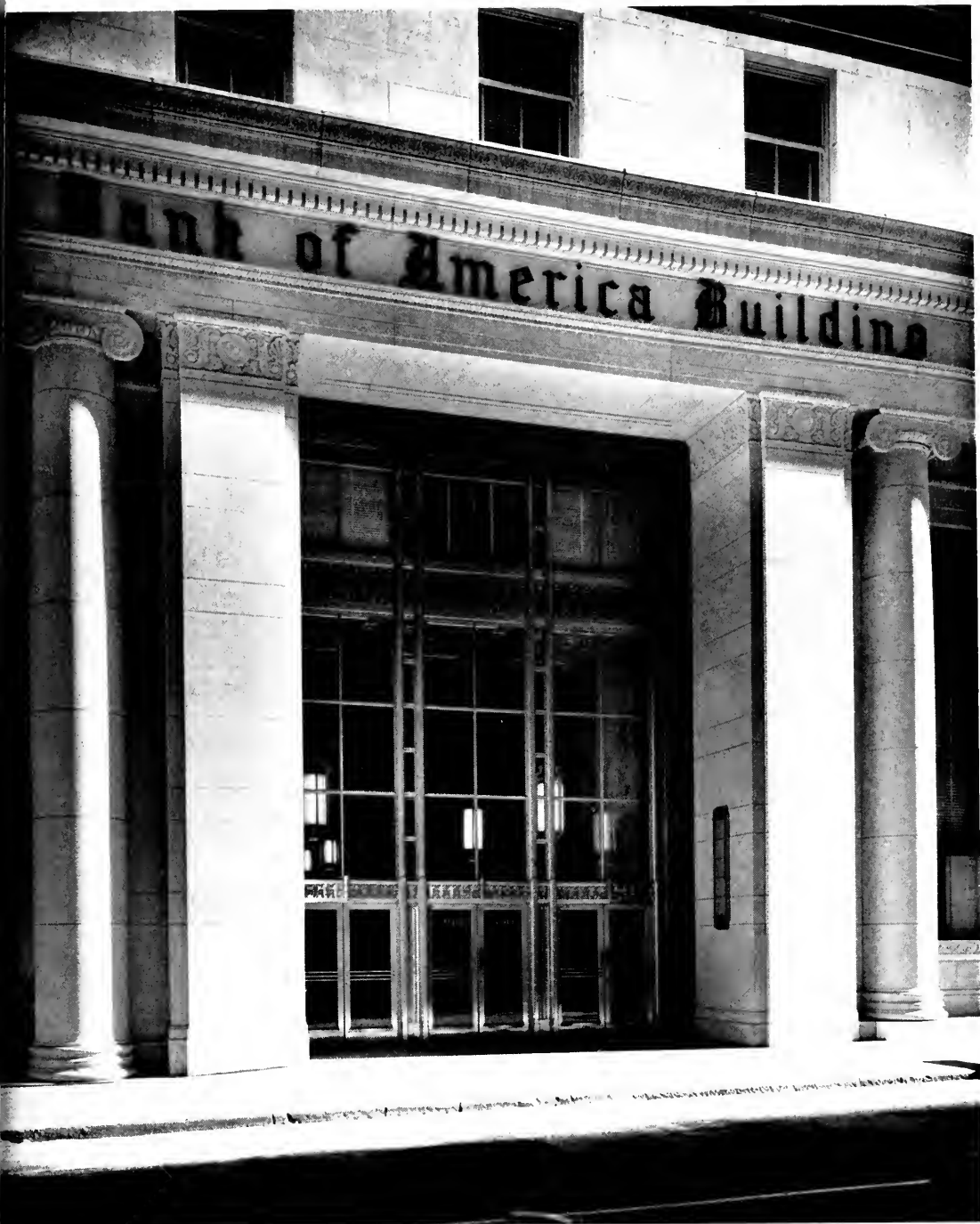
GROUND FLOOR PLAN, BANK OF AMERICA BUILDING, SAN FRANCISCO



Moulin

**DETAIL OF MONTGOMERY STREET FACADE, BANK OF AMERICA BUILDING, SAN FRANCISCO**

The frontage is 275 feet. Sturdy Ionic columns dominate the architectural treatment of the lower stories.



**CLOSE UP OF MAIN ENTRANCE, BANK OF AMERICA BUILDING, NUMBERED 300 MONTGOMERY STREET**

The address is destined to become as familiar to the financial world as No. 1 Powell, the bank's former headquarters.

Moulin



NORTHERLY END OF MAIN BANKING ROOM, LOOKING TOWARDS CALIFORNIA STREET

The original architectural treatment of the old building has here been preserved to a considerable extent

Moul



**VIEW OF MAIN BANKING ROOM FROM MONTGOMERY STREET ENTRANCE LOBBY**

Tellers' windows are visible on both sides

Moulin



**Upper left—Entrance to main banking room from Montgomery street lobby.**

**Lower left—Close-up of elevator doors in main lobby.**

**Above—Bronze medallion which forms the decorative feature of the elevator doors.**

**Below—View of elevator lobby on eleventh floor.**



**LOOKING TOWARDS MAIN ELEVATOR LOBBY FROM ENTRANCE VESTIBULE**

**Marble walls, bronze chandeliers and modern fluorescent lighting illumines an entry of strength and simplicity**

Moulin



Moulin



Upper picture shows block long general executive offices, 275 feet, on the eleventh floor.

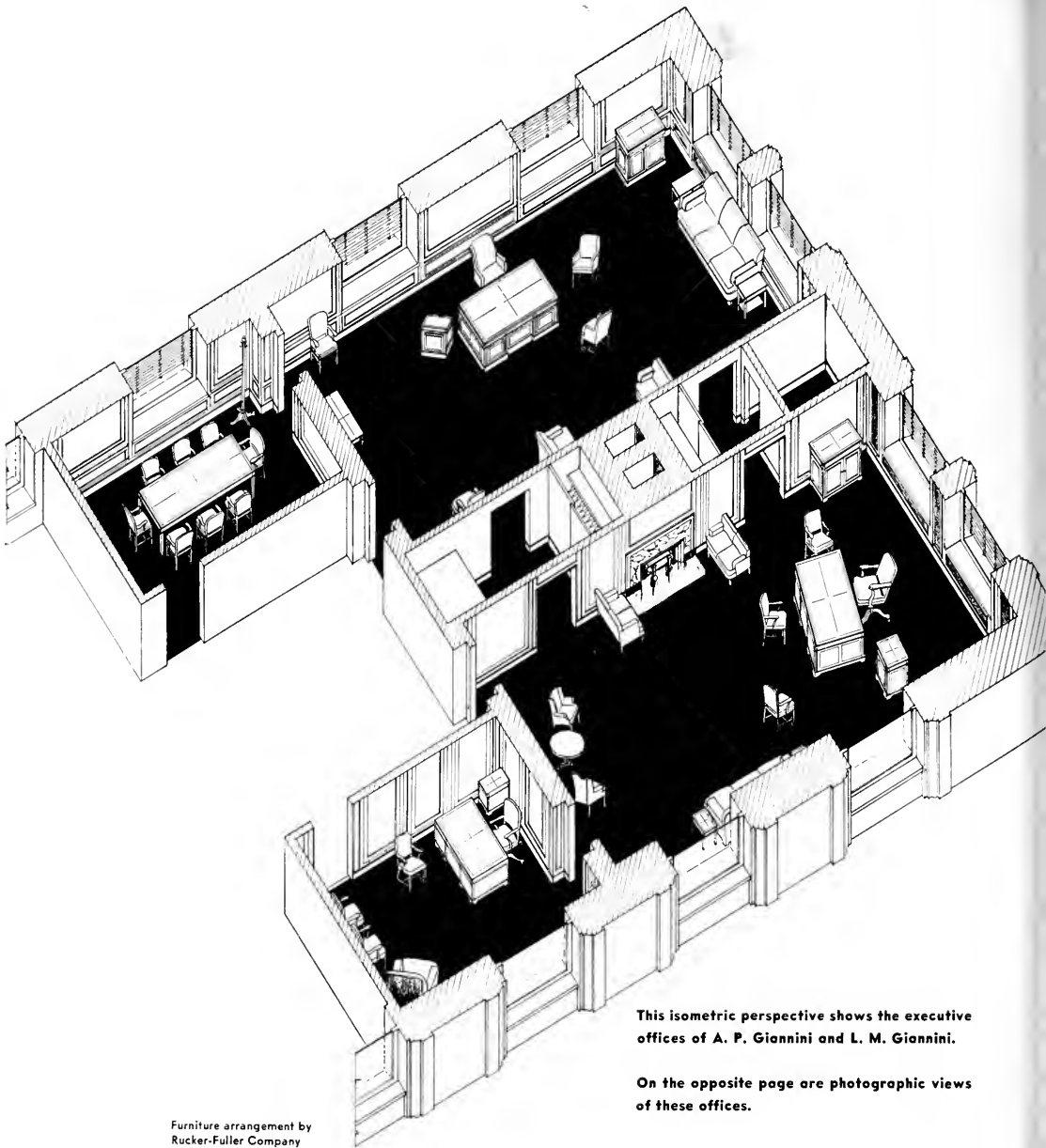
At the extreme upper right is A. P. Giannini, founder of the Bank, at the helm of the "Portsmouth" which was the first craft docked on the site of the first Bank of America to be built in San Francisco.

Another photo of the Portsmouth's helm in the reception lobby is shown below.

A close up of the general executive floor is shown on the left. The figures are American walnut panels ore by the Fink & Schindler Co.





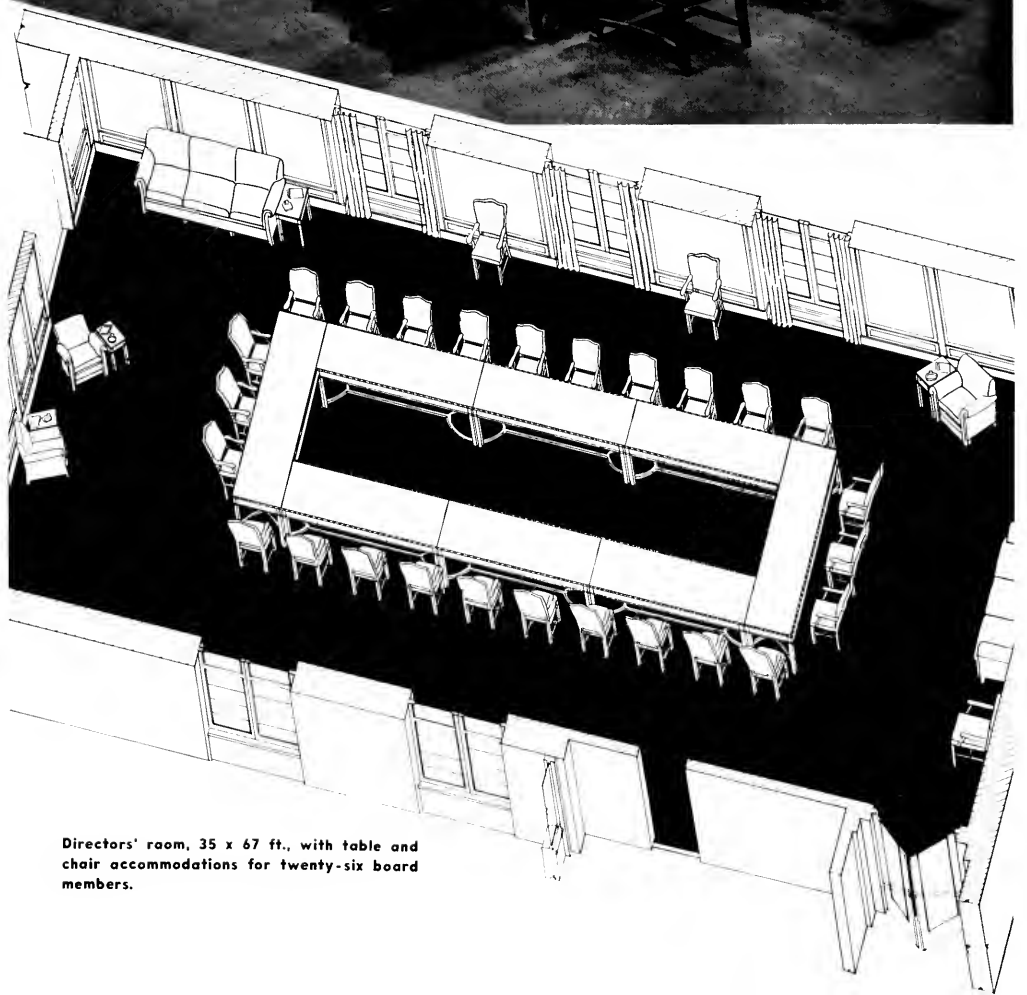


Furniture arrangement by  
Rucker-Fuller Company

**This isometric perspective shows the executive  
offices of A. P. Giannini and L. M. Giannini.**

**On the opposite page are photographic views  
of these offices.**





Directors' room, 35 x 67 ft., with table and chair accommodations for twenty-six board members.



ARCHITECT'S SKETCH OF ROOF GARDEN FOR WOMEN EMPLOYEES OF BANK OF AMERICA



Moulin

BANK OF AMERICA'S PRIVATE TELEPHONE EXCHANGE IS LARGER THAN THE AVERAGE PUBLIC EXCHANGE IN A CITY OF 20,000 INHABITANTS



the appearance and provide the efficiency of a complete new structure. And virtually a new structure it is when one considers the extensive alteration work undertaken. None but an expert could tell where the old building stops and the new building begins. Suffice to say the builders have made a good job of it.

The main entrance lobby is on Montgomery Street, No. 300, with other entrances on California Street. This lobby connects directly with the two main banking rooms, also to a passageway leading to the Merchants' Exchange Building and to the elevator lobby from which a battery of six gearless variable voltage, automatic electric passenger elevators are operated at a maximum speed of 600 feet per minute. Five other passenger elevators are located in various parts of the building.

Design of the entrance lobby is simple, but attractive. The decorators have relied upon the coloring and matching of the Escalette wall marble and the glazed gold leaf ornamental ceiling for effect. Above the opening leading to the elevator lobby and facing the main entrance is a carved limestone panel, 12'x5', by sculptor Haig Patigian, the central figure of which is a splendid likeness of A. P. Giannini, founder of the Bank of America. Flanking the portrait are symbolical figures of California agriculture and commerce. The artificial lighting in the lobby is from bronze lanterns suspended from the ceiling with a combination of fluorescent and incandescent lamps behind diffusing lenses.

The 2nd, 3rd, 4th, 5th, 11th and 12th floors are used by the Bank for administrative purposes. Noise level intensity in these areas has been lowered by the use of rubber tile flooring (a total of some 90,000 square feet) and Acousti-Celotex ceilings. Semi-indirect lighting has been used throughout all of the office space with intensity of 40 to 60 foot candles at desk height, depending upon the type of work to be done.

Subdued elegance characterizes the interior appointments throughout the building. In every instance the offices reflect expert understanding of color, design and craftsmanship. The

bank's executive offices are on the eleventh floor. Here the heads of all administrative departments share a common room, where they may consult with one another or meet clients.

On this floor also are the offices of the President and Chairman of the Board. The President's office is approximately 20' x 30', paneled full height with matched laurel wood veneer and carved cornice of modern treatment. Office of the Chairman of the Board is finished in American walnut in the Georgian style. Adjoining conference rooms in each case are treated similarly.

Two Maynard Dixon paintings "The Ranger" and "The Redwoods" adorn the paneled walls of the executive offices and in each of the two rooms is an attractive fireplace of curly green marble. Bronze and lucite lighting fixtures, carpeted floors and solid walnut desks and chairs complete the interior furnishings.

One cannot but be impressed with the elaborate installation of office equipment supplied by the Rucker-Fuller Company. The furniture not only commands, it fascinates. Desks of special step-up veneer panels, daringly new—secretarial desks with innovations in conveniences—removable conference table arrangement for the directors' sanctorium—general office desks with set-back legs and splinter-proof edges—oversize desks for general executives—rare and unusual wood selections—colossal high-back directors' chairs—special leather upholstery of a novel new color . . . these are but a few of the noted high lights conspicuously present in an air of business and banking.

One of the interesting displays on the executive floor is a trophy cabinet, its shelves laden with cups won by employees of the bank in various sporting events. Intriguing also is the original helm that steered the old United States navy sloop-of-war, "The Portsmouth," into San Francisco Bay in 1846.

Landing a detachment of marines under command of James B. Montgomery at a point afterwards the site of Bank of America's first San Francisco building, Commodore Montgomery planted the first stars and stripes over the city. After active service in all parts of the

world "The Portsmouth" was burned to salvage copper and other metals and the helm, consisting of two joined wheels, of sturdy Honduras mahogany with spokes of oak, was presented to the Portsmouth, New Hampshire, Yacht Club. Staff members of the Bank of America throughout California, by voluntary contributions raised a fund with which the helm was purchased and presented to the Bank's founder, A. P. Giannini, on the day the new building was dedicated last December.

The executive officers' space on the eleventh floor extends the full length of Montgomery Street frontage—some 275 feet. This room is paneled full height in American walnut grown in the State of Arkansas, and the veneers used originated from but two logs of similar size, with the result that there are no great variations in the grainings and markings of the paneling. The indirect lighting fixtures of glass and bronze were specially designed for the space. The room is acoustically treated.

A photograph and working drawing of the directors' room on the eleventh floor shows its great size, 35 x 67 feet, the spacious table and seating arrangement. This room, by the way, serves a dual usefulness. When not occupied by the directors it may be used as an assembly room. Flexible construction of the large table makes its removal comparatively simple.

For the enjoyment in off hours of the employees the twelfth floor is provided with an attractive lounge, sun room and roof garden.

A private telephone exchange with facilities equal to those of a public exchange, is maintained and gives the bank and its Bay area branches a semi-automatic service, independent of the main San Francisco exchange. An autocal paging system is also provided, this with four zones for paging throughout the building.

All the areas used by the bank are air conditioned. Incoming air is introduced by means of ceiling diffusing units, and vitiated air is withdrawn through wall grills near the floor. It is said to be the largest air conditioned installation of its kind in the city. The building has a combination direct and indirect steam heating plant. Every floor has its time piece regulated

by a master clock, and every floor has two good looking Haws drinking fountains and special equipment for fire prevention.

The design of the building was handled by the Capitol Company, L. J. Henty, architect. L. H. Nishkian was the structural engineer and G. M. Simonson the mechanical engineer.

Inspection of the building is welcomed and anyone may do so by appointment with the building manager.

---

## DEPARTMENTAL DIRECTORY OF BANK BUILDING

### Basement—

Safe Deposit Vault	Record Vault
Cash Vault	Mailing Department
Securities Vault	Securities Department

### Ground Floor

San Francisco Main Office (banking)  
International Banking Department

### Mezzanine Floor—

General file room	Photostat Department
Telefiles (credit records)	Duplicating Department

### Second Floor—

Trust Department  
Analysis and Research Department  
Bond Investment Department  
Library

### Third Floor—

Tax Research and Appraisal Department  
Loan Adjustment Department  
Commodity Loan Department  
Loan Supervision Department  
FHA Department  
Installment Credit Loan Department  
Credit Department  
Drafting Department

### Fourth Floor—

Advertising and Publicity Department  
Telegraph Department  
Legal Department  
Stenographic Department

### Fifth Floor—

Personnel Relations Department  
Controller's Department  
Business Extension Department

### Eleventh Floor—

Executive floor  
Chairman of the Board  
President  
Executive Vice President  
Vice Presidents, Administrative

### Twelfth Floor—

Board of Directors  
Employees' lounge, sun room and roof garden.



# A FEW NOTES ON THE BANK OF AMERICA STRUCTURAL DESIGN

By L. H. NISHKIAN, C. E.

It has been over ten years since the construction of tall steel frame buildings occurred with some frequency in San Francisco. The Bank of America Building at the N. E. corner of Pine and Montgomery is the first to break the silence, so to speak. It is natural to expect, therefore, that it may reflect in its design some of the structural trends which have been developed by California structural engineers in the last decade.

In the writer's opinion the most important change that has occurred is psychological. As in nearly all our human activities, the engineer now approaches his problems in a more realistic manner than in the 1920's. An engineer is not supposed to be allergic to facts, but, nevertheless, many taboos governed our designs. A few might be mentioned. "A reinforced concrete curtain wall can carry no load," "all lateral forces on a steel building must be resisted by the steel frame," "friction must always be disregarded in design," "bolts and nails cannot act together," etc.

Earthquakes, "relative rigidities," and the general trend have fortunately removed most of these "don'ts."

In the design of the Bank of America Building, a steel frame structure with reinforced concrete floors and walls with foundations of reinforced concrete cylindrical caissons, these "taboos" were disregarded to the fullest possible degree. The site had been partially filled in and it was necessary to go through this fill to a sand clay foundation. This material was found excellent for caisson work and a very economical foundation was obtained though the depths were 43' 6" feet below the sidewalk at the east side of the building.

The steel girders and beams framing into the columns, as well as intermediate beams where conditions permitted, were designed with end connection which practically developed the respective resisting moments. As welding to the heavy columns was not permitted, it was not always possible to develop the necessary resist-

ing movement by the use of structural steel alone. In such cases reinforcing rods imbedded in the floor slab were provided to make up the deficiency. This type of design resulted in very large panel size 27' x 27' without increasing the weight of the steel frame, had it been designed with the customary connections and normal panel areas of about 250 to 300 square feet. The use of greater column spacing very much increased the utility of the building and has a decided economic value. Future buildings will tend toward longer spans.

Though heavy girder connections were provided, the lateral forces were carried principally by the reinforced concrete exterior walls and elevator shaft walls as was required by the rigidities involved. The "lateral force" load used in the design averaged about 4% of gravity. This percentage, however, was not uniform throughout the building, but was greater on the upper stories and less on the lower stories.

The accompanying drawing (Fig. 1) shows a typical connection of girder to column which developed approximately full continuity in the frame.

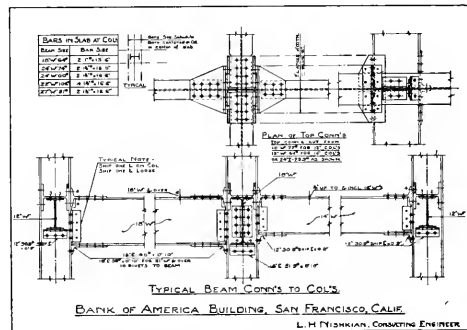


Fig. 1.—Typical connection of girder to column

Connecting the new building to the existing building necessitated some variation of the usual design rule of using a uniform soil pressure on all the foundation. The existing building foundations had taken their settlement whereas the new foundation in the first row of columns could be expected to get a pos-

# MECHANICAL AND ELECTRICAL INSTALLATION BANK OF AMERICA BUILDING

By G. M. SIMONSON, M.E.

**The same** careful consideration that has made the new Head Office Building for the Bank of America at 300 Montgomery Street, San Francisco, the most modern office building on the Pacific Coast has been carried out in the mechanical and electrical work.

All the necessary provisions for air conditioning and illumination have been made to insure the maximum in efficiency and comfort for the executives and their staffs.

The building is heated with gas fired low pressure steam with three steel boilers of 125-horsepower each. Steam is distributed at two pound pressure to wall radiators and recessed convectors, and to heating coils in the fan rooms. Recessed convectors are used in the lobby and the eleventh and twelfth floors only. The balance of the building is provided with wall-hung radiators.

All floors occupied by the bank are provided with a complete air conditioning system automatically controlling direct radiation and steam coils for the heating cycle and chilled water coils for the cooling cycle.

The air conditioning system is designed for twelve supply and exhaust fan systems, two of which are future systems. There are at present seven fan rooms with provisions for two future rooms.

The cooling medium is chilled water pumped throughout the building to the cooling coils in the fan rooms. The cooling is obtained by three 100-ton, eight-cylinder, V type, refrigerating condensers, using Freon as a refrigerant, located in the basement with shell and tube water chillers and the chilled water pump. The evaporative condensers are induced draft out-

door type and are located on the third floor roof in the light well. The three refrigerating condensers and their associated water chillers are automatically controlled with an electrical control system. The system is arranged so that the load may be carried in increments by the three refrigerating condensers, each unit being arranged to operate at one-half load, three-quarters load and full load and each condenser to be started in sequence to meet the load requirements. Selective switches are provided so that the three condensing units may be operated in any sequence, thus insuring equal hours of operation for each unit. Full automatic controls are provided to insure the operation of the chilled water pump and evaporative condensers at all times when the system is in operation, together with temperature limiting controls for chilled water temperature and other safety requirements. Heating, ventilating and air conditioning installations were handled by Cory & Joslin, Inc., contracting engineers, of San Francisco.

The telephone operators' room in the twelfth floor pent house has a separate self-contained three-ton air conditioning unit to provide both summer and winter conditioning independent of the main plant. This was deemed necessary due to the different load conditions and hours of operation in this particular area. The steam coil for this unit is supplied with steam from the main steam plant.

With the exception of the two fan systems serving the California - Montgomery Branch Bank and the mezzanine floor of the original building at 485 California Street, which are the conventional duct connected type, the fan

---

sible settlement of about one-quarter inch. As the two buildings have a common facing material of terra cotta and granite such a movement, if permitted to occur, would undoubtedly cause cracks at the junction of the two buildings.

The next three rows of footings paralleling

the plane of connection between the two buildings were therefore designed with gradually decreasing soil pressures so that the differential anticipated settlement between adjoining footings would not exceed 1/16". This method seems to be successful as no cracking is apparent in the building walls and floor.

systems are of the plenum type. Fresh air is admitted through roof and wall openings and drawn through automatic, self-cleaning multi-panel, motor operated air filters through backward curving blade supply fans to plenum changers. Each area to be conditioned is zoned into three or more zones, as determined by exposure to the weather and each such zone has separate heating and cooling coils all automatically controlled.

Each fan system has an exhaust fan electrically interlocked with its supply fan and is arranged with pneumatically operated dampers, so that the return air may be partially or entirely recirculated, either automatically or manually as desired.

Air is admitted to the conditioned areas at the ceiling through ceiling units and exhausted at the floor through wall grilles.

The temperature control system is the Johnson Service Company's pneumatic system and is arranged with full automatic controls so that the various zones may be automatically controlled through the heating and cooling cycles as required by temperatures in the conditioned areas.

Auxiliary electrical fan-type heaters with thermostatic controls are provided in the private offices of the Chairman of the Board and the President for emergency use when the steam heating system is not in operation. These units are recessed in the walls under the windows to match the steam convectors.

All the fans and air-conditioning equipment are controlled from the central air-conditioning switchboard in the basement compressor room.

The steam supply piping is black steel and the return piping and chilled water lines are red brass. The freon piping is copper.

The plumbing installation embraces the most modern type plumbing fixtures available. Provisions have been made for installation of lavatories at all interior columns to permit of rearrangement of office spaces in the future. The cold water system is arranged in two systems, the four lower floors being served from the street main pressure, and the upper floors from roof tanks. Booster pumps in the basement pump the water to the upper tanks. Two 1000-

gallon hot water storage tanks are provided, one for the lower system and one for the upper system with gravity circulation.

A water chiller has been provided for chilled drinking water serving Haws drinking fountains on the bank floors.

An automatic motor-driven fire pump of 500 g.p.m. capacity supplies Shand and Jurs hose racks throughout the building.

All hot and cold water piping is red brass.

The electrical system is served by a bank of star connected network transformers installed in a vault under the sidewalk on Montgomery Street and supplying three-phase, 4-wire, 120/208-volts, 60-cycles for both light and power. All light and power is metered on one poly-phase meter on a combination schedule.

The main switchboard located immediately adjacent to the transformer vault has a total capacity of 2000 k.w. and is dead front, live rear, with steel panels and circuit breakers.

The distribution system is three-phase, four-wire, 120/208 volts with four-wire feeders and branch circuits.

Lighting outlets have been provided for all large areas for light outlets on approximately 9'-6" centers, with three outlets per circuit. Special arrangements have been made in all smaller offices for lighting outlets, suitable to each such office. Outlets on the first floor for Branch Banks and on the twelfth floor Directors' Rooms are for special recessed lighting units arranged in harmony with the architectural design.

The light outlets on the eleventh and twelfth floors are controlled through mercury-type relays and low voltage control wiring by compact groups of small switches to eliminate large switches in the wood-panelled walls.

Outlets in large offices are controlled from panelboards and those in small offices by heavy duty flush switches.

The recessed lighting units for the first floor banks and the Directors' Room are Holophane Inbuilt units with twelve-inch-square lenses. The Banking Room units are arranged in groups of four 300-watt units. The Directors' Room units are arranged in groups of two symmetrically arranged in the accoustical ceiling tile pattern.



**EXECUTIVES' FLOOR, BANK OF AMERICA BUILDING, SAN FRANCISCO**  
Ceiling is Acousti-Celotex

## **BANK MAKES PROFIT OUT OF NOISE**

Banks are a representative institution of business and vitally interested in any element affecting business, particularly so if those elements are detrimental and menace the profitable execution of their business.

The Bank of America, California's largest banking institution, upon proper investigation into the effects of noise, have invested in "Noise quieting" in their new San Francisco headquarters, 300 Montgomery Street, and also in many of their branch banks.

The major proportion of the investment is in the control of noise in office areas, both for the bank and for the rentable space.

Noise is unnecessary; reduces efficiency, affects the judgment of executives, reduces accuracy, impairs health and worst of all at this time, tends to create a fear reaction. All these adverse effects of noise make for loss in time and money.

Noise cannot be completely controlled; but by installing acoustically-treated ceilings as used in the Bank of America Building, its adverse effects can be reduced to a degree of non-disturbance to those subjected to its influence.

Noisy offices and industrial quarters add to production costs and many banks, buildings and large organizations have now found the way to turn noise losses into profit, through the use of Acousti-Celotex.

# MORE ABOUT AIR RAID SHELTERS

**Supplementing** its first bulletin from which extracts were made in the January number of *Architect and Engineer*, the Air Raid Shelter Committee of the San Francisco Civilian Defense Council has prepared a second bulletin containing valuable suggestions for air raid shelters for residence districts, flats and small apartment houses.

The committee has profited by a study of the published data on the experiences of bombed communities and has utilized the talents of the engineers ordinarily charged with structural design. Nevertheless, air-raids being what they are, the report states that the committee cannot assume responsibility for, nor guarantee, the adequacy of, these shelters. With reasonably good construction, these designs will afford a good measure of protection from most bomb splinters, blasts, falling fragments and machine gun and rifle fire.

High explosive bombs are manufactured in various sizes. Those in most general use for bombardment of cities range between 100 and 500 lbs. British authorities generally have adopted recommendations for civilian protection against 500 lb. bombs exploding at 50 feet or more away. No protection can reasonably be had against direct hits or hits within about 50 feet. Fortunately this zone of destruction is very small and the chance of any one particular shelter being demolished is very remote.

Destructive effects of exploding bombs are twofold: those of blast, i.e., the air pressure and waves created by the explosion, and those of fragmentation, i.e., the breaking up of the steel case of the bomb into jagged pieces of splinters. These splinters are projected in large numbers in every direction. Unless sufficiently resisted in their path they may inflict fatal injury at points distant from the explosion.

Near effects from blast are the possible complete destruction of buildings or collapse of wall panels, roofs, doors and windows.

Distant effects are the falling of lightly constructed features such as balconies, cornices, roof tile, plaster from ceilings, and window glass caused by violent shaking. Flying pieces of glass are a source of utmost danger.

Under unfavorable conditions enemy aircraft may attack from low altitudes, spraying unprotected persons in the street and at windows with machine-gun bullets.

Air combat contributes many falling missiles such as spent machine-gun bullets and metal from bursting anti-aircraft shells.

The San Francisco committee has adopted the British recommendation, as a practical standard, to suggest protection in varying degrees against the effects of a 500 lb. bomb bursting 50 feet away. This requires:

1. Lateral protection against splinters and blast.
2. Overhead protection as follows:
  - (a) Against falling debris if the building should collapse, in case the shelter is constructed in or under the building, or at a distance from any building or less than half the height of that building.
  - (b) Against light incendiary bombs and falling splinters from anti-aircraft shells.

The British standard recommended for bomb splinter protection is about as follows:

Plain concrete, minimum exterior wall thickness, 12 inches; timber, 18 inches; earth or sand in bags between two layers of wood sheathing, 30 inches; ballast (broken brick, stone, etc.), 24 inches.

The wisdom of seeking shelter during an air

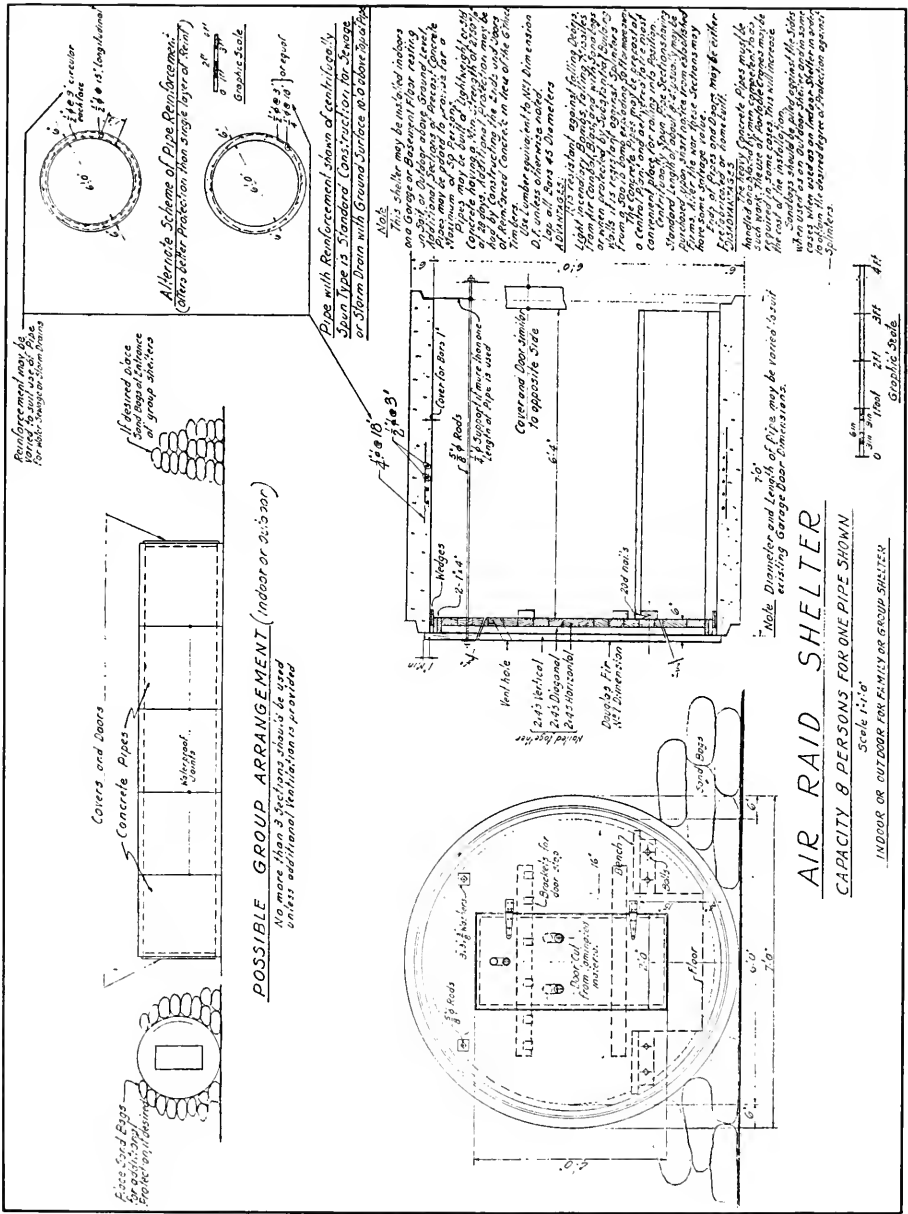


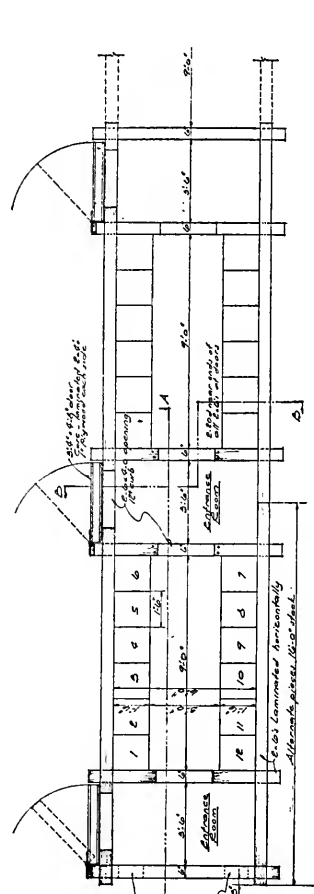
FIG. 1—INDOOR OR OUTDOOR GROUP SHELTER

NOTE:

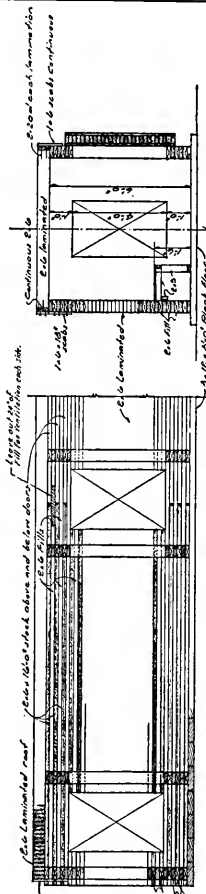
This shelter must be built in units and not more than four units in any group. Douglas Fir 2x4 rafters otherwise noted. If offers good protection against falling debris or a collapsed wood frame building not more than four stories in height, also against air bombs, and falling missiles from aircraft.

**ADVANTAGES:** If offers good protection per dollar invested. This shelter is one of the most economical types for a wide range of heights. It can be erected on any properly designed and constructed house floor or basement.

**DISADVANTAGES:** It is not completely fireproof. It offers no protection against gas. It is built and splices when used indoors without walls of substantial strength. It will not work on an upper floor. It is more expensive than other flying splinters than high & shelter.



PLAN  
8' x 10'



A-A  
8' x 10'

**Roofing Notes:**

All horizontal ends - 2x4 of wood lag bolts  
Fasten to on floor joists or 2x4's  
2x4's on floor joists or 2x4's  
2x4's on floor joists or 2x4's  
2x4's on floor joists or 2x4's  
2x4's on floor joists or 2x4's

**INDOOR SHELTER**

**EQUIPMENT AGAINST FALLING DEBRIS AND SPLINTERS**

For use as an outdoor shelter, provide one layer of sand-bagging of roof and walls.

1942 - 111 371 371 371  
GRANITE STATE

FIG. 2—INDOOR SHELTER TO PROTECT FROM FALLING DEBRIS

raid has been fully demonstrated in Europe. That experience can be summarized in convincing terms, as follows:

**Comparative degree of risk resulting from taking cover in various ways—**

standing outside in the open	assumed	100%
lying down flat outside in the open		50%
lying down behind low cover in the open or in doorways		33%
having the protection of a frame house		30%
having the protection of a brick house with sandbag window coverage		12%
having protection of a concrete basement, structurally reinforced		5%
having the protection of an Anderson type shelter		2%
having the protection of a heavy reinforced concrete or equivalent shelter (approximately bomb-proof construction)		0%

It appears to be a fact that the total number of deaths from enemy air raids in Great Britain is less than that caused during the same period of time upon the highways of the United States by our own motorists.

In considering the design of any air raid shelter, the most important thing to accomplish is the protection of the civilian population against the lateral effects of bomb splinters and blasts.

Houses afford some protection. A properly prepared refuge room or indoor shelter can give almost as good protection as an outdoor shelter, and is the method most householders would adopt.

If no garage or basement is available, a small or narrow room on the ground floor is to be

preferred for the refuge because it will better withstand collapse of the house. If the ceiling of larger rooms cannot be propped up, the shelter should be constructed to support the materials of the building in case of collapse.

Avoid rooms with large windows.

Bomb splinters may strike upwards, hence residents in upper stories of flat and small apartment houses should seek refuge on the lower floor or in the basement away from unprotected windows. A common staircase or central hallway sometimes can be adapted for use as a refuge for all.

European experience strongly indicates the protective value of almost any sort of earthen barrier or "hole in the ground."

Trenches with unsupported sides should only be considered where the ground is rock or otherwise very hard. Should the sides of the trench collapse, the occupants may become hopelessly trapped.

Indoor or outdoor shelters of approved design provide good protection from air raids. (Fig. 1.) Entrance to outdoor shelters should be toward the house in order to facilitate ingress and egress of the occupants, and to obtain the protection of the house against flying splinters.

The problem of providing shelters for residents of apartment houses and flats is quite involved because of the large variety of types of construction. (See Fig. 2.)

In each shelter there should be provided picks, shovels, small or large crowbars, buckets of sand, first aid kits, fresh drinking water, food, etc., the number and amounts depending upon the size and type of shelter. A live garden hose should be readily available during air raids.





GALLATIN COUNTY COURT HOUSE, SHAWNEETOWN, ILL.

## NEW TYPE OF WALL CONSTRUCTION

The new Gallatin County Courthouse at New Shawneetown, Illinois, presents an interesting type of wall construction. Both interior and exterior walls are of cinder blocks, resting on concrete footings. The exterior walls are veneered with native sandstone, quarried locally and cut to the approximate size of bricks. A well-blended trim of pre-cast concrete, accomplished by using white cement and an aggregate of sandstone dust and crushed limestone, creates an attractive and unique effect.

Millwork for the building, including the doors, facings, trim and judge's bench, was fabricated on the project in a production shop set up for this purpose and accomplished with WPA labor available from certified relief rolls.

Some material was salvaged from the old courthouse, the principal items removed being the vault doors and the hundred-year-old bell.

Modern systems of air conditioning, warm air and steam heating, lighting and plumbing were installed for convenience of officials and the public. Approximate cost of the completed

structure was \$71,000.

Inside, the courtroom presents a fine example of modern treatment. A mural of three panels, back of the judge's bench, depicts early scenes in the history of Gallatin County.



Court chambers showing three panel mural in background

# **AUTOMOBILE "GRAVEYARDS" YIELD TONS OF SCRAP IRON**

**A national** directory of automobile "graveyards," now being prepared by the War Production Board, with the assistance of the Work Projects Administration and the Department of Agriculture, will determine the amount of scrap iron and steel available from that source and help to speed the flow of these important materials to furnaces where they may be melted for use in the production of tanks, guns and other implements of war.

Any lot or building with five or more passenger cars or trucks in various stages of dismantling, will be classified as a "graveyard." WPB officials estimate that there are 30,000 such "graveyards" throughout the country.

Cities and suburban areas are being canvassed, while rural sections are being checked by the Department of Agriculture. In all, approximately 30,000 persons are engaged in the undertaking which was started February 18. WPA workers have been assigned to cities which in 1940 had a population of 15,000 or more, but in some instances are assisting representatives of the Department of Agriculture in canvassing suburban areas of less than 15,000 which are adjacent to larger cities.

The directory will list the name of the owner or operator and the number of jalopies on each lot. The field workers forward their returns to their local agencies, which in turn send them to Washington for tabulation by the Bureau of Industrial Conservation. The results of the survey are not being made public locally.

In addition to iron and steel, the old cars are also expected to yield considerable supplies of other metals, particularly aluminum, copper, brass and zinc.

The survey is intended to eliminate much of the confusion concerning the potential source of scrap in the graveyards, and also enable the Bureau of Industrial Conservation to aid in the solution of special situations where local factors have hindered regular movement of scrapped jalopies. Approximately 80 of the larger users of scrap have been asked by the War Production Board to make sure that dealers through whom these companies normally buy scrap, make fair offers for the contents of graveyards within economical transportation distance of the various steel plants. A regular reporting procedure has been set up under which the potential buyers notify the WPB of the results of their visits to the graveyards. If an offer is refused, field men from the Bureau of Industrial Conservation will investigate the case, it has been announced, and, if it is considered advisable, the War Production Board may requisition the entire collection of cars on the lot.

Although there has never been a complete record of the total number of auto graveyards, nor an exact estimate of the number of junked cars, the most recently available figure places the number of obsolete cars in the graveyards at between three and four million. They are expected to provide from two to three million tons of scrap critically needed for the war program.

# AERIAL ATTACK ON SCHOOL BUILDINGS STUDIED

The Division of Architecture, State of California, is studying the effects of aerial attack on school buildings and will shortly be in position to offer responsible school authorities valuable advice regarding problems arising from the war situation. In a statement for the press Frank W. Clark, State Director of Public Works, says:

"It must be recognized that classrooms in school buildings are places of great hazard in case of bombing attacks because of the large expanse of windows. At times of aerial attacks children should be moved from classrooms to parts of the building which have been prepared to afford protection. It may be possible to provide such refuges in basements, in corridors or, in some other part of the building which proper structural inspection indicates to be suitable.

"Experience in England and Spain indicates that structures designed to resist lateral forces have shown superior resistance to all sorts of bomb effects on the buildings themselves. This should give encouragement to those districts with earthquake-resistant buildings constructed under the supervision of the Division of Architecture. However, it must be borne in mind that some of these buildings, while not subject to collapse, will afford no refuge from bomb fragmentation and glass splinters."

Clark has advised school authorities throughout the State that all these structures, as well as those not earthquake resistant, should be studied and be classified into one of the following groups, with respect to war hazards.

Group 1: Buildings which are very hazardous and intensify the dangers to occupants during aerial attack.

Group 2: Buildings which afford some protection to occupants.

Group 3: Buildings which, with minor alterations will provide reasonable safety (except from direct hits).

In group 1, Clark said, comes masonry buildings with no lateral force resisting elements and the possible collapse of which would increase the hazard from aerial attack and buildings so arranged that no section will afford protection from flying glass splinters and bomb fragments. Buildings with classrooms arranged on one side of open or glassed-in corridors, without basements, are of this type.

In group 2 are buildings which will provide a place of refuge from glass splinters such as a frame building with interior corridors, and buildings which provide safety from glass and bomb fragments but are subject to damage from incendiary bombs and anti-aircraft shell fragments such as well-built masonry buildings with wood floors and wood roofs.

In group 3 are well-constructed fireproof buildings

with interior corridors (corridor walls of masonry) or basements which may be made reasonably safe from glass splinters and which will resist bomb fragments. Protection may be provided in corridors by the removal or protection of glass in transoms, windows, doors and skylights, and by the provision of adequate baffles at exposed corridor ends.

Areas classified as to hazard, Mr. Clark lists as those in the vicinity of vital military establishments or vital war industries which are likely to receive bombs aimed at an important target or fragments from anti-aircraft shells and aerial combat planes.

Densely built-up coastal cities which form an attractive target for aerial attack but are less hazardous than areas in Area 1;

Suburban areas where buildings cover only a small percentage of the ground and interior cities without vital military establishments or war industries are not very satisfactory targets for high-explosive shells, but due to the combustible nature of the buildings usual in such areas, might be good targets for incendiary bombs; and

Rural areas which present no worthwhile targets and would rarely be attacked by enemy planes.

"School authorities should examine their buildings and classify them as to groups and areas," Mr. Clark said.

"Having estimated the hazard involved, the authorities should select places for refuge in case of an attack, take reasonable steps to remove hazards from such places of refuge, and plan the program to be followed in event of attack.

"The recommendation of the State Fire Marshal and local firefighting authorities should be followed in regard to precautions against fire disasters.

"In Area No. 1, when there is a likelihood of air attack, buildings in group 1 should not be occupied day or night, and buildings of group 2 should not be occupied at night, unless adequate and accessible air-raid protection is available.

"In Area No. 2, group 1 buildings should not be occupied at night unless air-raid protection is provided.

"The State Division of Architecture warns school authorities against a feeling of false security just because a proposed refuge is surrounded by blank walls. Some sections of school buildings which have been selected as a refuge have been found on examination to be but little safer than the classrooms.

"The Division of Architecture has prepared regulations governing the design of air-raid shelters. Alteration work costing more than \$4,000 or new construction of any amount must be submitted to the Division for approval in accordance with law."

## ARCHITECTS ATTENTION!

A press dispatch from Washington dated March 4, reads:

"A new type of army building contract, which is expected to save millions of dollars in construction costs, was announced today by a civilian official of the War Department.

"M. J. Madigan, special adviser on construction to the Undersecretary of War, said the new contract form, known as an architect-engineer-manager contract, 'makes a virtue of subcontracting,' unlike the cost-plus-fixed-fee contract, under which most of the large army camps, industrial and ordnance plants were built in the current program.

"Under the new system the prime contractor is a manager for the War Department, doing the engineering work and some of the actual construction, but recommending subcontracts for as much as 40 to 50 per cent of the work.

"In such cases the subcontracts are awarded, not by the prime contractor, but directly by the army district engineer responsible for general supervision of the entire project.

"Fees for the architect-engineer-manager, Madigan said, are based on the cost of the project, the length of time required, and the technical difficulties involved."

---

## HARRY DEVINE IN WASHINGTON

Harry J. Devine, architect of Sacramento and former president of the State Association of California Architects, was recently called to Washington for a conference with the National Commissioner of Public Buildings. Mr. Devine is in charge of the Federal school building in Vallejo. He is a world war veteran, having served as commander of a submarine chaser.

---

## TWELVE YEARS CITY MANAGER

James S. Dean, architect, recently celebrated his twelfth year as City Manager of Sacramento. His friends gave him an impromptu party in commemoration of the event. Sacramento, under Dean's leadership, has gained a nation-wide reputation for good government.

---

## DISSOLUTION OF PARTNERSHIP

Albert Farr and J. Francis Ward, architects, announce the dissolution of their partnership. Mr. Ward will continue the practice of his profession under the name of J. Francis Ward, 369 Pine Street, San Francisco, where he will be an associate of Blanchard & Maher, architects in the execution of defense projects.

---

## E. C. PITCHER MOVES

E. C. Pitcher Company, manufacturers of sliding door hardware and frames, has moved his business to 4728 Foothill Boulevard, Oakland. Mr. Pitcher will retain exhibit space, however, at his former business address, 557 Market Street, San Francisco.

## STIRRUP PUMPS TO FIGHT FIRE

One million stirrup pumps to enable California householders to fight fire bombs effectively are more urgently needed than the five million gas masks already allocated to California cities by the Office of Civilian Defense, according to the Architects' and Engineers' Air Raid Protection Advisory Board of San Francisco.

Emphasizing that the stirrup pump is now standard equipment in over six million British homes and offices, the board outlined a plan whereby groups of citizens could obtain pumps cheaply through a "block order" system. The pumps could be produced locally by small manufacturers.

"Air raids in Europe and Asia demonstrate that attacks with high explosive and incendiary bombs are far more effective than gas attacks," said Harold M. Engle, member of the ARP board and consulting structural engineer to the Board of Fire Underwriters of the Pacific. "Gas masks will, of course, be welcome. But we must recognize that fire bomb raids on California's largely wood-built cities are probable and that our coastal winds could treble their effectiveness.

"British experience shows that in such raids municipal fire apparatus must be augmented by small auxiliary units in every home and other building, with every civilian trained as a fire fighter. Hoses attached to faucets are effective only if the water mains remain unbroken or if there is not too great a strain on the water system," Engle added.

"But in a citywide emergency the stirrup pump, which can be operated independently from a bathtub, barrel or any other water container, has proved to be the most effective and durable equipment. This light, double-action pump, which can be operated even by children, is particularly useful because it alternately provides a jet of water to extinguish fires and a fine spray which enables one to fight fire bombs from a safe distance of 15 ft. The pump can be handled by one person if necessary."

The ARP board, recently established by the State Association of California Architects, suggested that citizens' groups could place block orders for pumps with their municipality, which would then be granted a priority rating in Washington for its combined order. **In this way the complete pump, including 30 ft. of hose, could be mass produced and retailed for \$8.00 or less. The hose could be produced from reclaimed rubber. The pump can also be manufactured with an adaptor to fit it to an ordinary garden hose at a cost of about \$5.00 a pump.**

---

## WESTON SUCCEEDS KAUFMANN

Eugene Weston, Jr., of Los Angeles, succeeds Gordon B. Kaufmann as Director of the Sierra-Nevada District of the A.I.A. Mr. Weston will serve for the remainder of Mr. Kaufmann's unexpired term, the latter having resigned on account of pressure of defense program work.

# ARCHITECTS' BULLETIN

Issued For

THE STATE ASSOCIATION OF CALIFORNIA ARCHITECTS

Northern Section

STATE ASSOCIATION MEMBER  
OF THE  
AMERICAN INSTITUTE OF ARCHITECTS

Editor

Harris C. Allen

Address all communications for publication in the Bulletin to the Editor (Harris C. Allen) 557 Market Street, Room 218, San Francisco, California.

## STATE ASSOCIATION OFFICERS

President.....Wayne S. Hertzka, San Francisco  
Vice-Pres., Walter R. Hagedohm, Los Angeles  
Sec'y.....Rowland H. Crawford, Beverly Hills  
Treasurer.....David H. Horn, Fresno

## Regional Director—Southern Section

Gordon B. Kaufmann

## Regional Director—Northern Section

Harry M. Michelson

## Executive Board—Northern Section

President.....Wayne S. Hertzka, San Francisco  
V.-Pres., Norman K. Blanchard, San Francisco  
Secretary.....Andrew T. Hass, San Francisco  
Treasurer.....David H. Horn, Fresno

## Directors

Russell G. de Lappe, Modesto; Clarence W. Mayhew, Harry M. Michelson, Frederick H. Reimers, Ernest E. Weihe, San Francisco

## Northern Section Advisory Council

San Francisco District #1:  
Clarence W. Mayhew, President  
Elizabeth Boyter Henry Collins  
Francis Chinn Edmund de Martini  
Rudolph Igaz Mark Daniels  
Charles W. Masten Vincent G. Raney  
Noble Newsom  
East Bay District #2:  
Theo N. Thompson, Chairman  
A. C. Williams  
Loy Chamberlain  
Berkeley District #3:  
Gwynn Officer, Berkeley  
North Bay District #4:  
William F. Herbert, Santa Rosa  
Marin District #5:  
John S. Bolles, Ross  
Lower San Joaquin District #6:  
Russell G. de Lappe, Modesto  
Upper San Joaquin District #7:  
David H. Horn, Fresno  
Santa Clara District #8:  
Gifford E. Sobey, San Jose  
Palo Alto District #9:  
William F. Hempel, Palo Alto  
San Mateo District #10  
Leo J. Sharps, Burlingame  
Sacramento District #11:  
Herbert E. Goodpastor, Sacramento  
Upper Sacramento District #12:  
Clarence C. Dakin, Redding  
Lassen District #13:  
Ralph D. Taylor, Susanville  
Monterey District #14:  
Thomas B. Mulvin, Del Monte  
Redwood Empire District #15:  
F. T. Georgeson, Eureka

## AIR RAID PROTECTION

**The Association** Advisory Board continues to bring timely information to architects, engineers and official civilian defense organizations. Their February Bulletin (No. 5) comprises sixteen pages, besides illustrations and tables, and a pamphlet on the protection of industrial and public buildings issued by the Office of Civilian Defense from Washington.

Considering all the data, advice and explanations given through these bulletins, there will be no grounds for criticism of our profession, if and when there is damage from enemy air raids.

### Standards and Codes

The requirements of war production make it necessary to conserve certain materials used in building construction. From a recent bulletin issued by the Producers' Council we quote concerning methods advisable to meet this situation:

"Architects, engineers, technicians of the National Bureau of Standards and other research agencies, and representatives of producers interested in the establishing and maintaining of those qualities in building materials, items of equipment, and methods of construction, which insure durability and other desirable qualities, have been the principal factors in the formulation of specifications, standards and codes for the construction industry."

### Fire Hazard

In considering protective measures against air raids, more than safety for individuals is to be included. The last "Octagon," in reporting a New England conference, quotes a speaker on this subject, which is even more applicable to the west coast cities:

"Conflagration is the number one menace to America's civilian population, George H. Gray of New Haven, speaking for the Connecticut Defense Council, pointed out during the discussion of civilian defense. 'The cities of the United States are tinder-boxes ready to be set off with ridiculous ease by a few incendiary bombs. Fire breaks should be cut through important areas to prevent flames spreading over wide sections of cities. Fire hazards around defense plants, hospitals, communication centers, and other vital zones should be removed at once. Families living in densely populated neighborhoods surrounding natural targets for bombs should be evacuated to temporary camps, spaced apart, beyond city limits.'"

"Other recommendations made for civilian defense were that architects should make surveys on which buildings in a city, and which rooms in these buildings, are safest during an air raid, and that all plans for new defense plants include basic provisions for camouflaging. It was also suggested that cities and towns should begin now to plan for post-war public works projects to take up the slack in industrial employment after the emergency has passed."

## Recent Losses

The recent death of Louis Christian Mullgardt has taken from the architectural profession one of its unique characters. A brilliant designer—almost a genius—Mr. Mullgardt has left a record of achievement that will not soon be forgotten. His personal qualities brought him many friends, and some enemies. He was impulsive, enthusiastic, hot-tempered, warm-hearted, prejudiced, generous, visionary—in short, an artist! and one of the select few who have lifted the profession of architecture out of the routine of commercial livelihood, in every generation.

The profession has also lost two other architects, long of good standing, and greatly to be missed—Sidney B. Newsom and Edward W. Cannon.

## Housing Shortage

From an active community in the Bay Region comes a plea which is too realistic to suppress—except for names and location:

"Office of Production Management, Division of Priorities. Dear Sir: On October 10, 1941 I opened my home to defense workers, and found the demand so great that I added on a large bunk bedroom, and still they come. I have had them bunking on my chesterfield, in the garage and sleeping in their cars; therefore, I see the need for more room and it is after much thought and due consideration that I have decided to build as soon as possible an addition of a four bedroom cottage onto the garage (now existent); the bath and kitchen fixtures are included, so that the cottage may be used in future years as a one family unit. If necessary, I will send you the names and badge numbers of the men I am now housing and boarding, also the ones on my waiting list. Hoping to hear from you soon, I remain . . ."

## A.I.A. DISCUSSES AIR RAIDS

Air raid protection was the subject for discussion at the February 10th meeting of Southern California Chapter, A.I.A., in Los Angeles. C. J. Derrick, structural engineer, led the debate, first urging that immediate steps to provide, where it is most needed, protection against possible token air raids, with particular attention being given to air raid shelters at defense plants and the shielding of vital equipment, such as secondary light plants in hospitals. He discounted the necessity in this area of any extensive system of shelters for civilians and warned against the use of half-way protective measures.

Fire is the serious menace, Mr. Derrick stated, the contributing factors being the incendiary bomb, damage to gas lines and damage to water supply. He advocated the elimination of all fire hazards from buildings. In London, he said, they are using materials that are fireproof and almost splinter-proof for backing up show windows.

A history of civilian defense work in the Institute was

outlined by Herbert Powell, chairman of the Chapter committee on defense. The country, he said, has been divided into nine areas, with headquarters for this area established in San Francisco. Reports of groups within the local committee were made by William H. Harrison, on air raid shelters, and by Whitney Smith, on evacuation and temporary housing. It was stated that a library of all available information on defense will be established in the Chapter office in the Architects Building.

An interesting feature of the program was an action sound film, belonging to the Canadian Trade Commission, of war scenes and conditions in England. It was procured by Mr. Powell's committee and was shown following the reading, by Eugene Weston, Jr., of a letter from England describing in detail an air raid and the effect of the raid on buildings and people occupying the buildings.

## OREGON CHAPTER ANNUAL MEETING

The annual meeting and banquet of Oregon Chapter, A.I.A., was held at the Congress Hotel in Portland, January 22nd. President Roi Morin, presiding. Guests included Messrs. Harlan Thomas, Wm. A. Bowes, Harry Cappel, Wm. Silverthorne, E. Kinne, D. Edmundson, W. Gordon, C. Kaufman, Ralph Johnston and J. Scott. A letter from Fred Baker was read regarding availability of materials for residence construction. Mr. Folger Johnson told of his recent visit to Washington, D. C., stating that the governmental agencies appeared to be planning further restrictions on materials. Harlan Thomas expressed a similar opinion. Mr. Morin read a letter from Mr. Purvis regarding employment of architects for the war building, Washington, D. C.

Mr. Jacobberger mentioned that the State Board of Health is making drastic regulations on certain types of buildings.

The 1942 officers of the Chapter were elected as follows: President, Roi L. Morin; Vice-President, Harry A. Herzog; Secretary, Clarence H. Wick; Treasurer, R. Burke Morden; Trustee, Pietro Belluschi.

Harry Cappel, President of the Oregon Building Congress, spoke on the necessary cooperation between architect and builder.

Ben Smith, the congenial City Plan Examiner, told of his experience in the Philippines during the Spanish American War and expressed his views on the outcome of the situation in the Philippines, and introduced Commissioner Wm. A. Bowes, who spoke on the subject: "What the City Government Is Doing to Meet the Present War Conditions."

The President introduced Regional Director Harlan Thomas who spoke briefly.

## 1942 INSTITUTE CONVENTION

The Seventy-fourth Convention of the American Institute of Architects will be held this year in Detroit, beginning June 23 and continuing till the 26th.

# Estimator's Guide

## Giving Cost of Building Materials, Wage Scale, Etc.

Amounts given are figuring prices and are made up from average quotations furnished by material houses to San Francisco contractors. 3% Sales Tax on all materials but not labor.

All prices and wages quoted are for San Francisco and the Bay District. There may be slight fluctuation of prices in the interior and southern part of the state. Freight cartage, at least, must be added in figuring country work.

**Bond**— $1\frac{1}{2}\%$  amount of contract.  
Government work  $\frac{3}{4}\%$ .

**Brickwork**—

Common, \$40 to \$45 per 1000 laid, (according to class of work).  
Face, \$90 to \$100 per 1000 laid, (according to class of work).  
Brick Steps, using pressed brick, \$1.00 lin. ft.  
Brick Veneer on frame buildings, \$1.00 sq. ft.  
Common f.o.b. cars, \$14.00 at yard. Cartage extra.  
Face, f.o.b. cars, \$40.00 to \$80.00 per 1000, carload lots.

**Building Paper**—

1 ply per 1000 ft. roll.....	\$3.50
2 ply per 1000 ft. roll.....	5.00
3 ply per 1000 ft. roll.....	5.25
Stalcraft, 500 ft. roll.....	5.00
Sash cord com. No. 7.....	\$1.20 per 100 ft.
Sash cord com. No. 8.....	1.50 per 100 ft.
Sash cord spot No. 7.....	1.90 per 100 ft.
Sash cord spot No. 8.....	2.25 per 100 ft.
Sash weights, cast iron, \$50.00 ton.	
Nails, \$3.50 base.....	
Sash weights, \$45.00 per ton.	

**Concrete Aggregates**—

**GRAVEL** (all sizes) \$1.45 per ton at bunker; delivered to any point in S. F. County \$1.85.

	Bunker	Delivered
Top sand.....	\$1.45	\$1.85
C. concrete mix.....	1.45	1.85
Crushed rock, $\frac{1}{4}$ to $\frac{3}{8}$ .....	1.60	2.00
Crushed rock, $\frac{3}{8}$ to $1\frac{1}{2}$ .....	1.60	2.00
Roofing gravel.....	1.60	2.00
City gravel.....	1.45	1.85
River sand.....	1.50	2.20
Bank sand—\$1.00 per cubic yard at bunker or delivered.		

**SAND**—

	Bunker	Delivered
River sand.....	\$1.50	\$1.85
Lapis (Nos. 2 & 4).....	2.00	2.40
Olympia Nos. 1 & 2.....	1.50	2.20
Headburg plaster sand.....	\$1.80 and \$2.20	
Del Monte white.....	.50c per sack	
Common cement (all brands, paper sacks) carload lots \$2.52 per bbl, f.o.b. car; delivered, \$2.70; less than carloads delivered, 70c per sack.		
Cash discount on carload lots, 10c a barrel, 10th Pror.; cash discount less than carload lots, 2%.		

Atlas White }  
Calaveras White } 1 to 100 sacks, \$2.00 sack,  
Medusa White } warehouse or delivery.

Forms, Labors average \$40.00 per M.  
Average cost of concrete in place, exclusive of forms, 35c per cu. ft.; with forms, 60c.  
4-inch concrete basement floor..... $12\frac{1}{2}$ c to 14c per sq. ft.  
Rat-proofing..... $7\frac{1}{2}$ c  
Concrete Steps.....\$1.25 per lin. ft.

**Dampproofing and Waterproofing**—

Two-coat work, 20c to 30c per yard.  
Membrane waterproofing—4 layers of saturated felt, \$4.50 per square.  
Hot coating work, \$2.00 per square.  
Medusa Waterproofing, 15c per lb., San Francisco Warehouse.  
Tricoel waterproofing.  
(See representative.)

**Electric Wiring**—\$12.00 to \$15.00 per outlet for conduit work (including switches).  
Knob and tube average \$3.00 per outlet.

**Elevators**—

Prices vary according to capacity, speed and type. Consult elevator companies.  
Average cost of installing an automatic elevator in four-story building, \$2800; direct automatic, about \$2700.

**Excavation**—

Sand, 60 cents; clay or shale \$1 per yard.  
Teams, \$12.00 per day.  
Trucks, \$22 to \$27.50 per day.

Above figures are an average without water. Steam shovel work in large quantities, less; hard material, such as rock, will run considerably more.

**Fire Escapes**—

Ten-foot galvanized iron balcony, with stairs, \$150 installed on new buildings; \$160 on old buildings.

**Floors**—

**Composition Floors**—22c to 40c per sq. ft.  
In large quantities, 18c per sq. ft. laid.  
**Mosaic Floors**—80c per sq. ft.  
**Duraflex Floor**—23c to 30c sq. ft.  
**Rubber Tile**—50c to 75c per sq. ft.  
**Terezzo Floors**—45c to 60c per sq. ft.  
**Terezzo Steps**—\$1.60 lin. ft.

**Hardwood Flooring** (delivered to building)—

	$3\frac{1}{2} \times 2\frac{1}{2}$ "	$3\frac{1}{2} \times 2$ "	$3\frac{1}{2} \times 2$ "
	18c	18c	Sq. Ed.
Clr. Otd. Oak.....	\$144.00 M	\$122.00 M	\$141.00 M
Sel. Otd. Oak.....	118.00 M	101.00 M	114.00 M
Clr. Pla. Oak.....	120.00 M	102.00 M	115.00 M
Sel. Pla. Oak.....	113.00 M	92.00 M	107.00 M
Clr. Maple.....	125.00 M	113.00 M	
Wage—Floor layers, \$12.00.			
Note—Above quotations are all board measure except last column which is sq. ft.			

**Glass** (consult with manufacturers)—  
Double strength window glass, 20c per square foot.  
Plate 80c per square foot (unglazed) in place, \$1.00.  
Art, \$1.00 up per square foot.  
Wire (for skylights), 40c per sq. foot.  
Obscure glass, 30c to 50c square foot.  
Glass bricks, \$2.50 per sq. ft. in place.  
Note—if not stipulated add extra for setting.

**Heating**—

Average, \$1.90 per sq. ft. of radiation, according to conditions.  
Warm air (gravity) average \$48 per register.  
Forced air, average \$68 per register.

**Iron**—Cost of ornamental iron, cast iron, etc., depends on designs.

**Lumber** (prices delivered to bldg. site)—

No. 1 common.....	\$43.00 per M
No. 2 common.....	41.00 per M
Select O. P. common.....	46.00 per M
2x4 No. 3 form lumber.....	32.00 per M
1x4 No. 2 flooring VG.....	50.00 per M
1x4 No. 3 flooring VG.....	55.00 per M
1x6 No. 2 flooring VG.....	76.00 per M
1x4x4 and 6, No. 2 flooring.....	75.00 per M

**Slash grain**—

1x4 No. 2 flooring.....	\$65.00 per M
1x4 No. 3 flooring.....	52.00 per M
No. 1 common run T. & G.....	48.00 per M
Lath.....	7.50 per M

Shingles (add cartage to price quoted)—  
Redwood, No. 1.....\$1.20 per bdl.  
Redwood, No. 2.....1.00 per bdl.  
Red Cedar.....1.45 per bdl.

**Plywood—Douglas Fir** (add cartage)—

"Plyscord" sheathing (unsanded)  
"3" 3-ply and 48"x96".....\$39.75 per M  
"Fwal" (wallboard grade)—  
"4" 3-ply 48"x96".....\$43.70 per M  
"Plyform" (concrete form grade)—  
"5" 5-ply 48"x96".....\$117.30 per M  
Exterior Plywood Siding—  
"5" 5-ply Fir.....\$132.00 per M  
Redwood (Rustic) 1x8" clear heart, \$ 95.00 per M \$ 55 less per M for A grade.

**Millwork—Standard.**

O. P. \$100 per 1000. R. W. rustic \$120.00 per 1000 (delivered).  
Double hung box window frames, average with trim, \$6.50 and up, each.  
Complete door unit, \$10.00.  
Screen doors, \$3.50 each.  
Patent screen windows, 25c a sq. ft.  
Cases for kitchen pantries seven ft. high, per lineal ft., \$8.00 each.  
Dining room cases, \$8.00 per lineal foot.  
Rough and finish about 75c per sq. ft.  
Labor—Rough carpentry, warehouse heavy framing (average), \$17.50 per M.  
For smaller work average, \$35.00 to \$45.00 per 1000.

**Marble**—(See Dealers) JASCO 14  
BEST 131

**Painting**—

Two-coat work.....	per yard 50c
Gold-water painting.....	per yard 70c
Whitewashing.....	per yard 10c
Whitewashing.....	per yard 4c

Turpentine, 65c per gal., in 5 gal. cans, and 55c per gal. in drums.

Raw Linseed Oil—95c gal. in light drums, Boiled Linseed Oil—98c gal. in drums and \$1.08 in 5 gal. cans.

**White Lead in oil**

Per Lb.  
1 ton lots, 100 lbs. net weight.....113/4c  
500 lbs. and less than 1 ton.....12c  
Less than 500 lb. lots.....121/2c

**Red Lead and litharge**

1 ton lots, 100 lbs. net weight.....113/4c  
500 lbs. and less than 1 ton.....12c  
Less than 500 lb. lots.....121/2c

**Red Lead in oil**

1 ton lots, 100 lbs. net weight.....123/4c  
500 lbs. and less than 1 ton.....13c  
Less than 500 lb. lots.....131/2c

Note—Accessibility and conditions cause some variance in costs.

**Patent Chimneys—**

6-inch .....\$1.25 lineal foot  
8-inch .....1.50 lineal foot  
10-inch .....2.25 lineal foot  
12-inch .....3.00 lineal foot

**Plastering—Interior—**

Yard  
1 coat, brown mortar only, wood lath.....\$0.50  
2 coats, lime mortar hard finish, wood lath .85  
2 coats, hard wall plaster, wood lath.....72  
3 coats, metal lath and plaster.....1.25  
Keene cement on metal lath.....1.30  
Ceilings with 3/4 hot roll channels metal lath (lathed only)......90  
Ceilings with 3/4 hot roll channels metal lath plastered.....1.80  
Single partition 3/4 channel lath 1 side (lath only)......85  
Single partition 3/4 channel lath 2 inches thick plastered.....2.90  
4-inch double partition 3/4 channel lath 2 sides (lath only).....1.70  
4-inch double partition 3/4 channel lath 2 sides plastered.....3.30  
Thermax single partition; 1" channels; 3/4" overall partition width. Plastered both sides.....2.50  
Thermax double partition; 1" channels; 3/4" overall partition width. Plastered both sides.....3.40

3 coats over 1" Thermax nailed to one side wood studs or joists.....1.25  
3 coats over 1" Thermax suspended to one side wood studs with spring sound insulation clip.....1.45

**Plastering—Exterior—**

Yard  
2 coats cement finish, brick or concrete wall.....\$1.00  
3 coats cement finish, No. 18 gauge wire mesh.....1.75  
Wood lath, \$5.50 to \$6.50 1000.  
2.5-lb. metal lath (dipped)......19  
2.5-lb. metal lath (galvanized)......21  
3.4-lb. metal lath (dipped)......22  
3.4-lb. metal lath (galvanized)......24  
3/4-inch hot roll channels, \$72 per ton.  
Finish plaster, \$18.90 ton; in paper sacks.  
Dealer's commission, \$1.00 off above quotations.  
\$13.85 (brute 10c sack).  
Lime, f.o.b. warehouse, \$2.25 bbl.; cars, \$2.15  
Lime, bulk (ton 2000 lbs.), \$16.00 ton.  
Wall Board 5 ply, \$50.00 per M.  
Hydrate Lime, \$5.50 ton.

Plasterers Wage Scale.....\$1.67 per hour  
Lathers Wage Scale.....1.60 per hour  
Head Carriers Wage Scale.....1.40 per hour

Composition Stucco—\$1.80 to \$2.00 sq. yard (applied).

**Plumbing—**

From \$100.00 per fixture up, according to grade, quantity and runs.

**Roofing—**

"Standard" tar and gravel, \$7.00 per sq. for 30 sqs. or over.  
Less than 30 sqs. \$7.50 per sq.  
Tile, \$20.00 to \$35.00 per square.  
Redwood Shingles, \$7.50 per square in place.  
Copper, \$16.50 to \$18.00 per sq. in place.  
5/2 # 1-16" Cedar Shingles, 8.00 Square  
4 1/2" Exposure.....  
5/8 x 16" — # 1 Cedar Shingles, 5" Exposure.....9.00 Square  
4/2 # 1-24" Royal Shingles, 9.50 Square  
7/2" Exposure.....  
Re-coat with Gravel, \$3 per sq.  
Asbestos Shingles, \$15 to \$25 per sq. laid.  
Slate, from \$25.00 per sq., according to color and thickness.  
1/2 x 25" Resawn Cedar Shakes, 10" Exposure.....10.50  
3/4 x 25" Resawn Cedar Shakes, 10" Exposure.....11.50

1 x 25" Resawn Cedar Shakes, 10" Exposure.....12.50  
Above prices are for shakes in place.

**Sheet Metal—**

Windows—Metal, \$1.75 a sq. ft.  
Fire doors (average), including hardware, \$1.75 per sq. ft.

**S Skylights (not glazed)**

Copper, 90c sq. ft. (flat).  
Galvanized iron, 40c sq. ft. (flat).  
Vented hip skylights 60c sq. ft.

**Steel—Structural (None available except for defense work)**

\$150 ton (erected), this quotation is an average for comparatively small quantities. Light truss work higher. Plain beams and column work in large quantities \$140 per ton.

**Steel Reinforcing (None available except for defense work).**

\$150 to \$200 per ton, set.

**Stone—**

Granite, average, \$6.50 cu. foot in place.  
Sandstone, average Blue, \$4.00. Boise, \$3.00 sq. ft. in place.  
Indiana Limestone, \$2.80 per sq. ft. in place.

**Store Fronts—**

Copper sash bars for store fronts, corner, center and around sides, will average \$1.00 per lineal foot.  
Note—Consult with agents.

**Tile—Floor, Wainscot, etc. — (See Dealers)**

Asphalt Tile—18c to 28c per sq. ft. installed.

**Wall Tile—**

Glazed Terra Cotta Wall Units (single faced) laid in place—approximate prices:  
2 x 6 x 12.....\$1.00 sq. ft.  
4 x 6 x 12.....1.15 sq. ft.  
2 x 8 x 16.....1.10 sq. ft.  
4 x 8 x 16.....1.30 sq. ft.

**Venetian Blinds—**

40c per square foot and up. Installation extra.

**Windows—Steel**

Factory type sash 30c ft.  
Ventilators for steel sash \$5.00 each.

**1942 BUILDING TRADES WAGE SCALES FOR NORTHERN CALIFORNIA**

\*6-hour day \*\*7-hour day

CRAFT	San Francisco	Alameda	Fresno	Marin	Sacramento	San Jose	San Mateo	Yallico	Stockton
ASBESTOS WORKERS	\$1.50	\$1.25	\$1.25	\$1.37 1/2	\$1.12 1/2	\$1.25	\$1.25	\$1.25	\$1.25
BRICKLAYERS	.175	.175	.150	.175	.175	.200	*.179-1/6	.175	.175
BRICKLAYERS' HODCARRIERS	1.35	.125	.125	.125	.105	.135	.135	.140	.114
CARPENTERS	*1.37 1/2	*1.37 1/2	*1.25	*1.37 1/2	*1.25	*1.25	*1.37 1/2	*1.25	*1.25
CEMENT FINISHERS	1.50	1.50	1.50	1.50	1.50	1.50	1.50	1.25	1.25
ELECTRICIANS	1.61	1.54	1.50	1.61	1.41	1.50	1.50	1.50	1.37 1/4
ELEVATOR CONSTRUCTORS	1.50	1.37 1/2	1.25	1.50	1.37 1/2	1.62 1/2	1.37 1/2	1.37 1/2	1.25
ENGINEERS: Material	1.75	1.60	1.60	1.75	1.75	1.75	1.62 1/2	1.75	1.60
ENGINEERS: Structural	1.75	1.60	1.60	1.75	1.75	1.75	1.60	1.60	1.37 1/2
GLASS WORKERS	1.25	1.25	1.12 1/2	1.25	1.12 1/2	1.21	1.25	1.25	.....
IRONWORKERS: Ornamental	1.50	1.31 1/4	1.37 1/2	1.31 1/4	1.37 1/2	1.31 1/4	1.25	1.31 1/4	.....
IRONWORKERS: Reinf. Redmen	1.50	1.31 1/4	1.31 1/4	1.31 1/4	1.31 1/4	1.40	1.31 1/4	1.31 1/4	.....
IRONWORKERS: Structural	1.75	1.60	1.60	1.60	1.60	1.75	1.50	1.60	1.37 1/2
LABORERS: Building	.85	.87 1/2	.82 1/2	.81 1/4	.85	.81 1/4	.81 1/4	.81 1/4	.80
LABORERS: Concrete	.87 1/2	.93 1/4	.90	.81 1/4	.92 1/2	.85	.85	.90	.90
LATHERS	*.175	*.175	*.150	*.175	*.160	*.175	*.175	*.150	*.150
MARBLE SETTERS	1.43 1/4	1.25	1.25	1.31 1/4	1.37 1/2	1.25	1.31 1/4	.....	.....
MOSAIC & TERRAZZO	1.00	1.25	1.12 1/2	1.12 1/2	1.15-5/8	1.25	1.25	1.25	1.25
PAINTERS	**1.37 1/2	**1.50	**1.28-4/7	**1.37 1/2	1.25	**1.35-5/7	**1.42-4/7	**1.50	1.25
PILEDRIVERS	1.47	1.40	1.40	1.50	1.40	1.47	1.40	1.40	.....
PLASTERERS	*1.64-2/3	*1.64-2/3	*1.75	*1.64-2/3	1.75	*2.00	*2.00	*1.75	*1.83-1/3
PLASTERERS' HODCARRIERS	*.150	*.145	*.140	*.140	*.118 1/4	*.135	*.175	*.140	*.150
PLUMBERS	1.52 1/2	1.50	1.53-1/8	1.50	1.56 1/4	1.62 1/2	1.50	1.50	1.37 1/2
ROOFERS	1.37 1/2	1.37 1/2	1.12 1/2	1.25	1.25	1.25	1.25	1.25	1.25
SHEET METAL WORKERS	1.37 1/2	1.37 1/2	1.43 1/4	1.37 1/2	1.37 1/2	1.50	1.37 1/2	1.25	1.37 1/2
SPRINKLER FITTERS	1.50	1.37 1/2	1.25	1.25	1.25	1.62 1/2	1.50	1.50	.....
STEAMFITTERS	1.50	1.50	1.53-1/8	1.50	1.56 1/4	1.62 1/2	1.50	1.50	1.50
STONESETTERS (Masons)	*.150	*.175	.150	*.175	*.175	*.150	1.75	*.175	*.150
TILESETTERS	1.50	1.37 1/2	1.37 1/2	1.37 1/2	1.37 1/2	1.50	1.50	1.37 1/2	.....

Prepared and compiled by  
CENTRAL CALIFORNIA CHAPTER, ASSOCIATED GENERAL CONTRACTORS OF AMERICA  
with the assistance and cooperation of secretaries of General Contractors Associations and Builders Exchanges of Northern California.



## REVIEWS OF LATE BOOKS

"AERIAL BOMBARDMENT PROTECTION," by Harold E. Wissman and William A. Rose; published by John Wiley & Sons, Inc., New York, 1942—Price \$4.00.

This timely and excellent book is the outgrowth of lectures delivered by the authors at the College of Engineering of New York University, under the auspices of the Engineering Defense Training Program of the U. S. Office of Education.

Much of the material in the book has been obtained from the A. R. P. publications of the British Government, but due to the wide variation in British and American building methods and in general conditions, the necessity of such a volume is more than justified. The book should prove of great value not only to architects and engineers but also to insurance companies and manufacturers of construction.

The subjects covered in "Aerial Bombardment Protection" include a short review of the fundamentals of structural design and of the new problems that have been added by reason of the necessity of design to resist energy loads, blast shock and fragmentation. Chapters included, deal with the subjects of bomb types, penetration and perforation and there are appendices giving the analysis of structural vibration from explosive effects and a description of the U. S. Army tests conducted at the Edgewood Arsenal. Other chapters cover materials, analysis of the structural design offered by different types of buildings, multi-story buildings, the design of air raid shelters and a short discussion on protective concealment (camouflage).

A SHORT HISTORY OF JAPANESE ARCHITECTURE by Professor A. L. Sadler, M. A., University of Sidney. Published by Angus & Robertson, Ltd., Sidney and London. Price \$6.00.

Most histories are tiresome, dry reading. Some few depart from the didactic relating of sequential facts and admit, now and then, some elements of romance and possibly amusement; but Professor Sadler's book on "Japanese Architecture" is tiresome indeed.

The constant use of foreign words and parenthetical interpretations is not only confusing, but it sometimes makes the contents almost unreadable. The drawings and illustrations are poor and the unleavened historical accounts of Rulers and their sequence is monotonous; in fact with less interest than will be found in the 11th edition of the Encyclopedia Britannica on the same subject.

Of course it is difficult for a Chinophile to review a book on any phase of Japanese interest, particularly at this time. Nevertheless, I do feel that this "History of Japanese Art and Architecture" smacks of "Much Ado About Nothing."

Professor Sadler seems to be struggling to make something out of architecture in Japan. Yet he says there is no monumental architecture there. He tells us that in China the great Tang dynasty in the 7th and 8th centuries influenced the world from the "yellow

sea to Persia," and goes on to say "Japan, as might be expected of her, threw herself wholeheartedly into adapting this brilliant civilization." Many times in his strictly historical sections he speaks of similar imitations. Then why not put a little more time on the original? Such great and powerful works as those of Siren's "History of Chinese Art," Richard Wilhelm's "Short History of Chinese Civilization," and De Morant's "History of Chinese Art" might have been models to pattern after, for they are great and powerful works, but I suppose it is impossible to wax eloquent over an unworthy subject.

When Professor Sadler takes up the subject of shops, inns, small houses, coffered ceilings, and other details the book becomes interesting but there is too little of this. Surprising as it may be he devotes very little time to the Japanese gardens on which Joseph Conder devotes two good size volumes. There is none of the stately grace of the great tapering Chinese pagodas in any of his illustrations nor any evidence of that subtle art of eternity to be found in China.

All in all, I would not spend time reading a book on clumsy, wooden imitations of a great art that has lived a thousand or more years longer than its imitator. So why spend effort or time on a poor imitation of a great civilization except out of curiosity?—Mark Daniels.

ENGINEERING SURVEYS, Elementary and Applied, by Harry Rubey, G. E. Lommel and M. W. Todd; published by The Macmillan Company, 60 Fifth Avenue, New York. Price \$4.50.

Surveyors will find this 650 page book a useful addition to their library. Many phases of surveying are advancing so rapidly that they must be followed in technical periodicals and in engineering practice rather than in textbooks. For this reason a sound fundamental treatment is given this new book together with adequate annotated references at the ends of the "Applied" chapters and elsewhere. Purpose of the authors is to present a practical, up to date text and reference book covering material most needed by practicing engineers and adapted to modern trends in surveying instruction for all departments of engineering and suitable for either campus classes or surveying camp. Many valuable tables are listed together with numerous illustrations.

## ARCHITECTS MIGRATE

Change of addresses are announced by the following architects:

Leslie J. Hendy to 1 Powell Street, San Francisco.

Albert H. Larsen to Post Office Box 69, Belmont.

Harold F. Genss to 1319 McGee Street, Berkeley.

W. B. Faville to 35 Central Avenue, Sausalito.

Henry W. Howell to 476 Landfair, Los Angeles.

H. B. Douglas to 75 Benton Way, San Luis Obispo.

Samuel Homsey to Lancaster Pike, Hockessin, Delaware.

## HOGAN LUMBER CO.

Wholesale and Retail

### LUMBER

MILL WORK • SASH & DOORS

Office, Mill, Yard and Docks

SECOND AND ALICE STREETS • OAKLAND, CALIF.

Telephone GLencourt 6861

## SISALKRAFT

REG. U. S. PAT. OFF.

"More than a building paper"

### THE SISALKRAFT CO.

205 West Wacker Drive  
(Canal Station) Chicago, Ill.

55 New Montgomery Street  
San Francisco, Calif.

## ALADDIN Heating Corp.

Specializing in  
QUALITY HEATING EQUIPMENT

2222 San Pablo Avenue, Oakland  
TWinoaks 1022

## FRANK J. McCOY HOTELS

SANTA MARIA INN—Santa Maria,  
California • Orville E. Sammann, Mgr.

WORLD FAMOUS STOP-OVER, BETWEEN  
SAN FRANCISCO AND LOS ANGELES

EL ENCANTO HOTEL & VILLAS—Santa  
Barbara, California • Fred E. Pimentel, Mgr.  
AMERICA'S HOTEL BEAUTIFUL, IN A  
MATCHLESS SETTING ON THE RIVIERA

### HOUSING SHORTAGE FOUND "CRITICAL"

Residential vacancies were below normal during 1941 in nine-tenths of the nation's key defense areas and so low in two-fifths of the areas as to indicate a critical housing shortage, according to a summary of vacancy surveys conducted during the year by the Work Projects Administration.

In all but 25 of the 287 defense areas surveyed the gross number of vacant family dwelling units was less than 5 per cent, the figure considered "normal" by housing authorities, and in most cases less than half of the dwellings found to be vacant were habitable and for rent.

In 111 of the areas the gross vacancy ratio was less than 2 per cent, indicating a "critical" housing shortage and a serious lack of habitable dwellings for rent. The figures are based on the number of family dwelling units and do not include single rooms, which are listed separately in the individual reports.

The surveys covered virtually all communities in the United States designated by the government as defense areas, from metropolitan centers such as Chicago, Los Angeles, and parts of New York City, to small towns adjacent to Army camps. The information assembled is being used in planning the defense housing program.

In most areas the number of dwelling units in good condition and offered for rent was less than half of the total vacancies, and in some cities many of these houses were still under construction and not available for immediate occupancy. Houses held for sale or being constructed for owner occupancy, and dwellings unfit for use, comprised most of the non-rental vacancies.

Connecticut, Pennsylvania and other heavily-populated states which have become centers for tremendous war production, disclosed the lowest vacancy ratios. Of nine key areas surveyed in Connecticut, only one had a habitable rental vacancy rate of as much as one per cent and one city, Meriden, had almost no rental vacancies.

Resurveys, made at varying intervals in 71 of the areas, showed that habitable rental vacancies decreased during the year in 53 of the resurveyed areas. In a few of the resurveyed areas vacancy rates increased slightly; in most cases this was due largely to new construction, not yet completed.

### WAR SERVICE REGISTER

The San Francisco Section, American Society of Engineers, is preparing a list of members who may be available for employment on design, construction or other war service work for the government and who have special experience and qualifications along particular lines. One list will be made available to the government agencies concerned. Those members willing to have their names included in this list are requested to communicate with Brig. Gen. G. B. Pillsbury, P. O. Box 407, Ross, California, or F. E. Bonner, President of the Section.

### "IT CAN HAPPEN HERE"—NEWTON

Henry C. Newton (Lieutenant-Colonel, if you please), architect of Los Angeles, whose work was extensively publicized in *Architect and Engineer* recently, is stationed at Fort Knox, Kentucky. It was not so long ago when Colonel Newton was practicing architecture that he remarked casually to friends who were discussing the war situation with emphasis on possible bombing of U. S. possessions: "It can happen here." Incidentally Newton all along advocated adequate defense of the Pacific Coast—at a time, too, when most people laughed at his pessimism.

Other members of the Los Angeles Chapter of Architects who have joined the colors include: Messrs. McCay, Cook, Fry, Spielman, and Stoshitch. Serving in the defense effort without uniform are: Messrs. Taylor, Maybury, Kaufmann, Walker & Eisen, Hunt & Chambers, Parkinson, Sabin, Beelman, Hayward, Witmer, Pier Davis, Bergstrom, Farquhar and Keith Marston.

### WINS AND LOSES

A \$34,454 verdict awarded by a superior court jury to Harrison A. Atwood, architect, for drawing plans for a once-proposed girls' high school in Roxbury was invalidated by a full bench decision of the supreme judicial court of Massachusetts. The city of Boston paid Atwood \$40,536 for drawing the specifications in 1929, but the school was never built. The architect submitted a bill for \$64,800, and later sued for the balance of \$24,264 plus interest. The city appealed the verdict of the superior court jury; and in upholding this appeal and reversing the lower court's finding, the high court said: "We are of the opinion that the terms of the plaintiff's contract and the abandonment of the main project before construction, that no basis existed under the contract for the payment of additional compensation to the plaintiff."

### NOTICE OF JOINT MEETING OF ENGINEERS

The annual joint meeting of the member societies of the San Francisco Engineering Council was held at the Pacific Gas and Electric Company Auditorium, 245 Market Street, San Francisco, Friday evening, February 27th. Dr. D. H. MacLaughlin delivered an address on "Gold vs. Strategic Minerals."

Dr. MacLaughlin is Dean of Mining and Dean-elect of the Engineering Schools of the University of California. He is an international authority on this subject.

Preceding the meeting, dinner was served at the Engineers' Club.

### NEW SUPERVISING ARCHITECT

George Howe of Philadelphia, Pa., has been appointed Supervising Architect of the Public Buildings Administration, Federal Works Agency, succeeding Louis A. Simon, retired. Mr. Howe is the 17th architect to be appointed to the post of Supervising Architect since 1836. He has been associated with the office since 1939 in a consulting capacity.

**The Most Complete Line of  
STEELS and BUILDING MATERIALS  
Made by a Single Producer**



See Sweet's Catalog File or write us for full information.

**REPUBLIC STEEL CORPORATION**  
GENERAL OFFICES: CLEVELAND, OHIO

DENVER, COLORADO . . . . . CONTINENTAL OIL BUILDING  
LOS ANGELES, CALIFORNIA . . . . . EDISON BUILDING  
SALT LAKE CITY, UTAH . . . . . WALKER BANK BUILDING  
SAN FRANCISCO, CALIFORNIA . . . . . RIALTO BUILDING  
SEATTLE, WASH. . . . . WHITE-HENRY-STUART BUILDING

**CLINTON  
CONSTRUCTION CO.  
OF CALIFORNIA**

**General Contractors**

**923 FOLSOM STREET • SAN FRANCISCO**

**SUtter 3440**

**VERMONT  
MARBLE COMPANY**

Producers and Finishers  
of  
**Domestic and Imported Marbles**

Write for new pamphlet describing our  
Marble Toilets and Showers

**San Francisco and Los Angeles**

**San Francisco phone: SUtter 6747**

**"AMERICAN MARSH"  
Redi-Vac Vacuum Heating Pump**



Send for  
Bulletin 441

**SIMONDS MACHINERY CO.**

San Francisco  
816 Folsom St.

Los Angeles  
455 East Fourth St.

# Quality Photographs

Since 1884

- ☆ *Architectural*
- ☆ *Portraits*
- ☆ *Commercial*

**GABRIEL MOULIN STUDIOS**

181 Second Street, San Francisco

## STRUCTURAL STEEL

For Class A Buildings,  
Bridges, etc.

**JUDSON PACIFIC CO.**

1200 SEVENTEENTH STREET  
SAN FRANCISCO

Plants: San Francisco - Oakland

Fine Water Colors and Papers  
For Architectural Renderings

**H. S. CROCKER  
COMPANY, Inc.**

720 MISSION STREET

Market Street at Second • San Francisco

## BASALITE

CAMBERED SHINGLE TILE

PERMANENT • FIREPROOF • STORM-  
SAFE • COLORFUL • ECONOMICAL

Manufactured by

**BASALT ROCK CO., INC.**

NAPA, CALIFORNIA

## RUNNING FIRE

(Continued from Page 1)

### • ANOTHER REASON

We architects say the Public are beginning to pooh-pooh at us. Well, why not? Some years ago a structure was planned for a location that would terminate the vista of an important street. It was discovered that what was classed as the main vertical axis of the structure was off the central axis of the street. Oh tragedy! The permit was held up until the problem could be submitted to the architectural bigwigs of the city. They couldn't agree. Time wore on. The delay was costly. But while the architects all agreed that something should be done, they could not agree on whether the main motif should be moved 11 inches north or 19 inches west, and the situation was serious. Finally, to avoid bankruptcy, the owner built the thing as planned.

Within a few years artists were working at their easels painting pictures of the exquisite vista so skillfully perfected by placing the terminating structure slightly off axis.

### ARCHITECTS GETTING COMMISSIONS

Some of our San Francisco Bay architects are getting busy on Defense work.

Will P. Day and Harry Michelson will work with L. H. Nishkian and others preparing plans for a \$5,000,000 Ordnance Ammunition Depot in Utah.

Ernest E. Weihe, Edward L. Frick, Lawrence Kruse and Blanchard & Maher, San Francisco, are preparing plans for a \$2,000,000 Navy Hospital to be built near the Oak Knoll Country Club in Alameda County.

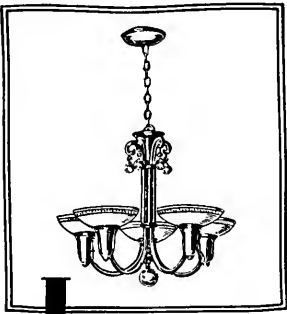
William W. Wurster of San Francisco and Charles F. Dean of Sacramento are the architects for 332 units of Defense housing in the Haggewood District, near Sacramento. Bids for some of the work have already been taken. All the houses will be wood frame.

### WM. B. GESTER

William B. Gester, a life member of the American Society of Civil Engineers, and for many years manager of the San Francisco office of the Robert W. Hunt Company, died at his home in Berkeley in December. He was of an advanced age, past 90, yet able to take daily walks near his home up to within a few days of his passing. Mr. Gester was a man of deep intellect and a linguist, master of many languages.

### TELLS OF MAGNESIUM INDUSTRY

An open meeting of the Structural Engineers Association of Northern California, was held at the Engineers Club the evening of March 3. Professor Earl C. Thomas, on leave of absence from Stanford University, addressed the meeting on "The Magnesium Industry and its Importance to America's War Effort." Magnesium is a newly developed product now being manufactured in Santa Clara County.



## INDIRECT

A fixture to impress your guests with its beauty and your good taste. Your home is only as lovely as its lighting.

So—may we offer the assistance of our "lighting stylists" in selecting the correct fixtures on your limited budget?

**INCANDESCENT  
SUPPLY COMPANY**  
726 MISSION ST., SAN FRANCISCO

Phone GARfield 1164

## Thomas B. Hunter

*Consulting Engineer*  
DESIGNER OF HEATING  
AIR CONDITIONING  
VENTILATING AND WIRING  
SYSTEMS, MECHANICAL  
AND ELECTRICAL EQUIP-  
MENT OF BUILDINGS

41 SUTTER STREET  
ROOM 710  
San Francisco California

## Robert W. Hunt Company

ENGINEERS

Inspection · Tests · Consultation  
Schools and Other Structures  
Are Built as Designed

*When Construction Materials are  
Inspected at point of Manufacture  
and during Erection by*

**ROBERT W. HUNT COMPANY**

*Cement, Concrete, Chemical, Metallurgical,  
X-Ray and Physical Laboratories*

Chicago · New York · Pittsburgh  
Los Angeles · All Large Cities  
San Francisco, 251 Kearny Street

## UNCLE SAM AND THE A.I.A.

Cooperation between the government and the American Institute of Architects to speed the war construction program is urged by Elbert I. Harrison, vice president of the Central Illinois Chapter of the American Institute of Architects.

"The Institute, representing the profession, should be selected by the governmental agencies to classify the architectural firms or groups of firms of the nation according to their qualifications, and assign to established firms the responsibility of executing the necessary architectural work for construction nearest their established locality," Mr. Harrison says.

"Local building industry could be utilized and delays and transportation reduced to a minimum. The utilization of the talents, ability and experience of the architects of the nation could accelerate the tremendous program required with economy, efficiency and dispatch, and at the same time effect the decentralization program and avoid the bottleneck of the Washington merry-go-round.

"The War Production Board has found this same idea necessary to utilize our established production facilities and organizations throughout the nation.

"The specialized technical training and experience of the architectural profession should be utilized by the various governmental agencies to the maximum extent throughout the entire war program and the post-war reconstruction period."

## WOOD AS WAR MATERIAL

According to the Canadian Forest Products Laboratories, the value of wood as a war material is attested by its inclusion in certain lists of war contraband. Timber is essential for boxes for ammunition and supplies, for the building of aerodromes, aircraft, dug-outs, shelters and pontoon bridges and to provide railway sleepers. It is also used in the manufacture of war equipment, as for example in the stocks of rifles and light machine guns. Cart-ridge wrappers consist of paper made from wood pulp and large quantities of fibre-board and corrugated board

## Mailway Banking

Brings our Services  
to You



Wherever you work or live, Mailway Banking brings the outstanding services of this bank right to your doorstep. Probably nine out of ten of your banking transactions are routine anyway, so why not handle them by mail? Our special Mailway envelopes and forms assure confidential and safe handling, with overnight service to most points in California.

*Write for information today.*

## CROCKER FIRST NATIONAL BANK

OF SAN FRANCISCO

*California's Oldest National Bank*

Member Federal Deposit Insurance Corporation  
ONE MONTGOMERY STREET

## THE TORMEY COMPANY

GENERAL PAINTERS  
AND DECORATORS

Phone UNDERhill 1913

563 FULTON STREET  
San Francisco

## G. P. W. JENSEN & SON

Building Construction

320 Market Street, San Francisco  
Phone: GARfield 2444



**T**HE Wesix "49'er" ELECTRIC BATHROOM HEATER gives forty-nine inches of INSTANT RADIANT HEAT and QUICK CIRCULATING HEAT.

A smart new heater for \$21.50  
Factory and Office

**WESIX BLDG., SAN FRANCISCO**

**WESIX**

**WESIX ELECTRIC HEATER CO.**

are used in packaging. Further purified wood pulp yields cellulose nitrate used in explosive manufacture and also as the chief ingredient for smokeless powders, photographic films and celluloid plastics. Blasting explosives of which wood flour forms an appreciable part, are employed in construction work outside of war zones. Specially prepared charcoal is the chief working substance in gas masks. Acetone, obtained as one of the products from the destructive distillation of wood, performs the function of a solvent or diluent in some explosives.

Wood is also an important auxiliary war material. Rayon and staple fibre from wood pulp can be more extensively used in place of cotton. Producer gas from wood and charcoal may be used for developing power for cars and trucks and so release petrol for military purposes. Thus the timber resources of any country which are so important in peace time trade, play an equally important role in war.

**SPECIALISTS' CORPS FOR ARMY**

Creation of an Army Specialist Corps with Dwight W. Davis, secretary of war in the Coolidge Cabinet as head, was announced by the War Department.

The corps will establish — "under military control and in distinctive uniform"—a selected group of skilled individuals for all arms of the service, the War Department said.

"For the greater part," it said, "the corps will consist of uniformed civilians who are highly qualified in professional, labor and scientific fields, but who do not necessarily have to possess military knowledge and training."

The department said the corps will place men of "outstanding skills" wherever needed. Except in special cases, the department said, appointees will be over the active draft age.

Because some organization work remains to be done, the department asked that applications for the corps be withheld pending further announcement.

**Save 20% Space**

*Specify*

**PITCHER**

**IMPROVED DISAPPEARING DOORS**

Send for prices and details on our new wood frame sliding doors

Display at  
557 Market Street, San Francisco

**E. C. Pitcher Co.**

Mailing address  
4728 FOOTHILL BLVD., OAKLAND  
Phone ANdover 4193

**VAUGHN - G. E. WITT Co.**

*Manufacturers and Distributors*

Pump Governors	Oil Heaters
Safety Pump Governors	Relief Valves
Automatic Gas Regulating Valves	Oil Burner Governors
Gas Burning Equipment	Oil Burners
Vacuum Pump Governors	Oil Pumping Sets
	Oil Valves
	Oil and Steam Strainers
Vacuum Regulating Valves	Duplex Oil Pumps
Continuous Flow Steam Traps	Rotary Oil Pumps
Thermostats	Boiler Feed Pumps
Reducing Valves	Water Heaters
	Boiler Feed-Water Regulators

4224-28 Hollis St., Emeryville, Oakland



**HERRICK IRON WORKS**

**STRUCTURAL STEEL REINFORCING STEEL**

18TH AND CAMPBELL STS.  
OAKLAND, CALIF.  
Phone GLencourt 1767

**FORDERER CORNICER WORKS**

*Manufacturers of*  
Hollow Metal Products  
Interior Metal Trim

Elevator Fronts and Cabs  
Metal Plaster Accessories  
Sanitary Metal Base  
Metal Cabinets  
Flat and Roll Metal Screens  
Commercial Refrigerators

**269 POTRERO AVE.**  
San Francisco, Calif.  
HEMlock 4100

**Independent Iron Works**

Structural Steel  
Ornamental Iron  
Steel Service Stations  
Steel Tanks  
Standard Steel Mill Buildings  
Bridges

821 Pine Street      Oakland

**ANDERSON & RINGROSE**

General Contractors

320 Market Street, San Francisco  
Phone GAfield 2245

**HEATING  
VENTILATING  
AIR CONDITIONING**

For new head office of  
**BANK OF AMERICA**

Installed by

**Cory & Joslin, Inc.**

**ENGINEERS AND  
CONTRACTORS**

50 Hawthorne Street  
**SAN FRANCISCO**

Phone EXbrook 8772

**ABBOT A. HANKS, INC.**  
**Engineers & Chemists**

INSPECTING — TESTING — CONSULTING  
CONCRETE • STEEL • MATERIALS  
CHEMICAL AND TESTING  
LABORATORIES  
• RESEARCH AND INVESTIGATION •

TESTS OF STRUCTURAL MATERIALS  
DESIGN OF CONCRETE MIXES  
SHOP AND ERECTION INSPECTION OF  
STRUCTURES AND EQUIPMENT  
INVESTIGATION OF STRUCTURES  
AND MATERIALS  
TESTS AND INVESTIGATION OF  
FOUNDATION SOILS  
FIRE RESISTANCE AND INSULATION  
TESTS

624 Sacramento Street, San Francisco

**MULLEN MFG.  
COMPANY**

**BANK, STORE AND OFFICE  
FIXTURES—CABINET WORK  
OF GUARANTEED QUALITY  
CHURCH SEATING**

Office and Factory:  
60-80 RAUSCH ST., Bet. 7th and 8th Sts.  
San Francisco  
Telephone UNderhill 5815

**ARCHITECTS MIGRATE**

Architects are moving about, some are getting into defense work, others are eliminating office expense by moving to their homes. Here are a few subscribers who have lately changed their addresses:

D. E. Jaekle moved to R.F.D. No. 1, Box 166B, Los Altos.

Herman A. Schoening moved to 6616 Telegraph Ave., Oakland.

Mario F. Corbett (from San Francisco) to 2122 Sepulveda, San Bernardino.

Albert W. Burgren (from San Francisco) to 4905 Sixth Ave., Los Angeles.

A. E. Doyle & Associates moved to 2040 S.W. Jefferson St., Portland.

Raymond W. Jeans moved to 1824 San Pedro Ave., Berkeley.

Crowder & Millar (from Pasadena) to 918 Eye Street, Bakersfield.

William E. Foster moved to 686 San Lorenzo Street, Santa Monica Canyon, Santa Monica.

Kenneth A. Gordon moved to 2564 North Foothill Blvd., Altadena.

Henry W. Howell moved to 2538 Fourth Ave., Los Angeles.

Walter E. Wagner moved to 1402 Harrison Street, Fresno.

Train & Schaefer now at 405 South Hill Street, Los Angeles.

Harold G. Spielman moved to 614 South Hope Street, Los Angeles.

**PAINT BRUSH CLEANSER**

Gunn, Carle Company announce in their advertising this month a new solution to the paint brush problem, a product of the Samuel Cabot Company and which Gunn, Carle are marketing here for the first time. The cleaner is a non-caustic liquid solvent manufactured especially for cleaning brushes and softening and removing old dried paint and varnish from them. The preparation is ready to use just as it comes from the can, will not evaporate and is non-inflammable. It will save buying a new brush and unlike other preparations will not injure the life of the old brush or cause the bristles to come out. Gunn, Carle are the Northern California distributors of all Samuel Cabot specialties.

**Plumbing System,  
Fire Protection**

IN

**BANK OF AMERICA  
Head Office Building**

*Furnished and installed by*

**ALEX. COLEMAN**

**Plumbing Contractor  
Heating & Ventilating**

746 Ellis Street  
San Francisco

Phone ORdway 7676

**F E R R O -  
P O R C E L A I N**

A permanent and beautiful exterior finish . . . particularly adaptable to modern design. Eliminates upkeep costs . . . such as painting . . . choose your own color.

The entire fronts of the Chestnut Tree restaurants in San Francisco are Ferro-Porcelain Enamel.

We will be pleased to work out details for Ferro-Porcelain construction in connection with most any type of building.

**FRANK ALLEN CO.**  
**Ferro-Porcelain Constructors**

320 Market St.  
San Francisco

832 W. 5th St.  
Los Angeles

## INCLUDE TREES IN YOUR PLANS

DAVEY, ORIGINATOR OF TREE SUR-  
GERY, OFFERS FREE INSPECTION  
AND ESTIMATE.



SAN FRANCISCO Sutter 3377  
Russ Bldg.

FRESNO  
Maffei Bldg.

LOS ANGELES Tuckler 1929  
Story Bldg.

Local phones in: Pasadena, Palo Alto,  
Oakland, San Rafael, San Mateo

SKILL - KNOWLEDGE -  
RESPONSIBILITY

## BUILDING COSTS UP

Construction costs for a standard six-room house in January were only six-tenths of one per cent above costs in December but 10.3 per cent higher than in January, 1941, according to economists of the Federal Home Loan Bank Administration. The January cost index, based on the average month of 1935-1939 as 100, was 120.6.

Both material and labor costs continued to rise slightly during the month. Materials used in the standard house advanced 0.8 per cent over December, an increase of 11.3 over January, 1941. Labor costs were 0.2 per cent higher than December, making an increase in this price factor of 8.7 since January, 1941.

The estimated number of building permits issued during January showed a marked decrease from January, 1941, according to the U. S. Department of Labor, but the drop was much less pronounced in the private 1- and 2-family dwellings. For this latter class of homes the 15,116 permits recorded during January was a decrease of less than 17 per cent from the corresponding month last year while the total of 17,072 permits for all residential building for the month was a reduction of nearly 37 per cent.

The cost of building the standard house increased in nearly all cities from which reports were received during the period between November 1, 1941, and January 31, an analysis of the individual communities by the Bank Administration's Division of Research and Statistics revealed. Of the 24 cities which reported changes from November, 12 indicated a rise of at least \$100 in total costs. Current figures for all of the 24 communities were well above the January, 1941, average.

Changes in the wholesale prices of building materials usually precede fluctuations in retail costs as reflected in the standard cost index, the Bank Administration's report pointed out, adding that increases in these wholesale costs were evident through January. Labor Department statistics show plumbing and heating materials increased 5 per cent over December, with the 2.7 per cent rise in prices of paint and paint materials.

## LIGHT, AIRY OFFICES

*Especially suitable for architects  
at the*

## HALLIBURTON BUILDING

- Convenient to town but out of the congested traffic areas
- Geographically situated so that there is no telephone toll charge to Beverly Hills or Hollywood
- Free parking for tenants and patrons and no time limit on parking on surrounding streets
- Economical rentals
- MODERN CONSTRUCTION . . .  
. . . BEAUTIFUL . . . DIGNIFIED

## Halliburton Building

(Formerly Beaux Arts Building)

1709 WEST EIGHTH STREET  
LOS ANGELES

## JOHN CASSARETTO

—Since 1886—And Still Active—

### Building Materials

READY MIX CONCRETE  
ROCK - SAND - GRAVEL - LIME  
CEMENT - PLASTER - MORTAR  
METAL LATH - WOOD LATH  
STUCCO - WIRE NETTING

### Service Unexcelled

Bunkers  
Sixth and Channel, San Francisco  
Phones: GARfield 3176, GARfield 3177

## DINWIDDIE CONSTRUCTION COMPANY

## BUILDERS

CROCKER BUILDING  
SAN FRANCISCO

HIGH GRADE MILLWORK  
AND INTERIOR FINISH  
SASH AND DOORS

## LANNOM BROS. MFG. CO.

FIFTH AND MAGNOLIA STREETS  
OAKLAND, CALIFORNIA  
Telephone: TEmplebar 3663

Phone Fruitvale 0443

## Eureka Mill & Lumber Co.

### Lumber and Millwork

38th Ave. and San Leandro St.  
Oakland, California

ARCHITECT AND ENGINEER









